

SUPPRESSED &

INCREDIBLE

INVENTIONS

THE UN-ALTERED ORIGINAL WORK.

BY JOHN FREEMAN

Amazing Locomotion

& Energy Systems

Super Technology

& Carburetors

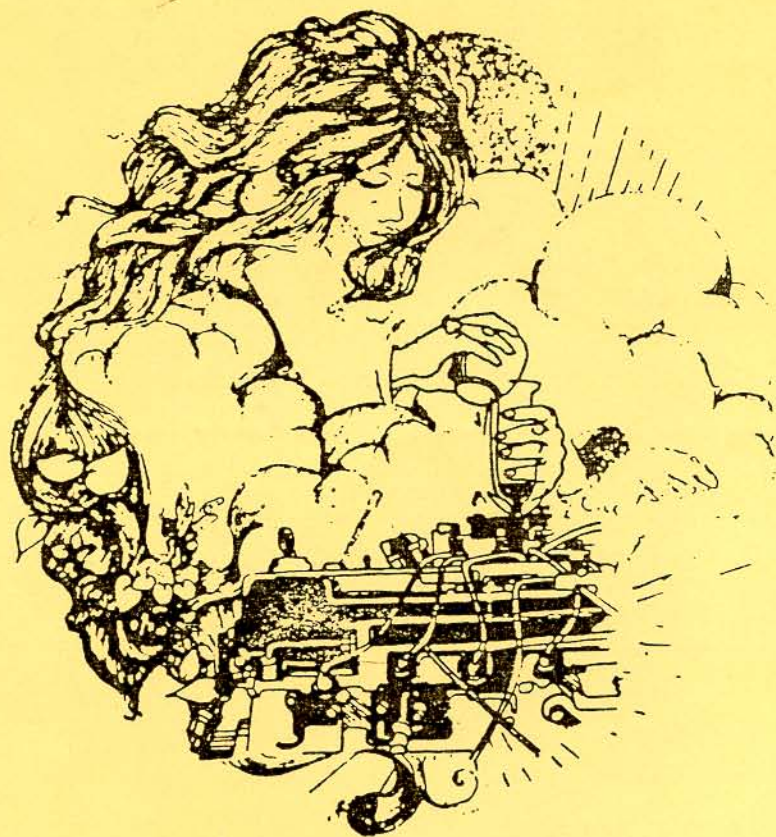

FRY'S

PDF MAKER' S NOTE

The publisher, Al Fry (Fry's Incredible Inquiry's), is retired.

Consequently, I've erased his contact information from this scan.

– Logos



Suppressed and Incredible Inventions

by John Freeman

Dedicated to all who have had the courage to act against technological limitations.

"The prophecies of our science-fiction writers have proven more accurate than the expectations of our scientists and statesmen."

-Lord Bertrand Russell



Chapters

1. Super Mileage Autos & Fuel Systems
2. Incredible & Unusual Motors
3. Flight & Anti-Gravity Concepts
4. Unusual & Free Energy Systems
5. Unusual Machines & Inventions
6. Unusual Concepts & Principles

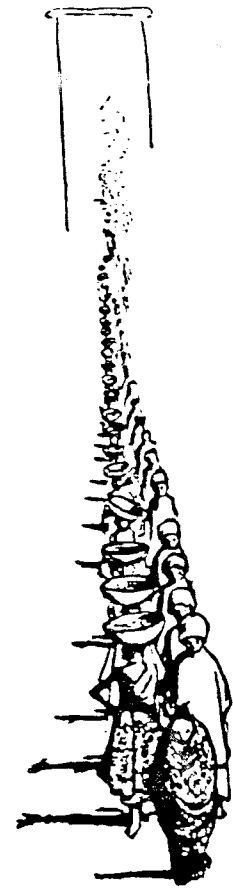

The Past

The more radical concepts in this work have good company in the 'Buck Rodgers' of yesterday. . .yet they too will be but 'tinker toy' technology to the material changes of the future. Some of the more radical concepts here may be incorrect. . .but the goal is the thing of importance. References to some of the exotic technology of the past has been included to help kindle an interest in these areas. In the recurring cycles of life, know that legends will live again and today's dreams will become the reality of our tomorrows. The 'when will be up to you.' (Note. The publisher has manuscripts, yet unprinted, which can later fill in many details of the goal and potential).

J.F.

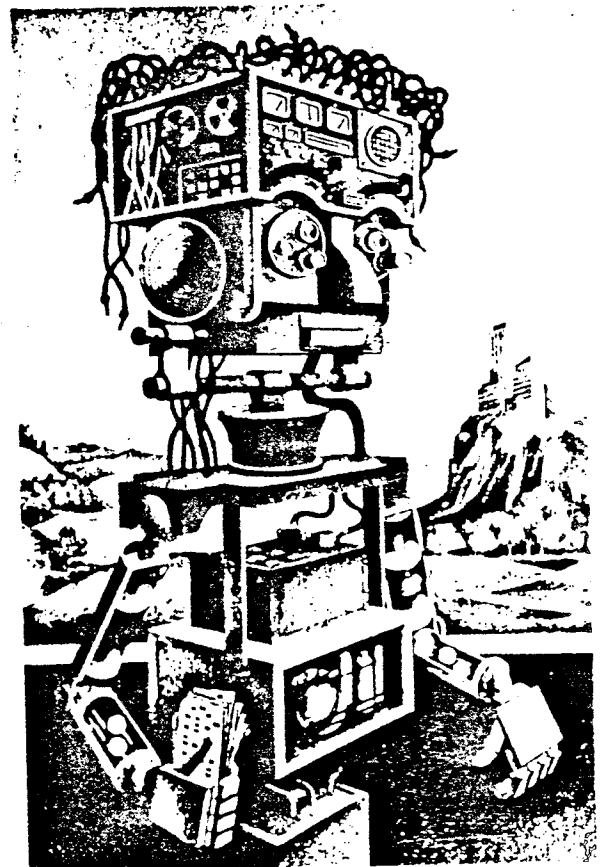
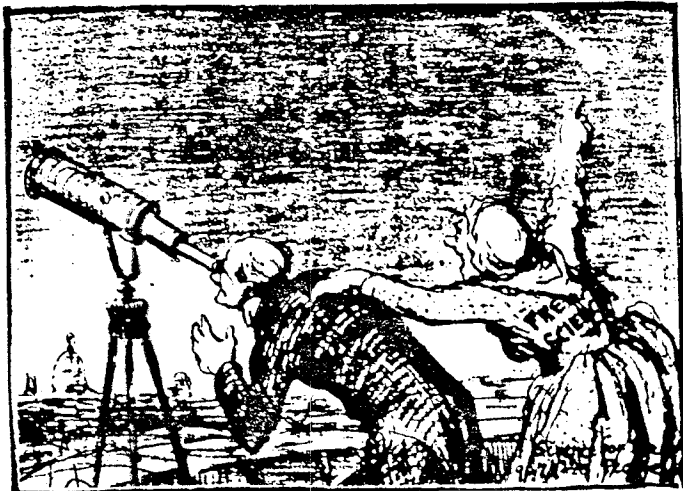

Masami Miyamoto, *Science for the People*

"Suppressed & Incredible Inventions" by John Freeman.
 2nd Revised Edition.
 Copyright © 1976 by A.H. Fry

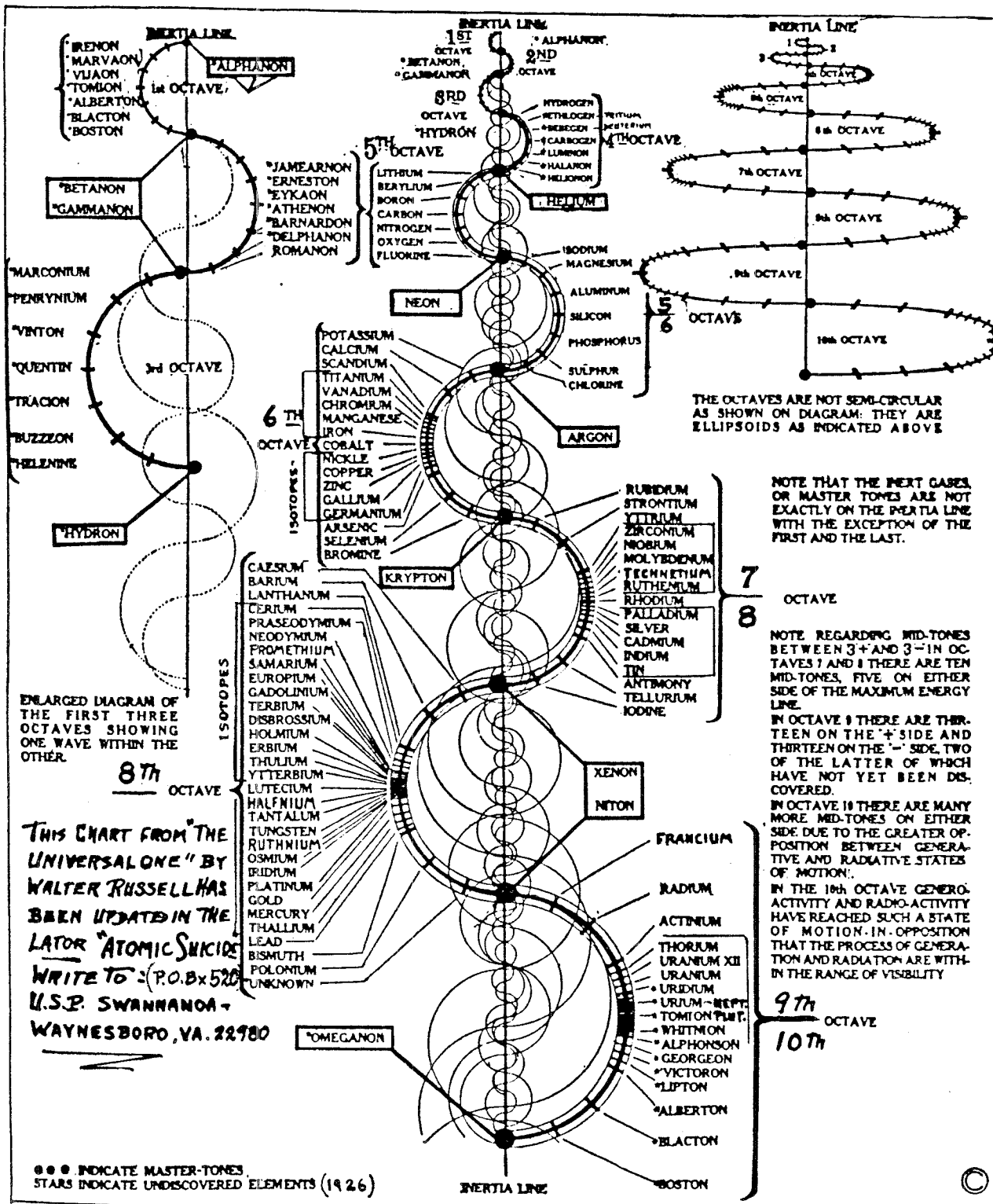

DIAGRAM SHOWING THE TEN OCTAVES OF INTEGRATING LIGHT, ONE OCTAVE WITHIN THE OTHER. THESE TEN OCTAVES CONSTITUTE ONE COMPLETE CYCLE OF THE TRANSFER OF THE UNIVERSAL CONSTANT OF ENERGY INTO, AND THROUGH, ALL OF ITS DIMENSIONS IN SEQUENCE

Chapter 1

Super Mileage Autos and Fuel Systems

Carburetors. The most productive inventor in the field of carburetion was probably G.A. Moore. Out of some 17,000 patents that he held, 250 of them were related to the automobile and its carburetion. While industry today relies on his air brakes and fuel injection systems, it has completely ignored his systems for reducing pollution, gaining more mileage, and improving engine performance in general. As far back as the mid '20's Moore's systems were found to be capable of virtually eliminating carbon monoxide pollution. Persons involved in the automotive field viewed Moore as an authentic genius and could not understand why the industry ignored his advanced automotive designs (17 of his patents are reprinted in "The Works of George Arlington Moore.")(1)

The Bascle carburetor was developed and patented in the mid '50's. It supposedly raised mileage by 25% and reduced pollution by 45%. Its inventor, Joseph Bascle, was a well known Baton Rouge researcher who remodified every carburetor in the local Yellow Cab fleet shortly after his arrival there. In the 1970's he was still optimistic and hinted that the time had come for selfishness to be put aside in regard to fuel systems.(2)

Kendig Carburetors. In the early '70's a small concern in the Los Angeles area turned out a number of remarkable Variable Venture Carburetors. Most of these were hand made for racing cars. Buying one of their less sophisticated prototypes, a young college student mounted it on his old Mercury 'gas hog.' Entering it in a California air pollution run, the student won easily. Not only did the carburetor reduce pollution; it gave almost twice the mileage. Within the week the student was told to remove his carburetor—it was not approved by the Air Resources Board. Due for production in 1975, the simpler Kendig model has yet to be produced.(3)

Super Carburetors. In the late '30's there was an inventor in Winnipeg, Canada, that developed a carburetor which got at least 200 mpg by using superheated steam in its system. C.N. Pogue was quite open about his work until very professional thefts indicated his invention was in danger. Local papers of the time stated that his various backers declined many outside offers they received, and, toward the end, used as many as five guards protecting their interests. What eventually happened is still unclear.

In the early '40's there was another inventor who developed a design that cost him many years of heartache and 'dead ends.' John R. Fish was cut off from every direction, and when he finally resorted to selling his carburetors by mail, the post office stopped him. In tests by Ford, they admitted that his carburetors were a third more efficient than theirs, yet no one helped. As late as 1962 Firehall Roberts used a 'Fish' on his winning Indianapolis 500 car.(5)

The Dresserator. In Santa Ana, California Lester Berriman spent 5 years designing a pollution reducing carburetor for the Dresser Co. Basically, the Dresserator is able to keep the airflow through its throat, moving at sonic speeds even at small throttle openings. By allowing super-accurate mixture control, the device could run a car on up to a 22-to-1 mixture. Test cars passed the pollution control standards with ease and got a typical 18% mileage gain, besides.

Holley Carburetor and Ford signed agreements to allow them to manufacture the carburetor in 1974.(6)

Water Into Gas. One of the most controversial figures of his kind was Guido F. Franch. In the '70's he created a sensation when he began demonstrating his water-to-gas miracle. Chemists at Havoline Chemical of Michigan and the University were among the first to test his fuel. According to both, it actually worked better than gasoline. According to Franch, his secret lay in using a small quantity of 'conversion powder' which was processed from coal. He stated that he processes coal in a series of barrels containing liquid. Supposedly as the 'processed' coal sank to the bottom, a greenish substance rose to the top. It is this residue that was dried into the mysterious 'conversion' powder. Franch said he learned the formula from a coal miner, Alexander Kraft, over 50 years before. While it cost Franch over a dollar a gallon to make his fuel in small quantities, he claimed that it could be produced for a few cents a gallon if mass produced.

A number of private groups tried to deal with Franch for his formula. According to some, the inventor was just too difficult to deal with, and there was just too much gamble involved for the concrete facts they got. Franch continued to put on his demonstrations for years and claimed the auto manufacturers, Government, and private companies just weren't interested in his revolutionary fuel.(7)

Burn Water. Back in the 1930's a number of the early tractors squeezed great economy from a number of simple adaptations. Some simply used a heated manifold to further atomize the gas; others used cheaper fuels. The Rumley Oil Pupp tractor had a carburetor with three chambers and floats in it. One was used for gas, one for kerosene, and the third was for water. After owners started the tractor on gas, they simply switched over to a cheaper mixture of kerosene and water.

With the advent of ultra-sonic devices there were a number of researchers in the early '70's who successfully mixed up to 30% water in gasoline—and used it to run their automobiles.

Some disgruntled motorists just 'spudded' into their carburetors—ran a hose to a container of water and let their engines suck in an extra water ration. Experts claimed this could damage valves if cold water hit them, but few seemed to have trouble.

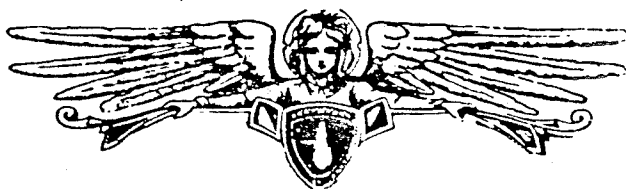

Gas and Water Mix. In the mid-'70's a Dr. Alfred R. Globus of United International Research presented his Hydro-fuel mixture concepts at a meeting of petroleum refiners in Houston, Texas. According to reports, this fuel was a mixture of 45% gasoline, 50% or more of water, and small percentages of crude alcohol and United's 'Hydrelate.' This latter chemical was a bonding agent which kept the fuel's ingredients mixed. Even though it was estimated that a hundred million gallons of gas a day could be saved through the use of this product, no one seemed to be interested.(9)

Water & Alcohol Motor. A Paris engineer ran his private cars on a mixture of denatured alcohol and water according to the French magazine Le Point. The 49 year old inventor-mechanical engineer Jean Chambrin maintained that his motor design could be mass produced for only a fraction of the cost of present engines. As publicity surrounded his achievements the inventor took even greater precautions for security.(10)

Super Mileage Additives. L.M. Beam, who had had his super-mileage carburetor bought out back in the '20's, worked out a catalytic vegetable compound that produced much the same results. By rearranging the molecules of gas and diesel, he obtained better combustion, mileage, and emission control. At one cent a gallon he guaranteed his W-6 formula would save at least 10% in fuel costs. Refused and rejected by State and Federal certification agencies (Air Pollution and Environmental Pollution agencies), Beam was finally forced to surviving in the mid-'70's by selling his formula abroad.(11)

The Lacco Gas Additive Formula. 80% Water, 15% Gas, 5% Alcohol, 2% Lacco.(12)

According to an article in the 1-20-74 San Bernardino, Calif., "Sun Telegram" a man named Mark J. Meierbachtol of that city patented a carburetor which got significantly greater mileage than was usual. At this time the patent (#3,432,281 March 11, '69) is being held by attorney T.F. Peterson for the inventor's widow, Ola.(13)

Highway Aircraft Car. One of the more determined crop of radical auto designers was Paul M. Louis of Sidney, Nebraska. For many years he promoted aircraft design, streamlining to provide super economy in his proposed "Highway Aircraft." He called cars of current design "shoeboxes." His first attempt at marketing a car was in the late '30's. He was stopped by the Securities and Exchange Commission, and it was not until his company withered away that he was given a clean 'bill of health.' In the mid-'70's at the age of 78 he again tried to put his unique designs on the road.(14)

Ultrasonic Fuel Systems. With the advent of the fuel crisis of 1973 there were a number of experimentors who found solutions involving the use of ultrasonic fuel systems. Much of this work involved using sonic transducers to 'vibrate' existing fuels down to much smaller particles. This procedure simply increased the surface area of the fuel and made it work more efficiently. Using a magneto-strictive or piezoelectric vibrator, conical or cylindrical cones were used at from 20 to 40 thousand vibrations per second. An increase in fuel mileage of at least 20% was expected of these units.

Eric Cottell was one of the first persons to proclaim the fact that water could be mixed with gas and used as fuel with these units. His customers had been using his commercial units to emulsify foods, paints, and cosmetics for some time. When the word suddenly got out that the super fine S-onized water would mix perfectly with up to 70% oil or gas, there was congratulations from many sides (June 17, '74, Newsweek, etc.). Later there was nothing but silence again.

Later in 1975 Cottell was interviewed again and explained that Detroit was so miopic that they would probably turn down even the wheel if it were a newly offered invention. Because installations of his reactors was so simple, Cottell ran several of his own cars on a water-gas mixture. He explained that an ultra-sonic unit caused internal stresses so great in gasoline that the molecules can actually absorb water to become a new type of fuel.(15)

Super Mileage from Fuel Vaporization. L.Mills Beam developed a simple heat exchange carburetor back in 1920. In principle it was nothing more than a method of using the hot exhaust gases of an engine to vaporize the liquid gas being burned. Using simple logic Beam reasoned that raw gas going through a normal carburetor simply could not be atomized with high efficiency. As a result there was a waste of fuel when microscopic droplets burned instead of exploded. This, of course, created unnecessary heat and inefficiency.

Since he was easily able to double and triple the gas mileage of the cars he tested, it was not long before Beame was offered a settlement and percentage fee for the rights to his device. Accepting the offer, he never again saw any attempt to market his device or the parties who gained control of his device.

In his "Suppressed Inventions" Mike Brown spoke with Mr. Beame and found that the shadowy trail seemed to lead to a major oil company—but, of course, little could be proved.

Brown tells of a later device which used the same principle. John W. Gulley of Gratz, Kentucky, could supposedly get 115 mpg out of his big 8 cylinder Buick, using his vaporizing arrangement.(16) Typically, this device was assured of obscurity when Detroit interests bought it in 1950. (See diagram and Brown's book)

In the early '70's there was a device made by Shell Research of London that was a bit more sophisticated in design. Vaporizing the gas at around 40 degrees Centigrade a certain amount was allowed to go around the vaporizer to reduce pressure losses. The "Vapipe" unit was supposedly not marketed because it did not meet Federal emission standards.(17)

Another advocate of vaporizing gasoline is Clayton J. Querles of Lucerne Valley, California. According to a Sun-Telegram of 1-2-74, Querles claimed that he could easily develop an engine which could run all day on a gallon of gas. This inventor claims that all he needs to produce such a carburetor is money from an honest backer.(18)



This same inventor said that he took a 10,000 mile trip across the country in his 1949 Buick for \$10 worth of carbide. Building a simple carbide generator, which worked on the order of a miner's lamp, he said that a half pound of acetylene pressure was sufficient to keep his car running. Because acetylene was dangerous, he put a safety valve on his generator and ran the outlet gas through water to insure there would be no 'blow back.'

The Alexander Fuelless Car System. Robert Alexander and a partner spent only 45 days and around \$500 to put together a car that confounded experts. A small 7/8ths 12 v-motor provided the initial power. Once going, a hydraulic and air system took over and actually recharged the small electric energy drain. The Montebello, Ca. inventors were at last reports, very determined that the auto industry would not bury their "super power" system. What happened?(19) ~~US Pat. # 3113064~~

One inventor in the '20's used an electric car which ran off of high frequency electricity which he generated at a distance. Using principles similar to Tesla's ideas, he simply broadcast the re-radiated atmospheric energy from a unit on his house roof.(20)

Henry Ford, acting for himself and the other Detroit oil "powers," quickly bought and quietly shelved this invention. (BSRAJ M-J '73)

John W. Keely used harmonic magnetic energies from the planet to run his mysterious motor. Later, Harold Adams of Lake Isabella, California, worked out a motor thought to be similar to Keely's. In the late '40's it was demonstrated for many persons, including Naval scientists. After a round of "dead ends," it, too, vanished into the pages of the past.(21)

Water to Hydrogen Fuel The process of converting water to hydrogen has long been known, and the standard electrolysis method was developed back at the turn of the Century. The only trouble has been that it takes a great deal of electrical current to convert the water over. With a 40% efficiency at best, a lot of persons were hoping for the advent of cheap fuel cells which would convert the hydrogen and oxygen to electricity at a much higher efficiency. The standard procedure for the electrolytic extraction included using platinum electrodes in an acidic water solution—with at least 1.7 volts of D.C. current.

What gives many hope are reports of early experimenters who overcame the conversion problems. W.C. Hefferlin wrote of using a superior conversion method back in 1921. According to the reports, he worked out a method which used a high frequency current passing through steam. Being associated with some unusual projects (See UFO section) made him suspect to a degree . . . but there are some who feel he put his discovery to good use despite the continued rejections he faced.

Hydrogen is probably one of the most ideal and easily adaptable forms of fuel that we could ask for at the present. Because it returns to water after it burns in the presence of oxygen, it is also pollution-free, and a joy to work with. Regardless of adverse criticism, it has been proven to be less expensive and dangerous than ordinary gasoline when used in automobiles.(22)

An experiment was mentioned in the "Alternate Sources of Energy Journal" in which a couple of readers ran a car for a short period of time on chemically made hydrogen. Tossing some zinc in a bottle of water and acid (any strong acid), they captured the hydrogen given off in a balloon and manually fed it to their auto later.(23)

Actually, feeding hydrogen to a standard auto engine can be a little involved, depending on one's source. I recall a group of California experimenters who fed their old Model A Ford on straight 'tank gases' with not much more than some gas pipe plumbing. Later they developed a more sophisticated (oxyburetor) and allowed their motor suction to feed the correct hydrogen-oxygen mixture. To start the engine on these gases, they allowed the hydrogen to be sucked in first. Later they were in need of a variable Venturi carburetor to aid this procedure.(24)

It is interesting to note that Deuterium, or 'Heavy Hydrogen,' is what powers the 'H' Bomb. A pound of this fuel at less than a hundred dollars (recent estimates) will produce the power of \$75,000 worth of fossil fuels. The proposed methods of producing cheap deuterium now have already become details of the suppressed past.

A classic case of the 'water to auto engine' system was that worked out by Edward Esteval in Spain during the late '60's. This system was highly heralded, then sank among other such 'high hope' hydrogen systems. Foul play? Who knows!

Hydrogen Generator. Sam Leach of L.A. developed a revolutionary hydrogen extraction process during the mid-'70's. This unit was said to easily extract free hydrogen from water and yet be small enough for use in automobiles. In 1976 two independent labs in L.A. tested this generator with perfect results. Mr. M.J. Mirkin who began the Budget car rental system purchased rights for this device and hoped to develop it — against the usual ridicule of a number of scientists. Leach who was very concerned about his security was said to be greatly relieved by Mirkins aid.(25)

Hydrogen Auto Conversions. Rodger Billings of Provo, Utah, headed a group of inventors who worked out efficient methods of converting ordinary automobiles to run on Hydrogen. Rather than rely on heavy cumbersome Hydrogen tanks, his corporation used metal alloys, called Hydrides, to store vast amounts of Hydrogen. When hot exhaust gases passed through these Hydride containers, it released the Hydrogen for use in the standard engines. Billings estimated that the price might run around \$500 for the conversions; gas consumption would be greatly reduced.

Because of the nature of this conversion, there even seemed to be favorable interest from various auto and petroleum interests in the mid-'70's.(26) P.S. In Florence, Italy, an inventor used a special tube to divide water into Hydrogen and Oxygen—without the usual electricity and chemical requirements (unconfirmed '75 report).

Burning Alcohol. Around 1910 there were a number of automobiles burning alcohol, and for some years it was common to find data on burning it in the popular automobile manuals of the day. A number of carburetors were designed to use alcohol or alcohol and gas. In these earlier days, alcohol was almost as cheap as the various benzines—or what we now refer to as gasoline. One of the drawbacks to burning alcohol during this early period was the fact that the engines didn't have enough compression to burn the fuel at high efficiency. Today's automobiles, then, are almost perfectly adapted to using not only the alcohol-gas mixtures but pure alcohol.

Over the years, racing car drivers used cheap methanol, or non beverage alcohol, in many racing cats, and only the availability of reasonably priced gasoline kept the practice from becoming more popular. In the gas crunch of 1973 only a few (old timers) remembered alcohol as a fuel. Reluctant as the oil companies were to recognize the fact, it remained that alcohol could be made cheaply and used without major problems.

M.I.T. testing at Santa Clara, California, retraced the steps of conversions worked out 60 years earlier. First it was found that the carburetors needed to be heated to properly volatilize the methanol. This was done by utilizing the exhaust heat or by running hot water to a jacketed carburetor. Next, because methanol conducts electricity, it can set up an electrolytic action which attracts many modern plastics and metal alloys. Gas tanks, for instance, would often fill with tiny metal particles which required large gasoline line filters to eliminate a plugged up carburetor. Other idiosyncracies included trouble with cars tuned to conform to pollution control standards, and difficulty in starting without a heated carburetor.

In the early days a dual carburetor bowl allowed starting on gasoline, but M.I.T. introduced a fog of propane from a small tank and valve, operated manually. In the case of a methanol-gasoline mixture, it was found that only cold weather hampered excellent mixing and performance.

A breakthrough at the Army's Nalick Laboratories in Massachusetts led many persons to believe that a cheap 'methanol from waste system' was assured. In the early '70's they discovered and developed certain fungi which could convert a wide variety of cellulose into the sugars necessary for producing alcohol. Researchers felt that a ton of paper scrap, for instance, could produce over 65 gallons of high grade alcohol.(27)



Moore Anterior Throttle Carburetor
Brown's Book of Carburetors
MADISON CO.

AIR POWERED CARS. Because air is non-polluting and does not tend to heat nor contaminate engines it is used in, it is an ideal power source. The one major problem, however, has always been just how to store enough compressed air for lengthy travel.

Air has been used for years to power localized underground mine engines, and even a number of experimental 'air autos' have been successful. In 1931 L.A. Engineer R.J. Meyers built a 114 lb, 6 cylinder radial air engine that produced over 180 H.P. Newspaper articles reported that the Meyers vehicle could cruise several hundred miles at low speeds. Compressed air stored as a liquid was later used on advanced air auto designs in the '70's. Vittorio Šorgato of Milan, Italy, (Via Cavour, 121; 2003 Senago), created a very impressive model that was received with a great deal of interest from Italian sources.

One of the outstanding services for persons wishing to keep up with current scientific discoveries are the "Scientific American" Reprints. They are inexpensive and are listed on current order forms from The S.H. Freeman Co., 660 Market Street, San Francisco, CA., 94104.

While few renegade scientists cared to make themselves conspicuous by divulging 'maverick' ideas or 'hush-hush' projects, a number of small journals carried very revealing articles. (See progressive science periodicals listing.) Individuals daring to share data on faster than light radio, exotic space drives, nuclear fission, matter-space-and-time theories, New Math, gravity concepts, etc., could often be contacted through current one dollar folios from the publisher.

THE ELECTROMATIC AUTO. Any mention that an electric car could be made which could regenerate its own power as it was driven was a joke to most 'experts.' Yet, in 1976, this author actually saw such a car function. Using various standard automobile parts and an electric golf cart motor, Wayne Henthron's first model functioned perfectly. Once this remarkable auto reached a speed of 20 MPH, it regenerated all of its own electricity. In normal stop and go driving, it gave several hundred miles of service between recharges.

The secret to the system lay in the way that the inventor wired the batteries to act as capacitors once the car was moving. Four standard auto alternators acted to keep the batteries recharged. With little official interest shown this remarkable system, the inventor became involved with other persons of equally far-sighted aims and resolved to make the car available to the public. (World Federation of Science and Engineering, 15532 Computer Lane, Huntington Beach, CA., 92649).

GAS FROM WATER. Portugese chemist, John Andrews, gave a demonstration to Navy officials that proved his additive could reduce fuel costs down to 2c per gallon. It allowed ordinary gasoline to be mixed with water without reducing its combustion potentials. When Navy officials finally went to negotiate for the formula, they found the inventor missing and his lab ransacked. (Saga 5-'74)

United States Patent

3,890,548

June 27, 1975

18 Claims, 19 Drawing Figures

PULSED CAPACITOR DISCHARGE ELECTRIC ENGINE

Inventor: Edwin V. Gray, Northridge, Calif.
Assignee: KvaRay Enterprises, Inc., Van Nuys, Calif. 91337

Requires only a fraction of the electricity of a standard electric motor design.

The engine or rotary electric machine of the invention is believed to operate on the principle of conservation of energy...

In a linear motion device according to the invention, only a single pulse discharge is needed to perform work.

The applications of the engine include use as an electric automotive engine which is economical.

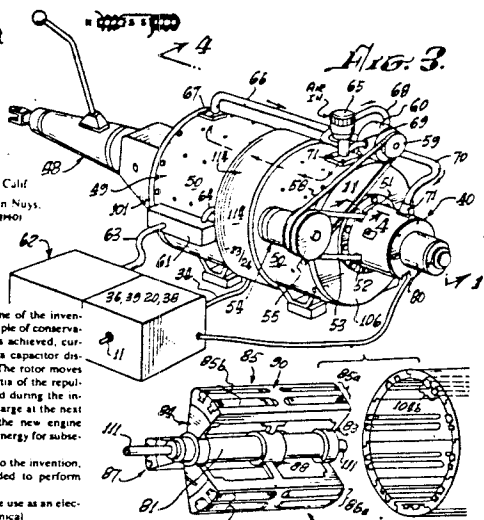

[54] COMBUSTION METHOD AND APPARATUS BURNING AN INTIMATE EMULSION OF FUEL AND WATER

Inventor: Eric C. Collier, "Windermer", Bayville, Long Island, N.Y. 11709
Filed: Mar. 1, 1971
Patent: 3,749,318

FIG. 1 shows, in diagrammatic form, a sonic emulsifier... FIG. 2 is a detail on a somewhat enlarged scale partly in section of the emulsifier.

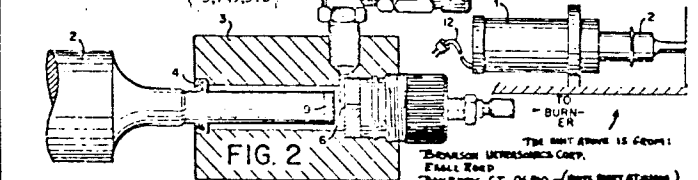

In FIG. 1 a sonic generator 1 is shown powering a vibrator 2 in the form of an acoustic transformer... through an outlet conduit 6 in a plate 10 which is located closely adjacent to the vibrating end 9 of the sonic probe...

FIG. 1 shows, in diagrammatic form, a sonic emulsifier for combustion... FIG. 2 is a detail on a somewhat enlarged scale partly in section of the emulsifier.

Advertisement for a patent titled 'Run Your Car on Water' by W. H. Holland, Jr. The ad includes a diagram of a water-based engine and text describing the invention's benefits.

Advertisement for 'Fuel for Internal Combustion Engines' by Paul A. Goules and Basil Rawes Vaughan. It features a diagram of a carburetor system and text explaining the fuel's composition and benefits.

Advertisement for a carburetor by J.R. Fish, dated April 1, 1941. It includes a detailed diagram of the carburetor's internal components and technical specifications.

Typical Installation using BEAM Carburetor Adapter

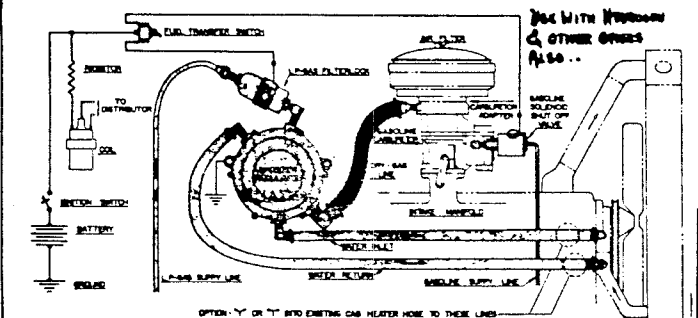

Advertisement for 'The COMET The New Lightweight Car (1976)'. It features images of the car and a motorcycle, along with text describing their specifications and features.

Advertisement for a 'Heat-Electrical Power Interconversion Device' by A.M. Marks, dated Dec. 17, 1968. It includes a diagram of the device and text describing its function and efficiency.

Advertisement for 'The Survival Kit' by ATLAN FORMULARIES. It features images of people and text describing the kit's contents and utility for survival.

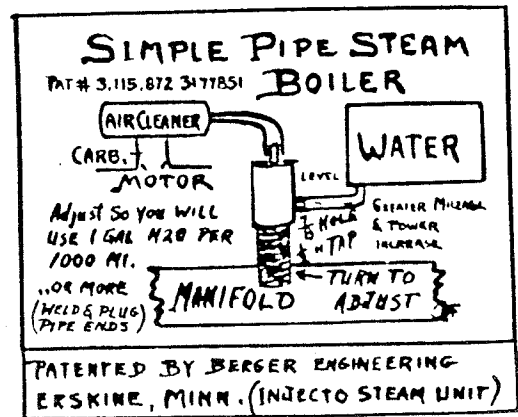
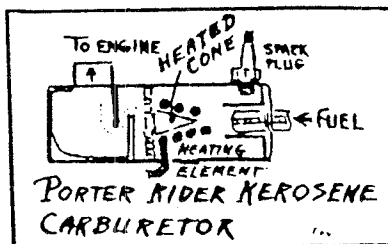
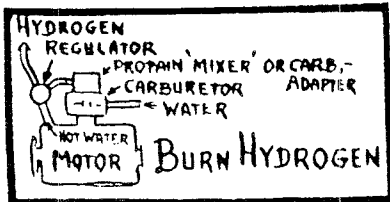
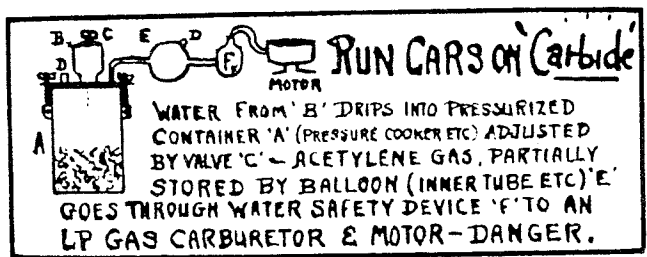
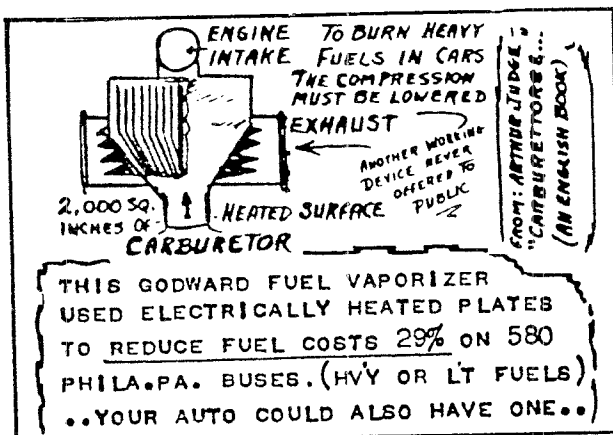
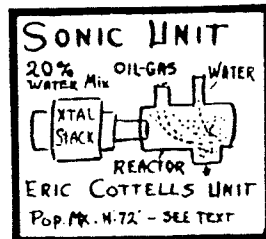
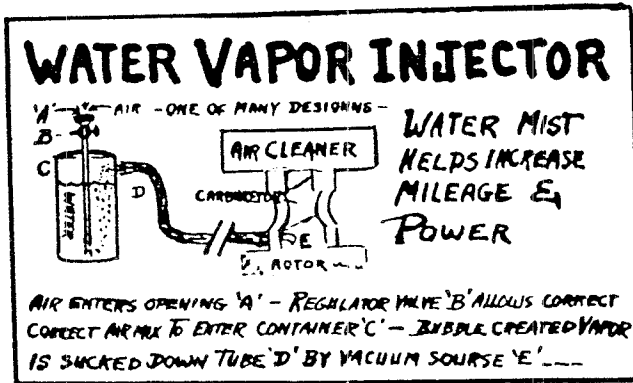
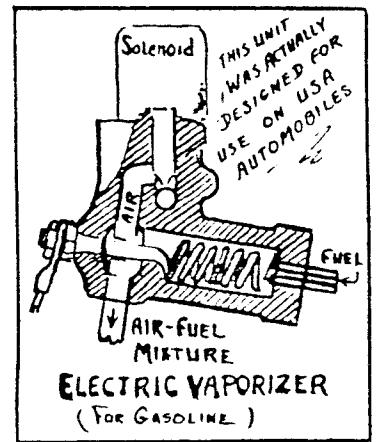
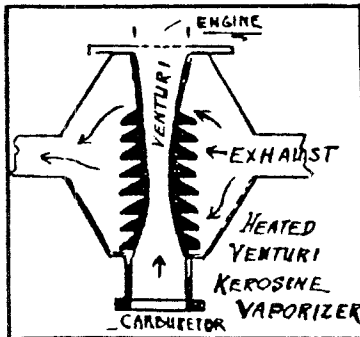
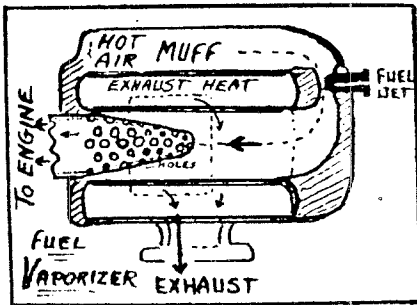
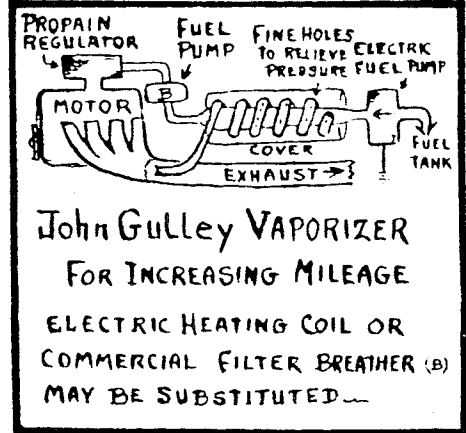
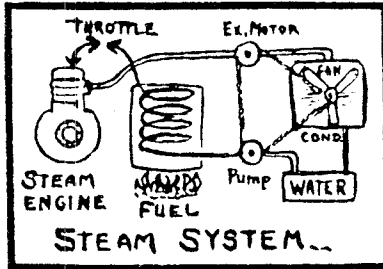
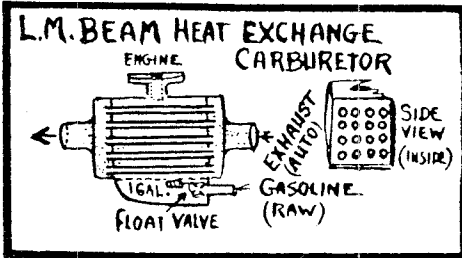

Chapter 2

Incredible and Unusual Motors

Russell Bourke was probably one of the true geniuses in the field of internal combustion engines. Upon noting the incredible waste of motion in the standard auto engine, he set about designing his own engine in 1918. In 1932 he connected two pistons to a refined "Scotch yoke" crankshaft and came up with a design using only two moving parts.

For over thirty years this engine was found to be superior in most respects to any competitive engine, yet it was rejected by all of the powers that be. This amazing engine not only burned any cheap carbon-based fuel, but it delivered great mileage and performance. Article after article acclaimed his engine and its test performance results, yet nothing ever came of his many projects except frustration and blockage.

Just before Bourke's passing, he assembled material for a book, and "The Bourke Engine Documentary" is a most revealing work on engine design and on the Bourke engine in particular.(28)

The LaForce Engine. Edward La Force struggled for years in Vermont to get backing to perfect his amazing engine. Ignored for years by the automotive industry, Edward and Robert, his brother, survived on the contributions of several thousand individuals who believed in them. His engine design manages to use even the harder to turn heavy gasoline molecules. Current engines are said to waste these, and, since they make up to 25% of the current fuels, the use of the heavy molecules was a great step forward.

According to a 'Los Angeles Examiner' article (Dec. 29, 1974), the cams, timing, and so on were altered on stock Detroit engines. These modifications not only eliminated most of the pollution from the motor, but, by completely burning all of the fuel the mileage was usually doubled. One Examiner reporter saw a standard American Motors car get a 57% increase in mileage at the Richmond, Vermont, research center.

With such publicity, the E.P.A. was forced to examine the situation, and, of course, they found that the motor designs were not good enough. Few persons believed the E.P.A., including a number of Senators. A Congressional hearing on the matter in March, '75, still brought nothing to light—except silence.

The LaForces were interviewed by newspapers and auto manufacturers across the world, even though they only modified the basic Detroit designs. Detroit was not interested. Anyone need 80% more mileage?(29)

In his "Suppressed Inventions" author Brown tells of John Gulley of Gratz, Kentucky, who turned down a G.M. offer of 35 million when they wouldn't guarantee to market his amazing magnetic engine. Gulley built his first model from old washing machine parts, and the patent is still available from the patent office file.(30)

FUELLESS 15c per hour PAPP ENGINE. One of the most astonishing engine designs of the '60's was the PAPP engine which could run on 15c an hour on a secret combination of expandable gases. Instead of burning a fuel, this engine used electricity to expand the gas in hermetically sealed cylinders. Far from being complex, the first prototype used a ninety horsepower Volvo automobile engine with upper end modifications. Attaching the Volvo pistons to pistons fitting the sealed cylinders, the engine worked perfectly and showed an output of three hundred horsepower. In a December '68 "PRIVATE PILOT" article, the inventor, Joseph Papp, claimed that it would cost about twenty-five dollars to charge each cylinder every sixty thousand miles. Subscribers couldn't help but wonder why "PRIVATE PILOT" soon changed hands, moved across the Country, and failed to follow up on this project as promised.

TWO CHAMBER COMBUSTION. Because very lean mixtures of fuel do not ignite easily, there were numerous attempts at solving the problem with a separate and smaller compression chamber. By feeding gas separately to such a chamber, it could easily detonate the very lean mixtures in the larger chamber.

A patent in the early '20's covered this idea and Ford perfected the idea shortly after the war. It actually wasn't until the mid '70's that Honda of Japan used the design to make a joke of the various emission control efforts of the U.S. auto industry. (See numerous Pop. Sci. articles, like 7-68).

SALTER'S DUCKS. While confined to his bed a couple of days, an Edinburgh professor doodled up a method of using ocean wave action to produce an amazing amount of electric energy. Large pods shaped something like a duck simply bobbed up and down in a pumping action that used 90% of the waves' energy. Scale models actually functioned perfectly and indicated that larger units should produce hundreds of kilowatts. (Pop Sci 3-'77)

TROYAN MOTOR. Joseph P. Troyan designed a remarkable air-powered flywheel that he claimed could propel an auto for 2c per mile. Using a principle of "ratio amplification of motion" in a closed system, the motor was easily attached to electric generators for pollution-free variable power systems. (See: Troyan Air-Mobile; T.M. Reg. U.S. Patent #040011 or W F S E)

WATER-GAS MIX (University of Arizona). Marvin D. Martin told the press in 1976 that their University funded "Fuel reformer" catalytic reactor could probably double auto mileage.

Designed to cut exhaust emissions, the units mixed water with hydro-carbon fuels to produce an efficient Hydrogen, Methane, Carbon-Monoxide fuel. Letters to their Aero Building #16 Lab brought replies that indicated little of how the units functioned but indications that the Hydrogen was responsible for the great efficiency.

From P.O. Box 3146, Inglewood, Ca. 90304 (1977)

Zubris Electric Car Circuit Design. In 1969 Joseph R. Zubris became disgusted with his ailing automobile and decided to gamble a couple of hundred dollars on putting together an electric car. Using an ancient ten horse electric truck motor, Zubris figured out a unique system to get peak performance from this motor; he actually ran his 1961 Mercury from this power plant. Estimating that his electric car costs him less than \$100 a year to operate, the inventor was sure that larger concerns would be very interested, and he could hardly believe the lack of response he received from his efforts. In the early '70's he began selling licenses to interested parties at \$500. Thirty-five small concerns were interested enough to respond.

The Zubris invention actually cut energy drain on electric car starting by 75%. By weakening excitation after getting started, there is a 100% mileage gain over conventional electric motors. The patent probably doubled the efficiency of the series electric motor. (Patent #3,809,978)(31)

Electric Motor. One of the startling electric motors designs of the 1970's was the E.M.A. motor. By recycling energy this astounding motor was able to get a better than 90% efficiency. Using a patented Ev-Gray generator, which intensified battery current, the voltage was introduced to the field coils by a simple programmer. By allowing the motor to charge separate batteries as it ran, phenomenally small amounts of electricity were needed. In tests by the Crosby Research Institute of Beverly Hills, Ca., a ten horsepower E.M.A. motor ran for over a week on four automobile batteries.

Using conservative estimates, the inventors felt that a fifty horsepower electric car could travel 300 miles at 50 mph without recharging. With such performance the engine could be applied to airplanes, cars, boats, and even electric generators.(32)

According to Dr. Keith E. Kenyon of Van Nuys, California, he discovered a discrepancy in long accepted laws relating to electric motor magnets. When Dr. Kenyon demonstrated his radically different motor to physicists and engineers in 1976, there reaction was typical. They admitted the motor worked remarkable well but since it was beyond the 'accepted' laws of physics they chose to ignore it. Because this system could theoretically run an auto on a very small electrical current, entertainer Paul Winchell saw a great potential and began to work with Dr. Kenyon.(pat. pending).

Diggs Liquid Electricity Engine. At an inventors workshop (I.W. International) an amazing electrical auto engine was shown by inventor Richard Diggs. Using what he called liquid electricity, he felt that he could power a large truck for 25,000 miles from a single portable unit of his electrical fuel. Liquid electricity violated a number of the well known physical laws the inventor pointed out. Melvin Fuller, the expositions president, felt that this breakthrough would have a most profound effect upon the worlds economy. Some speculated that it only could if . . .(34)

In the June 1973 issue of "Probe" there was an article on an electromagnetic engine that was fuelless (See ASE).

Electric Motor Breakthrough. In the '70's it was found that ceramic permanent magnets could replace conventional field coils in electric motors. This resulted in low current drain, high performance, and freedom from burn out, an ideal prescription for electric cars. Two 6 V. batteries are supposedly enough to run a 1 1/4 h.p. motor 50 miles at 30 mph.(33)

Magna-Pulsion Engine. A retired electronics engineer named Bob Teal of Madison, Florida invented a motor which ran by means of six tiny electromagnets and a secret timing device. Requiring no fuel the engine of course emitted no gases. It was so simple in design that it required very little maintenance and a small motorcycle battery was the only thing needed to get it started. Typically, most persons who had professional background in this field felt that the machine must be a farce and viewed it and the inventor with suspicion. After seeing the machine run a power saw in the inventors workshop a number of persons were forced to expand their thinking somewhat. Teal dreamed up his engine design after working on a science fiction novel. His first model was made to a large degree of wood and he estimated that it shouldn't cost over a few hundred dollars to put out larger precision models for use in automobiles. Because he lost an estimated \$50 million invention while he was working on an earlier government project, he was hoping for a better reward on his "impossible" magnetic motor.(36)

The Hendershot Generator. In the late 1920's there was considerable publicity on a device built by Lester J. Hendershot. Through inspiration and an unusual dream this inventor wove together a number of flat coils of wire and placed stainless steel rings, sticks of carbon and permanent magnets in various positions as an experiment. With later adjustments this device actually produced current. According to the reports the inventor had no idea how the device worked and it was often just a case of working by trial and error to get results. A number of persons speculated that the various magnetic currents of the Earth were used when the resination of this device was tuned to the proper frequency.(37)

Thermanuclear Noble Gas Plasma Engine. As nuclear power plants became more refined, it was natural that some designs were carried over into smaller units that could be used in automobiles. On the west coast one group supposedly had one perfected and ready to market by 1976. According to reports it used about \$25 worth of fuel for one cylinder charge, and this would last for around 70 thousand miles of driving. Paul Louis was interested in this design for his Highway Aircraft Car in 1975.(38)

Electro Magnetic Super Motor. In 1975 there was word of an engine which used no fuel whatsoever; it was being developed in North Carolina. This Electro Magnetic Power device was worked on by a group which shunned publicity. There was some speculation that might be used in the Highway Aircraft Automobile.(no confirmation)(38)

Electro Magnetic Super Motor. In 1975 there was word of an engine which used no fuel whatsoever; it was being developed in North Carolina. This Electro Magnetic Power device was worked on by a group which shunned publicity. There was some speculation that might be used in the Highway Aircraft Automobile. (no confirmation)(39)

Temperature Change Wheel. Wally Minto donated a most remarkable design to the world in 1975. His unique unpatented wheel worked on an change of temperature—as low as $3\frac{1}{2}^{\circ}\text{F}$. and was so simple that anyone with material and a welder could build a full scale model. Using any gasproof tanks around the outer form of the wheel, a simple pipe connection between the upper and lower tanks allows the needed exchange of gas. A warmer lower tank would lighten as the upper tank collected the vaporized propane—or low boiling point gas. While slow, the design gave considerable torque and held great promise for applications in backward areas.(40)

It is interesting to note that some of these perpetual motion machines relied on heavy flywheels. Studies in the '70's concluded that flywheels were about the most efficient energy storing device available. Better than fuel cells, lead acid batteries, or compressed gas, the flywheel could carry the wasted power of high horsepower and save motorists big money.

In 1972 Lockheed found that an ordinary iron flywheel spinning at around 24,000 rpm in a reasonable vacuum (anti-friction) worked quite well. In fact, it was estimated that it would require very little research money to quickly raise the efficiency of most current motor drive systems.

Hot and Cold Engine. A 65 year old Swedish inventor made a major breakthrough in the thermo-electric engine field. Because wires of different metals produce electricity if they are joined and heated, there has long been a potential in this principle. B. Von Platen's secret breakthrough is said to give more than 30% efficiency in motors, and, with a radioactive isotope for power, it could free it from fossil fuels. In 1975 Volvo of Sweden obtained rights to his power unit, and it was hoped that the design would soon be in use.

Air Fuel. In the 1920's a Los Angeles (Baldwin Hills) resident worked out a method to run an ordinary automobile on the constituents of ordinary air. Working out a system to keep his motors from melting from the high heat produced by the burning oxygen, he contacted the auto makers. General Motors, acting for the industry, eventually got controlling stock of the small company, and that was the end. A reader of M-J BSRA Journal recalled that the motor was warmed up on ordinary fuel and then switched over to air after it became hot.(44)

A few years ago, in the '50's, there was one intrepid experimenter who could beat the 'gas hog habit' with 'Hydraulics.' He simply attached little hydraulic motors to each wheel and "pumped" his little car around with nothing more than a little lawn mower engine and hydraulic pump.(35)

Air Powered Autos. Air power was used to power rail locomotives and mining equipment for years before the so-called energy crunches. Like the steam engine, the air engine does not need torque converters (transmissions) and lasts for years because of low speeds. L.A. Engineer Roy J. Meyers built a 6-cylinder air car in 1931 and it supposedly had a cruising range of several hundred miles at lower speeds. There seems too few reasons why the air system wouldn't work very well in pollution sensitive cities. Air fueling tanks at the strategic spots would be simple.

In 1973 Claud F. Mead of San Diego, California, thought up a simple air car design. Using a scuba bottle full of air, he ran a hose to an air impact wrench. The wrench shaft was, in turn, hooked to the wheel of his small cart. By using a battery to pump up his tank, he was able to go some distance at speeds up to 50 mph. Because of the amazine potential of this system, Mead wanted to put a more sophisticated design on the market.

Air Powered Engines. Back in 1816 a Scottish clergyman, Robert Sterling, designed an external combustion engine that ran on hot air. Since that time, many experiments have been made trying to perfect his idea. In 1975 there was a breakthrough of some significance in the British Atomic Energy Research Lab at Harwell. There they came up with a working fluid pump which was nothing more than a container with an assortment of pipes and valves. (See illustration) This means that solar energy should be capable of pumping water—or your hot springs or hot air supply can furnish pumping power.

A pistonless version of the Sterling motor was designed by the British Atomic Energy Research Lab. It was connected to a linear (non-rotating) alternator and could put out 27 watts of power a day on less than a quart of propane.

To power autos there have been a number of Sterling designs. Some European firms have run these designs successfully, and such non-polluting engines just hum along under a continuous (not instant) combustion. These engines are simple, non-polluting, and will run on anything from charcoal to sunshine.(48)

In Wolvega, Holland, there was a 21 year old inventor who developed a piston engine which reportedly could run for three months before needing recharging. The engine was remarkable in that it ran on hot compressed air. Before he had a chance to market the engine, he was sent to a mental institution, and his working models disappeared.(49)

In the '60's Louis Michaud designed a simple thermodynamic engine which resembled the internal part of a huge squirrel cage blower. Sitting so that the vanes were horizontal, this machine deflected the air flow path inward and upward to form a miniature hurricane action. Because this system could, theoretically, produce or decrease different types of weather (change temperature and humidity and disperse pollution), it could be a very worthwhile system. Harnessing just a fraction of the energy potential from thermal changes on our planet would supply awesome power.(50)



Hydrogen Car Engines. Many persons believe that hydrogen is the ideal motive force for man. Containing no carbon, H₂ can be burned safely in any enclosure and broken up into safe components whatever the conversion.

A number of minor experimental successes proved the worth of these conversions over the years. Some neighbors' experiments were typical. They simply hooked up a mixing chamber instead of a carburetor on their car, and they experimented with combinations of oxygen and hydrogen until successful.(5)

In 1972 a U.C.L.A. team built an automobile to compete in a 'clean air' race. Using a stock gasoline engine, they lowered its compression rate and made a few alterations to allow for a greater heat build-up. Next, they recirculated part of the exhaust gas to decrease the excess oxygen and slow the combustion process slightly. The result was a success. The only real problem was in the bulky, quickly exhausted tanks of fuel.(52)

Billings Energy Research of Provo, Utah, solved the bulky tank problem a couple of years later when they built a hydride storage system. Hydrogen is chemically locked in powdered iron titanium and is released when heat from the engines' cooling fluid warms it. With this, or a less expensive Hefferlin System (See UFO section) there is little reason for our continuing dependence on fossil fuels.

Justi and Kalberlah wrote in a '66 French bulletin that they could convert water to hydrogen and oxygen using D.C. current and simple nickel, double layer, porous electrodes (3). Their system could store the gases under 100 ATM without a pump being used, and they attained a phenomenal 50% to 65% energetic efficiency.(53)

In '75 U.C.L.A. experimenters ran liquid hydrogen to a standard propane regulator and mixer atop a standard carburetor. In the carburetor they used water to lower combustion temperatures and to act as a combustion and backfire control. (An 'approved' gas mixer or carburetor is necessary in California—Impoo, etc.)

Rockets. The use of rockets in warfare is hinted at in works that are thousands of years old. More recently, however, an 18th-century Prince Hyder Ali used some smaller versions with shocking success against the British. Later the British used thousands of similar improved rockets against Copenhagen in 1806.

In this country private rocket experimenters developed very sophisticated rockets in the 1920's, and, while offering their work to our Government, they received absolutely nothing but rejection. The various short-sighted armed services felt that their standard armament was more than sufficient.

Both R.H. Goddard and H. Cherth predicted space travel back in the '20's. Goddard actually launched one advanced rocket design that rose to 7,500 feet in the mid-'30's. Being more open-minded the German General Staff hired Walter Riedel and a former Cherth assistant, Von Braun, to design rockets for them a short time later.

Using pressurized hydrogen peroxide and permanganate as a propellant, early V-1 rocket design awoke up short-sighted Allied military leaders in a most effective manner. Later the alcohol and liquid oxygen burning V-2's hurtled down on targets up to 200 miles distant.

As the 'Cold War' threat hastened super-space technology, exciting data began to roll in. The Explorer I, for instance, carried Geiger counter equipment by J.A. Van Allen that detected the radiation belt that bears his name. While many gave little significance to this event, there were others who recognized this belt as the restrictive belt which blocked off certain charged particles or energies from reaching Earth — radiation energies that, according to some mystics, once did reach Earth and nurtured the fantastically prolific life during ancient periods. Such persons long maintained that even the huge prehistoric animal life during very ancient times benefited from such radiations and that such animals simply could not gorge enough flora and fauna down their dainty gullets to keep their huge hulks supplied with nourishment. As startling as this theory may sound, there is mounting evidence.(54)

Electrostatic Cooling. For some reason, when static electricity is played on a red hot object, it will suddenly cool the object. This 'electric wind' seems to break up the insulatory boundary layers of air, and it will have numerous applications in our Century.(55)

The 'tabernacle' of Moses in the Bible was said by Lakovsky to be nothing more than a large electro-static generator. While the friction of air against the silk curtains generated the static electricity, the box condenser stored this energy. Mention is made in the '70's of a man who used the Biblical dimensions of the 'ark' and actually made a working duplicate. . . the story has him disassembling it because it was too dangerous.(56)

Steam Locomotion. Who could exclude the beloved steam car from a work like this! In 1907 a Stanley Steamer car traveled down a Florida beach at 170 mph before a bump sent it out of control. Losing ground to the cheaper gasoline vehicles, a number of the old steamers were resurrected and run during the World War II fuel shortages. Even in the '50's a Stanley engine carried one researcher and his newer car across the U.S. for \$6 worth of kerosene.

The Doble Steam Auto was probably the first steamer of modern design. Instead of allowing the steam to escape, it recirculated it so that an owner could drive a thousand miles before refilling the twenty-five gallon water tank. With less than a minute warm-up owners could get performance equal to the best gasoline automobiles.

The amazing Doble engines were guaranteed for 100 thousand miles, and some owners reported having gotten a phenomenal 800 thousand miles from them. From his first auto show Doble got 27 million dollars in orders. The War Emergency Board of the period (1917 plus) discouraged production completely, so Doble was forced to survive abroad building steam trucks for an English firm.

Steam power plants have been no problem. Kinetics, Inc. of Sarasota, Florida, had a superb engine developed for cars of the late '60's. The Gibbs-Hosick Steam described in Popular Science 2-'66 was to use a tiny piston motor to give it impressive performance. A super efficient steam engine was developed by Oliver Yunick in 1970 (Pop. Sci. Dec. '71); another, the H.B.H., in Pop. Sci, Nov. '71. One of the most advanced steam turbine designs came from the DuPont Laboratories in late 1971. Using a recyclable fluid of the freon family. Presumably it contains within its design no need for an external condenser, valves, or tubes. (Pop. Sci. Jan. '72).

Using more basic designs, Sundstrand Aviation put one of their steam power plants in a Dallas city bus. At the same period William M. Brobeck of Berkeley, California, with his assistants, equipped three Oakland buses with similar 'Doble' designs.

Lear Motors Corp. of Reno, Nevada, spent millions on advanced steam designs until it was apparent there would probably be little financial reward in the end. Steam Power Systems of San Diego was another principal experimenter during this period.

About as close as anyone came to putting a production model on the market in the '70's was the attempt by W. Minto. Using Swedish Sullair rotary compressors for motors, he mounted his system on a standard Datsun and got a contract for at least a hundred more. Later modifications included a gyrator engine, which was actually a pump motor working backward.

One of the few new steam engine designs able to be directly tied to the drive wheels of an auto is the KROV design of 1973. Claiming at least a one-third advantage in economy over conventional gas engines, all this engine needed was financing.(57)

I recall that one enterprising gentleman sold a kit to convert gas engines to steam engines during the second World War. He ran around Los Angeles in a converted Model A Ford until he dropped from sight. In the '60's there was a similar conversion kit put out by a small company in Oregon. Furnishing a smaller cam timing gear sprocket the size of the crankshaft sprocket and a modified camshaft, a normal 'gas' engine could easily be converted. This company did not advocate using their units for any but stationary engines, but hinted at a new super fuelless steam power unit coming up.

Super Steam Generator. According to a Texas inventor, Bill Gray, he developed an unusual motor that should get up to 45% efficiency (I.C. Engine is 20%. Rather than a 'flame against boiler design,' he uses a 'combustion product and water in the same chamber design.' His turbine actually uses low pressure to get a good torque, and Gray felt that the design would succeed despite the lack of interest from Detroit.(59)

Another Steam Engine. In the early '70's William Bolon in Rialto, California, developed an unusual steam engine design that was purported to get 50 miles to the gallon. The engine, which used only 17 moving parts, weighed less than 50 pounds and eliminated the usual transmission and drive train in

an auto. After contacting Detroit interests, the inventor was required to sign forms releasing these interests from acknowledging his claims to the design before they would even look at it.

After a Sun-Telegram article on the project, his factory was fire bombed to the tune of \$600,000. After letters to the White House, the inventor finally gave up and let Indonesian interests have the design. At last word, the engine and a new car to fit it will be put out by a Jakarta firm, with the inventor getting his rightful royalty.(60)

Aside from a token steam project by Ford, the steam auto was ignored right up to the time of various Senate pollution control committees of late '60's. Typically, the representatives of the auto industry alleged that steam systems were not dependable, safe, or necessary—especially since Detroit would soon have good minimal emission designs. So, without funding, the small experimenters of this period tended to fade into obscurity.

A notable exception was Bill Leer, who spent millions perfecting systems in his Reno plant. The complete lack of cooperation and interest from major industries or 'powers' eventually even discouraged Leer.

Dr. Rudolph Diesel took the crude heavy fuel burning engine designs of those before him and refined them into the major engineering success of the 1900's. His invention immediately threatened the whole steam engine industry, and just as he was plunging into fame and success, he permanently disappeared from the ship on which he was traveling to Europe.

Electrostatic Motors. The modern world's first electric motor was an electrostatic motor invented by Benjamin Franklin in 1748. Through the years, little was done in this field until a Dr. Jefimenko came on the scene. This good physicist felt it was a 'waste-not' to be using some of the abundant free atmospheric electricity, so he built the most powerful Corona motor so far tested ('74).

He has visions of being able to put his Earth-field antennas on the tops of mountains, where electrostatic energy is particularly concentrated and use an ultraviolet laser beam to ionize the air and send the energy to receiving sites below. To run smaller motors, experimenters find that a few inches of needle pointed music wire will start a Corona. This wire is attached to at least two or three hundred feet of copper lead-in wire held aloft by a balloon, kite, or tower. Tolerances are critical on electrostatic motors, but they are simple to make.(62)

Using more conventional research methods, the Argonne National Labs (Atomic Energy Comm.) spent millions in the early '70's developing numerous "Super Batteries." Somehow, as usual, the public gained little benefit from these breakthroughs (see later sections).

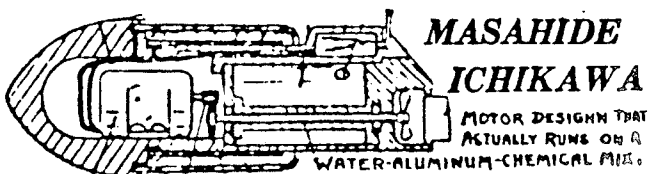

Chapter 3

Flight and Anti-Gravity Concepts

Anti-Gravity Propulsion. A number of researchers feel that if the poles of the atomic fields in matter are arranged in a linear polarity, one can produce an anti-gravity effect. This is the principle a magnet works under when its molecules are in alignment. The perfect example of this principle in application is the bumblebee. Flying against all aerodynamic principles, the wings simply produce enough electro-static polarity bands around the bee's body to carry it aloft.

Anti-gravity can actually come from creating any system which will use the confusion of matter against the orderly flow of energy. In designing a system to use positive and negative (night and day, the Ancients called it) polarities against each other, a Toroid coil with a caduceus winding can be used to separate these fields—and play them against each other. By orienting the poles of the atomic structure of matter instead of the molecular structure (magnet), even non-ferrous metals can gain attraction repulsion qualities.

If technology continues in tact, we should shortly be using propulsion units which are little more than diaphragms of matter sending out discordant vibrations—out of harmony to the resonance of space. (Further data on the working of matter from works by Walter Russell and Geo. Van Tassel)

Back in 1952 John Searl of Mortimer, England, developed what he called a levity disc generator. While working on electrical motors, he noticed that electromotive force was given off as the parts spun. Getting later slip rings to spin out electrons as they turned, he found there was no electricity used. His first generator was surrounding itself with a pink halo as it built up speed and disappeared for good.

Later on refined levity discs were added to small circular aircraft. Almost forty of these twenty-to-forty-foot radio controlled craft were built and flown around Warminster, England.

Searl felt that the simple weightless action of his generator had not been found before because air ordinarily shorts out the high electro-static voltage of most generators. His design created a vacuum around the generator, and, of course, once free of gravitational force, his craft were theoretically free to travel at speeds of thousands of miles an hour. Because Searl found little help from public and official agencies, he started a publically owned space project in the '60's.(63)

While the electrical resistance of various metals has long been affected by super cold temperatures, it was not until the mid-'60's that scientists found a 'breakthrough.'

Niobium with tin zirconium or titanium were found to produce superconducting magnets ten times as strong as ordinary magnets.

As with the 'live' metals mentioned elsewhere, such super-conductive characteristics could allow a super magnetic shield for space ships. This would, in effect, act as a 'force field' protector against dangerous protons and radiation. Superconductive wire, of course, could allow frictionless gyros, and ultra small computers and electrical circuits.

When larger superconductive metals act to repel magnetic fields, we have an actual 'levitation.' At Avco-Everett Labs in Everett, Mass., certain 'wrinkles' are being worked out, and, although all of this work is going toward space flight problems, there is hope.(64)

Vibrations. Besides the well-known oracle caves of antiquity such as Delphi, there were lesser-known objects used for the same purpose. At Dodona there were vases fashioned of metal that supposedly would ring for hours when struck. It would seem logical that certain tonal ranges or octaves would, indeed, assist some to blank out unwanted thought patterns.

Pythagoras was the first person history records as working out a reasonably sound harmonic musical scale. He was also convinced that certain modes or keys had profound effects upon emotions. The 'Hard Rock' music of the '70's, then, was probably far worse on the listeners' well being than the less chaotic music he warned his disciples against.

The early Greeks had great knowledge on the use of vibrations, and the priests were able to build highly unique sound chambers to use in their rituals and religious ceremonies.

Many persons have felt that all elements have certain keynotes, and, if such a keynote is duplicated, it can disintegrate the compounds into their various parts. The mystical principle that two exact things cannot occupy the same space at the same time is valid whether applied to a mind system or to a wall of Jericho.

According to a number of ancient records, round metal discs of certain shapes and resonance could lift men and objects if sounded. Two such discs were made for the king and queen of Spain by the Aztec ruler Montezuma. About the size of phonograph records, one of these gold discs was said to be thicker than the other. Numerous myths spoke of persons flying when they struck or made songs on plates. Indian Sankrit records are usually more detailed and indicate a science of acoustics far ahead of ours. The 716 ancient stone discs found in China by the Russians in the '60's were said to vibrate in a peculiar manner when struck.

In a work called "Secrets Of The Andes" mention is made of a large disc from ancient Lemuria which was used by the Incas in a sacred temple. If struck in a certain manner it could supposedly cause earthquakes, if tuned to an individual vibrational rate it could transport the person to a distant place. The Spaniards found this disc gone when they finally located the temple. In "Seth Speaks" there is some mention of the highly refined Lemurian sonar technology.

אורטו סטונוגראפיקו אל אורטו סטונוגראפיקו

Well-known occult writer, Annie Basant, explained in some of her works that the gigantic stones moved by the ancients were rendered weightless by a simple application of natural magnetic law. Legends of almost every continent give accounts of persons striking objects or singing songs to move themselves or other objects around. Catching up. . .

In 1971 the conventional spinning gyroscope used in navigation was threatened by a tiny two inch Beryllium copper wire held between the magnetic flux of two electro-magnets. This vibrating wire created a major breakthrough in this field. (Honeywell)

Throughout the ages there have been a certain few who have had the ability to match odors to vibratory levels. Even in the present age there are certain perfumes that are said to use a scale of odors just as a musician uses a harmonic scale of notes.

The mystics of the world have used chants to vibrate areas of the body to fuller efficiency. A typical chant has a mental, love, and power tone, ranging from higher to lower.

Early work by Dr. Oscar Brunler found a direct relationship between the output frequency of the brain and intelligence.

The Energies Science has yet to understand what we could call the 'other energies.' Throughout this work, these energies will be mentioned by the various names we are more familiar with.

These energies—or let's say, 'this energy,' can be operated at great distance without any 'grounding' actions by physical bodies. It can even be reflected by mirrors and transported, concentrated, and increased by sound.

The mystics referred to this other energy as 'life force,' and 'Prana.' Eeman called it the X force. Reichenbach called it 'Odic Force; Paracelsus called it 'the mumia,' and the ancients referred to it in various ways as the 'binding force.' Frankly, I suspect it is all a part of 'Mind.'(65)

UFO's and Propulsion Systems. Back in the '20's a former classmate of Einstein, Dr. Biefield, and a University professor, Townsend Brown, teamed up and discovered a new principle of propulsion. It started with a charged condenser on a string and led into miniature flying saucers.

It was found that the closer the condenser plates, the wider area they covered, and the more voltage difference between them the greater the resistance to the effects of gravitation.

Brown continued this propulsion work into the '50's and is thought to have concluded that 3 large condensers under a saucer, (120° control) would be sufficient to make practical flight possible. Theoretically, the condensers act in creating a modification of the gravitational field around a craft, and, by using a "Caduceus" coil to change field polarity, directional guidance can be attained.

As late as the early 1970's one inventor in the Northwest demonstrated similar anti-gravity discs before Portland TV Channel 8 viewers. His 'Sicorsci Aviation' spent seven million dollars on the project before it all faded away.

U.F.O.'s, as reported



These and other propulsion systems were all but ignored, officially. They went against the notions of gravity, for one thing, and for another, how would the Powers That Be make money from them. Jets cost millions. . . these systems were too simple.

A saucer developed by Germany about 1940 consisted of a wing wheel design in which a dozen variable wings acted in principle like a helicopter. The perfect balance required on this design was very difficult to attain, but with jet propulsion, it was said to be capable of almost 2000 km/hr.

One of the more advanced German designs was said to be powered by a 'Schauberger' flameless, smokeless implosion motor. These power plants ringed the craft and tilted at angles necessary to give direction and speed. By incorporating suction openings at the top of the craft, an added boost in speed came from the vacuum created.

Incredible as it may seem, there were many documentations of all this in various reports at the time. A friend of mine told of tons of Germanium he found in one such plant. It was in some way connected with the drive system of one saucer design. Renato Vesco told an "Argosy" author (issue of Aug '69) that most of the data on the German saucers was taken by British "T" teams to Bedford, England, to various secret facilities in Australia, and to B.C., Canada. After continued work on the better projects, various British sources let it be known in 1946 that Britain would soon have aircraft that would be capable of thousands of miles per hour and need no fuel. By 1960 the Canadians had set aside 125,000 acres of very remote land in B.C. for 'experimental aircraft' and the word sifted through that 'Canada had some very advanced aeronautical technology.'

Because the U.S. was unwilling to share the nuclear data she came away with after Germany's fall, Britain and Canada were not about to share their aeronautical data with us. It was their ace in the hole. Huge RAF budgets along with continued sightings of slower and more 'solid' UFO's has led many persons to suspect that our pilots are ordered not to fire upon such craft with good reason. They are our friends—or maybe even us.

A certain Hefferlin manuscript entitled "Rainbow City" (BSRF) explains that the hero developed a very advanced space ship and offered it to the Hungarians just before Hitler took the Country over. Because the Hungarians lacked funds to continue and Germany was closing in, Emery flew two ships to the U.S. and stored them here.

After offering them to the U.S. Government, Emery was rebuffed for a second time; he eventually flew, according to the manuscript, to a small secret protected valley in the antarctic. Mention is made in this work of a fuelless motor which utilizes water electrolysis.

It is also pointed out that other alien UFO's, having no connection with these projects, commonly exist. As an example, in 'unofficial' conversations with the various astronauts, certain reporters stated that all the early 'moon shots' had alien visitors following them for a time. But then, this work is not large enough to go into data on such alien craft.

When Will Our Government Confide in Us? As the space projects of earth pushed ahead in the 1960's very few persons were aware of the fact that some of our most sophisticated advances came from duplicating the equipment on 'alien' craft. A number of wrecked craft of this period got rushed to the Wright Patterson installation and thoroughly dissected. As stacks of UFO documents became de-classified in the '70's it was still almost impossible to obtain them from the responsible sources.

Frogstein Anti Gravity Craft. In 1976 experimenter Walter Baumgartner finally completed preliminary work on a very advanced but simple anti gravity craft in British Columbia. Moving to California, the inventor affiliated himself with the WFSE (see source section).

Alien Triad Propulsion Systems. . . . A number of UFO reports have included the fact that some of these crafts propulsion systems used a triad configuration. A typical case involved a Sgt Moody who was shown a system which used what appeared to be three large crystals joined by sloping rods. According to Moody the alien had told him that "with a little thought on your own, this could be developed by your people."(69)

Electrostatic Anti Gravity? . . . with the help of two electrodes charged with 200 kv.d.c., a piece of aluminum with a bead of mercury on it can be suspended between the posts. Mercury engines are described in ancient manuscripts from India.

Anti-Gravity. Henry William Wallace patented an anti-gravity generator in 1971, and many experimenters in this field were given encouragement and help by the new ideas.

Wallace's device uses rotors traveling from 10 to 20 thousand RPM and the inventor suggests that the intensity of weightlessness can be increased by using mercury — just as is mentioned in the ancient Indian manuscripts.(71)

Dean Space Drive. Norman L. Dean was an amateur experimenter who made modifications to a harmonic drive mechanism known as a 'Buehler Drive.' Consisting of two counter rotating eccentric masses, the Buehler Drive, is used by industry in generating oscillatory motion or vibrations. Over a period of years a number of witnesses swore that Deans drive system actually worked on actual models. Because of various complicated circumstances and the death of the persons involved, nothing ever came out of this invention. No government agency ever showed an interest in it, of course. (70)

Early Flight. Surprisingly, a number of legends and records exist concerning pre-historic flight. A number of these stories concern men who learned the art of flying from their more able 'Gods.' Emperor Shun in China, for instance, was able to fly after such instruction, and medieval drawings from such early periods are pretty convincing. Hindu writings are filled with 'celestial' vehicles which transported the kings and gods. Other accounts of flying machines are recorded in various ancient records and myths including, it would seem, the Bible.

The more mystical works of Phyllos and James Churchward tell of how some of these ancient airships worked. One design mentioned by Churchward took power from the atmosphere in what could correspond to a turbine running on atmosphere gases. He claimed that temple records he saw gave specific instructions for building not only a very advanced airship but its power supply, as well.(73)

In "A Dweller on Two Planets" Phyllos explains how some early airships ran by a balancing of the day and night sides of Nature—anti-gravitational forces were matched against gravity to maneuver such ships perfectly. Some feel that such forces are beyond our present grasp because of certain energies unavailable to the Power Sources (Xtals), but that is a story told elsewhere.

The Vedic manuscript, "The Samarangana Sutrachara," gives no less than 49 types of 'propulsive fire' used in the wingless flying vehicles of India. This work devoted over 200 pages to describing how to build and fly these advanced ships. Some of the propulsion systems used the power of heated mercury, others that of electrical or magnetic forces.

The "Mahabharata," "Drona Parva," and "Ramayana" also give accounts of these 'Vimanas' and their remarkable abilities.

According to Dr. Ruth Reyna, there are Sanskrit texts in the University of the Punjab that tell of space flights 3,000 B.C. Commissioned by U.S. Space authorities, Reyna found that these flights were considered imperative due to the threat of a deluge on Earth.

Gravity Defying Gyroscopes. Edwin Rickman, an English electrical engineer, had recurring dreams about an anti-gravity device in the early '70's. After a patent was obtained on the basic principles, it came to the attention of Prof. Eric Laithwaite of London's Imperial College of Science and Technology. With certain modifications, this scientist declared in 1974 in press releases that this anti-gravity motor should enable us to travel to other solar systems.

Theoretically, the motor could be adapted to drive various land vehicles, and, in demonstrations at the Royal Institute at London, his little 20 pound electrically driven gyroscope, motors rose against the force of gravity with no problem. Researchers in this field feel this device is based upon electromagnetism and vector multiplication.(72)

Laithwaite Anti-Gravity Machine. Prof. Eric Laithwaite of the Imperial College of Science and Tech. in England invented an anti-gravity machine in 1975. Defying the laws of Newton, it depended upon the fact that no energy was required to return its two gyroscopes arms to their starting position.(47)

Flying Suits. The Asian conflicts prodded the development of one man flying suits in the '60's. In his "Gold of The Gods" Von Daniken points out numerous earlier models depicted on monuments, tablets, pots, and even as Polynesian ritual objects.

UFO's. Many strange stories have circulated about the flying saucers being built by various governments on our planet. While there is good reason to believe that alien saucers do exist and do visit our planet, there is a surprising amount of evidence concerning the models of local origin.

Several ancient manuscripts give details on building craft that would fit into the flying saucer category. However, in recent times, the most authentic reports come from records concerning the work of Hitler's scientists.

In the few short years that Hitler gave his scientists free rein to develop technology, there was astonishing progress. Allied teams who rushed into the secret underground bases and projects after the War were dumbfounded by the technological advancement they found. A small plant in central Germany (M-Werke) was on the verge of producing missiles which could destroy entire U.S. cities. Co-operation between G-Works and various other installations produced the 'Kugelblitz.' This was an advanced lens-shaped craft that destroyed Allied bombers by Electrostatic firing systems. It could travel by remote control, seek a target by infra-red detection, and remain undetectable on radar screens. According to a number of later Allied intelligence reports, there were super turbine engines capable of running on liquid oxygen or hydrogen peroxide, a gelatinous, organic-metallic fuel—and on even the atmosphere.

More recently a number of researches have been interested in advanced power systems. Cathode ray generators around a craft were felt to be capable of pulling it into space. Atomic fusion instead of fission was felt to be a method of using magnetic field propulsion by converting atoms.

More theoretical was a design based upon the "Lense-Therring effect." Here a torus wrapped in a tube of accelerating dense matter should create a gravity field strong enough to overcome the gravity of Earth. Another device possible under the present accepted laws of physics is built of a thin disc of nuclear matter. Such a device is lightly covered in an 8/75 Analog-Science Fact Magazine.

In this issue Dr. Forwards mentioned another system. Because any mass with velocity and acceleration can create force (according to accepted laws), a round torus rotating outward on itself should cancel Earth's gravity. Unfortunately, these machines would require quantities of dense matter.

Because many can't accept the current gravitational theories, there are many theoretical designs which use what we could call negative matter. Because an object of negative matter would repel an object of positive matter, we would get a principle of great potential. This, of course, would be similar to the 'Day and Night' energies supposedly used by the ancients, mentioned elsewhere.

In a similar vein, one could theoretically use the polarity of inertia. By changing inertia from positive to negative—or even redistributing it, one might easily overcome gravity.

Einstein observed that if the UFO occupants had mastered gravity, they would also have overcome inertia. Saucers with anti-gravity screens could ignore both gravity and inertia. They can instantly change direction and speed. Anyone who has observed the darting movements of some UFO's must concede that something is breaking the laws of inertia.

Many persons with a link to their own higher knowledge levels maintain that we live in a contracting and expanding universe of many dimensions. By using technology which can contract a space craft for example, the craft cannot only pass into the other dimensions, but easily pass through less dense materials. Because light rays would be less rapid than the event itself, distortions would result—which seem to be well recorded in documented encounters.

Will our leaders continue to assume that we are too dense to understand—or, perhaps, too dangerous to know? It wouldn't surprise some persons to see the 'leaders' looking down from advanced craft, in event there were a major disaster.

Exactly how many Government rooms are filled with data on UFO's could be anyone's speculation. What is well remembered by many is the fact that many samples of strange materials and machinery have been handed over to Government authorities. In all of these cases, the samples have simply disappeared and have been denied to later inquirers. Examples of this can be found in UFO publications of the '50's and '60's.(76) A typical case in 1969 involved a material found by professor R. Bracewell, the man who solved our spinning satellite problem. Absorbing heat and releasing it slowly by over a period of several days, this material could not be analyzed nor duplicated by our best procedures.

Is there actually an organized force to stamp out rational data on UFO's? Some think so. An Argosy Magazine article mentioned dozens of saucer researchers who mysteriously disappeared. Albert Bender, a well-known researcher, told of seven visitations by mysterious 'men in black.' He felt that with such powers to cloud men's minds as those visitors seemed to possess, they could be of alien origin.

Another well-known UFO researcher with a similar feeling is Laura Mundo. She felt that the 'man in black' who contacted her were 'front men' for aliens who wished to frighten her out of the work.

Grey Barker wrote his "They Know Too Much about Flying Saucers" during the period when the 'men in black' were most active.

What occurs to many persons of open minds in this area is that there are not only UFO's of Earth origin, but there are very sophisticated craft of extraterrestrial 'alien' origin as well. With literally hundreds of UFO publications and groups and thousands of sightings, the evidence is pretty overwhelming for either or both craft.(77)

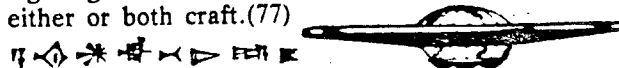

United States Patent

2,886,976 19 Claims Patented May 19, 1959
SYSTEM FOR CONVERTING ROTARY MOTION INTO UNIDIRECTIONAL MOTION

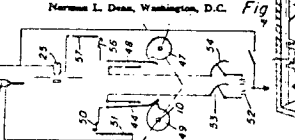

SUPPRESSED IN BRITAIN UNDER NAME 'VORTELLA'S' DATA IN U.K. TECH. DIS. PAPERS

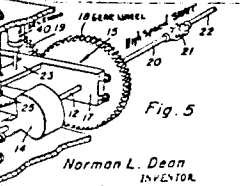

THE DEAN SPACE DRIVE

3,636,605
METHOD AND APPARATUS FOR GENERATING A SECONDARY GRAVITATIONAL FORCE FIELD
Henry Wm. Wallace, 402 New Pa. (PO) Chiro, Inc. Laurel, Md. 20640
Filed Nov. 4, 1964, Ser. No. 773,051
U.S. Cl. 35-19 Int. Cl. G09B 27/60 18 Claims

ABSTRACT OF THE DISCLOSURE
Apparatus and method for generating a time variant secondary electromagnetic force field due to the dynamic interaction of relatively moving bodies and for transforming such force fields into energy for doing useful work

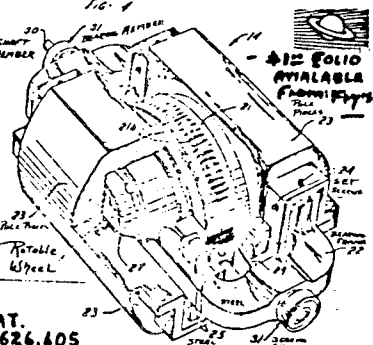
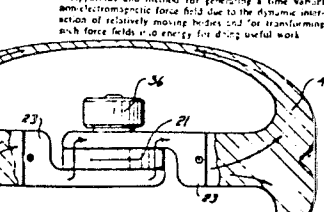

PAT. 3,626,605

AIRCRAFT OF C.B. Lennon et al
US PATENT 3,312,425
April 4, 1967

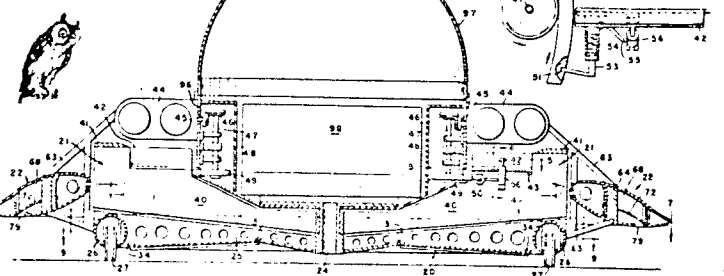

FURTHER UFO SOURCES
'FLYING SAUCER REVIEW' (\$1.25)
281 Camden High St. London, NW 1, U.K.
'NEW ATLANTIAN JOURNAL' (\$0.45)
4280 68th Ave. N. Pinellas Park, FLA.
APRO Org. 3910 E. Kleindale Rd, Tucson
NICAP, 3535 Univ. Blvd. W. Kensington, MD
MUFON, 40 Christopher Ct, Quincy, Ill.
UFO Clipping Service, 3521SW 104th
Seattle, Washington, 98146 (\$4 Mo.)



The CIA - UFO Cover-Up
A report concerning the State and the cover-up of UFO sightings... (CIA report on the existence of UFOs...)

Sunday Mirror November 28th 1971, Derbyshire Dirt
Forty-year-old Mr. ... (text about a UFO sighting in Derbyshire...)

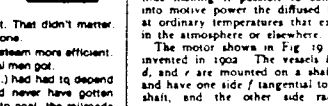

cycle of working in which the heat rejected in the Carnot cycle is intercepted and returned to the source, thus making it possible to convert into motive power the diffused heat at ordinary temperatures that exists in the atmosphere or elsewhere. The motor shown in Fig 10 was invented in 1902. The vessels b, c, d, and e are mounted on a shaft f, and have one side f tangential to the shaft, and the other side radial.

Patents as First Line of Foreign Penetration

The purpose of this analysis is to explore the relationship which the less developed countries (LDC) have with the United States, Europe, and Japan concerning technological dependence. This dependence, engendered by the patent system along with the sale and distribution of technology by transnational corporations, further contributes to the drain of capital-already scarce-from these countries.

Outright stock ownership is the usual means of economic penetration by transnational corporations. However, in the less developed countries where conditions of economic nationalism prevail, minority ownership can become equally important. This is because nationalization of strategic industries can succeed only if development of the necessary technology is foreign since this dependence upon committed foreign control over decision-making and profits.

The out of technology is a crucial ideological creator and perpetuator of economic dependence because it so elevates and mystifies technology as to make independent experimentation next to impossible. Workers and peasants are excluded from control over technology and made to feel "unprepared" to tackle technological questions, even at the local level of broken parts, repairs, etc. study suggests that foreign corporations divide markets among themselves, "arrangements of patent crosslicensing among transnational corporations, cartel agreements, joint segmentation of markets..." (LDCs often constitute a common behavior rather than the exception [10]. By 1970 more than 100 U.S. controlled corporations, with investments worth over \$1 billion, were operating in Chile [11]. Twenty-four of the top 30 U.S. controlled transnationals were involved.

It should be noted that private U.S. corporations that have done general research and development in U.S. industrial agencies retain all patents coming out of such research, except in cases where the patents for the R&D are concluded with the Atomic Energy Commission or NASA. The Federal Electric Administration has been accused of "stealing" patents at the expense of U.S. taxpayers [12]. According to George Sanyalis, "abstracted from a chapter in Jack I. Johnson et al, 'The Chilean Road to Socialism' (Spanish Edition), Mexico City, Fondo de Cultura Economica, 1974."

- While people are struggling for liberation, science is mobilized to maintain their subjugation. From overt counterinsurgency weapons to the most subtle behavior control technology (see S/P/ no. VI, no. 3, May 1974), from the battlefield to the streets to the prisons to the schools, science is being marshaled by the ruling class to maintain its political control.
- While people are dying from pollution, industrial hazards, U.S. bombs and bullets, squalid conditions, and inadequate preventive medicine millions of dollars are being spent in developing artificial organs, dangerous drugs, sophisticated medical machinery, and new strains of (potentially lethal) viruses.
- While people go hungry throughout the world because they are too poor to buy the food that exists or because their land has been turned over to cash crops which they cannot eat, science is called on to develop "miracle" seeds that require miracle fertilizers and miracle pesticides, miracle irrigation schemes and miracle agricultural machinery. By the same "miracle," this Green Revolution has served to enrich capitalist control of agricultural production, but not to feed the poor. (Walden Street Science for the People #78 Jamaica Plain, Mass.)

PERPETUAL MOTION JOURNALS

The earliest history of perpetual motion that is traceable is "Surya-Siddhanta" and "Sidhanta-Siro-mani" written in Sanskrit by Indian astronomers about 6th and 12th century by 'Varahamihira' and 'Bhaaskaracharya' respectively. The text of former first describes a demonstration of a perpetual motion machine, having become lost, is, by the Sun's favour, again revealed to some one or other, at his pleasure". This is continuing till to-day, The belief in the feasibility of perpetual motion machines must have reached Arabs from India during the 12th century. The perpetual motion mercury wheels of the Indians and Arabs, travelling westward introduced it in Europe during the 14th century. The note books of Villard de Honnecourt began to use the expression 'Perpetuum Mobile' in 1237. Perpetual motion is considered an impossibility by academicians, even when they can buy a 'Perpetual Motion Clock' or a 'Thirity Bird' powered from continuous sources of energy in Nature. Should we call them NATURE [ENGINE] after the type of 'fuel' utilized? Shortage of fossil fuels is in view, consequently a search for utilization of free sources of energy and development of old projects is desirable.

D. R. DUTTA
(1) Nature Engine, by Dutta D.R., Calcutta, 1971.

At that time, steam engines were bulky and inefficient. That didn't matter. Just build them bigger, pour in more coal and get the job done.

The coal companies had no interest in research to make steam more efficient. The more coal the steam engines wanted, the richer the coal men got. If the developers of the Internal Combustion Engine (I.C.) had had to depend on the coal men to back their research, the I.C. would never have gotten anywhere. While the I.C. was in its infancy and no threat to coal, the railroads actually lobbied against and held up the development of steam engines for non-rail vehicles.

So back then, the I.C. was a genuine promise, a real benefit. The oil companies, making slow progress competing with coal, saw the I.C. as the key to their survival in the energy field. They weren't interested in the steam engine, however. The unsophisticated steamer could still use their competitor's coal. Developed, it would never need their more expensive gasoline but would do very well on cheap kerosene, as it still does today.

An Internal Combustion Engine starts going to hell after about a year. Due to its inferior conservation and the lack of internal bettering, a steamer would outlast at least five I.C.'s. Detroit would rather sell five engines than one. Wouldn't you? If this were the only reason, it would be enough for the permanent rejection of steam engines by Detroit. from the SURVIVOR

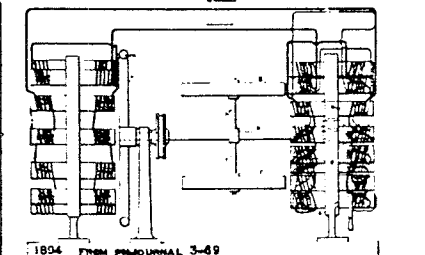

May 24, 1932

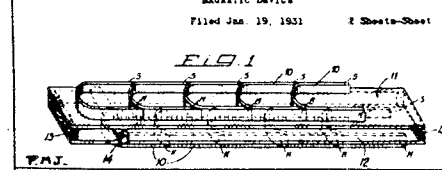

G.H. BOUGON 1,859,764
MAGNETIC DEVICE
Filed Jan. 19, 1931 2 Sheets-Sheet 1

Amazing Klein-Fogelman Wing... avoids stall phenomena. Came from toy paper plane & works against recognized principles. U.S. Press '76'

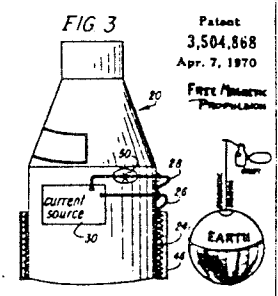
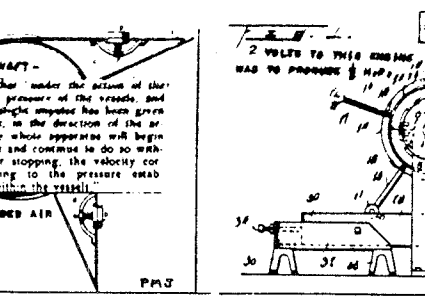

3,504,848
SPACE PROPULSION SYSTEM
Joseph F. Engelberger, Norwood, Conn., assignor to Consolidated Control Corporation, Danbury, Conn., a corporation of New Jersey
It is a primary object of the present invention to provide a new and improved space propulsion system in which thrust is produced without the development of physical reaction forms.

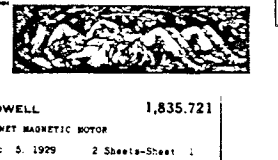

A POWELL 1,835,721
PERMANENT MAGNET MAGNETIC MOTOR
Filed Dec. 5, 1929 2 Sheets-Sheet 1
Dec. 8, 1931.

PERPETUAL MOTION ARTICLES IN 'SCIENTIFIC AMERICAN' 12/24/1912 - 11/18/1911

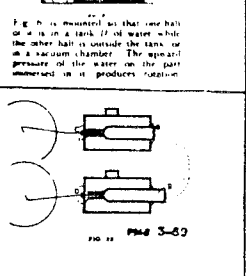

Fig. 6 is mounted so that one half of the wheel is inside the tank or a vacuum chamber. The upward pressure of the water on the part immersed in it produces rotation.



DR. GODDARD FLYING A ROCKET IN 1929 (designed BAZOOKA in 1918)..he was scoffed at and ignored until later WW II.

Patent 3,113,314

ELECTROMAGNETIC PROPULSION
 Thomas F. Tompkins, Inventor in
 Washington, D.C., Washington, D.C., a corporation
 of the District of Columbia

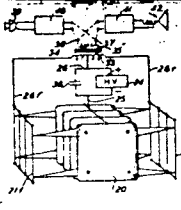
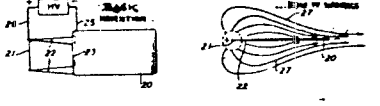

Patent 3,106,858 Patented Oct. 8, 1963

PROPULSION SYSTEM
 Warren A. Blum, Inventor, Milton, Mass., assignor to
 Curt E. Greig, Milton, Mass.

The present drive or propulsion system is applicable to all vehicles, such as ships, submarines, torpedoes, and the like traveling in salt water. Insects, so can be experimentally shown the device also has utility as a space drive system for imparting thrust to a vessel traveling in an outer atmosphere, for example, space.

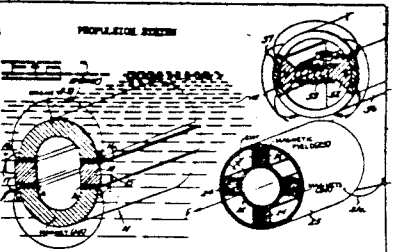

Patent 3,662,554
 May 16, 1972

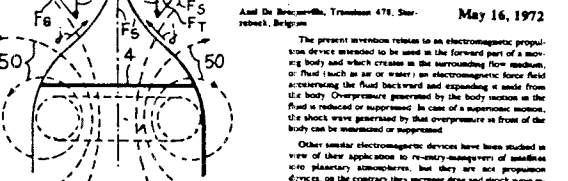

The present invention relates to an electromagnetic propulsion device intended to be used in the forward part of a moving body and which creates in the surrounding flow medium, or fluid (such as air or water) an electromagnetic force field accelerating the fluid backward and expelling a wake from the body overpressure generated by the body motion as the fluid is reduced or suppressed in case of a supersonic motion, the shock wave generated by that overpressure in front of the body can be maintained or suppressed.

Patent 3,071,705
 Jan. 1, 1963

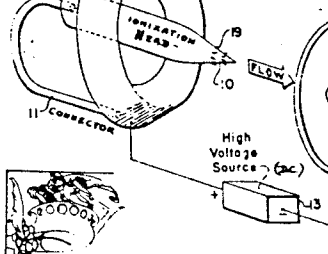

ELECTROSTATIC PROPULSION MEANS
 William J. Conroy, Paul Jefferson, and Donald F. De Soto, Inventors, New York, assignors to General Motors Aircraft Engineering Corporation, Warren, N.Y., a corporation of New York

The invention relates to electrostatic propulsion means, and more particularly to means for propelling air and other fluids by electrostatic forces acting across such fluids and for propelling devices through air and other fluids by such forces.

Patent 3,495,791
 Patented Feb. 17, 1970

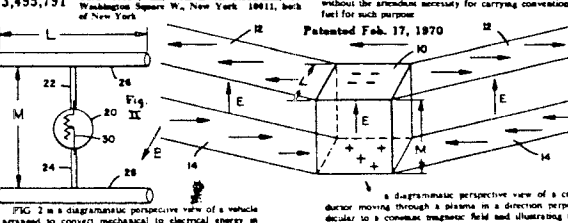

Accordingly, it is a general object of the present invention to provide a method of and apparatus for effecting an electro-mechanical interchange in a moving space vehicle so that, for example, propulsions of the vehicle can be effected to overcome the mentioned drag forces without the expenditure necessary for carrying conventional fuel for such purpose.

Patent 3,095,167
 June 25, 1963

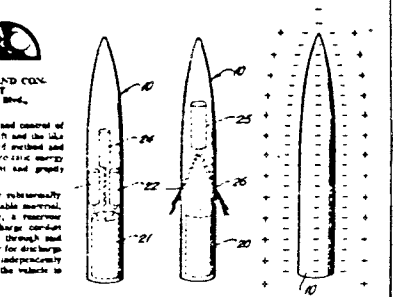
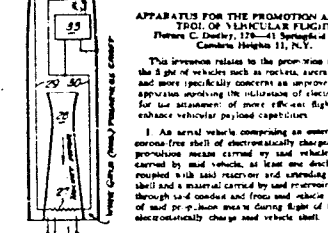

APPARATUS FOR THE PROMOTION AND CONTROL OF VEHICULAR FLIGHT
 Thomas C. Deary, 128-21 Springfield Blvd., Canarsie, Brooklyn 11, N.Y.

QUASI-CORONA AERODYNAMIC VEHICLE
 Ernest C. Olson, Elizabeth, N.J., assignor to American Research Corp., a corporation of Delaware

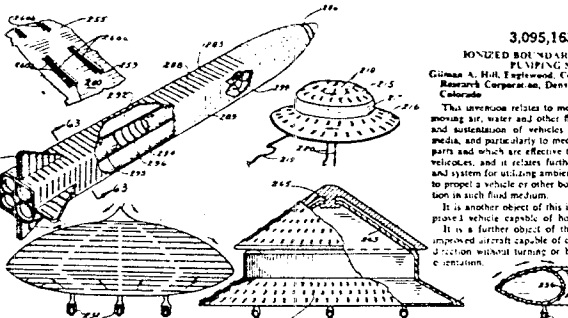

Patent 3,095,163 June 25, 1963

IONIZED BOUNDARY LAYER FLUID PUMP SYSTEM
 Gilman A. Hill, Englewood, Colo., assignor to Petroleum Research Corporation, Denver, Colo., a corporation of Colorado

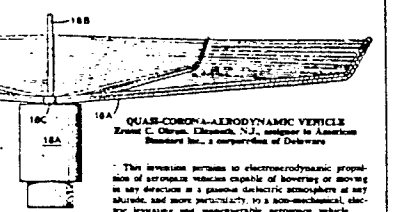

FLYING APPARATUS
 Glenn E. Hagan, Frank Meadows, N.Y., assignors to Electro-Corpus, New York, N.Y., a corporation of New York

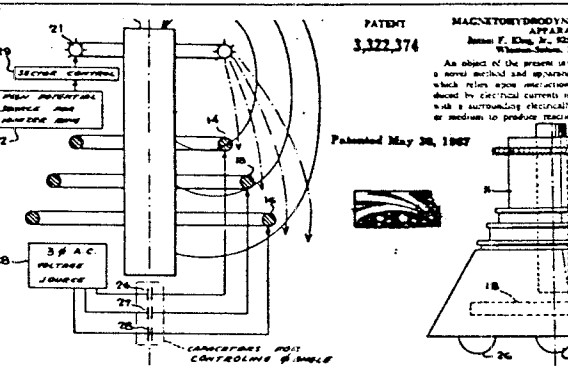

Patent 3,322,374
 Patented May 20, 1967

MAGNETO-HYDRODYNAMIC PROPULSION APPARATUS
 James F. Elm, Jr., 923 Commercial Road, Wilmington, N.C. 27404

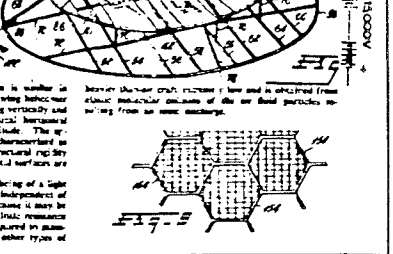

United States Patent 3,518,462 June 30, 1970
 T. T. BROWN
FLOW CONTROL SYSTEM

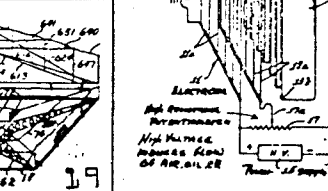
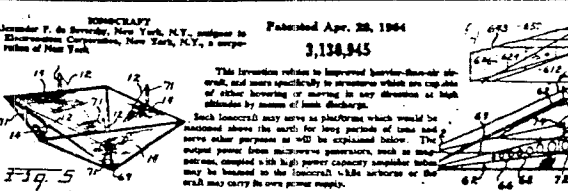

PLASMA FLOW CONTROL SYSTEM
 It has been heretofore proposed that electrohydrodynamic phenomena and electroviscosity be harnessed to convert electrical energy directly into fluid flow without the aid of moving parts. Typical examples of structural arrangements suitable for this purpose are disclosed in the present application prior U.S. Pat. Nos. 2,919,510 and 3,014,318.

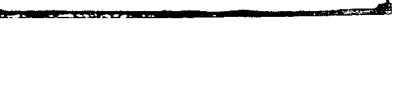
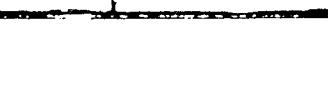
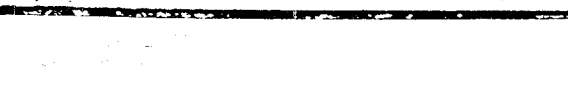

GYROSCOPE INERTIAL FORCE DRIVE

A gyroscope force generator, which design limits of capacity, is effective in turning any vehicle which is free to move on land, sea, air or outer space. Power contained in a gyroscope force generating system can be accounted for by the inertial precessional momentum which is acquired by the precessed vehicle.

A table model, gyroscope force generator is shown schematically in the drawing, FIGURE 1. Portable, suspended, free-wheeling or freely floating models, with mountings suitable for attachment to any vehicle could be similarly depicted. Essential clutching and decoupling means as indicated, will be common to all effective rotary gyroscope force generators.

PATENT 3,203,644
Aug. 31, 1965
H. D. KELLOGG, JR.

United States Patent 3,584,515

ABSTRACT: A propulsion apparatus having a movable frame which mounts a plurality of masses for rotation about a common axis, and which includes various systems for varying the radius of gyration of each of the masses as they pass through a predetermined sector of the path of rotation. This results in an unbalanced centrifugal force which propels the frame in a direction which depends upon the location of the sector in which the imbalance occurs.

2,636,340

Patented Apr. 28, 1953

United States Patent 3,897,692
Aug. 5, 1975

CENTRIFUGAL PROPULSION DRIVE AND STEERING MECHANISM

Inventor: **Arthur N. Lohberger, A.N.I.**
 Research & Manufacturing Co. 25th
 Winfield Ter., Union, N.J. 07087

It is another object of the invention to provide an energy producing propulsion drive and steering mechanism resulting from centrifugal action which can be easily so installed in vehicles wherein while giving direction movement to the vehicle in one direction can also serve as an easy means for effecting the changing or transferring of direction from one direction to another and which thereby has capability of being a steering mechanism as well as a propulsion mechanism.

For a better understanding of the invention, reference may be had of the following detailed construction taken in connection with the accompanying drawings in which

Patent 3,530,617 Sept. 29, 1970

E. M. HALVORSON ET AL

VIBRATION DRIVEN VEHICLE

This invention relates to a vibration driven vehicle which moves upon a flat surface in the horizontal direction without any visible propelling means. More particularly, the invention relates to a vehicle having three rotating imbalance masses on a spring member which transforms the vibratory forces generated by the rotating imbalance into a propulsive force.

DIRECT PUSH PROPULSION UNIT

Juan D. Mendez Llamas, Caracas, Venezuela

In accordance with the present invention, the reaction for propelling the vehicle is created not in an adjacent or surrounding medium but inside of the propulsion unit itself. For that reason, the apparatus is referred to as a "direct push" motor or propulsion unit, the propulsive force being exerted without utilization of conventional means such as wheels, screws, pistons, propellers, etc. acting on an outside medium.

2,636,340

Patented Apr. 28, 1953

United States Patent 3,653,269

CONVERTING ROTARY MOTION INTO UNIDIRECTIONAL MOTION

Inventor: **Richard E. Famer, 5342 Sycamore Street, Baton Rouge, La. 70803**

Apr. 4, 1972

Various uses to which such systems may be put are indicated, for example, in U.S. Pat. No. 3,276,976 and Popular Mechanics, Volume 118, No. 3, 80 (13) of Aug. (September 1941). Of particular interest in the application of these systems to vehicle (prime) movers which may carry a load from one place to another is what is termed a "direct push" motor or propulsion unit, the propulsive force being exerted without utilization of conventional means such as wheels, screws, pistons, propellers, etc. acting on an outside medium.

Patent 3,807,244 **DEVICE FOR TRANSFORMING KINETIC ENERGY**

Apr. 30, 1974
 Inventor: **Fernand Estrada, Tananarive, France**

The device according to the present invention can be used for laboratory work as well as for driving any moveable bodies such as road or rail vehicles, or aircraft and spacecraft.

The device can also be used as a scientific toy.

The present invention thus relates in general to a device for transforming kinetic energy comprising a motor, characterized in that the motor drives the moveable bodies along a predetermined non-circular trajectory to create a thrust which drives the device.

According to another characteristic feature of the invention, the device consists of a rotatable component, driven by a motor which rotates the flywheels describing a non-circular trajectory.

The heavy moveable bodies are grouped two by two as an integral part of a non-extendable component rotated by motor. This component can slide freely with respect to the axis of rotation. A deflector is provided on at least part of the trajectory of the moving bodies and comes into contact with the moving bodies during their movement, and transforms the kinetic energy of the moving bodies into a driving thrust.

United States Patent 3,404,854

APPARATUS FOR IMPARTING MOTION TO A BODY

Patented Oct. 8, 1968

Alvin H. Bell, Via Viamerita 1, Geneva, Switzerland

This invention is a continuation-in-part of application Ser. No. 513,443, the apparatus may be mounted in or on a water vessel, in a boat or a ship, and the operation of the apparatus will impart a net translational motion to the water vessel, moving it through the water. Furthermore, the apparatus may be attached to lighter-than-air vehicles and the operation of the apparatus will impart a net translational motion to the lighter-than-air vehicle, moving it through the air. Typically, the lighter-than-air vehicle is a light-weight shell, balloon or bag filled with hydrogen gas or helium gas. Commonly known lighter-than-air vehicles which may be propelled by means of the apparatus and method of the invention are blimps, dirigibles and balloons.

This application is a continuation-in-part of application Ser. No. 389,735 filed Aug. 13, 1964 and of my application 512,745 filed Dec. 23, 1964, now both abandoned. This invention relates to apparatus for imparting motion in a predetermined direction to a body.

UNITED STATES PATENT 2,008,780

CENTRIFUGAL VALLARTA TURBINE INERTIA

July 30, 1936.

L. B. LASKOWITZ

PATENT 3,266,233 **INERTIA PROPULSION DEVICE** **A. W. FARRALL**

Aug. 16, 1966

PATENT 2,088,115 **July 27, 1937**

This invention relates to motors and propulsion devices, and it has reference, more particularly to what may be termed "reaction motors" of that kind wherein energy from a prime mover, such as an electric motor, is positively applied to an eccentrically and rotatably mounted weight. In a manner whereby the centrifugal forces that are incidentally set up in the rotating weight may be converted and utilized as a propulsion force for the vehicle with which the motor is utilized.

It is the principal object of this invention to provide a machine, or motor, of the above stated kind that may be utilized as a propulsion device for various types of vehicles and which is

REACTION MOTOR
 Thomas Maff, Seattle, Wash.

Patent 3,492,881 Feb. 3, 1970

A. J. VANDEN AUWEELE

PRIME MOVER

The invention has for purpose to provide a prime mover which may be used to propel a vehicle in space, or vertically, in the water, or in the air. This prime mover may also be used to drive a dynamo or any other machine.

For this purpose, according to the invention, the prime mover comprises two associated masses which are hinged with respect to one another, one of these masses being reciprocally driven by a motor in forward and reversed stroke along a straight line parallel and inclined relationship with the propulsive direction.

Patent 3,555,915

Patented Jan. 10, 1971

DIRECTIONAL FORCE GENERATOR

Henry W. Young, Jr., Arden, Calif., assignor to Omega Astronautical Center, Chryseus, Wyo., a corporation of Oregon

This invention relates to a directional force generator which may be embodied in a vehicle such as a wheeled vehicle, boat, or aircraft, for the purpose of moving the vehicle in a predetermined direction without the use of other propelling or steering means.

Patent 3,530,617 Sept. 29, 1970

E. M. HALVORSON ET AL

VIBRATION DRIVEN VEHICLE

This invention relates to a vibration driven vehicle which moves upon a flat surface in the horizontal direction without any visible propelling means. More particularly, the invention relates to a vehicle having three rotating imbalance masses on a spring member which transforms the vibratory forces generated by the rotating imbalance into a propulsive force.

Chapter 4

Unusual and Free Energy Systems

Mind. To the materialistic scientist there is absolutely no logical explanation for Man's great superiority among the animal kingdoms. Since it has been determined that all animal brains work the same, there is just no materialistic way to explain why Creature Man, with his small brain, can have mind capabilities so far advanced. While men continue to drive automobiles, send themselves to the moon, and communicate symbolically, his animal brethren, often with large brains, do not change. It shocks and exasperates much of scientific community that there are no materialistic concepts to cover this condition. The simple facts are, however, that Man is obviously more than just a brain, and within the world of Man's being there exists an invisible, anti-matter mind.

The most easily detectable difference between a man with 'mind' and an animal without mind, is the fact that 'mind' can use symbols. Actually, the mind protects the brain to a great extent, and if the brain experiences unpleasant memories and experiences, the mind often erases them, to a degree. Left with only brain, a man would go mad as quickly as the rats do under the scientists' stress experiments. The wonder of the Century is that man still rejects the obvious.(79)

In the book, "A Dweller on Two Planets," we find mentioned that: "In the realm beyond magnetism were yet other forces, superior and more intense of pulsation, forces operated by the mind." A little further on page 64 it is pointed out that what men perceive as different energies and chemicals are in reality only part of one (The Father) like following little courses of water to their sources or endings. It is only relative.

In viewing how some of the simpler forms of mind power are harnessed, it is well to notice that persons often need each other to increase such 'power.' People of weak mind power usage get together and hold hands or 'link up' in order to levitate objects, to heal, or otherwise to focus the energies. At least three are usually needed in healing circles. . . and where they are gathered in my name. . .

Mind Operation through Objects. While it is probably best that we don't get too involved in occult theory in a work of this nature, certain principles are important and should be understood.

In influencing others, the use of mind power may be used in various ways. 1. A direct force or current can come from direct mental concentration. 2. Or the power can be used through a storage unit such as an object (inanimate or especially created). 3. With a vibrating link (personal object) and magnetic hypnotic suggestions. The use of talismans, substitution dolls,

and the like, then, are very effectual in holding magnetic mind energies or helping in the concentration of these energies.

Because negative mental forces send against the better conscience of the sender can return to the sender and bring retrobution 'Karma), wise control is a necessity for operatives.

Truly the most incredible things of all are wrought by 'mind.'(80)

Mind Powered Machines. There are certain high level 'mental' beings or teachers on our planet that have explained that many of the 'mental' limitations on the planet have been lifted. Between the time of Moses and Christ, for instance, there were no real 'miracles' in the true sense. After Christ's visit, it is alleged that the powers of mind were once again available to change matter. The extent to which this energy change ability can be used, however, is said to be strictly controlled until the masses are able to develop a valid degree of control. We shall see. . . Legends and records are filled with the tales of gods changing around matter to suit themselves.

In V.R. Ramadrandra's "Warfare in Ancient India" he mentions records showing no less than a dozen types of awesome 'throwing out' (soposamhara) weapons. Capable of destroying up to 10,000 men or more with ease, a number of these devices were run by the power of mind.

In present times there are numerous motors and such that would run only for their inventors. John W. Keely's twenty pound motor of 1890 was an example. It reportedly used a combination of sound and mind. Throughout the pages of this work are a number of machines which I frankly suspect work from powers of mind.

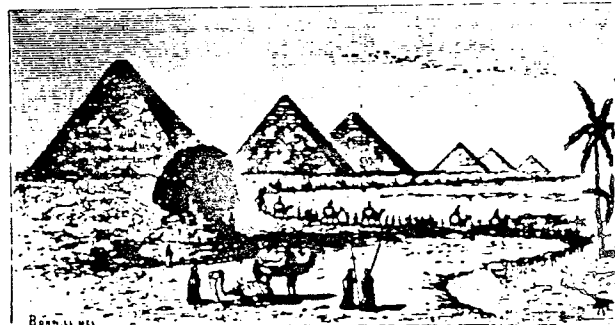
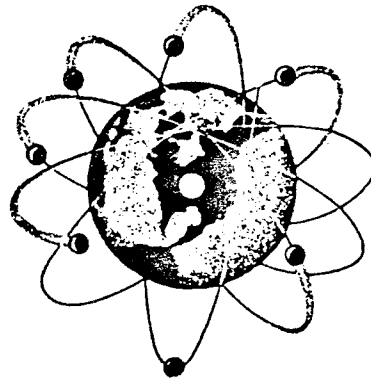

THE PYRAMIDS OF EGYPT.

गय ल्कारशु पारशु पिपावचिषन्ति एवं

Radionics and Psionics. While radionics began as a tool to use in diagnosing and treating disease, the art has now slipped into the broader form of 'psionics.' Investigators and researchers are finding these fields so new and shattering to scientific laws that there is no precedent. Machines that are against all recognized concepts send and receive new mind energies with startling results. To see where things stand in the '70's, however, we should start at the beginning.

Back in the early 1900's a man named Dr. Abrams found that all matter radiated at different amplitudes and that these radiations could be measured on special machines. The scientific community would have none of this theory at the time, of course. With time, Abrams and other unorthodox researchers found methods to tune their therapy machines to treat every type of disease. If a gland was not functioning correctly, they would increase (or decrease) its function by tuning in the correct radiation amplitude. Micro-organisms and harmful irritating substances within the body were neutralized or excreted by proper tunings. Results ran from nil to phenomenal.

The famous chemist, Baron Von Reichenbach, was so impressed by the findings of Abrams and Mesmer that he devoted the rest of his life to the study of radionic principles.

George De La Warr and Ruth Drown took up where Abrams left off and typically received little but ridicule and harassment. Mrs. Drown died in prison after A.M.A. authorities convicted her of fraud and quackery. Never once did they bother to test the machines they denounced.

De la Warr machines were used by such researchers as Langston Day ("New Worlds Beyond the Atom") and whole new concepts began to open up. It was found that each molecule of matter carries an electrical charge that is a 'prototype' of the thing it is from. A single molecule was found to give off any number of wave lengths but only on one frequency at a time. No two persons, animals, or plants gave off the same broadcast signals, and this generic pattern was found to be transmittable by photographic negative as well as a tiny piece of the whole.

Since each molecular charge also acted as a receiving station, there was also evidence that life forms reacted to a myriad of outside influences. Some persons could see for the first time the underlying principles of the mystical teachings, voodoo, and even witchcraft.

The real dawning of psionic research came, however, after T. Galen Hieronymus came on the scene with his 1948 patent on the Hieronymus instrument. Introducing his machine simply as a detector of new unknown emanations from matter, he was probably quite aware of the instrument's unusual life-affecting abilities. In working the Hieronymus device, there seems to be a definite line between the mind of the operator and the generic pattern of the subject or object tuned in. A person who thinks of gold and turns the radiation scale pointer will get a gold vibration at the correct point. Emanations from plants, animals, insects, blood samples, or any other material can be detected and tested.

One unusual and worthwhile early use of a modified hieronymus came when Dow Chemical researcher, Dr. W.J. Hale, photographed a blighted citrus orchard and inserted an insect repellent treated negative into the machine. After several two-hour treatments over a week's time, the areas treated on the film were completely free of insects, while those untreated on film were still infested. The Nov. 3, '69 "Journal of Paraphysics" reported similar results on termiles without even using chemicals. Fifty thousand acres of California and Arizona trees were later treated for infestation and disease; results were remarkable. Persons treating smaller numbers of trees have produced the same results by using small samples of the trees.

Even more devastating to stagnant concepts is the use of psionic devices as 'time machines.' De La Warr once tuned his camera connected machine on the mental thought of his wedding thirty years previously, using blood samples of both him and his wife. The resulting photo disclosed the exact event—outdated clothes and all. Later researchers delighted in developing pictures from the fossils and relics of the past. Prehistoric beasts of the ancient world were faithfully recorded from tiny 'master link' materials.

Using a patient's blood, some laboratories have photographed persons ill or pregnant before and after the experiment. Placing seeds in psionic devices has allowed researchers to actually see various stages of the plant's growth. Do these experiments prove that time only exists in the awareness of motion?

Whatever...the simple magic ingredient in these experiments is the mind. The machines themselves seem to be simply tools to get the brain to receive from the invisible force of mind. Much as persons need a pencil and paper to focus their minds, so, too, the new crop of machines serve the same purpose.

Dr. A.K. Bhattacharya uses his radionic treatment design to send healing vibratory levels to his patients. To determine the Vibration, or 'color hunger,' of his patients, he uses a witness or photograph negative of the subject and allows a magnetically weighted pendulum to swing toward a row of colored lights on his 'box.' Once the right color needed is determined, he places the appropriate colored gem with the witness sample in front of a charged and vibrating radio speaker. Treatment can continue for days, or until there are positive results.

Researcher John Campbell was one of the first to learn that an outside power source was unnecessary with the Hieronymus device. Going a step further, he simply drew a circuit of the machines on paper with India ink. Linking some sections with sewing thread, he immediately got the same results from this symbol machine as he did from the actual 'plugged in' machines.

Because the Hieronymus machine is only labeled an analyzer and not an influence upon life forces, many pretty respected researchers have acknowledged working with it. These men can just ignore the life force value of the machine and concentrate on its diagnostic and detection potentials. After all, the human brain can only react to things it cannot comprehend with fear.

Dowsing. The art of dowsing has been used in its various forms for about as long as there have been written records. Briefly, it allows the brain to receive information beyond the standard human senses. In practice some dowsers have need of instruments, others do not. Australian Aborigines can detect water or animals up to ten miles away without instruments. Current treasure hunters claim to be able to detect large deposits of precious metals with instruments from twenty miles.

Normally, dowsers may search for water, oil, gas, caverns, pipes, ore bodies, treasure, or even missing objects or persons. Instruments generally fall into the categories of angle rods, wands, pendulums, and forked shapes. To use these devices a dowser will go into the field, since the object is often searched for by determining the direction, then 'triangulating' it in or by random walking; or the dowser may gain the data from a map (map dowsing) or he may use 'yes' and 'no' answers.

While some instruments, such as various angle rods, depend on energy rays from the objects sought, other instruments, such as the pendulums, depend more on mental response. Persons depending on mental help usually must be very careful to think only of 'what' they are seeking and not of 'where it is thought to be.' By creating mental pictures of where an object should be, it often reacts upon the instrument as an actuality—and a false reading.

Both water and treasure hunters must be careful to compute the sun's ray angle into pinpointing a 'find.' Since sun rays reflect upward and off of underground deposits, etc., the attraction is usually directly above an object only if the sun is directly overhead.

A high percentage of the world's water wells have been located by dowsing. Typical of the good professional dowser was Verne Cameron, who located many hundreds of cold and hot water wells across the world. (See his history and methods by Pyramid Guide Publishers. A good professional treasure dowser is Sam Wolfe, who thinks nothing of locating potential rich deposits on a map before he ventures out into the field. Men like Wolfe often choose to spend time on only deposits that are exceptionally rich and easy to work. (See "Dowsing for Treasure and Minerals"). Many good dowsers are in demand for their ability to locate lost objects and lost persons. In such work a 'witness' sample or a picture negative is used, and the principle is similar to that used in 'radionic' and 'psionic' machine work.(81)

Electricity. One of the forgotten geniuses of our Century was Nikola Tesla. Without his unselfish work on harnessing the energies around us, we would no doubt be decades behind in the present technology. His favorite field was electricity, and it was he who first developed the field of radio broadcasting, the laser beam, neon light, radar, electrical oscillators, alternating current, and a number of other inventions which our industry and people now take for granted. From the beginning he had trouble getting the major 'energy moguls' to put his inventions into production.

Edison, who was building machinery to produce the limited range D.C. voltage, saw that Tesla's path was

blocked until control was gained. For decades many of Tesla's electric motors and minor inventions were ignored. In some of his later records, it is hinted that he felt homeowners could soon precipitate their own free energy from natural sources. As it was, he could power light bulbs without wires from several miles distance—or take X-rays of the body 40 feet from the radiation source. A number of major inventions have been attributed to others simply because others finished what Tesla had begun.

Using his Tesla coil principle, he envisioned sending wireless energy to all parts of the world. It was this project that took up his time before his death. Could it work?

Frankly, I feel that our Government has tried some of these principles out and there are certain problems. In secret tests conducted in the Arizona desert some years ago, there were a number of electrical power blockages in all directions. Motorists found themselves stalled along the road, power line voltages were altered, and, according to the grapevine, the health of life in the near vicinity was endangered. In a word, massive alteration of natural electric currents in the atmosphere was a little too much. To visionaries, however, this doesn't mean failure of the theory. Wireless energy transmission will come just as fast as man can upgrade technology to fit his visions. The thing that will endanger this is, as always, a halt to technology because of war.

To offset war, Tesla designed what just may be the most important invention of all, the 'anti-war' machine. Designed to put up protective 'force fields,' the machine would also blow up warhead rockets before they left their home base.(82)

As this work is written, there is new hope for cheap electricity from solar cells. As these were brought on the market a few years ago, there were high hopes. Only with the energy crisis of 1973 did some of the freer and smaller companies work on materials to bring the prohibitive prices down. ("Electronics," April 4, '74).

The other principle hope in this area is development of magneto-hydro-dynamics. If a reasonably priced M.H.D. unit can be developed, it would be possible to produce our home electrical energy needs through the energy conversion from a small flame. Would existing power structures allow this?

Word came in the early '70's about a super method of storing huge amounts of electricity with the aid of super conductor magnets. (Prof. Boon, Univ. of Wisconsin).

And there are other unusual electrical sources. . . I have heard of researchers making pure iridium crystals, and, later, with a glazed look in their eyes, turn to other subjects of conversation.

In the late '40's it was discovered that when a slight impurity was added to germanium, it would give it the capability of amplifying the weak power of an A.C. radio signal. While these first transistors resembled crystal radio units, the picture soon changed and each year brings radical new changes in this field.(83)

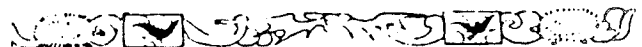

Lyle D. Atkins of Houston worked out an astounding system to convert cheap organic waste material to electricity in the early '70's. Using moistened organic matter or dung between aluminum and copper electrode plates, he was able to make amazingly efficient batteries of any size. A secret bacteria solution activated the material for a constant output and promised to revolutionize a number of other conversion problems. Typically, backers for this project never seemed to come through.(84)

One of the outstanding electrical power hopes of the early '70's came from word that the Russians were showing U.S. officials how we could get electricity worth 75 thousand dollars from 30 dollars worth of heavy hydrogen. Years later we could only wonder at what happened.

During the same period, a California inventor named Grey came up with a system to step up the existing potential of electricity 600%. In effect, his system could light a home on the slight current of a small battery. As he progressed, he worked out a magnetic motor that was simply astounding and could run a car on small, easily-carried sources of current. Technically, his system involved using only the positive side of the sine wave. From a battery the current would pass through a series of capacitors and continue along only one wire through both coil windings of the repulsion magnets on the motor. Only after it had activated the magnetic push would it travel back to the negative side of the pole.(85)

It seems as though few of the advances made in the electrical field ever do the average person much good. Where do super systems go? Physicist Alvin M. Marks patented an astounding new electrical generator in the late '60's. His tiny two foot long model put out 10 watts and 50,000 volts of D.C. power, using nothing more than a jet of electricity charged air and water vapor. He claimed that the potential was so great that each home could be powered from waste furnace heat. As charged particles shoot from a generator unit, they run into a repulsive field and build up an electrical potential. As they reach the collector unit, the electricity is accumulated and can be carried off. (Pop Sci Aug '67. See Illustration).

Alchemy Principles. One of the most valuable and yet the most over looked arts of our planet is alchemy. For the past several centuries Religion and Science have ignored the continual references to the potentials in this area. What is even more unusual is that, confronted with 'positive' evidence, persons in the "accepted professions" have still turned a deaf ear to such evidence. In view of the fact that much of the sickness and poverty of the world could be reduced through alchemical means, this is a pitiful situation.

Before the time of accepted science, most of the researches into chemical and material changes were conducted by alchemists. According to many of the very early alchemical works, the art was handed down from the fallen angels before the time of Egypt. Even the Bible gives interesting historical views on this subject. Cassien attributes Ham with being the first alchemist. In Exodus Chapters VII and VIII it is

mentioned that the first three miracles of Moses were imitated by the Pharaoh's magicians. According to ancient writings Ham was not permitted to bring his magical and alchemical books on the ark, and so he engraved the contents on hard materials, which he recovered after the water subsided. A work of Cecco d'Ascoli mentions that the author actually saw a manuscript written by Ham—and that he taught this science to his son Misrain.

In the British Museum there are many volumes that give accounts of matter changes still far beyond the realm of accepted science. Today's scientists may be prone to scoff at most of these accounts, but, if technology can continue on unimpeded into the 1980's and '90's, there may be some change of thought on the subject.

In the "Goldmakers" by K.K. Doberer (London, '48) there are references to the first castes of priests, who guarded the secrets they obtained from the earliest Pharaohs. Little of the art of transmutation even got beyond such high-born and priests, and most of the works on the subject deal with alchemy after the time of Greece.

Charlatans took full advantage of peior myths, and, now and then, a possibly valid case of transmutation was overshadowed by prevailing skepticism. The wise teachers of the world have long pointed out, however, that there must be a valid 'original' in order for there to be counterfeits. A point to ponder.

While the history of alchemy is fairly well covered in many volumes, there has been little practical data which was easily accessible. This situation is changing. More recent users of alchemical principles in transmutation were some of the early Spanish miners. Using simple and primitive methods, the early Spaniards could smelt and get good returns from ores that often stymied later miners. In rare manuscripts of this era one can occasionally find reference to smelting or refining the same material seven times. Of little importance to the average person, these steps were the 'secret' and vital 'keys' to a simple form of transmutation to persons versed in alchemical principles.

It would seem to the average person that any method that could transform a base metal to a precious metal just couldn't be kept from the official-powers-that-be. Yet the evidence is mounting. Actually, the few persons who do learn certain alchemical arts which could be financially rewarding usually know enough to keep their mouths shut. At present there are a handful of persons who "upgrade" raw ore on a small scale, but even these persons work on a small scale in fear of organized crime and governmental agents and any 'elements' that could be dangerous through the ramifications of 'greed.'

Hundreds of persons know the more fundamental alchemical principles that can be used in healing, and it is from such beginnings that many hope the greater problems of the future can be tackled. The simple fact is that what Nature made Man is often given domain to duplicate—if he is intelligent and persistent enough.

Alchemy usually involves the simple art of growing things according to Nature's present laws. In the case of minerals, it is necessary to also use a 'seed' and the proper environment.

In the past the simple alchemical formulae have been masked in symbolism and misleading abstractions. Today the picture brightens as Science recognizes the existence of valid unorthodox concepts, dimensions. . . and the few true researchers awaken. Alchemy's terminology usually included these typical precepts: Mercury is the essence, or life force, that exists in matter.

Vegetable, animal, and mineral kingdoms each have differing vibratory range. In extracting the mercury (essence) from a plant, the dead residue, or 'Caput Mortum,' can be burned to ashes and become a separate 'salt' used later in an alchemical elixir. By combining the essence, which is used by herbal healers, with the 'salts,' used by other medical practitioners, the healing results can be multiplied.

In the more advanced work with plants, there is an oily substance combined with the mercury that is typically separated. This 'Sulphur' is a vital part of the alchemical medications, and, in the transmutation of metals, it is the vital 'seed.'

In healing, alchemy is the only therapeutic system that supplements the deficient vital forces with the complete elixir of three healing agents.

Alchemy uses terminology that is confusing to many persons, but in all life the principles are similar. There are life forces nurturing the life forms and their 'seeds.' Depending upon what environment the 'seed' is nurtured in, Nature produces differences. Because all carbon based planets have a negative and a positive duality, Nature projects matter by this sex generation principles. In the "New Chemical Light," by Michael Sendivogius, (extracts of which appear in "The Alchemists' Handbook" by Albertus), this subject is pursued in great detail; it is a little too deep for the goals of these pages.(88)

As our technology multiplies upon itself, scientists are continually being confronted with evidence which explodes their favored theories. In 1970 the principle biologists of the world met in France to determine how life began. Surprisingly enough, they concluded that the gases and various rays and energies co-mingled to form the agents of life, such as amino acids. In the chemical mediums such as water, the basic protein building blocks became the various life forms. While the Earth, water, fire, and air principles long scoffed at were not specifically mentioned, it is obvious how the circle is turning.

The universal transmuting agent (the Philosophers' Stone) long mentioned in alchemy is a principle that has validity but is misunderstood, to some extent, by laymen and alchemists alike. To aid in understanding the truth in this area, the following concepts should be studied.

In the mineral kingdom, the alchemist does not deal in the transmutation of 'dead' metals, but, instead, he uses the ores of metals which are still partially 'alive' and which contain the vital 'seeds,' which can be used

to effect a continued growth. When a metal is spoken of, then, it is frequently a reference to the 'seed ore,' or the mineral mercury.

In dim tradition we find that the planet was once 'alive' and the various combinations of vital energies and environment co-mingled to grow the various mineral and metal deposits. It has also been known to certain 'avatars' that events upon our planet changed at a point approximately thirteen thousand years ago, and a number of vital solar rays were blocked from our planet at that time. Because this event halted the growth of minerals, ordinary science has yet to grasp the true facts concerning the origin of metals—even though there are the numerous radioactive 'dead' metals confronting them, and even though there is little visual proof to substantiate their own current theories. Time after time, deposits of such metals as gold, for instance, will be found in such unlikely places as near the surface of old lake beds, etc.

What is also continually overlooked is the fact that the capillary system of our once 'live' planet is deteriorating. Under the protective layer of lave flows, scientists find networks of holes that defy all reasonable explanation. (Giant earthworms was a typical speculation). As any geologist knows, this whole planet contains vast networks of underground rivers and streams. A number of scientists are awaking to the fact that the long-held theories of where all the water comes from just fail to fit well-known facts of physics.

But, to restrain ourselves from getting too involved in this area, there are only a few principles necessary to understanding these subjects.

First, the correct terminology for 'life' is 'that which can sustain itself.'

Second, Earth is no longer sustaining itself but is existing on stored up energies.

Third, the other life forms of Earth, such as plants and animals, are existing on these stored up energies of Earth. Minerals at this time are 'dead.'

Alchemy is based upon upgrading or concentrating the life energies of the various kingdoms, but it is now limited by the amount of energies available. In ancient times this was not the case, as numerous legends tend to indicate. Sprinkled throughout this work are references to 'transforming devices' which used these early 'full power' energies. Again, at present some of these energies exist only in a greatly diminished 'stored' form.

Alchemy is a key to understanding how a number of these life energies are used in Nature. Alchemy can, also, produce truly amazing healing agents and transform the essence of 'seed' of minerals into metals.

What we would like to make clear is that the potentials of 'mind' are even greater by far. . . and with the return of our planet to a 'free' status, our planet could not only regain life, but we could regain the awesome use of 'mind.'

In the meantime, "The Alchemists' Handbook" is one of the better beginning works on the subject and can fill in the procedures.

Smelting & Refining procedures for work in mineral alchemy. . . Ore must first be released from what we call 'binders'. . . a fast method involves cooking it with a high amperage AC current in the proper solution (4 to 10 hrs). These fumes can kill you, so adjust and act accordingly.

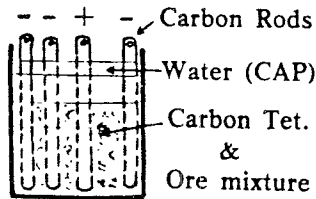

. . . next smelt ore and use the metal as cathode or anode in the refining procedure etc. . . or you may put ore in cloth bag and refine out metal electrically. . . see data on the Leclanch or Daniell cells. Use around 20 to 1 Sulphuric acid. . . working out procedure you can eventually grow astounding crystals from the metals thus produced. . . their resistance factors will be unlike any usual 'dead' metals.

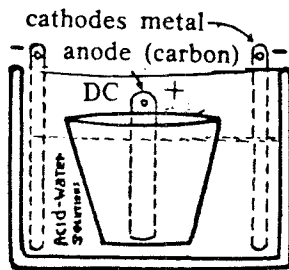

Smelting hints. The following chemicals must be used in combination with the ore.

Parts	Item	Use & Reason
10	Ore	
13	Silica	.use on high lime ore-cut down on high quartz ore.
6½	Borax	.low melting glass vehicle. .thins down mixtures.
3½	Sodium Nitrate	.eliminates oxygen of sulphurs. .electrostatically - not used on high heat ores.
4	Potassium Carbonate	.don't use with platinum ores.
10	Soda Carbonate	.
1½	Flourspar	. glass. . .thins. . .can use less.
½	Sodium Chloride (table salt)	.use as top layer in crucible
½ or less	Charcoal	.helps to keep metal metal - can use sugar (frothy).

HINTS. .Zinc can be used as a final gathering agent (burned off).

A nail (iron) in crucible helps irradiate sulphur. Red Lead (litharge) often used in gold ore if no lead present.

A clear slag indicates metal has separated correctly. The very old books are of most help in smelting operations.

Repetition of certain steps 7 times if often very useful.

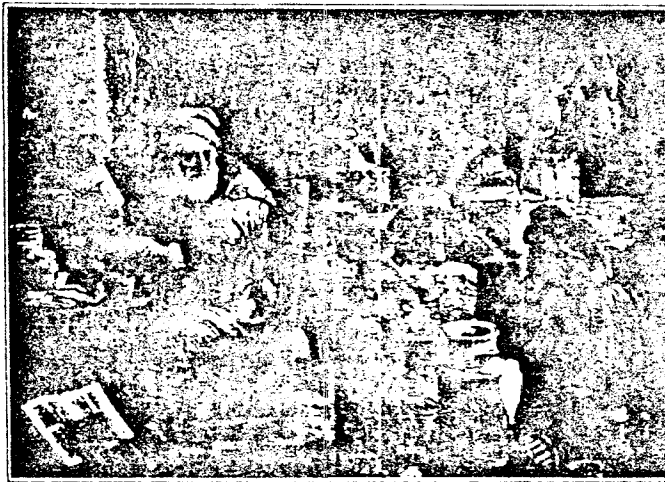

FED UP WITH THE ESTABLISHMENT? Science for the People, 9 Walden St., Jamaica Plain, Mass., 02130.

Reading *Science for the People* magazine isn't the answer, of course, but it's a good way to learn of what others are doing about it. *Science for the People* is the bimonthly publication of SESP/StrP (Scientists and Engineers for Social and Political Action/Science for the People). It analyzes the systematic misuse of science and technology in our society, reports on the activities of scientific and technical workers struggling for political change, and serves as an instrument for increasing our political understanding and development.

Gems and Xtals. Accounts of magical rings and jewels come to us from the most ancient legends. Historical mention of them begins with Moses and King Solomon and continues through the later philosophers and magicians, such as Agrippa and Levi.

As we of the present century uncover more of the mysteries of Nature, there is a good chance that we shall find some validity to the magic ring business, also. Manley Hall and several others go into how some of these rings were made according to Zodiacal formulae. The crystals and talisman stones of the more ancient world may very well have worked on a number of different principles. There are some who feel that prior to 13,000 years ago there were energies interchanged on our planet that no longer exist. Such energies gave metals and the various crystals powers that they do not possess at present. Certain mystics explain that the 'dying elements' we know as 'radioactive' were once 'living' elements until 'the change.' This 'change period' is touched upon lightly in "Earth Story." (90)

I once worked with a woman who evidently retained some of this information as her knowledge. Working with certain alchemical formulae, she produced a type of special copper metal that possessed electrical resistance factors quite different from the ordinary metal. Creating crystals from such metals produced a most unusual effect. The Xtals seemed to have minute interconnecting wires within their structures. Assuring me that such Xtals had certain life energy and memory factors, she compelled me to connect a very sensitive electrometer to each end of a crystal. Any doubt of her exaggerating disappeared as I saw the electrometer needle behave in the same manner as a living plant would. I recall that she used a liquid form of carbon and electricity to alter the ore she smelted, dispensing with the normal, long-processed precipitations of alchemy.

The advanced technology of industry may not be far behind the ancients. Small crystals are at this writing being used to store large amounts of data.

I suspect that many of the devices used by the ancients could not work correctly without the somewhat different metals in use at the time. I recall a woman who showed me a machine that she seemed to remember from a former age. It consisted of three large crystals held up over and focused upon an area some inches below. Caduceus coil windings (separates positive from negative fields) of wire led from the upper core of one crystal to the bottom core of another. While one young researcher she knew supposedly got the device to work to such an extent, he never fooled with it again, after a minor disaster. It never, according to her, acted as it should. With the resistance of today's wire as a factor, it could be assumed that the results might always be disappointing. The lady alchemist previously mentioned once got a little wire from her super metal tested by a well-known aerospace lab. After testing it, the technicians were dumbfounded, and, through her 'inside sources,' she learned that 'the word was out' that she and her metal should be found and 'sewed up' fast. If you can visualize how important a wire could be without the usual resistance, you can see that

the whole electronics field would be changed.

I recall that Richard Shaver advocated using the human mind as the third junction to two triad coils. Such a triangulation configuration, he claimed, held awesome power.

One principle which stones and Xtals probably work on is in their bio-magnetic influence on the body. Many ancient priests, you will remember, were precious stones at the center of their foreheads. The well-known Edgar Cayce confirmed that a combination of azurite and chrysacolla (lapis Lingua) did, indeed, enhance the E.S.P. ability of the wearer. Cayce also mentioned the use of energy-collecting crystals on Atlantis.

Dr. Bhattarachaya (mentioned elsewhere) used his well-known seven-principle gem remedies for years. One method he used in dispensing was to soak the proper gems in alcohol a week (in the dark) and then add a portion of sugar. The separated crystals of sugar were later stored and retained the vibrational qualities of the gems.

In recent years a bank of special crystals in an ultra sonic unit is what makes these units work. The back and forth current of A.C. electricity causes a swelling and contracting in the crystals and can brutally rip apart water molecules. This in turn tears loose dirt and food particles. Sonar is another typical U.S. application.

According to some, rocks that are of silicon can, under certain conditions, store and release images. Temperature can release the electrical resistance, and, according to the energy band theory, molecular changes can occur from several negative or positive influences.

The controversial Richard Shaver has maintained that some ancients constructed holiographic record discs that recorded their history in 3-D. Shaver has produced a number of unusual specimens to prove his contentions, but, as yet, it is pretty hard evidence to get into 2-D perspective. There are a few persons who feel the picture rocks he collects gained their images from the nature of their early qualities of 'live,' 'sensitized' rock material, not from the purposeful efforts of the ancients. Regardless, the theories and rock examples of Shaver are fascinating, and his Rok Fogo Mur Men and Women would do justice to the best that 'Phantacy' Phandom has to offer. (91)

In 1927 the famed crystal 'Skull of Doom' was found in one of the Mayan ruins. A solid two piece replica of a human skull, authorities still don't understand how it could have been produced. Remaining at a constant 70 degrees regardless of surrounding temperature, the skull has been found to transmit to all of the five senses of the brain. It changes color; it can emit odor; it can express sound; it can create thoughts and thirst in viewers' minds. It can even give sensations of heat or cold to those in close promimity. It also contains an intricate system of prisms, light pipes and lenses. (92)

Legends, of course, occasionally mention the crystals that could render the holder of them invisible and cause weightlessness. Was it all in the size and shape? Or did it involve mental forces and special 'live' qualities within the crystal? We just may live long enough to find out!

It is intriguing to remember the traditions concerning the ancient 'ELS' libraries that have fast knowledge stored in tiny crystals. These ancients supposedly discovered how to enter and to escape time by negotiating a ninety degree phase shift—a right angle 'EL' shift. Using the 'live' crystals of that age, which held the vibratory levels of various thoughts, all that was required to learn was to hold the crystal (forehead, also) and regain the thoughts.

According to writer Maurice Guignard, the Odin priests collected cosmic energy for thousands of years by means of an emerald cylinder. When needed, they would transport it in a small accumulator called Volu-Volt.

The Holographic record rocks of Shaver may yet be duplicated by our science of the '80's. The camera is a very close duplication of the human eye, and, by using more advanced cameras in conjunction with crystal storage units, it could make it all possible. The Navy is said to have cameras (psionic units?) that can now photograph pictures of the recent past.

In the '70's G.H. Haertling invented little ceramic chips that could not only be used in picturephones but could be used in super computer memory banks.(93)

Interesting applications of crystals will continue at an astounding rate in our century, and, as this is written, the tuning forks which replaced watch movements are themselves being replaced by liquid crystal digital readout watches.

Because certain inexpensive liquids contain long light manipulating molecules, these liquids can be confined in between two solid surfaces and be made to light up over the area receiving current.

Little of stone lore we have today makes much sense. In the works of G.F. Kunz and W.T. Fennie we find the typical assembly of a science reduced to superstition. The limited dominated man of the dark ages simply couldn't carry over the great knowledge of this great science. According to some Solomon was one of the few beings with a knowledge of shape and form after the great fall of the kings at the time of Moses. Using stones and seals Solomon was said to be able to gain the aid of other dimensional powers. According to these same sources, Christ reinstated the blocked usage of 'mental' powers. Regardless of authenticity, such views could yet prove valid, — and we do want this work to be 'open minded.'(94)

Shapes. It is a literal fact that most of our planet is made up of crystals of specific shapes. The present energy problems will be a thing of the past when we start using the wondrous potential of these shapes. Even the food we eat must be converted to tiny crystalline shapes before it can pass through the tissue walls. The ancient Central American word for blood was 'Chalchihuatl' and it literally meant 'water of precious stones.'

Rulers of the ancient 'super cultures' often had access to the remarkable stones which the more common people only heard rumors of. Dominating governments, differing little from those of today, only chose to use the people. Because certain creative patterns had concentrated one type of incredibly

powerful crystal under the area known once as Atlantis, the rulers, of this civilization put great masses of people to work digging for them. In the British museum are ancient manuscripts which give some detail to all of this, and when the scholar J.R. Tolkien was gathering data for his celebrated "Lord of the Rings" he ran across much of it. The references to the deep mines of Mordor are historical facts. In the 3rd volume he takes great pains to present the facts of some of these ancient times. . . and yet his efforts are largely pronounced 'great fiction.'

Actually, according to persons who can mentally tap into the past, or 'akishic' records, these great crystals were composed of what our scientist now consider one of the dying metals. When and why this element changed from a self sustaining 'Live' state is a story for later.(95)

We might point out that if ever one of these legendary 'fire 'star fire' crystals is ever found it will be encased in a well sealed light free case. According to those with knowledge of such things, to expose it to the sun would cause instant dematerialization to all matter in front of it. Some feel that the strange events of the Bermuda triangle are from the effect of some of these long buried crystals. Perhaps we shall all live long enough to see the so-called legends confirmed.

Sun Power. . .With the fossil fuel problems which arose in the 70's there was a sudden increase in seeking answers from the sun. Break-throughs came quickly, and while it was easy to collect the solar heat by means of a dark surface, it was not easy to retain the heat. A typical successful answer lay in using a collector consisting of several layers of various materials. Passing through a non-reflective surface layer, the suns rays were absorbed by a dull surfaced layer of silicon. Attached to a surface of reflective coated metal to hold the heat, this silicon was transparent in the normally reflected infrared range. In addition, the reflective surfaced metal also helped hold the heat well.

Super Solar Heat Collector. In the mid-'70's I.B.M. researchers accidentally discovered that a special fabrication technique allowed tungsten to become a super heat collector. Because the tiny spear-like structures formed on the surface of the tungsten, it absorbed sunlight without the usual heat losses. Used in solar energy collectors, this material could lead to a myriad of applications.(96) A big breakthrough in Solar Energy cells came in 1975 when gallium arsenide cells were found to produce a fantastic 20% efficiency. This work, however, will not cover solar energy because of the drastic changes continuing in this field.

The ancients used a number of solar energy conversion devices (some of which are covered elsewhere). Legends tell of 'collectors' which collected and converted various solar rays. One document coming from the Roman Era tells of a special reflector weapon used during an attack by sea. Aiming the reflector at the incoming enemy ships caused them to ignite and burn—with thousands of troops aboard.

The reflector, as I recall, was composed of a large parabolic plate coated with a crystalline reflective surface (a type of sea salt?). Whatever its make-up, it was far ahead of what we have today. The amazing Fresnel lens used as a solar collector and light projector is the biggest breakthrough in a somewhat similar area.(97)

Solar Influence Transfers. The Hieronymus Energy Transfer Plate. Science has assumed that plants would not grow in darkness because the various energy waves and vibrations found in light were absent. Hieronymus sprouted seeds and grew plants in total darkness by using simple metal 'conductor plates.' Plates above the plants were connected by wire to plates exposed to sunlight. Using this principle, it would not be unreasonable to assume that underground living would be entirely possible.

The Amazine De Land Frost-Guard Orchard Protector. Prior to 1951 there was a gentleman in the Southwest who not only dispensed with smudge pots but grew an amazing amount of oranges from trees which were often considered too old to be commercially productive.

Starting with a 32 foot high tower, Mr. De Land would string a series of seven underground wires from the top of the tower down and out to a maximum radius of 144 feet from the tower. At the end of each wire there was a 5 inch alnico magnet which was wound with the wire. Pointing the magnets toward the magnetic North Pole (and toward the tower, slightly, 45°) there was allowed just enough free wire to extend above the ground—and point toward the top of the tower, upward. The wire end at the top of the tower was, likewise, pointed to the opposite end of the wire and magnet. One of the 51 degree 'spokes' or wires of this design was also carefully aligned to the magnetic North Pole. As long as fruit remained on the protected trees, they did not freeze, above 20 degrees F. Fruit which dropped could freeze, however.(87)

Air to Fertilizer. Few persons are aware that Mother Nature uses the winter mantle of snow to enrich her soil. Frank Shutt of the Canadian Department of Agriculture concluded after 17 years of research that both hail and snow act as natural nitrogen collectors. Back when he did his research, Shutt claimed that an average winter's snow would enrich the soil to the extent of \$14 worth of the commercial product. Several researchers found that considerable nitrogen is transferred to soil after electrical storms and rain (see Bible, book of Job 38:22).

A few persons have wondered what happened to the amazing machine at the turn of the Century's Chicago World's Fair. It pumped nitrogen from the air and produced what was referred to as 'fertilizer.' With the critical need for fertilizer at this time, it does make one wonder.

Magnetic Alteration of Life. Cell structure can be altered to some degree by magnetic fields. One interesting set of plans put out in the '70's is purported to enable one to make a machine to accomplish this.(101)

Pyramids. The Great Pyramid is thought to be a giant witness to thought and life by some persons. They feel it contains a prophetic and historical record within the measurements of its chambers and passage systems. From the 1850's to the present times there has been no let up in the scientific interest in this remarkable structure.

According to Egyptian-Coptic accounts, the pyramid was the instrument for the preservation of the wisdom of the different arts and sciences. Hebrew and Arabic tradition tends to confirm this theory, but this case is too well documented to get involved here. One thing is certain. The awesome structure does generate unusual types of energy.

According to very old records, the King's Chamber of the Great Pyramid was used to revive dead leaders and VIP's. If it failed in this respect after three days, the bodies were supposedly mummified in one moon cycle of twenty eight days.

An observing Frenchman named Bovis was the first to make public the fact that it did, indeed, stop decay. Experimenters later showed that both flesh and food could be dehydrated by these unknown energies.

All over the world experimenters began using small pyramid models to catch these energies. If the small pyramids were placed so that one side faced the exact magnetic North, an area within approximately one third of the distance from the bottom of the structure became 'energized.' Using sides sloping at a 51½° angle, it was not too long before some persons found that solid sides were not actually needed—all that was required was the outline and four corners. In such a structure the albumen of an egg would harden in a week, or the edge of a razor blade (crystalline) would realign itself to become sharp overnight. To assure the right influence on this sharpening technique, the edges of the blade should be facing East or West, be made of carbon steel, and, for the first change, be allowed to sit in the pyramid 'charging' area for a week.

In the book, "Psychic Discoveries Behind the Iron Curtain," it is told how scientists using new equipment to probe or X-ray the interior of the pyramid were baffled when some sort of force rendered their equipment useless. In the meantime, people like Van Tassel (Integration) claim new uses. The smog of civilization could be eliminated, he maintains, if a series of seven large simulated (wire frame) pyramids are placed around a smog basin.

By capping a pyramid with a laminated quartz condenser (Germanium separating the quartz), Van Tassel feels that different energies can be easily created and used. In another experiment, he indicated that pyramid generated power can de-salinize salt water. After years of analysis, he feels that the pyramid was used to produce power, make mummies, was used for rejuvenation and to restore life, and finally, was used as a launching power to start space ships out of the Earth's gravity. This last usage is mentioned by several persons who claim prior memory. One theory is that the propulsion unit thrust was safely dispersed by the pyramid.

Noting that while the major portion of the pyramid is a non-conducting limestone, Van Tassel observes that the granite surrounding the King's Chamber is made up of 'piezo-electric' producing quartz crystals, mica and feldspar. Running a wire from the top of several pyramids, he wound the end of the wire around a pipe, pointed it toward the horizon, and followed the beam of detectable energy for three miles.

He points out in his 'Proceedings' that the principle of pyramid power will create a 'cube of infinity,' a 'cone of silence,' a 'capstone of eternal youth,' a 'sarcophagus of preservation,' a 'vortex of cosmic power,' and, finally, a transmutation of matter.

Tradition would almost confirm these contentions, and a number of authors observed that the agricultural prosperity of all of North Africa declined after the pyramid lost its tip of crystal and gold. Arab legends refer to the pyramid being pointed with vivid colors starting with the red top. This has been confirmed to an extent, but, again, it is only one of the missing links to an amazing puzzle.

In the '70's, structural engineer, William E. Peterson of Seattle, advanced the theory that the pyramid was built by space colonists who used it to keep the Earth aligned and prevent the periodic 'Earth flip' and 'ice ages.' Along with nuclear canon these people used two pyramids with energy pointing barrels to control both angle and orbit of the Earth.

According to Raymond Bernard, the French Rosicrucian, the great technology of the ancients was brought by extraterrestrials, and many of the monuments and megaliths around the world were used to amplify cosmic energies—in conjunction with the great pyramid, itself. When the great pyramid was altered by later intrigues, and ignorance, it allowed the cataclysmic and cyclic floods or Earth flips to once again occur. (L'Empire Invisible)

Pharaohs Pump. Back in the early 1930's Edward Kunkel became interested in how the great pyramids were built. In the course of his research over the years, astonishing indications and facts were uncovered. The evidence all pointed to the fact that the great original pyramid was a giant water pump, and all the chambers were exacting parts for its functioning. Working models of this pump design proved the Kunkels contentions from the '40's to the '60's. Despite a U.S. Patent and overwhelming logical and physical evidence, the inventor was ignored. Dozens of government agencies, research centers, and universities were contacted and failed to show the slightest interest. Finally Kunkel printed a little book on the whole subject. It told how the pyramid was really built, how a phenomenal amount of water was pumped at practically no cost, and how each portion of this amazing pump functioned. When, with even the slightest effort, such a pump design could furnish free water to the parched lands and peoples of the world, the author could not explain its rejection. (E.J. Kunkel, 295 W. Market(509), Warren, Ohio 44481 — \$4.00).

Electroculture for Plants. Recent research has uncovered many ways in which plants are stimulated through thought, music, and trapped energies of various types. Generally, electroculture and magnetotropism are the cheapest and easiest forms of plant boosting for the gardener. Plant rootlets are seemingly stimulated by sending weak currents through soil, and growth rate zooms by rigging properly set-up wires above the plants. Some experimenters claim that a wire going some distance (preferably up) will catch the electrical potential and bring it in to the area needed. Mulching, incidentally, was found to increase the electrical field potential.(99)

Russia is using a few of these new methods at the moment and is finding that, if you point the seed tip toward the south, it will germinate much more quickly. Even facing the buds of transplanted plants toward the south made a difference in growth rate. And to top it off, they found that you could bring various fruits to ripeness by influencing them under the south pole bar of a magnet.

Fungus Power. During World War II a fungus called *Trichoderma Viride* was adept at turning clothes and wood into useless goo. In the '70's a number of researchers were using this hydrolysis action to make glucose from waste material. Once the glucose was obtained, the conversion to proteins, fuel and chemical raw materials was fairly easy. . . conversion plants where are you. . .

Algae energy and fuel. In the brackish ponds along the dead sea a variety of algae known as *Dunaliella Parva* is super rich in glycerol. Israeli scientists felt that in the late 70's this could be a very important source of fuel and dozens of other glycol based products.(100)

Self-Charging Lameyer Engine. Michael Lameyer was inspired to work on a radical new electromagnetic engine after he had an unusual dream. His engine is similar in design to an ordinary electrical motor running from a 24-volt battery. What makes it unique is that it actually recharges the battery it runs from, as it runs. While Michael did not wish to credit his engine with any set degree of efficiency, the Patent Office did give the device a phenomenal 80%.

Michael also said his engine was designed so that models could easily be placed in existing automobile designs. In 1975 at least half a dozen companies were negotiating with Michael on rights to his design.(108)

Gravity Wave Motor. In 1975 inventor Eddy Saballos of Venezuela claimed that he had a motor design using no fuel. After offering his patent to anyone in the U.S. who would patent and manufacture his engine, lack of response soon changed his approach. The next year he put out a series of six drawings of his designs for from \$10 to \$20 each. Several of his designs are supposedly able to function with or without outside power sources.(107)

Energy Coils and Cones. Verne Cameron discovered that simple cones gave off an energy thought to be beneficial. 'Charging oneself' could consist of contacting a plate of metal which was connected to a cone tip by means of a wire, or by drinking water charged overnight by the same principle. Even simple aluminum foil electric condensers are used by some persons who claim they get good results by contacting a lead wire in each hand. It is assumed that certain energies are accentuated by many types of sheets and coils.

The copper bracelets so popular with rheumatic sufferers are thought by some to combine the effect of an energy entrapment coil with the beneficial vibratory rates of copper.

The Power Shapes. In the book, "Psychic Discoveries Behind the Iron Curtain," there are mentioned psychotronic energy machines that are combinations of certain metals and shapes. If such generators are properly made, all one must do is look at them and they will collect and store energy. Once the energy is stored, it can purify polluted water, speed up plant growth, and even run motors.

A number of persons feel that because certain psychotronic generators and psionic machines can kill lower forms of life, we may be on the verge of having mind warfare machines again. (See "Warfare in Ancient India").

Because the energies stored by these psychotronic machines do not have the shortcomings of electrostatic energy, there are many applications awaiting. Able to attract non-magnetic metals and work under water, such machines could be applied to sophisticated precious metal mining machines. Used in healing, analyzation, and goodness knows what else, these little figures and funny shapes, called 'machines,' may not even be necessary.

Metal cones which are held in magnetic fields at the correct point have been able to produce the electromagnetic frequency of silica in the spectrum—and to produce the element itself. Scientists are on the verge of producing all elements under similar principles.

Actually our present science has bypassed a most useful science in ignoring shapes. Nature builds and patterns matter around cubes and spheres. If the shape and resonance of a thing is in discord, it can cause change and breakage. Whole buildings have collapsed from this lack of harmony. Ancient symbols often represented a principle in this ancient art.

All shapes are apparently collectors of certain energies. This is one of Nature's building principles. Certain crystalline shapes collect certain energies to form certain metals. This is a view held by many of the 'great' avatars and teachers of the past.(102)

Certain coils and metal combinations have long been held to be of benefit to man. The Africans adorning themselves with all that copper coil jewelry were very probably using valid basic instincts. Western Man and his gold jewelry may very well be responding to more than vanity. All circular metal forms have been found to act as condensers, and gold has been found to absorb, to some extent, and to act as a 'chelation' compound in resisting certain bacteria.

We cover the unusual properties of a number of effective energy-producing shapes elsewhere, but there are many more. Various symmetrical geometric solids were used by the Pythagoreans in healing. The influence of perfect proportion was said to be beneficial and practiced before them by the Egyptians. Even today certain mystics imagine themselves in a large cube facing the East. This is said to break the mind free of the influence of stereotyped crystallizations and images. Symbolizing the Universe, thoughts are visualized striking the Universe and reflecting back what is sent.

Present mystics still use ancient 'centering device' designs that have been handed down for ages. Visual mantra is said to focus and center the psychic energy to help to beneficially alter the level of consciousness.(103)

'Borderline Research Journal's Riley Crabb was the first to introduce present researchers to the 'Rainbow Toner.' One of the persons who 'rediscovered' this device is said to have had all sorts of beneficial results from its use. A typical experiment included running a lead-in wire from the device to the drinking water of some sick chickens. Typically, the clarity of the water was changed, the chickens got well, and his wife couldn't understand why her washing machine soap was suddenly so effective.

Mr. Crabb receives letters from all over the country attesting to the effectiveness of this simple little unit. In theory it just seems to be a way of stepping up a wide spectrum of cosmic energy. Persons low in certain vibratory levels seem to benefit. Variations in the simple dimensions and parts of this device (see illustration) have not improved it to date, and it must normally be placed at least five feet above the ground to work effectively.(104)

Perpetual Motion. Perpetual Motion has long been ridiculed by men of science yet the heavens still continue to function with perfect regularity from natural perpetual energies. In a number of ancient writings there are references to perpetual motion machines. The Siddhanta Siromani by Bhaskara and the Surya-Sidhanta by Varahamihira are two very ancient sanskrit works. Later mention is made of perpetual motion mercury wheels in 12th century Arab and Indian manuscripts.

Since the patent office throws out patents which presume to offer any attributes of perpetual motion, many persons wonder if some of the stories about them could be true. An 18th century genius supposedly developed one such P.M. wheel. According to reports, this device was powerful and hooked to no visible means of power. Unfortunately, before a benefactor could market the machine, its inventor, Johan Bessier, had a change of heart and destroyed it.(105)

The W.F.S.E. group started preliminary work in 1976 on crystal technology which could multiply electrical currents without power loss. A score of individuals during this same period had similar knowledge that they hesitated to disclose for obvious reasons.





Optical Telephone Systems. Scientists of the '70's felt that communication on the light beams passing through glass fibers would replace wires. Cables carrying these pulses of light would not leak electricity and being made of silicon, would be cheaper.(137)

Perpetual Lamps and New Light. Over the past few ages, there have been well over a hundred writers who have mentioned ever-burning lamps. Most believed that such lamps would burn for centuries, but some felt there were certain varieties that would perpetually be fed by inexhaustible and permanent energies. A good example is the lamp that was found in a hermetically sealed tomb vault opened during the Papacy of Paul III. According to records it had remained lit for 1,600 years. Priests assured Plutarch that a lamp burning over the door of a certain temple to Jupiter of Ammon had been burning there for centuries with no fuel. Other such lamps mentioned in Manley Hall's great "Symbolical Philosophy" book included one created by Numa Pompilius, King of Rome. One which burned for 2,000 years in the Sepulcher of Pallas (Virgil's *Aeneid* mentions Palles), and another, which was found in England and which had burned since the 3rd Century A.D.

H.P. Blavatsky mentioned in "Isis Unveiled" that some of these lamps used asbestos wicks and certain alchemical fuels which allowed them to burn continually. Two formulas are even given. Some even felt that the Roman Vestal fire and certain more ancient lamps were lighted from the generation of static electricity. (See Tabernacle of Moses)

In the early '70's it was found that chemicals could be combined to produce light, and this 'chemiluminescence' was soon used in all sorts of unusual applications. Going a step further, researchers recently found that an organic chemical, like an aromatic hydrocarbon, could give off any number of light color combinations if chemicals were mixed and electrodes introduced. Using any type of current, such lights worked cold; they promised to revolutionize the industry when their efficiency was raised.(109)

Because nature gifted a number of her little creatures with the ability to produce light, it was not long before technology of the '70's extracted their secrets. Luciferin and luciferase were found to be 100% efficient in working for man as well as for fireflies. The only catch was that these chemicals were expensive to synthesize and a tiny bit of ATP (chemical from living creatures) was needed. Did the ancients use this process to better advantage than we?

In the early '70's it was discovered that certain types of translucent semiconductor material could give off light if another type of current carrying semiconductor material was sandwiched to it. These light-emitting diodes (LED's) ran cool, had a remarkably long life, and were very efficient. Some, using a laser principle of light emission, proved to be a real threat to the short-lived incandescent light. (Pop Sci Dec '70)

With all of our technology, however, we still have nothing to compare to the legendary maxin light, which was said to rest on its huge crystal quartz base in Atlantis (See other section). Unfed for generations, it was capable of not only giving off great amounts of dazzling light, but was capable of de-materialization, besides.

Night Into Day. The Viet Nam war technology forever ended the standard 'cover of darkness' principle. The Star Tron viewer simply amplified starlight or moonlight to give the viewer a 'good as daylight' view.

Atomic Power. The Viruci, Dart of Indra, and Agni Astras mentioned in Ramachandra's "Ancient Warfare" book could all conceivably be weapons of atomic power. Such places as Sodom (Palestine) and a noted area near Death Valley, California, are said to be covered with a fusion material exactly like that of an atomic blast. Bits of glass-like rock found in Lebanon contain radioactive aluminum isotopes.

It would seem, however, that the ancients of culture and wisdom gave this power source a wide berth. Such advanced and farsighted beings as Walter Russell felt that nuclear power was dangerous beyond accepted belief and that a civilization making use of it could not long endure.(112)

In 1975 Senator Stuart Symington estimated that the United States alone possessed the equivalent of 615 thousand Hiroshima bombs. What he and we are not aware of would probably be even more shocking. Is it not time we concentrated on using the force flowing through the atom, not splitting it?

The Most Ignored Document of Ancient Technology. There are certain scholars that have long felt that one of the most important documents written concerning ancient history was "The Thousand and One Nights." Few persons of the western world have ever given any thought to this work containing true history, but in this work we are trying to examine all possibilities, especially the more obscure ones.

If you will recall, King Shahriar ordered the cultured Scheherazade to write of the past. Her detailed stories occupied 30 volumes and cover a span of history from the most ancient times to 10 A.D.

In true Muslim tradition these stories were unembellished reproductions of earlier accounts. Fantasy was never known to exist in their culture. What we of the West have had to read have been 'watered down' versions, which were done by short sighted censors. There are, of course, plain anecdotes and fanciful dreams among these tales, but the majority are narrations of historical events. Mixed in throughout these stories are descriptions of 'super' men conforming to the various cultural views of 'gods.' The exploits of these 'Genn' are often beyond the understanding of the various writers, but what they and their machines did is faithfully recorded. Intertwining with Biblical data on Solomon, some of these tales show how he rose to power through advanced technology.

The Genn and their use of transmutation, anti-gravity super-weapons and aircraft are recorded in many documents, but few are as complete as the uncondensed "Thousand and One Nights."(113)

Sept. 27, 1949.

2,482,773

THE FAMED HIERONYMUS RADIONIC MEASUREMENT UNIT

12 THIS PICK UP COIL IS 1 1/2" DIA. & WIRE WINDING IS NOT CRITICAL
 11-14 STANDARD VARIABLE RADIO CONDENSERS
 50-56 16,100,000 OHMS RA (NOT CRITICAL)
 58 UNBIALED RADIO FREQUENCY TRANSFORMER

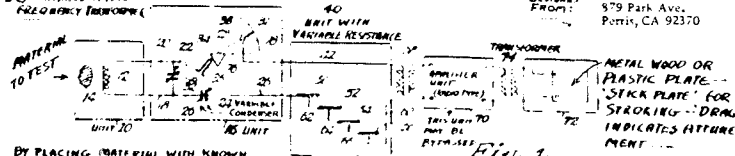

BY PLACING MATERIAL WITH KNOWN ATOMIC WEIGHTS AT 14 SCALE (31) CAN BE CALIBRATED.

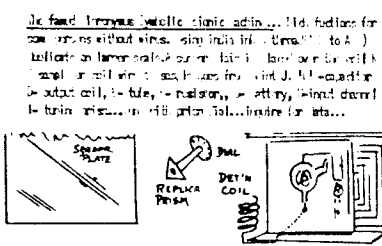
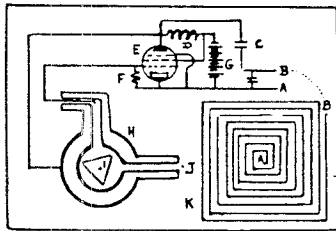
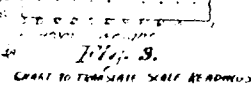
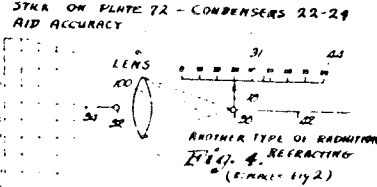
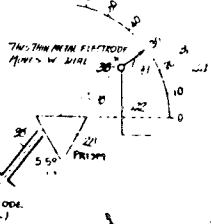

It found traces of electric activity... Indications for some persons without wires... (See instructions to A.) Indicate on lower dial of the unit... (See instructions to B.)

THE REICH CLOUDBUSTER (1 to 10 tubes) DANGER: Never touch with bare hands

ORGONE ENERGY ACCUMULATORS (ORACC)

Layers of:
 1. Wood or Celotex
 2. Plastic film or Styrofoam
 3. Cotton or Rock Wool
 4. Metal (not aluminum)
 5. Contact Plate (from metal)

NEVER USE NEAR X-RAYS - FLUORESCENT LIGHTS ETC.

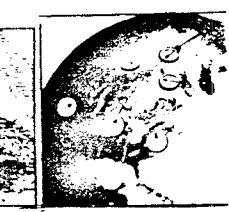
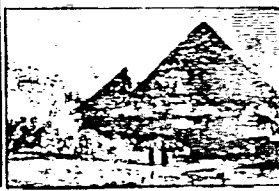
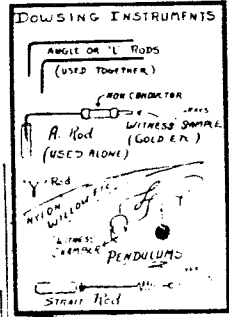

2,026,798 Jan. 7, 1936. C. N. POGUE OTHER OLDER & SIMILAR PAT'S NO. 1,938,497 NOV '34 (SQ. TP) NO. 1,997,497 DEC '33 NO. 3,53538 JAN '35 (NOT AVL)

OF 5 RESIGNING, TWO DEALING WITH STEAM INJECTION ARE UNAVAILABLE FROM PAT. OFFICE ??

Fig. 3 VERTICAL VIEW (SECTIONAL)

THIS DESIGN TOTALY VARIES W/ET FUEL INTO DRY FUEL. THEN EXHAUST DRY GAS ENTERS SHUT PRESSURE WATER LINE - FOLLOWING ABOVE TO SEE PATH OF GAS.

VARIOUSLY REFRIGERATING CHAMBER

PREPARED FUEL BOTTOM - 12. FLOAT VALVE. EYES GAS REMOVES VIA B 19

THESE SPINDLE SUPER HEATING SECTIONS EXPAND THE VAPORIZED GAS, & WITH A MIXTURE OF AIR BECOME A TRUE 'LAV' GAS WITH A HIGHER HEAT POTENTIAL

Charles N Pogue

Fig. 2 TOP VIEW

Fig. 1 SIDE VIEW

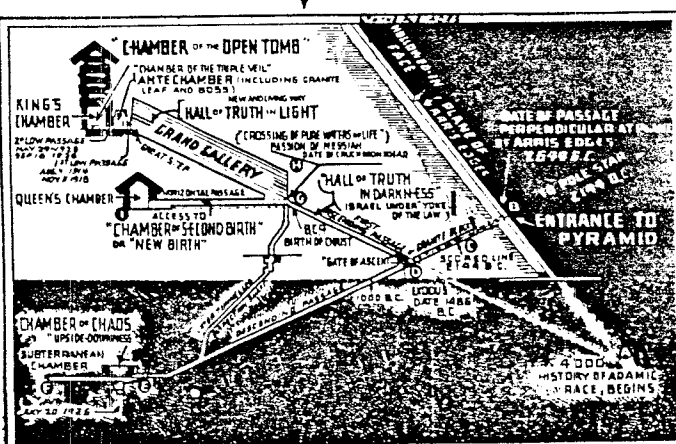
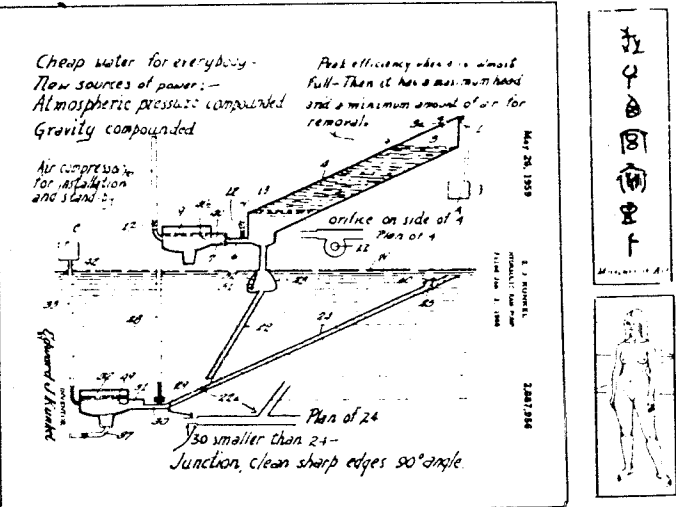

Inventor: Eddy Saballos

GRAVITY MOTOR



ARMANDO-2025- CARACAS, VENEZUELA (Zone 101)
 More Complete Data on a
 HUNDREDS OF ADAPTATIONS
 OF THIS MOTOR DESIGN
 FOR 4 & 8 CC
 (Name Stamp)

Construction
 Same as by Drawing No. 1
 Shaft - 2 Flywheel.
 2 Railing Jumper.
 4 Jumper Motor.
 2 Electric Disc.
 3 Worm Gear.
 1 Speed Governor.
 Generator, Starter.
 Battery, Clutch
 & Platform &
 Springs Support.

"This Turbine Can
 attract the
 Gravity Waves
 and produce
 high speed
 rotation when
 in use and
 is well balanced"

The Magnetized Heavy
 Gear wheel No. 5
 has RATCHETS in the
 shaft, so only turns
 in one direction.

EDDY CAR TURBINE PLAN
 CHIT No. 77 FOR \$10.00 (ADDED ADDRESS)

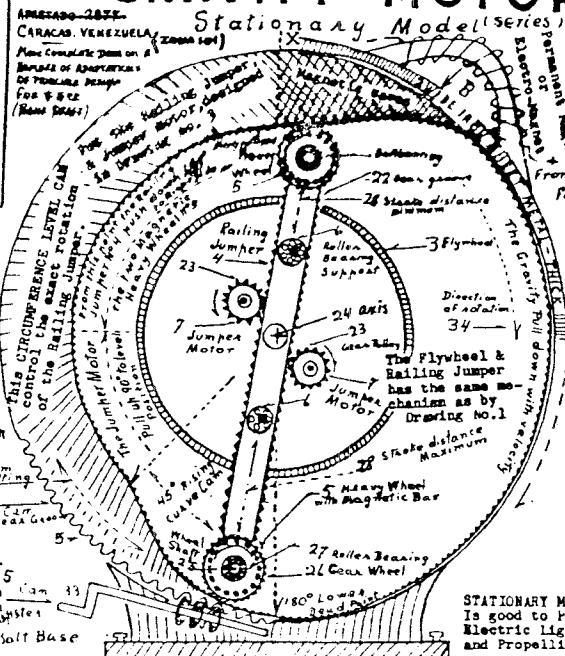

Instructions
 The Magnetized Heavy
 Wheels No. 5 with Magnet
 Bars all around the
 surface to GRASP
 the Level Can between
 X & Y-iron metal made.
 The Railing Jumper
 loose weight in this part
 Level Cam, and be pull
 to the right side.
 from X & Y The Circum-
 ference Level Cam
 must be made
 with Iron or Steel
 The Electro-Magnet-B.
 are one Device that
 receive Current from the
 Battery for Starting,
 and from Generator for
 Running.
 Pull Up the Magneti-
 zed Heavy Wheel No. 5
 from Z all
 around the
 metal must be
 Aluminum Alloy

The Magnetized Heavy
 Wheels get high speed
 rotation to produce
 centrifugal force
 capable to continue rot-
 ating the Flywheels
 for a long time with-
 out the current drain
 in the Jumper Electric
 Motors.

STATIONARY MODEL
 Is good to power
 Electric Light Plant
 and Propelling Ships.

FIG. 1

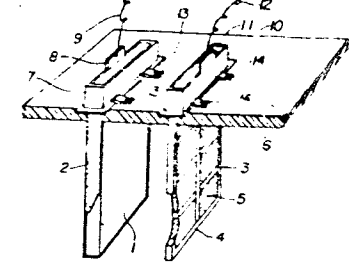

United States Patent
 3,785,871 BRINE BATTERY
 Inventor: Masahide Ichikawa, No. 13-11,
 Jan. 15, 1974
 I-choose, Hmo, Tokyo, Japan

Thus, the brine battery of the present invention comprising an anode body made of metallic magnesium or a compound thereof a cathode body most of an oxide of lead has the decided advantage of being capable of supplying a high voltage of +220 V as mentioned above when the cathode leads and anode body are soaked together into brine or sea water.

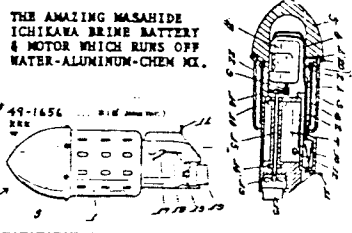

SOMETHING TO THINK ABOUT...
 "If the 'Father' were one atom sequence less perfect you might be a worm or a mountain boulder. What you humans have done with knowledge since it was first introduced is truly amazing. Using it totally in the wrong direction and correcting knowledge to hide your own mistakes from yourselves, has turned knowledge into a terrible weapon..."
 "The Earth's core was at one time not iron. Using their imperfect data to base their knowledge on has resulted in an imperfect chain of formulas. The organic chain of death is totally wrong in relationship to Earth minerals and succeeding levels of organic death change." From: News-Nevel #11 available from MOVE (source #79)



DR. RUSSELL FELT THAT MAN WOULD BE FREED FROM DEPENDENCE UPON THE RESOURCES OF EARTH IN 2 STAGES. IN THE TRANSMUTATION OF THE ATMOSPHERE INTO FREE HYDROGEN, & LATOR BY TRANSFORMING SOLAR RADIATION INTO SOLAR GENERATION. (112)

The science of crystallography is today without the basic foundation of a fundamental law. It is today but an organized rotation of known effects of unknown causes. It is today but a determination in advance of the exact crystallization of any element, compound, mixture or alloy. Not an increase, learning or other effects of crystallization be determined in advance of experiment or observation. (see 'SOURCES' #112)

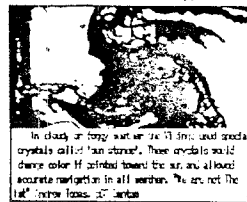
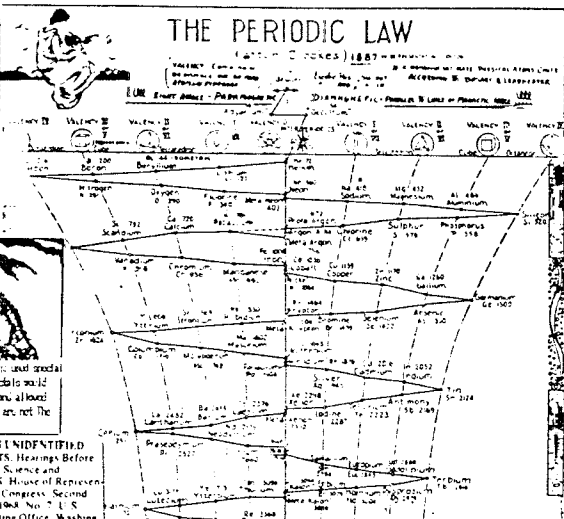
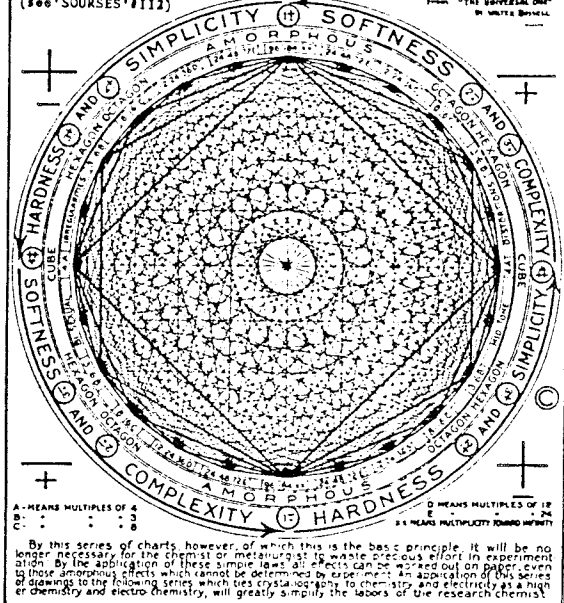

Symposium on Unidentified Flying Objects. Hearings Before the Committee on Science and Astronautics, U.S. House of Representatives, Ninetieth Congress, Second Session, July 29, 1966, No. 2, U.S. Government Printing Office, Washington, 1968.

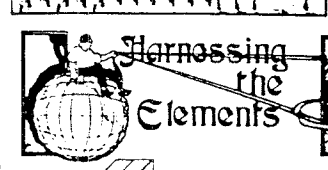
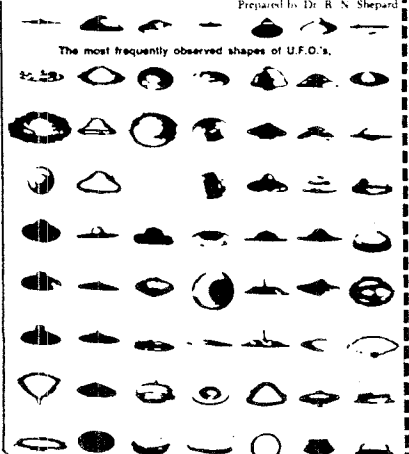

Patent 3,882,416
 May 6, 1975
 THERMALLY PUMPED GANODYMIUM LASERS
 COOLING DOWN THE POWERFUL DEATH RAY LASERS ETC.
 Roland F. Bergin,
 Chateau Malador, Marc A. Charpentel, Longueuil,
 Jean-Pierre Taran,
 Bures-sur-Yvette, France

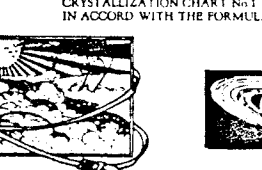

THE MARSHALL ROTARY CADUCEUS COIL PYRAMID ENERGY AMPLIFIER
 INTERNAL COIL WIRE IS CROSSED 90° THROUGH USE OF RIBBON
 ..HIGH AMPLIFICATION POSSIBLE.

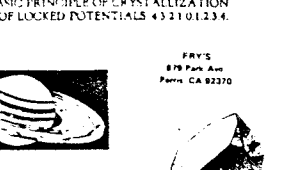

NATURAL OPTICALS ARE NOW CRUSHED & THEIR ENERGY ALLOWED THE MATERIAL TO RE-FORM IN OPTICALLY SIZES. An 8 1/2 INCH EXAMPLE CAN PRODUCE OVER 2000 VOLTS IF VIBRATED (1 HERTZ FREQUENCY)

Chapter 5

Unusual Machines and Inventions

Wilhelm Reich. Wilhelm Reich's fate is such a typical example of what befalls those who advance away from accepted science too quickly that this little work would not be complete without mentioning him. Fleeing from Nazi Germany, Reich plunged right into questioning the validity of psychoanalytic procedure in this country. He maintained that the 'life force' (Orgone), itself, was connected with the energy exchanges in the sex act. (It was found in later studies males had only one beneficial energy releases, females had at least three of these releases). Such releases were found to be normal, therapeutic, and necessary for optimum health.

Reich contended that breathing charged the cells with Orgone and it was carried through the body by the non-conducting organic material. Creating a machine to collect this non-electromagnetic energy led to his undoing. Because it went against 'accepted theory,' the Food and Drug Administration promptly acted and Reich found himself jailed. Actually, Reich was hounded for years by the psychoanalytic profession and the sexual Puritans before the State acted. In 1954 the authorities moved in and burned the majority of his books, and in 1957 he died in prison.

Back in the mid-'30's, Dr. Wilhelm Reich found a number of indications that the theories concerning germs coming from the air were absurd.

In one 1939 experiment designed to confirm Reich's belief that bacteria came from bions, a lab assistant accidentally used a wrong media in an experiment. It was later found that the resulting materials would paralyze cancer cells and give off enough radiation to adversely affect the eyes. It was only a step or two later when Dr. Reich found himself involved with what many have considered one of the century's major breakthrough: The discovery of the orgone energy.

Orgone Accumulation. To capture the therapeutic OR, Reich found that alternate layers of organic and metal materials worked very well. The organic material seemed to collect the energy and the metal reflected it. By using alternate layers of these materials, the drawing and concentrating powers of the accumulators were greatly increased. The innermost layer, of course, would tend to reflect, trap, and contain the OR. If a wire were run to a distant contact plate, the energy could be easily transferred to a suitable receiver.

Because the boxes could also trap the unhealthy OR, they were made so that they could be quickly disassembled. There was just no way to switch them off.

In treating patients, it was generally considered unnecessary to exceed a half-hour in most cases. In areas around the head and heart it was a policy never to exceed a couple of minutes. Often a warm sensation in the treated areas would indicate that the therapy

was completed. Dr. Reich had amazing success with such treatments. Everything from minor abrasions to cancer seemed to respond to these simple Orgone machines.

To understand the work in this area more completely, one should probably get a copy of the book, "The Cancer Biopathy," W. Reich, Orgone Inst. Press, 1948, from bookstores.(114)

This work points out that Reich could not accept the air germ theory, why he could not, and how the Orgone was first discovered. It explains functional concepts of Nature, shows how to build a scope to view the Orgone (the Orgonoscope), how to build a device to measure Orgone energies, and finally, it explains many of the technical aspects of the Orgone accumulator (ORACC).

In later experiments, it was also found that Geiger counters actually measured the reaction of OR energy to radioactive material. Careful, exacting, and scientific as he was, Reich could hardly believe his numerous and unique findings without months of calibrating and experimenting.

Because the majority of his experiments tended to shatter the pet beliefs of experts in the field, in

What became apparent over the years was that the natural Orgone Energy surrounding the planet was very therapeutic if it was collected in a clean environment. If it was contaminated by heavy air pollution and various radiations (TV's, fluorescent lights, or other alpha-beta sources), it could cause various illnesses.

In one of his early experiments Reich tried to prove the existence of Orgone energy by actually running a small motor on it. This was accomplished by soaking regular Geiger-Mueller survey meter tubes in multi-layered ORACC boxes until they had stored up sufficient OR. It was said that almost a third of the tubes could also illuminate blue in these tests (again, against all recognized concepts).

Later these tests were dropped when it was found that the motor force in the OR energy could be obtained directly from the human body.

The Oranur Catastrophy. After Reich's death, it became difficult to find his more important works on his machines. This situation existed until well into the mid-'70's, when a new wave of interest in his work tempted a number of small publishers. Some of the more interesting highlights of Reich's experiments, however, never got into print.

One of his associates and assistants, B. McCullough, told of an incident in which several milligrams of radium was left for a short time in a large 20 foot square Orgone Energy accumulator. The effects were devastating. There was a "cold fire inferno" within a radius of almost 60 miles. The OR energy and the nuclear energy engaged in what could only be termed a battle to the end, and, as the surrounding area began to turn blue, everyone in the area was seriously affected. The reactions varied from actual passing out to extreme tension, nausea, and depression. Each person was seemingly attacked at his weakest point. Fortunately, the platinum needles containing the radium were quickly taken from the

area and buried at a great distance. McCullough felt that only providence averted a chain reaction and great disaster, because the very rocks in the nearby buildings soon began to turn black and be eaten away—and because persons working in or near the buildings became ill and couldn't sleep. Something had to be done.

In the months after this ORANUR experiment, a number of malefic or harmful energies and materials were eventually tamed with new machinery and new methods. Without getting too far into ORANUR chemistry, it could be said that the most effective weapons against these energies were along the lines of what could be called the malefic energy cannon, or 'cloudbuster.'

Once the means was found to draw in these energies, they were eliminated by grounding them out in water.

Whether Reich's exotic creations actually worked by the power of the will forces (or mind) is of course a question the reader must settle. Whatever worked them, the fact remains there have been many persons who have gotten the same amazing results with the same machine design.

Because the ORGONE Energy, when killed, became the life destroying DOR, Reich finally worked out his 'cloud-' or 'DOR-busters' to clear the air of this menace. Once grounded, the magnetic clinging masses of DOR were replaced by the fresh influx of OR. While the experiment to investigate the relationships of OR and nuclear energy prompted all of this helpful 'crash program' work, there were still unique after effects to come. For instance, it was later found that radioactive substances in the area had, against all scientific law, been drastically reduced in Rad Count.

Typically, one of the persons to see these demonstrations was a lawyer named Mills. Despite an affidavit he had signed to the success of the project, he was the very person who directed the prosecution of Dr. Reich after he became a District Attorney.

In a later project which employed what Reich termed a Y-function of Nature, the only witness and assistant to Dr. Reich disappeared. William Washington and all of the working models were, according to some rumors, whisked away to Argonne National Labs in Illinois, but again. . .no one, not even his closest relatives, ever heard from him again.

Cloudbusting. Probably the most unique of all of Reich's inventions was the cloudbuster and its modifications. After the oppressive effects of the ORANUR experiment, there was little choice but to clear up the DOR or move away from the area. Rigging up 10 twelve-foot brass tubes connected to water proved to be the answer. Sucking in the heavy concentrations of this clinging malefic energy allowed the normal OR to once again circulate and replenish the area with life energy. Because still water tends to turn blackish-yellow and lose its 'life' after serving as a grounding agent, it was usual to use a running water body for this purpose.

In learning to eliminate this harmful chemical ether (so often referred to in etherian physics), Reich evidently created unusual enemies. It is said that actual blobs of energy engaged Reich and his assistants in unique 'ether battles.' This could only be hinted at, of course, until the late '60's when Trevor James had similar experiences and actually caught the UFO's on film.(115)

Using a cloudbuster was not physically difficult once certain basic concepts were learned. The danger lay in using the awesome power inherent in this work. Foolishly 'playing' with a cloudbuster could bring on a destructive twister's wild weather with other harmful results. Likewise, when proper water grounding was not used, it almost killed early experimenters.

As Reich once pointed out, Orgonomy was contrary in principle to the second law of thermodynamics. Instead of reducing in energy, OR energies actually increased as they were worked with. This meant that in using a cloudbuster, you could aim near and encircle a small cloud continually to enlarge it, or you could aim directly at a cloud to destroy it.

Reich could draw from the zenith of fog banks, etc., and actually dissipate them in slow spiral-horizontal sweeps. He claimed that he could feel when proper rhythms and sweeps were used—"almost like dancing with you." Reich advised that operators should always be very careful to get overcharged or carried away with the new found power.

Reich's advice included a warning against playing God. What he aimed at was simply assisting nature. He advocated that all equipment with metal parts be grounded and that in these experiments the metal parts should never be touched with the bare hands. If gentle breezes turned to strong winds, it was time to stop.

In creating clouds, Reich created differences of OR energy potentials with sweeping draws against the run of the OR envelope. Typically, drilling a hole overhead could frequently bring a long rain. In all of this work Reich had his assistants wash and ground themselves frequently with water. Failure in this area often brought cases of dizziness with blue or purple faces as the warning.

The DORbuster. The DORbuster was in effect a small cloudbuster unit hooked up to an ORACC box and a container of water. It was used to draw off large unhealthful accumulations of DOR in seated patients. Its use could be dangerous when long term armor segment in patients was lifted. Shock and even catatonic stupor could result. These small units usually used 8 or 10 half-inch stainless tubing, but again, fewer tubes could be used with a longer working time required.

While many other unique Reich discoveries are not mentioned in this section, they have been well recorded elsewhere.(116)



The Laser. When Dr. Maiman of Douglas Aircraft developed the Laser in 1960, it shock the scientific world like nothing since the atomic bomb. Overnight there were at least 2000 scientists working on laser projects. Four hundred companies began the race for peacetime and wartime use. Staggering sums many times that of the astronaut program were spent on these secret projects.

The laser rods used by the ancients were mentioned in a number of ancient works, but they were usually referred to as the 'Ruby Rods,' etc. We now use this re-discovered wonder crystal to send multiple thousands of messages over great distances, to perform delicate internal operations, to drill minute holes in substances like diamonds, and other uses too numerous to mention.

When Charles Townes stumbled into the maser principle, he little realized that it would bear the laser and Hologram systems later. These three inventions, along with the transistor (a crystalline chip), are probably the most important inventions of the Century. (May '72 'Pop. Science.')

According to some persons in this field, it will be possible to feed certain energies into a modified laser and get a certain type of matter produced at the focal point. At this point, of course we of planet Earth will be freed of many physical threats to our existence like hunger. Will we be able to master the non-physical threats and remain free? We shall soon see.

One of the big laser breakthroughs came in the early 1970's when it was found that organic dye filled tubes can last as well as expensive rubies and glass rods. Such dye lasers can now be made to last continuously—and this is the beginning. . .

Using a mirror at the end of a tin foil wrapped rod was all that one enterprising lad I know needed to construct a laser.

In the years after World War II, technology began to accelerate at an awesome rate. By the '70's it was possible for the U.S. to send whole space 'platforms' into orbit. At several hundred miles above earth, it was recognized that such stations could provide instant control to weapons needing a change of target. Because it would take time for weapons to reach such distant platforms, the precious seconds gained could be invaluable. As mentioned elsewhere, surveillance of hostile movements and launchings was also to be carried on from the hundreds of manned and unmanned space machinery.

On a day to day basis the smaller satellites kept track of the more mundane affairs of our weird neighbors.

The major powers worked feverishly all during the '70's to develop various means to negate the others' nuclear attack and defense systems. By the late '70's it is obvious that the laser will be developed to the point that it will be a key ingredient in such systems. By beaming intense heat at the controls of an oncoming nuclear missile, the mechanism of such an enemy missile could be fused and rendered inoperable. By focussing an intense beam of heat from a space platform, the laser could easily be a 'super weapon' of stunning effectiveness.

In the foreword to the 1976 "Jane's Weapons Systems" editor Pretty acknowledged that he felt the 'superpowers' were locked in a suprascientific struggle to be the first out with practical death rays. Both the U.S. and Russia have spent huge amounts of money on such projects.

Just how close this comes to the 'legends' about ancient 'super weapons' and their usage should strike home about here.

In effect, the laser could track an object at any distance, miles on light beams, and burned through world's hardest substances. What the military was interested in, however, was weapons. If the laser was perfected to the point of sending sufficient heat, there would be no weapons of standard design that would remain invulnerable. Tanks, planes, rockets, and satellites could be destroyed or thrown off course with ease.

Russian's Lebedev Institute worked hard to keep abreast of our discoveries, and by the 1970's the startling weapon based break-throughs in this field seldom reached the public anymore. Because of early plans by the Russians to defeat the U.S. before the 1970's, it was suspected by some persons that it was our super-sophisticated defensive weapons that held off the Russian plans.

One of the early goals of the more ultra secret U.S. laboratories was to make a laser that would send rays more deadly than heat and light. Experiments with Gamma and X-rays were being conducted by the major powers from the beginning. By concentrating X-rays on a distant victim, their whole internal system could be roasted while they remained unaware of the fact.

Only a handful of persons mentioned plans to put the super laser weapons into orbit. From satellites whole portions of the planet could be controlled. Whole populations could be crippled and paralyzed by invisible rays. Exactly how far along work on these super weapons got, few know. Peacetime uses of the laser are still covered in industrial journals; the awesome wartime developments are still censored.

Could it happen? With a thousand nuclear armed satellites circling overhead by the early '70's, it was not hard to suspect that some were lethal hardware of a different nature.

Our ancient literature mentions thousands of people struck down by such super weapons of the dim past. As the bugs are worked out of the new version of the 'Ruby Rod,' it is time to begin thinking about worrying again.(117)

Crystal Power Data. Many requested further information on crystals after reading the smaller first edition of this work. Alchemist Stephen Marshal helpfully furnished material that went in a separate folio because of its exotic nature (Fry's).

With the reprinting of Walter Russells "Universal One" '76, there was again available material that covered the formation and true nature of crystals.

As this is written the Laser is being perfected to a point that it should soon be possible to change matter with it. By introducing a specific type of energy to such perfected lasers, food and other materials needed by society can be produced at the focal point. We can only suggest patience at this point in time.

The Super Spy Technology. Only a small segment of the public is aware of how sophisticated the technology of their Governments are. The unfortunate problem is that much of this technology is designed around a military need and too little of it is aimed at uplifting man and his freedoms.

Aside from more than a thousand satellites bearing lethal bombs overhead, there are goodness knows how many others observing everything that goes on upon the planet's surface. U.S. SAMOS (spy) satellites are launched with clocklike regularity at least once a month, and weekly loads of data and film are ejected from them. One of these little 22 foot wonders is so efficient that it can monitor hundreds of the world's various communications systems and take pictures of details as it does so. At the moment, the U.S. is as aware of what Russian factories are turning out as they are of what our farmers are growing.

In the "Myth and the Madness," P.J. McGarvey points out that the information collected by 50,000 spies abroad is measured in tons of material. And at least 30,000 servicemen man intelligence listening posts, monitoring broadcasts.

Some of the electronics involved in defense is mind boggling. When the U.S. developed 'jammers' capable of blocking out Russian radar, false image projectors, and even anti-missile weapons, the Russians promptly developed anti-jammers, false image projector filters, and anti-missile missiles. (See As a side benefit to all of the super satellite technology, it is gratifying to many that a few good ERTS photos from these satellites can save hundreds of thousands of dollars in aerial photo 'masters' for maps. (120)

It is interesting to keep up with the unprovable reports which filter out of the Communist nations. After the Russians took Adolphys Reifschneider (Hitler's Buzz Bomb genius) to Moscow, he reportedly designed super-sensitive spy machines and techniques. He had access to the 800 insane asylums in Russia to furnish 'fodder' for his hypnotically controlled robot and mind control experiments. Body switching for spy purposes is an actuality. . . from the reports.

How far our Governments have come in the art of mind control would probably stagger the public if it were known. Only small pieces of the whole picture as yet filter out. Typical of the machinery is a device made up by Italian parapsychologist, Prof. Renato Novelli. In a January 6, 1975, 'Midnight' issue he claims that his device can monitor a person's thoughts up to 15 miles away, and, if he wishes, he can actually alter the intended actions of the person being monitored. In other words, the professor can make persons act as he wishes them to unless the persons can put up a mental or mechanized defense. (See section on 'Psionic' machines)

It is not well known that Russia and the U.S. both have 'mental spies' who are employed to simply pick up mental impressions from distant points. The more important gleanings are then run through a computer to declare their value.

The Russians once used a little transmitter of about 388 MHz to mentally confuse American embassy officials. The American C.I.A. was not long in developing even more sophisticated transmitters in this same frequency. With around an 11 cycles per second pulse, their model could easily cause permanent brain damage if misused.

Sounds in the very low range of 5 to 20 cycles a second can literally tear apart human organs or buildings if they are amplified sufficiently.

In the 1970's the French police occasionally used very high frequency generators (25-35 KHz) to control crowds. Unfortunately permanent brain damage could also result from an overdose.

Unbearable pain was able to be controlled to a large degree in the '70's. Avery Labs, of Farmingdale, New York, and Medtronic, Inc., Minneapolis, are two firms which supply dorsal column stimulators that are typical of the needed machinery. By altering the pain signals going to the brain through these electrical implant devices, the pain is blocked.

According to reports, the CIA developed a device in the '70's which could change the roles of electric insulators and conductors. Attached to almost any electrical appliances or other innocent device, an unsuspected and lethal current could result. (121)

The Great Spy In The Sky. By the Mid-'70's the U.S. had satellites that were capable of stopping over a specific area of earth, taking a picture of very high detail, and then transmitting this picture to any point on the planet. As the 'super powers' began to record the strengths and weaknesses of their neighbors, thousands of spies were no longer needed. In this same period equipment that could see through foliage was developed for combat use. Some persons speculated that it could come to pass that it would be impossible to escape a 'Big Brother' behind locked doors.

A Bugged Ocean. Few persons of the '70's were aware that a large part of the worlds oceans were 'bugged.' U.S. Computers could easily know where most of the larger vessels of the world were, by their sound frequencies.

Super Distress Weapon. According to reports a research technician in a musical factory accidentally discovered a vibrational rate that relaxed the human sphincter muscle. Later tested in riot control and the Viet Nam War, the 'ultimate weapon,' as it was called, proved remarkably effective within its scope. (122)

In a similar vein, there was limited use of a certain sonic device by the large timber companies in the '60's. It seems that while the device could destroy the wood boring worms of Pacific N.W. trees, it would also cause instant distress to those humans caught in its range.

Amazing Spy Weapons. As this work is written there are counterspy weapons in existence that would create wonder in all but the most 'with it' science fiction afficianados. Were some of these marvels to get put down on pages such as these, there would be some immediate displeasure by this nation's security and Gestapo elements. (The CIA is said to employ

over 500 periodical checkers.) If this area intrigues the reader, may we suggest a couple of works which were compiled recently on the World War II spy weapons.

"OSS Special Weapons Catalog," \$5.95, lists over 60 astonishing weapons issued to our spies by the OSS Research and Development Branch. This is the so-called 'Plumbers' catalog the public never saw. And "The Plumbers' Kitchen," \$12.95, lists not only the mind boggling gadgets and hardware of the World War II super spy, but gives the interesting history and little known details as well.(123)

What are current projects like? I couldn't speak if I knew. One contact of the '70's told me NASA has a black hood which can be used to electrically alter or rearrange the mental capabilities of us humans. . .and I have enough trouble with my brain now.

Because there is still no printed data on the amazing 'Enigma Machine' of Hitlers, a few brief words on this cipher machine are probably in order. Resembling a large typewriter, this device had three random locking drums and a super sophisticated plug board to scramble and convert words. Only by using a stolen machine and the best brains of both our countries did Churchill eventually crack the ultra-code system. One of the most well-kept secrets of the War was the cracking of this code. Thousands were sacrificed to preserve the secret.

The First Wireless. Nathan Stubblefield invented a wireless communication device in 1892. Until 1902 he was ridiculed for his efforts. . .and when he finally did get recognition he was overly suspicious and died with his secret. He had claimed that he was merely using the electrical field which permeated the earth, water and atmosphere. By sticking two iron rods in the ground at separate points, he could apparently send clear voice signals to great distances."(124)

Mechanical Computers. While the ancients are suspected by some of putting data in crystal and ceramic recorders, few persons realize that even the more primitive calculators and such were in use ages ago. One bronze device dating around 65 B.C. was quite complicated and could display the positions of various planetary bodies and give these positions in exact figures. Such highly advanced technology completely altered the views of many scholars after it was found (1900).

At this writing magnetic cores are used in the various computer systems, and such systems will, hopefully, advance to an astonishing degree if civilization can survive.(125)

Thinking Machines. With millions of pages of scientific data and 100,000 technical journals spewing out new ideas, science would be crushed under their own output if it were not for one of their inventions. The computers, love 'em or hate 'em, have saved the day for us all. The big companies could not function and store data if it were not for the computers and we, the public would just not be getting the benefits of technology without them.

True, in the early days of computer change-over there were some big bloopers, and, true, the average person isn't touched very directly by them yet. But that is changing. To survive in the future, it is likely that even speed-reading will not be sufficient to keep

us updated. With the computer, you will ask a question, push a button, and get your answer. No sorting and sifting through piles of paper.

Potentials are staggering even many scientists who now feel that the machines can actually think and create. 'Artificial Intelligence' they call it. It is no problem at all for computers to solve problems by trial and error. By getting some of the intelligence refinements worked out, the problems of sloppy programming will disappear. Sounds like Science Fiction? Well, 10,000 years ago there was once a city called 'Shamballa.' According to some obscure writings, this is where a special cycloptic humanoid was developed and used. In the early '70's a jaw with a double set of teeth was found (a cycloptic characteristic) and some persons awaited the next logical step: A skull with one eye socket. While traces of all this lie buried beneath the Gobi Desert, it is just possible that our computer technology will some day surpass that of this ancient technology center.

In the '70's few persons were actually aware of just how far computer technology had gone. While Phase I computers kept the paperwork of industry moving, the Phase II models were solving problems, correcting human errors, and getting man in space, and Phase 4 & 6 models could only be compared to models in works of Science Fiction.

Examples. Stanford University Research Institute in Menlo Park, California, developed a computer that read human thoughts in the early 1970's. The computer was able to detect brain wave tracings that corresponded to thoughts and words. Technically, then, it would be possible with this system to run sophisticated machinery with thought—or with mechanical implants to run persons. . .

During the early stages of the Vietnam War it was rumored that the U.S. Army tried a very unusual communications device made by a concern called Intellectron. According to reports, these units functioned without wires and was to be used because it would not be affected by the noise of the war.

Mind Reading and Control Machine. The Pentagon funded a Stanford project in the mid '70's to actually read minds. Thoughts were televised to a computer which could change an action before the human body could react. Stanford Dr. L. Pimmo told a 'Star' tabloid reporter that if there was a mind control danger. . . "It's up to the people to be vigilant against misuse of the computer."

Force Field Detectors. An invention by David Thomas can transmit 'anxiety' or 'calm' frequencies, or waves. This can calm nervous patients or clear out a room, according to those who have tried the instrument. His recorder can tell from a distant person's invisible aura whether they are anxious or at ease. The recorder is said to consist of two capacitor plates, a preamplifier, and a line recorder.(126)

Sight for the Blind. In the early '70's a couple of researchers at the Smith-Kettlewell Institute in San Francisco developed a tactile vision substitution system (TUSS) which allows the blind to see by the use of a little five pound television camera unit and special lenses.(127)

Sonics. In the 1960's the amazing potentials of sound finally reached the moguls of the industry. All sorts of unusual applications for noise generators arose. One mild little model drowned the sounds of the night out with a gentle hissing noise. Ling Electronics of California went to the other extreme. They supplied industry with units that could literally tear apart electronic equipment. That's how space flight hardware was tested. And Smith-Kline Instrument Co. made miniature sonar units to find specks of metal in the eye and body. Other researchers are shaking slow penetrating medicines into the body—right through the tissues.

Where the really bazaar research is going on, though, is in Government-funded labs. MIT, RCA, and Bell are working on things that could probably only be accepted by a science-fiction buff.

Sound Cannon. Besides the super sonar systems, the Government is looking into sound as a super weapon. As early as the 1960's it was possible to kill animals (and people) and to ignite distant objects with sound beams.

Hitler's incredible sound cannon was used against American planes at least once and against the Russians on another occasion. Not until 30 years later did the public hear more than hazy rumors of these events.

Somewhat resembling an ordinary cannon, the secret to its success was a rear chamber that ignited a methan-oxygen mixture. By creating a series of powerful explosions, the projected shock waves were devastating. It is said that hundreds of animals were disoriented, paralyzed, and eventually killed in the first tests of this remarkable weapon.(133)

A second similar experimental weapon was the so-called 'Acelus Bag'. Using Hydrogen and Oxygen, it produced a devastating amount of shock waves. It is said that this weapon was actually successful against hordes of Russian-Mongolians. Plans for this weapon were thought to have faded from Allied access.(134)

Ultrasonic waves can be concentrated to do a mind-boggling amount of useful services. Since almost anything that is loose can be shaken from a solid object, one of the more mundane uses of ultrasonics is cleaning things.

In the '50's a pair of intrepid Australians came to our West Coast with a little ultrasonic box by which the housewife was supposed to be able to replace her bulky, expensive washing machine. After a number of short news media interviews, these gentlemen just disappeared from sight. It sparked some curiosity in a number of persons as to just what potential lies in this direction.

As we pointed out in our section on vibrations, there are legends which indicate that sound was used to render objects weightless. As early as the late '50's Penn State researchers could make small objects defy gravity and float with their sound fields. As sonic generators increase in size and efficiency, it is certain that such applications must now be pretty awesome.

Because Government sonics contracts will continue to remain secret, the public will only be able to catch glimpses of the awesome control potentials of sound.

A number of police departments can disperse rioters with ease with sirens of a few dozen decibels. Considering that the military now has units of 200 decibels and far over, it takes little imagination to see the potential effectiveness of these super models. The human brain is stopped short and cannot function on far less power. Findings in the '70's indicated that one of the curses of modern civilization was common noise pollution. It drives civilized people to uncivility—just plain nuts.

If you are interested in this field, remember it takes considerable power to really get into the 'big league' of sound. Sounds above 150 db can also burn your body, deafen you, start your neighbor's house on fire and generally derange you altogether. (See your library for current magazine articles and books on the subject.)

Professor Vjadimis Gevreau developed a very powerful infra-sound generator which was discussed in Nat'l. Inquirer, March 10, 1968; Patent for 40 francs from French Patent Office, 26 bis Rue de Leningrad, 75800, Paris, France.)

Blinding Force Meter. A unique "binding force" meter was developed by W.B. Smith and friends of Ottawa, Canada. Smith maintains that there are areas on our planet where there is a reduction in the binding force of matter and that a number of plane crashes have resulted when planes weakened while flying through such areas.

Atomic testing seems to produce a number of such temporary areas of danger, and it was not long ago when atomic physicists first discovered how to release the binding force in the nucleus of the atom.

In Smith's book, "The Boys from Topside" (T.G. Beckley, Box 2228, Clarksburg, W.V. 26301, Saucerian Books '69), he explains that if nylon fishing leader is pre-stressed to about 75% of its breaking point, it will serve well in a simple binding force meter. In the illustration provided, you will notice that the fiber is simply wound around a spindle and that this turns a dial. The tube covering the fiber is to minimize humidity factors, etc.

Smith found a number of regions roughly a thousand feet in diameter that could be called danger zones. Typically, his theories were relocated to 'file 13' by authorities.

Voice Phenomenon. In the '50's and '60's there were a number of experimenters who built crude devices to pick up extra sensory communications. Only a few seemed successful, and their instruments would seldom work for others. With the accidental discovery that tape recorders could sometimes pick up 'outside' conversations, in the '70's a whole new approach opened up. Experimenters would turn up their tape recorders full volume and let a diode or microphone serve to pick up other dimension conversion—just as 'spiritualists' used trumpets decades ago. Very low frequency also works.(128)



Electrometers. The first successful electrometer (Potentio-meter) healing device was probably the Mathison Electropsychometer. Volney G. Mathison, its inventor, would use it to determine what problems were hidden deeply away in his patients, and then he would produce self-hypnosis tapes to help the patients overcome this 'inner' problem. An alcoholic, for instance, would be hooked up to this sophisticated little lie detector and it would soon be found that he might be drinking to punish himself for a previous wrong action. A later 'sleep tape' would explain this fact and repeat thousands of times that the patient would no longer need to drink for this reason. Recalling my visits at the height of his career, I remember that, while his results were outstanding, he was typically fought by the Medical Profession.

Somewhat later the originator of Dianetics and Scientology, Ron Hubbard, made use of a smaller transistorized electrometer. In practice, the auditor would ask key questions of a church member being audited. By getting a person to remember their former traumatic experiences (unfaceable), the auditor could tell by the 'E' meter when the experienced had been duplicated or 'faced' enough, mentally, to ease off the restrictive unconscious side reactions, or 'engrams.'

Gaining remarkable results, to a point, the Scientology system was fought by everyone from the Communist front groups of the '50's to the Government in the '60's. Extremely high auditing fees and a very controlling restrictive methodology slowed down membership in Scientology Church after the '60's.

Some persons have had good results by using simple and Cheaper 'E' meters in helping themselves make sure of their own recognition in this mental delving.

Later, a popular use of electrometers came about when it was discovered that plants can respond emotionally. Researchers in the '70's delighted (as I did in the '60's) in attaching 'E' meter electrodes to plants and noting the minute electronic changes as the plants respond to stimuli. (See "The Secret Life of Plants," and many private groups).(129)

One of the super bombs which waits to be 're-discovered' in the chaotic present times is the neutron bomb. Unlike the other super bombs, this weapon would leave most surrounding property intact. The destructive effect would come from its ability to destroy tissue by a 'death ray' effect.

As the laser development increases, it is suspected that the size and cost factors which confront developing this weapon will slowly fade. It is hoped that the world's insanity will have subsided a bit by this time.

In 1975 Russian leader Brezhnev wanted to have a ban on weapons more powerful than nuclear weapons. Logical reasoning would indicate that such weapons must exist.

Theories concerning the legendary Atlantean energy crystals were usually ignored by more 'reputable' (?) scientists. In 1975 many had to take a second look at the situation. It seems that a

well-known Dr. R. Brown from the S.West actually admitted finding one of a minor energy potential.

Using a special magnetic detection device, the Doctor and his diving companions got a strong reading in a particular area of the notorious Bermuda Triangle. Diving down in the area shortly after a hurricane, Dr. Brown discovered a pyramid with a blue capstone. Entering into an open passage, he found a room containing a unique pedestal. This pedestal consisted of two hands holding a crystal.

Later, the Doctor found that his unique crystal would emit a blue-violet glow after being subjected to a strobe light.(130)

Kirlian Photography. In 1939 Semyon Kirlian was repairing a high frequency massager and decided to photograph what appeared to be an interesting discharge between the machine and his hand. The results were so astonishing that he and his wife spent the next 25 years studying newly exposed bio-energetic processes in living organisms.

High Voltage Photography. (Electropsychography EPG). In the early 1970's, it became popular for unusual phenomena researchers to experiment with Kirlian photography. In practice, a small high voltage Tesla coil charged an object with high voltage, and, as this voltage bled off, it could be photographed. The corona surrounding the live or inanimate object was usually very striking and could change according to varying conditions. A live organism, for example, might have a very faded or incomplete corona if there was sickness or abnormality present.

Many felt that inside all organisms there is an invisible flow of electrical energy and this 'fuel' can be studied to show the various vital processes. Because the technique allowed detection of the various nerves which correspond to the acupuncture points. It was only a matter of time before a machine was made to locate these points.

By substituting helium-neon Lasers for needles, it was found that any competent doctor could get amazing medical results without the years of training normally required in this approach. By beaming light in the red area of the spectrum into certain vital centers, all types of metabolic, hypertension, and joint disorders could be effectively treated.

It was 25 years before the Kirlians' work was made public and another 33 years before there was any widespread response from the amazing discoveries in this field, and, as this is written, the public still gains little benefit.

Researcher David Sheinkin of the Rockland Mental Health Center, New York, found that coronas which were flared or blank in spots could indicate symptoms of disease. Such findings supported the work of Semyen Kirlian, who developed these techniques in Russia in the late 1930's. Typical small researchers of the '70's used electrical units designed for use in electrical beauty shop treatments. Charging objects over light shielded film gave good results at a minimal cost.(131)



Rock Cutting. According to the South American explorer, Col. Fawcett, he once stumbled by accident across a plant whose juice could soften the hardest rock. Did the ancients employ this method in erecting their giant monuments? Colonel Fawcett also described subterranean tunnels which penetrated for miles under the surface of the earth. Numerous accounts tell of similar smooth walled tunnels under lands across our globe. Will our technology again reach this probable state?

In 1971 an electronic beam rock cutter by Westinghouse was able to cut up to 4 inches of rock like butter. (Pop Sci March '71).

Since rock melts at about 1200° C. atomic energy technicians of the '70's used molybdenum drills heated to 1600° for drilling through rock easily.

When Solomon forced Asmodeus to erect the temple in Jerusalem, it is written that the whole structure was built with the use of a stone that cut other stones.

According to obscure writings, Diorite was supposedly used as a tool for carving stone. Since diorite contains hornblende and feldspar (containing aluminum) perhaps there is some key here to some molecular change action.

Friend Beryl Pounds speculated that there is a link in the fact that silicons can, in general, be altered in nature by introducing heat and impurities. Impurities of a negative group 5 variety (antimony, phosphorus, arsenic) tend to free electrons and, conversely, the group 3 positive-type conductors (aluminum, boron, gallium) tend to cut down on the electrons in the silicon atoms. An open minded look into the energy band theory and this line of thought may be rewarding for the truly curious.

Keely. While many persons learned of Keely through his remarkable motor, few were aware that he had a number of other inventions equally unconventional. In the French theosophical journal of 1888 'Le Lotus,' there was some detail on a complicated little resonator ring that could disintegrate rock to dust in seconds. According to the article, there was a great stir in mining circles after the device was demonstrated before some mining industry magnates. Another device mentioned was supposedly capable of lifting objects weighing tons by simply passing an electrified wire around them. Keelys microscopes and telescopes were even beyond the capabilities of present models. . .if reports are correct. (See: "Masters of the World" Charroux. Berkeley).

As knowledge expanded during the space programs it forced public acceptance of exotic history and ideas that were closed to evaluation before. Dozens of writers delved into the fascinating past and dredged up great quantities of material. The dozens of sacred books of India for example were an almost endless source of exotic data. The Mahadharata for example mixed the teachings, customs, and history of ancient times with constant mention of air ships, rockets, interplanetary ships. . .and, of course, weapons to rival our own.

Scientists at Los Alamos developed a thermal drill that eats through rock without leaving waste material in 1971. (Der Spiegel 4-3-72). Westinghouse developed an electron ray generator capable of disintegrating rock shortly after. Did the ancients use similar technology? The hard glaze on the walls of many ancient tunnels would indicate they did.

Electricity from Silicon. Because we are living on a carbon based planet, substances which are opposite to carbon bring on unusual influences. One of the more recent beneficial discoveries was that silicon crystals could produce electricity when exposed to solar rays.

For some years these solar cells were expensive because each crystal had to be sawed up into thin wafers. In 1974 a method of producing long thin ribbons of crystal was developed and was expected to make solar energy much more feasible. Many amazing discoveries will come from understanding where silicon fits into our Earth's system.

As a side observation on Silicon, did you know that there are many Silicon based planets in our solar systems? Invisible to our eyes (some animals could see in this range) only instruments can detect them.

Laser Electricity. By dropping pellets of frozen heavy Hydrogen into a crossfire of laser beams, a fusion will produce enough heat to produce cheap steam generated electricity. A 1975 breakthrough.

In the late '60's, Argonne Labs found that lithium and tellurium batteries gave phenomenal outputs per pound. Unfortunately, tellurium is in short supply and the batteries had to be operated at high temperatures.

John Wayne's Oil Recovery Project. John Wayne, the movie actor, felt sure that the oil moguls would be interested in his venture to extract oil from old tires. His Duke Engineering plant at Irvine, California could extract four barrels of oil a day from every ton of tires—without pollution. Typically he got little encouragement from officials.(135)

Pine Tree Gasoline. Researcher Dr. D.R. Roberts of the Lake City, Florida, Forest Service was quite surprised at a phenomenon he observed. When an herbicide named Parquat was sprayed on an exposed layer of pine tree trunk, it caused a chemical reaction which violently altered the whole tree. The whole tree's trunk cells became soaked with up to 48% clearesin. This compound was almost pure Carbon and Hydrogen and could be used to make gasoline and certain oils. Estimating that billions of barrels of crude oil could come from standard forestry operations, researchers nevertheless talked of there being many years until concrete action could come.(132)

Heat from Air Movement. In the late '60's there was great hope for the heat pump to supply inexpensive heat. While most of the systems first developed used an electric fan, the basic heat was taken from air currents that had the warmer air separated.(140)



Electric Insect Control. Because the high power needed to supply insect lethal ultrasonic waves and electromagnetic fields was expensive, biologists of the '50's and '60's felt that a shortcut method could be used. By feeding the insects inexpensive chemicals or enzymes that would later react with to very weak and cheap electric pulses, insect control could be cheap, effective, and non-toxic.(138)

Wireing Plants for Higher Yields. A number of independent experimenters have found that various coil configurations of wire have boosted plant growth and cut down plant damage from insects. Many persons felt that plants require a certain amount of radio frequency for maximum stimulation and that most plants never get enough without help. BSRF experiments indicated that single coils (without ends touching) were effective. WFOE experiments proved that 9 turn conical coils wound counter clockwise (N of equator) were efficient when upright near plants. Actually tests showed that any wire a foot or so from plants tended to help the soil retain moisture and help the plants grow better.(139)

Electro Magnetic Gardening. In 1900 a Government Agricultural station in Amherst, Massachusetts, got a 30% larger growth of vegetables by the use of atmospheric electricity. The workers simply caught the electricity with wires and masts above the gardens. Through the years only a handful of experimenters utilized similar methods until the '50's and '60's. Around that time there were occasional articles in various mystical publications. A little later publications such as "Organic Gardening" and the "BSRA Journal" occasionally had articles written on the subject. Using everything from chicken wire to wire loops, experimentors had more ideas and good results than I can include here.

Giberellic Acid. In the late 1930's Japanese scientists discovered that a substance extracted from a certain rice fungus stimulated plant growth. It was not until the 1950's that our scientists used this Giberellic Acid in growth research. They were astonished when yields of grass increased by 40% when sprayed with dilute G.A. mixtures. Certain food crops grew 20 times as fast under such treatment, and the hormone-like 'Gibberellins' were thought to be a key to great agricultural advances. (See J.G. Crowther's work).

Super Micro-Wave Machines. Because of the insidious effect of poisonous sprays upon the human body, there were a number of harmless insect killers developed to replace them. In the '70's one such method involved a large microwave soil sterilizer.

Simply driving up and down rows of vegetables with a microwave machine was said to eliminate the insect problem. Since poisons often cost up to \$150 per acre as against \$50 an acre for the microwave method, many persons suspected another dose of suppression. (See 'Prevention' Magazine for plant protectors beyond this work's scope).

Beyond The Five Senses. More sophisticated instruments constantly expand our horizons. It is claimed by a number of persons for instance, that there are at least 60 planets in our system. As instruments detected three such planets of a silicon base in the '60's it became evident that there was more than greeted the eye in any direction we chose to look.(1960's News releases).

EEG. Back as far as the 1860's it was recognized that the train functioned as a dual unit. Neurologists found that one side of the brain covered the various faculties of recognition and expression while the other seemed to be the seat of more creative thought.

Later work at the California Institute of Technology pretty well proved this duality principle to 'die hards.' Then in the '70's the EEG machines made it possible to learn exactly what part of the brain responded to different stimuli.

The dual 'rational and intuitive' portions of the brain made it obvious that the majority of men were not bringing more creative ideas into their lives because they were depending too much on the verbal 'analyzer' part of the brain.

As I have pointed out elsewhere, the brain does not wish to relinquish any useful amount of control. To get a 'flow line' from the mind to the intuitive portion of the brain takes a great deal of effort.

X-ray. While technology brings new and sophisticated devices to detect and show what is within objects, there are probably simple principles just awaiting discovery. In his "Prehistory of Aviation," B Laufer relates that the Chinese Emperor, Tsin Shi, 250 B.C., had a device that made it possible to see the bones of the body through the flesh.

Back in 1933 mining engineer, G. Warren Shufelt, put together an apparatus that would indicate underground objects and cavities. Claiming there were deep underground rooms and metal sheets (tablets?) below an area near the Los Angeles Library, he worked for several months on the project until some unknown problem halted him.

Modern hospitals are scanning the insides of patients by a number of methods. Sonar, heat detection machines, radioactive tracings, and technicolor X-rays are all used with unusual success. X-ray film will soon be replaced by Xerox-type sheets, and cancer will be detected through three dimensional ultrasound shots.

In the field of industry there is a limited use of alpha particles and electrons, protons and 'N' rays for radiography.

Sun Cannon. Few reports of Hitler's Sun Cannon ever filtered through wartime censorship. According to one African Corps member, however, it was actually successful on several occasions. This weapon was simply a group of truck-mounted parabolic mirrors which were focussed at an enemy's planes long enough to blind the pilots.



Super Plastic. The ancients used certain types of plastic, and I had a friend who once found an unusual specimen while mining in Arizona. The sample contained twisted silver wire and it was hard and quite clear, much like a piece of present day wire safety-glass. Dozens of remarkable plastics are used at this writing. Some, pre-compressed, will expand, later; others, treated in various ways, will allow only certain rays and vibrations to pass (Polaroid, etc.). Trade journals can keep one abreast in this field.

Hydion plastic has the unusual property of turning soft when contacting water. Because it absorbs moisture, it was used in the '70's for contact lenses, artificial body parts. Future uses will include leather and cloth substitutes, non-fogging glass, and filters.

Cheap Cheap Plastic 'B' and 'C'. Robert Morse felt he had come up with one of the discoveries of the century when he developed his plastic 'B' formula. Using cheap waste molasses from paper mills, along with fuel oil and catalysts, he could produce everything from paving materials and building blocks to table tops and pipes.

Because wood molasses was one of the largest pollutants in the U.S., Morse thought giant industry would welcome his process as a means of utilizing a waste. But that isn't the way it works, is it?(118)

Early U.S. Technology and Housing. After the Civil War, mechanization leapt forward in every part of American life. Agricultural machines spewed out of American factories just as fast as settlers flocked westward. American inventiveness far surpassed that of Europe simply because the manufacturers were given free rein. Even simple tools such as the ax were greatly refined, and, under the yoke of Big Business monopolies, it took Europe decades to catch up.

In 1864 seventy thousand reapers were built, and out of Chicago came hundreds of prefabricated houses for the prairie settlers. It is of interest to note how various groups began to throttle such cheap housing after the second World War. Unions saw that building codes excluded such housing in most states, and even as early as the '50's, state real estate interests began to see that laws were enacted discriminating against cheap temporary housing, such as small trailer homes.

The 'Integration' Rejuvenator & Moses T. In various works describing the early civilizations such as Atlantis, larger 'rejuvenation' machines are sometimes mentioned. At present, the only machine worthy of this category is George Van Tassel's 'integration.'

Since the mid-'50's, Van Tassel has spent many thousands of dollars on this 55 foot dome-shaped generator in the California Desert. Working on a principle similar to that used by Lakonsky in his M.W. oscillator, the machine will be capable of treating 10,000 people a day if its ever successful. Controlling resonance and polarity—reversal interruptions, the machine is supposed to create a common core flux from these split fields—and, thus, a 'time zone.'(141) The device combines a field of soft high frequency radio waves, magnetism, and a negative-charged atmosphere.

CBW Threat. Back in 1925 the U.S. drafted up the Geneva protocol banning the use of poison gases and bacteriological warfare. While virtually every advanced nation eventually agreed to this agreement, the little known fact is the U.S. is still not formally bound by it. Before it was ratified by our Senate, it was allowed to die.

In the late 1960's, then, it became an all too frequent practice to use incapacitating gases to drive our Asiatic enemies away from cover in order to destroy them. Not only did we act against all world sentiment in this, we also began to systematically use chemical defoliants. In the case of Vietnam we defoliated at least one fifth of the total forested area of the country. Such thoughtless violations of moral responsibility reaped terrible and staggering damage to the forests and ecology of this nation—some feel to their population, as well.

The reason we mention all of this is that both the U.S. and Russia are constantly developing new and mind-boggling chemical and biological weapons. The toxins, pathogenic viruses and chemicals that are invented and developed to destroy life are part of the suppressed information flow that seldom reaches the public. Fortunately, some of the picture can be seen through new books out on the subject, typical of which are 'Ultimate Folly: War by Pestilence, Asphyxiation, and Defoliation,' McCarthy, R.D. '69, Knopf, N.Y. and 'CBW Chemical and Biological Warfare,' Rose, S., '69, Beacon Press, Boston.

Nerve Gases. Hitler, of course, was responsible for the first really effective nerve gases. His 'G' agents could kill a person with less than a 'whiff.' Later on in the '50's the British discovered the so-called 'V' agents, and these were so powerful and so toxic that a drop the size of a pinhead could kill dozens of people. These agents are all hundreds of times more deadly than the mustard gases and gas masks provide little protection against them. Upon being exposed to one of the newer agents all of the muscles in your body seize and you die when your lungs fail to function.

As this is written, the U.S. has large stockpiles of its deadly VX agent, and Russia has at least as much of a similar agent. If you think 50 million pounds of chemical munitions can make any worthwhile contribution, let this author know.

The biological weapons of the '70's included not only the living organism such as anthrax, tularemia, and brucellosis, but the highly toxic chemicals such as botulinus toxin. The death rate for those infected with anthrax would be around 90%, and a few ounces of type E. Botulinus Toxin could theoretically poison everyone in the world.

Typically, I suspect that most of these stockpiles are simply built up to keep money rolling to the internationalists' coffers. I.G. Farbon of Germany developed Napalm and the deadly Cyclon B gas that exterminated a few million Jews. Today they are affiliated with Dow Chemical, whose VX gas quickly eliminated 6000 Utah sheep when the wind changed. These deadly gases are sold to our Armed Forces regardless of whether our Congress approves of them or not (Les Aspin, D. Wis. '75). As usual, the public remains stationary and pays the bills.

Water from Air. As far back as the 1900's Lyman Gilmore or Grass Valley, California, was building inventions far ahead of his time. He built and flew an airplane before the Wright Brothers. He built a mine tunnel boring machine that worked with amazing efficiency (70 years ahead of its time), a super efficient automatic water pump, a gold saving machine so efficient it couldn't be readily accepted, a 1916 submarine, a World War I helicopter, a safe pre-World War II high speed train, a 1930's super thrust propeller, a 1900's tank, a 1930 electric anti-aircraft cannon, and goodness knows how many other unrecorded and tested designs and machines. Typically, all of his advanced designs, except the landing barge of World War II, were rejected by the Government.

Using his uncanny 'visualization' techniques, he developed one thing that corresponds to a device that the legendary Atlantians were alleged to have. This machine was supposedly able to distill water from apparently dry land in a way similar to that used by desert plants. Because early investorts, and even the Jewish Resettlement Organization, later, were not interested in his machine, it, too, disappeared.

In "A Dweller on Two Planets," by Phyllos, we have an account of the device used in Atlantis. The models capable of producing a quart of water a minute confined several hundred square yards of metal plate surface arranged in banks like that of the gills of a fish. Enclosed in a box and cooled by natural forces of nature, the plates trapped the water in the atmosphere as air was circulated through the device.

It is not generally recognized that many ancient people used rocks to collect water in barren lands. Using limestone (as I recall), they would pile the stones in a certain manner near the trees and plants they wished watered. With possibly a white-washing, the rocks were capable of collecting enough moisture from the atmosphere to dampen the ground and supply the plant roots. There are places in the world that still have small water holes supplies by this principle.

Present technology is catching up. The solar MEC Box developed in 1974 doesn't make water, but it uses simple honeycomb moisture transfer plates which replace the exotic fluids and condensing coils of the usual heater-coolers. (Pop Sci Jan '75)

Weather Manipulation. Wilhelm Reich devised what he called a 'cloudbuster' to manipulate the chemical ether, change the weather, and defend himself against occasional malific alien energy forms.

At his research center in Rangeley, Maine, (P.O. Box 53, 04970) there are still a number of Orgonon Draw Units he used for weather manipulation. Such units could be said to resemble weird canons with anywhere from a few to ten pipe barrels aimed skyward. Grounding such units well, he was able to draw energy from the 'OR' atmospheric envelope and to create or disperse clouds at will. For rain he would sweep around the edges of a particular area together in the proper clouds. To stop rain he would aim his devices at the center of the heaviest clouds. He was able to create clouds by disturbing the evenness of what he called the 'OR' envelope, creating different energy potentials.

Such work as Reich's could be dangerous, and, if experimenters touched his units while they were functioning, they could become blue in the face and dizzy. Seldom working his units longer than from 15 to 45 minutes, Reich would cease immediately if his work started bringing on a slight wind. All sorts of unusual problems arose in playing this role of becoming a minor 'Weather God.'

After Reich's death, researchers such as Trever James took up his work in earnest. In his "Pulse of Life" James tells of how he used the cloud busting units to attract and photograph etheric space ships.(153)

Using somewhat different methods, there were a number of researchers who tied in with the works of Drown Steiner, Wachsmuth, or Lehrs, and became quite proficient in cloud busting. Some felt that the energy involved was biological and not electromagnetic. Most were very secretive, simply because of the damage that could be done by persons who used the units without restraint and tight control.

While passing stringent laws to prevent air pollution, our Government used hundreds of tons of chemicals to control weather in the '60's and '70's. Silver and lead-iodide, salt, and other chemicals were not only dumped all over the U.S. but were used to extend the monsoon rains over vital supply trails in the Asiatic 'conflicts.' Many knowledgeable persons felt such practices directly caused much of the adverse weather (draughts and heavy rains) which affected the world later.

Whatever the long term results, the cloud seedings of the '70's were effective. In the '60's it was considered great to have a 300% increase in a specific cloud formation's 'release' rate. In the '70's they have been able to merge cloud formations and get an increase in rainfall up to 10 times. Cloud seeders use electronically ignited flares of silver iodine to saturate the clouds with particles, and, in heavy doses, to extract far more rain from a cloud than it contains.(154)

Because silver iodide had a crystalline structure similar to ice crystals, it was used to attract the moisture in clouds and fall as rain. Various environmentalists had maintained for years that this substance was harmful, but it was not until the late '60's and early '70's that University of Denver scientists confirmed these suspicions and found a substitute. Metaldehyde and 1,5 dihydrorynaphthalene were found to be completely safe biodegradable compounds that not only worked well but were much cheaper and were easy to obtain, as well. Chalk one up to research and technology.(155)

Rain and snow makers have been plying their trades for centuries—articles written about them and their successes would fill a book. Fate Magazine has had a number of such articles, typical of which is a recent mention of a Finnish snow dancer named Heikke Lunta. After a Michigan snowmobile club hired him, he demonstrated his ability twice. How much power can the mind focus in such pursuits? I suspect we are on the verge of knowing.

Chapter 6

Unusual Concepts and Principles

Nothing New? While the various prior periods of high technology were brief, many were amazingly equal to our own advances. Hot water on tap, thermos containers, clocks, water pumps, indirect lighting, radiant heat, rustless steel, optical lenses, drilling tools, wheeled vehicles, counting devices, fine cloth, advanced medicine and even napalm were realities. Even some of the early architecture has stood far longer than 99% of ours can hope to. As it stands, even our most advanced technology is duplicated in some ancient document or legend.

Rediscovery of Science. The rediscovery of technology and science came about regularly as war and floods wiped out the various civilizations. While official science prefers to ignore much of the evidence, there are just too many thousands of valid historical records to cover up the facts.

Immanuel Velikovsky was one of the first to gather much of this historical flood data in recent times. This bestselling "Worlds in Collision"(142) caused a furious controversy. The publishers were intimidated by threats from academicians and scientists across the world, and even today, 25 years later, the controversy continues. In the 1970's, however, the truth just kept pouring from the unrecognized authors. Andrew Thomas compiled many records dealing with ancient science. His "We are not the First"(143) pointed out that space travel, aviation, advance astronomy, atomic theory, and other present achievements were arts long forgotten.

Aviation, for instance, was covered in ancient works at the time of Daedalus (2500 B.C.), Ki Kung Shi (1766 B.C.), Emperor Shun (2290 B.C.) and other ancient rulers. After examining ancient documents scattered across war torn Europe, Alfred Glaser (News-Novels) concluded in the 1940's that there was little doubt that the so-called 'floods' came with precise regularity and that the ancients were quite aware of this cycle, and in many cases they tried to preserve their knowledge and technology against such events. Will we progress to a point of a technologically advanced Utopia before war or cataclysm destroys us, also?

Science 11,000 Years Ago? Because the old volume "Dweller on Two Planets," by Phyllos (1894, F.S. Oliver) contains so many interesting concepts, it might be well to view some of them in light of what Science is now finding.

The first part of this unique old book contains data about the power sources and history of later Atlantis. Some years ago, such ideas were viewed as nonsense by respectable historians and scientists. Today the picture is rapidly changing, and the book becomes more valid as new discoveries are made.

Phyllos pointed out, for instance, that the Atlanteans knew that light gave off sound when correctly resisted. Light from the sun or any source then could and did run astounding inventions by this conversion. He maintained, further, that while Atlanteans were very much aware that resisted magnetism gave electricity under the same principle, they often chose to utilize more efficient and powerful energies. As a principle, then, you could say that from this damming up of electricity, you could resist this to get light, you could resist light to get heat and sound and, finally, energy would appear as a pulsing motion. Jumping across any of these steps, of course, could produce more specialized efficiency.

Beyond this elementary usage of magnetism was a realm of force which could produce a much greater pulsation and potential. This force was the awesome energy operated by mind—the part of the father that is responsible for a perfectly functioning universe.

Ancient Metal Technology. Despite the continuing mountains of evidence that ancient races often had advanced technology, the history books have remained almost unchanged. It would seem that even in our so-called 'enlightened age' truth is all too often an unwelcome visitor.

From the '50's to the '70's there were a great many startling discoveries to add to the already abundant evidence. In S. Africa officials found Ngwenya hematite mines that had been mined over 25,000 years ago. Ancient South Americans, it was found, not only smelted and cast platinum from furnaces of extremely high heat, but they could plate precious metals by the electrolytic process. And in Southern Armenia, the Russians discovered a metallurgical factory at least 5,000 years old. Steel and most other common metals, including fourteen different varieties of bronze, were distributed as tools all over the Near East by the ton. Yet still our history books tell us that people of this period were using stone at this time.

The Atlans, as Phyllos called them, recognized that nature was only a manifestation of the Father, or the 'All That Is' Deity. They knew also, that force moved in circles so that whatever vibrations bring in energy, there will be an opposite polarity to carry the vibrations out again. In learning to balance the 'Day and Night' sides of nature, the Atlans could propel great wingless craft or have wireless TV, telephones, or heaters.(144)

Super Accuracy. During World War II Hitler's scientists rejected the accepted mathematical systems of dividing a circle into 350 parts in certain sights. Using what some felt was a 400-figure, the Germans could hit a target with the first shot. . .while the allies had to troup in the shots. Some persons feel that the accepted figure we now use for pi is very inferior and extreme 'space age' accuracy is impossible with the present math in use. Mathematician G.L. Brandes astonished a number of scientists when he brought out his 'hyperspace' math concepts in 1976. His math was based on a trinary concept and proved to be absolutely accurate to the persons who were open minded enough to try it. (See Bankton Paradox Folio & 'H'Math. from Fry's).

Hitlers Fantasy Projects? We have mentioned the amazing aeronautical technology that Hitlers scientists so quickly produced. Few persons have ever heard of the projects that were to be considered after Germany ran the world. While not strictly inventions, a couple of these projects will show what a little imagination could create.

The Gibraltar Dam of Herman Soergel would have dammed up the Strait of Gibraltar and produced around 255,000 square miles of land and huge amounts of electricity. Because the Mediterranean Sea is fed vast amounts of water from the Atlantic, a huge dam would have conceivably dropped the water level of the lower side over 600 feet. Because the Germans didn't have the technology to pull this off at the time they put Soergel to work on another project. The Congo Sea was to be a huge pair of water bodies in the very center of Africa. Because of the huge natural Basins which exist in the center of this continent, it was only necessary to dam up the outgoing canyons to create huge lakes. Such dams would furnish cheap electricity to the whole continent and create much more desirable weather conditions besides. By running the various diverted water sources correctly there was to be a waterway for ships, to the very center of Africa. Equally ridiculous sounding to his critics, was his **Solar Mirror Project**. As we work out details of supporting a very similar unit in outer space ourselves, some begin to feel that foresight and madness may be frequent bedfellows on our chaotic planet.

Telluric Currents. Being a part of the very carefully balanced energy system of this galaxy, Earth has a good many energies entering and leaving her at different points. Some writers have felt that certain flying craft once, and continue to, use such currents in their propulsion.

The few studies made indicate that Telluric currents for the most part, run north and south. The ancients of course, were always careful to build their structures in alignment with such currents.

Harmony Grove is an interesting energy vortex area that is historically unique. Five miles west of Escondido, California, this area contains some of the most interesting rock etchings to be found anywhere. According to 'Akishic' records, this is the spot that one of the 'Earthbound' gods tried to escape his restriction after the 'War in Heaven.' The deeply etched rocks here contain the diagrams of his machine.

Creation of Life? . . . In the summer of 1900 Andrew Crosse of Elworthy, England seemingly created insects from his experiments with high frequency electricity. In his private lab he sent electrical currents through a strobe in a jar of acid. In a couple of weeks unusual types of tiny insects began to form on the stone. Repeated experiments indicated that with the proper adjustments of a spark gap and voltage regulation, he could produce a crop of living insects within 140 days. Many witnesses saw this phenomena repeated and yet he was scorned and denounced as a fraud.(146)

Pyramid energies. The world of matter exists through the energies given off and collected by shapes. Each mineral in our body has a different shape and causes an electromagnetic continuity. The Pyramid is one energy dispersal design that has long been recognized by intelligent beings. Photos brought back from Mars show that there are clearly even visible models on this distant planet. While it is felt by many that the great pyramid of Giza is primarily an accurate depository of knowledge mathematical and astronomical knowledge, nevertheless amazing results have come from using pyramid generated energies.

The best results seem to come from using the 51½ side angle of the original structure. When an object is placed within this conformation there seems to be an action which excludes moisture. This action is very useful in preserving food and problems caused by fungi, bacteria, mold, and rancidity are greatly reduced in such an environment.

Because steel razor blades and knives frequently lost a very fine edge from the effects of moisture, much greater blade life could result from using a protective pyramid encasement.

Living plants seem to be immune from the demisting effect and many persons found that their young plants would grow faster if treated under a pyramid. . . or watered with 'treated' water. (See local bookstore for current titles on subject).

Herbal 'Stones'. . . . Deep within the bowels of the earth there are certain actions that produce stones with remarkable powers. On the surface these stones look like ordinary smooth white pebbles. When they are placed in a steeping jar of medicinal herbs however, they have the remarkable ability to pull the virtue of the herbs out of the plant and into the liquid. Such stones were prized by many of the ancient and more primitive? races of the world. In Alchemy the making of these herbal 'stones' is not a great mystery and continues to be an exercise for the neophyte students in this work. Briefly the process involves continual purification of the three essential parts of living plants until eventually a 'stone' is formed.(145)

Mental Birth Control. A number of persons with high levels of 'awareness' insist that while animals may not have complete free choice, man does. Among other things, humans can will themselves to sickness or perpetual health by using the brain patterns responsible. Such free choice is even responsible in conception. To prevent conception a woman need only stop the anti matter 'proto type- life germ' from entering her at the same time as the semen. This is accomplished by simple mental 'will.' It occasionally happens that the forceful will of a rapist or dominating male can overcome the 'half hearted' or subdued will of the woman. But in the end a 'Knowing' woman has the choice. Many women of ancient and primitive cultures practices this art and a surprising number do, intentionally, today. (Some data in: "The Natural Birth Control Book' Tao Pub. Boston).

Mind Training Dangers. Because most persons can control their own mental and emotional states, there have been different systems to help guide persons to enhancement of their potentials. While some such systems have used hypnosis, there was an increasing number in the '60's and '70's who relied on progressive relaxation or simply getting into a proper mental state to reach their goals.

If such methods were free of hard profit motives, made allowances for different rates of advancement, and were able to see that adychic or mental unfoldment didn't lead to destructive psychosis or neuroses, all was usually well. If, however, the student began to lose the all important self-control, there was often trouble.

In hypnotic training courses these dangers continually arose. Typically, persons were forced into realms that they could not protect themselves on. They could lose control not only to their own unconscious states but to outside influence as well. All too often the teachers of the courses were unwitting tools for alien influences themselves, and once a student lost a measure of self control, a continued dependence was all too frequent. Seldom is this loss of control apparent and it is usually denied by all involved.

While many practitioners maintain that they and their programs are free from selfish or ignoble motives, it is impossible to guarantee the fact or to hope for much more than a frail and wandering set of influential mental projections. The fact is that hypnotic programming in mind training courses is just not safe.

There are areas of safe exploration into the mental and psychic domains. Brainwave training, meditation, and methods that insure safe, self-adjusting self-control are often great helps to a fuller, richer life. . . a life based on more freedoms.

Man the Robot? In a number of ancient manuscripts there are references to a highly advanced civilization that once created special humanoids on our planet. It is also said that during this same period, this highly intelligent race bred the species man (apart from Human) very selectively for certain physical traits.

Without spending precious space trying to authenticate such ideas, let's look at the present parallel. In the early '70's the British had a sterile woman bear a child that was started in a test tube. During this same period several thousand robots were designed to take over unpleasant or hazardous jobs in factories. UCLA researchers also found methods to implant units in the brain to inform persons at a distance when certain thought patterns developed. They reasoned that a criminal could be monitored for bad thoughts. With the advent of techniques to control thought as well as physical freedom the human species could probably be altered to become a complete type of robot.

As the crystal data storage technology progresses, it will be only a short time until humanoid robots are all too possible. How this technology will affect you and me under the present Domination Systems is a sobering question.

In a similar vein of thought, Alfred Glaser (MOVE) has pointed out that beyond the **Van Allen Radiation Belt** the human 'mind' ceases to function, and the astronauts' using strictly 'brain' are very limited. Complex space travel, of course, even now requires a great deal of automation.

Invisibility. The secret Navy Invisible Ray experiment (The Philadelphia Experiment). In 1943 the U.S. Navy experimented with powerful magnetic generators, which, according to Philadelphia, Pa., experiments, could cause strange 'time warp' phenomenon. Using pulsating and non-pulsating 'degaussers' an experimental craft was said to be rendered completely invisible. The only problems arose when the crew began to disappear and could be brought back into visibility only with bazaar and difficult methods. Rumors persisted that a number of the crew never fully recovered from the experiment.

In theory the Navy discovered a way to hook up their generators to produce a third magnetic field to complete the three planes of space needed. Since an electrical field in a coil produces a right angle magnetic field, it is presumable that the secret lay in getting the third field through the principle of resonance. (M.K. Jessup, a well-known scientist astronomer ("The Case for UFO's") supposedly committed suicide after this material leaked out).

Anti-Radar Paint. Our War Department was astonished when some of Hitler's planes failed to show up on our radar screens. It was some years before we were able to duplicate this special paint.

Time Machines. In the Science Fiction stories of Post World War II the idea that speed slows down the aging time was well used. Other ideas began to be used in the '70's as technology progressed. A momentous concept was born when 'Physical Review' published F.J. Tipler's Data (Vol. D-9, 1974) on a theoretical two-way time machine. Because a cylinder spinning at at least half the speed of light creates within it a region outside the man itself, one could go in, mix, and come out in the future or the past. Dr. Forward maintains that by going into a sphere of dense matter, we should theoretically speed up time for ourselves.(147)

Because much of yesterday's Science Fiction is the reality of today, outdated theories should not hold up our thinking or our future. Time machines exist in legend and mind and so. . .

Copper Healthy. Primitives have long used copper ornaments as a protection against various problems like arthritis. In the mid '70's several researchers found that, sure enough, copper did help. A little copper in aspirin for instance, gave this drug 20 times the ant-inflammatory action it normally had.(148)

Like to Like. A principle used in various therapies involves recycling and duplicating. As examples we can use the work done by various glandular rejuvenation practitioners in Switzerland. They found that organ cells injected into the body would fortify the same kind of organ. Urine therapy has long existed, and it is probably instinctively practiced by animals.

Rebreathing one's oxygen was a very old cure for old age pains, and who is to say the ostrich with his head in the sand or the buried-in-sand Yoga in suspended animation are not recycling, also?

Homeopathic medicine relies on minute quantities of a 'like compound' to cure. And mental healing techniques, such as 'Dianetics,' rely on re-thinking one's aberrations to eradicate them. No two exact things in the universe can exist in the same place.

Outdated Gravity Concepts. When we make a coil of wire and send current through it, whatever susceptible material that is in the center will leave. Metal filings, for instance, will disperse for the coil edges immediately. When a metal bar is held within a coil, there is resistance and heat because the still or zero condition of this electric motion is disturbed. It is the same in all of Nature's creations. Every energy spiral has a still center in it with the energies spiralling only around these centers. This is true in local tornadoes or in the great swirling nebulas of our universe.

Because of such obvious effects, there are many who feel that our current laws of gravity are absurd. As far back as the late '30's Dr. Walter Russell tried to explain more rational principles to the noted scientists. He maintained that gravity is changelss and motionless, and polarity was not motion but the stillness of gravity which centered motion. He felt that gravity neither attracted nor repelled but that things sought their own pressure conditions in motion. A rock, for instance, was pulled by vortexes of compressing motion.

To refrain from going too far into these logical concepts for want of space, we suggest that the open-minded consult Russell's words, "Atomic Suicide" (Chapter 6 The True Nature of Electricity and Gravitation), \$10.50, University of Science and Philosophy, Swannanoa, Waynesboro, Virginia.

From the 1960's to '70's, there were enough scientists against the old concepts of Gravity to form a loose group looking for better answers. The outstanding group in this pursuit was the "Association for Pushing Gravity Research." (149) This group published a periodic compilation of New Ideas in why gravity exists and gave awards for outstanding essays on the subject.

Gravity Communication. Gravity Radiation should theoretically allow us to send and receive communications on a very wide new broadcast scale. Because normal mass does not stop these fields, a point to point communication should be possible right through our planet.

For some years, now, a number of far-sighted experimentors have been able to construct crude receivers. The big problem is constructing a gravitational radiation transmitter. A very interesting article on the problems and potentials in these directions was in Dr. R.L. Forward's "Far Out Physics," (150)

Listening to the Stars? Several giant dishes were placed at spots across the globe in the 1960's to listen in on distant sounds. The public was told that such installations were to investigate "hissing stars," etc. After a number of amateurs picked up what they considered 'intelligent signals' on their homemade

dishes, there was some speculation that the whole story was not out. After thousands died defending one such installation in Cambodia in 1975—and after repeated attempts of reporters and representatives to inspect them were spurned, the taxpayers could only keep on speculating—and financing them.

Cleaning It All Up. My first experience with the pollution control mechanism began as a friend developed a compound that would grab oil on water and pull it below the surface. While making futile rounds of various concerns that should have been interested in such a thing to clean up oil spills, I discovered that the prominent figure in one concerned-citizens conservation group was actually on the payroll of the oil companies. This same friend used a similar treatment (carbon compound?) to create a cement which would float and withstand high heat. At each turn he was blocked, unless he relinquished his control—or the formulas.

This is the standard story regarding inventions. Either full control is gained, or the process is duplicated by research, theft of the formula, or by bypassing the patent. If full control is given, it frequently happens that the invention is simply shelved to prevent it bringing competition.

A former 'in-law' of mine once made the mistake of trying to bypass the local 'authorities' when he set up a unit to recycle most of the water of his 'subdivision.' The trouble that followed probably cost him the 'wages' made from his whole building contract. Such recycling systems are simple and only require plates, tanks, and electricity. Using simple ozone injectors, cities like Paris, France, have had sterilized chlorine-free water for at least 75 years. Chlorine has been found to be a great detriment to proper digestion; it is an unhealthy gas, generally. Let water stand overnight to eradicate it from a water supply in the home.

With the advent of ultrasonic devices (see crystal section) an even better system than just ozone came into being. Working on principles as yet not completely understood, ozone treated sewage water flowing by a simple ultrasonic unit astounds engineers because of its remarkable purity. (Sonozone units, Telecommunications Ind. Inc., Long Island, N.Y.)

When you think of the power generated by the draft of a stove pipe, you might appreciate the answer to pollution that an acquaintance of mine offered. He said there was at least one ancient civilization that used large metal draft pipes to carry away the pollution from their industrialized areas. The pipes were simply run up nearby mountains and would work with efficiency as the sun came up. H-m-m-m By placing a turbine on the end of such a chimney, we have the 1925 atmospheric engine of Bernard Dubos. (151)

One of the more interesting references to ancient cremation is given by Phyllos ("Dwell. "). Sitting on a large quartz stone, the tall pointed maxin light could instantly dematerialize all matter that was put into it. According to the history of the time, this spectacular odic light was created by an early leader who told the people he was of 'The Father' and had come to bring the people a just set of laws.

Carbon monoxide from pollution was only a small fraction of that produced by plants and any alteration in nature's accepted levels could be taken care of by a number of fungi varieties. Mass anti pollution enforcement in certain inversion trap areas was of pitifully small consequence in the overall view. As usual, the public paid dearly for such mistaken judgements.

Radiation—Bad or Good. The 'dirty' radiation of the early nuclear bombs was often lethal. A few persons later found that niacin could allow the body to throw off excess radiations, and in the '70's the Russians had a pill developed for this purpose. (See Fry's for further data).

In the early days of nuclear experimentation, some persons found that a low rad count could actually increase the life span of animals. In Paul Campbell's "Medical and Biological Aspects of Energies of Space," Columbia Univ. Press, '61, pp. 411, it is pointed out that below a rad count of 30 radiation actually increased the life span of mice.

Some persons thought that the costly Russian ginseng was more effective than our domestic supply because it was grown in somewhat radioactive soil, and, being one of the few medicinals capable of storing mitogenic radiation, it could stimulate the glands to a greater degree.

Nuclear Reactors. Few persons of imagination feel that we will retain the dangerous and inefficient nuclear reactors of the present for long. Already there are scientists with better concepts. In a subcritical reactor, we could use Beryllium and Lithium as well as Uranium. The only problem would lie in using a non-statistical method of controlling the neutrons(156)

Lasers may be the key to preventing or speeding the breakdown of radioactive energy in radical new reactors, which have so far been ignored.(157)

Black holes supposedly warp space and time. They are charged mass with momentum and violate a lot of pet laws.

In a similar vein, it was observed that most of the nuclear energy sources and deposits were in the hands of the oil companies in the early 1970's.

Few persons were aware that the most important metal in modern technology was platinum, and that only because of platinum's catalytic conversion properties can oil be converted to fuels. Fewer, still, realized that powerful cartels tightly controlled its manufacturing and processing techniques and distribution. Many domestic platinum deposits were totally ignored because of such control.

Resource Reapage. One of the first persons to use his ingenuity to reap a fortune from the ocean floor was Sam Collins of Texas. Designing a dredge to suck up and process gravel from the ocean floor in the '60's, he moved his dredge to the coast of South Africa and started sucking up diamonds. Acting quickly, the powerful De Beer's Cartel bought Collins out and assured themselves of their continuing diamond monopoly.

Large corporate 'fronts' acted for several powerful interests in designing equipment to mine the ocean floor of various minerals in the '70's. Billions of tons of available manganese helped lure forty countries into ocean exploration.

Nature's Microphones. Recent experiments have shown that it is often not the sound made by insects and animals that relate their messages. Rather, it is the electromagnetic waves given off when the sound and thoughts are transformed from their 'broadcasting material.' In the case of birds, feathers seem to transmit; in bats, the wings; in animals, the hair.

When we recall the bird feather costumes of the Hawaiian 'Hunas' and the animal skin costumes of the 'sorcerers,' we can get a hint of how they are able to send instantaneous communications a great distance. It is only a step further to use these strange materials as super microphones and transmitters. . . and a step further to. . .

Stimulation Machines. Richard Shaver, the writer on ancient cycloptic worlds and people, has long maintained that some of the older 'Elder' races had what he called 'stim' machines. These machines, he feels, were used to give the users pleasurable sensations.

As early as the mid '50's the "Scientific American" had articles which dealt with creating electronic pleasure sensations in animals. Using needles inserted into various regions of the brain, a small current up to 5 volt current was introduced. In areas affecting the sex, excretory, and digestive functions, the animals would stimulate themselves hundreds or thousands of times an hour.

We are only a step away from learning to focus such currents into certain brain areas without needles. Whether we can channel such technology into control-free progress will be a question soon upon us.

Natural Alleys. We all know of the earthworms' work in secreting plant growth-promoting compounds and tilling the soil. The ecological chain is becoming public knowledge. . . poison cut one specie or link and it affects a whole chain. The obvious answer is to put a halt to the poisoning. To do this we must get substitutes for the 'unaware' or 'consumer pawns.'

'Super microbes' such as Bacillus Thuringensis are one answer. Agricultural pests are easily 'knocked out' by this lethal bacterium which has the combined virulence of two disease agents in one microbe.

The organic gardening methods really work, but we're kidding ourselves if we think the chemical industries are going to obligingly let the big producers reverse directions. Nature has root and plant exudates which can control fungi, bacteria, nematodes, pests, and diseases. To synthetically and cheaply produce these non-toxic substances is a long overdue answer. It's going to take your effort in demanding work, money, and research in these areas.

Our Self Adjusting Planet. The creator of all that is, created more ecological safe guards on earth than man could begin to comprehend. While 'environmentalists' predicted disaster from man's many minor alterations of the environment, each pet theory was soon discredited. Cosmic rays for instance were found to be the active agent in creating the oxygen. . . in our upper atmospheres. Photosynthesis by plants was really of little import.

New Matter. Since this work is going to examine aspects of each subject, it is fitting we mention the anti-metals. These metals are mentioned a few times, I suspect, in some of the early alchemical works (Philosophical Research Society, L.A. Library). More recently, Germany had all kinds of trouble before 1910 getting iron to behave like iron. Her whole industry was threatened until it was discovered that a little iodine would kill the instability. Not long ago, scientists actually found and measured anti-matter in their huge testing apparatus. Instead of gasping at this astounding confirmation of the ancients' and mystics' assertions, the majority of scientists and public, alike, went 'Ho-hum' and ignored the subject.

As I pointed out in the section on crystals, the ancients utilized crystals to gain fantastic amounts of free energy. They were made from a metal which was the neutral point between matter and non-matter (dimensions). These crystals were dangerous if they were exposed to sunlight, and they had to be grown in the dark. I feel that when our civilization reaches a point again when we are 'free' enough in action and responsibility, these metals and crystals will again come in to use.

To experimenters in this field we should point out that ordinary matter has only a memory. In smelting and testing it, the results will be according to predicted patterns. Anti-matter, on the other hand, has memory and brain action. Metals with a little anti-matter in them will be unstable and not act according to predicted patterns. The alchemists took advantage of this in transmutation in the past—and they do so in secret today—fully aware that they would endanger themselves with publicity, as in the past.

Some bases for legends of unusual forms of matter were found in a number of official 20th Century discoveries.

In ultra high pressure research of the '70's, GE was able to make dozens of new forms of matter. Using their huge furnace presses, they were also able to duplicate Nature's method of making large diamonds.(158)

It is interesting to turn back to outdated books on previous civilizations and compare. In "A Dweller on Two Planets," Phylos, pp. 85, the author explained that metals were once inexpensively obtained by raising the atomic speed of clay until it became a white light and reduced to a chemical 'mile post' of a desired metal.

One of the most controversial and interesting discoveries of the late '60's was Polywater. Bearing some resemblance to a substance alchemists have mentioned, this strange substance defies many normal laws of physics. Resembling normal water, it is 50% denser, refuses to freeze or boil at regular temperatures, and even has different optical qualities. Make your own.(159)

In the '60's it was found that the anti-protons found in cosmic rays are the particles which build the invisible atoms made up of Negative Nuclei and Positive Satellites. What we see as 'matter' are the

reflections of such atoms. Actually, the human sees only a small range of matter in the carbon-3rd dimension. Birds see in the silicon range; dogs and snakes see in the ultra violet (heat) range; cats see in the Pheta (close to the 4th dimension). This means that your dog sees you as a mass of heat rays. The most amazing part of human observation, of course, is the fact that many refuse to accept anything they cannot touch or see, regardless of facts and reason.

Some scientists admitted that the discovery in 1973 of the sub-atomic magnetic monopole particles could lead to a change in most of the cherished theories of science. If such particles were manufactured or captured in quantity, it could bring on the use of very unusual and efficient motors and healing machines.(160)

See the Real Sun. Many of the ancients and great philosophers were fond of referring to the links and similarities of all material creations. They might point to an apple and its stem indentation and relate it with the same characteristic of a blood cell or to planets. Observing a tree, they might liken the part above ground to the material universe we see and the root system below ground to the opposite anti-matter world we fail to see. Each bud, flower, or leaf they might relate to man and his relationships. While few are ever moved to forsake the opinions of Man's textbooks for the subtle truth found in nature, there is hope.

One forgotten sage of cosmology was a writer named S.H. Watson in his "The Secrets of Time and Space"(161) He gave explicit details for actually viewing the fantastic energy exchanges in our universe.

Ignoring the usual expensive telescopes and elaborate measurement and viewing devices, he used methods astonishingly simple. Because the corona or luminous envelope surrounding the sun veils its interior to a great extent, Watson first experimented with simple solutions to this problem. His answer was a bowl full of tincture of iodine or a shallow tray of mercury. Placing his solutions in the sunlight, he would arrange a white or yellow sheet of paper a short distance away to catch the focused reflection. Astonished at the results of his first experiments, Watson found that right before his eyes were proofs that many of the pet theories of science were utter nonsense. Ancient myths began to make better sense to him, and, as he continued experimenting, he found that the human body's structure bore a striking resemblance to the structure and functionings of our universe.

Using a tray of common milk, Watson was able to observe the long rays of the sun and note how they bore a strikingly similar appearance and function to the siliary processes of the eyes. Before long the whole incredible energy interchanges of the universe and planets began to unfold.

Because the methods are so simple, it is now possible for any amateur experimenter to go beyond the shortsighted theories of how energies are interchanged. Few methods are as effective as actually viewing the truth.

Amazing Magnetic Applications. When two coils of wire are wrapped around each other, the secondary coil will capture some of the energy of the primary coil if electricity is applied. Eddy currents are usually lost around these inductors, and it is this eddy current that was put to use in the '60's and '70's to heat objects with so-called 'cold heat.' Special cooking pots, for instance, could capture heat while sitting on a cold stove.

Magnetic ferrofluids came from research evolving out of weightless space problems. Magnetic iron powder was pulverized to microscopic size and added to things like rocket fuel. Later, it was found these ferrofluids could be held in place magnetically around a shaft and act as a frictionless bearing and seal. All of this will lead to amazine developments. . . hopefully in areas of free energy motors, etc.

Unlque Processes and Metals. In an issue of News-Novel(152) there is a case mentioned in which lead was hardened to an unheard of degree. Accidentally spilling some molten lead into a bucket of unusual mineral they had found, two rockhounds were astounded as the lead turned to a hardness of Rockwell 52. This is hard enough to cut steel with.

It is only recently that scientists found that feldspar would harden bronze. Up to this time the stories of very hard bronze weapons were often taken with a grain of salt.

This same issue of News-Novel mentions the little-known fact that platinum is a tightly controlled metal. Because of its mysterious catalytic action on substances like oil, it is one of the most important metals of civilization. Yet processes which could make the U.S. independent of other platinum 'source nations,' like Russia, are ignored.

Gold is held by some occultists to be the most important metal in a mystical sense. Untarnishable and uncorruptible, it nevertheless is said to attract spirits which attach the same passion for it that a miser does. Anyone who has seen what influence gold can have, as against ordinary goods or paper money, can see the point. This heavy condensing power seems to bring out the best or worst in persons—as well as nations. In a form that the body can utilize (such as the ancients' secret oil of gold) or microscopic particles, gold has a beneficial medicinal 'chelating' effect upon the body. It is probably very true that gold worn upon the body has a beneficial effect, also. No doubt about it, gold is the King of Metals. Civilizations rise and fall upon the amount of this metal they retain or lose.

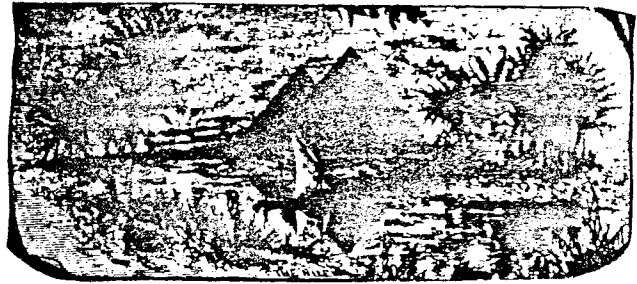

Working with Nature's Cycles. A good part of the world's inhabitants made use of timing in their farming and business before our modern science turned its back on their unquestionably effective approach.

Pick any edibles during a full moon or watery sign and your storage problems ncrease—potatoes sprout, rot quickly, and so on. There are scientific tests which show the effect of the moon upon all life forms—go with nature and get in step. Most any Farmer's Almanac will supply you with the basics, and "The Moon Sign Book,"(162) is probably the best of the lot. If you're in doubt, even your public library should have enough evidence and data to move you to find out for yourself.

Man is Governed by Cycles. As civilizations rise and fall there is always the chance to build and keep a 'paradise' through technology. In the past domination principles ended such dreams. With the advent of World War II we have catapulted to a point of technology where we are at the 'crossroads' again. Knowledge doubles on itself and if we can retain our present course without losing our freedoms of choice, the paradise can soon come. If not, we shall sink. . just as those before us did.

This little work was compiled to simply provide food for thought. It was not intended to be scholarly or complete. It is simply a view of things as they were, are, and can be.

The 'paradise' will not come without your action. If you are a 'visionary' to any degree, please use the sources provided here. The balance point has been reached, and your assistance is needed.

I am asked about suppression and can only pass over opinions and points to the facts you see. It is not specifically the engineers, auto makers, or scientists that are to blame, it is the 'elite' of power and their dynasties and consortiums. They still control this planet through financial systems and ideologies or mind. (See "Earth Story").



SOURCES

1. "The Works of George Arlington Moore" Madison Co., P.O. Box 206, Berea, Ky. 40403. . . or Fry's.
2. Madison Co. Publishing.
3. Pollution Control Systems, 2207 Border Ave., Torrance, Ca. 90500.
4. See Illustrations and Patents from U.S. Patent Office.
5. Patent #2,236,595.
6. Car and Driver Magazine, Dec. '74.
7. National Tattler. July 7, 1974.
8. Popular Science. July 1974.
9. Anaheim Bulletin (CA) 9-15-75.
10. Le Point. 1-7-73.
11. "Suppressed Inventions" Madison Co.
12. L.A. Chemical, ~~4545 Andine St., South Gate, Ca.~~
14. Highway Aircraft Co., Box 651, Sidney, Nb. 69162.
15. Tymponic Corp., 202 Terminal Dr., Plainview, N.Y. 11803.
16. Madison Co. Publications.
17. News Reports. 9-73.
18. Suppressed Inventions, Madison Co.
19. National Tattler. Nov. 11, 1973.
20. Borderline Sciences Research Fd'n. Journal. (Box 548, Vista, Ca. 92083).
21. "Keely and his Discoveries," Moore. Health Research, Box 70, Mokelumne Hill, Ca. 95245.
22. B.S.R.F. Journal.
23. 'Alternate Sources of Energy,' Box 90-A, Milaca, Mn. 56353.
24. Dieges Report (~~1970~~), Box 892, Perris, Ca. 92370.
25. Pollution Control Div. -Smith Emery- M.J.M. Hydrotech Co. & Approved Engineering of Los Angeles (testing).
26. B.E. Research Corp. Box 555, Provo, Utah 84601.
27. Popular Science Magazine. 3-75 & Science 11-73.
28. "The Bourke Engine Documentary," Fry's.
29. The La Force Co. (Sherwood Webster Pres.), Richmond, Vt. & Arizona Highways, 1-75.
30. Reg. #211,702,317, Electric Auto Ass'n. Newsletter, 5831 Ross St., Oakland, Ca. 94018, \$1.00.
31. Zubris Electrical Co. 1320 Dorchester Ave., Boston, Mass. 02122.
32. E.M.A. Motors, 14737 Calvert St., Van Nuys, Ca. 91400.
33. Applied Motors Inc., P.O. Box 106, 4801 Boing Dr., Rockford, Il. 61105.
34. San Fernando Valley News. 5-14-76.
35. Popular Mechanix (older issue).
36. UPI Press release - 1976.
37. Fate Magazine. 1-50. BSRF -62. Perpetual Mt'n Journal #2 & 3.
38. (See #14).
39. (See #14).
40. SPSI, 1121 Lewis Ave., ~~Sarasota, Fl. 33577.~~ (plans \$2.00).
41. 43.
44. See #20.
47. "Handbook of Universal Engineers."
48. Popular Science 6-71 & 2-75.
49. This World. 9-16-73.
50. L. Michaud, P.O. Box 561, Port Elgin, Ontario, Canada.
51. See #24.
52. Pop. Sci. 8-72.
53. Alt. Sources of Energy (23).
54. See Fry's Pub'n. list.
55. Pop. Sci. 3-73.
56. Fry's.
57. Steam Club of American Journal, 333 N. Mich. Ave., Chicago (\$10 year) & Light Steam Power, Michael Kirk, Isle of Man, United Kingdom.
58. Steam Power Co. (D.R. Vain), Star Rt., Box 25, Greenleaf, Or. 97445.
59. Grey Enterprises, 7701 N. Stemmons Freeway, Dallas, Tx. 75247.
60. Sun Telegram, San Bernardino, Ca. 11-10-74.
62. Pop. Sci. 5-71.
63. W.T. Sherwood, 200 Pinnacle Rd., South Rochester, N.Y. 14623 (Searl Journals).
64. Pop. Sci. 1-69.
65. See Fry's book list.
66. "UFO's Nazi Super Weapon" Fry's.
- x 69. National Inquirer 5-11-76.
70. Pat. #2886976. Analog Mag. 6-60, 6-70 (350 Madison Ave., N.Y. City).
71. Pat. #3,626,805.
72. "Propulsion Without Wheels," Laithewait. 'Bigelow Anti Gravity Newsletter, 2140 North Pennsylvania, Indpl's, Inc. 46202.
- x 73. "Cosmic Forces of Mu," James Churchward.
- x 76. A listing of over 200 older groups from Fry's (\$2.00).
- x 77. Laura Mundo, ~~23084 Brookforest Rd., Novi, Mich. 48050~~ (30c newsletter).
78. Radionic Machine Plans from Fry's.
79. MOVE, P.O. Box ~~3232, Riverside, Ca. 92504~~ (publishers of Expose data).
80. "Psychic Self Defense" Fortune, Weiser, N.Y.C.
81. American Society of Dowsers, Dansville, Vt. 05828 or Fry's.
82. Health Research Publishing (Tesla Book Reprints).
83. Pop. Sci. 6-68.
84. Houston Post. 11-16-73.
85. See 32.
86. Pop. Sci. 8-67.
87. Proceedings, P.O. Box ~~458, Yucca Valley, Ca. 92284.~~ 5-55 & BSRF Folio.
88. "Alchemists Handbook," Albertus. Weiser, N.Y.C.
89. Paracelsus Research Soc., P.O. Box 6006, Salt Lake City, UT. 84106 (Alchemy).
90. Fry's (\$1.50).
- x 91. Richard Shaver, P.O. Box ~~356, Summi Rock House, Summitt, Ark. 72677.~~
92. Argosy, 4-73.
93. Pop. Sci. 5-71.
97. Edmunds S.Co. Edscorp Bldg., Barrington, N.J. 08007.
98. 'Pyramid Guide,' P.O. Box ~~1929, N. Hwd, Ca. 91604~~ (latest Pyramid data).
- (latest Pyramid data), "Secrets of the Great Pyramid" Tompkins (one of largest and best wks).
99. World Federation of Science & Eng., ~~1552 Computer Ln. Huntington Beach, Ca. 92649~~ (many unusual new projects).
100. Pop. Sci. 3-76.
101. Jack Ford Science Projects, 1316 Naldo Ave., (P.O. Box 5750), Jacksonville, Fl. 32207 (\$5).
102. "First Principles of Theosophy" Theos. Press. Weaton, Il.
103. Tantra, Bx. 13149, Oakland, Ca. 94661.
104. See 21.
105. Pageant Magazine 6-66.
106. Various Perp. Mt'n. Journals - Fry's.
107. Eddy Saballos, Apt 2877, Caracas, Venezuela, (data \$1.00).
108. Michael Lameyer, West Palm Beach, Fl. 33401.
109. Pop. Sci. 1-75.
110. Pop. Sci. 12-70.
111. Pop. Sci. 10-68.
112. "Atomic Suicide" Russell. UOSF. Swannanos, Waynesboro, Va. 22980 (\$10).

1992 REVISIONS
DELETIONS →

For further material on suppressed & exotic inventions order our Suppressed Inventions Report at \$5. This and many other unique titles are in the 'Incredible Inquiry Catalog at \$1.

(Summers)

113. "1001 Nights Outline," Fry's (\$1.95).
- x 114. Students for Orgonomy, Box 588, Rangely, Me. 04970. . .Health Research Pub.
115. BSRF Journal, 1-2-74.
116. DUDA, Apt. 574, Alajuela, Costa Rica, Cen. Am. (Reich history - data \$1.00).
117. Various technical journals are found in many libraries.
118. Robert Morse, ~~15-20 202nd St., Bayside, N.Y.~~ 11360.
119. Pop. Sci. 1-71.
120. EROS Data Center, Souix Falls, S.D. 57198 (10x10 prints \$7).
121. Saga Magazine.
122. Kansas City Police Chiefs Convention.
- x 123. Normount Pub's, Dr. N-2, Wickenburg, Az. 85358.
124. "Stranger than Science," Edwards. Ace-51.
125. "Discoveries & Inventions of the 20th Century," Crowther, Rutlage, London.
126. "Psychic Discoveries Behind the Iron Curtain."
127. Telosensory Systems, Opticon Div. 2626 Hanover St., Box A, Palo Alto, Ca. 94304.
128. "Breakthrough," Raudine, Lancer Books, 1560 Broadway, NYC.
129. Pop. Sci. 5-73 (potentiometer project).
130. Pyramid Guide Report (98).
131. MRU, 1143 N. Hampshire Ave., N.W. Wash. D.C. 20037.
132. Christian Science Monitor, John Dillin.
133. See #66.
134. See #66.
135. 16591 Noys Ave., Irvine, Ca. 92664.
136. Pop. Sci. 6-71.
137. Time Mag. 3-22-76.
138. "Radiation Biology," McGraw Hill 56.
139. See 99.
140. Pop. Sci. 10-73 & 6-74.
141. G.E. Van Tassel, P.O. Box 419, ~~Yucca Valley, Ca. 92284. OR. Box 3867, LANDERS, CA 92284~~
142. Laurel Paperback 1950.
143. Bantam 73.
144. De Vorss & Co., Box 550, Marina del Rey, Ca. 90291.
145. PRS see 89.
146. "Strange Destinies" & "Stranger Than Science" Edwards Ace-57.
147. Analog 8-75.
148. Chem. & Eng. News, Vol. 53 #16.
149. Carnahan, 3204 Breeze Terrace, Austin, Tx. 78722.
150. Analog 8-75 (Analog, P.O. Box 1348, Gr. Ct. Stn., NYC 10017).
151. "Engineers Dreams," Vikings Press, N.Y.C.
152. P.O. Box 3232, Riverside, Ca. 92509 (\$1.00).
153. B.S.R.F. (20).
154. Pop. Sci. 9-71.
155. Pop. Sci. 3-75.
156. Analog 8-75.
157. IRE Proceedings 1-63 (V. Vali).
158. Pop. Sci. 9-70.
159. Pop. Sci. 6-73.
160. Associated Press, Berkeley.
161. "Hidden World" A-9 Palmer Pub., Amherst, Wi. 63.
162. Llewellyn Pub. 100 S. Wabash St., St. Paul, Mn. 55107 (Box 3383).

x- NO LONGER VALID

Further contacts:

Science for the People Magazine, 9 Poland St., London, W. 13DG U.K. (\$1.00).

Union of Concerned Scientists, P.O. Box 289, Cambridge, Ma. 02139.

Science Pub's. Newsletter, 1231 E. Belmont Ave., Anaheim, Ca. 92805.

Pursuit Magazine, RD 1, Columbia, N.J. 07832 (the Unusual).

Radical Science Journal, 9 Poland St., London, WI, England (\$1.50).

Directories of unusual publications and organizations are listed by Fry's.

ABOUT THE ASTONISHING NEW 'MODERN HUMAN SESSIONS'

Persons seeking 'answers' can easily spend a fourth of their lives in school now. Courses which are supposed to cover the workings of the human however, all to often just further entangle the student in complexities. Even the psychology teachers who should be examples, frequently have domestic lives that are in shambles. Reason would indicate that valid systems of behavioral learning would work. With discontent seekers searching for answers in hundreds of cults and schools, it should be obvious that most courses just don't have the answers. I honestly feel that the M.H. courses do have the majority of answers, and that they will strike you like a light at the end of a dark tunnel. You can know, and know that you know.

These courses contain very easy to understand condensed facts that are not embellished with what others in the field believe or suspect. Each paragraph is very significant and builds up the foundation of the total structure: How you really function.

We humans have different backgrounds, ambitions and goals. There are millions of us who want to be free of this planet and explore the universe. There are millions more of us who find such ideas ridiculous . . . and who simply want to live quiet domestic lives of natural tranquility . . . free of complicated goals and decisions. The keys to both goals are to be found in the modern human sessions. If you find your level and aspirations included in the 2nd course, you can stop at that point. If you still have an inner thirst for the blueprints of higher self action goals, you can continue to the very astounding final sessions. Whatever your goals, you will have the privilege of finding your own lost comprehension level. This is the only work ever available that has offered such a wide spectrum of self knowledge data. Whatever your goals. You can now recognize the keys you must use to run the parts of you which can complete these goals.

The Secrets of Metals. Pelikan. . . Fascinating data on how the various metals were really formed and their relationships with man, healing, with each other, etc. A must if you are into alchemy or have an interest in the 'live' metal concepts of Freeman.

Please include a stamp with your inquiry letters, use money orders on orders above \$15.00 and give us 3 weeks to get all of your order [or explanation] to you. Al Fry — Fry's, 879 Park, Perris, Ca. 92370.

Editors note; With roughly 10% of addresses changing yearly, most of the sources above are no longer in business. (Write for \$4.00 directory of exotic information and research organizations from publisher.)

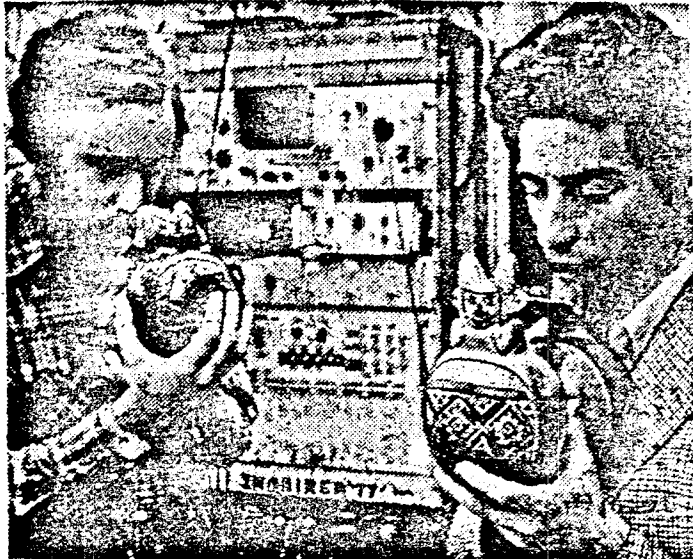

As millions of dollars worth of consciousness-altering machines were sold to 'seekers' during the 1970's, it was ironic that primitive Indians had long ago found a simpler answer. Researcher Dan Stat made tests at U.C.L.A. on double chambered Peruvian jugs. He found that blowing over the pots' openings produced sounds that definitely elevated most subjects' state of consciousness.

POWER FROM THE SEA. Aside from several unique projects mentioned already, there are a number of unusual schemes to tap the fluctuations of an every-changing ocean. (Refer to Pop Sci 3-'77)

Many inventors in Europe worked on astonishing inventions to equal that of our own Country. In most cases, they were equally frustrated in their attempts to gain recognition or a backing. Some Italian examples should include an inventor in Florence who broke down water to form a potent explosive and auto fuel. A Naples engineer developed a simple device for gaining super-mileage from an ordinary auto motor. Another physicist was able to send TV signals an extraordinary distance without satellite assistance and even light distant globes, much as Tesla did in the U.S. His colleagues, it is reported, ostracized him for such efforts. And in the late '30's, a scientist from Rome used electrical impulses to fertilize very arid ground which was ordinarily unreclaimable.

Because of language barriers involved in these and many other unusual projects, it is usually necessary to contact persons on the Continent who will act to some degree as 'go-betweens' and data sources. (Current addresses from Publisher for S.A. envelope .)

MENLO PARK, Calif. — Scientists are working on a computer that can read minds — and put thoughts into action.

A person's thoughts are flashed onto a television screen and the computer reacts, much faster than a human could.

It was developed by a team at the Stanford Research Institute here.

Dr. Lawrence Pimmo, in charge of the project, told the Star: "Basically, the computer works on the principle that thoughts are simply silent words.

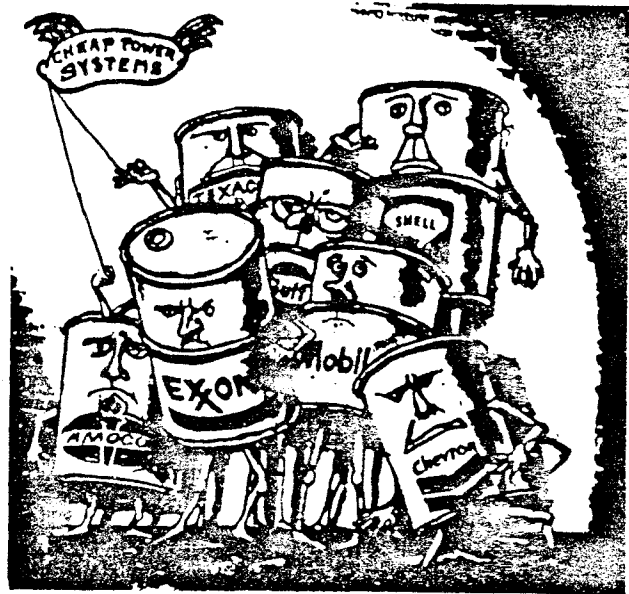

Conspiracy Digest is meaningful to only a small elite of sophisticated, advanced students. No re-hash of well-known and elementary conspiracy theories will be given. No valuable space will be wasted re-presenting the evidence that powerful, conspiratorial dynasties are the most important factors in national and international affairs. Proving the existence of the ruling, bankster elite is "old hat" to our well-read audience. The esoteric questions of conflict, strategy, goals, and time-tables within the elite is the primary focus of *Conspiracy Digest*. Knowing that there is a conspiratorial elite is easy. Determining *what they are up to* in time to thwart their plans is the *real challenge*.

ALPINE ENTERPRISES

P.O. BOX 266 20272
DEARBORN, MICHIGAN 48121
FERNDALE " 48220

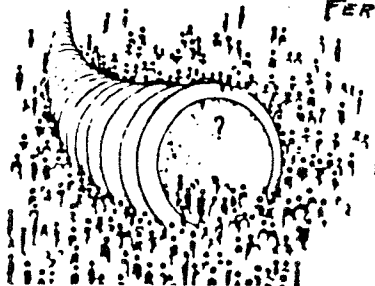

German U.F.O. prototype
SAMISDAT PUBLISHERS LTD
206 CARLTON STREET
TORONTO, CANADA



A HENDERSHOTT MOTOR — PERPETUAL MOTION JOURNAL, 11008 EAST ST. ANN. MO. 63074
(SEE TEXT: PAGE 10)

By TOM VALENTINE

M. Deane Harper of Dunbar, West Virginia has invented a rotary engine surpassing anything all the money and engineering brainpower of Detroit could come up with. Good, old-fashioned American ingenuity and inventiveness triumph again!

Harper, a machinist, mechanical engineer and teacher who has a number of inventions to his credit, has developed a rotary engine far superior to the famed Wankel that made Mazda's go hmmm, but also fizzled due to inherent engineering shortcomings.

One doesn't have to be an expert to realize that an efficient rotary engine is far superior to the present day piston engines. However, it remains to be seen whether the Harper rotary has come along too late in the heyday of gasoline driven motors.

On the other hand, Harper stresses his rotary engine will run well on steam and would be an excellent turbine motor, too.

The Harper design has unlimited potential. The inventor's partner, Robert Weidlich of Charleston, West Virginia said:

"The number of descriptive names for this engine is readily outnumbered by the vast potential of use for this new mechanism that changes expanding gas pressure to rotary motion more efficiently than any other design."

Harper has obtained his patent: Number 3,809,025.

The inventor and his partner drove from West Virginia to Chicago a few weeks ago just to show this reporter the working prototype. "You can't very well write about something you haven't seen," Weidlich emphasized.

The four cylinder, gasoline driven, rotary spins like a flywheel when it runs. The entire engine rotates.

"It's a rough prototype that we run for only a few minutes at a time because we've not designed any cooling system," Harper explained. "I built it from scrap materials found around my machine shop."

While my knowledge of engines is limited, I do know enough to understand that I was viewing an important moment in engine history as the Harper rotary whirred into action.

The future of the gasoline powered engines may be in doubt, but there's no doubt they'll be around at least a decade or two longer and Harper's invention appears to be the highest state of the art.

The working model was built to prove to doubting patent office officials that the design worked. Then it was transported to Denver where scientists from the University of Denver, Denver Re-



Harper Rotary engine



James Worrell Keely was photographed during a demonstration of his motor in 1897.

The Keely motor is as much an enigma today as it was a century ago. The jury is still out, and may never reach a verdict; but the Keely case offers insights into the intricacies of inventiveness and skeptical dogma like no other.

Financiers and scientists of his day either raved about the man and his motor, or they raged that he was a magnificent hoaxer.

What Keely demonstrated was the potential power in certain vibratory rates. For example one device demonstrated the movement of weight by striking the strings of a zither; another device indicated tremendous power generation by simply pouring a quart of water into a cylinder where tuning forks "liberated" energy inherent in the molecules of water.

He fired a small cannon with this same mysterious force that he claimed to be harnessing.

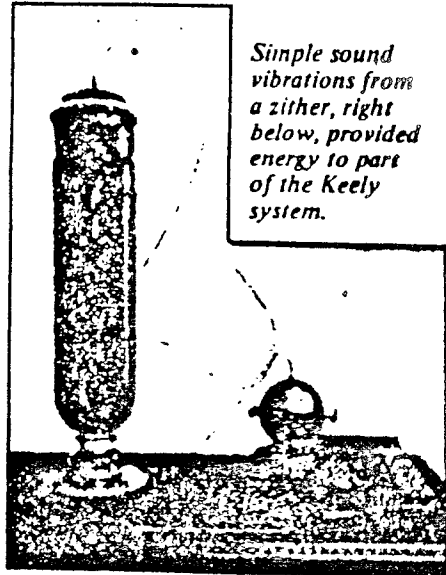

Simple sound vibrations from a zither, right below, provided energy to part of the Keely system.

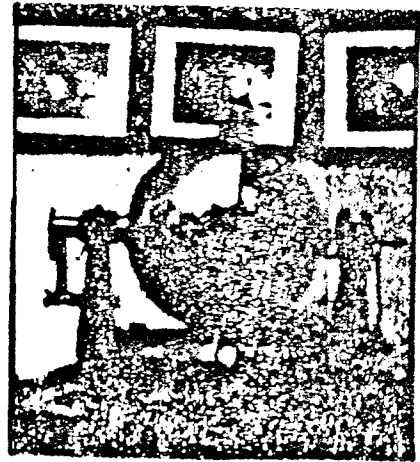
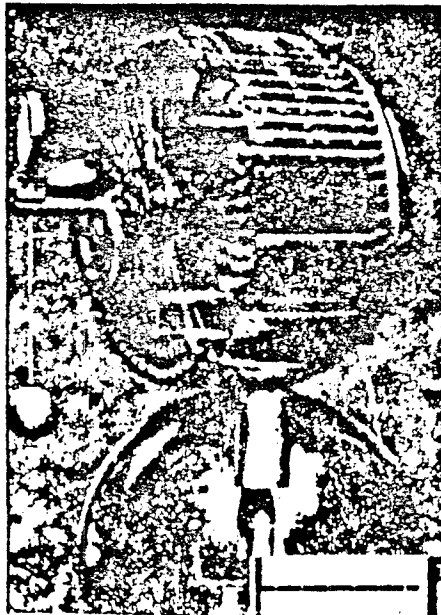

THE NATIONAL Exchange

P.O. BOX 147, MORTON GROVE, ILL., 60053

YES! PLEASE SEND ME MY ONE YEAR SUBSCRIPTION TO NATIONAL EXCHANGE. ENCLOSED PLEASE FIND CHECK OR MONEY ORDER FOR \$9.99.

FROM MAY & JULY ISSUES NAT. EXCH.

Thanks to Tom Valentine R4

ELECTROMAGNETIC "FREE ENERGY" TECHNOLOGY IN REVIEW

PART ONE: SOLID-STATE GENERATORS

by Mobius Rex

Over the previous several centuries, hundreds of designs and models of so-called "perpetual motion" machines have been publicized, but none worked, and many were outright frauds except the mysterious Orffyreus Wheel (17th century), the secret of which is lost. Despite the failure of past efforts, many inventors still believe in the possibility of tapping a source of unlimited free energy.

In the 20th century, about fifty functional free energy devices have been built, usually employing electromagnetic means. Several are fluid systems (hydraulic, steam or other gases and chemicals) but those will not be considered in this report. The electric/magnetic inventions will be presented here in two groupings, Solid-State Devices [in this issue] and Dyna-Motor-Generators [next issue] and in chronological order.

1) This brief notice appeared in the New York Times on June 9, 1902; "Electricity from the Air! Engineer Discovers a method of Using it without Chemicals or Dynamos... A dispatch to the London Daily Mail from Los Palmas, Canary Islands, says that a prominent engineer of that town named Figueras claims to have discovered a method of utilizing atmospheric electricity without chemicals or dynamos, and that he is able to make practical application of this method without employing any motive force. Figueras believes that his invention will bring a tremendous industrial revolution." Obviously, this has not occurred yet. No other details are known today.

2) In February, 1909, Walter J. Pennock of Philadelphia received US Patent # 911,260 for his Apparatus for Collecting Atmospheric Electricity. The invention consists simply of a balloon covered with pointed metal collectors, elevated to a high altitude and tethered with a conductive cable -- a glorified lightning rod! In January, 1912, Pennock also received USP # 1,014,719 for improvements in his apparatus.

3) In the 1920's Henri Plauson of the Traum Research Laboratory in Hamburg, Germany devised a scheme for harnessing atmospheric electricity with tethered balloons, the metal surfaces of which were covered with spikes to collect positive electric charges. Metal cables conducted the ions to earth, where special transformers converted the electrostatic energy into electromagnetic power. In 1922 he tested two balloons at a height of 1000 feet, and claimed to have obtained power equal to 81 kilowatt hours per day. Plauson obtained USP # 1,540,998 for his invention in June, 1925.

4) The following letter from K.B. Isselstein of Spokane, Washington, describing a "Mysterious Invention" appeared in FATE magazine in October, 1956 (pp.123-125): "The Hubbard Energy Transformer [story] brought back to me exciting memories of another inventor. In 1918, while doing painting and decorating, I was hired to paper several bedrooms in a large two-story house. While I was at this work I went down to the back porch to pick up some materials. I happened to glance at the light meter and saw it was not moving.

"I opened the fuse box and saw the main power fuses had been removed. It took only a minute to make sure the line had not been tapped beyond the meter. The only member of the family at home at the time was a young man in his early 20's. I asked him, "Earl, where do you get your juice? I noticed it does not come from the power lines."

"Come along and I'll show you", he said. He led me up to the attic. He placed some steel bars on a work table and picked up a coil which looked like a loose couple. After placing the coils on the steel rods he connected one wire to a door bell. Then, with the other wire, he touched the opposite terminal. The bell rang with great force and there was quite a spark too.

"I picked up the coils to make sure there was no contact with other appliances. I could just see right through them. There was no battery inside. The bell rang just as vigorously. The wire was iron.

"In the basement Earl had what he called an Activator Transformer, the size of two fists, which had to be within ten miles of the generator coils. The activator was not in contact with any visible wires or appliances. It was activated by the electric currents which surge around the Earth and activate the compass needle. By cutting into these currents, Earl said, we can obtain unlimited power.

"A year later Earl demonstrated his Cosmo Electric Generator in Denver. He had placed two copper spheres on the front fenders of his car in place of the headlights. From these copper spheres he obtained enough power to drive all over Denver as reported in the Denver Post at the time.

"While Earl was demonstrating his invention in the streets of Denver, the power had been shut off in the foothills. When he went to Washington DC shortly afterwards to try and obtain a patent on his Cosmo Electric Generator, he

found that that charges had been filed against him claiming that he had a device to steal power from the power lines."

5) The following letter from Bert Grater of White Salmon, Washington appeared in FATE magazine in November, 1956 (pp 126 & 128):

"The story of Alfred Hubbard and his coil in the July, 1956 issue of FATE made me recall another mysterious device. This model performed better than expected, and Huston and his father took it to San Francisco to demonstrate it. They hoped to interest manufacturers in building the device on a royalty basis.

"I talked to Huston after he returned to Prineville. He told me, the machine can be made so hot that it will destroy itself. Reverse the machine, and the temperature will go as low as 290 degrees below zero.

"He said manufacturers in San Francisco refused to build the machine because it would throw too many men out of work. It would also kill the sale of fuels, the major cargo of steamships at that time.

"Huston also told me he had patented his device in Canada and England. The USA had refused to patent it. Huston evidently got nowhere with his device and I do not know what became of it. He died a young man of 22 in 1920 or 1921."

A search for Huston's Canadian patent was initiated in 1984, but it could not be located.

6) In the mid-1920's, Harry E Perrigo claimed to have developed a method of transforming atmospheric energy into useful power. His invention used 100 roofing nails partially pounded into a foot-square board. Each nail was wrapped with fine-gauge wire in a zig-zag pattern of interconnections and taps, all connected with two antenna coils and a transformer. Perrigo supposedly held a US patent for his invention, but several searches of the literature for that period have failed to retrieve any record of Perrigo.

7) In 1922, Fred Walden and E G Lewis of Denver, Colorado announced their invention for extracting electricity from the air. In tests before representatives of General Electric Company, the machine showed 120 volts on a meter and burned out a 200-watt light bulb. In another test, it supplied enough power to operate a 175-watt light and a 110-watt electric fan.

Unfortunately, the device never reached the marketplace, and the secret of its operation remains unknown today. I have been unable to locate any patent for the invention.

8) Electric light and power "as free as air" was the literal promise of Chauncey J Britten of Charlotte, Michigan in the 1930's. He obtained US Patent #1,826,727 for his "Radio Apparatus" which extracted electricity from the airwaves without the aid of the customary generators and motors, etc. It consisted of an aerial, a home-made generator-transformer, and storage batteries. An unidentifiable newspaper photo of him shows Britten standing in front of his home, which at that time, according to the caption, he had lit for two years without expenditure of a penny for maintenance.

9) In the 1930's an inventor named Karl Schappeller constructed a device for the production of electrical power without a prime mover. Very little is known about the so-called "Schappeller Sphere" today, but an available description states that it was a hollow ten-inch sphere filled with quarter-inch copper tubing coils containing an unspecified substance which hardens under the effect of direct current and a magnetic field and acts "like a dielectric in an electrolytic capacitor, and as a diode."

Two bar magnets penetrate the sphere at opposite poles between the copper coils. One magnet is grounded through a tuning capacitor and the earth. The magnetic stress on the system generates the electrical power.

Schappeller called the force he utilized "glowing magnetism". He said that "The only way to produce a true electric generator is to produce an electrodynamic field in which the electric field is stationary (static) while a current of glowing magnetism is produced." Schappeller's "glowing magnetism" is probably what is known as plasma today.

10) Hans Coler was a German inventor who in the 1930's and 1940's developed two devices, the "Magnetstromapparat" and "Stromzeuger", which consisted only of permanent magnets, copper wire coils, and condensers in a static arrangement which produced electrical energy. The most powerful version of the "Stromzeuger", built in 1937, had an output of six kilowatts.

During World War Two the German Admiralty officiated further development of the inventions. After the war, two officers of the British Intelligence Objectives Subcommittee interrogated Hans Coler, who built a small working model of the Magnetstromapparat for them. In their report the investigators concluded that Coler was an honest experimenter and not a fraud. The result obtained was genuine, but no attempt was made to find an explanation of the phenomenon, though the Barkhausen Effect was thought to be involved.

The investigative report was declassified in 1962, and a few copies began to circulate and become publicized in the 1980's. A few experimenters since then have replicated the Magnetstromapparat, but not the Stromzeuger since few details of its construction are given in the BIOS Report #1043.

11) One of the best documented, proven, and most powerful free energy generators was invented in the 1930's by Dr Thomas Henry Moray of Salt Lake City, Utah. On numerous occasions he demonstrated that he could generate large amounts of electrical power, up to fifty kilowatts, from a natural source he called "radiant energy". His small device consisted of an antenna, some solid-state circuitry -- this was before the transistor was invented -- and specially designed cold-cathode ray tubes.

Unfortunately, the largest and only remaining model of the receiver-generator was destroyed by an engineer of the Federal Rural Electrification Administration. The man went berserk and smashed it with an axe. Dr Moray could not afford to rebuild the device, on which he had spent \$200,000 of his own money over twenty years of its development.

Dr Moray also applied for a US patent, but was refused by the examiners who at that time could not comprehend its operation, especially the transistor-like components and the cold-cathode tubes. However, Dr Moray did obtain Patent # 2,460,707 for an "electrotherapy device" which is believed to be the Radiant Energy Receiver in thin disguise -- a common practice of inventors. This and other technical information that is available gives some hope that this wonderful invention will be redeveloped someday.

12) In the 1950's, Dr Wilhelm Reich, who famous for his discovery of the mysterious cosmic energy known as Orgone, also demonstrated its force in a free energy motor. Robert McCollough, who worked as an assistant with Dr Reich, described the experiment in the following excerpt from personal correspondence:

VACOR (Vacuum Orgone) tubes "...are regular Geiger-Mueller survey meter tubes which were left soaking in different orgone accumulators of three to twenty layers. They soaked up Orgone energy and from then on could be used to drive small electric motors...Not all of the tubes so exposed did so, but about a third of them did.

"This work with a motor force in the VACOR tubes was more or less shelved when Dr Reich found a different way to demonstrate a motor force in the Orgone energy. This was to use the body's own organismic Orgone energy to drive a small spinner-type electric motor. He also employed what he called a Y-function, the nature of which only one other person knows -- a young black physicist that worked there, William Washington. He disappeared right after with all of the working models -- reportedly to work at the Argonne National Laboratory in Illinois. The FBI refused to help.

"Dr Reich once demonstrated this motor effect to a group of people including his then-lawyer Peter Mills. He signed an affidavit to this effect. Later this same Peter Mills rose to be district attorney and as such directed the persecution of Dr Reich for claiming the Orgone energy existed."

13) Lester Hendershot first demonstrated a small version of his fuelless generator in the late 1920's. He reasoned that his device was tapping the Earth's magnetic field and deriving electrical power from it.

Hendershot received considerable publicity for his invention at various times until his death in 1961, and today there is renewed interest in his generator.

The circuit was constructed of basket-weave coils, condensers, transformers and magnets, and produced several hundred watts of power as witnessed by many people. Fortunately, some schematics of the device are available, and a few persons have built marginally successful models -- but only with considerable difficulty, as the device is very sensitive and finicky.

14) In the late 1970's Professor Shinichi Seike of Japan developed a simple transistorized electrical generator, called the "Endless Amplifier", which derived power from the gravitational energy by manipulation of positrons, or an unoccupied state of negative energy. The device consists of three transistors, three capacitors, and several resistors. This so-called transistorized coil also is a three-phase oscillator operating at about 1.26 megacycles. In one embodiment it produces 21 volts when fed with 15 volts, and is rated at 162% efficiency.

15) Another simple circuit that powers electrical devices with electromagnetic energy extracted from the atmosphere, was invented by Lloyd Crump, who received US Patent # 3,813,242 for it in 1957. The invention provides only low power, but it indeed works.

16) Canadian inventor Peter Markovich developed the ATREE (Apparatus to Rectify Ether Energy) in 1977 in the course of testing and seeking improvements on Nikola Tesla's invention, USP # 725,605 entitled "System of Signaling".

By 1978 he had developed the technology to produce about 500 watts of DC electricity. Markovitch's apparatus collects ether energy in "a hollow ball whose diameter is approximately one sixth that of the rectification component... The ball should be composed of very thin (260-gauge or less) metal of high electrical conductivity -- such as gold, silver or copper. A converter transforms the ether to electrical energy by augmenting the the vortex motion of the ether in a copper rod which has the upper 5% of its length inserted inside the copper collection ball. The rod has a needle point and is tightly wound with 26-gauge copper wire directly beneath the ball down to the opposite end of the copper rod. Also, an outer coil of #14 wire is used in the converter. This outer coil has a diameter equal to the inside diameter of the protective copper tube that covers the converter. This second coil is attached on one end to the outside of the collection ball and on its opposite end to the working electrical circuit... The outer coil must be wound counter to the winding of the inner coil... The outer coil acts as an amplifier of the electrical potential and current since its fields (the electrical circuit return to the ball) have the property to amplify the quasi-electricity produced by the induction process in the copper rod and inner coil. In this fashion the ATREE is able to convert ether energy into usable DC electricity."

The operation of this device has been witnessed by dozens of persons, including US Senators, who have signed affidavits to the effect.

17) A prestigious British engineer named Arthur Adams is said to have discovered a power-generating mineral sometime in the 1970's while prospecting with a machine that combines isotopic analysis and sound waves. The substance had not been discovered before because it required such a combination of detection techniques to locate it. A single lump of the mineral has served to power Adams' radio, TV and clock. Adams applied for a British patent for the formula for the stone, but the Defense Department suppressed his application under the Official Secrets Act because of its strategic potential.

Adams says the exotic mineral is very common in Wales.

18) According to an article in the Boston Evening Globe, December 4th, 1974, during the Great Blackout a Mr Baldinelli provided full power for his house with some batteries which did not run down as they were being charged by a "solid-state two relay AC oscillator."

The article in the Globe stated that Baldinelli had obtained a patent for his invention, but this writer has not been able to locate it.

Private citizens invested some \$500,000 for development of the device, but Baldinelli subsequently fell under investigation by the attorney general of Massachusetts. The state of this invention is unknown today and it may be lost to us.

19) In 1980, Xtec, Inc. of New Britain, Connecticut announced the development of an invention that is claimed to amplify the electrical power from conventional sources by extracting environmental energy and utilizing it to supplement or amplify the wattage of a battery or other power supply.

Xtec has stated that "It uses a specially designed antenna to gather this external power, which has been successfully applied in laboratory tests to power a metal-cutting lathe and an industrial tricycle."

An input signal applied by a battery to the antenna amplifies the potential between the system and the environment. The amplified potential is drawn upon through an inductive coupling. Possibly the energy being extracted exists between the antenna and low-frequency ground currents or an external pulsing magnetic field, but this phenomenon remains to be explained and proven by Xtec's research program. A patent has been applied for in the US and all other major industrial nations.

20) John C Bedini of Sylmar, California has invented a prototype free-energy motor-generator and an auxiliary solid-state electrical circuit which serves to oscillate storage batteries at their electrolytes' ionic resonance frequency between one and six million cycles per second, thereby recharging the battery, or several, without any energy drain. These devices have been publicly demonstrated, and construction details may be obtained from the Tesla Book Company, PO Box 1649, Greenville, TX 75401.

Several persons have replicated this system and are developing it in various embodiments.

The battery is connected to a simple flip-flop circuit which drives the amplifier and a load. The output of the oscillator-amplifier pulses the electron pool of the system in such a way that the ions in the electrolyte of the battery are driven backwards to recharge the battery while, in pulsing forward, work is being performed simultaneously.

In essence, the electron pool is made to quiver back and forth in part of the circuit, rather than being driven wholly "forward". But this "quivering" is not to be confused with alternating current or pulsed direct current. Rather, the effect has been attributed to the practical application of scalar potential "phi" waves such as discovered by Nikola Tesla.

FROM: NOW WHAT (#3:1) P.O. Box 768 MONTEREY
CALIFORNIA 93942 USA — 1989

DR. TECHIE'S LOST TECHNOLOGIES of the 50's

George M. Ewing
PyroTechnics - Box 217
West Chicago, Ill. 60185

Issue 42 - \$2.00 Sample

Over the last few years, there has been a building wave of nostalgia for the Fifties. We've had conservative Republicans in the White House, relatively low gas prices, and on the world scene, "there's been fighting in Africa, and strife in Iran." Following on the success of *Back to the Future*, we've had a rash of borderline SF Fifties movies, and the TV commercials are filled with pop songs from the Fifties and early Sixties (Culturally, you can make a case that the "Fifties" actually ran until about nineteen sixty three - nineteen sixty four, when a number of mileposts appeared, I.E. I graduated from high school, Kennedy was assassinated, the Beatles started becoming noticed, outside Liverpool and Hamburg, etc. Lots of pop culture hits thought of as "fifties" nostalgia, from *Happy Daze* and *Animal House* to *Laverne and Shirley* and *American Graffiti* were actually set around nineteen sixty three.) Besides all the campy pop culture impedimenta from the fifties, the hula hoops and Davy Crockett stuff, there is also renewed interest in the explosive technological boom of the period. The nineteen fifties were a time of phenomenal growth in science, with milestones like the discovery of the structure of DNA, the development of the transistor, the solar cell, the artificial satellite, and the first beginnings of manned space travel. In addition to the big 50's milestones, like Sputniks, H-bombs, and atomic subs, and the more mundane technologies, like color TV, Polaroid photography, and the Xerox machine, there were myriad techie developments that never seemed to quite make it. You read about them in *Popular Science* and the newspaper Sunday supplements, and great breakthroughs were always just around the corner, but somehow they never quite fulfilled their promise, though SF writers of the period used them heavily in near-future backgrounds. I cornered the famous 'Dr. Techie' at a recent SF and Fantasy convention in Florida, and asked him about some of the ones I could remember from my own Fifties childhood. It was the most fun I'd had pestering an expert since I got into (and lost!) a convoluted argument with John W. Campbell at the 1966 Worldcon about the Farrell Drive, or the time they invited a bunch of GT people to lunch in the center of the main neutrino beam at Fermilab, and we spent most of the time arguing about World War I zeppelins and the possibility of scrounging radioactive steel shot from a particle detector for homemade 12 gauge duck hunting reloads. I found Dr. Techie in the con suite bathroom, watching a couple of con members mixing a fresh batch of Blog in the bathtub. The room was murky with CO₂ from the dry ice, and he was swapping good-natured lecherous remarks with a couple of tall, willowy, albino women in fantasy costumes from a central Florida SF group. As an SFWA member, I have a pretty good idea of the doctor's real name and occupation, but of course I have promised not to reveal it. However, he is NOT: A. Isaac Asimov, B. James Corum Whiting, C. Christopher Anvil, D. Forry Ackerman, or E. Anyone connected with the Duck's Breath Mystery Theater! As we had been talking about atomic rockets for

some time in the con suite following a long discussion of the nuclear steam rocket in Robert Heinlein's film, 'Destination Moon,' it was only natural that this would be the subject of my first lost technology question...

GME: "What ever happened to REAL atomic rockets?"

Dr. T: "Disregarding what the Soviets were working on, there were two programs in the U.S. that were significant. The more widely known of these was project NERVA, which actually extended into the 1960's. It was based on a long-path, axial flow reactor, with relatively large diameter gas tubes, more than a meter or so long, arranged in cells with a hexagonal cross section. It worked fine, but the conservative design made it heavy, and relatively inefficient. NERVA's specific impulse was better than chemical rockets, but the internal turbulence in the large passageways hurt efficiency, and the thrust-to-weight ratio was not as good as modern chemical rockets; you'd probably never be able to launch a NERVA rocket

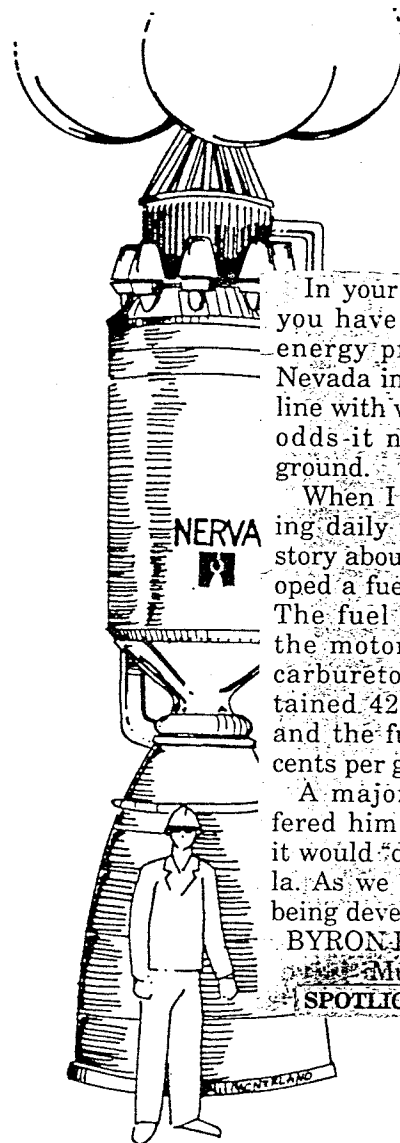

In your February 15 issue you have an answer to our energy problem wherein a Nevada inventor mixes gasoline with water. I will lay you odds-it never gets off the ground.

When I was a boy delivering daily papers, they ran a story about a man who developed a fuel for his old Essex. The fuel was dispensed to the motor via an atomizer carburetor. His vehicle obtained 42 miles per gallon, and the fuel cost him eight cents per gallon.

A major oil company offered him \$1 million saying it would "develop" the formula. As we all know, it is still being developed.

BYRON R. HARTENSTINE

Muncy, Pennsylvania

SPOTLIGHT March 1, 1993

from the surface of the Earth into orbit, even if the environmentalists would let you, but it would make a pretty good orbital space tug or shuttlecraft for trips in cislunar space, and lunar surface landings and takeoffs would be possible." "A more tantalizing project for space advocates is the DUMBO technology, developed in the mid-50's at one of the Los Alamos nuclear weapons laboratories as part of a secret research program. DUMBO utilized RADIAL flow heat exchangers with a

very short path, only a centimeter or two, and a tiny passage diameter, almost microscopic in size to provide laminar flow and to reduce turbulence. Dumbo was much lighter and more efficient, with a specific impulse that was similar to NERVA, but with a thrust-to-weight ratio about an order of magnitude better. Direct launches from the surface of the Earth to orbit were perfectly practical, though probably only for large, unmanned payloads, because of the shielding requirements for a manned mission. "The exhaust was only slightly radioactive; One estimate, in Donald Kingsbury's 70's Analog article on DUMBO, (12/75, p.38--GME) was that you could put nearly a thousand Skylab-sized payloads into low Earth orbit for about as much radioactivity released into the environment as one of the 50's Pacific Island weapons tests. DUMBO engines were also easily throttleable. Probably the main reason we aren't using them today, besides the generally anti-nuclear political climate, is that the program was victim to political rivalry from NERVA, the "not-invented-here" syndrome, and competition from the big chemical rocket companies, who had a lot of money at stake, and powerful friends with a lot of clout in both NASA and the military missile programs.

GME: "Didn't DUMBO have ANY shortcomings? It sounds almost too good to be true!"

Dr. T: "Well, I'd like to see some more information on engine lifetime. NERVA was big and heavy, but probably would keep on running for years, so long as it could get reaction mass. The nuclear fuel in DUMBO was bonded to a tungsten/nickel cermet substrate in thin layers. I expect it would be used up rather quickly, and because of the way it was built, recycling and processing spent uranium fuel from a DUMBO engine might be extremely difficult, if not impossible. Treating the engine as expendable after so many hours is perfectly reasonable, but raises potential problems with secure waste disposal and so forth. Of course, a lot of the details on DUMBO are probably still classified, or at least they were in the mid-70's. I surely hope the SDI people haven't forgotten about it.

GME: "Why do we have to use rockets at all to get into space? Why can't we use the Dean Drive, another one of those great lost inventions of the 50's?" (There was a short interruption here as several of the older fans in the con suite began chanting, "The Dean Machine! the Dean Machine! You put it in a Submarine!"...etc.)

Dr. T, (laughing): "First of all, just like NERVA, the Dean Drive continued on into the 1960's; the famous Analog article with the flying submarine on the cover was in the June, 1960 issue, I believe, while the magazine was still changing over from the old 'Astounding' title. "Second, the main thrust of Mr. Campbell's argument was not on whether the Dean Drive would work, but that scientists and government officials automatically dismissed Dean as a crackpot, another Velikofsky, without bothering to actually watch a demonstration.

GME: "Well, did the Dean Drive actually work? Norman Dean got a patent on it, didn't he.?"

Dr. T: "I'll answer that with a question for you, Mr. Ewing: Did the Farrell Drive at Michigan State Really work? There's a valid patent on that, too, and you were there."

GME: "Well, yes, but..."

Dr. T, (interrupting): "Exactly! 'Yes, but...' Of course the Dean Drive, and the Farrell Drive, and that secret Marine Corps drive that was on the cover of Popular Science Magazine all work, but they're NOT space drives; they're static friction devices. The difference between static and dynamic friction causes a one-way ratcheting action, just like the effect of a good ski wax on cross country skis.

They work fine for pulling a piece of farm machinery out of the mud or running a military landing craft up on a beach, but in a zero-friction state like in space they just sit there and buzz and shake. Next question..."

GME: "Okay, as long as we are talking about 50's things that could have flown, or that people claimed could have flown, how about something that really did fly: what about the flying wing?"

Dr. T: "Ah yes...The flying wing technology was around for a while before the 50's, of course. Most fans have seen the models used in H.G. Wells' 'Things to Come' in the 1930's, and those were based on real designs. Both the British, and Northrop Aviation in the U.S., had flying prototypes during the Second World War, propeller driven, of course. The Northrop model looked a great deal like the phony German aircraft in the first Indiana Jones movie, though I think the wingtip stabilizers were different. Of course, the Northrop plane was first operational around 1944 or so, not 1936, but jumping the gun eight or ten years doesn't bother Hollywood; they had 1940's German Panzerfaust bazookas and type-VII U-boats in that movie, too, long before they were really available.

GME: "Yes, but when most SF fans think of flying wings, they think of THE Flying Wing, the jet one from the movies. Everyone has seen that clip from the film, 'War of the Worlds' where they drop a nuclear weapon on the attacking Martians..."

Dr. T: "Yes, I know; I think its designation was B-49 or YB-53, or some such. You'd have to check with a real aviation buff at Wright Patterson or the Smithsonian. It was really a late 40's design, though. There were several designs competing for a strategic bomber to replace the B-29 and B-36, The flying wing from Northrop, the B-52 from Boeing, and a similar conventional design from Convair. The B-52 finally won out, of course, and the darn things are still flying. The flying wing had about a 20% payload advantage over the B-52, but was somewhat tricky to fly. Also, there was a crash early in the program. The best guess is that the Air Force picked the B-52 because the SAC generals thought it would be more fun (and safer) to fly, and had built up a big loyalty to Boeing because they'd all begun their careers flying the B-17 during the war. "Anyway, a first batch of 35 or so flying wings was actually built, then the whole program was scrapped, and the planes allegedly destroyed. John Northrop claimed in a TV interview later that it was all Pentagon politics, and that somebody, either the Secretary of Defense or the Secretary of the Air Force, had a grudge against his company, or else was wheeling and dealing to try and force a merger of Northrop with Convair, or the company which later became Convair.

GME: "Were ALL those 35 flying wings actually destroyed?"

Dr. T: "Probably, though it's fun to speculate. The flying wing had another advantage over the B-52, besides the 20% payload factor, one we are only beginning to appreciate a generation later, namely a greatly reduced radar image. In fact, artist's sketches of today's STEALTH bomber designs look a hell of a lot like it. Suppose a few of those planes weren't destroyed, but went on to make secret spy flights in the 50's over Soviet and Chinese territory; that might explain the rash of UFO sightings from those years that often described a big, silver, boomerang shape... Maybe somebody from the CIA or the Skunk works will eventually spill the beans, and we'll all know for sure! (There was a another brief fannish interruption here, with a jumble of questions about other real and imagined projects from the 50's and early 60's from a number of bystanders.)

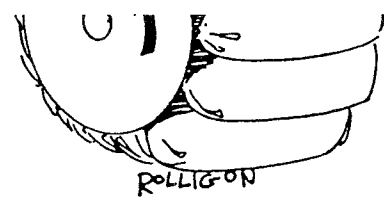
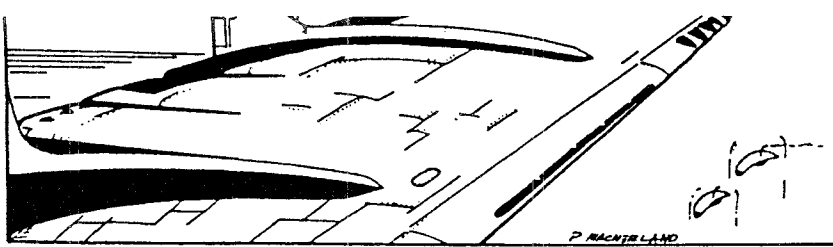

Dr. T: "Okay, okay, one at a time... First, the gentleman in the chain mail was asking about project MOUSE and the IGY. You know what the IGY was?"

GME: "That's easy: it was the International Geophysical Year, an extended period of co-operative science projects for about 18 months during 1957 and 1958. I remember reading in National Geographic about a lot of bases in Antarctica."

Dr. T: "Not too shabby. What can you tell me about that? it was called 'Operation Deepfreeze'..."

GME: "Well, the high point was probably the first plane landing at the physical South Pole since the Byrd expedition. A Navy R4D, essentially a DC-3 with skis, landed right at the pole. The name of the plane was the 'Que Sera, Sera...' But back to project Mouse. wasn't that some kind of satellite?"

Dr. T: "Hey, the youngster has been doing his homework! Probably just leafing through the back issues to leer at all the topless third world native T&A, eh?, Yes, Project MOUSE was a satellite. The acronym stood for Minimal Orbital Unmanned Satellite of the Earth. SF writers like Arthur Clarke and George O. Smith had been playing with satellites for years, but the MOUSE project, I think it was in Life magazine, was one of the first mainstream pre-Sputnik satellite proposals. If they'd gone ahead and built it, and then unleashed Werner Von Braun at Huntsville, the U.S. probably could have beaten the Russians into orbit by a few months, maybe a year or more. What was the next one? project Farside?"

GME: "Yeah, what WAS project Farside?"

Dr. T: "First of all, it didn't have a damn thing to do with the far side of the moon. It was a program for testing nose cones and ablative heat shield material. They took a multistage rocket up out of the atmosphere, and then fired the last stage straight down into the atmosphere again. Mostly for missile nose cones, of course, but the designs they developed saved a lot of weight on the manned shots, especially Apollo. In the early days before Farside, most scientists didn't think it would be possible to return straight from lunar orbit and slam right into the Earth's atmosphere without a lot of heavy retrorockets, or a heat shield so massive that it wouldn't be practical. They were wrong, of course."

GME: "The young lady in the silver rat suit asked about SNAP."

Dr. T: "S.N.A.P. was the general name for a whole line of small nuclear power generators for satellites and un-

manned spacecraft. Some of the smaller ones were just little isotope heat sources driving a bank of thermocouples; some of the bigger ones were actual reactors, with adjustable beryllium reflectors and thermionic generators, and Esaki diode inverters to step up the low voltage for electronics packages and ion drives. I think the power source for the Apollo instrument packages they left behind was an isotope thermal type."

GME: "This discussion is getting awfully lopsided towards space and aviation, and we haven't even gotten to the flying platform, The Chrysler Aerospike, the jet seaplane, and Project Pogo yet. What about the more mundane lost technologies, like the Rollagon truck, fluidics, and the PFA carburetor?"

Dr. T: "Some of those are really from the 60's or even later. What about the Rollagon truck? Well, it was a cross-country vehicle that used big, soft, cylindrical airbags instead of tires. Propulsion was by means of friction rollers instead of torque through the hubs. They worked okay, but there were lots of little picky engineering and economic problems. There was a problem with heavy mud and dust getting into the drive rollers, for one. The bags were pretty durable, but when they did fail, they were expensive and troublesome to replace. Since the actual vehicle was never really mass produced in large volume, the poor economy of scale put it at a disadvantage with more conventional trucks with standard off-road tires, which WERE mass-produced by the millions. A modern truck with big off-road tires can go almost anywhere a Rollagon could go, and you can also drive it sixty miles per hour on the freeway."

GME: "I think the next question was on Project Pilgrim."

Dr. T: "That was a fictional project in the Saturday Evening Post about a cheap-and-dirty one-way moon shot that ran in the Sixties. It wasn't a real project, though there were serious proposals for doing something like that, soft landing a number of canisters of supplies at a spot on the moon, and then sending a man on a one-way trip, to live there for a few years until he could be picked up by an Apollo mission. It was considered too dangerous, though later Apollo missions were able to land within a few hundred meters of a downed Surveyor spacecraft. Digging in deep enough on the lunar surface to be safe from solar flares while wearing a clumsy spacesuit would probably have been the toughest part. Anyway, back to the Fifties..."

GME: "What about the Flying Platform?"

Dr. T: "What is this, a secret front organization for the Confederate Air Force Ghost Squadron? All right, All,

Page 6

right... The flying platform, as opposed to the hovercraft, was just a big ducted fan with a sewer grating on top. You stood on the grating, grabbed a handlebar or a railing about belt high, depending on the design, and flew the thing by leaning your weight and tilting the platform. The Army played around with them in the 50's and early 60's, along with other aircraft like the COIN, and the inflatable rubber airplane. Anyway, they worked okay for flying along over swampy ground and level terrain, so long as you stayed low, within a few feet of the ground, and could pick up some ground-effect cushion. If you were careful, it was just like operating a narrow, tippy, but very fast hovercraft. However, G.I.'s tended to do things like fly them into a mangrove thicket at seventy miles an hour, or take them up to five thousand feet, where they were very unstable and dangerous. At any real altitude, flying them

was like balancing on a unicycle. A real expert test pilot, like a Chuck Yeager or an Iven Kincheloe could probably fly them safely, but putting a bunch of hotrod infantrymen on them was just asking for trouble...

(at this point, there was another interruption: Dr. Techie was just starting to explain the inflatable rubber airplane, when two voluptuous young fannish women wearing black fur bikinis and moose antler skull caps came into the con suite bathroom, grabbed him by the belt buckle, and dragged him off down the hotel corridor for some panel that was about to start; at least they SAID it was a panel... Anyway, next chance I get, I hope to interview the Doctor on some more modern technologies of interest to SF fans, such as the synchronous skyhook, the Moravec pinwheel, stochastic precooling of antiprotons, the Kleiner blinkie, and stuff like that...)

SURVIVAL REPORT #1. All the prophesies and common sense indicators put us in collapse very soon. Here is a huge collection of little known data from many experts and sources. Typically covers what is coming, overcoming emergencies, helpful gear, foraging, little known foods, medical improvising, fast, cheap shelters, snares, foods & their preservation. \$9.95



SURVIVAL REP. #2. ... continues with further details on starvation dangers. Plagues & remedies, New land mass, cheap living, health dangers, City housing & squatting, Nostradamus' predictions of plagues & war etc. \$9.95

SURVIVAL REP. #3. FURTHER updating, gardening, retreat tactics, food storage shelters, suppliers, Thoreau philosophy and much more. \$9.95

POOR MANS HOUSING REP. Articles and data on cheaper domes & homes, City homesteading and squatting, Straw bale houses, Underground housing & caves, etc. \$6.00

RETREATS & COMMUNES REP. Examples and scandals of past, Good & bad cults, Rainbow gatherings, directory of communities. \$4.95

PLAGUE DEFENSE EXPOSE Dozens of killer genetic hybrids and resistant viruses are killing millions without a fuss from our press and pill pushers. This astonishing report tells of dangers and gives dozens of ways to fight without expensive drugs. Covers oral immune stimulants, Flu mouthwash, old Russian formulations, Silver, Malaria, Nostradamus plague treatment, Fever aid, many easily obtainable herbs for immunity. \$7.95

INDIAN USE OF NATIVE PLANTS (of the West) Foods, Beverages, meat, greens, seeds medicines, tanning, Tipis, etc. \$9.95

WILD EDIBLE PLANTS OF THE WEST In depth book with illustrations and pictures to make it easy..... \$9.95

POLARIZATION REP #1. For beneficially altering foods exposed to many of the devitalizing, poisonous processing and electro-mag exposure. \$3.95

Polarizer Beads with life time capabilities are \$20 for two. (Free flyer)

HARD TIMES SURVIVAL MANUAL. Bargain priced newsprint expose on what is coming up and the options to disaster. Where to go, shelter, investments, necessities, unseen dangers, food facts, who is running the show. \$4.95

RETIRE WITHOUT MONEY REPORT. Little known secrets of getting by for pennies. Areas & lifestyles. \$6.00

FREEDOM WAY. Old live on \$2 a week classic \$3.00

SURVIVAL SECRETS REPS (3) Huge collections, ea. \$9.00

"LESS IS MORE" Book. Philosophic revelations \$12.00

"BARGAIN PARADISES OF THE WORLD" Classic \$9.00

WHAT'S AHEAD REP. Coming disasters outlined \$4.00

OWN A PLACE IN PARADISE REP. All nations visa requirements with hidden Eden spots \$4.00

SOUTH PACIFIC PARADISES REP. Spl places & view \$4.00

LIVE ON WHEELS REP. Vans-buses & many more \$5.00

NEW SYSTEMS REPORT. Better world systems \$5.00

NEW FOODS REP. Better world systems \$5.00

STRANGE & EXOTIC FOODS R. Great variety of bugs \$5.00

FARMING THE SEA R. Various fish farming I etc \$3.00

SOIL SECRETS REP. Upgrading fertility methods \$9.00

SUPER YIELD REP. Little known secrets-methods \$9.00

SUPERGROWTH COILS R. to stimulate. Simple des. \$5.00

MOTHER EARTH SECRETS Esoteric secrets to heal \$8.00

POLE SHIFT REPORTS (3) End of century disasters \$6.00

DISASTER REPORTS (3) prophetic disasters etc ea. \$8.00

ENVIRONMENTAL DETOXIFICATION R. little kwn \$8.00

NUCLEAR DISASTER RELIEF R De-tox secrets etc \$8.00

HIDDEN POISONS REPORTS (3) additives-envir.p.ea. \$7.00

BEVERAGE DANGERS R Shocking exposes of bev. \$7.00

MAKE WATER CONDITIONERS R Many types-ways \$5.00

STRANGE & WONDERFUL FOOD ALTERATIONS \$5.00

REP. Misc t. \$5.00

DESALINIZATION SECRETS R Unique design \$8.00

FREE HEAT REP Many unique designs-ideas \$4.00

PUMPING WATER FOR FREE REP Strange & unique \$4.00

FREE COOLING R will surprise you by variety \$4.00

BURN METHANE REP also make carb easily \$9.00

BURN WATER REP Run as steam & mist to carb. \$7.00

PEDAL POWER REPS (2) For loads or travel ea. \$3.00

BRAINWASHING REPS (2) Subliminals etc ea. \$10.00

POOR MANS MEDICINE REP Treat yourself cheap \$10.00

BUG IRRADICATION WITHOUT POISONS R surp. \$6.00

PSYCHIC SELF DEFENSE R (2) simple & safe ea. \$6.00

NATURAL SELF DEFENSE REP Awesome secrets \$10.00

SPACE TRAVEL COLLECTION Exotic clips, concepts and articles on visiting various places in the universe using aliens tech & time travel. Covers: 5th dimension forces, Tachyon energy & drives, Frequency of planets, teleportation, tones, star navigation maps, hyperspace math etc. \$9.95

VOLUME 2 This volume covers the Ummo papers, Pajack Magnocraft, NPD (Brown), Searl, Magneto Hydor Dynamics, UFO detection device, Starship propulsion, etc. \$9.95

ADVANCED EXTRATERRESTRIAL SPACECRAFT PROPULSION(Huntly) Overview of many designs.... \$12.00

INCREDIBLE AIRCRAFT REPORT Searl designs and a condensation of Spacecraft designs mentioned above. \$7.95

SUBTERRANEAN UFO ORIGINS REPORT Aside from the visitors with a hands-off policy, there are many unethical types who deal with out 'elite' and have bases across the globe. A superb 40,000 word report. \$6.95

EXOTIC AIRCRAFT REPORT Unconventional craft like: Farr saucer, Stealth, Army discs, Kasper, Zeppelins, Coptors, air cushion craft, wings; etc. \$7.95

HENTHORN ELECTRIC RECHARGE AS IT RUNS CAR REPORT Several alternators on a front wheel drive differential are especially wired to do what is considered impossible. (I saw it work) Pictures and diagrams. \$9.95

FREE AND CHEAP HEATING REPORT Burn water furnaces, astonishing heat from air, friction heaters, solar, boilerless steam, geo thermal, crystal heat, etc. \$4.00

REPORT #2 This report continues with free power collectors, pyramid stoves, solar collectors, heat pumps, pulse furnaces, solar ponds, Cottell furnace, etc. \$3.95

FREE WATER PUMPS AND MOTORS Includes little known designs using hydraulics, air vortexes, dielectrics, osmosis, buried coils, thermoclines, air vortexes, vacuums, water pressure, Sun, Mercury and gas. \$4.95

FREE AND CHEAP ELECTRICITY REPORT 20 suppressed design in brief, more depth on use of sea water, air vortex, generatorless coal, infra red, and gravity rods. \$5.00

FREE OR CHEAP COOLING REPORT Design using: magnetism, Sun, Ground heat exchangers, compressed air, chemicals, sound, air wells, M.D. tubes, etc. \$5.00

PEDAL POWER REPORTS One DOZEN unusual bikes and pedal cars illustrated. Indian passenger and load hauling designs, Railroad cycles, exotics. \$3.95

REPORT #2 Many more designs to inspire.... \$3.95

MIDWIFES PREGNANCY & CHILDBIRTH BOOK. Shows why most popular birth methods are harmful and how to avoid them. Ie Pain, Episiotomy, Cesarians, and drugs. Great data. \$11.95

HERBAL HEALTH CARE John Christopher was one of the truly great modern herbalists and this gives his secrets for most family related problems. An emergency 'must have' title. \$15.

HEALING CLAY How it heals, treatments, history, Eyes, Ulcers, ears, hernias, tumors, burns, etc. \$12

MORE PRECIOUS THAN GOLD The results of special Wyoming clay. (I have sent this all over the world or a dozen years now and the clay or the book is, \$15

CHELATION THERAPY ... unplugs arteries and aids most degenerative diseases. (I get them to stay in top shape) Book \$4.95 Report \$4.95

WATER OF LIFE BOOK Animals use urine to heal themselves and practitioners who buck the system get startling results in humans. \$11.95

CHEAP WONDER HEALERS COLLECTION. Little known and inexpensive substances and products including: De tox methods, Chelation, anti cancer, avoidance, anti-biotic dangers, homeopathics, Uranium, candy with hormones, elixir of youth, super cell regeneration meat prod., herb immunity, tree bark imm. healing emotions, food cleansing, reg. tea, antigen preparations etc. \$9.95

IMMUNE SYSTEM ENHANCEMENT REPORTS Simple-natural disease blockers including: herbs, BAT, CoQ, Light, spl meats, Colostrum, diet, ph values and miracle virus killers like Gaia solutions. \$6.95 ea. Vol. #2 covers minerals, roots-herbs, household spices, antigens, tree bark, Fevers, plus overseas contacts for super drugs.



