

MIN'S LIGHT & SOUND

©2004 Daniel Joseph Min
All rights are free

Min's Free Press

Continental Divide, CO

Min's Google-archived digital edition April 21, 2003.

First printed edition published by MFP on July 1, 2004.

Contents

Ch 1 – <i>Dark Side of the Moon</i>	1
Ch 2 – <i>Primaries and Secondaries</i>	6
Ch 3 – <i>Signs, Decans & Pentads</i>	9
Ch 4 – <i>Chart of a Genius</i>	28
Ch 5 – <i>Chromatic Transposition</i>	36
Ch 6 – <i>Going In Circles</i>	43
Ch 7 – <i>Center Of Creation</i>	49
Ch 8 – <i>By Jove!</i>	59
Ch 9 – <i>13 Baktun</i>	66

Chapter 1 Dark Side of the Moon

THE CHROMATIC IRIS & octave of the planetary zodiac are referred to the familiar spectrums of visible light and audible sound, respectively. Light & Sound bear witness to the diatonic and chromatic qualities of astrological forces from which the four elements of creation derive and manifest throughout the universe. As we humans see and hear, these forces are perceived in primary colors: Red, Yellow and Blue; secondary colors Orange, Green, Violet; and tertiary colors russet, citron and olive (composite Indigo), hence the diatonic “ROYGBIV” primary colors of light, i.e., Red-Orange-Yellow-Green-Blue-Indigo-Violet refraction dispersal of visible wavelengths — as through a prism, from about 700 nm just above infrared, down to about 400 nm which is just below ultraviolet. Color intensity or chroma is its degree of saturation -AND- departure from pure light, whose “color” is white; although white, and black, are not really colors by strict definition, since pure white is generally the appearance of all visible wavelengths, whereas pure black is the absence of the appearance of any visible wavelength.

As with light, the primary “colors” of audible sound are Red, Yellow and Blue, the three diatonic tones numbered 1-3-5, which are the root tone, major third and perfect fifth, which together form the C-major triad. The secondary colors Orange, Green, and Violet correspond to the root tone, minor third and natural sixth (note perfect sixth implies a major third but the minor third is dissonant), which form the D-minor sixth triad. The tertiary colors are formed by the interval of two chromatic tones, such as olive which is yellow-green of diminished saturation, which falls between the E and F, thus is E and F played together, E as the root tone, and F as the minor second, the epitome of dissonance like the theme from the movie “Jaws” which is exemplary of how this interval is used in music to build tension or conflict by the complex ratio of 11:12 (cf. Judas Iscariot and the ensign of Jupiter-inferior, the twelfth sign Pisces, archetypal “Hanged Man” of Tarot, his mystical musical niche succeeded by Matthias).

Thus there are seven diatonic colors in the iris: 1 Red, 2 Orange, 3 Yellow, 4 Green, 5 Blue, 6 Indigo, 7 Violet; therefore there are twelve chromatic colors in the iris, 1 Red, 2 Red-Orange, 3 Orange, 4 OrangeYellow, 5 Yellow, 6 Green, 7 Green-Blue, 8 Blue, 8 Blue-Indigo, 10 Indigo, 11 Indigo-Violet, 12 Violet. These are the 7 x 12 colors in the planetary zodiac having 7 x 12 corresponding tones.

The chart below illustrates the color/tone relationship in the zodiac with the planets and their signs. See how the C-major scale corresponds with the “ROYGBIV” colors, the C-major triad is consonant with Red, Yellow, & Blue, the D-minor sixth triad matches Orange, Green, & Violet:

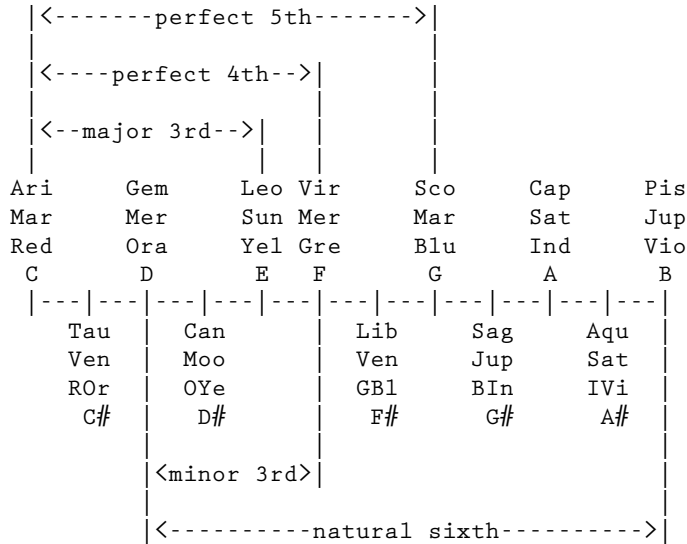

For example, the C-major triad is dominated by the ‘C’ with the major third ‘E’ and perfect fifth ‘G’ mixing their respective colors on full intensity. This color is dominated by ‘C’ or Red, but the Yellow of ‘E’ and Blue of ‘G’ are charted as if mixed on full intensity. As such color/sound analyses are refined and expanded, dynamic colors and tones may be further accounted for such as tertiary colors which are of a lower intensity, on down to the intuitive level — which is just as well, since intuition is truly the lifeblood of imagination, while empirical observation and theoretical knowledge alone are only the beginning of such applied learning. Sooner or later this knowledge and experience must be integrated into ones cognizance and feeling of living, which clearly transcends mundane secular academia.

In all fairness to “RGB” advocates, the primary color of Green corresponds to the perfect fourth above Red, thus is Red-Green-Blue equal to 1-4-5, the very fundamentals of music, a convincing argument except that Green is made by Blue plus Yellow. Conversely, however, Cyan is made by Green plus Blue. When you look at the zodiac of these primary and secondary colors, you immediately see that Cyan and Yellow, with Green between them, oppose Magenta, and this is precisely the CYM color model of subtractive color. And furthermore, Green and Blue, with Cyan between them, is at opposition to Red, i.e. the additive RGB color model. The following color zodiacal diagram demonstrates this principle:

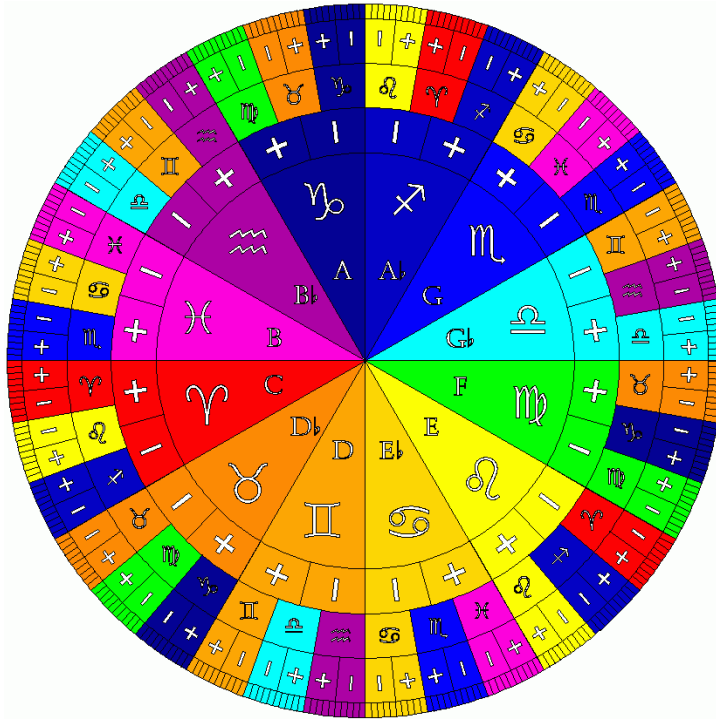

For the purpose of zodiacal delineation, the diatonic ROYGBIV primary-color model is the most natural color model of all, and is the one most familiar to all — just as it has been for many hundreds of millions of years and counting. It's the iris, rainbow, the zodiac of color, with seven primaries and five secondaries comparable to the classification & numbering of human ribs, human chakras, etc. (I've examined this human correspondence in modest detail in my 'Interlinear Apocalypse & Concise Commentary', published on the Google-archives & in print where available). The ROYGBIV color-model is perfectly natural, and corresponds to the C-Major (Ionian-ascending) scale, as the physical refraction of light forever bears witness.

The chart on the following page summarizes the relationship of the planets, and the zodiac, with tones and colors, and the 12 signs, & 10 planets of the major arcana.

Any single tone or combination of tones, signs, or colors, or major arcana trumps etc. results in the denoted mixture of the aforesaid; e.g., Gemini and Libra/D + F#/Orange + Green-Blue, is a major third with D as the root, or a diminished sixth below Gb, emphasizing the root tone, color, sign, trump, etc., as comparing the aspect of tension Libra to Gemini verses Gemini to Libra. Musical intervals help you to recognize respective astrological relationships, as with colors in contrast, or when mixed together. This forms the essence of the music of the spheres, the harmonic tension among and between the planets in their innate sidereal modes and synodic motions to Earth. See "Beginner's Reference" for more info.

Note that “lunaires” refers to the synodic aspects or phases of the planets to the Earth, or “lunars”; while the “solaires” refers to the innate sidereal orbits of the planets about the Sun, ergo “solars”:

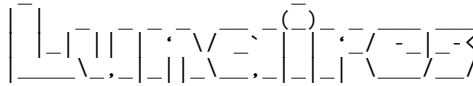

F O R	W O R	T E M	H A N	D E V	H I E	L O V	C H A	S T R	P R I	J U S	D E A	F O R	W O R	T E M	H A N	D E V	H I E
S A G	C A P	A Q U	P I S	A R I	T A U	G E M	C A N	L E O	V I R	L I B	S C O	S A G	C A P	A Q U	P I S	A R I	T A U
J U P	S A T	S A T	J U P	M A R	V E N	M E R	M O O	S U N	M E R	V E N	M A R	J U P	S A T	S A T	J U P	M A R	V E N
B I N	I N D	I V O	V I O	R E D	R O R	O R A	O Y E	Y E L	G R E	G B L	B L U	B I N	I N D	I V I	V I O	R E D	R O R
Ab G#		Bb A#			Db C#		Eb D#			Gb F#		Ab G#		Bb A#			Db C#
S T A	H E R	F O O	S U N	T O W	E M P	J U D	M O O	M A G	E M P	J U D	M O O	M A G	M A G	M E R	V E N	E M P	
U R A	N E P	P L U	S U N	M A R	J U P	S A T	M O O	M E R	V E N	S A T	M O O	M E R	M E R	M E R	V E N	V E N	
8	9	10	4	5	6	7	1	2	3								
A	B	C	D	E	F	G	A	B	C								

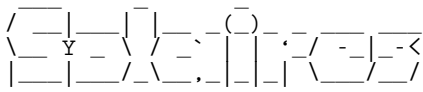
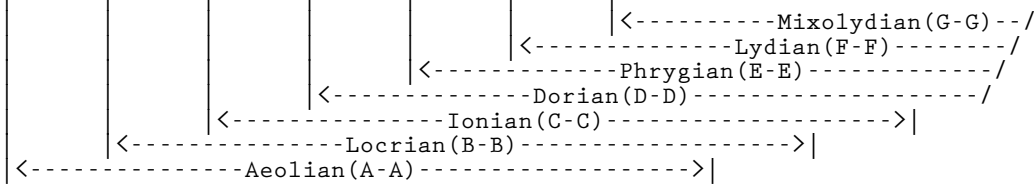

Before moving on to chapter 2, it should be noted that theories regarding energy and cosmology in general are numerous and often in conflict one with the next. This is why it is so important to see the actual results of plausible theories — and put their veracity to the test. Many theories show merit or repeatable demonstrability, promoting acceptance among the experts of world renown. The problem is that most of these experts share common agendas in that their motives are venal, or reinforced by repeated oversights compounding into daft sophistry as perpetuated in even the finest of university libraries. “A lie is not a lie when you are ordered (paid) to lie”, to quote “Chemical Ali” who worked under the tyranny of Saddam Hussein.

Conversely, an ancient maxim survives the test of time, as with proverbs, parables, and all providential admonishments. That which holds true for thousands of years is likely to be true. But that which is promoted as some “new truth” or “fact” for mere decades is more likely to be faulty; such theories must endure for millennia at least to be judged over the course of time to be good and reliable.

More often than not we find that worldly academia have promoted mistaken conclusions by their fellow gentiles, taking for granted the auspice of those who are misled in their collective arrogance and disdain for the Gods. These aren't accusatory assertions, but is observation of their own word & deed. *They* do not believe in God. And they are the first to admit it — even brag about it!

For example, consider the misguided notion that modern science is somehow “wiser” than the wisdom of the ages. Unscrupulous scientists and whole institutions disavow facts & truths universally held for thousands of years around the ancient and antediluvian world. Nothing new under the sun — the decline of civilization is reaching its zenith after the first holocaust and the elemental energies join in bringing devastation to a stiffnecked and adulterous people (to paraphrase Edgar Cayce reading 5750-001#5).

Only the teacher within can instruct you in the way of the light and sound. Mere men can only hope to inspire, lest they seek to mislead you even as they were misled.

Chapter 2 Primaries and Secondaries

CONTINUING WITH our analysis of the demonstrably zodiacal qualities of light & sound, Newton's experiments in light and color show — i.e., vs. “tell” — that light refracts primarily into Red or “least refrangible”, Orange, Yellow, Green, Blue, Indigo & Violet, with gradients between them. Nature has demonstrated this for God knows how long, with rainbows of color appearing everywhere you look in nature.

To wit, “nor are there only rays proper and particular to the more eminent colors/all their intermediate gradations” To paraphrase “two sorts of colors...original...the other compounded of these...original or primary colors [ROYGBIV] and two, an indefinite variety of intermediate gradations”—*ibidem* from Isaac Newton's first paper on Light & Color

Newton shows that “one sort of rays hath been well parted from those of other kinds, it hath afterwards obstinately retained its color notwithstanding my utmost endeavors to change it”; ergo any infinitesimal slice of the color pie retains its quote “species of color”. Furthermore, Newton shows that any two or more colors in composite reveal the compounding of those colors, yet their composited mixture can again be separated into its integral color components; to paraphrase “rays severed exhibit the same colors which they did before they entered the composition” (of colors), as in modern color televisions or computer monitors where the “red” is in fact a slightly orangish-red, and “green” is slightly yellowish-green, with slightly indigoish-blue, no doubt in compensation. Practice oft-exceeds chalkboard theories, e.g., “additive” and “subtractive” color, since the human eye makes no distinction whatsoever as to where light & color originates before entering through its lens and pupil, but only sees a light that has reached the eye and is processed, and is finally interpreted by the brain as visible light/color from moment to moment, in realtime. Whether light is refracted or reflected the eye cares not. The brain cares very much as the brain interprets signals.

Judicial astrology holds that there are seven primary and five secondary colors visible to the naked eye, with very smooth — apparently infinite — gradations between them. The human iris is named for the goddess of the rainbow or the visible spectrum of light, as called the covenant, or bow.

The persistence and attenuation of signals after entering the human eye and brain processes ultimately decides what colors are seen by each human observer. It's the majority consensus among humans which confirms for us that “red is red” and “yellow is yellow”. Some people experience forms of color blindness, and a host other vision abnormalities. And some persons might report seeing a shade that you see as gray as something that has distinctive color, or might report reading “black” printed text on a neutral paper as having distinctive colors or audible tones, or vice versa. This demonstrates that human brain functions are inte-

gral to how human eyes see and human ears hear light and sound. Theoreticians would like to keep these components totally separate, but in practice the human brain is more complex than their simpleton theories can account for or agree on.

Ultimately the human soul experiences the light and sound. Psyche is the scourge on the back of secular science! The soul of man is always an integral component of experience in the living human body. Ignore soul and you ignore life; ignore life, and you are no longer a scientist but you've abandoned logic and reason for superstition and ignorance.

While his observations on biblical prophecies are inexact, Newton's empirical observations and scientific deductions are impeccable, as I've abundantly quoted from this paper that was first published 1672, Philosophical Transactions, hereinbelow redacted for emphasis, brevity, justification. Newton's original color-wheel is copied hereinbelow:

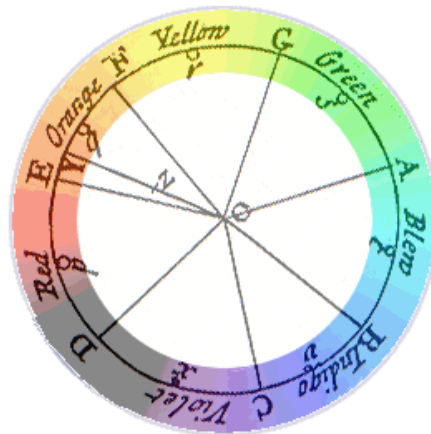

“6. The same colors in specie with these primary ones may be also produced by composition: for a mixture of yellow and blue makes green; of red and yellow makes orange; of orange and yellowish green makes yellow...colors not too far distant one from another, they by their mutual alloy compound that color...midway between them.... Orange and indigo produce not intermediate green, scarlet and green not intermediate yellow....”

“7. But the most surprising and wonderful composition was that of whiteness....no one sort of rays which alone can exhibit this....to its composition are requisite all the aforesaid primary colors mixed in due proportion....”

“8....whiteness is the usual color of light; for light is an aggregate of rays indued with all sorts of colors.... but if any one predominate must incline to that color as in the blue flame of brimstone....yellow flame of candle and the various colors of the fixed stars.”

“9...rays constituting incident light, those which differ in color proportionally differ in refrangibility...”

“10...colors of the rainbow..drops which refract the rays”

“11...disposed more or less to reflect or transmit color.

“12...transparent vessels, tilled the one with a red, the other with blue liquor...if one transmitted only red and the other only blue, no rays could pass through both.”

“13...natural bodies reflect one sort of light in greater plenty than another...any body may be made to appear any color...”—ibid

ref. http://iweb.tntech.edu/chem281-tf/newton_colors.htm

The correlation of the visible light spectrum and audible sound with the planetary zodiac is fundamentally diatonic and chromatic, i.e. seven by twelve, sidereal and synodic. Within these broad and fundamental relationships are more complex dynamics of light and sound, just as planets move sidereally and synodically, with reference to the Sun and the Earth respectively. The zodiac begins its subdivision with the bisection of the 360-degree caelestial firmament, with Libra beginning the caelestial hemisphere of evening, and Aries commencing the caelestial hemisphere of morning.

The two celestial hemispheres are bisected into quadrants, with Capricorn beginning the center of caelestial evening, and Cancer commencing at the center of caelestial morning. The caelestial quadrants are each trisected forming three signs per quadrant. Each sign is trisected into decanates of ten sidereal degrees ecliptic longitude by one hundred and eighty degrees in sidereal latitude (ecliptic pole to pole). Each of these thirty-six decanates are bisected into pentades of five sidereal degrees longitude each. This means that there are three decanates and six pentades per zodiacal constellation on the Earth’s celestial firmament.

The rudiments of this astrological delineation of the sky are unambiguously mathematical — the universal language of the cosmos. While the corporeal manifestations of numbers run the gamut from kindergarten maths to hyperdimensional physics, from counting sheep to ecstatic luminations, the astrological division of the zodiac is far from arbitrary, but resounds in nature, and resonates with human instinct. The ancients recognized the inherent mathematical quality of light & sound as the planetary zodiac clearly reflects.

In the chapter three, I’ve charted the relationships with visible colors & audible tones and the decanates/pentades within each sign of the zodiac. These principles, applied to planets on Earth’s caelestial sphere are archetypal or universal in nature; whereas, the same principles applied to planets in Earth’s terrestrial sphere — meridian houses of the horoscope — are temporal, and correspond to life in the body. Soul is universal while the body is terrestrial, and where the Gods congregate there is judicial astrology.

Chapter 3

Signs, Decans & Pentads

WITH THE ONE-to-one correspondence of colors and tones with the twelve signs of the planetary zodiac established (refer to *Compleat Tarot Manual* for detailed exposition w/ charts), the detailed charts at the end of this chapter match the colors and tones of the signs and their decanates according to the fixed sidereal modalities of each planet transposing therein thus physically correlating these subdivisions with the planets which empower their astrological characteristics.

More than a mnemonic, these show the actual associations of chromatic colors and tones under their planetary modalities. E.g., the inferior aspect of Mars empowers the qualities of Aries, which is a definitively synodic relationship of Mars to the Earth — all relative to Earth's sidereal relationship with the Sun. Signs or synodic aspects are chromatic, while the sidereal orbits of the planets are diatonic. Again this is covered in meticulous detail in my *Compleat Tarot Manual*.

The first or cardinal decan of each of the twelve celestial signs denotes the “creative” aspect of the planet who rules it relative to that planet's synodic aspect to the Sun. See? Similarly the second decanate denotes the “fixed” qualities of that aspect while the third or mutable decan denotes the changeable qualities of the same aspect. These are directly related to the universal or archetypal qualities of planets, much as the “constellation” (asterism) Orion inspires us to recount the classical myth associated with Orion the Hunter, or the deadly sting of Scorpio, whose heart “Ante-Aries” or Antares, is similar in apparent size and color to Mars, who rules Scorpio from his superior aspect to Earth via the Sun.

These are universal archetypes of the planets, inspiring us to recount the classical Greek mythos of the planets in our solar system. When we consider the variants of mythology in ancient history, as Babylonian, Egyptian, Mayan, et al more ancient and antediluvian cultures who are lost to antiquity, we find common denominators echoing across the ages and the continents. For example, Mars is always associated with war and combativeness, victory and self-preservation. Venus, by contrast, is forever associated with beauty and balance, as Jupiter is universally the “king” planet and God of fortune. Saturn is universally father time, the Scythe who reaps the harvest in due time. The prevailing threads of ancient myth underscore the common or universal qualities of the planets.

As a planet transits through one of the signs that it rules on the caelestial firmament, these are universal rulerships of that sphere. Contrarily, any planet in a sign it opposes is in its universal or archetypal detriment—hence the myth of the planet in contention with the other Gods & Goddesses. The decans within each sign reveal which quality of aspects that its ruling planet is coloring any planet found therein under that dispositive planet. In other words, a

planet who rules the sign of the zodiac disposes, or inclines visiting planets therein to its prevailing synodic aspect to the Sun. E.g., a planet in Scorpio is under the influence of Mars in superior aspect to the Sun, which is necessarily “sustenant” in its first decan, “changeable” second decan and “creative” third decan, meaning that the first decan of Scorpio is the cardinal decan of Mars in superior aspect to the Sun. These relationships within elemental triplicities and qualitative quadruplicities to the decans are covered in later chapters. Just remember, synodic aspects define influences for decans through the great circle of the zodiac under ruling planets.

Astronomy & Astrology inspires all of our mythic archetypes. Recognizing how the diatonic and chromatic colors and tones correlate with the caelestial zodiac is tantamount to understanding the archetypal myths associated with the planets and whether they are receding or closing by radial velocity. These associations are innate and inextricable, just as the relationship between the sidereal and synodic orbits of the planets reveal their astrological interaction in the zodiac.

How planets interact with the universal sphere of the Earth is hereinabove summarized. How these same planets interact in the houses of Earth’s terrestrial sphere are similar, in that the sidereal/diatonic qualities with synodic/chromatic aspects to the Earth are clearly defined: as planetary Gods with sidereal modalities & synodic ensigns. These modes and signs are universal on Earth’s caelestial firmament just as spirit is universal. The same modes and signs are elemental in Earth’s terrestrial sphere of experience. The human body is temporal and soul is eternal in the fallen nature of man; as the bible calls “son of man”. The “Son of God” refers to the eternal body and soul of God reunited, perfected in the trinity. In this sense, the God-Man is universal, and lives in the incorruptible body of Christ called the Resurrection.

This is very important, since we must differentiate between mans rebellious corruption, and mans harmony with S. Spirit in order to discern the qualities and portents of the stars. The incorruptible man lives in harmony over creation, while the corruptible man dies by his extent of discord hereunder. The incorruptible man rules slightly above the stars, while the corruptible man is overruled under the stars. With this in mind, the following charts include colors and tones with corresponding decanates and pentades of the planetary signs according to the sidereal modalities of the planets therein.

Blending lesser colors & tones of decans with dominant colors of their sign (e.g. Aries is RED) is simple; as the first pentad of the first decan of Aries gradually adds its reddish high-lights, thereafter the second pentad gradually subtracts it. Thus the beginning of each decan is simply the color of the sign, as in this case, Aries. The second decan gradually subtracts its lesser yellow from the dominant Red until reaching the second pentad therein, at which point the same tint of yellow is gradually added back in — which again leaves us with Red at the end of the second decan. At this point, the third decan begins adding a tint of blue-indigo to

the default Red color of Aries. This does not effect Aries' color at all but only pertains to its decans & pentads. Finally, the second pentad of the third decan of Aries gradually subtracts the (previously added) blue-indigo.

The same holds true for colors, tones and modes of the planets as they are transposed across the twelve signs, and within each sign's decans and pentads. Pentads add or subtract each decan's softer tones and modes within the sign to its fundamental or tonic tonality, as with Aries which is always C. Hence the first pentad of the first decan of Aries highlights the Arian C with a 'c' on the octave, emphasizing the fundamental Arian tonic by a gradual increase in volume of the high 'c' octave, until reaching the second pentad. From there, the high 'c' is gradually softened, until barely audible before reaching the start of the second decan, at which point only the tonic C is played. Entering this second decan gradually adds a negative 'e' or inversion below the C, until the second pentad therein after which the 'e' is gradually softened until the third decan — which brings us again back to the C. Now begin to add 'a flat' softly above the tonic C until the last or sixth pentad of Aries, at which point this augmented fifth above the C reaches its greatest prominence, and the volume of the 'a flat' is on par with the C albeit the tonic for any sign must always be kept in the forefront of its theme. That's easy to do with a major third, like 'e' above C, which is happy right where it is. Whereas an augmented fifth sound in conflict with its tonic, and is unhappy where it is — as if begging for resolution to the fifth just below it or else to the octave above of the tonic.

These principles are readily demonstrated in all seven tones and colors of each mode as they transpose across the twelve signs of the zodiac. More on this later....

LEGEND

ARIES	<--Caelestial
DEVIL	<--Tarot Synonym
RED	<--Color
C	<--Tone
1st House	<--Terrestrial
Court of the King of Wands	<--Tarot Synonym
Aries - Aeolian	<--Ensign/Mode
MOON (Moon) - Ace of Wands	<--Tarot/Planet/Pip
STAR (Uranus) - Eight of Wands	<--Tarot/Planet/Pip
VII I II III IV V VI	<--Modal Order
Bb C D Eb F G Ab	<--Modal Tone
IVi Red Ora OYe Gre Blu BIn	<--Modal Color
Aqu Ari Gem Can Vir Sco Sag	<--Modal Sign
Sat Moo Mer Ven Sun Mar Jup	<--Modal Planet
R R R R R R	<--Modal Rulership
first decan/creative fire	<--decan/triplicity
aries/red/c	<--sign/color/tone
plus/minus	<--pentad direction
vii i ii iii iv v vi	<--modal order
bb c d eb f g ab	<--modal tone
ivi red ora oye gre blu bin	<--modal color
aqu ari gem can vir sco sag	<--modal sign
sat moo mer ven sun mar jup	<--modal planet
r r r r	<--modal rulership
second decan/sustenant fire	<--decan/triplicity
leo/yellow/e	<--sign/color/tone
minus/plus	<--pentad direction
v vi vii i ii iii iv	<--modal order
b c d e gb g a	<--modal tone
vio red ora yel gbl blu ind	<--modal color
pis ari gem leo lib sco cap	<--modal sign
mar jup sat moo mer ven sun	<--modal planet
f	<--modal rulership
third decan/destructive fire	<--decan/triplicity
sagittarius/blue-indigo/ab	<--sign/color/tone
plus/minus	<--pentad direction
ii iii iv v vi vii i	<--modal order
bb b db eb e gb ab	<--modal tone
ivi vio ror oye yel gbl bin	<--modal color
aqu pis tau can leo lib sag	<--modal sign
mer ven sun mar jup sat moo	<--modal planet
e e d e	<--modal rulership

There is a need for added clarification regarding the “Key Signature Of The Gods” charts with decan/pentads before studying them in 4 parts...three signs apiece).

Recall what Ed Leedskalnin said about these so called “electrons” — that no such thing ever existed, save in the minds of those who’re bitten rabid! That which we call the “electron” is in fact a “little magnet”. You can argue this till you’re blue in the face, but that won’t change the fact that Leedskalnin proved this by building Coral Castle using the method of the ancient builders of the Great “Belt of Orion” Pyramids in the midst of Egypt—which were built circa 10,500 BC just as Edgar Cayce described in his many psychic readings:

“I have discovered the secrets of the pyramids, and have found out how the Egyptians and the ancient builders in Peru, Yucatan, and Asia, with only primitive tools, raised and set in place blocks of stone weighing many tons!”
—Edward Leedskalnin (Latvia 1887-Miami 1951)

“Ed used no heavy machinery or any human help in carving and constructing his home, according to sworn affidavits dated 1955 from people who knew him. The statements, which cover a wall inside the small gift shop, were collected by a later owner of the property. Ed managed to carve out giant blocks of coral weighing up to 56,000 pounds and position them into what he named Rock Gate.”—S. Shapiro, Tampa Tribune

*Ed Leedskalnin’s MAGNETIC CURRENT:

<http://groups.google.com/groups?selm=8800N8VQ37281.7281597222@anonymous.poster>

*Ed Leedskalnin’s BOOK IN EVERY HOME:

<http://groups.google.com/groups?selm=4GJHYS2W37281.7235763889@anonymous.poster>

See also...

\EdgarCayce\readings\0384-001#38:

“...there came the periods when peace was made, so that the priest with the activities returned to the Egyptian land proper, and there began the buildings of the pyramids, the rebuilding and re- enacting of the temple worship, and the laying out of and the building of the sphinx - and the opening of the Nile and the other canals...”

\EdgarCayce\readings\5748-006#7:

“(Q) What was the date of the actual beginning and ending of the construction of the Great Pyramid?

(A) Was one hundred years in construction. Begun and completed in the period of Araaraart’s time, with Hermes and Ra.

(Q) What was the date B.C. of that period?

(A) 10,490 to 10,390 before the Prince entered into Egypt. . .”

\EdgarCayce\readings\5748-006#1:

“Much has been written respecting that represented in the Great Pyramid, and the record that may be read by those who would seek to know more concerning the relationships that have existed, that may exist, that do exist, between those of the Creative Forces that are manifest in the material world. As indicated, there were periods when a much closer relationship existed, or rather should it be said, there was a much better understanding OF the relationship that EXISTS between the creature and the Creator.”

Continuing. . .

“(Q) How was this particular Great Pyramid of Gizeh built?

(A) By the use of those forces in nature as make for iron to swim. Stone floats in the air in the same manner. This will be discovered in ‘58. . .”

[Min’s note: Iron oxide naturally “swims” in water]

“(Q) What is the significance of the empty sarcophagus?

(A) That there will be no more death. Don’t misunderstand or misinterpret! but the INTERPRETATION of death will be made plain.

(Q) If the Armageddon is foretold in the Great Pyramid, please give a description of it and the date of its beginning and ending.

(A) Not in what is left there. It will be as a thousand years, with the fighting in the air, and — as has been — between those returning to and those leaving the earth.”

There are surely 100s of other equally pertinent quotes which could be cited from Leedskalnin and Cayce regards the forces of nature, and the building of the Pyramids, Coral Castle, and the principles which permitted their construction using methods lost to the Neo-Babylonians; but the above quotes serve to inspire those interested in facts — not fiction — to study the words of Cayce and Leedskalnin very carefully, and recognize that the methods for building these very ancient and latter-day marvels of architecture and purpose are proven fact by their very existence. . . “show me, don’t tell me”. See?

Keeping this in mind, the so-called “electro”magnetic spectrum manifests from =>zero Hz up to =>infinity Hz.

The infinitesimal audible and visible portion of the universal energy spectrum bears witness to its basis. Realize that the universal precepts of Astrology are fundamental to all of creation throughout the cosmos: from wavelengths crossing galaxies per cycle down to supercosmic wavelengths approaching infinity! And so music is the no. one best teaching tool in the world to assist students and teachers of any subject learn about the demonstrably Astrological rudiments of all energy and its manifestations across life's spectrum; hence Music of the Spheres, 7×12 , i.e. Eighty-Four radiant Key Signatures of the Gods—of all existence. This requires participation on the part of the human who studies Light & Sound and the behavior of energy.

The following pages chart the Key Signatures Of The Gods by Signs, Decans & Pentads:

Aries - Aeolian
 MOON (Moon) - Ace of Wands
 STAR (Uranus) - Eight of Wands

first decan/creative fire
 aries/red/c
 plus/minus

vii	i	ii	iii	iv	v	vi
bb	c	d	eb	f	g	ab
ivi	red	ora	oye	gre	blu	bin
aqu	ari	gem	can	vir	sco	sag
sat	moo	mer	ven	sun	mar	jup
r		r			r	r

second decan/sustenant fire
 leo/yellow/e
 minus/plus

v	vi	vii	i	ii	iii	iv
b	c	d	e	gb	g	a
vio	red	ora	yel	gbl	blu	ind
pis	ari	gem	leo	lib	sco	cap
mar	jup	sat	moo	mer	ven	sun
				f		

third decan/destructive fire
 sagittarius/blue-indigo/ab
 plus/minus

ii	iii	iv	v	vi	vii	i
bb	b	db	eb	e	gb	ab
ivi	vio	ror	oye	yel	gbl	bin
aqu	pis	tau	can	leo	lib	sag
mer	ven	sun	mar	jup	sat	moo
e	e		d		e	

Aries - Locrian
 MAGICIAN (Mercury) - Two of Wands
 HERMIT (Neptune) - Nine of Wands

first decan/creative fire
 aries/red/c
 plus/minus

vii	i	ii	iii	iv	v	vi
bb	c	db	eb	f	gb	ab
ivi	red	ror	oye	gre	gbl	bin
aqu	ari	tau	can	vir	lib	sag
moo	mer	ven	sun	mar	jup	sat
	r					

second decan/sustenant fire
 leo/yellow/e
 minus/plus

v	vi	vii	i	ii	iii	iv
bb	c	d	e	f	g	a
ivi	red	ora	yel	gre	blu	ind
aqu	ari	gem	leo	vir	sco	cap
jup	sat	moo	mer	ven	sun	mar
d		d		e		

third decan/destructive fire
 sagittarius/blue-indigo/ab
 plus/minus

iii	iv	v	vi	vii	i	ii
b	db	d	e	gb	ab	a
vio	red	ora	yel	gbl	bin	ind
pis	tau	gem	leo	lib	sag	cap
sun	mar	jup	sat	moo	mer	ven
	f	f	f		f	

Aries - Ionian
 EMPRESS (Venus) - Three of Wands
 FOOL (Pluton) - Ten of Wands

VII	I	II	III	IV	V	VI
B	C	D	E	F	G	A
Vio	Red	Ora	Yel	Gre	Blu	Ind
Pis	Ari	Gem	Leo	Vir	Sco	Cap
Mer	Ven	Sun	Mar	Jup	Sat	Moo
F	F			F		F

first decan/creative fire
 aries/red/c
 plus/minus

vii	i	ii	iii	iv	v	vi
b	c	d	e	f	g	a
vio	red	ora	yel	gre	blu	ind
pis	ari	gem	leo	vir	sco	cap
mer	ven	sun	mar	jup	sat	moo
f	f			f		f

second decan/sustenant fire
 leo/yellow/e
 minus/plus

v	vi	vii	i	ii	iii	iv
b	db	eb	e	gb	ab	a
vio	ror	oye	yel	gbl	bin	ind
pis	tau	can	leo	lib	sag	cap
sat	moo	mer	ven	sun	mar	jup
	e			d		d

third decan/destructive fire
 sagittarius/blue-indigo/ab
 plus/minus

ii	iii	iv	v	vi	vii	i
bb	c	db	eb	f	g	ab
ivi	red	ror	oye	gre	blu	bin
aqu	ari	tau	can	vir	sco	sag
sun	mar	jup	sat	moo	mer	ven
f	r		f			

Aries - Dorian
SUN (Sun) - Four of Wands

first decan/creative fire
aries/red/c
plus/minus

vii	i	ii	iii	iv	v	vi
bb	c	d	eb	f	g	a
ivi	red	ora	oye	gre	blu	ind
aqu	ari	gem	can	vir	sco	cap
ven	sun	mar	jup	sat	moo	mer
	e		e		d	

second decan/sustenant fire
leo/yellow/e
minus/plus

v	vi	vii	i	ii	iii	iv
b	db	d	e	gb	g	a
vio	ror	ora	yel	gbl	blu	ind
pis	tau	gem	leo	lib	sco	cap
moo	mer	ven	sun	mar	jup	sat
		r	f		r	

third decan/destructive fire
sagittarius/blue-indigo/ab
plus/minus

ii	iii	iv	v	vi	vii	i
bb	b	db	eb	f	gb	ab
ivi	vio	ror	oye	gre	gbl	bin
aqu	pis	tau	can	vir	lib	sag
mar	jup	sat	moo	mer	ven	sun
	r		r	r	r	

Aries - Phrygian
TOWER (Mars) - Five of Wands

first decan/creative fire
aries/red/c
plus/minus

vii	i	ii	iii	iv	v	vi
bb	c	db	eb	f	g	ab
ivi	red	ror	oye	gre	blu	bin
aqu	ari	tau	can	vir	sco	sag
sun	mar	jup	sat	moo	mer	ven
f	r		f			

second decan/sustenant fire
leo/yellow/e
minus/plus

v	vi	vii	i	ii	iii	iv
b	c	d	e	f	g	a
vio	red	ora	yel	gre	blu	ind
pis	ari	gem	leo	vir	sco	cap
mer	ven	sun	mar	jup	sat	moo
f	f		f		f	

third decan/destructive fire
sagittarius/blue-indigo/ab
plus/minus

iii	iv	v	vi	vii	i	ii
b	db	eb	e	gb	ab	a
vio	ror	oye	yel	gbl	bin	ind
pis	tau	can	leo	lib	sag	cap
sat	moo	mer	ven	sun	mar	jup
	e			d		d

Aries - Lydian
EMPEROR (Jupiter) - Six of Wands

first decan/creative fire
aries/red/c
plus/minus

vii	i	ii	iii	iv	v	vi
b	c	d	e	gb	g	a
vio	red	ora	yel	gbl	blu	ind
pis	ari	gem	leo	lib	sco	cap
mar	jup	sat	moo	mer	ven	sun
					f	

second decan/sustenant fire
leo/yellow/e
minus/plus

iv	v	vi	vii	i	ii	iii
bb	b	db	eb	e	gb	ab
ivi	vio	ror	oye	yel	gbl	bin
aqu	pis	tau	can	leo	lib	sag
mer	ven	sun	mar	jup	sat	moo
e	e		d		e	

third decan/destructive fire
sagittarius/blue-indigo/ab
plus/minus

ii	iii	iv	v	vi	vii	i
bb	c	d	eb	f	g	ab
ivi	red	ora	oye	gre	blu	bin
aqu	ari	gem	can	vir	sco	sag
sat	moo	mer	ven	sun	mar	jup
r		r			r	r

Aries - Mixolydian
JUDGMENT (Saturn) - Seven of Wands

first decan/creative fire
aries/red/c
plus/minus

vii	i	ii	iii	iv	v	vi
bb	c	d	e	f	g	a
ivi	red	ora	yel	gre	blu	ind
aqu	ari	gem	leo	vir	sco	cap
jup	sat	moo	mer	ven	sun	mar
	d		d	d		e

second decan/sustenant fire
leo/yellow/e
minus/plus

v	vi	vii	i	ii	iii	iv
b	db	d	e	gb	ab	a
vio	ror	ora	yel	gbl	bin	ind
pis	tau	gem	leo	lib	sag	cap
sun	mar	jup	sat	moo	mer	ven
	f	f	f	f		

third decan/destructive fire
sagittarius/blue-indigo/ab
plus/minus

ii	iii	iv	v	vi	vii	i
bb	c	db	eb	f	gb	ab
ivi	red	ror	oye	gre	gbl	bin
aqu	ari	tau	can	vir	lib	sag
moo	mer	ven	sun	mar	jup	sat
	r					

Taurus - Aeolian

MOON (Moon) - Ace of Pentacles
STAR (Uranus) - Eight of Pentacles

first decan/sustenant earth
taurus/red-orange/db
minus/plus

vii	i	ii	iii	iv	v	vi
b	db	eb	e	gb	ab	a
vio	ror	oye	yel	gbl	bin	ind
pis	tau	can	leo	lib	sag	cap
sat	moo	mer	ven	sun	mar	jup
	e		d		d	

second decan/destructive earth
virgo/green/f
plus/minus

iv	v	vi	vii	i	ii	iii
bb	c	db	eb	f	g	ab
ivi	red	ror	oye	gre	blu	bin
aqu	ari	tau	can	vir	sco	sag
sun	mar	jup	sat	moo	mer	ven
f	r		f			

third decan/creative earth
capricorn/indigo/a
minus/plus

ii	iii	iv	v	vi	vii	i
b	c	d	e	f	g	a
vio	red	ora	yel	gre	blu	ind
pis	ari	gem	leo	vir	sco	cap
mer	ven	sun	mar	jup	sat	moo
f	f		f		f	

Taurus - Locrian

MAGICIAN (Mercury) - Two of Pentacles
HERMIT (Neptune) - Nine of Pentacles

first decan/sustenant earth
taurus/red-orange/db
minus/plus

vii	i	ii	iii	iv	v	vi
b	db	d	e	gb	g	a
vio	ror	ora	yel	gbl	blu	ind
pis	tau	gem	leo	lib	sco	cap
moo	mer	ven	sun	mar	jup	sat
		r	f		r	

second decan/destructive earth
virgo/green/f
plus/minus

iv	v	vi	vii	i	ii	iii
bb	b	db	eb	f	gb	ab
ivi	vio	ror	oye	gre	gbl	bin
aqu	pis	tau	can	vir	lib	sag
mar	jup	sat	moo	mer	ven	sun
	r		r	r	r	

third decan/creative earth
capricorn/indigo/a
minus/plus

ii	iii	iv	v	vi	vii	i
bb	c	d	eb	f	g	a
ivi	red	ora	oye	gre	blu	ind
aqu	ari	gem	can	vir	sco	cap
ven	sun	mar	jup	sat	moo	mer
	e		e		d	

Taurus - Ionian

EMPRESS (Venus) - Three of Pentacles
FOOL (Pluton) - Ten of Pentacles

first decan/sustenant earth
taurus/red-orange/db
minus/plus

vi	vii	i	ii	iii	iv	v
bb	c	db	eb	f	gb	ab
ivi	red	ror	oye	gre	gbl	bin
aqu	ari	tau	can	vir	lib	sag
moo	mer	ven	sun	mar	jup	sat
		r				

second decan/destructive earth
virgo/green/f
plus/minus

iv	v	vi	vii	i	ii	iii
bb	c	d	e	f	g	a
ivi	red	ora	yel	gre	blu	ind
aqu	ari	gem	leo	vir	sco	cap
jup	sat	moo	mer	ven	sun	mar
	d		d	d		e

third decan/creative earth
 capricorn/indigo/a
 minus/plus

ii	iii	iv	v	vi	vii	i
b	db	d	e	gb	ab	a
vio	ror	ora	yel	gbl	bin	ind
pis	tau	gem	leo	lib	sag	cap
sun	mar	jup	sat	moo	mer	ven
	f	f	f	f		

Taurus - Dorian
 SUN (Sun) - Four of Pentacles

first decan/sustenant earth
 taurus/red-orange/db
 minus/plus

vi	vii	i	ii	iii	iv	v
bb	b	db	eb	e	gb	ab
ivi	vio	ror	oye	yel	gbl	bin
aqu	pis	tau	can	leo	lib	sag
mer	ven	sun	mar	jup	sat	moo
e	e		d		e	

second decan/destructive earth
 virgo/green/f
 plus/minus

iv	v	vi	vii	i	ii	iii
bb	c	d	eb	f	g	ab
ivi	red	ora	oye	gre	blu	bin
aqu	ari	gem	can	vir	sco	sag
sat	moo	mer	ven	sun	mar	jup
r		r		r	r	

third decan/creative earth
 capricorn/indigo/a
 minus/plus

ii	iii	iv	v	vi	vii	i
b	c	d	e	gb	g	a
vio	red	ora	yel	gbl	blu	ind
pis	ari	gem	leo	lib	sco	cap
mar	jup	sat	moo	mer	ven	sun
			f			

Taurus - Phrygian
 TOWER (Mars) - Five of Pentacles

first decan/sustenant earth
 taurus/red-orange/db
 minus/plus

vii	i	ii	iii	iv	v	vi
b	db	d	e	gb	ab	a
vio	ror	ora	yel	gbl	bin	ind
pis	tau	gem	leo	lib	sag	cap
sun	mar	jup	sat	moo	mer	ven
	f	f	f	f		

second decan/destructive earth
 virgo/green/f
 plus/minus

iv	v	vi	vii	i	ii	iii
bb	c	db	eb	f	gb	ab
ivi	red	ror	oye	gre	gbl	bin
aqu	ari	tau	can	vir	lib	sag
moo	mer	ven	sun	mar	jup	sat
	r					

third decan/creative earth
 capricorn/indigo/a
 minus/plus

ii	iii	iv	v	vi	vii	i
bb	c	d	e	f	g	a
ivi	red	ora	yel	gre	blu	ind
aqu	ari	gem	leo	vir	sco	cap
jup	sat	moo	mer	ven	sun	mar
	d		d			e

Taurus - Lydian
 EMPEROR (Jupiter) - Six of Pentacles

first decan/sustenant earth
 taurus/red-orange/db
 minus/plus

vi	vii	i	ii	iii	iv	v
bb	c	db	eb	f	g	ab
ivi	red	ror	oye	gre	blu	bin
aqu	ari	tau	can	vir	sco	sag
sun	mar	jup	sat	moo	mer	ven
f	r		f			

second decan/destructive earth
 virgo/green/f
 plus/minus

iv	v	vi	vii	i	ii	iii
b	c	d	e	f	g	a
vio	red	ora	yel	gre	blu	ind
pis	ari	gem	leo	vir	sco	cap
mer	ven	sun	mar	jup	sat	moo
f	f		f		f	

third decan/creative earth
 capricorn/indigo/a
 minus/plus

ii	iii	iv	v	vi	vii	i
b	db	eb	e	gb	ab	a
vio	ror	oye	yel	gbl	bin	ind
pis	tau	can	leo	lib	sag	cap
sat	moo	mer	ven	sun	mar	jup
	e			d		d

Taurus - Mixolydian
JUDGMENT (Saturn) - Seven of Pentacles

first decan/sustenant earth
taurus/red-orange/db
minus/plus

vi	vii	i	ii	iii	iv	v
bb	b	db	eb	f	gb	ab
ivi	vio	ror	oye	gre	gbl	bin
aqu	pis	tau	can	vir	lib	sag
mar	jup	sat	moo	mer	ven	sun
	r		r	r	r	

second decan/destructive earth
virgo/green/f
plus/minus

iv	v	vi	vii	i	ii	iii
bb	c	d	eb	f	g	a
ivi	red	ora	oye	gre	blu	ind
aqu	ari	gem	can	vir	sco	cap
ven	sun	mar	jup	sat	moo	mer
	e		e		d	

third decan/creative earth
capricorn/indigo/a
minus/plus

ii	iii	iv	v	vi	vii	i
b	db	d	e	gb	g	a
vio	ror	ora	yel	gbl	blu	ind
pis	tau	gem	leo	lib	sco	cap
moo	mer	ven	sun	mar	jup	sat
			r	f		r

Gemini - Aeolian
MOON (Moon) - Ace of Swords
STAR (Uranus) - Eight of Swords

first decan/destructive air
gemini/orange/d
plus/minus

vi	vii	i	ii	iii	iv	v
bb	c	d	e	f	g	a
ivi	red	ora	yel	gre	blu	ind
aqu	ari	gem	leo	vir	sco	cap
jup	sat	moo	mer	ven	sun	mar
	d		d	d		e

second decan/creative air
libra/green-blue/gb
minus/plus

iv	v	vi	vii	i	ii	iii
b	db	d	e	gb	ab	a
vio	ror	ora	yel	gbl	bin	ind
pis	tau	gem	leo	lib	sag	cap
sun	mar	jup	sat	moo	mer	ven
	f	f	f		f	

third decan/sustenant air
aquarius/indigo-violet/bb
plus/minus

i	ii	iii	iv	v	vi	vii
bb	c	db	eb	f	gb	ab
ivi	red	ror	oye	gre	gbl	bin
aqu	ari	tau	can	vir	lib	sag
moo	mer	ven	sun	mar	jup	sat
		r				

Gemini - Locrian
MAGICIAN (Mercury) - Two of Swords
HERMIT (Neptune) - Nine of Swords

first decan/destructive air
gemini/orange/d
plus/minus

vi	vii	i	ii	iii	iv	v
bb	c	d	eb	f	g	ab
ivi	red	ora	oye	gre	blu	bin
aqu	ari	gem	can	vir	sco	sag
sat	moo	mer	ven	sun	mar	jup
	r		r		r	r

second decan/creative air
libra/green-blue/gb
minus/plus

iv	v	vi	vii	i	ii	iii
b	c	d	e	gb	g	a
vio	red	ora	yel	gbl	blu	ind
pis	ari	gem	leo	lib	sco	cap
mar	jup	sat	moo	mer	ven	sun
				f		

third decan/sustenant air
aquarius/indigo-violet/bb
plus/minus

i	ii	iii	iv	v	vi	vii
bb	b	db	eb	e	gb	ab
ivi	vio	ror	oye	yel	gbl	bin
aqu	pis	tau	can	leo	lib	sag
mer	ven	sun	mar	jup	sat	moo
	e			d		e

Gemini - Ionian
EMPRESS (Venus) - Three of Swords
FOOL (Pluton) - Ten of Swords

first decan/destructive air
gemini/orange/d
plus/minus

vi	vii	i	ii	iii	iv	v
b	db	d	e	gb	g	a
vio	ror	ora	yel	gbl	blu	ind
pis	tau	gem	leo	lib	sco	cap
moo	mer	ven	sun	mar	jup	sat
			r	f		r

second decan/creative air
 libra/green-blue/gb
 minus/plus

iii	iv	v	vi	vii	i	ii
bb	b	db	eb	f	gb	ab
ivi	vio	ror	oye	gre	gbl	bin
aqu	pis	tau	can	vir	lib	sag
mar	jup	sat	moo	mer	ven	sun
	r		r	r	r	

third decan/sustenair air
 aquarius/indigo-violet/bb
 plus/minus

i	ii	iii	iv	v	vi	vii
bb	c	d	eb	f	g	a
ivi	red	ora	oye	gre	blu	ind
aqu	ari	gem	can	vir	sco	cap
ven	sun	mar	jup	sat	moo	mer
	e		e		d	

Gemini - Dorian
 SUN (Sun) - Four of Swords

first decan/destructive air
 gemini/orange/d
 plus/minus

vi	vii	i	ii	iii	iv	v
b	c	d	e	f	g	a
vio	red	ora	yel	gre	blu	ind
pis	ari	gem	leo	vir	sco	cap
mer	ven	sun	mar	jup	sat	moo
f	f			f		f

second decan/creative air
 libra/green-blue/gb
 minus/plus

iv	v	vi	vii	i	ii	iii
b	db	eb	e	gb	ab	a
vio	ror	ora	yel	gbl	bin	ind
pis	tau	can	leo	lib	sag	cap
sat	moo	mer	ven	sun	mar	jup
	e			d		d

third decan/sustenair air
 aquarius/indigo-violet/bb
 plus/minus

i	ii	iii	iv	v	vi	vii
bb	c	db	eb	f	g	ab
ivi	red	ror	oye	gre	blu	bin
aqu	ari	tau	can	vir	sco	sag
sun	mar	jup	sat	moo	mer	ven
f	r		f			

Gemini - Phrygian
 TOWER (Mars) - Five of Swords

first decan/destructive air
 gemini/orange/d
 plus/minus

vi	vii	i	ii	iii	iv	v
bb	c	d	eb	f	g	a
ivi	red	ora	oye	gre	blu	ind
aqu	ari	gem	can	vir	sco	cap
ven	sun	mar	jup	sat	moo	mer
	e		e		d	

second decan/creative air
 libra/green-blue/gb
 minus/plus

iv	v	vi	vii	i	ii	iii
b	db	d	e	gb	g	a
vio	ror	ora	yel	gbl	blu	ind
pis	tau	gem	leo	lib	sco	cap
moo	mer	ven	sun	mar	jup	sat
			r	f		r

third decan/sustenair air
 aquarius/indigo-violet/bb
 plus/minus

i	ii	iii	iv	v	vi	vii
bb	b	db	eb	f	gb	ab
ivi	vio	ror	oye	gre	gbl	bin
aqu	pis	tau	can	vir	lib	sag
mar	jup	sat	moo	mer	ven	sun
	r		r	r	r	

Gemini - Lydian
 EMPEROR (Jupiter) - Six of Swords

first decan/destructive air
 gemini/orange/d
 plus/minus

vi	vii	i	ii	iii	iv	v
b	db	d	e	gb	ab	a
vio	ror	ora	yel	gbl	bin	ind
pis	tau	gem	leo	lib	sag	cap
sun	mar	jup	sat	moo	mer	ven
	f	f	f		f	

second decan/creative air
 libra/green-blue/gb
 minus/plus

iii	iv	v	vi	vii	i	ii
bb	c	db	eb	f	gb	ab
ivi	red	ror	oye	gre	gbl	bin
aqu	ari	tau	can	vir	lib	sag
moo	mer	ven	sun	mar	jup	sat
				r		

third decan/sustenant air
aquarius/indigo-violet/bb
plus/minus

i	ii	iii	iv	v	vi	vii
bb	c	d	e	f	g	a
ivi	red	ora	yel	gre	blu	ind
aqu	ari	gem	leo	vir	sco	cap
jup	sat	moo	mer	ven	sun	mar
	d		d			e

Gemini - Mixolydian

JUDGMENT (Saturn) - Seven of Swords

first decan/destructive air
gemini/orange/d
plus/minus

vi	vii	i	ii	iii	iv	v
b	c	d	e	gb	g	a
vio	red	ora	yel	gbl	blu	ind
pis	ari	gem	leo	lib	sco	cap
mar	jup	sat	moo	mer	ven	sun
				f		

second decan/creative air
libra/green-blue/gb
minus/plus

iii	iv	v	vi	vii	i	ii
bb	b	db	eb	e	gb	ab
ivi	vio	ror	oye	yel	gbl	bin
aqu	pis	tau	can	leo	lib	sag
mer	ven	sun	mar	jup	sat	moo
e	e		d		e	

third decan/sustenant air
aquarius/indigo-violet/bb
plus/minus

i	ii	iii	iv	v	vi	vii
bb	c	d	eb	f	g	ab
ivi	red	ror	oye	gre	blu	bin
aqu	ari	gem	can	vir	sco	sag
sat	moo	mer	ven	sun	mar	jup
r		r			r	r

Cancer - Aeolian

MOON (Moon) - Ace of Cups

STAR (Uranus) - Eight of Cups

first decan/creative water
cancer/orange-yellow/eb
minus/plus

v	vi	vii	i	ii	iii	iv
bb	b	db	eb	f	gb	ab
ivi	vio	ror	oye	gre	gbl	bin
aqu	pis	tau	can	vir	lib	sag
mar	jup	sat	moo	mer	ven	sun
	r		r	r	r	

second decan/sustenant water
scorpio/blue/g
plus/minus

iii	iv	v	vi	vii	i	ii
bb	c	d	eb	f	g	a
ivi	red	ora	oye	gre	blu	ind
aqu	ari	gem	can	vir	sco	cap
ven	sun	mar	jup	sat	moo	mer
	e		e		d	

third decan/destructive water
pisces/violet/b
minus/plus

i	ii	iii	iv	v	vi	vii
b	db	d	e	gb	g	a
vio	ror	ora	yel	gbl	blu	ind
pis	tau	gem	leo	lib	sco	cap
moo	mer	ven	sun	mar	jup	sat
			r	f		r

Cancer - Locrian

MAGICIAN (Mercury) - Two of Cups

HERMIT (Neptune) - Nine of Cups

first decan/creative water
cancer/orange-yellow/eb
minus/plus

vi	vii	i	ii	iii	iv	v
b	db	eb	e	gb	ab	a
vio	ror	oye	yel	gbl	bin	ind
pis	tau	can	leo	lib	sag	cap
sat	moo	mer	ven	sun	mar	jup
	e			d		d

second decan/sustenant water
scorpio/blue/g
plus/minus

iii	iv	v	vi	vii	i	ii
bb	c	db	eb	f	g	ab
ivi	red	ror	oye	gre	blu	bin
aqu	ari	tau	can	vir	sco	sag
sun	mar	jup	sat	moo	mer	ven
f	r		f			

third decan/destructive water
pisces/violet/b
minus/plus

i	ii	iii	iv	v	vi	vii
b	c	d	e	f	g	a
vio	red	ora	yel	gre	blu	ind
pis	ari	gem	leo	vir	sco	cap
mer	ven	sun	mar	jup	sat	moo
f	f			f		f

Cancer - Ionian
 EMPRESS (Venus) - Three of Cups
 FOOL (Pluton) - Ten of Cups

first decan/creative water
 cancer/orange-yellow/eb
 minus/plus

v	vi	vii	i	ii	iii	iv
bb	c	d	eb	f	g	ab
ivi	red	ora	oye	gre	blu	bin
aqu	ari	gem	can	vir	sco	sag
sat	moo	mer	ven	sun	mar	jup
r		r		r		r

second decan/sustenant water
 scorpio/blue/g
 plus/minus

iii	iv	v	vi	vii	i	ii
b	c	d	e	gb	g	a
vio	red	ora	yel	gre	blu	ind
pis	ari	gem	leo	lib	sco	cap
mar	jup	sat	moo	mer	ven	sun
				f		

third decan/destructive water
 pisces/violet/b
 minus/plus

vii	i	ii	iii	iv	v	vi
bb	b	db	eb	e	gb	ab
ivi	vio	ror	oye	yel	gbl	bin
aqu	pis	tau	can	leo	lib	sag
mer	ven	sun	mar	jup	sat	moo
e	e		d		e	

Cancer - Dorian
 SUN (Sun) - Four of Cups

first decan/creative water
 cancer/orange-yellow/eb
 minus/plus

v	vi	vii	i	ii	iii	iv
bb	c	db	eb	f	g	ab
ivi	red	ror	oye	gre	gbl	bin
aqu	ari	tau	can	vir	lib	sag
moo	mer	ven	sun	mar	jup	sat
	r					

second decan/sustenant water
 scorpio/blue/g
 plus/minus

iii	iv	v	vi	vii	i	ii
bb	c	d	e	f	g	a
ivi	red	ora	yel	gre	blu	ind
aqu	ari	gem	leo	vir	sco	cap
jup	sat	moo	mer	ven	sun	mar
	d			d		e

third decan/destructive water
 pisces/violet/b
 minus/plus

i	ii	iii	iv	v	vi	vii
b	db	d	e	gb	ab	a
vio	ror	ora	yel	gbl	bin	ind
pis	tau	gem	leo	lib	sag	cap
sun	mar	jup	sat	moo	mer	ven
	f	f	f		f	

Cancer - Phrygian
 TOWER (Mars) - Five of Cups

first decan/creative water
 cancer/orange-yellow/eb
 minus/plus

v	vi	vii	i	ii	iii	iv
bb	b	db	eb	e	gb	ab
ivi	vio	ror	oye	yel	gbl	bin
aqu	pis	tau	can	leo	lib	sag
mer	ven	sun	mar	jup	sat	moo
e	e		d		e	

second decan/sustenant water
 scorpio/blue/g
 plus/minus

iii	iv	v	vi	vii	i	ii
bb	c	d	eb	f	g	ab
ivi	red	ora	oye	gre	blu	bin
aqu	ari	gem	can	vir	sco	sag
sat	moo	mer	ven	sun	mar	jup
r		r			r	r

third decan/destructive water
 pisces/violet/b
 minus/plus

i	ii	iii	iv	v	vi	vii
B	C	D	E	Gb	G	A
vio	red	ora	yel	gbl	blu	ind
Pis	Ari	Gem	Leo	Lib	Scp	Cap
Mar	Jup	Sat	Moo	Mer	Ven	Sun
					F	

Cancer - Lydian
 EMPEROR (Jupiter) - Six of Cups

first decan/creative water
 cancer/orange-yellow/eb
 minus/plus

v	vi	vii	i	ii	iii	iv
bb	c	d	eb	f	g	a
ivi	red	ora	oye	gre	blu	ind
aqu	ari	gem	can	vir	sco	cap
ven	sun	mar	jup	sat	moo	mer
	e		e		d	

second decan/sustenant water
scorpio/blue/g
plus/minus

iii	iv	v	vi	vii	i	ii
b	db	d	e	gb	g	a
vio	ror	ora	yel	gbl	blu	ind
pis	tau	gem	leo	lib	sco	cap
moo	mer	ven	sun	mar	jup	sat
		r	f		r	

third decan/destructive water
pisces/violet/b
minus/plus

vii	i	ii	iii	iv	v	vi
bb	b	db	eb	f	gb	ab
ivi	vio	ror	oye	gre	gbl	bin
aqu	pis	tau	can	vir	lib	sag
mar	jup	sat	moo	mer	ven	sun
	r		r	r		

Cancer - Mixolydian
JUDGMENT (Saturn) - Seven of Cups

first decan/creative water
cancer/orange-yellow/eb
minus/plus

v	vi	vii	i	ii	iii	iv
bb	c	db	eb	f	g	ab
ivi	red	ror	oye	gre	blu	ind
aqu	ari	tau	can	vir	sco	sag
sun	mar	jup	sat	moo	mer	ven
f	r		f			

second decan/sustenant water
scorpio/blue/g
plus/minus

iii	iv	v	vi	vii	i	ii
b	c	d	e	f	g	a
vio	red	ora	yel	gre	blu	ind
pis	ari	gem	leo	vir	sco	cap
mer	ven	sun	mar	jup	sat	moo
f	f		f		f	

third decan/destructive water
pisces/violet/b
minus/plus

i	ii	iii	iv	v	vi	vii
b	db	eb	e	gb	ab	a
vio	ror	oye	yel	gbl	bin	ind
pis	tau	can	leo	lib	sag	cap
sat	moo	mer	ven	sun	mar	jup
	e		d		d	

Leo - Aeolian
MOON (Moon) - Ace of Wands
STAR (Uranus) - Eight of Wands

first decan/sustenant fire
leo/yellow/e
plus/minus

v	vi	vii	i	ii	iii	iv
b	c	d	e	gb	g	a
vio	red	ora	yel	gbl	blu	ind
pis	ari	gem	leo	lib	sco	cap
mar	jup	sat	moo	mer	ven	sun
				f		

second decan/destructive fire
sagittarius/blue-indigo/ab
minus/plus

ii	iii	iv	v	vi	vii	i
bb	b	db	eb	e	gb	ab
ivi	vio	ror	oye	yel	gbl	bin
aqu	pis	tau	can	leo	lib	sag
mer	ven	sun	mar	jup	sat	moo
e	e		d		e	

third decan/creative fire
aries/red/c
plus/minus

vii	i	ii	iii	iv	v	vi
bb	c	d	eb	f	g	ab
ivi	red	ora	oye	gre	blu	bin
aqu	ari	gem	can	vir	sco	sag
sat	moo	mer	ven	sun	mar	jup
r		r			r	r

Leo - Locrian
MAGICIAN (Mercury) - Two of Wands
HERMIT (Neptune) - Nine of Wands

first decan/sustenant fire
leo/yellow/e
plus/minus

v	vi	vii	i	ii	iii	iv
bb	c	d	e	f	g	a
ivi	red	ora	yel	gre	blu	ind
aqu	ari	gem	leo	vir	sco	cap
jup	sat	moo	mer	ven	sun	mar
	d		d		e	

second decan/destructive fire
sagittarius/blue-indigo/ab
minus/plus

iii	iv	v	vi	vii	i	ii
b	db	d	e	gb	ab	a
vio	red	ora	yel	gbl	bin	ind
pis	tau	gem	leo	lib	sag	cap
sun	mar	jup	sat	moo	mer	ven
	f	f	f		f	

third decan/creative fire
aries/red/c
plus/minus

vii	i	ii	iii	iv	v	vi
bb	c	db	eb	f	gb	ab
ivi	red	ror	oye	gre	gbl	bin
aqu	ari	tau	can	vir	lib	sag
moo	mer	ven	sun	mar	jup	sat
		r				

Leo - Ionian
EMPRESS (Venus) - Three of Wands
FOOL (Pluton) - Ten of Wands

first decan/sustenant fire
leo/yellow/e
plus/minus

v	vi	vii	i	ii	iii	iv
b	db	eb	e	gb	ab	a
vio	ror	oye	yel	gbl	bin	ind
pis	tau	can	leo	lib	sag	cap
sat	moo	mer	ven	sun	mar	jup
	e		d		d	

second decan/destructive fire
sagittarius/blue-indigo/ab
minus/plus

ii	iii	iv	v	vi	vii	i
bb	c	db	eb	f	g	ab
ivi	red	ror	oye	gre	blu	bin
aqu	ari	tau	can	vir	sco	sag
sun	mar	jup	sat	moo	mer	ven
f	r		f			

third decan/creative fire
aries/red/c
plus/minus

vii	i	ii	iii	iv	v	vi
b	c	d	e	f	g	a
vio	red	ora	yel	gre	blu	ind
pis	ari	gem	leo	vir	sco	cap
mer	ven	sun	mar	jup	sat	moo
f	f		f		f	

Leo - Dorian
SUN (Sun) - Four of Wands

first decan/sustenant fire
leo/yellow/e
plus/minus

v	vi	vii	i	ii	iii	iv
b	db	d	e	gb	g	a
vio	ror	ora	yel	gbl	blu	ind
pis	tau	gem	leo	lib	sco	cap
moo	mer	ven	sun	mar	jup	sat
		r	f		r	

second decan/destructive fire
sagittarius/blue-indigo/ab
minus/plus

ii	iii	iv	v	vi	vii	i
bb	b	db	eb	f	gb	ab
ivi	vio	ror	oye	gre	gbl	bin
aqu	pis	tau	can	vir	lib	sag
mar	jup	sat	moo	mer	ven	sun
	r		r	r	r	

third decan/creative fire
aries/red/c
plus/minus

vii	i	ii	iii	iv	v	vi
bb	c	d	eb	f	g	a
ivi	red	ora	oye	gre	blu	ind
aqu	ari	gem	can	vir	sco	cap
ven	sun	mar	jup	sat	moo	mer
	e		e		d	

Leo - Phrygian
TOWER (Mars) - Five of Wands

first decan/sustenant fire
leo/yellow/e
plus/minus

v	vi	vii	i	ii	iii	iv
b	c	d	e	f	g	a
vio	red	ora	yel	gre	blu	ind
pis	ari	gem	leo	vir	sco	cap
mer	ven	sun	mar	jup	sat	moo
f	f		f		f	

second decan/destructive fire
sagittarius/blue-indigo/ab
minus/plus

iii	iv	v	vi	vii	i	ii
b	db	eb	e	gb	ab	a
vio	ror	oye	yel	gbl	bin	ind
pis	tau	can	leo	lib	sag	cap
sat	moo	mer	ven	sun	mar	jup
	e		d		d	

third decan/creative fire
aries/red/c
plus/minus

vii	i	ii	iii	iv	v	vi
bb	c	db	eb	f	g	ab
ivi	red	ror	oye	gre	blu	bin
aqu	ari	tau	can	vir	sco	sag
sun	mar	jup	sat	moo	mer	ven
f	r		f			

Leo - Lydian
EMPEROR (Jupiter) - Six of Wands

first decan/sustenant fire
leo/yellow/e
plus/minus

iv	v	vi	vii	i	ii	iii
bb	b	db	eb	e	gb	ab
ivi	vio	ror	oye	yel	gbl	bin
aqu	pis	tau	can	leo	lib	sag
mer	ven	sun	mar	jup	sat	moo
e	e		d		e	

second decan/destructive fire
sagittarius/blue-indigo/ab
minus/plus

ii	iii	iv	v	vi	vii	i
bb	c	d	eb	f	g	ab
ivi	red	ora	oye	gre	blu	bin
aqu	ari	gem	can	vir	sco	sag
sat	moo	mer	ven	sun	mar	jup
r		r			r	r

third decan/creative fire
aries/red/c
plus/minus

vii	i	ii	iii	iv	v	vi
b	c	d	e	gb	g	a
vio	red	ora	yel	gbl	blu	ind
pis	ari	gem	leo	lib	sco	cap
mar	jup	sat	moo	mer	ven	sun
				f		

Leo - Mixolydian
JUDGMENT (Saturn) - Seven of Wands

first decan/sustenant fire
leo/yellow/e
plus/minus

v	vi	vii	i	ii	iii	iv
b	db	d	e	gb	ab	a
vio	ror	ora	yel	gbl	bin	ind
pis	tau	gem	leo	lib	sag	cap
sun	mar	jup	sat	moo	mer	ven
	f	f	f		f	

second decan/destructive fire
sagittarius/blue-indigo/ab
minus/plus

ii	iii	iv	v	vi	vii	i
bb	c	db	eb	f	gb	ab
ivi	red	ror	oye	gre	gbl	bin
aqu	ari	tau	can	vir	lib	sag
moo	mer	ven	sun	mar	jup	sat
		r				

third decan/creative fire
aries/red/c
plus/minus

vii	i	ii	iii	iv	v	vi
bb	c	d	e	f	g	a
ivi	red	ora	yel	gre	blu	ind
aqu	ari	gem	leo	vir	sco	cap
jup	sat	moo	mer	ven	sun	mar
		d		d		e

Virgo - Aeolian
MOON (Moon) - Ace of Pentacles
STAR (Uranus) - Eight of Pentacles

first decan/destructive earth
virgo/green/f
minus/plus

iv	v	vi	vii	i	ii	iii
bb	c	db	eb	f	g	ab
ivi	red	ror	oye	gre	blu	bin
aqu	ari	tau	can	vir	sco	sag
sun	mar	jup	sat	moo	mer	ven
f	r		f			

second decan/creative earth
capricorn/indigo/a
plus/minus

ii	iii	iv	v	vi	vii	i
b	c	d	e	f	g	a
vio	red	ora	yel	gre	blu	ind
pis	ari	gem	leo	vir	sco	cap
mer	ven	sun	mar	jup	sat	moo
f	f			f		f

third decan/sustenant earth
taurus/red-orange/db
minus/plus

vii	i	ii	iii	iv	v	vi
b	db	eb	e	gb	ab	a
vio	ror	oye	yel	gbl	bin	ind
pis	tau	can	leo	lib	sag	cap
sat	moo	mer	ven	sun	mar	jup
	e			d		d

Virgo - Locrian
MAGICIAN (Mercury) - Two of Pentacles
HERMIT (Neptune) - Nine of Pentacles

first decan/destructive earth
virgo/green/f
minus/plus

iv	v	vi	vii	i	ii	iii
bb	b	db	eb	f	gb	ab
ivi	vio	ror	oye	gre	gbl	bin
aqu	pis	tau	can	vir	lib	sag
mar	jup	sat	moo	mer	ven	sun
	r		r	r	r	

second decan/creative earth
capricorn/indigo/a
plus/minus

ii	iii	iv	v	vi	vii	i
bb	c	d	eb	f	g	a
ivi	red	ora	oye	gre	blu	ind
aqu	ari	gem	can	vir	sco	cap
ven	sun	mar	jup	sat	moo	mer
	e		e		d	

third decan/sustenant earth
taurus/red-orange/db
minus/plus

vii	i	ii	iii	iv	v	vi
b	db	d	e	gb	g	a
vio	ror	ora	yel	gbl	blu	ind
pis	tau	gem	leo	lib	sco	cap
moo	mer	ven	sun	mar	jup	sat
		r	f		r	

Virgo - Ionian
EMPRESS (Venus) - Three of Pentacles
FOOL (Pluton) - Ten of Pentacles

first decan/destructive earth
virgo/green/f
minus/plus

iv	v	vi	vii	i	ii	iii
bb	c	d	e	f	g	a
ivi	red	ora	yel	gre	blu	ind
aqu	ari	gem	leo	vir	sco	cap
jup	sat	moo	mer	ven	sun	mar
	d		d		d	e

second decan/creative earth
capricorn/indigo/a
plus/minus

ii	iii	iv	v	vi	vii	i
b	db	d	e	gb	ab	a
vio	ror	ora	yel	gbl	bin	ind
pis	tau	gem	leo	lib	sag	cap
sun	mar	jup	sat	moo	mer	ven
	f	f	f		f	

third decan/sustenant earth
taurus/red-orange/db
minus/plus

vi	vii	i	ii	iii	iv	v
bb	c	db	eb	f	gb	ab
ivi	red	ror	oye	gre	gbl	bin
aqu	ari	tau	can	vir	lib	sag
moo	mer	ven	sun	mar	jup	sat
		r				

Virgo - Dorian
SUN (Sun) - Four of Pentacles

first decan/destructive earth
virgo/green/f
minus/plus

iv	v	vi	vii	i	ii	iii
bb	c	d	eb	f	g	ab
ivi	red	ora	oye	gre	blu	bin
aqu	ari	gem	can	vir	sco	sag
sat	moo	mer	ven	sun	mar	jup
r		r			r	r

second decan/creative earth
capricorn/indigo/a
plus/minus

ii	iii	iv	v	vi	vii	i
b	c	d	e	gb	g	a
vio	red	ora	yel	gbl	blu	ind
pis	ari	gem	leo	lib	sco	cap
mar	jup	sat	moo	mer	ven	sun
					f	

third decan/sustenant earth
taurus/red-orange/db
minus/plus

vi	vii	i	ii	iii	iv	v
bb	b	db	eb	e	gb	ab
ivi	vio	ror	oye	yel	gbl	bin
aqu	pis	tau	can	leo	lib	sag
mer	ven	sun	mar	jup	sat	moo
e	e		d		e	

Virgo - Phrygian
TOWER (Mars) - Five of Pentacles

first decan/destructive earth
virgo/green/f
minus/plus

iv	v	vi	vii	i	ii	iii
bb	c	db	eb	f	gb	ab
ivi	red	ror	oye	gre	gbl	bin
aqu	ari	tau	can	vir	lib	sag
moo	mer	ven	sun	mar	jup	sat
		r				

second decan/creative earth
capricorn/indigo/a
plus/minus

ii	iii	iv	v	vi	vii	i
bb	c	d	e	f	g	a
ivi	red	ora	yel	gre	blu	ind
aqu	ari	gem	leo	vir	sco	cap
jup	sat	moo	mer	ven	sun	mar
	d		d			e

third decan/sustenant earth
taurus/red-orange/db
minus/plus

vii	i	ii	iii	iv	v	vi
b	db	d	e	gb	ab	a
vio	ror	ora	yel	gbl	bin	ind
pis	tau	gem	leo	lib	sag	cap
sun	mar	jup	sat	moo	mer	ven
	f	f	f	f		

second decan/creative earth
capricorn/indigo/a
plus/minus

ii	iii	iv	v	vi	vii	i
b	db	d	e	gb	g	a
vio	ror	ora	yel	gbl	blu	ind
pis	tau	gem	leo	lib	sco	cap
moo	mer	ven	sun	mar	jup	sat
		r	f		r	

Virgo - Lydian

EMPEROR (Jupiter) - Six of Pentacles

first decan/destructive earth
virgo/green/f
minus/plus

iv	v	vi	vii	i	ii	iii
b	c	d	e	f	g	a
vio	red	ora	yel	gre	blu	ind
pis	ari	gem	leo	vir	sco	cap
mer	ven	sun	mar	jup	sat	moo
f	f		f		f	

second decan/creative earth
capricorn/indigo/a
plus/minus

ii	iii	iv	v	vi	vii	i
b	db	eb	e	gb	ab	a
vio	ror	oye	yel	gbl	bin	ind
pis	tau	can	leo	lib	sag	cap
sat	moo	mer	ven	sun	mar	jup
	e		d		d	

third decan/sustenant earth
taurus/red-orange/db
minus/plus

vi	vii	i	ii	iii	iv	v
bb	c	db	eb	f	g	ab
ivi	red	ror	oye	gre	blu	bin
aqu	ari	tau	can	vir	sco	sag
sun	mar	jup	sat	moo	mer	ven
f	r		f			

Virgo - Mixolydian

JUDGMENT (Saturn) - Seven of Pentacles

first decan/destructive earth
virgo/green/f
minus/plus

iv	v	vi	vii	i	ii	iii
bb	c	d	eb	f	g	a
ivi	red	ora	oye	gre	blu	ind
aqu	ari	gem	can	vir	sco	cap
ven	sun	mar	jup	sat	moo	mer
	e		e		d	

third decan/sustenant earth
taurus/red-orange/db
minus/plus

vi	vii	i	ii	iii	iv	v
bb	b	db	eb	f	gb	ab
ivi	vio	ror	oye	gre	gbl	bin
aqu	pis	tau	can	vir	lib	sag
mar	jup	sat	moo	mer	ven	sun
	r		r	r	r	

Libra - Aeolian

MOON (Moon) - Ace of Swords

STAR (Uranus) - Eight of Swords

first decan/creative air
libra/green-blue/gb
plus/minus

iv	v	vi	vii	i	ii	iii
b	db	d	e	gb	ab	a
vio	ror	ora	yel	gbl	bin	ind
pis	tau	gem	leo	lib	sag	cap
sun	mar	jup	sat	moo	mer	ven
	f	f	f		f	

second decan/sustenant air
aquarius/indigo-violet/bb
minus/plus

i	ii	iii	iv	v	vi	vii
bb	c	db	eb	f	gb	ab
ivi	red	ror	oye	gre	gbl	bin
aqu	ari	tau	can	vir	lib	sag
moo	mer	ven	sun	mar	jup	sat
		r				

third decan/destructive air
gemini/orange/d
plus/minus

vi	vii	i	ii	iii	iv	v
bb	c	d	e	f	g	a
ivi	red	ora	yel	gre	blu	ind
aqu	ari	gem	leo	vir	sco	cap
jup	sat	moo	mer	ven	sun	mar
		d		d		e

Libra - Locrian
 MAGICIAN (Mercury) - Two of Swords
 HERMIT (Neptune) - Nine of Swords

first decan/creative air
 libra/green-blue/gb
 plus/minus

iv	v	vi	vii	i	ii	iii
b	c	d	e	gb	g	a
vio	red	ora	yel	gbl	blu	ind
pis	ari	gem	leo	lib	sco	cap
mar	jup	sat	moo	mer	ven	sun
				f		

second decan/sustenant air
 aquarius/indigo-violet/bb
 minus/plus

i	ii	iii	iv	v	vi	vii
bb	b	db	eb	e	gb	ab
ivi	vio	ror	oye	yel	gbl	bin
aqu	pis	tau	can	leo	lib	sag
mer	ven	sun	mar	jup	sat	moo
e	e		d		e	

third decan/destructive air
 gemini/orange/d
 plus/minus

vi	vii	i	ii	iii	iv	v
bb	c	d	eb	f	g	ab
ivi	red	ora	oye	gre	blu	bin
aqu	ari	gem	can	vir	sco	sag
sat	moo	mer	ven	sun	mar	jup
r		r		r	r	r

Libra - Ionian
 EMPRESS (Venus) - Three of Swords
 FOOL (Pluton) - Ten of Swords

first decan/creative air
 libra/green-blue/gb
 plus/minus

iii	iv	v	vi	vii	i	ii
bb	b	db	eb	f	gb	ab
ivi	vio	ror	oye	gre	gbl	bin
aqu	pis	tau	can	vir	lib	sag
mar	jup	sat	moo	mer	ven	sun
	r		r	r	r	

second decan/sustenant air
 aquarius/indigo-violet/bb
 minus/plus

i	ii	iii	iv	v	vi	vii
bb	c	d	eb	f	g	a
ivi	red	ora	oye	gre	blu	ind
aqu	ari	gem	can	vir	sco	cap
ven	sun	mar	jup	sat	moo	mer
e		e		d		

third decan/destructive air
 gemini/orange/d
 plus/minus

vi	vii	i	ii	iii	iv	v
b	db	d	e	gb	g	a
vio	ror	ora	yel	gbl	blu	ind
pis	tau	gem	leo	lib	sco	cap
moo	mer	ven	sun	mar	jup	sat
			r	f		r

Libra - Dorian
 SUN (Sun) - Four of Swords

first decan/creative air
 libra/green-blue/gb
 plus/minus

iv	v	vi	vii	i	ii	iii
b	db	eb	e	gb	ab	a
vio	ror	oye	yel	gbl	bin	ind
pis	tau	can	leo	lib	sag	cap
sat	moo	mer	ven	sun	mar	jup
	e			d		d

second decan/sustenant air
 aquarius/indigo-violet/bb
 minus/plus

i	ii	iii	iv	v	vi	vii
bb	c	db	eb	f	g	ab
ivi	red	ror	oye	gre	blu	bin
aqu	ari	tau	can	vir	sco	sag
sun	mar	jup	sat	moo	mer	ven
f	r		f			

third decan/destructive air
 gemini/orange/d
 plus/minus

vi	vii	i	ii	iii	iv	v
b	c	d	e	f	g	a
vio	red	ora	yel	gre	blu	ind
pis	ari	gem	leo	vir	sco	cap
mer	ven	sun	mar	jup	sat	moo
f	f			f		f

Libra - Phrygian
 TOWER (Mars) - Five of Swords

first decan/creative air
 libra/green-blue/gb
 plus/minus

iv	v	vi	vii	i	ii	iii
b	db	d	e	gb	g	a
vio	ror	ora	yel	gbl	blu	ind
pis	tau	gem	leo	lib	sco	cap
moo	mer	ven	sun	mar	jup	sat
			r	f		r

second decan/sustenat air
aquarius/indigo-violet/bb
minus/plus

i	ii	iii	iv	v	vi	vii
bb	b	db	eb	f	gb	ab
ivi	vio	ror	oye	gre	gbl	bin
aqu	pis	tau	can	vir	lib	sag
mar	jup	sat	moo	mer	ven	sun
	r		r	r	r	

third decan/destructive air
gemini/orange/d
plus/minus

vi	vii	i	ii	iii	iv	v
bb	c	d	eb	f	g	a
ivi	red	ora	oye	gre	blu	ind
aqu	ari	gem	can	vir	sco	cap
ven	sun	mar	jup	sat	moo	mer
	e		e		d	

Libra - Lydian

EMPEROR (Jupiter) - Six of Swords

first decan/creative air
libra/green-blue/gb
plus/minus

iii	iv	v	vi	vii	i	ii
bb	c	db	eb	f	gb	ab
ivi	red	ror	oye	gre	gbl	bin
aqu	ari	tau	can	vir	lib	sag
moo	mer	ven	sun	mar	jup	sat
	r					

second decan/sustenat air
aquarius/indigo-violet/bb
minus/plus

i	ii	iii	iv	v	vi	vii
bb	c	d	e	f	g	a
ivi	red	ora	yel	gre	blu	ind
aqu	ari	gem	leo	vir	sco	cap
jup	sat	moo	mer	ven	sun	mar
	d		d		e	

third decan/destructive air
gemini/orange/d
plus/minus

vi	vii	i	ii	iii	iv	v
b	db	d	e	gb	ab	a
vio	ror	ora	yel	gbl	bin	ind
pis	tau	gem	leo	lib	sag	cap
sun	mar	jup	sat	moo	mer	ven
	f	f	f	f	f	

Libra - Mixolydian
JUDGMENT (Saturn) - Seven of Swords

first decan/creative air
libra/green-blue/gb
plus/minus

iii	iv	v	vi	vii	i	ii
bb	b	db	eb	e	gb	ab
ivi	vio	ror	oye	yel	gbl	bin
aqu	pis	tau	can	leo	lib	sag
mer	ven	sun	mar	jup	sat	moo
e	e		d		e	

second decan/sustenat air
aquarius/indigo-violet/bb
minus/plus

i	ii	iii	iv	v	vi	vii
bb	c	d	eb	f	g	ab
ivi	red	ror	oye	gre	blu	bin
aqu	ari	gem	can	vir	sco	sag
sat	moo	mer	ven	sun	mar	jup
r		r			r	r

third decan/destructive air
gemini/orange/d
plus/minus

vi	vii	i	ii	iii	iv	v
b	c	d	e	gb	g	a
vio	red	ora	yel	gbl	blu	ind
pis	ari	gem	leo	lib	sco	cap
mar	jup	sat	moo	mer	ven	sun
				f		

Scorpio - Aeolian
MOON (Moon) - Ace of Cups
STAR (Uranus) - Eight of Cups

first decan/sustenat water
scorpio/blue/g
minus/plus

iii	iv	v	vi	vii	i	ii
bb	c	d	eb	f	g	a
ivi	red	ora	oye	gre	blu	ind
aqu	ari	gem	can	vir	sco	cap
ven	sun	mar	jup	sat	moo	mer
e		e		d		

second decan/destructive water
pisces/violet/b
plus/minus

i	ii	iii	iv	v	vi	vii
b	db	d	e	gb	g	a
vio	ror	ora	yel	gbl	blu	ind
pis	tau	gem	leo	lib	sco	cap
moo	mer	ven	sun	mar	jup	sat
			r	f		r

third decan/creative water
cancer/orange-yellow/eb
minus/plus

v	vi	vii	i	ii	iii	iv
bb	b	db	eb	f	gb	ab
ivi	vio	ror	oye	gre	gbl	bin
aqu	pis	tau	can	vir	lib	sag
mar	jup	sat	moo	mer	ven	sun
	r		r	r	r	

Scorpio - Locrian
MAGICIAN (Mercury) - Two of Cups
HERMIT (Neptune) - Nine of Cups

first decan/sustenant water
scorpio/blue/g
minus/plus

iii	iv	v	vi	vii	i	ii
bb	c	db	eb	f	g	ab
ivi	red	ror	oye	gre	blu	bin
aqu	ari	tau	can	vir	sco	sag
sun	mar	jup	sat	moo	mer	ven
f	r		f			

second decan/destructive water
pisces/violet/b
plus/minus

i	ii	iii	iv	v	vi	vii
b	c	d	e	f	g	a
vio	red	ora	yel	gre	blu	ind
pis	ari	gem	leo	vir	sco	cap
mer	ven	sun	mar	jup	sat	moo
f	f		f			f

third decan/creative water
cancer/orange-yellow/eb
minus/plus

vi	vii	i	ii	iii	iv	v
b	db	eb	e	gb	ab	a
vio	ror	oye	yel	gbl	bin	ind
pis	tau	can	leo	lib	sag	cap
sat	moo	mer	ven	sun	mar	jup
	e			d		d

Scorpio - Ionian
EMPRESS (Venus) - Three of Cups
FOOL (Pluton) - Ten of Cups

first decan/sustenant water
scorpio/blue/g
minus/plus

iii	iv	v	vi	vii	i	ii
b	c	d	e	gb	g	a
vio	red	ora	yel	gre	blu	ind
pis	ari	gem	leo	lib	sco	cap
mar	jup	sat	moo	mer	ven	sun
				f		

second decan/destructive water
pisces/violet/b
plus/minus

vii	i	ii	iii	iv	v	vi
bb	b	db	eb	e	gb	ab
ivi	vio	ror	oye	yel	gbl	bin
aqu	pis	tau	can	leo	lib	sag
mer	ven	sun	mar	jup	sat	moo
e	e		d		e	

third decan/creative water
cancer/orange-yellow/eb
minus/plus

v	vi	vii	i	ii	iii	iv
bb	c	d	eb	f	g	ab
ivi	red	ora	oye	gre	blu	bin
aqu	ari	gem	can	vir	sco	sag
sat	moo	mer	ven	sun	mar	jup
r		r			r	r

Scorpio - Dorian
SUN (Sun) - Four of Cups

first decan/sustenant water
scorpio/blue/g
minus/plus

iii	iv	v	vi	vii	i	ii
bb	c	d	e	f	g	a
ivi	red	ora	yel	gre	blu	ind
aqu	ari	gem	leo	vir	sco	cap
jup	sat	moo	mer	ven	sun	mar
	d			d		e

second decan/destructive water
pisces/violet/b
plus/minus

i	ii	iii	iv	v	vi	vii
b	db	d	e	gb	ab	a
vio	ror	ora	yel	gbl	bin	ind
pis	tau	gem	leo	lib	sag	cap
sun	mar	jup	sat	moo	mer	ven
	f	f	f		f	

third decan/creative water
cancer/orange-yellow/eb
minus/plus

v	vi	vii	i	ii	iii	iv
bb	c	db	eb	f	gb	ab
ivi	red	ror	oye	gre	gbl	bin
aqu	ari	tau	can	vir	lib	sag
moo	mer	ven	sun	mar	jup	sat
		r				

Scorpio - Phrygian
TOWER (Mars) - Five of Cups

first decan/sustenant water
scorpio/blue/g
minus/plus

iii	iv	v	vi	vii	i	ii
bb	c	d	eb	f	g	ab
ivi	red	ora	oye	gre	blu	bin
aqu	ari	gem	can	vir	sco	sag
sat	moo	mer	ven	sun	mar	jup
r		r		r		r

second decan/destructive water
pisces/violet/b
plus/minus

i	ii	iii	iv	v	vi	vii
b	c	d	e	gb	g	a
vio	red	ora	yel	gbl	blu	ind
pis	ari	gem	leo	lib	sco	cap
mar	jup	sat	moo	mer	ven	sun
				f		

third decan/creative water
cancer/orange-yellow/eb
minus/plus

v	vi	vii	i	ii	iii	iv
bb	b	db	eb	e	gb	ab
ivi	vio	ror	oye	yel	gbl	bin
aqu	pis	tau	can	leo	lib	sag
mer	ven	sun	mar	jup	sat	moo
e	e		d		e	

Scorpio - Lydian
EMPEROR (Jupiter) - Six of Cups

first decan/sustenant water
scorpio/blue/g
minus/plus

iii	iv	v	vi	vii	i	ii
b	db	d	e	gb	g	a
vio	ror	ora	yel	gbl	blu	ind
pis	tau	gem	leo	lib	sco	cap
moo	mer	ven	sun	mar	jup	sat
			r	f		r

second decan/destructive water
pisces/violet/b
plus/minus

vii	i	ii	iii	iv	v	vi
bb	b	db	eb	f	gb	ab
ivi	vio	ror	oye	gre	gbl	bin
aqu	pis	tau	can	vir	lib	sag
mar	jup	sat	moo	mer	ven	sun
	r		r	r	r	

third decan/creative water
cancer/orange-yellow/eb
minus/plus

v	vi	vii	i	ii	iii	iv
bb	c	d	eb	f	g	a
ivi	red	ora	oye	gre	blu	ind
aqu	ari	gem	can	vir	sco	cap
ven	sun	mar	jup	sat	moo	mer
	e		e		d	

Scorpio - Mixolydian
JUDGMENT (Saturn) - Seven of Cups

first decan/sustenant water
scorpio/blue/g
minus/plus

iii	iv	v	vi	vii	i	ii
b	c	d	e	f	g	a
vio	red	ora	yel	gre	blu	ind
pis	ari	gem	leo	vir	sco	cap
mer	ven	sun	mar	jup	sat	moo
f	f			f		f

second decan/destructive water
pisces/violet/b
plus/minus

i	ii	iii	iv	v	vi	vii
b	db	eb	e	gb	ab	a
vio	ror	oye	yel	gbl	bin	ind
pis	tau	can	leo	lib	sag	cap
sat	moo	mer	ven	sun	mar	jup
	e			d		d

third decan/creative water
cancer/orange-yellow/eb
minus/plus

v	vi	vii	i	ii	iii	iv
bb	c	db	eb	f	g	ab
ivi	red	ror	oye	gre	blu	ind
aqu	ari	tau	can	vir	sco	sag
sun	mar	jup	sat	moo	mer	ven
f	r		f			

Sagittarius - Aeolian
MOON (Moon) - Ace of Wands
STAR (Uranus) - Eight of Wands

first decan/destructive fire
sagittarius/blue-indigo/ab
plus/minus

ii	iii	iv	v	vi	vii	i
bb	b	db	eb	e	gb	ab
ivi	vio	ror	oye	yel	gbl	bin
aqu	pis	tau	can	leo	lib	sag
mer	ven	sun	mar	jup	sat	moo
e	e		d		e	

second decan/creative fire
aries/red/c
minus/plus

vii	i	ii	iii	iv	v	vi
bb	c	d	eb	f	g	ab
ivi	red	ora	oye	gre	blu	bin
aqu	ari	gem	can	vir	sco	sag
sat	moo	mer	ven	sun	mar	jup
r		r		r	r	

third decan/sustenant fire
leo/yellow/e
plus/minus

v	vi	vii	i	ii	iii	iv
b	c	d	e	gb	g	a
vio	red	ora	yel	gbl	blu	ind
pis	ari	gem	leo	lib	sco	cap
mar	jup	sat	moo	mer	ven	sun
				f		

Sagittarius - Locrian
MAGICIAN (Mercury) - Two of Wands
HERMIT (Neptune) - Nine of Wands

first decan/destructive fire
sagittarius/blue-indigo/ab
plus/minus

iii	iv	v	vi	vii	i	ii
b	db	d	e	gb	ab	a
vio	red	ora	yel	gbl	bin	ind
pis	tau	gem	leo	lib	sag	cap
sun	mar	jup	sat	moo	mer	ven
	f	f	f	f		

second decan/creative fire
aries/red/c
minus/plus

vii	i	ii	iii	iv	v	vi
bb	c	db	eb	f	g	ab
ivi	red	ror	oye	gre	gbl	bin
aqu	ari	tau	can	vir	lib	sag
moo	mer	ven	sun	mar	jup	sat
	r					

third decan/sustenant fire
leo/yellow/e
plus/minus

v	vi	vii	i	ii	iii	iv
bb	c	d	e	f	g	a
ivi	red	ora	yel	gre	blu	ind
aqu	ari	gem	leo	vir	sco	cap
jup	sat	moo	mer	ven	sun	mar
	d			d		e

Sagittarius - Ionian
EMPRESS (Venus) - Three of Wands
FOOL (Pluton) - Ten of Wands

first decan/destructive fire
sagittarius/blue-indigo/ab
plus/minus

ii	iii	iv	v	vi	vii	i
bb	c	db	eb	f	g	ab
ivi	red	ror	oye	gre	blu	bin
aqu	ari	tau	can	vir	sco	sag
sun	mar	jup	sat	moo	mer	ven
f	r		f			

second decan/creative fire
aries/red/c
minus/plus

vii	i	ii	iii	iv	v	vi
b	c	d	e	f	g	a
vio	red	ora	yel	gre	blu	ind
pis	ari	gem	leo	vir	sco	cap
mer	ven	sun	mar	jup	sat	moo
f	f			f		f

third decan/sustenant fire
leo/yellow/e
plus/minus

v	vi	vii	i	ii	iii	iv
b	db	eb	e	gb	ab	a
vio	ror	oye	yel	gbl	bin	ind
pis	tau	can	leo	lib	sag	cap
sat	moo	mer	ven	sun	mar	jup
	e			d		d

Sagittarius - Dorian
SUN (Sun) - Four of Wands

first decan/destructive fire
sagittarius/blue-indigo/ab
plus/minus

ii	iii	iv	v	vi	vii	i
bb	b	db	eb	f	g	ab
ivi	vio	ror	oye	gre	gbl	bin
aqu	pis	tau	can	vir	lib	sag
mar	jup	sat	moo	mer	ven	sun
	r		r	r	r	

second decan/creative fire
aries/red/c
minus/plus

vii	i	ii	iii	iv	v	vi
bb	c	d	eb	f	g	a
ivi	red	ora	oye	gre	blu	ind
aqu	ari	gem	can	vir	sco	cap
ven	sun	mar	jup	sat	moo	mer
	e		e		d	

third decan/sustenant fire
leo/yellow/e
plus/minus

v	vi	vii	i	ii	iii	iv
b	db	d	e	gb	g	a
vio	ror	ora	yel	gbl	blu	ind
pis	tau	gem	leo	lib	sco	cap
moo	mer	ven	sun	mar	jup	sat
		r	f		r	

second decan/creative fire
aries/red/c
minus/plus

vii	i	ii	iii	iv	v	vi
b	c	d	e	gb	g	a
vio	red	ora	yel	gbl	blu	ind
pis	ari	gem	leo	lib	sco	cap
mar	jup	sat	moo	mer	ven	sun
				f		

Sagittarius - Phrygian
TOWER (Mars) - Five of Wands

first decan/destructive fire
sagittarius/blue-indigo/ab
plus/minus

iii	iv	v	vi	vii	i	ii
b	db	eb	e	gb	ab	a
vio	ror	oye	yel	gbl	bin	ind
pis	tau	can	leo	lib	sag	cap
sat	moo	mer	ven	sun	mar	jup
	e		d		d	

third decan/sustenant fire
leo/yellow/e
plus/minus

iv	v	vi	vii	i	ii	iii
bb	b	db	eb	e	gb	ab
ivi	vio	ror	oye	yel	gbl	bin
aqu	pis	tau	can	leo	lib	sag
mer	ven	sun	mar	jup	sat	moo
e	e		d		e	

Sagittarius - Mixolydian
JUDGMENT (Saturn) - Seven of Wands

first decan/destructive fire
sagittarius/blue-indigo/ab
plus/minus

vii	i	ii	iii	iv	v	vi
bb	c	db	eb	f	g	ab
ivi	red	ror	oye	gre	blu	bin
aqu	ari	tau	can	vir	sco	sag
sun	mar	jup	sat	moo	mer	ven
f	r		f			

ii	iii	iv	v	vi	vii	i
bb	c	db	eb	f	gb	ab
ivi	red	ror	oye	gre	gbl	bin
aqu	ari	tau	can	vir	lib	sag
moo	mer	ven	sun	mar	jup	sat
		r				

third decan/sustenant fire
leo/yellow/e
plus/minus

v	vi	vii	i	ii	iii	iv
b	c	d	e	f	g	a
vio	red	ora	yel	gre	blu	ind
pis	ari	gem	leo	vir	sco	cap
mer	ven	sun	mar	jup	sat	moo
f	f		f		f	

second decan/creative fire
aries/red/c
minus/plus

vii	i	ii	iii	iv	v	vi
bb	c	d	e	f	g	a
ivi	red	ora	yel	gre	blu	ind
aqu	ari	gem	leo	vir	sco	cap
jup	sat	moo	mer	ven	sun	mar
	d		d	d		e

Sagittarius - Lydian
EMPEROR (Jupiter) - Six of Wands

first decan/destructive fire
sagittarius/blue-indigo/ab
plus/minus

ii	iii	iv	v	vi	vii	i
bb	c	d	eb	f	g	ab
ivi	red	ora	oye	gre	blu	bin
aqu	ari	gem	can	vir	sco	sag
sat	moo	mer	ven	sun	mar	jup
r		r		r	r	

third decan/sustenant fire
leo/yellow/e
plus/minus

v	vi	vii	i	ii	iii	iv
b	db	d	e	gb	ab	a
vio	ror	ora	yel	gbl	bin	ind
pis	tau	gem	leo	lib	sag	cap
sun	mar	jup	sat	moo	mer	ven
	f	f	f		f	

Capricorn - Aeolian
 MOON (Moon) - Ace of Pentacles
 STAR (Uranus) - Eight of Pentacles

first decan/creative earth
 capricorn/indigo/a
 minus/plus

ii	iii	iv	v	vi	vii	i
b	c	d	e	f	g	a
vio	red	ora	yel	gre	blu	ind
pis	ari	gem	leo	vir	sco	cap
mer	ven	sun	mar	jup	sat	moo
f	f			f		f

second decan/sustenant earth
 taurus/red-orange/db
 plus/minus

vii	i	ii	iii	iv	v	vi
b	db	eb	e	gb	ab	a
vio	ror	oye	yel	gbl	bin	ind
pis	tau	can	leo	lib	sag	cap
sat	moo	mer	ven	sun	mar	jup
	e			d		d

third decan/destructive earth
 virgo/green/f
 minus/plus

iv	v	vi	vii	i	ii	iii
bb	c	db	eb	f	g	ab
ivi	red	ror	oye	gre	blu	bin
aqu	ari	tau	can	vir	sco	sag
sun	mar	jup	sat	moo	mer	ven
f	r		f			

Capricorn - Locrian
 MAGICIAN (Mercury) - Two of Pentacles
 HERMIT (Neptune) - Nine of Pentacles

first decan/creative earth
 capricorn/indigo/a
 minus/plus

ii	iii	iv	v	vi	vii	i
bb	c	d	eb	f	g	a
ivi	red	ora	oye	gre	blu	ind
aqu	ari	gem	can	vir	sco	cap
ven	sun	mar	jup	sat	moo	mer
	e		e		d	

second decan/sustenant earth
 taurus/red-orange/db
 plus/minus

vii	i	ii	iii	iv	v	vi
b	db	d	e	gb	g	a
vio	ror	ora	yel	gbl	blu	ind
pis	tau	gem	leo	lib	sco	cap
moo	mer	ven	sun	mar	jup	sat
		r		f		r

third decan/destructive earth
 virgo/green/f
 minus/plus

iv	v	vi	vii	i	ii	iii
bb	b	db	eb	f	gb	ab
ivi	vio	ror	oye	gre	gbl	bin
aqu	pis	tau	can	vir	lib	sag
mar	jup	sat	moo	mer	ven	sun
	r		r	r	r	

Capricorn - Ionian
 EMPRESS (Venus) - Three of Pentacles
 FOOL (Pluton) - Ten of Pentacles

first decan/creative earth
 capricorn/indigo/a
 minus/plus

ii	iii	iv	v	vi	vii	i
b	db	d	e	gb	ab	a
vio	ror	ora	yel	gbl	bin	ind
pis	tau	gem	leo	lib	sag	cap
sun	mar	jup	sat	moo	mer	ven
	f	f	f		f	

second decan/sustenant earth
 taurus/red-orange/db
 plus/minus

vi	vii	i	ii	iii	iv	v
bb	c	db	eb	f	gb	ab
ivi	red	ror	oye	gre	gbl	bin
aqu	ari	tau	can	vir	lib	sag
moo	mer	ven	sun	mar	jup	sat
		r				

third decan/destructive earth
 virgo/green/f
 minus/plus

iv	v	vi	vii	i	ii	iii
bb	c	d	e	f	g	a
ivi	red	ora	yel	gre	blu	ind
aqu	ari	gem	leo	vir	sco	cap
jup	sat	moo	mer	ven	sun	mar
	d		d	d		e

Capricorn - Dorian
 SUN (Sun) - Four of Pentacles

first decan/creative earth
 capricorn/indigo/a
 minus/plus

ii	iii	iv	v	vi	vii	i
b	c	d	e	gb	g	a
vio	red	ora	yel	gbl	blu	ind
pis	ari	gem	leo	lib	sco	cap
mar	jup	sat	moo	mer	ven	sun
					f	

second decan/sustenant earth
taurus/red-orange/db

plus/minus						
vi	vii	i	ii	iii	iv	v
bb	b	db	eb	e	gb	ab
ivi	vio	ror	oye	yel	gbl	bin
aqu	pis	tau	can	leo	lib	sag
mer	ven	sun	mar	jup	sat	moo
e	e		d		e	

third decan/destructive earth
virgo/green/f

minus/plus						
iv	v	vi	vii	i	ii	iii
bb	c	d	eb	f	g	ab
ivi	red	ora	oye	gre	blu	bin
aqu	ari	gem	can	vir	sco	sag
sat	moo	mer	ven	sun	mar	jup
r		r		r	r	r

Capricorn - Phrygian
TOWER (Mars) - Five of Pentacles

first decan/creative earth
capricorn/indigo/a

minus/plus						
ii	iii	iv	v	vi	vii	i
bb	c	d	e	f	g	a
ivi	red	ora	yel	gre	blu	ind
aqu	ari	gem	leo	vir	sco	cap
jup	sat	moo	mer	ven	sun	mar
	d		d			e

second decan/sustenant earth
taurus/red-orange/db

plus/minus						
vii	i	ii	iii	iv	v	vi
b	db	d	e	gb	ab	a
vio	ror	ora	yel	gbl	bin	ind
pis	tau	gem	leo	lib	sag	cap
sun	mar	jup	sat	moo	mer	ven
	f	f	f		f	

third decan/destructive earth
virgo/green/f

minus/plus						
iv	v	vi	vii	i	ii	iii
bb	c	db	eb	f	gb	ab
ivi	red	ror	oye	gre	gbl	bin
aqu	ari	tau	can	vir	lib	sag
moo	mer	ven	sun	mar	jup	sat
	r					

Capricorn - Lydian
EMPEROR (Jupiter) - Six of Pentacles

first decan/creative earth
capricorn/indigo/a

minus/plus						
ii	iii	iv	v	vi	vii	i
b	db	eb	e	gb	ab	a
vio	ror	oye	yel	gbl	bin	ind
pis	tau	can	leo	lib	sag	cap
sat	moo	mer	ven	sun	mar	jup
	e			d		d

second decan/sustenant earth
taurus/red-orange/db

plus/minus						
vi	vii	i	ii	iii	iv	v
bb	c	db	eb	f	g	ab
ivi	red	ror	oye	gre	blu	bin
aqu	ari	tau	can	vir	sco	sag
sun	mar	jup	sat	moo	mer	ven
f	r		f			

third decan/destructive earth
virgo/green/f

minus/plus						
iv	v	vi	vii	i	ii	iii
b	c	d	e	f	g	a
vio	red	ora	yel	gre	blu	ind
pis	ari	gem	leo	vir	sco	cap
mer	ven	sun	mar	jup	sat	moo
f	f		f		f	f

Capricorn - Mixolydian
JUDGMENT (Saturn) - Seven of Pentacles

first decan/creative earth
capricorn/indigo/a

minus/plus						
ii	iii	iv	v	vi	vii	i
b	db	d	e	gb	g	a
vio	ror	ora	yel	gbl	blu	ind
pis	tau	gem	leo	lib	sco	cap
moo	mer	ven	sun	mar	jup	sat
		r	f		r	

second decan/sustenant earth
taurus/red-orange/db

plus/minus						
vi	vii	i	ii	iii	iv	v
bb	b	db	eb	f	gb	ab
ivi	vio	ror	oye	gre	gbl	bin
aqu	pis	tau	can	vir	lib	sag
mar	jup	sat	moo	mer	ven	sun
	r		r	r	r	

third decan/destructive earth
virgo/green/f
minus/plus

iv	v	vi	vii	i	ii	iii
bb	c	d	eb	f	g	a
ivi	red	ora	oye	gre	blu	ind
aqu	ari	gem	can	vir	sco	cap
ven	sun	mar	jup	sat	moo	mer
	e		e		d	

Aquarius - Aeolian
MOON (Moon) - Ace of Swords
STAR (Uranus) - Eight of Swords

first decan/sustenent air
aquarius/indigo-violet/bb
plus/minus

i	ii	iii	iv	v	vi	vii
bb	c	db	eb	f	gb	ab
ivi	red	ror	oye	gre	gbl	bin
aqu	ari	tau	can	vir	lib	sag
moo	mer	ven	sun	mar	jup	sat
		r				

second decan/destructive air
gemini/orange/d
minus/plus

vi	vii	i	ii	iii	iv	v
bb	c	d	e	f	g	a
ivi	red	ora	yel	gre	blu	ind
aqu	ari	gem	leo	vir	sco	cap
jup	sat	moo	mer	ven	sun	mar
	d		d		d	e

third decan/creative air
libra/green-blue/gb
plus/minus

iv	v	vi	vii	i	ii	iii
b	db	d	e	gb	ab	a
vio	ror	ora	yel	gbl	bin	ind
pis	tau	gem	leo	lib	sag	cap
sun	mar	jup	sat	moo	mer	ven
	f	f	f		f	

Aquarius - Locrian
MAGICIAN (Mercury) - Two of Swords
HERMIT (Neptune) - Nine of Swords

first decan/sustenent air
aquarius/indigo-violet/bb
plus/minus

i	ii	iii	iv	v	vi	vii
bb	b	db	eb	e	gb	ab
ivi	vio	ror	oye	yel	gbl	bin
aqu	pis	tau	can	leo	lib	sag
mer	ven	sun	mar	jup	sat	moo
	e	e		d		e

second decan/destructive air
gemini/orange/d
minus/plus

vi	vii	i	ii	iii	iv	v
bb	c	d	eb	f	g	ab
ivi	red	ora	oye	gre	blu	bin
aqu	ari	gem	can	vir	sco	sag
sat	moo	mer	ven	sun	mar	jup
	r		r		r	r

third decan/creative air
libra/green-blue/gb
plus/minus

iv	v	vi	vii	i	ii	iii
b	c	d	e	gb	g	a
vio	red	ora	yel	gbl	blu	ind
pis	ari	gem	leo	lib	sco	cap
mar	jup	sat	moo	mer	ven	sun
				f		

Aquarius - Ionian
EMPRESS (Venus) - Three of Swords
FOOL (Pluton) - Ten of Swords

first decan/sustenent air
aquarius/indigo-violet/bb
plus/minus

i	ii	iii	iv	v	vi	vii
bb	c	d	eb	f	g	a
ivi	red	ora	oye	gre	blu	ind
aqu	ari	gem	can	vir	sco	cap
ven	sun	mar	jup	sat	moo	mer
	e		e		d	

second decan/destructive air
gemini/orange/d
minus/plus

vi	vii	i	ii	iii	iv	v
b	db	d	e	gb	g	a
vio	ror	ora	yel	gbl	blu	ind
pis	tau	gem	leo	lib	sco	cap
moo	mer	ven	sun	mar	jup	sat
		r		f		r

third decan/creative air
libra/green-blue/gb
plus/minus

iii	iv	v	vi	vii	i	ii
bb	b	db	eb	f	gb	ab
ivi	vio	ror	oye	gre	gbl	bin
aqu	pis	tau	can	vir	lib	sag
mar	jup	sat	moo	mer	ven	sun
	r		r	r	r	

Aquarius - Dorian
SUN (Sun) - Four of Swords

first decan/sustenant air
aquarius/indigo-violet/bb
plus/minus

i	ii	iii	iv	v	vi	vii
bb	c	db	eb	f	g	ab
ivi	red	ror	oye	gre	blu	bin
aqu	ari	tau	can	vir	sco	sag
sun	mar	jup	sat	moo	mer	ven
f	r		f			

second decan/destructive air
gemini/orange/d
minus/plus

vi	vii	i	ii	iii	iv	v
b	c	d	e	f	g	a
vio	red	ora	yel	gre	blu	ind
pis	ari	gem	leo	vir	sco	cap
mer	ven	sun	mar	jup	sat	moo
f	f		f		f	f

third decan/creative air
libra/green-blue/gb
plus/minus

iv	v	vi	vii	i	ii	iii
b	db	eb	e	gb	ab	a
vio	ror	oye	yel	gbl	bin	ind
pis	tau	can	leo	lib	sag	cap
sat	moo	mer	ven	sun	mar	jup
e			d		d	

Aquarius - Phrygian
TOWER (Mars) - Five of Swords

first decan/sustenant air
aquarius/indigo-violet/bb
plus/minus

i	ii	iii	iv	v	vi	vii
bb	b	db	eb	f	gb	ab
ivi	vio	ror	oye	gre	gbl	bin
aqu	pis	tau	can	vir	lib	sag
mar	jup	sat	moo	mer	ven	sun
	r		r	r	r	

second decan/destructive air
gemini/orange/d
minus/plus

vi	vii	i	ii	iii	iv	v
bb	c	d	eb	f	g	a
ivi	red	ora	oye	gre	blu	ind
aqu	ari	gem	can	vir	sco	cap
ven	sun	mar	jup	sat	moo	mer
e		e		d		

third decan/creative air
libra/green-blue/gb
plus/minus

iv	v	vi	vii	i	ii	iii
b	db	d	e	gb	g	a
vio	ror	ora	yel	gbl	blu	ind
pis	tau	gem	leo	lib	sco	cap
moo	mer	ven	sun	mar	jup	sat
			r	f		r

Aquarius - Lydian
EMPEROR (Jupiter) - Six of Swords

first decan/sustenant air
aquarius/indigo-violet/bb
plus/minus

i	ii	iii	iv	v	vi	vii
bb	c	d	e	f	g	a
ivi	red	ora	yel	gre	blu	ind
aqu	ari	gem	leo	vir	sco	cap
jup	sat	moo	mer	ven	sun	mar
	d		d			e

second decan/destructive air
gemini/orange/d
minus/plus

vi	vii	i	ii	iii	iv	v
b	db	d	e	gb	ab	a
vio	ror	ora	yel	gbl	bin	ind
pis	tau	gem	leo	lib	sag	cap
sun	mar	jup	sat	moo	mer	ven
f	f	f	f	f		

third decan/creative air
libra/green-blue/gb
plus/minus

iii	iv	v	vi	vii	i	ii
bb	c	db	eb	f	gb	ab
ivi	red	ror	oye	gre	gbl	bin
aqu	ari	tau	can	vir	lib	sag
moo	mer	ven	sun	mar	jup	sat
		r				

Aquarius - Mixolydian
JUDGMENT (Saturn) - Seven of Swords

first decan/sustenant air
aquarius/indigo-violet/bb
plus/minus

i	ii	iii	iv	v	vi	vii
bb	c	d	eb	f	g	ab
ivi	red	ror	oye	gre	blu	bin
aqu	ari	gem	can	vir	sco	sag
sat	moo	mer	ven	sun	mar	jup
r		r			r	r

second decan/destructive air
gemi/orange/d

minus/plus
vi vii i ii iii iv v
b c d e gb g a
vio red ora yel gbl blu ind
pis ari gem leo lib sco cap
mar jup sat moo mer ven sun
f

third decan/creative air
libra/green-blue/gb

plus/minus
iii iv v vi vii i ii
bb b db eb e gb ab
ivi vio ror oye yel gbl bin
aqu pis tau can leo lib sag
mer ven sun mar jup sat moo
e e d e

Pisces - Aeolian
MOON (Moon) - Ace of Cups
STAR (Uranus) - Eight of Cups

first decan/destructive water
pisces/violet/b

minus/plus
i ii iii iv v vi vii
b db d e gb g a
vio ror ora yel gbl blu ind
pis tau gem leo lib sco cap
moo mer ven sun mar jup sat
r f r

second decan/creative water
cancer/orange-yellow/eb
plus/minus

v vi vii i ii iii iv
bb b db eb f gb ab
ivi vio ror oye gre gbl bin
aqu pis tau can vir lib sag
mar jup sat moo mer ven sun
r r r r

third decan/sustenant water
scorpio/blue/g

minus/plus
iii iv v vi vii i ii
bb c d eb f g a
ivi red ora oye gre blu ind
aqu ari gem can vir sco cap
ven sun mar jup sat moo mer
e e d

Pisces - Locrian

MAGICIAN (Mercury) - Two of Cups
HERMIT (Neptune) - Nine of Cups

first decan/destructive water
pisces/violet/b

minus/plus
i ii iii iv v vi vii
b c d e f g a
vio red ora yel gre blu ind
pis ari gem leo vir sco cap
mer ven sun mar jup sat moo
f f f f

second decan/creative water
cancer/orange-yellow/eb

plus/minus
vi vii i ii iii iv v
b db eb e gb ab a
vio ror oye yel gbl bin ind
pis tau can leo lib sag cap
sat moo mer ven sun mar jup
e d d

third decan/sustenant water
scorpio/blue/g

minus/plus
iii iv v vi vii i ii
bb c db eb f g ab
ivi red ror oye gre blu bin
aqu ari tau can vir sco sag
sun mar jup sat moo mer ven
f r f

Pisces - Ionian
EMPRESS (Venus) - Three of Cups
FOOL (Pluton) - Ten of Cups

first decan/destructive water
pisces/violet/b

minus/plus
vii i ii iii iv v vi
bb b db eb e gb ab
ivi vio ror oye yel gbl bin
aqu pis tau can leo lib sag
mer ven sun mar jup sat moo
e e d e

second decan/creative water
cancer/orange-yellow/eb

plus/minus
v vi vii i ii iii iv
bb c d eb f g ab
ivi red ora oye gre blu bin
aqu ari gem can vir sco sag
sat moo mer ven sun mar jup
r r r r

third decan/sustenant water
scorpio/blue/g
minus/plus

iii	iv	v	vi	vii	i	ii
b	c	d	e	gb	g	a
vio	red	ora	yel	gre	blu	ind
pis	ari	gem	leo	lib	sco	cap
mar	jup	sat	moo	mer	ven	sun
				f		

second decan/creative water
cancer/orange-yellow/eb
plus/minus

v	vi	vii	i	ii	iii	iv
bb	b	db	eb	e	gb	ab
ivi	vio	ror	oye	yel	gbl	bin
aqu	pis	tau	can	leo	lib	sag
mer	ven	sun	mar	jup	sat	moo
e	e		d		e	

Pisces - Dorian
SUN (Sun) - Four of Cups

first decan/destructive water
pisces/violet/b
minus/plus

i	ii	iii	iv	v	vi	vii
b	db	d	e	gb	ab	a
vio	ror	ora	yel	gbl	bin	ind
pis	tau	gem	leo	lib	sag	cap
sun	mar	jup	sat	moo	mer	ven
	f	f	f	f		

third decan/sustenant water
scorpio/blue/g
minus/plus

iii	iv	v	vi	vii	i	ii
bb	c	d	eb	f	g	ab
ivi	red	ora	oye	gre	blu	bin
aqu	ari	gem	can	vir	sco	sag
sat	moo	mer	ven	sun	mar	jup
r		r			r	r

Pisces - Lydian
EMPEROR (Jupiter) - Six of Cups

second decan/creative water
cancer/orange-yellow/eb
plus/minus

v	vi	vii	i	ii	iii	iv
bb	c	db	eb	f	gb	ab
ivi	red	ror	oye	gre	gbl	bin
aqu	ari	tau	can	vir	lib	sag
moo	mer	ven	sun	mar	jup	sat
	r					

first decan/destructive water
pisces/violet/b
minus/plus

vii	i	ii	iii	iv	v	vi
bb	b	db	eb	f	gb	ab
ivi	vio	ror	oye	gre	gbl	bin
aqu	pis	tau	can	vir	lib	sag
mar	jup	sat	moo	mer	ven	sun
	r		r	r	r	

third decan/sustenant water
scorpio/blue/g
minus/plus

iii	iv	v	vi	vii	i	ii
bb	c	d	e	f	g	a
ivi	red	ora	yel	gre	blu	ind
aqu	ari	gem	leo	vir	sco	cap
jup	sat	moo	mer	ven	sun	mar
	d		d		e	

second decan/creative water
cancer/orange-yellow/eb
plus/minus

v	vi	vii	i	ii	iii	iv
bb	c	d	eb	f	g	a
ivi	red	ora	oye	gre	blu	ind
aqu	ari	gem	can	vir	sco	cap
ven	sun	mar	jup	sat	moo	mer
	e		e		d	

Pisces - Phrygian
TOWER (Mars) - Five of Cups

first decan/destructive water
pisces/violet/b
minus/plus

i	ii	iii	iv	v	vi	vii
b	c	d	e	gb	g	a
vio	red	ora	yel	gbl	blu	ind
pis	ari	gem	leo	lib	sco	cap
mar	jup	sat	moo	mer	ven	sun
				f		

third decan/sustenant water
scorpio/blue/g
minus/plus

iii	iv	v	vi	vii	i	ii
b	db	d	e	gb	g	a
vio	ror	ora	yel	gbl	blu	ind
pis	tau	gem	leo	lib	sco	cap
moo	mer	ven	sun	mar	jup	sat
		r	f			r

Pisces - Mixolydian
 JUDGMENT (Saturn) - Seven of Cups

first decan/destructive water
 pisces/violet/b
 minus/plus

i	ii	iii	iv	v	vi	vii
b	db	eb	e	gb	ab	a
vio	ror	oye	yel	gbl	bin	ind
pis	tau	can	leo	lib	sag	cap
sat	moo	mer	ven	sun	mar	jup
	e			d		d

second decan/creative water
 cancer/orange-yellow/eb
 plus/minus

v	vi	vii	i	ii	iii	iv
bb	c	db	eb	f	g	ab
ivi	red	ror	oye	gre	blu	ind
aqu	ari	tau	can	vir	sco	sag
sun	mar	jup	sat	moo	mer	ven
f	r		f			

third decan/sustenant water
 scorpio/blue/g
 minus/plus

iii	iv	v	vi	vii	i	ii
b	c	d	e	f	g	a
vio	red	ora	yel	gre	blu	ind
pis	ari	gem	leo	vir	sco	cap
mer	ven	sun	mar	jup	sat	moo
f	f			f		f

Chapter 4 Chart of a Genius

NOW THAT you've been familiarized with the decans and pentades in the zodiac, with the transposition of planetary modalities therein, then the next step is to show by example how to interpret a judicial astrological horoscope, using our famous scientist.

Sir Isaac Newton was born prematurely to Isaac (died Oct 1642 OS) & Hannah Ayscough-Newton at Woolsthorpe Manor house, located at 23 Newton Way, Woolsthorpe-by-Colsterworth, Grantham, NG33 5NR, Lincolnshire, geographical coordinates 00W37:51 52N48:33, at about one o'clock in the morning 25 December 1642 (Julian), which was 4 January 1643 (Gregorian), with Arcturus rising on the Ascendant. A simple chart is made using Astrolog v. 5.41G, with positions strictly in reference to the caelestial zodiac using classical vedic "houses", which simply number the signs on the caelestial sphere with Ascendant numbering first house, which in Newton's natal chart is near the cusp of Virgo-Libra (29Vir26) and so the Ascendant numbers caelestial Libra first. These are called whole houses under the Astrolog menu setting:

Body	Caelest.	Latitu.	r	House	Rul.	Veloc.	Decan.
/Ascendant	: 29Vir26	_____		[1st]		_____	28Tau17
\Arcturus	: 29Vir27	+30:59'		[1st]		alBoo	-
East Point:	10Lib05	+ 0:00'	F	[1st]		_____	0Aqu14
Uranus	: 25Lib51	+ 0:22'	-	[1st]	[-]	+0.040	17Gem34
Neptune	: 11Sco09	+ 1:38'	-	[2nd]	[-]	+0.030	3Pis28
Mercury	: 1Sag06	+ 1:19'	F	[3rd]	[R]	+1.158	3Sag18
Gal.Center:	2Sag03	- 5:34'		[2nd]		SgrA*	-
Sun	: 23Sag51	- 0:00'	-	[3rd]	[-]	+1.019	11Leo32
IC	: 6Cap00	+ 0:00'		[4th]		_____	17Cap59
Venus	: 7Aqu22	+ 0:20'	-	[5th]	[-]	+0.692	22Aqu07
Jupiter	: 24Aqu19	- 1:11'	-	[5th]	[-]	+0.175	12Lib57
Saturn	: 0Pis05	- 2:11'	-	[6th]	[-]	+0.073	0Pis15
Spirit	: 17Pis53	_____	e	[6th]	[d]	_____	23Can40
Descendant:	29Pis26	_____		[6th]		_____	28Sco17
Fortune	: 10Ari58	_____	-	[7th]	[-]	_____	2Leo53
Mars	: 17Ari42	+ 1:29'	R	[7th]	[F]	+0.318	23Leo06
Vertex	: 22Ari41	_____	F	[7th]		_____	8Sag04
Pluto	: 12Tau47	-11:53'	F	[8th]	[R]	-0.014	8Vir22
Aldebaran	: 15Tau00	- 5:30'		[8th]		alTau	-
Moon	: 12Gem19	- 4:57'	-	[9th]	[-]	+12.27	6Lib56
Midheaven	: 6Can00	+ 0:00'		[10th]		_____	17Can59
OsciLilith:	23Can11	- 4:10'	-	[10th]	[-]	+3.972	9Pis34
MeanLilith:	27Can48	- 4:04'	-	[10th]	[-]	+0.112	23Pis23
True Node	: 19Vir38	+ 0:00'	e	[12th]	[d]	+0.241	28Cap55
Spica	: 29Vir03	- 2:02'		[12th]		alVir	-

The first thing to note in the above chart is that decans are referenced as if every decan occupies fully thirty degrees in caelestial longitude even though each one is just ten degrees. This is done because decans themselves refer to the elemental triplicities of the whole zodiac which enable their existence and astrological influence as decans within each of the signs, thus drawing attention to the thirty-degree signs and planets whose very existence and influence is enabled by the elements.

Also, because the elemental triplicities and qualitative quadruplicities are enabled by the planets, then fiducial marking stars used to refer the planetary positions to the caelestial sphere do not empower the decans and so are not accorded them. Influences of the planets are empowered by the elements which comprise them in their respective sidereal and synodic orbits.

And so decans are tied directly to the thirty-degree signs of like-elements which comprise their elemental triplicity. This means that planets in signs of like-elements are in elemental synergy, according to the decan that corresponds to that sign.

As in our example, Isaac Newton's natal Mars is about 17Ari42, which transliterates to "23Leo06" in Aries' second decan. See? Newton's natal Sun is 23Sag51, which is "11Leo32" Sagittarius third decan. Astrolog summarizes Newton's natal chart like so:

	Car	Fix	Mut	TOT	
					+:10
Fir	3	0	2	5	-:10
Ear	1	2	2	5	M: 8
Air	2	2	1	5	N: 8
Wat	2	1	2	5	A: 7
TOT	8	5	7	20	D: 9
					<:10

Astrolog's helpfile only briefly explains this summary chart,

“Also in this main display, the total number of planets in each of the hemispheres of the wheel, as well the number of objects in yang/ positive/ masculine and yin/negative/feminine quality signs, are counted. To the right of the element table, we have a column of seven numbers labeled as follows: “+” is the number of “yang” objects (i.e. in Fire or Air signs); “-” is the number of “yin” objects (i.e. in Water or Earth signs); “M” is the number of objects above the horizon (i.e. in the “Southern” hemisphere of the Midheaven); “N” is the number of objects below the horizon (in the “Northern” hemisphere of the Nadir); “A” is the number of objects in the Eastern half of the sky (in the hemisphere of the Ascendant); and “D” is the number of objects in the Western half of the sky (in the hemisphere of the Descendant). Note that cusp

objects are left out of hemisphere counts (but still included in the other object summaries) as they would skew things since they are always in a particular hemisphere. Finally we have a field indicating the division of objects into the first six and second six signs of the zodiac. The number of objects in the first six signs of the zodiac will be printed, labeled by the character "<". (The number in the second half isn't printed; just subtract from the total if you want to know.) According to a book on the Kaballah, the emphasis of the first six signs on the zodiac is on "what's to learn", and the emphasis on the second six signs is on "what's to share". Use or interpret this as you wish." [end quote]

Astrolog's helpfile goes on only to mention this about decans:

"Decan displays are supported in Astrolog, and one can display a decan influenced chart with the -3 switch. The decan theory is that each sign in the zodiac can be divided into three parts: The first 10 degrees (i.e. the first decan) is mainly influenced by the sign in question, the second 10 degrees (second decan) although still influenced by the sign in question is also somewhat influenced by the next sign of the same element, while the last decan is influenced by the third sign of the same element. The -3 switch applied to a chart will move each object into the sign of its decan. For example, if the Sun is at 29 degrees Aquarius and the Moon at 5 degrees Virgo, in the resulting chart, the Sun will go to Libra (26 degrees) and the Moon will remain in Virgo (although be at 15 degrees now since it was previously in the middle of the first decan of Virgo.)" [end quote]

As you can see, there's more to understanding the meaning and influence of decans & pentads than the quoted author realized. So much more, that it takes light & sound to fully explain it. Music is the perfect expression of how astrology really works. The ancients knew this. That's why they understood it so well. That's why modern astrologers really don't understand a thing about astrology but merely pretend to. Look at Newton's chart again, this time using the terrestrial meridian houses of the horoscope—numbered by the ruling planets who in turn give us the key that unlocks the mystery of signs, decans and pentads.

Body	Houses	RUL.	Decans	r
Moon	: 4Ari28	[-]	13ari23	-
Midheaven	: 0Tau00		0tau00	
OsciLilith:	17Tau22	[F]	22vir05	d
MeanLilith:	22Tau00	[F]	6cap01	-
True Node	: 11Can01	[d]	3sco02	-
Spica	: 19Can46		29sco17	
/Ascendant	: 20Can06		0pis18	
\Arcturus	: 20Can07		0pis22	
East Point:	0Leo00	[-]	0leo00	-
Uranus	: 15Leo44	[F]	17sag11	-
Neptune	: 1Vir03	[F]	3vir09	f
Mercury	: 22Vir25	[R]	7tau16	-
Gal.Center:	23Vir27		10tau21	
Sun	: 16Lib54	[d]	20aqu42	-
IC	: 0Sco00		0sco00	
Venus	: 1Sag33	[-]	4sag40	-
Jupiter	: 17Sag24	[R]	22ari12	-
Saturn	: 22Sag48	[-]	8leo23	f
Descendant:	20Cap06		0vir18	
Fortune	: 0Aqu53	[-]	2aqu38	-
Mars	: 7Aqu36	[-]	22aqu48	-
Vertex	: 12Aqu34	[-]	7gem42	-
Pluto	: 2Pis48	[d]	8pis24	d
Aldebaran	: 5Pis10		15pis30	

	Car	Fix	Mut	TOT	+	:
Fir	1	1	3	5	-	6
Ear	0	1	2	3	M:	8
Air	1	1	0	2	N:	5
Wat	2	0	1	3	A:	7
TOT	3	3	6	13	D:	6
					<:	7

Newton's horoscope shows Mercury ruling in the sixth house as Neptune is fallen there-under, while Jupiter rules ninth house over Saturn & Venus therein. Hence the theme of the horoscope is dominated by Jupiter's Lydian mode & Mercury's theoretical Locrian modality—the latter especially, with Poseidon adding his Locrian bass under Hermes. Recall from chapter 3 that the planets Jupiter, Mercury, Venus, & Moon mutually benefit from Mercury & Neptune in the court of Knight of Pentacles, to wit:

Virgo - Locrian						
MAGICIAN (Mercury) - Two of Pentacles						
HERMIT (Neptune) - Nine of Pentacles						
IV	V	VI	VII	I	II	III
4	5	6	7	1	2	3
Bb	B	Db	Eb	F	Gb	Ab
IVi	Vio	ROr	OYe	Gre	GB1	BIn
Aqu	Pis	Tau	Can	Vir	Lib	Sag
Mar	Jup	Sat	Moo	Mer	Ven	Sun
	R		R	R	R	

The decans of the Locrian theme in Virgo show Neptune helping the same planets, while Mercury is helping the Sun and Saturn, subduing only Mars, Neptune first decan & Mercury third decan:

first decan/destructive earth
virgo/green/f
minus/plus

iv	v	vi	vii	i	ii	iii
bb	b	db	eb	f	gb	ab
ivi	vio	ror	oye	gre	gbl	bin
aqu	pis	tau	can	vir	lib	sag
mar	jup	sat	moo	mer	ven	sun
	r		r	r	r	

third decan/sustenant earth
taurus/red-orange/db
minus/plus

vii	i	ii	iii	iv	v	vi
b	db	d	e	gb	g	a
vio	ror	ora	yel	gbl	blu	ind
pis	tau	gem	leo	lib	sco	cap
moo	mer	ven	sun	mar	jup	sat
			r	f		r

Jupiter ruling in the court of the Knight of Wands is helping Saturn, Mercury, Mars, & Jupiter, second decan subduing Venus:

Sagittarius - Lydian
EMPEROR (Jupiter) - Six of Wands

II	III	IV	V	VI	VII	I
Bb	C	D	Eb	F	G	Ab
IVi	Red	Ora	OYe	Gre	Blu	BIn
Aqu	Ari	Gem	Can	Vir	Sco	Sag
Sat	Moo	Mer	Ven	Sun	Mar	Jup
R		R			R	R

second decan/creative fire
aries/red/c
minus/plus

vii	i	ii	iii	iv	v	vi
b	c	d	e	gb	g	a
vio	red	ora	yel	gbl	blu	ind
pis	ari	gem	leo	lib	sco	cap
mar	jup	sat	moo	mer	ven	sun
				f		

At 1Sag33, Venus is positive in the first decan, helping Mars at the expense of the Sun & Saturn, as the Ionian chart shows:

```

first decan/destructive fire
sagittarius/blue-indigo/ab
plus/minus
ii  iii  iv  v  vi  vii  i
bb  c   db  eb  f  g   ab
ivi red  ror  oye gre blu bin
aqu ari  tau  can vir  sco sag
sun mar  jup  sat moo mer ven
f    r          f

```

At 22Sag48, Saturn is positive third decan, for which Mercury, Saturn, Jupiter & Mars pay under Saturn's Mixolydian modality:

```

third decan/sustenant fire
leo/yellow/e
plus/minus
v   vi  vii  i   ii  iii  iv
b   db d   e   gb  ab  a
vio ror ora  yel gbl bin ind
pis tau  gem  leo  lib sag cap
sun mar  jup  sat moo mer ven
f     f   f     f

```

Similarly, each planet's sidereal order of modality, or ethos, are transposed across the planetary zodiac according to their relative positions within the hierarchy of the ruling planets. As in this case of Sir Isaac Newton's horoscope, we find that the modal order of Mercury, Locrian, and Jupiter, Lydian, are the dominant theme for this horoscope—especially benefic for clever Mercury, & expansive Jupiter, but also for disciplined Saturn, assertive Mars, imaginative Moon, well-balanced Venus. The decans reveal more subtle highlights within the horoscope, softer themes in the background. But for Isaac Newton, we can immediately recognize his innate cleverness and expansiveness as the dominating theme or common thread to his life and work.

Recall this chart from chapter 9 of the Compleat Tarot Manual:

Sign	House	Rulership	Rul-phase
Ari	1	Ego	Mar-inf
Tau	2	Riches	Ven-inf
Gem	3	Brothers	Mer-inf
Can	4	Parents	Moo-inf
Leo	5	Sons	Sun-sup
Vir	6	Servants	Mer-sup
Lib	7	Marriage	Ven-sup
Sco	8	Death	Mar-sup,Plu-inf
Sag	9	Spirit	Jup-sup
Cap	10	Society	Sat-sup
Aqu	11	Friends	Sat-inf,Ura-sup
Pis	12	Debts	Jup-inf,Nep-sup

By substituting the classical nomenclature for the houses, in place of Astrolog's default zodiac convention, when using the "flip signs & houses" feature under the "house settings" menu, Newton's horoscope is immediately easier to read & understand:

Body	Houses	RUL.	Decans	r
Moon	: 4Ego28	[-]	13ego23	-
Midheaven	: 0Ric00		0ric00	
OsciLilith:	17Ric22	[F]	22ser05	d
MeanLilith:	22Ric00	[F]	6soc01	-
True Node	: 11Par01	[d]	3dea02	-
Spica	: 19Par46		29dea17	
/Ascendant	: 20Par06		0deb18	
\Arcturus	: 20Par07		0deb22	
East Point:	0Son00	[-]	0son00	-
Uranus	: 15Son44	[F]	17spi11	-
Neptune	: 1Ser03	[F]	3ser09	f
Mercury	: 22Ser25	[R]	7ric16	-
Gal.Center:	23Ser27		10ric21	
Sun	: 16Mar54	[d]	20fri42	-
IC	: 0Dea00		0dea00	
Venus	: 1Spi33	[-]	4spi40	-
Jupiter	: 17Spi24	[R]	22ego12	-
Saturn	: 22Spi48	[-]	8son23	f
Descendant:	20Soc06		0ser18	
Fortune	: 0Fri53	[-]	2fri38	-
Mars	: 7Fri36	[-]	22fri48	-
Vertex	: 12Fri34	[-]	7bro42	-
Pluto	: 2Deb48	[d]	8deb24	d
Aldebaran	: 5Deb10		15deb30	

Mercury & Neptune are in the house of Servants, which is the court of the Knight of Pentacles, the color Green and key of F-Locrian, the theoretical mode in which the tonic favors no other tone apart from itself. The servant is meticulous, and diligent in his pursuits. This mer-

curial mind is always hard at work in the sixth house with the wisdom of Neptune at his disposal. Mercury's quickly acquiring conjunction within one arcdegree of the super-powerful galactic center Sgr A*, also called the "Sun of our Sun" (\backslash sgrab is the standard of rest), is most notable. Next, Jupiter ruling in the house of Spirit is the color blue-indigo and key of A-flat Lydian, expansive augmentation in the court of Knight of Wands. Jupiter is the father of the music of the spheres, verily the tarot Emperor, with Empress Venus by his side, and Saturn's golden Judgment, while the mind of Mercury the Magician and wisdom of Neptune the Hermit combine their efforts in Virgo's house of science.

Clearly, the Gods were smiling on the great Sir Isaac Newton, as his natal horoscope testifies. Similarly any horoscope properly adjudicated paints a mans portrait by the light of the stars and notates his composition by the music of the spheres. The next chapter charts the horoscope of a world-famous composer, to further elucidate how Light & Sound deciphers its portent.

Chapter 5 Chromatic Transposition

CERTAINLY THE GREATEST musical genius of all recorded history, Ludwig van Beethoven was born to Johann van & Maria Magdalena Keverich (Leym)- Beethoven at their house,—now a museum—the Beethoven-Haus, Bonngasse 20, D- 53111 Bonn, Koln, Nordrhein- Westfalen, Deutschland (exact coordinates 007E06:03 50N44:13) Sun's day December 16th anno Domini 1770, near h.I m.XXX post meridiem horologii mathematici; he was baptised the following day as recorded on Monday morning the 17th. Note that Neptune transits the cusp less than five minutes prior to calculation.

The competition between Mercury and Jupiter tricked Zeus into submission (the untamed Locrian modality of shrewd and crafty Hermes readily steals from the other Gods), so thank goodness for Neptune's transit to wisdom's resuscitation on the octave of Mercury toward Saturn second house of horoscope @ 13:24:05 LAT (13:20:18 LMT i.e. within five minutes before birth time). In approaching superior conjunction, Mercury takes to rule in the sixth house of the horoscope, with the Sun & Moon therein, the Sagittarian falls under the control of Mercury's Servants.

Venus superior is ruling nearby in the first house of evening, i.e. seventh house of the horoscope, of Marriage, tail of the dragon therewith is for Pluton-souljourn by or before transit on the local meridian, that is necessarily after 13:20:18 LMT but before 13:31:04 LMT: the judicial window of rectification since souljourns occur at, or within hours after, the time of birth as in this case after Neptune's transit at 13:20:18 LMT (which is 13:24:05 LAT or 12:51:54 UT). Remember, that Pluton is the center of human hearing, who is on the resonant Ionian octave of Aphrodite (Venus). Mercury's theft of the horoscope from Mars forces the Pluton souljourn under Aphrodite's reign.

Thus, the percussive meter of father time, Kronus, there with earthquaking Poseidon in the second house of morning, that of Riches, Saturn & Neptune are together ruled by Venus inferior, Lucificus who is our fiery passion for life and living in sin.

On account of latitudinal ascendant (50N44:13) first house of morning (i.e. of terrestrial zodiac), thus part of fortune is therealoft in tenth house of the horoscope which is the house of Society; Ouranos is yet a quarter-hour below the ascendant with the part of spirit—a very strong influence in the chart, but not strong enough to dethrone Hermes from the sixth house. Thus Mars at opposition to Mercury is in the twelfth house of the horoscope in Indebtedness to Neptune and Jupiter-inferior. The head of the dragon falls in the fifth house, that of Sons.

Mars, Saturn, Uranus & Neptune are retrograde, the Sun, Venus, Saturn & Neptune are closing benefic by radial velocity, with Venus the nearest planet at 0.337 AU and closing the distance.

Since we covered decans and pentads in previous chapters, the chart of Beethoven focuses on its astronomical precision, and dominant key characteristics as are revealed in his horoscope, telling us a lot about the man and his mastery of composition:

Cardinal Day: 09:24.42:37
 Tropical Day: 09:24:43:08
 Julian Day: 2367889.03931
 LAT: 13:28:47 16-Dec-1770
 LMT: 13:25:00 16-Dec-1770
 UTC: 12:56:36 16-Dec-1770
 TDT-UT: +15.3836 sec
 Obliquity: 23* 28' 09"
 Sidereal Time: 19h 05m 45s
 Metonic calendar: 29 Kislev 5531
 Islamic calendar: yawm al-'ahad
 27 Sha`ban 1184 (1948439.17=1AH)
 Mayan Long count: 12.7.14.8.6
 Haab: 19 Yax; Tzolkin: 10 Cimi

Body	Caelestial	Latitude	r	Hs	RUL.	Velocity
Antemidhea:	23Gem32'34"	+ 0:00'00"	1			
Wasat :	23Gem44'05"	- 0:12'18"	1		deGem	
Saturn :	24Can12'04"	+ 0:53'16"	F	2	[-]	-0.0355277
Merak :	24Can37'10"	+45:06'27"	2		beUMA	
Mizar :	20Leo51'16"	+56:21'54"	2		zeUMA	
/Neptune :	22Leo23'37"	+ 0:58'44"	-	2	[-]	-0.0002224
\6th Cusp :	23Leo39'55"	+ 0:00'00"	3			
Vertex :	21Vir36'44"		d	3	[-]	
Descendant:	14Lib10'56"		4			
True Node :	4Sco54'01"	+ 0:00'00"	-	5	[F]	-0.0432663
9th Cusp :	25Sco55'22"	+ 0:00'00"	6			
Moon :	26Sco23'44"	+ 1:55'01"	d	6	[-]	+12.220225
Mercury :	1Sag00'32"	- 1:12'59"	F	6	[R]	+1.5760049
Gal.Center:	2Sag03'12"	- 5:34'40"	6		SgrA*	
Sun :	3Sag07'16"	- 0:00'00"	-	6	[-]	+1.0188727
Eltanin :	3Sag09'41"	+74:57'12"	6		gaDra	
Jupiter :	11Sag38'29"	+ 0:03'47"	R	6	[F]	+0.2299043
/Midheaven :	23Sag32'34"	+ 0:00'00"	7			
*Pluto :	24Sag57'25"	+ 0:00'36"	-	7	[-]	+0.0319349
Venus :	5Cap10'16"	- 0:32'25"	-	7	[R]	+0.1376402
Lilith :	12Cap03'31"	+ 4:47'44"	-	7	[-]	+0.1119266
V.Equinoct:	8Pis24'08"	+ 0:00'00"	9			-0.0000385
East Point:	26Pis13'45"	+ 0:00'00"	-	10	[e]	
Fortune :	7Ari27'23"		-	10	[-]	
Sheratan :	9Ari10'55"	+ 8:28'41"	10		beAri	
Hamal :	12Ari52'13"	+ 9:57'32"	10		alAri	
Ascendant :	14Ari10'56"		10			
Uranus :	20Ari32'09"	- 0:23'11"	-	10	[-]	-0.0272934
Spirit :	20Ari54'28"		-	10	[-]	
Aldebaran :	15Tau00'00"	- 5:29'02"	11		alTau	
Mars :	0Gem54'39"	+ 2:56'03"	-	12	[-]	-0.3889445
Saiph :	1Gem36'51"	-33:06'02"	12		kaOri	

Radial Distance/v
 Earth: 00.0000000~
 Pluto: 34.5712237-
 Neptune: 29.9928352+
 Uranus: 18.9085958-
 Saturn: 08.4785687+
 Jupiter: 06.1853794-
 Mars: 00.5822229-
 Sun: 00.9837156+
 Venus: 00.3369469+
 Mercury: 01.4472653-
 Moon: 00.0026699-
 Node: 00.0026336+
 Lilith: 00.0027106~

Fundamental Aspects

1: Sun (Sag) Con (Sag) Mercury - orb: a2:06'
 2: Moon (Sco) Con (Sco) 9th Cusp - orb: a0:28'
 3: Sun (Sag) Opp [Gem] Mars - orb: s2:12'
 4: Mercury (Sag) Opp [Gem] Mars - orb: s0:05'
 5: Sun (Sag) Con (Sco) Moon - orb: a6:43'
 6: Pluto (Sag) Con (Sag) Midheaven - orb: a1:24'
 7: Moon (Sco) Con (Sag) Mercury - orb: a4:36'
 8: Neptune [Leo] Tri (Sag) Pluto - orb: s2:33'
 9: Uranus [Ari] Tri [Leo] Neptune - orb: s1:51'
 10: Moon (Sco) Tri [Can] Saturn - orb: s2:11'
 11: Venus (Cap) Sex [Sco] Node - orb: s0:16'
 12: Moon (Sco) Opp [Gem] Mars - orb: a4:30'
 13: Moon (Sco) Squ [Leo] Neptune - orb: s4:00'
 14: Uranus [Ari] Tri (Sag) Pluto - orb: s4:25'
 15: Neptune [Leo] Con (Leo) 6th Cusp - orb: s1:16'
 16: Saturn [Can] Squ [Ari] Uranus - orb: a3:39'
 17: Venus (Cap) Squ (Ari) Fortune - orb: s2:17'

Fiducial Aspects

18: Sun (Sag) Con (Sag) Eltanin - orb: a0:02'
 19: Saturn [Can] Con (Can) Merak - orb: s0:25'
 20: Mars [Gem] Con (Gem) Saiph - orb: s0:42'
 21: Antemid (Gem) Con (Gem) Wasat - orb: a0:11'
 -adjudicated by Daniel Joseph Min 7 February 2002

Notably, Ludwig van Beethoven died about three-quarters of an hour before sunset, Monday 26 March 1827 at about 5:30 PM LMT (GMT +1:05), Polaris souljourn at the zenith in the lightning.

Chart Interpretation By Light & Sound

The musical theme of Beethoven's natal chart is in the key of F-Locrian for ruling Mercury and Gb-Ionian for Venus & Pluton, in effect transposing the relative diatonic positions between the half-step interval 'B' to 'C', for the Locrian and Ionian respectively, likewise to the 'F' and 'Gb' of Virgo and Libra on the chromatic scale, in this case of the horoscopic zodiac.

Like Isaac Newton, Beethoven's natal Mercury was acquiring in conspicuously close conjunction to the galactic center Sgr A*, though Beethoven enjoyed a distinct advantage with the nearby Sun & Moon joining side by side together with Mercury therein the house of Servants, Jupiter also. Venus with Pluto seventh house brings their beautiful Ionian modality to the center of the horoscope, with Venus on the crest of the wave. As we see, Jupiter, Moon, Mercury & Venus reap the benefit of the Ionian in Gb and a half-step down, the same planets benefit from the Locrian in the same respective tones and colors of the zodiac:

Libra - Ionian						
EMPRESS (Venus) - Three of Swords						
FOOL (Pluton) - Ten of Swords						
III	IV	V	VI	VII	I	II
Bb	B	Db	Eb	F	Gb	Ab
IVi	Vio	ROR	OYe	Gre	GB1	BIn
Aqu	Pis	Tau	Can	Vir	Lib	Sag
Mar	Jup	Sat	Moo	Mer	Ven	Sun
	R		R	R	R	
Virgo - Locrian						
MAGICIAN (Mercury) - Two of Pentacles						
IV	V	VI	VII	I	II	III
Bb	B	Db	Eb	F	Gb	Ab
IVi	Vio	ROR	OYe	Gre	GB1	BIn
Aqu	Pis	Tau	Can	Vir	Lib	Sag
Mar	Jup	Sat	Moo	Mer	Ven	Sun
	R		R	R	R	

Which brings us to a very important principle regarding these sidereal modalities of the planets, in that each mode is made according to the planets' sidereal orbital distances from the Moon to Pluton. Of course the Sun and Moon are unique in that they both orbit Earth, relatively speaking. They are referred to as "twins", since the Sun is around 400 times further away from the Earth than the Moon is and the Sun is also about 400 times greater in diameter than the Moon is, hence they appear to be approximately the same size, as becomes apparent during a total solar eclipse. The principle of the sidereal modes of planets is that each planet is part of one whole solar system, just as each synodic phase or aspect of the very same planets to the Earth renders one whole zodiac. We cannot consider the sidereal modality of any particular planet, without reference to the other planets who compose the particular planet's mode. Similarly, we cannot consider a particular sign of the zodiac without regard to the entire zodiac and planets who define it.

In other words the synodic aspect of a particular planet made to the Earth is geocentrically either superior or inferior at the time for which the chart is calculated — this irrespective of the horoscope, but strictly with respect to the Sun to the Earth, since the planets orbit the Sun

and the Sun orbits the Earth, so the planets in effect orbit the Earth epicyclically, just as Earth's Moon effectively orbits the Sun epicyclically.

While the apparent relationships of the planets and planetary orbits are easy enough to visualize, describing this in terms of simple English isn't so easily accomplished as you can see. But I've had plenty of practice translating analytic geometry into plain text, so I won't hesitate to do so in this chapter.

Imagine yourself at the center of a planet, then "seeing" the other planets in motion relative to you. That's simple enough for our home planet Earth, but takes some creative discipline to visualize seeing from the other planets, including the Sun and Moon, from whose respective vantage points we can see the Earth in orbit relative to other planets in this solar system (some refer to this as "soul travel", which between lifetimes is literally the case). Here, we are merely using imagination.

As in Beethoven's natal horoscope we must consider the Ionian mode as being transfixed under the key of Gb, i.e. Venus, Sun, Mars, Jupiter, Saturn, Moon and Mercury in the signs of Libra, Sagittarius, Aquarius, Pisces, Taurus, Cancer, and Virgo, respectively. We acknowledge the behavior of each planet in each respective sign, as with Venus in Libra by virtue of her rule thereover and therefore therein: Libra is the superior aspect of Venus within the zodiac; notably, Venus is approaching her maximum elongation from the Sun (Thu 20-Dec-1770 12:28:58 UT), reinforcing her Libran reign by horoscope and radial velocity.

These are two distinctive issues: one, the synodic phase of a planet to the Earth; and two, the sidereal orbital pathway of the planets in the context of the whole solar system together. Beethoven's horoscope finds Venus ruling in two distinct ways:

1) The apparent synodic motion of Venus with respect to the Sun i.e. Venus synodic and the Sun sidereal to the Earth, and this without specific reference to the other planets. This reign of Venus is for the soul, the ensign of Libra, ergo the third heaven closing benefic by radial velocity.

2) The sidereal orbital path of Venus around the Sun wholly with respect to the other planetary orbits which compose Venus' sidereal Ionian modality, and all of which refers to the sidereal order of the planets based on the orbits, and therefore, results in the numbering of the horoscope; Venus' mode is transposed to the key of Gb in the zodiac. Again, this requires all of the planets and zodiac signs to be considered as one, all as part of the whole system, which altogether pertains to soul's terrene incarnations.

The planetary modalities are sidereal while transposition is synodic; the former eternal, the latter temporal. Understand?

So you see Beethoven's natal Venus is acquiring near maximum superior elongation from the Sun, verily the ensign of Libra. Also, Beethoven's natal horoscope finds Venus in the seventh house, thus her sidereal orbital modality transposes all the other planets' orbits accord-

ingly, with our souljourns among the ten heavens empowering its mode since each mode requires all seven of the planetary orbital paths for its composition, as the three outer planets add their repeat mode in the bass, as Earth's caelestial firmament, atmosphere, and terra firma, as carefully explained & charted in my Compleat Tarot Manual.

In other words, it is our individual and collective sojourns in each heavenly sphere which enables the planetary modality and characteristics for that order of the planets or heavens, in which we as souls are moving along the path of the planet, which in turn influence us as souls-incarnate upon the Earth according to each planet's muse, its relative ethos in heaven. This sojourning influence includes our incarnations on Earth to the aggregate sum-totality of experience in soul-and-body.

The pronounced distinction between the planetary spheres and their sidereal orbital distances vs. apparent synodic motion to the Earth is best illustrated by the relationship between a violin bow and the violin string. The "bow" is the planets, the "strings" their respective orbits. Strings on our violin represent the sidereal orbits & macrocosmic valence bands of the planets in our solar system. We can visualize this solar system connecting with other solar systems, much as elements combine into molecules, as tiny magnets following attraction one to the other. In this sense, the entire universe is somehow and in some way interconnected by the astrological forces, just as huge molecules of galaxies are connected in clusters and so on ad infinitum. In every solar system, orbital paths of the planets form or splay out in diatonic intervals, from the primordial soup of their conception, inception, creation, until fruition, extinction, decomposition and disintegration. Hence, the planets and their orbits are inextricably related, each planet to its orbit, each planet and orbit to the whole.

This is our development, the exegesis of universal astrology. The cosmic bow of the planets is bowing the strings of their orbits always in real-time or the ever-presence of existence. The strands of the bow always work together, resonating each string according to its open tuning and position. Every fret, or chromatic fingering positions along the fretless neck, is representative of the houses of the horoscope, each a unique composition comprised of soul-in-body, as houses and planets in our adjudicated horoscope, the undulating snake of rhythm as the meter of the planets transposing across the zodiac of the horoscope as they transit house-cusps in sidereal hourly intervals, roughly speaking, rectified by the synodic motion of planets within the Earth's houses as numbered by the same. These are called "progressions" and pertain to the horoscope.

Beethoven's natal Mercury rules in the sixth house, although Mercury is barely inferior to the Sun acquiring in close orb of about 2 minutes 6 seconds of arc. Here we find Mercury is having the same effect on the planets in the Locrian mode, a half-step below the Ionian mode of Venus in horoscopic Libra. Thus you see, a planet need not be in corresponding inferior or superior aspect in order to be ruling via its superior or inferior house in the horoscope. As in

this case, Mercury is inferior (to the Sun), but rules in Mercury's superior house, because Mercury's phase depends only on the Sun to the Earth, while the horoscope is composed of the Pantheon of the Gods.

There's certainly much more which could be said of Beethoven through reading his natal horoscope but I leave such reading to others. Chapter six will focus on the circle of fifths in the zodiac and how each mode is transposed through its signs.

Chapter 6 Going In Circles

SO FAR we've learned about diatonic & chromatic colors and tones of the zodiac, diatonic modes of the planets, the decanates & pentades in the horoscope and how they are computed—using the natal chart of Isaac Newton as an example; the natal chart of Ludwig van Beethoven as the preeminent example of horoscope interpretation via modes of ruling planets by transposition in the zodiac, and the general distinction between sidereal & synodic orbits of the planets and their astrological influence on the eternal soul and temporal body of life on Earth.

Music is the divine expression of the Gods & Goddesses, as the most esteemed ancient philosophers and prophets have concertedly reiterated, with latter-day musicians demonstrating time and time again that music is sacred, even magical, since music itself exists because of the very Gods who created it—and the Muses who promote it! The Muses, the beautiful daughters of Zeus & Mnemosyne, the nine who are in fact the seven diatonic modalities of the heavens with two repeat modes in the bass, then middle C, the tone of Pluton at the center of activity.

Astrology is built on the mathematics of music and its rudimentary tones, its harmonies, melodies and rhythms, its crescendos and overtones, consonances, dissonances, and resonances, its colors, its hues, its unparalleled capacity to express that which is otherwise intangible; Bach, Beethoven, Beatles, Hendrix, Zeppelin, Floyd, or any other composer or performer of music who you enjoy, be it classical, rock or jazz, country, hip hop or any other style of music that you savor — that's good music. Even the music that you don't care for, or even detest, if anyone out there likes it, it's good music for them, hence the maxim "beauty is in the eye of the beholder". Mother nature is alive with her own genres of music in concert twenty-four hours a day. Everywhere you listen in nature her songs can be heard. One need only listen.

Now we come to the traditional circle of fifths, which is the order of major key signatures linked by perfect fifths, beginning with the key of C, the center of our human hearing, and diatonic tone of Pluton & Mnemosyne (recall that Pluton and Poseidon are brothers of Zeus).

This circle of fifths adds one sharp per perfect fifth above C in a contiguous series; the key of C is simply the diatonic Ionian modality beginning on C, whose key has no sharps or flats. Next the perfect fifth above C begins the key of G, which adds its one sharp tone, F#. Climb up another perfect fifth from the G and you land on D, which key signature adds a C# in addition to the F#, so the key of D has two sharps, F# and C#. Next we climb to the key of A with three sharps F#, C#, and G#. The fifth up to E needs four sharps F#, C#, G#, and D#. Then the fifth up to B has five sharps, F#, C#, G#, D#, and A#. From here the key signature jumps up a perfect fifth to F#, with six sharps F#, C#, G#, D#, A# and E#, where the E# is the same

as the F, but is notated as a E# in the key signature of F# major. Lastly, the seven sharps are F#, C#, G#, D#, A#, E# and B# in the key of C#, where the B# is really the C, but is notated as B#.

Notably, the seven days of the week are actually named for the sidereal orbits of the seven naked-eye visible planets in diatonic fifths — no sharps or flats allowed, from the Sun’s Dorian mode to Saturn’s Mixolydian mode. The difference from our circle of fifths is that these are strictly diatonic fifths, but not chromatic fifths as we see above using the traditional circle of fifths; meaning that the perfect-diatonic fifth above B is not F#, but is necessarily the diminished fifth to Jupiter, the Lydian mode which is naturally in the diatonic key of F, not F# as in our chromatic circle of fifths. See?

Thus the first day of the week is Sun’s day and Dorian mode, which begins on D. Up a fifth for the second day of the week, Moon’s day, Aeolian mode and the key of A. Up a fifth to Mars’ day, whose Phrygian mode is in the diatonic pitch key of E. Up a fifth to B, is Mercury’s day in the theoretical Locrian mode. Next is the fifth day of the week, Jupiter’s day, the Lydian mode in the diatonic key of F natural. Up a fifth to the sixth day, Venus’ day, her beautiful Ionian mode, in the key of C. Lastly, with the days of creation complete is Saturn’s day in the Mixolydian modality, and the pitch key of G.

The following charts illustrate tonal relationships in raising each of the seven modalities by perfect fifths. You’ll notice that each mode adds the same sharp tones for every perfect fifth on the entire circle of fifths:

DIATONIC MODALITY - ZERO SHARPS:

A	B	C	D	E	F	G	Aeolian						
	B	C	D	E	F	G	A	Locrian					
		C	D	E	F	G	A	B	Ionian				
			D	E	F	G	A	B	C	Dorian			
				E	F	G	A	B	C	D	Phrygian		
					F	G	A	B	C	D	E	Lydian	
						G	A	B	C	D	E	F	Mixolydian

UP ONE PERFECT FIFTH - ONE SHARP:

A	B	C	D	E	F#	G	Dorian						
	B	C	D	E	F#	G	A	Phrygian					
		C	D	E	F#	G	A	B	Lydian				
			D	E	F#	G	A	B	C	Mixolydian			
				E	F#	G	A	B	C	D	Aeolian		
					F#	G	A	B	C	D	E	Locrian	
						G	A	B	C	D	E	F#	Ionian

UP TWO PERFECT FIFTHS - TWO SHARPS:

A	B	C#	D	E	F#	G	Mixolydian
	B	C#	D	E	F#	G	A Aeolian
		C#	D	E	F#	G	A B Locrian
			D	E	F#	G	A B C# Ionian
				E	F#	G	A B C# D Dorian
					F#	G	A B C# D E Phrygian
						G	A B C# D E F# Lydian

UP THREE PERFECT FIFTHS - THREE SHARPS:

A	B	C#	D	E	F#	G#	Ionian
	B	C#	D	E	F#	G#	A Dorian
		C#	D	E	F#	G#	A B Phrygian
			D	E	F#	G#	A B C# Lydian
				E	F#	G#	A B C# D Mixolydian
					F#	G#	A B C# D E Aeolian
						G#	A B C# D E F# Locrian

UP FOUR PERFECT FIFTHS - FOUR SHARPS:

A	B	C#	D#	E	F#	G#	Lydian
	B	C#	D#	E	F#	G#	A Mixolydian
		C#	D#	E	F#	G#	A B Aeolian
			D#	E	F#	G#	A B C# Locrian
				E	F#	G#	A B C# D# Ionian
					F#	G#	A B C# D# E Dorian
						G#	A B C# D# E F# Phrygian

UP FIVE PERFECT FIFTHS - FIVE SHARPS:

A#	B	C#	D#	E	F#	G#	Locrian
	B	C#	D#	E	F#	G#	A# Ionian
		C#	D#	E	F#	G#	A# B Dorian
			D#	E	F#	G#	A# B C# Phrygian
				E	F#	G#	A# B C# D# Lydian
					F#	G#	A# B C# D# E Mixolydian
						G#	A# B C# D# E F# Aeolian

UP SIX PERFECT FIFTHS - SIX SHARPS:

A#	B	C#	D#	E#	F#	G#	Phrygian
	B	C#	D#	E#	F#	G#	A# Lydian
		C#	D#	E#	F#	G#	A# B Mixolydian
			D#	E#	F#	G#	A# B C# Aeolian
				E#	F#	G#	A# B C# D# Locrian
					F#	G#	A# B C# D# E# Ionian
						G#	A# B C# D# E# F# Dorian

UP SEVEN PERFECT FIFTHS - SEVEN SHARPS:

A#	B#	C#	D#	E#	F#	G#	Aeolian
	B#	C#	D#	E#	F#	G#	A# Locrian
		C#	D#	E#	F#	G#	A# B# Ionian
			D#	E#	F#	G#	A# B# C# Dorian
				E#	F#	G#	A# B# C# D# Phrygian
					F#	G#	A# B# C# D# E# Lydian
						G#	A# B# C# D# E# F# Mixolydian

Similarly, while we descend by perfect fifths down the scale for each mode, flat keys are added in succession:

DIATONIC MODALITY - ZERO FLATS:

A	B	C	D	E	F	G	Aeolian						
	B	C	D	E	F	G	A	Locrian					
		C	D	E	F	G	A	B	Ionian				
			D	E	F	G	A	B	C	Dorian			
				E	F	G	A	B	C	D	Phrygian		
					F	G	A	B	C	D	E	Lydian	
						G	A	B	C	D	E	F	Mixolydian

DOWN ONE PERFECT FIFTH - ONE FLAT:

A	Bb	C	D	E	F	G	Phrygian						
	Bb	C	D	E	F	G	A	Lydian					
		C	D	E	F	G	A	Bb	Mixolydian				
			D	E	F	G	A	Bb	C	Aeolian			
				E	F	G	A	Bb	C	D	Locrian		
					F	G	A	Bb	C	D	E	Ionian	
						G	A	Bb	C	D	E	F	Dorian

DOWN TWO PERFECT FIFTHS - TWO FLATS:

A	Bb	C	D	Eb	F	G	Locrian						
	Bb	C	D	Eb	F	G	A	Ionian					
		C	D	Eb	F	G	A	Bb	Dorian				
			D	Eb	F	G	A	Bb	C	Phrygian			
				Eb	F	G	A	Bb	C	D	Lydian		
					F	G	A	Bb	C	D	Eb	Mixolydian	
						G	A	Bb	C	D	Eb	F	Aeolian

DOWN THREE PERFECT FIFTHS - THREE FLATS:

Ab	Bb	C	D	Eb	F	G	Lydian						
	Bb	C	D	Eb	F	G	Ab	Mixolydian					
		C	D	Eb	F	G	Ab	Bb	Aeolian				
			D	Eb	F	G	Ab	Bb	C	Locrian			
				Eb	F	G	Ab	Bb	C	D	Ionian		
					F	G	Ab	Bb	C	D	Eb	Dorian	
						G	Ab	Bb	C	D	Eb	F	Phrygian

DOWN FOUR PERFECT FIFTHS - FOUR FLATS:

Ab	Bb	C	Db	Eb	F	G	Ionian						
	Bb	C	Db	Eb	F	G	Ab	Dorian					
		C	Db	Eb	F	G	Ab	Bb	Phrygian				
			Db	Eb	F	G	Ab	Bb	C	Lydian			
				Eb	F	G	Ab	Bb	C	Db	Mixolydian		
					F	G	Ab	Bb	C	Db	Eb	Aeolian	
						G	Ab	Bb	C	Db	Eb	F	Locrian

DOWN FIVE PERFECT FIFTHS - FIVE FLATS:

Ab	Bb	C	Db	Eb	F	Gb	Mixolydian						
	Bb	C	Db	Eb	F	Gb	Ab	Aeolian					
		C	Db	Eb	F	Gb	Ab	Bb	Locrian				
			Db	Eb	F	Gb	Ab	Bb	C	Ionian			
				Eb	F	Gb	Ab	Bb	C	Db	Dorian		
					F	Gb	Ab	Bb	C	Db	Eb	Phrygian	
						Gb	Ab	Bb	C	Db	Eb	F	Lydian

DOWN SIX PERFECT FIFTHS - SIX FLATS:

Ab	Bb	Cb	Db	Eb	F	Gb	Dorian
	Bb	Cb	Db	Eb	F	Gb	Ab Phrygian
		Cb	Db	Eb	F	Gb	Ab Bb Lydian
			Db	Eb	F	Gb	Ab Bb Cb Mixolydian
				Eb	F	Gb	Ab Bb Cb Db Aeolian
					F	Gb	Ab Bb Cb Db Eb Locrian
						Gb	Ab Bb Cb Db Eb F Ionian

DOWN SEVEN PERFECT FIFTHS - SEVEN FLATS:

Ab	Bb	Cb	Db	Eb	Fb	Gb	Aeolian
	Bb	Cb	Db	Eb	Fb	Gb	Ab Locrian
		Cb	Db	Eb	Fb	Gb	Ab Bb Ionian
			Db	Eb	Fb	Gb	Ab Bb Cb Dorian
				Eb	Fb	Gb	Ab Bb Cb Db Phrygian
					Fb	Gb	Ab Bb Cb Db Eb Lydian
						Gb	Ab Bb Cb Db Eb Fb Mixolydian

So you see, there are only seven unique key signatures that are built on the explicitly diatonic scale of the planets. All others require at least one sharp or flat tone for its modal transposition. The circle of fifths ascending & descending begins on the diatonic scale of the planets but expands by scalar transposition to the chromatic zodiac along the twelve-tone scale. There're two particularly notable features regarding this modal behavior. One, that the seven naturally-diatonic tones of the seven planetary modalities are centered just as the naturally-chromatic tones for the twelve planetary signs of the zodiac are likewise centered: on middle-C.

And two, that this correspondence between the diatonic modes and chromatic scales is fixed by sidereal orbits of the planets in their synodic positions superior and inferior to the Sun. It's the Earth's orbital distance from the Sun i.e. between the orbits of Venus and Mars, which numbers the Sun as the fourth heaven, with Venus third and Mars fifth, our Moon first, & Mercury second.

Thus the natural key characteristics of the planets in their respective modalities is established strictly by their sidereal order of orbit. Since the natural pitch key for each planet is inextricably fixed to the first tone commencing its diatonic modality, it is necessary that the Moon be associated first with the A above the middle-C, ergo the Aeolian modality for which her muse Klio is named. By impressing this upon your memory you will begin to automatically recognize the diatonic key of A as the Moon's by her Aeolian order in the heavens; which order emerges from the sidereal order of planets, just as the planets themselves emerged in their orbits according to the very same order thereby empowering it. It seems the creation and the idea of the creation are one in the same where the Gods & Goddesses are present.

By associating the sidereal order of the other planets with their respective modes and fundamental pitch keys, you will begin to hear the relative key characteristic for each planet

among the solar system thus altogether as a team, since each planet's modality shares exactly the same seven tones as the other planets do, only the order is unique to each planet. That's what determines each planet's natural key characteristics — in contrast to those key characteristics for the other six planets out to Saturn, and repeat modalities for outer planets.

You've seen by transposition how these unique keys and modes of planets interact & overlap in the spectrum of the zodiac, including how they share common sharps and flats when transposed through the circle of fifths, up and down the chromatic scale. Above this lofty plateau would be the study of music theory, chord progressions, inversions, smooth voicing, composition, orchestration, etc. That's all fine, but this study is focused on the astrology of light & sound — light & sound of astrology. The planets and signs are the stars of this exhibition. They are I AM of the Gods, as the bible calls LORD God. Music is divine, color is divine & astrology is divine.

Therefore, the next chapter will focus on the profound associations of Light & Sound with the planets & signs, the essentials for understanding who the Gods are, and how they behave in our zodiac — the real source of myth, and the true composition of our psyche for we are Gods.

Chapter 7

Center Of Creation

THE SOLAIRES-LUNAIRES chart as depicted in chapter one reiterates the direct correspondences between sidereal orbits and synodic aspects of the planets to the Earth, by using the piano keyboard to show the diatonic scale of the white keys and the chromatic scale adding black keys, which together demonstrate the musical basis for the activity of the planets, ergo music of the spheres. Remember, this is the foundation of all classical myth.

For convenient reference, here is the same chart again, but this time labeling only the planets and ensigns to the corresponding tones relative to middle C—which is the center of human hearing. This natural relationship between the sidereal planets and their chromatic signs reveals the tonal resonance of the planetary orbits to their planetary ensigns, which they mutually co-create; to wit, see how Pluto sidereally correlates with Aries at the center of our chromatic scale; Venus with Aries on the octave above middle-C; Saturn goes with Scorpio; Moon with Capricorn above middle C, and Uranus is also with Capricorn one octave below the Moon; Neptune with Pisces is the only planet/sign correspondence which is congruent with its sidereal orbit -and- synodic ensign. Note how Jupiter and Mercury are in direct competition, not by mutual rejection in the houses, but is fixed by sidereal-to-synodic transliteration—the zodiac itself. This distinction is the subject of this entire chapter:

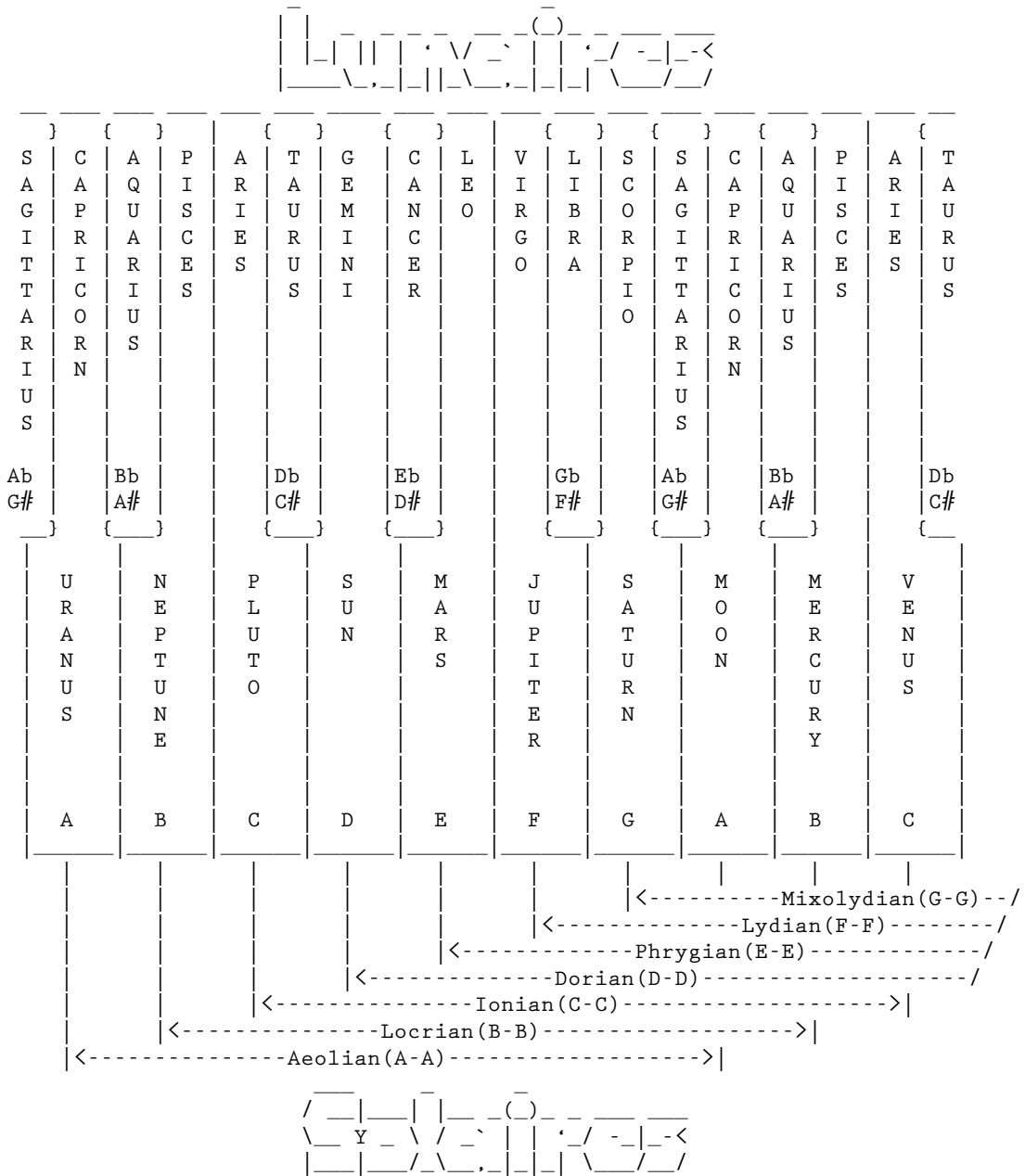

Thus, there is a bidirectional synergy of the sidereal orbits of the ten planets with the twelve signs of the planetary zodiac which is altogether fixed directly to the center of our hearing. This last point is critical, since without our direct psychic-connectivity with the planets

on the caelestial sphere plus our direct human relationship with very same planets in our terrestrial sphere (i.e. planets in our horoscope), then the study of the astrological influence between the planets with the Earth and with each human being hereon (really all life, be it animal, vegetable or mineral), any pursuit that ignores these fundamental principles of astrology quickly loses its psychological & physical lustre, its real and active judicial-astrological influence on all of us—each in concert with his or her natal horoscope, and collectively in the orchestra of our life on Earth.

Sometimes, the best way to expound and reinforce an established precept, or universal principle, is achieved by applying the same set of self-evident rules to some common but incongruous object; whereby juxtaposing the most extrusive qualities of both thereby we notice its coincident protrusions. Such is instantly accomplished by applying the same principles of sidereal-to-synodic transliteration for any other solar system planets i.e. besides the Earth. In this example, I've selected Mars given its many anomalous and likely man-made monuments found thereon beginning with the old Viking photos, as have been analyzed & scrutinized by a panel of experts:

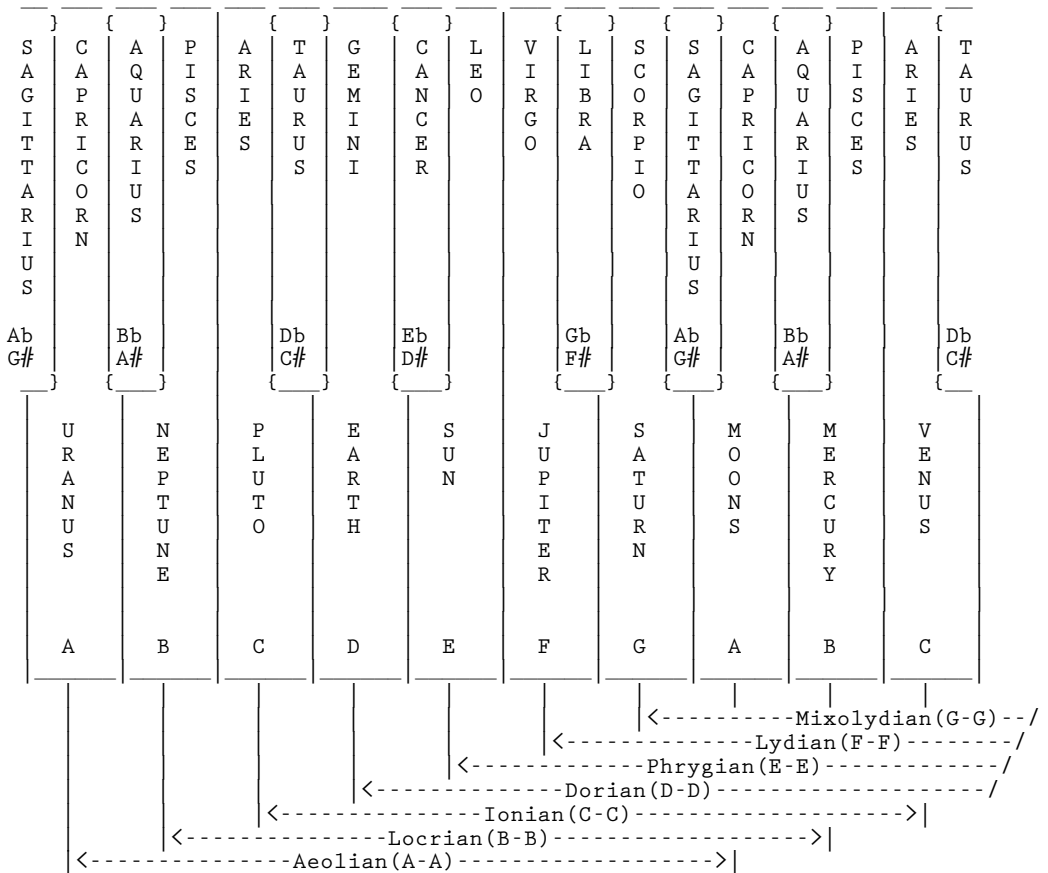

In stark juxtaposition, we find surprisingly identical diatonic-to-chromatic correspondence as found on Earth; don't be so surprised. Astrology is a bonafide science. As we shift the universal law to each planet, then the astrology of that planet reflects the rules we applied. Of course, such principles extend to all other planets, each according to its solar orbit and synodic position. IOW, the Sun describes every planet's ecliptic. Get it? The implications of this are staggering...and pristine.

E.g. using the Astrolog (5.41G) program you can change the central planet under settings>calculation settings, albeit the ecliptic is fixed to the Earth irregardless. Forgive such limitations—humans are confined to Earth! It's a cinch to adjust for any other planet's ecliptic, by adding or subtracting its relative degrees to Earth. Of course these are approximate, depending on latitude. For exact equations, you need to use analytic geometry.

Whether or not Mars is disclosing artificially-erected structures is irrelevant to this tit-for-tat rendition of classical astrology onto the Red Planet. Let us put ourselves standing thereon: Look! The Earth & Moon are now a distant inner-planet with its satellite thus are seen in league with Mercury & Venus, in that all three are revolving synodically faster about the Sun. Notice two rather small and ill-proportioned moons encircling us. The great asteroid belt bears mute testimony to an ancient planet destroyed by nature, or perhaps by some man-made cataclysm? No matter, since we're but looking at the sidereal-to-synodic protocol as applied to Mars, using the very same diagram as we use for planet Earth; moons phobos & deimos count as one as with all planets, as Gods testify that even dozens of moons count as one.

Please don't misinterpret, these moons are still moons; IOW, such influence of moons are massively distributed. Take the mass equations of the composite force. Get it? The proximate sphere of each moon defines its "sphere". The need of souls to interact with each sphere is real. Their composite orbit retails by the center of Jupiter.

These asteroids are all that remains of the old planet. I do not believe that souls inhabit this extinct realm. Asteroids have slightly more effect to Mars than Earth. The "king planet" Jupiter seems to dominate the effect, since Jupiter is no doubt a centered mass; whereas the asteroid belt embodies the epitome of centerless orbit.

While not one other planet besides Earth is inhabited at the present time, our soul dwells in one or more spheres before incarnating again at some point in Earth's future; eventually experiencing the heavens many times over till we've learned to sow righteousness and reap thanksgiving. IOW, until we've experienced enough lessons to be humble under God the Creator and participate in Gods' handiwork, which are the heavens and the earth, and all life herein.

As Cayce said in reading 3744-4 (dated Nov. 1923), these heavenly interludes are just outside relativity of force. These interconnective conditions for each heavenly realm, as they relate to one another, exist "just outside" this mundane realm of our earthly, soul-with-body experi-

ences. So it isn't until that discarnate soul, who returns from its place in heaven, its plane of consciousness, its own view of Earth from that sphere of souljourning, it isn't until that soul intercepts the newborn infant body, that the aforesaid vantage point from heaven exerts an actual force or astrological influence upon our temporal living, influencing our will, and every choice that we will ever make. It's the choices we've made that define conditions in the after-life for each departed soul... choose wisely!

Probably the best single revelation Cayce ever stated on astrology is made in reading 0398-002; here's an excerpt:

“EC: Yes, we have the body, [398], and those conditions in the astrological aspects; especially in reference to those adverse influences that appear eminent in the experience of the entity in the near future; as well as that which has been builded by the entity in its sojourns through the spheres of activity where there is such a gathering of influences as to become active in a body-entity. In giving that which may be understandable, and that which may be helpful from the material angle at this time, as we find, it would be well that all consider the varying aspects from that considered an astrological influence. As we have given through these channels, astrological influences are effective in the experience of each and every entity. However, when the activities of a soul-entity have been such as to cause or to form the appearance of the entity in a particular sphere of activity, the position of the sojourn of the entity to the earth has the greater influence than just the adverse or benevolent positions of the planet or of a whole solar system upon the entity's activity! Is this understood? (Pause) You should answer!”

“GC: I don't quite understand.

*(Continuing) Then, it is as this: When the activities of an entity, a soul in the earth, have been such that its passage ****from**** the earth would become a birth into the realm of matter known as Mars, Venus, Jupiter, Uranus, Neptune, Moon, Mercury, Polaris, or any of these that are effective in the universal influence, you see, the sojourn there and the position of the planets are more effective than the influence brought to bear because of a position in a certain place or portion of the universal forces, see? Hence, as we find, these conditions are only as urges; or, as may be termed from some reasons or seasons of thought, the planetary influences from their positions are either benevolent, adverse or inter-between these activities - one drawing upon another; but the entity's sojourn in those environs makes the impulse for the mental activity, rather than the position of these! Do we gather the variation?...”**[**emphasis added]***

Note where Cayce explicitly states that “a position in a certain place or portion of the universal forces” is not the effective force in astrology, but is our experiences in heaven and the relative positions of the same heavens to Earth at the time of birth...the first breath of life. I.e. heavenly experience of soul and earthly incarnation of body; heavenly psyche with elemental body. Understand?

That’s why sidereal astrology is used only to locate the planets relative to fixed stars, but not to misinterpret that caelestial chart as having substantial astrological influence by virtue of some planet in some constellation. Caelestial archetypes are universal forces so a planet’s position against the stellar constellations is arbitrary. Rather it’s the planets’ relative positions to the Earth, each planet “drawing one upon another” together exerting their combined rulerships in the houses of the horoscope, and in particularly by those planets nearer to the Earth, to wit, Mercury, Venus, Sun, Moon, Mars, Jupiter, Saturn. Cayce knew this. Nostradamus knew this. I know this, and now you know this, too. That’s why judicial astrology is the only realistic method for casting horoscopes. Others who depend solely on sidereal or tropical astrology have lost their sensibilities, thus misleading themselves and their students. Don’t fall into their abyss of ignorance.

We can say that the major arcana planets and signs shall “trump” minor arcana planets and signs in the tarot. Why? Because the divine willpower is slightly above influence, just outside, slightly beyond the temporal forces. While the forces rule the body (hence “the flesh is weak”), it is said that our eternal soul and the holy spirit are in concert with freewill else our will be not entirely free, but each to its own degree and its own extent rebellious against the Gods. Since the inception of Autumn & Even’s banishment from the Garden of Eden, death with soul’s de- parture to those conditions of each heaven of oversoul’s own devising—where the experience for soul is requisite.

It’s being there, being in heaven between incarnating on the Earth, that is soul’s “actuator” of consciousness as amassed over long epochs of experience in and out of the body. Wherever soul goes, there soul is! Our most recent souljourn is, not surprisingly, the most effective on us. We bring our heavenly diploma back with us to Earth, and apply that experience in our earthly existence. The more degrees we get, the better able we are to live our lives.

The proverbial old soul is far more experienced than the neophytes. The old soul knows that the beginner is wiser than the proud journeyman. An old soul is truly The Fool of tarot, which is the planet Pluto, the center of Earth, which as Cayce repeatedly says, is constantly developing. It manifests in ones awareness of others, of other souls. It’s the transcendence of oneself, the temperance of ego, to rule The Devil of the major arcana—archetype of self; lest that old beguiler rule you, and you don’t want that?

Now each of these ten heavenly spheres exists in its own plane of consciousness, or as called a thought-dimension. Each sphere performs its vital role in this solar system, with each

URANUS

S A G	C A P	A Q U	P I S	A R I	T A U	G E M	C A N	L E O	V I R	L I B	S C O	S A G	C A P	A Q U	P I S	A R I	T A U
Ab G#		Bb A#			Db C#		Eb D#			Gb F#		Ab G#		Bb A#			Db C#
	S U N	N E P		P L U	E A R		M A R		J U P		S A T		M O O		M E R		V E N
	A	B		C	D		E		F		G		A		B		C

NEPTUNE

S A G	C A P	A Q U	P I S	A R I	T A U	G E M	C A N	L E O	V I R	L I B	S C O	S A G	C A P	A Q U	P I S	A R I	T A U
Ab G#		Bb A#			Db C#		Eb D#			Gb F#		Ab G#		Bb A#			Db C#
	U R A	S U N		P L U	E A R		M A R		J U P		S A T		M O O		M E R		V E N
	A	B		C	D		E		F		G		A		B		C

PLUTO

S A G	C A P	A Q U	P I S	A R I	T A U	G E M	C A N	L E O	V I R	L I B	S C O	S A G	C A P	A Q U	P I S	A R I	T A U
Ab G#		Bb A#			Db C#		Eb D#			Gb F#		Ab G#		Bb A#			Db C#
	U R A	N E P		S U N	E A R		M A R		J U P		S A T		M O O		M E R		V E N
	A	B		C	D		E		F		G		A		B		C

MOON

S	C	A	P	A	T	G	C	L	V	L	S	S	C	A	P	A	T
A	A	Q	I	R	A	E	A	E	I	I	C	A	A	Q	I	R	A
G	P	U	S	I	U	M	N	O	R	B	O	G	P	U	S	I	U
Ab		Bb			Db		Eb			Gb		Ab		Bb			Db
G#		A#			C#		D#			F#		G#		A#			C#
}		}		}		}		}		}		}		}		}	
U	N	P	E	M	J	S	S	M	V								
R	E	L	A	A	U	A	A	O	E								
A	P	U	R	R	P	T	N	R	N								
A	B	C	D	E	F	G	A	B	C								

MERCURY

S	C	A	P	A	T	G	C	L	V	L	S	S	C	A	P	A	T
A	A	Q	I	R	A	E	A	E	I	I	C	A	A	Q	I	R	A
G	P	U	S	I	U	M	N	O	R	B	O	G	P	U	S	I	U
Ab		Bb			Db		Eb			Gb		Ab		Bb			Db
G#		A#			C#		D#			F#		G#		A#			C#
}		}		}		}		}		}		}		}		}	
U	N	P	E	M	J	S	M	S	V								
R	E	L	A	A	U	A	O	U	E								
A	P	U	R	R	P	T	O	N	N								
A	B	C	D	E	F	G	A	B	C								

VENUS

S	C	A	P	A	T	G	C	L	V	L	S	S	C	A	P	A	T
A	A	Q	I	R	A	E	A	E	I	I	C	A	A	Q	I	R	A
G	P	U	S	I	U	M	N	O	R	B	O	G	P	U	S	I	U
Ab		Bb			Db		Eb			Gb		Ab		Bb			Db
G#		A#			C#		D#			F#		G#		A#			C#
}		}		}		}		}		}		}		}		}	
U	N	P	E	M	J	S	M	M	S								
R	E	L	A	A	U	A	O	E	U								
A	P	U	R	R	P	T	O	R	N								
A	B	C	D	E	F	G	A	B	C								

It seems that once again, we see that a picture is worth a thousand words. This chapter set out to show how signs and planets share common astrological basis, not only in fact, but also by design—in the grande scheme of things.

Frankly I didn't expect this pattern to emerge so easily and obviously but it has. It is proven that this pattern of the sidereal planets and synodic zodiacs apply to all of the planets

as each is made the central planet. These are pristinely repeated from planet to planet, simply by algebraic equality as each planet's ecliptic is relative to the Sun by sidereal orbit. I.e., if $A = B$, then $B = A$. See?

It's readily apparent that the interaction of planets to each planet's respective zodiac is uniform, as the inner planets' orbits are shorter and faster, while each outer planet becomes an inner planet relative to its immediate sidereal successor, in order moving outward from the Sun.

That's plenty to think about for the present. I'll focus the next chapter on integration and synthesis of what we have already covered, to consider practical applications, and how these astrological principles emerge universally.

Chapter 8

By Jove!

GETTING BACK TO the basics. It's the light and sound of the astrological forces which help man to recognize the hierarchical quality and magnitude of the aforesaid. It is especially the sound and range of human hearing that provides us with multiple octaves of astrologic insight, thereby focusing our consciousness and vastly improving our understanding of the stars and their active portent, which we know extends across the spectrum of all energy in the universe. And we also know is centered on middle C where our human ears are concerned. Human eyesight is confined to a very narrow slice of this energy spectrum, beginning on the color Red and falling off after Violet, i.e. just above Infra-Red up to just below Ultra-Violet. Sound covers about ten times the octave as light covers, making sound perhaps ten times more conducive to gnosis.

Considering the unique and distinctive qualities of the variations of visible light and audible sound as we see and hear, we can be sure that each octave of electromagnetic energy reveals similarly distinct characteristics, yet all manifesting by the law of octaves as applies to light and sound, that law being the seven by twelve, or the music of the spheres. Nostradamus referred to these as *La loy du Sol & Venus*, or *The law of the Sun & Venus*, in quatrain C5Q53. This law is manifested by the orbits of the planets around the Sun, ergo “Solaires”, and the relative orbits of the planets to the central planet of activity, which in our case is the phases or aspects of the planets to the Earth, hence “Lunaries”. We'll refer to these as the Law of Sidereal Orbits & Synodic Phases.

Essentially, the heliocentric orbits and the geocentric phases of the planets in our solar system are fixed and unchangeable. In this sense we can think of the planets as “Titans”, the great spheres held in orbit by the Sun. The “Olympians”, in contrast, draw one upon another, as their combined forces usurp the rule of the Titans, and expropriate by right of eminent domain — for our benefit!

The Olympians reign supreme over the Titans via the war of ten sidereal years reigning “as a thousand years” in the language of the bible. And no wonder, since what we call the “Devil” is self, whereas the planets' combined rule serves the greater good, “thy neighbor as thyself”. The self is ruled by Mars, whereas, others are ruled by Venus with Pluto at the center of hearing. It's notable that the ancients knew that Venus has the longest predictable periodic multiple, i.e. 1151 mean tropical years, and this is precisely why the old testament book of Daniel explicitly states “עַרְבַּ בִּקְרַ אֱלֹפִים וּשְׁלֹשׁ מֵאוֹת” in Daniel 8:14, which translates “till evening-morning two thousand three hundred”, in reference to Venus' grand century of 1151 years two times, once for evening (superior) & once for morning (inferior) ergo 2300 tropical years:

ANCIENT BABYLONIAN SIDEREAL-SYNODIC-TROPICAL MULTIPLES
 (the five planets with evening & morning zodiac signs)

*MAGICIAN/Mercury:

85 mean-synodic periods \approx 27 tropical years;
 191 sidereal \sim 145 mean-synodic \sim 46 tropical

*EMPRESS/Venus:

157 mean-synodic periods \approx 251 tropical years;
 1871 sidereal \sim 720 mean-synodic \sim 1151 tropical \leq Dan 8:14

*TOWER/Mars:

22 mean-synodic periods \approx 47 tropical years
 151 sidereal \sim 133 mean-synodic \sim 284 tropical

*EMPEROR/Jupiter:

76 mean-synodic periods \approx 83 tropical years
 36 sidereal \sim 391 mean-synodic \sim 427 tropical

*JUDGMENT/Saturn:

57 mean-synodic periods \approx 59 tropical years
 9 sidereal \sim 256 mean-synodic \sim 265 tropical
 Saturn's rings edge-on \approx avg. 14.75 years

It's notable that the above chart dates circa 1800 BC, and yet modern orthodox academia flat refuses even to acknowledge that the ancients were expert astronomers. Much extant evidence combines to refute the orthodoxy whether they're willing to admit to this or otherwise.

Back in chapter six, you saw how the circle of fifths proves that there are only seven key signatures which coincide with the diatonic scale of all white keys on the piano keyboard, and that all other key signatures require at least one black key to satisfy its transposition. Think of white-keys-only as the Titans, since the seven diatonic tones, seventh day, seventh heaven, the seven is sanctified under Saturn's rule, which is father time, the Scythe & second-largest Jovian giant in our solar system. Time is unstoppable, it can't be undone. In the sense of time, Saturn is unconquerable.

Yet, the Olympians managed to defeat the Titans, How? It's accomplished by transposition with the inclusion of black keys. Jupiter limited Saturn on the diatonic seventh of Saturn's Mixolydian modality. Look closely:

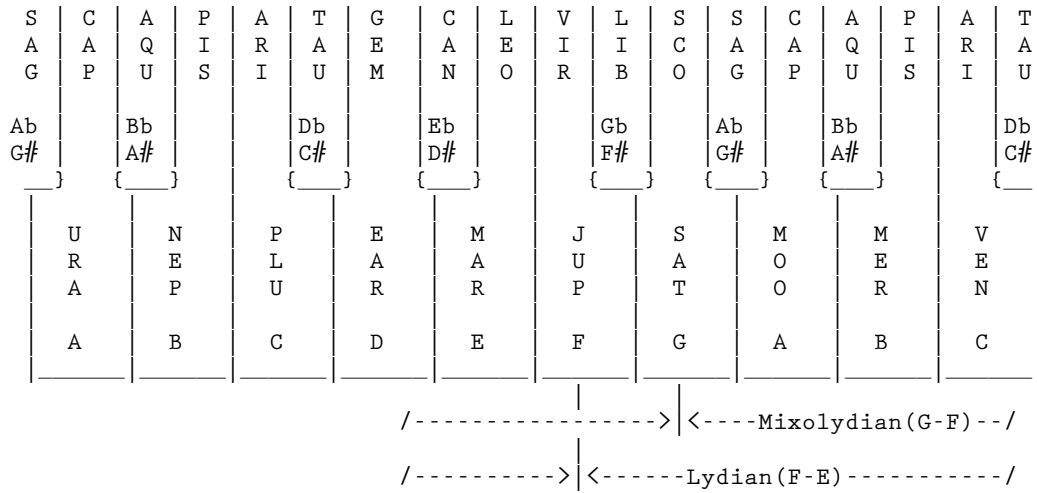

See how the diatonic tone of Jupiter is the F, which is the pitch key of the sidereal Lydian modality? It is Mercury who augments Jupiter’s diatonic fourth on the B, denoting Jupiter’s expansive/augmented nature. By modal contrast, it is Jupiter who limits Saturn’s diatonic seventh on the F, denoting Saturn’s limited nature, as Saturn is at the upper or outer limits of naked-eye visible planets (albeit Uranus can be seen on rare occasions by those who know exactly when and where to look, but only as a tiny pinpoint of light).

Hence Jupiter limits Saturn, and the myth associated with Kronos being tied “as a thousand years” by Zeus is readily understood—thanks to the light and sound of astrology! Recall that Jupiter is father of muses by Mnemosyne. Jupiter rules the music of the spheres, which limits the rule of father time. Thus, Olympian Gods denote the seven pitch keys by transposition in the twelve-tone scale of the zodiac. This is exactly the basis for judicial astrology, where Gods combine in the predominant hierarchy of their rulership from their respective positions to the Earth. Again I say, this is why the Titan Atlas “holds up the Earth” for the Olympian Gods as Atlas holds the meridian houses of Earth where the reign of the planets numbers them accordingly under transposition of the Titan’s modes across the mundane zodiac, in effect overruling time itself by taking full advantage of the divine powers exerted upon the Earth by the Gods in Heaven thereby recognizing that we are Gods-incarnate asserting our authority on the Earth by our divine birthright. See?

Now you know from where the classical myth of Saturn being conquered by Jupiter in the ten years war came from. If you’re not familiar with this and the other related myths, be sure to read Hesiod’s Theogony, on this URL. Note the elevated status awarded the muses, who sing great delight to the Spirit of the Almighty. E.g., and I quote Hugh G. Evelyn-White’s translation:

“Come thou, let us begin with the Muses who gladden the great spirit of their father Zeus in Olympus with their songs, telling of things that are and that shall be and that were aforetime with consenting voice.”

<http://groups.google.com/groups?selm=3GMYMZH037542.8757986111@Gilgamesh-frog.org>

So you see, the modalities of the planets rank first in the Pantheon, singing the very music of the Gods. Once you recognize the astrological-musical basis of classical myth, then your understanding thereof will abound an hundred-fold, a thousand-fold, & then some.

There’s much to be learned by the study of myth, and to learn it in the spirit by which it was originally intended. You may be surprised how many new insights you’ll gain into sacred texts like the Bible, or the Pyramid Texts. The divine music illuminates the soul, and elevates the consciousness in spirit and in fact, in truth and in practice—judicial astrology at work!

Many a great composer, music theorist, mathematician and philosopher have presented their observations on the affective key characteristics of the seven modes and three repeat modes as they are transposed across the twelve signs of the natural zodiac. Subsequently, there have been many books published that attempt to synthesize the opinions of the most renowned experts on the subject, concluding that a majority consensus emerges as if on some grande bell curve. I’m pleased to report that the consensus is somewhat intact upon subjecting them to astrological scrutiny, the voices of the muses transposed along the chromatic spectrum of the zodiac. Perhaps the agreement would be better if all seven modalities had received equal treatment over the millennia, but the Ionian and Aeolian modes have certainly enjoyed more attention than, say, the Phrygian or Locrian for example. Major keys or minor keys clearly dominate musical composition, and these two modes correspond to the Moon & Caelestial Sphere for the minor, and Venus & Pluto for the major. It’s no wonder then, that these two modalities get played more than any other. Picture the crescent Moon, with beautiful Venus centered beside her near the maximum superior elongation against the starry background on a clear night sky. The uniqueness of each key characteristic comes by transposition in the horoscope, as the dominant hierarchy of planets exert their reigns.

Where Venus reigns in the seventh house and the Moon is therein with ruling Venus, then the major & minor modes are performed in the key of F# or Gb, which is a wonderful combination for musical composition. But as the minutes and hours go by, then certain planets are bound to transit the meridian cusps of the Earth into that rulership for that interval of time, until Venus regains her rule in the seventh house, and the cycle repeats about every two sidereal hours per day and night, twenty-four hours a day seven days a week. For an example of this using the Sun & distant stars, see the following URL. This only charts the transits:

<http://groups.google.com/groups?selm=4TZVMYGYZ37285.0288773148@frog.gilgamesh.org>

This cyclic nature of horoscopic rulerships over the course of approximately two, sidereal-hour intervals indicates which of the planetary Gods are dominating, more at monopolizing, any particular daily horoscope, which naturally holds true for any location on Earth.

These repeating patterns of rulerships themselves do not continue repeating but change over the course of days, weeks, months, years, decades and centuries as the synodic positions of planets are dynamic, and so they gradually progress over the long course of time.

Remember our study of decans that began back in chapter three? Ruling planets ingressing the third decan of its house invite the imminent change of rulership, awaiting only the impending planetary transit(s), as the rotation of Earth's meridian house-cusps dictate. This is sufficiently important to understand, that I'll devote the next chapter to just such an example.

Pattern-recognition is the key resource of astrology. This is of fundamental, even paramount importance to the judicial astrologer, or as Nostradamus called us sovereign Astrologue, in honor of Ab-Ram, or Abraham, father to the letters Chaldiac — whose sacred symbols correspond to certain sounds and colors, or to signs and planets as the “harsh by letters” corresponds to the Scythe, i.e. God of father time, which is Saturn, as in the case of Nostradamus' quattrin C10Q65 to wit:

O vaste Rome ta ruyne s'approche,
O vast Rome your ruin is approaching,

Non de tes murs, de ton sang & substance,
Not of your walls, of your blood & substance,

L'aspre par lettres fera si horrible coche,
The harsh by letters will make so horrible notch,

Fer pointu mis a tous iusques au manche.
Iron pointed put to all until the grip.

The notch is the skor or indelible mark of reckoning indebtedness. Saturn is Judgment in the major arcana. In this context, the last Judgment is the Apocalypse, which will “settle the score” in the universal sense. Remember the war of ten sidereal years? Yes, as if a thousand years for the battle of Armageddon to occur, given Venus' 1871 sidereal/720 synodic/1151 tropical. Verbatim as Edgar Cayce reiterated in reading 5748-6:

“(Q) If the Armageddon is foretold in the Great Pyramid, please give a description of it and the date of its beginning and ending. (A) Not in what is left there. It will be as a thousand years, with the fighting in the air, and - as has been - between those returning to and those leaving the earth.”

The war of ten sidereal years and battle forevermore. Read what the great historian Flavius Josephus wrote in his discourse to the Greeks concerning Hades bk 1 ch 1 and note where he warns of this future judgment:

“the just are guided to the right hand, and are led with hymns, sung by the angels appointed over that place, unto a region of light, in which the just have dwelt from the beginning of the world; not constrained by necessity, but ever enjoying the prospect of the good things they see, and rejoice in the expectation of those new enjoyments which will be peculiar to every one of them, and esteeming those things beyond what we have here; with whom there is no place of toil, no burning heat, no piercing cold, nor are any briars there; but the countenance of the and of the just, which they see, always smiles them, while they wait for that rest and eternal new life in heaven, which is to succeed this region. This place we call The Bosom of Abraham.

*“But as to the unjust, they are dragged by force to the left hand by the angels allotted for punishment, no longer going with a good-will, but as prisoners driven by violence; to whom are sent the angels appointed over them to reproach them and threaten them with their terrible looks, and to thrust them still downwards. Now those angels that are set over these souls drag them into the neighborhood of hell itself; who, when they are hard by it, continually hear the noise of it, and do not stand clear of the hot vapor itself; but when they have a near view of this spectacle, as of a terrible and exceeding great prospect of fire, they are struck with a fearful expectation of a **future judgment**, and in effect punished thereby: and not only so, but where they see the place [or choir] of the fathers and of the just, even hereby are they punished; for a chaos deep and large is fixed between them; insomuch that a just man that hath compassion upon them cannot be admitted, nor can one that is unjust, if he were bold enough to attempt it, pass over it.” [emphasis added]*

You can read this in the broader context on this URL:

http://bible.crosswalk.com/History/BC/FlaviusJosephus/?book=Hades_1&chapter=1

One lesson which we can draw from this, is that each planetary God exerts tremendous powers to the Earth! Learning to respect the powers of the Gods is a part of our re-education process. Let's face it. You were not taught to respect the powers of the Gods by your school or university were you? Yet it's prerequisite for practicing judicial astrology. You must learn to remember to revere the Gods, and our Almighty Father. Sound familiar? It should, it's how

John the Baptist and his first cousin Jesus taught us how to pray — as Moses did, whose books of law echoed the golden rule:

*“Thou shalt not avenge, nor bear any grudge against the children of thy people, but thou shalt love thy neighbour as thyself: I am the LORD”—Lev 19:18
“And thou shalt love the LORD thy God with all thine heart, and with all thy soul and with all thy might” —Deu 6:5 AV*

The other obvious lesson which we can draw from this, is that the term “judicial astrology” is really just another way of saying Judeo-Christian astrology. See? It’s not for the irreverent but is for the religious. Do not confuse the astro-illogy of gentiles with the vigilant astrology of the elect. For example, we can not compare today’s pagan astrologers with the Magoi who visited then 10 ½ month-old Jesus in Bethlehem. The Parthian kings were expert astronomers, and were likely the most able astrologers of recorded history.

Don’t be deceived by halfwits who misquote scripture in order to “justify” their criticism of the subject. You’ll find that none who read ancient Hebrew, Greek and Aramaic will ever speak out against the Magoi or anyone else in their league. Reverence begets gnosis. Irreverence begets confusion and unwarranted evasion of the facts of the matter. Not only does God permit judicial astrology, his creation bears Witness to it. Even the covenant, the bow or the iris set in heaven. Judicial astrology isn’t for anyone but the faithful.

If you don’t believe in God you’d be well-advised to avoid any brand of paranormal research or activities. It is good, then, that atheists evade the paranormal across-the-board. Do not delve into astrology unless you’re prepared to trade your faith in faithlessness for that zealous undying faith in the God of Abraham. That’s what true astrology is about and nothing less.

Chapter 9

13 Baktun

THIS CHAPTER involves a little more math and geometry than my previous chapters. You could probably skip it and go on to the final chapter, number ten, if you're not comfortable with mathematical subject matter. For those who got A's in highschool algebra, trigonometry, physics, etc, that should suffice to understand these principles of charting daily horoscopes, transits and identifying their prevailing themes for any given day. It also helps if you've had years of musical training, music theory, and a working background in composition.

Depending on the software you are using, examples can be reliably charted from circa 2000 BC, up to 2331 AD. For this exercise, we'll use an upcoming date that is relatively near to the present, December 21st 2012 AD, bka the "final day" of the Mayan calendar.

First, it should be noted that the Mayans were expert astronomers, rivaling even surpassing the Babylonians, who were top-notch astronomers and astrologers albeit these sister disciplines used to be considered merely a subset of mathematics, as was music, as was perhaps everything...mathematics being the universal language. Expert astrologers were referred to as mathematicians. And because math is the common language of the cosmos, it is imperative that the sovereign astrologer learns to read, write and speak this language from his youth. And while we're on that subject, ancient languages of the world commonly used the neuter gender to describe what we call his/hers, him/her, simply as his, or him. Got it? It's well-understood that the Gods created us male and female, to wit the first scroll of the Torah. It's like the fifth house, that of "sons" which means the house of sons & daughters for all you laymen. See? We'll dispense with these minutiae for brevity's sake.

As with all of my astronomical calculations I've been using Astrolog version 5.41g with swiss ephemeris, as this combination of freeware is easy to use and gives astronomically accurate & reliable results every time.

The long-awaited Mayan calendar date of 13 Baktun has been the subject of books and much speculation. There is little consensus with regards to what might happen on this date which by the Gregorian correction to the old Roman (Julian) calendar turns out to be precisely on the winter solstice of 2012 AD, Friday December 21.

In a sense this date is somewhat arbitrary since I've selected it by virtue of its ever-widening popularity, a date in our not too distant future which most of us will live to see—if not in the flesh, then in spirit. The significance of Dec 21, 2012 is at the very least astronomical, i.e. literally astronomical. The winter solstice of 2012 coincides with our own Sun's transit on the Mayan "Sacred Tree" at five degrees caelestial Sagittarius. More than mere coincidence, but this day marks the end of the seventh precessional age and the beginning of the eighth

precessional age which by the Mayan long count is charted per the long-term average as counting five equal ages of the Sun per great year.

As long-term predictions of sidereal-synodic-tropical multiples were well known to the ancient world, it is probable that the Babylonians, Egyptians, Mayans, and other advanced civilizations had common access to the long-term ephemeris which may have come from Atlantis, since antediluvian science was more advanced than JPL.

I've already written extensively on this subject, and we have other charts to study for this lesson. But if you'd like to study the Mayan Long Count & Precession, you can find more detailed information on these links:

<http://groups.google.com/groups?selm=ISN8J0YL37297.8391435185@frog.gilgamesh.org>
<http://groups.google.com/groups?selm=FG9XPVDI37297.9342361111@frog.gilgamesh.org>
<http://groups.google.com/groups?selm=D8YC5X7P37232.097337963@frog.gilgamesh.org>
<http://groups.google.com/groups?selm=HRO8N0QP37297.2780208333@frog.gilgamesh.org>
<http://groups.google.com/groups?selm=adelff09c6cd6fee77fcbe3aa2964fb8@aarg.net>

Now, we'll chart the two sidereal-hour interval using the winter solstice 2012 as the center of calculation, and the Great Pyramid at Gizeh for our local meridian. Again, this location is somewhat arbitrary since this horoscopic progression holds true for any location on Earth, given that only the local ascendant and descendant varies with latitude, and any change in location longitude is dependent on sidereal time -or- distance, where meridians of longitude plus or minus this local meridian at the Great Pyramid in sidereal angle-hours describes a geographical longitude per relative angle as measured along the reference plane of the ecliptic.

First we plot the horoscope for the local meridian at southing at the time of the winter solstice. Note the reference to the Great Alnitak Pyramid is used as our prime meridian exactly 00E00:00 longitude. Our modern measurement from Greenwich can be converted by adding the modern value west of Greenwich, or subtracting it east of Greenwich, with the Pyramid at 31E09:00 there- from. E.g., as in our first chart below, we're taking the meridian of southing on the winter solstice, 2012, which is 11:43:46E of Greenwich. We subtract 11E43:46 from 31E09:00 to get the meridian west of the Pyramid, which is 19W25:14 at southing (Sun post meridiem LAT):

Fri 21-Dec-2012		11:11:23 UT	11E43:46 G.M.		
Body	Houses	RUL.	Veloc.	Decans	r
Venus	: 4Pis50	(e)	+1.250	14pis30	e
Mercury	: 13Pis33	(F)	+1.480	10can40	-
/Sun	: 29Pis60	(-)	+1.018	0pis00	-
\Midheaven	: 0Ari00		_____	0ari00	
Pluto	: 9Ari37	(-)	+0.035	28ari51	-
Mars	: 28Ari24	(R)	+0.781	25sag13	-
Neptune	: 2Gem47	(d)	+0.022	8gem22	d
East Point:	0Can00		_____	0can00	
Uranus	: 4Can20	(-)	+0.007	12can59	-
Moon	: 13Can17	(R)	+12.27	9sco50	d
OsciLilith:	27Leo52	(-)	+0.567	23ari36	-
Jupiter	: 7Vir19	(F)	-0.118	21vir58	f
MeanLilith:	9Vir42	(d)	+0.111	29vir07	d
IC	: 0Lib00		_____	0lib00	
Saturn	: 6Aqu30	(R)	+0.090	19aqu30	r
True Node	: 23Aqu30	(R)	+0.023	10lib30	-

Remember, our latitude north or south makes no difference to meridian transits of the planets, but it only effects the local ascendant and descendant thus every Arabic part which references the local ascendant. The only time we include part of Fortune, etc. to adjudge any horoscope, is for event charts, natal, death, etc. All latitudes north of the arctic circle and south of the antarctic circle simply turn to retrograde motion. Same transits, same horoscope. It makes no difference.

Remember that the daily horoscope is effective on the whole world, since we're dealing with the predominant rulerships of the planetary Gods by hierarchical rule over the period of one sidereal day. We needn't chart the entire day to analyze this since any two sidereal hour interval is generally reiterative for all twelve such intervals on any given day. The exception is the Moon since she traverses Earth's caelestial firmament much faster than any other planet. On occasion, we'll find that Mercury has entered the fray, by transit on any one of the meridian house-cusps, as with the Moon.

By contrast, more distant planets like Mars & Jupiter move more slowly over the course of a day, thus their daily meridian transits are more consistent, and less likely to affect changes in the predominant horoscope. Where the Moon & any other planet is likely to change the horoscope per acquiring proximity to a house-cusp is most readily found by comparing synodic velocities of the planets as shown near the right-hand column of Astrolog's "standard list" charts. How much time they spend dominating the horoscope over the course of any two sidereal-hour period as calculated within the day in question, and which direction the planets are seen to move towards or away from their proximity to cusps (as with planets in retrograde),

such are the primary considerations which the astrologue must examine, and judge, ergo the term “Judicial” astrology. Understand?

Rather than spend several arduous hours charting each planetary transit over a two hour period, it’s vastly preferable to use the convenient animation feature of Astrolog. It’s very easy to do. Hold <Alt+r> to bring up the “restrictions” dialog box & click on “toggle cusps” to un-restrict any previously restricted cusps. Uncheck any cusps which got toggled to the restricted status. You can save these settings in your “parallel transit restriction set”, then simply click the “copy from other restriction set” button to recall this set.

Set animation jump rate to minutes and jump factor to one, enable “show graphics” and you’re ready to study the horoscopic transits of the planets for that daily horoscope. Simply look for the most ruling planets at any time of day. The planets that you must include in your examination are, and in no particular order, the Moon, Mercury, Venus, Sun, Mars, Jupiter & Saturn. We must also include the head & tail of the dragon since these rate on par with other planets in the horoscope. Take the true node, and mean lilith, for these values. The exception to this is when mean lilith is near the cusp -AND- oscillating lilith is more than about five degrees into the adjacent house; in those cases it is prudent to use oscililith <Enter -YL> for calculation (true lilith is never more than ~5* from mean lilith). Notably, the Moon and head of the dragon decided what rulerships apply to our southing chart as shown above.

Outer planets are not considered until after you have determined the predominant horoscope (Moon to Saturn). That means you can ignore Uranus, Neptune & Pluto for the time being, but be sure to include them for final analysis. For this example, set your date to December 21, 2012, and set your time to 11:11:23 UT. Longitude is set at 11E43:46, in order to match the solstice to the Sun at southing on the local meridian. Click okay and you’re ready to animate the horoscope. There’s an option to pause and un-pause simply by typing p. Since by now I’ve done several hundred horoscopes using the Astrolog program, I’ve always found it more efficient to manually toggle the chart using the - or + keys on the numeric keypad. You’ll notice that since you have enabled all twelve house-cusps as objects, every time a planet transits a cusp, it swaps sides with the number that shows which house-cusp that planet transited.

Until your familiarity with the signs and the planets becomes second nature to you, and you can readily see which planets are dominating the horoscope, and doing so for the greater part of any two hour interval over any given day, you’ll discover that by animating your chart in two hour intervals, with “show graphics” off, that helps immensely to narrow down by process of elimination the most prominent horoscopes in that day as they will have the most ruling planets—this irrespective of how many planets are fallen, debilitate or exalted. What counts is RULERSHIP: The more the merrier. Just look for the most R’s appearing under “House Rul.”

In the above default horoscope, with the Sun southing on the winter solstice 2012, it's Mars' transit about 11:05:10 UT which adjudges Mars ruling in first house. This theme holds until the Moon's transit 12:05:23 UT, giving us a one hour window from the time Mars reigns in the first house till the Moon abdicates by transit on the cusp. The Moon's momentary synodic velocity at the time of transit is 12.26 arcdegrees per solar day, just a little faster than the Moon's average velocity; which reminds us that the Moon progresses by a little more than one arcdegree every two hours, delaying the lunar transit times, on the daily average three and a half minutes in horoscopic succession. In effect this proves that Mars is hierarchically acquiring his rule in the first house, Moon fourth, Saturn eleventh then tenth house (Saturn's inferior & superior rulerships), and head of the dragon eleventh house. Therefore, the horoscope of Mars first house will be dominating come Friday, December 21st, 2012, beginning after 11:05 UT.

Thus with Mars cornering the horoscope for the second part of the day on December 21st, 2012, then which of the planets abdicate to make room for this Red Planet? Actually, the answer is Mars, who yields his reign in the eighth house to seize his rule in the first house.

Remember that the five planets of evening and morning make two courts of rulership apiece. In this instance, Mercury's transit at 10:04:52 UT, which was about one hour before Mars' transit at 11:05:10 UT, put Mercury ruling in the sixth house, Mars in the eighth house & Jupiter in the twelfth house. This theme is decidedly more malefic than Mars first house, on account of the Moon fallen tenth house and Saturn fallen fifth house, albeit the head & tail of the dragon enjoy exaltation for this interval before Mars transits the cusp about 11:05 UT as noted above. The key to this "changing of the guard" is the Moon's comparatively rapid velocity which is widening the window for Mars first house and closing the window on Mars ruling in the eighth house.

Because Mercury's synodic velocity is many times less than the Moon's e.g. at Mercury's transit 10:04:52 UT, Mercury's momentary synodic velocity is +1.48 degrees per day while the Moon is charioting along over eight times that. Thus the Moon's transit window is opening as Mercury's window is closing relative thereto. See? But wait! Remember that we are only doing a horoscope for one day. The Moon's acquiring reign in the fourth house is only temporary since she's moving so rapidly. The Moon's window will soon be closing and separating from the dominant theme. This Lagrange point is found when the Moon's transit delta passes square with Mars, the following day December 22, 2012 about 12:56:46 UT. But we must understand that this is the daily average. Transits on a local meridian cusp will naturally vary, as much as by nearly five degrees of arc on MC and IC.

Now the cusps of Earth's houses are where her equally- divided meridians intersect the ecliptic. Because the obliquity of Earth's rotational axis is nearly 23.44*, then her meridian cusps, which average thirty degrees of arc around the Earth along the ecliptic plane, are per-

petually oscillating relative to the east point or first house-cusp and seventh house-cusp, which remain stationary at opposition east to west on the ecliptic. That means that planets transit the first and seventh cusps at $360^{\circ}/\text{day}$ minus a planet's momentary velocity; to wit planets in retrograde transit that much faster.

Also the maximum oscillation is on the local meridian from midheaven to antemidheaven. The rotational cycle of these cusp-oscillations repeats once each sidereal day. Notably the local Ascendant and Descendant cycle above and below the east point and seventh house cusp, alternately over the course of each sidereal day, and is how “fliptypes” for Arabic parts or Greek lots are determined—which also indicates magnitude, since the Ascendant's oscillation increases with latitude above or below the equator but that's not important for now. We are doing daily horoscopes, not event charts. This makes it much faster to look for changes in horoscope scenarios for any given day by looking at the planets' synodic motions, since the meridian houses average 30 degrees of ecliptic arc per sidereal day. This is the daily average of rulerships or global daily horoscope. This helps us to quickly identify dominant rulerships, but is only a quick approximation. There's more to it.

The synodic motions and velocities of the planets are compared to their transits over the course of one day. As one horoscopic window closes another is invariably opening. The Sun at southing on the local meridian is the de facto measure of a day, but the progression of the horoscope is essentially independent of the solar day, and is instead totally dependent on the sidereal day, and the aforesaid synodic aspects of the planets. For daily horoscopes, it's much easier simply to look at planetary synodic aspects, and adjudicate based on these alone. But in order to reference planetary transits to a specific location, this requires exactitude.

And in any case we must always refer to a calendar of one kind or another, whether it's gregorian or julian date, jewish, or islamic, mayan or aztec, or whatever other calendars you might prefer. Using the gregorian improvement to the old Roman calendar is the one most people are familiar with, hence the date Dec 21, 2012. But even the best calendars need a reference meridian!

In this day and age it's the greenwich prime meridian that is our universal time-standard. In ancient times it was the giza pyramid, yet in more remote antiquity who knows where the prime meridian might have resided? Catastrophic crustal displacements can only leave one to wonder. It's really just an arbitrary meridian but is our contemporaneous majority consensus which makes it become recognized as a prime or universal meridian, our reference standard by which the Earth is measured, hence the Earth's rotation and orbital motion is likewise referenced. The point being, that it's customary to reference the Sun at southing as the center of day, no doubt since the style or gnomon that casts shadows on the sundial is oriented toward the nearest pole of Earth's rotational axis — parallel to the Earth's axis. Weather permitting, at twelve o'clock noon the shadow extends momentarily straight off the end of the style

in opposition to the Sun. That's 12 PM LAT and is the gospel of ephemeris time. It's the caelestial witness to the fact that it's twelve noon on that day, and at that geographical longitude. With the DE406 ephemeris so refined and exacting, you can calculate the Sun at southing for your local meridian, then test it to see if the southing Sun doesn't cast a perfectly straight shadow due north off the gnomon of your sundial, that is assuming you have one. If you don't, and you would like to experiment with this, you can download a very precise free-ware program for making sundials off this link: <http://web.fc-net.fr/frb/sundials/gb/default.htm>. Or you could just set a plumbbob above a straightedge pointing due north, but that takes all the fun out of it. You will find the JPL-DE406 ephemeris is accurate.

In conclusion, there are two basic methods for making the daily horoscope. Using planetary aspects alone is convenient but less accurate. The local method is far more accurate, but is more tedious and time-consuming. For quarterly or yearly almanachs with meteorological and astrological prognostications, you'd probably use the greenwich meridian and coordinated universal time for all calculations. You needn't fully chart the Sun at southing but at least identify what time it occurs for each day in question. After you've charted and adjudicated several hundred horoscopes you'll become an expert in no time...just practice, practice, practice.

- From near the Continental Divide
of Central Colorado, USA
This 21. of April, 2003.
Done by Daniel Joseph Min