

[unedited]

**The Qabalistic Primer of Creative Consciousness**  
[previously entitled  
*The Spectrograms of Hebrew Alphabet*  
published and entitled in French as  
*(les Spectrogrammes de l'Alphabet Hébraïque:*  
**Mont-Blanc Suisse)**]

by

**Carlo Suarès (deceased)**

in collaboration with Fred Alan Wolf, Ph.D.

for the English language rendition

## Contents

### Preface by F. A. Wolf 5

1. Introduction 6
2. The Autiot 8
3. The Periodic Table of the Autiot 12
4. The "Physics" of the "Periodic Table" 13
5. The Anatomical Charts of the Autiot 18  
The Aleph (1) 18

### The Two Other Mother Letters 21

- Mem (40) 21
- Sheen (300) – Seen 21

### The Three Letters that "Play the Game" with Aleph 23

- Bayt (2) – Vayt 23
- Yod (10) 24
- Tav - Thav (400) 24

### The Two Letters which Link the Two Flows, Energy and its Inverse 25

- Zayn (7) 25
- Ayn (70) 26

### Archetypes of Organic Movement and Resistance (Response to Information) 27

- Ghimel Djimel (3) 27
- Dallet-Thallet (4) 28

### The Male and Female Sexual Energies 28

- Vav - Waw (6) 28
- Sammekh (60) 29

### Life 29

Hay (5) 29

Nonelaborated Substance and Birth of the Cell 30

Hhayt (8) 30

Tayt (9) 31

Phay-Pay (80) 32

The Structuring of Energy 32

Tsadde (90) 32

The Organic Life – Movement 33

Lammed (30) 33

The Action of Physical Supports 34

Kaf, Khaf (20) 34

The Existential Life 34

Noon (50) 34

The Cosmic Aleph 35

Qof (100) 35

The Cosmic House 36

Raysh (200) 36

The Two Breaths 37

The Two Full Breaths 39

6. The Spectrograms 41

Aleph 43

Mem 44

Sheen 44

Seen 45

Bayt 45

Vayt 47

Yod 47

Tav 48

Thav	49
Zayn	49
Ayn	50
Ghimel	51
Djime	51
Dallet	52
Thallet	52
Waw	53
Samekh	53
Hay	54
Hhayt	54
Tayt	55
Phay	56
Pay	56
Tsadde	57
Lammed	57
Kaf	58
Khaf	58
Noon	59
Qof	59
Raysh (hard)	60
Raysh (soft)	60

Conclusion 61

## Appendix by F. A. Wolf 62

The Development of the Mother Letters 62

(a) The Physico-Physiological Analogy 65

(b) The Biblical Analog 66

(c) The Political Analog 67

(d) The Quantum Physical Analog 68

The Mystery of Water 70

## PREFACE BY F. A. WOLF

"Please allow me to introduce myself" sings Mick Jagger as he begs for "Sympathy for the Devil". And so, I, a physicist, find myself writing in collaboration with Carlo Suarès on a subject seemingly far removed from physics would also like to beg your collective indulgence.

I first met Mr. Suarès in February of 1974 while in Paris on leave of absence from my then normal academic position as Professor of Physics at San Diego State University. I was appointed as *professeur associé* at the University of Paris-Orsay for the year. My interest in those elements that lie outside our space-time continuum had already been developing while in California. Through the efforts of my close friend and fellow worker Mr. Bob Toben I became acquainted with Mr. Suarès work on the *Cipher of Genesis*. It interested me, as I am sure it will interest you who are reading this. After several meetings with Mr. Suarès in which Aleph stirred in me a few sparks of "oh yeah, wow, I see", it became apparent to me that my work with Mr. Suarès was just beginning. I still feel the same way. To you our readers I can only say don't feel discouraged if you don't understand all of the following material. As I have learned after much study and thought, "it will find you". But don't stop seeking it.

Now with respect to the following material, I would like to make a few comments if only to clarify my own role in all of this.

*Les Spectrogrammes de l'alphabet hébraïque* was first published in French in 1973 (Editions du Mont-Blanc Geneve). When Mr. Suarès showed it to me and asked me to work on it for an English edition I became quite excited and decided that it would serve several purposes. First of all it is an excellent primer to Mr. Suarès' ideas and I believe should be read before taking on his other works. Second of all it is a beautiful concise presentation of several factors concerning the "code" as Suarès puts it. These factors include the "periodic table of the letters," "the anatomic charts of the letters," and the "two breaths—a stream of letters which show correspondences when place back to front," and finally, the spectrograms themselves. Thirdly, it contains some remarkable insights and ideas. Most or nearly all of them are Mr. Suarès'. I have added some ideas of my own. Particularly to the section on the Periodic Table (Section III), the Autiot (Section IV), and in the Appendix, where I have developed and expanded Mr. Suarès' remarkable relationship which exists between the mother Letters', Aleph, Mem and Sheen. Most of these ideas have been in the way of extension, clarification, and development of those kernels of insight already professed by Mr. Suarès. Except for the introductory paragraph of Section V, Mr. Suarès has given all of the descriptions of the Spectrograms themselves.

For clarity and where necessary, my comments are written in a different font throughout the text to distinguish them from Mr. Suarès' writing.

Thank you. Enjoy it.

Love. F. A. Wolf

London November 1974.

Revised San Francisco, May 2000.

## 1. INTRODUCTION

The spectrograms that we shall present here have been obtained in the laboratory of Dr. A. A. Tomatis of Paris. They were obtained as follows. First, Mr. Suarès pronounced the letters of the Hebrew alphabet into a microphone connected to a recorder. After ensuring that the letters were being recorded satisfactorily, the remainder of the operations actually took place in silence. The recorder was linked to a spectrograph (This was a standard Key Sonograph manufactured by Kay Elemetrics Co., Pine Brook, N.Y., USA) consisting in part of a rotating cylinder wrapped in a foil of special recording paper. The purpose of this device is to give a graphic display of the sound by presenting essentially a Fourier analysis of it. In brief, this analysis enables one to obtain for each sound a frequency-intensity-time distribution displayed on the foil of paper. In the original introduction to this book, Mr. Suarès went into some detail describing the technical side of the registering operation. This can be obtained from the manufacturers if the reader is interested further, but will be omitted in this rendition of Mr. Suarès' work.

The images thus obtained were approximately 10 cm x 5 cm in size and have been photo-reproduced here. In one recording session: Mr. Wolf decided to compare his spoken "Aleph" with that of Mr. Suarès. Amazingly enough there were similarities but also striking differences. In Mr. Wolf's "Aleph" which also resembled a foot, the maximum intensity was observed to be in the foot itself (see fig. 1, page 50) indicating an intensification of the lower frequencies. While in Mr. Suarès' "Aleph" shown in the above figure, one sees an intensification in the upper or higher frequencies (the pant leg part). Mr. Suarès jokingly calls Mr. Wolf "my poor one with the buried Aleph".

They show consistently the semantic content of these letters as we have previously given them<sup>1</sup> They express a code which enabled us to determine the true meaning of original biblical texts such as Genesis which when read in translation often indicate a meaning which is opposite to its original meaning.

In our earlier works<sup>2</sup> we wrote that the signs and numbers which constitute the Hebrew alphabet were originally the key to a very ancient science. This science illustrates the structure of universal energy seen in its unity and in its multiplicity, in objects and in consciousness, in the intemporal and in the temporal. The memory of that science, faded away and degenerated into that which people called Cabala or Qabala, is buried in two or three thousand occult-mystical-symbolical and allegorical writings.

On the one hand, today, many people who call themselves Qabalists, although very learned in ancient scripts, are to the Qabala as people who call themselves physicists would be to physics had they only studied the works of Archimedes and Euclid.

On the other hand, scientific research is continually discovering many structures in the energy contained in galaxies and atoms, and is persistently directed towards unification of human phenomena in its different conscious and unconscious manifestations, with biological physical-chemical phenomena.

---

<sup>1</sup> *The Cipher of Genesis, The Song of Songs, The Sepher Yetsira* (Shambala) and Bantam Books paperback.

<sup>2</sup> See footnote 1.

We read, however, from certain well-known scientists that man has no part to play in the universe, that he is the product of chance, etc. So it seems that a revitalization of that ancient science of Qabala is called for to enable us to rethink it with our modern minds. Although through evolution we have assuredly lost certain means of perception possessed by our forefathers, we have gained and developed other and better faculties by which various non-verifiable observations became experimentally verifiable. Thus through this revitalization we can investigate this universal energy at work in our own psyches.

When we tackle the psyche we deal with language and we journey to the very heart of the problem of knowledge, whatever approach we take.

Contemporary psychology—is it necessary to point out (?)—is based on analysis and is satisfied to use our ordinary language in therapy. It is only recently that people have come to suspect a fundamental fact, i.e. that the “signifying” could have a relation other than conventional with the “signified”. Thus, those therapies which use words that have no real relationship with that to which they refer, do not even attempt to link the patient with reality and leave him cloistered in a sphere of mental projections. [For example, the word “door” is not a door merely a sound which conveys a picture of a door to a person’s mind. Here Suarès points to a deeper connection between a spoken sound and its meaning.](#)

But if it is true that we have, in the original code of the Qabala, an order of reference that defines the exact nature, in terms of energy, of the twenty-two letters of the Hebrew alphabet, and if it is true (as we hope to prove in this volume) that the spectrograms of the sounds of these letters confirm and even explain and deepen their “signification”, then, for the first time in history, we would be able to decipher what is called “the Sacred Language” upon which is based the biblical assumption of a “Revelation through the Word.”

That “Revelation” is totally included in the first five chapters of Genesis. We know that originally all of the letters of the first verses followed each other without spatial separation indicating word units or sentence structures.<sup>3</sup> Each letter, thus, acted as a flash or sudden burst of insight. [Connecting them together leads to further flashes.](#) Those verses are a Qabalistic text. If we read them sign by sign, with the knowledge of what they stand for, and if we abstain from recalling ancient mental pictures, we discover an analogical language covering every sphere of all that exists. [As we will see, each letter contains other letters, much as a fundamental particle contains other particles. Hence we see that each letter contains a hierarchical structure.](#) Then the hierarchy of structures establishes its relationship in good order with that which is beyond itself and [relativistically speaking](#) links this hierarchy ([matter](#)) which exists on this side of the “wall of light” i.e. our own space time continuum, with that which lies on the other side ([tachyonic](#)).

Let us make it very clear that these signs, although they are used as letters in the Hebrew language, are in reality fundamental parameters, which include themselves as well as other parameters, so as to vary in meaning and other in the direction of the flow of energy that they represent. To distinguish them from any other set of signs we will

---

<sup>3</sup> We have seen a very ancient pre-Masoretic Torah handwritten on leather in which all the letters followed each other without spaces or vowel signs.

designate them with the Hebrew word: *Aut*, in the singular and *Autiot* in the plural.

Further on we shall display tables depicting their anatomic pattern showing only one component of their complexity. Not only is everyone of them an endless process or flow of energy but the direction of that flow is always streaming and counter-streaming, clockwise and counter-clockwise, in and out, up and down, for and against, endlessly, as it is in all living elements (a cell receives information and responds to it; the energy flows in and flows out). So an *Aut* is never to be viewed as a fixed data point; it has two opposite meanings depending on how it is considered.

Therefore, to consider them simply as a language code that one translates into other languages is hopelessly inadequate. Before using them we must allow them to come alive in us. When this happens, we realize that their language has no grammar. The *Autiot* therefore acts upon us in a way clearly pointed out by Dr. A. A. Tomatis<sup>4</sup>. He noted that any ordinary language builds itself grammatically. That is, according to certain laws that are in reality only neuronics processes initially structured on the total nervous system, reflecting actions and reactions of different control circuits at a primary level. Therefore a grammar defines a neurological representation of a language.

It is therefore clear that a language made up of elements representing energy fluxes cannot be translated into any idiom without grammar.

According to our experience, the language that we present here is analogical and all-inclusive, whereas the words of any ordinary idiom are **digital and** exclusive. For example, the word *house* is a digital unit (in computer language "word" connotes a precise digital unit) that excludes everything that is not actually a house. But, the *Aut Bayt* that means house in Hebrew also means any container. On one occasion when Mr. Suarès pronounced the word *Bayt* into the spectrograph, a rather mysterious result ensued, for which Mr. Wolf has no explanation, the result (shown on p. 46) as a somewhat blurred but recognizable portrait outline of his face. Thus our *Bayt* is our body.

So when this all-inclusive grammarless language becomes familiar to us, it probably modifies the structures of our neuronics processes, enabling us to receive that universal or cosmic energy that every *Aut* expresses and emanates, and to respond to it.

We are very far from simple phonetics that only designates the phenomena of existence. We hope that our line of research, which is deeply religious and at the same time strictly scientific, will call attention to the extraordinary semantic mechanism of the original code of our Scriptures, which has been for so many centuries forgotten and betrayed.

Many years of study and research have shown us that it is difficult to introduce an entirely new way of thinking, so different from any philosophy or theology. We deem it, therefore, necessary to produce a general view of the meaning of the *Autiot* before going into the spectrograms. Without this overview the spectrograms would serve only as simple matters of curiosity.

## 2. THE AUTIOT

The graphic form of the Hebrew characters in square letters is said, by the Talmud, to come from Ezra. According to the biblical text (Ezra VII) Artaxerxes gave him the

---

<sup>4</sup> *La Liberation d'Œdipe* (p.63). Les Editions ESF. 17 rue Viete. Paris 17e.



mission to re-establish the Law of the Torah after his return from captivity in Babylon. Ezra is supposed to have returned to Jerusalem in 459 BC with 1800 exiles and to have laid the basis for a revival of Judaism, including the recreation of a language that had been forgotten. The Talmud goes on saying that had Moses not preceded Ezra, "God" would have given the Torah through Ezra.

One knows, for example, that the ancient Hebrew character for Aleph is an A lying on its side, Sheen appears as W, Tav looks like an X, or sometimes is written as a cross (+), etc.

Even further back in time as we know it, we find the Sepher Yetsira referring to Abraham. This scientific textbook deals with the structure of energy by only using the 22 signs of the Autiot and their combinations as parameters. Each sign with the exception of Hay (Hay =5, meaning life, seen further on) can be related to variable structures (Sepherot) of energy. Its variation and progression determining quality and intensity can be compared for example to the action of a simple electromagnetic transformer. On one side of the transformer we have a certain electrical input determined by the voltage and current, while on the other side we have a transformed output expressed by say a higher voltage but smaller current. The net energy is the same on both sides of the transformer but its quality and intensity are different. The use of such transformers enables electrical impulses to be converted into sound waves, for example.

Surprisingly, the unknown authors of the Sepher Yetsira wrote so as to deliberately confuse or mislead their readers. That is, by interpreting the Autiot as simply an alphabet and forming word units with rules of grammar one is led to such free translations as: "As soon as Abraham, our father (let him dwell in peace) participated in vital flux, Adon Hakol made a covenant with him between his ten toes, and it is the covenant of circumcision, and between his ten fingers, and it is covenant of the tongue and attached twenty- two Autiot to the tongue and revealed to him their foundation, and washed them with Maiyim (the waters) and scorched them with Esh (fire) and agitated them with Rouah (breath) and consumed them by the seven and led them by twelve constellations"

Reading the above without the code of the Autiot may appear as a joke to the reader, however, the original text contains all the elements for the understanding of man: his nature, life and action in the universe.

Abraham was Chaldean. We have not searched for the Autiot in the ancient Chaldean cuneiform writing. But, we were fortunate enough to discover their meaning in terms of energy, by decoding the name of certain Sumerian deities using the Hebrew code, previously given in our earlier works and again here further on. Its semantic roots carry us into the heart of Asia. The name Tam in Vietnamese meaning heart and mind is the name given to Jacob, Yaaqov Eesh Tam (Genesis XXV, 27). These words have never been properly translated in any Bible, in any language, but can be easily understood, when we know that Tam (Tav, Mem) is the opposite of Met (Mem, Tav) which means dead, Tam is a quality of life.

The study of the language of the Hebrew code is a science, whose origin is lost in pre-history. This science, the original Qabala, enmeshed in the allusions of time, ignorance, and religious myths, became disfigured, however, in several occult traditions. Its purpose is to project cosmic or universal energy into its students, enabling them to concentrate and put into order, their psychological, mental and physiological elements

forming a creative and active focus.

This language is thus of an entirely different nature from any idiom. It is analogical, all-inclusive, and immediate. Its element is a thought, like no thought, which is free of duration (intemporal, instantaneous) and free of the succession of concepts linked one to another in process conditioned by time and by grammar. Hence a thought that grasps in a single act of understanding, the real meaning of any fragment of the Scriptures. Such a reading destroys the religious myths based on mistaken translations. We have often said that we must return to the source, to the origin. This does not mean as some would argue, a return to Abraham, or to Moses, or to Pontius Pilate, or to Karl Marx, but to the present time, wherein we find most people with their psyches blocked by archaic barriers of incomplete thoughts, not willing to experience time, now. Between the explosion of the new and the resistance of our own inert memory we have witnessed in a single act of perception the prodigious coming and going of the Autiot, passing from Aleph to Tav and back from Tav to Aleph, the one flow hurling against the resistance of the other, and thus hardening itself so as to contain the first, and having it rebound towards itself again, thus in a flash the two flows becoming one.

But we had yet to demonstrate experimentally, the existence of that vital, moving energy, which is the totality of existence. The symbol of Jacob's ladder is no longer enough and no angelology is accessible to scientific experimentation. Let us keep in mind that between the ten fingers, i.e. the two hands are the covenant of the tongue to which are attached the twenty-two Autiot, according to the Sepher Yetsira.

Before trying to verify whether Bayt forms Saturn and the right eye, or Ghimel Jupiter and the left eye, Dallet, Mars and the right ear, Kaf, the sun and the left ear, etc., we had to establish the Autiot one by one, graphically and phonetically; record the phonemes graphically, and then finally to compare the results with the earlier written code to see if that code can be verified and as well enlarged with deeper meaning.

We have adopted, unhesitatingly, the canonical graphic form, supposed to have been established by Ezra, if only for the very lucid shape of the Aleph. And we have adopted the Sephardic pronunciation, because it differentiates clearly (as in the Arabic Koran) the two Ks, Kaf (20) and Qof (100); the Ss; Sammekh (60) and Seen (300); the two Ts, Tayt (9) and Tav (400); and the complete scale of Hs, going from the light Hay (5:) to the strongly breathed Hhayt (8), free from the throat, to the scraping Khaf (20), that unfortunately is used phonetically in the jargon called "modern Hebrew", for the unscraped Hhayt. One other Aut is phonetically important, but has no equivalent in our alphabets, except in Arabic, when it is pronounced, as it ought to be in Hebrew. It deeply involves a movement of the glottis. We will explain it, later on more in detail, and now can only write it Ayn (although in this spelling it would be pronounced Aleph - Yod - Noon) Its number is 70.

In this book we are not phonetically considering the five Autiot that change shape and numerical significance when written in finals (i.e. at the end of a word). These are Kaf, Mem, Noun, Phay and Tsadde. We have simply recorded every letter independently. We have not attempted to record any schemata, because in our stage of experimentation we wish to have as simple a picture as possible. But such schemata or combinations of Autiot do suggest themselves.

However, we did record the seven double letters: those without a point; pronounced Vayt (2), Djimmel (3), Thallet (4), (pronounced as in "the", "this"), Khaf (20),

Phay (80), Raysh (200) (pronounced as the French, grating the throat), Thav (400) (pronounced as in thunder, thought); and when written with a point are Bayt, Ghimel, Dallet, Kaf, Pay, Raysh, and Tav. We also recorded separately Seen (a dot on the left) and Sheen (a dot on the right) both 300, but yet different energetically.

Since we were using a sensitive apparatus we needed to repeat our recording several times, and this led to differences in our results as we might have expected, depending on various external conditions and the way a phoneme was pronounced. If you utter ah, casually, or in anger or in lamentation, somewhat shorter or longer, you will have different recordings. One of Mr. Suarès' problems therefore, was to pronounce the Autiot impersonally with a minimum of interference from his national or individual idiosyncrasies, and with a clear understanding of what he was saying.

This needed a tremendous concentration. Fortunately Mr. Suarès was born in Egypt and had spent many years there, listening to the Muezzins chanting from the top of their minarets. He also remembers, how as a child, he was taught to pronounce the Koranic Arabic, and his discovery that the Hebrew and Arabic phonemes were identical. It was at the "El Azhar" Koranic University in Cairo that he found the traditional Semitic phoneme and it was these that he uttered to the best of his ability. We also point out that Mr. Suarès ascendancy is Hebrew on both sides of his family tree and that his family had never left the Mediterranean as far back as he remembers, to the best of his knowledge. His physiological conditioning would be such then that we could trust his pronunciation.

One more point: any one of the 27 Autiot (the 22 plus the 5 terminals) must always be written beginning with a Yod. The reason for this we shall dwell upon later. Thus all the fancy drawings of the Autiot and above all, the adopted handwriting of the new Hebrew must be completely rejected in our study. They bear no relationship with the ontological sacred language.

### 3. THE PERIODIC TABLE OF THE AUTIOT

א	ב	ג	ד	ה	ו	ז	ח	ט
Aleph	Bayt Vayt	Ghimel	Dallet	Hay	Vav or Waw	Zayn	Hhayt	Tayt
1	2	3	4	5	6	7	8	9
י	כ	ל	מ	נ	ס	ע	פ	צ
Yod	Kaf Khaf	Lamed	Mem	Noun Noon	Sammekh	Ayn	Pay Phay	Tsadde
10	20	30	40	50	60	70	80	90
ק	ר	ש	ת	ך	ם	ן	ף	ץ
Qof	Raysh	Seen Sheen	Tay	final Khaf	final Mem	final Noun	final Phay	final Tsadde
100	200	300	400	500	600	700	800	900

We have arranged the 22 Autiot together with the five extra terminal forms of the Autiot Kaf, Mem, Noon, Phay and Tsadde, in the tabular form of 27 shown above. This "periodic table of the Autiot" has to the science of Qabala the same significance as the periodic table of the elements has to the science of physics. (We point out that 27 is  $3^3$  and that the number three has special significance both as a power and as a base). Before explaining the "physics" of this table we wish to make a few remarks. These signs are both letters and numbers. Aleph is No. 1, but 1 spoken in Hebrew is Ehad or Ahdad in the masculine and Ahat in the feminine. Likewise all of the spoken numbers are different from the spoken letters: Bayt (2) is in the Hebrew masculine Shna'im or Shnei and in the feminine Shtaiim or Shtei, etc.

Each Aut is also a word that is spelled in terms of itself and other Autiot. This enables us to view each letter as a kind of infinite continued fraction as seen in mathematics, containing a repeating pattern, like,

$$1 + \frac{2}{1 + \frac{2}{1 + \frac{2}{1 + \dots}}} = 2$$

$$1 + \frac{1}{1 + \frac{1}{1 + \frac{1}{1 + \dots}}} = \phi = 1.618033989 \text{ etc.}$$

where phi is the Golden Ratio of Greek mathematics.

The idea that each Aut is in some sense a combination of all Autiot is very similar to the “bootstrap” principle in fundamental particle physics, where each elementary particle is broken up into other particles so that in a sense no particle is even truly elementary. However here we speak of a comparative analysis of the spoken schemata and the written one when opened, i.e. analyzed. For example Aleph is spelled Aleph - Lammed - Phay. The Lammed is spelled Lammed - Mem - Dallet. The Phay is spelled phay-Hay and Hay is itself. Thus as we spell out each letter of the Aut we see that we use other letters which in turn are spelled out and so on going endlessly, but as, in George Canter’s hierarchy of infinities, constituting a denumerable countable infinity called Aleph-naught.

Every sign expresses a particular aspect of energy changeable in both direction and intensity, in the same sense for example that light energy can be diffuse and wave-like or directed and coherent or laser-like, according to the variation of its components. This fact explains why a single root can have two opposite meanings in Hebrew.

#### 4. THE “PHYSICS” OF THE “PERIODIC TABLE”

We notice first of all that the 27 Autiot are arranged in tabular form similar to the periodic table of the elements. Both the rows of the signs and the columns have meaning. The first row of nine symbols represent archetypes or primitives of basic energy structures. They also are the numbers one to nine.

We may view this first row as seeds or potential energies which do not reach fruition in any of the fruitions contained within our own limited awareness of space-time, which lies on this side of the “wall of the light”. Or have they blossomed into the cosmic unlimited space-time which lies on the other side of the wall of light. The second row of nine elements, ranging from 10 to 90, expresses those primitive elements as actualized in our space-time awareness or in existence as we know it or perceive it, thus these nine represent energies whose flows are limited from above by the speed of light and thus on “this” side of the “wall of light”. The third row of elements from 100 to 900 are “far out” or cosmic and represent energies beyond our ordinary space-time. They lie if you will on the other side of the light wall. They are limited from below by the speed of light. They can be instantaneous or even backward flowing in time for some observers. They thus represent cosmic influences-intuitive flashes, second sight; thought transfer, permeating the wall of light, and acting therefore in us. They are the stuff that dreams are made of, but their effect on us is the most important. This third series of nine contain the five terminals.

Briefly, then, the first row we label as primitives the second row as space-time actualized and the third row as beyond space time or cosmic. We point out that the word cosmic when used to describe our observed physical universe is contained within the second row not the third. The word cosmic used for the third row elements has a more general meaning, i.e. beyond ordinary space-time, faster than the speed of light.

Aleph (1) is the supreme energy, subtle, alive, but not existing as itself in the space-time world we know, because it is relative. It is the primal energy, it is in all and all is in aleph. It is beyond definition, incapable of being defined or limited. It can be seen to move at infinite speed and thus evades time. It can be viewed as primal consciousness unknown to itself. Its action in the temporal is explosive and discontinuous.

Bayt (2) is any container, any physical support, any gestalt. It is the first or primary divisor or separator for to contain or hold is to separate that which is held from that which is not. It is the primary act of consciousness recognizing itself. If Aleph is spiritual, Bayt is material.

Ghimel (3) is the archetype of all organic movement - the motion of all Bayts containing Aleph. It is primary that to move, space-time is necessary so it may be viewed as the primary seed of space-time, for to know motion is to know space-time. If Bayt is matter then Ghimel is space-time. So we see that Aleph-Bayt-Ghimel are primary seeds or kernels to the world from which matter - space - time the so-called arena of existence is manifested. But without Aleph, Bayt-Ghimel is not possible. without Aleph mass-space-time is not possible, The physicist would have no play toys.

Dallet (4) is all resistance or response to movement. It is inert in minerals and it acts as a feedback in the biosphere. It is the response to all Ghimel of the Bayts containing Aleph. Dallet can be viewed as the interaction between material objects in states of motion. Dallet is Newton's discovery that between any two bodies there is a force equal and opposite, for every action there is an equal and opposite reaction. i.e. a response. It is also the principle of inertia which is logically connected to the action-reaction concept of Newton.

It is indeed inertia and it plays a vital role. It gives the hardness of all solid material and it is the means by which we learn or take things in memory for it is the response or resistance offered to Ghimel that is recorded. The prefix re is Dallet.

And thus we come to:

Hay (5) is Life as such, an all-inclusive notion that justifies our writing it with an uppercase letter, for when there is response to motion of material moved by the spirit we have Life. Thus the first four Autiot are the seeds for the primary seed of Life. Hay is spoken like a breath. The new born child comes to life with a breath (Hay) caused by its response (Dallet) to the motion (Ghimel) of the doctors hand (Bayt) on its backside awakening in it the spirit (Aleph).

Waw or Vav (6) is the copulative element (the "male" energy) the primary or fundamental act of fertilization. It is male in both its action and in its form or representation. It is interesting that it is an archetype for potential belonging to the first row while its projection in the existence - space- time called Sammekh (60) is the female sex.

Zayn (7) is energy in a free state of lyses. This could mean several things. In biochemistry lysis is the process of dissolution or cellular destruction. It represents all the possibilities of that act of fertilization. It is indeed the potential for possibilities and can

be thus viewed as in quantum physics as the probability amplitude for anything. It may also be thought of as the primary or principal principle of indeterminacy.

Hhayt (8) is an archetype of fundamental energy. In physics, it is the element of hydrogen that fills the universe. In psychology it is the unconscious. As we progress we see that each Aut is in a sense coming out of the previous Aut in a natural flowing fashion. Here we have in a sense the dim beginning of existence. Although still a seed and a first line element Hhayt (8) represents the summing up or storage of the various possibilities represented by Zayn (7). It can be viewed as a pool of unstructured energies not specifying any state of energy itself. In quantum physics it is the sum over states, the wave function while Zayn (7) is the probability amplitude for a particular state. It is also the collective unconscious in Jung's psychology. But remember it is still unactualized as such because it is still in the seedling state.

Tayt (9) represents the cell, any focus or center or concentration of energy that becomes female. With this Aut we are becoming closer to existence than any other Aut so far, for it is a result of Hhayt - a direct formation of the concept of "come together." In a sense it is similar to Bayt (2) and Hhayt (8) in its action, but it is more defined than these two. It is any focus or center or concentration of energy. In the theory of General Relativity it may be the "black hole". It is female in its action. It is a further summing up of the wave function represented by Hhayt in a special way giving rise to a primary structure of a cell or a womb, a place for birth to begin.

And this ends the first Row Elements and begins the second row which is the projection of these archetypes or seeds into existence, space-time on this side of the wall of light; the space-time actualized symbols. The second row ranging from 10 to 90 because they are actualized i.e. the seeds have reached the first stage of evolution, these symbols often appear as the opposites of their seedlings just above them.

Yod (10) represents the world of structures and is the opposite of Aleph (1). Thus where Aleph was potential or able-to-be, Yod is being. Where Aleph was timeless and beyond any limit, Yod is in time and thus is limited. Thus in a sense Yod being Aleph in existence is in a state of perpetual contradiction for Aleph is timeless and not existing but not non-existent while Yod is time-like and in existence. For as we become aware of existence so do we change it, It is the first manifestation of that quantum principle that by measuring something we alter the qualities we wish to measure. Thus Yod is in conflict with Aleph because it is a contradiction or paradox a wave - particle duality. The war with time enters into all existence and is the war between Aleph and Yod. A cosmic game is being played out in all that exists everywhere between, If you wish, the ideal and the actual.

Kaf (20) is the action of Bayt (in humans). It is in reality the physical container, the dividing line. It is the basis for reason in man - his ability to separate and analyze. It not only represents the scientist's test tube but as a container for Yod it is the man itself.

It is any material object and thus it is here that we are led to the idea that consciousness in existence (Yod) is in all things. All things are containers of Yod, and thus all the Autiot began with Yod, for the Autiot are in existence.

Lammed (30) in opposition to the functionally uncontrolled Ghimel (3) is organic movement, an agent of conscious relationship. Where Ghimel is uncontrolled, Lammed is controlled animate motion. It is the motion of the planets and of the things which move on the planets. It is in space-time and thus is in opposition to uncontrolled motion of its basis Ghimel. It is man, moving, and it is mans cells performing motion)it is the actual movement

of all things, all matter. Where Ghimel is unconscious motion, Lammed is conscious - willful directed motion. Lammed is to Kaf the same as Ghimel is to Bayt, but its relationship is actualized--seen or witnessed or felt at the known conscious level.

Mem (40) as waters (Maïm) has practically no energy, no resistance at all, or else life could not be born into it. It is the opposite of Dallet (4), the prototype of resistance. It has no hardness, but is responsive to forces acting on it. In fluid mechanics water is often imagined to be a perfect fluid without resistance. However, Mem also responds as the waters and is vital to life as we understand it.

Noon (50) in opposition to the unlimited--“seed” Life in Hay (5) is a life of cycles, repeating itself in time, every type according to its seed. Thus we are led to a kind of formula for life in man via Yod acting through Kaf giving rise to Lammed responding by Mem.

Sammekh (60) is the female sex energy in its own activity. This can be viewed as the proliferation of biological cells or as parthenogenesis.

Ayn (70), phonetically untranslatable, is the key to freedom. It is the projection of Zayn (7); it is the real probability of a state measurable and logical for definite alternatives. It can be viewed as the logical evolution of species alternatives, through the action of Sammekh.

Phay (80) is Hhayt (8) in existence. It is the summing up of the realization of alternatives of living energy. While Sammekh and Ayn refer to process Phay is the superposition of processes. If we view Hhayt as a primary sum of probability amplitudes in which many states contribute, then Phay is the realization of that sum as a definite probability. This leads naturally to:

Tsadde (90) which is the symbol for all structures. It is here that we have the culmination of Ayn and Phay to the formation of the stuff of the material world. In space-time Tsadde is the female principle of a cell.

And thus we begin the cosmic hundreds. The hundreds have a fundamental part in the structure of cosmic energy, both in the universe and in the human being. Here we speak of existence beyond ordinary existence, signals moving at speeds beyond the speed of light and thus to multidimensionality of existence.

Qof (100) comes through Aleph (1) - Yod (10) - to Qof (100). It is difficult to understand because it integrates Aleph and Yod in a cosmic action through the entire hierarchy of structures. Qof plays the game of contradiction. Qof includes timeless Aleph acting through its projection Yod in time against itself—resulting in the cosmic victory of deathless Qof. It is here that the illusion of space-time is destroyed; the game both begins and ends continuously without end.

As Qof is the cosmic Aleph then;

Raysh (200) is the universe as the home of the One energy, and as that One energy becomes its own container. It is the cosmic Bayt (2) acting in projection through Kaf (20) to become Raysh (200). Raysh is the cosmic container, itself, thus is a paradox for its contents is at once its own container. It is the universe wherein the one energy exalted Qof lives. A key to its meaning comes from the Hebrew word Aleph - Vav - Raysh which we interpret as Aleph copulating or fertilizing the cosmos. What can that mean? This word is the Hebrew word for light. In relativity physics, light plays a special role for it moves in space-time at one speed, has no rest mass and for it, there is no passage of time or extension of space in the direction in which it moves. It rides the “wall of light”

When we jump off the wall of light we create at one shot space-time and matter or



rest mass, provided we jump into existence at speeds less than light. In the game of the hundreds we are on the other side of this wall. Through the action of Qof on Raysh we have the ultimate movement of:

Sheen (300) is the “Breath” or organic movement of the universe. It is symbolically the “Breath” of God. Sheen looks very similar to the symbol for the wave function in quantum mechanics ( $\psi$ ) or the psi field of extrasensory perception. Sheen then represents a motion beyond the speed of light. It thus can be compared to pure thought, instantaneous communication, or the collapse of the wave function paradox in quantum physics. Sheen is the projection of Ghimel (3) through Lammed (30), breaking through the light barrier.

Tav (400) is the receptacle or tabernacle of the life of Aleph (1) in the unmanifested universe, which, so as to contain that life, opposes Aleph and energy equal to it and opposite in sign. Without Tav (400) nothing would exist. It is the spacetime continuum. Tav is the cosmic resistance acting in projection from Dallet (4) through Mem (40) and thus is the ultimate end or finality of all resistance and response. It is also the final Hebrew letter. It can be viewed as the enclosure of the life of Aleph ascending through all of the Autiot. Thus it is here that a rebound or ultimate opposition to Aleph is found by literally reflecting Aleph as would a perfectly hard cosmic mirror. Thus it reflects an energy equal and opposite to Aleph and its here that the two flows Aleph to Tav and Tav back to Aleph always giving life when they are in balance, can be viewed as originating. We shall have more to say about this dual flow later.

With Aleph to Tav and back again we have a circle or continuum vital for existence. Kaf in final (the 20 becomes 500) is the action of Kaf acting cosmically. It then becomes the universal Life. We remember that Kaf (20) is the physical container of Aleph i.e. of Yod and thus in space-time is man. Thus Kaf becoming 500 is man realizing his cosmic ultimate which is Hay (5) projecting through Noon (50) to cosmic Life - Kaf (500). It is here through the finals that we see the cross-connection of 20 projecting to 500 and of 5-50-500 and it is here that man's hope and destiny of cosmic fulfillment are found. It is here that we have universal life-cosmic consciously alive.

Mem in final (the 40 becomes 600) is, in the alchemical sense, the Waters in which is born the autogenesis of the universe. Mem represents the ultimate creative process of all that is. It is difficult to comprehend mem (40) itself for it represents that mysterious substance of water wherever all life originates. Presently water: still represents an unsolved problem in physics. We clearly know many of its properties but there are still deep problems. Nobel Laureate A. *Szent-Gyorgyi* writes that it is by the suns light separating the elements of water that oxygen is given up to the atmosphere and plants form their structures by which life on earth is possible. In Genesis I 6-8 it is written that God divided the waters. Perhaps there is a connection with the process of Photosynthesis or perhaps here we have the message of the two Mems 40 and 600. We shall say more about this in an appendix. But whereas Mem (40) is the non-resistance allowing life to continue. Mem (600) in its final form is the alchemical water that produces all living things. It is the projection Vav (6) - Sammekh (60) - Mem (600), and thus is the ultimate self generation of the universe. It is both a projection cross-wise across the table of non-resisting response and the cosmic process of fertilization. Perhaps here is the vital secret of the origin of life. At the cosmic level Kaf (500) the human being acting universally through the creative actions of his or her own hands gives rise to the cosmic creativity of

Mem (600).

Noon in final (the 50 becomes: 700) is the Principle of Indetermination in which is at stake the whole universe. The projection of Zayn (7) --Ayn (70) --Noon (700) represents the seed or probability amplitude acting through probability leading to indetermination, the ultimate freedom. In Physics this is Heisenberg's Uncertainty Principle without which no universe is possible. It is vital and still eludes the Physicists grasp and perhaps it is here that we see why, for it is a principle whose ultimate rationale lies on the cosmic side of the wall of light. Yet it is in cross- projection Noon (50) which is life in man becoming ultimately cosmically indeterminate Noon (700) that we again find man's destiny.

Phay in final (the 80 becoming 800) is its own projection of Hhayt (8) -Phay (80) to Phay (800). It is the total mass of all neutral energy and is constituted as a reservoir of universal energy. Here we find that the alternatives of living energy beginning in the pool of unstructured energy - coming into life - comes ultimately into cosmic or universal energy, literally all is possible.

Tsadde in final (the 90 becomes 900) is the ultimate realization and accomplishment of the universal structuralization under the sign of the transfigured female and of beauty. It progresses from Tayt (9) the primary cell to Tsadde (90) - the living cell and female principle of coming together - to the ultimate Tsadde (900) the sign of the transfigured female and supreme beauty.

## 5. THE ANATOMICAL CHARTS OF THE AUTIOT

As we have stated earlier each Aut is also a word which can be spelled beginning with itself and using other Autiot. In this section we shall examine this in more detail.

### THE ALEPH (1)

(The diagonal that constitutes the body of this sign begins with a Yod, the symbol of the existent. This diagonal expresses a life in movement, that links itself with all the other signs. According to Qabala, Aleph exists in every letter, and thus all letters being in existence must start with Aleph in existence, Yod. Furthermore, we see that aleph is not a symmetrical letter but is almost symmetric and that none of the Autiot are symmetric as are our letters A, H, I, M, O, T, U, V, W, and X. In Physics we often search for symmetries at very deep levels and their existence adds to our understanding of physical phenomena. Yet the absence of symmetry or near symmetry, spoken of as broken symmetries by the physicist always manifests itself at all levels of physics. Thus we are led to believe that the breaking of symmetry is vital for Life and that we were not intended to be as perfect crystalline structure).

(The diagonal element of Aleph is thus the rupture of the inert crystal static state. One can well wonder why it has been found necessary to draw such a complicated symbol to signify the number "one," whereas a single vertical line is enough in many writings. It is apparently not logical. The reason, of course, as we have been pointing out, is its meaning goes beyond that. That "one" i.e. the diagonal is both the separation and the union of two worlds. On the right top of Aleph there appears a hammer, a symbol of discontinuity because its action consists of beats; while on the lower left side there appears a leg walking in continuous duration. The Aleph has always been the symbol of the greatest possibly energy. In very ancient times it represented the head of a

bull because that animal appeared as being the very prototype of power. As it is today, we can see it as a cross for it has those attributes, but it is across in movement, unseizable, a symbol of life that is double and mysterious. According to the categories of our thought, it is the sign of the motion of functions such as vibration and wave undulations or intemporal and temporal, or discontinuous and continuous, or the Bohr principle of complementarity, the wave-particle duality, or explosion and compression, or otherwise. It is a totality by itself).

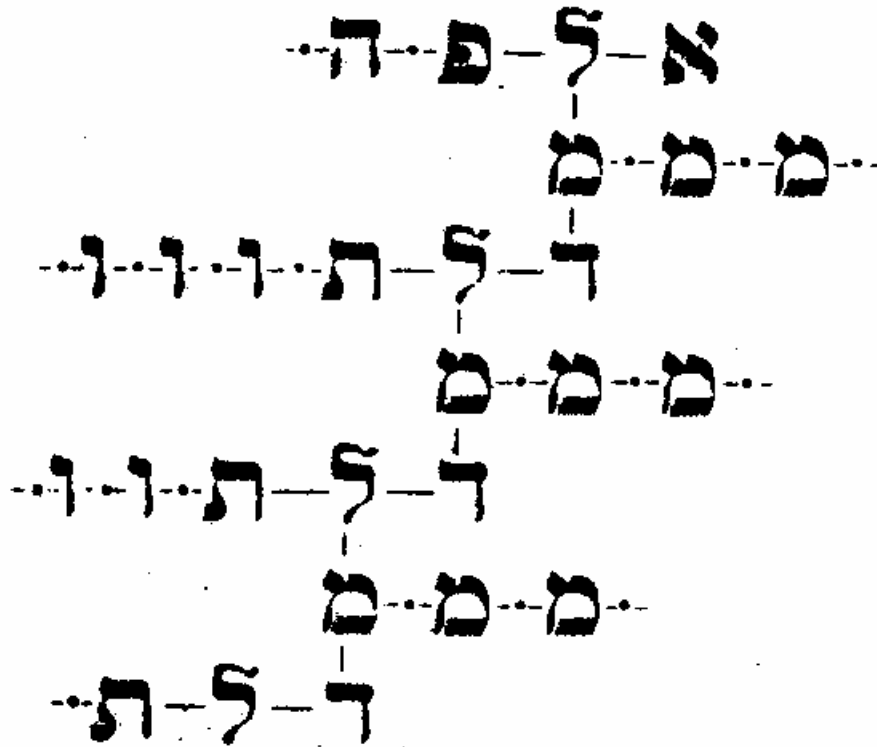

The top line of our chart is Aleph, spelled out as Aleph - Lammed - Phay going from right to left. Next we have the Phay (80) spelled Phay - Hay (80 - 5). Hay is the only Aut that does not contain any other.

It expresses Life, a word that we thus are justified to write with a capital L. It is that life that the Sepher Yetsira mentions when it is written that Adon Hakol “authenticates” Abraham with Hay (Abram becoming Abraham). As we explained earlier Phay (80) itself expresses the realization of alternatives of living energy, a superposition of processes projected from Hhayt, the collective unconscious. Then we can view Aleph - Lammed - Phay as a word representing Aleph, its action through Lammed (30) gives rise to controlled animate motion of all things which then in turn allows the realization of all alternatives of energy process (Phay). This action means that

these alternatives which are undivided become alive (Hay), (When Phay becomes Hay, Aleph becomes Eloh).

Next we move vertically downward into another dimension to represent the spelling of Lammed as Lammed - Mem- Dallet. We then have on the second line the spelling of Mem which is itself in infinite repetition - Mem - Mem- Mem - etc. Then horizontally on the third line we spell out Dallet as Dallet - Lammed - Tav, the Tav is spelled out further on the same line as Tav Vav, and Vav like Mem is an infinite repetition Vav-Vav-Vav, etc.

Through these actions then, we see in this chart a characteristic of two indefinitely repetitive processes: the Mem nourishes itself with itself, being the waters in infinite plurality, whose energy is almost nil (Mem is the second “mother Letter”), and the Vav the sign of masculine copulative outer seeking energy for itself endlessly.

The movement of Lammed is entirely different.

Passing downward through the Mem of waters, it becomes organic life motion by developing its response to the information it receives from the waters. This response is the Dallet (4), the archetype of that which resists or opposes itself to Aleph, for otherwise the Aleph could not exist. The Dallet then by feedback stabilization re-introduces this organic movement of Lammed which is thrust against the cosmic resistance of Tav which itself gives birth to endless out-seeking copulative action (Vav). The Tav is the symbol of the totality of the cosmic resistance, the hard mirror to the explosive power of Aleph. And so it goes on endlessly repeating and resonating giving rise to the chain of lines through the action of Lammed and Dallet, with Lammed always passing through the waters Mem to the archetypes of resistance Dallet giving rise to Lammed passing through the waters . . .ad infinitum.

When we integrate the sum of these processes into a single act or timeless flash of thought, we perceive, and receive the impact of this energy, both singly and doubly, whose Life is that of the entire universe. Between Aleph and Tav is everything that exists, coordinated into a hierarchy. Whenever and wherever the explosive power of Aleph prevails, galaxies rush towards their disappearance, the universe expands; wherever and whenever Tav prevails substances weighing thousands of tons per cubic centimeter exist.

With Aleph we have the rush outward of explosive light energy, with Tav, the reflection inward of the densest matter. Between the two is the human cycle. We as human beings must find our vocation, our path, which is to fertilize the repetitive memories of the Tav and use them to drive towards the creative explosion of the Aleph.

In brief, the anatomic chart of Aleph shows, first of all, that it confers life and energy to the undifferentiated Phay, and thus initiates the process Eloh (i.e. to be clear on this we have Aleph - Lammed - Phay, which is Aleph becoming Aleph - Lammed - Hay which is Eloh) mystically and traditionally, “God”. It then shows that the organic movement of Lammed initiates a vibration in the “waters”, Mem, finally it illustrates the endless process of the biosphere in the game between Lammed and Dallet at each stroke yielding the endless male copulative force always outward seeking (the 30 of movement plays against the archetype ~ of resistance- response through the 40 of response yielding the procreation force 6).

That game is apparent in every letter that introduces Lammed and Dallet (Sheen, Bayt, Yod, Zayn, Ayn, Ghimel, Hhayt, Tayt, Tsadde, Raysh and of course Dallet and

Lammed themselves). Thus in discussing these letters we must keep this “game” in mind, we need not comment any further on it. With this somewhat lengthy explanation of the reading of the Anatomic Chart of the Aleph, we have given all the necessary keys for the reading of most of the charts, We shall only add comments to new structures.

### THE TWO OTHER MOTHER LETTERS

#### MEM (40)

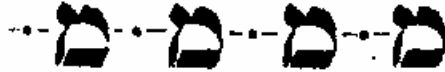

(Every drop of water responds to the other drops, so that living cells can develop without meeting any static resistance to stop them from doing so).

#### SHEEN (300) – SEEN

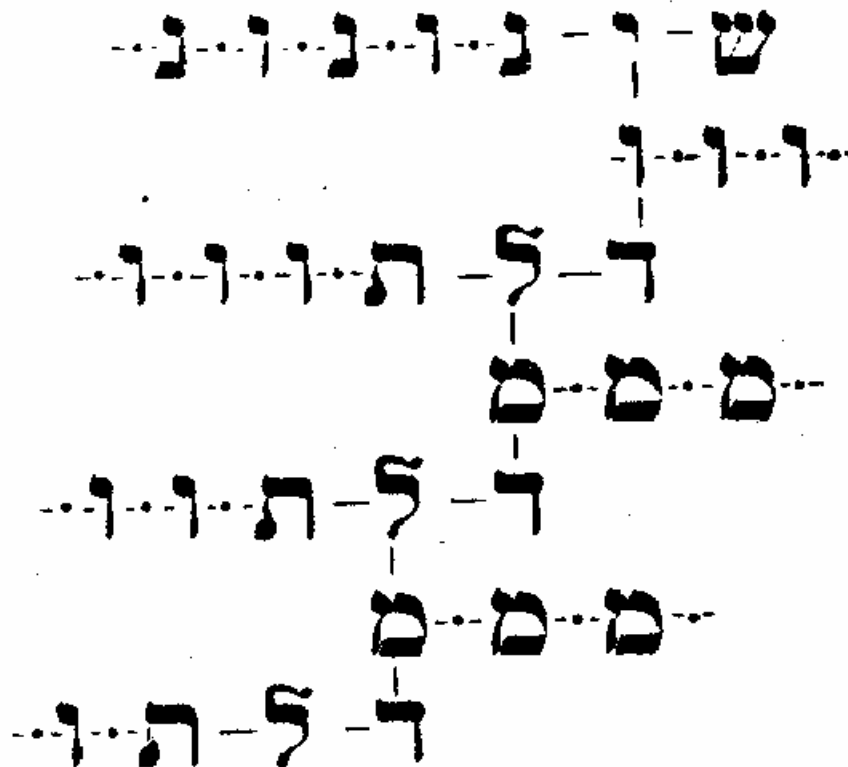

We have on the top line Sheen - Yod - Noon and Noon spelled as Noon Vav - Noon - Vav - etc. in endless double bonding. Thus we have the active agent of Aleph, the cosmic

breath of "God" or cosmic movement - acting through existence - space time (Yod) giving rise to Life in Man (Noon (50)) which then endlessly through copulation gives rise to Man which through copulation .. and so on. Or we can give Noon its cosmic significance, Noon (700) wherein the cosmic wind Seen acting against existence is reflected in the Noon (700) yielding the principle of indeterminacy, which propagates like seeds from a dandelion endlessly yielding multiples of indeterminacy at the cosmic level. This chart is both for Sheen and Seen: one single letter in a double vibration: Sheen acting wavelike and Seen acting particle like (see spectrograms on p --) In an approximate statement we can say that the action of Sheen finds its response in Noon (50) i.e. life in existence, whereas Seen, when fulfilled, meets Noon (700) the principle of cosmic indeterminacy. Through either picture, and both are right, Sheen leads the Dallet-Lammed game of existence.

It is clear why Aleph, Mem, and Sheen are mother letters for in them all the ingredients of the game are contained. The reason is that in Aleph we have the archetype of maximum energy, in Mem we have the minimum energy, and in Sheen we have the movement from Aleph acting towards and through Mem. This process is found in our own atmosphere whenever a high pressure area (Aleph) and a low pressure Area (Mem) are near enough to allow the one to feed the other by convection (Sheen).

Sheen is the cosmic vital flow from Aleph. It acts upon the waters (Mem) cosmically and thus nourishes them, providing the life sustenance. But this sustenance is not to be confused with food. For before life can eat it must exist. Sheen carries the vital seed of consciousness from Aleph. It is that which is deposited in the waters, and it is that that characterizes life. Life is knowledge and is thus a mystery. Here we begin to offer a clue, a speculation. We know that water is a mystery. Its molecular structure when in liquid state is capable of being analyzed many ways, the liquid state is not completely known or understood. Even in the gaseous state our atmospheric scientific investigations find its basic structure  $H_2O$  linked with itself forming complexes of greater complexity. Water exists. It is Mem (40). But 4- 40 - 400 symbolizes the prefix "re", as in resist, respond, and also in record, remember. That is water is capable of holding a pattern, i.e. remembering. Our brains are nearly all water. We are nearly 70% water. Sheen gives to water the property of storing information-knowledge.

We see water as a projection from Aleph. It is a projection from unconscious consciousness. It is in the state the darkness of mind unaware of itself. In this stage Mem is the symbol of a fundamental contradiction, whose name is consciousness. Sheen projects into it (Sheen - Mem - Yod - Mem) Shamiyim and thus attempts to resolve this contradiction by becoming aware of itself.

It is here that we find we must intercept this vital flow of thought so as to develop the remaining Autiot. We will continue this development in the appendix. It is extremely important that the reader re-establishes his link to the three Mother Letters after studying the remaining charts. For here we hope to connect analogically the bioprocess, the bible and Einstein's equation.

Wow! or should we write Waw (6) !

Next we have:



## YOD (10)

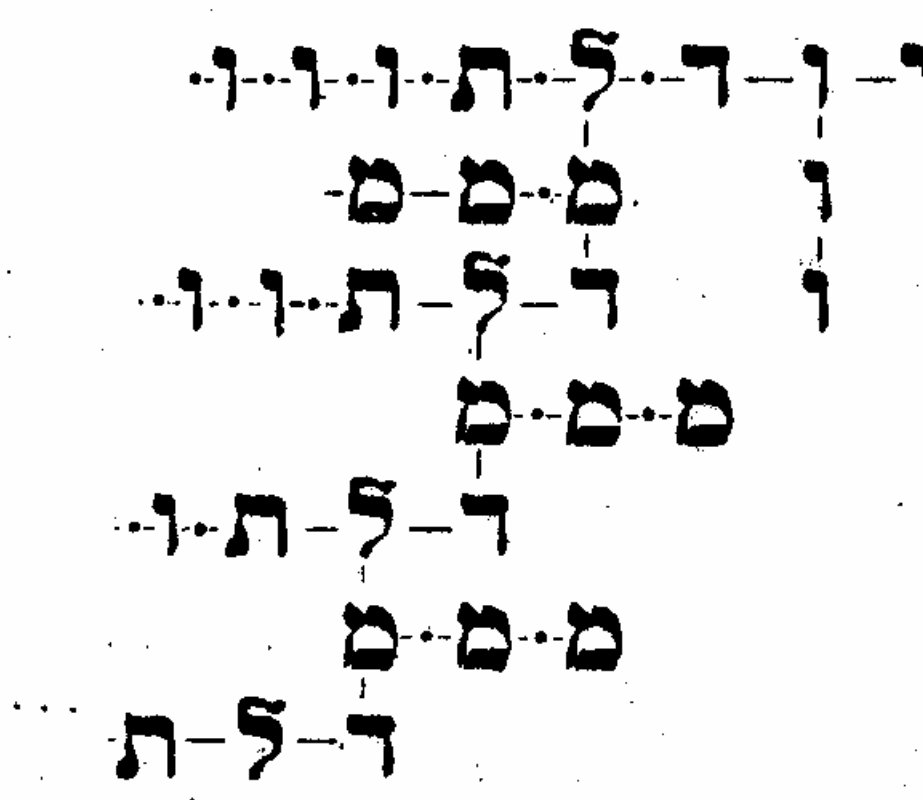

The first line contains Yod - Waw - Dallet. The Dallet then gives rise to biological process through Dallet-Lammed. The Waw acting endlessly vertically.

Thus Aleph in existence i.e., space-time (Yod) moves or thrusts itself endlessly propagating into or against Dallet that which resists or opposes Aleph. Here we have a vital message about existence namely that where Aleph is supreme, Aleph in space-time, Yod, meets resistance by becoming temporal. It indicates also that biological process is Aleph projecting itself from timeless to temporal).

## TAV - THAV (400)

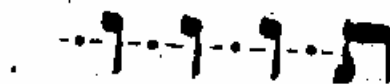

The cosmic Tabernacle of Aleph which is Aleph itself acting compressionally in its fertile power. Without Tav no-thing would exist. Without Aleph there is nothing.



**THE TWO LETTERS WHICH LINK THE TWO FLOWS, ENERGY  
AND ITS INVERSE**

ZAYN (7)

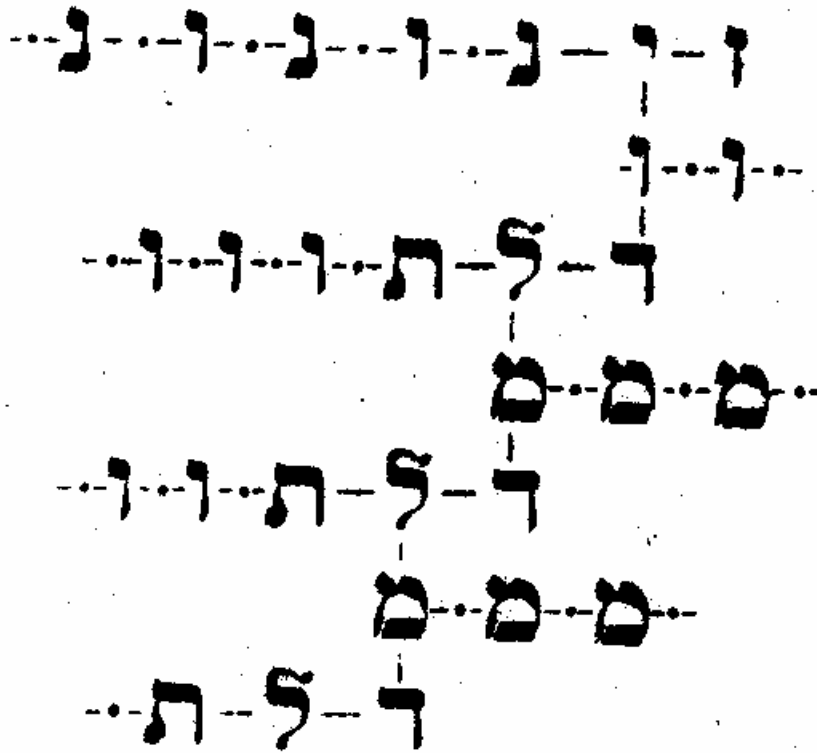

The energy in its free state of lysis engenders (a) a double waste of germs; in existence and in capacity to exist; (b) the biological process.

The amplitude of probability Zayn acts in existence to give rise to Noon (50) or Noon (700) which itself acts copulatively ever reproducing itself.

Through either connection we must pass through Space-Time (Yod) thus giving rise to the Biological Game of Dallet-Lammed. For the physicist this is a significant letter for we see that Zayn (7) like Sheen (300) gives rise to the human form, the container of Yod in space-time (Noon (50)) and/or to the Principle of Indetermination Noon (700). As Sheen could be viewed as Psi the wave function, Zayn is the amplitude of a probable occurrence or event. As itself it is represented by a complex function or number in quantum mechanics, thus it has both a real and imaginary part. Its imaginary part keeps it from being measured in space-time and so its domain is at the archetype . reed-level. Its action is both cosmic and existent.

AYN (70)

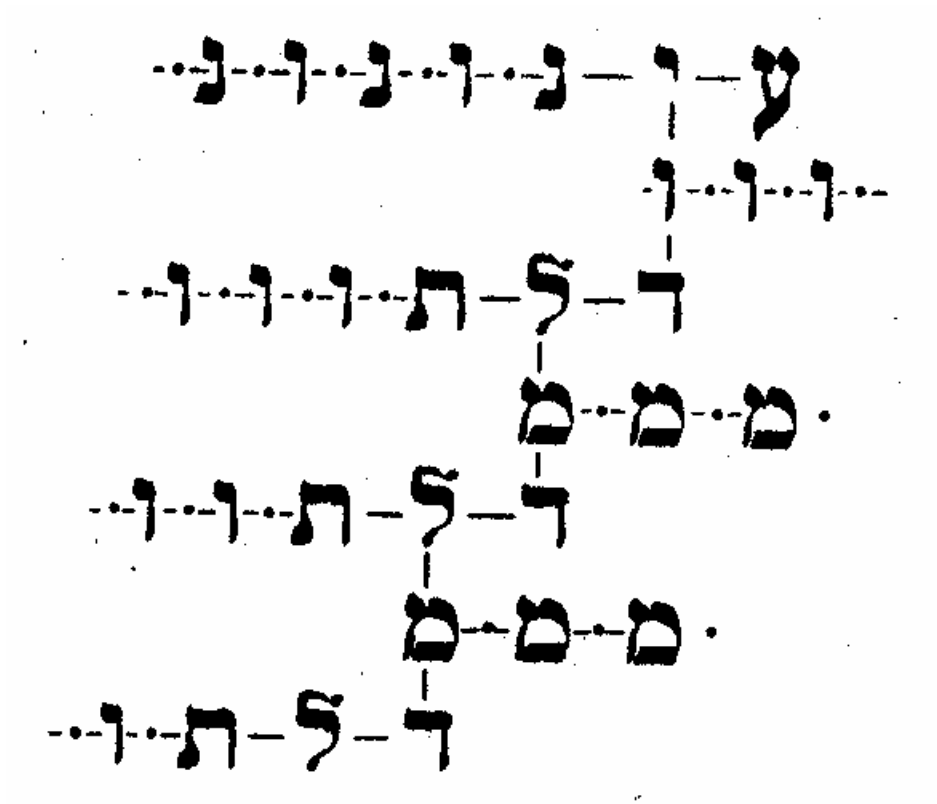

It has the same anatomy as Zayn. Only it represents probability not amplitude for probability, thus it reinforces the action of the ascendance Zayn (7) - Ayn (70) - Noon (700).



**DALLET-THALLET (4)**

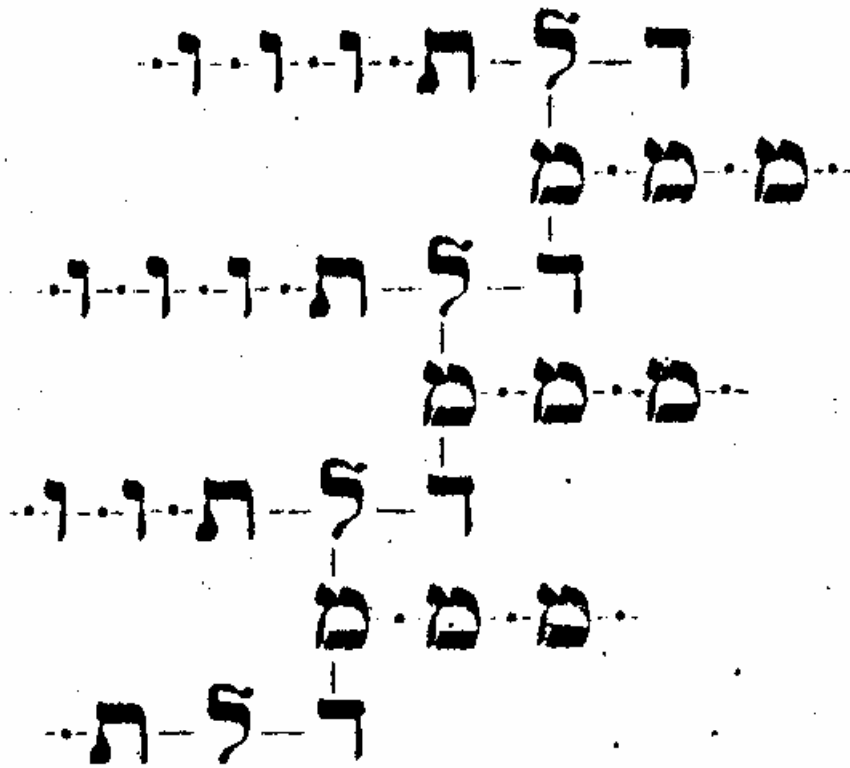

By resisting Aleph, Dallet gives rise to the endless cycle of motion- resistance- motion etc., in all biological systems. This is seen in the biosphere as resistance and response necessary for life to continue.

**THE MALE AND FEMALE SEXUAL ENERGIES**

**VAV - WAW (6)**

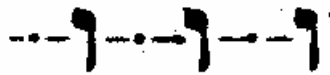

Endless copulative action with no purpose, its copulative energy exhausting itself in its own repetition if it has nothing to fertilize.

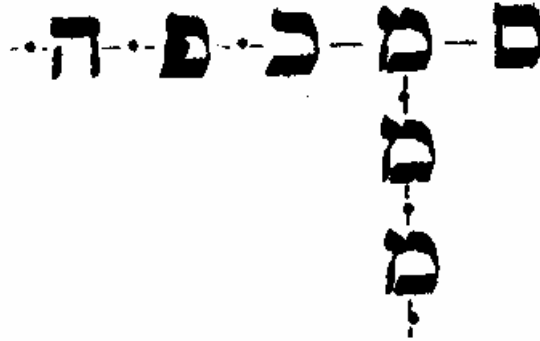
**SAMMEKH (60)**

The Female energy like Vav, only wrapping around itself and passing or acting through the waters (Mem), produces the physical container of Yod that is Kaf (20) and/or the cosmic principle of Life Kaf (500) that continues as in Aleph with Phay-Hay, the birth of life (Hay) from undifferentiated energy processes (Phay). We point out the sexual role of the female in space-time is both in existence by literally giving birth to physical containers of life Kaf (20) and in the cosmos by providing mankind with his destiny Kaf (20) becoming Kaf (500). In either or both cases the final product is the same - Life (Hay).

**LIFE****HAY (5)**

Life is a simple and absolute fact. Some authors spell it Hay-Aleph, others Hay-Yod. Both of these spellings are mistaken. Moses Revelation (Ex. III, 14) Ehieh-Asher-Ehieh, translated differently as an assertion of a personal deity, means Aleph alive Yod alive, or the timeless and the temporal are both alive).

NONELABORATED SUBSTANCE AND BIRTH OF THE CELL

HHAYT (8)

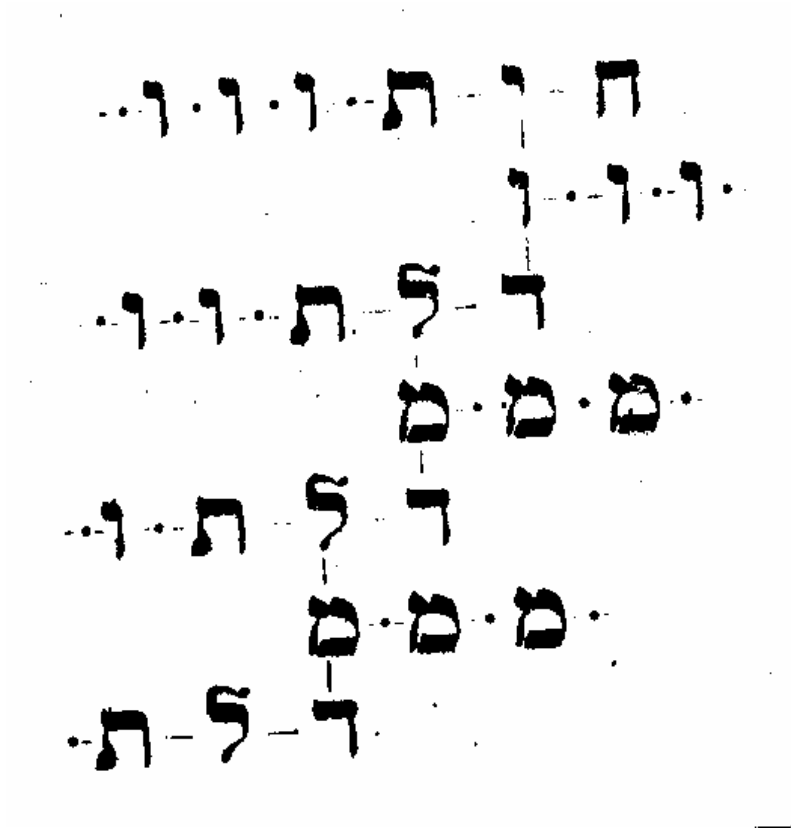

## TAYT (9)

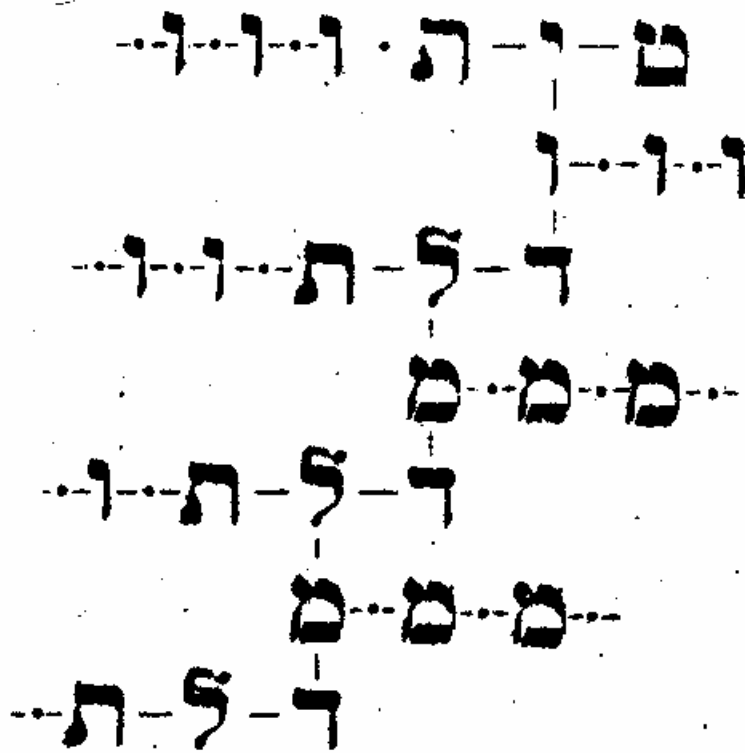

Bayt, the archetype of forms, Hhayt, the archetype of non-elaborated substance or undivided structures or alternatives, and Tayt, the archetype of a differentiated structure, the cell, have the same anatomy. All three show that their existence (Yod) comes from Tav. As in Bayt we have two fertilizations through Tav and Yod, they both may be viewed as giving rise to organic life through Dallet-Lammed. The first comes from Tav the Tabernacle of Aleph and the second from Yod, Aleph in existence. In Genesis I we have in the equation Elohim Life through Aleph. Also in the equation Yod-Hay-Vav-Hay, Yahweh sometimes Jehovah mentioned as the Lord we have two lives from the two Hay. When Abram is said to receive a Hay of Life and become Abraham, he was obviously alive before receiving it. The extra Hay can be considered as being the 'inner life'. The contention sometimes becoming a violent conflict, between those who possess the 'two lives' (Cain, Jacob, Jesus) and those who only have Elohim (Abel, Esau, the apostle Peter) has its climax in *The Song of Songs*<sup>5</sup> the holiest of holy scriptures according to Aqiva.

<sup>5</sup> (1) *The Song of songs* by Carlo Suarès, Shambala publications

PHAY-PAY (80)



Here the nonelaborated energy, although unstructured, has a life that appears on the surface of things. Undifferentiated probability gives rise to life.

THE STRUCTURING OF ENERGY

TSADDE (90)

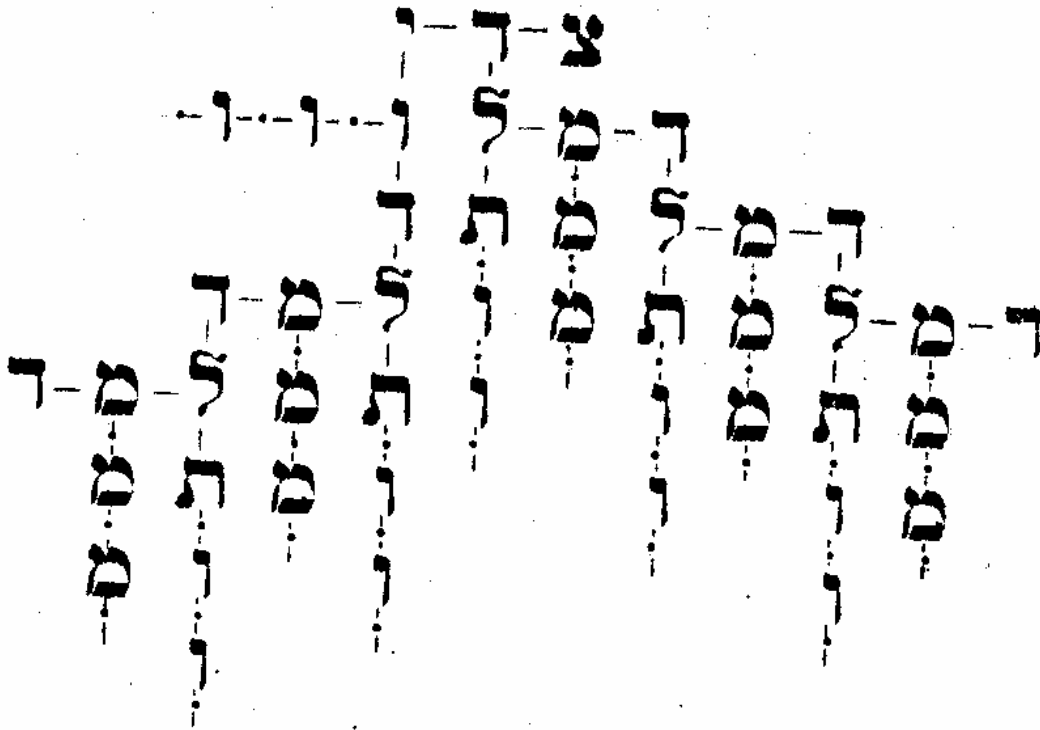

This anatomy, the most complex of all, shows the quality of Tsadde as the expression of structural energy. Its meaning may be expressed as well by the cell acting through or responding to existence proliferating in a double structure—the Lammed-Dallet game of Organic Life—nonsymmetrically but yet mirror imaged through Yod and Dallet one in a building upon the other in endless rains of fertile activity.





## THE ACTION OF PHYSICAL SUPPORTS

KAF, KHAF (20)

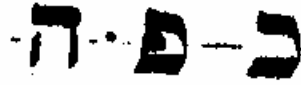

The action of Bayt (2) when made factual is Kaf (20). [As in the code for Sammekh, Kaf represents the physical support or container acting through unstructured probability to give life.](#)

## THE EXISTENTIAL LIFE

NOON (50)

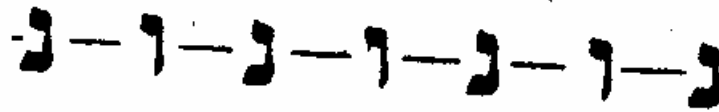

Life in existence proliferating giving Life on endlessly for itself in itself.

# THE COSMIC ALEPH

QOF (100)



This chart is total in itself; the cosmic Aleph fertilizes the undifferentiated probability.

## THE COSMIC HOUSE

RAYSH (200)



Raysh, the cosmic container acts through existence to give rise to Sheen, the “Breath of God” which is surrounded symmetrically by the two Yods, yielding endless symmetric mirror existences of organic life through Dallet-Lammed. This symmetry is often found in the equation Yod-Hay-Waw-Hay, condensed as Yod-Yod, the mystical name of the Deity. In physics we could view this as the matter-anti-matter mirror symmetry of the properties of the fundamental particles). It may also illustrate the double flow of life to death and back again into life known as the “the two breaths” or the double movement of the quantum wave function.

### THE TWO BREATHS

x1	1	א	1	ט	4	x100
	2	ב	2	ד	3	
	3	ג	3	ה	2	
	4	ד	4	ו	1	
	5	ה	5	ז	9	
	6	ו	6	ח	8	
	7	ז	7	ט	7	
	8	ח	8	כ	6	
	9	ט	9	כ	5	
x10	1	י	10	ל	4	
	2	כ	11	מ	3	
	3	כ	12	נ	2	
	4	ל	13	ס	1	
	5	מ	14	ע	9	
	6	נ	15	פ	8	
	7	ס	16	צ	7	
	8	ע	17	ק	6	
	9	פ	18	ר	5	x1
x100	1	צ	19	ש	4	
	2	ק	20	ת	3	
	3	ר	21	י	2	
	4	ש	22	כ	1	

We have arranged the Autiot into two columns from Aleph to Tav and from Tav to Aleph. The first nine letters beginning with Aleph have an energy value corresponding to

their numerical order. The next nine (10-18) have the value of the sum of their digits multiplied by 10 (for example the 15th letter Sammekh has the value of one plus five times ten or 60  $[(1+5) \times 10 = 60]$ ). The four remaining letters are also worth the sum of their digits only this time multiplied by 100 (for example the 21st letter Sheen is worth  $(2+1) \times 100 = 300$ ).

Going from Tav to Aleph in reverse order does not give the same values because for example Tav is 400 etc. However, it is only at certain levels where we find values coming from opposite directions coinciding. These are at the two levels of sevens Zayn - Ayn Hence it is here that the two flows or breaths have connections. For clarity note that at the 12th level for example Lammed ( $3 \times 10$ ) is not the same as Kaf ( $2 \times 10$ ). At the 7th level there is a resonance between Zayn ( $7 \times 1$ ) and Ayn ( $7 \times 10$ ), and again at the 16th level.

Psychologically, such junctures where the two energies meet each other appear as conflicts such as between love and duty, flesh and spirit, authority and revolt, etc. To know that these oppositions are inverted flows of the one energy is to learn that these conflicts are superficial and that in their depth lies freedom.

Philosophically we point out one other feature of the Two Breaths. If one extracts the digital root (sometimes called the Qabalistic root) of each Aut and its counter streaming member at each level one finds the numerical value of 5, life. For example, at the first level is Aleph (1) and Tav (400). The digital root of Tav ( $4+0+0 = 4$ ) is 4. The digital root of Aleph is 1. Adding up we have  $4 + 1 = 5$ . Or at the 18th level we have Tsadde with its digital root of 9 plus Hay (5) giving  $9 + 5 = 14$ ,  $1+4 = 5$ , etc. Thus all conflicts are in a sense part of life, or give life its meaning. (If you wish you could have added Tsadde to Hay directly, i.e.  $90 + 5 = 95$ ,  $9+5 = 14$ ,  $1+4 = 5$ , the digital root of a sum of numbers is the same as the sum of digital roots of each number.

The anatomical charts, in the order that we have presented them, show that the Autiot comprise a complex mode of thought that embraces many categories. The three “mother Letters” are those mentioned in the Sepher Yetsira. They give a synthetic view of the cosmic energy contained in the concepts of: maximum energy (Aleph), minimum energy (Mem) and the action of one upon the other (Sheen). The three that “play the game with Aleph” are the leitmotifs of Sepher Yetsira (Bayt), Genesis (Yod), and the Song of Songs (Tav)—the three fundamental textbooks of Qabala. The other Autiot analyze the cellular life in its functions and organs, but astrologers can see them in action in the zodiac, historians in the succession of events, psychologists in the psyche etc. because as we have already said, that thought is analogical and inclusive. To penetrate it, the Qabalists never forgets to read the Alphabet from Aleph to Tav and from Tav to Aleph, so as to allow the two flows of the one energy in inverted order, to appear as carriers of life (5).

### THE TWO FULL BREATHS

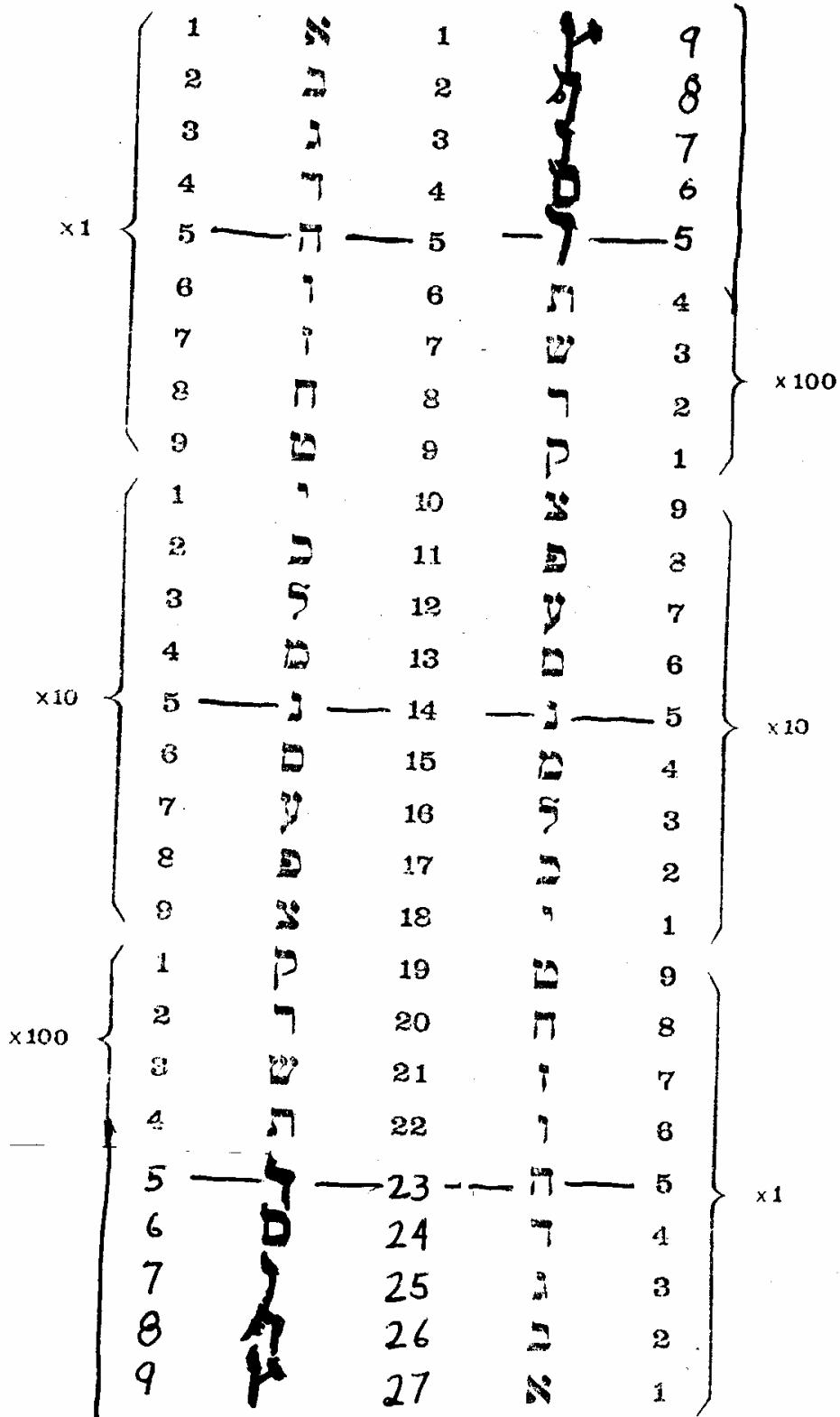

It is also possible to reconsider the two breaths in opposition but at this time to consider the full 27 Autiot that is to include the finals as well. As we see here another remarkable feature is exhibited. By using the same principle of determining the digital or Qabalistic root of each level we find the result is unity of Aleph. (For example, at the 21st level Sheen (300) + Zayn (7) gives  $7 + 300 = 307$ ,  $3 + 7 + 0 = 10$ ,  $1 + 0 = 1$ ). The correspondences or resonances now occur at three levels, at the 5th (Hay and Kaf (final)) at the 14th (Noun and Noun) and again at the 23rd level with Kaf (final) and Hay. All of these levels have Qabalistic roots of 5 (5,  $14(1+4=5)$ , and  $23(2+3=5)$ ). And all of these levels have fives as the coincidence value. Thus five is the number for life and what these two breaths indicate is that through these conflicts life at the archetype - existent and cosmic levels is **forever** reinforcing itself.



## 6. THE SPECTROGRAMS

The Spectrograms were recorded on a rotating cylinder whose sense of rotation gave images of the flow of energy going from left to right, as one would write in ordinary English. We present them here as flowing from right to left so as to conform to the Semitic way of writing and thus to show the flow of Aleph in that direction.

Specifically these spectrograms exhibited graphically three qualities of speech. Intensity or loudness, frequency (that quality which differentiates a high voice from a low voice, soprano to bass) and extent (how long in time a phoneme is pronounced). Thus we have graphs of frequency drawn vertically and intensity shown as a darkening or blackening of the picture, displayed as functions of time drawn horizontally from right to left. To obtain some idea of scale when looking at the spectrograms the width of each photo corresponds roughly to a one-second time interval, while the height of each photo corresponds to a frequency range of 8000 Hertz or 8.0 kilocycles per second. If one finds a dark area extending across the spectrogram at a certain level it means that the sound at that particular range of frequencies which is centered about the frequency at that level is very intense (loud).

Each dark band shown here corresponds to an instrument setting of the band pass filter to the "narrow" range of 80 Hertz. This fine scale range produces the "grainy" texture of each photo. Spectra can also be obtained at a setting of the band pass filter to the "wide" range of 300 Hertz in which case there would be fewer dark and light gaps and each photo would appear smoother. We point this out to indicate that at the setting of 80 Hertz we are obtaining more detailed information concerning the intensity of the sound produced at any particular level of frequency, in much the same way that a fine-tooth comb gives more information about the texture of hair than an ordinary comb with large spaces between the teeth. Regular gaps or bands at different levels do often appear. These indicate harmonic or octave content at certain frequencies in the same way that musical instruments playing the same note sound differently because they have different content at their octave levels. The strongest, most penetrating, and most subtle energy is at the top of the image while the lower part symbolizes bodily concretized solidified energy.

If one imagines these three qualities (frequency, intensity, time) as labels to three spatial axes then each Aut would appear as a three-dimensional surface or solid. Thus one can view each image as a contour diagram similar to a contour geographical map only here the intensity or force of the sound replaces the geographical concept of altitude.

In quantum physics we know that all matter and radiation can be represented as being made up of packets of energy. Each packet contains a spectrum of pure waves at isolated frequencies. Each part of the spectrum corresponds to a certain energy, as first elucidated by Planck and Einstein and later by De Broglie. Thus each band of these images represents an energy packet disturbed or in existence: for the brief period of time exhibited. The higher the frequency, the higher the energy content of any packet. The amount of energy multiplied by the time that energy is in existence (i.e. integrated over) gives the "action" content of that packet. Thus when one is observing these images one should keep in mind these concepts in order to obtain a better understanding of their meaning as well as the explanation of them offered by Mr. Suarès. For example, if we compare the spectra of Aleph with that of Mem as spoken by Mr. Suarès we see several remarkable differences. I should like to point out some of them.

Mr. Suarès' Aleph (p. ), for example, shows a remarkable quantity of action at the higher frequencies where one sees a broad smear of that high frequency action shaped like the head of a cobbler's hammer. At the base of the photo where one sees an apparent foot in a pant leg we see that the action of the foot is of much shorter duration than the action of the head of the high frequency hammer. Thus Aleph exhibits the hammer and foot of its symbols as well as the meaning.

Mem (p. ) on the other hand shows hardly any action at all. A slight smear at the high frequency indicates some of Aleph's property but not much. However Mem does show an almost equal quantity of action at all levels of frequency as if to indicate its passivity or equal response at all levels. Clearly aside from Mem's spectra resembling a waterfall it appears to have the property of equal response at all levels, perhaps the reader may wish to keep some of these ideas in mind as he reads Mr. Suarès' descriptions.

Since this line of research is somewhat new we would like the reader to consider our results as preliminary subject to many improvements. Obviously (as it is shown by the Bayt who projected a blurred but recognizable face of Mr. Suarès) the energy that is emitted is molded by the person who speaks it, not only by the sound of the voice and the pronunciation, but by the more or less intimate connection of that person to that energy.

This in our mind ought to open a wide range of studies in the field of psychokinetics. The characters of the sounds emitted in speech not only by individuals, but also by committees, classified according to climate, continent, social class, etc. . . . have been little studied as expressions of inner motivations and psychological structures considered globally.

We hope to give, with this book, an entirely new outlook on these subjects. Not only have we here (perhaps for the first time in history, to our knowledge) a semantic scale of references with the original code of the Hebrew letters (the Sacred language) but also a dramatic confirmation of the rereading of the Bible according to that code.<sup>6</sup> Further directions for research in this field suggest themselves. For example, it would be useful, we believe, to study various schemata such as combinations of Autiot to see what images they conjure up.

By use of echo chambers and sophisticated recording techniques perhaps a new field of psychophonetics may develop. Who knows? We have it in mind to try some further experimentation ourselves perhaps with the anatomic charts as a challenging experiment. We encourage others in this effort.

Finally, I, (Mr. Wolf) wish to comment on the descriptions of the Spectrograms that follow. Without exception and with only minor corrections these words are those of Mr. Suarès describing his own spectrograms. I feel that these descriptions personally felt by Mr. Suarès need no additional comment of mine.

---

<sup>6</sup> *The Cipher of Genesis*, by C. Suarès, Shambala, London and Berkeley, paperback by Bantam, N.Y.

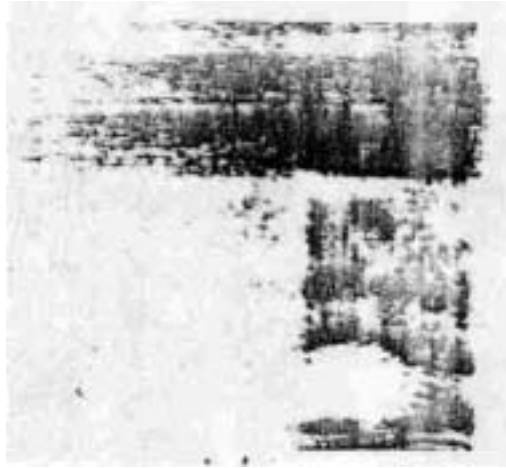
**ALEPH**

Aleph, the first “Mother-letter” is a consonant. It must be pronounced with a strike of the throat as when slightly coughing. The tonic accent must be strongly and briefly emphasized on the “A”. Aleph is essentially different from the Indian AUM, which is a long vibration from the lungs that finds no resistance in the throat. Moreover, AUM always starts with an open “Ah”, whereas Aleph, often mistaken as being “A”, is, according to the schemata where it appears, sometimes Ay, O, or Ee, or not pronounced at all. This polyphonic quality suits Aleph, and in a way describes that infinite energy that cannot allow it to be stepped down in the temporal world.

In the minerals, Aleph is dead; in the vegetables it is reduced to the repetition of archetypes structured by the memories of the plants; in man it is immersed in blood (it is the name of Adam; Dam meaning blood).

Its spectrogram shows an unequalled energetic power at the top of the photo, that our device recorded to its maximum capacity. There are three horizontal fluxes of this energy (the topmost is cutoff). The picture shows that it has been captured and projected principally in its lower third, which was, of course, the most accessible to the person who emitted it. A few scattered clouds appear as a degradation of that energy. In the center of the picture, a suspended intensity rests as a layer between sky and earth. A twofold flow goes towards what appears as a leg, whose foot reconstructs a threefold energy for “the march of time”.

**MEM**

Mem, the 2nd “mother-letter” is the water. Its ancient script, similar to a small “m” and its schema written in our italics, suggest a movement of waves. Although Mr. Suarès pronounced it with all the strength he could muster, its spectrogram shows that it has practically no energy, and has no link either with the top or with the bottom. So Mem is in total opposition to Aleph; a quality that rightly confers to the water the name of “primary element.”

The miracle of its mysterious and contradictory non-energy allows life to be born in waters. This occurs by the fact that every drop of water responds in every direction to the information it receives; therefore its non-resistance allows life to develop freely.

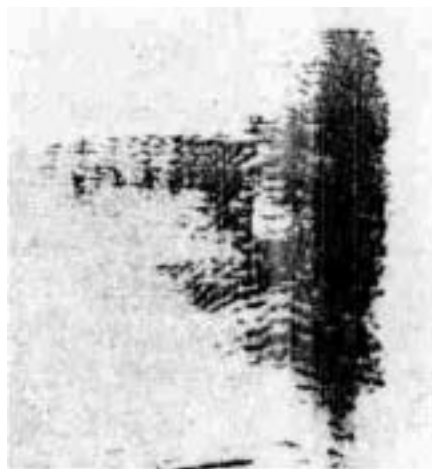
**SHEEN**

Sheen, the 3rd “Mother-letter” is pronounced as it would be in its English spelling. Its number, 300, is equivalent in Gematria to Ruach Elohim Hhaïm (the Breath of God alive). It is the organic movement of the Universe (3, 30, 300 all express the organic movement in different spheres) and, as such, it is the active agent of Aleph. Its spectrogram illustrates that fact. The very high potentiality of Aleph, as we have seen it in its spectrogram, rushes horizontally past our space-time evolutionary continuum. Sheen, as its agent, vertically reverses that energy, through all the layers of existence, and its spectrogram shows that the mere sound “Sheen” does exactly that. Thus, an interesting feature shown in this photo is that the three flows of Aleph are in

inverted order: the strongest action is on top. It shows the reducing of energy, to the point of disintegrating in the lowest level (which we can consider as that of the waters). In brief, Sheen projects the highest energy of Aleph into the lowest, Mem.

These three letters are well named the “Mothers”, because they sum up the entire process of the cosmic energy. (Sheen upon Maïm, the waters, or Shamaïm is wrongly translated “heaven”.)

### SEEN

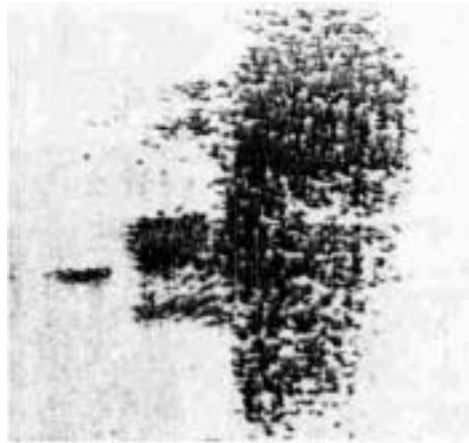

Seen is Sheen active at one point. Its energy is less powerful in the innumerable layers of existence, but more effective and penetrating. Seen compares to Sheen, as a laser ray compares to diffused light. The spectrogram shows it is an apparent duality before emitting the single thin dart that will pass through a cell, perhaps. The letter Seen is the initial letter of such words as Semol (left hand side) and Satan.

An attentive look at its spectrogram reveals an astonishing world, where the power of Aleph has not penetrated through as with Sheen.

### BAYT

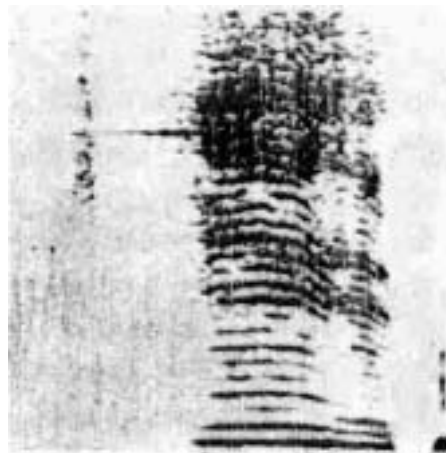

This is the spectrogram of the 2nd letter of the Alphabet, generally written Beth, which is a double mistake. Its pronunciation ends with “T” and not with the English “TH”, and it is

prolonged. It compares to Bet, as feet compares to fit. That is why I spell it Bayt, although the vowel is pure, as is seldom the case in English when the vowel is long; here the “Y” must only help to sharpen the sound. It must not be pronounced.

Bayt is the first Aut that I introduce as “playing the game with Aleph” (Keep in mind the postulate of the Sepher Yetsira: everything with Aleph, Aleph with everything, everything with Bayt, Bayt with everything).

The fact that Genesis begins with Bayt (Beresheet) has been the origin of many allegorical and mythological stories, such as the competition of the Autiot for the honor of beginning that scripture. Simply and rationally stated, Bayt is the archetype of any given physical support of energy. It is spelt Bayt - Yod - Tav. Although, with its Yod it covers all existence and with Tav it meets the cosmic resistance to Aleph, its action is always on one single container.

Its spectrogram fits that description. It shows vibrations on every level, from Aleph to Tav, with a concentration on a particular zone, emitting a very thin spear towards a slight vertical condensation (the cosmic resistance): it is probably a symbol of the life of the speaker’s body, or Bayt. On the right of the spectrogram, a pebble of a sort is on the ground; an inanimate residue, a piece of energy whose positive and negative energies are in deadlock.

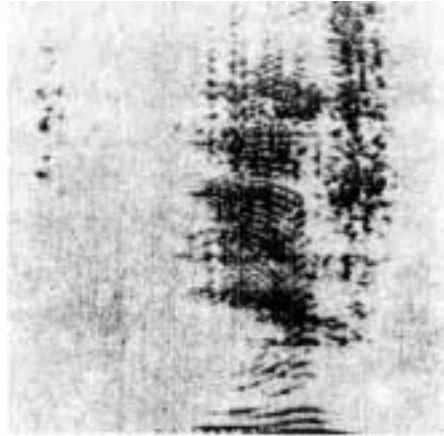

Bayt, as all the Autiot has been pronounced several times. Even when we think that we have repeated a sound, it varies, since as well as other reasons, the room was not soundproof. Here is another projection of the Bayt - or body - of the experimenter, in Fig. a. It is somewhat blurred, but the face is recognizable. We asked the, photographer who made the “Photo Vero” snapshot of Mr. Suarès to consider Fig. a. He superimposed Figs a and b, and obtained Fig. c. The two faces are seen to coincide. In a frame shaped as the Hebrew letter Bayt. We abstain from further commentaries.

**VAYT**

Graphically, Vayt is a Bayt without its dot. There are seven such letters in the Alphabet, called the seven double letters. The Sepher Yetsira introduces the seven without dots as expressing their inner nature, and the seven with dots as presenting either a barrier to the cosmic energy, or a response to it in action. In other words, the seven “soft” **letters**, so to speak, absorb the cosmic life in their inner life or allow it to flow by them, as through a sieve, whereas the seven “hard” ones, by their very resistance, are operative, positively or negatively, according to circumstances. The pronunciation of everyone of those letters corresponds to its quality. Thus, Vayt is obviously soft and Bayt hard. In the Zodiac, according to the Sepher Yetsira, Vayt forms one Shabatai (Saturn), alive in Capricorn, and Bayt forms it dead in Aquarius, and it is stated that the seven doubles form the seven Planets (Uranus, Neptune and Pluto were not known at that time).

As its spectrogram shows, Vayt is incapable of concentrating Aleph’s energy and of projecting a piercing dart upon Tav’s resistance. On the contrary, it appears as if it were drinking a disordered Aleph by means of a beak. Its life, with five fringes (5 is the symbol of life) is suspended in itself, without any contact, in any realm. The pebble that appeared in Bayt, here does not exist. All in all, the difference between the two spectrograms is greater than could be expected, between two phonemes so similar.

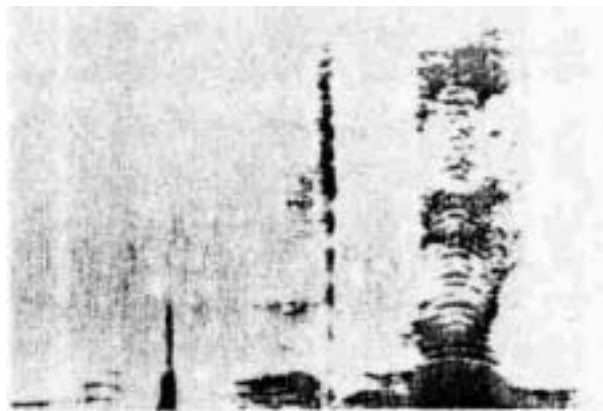
**YOD**

Yod, archetype of temporal existence, is the letter that, more than any other, “plays the game”

with Aleph from the very beginning of the biblical Genesis. Its spectrogram is a good picture of its character.

In Hebrew, Yod is the hand, and the hand manufactures all sorts of objects, always incomplete always substituted by newer ones, according to the technical evolution, and it is unrelated to Aleph.

We see, in this spectrogram, resting on the floor, a strong concentration of energy, acting as a support for a broken vase or an attempt of building a column. Higher up, there are two successive unrelated concentrations, in which it could be possible to discern faces. On the left, scattered in disorder, we see different attempts towards gathering enough strength to form a readable picture, all unsuccessful for lack of coordination.

### TAV

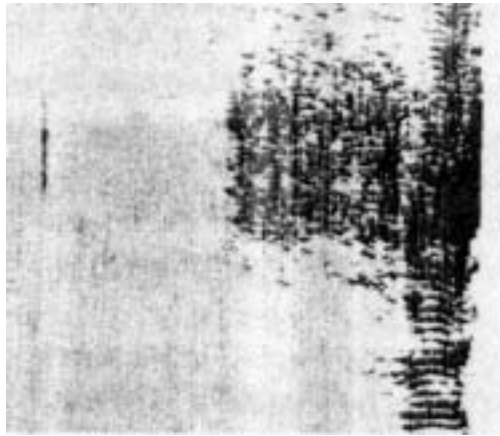

Tav is the hard aspect of a double letter. It is that Aut in which Aleph becomes its own sanctuary; the last letter of the Alphabet, whose number is 400. Its “T” must be pronounced with the tongue against the teeth. Its spectrogram occupies the whole vertical space of the recording instrument. It connects the top and bottom of Aleph’s resistance to itself. In the middle, that double one energy is concentrated in the shape of an unfolded flag, in three distinct layers. Tav, in the idiom, is a mark, a sign; meaning perhaps originally “something exists” and it is a fact that without Tav nothing would exist. It plays a deep game with Aleph. Their dialogue inside their unity is allegorically expressed in that which the great Reb Aqiva said was “the holiest of the Holy Scriptures”: *The Song of Songs*,<sup>7</sup> so erroneously believed to be a simple love story told by Solomon.

---

<sup>7</sup> See under that title, Suarès Vol. published by Shambhala, Berkeley.

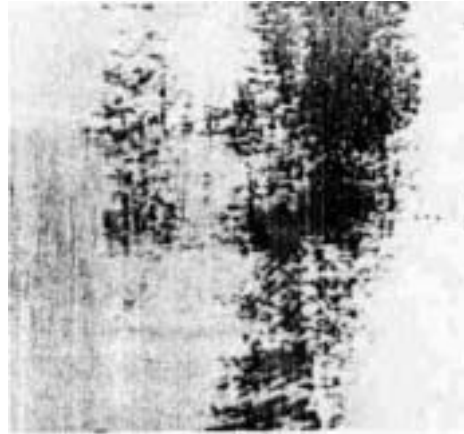

**THAV**

Thav, the soft aspect of that double letter, is pronounced with its “Th” sustained as in “thick”, “thing”. This letter obeys the rule of all the soft letters: it captures the cosmic energy and does not structure it in action. The threefold “flag” of Tav is no longer there, but a vague inoperative double flow appears without much meaning.

In the Zodiac, Tav and Thav form the Moon in Sartan (Cancer). Tav buries the solar energy. Thav emits it psychologically.

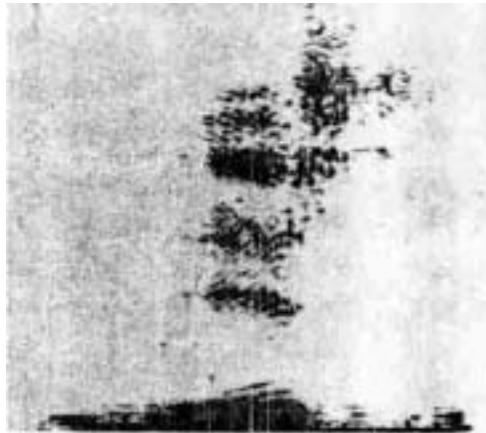
**ZAYN**

The vowel of Zayn is pronounced as that of Bayt. Symbol of number 7, blessed and sanctified, (Gen. II, 3) it calls for an explanation.

According to a very popular version of the “seventh day”, it was the time when the deity was supposed to have a rest, after his very active six days of labor. Read with the help of the code, the words “Ishvot” and “Shavat” that express that Sabbath, have a very different meaning. They say that the Sheen, or organic cosmic movement, has penetrated as far as Tav, through Bayt and Vayt, or, in other words, that that movement is adequate to its function, its flow having irrigated the entire container of Aleph, down to its utmost resistance, Tav. Thus, the universe has enough energy in itself to carry on without the help of the mythical deity. The blessing and sanctification of number 7 can therefore be translated in such words as: “Go: You are strong

enough to go to your freedom alone”.

The word Zayn (in the idiom, spelt Zayn, Yod, Noon) is a weapon or an arrow. It could well have meant, originally, that No. 7 is well armed for freedom.

That freedom is a response to Aleph, and this spectrogram shows a double flow of energy oriented in opposite direction to Aleph's: an answer from the duality. The rest of the disintegrating body is in five pieces: 7 in all, floating in a free space, while the static energy, spilt on the ground, is left to its rigidity.

### AYN



Ayn, impossible to spell phonetically, is pronounced by emitting a sub-glottal, postlingual sound at the level of the epiglottis, the palate being lowered in that process. The vowel is the same as that of Bayt and Zayn. The sound is sharp and prolonged, when met in a word, it must always, without exception, be pronounced as a consonant, with a strong sub-glottal sound, and never appear as in Aleph-Yod.

In the idiom, that Aut is a word meaning eye or source, and this 70, projecting No. 7 in existence, is truly the fount and origin of a free vision of the world in every possible sphere, where the holy Indetermination of the Universe is alive and active.

Its action is disconcerting for the non-initiates: it appears basically in the roots of opposed meanings such as bad, evil, calamity and friend, comrade, shepherd; it is the primal element of iniquity and enjoyment, of sin and delight. It is disturbing because its fundamental meaning is “uncertainty”, whereas the fundamental craving of the psyche is not freedom, but security.

Its spectrogram appeared as a funny grinning joker dancing in mid-air, connecting the higher and the lower energies in a whimsical zigzag: a puzzling person, indeed!

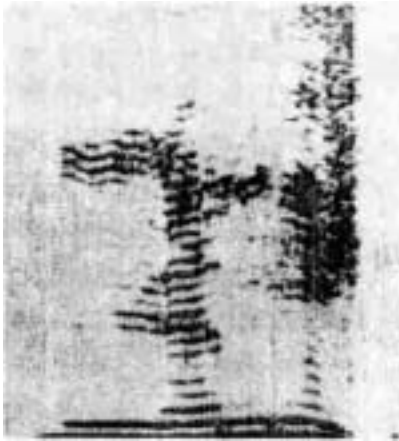
**GHIMEL**

Pronounce it GMEE-mel, emphasize the EE, but make it short. It is the root of the Greek *Kamelos* and of our “camel”, and it is its idiomatic meaning, probably because its number 3 means movement; a good symbol for the camel. The sound “Ghimel” produced its head and a sketch of its rider, with a concentration of energy where man and animal are related (an unfinished picture floating in mid-air). Ghimel is a double letter.

**DJIMEL**

This is the Ghimel without its dot. It obeys the law of the “soft” aspect of the double letters; it absorbs the energy (here the Aleph’s) and fails to structure it beyond its own self. Ghimel forms Tsedek (Jupiter) in Qeshet (Sagittarius) and Djimel forms it in Dagheem (Pisces).

**DALLET**

In the idiom, the letter Dallet, (enforce the “a,” pronounce it DAH-let) is related to the word "Dallet" meaning “door”. Its number 4 is the symbol of resistance: either as an obstruction to the cosmic energy, where its two poles are stilled in the deadlock of inanimate substance (the “door” is shut) or in the biosphere where the resistance becomes a response (the “door” is open). In some schemata Dallet is repeated, as in David or Dod (lover), and is extremely alive and active.

This spectrogram shows that Dallet, emitted vitally, consists of three barriers opened to the flux of energy. Between the first and second (right of the picture) a man’s face appears clearly. The first corresponds to the D, and is linked to the second (which stands for the L). Further, and isolated, is the concentration of the vertical barrier of T (for Tav: see the anatomic chart of Dallet).

The three vertical columns formed by No 4, Dallet, portray the binomial 3-4 or 4-3 that expresses all the biological processes) seen in their origin in the zodiac, as Ghedi (Capricorn) and Deli (Aquarius). Without the opposition of Dallet to Ghimel or Lammed (3 and 30) no movement would be possible.

**THALLET**

This Th must be pronounced as the English soft “the, this”. Thallet unpointed, does not play its

part as resistance. Its spectrogram shows a scattered, disorderly, inconsistent energy.

Dallet forms Meadim (Mars) in Toleh (Aries) and Thallet forms it in Aqarav (Scorpio).

### WAW



Waw loses in most words its quality of consonant. It is at times ow, at times Ve or Wo or O. It ought to be pronounced with an extremely light touch of the lower lip against the teeth, not as the outspoken V of Vayt.

Its “a” is as brief as possible. This archetype of the male copulative strength, is, in spite of the vainglorious boasts of the “hundred per cent he-men”, absolutely void of dynamism. When left to itself it is a masturbation, and the spectrogram, indeed shows it spilled on the ground. It has no contact with Aleph’s energy, and, ironically, shows an old bearded man with a female bonnet and a female bust: a disguised grinning faun. (In Hebrew, the physical father, Av - not to be mistaken for the cosmic “Father”, AB, who in the Bible declares “Israel is my son, my first born” - is, in the plural Auot, female).

### SAMEKH



The S of this Aut is very different from the S of Seen. It must be pronounced with the tongue as far back in the palate as possible (whereas in Seen the tongue is near the teeth), and that gives it a guttural character. The “a” is wide and strongly said (SAH-mekh) and the Kh is a grating of the throat.

This Aut stands for the female sex. As it was pronounced by a man whose explosive psyche is inspired by Aleph, the energy appearing in this spectrogram comes from it, and what appears to be a womb is empty. As, however, we all have something of the opposite sex in us, this picture shows an impregnation beyond and above that hollow, with a concentration of energy, followed by different vibrations.

### HAY



Hay is a short breathing out, as in “how, house”. Its sound must be heard, except in finals, where Hay often forms the feminine of a word. Hay is the symbol of a life that transforms Abram into Abraham: evidently an inner life emanated by the infinite energy of Aleph.

But life is active and manifested in every realm of existence, and the sound recorded for this spectrogram could only appear as the life of the body who emitted it. The picture shows that body. On the higher upper part, a face seems to be astonished at what is happening. There are three distinct concentrations of energy, corresponding to the lungs, where it is double, to the belly down to the knees, where it is triple, and to the feet, where it is single.

### HHAYT

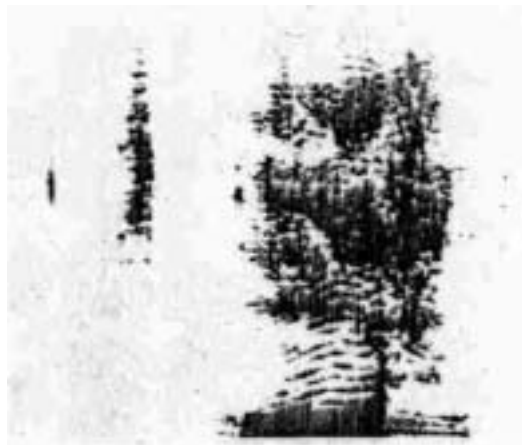

This is a very deep breathing out, involving the action of the lungs, and must never grate the throat. I must insist on that point, because in the Israeli dialect Hhayt is pronounced as if it were

Khaf. Most of the Jews of Polish, German or Russian extraction find it almost impossible to give a powerful HH with the throat absolutely free. But unless it is, the somatic quality of Hhayt is lost. The vowel is long and similar to Bayt, Zayn and Tayt.

The spectrogram of that energy shows a central concentration and others surrounding it. It is as a sort of container of unstructured elements, without any connection with the power of Aleph, but with a foot strongly resting on the ground. At a *distance*, a vertical column is a reminder of the resistant Tav, which ends the sound Hhayt.

### TAYT



The two Ts of this sound are very different. The first, which is the letter proper, must be pronounced with the tongue as far back as possible against the palate, whereas the second, belonging to Tav is a beat against the teeth. This gives to the complete phoneme a double quality, first guttural, then dry, that corresponds to the double function of the cell, which is the meaning of this letter.

And, in fact, the picture shows a cell, nourished by Aleph, and ready to eject its seed life, seen as the face of an infant. Below are two emanations as seeds driven by the wind, lower still a condensation of energy. All are more or less in touch with a scattered strength projected vertically from Aleph. The resistant Tav is far away, as a weak reminder of itself, against the prevailing five flows of the main figure.

**PHAY**

Phay needs an introduction. Of the seven doubles, six appear in their hard aspect in the alphabet: Bayt, Ghimel Dallet, Kaf, Raysh, and Tav, whereas the only exception is Phay. And we must not forget that it is a part of Aleph: the terminal of Aleph's flow through Lammed.

When that flow of life permeates Phay, its spelling being Phay-Hay, the Hay that was immanent, not active, becomes operative and structures the unstructured Phay, thus transforming it into Hay, and Aleph becomes Eloah, a mythical deity.

In the psyche, Phay is what is known as the unconscious: a timeless energy, perhaps. Its spectrogram shows three concentrations of energy, related to Aleph and unrelated to the lower part of the record, where no strongly structured energy is apparent.

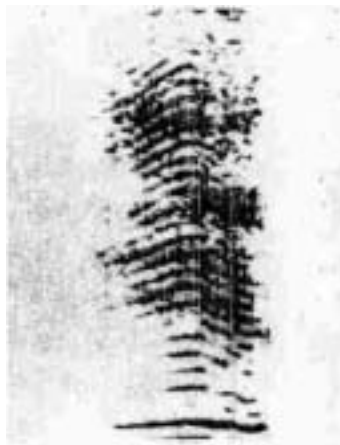
**PAY**

Pay, being a resistance, does not allow Aleph to penetrate it. This spectrogram shows an absence of both the higher and the lower energies. It is a somewhat disorderly self-contained energy. In the idiom, with its exact spelling, Pay-Hay, it is the mouth: a definition that suits it. Paradoxically, the mouth is honored in certain traditions for the very dubious reason that "it addresses praises to God".

In Genesis (I, 2) Pay appears in Phay as the "face" of the deep and the "face" of the



waters, upon which tradition sees floating the “spirit of God”: an unconscious translation of the forgotten original code: The Aleph does not penetrate into Pay.

### TSADDE

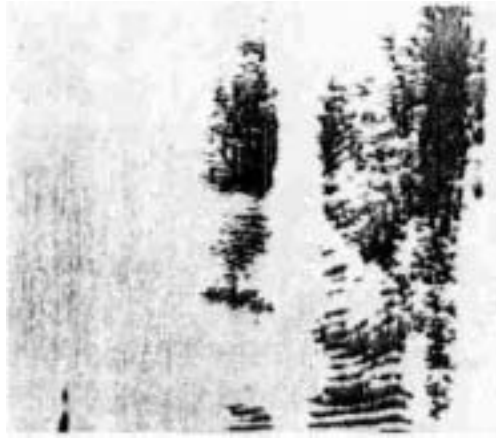

This letter is pronounced by stressing upon the A (TSAH-de). Its structural power is such that it has projected its written shape in its spectrogram. The power descending from the upper layers is very great, and, on the left, the Dallet is also powerful. This spectrogram is interesting to study because of the suggestive relationship of its different elements.

### LAMMED



The same stress as in Tsadde must be put on this A. Every letter has its mystery, but Lammed must be specially studied (in the idiom “lamed” means to learn, study). It is Aleph’s faithful companion. Without Lammed, Aleph would not exist. Al, or El is in the idiom deity and power, but it can also mean “nothing” or “going towards”. Its number 30 is the originator of many myths, including the age of Jesus when he is said to have begun his teaching, and Judas’ supposed thirty pieces of silver. In fact, it is the controlled organic movement in the biosphere, which receives, acknowledges and testifies to the action of Aleph.

Whereas we saw Ghimel, No. 3, as an outer movement symbolized by a camel and its rider, Lammed’s 30 is a disruptive movement in the inner substance of what we call matter. We

see it in its spectrogram as a threefold projection of vibrations, the first being the strongest, and the last (the final Dallet) hardly resistant.

### KAF



Kaf in the idiom is a hollow, a cave, a vault, and also (and mostly) the palm of the hand. Its spectrogram evokes Abraham's gesture described in the Sepher Yetsira, capturing the cosmic energy in his elevated hand. Here we see a sort of cup above that has captured a powerful strength from the Aleph region, and a threefold emanation towards the outside world.

### KHAF



This soft double of Kaf cannot capture the energy as Kaf does, so as to project it creatively. In the flux that goes from Aleph to Tav, Khaf obtains two concentrations that exhaust themselves in a trinary life, after having abundantly nourished its captor.

In the zodiac, Kaf and Khaf form the sun in Arie (Lee) Kaf in poverty (probably because that which is received is given away) and Khaf in richness (the energy is absorbed).

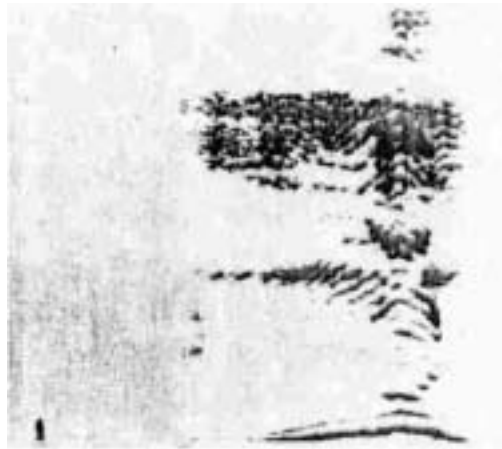
**NOON**

Noon, the existential life, shows a spectrogram in unconnected pieces, one on top of the other, each according to itself. The higher levels are the most alive, but are very far from the Aleph, whose energy is hardly apparent.

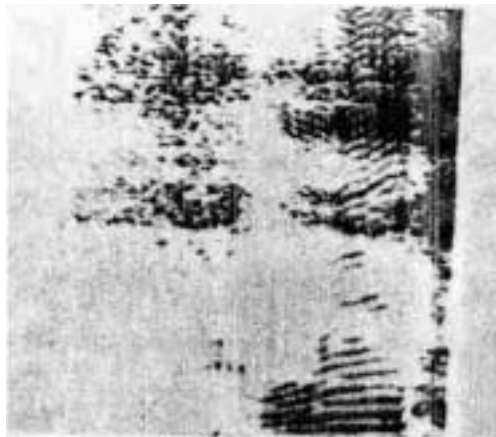
**QOF**

This letter must be pronounced with a guttural sound coming from the bottom of the throat. It is a difficult letter to understand, because this cosmic Aleph (who's number is 100) is a combination of Aleph whose power exceeds anything our space-time continuum can produce, and of Yod which as a symbol of existence in our continuum, is its opposite projection.

In a way, Qof is akin to Sheen, because it projects Aleph's power through every realm of manifestation. But it does it more dramatically than Sheen. It characterizes Cain (to be pronounced Qah-een) whose erect appearance destroys Hevel (meaning vanity, erroneously named traditionally Abel). There is a sense of aggressiveness in this spectrogram: three flows conspire dangerously against an escaping cloud. Unimportant fragments seem to be decaying on the ground,

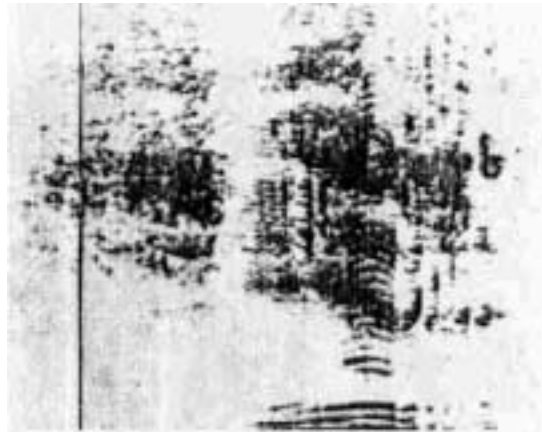
**RAYSH (HARD)**

Raysh, the cosmic habitat of the one double energy, totality of all that exists, was originally a double letter, pointed and not pointed. The Sepher Yetsira says of the pointed Raysh that it forms Kawkab in Teomaïm (Mercury in Gemini) and of the non-pointed that it forms it in Betola (Virgo). The idiom ignores the two pronunciations of Raysh. I believe that the pointed is a hard roll of the tongue against the palate, whereas the soft ought to be pronounced with the throat, as most French people do. It would correspond to the Arabic Ghein, which has no corresponding sound in the Hebrew alphabet. That is .the way I pronounced the two Rayshs.

The first, hard and rolling, gave the above spectrogram. It shows a double concentration of power (Raysh, 200, is a duality) and it is the image of the very alive confusion said to be, in Genesis, the Tohou and Bohou of Eretz (translated Earth). It is far from being a void! It literally swarms with primitive life.

A remarkable feature of this spectrogram is the double direction of its energy, the strongest is opposite to that of Aleph; it is a response to Aleph buried in Raysh. The second, weaker and confused, shows that the original movement is still alive.

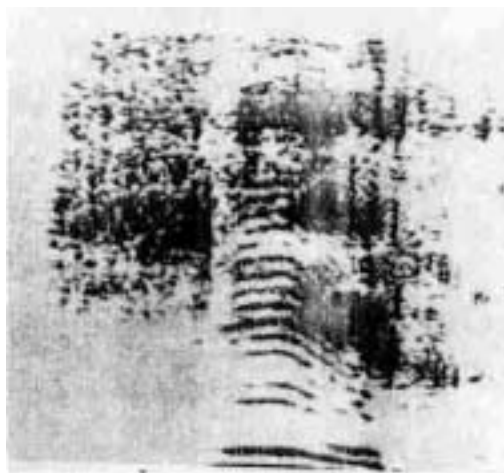
**RAYSH (SOFT)**

This spectrogram shows a very definite and powerful response to Aleph (or, rather to Sheen) in inverse direction. In fact, this is, indeed the Sheen emitted by Raysh. And we must not forget

that Raysh introduces Sheen in the alphabet. There are therefore two Sheens; one is Aleph's direct active agent, the other is produced by the manifestation of Aleph's habitat.

## CONCLUSION

The results of our experiments go beyond the questions we had in mind at the beginning. We only hoped to find out whether the sonograms of the 22 letters had any relationship with the original code as I have given it persistently. We hoped they could confirm it, and we were well aware of the danger, when reading such images, of interpreting them according to one's own unconscious or willful projections. So we began by questioning the code itself. We did not want to base our experiences on any certainty. Then, we examined carefully every picture during several months, and only adopted the interpretations that seemed clearly justified to several people.

Some striking results were: the unique power of Aleph; the practically nonexistent energy in Mem (the waters) that came as a surprise; the blurred but recognizable face of the experimenter; the joker of Ayn (70); the inverted energies, particularly of Raysh; were already good enough confirmations of the code and of the possibility of projecting the letters as carriers of power. The least that can be said is that a door can be opened on the quality of speech as the generator of energy and particularly on the deep meaning of the elements of the sacred language, for which we now have a scale of references. We need not go as far back as Jericho, whose walls were said to have fallen by the sounds of trumpets, to know that sounds have a physical action. But to our knowledge, this is the first time in History that sounds are translated rationally in their energetic value.

Many factors of imprecision must be taken into account, and first of all the personality of the experimenter. But this again can open a field of inquiry as to the psychological causes of the different pronunciations of the same phonemes by people from different countries, etc.

All in all, we only present candidly some experiments, and our best conclusion is not a conclusion, but rather a report on suggested possibilities of research.

## Appendix by F. A. Wolf

### THE DEVELOPMENT OF THE MOTHER LETTERS

Now we have talked about the mother letters, why do we call them that? It is because in them we have the seed-containers of all that is – the whole of creation. In this part we shall try to develop these ideas more clearly. We have mentioned that the Autiot build a language like no other - for each Aut whether it is primitive, existent, or cosmic is truly analogical, it stands for a whole which is greater than any of its projected parts. These projections are to be found in all that we know, whether it is physics, mathematics, philosophy, history, engineering, even love making. One of my teachers was the physicist Richard Feynman. He often pointed out that once we have an equation for something even though we are talking about only one limited use of that equation its solution determines not only the behavior of whatever it is we are talking about but of any possible projection which has the same equation. To be perhaps a bit clearer we know that the equation

$$V=IR \tag{1}$$

can be read the voltage drop or potential energy difference across any electrical circuit (V) equals the current in that circuit (I) multiplied by the resistance of the circuit (R). The meaning of this is that if we are given a large difference in potential energy or stored energy it can become dynamic or kinetic energy by giving rise to a current or motion of electrical charge. The intensity of the current depends on the resistance it meets. If that resistance (R) is small the current (I) is high. If (R) is large, (I) is small, you see, it is really simple. Yet this equation also describes the entirely different physical phenomenon of the motion of water in a pipe! Instead of V being the electrical potential difference, it now becomes the water pressure difference across a tube of flowing water. I represents a flow but this time it is the water current and R is a resistance, but here it is related to the diameter of that pipe.

In a more complex but perhaps clearer manner we have the equation

$$\partial^2\psi / \partial t^2 = c^2\nabla^2\psi \tag{2}$$

This equation is perhaps indecipherable to you our readers, but bear with us for a moment. The rather complex term on the left of the equal sign describes how the amplitude of a wave ( $\psi$ ) changes as it moves in time. The two “2s” refer to double changes. Had we written this symbol without the twos it would mean the first or primary change of that amplitude in time. Thus if we repeat that process by asking how it is that the change of  $\psi$  itself is changing we have the meaning of the left-hand term.

On the other hand, on the right hand side of the equal sign we have two terms  $c^2$  and  $(\nabla^2\psi)$ . The  $c^2$  is the speed with which that amplitude moves through spacetime. The square of  $c$  is obtained because as in the time change of  $\psi$  we have here two changes in space, symbolized by the inverted Greek delta symbol. All together the equation describes the propagation of an electromagnetic wave in space-time when  $c$  is the speed of light. But if we

decide to stretch a rope between two walls and then pluck it, the equation would describe the behavior in spacetime of that rope. Only now the  $c$  would refer to the speed of the wave on the rope.

Now my point in all of this is that in physics we find this happening all of the time: the same equation, yielding the same abstract solution, describes any and all of its analogical projections. This principle was in fact incorporated in the design of analogue computers where the measured voltages and currents corresponded to solutions to complex differential equations, the terms of which were represented by elements of the circuits in the computer.

Let us now return to the Qabala. It is without doubt the “big analogue computer in the sky” meaning it is the science of analogy beyond all others in which physics plays a small but vital part. Thus the discovery of a relation or a connection between the letters is extremely important and must have great consequences for humankind. And that is what the sacred writings are all about. And that is why some of these writings still appear indecipherable to many readers!

At this stage of our work we are attempting to-understand the connections between these symbols in somewhat the same way as you our readers are perhaps attempting to understand the wave equation (2). Once we know the rules we can do it. Hence we are on the threshold of a new creative venture. The “straight-jacket” which forces the physicists creativity to be nearly strangled to death - the huge resistance of all those laws and relations - can perhaps be overcome. For we see that physics is nearly at the end of its tether, and we also see that we humans are also.

We shall begin with the Mother letters and interpret them in terms of the present time. We shall try to invent a relation. If we analogically extend the relation  $V = IR$  we perhaps might write, simply by replacement, some Aleph for  $V$ . What could that be? Well let's go whole hog! Let  $V$  (stored or potential energy) be Aleph (mythically the immanent energy). Now for  $I$  we have the flow of anything hence going all the way we can write for  $I$ , Sheen. For  $R$  we need a resistance. It could be Dallet, Mem or Tav. Which should we use? We know already that Mem, is the correct choice because in Genesis we have that which Aleph sends forth, Sheen, acts upon the waters Mem.

So let us write

$$a = mc \quad (?)$$

Now what can that mean? First of all the equal sign is out of place. Aleph is beyond just simple equality - yet the feature of stored or potential energy giving rise to cosmic wind resisted by the medium is attractive.

But should we use Sheen or Seen? And here it is we must connect up all that we have learned from Aleph to Tav and Tav back to Aleph – there are, there must be two cosmic winds. Below we have the picture of creation.

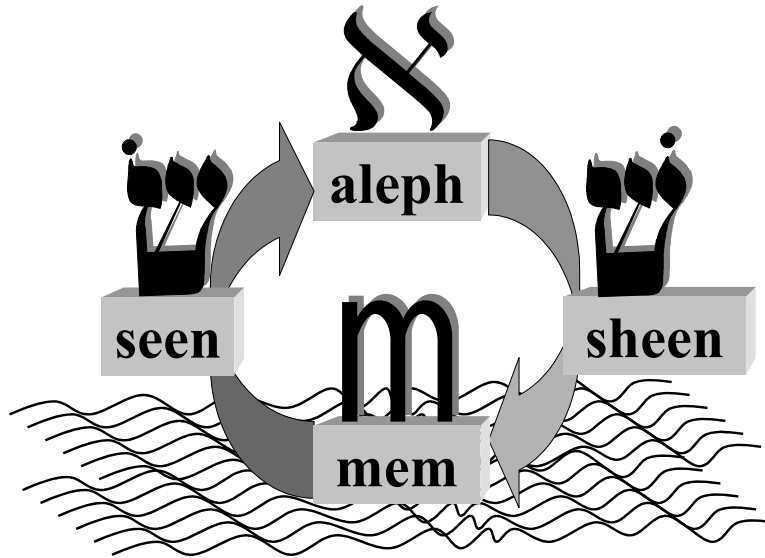

This is the complete circuit. One of its analogical projections is shown below.

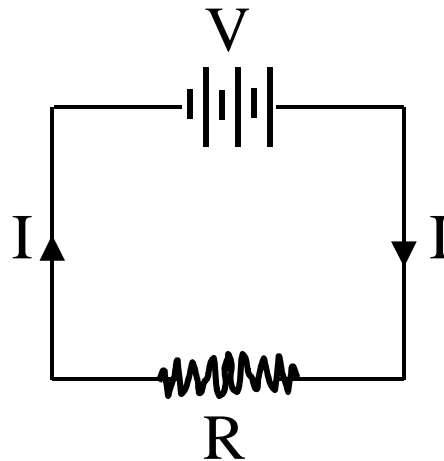

Now from the above figure we see below that the equation,  $V = IR$  is just a projection from the more general scheme which must be all inclusive which we write:

$$a \leftrightarrow \overset{\bullet}{c} m \overset{\bullet}{c} \tag{3}$$

We replace the equal sign by a two-headed arrow indicating the cosmic flows. Between them is Mem that which resists and responds to the vital force of the wave wind of Sheen. Sheen passes through the waters and what results are magical. Sheen in so passing becomes Seen. The wave becomes a particle. (This is symbolized above with sheen,  $\overset{\bullet}{c}$  having a dot on the right of the letter and seen,  $\overset{\bullet}{c}$  with a dot on the left.) Look again at the spectrograms of Sheen and Seen (pp. ---).



Is it not clear? In Sheen we see the three reversed tiers of Aleph. In Seen we have the birth of a dart – the particle of existence. Thus with the creation of matter Seen returns to Aleph. The Mother Autiot again causes the march from Aleph to Tav and back. This is the meaning of the two breaths.

If we add to this the two Tavs we find this picture:

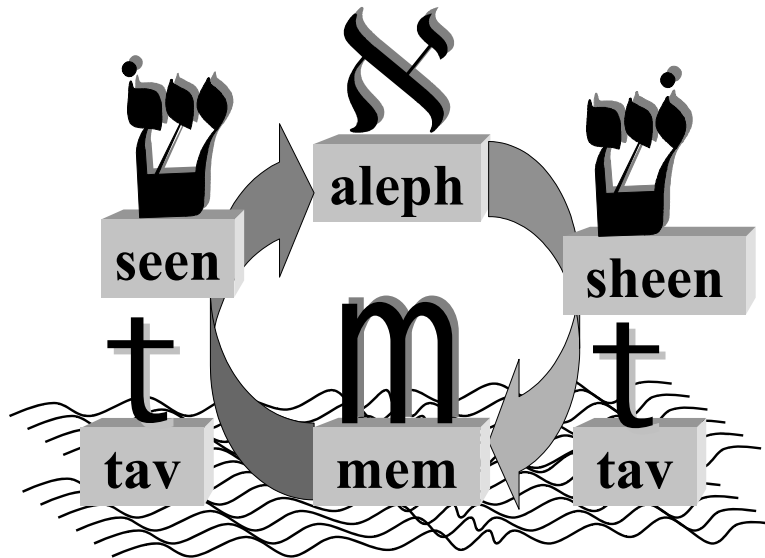

Why do we do this? Here we see Tav-Mem becoming Mem-Tav. This means in Hebrew that the quality of life through Mem gives Met that is death.

So death is the return to Aleph. That is why Tav is the sanctuary of Aleph - so to speak it is Aleph at rest - at death.

### (A) THE PHYSICO-PHYSIOLOGICAL ANALOGY

What does this equation (3) mean in this realm. We look at the brain. We know that it is mostly water. So what is thought? We offer an idea - perhaps crazy - perhaps not - we don't know - we are reasoning from the Qabala in an analogical-creative sense. Perhaps the reader is a psychologist or physiologist. We see that the brain is a container of water with myriads of permeable or semi-permeable membranes forming thus structuring cells of water. Water is any one cell does not flow to another cell, it is held captive in it.

But now my stomach is upset. It sends its message along the nervous system to the brain - to a select few of these cells. And there after an explosion takes place literally, waves of information are sent out from these select cells. These waves travel through the brain - all the cells are alerted. But the brain is not calm. Multitudes of these creative explosions take place; each is a particle-like event acting through a cell. All that energy of creation is liberated as waves. But there are so many acts of spontaneous creation in these cells of water. Literally the brain is a jumble of incoherent waves. All possibilities arise from this jumble. Now these wave like motions in the brain are thoughts. Just plan ordinary thoughts existing in time. These are not timeless flashes or insights. They are random ordinary thoughts. My stomach hurts - my nose is running - my bladder is full-etc. Before we go on let us look at what is happening here. Each impulse from the nervous system to the water of the brain is a kernel or particle like event. It is therefore the action of Seen. The response of the water is the response of all medium to a wave motion which is Sheen - Sheen is the wave - Seen is the particle. Here the Seen acts through the cell Tayt - giving rise to cosmic indetermination, Noon. Read from right to left this is,

Noon - Tayt – Seen

n f c

This is Satan - the devil - who I introduced to you earlier. Thus Satan is part of man. This is just an excursion into the meaning of those symbols.

Now we go back to our equation. From Aleph comes Sheen - not Seen. The wave travels not the particle. Sheen enters the waters of the cells simultaneously - but nothing happens in the brain. No response to all that is taking place. But when we struggle against it when we seek knowledge - when we allow that process to take place. It does.

Then what happens is amazing. The diffuse wave of Sheen is able to become concentrated into individual Laser-like spears activating individual cells in the brain. This is a collapse of the wave-nature of Sheen into Seen. Creativity arises. The sparks fly the other way down the nervous system. We tell our stomachs, our noses etc. what is going on. These kernel-like individual sparks of course give rise to wave-like Sheen again, and so it goes, the timeless flash - the quantum wave collapse - in the brain - the intuitive flash - bang spark goes off giving rise to more thoughts - this time, in time Yod comes - existence is, Aleph has done its work.

This then constitutes the act of creative awareness. Here we separate the two acts of consciousness. One is the activity of Sheen. It comes from Aleph. In the mysterious collapse of the wave function individual cells are triggered. This is the timeless flash. But to what avail? For if there is no time, space, or matter the game is terribly boring, To complete the cosmic game Sheen must return to Aleph. And so it is that Seen is created from the action of Sheen on Mem. Seen is the particle of the existence state. Its particle-like behavior gives rise to Sheen waves again in the brain which are our thoughts in time. And in its birth - creation, so is its death. This means that Seen must return to Aleph. That is what Mem-Tav is all about.

Now we need to be a little clearer. All so-called ordinary experiencing is contained in this continual on-going game, automatically -but we are not tapping Aleph to its fullest. For Aleph has infinite energy or if you want it to, it has no energy at all. It is in a sense up to us to recognize its power. We must allow it to come alive in our brains. To do this means we must begin to think analogically about all that we experience. But this is not easy to do nor was it ever meant to be easy.

It is in the struggle itself that the process is allowed to take place!

### (B) THE BIBLICAL ANALOG

This struggle has been told before. It is Jacob wrestling with angel, (erroneous), For the Hebrew word for that person that Jacob wrestles with is written Aleph - Yod - Sheen. Aysh is a man. But what a man -for we see here directly that Jacob must fight with that which comes directly from Aleph -and to be doubly sure we understand that struggle - is a real struggle -Aleph comes through Yod - that is into our own space time or in this case the space time of Jacob. And what is it that is acting in Yod from Aleph? It is Sheen. Who is Jacob by the way? He is Yod - Ayn - Qof – Vayt (10 -70 -100- 2). He is a container (2) of the unlimited probability (70) acting in spacetime (10) - containing the cosmic Aleph (100). Symbolically he is truly remarkable. Now what happens next to Jacob? He succeeds in his struggle, of course. Who wouldn't who already contains the cosmic Aleph, Qof? And then what happens to Jacob? He has his name changed. Something that happens quite often for we are dealing with transformation of energy. And what is Jacob's new name? It is a mind blower. He is now called Yod-Seen-Raysh-Aleph-Lammed. Yes the Sheen becomes a Seen.

Jacob + “the angel” → ?  
 Yod-Ayn-Qof-Vayt + Aleph-Yod-Sheen → Yod-Seen-Raysh-Aleph-Lammed)

Now this is a kind of alchemical reaction. The result is that Jacob is now called Israel. Not “Ish-real.” The Sheen becomes Seen and Jacob plus “that man” become Israel.

**(C) THE POLITICAL ANALOG**

And so Israel is born. And from its very conception we see paradoxically its death. For it is Seen that comes from its existence Yod. It is the particle individual behavior that is cosmically returning to Aleph. It is in the cosmic container Raysh that Sheen, the cosmic wind —hidden in the “r” of Israel—is allowed to blow again. But Israel ends with Aleph giving rise to all organic motion Lammed. In its name so lies its story. We interpret this to mean that the Israel will always be moving in particle-like ways - its Sheen remains buried in Israel. It is in a sense destined to close itself to Sheen but in its particle like behavior we find tremendous concentrations of energy. Sheen is there but hidden in Raysh.

On the other hand we find Ishmael,

*Yod - Sheen - Mem - Ayn - Aleph - Lammed,*

and Israel,

*Yod - Seen - Raysh - Aleph - Lammed,*

quite similar. We talk about this next.

Israel, its people - a people characterized by great individuality all moving with Sheen hidden in them —express vital moving energy but always in time, seemingly missing the atemporal quality of Aleph. Its hardness, its particle like behavior, its concern with materialism, always manifests itself.

But across the waters (Mem) we have the half-brother of Isaac, Ishmael. Here we find some outstanding differences and amazing similarities.

ISRAEL = *Yod - Seen - Raysh - Aleph - Lammed*

ISHMAEL = *Yod - Sheen - Mem - Ayn - Aleph - Lammed*

In Ishmael we have the silent Aleph. We see that both Israel and Ishmael are but wave-particle – reflections of each other across the waters Mem.

Their difference is seen below.

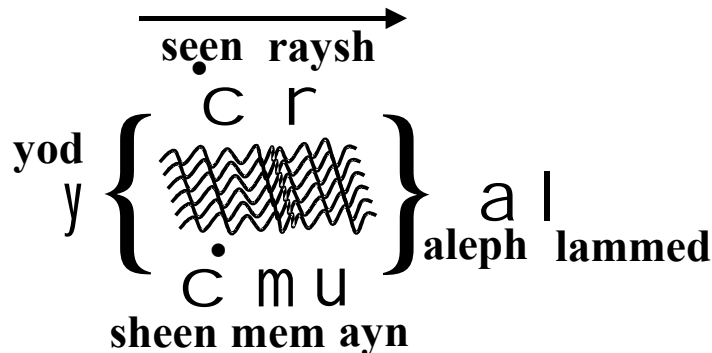

Both begin in existence (Yod). But the breath of God is a hard particle is Israel and a soft diffuse wave in Ishmael. The particle-like nature of Israel is acting through or into the cosmic container-Raysh, In it, it finds Aleph - which then gives rise to organic motion. The wave-like nature of

Ishmael acts as we have been saying on the waters Mem - giving rise to real probabilities, real alternatives. But here there is no particle, no substance, or material created. The Aleph is there but is silent in Ishmael - but it moves onward into Lammed. What is the meaning of all of this?

We could say that Israel seeks its cosmic destiny by literally sending its Seen, its hard particle, into Raysh. Why does it do this? Because Seen is missing something, it must return to Aleph. It is empty of something. That something is carried by Sheen. Sheen by becoming Seen and thus creating its particle or material-like universe has lost its quality of being Aleph's direct emanation - which is Esh (Fire). Aleph -Sheen. It has conditioned itself to the process of existing just as Jacob became Israel. In so doing in so creating a particle it closes itself from Aleph. It forms a shell - a container - a Bayt. It really becomes Seen - Vayt - "an-old man". It will have to live, die, live again, and die again indefinitely. This illustrates the tragic history of the Jews - to find their way back to Aleph.

So we see that Israel as a nation is part of that cycle, but as its very name implies it cannot complete it. Something is missing. The reader may be tempted to try to spell out the difference between Sheen and Seen, But there is no Autiot separating them. This quality of difference is nameless symbolically. We could call it cosmic life or Cosmic consciousness. The cosmic life-consciousness is there in Sheen. But the Sheen is hidden in Raysh. The Aleph is heard in Israel. It is alive but not complete. On the other hand in Ishmael we find the gentle wave like nature the beauty of the Arab tradition - the Sephardic Jew the Eastern - non focused - non particle-like - non hard reality of diffuse energy, ever expanding outward leading to a dead Aleph and meaningless motion. By literally bringing them together - we would have a complete cycle.

Between Yod and Aleph - Lammed we have the simultaneous return of Seen to Raysh and the births of Sheen or Mem giving rise to real alternatives. The Seen and Sheen are both there, The possibilities become unlimited. Clearly there is immense attraction of one for the other and yet in a sense, the existence of one denies the existence of the other.

To understand this we now consider another analogy.

#### (D) THE QUANTUM PHYSICAL ANALOG

In quantum physics we deal with two basic concepts, what happens when something is measured or observed and what happens in between these observations. Our reality is constructed from the acts of measurements but we have no equations describing these very acts. Paradoxically we never observe what happens in between our observations and yet we have equations describing these in between dramas. I sometimes think that this is a cosmic joke. The result of all this is that the act of observation of anything always registers itself as a particle, but the in between acts, the entrée-acts so to speak, always move in space-time like a wave.

Hence to know something matter must appear—a particle must be created. For this to happen, the entrée-act wave suddenly collapses when an observer observes. The wave bursts like a balloon and a viable material alternative appears. That is the way it is. Hence the wave and particle like duality are complimentary to each other. For to observe, or to know anything at all, an observer must create by the action of observation and that creation is a hard particle-material universe. That is all we can see "out there."

Here in this action we see the cycle of *Aleph - Sheen - Mem - Seen* and what a cycle it is. We have a further development. In quantum mechanics we describe the results of a measurement in terms of an operation. That operation is performed on the entrée-acts state of knowledge which is symbolized by the term  $|\psi\rangle$  called a "ket" vector. The ket represents a flow of possibility-knowledge from past to present.

When a physicist wishes to see what  $\psi$  consists of he or she needs to perform an experiment in which some "observable" is measured. In that way he or she conditions the in between acts to conform to expectations. In physics we symbolize this action by writing it as

$$O |\psi\rangle. \quad (4)$$

What this means is that the operator  $O$  acts on the state of our knowledge or as physicists call it, the wave function,  $\psi$ .

As a result of this something is produced. Only when that operation yields a real numerical value say “6 units of something” does the result of the operation lead to an observation. Yet the ket  $|\psi\rangle$  is never measured. To find what is measured we need to write:

$$\langle \psi | O | \psi \rangle = 6 \quad (5).$$

Now  $\langle \psi |$  is called a “bra” vector and  $|\psi\rangle$  as I mentioned above is a ket vector, so together they “bracket” the observation. A bra vector represents a flow of possibility-knowledge from future to present. Bras and kets are like images of each other. When an observation occurs in the present, the two flows must come together. That is what is symbolized in the above equation. If no observation occurs the flows also come together and their closure is unity if they are mirror images and nothing if they differ from each other. That is

$$\langle \psi | \psi \rangle = 1 \quad (6a).$$

$$\langle \phi | \psi \rangle = 0 \quad (6b).$$

where  $\phi$  is a different wave function. Now here again we see another analogy represented by our equation (3). The meaning of  $\langle \psi | \psi \rangle = 1$  is the same as the completeness of the cycle of Sheen - Seen. That is  $|\psi\rangle$  is a projection of  $\overset{\bullet}{C}$  (dot on the right) and  $\langle \psi |$  is a projection of  $\overset{\bullet}{C}$  (dot on the left). The actions of Sheen - Seen are the passage to Aleph (1). (The symbols for  $\psi$  and  $C$  even look alike.) Now  $O$  is an operator, which means it, resists and changes  $|\psi\rangle$ . In its resistance, reality is created. If it resists or changes in the wrong way the result is  $\langle \psi | O | \psi \rangle = 0$ . Aleph is careful.

Finally we bring out the analogy of Einstein’s equation  $E = mc^2$ .

Qabalistically it would be written  $E = cmc$ .

We contend that this is a projection of equation (3). We know that it is silly to write it this way, but we can understand it.  $E$ , like  $a$ , is the maximum energy meaning expanded and  $m$ , like  $m$ , the mass, is like the minimum energy meaning contracted for it is all bound up in the shell of matter, trapped. The two  $cs$ , like  $\overset{\bullet}{C}$  and  $\overset{\bullet}{C}$ , refer to the speed of light. This equation means that if all the matter contained in  $m$  were to be moving at the speed of light it would no longer be matter but energy. That amount is given by  $E$ . It is the maximum energy available. The equation also goes the other way. From  $E$  we can distill out the particle of mass  $m$ .

We have already pointed out this extreme process in the chapter describing the Autiot. The building of the letters Aleph, Bayt, Ghimel has the meaning, maximum non-existence energy divides itself and gives birth to space-time. Its agent for this was Sheen. Sheen comes out of Raysh. Raysh comes from Aleph in an act of masculine fertilization through Aleph - Vav - Raysh, pronounced *aur* and means light. This was the light that was created from Aleph. And in the cosmic container - only hidden, is the marvelous messenger of creative consciousness, feminine in its action, called Sheen. Now with light we do not have matter or space-time. The

seeds are there but remember, relativity teaches us that at this speed,  $c$  no matter exists, time does not pass and space has no extension in the direction in which light travels. To create matter we jump off this wall of light and simultaneously create the universe of mass and space-time. But Sheen is hidden. We need to let it enter us - consciously.

## THE MYSTERY OF WATER

We need to conclude our commentary. We point out that the farther we go the more openings we find. It is endless, yet, we do become more aware of what consciousness is. One final point is one that Mr. Suarès has insisted upon for a long time. Water (Mem) is, in our own spacetime, the symbol of the inner contradiction that is the essence of consciousness. We now explain this mystery, i.e., we conclude with the mystery of water. We believe we have resolved it. First we present the mystery.

In Genesis (1.2) we have “and the spirit of God moved upon the face of the waters.” Surprising since water has not been created as yet. Where did it come from?

To find the answer we go back to Genesis 1.1. Here we find created in the beginning heaven—Sheen-Mem-Yod-Mem (pronounced Shamai-yim) and earth Aleph-Raysh-Tsadde (pronounced Eretz). We hope that the reader begins to see the mistake. These are not heaven and earth. The word for heaven is simply showing you the action of Sheen on the waters, by bringing them into existence. Their existence necessitates their division - we see this in the word Sheen - Mem - Yod - Mem. (We return to this in a moment. Eretz is not earth either; it is a principle. It is the principle of structuring and beauty; the ability to perceive symmetries, Tsadde (900), coming from Aleph acting directly on Raysh. It is that direct. No light is there to see it.) Back to the waters. Thus even before light - water was there. It is the primal or first projection of Aleph. It is found in the word Elohim (Aleph-Lammed-Hay-Yod-Mem) mistakenly taken to mean the Gods.

Thus we end where we begin - any given universe is the projection of a consciousness in search of its awareness of itself. Aleph - Mem is the first state of a consciousness in which no space exists between itself and its projection (hence Yod - Mem is attached to Eloh: Aleph-Lammed-Hay-Yod-Mem) It is in a state of Hhayt- Sheen - Khaf (Hhoshekh) meaning darkness.

The cloud of water, is projected. Sheen moves. That is heaven. Sheen moves on the face of the water. Aleph copulates with the cosmos and there is light. Next God divides the light from the darkness. What can that mean? It means that darkness is not darkness it is more than that. Now we begin it all over again. After the creation of light there is the separation of light from darkness. Rationally, how can it be necessary to separate light from darkness, if light is already there? It is the first act of awareness. Consciousness realizes that its projection is cosmically alive. Look at the words for light and darkness. Light (aur אור) and darkness (Hhoshek חֹשֶׁק). In light we have Raysh, while Sheen is in darkness. In darkness we have Sheen, cosmic consciousness alight, awakened. Thus the naming of darkness is the creation of that ability to know. Consciousness is born out of its own Genesis - it is thus autogenetic.

Now we come to the division of the waters. This act is already contained in Shmaiym but it is not called that yet. Because the act of calling i.e. knowing - awareness has not appeared. That comes with the aspect of Aleph - its cosmic projection Qof.

It appears the first time in Genesis 1.5, when God calls light - day, and darkness - night; The development of these words is endless, but the word we are interested in is Qof-Raysh-Aleph. That word Qorah written, אורח, means to call something by a name. Now after the naming of the creations, God creates that which enables consciousness to become aware of its own creations. It is found in the word Raysh-Qof-Yod-Ayn. This means expanse, i.e. a space. This is the response to calling something - it is, if you will, the echo of Qof-Raysh-Aleph. Now this space is created between the waters. It really is already there. But consciousness doesn't know it yet. It can't

know it until the cosmic Aleph comes from Aleph. Thus the division of the waters represents my own ability to see the difference between that water that is me, i.e, is the response of Aleph in me to that water which is not me.

Thus we see that creation is a double process - both the act and the knowing of the act. And on it goes. But we'll stop here. It is enough for it is the end of the first day. Tomorrow is another day. Love.