

SECOND EDITION

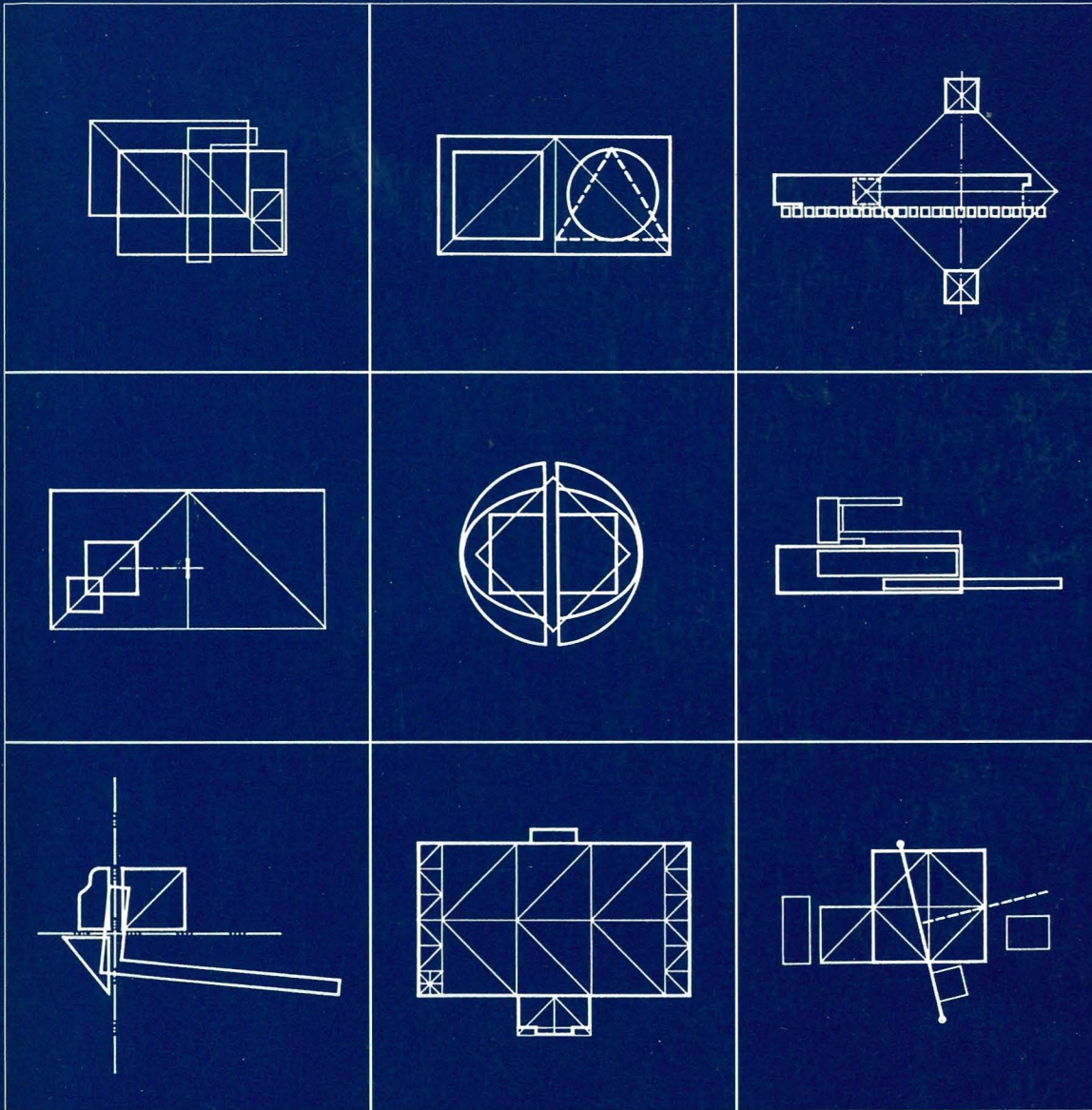

PRECEDENTS IN ARCHITECTURE

ROGER H. CLARK
MICHAEL PAUSE

Precedents in Architecture provides a vocabulary for architectural analysis that will help you understand the works of others, and aid you in creating your own designs. Here, you will examine the work of internationally known architects with the help of a unique diagrammatic technique, which you can also use to analyze existing buildings.

In addition to the sixteen original contributors, the Second Edition features seven new, distinguished architects. All 23 architects were selected because of the strength, quality, and interest of their designs.

Precedents in Architecture, 2/e is an invaluable resource offering:

- Factual graphic information on 88 buildings that represent a range of time, function, and style accompanied by detailed analysis of each building
- A reference for a technique of graphic analysis as a tool for understanding and designing architecture

Whether you are a novice or a seasoned professional, *Precedents in Architecture, 2/e*

will enrich your design vocabulary and give you an invaluable tool for the ongoing assessment of buildings you encounter every day.

ABOUT THE AUTHORS

Roger H. Clark, F.A.I.A., is a Professor of Architecture at North Carolina State University, School of Design, Raleigh, North Carolina. He has received over 50 design awards, publishes regularly in professional journals, and co-authored *Kinetic Architecture* for VNR in 1970. Mr. Clark holds a Master of Architecture degree from the University of Washington, Seattle, Washington.

Michael Pause is a Professor of Design at North Carolina State University, School of Design, Raleigh, North Carolina. In addition, he is a color and light, graphic, and residential design consultant. Mr. Pause holds a Master of Architecture degree from Washington University, St. Louis, Missouri, and a Doctor of Philosophy from Massachusetts Institute of Technology.

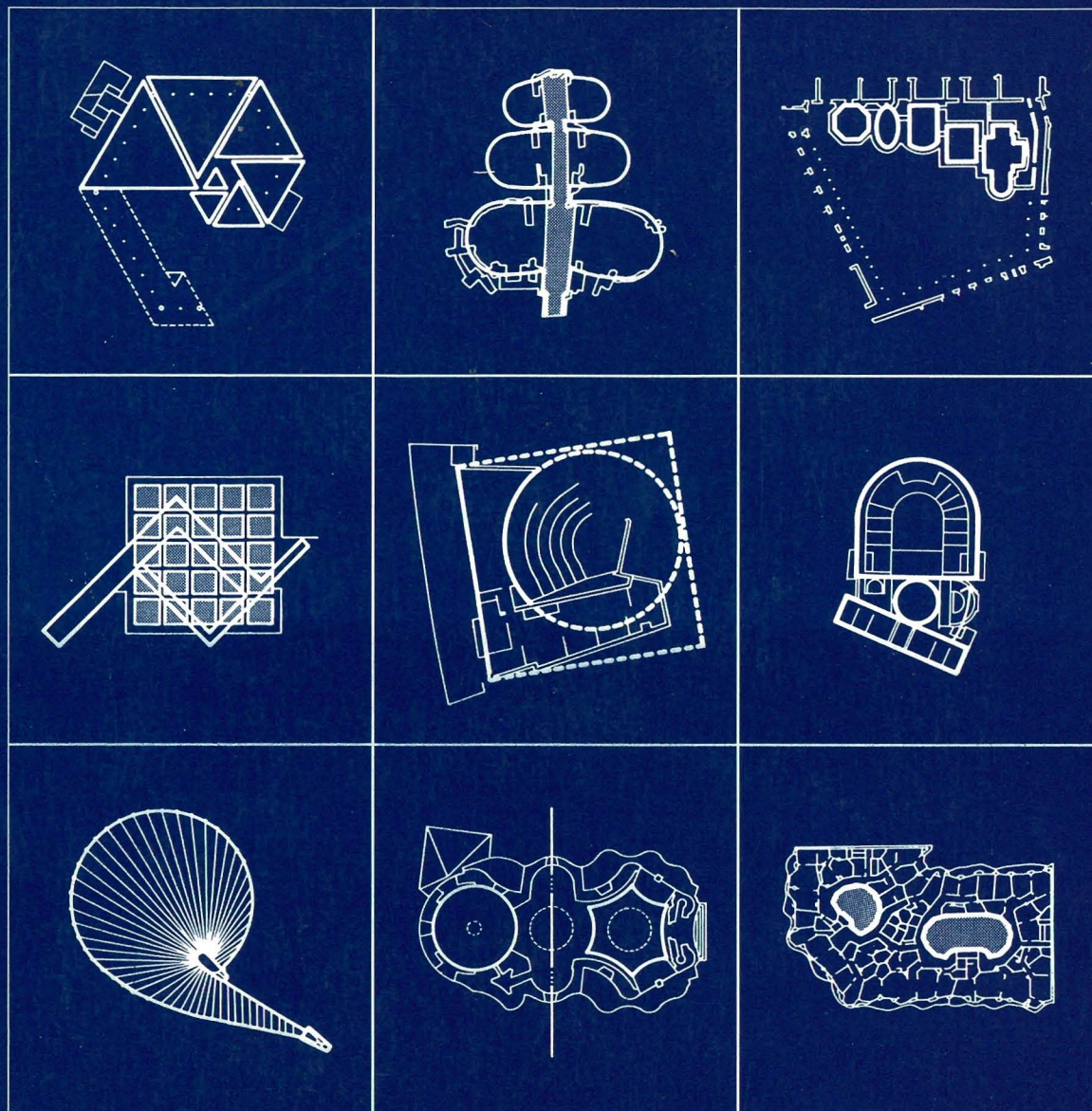

ISBN 0-442-02051-1

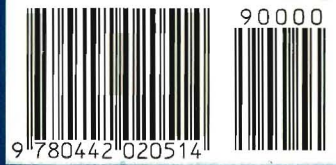

VAN NOSTRAND REINHOLD
115 Fifth Avenue, New York, NY 10003

PRECEDENTS IN ARCHITECTURE

Second Edition

Roger H. Clark
Michael Pause



VAN NOSTRAND REINHOLD

ITP® A Division of International Thomson Publishing Inc.

New York • Albany • Bonn • Boston • Detroit • London • Madrid • Melbourne
Mexico City • Paris • San Francisco • Singapore • Tokyo • Toronto

Research for the first and second editions of this publication have been partially supported by a grant from the Graham Foundation for Advanced Studies in the Fine Arts. Research for the second edition was also partially funded by a grant from Van Nostrand Reinhold.

Cover design: Clark and Pause

Van Nostrand Reinhold Staff

Editor: Jane Degenhardt
Production Editor: Carla M. Nessler
Production Manager: Mary McCartney

Copyright © 1996 by Van Nostrand Reinhold

ITP® A division of International Thomson Publishing Inc.
The ITP logo is a registered trademark under license

Printed in the United States of America
For more information contact:

Van Nostrand Reinhold
115 Fifth Avenue
New York, NY 10003

Chapman & Hall GmbH
Pappelallee 3
69469 Weinheim
Germany

Chapman & Hall
2-6 Boundary Row
London
SE1 8HN
United Kingdom

International Thomson Publishing Asia
221 Henderson Road #05-10
Henderson Building
Singapore 0315

Thomas Nelson Australia
102 Dodds Street
South Melbourne, 3205
Victoria, Australia

International Thomson Publishing Japan
Hirakawacho Kyowa Building, 3F
2-2-1 Hirakawacho
Chiyoda-ku, 102 Tokyo
Japan

Nelson Canada
1120 Birchmount Road
Scarborough, Ontario
Canada M1K 5G4

International Thomson Editores
Seneca 53
Col. Polanco
11560 Mexico D.F. Mexico

All rights reserved. No part of this work covered by the copyright hereon may be reproduced or used in any form or by any means—graphic, electronic, or mechanical, including photocopying, recording, taping, or information storage and retrieval systems—without the written permission of the publisher.

1 2 3 4 5 6 7 8 9 10 QEB-KP 02 01 00 99 98 97 96

Library of Congress Cataloging-in-Publication Data

Clark, Roger H.

Precedents in architecture / Roger H. Clark, Michael Pause. -- 2nd ed.

p. cm.

Includes index.

ISBN 0-442-02051-1

1. Architectural design. I. Pause, Michael. II. Title.

NA2750.C55 1996

729--dc20

95-47758

CIP

To Judy and Kathy

P R E F A C E S

PREFACE TO THE FIRST EDITION

This book is about architecture.

In particular, it focuses on a way of thinking about architecture that emphasizes what is in essence the same, rather than different. Our concern is for a continuous tradition that makes the past part of the present. We do not wish to aid the repetition or revival of style whether in whole or part. Rather, by a conscious sense of precedent that identifies patterns and themes, we hope to pursue archetypal ideas that might aid in the generation of architectural form.

While architecture embodies many realms, we concentrate on built form. Without apology, we make no attempt to discuss the social, political, economic, or technical aspects of architecture. The domain of design ideas lies within the formal and spatial realm of architecture, and thus it is this arena that is explored in this book.

Obviously, a sound architectural idea will not, as a tool for design, inevitably lead to a good design. One can imagine many undesirable buildings which might originate with formative ideas. To be sensitive to the potential of archetypal pattern in design does not lessen the importance of concern for other issues or for the building itself. However, one commonality shared by the great buildings of this era with those of the past, is a demonstrated understanding of basic architectural ideas which are recognizable as formative patterns.

Our analysis and interpretations are of built form, and therefore, may not necessarily coincide with the architect's intentions or the interpretations of others. The analysis is not all-inclusive in that it is limited to characteristics which can be diagrammed.

The intentions of this study are to assist the understand-

ing of architectural history, to examine basic similarities of architects' designs over time, to identify generic solutions to design problems which transcend time, and to develop analysis as a tool for design. Of importance is the development of a vehicle for the discussion of ideas through the use of example. The understanding of history derived from this kind of investigation can only be obtained by far greater labor than that involved in acquiring a knowledge of history that focuses on names and dates. The reward for this effort is a design vocabulary that has evolved and been tested over time. We believe designers benefit from a comprehensive understanding of formative ideas, organizational concepts, and *partis*.

As a resource, this book offers factual graphic information on 64 buildings, a detailed analysis of each of these buildings, a range of designs by individual architects, a compilation of formative ideas for design generation, a collection of architectural images, and a reference for a technique of analysis. Some of this information is not readily available in other sources.

We are indebted to the Graham Foundation for Advanced Studies in the Fine Arts for support to make this study possible.

Any effort of this nature is the fruit of many encounters with individuals and ideas, but one debt in particular stands out as significant. Through a series of conversations with George E. Hartman, Jr. several years ago, some of our thoughts and ideas about architecture and history were focused. Since that time, he has continuously and enthusiastically offered support and encouragement. James L. Nagel, Ludwig Glaser, William N. Morgan, and the late William Caudill each generously sponsored our efforts to secure assistance from the Graham Foundation. Roger

Cannon, Robert Humenn, and Debbie Buffalin provided valuable help in locating material and information. For their assistance and support we thank several persons in the School of Design: Dean Claude E. McKinney, Winifred Hodge, the secretaries, and the librarians. The students in our classes have enriched, stimulated, and challenged our ideas, and encouraged us to record them in this volume. We fully acknowledge our debt to them.

A special acknowledgment is reserved for Rebecca H. Mentz and Michael A. Nieminen, whose considerable talents were used to draw the sheets reproduced in this volume. Without their skill, patience, diligence, and dedication this volume would not have been possible.

Our gratitude is extended to our families who have aided our efforts through sacrifice, devotion, and understanding.

To all other persons who have encouraged or in some way contributed to this study we collectively give thanks.

By making available the information that is presented in this volume, we hope to expand the understanding of precedents in architecture; to illustrate an educational technique that is useful to students, educators, and practitioners; and to demonstrate an analytic technique that can have impact on architectural form and space decisions.

PREFACE TO THE SECOND EDITION

The success of the first edition indicated that there was a need for conceptual and analytic information about architecture. Our experience with the first edition over the past decade demonstrated that the material has been useful as a tool for teaching architecture. It has provided a vocabulary for analysis that helps students and architects understand the works of others and aids them in creating their own designs. This approach continues to be useful and there was no apparent need to revise the information. Instead, the second edition gave us the opportunity to enrich the content of

the analysis section by adding the works of seven architects. They were chosen initially to augment the content of the original sixteen architects. Some were selected for historical significance, some for lack of widespread documentation of their work. Others were picked because of emerging reputations and the production of a meaningful body of work since the publication of the first edition. All were selected because of the strength, quality, and interest of their designs. It is our intent to continue to show that design ideas transcend culture and time. Keeping the same format, we have added factual and analytic information on two or four buildings by each of the seven new architects.

While some may find this book useful for information about a particular architect or building, it is not our primary purpose to present any one building or architect exhaustively (e.g., photographs, written descriptions, or contract documents). Rather, our intention is to continue to explore the commonality of design ideas through comparison. To achieve this we have used the diagrammatic technique that was developed in the original study. While some of the architects and architectural authors have used diagrams to explain or inform others about the buildings included in this volume, the diagrams in this book are our own creation.

In addition to the acknowledgments cited in the preface of the first edition the following have helped make this edition a reality. The Graham Foundation for Advanced Studies in the Fine Arts supported our work for a second time; for this we are grateful. Van Nostrand Reinhold also contributed grant money to make this edition possible. Both of these sources aided our research and allowed for the production of the drawings.

While difficult to acknowledge all individuals who have contributed to or influenced our ideas, certain people's efforts deserve recognition. We are indebted to Wendy Lochner for persuading us to attempt a second edition. Her support and encouragement were critical. The editorial staff at Van Nostrand Reinhold provided us with willing and valu-

able assistance. James L. Nagle, Victor Reigner, and Mark Simon supported our efforts through encouragement, suggestions, and recommendations. Peter Bohlin and Carole Rusche generously contributed valuable information on the works of some of the architects. Collectively, we thank the staff of the School of Design for their willing assistance.

Special recognition goes to Mara Murdoch who single-

handedly, with great skill, dedication, and patience drew all of the new pages.

Finally we wish to acknowledge all of our students who have shown us that the study of precedents is a valuable tool for learning to design, and who continue to challenge us.

Roger H. Clark and Michael Pause

INTRODUCTION

The renewed and growing interest in architectural history and historic architectural example has focused the need to clarify the link between history and design. History studied in the academic sense of seeing our place within a continuum, or in the strictly scholarly sense of knowing the past, can limit our knowledge as architects to little more than names, dates, and style recognition. Seeing between and beyond the layers of historical styles, within which architecture is generally categorized and presented, can make history a source of enrichment for architectural design.

The search, in this study, is for theory which transcends the moment and reveals an architectural idea. The technique for this search is the careful examination and analysis of buildings. The desired result is the development of theory to generate ideas with which to design architecture.

This volume is organized into two parts. The first concentrates on the analysis of 88 buildings which are presented in both conventional drawings—site plan, plan, and elevation—and diagrams. The second identifies and delineates formal archetypal patterns or formative ideas from which architecture might evolve. It can be observed that certain patterns persist through time, with no apparent relationship to place.

Buildings that represent a range of time, function, and style, and architects who exemplify seemingly different approaches to architecture, were selected. This selection was tempered by availability of information; some architects and some buildings were not included because the material available did not permit thorough analysis.

Preference was given to built buildings in lieu of projects which are included in the second part only when they represent pertinent examples of an idea. While the analytic technique utilized in this volume is applicable to groups of

buildings, this study is limited to single works of architecture.

The information available for the selected buildings contained inconsistencies in some areas. When discrepancies did occur, every effort was made to verify the accuracy of the information. If it could not be totally verified, then reasonable assumptions were made. For example, a site plan was never drawn by Robert Venturi for the Tucker House; therefore, the site plan indicated in this volume is inferred from other information.

In some instances, particular buildings are cited in the literature by more than one name. For example, La Rotonda by Andrea Palladio is often referred to as Villa Capra. Less frequently it is called Villa Almerico, after the name of the family for whom it was originally built. In cases where such multiplicity occurs, buildings are identified in the body of this study by the most frequently used name, and in the index by the several names utilized.

Opinion also differs about dates attributed to several buildings. Because of the length of time it takes to complete a building or because of the imprecision of recorded history, it is often difficult to establish a date or a series of dates that are exact for a building. The importance of the date is to place the work in a chronological context. When conflict did occur between sources, the date that is ascribed most often is the one used.

Undoubtedly, the complexity of architecture often makes it difficult to attribute the work of a building to a single person. It is clear that buildings, regardless of when executed, are the products of partnerships or collaborations, and are the result of inputs from several persons. However, for the sake of clarity, the buildings in this study are assigned to the person who is normally recognized as the designer. For in-

stance, Charles Moore is listed rather than the several associations which might be included for each building. Similarly, Romaldo Giurgola is acknowledged instead of the firm in which he is a partner.































In the analysis part of the study, the plan, elevation, and section for any individual building are drawn at the same scale. However, the scale between any two buildings varies depending upon building size and presentation format. Site plans are oriented to correspond generally to the orientation of the floor plan, and north is indicated where known.

To communicate the analysis of the buildings and the formative ideas in this study, a diagram or a set of diagrams is utilized. The diagrams are drawings that, as abstractions, are intended to convey essential characteristics and relationships in a building. As such, the diagrams focus on specific physical attributes which allow for the comparison of that attribute between buildings independent of style, type, function, or time. The diagrams are developed from the three-dimensional form and space configurations of the building. They take into account more information than is normally apparent in a plan, and elevation, or a section. In

order to reduce the building to its essentials, the diagrams have been intentionally simplified. This elimination of all but the most important considerations makes those that remain both dominant and memorable.

For the analysis, it was necessary to establish a graphic standard so comparison could be made between the diagrams. In general, heavy lines are used on each diagram to accent the issue. In the formative idea part of the study, the plan, elevation, or section of the building is drawn lightly for orientation purposes, while the issue being analyzed and compared is indicated by heavy line or shading. The legend on page xi indicates the specific graphic standard used on the diagrams in the analysis section.

This study is not exhaustive; rather, examples, are included to illustrate the nuances of the idea. It is rare to find a building configuration which embodies a single formal theme in absolute purity. More normal is a variety of patterns layered upon one another—the consequence of which is the potential for richness that can evolve from multiple interpretations. In this study dominant patterns have been identified, but this is not to suggest that others do not exist.

LEGEND	STRUCTURE	PLAN TO SECTION	REPETITIVE TO UNIQUE	SYMMETRY AND BALANCE
<p>FACTUAL SHEET</p> <p>  NORTH INDICATOR  ELEVATION  SECTION </p>	<p>NATURAL LIGHT</p> <p>  DIRECT  DIFFUSED  INDIRECT  INTERIOR SPACE </p> <p>MASSING</p> <p>  MAJOR MASSING  SECONDARY MASSING </p>	<p>CIRCULATION TO USE-SPACE</p> <p>  MAJOR CIRCULATION  SECONDARY CIRCULATION  USE-SPACES  REMAINDER OF BUILDING  VERTICAL CIRCULATION </p> <p>UNIT TO WHOLE</p> <p>  UNITS  REMAINDER OF BUILDING </p>	<p>GEOMETRY</p> <p>  SQUARE  1.4 RECTANGLE  1.6 RECTANGLE  DIMENSION OR UNIT  ANGLE  GRID LINES  RADIUS CENTER </p>	<p>ADDITIVE AND SUBTRACTIVE</p> <p>  ADDITIVE UNITS  SUBTRACTION  WHOLE  SUBTRACTIVE UNIT </p> <p>HIERARCHY</p> <p>  MOST DOMINANT  TO  LESS DOMINANT </p>

CONTENTS

Prefaces / v

Introduction / ix

Analysis / 1

Alvar Aalto / 8
Tadao Ando / 16
Erik Gunnar Asplund / 20
Peter Q. Bohlin / 28
Mario Botta / 36
Filippo Brunelleschi / 44
Sverre Fehn / 52
Romaldo Giurgola / 56
Nicholas Hawksmoor / 64
Louis I. Kahn / 72
Le Corbusier / 80
Claude Nicholas Ledoux / 88
Edwin Lutyens / 96
Richard Meier / 104
Charles Moore / 112
Andrea Palladio / 120

Henry Hobson Richardson / 128
James Stirling / 136
Louis Sullivan / 144
Giuseppe Terragni / 152
Ludwig Mies Van Der Rohe / 160
Robert Venturi / 168
Frank Lloyd Wright / 176

Formative Ideas / 185

Plan to Section or Elevation / 200
Unit to Whole / 207
Repetitive to Unique / 214
Additive and Subtractive / 220
Symmetry and Balance / 222
Geometry / 228
Configuration Patterns / 242
Progressions / 252
Reduction / 256

Index / 261

ANALYSIS

Alvar Aalto / 8

Town Hall, Saynatsalo
Vouksenniska Church, Imatra
Enso-Gutzeit Company Headquarters, Helsinki
Cultural Center, Wolfsburg

Tadao Ando / 16

Chapel on Mt. Rokko, Kobe
Church on the Water, Tomamu

Erik Gunnar Asplund / 20

Snellman House, Djursholm
Woodland Chapel, Stockholm
Lister County Courthouse, Solvesborg
Stockholm Public Library, Stockholm

Peter Q. Bohlin / 28

Weekend Residence for Mr. and Mrs. Eric Q. Bohlin,
West Cornwall
Gaffney Residence, Romansville
House in the Adirondacks, New York State
Guest House, Gates Residence, Medina

Mario Botta / 36

Single Family Residence, Riva San Vitale
Church of San Giovanni Battista, Mogno
Bianda Residence, Losone
The Church of Beato Odorico, Pordenone

Filippo Brunelleschi / 44

Old Sacristy, Florence
Ospedale Degli Innocenti, Florence
Church of San Maria Degli Angeli, Florence
Church of San Spirito, Florence

Sverre Fehn / 52

Villa Busk, Bamble
The Glacier Museum, Fjaerland

Romaldo Giurgola / 56

Adult Learning Research Laboratory, Bryn Mawr

Lang Music Building, Swarthmore
Student Union, Plattsburgh
Tredyffrin Public Library, Stafford

Nicholas Hawksmoor / 64

Easton Neston, Northamptonshire
St. George-In-The-East, Wapping
Christ Church, Spitalfields
St. Mary Woolnoth, London

Louis I. Kahn / 72

Alfred N. Richards Medical Research Building,
Philadelphia
Salk Institute of Biological Studies, La Jolla
Kimball Art Museum, Fort Worth
Library, Exeter

Le Corbusier / 80

Villa Savoye, Poissy
Unite D' Habitation, Marsailles
Notre Dame Du Haut Chapel, Ronchamp
The Palace of Assembly, Chandigarh

Claude Nicholas Ledoux / 88

Hotel De Montmorency, Paris
Hotel Guimard, Paris
Theater, Besancon
Director's House, Saltworks of Arc and Senans

Edwin Lutyens / 96

Homewood, Knebworth
Nashdom, Taplow
Heathcote, Ilkey
The Salutation, Sandwich

Richard Meier / 104

Smith House, Darien
The Atheneum, New Harmony
Ulm Exhibition and Assembly Building, Ulm
Weishaupt Forum, Schwendi

Charles Moore / 112

Moore House, Orinda
Condominium I, Sea Ranch
Hines House, Sea Ranch
Burns House, Santa Monica Canyon

Andrea Palladio / 120

Villa Foscari, Malcontenta
Church of San Giorgio Maggiore, Venice
La Rotonda, Vicenza
Redentore Church, Venice

Henry Hobson Richardson / 128

Trinity Church, Boston
Sever Hall, Cambridge
Allegheny County Courthouse, Pittsburgh
J. J. Glessner House, Chicago

James Stirling / 136

Engineering Building, Leicester
History Faculty Building, Cambridge
Florey Building, Oxford
Olivetti Training School, Haslemere

Louis Sullivan / 144

Auditorium Building, Chicago
Wainwright Building, St. Louis

Carson Pirie and Scott Store, Chicago
National Farmer's Bank, Owatonna

Giuseppe Terragni / 152

Novocomum Apartment House, Como
Casa del Fascio, Como
Sant' Elia Nursery School, Como
Villa Bianca, Seveso

Ludwig Mies van der Rohe / 160

German Pavilion at International Exhibition, Barcelona
Tugendhat House, Brno
Farnsworth House, near Plano
Crown Hall, Chicago

Robert Venturi / 168

Vanna Venturi House, Philadelphia
Fire Station Number 4, Columbus
Peter Brant House, Greenwich
Carll Tucker III House, Mount Kisco

Frank Lloyd Wright / 176

Unity Temple, Oak Park
Frederick G. Robie House, Chicago
Fallingwater, Ohio
Solomon R. Guggenheim Museum, New York

ANALYSIS

In this section, 88 works of architecture are documented. The buildings are the designs of 23 architects. For most architects, four buildings are presented which are representative of that person's work. The material is ordered with the architects arranged alphabetically, and the buildings for each architect presented chronologically and successively.

Each building is recorded on two adjacent pages; the left-hand page documents the building with name, date, and location as well as drawings of the site plan, floor plans, elevations, and sections; illustrated on the right-hand page is a series of eleven analysis diagrams and the parti diagram which culminates and summarizes the analysis for the building. The parti is seen as the dominant idea of a building which embodies the salient characteristics of that building. It encapsulates the essential minimum of the design, without which the scheme would not exist, but from which the architecture can be generated.

A major concern of the analysis is to investigate the formal and spatial characteristics of each work in such a way that the building parti can be understood. To accomplish this, 11 issues were selected from the widest range of characteristics: fundamental elements which are common to all buildings, relationships among attributes, and formative ideas. Each issue is first explored in isolation and then in relationship to the other issues. This information is studied to discern reinforcement and to identify the dominant underlying idea. From the analysis and the resulting parti for each building, similarities and differences among the designs can be identified.

The issues selected for the analysis are: structure; natural light; massing; and the relationships of plan to section, circulation to use-space, unit to whole, and repetitive to

unique. Also included are symmetry and balance, geometry, additive and subtractive, and hierarchy.

STRUCTURE

At a basic level, structure is synonymous with support, and therefore exists in all buildings. At a more germane level, structure is columnar, planar, or a combination of these which a designer can intentionally use to reinforce or realize ideas. In this context, columns, walls, and beams can be thought of in terms of the concepts of frequency, pattern, simplicity, regularity, randomness, and complexity. As such, structure can be used to define space, create units, articulate circulation, suggest movement, or develop composition and modulations. In this way, it becomes inextricably linked to the very elements which create architecture, its quality and excitement. This analysis issue has the potential to reinforce the issues of natural light, unit to whole relationships, and geometry. It can also strengthen the relationship of circulation to use-space and the definition of symmetry, balance, and hierarchy.

NATURAL LIGHT

Natural light focuses on the manner in which, and the locations where, daylight enters a building. Light is a vehicle for the rendering of form and space, and the quantity, quality, and color of the light affect the perceptions of mass and volume. The introduction of natural light may be the consequence of design decisions made about the elevation and section of a building. Daylight can be considered in

terms of qualitative differences which result from filtering, screening, and reflecting. Light which enters a space from the side, after modification by a screen, is different from light which enters directly overhead. Both examples are quite different from light which is reflected within the envelope of the building before entering the space. The concepts of size, location, shape, and frequency of opening; surface material, texture, and color; and modification before, during, or after entering the building envelope are all relevant to light as a design idea. Natural light can reinforce structure, geometry, hierarchy, and the relationships of unit to whole, repetitive to unique, and circulation to use-space.

MASSING

As a design issue, massing constitutes the perceptually dominant or most commonly encountered three-dimensional configuration of a building. Massing is more than the silhouette or elevation of a building. It is the perceptual image of the building as a totality. While massing may embody, approximate, or at times parallel either the outline or the elevation, it is too limiting to view it as only this. For example, on the elevation of a building the fenestration may in no way affect the perception of the volume of the building. Similarly, the silhouette may be too general and not reflect productive distinctions in form.

Massing, seen as a consequence of designing, can result from decisions made about issues other than the three-dimensional configuration. Viewed as a design idea, massing may be considered relative to concepts of context, collections and patterns of units, single and multiple masses, and primary and secondary elements. Massing has the potential to define and articulate exterior spaces, accommodate site, identify entrance, express circulation, and emphasize importance in architecture. As an issue in the analysis, massing can strengthen the ideas of unit to whole, repetitive to

unique, plan to section, geometry, additive and subtractive, and hierarchy.

PLAN TO SECTION OR ELEVATION

Plan, section, and elevation are conventions common to the simulation of the horizontal and vertical configurations of all buildings. As with any of the design ideas in this analysis, the relationship of plan configuration to vertical information may result from decisions made about other issues. The plan can be the device to organize activities and can, therefore, be viewed as the generator of form. It may serve to inform about many issues such as the distinction between passage and rest. The elevation and section are often considered as being more closely related to perception since these notations are similar to encountering a building frontally. However, the use of plan or section notations presumes volumetric understanding; that is, a line in either has a third dimension. The reciprocity and the dependence of one on the other can be a vehicle for making design decisions, and can be used as a strategy for design. Considerations in plan, section, or elevation can influence the configurations of the other through the concepts of equality, similarity, proportion, and difference or opposition.

It is possible for the plan to relate to the section or elevation at a number of scales: a room, a part, or the whole building. As an issue for analysis, the plan to section relationship reinforces the ideas of massing, balance, geometry, hierarchy, additive, subtractive, and the relationships of unit to whole and repetitive to unique.

CIRCULATION TO USE-SPACE

Fundamentally, circulation and use-space represent the significant dynamic and static components in all buildings. Use-space is the primary focus of architectural decision making

relative to function, and circulation is the means by which that design effort is engaged. Together, the articulation of the conditions of movement and stability form the essence of a building. Since circulation determines how a person experiences a building, it can be the vehicle for understanding issues like structure, natural light, unit definition, repetitive and unique elements, geometry, balance, and hierarchy. Circulation may be defined within a space that is for movement only, or implied within a use-space. Thus, it can be separate from, through, or terminate in the use-spaces; and it may establish locations of entry, center, terminus, and importance.

Use-space can be implied as part or all of a free or open plan. It can also be discrete, as in a room. Implicit in the analysis of this issue is the pattern created by the relationship between the major use-spaces. These patterns might suggest centralized, linear, or clustered organizations. The relationship of circulation and use-space can also indicate the conditions of privacy and connection. Basic to employing this issue as a design tool is the understanding that the configuration given to either circulation or use directly affects the manner in which the relationship to the other takes place.

UNIT TO WHOLE

The relationship of unit to whole examines architecture as units which can be related to create buildings. A unit is an identified entity which is part of a building. Buildings may comprise only one unit, where the unit is equal to the whole, or aggregations of units. Units may be spatial or formal entities which correspond to use-spaces, structural components, massing, volume, or collections of these elements. Units may also be created independently of these issues.

The nature, identity, expression, and relationship of units to other units and to the whole are relevant considerations in the use of this idea as a design strategy. In this context, units

are considered as adjoining, separate, overlapping, or less than the whole. The relationship of unit to whole can be reinforced by structure, massing, and geometry. It can support the issues of symmetry, balance, geometry, additive, subtractive, hierarchy, and the relationship of repetitive to unique.

REPETITIVE TO UNIQUE

The relationship of repetitive to unique elements entails the exploration of spatial and formal components for attributes which render these components as multiple or singular entities. If unique is understood to be a difference within a class or a kind, then the comparison of elements within a class can result in the identification of the attributes which make the unique element different. This distinction links the realms of the repetitive and the unique through the common reference frame of the class or kind. Essentially, the definition of one is determined by the realm of the other. In this context, components are determined to be repetitive or unique through the absence or presence of attributes. Concepts of size, orientation, location, shape, configuration, color, material, and texture are useful in making the distinctions between repetitive and unique. While repetitive and unique elements occur in numerous ways and at several scales within buildings, the analysis focuses on the dominant relationship. In the analysis, this issue generates information which strengthens or is reinforced by the concepts of structure, massing, units related to whole, plan related to section, geometry, and symmetry or balance.

SYMMETRY AND BALANCE

The concepts of symmetry and balance have been in use since the beginning of architecture. As a fundamental issue of composition, balance in architecture occurs through

the use of spatial or formal components. Balance is the state of perceptual or conceptual equilibrium. Symmetry is a specialized form of balance. Compositional balance in terms of equilibrium implies a parallel to the balance of weights, where so many units of "A" are equal to a dissimilar number of units of "B." Balance of components establishes that a relationship between the two exists, and that an implied line of balance can be identified. For balance to exist, the basic nature of the relationship between two elements must be determined; that is, some element of a building must be equivalent in a knowable way to another part of the building. The equivalency is determined by the perception of identifiable attributes within the parts. Conceptual balance can occur when a component is given additional value or meaning by an individual or group. For example, a smaller sacred space can be balanced by a much larger support or secondary space.

Whereas balance is developed through differences in attributes, symmetry exists when the same unit occurs on both sides of the balance line. In architecture this can happen in three precise ways: reflected, rotated about a point, and translated or moved along a line.

Both symmetry and balance can exist at the building, component, or room level. As scales change, a distinction is made between overall and local symmetry or balance. Consideration of size, orientation, location, articulation, configuration, and value is involved in its use as a formative idea. Balance and symmetry may have an impact on all of the other analysis issues.

GEOMETRY

Geometry is a formative idea in architecture that embodies the tenets of both plane and solid geometry to determine built form. Within this issue, grids are identified as being developed from the repetition of the basic geometries

through multiplication, combination, subdivision, and manipulation.

Geometry has been used as a design tool since the very beginnings of architectural history. Geometry is the single most common determinant or characteristic in buildings. It can be utilized on a broad range of spatial or formal levels that includes the use of simple geometric shapes, varied form languages, systems of proportions, and complex form generated by intricate manipulations of geometries. The realm of geometry as an architectural form generator is a relative one of measurement and quantification. As a focus for this analysis, it centers on the concepts of size, location, shape, form, and proportion. It also concentrates on the consistent changes in geometries and form languages that result from the combination, derivation, and manipulation of basic geometric configurations. In the analysis, grids are observed for frequency, configuration, complexity, consistency, and variation. As the pervasive attribute of buildings, geometry can reinforce all of the issues used in the analysis.

ADDITIVE AND SUBTRACTIVE

The formative ideas of additive and subtractive are developed from the processes of adding, or aggregating, and subtracting built form to create architecture. Both require the perceptual understanding of the building. Additive, when used to generate built form, renders the parts of the building as dominant. The perception of a person engaging an additive design is that the building is an aggregation of identifiable units or parts. Subtractive, when utilized in designing, results in a building in which the whole is dominant. A person viewing a subtractive scheme understands the building as a recognizable whole from which pieces have been subtracted. Generally, additive and subtractive are formal considerations which can have spatial consequences.

Richness can occur when both ideas are employed simul-

taneously to develop built form. For example, it is possible to add units together to form a whole from which pieces are subtracted. It is also possible to subtract pieces from an identifiable whole and then to add the subtracted parts back to create the building.

The manner in which the building whole was articulated, and the ways in which the forms were rendered, was important to the analysis. This was achieved by observing massing, volumes, color, and material changes. Additive and subtractive, as ideas, can strengthen or be reinforced by massing, geometry, balance, hierarchy, and the relationships of unit to whole, repetitive to unique, and plan to section.

HIERARCHY

As a formative idea, hierarchy in the design of buildings is the physical manifestation of the rank ordering of an attribute or attributes. Embodied in this concept is the assign-

ment of relative value to a range of characteristics. This entails the understanding that qualitative differences within a progression can be identified for a selected attribute. Hierarchy implies a rank ordered change from one condition to another, where ranges such as major-minor, open-closed, simple-complex, public-private, sacred-profane, served-servant, and individual-group are utilized. With these ranges the rank ordering can occur in the realm of the formal, spatial, or both.

In the analysis, hierarchy was explored relative to dominance and importance within the built form through examination of patterns, scale, configuration, geometry, and articulation. Quality, richness, detail, ornament, and special materials were used as indicators of importance. Hierarchy, as a design idea, can be related to and support any of the other issues explored in the analysis.

ALVAR AALTO

ALVAR AALTO

TOWN HALL
SAYNATSALO, FINLAND
1950-1952

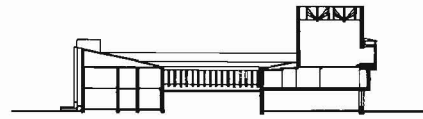

SECTION A

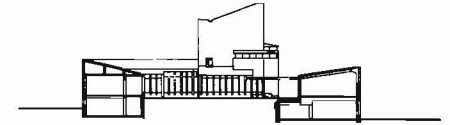

SECTION B

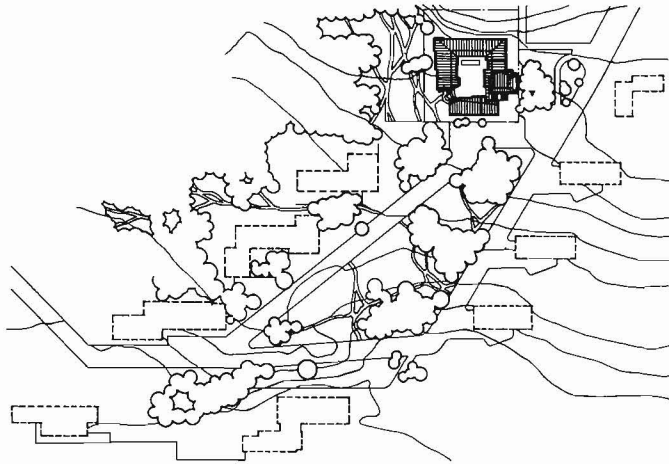

SITE PLAN

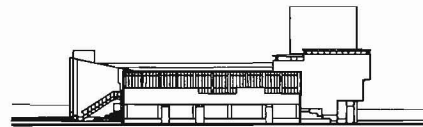

ELEVATION 1

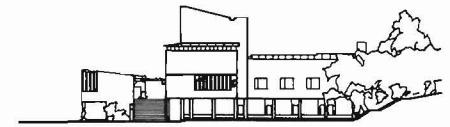

ELEVATION 2

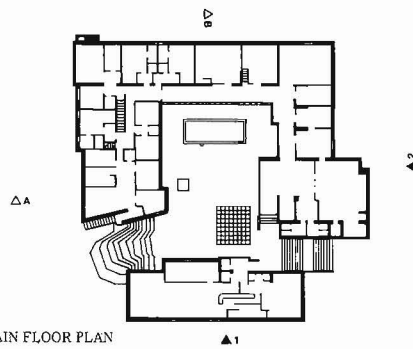

MAIN FLOOR PLAN

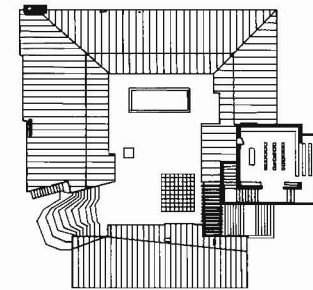

UPPER FLOOR PLAN

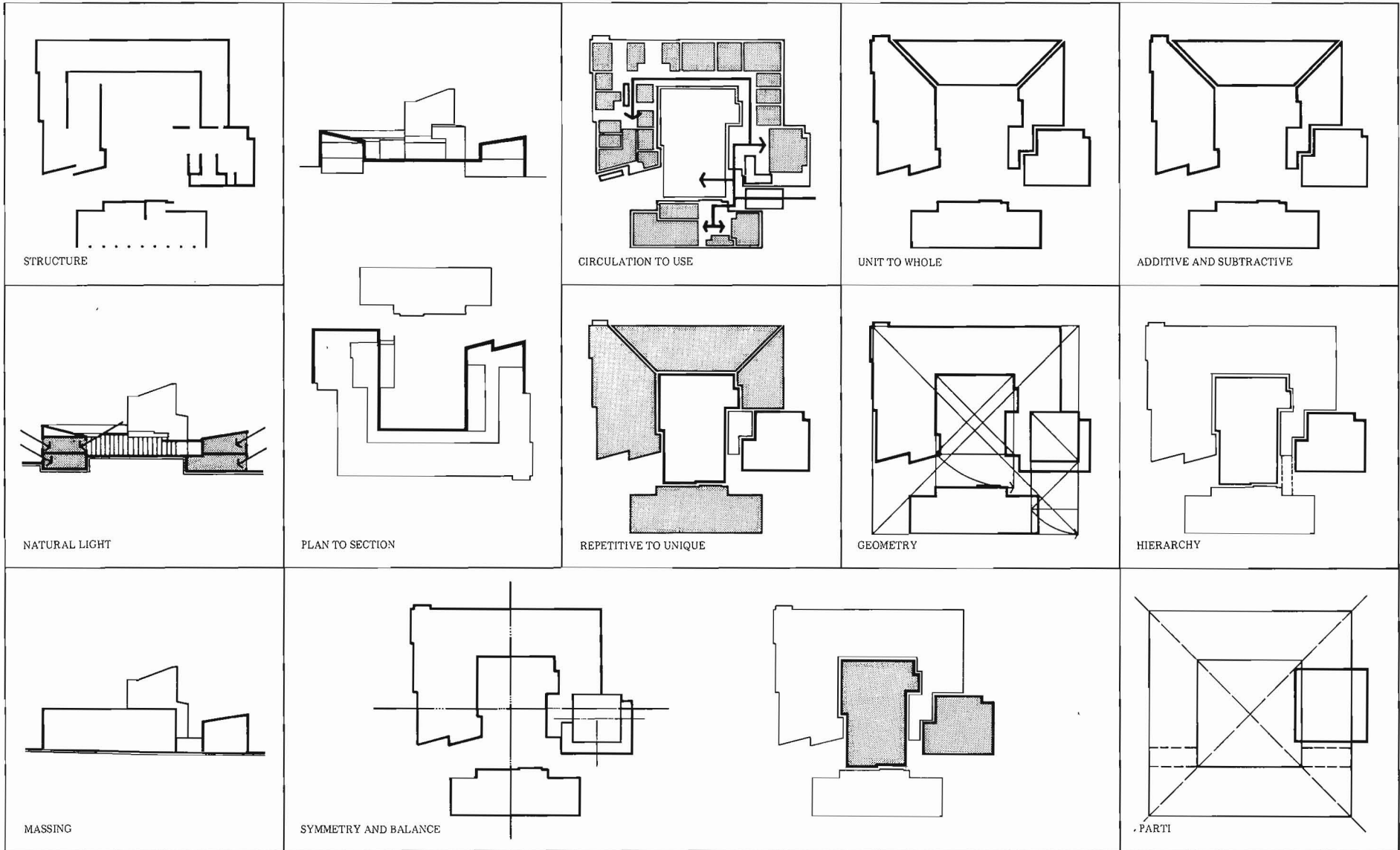

ALVAR AALTO

VOUKSENNISKA CHURCH
IMATRA, FINLAND
1956-1958

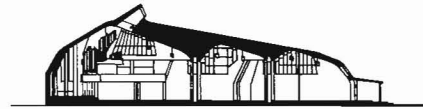

SECTION A



SECTION B

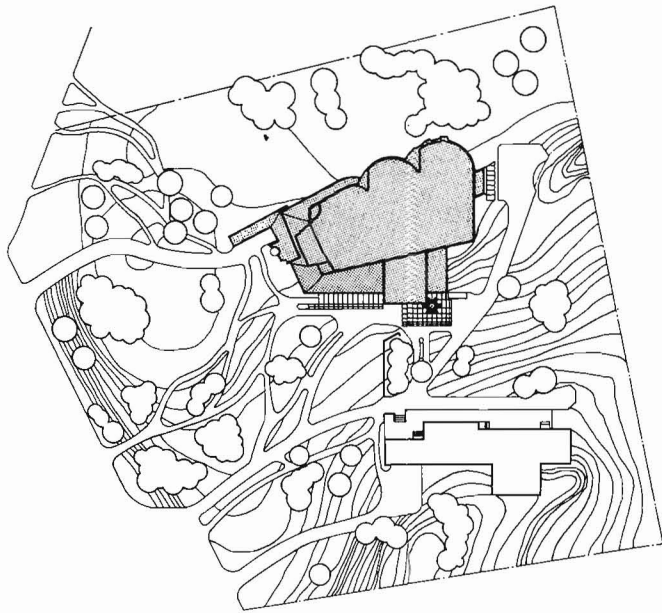

SITE PLAN

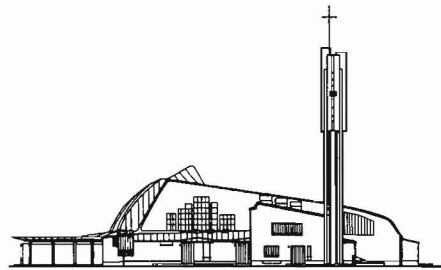

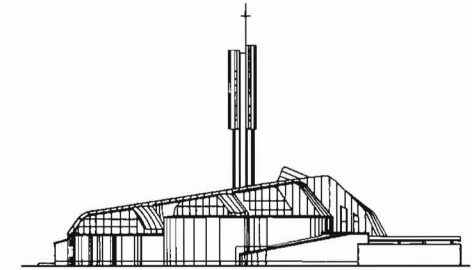

ELEVATION 1

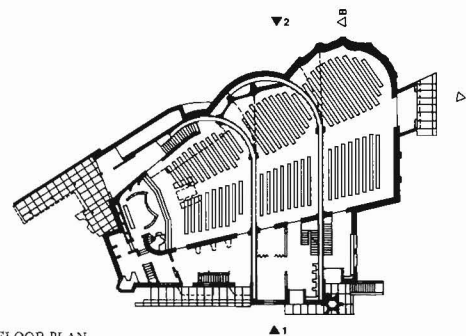

ELEVATION 2

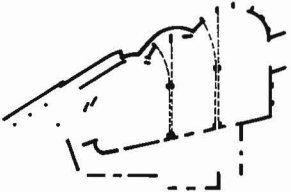

FLOOR PLAN

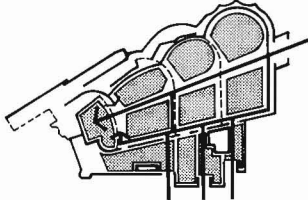
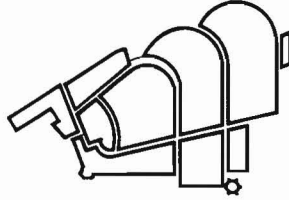
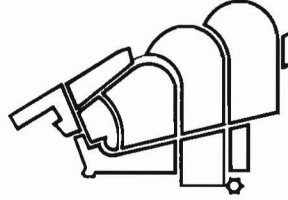
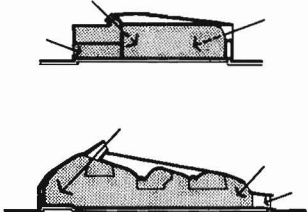
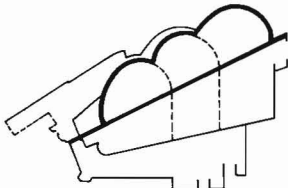
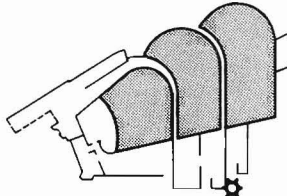
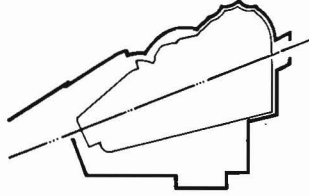
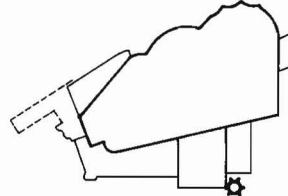
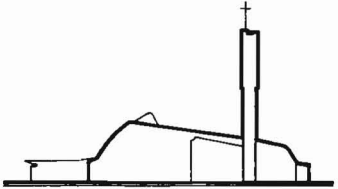
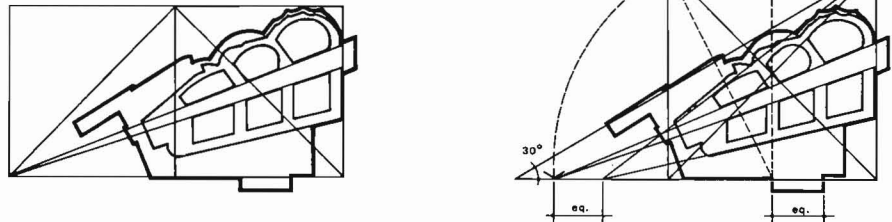
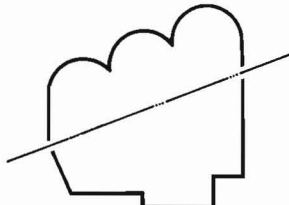
 <p>STRUCTURE</p>		 <p>CIRCULATION TO USE</p>	 <p>UNIT TO WHOLE</p>	 <p>ADDITIVE AND SUBTRACTIVE</p>
 <p>NATURAL LIGHT</p>	 <p>PLAN TO SECTION</p>	 <p>REPETITIVE TO UNIQUE</p>	 <p>SYMMETRY AND BALANCE</p>	 <p>HIERARCHY</p>
 <p>MASSING</p>	 <p>GEOMETRY</p>		 <p>PARTI</p>	

ALVAR AALTO

ENSO-GUTZEIT COMPANY HEADQUARTERS
HELSINKI, FINLAND
1959-1962

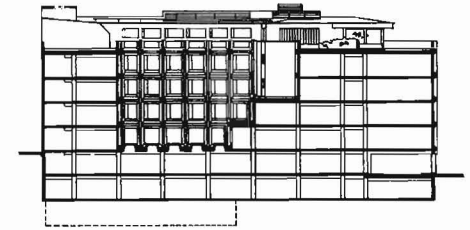

SECTION A

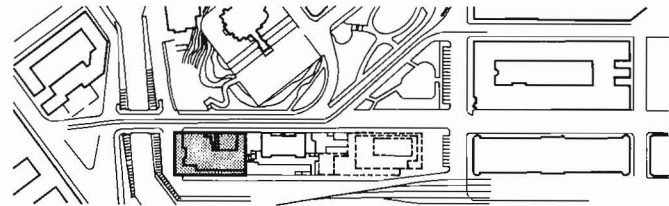

SITE PLAN

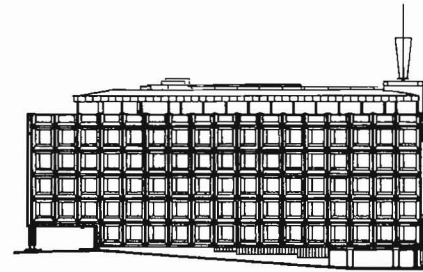

ELEVATION 1

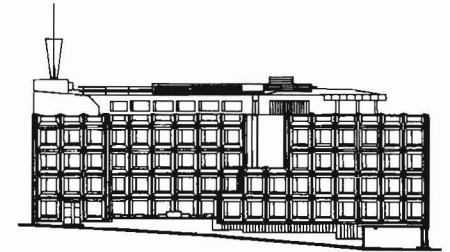



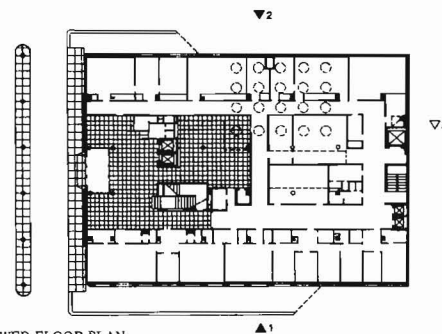

ELEVATION 2

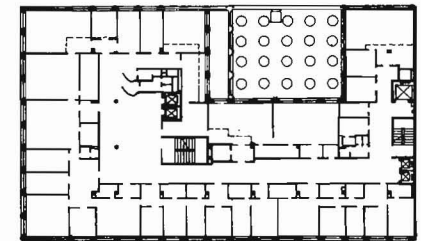

LOWER FLOOR PLAN

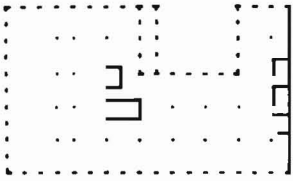

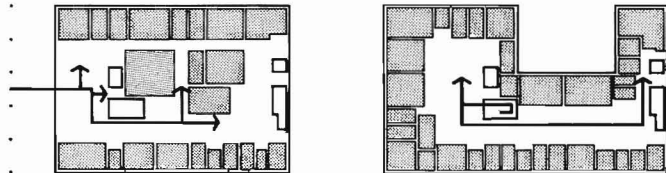
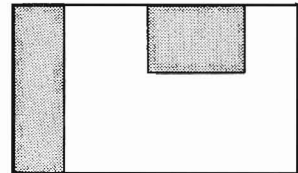
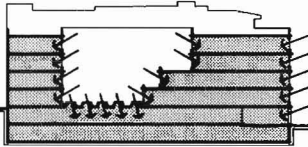
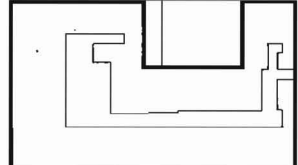
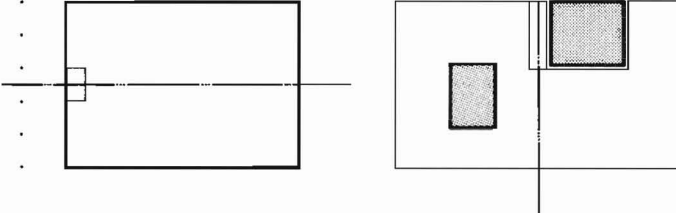
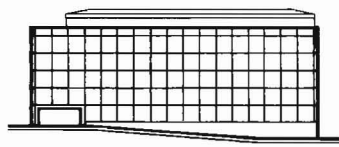
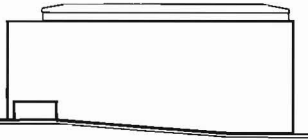
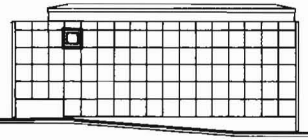
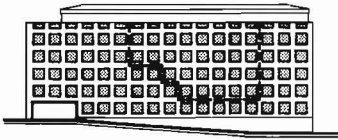
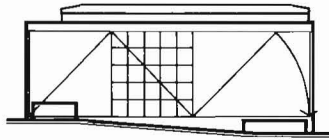
UPPER FLOOR PLAN

 <p>STRUCTURE</p>		 <p>CIRCULATION TO USE</p>		 <p>ADDITIVE AND SUBTRACTIVE</p>
 <p>NATURAL LIGHT</p>	 <p>PLAN TO SECTION</p>	 <p>SYMMETRY AND BALANCE</p>		 <p>HIERARCHY</p>
 <p>MASSING</p>	 <p>UNIT TO WHOLE</p>	 <p>REPETITIVE TO UNIQUE</p>	 <p>GEOMETRY</p>	 <p>PARTI</p>

ALVAR AALTO

CULTURAL CENTER
WOLFSBURG, GERMANY
1958-1962



SECTION A



SECTION B

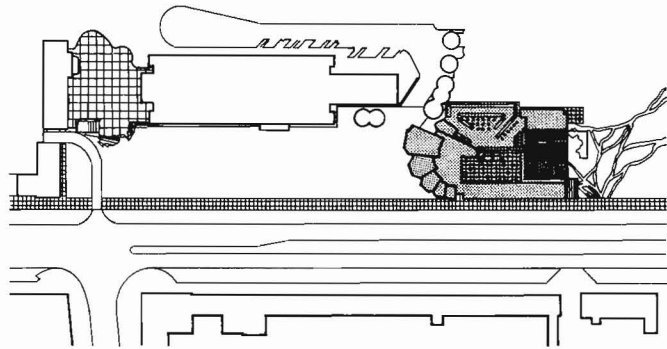

SITE PLAN





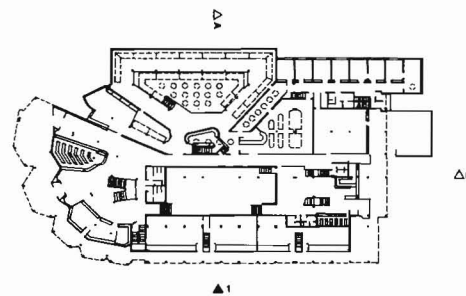

ELEVATION 1

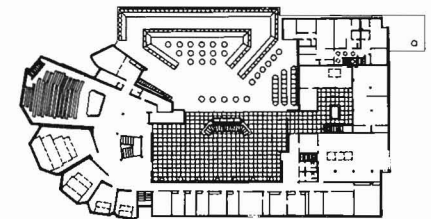

LOWER FLOOR PLAN

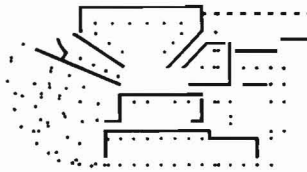

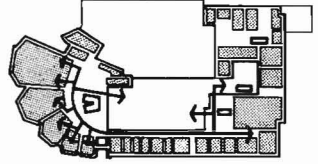
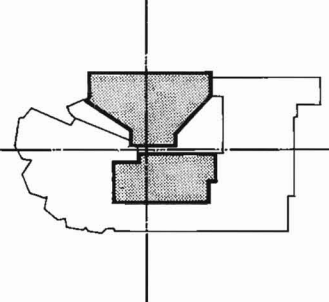
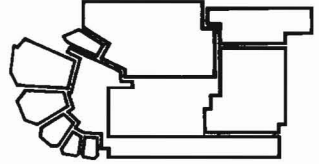
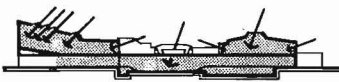
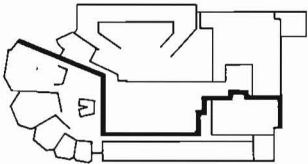
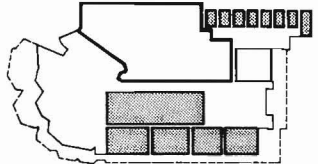
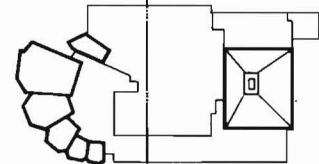
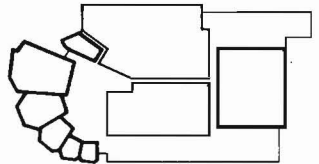
UPPER FLOOR PLAN

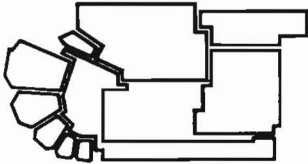
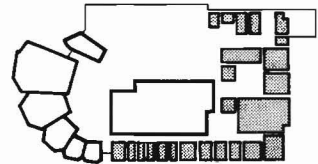
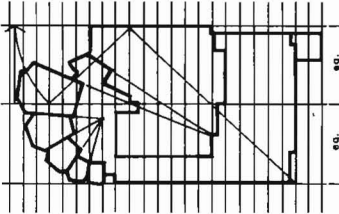
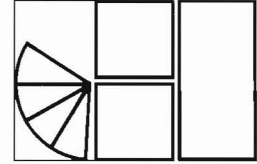
 <p>STRUCTURE</p>		 <p>CIRCULATION TO USE</p>		 <p>ADDITIVE AND SUBTRACTIVE</p>
 <p>NATURAL LIGHT</p>	 <p>PLAN TO SECTION</p>		 <p>SYMMETRY AND BALANCE</p>	 <p>HIERARCHY</p>
 <p>MASSING</p>	 <p>UNIT TO WHOLE</p>	 <p>REPETITIVE TO UNIQUE</p>	 <p>GEOMETRY</p>	 <p>PARTI</p>

TADAO ANDO

TADAO ANDO

CHAPEL ON MT. ROKKO
KOBE, HYOGO, JAPAN
1985-1986

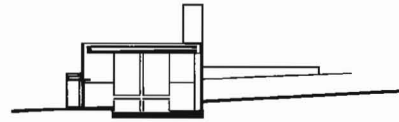

SECTION A

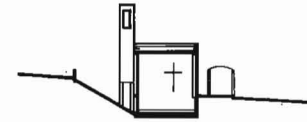

SECTION B

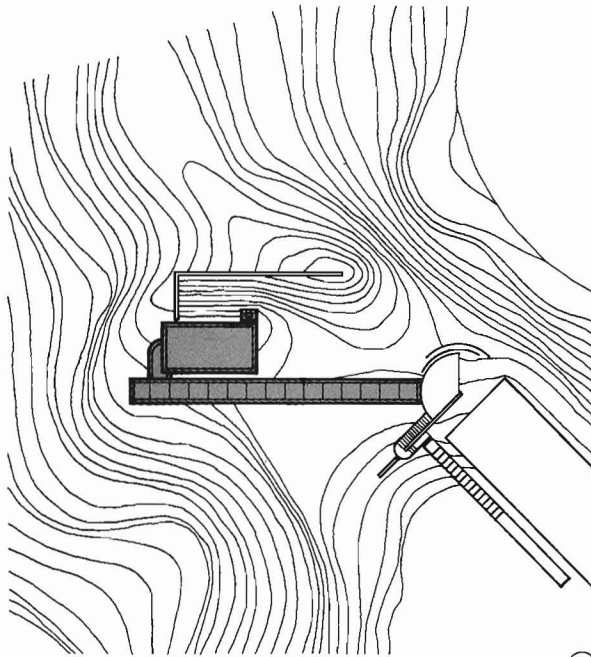

SITE PLAN

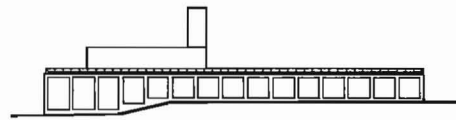

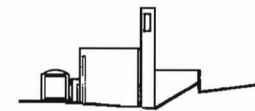

ELEVATION 1

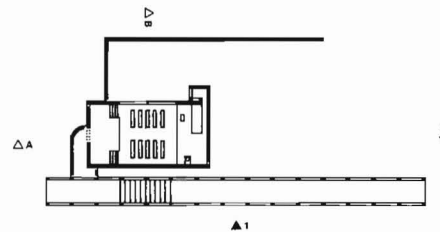

ELEVATION 2

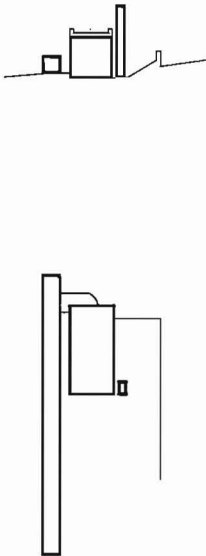
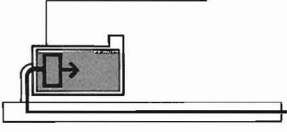
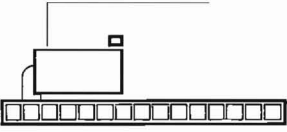
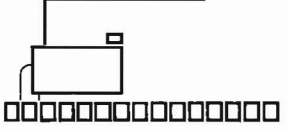
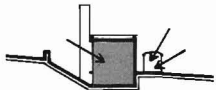
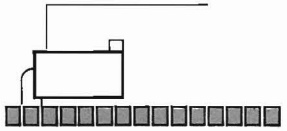
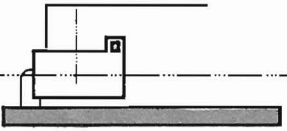
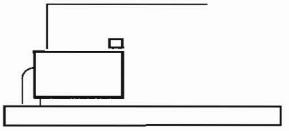

FLOOR PLAN

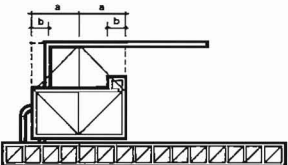
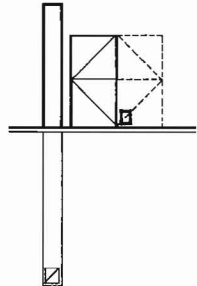
 <p>STRUCTURE</p>	 <p>PLAN TO SECTION</p>	 <p>CIRCULATION TO USE</p>	 <p>UNIT TO WHOLE</p>	 <p>ADDITIVE AND SUBSTRACTIVE</p>
 <p>NATURAL LIGHT</p>		 <p>REPETITIVE TO UNIQUE</p>	 <p>SYMMETRY BALANCE</p>	 <p>HIERARCHY</p>
 <p>MASSING</p>		 <p>GEOMETRY</p>	 <p>PARTI</p>	

TADAO ANDO

CHURCH ON THE WATER
TOMAMU, HOKKAIDO, JAPAN
1985-1988



SECTION A

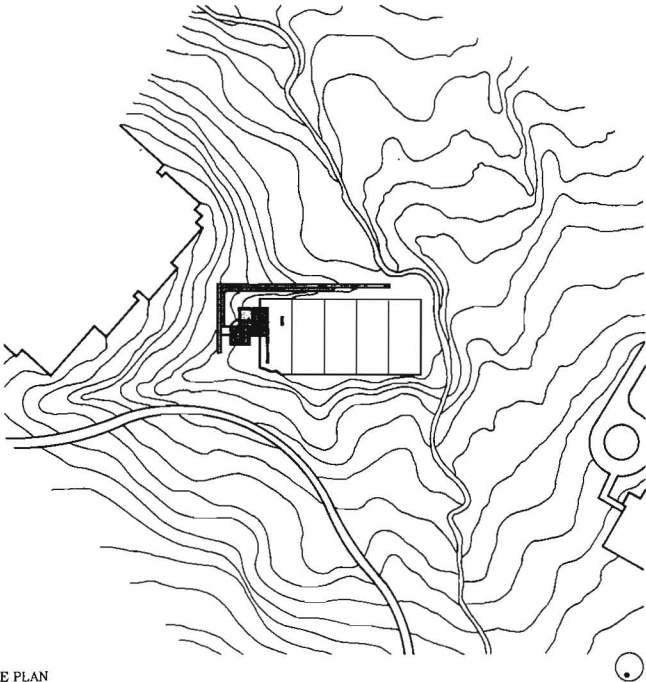

SITE PLAN



ELEVATION 1

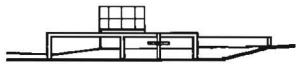

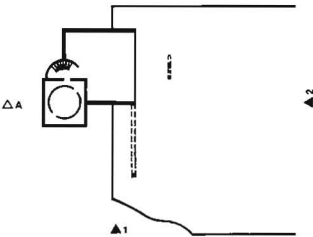

ELEVATION 2

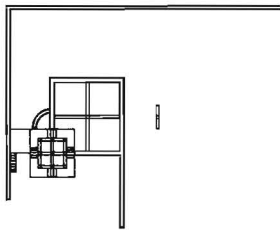

MAIN FLOOR PLAN

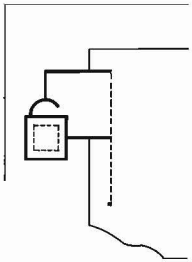
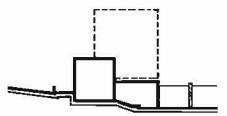
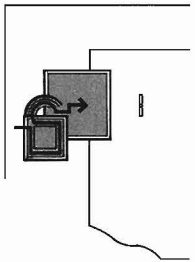
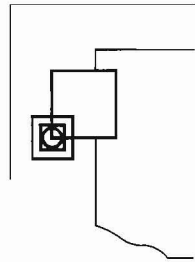
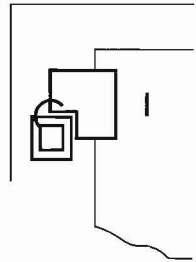
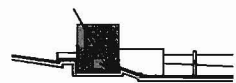
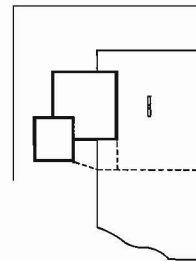
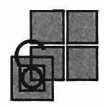
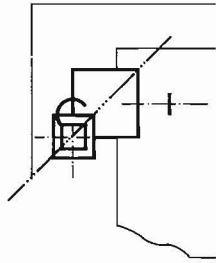
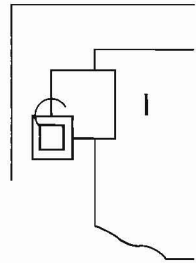

UPPER FLOOR PLAN

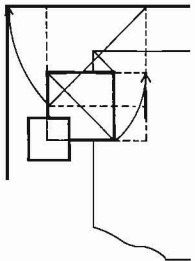
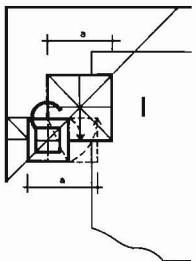
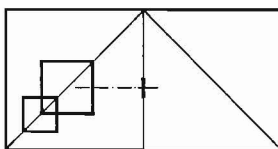
 <p>STRUCTURE</p>		 <p>CIRCULATION TO USE</p>	 <p>UNIT TO WHOLE</p>	 <p>ADDITIVE AND SUBSTRUCTIVE</p>	
 <p>NATURAL LIGHT</p>	 <p>PLAN TO SECTION</p>	 <p>REPETITIVE TO UNIQUE</p>	 <p>SYMMETRY AND BALANCE</p>	 <p>HIERARCHY</p>	
 <p>MASSING</p>	 <p>GEOMETRY</p>				 <p>PARTI</p>

ERIK GUNNAR ASPLUND

ERIK GUNNAR ASPLUND

SNELLMAN HOUSE
DJURSHOLM, SWEDEN
1917-1918

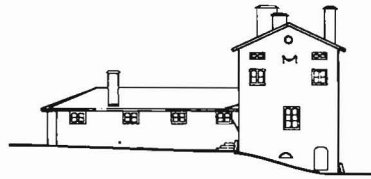

ELEVATION 1



SECTION A

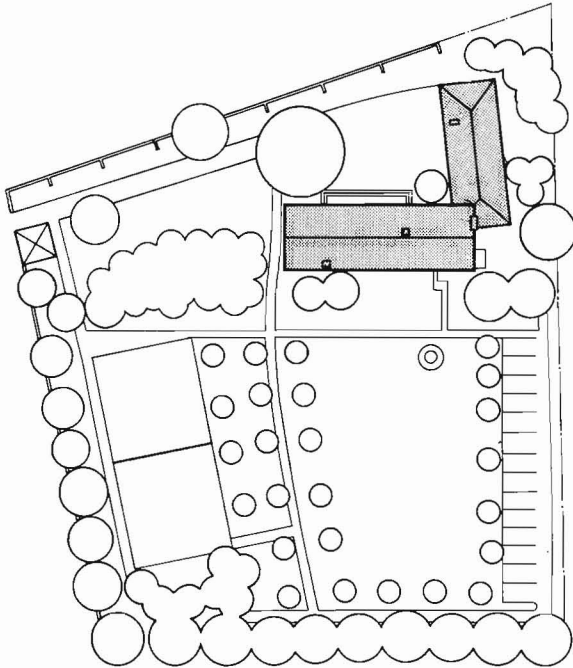

SITE PLAN

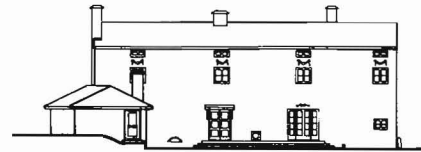

ELEVATION 2

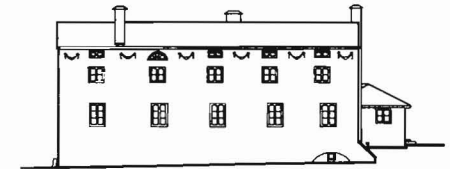

ELEVATION 3

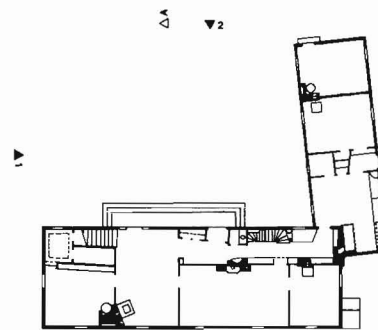

LOWER FLOOR PLAN ▲ 3

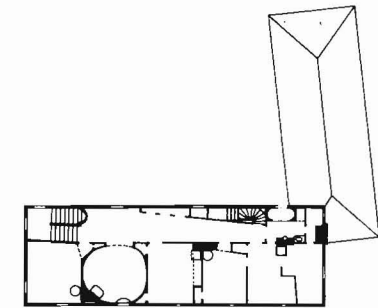

UPPER FLOOR PLAN

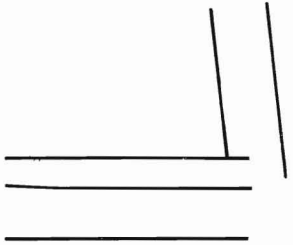
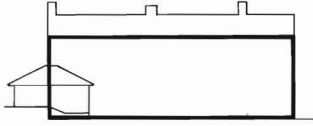
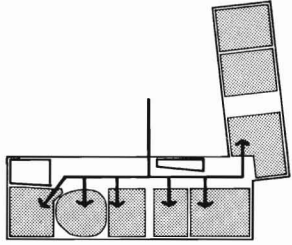
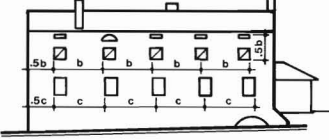
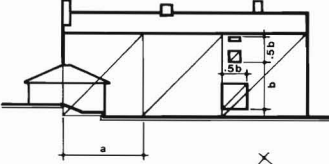
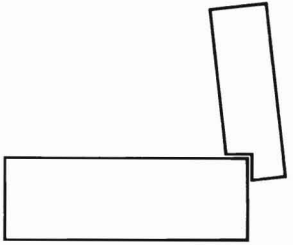
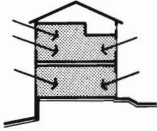
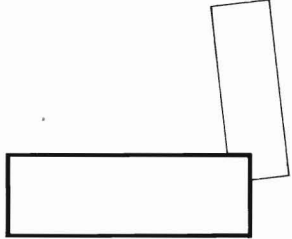
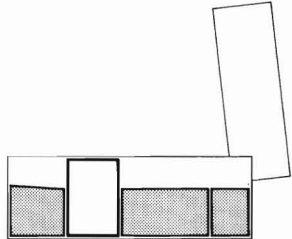
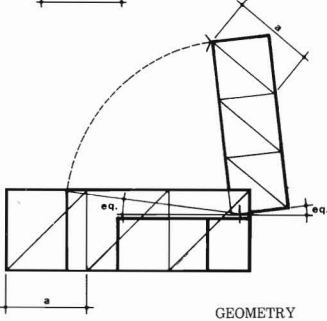
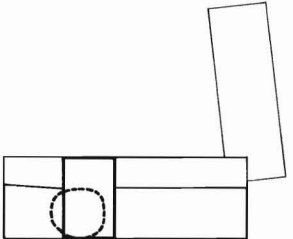
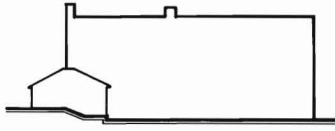
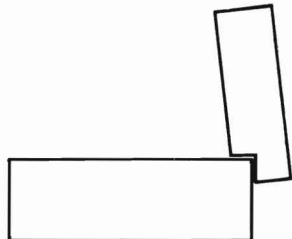
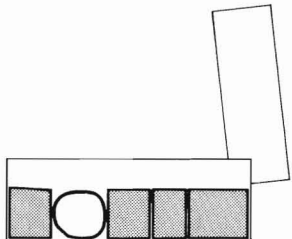
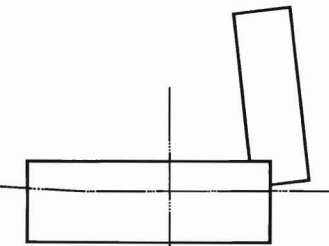
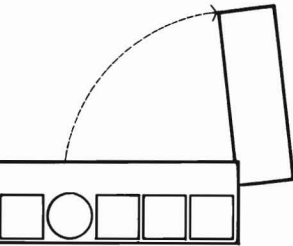
 <p>STRUCTURE</p>		 <p>CIRCULATION TO USE</p>	 	 <p>ADDITIVE AND SUBTRACTIVE</p>
 <p>NATURAL LIGHT</p>	 <p>PLAN TO SECTION</p>		 <p>GEOMETRY</p>	 <p>HIERARCHY</p>
 <p>MASSING</p>	 <p>UNIT TO WHOLE</p>	 <p>REPETITIVE TO UNIQUE</p>	 <p>SYMMETRY AND BALANCE</p>	 <p>PARTI</p>

ERIK GUNNAR ASPLUND

WOODLAND CHAPEL
STOCKHOLM SOUTH BURIAL GROUND
STOCKHOLM, SWEDEN
1918-1920

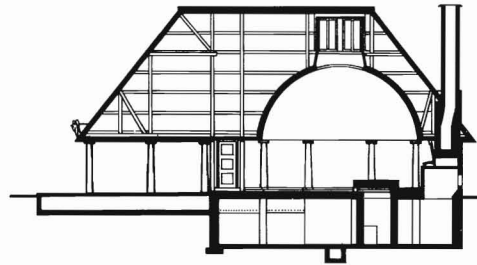

SECTION A

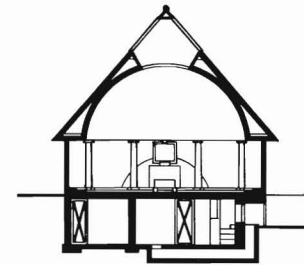

SECTION B

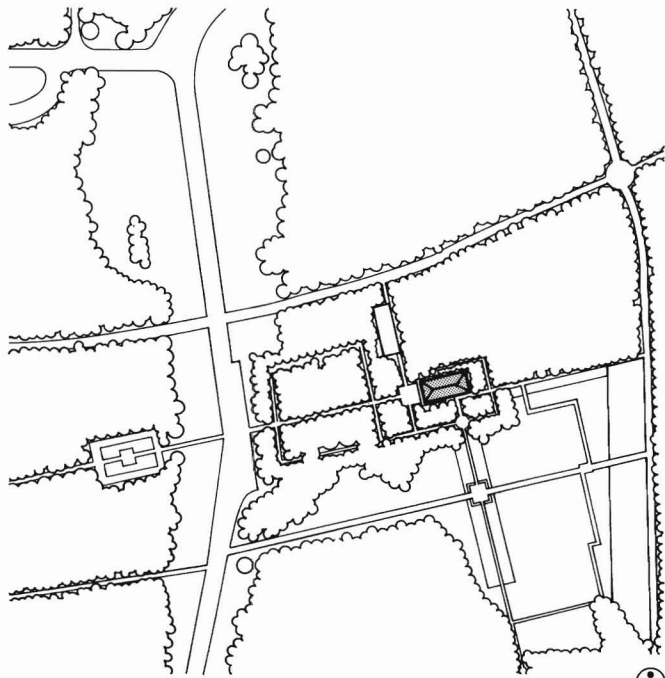

SITE PLAN

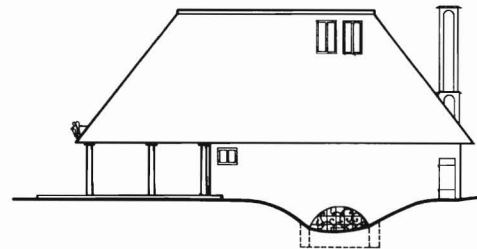

ELEVATION 1

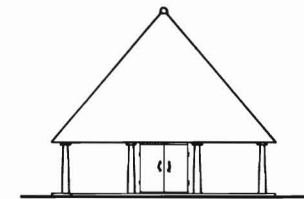

ELEVATION 2

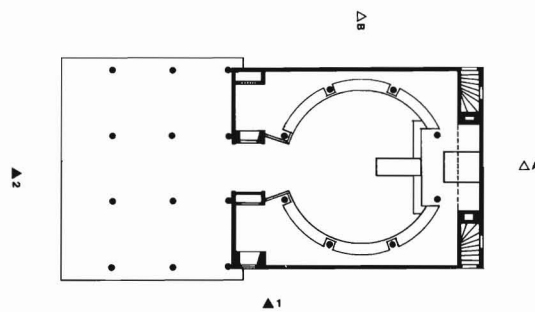

FLOOR PLAN

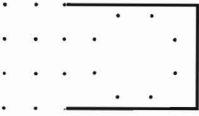
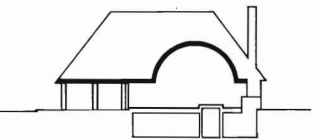
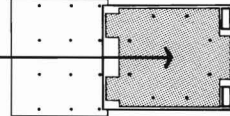
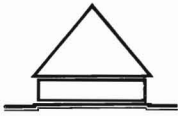
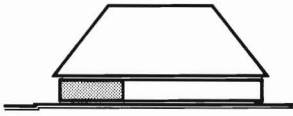
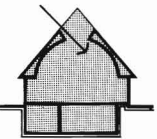
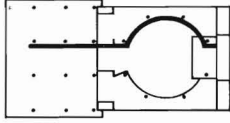
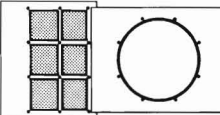
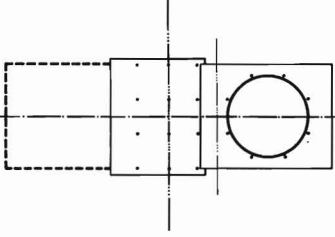
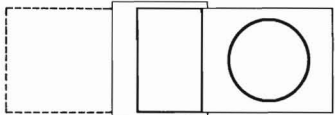
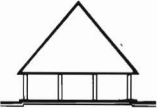
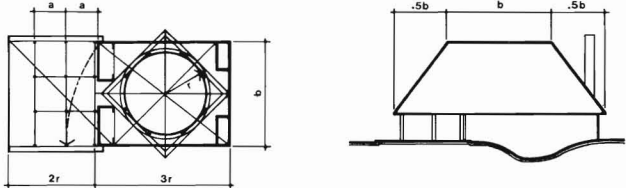
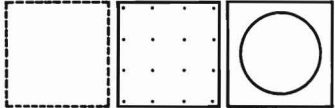
 <p>STRUCTURE</p>		 <p>CIRCULATION TO USE</p>	 <p>UNIT TO WHOLE</p>	 <p>ADDITIVE AND SUBTRACTIVE</p>
 <p>NATURAL LIGHT</p>	 <p>PLAN TO SECTION</p>	 <p>REPETITIVE TO UNIQUE</p>	 <p>SYMMETRY AND BALANCE</p>	 <p>HIERARCHY</p>
 <p>MASSING</p>	 <p>GEOMETRY</p>		 <p>PARTI</p>	

ERIK GUNNAR ASPLUND

LISTER COUNTY COURTHOUSE
SOLVESBORG, SWEDEN
1917-1921

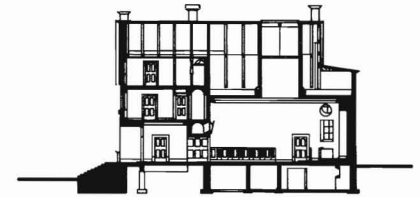

SECTION A

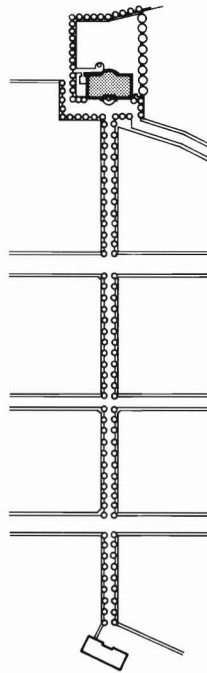

SITE PLAN

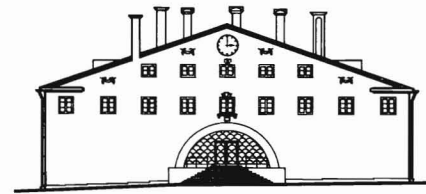

ELEVATION 1

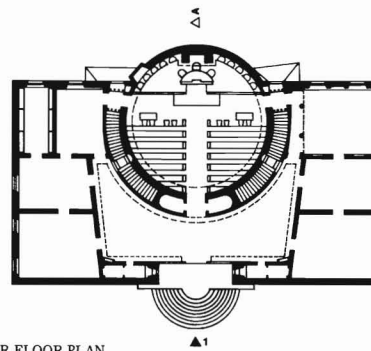

LOWER FLOOR PLAN

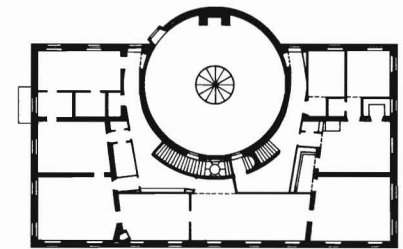

UPPER FLOOR PLAN

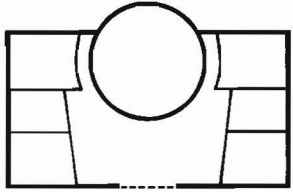
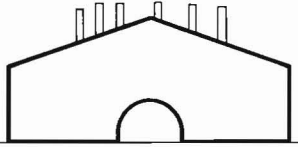
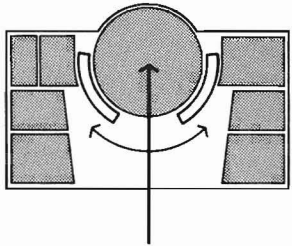
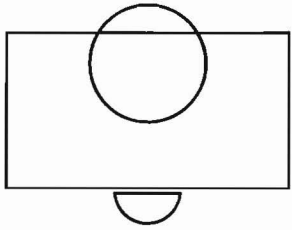
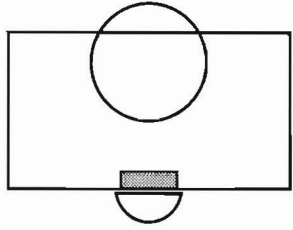
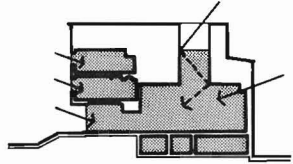
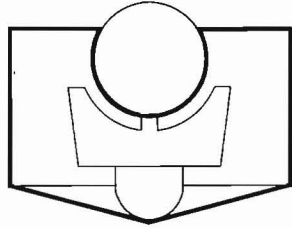
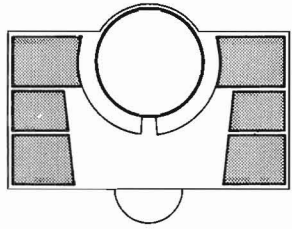
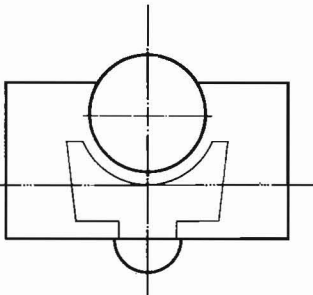
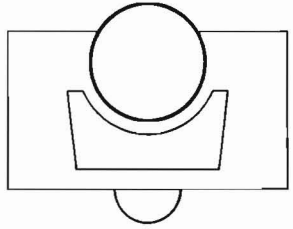
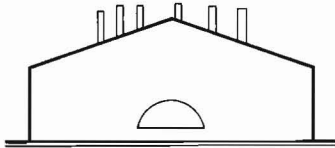
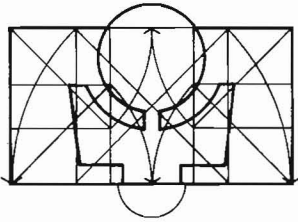
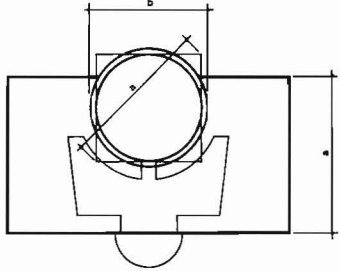
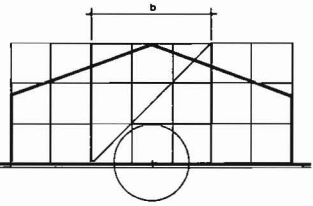
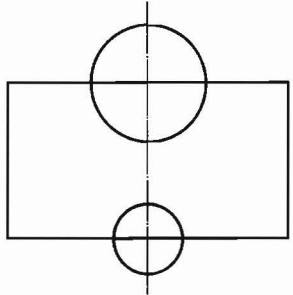
 <p>STRUCTURE</p>		 <p>CIRCULATION TO USE</p>	 <p>UNIT TO WHOLE</p>	 <p>ADDITIVE AND SUBRACTIVE</p>
 <p>NATURAL LIGHT</p>	 <p>PLAN TO SECTION</p>	 <p>REPETITIVE TO UNIQUE</p>	 <p>SYMMETRY AND BALANCE</p>	 <p>HIERARCHY</p>
 <p>MASSING</p>	 <p>GEOMETRY</p>			 <p>PARTI</p>

ERIK GUNNAR ASPLUND

STOCKHOLM PUBLIC LIBRARY
STOCKHOLM, SWEDEN
1920-1928

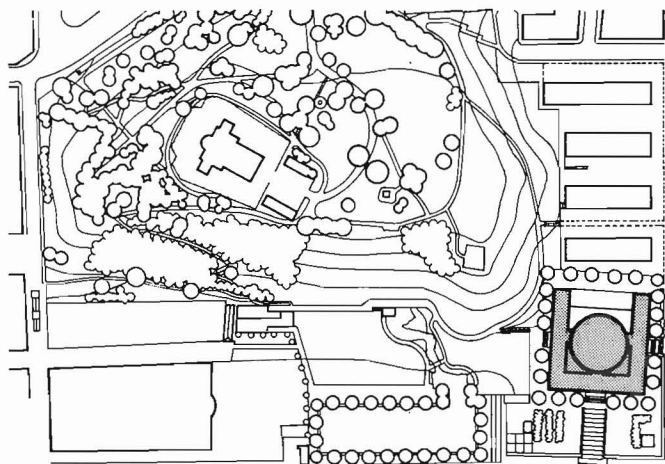

SITE PLAN

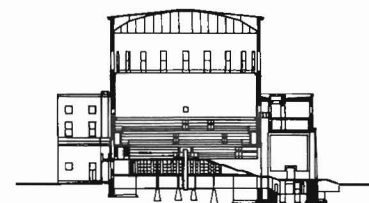

SECTION A

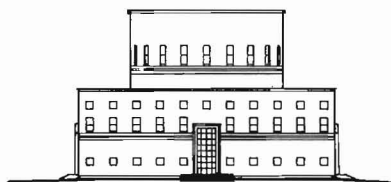

ELEVATION 1

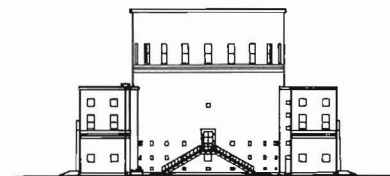

ELEVATION 2

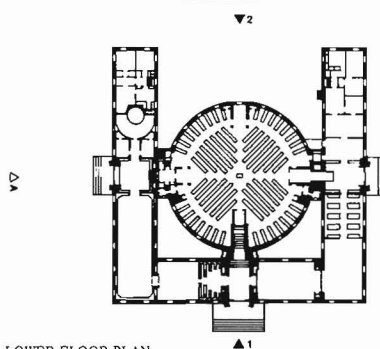

LOWER FLOOR PLAN

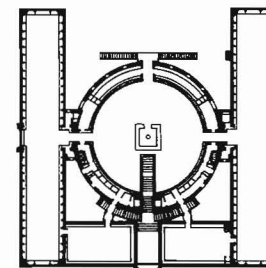

UPPER FLOOR PLAN

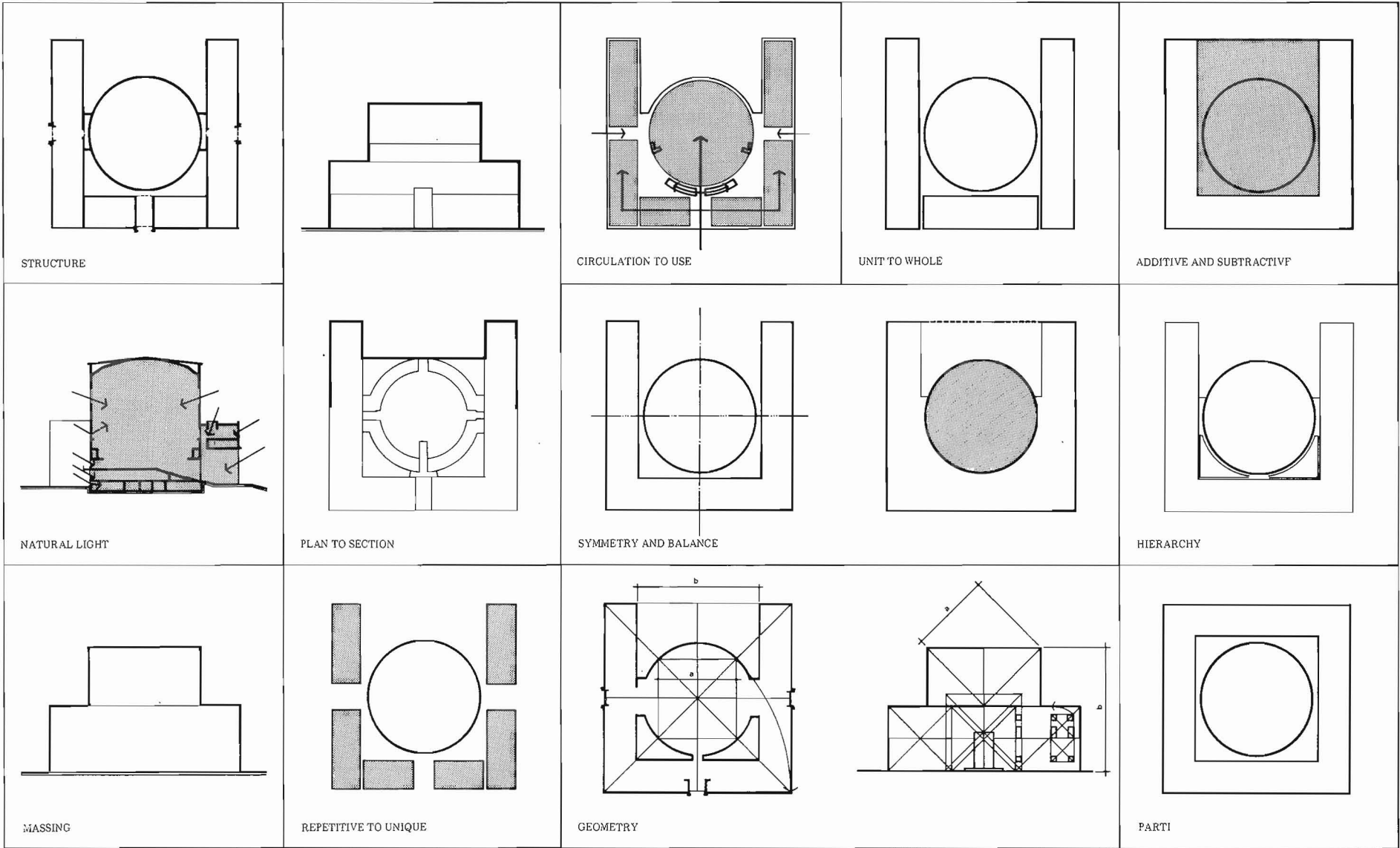

PETER Q. BOHLIN

BOHLIN AND POWELL (PETER BOHLIN)

WEEKEND RESIDENCE FOR MR. AND MRS. ERIC Q. BOHLIN
WEST CORNWALL, CONNECTICUT
1973-1975

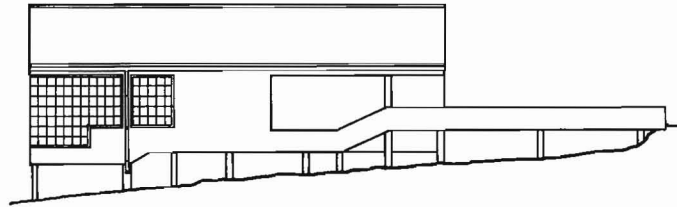

ELEVATION 1

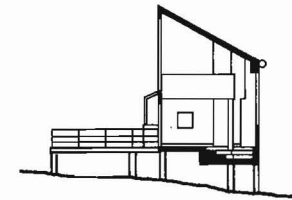

SECTION A

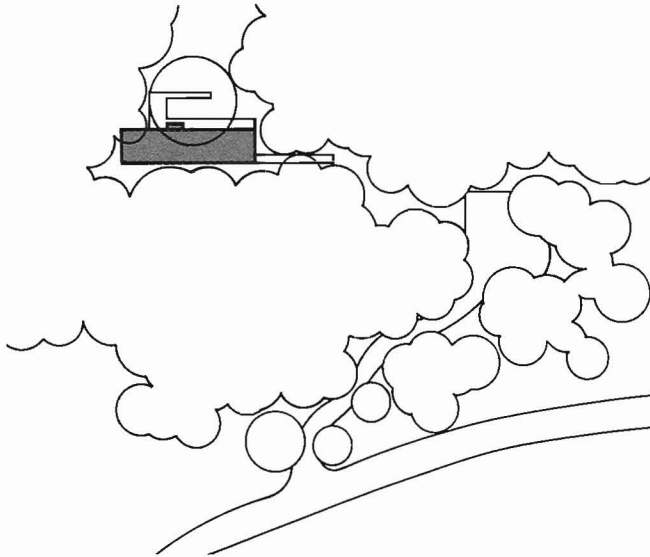

SITE PLAN





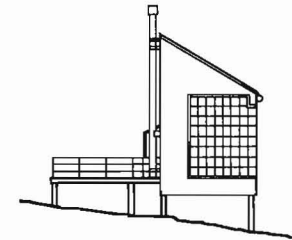

UPPER FLOOR PLAN

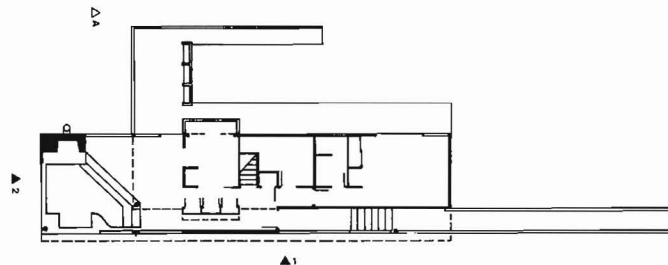

ELEVATION 2

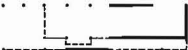
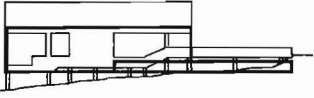
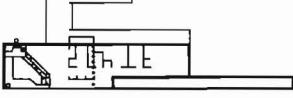
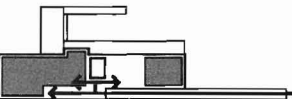
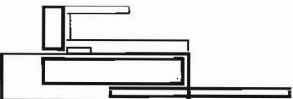

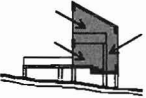
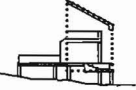
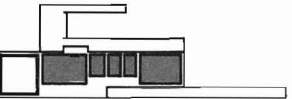
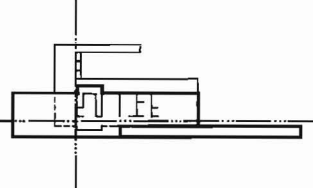
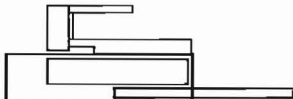
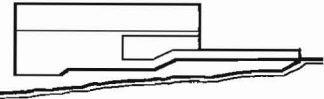
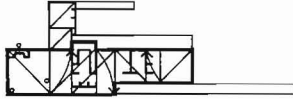
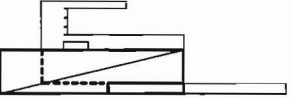
MAIN FLOOR PLAN

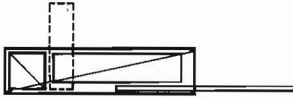
 <p>STRUCTURE</p>	 	 <p>CIRCULATION TO USE</p>	 <p>UNIT TO WHOLE</p>	 <p>ADDITIVE AND SUBSTRUCTIVE</p>
 <p>NATURAL LIGHT</p>	<p>PLAN TO SECTION</p> 	 <p>REPETITIVE TO UNIQUE</p>	 <p>SYMMETRY AND BALANCE</p>	 <p>HIERARCHY</p>
 <p>MASSING</p>	<p>GEOMETRY</p>   			 <p>PARTI</p>

BOHLIN CYWINSKI JACKSON (PETER BOHLIN)

GAFFNEY RESIDENCE
ROMANSVILLE, PENNSYLVANIA
1977-1980



SECTION A



SECTION B

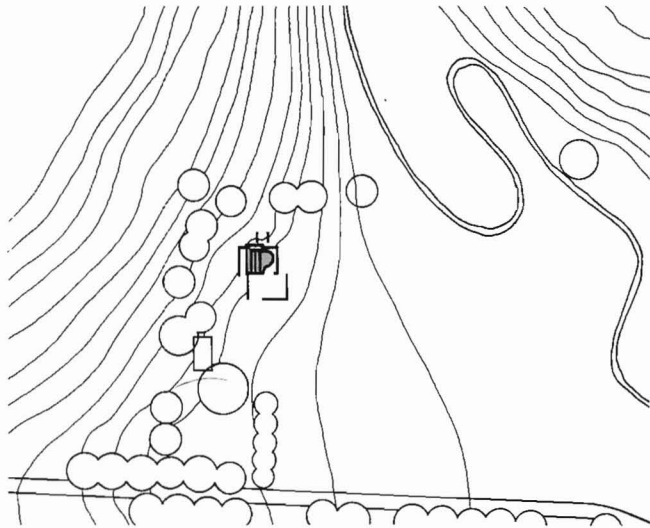

SITE PLAN



ELEVATION 1

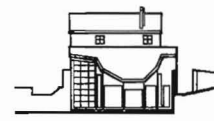

ELEVATION 2



ELEVATION 3

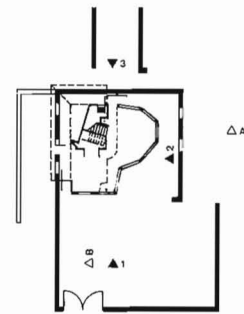

LOWER FLOOR PLAN

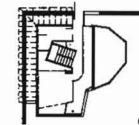

MIDDLE FLOOR PLAN

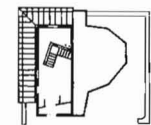

UPPER FLOOR PLAN

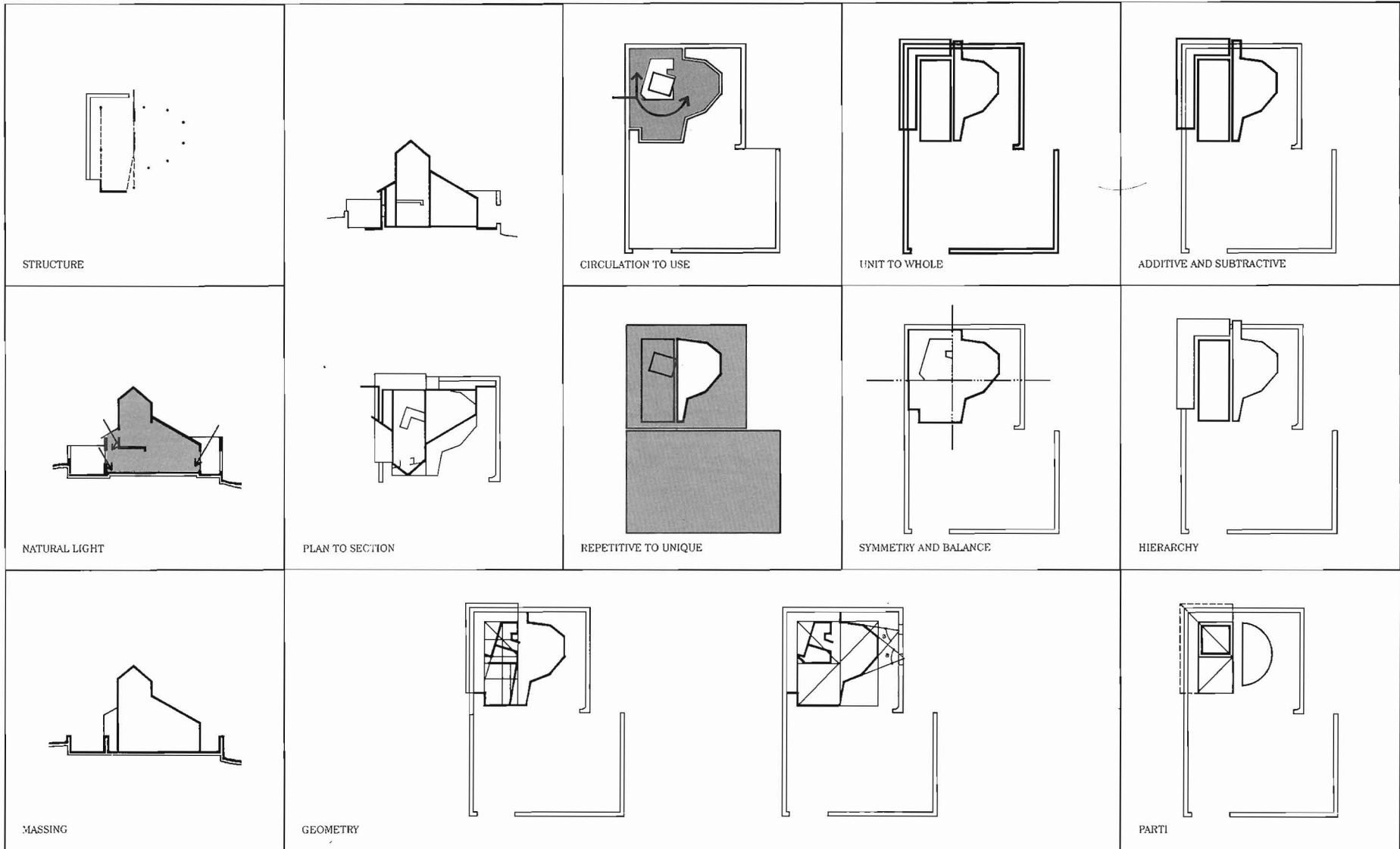

BOHLIN CYWINSKI JACKSON (PETER BOHLIN)

HOUSE IN THE ADIRONDACKS
NEW YORK STATE
1987-1992



SECTION A

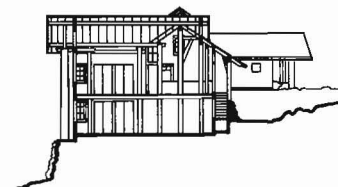

SECTION B

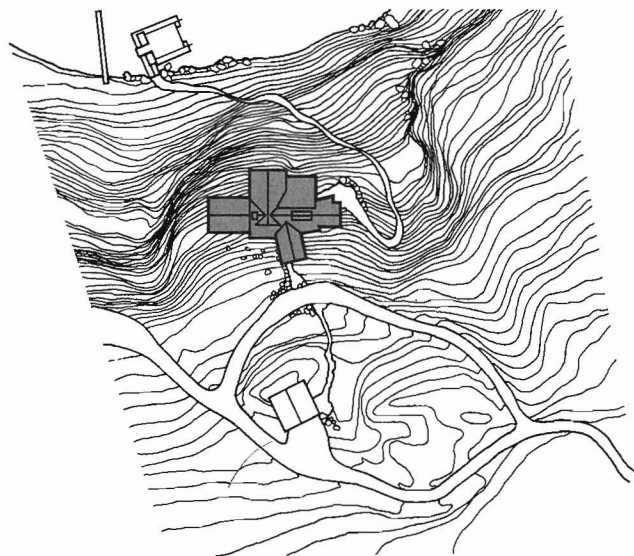

SITE PLAN



ELEVATION 1



ELEVATION 2

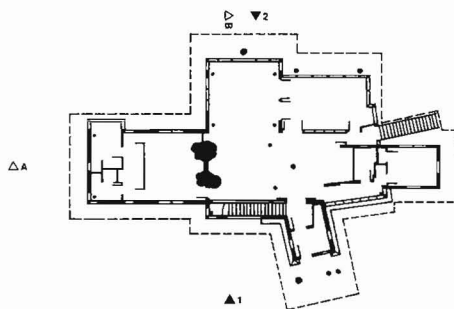

MAIN FLOOR PLAN

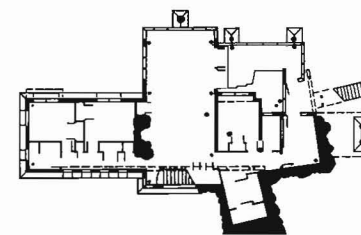

LOWER FLOOR PLAN

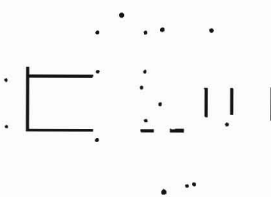
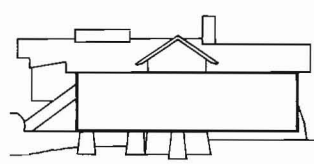
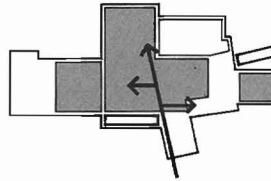
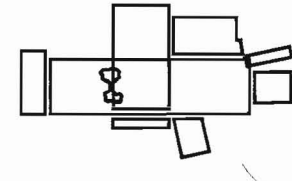
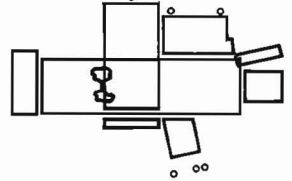
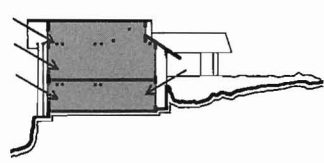
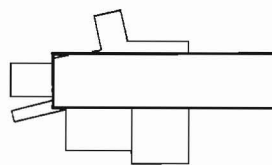
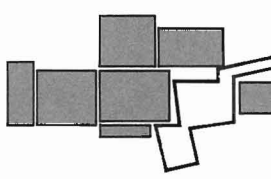
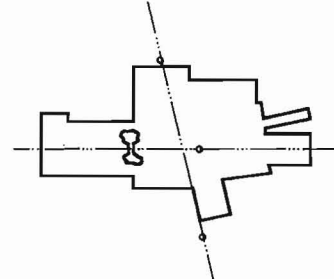
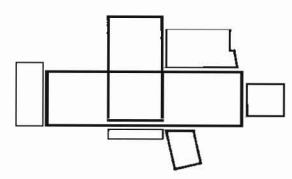
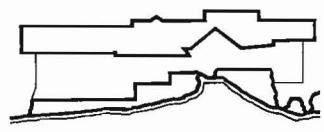
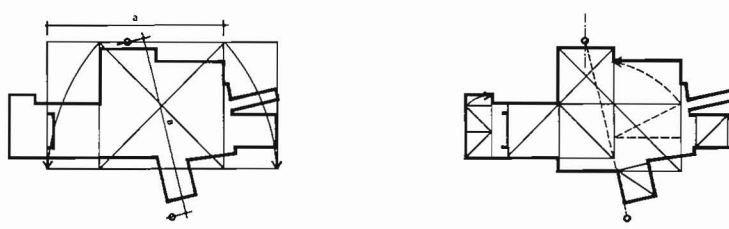
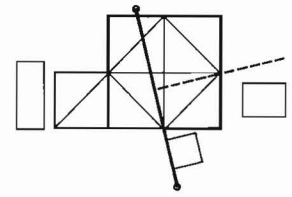
 <p>STRUCTURE</p>		 <p>CIRCULATION TO USE</p>	 <p>UNIT TO WHOLE</p>	 <p>ADDITIVE AND SUBTRACTIVE</p>
 <p>NATURAL LIGHT</p>	 <p>PLAN TO SECTION</p>	 <p>REPETITIVE TO UNIQUE</p>	 <p>SYMMETRY AND BALANCE</p>	 <p>HIERARCHY</p>
 <p>MASSING</p>	 <p>GEOMETRY</p>		 <p>PARTI</p>	

**BOHLIN CYWINSKI JACKSON/JAMES CUTLER
ARCHITECTS (PETER BOHLIN)**

GUEST HOUSE, GATES RESIDENCE
MEDINA, WASHINGTON
1990-1993



SECTION A

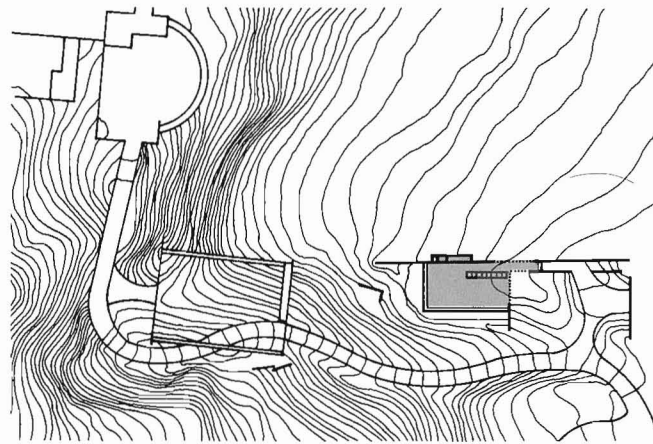

SITE PLAN

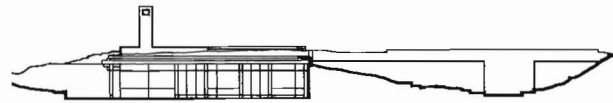



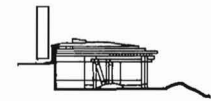



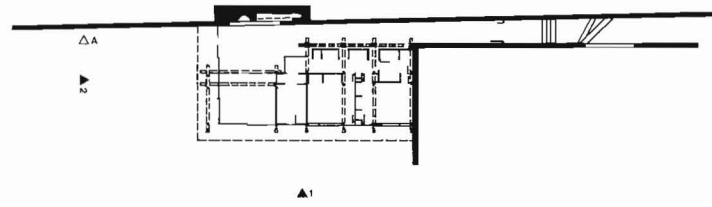

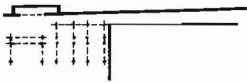

ELEVATION 1

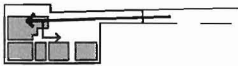

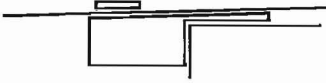
ELEVATION 2

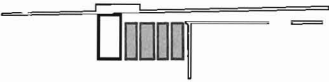
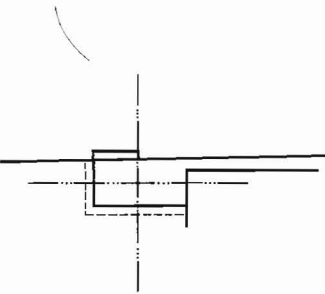

FLOOR PLAN

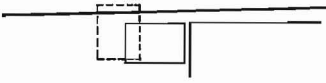
 <p>STRUCTURE</p>		 <p>CIRCULATION TO USE</p>	 <p>UNIT TO WHOLE</p>	 <p>ADDITIVE AND SUBTRACTIVE</p>
 <p>NATURAL LIGHT</p>	 <p>PLAN TO SECTION</p>	 <p>REPETITIVE TO UNIQUE</p>	 <p>SYMMETRY AND BALANCE</p>	 <p>HIERARCHY</p>
 <p>MASSING</p>	 <p>GEOMETRY</p>		 <p>PARTI</p>	

MARIO BOTTA

MARIO BOTTA

SINGLE FAMILY RESIDENCE (BIANCHI RESIDENCE)
RIVA SAN VITALE, TICINO, SWITZERLAND
1971-1973

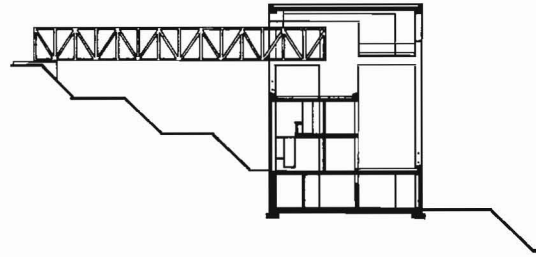

SECTION A

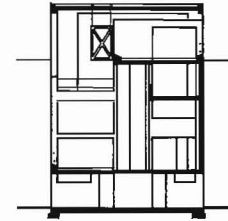

SECTION B

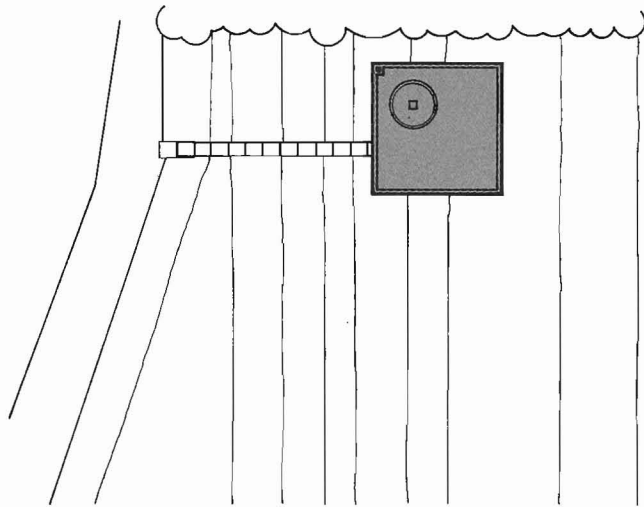

SITE PLAN

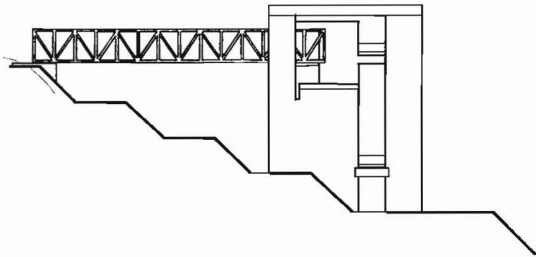

ELEVATION 1

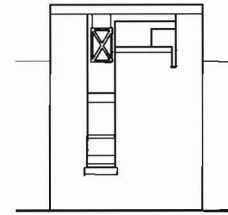

ELEVATION 2

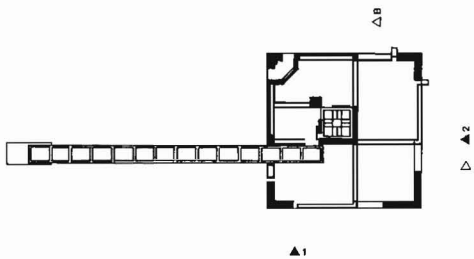

TOP FLOOR PLAN

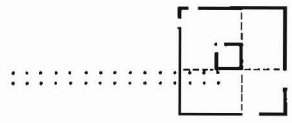
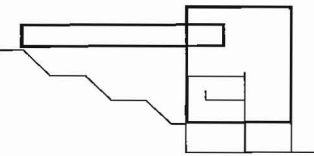
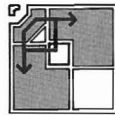
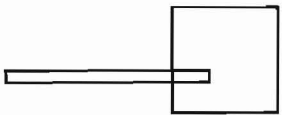
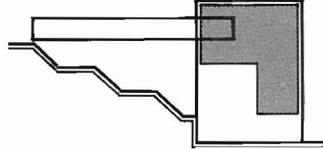
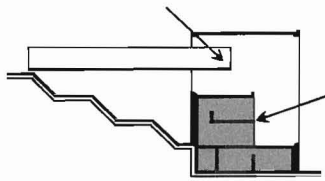
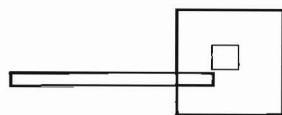
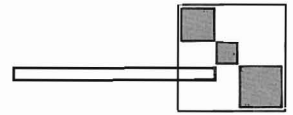
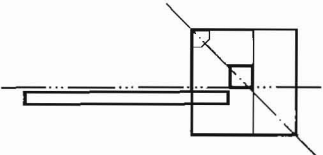
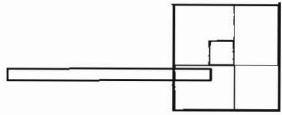
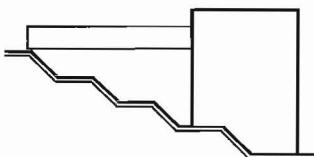
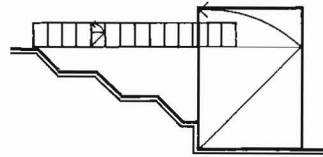
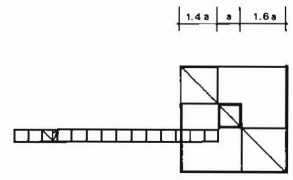
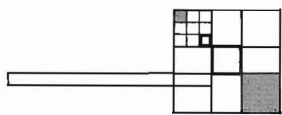

MAIN FLOOR PLAN

 <p>STRUCTURE</p>		 <p>CIRCULATION TO USE</p>	 <p>UNIT TO WHOLE</p>	 <p>ADDITIVE AND SUBTRACTIVE</p>
 <p>NATURAL LIGHT</p>	 <p>PLAN TO SECTION</p>	 <p>REPETITIVE TO UNIQUE</p>	 <p>SYMMETRY AND BALANCE</p>	 <p>HIERARCHY</p>
 <p>MASSING</p>	 <p>GEOMETRY</p>			 <p>PARTI</p>

MARIO BOTTA

CHURCH OF SAN GIOVANNI BATTISTA (SAINT JOHN THE BAPTIST)
MOGNO, TICINO, SWITZERLAND
1986-1995

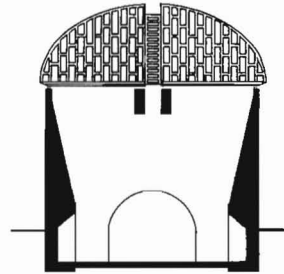

SECTION A

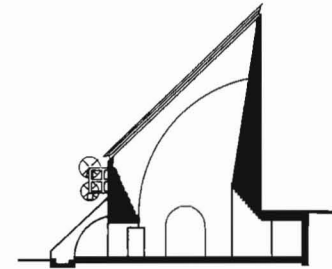

SECTION B

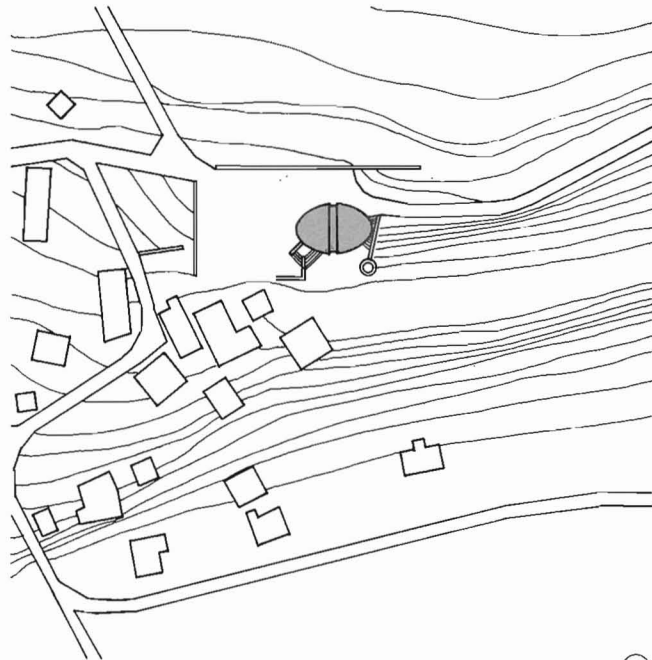

SITE PLAN

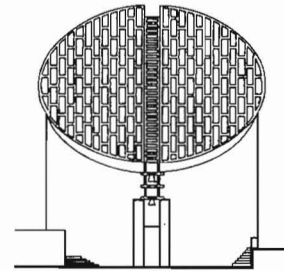

ELEVATION 1

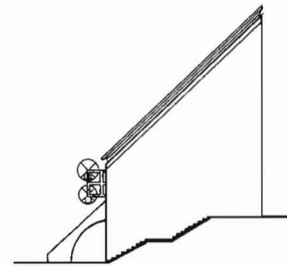

ELEVATION 2

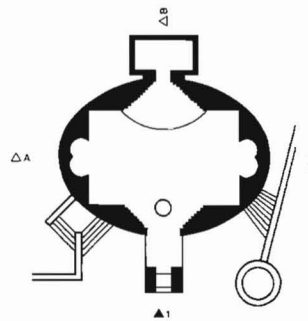

FLOOR PLAN

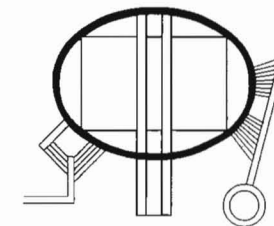

PLAN WITHOUT T ROOF

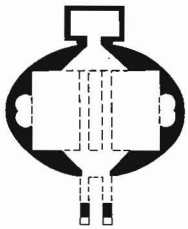
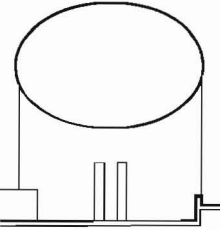
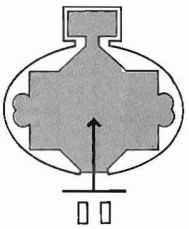
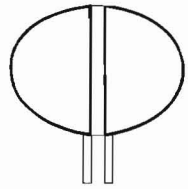
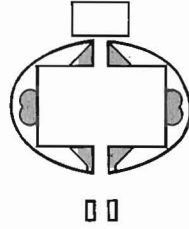
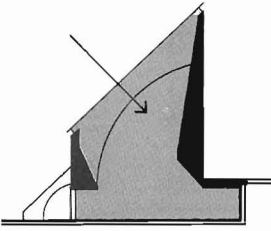
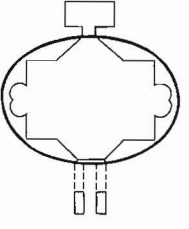
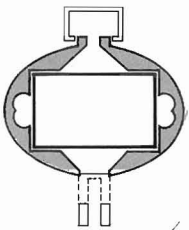
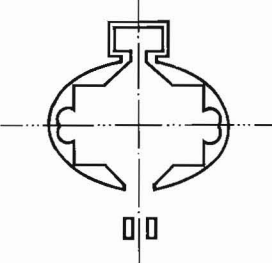
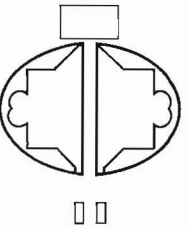
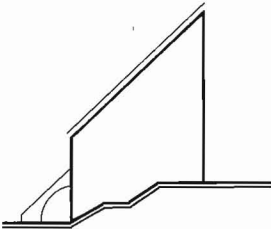
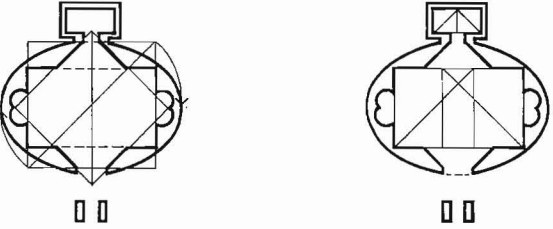
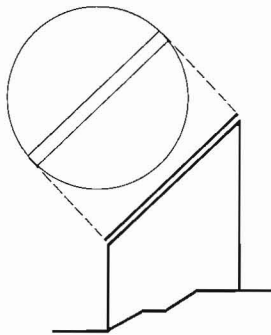
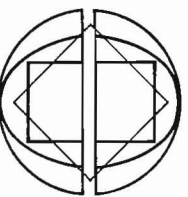
 <p>STRUCTURE</p>		 <p>CIRCULATION TO USE</p>	 <p>UNIT TO WHOLE</p>	 <p>ADDITIVE AND SUBTRACTIVE</p>
 <p>NATURAL LIGHT</p>	 <p>PLAN TO SECTION</p>	 <p>REPETITIVE TO UNIQUE</p>	 <p>SYMMETRY AND BALANCE</p>	 <p>HIERARCHY</p>
 <p>MASSING</p>	 <p>GEOMETRY</p>			 <p>PARTI</p>

MARIO BOTTA

BIANDA RESIDENCE
LOSONE, TICINO, SWITZERLAND
1987-1989

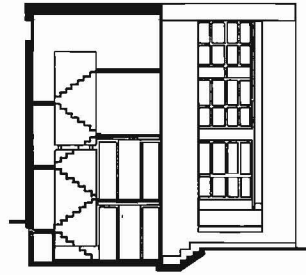

SECTION A

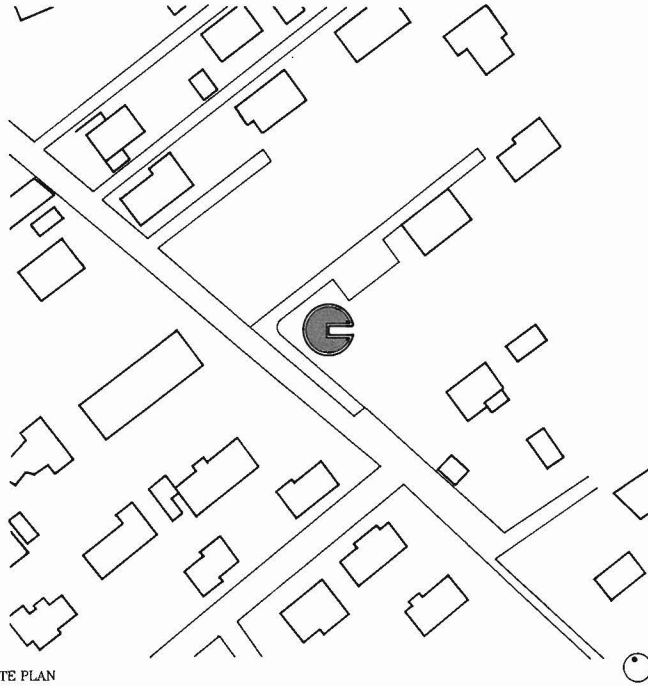

SITE PLAN

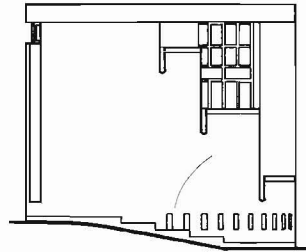

ELEVATION 1

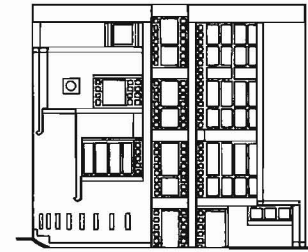

ELEVATION 2

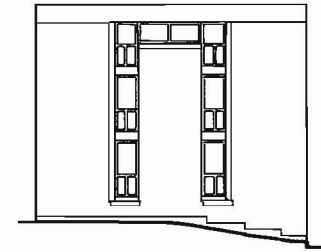

ELEVATION 3

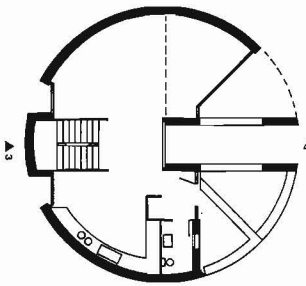

FIRST FLOOR

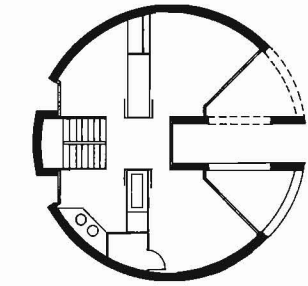

SECOND FLOOR

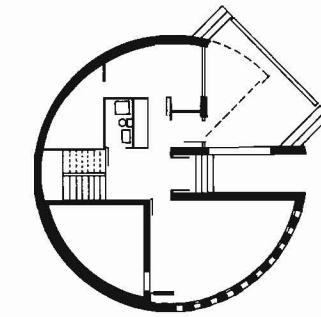

GROUND FLOOR

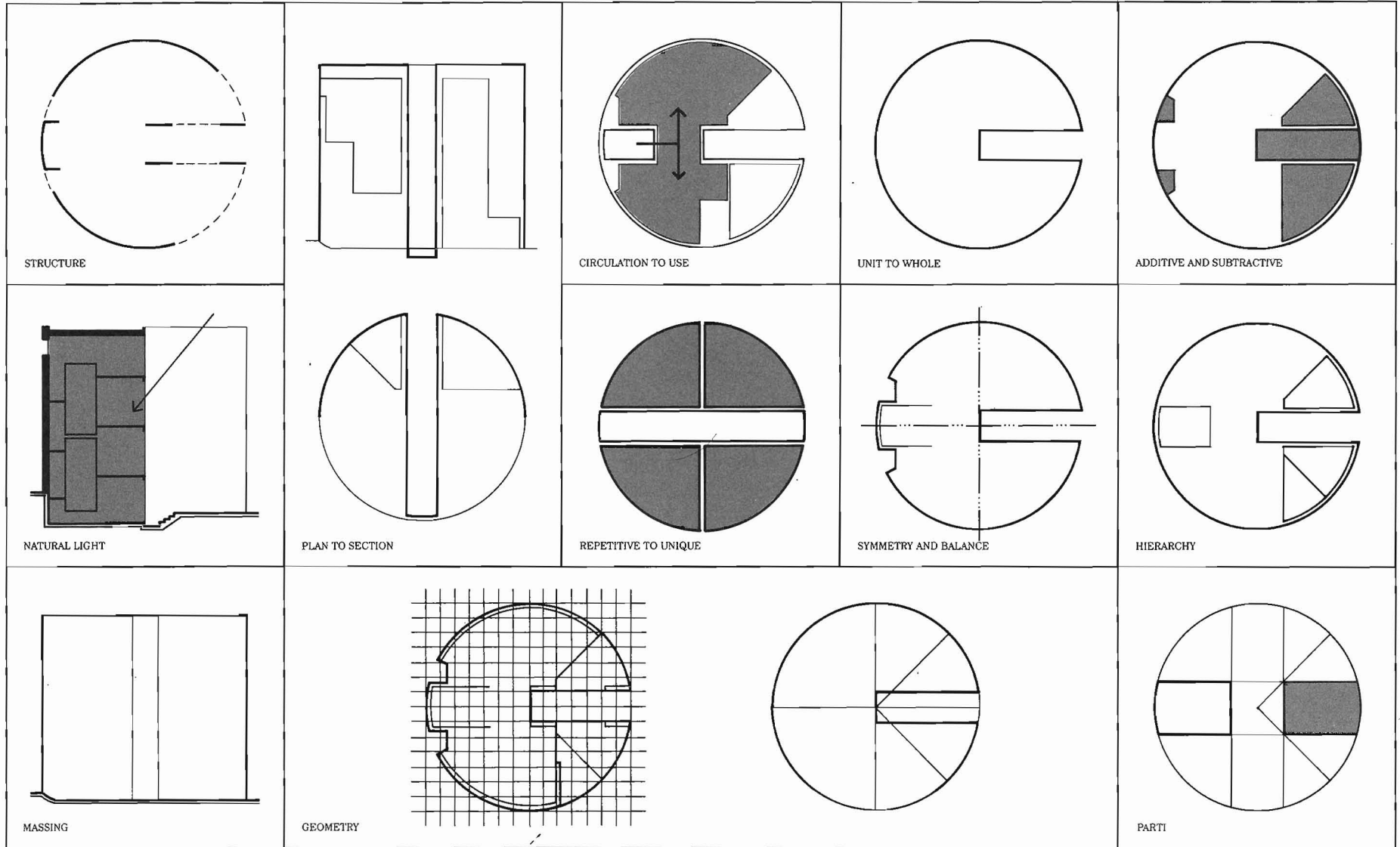

MARIO BOTTA

THE CHURCH OF BEATO ODORICO
PORDENONE, ITALY
1987-1992

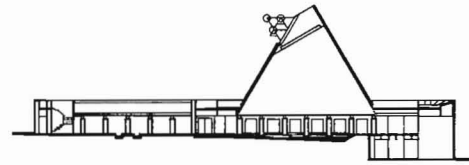

SECTION A

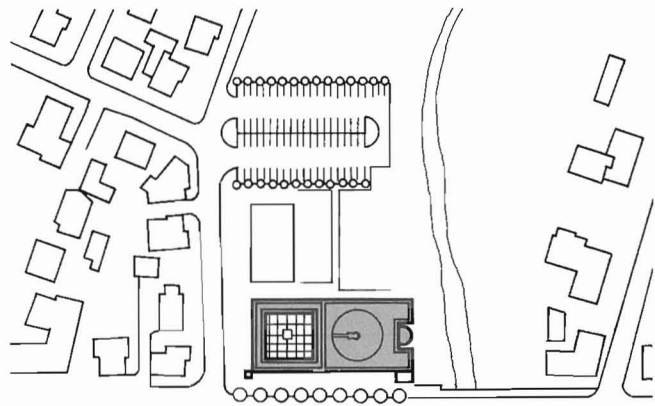

SITE PLAN

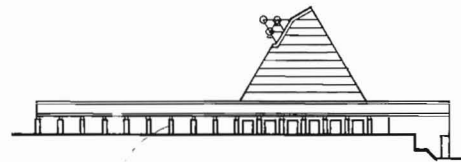

ELEVATION 1

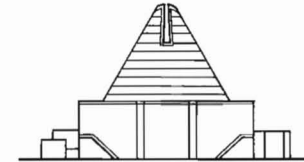

ELEVATION 2

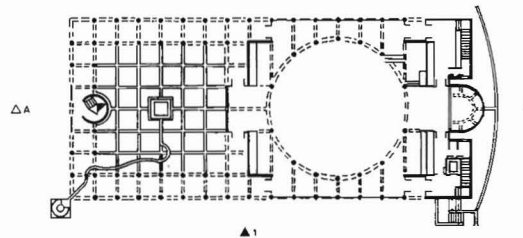

MAIN FLOOR PLAN

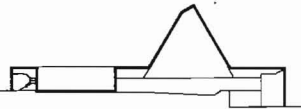
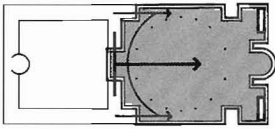
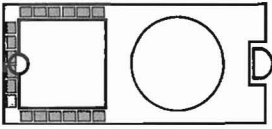
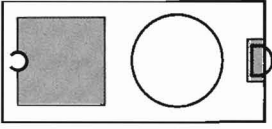
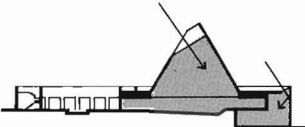
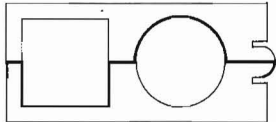
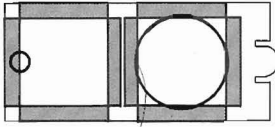
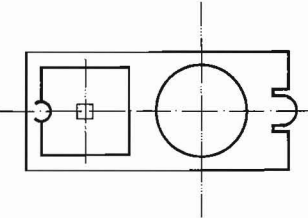
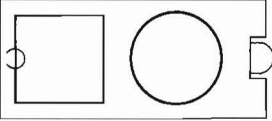
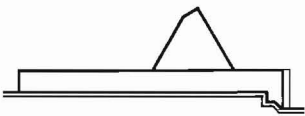
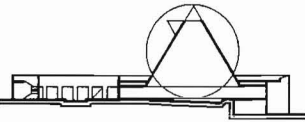
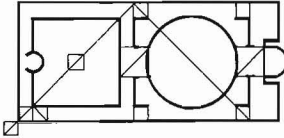
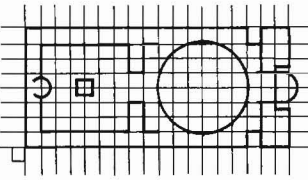
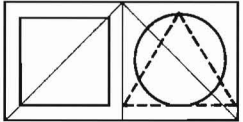

LOWER FLOOR PLAN

 <p>STRUCTURE</p>		 <p>CIRCULATION TO USE</p>	 <p>UNIT TO WHOLE</p>	 <p>ADDITIVE AND SUBTRACTIVE</p>
 <p>NATURAL LIGHT</p>	 <p>PLAN TO SECTION</p>	 <p>REPETITIVE TO UNIQUE</p>	 <p>SYMMETRY AND BALANCE</p>	 <p>HIERARCHY</p>
 <p>MASSING</p>	 <p>GEOMETRY</p>			 <p>PARTI</p>

FILIPPO BRUNELLESCHI

FILIPPO BRUNELLESCHI

OLD SACRISTY
CHURCH OF SAN LORENZO
FLORENCE, ITALY
1421-1440

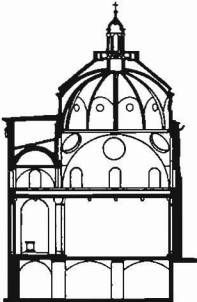

SECTION A

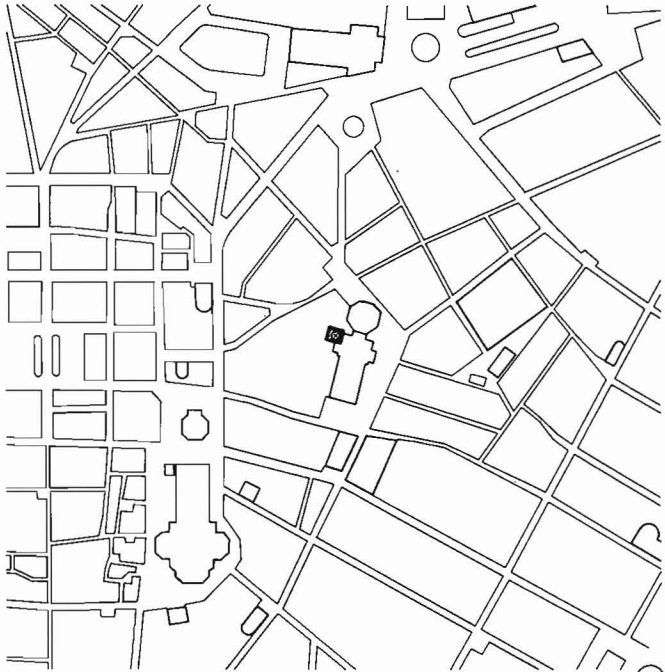
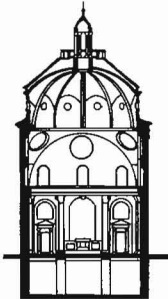

SITE PLAN

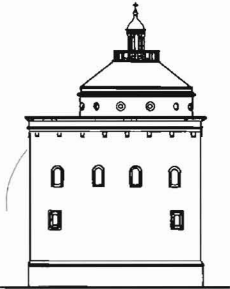

ELEVATION 1

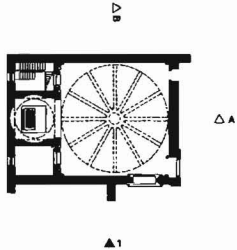

FLOOR PLAN

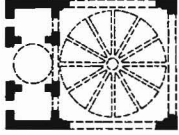
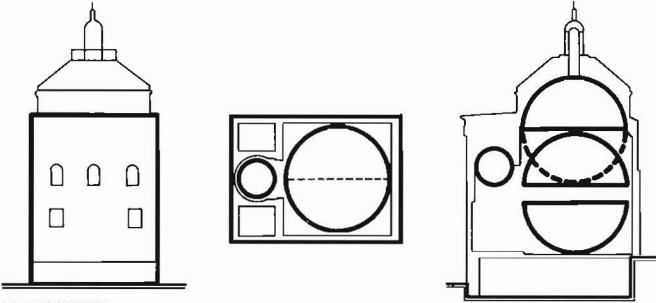
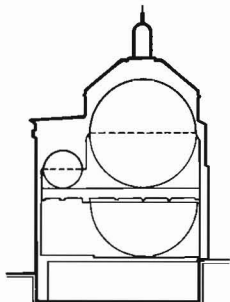
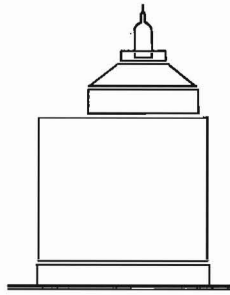
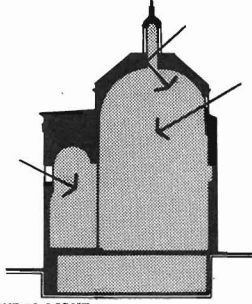
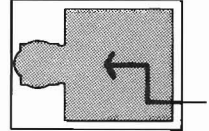
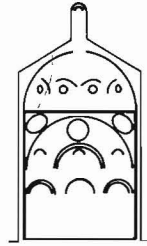
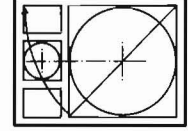
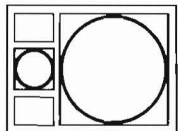
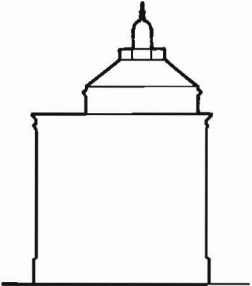
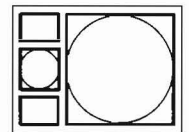
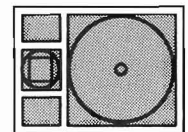
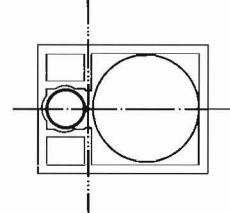
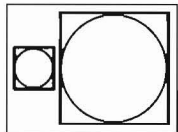
 <p>STRUCTURE</p>	 <p>PLAN TO SECTION</p>			 <p>ADDITIVE AND SUBTRACTIVE</p>
 <p>NATURAL LIGHT</p>	 <p>CIRCULATION TO USE</p>		 <p>GEOMETRY</p>	 <p>HIERARCHY</p>
 <p>MASSING</p>	 <p>UNIT TO WHOLE</p>	 <p>REPETITIVE TO UNIQUE</p>	 <p>SYMMETRY AND BALANCE</p>	 <p>PARTI</p>

FILIPPO BRUNELLESCHI

OSPEDALE DEGLI INNOCENTI
FLORENCE, ITALY
1421-1445

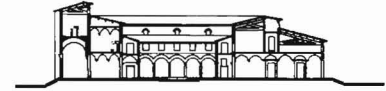

SECTION A

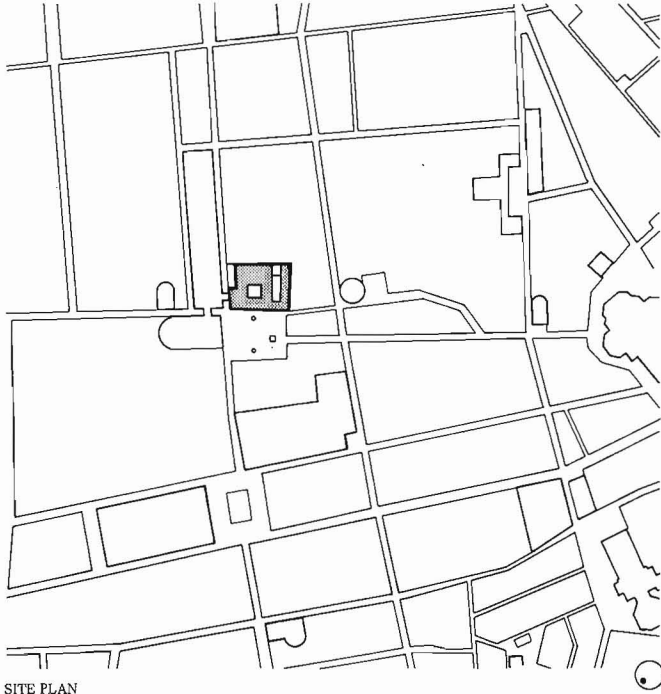

SITE PLAN

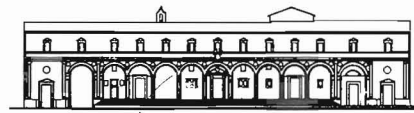

ELEVATION 1

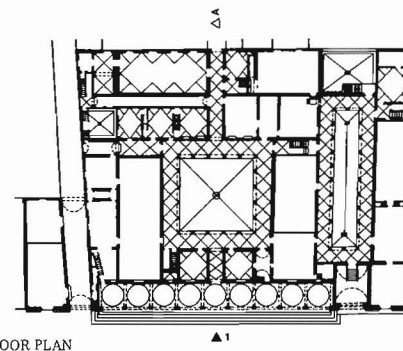

FLOOR PLAN

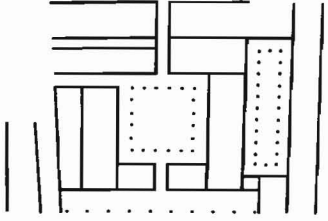
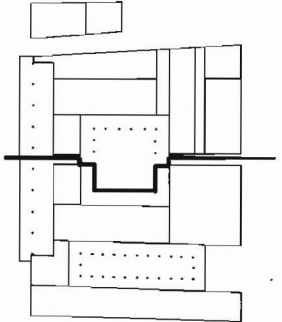
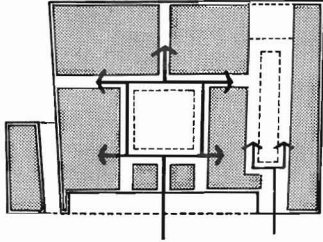
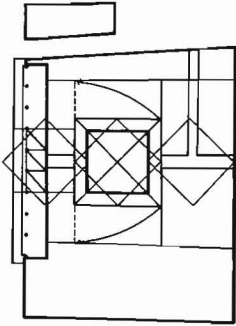
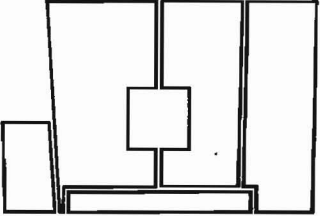
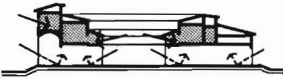
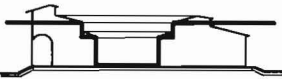
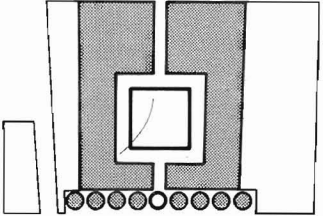
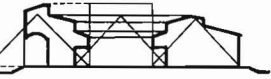
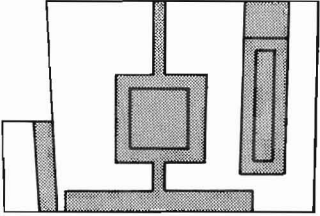
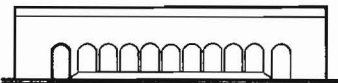
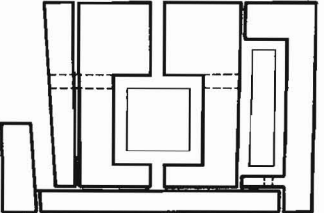
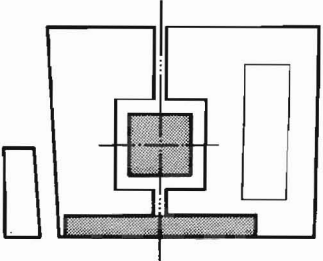
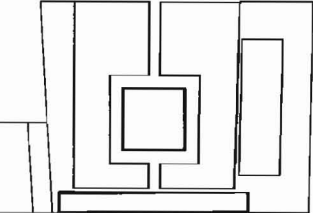
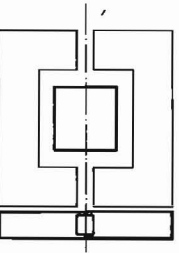
 <p>STRUCTURE</p>	 <p>PLAN TO SECTION</p>	 <p>CIRCULATION TO USE</p>	 <p>GEOMETRY</p>	 <p>ADDITIVE AND SUBTRACTIVE</p>
 <p>NATURAL LIGHT</p>	 <p>PLAN TO SECTION</p>	 <p>REPETITIVE TO UNIQUE</p>	 <p>GEOMETRY</p>	 <p>ADDITIVE AND SUBTRACTIVE</p>
 <p>MASSING</p>	 <p>UNIT TO WHOLE</p>	 <p>SYMMETRY AND BALANCE</p>	 <p>HIERARCHY</p>	 <p>PARTI</p>

FILIPPO BRUNELLESCHI

CHURCH OF SAN MARIA DEGLI ANGELI
FLORENCE, ITALY
1434-1436

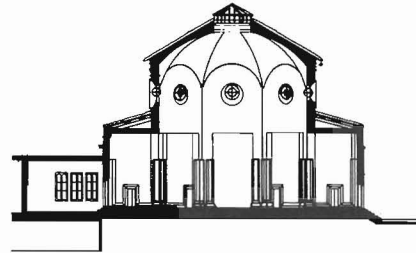

SECTION A

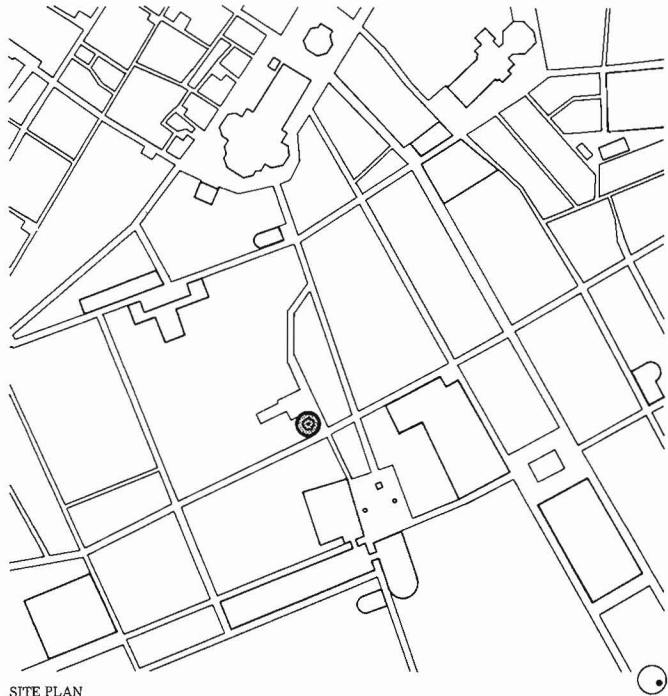

SITE PLAN



ELEVATION 1

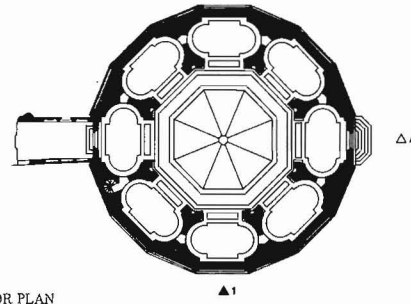

FLOOR PLAN

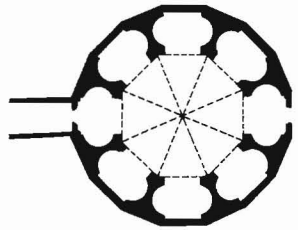
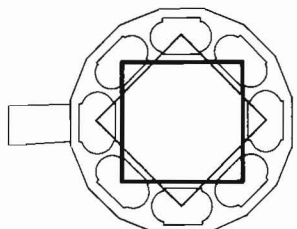
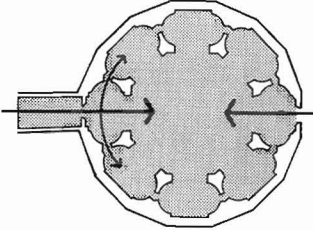
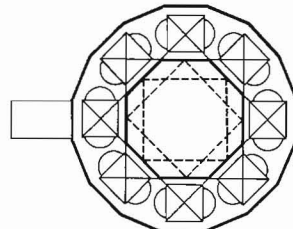
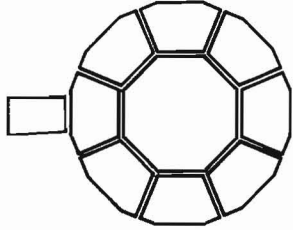
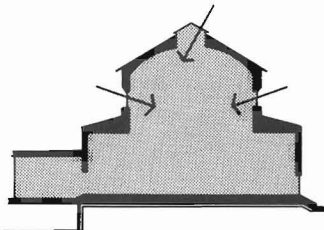
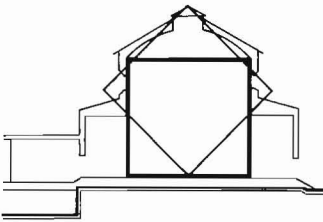
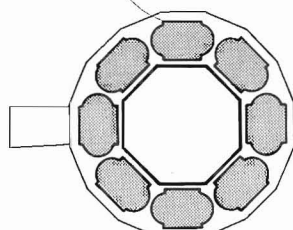
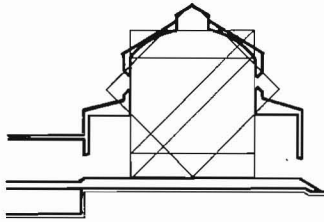
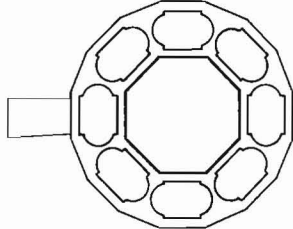
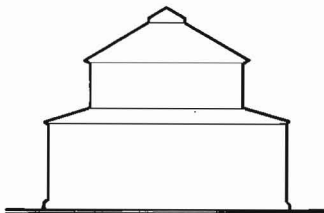
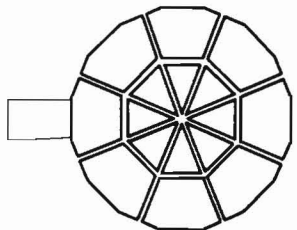
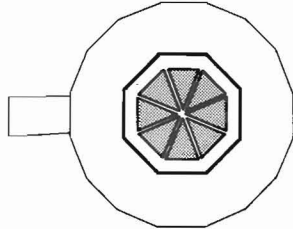
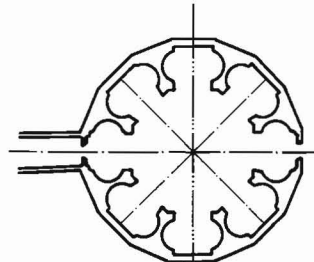
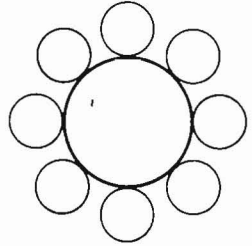
 <p>STRUCTURE</p>		 <p>CIRCULATION TO USE</p>		 <p>ADDITIVE AND SUBTRACTIVE</p>
 <p>NATURAL LIGHT</p>	 <p>PLAN TO SECTION</p>		 <p>GEOMETRY</p>	 <p>HIERARCHY</p>
 <p>MASSING</p>	 <p>UNIT TO WHOLE</p>	 <p>REPETITIVE TO UNIQUE</p>	 <p>SYMMETRY AND BALANCE</p>	 <p>PARTI</p>

FILIPPO BRUNELLESCHI

CHURCH OF SAN SPIRITO
FLORENCE, ITALY
(Begun) 1434

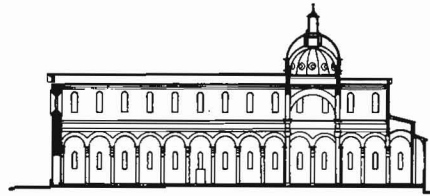

SECTION A

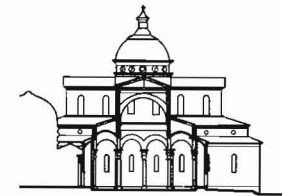

SECTION BB



SITE PLAN

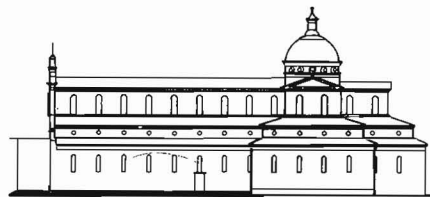

ELEVATION 1



ELEVATION 2

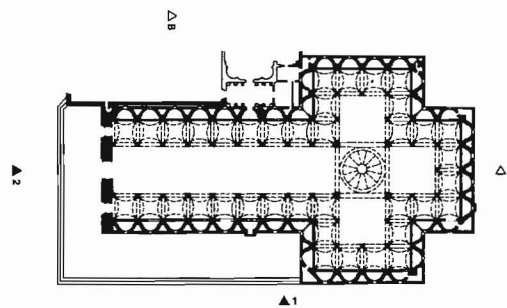

FLOOR PLAN V

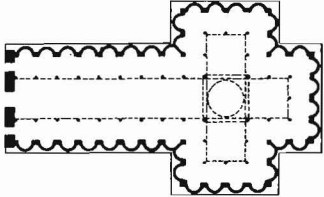
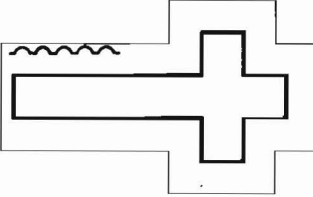
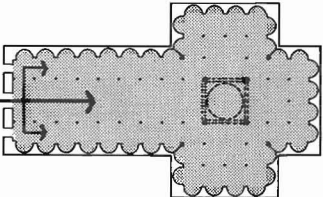
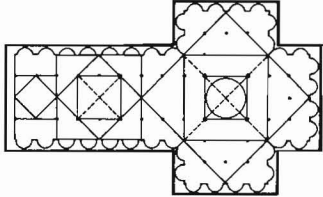
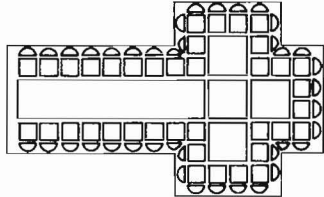
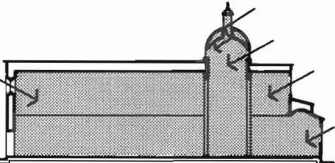
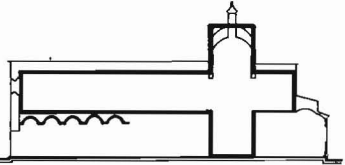
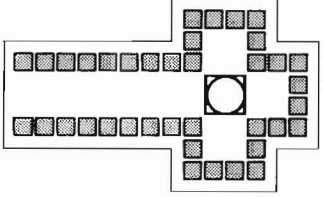
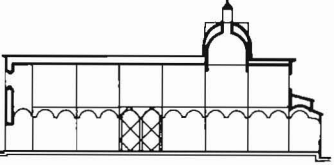
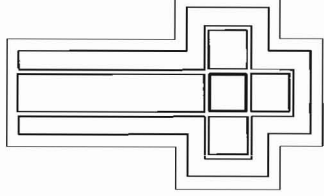
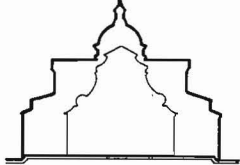
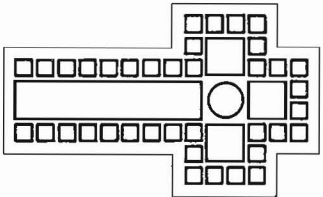
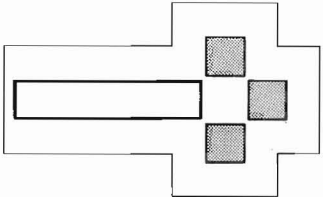
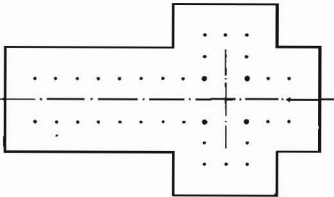
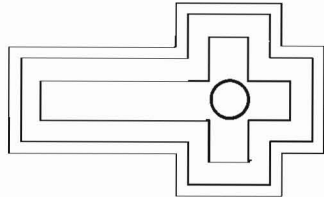
 <p>STRUCTURE</p>		 <p>CIRCULATION TO USE</p>		 <p>ADDITIVE AND SUBTRACTIVE</p>
 <p>NATURAL LIGHT</p>	 <p>PLAN TO SECTION</p>		 <p>GEOMETRY</p>	 <p>HIERARCHY</p>
 <p>MASSING</p>	 <p>UNIT TO WHOLE</p>	 <p>REPETITIVE TO UNIQUE</p>	 <p>SYMMETRY AND BALANCE</p>	 <p>PARTI</p>

SVERRE FEHN

SVERRE FEHN

VILLA BUSK
BAMBLE, TELEMARK, NORWAY
1990

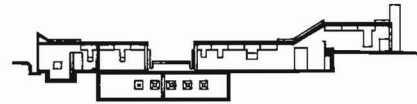

SECTION A



SECTION B



SECTION C

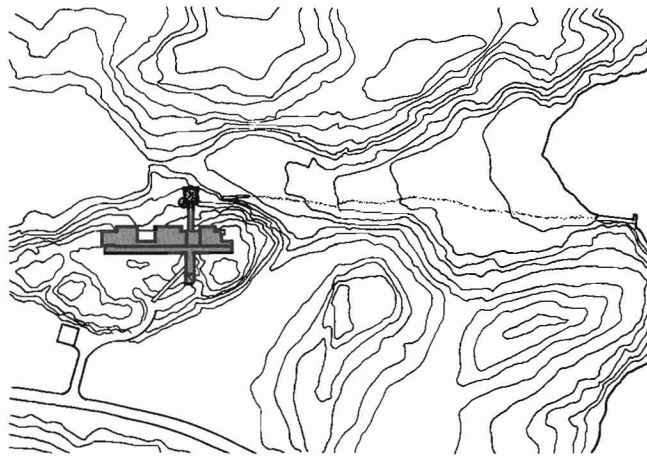

SITE PLAN

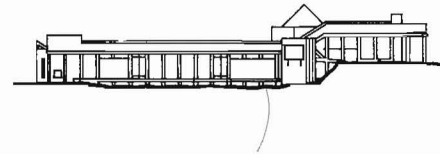

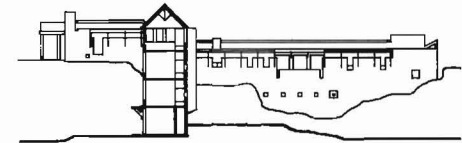

ELEVATION 1

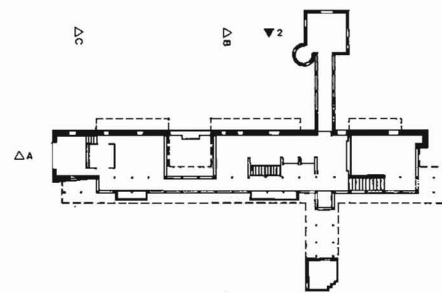

ELEVATION 2

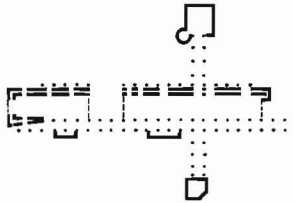
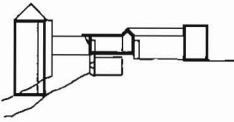
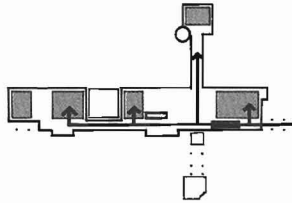
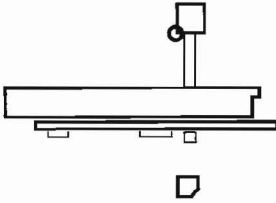
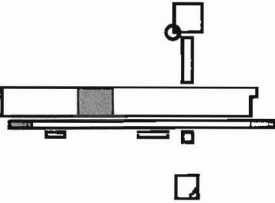
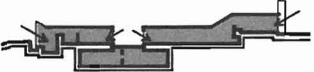
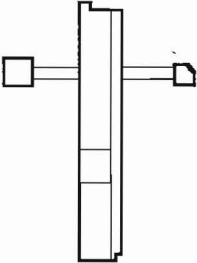
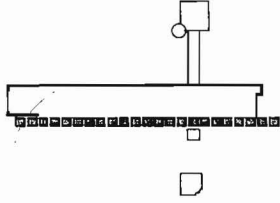
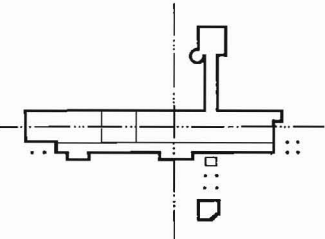
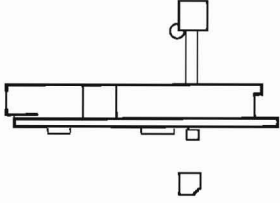

FLOOR PLAN

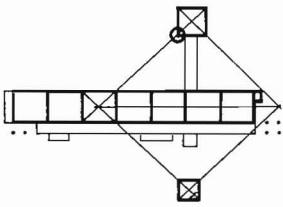
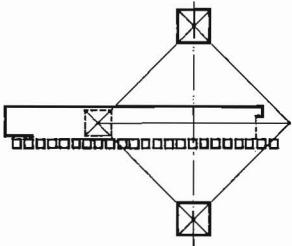
 <p>STRUCTURE</p>		 <p>CIRCULATION TO USE</p>	 <p>UNIT TO WHOLE</p>	 <p>ADDITIVE AND SUBTRACTIVE</p>
 <p>NATURAL LIGHT</p>	 <p>PLAN TO SECTION</p>	 <p>REPETITIVE TO UNIQUE</p>	 <p>SYMMETRY AND BALANCE</p>	 <p>HIERARCHY</p>
 <p>MASSING</p>	 <p>GEOMETRY</p>		 <p>PARTI</p>	

SVERRE FEHN

THE GLACIER MUSEUM
FJAERLAND, BALESTRAND, NORWAY
1991

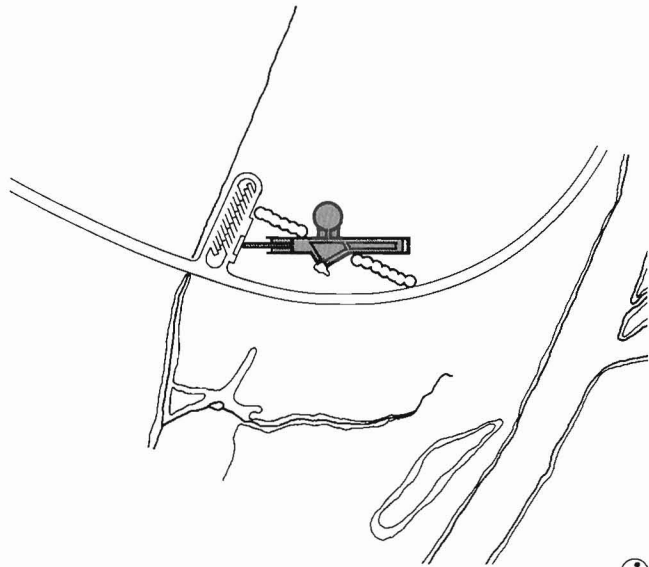

SITE PLAN



SECTION A



SECTION B

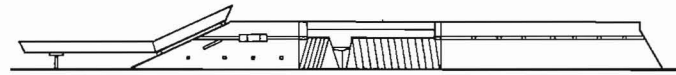

ELEVATION 1

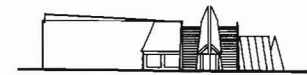

ELEVATION 2

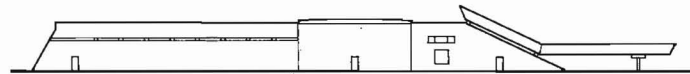



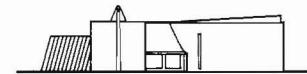

ELEVATION 3

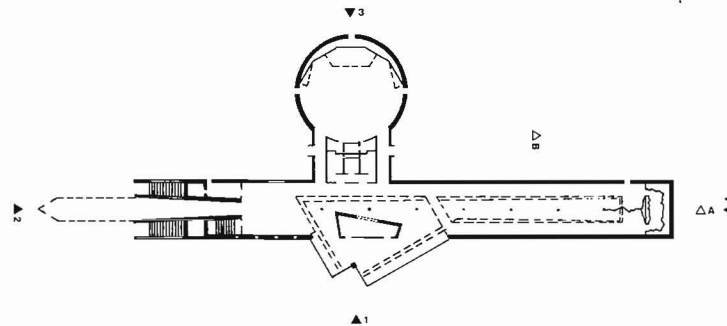

ELEVATION 4

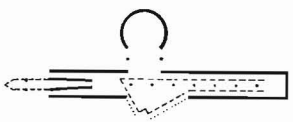
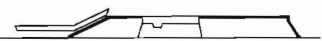
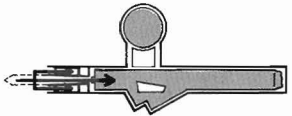
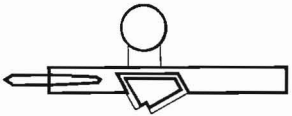
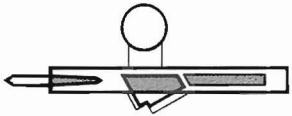

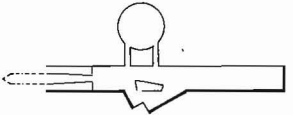
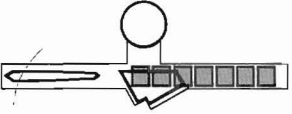
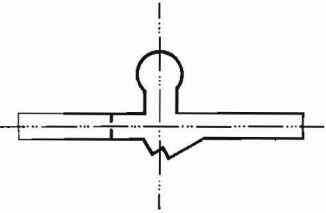
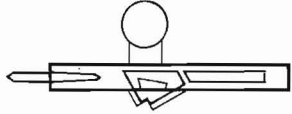
MAIN FLOOR PLAN

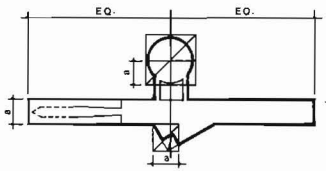
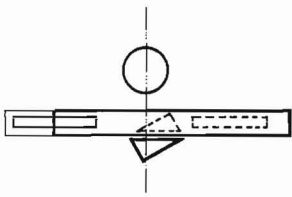
 <p>STRUCTURE</p>		 <p>CIRCULATION TO USE</p>	 <p>UNIT TO WHOLE</p>	 <p>ADDITIVE AND SUBTRACTIVE</p>
 <p>NATURAL LIGHT</p>	 <p>PLAN TO SECTION</p>	 <p>REPETITIVE TO UNIQUE</p>	 <p>SYMMETRY AND BALANCE</p>	 <p>HIERARCHY</p>
 <p>MASSING</p>	 <p>GEOMETRY</p>	 <p>PARTI</p>		

ROMALDO GIURGOLA

ROMALDO GIURGOLA

ADULT LEARNING RESEARCH LABORATORY
BRYN MAWR, PENNSYLVANIA
1972

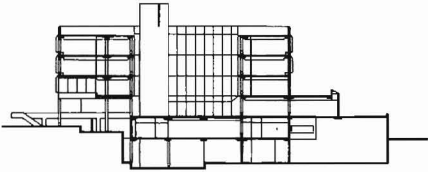

SECTION A



SITE PLAN

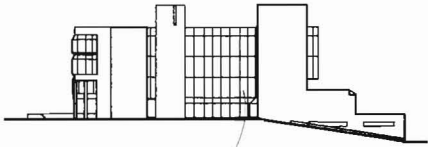

ELEVATION 1

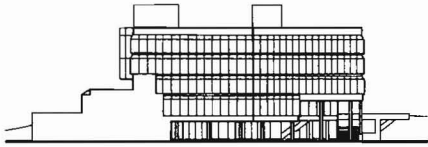

ELEVATION 2

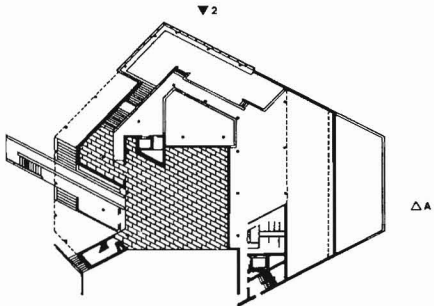

LOWER FLOOR PLAN

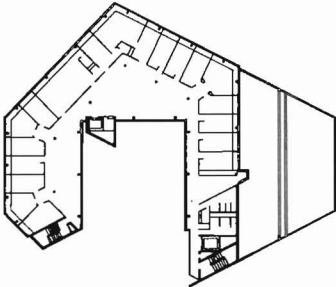

UPPER FLOOR PLAN

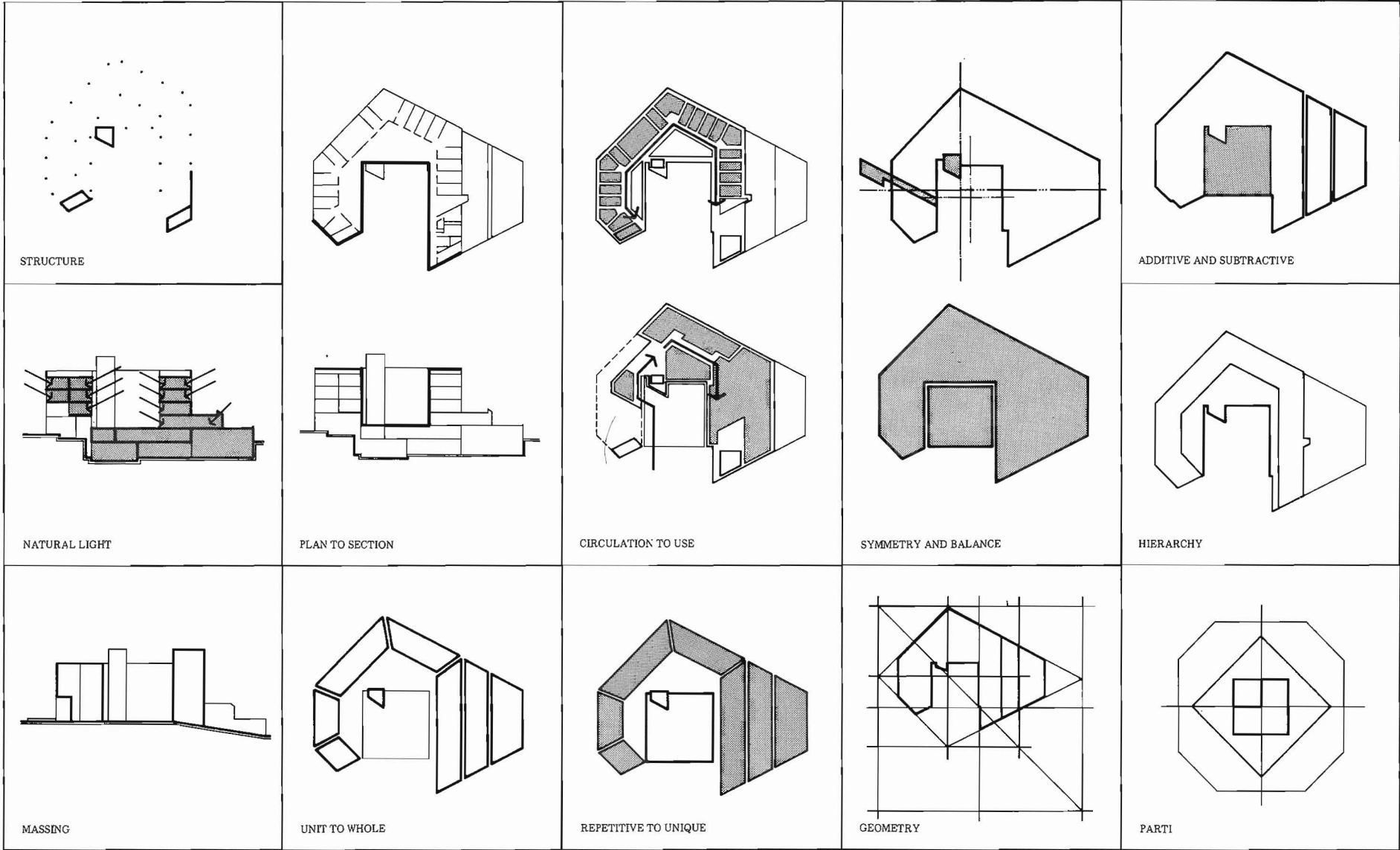

ROMALDO GIURGOLA

LANG MUSIC BUILDING
SWARTHMORE COLLEGE
SWARTHMORE, PENNSYLVANIA
1973

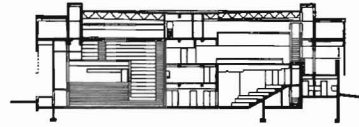

SECTION A

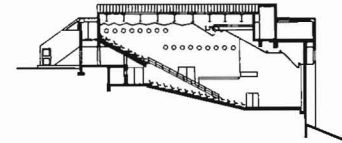

SECTION B

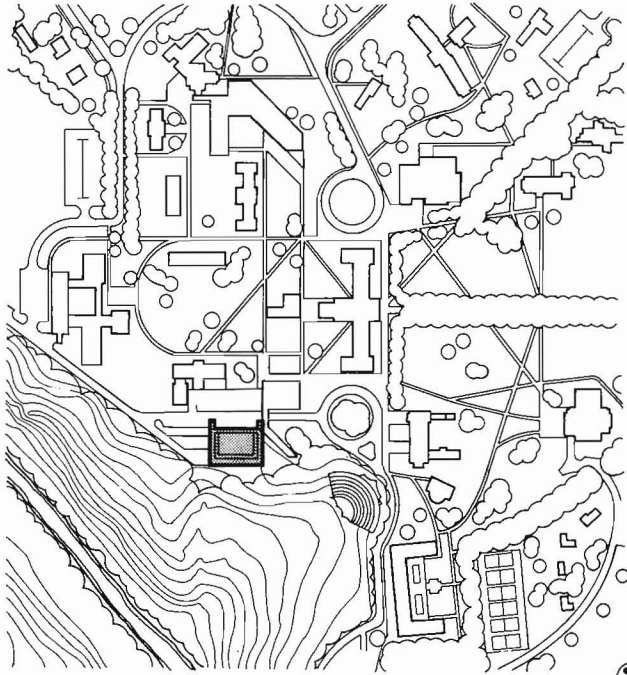

SITE PLAN



ELEVATION 1

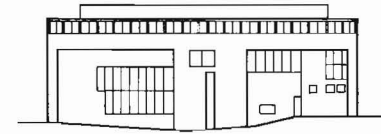

ELEVATION 2

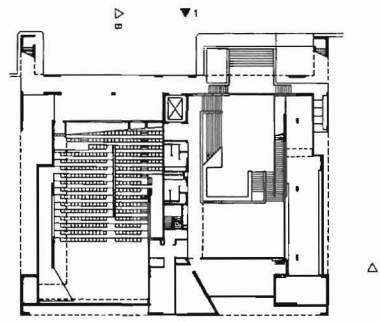

LOWER FLOOR PLAN

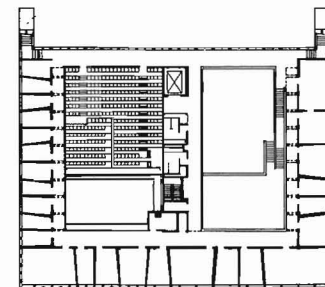

UPPER FLOOR PLAN

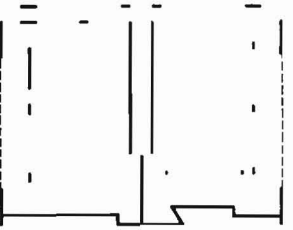
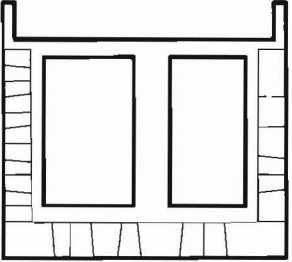
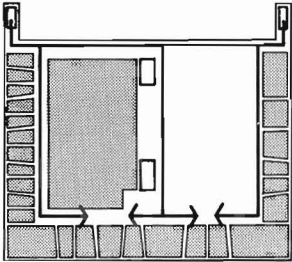
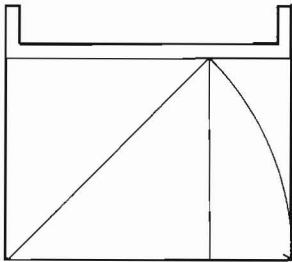
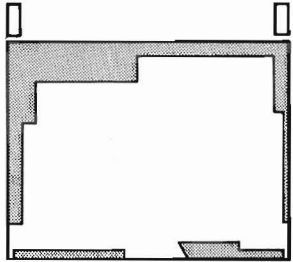
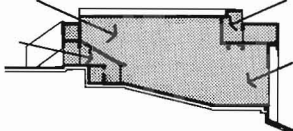
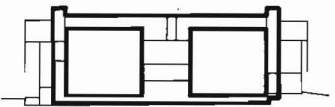
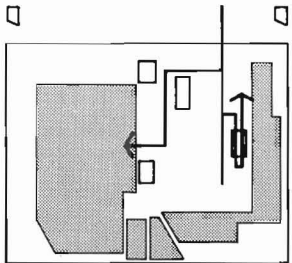
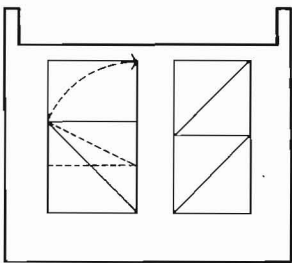
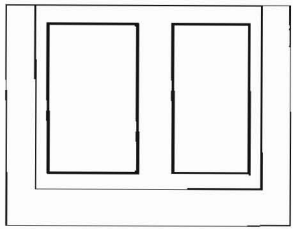
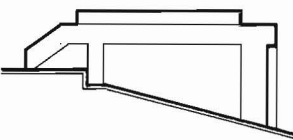
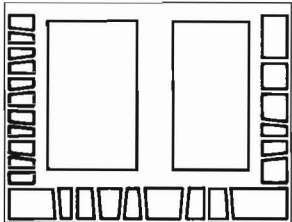
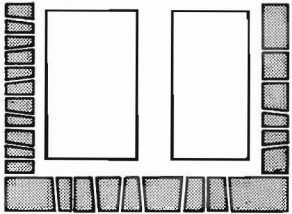
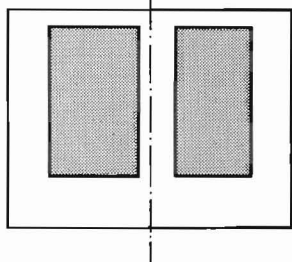
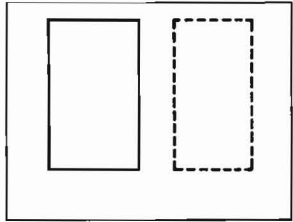
 <p>STRUCTURE</p>				 <p>ADDITIVE AND SUBRACTIVE</p>
 <p>NATURAL LIGHT</p>	 <p>PLAN TO SECTION</p>	 <p>CIRCULATION TO USE</p>	 <p>GEOMETRY</p>	 <p>HIERARCHY</p>
 <p>MASSING</p>	 <p>UNIT TO WHOLE</p>	 <p>REPETTIVE TO UNIQUE</p>	 <p>SYMMETRY AND BALANCE</p>	 <p>PARTI</p>

ROMALDO GIURGOLA

STUDENT UNION
STATE UNIVERSITY COLLEGE OF NEW YORK
PLATTSBURGH, NEW YORK
1974

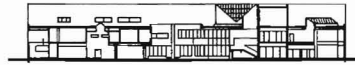

SECTION A

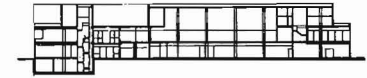

SECTION B

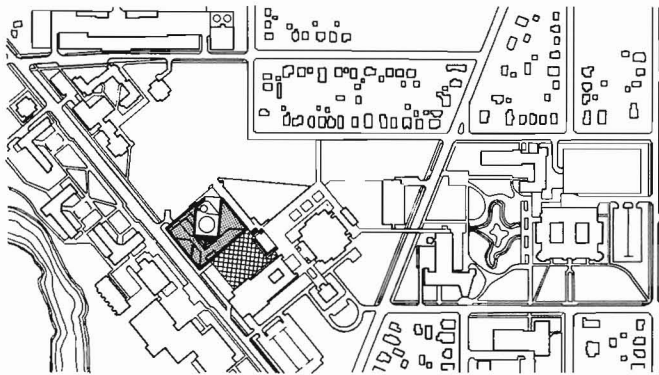

SITE PLAN

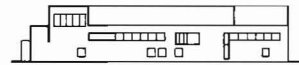

ELEVATION 1

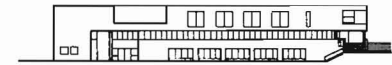



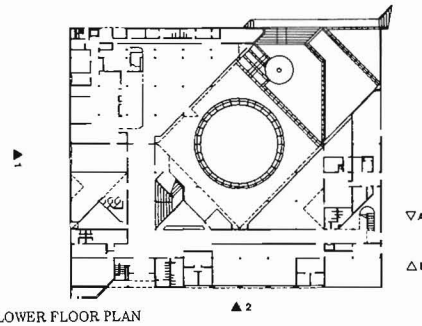

ELEVATION 2

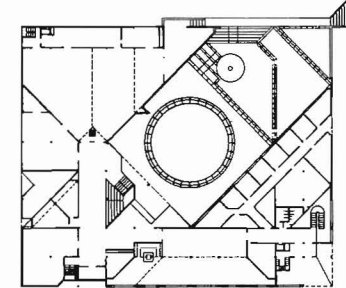

LOWER FLOOR PLAN

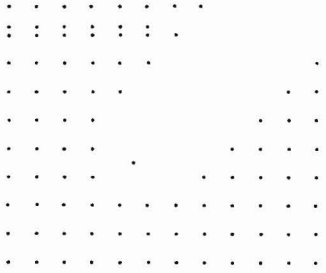
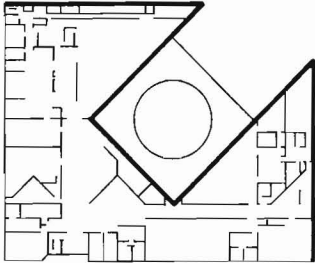
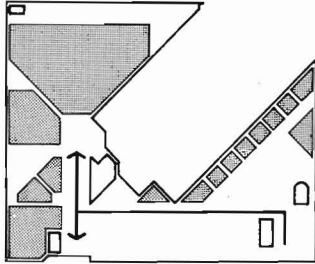
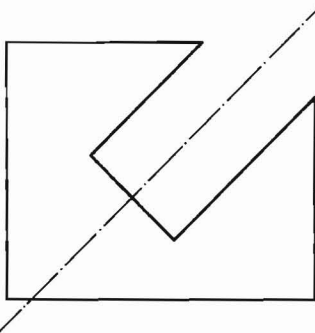
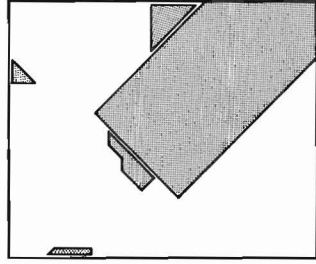
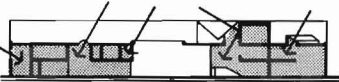

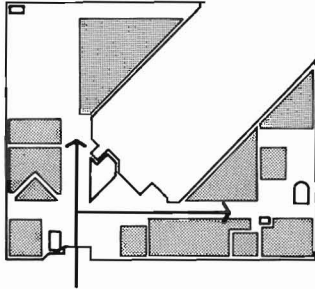
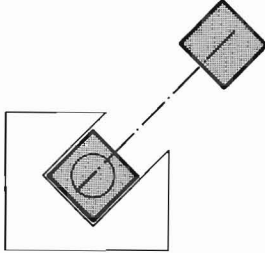
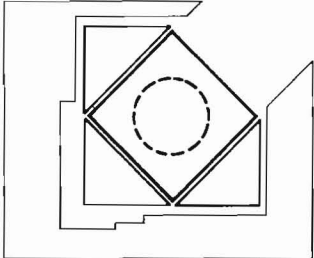
UPPER FLOOR PLAN

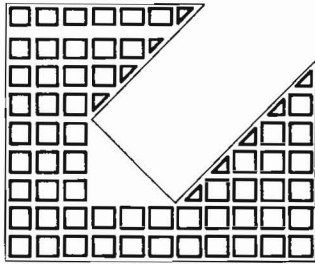
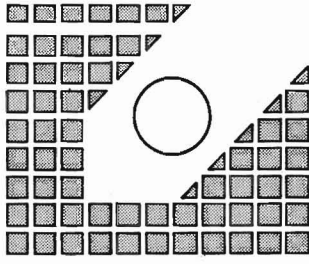
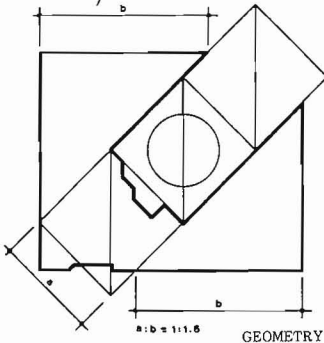
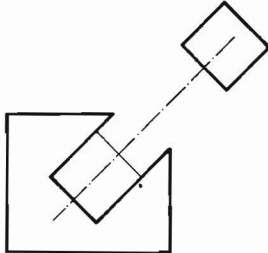
 <p>STRUCTURE</p>				 <p>ADDITIVE AND SUBRACTIVE</p>
 <p>NATURAL LIGHT</p>	 <p>PLAN TO SECTION</p>	 <p>CIRCULATION TO USE</p>	 <p>SYMMETRY AND BALANCE</p>	 <p>HIERARCHY</p>
 <p>MASSING</p>	 <p>UNIT TO WHOLE</p>	 <p>REPETITIVE TO UNIQUE</p>	 <p>GEOMETRY</p>	 <p>PARTI</p>

ROMALDO GIURGOLA

TREDYFFRIN PUBLIC LIBRARY
STRAFFORD, PENNSYLVANIA
1976

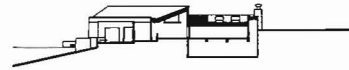

SECTION A

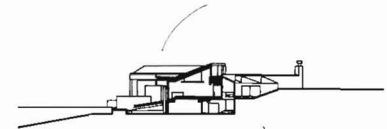

SECTION B

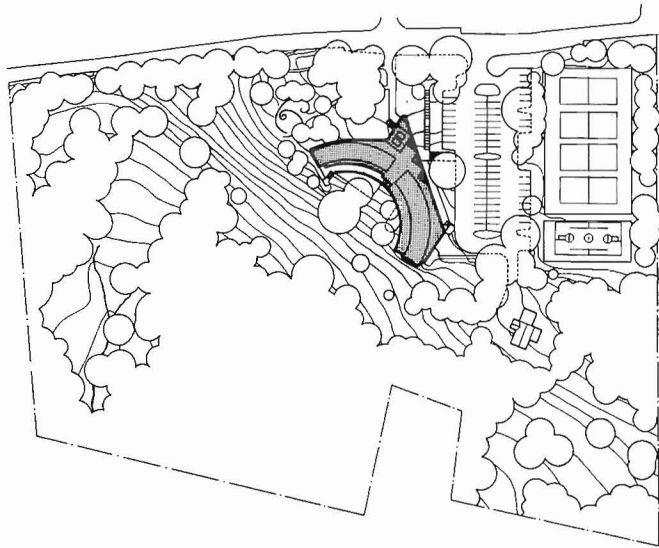

SITE PLAN

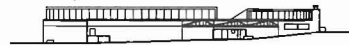

ELEVATION 1





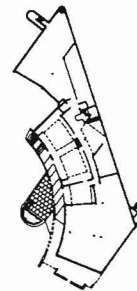

ELEVATION 2

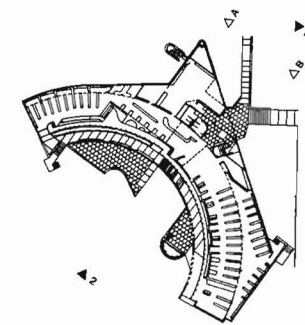

LOWER FLOOR PLAN

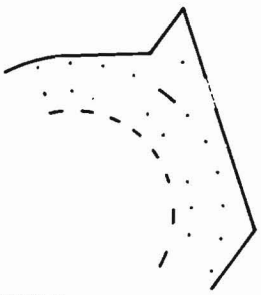

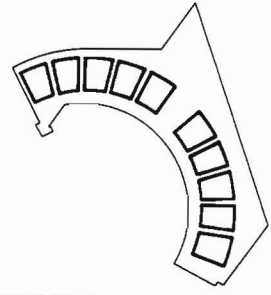
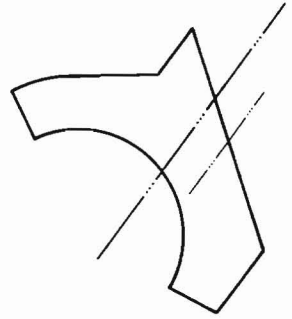
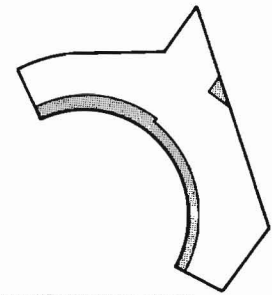
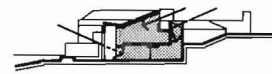
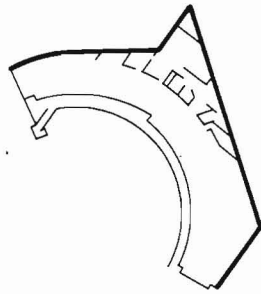
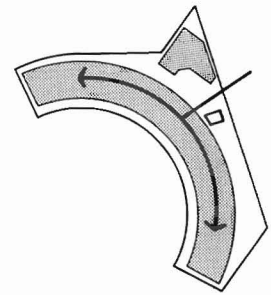
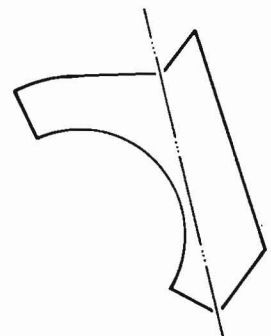
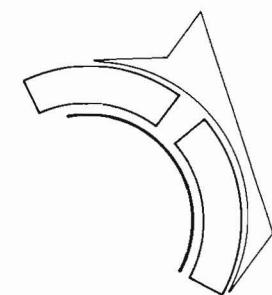
MAIN FLOOR PLAN

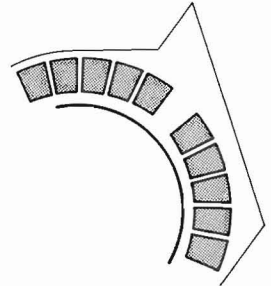
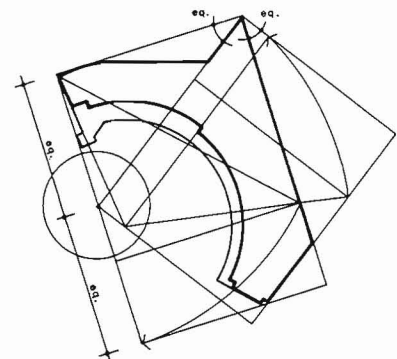
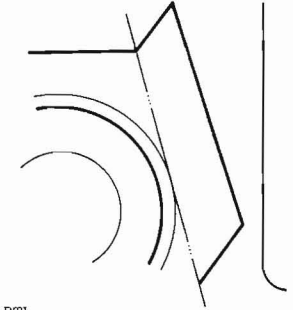
 <p>STRUCTURE</p>		 <p>UNIT TO WHOLE</p>	 <p>SYMMETRY AND BALANCE</p>	 <p>ADDITIVE AND SUBTRACTIVE</p>
 <p>NATURAL LIGHT</p>	 <p>PLAN TO SECTION</p>	 <p>CIRCULATION TO USE</p>	 <p>SYMMETRY AND BALANCE</p>	 <p>HIERARCHY</p>
 <p>MASSING</p>	 <p>REPETITIVE TO UNIQUE</p>	 <p>GEOMETRY</p>	 <p>PARTI</p>	

NICHOLAS HAWKSMOOR

NICHOLAS HAWKSMOOR

EASTON NESTON
NORTHAMPTONSHIRE, ENGLAND
c. 1695-1710

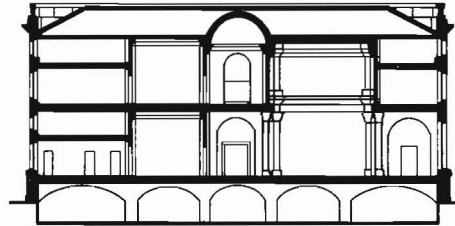

SECTION A



ELEVATION 1

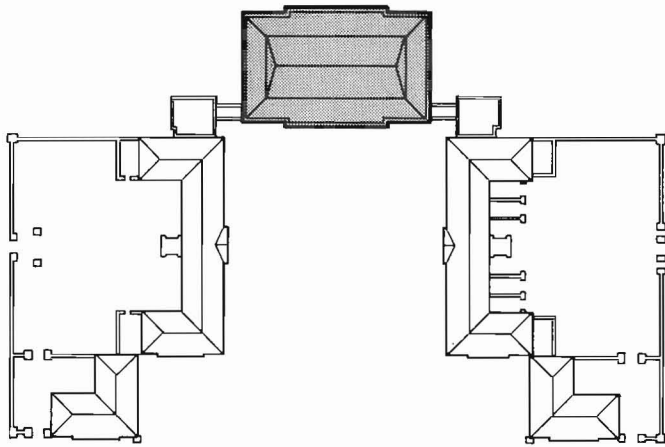

SITE PLAN





ELEVATION 2

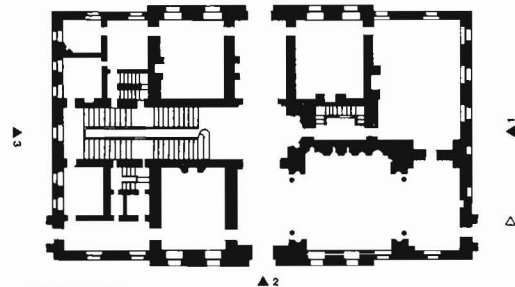

ELEVATION 3

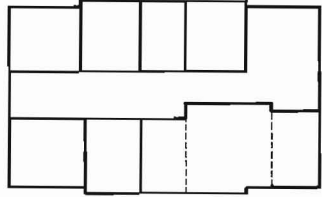
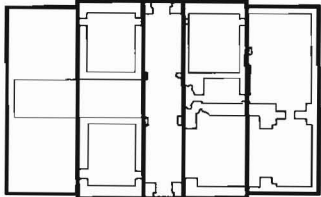
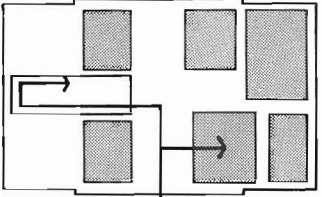
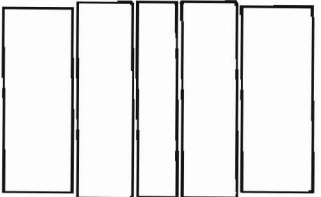
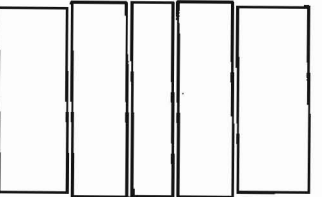
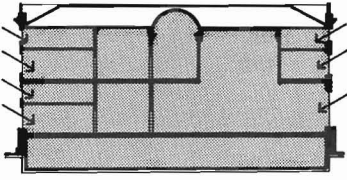

FLOOR PLAN

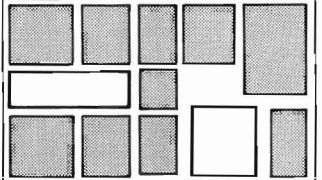
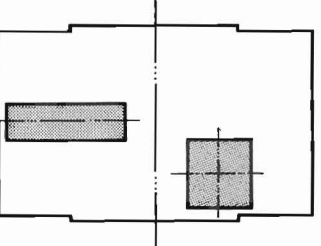
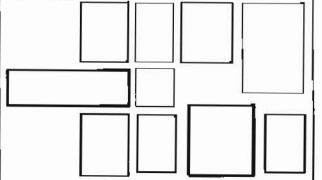
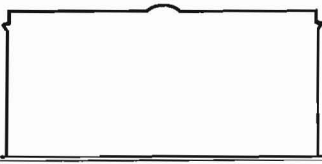
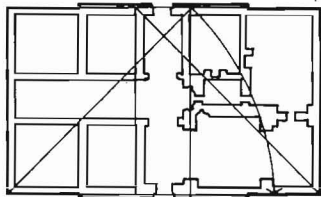
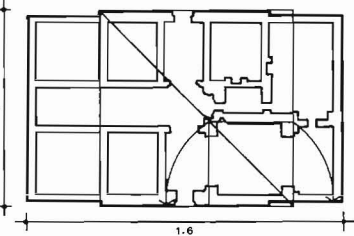
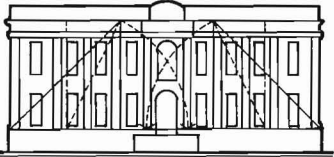
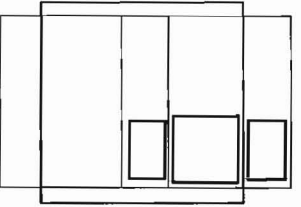
 <p>STRUCTURE</p>	 <p>PLAN TO SECTION</p>	 <p>CIRCULATION TO USE</p>	 <p>UNIT TO WHOLE</p>	 <p>ADDITIVE AND SUBTRACTIVE</p>
 <p>NATURAL LIGHT</p>	 <p>PLAN TO SECTION</p>	 <p>REPETITIVE TO UNIQUE</p>	 <p>SYMMETRY AND BALANCE</p>	 <p>HIERARCHY</p>
 <p>MASSING</p>	 <p>GEOMETRY</p>	 <p>1.6</p>		 <p>PARTI</p>

NICHOLAS HAWKSMOOR

ST. GEORGE-IN-THE-EAST
WAPPING, STEPNEY, ENGLAND
1714-1729

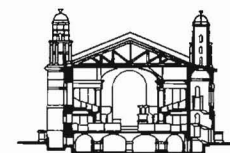

SECTION A

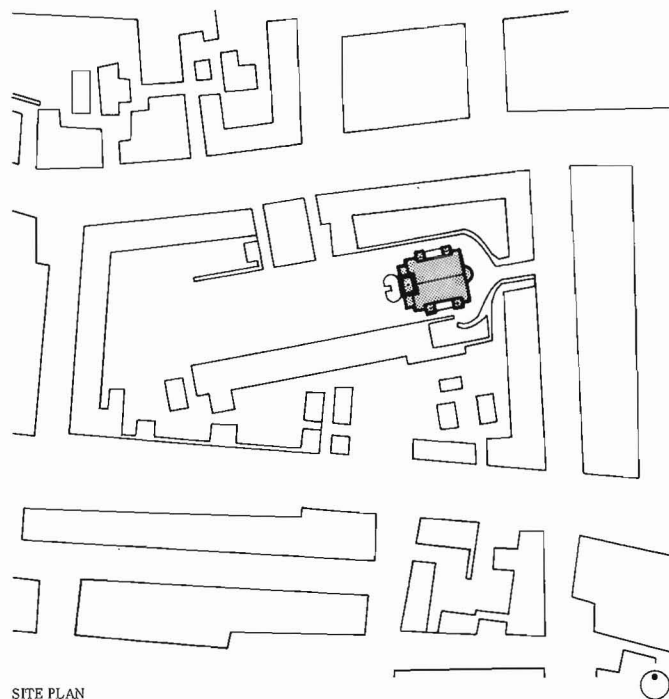

SITE PLAN

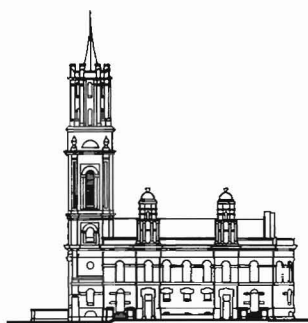

ELEVATION 1

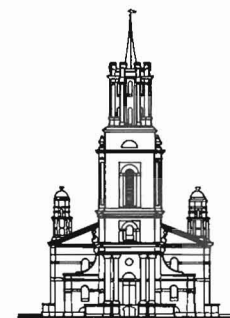

ELEVATION 2

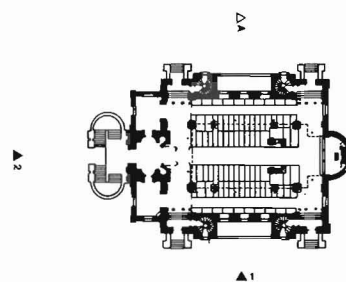

MAIN FLOOR PLAN

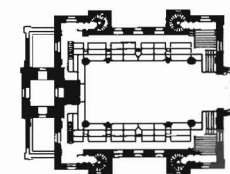

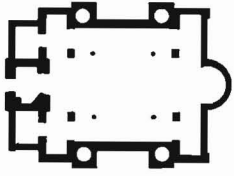
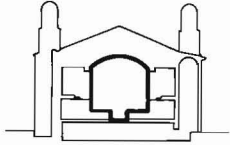
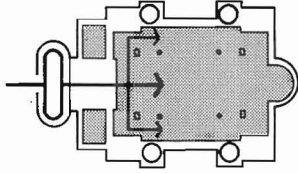
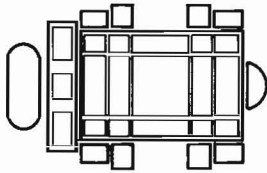
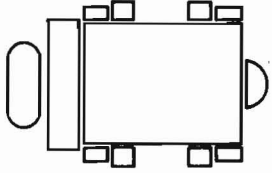
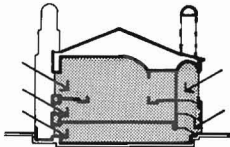
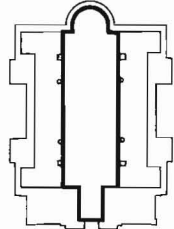
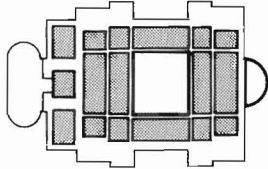
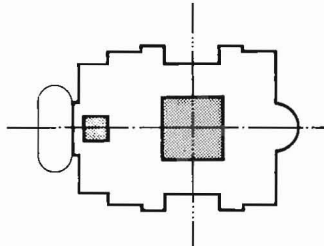
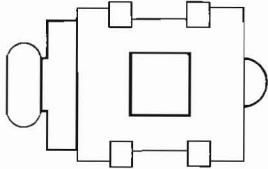
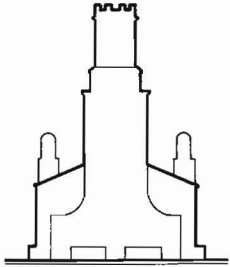
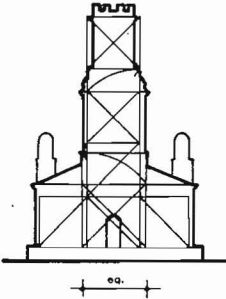
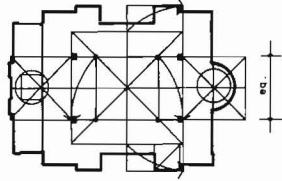
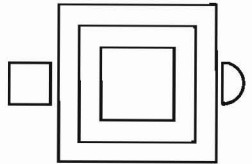

UPPER FLOOR PLAN

 <p>STRUCTURE</p>		 <p>CIRCULATION TO USE</p>	 <p>UNIT TO WHOLE</p>	 <p>ADDITIVE AND SUBTRACTIVE</p>
 <p>NATURAL LIGHT</p>	 <p>PLAN TO SECTION</p>	 <p>REPETITIVE TO UNIQUE</p>	 <p>SYMMETRY AND BALANCE</p>	 <p>HIERARCHY</p>
 <p>MASSING</p>	 <p>GEOMETRY</p>			 <p>PARTI</p>

NICHOLAS HAWKSMOOR

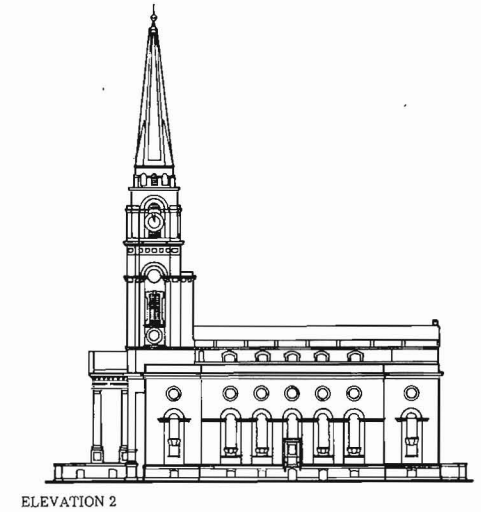
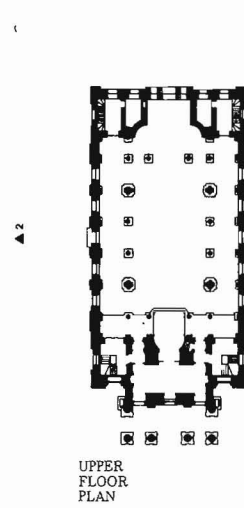
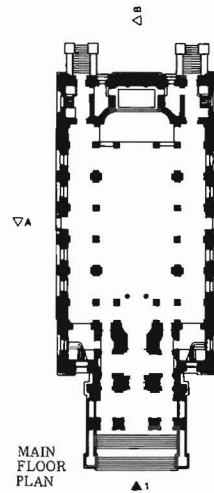
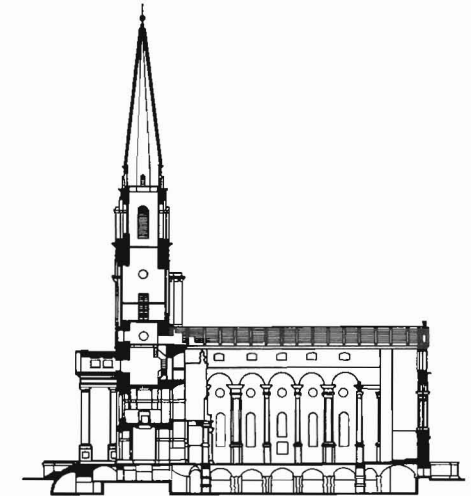
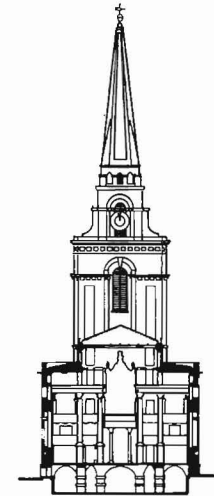
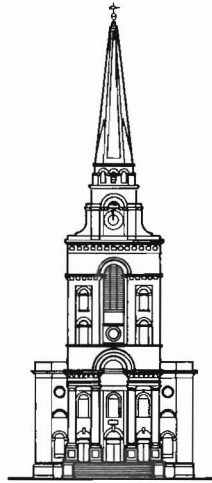
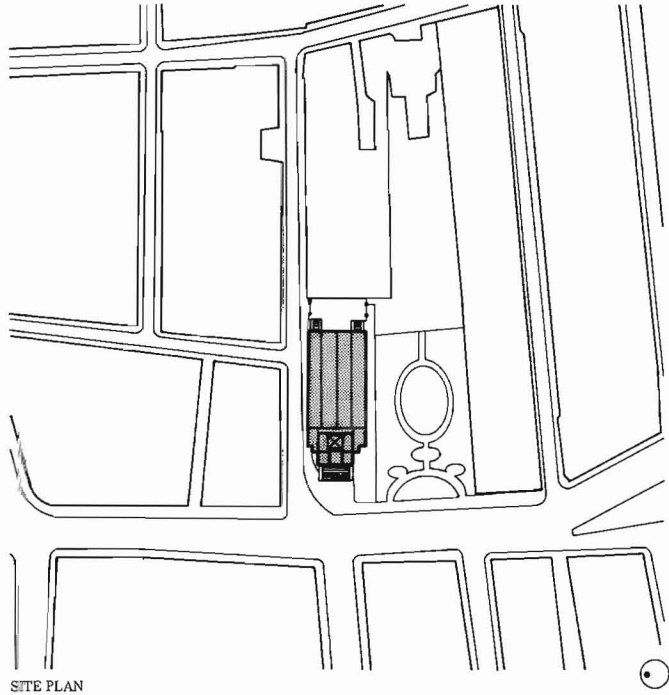
CHRIST CHURCH
SPITALFIELDS, LONDON, ENGLAND
1715-1729

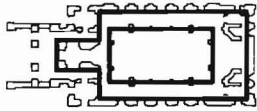
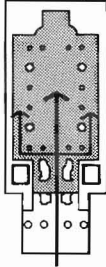
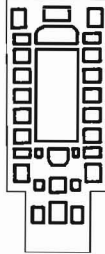
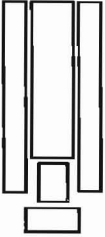
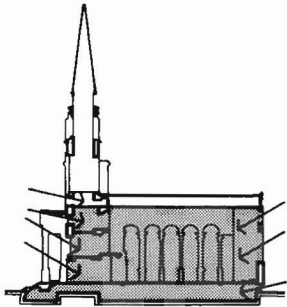
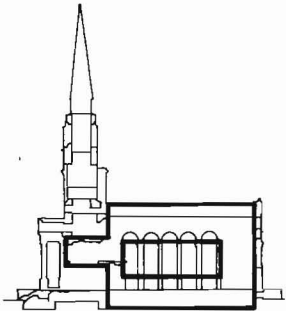
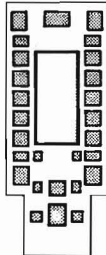
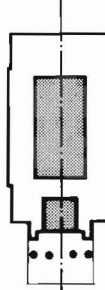
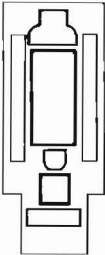
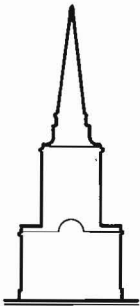
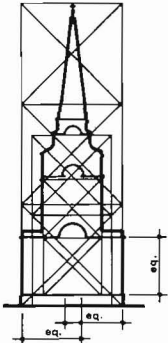
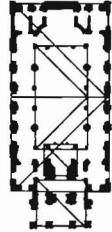
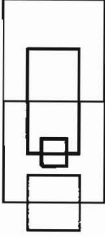
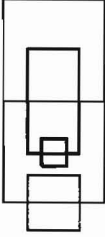

 <p>STRUCTURE</p>		 <p>CIRCULATION TO USE</p>	 <p>UNIT TO WHOLE</p>	 <p>ADDITIVE AND SUBTRACTIVE</p>
 <p>NATURAL LIGHT</p>	 <p>PLAN TO SECTION</p>	 <p>REPETITIVE TO UNIQUE</p>	 <p>SYMMETRY AND BALANCE</p>	 <p>HIERARCHY</p>
 <p>MASSING</p>	 <p>GEOMETRY</p>			 <p>PARTI</p>

NICHOLAS HAWKSMOOR

ST. MARY WOOLNOTH
LONDON, ENGLAND
1716-1724

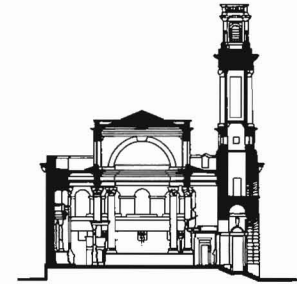

SECTION A

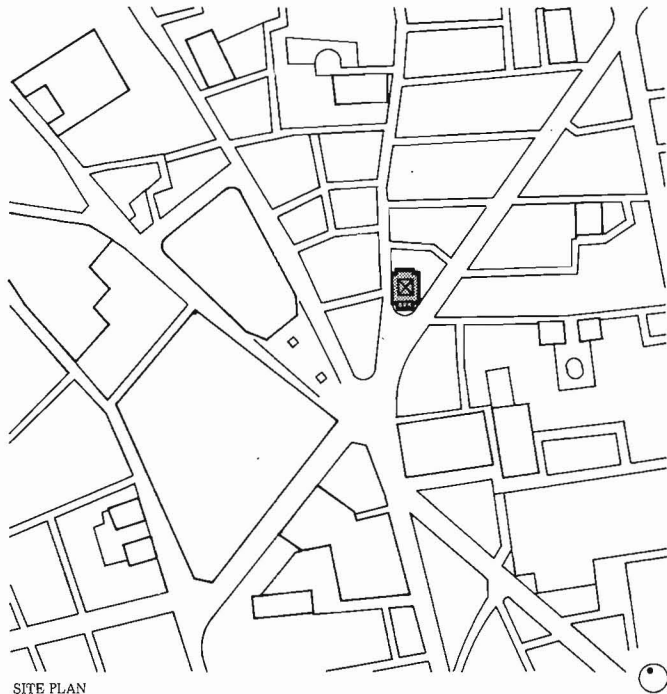

SITE PLAN

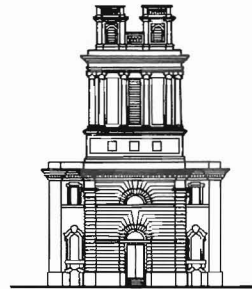

ELEVATION 1

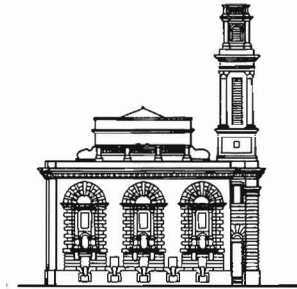

ELEVATION 2

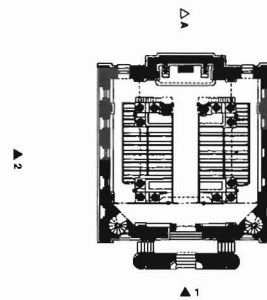

FLOOR PLAN

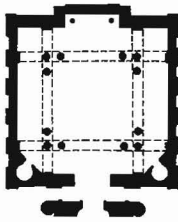
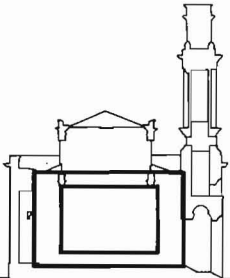
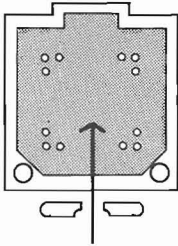
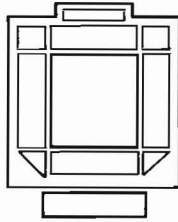
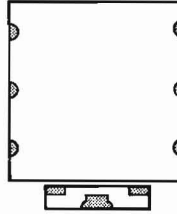
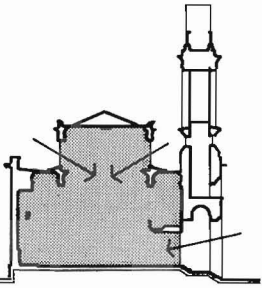
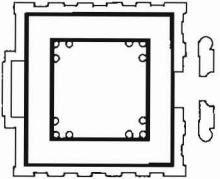
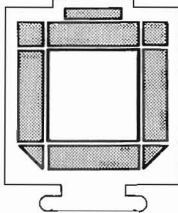
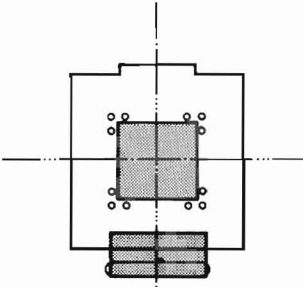
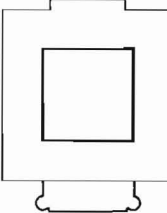
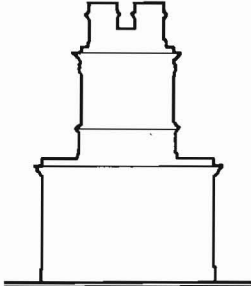
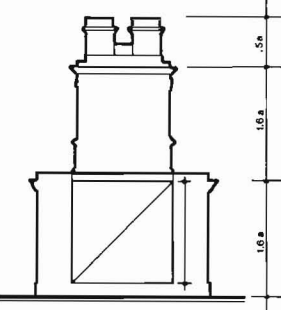
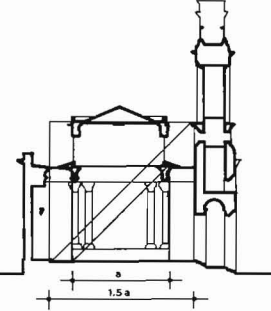
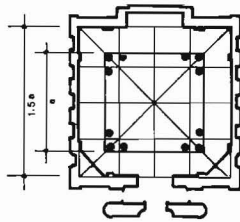
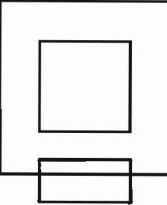
 <p>STRUCTURE</p>		 <p>CIRCULATION TO USE</p>	 <p>UNIT TO WHOLE</p>	 <p>ADDITIVE AND SUBTRACTIVE</p>
 <p>NATURAL LIGHT</p>	 <p>PLAN TO SECTION</p>	 <p>REPETITIVE TO UNIQUE</p>	 <p>SYMMETRY AND BALANCE</p>	 <p>HIERARCHY</p>
 <p>MASSING</p>	 <p>GEOMETRY</p>			 <p>PARTI</p>

LOUIS I. KAHN

LOUIS I. KAHN

ALFRED N. RICHARDS MEDICAL RESEARCH BUILDING,
UNIVERSITY OF PENNSYLVANIA
PHILADELPHIA, PENNSYLVANIA
1957-1961

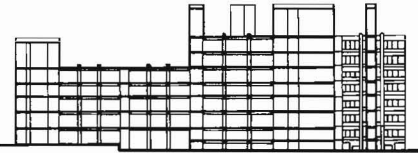

SECTION A

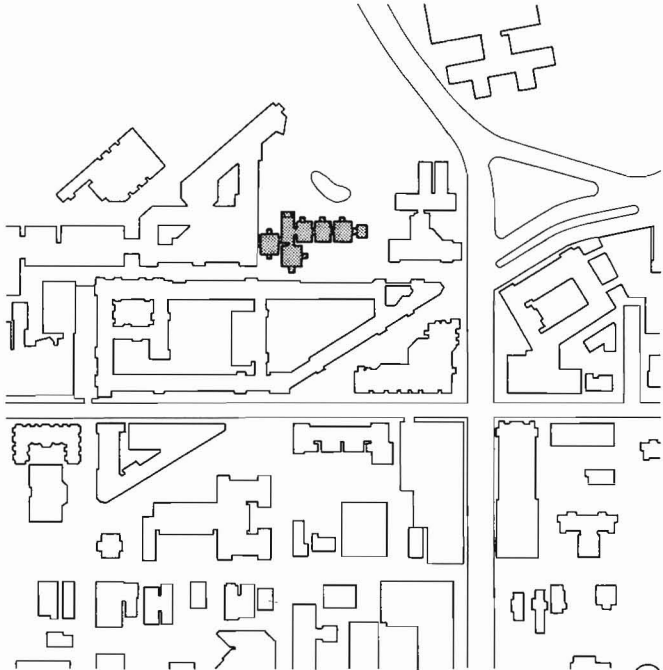

SITE PLAN



ELEVATION 1



ELEVATION 2

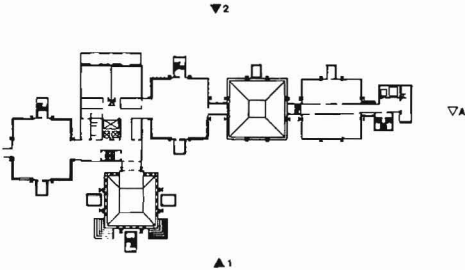

LOWER FLOOR PLAN

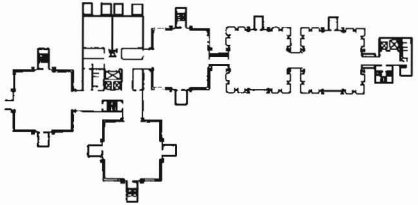

UPPER FLOOR PLAN

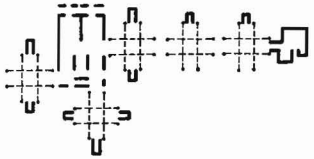
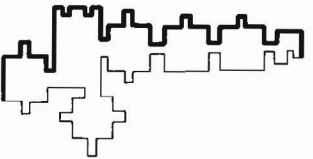
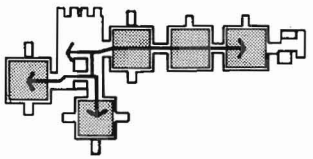
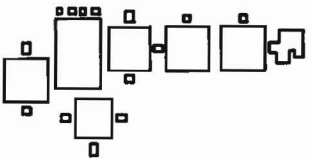
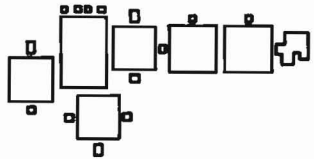
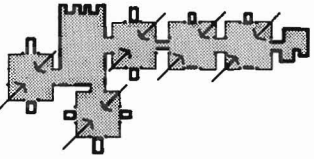
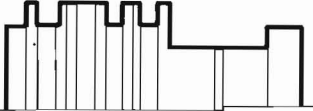
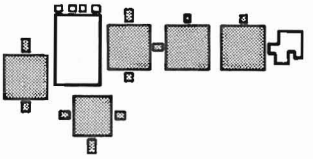
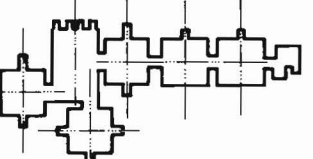
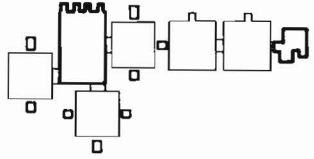
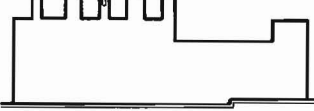
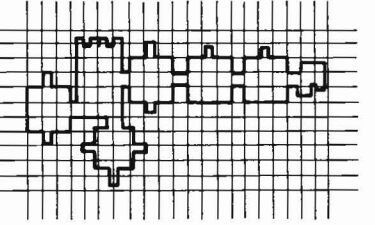
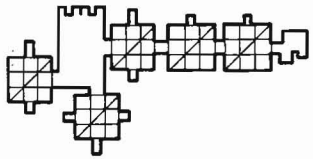
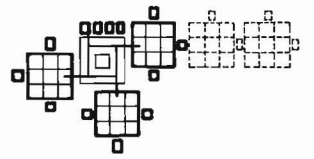
 <p>STRUCTURE</p>		 <p>CIRCULATION TO USE</p>	 <p>UNIT TO WHOLE</p>	 <p>ADDITIVE AND SUBTRACTIVE</p>
 <p>NATURAL LIGHT</p>	 <p>PLAN TO SECTION</p>	 <p>REPETTIVE TO UNIQUE</p>	 <p>SYMMETRY AND BALANCE</p>	 <p>HIERARÇHY</p>
 <p>MASSING</p>	 <p>GEOMETRY</p>			 <p>PARTI</p>

LOUIS I. KAHN

SALK INSTITUTE OF BIOLOGICAL STUDIES
LA JOLLA, CALIFORNIA
1959-1965

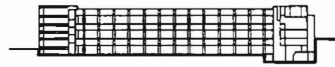

SECTION A



SECTION B

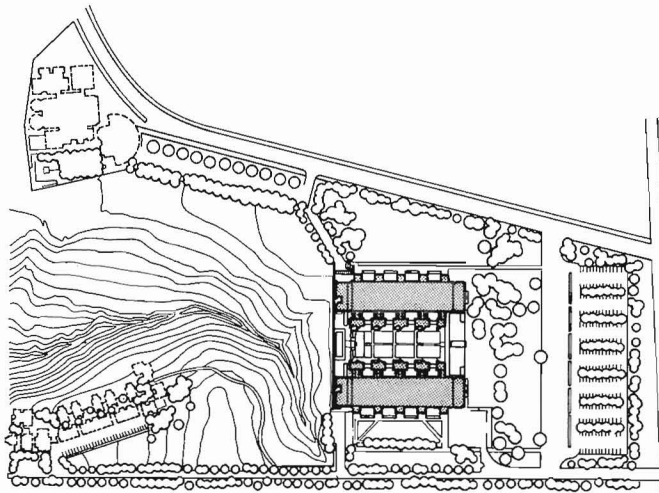

SITE PLAN



ELEVATION 1



ELEVATION 2

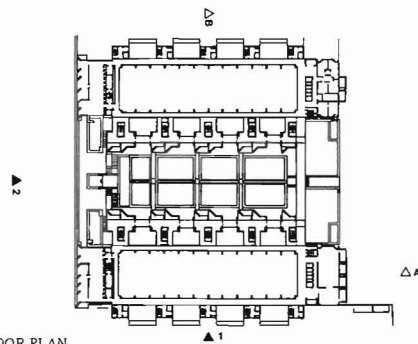

FLOOR PLAN

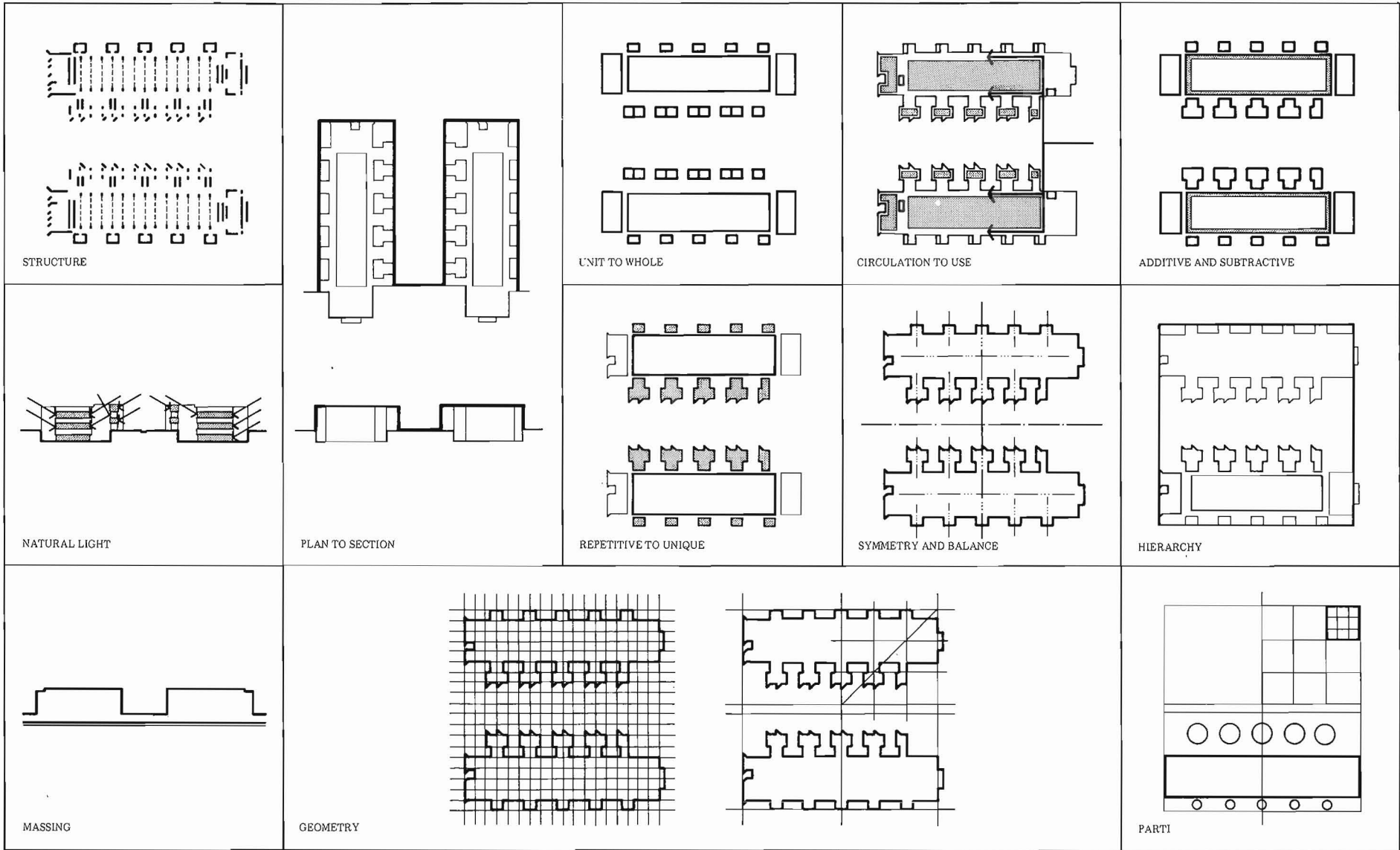

LOUIS I. KAHN

KIMBALL ART MUSEUM
FORTH WORTH, TEXAS
1966-1972



ELEVATION 1

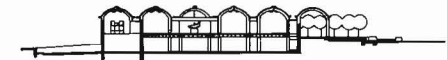

SECTION A

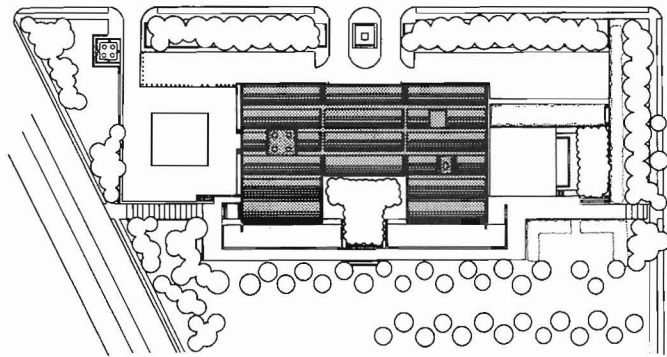

SITE PLAN



ELEVATION 2



ELEVATION 3

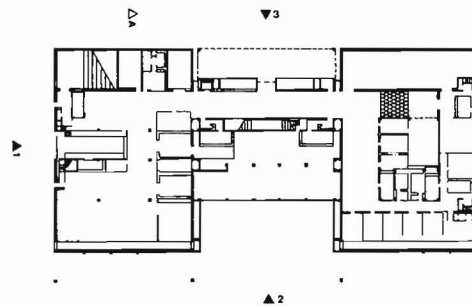

LOWER FLOOR PLAN

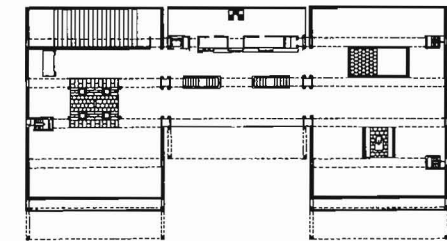

UPPER FLOOR PLAN

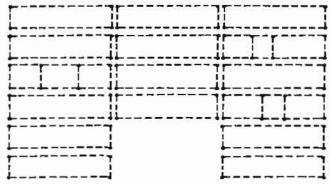

STRUCTURE

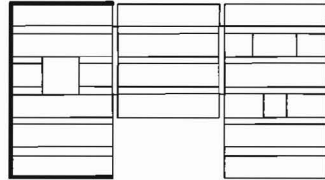

PLAN TO SECTION

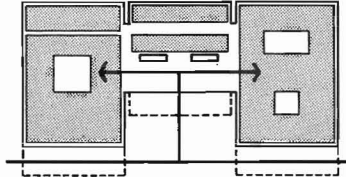

CIRCULATION TO USE

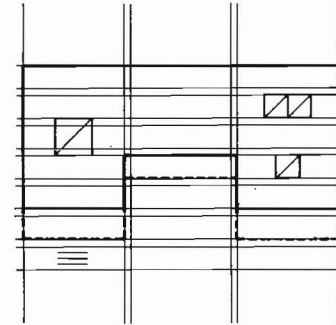

GEOMETRY

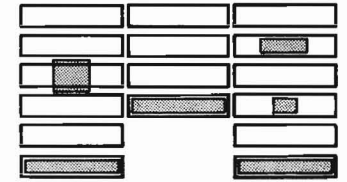

ADDITIVE AND SUBTRACTIVE

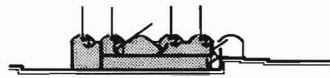

NATURAL LIGHT



PLAN TO SECTION

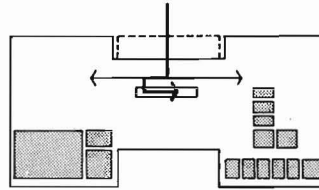

CIRCULATION TO USE

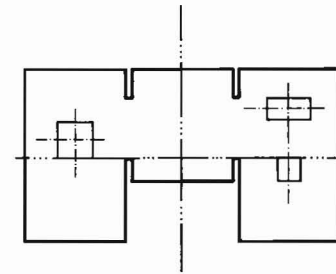

SYMMETRY AND BALANCE

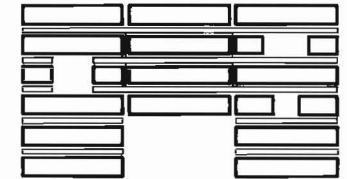

HIERARCHY



MASSING

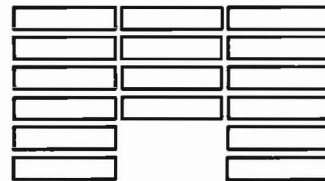

UNIT TO WHOLE

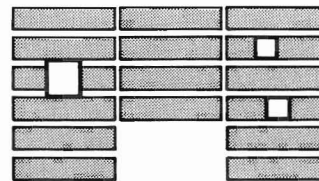

REPETITIVE TO UNIQUE

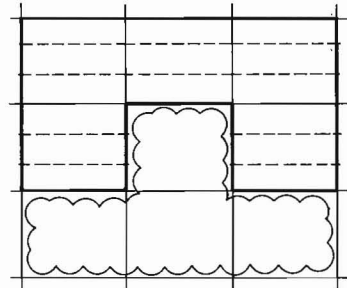

PARTI

LOUIS I. KAHN

LIBRARY
PHILIP EXETER ACADEMY
EXETER, NEW HAMPSHIRE
1967-1972

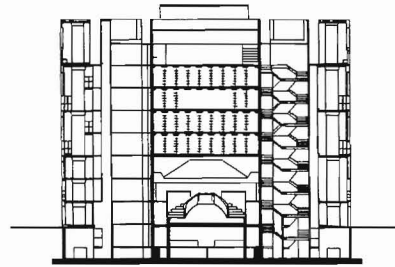

SECTION A

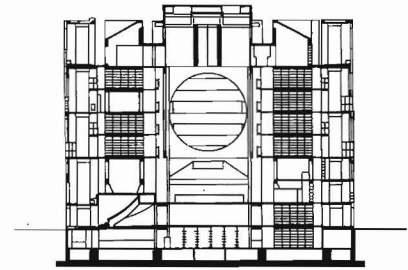

SECTION B

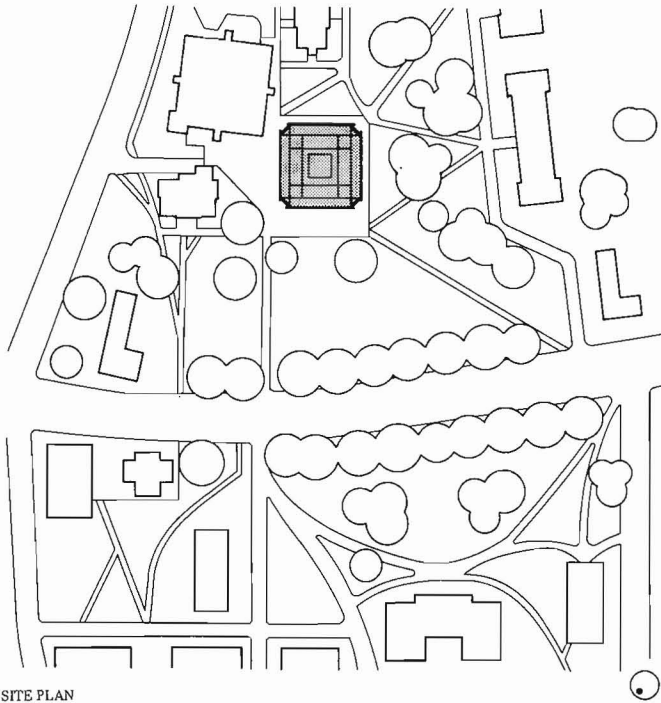

SITE PLAN

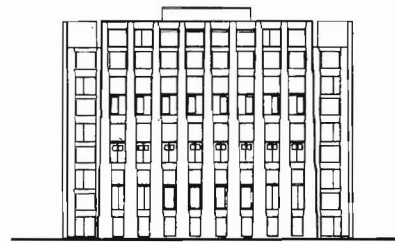

ELEVATION 1



ELEVATION 2

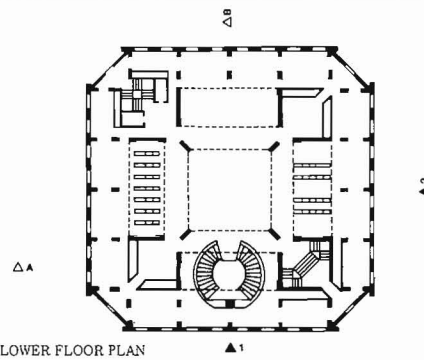

LOWER FLOOR PLAN

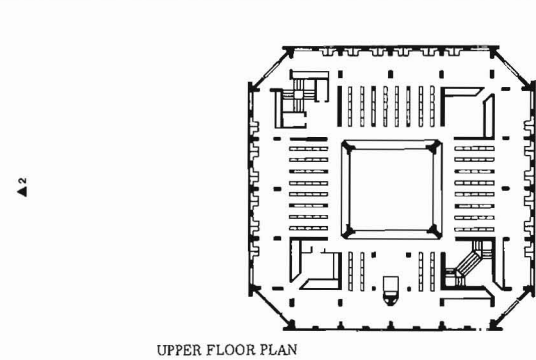

UPPER FLOOR PLAN

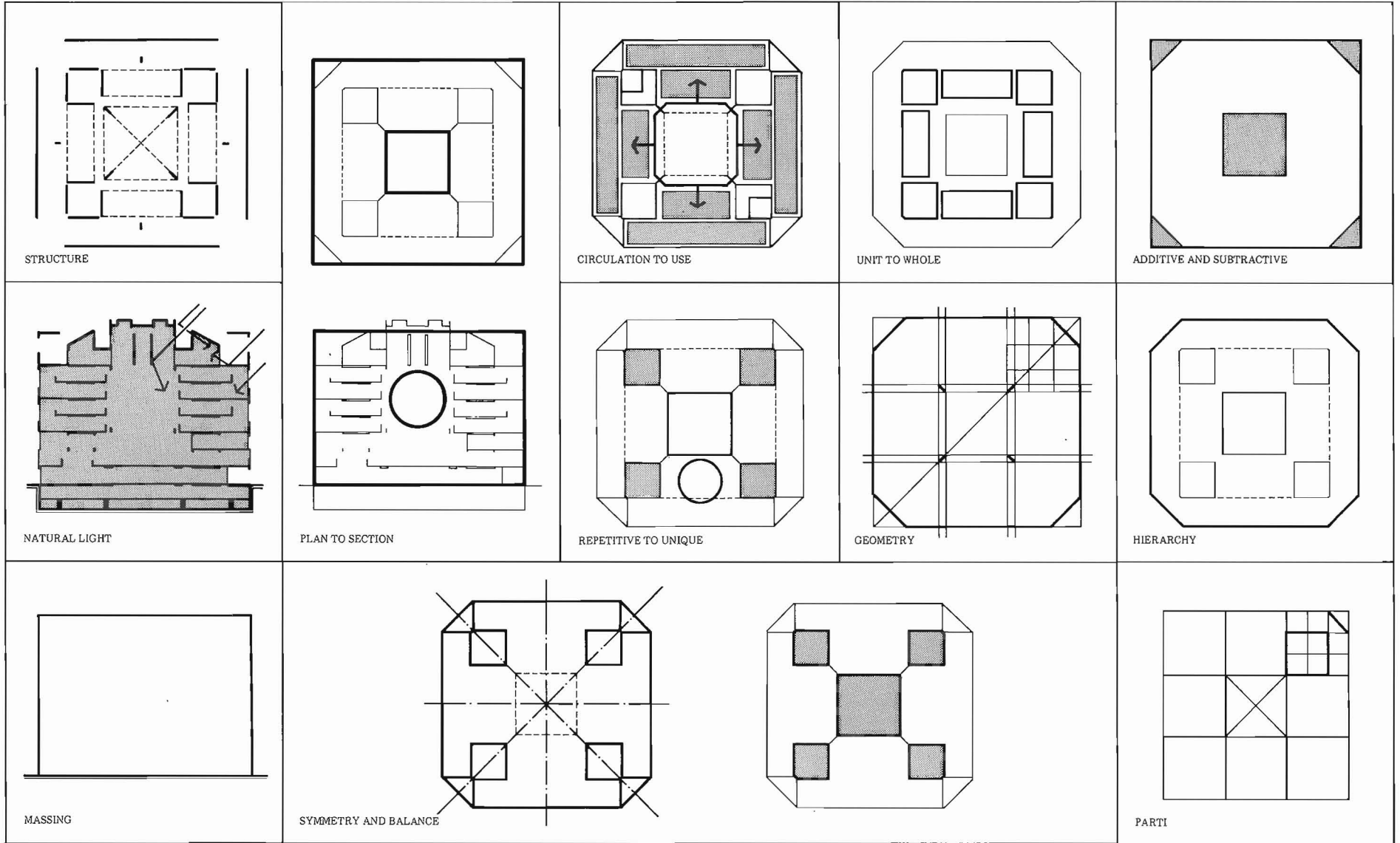

LE CORBUSIER

LE CORBUSIER

VILLA SAVOYE
POISSY, FRANCE
1928-1931

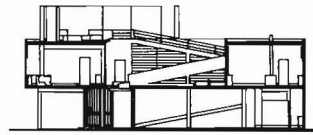

SECTION A

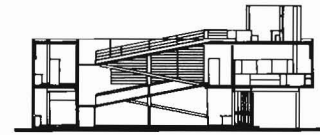

SECTION B

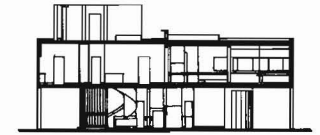

SECTION C

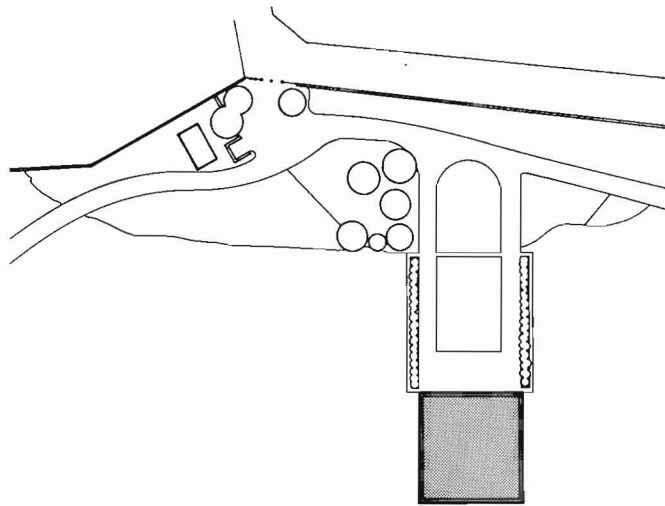

SITE PLAN

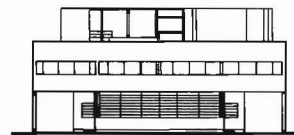

ELEVATION 1

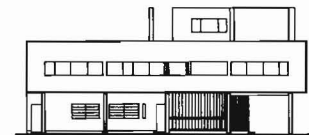

ELEVATION 2

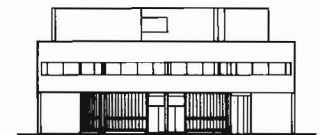

ELEVATION 3

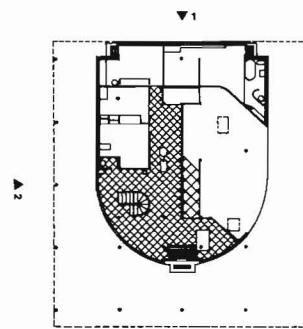

LOWER FLOOR PLAN ▲ 3

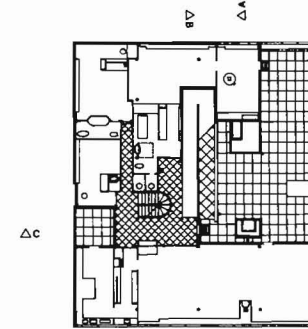

MIDDLE FLOOR PLAN

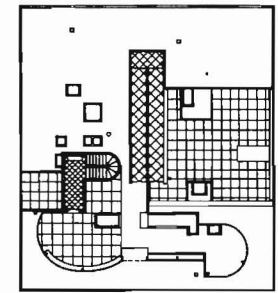

UPPER FLOOR PLAN

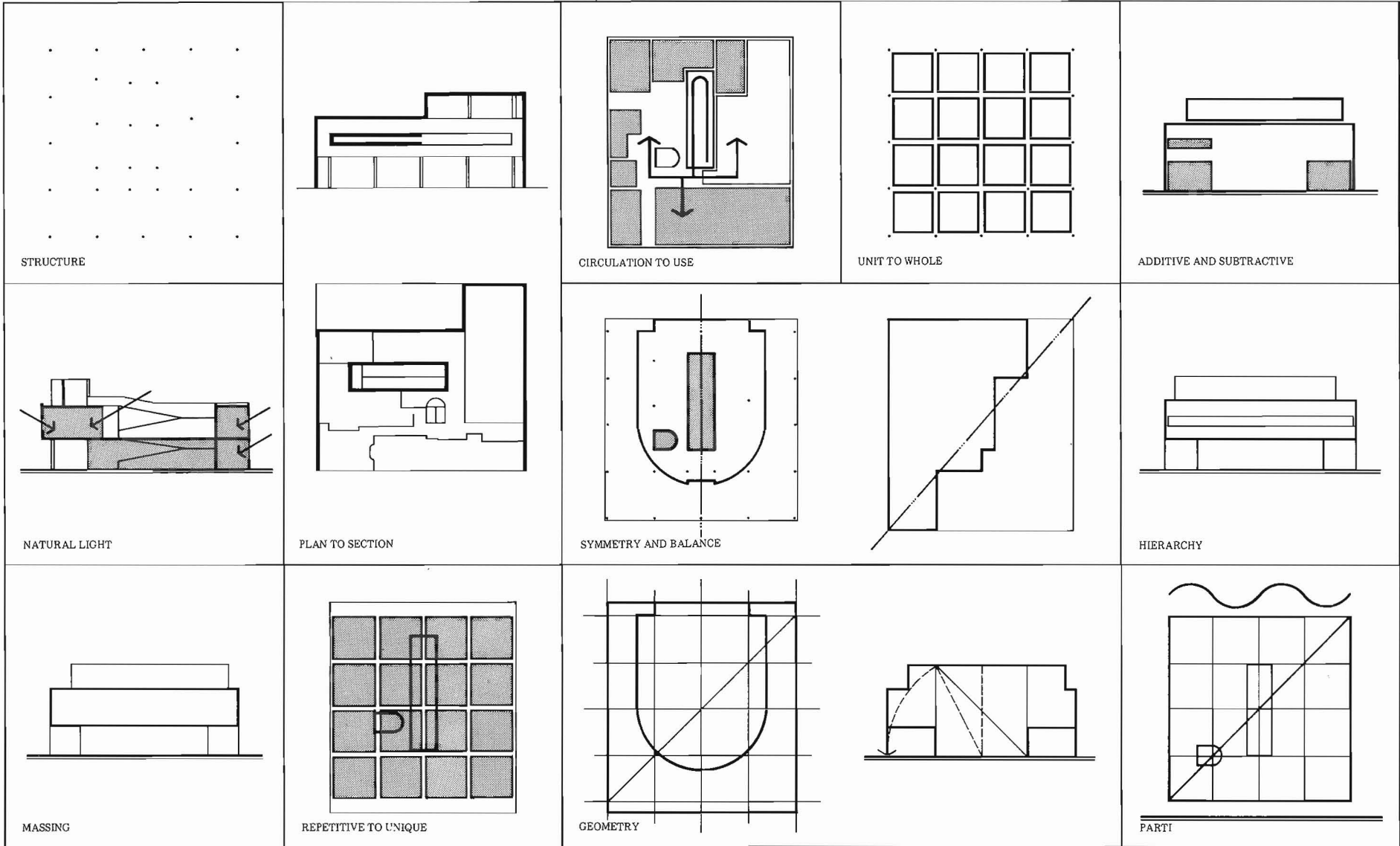

LE CORBUSIER

UNITE D'HABITATION
MARSAILLES, FRANCE
1946-1952

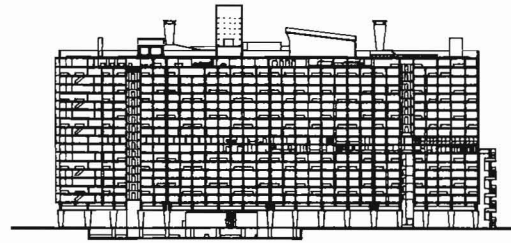

SECTION A

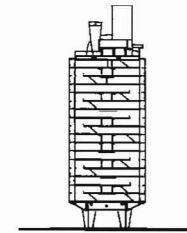

SECTION B

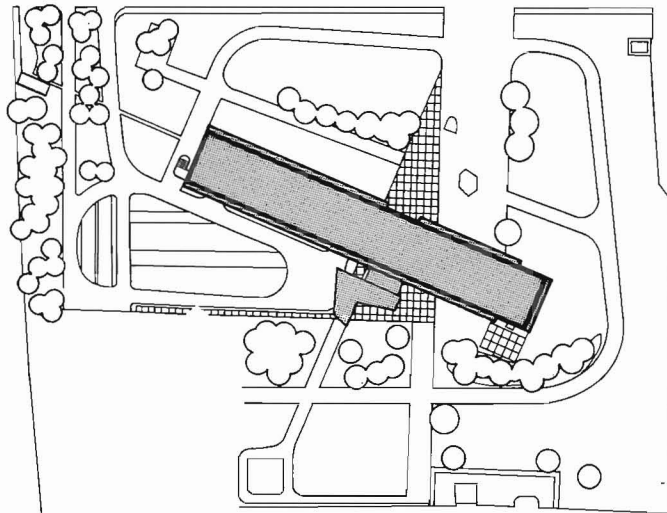

SITE PLAN

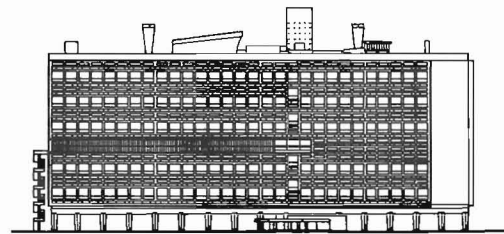

ELEVATION 1

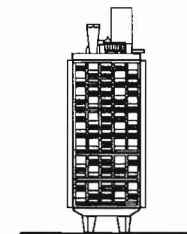

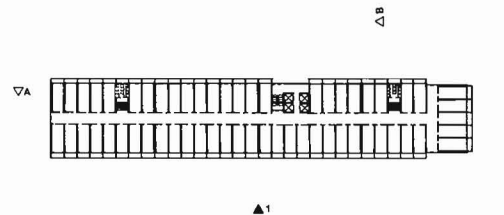

ELEVATION 2

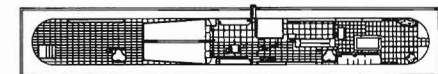

TYPICAL FLOOR PLAN

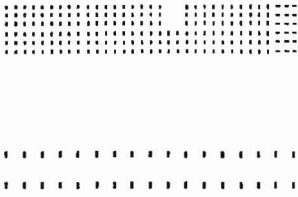
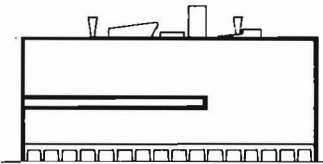

ROOF FLOOR PLAN

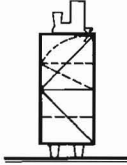
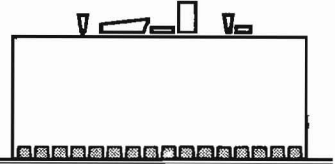
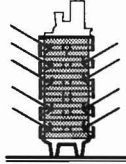
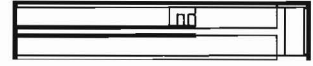
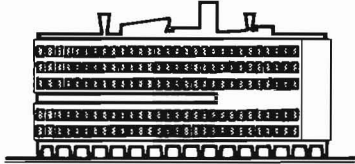
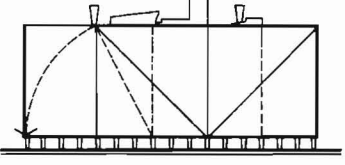
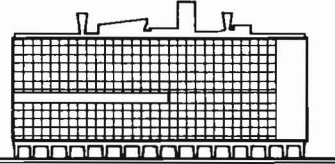
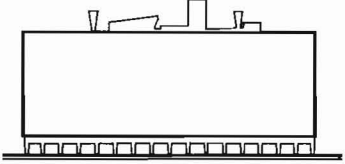
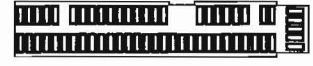
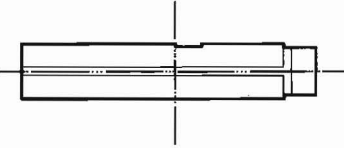
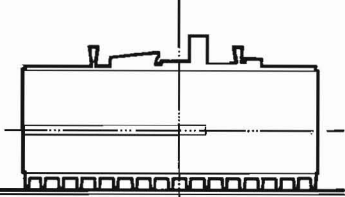
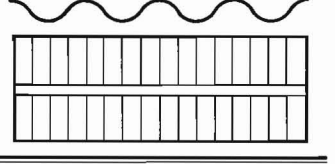
 <p>STRUCTURE</p>		 <p>CIRCULATION TO USE</p>		 <p>ADDITIVE AND SUBTRACTIVE</p>
 <p>NATURAL LIGHT</p>	 <p>PLAN TO SECTION</p>	 <p>REPETITIVE TO UNIQUE</p>	 <p>GEOMETRY</p> <p>$a:b = 1:1.6$</p>	 <p>HIERARCHY</p>
 <p>MASSING</p>	 <p>UNIT TO WHOLE</p>	 <p>SYMMETRY AND BALANCE</p>		 <p>PARTI</p>

LE CORBUSIER

NOTRE DAME DU HAUT CHAPEL
RONCHAMP, FRANCE
1950-1955

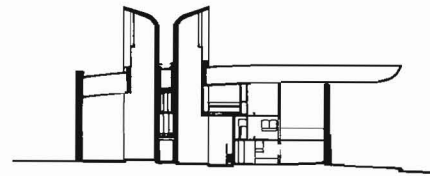

SECTION A

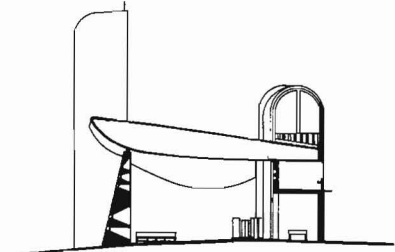

SECTION B

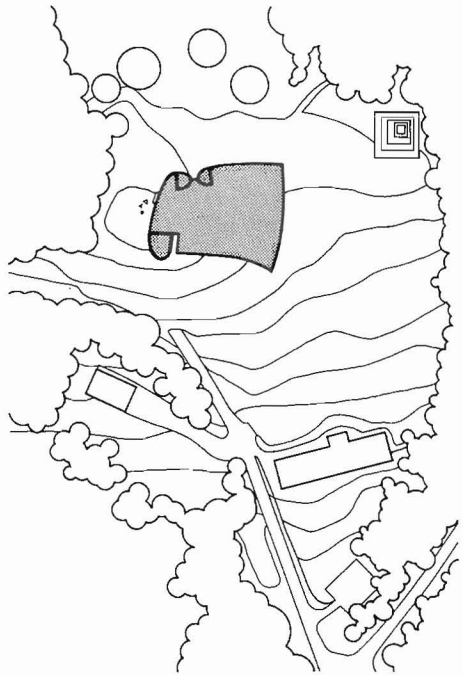

SITE PLAN

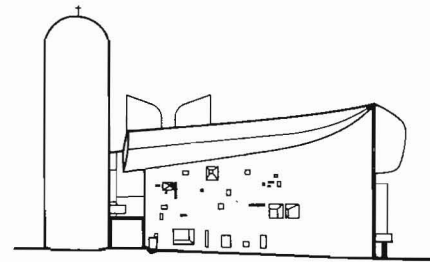

ELEVATION 1

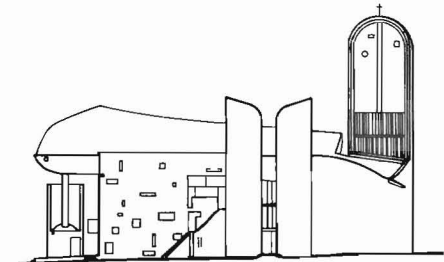

ELEVATION 2

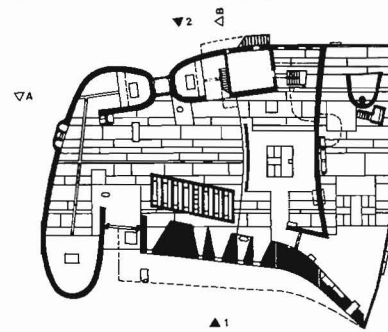

FLOOR PLAN

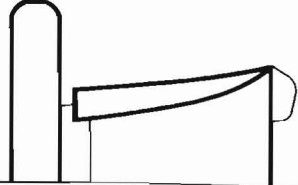
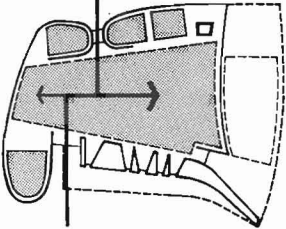
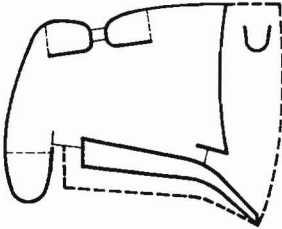
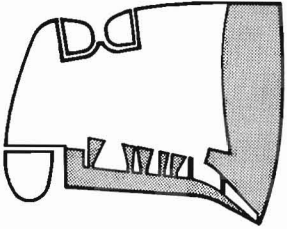
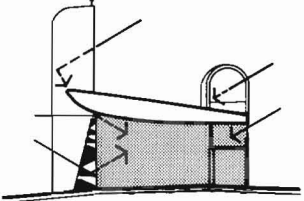
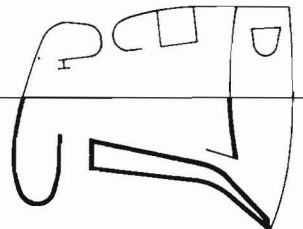
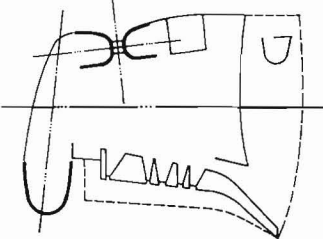
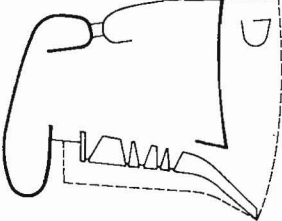
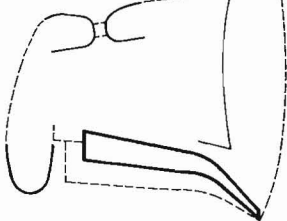
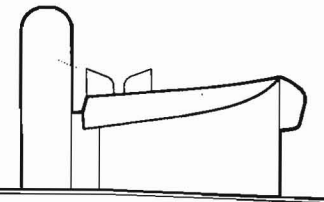
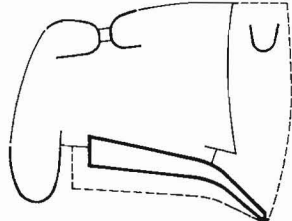
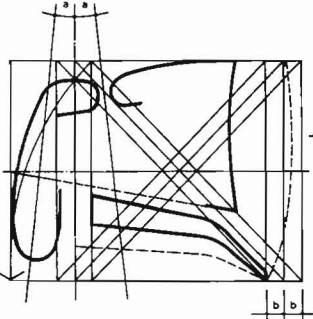
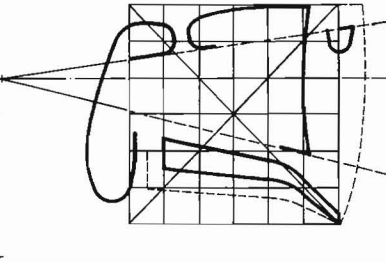
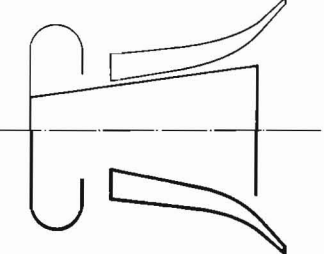
 <p>STRUCTURE</p>		 <p>CIRCULATION TO USE</p>	 <p>UNIT TO WHOLE</p>	 <p>ADDITIVE AND SUBTRACTIVE</p>
 <p>NATURAL LIGHT</p>	 <p>PLAN TO SECTION</p>	 <p>SYMMETRY AND BALANCE</p>	 <p>HIERARCHY</p>	
 <p>MASSING</p>	 <p>REPETITIVE TO UNIQUE</p>	 <p>GEOMETRY</p>		 <p>PARTI</p>

LE CORBUSIER

THE PALACE OF ASSEMBLY
CHANDIGARH, INDIA
1953-1963

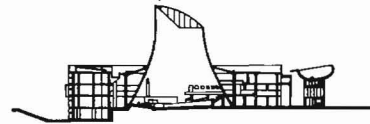

SECTION A



SECTION B

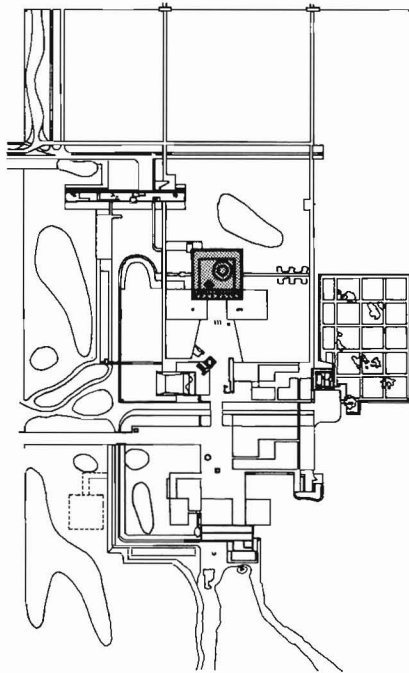

SITE PLAN

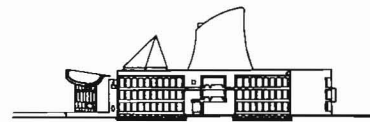

ELEVATION 1

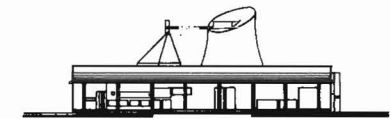

ELEVATION 2

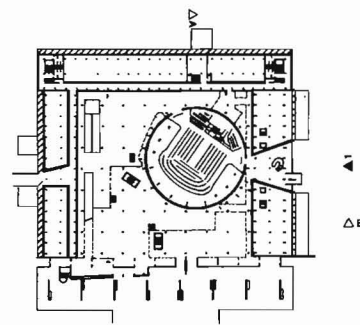

LOWER FLOOR PLAN

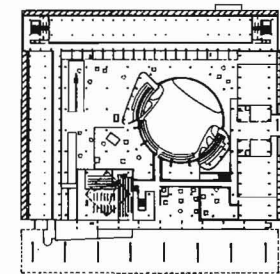

UPPER FLOOR PLAN

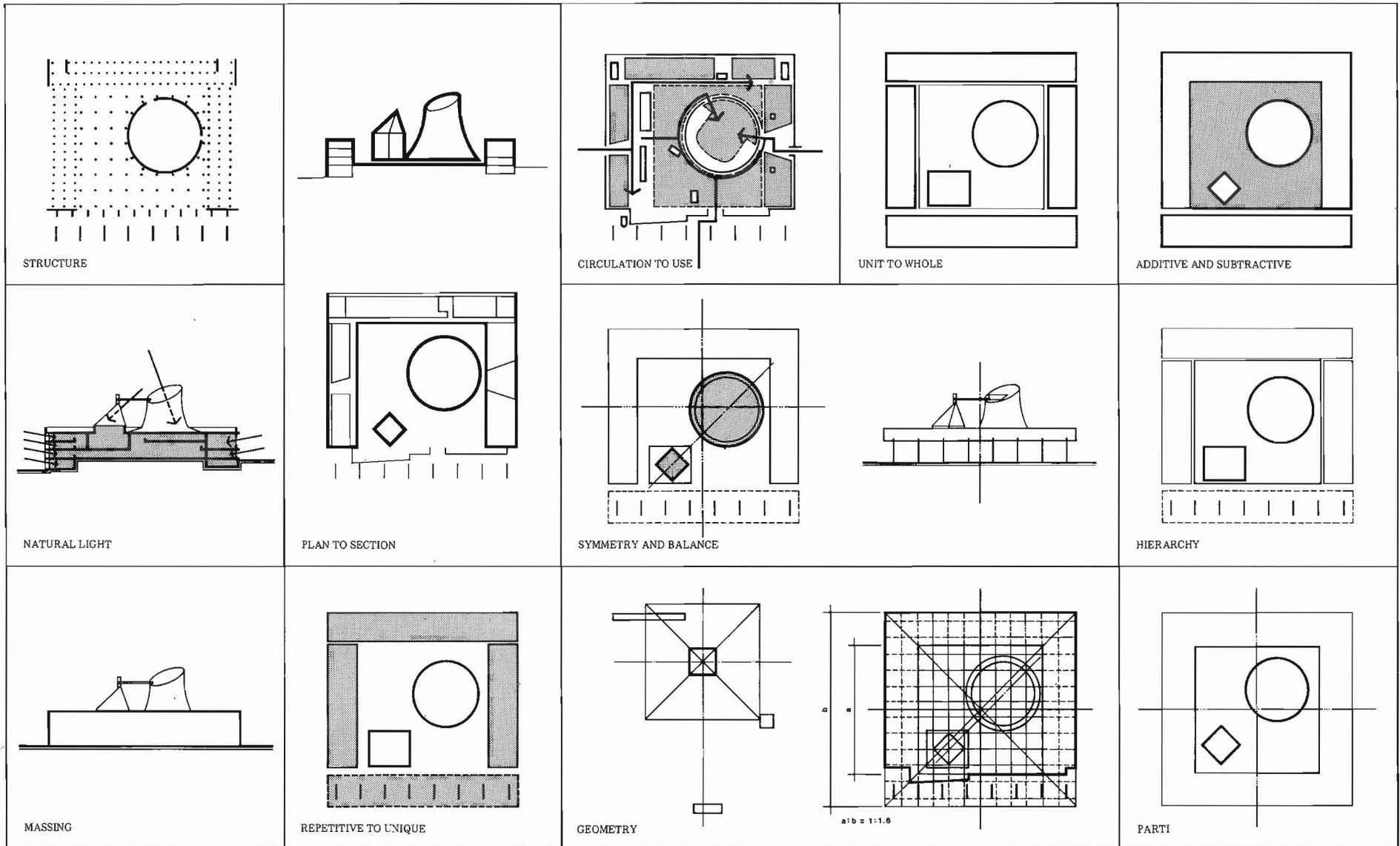

CLAUDE NICHOLAS LEDOUX

CLAUDE NICHOLAS LEDOUX

HOTEL DE MONTMORENCY
PARIS, FRANCE
1769



SECTION A

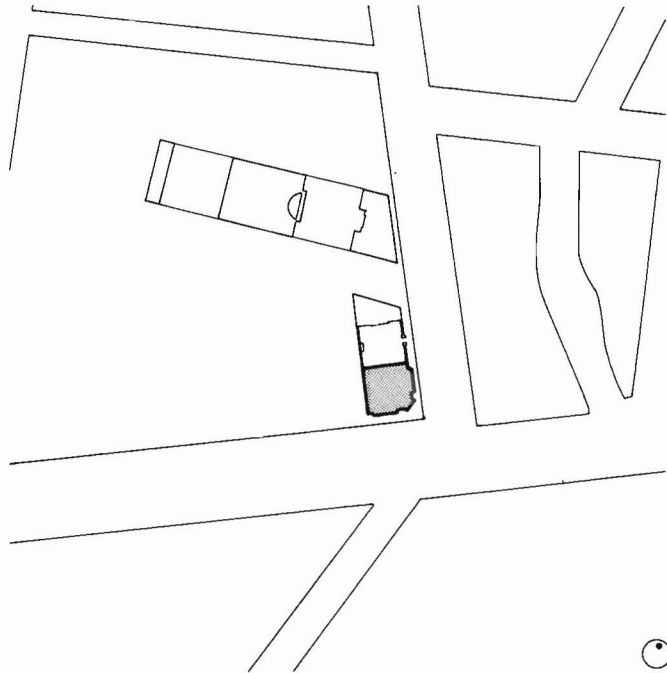

SITE PLAN

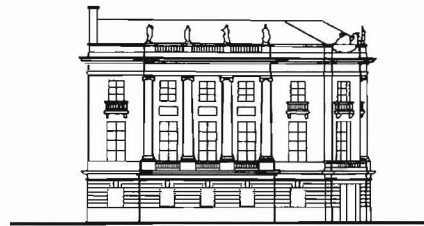

ELEVATION 1

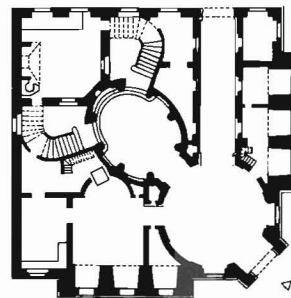

LOWER FLOOR PLAN

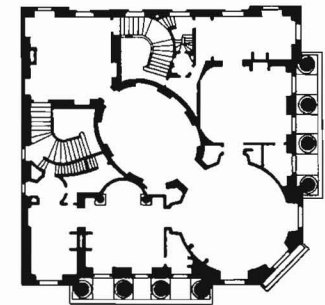

MAIN FLOOR PLAN

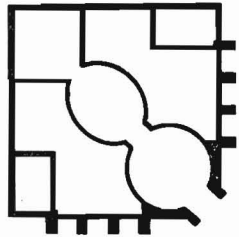

STRUCTURE

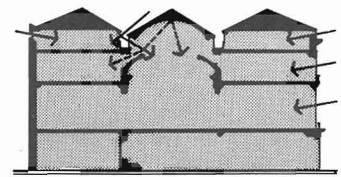
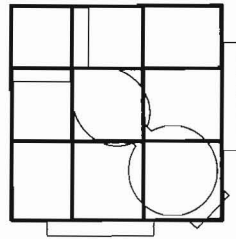

NATURAL LIGHT

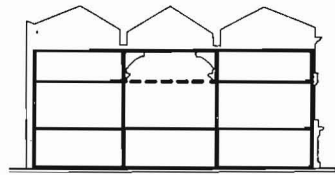

PLAN TO SECTION

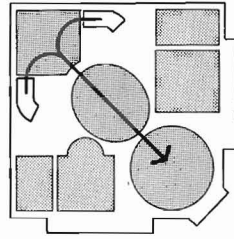

CIRCULATION TO USE

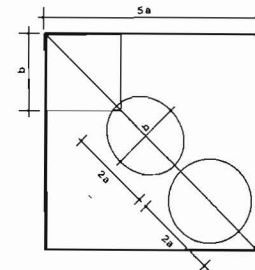
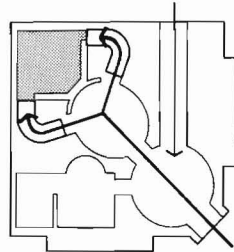

GEOMETRY

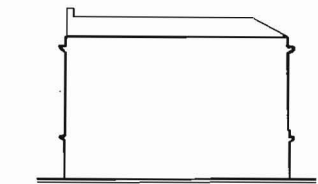
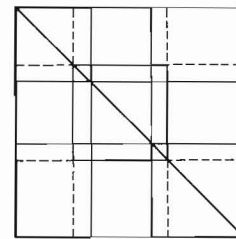

MASSING

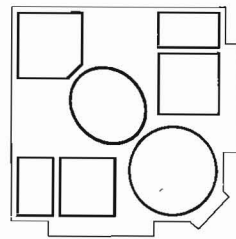

UNIT TO WHOLE

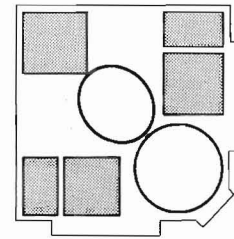

REPETITIVE TO UNIQUE

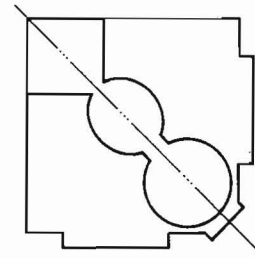

SYMMETRY AND BALANCE

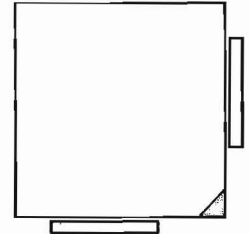

ADDITIVE AND SUBTRACTIVE

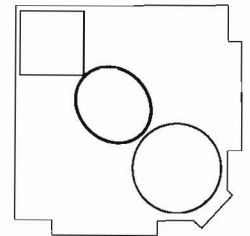

HIERARCHY

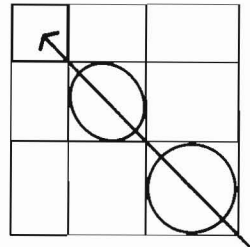

PARTI

CLAUDE NICHOLAS LEDOUX

HOTEL GUIMARD
PARIS, FRANCE
1770

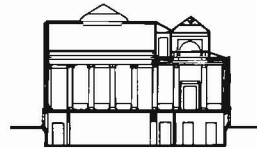

SECTION A

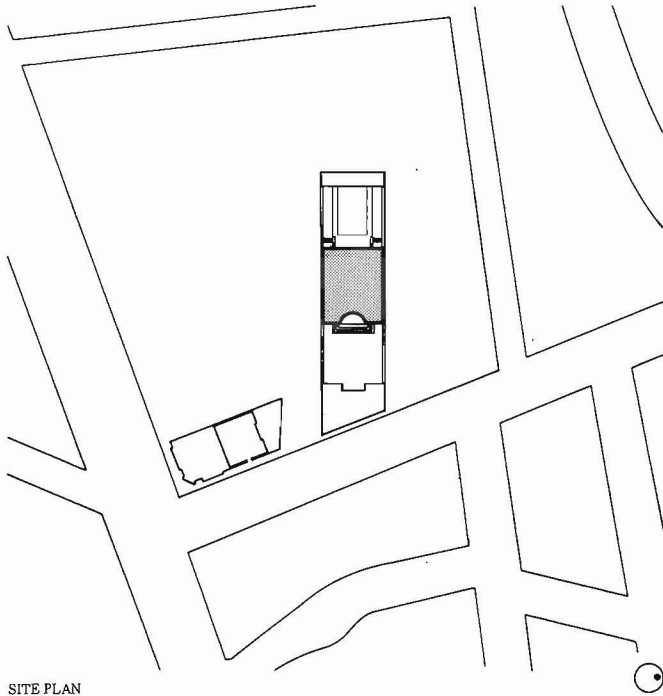

SITE PLAN



ELEVATION 1

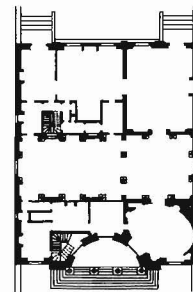

MAIN FLOOR PLAN

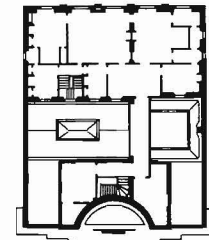

UPPER FLOOR PLAN

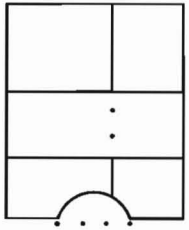
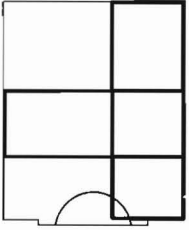
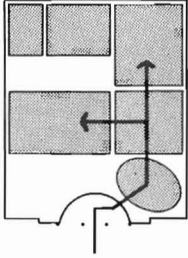
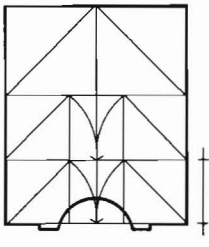
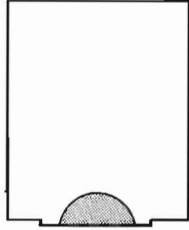
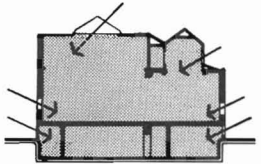
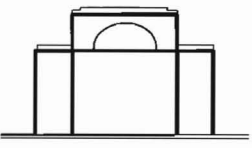
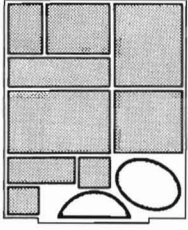
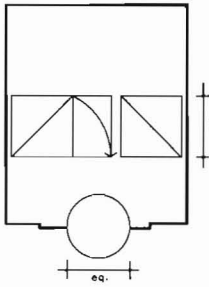
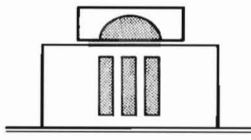
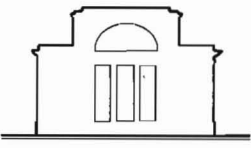
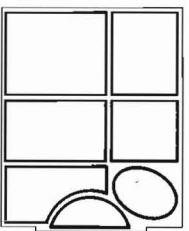
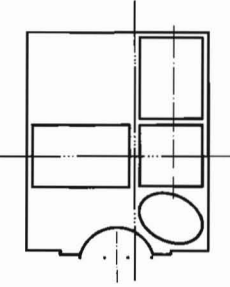
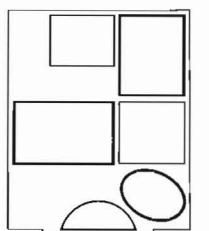
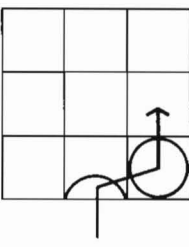
 <p>STRUCTURE</p>		 <p>CIRCULATION TO USE</p>		
 <p>NATURAL LIGHT</p>	 <p>PLAN TO SECTION</p>	 <p>REPETITIVE TO UNIQUE</p>	 <p>GEOMETRY</p>	 <p>ADDITIVE AND SUBTRACTIVE</p>
 <p>MASSING</p>	 <p>UNIT TO WHOLE</p>	 <p>SYMMETRY AND BALANCE</p>	 <p>HIERARCHY</p>	 <p>PARTI</p>

CLAUDE NICHOLAS LEDOUX

THEATER
BESANCON, FRANCE
1775

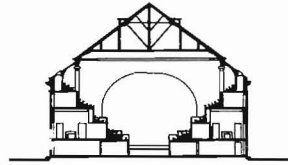

SECTION A

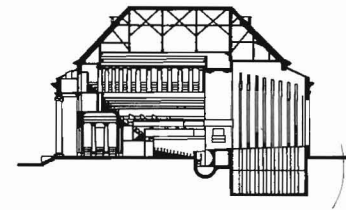

SECTION B

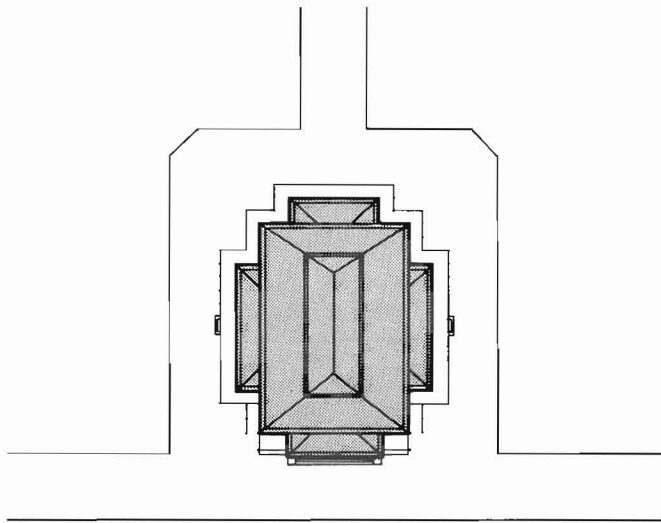

SITE PLAN

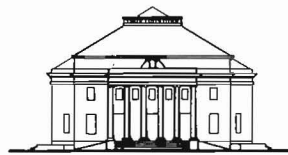

ELEVATION 1

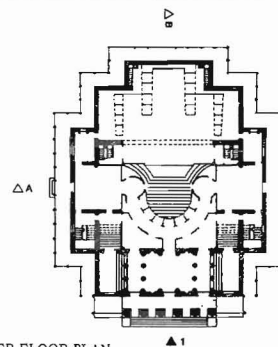

LOWER FLOOR PLAN

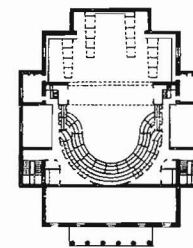

MIDDLE FLOOR PLAN

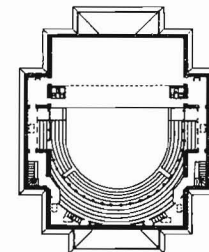

UPPER FLOOR PLAN

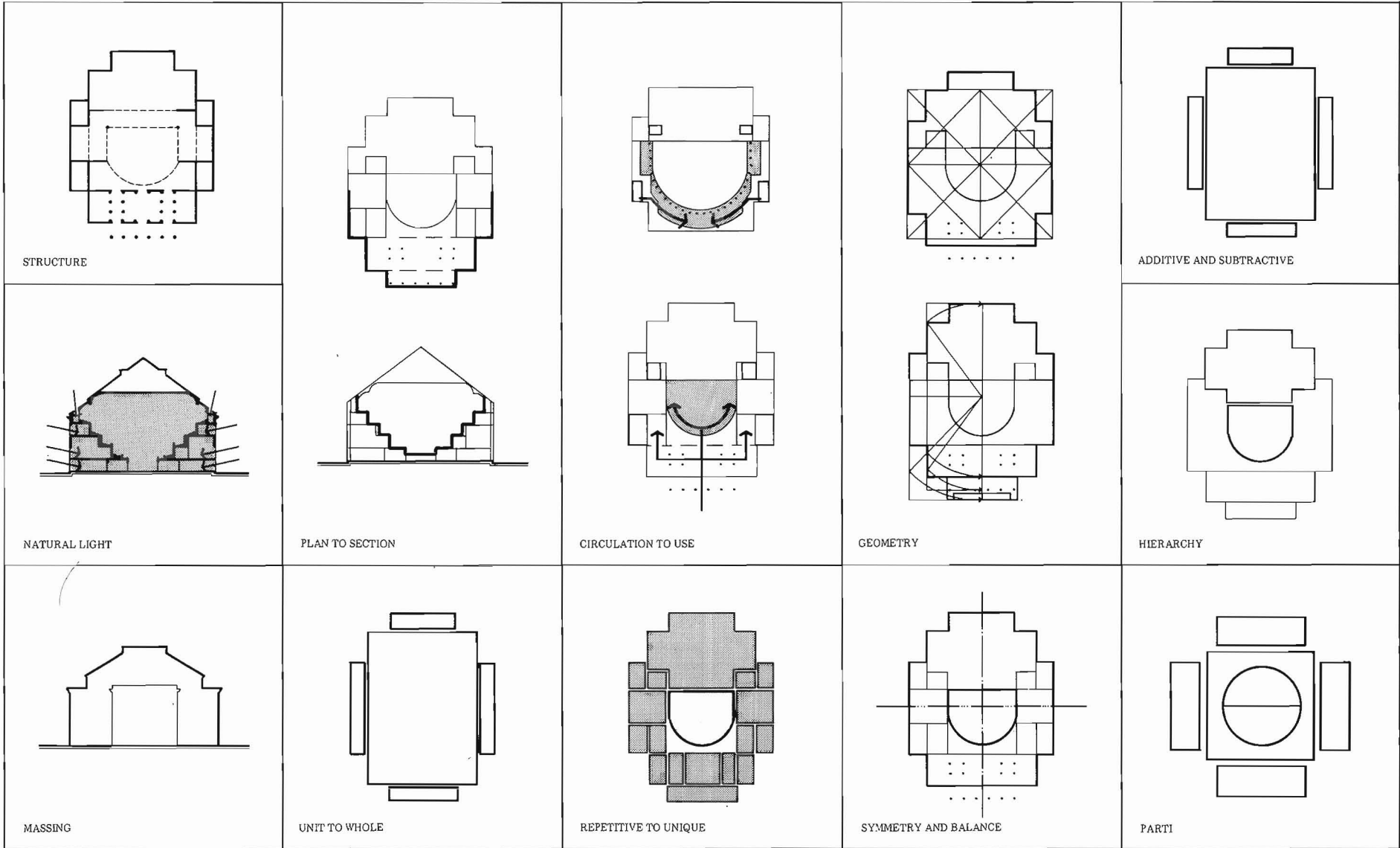

CLAUDE NICHOLAS LEDOUX

DIRECTORS HOUSE
SALTWORKS OF ARC AND SENANS
NEAR BESANCON, FRANCE
1775-1779

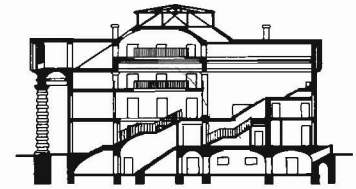

SECTION A

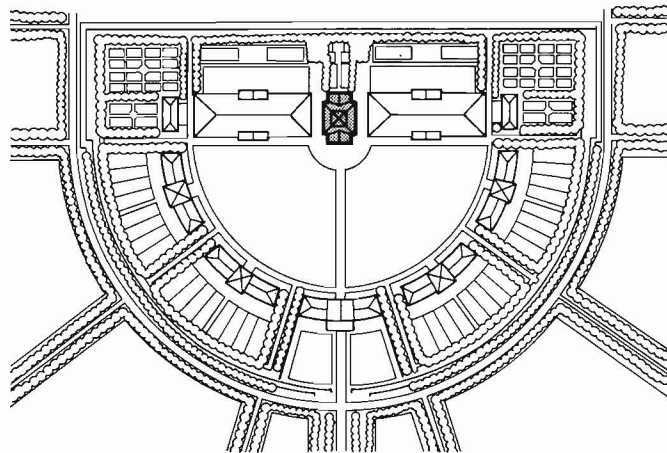

SITE PLAN

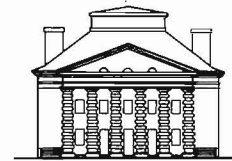

ELEVATION 1

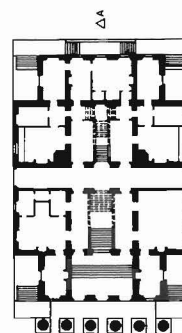

LOWER FLOOR PLAN



MIDDLE FLOOR PLAN

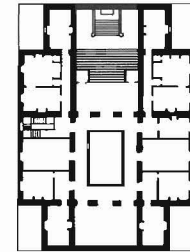

UPPER FLOOR PLAN

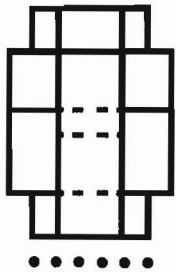

STRUCTURE

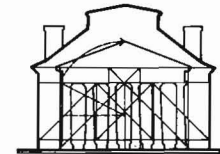
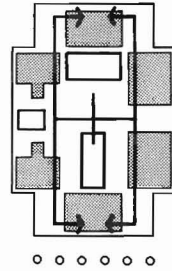
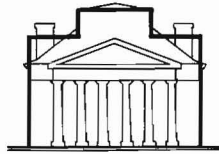

ADDITIVE AND SUBTRACTIVE

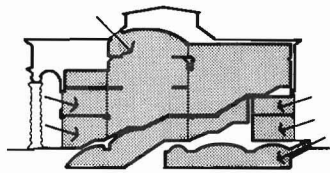
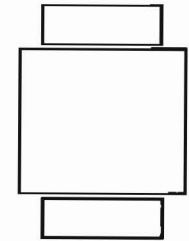

NATURAL LIGHT

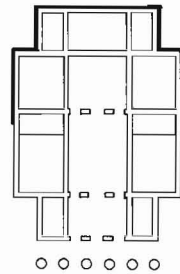

PLAN TO SECTION

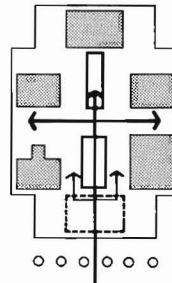

CIRCULATION TO USE

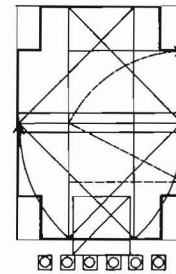

GEOMETRY

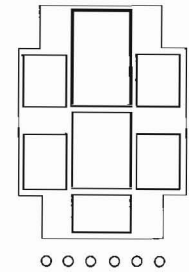

HIERARCHY

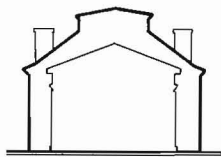

MASSING

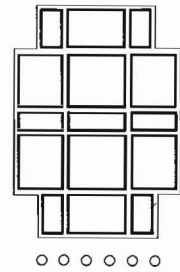

UNIT TO WHOLE

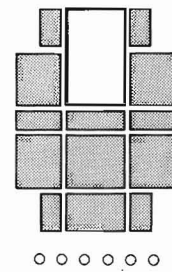

REPETITIVE TO UNIQUE

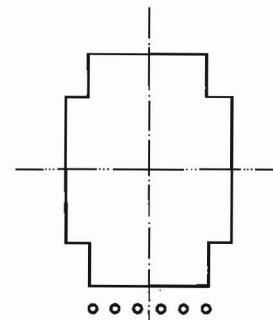

SYMMETRY AND BALANCE

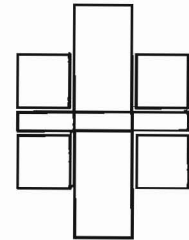

PARTI

EDWIN LUTYENS

EDWIN LUTYENS

HOMEWOOD (EARL OF LYTTON HOUSE)
KNEBORTH, HERTFORDSHIRE, ENGLAND
1901

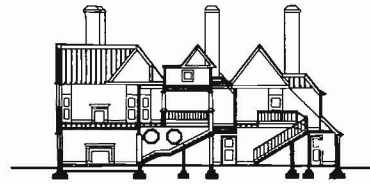

SECTION A

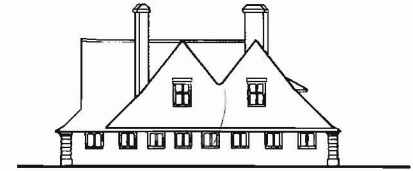

ELEVATION 1

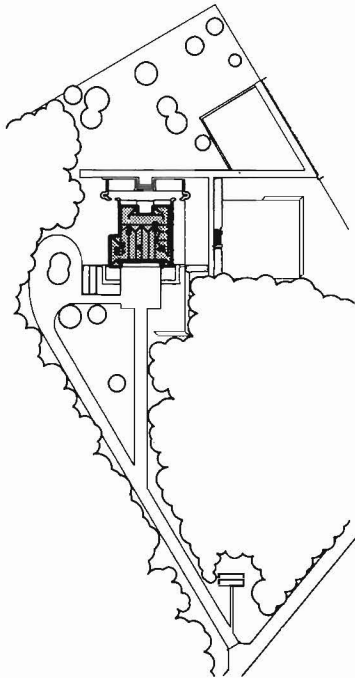

SITE PLAN



ELEVATION 2



ELEVATION 3

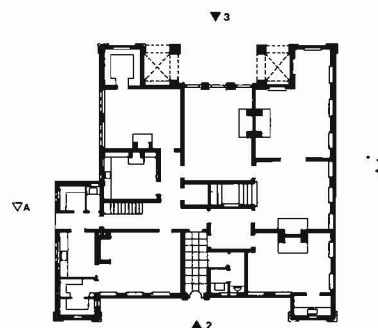

MAIN FLOOR PLAN

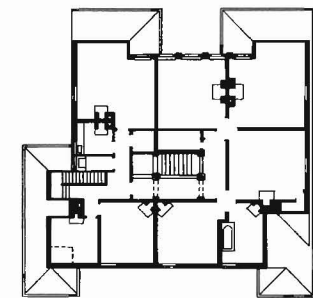

UPPER FLOOR PLAN

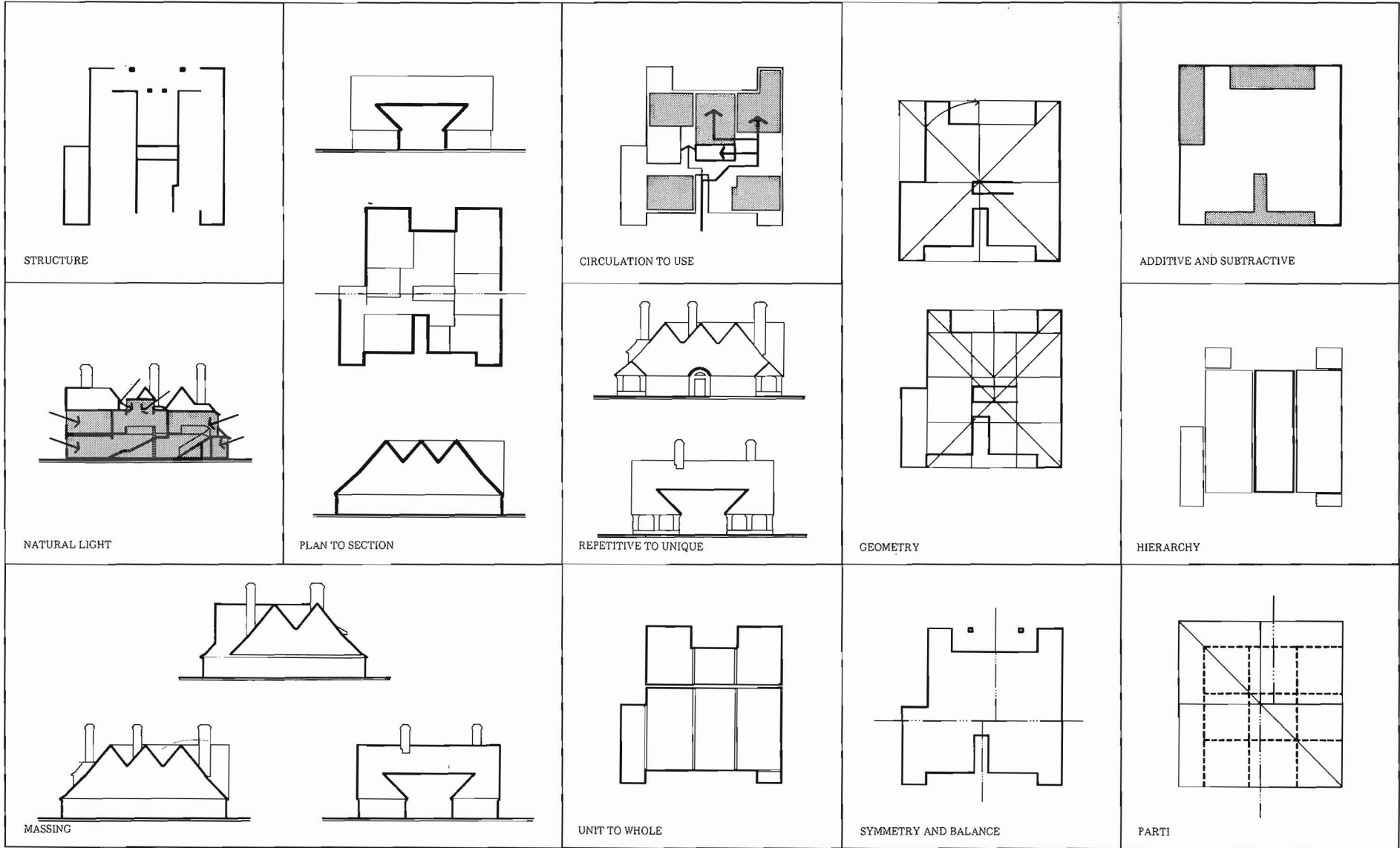

EDWIN LUTYENS

NASHDOM (PRINCESS ALEXIS DOLGORONKI HOUSE)
TAPLOW, BUCKINGHAMSHIRE, ENGLAND
1905-1909



SECTION A

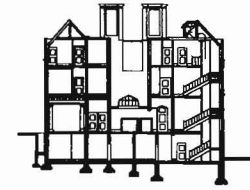

SECTION B

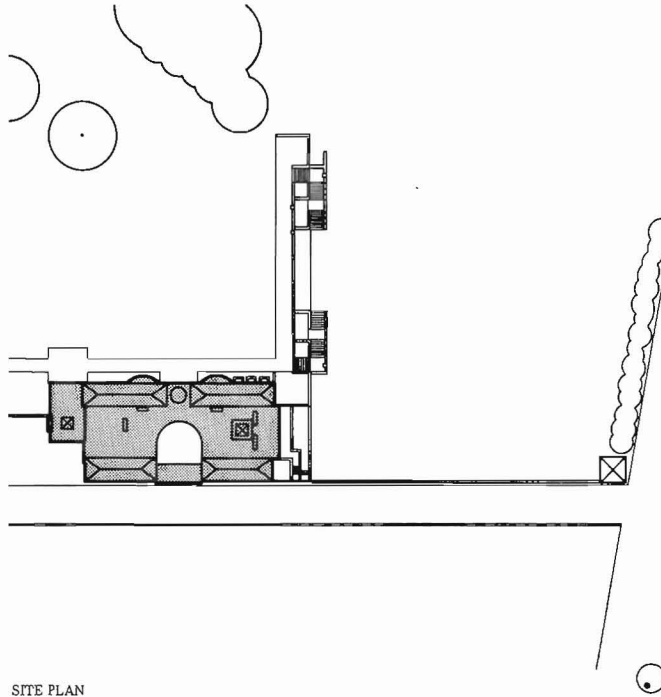

SITE PLAN



ELEVATION 1





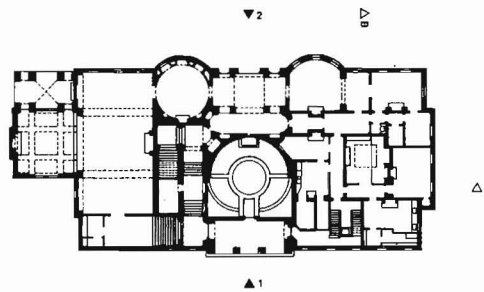

ELEVATION 2

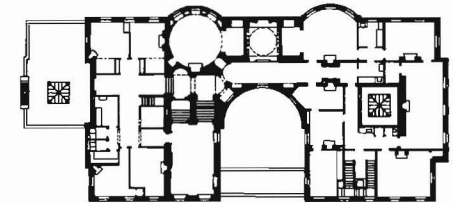

LOWER FLOOR PLAN

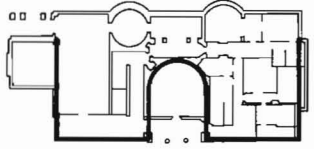
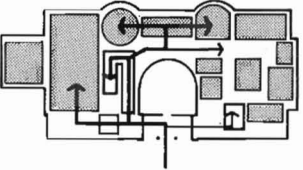
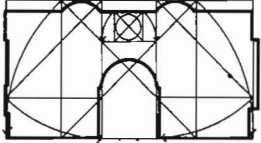
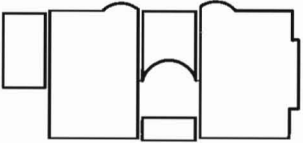
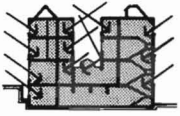
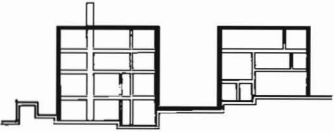
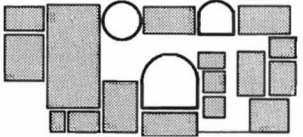
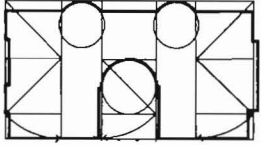

UPPER FLOOR PLAN

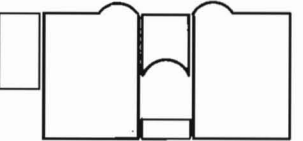
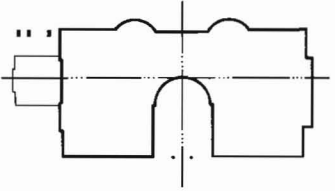
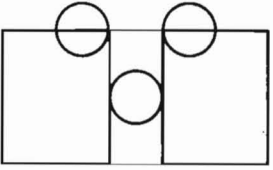
 <p>STRUCTURE</p>		 <p>CIRCULATION TO USE</p>		 <p>ADDITIVE AND SUBTRACTIVE</p>
 <p>NATURAL LIGHT</p>		 <p>REPETTIVE TO UNIQUE</p>	 <p>GEOMETRY</p>	 <p>HIERARCHY</p>
 <p>MASSING</p>	 <p>PLAN TO SECTION</p>	 <p>UNIT TO WHOLE</p>	 <p>SYMMETRY AND BALANCE</p>	 <p>PARTI</p>

EDWIN LUTYENS

HEATHCOTE (HEMINGWAY HOUSE)
ILKLEY, YORKSHIRE, ENGLAND
1906



SECTION A

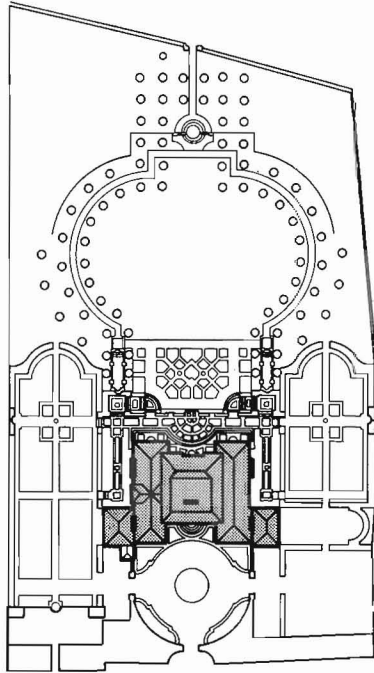

SITE PLAN



ELEVATION 1



ELEVATION 2

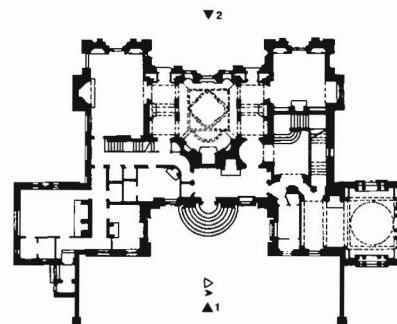

LOWER FLOOR PLAN

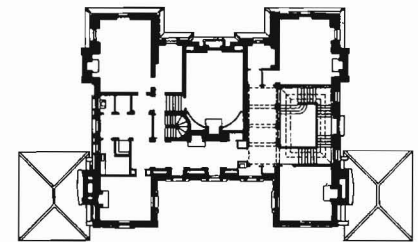

UPPER FLOOR PLAN

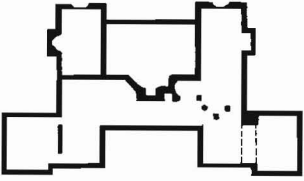
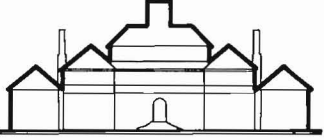
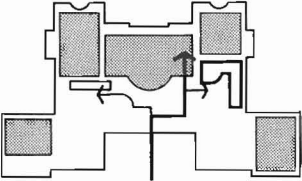
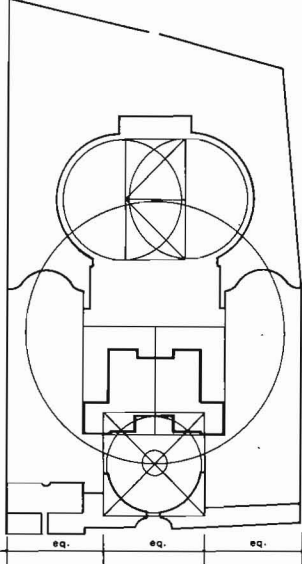
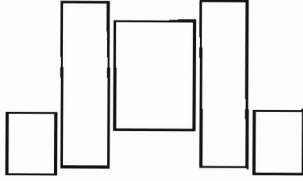
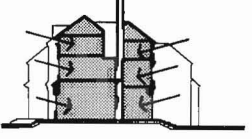
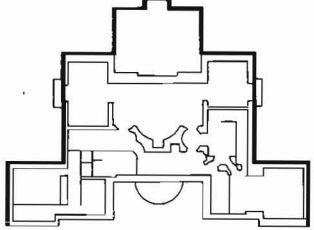
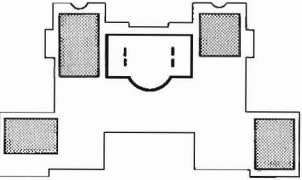
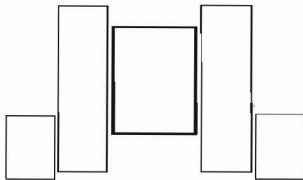
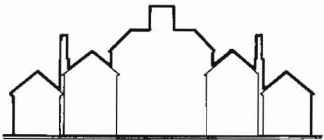
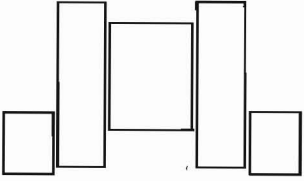
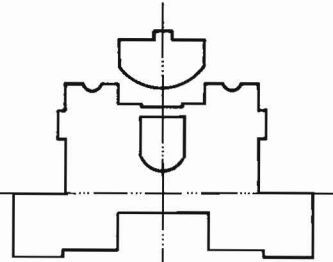
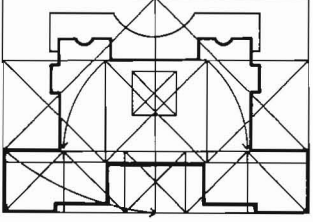
 <p>STRUCTURE</p>		 <p>CIRCULATION TO USE</p>		 <p>ADDITIVE AND SUBTRACTIVE</p>
 <p>NATURAL LIGHT</p>	 <p>PLAN TO SECTION</p>	 <p>REPETITIVE TO UNIQUE</p>		 <p>HIERARCHY</p>
 <p>MASSING</p>	 <p>UNIT TO WHOLE</p>	 <p>SYMMETRY AND BALANCE</p>		 <p>GEOMETRY</p>

EDWIN LUTYENS

THE SALUTATION (HENRY FARRER HOUSE)
SANDWICH, KENT, ENGLAND
1911

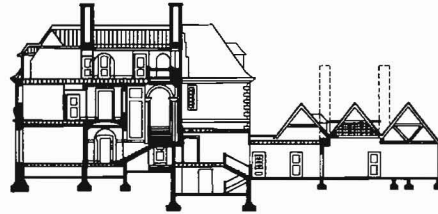

SECTION A

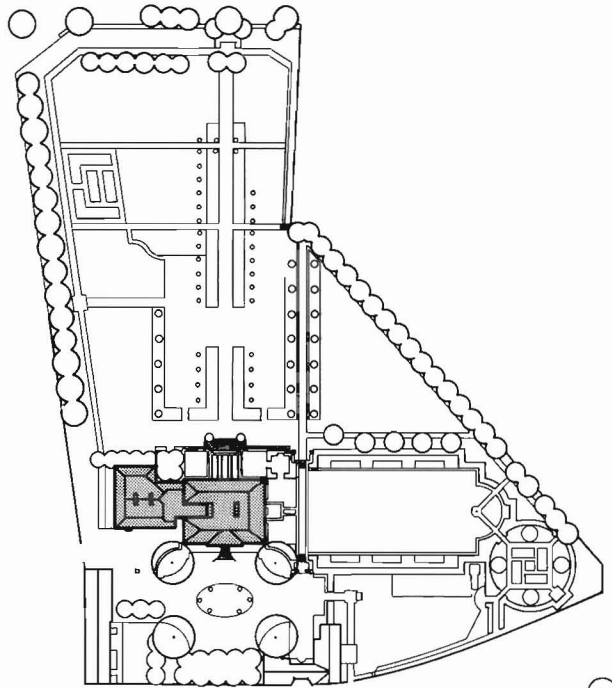

SITE PLAN



ELEVATION 1



ELEVATION 2

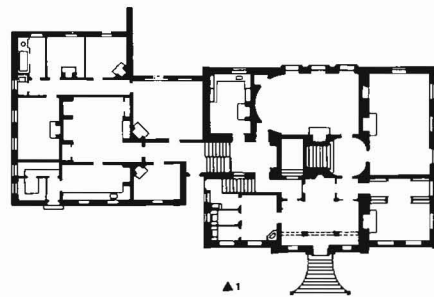

LOWER FLOOR PLAN

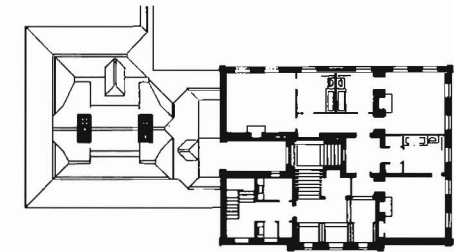

UPPER FLOOR PLAN

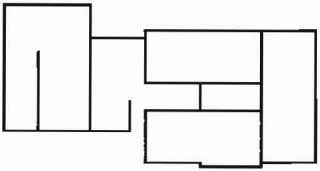
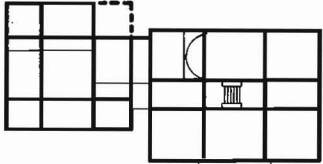
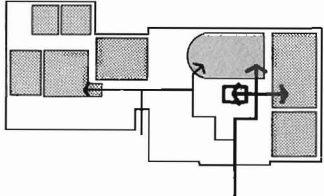
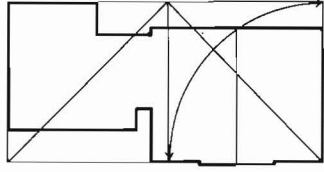
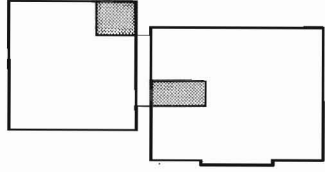
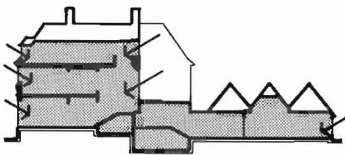
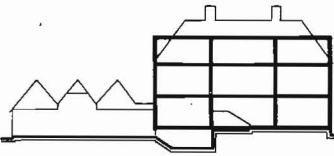
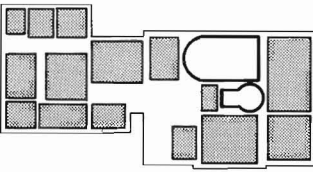
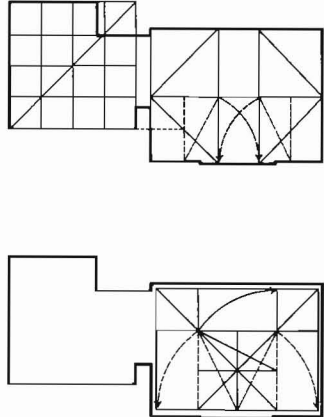
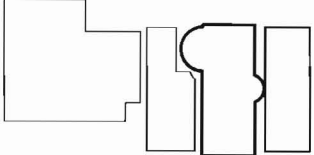
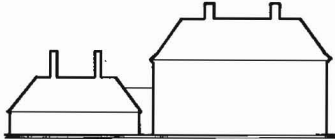
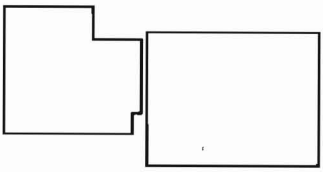
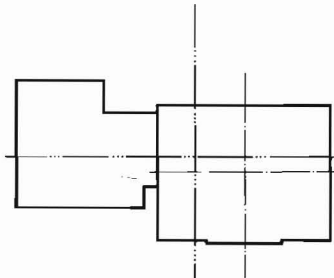
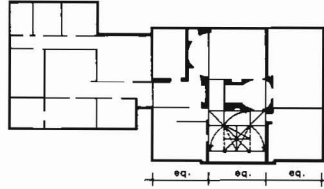
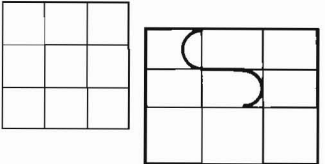
 <p>STRUCTURE</p>		 <p>CIRCULATION TO USE</p>		 <p>ADDITIVE AND SUBTRACTIVE</p>
 <p>NATURAL LIGHT</p>	 <p>PLAN TO SECTION</p>	 <p>REPETITIVE TO UNIQUE</p>		 <p>HIERARCHY</p>
 <p>MASSING</p>	 <p>UNIT TO WHOLE</p>	 <p>SYMMETRY AND BALANCE</p>	 <p>GEOMETRY</p>	 <p>PARTI</p>

RICHARD MEIER

RICHARD MEIER

SMITH HOUSE
DARIEN, CONNECTICUT
1965-1967

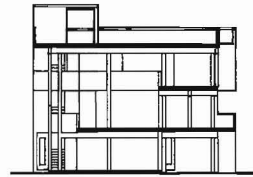

SECTION A

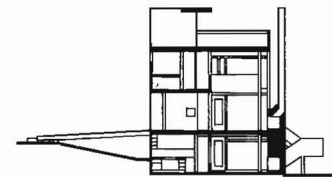

SECTION B

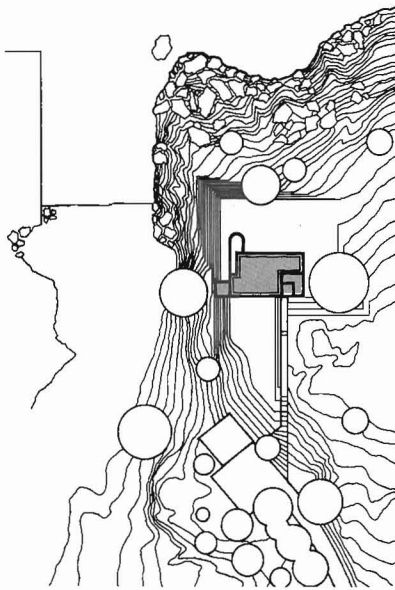

SITE PLAN

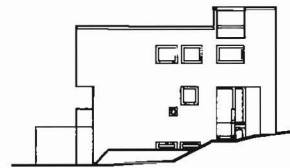

ELEVATION 1

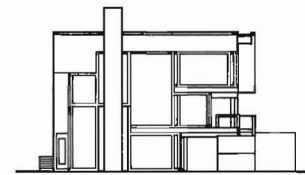

ELEVATION 2

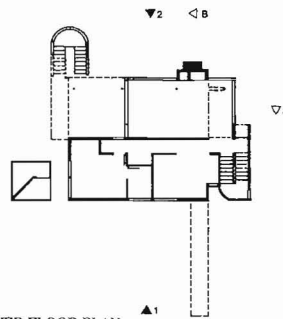

LOWER FLOOR PLAN

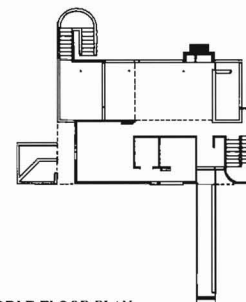

MIDDLE FLOOR PLAN

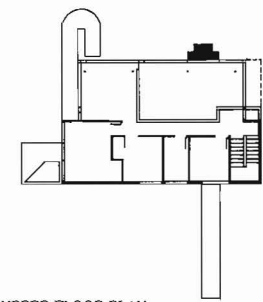

UPPER FLOOR PLAN

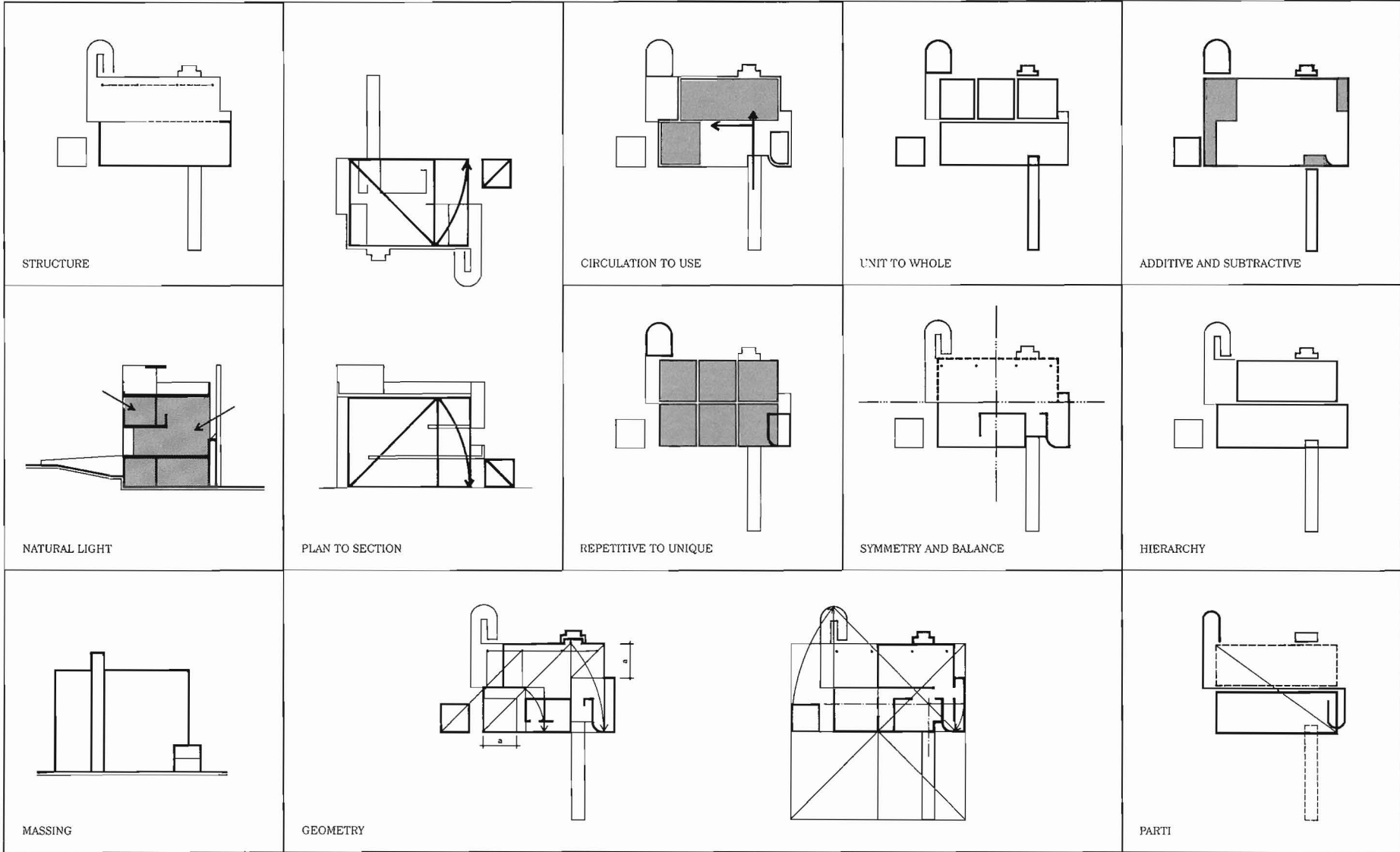

RICHARD MEIER

THE ATHENEUM
NEW HARMONY, INDIANA
1975-1979



SECTION A

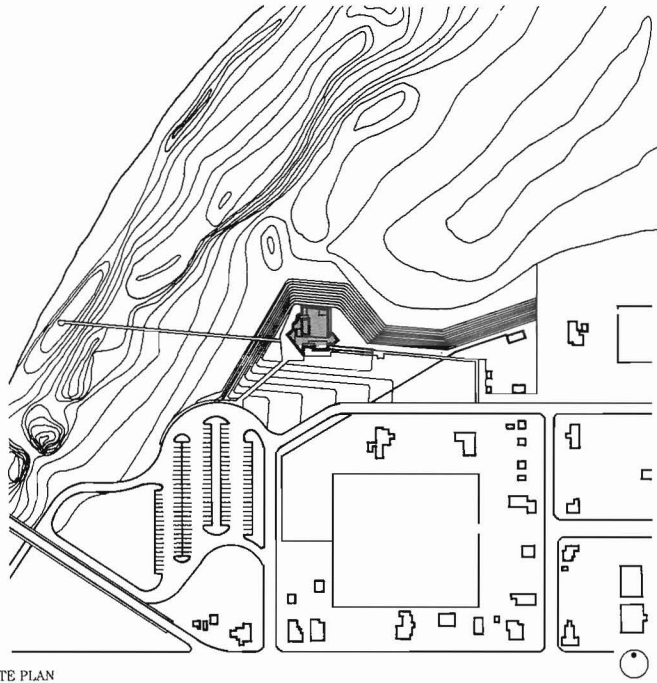

SITE PLAN

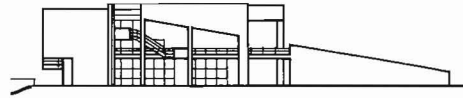

ELEVATION 1

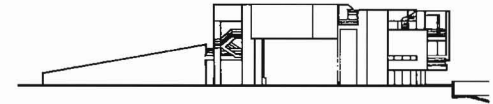



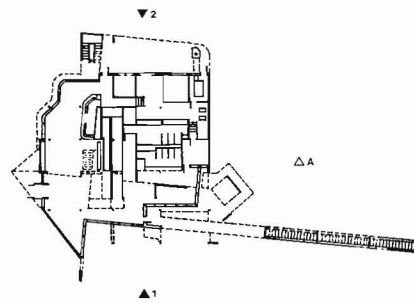

ELEVATION 2

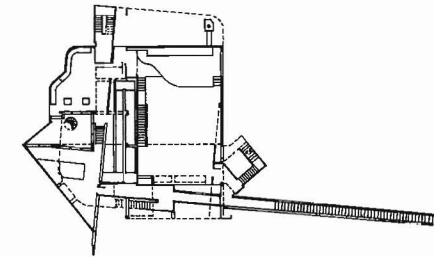

LOWER FLOOR PLAN

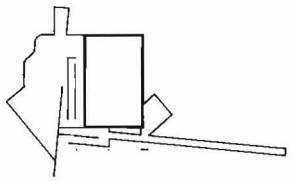
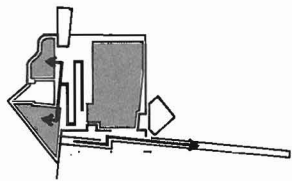
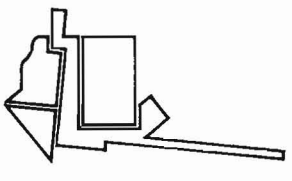
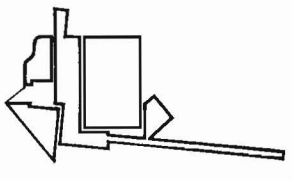
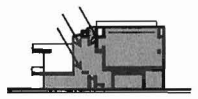

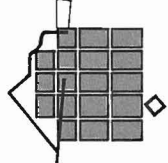
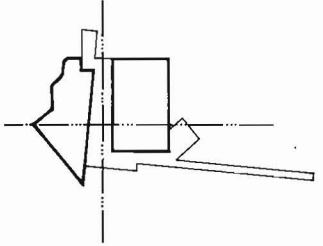
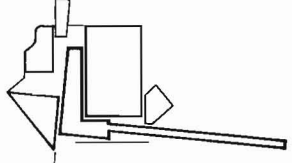
MIDDLE FLOOR PLAN

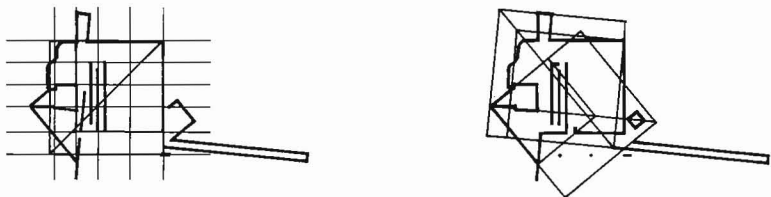
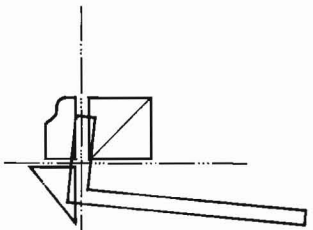
 <p>STRUCTURE</p>		 <p>CIRCULATION TO USE</p>	 <p>UNIT TO WHOLE</p>	 <p>ADDITIVE AND SUBTRACTIVE</p>
 <p>NATURAL LIGHT</p>	 <p>PLAN TO SECTION</p>	 <p>REPETITIVE TO UNIQUE</p>	 <p>SYMMETRY AND BALANCE</p>	 <p>HIERARCHY</p>
 <p>MASSING</p>	 <p>GEOMETRY</p>		 <p>PARTI</p>	

RICHARD MEIER

ULM EXHIBITION AND ASSEMBLY BUILDING
ULM, GERMANY
1986-1992

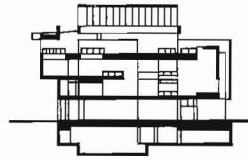

SECTION A

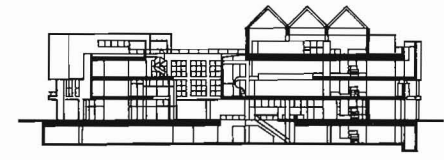

SECTION B

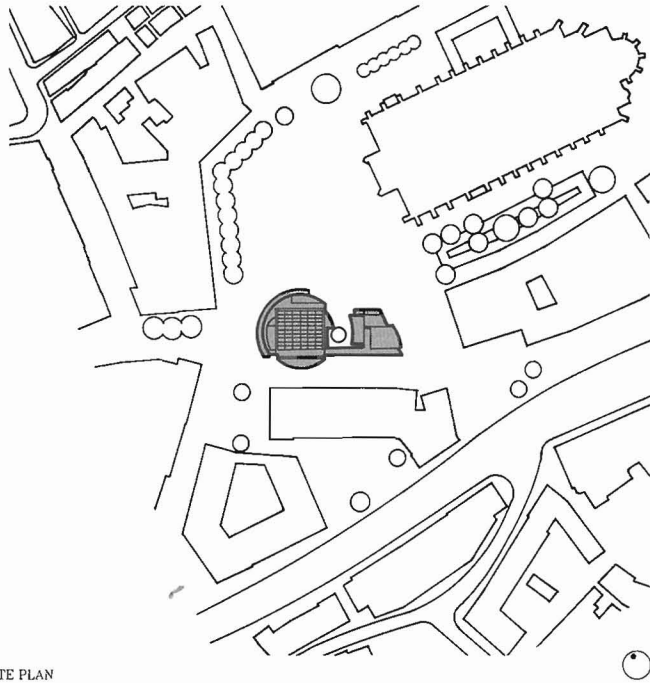

SITE PLAN



ELEVATION 1



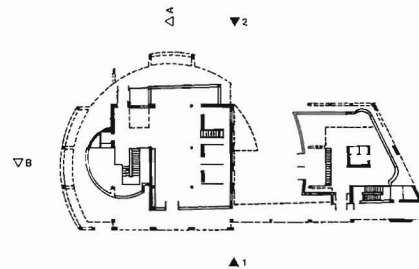

ELEVATION 2

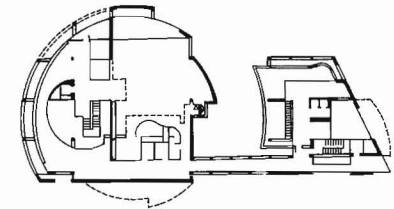

FIRST FLOOR PLAN

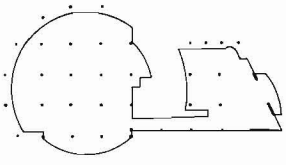
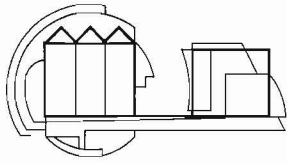
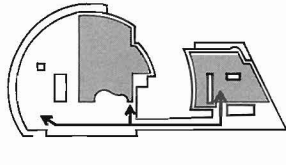
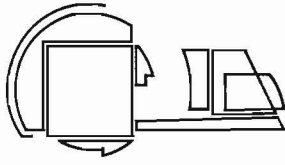
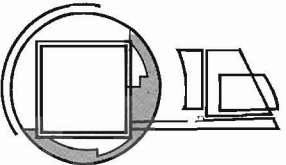
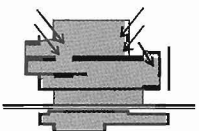

SECOND FLOOR PLAN

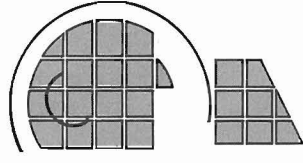
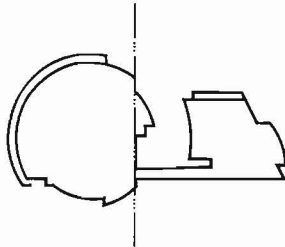
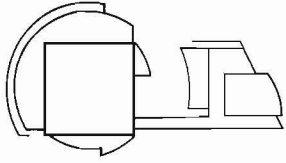
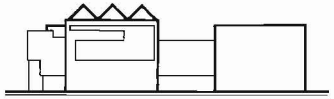
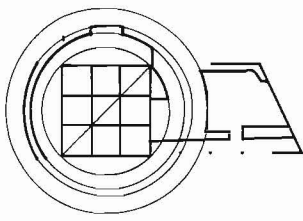
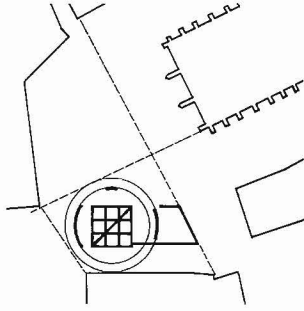
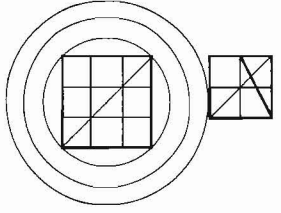
 <p>STRUCTURE</p>		 <p>CIRCULATION TO USE</p>	 <p>UNIT TO WHOLE</p>	 <p>ADDITIVE AND SUBRACTIVE</p>
 <p>NATURAL LIGHT</p>	 <p>PLAN TO SECTION</p>	 <p>REPETITIVE TO UNIQUE</p>	 <p>SYMMETRY AND BALANCE</p>	 <p>HIERARCHY</p>
 <p>MASSING</p>	 <p>GEOMETRY</p> 		 <p>PARTI</p>	

RICHARD MEIER

WEISHAAPT FORUM
SCHWENDI, GERMANY
1987-1992



ELEVATION 1



SECTION A

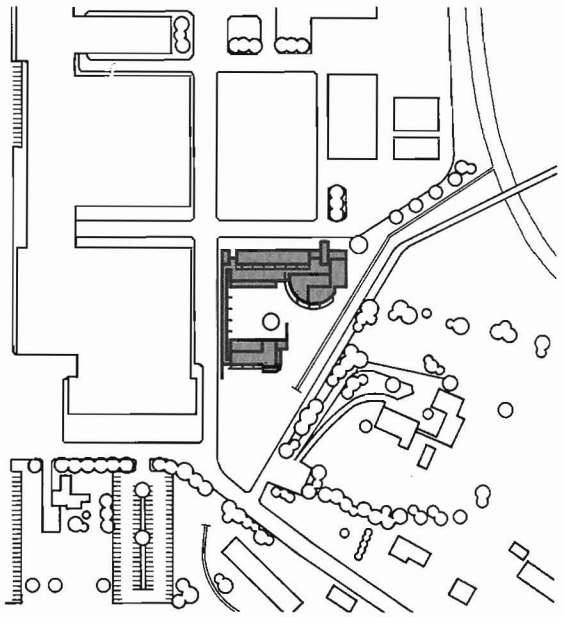

SITE PLAN



ELEVATION 2



ELEVATION 3

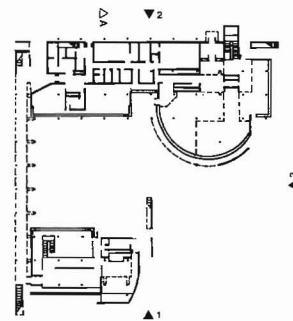

LOWER FLOOR PLAN

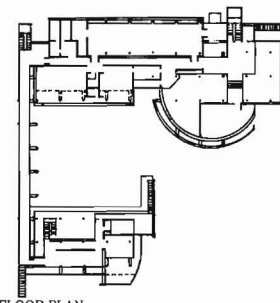

UPPER FLOOR PLAN

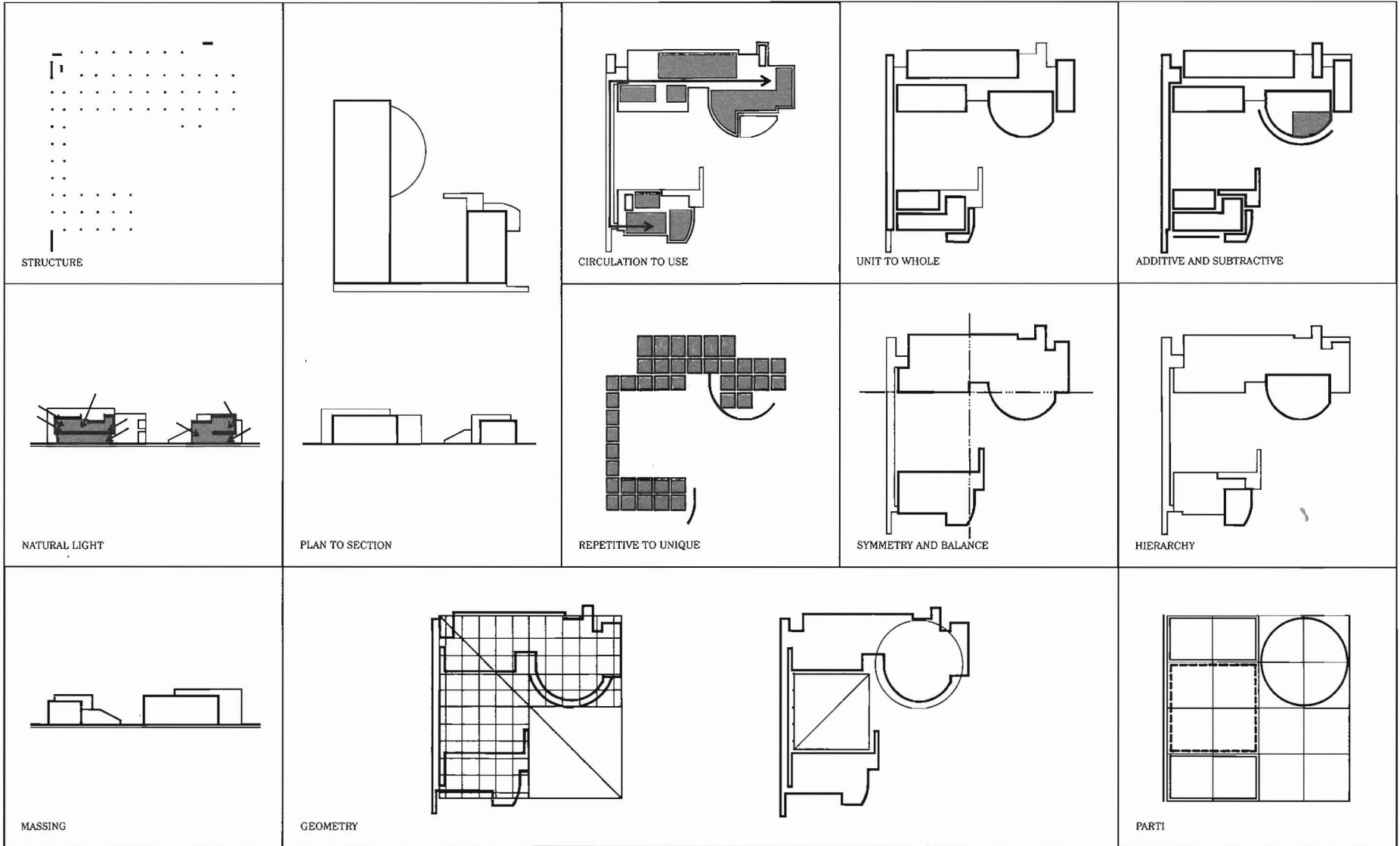

CHARLES MOORE

CHARLES MOORE

MOORE HOUSE
ORINDA, CALIFORNIA
1962

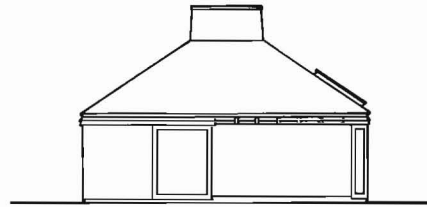

ELEVATION 1

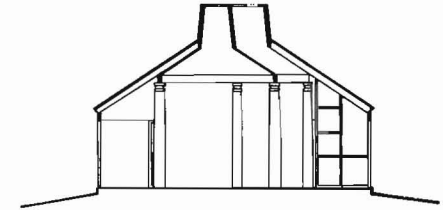

SECTION A

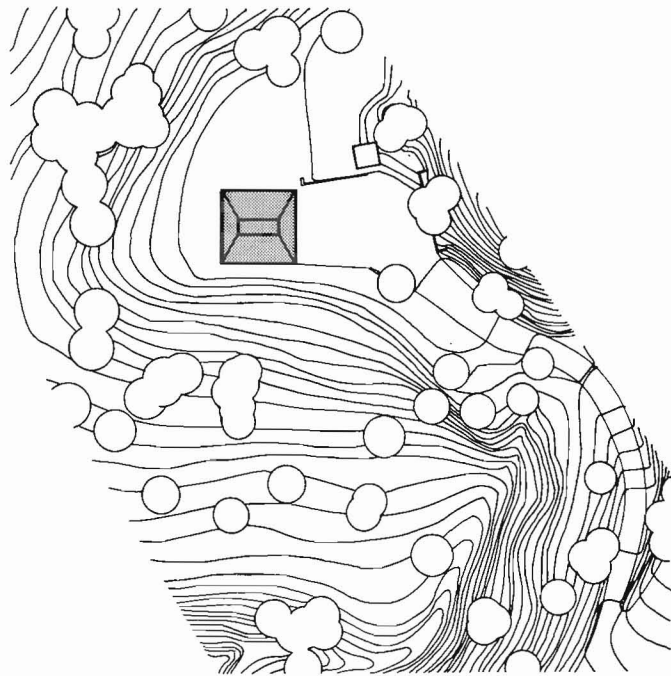

SITE PLAN

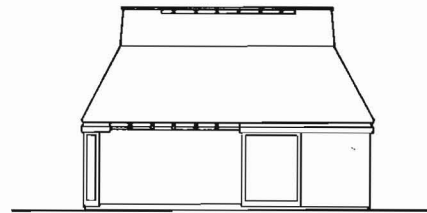

ELEVATION 2

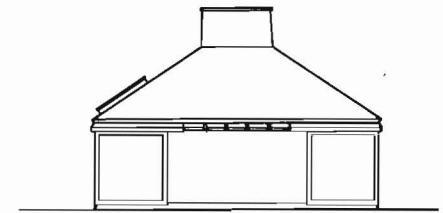

ELEVATION 3

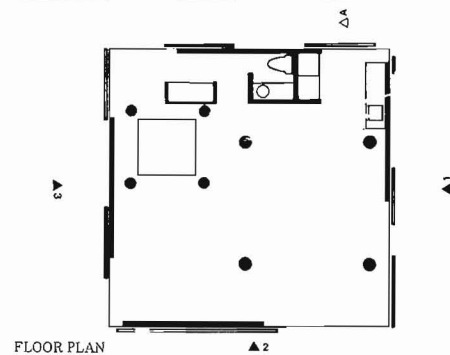

FLOOR PLAN

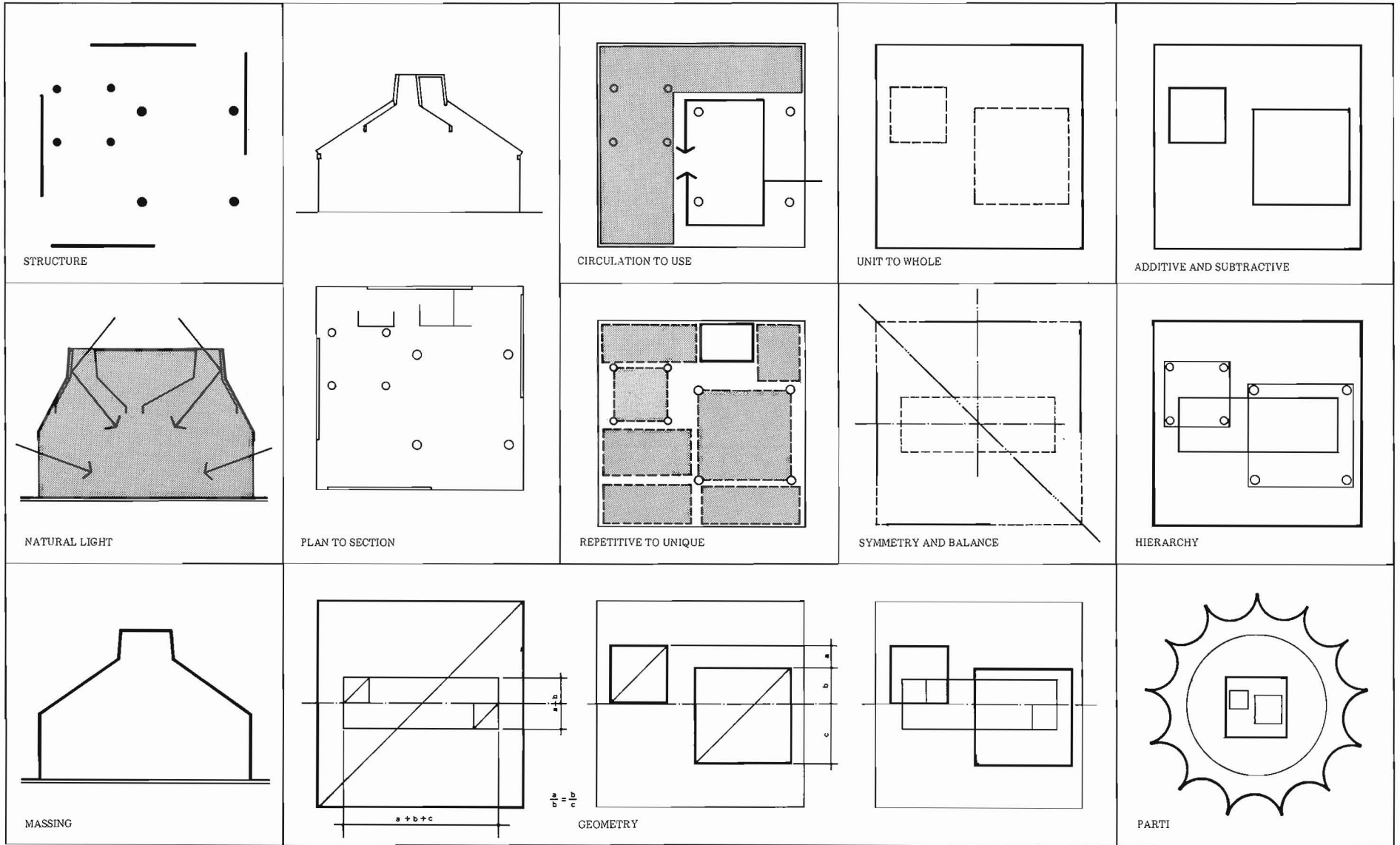

CHARLES MOORE

CONDOMINIUM I
SEA RANCH, CALIFORNIA
1964-1965

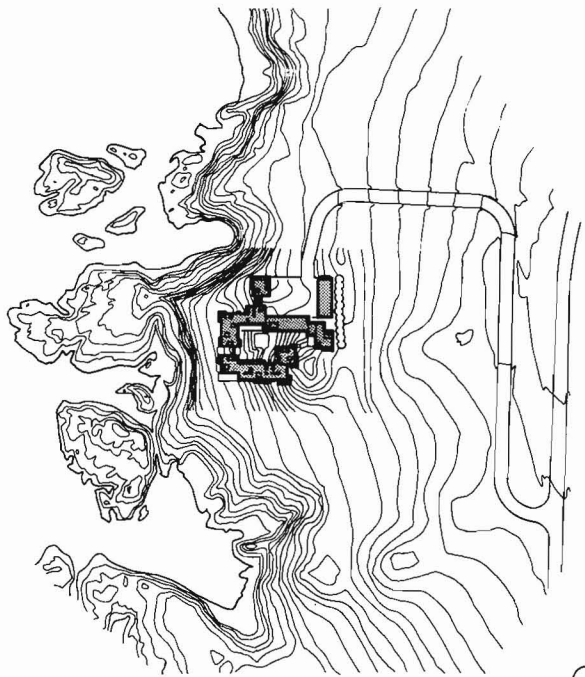

SITE PLAN

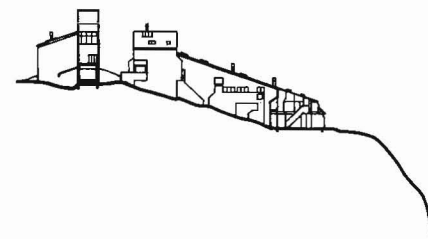

SECTION A



ELEVATION 1

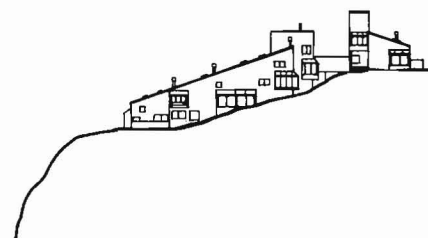

ELEVATION 2

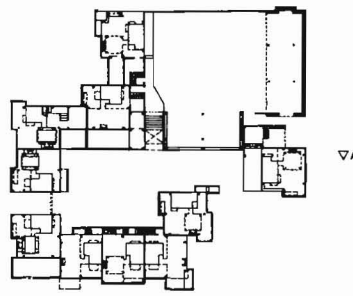

MAIN FLOOR PLAN

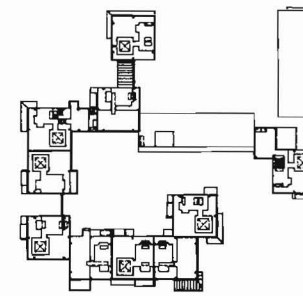

UPPER FLOOR PLAN

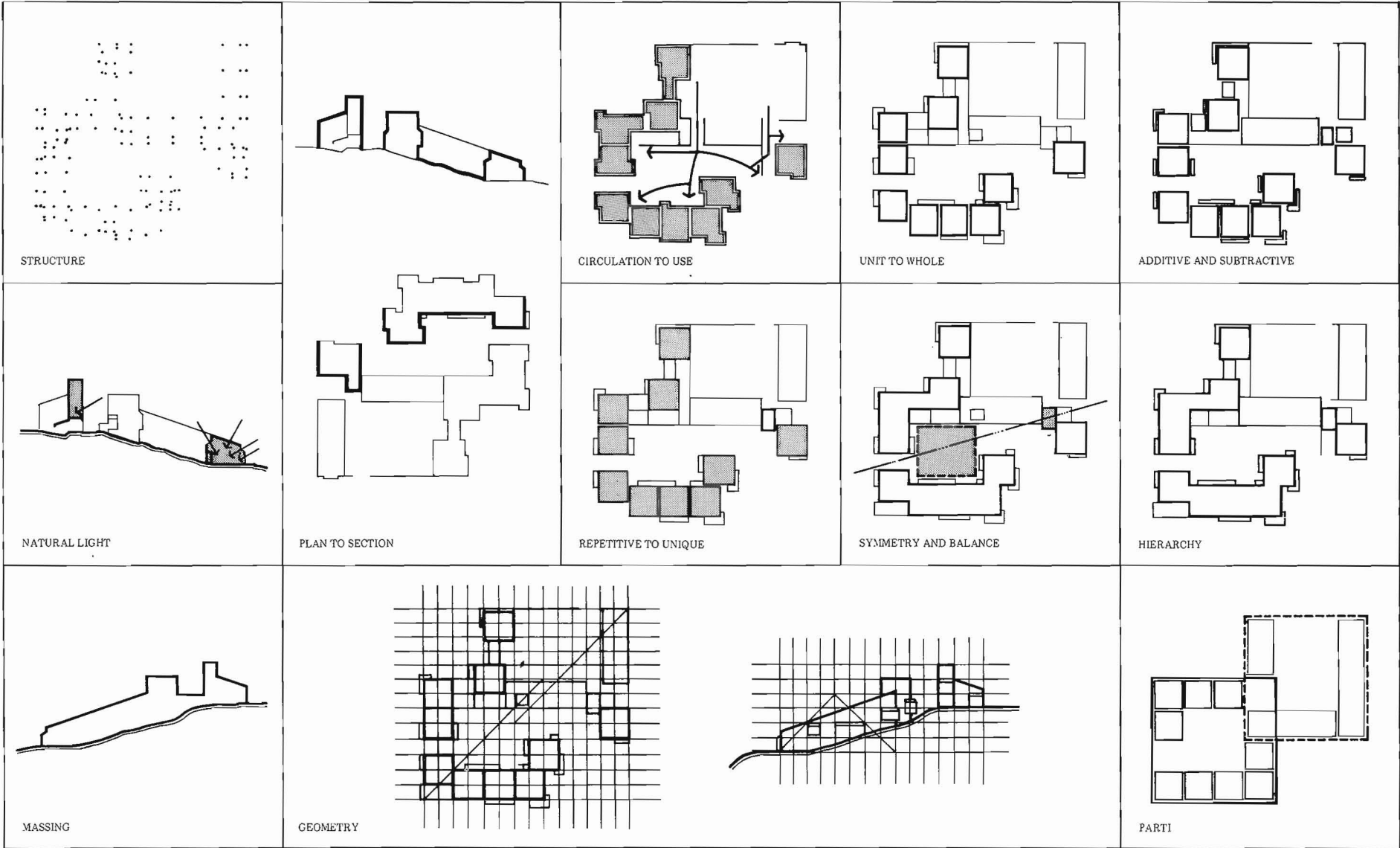

CHARLES MOORE

HINES HOUSE
SEA RANCH, CALIFORNIA
1967



SECTION A

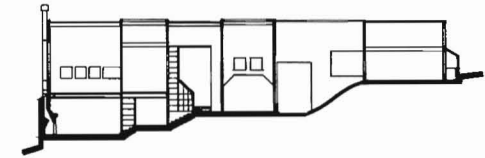

SECTION B

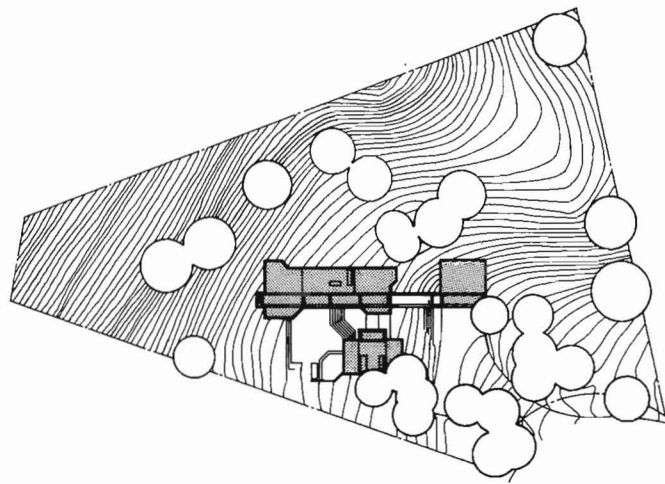

SITE PLAN

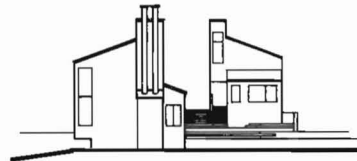

ELEVATION 1

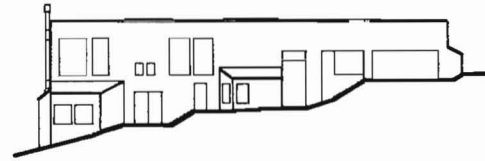

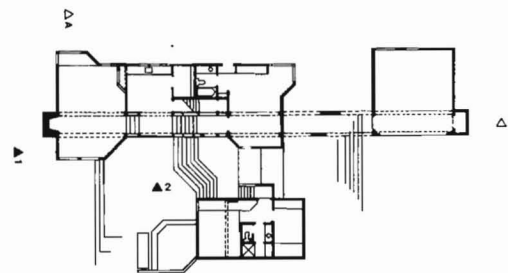

ELEVATION 2

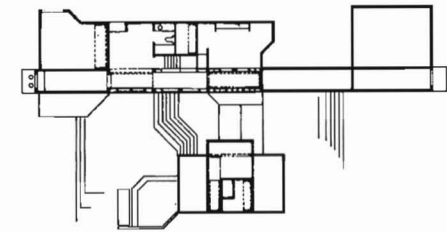

MAIN FLOOR PLAN

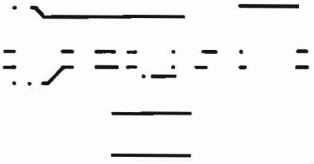
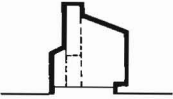
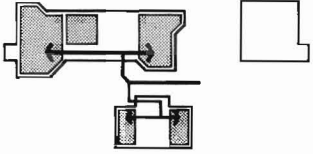
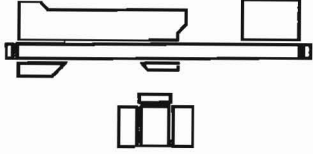
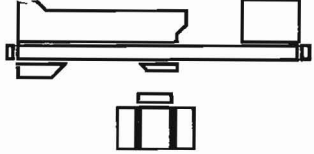
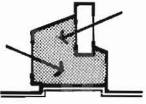

UPPER FLOOR PLAN

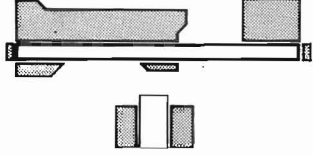
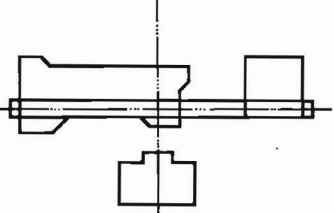
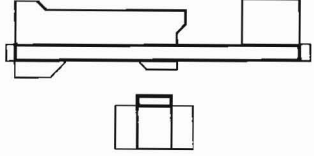
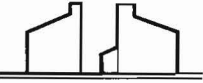
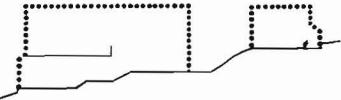
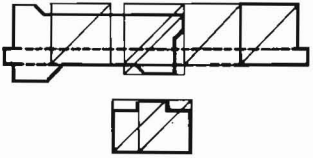
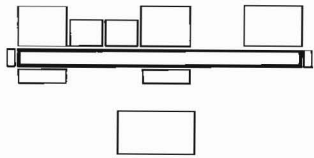
 <p>STRUCTURE</p>		 <p>CIRCULATION TO USE</p>	 <p>UNIT TO WHOLE</p>	 <p>ADDITIVE AND SUBTRACTIVE</p>
 <p>NATURAL LIGHT</p>		 <p>REPETITIVE TO UNIQUE</p>	 <p>SYMMETRY AND BALANCE</p>	 <p>HIERARCHY</p>
 <p>MASSING</p>	 <p>PLAN TO SECTION</p>	 <p>GEOMETRY</p>	 <p>PARTI</p>	

CHARLES MOORE

BURNS HOUSE
SANTA MONICA CANYON, CALIFORNIA
1974

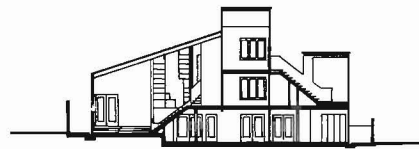

SECTION A

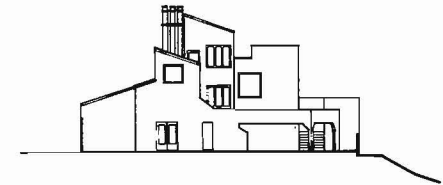

ELEVATION 1

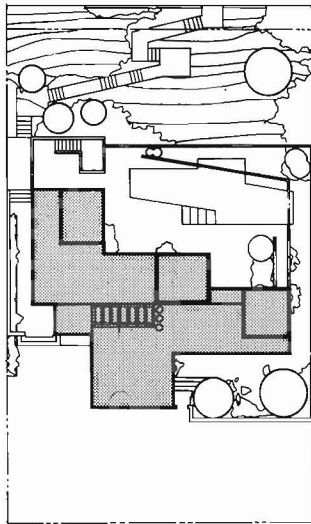

SITE PLAN

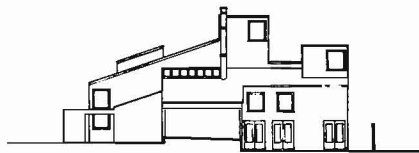

ELEVATION 2



ELEVATION 3

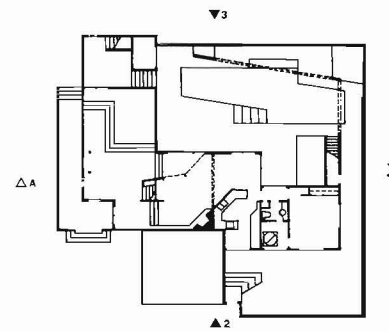

MAIN FLOOR PLAN

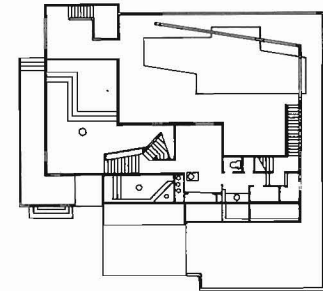

UPPER FLOOR PLAN

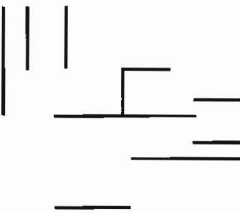
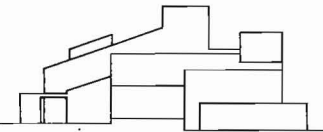
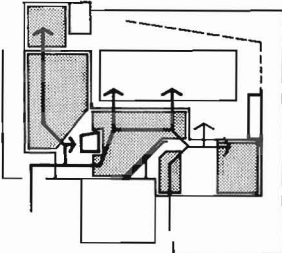
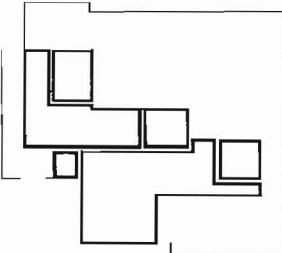
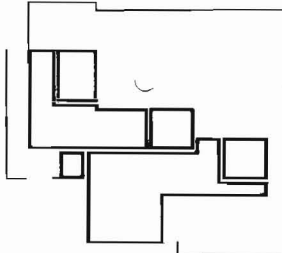
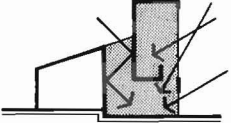
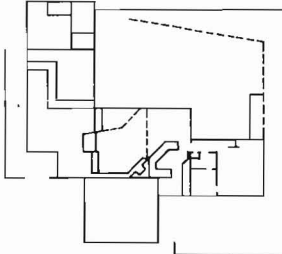
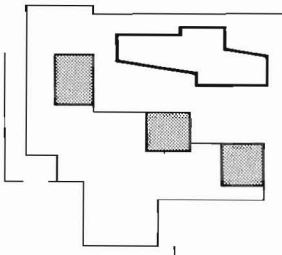
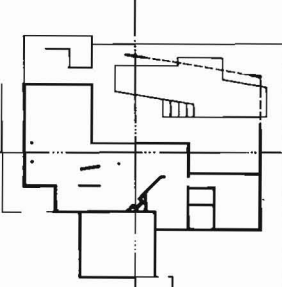
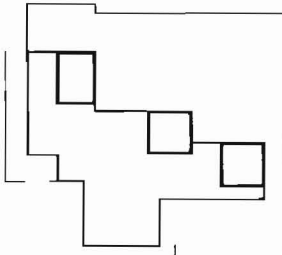
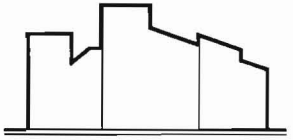
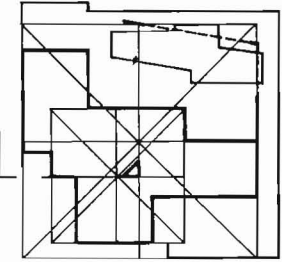
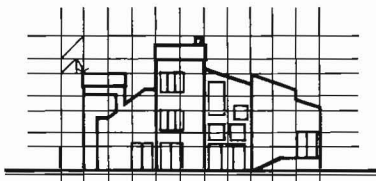
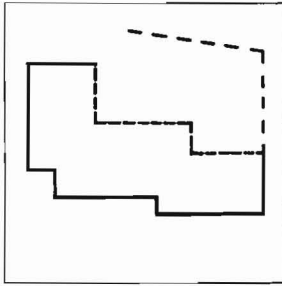
 <p>STRUCTURE</p>		 <p>CIRCULATION TO USE</p>	 <p>UNIT TO WHOLE</p>	 <p>ADDITIVE AND SUBTRACTIVE</p>
 <p>NATURAL LIGHT</p>	 <p>PLAN TO SECTION</p>	 <p>REPETITIVE TO UNIQUE</p>	 <p>SYMMETRY AND BALANCE</p>	 <p>HIERARCHY</p>
 <p>MASSING</p>	 <p>GEOMETRY</p>			 <p>PARTI</p>

ANDREA PALLADIO

ANDREA PALLADIO

VILLA FOSCARI
MALCONTENTA, ITALY
c. 1549-1563

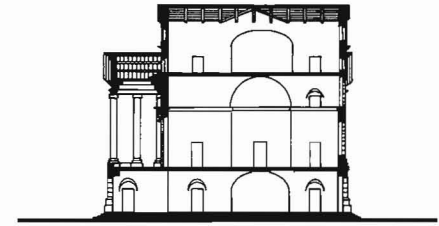

SECTION A

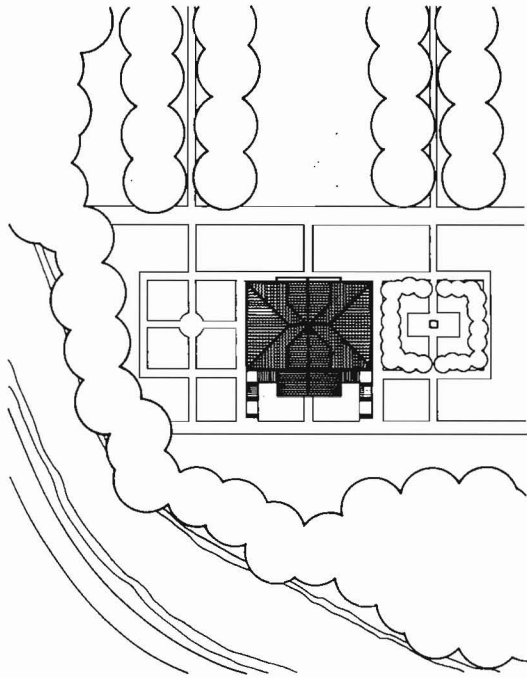

SITE PLAN



ELEVATION 1

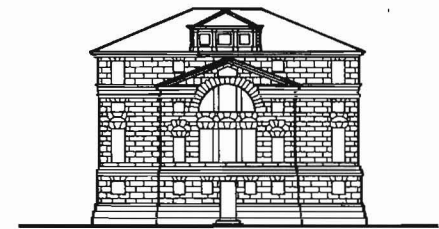

ELEVATION 2

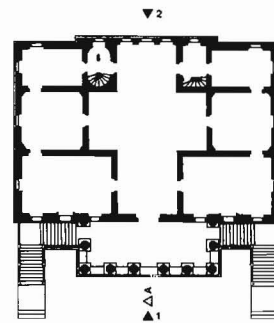

FLOOR PLAN

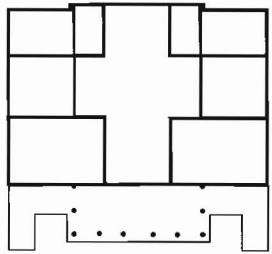

STRUCTURE

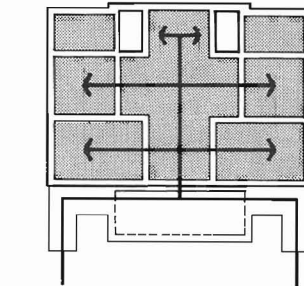
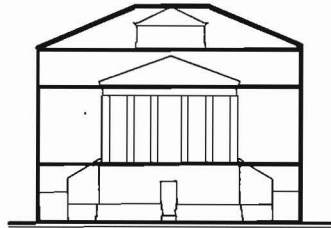

CIRCULATION TO USE

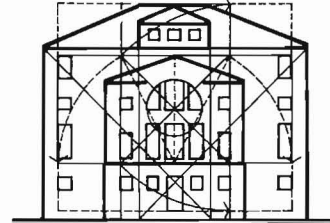

GEOMETRY

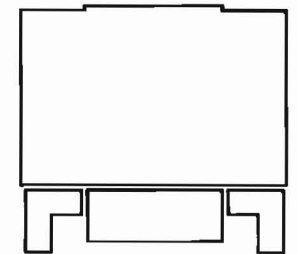

ADDITIVE AND SUBTRACTIVE

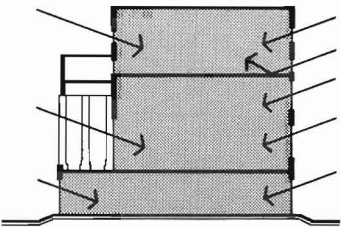

NATURAL LIGHT

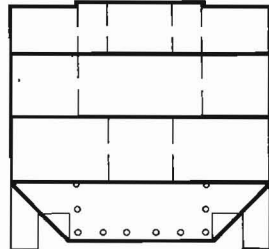

PLAN TO SECTION

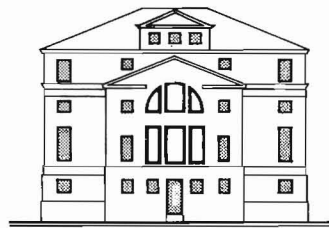

MASSING

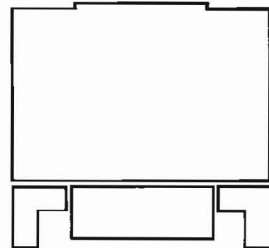

UNIT TO WHOLE

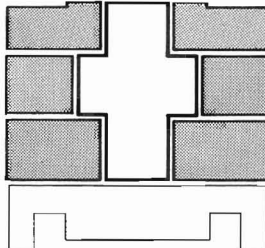

REPETITIVE TO UNIQUE

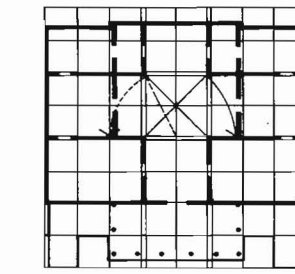

SYMMETRY AND BALANCE

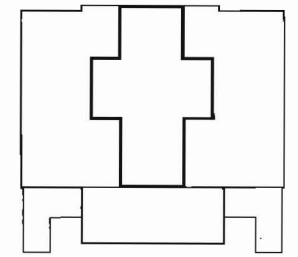

HIERARCHY

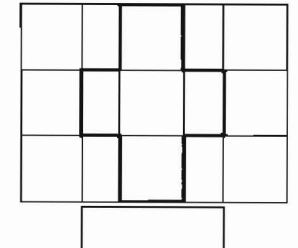
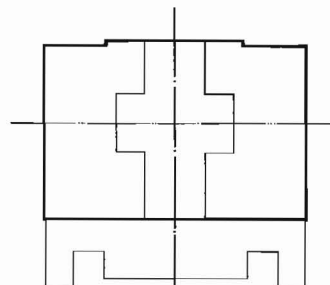

PARTI

ANDREA PALLADIO

CHURCH OF SAN GIORGIO MAGGIORE
VENICE, ITALY
1560-1580

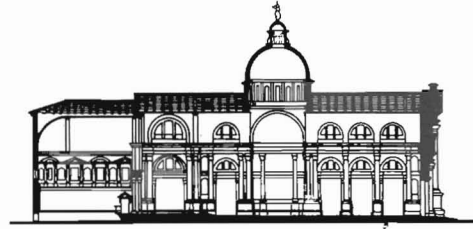

SECTION A

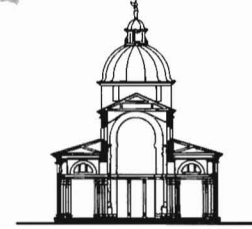

SECTION B

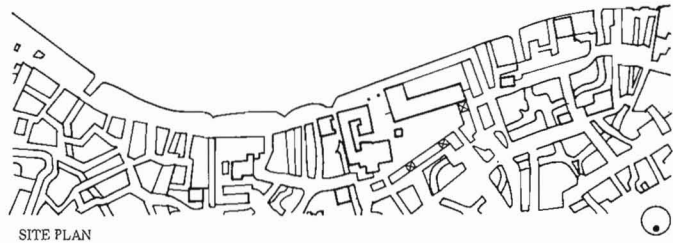
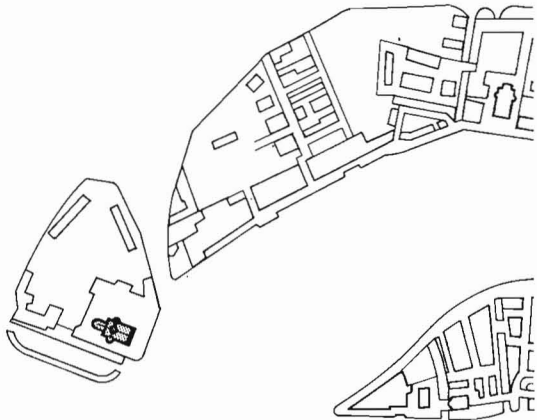

SITE PLAN

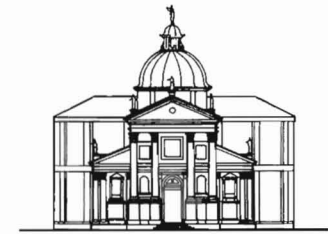

ELEVATION 1

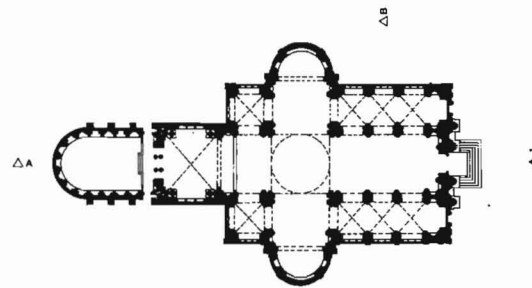

FLOOR PLAN

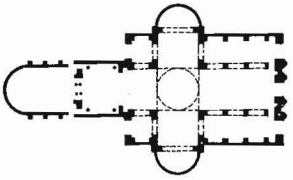
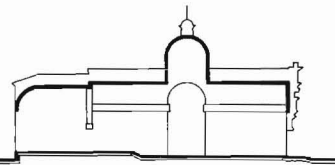
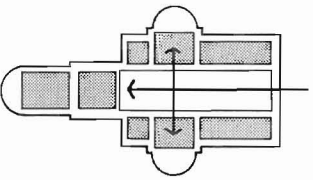
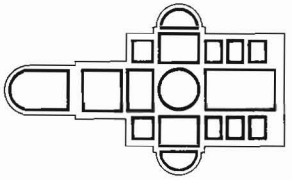
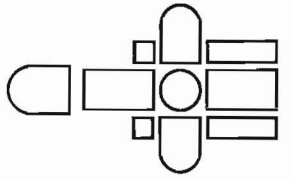
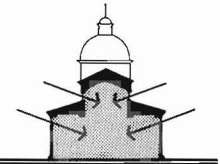
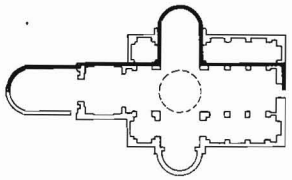
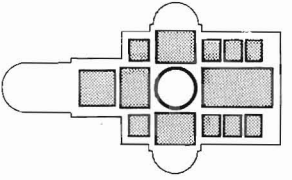
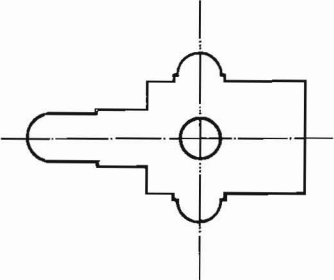
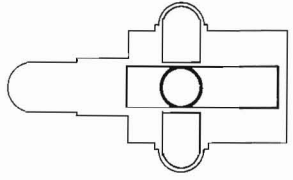
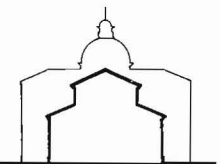
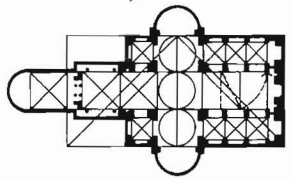
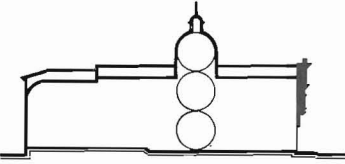
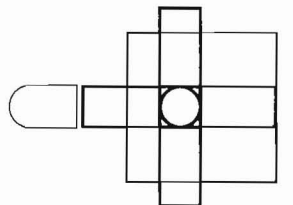
 <p>STRUCTURE</p>		 <p>CIRCULATION TO USE</p>	 <p>UNIT TO WHOLE</p>	 <p>ADDITIVE AND SUBTRACTIVE</p>
 <p>NATURAL LIGHT</p>	 <p>PLAN TO SECTION</p>	 <p>REPETTIVE TO UNIQUE</p>	 <p>SYMMETRY AND BALANCE</p>	 <p>HIERARCHY</p>
 <p>MASSING</p>	 <p>GEOMETRY</p>		 <p>PARTI</p>	

ANDREA PALLADIO

LA ROTONDA (VILLA CAPRA or ALMERICO)
VICENZA, ITALY
1566-1571

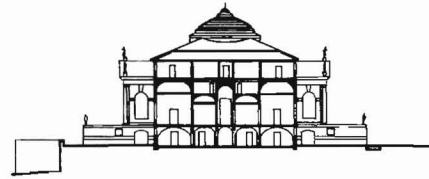

SECTION A

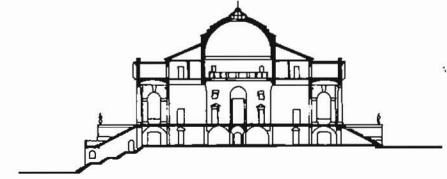

SECTION B



SITE PLAN

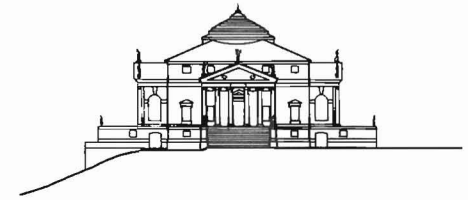

ELEVATION 1

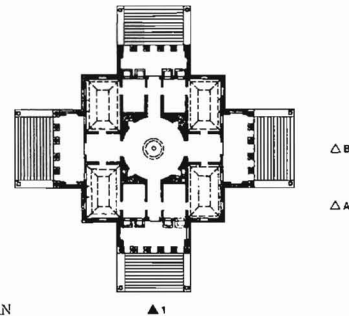

FLOOR PLAN

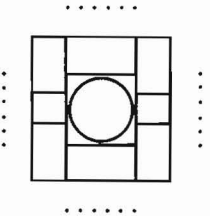
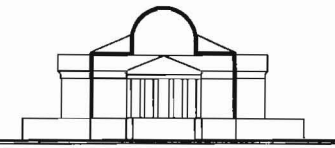
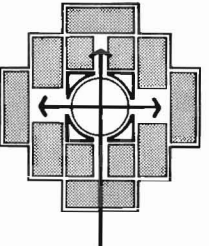
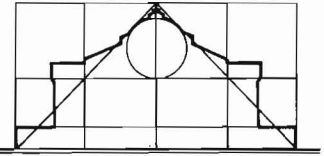
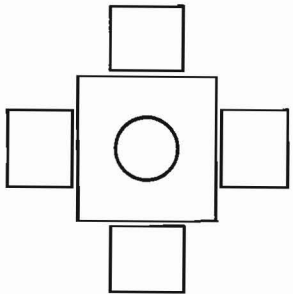
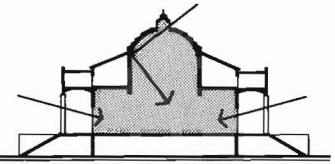
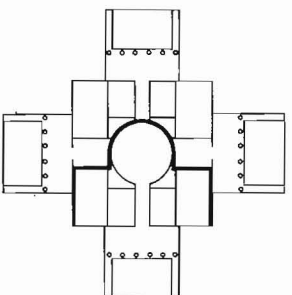
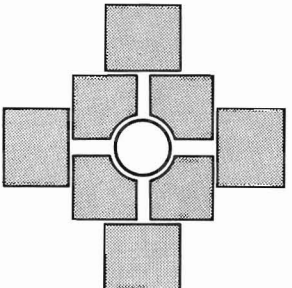
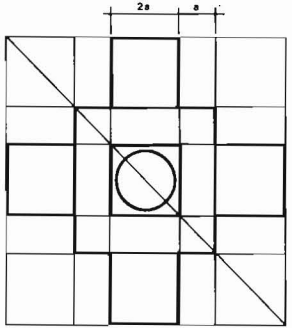
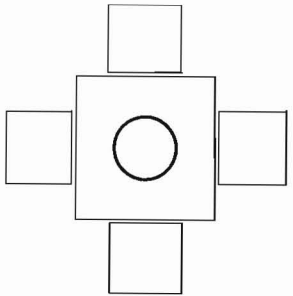
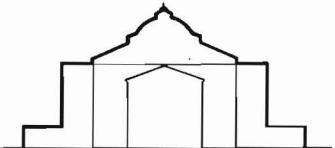
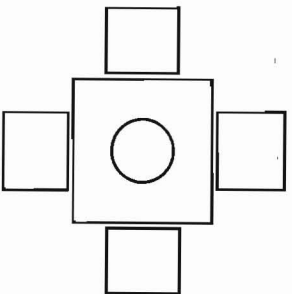
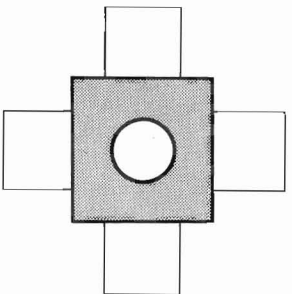
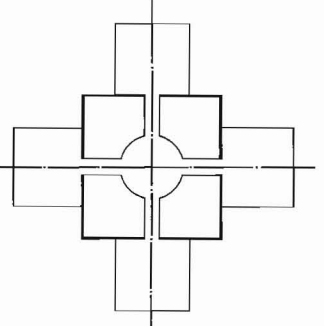
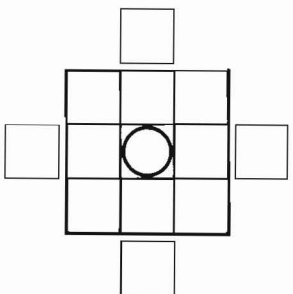
 <p>STRUCTURE</p>		 <p>CIRCULATION TO USE</p>		 <p>ADDITIVE AND SUBTRACTIVE</p>
 <p>NATURAL LIGHT</p>	 <p>PLAN TO SECTION</p>	 <p>REPETITIVE TO UNIQUE</p>	 <p>GEOMETRY</p>	 <p>HIERARCHY</p>
 <p>MASSING</p>	 <p>UNIT TO WHOLE</p>	 <p>SYMMETRY AND BALANCE</p>		 <p>PARTI</p>

ANDREA PALLADIO

REDENTORE CHURCH
VENICE, ITALY
1576-1591

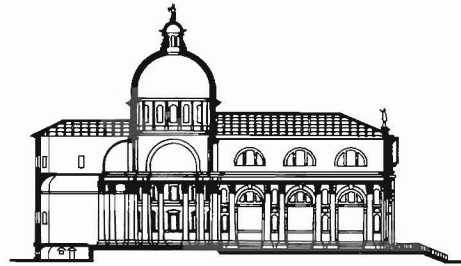

SECTION A

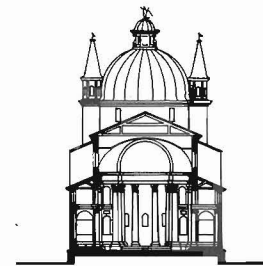

SECTION B



SITE PLAN

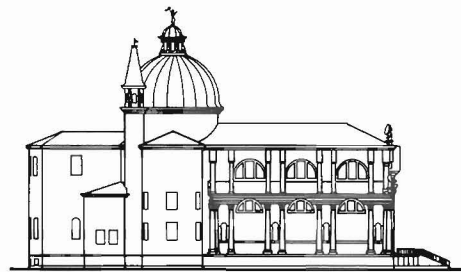

ELEVATION 1



ELEVATION 2

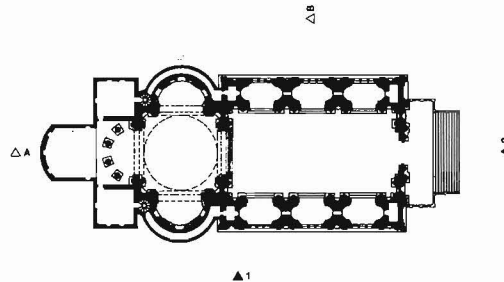

FLOOR PLAN

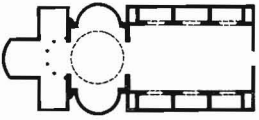
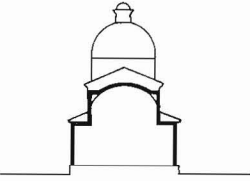
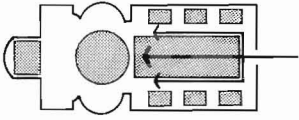
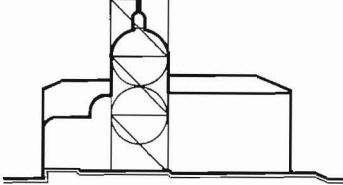
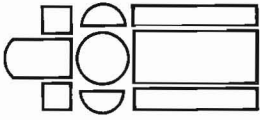
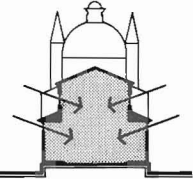
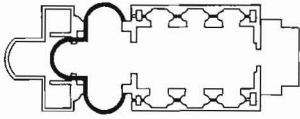
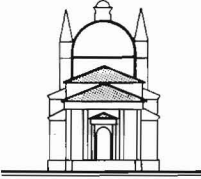
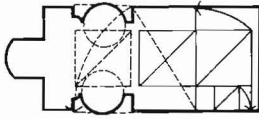
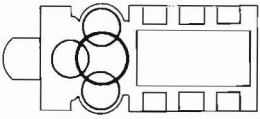
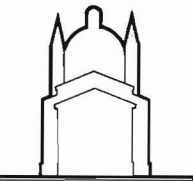
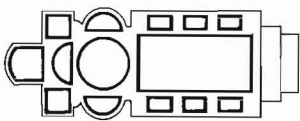
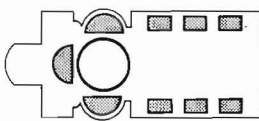
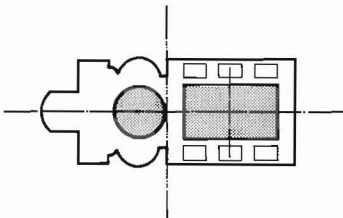
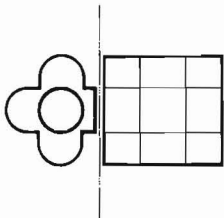
 <p>STRUCTURE</p>		 <p>CIRCULATION TO USE</p>		 <p>ADDITIVE AND SUBTRACTIVE</p>
 <p>NATURAL LIGHT</p>	 <p>PLAN TO SECTION</p>		 <p>GEOMETRY</p>	 <p>HIERARCHY</p>
 <p>MASSING</p>	 <p>UNIT TO WHOLE</p>	 <p>REPETITIVE TO UNIQUE</p>	 <p>SYMMETRY AND BALANCE</p>	 <p>PARTI</p>

HENRY HOBSON RICHARDSON

HENRY HOBSON RICHARDSON

TRINITY CHURCH
BOSTON, MASSACHUSETTS
1872-1877

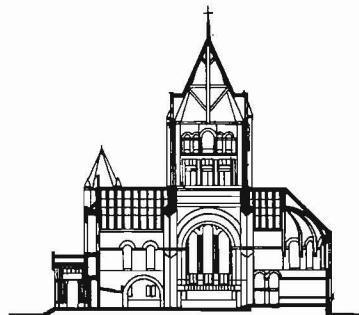

SECTION A

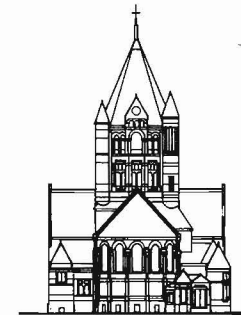

ELEVATION 1

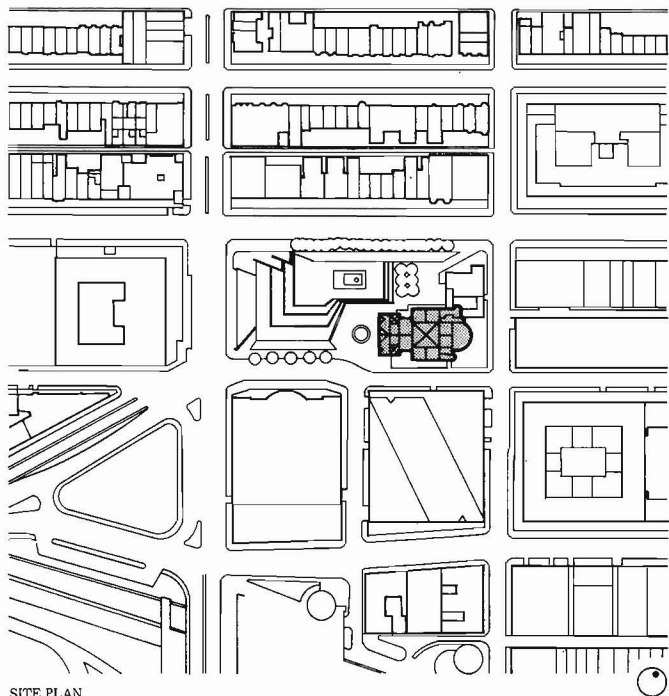

SITE PLAN

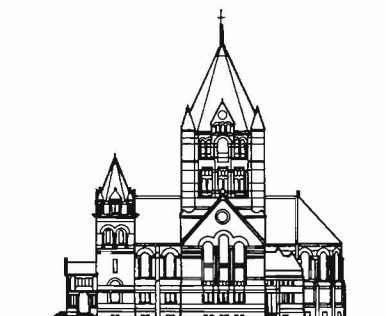

ELEVATION 2

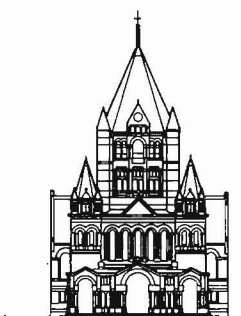

ELEVATION 3

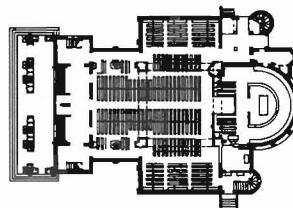

MAIN FLOOR PLAN

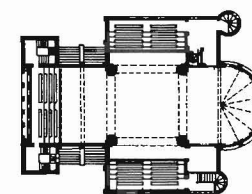

UPPER FLOOR PLAN

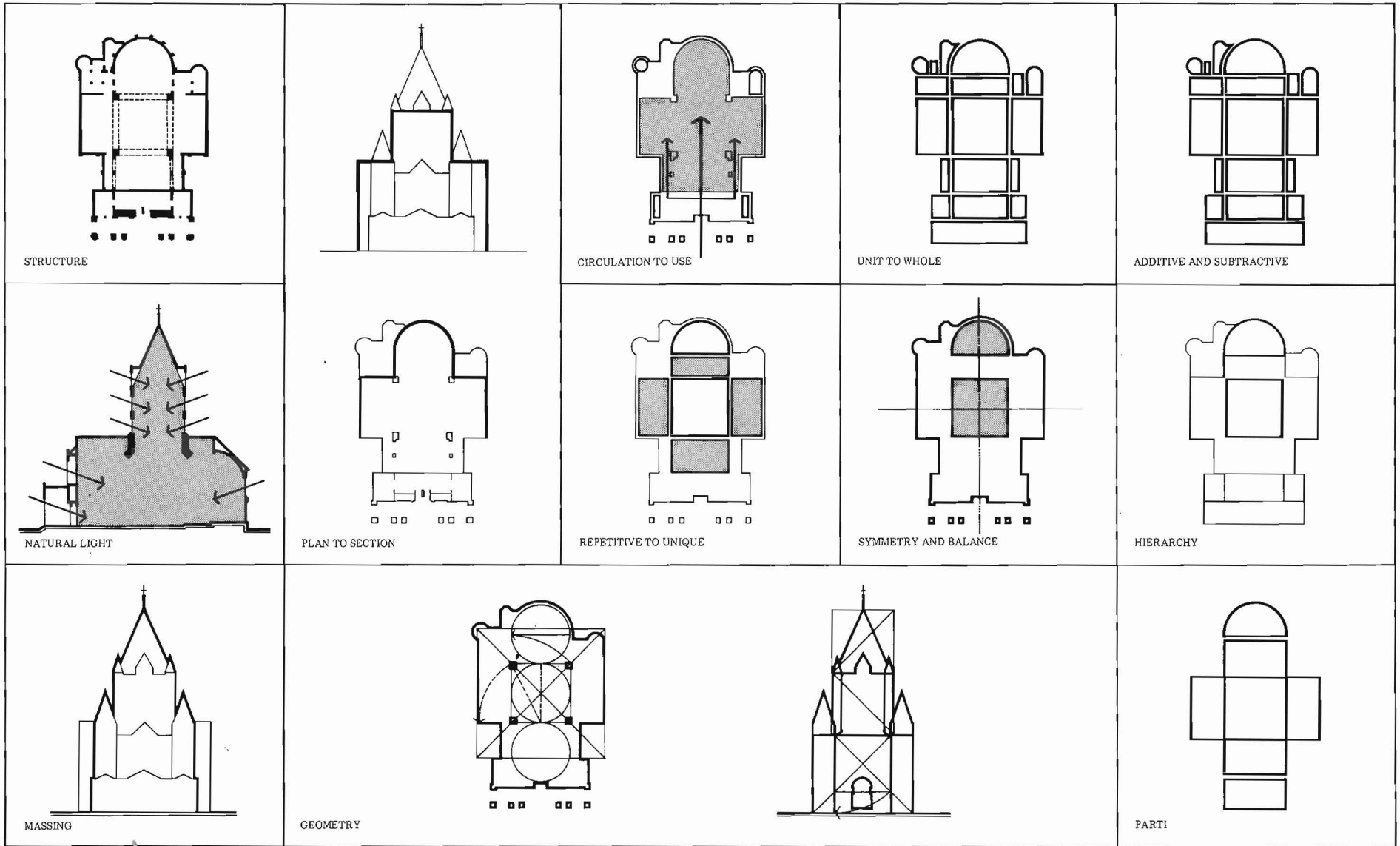

HENRY HOBSON RICHARDSON

SEVER HALL
HARVARD UNIVERSITY
CAMBRIDGE, MASSACHUSETTS
1878-1880

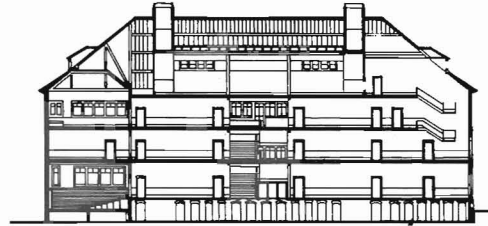

SECTION A

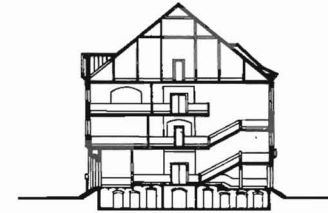

SECTION B

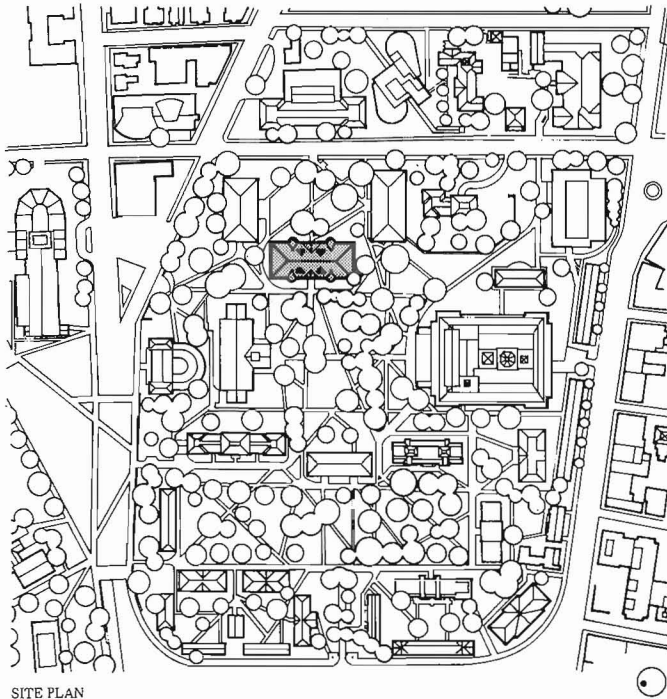

SITE PLAN



ELEVATION 1

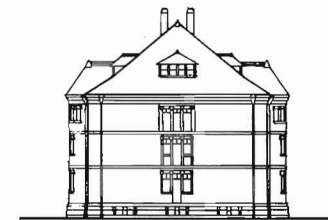

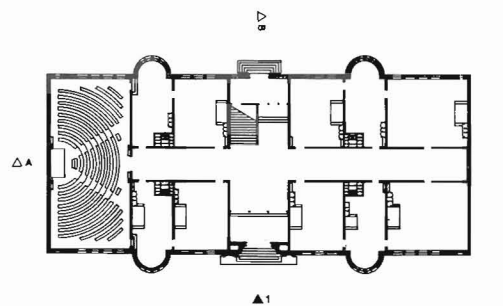

ELEVATION 2

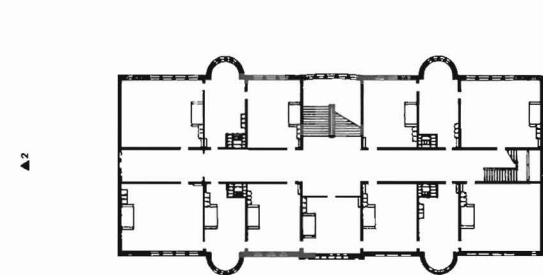

LOWER FLOOR PLAN

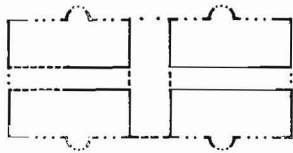
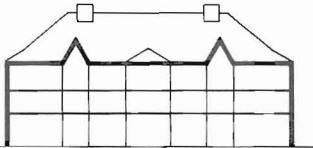
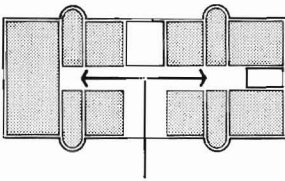
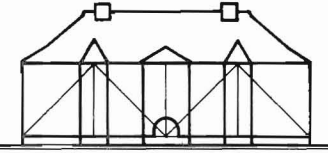
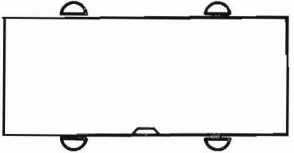
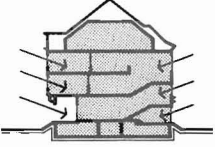
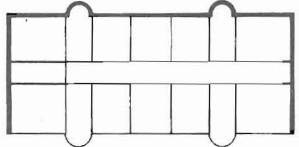

UPPER FLOOR PLAN

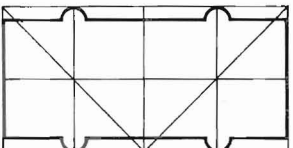
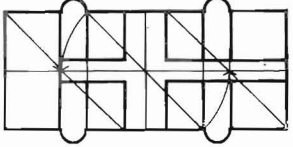
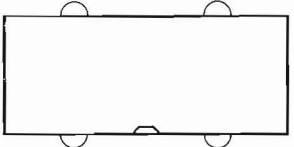
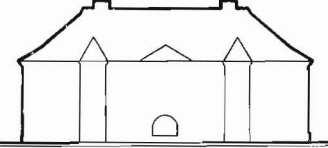
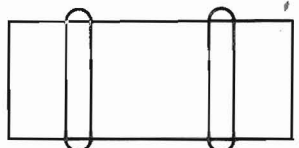
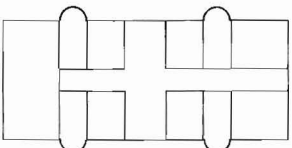
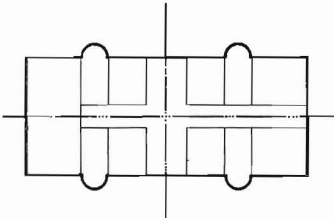
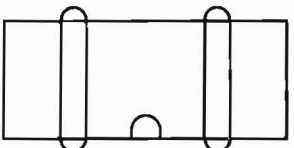
 <p>STRUCTURE</p>		 <p>CIRCULATION TO USE</p>		 <p>ADDITIVE AND SUBRACTIVE</p>
 <p>NATURAL LIGHT</p>	 <p>PLAN TO SECTION</p>		  <p>GEOMETRY</p>	 <p>HIERARCHY</p>
 <p>MASSING</p>	 <p>UNIT TO WHOLE</p>	 <p>REPETITIVE TO UNIQUE</p>	 <p>SYMMETRY AND BALANCE</p>	 <p>PARTI</p>

HENRY HOBSON RICHARDSON

ALLEGHENY COUNTY COURTHOUSE
PITTSBURGH, PENNSYLVANIA
1883-1888

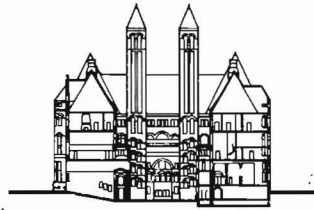

SECTION A

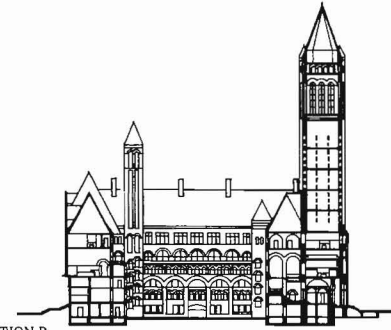

SECTION B



SITE PLAN

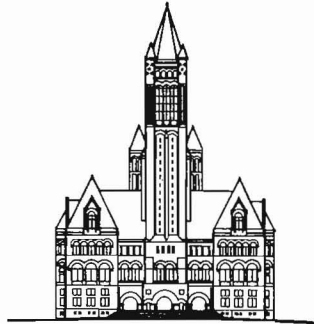

ELEVATION 1

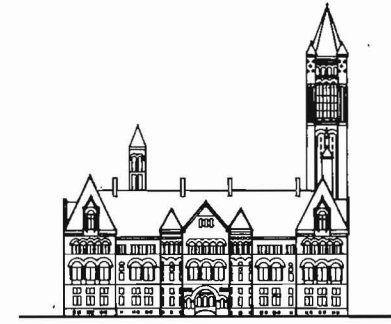

ELEVATION 2

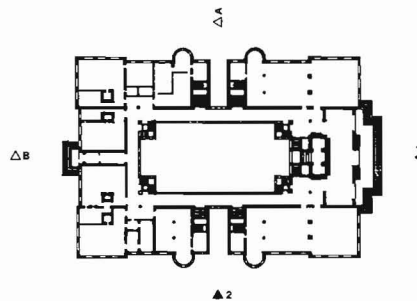

LOWER FLOOR PLAN

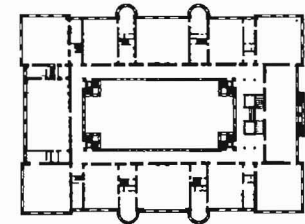

UPPER FLOOR PLAN

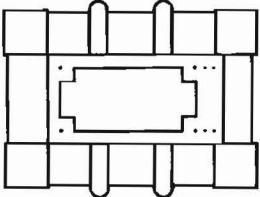
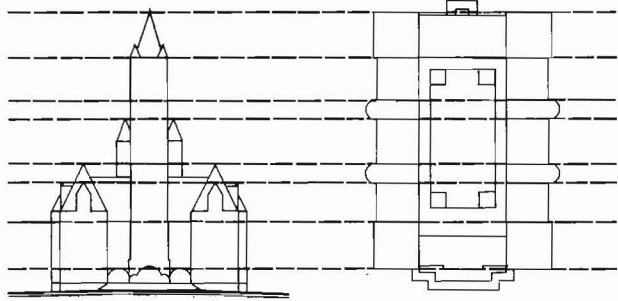
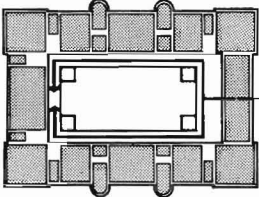
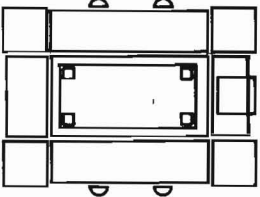
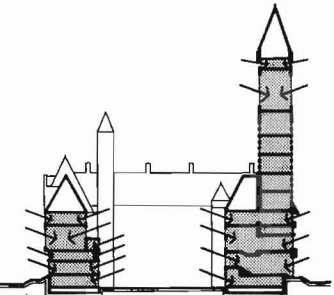
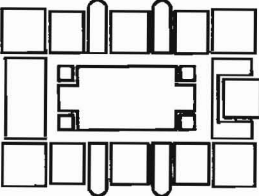
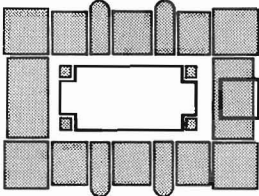
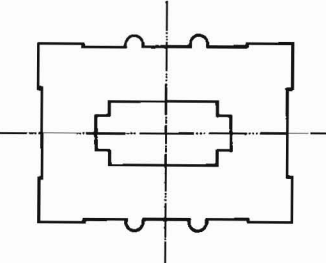
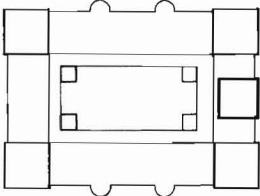
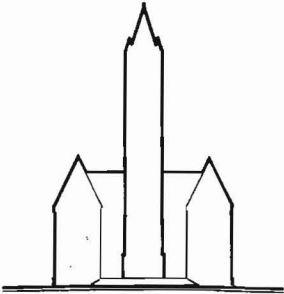
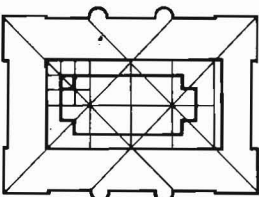
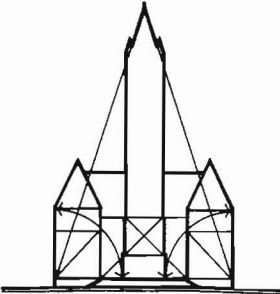
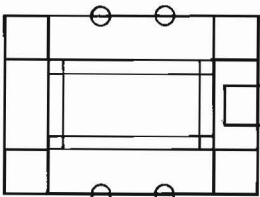
 <p>STRUCTURE</p>	 <p>PLAN TO SECTION</p>		 <p>CIRCULATION TO USE</p>	 <p>ADDITIVE AND SUBRACTIVE</p>
 <p>NATURAL LIGHT</p>	 <p>UNIT TO WHOLE</p>	 <p>REPETITIVE TO UNIQUE</p>	 <p>SYMMETRY AND BALANCE</p>	 <p>HIERARCHY</p>
 <p>MASSING</p>	 <p>GEOMETRY</p> 		 <p>PARTI</p>	

HENRY HOBSON RICHARDSON

J. J. GLESSNER HOUSE
CHICAGO, ILLINOIS
1885-1887



SECTION A

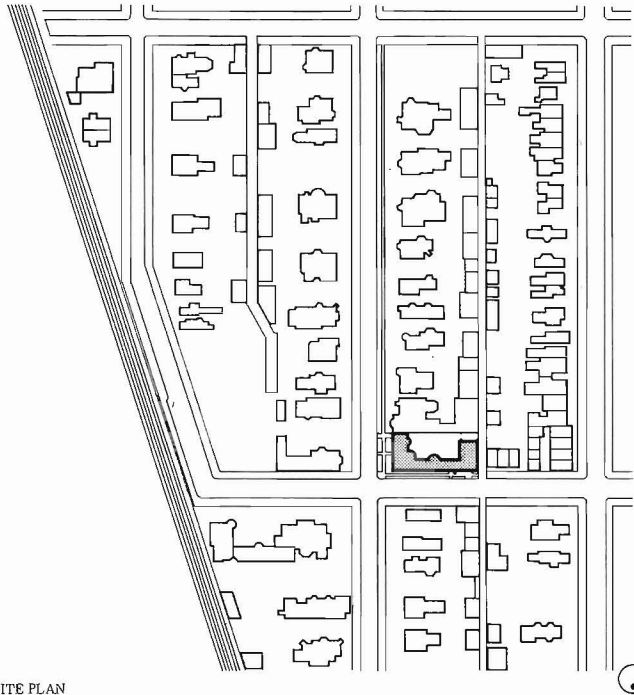

SITE PLAN



ELEVATION 1

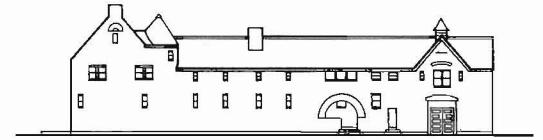

ELEVATION 2

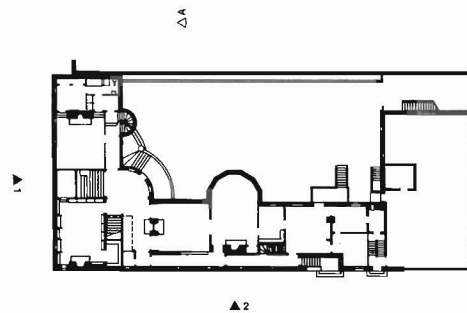

MAIN FLOOR PLAN

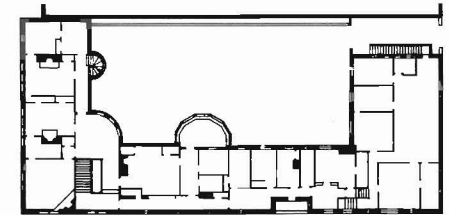

UPPER FLOOR PLAN

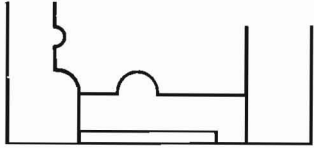
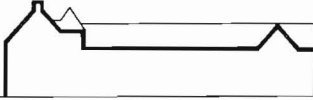
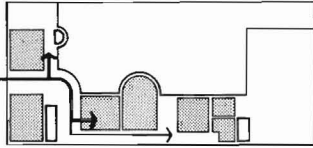
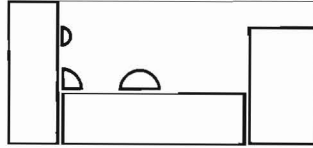
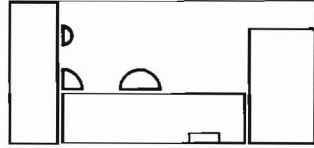
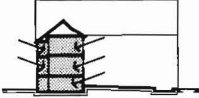
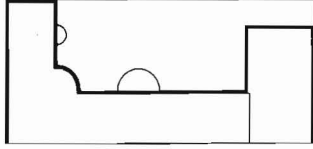
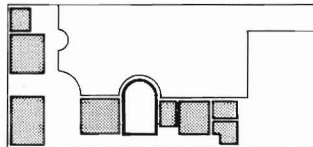
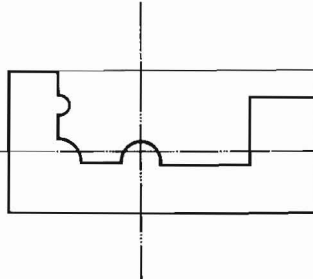
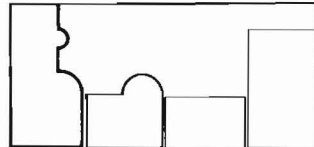
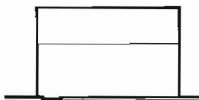
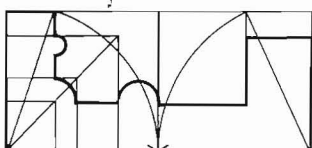
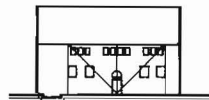
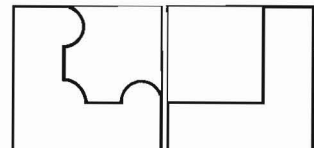
 <p>STRUCTURE</p>		 <p>CIRCULATION TO USE</p>	 <p>UNIT TO WHOLE</p>	 <p>ADDITIVE AND SUBTRACTIVE</p>
 <p>NATURAL LIGHT</p>	 <p>PLAN TO SECTION</p>	 <p>REPE TITIVE TO UNIQUE</p>	 <p>SYMMETRY AND BALANCE</p>	 <p>HIERARCHY</p>
 <p>MASSING</p>	 <p>GEOMETRY</p>			 <p>PARTI</p>

JAMES STIRLING

JAMES STIRLING

ENGINEERING BUILDING
LEICESTER UNIVERSITY
LEICESTER, ENGLAND
1959

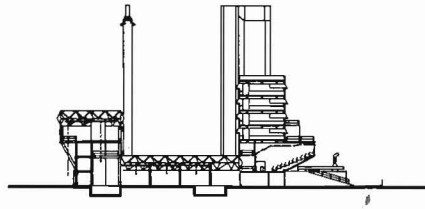

SECTION A

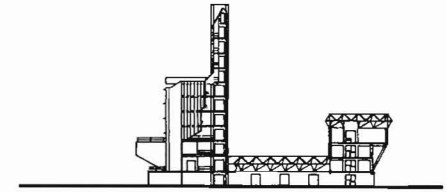

SECTION B

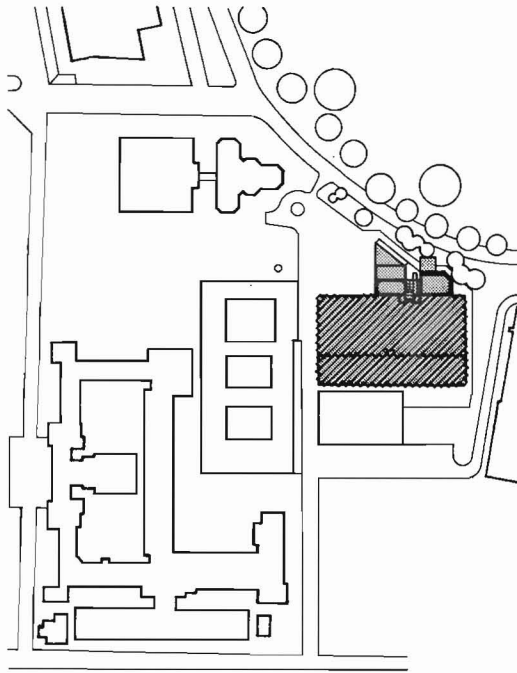

SITE PLAN

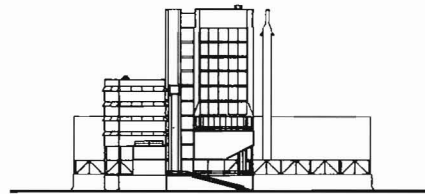

ELEVATION 1

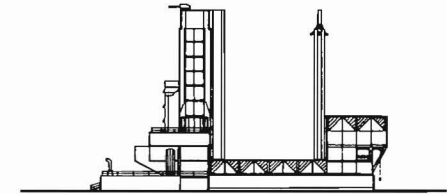

ELEVATION 2

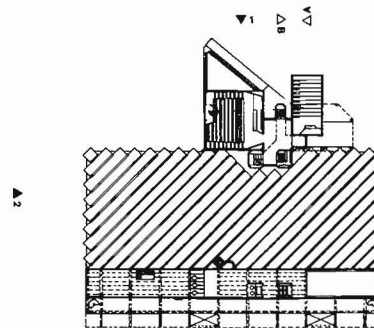

MIDDLE FLOOR PLAN

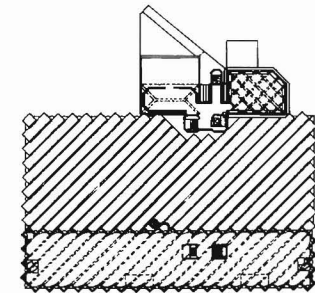

UPPER FLOOR PLAN

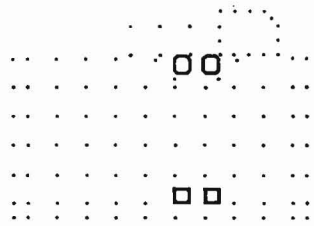
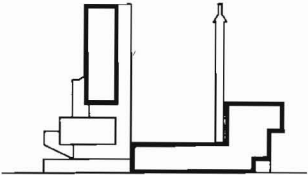
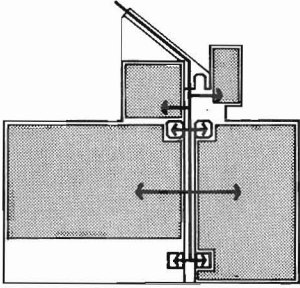
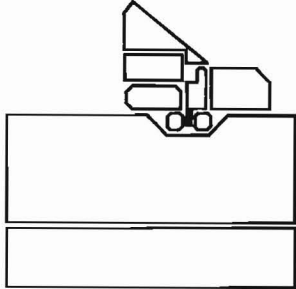
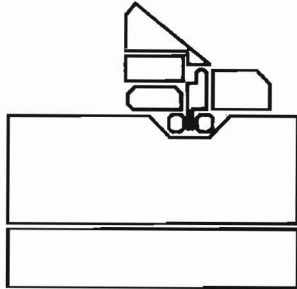
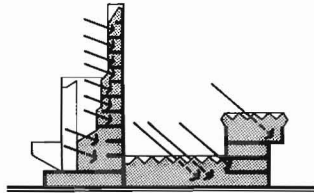
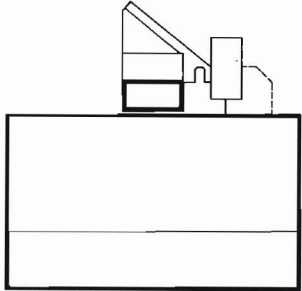
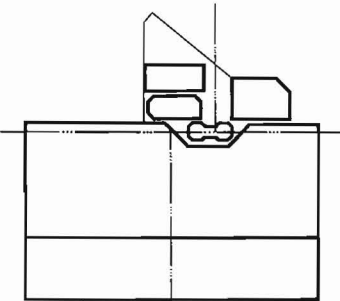
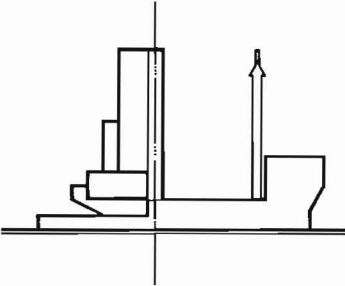
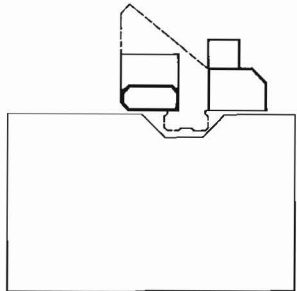
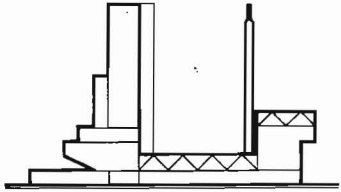
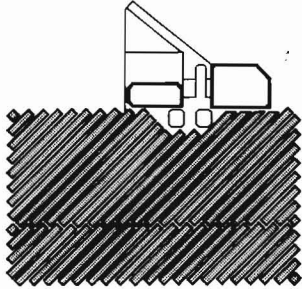
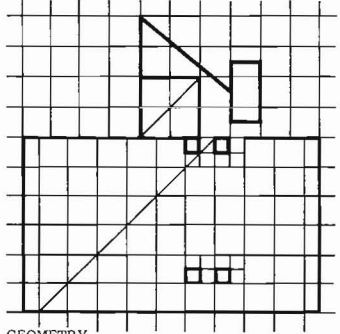
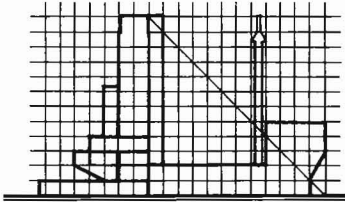
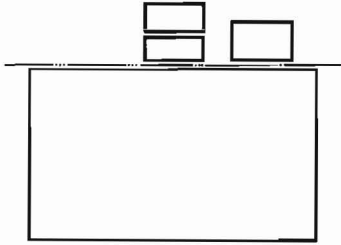
 <p>STRUCTURE</p>		 <p>CIRCULATION TO USE</p>	 <p>UNIT TO WHOLE</p>	 <p>ADDITIVE AND SUBRACTIVE</p>
 <p>NATURAL LIGHT</p>	 <p>PLAN TO SECTION</p>	 <p>SYMMETRY AND BALANCE</p>	 <p>HIERARCHY</p>	 <p>HIERARCHY</p>
 <p>MASSING</p>	 <p>REPÉTITIVE TO UNIQUE</p>	 <p>GEOMETRY</p>		 <p>PARTI</p>

JAMES STIRLING

HISTORY FACULTY BUILDING
CAMBRIDGE UNIVERSITY
CAMBRIDGE, ENGLAND
1964

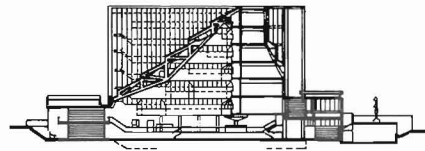

SECTION A

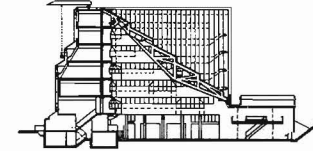

SECTION B

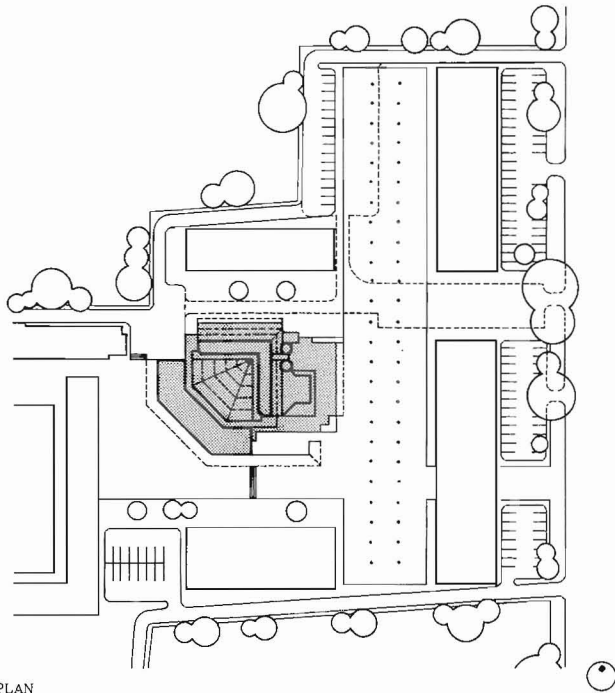

SITE PLAN

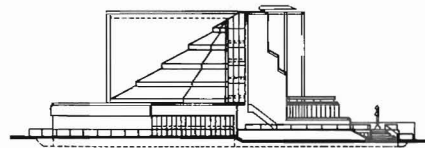

ELEVATION 1

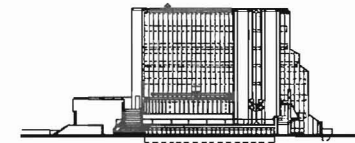

ELEVATION 2

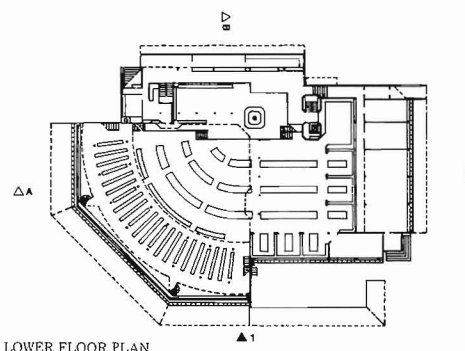

LOWER FLOOR PLAN

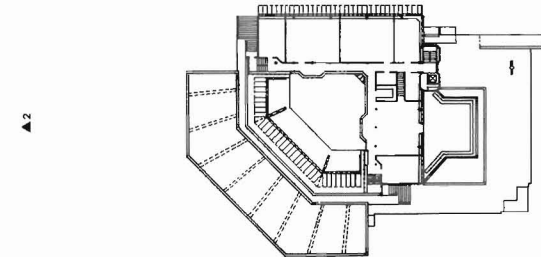

UPPER FLOOR PLAN

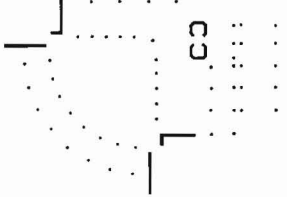
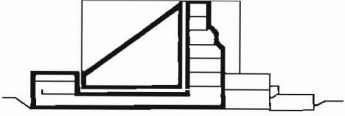
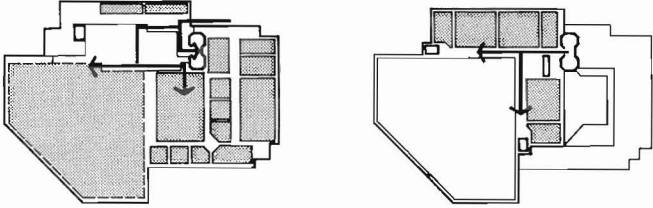
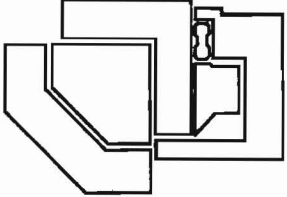
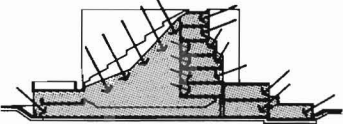
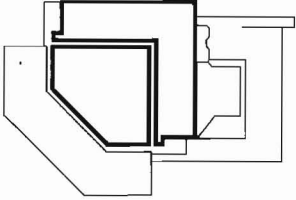
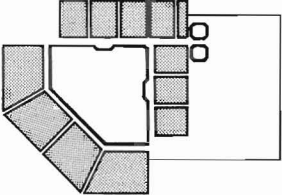
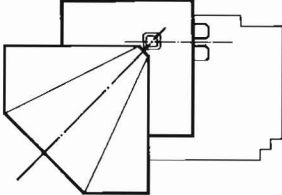
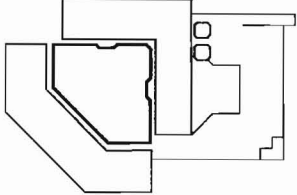
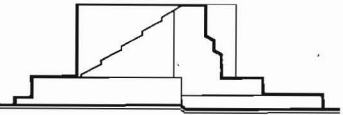
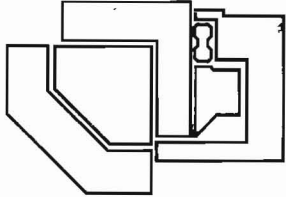
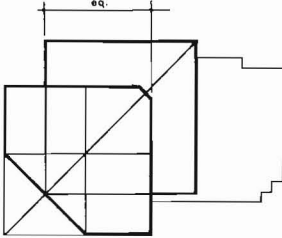
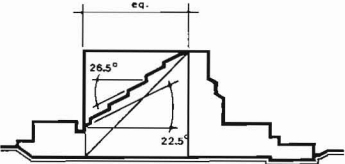
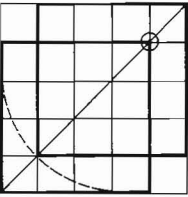
 <p>STRUCTURE</p>		 <p>CIRCULATION TO USE</p>	 <p>ADDITIVE AND SUBTRACTIVE</p>	
 <p>NATURAL LIGHT</p>	 <p>PLAN TO SECTION</p>	 <p>REPETITIVE TO UNIQUE</p>	 <p>SYMMETRY AND BALANCE</p>	 <p>HIERARCHY</p>
 <p>MASSING</p>	 <p>UNIT TO WHOLE</p>	 <p>GEOMETRY</p>		 <p>PARTI</p>

JAMES STIRLING

FLOREY BUILDING
QUEENS COLLEGE
OXFORD, ENGLAND
1966

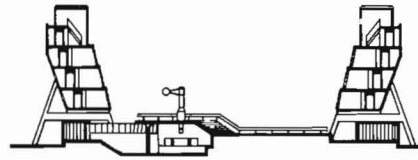

SECTION A

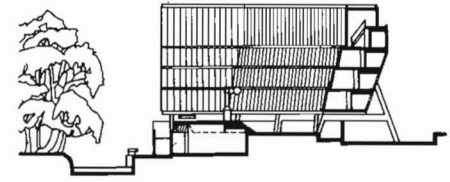

SECTION B

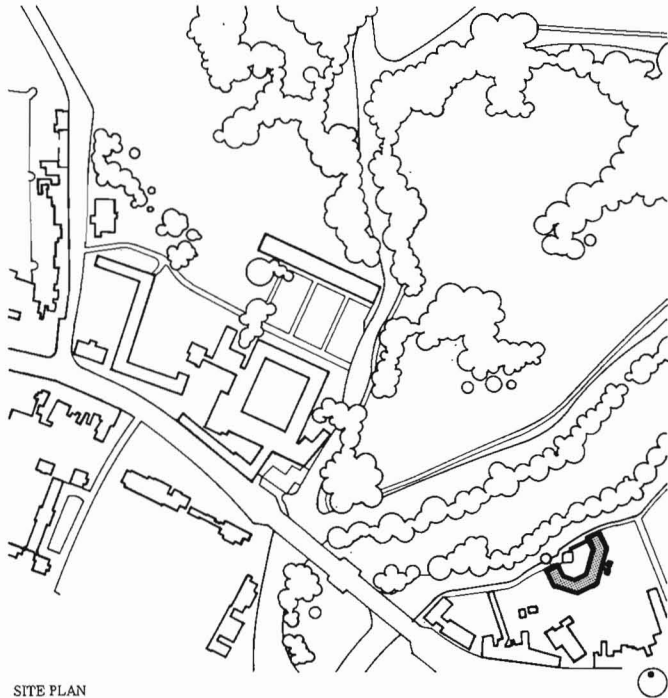

SITE PLAN

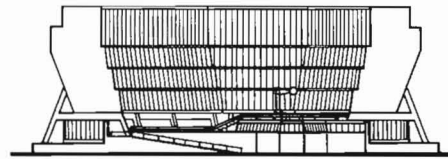

ELEVATION 1

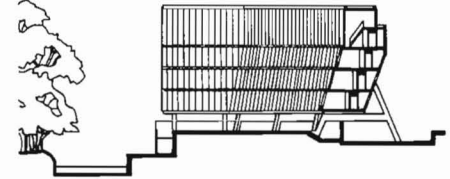

SECTION C

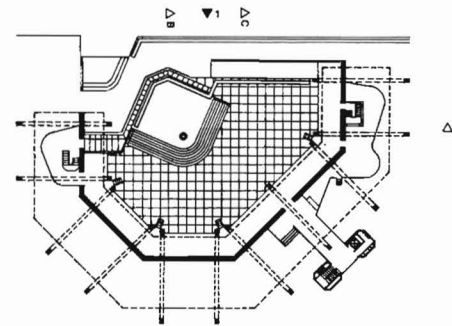

LOWER FLOOR PLAN

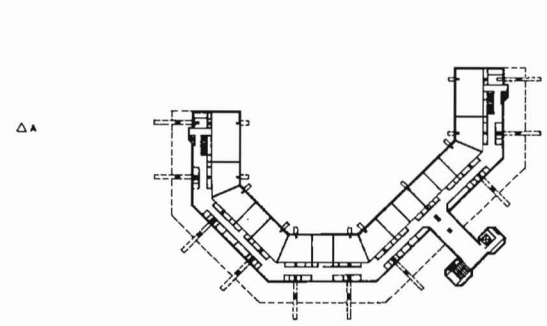

TYPICAL FLOOR PLAN

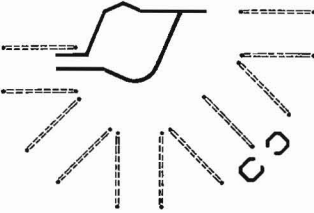
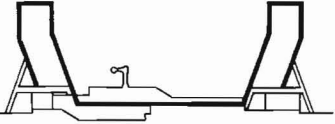
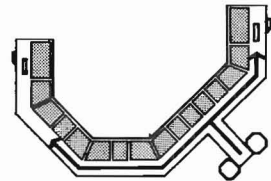
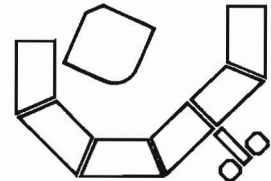
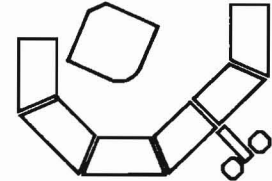
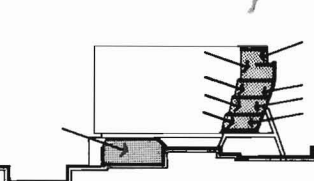
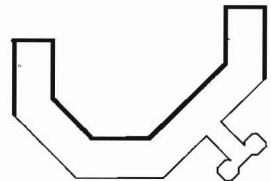
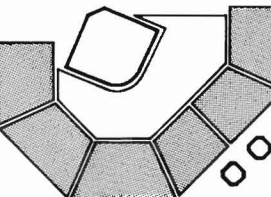
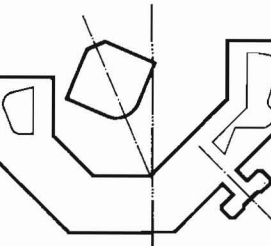
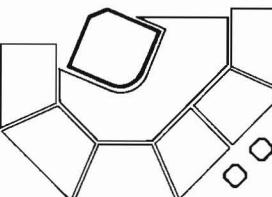
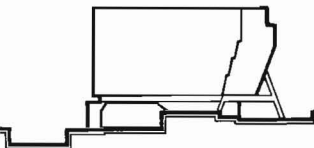
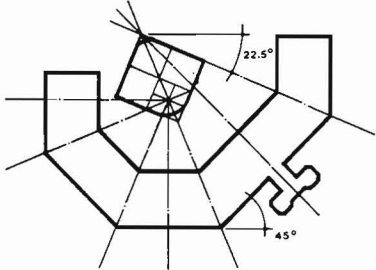
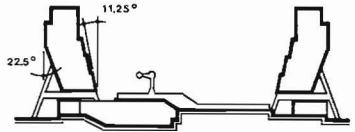
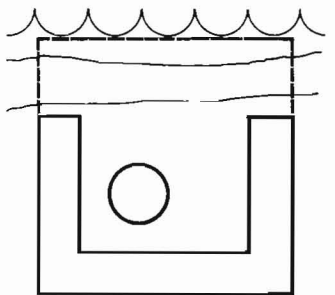
 <p>STRUCTURE</p>		 <p>CIRCULATION TO USE</p>	 <p>UNIT TO WHOLE</p>	 <p>ADDITIVE AND SUBTRACTIVE</p>
 <p>NATURAL LIGHT</p>	 <p>PLAN TO SECTION</p>	 <p>REPETITIVE TO UNIQUE</p>	 <p>SYMMETRY AND BALANCE</p>	 <p>HIERARCHY</p>
 <p>MASSING</p>	 <p>GEOMETRY</p>			 <p>PARTI</p>

JAMES STIRLING

OLIVETTI TRAINING SCHOOL
HASLEMERE, SURREY, ENGLAND
1969



SECTION A



SECTION B



SITE PLAN





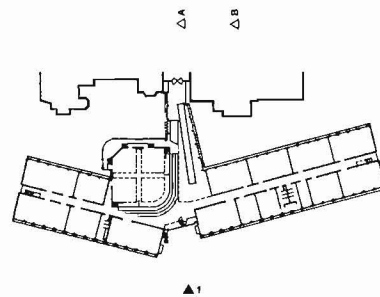

ELEVATION 1

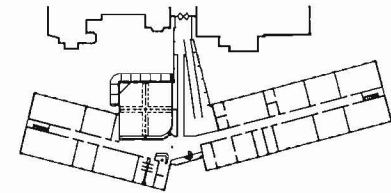

LOWER FLOOR PLAN

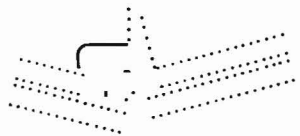

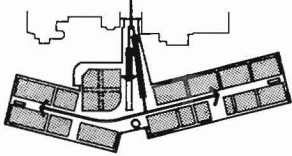
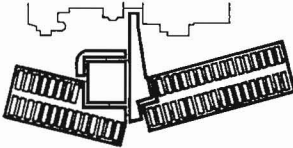
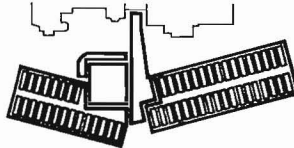
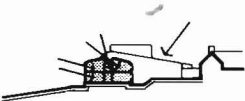
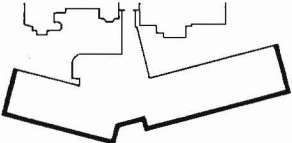
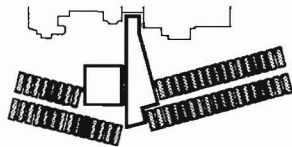
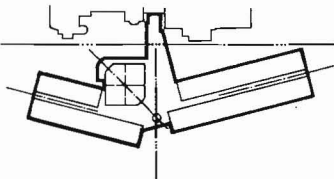
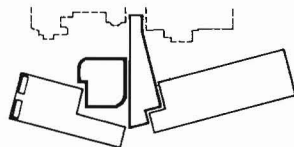
UPPER FLOOR PLAN

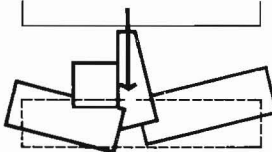
 <p>STRUCTURE</p>		 <p>CIRCULATION TO USE</p>	 <p>UNIT TO WHOLE</p>	 <p>ADDITIVE AND SUBTRACTIVE</p>
 <p>NATURAL LIGHT</p>	 <p>PLAN TO SECTION</p>	 <p>REPETITIVE TO UNIQUE</p>	 <p>SYMMETRY AND BALANCE</p>	 <p>HIERARCHY</p>
 <p>MASSING</p>	 <p>GEOMETRY</p>		 <p>PARTI</p>	

LOUIS SULLIVAN

LOUIS SULLIVAN

AUDITORIUM BUILDING
CHICAGO, ILLINOIS
1887-1890

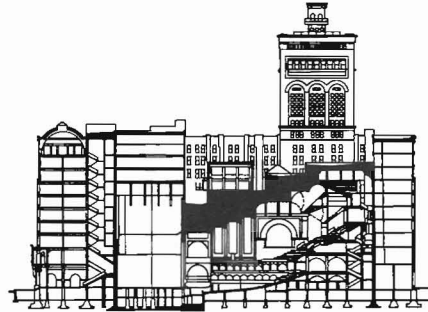

SECTION A

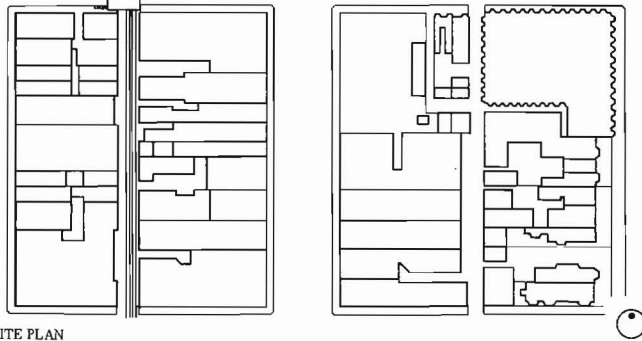
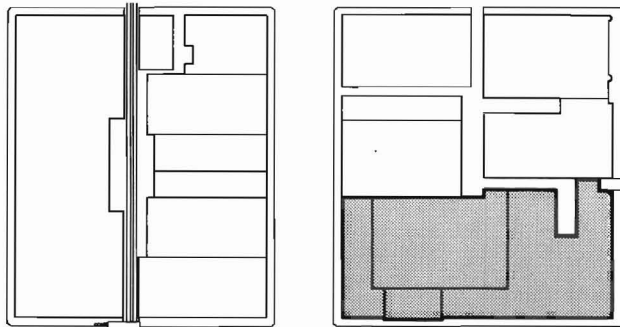

SITE PLAN

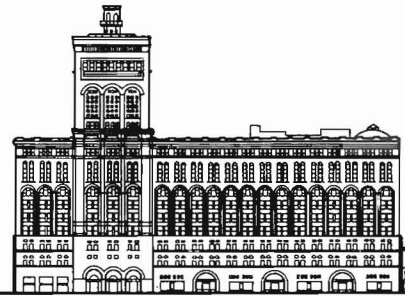

ELEVATION 1

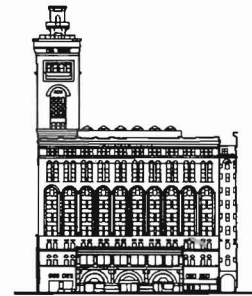

ELEVATION 2

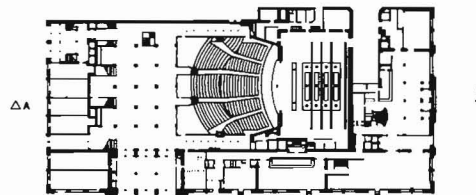

Δ A





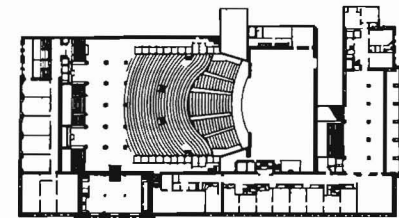

Δ 2

▲ 1

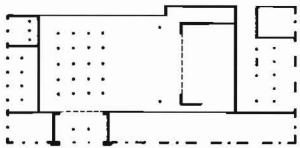
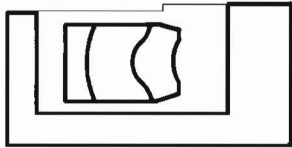
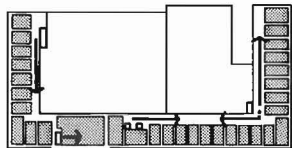
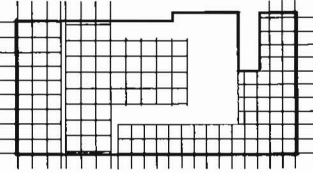
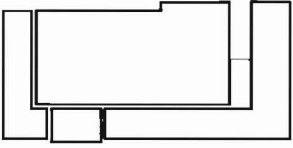
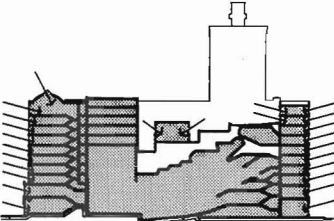
LOWER FLOOR PLAN

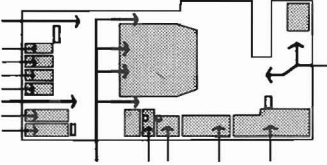
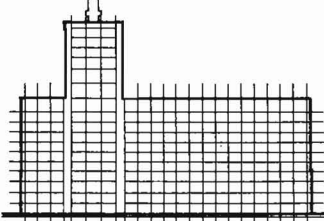

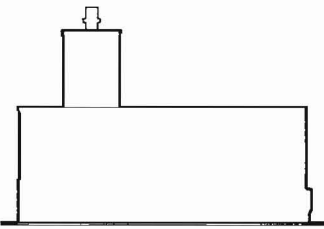
UPPER FLOOR PLAN

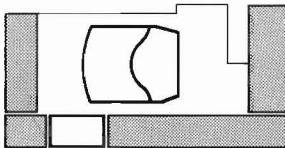
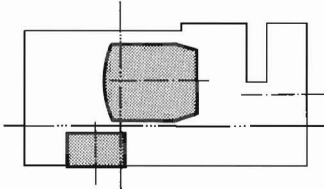
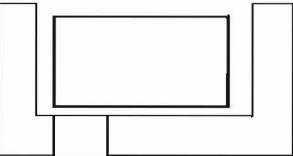
 <p>STRUCTURE</p>				 <p>ADDITIVE AND SUBTRACTIVE</p>
 <p>NATURAL LIGHT</p>	 <p>PLAN TO SECTION</p>	 <p>CIRCULATION TO USE</p>	 <p>GEOMETRY</p>	 <p>HIERARCHY</p>
 <p>MASSING</p>	 <p>UNIT TO WHOLE</p>	 <p>REPETITIVE TO UNIQUE</p>	 <p>SYMMETRY AND BALANCE</p>	 <p>PARTI</p>

LOUIS SULLIVAN

WAINWRIGHT BUILDING
ST. LOUIS, MISSOURI
1890-1891

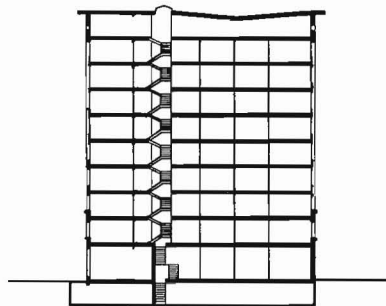

SECTION A

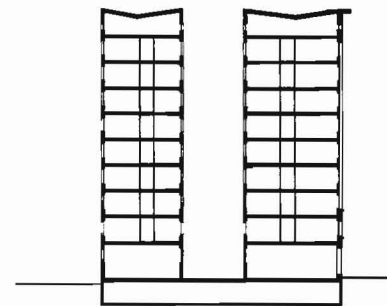

SECTION B

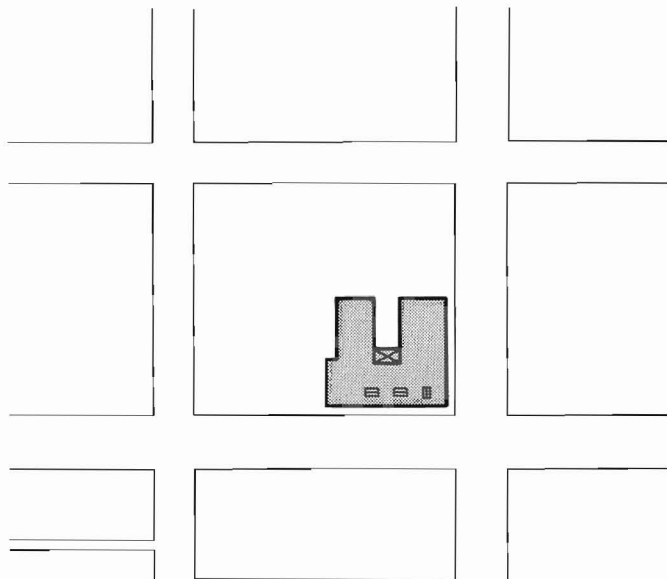

SITE PLAN

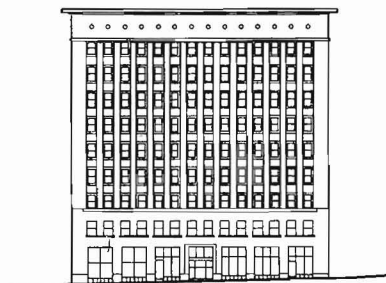

ELEVATION 1

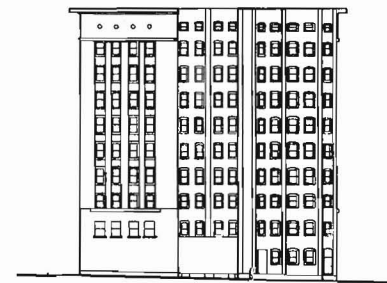

ELEVATION 2

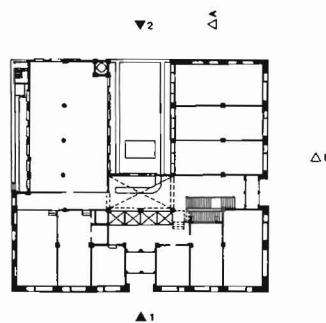

LOWER FLOOR PLAN

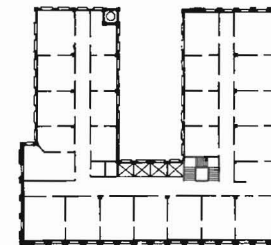

UPPER FLOOR PLAN

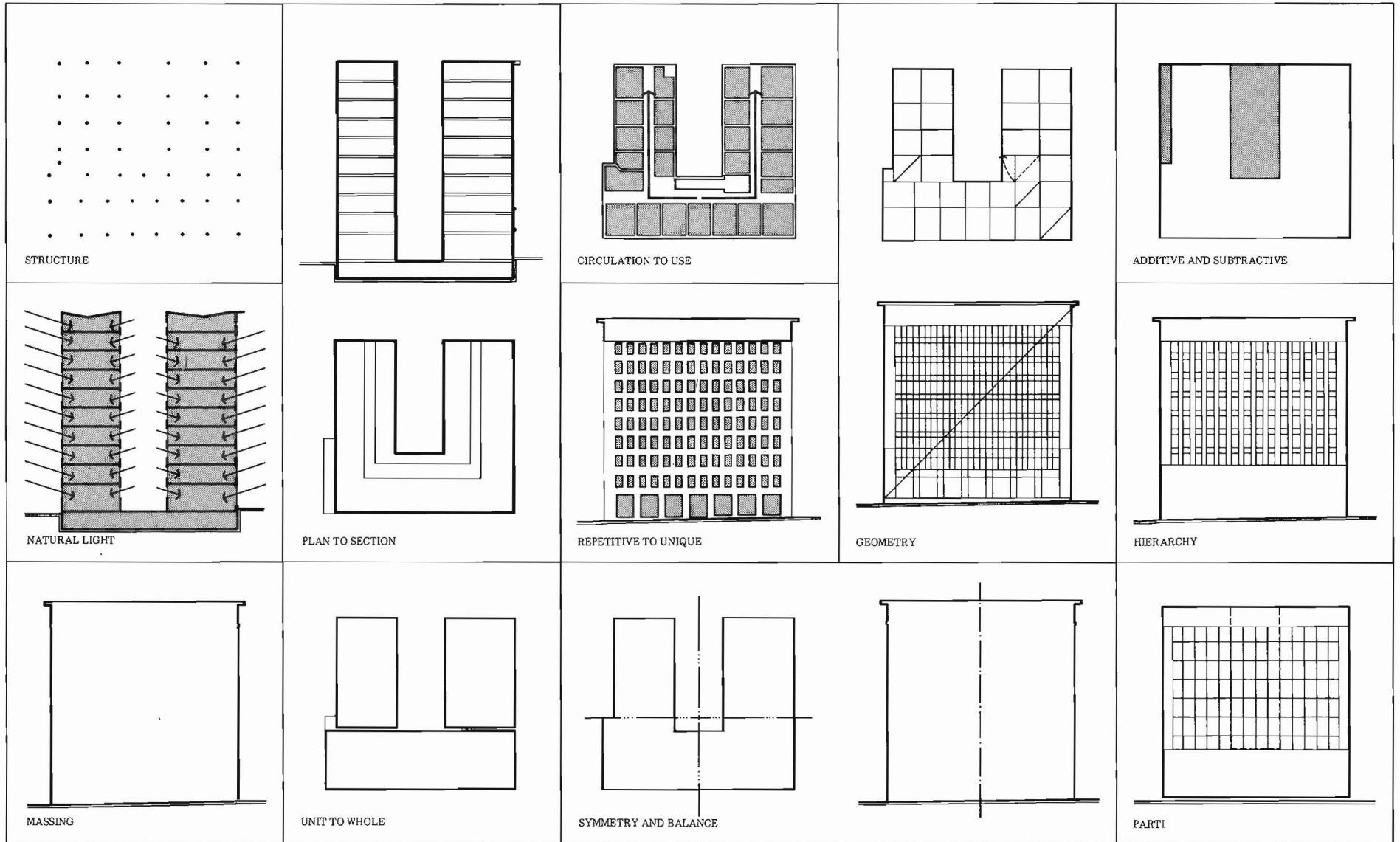

LOUIS SULLIVAN

CARSON PIRIE AND SCOTT STORE
(SCHLESINGER AND MAYER DEPARTMENT STORE)
CHICAGO, ILLINOIS
1899-1903

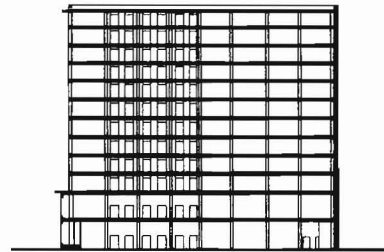

SECTION A

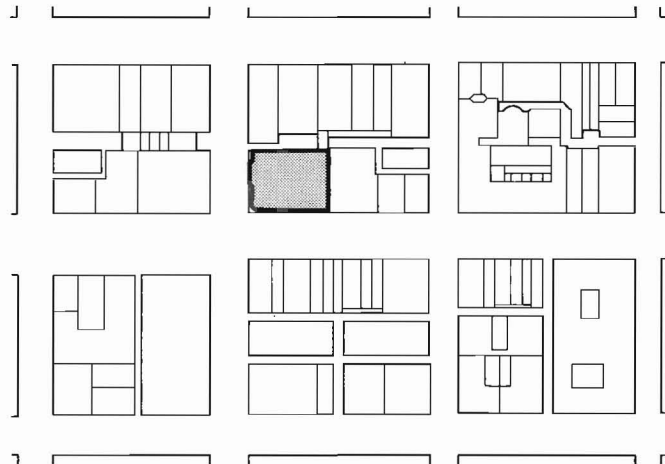

SITE PLAN

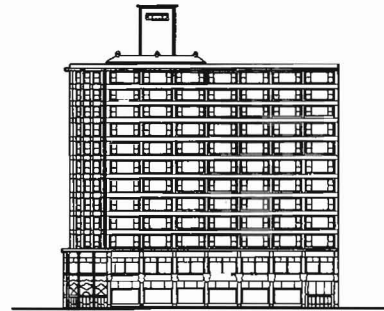

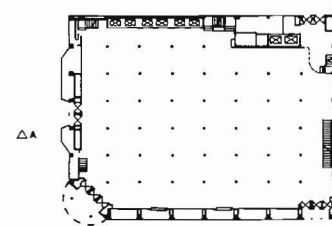

ELEVATION 1

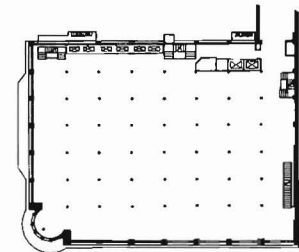

MAIN FLOOR PLAN

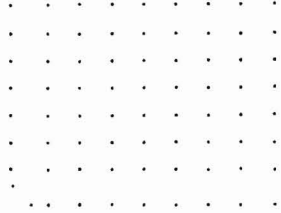
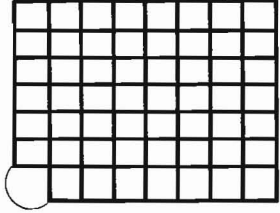
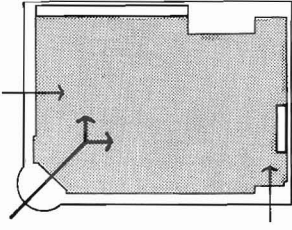
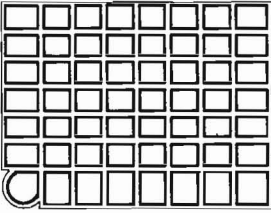

TYPICAL FLOOR PLAN

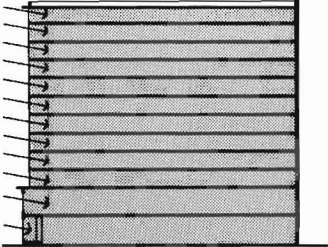
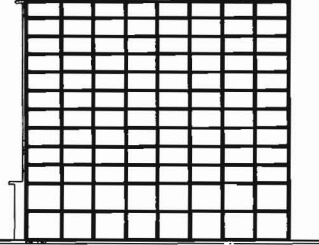
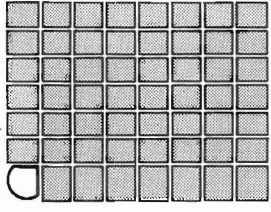
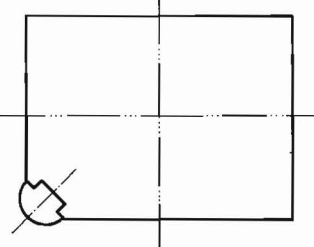
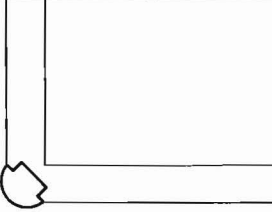
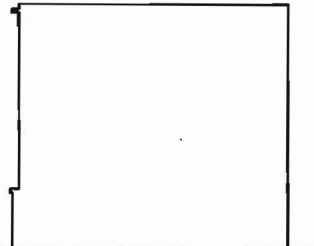
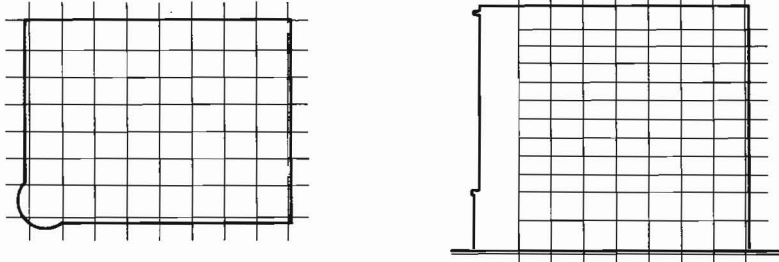
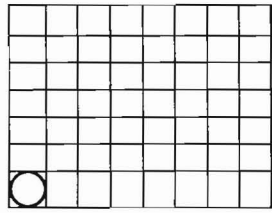
 <p>STRUCTURE</p>		 <p>CIRCULATION TO USE</p>	 <p>UNIT TO WHOLE</p>	 <p>ADDITIVE AND SUBTRACTIVE</p>
 <p>NATURAL LIGHT</p>	 <p>PLAN TO SECTION</p>	 <p>REPETITIVE TO UNIQUE</p>	 <p>SYMMETRY AND BALANCE</p>	 <p>HIERARCHY</p>
 <p>MASSING</p>	 <p>GEOMETRY</p>		 <p>PARTI</p>	

LOUIS SULLIVAN

NATIONAL FARMERS' BANK
OWATONNA, MINNESOTA
1907-1908

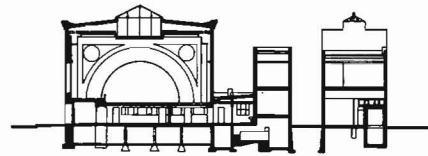

SECTION A

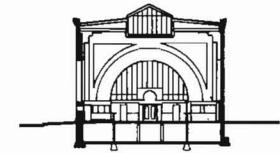

SECTION B

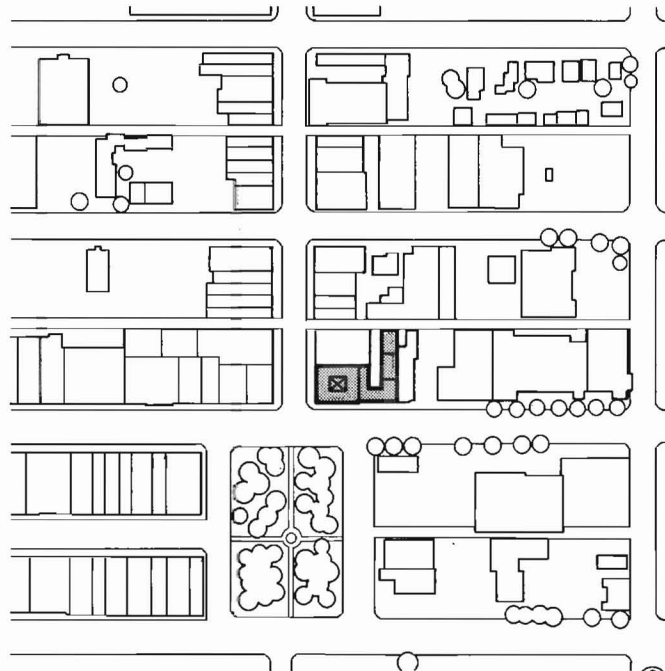

SITE PLAN

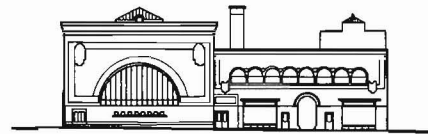

ELEVATION 1

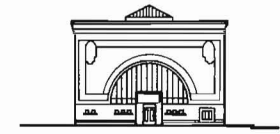

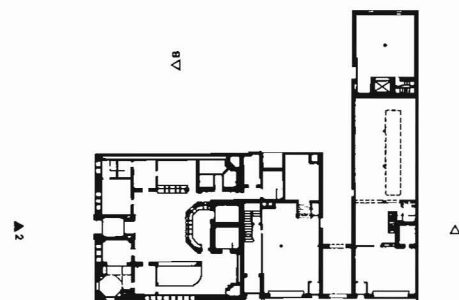

ELEVATION 2

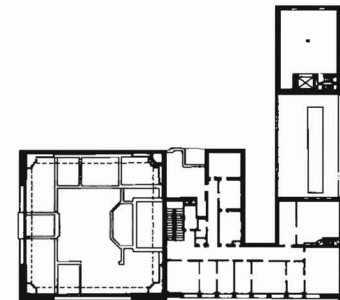

MAIN FLOOR PLAN

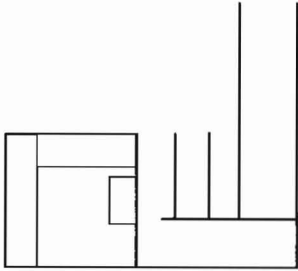
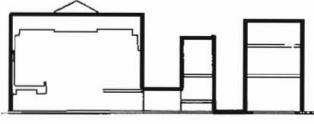
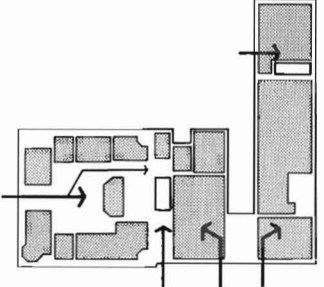
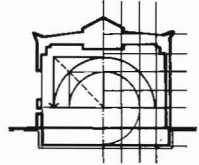
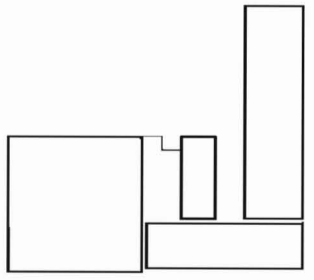
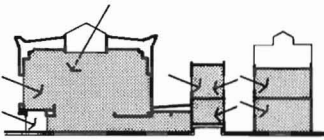
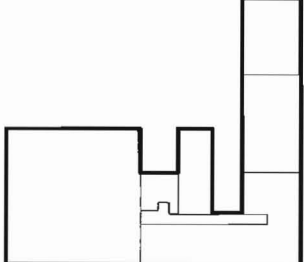
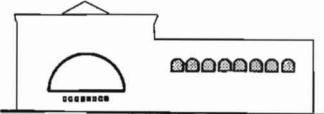
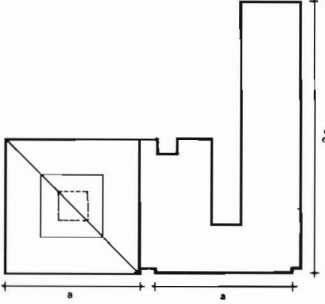
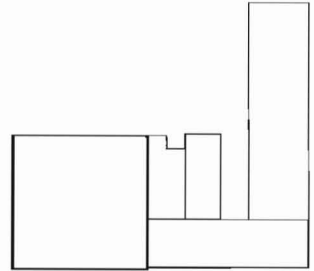

UPPER FLOOR PLAN

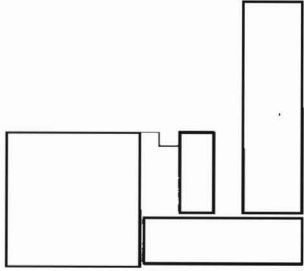
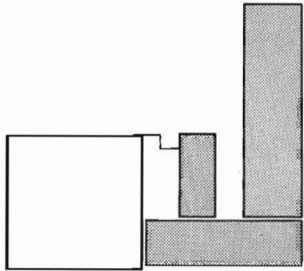
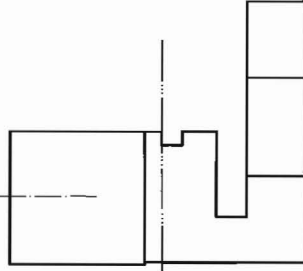
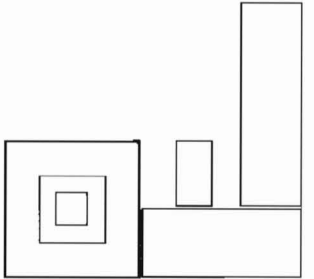
 <p>STRUCTURE</p>	 <p>PLAN TO SECTION</p>	 <p>CIRCULATION TO USE</p>	 <p>GEOMETRY</p>	 <p>ADDITIVE AND SUBTRACTIVE</p>
 <p>NATURAL LIGHT</p>	 <p>UNIT TO WHOLE</p>	 <p>REPETITIVE TO UNIQUE</p>	 <p>SYMMETRY AND BALANCE</p>	 <p>HIERARCHY</p>
 <p>MASSING</p>	 <p>PARTI</p>	 <p>SYMMETRY AND BALANCE</p>	 <p>PARTI</p>	 <p>PARTI</p>

GIUSEPPE TERRAGNI

GIUSEPPE TERRAGNI

NOVOCOMUM APARTMENT HOUSE
COMO, ITALY
1927

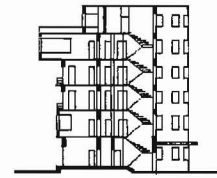

SECTION A

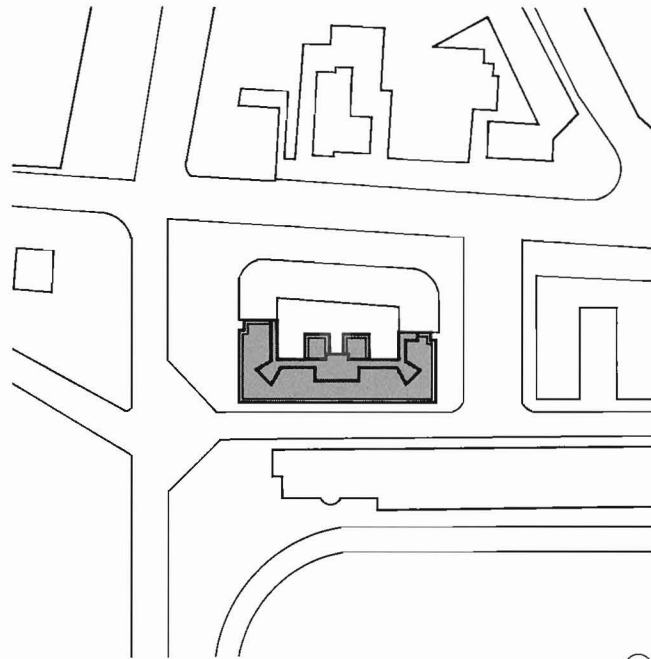

SITE PLAN





ELEVATION 1

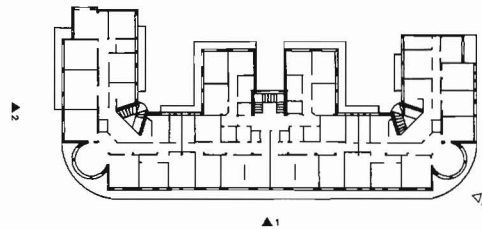

ELEVATION 2

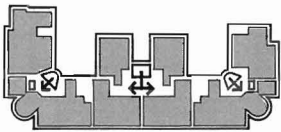
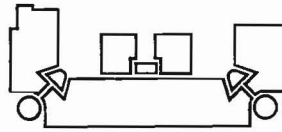
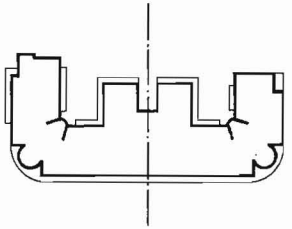
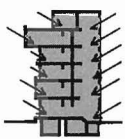
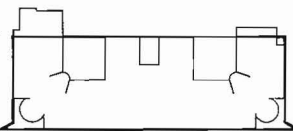
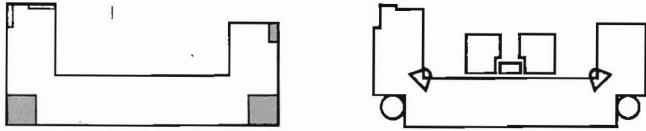
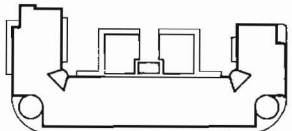
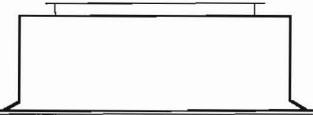
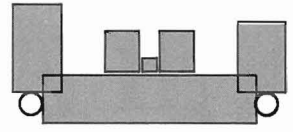
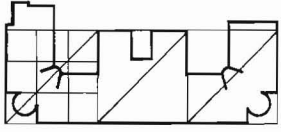
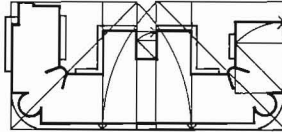

FLOOR PLAN

 <p>STRUCTURE</p>		 <p>CIRCULATION TO USE</p>	 <p>UNIT TO WHOLE</p>	 <p>SYMMETRY AND BALANCE</p>
 <p>NATURAL LIGHT</p>	 <p>PLAN TO SECTION</p>	 <p>ADDITIVE AND SUBTRACTIVE</p>		 <p>HIERARCHY</p>
 <p>MASSING</p>	 <p>REPETITIVE TO UNIQUE</p>	 <p>GEOMETRY</p>	 <p>PARTI</p>	

GIUSEPPE TERRAGNI

CASA DEL FASCIO
COMO, ITALY
1932-1936

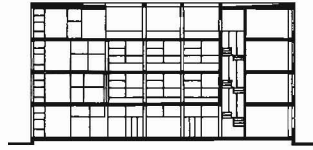

SECTION A



SECTION B

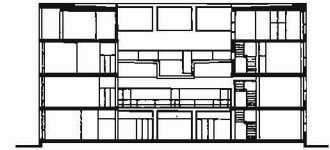

SECTION C

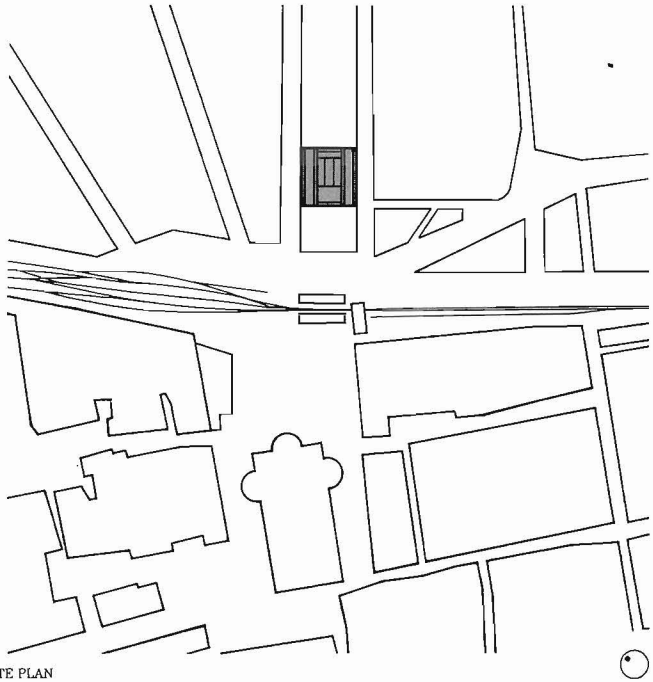

SITE PLAN



ELEVATION 1

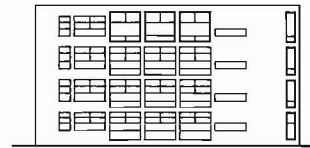

ELEVATION 2

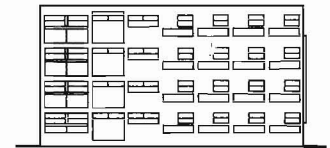

ELEVATION 3

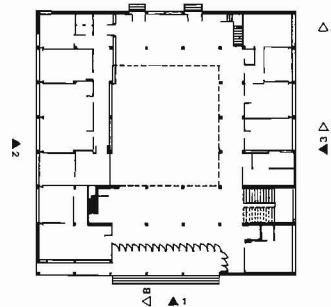

GROUND FLOOR PLAN

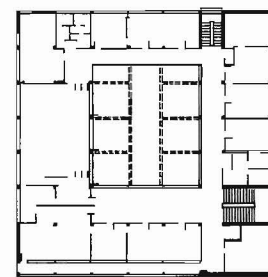

FIRST FLOOR PLAN

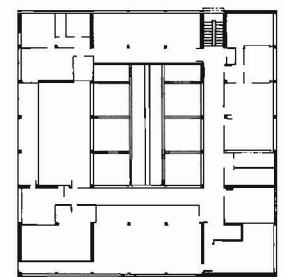

THIRD FLOOR PLAN

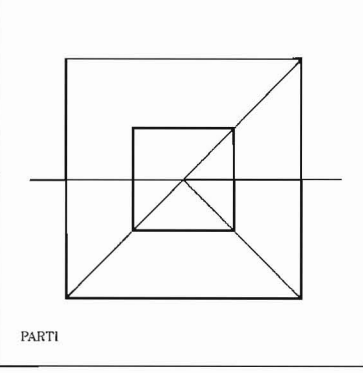
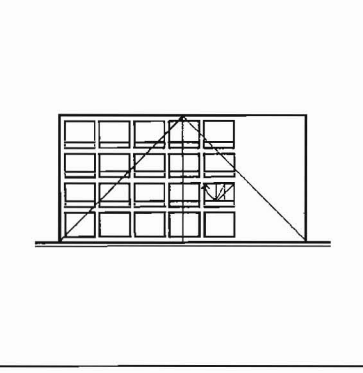
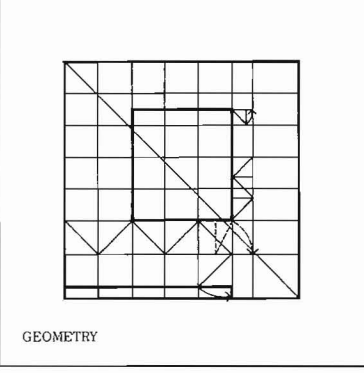
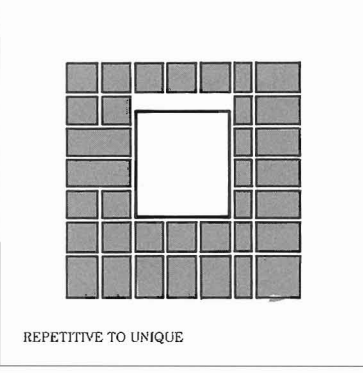
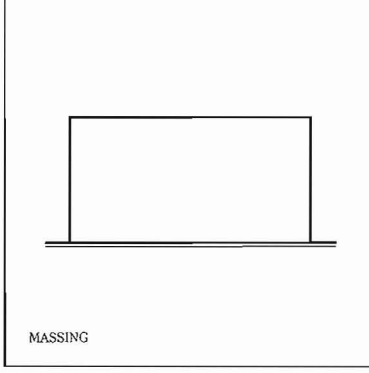
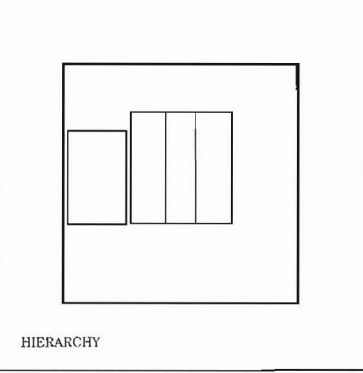
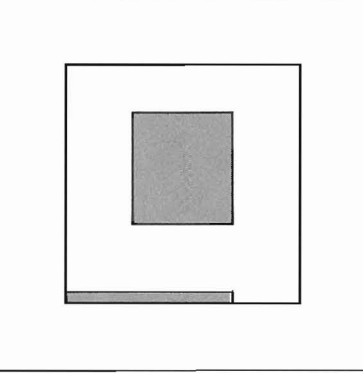
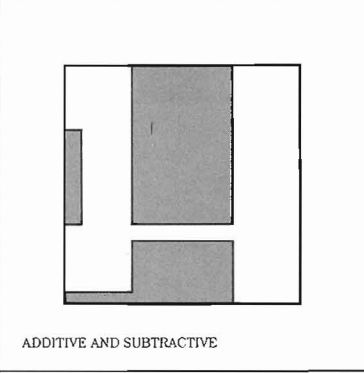
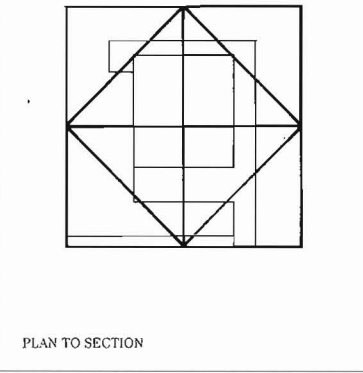
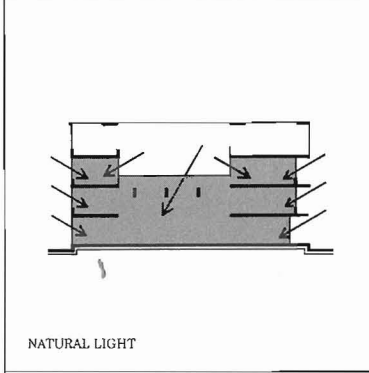
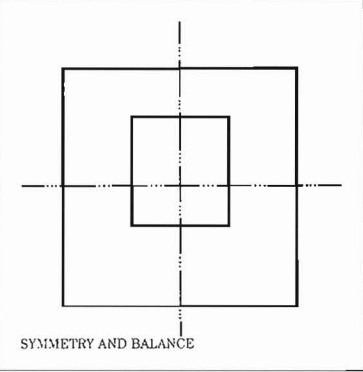
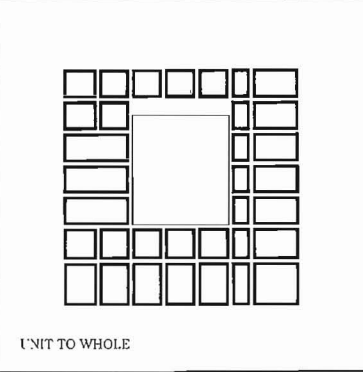
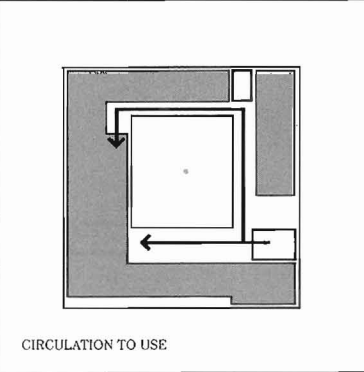
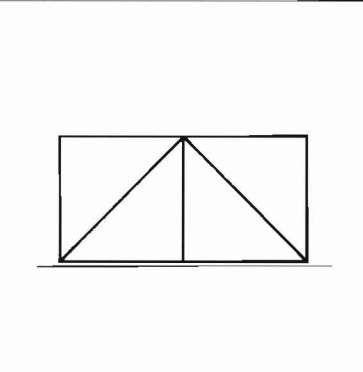
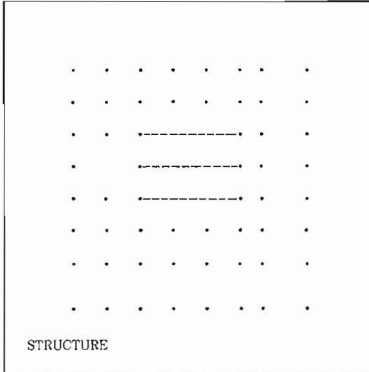

GIUSEPPE TERRAGNI

SANT' ELIA NURSERY SCHOOL
COMO, ITALY
1936-1937

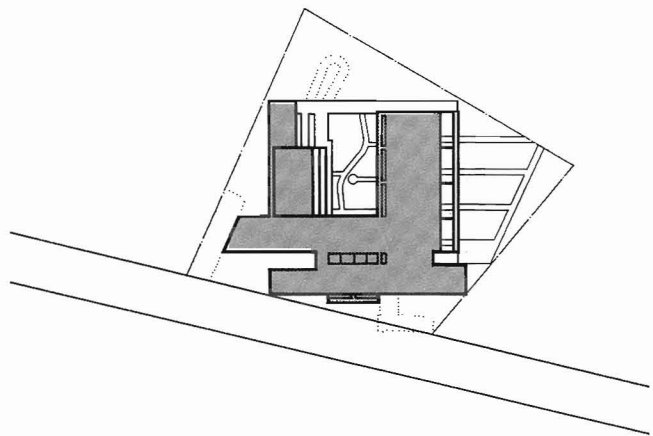

SITE PLAN



SECTION A

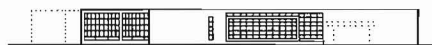

ELEVATION 1



ELEVATION 2

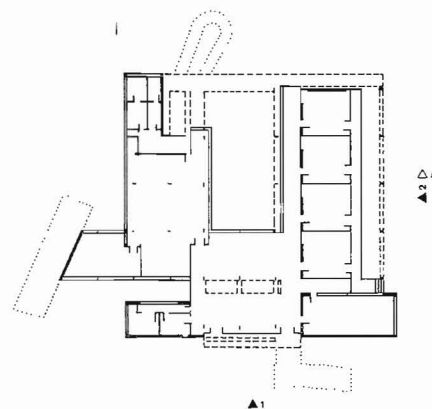

MAIN FLOOR PLAN

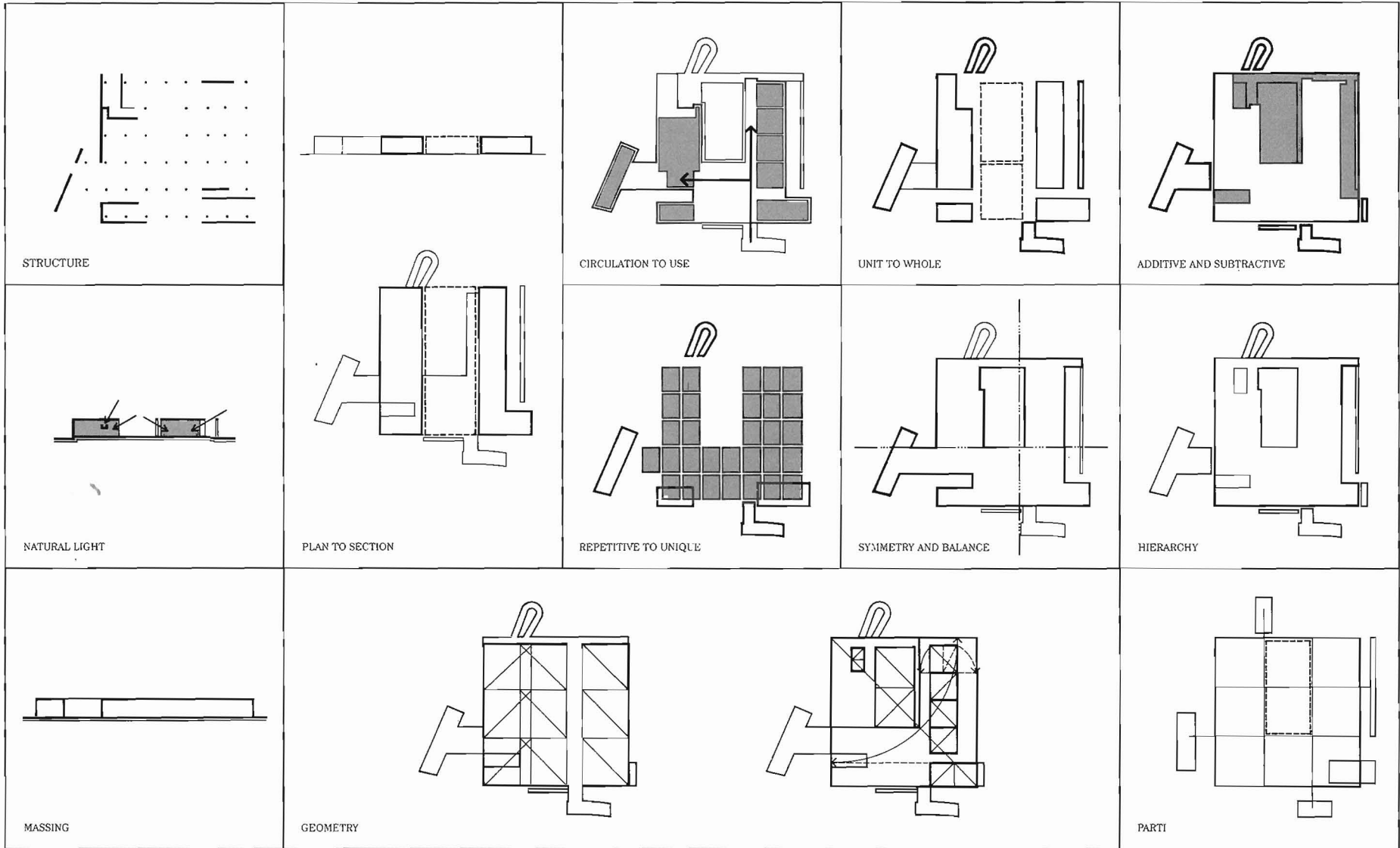

GIUSEPPE TERRAGNI

VILLA BIANCA (ANGELO TERRAGNI HOUSE)
SEVESO (MILAN), ITALY
1937

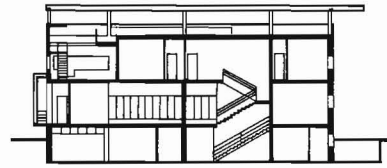

SECTION A

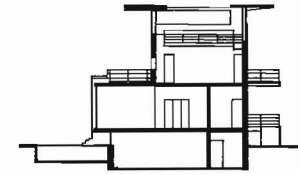

SECTION B

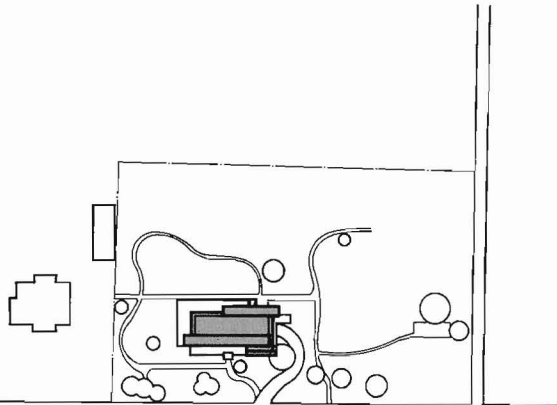

SITE PLAN

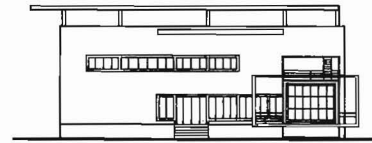

ELEVATION 1

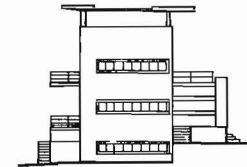

ELEVATION 2

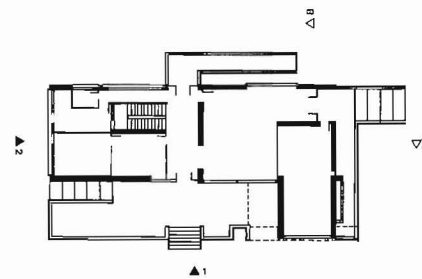

MAIN FLOOR PLAN

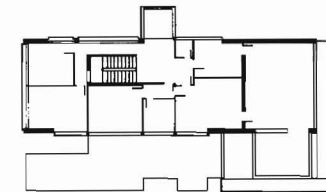

UPPER FLOOR PLAN

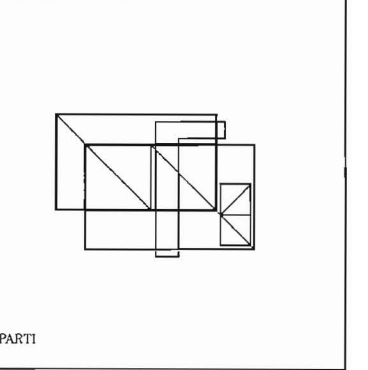
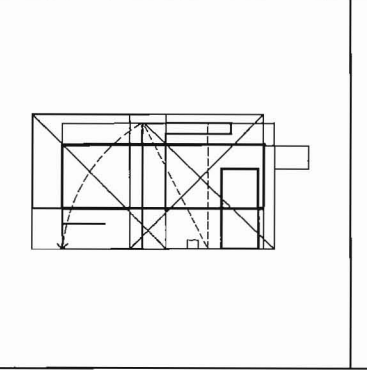
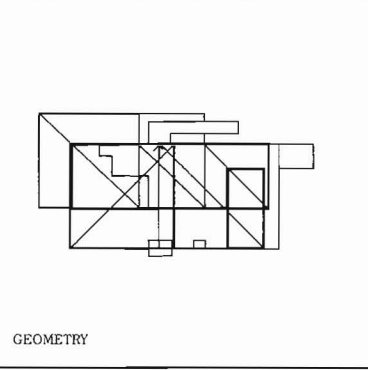
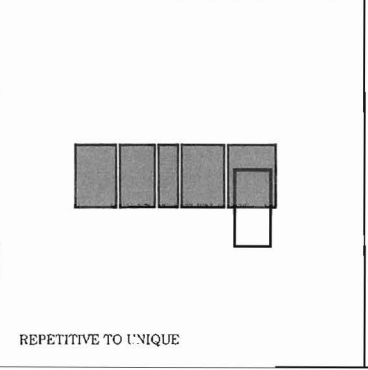
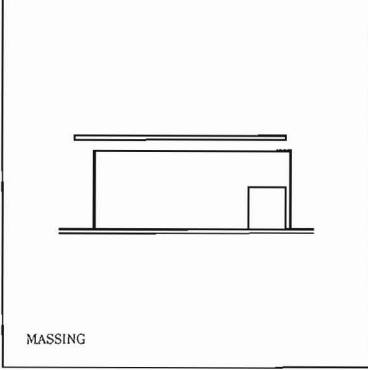
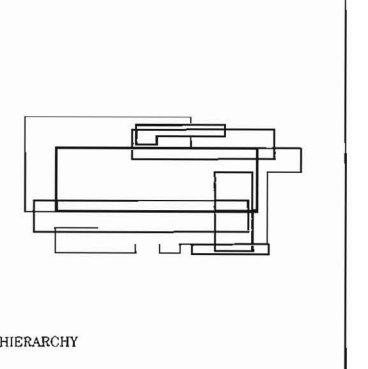
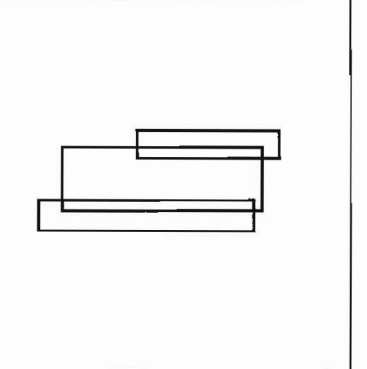
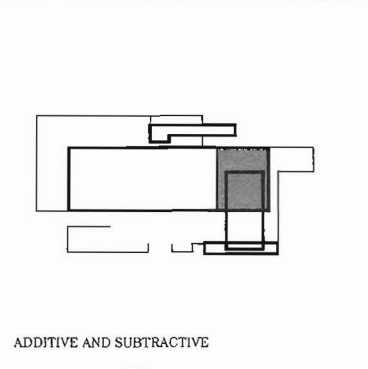
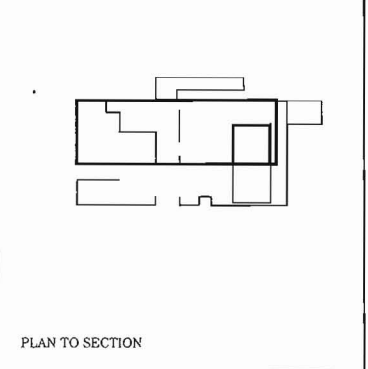
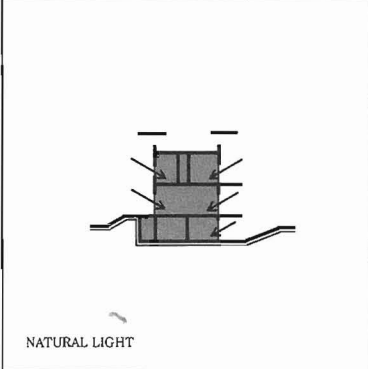
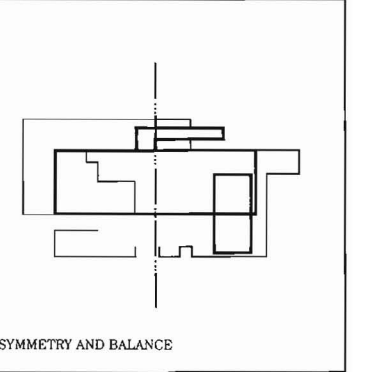
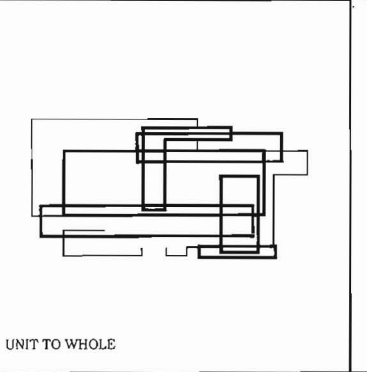
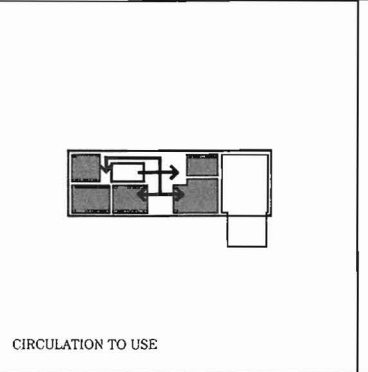
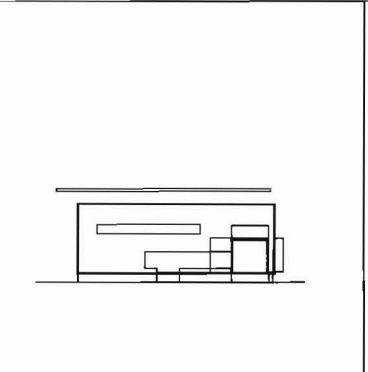
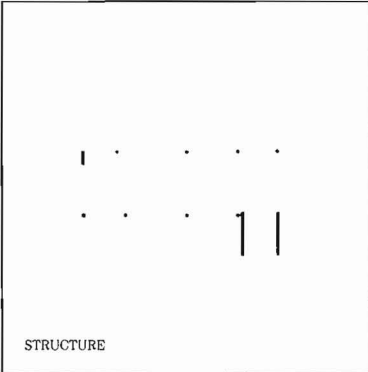

LUDWIG MIES VAN DER ROHE

LUDWIG MIES VAN DER ROHE

GERMAN PAVILION AT INTERNATIONAL EXHIBITION
BARCELONA, SPAIN
1928-1929



SECTION A



SECTION B

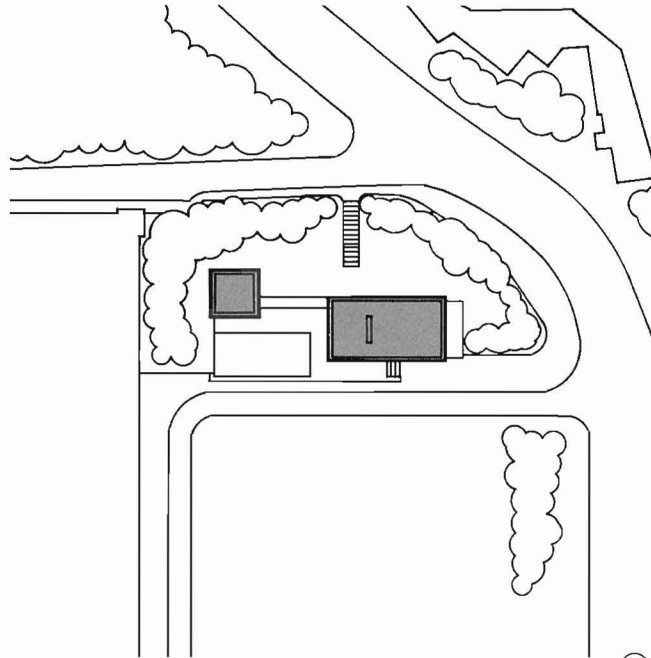

SITE PLAN

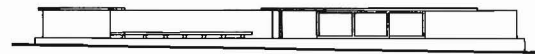





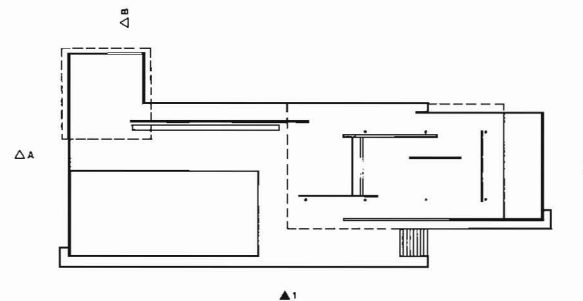

ELEVATION 1

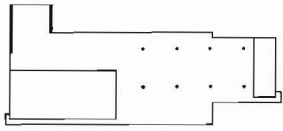

ELEVATION 2

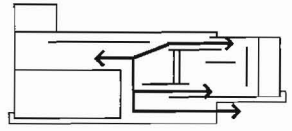
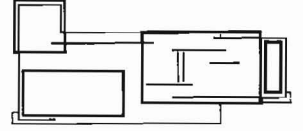
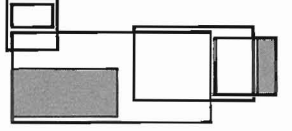

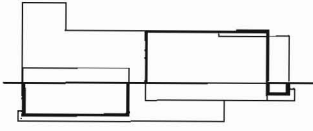
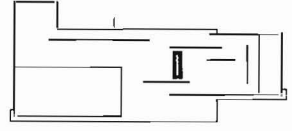
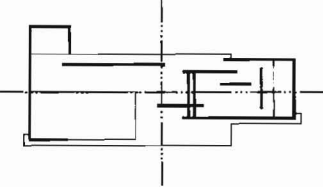
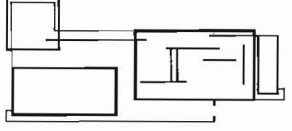
FLOOR PLAN

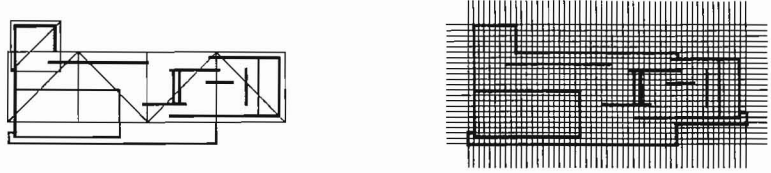
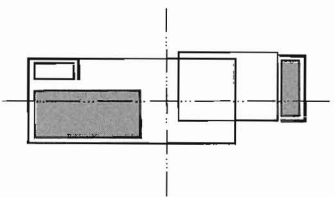
 <p>STRUCTURE</p>		 <p>CIRCULATION TO USE</p>	 <p>UNIT TO WHOLE</p>	 <p>ADDITIVE AND SUBTRACTIVE</p>
 <p>NATURAL LIGHT</p>	 <p>PLAN TO SECTION</p>	 <p>REPETITIVE TO UNIQUE</p>	 <p>SYMMETRY AND BALANCE</p>	 <p>HIERARCHY</p>
 <p>MASSING</p>	 <p>GEOMETRY</p>		 <p>PARTI</p>	

LUDWIG MIES VAN DER ROHE

TUGENDHAT HOUSE
BRNO, CZECHOSLOVAKIA
1928-1930

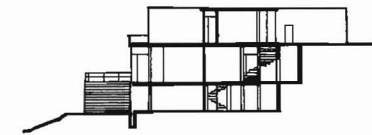

SECTION A

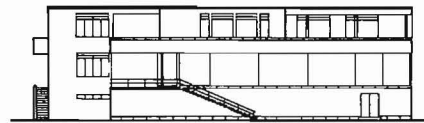
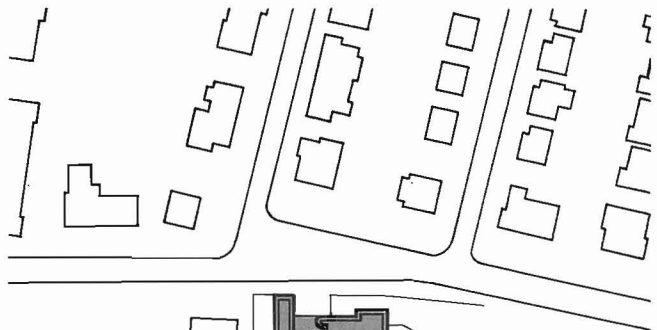

ELEVATION 1

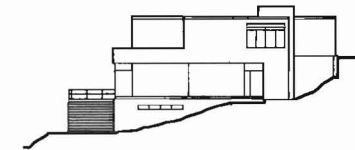

ELEVATION 2

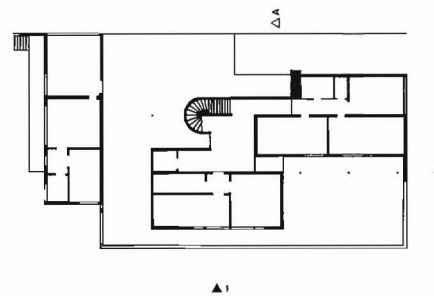

UPPER FLOOR PLAN

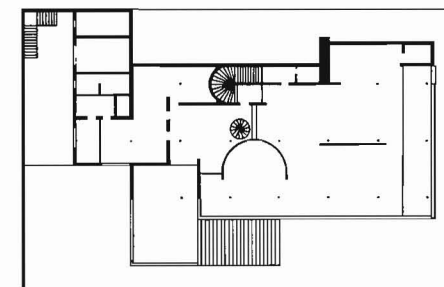

LOWER FLOOR PLAN

SITE PLAN

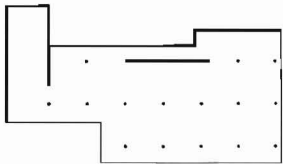
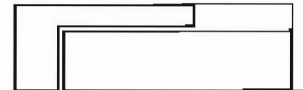
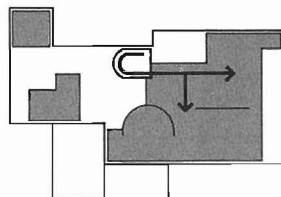
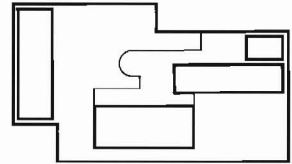
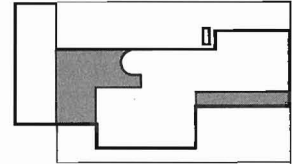
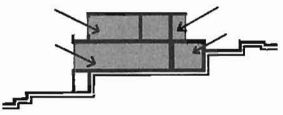
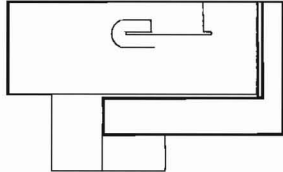
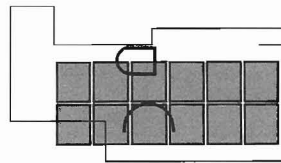
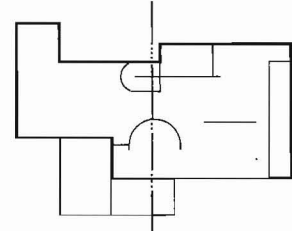
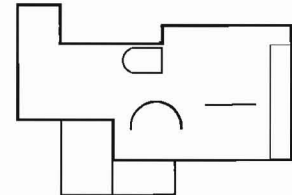
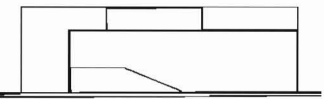
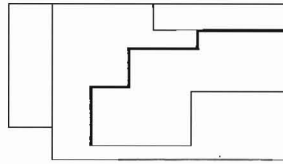
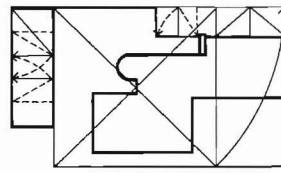
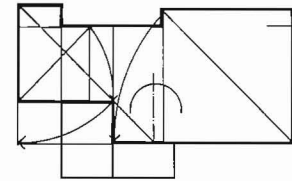
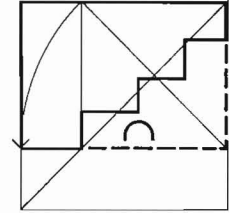
 <p>STRUCTURE</p>		 <p>CIRCULATION TO USE</p>	 <p>UNIT TO WHOLE</p>	 <p>ADDITIVE AND SUBRACTIVE</p>
 <p>NATURAL LIGHT</p>		 <p>REPETITIVE TO UNIQUE</p>	 <p>SYMMETRY AND BALANCE</p>	 <p>HIERARCHY</p>
 <p>MASSING</p>	 <p>PLAN TO SECTION</p>	 <p>GEOMETRY</p>		 <p>PART</p>

LUDWIG MIES VAN DER ROHE

FARNSWORTH HOUSE
FOX RIVER VALLEY (NEAR PLANO), ILLINOIS
1945-1951

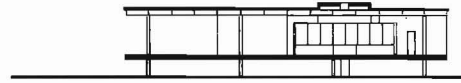

SECTION A

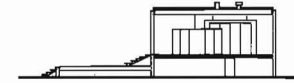

SECTION B

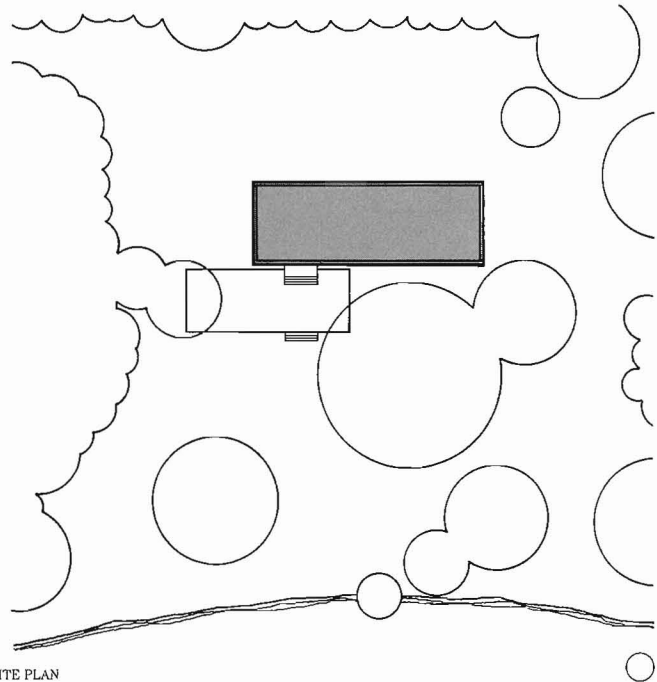

ELEVATION 1

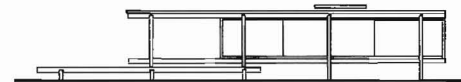





ELEVATION 2

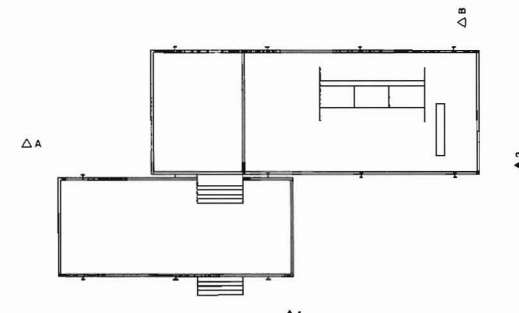

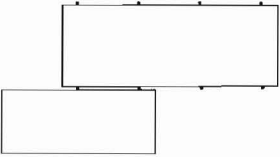
FLOOR PLAN

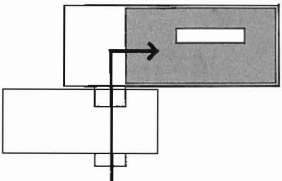
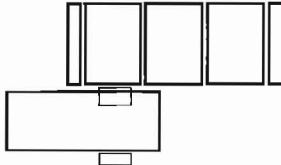
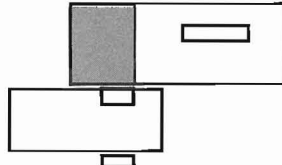
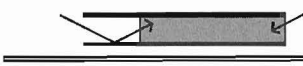
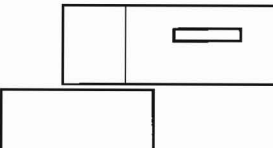
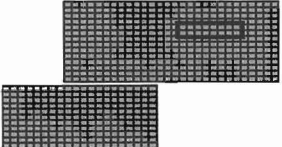
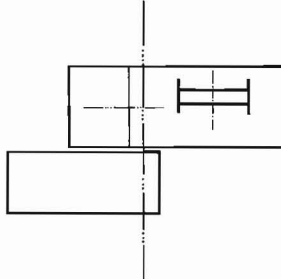
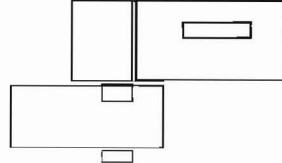

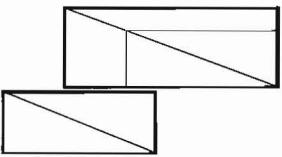
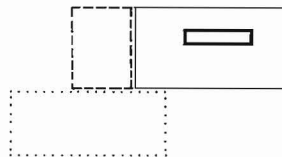
 <p>STRUCTURE</p>	 <p>PLAN TO SECTION</p>	 <p>CIRCULATION TO USE</p>	 <p>UNIT TO WHOLE</p>	 <p>ADDITIVE AND SUBTRACTIVE</p>
 <p>NATURAL LIGHT</p>	 <p>HIERARCHY</p>	 <p>REPETITIVE TO UNIQUE</p>	 <p>SYMMETRY AND BALANCE</p>	 <p>HIERARCHY</p>
 <p>MASSING</p>	 <p>GEOMETRY</p>		 <p>PARTI</p>	

LUDWIG MIES VAN DER ROHE

CROWN HALL (ARCHITECTURE, CITY
PLANNING AND DESIGN BUILDING)
ILLINOIS INSTITUTE OF TECHNOLOGY
CHICAGO, ILLINOIS
1950-1956



SECTION A

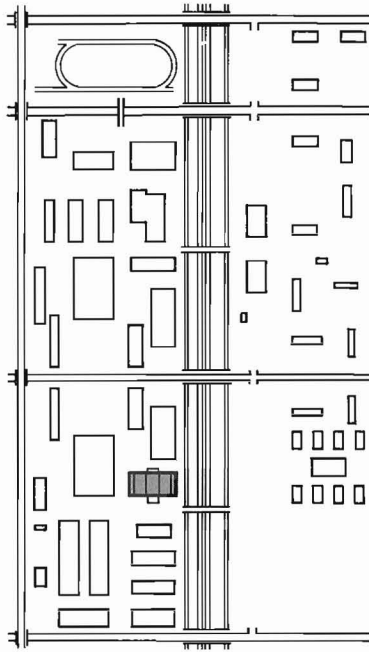

SITE PLAN



ELEVATION 1





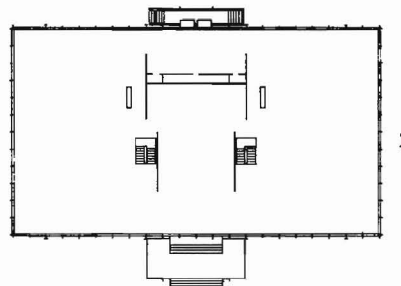

ELEVATION 2

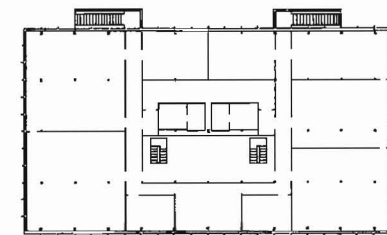

MAIN FLOOR PLAN

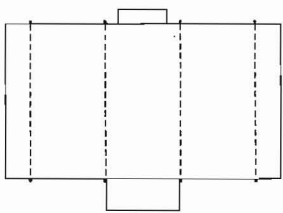

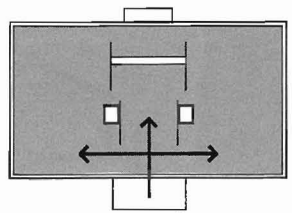
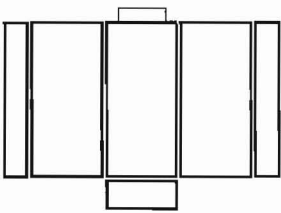
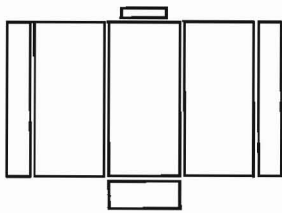
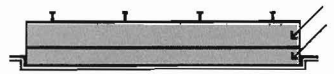
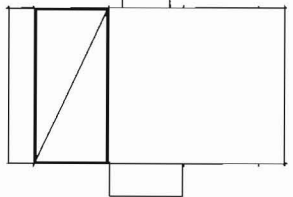
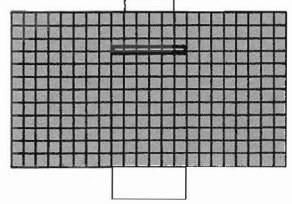
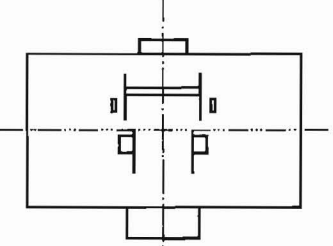
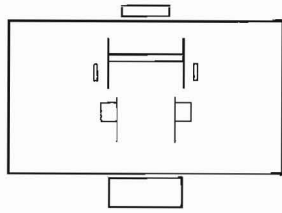
LOWER FLOOR PLAN

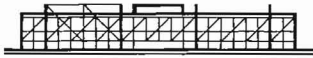
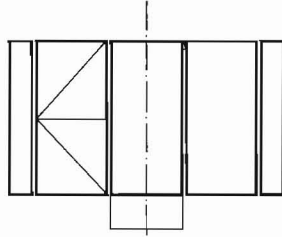
 <p>STRUCTURE</p>		 <p>CIRCULATION TO USE</p>	 <p>UNIT TO WHOLE</p>	 <p>ADDITIVE AND SUBTRACTIVE</p>
 <p>NATURAL LIGHT</p>	 <p>PLAN TO SECTION</p>	 <p>REPETITIVE TO UNIQUE</p>	 <p>SYMMETRY AND BALANCE</p>	 <p>HIERARCHY</p>
 <p>MASSING</p>	 <p>GEOMETRY</p>		 <p>PART</p>	

ROBERT VENTURI

ROBERT VENTURI

VANNA VENTURI HOUSE
PHILADELPHIA, PENNSYLVANIA
1962

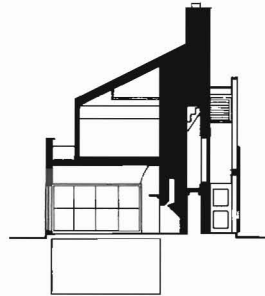

SECTION A

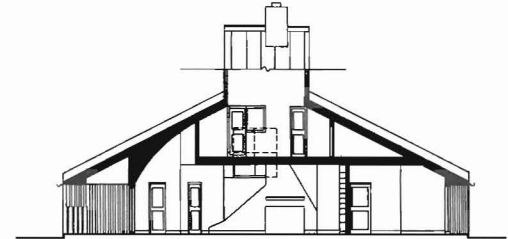

SECTION B

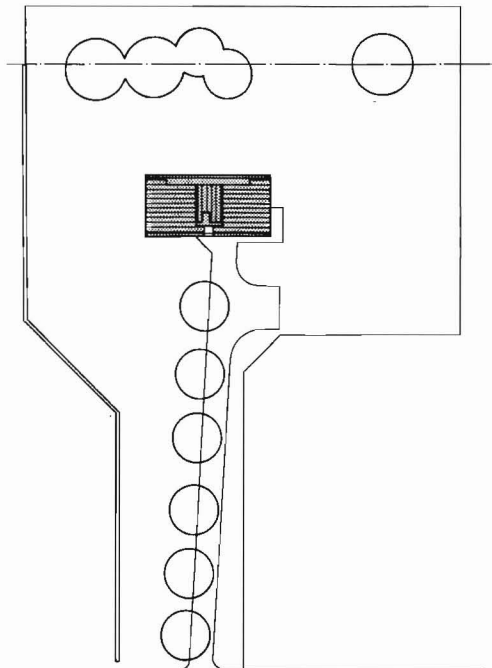

SITE PLAN

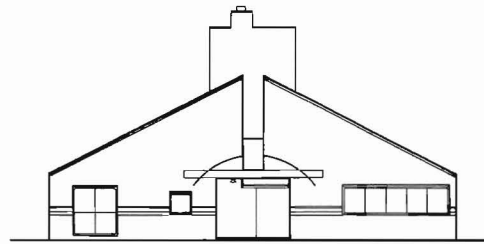

ELEVATION 1

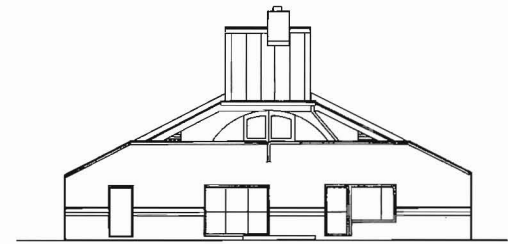

ELEVATION 2

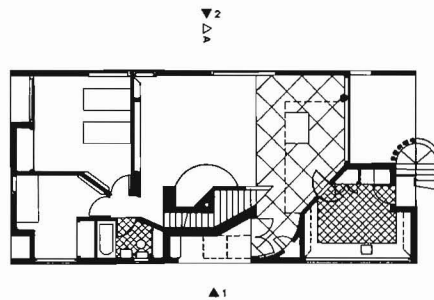

MAIN FLOOR PLAN

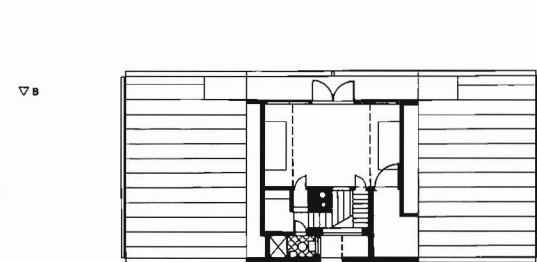

UPPER FLOOR PLAN

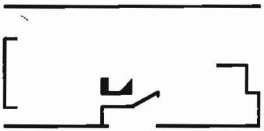
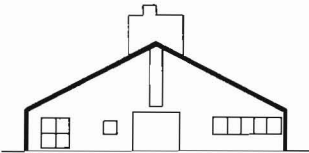
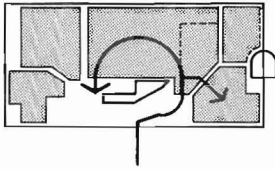
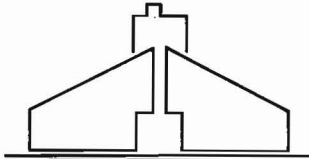
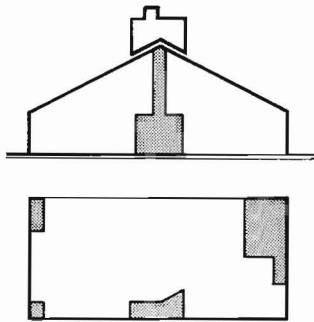
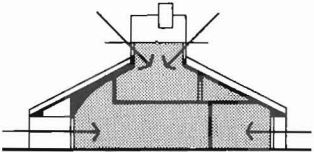
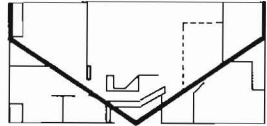
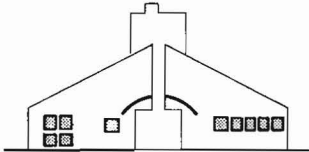
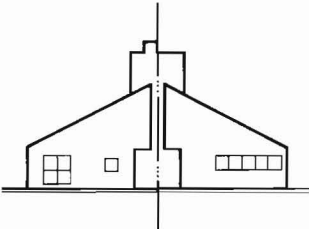
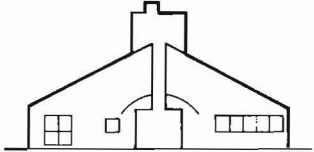
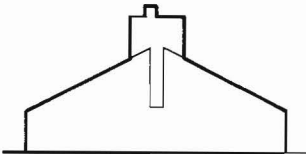
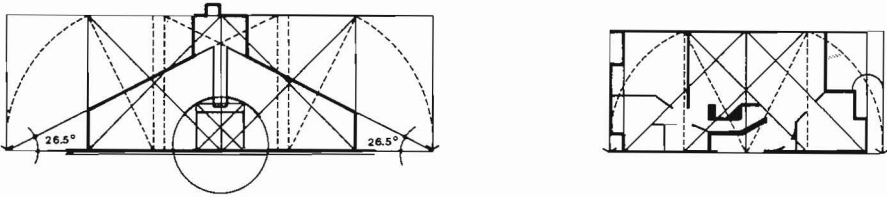
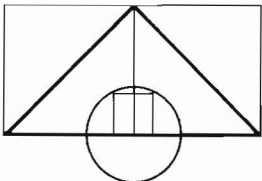
 <p>STRUCTURE</p>		 <p>CIRCULATION TO USE</p>	 <p>UNIT TO WHOLE</p>	 <p>ADDITIVE AND SUBTRACTIVE</p>
 <p>NATURAL LIGHT</p>	 <p>PLAN TO SECTION</p>	 <p>REPETITIVE TO UNIQUE</p>	 <p>SYMMETRY AND BALANCE</p>	 <p>HIERARCHY</p>
 <p>MASSING</p>	 <p>GEOMETRY</p>		 <p>PARTI</p>	

ROBERT VENTURI

FIRE STATION – NUMBER 4
COLUMBUS, INDIANA
1966

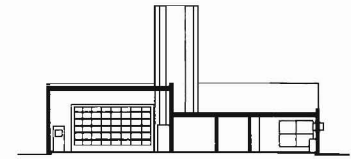

SECTION A

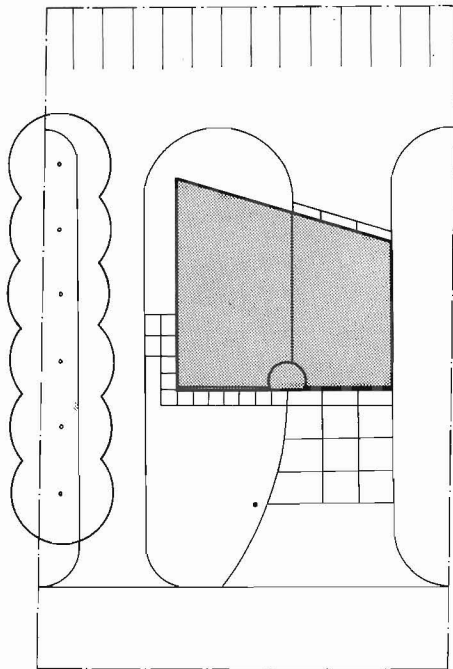

SITE PLAN

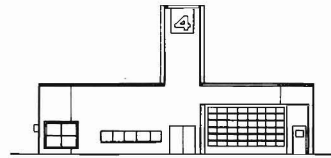

ELEVATION 1

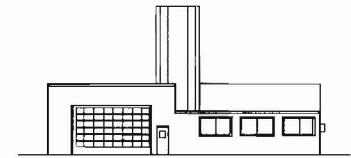

ELEVATION 2

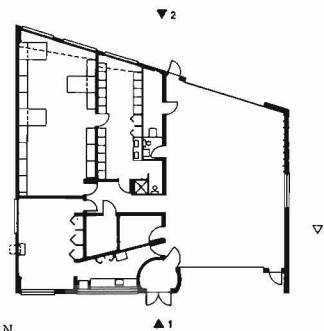

FLOOR PLAN

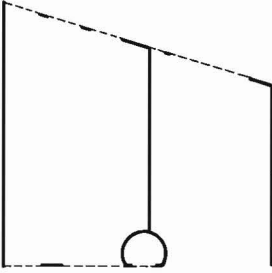
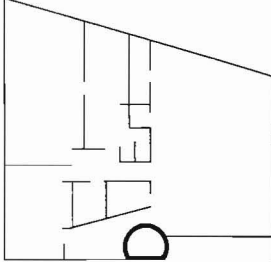
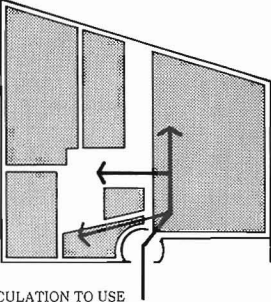
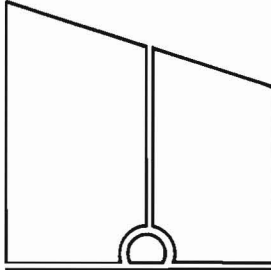
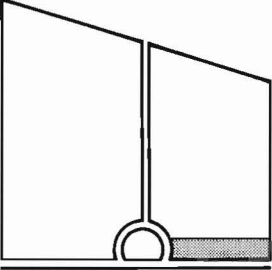
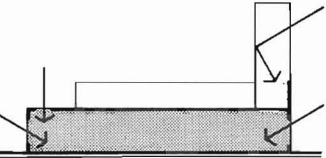
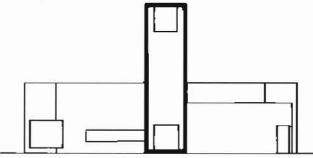
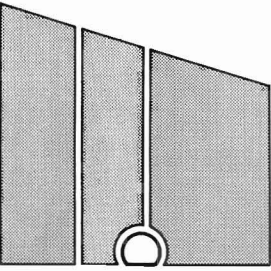
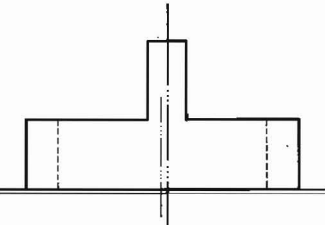
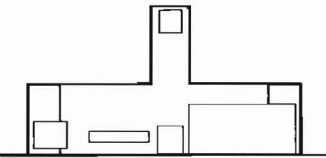
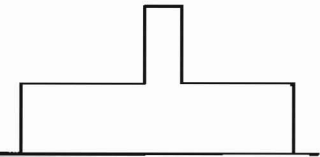
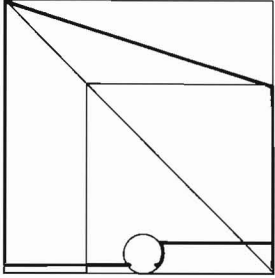
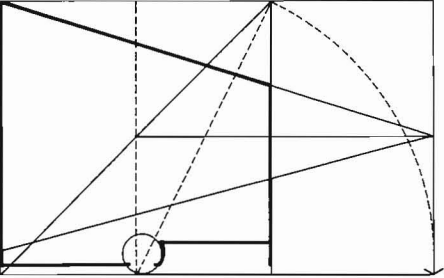
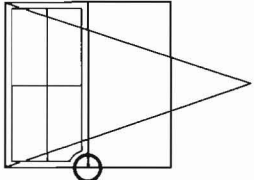
 <p>STRUCTURE</p>		 <p>CIRCULATION TO USE</p>	 <p>UNIT TO WHOLE</p>	 <p>ADDITIVE AND SUBTRACTIVE</p>
 <p>NATURAL LIGHT</p>	 <p>PLAN TO SECTION</p>	 <p>REPETITIVE TO UNIQUE</p>	 <p>SYMMETRY AND BALANCE</p>	 <p>HIERARCHY</p>
 <p>MASSING</p>	  <p>GEOMETRY</p>		 <p>PARTI</p>	

ROBERT VENTURI

PETER BRANT HOUSE
GREENWICH, CONNECTICUT
1973

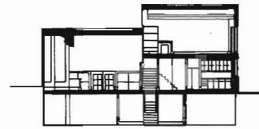

SECTION A

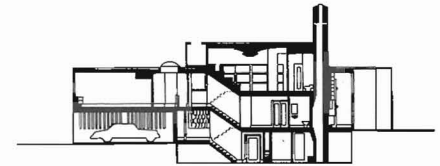

SECTION B

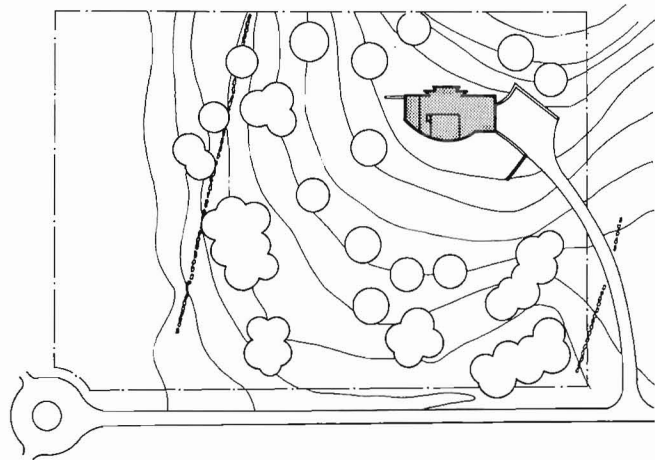

SITE PLAN

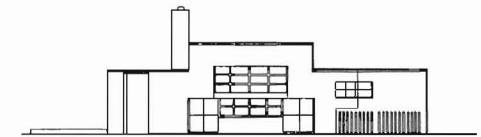

ELEVATION 1

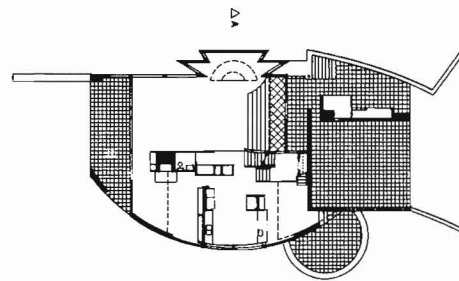

LOWER FLOOR PLAN

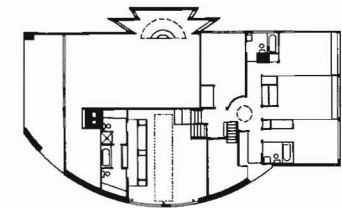

UPPER FLOOR PLAN

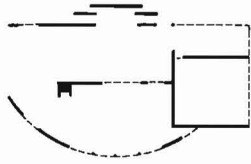
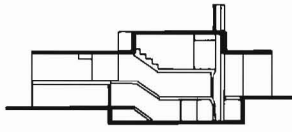
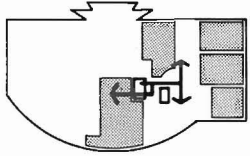
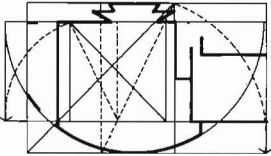
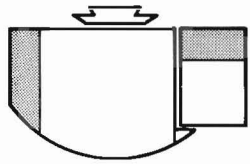
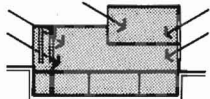
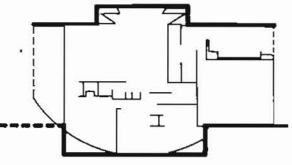
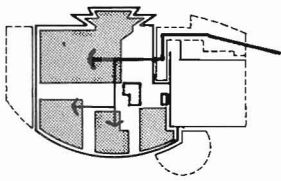
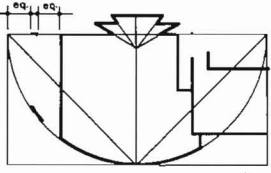
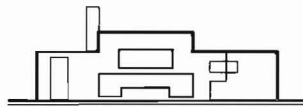
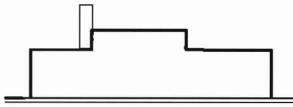
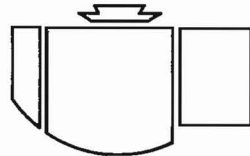
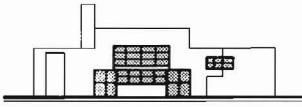
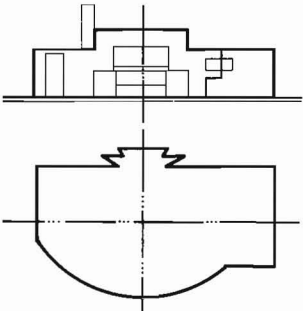
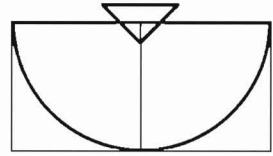
 <p>STRUCTURE</p>				 <p>ADDITIVE AND SUBTRACTIVE</p>
 <p>NATURAL LIGHT</p>	 <p>PLAN TO SECTION</p>	 <p>CIRCULATION TO USE</p>	 <p>GEOMETRY</p>	 <p>HIERARCHY</p>
 <p>MASSING</p>	 <p>UNIT TO WHOLE</p>	 <p>REPETITIVE TO UNIQUE</p>	 <p>SYMMETRY AND BALANCE</p>	 <p>PARTI</p>

ROBERT VENTURI

CARLL TUCKER III HOUSE
MOUNT KISCO, WESTCHESTER COUNTY, NEW YORK
1975



SECTION A

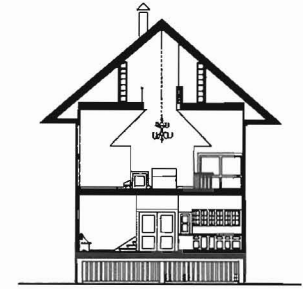

SECTION B

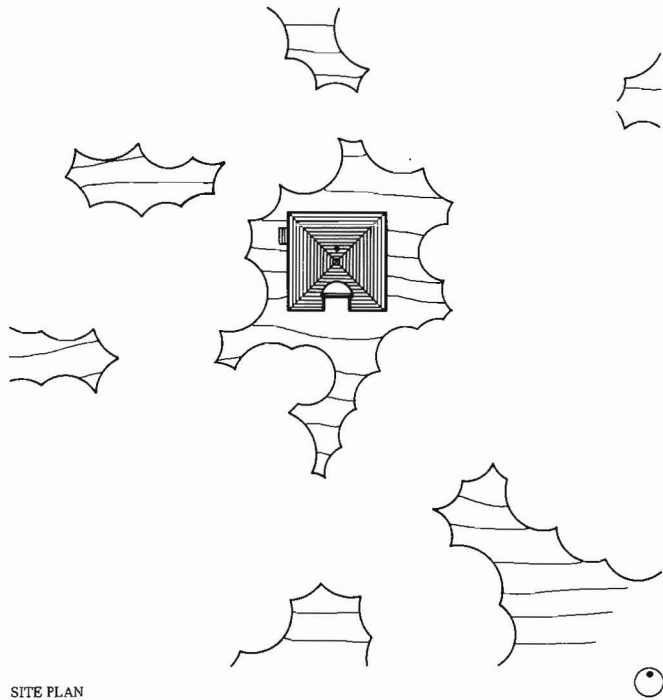

SITE PLAN



ELEVATION 1

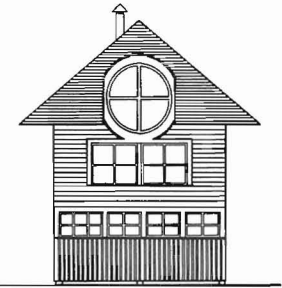



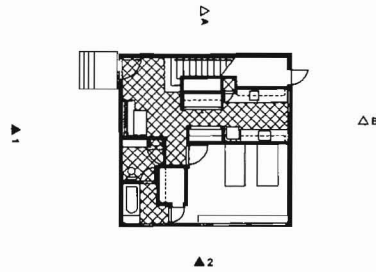

ELEVATION 2

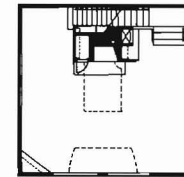

LOWER FLOOR PLAN

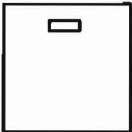
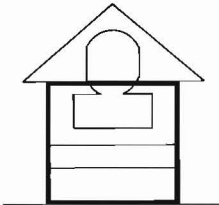
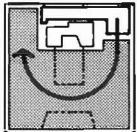
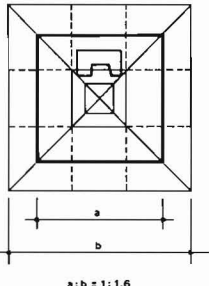
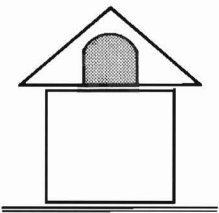
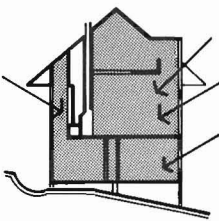
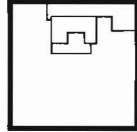
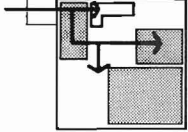
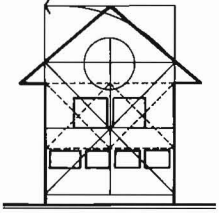

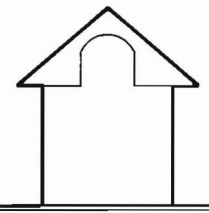
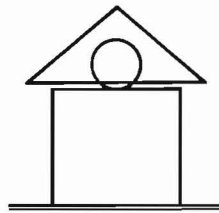
MAIN FLOOR PLAN

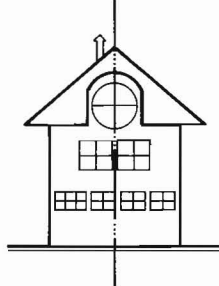
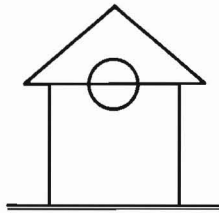
 <p>STRUCTURE</p>			 <p>a:b = 1:1.6</p>	 <p>ADDITIVE AND SUBTRACTIVE</p>
 <p>NATURAL LIGHT</p>	 <p>PLAN TO SECTION</p>	 <p>CIRCULATION TO USE</p>	 <p>GEOMETRY</p>	 <p>HIERARCHY</p>
 <p>MASSING</p>	 <p>UNIT TO WHOLE</p>	 <p>REPETITIVE TO UNIQUE</p>	 <p>SYMMETRY AND BALANCE</p>	 <p>PARTI</p>

FRANK LLOYD WRIGHT

FRANK LLOYD WRIGHT

UNITY TEMPLE
OAK PARK, ILLINOIS
1906

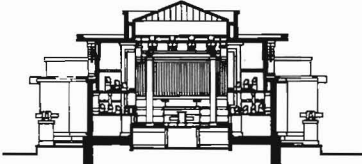

SECTION A

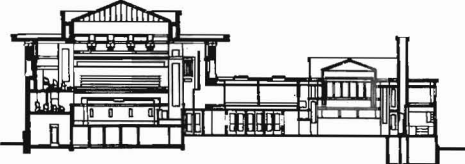

SECTION B

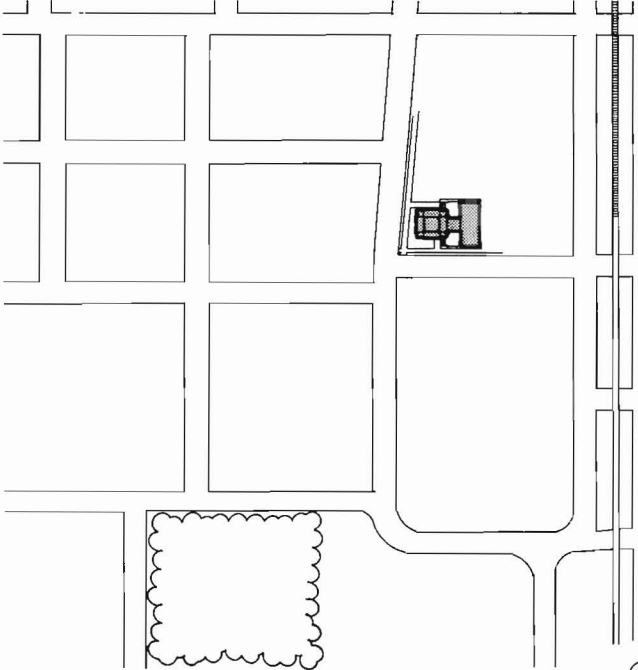

SITE PLAN

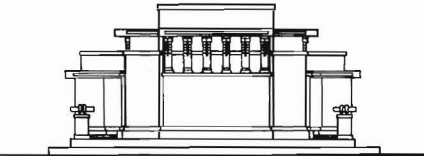

ELEVATION 1

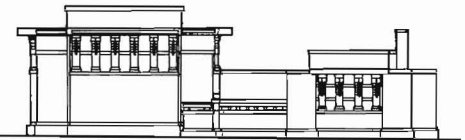



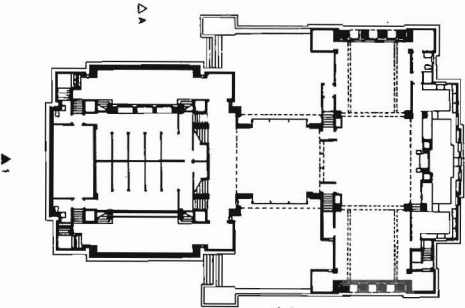

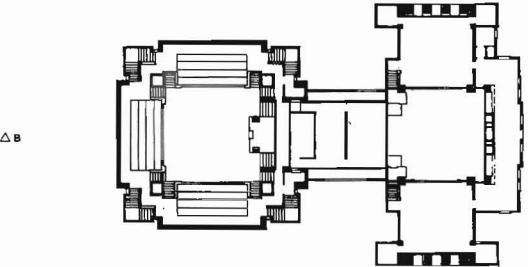

ELEVATION 2

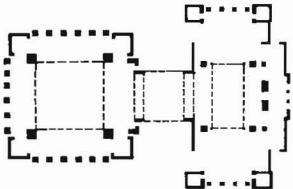

LOWER FLOOR PLAN

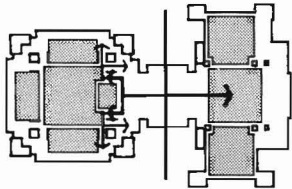
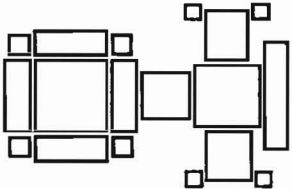
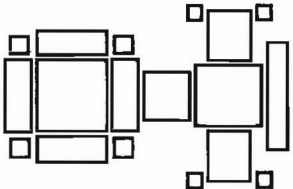

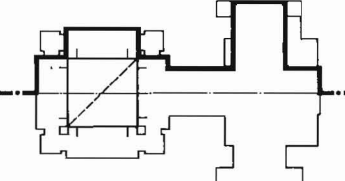
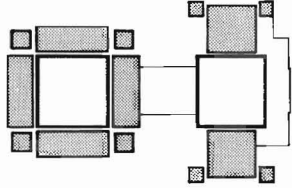
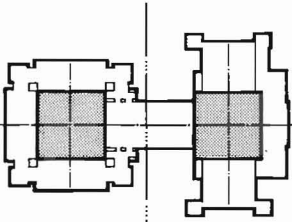
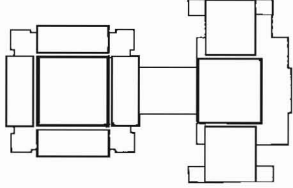
MAIN FLOOR PLAN

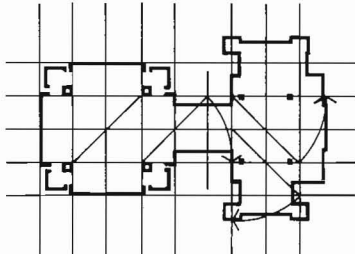
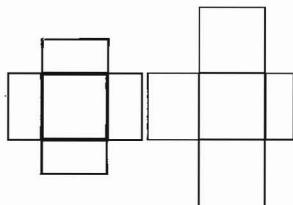
 <p>STRUCTURE</p>		 <p>CIRCULATION TO USE</p>	 <p>UNIT TO WHOLE</p>	 <p>ADDITIVE AND SUBTRACTIVE</p>
 <p>NATURAL LIGHT</p>	 <p>PLAN TO SECTION</p>	 <p>REPETITIVE TO UNIQUE</p>	 <p>SYMMETRY AND BALANCE</p>	 <p>HIERARCHY</p>
 <p>MASSING</p>	 <p>GEOMETRY</p>		 <p>PARTI</p>	

FRANK LLOYD WRIGHT

FREDERICK G. ROBIE HOUSE
CHICAGO, ILLINOIS
1909



SECTION A

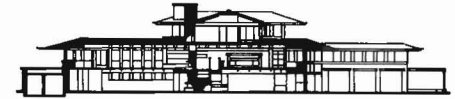

SECTION B

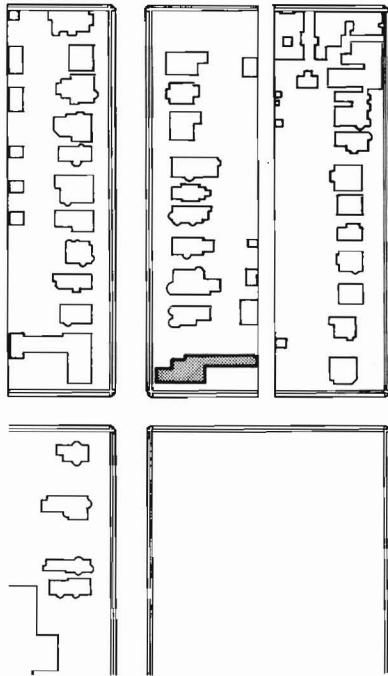

SITE PLAN



ELEVATION 1

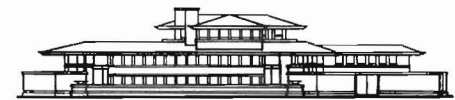



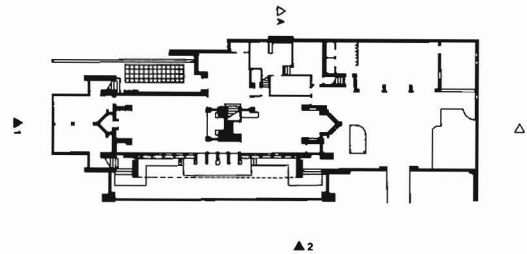

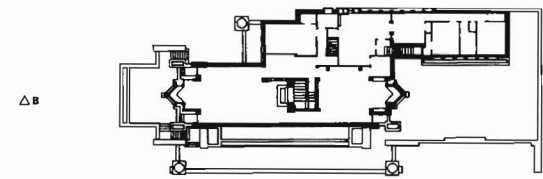

ELEVATION 2



LOWER FLOOR PLAN

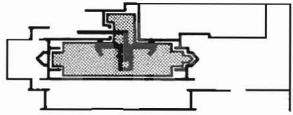
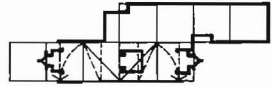
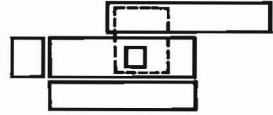

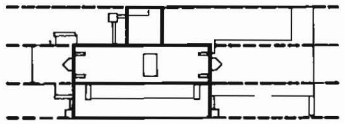
UPPER FLOOR PLAN

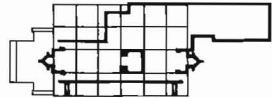
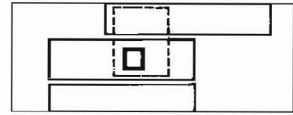
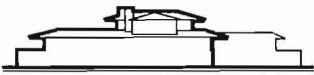
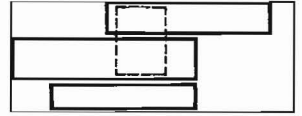
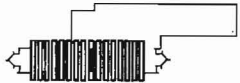
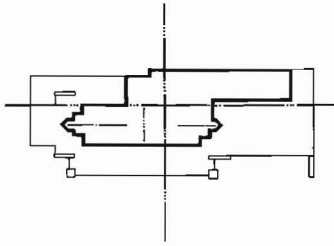
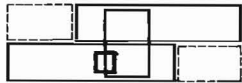
 <p>STRUCTURE</p>	 <p>PLAN TO SECTION</p>	 <p>CIRCULATION TO USE</p>	 <p>GEOMETRY</p>	 <p>ADDITIVE AND SUBTRACTIVE</p>
 <p>NATURAL LIGHT</p>	 <p>PLAN TO SECTION</p>	 <p>REPETITIVE TO UNIQUE</p>	 <p>SYMMETRY AND BALANCE</p>	 <p>HIERARCHY</p>
 <p>MASSING</p>	 <p>UNIT TO WHOLE</p>	 <p>REPETITIVE TO UNIQUE</p>	 <p>SYMMETRY AND BALANCE</p>	 <p>PARTI</p>

FRANK LLOYD WRIGHT

FALLINGWATER (EDGAR J. KAUFMANN HOUSE)
OHIOPYLE, PENNSYLVANIA
1935

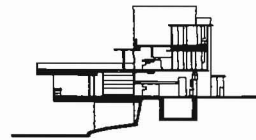

SECTION A



SECTION B

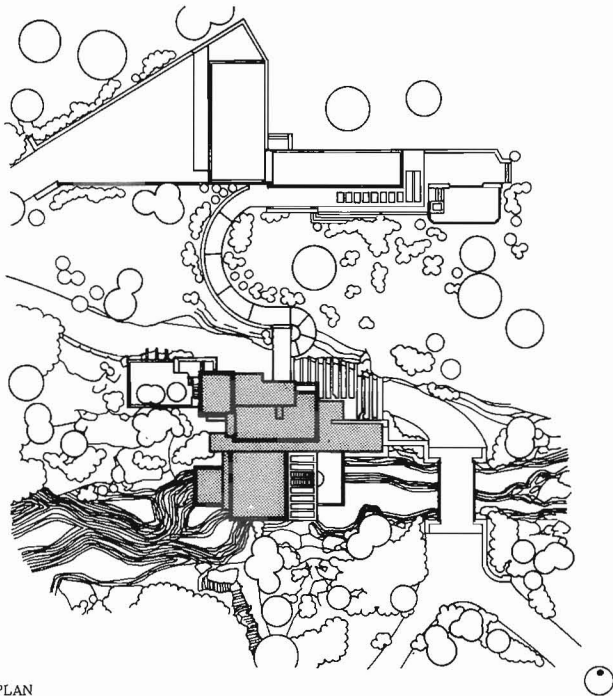

SITE PLAN

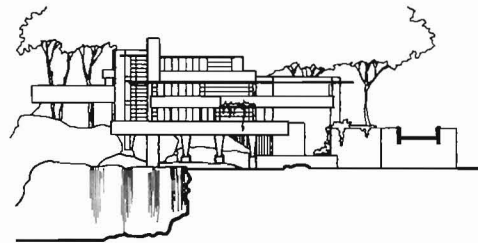

ELEVATION 1

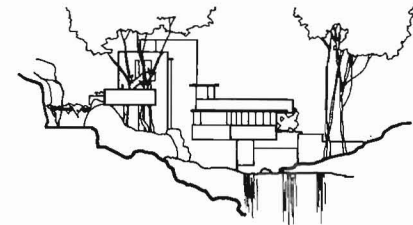

ELEVATION 2

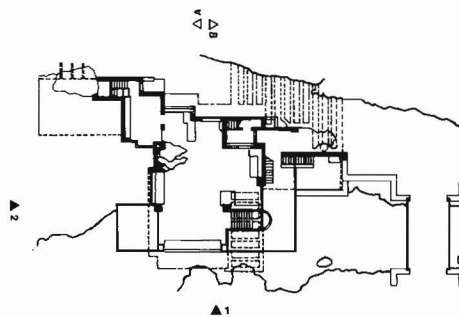

LOWER FLOOR PLAN

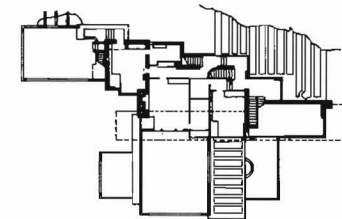

UPPER FLOOR PLAN

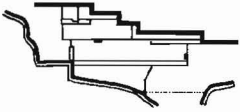
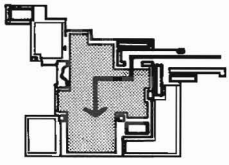
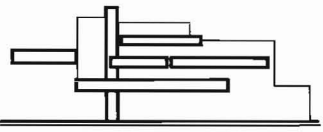
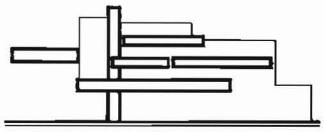
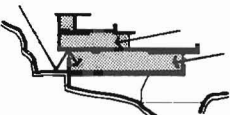
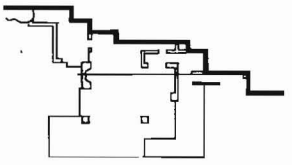
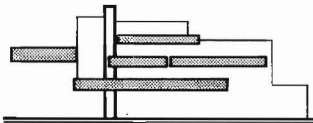
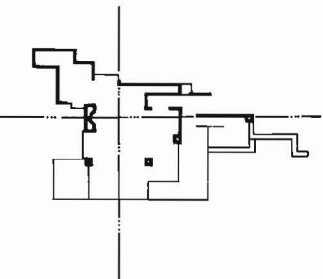
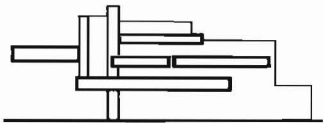
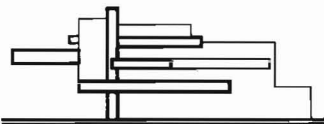
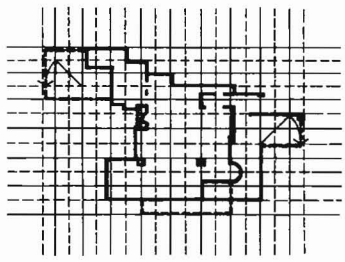
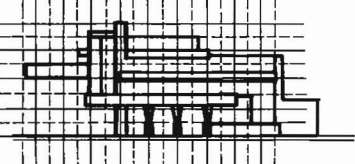
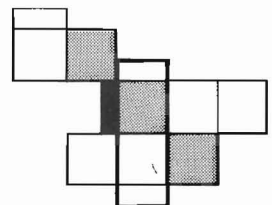
 <p>STRUCTURE</p>		 <p>CIRCULATION TO USE</p>	 <p>UNIT TO WHOLE</p>	 <p>ADDITIVE AND SUBRACTIVE</p>
 <p>NATURAL LIGHT</p>	 <p>PLAN TO SECTION</p>	 <p>REPETITIVE TO UNIQUE</p>	 <p>SYMMETRY AND BALANCE</p>	 <p>HIERARCHY</p>
 <p>MASSING</p>	 <p>GEOMETRY</p>			 <p>PARTI</p>

FRANK LLOYD WRIGHT

SOLOMON R. GUGGENHEIM MUSEUM
NEW YORK, NEW YORK
1956

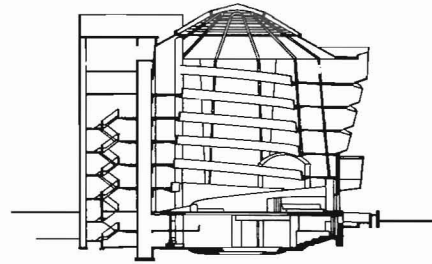

SECTION A

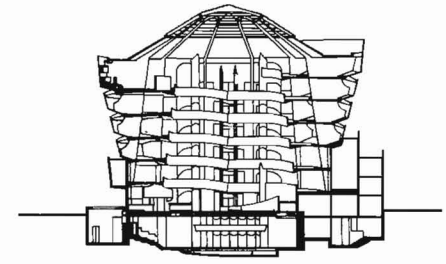

SECTION B

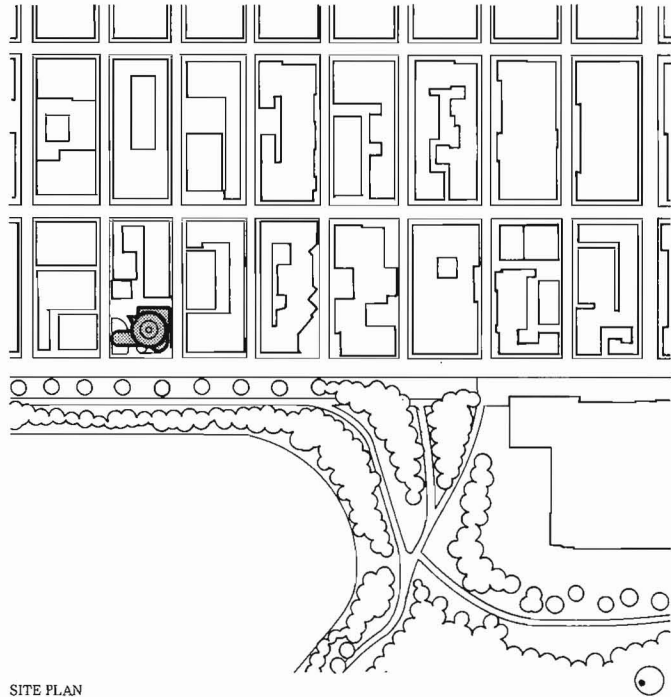

SITE PLAN

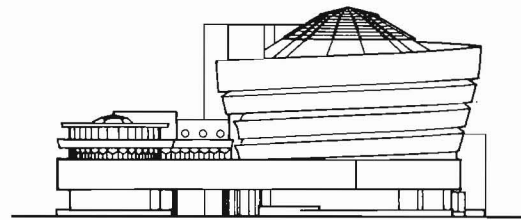

ELEVATION 1

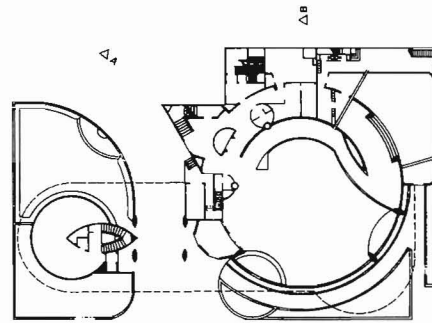

LOWER FLOOR PLAN

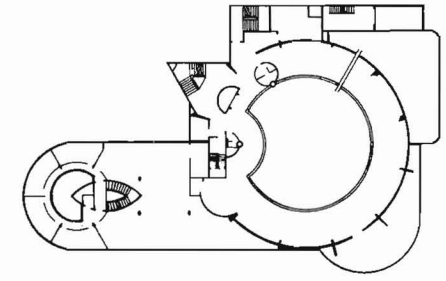

UPPER FLOOR PLAN

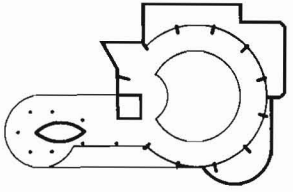
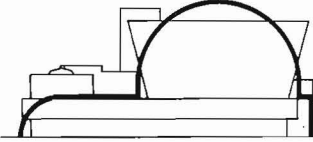
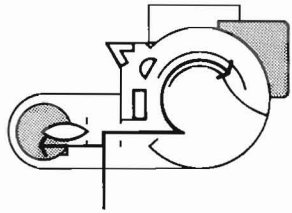
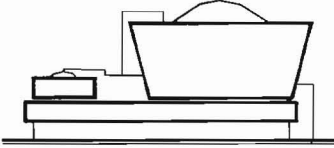
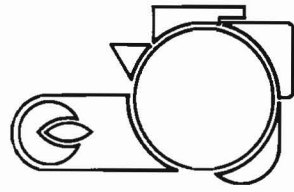
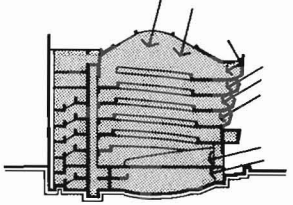
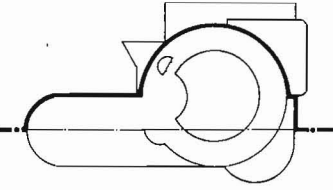
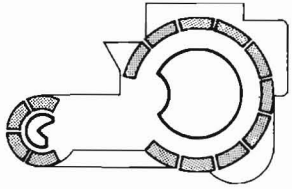
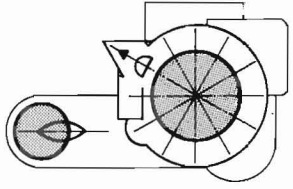
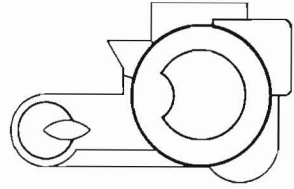
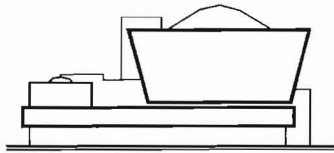
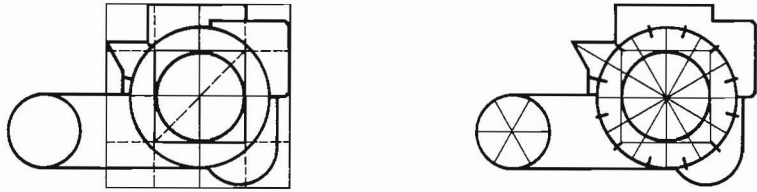
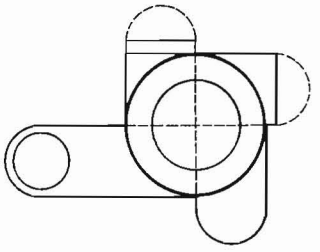
 <p>STRUCTURE</p>		 <p>CIRCULATION TO USE</p>	 <p>UNIT TO WHOLE</p>	 <p>ADDITIVE AND SUBTRACTIVE</p>
 <p>NATURAL LIGHT</p>	 <p>PLAN TO SECTION</p>	 <p>REPETITIVE TO UNIQUE</p>	 <p>SYMMETRY AND BALANCE</p>	 <p>HIERARCHY</p>
 <p>MASSING</p>	 <p>GEOMETRY</p>		 <p>PARTI</p>	

FORMATIVE IDEAS

Plan to Section or Elevation / 200

- Equal
- One to One-Half
- Analogous
- Proportional
- Inverse

Unit to Whole / 207

- Unit Equals Whole
- Units Contained in Whole
- Whole Greater than Sum of the Units
- Units Aggregate to Form Whole
 - Units Adjoin
 - Units Overlap
 - Units Separate

Repetitive to Unique / 214

- Unique Surrounded by Repetitive
- Unique by Transformation of Repetitive
- Unique in Repetitive Field
- Unique Added to Repetitive
- Unique Defined by Repetitive

Additive and Subtractive / 220

- Subtractive
- Additive

Symmetry and Balance / 222

- Symmetry
- Balance by Configuration
- Balance by Geometry
- Balance by Positive and Negative

Geometry / 228

- Basic Geometry
- Circle and Square
- Rectangle Overlapped by Circle
- Two Squares
- Nine-Square
- Four-Square
- 1.4 and 1.6 Rectangles
- Geometric Derivatives
- Rotated, Shifted, and Overlapped
- Pinwheel, Radial, and Spiral
- Grid

Configuration Patterns / 242

- Linear: Use
- Linear: Circulation
- Central: Use
- Central: Circulation
- Double Center
- Cluster
- Nested
- Concentric
- Binuclear

Progressions / 252

- Hierarchy
- Transition
- Transformation
- Mediation

Reduction / 256

- Large Plus Small Reduction
- Part of Whole Reduction

FORMATIVE IDEAS

From the analysis of the 88 buildings in the first section, patterns in the design consideration of various architects were identified. Similarities in design approaches appeared among many of the architects' works, independent of time, style, location, function, or type of building. The similarities can be grouped into dominant themes or formative ideas which were conceivably used in the generation of the building designs.

A formative idea is understood to be a concept which a designer can use to influence or give form to a design. The ideas offer ways to organize decisions, to provide order, and to consciously generate form. By engaging one formative idea instead of another, a designer begins to determine the formal result and the manner in which it will differ from other configurations. The use of different ordering ideas may generate different results.

Presented in this section of the book is a series of connections among architects' designs organized by formative idea. Each concept is defined and explored through the presentation of generic manifestations of the idea. The written description is followed by a set of diagrams which exemplify some, but not all, of the generic alternatives. The inventory is not exhaustive: every idea is not explored, nor is every example included. Generally, diagrams developed in the analysis section are supplemented with other examples to illuminate a formative idea. Diagrams were selected which best illustrate the idea, show a variety of manifestations, and represent the widest range of building types from the broadest time frame.

PLAN TO SECTION OR ELEVATION

As a formative idea, the relationship of a plan to a section or an elevation entails design by using an identifiable correlation between the horizontal and vertical configurations of the building. Embodied in this is the linking of the two realms so that decisions in one arena determine or influence the form of the other.

The most direct connection between the plan and section occurs when they are the same—when the delineation of the two is equal. This can be described as a one to one relationship. A sphere, for example, is a figure in which the plan and section are represented by one circle. It is also possible to relate part of one configuration to the whole of the other. For example, a one to one-half relationship exists in a building that has a section or elevation equal in figure and dimension to one-half of the plan. In this case, a circle in plan becomes a half-circle in section, creating a hemisphere. The reciprocal condition is also possible, where the whole plan form of a building is the same as one-half of the section or elevation. In either case, the figures that appear in both plan and section are equal in dimension. In those circumstances in which the section is one-half the plan, a laterally symmetrical plan configuration can be achieved by utilizing the section form twice to create the whole plan. A special condition occurs when the same part of each figure overlaps, such as in the definition of the main space at the Villa Rotonda.

A relationship of proportion by ratio can be used to link the plan with section or elevation. Distinct from the part to

whole connection just described, the relationship of proportion establishes the plan and the section as the totality of the other, though different in scale. This relationship is predicated on more information in plan and section being paired than just the outline of each. Examples of ratios which are often used because of their compatibility with primary geometry are 1 : 2, 2 : 3, and 1 : 5. In each case, the plan and section have configurations that differ by dimension in one direction only. In the case of a 1 : 2 relationship, the plan and the section have the same shape, but one is twice the other in one dimension. For example, a circle in plan would be an oval in section, with the height one-half the width. It is not necessary, though, for each of the parts in the plan to be reduced or increased at the same rate when they are utilized in the section or elevation. In Christ Church, by Hawksmoor, for instance, while one element is reduced when it appears in the other realm, the other element is increased.

Plan and section or elevation can have a relationship identified specifically as analogous when the information from one is seen to resemble generally the shape of the other. This type of relationship between the plan and section is the most common, and often involves part of the plan and section rather than the entire plan or section form. Differences between the two may be due to a form language change, size or location shift, or irregular increments of change. In a form language change an orthogonal element in plan or section may be paired with a comparable curve form in the other realm. When size and location shifts occur, an element in the horizontal arena is larger or smaller, or in a slightly different location than in the vertical dimension. In increment change the plan or section information changes at one rate while the correlative information in the other changes in a similar way, but at a different rate.

An inverse relationship exists between the plan and section when the configuration of one is paralleled with some opposite condition in the other. For example, when the plan form has components which are large, or simple, or positive, or random, that correspond to section elements that are

small, or complex, or negative, or ordered, respectively, then an inverse relationship exists between the two.

Whereas the relationships of equal, part to whole, proportional, analogous, and inverse establish a link between plan and section in which decisions about one determine the configuration of the other, it is also possible to have a connection that is less deterministic and more influential in nature. In this type of relationship, decisions about the plan or section establish a range of possible configurations for the other.

A part to whole relationship can be created between the plan and the section. In this context, one configuration serves as the whole shape, which, by reduction, becomes a part in the other configuration. The whole is evident in this relationship in its entirety as a part in the other domain, but in reduced dimensions. An example of this form of relationship exists in the Yano House by Arata Isozaki. In this house, which is diagrammed on page 259, the whole configuration of the plan is repeated as part of the section.

Plan and section can also have a coincident relationship when significant points and limits in the plan form coincide with important points in the section. Essential is the alignment of the locations where major changes occur in both plan and section even though the actual configurations are quite varied. The Allegheny Courthouse by H. H. Richardson, which is analyzed in the first part of this book, exemplifies this relationship.

A final alternative to the plan and section relationship is that of common derivation or common origin. In this case, the plan and the section configurations are determined by separate derivation from a common origin. For example, in San Maria degli Angeli by Filippo Brunelleschi, which is also in the analysis section, the plan and section forms are both developed from two overlapped squares that are rotated 45 degrees to each other. In the plan, the two squares have a common center, while in the section, the corner of one square intersects the middle of a side of the other. Both plan and section derive from the same size squares, but the resulting configurations are quite different.

UNIT TO WHOLE

The unit to whole relationship is a formative idea which involves the concept of unit and the understanding that units can be related to other units in specific ways to create built form. A unit is a major recognizable component of a building that generally has a scale that approaches, or is one level removed from, the scale of a whole building. Units can exist within a building at several scales. However, while a brick can be seen as a unit at the scale of a wall, it is less productive to view the brick as a unit at the scale of a building; otherwise, all brick buildings will have the same unit to whole relationship. Units, then, are normally spatial volumes, use-spaces, structural elements, massing blocks, or composites of these elements.

The most direct relationship between a unit and the whole occurs when the two are the same entity—when the unit is equal to the whole. This usually occurs in buildings which are designed as minimal monolithic forms. For example, Cheop's pyramid comprised enormous quantities of stone blocks and cladding pieces. Yet, the dominant perception of this building is that of an identifiable entity. At a greatly reduced level of importance this perception may be qualified to include the surface texture or pattern developed by the fine scale cladding units. Similarly, the glass, tight-skinned cladding on some modern buildings is secondary to the overall monolithic form.

The most prevalent form of unit to whole relationship is the aggregation of units to create the whole. To aggregate units is to put the units in proximity with each other such that some relationship is perceived to exist. The units may or may not be in physical contact with each other in order for a relationship to be identified. The alternative forms of creating a whole through the aggregation of units are characterized as adjoining, separate, and overlapped.

Adjoining is the most common form of aggregation. In this relationship the units are visible, perceived as entities, and relate to other units through face to face, face to edge,

or edge to edge contact. Interlocking is one variation of face to face adjoining.

Units may be separate and at the same time related to other units to form a whole. Separation can occur through physical isolation or through the articulation of the connection between the units such that the units are perceived to be separate. Essential to this type of relationship is the perceived segregation of units and the proximity of the units so as to establish a compositional relationship.

Units may also aggregate to form a whole through overlap. Since architecture is a three-dimensional phenomenon, the overlap of units in the volumetric realm is by interpenetration. For this to happen the units are identified as entities that partially share form or space with other units. The portion of the overlap is seen as part of each unit and at the same time common to both.

Units can also be contained within a built whole. To distinguish this relationship from units adjoined to form a whole, the building as a whole is the dominant expression with the units contained and not expressed. Embodied in this relationship is the concept of a building as a wrapper or container for units which are usually spatial or structural volumes.

It is possible for a building whole to have more built form than that generated by the assemblage of the identified units. This relationship can be described as the whole is greater than the sum of the parts. In this case, some of the built form serves as a matrix which holds, connects, or at times, just has contact with the units. The units may be formal or spatial, and visible or not. Important to this relationship is the concept of *poche*, which is the defined difference between interior volume and exterior configuration.

REPETITIVE TO UNIQUE

The formative idea of relating repetitive and unique elements entails the design of built form through the establishment of relationships between components which have mul-

tiple and singular manifestations. Fundamental to this idea is the understanding of unique to be a difference within a class or a kind. This distinction allows for the common reference frame of class or kind to couple the domain of the repetitive with the unique. The definition of the unique, in terms of the repetitive, permits the identification of the differences in attributes of common elements. For example, massing units are compared with massing units to determine the differentiating features which make one unit unique. If massing units were compared to windows or structure, the nature of the difference might never be discerned because of the disparity of characteristics to be compared. Repetitive and unique elements can occur at a number of varied scales and levels within a building. As with the unit to whole relationship, the concern is with the dominant manifestation of the idea.

In the realm of architecture, the repetitive and unique elements are usually three-dimensional, and, as such, can be communicated through the conventions of plan and section. In most cases, the repetitive and unique will appear in the same vertical or horizontal arena. However, it is possible for the repetitive elements to occur in plan and the unique element to occur in section, or conversely for the unique to appear in plan and the repetitive in section. San Maria degli Angeli by Brunelleschi is an example of this separation.

A unique element can be developed through the transformation of repetitive units through changes in size, color, location, and orientation. Shape, geometry, and articulation changes can also render an element unique. The distinction between a change in shape and one in geometry is determined by the degree of difference between the two figures. If the unique element is in part the same configuration as the repetitive, then a transformation by shape exists. For example, a square can be transformed into a figure that has three straight, equal length lines at right angles to each other and is closed by an arc of a circle. If the unique component is different in form language from the repetitive, then a transfor-

mation by geometry occurs. In this situation, a circle is unique to repeated squares. A change in articulation happens when the same form or configuration is made manifest in two ways. For example, a transparent cube is unique by articulation to a series of opaque cubes.

The unique component can be surrounded by the repetitive. In this case, the unique is central and has its own configuration. The repetitive elements are located around it. It is possible, but not necessary, for the repetitive elements to be coincident with the boundary of the unique. However, a change in the arrangement of the repetitive elements will not change the unique that is surrounded. The counterpart relationship where the unique surrounds the repetitive is also possible.

An alternative to the unique surrounded configuration occurs when the unique is defined by the arrangement of the repetitive. The distinction between this alternative and the unique surrounded model is determined by the manner in which the unique is established. In this case, the unique is dependent upon the configuration of the repetitive elements for its shape or form. The unique does not exist without the repetitive, or, at least, its form will change if the repetitive elements or their arrangement changes.

Unique and repetitive elements can be added together to create built form. The determination of whether repetitive is added to unique or unique is added to repetitive is made perceptually by consideration of relative scales, configuration, location, or some combination. Generally, that which is added to will appear to be dominant.

Unique elements can be formed as a result of overlapping repetitive units where the shared configuration is unique. In some cases, the unique component in a building is the remainder of the built form after the repetitive units have been defined. In this instance, the unique is the difference between the overall building configuration and the sum of the repetitive parts.

If units are in proximity to each other so that a relation-

ship exists, then the unique element can be separate from the repetitive. The nature of the separation can be physical or perceptual, as it is in the unit to whole relationship. Unique elements may also be located within a field in which the repetitive elements have a scale, configuration, and uniformity of relationship that renders them a larger unit that can be identified as a field or network. In this relationship, the difference between the repetitive and the unique is heightened by the disruption of the field by the unique.

Location can establish an element as unique. Singular occurrence in a linear arrangement can be the basis of uniqueness. Therefore, a unit at the center, one which is a terminus to a path, or one that is shifted out of alignment, can be rendered unique. It is also possible in a linear configuration to view the ends as unique units connected by repetitive elements.

ADDITIVE AND SUBRACTIVE

Additive and subtractive are formative ideas which entail the design of buildings through the aggregation or removal of built form. Basic to these related ideas is the understanding that an additive design has perceptually dominant parts and a subtractive scheme has a perceptually dominant whole. The image a person has of an additive design is that the building is an assemblage of identifiable units. A person engaging a subtractive design understands the building to be a recognizable totality from which parts are removed. Buildings may embody both images, but it is the dominant perception of parts added or parts subtracted from a whole which renders them additive or subtractive, respectively. Generally, these ideas have the greatest bearing on formal considerations of a building, with massing a particular concern. However, as with any formal issue, spatial consequences can result from decisions made in this realm. Although additive and subtractive, as formative ideas, operate at the scale

of the building, it is possible to use these concepts to make design decisions at other scales, like parts of buildings and rooms.

Additive and subtractive differ from the other concepts presented in that they are the generic examples of the idea. Alternatives are possible when the ideas are used in conjunction with each other to determine a building design. As noted previously, the potential for design richness is enhanced by the use of the two concepts in consort. This normally occurs when the use of the alternative is sequenced in some manner. For example, the creation of a form by subtracting pieces from a recognized whole, and then after adding parts to form a new whole, subtracting again. The amount of imagery developed by any one step, the dominance of the perception, and the sequence of the processes allow a broad range of alternatives within this formative idea.

SYMMETRY AND BALANCE

Symmetry and balance are formative ideas which entail the design of buildings through the establishment of perceived and conceived equilibrium between components. Intrinsic to an understanding of balance and symmetry in architecture are the notions that elements can be identified as equivalent, and that the nature of the equivalency can be discerned. The generic alternatives for balance and symmetry exist in the nature of these equivalencies. Balance and symmetry both create a stable state relationship between components on either side of an implied line or point. Generally, balance is perceptually based and focuses on the composition of elements. It becomes a conceptual phenomenon when components are given added value and meaning.

Symmetry, as a specialized form of balance, is perceptual in nature. Symmetry differs from balance in that the same unit occurs on both sides of the line of symmetry. The most familiar form of symmetry is referred to as axial, re-

flected, or mirrored, because the components are oriented such that one unit appears to be reflected in a mirror to create a second unit. In this type of symmetry, the elements are equal in configuration and opposite in handedness. That which occurs on the left side of one element will be on the right side of the other. Biaxial or bilateral symmetry is reflected symmetry that occurs in two directions.

A second form of symmetry is developed through the rotation of components about a common center. Implied in this situation is the central point, which by definition establishes patterns that are different from those developed by symmetry about a line. The central point can be located within, at the edge of, or outside the figure. If the point of rotation is within the figure, a series of overlapping forms will be created. This type of symmetry might also result in pinwheel configurations if the center of rotation is asymmetrically located in both directions. Besides the location of the center of rotation, other important variables are the number of times the figure is rotated, and the increments between the rotations.

Symmetry by translation occurs when elements with identical shape and orientation are shifted. This symmetry allows for the development of linear organizations through the aggregation of multiple, equal units, where the symmetrical relationship exists between any two components. Configurations are not limited to straight lines, and can be serial in nature. It is also possible to incorporate more than one sequence of translation into a design. For example, the atrium housing by Jørn Utzon utilizes two sets of symmetrically related units, each with a different orientation.

While symmetry is predicated on equal units occurring on each side of a line or point, balance exists when the units on each side are different in some identifiable way. Differences in attributes which can create a balanced situation between elements include geometry, orientation, location, size, configuration, and a positive-negative reversal. Balance by geometry results from the relationship of equivalent units that vary in form language. For example, one element could be circular and the other rectilinear.

Equal units that have an orientation difference other than those stipulated in reflected and rotational symmetry can be balanced about an implied line. Unit size and relative distance from the line of equilibrium determine balance by location, which closely parallels the concept of balance by weights on a scale.

Units that vary in size can be equidistant from the line of balance when balanced by ratio. In this relationship, the difference in size is balanced by an intensification or concentration of other attributes within the smaller unit, such that the line of balance is created midway between the two. This occurs when a special condition, given importance, like a jewel, balances a much larger, less significant component. For example, two dissimilar size units can be related to a balance line midway between them through the utilization of special materials on the smaller unit.

Balance can also be developed through configuration differences in two and three dimensions. Visual equilibrium on a surface or in a form is achieved by the manipulation of area or mass, respectively. This distinction applies to a building elevation which can be understood in two dimensions, and to architecture which is a three-dimensional phenomenon. In this relationship, the issues of number, shape, and pattern are engaged through consideration of ranges of attributes like open-closed, few-many, and simple-complex.

Finally, balance can occur when two equivalent components exist in positive and negative form. It is this type of balance that can utilize the very essence of architecture, for it embodies equilibrium between mass and space. In this context, the positive tower form balances the void of the courtyard.

GEOMETRY AND GRID

As a formative idea geometry entails the use of the tenets of both plane and solid geometry to determine built form. Geometry in one form or another exists in all buildings, but

as a formative idea it must be knowingly central to decisions regarding form at several levels.

The most fundamental use of this idea incorporates the basic figures of geometry as form or space to determine the overall configuration of a building. Thus, a building might be a circle, a square, a triangle, a hexagon, an octagon, or any other singular describable and recognizable geometric form. While the geometric figure may not totally incorporate every piece of the building, it is necessary that the basic figure be dominant and perceptible.

Although architecture might be developed from one geometric figure, these forms can also be combined to generate a building; that is, a circle and square can be added together to create a building. Similarly, any two or more other basic forms might be combined, providing each is perceptible as a whole figure. The forms do not have to physically exist, but each must at least be implied. Within the realm of combinations, it is possible to locate one geometry that is within, contiguous to, or overlaps the other. When one geometry is located inside the other, the inner geometry might be an object, a room, a courtyard, a defined precinct, or an implied space.

A specialized form of geometric overlap prevalent in architecture is the combination of a rectangle and a smaller circle. A circle or a series of circular forms can overlap the rectangle at a side or corner. The overlap can result in a number of specific configurations, including the circle engaged on the centerline of the major side of the rectangle. A circle at the corner of the rectangle can overlap both sides, can have its center at the corner, or can be tangent to one of the sides.

As differing geometries are assembled, so too can similar geometries be combined. For example, buildings may consist of two circles, three triangles, or two hexagons of the same or different size. When square figures of the same size are combined in specific ways, some interesting and very particular phenomena occur.

Two identical squares combined with one congruent face create a rectangle with a 2 : 1 proportion. However,

these same squares can be overlapped to make other rectangles smaller than 2 : 1, or separated to imply rectangles larger than this proportion. Normally, the space formed by the overlap or the space implied by the separation is used for special purposes, like entrances, or the main hall of building. Two squares can also be overlapped and rotated about a central point such that an eight-cornered figure is developed. It is also possible to unite two squares by attaching the corner of one to the face of the other.

Particular combinations of squares have the characteristics of being either multiples or equal subdivisions of a square. The distinguishing characteristic of these combinations is that they actually form another larger square. When four squares are assembled into a two-square by two-square configuration, the result is a figure that can be viewed as a four-part subdivision of the larger square or as a multiple of the smaller square. Similarly, nine squares can be assembled into a three-square by three-square configuration. By extension, squares can be assembled into 16-square and 25-square constructs.

In a nine-square configuration there are three types of squares, each with its own characteristics. Four of the squares are located on the corners and are bounded by two other squares. Four others are located on the sides and are bounded on three sides by other squares. The final square is located in the center and is completely surrounded. This bounded center square makes the nine-square format an identifiable and unique configuration. Whereas this arrangement emphasizes a central square or space, the four-square format articulates a central point.

Identifiable variations within the nine-square configuration are possible by removing certain squares, while maintaining others in their normal location. Thus, by using only the eight squares on the perimeter, a square ring is created. An "X" form is possible by using only the corner and center squares. By utilizing the middle square on each side and the square in the center a "plus" configuration is made. Leaving out two side squares opposite each other results in an "H"

shape. Finally, a stepped configuration is possible by removing one corner and the two contiguous side squares.

Forms can also be derived by using parts of the basic geometric shapes. In the simplest terms, this might be one-half or some other fraction of a circle, square, or triangle. However, more complex configurations are possible through combinations of forms derived from several geometric shapes. Though clearly derived from geometry, these configurations are not describable in simple geometric terms. Another geometric derivation is the implying of a larger geometric shape by points located within the architectural configuration. For example, at the Guild House by Robert Venturi the corners of the building align to project a large triangle.

Certain derivations from a square result in three different rectangles with sides of particular proportions. The proportions are all less than the 2 : 1 proportion that results from combining two squares. The first, the square-root-of-two rectangle, is derived from the 45 degree rotation of the diagonal of a square, to form the long side. A 1.5 : 1 rectangle can be formed by adding one-half of a square to a square. The third, the golden-section rectangle, is derived from the rotation of the diagonal of one-half the square to form the major side of the figure. The center of rotation in this case is the midpoint of one of the sides of the square. Each of these rectangles, used either alone or in combinations, is frequently utilized to form buildings or parts of buildings.

Another series of configurations can be developed through the manipulation of geometries by rotation, shift, and overlap. These manipulations, all described by a process of implied movement, can be used in combinations to create more complex forms: for instance, rotation used in conjunction with overlapping.

Rotation is the conceptual process of moving a part or parts about a center. This center of rotation may be, but is not necessarily, the same for all the parts. Rotational movement naturally changes the orientation of the part involved.

A particular configuration that results from rotation is the hinge in which two linear and connected elements are normally oriented in different directions. In some examples, the pin of the hinge or connector actually appears as a figure in the building; in other cases it is implied.

When the manipulation by shifting occurs, the parts move, but unlike rotation, the orientation of the parts remains the same. While the shifting is often orthogonal in nature, a diagonal shift can create added richness by resulting in change in two directions through movement in one. Shifting might also be understood as sliding of two parts against one another. When this occurs, a third space or form is usually introduced between the shifting parts to neutralize the fissuring.

Overlap has the unique characteristic of creating a third figure from the combining of two other figures. The overlap of relatively simple shapes can result in a common space, as well as a total configuration, that is quite complex. Depending upon the nature of the overlap, the figure of the common area might be quite different from either of the overlapping figures.

The geometric configurations of radial, pinwheel, and spiral share the common attribute of being center originated. Buildings that can be considered radial have dominant multiple elements that extend from a center. These raylike elements may be intersected with other elements that are in a concentric arrangement. Both spiral and pinwheel configurations are more dynamic than radial. Spirals move away from a center at a constant rate of change and in a rotational direction. Pinwheels consist of offset linear elements that are connected to a common core or abut to form an implied core. The parts of this configuration are positioned so that the centerlines of the elements do not intersect at a common center. These elements do, however, occur radially at regular intervals, and have similar relationships to the core and to each other. Spinning is the implied dynamic of a pinwheel configuration.

Grids are developed from the repetition of the basic geometries. Multiplication, combination, subdivision, and manipulation are the processes used to create the repetitions. Conceptually, grids are infinite fields in which all units relate equally to all other units. A grid can be described as a series of parallel lines that intersects at least one other series of parallel lines.

The intervals between lines can repeat or vary. In the series's simplest form, all intervals would be equal. The complexity of the series can be altered by increasing the number of intervals that occur within it. The frequency with which a particular interval occurs, and its relationship to another interval and its frequency, will determine whether a discernible pattern exists, and the nature of that pattern. Thus, if "a," "b," and "c" represent intervals on a grid, and if "a" is to occur at the frequency of every fourth interval, then the pattern might be "a, b, c, a, b, c, a, b, . . ."; but it might also be "a, b, b, a, c, c, a, b, . . ." or "a, b, c, a, c, b, a, b, . . ."

Another aspect of grid is the relationship between one series and another. Two series might or might not be orthogonal to each other. If the relationship is orthogonal, with all intervals in both series equal, a square grid results. A regular rectangular grid occurs when two series, each with a different interval, are orthogonal, and the intervals within each series are equal. Two orthogonal series, each with more than one equal interval, create a rectangular, plaid grid. Two nonorthogonal series of lines constitute a parallelogram grid. A triangular grid is formed by three intersecting series of lines which have common points of intersection. The number of series of lines which might exist coincidentally is conceptually infinite, but practically, the number is significantly lower.

Within the grid, a critical construct is the intersection created by any two lines in the series. However, intersections alone do not provide enough information to describe a grid accurately. For instance, a series of intersections arranged in what is apparently a square grid configuration,

also can describe a parallelogram or triangular grid if the intersections are connected differently.

Important to the total understanding of a grid is the method of articulating both the line and the intersection. As discussed, both must exist conceptually and be defined, but either may be implied by the existence of the other; that is, at least two points or intersections must exist in order to imply a line. If enough of the field exists so that an expected pattern can be perceived, then it is also possible for an intersection or part of a line in the grid to be removed. Expectations, then, complete or fill in the implied piece. Articulation of the lines and intersections can establish importance or give major and minor emphasis to the grid. Like the basic geometric figures, grids can be combined or manipulated through the processes of rotation, shift, and overlap.

CONFIGURATION PATTERNS

As a formative idea, patterns of configuration describe the relative disposition of parts. The patterns are essentially themes that have the potential for making space and organizing groups of spaces and forms. The terms that describe these basic patterns are: central, linear, cluster, concentric, nested, double-centered and binuclear.

Central configuration patterns can be classified as those that are central dominant and those in which the central space is used to organize other spaces. How the center is engaged is the primary difference in each of these cases. In the first, one goes to or around the center while in the second, one goes through the center. A third model of central configuration, but one that is not included in this study, is that of a central solid, such as a fireplace.

In the central dominant model, the center is the focus with the most important use-space located in that position. If this space is covered, it is very often done so by forms that are higher in the center than at the edges—a hemisphere or

dome, a cone, or a pyramid. Thus, the idea of center is reinforced by the roof or ceiling configuration. A primary characteristic of central dominant space is that the center appears to generate the entirety of volume and form. This space can be functionally or symbolically dominant. In some cases it is considered sacred; in others it is less sacred, but no less important. The configuration of this pattern may suggest a singular volume or a spatial composition that extends from the center. These volumetric extensions which might create complex patterns emanate from the center. Each successive volume reinforces the center, but lessens in its own importance. Excessive extensions will at some point diminish the importance of the center itself. A fundamental difficulty in this configuration is maintaining the center focus or dominance while introducing entrance. Ideally, though it is not usually feasible, the entrance should be introduced at the center or through a continuous series of openings equally spaced around the perimeter.

Circulation within the central dominant configuration is either to or around the center space. Therefore, the central space can be an outdoor space that one walks around, but generally not through. A cloister, in which the outdoor space is a sanctuary, or a multistoried atrium that one walks around, might be examples of voids that are central dominant. Within this idea, the central space does not necessarily have to have external visual impact.

The other model of central configuration employs the center as an organizer of spaces. In this case, the center space can be considered a servant space that is used for circulation and as a clearinghouse that resolves circulation problems. The classic rotunda is an example of such a space. It may have great significance externally, and formally may unify the building, but functionally, it is not important as a use-space. This configuration, like the central dominant organization, does not necessarily have to be expressed externally. It can be a void, such as a courtyard or atrium, that is used for circulation.

Whereas the previous configurations developed from the concept of center, linear configuration patterns focus on line and movement. They entail the critical issues of path and direction. As with central configuration, linear patterns are classified into two types. The primary distinction is identified by the relationship of use-space and how one engages it through circulation. In the first model, the circulation is separate from the use-space, and can be referred to as a spine. In the second type, circulation is through the use-space and the spaces are linked, much as the chain of a necklace links beads by passing through them.

The spine is a servant space that provides access to a series of independent parts or rooms. Often, the common circulation route allows parts that have no direct relationship to each other to be grouped. The spine may be dominant in the form of the building or it may be hidden within. In the latter case, the spine is reduced to a single- or double-loaded corridor. Symmetrical or asymmetrical arrangements of parts is possible along the spine. By nature, a spine is not hierarchical, nor is it of a given length, but what it serves may begin to determine its limits. Other architectural issues, like entrance, also influence the actual spine configuration and the way it is experienced. Normally, spines are assumed to be straight, but they can be bent to create enclosed space, to focus view, to reduce its apparent length, or to respond to some exterior situation. Within a building there also may be more than one spine. In these instances, spines that cross and the nature in which they cross might suggest hierarchy or special areas.

A use-space that is traversed longitudinally, or a series of spaces that are linked to suggest movement from one to another, describes that second type of linear configuration. Thus, a path is either through the space or from space to space. In the space to space circumstance, the pattern of the location of openings between spaces will determine the configuration and the legibility of that path. Volumetric extensions may enrich the path if the extensions are rendered sec-

ondary to the primary space and are located in a manner that reinforces the linear quality of the space.

In this type of linear configuration exists the opportunity to exploit the potentials of serial progressions. While progressions themselves are discussed later, it is important to realize that space to space linear configurations are normally engaged sequentially. Therefore, it is possible to place importance on any space in the sequence. Accent can be at the beginning of, along, at the center of, or at the end of the path.

Cluster organizations refer to groupings of spaces or forms in which there is no discernible pattern. The units, whether forms or spaces, need to be in proximity to one another, yet the relationship between these units is irregular. While not a prerequisite for clustering, the random character of the relationships may permit the units to be irregular. Spaces can cluster within an overall form and in a way that influences or determines three-dimensional forms. Forms that cluster may have spatial subdivisions that are not important or dominant within them.

The concentric configuration pattern is analogous to the pattern created by dropping a pebble into water. The pattern is concentric when a series of units of differing sizes have the same center. This configuration can also be viewed as layering in which one element is viewed in the context of another. A characteristic of concentric organizations is that several rings are necessary to begin to see the pattern. However, it is important to note that the rings, though they share a common center, may not be of the same form language.

Nested configuration patterns share certain characteristics with concentric patterns. While both patterns have units inside one another, in nested patterns the center of each unit is different. Nested units can have other parts, such as one or more sides or a centerline, in common. Both nested and concentric patterns can be created at the formal or spatial level, and both imply layering.

A configuration pattern with two equally important foci is called double-centered. Prominent to the understanding of

double-center is the idea of a precinct or field that has definite boundaries. The precinct can be either solid or void. If a void, the field can be a room, a large interior volume, or an outside space, like a court or a discernible area.

If the building is considered a mass, then the precinct is a solid. In either case of precinct as void or as solid, the double-centers are rendered opposites within the field. Thus, if the precinct is void, the double-centers refer to objects within a defined space. If the precinct is considered solid, the double-centers are spaces that are hollowed from the mass, and the remainder is considered poche.

Binuclear configuration patterns have the primary attribute of two equally dominant parts, which, as forms, comprise the general building configuration. The two forms establish a line of symmetry or balance. While the nuclear parts may be the same they also may be different through changes of geometry, orientation, configuration, or state. A third form may create a link between the nuclear forms, but it is not essential. Normally, this connector is a secondary or neutral space which is exclusive of both dominant parts. On occasion, though, it can be a major use-space or a solid in the form of a wall. The dominant parts are often engaged by entering between them, or by entering into one and then proceeding to the other in a linear fashion.

PROGRESSIONS

The archetypal themes that comprise the formative idea of progressions, focus on patterns of incremental change that occur between one condition and another. Progressions embrace ideas of multiplicity, rather than duality. Therefore, in order to discern a pattern, more than two increments of change are normally necessary. Hierarchy, transition, transformation, and mediation are the generic progression types discussed in this study. An important distinction between these generics and the overall progression category is that

the generics are bounded subsets of progressions. Whereas progressions can be infinite, the four generic examples are finite, with definite beginnings and ends. In these bounded sets, the characteristics of the increment are describable in relation to the next increment, rather than as an isolate. Similarly, the increment can be understood in relation to the boundaries. Something large, for example, in one instance, is actually small in another.

Hierarchy refers to the rank ordering of parts relative to a common attribute. This ranking differentiates among the parts by assigning importance. Sacred to profane, large to small, figure to poche, center to edge, servant to served, tall to short, few to many, and inclusive to exclusive are some of the hierarchies often found, either alone or in any number of combinations, in architecture. In some instances, it is necessary to determine more about the attribute before knowing the importance. Large, for instance, is not necessarily more important than small. Rank orderings from large to small and from small to large are both evident in buildings.

The dominance of hierarchy within a building is often reinforced through the layering of more than one progression type. The Temple of Horus at Edfu, for example, employs several architectural hierarchies to reinforce the importance of the room for the main god. These architectural hierarchies support the religious and social hierarchical beliefs of the society. The Temple's hierarchies are based upon the importance of the sacred to the profane, and are architecturally rendered as small to large, one to many, dark to light, rooms to areas, and closed to open. The openings between the various precincts of the building change with gates in the profane areas and with the openings of increasingly smaller size that are closed by doors at the more sacred rooms. Changes in floor height through steps and sloping floors, even though slight in nature, also signal the movement to the sacred. The most holy space, which is protected and separated from the outside world by a series of walls, then, is the smallest, darkest, most enclosed, and roomlike precinct in the Temple. This sanctuary is for a few

worshippers and the main god, as opposed to the many lesser gods found in other areas of the Temple. Immediately behind the large entrance gate is the great court or "hall for the masses." This precinct is large, open to the sky, and the least roomlike area in the Temple.

In other buildings, evidence indicates that the most important increment in a hierarchy is often rendered by architects with the most ornament, the most intense polychromy, the most precious materials, or the highest level of detail and texture. Location, as in the center, or at the end of an axis, might also reinforce the specialness of a space or form. In general, those qualities which make something special or precious in relation to others suggest the devices which are available to create importance in a piece of architecture.

Transitions are bounded progressions in which change takes place in an attribute without a change in form. A change from open to closed, inside to outside, simple to complex, movement to rest, individual to collective, and one size to another are typical transitions. As with hierarchy, transitions have definite limits, but as opposed to hierarchy, there is no value placed on the end condition of the limits; that is, simple is not seen as being more important than complex, or vice-versa. While the end states are seen as equal, the individual conditions between those ends must also be equal. Aldo van Eyck's discussions of the "in-between" and "twin phenomena" are of value in understanding transition and its potentials. Within a transition there is necessarily a series of intermediate steps. Each of the increments between the extreme conditions of the transition will suggest what is on either side, and thus, will form a link for the conditions on either side.

Transformation is a progression in which changes in form take place within the boundary of the object itself. It is similar to transition, but more specific in that the attribute being changed is in the configuration. This configuration change may have impact on either the two or three dimensional form. A reference frame of multiple images is necessary so the change from one form to another is perceptible.

Transformation is not, then, a comparison between two forms, but is a series of form changes, with each form in the series hierarchically undifferentiated.

Mediation is distinct from the other generic progressions in that the end states are conditions which exist outside the building itself. The building is viewed as a bridge, or a piece of connective tissue, between conditions that exist in the context. Thus, the building cannot be considered autonomous, but must be seen in relation to its context. In order to utilize mediation as a formative idea, a position is taken or a statement is made about the context in which a building is to exist. Generally, this is achieved by a certain amount of abstraction. For example, Richard Meier in the Atheneum at New Harmony abstracts the river on one side as a wavy wall and the grid of the town on the other side as orthogonal geometry. Preferably, such a position entails at least two conditions which might be in either the natural or the built context. Thus, the new building might mediate between two built situations, between two circumstances in the natural environment, or between a built condition and a natural one.

Within this idea, the building is seen as a fragment of a larger piece. Through mediation the building reconciles differences that exist in the context. In the building, a series of gestures might be made which modulate the form to reflect the external conditions. Alternately, one condition can be repeated in some form in part of the building and then altered to be more like the other external condition. Another possibility is that the building is a midpoint or series of intermediates between the two external circumstances.

REDUCTION

Reduction is a formative idea in which a configuration is repeated at a lesser size within the building. This miniaturization can occur in two ways: part of the whole, and large to small. In the first type, the whole, or a large portion of the

whole, is reduced in size, and utilized as a part. Normally, in this case, the reduced piece is located within the whole. Alternately, a large unit and at least one reduction of that unit are combined to form a building or part of a building. The reduced unit may be repeated or reduced further. In this type, the reduced piece is usually located next to, rather than within, the larger unit. In either case, but particularly in the part of the whole type, the reduction may involve a positive to negative state change. At one size, for instance, the configuration might be a solid or mass while at the other size the configuration might be a void or space.

A unique quality of the part of the whole type of reduction is that an observer can learn about the whole by encountering a part. With this capacity to inform the observer, this type transcends the perceptual to the conceptual. Thus, by observing the configuration of a room, a court, or a wing of a building it is possible to infer the configuration of the entire building. The conceptual transference of information may also take place between the plan and the section. In this case, the whole of the plan or section may be repeated in miniature form in the other position. For example, the section of a space or room may correspond to the configuration of the plan of the entire building, as in the Yano House by Isozaki.

On the other hand, in large to small type reduction, comprehending one part may inform about only another part, and not the whole. Therefore, this type remains purely perceptual. In many cases, large to small reductions are incorporated into buildings with major and minor parts so that less important aspects of the building occur in the reduced piece. Typical examples of this are the several buildings in which servant spaces, literal and otherwise, are the small parts. An interesting reversal to this more typical interpretation, though, is that small might mean intense, and thus, more important. Alvar Aalto's Town Hall at Saynatsalo is an example where the small piece, which is the town meeting space, is the more important in the large to small reduction.

1. **SNELLMAN HOUSE**
ERIK GUNNAR ASPLUND
1917-1918
2. **SMITH HOUSE**
RICHARD MEIER
1965-1967

3. **PANTHEON**
ARCHITECT UNKNOWN
c. 100
4. **CARLL TUCKER III HOUSE**
ROBERT VENTURI
1975

5. **OLD SACRISTY**
FILIPPO BRUNELLESCHI
1421
6. **VILLA STEIN**
LE CORBUSIER
1927

PLAN TO SECTION OR ELEVATION

Plan, section, and elevation are conventions common to the horizontal and vertical configuration of all buildings. Decisions made in one of these arenas can determine or influence the form of the other. Illustrated are examples of equal, one to one-half, proportional, inverse, and analogous relationships.

Equal

The most direct relationship between the plan and section or elevation occurs when they are the same. In its simplest form, this equal relationship entails only the overall building configuration. At Asplund's Snellman House (1) the rectangle of the main house becomes the figure of the elevation, excluding the roof. Similarly, the rectangle of the overall plan form at the Old Sacristy (5) is repeated in the major mass of the elevation. Richard Meier, in the Smith House (2), employs a 1.4 rectangle for both the plan and section. The small out-building is a cube that is related to the major house form in the same way in both arenas. In the Pantheon (3), the circle that forms the major space in plan determines the interior configuration of that space. The dome of this space is a hemisphere with its crown located at a height equal to the diameter of the circle in plan. This space may be as close to a sphere in form as practically can be achieved. The Tucker House (4) by Robert Venturi is, without the roof form, a cube. Le Corbusier's Villa Stein (6) has plan and elevation configurations which are the same, not only in overall form, but also in their plaid grid subdivisions.

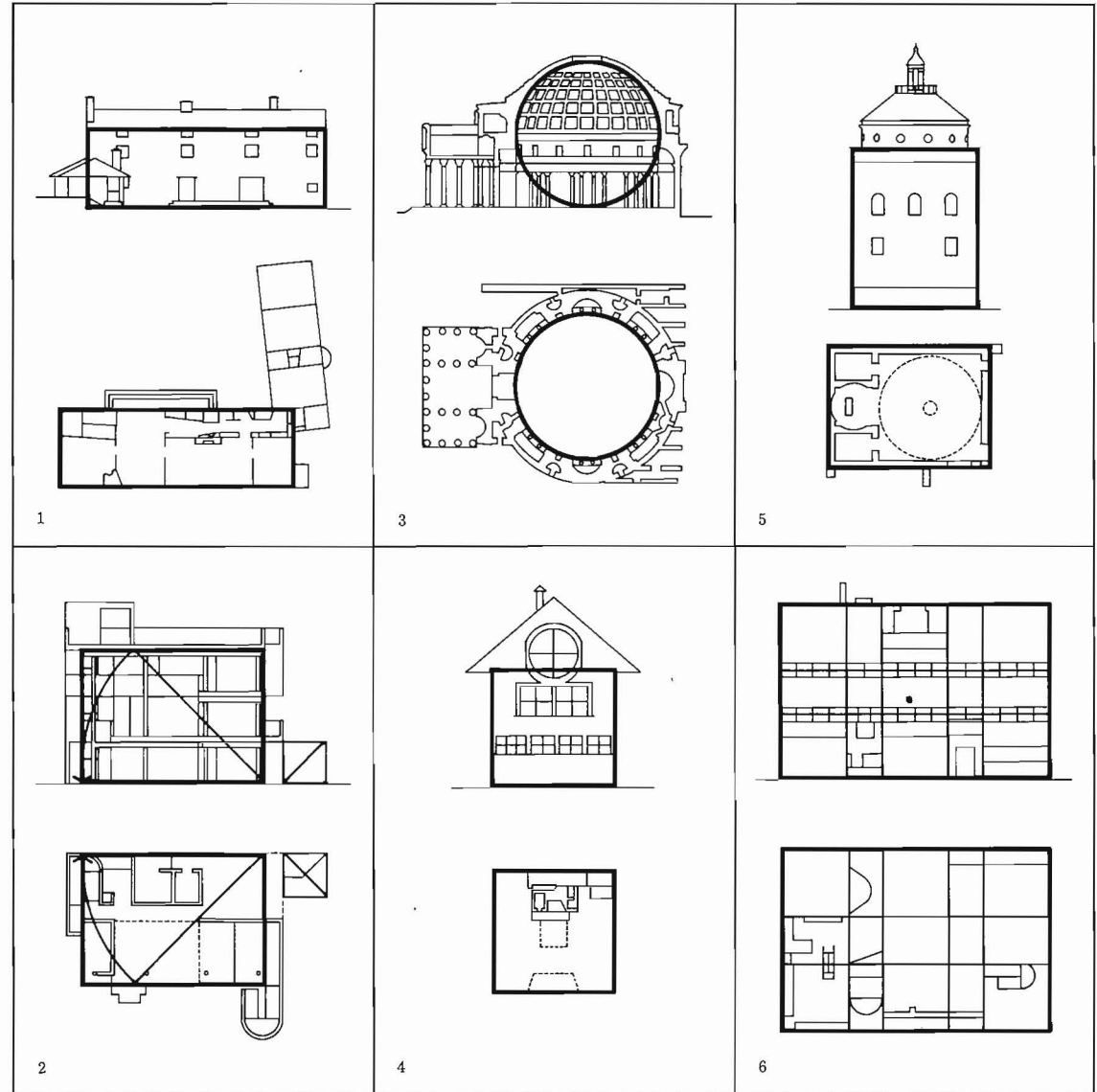

1. STOCKHOLM EXHIBITION HALL
LE CORBUSIER
1962
2. NAKAYAMA HOUSE
ARATA ISOZAKI
1964

3. CHAPEL AT RONCHAMP
LE CORBUSIER
1950-1955
4. YALE HOCKEY RINK
EERO SAARINEN
1956-1958

5. RUSAKOV CLUB
KONSTANTIN MELNIKOV
1927
6. ST. JOHN'S ABBEY
MARCEL BREUER
1953-1961

7. SAN GIORGIO MAGGIORE
ANDREA PALLADIO
1565
8. LA ROTONDA
ANDREA PALLADIO
1566-1571

One to One-Half

The configuration of the whole plan or section can be equal to a part of the other, as in the Stockholm Pavillion (1) by Corbusier in which the elevation wall is the same as one-half the plan. The large, dominant squares and smaller square skylights which constitute the major portion of the elevation in Isozaki's Nakayama House (2) are repeated as part of the plan. Generally, one-half the plan at Ronchamp (3) becomes the elevation where the thick wall corresponds to the roof. Saarinen, at the Yale Hockey Rink (4), utilizes the exact curve form that is the center rib of the roof as the outside configuration of each side. On the other hand, one-half the plan at Melnikov's Rusakov Club (5) and Breuer's St. John's Abbey (6) approximates the general configuration of the sections. In Palladio's San Giorgio Maggiore Church (7) the configuration of the main ceiling forms is equal to one-half of the plan form of this space. At Villa Rotonda (8), one-half of the plan is similar to the dominant exterior form.

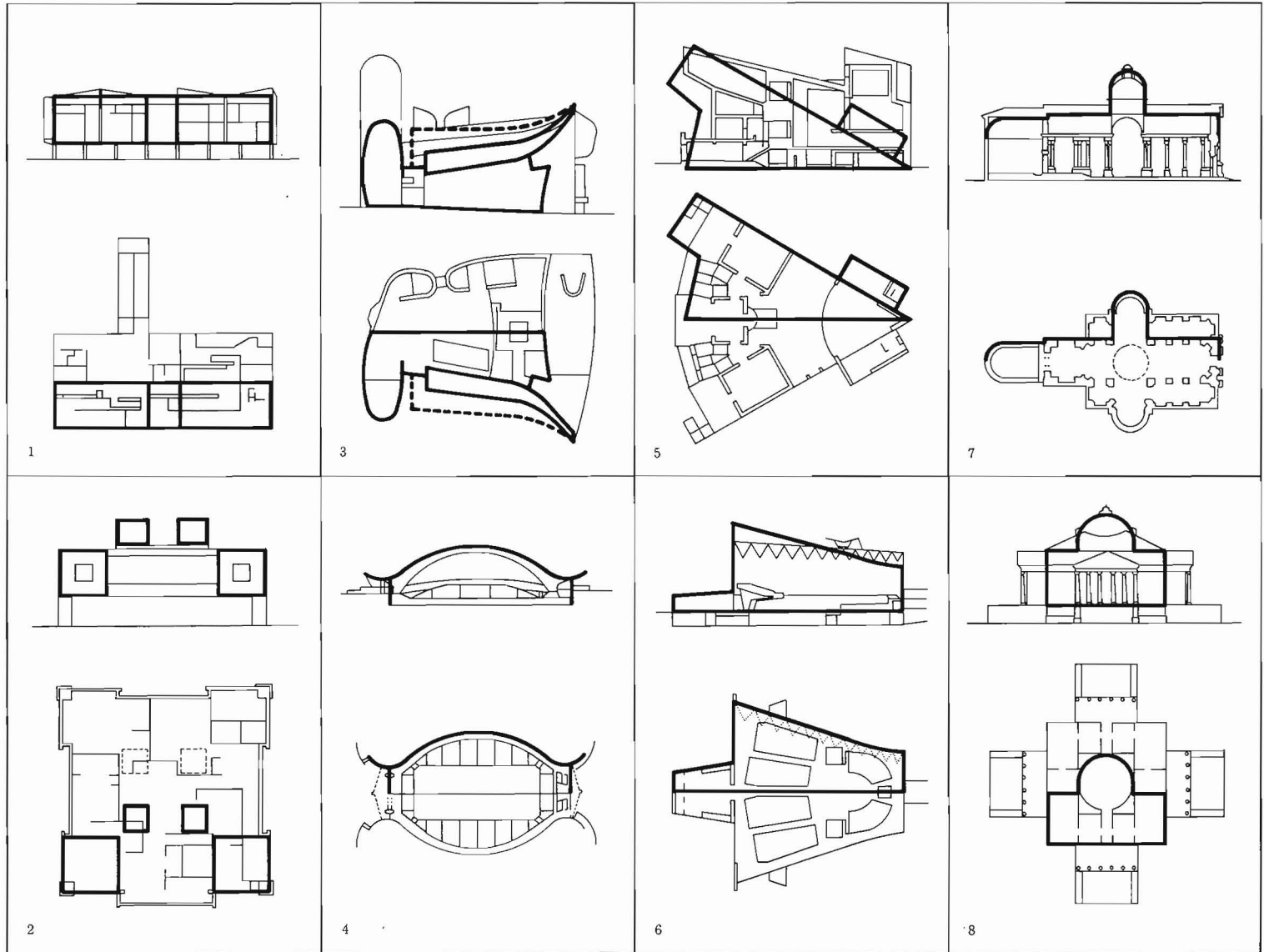

1. FLOREY BUILDING
JAMES STIRLING
1966
2. ADULT LEARNING LABORATORY
ROMALDO GIURGOLA
1972

3. CAMBRIDGE HISTORY FACULTY
JAMES STIRLING
1964
4. THE PALACE OF ASSEMBLY
LE CORBUSIER
1953-1963

5. TEMPLE OF THE SCOTTISH RITE
JOHN RUSSELL POPE
1910
6. POPLAR FOREST
THOMAS JEFFERSON
c. 1806

7. THE FORD FOUNDATION BUILDING
ROCHE-DINKELOO
1963-1968
8. EXETER LIBRARY
LOUIS I. KAHN
1967-1972

Analogous

An analogous relationship exists between plan and section when the configuration of one generally resembles the shape of the other. Differences in form language, size, location, or irregular increments of change may account for the resemblance rather than equivalence. The Florey Building (1) and Adult Learning Labs (2) have 'U'-shaped configurations in plan and section. Differences in size occur between plan and section in the Scottish Rite (5), Poplar Forest (6), Salutation (9), and Sullivan's bank (16). In the Hines House (13) size differences occur in two directions. Increment changes account for the variations in plan and section in the Ford Foundation Building (7), Fallingwater (14), Wolfsburg Cultural Center (15), Enso-Gutzeit (17), and the Besancon theater (18). Plan and section differ by form language in Exeter Library (8), Sever Hall (10), and Redentore Church (11). Location shift renders the plan of St. Clement Danes (12) somewhat different from the section. A combination of form language and size changes create the variation in the Palace of Assembly (4). Form language and increment changes make the plan and section of the History Faculty Building (3) analogous, rather than equal.

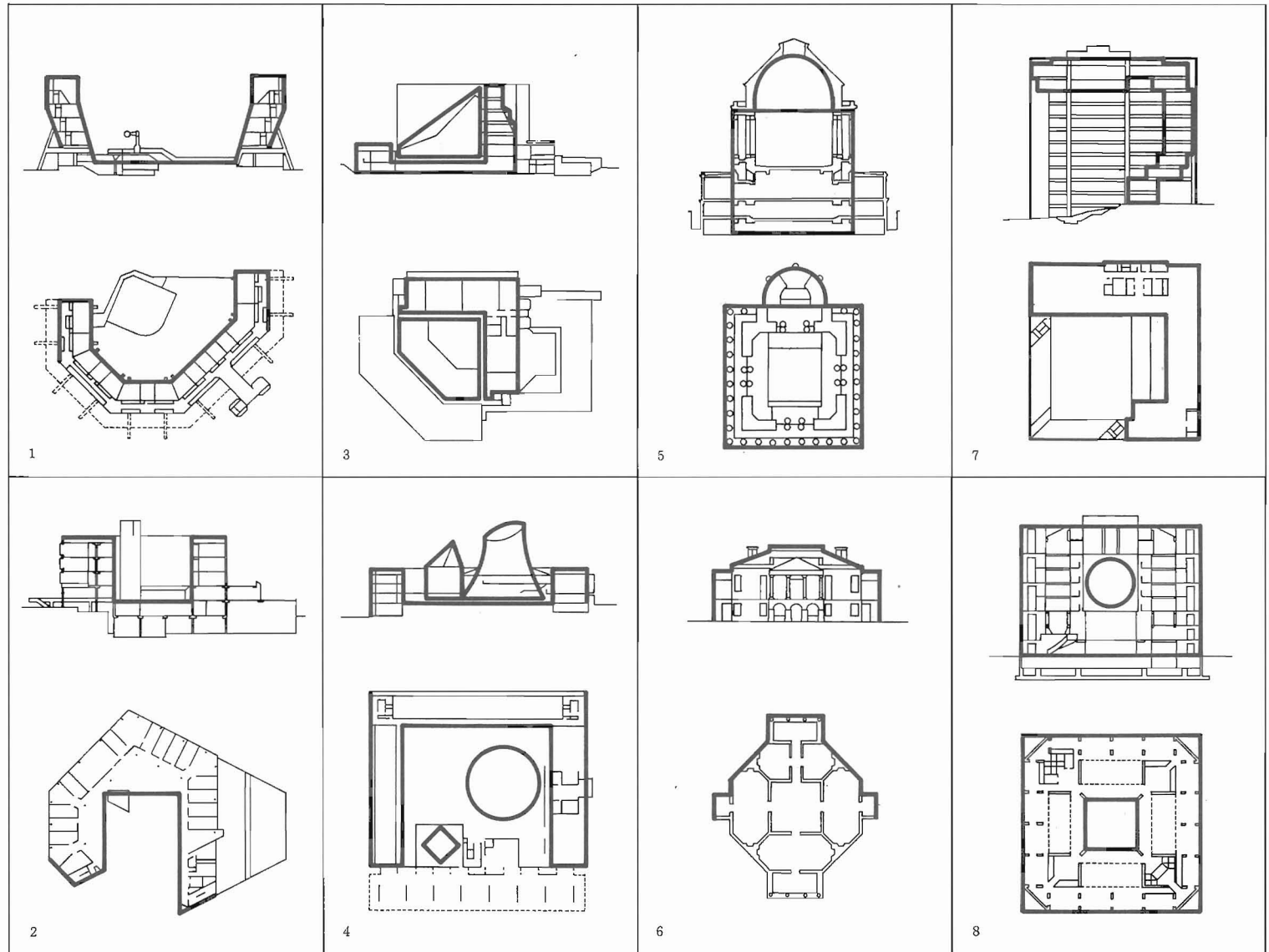

9. THE SALUTATION
EDWIN LUTYENS
1911

10. SEVER HALL
HENRY HOBSON RICHARDSON
1878-1880

11. REDENTORE CHURCH
ANDREA PALLADIO
1576-1591

12. ST. CLEMENT DANES
CHRISTOPHER WREN
1680

13. HINES HOUSE
CHARLES MOORE
1967

14. FALLINGWATER
FRANK LLOYD WRIGHT
1935

15. WOLFSBURG CULTURAL CENTER
ALVAR AALTO
1958-1962

16. NATIONAL FARMERS' BANK
LOUIS SULLIVAN
1907-1908

17. ENSO-GUTZEIT HEADQUARTERS
ALVAR AALTO
1959-1962

18. THEATER IN BESANCON FRANCE
CLAUDE NICHOLAS LEDOUX
1775

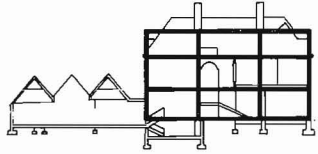

9

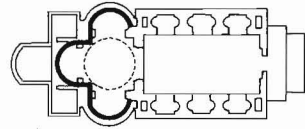
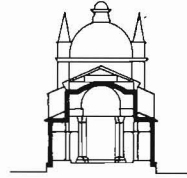

11

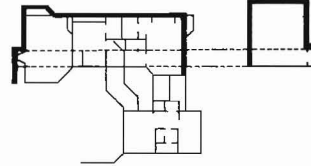

13

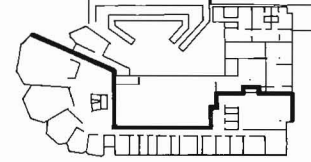

15

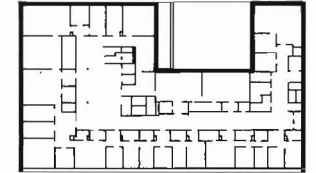
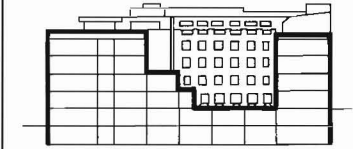

17

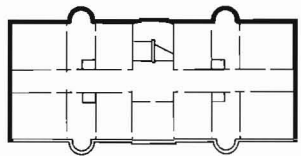

10

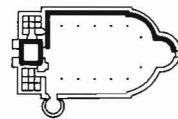
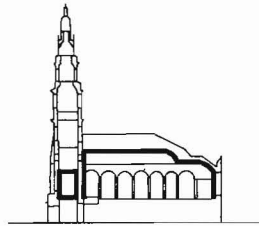

12

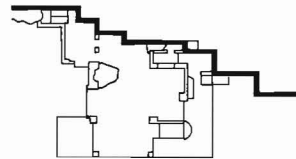

14

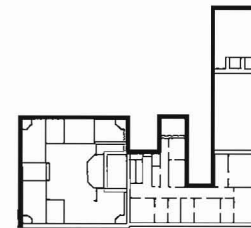
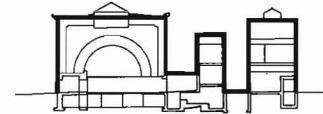

16

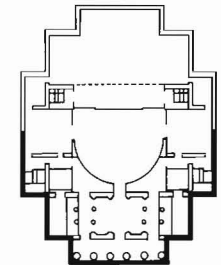
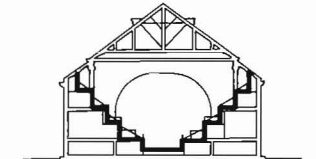

18

Proportional

In the proportional plan to section relationship, the plan and section or elevation are totalities of each other, but have a dimension change in one direction. Connections between the two realms should involve more than just outlines of the plan and section. Most of the examples have section configurations that are uniformly smaller than the plans, but Unite d'Habitation (5) and the residence in Cadenazzo (10) are exceptions. At Carson Pirie and Scott (11), the increments between parts in plan reduce in section, but the number of increments in section increases. In Christ Church (7) a reversal occurs in the proportional change between plan and section. The interior form is section increases

in plan while the exterior form decreases. Different parts of the Khuner Villa (13) have different rates of change between plan and section. The Brant House (14) and Lister Courthouse (15) both have modified form languages in plan or section. The Farnsworth House (1), Hotel Montmorency (2), Villa Savoye (3), Schinkel's Residence (4), and the Charof Residence (6) exemplify proportional plan to section relationships with the sections smaller than the plan, and some but not all of the interior configuration related. Additional examples of this are St. Mary Woolnoth (8), the Lang Music Center (9), and the Salk Institute (12).

1. FARNSWORTH HOUSE
LUDWIG MIES VAN DER ROHE
1945-1950
2. HOTEL DE MONTMORENCY
CLAUDE NICHOLAS LEDOUX
1769

3. VILLA SAVOYE
LE CORBUSIER
1929-1931
4. RESIDENCE IN BERLIN
KARL FRIEDRICH SCHINKEL
1823

5. UNITE D'HABITATION
LE CORBUSIER
1947-1951
6. CHAROF RESIDENCE
GWATHMEY-SIEGEL
1974-1976

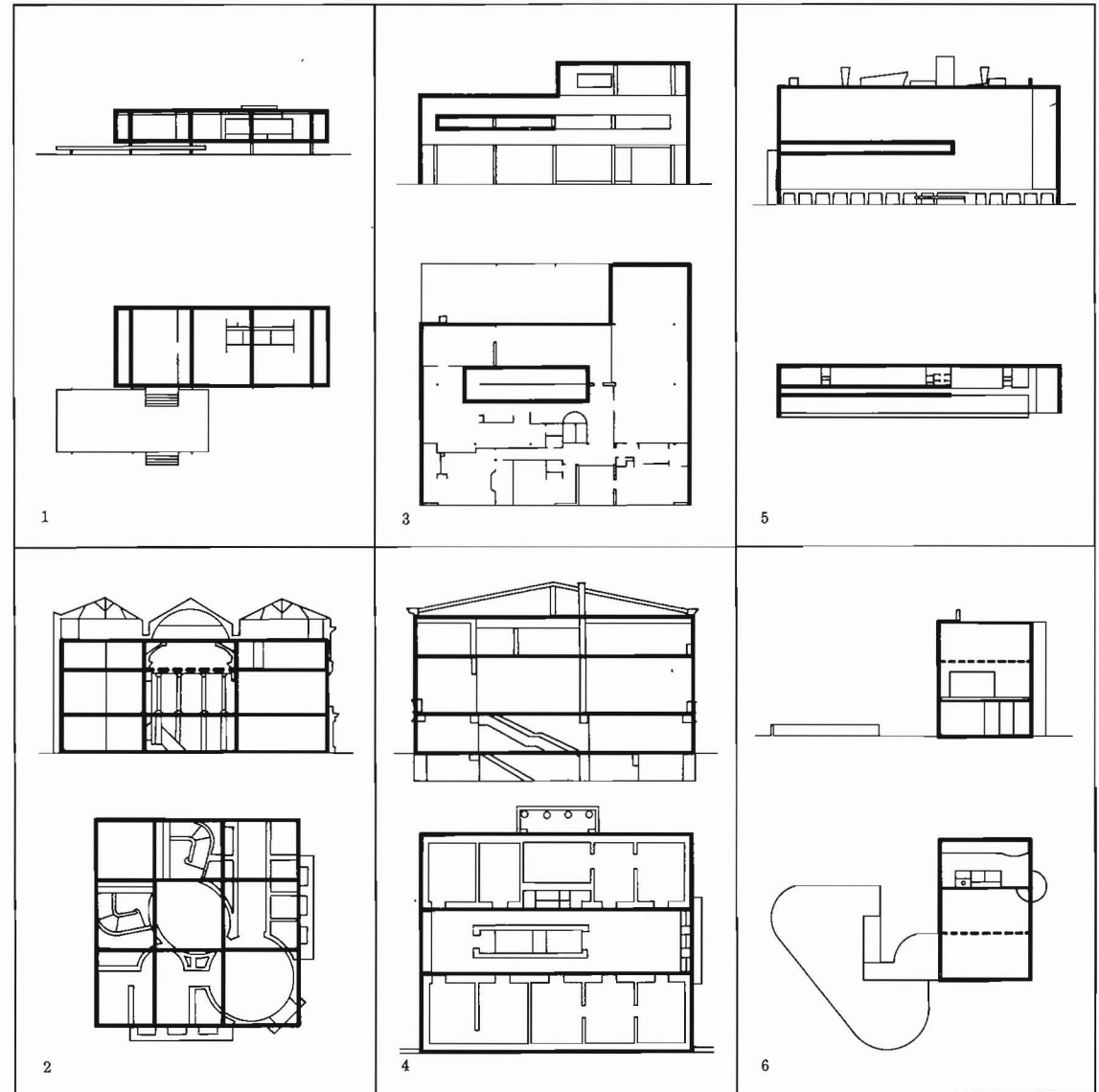

7. CHRIST CHURCH
NICHOLAS HAWKSMOOR
1715-1729

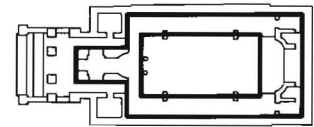
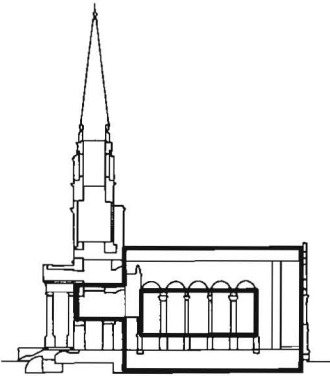

7

8. ST. MARY WOOLNOTH
NICHOLAS HAWKSMOOR
1716-1724

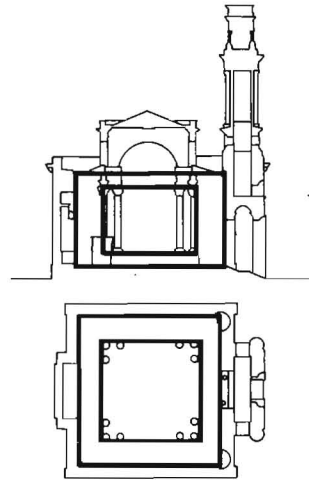

8

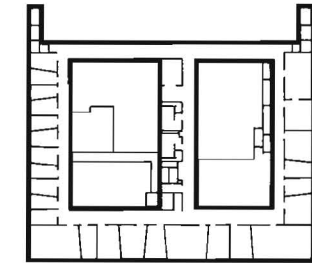
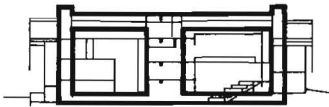

9

10. RESIDENCE IN CADENAZZO
MARIO BOTTA
1970-1971

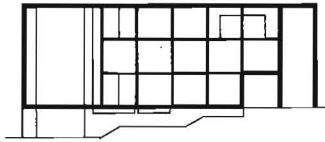

10

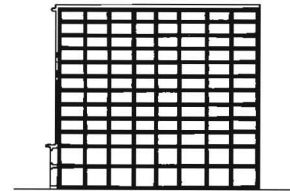
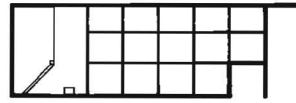

11

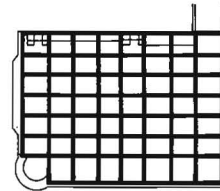

12. SALK INSTITUTE
LOUIS I. KAHN
1959-1965



12

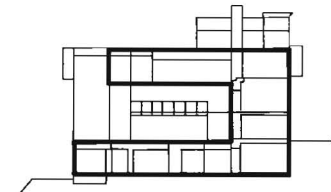
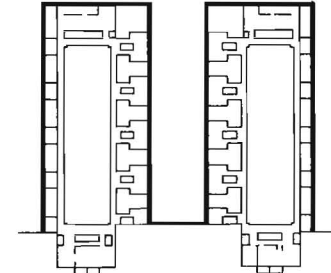

13

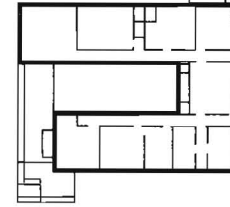

14. PETER BRANT HOUSE
ROBERT VENTURI
1973

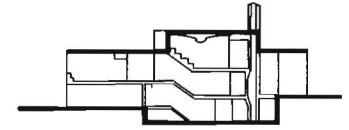

14

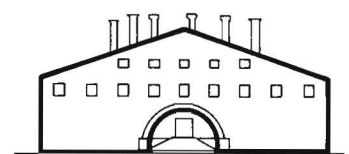
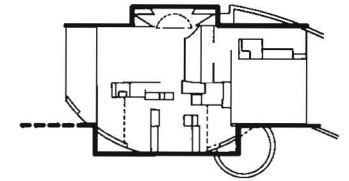

15

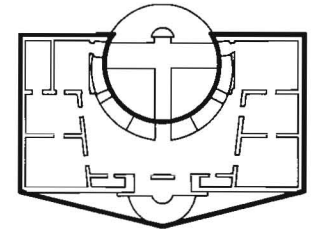

1. FIRESTATION NUMBER 4
ROBERT VENTURI
1966
2. ST. MARY LE BOW
CHRISTOPHER WREN
1670-1683

3. LEICESTER ENGINEERING BUILDING
JAMES STIRLING
1959
4. STOCKHOLM PUBLIC LIBRARY
ERIK GUNNAR ASPLUND
1920-1928

5. VOUKSENNISKA CHURCH, IMATRA
ALVAR AALTO
1956-1958
6. WEEKEND HOUSE
EDWARD LARABEE BARNES
1963

7. KIMBALL ART MUSEUM
LOUIS I. KAHN
1966-1972
8. ANNEX TO OITA MEDICAL HALL
ARATA ISOZAKI
1970-1972

Inverse

An inverse relationship exists between plan and section when the configuration of one is connected to some opposite condition in the other. In the fire station (1) and St. Mary Le Bow (2) a lesser plan form is the dominant element in section or elevation. This reversal of dominance occurs twice in the Leicester Engineering Building (3), where the major plan form is less significant in elevation and the dominant elevation component is small in plan. The inverse configurations in the Stockholm Library (4) have positive and negative manifestations; the central drum in elevation and the recess in plan. The inverse configurations in the Stockholm Library (4) have positive and negative manifestations; the central drum in elevation and the recess in plan. The church in Imatra (5) has a sequence of three curved and increasingly larger plan forms related to three decreasing forms in section. In the weekend house (6) the long side of the plan is low in section and the short side is tall. Simple plan forms relate inversely to a complex section and elevation in the Kimball Art Museum (7). At the medical building (8), two forms in elevation, one curvilinear and simple, the other rectilinear and articulated, reverse their characteristics in plan.

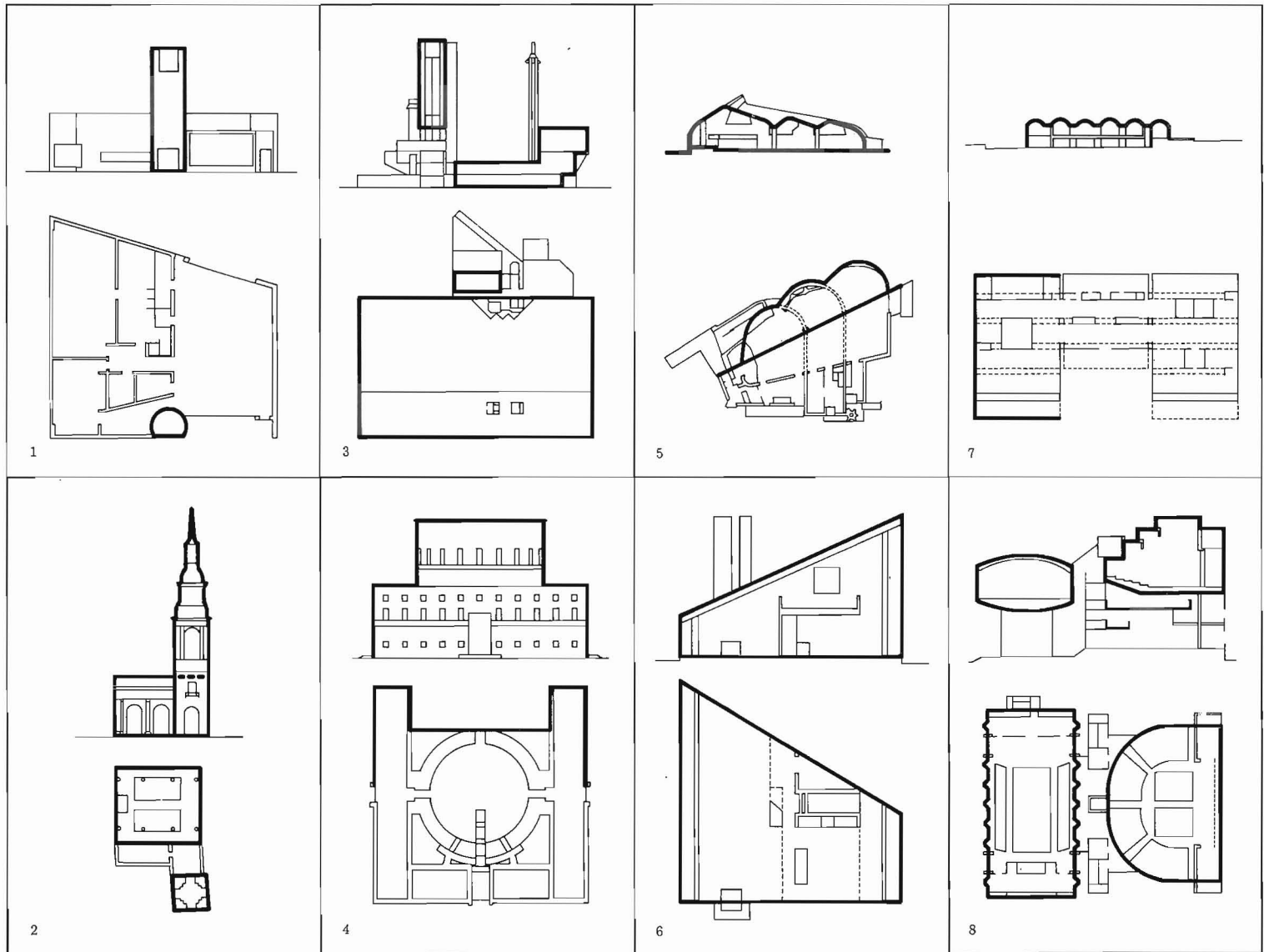

1. PYRAMID OF CHEOPS
ARCHITECT UNKNOWN
c. 3733 B.C.
2. RUFER HOUSE
ADOLF LOOS
1922
3. FROG HOLLOW
STANLEY TIGERMAN
1973-1974

4. HOUSE AT WEISSENHOF
LE CORBUSIER
1927
5. U.N. PLAZA
ROCHE-DINKELOO
1969-1975
6. KRESGE AUDITORIUM
EERO SAARINEN
1955

7. RESIDENCE IN RIVA SAN VITALE
MARIO BOTTA
1972-1973
8. ELPHINSTONE TOWER
ARCHITECT UNKNOWN
16th CENTURY
9. SMALL OLYMPIC ARENA
KENZO TANGE
1961-1964

UNIT TO WHOLE

The unit to whole relationship is a formative idea that relates units to other units and to the whole in specific ways to create built form. Illustrated are examples of units equal to, contained within, less than, and aggregated to form the whole.

Unit Equals Whole

The most direct relationship between a unit and the whole occurs when the unit equals the whole. In Cheop's Pyramid (1) and the Rufer House (2) surface material, color, and form render the unit as the whole. At Frog Hollow (3), the application of the color black unifies the roof, walls, and windows into a single entity. The unified grid becomes a wrapper that makes the United Nations Plaza (5) a unit and whole concurrently. As a segment of a sphere, Kresge Auditorium (6) is at once a unit and the whole. Le Corbusier's house at Weissenhof (4) and Mario Botta's house in Switzerland (7) are examples of whole forms that are subtractive. Thick walls that are unified in material and color along with the simple block form of Elphinstone Tower (8) render it a unit equal to the whole. A singular sculptural form makes the unit and whole equal in the Olympic Arena (9).

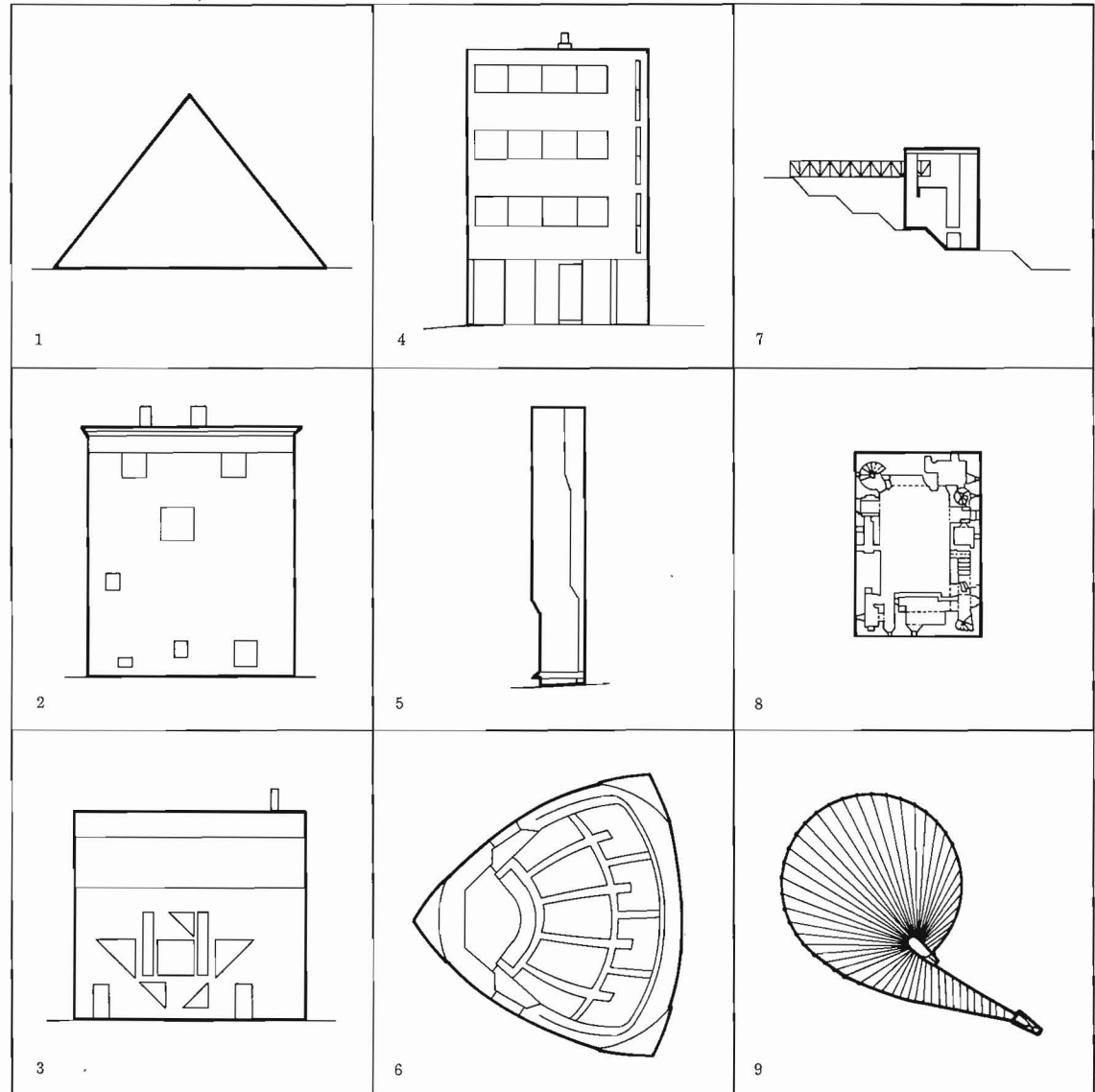

1. SAN GIORGIO MAGGIORE
ANDREA PALLADIO
1560-1580
2. STUDENT UNION
ROMALDO GIURGOLA
1974
3. SAN SPIRITO
FILIPPO BRUNELLESCHI
1434

4. REDENTORE CHURCH
ANDREA PALLADIO
1576
5. CARSON PIRIE AND SCOTT STORE
LOUIS SULLIVAN
1899-1903
6. CHRIST CHURCH
NICHOLAS HAWKSMOOR
1715-1729

7. AUDITORIUM BUILDING
LOUIS SULLIVAN
1887-1890
8. ST. MARY WOOLNETH
NICHOLAS HAWKSMOOR
1716-1724
9. OLD SACRISTY
FILIPPO BRUNELLESCHI
1421-1440

10. DIRECTOR'S HOUSE
CLAUDE NICHOLAS LEDOUX
1775-1779
11. LANG MUSIC BUILDING
ROMALDO GIURGOLA
1973
12. HOTEL GUIMARD
CLAUDE NICHOLAS LEDOUX
1770

Units Contained in Whole

In the relationship of units contained in the whole, the units are structural components, use-spaces, or blocks of use-spaces. The whole is the dominant image, with the units not expressed on the exterior. Christ Church (6) and the churches of San Giorgio (1), San Spirito (3), and Redentore (4) are composed of implied spatial units in configurations that emphasize major subdivisions in the forms. The Student Union (2) and Carson Pirie and Scott Store (5) are designed with units that are structural modules. In the Auditorium Building (7), the units are blocks of use-spaces which generally are divided into different types of uses. Lesser spatial units are organized around the main central space in St. Mary Woolnoth (8). Spatial volumes form the major units in the Old Sacristy (9), while domed ceiling forms create secondary units. In the Director's House (10) the units generally coincide with use and circulation spaces. Major rooms and groupings of smaller rooms create the units in the Lang Music Building (11) and the Hotel Guimard (12).

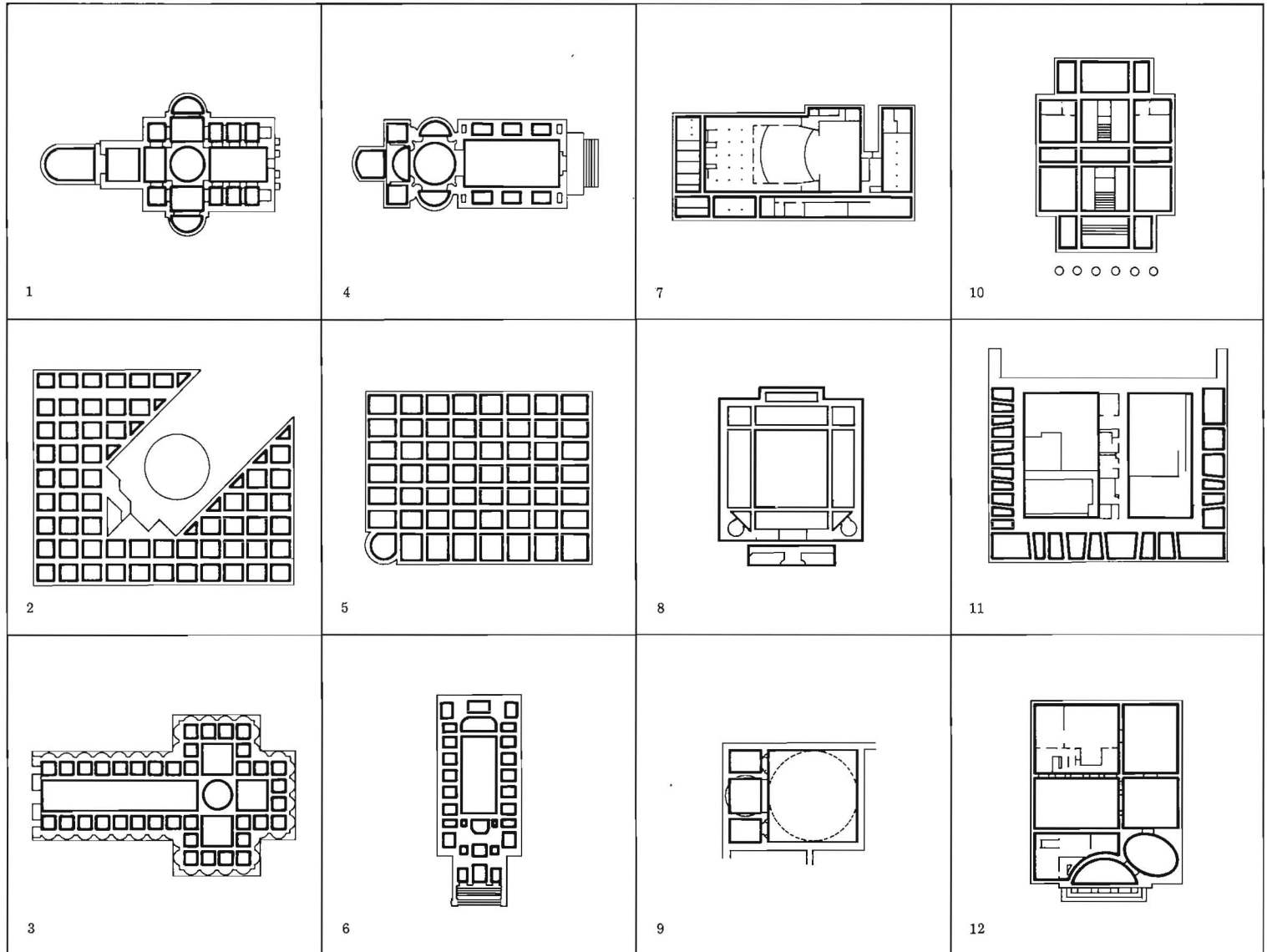

1. EXETER LIBRARY
LOUIS I. KAHN
1967-1972

2. TREDYFFRIN LIBRARY
ROMALDO GIURGOLA
1976

3. HOTEL DE MONTMORENCY
CLAUDE NICHOLAS LEDOUX
1769

4. TENDERING HALL
JOHN SOANE
1784-1790

5. J. PIERPONT MORGAN LIBRARY
McKIM, MEAD, AND WHITE
1906

6. ANNAGLEE
RICHARD CASTLE
1740-1770

7. TEMPLE OF HORUS
ARCHITECT UNKNOWN
237 B.C.-57 B.C.

8. THE PALACE OF ASSEMBLY
LE CORBUSIER
1953-1963

9. FALLINGWATER
FRANK LLOYD WRIGHT
1935

10. MUSGUM VILLAGE
ARCHITECT UNKNOWN
DATE UNKNOWN

11. SEA RANCH CONDOMINIUM
CHARLES MOORE
1964-1965

12. FINLANDIA HALL
ALVAR AALTO
1967-1971

Whole Greater than Sum of the Units

In this relationship, the whole incorporates more built form than that ascribed to the identified units. The central space in the Exeter Library (1) is not a use-space, and therefore, not a unit. Tredyffrin Library (2) is more than the major use-space formed by the structural bays. In Hotel Montmorency (3), Tendering Hall (4), Morgan Library (5), the Irish house (6), and Finlandia Hall (12), the major figured use-spaces form the units, and the lesser, servant spaces are poche. The units in Edfu Temple (7) are major building blocks set within a whole defined by a wall; the difference between the wall and the units is exterior space. In the Palace of Assembly (8), the units are the two unique central forms and the blocks of use-spaces at the perimeter; the remainder of the interior court is the excess. At Fallingwater (9), the units are expressed in elevation by balcony forms and chimney mass, viewed against the remainder of the building. A wall defines the whole in the Musgum Village (10) which is more than the units combined. At Sea Ranch (11), the units are the living spaces, while the whole also includes the central space and the secondary units added to each dwelling.

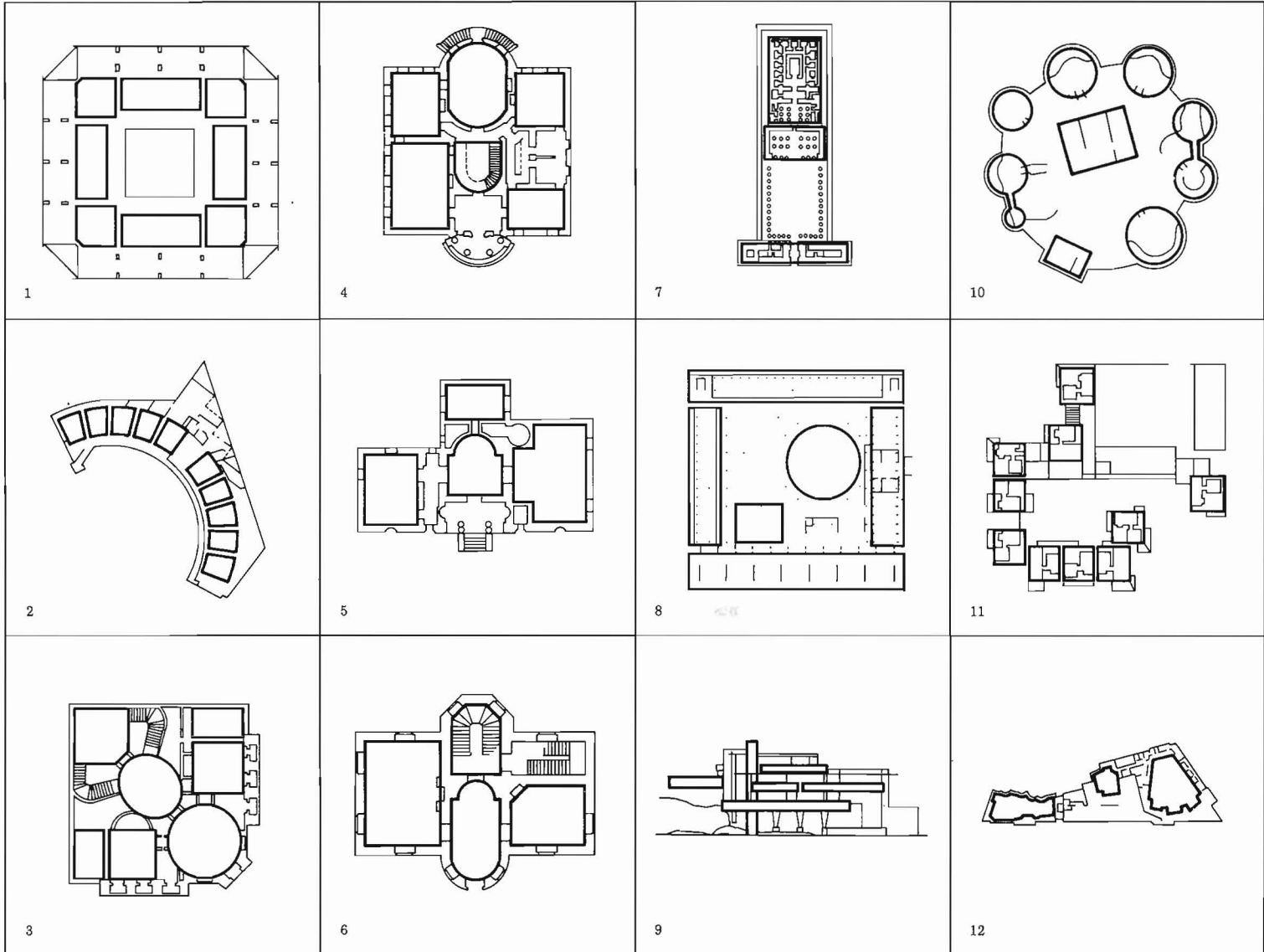

1. LEICESTER ENGINEERING BUILDING
JAMES STIRLING
1959
2. CAMBRIDGE HISTORY FACULTY
JAMES STIRLING
1964
3. FLOREY BUILDING
JAMES STIRLING
1966

4. EASTON NESTON
NICHOLAS HAWKSMOOR
c. 1695-1710
5. ST. GEORGE-IN-THE-EAST
NICHOLAS HAWKSMOOR
1714-1729
6. THEATER IN BESANCON, FRANCE
CLAUDE NICHOLAS LEDOUX
1775

7. NASHDOM
EDWIN LUTYENS
1905-1909
8. TRINITY CHURCH
HENRY HOBSON RICHARDSON
1872-1877
9. ALLEGHENY COUNTY COURTHOUSE
HENRY HOBSON RICHARDSON
1883-1888

Units Aggregate to Form Whole

Units are aggregated to form a whole when they are arranged in proximity to other units to establish a perceived relationship. This is done by adjoining, separating, and overlapping.

neering Labs (1), History Faculty (2), and the Florey Building (3). At Easton Neston (4) and Nashdom (7), assembled units emphasize the classic central entrance. Built form and spatial units are combined in St. George (5). The Besancon Theater (6) and Trinity Church (8) exemplify units added around a dominant central form. In Richardson's Courthouse (9) and Aalto's Town Hall (13), units as groups of use-spaces adjoin around a central court, and at Aalto's Church (12), Cultural Center (14), and Sanitorium (15) they adjoin to create the building itself. At Unity Temple (10), two sets of added units are combined. Major and minor units connected by a third unit define the Guggenheim Museum (11). In La Rotonda (16) the units are added symmetrically about a central space, while at Karlskirche (19) the use-space units adjoin symmetrically. Major volumes and components comprise the fire station (17) and the Brant House (18), and units occur around a central form or space in Stockholm Library (20) and San Maria (21). Structural units adjoin in Villa Savoye (22) and the Kimball Art Center (23). Kahn's Convent (24) is a series of forms partially contained by units which are groups of spaces.

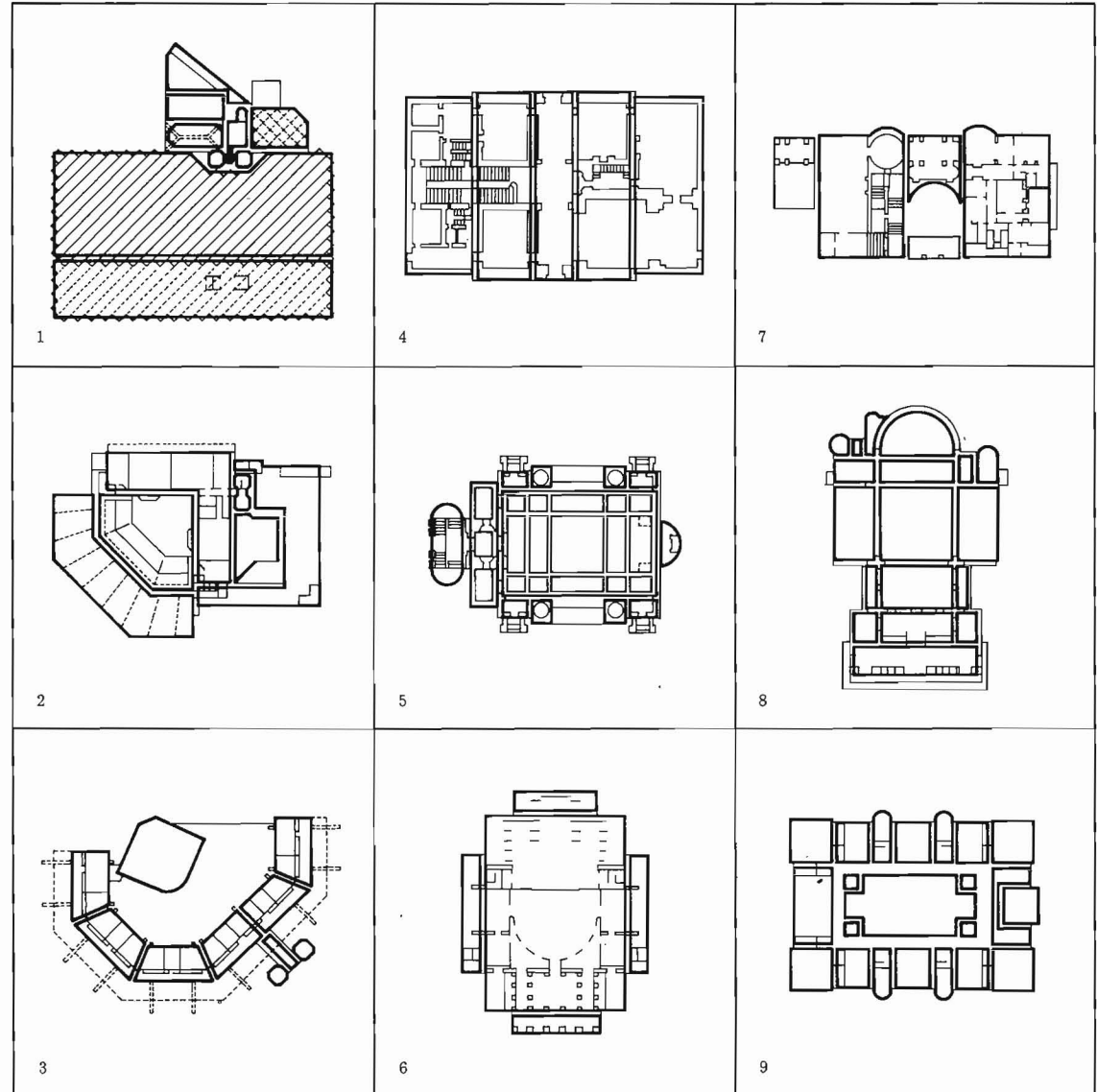

Units Adjoin

Units adjoin to form a whole when the units are visible, perceived as entities, and relate to other units through surface contact. Adjoining, indicative of James Stirling's work at this time, is exemplified in the Engi-

10. UNITY TEMPLE
FRANK LLOYD WRIGHT
1906

11. GUGGENHEIM MUSEUM
FRANK LLOYD WRIGHT
1956

12. VOUKSENNISKA CHURCH, IMATRA
ALVAR AALTO
1956-1958

13. SAYNATSALO TOWN HALL
ALVAR AALTO
1950-1952

14. WOLFSBURG CULTURAL CENTER
ALVAR AALTO
1958-1962

15. PAIMIO SANITORIUM
ALVAR AALTO
1929-1933

16. LA ROTONDA
ANDREA PALLADIO
1566-1571

17. FIRESTATION NUMBER 4
ROBERT VENTURI
1966

18. PETER BRANT HOUSE
ROBERT VENTURI
1973

19. KARLSKIRCHE
JOHANN FISHER VON ERLACH
1715-1737

20. STOCKHOLM PUBLIC LIBRARY
ERIK GUNNAR ASPLUND
1920-1928

21. SAN MARIA DEGLI ANGELI
FILIPPO BRUNELLESCHI
1434

22. VILLA SAVOYE
LE CORBUSIER
1928-1931

23. KIMBALL ART MUSUEM
LOUIS I. KAHN
1966-1972

24. CONVENT FOR DOMINICAN SISTERS
LOUIS I. KAHN
1965-1968

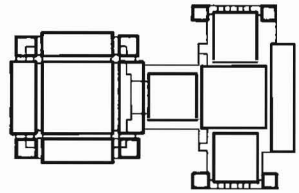

10

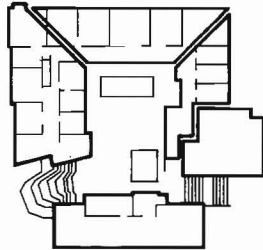

13

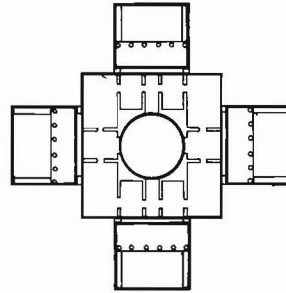

16

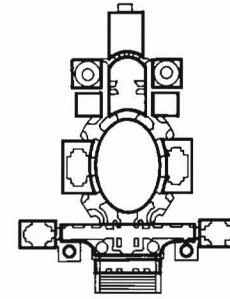

19

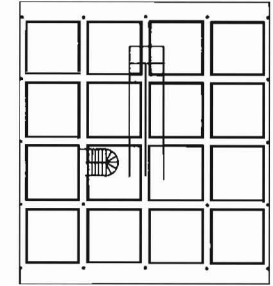

22

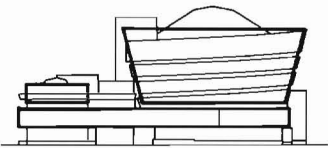

11

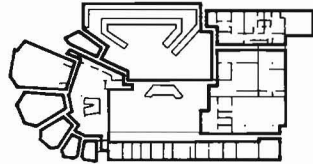

14

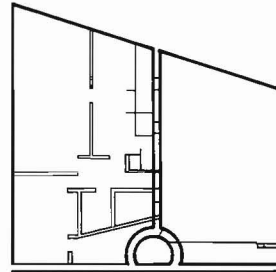

17

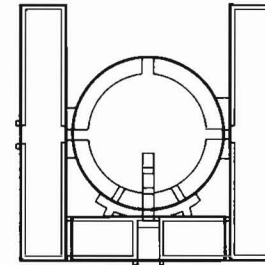

20

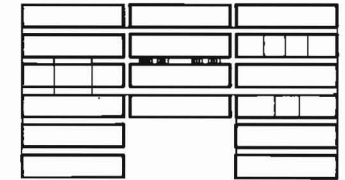

23

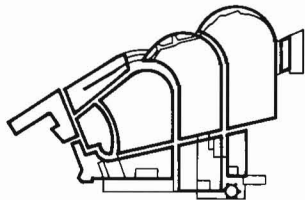

12

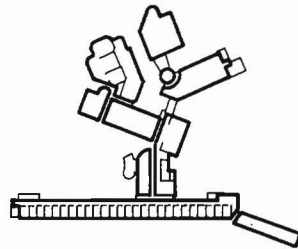

15

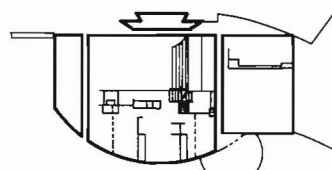

18

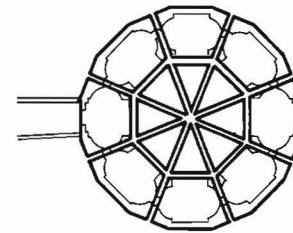

21

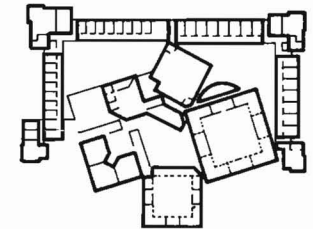

24

1. SEVER HALL
HENRY HOBSON RICHARDSON
1878-1880
2. FREDERICK G. ROBIE HOUSE
FRANK LLOYD WRIGHT
1909
3. YALE ART AND ARCHITECTURE
PAUL RUDOLPH
1958

4. LISTER COUNTY COURTHOUSE
ERIK GUNNAR ASPLUND
1917-1921
5. CARLL TUCKER III HOUSE
ROBERT VENTURI
1975
6. ERDMAN HALL DORMITORIES
LOUIS I. KAHN
1960-1965

7. OCCUPATIONAL HEALTH CENTER
HARDY-HOLZMAN-PFIEFFER
1973
8. PRATT RESIDENCE
HARDY-HOLZMAN-PFIEFFER
1974
9. SALISBURY SCHOOL
HARDY-HOLZMAN-PFIEFFER
1977

10. RESIDENCE IN BRIDGEHAMPTON
GWATHMEY-SIEGEL
1969-1971
11. COOPER RESIDENCE
GWATHMEY-SIEGEL
1968-1969
12. BARCELONA PAVILLION
LUDWIG MIES VAN DER ROHE
1929

Units Overlap

Units overlap to form a whole through volumetric interpenetration. Two elongated forms defined by four towers overlap the main block of Sever Hall (1), and an upper level wing with perpendicular orientation connects the two masses of the Robie House (2). In the Yale Architecture Building (3), a series of overlapping trays define interior space. The circular main space of Lister Courthouse (4) is partially engaged into the central mass, while the circle unites the triangle of the roof to the square of the building in the Tucker House (5). Overlapping corners allow for continuous circulation in the Bryn Mawr Dormitories (6). Rotated sets of forms overlap in the Occupational Health Building (7), the Pratt Residence (8), and the Salisbury School (9). At the Bridgehampton residence (10), implied circles overlap a rectangle and each other, and in the Cooper Residence (11), the overlapping forms create spatial subdivisions and imply a partial pin-wheel. The Barcelona Pavilion (12) is a complex series of interpenetrating, orthogonal, and implied spatial volumes.

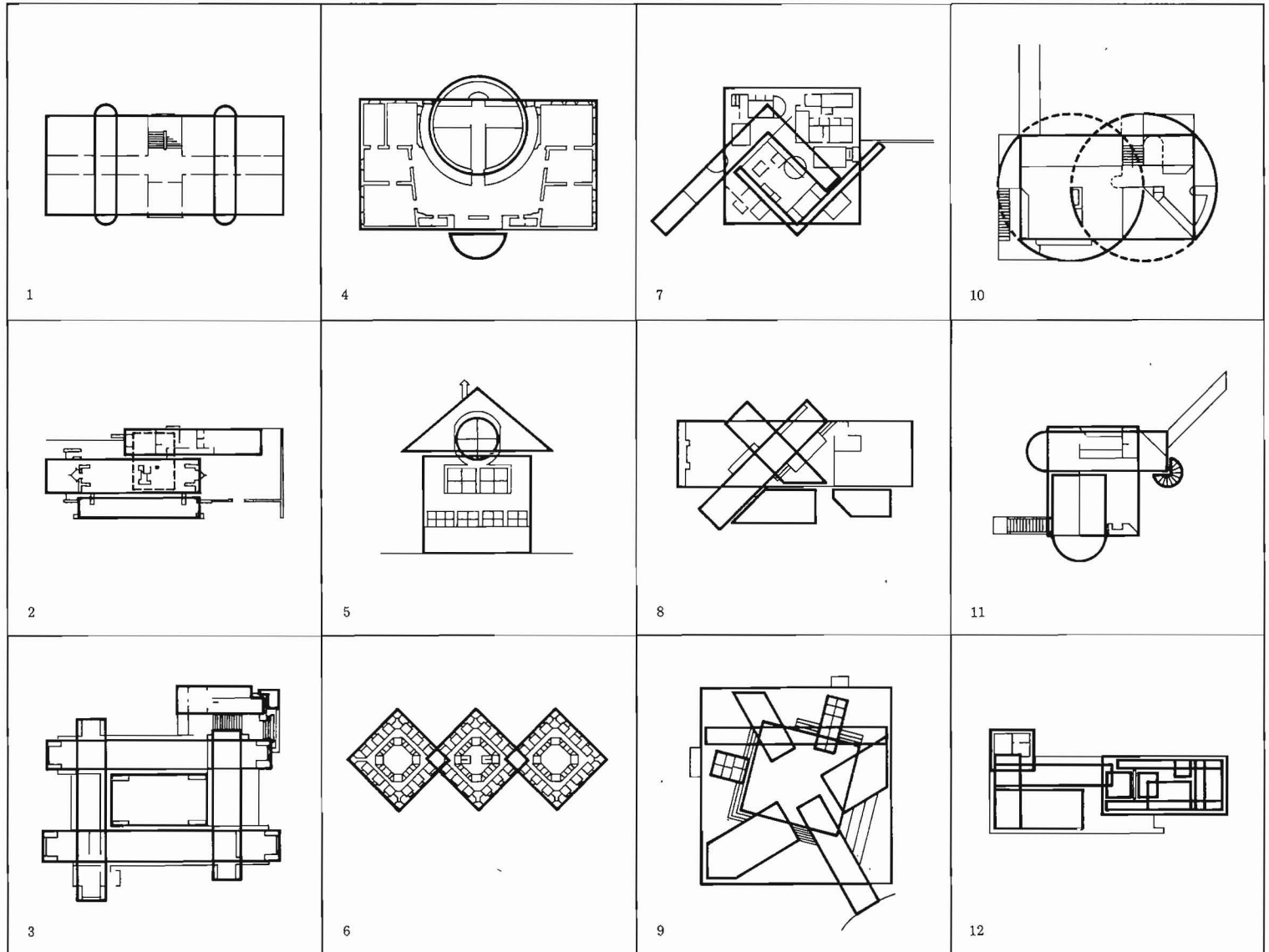

1. DEERE WEST OFFICE BUILDING
ROCHE-DINKELOO
1975-1976

2. OLYMPIC ARENA
KENZO TANGE
1961-1964

3. RESIDENCE IN STABIO, SWITZERLAND
MARIO BOTTA
1981

4. COLLEGE LIFE INSURANCE COMPANY
ROCHE-DINKELOO
1967-1971

5. RESIDENCE ON MT. DESERT ISLAND
EDWARD LARABEE BARNES
1975

6. PAUL MELLON ARTS CENTER
I. M. PEI
1970-1973

7. EVERSON MUSEUM OF ART
I. M. PEI
1968

8. NATIONAL ASSEMBLY
LOUIS I. KAHN
1962-1974

9. CHAPEL AT RONCHAMP
LE CORBUSIER
1950-1955

Units Separate

Units which are related to other units can be separated through isolation or articulation of the connection to create perceived separation. In the Deere Office Building (1) the units are separated by glass, a defined circulation element, and an atrium space. Glass is used to create perceptual separation in the Olympic Arena (2) and the house in Switzerland (3). The College Life Insurance Buildings (4) are isolated forms tenuously connected by a bridge at one level. A deck serves to unify isolated elements in the Mt. Desert house (5), and separated forms share a common roof in the Mellon Arts Center (6). Glass perceptually separates the units of the Everson Museum (7), and is also used to create apparent separation of units in the National Assembly (8) and the Chapel at Ronchamp (9).

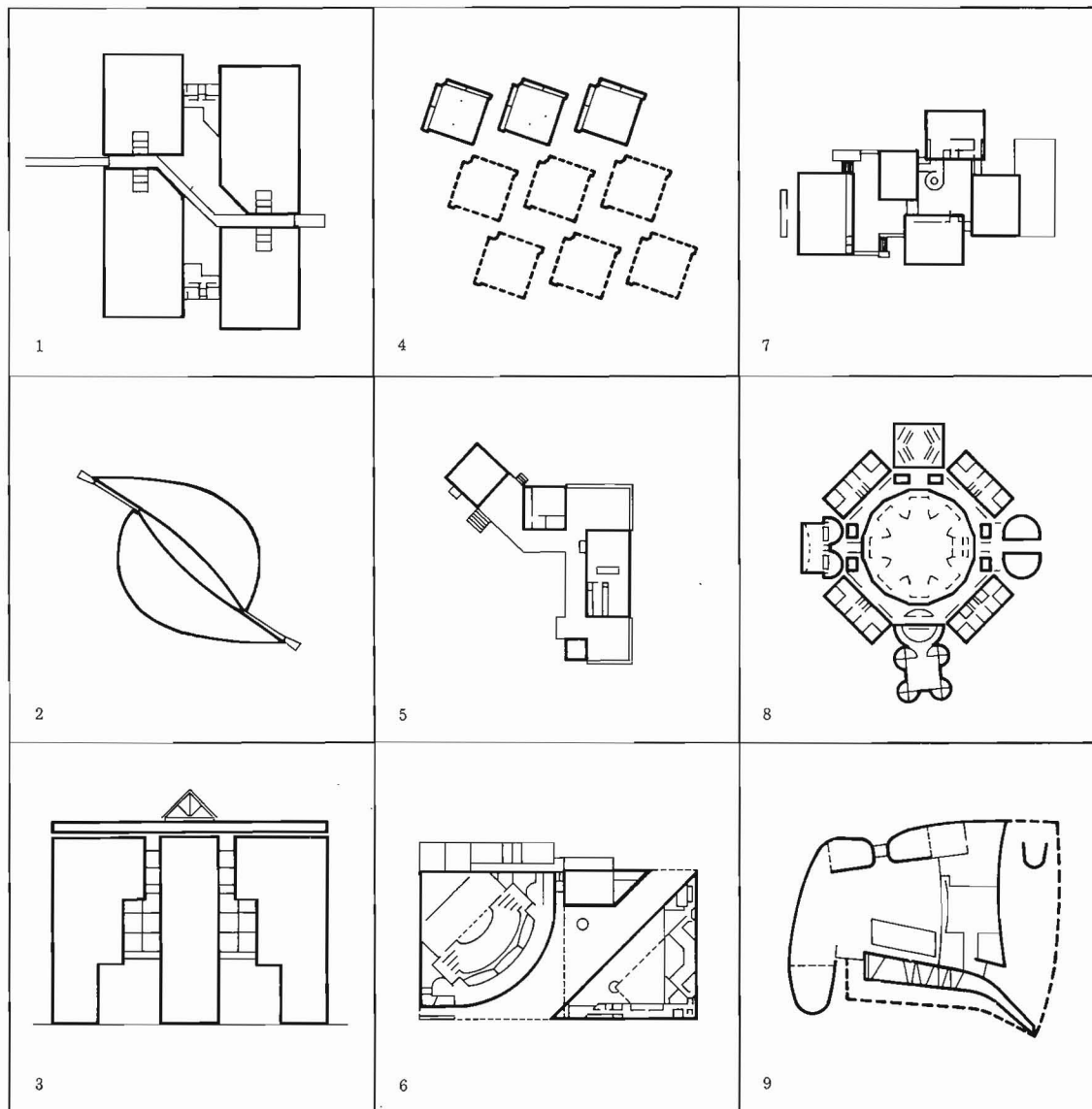

REPETITIVE TO UNIQUE

The formative idea of relating repetitive and unique elements is the design of buildings by establishing relationships between components which have singular and multiple manifestations. Illustrated are examples of unique surrounded by repetitive; formed by transformation in a repetitive field; added to repetitive; and defined by repetitive.

bounded form and is ringed by multiple equal units. Unique elements are located in larger spaces formed by the repetitive units in Schinkel's museum (1), the Florey Building (10), and the Palace of Assembly (18). In the Hunting Lodge (2) the unique center is surrounded. It is partially surrounded in the Adult Learning Lab (16). Unique elements are surrounded in the Rhode Island Capitol (3), Unity Temple (4), and San Spirito (23), and are partially ringed in the Guggenheim Museum (5), the Convent (13), the Auditorium Building (15), and the Lang Music Center (17). The repetitive elements form a pinwheel in the Archives Building (6), and a 'U'-shape in both the Khuner Villa (9) and the Stockholm Library (22). St. George (7), Cambridge History (11), Trinity Church (12), and San Spirito (23) exemplify two kinds of repetitive elements. In Christ Church (8) and Villa Foscari (20) the multiple units relate to the unique element in more than one way. A central unique element is totally surrounded at Exeter Library (14), the theater (19), and La Rotondda (21). San Maria (24) has a unique center surrounded by two sets of repetitive elements, one spatial and one structural.

Unique Surrounded by Repetitive

Repetitive elements surround a unique unit when the unique is a

1. ALTES MUSEUM
KARL FRIEDRICH SCHINKEL
1824
2. HUNTING LODGE
KARL FRIEDRICH SCHINKEL
1822
3. RHODE ISLAND STATE CAPITOL
McKIM, MEAD, AND WHITE
1895-1903

4. UNITY TEMPLE
FRANK LLOYD WRIGHT
1906
5. GUGGENHEIM MUSEUM
FRANK LLOYD WRIGHT
1956
6. SHENBOKU ARCHIVES
FUMHIKO MAKI
1970

7. ST. GEORGE-IN-THE-EAST
NICHOLAS HAWKSMOOR
1714-1729
8. CHRIST CHURCH
NICHOLAS HAWKSMOOR
1715-1729
9. KHUNER VILLA
ADOLF LOOS
1930

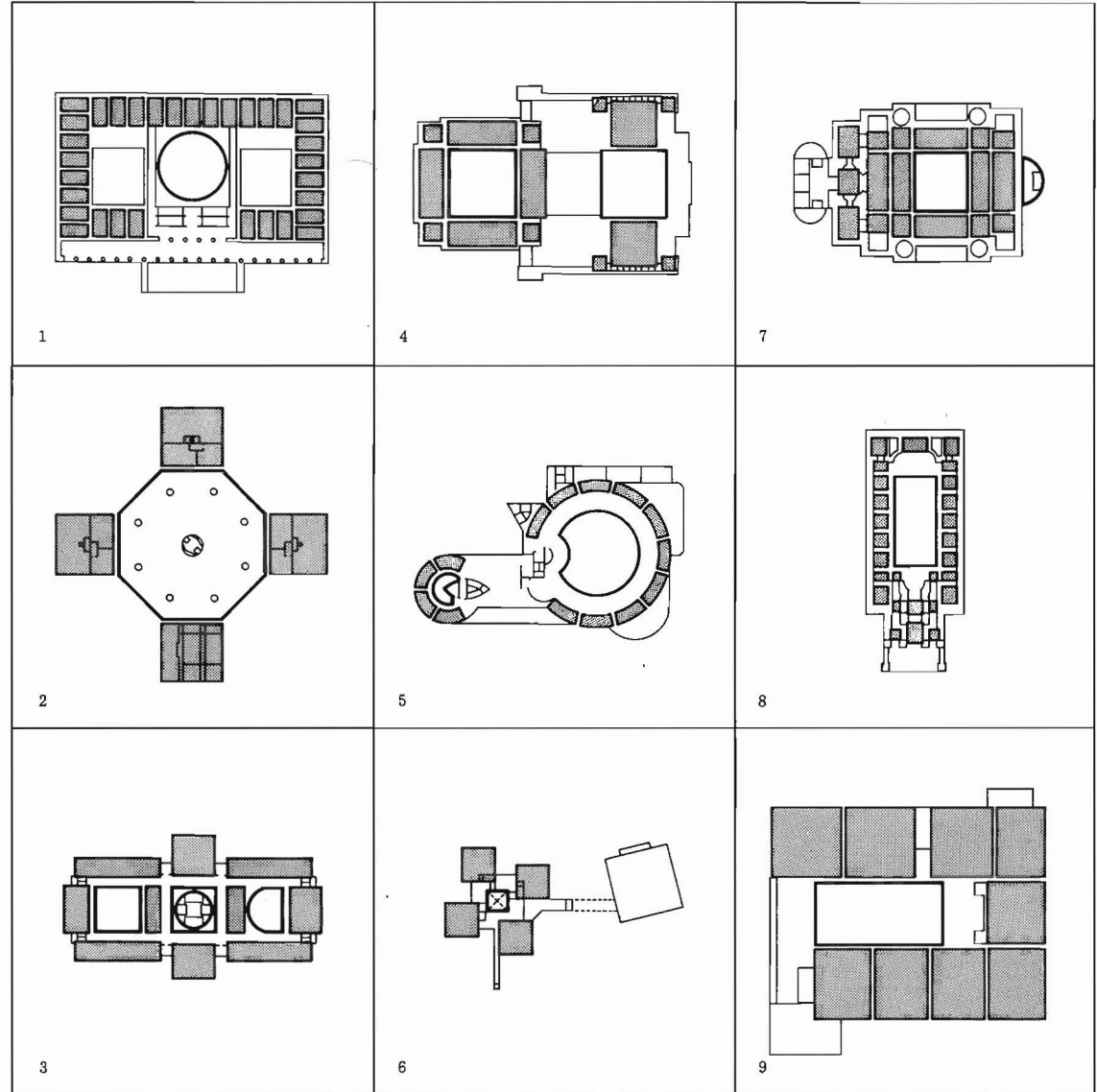

10. FLOREY BUILDING

JAMES STIRLING
1966

11. CAMBRIDGE HISTORY FACULTY

JAMES STIRLING
1964

12. TRINITY CHURCH

HENRY HOBSON RICHARDSON
1872-1877

13. CONVENT FOR DOMINICAN SISTERS

LOUIS I. KAHN
1965-1968

14. EXETER LIBRARY

LOUIS I. KAHN
1967-1972

15. AUDITORIUM BUILDING

LOUIS SULLIVAN
1887-1890

16. ADULT LEARNING LABORATORY

ROMALDO GIURGOLA
1972

17. LANG MUSIC BUILDING

ROMALDO GIURGOLA
1973

18. THE PALACE OF ASSEMBLY

LE CORBUSIER
1953-1963

19. THEATER IN BESANCON, FRANCE

CLAUDE NICHOLAS LEDOUX
1775

20. VILLA FOSCARI

ANDREA PALLADIO
c. 1549-1563

21. LA ROTONDA

ANDREA PALLADIO
1566-1571

22. STOCKHOLM PUBLIC LIBRARY

ERIK GUNNAR ASPLUND
1920-1928

23. SAN SPIRITO

FILIPPO BRUNELLESCHI
1434

24. SAN MARIA DEGLI ANGELI

FILIPPO BRUNELLESCHI
1434-1436

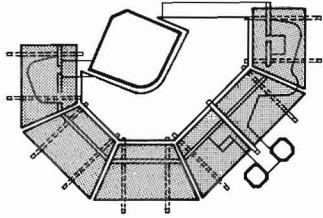

10

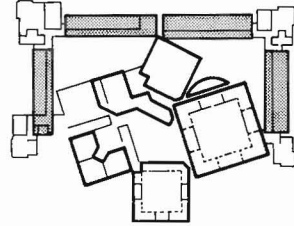

13

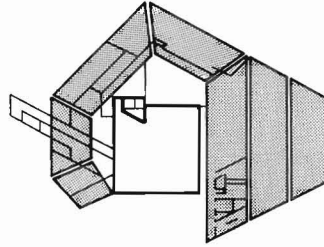

16

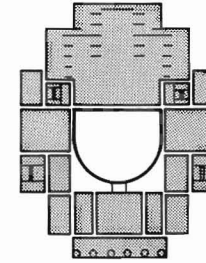

19

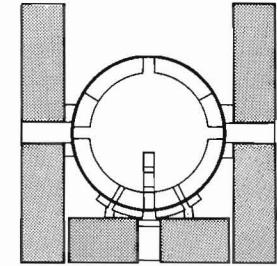

22

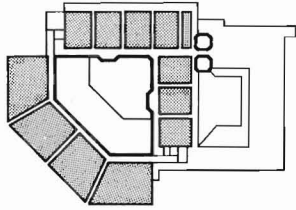

11

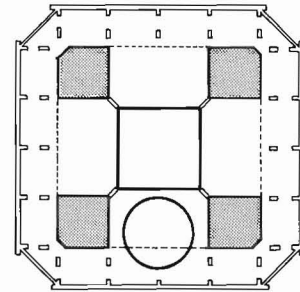

14

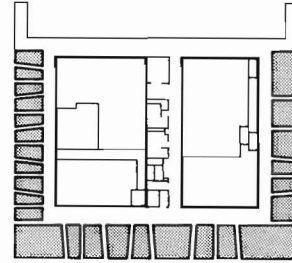

17

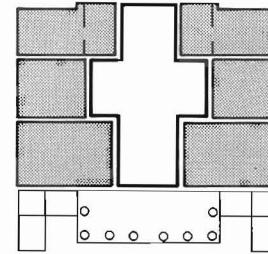

20

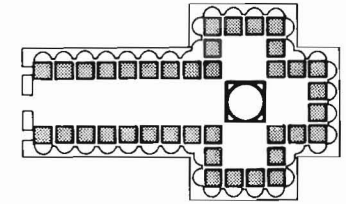

23

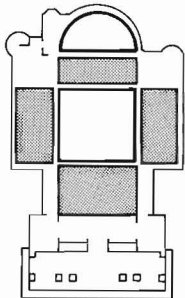

12

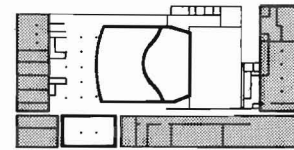

15

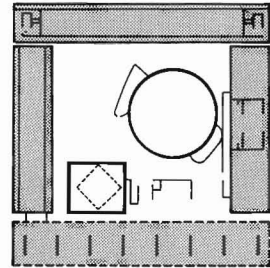

18

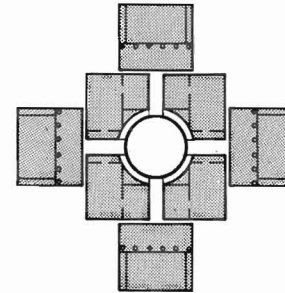

21

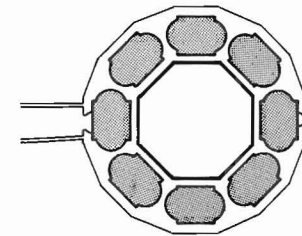

24

1. CARSON PIRIE AND SCOTT STORE
LOUIS SULLIVAN
1899-1903
2. STEINER HOUSE
ADOLF LOOS
1910
3. ALEXANDER HOUSE
MICHAEL GRAVES
1971-1973

4. SNELLMAN HOUSE
ERIK GUNNAR ASPLUND
1917-1918
5. HOTEL DE MONTMORENCY
CLAUDE NICHOLAS LEDOUX
1769
6. TENDERING HALL
JOHN SOANE
1784-1790

7. CARLL TUCKER III HOUSE
ROBERT VENTURI
1975
8. HOMEWOOD
EDWIN LUTYENS
1901
9. EASTON NESTON
NICHOLAS HAWKSMOOR
c. 1695-1710

10. MOORE HOUSE
CHARLES MOORE
1962
11. FALLINGWATER
FRANK LLOYD WRIGHT
1935
12. GUMMA MUSEUM OF FINE ARTS
ARATA ISOZAKI
1971-1974

Unique by Transformation of Repetitive

Unique elements can be developed by the transformation of repetitive units through changes in size, shape, configuration, orientation, geometry, color, and articulation. The changes of shape and geometry are similar and related, but usually shape involves less form change than does geometry. Carson Pirie and Scott Store (1), Snellman Residence (4), and Hotel Montmorency (5) exemplify unique elements developed by geometric transformations. This is also the case at Tendering Hall (6), the Tucker House (7), and Homewood (8). Related changes by shape occur in the Steiner House (2) and the Alexander House (3). Transformation by size creates the unique two-story spaces in Easton Neston (9). Unique by change in the articulation of the repetitive units is exemplified in the Moore House in Orinda (10). The unique components in Wright's Fallingwater (11) and the Gumma Museum (12) are created by change in orientation of the repetitive elements.

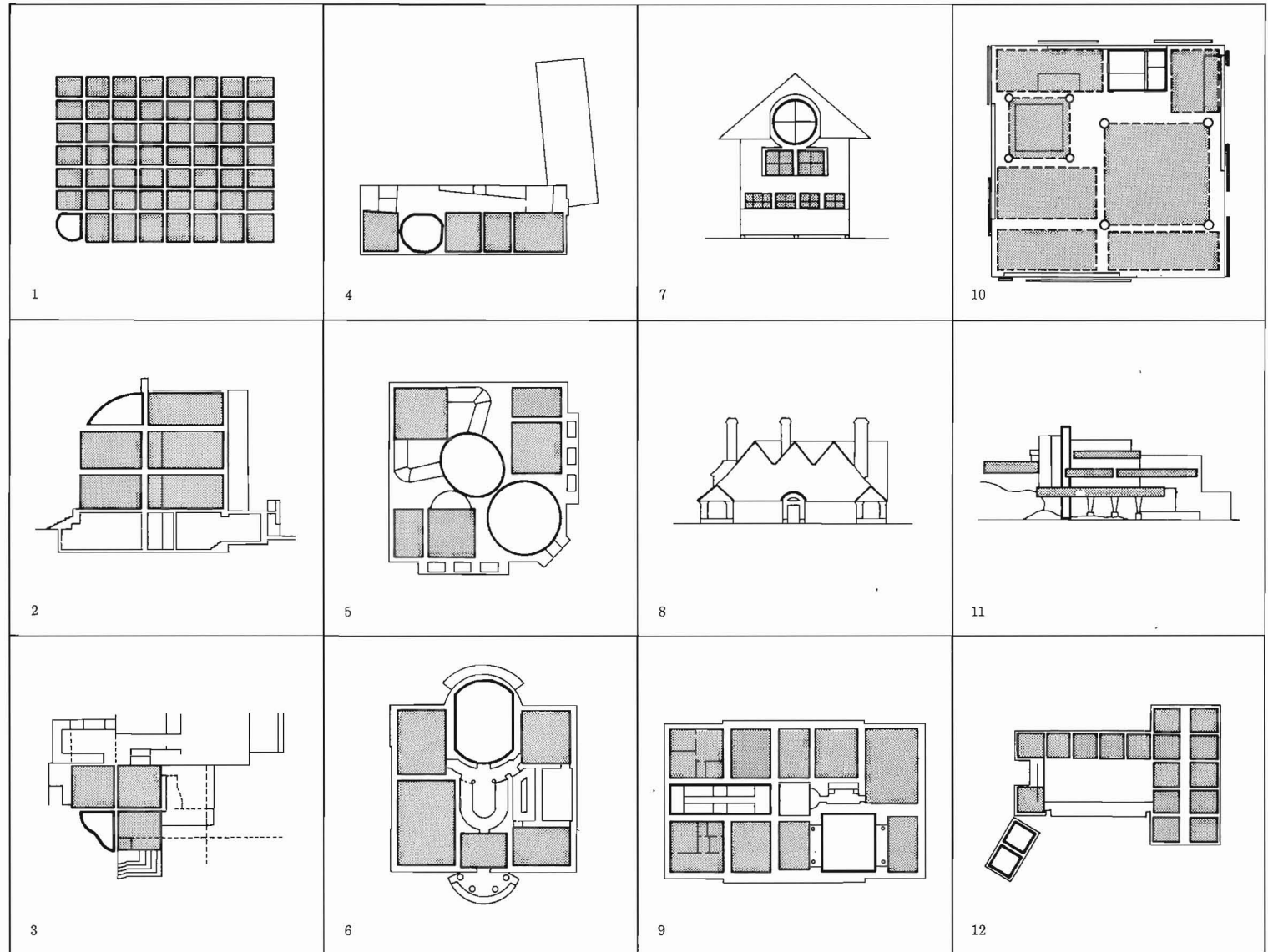

1. TEMPLE OF ARTEMIS
PAEONIUS AND DEMETRIUS
c. 356 B.C.

2. KIMBALL ART MUSEUM
LOUIS I. KAHN
1966-1972

3. INSTITUTE FOR ADVANCED STUDIES
GBQC
1968-1972

4. STUDENT UNION
ROMALDO GIURGOLA
1974

5. BROOKLYN CHILDREN'S MUSEUM
HARDY-HOLZMAN-PFIEFFER
1977

6. OCCUPATIONAL HEALTH CENTER
HARDY-HOLZMAN-PFIEFFER
1973

7. FREDERICK G. ROBIE HOUSE
FRANK LLOYD WRIGHT
1909

8. ST. STEPHENS WALBROOK
CHRISTOPHER WREN
1672-1687

9. VILLA SAVOYE
LE CORBUSIER
1928-1931

Unique in Repetitive Field

A field or network made from equal units in uniform relationships may be interrupted by a unique element. In the Artemis Temple (1), walls are located within a columnar field. Open courts that interrupt the structural system form the unique units in the Kimball Art Center (2) and the Student Union (4). At the Institute for Advanced Studies (3), unique geometric forms are placed within an orthogonal structural grid. A circulation element rotated in a structural field forms the unique element in the Brooklyn Museum (5), while at the Occupational Health Building (6), a skylight, rotated in the orthogonal grid, is unique. Structural fields are disrupted by a fireplace mass in the Robie House (7), by a dome in St. Stephens (8), and by two different vertical circulation elements in the Villa Savoye (9).

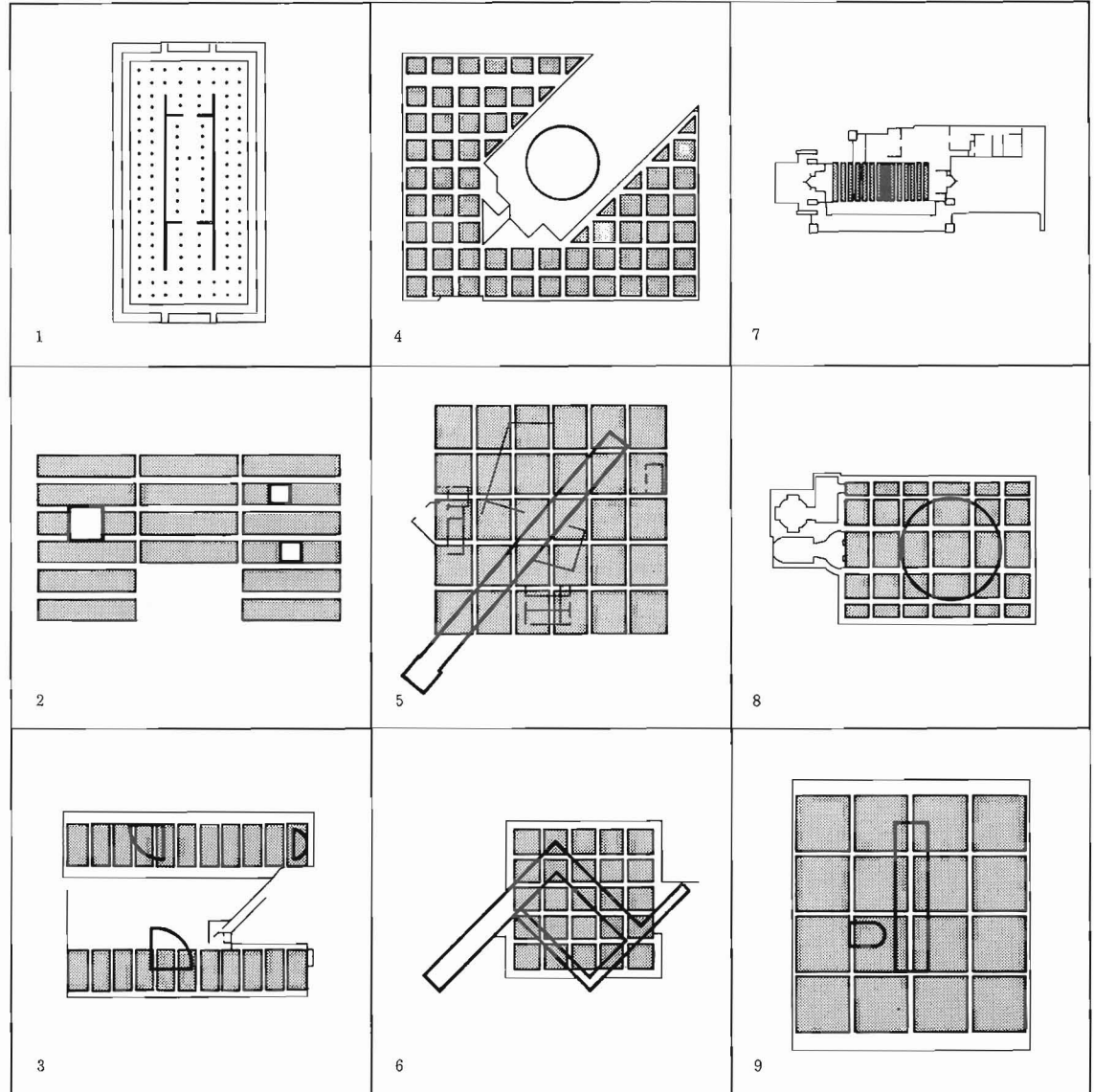

1. SEINAJOKI TOWN HALL
ALVAR AALTO
1962-1965
2. KAMIOKA TOWN HALL
ARATA ISOZAKI
1976-1978
3. BOYER HALL OF SCIENCE
GBQC
1970-1972

4. CONVENT OF LA TOURETTE
LE CORBUSIER
1957-1960
5. UNITE D'HABITATION
LE CORBUSIER
1946-1952
6. WAINWRIGHT BUILDING
LOUIS SULLIVAN
1890-1891

7. ST. NICHOLAS COLE ABBEY
CHRISTOPHER WREN
1671-1681
8. OLIVETTI TRAINING SCHOOL
JAMES STIRLING
1969
9. LEICESTER ENGINEERING BUILDING
JAMES STIRLING
1959

Unique Added to Repetitive

When the scale and mass of the repetitive elements are dominant, the unique is viewed as added to the repetitive. In the Seinajoki Town Hall (1), the unique component, added to the end of the repetitive, becomes a terminus. The Kamioka Town Hall (2) has a unique form added to the midpoint of a series of multiple elements. Three unique units are placed into an implied arena in Boyer Hall (3), and a cloister is formed by the joining of the unique and repetitive at La Tourette (4). In the Unite d'Habitation (5) elevation, the special forms are added to the top and bottom of the main block. A different kind of end is created in the Wainwright Building (6) with the addition of the unique top. The unique form is added to the front of St. Nicholas (7). At the Olivetti Center (8), two unique elements are adjoined to the middle of the multiple units, while the two unique components at Leicester Engineering Building (9) are added adjacent to the main blocks of the building.

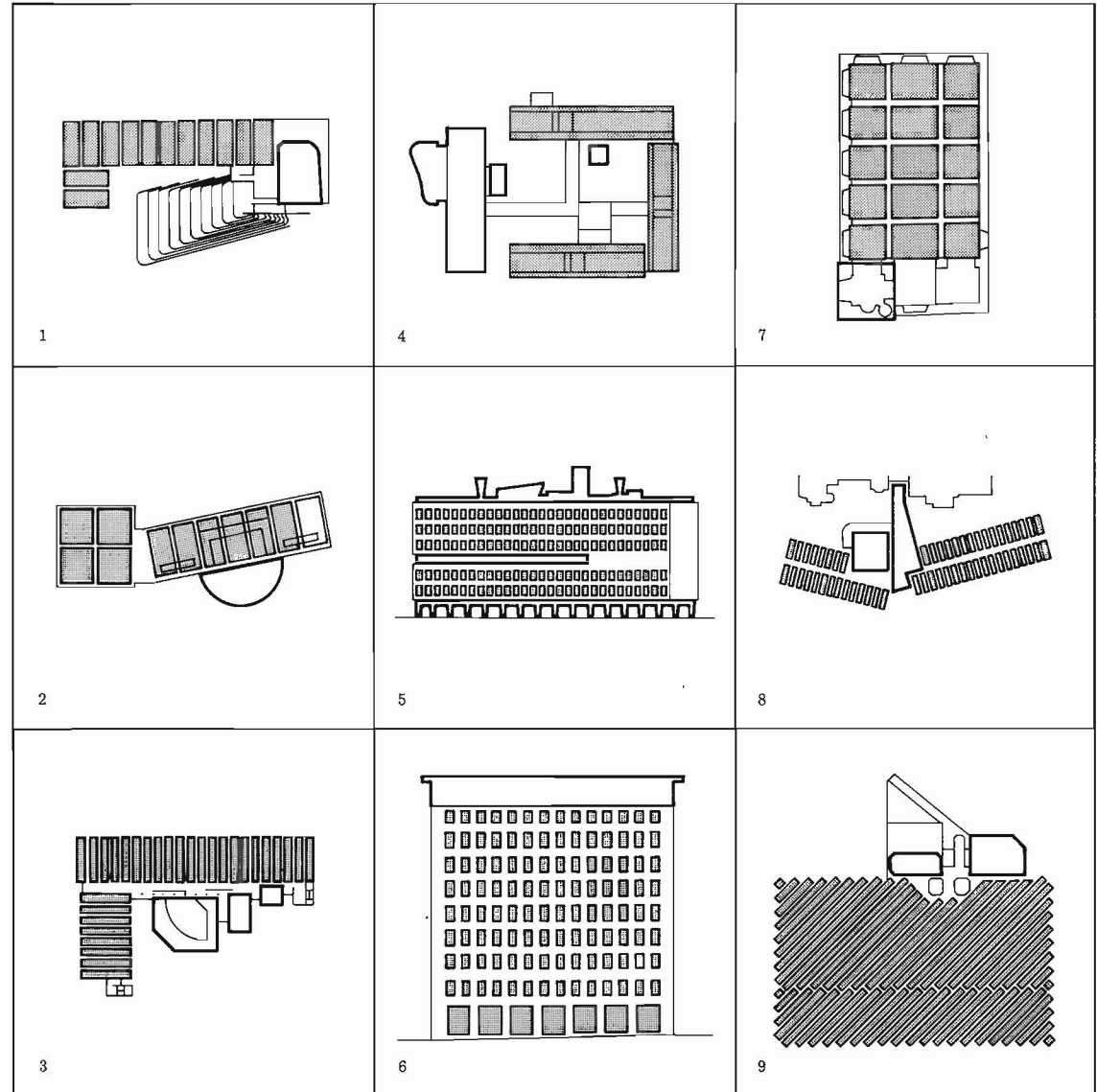

**Unique Defined
by Repetitive**

Unique is defined by repetitive when the form of the unique element is established by the configuration of the repetitive elements. All of the examples have unique forms that are either interior or exterior spaces. In the Colosseum (1), Pompei House (4), and Boston Public Library (5), a major exterior space is formed by the arrangement of the multiple units. This is also the case in Aalto's town hall (6) and the Allegheny Courthouse (9). Major interior spaces that are expressed on the exterior are the singular units in Wagner's Steinhof Church (2) and Wren's St. Antholin (3). Multistoried, unique spaces that serve as the foci for the surrounding repetitive spaces are exemplified in the Yale Architecture Building (7) and the Larkin Building (8).

1. COLOSSEUM
ARCHITECT UNKNOWN
70-82

2. ST. LEOPOLD AM STEINHOF
OTTO WAGNER
1905-1907

3. ST. ANTHOLIN
CHRISTOPHER WREN
1678-1691

4. HOUSE OF THE MENANDER
ARCHITECT UNKNOWN
c. 300 B.C.

5. BOSTON PUBLIC LIBRARY
McKIM, MEAD, AND WHITE
1898

6. SAYNATSALO TOWN HALL
ALVAR AALTO
1950-1952

7. YALE ART AND ARCHITECTURE
PAUL RUDOLPH
1958

8. LARKIN BUILDING
FRANK LLOYD WRIGHT
1903

9. ALLEGHENY COUNTY COURTHOUSE
HENRY HOBSON RICHARDSON
1883-1888

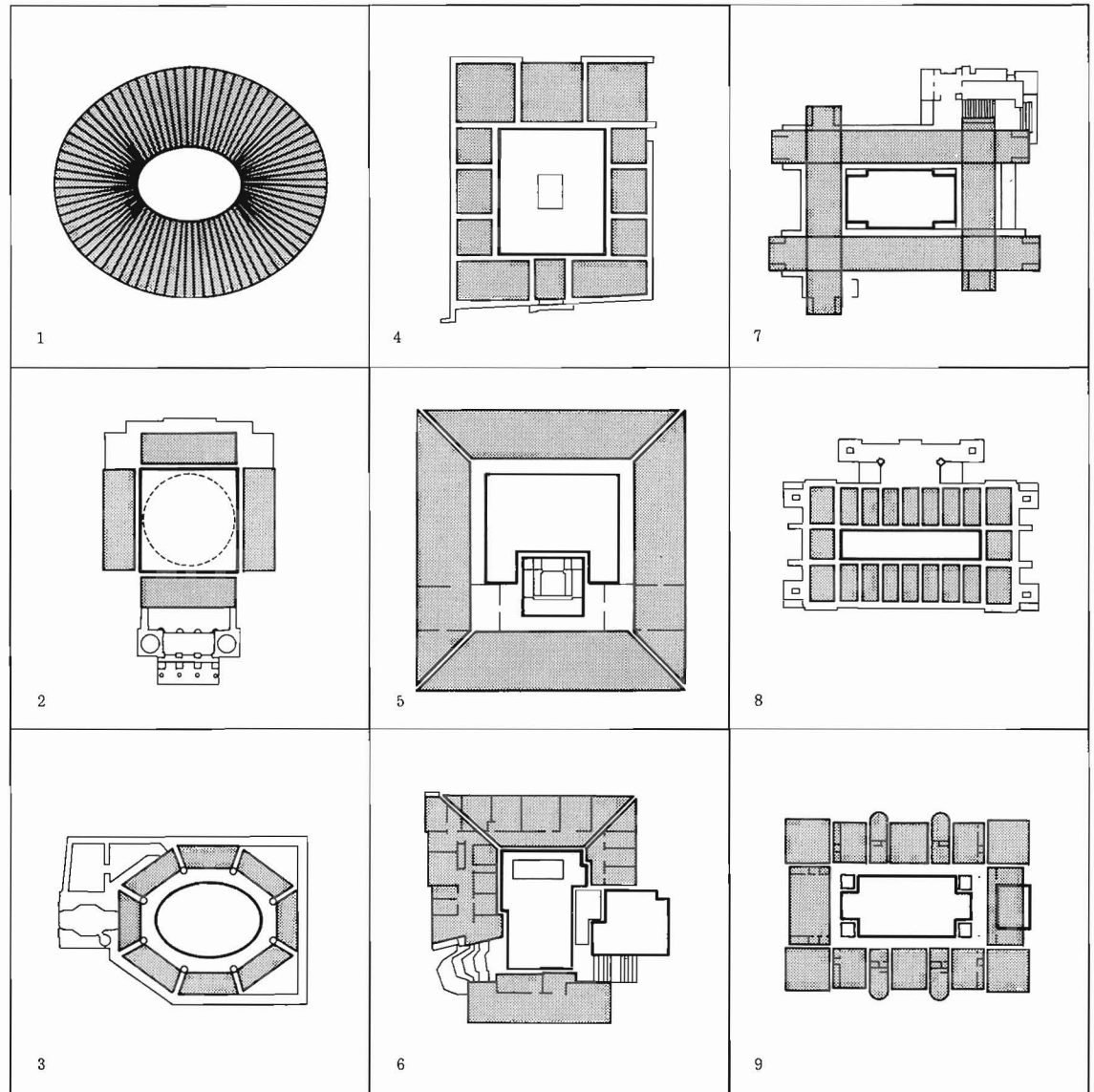

ADDITIVE AND SUBTRACTIVE

Additive and subtractive are formative ideas which involve the assemblage of parts or the removal of pieces to create built form. In additive, the parts are dominant, while in subtractive, the whole is dominant.

Subtractive

All of the examples present simple orthogonal configurations that are eroded to generate the building design. At Homewood (1), terraces and the entry are developed by the subtractions, while in the Wainwright Building (2), a light well is made. The Whitney Museum (3) shows erosion in section which allows for light to enter lower floors, the entry to be defined, and the building to establish a unique contact with the street. In Villa Savoye (4), the subtraction occurs within a bounded frame, and in the Stockholm Library (5), a drum is added into the courtyard created by the removal. The Venturi House (6) and Enso-Gutzeit Headquarters (7) are similar in that the subtraction establishes the entry. It also allows for the introduction of light into the interior at Enso. The major interior central space in Exeter Library (8) results from subtraction, while at the Student Union (9) a major exterior space, as well as the entry and smaller exterior spaces, is created by removal.

1. **HOMEWOOD**
EDWIN LUTYENS
1901

2. **WAINWRIGHT BUILDING**
LOUIS SULLIVAN
1890-1891

3. **WHITNEY MUSEUM OF AMERICAN ART**
MARCEL BREUER
1966

4. **VILLA SAVOYE**
LE CORBUSIER
1928-1931

5. **STOCKHOLM PUBLIC LIBRARY**
ERIK GUNNAR ASPLUND
1920-1928

6. **VANNA VENTURI HOUSE**
ROBERT VENTURI
1962

7. **ENSO-GUTZEIT HEADQUARTERS**
ALVAR AALTO
1959-1962

8. **EXETER LIBRARY**
LOUIS I. KAHN
1967-1972

9. **STUDENT UNION**
ROMALDO GIURGOLA
1974

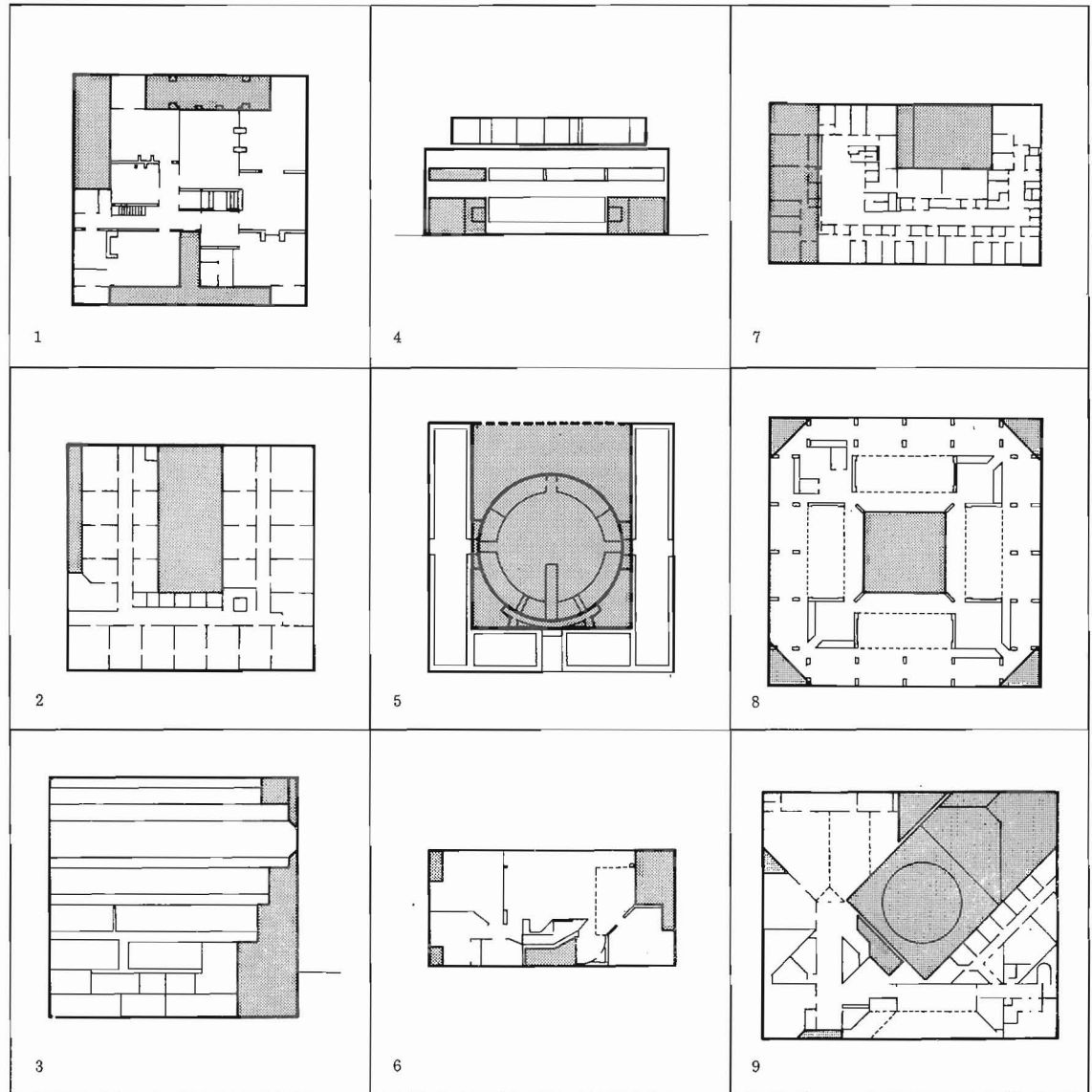

1. LA ROTONDA
ANDREA PALLADIO
1566-1571
2. RICHARDS RESEARCH BUILDING
LOUIS I. KAHN
1959-1961
3. THE SALUTATION
EDWIN LUTYENS
1911

4. LISTER COUNTY COURTHOUSE
ERIK GUNNAR ASPLUND
1917-1921
5. FLOREY BUILDING
JAMES STIRLING
1966
6. SEA RANCH CONDOMINIUM
CHARLES MOORE
1964-1965

7. UNITY TEMPLE
FRANK LLOYD WRIGHT
1906
8. ALLEGHENY COUNTY COURTHOUSE
HENRY HOBSON RICHARDSON
1883-1888
9. ST. GEORGE-IN-THE-EAST
NICHOLAS HAWKSMOOR
1714-1729

10. WOLFSBURG CULTURAL CENTER
ALVAR AALTO
1958-1962
11. SAN MARIA DEGLI ANGELI
FILIPPO BRUNELLESCHI
1434-1436
12. SAN VITALE
ARCHITECT UNKNOWN
c. 530-548

Additive

Additive designs are perceptually parts-dominant. In Villa Rotononda (1), the parts are attached to a major central unit. At Richards Medical Labs (2), a series of aggregations occur; service towers added to individual research labs form a composite unit which is added to other similar parts and to a central service core. In Salutation (3), the servants' quarters are a minor element which is joined to the major form. A major use-space is added into the dominant building form in the Lister Courthouse (4). In the Florey Building (5), a series of segments aggregate to create an exterior space into which the unique common space is added. The units at Sea Ranch (6), each a collection of forms, are assembled under a common roof. Two sets of repetitive, orthogonal units are joined to make the two dominant building parts in Unity Temple (7). In the Allegheny Courthouse (8), the parts form a central open space. Lesser units are assembled around the nave in Saint George-in-the-East (9), and components that are generally consistent with use areas are aggregate to form the Wolfsburg Cultural Center (10). In San Maria (11) and San Vitale (12) a series of lesser spaces ring a major space.

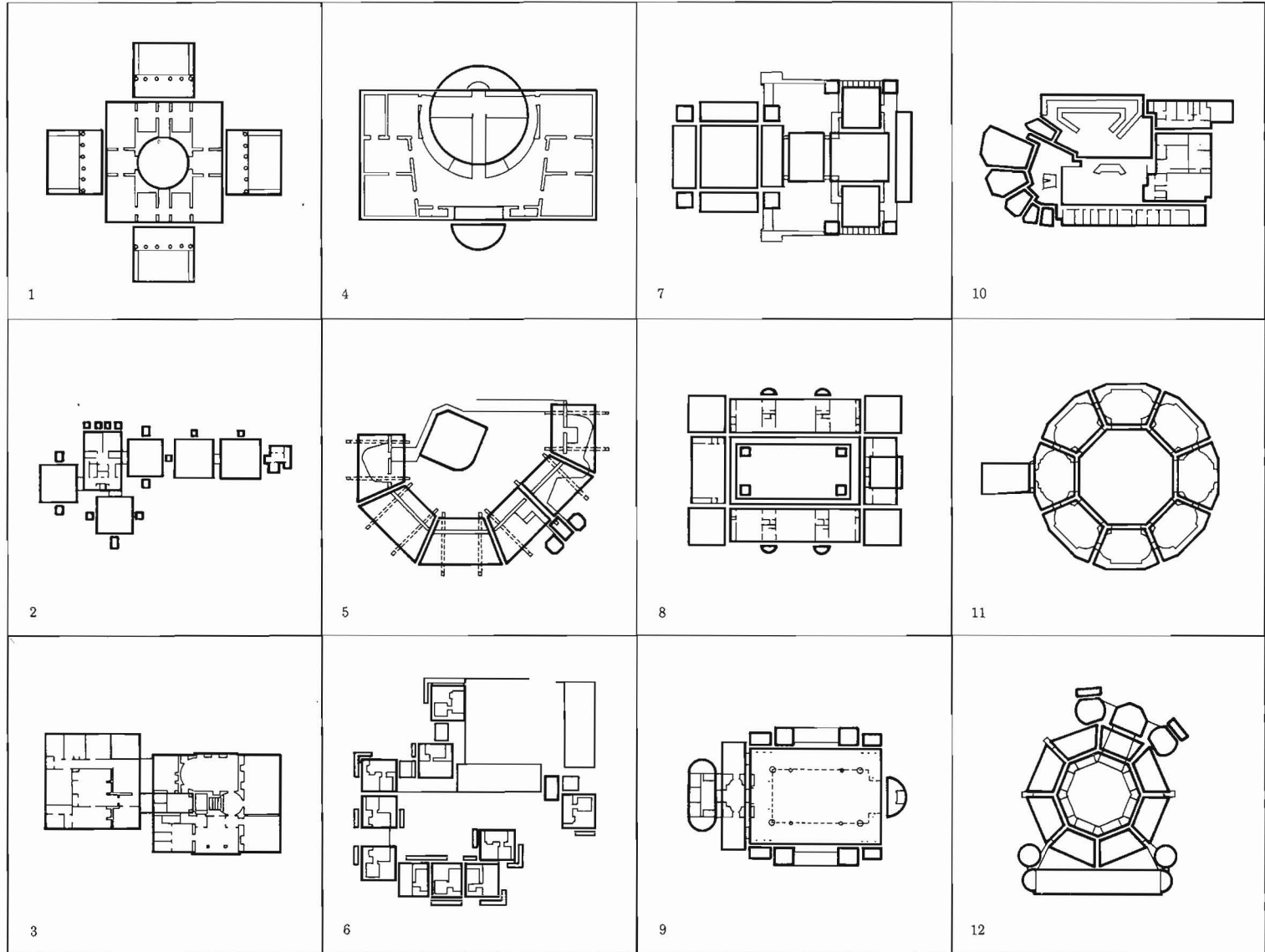

1. SALK INSTITUTE
LOUIS I. KAHN
1959-1965
2. DIRECTOR'S HOUSE
CLAUDE NICHOLAS LEDOUX
1775-1779
3. UNITY TEMPLE
FRANK LLOYD WRIGHT
1906

4. CHRIST CHURCH
NICHOLAS HAWKSMOOR
1715-1729
5. REDENTORE CHURCH
ANDREA PALLADIO
1576-1591
6. SAN SPIRITO
FILIPPO BRUNELLESCHI
1434

7. SAN MARIA DEGLI ANGELI
FILIPPO BRUNELLESCHI
1434-1436
8. LISTER COUNTY COURTHOUSE
ERIK GUNNAR ASPLUND
1917-1921
9. STOCKHOLM PUBLIC LIBRARY
ERIK GUNNAR ASPLUND
1920-1928

SYMMETRY AND BALANCE

Symmetry and balance are formative ideas in which states of perceived and conceived equilibrium are established between components to create built form. Illustrated are examples of axial, biaxial, rotational, and translational symmetry and balance by configuration, geometry, and positive and negative.

line or about a point. At Salk Institute (1), the line of axial symmetry is established through the major exterior space. In the Director's House (2), Unity Temple (3), Christ Church (4), Redentore Church (5), and San Spirito (6), it is through the major use-spaces. In San Maria (7), radial symmetry is changed to axial by the location of two opposite entries. Symmetry occurs through the main interior space in the Lister Courthouse (8) and the Stockholm Library (9). Biaxial symmetry in the Temple of Venus and Rome (10) is through and between the major spaces. In Exeter Library (11), it bisects the dominant space, and in La Rotonda (12) it occurs in the main circulation area. Symmetry by rotation in St. Mark's Tower (13) has four units about a point, while Castle del Monte (14) shows eight, and St. John Nepomuk (15) has five. St. Ivo (16), the Pilgrimage Church (17), and the Sepulchral Church (18) each has three units in symmetry by rotation. Units as rooms and groups of rooms are symmetrically translated into linear configurations at St. Andrews (19) and in a school by Botta (20). Two sets of units are translated in different directions in Utzon's atrium housing (21).

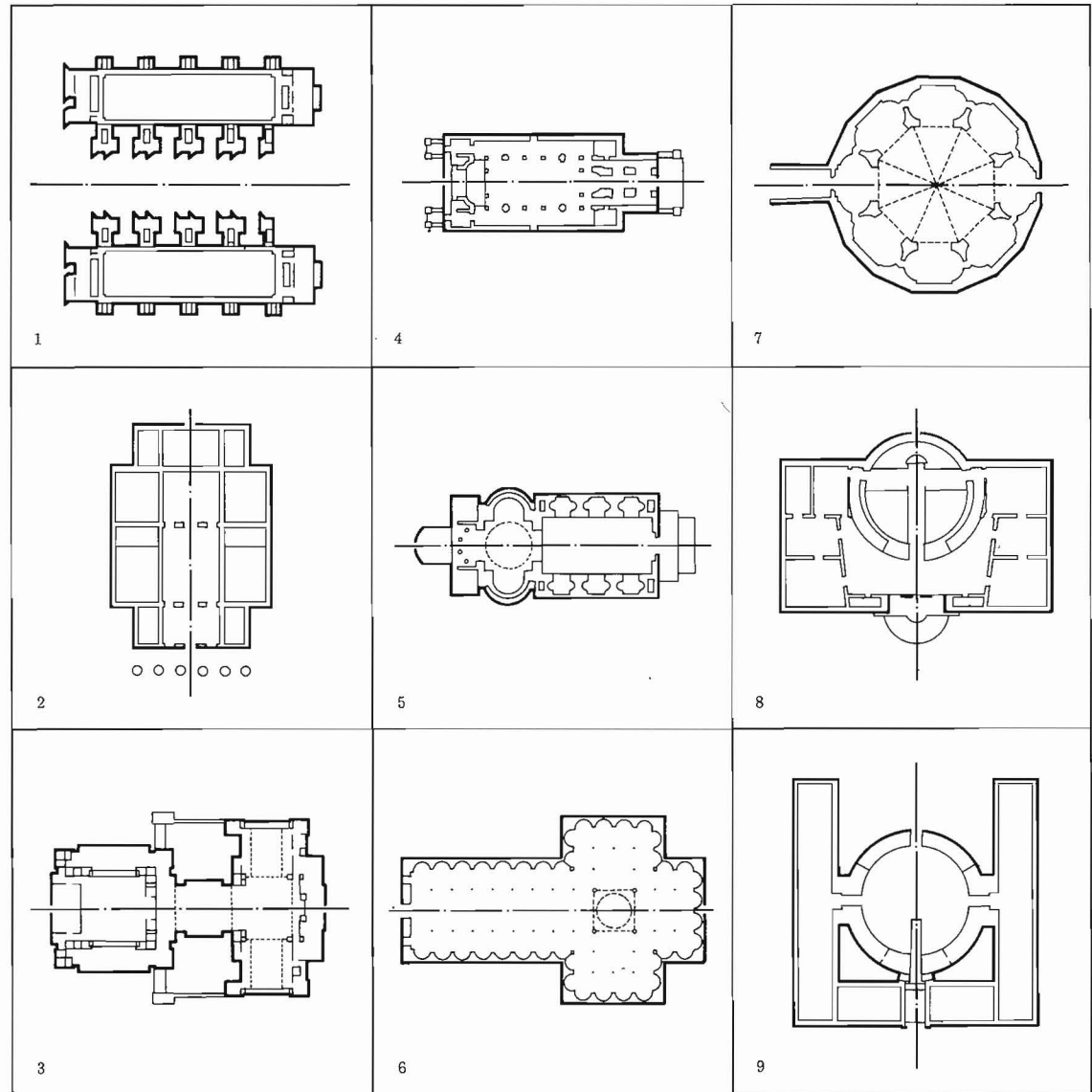

Symmetry

Symmetry, a specialized form of balance, entails the use of equal units on each side of an implied

10. TEMPLE OF VENUS AND ROME
HADRIAN
123-135
11. EXETER LIBRARY
LOUIS I. KAHN
1967-1972
12. LA ROTONDA
ANDREA PALLADIO
1566-1571

13. ST. MARK'S TOWER
FRANK LLOYD WRIGHT
1929
14. CASTLE DEL MONTE
ARCHITECT UNKNOWN
c. 1240
15. ST. JOHN NEPOMUK CHURCH
JAN BLAZEJ SANTINI-AICHEL
1719-1720

16. S. IVO DELLA SAPIENZA
FRENDESCO BORROMINI
1642-1650
17. PILGRIMAGE CHURCH
GEORG DIENIZENHOFER
1684-1689
18. SEPULCHRAL CHURCH
JOHN SOANE
1796

19. ST. ANDREWS DORMITORY
JAMES STIRLING
1964
20. SCHOOL IN MORBIO INFERIORE
MARIO BOTTA
1972-1977
21. ATRIUM HOUSING
JORN UTZON
1956

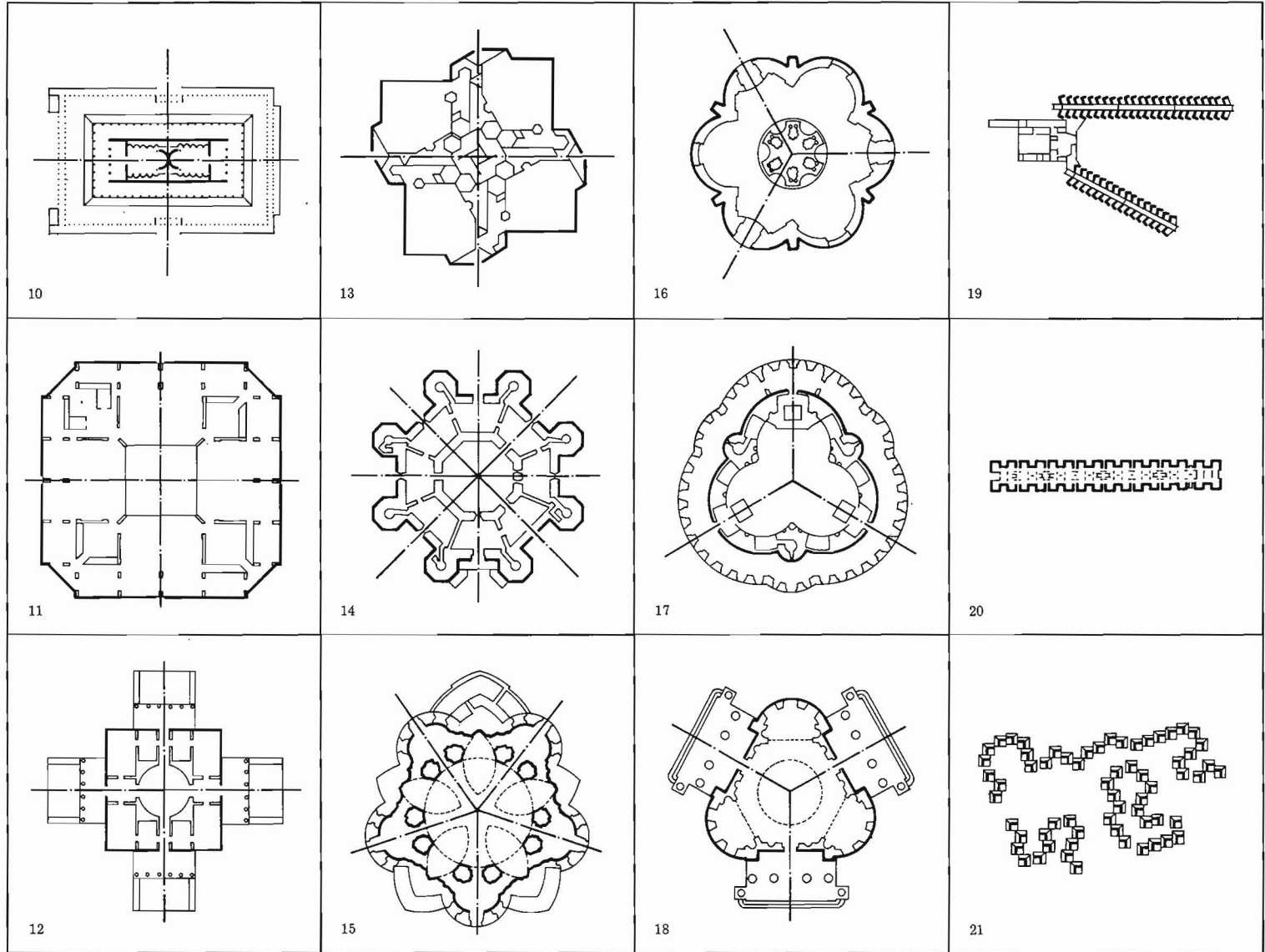

1. OLIVETTI TRAINING SCHOOL
JAMES STIRLING
1969
2. OSPEDALE DEGLI INNOCENTI
FILIPPO BRUNELLESCHI
1421-1445
3. SEA RANCH CONDOMINIUM
CHARLES MOORE
1964-1965

4. UNITY TEMPLE
FRANK LLOYD WRIGHT
1906
5. FREDERICK G. ROBIE HOUSE
FRANK LLOYD WRIGHT
1909
6. J. J. GLESSNER HOUSE
HENRY HOBSON RICHARDSON
1885-1887

7. ADULT LEARNING LABORATORY
ROMALDO GIURGOLA
1972
8. SAN GIORGIO MAGGIORE
ANDREA PALLADIO
1560-1580
9. PETER BRANT HOUSE
ROBERT VENTURI
1973

Balance by Configuration

Balance by configuration occurs when equilibrium between components that are different in form or shape is established. The Olivetti Training Center (1) balances the older existing building. Within it, the long wing equalizes the short wing plus the special space. The Ospedale (2) exemplifies balance of masses; one with a void, the other with an additional unit. In Sea Ranch (3), a diagonal balance line is established with six living units on one side, and four units with two garages on the other. Equal cores are rendered differently by the addition of secondary units, in Unity Temple (4). Public and private separation creates one line of balance in the Robie House (5) and the Glessner House (6). In Giurgola's Research Labs (7), the balance is developed through geometry and mass. San Giorgio (8) is symmetrical in one direction and balanced in the other with simple and complex shapes that reflect the sacred and secular areas. The configuration differences in the Brant House (9) occur at changes of floor plane and mass. At Ronchamp (10) in plan and at the Riola Parish Center (14) in section, single, larger units balance multiple smaller units. Fallingwater (11) is balanced between smaller enclosed and larger open spaces. In one direc-

tion, Lister Courthouse (23) and Dulwich Gallery (13) are symmetrical; in the other, the differences between public areas for Lister, and gallery size for Dulwich define the balance. External symmetry in Hotel Guimard (15) is shifted to balance by location of three major living spaces. Balance in the Florey Building (16) occurs between a form weighted with a pair of towers, and another with a special space. A special space, with a detached form, balances the remainder of the town hall (17), and the tower balances the void of the main space in two directions in the Auditorium Building (18). At Easton Neston (19), the two unique two-story spaces create the difference in configuration. Balance at Homewood (20) occurs at the line of shift between front and back arrangement. The configuration change at Snellman House (21) occurs between servant and main use-spaces in two directions. At Unite d'Habitation (22), the shopping street locates the balance line between the subtracted base and the additive top. At Leicester Engineering (12), the difference is between vertical and horizontal, and in the Venturi House (24), symmetry is shifted to balance by the window pattern.

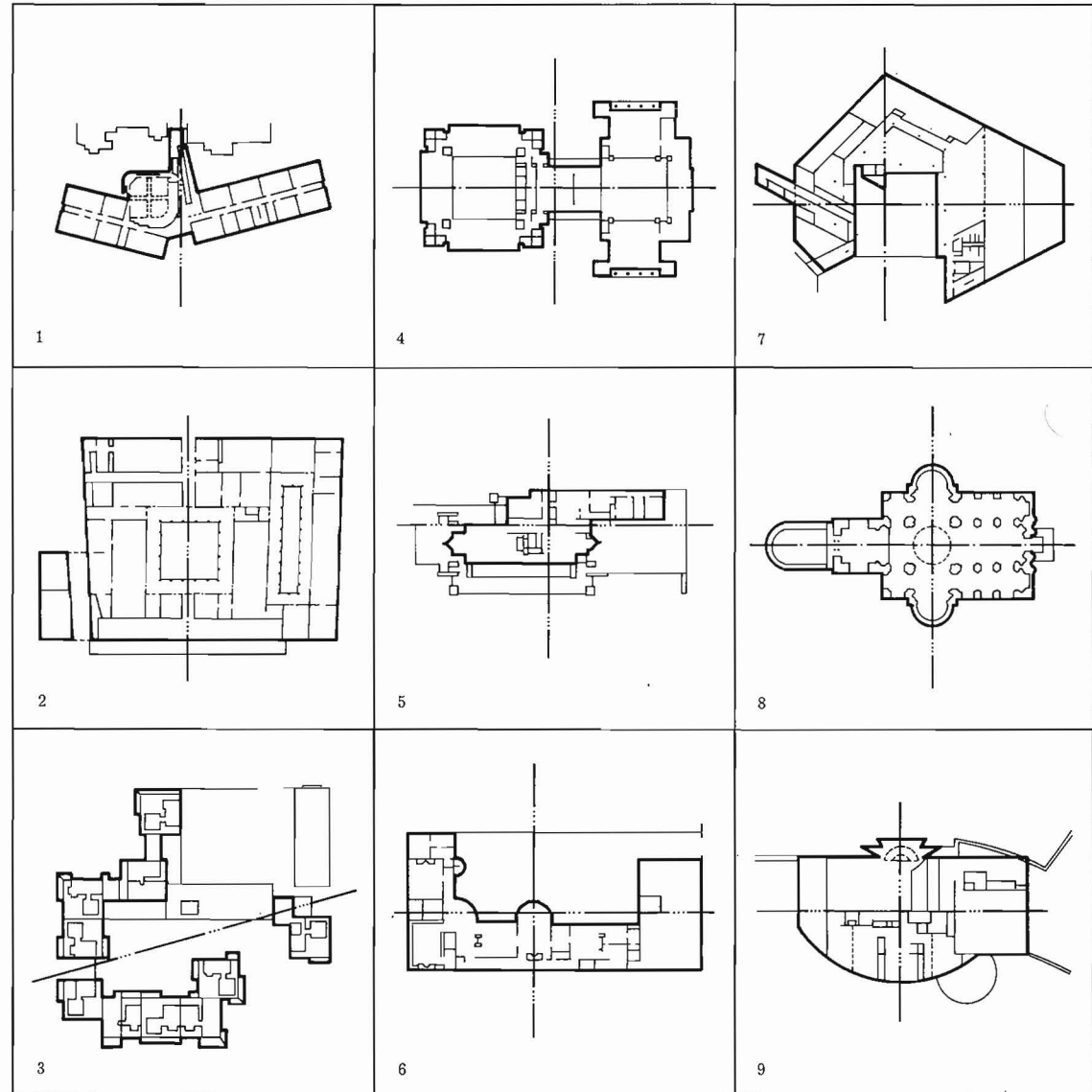

10. CHAPEL AT RONCHAMP

LE CORBUSIER

1950-1955

11. FALLINGWATER

FRANK LLOYD WRIGHT

1935

12. LEICESTER ENGINEERING BUILDING

JAMES STIRLING

1959

13. DULWICH GALLERY

JOHN SOANE

1811-1814

14. RIOLA PARISH CENTER

ALVAR AALTO

1970

15. HOTEL GUIMARD

CLAUDE NICHOLAS LEDOUX

1770

16. FLOREY BUILDING

JAMES STIRLING

1966

17. SAYNATSALO TOWN HALL

ALVAR AALTO

1950-1952

18. AUDITORIUM BUILDING

LOUIS SULLIVAN

1887-1890

19. EASTON NESTON

NICHOLAS HAWKSMOOR

c. 1695-1710

20. HOMEWOOD

EDWIN LUTYENS

1901

21. SNELLMAN HOUSE

ERIK GUNNAR ASPLUND

1917-1918

22. UNITE D'HABITATION

LE CORBUSIER

1946-1952

23. LISTER COUNTY COURTHOUSE

ERIK GUNNAR ASPLUND

1917-1921

24. VANNA VENTURI HOUSE

ROBERT VENTURI

1962

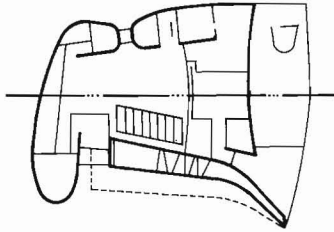

10

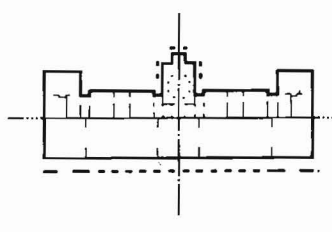

13

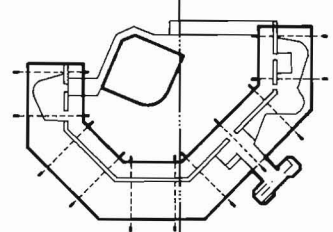

16

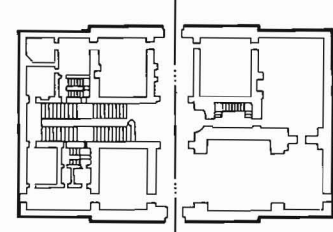

19

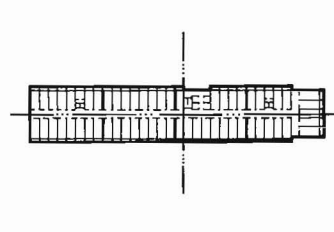

22

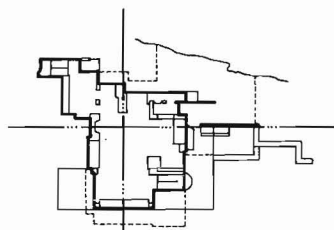

11

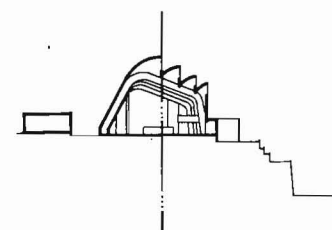

14

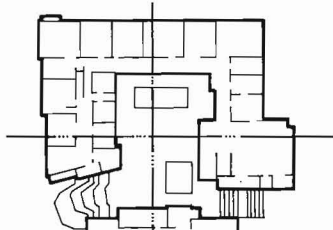

17

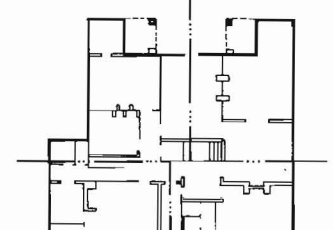

20

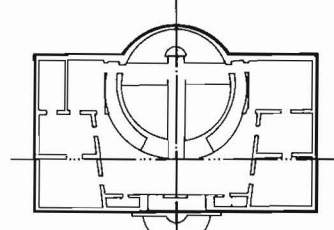

23

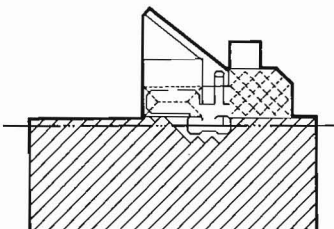

12

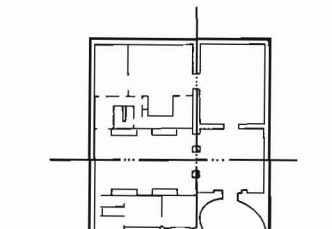

15

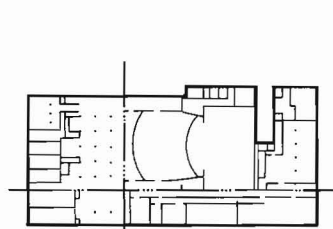

18

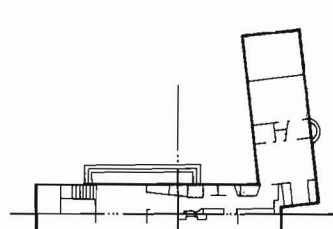

21

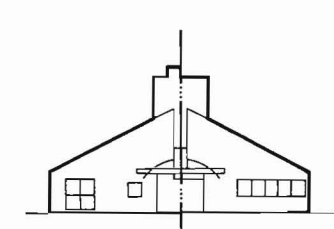

24

1. ST. PAUL'S CHURCH

LOUIS SULLIVAN
1910-1914

2. ANNEX TO OITA MEDICAL HALL

ARATA ISOZAKI
1970-1972

3. PAUL MELLON ARTS CENTER

I. M. PEI
1970-1973

4. OBSERVATORY IN BERLIN

KARL FRIEDRICH SCHINKEL
1835

5. REDENTORE CHURCH

ANDREA PALLADIO
1576-1591

6. SAN MARTA CHURCH

COSTANZO MICHELA
1746

7. VOUKSENNISKA CHURCH, IMATRA

ALVAR AALTO
1950-1952

8. WOLFSBURG CULTURAL CENTER

ALVAR AALTO
1958-1962

9. TREDYFFRIN PUBLIC LIBRARY

ROMALDO GIURGOLA
1976

10. DOMUS AUREA

SEVERUS AND CELER
c. 64

11. S. MARIA DELLA PACE

DONATO BRAMANTE
1478-1483

12. ARCHITECTURAL SETTING

DONATO BRAMANTE
1473

Balance by Geometry

Balance by geometry exists when components with two different form languages occur on opposite sides of a balance line. In St. Paul's (1), a wall separates the orthogonal support spaces from the semicircular worship space. Different simple geometries are balanced in the Oita Medical Hall (2) and the Mellon Center (3). In the Observatory (4) and Redentore Church (5), a single, subdivided form is balanced by a series of additive forms. San Marta (6) exemplifies two manifestations of a circle, while the church in Imatra (7) is an example of two varied form languages that meet at the main aisle to create perceptual tension. Tension also results from varied form languages in Aalto's Wolfsburg Cultural Center (8). At Tredyffrin Library (9), the curved geometry is balanced by the straight lines of the opposite side. Different geometric configurations balance about two perpendicular lines in the Domus Aurea (10). In San Maria della Pace (11), differences in geometry and orientation establish the balance. Bramante's architectural setting (12) exemplifies the essence of the idea of balance by geometry with two complete and different geometric forms.

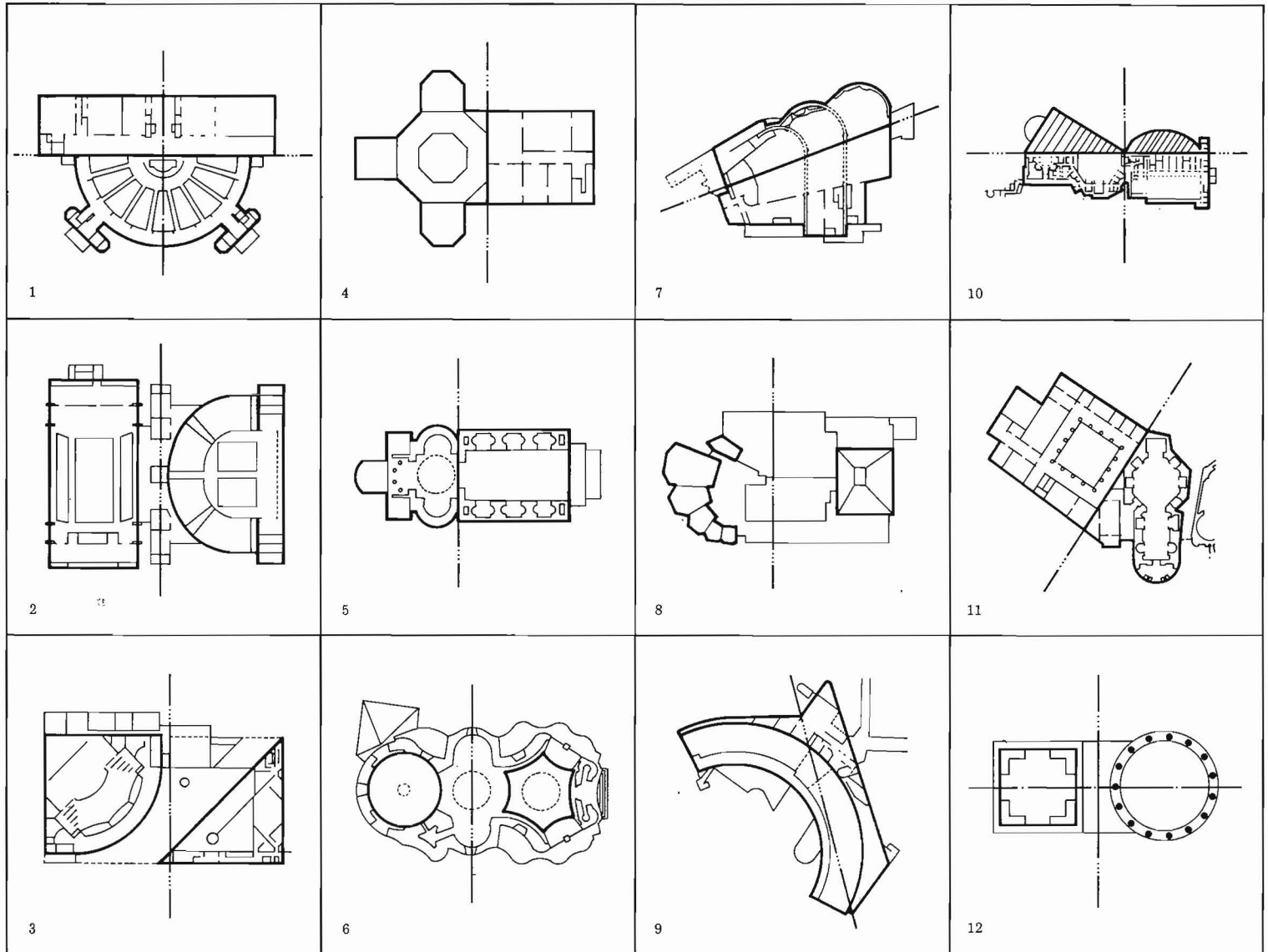

1. SMITH HOUSE
RICHARD MEIER
1965-1967
2. LANG MUSIC BUILDING
ROMALDO GIURGOLA
1973
3. WOLFSBURG CULTURAL CENTER
ALVAR AALTO
1958-1962

4. HANSELMANN HOUSE
MICHAEL GRAVES
1967
5. POWER CENTER
ROCHE-DINKELOO
1965-1971
6. WOODLAND CHAPEL
ERIK GUNNAR ASPLUND
1918-1920

7. CROOKS HOUSE
MICHAEL GRAVES
1976
8. THE FORD FOUNDATION BUILDING
ROCHE-DINKELOO
1963-1968
9. VILLA SAVOYE
LE CORBUSIER
1928-1931

Balance by Positive and Negative

Balance by positive and negative occurs when equivalent components differ only in the manner in which they are made manifest, as solid or void. In the Smith House (1), the closed private area is balanced by the open public area. The two major use-spaces in Lang Music Building (2) are the enclosed auditorium and the open lobby. Balanced by configuration in one direction, the Wolfsburg Cultural Center (3) is balanced in the other direction by the largest special space and the defined court. The building is the positive form, and the entry forecourt its negative manifestation in the Hanselmann House (4), the Woodland Chapel (6), and the Crooks House (7). A similar condition exists at Power Center (5), where the building is the positive, and an adjacent park, the negative. In the Ford Foundation Building (8), the volume of the interior greenhouse is the void, and the office spaces are the positive configuration. Differences between the interior and exterior living spaces establish the positive-negative balance line in Villa Savoye (9).

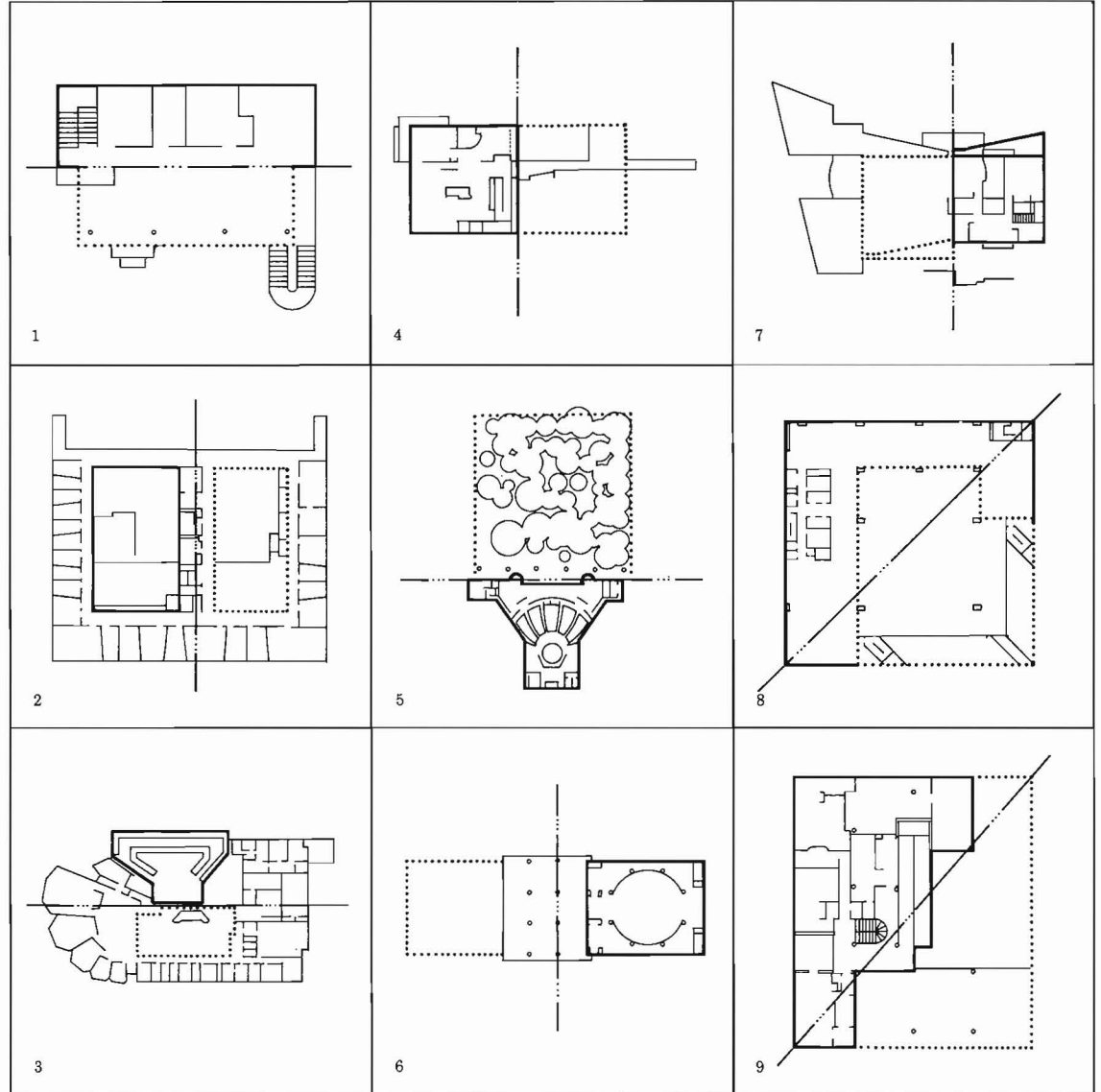

1. MOORE HOUSE
CHARLES MOORE
1962
2. CARLL TUCKER III HOUSE
ROBERT VENTURI
1962
3. RUFER HOUSE
ADOLF LOOS
1922

4. ST. ELIGIO DEGLI OREFICI
RAPHAEL
1509
5. ST. MARY WOOLNETH
NICHOLAS HAWKSMOORE
1716-1724
6. VILLA SAVOYE
LE CORBUSIER
1928-1931

7. RESIDENCE IN RIVA SAN VITALE
MARIO BOTTA
1972-1973
8. BOSTON PUBLIC LIBRARY
McKIM, MEAD, AND WHITE
1898
9. NEW NATIONAL GALLERY
LUDWIG MIES VAN DER ROHE
1968

GEOMETRY

Geometry is a formative idea in which the concepts of plane and solid geometry are used to determine built form. Besides examples of the basic geometries, illustrated are combinations, multiples, derivatives, and manipulations of geometries. Also included are examples of grids.

Basic Geometry

The basic geometric configurations used to determine a building's form include the square as used in the Moore House (1), the Tucker House (2), the Rufer House (3), and the churches of St. Eligio degli Orefici (4), and St. Mary Woolnoth (5). Squares were also used to design the Villa Savoye (6), a private residence in Switzerland (7), the Boston Public Library (8), and the New National Gallery (9) by Mies van der Rohe. The circle appears as the generator for the Tholos (10), the M.I.T. Chapel (11), St. Costanza (13), and the Pantheon in Rome (15). Thomas Jefferson used the circle in designing the Rotunda at the University of Virginia (14). Konstantin Melnikov used two circles in the design of his house (12), and the basic shape of the triangle in the Rusakov Club (16). Triangles also determined the Arena Building (17) and the Church and Parish Center in Hyvinkaa, Finland (18). The hexagon was used in designing the North Christian Church (19), a desert Synagogue (20), and Pfeiffer Chapel (21). Finally, the Baptistry at Ravenna (22), Popular Forest (23), and San Maria delgi Angeli (24) are developed from the octagon.

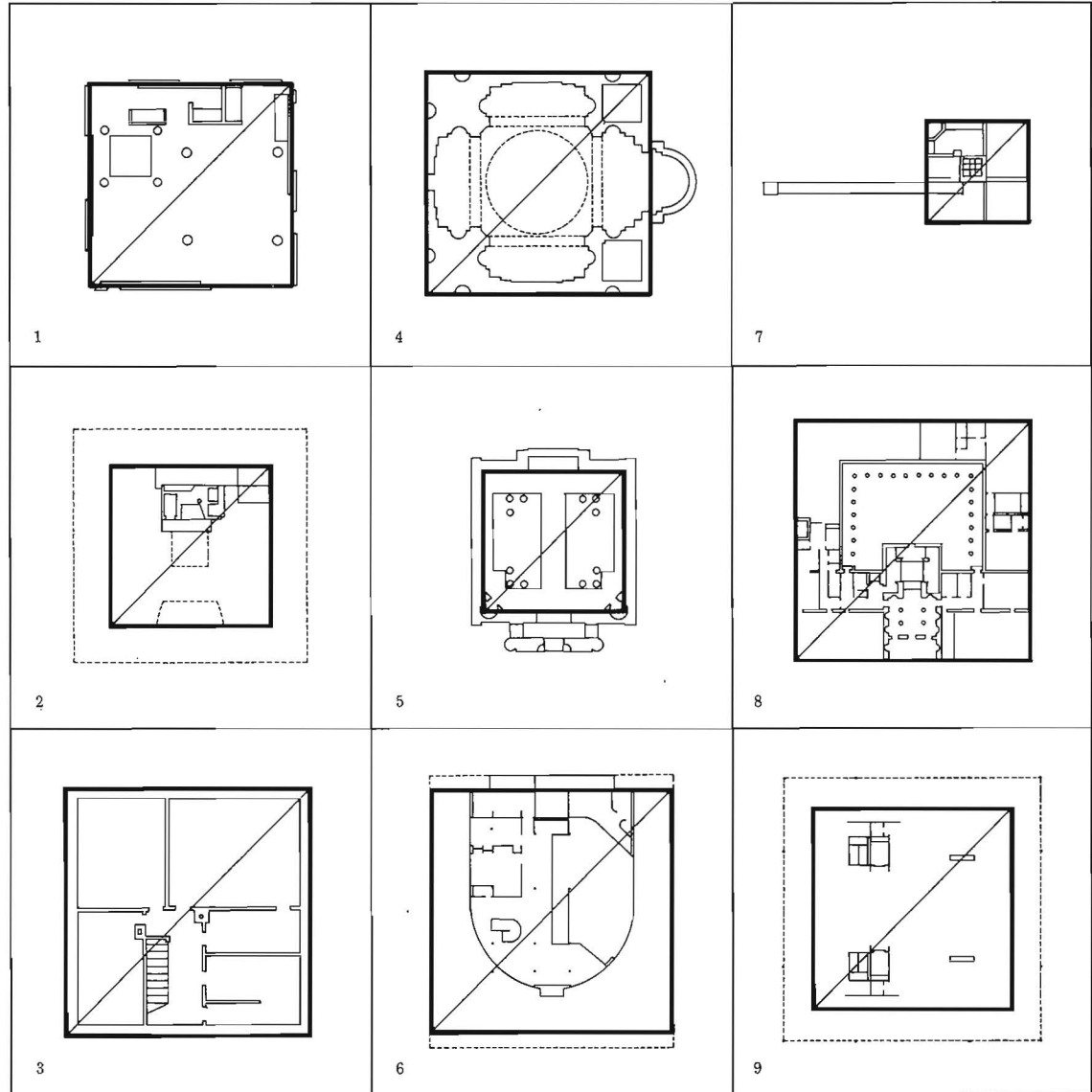

10. **THOLOS**
POLYKLETOS THE YOUNGER
c. 365 B.C.
11. **KRESGE CHAPEL**
EERO SAARINEN
1955
12. **MELNIKOV HOUSE**
KONSTANTIN MELNIKOV
1927

13. **ST. COSTANZA**
ARCHITECT UNKNOWN
c. 350
14. **UNIVERSITY OF VIRGINIA ROTUNDA**
THOMAS JEFFERSON
1826
15. **PANTHEON**
ARCHITECT UNKNOWN
c. 100

16. **RUSAKOV CLUB**
KONSTANTIN MELNIKOV
1927
17. **ARENA BUILDING**
LARS SONCK
1923
18. **CHURCH AND CENTER IN HYVINKAA**
AARNO RUUSUVUORI
1959-1961

19. **NORTH CHRISTIAN CHURCH**
EERO SAARINEN
1959-1963
20. **NEGEV SYNAGOGUE**
SVI HECKER
1967-1969
21. **PFEIFFER CHAPEL**
FRANK LLOYD WRIGHT
1938

22. **BAPTISTRY OF THE ORTHODOX**
ARCHITECT UNKNOWN
c. 425
23. **POPLAR FOREST**
THOMAS JEFFERSON
c. 1806
24. **SAN MARIA DEGLI ANGELI**
FILIPPO BRUNELLESCHI
1434

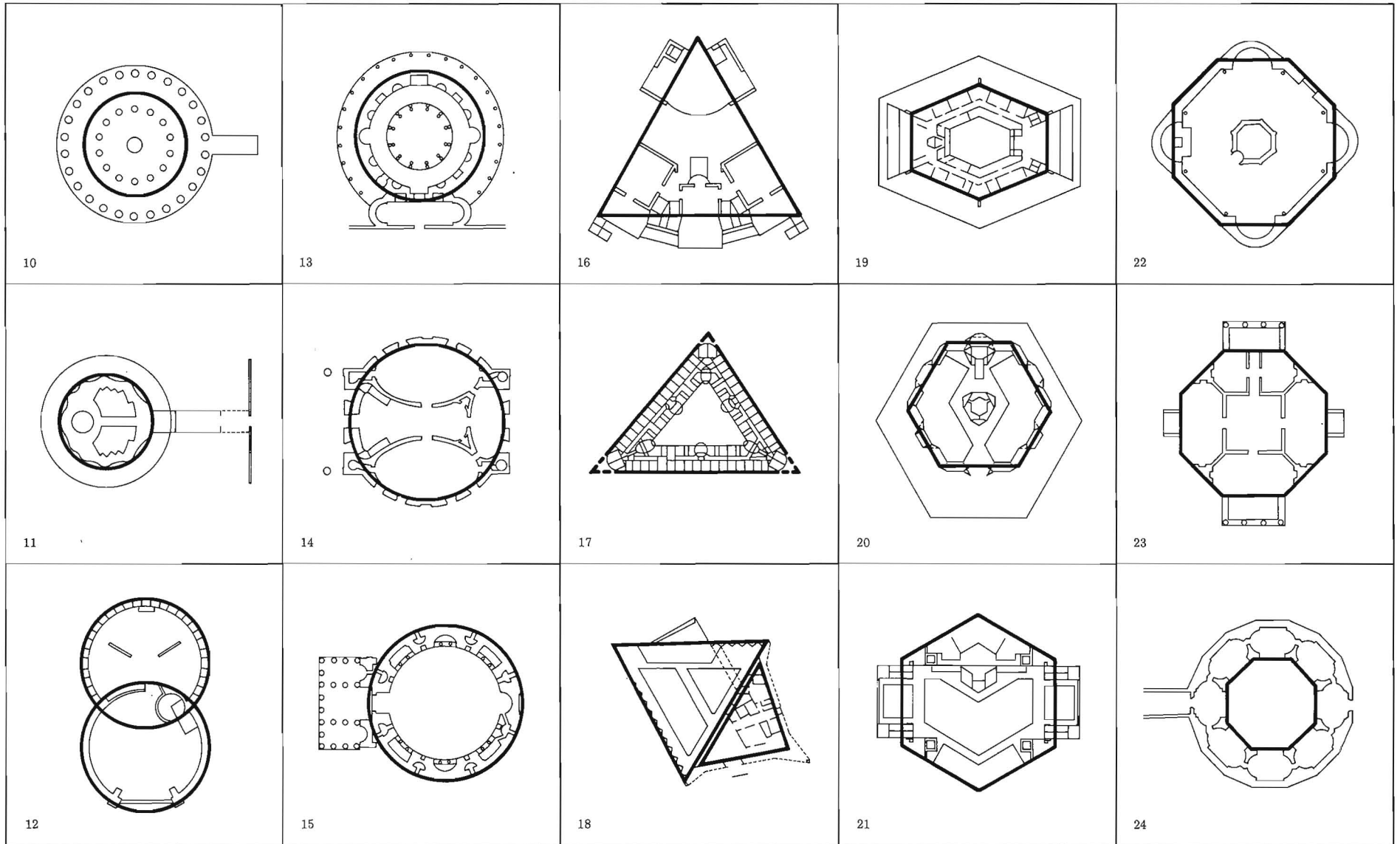

Circle and Square

The most direct combination of circle and square, where both forms are whole or easily implied, and share a common center, occurs at Villa Rotunda (1), the Old Sacristy (2), the Tempietto (3), and University Hall (4). Woodland Chapel (6) contains whole figures, while Stockholm Library (5) consists of a strongly implied square and a complete circle. The circle is a court in the Palace of Charles V (7), a cone in the Tomb of Metella (8), and an interior elevation opening in Exeter Library (9). The square is embodied in a larger form in St. Peter's (10) and the Customhouse (11), and is adjacent to a circle in St. Mary's Cathedral (12). In the Museum of Art (13),

Stirling uses two circle and square forms. The square contains the circle in the Arnheim Pavilion (14) and the Palace of Assembly (15). In Knights of Columbus (16), four circles are added to the corners of a square, while at Montmorency (17) a square contains a circle and its transformation. The Olympic Arena (18) and the Tomb at Tarquinia (19) exemplify circles containing squares. Aalto's Studio (20) is derived from a shifted circle in a square, and Sforza Chapel (21) is an elaboration of a circle holding a square. The Cathedral (22), Tucker House (23), and Venturi House (24), are examples of the combination of circle, square, and triangle.

- | | | |
|---|--|---|
| <p>1. LA ROTONDA
ANDREA PALLADIO
1566-1571</p> <p>2. OLD SACRISTY
FILIPPO BRUNELLESCHI
1421-1440</p> <p>3. TEMPIETTO OF SAN PIETRO
DONATO BRAMANTE
1502</p> | <p>4. JOHNS HOPKINS UNIVERSITY HALL
JOHN RUSSELL POPE
c. 1930</p> <p>5. STOCKHOLM PUBLIC LIBRARY
ERIK GUNNAR ASPLUND
1920-1928</p> <p>6. WOODLAND CHAPEL
ERIK GUNNAR ASPLUND
1918-1920</p> | <p>7. PALACE OF CHARLES V
PEDRO MACHUCA
1527</p> <p>8. TOMB OF CAECILIA METELLA
ARCHITECT UNKNOWN
c. 25 B.C.</p> <p>9. EXETER LIBRARY
LOUIS I. KAHN
1967-1972</p> |
|---|--|---|

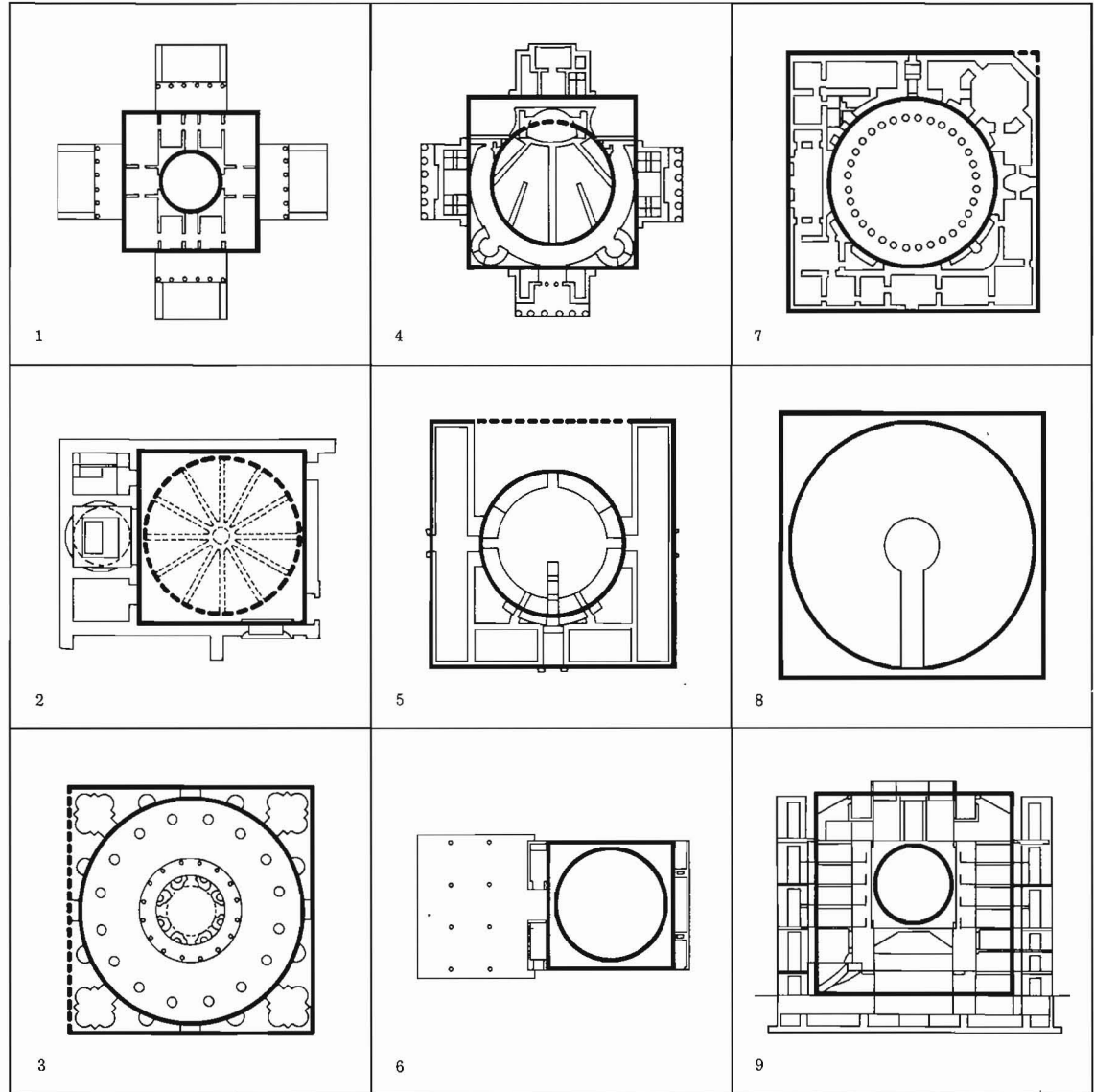

- | | | | | |
|---|---|---|---|--|
| 10. ST. PETER'S
MICHELANGELO
1506-1626 | 13. DUSSELDORF MUSEUM OF ART
JAMES STIRLING
1980 | 16. KNIGHTS OF COLUMBUS BUILDING
ROCHE-DINKELOO
1965-1969 | 19. TOMB AT TARQUINIA
ARCHITECT UNKNOWN
c. 600 B.C. | 22. CATHEDRAL
EDWARD LARABEE BARNES
1977 |
| 11. UNITED STATES CUSTOMSHOUSE
TOWN AND DAVIS
1833-1842 | 14. PAVILION IN ARNHEIM
ALDO VAN EYCK
1966 | 17. HOTEL DE MONTMORENCY
CLAUDE NICHOLAS LEDOUX
1769 | 20. AALTO STUDIO HOUSE
ALVAR AALTO
1955 | 23. CARLL TUCKER III HOUSE
ROBERT VENTURI
1975 |
| 12. ST. MARY'S CATHEDRAL
BENJAMIN HENRY LATROBE
1814-1818 | 15. THE PALACE OF ASSEMBLY
LE CORBUSIER
1953-1963 | 18. OLYMPIC ARENA
KENZO TANGE
1961-1964 | 21. SFORZA CHAPEL
MICHELANGELO
c. 1558 | 24. VANNA VENTURI HOUSE
ROBERT VENTURI
1962 |

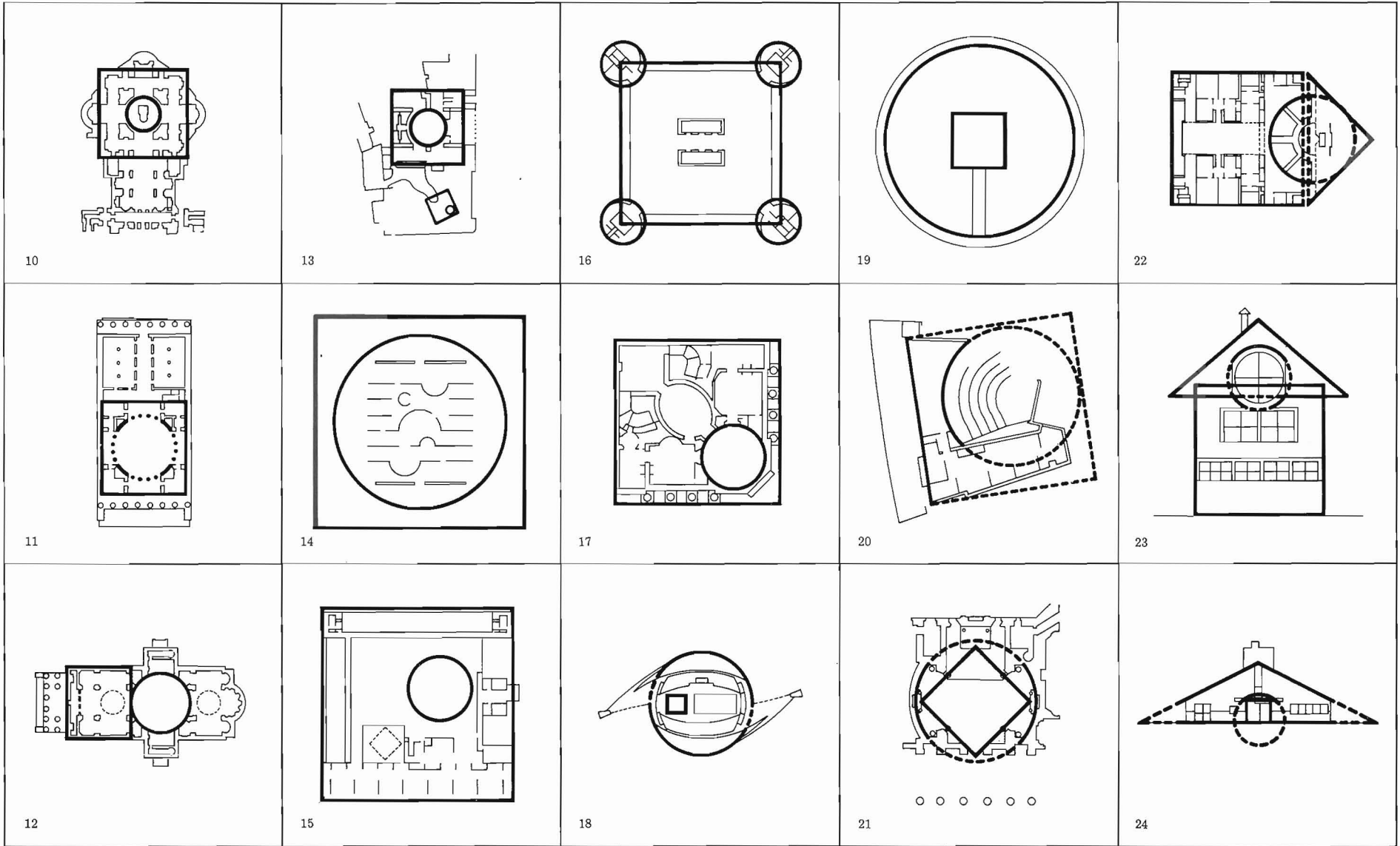

1. LISTER COUNTY COURTHOUSE
ERIK GUNNAR ASPLUND
1917-1921
2. GREEN PARK RANGER'S HOUSE
ROBERT ADAMS
1768
3. CASINO IN ROME
WILLIAM CHAMBERS
1754

4. THERMAE OF CARACALLA
ARCHITECT UNKNOWN
212-216
5. JAMES SWAN HOUSE
CHARLES BULFINCH
1796
6. RESIDENCE IN MASSAGNO
MARIO BOTTA
1979

7. CASTLEGAR
RICHARD MORRISON
1807
8. TENDERING HALL
JOHN SOANE
1784-1790
9. AUSTIN HALL
HENRY HOBSON RICHARDSON
1881-1884

10. F. L. HIGGINSON HOUSE
HENRY HOBSON RICHARDSON
1881-1883
11. TATESHINA PLANETARIUM
KISHO KUROKAWA
1976
12. WHEELS OF HEAVEN CHURCH
ALDO VAN EYCK
1966

Rectangle Overlapped by Circle

A specific geometric combination is a rectangle overlapped by a smaller circle. The Lister Courthouse (1), the Ranger Lodge (2), the Casino (3), the Thermae (4), and the Swan House (5) exemplify the circle as a major use-space half engaged on the centerline of the long side of a rectangle. The residence by Botta (6) has the same configuration with the circle, a stair, reduced in scale. In Castlegar (7), the rectangle is overlapped by an ellipse at the centerline, and in Tendering Hall (8), a circle and an ellipse overlap the rectangle. In Austin Hall (9), two rectangles are intersected by two circles with a third circle that overlaps at the entry. Richardson's Higginson House (10) has circles on opposite corners implying the diagonal, while in the Planetarium (11), two circles occur on the same side. Double major and minor circles overlap the rectangle in the Wheels of Heaven Church (12). In the castles, Rait (13) and Pitfichie (14), the circle overlaps the corner in two directions, and in Chateau de Chambord (15) multiple corners are overlapped by the circles.

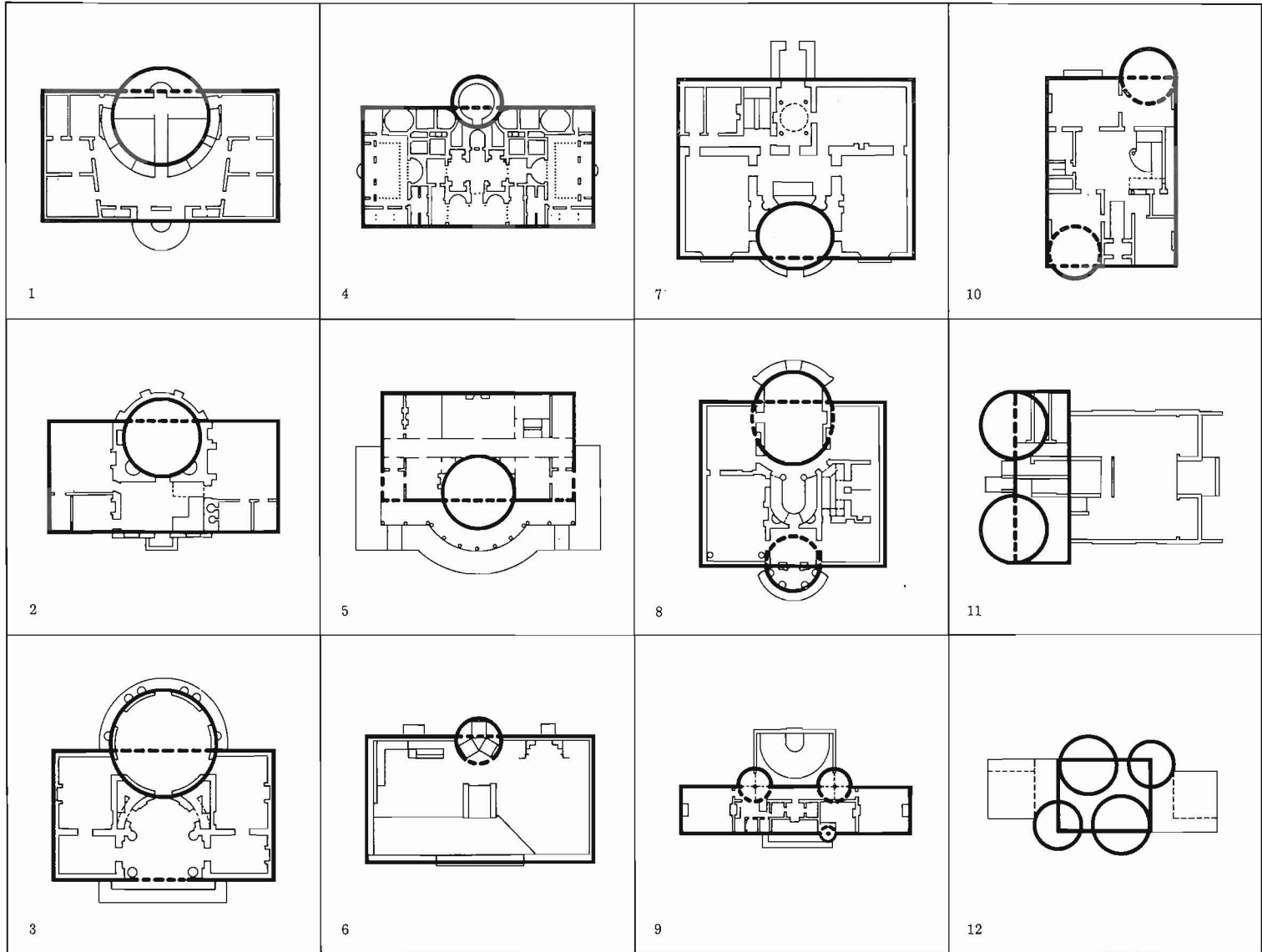

- 13. **RAIT CASTLE**
ARCHITECT UNKNOWN
c. 1300
- 14. **PITFICHIE CASTLE**
ARCHITECT UNKNOWN
c. 1550
- 15. **CHATEAU DE CHAMBORD**
DOMENICA DA CORTONA
1519-1547

- 1. **SEVER HALL**
HENRY HOBSON RICHARDSON
1878-1880
- 2. **CHRIST CHURCH**
NICHOLAS HAWKSMOOR
1715-1729
- 3. **VANNA VENTURI HOUSE**
ROBERT VENTURI
1962
- 4. **PETER BRANT HOUSE**
ROBERT VENTURI
1973
- 5. **EASTON NESTON**
NICHOLAS HAWKSMOOR
c. 1695-1710
- 6. **ALLEGHENY COUNTY COURTHOUSE**
HENRY HOBSON RICHARDSON
1883-1888

- 7. **VILLA TRISSINO**
ANDREA PALLADIO
1576
- 8. **DRAYTON HALL**
ARCHITECT UNKNOWN
1738-1742
- 9. **FARNESE PALACE**
ANTONIO DA SANGALLO
1534

Two Squares

Two adjacent squares directly determine the limits of the plans of Sever Hall (1), Christ Church (2), and the Venturi House (3). In the Brant House (4), two adjacent squares have a common side that is the radius of the major circular form in plan, and the same two squares set the limits of the total plan configuration. Two squares can overlap to create a special condition of the common area. In Easton Neston (5), the shared part of the two squares denotes the central hall, and in the Allegheny Courthouse (6), the overlap locates the towers. Villa Trissino (7), by Palladio, and Drayton Hall (8) exemplify two overlapping squares which define a major central use-space and entry. In the Farnese Palace (9), two adjacent squares set the limits of the major elevation.

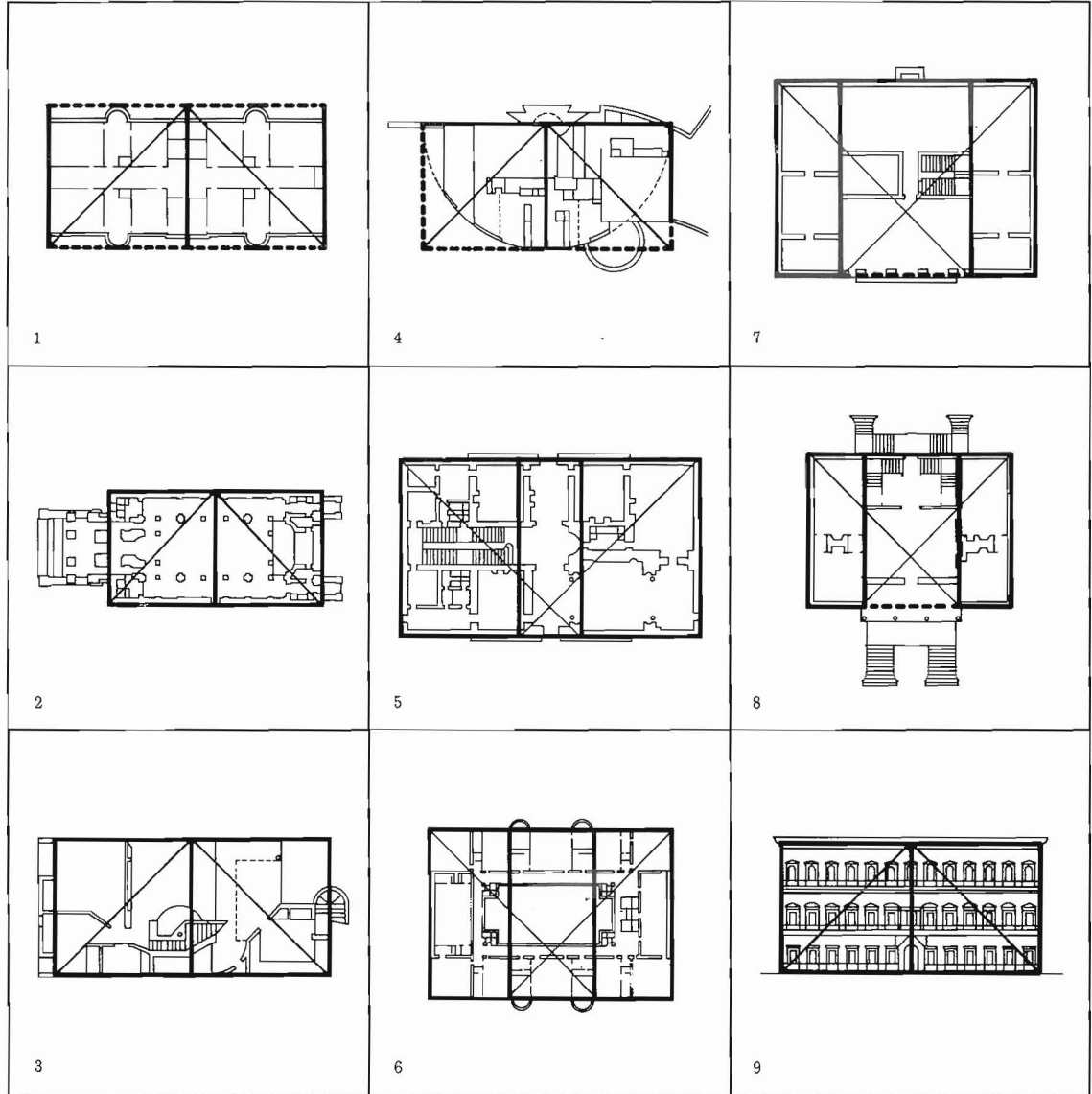
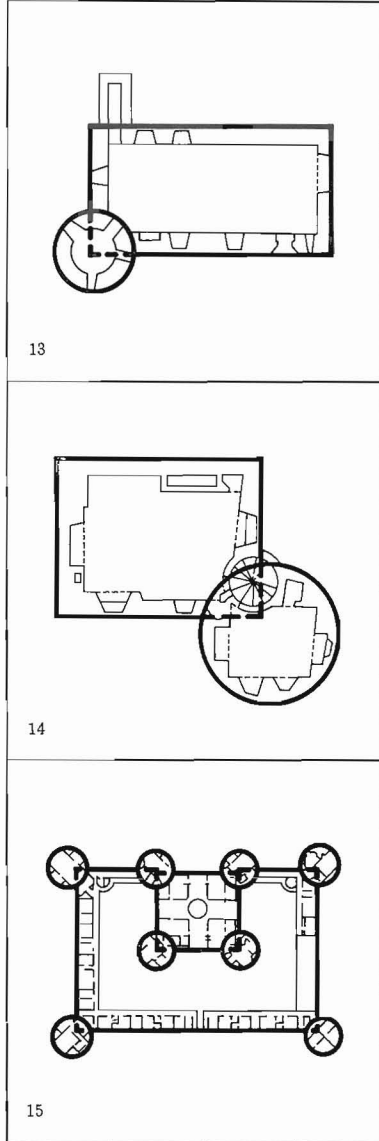

1. LA ROTONDA
ANDREA PALLADIO
1566-1571
2. CHISWICK HOUSE
LORD BURLINGTON
1729
3. YORK HOUSE
WILLIAM CHAMBERS
1759

4. ST. LOUIS DES INVALIDES
JULES HARDOUIN MANSART
1676
5. SAN MARIA DI CARIGNANO
GALEAZZO ALESSI
1552
6. HAGIA SOPHIA
ANTEMIUS OF TRALLES
532

7. HOTEL DE MONTMORENCY
CLAUDE NICHOLAS LEDOUX
1769
8. SAN FRUTUOSO DE MONTELIOS
ARCHITECT UNKNOWN
665
9. THE CAPITOL AT WILLIAMSBURG
ARCHITECT UNKNOWN
1701

10. UNITED STATES SUPREME COURT
CASS GILBERT
1935
11. WEEKEND HOUSE
LE CORBUSIER
1935
12. EXETER LIBRARY
LOUIS I. KAHN
1967-1972

Nine-Square

Nine-square is a classic geometric form created by joining three sets of three adjacent squares each to form a larger square. It is the three cell by three cell arrangement that is most commonly referred to as a nine-square configuration, even though the shape of the cells may be other than squares. Villa Rotonda (1), Chiswick House (2), York House (3), St. Louis des Invalides (4), and San Maria di Carignano (5) are examples of this classic configuration. Hagia Sophia (6) and Hotel de Montmorency (7) demonstrate nine-square arrangements of rectangles. By combining select cells within the nine cell array, specific patterns can be created. San Frutuoso (8) is an example of the cross variation with the corners implied. Flanking the center cell with two rows of three cells creates the 'H' configuration, as in the Capitol at Williamsburg (9). An 'X' configuration is suggested in the Supreme Court Building (10), by the pattern of the major articulated courts and the center cell. The three, two, one stepped configuration is exhibited in Le Corbusier's Weekend House (11), and the square ring with the center void is seen in the Exeter Library (12).

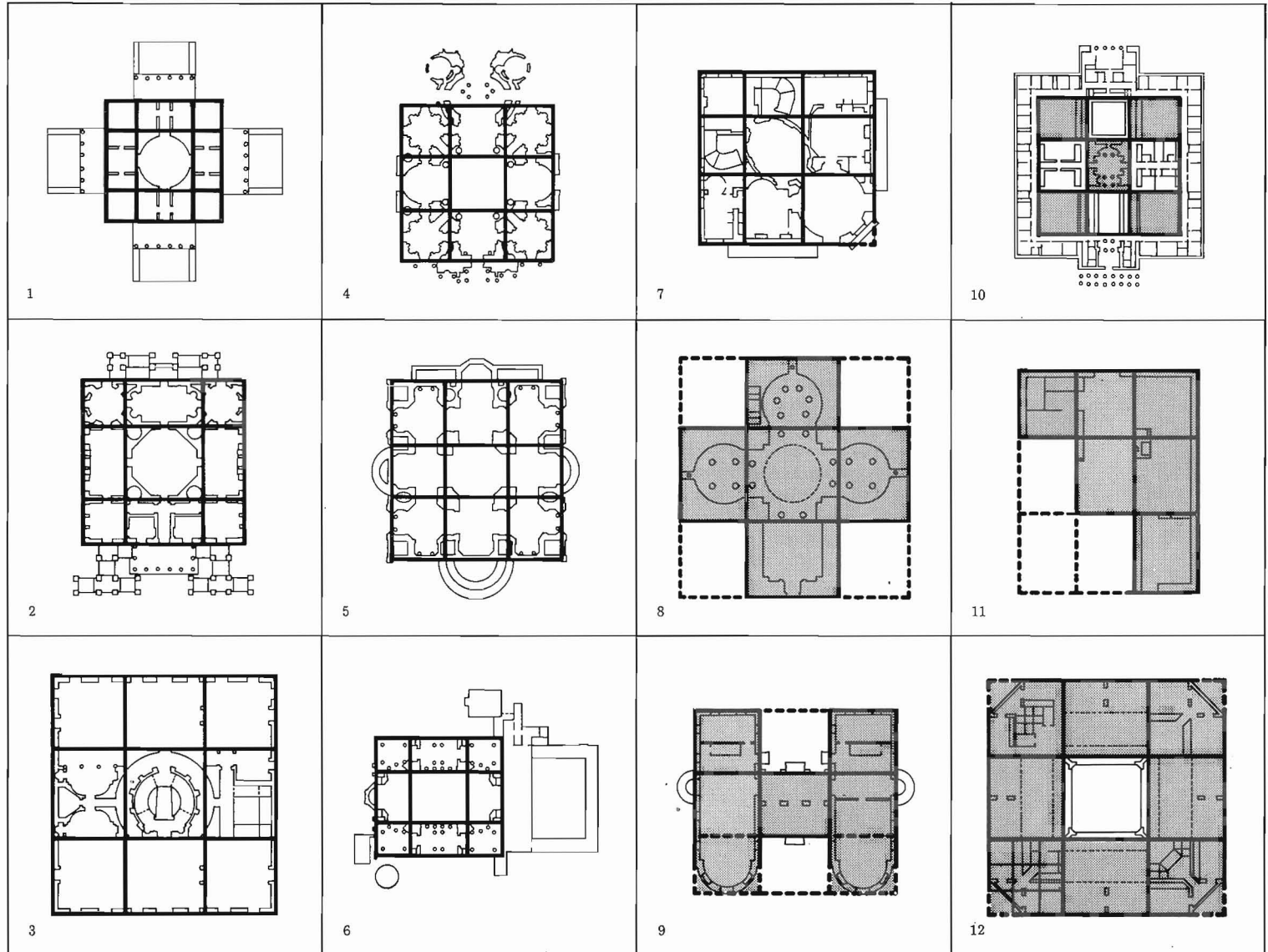

1. THEATER IN BESANCON FRANCE
CLAUDE NICHOLAS LEDOUX
1775
2. ST. GEORGE-IN-THE-EAST
NICHOLAS HAWKSMOOR
1714-1729
3. ADULT LEARNING LABORATORY
ROMALDO GIURGOLA
1972

4. VILLA SAVOYE
LE CORBUSIER
1928-1931
5. MUSEUM OF DECORATIVE ARTS
RICHARD MEIER
1981
6. TRUBEK HOUSE
ROBERT VENTURI
1972

7. ELIA-BASH HOUSE
GWATHMEY-SIEGEL
1971-1973
8. VILLA MAIREA
ALVAR AALTO
1937-1939
9. VIKING FORTRESS
ARCHITECT UNKNOWN
c. 1000

10. YALE CENTER FOR BRITISH ART
LOUIS I. KAHN
1969-1974
11. SALK INSTITUTE
LOUIS I. KAHN
1959-1965
12. HOMEWOOD
EDWIN LUTYENS
1901

Four-Square

A four-square is a geometric configuration that is two cells by two cells and has a common central point of contact. The most direct example is the Viking Fortress (9). Ledoux's theater (1) and Villa Savoye (4) have overall plans, and St. George-in-the-East (2) has an internal spatial organization developed from this construct. Four-squares are used in combination at Giurgola's Research Lab (3) and at the Frankfurt Museum (5) where the existing building becomes one quadrant of a four-square, which in turn becomes one quadrant of a larger four-square. It is not necessary to articulate the four cells equally, for instance, at the Trubek House (6) there are two sets of different sized cells. The Elia-Bash House (7) contains implied quadrants about a defined center, and Villa Mairea (8) has three cells as built form, with the fourth being a garden. In Kahn's British Art Center (10), the nine-square and four-square configurations are combined with the overall plan developed from overlapping nine-squares, each cell of which is subdivided into a four-square; while at the Salk Institute (11) the inverse occurs. In Homewood (12), a nine-square shares two edges with a four-square in a nested configuration.

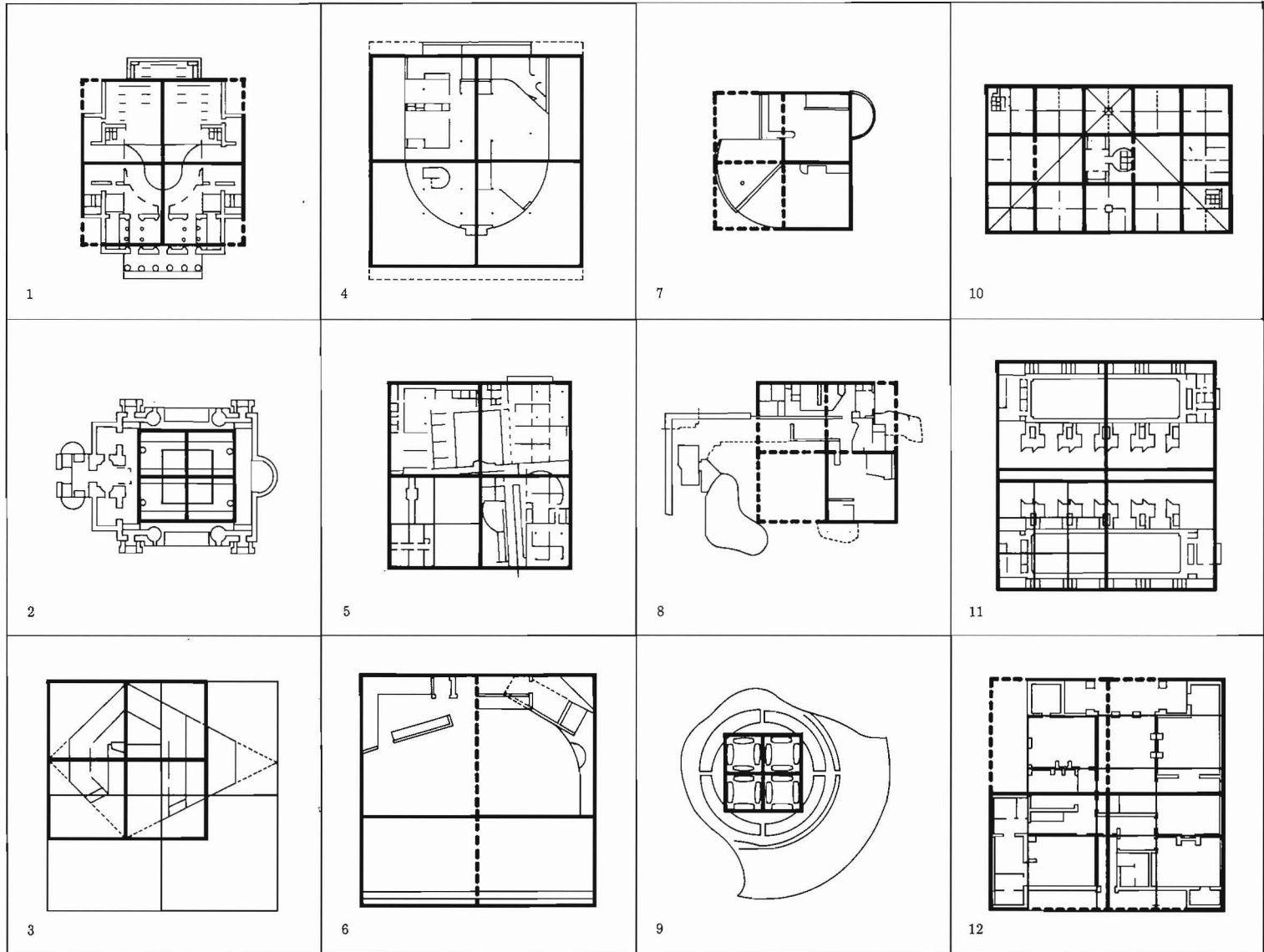

1. SHAMBERG RESIDENCE
RICHARD MEIER
1972-1974
2. OLD SACRISTY
FILIPPO BRUNELLESCHI
1421-1440
3. LANG MUSIC BUILDING
ROMALDO GIURGOLA
1973

4. ST. JAMES
CHRISTOPHER WREN
1674-1687
5. LISTER COUNTY COURTHOUSE
ERIK GUNNAR ASPLUND
1917-1921
6. NASHDOM
EDWIN LUTYENS
1905-1909

7. ALTES MUSEUM
KARL FRIEDRICH SCHINKEL
1823-1830
8. SAN MIGUEL
ARCHITECT UNKNOWN
913
9. COUNCIL CHAMBER OF MILETOS
ARCHITECT UNKNOWN
170 B.C.

10. VILLA STEIN
LE CORBUSIER
1927
11. CONVENT OF LA TOURETTE
LE CORBUSIER
1957-1960
12. IL TEATRO DEL MONDO
ALDO ROSSI
1979

1.4 and 1.6 Rectangles

The 1.4 rectangle is created by rotating the diagonal of a square 45 degrees to determine the length of the long side. This configuration sets the overall plan or internal spatial limits for the Shamberg House (1), the Old Sacristy (2), the Lang Music Center (3), and St. James Church (4). A square with both diagonals rotated creates a configuration which determines the plans for Lister County Courthouse (5) and Nashdom (6). The 1.6 rectangle, created by rotating the diagonal of one-half a square, sets the overall plan of Schinkel's museum (7), San Miguel (8), and the Council Chamber (9). With appendages excluded, Villa Stein (10) is developed within a 1.6 rectangle, and Le Corbusier also uses the 1.6 figure to set the limits of the court at La Tourette (11). The theater in Venice (12) has two concentric squares in plan with a 1 : 1.4 ratio relationship to each other. The larger square determines the overall form, less the stairs; the smaller square is the limit of the seating.

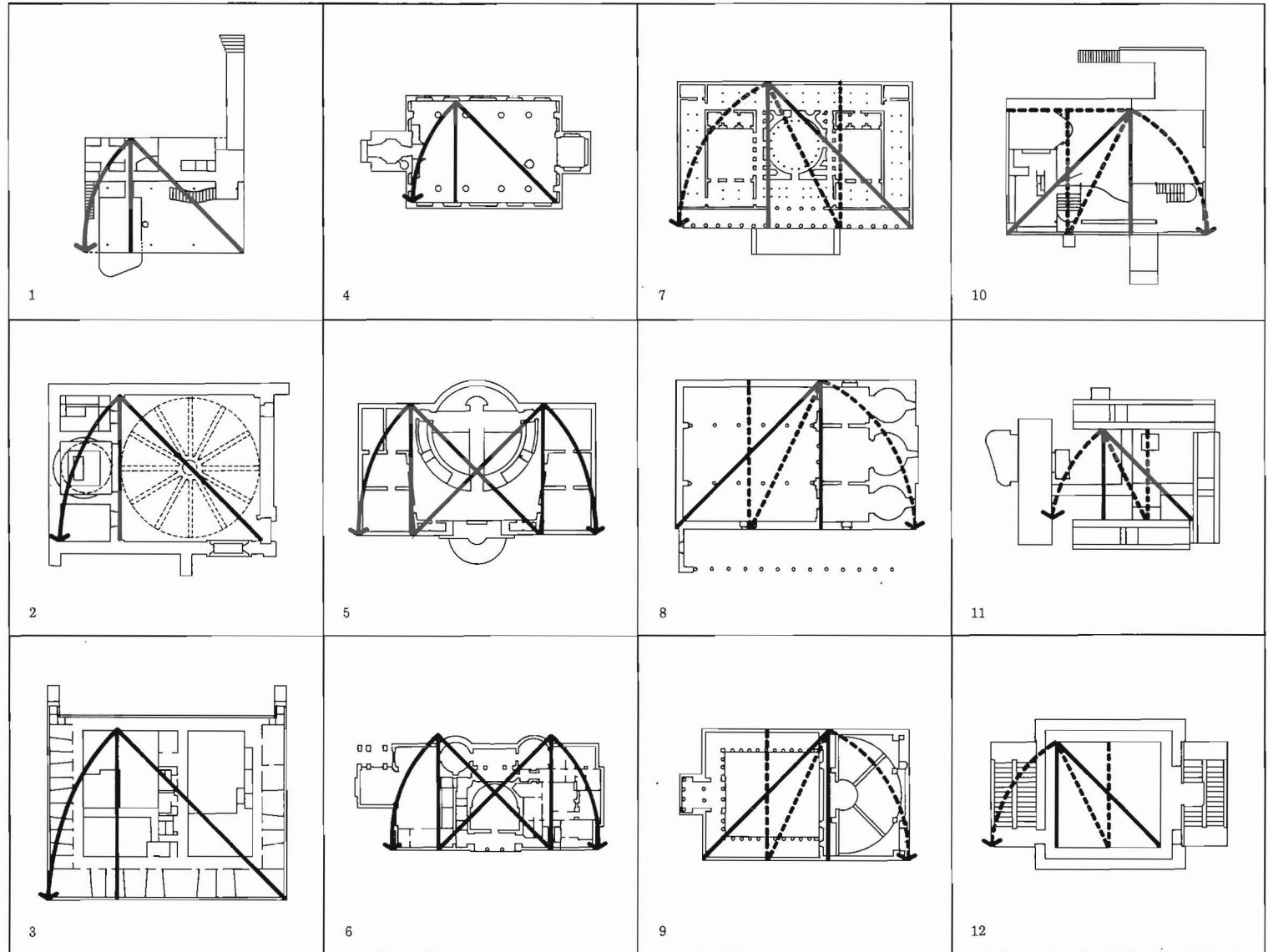

1. SNELLMAN HOUSE
ERIK GUNNAR ASPLUND
1917-1918
2. HOTEL GUIMARD
CLAUDE NICHOLAS LEDOUX
1770
3. ONE-HALF HOUSE
JOHN HEJDUK
1966

4. NEW LUTHERAN CHURCH
ADRIEN DORTSMAN
1668
5. HERBERT JACOBS HOUSE
FRANK LLOYD WRIGHT
1948
6. WIES PILGRIMAGE CHURCH
JOHAN & DOMINIKUS ZIMMERMAN
1754

7. ORIVESI CHURCH
HEKKI SIREN
1961
8. SAN CARLO ALLE QUATTRO FONTANE
FRANCESCO BORROMINI
1638-1641
9. SYDNEY OPERA HOUSE
JORN UTZON
1957-1968

10. POST OFFICE SAVINGS BANK
OTTO WAGNER
1904-1906
11. GUILD HOUSE
ROBERT VENTURI
1961
12. ROYAL CHANCELLERY
ERIK GUNNAR ASPLUND
1922

Geometric Derivatives

A multitude and variety of forms can be derived from basic geometries through combination, division, and the use of the parts. Three adjacent squares form the plan of the Snellman House (1), while two squares and four 1.4 rectangles set the limits of Hotel Guimard (2). The One-Half House (3) is designed by combining one-half a circle with an orthogonal half and a diagonal half of two squares. Where the Lutheran Church (4) and the Jacobs House (5) are derived from parts of two concentric circles, the Wies Church (6) is developed from two circles with different centers. The common area of overlap of two circles determines the plan of Orivesi Church (7). Borromini used an ellipse derived from parts of four circles to design San Carlo alle Quattro Fontane (8). A series of complex forms developed from multiple sphere segments is utilized at the Sydney Opera House (9). The Postal Savings Bank (10), the Guild House (11), and the Royal Chancellery (12) are derived from triangles. The triangles in the latter two are implied by a series of points at the corners of the building. The Chancellery design is also a composite of two triangles.

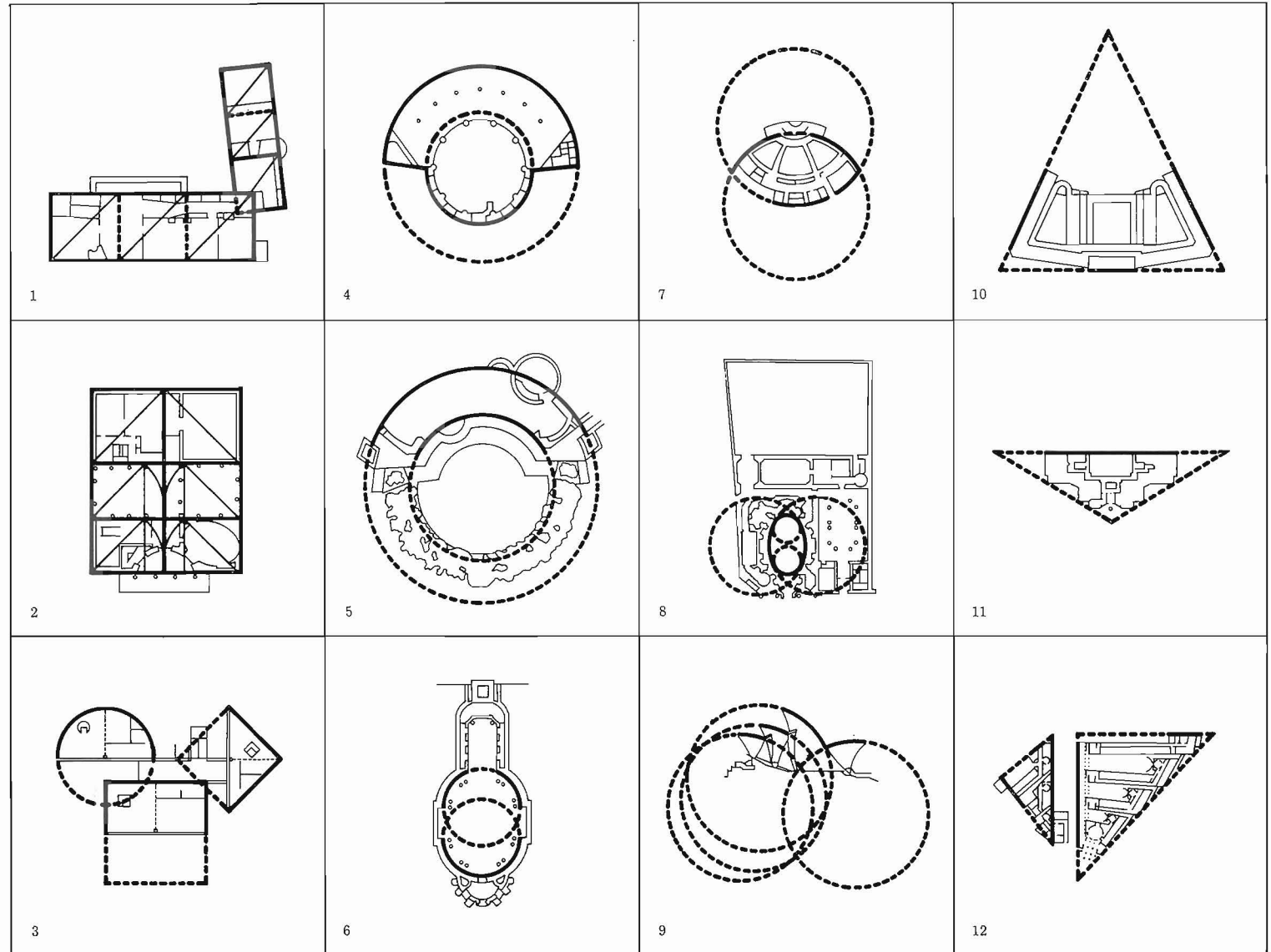

Rotated, Shifted, and Overlapped

Rotating, shifting, and overlapping are manipulations applicable to basic geometries to create built form. Two equal squares with a common center are rotated 45 degrees in San Maria degli Angeli (1). In San Spirito (2), three sequential sets, each with two rotated squares, are used. Two different orthogonal configurations are rotated and overlapped in the Occupational Health Building (3), while minimum connection between similar, rotated forms establishes the plan of the Fisher House (4). A circular element becomes a pivot for rotation of two forms in the Landerbank (5). The Herald Building (6), St. Andrews Dormitory (7), the Cuno House (8), and the Snellman House (9) are examples of hinge configurations—linear elements rotated about some common point of overlap. The change in the circulation element strengthens the shift about a common space in Deere West (10). In Carpenter Center (11), similar forms are inverted and shifted about a circulation ramp. Through a diagonal shift and overlap, Stirling creates the major use-space in the Cambridge History Faculty (12). Other examples of overlapping geometries are the Melnikov House, Drayton Hall, Easton Neston, and the Yale Center for British Arts.

1. SAN MARIA DEGLI ANGELI
FILIPPO BRUNELLESCHI
1434-1436
2. SAN SPIRITO
FILIPPO BRUNELLESCHI
1434
3. OCCUPATIONAL HEALTH CENTER
HARDY-HOLZMAN-PFIEFFER
1973

4. NORMAN FISHER HOUSE
LOUIS I. KAHN
1960
5. LANDERBANK
OTTO WAGNER
1883-1884
6. NEW YORK HERALD BUILDING
McKIM, MEAD, AND WHITE
1894

7. ST. ANDREWS DORMITORY
JAMES STIRLING
1964
8. CUNO HOUSE
PETER BEHRENS
1906-1907
9. SNELLMAN HOUSE
ERIK GUNNAR ASPLUND
1917-1918

10. DEERE WEST OFFICE BUILDING
ROCHE-DINKELOO
1975-1976
11. CARPENTER CENTER
LE CORBUSIER
1961-1963
12. CAMBRIDGE HISTORY FACULTY
JAMES STIRLING
1964

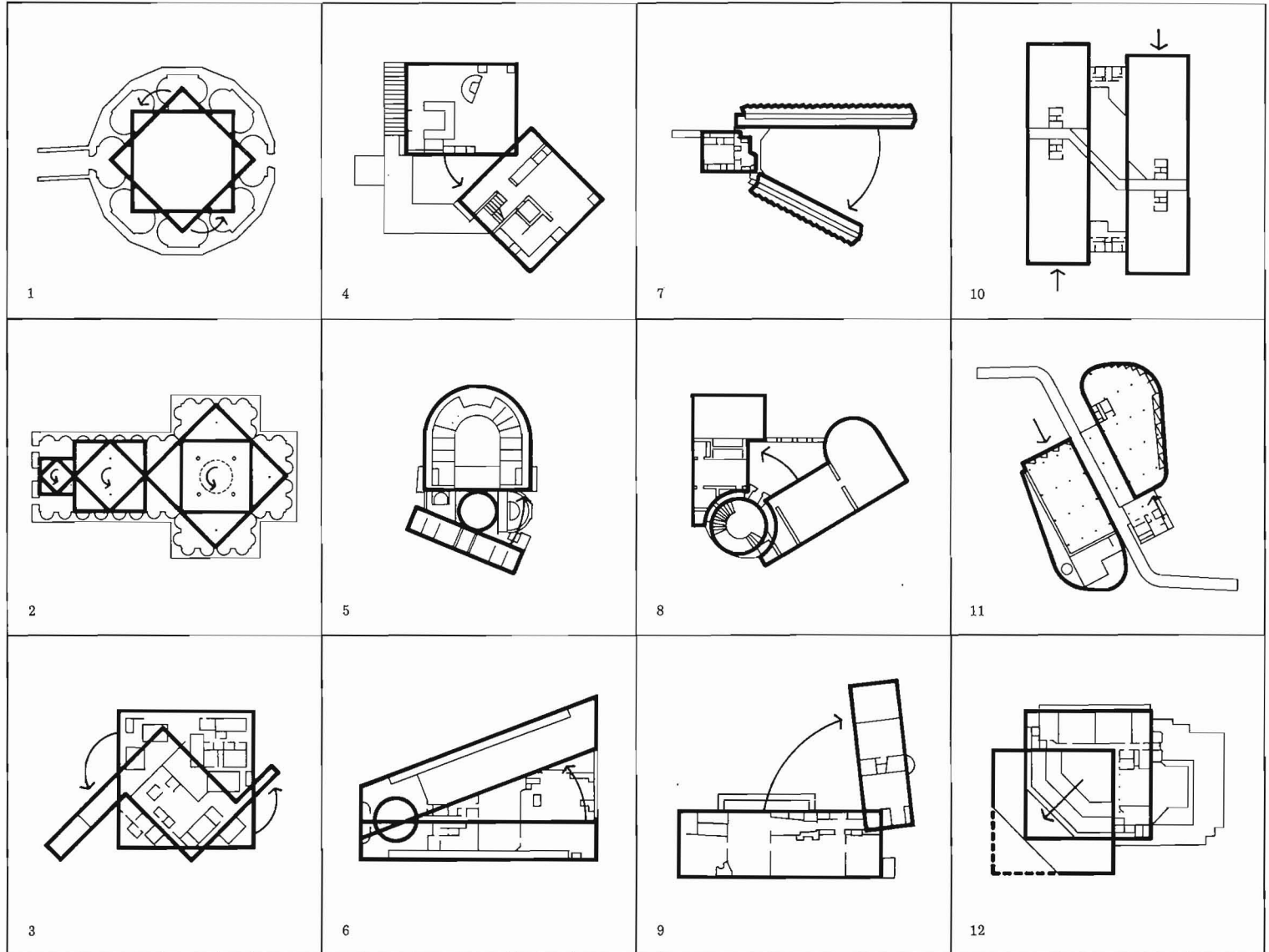

1. WINGSPREAD
FRANK LLOYD WRIGHT
1937
2. GUGGENHEIM MUSEUM
FRANK LLOYD WRIGHT
1956
3. NEW PARK
ARCHITECT UNKNOWN
c. 1775

4. RICHARDS RESEARCH BUILDING
LOUIS I. KAHN
1957-1961
5. MUSEUM AT AHMEDABAD, INDIA
LE CORBUSIER
1953-1957
6. FLOREY BUILDING
JAMES STIRLING
1966

7. MAUSOLEUM OF AUGUSTUS
ARCHITECT UNKNOWN
c. 25 B.C.
8. WOLFSBURG PARISH CENTER CHURCH
ALVAR AALTO
1960-1962
9. NEUR VAHR APARTMENTS
ALVAR AALTO
1958-1962

10. SMALL OLYMPIC ARENA
KENZO TANGE
1961-1964
11. ST. ANTONIUS CHURCH
JUSTUS DAHINDEN
1966-1969
12. NEW ENGLAND AQUARIUM
CAMBRIDGE SEVEN ASSOCIATES
1962

Pinwheel, Radial, and Spiral

Pinwheel, radial, and spiral are formal or spatial configurations which have in common a center of origin. A pinwheel is a uniform arrangement of linear elements about a defined core, as exemplified by Wingspread (1), or an implied core, as at the Guggenheim Museum (2). In Newpark (3), adjacent spaces pinwheel about a minor circulation core. Three complex units form a pinwheel about a service space in the Richards Medical Building (4). Two pinwheels, one within the main gallery, the second created by three built forms adjacent to the main building, are embodied in the Ahmedabad Museum (5). A radial configuration is denoted by a series of elements, defined or implied, which emanate from a center. The Florey Building (6) is developed from two centers, while Augustus's Mausoleum (7) is a classic radial configuration. In the Wolfsburg Parish Center (8), the structure radiates from a single origin, and in the Neur Vahr Apartments (9) the walls radiate from multiple centers. The spiral form occurs in the Small Olympic Arena (10) and the St. Antonius Church (11). The New England Aquarium (12) is developed from two spirals: a central circular one and a rectilinear one at the perimeter.

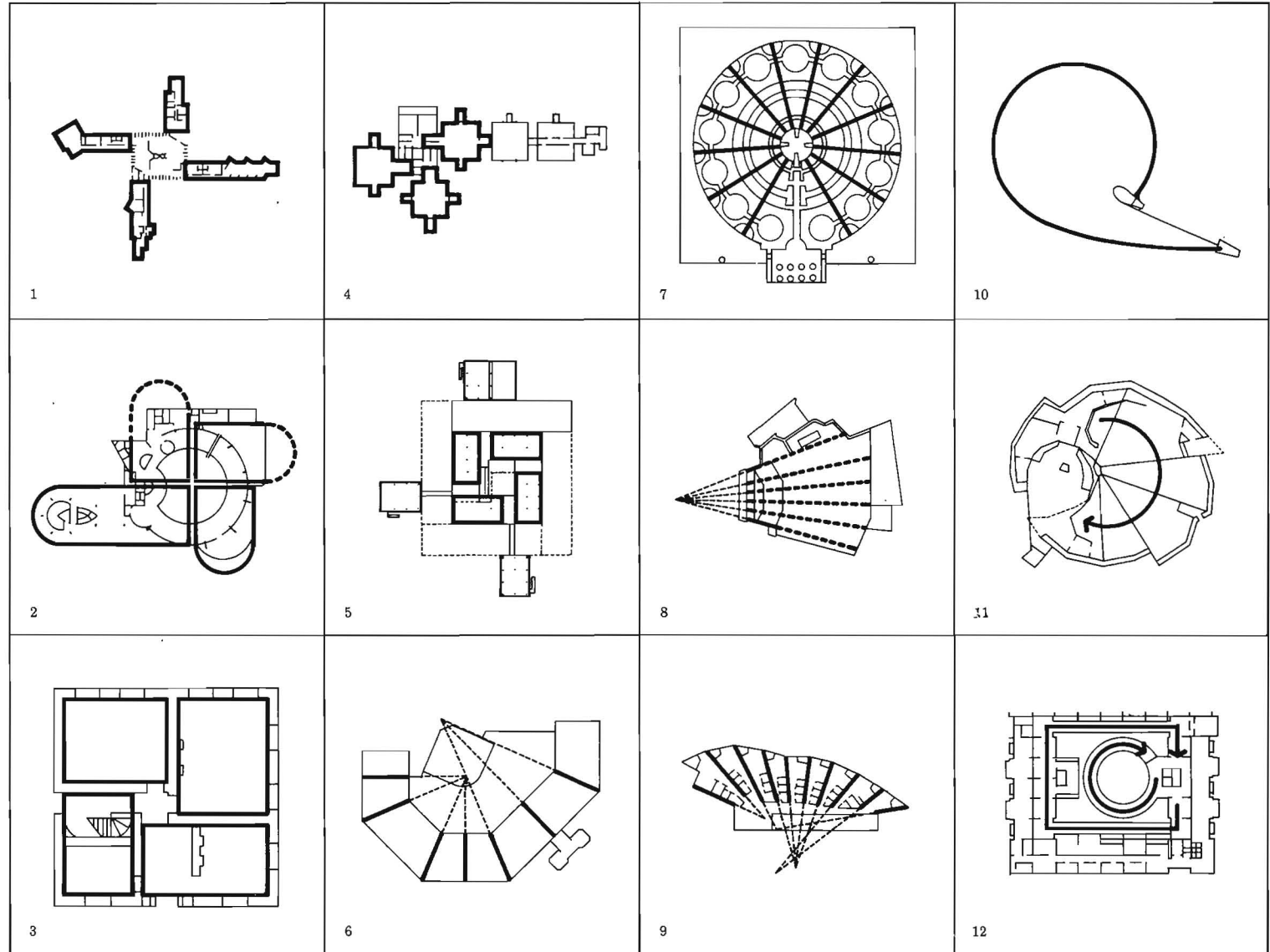

1. VILLA FOSCARI
ANDREA PALLADIO
c. 1549-1563
2. SEA RANCH CONDOMINIUM
CHARLES MOORE
1964-1965
3. CROWN HALL
LUDWIG MIES VAN DER ROHE
1950-1956

4. TEMPLE OF APOLLO
PAEONIUS AND DAPHNIS
c. 310 B.C.
5. FALLINGWATER
FRANK LLOYD WRIGHT
1935
6. ENSO-GUTZEIT HEADQUARTERS
ALVAR AALTO
1959-1962

7. CARSON PIRIE AND SCOTT STORE
LOUIS SULLIVAN
1899-1903
8. SAINTE GENEVIEVE LIBRARY
HENRI LABROUSTE
1838-1850
9. FARNSWORTH HOUSE
LUDWIG MIES VAN DER ROHE
1945-1950

10. LARKIN BUILDING
FRANK LLOYD WRIGHT
1903
11. A.E.G. HIGH TENSION FACTORY
PETER BEHRENS
1910
12. FOURTH TEMPLE OF HERA
RHOIKOS OF SAMOS
575 B.C.-550 B.C.

Grid

Grids are developed from the repetition of the basic geometries. At Villa Foscari (1), Sea Ranch (2), Crown Hall (3), and the Temple of Apollo (4), the square grid is the generator. It is used with major and minor emphasis in Fallingwater (5) and in the elevation of Enso-Gutzeit (6). In Carson Pirie and Scott (7), Sainte Genevieve Library (8), and the Temple of Hera (12), a rectilinear grid, coincident with structure, occurs. Rectilinear grids occur in the Farnsworth House (9), the Larkin Building (10), and the A.E.G. Factory (11). Kimball Art Museum (13), the Bath House (14), and San Sebastiano (15) exemplify plaid grids. The Nebraska State Capital (16) develops from a three unit plaid, as do Notre Dame Cathedral (17) and the Visser House (18). The Boomer Residence (19) and the Unitarian Church (21) have equilateral triangular grids, and the National Gallery (20) has an isosceles triangular grid. Leicester Engineering Labs (22), the Auditorium Building (23), and Turun Sanomat Offices (24) exemplify grid shifts that occur at junctures of major forms or spaces. Wells Library (25) developed from a plaid field created by grid rotation and overlap. The Anker Building (26) and the Gumma Museum (27) are examples of grids that are rotated.

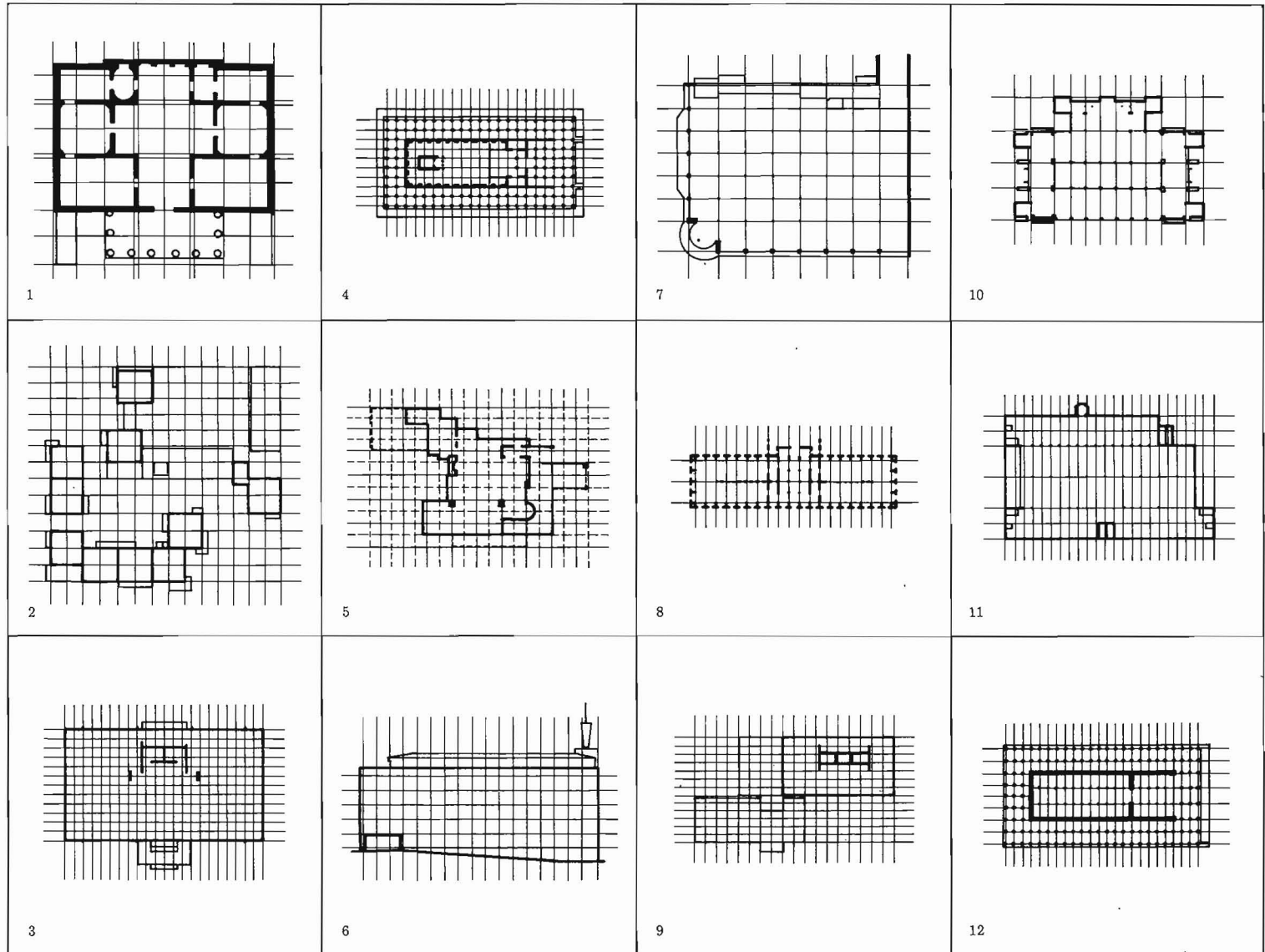

13. KIMBALL ART MUSEUM
LOUIS I. KAHN
1966-1972
14. TRENTON BATH HOUSE
LOUIS I. KAHN
1955-1956
15. SAN SEBASTIANO
LEON BATTISTA ALBERTI
1459

16. NEBRASKA STATE CAPITOL
BERTRAM GOODHUE
1924
17. NOTRE DAME CATHEDRAL
ARCHITECT UNKNOWN
1163-c. 1250
18. VISSER HOUSE
ALDO VAN EYCK
1975

19. JORGINE BOOMER RESIDENCE
FRANK LLOYD WRIGHT
1953
20. EAST WING OF NATIONAL GALLERY
I. M. PEI
1975-1978
21. UNITARIAN CHURCH
FRANK LLOYD WRIGHT
1949

22. LEICESTER ENGINEERING BUILDING
JAMES STIRLING
1959
23. AUDITORIUM BUILDING
LOUIS SULLIVAN
1887-1890
24. TURUN SANOMAT OFFICES
ALVAR AALTO
1927-1929

25. WELLS COLLEGE LIBRARY
SKIDMORE-OWINGS-MERRILL
1968
26. THE ANKER BUILDING
OTTO WAGNER
1895
27. GUMMA MUSEUM OF FINE ARTS
ARATA ISOZAKI
1971-1974

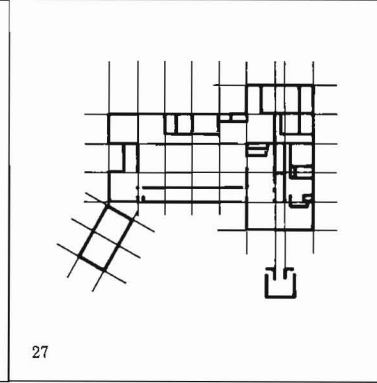
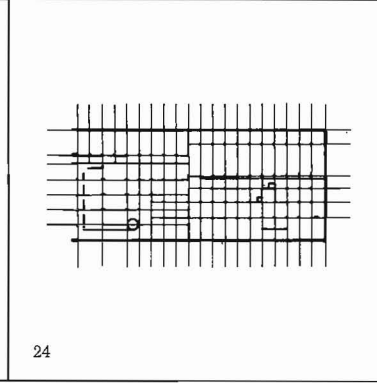
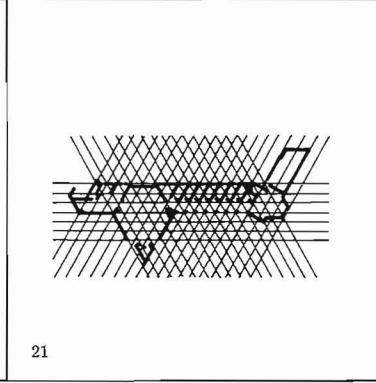
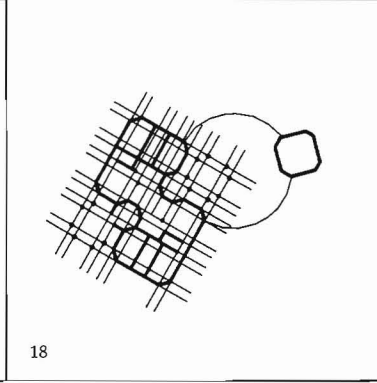
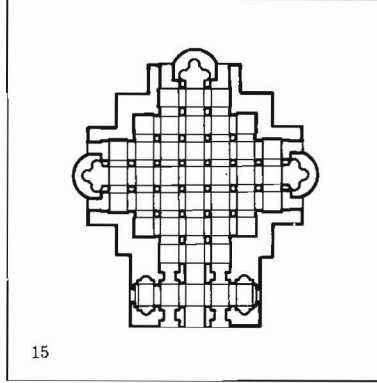
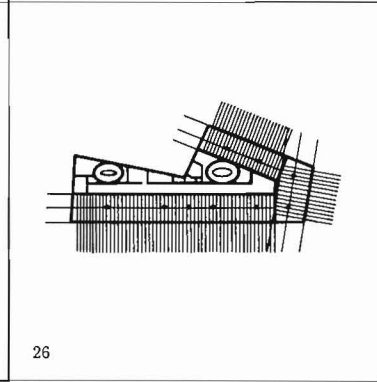
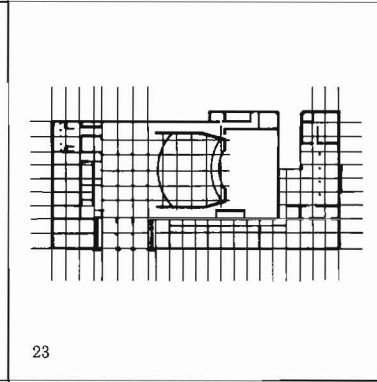
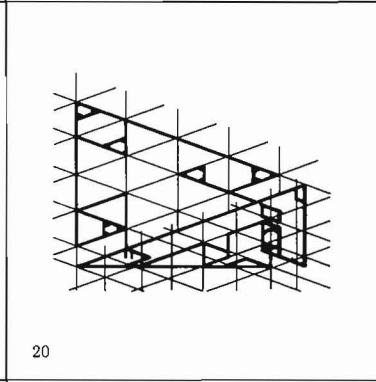
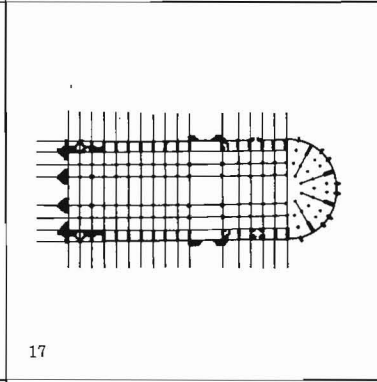
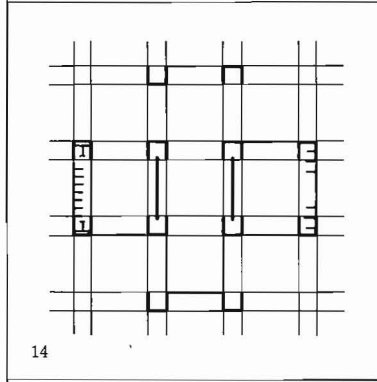
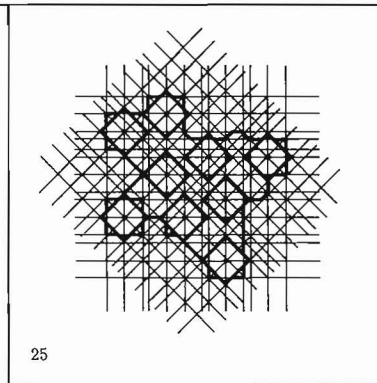
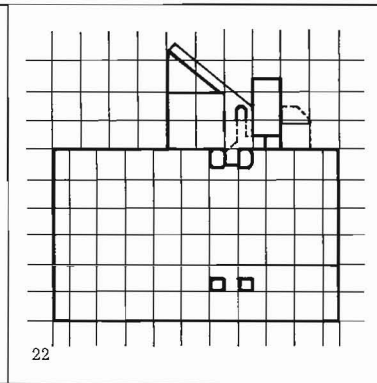
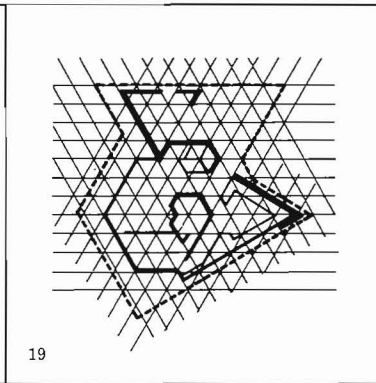
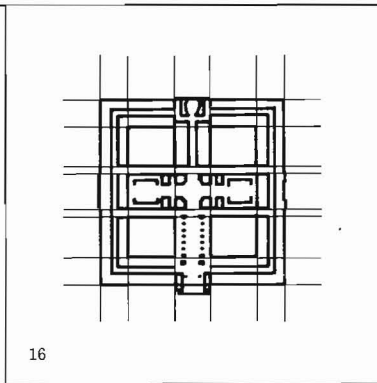
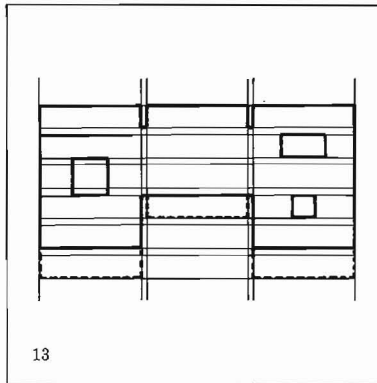

CONFIGURATION PATTERNS

Configuration patterns describe the relative disposition of parts, and are themes for designing space and organizing groups of spaces and forms. Illustrated are examples of linear, central, double-centered, clustered, nested, concentric, and binuclear configurations.

Linear: Use

There are two types of configurations in which path through use-spaces creates a linear organization. In the first, spaces are linked, and circulation is from space to space. In the second, one engages a singular space longitudinally. At the temple in Malta (1) the spaces are linked on the transverse axis, thus changing each longitudinal space into three implied spaces. The axial movement through a series of spaces places accent on the beginning and end of the path, and is exemplified at Solomon's Temple (2) and at the Temple of Horus, Edfu (4). At Ledoux's Hotel Montmorency (3), the path doubles back on itself on the second floor so that beginning and end are above one another. The spaces in the linear configuration at the Tomb of Setnakht (5) are both longitudinal and transverse. The change provides accent. At Soane's Dulwich Gallery (6), the entrance is in the middle of the linearly linked spaces. In Jacobsen's house (7), the center between the linked spaces is solid, and the circulation is along the edges. Redentore (8) and the Laurentian Library (9) are examples of singular spaces that are organized linearly. At Redentore, as at the Tomb of Setnakht, there is an accent along the path.

1. TEMPLE AT TARXIEN, MALTA
ARCHITECT UNKNOWN
2100 B.C.–1900 B.C.
2. SOLOMON'S TEMPLE
ARCHITECT UNKNOWN
1000 B.C.
3. HOTEL DE MONTMORENCY
CLAUDE NICHOLAS LEDOUX
1769

4. TEMPLE OF HORUS
ARCHITECT UNKNOWN
237 B.C.–57 B.C.
5. TOMB OF SETNAKHT
ARCHITECT UNKNOWN
13th CENTURY B.C.
6. DULWICH GALLERY
JOHN SOANE
1811–1814

7. HOUSE IN CENTRAL PENNSYLVANIA
HUGH NEWELL JACOBSEN
1980
8. REDENTORE CHURCH
ANDREA PALLADIO
1576–1591
9. LAURENTIAN LIBRARY
MICHELANGELO
1525

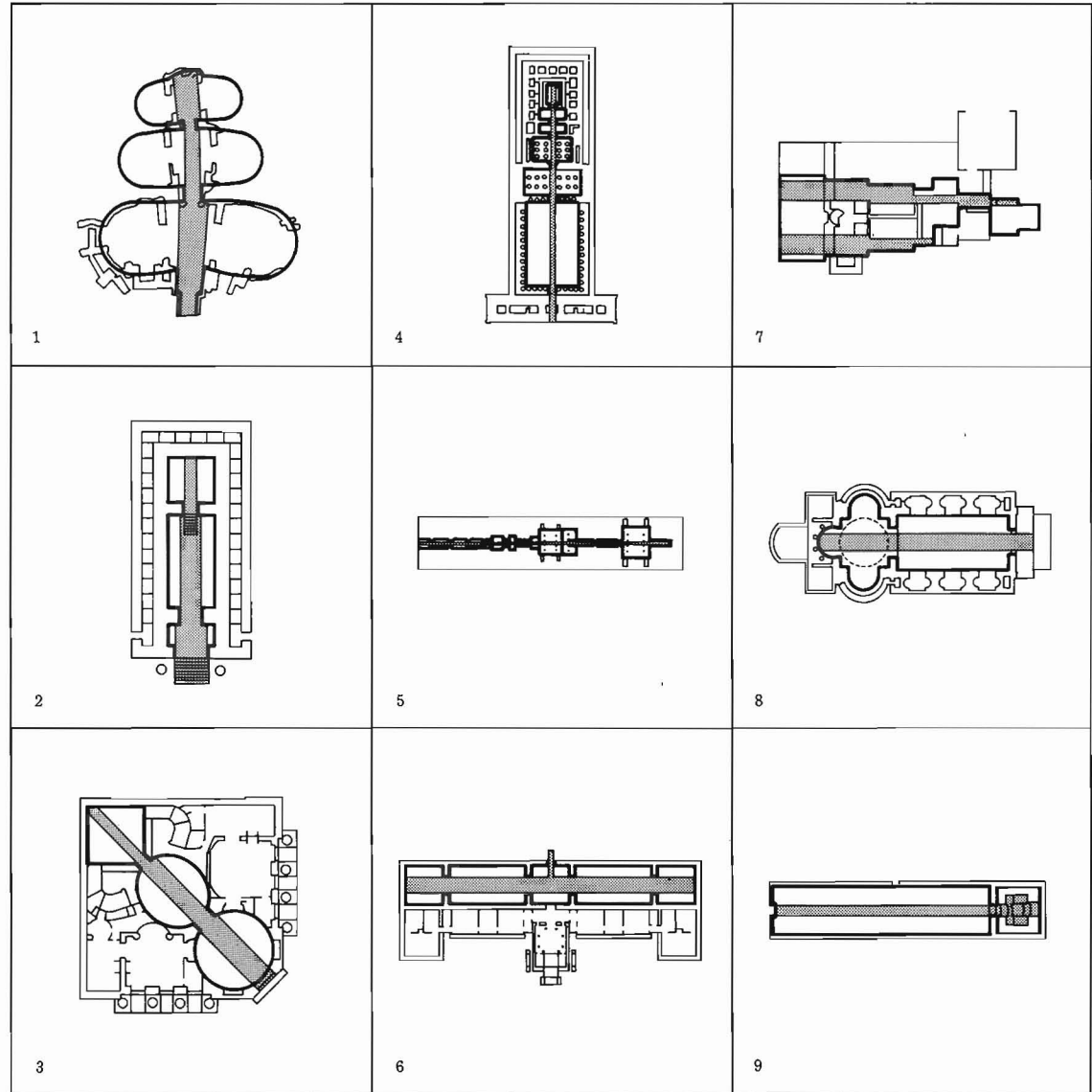

1. STOA IN SIKYON, GREECE
ARCHITECT UNKNOWN
c. 300
2. PHYSICAL EDUCATION FACILITY
KALLMAN-McKINNELL
1970
3. CHURCH IN BAGSVAERD, DENMARK
JORN UTZON
1973-1976

4. FORT SHANNON
ARCHITECT UNKNOWN
1800-1835
5. SNELLMAN HOUSE
ERIK GUNNAR ASPLUND
1917-1918
6. BAKER DORMITORY
ALVAR AALTO
1947-1948

7. UNITE D'HABITATION
LE CORBUSIER
1946-1952
8. FLOREY BUILDING
JAMES STIRLING
1966
9. ST. ANDREWS DORMITORY
JAMES STIRLING
1964

10. STERN HOUSE
CHARLES MOORE
1970
11. CENTRE BEAUBOURG
PIANO AND ROGERS
1972-1977
12. PEARSON HOUSE
ROBERT VENTURI
1957

Linear: Circulation

Linear configurations in which the circulation is separated from the use-space are spine or corridor organizations. A Greek stoa (1) is the simplest form of this organization, while the gymnasium at Exeter (2) represents a typical spine scheme. In this case, the spine dominates the form. The spine in Utzon's church (3) embodies a repetitive form vocabulary that is deployed to create places for use-spaces. Examples of single-loaded corridors are the Irish house (4) and the Snellman House (5). Aalto's dormitory (6) illustrates that the linear circulation need not be straight or symmetrical, while in Le Corbusier's Unite d'Habitation (7) circulation is significant in section. The circulation in the two buildings by Stirling (8 and 9) is visible externally and indicates the potential for the path to be not straight. It is also possible for two circulation spines to exist, as at Moore's Stern House (10), where they cross. At Centre Beaubourg (11), the two spines are parallel; one is for vertical circulation and the other for horizontal. Venturi's Pearson House (12) utilizes both types of linear configuration patterns. The private spaces are linked by a separate circulation path, while the public spaces have implied circulation through them.

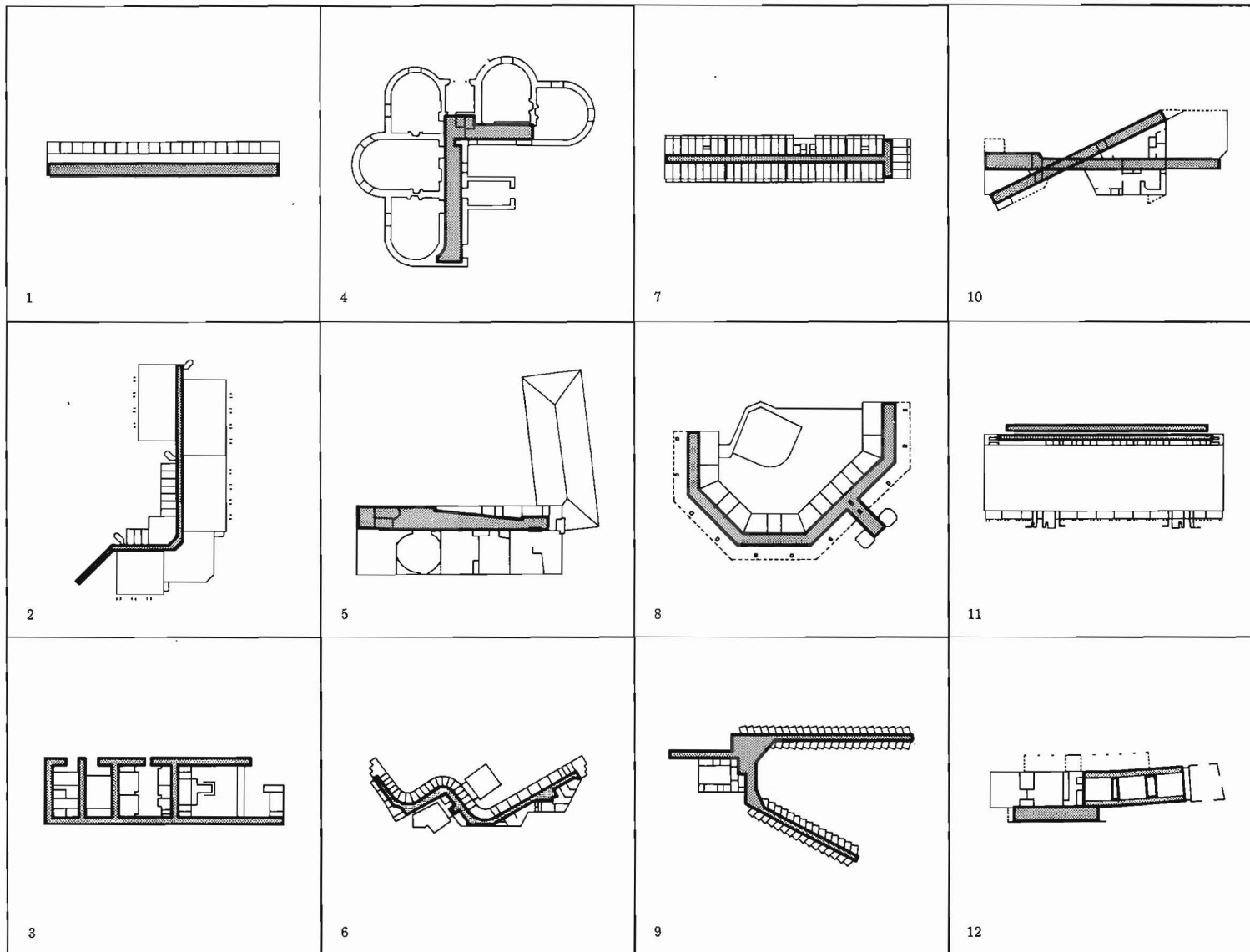

1. **FIRST UNITARIAN CHURCH**
LOUIS I. KAHN
1959-1967
2. **WOLLATON HALL**
ROBERT SMYTHSON
1580-1588
3. **SHAKER BARN**
ARCHITECT UNKNOWN
1865

4. **HUNTING LODGE**
KARL FRIEDRICH SCHINKEL
1822
5. **PALACE OF CHARLES V**
PEDRO MACHUCA
1527
6. **FARNESE PALACE**
ANTONIO DA SANGALLO
1534

7. **ST. COSTANZA**
ARCHITECT UNKNOWN
c. 350
8. **TRINITY CHURCH**
HENRY HOBSON RICHARDSON
1872-1877
9. **ST. MARY WOOLNETH**
NICHOLAS HAWKSMOOR
1716-1724

10. **SECOND BANK OF THE U.S.**
WILLIAM STRICKLAND
1818-1824
11. **STOKHOLM PUBLIC LIBRARY**
ERIK GUNNAR ASPLUND
1920-1928
12. **SAN MARIA DEGLI ANGELI**
FILIPPO BRUNELLESCHI
1434-1436

Central: Use

Configurations that place the most important space in the central position are engaged by going to or around this space. At Kahn's Unitarian Church (1) and at Wollaton Hall (2), the central hall, which is lit from above and dominant in form, is surrounded by minor use-spaces and separate circulation. Circulation at the Shaker barn (3) is around a central haymow which has symbolic, functional, and formal importance. The octagonal central hall in Schinkel's Hunting Lodge (4) has minor use-spaces on only four sides, with circulation at the perimeter. At the Palace of Charles V (5) and Farnese Palace (6), the central space is a court with a colonnade for circulation. At the center of St. Costanza (7) is the most sacred space, while at Trinity Church (8) and St. Mary Woolnoth (9) the center is located within a larger space. Strickland's Second Bank of the United States (10) has a dominant space that is central, with implied circulation and minor use-spaces on only two sides. Circulation at the Stockholm Library (11) is at the perimeter of the central space. Brunelleschi's San Maria degli Angeli (12) has a dominant central space that is surrounded by lesser spaces. Circulation is to and around the central space, but through the lesser spaces.

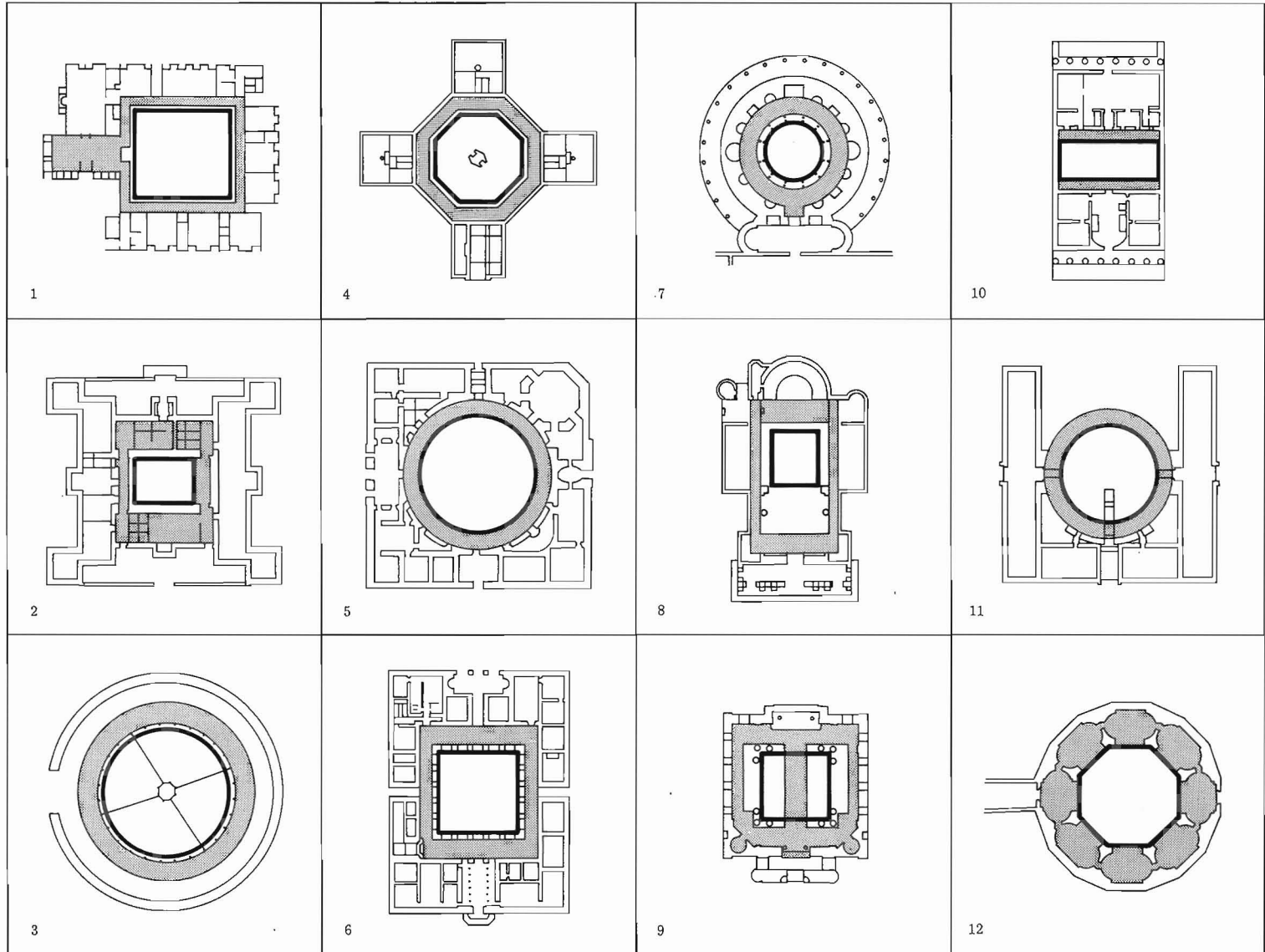

1. LA ROTONDA
ANDREA PALLADIO
1566-1571
2. NORTH CAROLINA STATE CAPITOL
TOWN AND DAVIS
1833-1840
3. UNITED STATES CAPITOL
THORNTON-LATROBE-BULFINCH
1793-1830

4. HOUSE IN UR
ARCHITECT UNKNOWN
2000 B.C.
5. HOTEL DE BEAUVAIS
ANTOINE LE PAUTRE
1656
6. BLOEMENWERF HOUSE
HENRY VAN DE VELDE
1895-1896

7. BALTIMORE-OHIO RAILROAD DEPOT
FRANK FURNESS
1886
8. BURN HALL
JOHN SOANE
c. 1785
9. THE SALUTATION
EDWIN LUTYENS
1911

10. EXETER LIBRARY
LOUIS I. KAHN
1967-1972
11. CONVENT OF LA TOURETTE
LE CORBUSIER
1957-1960
12. STRATFORD HALL
ARCHITECT UNKNOWN
1725

Central: Circulation

Villa Rotonda (1), the U.S. Capitol (2), and the North Carolina Capitol (3) are examples of classic rotundas. In these cases, the central space, though dominant on the exterior, is used for circulation and as an organizer of other spaces. The courtyards at the House in Ur (4) and the Hotel de Beauvais (5) are alternatives to the classic rotunda. In these two buildings, the courts are dominant plan forms and are used to organize circulation and lesser spaces, but have no external expression. At the House by Van de Velde (6), Furness's railroad station (7), Soane's Burn Hall (8), and Lutyens's Salutation (9), the central space is used for vertical circulation and organizes the building vertically. Kahn's library (10) has a central space that is a rotunda at the main level, while at the upper levels the circulation is around this space. In a somewhat similar fashion, the courtyard at La Tourette (11) incorporates the qualities of both types of central organizations. In some instances the circulation is around the court, as at a cloister, and at other times it is through the court. The central space at Stratford Hall (12) is the main use-space, and serves as a rotunda with circulation through it to lesser spaces.

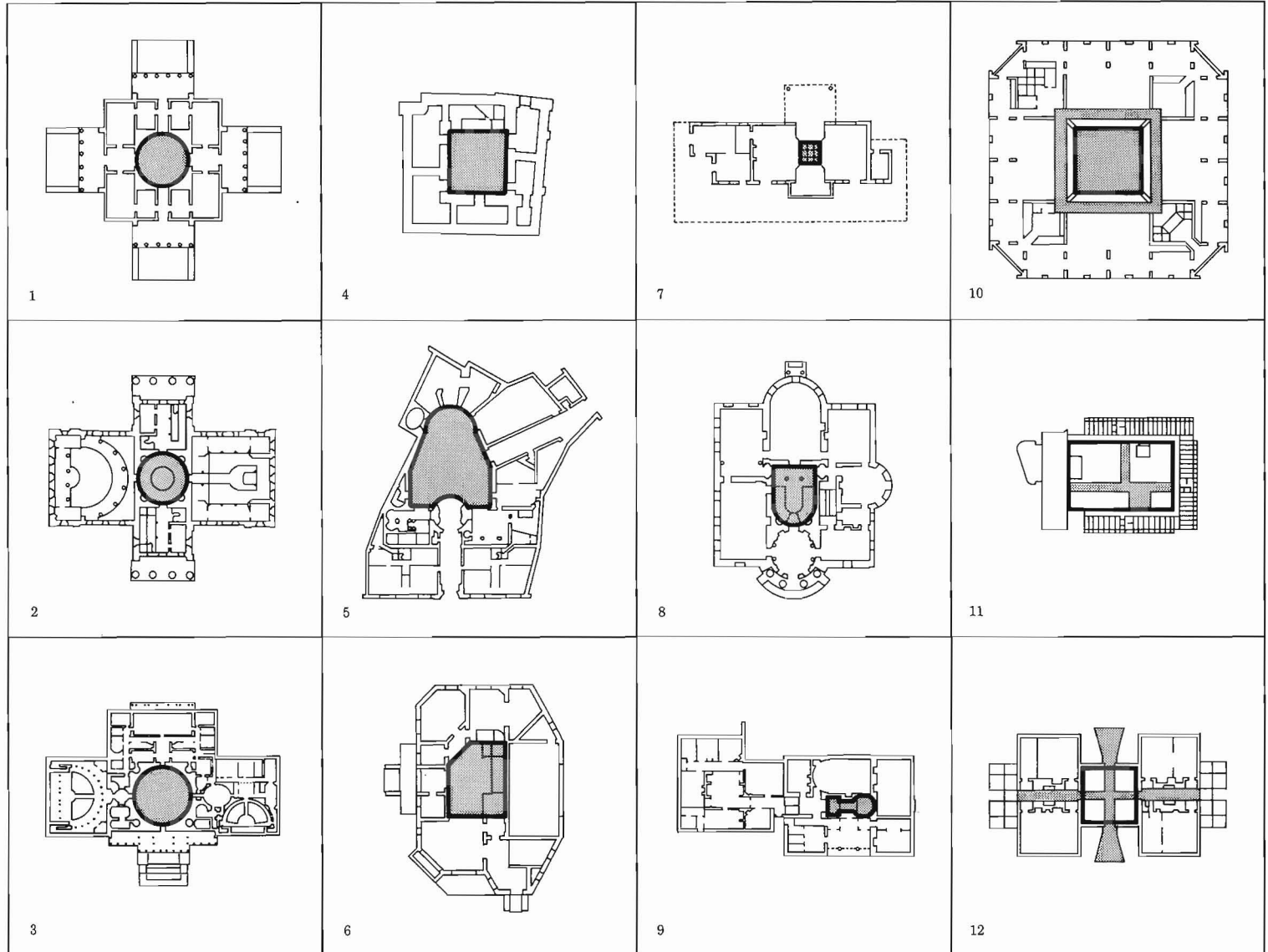

1. **TEMPLE OF VENUS AND ROME**
HADRIAN
123-135
2. **HORYU-JI TEMPLE**
ARCHITECT UNKNOWN
607
3. **MARKET IN LEPTIS MAGNA, LYBIA**
ARCHITECT UNKNOWN
8 B.C.

4. **MOORE HOUSE**
CHARLES MOORE
1962
5. **THE PALACE OF ASSEMBLY**
LE CORBUSIER
1953-1963
6. **BRION-VEGA CEMETARY**
CARLO SCARPA
1970-1972

7. **DOVER CASTLE**
ARCHITECT UNKNOWN
c. 1180
8. **PENNSYLVANIA ACADEMY OF ART**
FRANK FURNESS
1872
9. **YALE CENTER FOR BRITISH ART**
LOUIS I. KAHN
1969-1974

10. **OSPEDALE DEGLI INNOCENTI**
FILIPPO BRUNELLESCHI
1421-1445
11. **CHANCELLERY PALACE**
ARCHITECT UNKNOWN
1483-1517
12. **CASA MILO**
ANTONIO GAUDI
1905-1907

Double Center

Double centers are two equally important foci located within a precinct or field. The Temple of Venus and Rome (1) has two equal, primary rooms, oriented in opposite directions, within a field that is the remainder of the Temple. Each center is an object located within a precinct that is seen as a void. At the Horyu-Ji Temple (2) and the Market in Leptis Magna (3), the precinct is an outdoor court, whereas at Moore's Orinda House (4) and the Palace of Assembly (5), the precinct is a room and indoor space. The Cemetery by Scarpa (6) has one center as an object in an outdoor precinct, while the other center is a room inside the building. If the precinct is solid, then the centers might be voids carved from that solid. At Dover Castle (7) the voids are major rooms, and at the Academy of Fine Arts (8) the voids are special places. The remainder of the building is poche. It is also possible that the voids as double centers might organize surrounding spaces and allow light to enter the interior of the building as at the Center for British Arts (9), the Ospedale degli Innocenti (10), the Chancellery Palace (11), and Casa Milo (12).

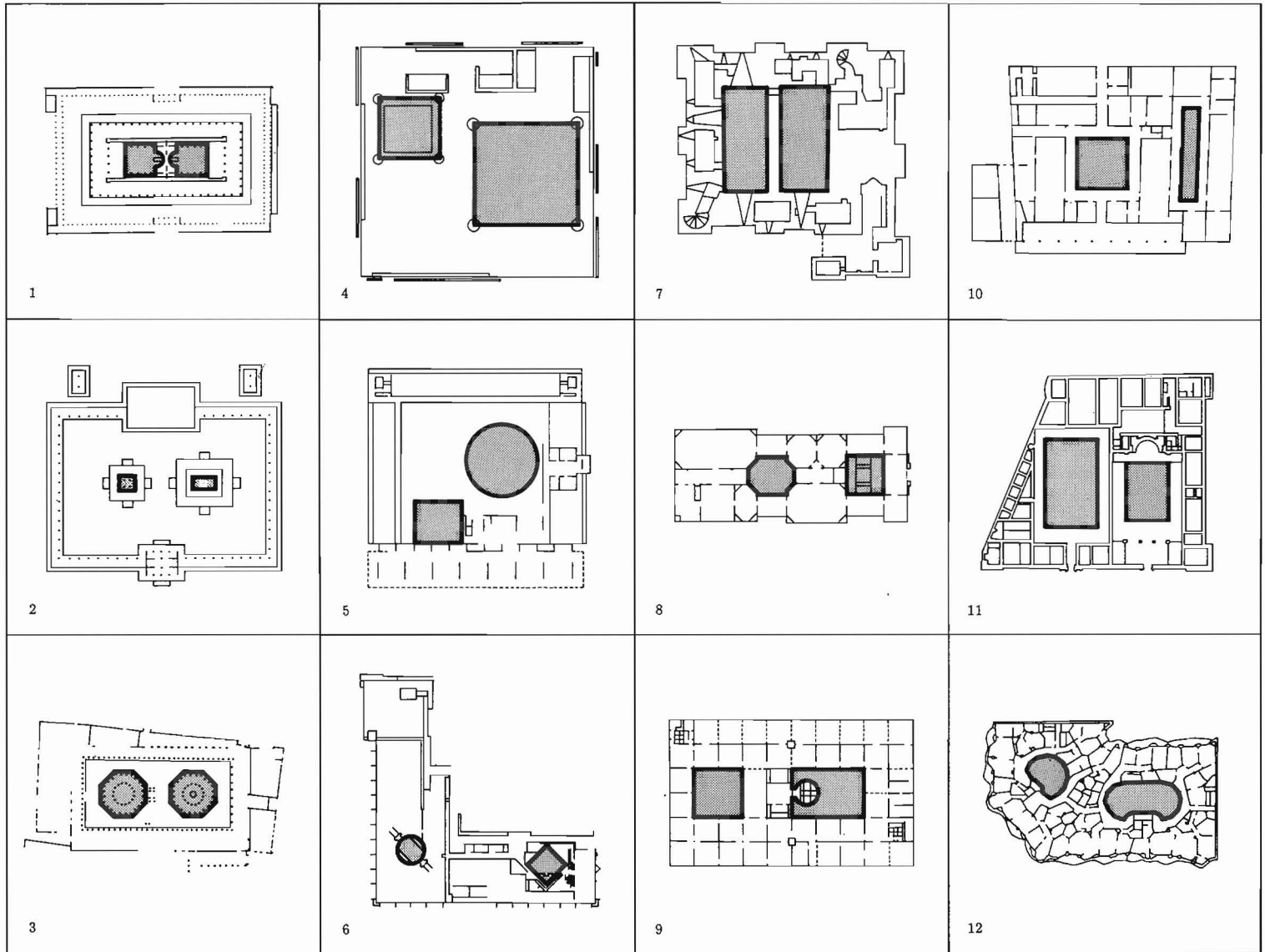

1. TOWER OF LONDON
ARCHITECT UNKNOWN
1070-1090
2. FORTRESS NEAR RUDESHEIM
ARCHITECT UNKNOWN
1000-1050
3. HOUSE OF VIZIER NAKHT
ARCHITECT UNKNOWN
1372 B.C.-1350 B.C.

4. W. WATTS SHERMAN HOUSE
HENRY HOBSON RICHARDSON
1874
5. D. L. JAMES HOUSE
GREENE AND GREENE
1918
6. OLAVINLINNA CASTLE, FINLAND
ARCHITECT UNKNOWN
1475

7. CASTLE IN SOBORG, DENMARK
ARCHITECT UNKNOWN
c. 1150
8. OCCUPATIONAL HEALTH CENTER
HANDY-HOLZMAN-PFIEFFER
1973
9. CONVENT FOR DOMINICAN SISTERS
LOUIS I. KAHN
1965-1968

10. HOUSE IN TUCKER TOWN, BERMUDA
ROBERT VENTURI
1975
11. OLIVETTI TRAINING SCHOOL
JAMES STIRLING
1969
12. FONTHILL-MERCER CASTLE
HENRY MERCER
1908-1910

Cluster

Spaces or forms that are grouped without discernible pattern are considered clustered. The clustering of spaces often can determine the form, or at least, have impact on the form, as in the Tower of London (1) and the Watts Sherman House (4). However, spaces might also be clustered within a form whose exterior configuration is predetermined. The fortress in Germany (2) and the House of Vizier Nakht (3) exemplify this category of spatial cluster. Both types of spatial clusters are apparent in the James House (5), with the cluster-determining form variation dominant. The castles in Finland (6) and Denmark (7) are clusters of both forms and spaces. One criterion of clustering is the necessity for proximity between those elements which are clustered. To a certain extent, the walls in the castles create that proximity, while in the Occupational Health Center (8) proximity is established by the large room in which the forms are gathered. Clustered forms may have spatial subdivisions within them as long as those subdivisions are minor. The Convent by Kahn (9), the Bermuda house by Venturi (10), the training center by Stirling (11), and Fonthill (12) are all examples of forms that are clustered.

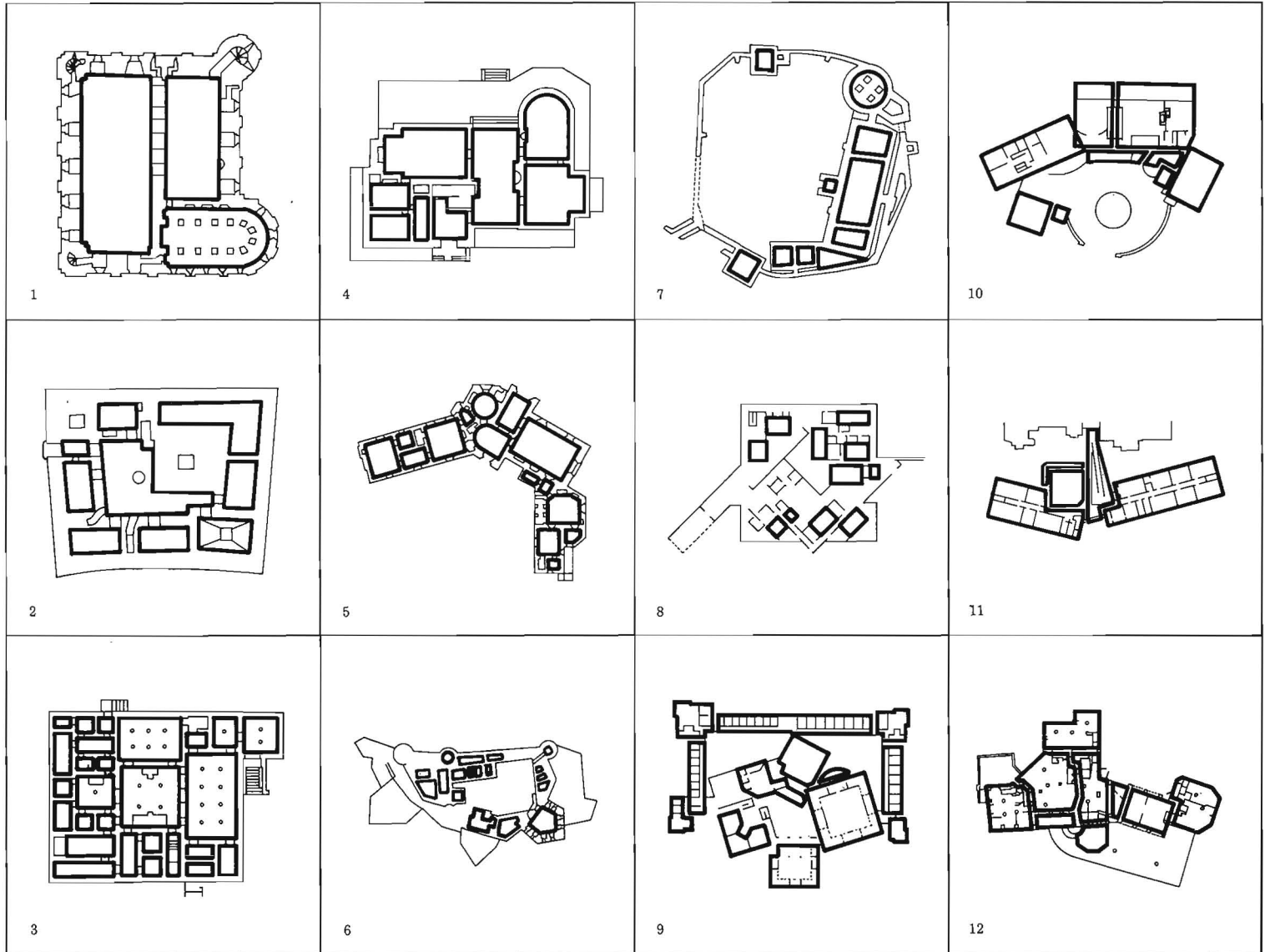

1. TEMPLE OF APOLLO
ARCHITECT UNKNOWN
c. 400 B.C.
2. TEMPLE OF KOM OMBO
ARCHITECT UNKNOWN
181 B.C.–30 A.D.
3. THE PALACE OF ASSEMBLY
LE CORBUSIER
1953–1963

4. MOORE HOUSE
CHARLES MOORE
1962
5. ENSO-GUTZEIT HEADQUARTERS
ALVAR AALTO
1959–1962
6. CAMBRIDGE HISTORY FACULTY
JAMES STIRLING
1964

7. J. J. GLESSNER HOUSE
HENRY HOBSON RICHARDSON
1885–1887
8. CHANDLER HOUSE
BRUCE PRICE
1885–1886
9. HOMEWOOD
EDWIN LUTYENS
1901

Nested

Nested configurations are patterns in which each unit in consecutive order is located inside the next larger unit so that each unit has a different center. At the Temple of Apollo (1) and the Temple of Kom Ombo (2) the units have a common centerline. The geometry change at the Palace of Assembly (3) illustrates that it is not necessary for the nested units to have the same form language. Charles Moore's House in Orinda (4) contains a double set of nested forms. Since nested units do not share a common center they may have other parts of their configurations in common. This might entail having one side common to all units, as at Aalto's Enso-Gutzeit Headquarters (5). More commonly, though, two sides and a corner are shared by the nested units. The units, then, generally nest diagonally. Stirling's History Building (6), Richardson's Glessner House (7), Price's Chandler House (8), and Lutyens's Homewood (9) exemplify this kind of nesting.

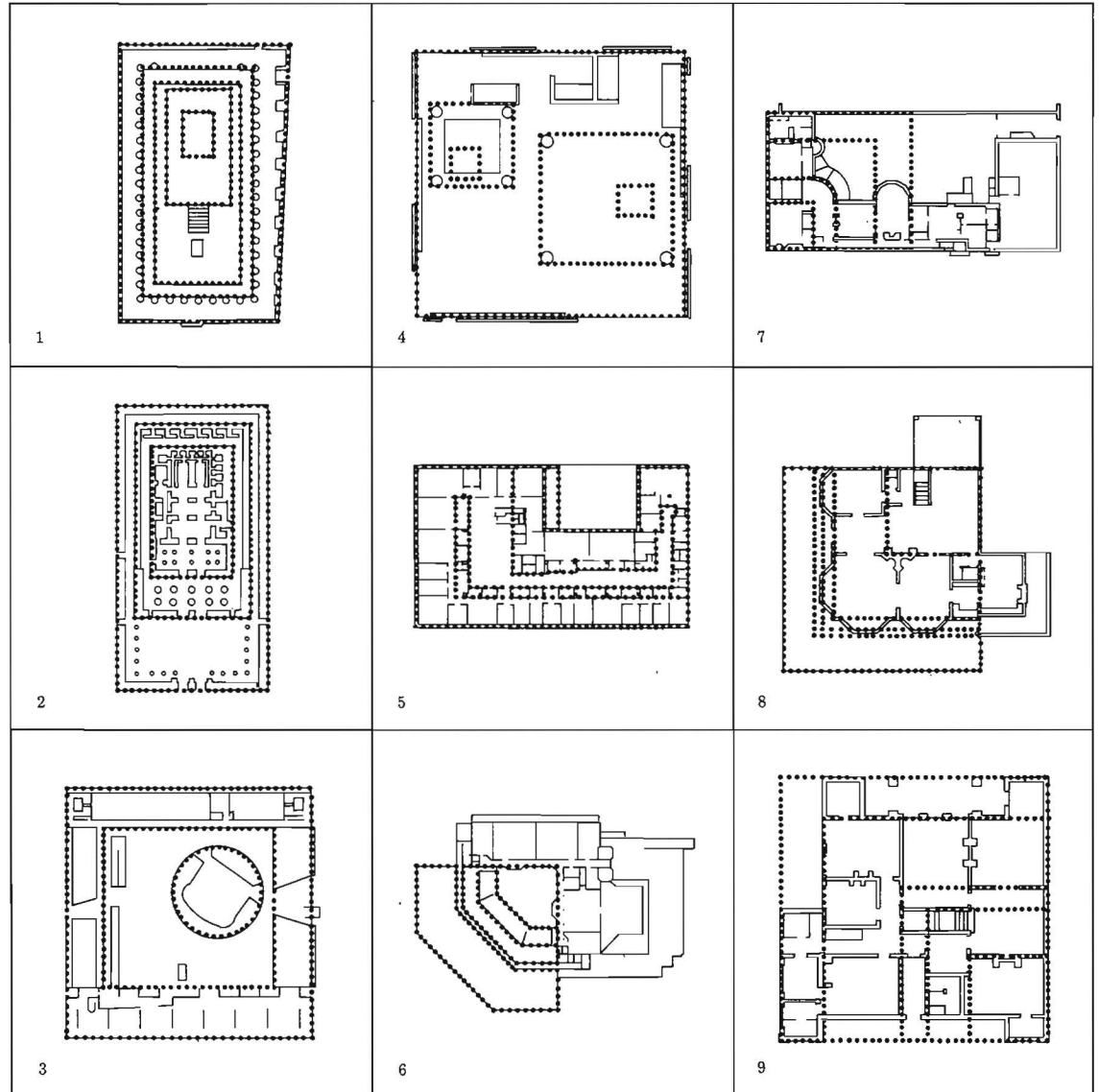

1. EXETER LIBRARY

LOUIS I. KAHN
1967-1972

2. STOCKHOLM PUBLIC LIBRARY

ERIK GUNNAR ASPLUND
1920-1928

3. PANTHEON IN PARIS, FRANCE

JACQUES GERMAIN SOUFFLOT
1756-1797

4. SAN STEFANO ROTONDO

ARCHITECT UNKNOWN
468-483

5. ALLEGHENY COUNTY COURTHOUSE

HENRY HOBSON RICHARDSON
1883-1888

6. UNITY TEMPLE

FRANK LLOYD WRIGHT
1906

7. FONTEVRAULT ABBEY

ARCHITECT UNKNOWN
1115

8. VILLA FARNESE

GIACOMO DA VIGNOLA
1559-1564

9. SAN LORENZO

GUARINO GUARINI
1666-1679

10. ST. GEORGE-IN-THE-EAST

NICHOLAS HAWKSMOOR
1714-1729

11. THEATER IN BESANCON, FRANCE

CLAUDE NICHOLAS LEDOUX
1775

12. PARTHENON

ICTINUS
447-430 B.C.

Concentric

Concentric configurations are patterns in which each unit in consecutive order is located inside the next larger unit so that each unit has the same center. The Exeter Library (1) is an example of concentric configuration created with simple geometric forms. Simple forms of different languages are utilized by Asplund in the Stockholm Library (2). Somewhat more complex, but basically repetitive units are used at the Pantheon in Paris (3). At San Stefano (4), simple geometric forms are repeated, but each ring is articulated in a different manner. The Allegheny Courthouse (5) illustrates a configuration in which each concentric unit is different in function. At Unity Temple (6), the concentric layering is in the major space only. Fontevrault Abbey (7), Villa Farnese (8), and San Lorenzo (9) exemplify the complexity that may result from changing geometries in each of the concentric units. Both nested and concentric configurations are employed by Hawksmoor at St. George (10). Ledoux's theater (11) is nested with half of the plan implied so that the total can be considered a concentric configuration. At the Parthenon (12), the pattern changes from concentric in the outer layers to nested at the inner units.

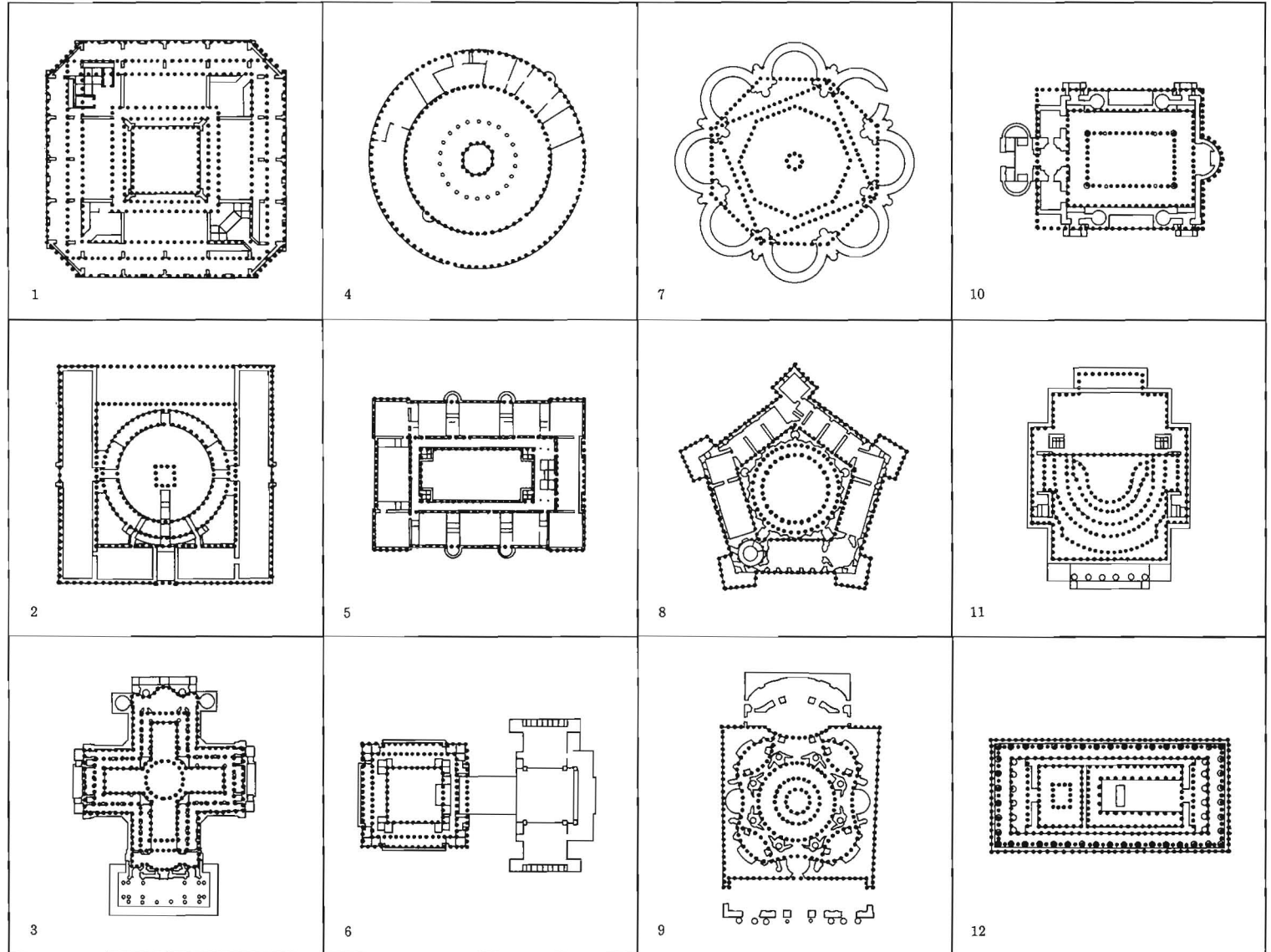

Binuclear

Binuclear is a configuration pattern with two equally dominant parts. The link between the binuclear components can be a built form which is an entrance space, as in the Robinson House (1), the Capitol at Williamsburg (2), and Unity Temple (4). The built link can also be the major use-space, as in Stratford (3), or a bridge, as in the Queen's House (5). Binuclear elements can be connected by a void or a space, which can be actual, as in the Salk Institute (9), or implied, as in the Postal Savings Bank (6), Olivetti (8), and Nashdom (7). Oita Medical Hall (10), Helsinki House of Culture (11), and the Mellon Arts Center (12) exemplify configurations with different geometries

which are separated. St. Paul's (13) and Dipoli Center (19) have two varied geometries united directly. The Observatory (14) and Redentore Church (15) bring complex and simple forms together. Binuclear elements as positive and negative forms occur in the Farnsworth House (16), the American Academy (17), and Power Center (18). Similar binuclear forms can have different orientations, as in the Carpenter Center (20) and Fisher House (21). Two elements can be similar in form and different in function, as in Lang Music Center (22) and the Robie House (23). Binuclear can also be made manifest in elevations like Le Corbusier's pavilion (24).

1. **ROBINSON HOUSE**
MARCEL BREUER
1947
2. **THE CAPITOL AT WILLIAMSBURG**
ARCHITECT UNKNOWN
1701
3. **STRATFORD HALL**
ARCHITECT UNKNOWN
1725

4. **UNITY TEMPLE**
FRANK LLOYD WRIGHT
1906
5. **THE QUEEN'S HOUSE**
INIGO JONES
1629-1635
6. **POST OFFICE SAVINGS BANK**
OTTO WAGNER
1904-1906

7. **NASHDOM**
EDWIN LUTYENS
1905-1909
8. **OLIVETTI TRAINING SCHOOL**
JAMES STIRLING
1969
9. **SALK INSTITUTE**
LOUIS I. KAHN
1959-1965

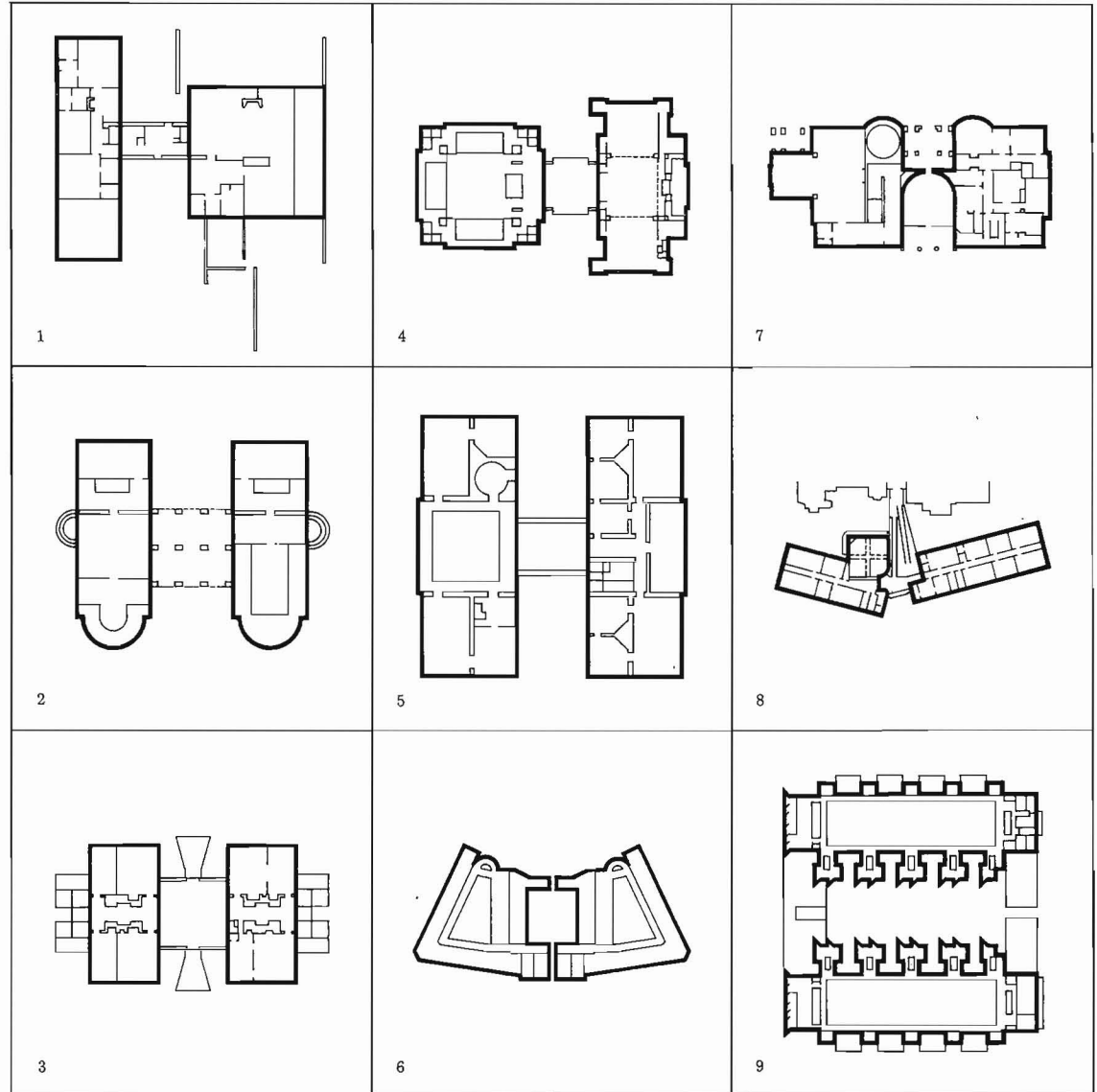

10. ANNEX TO OITA MEDICAL HALL
ARATA ISOZAKI
1970-1972
11. HOUSE OF CULTURE IN HELSINKI
ALVAR AALTO
1955-1958
12. PAUL MELLON ARTS CENTER
I. M. PEI
1970-1973

13. ST. PAUL'S CHURCH
LOUIS SULLIVAN
1910-1914
14. OBSERVATORY IN BERLIN
KARL FRIEDRICH SCHINKEL
1835
15. REDENTORE CHURCH
ANDREA PALLADIO
1576-1591

16. FARNSWORTH HOUSE
LUDWIG MIES VAN DER ROHE
1945-1950
17. THE AMERICAN ACADEMY IN ROME
McKIM, MEAD, AND WHITE
1913
18. POWER CENTER
ROCHE-DINKELOO
1965-1971

19. DIPOLI CONFERENCE CENTER
REIMA PIETILLA
c. 1966
20. CARPENTER CENTER
LE CORBUSIER
1961-1963
21. NORMAN FISHER HOUSE
LOUIS I. KAHN
1960

22. LANG MUSIC BUILDING
ROMALDO GIURGOLA
1973
23. FREDERICK G. ROBIE HOUSE
FRANK LLOYD WRIGHT
1909
24. EXHIBITION PAVILION IN ZURICH
LE CORBUSIER
1964-1965

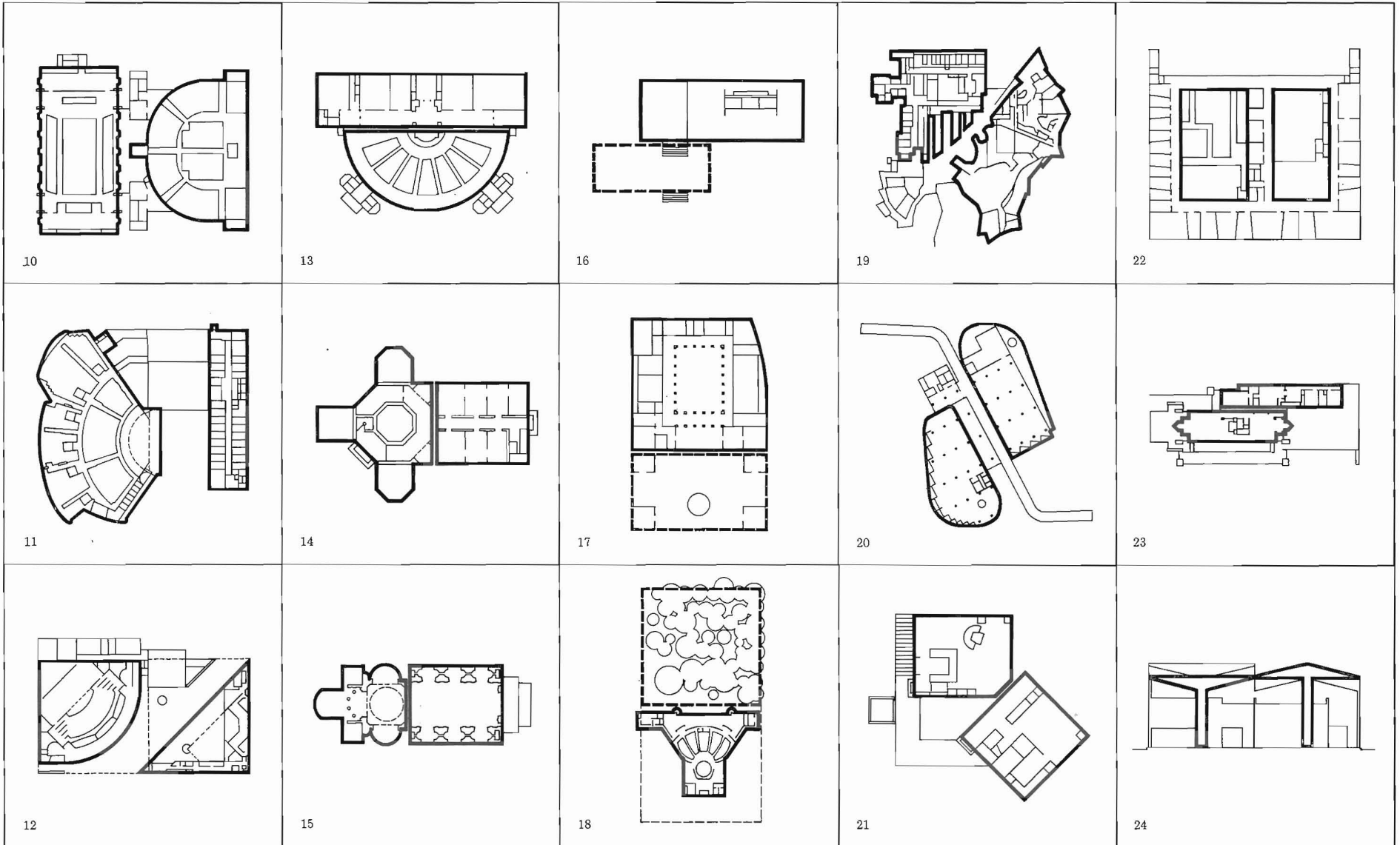

PROGRESSIONS

Progressions are patterns of incremental change that imply movement from one condition or attribute to another. The nature of the change determines the type of progression. Illustrated are examples of hierarchy, transition, transformation, and mediation.

Hierarchy

Hierarchy is the rank ordering of elements relative to the range of an attribute, such that importance or value is ascribed according to the presence or absence of the attribute. The hierarchy in Osterlars Church (1) is determined by size of interior space. Deal Castle (2), an example of concentric configuration, exhibits a rank ordering of centrality: the closer to the center, the more important the space. The Police Headquarters (3) has a hierarchy that is determined by the size, integrity, and memorability of the forms and spaces, and it ranges from dominant figure to background or poche. Sacred to profane establishes the hierarchies in Einsiedeln Abbey (4), Edfu Temple (5), and the Director's House (7). The difference among the three is that the sacred space occurs in two locations in Einsiedeln Abbey, and terminates in a single direction at Edfu Temple and the Director's House. The last example also shows the hierarchy in section. In Richards Lab (6), the hierarchy progresses from collective servant to individual servant to nonservant spaces. Heathcote's (8) elevation exhibits a rank ordering based on proximity to center, and in the Chapel at Ronchamp (9), hierarchy is a function of height and complexity of opening.

1. OSTERLARS CHURCH
ARCHITECT UNKNOWN
12th CENTURY
2. DEAL CASTLE
ARCHITECT UNKNOWN
c. 1540
3. POLICE HEADQUARTERS
HACK KAMPMANN
1918-1924

4. EINSIEDELN ABBEY
KASPAR MOOSBRUGGER
1719-1735
5. TEMPLE OF HORUS
ARCHITECT UNKNOWN
237 B.C.-57 B.C.
6. RICHARDS RESEARCH BUILDING
LOUIS I. KAHN
1957-1961

7. DIRECTOR'S HOUSE
CLAUDE NICHOLAS LEDOUX
1775-1779
8. HEATHCOTE
EDWIN LUTYENS
1906
9. CHAPEL AT RONCHAMP
LE CORBUSIER
1950-1955

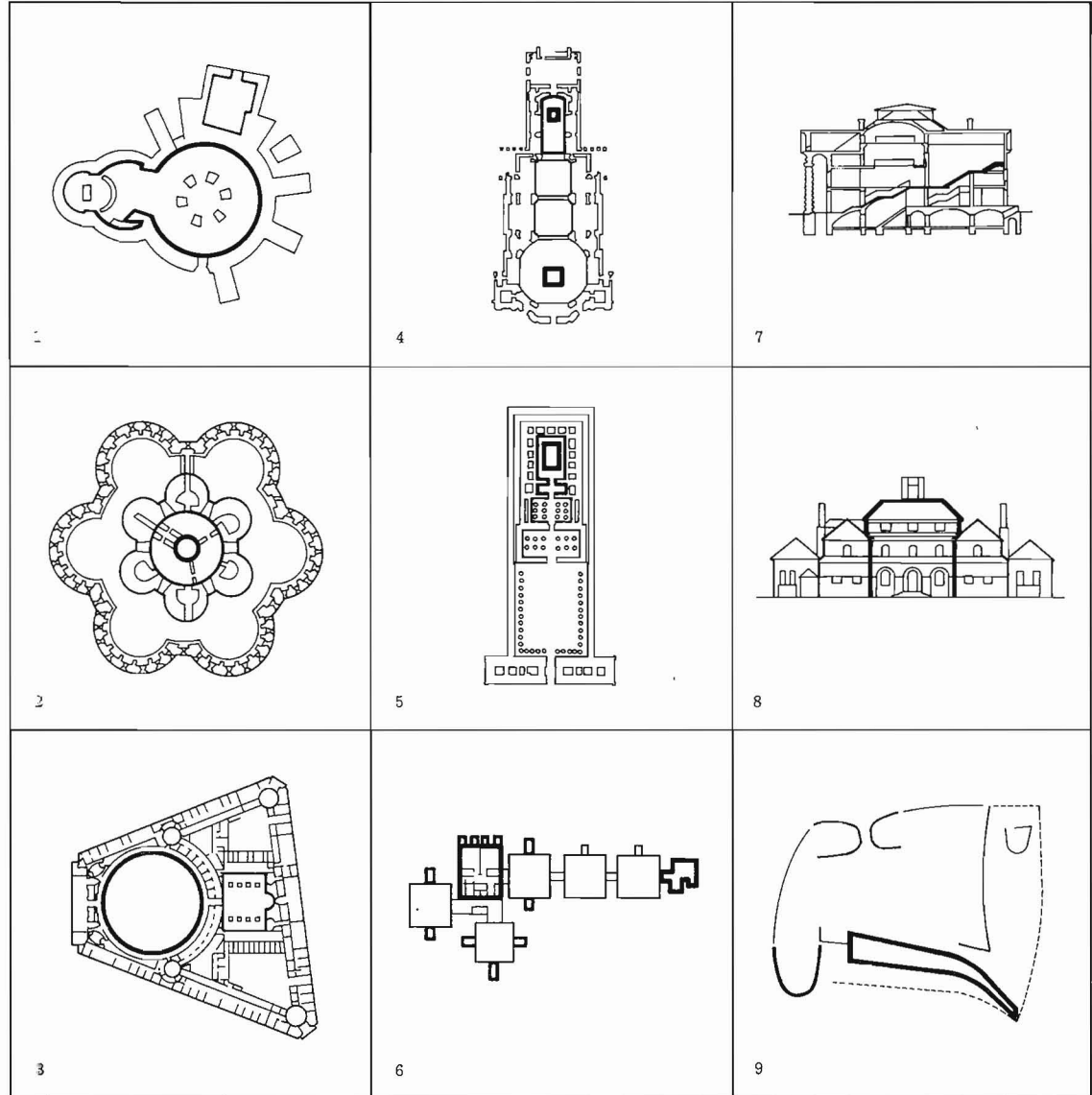

1. GUILD HOUSE
ROBERT VENTURI
1961
2. TEMPLE IN TARXIEN, MALTA
ARCHITECT UNKNOWN
2100 B.C.–1900 B.C.
3. BOYER HALL OF SCIENCE
GBQC
1970–1972

4. HOUSE OF THE FAUN
ARCHITECT UNKNOWN
2nd CENTURY B.C.
5. HOUSE IN CENTRAL PENNSYLVANIA
HUGH NEWELL JACOBSEN
1980
6. HOLY TRINITY UKRANIAN CHURCH
RADOSLAV ZUK
1977

7. SOUTH PLATFORM AT MONTE ALBAN
ARCHITECT UNKNOWN
c. 500
8. MOORE HOUSE
CHARLES MOORE
1962
9. PAZZI CHAPEL
FILIPPO BRUNELLESCHI
1430–1461

10. WOODLAND CHAPEL
ERIK GUNNAR ASPLUND
1918–1920
11. THE PALACE OF ASSEMBLY
LE CORBUSIER
1953–1963
12. FALLINGWATER
FRANK LLOYD WRIGHT
1935

Transition

Transition is the incremental change of an attribute within a finite limit. In the Guild House (1) the configuration of the walls progresses from simple on one side of the building to complex on the other. The Malta Tombs (2), Boyer Hall (3), the House of the Faun (4), and the house in Pennsylvania (5) are examples of transitions of size. This is also the case at Holy Trinity Church (6), the Temple at Monte Alban (7), and the Moore House at Orinda (8). The Pazzi Chapel (9), the Woodland Chapel (10), the Palace of Assembly (11), and Frank Lloyd Wright's Fallingwater (12) exemplify progressions from open to closed.

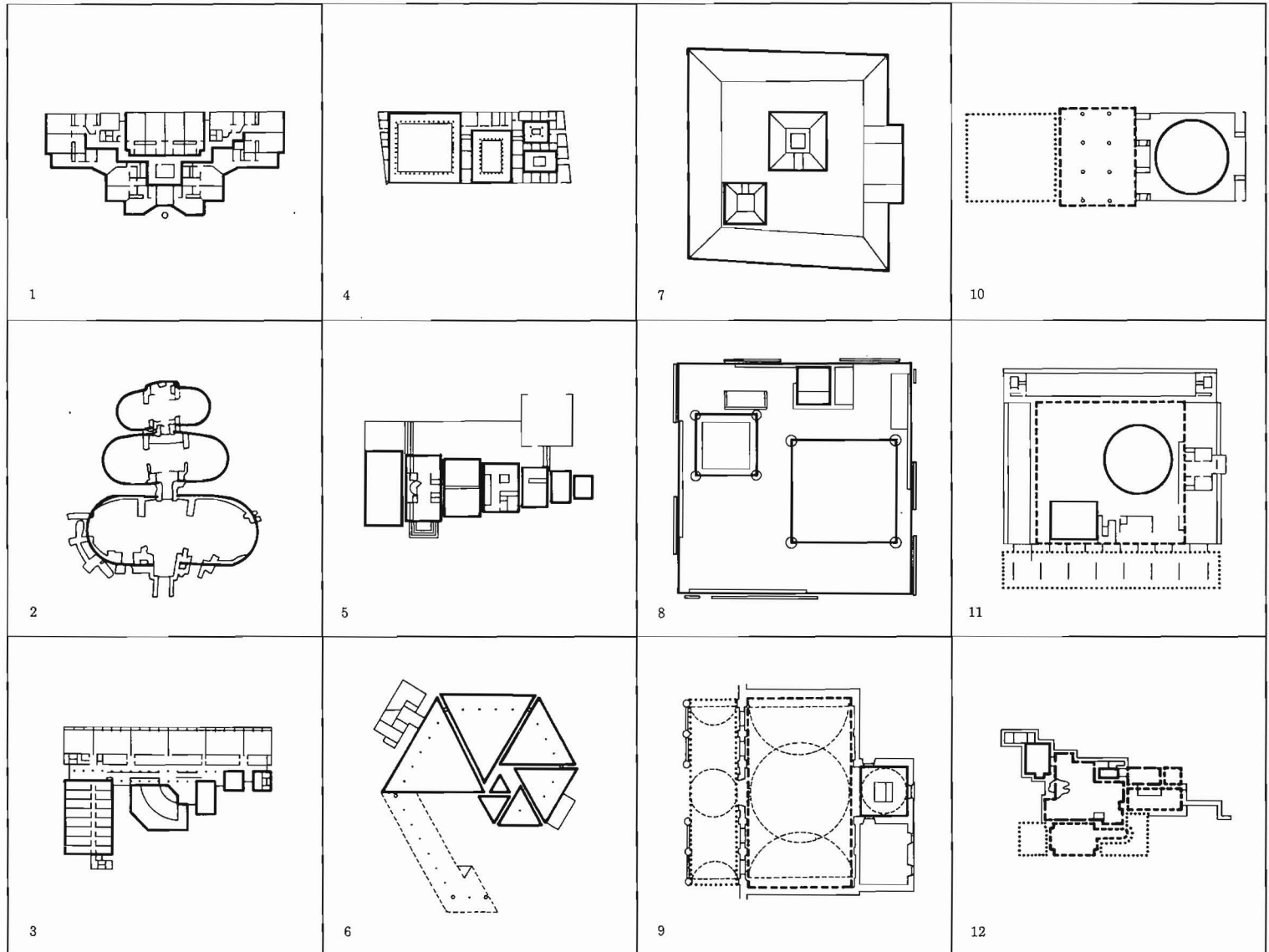

1. SAN LORENZO
GUARINO GUARINI
1666-1679
2. FONTEVRAULT ABBEY
ARCHITECT UNKNOWN
1115
3. HADRIAN'S MARITIME THEATER
ARCHITECT UNKNOWN
125-135

4. SAN MARIA DELLA CONSOLAZIONE
ARCHITECT UNKNOWN
1508
5. NATIONAL ASSEMBLY IN DACCA
LOUIS I. KAHN
1962-1974
6. ST. MARY'S CATHEDRAL
KENZO TANGE
1963

7. CHURCH AT FIRMINY
LE CORBUSIER
1963
8. LISTER COUNTY COURTHOUSE
ERIK GUNNAR ASPLUND
1917-1921
9. ADULT LEARNING LABORATORY
ROMALDO GIURGOLA
1972

10. KARLSKIRCHE
JOHAN FISHER VON ERLACH
1715-1737
11. BATHS AT OSTIA, ITALY
ARCHITECT UNKNOWN
c. 150
12. HOTEL DE MONTMORENCY
CLAUDE NICHOLAS LEDOUX
1769

Transformation

Transformation is the incremental change from one form to a different form. San Lorenzo (1), Fontevrault Abbey (2), Hadrian's Villa (3), San Maria della Consolazione (4), and the National Assembly (5) are examples of concentric transformations. In these buildings the form at the center transforms, through a series of changes, to a different form at the perimeter. In St. Mary's Cathedral (6) and the Church at Firminy (7), the transformation occurs vertically from ground level to top. St. Mary's changes from a diamond to a cruciform, and at Firminy a square is transformed into a circular form. The Lister County Courthouse (8) and the Adult Learning Research Lab (9) exemplify form change, from outside to inside, of significant elements within the building. Transformation of direction and change of adjacent forms occur in Karlskirche (10). In the Baths at Ostia (11) and Hotel Montmorency (12), a transformation of adjacent units occurs.

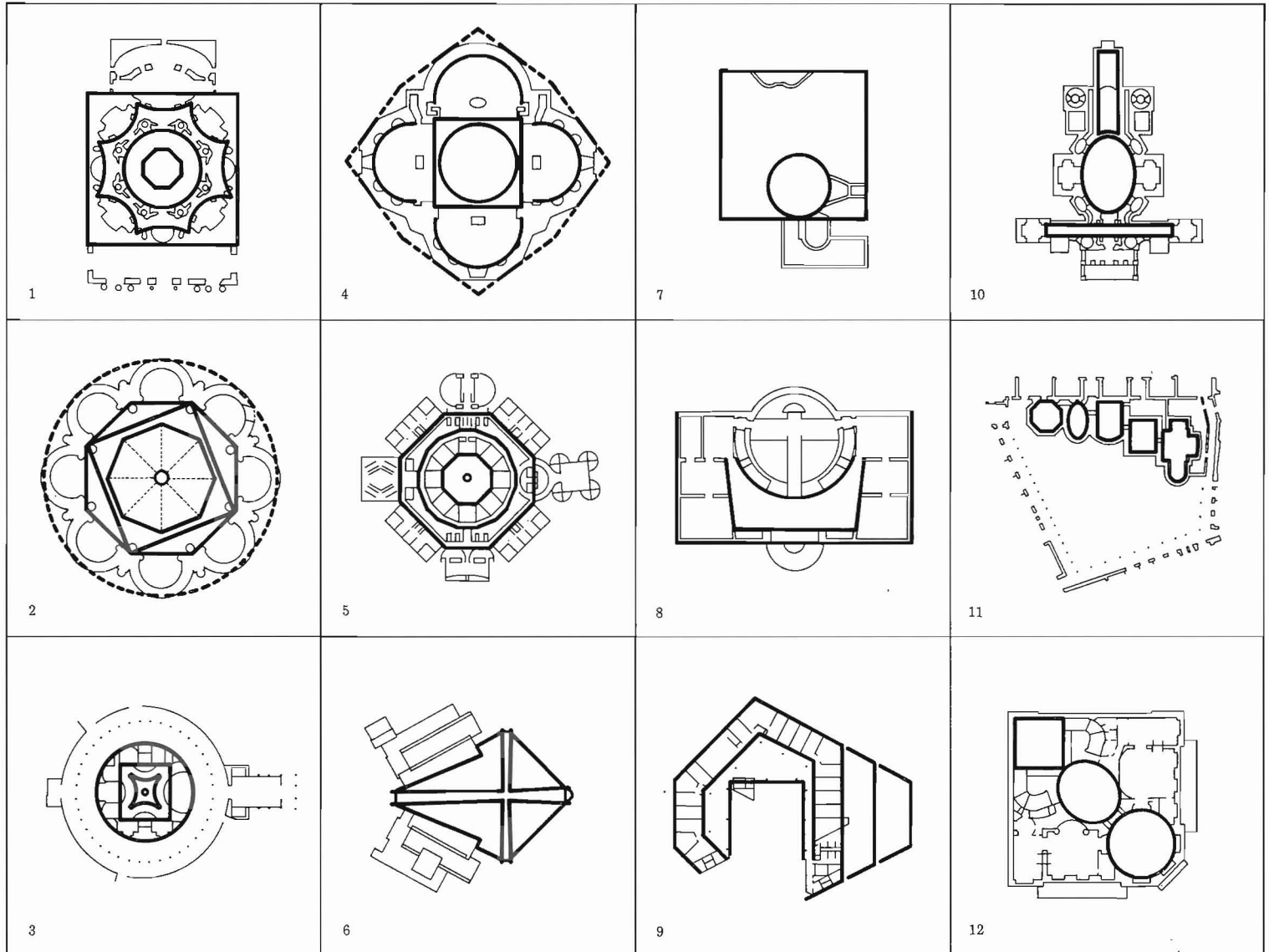

1. ROYAL CHANCELLERY
ERIK GUNNAR ASPLUND
1922
2. EURAM BUILDING
HARTMAN-COX
1971
3. ALAJARVI TOWN HALL
ALVAR AALTO
1966

4. ALLEN ART MUSEUM ADDITION
ROBERT VENTURI
1973-1976
5. AIA HEADQUARTERS
ROMALDO GIURGOLA
1967
6. WEEKEND HOUSE
EDWARD LARABEE BARNES
c. 1963

7. THE ATHENEUM
RICHARD MEIER
1975-1979
8. TREDYFFRIN PUBLIC LIBRARY
ROMALDO GIURGOLA
1976
9. VOUKSENNISKA CHURCH, IMATRA
ALVAR AALTO
1956-1958

Mediation

Mediation is the insertion of some form of progression between two conditions which occur outside the limits of the building. It is common for mediation to occur between two natural conditions, an element in nature and a built form, or two built situations. The Royal Chancellery (1), the Euram Building (2), the Alajarvi Town Hall (3), the Allen Art Center (4), and the AIA Headquarters (5) are buildings designed to mediate between existing contextual conditions within a built environment. The weekend house (6) mediates between two natural situations: the horizontality of the water and the verticality of the woods. The Atheneum (7), Tredyffrin Library (8), and Aalto's Church at Imatra (9) mediate between a component in nature and a condition in built form. The Atheneum occurs between the curvilinear form of the river and the orthogonal grid of the town. At Tredyffrin, the mediation is between a special point marked by a tree and the orthogonal built environment. In Imatra the design is inserted between other buildings and the natural context of the woods.

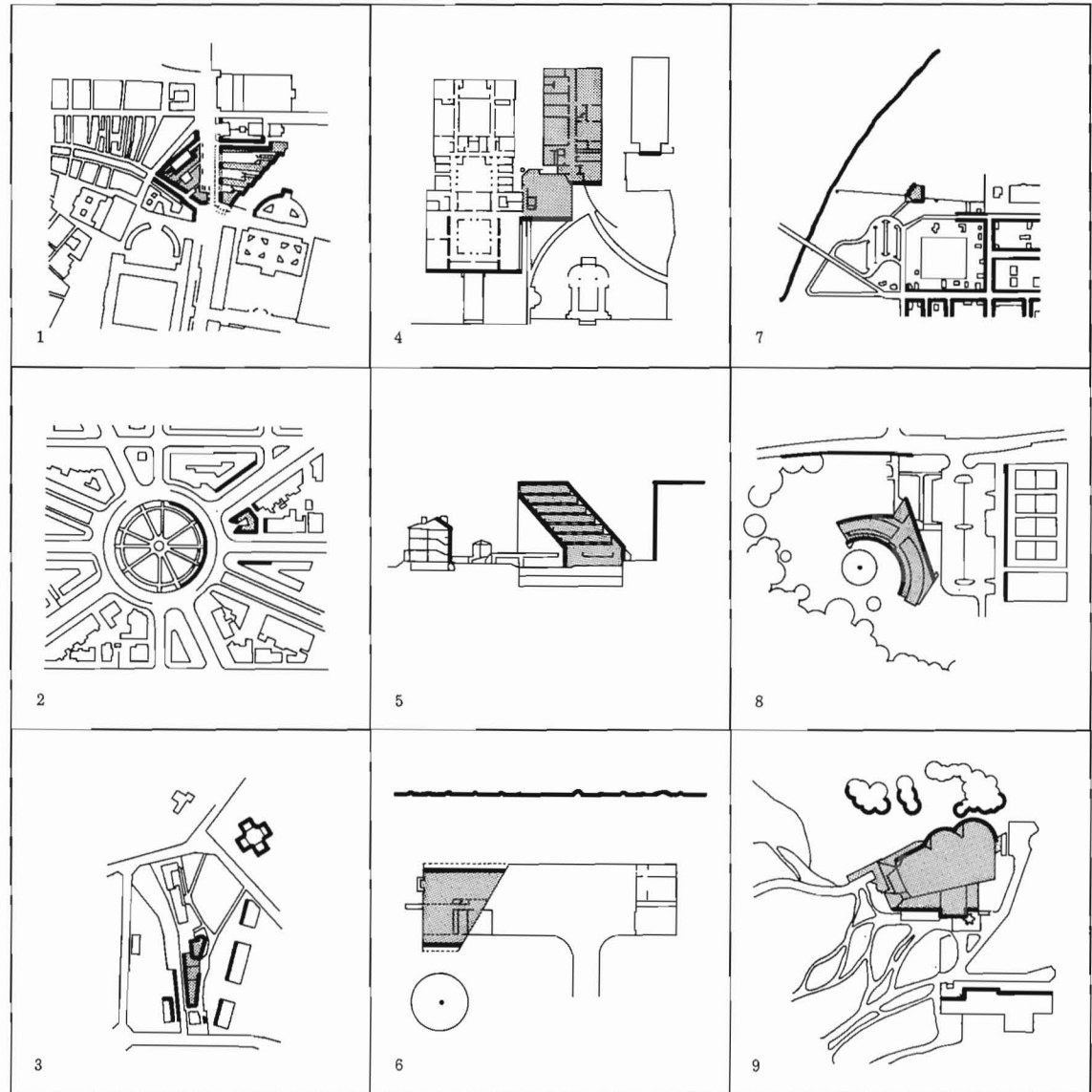

1. THE SALUTATION
EDWIN LUTYENS
1911
2. VILLA SHODHAN
LE CORBUSIER
1951

3. SYDNEY OPERA HOUSE
JORN UTZON
1957-1968
4. GOETHEANUM I
RUDOLF STEINER
1913-1920

5. SHUKOSHA BUILDING
ARATA ISOZAKI
1974-1975
6. SNELLMAN HOUSE
ERIK GUNNAR ASPLUND
1917-1918

REDUCTION

Reduction is the miniaturization of the whole or a major part of a building. This scaled down component can be included as a part within the whole or as a secondary element added to the primary form.

Large Plus Small Reduction

It is common for the reduced form to be the servant element, as at Salutation (1), Villa Shodhan (2), Shukosha Building (5), Snellman House (6), Robie House (7), and Coonley House (8). Unity Temple (9) is similar in that the reduced form is also servant, but the reduction occurs in elevation. Scaled down forms for comparable use occur in the Sydney Opera House (3), the Goetheanum I (4), the Mummens Theater (11), the Woodland Crematory (12), the Van Buren House (13), and the Wolfsburg Parish Center (14). Large plus small reduction is not limited to one form at each scale. Castle del Monte (10) is an example of multiple smaller units added to the original form. Interesting uses of this reduction concept include the design of an addition that is a miniaturization of the existing Claghorn House (15), and the design of the Council Chamber, as a reduction of the entire building, in Aalto's Saynatsalo Town Hall (16).

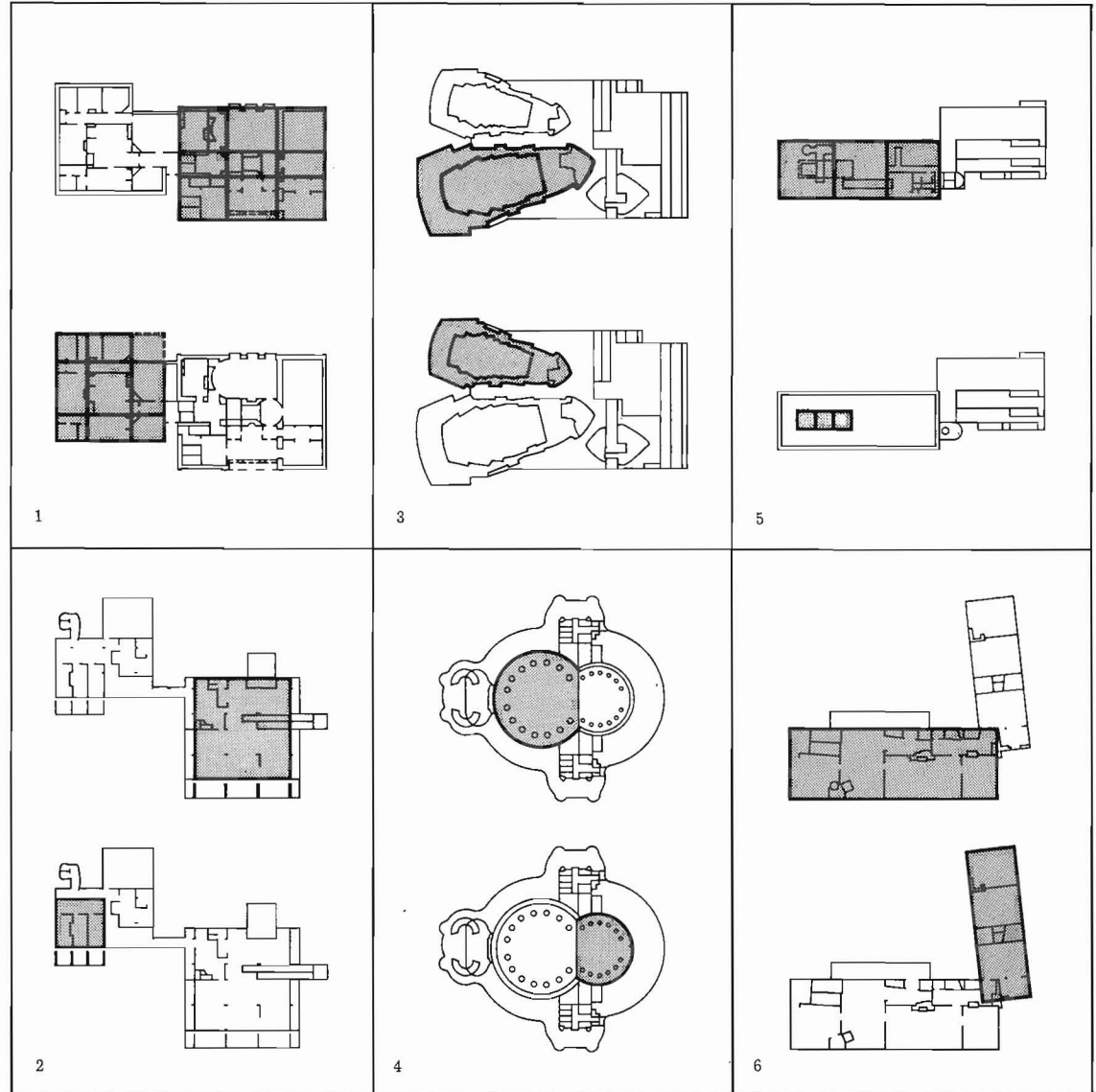

7. **FREDERICK G. ROBIE HOUSE**
FRANK LLOYD WRIGHT
1909

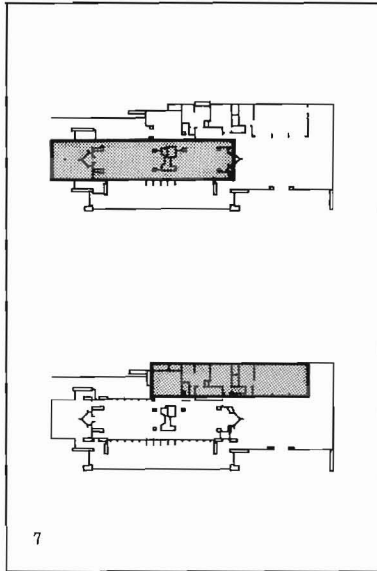

9. **UNITY TEMPLE**
FRANK LLOYD WRIGHT
1906

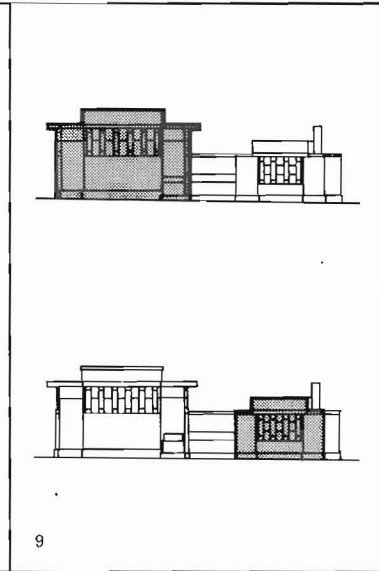

11. **MUMMERS THEATER**
JOHN M. JOHANSEN
1970

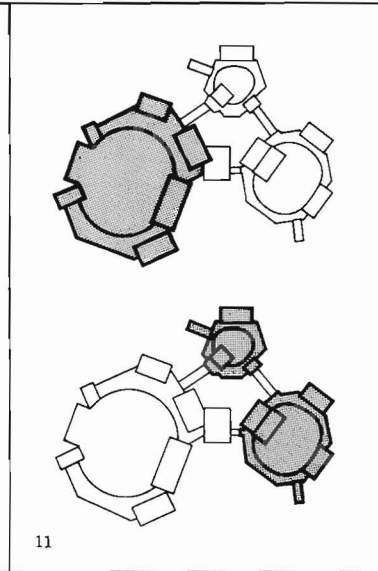

13. **TRAVIS VAN BUREN HOUSE**
BRUCE PRICE
1885

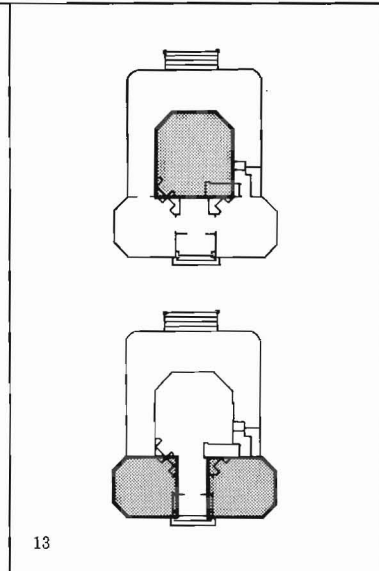

15. **CLAGHORN HOUSE**
MICHAEL GRAVES
1974

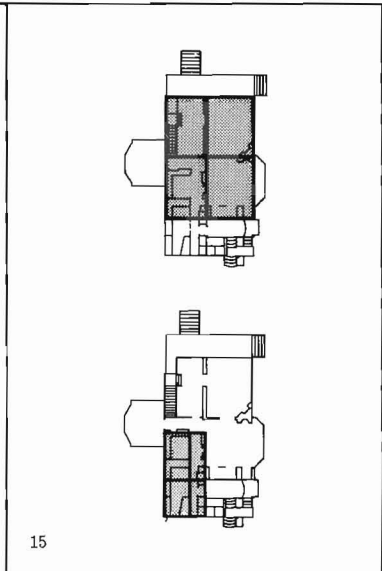

8. **AVERY COONLEY HOUSE**
FRANK LLOYD WRIGHT
1907

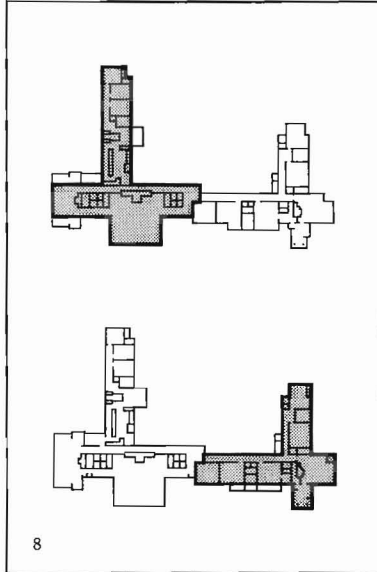

10. **CASTLE DEL MONTE**
ARCHITECT UNKNOWN
c. 1240

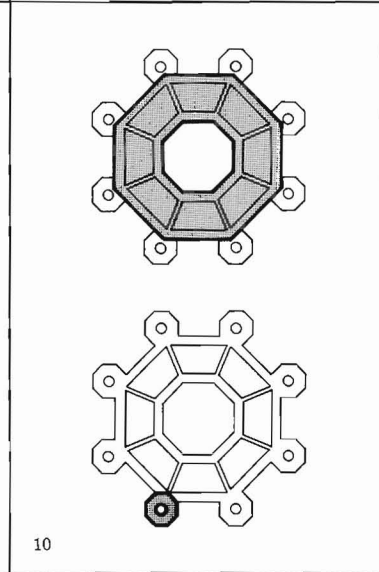

12. **WOODLAND CREMATORIUM**
ERIK GUNNAR ASPLUND
1935-1940

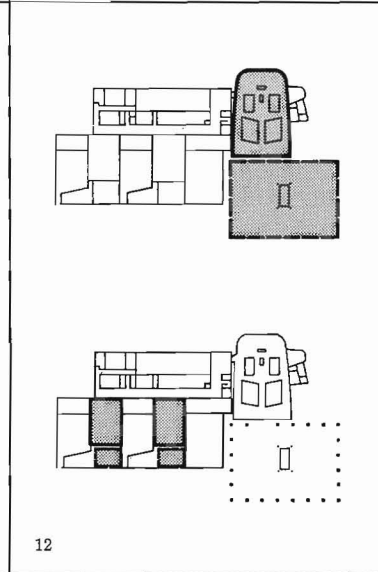

14. **WOLFSBURG PARISH CENTER HALL**
ALVAR AALTO
1960-1962

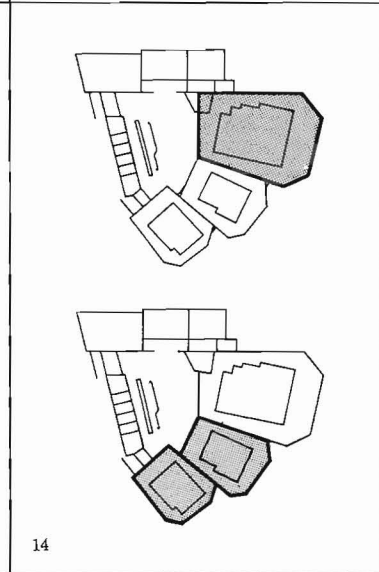

16. **SAYNATSALO TOWN HALL**
ALVAR AALTO
1950-1952

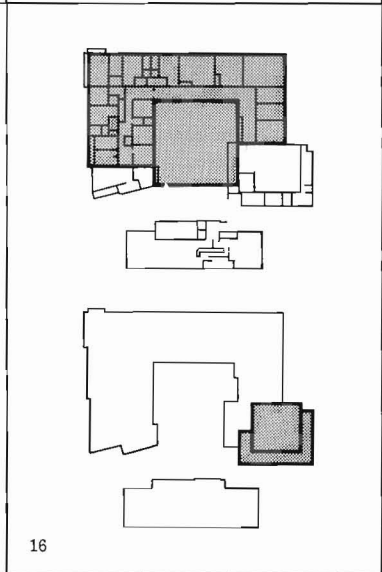

1. EASTON NESTON
NICHOLAS HAWKSMOOR
c. 1695-1710

2. THE SALUTATION
EDWIN LUTYENS
1911

3. STRATFORD HALL
ARCHITECT UNKNOWN
1725

4. BANK OF PENNSYLVANIA
BENJAMIN HENRY LATROBE
1798-1800

5. ERDMAN HALL DORMITORIES
LOUIS I. KAHN
1960-1965

6. ALLEGHENY COUNTY COURTHOUSE
HENRY HOBSON RICHARDSON
1883-1888

7. OLD SACRISTY
FILIPPO BRUNELLESCHI
1421-1440

8. LANDERBANK
OTTO WAGNER
1883-1884

Part of Whole Reduction

Major rooms, spaces, or groupings of spaces form the reductions of the whole building in Easton Neston (1), Salutation (2), Stratford Hall (3), and the Bank of Pennsylvania (4). This is also the case in Bryn Mawr Dormitories (5), the Allegheny County Building (6), and Guild House (14). In the Old Sacristy (7) and the Landerbank (8), the part, an altar space and main stair, respectively, is a reduction of the dominant space or form of the building. Christ Church (9) and St. Clement Danes (10) are similar in that adjacent spaces defined by columns are the buildings and towers reduced. Two aedicula in the Moore House (11) reflect the whole, and in St. Mary's Cathedral (12) the nave is reduced to a smaller dome and adjacent space. At Heathcote (13), the plan configuration of the garden side of the house is reduced to form the entry side. In the Parthenon (15), the reduction includes a reversal in space definition by walls or columns. The positive-negative configuration of the Hanselmann House (16) with its forecourt, is reduced to create the main living spaces. In the Yano House (17) the plan is reduced to form part of the section, and an elevation reduction forms the fireplace in the Tucker House. (18).

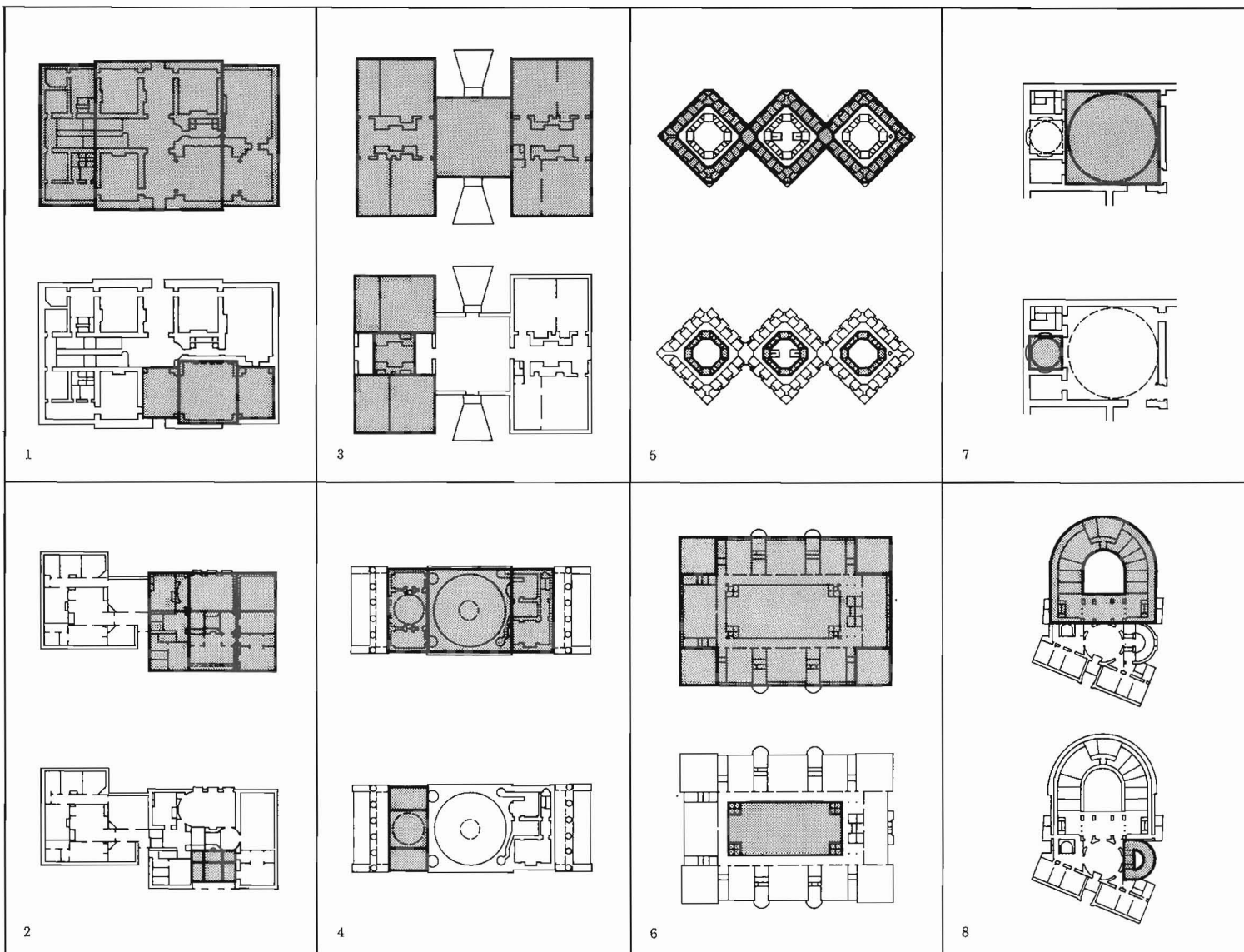

9. CHRIST CHURCH
NICHOLAS HAWKSMOOR
1715-1729

10. ST. CLEMENT DANES
CHRISTOPHER WREN
1680

11. MOORE HOUSE
CHARLES MOORE
1962

12. ST. MARY'S CATHEDRAL
BENJAMIN HENRY LATROBE
1814-1818

13. HEATHCOTE
EDWIN LUTYENS
1906

14. GUILD HOUSE
ROBERT VENTURI
1961

15. PARTHENON
ICTINUS
447 B.C.-430 B.C.

16. HANSELMANN HOUSE
MICHAEL GRAVES
1967

17. YANO HOUSE
ARATA ISOZAKI
1975

18. CARLL TUCKER III HOUSE
ROBERT VENTURI
1975

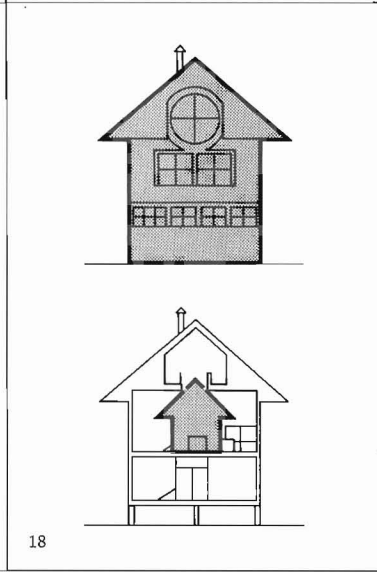
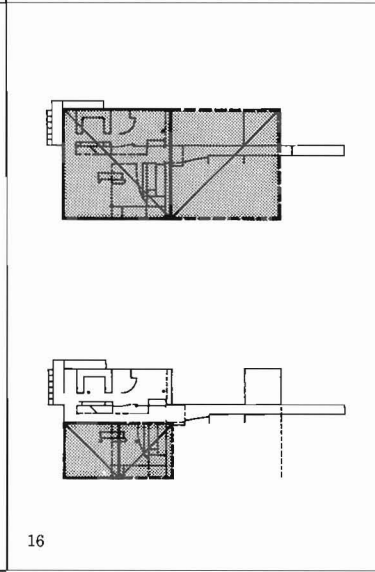
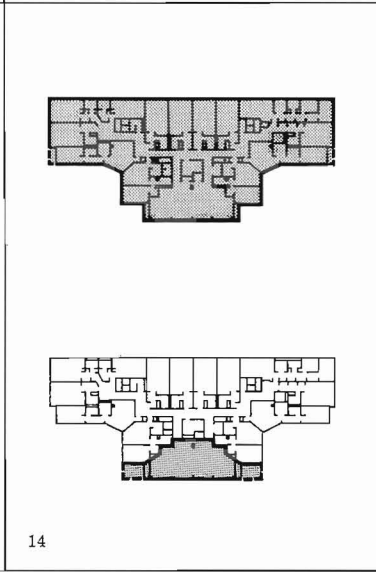
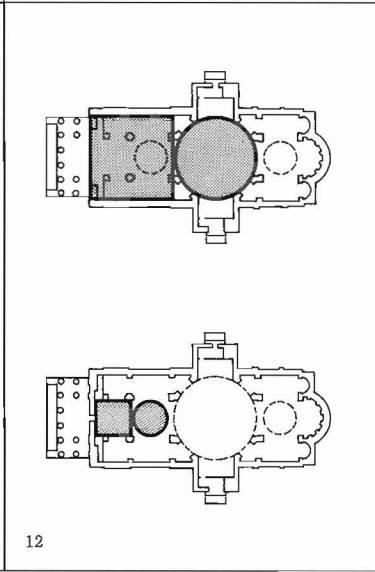
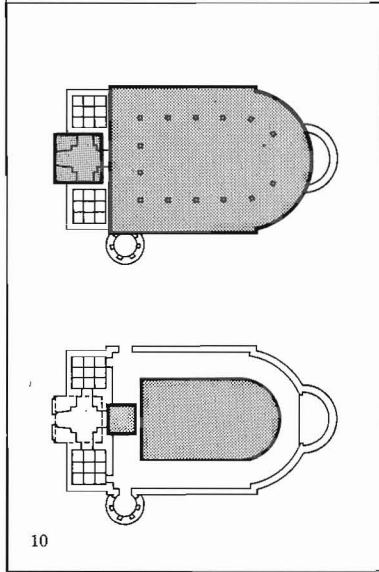
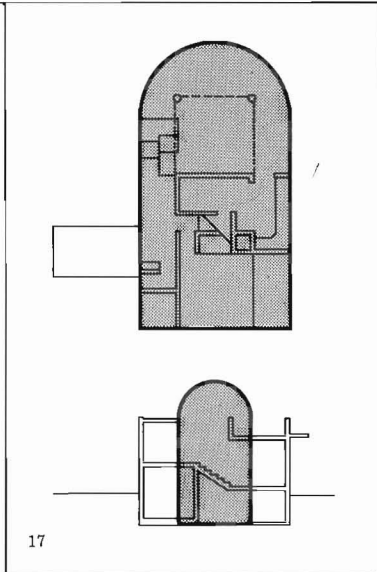
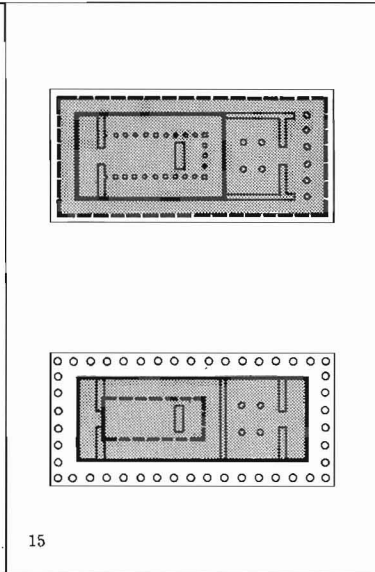
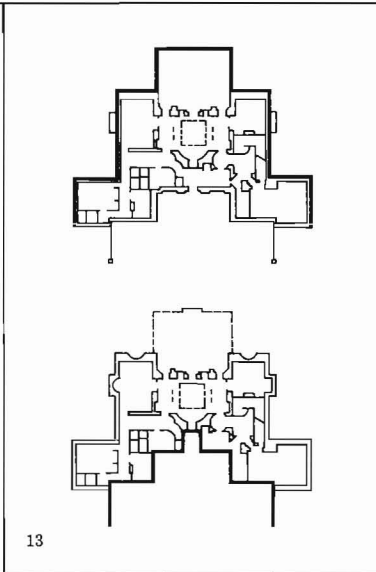
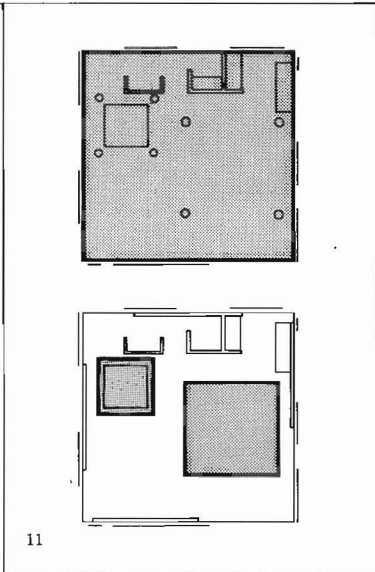
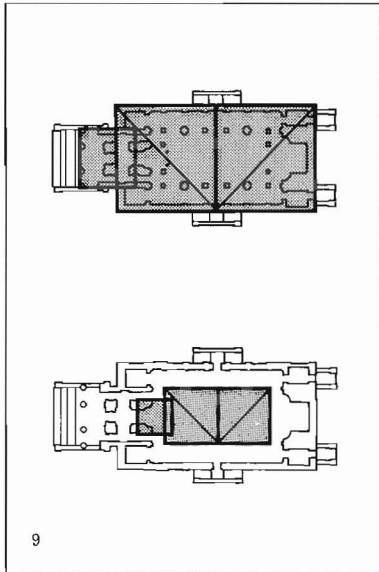

INDEX BY ARCHITECT

The information in this book has been indexed twice; by architect and by common building name. The index by architect includes the life dates of the person when known, the buildings by that architect that are included in this volume, and the dates of those buildings followed by the page number.

Aalto, Alvar 1898–1976

- Alajarvi Town Hall 1966 255
Baker Dormitory 1947–1948 243
Enso-Gutzeit Headquarters 1959–1962 12, 203, 220,
240, 248
Finlandia Concert Hall 1967–1971 209
House of Culture in Helsinki 1955–1958 251
Neur Vahr Apartments 1958–1962 239
Paimio Sanitorium 1929–1933 211
Riola Parish Center 1970 225
Studio House 1955 231
Saynatsalo Town Hall 1950–1952 8, 199, 211, 219,
225, 257
Seinajoki Town Hall 1962–1965 218
Turun Sanomat Offices 1927–1929 241
Villa Mairea 1937–1939 235
Vouksenniska Church 1956–1958 10, 206, 211, 226, 255
Wolfsburg Cultural Center 1958–1962 14, 203, 211, 229,
226, 227
Wolfsburg Parish Center Church 1960–1962 239
Wolfsburg Parish Center Hall 1960–1962 257
Adams, Robert 1728–1792
Green Park Ranger's House 1768 232
Alberti, Leon Battista 1404–1472
San Sebastiano 1459 241
Alessi, Galeazzo 1512–1572
San Maria Di Carignano 1552 234
Ando, Tadao 1941–
Chapel on Mt. Rokko 1985–1986 16
Church on the Water 1985–1988 18

Antemius of Tralles 6th Century

- Hagia Sophia 532 234
Asplund, Erik Gunnar 1885–1940
Lister County Courthouse 1917–1921 24, 205, 212, 221,
222, 225, 232, 236, 254
Royal Chancellery 1922 237, 255
Snellman House 1917–1918 20, 200, 216, 225, 237, 238,
243, 256
Stockholm Public Library 1920–1928 26, 206, 211, 215,
220, 222, 230, 244, 249
Woodland Chapel 1918–1920 22, 227, 230, 253
Woodland Crematorium 1935–1940 257

Barnes, Edward Larabee 1922–

- Cathedral of the Immaculate Conception 1977 231
Mt. Desert Island Residence 1975 212
Weekend House c. 1963 206, 255

Behrens, Peter 1864–1940

- A. E. G. High Tension Factory 1910 240
Cuno House 1906–1907 238

Bohlin, Peter Q. 1937–

- Gaffney Residence 1977–1980 30
Guest House, Gates Residence 1990–1993 34
House in the Adirondacks 1987–1992 32
Weekend Residence for Mr. and Mrs. Eric Q. Bohlin
1973–1975 28

Bohlin and Powell, See Peter Q. Bohlin

Bohlin Cywinski Jackson, See Peter Q. Bohlin

Bohlin Cywinski Jackson / James Cutler Architects, See Peter Q. Bohlin

Botta, Mario 1943-

Bianda Residence 1987-1989 40
Church of San Giovanni Battista 1986-1995 38
Residence in Cadenazzo, Ticino 1970-1971 205
Residence in Massagno, Switzerland 1979 232
Residence in Riva San Vitale 1972-1973 36, 207, 228
Residence in Stabio 1981 213
Secondary School in Morbio Inferiore 1972-1977 223
The Church of Beato Odorico 1987-1992 42

Boromini, Francesco 1599-1667

San Carlo Alle Quattro Fontane 1638-1641 237
S. Ivo Della Sapienza 1642-1650 223

Boyle, Richard (Lord Burlington) 1694-1753

Chiswick House 1729 234

Bramante, Donato 1444-1514

Architectural Setting 1473 226
S. Maria Della Pace 1478-1483 226
Tempietto of San Pietro 1502 230

Breuer, Marcel 1902-1981

Robinson House 1947 250
St. John's Abbey 1953-1961 201
Whitney Museum of Art 1966 220

Brunelleschi, Filippo 1377-1446

Old Sacristy at San Lorenzo 1421-1440 44, 200, 208,
230, 236, 258
Ospedale Degli Innocenti 1421-1445 46, 224, 246
Pazzi Chapel 1430-1461 253
San Maria Degli Angeli 1434-1436 48, 187, 188, 211, 215,
221, 222, 229, 238, 244
San Spirito 1434 50, 208, 215, 222, 238

Bulfinch, Charles 1763-1844

James Swan House 1796 232

Burlington, Earl of, See Boyle, Richard

Cambridge Seven Associates

New England Aquarium 1962 239

Castle, Richard C. 1695-1751

Annaglee 1740-1770 209

Chambers, William 1726-1796

Casino in Rome 1754 232
York House 1759 234

Cortona, Domenica da c. 1470-1549

Chateau De Chambord 1519-1547 233

Dahinden, Justus 1925-

St. Antonius Church 1966-1969 239

Dientzenhofer, Georg 1643-1689

Kappel Pilgrimage Church 1684-1689 223

Dortsman, Adrien 1625-1682

New Lutheran Church 1668 237

Fehn, Sverre 1924-

The Glacier Museum 1991 54
Villa Busk 1990 52

Fischer Von Erlach, Johann 1656-1723

Karlskirche 1715-1737 211, 254

Furness, Frank 1839-1912

Baltimore and Ohio Railroad Depot 1886 245
Pennsylvania Academy of Fine Arts 1872 246

Gaudi, Antonio 1852-1926

Casa Mila 1905-1907 246

G.B.Q.C., See Geddes, Brecher, Qualls, and Cunningham

Geddes, Brecher, Qualls, and Cunningham

Boyer Hall of Science 1970-1972 218, 253
Institute for Advanced Studies 1968-1972 217

Gilbert, Cass 1859-1934

U.S. Supreme Court 1935 234

Giurgola, Romaldo 1920- See Michell/Giurgola

Goodhue, Bertram 1869-1924

Nebraska State Capitol 1924 241

Graves, Michael 1934-

Alexander House 1971-1973 216
Claghorn House 1974 257
Crooks House 1976 227
Hanselmann House 1967 227, 259

Greene, Charles Sumner 1868–1957 See Greene & Greene

Greene, Henry Mather 1870–1954 See Greene & Greene

Greene and Greene

D. L. James House 1918 247

Guarini, Guarino 1624–1683

San Lorenzo 1666–1679 249, 254

Gwathmey, Charles 1938– See Gwathmey-Siegel

Gwathmey-Siegel

Charof Residence 1974–1976 258

Cooper Residence 1968–1969 212

Elia-Bash Residence 1971–1973 235

Residence in Bridgehampton 1969–1971 212

Hadrian 76–138

Temple of Venus and Rome 123–135 223, 246

Hardy, Hugh 1932– See Hardy-Holzman-Pfieffer

Hardy-Holzman-Pfieffer

Brooklyn Childrens Museum 1977 217

Occupational Health Center 1973 212, 217, 238, 247

Pratt Residence 1974 212

Salisbury School 1972 212

Hartman-Cox

Euram Building 1971 255

Hawksmoor, Nicholas 1661–1736

Christ Church, Spitalfields 1715–1729 68, 186, 205, 208, 214, 222, 233, 259

Easton Neston c. 1695–1710 64, 210, 216, 225, 233, 238, 258

St. George-In-The-East 1714–1729 66, 210, 214, 221, 235, 249

St. Mary Woolnoth 1716–1724 70, 205, 208, 228, 244

Hecker, Svi 1931–

Negev Desert Synagogue 1967–1969 229

Hejduk, John 1929–

One-Half House 1966 237

Ictinus 5th Century B.C.

Parthenon 447 B.C.–430 B.C. 249, 259

Isozaki, Arata 1931–

Annex to Oita Medical Hall 1970–1972 206, 226, 251

Gumma Museum of Fine Arts 1971–1974 216, 241

Kamioka Town Hall 1976–1978 218

Nakayama House 1964 201

Shukosha Building 1974–1975 256

Yano House 1975 140, 153, 259

Jacobsen, Hugh Newell 1929–

Central Pennsylvania House 1980 242, 253

Jefferson, Thomas 1743–1826

Poplar Forest c. 1806 202, 229

The University of Virginia Rotunda 1826 229

Johansen, John M. 1916–

Mummers Theater 1970 257

Jones, Inigo 1573–1652

The Queen's House 1629–1635 250

Kahn, Louis I. 1901–1974

Convent for Dominican Sisters 1965–1968 211, 215, 247

Erdman Hall Dormitories 1960–1965 212, 258

Exeter Library 1967–1972 78, 202, 209, 215, 220, 223, 230, 234, 245, 249

First Unitarian Church 1959–1967 244

Fisher House 1960 238, 251

Kimball Art Museum 1966–1972 76, 206, 211, 217, 241

National Assembly in Dacca 1962–1974 213, 254

Richards Medical Research Building 1957–1961 72, 221, 239, 252

Salk Institute 1959–1965 74, 205, 222, 235, 250

Trenton Bath House 1955–1956 241

Yale Center for British Art 1969–1974 235, 238, 246

Kallman and McKinnell

Exeter Physical Education Facility 1970 243

Kampmann, Hack 1856–1920

Police Headquarters 1918–1924 252

Kurokawa, Kisho 1934–

Tateshina Planetarium 1976 232

Labrouste, Henri 1801–1875

Sainte Genevieve Library 1838–1850 240

Latrobe, Benjamin Henry 1764–1820

Bank of Pennsylvania 1798–1800 258

St. Mary's Cathedral 1814–1818 231, 259

Le Corbusier 1887–1965

Carpenter Center 1961–1963 238, 251

Church at Firminy-Vert 1963 254

Convent of La Tourette 1957–1960 218, 236, 245

House at Weissenhof 1927 207

Museum at Ahmedabad 1953–1957 239

Notre Dame Du-Haut 1950–1955 84, 201, 213, 225, 252

Palace of Assembly 1953–1963 86, 202, 209, 215, 231,
246, 248, 253

Stockholm Exhibition Hall 1962 201

Unite d'Habitation 1946–1952 82, 204, 218, 225, 243

Villa Savoye 1928–1931 80, 204, 211, 217, 220, 227, 228,
235

Villa Shodhan 1951 256

Villa Stein 1927 200, 236

Weekend House 1935 234

Zurich Exhibition Pavilion 1964–1965 251

Ledoux, Claude Nicholas 1735–1806

Director's House 1775–1779 94, 208, 222, 252

Hotel Guimard 1770 90, 208, 225, 237

Hotel De Montmorency 1769 88, 204, 209, 216, 231, 234,
242, 254

Theater in Besancon 1775 92, 203, 210, 215, 235, 249

Le Pautre, Antione 1614–1691

Hotel De Beauvais 1656 245

Loos, Adolf 1870–1933

Khuner Villa 1930 205, 214

Rufer House 1922 207, 228

Steiner House 1910 216

Lutyens, Edwin 1869–1944

Heathcote 1906 100, 252

Homewood 1901 96, 216, 220, 225, 235, 248, 259

Nashdom 1905–1909 98, 210, 236, 250

The Salutation 1911 102, 203, 221, 245, 256, 258

McKim, Mead, and White

American Academy 1913 251

Boston Public Library 1898 219, 228

J. Pierpont Morgan Library 1906 209

New York Herald Building 1894 238

Rhode Island State Capitol 1895–1903 214

Machuca, Pedro 1485–1550

Palace of Charles V 1527 230, 244

Maki, Fumihiko 1928–

Shenboku Archives 1970 214

Mansart, Jules Hardouin 1645–1708

St. Louis Des Invalides 1676 234

Meier, Richard 1934–

Museum for Decorative Arts 1981 235

Shamberg House 1972–1974 236

Smith House 1965–1967 104, 200, 227

The Atheneum 1975–1979 106, 198, 255

Ulm Exhibition and Assembly Building 1986–1992
108

Weishaupt Forum 1987–1992 110

Melnikov, Konstantin 1890–1974

Melnikov House 1927 229, 238

Rusakov Club 1927 201, 229

Mercer, Henry 1856–1930

Mercer Castle 1908–1910 247

Michela, Costanzo 1684–1754

San Marta Church 1746 226

Michelangelo 1475–1564

Laurentian Library 1525 242

Sforza Chapel 1558 231

St. Peter's 1506–1626 231

Mitchell/Giurgola

- Adult Learning Research Laboratory 1972 56, 202, 215,
224, 235, 254
A.I.A. Headquarters 1967 255
Lang Music Building 1973 58, 205, 208, 215, 227, 236, 251
Plattsburg Student Union 1974 60, 208, 217, 220
Tredyffrin Public Library 1976 62, 209, 226, 255
Moore, Charles W. 1925-1993
Burns House 1974 116
Hines House 1967 116, 203
Moore House, Orinda 1962 112, 216, 228, 246, 248, 253,
259
Sea Ranch Condominium I 1964-1965 114, 209, 221,
224, 240
Stern House 1970 243
Moosbrugger, Kaspar 1656-1723
Einsiedeln Abbey 1719-1735 252
Morrison, Richard 1767-1849
Castlegar 1807 232

Paeonius (Paionios) and Daphnis

Temple of Apollo c. 310 B.C. 244

Paeonius (Paionios) and Demetrius

Temple of Artemis c. 356 B.C. 217

Palladio, Andrea 1508-1580

La Rotonda, *See* Villa Capra

Redentore Church 1576-1591 126, 203, 208, 222, 226,
242, 251

San Giorgio Maggiore Church 1560-1580 122, 201, 208,
224

Villa Capra (Almerico) 1566-1571 124, 185, 201, 211,
215, 221, 223, 230, 234, 245

Villa Foscari c. 1549-1563 120, 215, 240

Villa Trissino 1553-1576 233

Pei, Ieoh Ming 1917-

East Wing of National Gallery 1975-1978 241

Everson Museum of Art 1968 213

Paul Mellon Arts Center 1970-1973 213, 226, 251

Piano and Rogers

Centre Beaubourg 1972-1977 243

Pietilia, Reima 1923-1993

Dipoli Conference Center c. 1966 251

Polykleitos The Younger 4th Century B.C.

Tholos c. 365 B.C. 229

Pope, John Russell 1874-1937

Johns Hopkins University Hall c. 1930 230

Temple of The Scottish Rite 1910 202

Price, Bruce 1845-1903

Chandler House 1885-1886 248

Van Buren House 1885 257

Raphael 1483-1520

St. Eligio Degli Orefici 1509 228

Rhoikos of Samos c. 540 B.C.

Fourth Temple of Hera 575-550 B.C. 240

Richardson, Henry Hobson 1838-1886

Allegheny County Courthouse 1883-1888 132, 186, 210,
219, 221, 233, 249, 258

Austin Hall 1881-1884 232

J. J. Glessner House 1885-1887 134, 224, 248

F. L. Higginson House 1881-1883 232

Sever Hall 1878-1880 130, 203, 212, 233

W. Watts Sherman House 1874 247

Trinity Church 1872-1877 128, 210, 215, 244

Roche, Kevin 1922- *See* Roche Dinkeloo**Roche Dinkeloo**

College Life Insurance Company 1967-1971 213

Deere West Office Building 1975-1976 213, 238

Knights of Columbus Headquarters 1965-1969 231

Power Center 1965-1971 227, 251

The Ford Foundation Building 1963-1968 202, 227

U.N. Plaza 1969-1975 207

Rossi, Aldo 1931-

Il Teatro Del Mondo 1979 236

Rudolph, Paul 1918–

Yale Art and Architecture 1958 212, 219

Ruusuvouri, Aarno 1925–

Hyvinkaa Church 1959–1961 229

Saarinen, Eero 1910–1961

Kresge Auditorium 1955 207

Kresge Chapel 1955 229

North Christian Church 1959–1963 229

Yale Hockey Rink 1956–1958 201

Sangallo, Antonio da 1484–1546

Farnese Palace 1534 233, 244

Santini-Aichel, Jan Blazej 18th Century

St. John Nepomuk Church 1719–1720 223

Scarpa, Carlo 1906–1978

Brion-Vega Cemetery 1970–1972 246

Schinkel, Karl Friedrich 1781–1841

Altes Museum 1824 214, 236

Hunting Lodge 1822 214, 244

Observatory in Berlin 1835 226, 251

Residence in Berlin 1823 204

Severus and Celer 1st Century

Domus Aurea c. 64 226

Siren, Hekki 1918–

Orivesi Church 1961 237

Skidmore, Owings, and Merrill

Wells College Library 1968 241

Smythson, Robert c. 1535–1614

Wollaton Hall 1580–1588 244

Soane, John 1753–1837

Burn Hall c. 1785 245

Dulwich Gallery 1811–1814 225, 242

Sepulchral Church 1796 223

Tendering Hall 1784–1790 209, 217, 232

Sonck, Lars 1870–1956

Arena Building 1923 229

Soufflot, Jacques Germain 1713–1780

Pantheon in Paris, France 1756–1797 249

Steiner, Rudolf 1861–1925

Geotheanum I 1913–1920 256

Stirling, James 1926–1992

Cambridge History Faculty Building 1964 138, 202, 210, 215, 238, 248

Dusseldorf Art Museum 1980 231

Florey Building 1966 140, 202, 210, 215, 221, 225, 239, 243

Leicester Engineering Building 1959 136, 206, 210, 218, 225, 241

Olivetti Training School 1969 142, 218, 224, 247, 250

St. Andrews Dormitory 1964 223, 238, 243

Strickland, William 1787–1854

Second Bank of the United States 1818–1824 244

Sullivan, Louis Henry 1856–1924

Auditorium Building 1887–1890 144, 208, 215, 225, 241

Carson Pirie and Scott Store 1899–1903 148, 205, 208, 216, 240

National Farmer's Bank 1907–1908 150, 203

St. Paul's Church 1910–1914 226, 251

Wainwright Building 1890–1891 146, 218, 220

Tange, Kenzo 1913–

St. Mary's Cathedral 1963 254

Olympic Arena 1961–1964 231

Small Olympic Arena 1961–1964 207, 213, 239

Terragni, Giuseppe 1904–1943

Casa del Fascio 1932–1936 152

Novocomum Apartment House 1927 150

Sant'Elia Nursery School 1936–1937 154

Villa Bianca 1937 156

Thornton, William 1759–1828

United States Capitol 1793–1830 245

Tigerman, Stanley 1930–

Frog Hollow 1973–1974 207

Town and Davis

North Carolina State Capitol 1833-1840 245
United States Custom House 1833-1842 231

Utzon, Jorn 1918-

Atrium Housing 1956 190, 223
Bagsvaerd Church 1973-1976 243
Sydney Opera House 1957-1968 237, 256

UNKNOWN ARCHITECT

Baptistry of The Orthodox c. 425 229
Baths at Ostia, Italy c. 150 254
Capitol of Williamsburg 1701 234, 250
Castle Del Monte c. 1240 223, 257
Castle in Soborg, Denmark c. 1150 247
Chancellery Palace 1483-1517 246
Cheops Pyramid c. 3733 B.C. 187, 207
Colosseum 70-82 219
Council Chamber of Miletos 170 B.C. 236
Deal Castle c. 1540 252
Dover Castle c. 1180 246
Drayton Hall 1738-1742 233, 238
Elphinstone Tower 16th Century 207
Fontevrault Abbey 1115 249, 254
Fortress near Rudesheim 1000-1050 246
Fort Shannon 1800-1835 243
Hadrian's Maritime Theater 125-135 254
Horyu-Ji Temple 607 246
House in Ur 2000 B.C. 245
House of the Menander c. 300 B.C. 218
House of the Faun 2nd Century B.C. 253
House of Vizier Nakht 1372 B.C.-1350 B.C. 247
Market of Leptis Magna 8 B.C. 246
Mausoleum of Augustus c. 25 B.C. 239
Musgum Village Unknown 209
New Park c. 1775 239
Notre Dame Cathedral 1163-c. 1250 241
Olavinlinna Castle 1475 247

Osterlars Church 12th Century 252
Pantheon c. 100 200, 229
Pitfichie Castle c. 1550 233
Rait Castle c. 1300 233
St. Constanza c. 350 229, 244
San Frutuoso De Montelios 665 234
San Maria Della Consolazione 1508 254
San Miguel 913 236
San Stefano Rotondo 468-483 249
San Vitale c. 530-548 221
Shaker Barn 1865 244
Solomon's Temple 1000 B.C. 242
South Platform at Monte Alban c. 500 253
Stoa in Sikyon, Greece c. 300 243
Stratford Hall 1725 245, 250, 258
Temple at Tarxien, Malta 2100 B.C.-1900 B.C. 242, 253
Temple of Apollo c. 400 B.C. 248
Temple of Horus, Edfu 237 B.C.-57 B.C. 197, 209, 242, 252
Temple of Kom Ombo 181 B.C.-30 A.D. 248
Thermae of Caracalla 212-216 232
Tomb at Tarquinia c. 600 B.C. 231
Tomb of Caecilia Metalla c. 25 B.C. 230
Tomb of Setnakht 13th Century B.C. 242
Tower of London 1070-1090 247
Viking Fortress c. 1000 235

Van Der Rohe, Ludwig Mies 1886-1969

Barcelona Pavilion 1928-1929 160, 212
Crown Hall 1950-1956 166, 240
Farnsworth House 1945-1950 164, 204, 240, 251
New National Gallery 1968 228
Tugendhat House 1928-1930 162

Van De Velde, Henry 1863-1957

Bloemenwerf House 1895-1896 245

Van Eyck, Aldo 1918-

Arnheim Pavilion 1966 231

Visser House 1975 241
Wheels of Heaven Church 1966 232
Vignola, Giacomo Da 1507-1573
Villa Farnese 1559-1564 249
Venturi, Robert 1925- *See* Venturi and Rauch
Venturi and Rauch
Allen Art Museum Addition 1973-1976 255
Brant House 1973 171, 205, 211, 224, 233
Fire Station Number 4 1966 170, 206, 211
Guild House 1961 192, 237, 253, 259
House in Tucker Town, Bermuda 1975 247
Pearson House 1957 243
Trubek House 1972 235
Tucker House 1975 174, 200, 212, 216, 228, 231, 259
Venturi House 1962 168, 220, 225, 231, 233

Wagner, Otto 1841-1918
Anker Building 1895 241
Church of St. Leopold Am Steinhof 1905-1907 219
Landerbank 1883-1884 238, 258
Post Office Savings Bank 1904-1906 237, 250
Wren, Christopher 1632-1723
St. Antholin 1678-1691 219
St. Clement Danes 1680 203, 259
St. James 1674-1687 236
St. Mary Le Bow 1670-1683 206

St. Nicholas Cole Abbey 1671-1681 218
St. Stephens Walbrook 1672-1687 217
Wright, Frank Lloyd 1867-1959
Boomer Residence 1953 241
Coonley House 1907 257
Guggenheim Museum 1956 182, 211, 214, 239
Jacobs House 1948 237
Johnson House (Wingspread) 1937 239
Kaufmann House (Fallingwater) 1935 180, 203, 209, 216,
225, 240, 253
Larkin Building 1903 219, 240
Pfeiffer Chapel 1938 229
Robie House 1909 178, 212, 217, 224, 251, 257
St. Mark's Tower 1929 223
Unitarian Church 1949 241
Unity Temple 1906 176, 211, 214, 221, 222, 224, 249, 250,
257

Zimmerman Brothers
Wies Church 1754 237
Zimmerman, Dominikus 1685-1766 *See* Zimmerman
Brothers
Zimmerman, Johan 1680-1758 *See* Zimmerman
Brothers
Zuk, Radoslav Unknown
Holy Trinity Ukranian Church 1977 253

INDEX BY BUILDING

- Adult Learning Research Laboratory 1972 56, 202, 215,
224, 235, 254
A. E. G. High Tension Factory 1910 240
A. I. A. Headquarters 1967 255
Alajarvi Town Hall 1966 255
Alexander House 1971-1973 216
Allegheny County Courthouse 1883-1888 132, 186, 210,
219, 221, 233, 249, 258
Allen Art Museum Addition 1973-1976 255
Altes Museum 1824 214, 236
Anker Building 1895 241
American Academy 1913 251
Annaglee 1740-1770 209
Annex to Oita Medical Hall 1970-1972 207, 226, 251
Architectural Setting 1473 226
Arena Building 1923 229
Arnheim Pavilion 1966 231
Atrium Housing, Helsingor, Denmark 1956 190, 223
Auditorium Building 1887-1890 144, 208, 215, 225, 241
Austin Hall 1881-1884 232
- Bagsvaerd Church 1973-1976 243
Baker Dormitory 1947-1948 243
Baltimore and Ohio Railroad Depot 1886 245
Bank of Pennsylvania 1798-1800 258
Baptistry of The Orthodox c. 425 229
Barcelona Pavilion 1928-1929 160, 212
Baths at Ostia, Italy c. 150 254
Bianda Residence 1987-1989 40
Bloemenwerf House 1895-1896 245
Boomer Residence 1953 241
Boston Public Library 1898 219, 228
Boyer Hall of Science 1970-1972 218, 253
- Brant House 1973 172, 205, 211, 224, 233
Brion-Vega Cemetary 1970-1972 246
Brooklyn Childrens Museum 1977 217
Burn Hall c. 1785 245
Burns House 1974 116
- Cambridge History Faculty Building 1964 138, 202, 210,
215, 238, 248
Capitol at Williamsburg 1701 234, 250
Carpenter Center 1961-1963 238, 251
Carson Pirie and Scott Store 1899-1903 148, 205, 208,
216, 240
Casa del Fascio 1932-1936 154
Casa Mila 1905-1907 246
Casino in Rome 1754 232
Castle Del Monte c. 1240 223, 257
Castlegar 1807 232
Castle in Soborg, Denmark c. 1150 247
Cathedral of the Immaculate Conception 1977 231
Central Pennsylvania House 1980 242, 253
Centre Beaubourg 1972-1977 243
Chancellery Palace 1483-1517 246
Chandler House 1855-1886 248
Chapel on Mt. Rokko 1985-1986 16
Charof Residence 1974-1976 204
Chateau De Chambord 1519-1547 233
Cheops Pyramid c. 3733 B.C. 187, 207
Chiswick House 1729 234
Christ Church, Spitalfields 1715-1729 68, 186, 205, 208,
214, 222, 233, 259
Church at Firminy-Vert 1963 254
Church at St. Leopold Am Steinhof 1905-1907 219
Church of San Giovanni Battista 1986-1995 38

Church on the Water 1985–1988 18
Claghorn House 1974 257
College Life Insurance Company 1967–1971 213
Colosseum 70–82 219
Convent for Dominican Sisters 1965–1968 211, 215, 247
Convent of La Tourette 1957–1960 218, 236, 245
Coonley House 1907 257
Cooper Residence 1968–1969 212
Council Chamber of Miletos 170 B.C. 236
Crooks House 1976 227
Crown Hall 1950–1956 166, 240
Cuno House 1906–1907 238

Deal Castle c. 1540 252
Deere West Office Building 1975–1976 213–238
Dipoli Conference Center c. 1966 251
Director's House 1775–1779 94, 208, 222, 252
Domus Aurea c. 64 226
Dover Castle c. 1180 246
Drayton Hall 1738–1742 233, 238
Dulwich Gallery 1811–1814 225, 242
Dusseldorf Art Museum 1980 231

East Wing of National Gallery 1975–1978 241
Easton Neston c. 1695–1710 64, 210, 216, 225, 233, 238, 258
Einsiedeln Abbey 1719–1735 252
Elia-Bash Residence 1971–1973 235
Elphinstone Tower 16th Century 207
Enso-Gutzeit Headquarters 1959–1962 12, 203, 220, 240, 248
Erdman Hall Dormitories 1960–1965 212, 258
Euram Building 1971 255
Everson Museum of Art 1968 213
Exeter Library 1967–1972 78, 202, 209, 215, 220, 223, 230, 234, 245, 249
Exeter Physical Education Facility 1970 243

Fallingwater, *See* Kaufmann House
Farnese Palace 1534 233, 244
Farnsworth House 1945–1950 164, 204, 240, 251
Finlandia Concert Hall 1967–1971 209
Fire Station Number 4 1966 170, 206, 211
First Unitarian Church 1959–1967 244
Fisher House 1960 238, 251
Florey Building 1966 140, 202, 210, 215, 221, 225, 239, 243
Fontevrault Abbey 1115 249, 254
Fortress near Rudesheim 1000–1050 246
Fort Shannon 1800–1835 243
Fourth Temple of Hera 575 B.C.- 550 B.C. 240
Frog Hollow 1973–1974 207

Gaffney Residence 1977–1980 30
Glessner House 1885–1887 134, 224, 248
Goetheanum I 1913–1920 256
Green Park Ranger's House 1768 232
Guest House, Gates Residence 1990–1993 34
Guggenheim Museum 1956 182, 211, 214, 239
Guild House 1961 192, 237, 253, 259
Gumma Museum of Fine Arts 1971–1974 216, 241

Hadrian's Maritime Theater 125–135 254
Hagia Sophia 532 234
Hanselmann House 1967 227, 259
Heathcoate 1906 100, 252
Higginson House 1881–1883 232
Hines House 1967 116, 203
Holy Trinity Ukrainian Church 1977 253
Homewood 1901 96, 216, 220, 225, 235, 248, 259
Horyu-Ji Temple 607 246
Hotel De Beauvais 1656 245
Hotel De Montmorency 1769 88, 204, 209, 216, 231, 234, 242, 254
Hotel Guimard 1770 90, 208, 225, 237
House at Weissenhof 1927 207

- House in the Adirondacks 1987–1992 32
House in Tucker Town, Bermuda 1975 247
House in Ur 2000 B.C. 245
House of Culture in Helsinki 1955–1958 251
House of the Menander c. 300 B.C. 218
House of the Faun 2nd Century B.C. 253
House of Vizier Nakht 1372 B.C.–1350 B.C. 247
Hunting Lodge 1822 214, 244
Hyvinkaa Church 1959–1961 229
- Il Teatro Del Mondo 1979 236
Institute for Advanced Studies 1968–1972 217
- Jacobs House 1948 237
James House 1918 247
Johnson House (Wingspread) 1937 239
Johns Hopkins University Hall c. 1930 230
J. Pierpont Morgan Library 1906 209
- Kamoika Town Hall 1976–1978 218
Kappel Pilgrimage Church 1684–1689 223
Karlskirche 1715–1737 211, 254
Kaufmann House (Fallingwater) 1935 180, 203, 209, 216,
225, 240, 253
Khuner Villa 1930 205, 214
Kimball Art Museum 1966–1972 76, 206, 211, 217,
241
Knights of Columbus Headquarters 1965–1969 231
Kresge Auditorium 1955 207
Kresge Chapel 1955 229
- Landerbank 1883–1884 238, 258
Lang Music Building 1973 58, 205, 208, 215, 227, 236,
251
La Rotonda, *See* Villa Capra
Larkin Building 1903 219, 240
Laurentian Library 1525 242
- Leicester Engineering Building 1959 136, 206, 210, 218,
225, 241
Lister County Courthouse 1917–1921 24, 205, 212, 221,
222, 225, 232, 236, 254
- Market at Leptis Magna 8 B.C. 246
Mausoleum of Augustus c. 25 B.C. 239
Melnikov House 1927 229, 238
Mercer Castle 1908–1910 247
Moore House, Orinda 1962 112, 216, 228, 246, 248, 253,
259
Mt. Desert Island Residence 1975 212
Mummers Theater 1970 257
Museum at Ahmedabad 1953–1957 239
Museum for Decorative Arts 1981 235
Musgum Village *Unknown* 209
- Nakayama House 1964 201
Nashdom 1905–1909 98, 210, 236, 250
National Assembly in Dacca 1962–1974 213, 254
National Farmer's Bank 1907–1908 150, 203
Nebraska State Capitol 1924 241
Negev Desert Synagogue 1967–1969 229
Neur Vahr Apartments 1958–1962 239
New England Aquarium 1962 239
New Lutheran Church 1668 237
New National Gallery 1968 228
New Park c. 1775 239
New York Herald Building 1894 238
North Carolina State Capitol 1833–1840 245
North Christian Church 1959–1963 229
Notre Dame Cathedral 1163–c. 1250 241
Notre Dame Du-Haut 1950–1955 60, 201, 214, 225, 252
Novocomun Apartment House 1927 152
- Observatory in Berlin 1835 226, 251
Occupational Health Center 1973 212, 217, 238, 247

Olavinlinna Castle 1475 247
Old Sacristy of San Lorenzo 1421-1440 44, 200, 208,
230, 236, 258
Olivetti Training School 1969 142, 218, 224, 247, 250
Olympic Arena, Tokyo 1961-1964 231
One-Half House 1966 237
Ospedale Degli Innocenti 1421-1445 46, 224, 246
Orivesi Church 1961 237
Osterlars Church 12th Century 252

Paimio Sanitorium 1929-1933 211
Palace of Assembly 1953-1963 86, 202, 209, 215, 231,
246, 248, 253
Palace of Charles V 1527 230, 244
Pantheon in Paris, France 1756-1797 249
Pantheon in Rome, Italy c. 100 200, 229
Parthenon 447 B.C.-430 B.C. 249, 259
Paul Mellon Arts Center 1970-1973 214, 226, 251
Pazzi Chapel 1430-1461 253
Pearson House 1957 243
Pennsylvania Academy of Fine Arts 1872 246
Pfeiffer Chapel 1938 229
Pitfichie Castle c. 1550 233
Plattsburg Student Union 1974 60, 208, 217, 220
Police Headquarters 1918-1924 252
Poplar Forest c. 1806 202, 229
Post Office Savings Bank 1904-1906 237, 250
Power Center 1965-1971 227, 251
Pratt Residence 1974 212

Rait Castle c. 1300 233
Redentore Church 1576-1591 126, 203, 208, 222, 226,
242, 251
Residence in Berlin 1823 204
Residence in Bridgehampton 1969-1971 212
Residence in Cadenazzo, Switzerland 1970-1971 205
Residence in Massagno, Switzerland 1979 232

Residence in Riva San Vitale 1972-1973 36, 207, 228
Residence in Stabio 1981 213
Rhode Island State Capitol 1895-1903 214
Richards Medical Research Building 1957-1961 72, 221,
239, 252
Riola Parish Center 1970 225
Robie House 1909 178, 212, 217, 224, 251, 257
Robinson House 1947 250
Royal Chancellery 1922 237, 255
Rufer House 1922 207, 228
Rusakov Club 1927 201, 229

St. Andrews Dormitory 1964 223, 238, 243
St. Antholin 1678-1691 219
St. Antonius Church 1966-1969 239
San Carlo Alle Quattro Fontane 1638-1641 237
St. Constanza c. 350 229, 244
St. Clement Danes 1680 203, 259
San' Elia Nursery School 1936-1937 156
St. Eligio Degli Orefici 1509 228
San Frutoso de Montelios 665 234
Sainte Genevieve Library 1838-1850 240
St. George-in-the-East 1714-1729 66, 210, 214, 221, 235,
249
San Giorgio Maggorie Church 1560-1580 122, 201, 208,
224
S. Ivo Della Sapienza 1642-1650 223
St. James 1674-1687 236
St. John's Abbey 1953-1961 201
St. John Nepomuk Church 1719-1720 223
San Lorenzo 1666-1679 249, 254
St. Louis Des Invalides 1676 234
San Maria Degli Angeli 1434-1436 48, 187, 188, 211, 215,
221, 222, 229, 238, 244
San Maria Della Consolazione 1508 254
S. Maria Della Pace 1478-1483 226
San Maria Di Carignano 1552 234

St. Mark's Tower 1929 223
 San Marta Church 1746 226
 St. Mary's Cathedral, Baltimore 1814-1818 231, 259
 St. Mary's Cathedral, Tokyo 1963 254
 St. Mary Le Bow 1670-1683 206
 St. Mary Woolnoth 1716-1724 70, 205, 208, 228, 244
 San Miguel 913 236
 St. Nicholas Cole Abbey 1671-1681 218
 St. Paul's Church 1910-1914 226, 251
 Saint Peter's 1506-1626 231
 San Stefano Rotondo 468-483 249
 St. Stephens Walbrook 1672-1687 217
 San Vitale c. 530-548 221
 Salisbury School 1972 212
 Salk Institute 1959-1965 74, 205, 222, 235, 250
 San Sebastiano 1459 241
 San Spirito 1434 50, 208, 215, 222, 238
 Saynatsalo Town Hall 1950-1952 8, 199, 211, 219, 225, 257
 Sea Ranch Condominium I 1964-1965 114, 209, 221, 224, 240
 Second Bank of the United States 1818-1824 244
 Secondary School in Morbio Inferiore 1972-1977 223
 Seinajoki Town Hall 1962-1965 218
 Sepulchral Church 1796 223
 Sever Hall 1878-1880 130, 203, 212, 233
 Sforza Chapel 1558 231
 Shaker Barn 1865 244
 Shamberg House 1971-1974 236
 Shenboku Archives 1970 214
 Shukosha Building 1974-1975 256
 Small Olympic Arena, Tokyo 1961-1964 207, 213, 239
 Smith House 1965-1967 104, 200, 227
 Snellman House 1917-1918 20, 200, 216, 225, 237, 238, 243, 256
 Solomon's Temple 1000 B.C. 242
 South Platform at Monte Alban c. 500 253
 Steiner House 1910 216
 Stern House 1970 243
 Stoa in Sikyon, Greece c. 300 243
 Stockholm Public Library 1920-1928 26, 206, 211, 215, 220, 222, 230, 244, 249
 Stockholm Exhibition Hall 1962 201
 Stratford Hall 1725 245, 250, 258
 Studio House 1955 231
 Swan House 1796 232
 Sydney Opera House 1957-1968 237, 256
 Tateshina Planetarium 1976 232
 Tempietto of San Pietro 1502 230
 Temple at Tarxien, Malta 2100 B.C.-1900 B.C. 242, 253
 Temple of Apollo, Pompeii, Italy c. 400 B.C. 248
 Temple of Apollo near Miletus, Greece c. 310 B.C. 240
 Temple of Artemis c. 356 B.C. 217
 Temple of Horus, Edfu 237 B.C.-57 B.C. 197, 209, 242, 252
 Temple of Kom Ombo 181 B.C.-30 A.D. 248
 Temple of the Scottish Rite 1910 202
 Temple of Venus and Rome 123-135 223, 246
 Tendering Hall 1784-1790 209, 216, 232
 The Atheneum 1975-1979 106, 198, 255
 The Church of Beato Odorico 1987-1992 42
 The Ford Foundation Building 1963-1968 202, 227
 The Glacier Museum 1991 54
 The Queen's House 1629-1635 250
 The Salvation 1911 102, 203, 221, 245, 256, 258
 Theater in Besancon 1775 92, 203, 210, 215, 235, 249
 Thermae of Caracalla 212-216 232
 The University of Virginia Rotunda 1826 229
 Tholos c. 365 B.C. 229
 Tomb of Caecilia Metella c. 25 B.C. 230
 Tomb of Setnakht 13th Century B.C. 242
 Tomb of Tarquinia c. 600 B.C. 231
 Tower of London 1070-1090 247

- Tredyffrin Public Library 1976 62, 209, 226, 255
 Trenton Bath House 1955-1956 241
 Trinity Church 1872-1877 128, 210, 215, 244
 Trubek House 1972 235
 Tucker House 1975 174, 200, 212, 216, 228, 231, 259
 Tugendhat House 1928-1930 162
 Turun Sanomat Offices 1927-1929 241
- Ulm Exhibition and Assembly Building 1986-1992 108
 U.N. Plaza 1969-1975 207
 Unite d'Habitation 1946-1952 82, 204, 218, 225, 243
 Unitarian Church 1949 241
 United States Capitol 1793-1830 245
 United States Custom House 1833-1842 231
 United States Supreme Court 1935 234
 Unity Temple 1906 176, 211, 214, 221, 222, 224, 249, 250, 257
- Van Buren House 1885 257
 Venturi House 1962 168, 220, 225, 231, 233
 Viking Fortress c. 1000 235
 Villa Bianca 1937 158
 Villa Busk 1990 52
 Villa Capra (Almerico) 1566-1571 124, 185, 201, 211, 215, 221, 223, 230, 234, 245
 Villa Farnese 1559-1564 249
 Villa Foscari c. 1549-1563 120, 215, 240
 Villa Mairea 1937-1939 235
 Villa Savoye 1928-1931 80, 204, 211, 217, 220, 227, 228, 235
 Villa Shodhan 1951 256
 Villa Stein 1927 200, 236
- Villa Trissino 1553-1576 233
 Visser House 1975 241
 Vouksenniska Church 1956-1958 10, 206, 211, 226, 255
- Wainwright Building 1890-1891 146, 218, 220
 Weekend House near Paris 1935 234
 Weekend House on Fisher's Island c. 1963 206, 255
 Weekend Residence for Mr. and Mrs. Eric Q. Bohlin 1973-1975 28
 Weishaupt Forum 1987-1992 110
 Wells College Library 1968 241
 Wheels of Heaven Church 1966 232
 Whitney Museum of Art 1966 220
 Wies Church 1754 237
 Wingspread, *See* Johnson House
 Wolfsburg Cultural Center 1958-1962 14, 203, 211, 221, 226, 227
 Wolfsburg Parish Center Church 1960-1962 239
 Wolfsburg Parish Center Hall 1960-1962 257
 Wollaton Hall 1580-1588 244
 Woodland Chapel 1918-1920 22, 227, 230, 253
 Woodland Crematorium 1935-1940 257
 W. Watts Sherman House 1874 247
- Yale Art and Architectue 1958 212, 219
 Yale Center for British Art 1969-1974 235, 238, 246
 Yale Hockey Rink 1956-1958 201
 Yano House 1975 186, 199, 259
 York House 1759 234
- Zurich Exhibition Pavilion 1964-1965 251