

Ralph W. Liebing

Handbook of Detailing

The Graphic Anatomy
of Construction

Handbook of Detailing
The Graphic Anatomy of Construction

Ralph W. Liebing, RA, CSI, CPCA, CBO

SpringerWienNewYork

Ralph W. Liebing, RA, CSI, CPCA, CBO
Senior Architect – Specifications
HIXSON Architects, Engineers, Interiors
659 Van Meter Street
Cincinnati, OH 45202, USA

This work is subject to copyright.

All rights are reserved, whether the whole or part of the material is concerned, specifically those of translation, reprinting, re-use of illustrations, broadcasting, reproduction by photocopying machines or similar means, and storage in data banks.

Product Liability: The publisher can give no guarantee for the information contained in this book. The use of registered names, trademarks, etc. in this publication does not imply, even in the absence of specific statement, that such names are exempt from the relevant protective laws and regulations and therefore free for general use.

© 2009 Springer-Verlag/Vienna
Printed in Austria
SpringerWienNewYork is a part of Springer Science+Business Media
springer.at

This book contains 300 figures/details from many different sources, they are examples of use in daily practice, were part of actual project documents and not necessarily intended for publication. So in some cases the quality might – despite lithography – not be perfect, but deficiency of reproduction does not spoil the content, nor distract from the lessons that can be learned.

The publisher and editor kindly wish to inform you that in some cases, despite efforts to do so, the obtaining of copyright permissions and usage of excerpts of text is not always successful.

Layout: Vera Gehmayer, www.dieagentur.co.at, 2340 Mödling, Austria
Coverdesign: Walter Zivny, Springer-Verlag, 1201 Vienna, Austria
Photocredit back cover: photo courtesy of constructionphotographs.com
Printing and binding: Holzhausen Druck & Medien GmbH, 1140 Vienna, Austria

Printed on acid-free and chlorine-free bleached paper

SPIN: 12197842

Library of Congress Control Number: 2009924399

With numerous figures

ISBN 978-3-211-99134-3 SpringerWienNewYork

TABLE OF CONTENTS

PREFACE.....	6
FRAME OF REFERENCE	9
THE END RESULT.....	10
THE CONTEXT.....	29
INTRODUCTION.....	42
HISTORICAL PERSPECTIVE.....	49
THE THRUST OF DETAILING.....	58
THE REALITY OF DETAILING.....	77
QUESTIONS TO ASK ABOUT DETAILING	99
THE INDIVIDUAL EFFORT	105
REVIEW OF SAMPLE DETAILS.....	119
DISCUSSION OF CASE STUDIES.....	238
ANALYSIS OF A DETAIL	321
DETAILS "BY OTHERS"	336
EPILOGUE.....	370
APPENDICES: A: Excerpt of speech by Professor Edward Allen, FAIA	372
B: Construction Abbreviations.....	374
C: List of trade and professional organizations.....	385
D: Book List and Added Resources.....	392
GLOSSARY.....	396
INDEX.....	423

PREFACE

In a world of rapid and ever-changing practices, among design professionals, there is, we feel, a need to at least recall other times—times more sedate, slower paced, but nonetheless no less highly professional. And to bring them forward for expression, understanding and use in today's professional practice.

Indeed, they may have been MORE professional. This is not whining or lamenting about times passed by persons late in their career trying desperately to hold on to that past—to things obsolete, outmoded, archaic or snail-like slow. It is about being open, factual, and advisory about moving forward, in new ways, but maintaining a sense of and use of well proven values—basics and fundamentals so very vital and valuable to the success of project, but so easily lost, too quickly.

No one can rationally decry or dismiss the evolution of computerized drafting, and the increasing use and ever-evolving sophistication of the related systems. But in all this we are losing a sense of what we must be about and indeed, what we need to do and accomplish—using the expression of CAD and other computer capabilities. The loss centers on the lack of a truly hands-on and respectful relationship to our drawings, and with that the inherent thought process of what to do, how to relate it, and how to do it [i.e., the knowledge of appropriate construction materials, methods, techniques and systems]. Along with the "feel" of pencil on paper [or other manual drafting media] and the need to understand how to make a line properly, convincingly and correctly, we have, for the most part, lost track of both the intent and the content of the drawings.

What are the drawings "supposed" to do? Why do they even exist?

What should be shown on the drawings? How should the individual drawings be done?

When "mechanical drawing" and drafting efforts, even at the junior high school level, began to be computer activities, the drafter [operator] was literally "cushioned or isolated" from the feel of the lines and the drawings, by the keyboard. Punching a typewriter-like [look it up, it existed too] key is far distant from starting, drawing, and finishing a line, with proper weight, width and intensity, as well as style and understanding of impact and purpose. Now the "key" triggers an electronic sequence which instantaneously produces a line— but, oops! The line is yellow on the screen, what does that mean?

You don't know; well, how do you know the line is the right line at all?

Thus, our dilemma - of growing proportions. The further we move from mid-20th century the more we stray from the mindset, direction, execution and understanding of working drawings, and detailing of that time. We seek not to regenerate and reinstall those times— but we sincerely feel and strongly suggest that there needs to be a lasting expression of those times, and the filling of the voids left by time— from then ,til now. Techniques may change, but understanding, direction, orientation, and values from the past remain valid, important and of value— particularly when they were so successful. Here, history is not bad; it can teach; it can give context and meaning to the effort; it can make better simply by being able to talk to and inform today's drafters and those still coming on-board ... whenever.

This book was conceived to present a new understanding and approach to the task of detailing construction projects. There are numerous books which present "sample" or "representative" detail drawings, which may or may not be pertinent to the project in hand. Often these are used merely for reference, and to present thought-provoking impetus for correct detailing. In some cases, they are actually proposed as details that can be copied and directly utilized in project documents.

To date detailing remains an enigma rarely addressed specifically in architecture curricula.

One of prime exceptions where clarity is provided comes in the works, in years past, of Professor Edward Allen, both in his academic career, his comments and writing on the state of technical architectural courses in general and in his several books. But especially in his *ARCHITECTURAL DETAILING: Function, Constructibility, Aesthetics* [written with Professor Patrick Rand and published in second edition by John Wiley & Sons; 2007]

This is the one book on detailing committed to teaching the process of detailing [many other "detailing books" merely contain collections of suggested or example details, for consideration, adaption and re-use— no real teaching of the process]. Allen's book stems from his class notes he used at Yale, MIT, Oregon and other schools where his stated task was to teach detailing— this direction and his expertise and dedication earned him high esteem and the 2005 AIA/ACSA Topaz

Award. This exception is a book that can easily be portrayed, envisioned, suggested, and strongly recommended as a companion to this book.

Professor Allen introduces, explains, and elaborates on a series of very fundamental "patterns" for detailing, that he has developed for and through his courses at Yale, MIT and other schools of architecture. Each pattern acts as a firm conceptual basis and rationale for problem solving, in producing construction documents, and the requisite construction detailing. His fundamentals provide theoretical insight into the various solutions that can be extracted by utilizing or applying one or more of the principles [the "patterns"] to solve a particular problem.

This provides both student and professional with a reliable and basic resource catalog, which identifies problem areas that require detailing, sparks ideas, shows flexibility in problem solving, and facilitates innovation for common sense, and positive solutions. The concepts are fully developed in the text, and accompanied by illustrations, both written and graphic. I would like to pay more than merely due tribute to this excellent and insightful effort by Professor Allen, in conjunction with his numerous other books on the technical side of architecture— all are recommended here with highest regard!

In my communication with Professor Allen, he suggested that another book by the author of this book, could act as a resource for the "mechanics" of detailing, or the correct depiction and implementation of the solutions developed through use of his patterns. It seems appropriate, though, to extract and isolate the specific information on detailing [from other aspects of working drawings] since this process is so fundamental to the success of the transfer of information for every project, and indeed, to the project itself.

The use of the best and most appropriate mechanics to display the solutions, well-founded through use of Professor Allen's patterns, should provide the undergirding for good, well-conceived detailing solutions. The goal is the clear, accurate, pertinent, concise and complete communication of those solutions to the field, and in turn, high quality construction faithful to the approved design concept.

This effort is toward the graphic communications aspects of detailing, which are noted as an area of current interest. Allen's book is excellent, but does not address the graphics— rather it puts forth a system for assessing detailing needs, construction problems that require solution, and basic problem-solving formats. While he includes some detail drawings, his message

relates to the way in which details are conceived and formulated by using various considerations [which he calls "patterns"]. I feel his book is well founded and has the strength of history on its side having been his text for his classes at Yale and MIT.

This book, by virtue of a comment by Professor Allen, to the author, centers on the graphics or mechanics of detailing. That is the reason for setting out and then answering the 6 questions, "What, Why...." This text goes toward the rationale behind how solutions based on Allen's patterns can be conveyed to the field, in proper order and in a format that is usable by the trade workers. Also, the text goes to the understanding of the intent and content of details on the part of young professionals who do the detailing.

There is no competitive scenario here, with Professor Allen's book. Perhaps this text is parallel, but mainly it is supplementary and complimentary. The bottom line is that you can conceive very fine details via Allen's information but if you cannot successfully convey your information and solutions to the workers, via your graphics, you have failed to do your job as a detailer. And your project will suffer in more than one way. That is a shame, and professionally unsatisfactory or intolerable. If you have the capacity via Allen to produce very good details, only to come up short through poor execution and understanding of the process that disseminates that information, you are contributing as required.

So what started as a sincere quest to produce a relevant current text has now become a valid effort to pass along the standards and values from past years— those that are still vitally important, and crucial to successful construction. Certainly, this book can be projected as a supplementary text, since very few schools and courses support full courses dedicated to detailing [unlike Yale and MIT who utilize Edward Allen's expertise]. The information, it is felt, is invaluable to the young professional, no matter what format, equipment, office environment, or project is involved.

You solve problems by detailing, and then incorporate the solutions in the actual work by telling the trade workers exactly what is to be done!

It is my sincere desire that this effort not be perceived as old codger spewing forth archaic, fuddy-duddy information. I have had the grand opportunity to practice across a good number of years, and have had many wonderful people around me, who evidently saw some potential in me. They saw fit to teach me, to help me to understand and grasp the concepts of project documentation and detailing. They were talented and very competent people, skilled, knowledgeable

and experienced– successful! I seek only to put forth information that I feel is needed and is helpful to the current and future professionals. This information is not readily available elsewhere. Information that may be seated in the past, but which is the foundation of successful detailing today, and in coming years. The joy of practice, and successful employment lies, I feel, in the inner-self who is able to come to the conclusion [as I did one day during my co-op college days] that "I understand this [practice, detailing, documenting, etc.] and I can do it– and do it well".

Even today after a fairly long career, I can personally attest to the rush of pride, consuming joy, and personal satisfaction to solve a problem by creating a good, responsive detail– makes one want to pump the fist and shout out, "YES!!!"

That is a tremendous revelation that I wish to each of the readers.

Ralph W. Liebing, RA, CSI, CPCA, CBO

Cincinnati, Ohio, USA

Dedication: This book is dedicated to my wife Arlene, my daughter Alissa, son-in-law Bob and granddaughter, Mya; to my many colleagues over years of practice; and to all those architects, drafters, CAD drafters and others whose daily dedication to "getting the details right" for the project's design concept, yield successful projects in the clients' best interests.

FRAME OF REFERENCE

Before engaging and studying this book, the author invites/urges the readers to review the following.

This is the Abstract from a talk given by Professor Edward Allen* at a Faculty forum at Iowa State University in 2007. It is a true expression of the needs of the design professions, and what can and should be done.

Not Your Father's Technical Courses

*Edward Allen,
recent visiting professor in building technology, MIT*

Abstract

Technical courses should be about turning dreams into reality, drawing upon the dazzling array of materials, devices and physical principles that are available to designers. As such, technical courses ought to be the most exciting, empowering offerings in the architecture and engineering curricula. But in most universities, they are neither exciting nor empowering. We have managed to make them dull and often despised.

This situation has come about because we have failed to realize that technology is not synonymous with mathematics or science. We have tended to teach only what is mathematical or scientific about technical subjects, ignoring crucial concerns such as selection of materials and systems, design development of technical systems as integral components of architecture, detailing, [emphasis added] and planning for construction.

We turn out graduates who have been exposed to the math and science of buildings, but who are unable to build.

Students of architecture and engineering must be taught to build imaginatively and well. This presentation will offer several simple guidelines for creating powerful, exciting technical courses that develop the ability to build, and will show examples of their implementation.

Elsewhere Professor Allen had commented as follows:

"Detailing is your sole language of expression as ... an architect. Details tell others how to get your project built in the way that you want it built. If you can't design the major details yourself, someone else will have to do it for you- And that person is likely to have a greater effect on the outcome than you do."

Certainly astute comment that indicate and correctly place the function of detailing in the documentation process!

And it sets our frame of reference- the understanding of the process and methodology that facilitates the correct depiction, use and communication of the information that is developed through efforts similar to what Professor Allen outlines

*- See excerpt of speech by Professor Allen, in appendix, where he states his approach and philosophy for detailing.

THE END RESULT

Straight Talk

The strongest of cases must be made for the process of detailing!

This is not to emphasize or give undue status to an essential and important activity, that some see as inconsequential.

There is no pretension that detailing is the dominant, pre-eminent or superior function in the design and construction of architectural projects; but neither can it be claimed that it is minimal, inconsequential or unnecessary!

It is, however, the primary facilitating factor in achieving a successful project!

Rather it is to give due credit, in the grand scheme of architectural and construction projects, [and indeed to the whole of the professional services provided by architects] to an eminently important task that is too often murky in the minds of many, minimized by others and maligned by far too many. In addition, most unfortunately, many professionals do not understand the work involved, the necessity for it, and how to best accomplish its intent.

"Designing details is not a neat, linear, fully logical operation. Like any design process, it is engagingly messy and complex.

It involves false starts, wrong turns, mental blocks, dead ends, backtracking, and moments of despair— as well as purposeful progress, intelligent decisions, creative synthesis and gratifying moments of inspiration, in sight and triumph."

- Edward Allen,
FAIA Professor of Architecture (ret.)
Oregon; MIT; Yale University; Washington and
Montana State Universities

There is no way to shy away from, avoid or equivocate on this single, simple fact and direct premise that persists, undeniable and irrefutable:

To produce successful works of architecture, from the most modest to the most innovative/revolutionary, the architect [and allied staff] must have the wherewithal to utilize drafting skills [in one mode or another] to create meaningful depictions of the construction, calling upon and based on the application of a large and deep pool of construction knowledge in a format/configuration/manner fully supporting and true to the design concept.

The rhetoric of badgering, sermonizing or pontification simply fails in any attempt to deny or refute the truth that detailing is the overriding, fundamental, pre-requisite skill for all architects. Design may be considered as the architect's premier skill or forte, and may be to one's liking, but it must rely on detailing to be successfully executed. The higher the level of detailing skill [coupled with at least commensurate construction knowledge] the greater the capacity of the architect for innovative problem solving, flexibility of thinking, depiction of sound construction, good communication of the information and consistently successful projects.

The level of skill in detailing is the basis that determines the level of satisfactory achievement required in the finished project — high skill demands high result, etc.

Neither is this [mainly because there is no need to] an apologetic attempt to glamorize or glorify one function of professional practice for architects. It is really to provide a more balanced view of practice and one of the tasks that vitally needed, and which require skill, insight, flexibility and a good depth of construction knowledge. It does not [and there is no suggestion here] supplant design as the primary tasks in architecture, but rather this is openly stating the importance that detailing is to the final design concept— that which is approved by the Owner, and anticipated by all parties.

To better understand the underlying need for detailing, it may be a good idea to really understand the basic concepts that must be dealt with. The following is a wonderful quote from William Caudill, FAIA, one of the founding partner of the architectural firm of Caudill, Rowlett and Scott, Houston, TX [the quote is dated 1967]:

"There is general agreement that every building should have a strong concept behind its form. More obvious, but less understood simply because it is too obvious, is the fact that every form, particularly basic architectural forms, have simple, clear concepts contained within the forms. Let me see if I can spell out a few:

WINDOW:	<i>A look-out, let-in-air-and-light-idea. (More recent windows carry only the look-out or look-in aspect.)</i>
DOOR:	<i>An in-and-out idea.</i>
COLUMN:	<i>An economical way of holding up something vertically.</i>
ROOF:	<i>A permanent, large umbrella.</i>
WALL:	<i>A keep-in or keep-out kind of screen.</i>
STAIRS:	<i>The idea of vertical circulation for legs (a cross between a ladder and a sidewalk).</i>
RAMP:	<i>Another idea of vertical circulation for legs and wheels (a tilted side walk or street).</i>
GABLE ROOF:	<i>A two-way quick-drain roof.</i>
HIPPED ROOF:	<i>A four-way quick-drain roof.</i>
FLOOR:	<i>The walking-working-living plane.</i>
CHAIR:	<i>Mobile architecture for sitting.</i>
LAMP:	<i>The idea of an artificial sun.</i>
LUMINOUS CEILING:	<i>The idea of artificial sky.</i>
LIGHT SWITCH:	<i>Device to produce instant night and day.</i>
OVERHANG:	<i>An eyebrow.</i>
BEAM:	<i>An economical way of holding up something horizontally.</i>
STRUCTURAL SLAB:	<i>A beamless horizontal support.</i>
CLOSET:	<i>A convenient hideaway for things.</i>
CLERESTORY:	<i>A light trap or sky view frame.</i>

NAIL: *Steel glue.*

SPREAD FOOTING: *The idea of feet.*

FIREPLACE: *Safe container for visual
and thermal appreciation.*

There is still fuzz on some of these; nevertheless, it is plain to see:

"BEHIND EVERY BASIC ARCHITECTURAL FORM, THERE IS AN UNDERLYING IDEA WHICH WE CHOOSE TO CALL THE CONCEPT".

While these concepts may seem extremely simple, they are true. But beyond them are numerous solutions that provide for, or meet the concept. Once one of those solutions is selected as appropriate to the project need, then it is for detailing to properly incorporate that concept selection into the project work documents– that is, to provide all of the information required to correctly utilize the selection [product or system] selected into the overall construction of the project.

Detailing is a demanding task within what is really a simple process– simple in its basic function of communication; demanding in what it must cover and convey. It may sound simplistic and trite to say "communications", but there are aspects that must be respected.

The detailing of a building or other structure is an even more crucial activity when;

- *the project is a streamlined, non-ornamented, sleek, clean, simple, open design;*
- *the project is very complex and involves intricate relationships*
- *there is construction that needs to be, or that you wish done, in a manner different from the ordinary, or commonly done way*

For valuable communication, there must be a message "sender", a "receiver" to collect the message, and they must be of the same mind. But the language of design is far different from the language of construction. This situation must be resolved if the project is to be successfully executed. That is the various parties must easily understand the language of the messages

Detailing functions to convert and augment design information into useable construction information, in a form that can be clearly, easily and promptly communicated to the contractors, suppliers and manufacturers [and their field personnel] for proper execution; therefore in large [and important!] part, it is a communications tool!

and how to react; they must have at least enough of the same expertise to relate and understand both the information and the other part's intentions. The consequence of communications needs to be the ability to provide appropriate action—this is crucial in construction! Mere misquotes and misunderstandings can be extremely costly in time and money— as well as in the effort to resolve them.

By far, the most crucial operation, in construction is the taking of the idealized design concept for the project— based on the owner's program— and transforming it and all its parts into meaningful construction information, both graphic and written, and the clear and timely communication of the resulting information to the contractors and their personnel, for execution of the work.

NOTHING occurs on the project until this is done!

The design or design concept for an architectural or construction projects is a function of the knowledge, skill, expertise, rationale and creative mind of the designer. The designer[s] takes the wide variation of information from the Project Program [developed with the owner] and proceeds to apply and formulate physical areas, and relationships to meet the various elements of the program. This is taking raw, usually verbal information and converting it into shapes, areas and locations that resolve the problems and specific situations cited in the program. A straight-forward requirement may note a general office staff of 25 people can become a much more complex item for resolution— type of functions performed, area require person, interrelationships with other departments, "who works with who", equipment and ancillary area, etc. The designer must research much of this and then has the charge to formulate a proper space for these people, consistent with other project requirements. Note nothing here is related to materials, construction systems, etc., as all this comes later and is augmentation for the design concept.

These functional areas [now simply vacant shapes] are then worked into floor plan[s] and exterior elevations that depict how they can be molded into an overall scheme or design.

Here in various graphical or electronic forms, the start of the final scheme begins to evolve. These are studied and re-studied until one [or perhaps more] appear to satisfy the program, and able to be placed in the overall building configuration.

This process is then refined and developed until the designer is satisfied with it and can present this to the owner with confidence that the program has been resolved— and the project will have a physical appearance acceptable to the owner. The design concept for the most part at this time is a mental image within the designer. But there is nothing in these documents that show "how" the structure is to be constructed! The concept and preliminary design

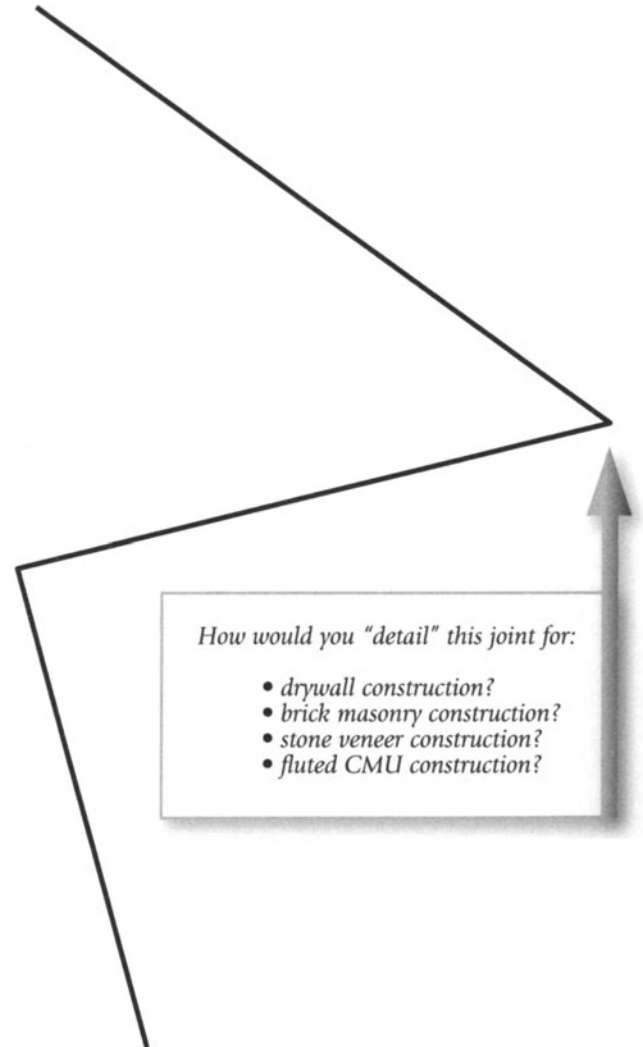

Fig. 1-1

needs to be augmented, and further explained through other documentation. Basically, though it is at a place with where

the owner can visualize and understand the grand overall scheme and appearance, so much so as to approved it and allow for its construction.

In the following time frame [Design Development phase] more and more generalized information is brought into the project in the ways of materials, systems, devices, equipment, construction methods, etc. Here these are not highly described and are not yet rendered project specific. For example, it may be determined that the project will have masonry exterior walls, but those are not described as brick, concrete masonry, pre-cast concrete, or some other system—except in the most general terms to support the aesthetics and design idea of the designer.

Next the project must be documented in both words and graphics. This is the phase where construction/contract drawings and specifications are created and developed. All of this is done to render the applicable information specific to the current project— meeting the intricate and numerous conditions created within the design or necessary to execute the design [as approved]. In the truest sense this process is converting design and conceptual information into communications to the contractors and

their field personnel who will actually perform the hands-on construction.

In architecture, the documentation must necessarily be changed from the initial generally conceptual, illustrative and "artistic", to the more extensive pragmatic, definitive, specific, instructional and explanatory that is easily read and assimilated to facilitate proper construction.

It is easily seen that the latter need precise information, directions, and instructions, so they can formulate and bold the project from "raw" generalized material into the specific project forms and construction. The masonry wall here becomes a composite wall, 12" wide with face brick, and concrete masonry unit backup, with joint reinforcement, etc— and all the applicable devices and features to serve the project well. [Fig. 1-2]

In the essence of the old saying, "A picture is worth a thousand words", the graphics on the drawings are highly explanatory to the trade workers. In addition, however, there are thousands of words required, since not all of the necessary information

SEQUENCE OF DETAIL DEVELOPMENT

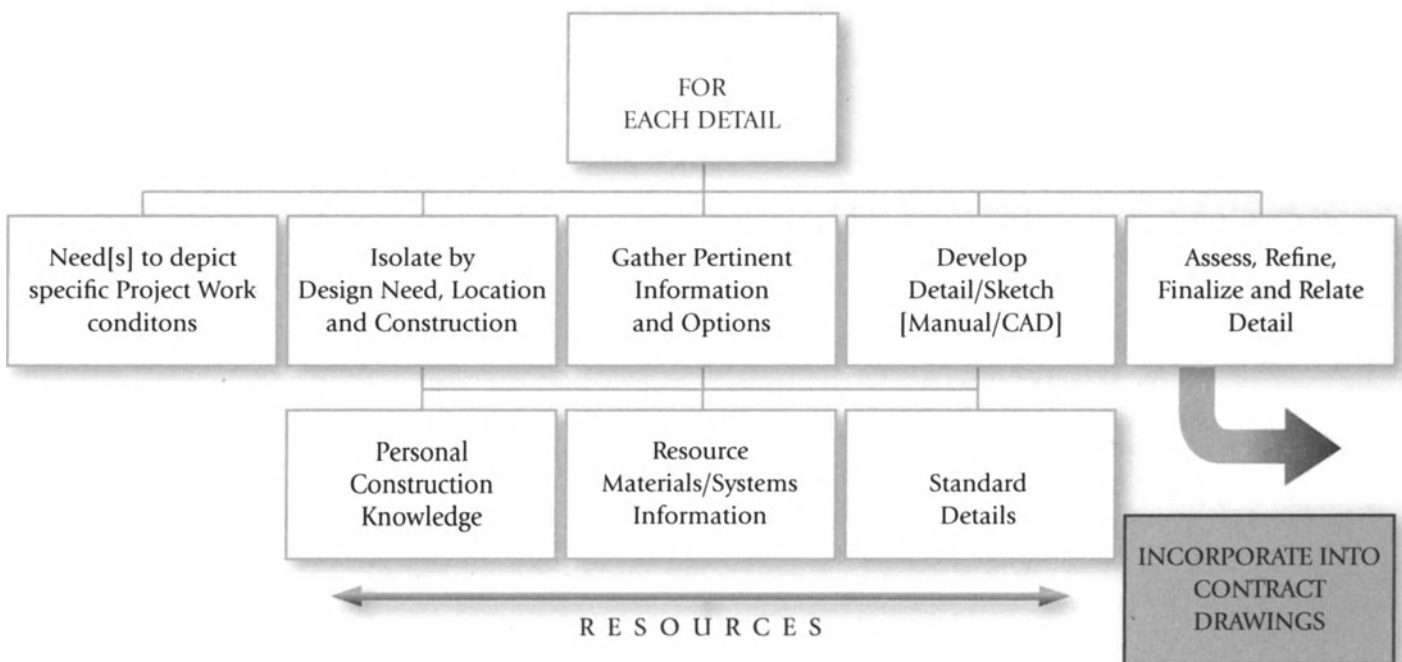

Fig. 1-2

Chart showing the sequence in the development of a detail and the sources used for information pertaining to the work displayed in the detail

can be shown graphically. Hence the project specifications. Within graphics is the sub-category of “details” – those invaluable snippets of information to display the numerous parts and relationship required within given portion of the total project work.

The two functions– design and detailing– are essential to the project’s success, and they need to be both understood and coordinated for their common goal. In truth they are inseparable– and most important to each other. The design sets the needs, direction and tone of the work while the detailing adds the minutia of information required to actually build the design concept. Without the other, each would flounder and prove inadequate to delivering the project satisfactorily. This is the present and will remain the on-going reality and for the foreseeable future, even in the face of ever changing technologies in both design and documentation methodology. *It is an absolute necessity that architects know how to put buildings together! And rudimentary to that is the need for functional ability to apply construction knowledge]* and to know and visualize how the necessary construction can or will be accomplished and the capacity to clearly communicate all this to the trade workers on the job site.

“The comment that caught my attention was the notion that „all the information“ will be contained within a model ... This has traditionally been the biggest misconception of CAD or BIM, that the machine or software will somehow, magically, automate out of existence the tedious process of construction detailing, coordination, and spec writing ... No matter how powerful the machine, it still needs an experienced and skilled hand to direct it where to go..... Even the best software can only reflect the wisdom and judgment of the person sitting at the controls ... ”

- Chip Daniels, CSI, Architect
Marina Del Rey, CA

“Well said Chip, I like a good number of you started on the drafting board. This process of physical [manual] drafting made you think about the details. Now don’t get me wrong, I am all for the new technology but as said before, it doesn’t replace the person, inputting the data in the first place– and thinking about it as it inserted a sense of awe into the work. I have seen a good number of younger drafters now who just think the CAD system will think for them. There is no doubt that technology has moved on, and now that we can now “build” buildings electronically before we put a spade in the ground has enormous benefits, but what we still have and will come to regret is the lack of construction knowledge at the design stage which is where these models are being created. Education in this area will ultimately take BIM to new levels”.

What the detailer brings to the project, first and foremost, is a depth and breadth of construction knowledge, not otherwise available to the owner, and the ability to envision how segments of this knowledge can be adapted and properly applied to the construction of the design concept.

This must be instilled, not just learned and understood, in every professional, and the developed skill made part of **individual Standard Operating Procedures** in regard to what must be done, and how. The inability to communicate using appropriate detailing will doom individual and collective efforts to produce quality and faithfully built projects.

The inability to detail, in a productive manner, is a short-coming that prevents the design professional from meeting the professional charge to give technical credence and substance to the project’s construction.

Architectural students, graduates, interns and young professionals need to be fully informed about the essential nature developing detailing skill. Their realization, understanding and embracing of this requirement is crucial to their success at any level in the profession. And in view of the fact that most of them have a gap in their education [or only minimal exposure] about project documentation including detailing, recognition of the need and an approach to resolving it falls to the employing professional office– or some entity prior to employment.

It is unclear whether the Intern Develop Program [IDP] – the post-graduate program of the National Council of Architectural Registration Boards [NCARB] adequately addresses, or **prioritizes correctly, the resolution of these important skills.** The open-ended enforcement of the IDP requirements [mere recording of time devoted to each requirement] tends to foster misuse since no strict oversight is available to what is virtually a voluntary sequence. There is no predictable end result or skill level that is **determined except the completion of the registration exams, which may or may not be dependent upon the honest completion of the IDP requirements.** And then of course, the resulting wide variation in meeting those IDP requirements only further aggravates the problem– and really short-changes the participants.

Employers, of course, want new hires who are immediately productive, and not in need of long period of intensive training and education. But the reality is that there is a lingering disconnect between academic training [in fundamental

skills other than design] and the "employment" need of productivity. Schools disdain the charge that they must train and educate students for employment— rather choosing the higher ground of educating the whole person and relegating technical training to the employer. So it falls to the student, graduate, intern and new professional to find out and know as much about their profession as possible— and more specifically the placed they feel they best fit into it [this is crucial to personal satisfaction and production]. While some other aspect of the profession may entice the new professional, they still need to know, understand and appreciate detailing— its value, its contribution and its production— and its credibility, validity and lack of professional stigma.

This is not a matter about something that is fading and will eventually "ride off into the sunset". Detailing is now, and will remain, fundamental and essential to the construction of each project. There is no "rah-rah" hype in this, or any need to artificially pump-up a marginal program for design professionals and staffers. The requirement for specific construction information, depiction, configurations and exact locations, etc. will come with each project and the various portions of it. The source of information, and perhaps even the display or production of it, may change with advancing technology, but the basic need will continue.

One cannot simply "will" good construction, or the fact that it must be present.

Detailing is a learned process whereby natural and manufactured materials and devices are re-sized, fashioned, fitted, combined and adapted to specific project circumstances— requiring knowledge of materials, methods and flexibility in their use.

The charge to the architect is to provide the correct array of information, IN ADDITION to the relevant and responsive design concept. This expertise needs to be in place to best serve the interest of the client by facilitating the construction of the project and maintaining the integrity of the design concept throughout construction, and in the final, completed project. There is a distinct continuity required in the detailing as the construction progresses, task upon task.

Even those who claim a dedication solely to the design activity and process, must have some, at least minimal, understanding of construction processes and materials. To execute a design is not merely to will its existence, but to have some idea about how to achieve it through construction that adapts and manipulates various materials, systems and techniques. It is inescapable!

The ultimate success of every architectural design and construction project lies in the details! And these details DO NOT exist in any computer software program— CAD, 3-D modeling and all of the rest serve to facilitate or display the details. But the details are human function, conceived and refined by the personnel serving the project.

Every design, no matter how mundane, how important, how visible or how cutting-edge and revolutionary, requires detail drawings and the execution of the work depicted. The finest of designs can be easily and drastically impacted, marred, or even ruined by inadequate, ill-conceived, poorly defined, or errantly displayed detailing— and worst yet, shoddy execution of shabby, ill-conceived details. This is so true it is axiomatic!

What separates good architecture from great architecture?

The difference lies in the details. The way an architect chooses to treat architectural detailing— screens and walls, doors and windows, roofs, bridges, and stairs—can transform the merely ordinary into the extraordinary.

- Excerpt from Product Description of book,
DETAILS IN PROCESS
[Princeton Arch. Press]

It is a principle of the profession that every professional needs to know, and understand, early-on— and must work diligently throughout a career to ensure— that detailing is pure in concept, well thought out, properly displayed in the documents, and accurately executed in the actual work. With times close at hand where the trade worker in the field will view the pictorial demands of the project work on an electronic gadget and screen [of a very limited size] perhaps in the format of an electronic 3-D model, the need for clear, decisive, and crystal clear detailing is even more imposing.

Many in the design professions and an increasing number in the CAD industry are recognizing that the more recent proliferation of software has outstripped the proper concept and route to decent and usable detailing. The acceptance, use of and satisfaction with CAD [and current movement toward Building Information Modeling— BIM], while wide spread, is not universal. (See discussion about CAD and BIM in Appendix).

"I agree that BIM is here and we will be seeing the development and wide acceptance of the system in the near future. I am not convinced that it will be the panacea that is currently touted.

It will have the same stupidity that CAD currently enjoys. Well educated professionals who use computer programs to design and detail and have never... never... been on a jobsite or worked in construction are using computer programs to substitute for their lack of experience.

This problem has already surfaced in the inability of today's children to add, subtract, multiply and divide without a calculator.

Currently CAD details that do not actually apply to the project construction are causing higher construction costs and delays when the detail has to be made applicable to the situation and submitted to the building department for approval during construction. This condition is called Change Orders.

Please do not assume I am against BIM, it is here to stay. Forensic and court work on this type of program pays well."

- Robert Cox CSI Emeritus, AIA retired, ACIA Hon.

The results from all the various iterations and bells and whistles in CAD programs are not servicing projects as they need to be. There is more and more movement toward remedial work, even back to manual drafting to ensure that detailing— and ultimate project success—is re-captured and ensured on wholly consistent basis. In fact there is renewed appreciation for what are perceived to be archaic [??] values such as line weight, readability, clarity, more "artistic" working drawings, etc.—hallmarks of manual drafting, lost in large measure in the electronics of CAD, etc.

Of course, the absolute basic concept needed to be firmly instilled in all future and budding professionals, is the concept that detailing is a necessary, and important personal skill; crucial to project success; unavoidable; and best learned, in principle, early-on, but in the context of the tools of choice— the computer and associated software! Cost of project, AND cost of documentation both are considerations

Details cost money!

Details are project requirements, and hence, part of the

contract, so if work is shown that is out-of-the-ordinary, excessive, quirky, and new/unusual to the trade workers, project cost will be impacted; but, at the same time, details still need to reflect and correctly match the project requirements, as contained in the design concept.

connected to the ability to create, and depict details. They simply must be done, well, appropriately, in context with the project work, quickly, accurately, and in a form that readily facilitates understand, assimilation and use in the field.

Detailing is not nearly as much about right and wrong, as it is about being appropriate! Solutions resolved by details need be as appropriate to the problem, the work involved, the materials and resources available, as to the project's design concept.

Beyond the designers is the overwhelming number of architects who find their professional niche by functioning in other related areas of practice. Each requires in-depth, flexible and breadth of knowledge that can be adjusted and used as necessary for each specific project situation. Each area of practice has its own "secrets", approaches, directions, plans, processes, and activities. None is any more important than creating, developing and refining the documentation that illustrates and shows others how the project is to be built— how the good judgment of the professional is put to use in creating the graphic and written instructions and directions for construction. Indeed, the direct communication between professional office and the job site, support facilities, and associated personnel, groups and organizations.

Construction projects necessarily thrive on, and are ultimately successful as a result of pertinent, prompt, and progressive communications!

Successful construction requires continual, prompt, decisive, specific, detailed, coordinated, and cooperative communication, among, and on the part of all participants, within their individual context.

The highly-skilled, hands-on work required to construct a project requires and heavily relies on the transfer of information, instruction and direction—simply to know what to do, and how to do it. In a single word, it is "communications"! This premise needs to pervade the production of project drawings and specifications, and must be the standard/normal

process throughout all operations and functions regarding the project.

[Regarding specifications as companion communication documents to the drawings and details]

"I don't think specifications will be model integrated things until we change how the guys on the jobsite view the documents. Right now, when I've gone to the jobsite, they can certainly view the model – on the computer in the trailer. Out on the actual project site, in that room that is piled with stuff... it is stacks of drawings, and the project manuals that folks are referring to, not the 3D model. Until that technological leap is made, I don't think we're abandoning the separate project manual.

And, we need a few more generations of computer advances as well. Currently our most complete model for an office building in Switzerland can only be opened 17% before crashing the computer. There's no value to including specification information in that model until the whole thing is more accessible."

- Anne Whitacre, FCSI, CCS
Specifications Writer,
Specifications Consultant

The process of producing the drawings required for construction, engineering and architectural projects has been so taken for granted that it is virtually ignored and has fallen into a non-plus status. It is treated in such an off-handed manner as to relegate it to the status of "begrudgingly needed"; a time consuming drag on both talent and the professional fee being collected. Silly sounding, perhaps, but realistic in that few outside the professional offices give this process much thought, much less credence.

Collegiate programs have long ago so minimized the process as to render it "unnecessary" or "irrelevant" in the course of architectural and similar education, leaving the recognition, essence, and teaching of it to the professional offices. It was something easily dispensed with when academic time and money became short, and priorities rose on other issues of practice. Trivialized, or marginalized at best, it is simply relegated to the realm of "someone else's work". There is almost a total lack of recognition that the drawings are requisite, not necessary evils, or "niceties" that are produced as mere professional amenities [to justify higher fees].

It is totally fallacious, most inappropriate, highly misleading, and a thorough mischaracterization to think of, or refer to detailing as "mere ticky-tacky", or "busy work"; for it is, indeed, crucial to the success of the project, its compliance to regulations for safe use, occupancy, and stability– and contractual requirements for appearance, longevity, value and proper function [all most important to the client/owner/user].

As far back as the junior high, and secondary school programs, the traditional "mechanical drawing" courses have disappeared in favor of computer operations. In a sense, it is a matter of glitz over matter! By eliminating manual drafting education and emphasizing the use of the computer the very foundation of the drawing production process has been not undermined, but removed.

Now the professions are faced with an ever more confounding problem of staff members who really, 1] do not understand the need for the drawings, 2] do not know the concept, intent and content of the drawings, and 3] do not know how to

Architectural design, documentation, detailing and construction are ALL predicated on the understanding of INTENT and CONTENT—

INTENT – What do you want to do/achieve?

CONTENT – What do you do/include to communicate your intent?

produce meaningful drawings. The thought is that all of these drawings are magically encased, entrenched or sequestered within the confines of each CPU. All one has to do is "think" of a drawing, click several times, wall-la the drawing appears.

Creating the requisite drawings from scratch is almost unheard of, and proves very mystifying to many—all too many—of the junior staffers. Then, when they do come by minimal information and understanding, they almost totally lack the insight and technique to produce the drawings in a manner that is readable, informative, and usable. Drawings are frequently re-used [a professional scourge 40 years ago], but even then are not carefully analyzed to ensure that they are fully appropriate to the project at hand. Irrelevant information, misleading and inaccurate, is often transmitted because of the lack of understanding of the technical content, the construction materials, system sand methods, and simply because, "the drawing seemed to fit"! And in many cases, other sources of drawings are used and relied on, or the drawings produced

are so short of information that they really provide nothing of relevance to the project work.

Projects are built much like jigsaw puzzles [remember them?] are produced. Small increments or pieces of work, fully and properly shown on the detail drawings, are fitted together to create the "puzzle" that we call "project". Bits of information, on the details, inform and direct the trade workers building the project on the requirements and methods to be employed to create the work and fit it into the overall project scheme.

Basically, this is simple communication. One telling another what is to be done, how and where, etc. But the current "communication" in far too many cases is murky, muddled, confused, unreadable, and simply unusable in the field. There is no longer any "feel" for line work—varied line weights, for example, which enhance—greatly—the readability of the drawing, and facilitate its easy assimilation and use.

Professionals increasingly lament the situation. They are forced into a position of having to expend their precious time and fee to literally teach their new hires how to work and what to do. The schools, both secondary and collegiate, continue to ignore or push out any semblance of instruction in this area, in favor of the more attractive computer, and design oriented operations. But still, every project MUST pass through the documentation stage that entails creating a maze of drawings which, when executed, produce the finished project—as designed and desired!

The graphics, of course, stem from the initial rendering [artistic view] of the preliminary design, but necessarily evolve and must be expressed in the singular process called, "detailing".

This is a step in the project process and sequence that simply cannot be denied, must be fully explanatory, complete and accurate, and must be planned for and allowed to proceed as required to convey all of the requisite information from the concept of the designer to the hands-on activities of the construction personnel.

It is unavoidable! And efforts to discredit or minimize it will directly impair, if not imperil the correct and faithful production of the project as designed. Field operations cannot proceed based on mental thoughts and images, innuendos, impressions, and indications. They work from cold, hard facts depicted and explained in the contract drawings and specifications.

To begin to understand details, there is need to understand Contract Documents, as used for construction.

These Contract Documents are composed of three essential elements— the Agreement [Contract] for Construction, the Contract Drawings and the Contract Specifications. While their formats and contents vary from project to project, this combination of the three instruments is necessary and does exist in every project.

CONTRACT DOCUMENTS [for Construction Projects]

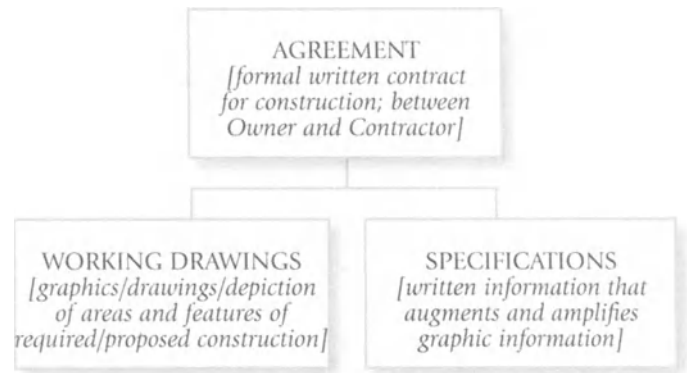

Fig. 1-3:
Chart showing the three sets of document that comprise "Contract Documents" these are interwoven in such a manner that each is required to properly construct the project

Combined these three documents set out the requirements for the projects; the Agreement in general overriding terms; the drawings [including details] and specifications in deeper terms. So the skill in developing these instruments truly determines what is or can be required in the finished project— without them, there is no common "measuring stick" for achievement.

The motivating perception should be that quality in the built project will always be a mirror of the quality in the contract drawings and specifications.

The Agreement is simply the contract between Owner and Contractor that establishes what will be done and what compensation will be paid. This is added to the specific procedures, processes, and parameters of this arrangement. [Note: the Architect or Design Professional is not party to this contract, their relationship to the Owner being prescribed in another contract form].

For quite varied and most unsubstantiated reasons, many people tend to separate drawings and specifications. Reality

shows, however, that they really are companion documents and are not removable one from the other. The essence of their relationship is simply that some information can be shown or depicted graphically [the drawings] while other information that defies depiction, is provided in written form, and more than likely provides added and more expansive information. The two sets of documents are complementary and supplementary and combined they are vital to successful project construction. Also, as contract instruments [documents] they are legally binding on the contractual parties [owners and contractors].

Within the context of Contract Documents, details are as legally binding as any array of written legalese statements!

Just as the specifications carry very decisive, direct and in-depth information, the drawings carry parallel in-depth information through their use of "detailed drawings"– or simply, "details". So it is equally mysterious why details are so maligned, or dismissed when their true value is so very apparent–their content vital to correct construction!

The building can no more be completely built without details, than it can be completely built using just the specifications or the architectural rendering!

Perhaps it is because they are improperly seen as demeaning or "non-architectural" [i.e., not part of the design effort] work by younger professionals who haven't been made aware of their value and contribution.

The End Result!

Simply put, a good project, well designed; carefully, substantially and faithfully constructed; within the contract time and the project budget; all to the satisfaction of the client!

But the issue here is how we get to that point and that result–the mechanics of the pragmatic approach that transcends theory and philosophy contained in the design process by resolving the technical construction issues that they identify and raise. At some point mechanics must be applied to transform design information and bring the correct "construction" information to the documents, and eventually to the field personnel who perform the hands-on work of construction. This is the "end result" that lies ahead!

It is, of course, highly unusual to start a book by discussing the final results, the ending or the goal to be reached, in the

very beginning [no murder mystery ever begins by saying, "The butler did it"!]. But in this case, it is a good idea to show what the book is all about, what is intended, and why– and only then how one can achieve the necessary end. This is not a contrivance but rather a simple point to show what is both expected and needed in the design professions, each and every day, and despite whatever type of project, design concept, motif, construction, delivery system, or media is used.

Definition

The basic definition may appear formidable, but in reality it covers the complete and necessary reach of the task or skill. It has many facets to it, but in the end expresses the often forgotten and maligned work involved. Read carefully to understand individual parts of this definition.

Architectural Detailing

The collection, development, and refinement, and conversion of design concept information, into construction "language", using both graphic and written forms, indicating "how" the project work is to be shaped and performed; and the conveyance of same, in coordinated/usable form, to the field personnel, for execution.

In addition to the insight of the definition, the most simple, sincere and forthright statement required is– Detailing is a required [never optional or incremental] professional service that addresses two vital aspects of the project;

- Detailing directs the construction, ornamentation and decoration of the project in faithful adherence to the design concept, by showing how that concept is to be executed in the configuration and various features required;
- Detailing is necessary to ensure the long-term wearing of the completed project in terms of how the various materials and systems perform and weather, and in the continuation of proper functioning of the owner's operations.

While there is a good array of basic services provided for each project by the professional, there is a commensurate number of staffers who perform the vast tasks. Not to suggest "pigeon-holing staff to a single function, it is impossible to understate the fact that the ability to "detail" is the overriding rudimentary skill that every architect needs to learn, understand, engage, develop, conquer and use consistently, in an informative manner. It is an unavoidable professional skill that needs to be learned and honed as the most crucial communication link between design concept and realized project. Detailing involves the innate ability

to communicate in the required or mutually understood vernacular, and in terms steeped and supported by strong, in-depth construction knowledge and information.

Yet in large measure detailing has been purged from the curricula for professional education, and relegated to a skill developed via OJT. And even this is a rather undisciplined and scattered approach, in the offices— and done more out of the goodness of others in the professional office who choose to engage the young practitioner and mentor detailing skills [in lieu of formal instruction]— what to show, how to best depict it, etc. With little to no formal instruction [and quite varied approaches in the offices] professional practice overall and a balanced understanding of the profession as a whole is an academic malaise at present. There is need for this to be part of the immersing new assessment, available to employers, regarding just exactly what the student/graduate has been taught and what skill level has been developed. The element and entire concept and impact of detailing is, of course, part of this and this only serves to reinforce the need for a common thread of understanding its principles and the common requirements that transcend all approaches, motifs, and production methods.

Detailing, of course, is a process common to every project, although the complexion and extent of the work, and the number of drawings may vary quite widely. It is a function of the professional effort that must directly reflect and react to the project and the construction involved. The design professionals must create a plan for the detailing, so their effort covers the crucial elements of construction without needlessly overburdening the construction, adding unnecessary engineering and construction costs, yet with enough information to depict the various elements of the work so they can be easily built.

Only through the mentoring of others, and experience with quite varied projects, can the individual professional come to understand and appreciate the tremendous breadth and scope of detailing, its limits, and the contribution that the project is heavily dependant on.

" ... Architects, as we all know, create unique structures and suitable environments for their clients, and have a tremendous amount of control and impact on what products are used to construct their designs. Historically speaking, architects are responsible for selecting 95% of the products installed on an average-sized project.

A recent [2002] study designed to uncover how architects make product decisions yielded a particularly interesting fact:

Architects, on average, must select 1,500 products and make over 17,000 decisions on what is best for the project and the owner. That's 17,000 answers to 17,000 important questions.

How big? How high? What color? What shape? What style? Moreover, what products will give the owner exactly what they have paid the architects to design? The list of questions about what products to incorporate in a project can be overwhelming for architect and their clients.

It is impossible for an architect to know every detail on all these products. By nature, they are generalists, but they carry a complexity of responsibilities. Architects are the design creators who desperately need trusted product information providers, someone they can rely on to provide objective answers and help them determine the right product for their project. An effective stone strategy, therefore, should not center on selling to architects. Instead, focus on influencing architects to incorporate stone products using the three E's: Education, Ease and Execution. "

**"Selling Stone Products to Architects"
by Dan Ouellette
STONE WORLD magazine, May, 2003**

It must be remembered, though, that there is no relationship between the concept and even the related execution of detailing, and the computerization. The entire concept of detailing is an expansion of the design process [we must detail to ensure faithful development of the design concept]. It is also the process whereby correct construction can be assured— i.e., giving the necessary information, in a usable form, to the trade workers, so they can build, erect, install or create what the project's features require. This process can be done whether or not there is a computer at hand [they could be done still using fully manual drafting techniques], and whether or not the software available has a wide array of "bells and whistles", and sophisticated maneuvers and functions.

First off, however, in any discussion of detailing and drafting, we must consider the tremendous disparity between professional offices. This is, in part, a direct function of the size of the staff in each office. There are a host of offices that consist of a single person; innumerable others with perhaps one or two employees, and with minimal computer capability. The office out of necessity and choice will fashion its computer operations to match its capability and direction. Often in smaller offices, the personal choice of the single proprietor, or the 2-3 employees

or partners, will prevail. In those instances, the software more than likely was carefully chosen to provide the maximum flexibility and capacity for the office, the work, and the expertise of the staff. They then will work with what programming and features they come-by through the purchase of the software they choose. Cost restricts changes to newer, faster, and more capable software, but this does not necessarily deter the effort of the office. Usually in circumstances like this, the staff becomes highly computer literate, quite innovative, and has attained a marvelous command of the computer operations. The computer by function, literally replaces the need for more employees, and provides a reliable and rapid method of production. It is easy to see that the computer, in the hands of a good operator can greatly aid the production of projects— especially where the firm is small, and the computer can literally produce the work of several employees [who are not on staff]. While limited in scope and computer "bells and whistles", these offices have attuned their production to the tools they have at their command. More than likely their work is highly professional, well executed, and proper for the practice and the projects.

In many cases though [although the numbers may vary] there are offices of high profile, cutting edge computer capabilities. Software is the latest available and easily changed-out when new versions are put on the market. In many instances there are entire departments, staffed full-time within the organizations, which are devoted to nothing except computer operations – hopefully dedicated in a manner by which they fully support the computer efforts, and NOT to the degree that they drive the professional effort [a wrongheaded direction!]. In the main these offices have professional staffs which number in the hundreds for engineering/architectural firms, and those multi-office firms with wide-ranging and international practices. The work projects also run to the very complex, and very costly— hundreds of millions of dollars. The computer operations are the lifeblood of such firms, since the amount of information required [to be transmitted, used, and documented is monumental]. The operation must be rapid, reliable, and in some cases, may operate 24 hours a day— plotting during the night for the next day's operations and transfers. A shutdown for a simple power outage or for equipment malfunction can be devastating, and extremely costly to the firm, since almost all operations will be stopped, and employees sitting idly by. Of course, in this, detailing could continue in the form of hand sketches and conversations, but actual production of usable details will have to cease.

These larger firms will also have the newest versions/releases of computer work, and such advanced programming as 3-D modeling whereby an electronic model is created which allows

development of electronic ["virtual"] design concept, and electronic "walking" through out the project to view the various elements within the design. This and other similar software programs are used to identify conflicts between walls, pipes, ducts, and structural elements. In very complex industrial projects, the elimination of conflicts by electronic means, in the office, is crucial to the progress and cost control of the actual construction. The interface between systems' elements can easily be displayed, rotated, inverted, and otherwise manipulated to give the best and most accurate views. While not a direct detailing effort, this work and system can be the source for more details, to explicitly show how instances of interference can be avoided, or other similarly important problem solving.

The design can be viewed further through use of computer generated renderings, and other electronic programs which advance drawing abilities to vivid and expert presentation skills, all with the capacity to manipulate and present numerous variation of the project. The same building design can be displayed in many and varied ornamentation and design concepts, without repeated copies or iterations of paper drawings. Details too, can be created by combining various items, or portions of other drawings, to create new drawings. Overall, the architectural profession currently lags other professions in document production via computerized programs. Initially, the computer was seen as a design tool [as noted above], but with more refined software, working drawing production is now utilizing the computer more and more.

While working drawings remain as the basic product of the firms, their computerization has advanced so their presentation and interference drawings are striking and clever, and their final projects free of conflicts— and relatively free of problems caused by too many items trying to occupy the same space at the same time. In this age of highly complex projects, this is an essential element of projects, and one, if resolved within the computer that can facilitate and lower the cost of projects. In reality this is part of the detailing process. But beyond this newer configuration there is still a basic need to detail— and to detail completely in context with all of the various requirements and needs each project presents.

There is relationship between the fact that we can, now, produce "better" drawings, in a shorter amount of time, and the fact the comprehensive detailing is driven by project needs. The "better" drawings are still a function of the human mind and decision making as to what to show and how. Speed of replication is handy when deadlines creep up and project requirements call for more information more quickly. This all indicates that CAD is, indeed, a tool; and a very fine tool when in the hand of a knowledgeable professional or operator/designer.

Detailing is a unique combination of insight, analysis, judgment and the judicious and adaptive application of construction knowledge.

Obviously there is a direct correlation between project size and the size of the professional firm hired to do the design and documentation work— smaller firms do "smaller" projects, etc.. This relationship does get murkier as you move toward the center location between the smallest firms and the largest. In other words, there is a point where firms must decide if production is best increased through use of more mechanization [i.e., computer-aided drafting, and etc.]. This is in lieu of trying to find, hire, and train more staff members.

As the firm expands, it appears that staff size increases, but certainly at a rate much more modest than that of added computerization. In a tight hiring market, it is far easier to find new and better software, than it is to find good new employees. In this, too, is an expansion of services— large corporate clients tend to desire more services, and stronger commitment [meaning more precise, well-documented, and watch-like production of contract documents]. Many such clients actually oversee their design professionals by co-locating staff in the professionals' offices. To stay abreast of the many facets of not only project document production, but also all of the nuances of the client's management process, requires computerization. Time is charted— projected/ forecasted, tracked, and modified with the slightest change in scope. There is always the delicate need to balance effort hours with scope of work. Competition among professionals means margins are close, so the professionals seek high-speed and reliable production techniques, with human input to make decisions required along the way. But the physical production— actual printing or plotting of drawings is but one aspect of the situation. There is still a need to match correct detailing with project requirements. This is still subjective, and not thoroughly analytic.

The process of detailing, while immersed in this scenario, remains a strong and necessary element to every project— bar none! To build the project, the trade worker needs a continual flow of incisive, correct and detailed information. This is translated, directly into more efficient construction, better progress, and more accurate and faithful project of the design concept. In fact, the word "detail" now has taken on a much more extensive and imposing meaning, in that the minutia of documentation and all of the aspects of the project, in toto, must be so widely and deeply and accurately described and recorded, that "details" no longer are just the vignette drawing showing portions of construction. Oh, the use of the word has always encompassed all this, but the emphasis, today, is far

more evident in the project minutia than in the project's contract documents [drawings and specifications]. Despite this, however, the import of the drawings remains the very same.

This is best expressed in the aphorism of Ludwig Mies van der Rohe, who was noted for his sleek, clean, straight-forward and unadorned designs— "God is in the details"! He knew that his details would be exposed, so they had to be neat, clean, well-executed [both in design and execution], and actually attractive, as they became part of the overall scheme. His details had to directly contribute to the design concept, since they were, in fact, part of the "ornament" and visual expression of the project. While claiming no divine right for detail drawings, this expression does set the bar of value a bit higher, and indeed, sets a standard of sorts. That is the fact that the details must be given the time and attention required to place them in the highest order as they support their associated design concept.

Granted those more dedicated to design functions may not use detailing, directly, but it is necessary that they understand the principles involved, the approaches required, and the content essential in detailing the construction required. It is through the details that the nuances and refinements of the design concept are shown, built, and provide the design concept as conceived, desired and approved.

Creation of the design concept requires that the designer have some indication, no matter how small, of how the various elements and features should be or need to be constructed. Without this information the design concept this indeed is a mirage or dream, and is at risk of being fulfilled, by others as they see fit, but at odds with the designer's intention. This occurs even within the single professional office where the various parties are in close proximity but never seem able to communicate and interact in a mutually satisfying manner. This can be ruinous to any practice.

Part of this is pure ego; part is pure selfishness; and all of this is wholly unacceptable.

To the vast numbers of architects, interns, drafting staffers, and related personnel, detailing is a requisite that is to mastered, nurtured, developed, refined, and utilized in both routine and innovative ways [as required by specific project conditions]. It is here— in the details— where the essence of the construction lies. It is here where the underlying support for the construction— and the design features and refinements— resides. It is here where the "building is put together" in the documentation.

The specifics of the details are depicted in one of two formats: one is an isolated piece of construction [a floor drain installation, for example] that may or may not be repeated on the project. The other is commonly called a "typical" drawing indicating that while shown but once, it is really applicable over a large area of the work [e.g., a parapet detail that applies along several hundred feet of roof/wall construction]. Usually this single detail is merely referenced in various locations where it is applicable.

Details create a mosaic of drawings that, if taken in proper sequence and relationship show the construction of the building, in 2-dimensions. With the continuing development of whole building modeling [i.e., BIM] details, eventually, will be depicted in 3-dimensions consistent with the entire modeling program.

"I would say that in our office, there is certainly no reduction in fees for architectural work, even though all of our projects are in 3D. What folks seem to forget is that by adding the model, you're adding one more contract document that needs to be coordinated.

The Model will not replace every 2D drawing out there – details will still be in 2D, at least for the foreseeable future. And, since the model takes time to develop, and we all know that contractors are trying to get pricing early, invariably the contractor bids off the early 2D drawings, and then once the model is produced, there has to be a scope definition issued to account for the differences between the 2D and 3D methods of representation.

It so far hasn't mattered that we define the 3D Model as the contract document – the schedule drives the project and as we know, contractors have little compunction about bidding from incomplete (or very incomplete) documents in order to meet their deadlines.

My office does get involved very early with subcontractors and we have the same issues as always: defining their scope; "scrubbing" their numbers – i.e., making sure they include what they are supposed to include and don't include it twice; working through phasing and constructibility issues.

The 3D model makes a huge difference at the production end – it saves the contractor (and us) a fair amount of time at the CA end, especially in the conflicts. However, that savings in CA time means that all the coordination issues are worked out in the CD phase – its not as if the conflicts magically disappear. They are just "front loaded" into the fee.

Large complicated projects make for large complicated documents and the issuance of them in multiple (very multiple)

packages are going to take time. Anyone who sees BIM as reducing professional fees either has very simple jobs, very repetitive jobs, or is delusional".

Anne Whitacre, FCSI, CCS
Specifications Consultant
Los Angeles, CA

Although obviously different in depiction, the details will still be required to illustrate the construction involved in a manner suitable to proper communication of what is to be done. Hence it is shown that most of the traditional values now in place for detailing, will survive and remain to guide the new modeling programs.

Details need to be well-founded, correct, clear, accurate, decisive, directional instructional, appropriate to the faithful production or expression of the design concept, and to be well coordinated into the total graphic depiction of the project. With this is the onus to depict the detail in such a manner as to be easily readable, easily understood and assimilated, and directly useable on the job site. To do otherwise can prove fatal to even the best conceived detail.

In addition, they need to require "buildable" construction, correct for the need and proper for the design– a tall order, but a distinct challenge to the document production effort. The more innovative or creative the design concept, the more the detailing needs to follow those same criteria. Quite often, though, relatively simple, or previously used details will suffice to meet the new design features. But in either case, there is need for personnel, both Project Architects and staffers to have working knowledge of construction– what works, what does not work; what is inappropriate; what is too complex or elaborate, etc. While their knowledge may not be on the hands-on level as a working contractor, it needs to be objective and insightful so the detailing does not require the impossible, or construction of a highly elevated cost.

If it is true that we are hired for "what we know", and not "how we do it", how is it that, fundamentally, our professional responsibility is really to others who do not hire us, and have no contractual relationship to us?

It may seem out of the ordinary, but to properly discuss the "detailing" of architectural construction projects, it seems advisable to start with the end result– with that which is expected from the process. There is a valid and important need

to set out a direction for where the effort is intended to go and what is set out to be the goal to be achieved. Then there can be exploration of the various methods and techniques to achieve the desired results.

It may sound very trite, but it is true that architecture is a sum of its parts! Renowned architect Mies van der Rohe set the tone with his comment that, "God is in the details"! This sets a very distinct and proper tone for the documentation of a construction project and the production of any type or example of architecture.

The construction of a building involves the installation and placement of numerous items, set in a variety of locations and positions, that come together, overall to produce the desired building/structure design.

This is a formidable task – but not forbidding!–

The most formidable task is not documenting a project, but in doing so by placing oneself in the place of those who must subsequently read, understand, assimilate and use the documents, in order to correctly execute the work shown.

when viewed from the start and in trying to grasp all that needs to be done. Accomplishing this task is to work through a good number of extremely complex and widely varied considerations, small pieces and relationships between items– materials, devices, systems, etc.—and their fit into the project concept overall. But eminently important is HOW all this is conveyed to the trade workers responsible to perform the hands-on construction work.

Detailed drawings ["details" in the common vernacular and construction jargon] are the method of communication that is used for this function.

Architectural Detailing

The collection, development, and refinement, and conversion of design concept information, into construction "language", using both graphic and written forms, indicating "how" the project work is to be shaped and performed; and the conveyance of same, in coordinated/usable form, to the field personnel, for execution.

Architecture becomes real only through a process that combines design and construction. Overall, this is a process of creating a design concept, documenting it in usable construction information and language, and building the structure as desired, depicted and specified [in written form].

In this the design concept is an overall program for the building wherein the subtleties of the project requirements are blended with design rationale and expertise, and converted and intermixed with innumerable small bits of information, that indicate large or continuous construction results.

In other words, the contractor is presented with an array of detail drawings ["details for short"] which are provided to show the materials, systems, etc. and their interface one to another, in various situations and locations around, in and throughout in the building. These are isolated, "snap-shot" type drawings more often than not in cut-away or sectional views, so as to expose the various parts of the individual portion of construction.

It cannot be stated long enough or loud enough that construction knowledge in the document production areas is absolutely vital to the success of the project. The documents must be clear, complete, concise and accurate so there is not only ample, but excessive information available for the contractor. This information needs to be distinct, absolute, and clear in intent and construction, and specifically fitted to the circumstance. Field knowledge of construction has no substitute in this situation; and even rudimentary knowledge is requisite and must be at a level well beyond basic, orientative or introductory. There must be constant, informed diligence to discover and avoid errors, and due diligence to find the best suited solution and its proper incorporation the work.

The "best" answers or solutions, [among the several available] are those reached by those with insight, knowledge and expertise, after due, careful and rational consideration of all aspects of the circumstances, and the best interest of the project– not necessarily always the easiest, simplest or cheapest.

In simple terms, the architectural profession [and more than likely other construction-related disciplines] has a program or task that is losing its importance, in the eyes of many, and has been relegated to a status where it is dangerously impaired. Impaired by lack of knowledge given over or available to it, lack of skill in executing it, and a new technique that is not fully supporting it, but rather is manipulating it to meet other agendas.

Truly flawed it is—irreparable, perhaps, but salvageable if action is started soon, and with impact.

The program is detailing— and important is the manner in which it is skillfully done with good basic construction knowledge and technology, and full understanding of the intent and use of the final product. The media of use or the method by which the final product is achieved is all but irrelevant! It is vitally important that the method be made to support the task/program, not vice versa.

The equation is simple to state, difficult to solve [like most math problems!]

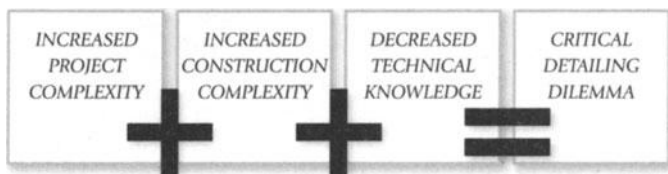

As implausible as this appears, it is true that while projects themselves have become immensely more complex, and while construction materials, components, systems, and their installations have become ever more numerous, varied, intricate and complex, the very knowledge required to resolve, incorporate and implement these elements has drastically decreased. Far too little attention [and instructional time] is being devoted to technical construction information, understanding and basic knowledge. This has led and continues to lead to professional and quasi-professional personnel who simply cannot cope with what should be utilized, and how what they may select is incorporated into the project work— in simple terms, how to detail the project.

To fully understand and appreciate the complexity and the proper use of new technology [of whatever ilk] one must have working knowledge, and understanding of the products or systems. In this, one must be fully aware of the correct and normal use of the product, as well as the other possible uses which become possible only when new and different circumstances or added products are involved. In essence one must have the mental flexibility to foresee and understand the adaptive use of the product— in fact, possible ALL the uses of it.

Armed with this information, the person can then assess project conditions where the product might be utilized. And with this comes the need for the added skill of detailing, or the ability to incorporate the product, even in an adaptive manner, into the project in a way which produces a better solution.

The current situation has new graduates of both professional and quasi-professional educational programs coming to the work place without even the basic understanding of products and their use. And certainly, even where there is a smattering of such knowledge, there is little if any adaptive or flexible capability within the graduates. Hence, they become candidates for extensive on-the-job training, at their employer's expense, and the need to create their own technical agenda, trying to find out "what to find out"! With little or no ability to understand how their work should progress, how it should be executed, or where their work should windup, the new employees are relegated to minimalized tasks. This, of course, creates a situation satisfactory to neither employee nor employer.

These tasks need to be so engrained and instill in the various staffers that they become SOPs, and actions that are automatically performed. Not in a perfunctory manner, but in a way that provides or creates the correct information or solution for the circumstances as they are encountered in the project. This requires a deep and fully functional knowledge of construction, not necessarily all inclusive so long as the staffers know and understand that asking questions is part of the process— both for the project and for their individual learning.

The cavalier regard for, the general diminution of, and the relegation of detailing to inexperienced staffers is a cause of growing concern in the profession. Far too often there is an immediate, knee-jerk reaction which equates detailing to CAD operations. CAD may straighten the lines of a hand-sketched, but with little or no technical expertise running the mouse and keyboard, the value of the resulting details is quite marginal—questionable to best! Oddly enough, all too often without due understanding or any sort of analysis, detailing has been re-classified as the proverbial "necessary evil"—a pure nuisance!

It has become all too easy to attribute this to, and for what appears to be, that primarily for cost reasons, detailing is considered as a real chore, too time and money consuming for the return— something that should not be allowed to siphon off production effort hours from the project budget. Few are looking objectively at this matter, and seeing that the level and quality of detailing is a direct factor in project cost. And, indeed, in the overall quality of the completed project. Simply, the need to convey invaluable construction information through various hands to the trade worker is minimize, if, indeed, it is recognized at all.

Quality is never an accident. It is always the result of high intention, sincere effort, intelligent direction and skillful execution. It represents wise choice of many alternatives.

-Anonymous

From ASCE Manual No. 73

QUALITY IN THE CONSTRUCTED PROJECT

In addition, where any semblance of the design-build [D/B] project delivery system is used on a project [short of the full-blown program] this tendency is elevated. The basic thought is that the construction personnel can and will discover the gaps, and mistakes, and will "cover them" as normal practice, and with their perspective all to the good of the D/B process. However, most good and reliable D/B operations acknowledge, and still remain convinced that complete working drawings enhance their field operations.

For example, the following is a valid and well executed construction detail [from any actual set of drawings for a project in the United States].

This is a rather complex detail, reasonably well executed, that depicts a construction project condition involving new wall construction [to the left] immediately adjacent to existing wall and roof construction. The new wall is to build independent from the one existing through the use of an expansion joint [open space] between them. The edge of the existing roof is to be re-worked to provide new curb-like framing to receive the flexible, "bellows" type expansion joint cover that is to be installed between the existing roof and the new building wall, covering and closing off the expansion joint void. This is to be done throughout the entire length of the adjacent walls [NOTE: This is a detail that would correctly be called, "typical", as it applies to a long stretch of work and is not a "spot" detail that occurs in a limited manner or in isolated locations].

The most unfortunate part of this detail is that it contains the indication of work that cannot be executed! Simply there is no way to install the "Continuous Fire Sealant" [see note left of detail] under the edges of the "Chase Barrier", when the barrier is installed between two walls [existing and new] with just a small distance [varies] between them. What is the solution?

The discussions throughout this book will be similar. There is no attempt to assess and award an academic grade, of A-, or C+, etc., or to compare one detail to another. Rather the discussion revolves around the success of the detail as a commu-

nication instrument, despite the method or technique used to produce them, the type, complexity or size of the project, the type or size of the professional office involved, and so forth. The effort is toward showing the good and bad points of the individual detail, in isolation from its project companions, and as an instructional tool to guide readers to increased awareness and understanding of how to produce truly quality details in their projects.

The application of mechanics to detailing is both the opportunity to resolve a problem [anticipated or real], to meet your analysis of the situation and to convey your solution to the constructors. It is your opportunity to depict the solution or configuration as you see fit to meet the circumstances of the project. These applications are individual and personal and should not always be perceived as circumstances addressed by standard [stored and retrievable] details [see later discussion]. It is most certainly as creative any basic design and as the scope and circumstances may be more limited it is still an essential contribution to the success of the project overall.

Good detailing enhances and produces good projects– those that meet the faithful production of the approved design concept.

The need for "creative detailing" is not a quest for an oxymoron, but rather a function commensurate with the effort made in the design concept– project success requires both!

And in that, for other than standard details [used repetitively] It can be said that details are much like snowflakes in apocryphal Folk Theory– "No two are the same"

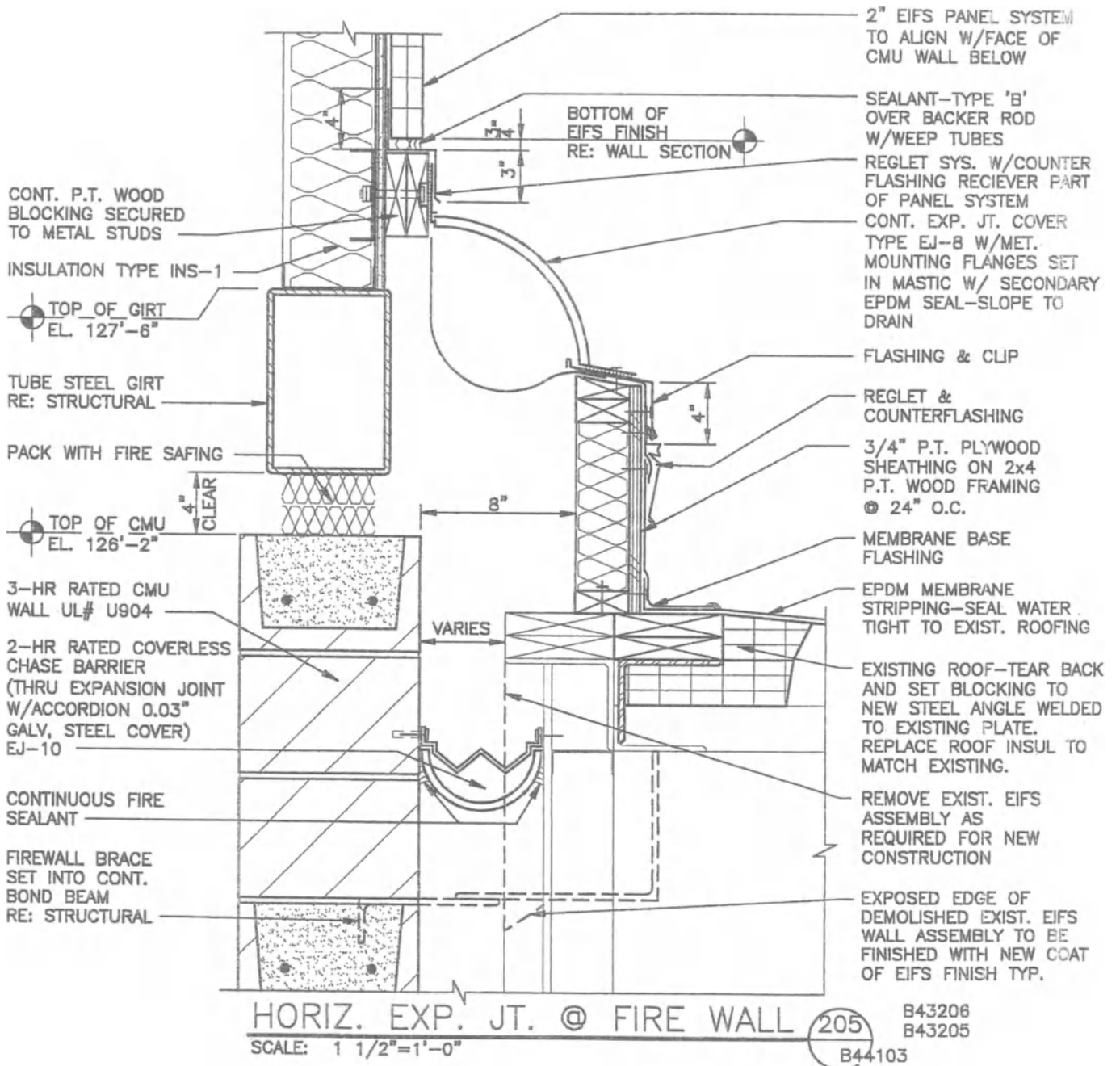

Fig. 1-4

An example of a typical "end result". As noted in the text this drawing is not perfect, but still is a good example [if corrected!] of what is needed and required, overall, in both content and execution of all details

 PERSPECTIVES ON DETAILING [from various sources]

Detail work: Dealing with the details can be annoying and troublesome.

Yet details are what make life [and projects] happen.

Those who consider themselves too important to be bothered with the details will likely end up being brought down by the details. Certainly it's important to look at the big picture, and paying attention to details will put you in a position to positively influence that big picture.

Details are not always fun and are rarely glamorous.

Taking care of the details is often just plain hard work. And it is in that work that value is created. In tending to those tedious details, you make possible all sorts of exciting and desirable things.

Each little detail may indeed seem too small and insignificant to be worth the trouble. But when you stand back and look at all those little details put together, the view can be truly magnificent. Little steps can take you on big journeys, when you are focused and persistent.

Value, appreciate and work on the details, and with them you can build anything.

– Ralph Marston

"Detail Drawings". The definition and detailing of the idea into good workable design therefore depends on drawing as the principal modeling technique.

A vital element of the process is the ability to identify and define progress; the detailing of the idea not only allows the designer to record development but enables clearer articulation of the results. This role in establishing the progression of the design gives the drawing a fundamental influence in both the refinement and the construction, and also enables prediction of future performance. Detailing's role, then, is double-faceted in illustrating the desired underlying construction and in depicting the desired refinements of the design concept as it appears in the completed project.

This ability to specify size, scale, and shape prior to actual building or manufacture is common practice today. However, in the later eighteenth century it was an important stage of development which was to have a major influence on the planning and organization of construction.

Examples show how an idea is detailed and how annotations are used to give specific information to assist in manufacture. The incremental nature of design is readily detectable in drawing, separating the process of trial and error from building and manufacturing and acting as an accurate and efficient model for change and development.

The drawing is the scaled-down clarification of decisions already made, which enables the architect and engineer to simulate what is eventually produced. This original need to mark out the different parts of a proposed building and their relative positions brought about the now obvious use of reduced scale onto an accessible flat surface. This ability to examine through drawing thus reduces and simplifies the numerous decisions that must be made."

– John B. Richardson, FISTC, FSIAD
 Northbrook College, UK
 Vol.2, Encyclopedia of Architecture

THE CONTEXT

Direction and Intent

Forthrightly, this is a book about “detailing” – the craft; the skill; and the process – and not about individual or collections of details in and of themselves.

This discussion has been written specifically to steer a course between other books. In that, it is not:

- A discussion on the content, methods or materials of sample/generic details [construction materials, etc.]
- The incorporation of standardization into the process.
- Discussion on the basic underlying approaches and principles for resolving problems via detailing.
- “near-perfect” details– not so much in content as in presentation using printed lines, and extremely crafted drafting, for a concept of perfection, and artificiality, that is really not the aim of detailing.
- An array of ready-to-use information about critical building details that can be merely selected and directly applied to any project.

NOTE OF CAUTION: The author makes no recommendation or indicated use for the details in this book. It is advised that only the greatest of care, understanding and appropriate modifications be used in the event a reader determines that a detail, presented here, is usable directly for similar project construction situations.

Fully respecting the expertise, time, thought, and effort connected with those other books, it is felt that some different perspective is needed, based on what is not happening in the academic effort, and only begrudgingly in many professional offices.

The primary reason here is to assist students, and new or prospective professionals [and even experienced professionals] in approaching, developing, fine-tuning and utilizing their understanding and knowledge of, and skill in detailing the architectural portion of construction projects. It is intended to be used as a basic guide for the development of details– which commonly number in the hundreds or even thousands for a single project– within the context of the needs of specific design concepts. With the considerations noted here, added professional advice or consultation and project-specific information, proper and productive detailing can be achieved.

The construction details in this book have been selected solely to help the reader to see, understand, and duly consider the problems that are most likely to occur. Information presented shows how to detail various conditions for various building locations and systems– i.e. roofing, cladding, interior partitions, etc. Any one detail, it must be remembered, is a single instance among many solutions that could be utilized. Their inclusion here is to show mistakes, erroneous depiction, misperceptions and the possibility for varied solutions that architects commonly make and seem to repeat far too often.

The material presented in this book should only be considered and used as a generalized and generic supplement to normal, competent professional knowledge and judgment. This is because there are an unlimited number of variations of any basic detail to fit the requirements of a specific building project. In addition, factors outside the limits of a particular detail, such as structural loading, climate, and occupancy conditions, may impinge on the detail’s performance or on the exact method of construction. Therefore, it should be remembered that the illustrations herein are merely sample details, single representatives of the innumerable solutions that have been or could be applied to the specific situation or condition. The shape, form and extent of the details and accompanying data have been compiled from well-regarded, professional and most authoritative sources. They are not intended as random pieces of a patch-work quilt!

Consider working drawings as a “collage”, made up of several hundred interrelated vignette “snap-shots” [called “details”] which show the make-up of various areas, sections, pieces, and portions of the work, all of which are necessary parts of the completed entity.

They use clearly drawn graphic details, accurate, to-the-point information is given to help the reader coordinate a detail with other parts of the design/building, specify materials, and develop a personal layout if necessary. In addition, the fact that many of the details were produced using manual drafting procedures and techniques should not distract from the information, format, and overall concept of the detail[s]. The medium of production is irrelevant to the value and credibility

of the detail, and the information it compiles and conveys. It is only where the production techniques get in the way of the drawing and information, and disrupts clear depiction and communication, that concern is justified.

Successful detailing involves the Design Concept appropriately DOCUMENTED for prompt and proper COMMUNICATION useful to the field personnel

Overview

The essence of architecture, good and bad, comes first in the design concept— the idea, inspiration, or calculated determination about the function and appearance of the project. This concept can be beautifully expressed in a drawing— a rendering done by manual drafting or by the astute manipulation of the computer. Either way, the design concept remains static and frozen in that state until it is moved along toward execution.

In the eyes of many, both inside the profession and in the more aware general population, architecture is indeed solely the visible images of the projects— i.e., what is really the visible tip of the project “iceberg”— the obvious; the recognizable; the published; the acclaimed with rhetoric of those in authority as the deciding factor; the unusual, the quirky, the startling different; in part, new configuration not yet understood but assumed to be proper, meaningful and as desired.

All this is based purely on what is seen, overall, in the completed project, and noted in various comments and reviews. Fundamentally, it is the expressions of good [?] design that “catch the eye” and impress the mind. In that, it is the function of architectural design that appears to be the sole determiner.

This effort is to expand the understanding about the profession of architecture beyond the concept of “design-design-design” [much in the same context as “location-location-location” is the foremost consideration in real estate]. It is not to discard or dispel design as a featured element of the profession, but to look beyond the myopic concept that “design is the only thing”, in regard to architecture. Surely, as the new student/professional is promised a professional education, then the instruction should cover, in correct proportion, the whole of the various aspects of that profession! Unfortunately in all too many cases, currently, this is not the case! Emphasizing design, in proper proportion is one thing; but casting it as the sole or exclusive driver or consideration is both misleading and shortchanging to the student professional—

Architecture involves more, and indeed, is more!

“Concept and implementation must be seamlessly related if the built work is to be architecture and not just a building.”

- J. Patrick Rand, FAIA
Distinguished Professor of Architecture
School of Architecture
North Carolina State University

“.....the act of architecture is not finished when the design is done, but when the building is built. However, most students see, and are taught, that a design is the end product.”

- Gerald G. Weisbach, FAIA
Architect/Attorney
San Francisco, CA

This is why you hear of so few of the individual 88,000+ members of the American Institute of Architects, and the other 30,000+ architects in the United States [and comparable numbers world-wide]— it is only the design oriented professional [“signature architects” or “starchitects”] who work at the cutting edge who gain the assorted celebrity and publicity. They and many of their projects are high-profile, radical/innovative in design, subject to high levels of rhetoric, highly publicized for various reasons, and too often seen as the essence of the profession. But for each of their projects, there is a host of other architects and offices who support their design efforts, and get them built.

Renowned architect Frank Lloyd Wright is a good example [among many] of one giving proper attention to detail, in some but not all portions of construction projects. He has been both saluted, and widely and rounded criticized for his details. How can this be? His projects were “cutting edge” in design concepts and in many cases, structural ingenuity. Many consider his designs to be revolutionary, distinctive, and far ahead of their times. It would seem to follow that Wright “must have” been concerned and involved in the details of each project, to produce work of such regard and stature.

Wright did paid close attention to “details” in his designs, but apparently ignored, or failed to follow through with many of them. This matter of detail, in Wright's designs, goes to the level of his personal involvement. He was meticulous in unique furniture design, exact/“correct” placement of furniture, accurate locations and orientations, precise matching of motifs, unique and specifically designed concrete block [to support

his design concept], accessories, and the other appurtenances which served to enhance his concept. Many of these were developed for a specific project and client and not for general use. In the main, they were cosmetic in nature— details which were included to serve as the "correct" [and only acceptable] accouterments for the Wright design concept.

Wright's approach is very typical of the "signature architect" who places high regard and high value on the visible portions of their projects. They revel in the details of the eye-catching aspects of their designs regarding high design, configurations, finishes, eye-appeal, innovation, drama, etc. Their "passion" quite often does not extend to the details of construction— those underlying and providing support for the more glitzy portions. But ALL of these are details of construction!

At the same time, the details "for the construction" of many of Wright's buildings, particularly the houses, have proven to be quite flawed and on-going maintenance problems— with leaking roofs, leaking windows, and structural nuances just short of collapse. This may be attributable to work that was done by Wright's "disciples" [his student drafting force]. Although he closely supervised their work, it is quite apparent that he was only as diligent as necessary in this, and failed to instill close and proper detailing in those who were not as skilled and experienced as he was. It may also indicate his lack of direct interest in the "mundane" details of construction— things that are not exposed to view, for example, or those things that directly effected, contributed to, or enhanced his design concept. [Similar to a man in white tie and tails, who has a hole in the bottom of his shoe!] Seems, though, that the Wright's clients came of a mind to "put up with" such maladies, simply because Wright was their architect and his designs, status, reputation and high rhetoric were highly celebrated— possession of a Wright-designed project was to be cherished and nurtured, in spite of shortcomings.

In reality, many times more money has been spent on repairs, through the years and by various owners [including charitable and historic groups] than the actual cost of the house. Of course, inflation plays in this scenario, but nonetheless, the cost of remediation and repair has not been small. Yet Wright's reputation and prowess remain strong— strong in support, and equally strong in criticism!

This general scenario seems to be a "perk" enjoyed, even today, by "signature architects" who use rhetoric to overcome physical shortcomings in their designs and completed projects. One can speculate on the approaches and techniques taken to achieve this expertise, but too often the buildings simply do not "weather or wear" well, or prove insufficient in

some way, which tends to downgrade the overall impression of the project, and certainly the appearance and function of the specific area[s] in question. Often such failures, are pointed to as "construction failures" attributable to the lack of care and expertise by the trade workers who installed the work. In fact, though, more often than not the trade workers are hamstrung by detailing that is incomplete, inadequate, inappropriate, or otherwise flawed in its concept. The workers are obligated to erect and install work "in full accord with the plans and specifications". So if the documentation is faulty, the resulting work will also be faulty, unless someone recognizes the problem[s] early, and takes added action to resolve the potential problems. Case law supports the workers in this manner since the contractors and workers do not conceive the details and are obligated as noted.

In the case of MAC KNIGHT FLINTIC STONE CO. v. THE MAYOR, 160 N.Y. 72, the appeals court heard about a contractor who had performed his work, "...in the manner and under the conditions prescribed and set forth in the "...plans and specifications..."

Problems developed, and remedy was sought from the contractor. The court found that:

"This is not the case of an independent workman left to adopt his own methods, but of one bound hand and foot to the plan of the defendant (the owner). The plaintiff (the contractor who appealed) had no right to alter the specifications if the plans and specifications were defective, it was not the fault of the plaintiff, but of the defendant, for it caused them to be made, and it alone had the power to alter them."

In Wright's case, a good lesson can be learned. This is that there are different types and levels of details, to which the architect must attend. Wright carried some of these [placement of furnishings, unique concrete block shapes, accessories, etc] to an extreme, but was able to please/satisfy the client's anticipation of a totally Wright-created living atmosphere. This said, the client unknowingly was also handed a bevy of problems, which would appear over a period of time [leaking roofs, structural inadequacies, etc.]. These would take more effort [than moving a chair] time and money to resolve— but still the clients remained Wright advocates.

Most of Wright's peers, and architects both then and now, followed other courses. They attempted to present their clients with substantial and reliable buildings, first, and then if asked, provided interior design services. Most got close enough

to their clients to understand them and to be able to ascertain the client's true wishes and then converted these into project features. Where done, this is a crucial exercise, and results in accurate and proper programming. However, this is extremely difficult to do in a corporate environment, where the personnel are reflecting corporate and not personal tastes, ideas, criteria and demands.

Nevertheless, the lesson is that details come in several kinds or types, and proper attention to each, in its way, leads to a far better product and one that more closely matches the complete array of client requirements. Obviously, design statements can and should be made in both the building and the interior furnishings and finishes. But at the same time, the same due regard for detail is necessary in seeing that the roof and windows do not leak, and that the construction overall, in a portion by portion review, works, functions correctly, and is time related for long term endurance.

And too, those thousands of others who have viable, active, productive and successful practices serving their clientele well with sound projects— well designed and executed. It is unfortunate that there is an impression both in the profession and with those who know something of the profession that these "others" are somehow second-class citizens – perhaps not even worthy of the title architect.

Detailing is much like many other things in life— mentioned only when it is done poorly, inappropriately, or when it fails.

Vetted out of the academic sequence, it is also relegated [if addressed at all] to extremely low priority in any professional or trade publications discussing projects. Even when mentioned or shown, the context is more about the "details of the design [concept]" and not the "details of the concept's construction".

It is interesting that, on the rare occasion that they are included, details in professional/ trade magazines are usually stylized, artistic, relatively incomplete, short on pertinent information and largely of a scale that renders them unreadable— why?

In the main, in such publications the few details used are usually greatly simplified and greatly stylized to present them in a more pictorial and artistic manner than actual "technical" reproductions of working drawing, or "nuts and bolts" expressions. While somewhat admirable for some added and more expansive explanation of the projects, these limited displays are often short on information and substance, and certainly belie if not obviate the true need for, use, depth and value of detailing.

Certainly this is a malady inherently part of any "starchitect's" project review, criticism or rhetoric. While certainly unmentioned much the project detailing is virtually strictly ignored, or so "taken for granted" by the designer/architect, that it is never even considered for mention. Some high profile architects find detailing, for other than the major design elements, boring and "beneath them"— so mundane they are not worth their time.

"When I went to graduate school, at Harvard, I knew how to detail buildings— my classmates did not! But then they knew all about Proust".

- Architect Michael Graves
Commenting on his basic education at the University
of Cincinnati, School of Architecture [1952-1958]

But then this is true for all high design elements— like automobile designs, fashion creation, etc. where how they got that way is lost in the "Wow, look at that" aspect.

Regardless, detailing is a valid, necessary, often rigorous, sweat-producing process that requires high ingenuity, creative use of materials and system, in-depth construction knowledge and understanding, and high dedication to the design concept. It is needless to say that the highest of expertise and excellence in design never can negate the necessity for adequate, appropriate and careful detailing. The clarion call is always, "How do we get that done!"

It is the necessity to create communication of construction information that drives detailing—the process of "giving over" the designer's wishes to the trade workers [in a form they can immediately use!]. The function has been around a long time, as seen before. It has thrived for years from the un-air-conditioned drafting rooms of the early 1900s [and before] completed with drafting boards on trestles or saw horses, incandescent lighting, sleeve garters, eye-shade, and yes, spittoons! Even to the massive areas of hundreds of detailers, some relegated to entire careers doing nothing but "ogee" gutter details in the last row in the far corner of the drafting room. Others still, turning out specific and new details for the ornamental elements that were not massed produced— still others "fitting" portions of the project together properly. All of the major historic names in architecture participated in such work— it is where they learned their craft and profession, whether they exercised it directly or saw it well executed in their later design efforts— no matter their time, era, style, approach, concept, intention, or result.

For proper and faithful project execution, the various contractors, suppliers, manufacturers and workers need a large and quite varied amount of in-depth construction information—far more than provided by any conceptual representation. No project can be built, with any reliability to satisfy any client by handing the rendering—the concept—to the contractors, etc. al. There simply is not enough information for construction.

The requisite information is, of course, developed by the design professionals in their project documentation. And it is here that the project is created, piece by piece, in the form of myriad details. For it is those details that convey much of the information needed for construction—the materials, their configurations, their connection, their interrelationships, their attachments, their coverings, etc.

While it is true today, perhaps more than ever that details are for the most part concealed in the final construction, in the 1950s design concepts were so streamlined, austere, “clean” and unembellished that the details were exposed and made part of the project’s appearance. True it was a style that is now mostly history, but still it was a time that highlighted, emphasized and delighted in good, direct and refined detailing. Concealment today does not diminish this, and the complexity of today’s projects really demands such a demeanor for details.

It is not that details did not exist prior to this time—they did—but were contained in the simple “that is the way we do it” mentality—necessity was the primary determination of the details. Of course, there were far fewer options available as the market of construction materials was quite small and restricted—i.e., the same type of work and details were simply reputed since they were the state of the art information at the time. An exception, and another direct contributor to innovative detailing was the Empire State Building and the techniques that had to be created, and developed, on the run, to build that building—in downtown New York City, in a mere 20 months, with 1930s machinery, materials, expertise and techniques.

But prior to this project in the United States, and in fact by the 1920’s, a new approach to architectural design relied on details. Influenced by the early 20th century work of Frank Lloyd Wright, a German school of architecture began to develop. It proved to be a major influence from about 1932 until 1984. The Bauhaus school produced the fundamentals of “modern” architecture and served to drastically highlight details and their function as both necessary construction information and when installed as actual ornamentation of the project. In 1932 under the strong leadership of Phillip Johnson, the modern movement was consolidated into the International Style of architecture.

The prime movers in the Bauhaus were Walter Gropius and Ludwig Mies van der Rohe, as well as Le Corbusier in France. The major change and influence was felt much more strongly during World War II when Gropius and van der Rohe both fled to the United States and the Harvard Graduate School of Design. Here the two became highly if not overwhelmingly influential and nurtured the international style into the prevailing architectural motif. There was a conscious and determined direction to break with architectural tradition and design simple, unornamented buildings. Sleek, straight-forward building design using glass facades with exterior supports of steel and concrete for floor slabs and interior supports, the resulting buildings relied strongly on exposed, but clean, well-executed detailing—in fact, the details literally became the ornament of the buildings. As van der Rohe noted, “God is in the details”.

Perhaps one of the more complete expressions about details at this time [and since] was expressed by Eliot Noyes, who was part of the group called “the Harvard Five”*, which included Gropius, van der Rohe, and others.

“I think of details in two senses. There are first the details of joints, connections, the attachment of different materials to each other, the turning of corners, and the physical relating of parts of the building to each other. But I also think of larger

* The Harvard Five was a collective group of architects — John M. Johansen, Marcel Breuer, Landis Gores, Philip C. Johnson and Eliot Noyes. All five attended the Harvard Graduate School of Design between the late 1930’s and 1950’s. The students were influenced by the professor Walter Gropius, a leader in the Bauhaus movement and the head of the architecture program at Harvard. In 1937, after being forced out of Germany during the Nazi regime, Gropius brought the teachings of the Bauhaus to the United States. Regarded as one of the pioneering masters of “modern” architecture, he taught “form follows function.” His designs, epitomizing the contemporary design of clean, simple, nuclear spaces with lots of natural light, used industrialized building materials of the time. All five architects spoke of him as an inspiration in their work. After the five completed their education from the Harvard Graduate School of Design, they migrated to New Canaan, Connecticut and went on to design a string of modern buildings. Their careers were in part devoted to building modern homes, creating an architectural experiment in the suburb of New Canaan, Connecticut.[1] The small town was soon nationally recognized for its many examples of the International style of architecture. About 80 modern homes were built in town, and about 20 have been torn down since then. Breuer and Noyes did a variety of other buildings along with the residences. But it was Johnson who had the longest and most influential and note-worthy practical life until his death in 2005. He taught and mentored a good many other architects, who gained some renown with their work, and had a deep impact on architecture with his outspoken approach. This, in effect carried on the initial orientation of the Harvard Five, and their dedication to exquisite detailing—practical, simple, direct, effective and yet beautiful.

special elements as details— such as stairs and fireplaces— in which there are of course numerous details in the first sense.

In each case the architect has a useful and expressive architectural device. In a way, such architectural details are the architecture, but details, alone— no matter how thought out or how consistent— cannot make architecture. Such details must play their part in relation to the overall concept and character of the building, and the means, by which the architect may underline his main idea, reinforce it, echo it, intensify it or dramatize it.

I like details of both sorts to be simple, practical, efficient, articulate, appropriate, neat, handsome and contributory to the clarity of all relationships.

The converse of this is that the spectator may observe and enjoy details, and find in them an extension of his experience and understanding of the architecture. In them he should be able to read, or least see reflected, the character and spirit of the entire building— as to see the universe in a grain of sand."

– Eliot Noyes, Architect
[1910-1977]

The attitude and philosophy that Noyes embraced is, of course, a reflection of the era in which he and his colleagues worked. Their designs were austere and details were the "ornament" of these buildings. Hence they took on added importance for precision and care in concept.

This basic approach is still valid today and can be seen in the need for such precision in detailing in the work of the signature architects and the revolutionary designs. But then too, detailing has been forced into another context and that being the complexity of projects, overall, and the need to provide constrictor for very unique and currently relevant construction— that has changed since the era of Noyes.

Therefore, Noyes remains intact and serves to reinforce the idea and need to understand that detailing is not simply a production process, but one that is required to both support and enhance the design concept [by providing the concept in its true form and intent, often through insightful and creative detailing]. "Attention to detail" has, indeed, taken on a much broader and more meaningful aspect in today's construction. This all serves to show that detailing is not the "dark side" of the profession, given over to wannabes who are short of, or devoid of design prowess. Also it makes it quite apparent that the process of detailing is a much more studious and measured activity— knowing construction methods and materials,

and with flexible aplomb manipulating and adapting them to drastically differing project conditions. It is, after all, the method for controlling the project work, not in a dictatorial manner ["You gotta do it this way!"] but in a way that provides the client with dollar value and project features as anticipated.

To control [in the context of construction] is to both direct and guide various actions and tasks, while also to regulate and ensure adherence to a prescribed pattern and path of work that leads to an established end— as opposed to disjointed, random, uncoordinated, unfettered, free-lance and directionless activities

AIA Document A-201, "General Conditions of the Contract for Construction", is widely used to provide the parameters of construction contracts and work. A-201 provides that it is the contractor who holds responsibility for the "methods and means" of construction. This, however, does not extend to "how" the project will be constructed, but rather to the methods used in executing the generalized scheme as contained primarily, in the details, other drawings and specifications. It is well to concentrate on and hold fast to the fact that all of this information from the design professional must be given over to the contractor who then determines the exact manner for the executing of each work item.

Production of Details

It is well for us to remember that there are still thriving professional offices that produce their contract documents using manual drafting methods and procedures. In addition, there are many others who range widely in regard to computerization— not all have the latest iterations of software, and many do not have more than a single program loaded on their equipment. Each office and practice must seek its own level of computer involvement and how it can or chooses to do its work.

These facts are often lost in the overwhelming discussion of current work apparatus and methods, but truth be known, this is a most accurate picture of reality in the professions.

Success in detailing is NOT in machines or software bells and whistles, but rather it is in how well humans use their skill, expertise, innovation and creativity ensuring that problems are solved and proper, usable solutions and information are conveyed to the field for execution!

Other Distraction and Influences

Standard details, CAD and even BIM influence and all too easily tend to siphon off creative thought, based on the er-

roneous assumption that they contain all needed information; hence, unfettered summary inappropriate application is fallacious and misleading. The malaise of today is this very scenario, so ingrained [and readily accepted] in students' and young professionals' mindsets and techniques that they ignore and tend to shut down the very creativity they need for better solutions, better designs, and indeed, better "selves"! It strongly appears that what is being embraced is indeed that which is undercutting the fundamental intent— better documentation for better projects! Obviously, the emphasis is in the wrong direction and giving students and young professionals the wrong set of values.

STANDARD DETAILS

The movements that led to the current circumstances began rather in conjunction and yet isolated from each other.

Thirty years ago, professionals were always self-pressured to reduce the time required for document production— and increase profits. Profit for a long time was simply never an issue openly addressed by "true professionals". Once recognized as a valid and important issue changes developed. This was part of a change in service to clients who were making increasingly restricted demands for speed in the entire design-documentation-construction sequence. Both time and money were heavily involved. Most of the clients had major concerns about the "cost of money", i.e., the interest that was required for money borrowed for construction [periodic payments due the contractors during construction required owners to have funding to cover this in place and ready for use— hence the "construction loan" concept and the interest required on such loans].

Reduce the time for overall project time [i.e., reduction of time in each phase] and you reduce the cost of the funding required. That demeanor brought about a new time frame approach and an era of composite drafting, scissors drafting, photographic reproductions and off-set printing of working drawings, and the drive to establish a litany of standard details [in some format] which can be drawn upon for re-use, "at the drop of the hat". All of these efforts, and others were worked side-by-side to see which best fit the office operations, and which produced the best value documents. Anything that could be done to reduce the amount of more time consuming manual drafting was considered.

Computerized drafting was on-line but in its infancy, and evolving through the early fascination as primarily a design tool to the point where it was almost devoid of programs directed toward document production. Of course, the burgeoning proliferation of both hardware and software made decisions for the

professional office even more complex and difficult. There was need to compare financial capability with production, and the offset between lower production time and costs as compared to the investment in the computerized system.

Even before the emergence of CAD began approximately 30 years ago, there was the start of fundamental and major cultural changes in the practice of architecture. This new attitude impacted how work was done, the value of work, the use of fee collected, the shifting of production hours, and a general attitudinal change disregard how practice could be run. For the many generations and centuries prior, architects and their counterparts created highly detailed drawings for their projects. These documents were both extensive and extremely minute as to content— they approached artistic masterpieces in execution, as draftsmanship was a highly skilled attribute.

There were, for that matter, little that was "standard production"— most all was custom produced for each project. So to achieve the look desired or the construction required, the details had to be highly developed and very carefully done. Developed over the years, the drafting skill reached a zenith in the first half of the 20th century. Expanded development and World War II served as catalysts for faster production of drawings, and highly abbreviated construction periods. Pre-fabrication was the development in the construction field with standard details being one of, if not the premier, the developments on the design and drafting side. Also, the final analysis, there was an enlightened business sense in that design professionals were not on a plain above others and certainly were fully entitled to full profit margins when ever possible.

Additionally, there was a growing trend toward specialization in practice, wherein an moved from a general practice [all types or buildings] to one where a substantial part of the work was in one general of work— i.e., school, or health facilities, for example. In this changed atmosphere it became more and more obvious that a single detail would stand up to use in any number of projects without imperiling the design concept, or intended function. While toward the more mundane items, chair rails, guard rails, display board "chalk trays", etc. were fodder to standard detail use. There was nothing in these and similar items that were so distinctive as to require re-detailing for each project. The only problem was the judicious use of them, so when a unique project did come along it was not allowed to become merely another project in the office, when special attention to detailing was really required.

By the late 1950s or so, some firms began the practice of re-using details from one project to another. This was easily done, as the projects often were not related and the work was

not exactly the same. The immediate reaction of the progression was that the principles of the firms were unscrupulous and highly unprofessional– one simply did not use the work done for one client on the project for another. Each project HAD to have its drawings re-done specific to the need!

CAD facilitated and enhanced the use of standard details what with electronic storage of information [no longer need for file cabinets, reproduction equipment, etc.]. As CAD evolved into an every day instrument, so too the reusable details– it moved from, albeit reluctantly from “unprofessional” and “unethical” [and the disparaging name of “factory”] to normal, routine SOP. The practice persisted and quietly remained and indeed grew into what is today “standard details” – those

reserved for innocuous, mundane work that is not in need of specific project parameters and where drawings can be apropos to any project– or a series of project.

The use of standard details is now a common, widely used and viable practice but one that requires careful monitoring and disciplines use. Granted many items of construction are very mundane and routine, to the point that their depiction need not be created anew for each project. However, circumstances on each project do vary, and it is fallacious to think that standard details can merely be included off-handedly, and without the requisite “made to fit” effort, where ancillary conditions are changed.

EXAMPLES OF DETAILS THAT CAN BE MADE “STANDARD”

The items listed are some of those that are often repeated from project to project because there is no particular project requirement to make them more specific or different. While certainly not unimportant, these items are more mundane, not subject to design concept influences, and represent manufactured or fabricated items produced by mass production [not custom built for a specific project].

<ul style="list-style-type: none"> HM door frames; in various wall types [CMU, gyp, etc.] and widths Bollards/pipe guards Overhead door mounts Stairs; <ul style="list-style-type: none"> Interior/exterior Steel, concrete, wood Tread-riser, landing dtls Stringer closure to wall Handrails- stringer or wall mount Applied floor covering Nosing; abrasive Curb/sidewalk; ramps Parking block; Stripping; <ul style="list-style-type: none"> Parking stall stripping ADA Interior aisles Toiler partitions; <ul style="list-style-type: none"> Layout Std stall; std ADA Hangers/bracing/ceil bulkheads Accessories in room; mounting heights Recesses Concrete joints Thresholds/transition strips at change in floor covering 	<ul style="list-style-type: none"> Wall base; vinyl, wood, ceramic tile <ul style="list-style-type: none"> Set-on Coved Straight Recessed Terrazzo/Tile setting systems Applied floor coatings; <ul style="list-style-type: none"> Resinous epoxy carpet tile- ceramic, quarry sheet material Casework; counters, worktops <ul style="list-style-type: none"> Cubicles; layout, equip Recessed cabinets for equip [FEC, etc.] Roof accessories; Curbs Hatches Reglets Coping Flashing Fascias Millwork; running trim [chair rail, coves, dentils, base, crown mold] Civil engineering items such as curbs, head walls, rip-rap are examples.
---	--

Fig. 2-1

A short [partial] list of details that can be typically set up by an office as “standard” details, stored and re-used from project to project.

It is likewise most fallacious to think that entire projects can be properly detailed by merely using just a wide selection of standard details. Every project presents its own set of circumstances that require special and specific attention in the detailing process. To force a design concept's execution by only using standard details is ill-conceived and will likely fail to meet the requirements of the concept and the client. Detailing should not drive design but rather shall support, show, explain and elaborate on the specifics of the design. Where proper and in accord with project demands, standard details MAY be used.

Standard details assist and augment good detailing skill– they DO NOT replace it!

In the past, offices have created their own cache of details, in various formats, for re-use. Their direction was to reduce production time by eliminating drafting for some items and work. Hence the system of retrieval and re-use of details created once, and stored for repetitive use. In the late 1960s and the 1970s, this was seen as a revolutionary direction and program and one that surely would make a drastic impression of the documentation process, by reducing time-for-effort. This was a time of increasing concern over the levels of professional fees, and the low levels of profits in offices. Really it was one of harbingers of a proliferation of changes in professional practice, aimed at reduced liability, increased profits, and timelier document production [the latter two elements tied together].

Some offices saw it more fitting to create a bevy of "construction parts" or modules, which could be retrieved and re-used, but in different context and formats, as well as being manipulated to meet new and varied conditions. The increasing use of CAD in the documentation process hastened the use of such details– full standard details and modules. Electronic storage was, of course, even cheaper and far quicker on the up-take and the process of inserting the material into the new set of documents.

In the beginning, for example, a firm in the mid-west saw a large part of its work load in the relatively small school addition, 2-6 classrooms [some even done to one classroom] with perhaps a locker room or wash rooms. The projects, done for different local school boards often adjacent to each other, were such that "standard details" could easily be used, without any stigma or comment. They depicted assemblies and materials that no one really cared about– they were not design elements per se, that impacted the image of the project. The materials and systems involved were sound and well manufactured by reputable companies. It was merely that windows, bar joists,

chalk boards [and their trim sections including chalk tray] roof deck, toilet partitions, doors and frames, etc, all were "similar" and in fact, suffer no loss by being identical!

Since the various designs varied mostly by design and layout and not by construction, these details were easily applied in their various locations– no problem. Some of these details, in fact, were merely bound into the specifications book [since photographic and or other copying means were not yet invented that allowed for direct incorporation into the drawing– that all came later].

The basic rationale, once you get beyond the implications of being unprofessional, is that a sound product selection can remain and certainly is fully reusable in similar circumstances. There was/is no need to reproduce the drawing, via any media, time after time. Concrete curbs, railing details, stairs, etc. all need perhaps some new information but in the long run could be incorporated with little if any revision. Indeed, there are numerous items that fall into that general range of details– and most especially where the practice does a lot of work within the very same type of project/building.

Of course, due caution and care need be taken to ensure correct application, avoiding irrelevance and inappropriate use– and with proper modification and added information where needed. Not all of this however, can or should be open to unfettered and unmonitored usage. There is a need to re-evaluate the detail and it's fit into the current project scenario. Details, always should be perceived, and developed to fit to the project– not the project to the details. Certainly no design concept should be sacrificed to the fact that there were no readily available details to satisfy it, so the concept was modified to fit what was at hand. Here we again define, unprofessional, if not unethical, and certainly will raise the risk of client disapproval and criticism– at a minimum.

Even today, many, many offices are computerized but with limited capacity because the cost of new machines, and even new software are too costly. This applies not only in actual direct costs, but also in time for training of staff, transition to new methods while maintaining project production schedules, etc. Often introduction of new software is a major disruption to office operations and production.

It is nice, comforting and perhaps far too naïve to think that there is an irreducible amount of time available for the research, development and refinement of a detail. However, though, this still is true. BUT there are, now, far too many "other" considerations at play that force solutions on a quicker but more risky time line. Certainly, even without these

"added" considerations, the peculiarities of the current array of projects causes deeper research and a greater than ever demand on experienced recall to find solutions, post haste, which are both creditable and operative— also within budget! The simple truth, in detailing, is that you cannot allocate a fixed number of hours for a specific type of detail, and use that factor repeatedly. Project factors vary too widely and too often to allow the time to be codified.

All these combined has re-configured current architectural practice so it utilizes a lot of details that are "quick grabs"— tried and true details, directly reusable, or slightly modified and re-used. This occurs both for the convenience [why redraw mundane details continually?] and for budget reasons. These "grabs" take a minimum of time, and hence allow more of the allotted hours to be used on other more complex details, or even other documentation tasks.

This, however, requires an experienced head leading the effort, so inappropriate and improper detailing is not the result, whereby information totally unsuited for the project is sent out.

There should be no misconception, however, that this procedure is "detailing". It is not!

This is merely re-using what another skilled person has developed, The selection and "use" of standard details is simply applying the information— it is not analyzing problems, or creating and developing appropriate solutions through use of a true skill in detailing. There is a vast and very important difference between these two aspects.

The new other considerations are, for the most part, non-technical, and tend to be driven not by the expertise of the detail, or its innovative solution, but by administrative aspects, which all too often do not take expertise, engineering prowess, or appropriate problem solving into account. Simply spoken, despite what managers may want or demand, some things, problems and situations require more time for in-depth investigation and correct resolution.

But, not to beat a dead horse, it is really true that it takes a period of time— [that is virtually impossible to define or quantify]— for the required research, material selection, configuring, and "visual building" of a detail, whereby a problem is identified and then fully and properly solved. How does one quantify that process, without an artificial deadline, i.e., "When you expend "x" number of hours, we will use whatever you have then"? Certainly, this is a most ill-advised course, and not the best criterion for correctness, prudence, and successful projects.

Innocuous: A detail that is commonly and repetitively used, and can be applied to a specific project with little if any modification; a curb detail for example, or toilet partition details. These, primarily are details which are stored [manually in files, or in computer libraries] with the specific intention that they do not need to be redrawn for each project. It is not that the work involved is minor or inconsequential, but rather that it simply does not rise to the level where new and innovative solutions are required.

The fact that these categories exist is not the precursor for assessing what effort is or is not required to produce or incorporate them in the contract documents. Obviously, a new, unique detail will take more time, thought and effort, than ensuring that a standard curb detail is appropriate for use. Again, it is really a matter of caring, and "attention to detail" on the part of design professional or drafter. In the latter case, if the detail is used too "quickly" without due consideration, it may prove improper where it does not reflect the current project intent or circumstances. This is directly akin to having portions of a project specification Section which are irrelevant and do not apply to the project. These both are maladies that the professional must be careful of, since incorrect or irrelevant information can lead to project problems and confusion, unnecessarily.

There are, unfortunately, precious few books, or other instructional aids, which address detailing, and the approaches to it. Many "drafting" books do not even mention detailing as a separate activity; some allude to it as merely another type of sectional drawings, with no other in-depth explanation or expansion. Both of these concepts are ill-conceived and erroneous, in that their net result is the off-handed minimizing of the detailing process. Yet detailing is the very process by which the design professionals convey their thoughts and solutions for specific construction directions and requirements to the contractors, and their trade personnel on-site.

With the terrible confusion, excessive awards in lawsuits, and general liability insurance malaise during the 1980s, many professionals sought to divest themselves from all things related to the actual project construction. Their view was that it was this phase of work where their liability was highest, and where reputations, time, and profit were imperiled. There simply was too much risk for the return; too much liability for the grief involved in getting things right. In this climate, came the professional practice configuration that limited its services to the production of "plans and specifications"— taking no part, whatever, in the actual construction process. Of course, new chaos erupted as projects were manipulated and mutilated— changes made without proper understanding, and with a high level of client dissatisfaction. The "abdication" of the

design professionals [which still exists to a fairly large degree today] brought no real solace, and still stained reputations and caused legal entanglements. While working drawings [including details] were still of professional quality, there was no recourse where questions and divergent conditions appeared. With no input from the professionals, the owners and contractors were left to manage and resolve the situations with their resources and perspectives, which often were at odds with each other, and more importantly with proper execution of the project work.

Included as part of this "reduction of effort" mentality, on the part of the professionals, came the regeneration of the thought that the re-use of drawings— particularly detail drawings— was another and valid way to reduce production costs, while still providing satisfactory service to the client and project. After all, it normally required about 40% of the professional fee to cover the cost of document production. Anything that could be devised to reduce time, and hence the cost, was now open to discussion. The perception was that a great many very common and mundane portions of the work really cross project lines, and are repetitive in nature. In that light, there was no need to re-create the detail specifically for each project. For example, a concrete curb detail can be re-used numerous times, on different projects, without any adverse impact. That detail contributed no new or added design feature to the project— in essence, the owners of the various projects would not care, at all, that their curb was constructed in the same manner as curbs on other projects.

Oddly enough it has not been that long ago that such a practice, as "standard" or repetitively used details, was considered to be most unprofessional, if not patently unethical. It was perceived to be an ill-advised methodology for reducing costs in the professional office, and scorned as a way that short-changed one's client— a highly unprofessional practice! Firms that used this method were declared to be "factories" in the most disparaging sense of the word. The thought was that the documents for every project needed to be unique and specific to the project at hand; that was, indeed, the "professional way!" But tighter time and money budgets that began to impose on professional process prevailed, and increased so more liberal, enlightened minds began to ask questions and find new answers. An evolution occurred which slowly allowed for more and more use of the bank of details that were stored in offices [in various forms and formats] for retrieval and re-use. There should be no illusion, however, that entire projects can be built using nothing but standard details. Every project contains numerous conditions, which require new, unique, and specific thinking, and information, which is not available in standard details, and "canned" information. The-

re is merit in the standard details when they are controlled, knowingly used, applied judiciously, and modified carefully [if necessary], for mundane and rather generic work.

There is virtually no reason, for example, for the sidewalk/curb detail to be so unique and different, project to project, that we cannot use one detail drawing, on a repetitive basis. Would any client care, or complain over this practice? Chances are, not. The list of similar detail situations is long— usually involving the innocuous, common work which is both needed and repetitive by nature, and which has no direct positive or negative on the project scheme, design, appearance, or function. But one aspect of such details remains the very same as for newly developed, unique and specific details— they all **MUST** be proper, and fulfill their intended purpose!

Over the last few decades, a drastic reversal of this thinking, coincident with, and propelled by the development of CAD, has produced a stronger and wider development and use of standard details. The primary impetus was to develop and draw the routine and mundane items— those innocuous and "common" items that really need not be changed or made unique on each and every project. In using the system of standard details, it is incumbent that they be generic, yet complete, accurate, and possibly quite flexible. The latter would allow for minor to moderate modifications while still using the basic detail.

Certainly, the use of standard details remains as a viable program— and, it may well be increasing in use. There are a number of sources of good details, including the collection of details that most offices now have developed and retain in their "libraries". Numerous books have been produced, at various junctures over the span of years, which depict sound detailing and good execution, in differing formats. For the most part, the books were aimed at professional needs present at the time of their writing. All of them, though, present typical standard details, as well as good drafting procedures for students and young professionals. The precise direction of each book is contained in the text, and each has a specific intent and audience in mind. As with all arrays of similar books, each book has a slightly different direction, motif, or methodology in it, not so much for the sake of appeal as for clarification and explanation. Almost all of these books warn against unfettered use of the details, without careful evaluation for appropriateness, etc.— others let this point be discovered by the reader.

Hence, one prevailing problem or situation remains— in the detail books, and indeed with all standard details— the way in which the details are incorporated into new project

contract documents. While the details can be traced, scanned or otherwise reproduced and used in the actual contract drawings, there is a distinct need for some evaluation and adjustment. A small portion of the details can be utilized directly without some sort of adjustment, adaptation, or revision. A very experienced and discerning eye is needed for this evaluation. In most cases, there is a need to change the production items, such as line weigh, notation fonts and sizes, material symbols, etc.

Some of these items change office to office; some are regional; some direct contradictions of standards. No firm pattern is in place, which necessitates a review and adjustment. This incorporation of standard details, from many sources, can entail a good period of time, and effort in "re-manipulating" the nuances of the detail. Do line weighs match those in the project drawings? Do notation fonts and sizes match? Do style of layout match? Do material symbols follow the standard already established and used?

PROCEDURE FOR STANDARD DETAILS

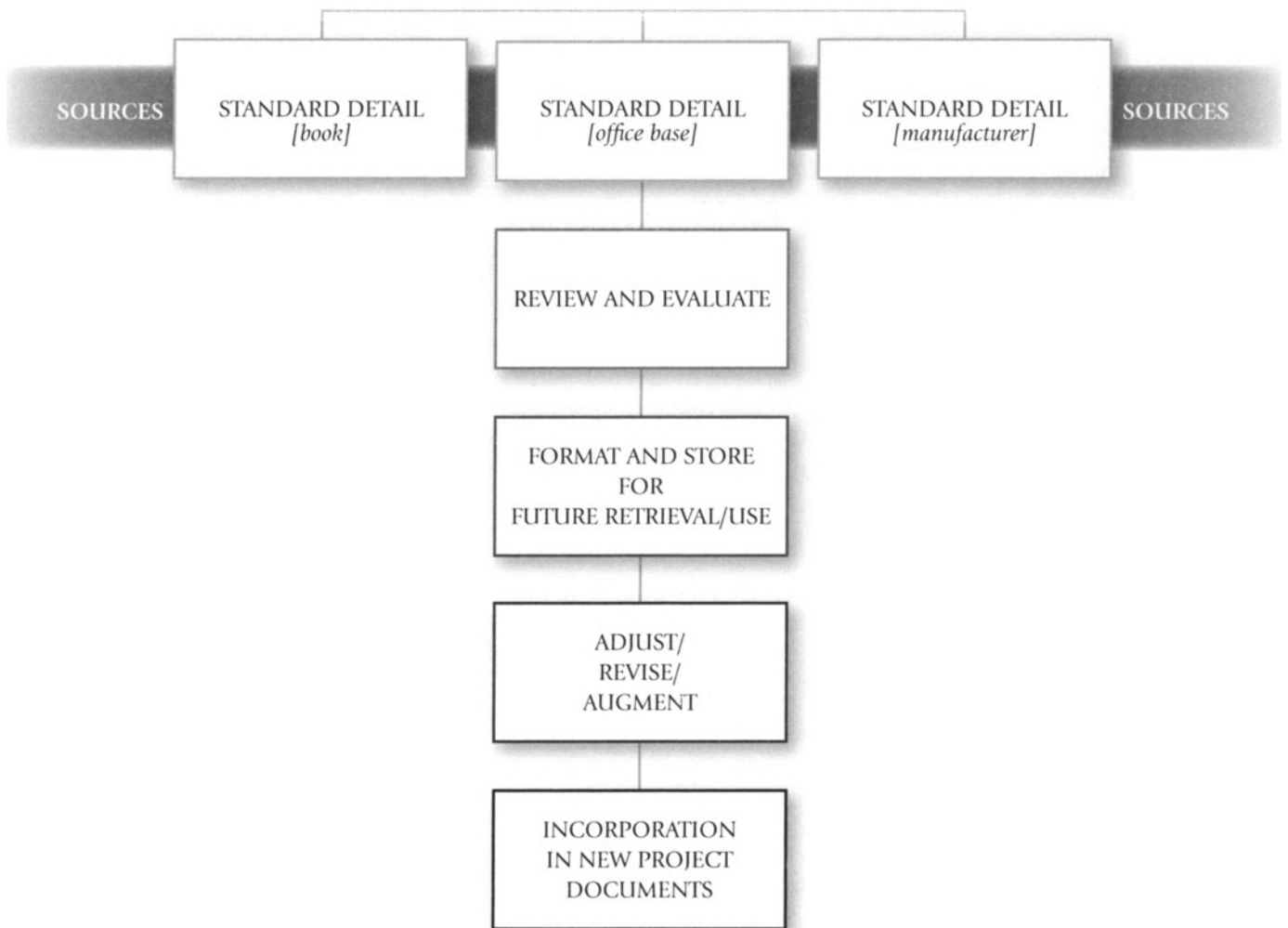

Fig. 2-2
Chart outlining how standard details are properly developed

This is necessary since very few offices tolerate the production of drawings with a very divergent look. Most prefer, or require, that drawings give a professional appearance that only one person produced the entire set [reality of course, tells us that a number of people are involved using similar/same techniques]. The ability to be very uniform in production is, of course, enhanced by the use of CAD— but even here there is a need of adjustment often items.

More importantly, the content and context of the standard detail must be assessed. This is to ensure that the construction materials and configuration shown are correct and appropriate for the construction anticipated for the project in question. Simply put, one is strongly advised that direct "unre-touched" use of standard details is extremely risky, and most improper. While the source of the detail[s] may be sound [it is difficult to impugn any fairly reliable source who has no directly related project information], there has been no project information given the author of the standard detail, so there can be no direct correlation to current project construction. Hence, a need to "proof read" the standard, at a minimum, and perhaps heavy revising where necessary.

Still, overall, there can be a saving of time [and money] by using standard details. It takes a period of time for staff to understand and accommodate the system, but once done, the standard details can be a very successful production tool.

The use of standard details is a fairly common and viable practice but one that requires careful monitoring and disciplines use. Granted many items of construction are very mundane and routine, to the point that they need not be created anew for each project. However, circumstances on each project do vary, and it is fallacious to think that standard details can merely be included directly or off-handedly, without the requisite "made to fit" evaluation and effort, where ancillary circumstances and conditions are changed.

In the past, offices have created their own cache of details, in various formats, for re-use. Their direction was to reduce production time by eliminating drafting for some items and work. Hence the system of retrieval and re-use of details created once, and stored for repetitive use. In the late 1960s and the 1970s, this was seen as a revolutionary direction and program and one that surely would make a drastic impression of the documentation process, by reducing time-for-effort. This was a time of increasing concern over the levels of professional fees, and the low levels of profits in offices. Really it was one of harbingers of a proliferation of changes in professional practice, aimed at reduced liability, increased profits, and timelier document production [the latter two elements tied together].

Some offices saw it more fitting to create a bevy of "construction parts" or modules, which could be retrieved and re-used, but in different context and formats, as well as being manipulated to meet new and varied conditions. The increasing use of CAD in the documentation process hastened the use of such details— full standard details and modules. Electronic storage was, of course, even cheaper and far quicker on the up-take and the process of inserting the material into the new set of documents.

None of this however, should be open to unfettered and un-monitored usage. There is a need to re-evaluate the detail and its fit into the current project scenario. Details, always should be perceived, and developed to fit to the project— not the project to the details. Certainly no design concept should be sacrificed to the fact that there were no readily available details to satisfy it, so the concept was modified to fit what was at hand. Here we again define, unprofessional, if not unethical, and certainly will raise the risk of client disapproval and criticism— at a minimum.

Once the standard detail is refined and finalized [perhaps even "tested" and proven in the field— with suitable feedback and adjustment if necessary] it is ready for "storage" usually in computerized form. In years past, paper or tracing copies were kept and filed, retrieved as needed, and copied into "sticky-backs", which were then applied to the tracings for the project. In any event, it stayed put until called-up, retrieved, replicated, and incorporated into the documentation of a new project. There is no deterioration, per se, but some information or technique could be somewhat obsolete [requiring upgrading] or may require slight one-time modification to meet a particular "need" in the new project. Fundamentally, though, the details can survive, as they are. With that, they "retreat" back to its computer home/library, and waits until next time.

Summation

The information, techniques and methods contained in the examples in this book, are representative of those in common use and have been compiled from many sources including various professional offices, industry standards, building codes, manufacturers' literature, and technical reference books. Every effort has been made to present reasonably accurate information; however, it is difficult to ensure that all of the information given is entirely accurate and the possibility of error cannot be entirely eliminated.

INTRODUCTION

Two identical art prints are available, but they are to be treated in two different ways. One will be treated as a finished item, mounted in a suitable matting and frame, and hung on the wall— finished; done; in need of only periodic dusting.

The other is to be fabricated and cut up into 1,000 pieces so that they can be boxed, and sold as a jig-saw puzzle. Here there is a need to take the picture from its current overall configuration, and re-fashion it into another form that is then made fully usable, but in another form that has to be re-assembled to be usable, viewable, and understood. In total by any one.

Now looking at building construction, reality tells us that there is no way in which we can ever receive a finished building— like the first picture above— and merely set it in place and use it immediately. Of course there is no way to transport such a structure, and really even to do that we must provide some other services and work to get to the place that is built and ready for transport.

Looking at the second picture, but in a reverse sequence, we can “build” that picture by merely fitting the various pieces together in proper sequence and location so as to produce the picture we started with. This, believe it or not, is closely akin to the construction process.

In architecture and construction, the overall design is created to meet the goals and program requirements of the owner. This creates the basis for a concept— an idea— about how the facility can be built, and what it will look like when finished. Notice that here there is a gap between the initial idea/concept, and the finished product. As noted above, we cannot physically fill this gap with a finished project, bought off of a store shelf and merely transported to the site.

But, in the same manner that we “build” the jig-saw puzzle into a complete and whole picture, we can construct and build the structure into a whole, complete and usable facility by placing an innumerable series of small portions of construction together—fitting them properly; attaching and applying them as necessary; and creating the whole project out the various pieces. The finished project—building, facility, structure, etc.— will truly be the “sum total of its parts”!

The “parts”, or portions of construction are developed and

built in accordance with a series of drawings, augmented by written information— the overall working drawings and specifications for the project. Except for the very mundane and innocuous features of a project, these are highly specific instructions and directions, for the construction of the particular project, created by the architect for conveying to the trade workers who work on the actual construction.

Within the set of working drawings these portions of the project appear as myriad smaller drawings called, “details”! The “pieces” are fashioned in the actual construction, in real size, to erect the completed building— safe, usable, and in keeping with the project program.

Every completed architectural and construction project is the result of an unusual sequence of events. This sequence or process includes fitting and piecing together a plethora of widely diverse pieces of construction information, seemingly quite random and isolated one from the other, into a new entity— a building or other structure ready for occupancy and use! The very explanation of the process shows the conversion of concepts, ideas, designs, other intangibles, and pertinent information into real or actual items, and their subsequent combination into a full-size, piece of real property.

Detailing is not new; not a technology that is just now emerging. It has been around as long as construction has been organized— from the time of immersing civilizations in Greece, Rome and Egypt, to biblical times, to Gothic and all eras of architectural design and development. Despite changes in construction methods, techniques and materials, and the designs/styles of architecture, there is a residual need for information on the job site. While excited in many forms, it is still details [following their historic function and pattern] that represent expression and explanations of how things are to be built. And in addition, how things of a rather mundane appearance can be decorated and enhanced with decorative detailing, from carvings, to added features, to coloration by paints, or covering with other material.

In this, there is no pretense or declaration that detailing is THE most important function. It is merely the fact that construction of the approved design concept is dependent on proper instructions, directions, and explanations being transmitted to the contractors. A good portion of this information— construc-

tion oriented information— can be depicted graphically on the drawings and the details. Another large portion is better conveyed via the written specifications for the project.

All architects, no matter their perspective and desire, and no matter the niche they choose or find themselves working in, need to understand fully and completely, the process that transforms the design concept for a project to the realized and occupiable building. This need, on the part of each professional, pervades the entire process and profession of architecture, and touches every person in the process from the most junior to the most senior. While expertise, ability, talent, and desired position vary widely, the most common of denominator is how the project is moved from an idea or perception on the owner's part, through all of the necessary phases, until the project is fully realized.

This process is replete with concepts, nuances, perceptions, and realities, coupled with materials, systems, and methods of construction. How all these are dealt with and how they are combined into proper documentation and actual construction is the process of architecture. One other requisite element is the transmittal of continual, accurate and appropriate communication from the professionals to the field trade workers— where words become hard "facts".

First, the owner/client perceives, envisions, anticipates and determines the need for the new project. Certain goals or requirements are set out, by the client, which the project is to achieve. But in addition to this information there is a need for the design professional to draw more and more information out from the client. This is the process of programming. This is the process whereby the design professionals seeks to create a written statement and formal document, which describes the project, based on its necessary functioning, and the expressed needs and desires of the owner, and how she/he expects the project to both look, and perform.

This program information becomes the basis for the design concept. The design concept produced through a series of diagrams, sketches, and plans, which are aimed at coordinating, and resolving the often diverse and even contradictory information collected in the program. Finally, a concept evolves that meets the program, in large measure, and is satisfactory enough for the client to approve it.

So far the project's documentation has been largely written, verbalized, and developed into sketched concept which should intent, but little in the way of specific information. These documents cannot be used for the actual construction— too much more information is required, and that information

must be of another kind which is usable by the constructors. The design professionals, hired by the client, are responsible for taking the program information and the approved design concept and refine, augment, and convert this collection of information into such forms as make the information of use by the individual trade worker, on the project site. Here this information must be quickly read, easily grasped, and properly executed as actual construction work— this is, yes, a transformation from "information" to "reality, i.e., actual 'things' at actual size".

To be fully usable the information must be subdivided into small portions. These drawings of very limited areas of the project must be coordinated and produced in such a manner as will allow the work depicted to be contributory to the project by being direct indications of how the project is to be built, and what materials and systems are involved. It is impossible to depict any size project with overall drawings, which are drawn at small scale. Following the axiom, "the general [information] must become specific".

These indispensable drawings are produced through a process called "detailing"— and individually, they are called "details".

Perspective on reality:

In the whole scheme of architectural practice and its vast array of tasks, detailing could be easily dismissed or relegated to a minor or seemingly inconsequential role. Surely it is not more important than design; not as important as client relations and securing new commissions. Surely, it could be perceived as a "throw around" activity, which is "imposed" on junior staff, or the "do-its" in the office. But without undue status, detailing does have a distinctive, recurring and truly indispensable [but not "supreme"] role in practice. It is given credence by the mere fact that the best of design ideas and concepts created in the office will never see "the light of day", or be a completed project without at least a minimal detailing effort.

Many professionals and offices have sought all sorts of ways to extricate themselves from the "demeaning" task— the almost unprofessional effort of almost getting ones hands dirty in duties relating to the actual construction process. Repulsive to some; flatly repugnant to others — but the reality of architecture to still others. To those who revel in putting building together— their way of bringing the wonderful design creations to their final form and to the satisfaction of the client, both initially and long-term. The cause and effort of detailing is noble— it is needed— it is part and parcel of the "complete" architect, who can both envision whole concepts as well as the many "parts" which make-up the whole of each project.

In the normal progression of creating a set of contract do-

cuments [working drawings and specifications] for a specific architectural/construction project, there is a fairly sizable segment of time [an entire phase of work!] where the design professional faces the task of project documentation. This involves providing, augmenting, converting, developing, expanding and making specific the generalities of the preliminary information, the design concepts, and the artistic renderings.

All of this information must be transformed into graphical [working drawings] and associated written [specifications] information, which is fully coordinated, and directly usable for the actual construction work. In this book, it is the "paying attention to THE details" that counts. Currently in our society we deal in activities of "detailing cars", "to detail", "in detail", "give me the details", and developing "detail persons". But these move around the periphery of the process of construction or architectural detailing.

"Attention to detail" is not merely a catch phrase, or motto. It is and has, for a long time, been a description of a personal attribute, present in some people. Often this is developed through the work that the person does or pursues. The phrase is really an expression of caring about the work, and trying to excel in execution.

It also indicates, at least in the mind of the worker, that the work needs to be precise, accurate and complete, to be successful, and fully acceptable to one's boss and to any client involved. Of course, this is in direct contrast to a cursory, ship-shod, arms-length approach where work is done quickly but with no attempt to ensure its veracity. For example, an accountant takes great pains to see that all accounts are correct and balanced. Ignoring or dropping a penny difference, here and there, seems quite innocent but, over the course of time, this can add up to an imbalance, which is intolerable.

"A detail-oriented architect optimizes the inborn value and tenacity to seek and achieve the level of precision and accuracy, which is short of perfection by only the slightest of margins. Yet the quest for completeness, and the caring for accuracy and correctness is pursued in a quiet, unassuming, and most professional manner, seeking assistance as necessary [but usually rarely] as his/her command of the information, material, devices, and systems are far beyond the level of mere familiarity, but approach a fully fluent and functional level. She/He is talented, beyond imagination, in the ability to concentrate, to focus the effort and masterful in satisfying clients with insight, professionalism and expertise".

-Anon.

Is this a description of Super-person, or of a reclusive Casper Milquetoast? Neither really— just a rather flamboyant view of the characteristics that many people carry with them to work [and more than likely use in their home life too]. Note the many facets to this "person", and how they all combine to produce work of high quality, which tends to maximize client satisfaction.

Obviously, there are details in every line of work, but the phrase really reflects more about how a person deals with information or techniques while performing the tasks. Most work can be done, in an adequate manner with relatively little regard for detail. This quite often is satisfactory, but may be less than desirable in the long-term. Dealing with detail and resolving "loose ends" and other problems tends to provide a better, longer lasting product, and a higher level of client satisfaction. Adding "exactness" aids the effort.

In architecture and construction, though, a less than vigorous effort at detailing will directly result in suspect work, perhaps inadequate, or unsafe, and quite often not satisfactory to the client [and clients are, now, more demanding with each passing day]. In many projects, the level of client satisfaction has been raised to "precision". Yet construction remains as it always has been— "an imperfect science". With worker-developed skill levels diminishing, and with less worker dedication, self-esteem, pride-of-work, and productivity, construction is trending toward even more imperfection. There is an attitude in many projects that accept almost any quality of work, so long as the work is finished, on time!— with little regard for any level of quality above adequate. Also, there seems to be some correlation with larger, more costly projects that are pursued on almost impossible time lines. Obviously there is a strong element of attitude and perception in this, where motivation is low and the worker is simply working "for a pay check", and not to produce work to enhance self-pride and satisfaction. This is most unfortunate since it is a widely held situation, with, of course, some extremes which defy the norm.

This trend has to be addressed, early-on and in a most positive manner on a project where the client and indeed the project itself demand near perfection because of both client and regulatory requirements. Every project needs to be perceived, by all participants, as a new opportunity to excel and to produce better work than before. Often the type of projects sets the demand for higher quality design and work. Projects where consumer goods, and particularly food products, medications, and similar human consumables are made or processed impose an elevated level of "perfection". This appears in sanitation, cleanliness, freedom from infestation, cleanability, wearability, etc.

However, in every project there is a need to establish a level of quality involving a search for near-perfection for proper construction and client satisfaction. No design professional should have, at any time, an attitude that "barely adequate" is the correct level of expertise and quality permitted. Even where building codes set out only "minimum" standards, providing better conditions, more substantial construction, etc. are in order to the point where they are still supportive and reflective of the budget and client demands. Doing more than required by code is admirable, extremely helpful, and certainly to the benefit of the client.

The trade worker too needs a renewed motivation to produce the highest quality work he/she is capable of, within the context of the project demands as expressed in the contract documents. While motivational talks, high-tone direction from supervisors, and firm instruction on the job site may induce some effort for increased quality-in-the-work, the work depicted and described on the contract documents also sets the "tone" of the project. If these works are clear, direct, instructive, positive, informational, and in a format for easy assimilation, they set demands on the workers. There may be need for a reminder that work is to be done "in strict accord with drawings and specifications". Free-lancing and lackadaisical efforts simply will not produce the work required, and will, therefore, not be tolerated— no threat! Just fact!!

Much of the "imperfection" in construction lies in the fact that professionals can draw details with great accuracy and "exactness". This is especially true even more now, with the CAD produced drawings. Often the precision seen in the drawing simply cannot be achieved, to the same degree, in the field. Even with power tools and good worker skill, the actual work will contain slight variations, which in the end product are of no consequence. The imperfection are not a matter of unsafe or inadequate construction, but rather a lack of the precision which can be achieved in creation of the documents— a matter of the "theoretical" versus the "actual". It is noted here, though, to defuse any impression on young readers and professionals that what they include or see on the drawings will exist exactly the same way in the actual construction. While quite similar, there will be normal and natural irregularities in the work. Realizing this is part of the experience that must be acquired to better understand construction as produced to meet the contract documents.

This also shows the direct impact that the professional has on the project by virtue of what is shown, and how well it is shown on the contract drawings. The drawings themselves set the level of quality the professional desires in the work [and by extrapolation, what is desired by the client in the finished pro-

ject]. This is an aspect of the work that is not readily apparent to the casual observer, but which is a real and important part of the professional effort. In fact it is better called a very crucial part since it is here where the professional provides the linkage [sets out the scheme or format] for matching actual work with the final finished project anticipated by the client by virtue of the approved design concept. This "matching" is worked from the beginning of work and moves toward completion. It consists of doing the work, as depicted on the drawings in a manner whereby the unseen ["rough"] construction provides a proper backing for the finishes, and hence the complete, and finished project.

The fundamental concept here is that like a great many things and efforts— the underlying frame, structure, or construction— simply must be fashioned and installed correctly and soundly. If done, this then provides a base, matrix or substructure whereby the thinner, finished products can be installed or applied, forming the correct shapes, features, and planes. Much like a photograph, if the negative [the fundamental "structure"] is faulty, the final print will be less than desirable. Misalignments, incorrect planes/shapes, lack of true/plumb/level work, improper sizing, weak construction, and other nuances in the underlying construction play havoc with the final appearance of the project. Therefore it is essential that the professional be well aware of these maladies.

Being so aware, it is incumbent on the professional to eliminate or prevent such conditions from occurring in future projects. The details of the projects will change, but the underlying principle in the details must survive and be accounted for, project by project. This is one of the considerations for determining whether a detail is a good candidate for storing and establishing as a "standard" repetitively-used detail. Obviously where variation, in such standards, is wide, and slight circumstantial conditions are variant, the detail will not be more than a "project-specific" detail, valid for a single use and project.

This construction detailing process is not reserved for certain clients or certain projects. Rather it occurs, or should occur on each and every project, from the smallest residential remodeling, to the most massive, elaborate, and imposing structures. The extent, scope, time and effort for the process will vary with the demands of the project itself— from size to complexity of construction and associated amenities. However, the concept and need for detailing remains in tact despite all other project requirements.

The following is a course description for a current college course in architectural detailing [a rarity in itself].

Course Objectives: Students use history and theory to gather and analyze information. Students are made awa-

re of architectural detailing as a manifestation of cultural, environmental and technological factors, which modify architectural expression in time and place. At a more specific level, students explore principles, which affect the science of building construction to learn and understand assemblies as an integrative process in which details are related to a larger linguistic whole. Students develop an aesthetic and technological awareness about the craft of making architecture as well as the ability to articulate and communicate their observations."

While this description is of the highest caliber academic standards, and incorporates the full range of detailing impact, it leads, at first blush, to a very overblown, complex, and highly festooned appearance for detailing. To explain in simpler terms:

1. Detailing does bring the technology to the project and the cultural and environmental aspects which are already addressed in the project concept.
2. Detailing, by necessity, reflects "time and place", as it is necessary to adjust the details to the specific project and the materials and systems to be used, all of which usually are tied to current trends, styles, and methods.
3. Detailing both "affects" building science, and applies building science— the affect being new uses or applications of building materials or methods, as a by-product to the application of them to the project at hand.
4. It is true that each and every detail is "an assembly" of work, which is as much a part of the "linguistic whole" just as any single piece of jig-saw puzzle is related to the completed picture.
5. Yes, through detailing comes an understanding that one must know the technical aspects of the profession, in "making architecture"[?] and one must develop the ability to carefully, completely and properly form, and transmit, not only "observations", but the conclusions, directions, and information about the work.

There is, of course, a correct perspective for the detailing process. It occupies a position of necessity. In that, though, it does not require pre-eminence, or a position of criticality which makes it the dominant or overwhelming process within the project sequence. True, appropriate attention must be paid to it; and true, it does provide a distinct and vital link between design professional, and trade worker— and between concept and the reality of actual construction. Perhaps it is best described as a necessary buffering process, and one of required translation. The buffer aspect comes by virtue of the detailing being inserted as a means to carry out the owner's wishes, and the attendant requirements of both the project program and the

design concept in a proper format. It is a process that must understand all that goes before. And still must understand all that follows, in that it produces new and quite different information as its primary product.

In producing that new information, the detailing process is indeed, a process of translation. Here requirements for ideas, concepts, and major elements of the project, are converted into portioned servings of reality-oriented construction information. Often items that seem quite innocuous in the owner's program become major detailing complexes, to ensure that the proper work is delivered, as required. Moving to construction information, with its distinctive lingo and nomenclature, is in itself a challenge. The design professional is charged with taking ideas, concepts and general references, which are rather meaningless to the trade workers on-site, and converting them into useful data. The workers are immersed in their particular perspective, their materials, their skills and their assigned work. Few have the understanding of the project as a whole; rather they concentrate on their specific portion of the work. But in addition to properly communicating to the workers, the design professional is required to express the deepest requirements of the project contract. This involves depicting or enumerating exactly what is required, and how the project [and its numerous "pieces"] is to be executed— how it must be done to remain in compliance with the contractual obligations of the contractors, manufacturers, suppliers, installers, fabricators, etc.

The perspective, then, is one of direct and meaningful assistance, and a buffered translation of one set of information into another set which is usable on-site, but which remains faithful to the owner's wishes and the design concept. Its highest value is in the ability it facilitates or conveys to bring the project to reality. It is a needed interface between aspects of the project and the project parties, which "understands" the requirements of them all, and provides methodology to meet them.

Clients, not being fully familiar with the phases of work under the architect's purview, are for the most part unaware of this phase of work. Indeed, where they may have some insight, they do not really understand it or the purpose for it. However, it is fundamental to the success of the project in more ways than any other phase of work. This is why, for a good many years, the traditional breakdown of the architect's fee allotted almost half to the production of contract documents, including, of course, details.

Conversion:

The conversion of the preliminary and conceptual design information involves realignment, formatting, research, decision making, and heavy augmentation. When completed, the infor-

mation must then be carefully and completely transmitted [via drawings and specifications] to the field personnel— for both the professionals and the constructors.

This task is so fundamental that if it is not done, or if it is poorly done, the project will never be built, as portrayed to the client earlier, and as now anticipated by the owner/client. Since the client is not that familiar with this process, and does not fully understand it, there can be pressure for quick completion during the period of time required for this work. Often the professional must explain the work, and its contribution and value, since hours will continue to be billed, and indeed, the billings may increase in substantial size, due to the added personnel and hours now being utilized.

In its simplest definition, detailing is the process whereby an inordinate amount of very technical and intricate information is developed by the design professional, and transmitted to the trade workers who build the project. It is the functional interface between the design concept of the professional, and the instructions, directions, indications and descriptions that the field personnel need to build the project as designed. It is the transformation, translation, and transmission of this information from one entirety, different perspective, and need to a far different one, without which no project could be built— and built true to the anticipation, expectation and concept approved by a third party [the owner/client]. Granted it is an unusual arrangement but one that is crucial to successful construction, at all levels, and in all disciplines.

However, there should be no illusion that the fundamental aspect of detailing equates to a simplistic, easily achieved/produced process. While fundamental, the process is certainly not simple. To facilitate successful construction is a matter of developing, refining, and converting conceptual information into usable information, and then properly conveying that information to the proper trade workers, who will execute the work to erect the project.

In its basic form, detailing is at once, complex, and simple. It is intended to simplify the complex— to openly and fully explain the minute information regarding the innumerable pieces of construction material and work that is required to erect the structure. No longer will general comments, innuendo, assumptions, and vague, incomplete information suffice. The time has come where decisions— thousands of them! — must be made, and the results portrayed in graphic form, in numerous small vignette drawings, and properly published with associated written specifications, on the contract documents. Later it is these documents that will be utilized in the bidding/costing process, and still later in the field by the managers, es-

timators, expeditors, superintendent, suppliers, forepersons, and the individual trade worker.

In an era when catch phrases have become a way of life, we must acknowledge that one very imposing word is now a major part of the architecture and construction lexicon. That word is "constructibility". While it is not found in the normal array of dictionaries, the word has developed into a major factor regarding construction, and actually is a valid consideration from the design phase of work forward.

Constructibility: the ability to be constructed as ascertained by an in-depth analysis of proposed construction to assess the "best" way [among many available] to proceed, the most cost effective methods and materials, and the most time-effective manner in [ease with which the work can be accomplished, faithful to the design concept.

Simply, is the work required to produce the project "buildable" [or i.e., constructible] — can it be performed relatively easily, and with advantageous cost implications? One of the major side issues in this is the fact that there are many solutions to any one problem. The matter of constructibility could well be the principle factor in the decision making process which selects the solution to be used. In the norm, constructibility is an on-going process, but is initiated and most heavily pursued during the design phase of the project. This is done, so the documentation [and the design concept if necessary] can be adjusted to portray the correct construction scenario as determined through the constructibility review[s]. In the past, the project was pursued solely as deemed appropriate by the design professionals. With the implementation and use of the Construction Manager [CM] project delivery system, the constructibility review was started and was given over to the CM, who had the deeper construction expertise. It is not a matter of assessing or checking on the design professional, but rather is a process to suggest and review alternatives which may be appropriate, without adverse impact on the aesthetic design reflecting the overall design concept. Overall, it establishes a more refined project for the owner, early-on in the process, primarily since the many possible solutions can be reviewed and the best of the lot utilized.

Trade workers, and the construction industry as a whole, take great pride in the fact that they [collectively] can build anything, given opportunity and enough money. Often there is need for very innovative and unique techniques, research for new, better and more appropriate materials and systems, and cutting edge intelligence and daring to achieve the goals required. Construction, as a whole, has been highly successful in this, and has been supported by a manufacturing sector,

worldwide, which has the wherewithal to provide everything the construction operations require.

But how does this impact an individual project, and why is it a consideration in a book about detailing?

Constructibility combined with detailing form the backbone of the construction project, and allows for the creation, development, refinement and construction of any construction project. In simple terms, the design concept must be examined to ensure that a proper program of constructible sequences can be applied to it, and from that comes the need to express those sequences, in the contract documents— as details. This information is then conveyed to the contractors and their trade workers for further analysis ["How are we going to approach this work?"] management, and actual execution of the work.

It is quite easy to fall into a trap, in design and detailing, where work is depicted to satisfy a problem, but is virtually impossible to build. How often and for what periods of time can workers be required to lie on their backs to install complex or intricate items overhead [or perhaps the real question is, can they?] Work must be accessible. No sequence of work can allow or tolerate one item to cover other work, which is to be installed after the first work, and so forth. Is there sufficient space to use the proper tools to install the work? "Blind work" is a continual nemesis in construction. For example, underpinning an existing wall is a common practice, yet the backside of that construction is never seen. One can only rely on proper preparation and construction in a hopeful manner that the work is both correct, and properly executed— if it cannot be readily or reliably verified!

This all serves to illustrate the true crux of detailing construction projects. The current direction and orientation of instruction is so bound to computer operations that it has all but totally lost sight of the primary factors— truly informative data being transferred to the field, and technical aplomb of the details themselves.

It has long been settled in the courts that muddled information, and poorly conceived designs [and details] executed as received by the contractors, will place liability on the design professional. Hence, the attitudes, approaches and accomplishments of correct detailing and communications cannot be overstressed. Both involve levels of "technical" understanding, knowledge, application, depiction and conveyance— simply the "right" information must be given the field personnel in a fashion fully usable and executable by them.

The route taken to accomplish this is of very rather limited importance—content rules greatly above method!

How onerous is detailing?

Despite its obvious importance and distinctive complexity, the basic concept of details, and "detailing" really is not as daunting and mysterious as one may think. Indeed, each of us deals in detail work, the specifics of any thing or situation, on a daily basis— and we start this at a very early age. Whenever we are given instructions to perform some task, there usually are some details involved. Any time we purchase an item, we mentally set out a series of details about that item— be it be the price, the color, the name, the type, the size, etc. We then follow these things as "details" of instruction given to a salesperson. Rarely in fact, do we do anything that is absolutely devoid of detail, i.e., explicit and specific requirements, or attributes that are to be part of the item or task involved.

We are so attuned to this process that it seems silly and needless to talk about it, as we are. We may say quickly, "Oh, yes, I deal with the details in my life all the time, without even thinking!" But in the context of the complex process called "construction", there is need to set out the fundamentals of details and detailing. While we each are steeped in the use of details, we need to focus, very keenly, on the unique need and process of detailing, in both written/verbal and graphic forms. Perhaps detailing is so engrained in our being that it is odd that we need to be "reminded" to use the process, although the need, in construction, has a much different orientation, and much more imposing effect.

There are some people that we all know, who, when asked to pass the mashed potatoes, will give us a dissertation on how the potatoes are grown, and cross-pollinated to produce larger and better potatoes. They also may describe the pottery making process that produced the dish now filled with potatoes. Obviously, this is "detail", perhaps carried to the nth degree— carried far too far, and providing obviously needless information. It is communication only in the fact that someone is speaking and saying something— despite the fact the no one cares what message and information is being passed— simply they are not interested!

However, this is NOT the process needed in the construction sequence! In fact, what IS needed is at another extreme— pertinent, concise, complete, and eminently clear, helpful, informational/ directive/instructional detail drawings, and associated specifications. Its goal is to be of value and direct assistance to the construction project's trade workers, various professionals, and managers — and to produce a high level of satisfaction in the owner.

HISTORICAL PERSPECTIVE

To understand and reach the end result discussed in Chapter 1, one should be equally aware of the past and its contribution to the initiation of, the refinement and development of the detailing process and the commensurate contribution the process has made to the whole body of work called "architecture".

In a purely historical context, it is readily seen that detailing has played, by necessity, a very important role in construction since its inception. Driven far more by necessity than theory or philosophy, detailing evolved and expanded as construction increased in both size and complexity— as well as with new materials and innovative designs. Other than structures built solely by the resident or owner, all other construction involved and still involves communication. And coupled with that is the essential elements of deciding how the various parts of the construction can or will be fitted together. It really seems too simple, straight-forward and clear.

In concept, yes; but in execution quite a different story, and one that has played out for a long time.

It is somewhat of a conundrum [baffling, perplexing, mysterious, confounding, and amazing], that detailing is perceived to be such a mundane and taken-for-granted task and held in such low esteem as it is. While having been part and parcel of professional efforts for centuries, why is it still so maligned, misunderstood, and relegated to second-class citizenry even among some practicing and experienced professionals?

"The process of detailing is a refined method of professional communication, accomplished with the excellence of a guild artisan."

Creation of the design concept requires that the designer have some indication, no matter how small, of how the various elements and features of the project should be or need to be constructed. Without this information the design concept, indeed, is a mirage or dream, and is at risk of being fulfilled, by others as they see fit, but at odds with the designer's intention. This often occurs even within the single professional office where the various parties are in close proximity but never seem able to communicate and interact in a mutually satisfying manner. This can be ruinous to any practice. Part of this is pure ego; part is pure selfishness; and all of this is wholly unacceptable.

Another portion of this can be directly attributed to the lack of academic exposure and discussion of this [much less formal instruction] and in-depth explanation. The inequality of detailing among the other contract documentation is simply unjustified, and extremely risky to all parties. They cannot be totally eliminated without doing grave harm to the progression of the work and successful interfacing between the contractual parties.

There is no basis, of course, for detailing to be the re-eminent task in the documentation of the project, but neither should the process be maligned, hampered, ignored or eliminated. The ironic part of this is that details are still being produced on most every project in spite of the lack of respect given them— why? How can that be?

In part this is due to the paradox known as "task divisioning" that is part of the architectural and engineering professions. In particular, architectural efforts concentrate, heavily, on the early-on design functions and feasts on the thrill and enthusiasm of a new project and the prospectus of a new and distinctive design statement. This creates, within the office an air of competition that tends to shuttle other associated [and requisite] tasks off to the side, giving them far less than due credit. But baffling as this must seem, the professional production personnel are NOT so strictly driven-off, shunted, cloistered or divided. There is an inordinate number of those professionals [and perhaps even the vast majority] who fully realize that the technical documents' explanation and description of the design concept is crucial to producing that project exactly as prescribed in the approved concept— and in fact they may well be wholly engaged in just that work.

It is in the detailing where a large portion of the necessary construction information and direction emanates— where the "nuts and bolts" of the project are contained. Without this translation of information [from the sketchiness and fragments of design concept to hard construction material and facts] the contracting agencies are at a loss to fully approach, understand and assimilate the project. The constructors "speak" another language from the designer and vitally need the translating function of the production staff— and their details.

While there is some fairly good-natured jostling and puffery about this odd situation no one casts it as dire, hopeless, or irresolvable. But for the sake of production in the construction industry and closer adherence to project requirements [from

administration to construction] there is a distinct and prevailing need to seek resolution, even if only in small measures. Complexity of project necessitates this both in the graphic and in the written material so understanding is made even clearer and direct, and straight-line production can be utilized.

A most interesting discussion can be begun by looking at the older building stock we have today– built over the last 2 or 3 centuries– and even looking much further back to the medieval eras of the Trade Guilds of the Middle Ages, and further back, still, to the ancient and biblical ages of the Master Builders. There still are remnants of even earlier Greek, Roman and Egyptian structures, as well as ruins, remains and relics in other countries. The vast majority of these projects are still quite impressive in their scope, and in the ingenuity used to

build them– and in their details! They are large, tall, and for their times, complex. All of these, collectively, can be used to pose a simple, innocent question, "How did that structure get built that way"?

Architectural Details & Trim / Styles & Glossary

The style of modern accents and trim evolved from many artistic and architectural styles through the ages. Although most moldings are either classic (clean) or baroque (ornate) style, modern effects can be achieved by combining various trim and molding styles. Explore various architectural styles, their attributes, picture examples and visual glossary of terms below.



Ancient	Description	
<p>Neolithic (also known as the New Stone Age)</p>	<p>Megalith stone system</p> 	<p>[7000 - 3000 B.C.] cave dwelling, wattle and daub simple dwelling construction combined with timber and huge erected stones (megaliths) like Stonehenge.</p>
<p>Egyptian</p>	<p>Stepped stone system</p> 	<p>[3000 - 30 B.C.] royal tomb pyramids and temples constructed of layered cut stone block or hollowed out rock tombs. Columned or pillared halls, porticos (entryways) and sacred chambers embellished with historical or royal inscriptions and relief sculptures.</p>
<p>Greek</p>	<p>Post-and-lintel-system</p> 	<p>[1200 - 30 B.C.] post-and-lintel (roof support) design. Colonnade porticos (entry ways) and roof detail including cornice surrounding the pediment on either end of the building length. Interior walls spanning the length of the building segment into rooms and provide roof support. Characterized by symmetric geometry and flanked with columns, capitals, cornices and pediments in a grid system.</p>
<p>Roman</p>	<p>Barrel vault and cross barrel vault</p> 	<p>[200 B.C. - 500 A.D] concrete coupled with formal engineering invented a new age of architecting both positive and negative space. Rounded arches, arcades (series of supported arches), vaults (elongated arch) and domes enabled buildings to have vast, unbroken spaces eliminating the need for support based designs of the past. These were enhancements from Greek and Etruscan design elements.</p>

Fig. 4-2

Detail of column capital, frieze and pediment. Note large amount of detailed work involved. In ancient times this was not drawn out but came simply from the mind of sculptor. Even today, much of this comes as models of standard configurations and can be ordered by model number and not by specific detail drawing– imagine the rigorous chore to detail all of this work!

Middle Ages	Description
Romanesque	[900 - 1150 A.D.] fortress like cathedral construction seeking to be fire and destruction proof which influenced the use of thick heavy stone work including the roof.
Gothic	[1120 - 1500 A.D.] deviated from classic architecture of the Greeks and Romans by using pointed arches (not semi-circular or restricted to two arches per vault) and ribbing along the intersections of all arches. Analogous to a web or skeletal framework from which the building is encased. This style of architecture sought to increase the amount of light by opening up the interior space with many narrow pointed arches per vault and was mainly used for cathedrals. High gothic architecture saw the creation of the flying buttresses which were extensions of ribs from interior vaults to the outside, connecting downward to the floor level to complete the skeletal structure.
Renaissance	[1350 - 1500 A.D.] Italian art and architecture characterized by embellished Roman art and architecture.
Baroque	[1600 - 1750 A.D.] the age of discovery brings a passion to design. Overly ornate classical motifs and eccentric mathematic architecture accented with bright colors and gold trim.
Romantism	[1750 - 1850 A.D.] opposition and departure from elaborate Baroque architecture, moving toward simple design which leads to Gothic revival.
Neoclassical	[1850 - 1900 A.D.] Greek and Roman revival.
Modern	Description
Art Nouveau	[1850 - 1940 A.D.] Flamboyant ornate motifs with strong organic curves. Architecture depicts cross lined designs, rounded corners and intersecting planes.
Art & Crafts	[1870 - 1960 A.D.] stylistic design of furniture and interior wood work emphasizing minimalistic design carried out through precise craftsmanship. English and Dutch origination.
International Style	[1910 A.D. - present] open expanses characterized by planes made possible through reinforced steel and concrete of the industrial age. Juxtaposition of form with elongated horizontals emphasized as seen in the work of Frank Lloyd Wright's work. Ornamental use is discontinued in favor of minimalism. This style remains prevalent in today's architecture.
Bauhaus	[1925 - 1950 A.D.] exploitation of the international style with segmentation of space into modular units showcased in glass, screens and moveable walls. The movement emphasized the study of all aspects of art including performance, music, design, painting, and architecture as a cohesive whole.
Post Modern	[1925 - 1980 A.D.] departure from generalized style into individual expression through innovative use of new building technology and materials to differentiate the structure, space and experience from all previous styles. The Guggenheim Museum by Frank Lloyd Wright exemplifies the flamboyant deviation from all previous architectural movements.

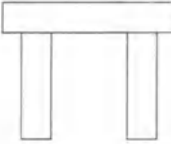
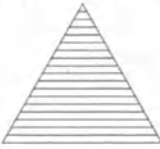
Of course, there are numerous familiar accounts about the construction methods and processes in each era in history, and the mind is often bogged by the instinctive work that was designed and built, without assistance from wide knowledge, calculation, related experience and set patterns and procedures—often resulting in a the context purely of, "How" did they do that? In most instances, there was no formal training, precedents, nothing to use as a model, or even as an inspiration—no "bad" design that one could improve on.

In some places you had insight and intuitive concern that resulted in such oversight and regulation as Hammurabi's code [the first building code]. Here was the first attempt to regulate quality into construction and to ensure that public safety had some meaning. The penalties for non-compliance were harsh [e.g., eye for an eye, etc.], but certainly they gained the attention of the "builders", who could protect themselves [as well as their clients] by adding strength, support, bracing, and greater protection to the structures [in-

cluding homes] that they built. Even then, however, there was no quantification of what to do— just simply, “If you don't do it right and this is the result, this is your penalty!” No ifs, ands or buts!

Mainly, what was being done was new, had no relevance or relationship to a specific style, format, or collection of examples. Each structure was, in itself, an inspiration, born in the mind of a designer [no professional design firms, per se, existed, which worked on a common philosophy], and was able to engender continual pleasure in the mind of the monarch or church of the realm. Much of the work was dedicated to a deity or a “crown”, and was served by the level and extent of appropriate embellishment that could be brought to bear. Nothing was “stock”, mass-produced, available on the Internet, or “just a phone call away”!

The most prevalent commodity, in all of the eras, was the vast numbers of workers available for the projects— from the enslaved work force on the Egyptian pyramids, to the “whole life” careers expended on Gothic cathedrals. There has always been a work force which was able to provide the brute force required to lift, drag, push, pull, beat in place, hone, place, connect, balance, anchor, set, cut, decorate, and place one piece of work upon another, over and over again, to finally produce the edifice required. Some of these we know, of course, were massive, intricate, extensive, complex, and designed and guided by an “engineering” effort that was evolving itself, and creating its own design solutions “on the fly”— simply solving problems as they occurred.

It was the brilliant minds of some who took the highly unsophisticated design principles, and gave them credence, and the status of respected, and reusable axioms, formulas, and techniques. But these few minds, brilliant as they were, had the daunting task of ensuring that what they developed, tested [by trial and error, not by calculation, or compliance with established principles], and created was correctly employed on the projects, at the correct instances or intervals. In effect, this was a simplification of the information by breaking it down into small amounts and pertaining to a limited portion of the project, understandable by the workers, almost all of whom were illiterate [despite their physical skills]. While there had to be numerous ways of getting the required information and instructions to the workers, the first more formal and well-known system was that of the Master Builders [the ancients of Greece, Rome and Egypt]— of drawing with chalk on a trestle board, or with a stick in the sand.

This was the first indication of a systemized effort to COMMUNICATE [to instruct, direct, order, explain, approve/disapprove,

change, expand, reduce] during construction, using both words and drawings. While this is an early indication of lessons learned, and need identified, it has not only endured until today but is no less important [and most certainly has become far more complex], as evidenced by the following comment by Deborah Slaton in her column, “Failure to Communication” [April, 2001 issue of THE CONSTRUCTION SPECIFIER. periodical of the Construction Specifications Institute];

“Many technical failures addressed in building construction and repairs have the same underlying cause: the failure to communicate specific details, performance requirements, or the technical or aesthetic goals of a project. Architectural and engineering design and construction require a constant effort to communicate, not only for proper dissemination of information but also to raise questions and prevent applying misinformation. Projects with a high level of effective communication are more likely to be successful and less likely to result in litigation. Constant and successful communication is required from the initiation of a project through its completion—from the instant a design concept is conceived through the completion of the structure's punch list items. Aside from ongoing discussion and the documentation of work in progress, construction documents—drawings, specifications, and their ancillary documents—are the keys to successful communication.”

The message in this article is crystal clear, definitive, and quite astute and correct. Of course, it addresses the actions of the design professionals and the documents they produce. We need to understand that even when the professionals' documents are well executed, there are innumerable chances for the lack of, or the breakdown of communication to and on the job site. Too often, changes in the work are made using Change Orders, Field Instructions, Bulletins and Addenda. All are valid forms of communication, which carry the status of a careful effort and an attempt at clarity and preciseness. But, if any of these documents are sent to the contractors' office[s], and are never then routed to the field personnel, communication is non-existent— failure is at hand!

This illustration serves to show that the best efforts by the professionals often meet with doom because of the action or inaction of others. There is little to prevent this, except due diligence by the professional seeing that her/his documents are in order, and then by following up in the field to ensure that new information issued along the line indeed does filter down to the trade workers. This certainly is a well-made case for field representation, at the job site, by the professionals! Of course, the ancient “system” was far simpler— crude and

unrefined; there simply was no better way known at the moment. Early-on chalk drawings soon enough became chalk dust; drawings in sand were obliterated quickly. There was no way to reproduce the drawings, except perhaps by carving them in stone— a long and arduous task, and forget it, if you needed 25 sets! Now remember the workers were guild artisans and apprentices at best, in times when work techniques, habits, skills, standards, and ethics were given one to the other, verbally, to be retained, honed, and utilized thereafter. It was a process of watching, side-by-side, observing, and then attempting to replicate. It was "instruction by example", not by following a checklist. Textbooks were not created; reference books were unheard of— mouth-to-ear worked, simply because it had to! [Gutenberg had not even begun to envision the printing press and had no impact, via the "printed" word].

The Middle Ages were a significant watershed period. Gradually but steadily civilization became more sophisticated, the variety of sciences and mathematics expanded rapidly with enlightened and studious research and study, travel by the artisan class widened, the exchange of ideas, information, and technology escalated and as literacy developed, more and more information was recorded. More was done and developed into establishing sound principles and lasting concepts that endure as "engineering" and "architectural design". Much of the information developed into procedures and methods to be followed for successful work. This process accelerated through the years and centuries and indeed, continues even unto today—and will continue as better and better ways are discovered and conceived. But while all this is available, it does not quantify detailing into a matter of "you always do it this way"— the final judgment, now and for the foreseeable future lies in assessing and resolving issues that are project specific in unique and appropriate ways called collectively, "detailing".

But still on a large, widespread construction project, the one-on-one relationship tends to break down, quickly, if it ever is allowed to exist. The thoughts of one, validated and legitimized by the client/owner, had to be given expression in every portion, piece, item, device, and segment of the project. How is it possible for the single "master" or "designer" to oversee, and direct the work so it brings forth a faithful production of the concept or idea in a full-sized, sound and usable project? The single person cannot be everywhere, overseeing everything, all the time. Obviously there had to be a pyramid system of conveying the information to the workers— a military type of organization where the information flowed from the one source to many workers. Certainly some form of overseer or foreman was borne here, to merely convey information and assure its proper execution. Picture Howard Roark [main character— an architect— in the book, *The "Fountainhead"*] in

toga and hard hat, yelling instructions through a bullhorn to the work force, trying valiantly to be in every place at once, demanding excellence in something the workers thoroughly did not understand!

"Howard Roark is an architect whose genius and integrity will not be comprised. He has ideas that work against conventional standards"

- *"The Fountainhead"*
by Ayn Rand, 1943

But of prime importance above and beyond the labor disposition was the fact that the information developed was aimed specifically and exclusively at the workers! Despite the number of interim years, the sophistication of our processes and projects, etc., it is the trade worker who is the final user of the information developed for the project, by the design professionals. The owner has little direct interest in the drawings and specifications except for the fact that they reflect her/his needs, and wishes – and she/he wants them produced at the lowest possible cost [to minimize the professionals' fee]. Many owners do not even attempt to understand the content of these documents, seeing them only as the vehicle necessary for getting their project built.

It is clear now, in this strangest of scenarios, that while the owner hires the design professional to design and document their project, it is the trade worker who is truly the final assessor, evaluator, and judge of the documents—indeed, the "end-user" extraordinaire. This, of course, flies in the face of contractual obligations and relationships, since the design professional and the trade worker have no mandated contractual arrangement— theirs being strictly a "working relationship". In essence, the owner is responsible for giving the correct and proper information about the project to the contractors. The design professional engaged as "agent" of the owner, acts on behalf of the owner, and is the party, by contract with the owner, who now becomes responsible for the transmittal of the information. The professional is, of course, also responsible for creation of the design concept and the documentation of the concept in terms and forms fully usable by the contractors and individual trade workers.

The project, in fact, is validated by the success the workers have in transposing the documents into real, hands-on construction work. The "grade" assigned to the documents is simply how easily and how well the trade workers can do the work required to produce the project anticipated. Odd as this

may seem, it is the truth, and has been so for centuries— only the names of the players have changed.

Yet it is this very fundamental truth which is forgotten, ignored, obviated, or not understood by many project people today. Also, it creates a very strong distinction between the perspectives of the design professionals and the project managers. The former must be able to create a concept and document it, fast enough and well enough, to provide the client with the project approved earlier. The managers provide control and oversight for timing, processing, recording, distribution, scheduling, and budgeting, some of which impacts the professionals, and some of which is effected by the professionals and the attributes of the project. We now, all too often, try to intermix these perspectives, which only leads to confusing, contention, misunderstandings, lack of respect, missed opportunities, and other nuances, almost all of which are unnecessarily adverse to the project.

Detailing is not an option!

It remains a constant even though other factors are at play, too. Each of the new array of project delivery systems may require slight modifications of the detailing process, but none of them eliminate the need for details. A Design/Build project, for example, may be able to minimize or slightly change the focus of detailing because of the working familiarity between design professionals and constructors, all of whom are employees of the same firm. But the need for the transfer of information regarding how the building is to be built is still a necessity. It is so fundamental that contract lines and arrangements are irrelevant.

Both information and knowledge are vast, imposing and crucial elements to the construction process. But both are benign, and have no method for triggering their own use.

The two MUST be touched by a human being who is able to assess evaluation, manipulate, understand, coordinate and incorporate the correct elements in the correct manner. Hence the really effective drafting technician, drafter, CAD designer, staff architect, graduate architect, intern or whomever really needs to be more than just a mechanic at graphic communication. These persons must develop skill, flexibility and ingenuity which they then need to couple with their rather wide knowledge of construction, construction materials, construction systems and techniques— and with sound judgment apply the basic principles. Often this application involves innovative use of the materials, etc., adapted to the nuances and requirements of the design concept.

The correct “coupling” of skill and knowledge is an absolute necessity for the design professionals in order to be fully and properly contributory, profitably productive, and successful in practice.

Good drafting, then, is an art as well as a science. This comprises the whole art of construction drafting. The information, and application thereof may vary, but the basic principles do not— they are set forth as the consistent guidelines that assure that the information is combined with the knowledge, and correctly passed on in usable form.

The principles must be learned and deliberately applied as a checklist until they become a tool as automatic as a built-in scale in the drafter's mind.

These principles are:

DEFINITION - establish the nature, size, and location of tangible elements on the drawings, and the quality, workmanship, and conditions in the specifications.

READABILITY - emphasize important information, and make each assembly appear as a unit with recognizable subunits showing their essential parts and materials

ACCURACY - every line, letter, and numeral must convey completely truthful information as precisely as may be required under established tolerances.

FRUGALITY - avoid duplication of effort, all decoration, superfluous detail, and unnecessary perfection of execution.

TOTALITY - each item is a coordinated part of a whole; any decision on any part must be considered in light of its effect on all other parts.

STANDARDIZATION - consistently use accepted conventions in drafting and standardized elements in construction wherever appropriate.

MANDATE - assume that every line, letter, and numeral is a mandate for a specification under a binding contract agreement.

EFFICIENCY - perform first things first and in any given phase do only that which is necessary to move on to the next phase.

NEATNESS - neatness is the quality that permits all of the other principles to become effective, and it is the standard by which others will judge your ability

Attitudes among design professionals also vary a good deal. Many professionals, knowing the expanded risk when engaged for construction services, choose to practice where production of the contract documents are the final service provided. Although this provides less than comprehensive services to the client, it does minimize professional liability exposure. Unfortunately, it also represents a complete loss of control over the project, by the professional. This is the "plans-and-specs" attitude, where the documents are prepared, but then merely turned over to the owner for execution— with no further involvement of the professional. Still if detailing is not included, the project will suffer and perhaps be voided or completely changed, due to the influence and thoughts from other sources. Here the project and the owner will suffer in that both are shortchanged— the drawings are less than what was expected/needed, and the owner will, more than likely, not receive full value or the final project as approved and expected.

There is, without any doubt, a fundamental and "direct" correlation between the documentation of a project, and the quality of the work in the built project, and the overall success of the project itself.

This fact must be fully understood by ALL parties to the parties— everyone who serves in any capacity whatsoever. This situation is long-standing, traditional and inherent in nature, and is really a continuation of the lack of meaningful interfacing between professionals and trade workers, coordinated and parallel training, and the mere mutual acceptance and respect between sets of parties involved with the project. The trade workers, for the most part, come by a "go and do" attitude, based on their experience and skills, and not on reasoned determinations. This can accomplish much, but too often it is disruptive or counterproductive, if not patently wrong.

The professional is trained and required to follow a much more reasoned path, whereby certain conditions and solutions are evaluated and eventually deemed to be correct, appropriate, or mandated. Their work reflects this demeanor. These differences in attitude and problem-solving are the root cause of the non-productive competitiveness, and irritation between the professionals and the trade workers. And this is still the source of puffery, one-upsmanship, and the lack of development of a true "team effort". Each side claims the greater expertise, when in fact, they need each other, and the good attributes that each can contribute.

By not having commonality in training, the professional parties have one perspective, and more than likely a deeper understanding of a broader range of materials, systems, devices, and so forth. Their task is to take mass-produced "stock" materials,

and customize them to fit the needs and configuration of the project. Often this involves innovative manipulations, not mis-using, but using materials in new and different ways. However, academic training usually does not include instruction about various materials and systems, and certainly does not extend to new materials. The instruction more usually involves the just basic materials— masonry, wood, steel, concrete, etc., but not the proliferation of off-shoot, by-products which evolve from these basics. Actually, it is left to the professional offices to educate and train their new hires about materials, material selection, and documentation. The senior staffers gain this type of information through years of experience and problem solving in project design and documentation, and investigation of the various products, as they occur, or seem viable for projects. It is from this array of information that the project materials and elements are selected— some thing or combination of things that meet or fulfill a project need are selected and incorporated into the work, via the drawings and specifications. The two documents giving graphic and written descriptions of what is intended, and expected as a final, in-place result. All this is to give credence and reality to the design concept.

It is also here where the lack of field experience on the part of the design professional comes into play. Without a good understanding of "what will" and "what will not" work, the incorporation of new elements in the project work becomes quite risky. The element may prove to be inadequate or improper; or the way it is used is inappropriate. The failure in all this leads directly to liability for the professional. The Victor O. Schinnerer Co., provider of professional liability insurance, has seen this situation for decades as a major shortcoming in professional offices. They have documented the fact that this lack of field experience is a direct, wide spread, and imposing cause of claims and litigation against design professionals. It is aggravated when an inappropriate use of a material is poorly documented, essentially requiring the wrong solution using the wrong products.

The trade workers do not have similar experiences. While highly skilled, and "field-savvy", they lack design office experience, and the project perspective from that vantage point. Their interests lie elsewhere. In fact, their training is based on an entirely different perspective— learning and developing physical skills. These are the skills that will allow execution of a wide variety of work involved with the building or installation of various features, materials, systems, and devices, required in the drawings and specifications for the project. These skills must be developed so the workers are capable of performing any type of work "thrown at them". Often this training is based on the skills required within the work jurisdiction of one trade— carpentry, or brick laying, for example. Still there is a need to train the trade worker

in a wide variety of skills, using numerous tools and pieces of equipment, so they are fully capable of building or installing any of hundreds of products they encounter on projects.

This is illustrated quite well by the typical apprenticeship program, which trains/educates the young persons, while they work a period of time [quite commonly, 4 years]. At the end of the entire sequence they are rewarded with full benefits and the indication of a journeyman level status. This is roughly equivalent to a professional who, through examination, has been registered to practice. The apprentices are trained in all of the basic skills, which hopefully, will allow them to perform a variety of tasks, normally assigned to their trade, to erect, build, install, or perform work as required. This apprenticeship program is typical of the trade unions, where specific jurisdictional areas of work are laid out which entail a fixed palate of materials and systems. Often these parameters are rather narrowly drawn, but do allow for the introduction of new materials as part of the jurisdictional area. This, of course, does foster a higher degree of skill and expertise within the given trade. Training efforts by other construction organizations and groups are quite similar with some attempting at least minimal cross training between trades, so the worker is more "marketable" because of the wider range of experience and skill [skilled in two or more trades].

However, as new materials come to the market it is necessary that manufacturers' instructions, and recommendations be read and followed [provided the contractor is sincere and conscientious in her/his approach]. Just as any layman is well advised to read and follow instructions for "putting together" some item for the home, so the trade workers need someone to lead them through the installation process. Usually this is done on a project by project basis [no continuous instruction is available which formally deals with new materials] and will be a supervisory person— foreperson, crew chief, etc. But being far less than familiar with the product there is a steep and rapid learning curve needed in the process. This necessitates the use of the basic trade skills for performing the work required for the new material or system. A simple task like cutting the material may require a special technique, a special saw blade, and other unusual precautions to prevent damage of the material. Oddly enough, this information is almost irrelevant to the design professional, who merely sees the material as being a product that is useful and appropriate for the project. They may be totally unaware of the special attention and care required to use and install the material.

Certainly there is no effort to stifle the use of new materials, but when the contractors become aware of them, there will be an incremental increase in cost to cover the added effort to

familiarize the trade workers with the special nuances of the material. Obviously, if the information about the product and its incorporation into the project work— from both professional and manufacturer— is inadequate, unclear, covertly complex, intricate, etc., the cost of doing the work will escalate further, and the time to produce the work, will elevate [adding even more cost, of course.] And contractors have a high sensitivity to these situations, and more than an uncanny knack for finding this type of work and adjusting their cost to cover such work. Usually the cost to the owner will not only cover the actual work but any "slush" money added, but unused, will remain and not be returned to the owner.

So if we portray a hypothetical situation where an inexperienced design professional using a rather well-trained CAD operator, [but both with limited field experience], sets out to detail work. The trade worker assigned to perform the work is also minimally skilled and trained, and is unfamiliar with the materials. We, then, have a very excellent chance for bad work, impacting the project— structurally? aesthetically? added cost? long-term adequacy? reduced longevity? Courts have held that if a contractor installs work, as it is depicted on the contract drawings, there is no liability on the contractor if the work fails due to wrong or poor design and detailing, on the part of the design professional [Mac Knight Flintic Stone Co. v. The Mayor, 160 N.Y. 72]. Conversely, if the work is depicted correctly and not properly installed, it is the contractor who is responsible for any failures.

The culmination of all this, more often than not is [and had better be] resolved in the detailing of the project work. Details are the common ground/element where professional and trade worker must interface, if the project is to move ahead. This is the point where ideas, thoughts, and concepts begin the transition into reality, full sized, and properly built, erected, installed and positioned in the actual project work. Does it, then, not make sense that the detailing be of the highest and best quality— fully faithful to, and illustrative of the project requirements— directional, accurate, complete, unambiguous, and easily understood and assimilated by the trade workers?

Today's projects are complex in design, extremely involved and convoluted, and necessarily extensive, expensive, and quite often extremely costly, for what seems to be rather ordinary work. The details we produce, therefore, need to be as simple as they can be— direct, straight-forward, correct, sound, constructable, and devoid of nuisance, impracticality, and devious construction.

The "4C's" so widely attributable to specification writing, are also perfectly valid and applicable within the context of detailing—

Clear; Concise; Complete; Care

The very nature of our work "pushes" us to extremes in technology, product selection and construction— we need to "push" ourselves to execute our work in commensurate style. But there is an added caution in that we must interpret and convert the information required into terms readily and directly usable by the skilled trades' persons active in the actual construction in the field, who unfortunately do not have the insight or depth of information that we have.

To be a true "interpreter" as the architect/detailer must be, one must have working knowledge the vernacular and information from both the design side and construction side, so true communication can be had between the two— understandable and useful to each.

By showing too much, or unrelated information, we can induce confusion— showing too little can lead to loss of control, extra costs, questions, and claims of all sorts, none of which serve the project or any participant well.

Doubtless, the construction workers can build anything we direct, via our drawings and specifications. Best we send them the most refined, simplified, expressive, and readable drawings, well executed and a true assistance to their effort in building our client's project.

THE THRUST OF DETAILING

Make no mistake, detailing as the skill that is a prerequisite to professional success, needs to be mastered and then continually modified, adjusted, developed, nurtured and refined over a the course of an entire career!

It is so fundamentally basic to the understanding and execution of the entire process of architecture, it is without peer or counterpart, much less substitution– concept, design, documentation, construction, observation, explanation, insight, justification, assessment, etc., all involve some level and type of detailing. It is totally fruitless to even try to ignore or avoid it!

It is pervasive throughout the project, at all levels, and for all participants.

It is wholly unrealistic, most unprofessional and legally risky to allow the contractors to guess-at and free-lance work, to fill information gaps with answers and solutions, and produce the project, as they see fit; and to merely abdicate one's professional responsibility to produce proper project documentation to ensure construction of the approved design concept.

It is not something that comes quickly, and is easily conquered; it is wide-ranging, quite variable, multi-faceted, and continually open to the dynamics of changes and new directions in construction materials, systems, methods and overall building design.

Detailing do not come through flashes of genius, strikes of lightening, direct divine intervention, messages in bottles bobbing in the ocean, or sudden realizations. It is not pre-ordained, and often is really not all that clear prior to establishing the overall construction scheme and system[s]. It is not automatic, constant, predictable, or stock! Even checklists fall short of fully comprehensive listings of details– mainly these note those details that are the most common [to all projects], most mundane and routinely utilized. Details are developed through a careful sequence that involves the gathering of information, from various sources, the analysis of the information and then correct application to the project.

It is necessary that detailing not be calculated, assumptive, or off-handed, but rather responsive to the conditions and the

specific needs of the construction and/or the project. Good details come from a full understanding of the construction currently being required for the project, or that which is easily and reasonably anticipated for use. With this there needs to be a flow of information from various participants and sources

Construction projects are not built by trial and error; therefore, in the one chance for success, all the participants must bring and bring their expertise, their best and most cooperative effort, and highest communication skills to the project, and actively play a proper role in the activities.

that contributes to and facilitates the subsequent application of a depth of construction knowledge allowing one to be most flexible and adaptive and fully able to response to changed conditions. No two projects are exactly alike.

The goal of detailing is ample construction knowledge, flexibly adapted, appropriate to the need, location and project, skillfully depicted and promptly communicated!

Even prototypical projects have some changes and nuances in them as they are set in new and different surroundings and circumstances.

Detailing may well be one of those proverbial situations where one must “feel” the approach and solution, without a known, quantified or specific path. In addition, one must be able to select from a host of proper and possible solutions, that one from the short list of possibilities that is “best” for the project’s situation. It is here, often times, where the most innovative and ingenious solutions in detailing are done– creative, responsive, and contributive!

It is simply not something that can be quickly, lightly, or off-handedly introduced, taught, picked-up, assimilated, applied, adapted, resolved and instilled in a few hours of class time.

One can begin the process in this way, but there is a need for the student, and the young professional, to catch the essence of the process, and fully understand what must be done; and

TYPES OF DETAILS

In addition to the various types of details, there are also "categories" of details. For example, consider the following:

Construction:

Details of portions of actual construction involving various materials and systems as well as customized fashioning of standard items to fit circumstances of the project. Many of such details will not be visible in the final construction but are needed to illustrate how the project is to be built; and as instructions to the contractors. Usually highly specialized due to particular requirements of the project and its construction—requires wide-ranging, in-depth and incisive construction knowledge and developed skill in the actual depiction and development of the detail [i.e., knowing what to do and how to do it].

Aesthetic:

A detail which supports or addresses a prominent design feature, element or decoration of the design, which is readily noticeable, unique, striking, high-profile, eye-catching, decorative, and which adds to the image of both the design scheme and the prestige of the client. Usually these details relate to the finishes, ornamentation or decoration, but they also most often involve the supporting construction items/work that underlies or forms the finished feature. This category of detail may exist in numerous forms throughout the project, in varying degrees, but with much of the same impact. Some such details may merely be evident, but still must be cleanly and carefully built to avoid adverse impression or impact; for example, expansion joints in drywall construction. These all require a careful, thoughtful and refined detailing approach to ensure that the final construction is of the highest quality, and does not distract from the desired result.

Utilitarian:

The detail of a footing, for example, [and other construction related items] which while unseen, requires careful execution to ensure that it is properly depicted in keeping with its distinct and important contribution to the specific project. Also, expansion joint cover details, adapted to project conditions. In

each example here, as in other details in this category, the specific requirements and circumstances change from project to project, but the general overall concept—i.e. footing, or joint cover—does not.

Innocuous:

Seemingly mundane, inconsequential details that are necessary for proper development and completion of the work. Low-impact details that are commonly in nature, involve ancillary elements of the project—necessary work that is often forgotten, disregarded or otherwise minimized. But at the same time have a direct impact of the quality of the project, its correct function—and on the overall cost of the project. Wrongly considered as "second-class" drawings, such details are nonetheless extremely important to a satisfactory project and a pleased owner.

The detail categories above often are manifest in one of the following formats:

Standard:

Detail developed for repetitive use; stored in tact; highly generic; rather inflexible and not modified; usually depict common, mundane, or unchanging work; HM door frames, bollards, overhead door mounts are architectural examples; civil items such as curbs, head walls, rip-rap are examples. [see separate list of possible std dtls.]

Component:

Common or "standard" detail segments [components/parts] that can be combined, as required, to form new, complete details pertinent to project at hand [flexible, adaptive, allow innovation]

Adaptive:

Complete [incl. standard] details that can be re-used, AND slightly modified/adjusted to reflect changed conditions in project at hand; often produced by trade associations to reflect "good practice" advocated by association and its members [BIA, NRCA] and repetitively used, and can be applied to a specific project with little if any modification; a curb detail for example, or toilet partition details. These, primarily are details which are stored [manually in files, or in computer libraries] with the specific intention that they do not need to be redrawn for each project. It is

not that the work involved is minor or inconsequential, but rather that it simply does not rise to the level where new and innovative solutions are required.

Manufacturer*:

Details which depict manufacturer's specific system or product, placed in generic surroundings, to illustrate flexibility, attributes or correct use of product; details supplied to promote sales rather than for a specific case or solution [thus modification is both expected and necessary]; changed conditions, in project at hand, may be substituted— with care

Shop Drawing*:

Details developed by manufacturer or fabricator to show, specifically, how a unit or work will be shaped, fastened, constructed, installed, etc.; often expands detail done by professional; should reflect or be unique to project conditions

The fact that these categories exist is not the precursor for assessing what effort is or is not required to produce or incorporate them in the contract documents. Obviously, a new, unique detail will take more time, thought and effort, than ensuring that a standard curb detail is appropriate for use. Again, it is really a matter of caring, and "attention to detail" on the part of design professional or drafter. In the latter case, if the detail is used too "quickly" without due consideration, it may prove improper where it does not reflect the current project intent or circumstances. This is directly akin to having portions of a project specification Section which are irrelevant and do not apply to the project. These both are maladies that the professional must be careful of, since incorrect or irrelevant information can lead to project problems and confusion, unnecessarily.

*In many cases, manufacturer details used in catalogs to illustrate their product[s] are also used as their shop drawing details— for example, toilet compartments, their layout and hardware are usually not highly detailed by the professional and for the most part are assemblages of standard parts. This all could be called, "common knowledge or understanding" within the industry, and outside any distinct need for detailing.

[Fig. 5-1]

Discussion of the various categories and types of details that illustrate the vast amount of work required on each project, and the various resources available for correct and appropriate detailing.

to accept the challenge to do the necessary work!

Trying to produce project documentation without the ability to provide technical input [i.e., construction knowledge] to the detailing, is like picking up the latest, high-tech cell phone, which uses satellite transmission, having nothing to say, and repeating what someone else tells you to say!

Beyond this is the desire, need/understanding of the process, and the continual collection of information, resources, feedback, and experiences to enhance and widen one's detailing background. It requires a wide breadth of knowledge and a flexible dexterity that leads to understanding how work can be designed, applied and incorporated. In fact, it is very much an ongoing, career-long process, as one continually encounters new design configurations, materials, processes, and circumstances.

Detailing is a valid and most vital method of control— control, properly exercised on the part of the design professional over exactly how the project shall be constructed. This is not a charge or direction for the professional to dictatorially "command" project construction,

To control [in the context of construction] is to both direct and guide various actions and tasks, while also to regulate and ensure adherence to a prescribed pattern and path of work that leads to an established end— as opposed to disjointed, random, uncoordinated, unfettered, free-lance and directionless activities.

but rather to ensure the integrity of the design concept which has been designed specifically for, and has been approved by the Owner— and perhaps more importantly, forms the basis of the Owner's expectations, expressed in the construction Contract. It must be remembered that everything shown on the contract drawings, and included in the specifications, are legal obligations of the Contractors.

Further, directions, instructions, and project information need to be clearly, completely and explicitly conveyed to the workers in the field [who do not have the insight or interpretation, and explanation; often they even receive inadequate direction from their own managers]. It is necessary that this information illustrate how the standard, manufactured components are customized and fitted into the work of the project. Obviously, this is a process that must be under the direct control of the design professional.

"The specifications (and the drawings [including details]) constitute an externalizing of project information resulting in the decisions made during the design process. We do this because there is so much that goes into even simple projects and we do it because those who do the construction contract administration for larger projects may have little or no contact with the design team ... Moreover, because of turnover, it may be that those involved in design (and even production) may no longer be working in that firm. [An] architect I worked with years ago liked to talk about his "Mack Truck theory"; a theory that the project should be documented well enough so that it keeps on going even if a key person was hit by a Mack Truck. My attitude ... is the same. It has to do with a more "corporate" than "personal" approach to practice".

Externalizing decisions and information into a set of contract documents means that research previously done and decisions previously made do not have to be revisited during construction.

The larger and more complex the project and the more remote the project site is from the design office, the more important contract documents become.

- J. Peter Jordan, AIA, CSI, CCS, LEED AP
Principal/Specifications Consultant
Jordan Consultants, LLC – Houston, TX

The Owner, in turn, is obligated, via the contract, to pay only for work done by the Contractors in agreement with their bid or negotiated costs and their contractual role to perform the work, "according to the plans and specifications." [See AIA contract forms] The project work, in no way, can be allowed to be a wide-open, free-wheeling, free-lancing, "do-as-you-wish", perpetual-motion, "snowballing" activity—control, then, is essential not only in formulating the specifics of the project, but also in seeing to their correct fabrication and installation.! Such control is a mandated contractual function of the design professional, on behalf of the client.

Detailing is, indeed, a matter of control— in-depth control of exactly how the project is to be built

DETAILING is the seeking, collecting, evaluating, selecting, manipulating, adapting, fitting, combining, and application of the minutia of construction devices, materials, equipment, and systems, and their accurate depiction, as to the small complex itself, and its location in the total project to support the overall design concept.

This control, though has several aspects that must be included—knowledge of the project requirements; knowledge of

construction materials, methods and systems; communication skills [graphic and written]. It is the place where technology is directly applied to various designs, concepts, configurations, assemblies, parts, systems, and types of construction, materials, and portions of the project.

Detailing requires a studious and measured approach for gathering information, seeking out and using resources and pertinent information, correctly applying it to the project circumstances, and engaging the processing of the detail drawings. In this it is necessary to follow a fairly consistent and prescribed path. In approaching this sequence, the professional and staffers must be aware of the information required, the sources of that information, and how they [along??] can formulate or manipulate the various components into correct and proper details—and then how to convey all of that information to the field workers.

This is the crux of what the student and young professional must become aware of, and then either be given instruction in this sequence, or left to find their way into and through the process. Obviously, instruction, education, continuing education and/or on-the-job-training provides a most valuable and important bundle of information. This is not project-specific, but is steeped in concept, construction technology, graphic communication skill, and overall and full understanding of the process, its value, the necessity of it, and how best to engage, and provide it.

This control is necessary to maximize the chances for a fully successful project. For that successful finale, one must control every aspect of the project. Not even the smallest of items can be relegated to others. This is the underlying, although unwritten, premise of the Owner-Architect contract. The project need not be "perfect", but must be relatively high in the successful accomplishment of the Owner's approved design concept.

Where detailing is lax, ambiguous, inappropriate, murky, or non-existent, the contractor(s) will attempt to fill in the information required; often without consulting the design professional. At this point control of the work is taken away from the professional, and is exercised by the contractor.

"The first problem I see, quite often, is that the plans and specifications lack a considerable amount of detail ... the lack of such details allow the dishonest contractor to play the classic shell game... by switching materials for less costly items, and solving problems as he alone sees fit".

- Tim Carter, Builder/Contractor
Syndicated newspaper columnist

However, the reality of the situation is that the Contractor is so bound and motivated toward schedule and budget that the lack of adequate information will not be allowed to impede job progress. The only two options open to the Contractor—proceed as deemed necessary without the information, or risk loss of time to make inquiry—both take control of the work from the design professional. This, of course, is not a good situation, nor one that should be tolerated.

While the professional is specifically prohibited from directing or advising about the construction means, methods, techniques, sequences, and procedures, the contractor(s) carry the responsibility in those areas, and are obligated, contractually, to construct the project as shown/described.

Where the plans and specifications prove inadequate to their task, the contractor will move ahead as best she/he can in an effort to fulfill the contract. Hence, there is an inherent onus on the professional to produce not only proper but complete contract documents. This ensures the proper level of control over the project, as the client expects of the professional.

The basic function of detailing is to isolate restricted areas of the work and to depict them, at an enlarged scale usually, so the specific work area/item is revealed, opened to expanded review,

and the intended construction, requirements, and methods are noted.

DETAILING

- Isolate:* Divide whole project into small, non-repetitive parts; joints, typical work, layered work, new/unusual configurations; Decide need, and function of each part; Decide on "pattern" to be utilized
 - Conceive:* Research possible systems/materials/devices that, when combined, will produce the chosen pattern
 - Formulate:* Study/sketch variety of possible solutions
 - Design:* Decide which solution works best, for each part?; if work fulfills need
 - Depict:* Fully, and describe work within parts based on final analysis of sketches
 - Relate:* Several parts one to another and to design concept
 - Chekpoin:* Is there enough information that YOU could build the part in question?
-

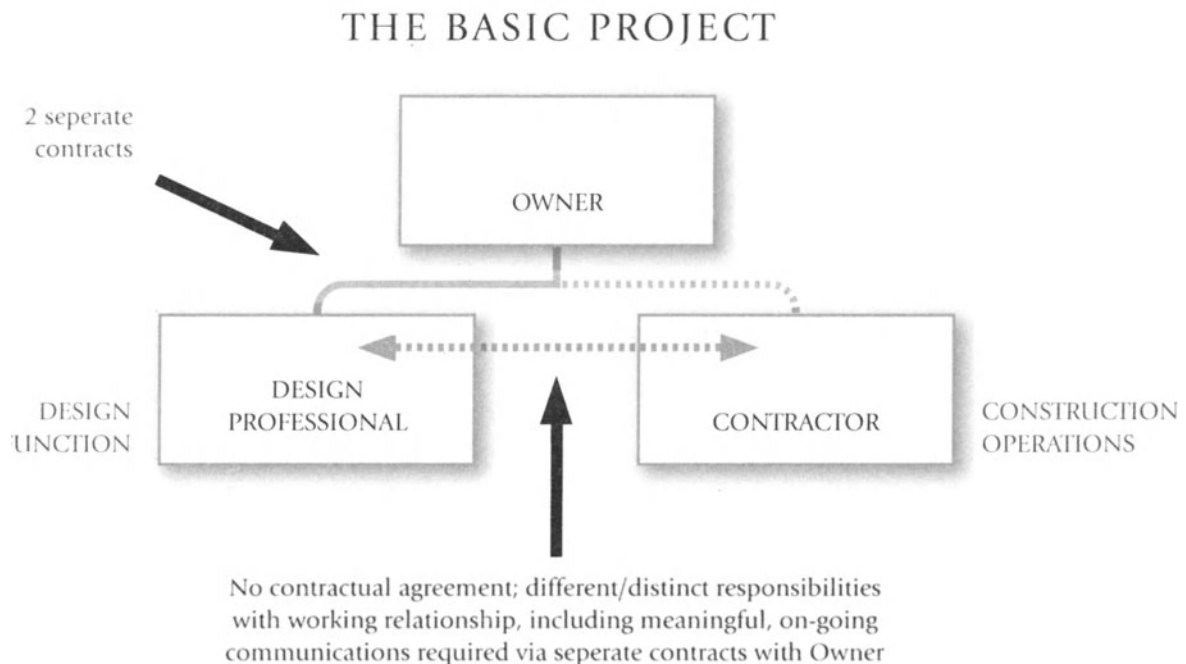

Fig. 5-2

Chart showing the breakdown and relationship of the three primary contractual parties in a construction project. Note there is no contractual relationship between design professional and contractor [both work under separate contract with the Owner]

The details are extracted from smaller scale drawings, which show their location(s), but not the degree of specific information required to construct the work. This is in full accord with the construction axiom that "the specific rules the general; detail rules concept."

Fundamentally, detailing entails, among several other things:

- What to show;
- How much to show;
- How to show it (as to both scale and scope of the drawing); and,
- Where/When to stop drawing.

The latter determination is difficult since it is a learned process and something that cannot be taught. Actually, only field experience and knowledge will allow one to stop detailing at the appropriate point, and permit the workers to provide the minute, final "how-to" to complete the detailed work. For example, rarely is every nail shown on the drawings; usually they are shown only where their placement and number are critical, as in the gusset plate joints of trusses. Sizes and numbers of any fasteners are not included UNLESS so vital to the success of the detail that a selection must be made by the design professional. Here, for example, custom cabinet-work may be detailed in general since a subsequent shop drawing, prepared by the fabricator will be the submitted for the professional's review [as a "shop drawing"]. The contractor/supplier, however, are responsible for the correct size, fit, and construction of the work involved (as per the General Conditions). This includes selecting and using the proper fasteners.

With all this aid, there is need to address the issue of personnel, knowledge and experience. In the main, detailing is not only best produced by persons who have developed skills for presentation and communication, but who also have the technical knowledge and construction background required for the work.

Trying to produce project documentation without the ability to provide technical input [i.e., construction knowledge] to the detailing, is like picking up the latest, high-tech cell phone, which uses satellite transmission, having nothing to say, and repeating what someone else tells you to say!

This is not to apply a stigma to some educational programs, but professional offices, "under the gun" to produce quality project documents, on short schedules, are ill-advised to misuse their personnel. Use of people who do not have technical knowledge of construction materials and methods, which they can apply correctly, adroitly and innovatively, are high-risk to

the project situation, and the firm— a scenario that will produce more pain than gain! The most unfortunate part of this is that the young graduate or professional cannot gain the necessary experience without hands-on work, and yet that work, unless monitored and mentored, can be counterproductive to the firm's production, the project schedule [in "re-work"], and its reputation [where details "slip through" in poor condition].

The situation is one of deterioration, which is approaching a crisis. With no overall coordination of the education process, new employees in professional firms come armed with a narrow range of highly developed skills. These skills, in the main, are operational, utilizing the latest, cutting-edge computer software available to the professions. The educational efforts in architecture are starved for technology, with neither college level instruction nor community college/technical institutes offering any comprehensive instruction on methods and materials of construction. Courses dedicated solely to detailing are exceedingly rare.

ARCHITECTURAL EDUCATION IS NEVER COMPLETE!

It is adequate when one has:

- 1) *Developed sufficient skills,*
- 2) *Absorbed every possible detail of knowledge, and*
- 3) *Accumulated enough experience to ensure reasonable solutions to problems encountered by new work.*

Without all three – SKILLS, KNOWLEDGE, and EXPERIENCE – The architect is hard-pressed to operate with any degree of competency.

If he hopes for precision in architectural practice, let's say the design approach, he must face the realization that education must continue at a greater pace than he experienced at the university.

William Wayne Caudill, FAIA

The resulting void forces the professional offices to develop and instruct the new staffers in the basic communication documents— working drawing, including details, and specifications—as well as in basic construction knowledge; a chore the offices don't care for, and which drain funds because of the non-productive nature of the development. Offices want new employees who are fully productive, but for the most part the various educational organizations are not providing this type of person. The resulting dilemma forces the more knowledgeable, and experienced professional personnel to create an

interface where sketch details with complete notations must be produced, and then given over to CAD savvy staffers. Refer to discussion located in Appendix A.

Many architectural employers are finding that it is to their benefit to use in-house training to elevate the technical expertise of their staffers. Many offices decry the need for this type of effort, claiming the schools should teach this work in their curricula. Others claim it is the function of the IDP to provide this instruction. However, that system is not set up to provide a fairly uniform level of instruction, and really relies on the offices to provide the environment and opportunity for experience in this work.

Nonetheless, no matter where the instruction or learning occurs, there is a distinct knack for "putting a building together", which involves a fluent and flexible knowledge of materials, systems and devices, which can be called upon to fashion work as necessary. Many architects relish this type of work, but their number is diminishing, and the art of detailing is being lost.

It certainly is in the best interest of young professionals to seek out as much construction knowledge as they can find, and add it to their personal attributes. The breadth and depth of this knowledge is so very important so correct, and appropriate— and innovative—solutions can be applied to any project situation. Detailing covers a tremendous amount of "ground" on any project— innumerable materials, devices, systems, interrelationships, etc. Hence the young professional needs to add layer upon layer of information held ready for re-use and adaptation over the broad range of projects and circumstances that can and will arise across one's career.

The more one does this, the more valuable an asset they become to any hiring office and to any office they currently work in. There is, of course, no guarantee, but this type of information and knowledge will stand young professionals in high regard not only for their initiative, but also for the elevation of their personal expertise, and rounding of their professional skills.

Can the case for reexamination and redirection of the detailing effort be overstated? It appears not. This is a pervasive, steady and progressive diminution of this effort, and one that is hurting many projects and professional office.

It is not that we are not producing enough details, but rather what we are producing is inadequate and inoperative in far too many cases. Without a separate, vigorous and continual process of proper initiation, close monitoring and careful final analysis, in the professional office, too many details are being sent out that are simply wrong! The primary reason behind this is the lack of understanding of the process itself and the

need for it— and in addition, how one assembles information, assesses needs and addresses technical construction situations.

So not only have we lost sight of how and what we detail, we also have lost the perspective of the end-user— those who must read, assimilate, understand and execute the work depicted in the details. Namely, the individual trade worker, on-site.

Computerization could be called the culprit in this debacle, but in reality it is the USE of computerization, and the human demands misplaced on the system that are the real demons. New agendas, new deadlines and project management tools have been super-imposed on the project documentation process, to the point that the value of proper technical content, true problem solving, and more than mere minimal communication is all but totally forgotten. CAD has drastically reduced the sensitivity for detailing "drafting" skill and knowledge application; and BIM [currently directed toward becoming an impressive design tool] still raises innumerable questions in regard to working drawings and specifications— in whatever form may eventually [15-20 years?] come to pass. Then we wonder why project work doesn't "work"; why there are so many claims; why there are so many problems in putting the project together, and why buildings deteriorate too rapidly.

In reality, the process of detailing has been, and for the most part remains, a traditional function of mentoring. This is best exemplified in the editorial from the December, 2000 issue of the "Architectural Record" [titled "The Chasm"], and the article from the June, 2001, "Construction Specifier" [titled "The Power of Mentoring"].

Both deal with the mentoring process of education, as applied in professional offices. The editorial incisively points out the long-standing tradition of the "happening" whereby the art of detailing is transferred on a one-to-one basis. A follow-up letter-to-the-editor in the February, 2001 number of the Record, verifies the sequence and the inherent value of the process to the point where it calls upon the colleges to address "project implementation" in their curricula. This triad of information provides a very pointed and poignant review of the situation, and really issues a trumpet call not only to the problem we have [and which will increase in severity] but some semblance of resolution— if proper attention is paid to it.

A few young architects [but not nearly enough] will not only accept this work, but will make it their primary direction throughout their careers. Every young professional makes decisions, conscious and unconscious, about their career. Each precipitates toward a certain type or aspect of professional work which is both to their liking, and where they tend to

PARTIAL LIST OF DETAILS

This is a partial list of not so much individual details or detail locations, as it is a list of detail "opportunities" or groupings. They all should be considered for every project. They may not all be present on each project, as this is merely an incomplete and minimal list to trigger consideration of the project situation to ascertain whether or not a detail is required. The details selected must, of course, be drawn in such a way as to correctly reflect the design and construction anticipated for the project.

Footing/foundation/basement slab	Roof hatches, curbs, equip. supports;
Footing/drain tile	Through penetrations; wall, floor ceiling
Isolated footings	Flashing details at various penetrations
Column base details; floor opening	Partition details; each type; fire rating
Waterstop between footing and wall	Masonry wall details; CMU, CMU/brick
Water- or damp-proofing	Unusual wall configurations; angles, radii, etc.
Special backfill; drainage	Ceiling details; layout, penetrations, bulkheads
Sill at top of foundation wall w/grade line	Flooring; coverings, trim, transitions
Floor construction at /connected to sill	Floor patterns, trim
Bottom of upper wall construction	Stair details; construction, finishes
Typical upper wall construction with interior finishes	Door, frame/window details
Window/door sills, and heads; also jamb details	Casework; built-ins; counters
Lintels over openings	Systems furniture layouts,
Construction at structural members; columns, beams, etc.	Glass frames; borrowed lights
Wall facings and veneer details	Toilet compartments
Joint[s] between floor construction and wall	Tile layouts, patterns, trim
Joints between roof construction and wall	Tile floor installation
Roof edge, or top of wall closure	Visual boards; A-V equip
Gutter, coping, gravel stop	Plaques
Parapet wall with flashing from coping to roof	Signage; interior/exterior
Roof construction; insulation, slope, coverings, deck	Graphics; paint patterns
Trim, surrounds, coves	Kitchen equipment
Paneling; furring; insulation	Special room layout and equip
Skylights	Ladders; ships ladders; alt tread
Changes in construction; joinery	Elevators/escalators; lifts, dumbwaiters
Expansion, contraction, construction, isolation joints	Mechanical shafts/areas
Closures	
Paving, curbs, ramps	
Landscape features [construction]	

Fig. 5-3

An incomplete list of possible items and work requiring detailing.

This list must be established, modified, augmented and changed for each project specifically, so the work is properly and completely details.

excel and feel most comfortable. Every architecture graduate is not cut out to be a designer! Some like more administrative roles; some like field operations; still others work exclusively in healthcare, or sports facilities– or educational or industrial projects; some go into ancillary fields of endeavors; and some simply like to "put buildings together"– i.e., detailing!

All to the good! However, the work of detailing is a challenging necessity on every project, and therefore it is something that EVERY architect and prospective architect needs to engage, embrace, and "grasp"– even if the primary interest is restricted to design.

Many professionals– young and old– disdain detailing and regard it as unattractive, unrewarding, unappreciated, mundane, drab, nuisance, and drudge work, and certainly something to be avoided at all costs. While each is free to come to her/his own decision and perspective, the fact remains that, in every case, detailing is the technical expression of the project. For this simple reason every young professional/designer/architect should have commitment, desire, and a "hand" in the detailing, if for no other reason than to ensure that the design concept is met, and faithfully produced by the construction work.

The architect, in every job position including designer needs to understand detailing, not to dictate or control it, but to appreciate the help it lends in ensuring that the process does enhance, reflect and contribute, properly to the design concept. This, though, does not mean that every small part of every detail needs to be reviewed or "approved" by the designer. Rather the "designer" must have the knowledge of detailing to be flexible as to how the design concept is executed, and the limits set forth by each material and system. Without knowing, in general terms, how to depict, construct, and/or describe the intended construction, the designer cannot hope to contribute to the documentation effort in a constructive manner. Here again, control by the professional is in jeopardy, although the documentation "team" can make every effort to resolve any issues by applying their expertise to the concept– with the designer as their guide.

It is not enough to be

- meticulously accurate;
 - all- inclusive;
 - impeccable in drafting; and
 - painstakingly complete
-

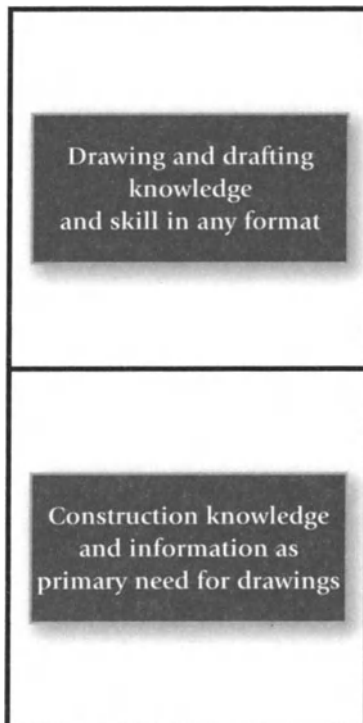

These two aspects of working drawings are shown here in approximately equal parts, or with equal status and expertise. There may be variations from this, but there still a mutual function and value added one to another -- i.e., the requisite information needs a mode of expression that is provided by the associated and commensurate drafting skill.

Fig. 5-4

Explanation of the need for balanced drafting skill and construction knowledge

Unless there is also an element of showiness, attractiveness, and an aura about the drawing that draws immediate attention to it.

Yes, each drawing needs this, although they do not compete with each other on this level. Blandness evokes bland, mediocre, make-do construction, which no construction project should put up with. Working drawings are not intended to be works of art, for display purposes only. They are "to work", by their very name. But with the current capacity to produce very intricate, closely related line work, via the CAD process, it is beyond essential that every drafter perceive the need and interject an aspect of "showiness" into the drawings- not to the point of distraction, but to the necessity for clarity and readability. Users of the drawings should never have to "hunt for", or guess about information, configuration, or intention- they all should be present and readily available, almost at a glance. Each drawing, and detail, needs to capture the reader/user in a way that "demands" immediate attention, reading, and the transfer of valued information.

This may seem like a strange set of attributes to assign to the drawings and details, but it is a truthful scenario. It is subtle in one way, and glitzy in another. It rejects a monotone, and

reaches out to the reader. It is the difference between a speaker with inflection, varied pace, and unique phrasing- as opposed to a monologue delivered with sameness, and almost a lack of enthusiasm and interest in the subject.

In no way does this suggest that working drawings, and details, be "jazzed up" simply for the sake of attractive presentation. Decoration is useless, and often confusing, but there are still several things that should be done to make the drawings/details better. Line weight variation, separation of information, separation of drawings, and other aspects of readability enhance the drawing, draw the eye, and hopefully presents a series of valuable pieces of project information.

A guiding thought about detailing:

It is well-settled that detailing with incorrect or inappropriate information but good presentation techniques is unacceptable; but more importantly we need always to assess the impact of detailing good and valid information with poor, substandard, murky, confusing or inappropriate presentation techniques that render it questionable.

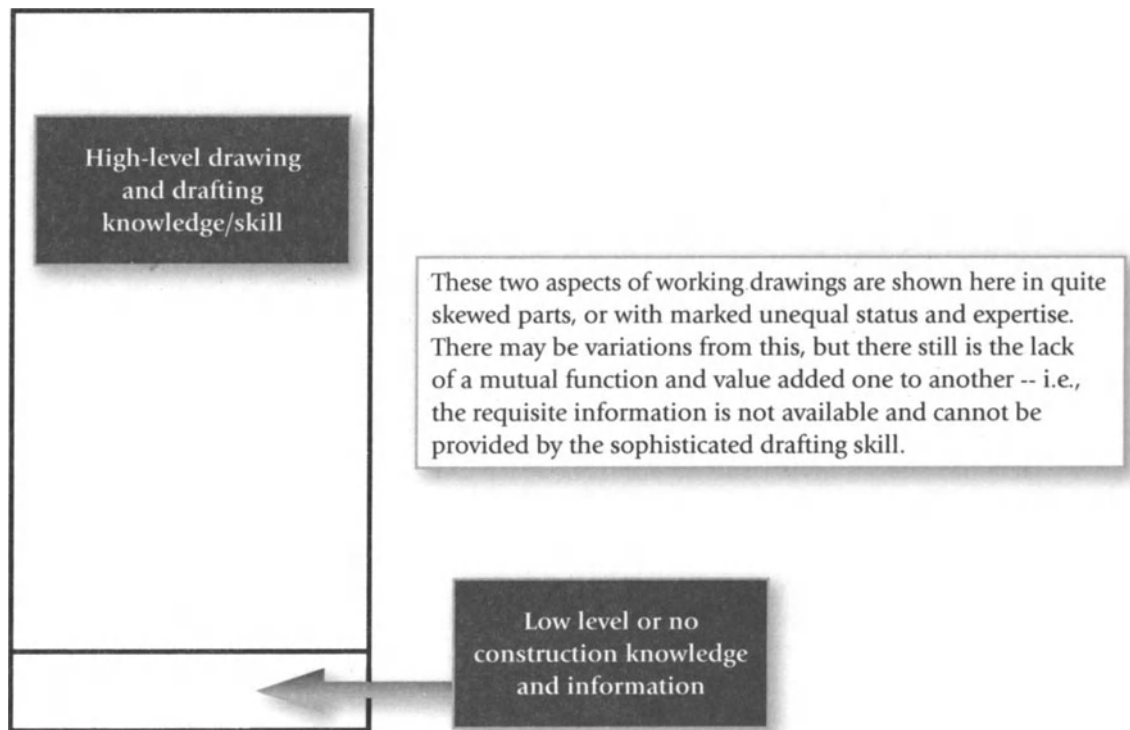

Fig. 5-5
Explanation where drawing skill and construction knowledge are drastically out of balance

So too it will elicit a higher quality in the actual construction. In a way, good drawings are contagious, in that the resulting work is of a marked higher quality, simply because the drawings was clear enough to direct easy and accurate construction. Simply, quality begets quality!

The definition and detailing of the idea into good workable design therefore depends on drawing as the principle modeling technique. A vital element of the process is the ability to identify and define progress– the detailing of the idea not only allows the designer to record development, but enables clearer articulation of the results. This role in establishing the progress of the design gives the drawing a fundamental influence in detail and construction, but also enables prediction of future performance. This ability to specify size, scale, and shape prior to building or manufacture is common practice today. However, in the late 18th century it was an important stage of development, which was to have a major influence on the planning and organization of construction.

The figure shows how an idea is detailed and how annotations are used to provide specific and added information to assist manufacturer and installer. The incremental nature of design is readily detectable in detail drawings, where the process of trial and error is separated from building and manufacturing, and acts as an accurate and efficient model for changes and development. The drawing is the reflection of decisions made, and clarification that enables the architect and engineer to simulate what is eventually produced, and installed in the project. The original need is to identify and illustrate different parts of a proposed building and their relative positions brought about the obvious use of a scaled on a flat surface [the detail drawing]. This subsequent ability to examine the project, in small portions, through drawings reduces and simplifies the numerous decisions that must be made. In the ancient days of the Master Builder, resources were not available for a permanent record of drawings and their use to illustrate progress and decisions. The "drawings" were fleeting, done in chalk, or in the sand, and were scrubbed away as work moved on. As-built drawings were left to coming ages and the archeologists!

Through the years of development in architecture and construction, this aspect of detailing has been refined and made more positive by the introduction of various technologies. What was once drawn [in the sand or on a trestle board with chalk], has evolved in a far more useful and permanent record. First, we hand-made, non-reproducible drawings on opaque media, followed by the "blueprint" system using translucent papers and various reproduction systems including the blueprint, ozalid, and similar reproduction pro-

cesses. Some use was made of offset printing, and then photocopying. Of course, today, we have the electronic creation, development, refinement, and changes in detailing, within a literal eye blink. This, of course, greatly enhances the tracking of development and design compliance of the details as they occur in the documentation cycle. This is an added feature of control, on ht part of the professional, who has the ability to monitor "how" the project will be executed by watching how the documentation is produced, through its various stages.

Firms

Detailing, of course, is a process common to every project, although the complexion and extent of the work, and the number of drawings may vary quite widely. It is a function of the professional effort that must directly reflect and react to the project and the construction involved. The design professionals must create a plan for the detailing process.

In this, their effort must cover all of the crucial elements of construction without needlessly overburdening the construction, adding unnecessary engineering and construction costs, yet with enough information to depict the various elements of the work so they can be easily built. Leaving out information and not providing complete detailing is as onerous as "over-detailing", or being redundant [especially to the point of confusion]. Only through the mentoring of others, and experience with quite varied projects, can the individual professional come to understand and appreciate the scope of detailing, its limits, and the contribution that must be made to the project.

It must be remembered, though, that there is no relationship between the concept and even the execution of detailing, and the computerization. The entire concept of detailing is an expansion of the design process– we must detail to ensure faithful development of the design concept! It is also the process whereby correct construction can be assured– i.e., giving the necessary information, in a sound, correct and usable form, to the trade workers so they can build, erect, install or create what the project's features require. This process can be executed whether or not there is a computer at hand [details still could be done using fully manual drafting techniques],

Truth be told, many details, even today, start as hand sketches, or manually drafted versions for study, review and revision prior to be given over for incorporation as CAD drawings. Many find this process to be necessary and a good value.

and whether or not the software available has a wide array of "bells and whistles", and the very latest sophisticated maneu-

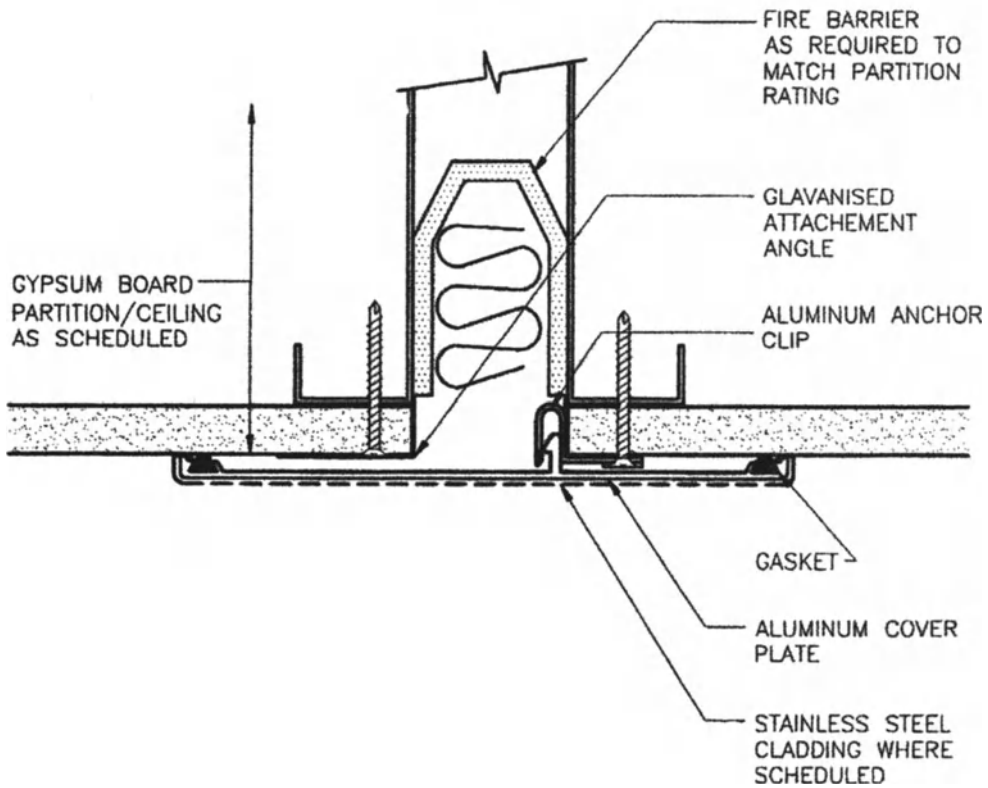
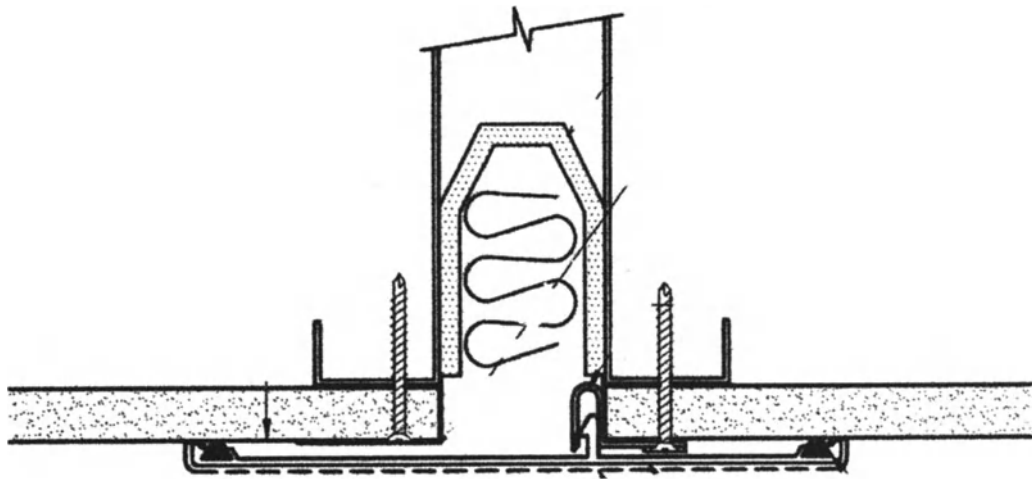

Fig. 5-6

Typical detail shown without notes of explanation [top] and with notes added [bottom].
Take particular note of the need for both drawing skill and correct notations to convey the information required.

vers and functions. It is not a repudiation of CAD, but a simple fact that most architects can more easily transform their thoughts via hand sketches than through immediate use of a computer. Such sketching, in fact, is perhaps the most universal attribute among architects, no matter their particular profession niche— design, document production, contract administration, etc. Strictly a human characteristic and not a regression to “old times” for the sake of opposing modern technology.

First off, however, in any discussion of detailing and drafting, we must consider the tremendous disparity between professional offices. This is, of course, a direct function of the size and expertise of the staff, the viability of the practice, the clientele, the types of projects, and the financial resources in each office. There is a host of offices that consist of a single person; innumerable others with perhaps one or two employees, and with minimal computer capability. The office, out of necessity and choice, will fashion its computer operations to match its capability and direction. Often in smaller offices, the personal choice of the single proprietor, or the 2-3 employees or partners, will prevail. In those instances, the software more than likely will be carefully chosen to provide the maximum flexibility and capacity for the office, the work, and the expertise of the staff. They then will work with what programming and features they come-by through the purchase of the software they choose. Cost restricts changes to newer, faster, and more capable software, but this does not necessarily deter the effort of the office. Usually in circumstances like this, the staff becomes highly computer literate, quite innovative, very flexible, and has attained a marvelous command of the computer operations.

The computer by function, literally replaces the need for more employees, and provides a reliable and rapid method of production. It is easy to see that the computer, in the hands of a good operator can greatly aid the production of projects— especially where the firm is small and the computer can literally produce the work of several employees [who are not on staff]. While limited in scope and computer operational attributes, these offices have attuned their production to those tools they do have at their command. Combining individual computer expertise and innovation, more than likely their work is highly professional, well executed, and properly to the practice, the clientele, and the projects.

In many cases though [although the numbers may vary] there are offices of high profile, cutting edge computer capabilities. These usually are offices with large staffs and a multi-discipline orientation. Software is multiple programs, and the latest available— easily changed-out when new versions are put on the market. In many instances there are entire departments, staffed full-time within the organizations, which are

dedicated to nothing except computer operations— hopefully dedicated in a manner by which they fully support the computer efforts, and NOT to the degree that they drive the professional effort [a wrongheaded direction!]. In the main these offices have professional staffs which number in the hundreds for engineering/architectural firms, and those multi-office firms with wide-ranging and international practices. The work projects also run to the very large, quite complex, and very costly— hundreds of millions of dollars.

The computer operations are the lifeblood of such firms, since the amount of information required [to be developed, coordinated, transmitted, used, and documented] is monumental. The operation must be rapid, reliable, and in some cases, may operate 24 hours a day— plotting during the night for the next day's operations and transfers. A shutdown for a simple power outage, or for equipment malfunction can be devastating, and extremely costly to the firm, since almost all operations will be stopped, and employees sitting idly by. Of course, in this, detailing could continue in the form of hand sketches and conversations, but actual production of usable details will have to cease.

These larger firms will also have the newest versions/releases of computer work, and such advanced programming as 3-D modeling [Building Information Modeling— BIM] whereby an electronic model is created which allows development of electronic [“virtual”] design concept, and electronic “walking” throughout the project to view the various elements within the design. This and other similar software programs are used to identify conflicts between walls, pipes, ducts, and structural elements. In very complex industrial projects, the discovery of conflicts [now more commonly called “interferences”] where two or more work items are shown to occupy the same space, and their elimination by electronic means, in the office, is crucial to the progress and cost control of the actual construction. The discovery or uncovering of such “surprise” conditions, on the job site, is disastrous— costly, time consuming, difficult to unravel, and certainly non-productive. The interface between systems' elements can easily be displayed, rotated, inverted, and otherwise manipulated to give the best and most accurate views— some software programs produce actual “clash reports”. While not a direct detailing effort, this work and system can be the source for more details, to explicitly show how instances of interference can be avoided, or other similarly important problem solving.

The design can be viewed further through use of computer generated renderings, and other electronic programs which advance drawing abilities to vivid and expert presentation skills, all with the capacity to manipulate and present numerous variations of the project. The same building design can be displayed in many and varied ornamentation and design concepts, without repea-

ted copies or iterations of paper drawings. Details too, can be created by combining various items, or portions of other drawings, to create new drawings. This extends to stored "libraries" of building component details which can be retrieved, manipulated, and combined to create entirely new details, specific to any project. Overall, the architectural profession currently lags other professions in document production via computerized programs. Initially, the computer was seen as a design tool [as noted above], but with more refined software, working drawing production is now utilizing the computer more and more.

While working drawings remain as the basic product of the firms, their computerization has advanced so their presentation and interference drawings are striking and clever. The final projects are virtually free of major conflicts– and relatively free of problems caused by too many items trying to occupy the same space at the same time. In highly complex projects, this is an essential element of projects, and one, if resolved within the computer that can facilitate and lower the cost of projects. In reality this is part of the detailing process.

But beyond this newer configuration there is still a basic need to detail– and to do so completely in context with all of the various requirements and needs each project presents.

There is relationship between the fact that we can, now, produce "better" drawings, in a shorter amount of time, and the fact that comprehensive detailing is driven by project needs. The "better" drawings are still a function of the human mind and decision

making as to what to show and how. Speed of replication is handy when deadlines creep up and project requirements call for more information more quickly. This all indicates that CAD is, indeed, a tool; and a very fine tool when in the hand of a knowledgeable professional or operator/designer.

Obviously there is a direct correlation between project size and the size of the professional firm hired to do the design and documentation work– smaller firms do "smaller" projects, etc.. This relationship does get murkier as you move toward the center location between the smallest firms and the largest. In other words, there is a point where firms must decide if production is best increased through use of more mechanization [i.e., computer-aided drafting, and etc.]. This is in lieu of trying to find, hire, and train more staff members.

As the firm expands, it appears that staff size increases, but certainly at a rate much more modest than that of added computerization. In a tight hiring market, it is far easier to find new and better software, than it is to find good new employees. In this, too, is an expansion of services– large corporate clients tend to desire more services, and stronger commitment [meaning more precise, well-documented, and watch-like production of contract documents]. Many such clients actually oversee their design professionals by co-locating staff in the professionals' offices. To stay abreast of the many facets of not only project document production, but also all of the nuances of the client's management process, requires computerization. Time is charted– projected/ forecasted, tracked, and

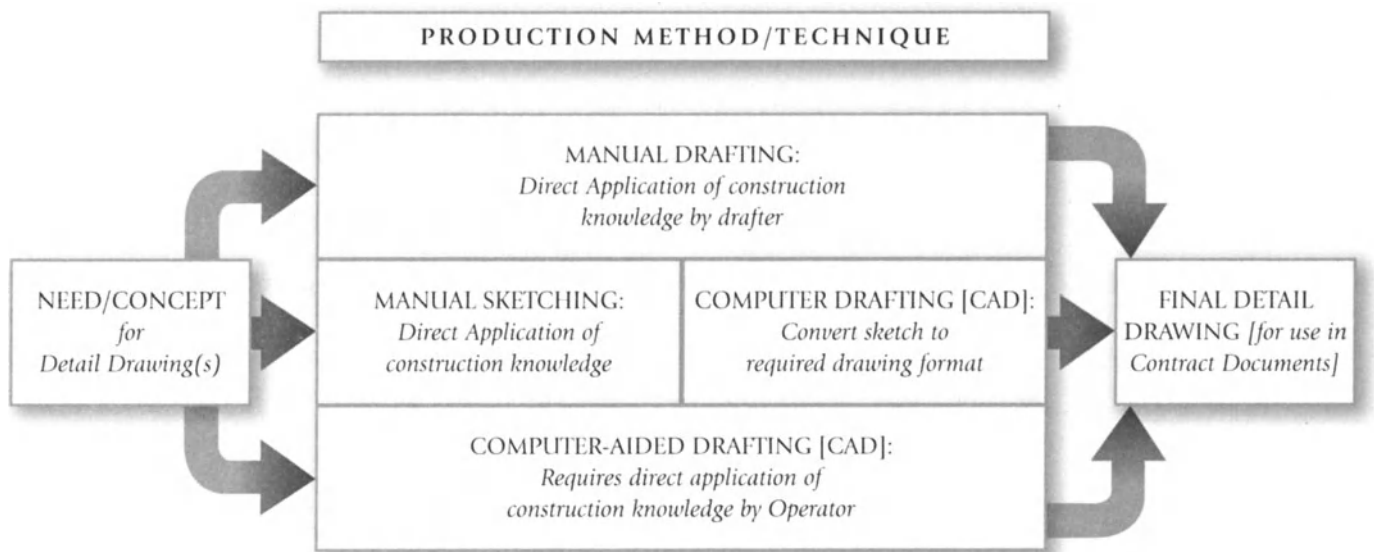

Fig. 5-7
Chart depicting the various routes and methods for the production of details

modified with the slightest change in scope. There is always the delicate need to balance effort hours with scope of work. Competition among professionals means margins are close, so the professionals seek high-speed and reliable production techniques, with human input to make decisions required along the way. But the physical production— actual printing or plotting of drawings is but one aspect of the situation. There is still a need to match correct detailing with project requirements. This is still subjective, and not thoroughly analytic.

The process of detailing, while immersed in this scenario, remains a strong and necessary element to every project— bar none! To build the project, the trade worker needs a continual flow of incisive, correct and detailed information. This is translated, directly into more efficient construction, better progress, and more accurate and faithful project of the design concept. In fact, the word "detail" now has taken on a much more extensive and imposing meaning, in that the minutia of documentation and all of the aspects of the project, in toto, must be so widely and deeply and accurately described and recorded, that "details" no longer are simply the vignette drawing showing portions of construction. The use of the word has always encompassed all this, but the emphasis, today, is far more evident in the project minutia than in the project's contract documents [drawings and specifications]. Despite this, however, the import of the drawings remains the very same.

DETAILING is the seeking, collecting, evaluating, selecting, manipulating, adapting, fitting, combining, and application of the minutia of construction information and knowledge [devices, materials, equipment, and systems] and their accurate depiction, as a wisely-chosen, carefully conceived and well-executed graphic representation of a small portion of the construction, accompanied and supported by appropriate and informative notations to the detail itself, and its location in the total project— all fully understandable by, and useful to the trade workers building the project

Every project, no matter its extent or its complexity, can be [and needs to be] reduced to, or expressed in a series of coordinated details. By careful selection of the areas to be detailed, and skill in showing the crucial work, every project relies on the information revealed in the details. Without realizing it, the trade worker, via the details, is exposed to the inner most parts of the project— the substance, nuances, quirks, idiosyncrasies, and minutia of the project, which supports and contributes to the image and function of the finished project. In this, the design professional must function as the translator and the conduit by which conceptual information becomes usable, and the execu-

tion of the information, in the details, brings forth the project as conceived, designed, and approved— as it is anticipated!

This is best expressed in the aphorism of Ludwig Mies van der Rohe, who was noted for his sleek, clean, straight-forward and unadorned designs— "God is in the details"! He knew that his details would produce elements in the finished project that would be exposed, so they had to be neat, clean, extremely well-executed [both in design and execution], and actually attractive, as they became part of the overall design scheme. His details had to directly contribute to the design concept, since they were, in fact, part of the "ornament" and visual expression of the project. Obviously, then his details had to be of equally high quality, so the actual construction would be an expression of an exacting criterion. While claiming no divine right for detail drawings, this expression does set the bar of value a bit higher, and indeed, sets a standard of sorts. That is the fact that the details must be given the time and attention required to place them in the highest order as they support their associated design concept.

The detailing of a construction project is a highly technical task that must be properly done, neither shortchanging, nor overwhelming the work and all the personnel involved.

In large measure modern day construction is a process of modifying, fitting, assembling and incorporating mass produced, "stock" [standard] products and materials into various forms, shapes, and relationships, all as required by the project at hand. Granted some products are ordered and manufactured or fabricated to precise dimensions and conditions for projects, but the vast majority of products come to the job site in their "normally manufactured form" [even most of those custom-made are composed of stock materials]. It is only a small percentage of the products required on a project that entail special attention, i.e., detailed information regarding a "custom-made" size, construction, shape, or other generally overall attribute. What is unique, on each project, are the methods by which the regular, mass-produced products are re-fashioned, utilized in, connected to, integrated, and interrelate with other project elements. It is here where the process of "detailing" comes to the fore— detailing specific to the conditions set out by the scheme of the design concept for the project.

It is the design professional who, in selecting products, is required to fashion the exact use and configuration of the manufacturer's standard product.

This, of course, is accomplished through the details included in the working drawings for the project. The very same product may appear in other locations on the same project, in several projects, or may be used, by the professional, on a

consistent basis– but each use requires at least a review of the detail, which shows the specific use and configuration.

This very same perspective is part of the task of detailing the project. From the wealth of possible details, and the variety of materials and devices available, the architect/drafter must decide on which of many scenarios is best suited to that circumstance of the project to be depicted in the detail. Many selections must be made; and decisions made to support and incorporate the selections. This all comes from insight and knowledge of the project, the intent of the detail, and how that detail empowers other work, and properly displays or contributes to the overall design concept. Other factors such as cost, availability, longevity, suitability, workability, ease of fabrication and installation, compatibility with other materials, etc. are part of the selection/decision/detailing scenario.

The following list is offered not so much as a checklist as merely a list of activities which constitute the process of establishing the need for a detail, and the start of the actual production of the detail drawing itself.

Activities Leading to Detail Production:

- Identify
- Research
- Analyze
- Assimilate
- Conclude
- Decide/Select
- Review
- Incorporate

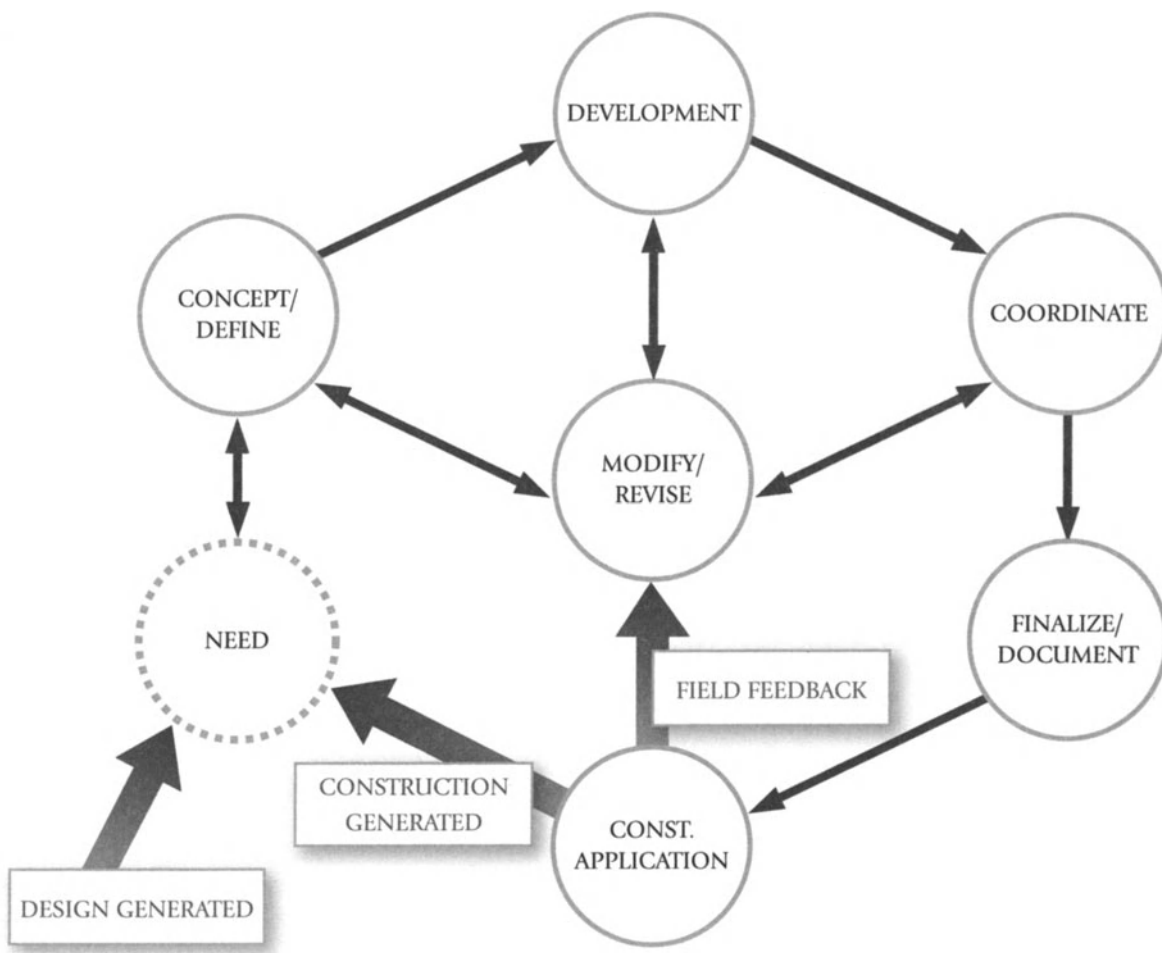

Fig. 5-8
 Chart of the whole of the detailing process as developed in the late 1960s by DeForrest Roggenbach of Smith-Hinchman and Grylls, Detroit, MI. Each pod noted has extensions and parts that further outline added information and activities– overall chart here indicates the complete interrelationship of details and how various portions contribute one to another.

Experienced personnel do much of this list mentally, quickly and without the need for some sort of recording or other documentation. Here it just sets out a logical sequence, which should bring to light the various aspects of each detailing situation. By using criteria such as this, consistently, we can better ensure the development of correct detailing methods, and a satisfactory basis for each and every detail. Certainly overall project needs and parameters are met and satisfied when there is consistency in method, and where solutions are correctly founded by combining the method with the specific [but changeable] circumstances of the project.

The list, above, is a shortcut version of a portion of a larger explanation of the detailing sequence. While this list addresses the approach to the actual detail drawing, it would be well to examine the overall program and perspective of detailing in the context of architectural working drawings. The following was developed a number of years ago, by DeForest R. Roggenbach, Director of Architecture of Smith, Hinchmann & Grylls, Associates, Inc. [now SmithGroup], in Detroit, MI. His intent was to formalize the detailing process using this chart as an index to a larger discussion. Suffice here, to note the overall cycle for the development of details and interplay and relationship of various increments, tasks, sources and information passed and exchanged. This is a time-tested process and remains quite valid, today, the only changes being in the methods that can be utilized. Certainly, several computerized operations, including CAD, have become part of this, when the program involves production of deliverable documents.

It is clearly evident, from this discussion, that detailing is a studious and careful process and not a mere "make-work", "busy-work" exercise with no real value, validity or contribution. It is both an intensive and extensive process and one that serves well when properly utilized and executed. Oddly enough little attention is paid to this effort, and there is no impetus in the educational climate toward understanding both the process and the real value of good detailing. This has directly led to further misunderstandings on the part of others who perceive the need and value to be either questionable or needlessly involved. Hence, there is always pressure and illicit suggestion that time allotted to detailing be minimized or cut short [or otherwise compromised], for the sole sake of meeting other deadlines.

Hopefully though, while not attempting to resolve the issue in total, this effort can bring some more open understanding of not only the value, but the essential need for detailing as a direct impact on projects overall. Where time is cut, or the process is "hurried" there will quite likely be a commensurate adverse effect, in the form of slowed construction [due to

questions, or lack of information], confusion, or even claims. None of these, obviously, contribute to the betterment or general welfare of any project.

It is fully understandable that any effort, like detailing, cannot be carried out unfettered by budget/time restraints. There is, though, a need to understand that where such a process is given inadequate time for the amount of work to be accomplished, there is a very good chance that there will be a commensurate reduction in the number of solutions explored/developed, the quality of the solutions, and quality in their documentation. This reduction can be checked to a degree where more experienced personnel are used— but here the cost will rise for the effort involved.

On the other hand, there is a need to eliminate the tendency to "tinker", or to attempt to create "perfect" details, by using elaborate concepts, numerous items, and intricate fashioning, shapes and relationships. Flatly, the criteria for good detailing should include the need to simplify the work [both in the detailing and in the actual execution of the work]. This requires straightforward approaches, which in turn are related to, or based on experience, and knowledge of what does and does not work. Also, the analysis of whether or not the detail faithfully supports the design concept, and contributes to its construction.

*"Good design can be ruined by poor detailing;
but poor design cannot be "saved" by good detailing".*

In far too many instances, the design and documentation efforts are misunderstood, maligned, and for all intents and purposes, demonized. It is not all that clear why this has come about, and is being perpetuated. However, facts show that management of the process and the project overall has escalated to the point that the resolution of program issues, design of the project, and proper and adequate documentation of the work has been reduced to being a necessary evil and a nuisance. Quite obviously, though, without the need for design and construction, there really is no project, per se!

No where else is this more apparent than in a review of project costs. When more than 50 % of the money allotted for a project is easily spent on management, control, costing, tracking, projections, computer time, and so forth, trouble is afoot. It is alarmingly obvious that the professional engineering work that creates the technical solution to the owner's programmed problems is reduced to far too little stature. Somehow attitudes have been changed to the point that this work is marginalized to a dangerous point. High levels of liability lie in this

work for both the professional, and the owners. If the work is poorly designed and documented the professional is at risk.

But where the owner is party to the process that created the atmosphere for hurried, cheap, and ill-performed work, the owner will suffer both for this act and for the hazards, non-compliance, etc. that may come to exit in the project itself. While not principally responsible for proper incorporation of correct work, the owner does maintain bottom-line responsibility for the propriety of the project. In the seal to get the project moving, and to have its operational at the earliest possible time, the owner contributes, heavily, to the atmosphere of the project and its production. If information flow is sporadic, where changes occur frequently, and where unreasonable demands are made, the owners adds more fuel to the highly volatile situation— some risk comes with such acts.

This is not, though, to point to a new "demon", but rather to instill the thought that the content of the documents, both drawings and specifications, is perhaps the most crucial and vital link to bringing the project to a fully successful completion. In addition, the time [and cost applied to that time] is extremely difficult to assess and assign, particularly where communications, and flow of information is intermittent, changeable, and problematic.

In the final analysis, how well the design concept is realized, in the actual construction, should be the truest measure of the success. The owner may well create an atmosphere of highly charged parameters for cost and time considerations, but even if the schedule and budget are met, but the project does not serve the operations well, the project will— quickly— be maligned and ridiculed. As time goes on, and if the project both functionally and actually continues to deteriorate, more will be the outcry about the inadequacies and the lack of proper execution of the owner's program.

Of course, the owner will always desire an "ideal" solution, where all aspects of the project are "perfect" and the number of glitches and problems is small. But currently the attitudes and approaches to projects, project atmospheres and project sequences are more imposing than productive, and projects continue to "hit the streets" in questionable form, both for bidding, and for functional occupancy. No one is seeking a blank check for the engineering effort, as all professionals well know that there are always deadlines and points where work must stop. What is being sought, and really is needed, in every project delivery system, and every Project Manager's mind, is the stark reality that to create the design of a structure to house a process [as yet undefined], and to support that process during operation takes time and effort— period. The

effort, by management, should be almost solely to facilitate the design and documentation processes, and to minimize [if not eliminate] the intrusion of the other administrative processes and procedures. This is simply recognizing that emphasis properly directed and supported can enhance the "products" developed— but can be destructive if not controlled, or if misdirected to meet the wrong agenda.

The issue being raised, here, is not one of pre-eminence or domination; it is one of a concerted and coordinated effort to facilitate construction of successful projects. Within that context, there are many "players" each with a slightly different perspective, but all of which need to have one agenda item or direction, and that is "the project!" It is often difficult to see what requires all of the administrative manipulations with projects, which now seem to overwhelm project work. What is so pervasive that non-essential [in regard to construction process] project information now has become so eminently important and has been given such credence as to become driving forces, impenetrable, and absolute, which in no way can be compromised? Without attempting to answer that question, let us simply allow that some person in the hierarchy of the project needs all of these exercises for some reason.

The issue that must be raised, though, is how, and how well project design information is developed and evolved into documentation that is complete, clear, decisive, directional, and as concise as possible consistent with clarity and completeness. This all, in turn, must be viewed as to its viability as "construction information" which is in the correct form, correct format, and in such terms as to be fully understood by the various trade workers.

DETAILING: The application of construction knowledge to the design concept [well-defined or not] by translating it into the specifics of construction, with definitive materials, systems, constructions, relationships, configurations, dimensions, and other information vital to correct project construction.

Here it must be observed that trade workers are trained to different standards and in different manners than the design professionals. This in itself cries out for the correct and proper interface between the lexicon of the professional and the "lingo", jargon, nomenclature, slang, and other terminology of the workers.

If the workers, by some outside chance are "dazzled" and overwhelmed with the eloquence of the documents, but cannot decipher and understand what is intended, the documents are

failures. The documents will be discredited [and may be discarded], and construction will either stall or prove improper if continued. Also, lack of understanding leads either to continual questioning, or to assumption. Interpolation, extrapolation, or proceeding in ways that one [the worker] thinks is correct. At this juncture, control of the project has been lost to the design professional, and could proceed on a very errant, and costly [to rectify] course. All of the latter lead to sizeable and difficult problems, almost without exception!

Clearly a prime function of the design professional is to convert concepts, needs, wishes, desires, and other programmed requirements into real objects ranging from individual pieces of material, or equipment, and formulating areas, surfaces and rooms which serve to correctly support functions of the owner. This is one documentation task that must take place. In addition, this interpretation and translation must be further transformed into another set of words, phrases, instructions, directions, and other verbal and written information which is fully functional and directly usable by the construction trade worker.

Where this multiple translation is not done, or is done in inadequate terms, the actual construction and its process and procedure will be inhibited, encumbered, and made slower and contentious. Clarity plays a major part in this, as do completeness, and correctness. This all creates the need for a major and imposing, and quite astute and professional effort—well executed in addition to being well conceived. In this, the results of this effort could be forwarded to the field personnel without all of the administrative festooning that we now use. Again, this is crass, but those administrative procedures serve one aspect of the project, but should not be permitted to intrude upon the engineering effort, which is the process fundamental to getting the project not only built, but built correctly as to form and function. The linkage is simple— the successful completion of the project, faithful to the approved design concept, is a matter of appropriate and complete documentation, including well-developed details!

A QUICK CHECKLIST FOR DETAILING

Questions to ask:

- What do I need to show at this location [the primary focus]?
- What must I include/show [to convey all pertinent information]?
- What would be "nice" for me to show [added information]?
- How much do I show [overall area of detail]?
- What is the best view to use?
- Can this be combined with other information for a better, more informative drawing?
- What should I show in the background [for reference]?
- What scale should I use for highest clarity?
- How does this relate to other surrounding details?
- Am I trying to show too much?
- What can/should I leave out?
- Is it too complex?
- Is it clear; confusing?
- What line weights are appropriate?
- What material symbols are necessary?
- What the best locations for notes/dimensions?
- What needs to be cross-referenced?

Fig. 5-9

Quick-read checklist of basic items necessary in the detailing process

THE REALITY OF DETAILING

The task of erecting a construction project is demanding— mentally and physically. But one who chooses to debate, which is more important— mental work or physical skill— is really re-viewing the chicken and egg debate. Each project is translated from a mental process into a written/drawn process during design and documentation, and then again translated into a physical exercise during construction. What can be left out?

Good detailing is the largely unseen underlying skeletal frame for the realization of all design concepts, and architecture.

Without working drawings and specifications the trade workers, and other

The building can no more be completely built without details, than it can be completely built using just the other working drawings; just the specifications or just the architectural rendering!

construction personnel would not know what and how to erect the project; the contractors would not know how to price it, and certainly the owner is of no mind to pay for "something" even if it is not what she/he wants or needs. Thus, the players and the processes of construction are intrinsically and inseparably intertwined— and the wise course is for all "players" to seek and establish an amicable, cooperative and productive project group. It is not a process focused on one entity or firm— the single focus for all parties needs to be proper and successful execution of the project work. Assi-

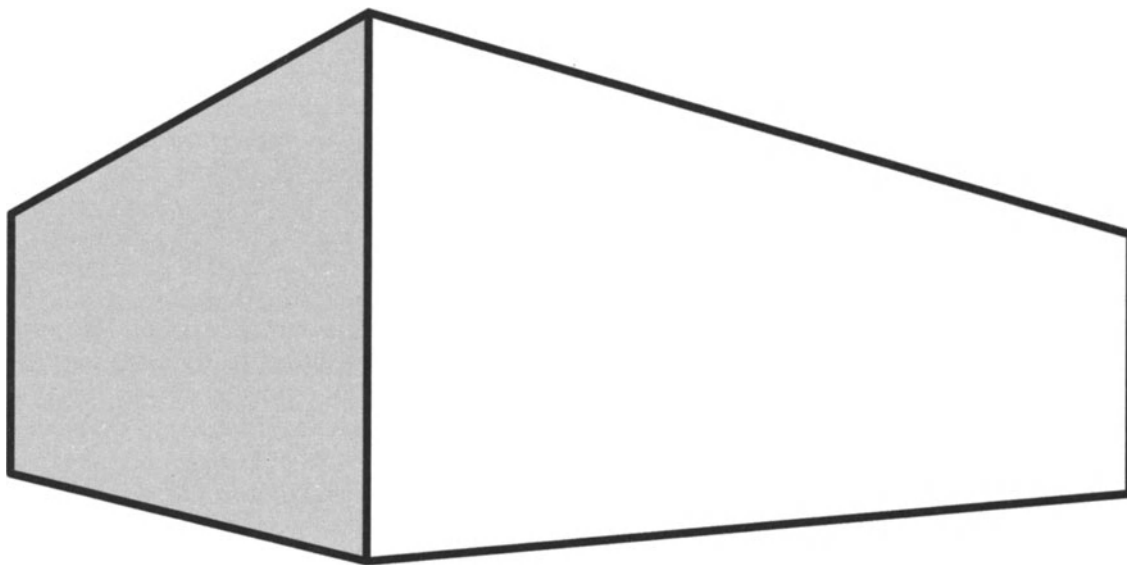

OK, now you have the drawing for the building - go build it!!

What? You need more information?

OK, make a list of what information you think you need - how many items would show up as "details"?

[Fig. 6-1]

sting and facilitating each other is not a sign of weakness, if the final result is enhanced, and made better! Construction should not be reduced to a nonsensical, competitive game of one-upmanship. Who wins in that?

Construction is NOT a competition!

To fulfill their obligation to their clients [producing successful projects] it behooves design professionals to produce quality documents that facilitate the construction operations by being fully and easily usable by the trade workers— clear! Complete! Unambiguous! Direct! Informative! Helpful!

The current workforce of trade workers still is trained in ways that are markedly different from the design professionals—and for obvious reasons. The work and perspectives of the two groups of workers has always been diverse, and there never has been any major or lasting effort to bring them closer together or coordinate them. Design professionals design; trade workers build! But their training must be brought to bear using new materials, new techniques, and new approaches for which their training may not, now, be appropriate. The professionals, though, have a greater need and opportunity to investigate, analyze, and understand the attributes of the products— trade workers need to know how to work and install the various products. There is a continuing need, then, for the documentation by the professionals to be more directed and instructional for the trade workers. To get the project work done, as required to meet the clients' needs, there must be a package of information that is, 1] correct, 2] proper, 3], coordinated, 4] timely, 5] easily understood, and 6] readily assimilated by the trade workers. Simply, how can they best do the work depicted on the documents?

If it is true that we are hired for "what we know", and not "how we do it";

How is it then, our fundamental professional responsibility is really to others who do not hire us, and have no contractual relationship to us? [i.e., contractors and trade workers]

This creates a new onus on the profession, and one it had better not ignore or minimize. Today every project puts a "team" in place to produce the project, and that team works in concert for the client— it does not include the client. Doesn't "team" indicate a need to work together, to assist and support one another, and to come together in ALL ways to produce the

"The construction team is the loosely knit, diverse group of individuals and organizations that performs the many functions necessary to bring buildings into being. Often thought of as only consisting of those who design buildings, and those who construct them, the building [construction] team is actually much more complex.....all elements, including owners, are essential in transforming a need for a building from an idea to a completed structure."

-William Dudley Hunt, Jr., FAIA
ENCYCLOPEDIA OF AMERICAN ARCHITECTURE,

final result or goal? To perpetuate a situation where documents have marginal value or create confusion and chaos is unthinkable. There must be adjustments to the true essence of "team" effort which entails both the documentation and the work effort which will produce the anticipated project.

That result or goal starts as a design concept that is approved by the client, and becomes the expectation of the client. It is then primarily a "paper exercise" which is not fully developed, and is seen mainly in preliminary sketches and drawings, and perhaps a rendering showing just some features and portions of the final project. To get to the point where you can see, and touch that project, there must be a process of documentation, and execution of those documents. The documents involved must convert and augment the preliminary information by developing it into a full-blown set of information, instructions, directions, and other parameters, which define the project and tell how it is to be built.

But yet another [and perhaps more imposing] problem continues to increase in its imposition on the projects. That is how well both the design personnel [including those who document the design concept], and the construction personnel are trained— not in management, not in scheduling, not in material ordering, not in personnel managed. But rather in pure and simple construction techniques, procedures, skills, knowledge, and expertise in understanding and adapting instructions [from the design professionals and the product manufacturers] to the specific needs and requirements of the project. Unfortunately, there are very few parallels in the instruction given to the two sets of personnel. The basic instruction, for both groups, is strongly founded in their specific perspectives. It is in no way a broadband explanation of what is to be expected of the other group, and how communication between the two must work. This fosters no cooperative understanding between the groups, and certainly does not facilitate the construction process. The more rigorous demands of the projects require solutions that often

necessitate new work directions, and doing work in new and more precise ways. Yet there is no current system that informs all parties to the project about the new demands and the increased demands on the work. This whole situation is a direct and continuing threat to smooth and correct communications between the two factions on the job site, and within the creation and use of the documents. Without due diligence, the documents can be produced in a form which inhibits quick understanding and assimilation, much less ease of construction. There is, of course, no place or opportunity to inform, and foster understanding among the trade workers about the new, increased sophistication needed in their work.

Of course, the design profession personnel are trained in how a concept [the design] is brought to fruition. This involves what must be shown or written and how those processes should be executed. The construction forces are trained in how work within their prescribed purview is to be done. The emphasis is on how to execute what is shown, whether that documentation is faulty or not [it is not their job to assess the quality or propriety of the design and detailing, but rather it is to execute and build what is shown and described]. The basic onus and liability for "correct" construction lies with the design professionals, who must constantly be aware of idealistic, dysfunctional, and "unbuildable" details or instructions in their documents. They must develop skills that utilize their knowledge to show precisely how the required construction, work, facility, unit, item, or complex is to be built. In turn, other skills are required to clearly, and completely convey the information and instructions to the trade workers in the field.

With the tremendous increase in the complexity of equipment, construction, and projects in general, there is an eminently stronger necessity for clearly knowing not only WHAT to depict and describe, but also HOW best to do that [see Figure]. Oddly enough, this assessment must involve, and be reinforced by an understanding of what is really required in the field, so the trade workers will quickly and fully understand and assimilate the written and pictorial instructions given them in the contract documents. In far too many instances, this interface is not properly acknowledged, much less properly addressed. Far too many design professionals, and their staffers do not have the background, education, training, and field-experience which one must possess to fluently communicate to the trade workers. This is not a competitive exercise; it is a matter of "design/construct team" members supporting each other in the common cause of constructing the project to the satisfaction of the client. If depicted and described correctly, and built to those terms, the project should easily meet the requirements of the owner/client.

Sequence for Design and for Development of Details	Depiction of Details and Conveyance of Information
<i>Research</i>	<i>Needs; Requirements; Problems</i>
<i>Analyze</i>	<i>Location: Limits/Area to depict</i>
<i>Assimilate</i>	<i>Choose Scale for clarity/completeness</i>
<i>Conclude</i>	<i>Good drafting/CAD Techniques; lines/notes/line work/symbols/lettering; adjust as necessary</i>
<i>Decide</i>	<i>Correlate</i>
<i>Review</i>	<i>Coordinate; contribute; fill need</i>
<i>Fit with project program</i>	<i>Label</i>
<i>Incorporate</i>	<i>Reference; Cross Reference Location in Drawing Set [set format] Re-Usable [make standard detail]; Retain</i>

What needs to be done?
How do we accomplish that end?

By far the most pervasive need for each construction project, is the conversion of concept into tangible things, items, materials, systems, procedures, directions, instructions, and information— from design to construction, Equally important is the conveyance of that information to the trade workers who are responsible for erecting, and installing the various materials, systems, items, devices, etc., required to produce the final result. That result, of course, is the building or structure that was envisioned in the originally approved design concept. It is the project that owner has contracted for and has come to expect!

Detailing is the "perspiration" that brings the inspiration [i.e., design concept] to realization!

The process of this conversion and conveyance is absolutely essential on every project— bar none! Of course, there is a good deal of variation in the amount, and depth of the information— A direct indication of the scope and comple-

xity of the project itself. Following the axiom that "specific information governs the general", the documentation of a project must be fully commensurate with the result desired/required, and which is anticipated.

The successful construction of any/every architectural or engineering projects requires that the basic idea or concept of the project configuration be realized in the final completed work.

To facilitate this, there is need to convert an idea and a preliminary design/concept into usable construction language, information and instructions.

A major part of this conversion lies in the details – augmented by other drawings and the specifications.

Inappropriate, inadequate, incomplete, and uncoordinated information will not produce a faithful execution of the concept no matter how expert the effort may be. Yet the level of completeness and the depth of the information are not things that one can capture and codify. Rather, it is a process where the design professional must call upon both training and experience to produce documents which will well serve the workers on the job site, and which will provide the basis for the correct expression of the project.

In essence, the principle of detailing is akin to the dissection of the frog in a high school biology class. There the whole item– the frog– can be studied "in detail" only if it is dissected into various parts, and then closely examined. Fundamentally, the construction project, overall, must be "dissected" [at least mentally] into a number of smaller parts, which when combined produce the project. If one starts [correctly] with a vision of the completed project, there is a need to isolate certain areas, or portions of the whole, so they can be designed, explained, and depicted and described on the document. Obviously every inch of every portion of the project will not be included, but with careful selection, and informed effort, the design professionals can engage a process called "detailing", and can provide a series of "details" regarding the construction of the project.

Construction does have the luxury to start with the whole project, but relies on mental processes whereby the design professional's staff takes the only overall concept [usually a rendering] of the project, and "builds" the project in their minds, and via the documentation. That documentation envisions and then depicts what and how the project work entails

and how it is fitted together. Basically, it is the process of dissecting the frog in reverse– starting with virtually nothing [except an idea or concept] and developing it, on paper, disk or hard drive, and transferring the contents [the information] to others. They, [the trade workers] in turn, physically build, construct, erect and install the multitude of work required to produce the finished project.

This scenario shows the vigor of the design process, and the expertise of the design professionals and their staffs. They must, first, develop the overall design concept, through a mental process that brings various elements and principles to bear on the needs wishes and desires of the client expressed in the written project program. Once this concept is fully developed, presented in laypersons terms understandable by the client, and approved, the professionals must both mentally and physically develop the various thoughts, ideas, concepts and principles into "pictures" which show how the concept should be built and fitted together.

Detailing starts not with masterful drafting skill, but with broad-based and deep construction knowledge of and ability to adapt– materials, devices, systems, methods; and use of a litany of reliable resources.

The project, at this point, enters the design development phase of work to be followed by the document production phase– the bailiwicks of detailing!

While some information is readily available [standard details, precedence from previous efforts, etc.] most details must be developed anew, and specifically for the conditions created by the new project. The mental flexibility required is obvious, when one understands that there is no large, standing pool or array of information, which the professionals can directly draw upon. Their mental faculties combined with stored experience will be triggered by the various problems, conditions and situations that must be solved for the new project. The adaptive application of their personal storehouse of construction knowledge regarding materials, systems, and construction methods, realigned to meet the new project requirements, is the crux of their professional expertise, and the primary direction of the professionals' entire direction, charge, and "reason for being".

Despite the fact that the content is as the client desires, and the intent is as we desire, the most overwhelming key to successful project documents are how easily they can be read, assimilated,

and implemented by the end-users– the trade workers building the project.

To uncover and assess the true value and appropriateness of details [even to compare versions of the same basic details] it is best to utilize a chart or outline. In this way, each attribute can be investigated, resolved, and decided upon. By treating each potential detail in exactly the same manner, one can be assured that the final decision and configuration of the detail is correct for the project condition– and correctly displayed for use by the trade workers. Each detail, and each version of the detail under consideration, needs to be measured as follows:

DETAIL ANALYSIS	
DESCRIPTION:	Brief description of need, location and other related details
LIMITATIONS OF USE:	Restrictions on application; scope/parameters/area of detail; items not addressed
DETAILING CONSIDERATIONS:	Dos, and Don'ts to be utilized, and show basic intent of detail
COORDINATION REQUIRED:	Location[s] for use; prohibitions, "watch-outs", pit falls, care to be taken
LIKELY FAILURE POINTS:	Reasonable expected results if certain things are done, or which detail cannot resolve; try to expose anticipated adverse consequences
MATERIALS:	List type, composition, strength, standard, finishes for each material in detail; A. B. C.
EXECUTION:	Direction to be followed both in detailing and in "call-out" notes for trade workers [exactly "how" to do the work shown]; can be done using groups of materials to illustrate their interfaces and relationships.

Simplistically, detailing can be defined as series of related glimpses, vignettes, or snapshots, of a proposed project, taken somewhat in isolation [one to another], and showing limited areas of work. In architecture and construction, of course, these would show selected portions of the proposed construction. In fact, this process is very much like the childhood workbooks of "dot-to-dot" exercises. Both in the workbooks and in architectural work, a hidden "object" is revealed as you connect the numbered dots laid out on the page.

Of course, the "objects" are known beforehand, but were reduced/translated into a series of dots placed at crucial positions along the outline of the object. The parallel is very close in architecture and construction. The project exists [at the time of detailing] only as preliminary plans and elevations, or perhaps just concepts, ideas, and visions in the mind's eye– perhaps as rough sketches, or an "artist's" rendering". In any event the entirety of the project is not shown or revealed– the drafter must develop the "views" of the project through production of the complete and detailed working drawings. Even then the working drawings are two-dimensional, for the most part, and are devoid of the distortion, or illusion of perspective [which is really the way the human eye sees]

Detailing:

- *Divide whole project into small, non-repetitive parts; joints, typical work, layered work, new/unusual configurations*
- *Decide need, and function of each part*
- *Decide on "pattern" to be utilized*
- *Research possible systems/ materials/ devices that, when combined, will produce the chosen pattern*
- *Study/sketch variety of possible solutions*
- *Decide which solution works best, for each part?; if work fulfills need*
- *Fully depict and describe work within parts based on final analysis of sketches*
- *Relate parts one to another*
- *Is there enough information that YOU could build the part in question?*

Architectural detailing begins with a need, or a desire to show some limited portions of the construction. The "need" is an educated perception that some explanation or graphic elaboration is necessary, or that some direction or clarity is required, so the design professional can ensure that the work will be clear, and readily executable by the trade workers, on-site, as necessary or appropriate.

In some cases the "need" is created separately from the design concept or the required configuration of the work. For example, the "need" to keep water from entering a wall at the jamb of a window. This "need" has nothing to do with the type of wall or windows, the shape, or the aesthetic appearance. The "need" lies beyond these as a fundamental premise or principal if you will, that lies within the realm of satisfactory and proper construction that will, ultimately, meet the owner's approval, and create no problems. Many such detailing needs come from the mind and expertise of experienced professional who are aware of the crucial aspects of building construction [without regard to a specific project].

In other instances, the perceived need for a detail is the belief that some direction or exact configuration is desired. This, of course, could be part of "keeping water out of the building" applied in some creative manner, as a portion of the work which must have a certain prescribed "look", shape or function, which is generally other than what one would normally expect. Note that the detail, here, is not as an assessment of the propriety of the work, but rather is a depiction of what is intended, desired, or required.

The detail drawings should be carefully and strategically selected much like the "dots" – at crucial junctures, changes in plane, changes in material, edges, or other locations of physical features or changes in the work. The architectural "dots" are connected by recurring work [continuous wall of masonry, other features of a wall section], which need not be shown. Typically the "connecting work" is quite redundant and nothing is added to the clarity or totality of the information for the project if the work is shown in its entirety.

This is the true crux of detailing! Starting with recognizing the need, how the need can be resolved, and how that resolution must be adapted, fitted into, and made to reflect the design concept requirements are the basic foundation of detailing.

While it is easy to see and understand the need for the design professional to convert information into a form usable by the trade workers and contractors, there are other considerations within that conversion process. These occur beyond the mere need for changing the type and format of the information.

Communications in the construction process are critical and vitally important to project success – and the success of every party to the project. The flow of information needs to be established early and must continue, unabated, on a continual and meaningful level. In the main the process starts with that person who develops the information, and acts in the role of the primary contact between design professional and

contractor[s]. A person who knows not only what to send, and in what form, but also, to whom the "message; should be directed [usually there is no direct communication between trade worker and professional]; a contractor's manager or superintendent is the intermediate who receives the message. This person, at the level of working drawings and specifications, is usually a person who is well versed in the technical aspects of the project – Project Architect, Lead Architect, etc. This places a tremendous onus on the professional's staff. There must be awareness of the type of information needed in the field, and the form it should be in.

Obviously, to achieve a successful communication, an experienced person needs to oversee the process of the documentation, so it satisfies the basic need, from the outset. Only a person knowledgeable of the field operation, perhaps even with construction experience in the background, needs to guide the thrust of the documents – both drawings and specifications. It is far more crucial for the drawings, since they are used by all hands in the field; the "specs" normally stay with supervisory and management personnel. Projects architects, Discipline Leads, Associate Architects, and experienced [not just trained persons with little if any field experience] drafters are vital to this effort, and must be dedicated to this singular task from start to finish – the process is that rigorous and important. The task revolves around both the correct expression of the information, and the vast amount of information that must be processed.

How does one successfully transmit a large volume of information in a correct manner? Two elements are key. First, the information transmitted should be reduced to the lowest quantity necessary to make the point or communicate the idea. Saying too much [or in the case of drawings, showing too much] leads directly to confusion, and a breakdown of the message to be communicated. One must apply a strict discipline to include "enough, but not too much" information – what is essential to the trade worker, and what is not?

Superfluous information does absolutely no good, and can do damage to the communication. If the trade worker cannot understand the lines shown, how is she/he to assimilate the drawing to the work required? Why show items or information which is so mundane and innocuous as to be needless and useless? There is no need to show the prowess of the detailer or designer, nor the in-depth knowledge being applied – show just what you want done, clearly, directly, and SIMPLY! Every detail needs the application of detailing techniques to shift down and remove the drafting "chaff", or unnecessary lines, and words Clarity and direct-reading are qualities valued in the working drawings and details.

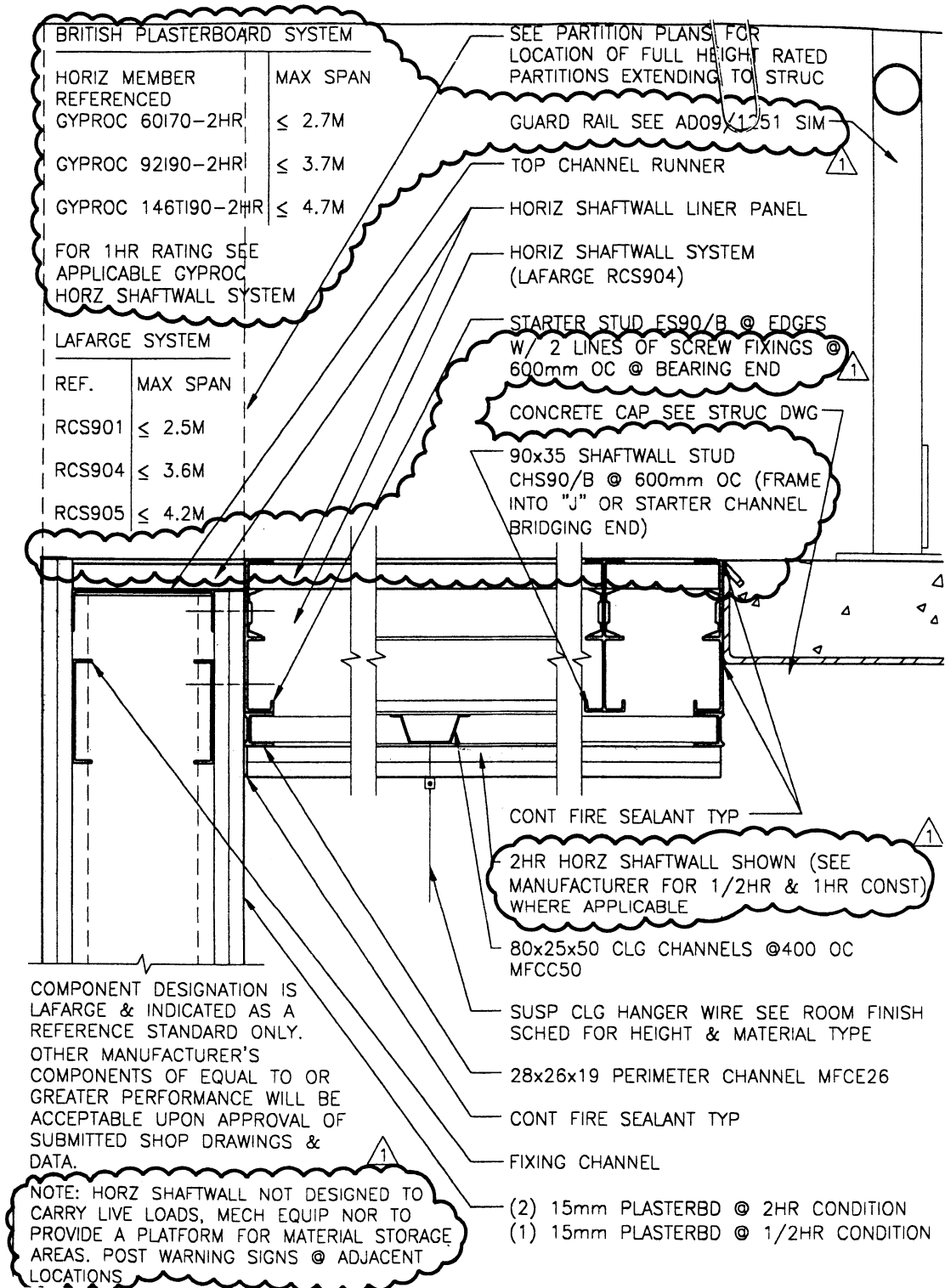

Fig. 6-2

Example of a detail that contains too much information.

Much of the text is improper and better located in the specifications to relieve the congestion around the graphic detail

CHECKLIST OF DETAILING TECHNIQUES

1. Analysis/Selection: Carefully analysis and keep track of locations/situations/ conditions which readily appear to require further explanation via detailing. Also, recognize that literally hundreds of details may be involved, and the list will expand when more information becomes available, and when more systems are shown in the project.
2. Set the context: Following selection of the location requiring a detail, set out the surrounding conditions [new and existing] of that location as a backdrop and base of reference for the new detail
3. Judicious separation of information: Use the strictest of discipline in what information to show on the detail, and what to delegate to the specifications; verbose notes do not "play" well in the field, and they often create confusion, when they include information which is superfluous to the trade worker.
4. Objective pruning: In a strict, objective manner, remove all line work which does not directly contribute to or help explain the detail; base information, set out in 1. above needs to remain, but additional information in that category does not [example, a column line is helpful, but the "column beyond" shown with 4 dotted lines is not]
5. Variable line weights: Plan to vary the weight of lines on purpose; follow a principle or system in all cases; be uniform. This is a tremendous aid to readability in drawings.
6. Piece-by-piece, and Total Fit: Ensure that each element or piece in the detail is correctly sized and shaped to fit as it should and to perform the task you plan for its; ensure adequate space for fasteners. Also, ensure that the detail as a whole, is correctly fitted into the base conditions and to other new work.
7. Reduction Simplification: Always look for opportunities to reduce and simplify both the pieces within the details, and the need for additional details [will another detail, already developed serve here?] Maintain and show the crux of the detail without surrounding "enhancements"

Fig. 6-3

Quick list summarizing detailing techniques

Words are the second key element. Here too a very strict discipline is required, in that information must be separated, and located in the MOST ADVANTAGEOUS place or document. In the zeal to produce "good details" the inexperienced staffer

Construction communications are necessarily complex [as each project requires]; thus, the communication of information must be finite, clear and complete, primarily accomplished by using graphic and written means—

GRAPHICS = DETAILS

WRITTEN = SPECIFICATIONS

usually jumps to the conclusion that "more is better". Not necessarily true! Certainly the drawings and the specifications need to be interrelated, cross-referenced and mutually supportive. This does not mean though that they must be duplicates, or that one is to be loaded with information, while the other is information-starved, and so anemic as to be ineffective. Not at all!

There needs to be a balance in the amount and format of information. As the chart shows, the best criteria to follow are the type or category of information and its proper location. The tendency, too often among young and older professionals, is to place too much information on the drawings. Often a good deal of this information is of no value to the workers, although it is useable by their managers. Often too information is placed on the drawings which has no direct field application, and only serves to confuse workers, and delay work during a RFI [Request for Information] sequence— i.e., "What does this mean?" This tendency is reinforced to some degree in that simpler buildings and houses in particular, use documents which are combination of specs and drawings. No formal Project Manual [specifications] is produced as a separate entity. In many instances this works, but extreme care must be taken that this technique is not utilized where the project is more complex, and the issue of clarity is pre-eminent.

In a large sense, information should be located where it is best applied. This applies to the location of the notations in relation to the detail itself, as well as the selection of the content of the detail. That is to say that notes should be located so there is no need for long, complex and numerous leader lines from the notes to the material or construction depicted. Such added line work is distracting and often leads to illegible drawings [i.e., so full of "linear spaghetti" that the actual drawing is hard to decipher]. Selection of the detail or details

Location of Construction Contract Information

SPECIFICATIONS

- Legalities; conditions
- General requirements
- Contractual obligations
- Project-wide parameters
- Written product data, selection, accessories installation instructions
- Required results of construction
- Type; materials, system equipment
- Quality; materials, products, manufactured equipment
- Results; fabrication, installation, erection
- Quality; workmanship
- Allowances, unit prices
- Alternates, options
- Regulatory requirements
- Reference standards rules, ordinances
- Submittal requirements
- Instructions; directions
- Warranties

WORKING DRAWINGS

- Project location
- Relationship to site/lot, surrounding properties
- Site features; utilities, natural, man-made
- Graphic representation of work required
- Extent, size, configuration of project
- Basis for quantities
- Work locations, dimensions; details
- Interrelationships
- Door, window, room finish, hardware, lintel and other schedules, etc.
- Equipment/fixture sizes, and locations
- Extent of alternatives
- Schematics; building services systems [MEP, etc.]
- Connections; various types, locations, materials

Fig. 6-4

Important chart showing placement of construction information in drawings and specifications, based on what can be drawn [better shown graphically] and what requires a write-up [non-graphic presentation] cannot be drawn

needs to be judicious so too much area is not covered, leading to extended leader lines or a number greater than necessary to make the point.

In addition, some things are more easily depicted than described, and vice versa. Why use voluminous notes to describe something that is easily shown? And certainly why fail to make the point by trying to draw something that is far more easily described [even if it takes sizeable notations]? Space on drawings is often strictly limited, and added information only serves to crowd the sheets and drawings and increase the chance for reduced clarity and confusion. While not advocating specifications in the thousands of pages, a lot of the work and its attributes are much more easily described than drawn,

and a good deal cannot be depicted at all. Of course, another good analysis for placement of information is, "who needs to know what?"

The significance of the foregoing cannot be lost on the drafter at any level of expertise. The basic configuration of the details is of important, both for proper construction and for communication. The leaders of projects do not all necessarily know every minute detail of the drawings [including the details] and rely on the expertise and conscientious efforts of their drafters. Obviously, this alludes to dedication, construction knowledge, the asking of questions, and ensuring that whatever is done is done well, in light of the impact on the project—from correct application and construction to costs.

It's not the creativity, the innovation, the clever mode of depiction, or other variables that count as the key point in detailing— it is the clear communication of valid, accurate, informative and useable information to the end users.

The recipient of the communication needs to be understood, as well as the message. That person acts individually on the information received, or relays/ distributes the pertinent information to others [one or more persons], and perhaps to files, notes or archives. While the message need not be changed, its final disposition is important, and it may be necessary to state that in the communication— i.e., what is to be done with the information and not necessarily leaving that decision to the recipient. Part of the responsibility here is to ensure that ALL of the personnel concerned with the message are informed,

and kept current on the communications. Too often pertinent communications are directed to the contractor's office and managers, and do not "find their way" into the field. Changes in the work, for example, are crucial to field operations. Of course, the initial distribution of contract documents are sent to the field for direct use, keeping of record drawings— and including a set of documents approved by the local governmental agency responsible for code administration [this is the set to which all subsequent work must comply].

While this sounds relatively easy and reasonable, there is another and most crucial element in this process. That is to ensure that the message and information is in such form that it is, 1] fully and correctly understood by the recipient, and 2] is something the recipient [and perhaps others] is expecting, needs, or is required to take action on. In this, the

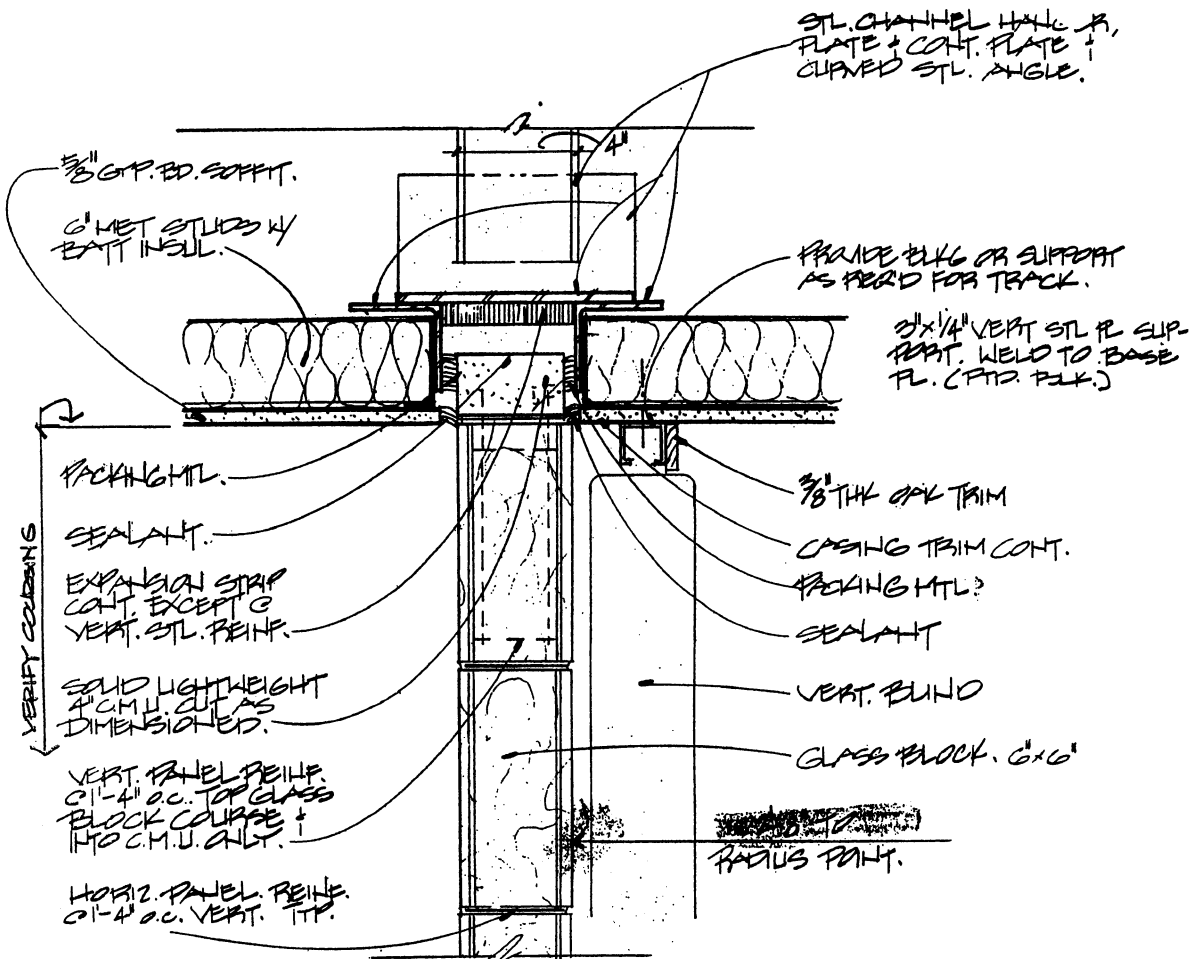

Fig. 6-5A

Above and following details that have a distractive nature due to the number of long and convoluted leader lines from the notes to the points of application in the graphic. A situation to be avoided.

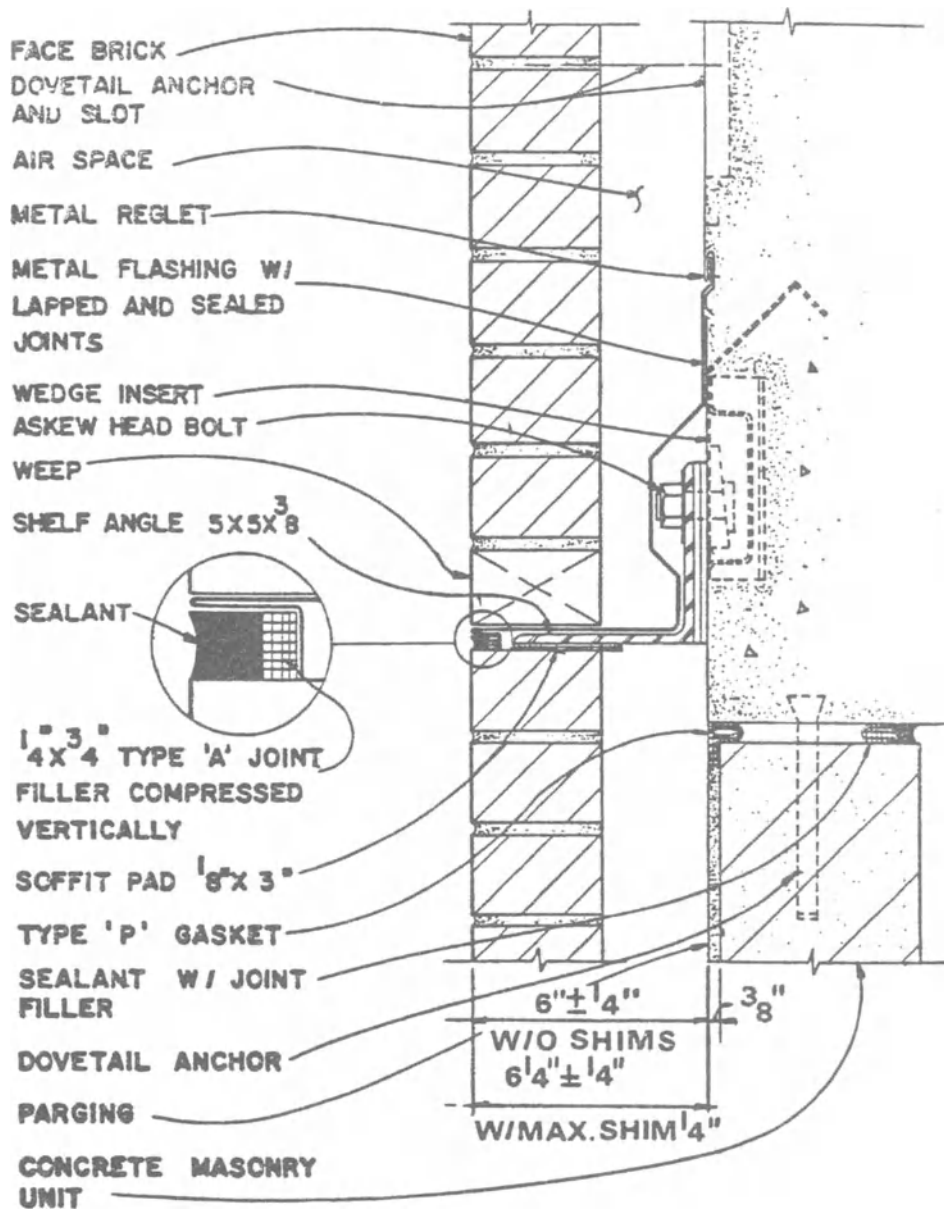

Fig. 6-5B

The most difficult task is not documenting a project, but in placing oneself in the place of those who must subsequently read, understand, and use the documents in order to correctly execute the work.

understanding is critically important. Simply, the message recipient must know what is being "talked about", what importance it has to the project work and who else needs the information, or parts of it. Too often, as seen on many court programs on television, the information received is given a personal interpretation or assumption when the information is processed. If these are erroneous [as they often are] they can directly void, change or cause confusion as to the real intent of the message.

It is so very easy for two parties to be talking about the same item or situation, but talking within their own perspective and not in synch with each other. This constitutes the lack of "the meeting of the minds" – i.e., both parties understanding and talking about the identical aspects of the same thing. Therefore, the mutuality of the understanding– the mere fact that both parties, sender and recipient are "on the same page", is crucial in all communications; often being on the same page is not enough– we need to be on the same "line" and "word". This lack of mutuality is a natural factor of the human, without taking into account the game-playing, where words are re-defined or true meaning is manipulated to avoid facing the facts. If there is no truly mutual understanding of the information, the communication has failed.

Quite often, even in school situation, the message sender [a professor or teacher, perhaps] knows well the information being transmitted. The problem comes from the fact that the recipient[s] [students?] has no idea what is being talked about, or how they are to utilize it. Hence, in this as well as in other communications– including in construction– we must ensure that we formulate our communications in terms fully and completely understood by the recipient we are addressing, and that that person knows what to do with the information received.

This, very pointedly, shows the need for the conversion of client/architect programming information, and subsequent conceptual design information, into "construction" lingo, jargon, nomenclature, lexicon, and terms. There is a very imposing element in this, in that the rhetoric of architecture, the theory of design, and the general demeanor of architects are quite different from that of the construction trade workers. In this discussion, the design professional both sends the information, and is the party responsible for correct construction of the

approved design concept. The professional, then, has an absolute mandate to create documents, and other communications, to the field personnel, in their vernacular! To do otherwise, runs the distinct risk of providing information which will be deemed useless [and perhaps will be discarded] simply because the tone, wording or message just doesn't seem to fit the needs and conditions, on-site. To provide the client/owner with a "bad" or marginal project directly due to lack of adequate communication is unforgivable, and certainly can be the source of nasty litigation.

The design professional plays a pivotal role in this. It is only the professional who can interface with and fully understand the extremes of the project spectrum and the nuances attributed to both. One end is the client who talks about a certain list of items. The other is the trade workers and contractors who talk about their list of items, the vast majority of which are not even indicated in the client's list. This is a chasm that requires bridging– bridging created by the professional, who needs the skill to take the "talking points" on one end of the spectrum, and convert them into "talking points" meaningful to those on the opposite end.

Specific to detailing, the communication aspect requires due attention when a particular need or piece of construction is conceived and needs depiction. It is at this juncture where the actual conversion of information takes place. Remember the

ACROSS THE SPECTRUM!

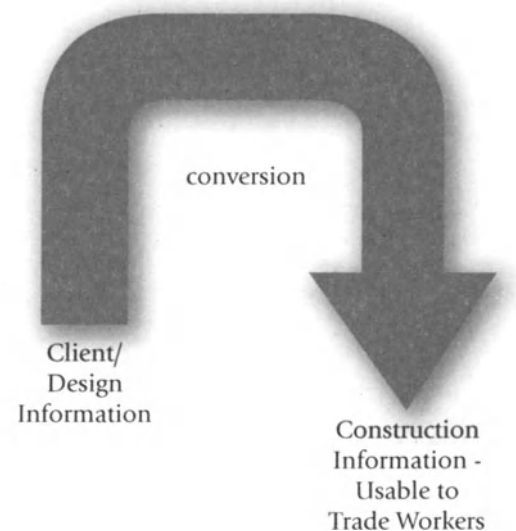

Fig. 6-6

Graphic showing how transfer of information crosses across the spectrum of the project work

ultimate use of the drawing is by the trade worker and hence it must be done in the vernacular of the field personnel. This need not include the slang, or misnomers so rampant in the field, but does include the correct identifications, instructions and directions.

In many instances, the standard material produced by the manufacturer will be received by, and fabricated, or re-formed by the subcontractor or supplier, in their shop, or more frequently in the field, on the job site. In order to produce the correct work required for the project, the supplier or subcontractor is required to produce submittals such as shop drawings for the review of the design professional. Basically, this is an exchange of information— details, if you will— to ensure that the work proposed to be provided indeed meets the requirements of the project design. There is a strong element of accuracy in all of these details. This includes correct portrayal of the surrounding conditions— existing or proposed. Then application of a correct – proper and accurate – solution to the problem or condition. Inaccuracy in either will lead to further problems either during construction or later. This is basic failure of the detailing.

The learned knack of "stopping" is something one must learn and come to understand, since going too far may confuse, will add unnecessary cost (by requiring extraordinary understanding, change of procedure, and/or effort), and will also increase the liability of the professional. The more that is shown, the greater the risk to the professional; where such "showing" is faulty, the professional will find added responsibility and need for remedy on his/her part.

Trade workers, in the main, are trained and taught to perform their specific work. No purposeful contracting firm will risk the "cost" of ineffective and poor workmanship by its personnel. Too often workers are made into "do-it-all's", whereby they are told to perform varying tasks from day to day, often outside their basic expertise. Of course, many persons can perform a multitude of tasks, but not necessarily up to the standards required on a construction site. The more of this that occurs the greater the risk involved (for the contractor) and the greater the need for accurate detailing (control!) by the professional.

In larger communities, however, the trades are rather distinctly defined, and workers work only within their expertise and prescribed duties. Here, then, they know the correct methods to be employed to produce quality and proper work, and will usually be supervised by competent persons who are knowledgeable and experienced in the work. Also, they know where and when to seek help, if necessary. No contractor or his /her superintendent will ever try to do more than required; some

will try to do less. For the most part, though, they will perform as required by contract, as this is in their best interest, overall. In much this same context, the design professionals' personnel must also work within their expertise. They should not seek to control the project by detailing to such a finite degree that the project is stifled, progress is impaired, costs are inflated, and the project imperiled in other ways.

There is no need, for example, for any architectural drawing to depict the minutia of the project by showing door knobs, hinges, pulls, fasteners, decorative features, etc., except where some very specific requirement or circumstance is involved. Then only general depiction is required, not detailed drawings of the fitting(s). Many construction items and devices are standard units, commonly used, widely understood and require little if any "new" information. The trade workers, through their training, are fully aware of, and perform the necessary tasks without any deep involvement of the contract documents, much less the details. Finish hardware for doors [hinges, locksets, closers, etc.] falls into this category. Therefore, there is no need to include them in any details.

The best of carefully conceived and well-executed graphic details, to be fully successful, need to support the design concept; but also must be accompanied and supported by appropriate and informative notations, all fully understandable by, communicated to and directly useful to the trade workers building the project.

Correct or proper detailing is not so much the showing of everything as it is the showing of the essential elements of the construction. Most professionals acknowledge and respect the expertise of the contractors' personnel, and use this as the line of departure, i.e., the juncture at which further detailing can be suspended. The contractor must be permitted the opportunity to incorporate her/his expertise [and contractual obligation], methods, means, and procedures into the work. Hence, the size, placement, and proper installation of every item is not involved on the professional's part.

Quite often the contractor will use methods of construction/ installation which are not what the professional envisioned. However, this does not necessarily make them wrong, per se, but simply another way of doing things. More often than not, these methods are equal to, or even superior to those the professional might use or anticipate; there are many ways, usually, to solve any given situation. However, where the professional feels that a distinct and specific methodology is required, this needs to be conveyed to the contractor, i.e., detailed! This

PROGRESSION OF INFORMATION FOR A PROJECT

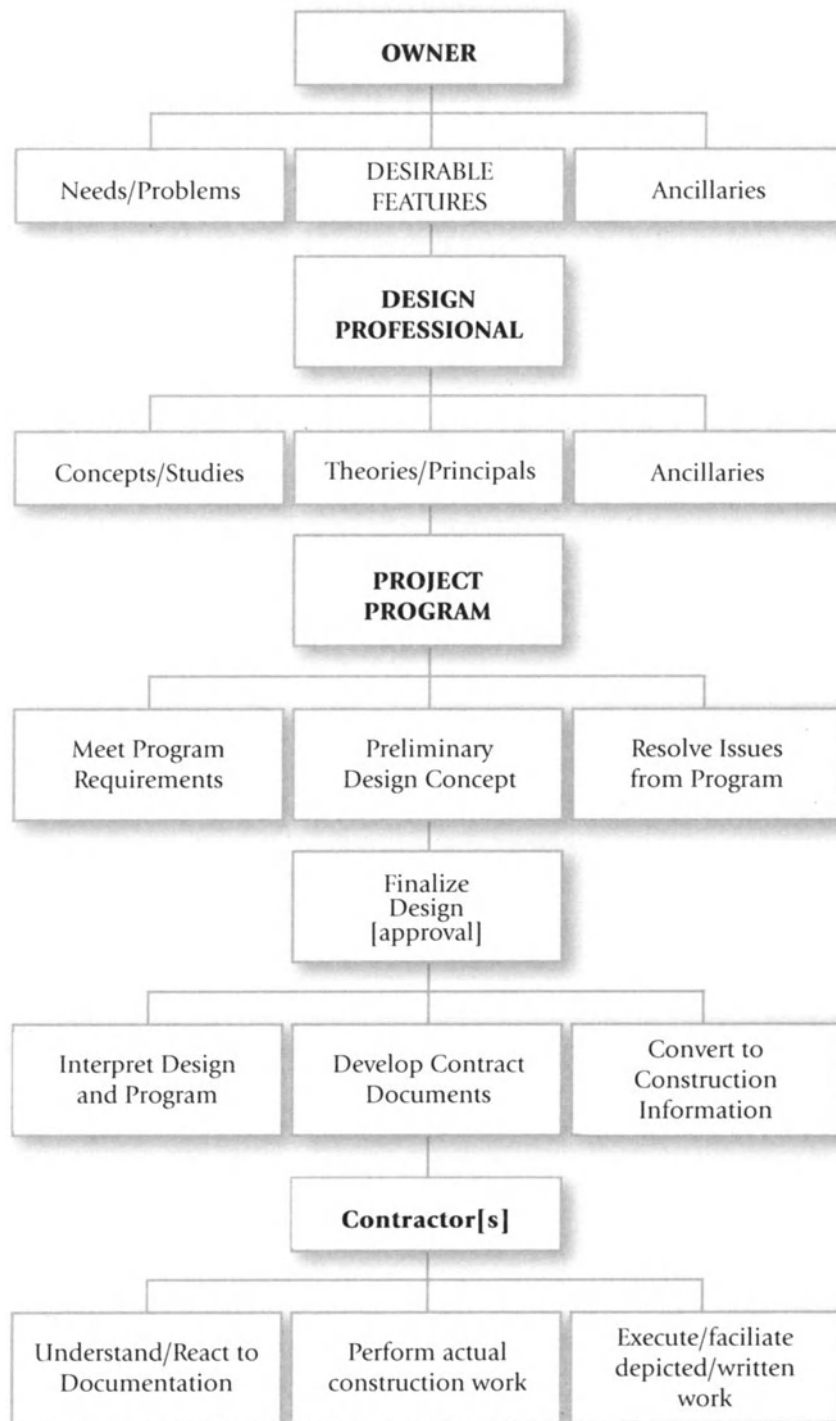

Fig. 6-7
Chart showing progress of information throughout the project sequence

interplay is not, and should not be perceived as the professional "giving up" authority or control, but rather as the meshing of the expertise of professional and contractor to the benefit of the client's project. With the vast number of materials, systems, devices, equipment, apparatus, etc., on the market for construction use, this combining of expertise is really crucial to a successful project. Usually it will produce the best possible solution.

There is also an interplay between the professional and the manufacturer of the material, system or device. This is usually played out through the manufacturers' representatives or sales personnel, and the time, literature, and knowledge that is given the professional regarding a specific product and its use on the project. While such sources as manufacturers' web sites, technical binders, and product catalogs provide a passive array of information, often a product will entail a number of installation possibilities. These all may be valid and correct, but usually are not universal (for every installation); in the main there is one, good and proper method for the condition under consideration. There may be a need to seek this out through personal contact. Here the professional must seek out this information, assess its impact on the project, adjust where necessary/ advisable, and then proceed to detail the installation in a method deemed to be "correct", in the view of the professional. This is the point at which the professional's expertise and experience come into balance with the liability risk. Also, this is the point at which the professional engages the prevailing standard of care; "Is this the right thing to do? Is this what the prudent person would do?"

Detailing is really a three-tier process. The product manufacturers issue details and detailed information, which illustrates the application of their products, as they envision and intend them. Each manufacturer obviously has established some direction, or has seen some need that the product is intended to fill—without this there would be no reason to produce the material or item. However, the material is usually produced in a form which is set by production methods, machinery type or capacity, or other criteria of manufacture. Or the products are made in such a form that makes them easily adapted to the range of normal construction [for example, plywood, siding and similar products in a basic 4-foot by 8-foot form]. These all can be considered as "standard" products, indicating that they are normally sold in the configuration noted; their adaptation is left to the design professional and the contractors.

The three-tier detail process is a matter of refining the details, and narrowing their focus and configuration so they fit and serve the project as shown and required on the contract documents [both drawings and specifications].

"Over-detailing": Needless and Dangerous

In many cases, excessive or "over-detailing" comes directly out of the three-tier process.

But this is a common malady that often presents unnecessary problems, and elevates the liability of the design professional. It is something to be avoided through a conscientious effort and insight by all parties involved.

Just as correct process and a distinct "plan" are necessary at the initiation of detailing [including answering the 6 basic questions], there is also need for a plan for ending or stopping not only the detailing process as a whole, but also in developing each individual detail. This is a vital element that must be learned to the point that it is an automatic reaction or feeling, and not something that is listed, categorized, quantified, or otherwise set forth by rule or checklist. For all intents and purposes, it is a self-imposed discipline, based on experience with successful and unsuccessful project details. It needs to be

"THINGS" THAT WILL MAKE A DETAIL FAIL!

1. Lacks precision
2. Lacks readability; unclear; confusing
3. Inappropriate scale
4. Inaccurate
5. Wrong or mixed patterns that do not support each other
6. Unbuildable; calls for "extraordinary work or new work process
7. Not true to or supportive of design concept
8. Wrong choice of materials; inappropriate; not compatible
9. Shows too much [area or elements of work; "over-detailing"]
10. Lacks information; dimensions, notes
11. Conflicts with other information or details
12. Includes voluminous/"specification" notations
13. Poor line work; separation; line weighs; distinctive/designated
14. Lacks cross-reference/coordination with other drawings
15. CARELESSNESS!!!! in concept or execution

Fig. 6-8

Quick list of things that can cause details to miss their target or otherwise go astray and fail to communicate

a strict, and strongly held discipline, and one that simply cannot tolerate vacillation, or indecision. Of course, the fundamental basis is the knowledge of what REALLY is needed, and what is not; where information should be located, and where it should not; and understanding that the axiom of "more is better" is not universally positive.

The individual drafter must take personal responsibility for learning this point where detailing is stopped. While the strict limits may vary from project to project, there is still a close proximity to the details. One must discard the idea and direction that "the more you do and the more you show, the better the detail will be". This is not the place for expression of personal skill, overzealous effort, or simply "doing everything possible". Keep in mind that the drawings and details are essentially schematic in concept, showing principles, shapes, devices and such, but without the unnecessary time and effort to show even nuance— the threads on screws and bolts; the heads on nails [even if a nailing pattern is required, usually some designator like a small "x" is used to show the nail centers, in lieu of each nail head drawn to scale]. A single line or centerline can and is used to denote a fastener [that can be of various types, but identified by note or specification]. A manufactured product need not be detailed— it is and comes to the project as a unit. A simple "box" on a drawing can depict a mass piece of mechanical equipment for example and its details are in the manufacturer's shop drawings, not the architects' design drawings.

Nowhere is there any professional principal, contract obligation, or other requirement for the project detailing to be meticulously all-inclusive, containing every possible piece of information that could be associated to the detail drawing. Attempting this runs the risk of creating details that outside the main stream and confusing to field personnel who are used to seeing more simplified drawings. Of course, the standing direction to all staffers, for detailing, is to be accurate [in both new and existing work and conditions shown], careful, true-to-scale, and complete. The "bar of excellence", however, is not set to exhaustive, meticulous, finite, or "excruciating".

Indeed, it is reasonable to expect that detailing will include a proper degree of understanding of the knowledge, skill and ability of the trade workers who will use the drawings, their overall expertise, and indeed, the axiom that "construction is an imperfect science, at best!" No set of working drawings has ever been perfect, and chances are very good that there never will be such. No design professional or contractor will ever sign a contract that requires "perfect performance" on their part. Certainly seeking to be perfect cannot be faulted, but human foibles do exist, and we must all be tolerant of them. In addition, there is a distinct cost [in time and dollars] when we

cross the line by showing too much, and too finite construction. There is absolutely no need or value in creating a whole new sub-culture of standards, techniques, materials, devices, or construction methods in our details.

As with any work there is an element of failure that is constantly present— so too with detailing. Obviously, each detail needs to be proper within itself, meeting criteria

There is a direct link between project success and detailing, in that failure in the smallest of details, can wreak havoc on the project, and tarnish the design concept in a most devastating and diminishing manner.

of what it is to achieve in the project construction. It would seem that meeting that requirement avoids failure. But the primary concern is to be fully aware of what may cause failure in the detail work. To know this allows us to avoid the pitfalls, and renews our effort to provide the best possible work. In this there is a need to be mindful of what contributes to failed details. Of course, the causes, with the details themselves, can be many and quite varied, but the more common faults are those repeated far too often.

Added to this is the failure to properly incorporate and coordinate a good detail in the appropriate location[s] in the construction, and tied to other pertinent information.

Cross-referencing in detailing is vital to the correct application of the details in their correct locations in the actual project work; without it, the value of the details is lost, and the work is confused and impaired.

Every detail must have at least one application in the project work or there is no need to include it at all. Most details will have a single use or location, but quite often a detail will apply in numerous locations, or in large areas of work [walls for example] in which case they can be called "typical" to indicate the use throughout the expanse of the work [the wall for example], or in each location noted on the floor plans or other more general drawings. Also, many details need to be cross-referenced to another or several details to augment them or to clarify the combination of the two details.

Hence the ominous onus of detail failure within the documentation takes on several aspects— all to be minimized, if not avoided. In addition, there are other points of possible failure.

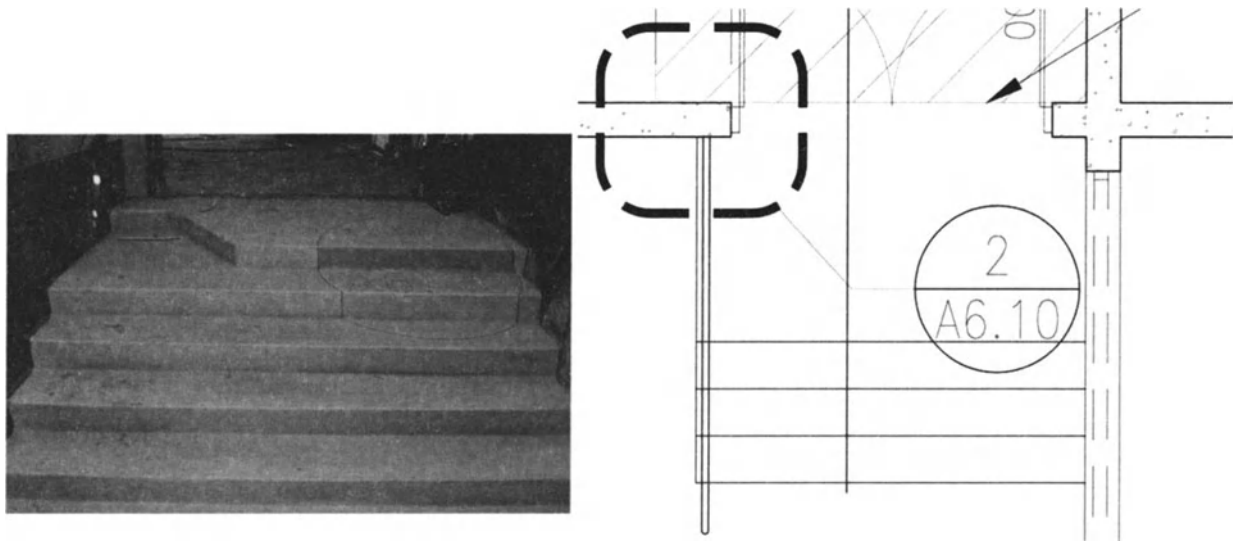

Fig. 6-9

A detail that misses. Note that the line connecting circle designator to detail area [in dotted lines] is mistaken by contractor and causes the installation of an unneeded stair riser and platform

In a parallel regard to reduce detail failure, Professor George Elvin, PhD [University of Illinois at Urbana- Champaign] has done extensive research on “wearable computers”. Not that these devices will forestall failure in detailing, but his comments are important:

“The construction industry has yet to solve the problem of communication at the point of production on site, and many experts suggest that this is the principal cause of the management inefficiencies costing the United States tens of billions of dollars a year.

Large-format paper documents are almost unusable at the point of work because of their volume, fragility, and in concurrent design and construction, the likelihood that project information they contain is out of date ... recent emerging innovations in personal compute ring hold considerable hope for improving communication at the point of work on site ... Wearable computers ... may potentially overcome many of the obstacles that have hindered on-site information exchange needed to complete a task without ever leaving the point of work”

Since Professor Elvin’s paper, of course, the electronics and computerization have taken giant leaps forward. Although not commonplace or widely used, at this point, the prospect for “on-person” computer terminals is far closer to reality than to futuristic thoughts. This was substantiated and reinforced in “Current Issues Surrounding the Quality of Construction Documents” [2003], a thesis by Jody L. Keniston. The conclusion is that construction communications will be enhanced by the increased and more prevalent use of

electronics, in both offices and on the job sites. This is similar to such devices are common in emergency medical care and similar tasks, but some adaptation is still required for their use in construction.

With younger trade worker being so familiar with computers, there is a likelihood of a minimum learning curve for implementation of the units. Interoperability may pose a greater problem where hardware and software between the various construction parties may be incompatible. In addition, wider use of wearable computers in construction may well modify the criteria for detailing, to facilitate quick, easy and direct reading on the devices.

But the indisputable fact remains that, oddly enough electronics notwithstanding, risk, liability and failure still lie not only in proper communications, lack of readability, and poor quality of document content [ample and appropriate construction knowledge skillfully and well depicted] Also, in doing things incorrectly but also in not doing enough, and curiously enough, in doing too much! The inability to discern and recognize when termination of effort is appropriate in detailing– a highly valued attribute.

Two primary aspects are involved in the termination of the detailing [on a drawing by drawing basis]. First is the need to understand that there is no single solution for each situation. It is possible that work shown in a single detail could be detailed in several dozen different ways– all valid, but somehow just not bought to the mind of the drafter at the moment– perhaps just not the right fit for the project.

In an era when catch phrases have become a way of life, we must acknowledge that one very imposing word is now a major part of the architecture and construction lexicon. That word is "constructibility". While it is not found in the normal array of dictionaries, the word has developed into a major factor regarding construction, and actually is a valid consideration from the design phase of work forward.

Constructibility: 1] the ability to be constructed; 2] in-depth analysis of proposed construction to ascertain "best" way [among many available] to proceed, most cost effective methods, and ease with which work can be done.

Simply, is the work required to produce the project "buildable" [or i.e. constructable] – can it be performed relatively easily, and with good cost-effective implications? One of the major side issues in this, is the fact that there are many solutions to any one problem, and the matter of "constructibility" could well be the deciding factor in which solution is used.

Trade workers, and the construction industry as a whole, take great pride in the fact that they [collectively] can build anything, given opportunity and enough money. Often there is need for very innovative and unique techniques, research for new, better and more appropriate materials and systems, and cutting edge intelligence and daring to achieve the goals required. Construction, as a whole, has been highly successful in this, and has been supported by a manufacturing sector, worldwide, which has the wherewithal to provide everything the construction operations require.

But how does this impact an individual project, and why is it a consideration in a book about detailing?

Constructibility combined with detailing form the backbone of the construction project, and allows for the creation, development, refinement and construction of any construction project. In simple terms, the design concept must be examined to ensure that a proper program of constructible sequences can be applied to it, and from that comes the need to express those sequences, in the contract documents– as details. This information is then conveyed to the contractors and their trade workers for further analysis ["How are we going to approach this work?"] management, and actual execution of the work.

It is quite easy to fall into a trap, in design and detailing, where work is depicted to satisfy a problem, but is virtually impossible to build. How often and for what periods of time can workers be required to lie on their backs to install complex or intricate items overhead [or perhaps the real question is, can they?] Work must be accessible. No sequence of work can allow or tolerate

one item to cover other work, which is to be installed after the first work, and so forth. Is there sufficient space to use the proper tools to install the work? "Blind work" is a continual nemesis in construction. For example, underpinning an existing wall is a common practice, yet the backside of that construction is never seen. One can only rely on proper preparation and construction in a hopeful manner that the work is both correct, and properly executed– if it cannot be readily or reliably verified!

In this, we must understand that the more we show on the detail, the more we obligate the contractor to perform as we note in the drawing. It is all too easy to require work, which only adds cost, and no real substance to the work. Or to require a technique that is new, rather revolutionary, and again costly for no particular added return. In the same light, it is also possible to "over-specify", but including too much, and perhaps superfluous information, or requiring work or techniques which are needless and only cost factors.

A factor often lost on young staffers and professionals is the ramifications of their work. Being remote from the actual work and work processes of construction, it is easy to become oblivious to the implications of one's work. Details do have a cost impact, in that any requirement on the detail that is out of the ordinary, requires extra thinking or work, or is more difficult to perform will impact the cost.

*CONSIDERATIONS:
Both Project & Detailing*

*COST:
The final/total cost of the project, when all work is complete.*

*SCOPE:
The total overall size, extent and complexity of the project*

*QUALITY:
The peculiar, inherent feature or characteristic of an item or project that establishes its level of value or excellence.*

Simply to require more thought adds cost since the time for thinking impacts the total cost of the performing the task. This may not show up directly, but is well accounted for where very astute and insightful estimators spot such circumstances during the bidding process– they then will "cover" their perceived costs, to their advantage– i.e., added cost to ensure work can be done, profitably even if additional effort, of any kind is required and enforced.

This factor, of course, creates need for proper indoctrination of the staffers, and the oversight to ensure propriety in their

work. There is no doubt that there are myriad solutions to any one detailing situation, so selection of the one that is both appropriate to the project and within cost bounds is essential. While perhaps not the overwhelming consideration, the cost needs to be a consideration at all times. Without this there can be misallocation of funds and the placing of wrong priorities on the actual work.

As noted before, control of the project work is a crucial and important factor— it is necessary! However, "strangulation" of the project work is not required! It is obvious that there is a very fine line that the professional must follow to be successful in the detailing pursuit. While it is necessary to provide complete and correct information, there is no requirement for the professional to accept self-inflicted added and needless liability by showing or otherwise requiring every minute nuance of the detail— every screw, tie, thread, device, clip, etc. Indeed, by utilizing a well-known and recognized construction principle or prescribed system for the work, there is no need to meticulously detail literally everything involved, to the point of liability. By doing this we eliminate the need for all-inclusive detailing, and still ensure that the work will be proper, adequate and in keeping with other demands. Trade workers while trained differently still are trained, and do understand and know how to execute work, and "put things together" correctly, true to both system required and specific project.

We must remember, too, that when our work, as professionals, is faulty, we stand in jeopardy on two very important counts. If the contractor installs the professional's erroneous work, exactly as shown on the drawings, and there are problems, these become; outright problems accrued to the professional effort, matters of professional liability. Likewise, where work is so tightly and precisely detailed as to needlessly add significant cost to the project, the professional will find harsh criticism and perhaps the need to re-design the project without cost to the owner.

This scenario cannot be overstated and is of ultimate importance to the professional. The charge to, and the status of the professional is NOT contingent on the depth or extent of information provided on details [or in the specifications]. This point is critical in that every project must be pursued in a way by which the client is served properly, the trade workers are instructed properly and completely, and the project can be built true to the design concept. In a pragmatic aspect, all this should be done in a way that provides the professional [or the office] with a good level of profit. And without undue liability! Yes, doing "too much" in this case, is as dangerous as not doing enough— again the very fine line which guides the professional. Therefore, each and every professional and drafter simply

must achieve a well-founded "feel" for the adequacy of what is shown— the "feeling" for what all the trade workers need to correctly build the detailed work. Obviously, this feeling comes only with experience, and an acquired understanding of the work involved; and its fit into, or contribution to the project. A good personal rule-of-thumb criterion is, "Is there enough information shown here, that I could build this work?" Of course, in this evaluation, one must be very objective, and must not overlook items or make assumptions.

"OVERDETAILING" is characterized by:

- trying to show too much in one view
- showing too many layers of work beyond the cutting plane
- detailing items that come as stock, standard or factory-fabricated units, and really require no detailing
- creating customized details/work when standardized, stock items are available, and appropriate
- detailing work that is open to minor changes which negate the need for added detailing
- including items that need not be shown as they will be included via other standards, or which are common practice
- producing overly complex and confusing drawings [this may indicate the need for other drawings, and/or a change of projection]
- expending time [and money] for depicting virtually useless or unneeded information, and for which there is no meaningful return such as minute details of a metal casting
- creating work which by its depiction will needlessly elevate the liability of the professional
- creating work which is redundant, uncoordinated, or not noted in the other drawings and work.
- producing drawings which, by various drafting techniques, places the emphasis in the wrong places
- making the drawing more complex by adding numerous dimensions, lines, notes, and other rather extraneous information, so the drawing is rendered unreadable

Fig. 6-10

Quick list of items that contribute to over-detailing [doing too much as to adversely effect the value of the drawing, or which adds undue cost of production for no added return or value]

The **second** aspect is the understanding of, and the respect for the ability, knowledge and skill of the trade worker[s] needed to perform the work shown. For example, details rarely if ever, show every nail required to fasten work together. The choice of the number of nails, the size of the nails, the placement of the nails, and the technique of nailing can be, should be, and is left to others. In fact, in every model building code, including the various editions of the more recently developed International Building Code, there is a "nailing or fastening schedule". This table sets a minimum scheme for nailing by listing size of nail, number and method to be used. These tables set only minimum standards, which in many instances require added work. So in reality there is little choice for the contractors, except to ensure substantial construction. While the training of both sets of personnel dealing with this detail [trade worker and professional] differs, each brings a level of knowledge to the work. The trade worker will "know" through the training how to best fasten the parts together, for a tight, long-term connection, stable and substantial.

Where the professional carries work requirements to the extreme, the professional will be held responsible for the added cost, the failure of the work if that occurs, or the other imperfections that are inherent to the work. The caution signal, again, is that work that is designed and/or documented in a faulty manner, but performed as shown on the documents [by the contractor] is the responsibility of the professional.

Through experience the professional will see more clearly how this interface works, and how very few problems occur when full respect for, and acceptance of the trade workers' discretion is permitted to contribute to the work. Experience teaches that adding needless information to details creates a situation of "diminishing return", or the fact that the more data shown, the less value received. The one item that does increase is the liability of the professional or drafter. It must be remembered that every item that is controlled or addressed, by the professional, becomes part of the liability exposure of the professional. Also, there is a good deal of work on any project that can be performed by the trade workers without innovative or newly developed techniques. Of course, where a distinctive or aesthetic item is in question, the detailing should reflect, precisely, what is required to achieve the effect or solution shown? Even in this, as in other more mundane work, the trade workers' "standard" work can be used without any jeopardy, or adverse aesthetic appeal.

Some may view this as the professional "not caring" how the work is done, so long as it supports the design concept, and is substantial and proper, long term. It certainly is not a matter

of "not caring"! Overdetailing [adding excessive or needless information] creates added risk for the professional that is wholly unnecessary. Quite often solutions by the

"Over-detailing" is the direct result of the inability to know when to stop detailing; or thinking about what really need NOT be shown!

workers will be better, cheaper, and at least equally sound. This really is a factor of skill, training and experience, and since there is a very substantial and different orientation between the experience of professional and worker, it is wise to follow the worker who has seen an array of actual solutions that could be applied. The workers and the contractors do, after all, have a stake and interest in the project. Certainly this does not include sub-standard or shoddy work [the workers won't stay employed long if that is the case; the contractor will not remain in business very long, if such work is allowed]. Of course, the professional has the right [and obligation] to hold firm in those instances where an element of the design concept is in question. It is not, however, a good idea to hold firm on every issue. Rather it should be one of recognizing that the knowledge and work of the trade workers are fully acceptable, and the work, no matter how it is done, exactly, will not have an adverse impact on the aesthetic, the long-term life, or the soundness of the project.

Contractors thrive on the foibles of the professional effort. Their management and estimating personnel are quite astute and keenly aware of missteps, errors, gaps, and other maladies in contract documents produced by design professionals. In the process of rectifying these problems, cost is often a major factor, and is usually elevated to the benefit of the contractors. This scenario should play a major part in the process of detailing. Doing too much, doing too little, requiring new and innovative work processes, and making overly restrictive demands in the work are but a few of the elements of detailing that can become issues with the contractors and hence their system for resolving them.

No one on a project site should be of a mind to "reap a profit" at the expense of others, particularly the owners. But glitches in documentation are open invitations to excesses and added cost factors. The prudent course is to hone one's detailing skills, knowing well how to start, what to do, how to do it, and when to stop—relying fully on the contractors' knowledge and abilities to fill out the actual work to a successful solution to the situation/problem depicted. To a good degree the process of construction management should be able to root out

these instances, and resolve them in the documentation stage, and forestalling them from getting to the bidding process, and the field operations.

The concept of stopping the detailing and allowing the contractor to fill-out the work is something that some design professionals find very hard to accept. Many professionals, unfortunately, really want or feel the need to control [or dictate] every move and operation on the project. They feel this level of control is their professional mandate, and validation for their efforts. This is, of course, unrealistic, and can become a real point of contention. [There are, though, those professionals who still do operate in this manner; it is not however, routine and commonly done]. It is far better to document properly and then observe the work within the limitations placed on the professional duties and responsibilities. This provides a method for controlling the work without becoming intrusive or wrongly dictatorial. Of course, if the work proves or appears to be inadequate or substandard, it can be stopped, and ordered re-done by the owner.

In the final analysis, it is better to provide good detailing, executed in such a way that the contractor knows exactly what is required, and how he/she must provide the additional resources to complete the work. Ideally, a true team effort atmosphere can be generated, where each participant recognizes, respects, and utilizes the expertise of the others for the collective good of all- including the project, and its owner!

Beyond detailing:

In addition, the ability to stop detailing at the correct juncture protects the effort, time and cost expended by the professional office. This is not to say that the professional should shortcut documentation to gain profit, but rather it says that a correct effort in detailing, without needless extra work, allows the professional to stay within budget, and can aid the development of a profit for the firm. Here again, the return diminishes when nothing is gained by the effort. Not depicting irrelevant items or not "re-inventing the wheel" is critical to professional profits. Certainly the client must be well served, but this is not contingent on the production of extra work which is of no use or value.

Overall, this requires knowledge of construction, knowing the new condition, use of resources of all types to gather the added data, and a participatory team attitude that pushes for added individual effort to properly resolve the detail- asking questions is a fully valid, positive, and helpful process!

It may appear to be a "losing battle", or a "lost cause", but it is not something that we can merely acquiesce to and let go. The

issue: the penchant of young professionals to literally avoid the detailing of projects. It must be overcome.

"But even as intern portfolios become more populated with computer work of all kinds, they are still lacking in the traditional area of weakness: an understanding of materials, details, construction methods, building codes, and other practical issues ...

Familiarity with these areas most often develops during internship. In the past, such learning was associated with years of manual drafting under the supervision and tutorage of a more experienced architect ...

... As a result, however, in comparison to their predecessors, many of the architects who will reach mid-level positions in the next 10 to 15 years will lack exposure to a broad range of practical experiences. What will this mean to the profession and the quality of buildings?"

-Digital Architect article
by B.J. Novitski
Architectural Record, 4/99

The "camps" have been divided in an odd arrangement; young architecture students on the one hand who are trained to, and use the computer for designing, almost to the point of exclusion of any other activity. And those with a technical background and education, who find their satisfaction in merely using their computer skills to produce documents for construction.

Both groups, in the main, are quite skilled and highly developed. However, their respective positions are irreconcilable unless there is a renewed interest and skill development in the very activity that brings the two factions together- the detailing of the design in a manner that provides for their computerized document production. This single activity, in itself, is so pervasive and so compelling that if there is continued attrition, by professionals, in this area, projects of the future will be at great risk.

Detailing needs to be the precise [but not brain surgery!] process of faithfully expressing the design concept in such a manner as to produce sound, durable construction, which supports, enhances and perpetuates the overall design. The vehicle between design professional and constructor to accomplish this work is the CAD produced working drawings, which must clearly and completely show and express the

work that is required. In this, it is obvious that someone must ascertain what is to be done and how it is to be accomplished.

The professional, in "making sure", will add extra work, devices, products, or other items to ensure proper and lasting installation and workability of the product, construction, or equipment detailed. Here, often, needless cost is added for no real return, except added peace of mind and assurance. This is not to say that every sales "pitch" should be accepted outright, but rather that very judicious decisions and additions are required, and only where the perceived installation appears to be marginal, or outright faulty, in the professional's view. This interplay is particularly important today in that new materials and products appear on the scene almost daily; just keeping up is a difficult task. Some of the new product lines are not thoroughly or well thought out, extensively tested, or engineered to meet the variety of conditions that they may encounter, over the long-term. Professional expertise and experience is the key (and only) factor that can assess and resolve this situation; making "better" is a professional function!

Where that function is deemed necessary, it is incumbent upon the professional to detail, precisely, what is required; this includes appropriate adjustments in the specifications where necessary. All this must be done carefully since the professional also has not been exposed to "every condition", and therefore, can create problems by unwittingly obviating the good features of the product or material. While the effort to make better is sincere, the result can be disastrous. Obviously, this is but one situation where the professional fully "earns his money".

Generally, contractors are aware of most of the materials and products presented to them via the contract documents. Of course, they too are no omnipotent and often taken unaware when confronted with new constructions and installations. Here they must forego any hint of macho egotism and seek the expertise and assistance they need. This also means the superintendent on the job site must accept the fact that she/he cannot always know and do everything; seeking help, here, is certainly not a sign of weakness, but one of propriety! Following instructions is vital, and necessary particularly where the details vary from the manufacturer's printed instructions is vital. Also, here, many times, materials are merely shipped to the job site for installation by inexperienced personnel; a key situation that bears close watching. More and more manufacturers are requiring that their products be installed by licensed or franchised personnel, who have been "factory-trained", franchised or approved [after testing of some sort], and have a meaningfully stake in correct installations.

Both professional and contractor must take great care that their determinations do not deteriorate into off-hand comments, of "I don't like that", "I wouldn't do it that way", or "that'll never work". Such untested assertions cannot substitute for a good faith effort on the part of the manufacturer to achieve good and predictable results, especially where calculation and/or testing have ensured. Good practice would have all of the project personnel [professional and contractor] consulting with the manufacturer where changes in the intended use, detail, or installation seem prudent.

While the final results on the contract drawings may belie the fact, detailing is a very involved process. It actually is an ongoing event that continues during the actual construction process. This process is analyzed and depicted in its entirety. Its pervasive nature is quite apparent as well as the fact that it is not a "busy work" chore, which carries relatively little impact on the project.

To the contrary, the best of design concepts will fail where detailing is not faithful, proper, and adequate. Even if the concept's far-away, overall appearance is achieved, the "close-up" view, and working life of the project will suffer, by being ill-conceived, inappropriate, or faulty/deteriorated.

DETAILING ! ! !

In addition to a good sense of accomplishment and satisfaction, detailing can bring a sense of sheer joy in task well done!

[This is tempered somewhat where a good number of standards details are used, in lieu of distinctive, innovative new detail solutions]

QUESTIONS TO ASK ABOUT DETAILING

Contrary to any first impressions, detailing of construction projects is not an easy task, engaged in easily, at a moment's notice, with little consideration and with ease of resolution. Although too often marginalized, relegated to a low priority, begrudgingly executed and generally maligned, detailing is crucial to have the finished project directly reflect the design concept. To achieve that, it is best a studied, carefully conceived program for displaying crucial points of construction in

Despite the fact that the content is as the client desires, as the project requires and the intent is as we desire, the most weighty key to successful documents is how easily they can be read, assimilated, and implemented by the end-users -- the trade workers building on the project.

unmistaken able terms. As noted previously, this requires in-depth knowledge of the project and its construction, careful analysis, good decision making and quality drafting and communication skills.

The application of mechanics to detailing is both the opportunity to resolve a problem [anticipated or real] and to convey the solution to the constructors. It is an opportunity to depict

One task of detailing, like that of the specifications, is to select, from among the many available, that singular solution, that "best" fits the project needs at that location, or in that circumstance, based on the design professional's analysis.

the solution or configuration as deemed a correct fit to meet the circumstances of the project. This application is individual to the project and personal to the drafter- and more often than not need not rely on or be a variation of standard details. It is as creative a basic design and while the scope may be more limited it is still an important contribution to the success of the project overall. Good detailing enhances and produces good projects- those that meet the faithful production of the approved design concept!

"Consequential buildings derive from a two-pronged discipline. On one level, they are conceived to stretch the bounds of architectural discourse—the built environment serving as an agent of societal progress. On a distinct yet complementary level, great works are about execution, pure and simple; artful detailing, well-research specifications, and vigilant site visits. Taken together, these simultaneous processes make for exceptional architecture."

ARCHITECTURE magazine

December, 2002; page 127

The following matrix chart sets out the prioritized listing of tasks needed to develop a single or a series of details. Using this matrix as a skeletal guide, it becomes apparent that a series of issues or topics must be addressed. The information provided via the answers and information contained in these topics provides the requisite base information for creation of a single detail, or a series of related details.

Complete and appropriate detailing relies on these topics and the answers given them. This serves well as a guide for the document production staff, and can in time become a mental process with each such staffer. This, in turn, sensitizes each person to the basic reason for a detail, and how best to execute it. Too, the detailing skill is elevated in each person in direct proportion to repeated and correct use of this matrix and associated information developed for it.

TOPIC 1- Where is the need or situation [to be detailed] located? [if location is not indicated previously] – in large areas or assemblies like walls, floors, foundations, roofs, etc.

In the majority of cases, details are extracted from larger portions of the project [and the drawings]. It is possible to project some details that become well known, and commonly used when some features or aspects of the project are made known. But generally, the actual construction details follow establishing large areas, surfaces or portions of the project. Also, knowing where the detail will apply helps to set the context or the general "atmosphere" for the detail. Often materials can be used in a variety of locations, with slight variations- and

those variations need to be utilized where appropriate.

TOPIC 2- What is the specific need or situation involved? Construction, termination, interconnection, relationship

Usually something will stand-out or be quite apparent that detailing is necessary– there just needs to be direction, instruction resolution or finishing to ensure correct construction. Once it is obvious a detail is required, and the location is established, it is necessary to ascertain what the needs] may be. This can vary from what type of construction is involved, what materials surround the area, and how the detail will be fitted into the location [is it a termination like the end of a wall; is it a matter of interconnecting two different materials or systems; or must two diverse portion of the building be resolved and interconnected?

TOPIC 3- Why must this be detailed? Single, isolated instance, repeated instances, reoccurring, lengthy/linear

The need for a detail varies a good deal, but basically is a decision that a particular situation must be addressed and resolved by shown a specific detail. Here is where construction knowledge and awareness coupled with experience come into play. This in turn will trigger the thought of idea for what should be depicted as the specific solution, best suited to the project. Examples are wall terminations [vertical and horizontal] changes in materials or systems. treatment of angles, radii and other non-typical work, a new approach to a familiar problem by using measures not commonly used– in essence, things that are too routine, And things that the architect feels a need to control again for a variety of reasons.

TOPIC 4- What “pattern[s]” or basic solutions seem appropriate? What must be done – e.g., prohibit entrance of water

In this area, it is a matter of translating a general principle or anticipated problem into a solution. This is preventative action, of course [as construction has not yet occurred] and not remedial. So the need is to be aware and familiar with the situation or circumstance and resolve it, with the context of a solution applied in concert with surrounding elements to the mutual benefit of all. Perhaps can be perceived as a diagnosis– checking circumstances [symptoms] in an effort ascertain the correct preventative construction methods and materials. [Reference: See ARCHITECTURAL DETAILING: FUNCTION, CONSTRUCTIBILITY, AESTHETICS, 2nd ed. by Edward Allen and Patrick Rand, for discussion of detailing patterns and diagnostic tools]

TOPIC 5- How do I best implement those patterns or solutions? Choice of construction, materials, systems, etc.

Much of what the detail entails comes from and directly relates to the surrounding work. There some materials will be established, some interfaces, positioning and intersections will be obvious and other project circumstances will be at least mental images of concern. The resolution of the new detail lies in assessing and addressing the factors that present the situation in the first place. It may be you will need to introduce or bring another material into play in order to resolve the one other with the third. You may need a device, a strip of materials or something of a form or shape different from that in the surrounding area. The prime concern is what you want to do with the detail! That new detail comes, then, from bringing existing or known construction of concern into focus, and how all of this interrelates– i.e., it is obvious the new detail must be fitted into the construction that surrounds it, for the sake of correct continuity, water-tightness, etc.

TOPIC 6- What should I show as the primary focus? How large an area; crucial relationships; interconnections; attachments

Of course, the critical content of any detail is the exact solution to an exact situation; then to give the detail context, meaning and location show some of the surrounding area– but be judicious. For example, if you are showing the bearing detail of a steel joist that is 26’-0” long, you do not have to show the entire joist, but merely enough of the bearing seat and end of the joist to give meaning and identification. If you wish to show other detail on the same joist, then make another isolated detail– do not expand the first one and try to cover too much area.

If you consider wall sections as a series of details [stacked one upon the other], there is always a question whether to show the full extent of the wall, or just the bottom [footing; slab] and the top [connection to roof]. All the area/wall/detail between these may well quite repetitive and simply a masonry unchanged in its full height- why show a lot of repetitive brick coursing/

TOPIC 7- What information should be shown or noted? What should be or is to be included? Am I trying to show too much? Be objective as unnecessary or superfluous information serves no purpose

This is the beginning of the tougher questions, since the answer will impact how well the detail works and communi-

cates. Judicious selection of information is required, and should center, initially, on the point, portion, specific location or situation requiring detailing— the center of interest or focal point of the detail. This needs to be identified and set out clearly and distinctly as it is the very issue that triggered the detail. The only valid erasure [and something that comes with experience] is just what and how much information is required— it cannot be quantified or reduced to a checklist. From this comes the instinctive “feeling” of what else to include [that contributes to clarity in the detail, but is simply “nice-to-know” information]. Lastly you must weed out the chaff and suppress the desire to be too expansive and wind up showing too much of related but inconsequential information.

TOPIC 8- What information is required that is not shown on the sketch? What doesn't come through to you if sketch is by others? What should I leave out? Too much shown in sketch?

Enough to get your point across and communicate it completely and clearly! Those criteria will come with experience and is part of depicting the mental process you use to envision the detail. Usually done without a checklist, you will develop a “feel” for what is needed and what really satisfies your own questions. Working from a sketch provided by someone else on the team or from another source, one must be careful, inquisitive and insightful as to the total content of the new/final detail. Often one of two scenarios happen— not enough information is shown; or too much information, mostly superfluous [reminders, check points, etc.] appear on the sketches or the standardized detail from other sources. Here it is necessary to ask questions, and resolve all open issues—and most certainly not simply to use everything shown on the sketch.

Experience will provide more and more construction knowledge of methods and materials, but the young staffer really needs to be aware of information that just does not seem to belong together— ask questions!!! Even if they seem silly or “dumb”. The insight shown in that instance can very well save the project and design team a good deal of angst later in the process. Learn from every sketch you work on because this will accumulate as part of your know-how and mental database.

This and the selection of scale [see below] are the primary reason for objectively checking and reviewing the drawings—using the eyes of someone else not working on or connected with the project [for pure objectivity and insight]— prior to issuing the drawing set for use.

TOPIC 9- What is the right or a good scale for this detail? Assess how information and notations vary with scale and with need to be included What is the best view to use? 2D; isometric? What scale should I use for highest clarity?

Selection of scale is directly and importantly tied to detail content, and to readability. If you have a complex detail, with many parts, of thin materials and situations of concern, you will use a scale that produces a larger drawing, and primarily one that more readily read— i.e., using scale selection as a method to increase clarity and ease of use. For things less complex, you can use a scaled down drawing, but ensure that all the information needed is still included and amply displayed. A scale producing a small drawing that results in a muddled, smeared, or highly illegible drawing is thoroughly unacceptable and problematic— avoid them. At the same time, judicious scale selection is required because it is impossible and inappropriate to try to use but one scale for all the details— content, number of pieces involved, and amount of information being conveyed are important issues in selecting a scale.

In some instances, the best direction is to develop one detail [at one scale] and then extract another, larger scale detail of a portion of the first [see examples in Chapter 10]. Here in lieu of one larger detail that would show too much mundane and needles information, the extraction can hone in on the crucial portion of the more elaborate detail.

A scale like $1/16" = 1'-0"$ the increment is so small that little information can be shown [this is used for overall building complex and site plans for example]. Using $1" = 1'-0"$ the drawing will be adequate for wall sections and other larger portions of the construction. Isolated details more often than not use a scale of $1-1/2" = 1'-0"$, $3" = 1'-0"$, and in some cases “full size” [showing smaller elements at their actual/true size]. Principal: the smaller the unit used to represent one-foot, the less the detail available, and the larger the area of coverage.

The consideration and selection of scale is really a “what is gained/lost?” situation. Every detail does not necessarily require the same scale on every project [this is where details often fail]. The identical detail, because of slight changes in circumstances may vary in size from project to project— the measure is what more [or less] information is required.

Facilitating reading the detail drawings [particularly on the job site] is most important. It should be at the forefront of consideration, since the best of information poorly depicted [i.e. illegible] serves no good end and can lead to confusion and errors. This can also lead to the use of other projections—

like isometric, which gives a three dimensional representation. Here a more realistic view is offered and should serve to clarify more complex and involved work.

TOPIC 10- What materials should be used?

Materials will be dictated to a large degree by the surrounding construction. There may be a need to include other or different materials from those in the related construction. This is an integral part of detailing ensuring that all necessary devices, implements, systems and materials are utilized, properly and to the end of completing the detail and resolving the problem. Again, too, the communication value is a paramount issue— showing the trade workers what exactly is required to execute the necessary work.

TOPIC 11- How much surrounding area should be shown? How much do I show [overall area of detail]? What should I show in the background and surrounding construction [for reference]? How does this relate to other surrounding details?

The basic issue here is to show the required detail and enough of the surrounding work to set it in its proper place/ location/environment. But not showing too much as to distract from or overshadow the basic detail. Of course, due care is required to ensure all of this, but primary is the detailed area itself. The other information is strictly to relate the detail to the other work... [e.g. 9 layers of work beyond the detail surface] This will vary with the circumstances and may have quirks in it, like showing more on one side of the detail than the other.

TOPIC 12- How other the materials interface and connect together? What must I show [to convey all pertinent information]? Can this be combined with other information for a better, more informative drawing?

Details by their very nature usually involve depiction of several different materials. Certain of them do deal with a single material or system, such as in an attachment detail where the material is applied to some substrate [even there the substrate is a different material and is shown in a superficial manner]. To a great extent details in general are drawings showing the interrelation of several different materials to a common "cause". Where these materials are about equal in importance, it is necessary to properly identify, dimension, size, and give pertinent data about each. Even where some are obviously subservient to others, it is best to give enough

information so the trade workers are not short of information, or uncover gaps in communication [which they tend to fill on their own volition]. No matter the number of different pieces, materials, devices, etc. the detail must give due justice to them all. Therein lies the basic task of detailing— bringing to bear whatever materials, devices and systems required to show how the particular circumstance in the construction is to be built.

TOPIC 13- Is there a standard detail available that could be the basis for this new detail?

With the plethora of standard details now residing in most offices, it is fair to say that looking, initially, to a standard detail, is good practice. BUT the mindset must be to ascertain IF that detail is sufficient within itself, or [as in most cases] is there need to revise the standard to correctly reflect current project conditions. This is a most critical decision— an inexperienced person may deem the standard detail proper, when in really some aspect is improper and wrong for the project. If the standard detail is a very close fit- i.e., very little is not appropriate— then use the standard; otherwise be prepared to modify the standard, and NEVER force project conditions to match the standard.

However, due care must be taken to avoid becoming dependent on standard details and using them too quickly or automatically. While no one dries their use, it is necessary to determine not just the validity for the use but the appropriateness of the application. Here the drafter needs to make sure, or to ask specific questions, when there is even the slightest hint that the standard detail obviates the intent of the designer and impact of the design concept. A newly created and drafted may very well be required!

TOPIC 14- Is there another detail, new or existing, which can be expanded to include the new work, or which provides a better basis for this detail?

The search for a better detail that meets the requirements is constant. Even though a standard detail is available, there is still a dynamic at work where that detail can be or should be changed. Perhaps simply an update, but more than likely some other factors [material, concept, etc.] that changes it for the better. The standard details tend to lie dormant for long periods of time, so it is importantly important that they be fully and carefully reviewed prior to any use, and modified as necessary— both a project details and as new versions of the standard detail.

TOPIC 15- Is there enough information here that I could build this work? What must I show [to convey all pertinent information]?

This question is one but a very good measure of the detail. Of course, one can be fooled, if not very objective, into thinking the detail is fine since the person understand it and could build it [but their assessment is jaded and inaccurate for some one else who is not fully familiar with the detail and circumstances].

TOPIC 16- How can I increase the readability of the detail?

Several key issues help greatly to increase readability and use. Use variations in line weights, so they do not appear all in the same value. Darken lines of objects; middle tone to changes in plane, protrusions, etc; and the lighter lines for things that happen "on" the planes [textures, material symbols, openings, minor elements, etc.]

Leave good amount of open ["white"] space around each detail. This need not be wide or expansive, but give each detail its own area. Also, it inadvisable to have two details "share" the same notes [leads to long leader lines, and can cause confusion]

Be extremely careful with placement of notes, and dimension, and the various ancillary [non-object] lines involved; leader lines from notes to the features and the dimension extension lines. Cross them as little as possible, and refrain from an unchecked location of information that causes "linear spaghetti" and which tends to place a mask of lines over the real objects themselves. Place notes close to point of application and list noted in vertical order where a series of small layers of material are involved [roof system for example].

**TOPIC 17- What line weight variations are appropriate and where should changes occur?
What line weights are appropriate?
Increasing readability**

Line weights are important, as noted above. A good guide is to use the darkest line as the edge of the object [building, etc.] That is the line with object on one side, and air or earth on the other— in a sense the "outline" of the entire object.

A medium weight line should be used to define changes in plane in the view, openings and other features within the edges of the object. The lightest lines should be things like material symbols, doors within door frames, window

muntins, etc. which are minor items but need to be placed on the drawing. In wall sections and details these same axioms hold— dark for edges of wall; medium for reinforcing, joints, etc. within the wall; and light for symbols, dimension etc.

As change in line weight serves to draw the attention of the eye to certain places in the drawing. So you want the lines to draw the reader to the important locations, and not those that are innocuous or superficial.

**TOPIC 18- How can I make the construction in the detail, better, less costly, less complex?
What material symbols are necessary?
What are the best locations for notes/dimensions?**

Knowledge of construction practices, methods and materials allows for a better analysis of detailing and for producing details that are correct in concept and within budgetary bounds and faithful to the design concept. It is here that one's flexibility is challenged, in that each situation requiring a solution has nuances and peculiarities to deal with. It is here where standard details begin to fall away by not being responsive and correct. One must [and will with experience] develop a sense of and feeling for detailing in the manner you detail, how you fit details into the scheme, how you turn to alternate solution and how you adjust to meet budgets.

Standard, commonly accepted material symbols need to be utilized [and defined on the cover sheet of the drawing set]. These are necessary to separate the various layers of materials, and are particularly vital where several rather thin materials are applied. The infill between lines of edges of material and give emphasis to the individual material involved.

**TOPIC 19- How can I make the detail drawing better, in presentation? Is it too complex?
Is it better to use 2 details?
Is it confusing? Too involved?**

It is always necessary to keep these thoughts in mind. Using them as basic guide will enhance the detailing and make for better documentation and ease of reading, assimilation and application. There needs to be a sense of how the drawing looks—from layout, to line weights, to content, to complexity to the adverse, crowded, muddled, parts obscured, wrong scale, etc.

It is acceptable to extract another detail out of a detail where a portion of the one is relatively small, but really needs better

depiction. If this occurs then do the added drawing and correlate to the original.

Usually plain common sense will indicate a detail that is improper– bad lines, poor layout, too complex, too large for need, etc.

TOPIC 20- Have I cross-referenced this detail completely and properly? What needs to be cross-referenced– to the set of drawings; to other details; location in set of drawings for easy access?

Cross referencing details is highly important. Remember most details apply in a specific location and therefore the drawing must be referenced to that location [and to each other location where it may apply]. Sometimes one detail relies on, or relates to another detail and these too need careful referencing.

Also, in designating details, some marker or designator is required that shows exactly where, in the drawing set, the detail is shown [and hence, its actual location in the construction]. The reader should never be made to “troll” through all of the drawings trying to find that one that they need.

In the final analysis, detailing is the opportunity to correctly and appropriately apply, modify, manipulate, relate and correctly position the nuances and minutia of construction materials, methods, devices, systems and assemblies to the project concept. In addition, it is the bridge between the project work and the requirements of the surrounding community, expressed in various codes, standards rules and regulations [considerations that are always present but not foremost in the minds of owners].

So we must come to

TOPIC 21- Do you understand the detail well enough that you can explain the reason it is needed, the concept of its as a solution [as opposed to other possibilities], what all is depicted, and how this fits into the overall scheme, and it serves the project work and the project itself?

There is nothing in the requirements for detailing, or in the call for developing and refining one’s detailing skill that “tricky”, misleading or deceitful. Neither is there any reason to blindly detail projects simply as a job task, and lacking any true understanding of what it is all about. Any young professional who has a career-eye at running projects and other more high-level positions needs to both conquer and learn from detailing, in all its aspects. Their success, in future project work does lie in that understanding and

skill– and in conveying that all to others working with/ under them later.

Detailing is the thread that binds all of the technical implications together, in a cohesive, compliant, and functionally proper manner. It is “people work” and requires dedication and talent for the best of results. Perhaps best seen as a mosaic of drawing that indicate the portion of work required to be pieced and fitted together to produce a well-constructed, attractive and fully functional building project.

TOPIC 22 - What is the right number of details required for this project? Have I included enough details to get all the information across to the trade workers– how many more do I need?

Rest easy here, there is NO “right” number of details for any particular project– [like a fixed 217 details required for every warehouse]. But in the same token be fully prepared for hundreds of details [maybe even thousands, depending on the size and complexity of the work]. Often experience and the individual eye for how much information is needed with resolve this numbers issue.

Truth be known, you simply have to detail until you [or your Project Architect] feel the work is truly well displayed and clearly communicated for field use. This is not something you should try to quantify, because it defies that! A small [in size and scope] project can require more details than a much larger project simply because of the complexity of the work, the issues with the site, etc. surrounding the work or other circumstances– no two projects are the same. Even in prototypical work [where virtually the same building is replicated] there can added details to accommodate that building on another site and meeting differing conditions.

While not necessarily listing every detail as it is produced, you do need to keep track of the details for cross-referencing, and in the event some details are dropped and others added [for some reason or another]. This cannot be a matter of an extensive array of details scattered about, unrelated or coordinated– that are run counter to a smooth running, smoothly produced projects.

THE INDIVIDUAL EFFORT

Across the full spectrum of tasks performed by architects [and basic services provided under the professional's contract with the Owner], the individual staffer can fit into any number of roles. It is not a situation where one is cast or mired forever in one position, format or job slot. The practice of architecture finds each and every participant "sliding" around between tasks and contributing in any number of ways—varying from project to project and of course, office to office.

Within this context, however, there is a strong thread of skill patently required within the "tools" of every professional—that, of course, is the ability to detail!

DETAILING: The requisite skill and process used by design professionals, in the seeking, collecting, evaluating, selecting, manipulating, adapting, fitting, combining, and application of the minutia of construction information and knowledge [devices, materials, equipment, and systems] and their accurate depiction, as a wisely-selected, carefully conceived, isolated, and limited areas and well-executed graphic representations as small portions of the construction [accompanied and supported by appropriate and informative notations to the detail itself];

developed, viewed, and adjusted, with benefit of foresight, to; faithfully adhere to the design concept, ascertain/meet needs, solve problems, assess constructibility, check relationship of parts, test future maintenance, and note how any or all of these may be revised, improved or simplified and its location in the total project— all fully understandable by, and useful to the trade workers building the project

This is not to say one must be solely dedicated only to detailing, but rather detailing needs to be some part of each and every architect's skills, to better understand the entire process of documenting the design concept to achieve its final and faithful construction. It's about knowing what to do, getting your point across and properly communicating it to others who can use it productively. On the following list of positions architects can fill, who can be summarily eliminated as not needing detailing, for at least a portion of their effort? [Fig. 8-1]

Detailing should never be considered as a "trick of the trade" or some sort of optional process, used or not used at the whim of the design professional. It is a professional necessity

Co-op Student	Project Manager	Technical Rep
Graduate architect	Project Lead	Materials R&D
Intern	Project Architect	Educator
Registered Architect	Designer	Professor
Sole Proprietor	Resource Architect	Regulatory Official
Partner	Administrative Architect	Governm't Architect
Principal	Staff Architect	Corporate Project Manager
Junior Partner	Job Captain	Corporate Architect
Senior Associate	Specifications Writer	Forensic Investigator
Senior Architect	Contract Administrator	Expert Witness
Associate	On-site Project Rep	Consultant
Junior Associate	Clerk-of-the-Works	Programmer
Marketing Associate	Drafter	Value/Cost-Cycle Engineer
Business Development	CAD Drafter/Operator/Technician	Estimator
Project Development	Graphic Illustrator	Project Expediter
Lead Architect	Architectural Delineator	Organization Architect
Discipline Lead	Material Sales	Building Manager
Chief Drafter	Manufacturers' Rep	Real Estate Manager
Chief Designer		

Fig. 8-1

A list of title or job positions open to those trained as architects [similar list for engineers] all of whom can be part of a construction project in one manner or another. To indicate that all architects are not just designers, but have other allied skills of value to successful construction.

[if not obligation!], on every project, to be an integral part of conveying graphic

As a basic service under the professional contract, proper project documentation becomes a "duty" [a mandated obligation; an irrevocable requirement] – so detailing, an indispensable part of the documentation, also becomes a "duty" on the part of professional.

and written information vital to the correct construction of the project, in full keeping with the approved design concept.

Options are available, within the process, as to what exactly to show and include, what scale to use for best presentation, and the number of details for any single location. In addition there is an option for alternative views other than just 2-dimensional, orthographic projection where only two surfaces [height and width] are shown. Isometric and other projections using a 3-surface format can be quite explanatory and help to minimize or reduce the number of details required, and with added clarity [however, these are not commonplace and should not be utilized on an "all-the-time" basis].

Putting a building together, in the mind's eye, is not easy task.

*If detailing was easy,
everybody would be wanting to do it!*

-Simple Insight

It requires an adaptive use of construction information and knowledge of construction methods and processes. Acquiring these, of course, is a chore that accumulates with experience, but which is so vital to the success of the details– the construction; their projects and their drafters. In addition this requires an on-going effort to keep pace with new methods, and systems, and the modifications that are [or can be] made in both manufacturer and utilization of those items. Everything [item, devices, implement, material, systems, complex, etc.] is not always used in exactly the same way. It is then to know how they can be used, in differing formats and situations, and still provide successful results.

AND this is very personalized since each person will gather varied experiences from each project that is worked on. The collection of this personal knowledge then lends itself to creative and proper solutions, achieving collectively in the new

project effort—it is that collection of individual information that is the major input to project success– the reason every building does not look like all the others!

In the final analysis, the success of the detailing process is a matter of the individual relationship with the information conveyed and given over in the process. It is simply that fundamental! While you have resources and support around you [since you a member of a team] your personal values, skills, attitude, experience, drive and professionalism are the critical factors. How you approach your tasks, how you pursue them and your caring about how they turn out are your paramount contributions to the team effort.

"Attention to detail" is not merely a catch phrase, or motto. It is and has, for a long time, been a description of a personal attribute, present in some people. Often this is developed through the work that the person does or pursues. The phrase is really an expression of caring about the work, and trying to excel in execution. This directly involves a personal, and individual dedication to the task– not exclusive, but exercised whenever detailing is being done. Certainly every task in the services of an architect or engineer require the same, but detailing, it is suggested, requires such dedication at a higher level.

The quest for perfection is most rewarding and satisfying, in how much better we become just for the sake of trying, even though the goal is never reached.

It also indicates, at least in the mind of the worker, that the work needs to be precise, accurate and complete, to be successful, and fully acceptable to one's boss and to any client involved. Of course, this is in direct contrast to a cursory, shipshod, arms-length approach where work is done quickly but with no attempt to ensure its veracity. For example, an accountant takes great pains to see that all accounts are correct and balanced. Ignoring or dropping a penny difference, here and there, seems quite innocent but, over the course of time, this can add up to an imbalance, which is intolerable.

"A detail-oriented architect optimizes the inborn value and tenacity to seek and achieve the level of precision and accuracy, which is short of perfection by only the slightest of margins. Yet the quest for completeness, and the caring for accuracy and correctness is pursued in a quiet, unassuming, and most professional manner, seeking assistance as necessary [but usually rarely] as his/her command of the information, material, devices, and systems are far beyond the level of mere

familiarity, but approach a fully fluent and functional level. She/He is talented, beyond imagination, in the ability to concentrate, to focus the effort and masterful in satisfying clients with insight, professionalism and expertise".

-Anon.

Is this a description of Superman, or of a reclusive Casper Milquetoast? Neither really— just a rather flamboyant view of the characteristics that many people carry with them to work [and more than likely use in their home life too]. And it should be added, this is no shame, or second-class designation for such people— their contributions are far too valuable to draw any level of scorn or dismissal. Hidden behind the scenes, their work is a direct and telling part of success— in self, in office, and elsewhere. Note the many facets to this "person", and how they all combine to produce work of high quality, which tends to maximize client satisfaction.

The Detailer is:

- able to plan ahead [what needs to be shown?]
- able to envision eventualities/possibilities [in the construction, and in the use of the project]
- able to mentally formulate solutions [since nothing exists during design/documentation], though also being:
- highly conversant, technically [construction knowledge]
- flexible in mind and application
- open to new materials, products and solutions
- ready to solve similar problems in differing ways
- resilient to meet changed conditions
- astute to construction processes, jargon, and skills
- mindful of potential impact on project cost
- skilled in clear depiction and communications
- cooperative with client, discipline colleagues, and field personnel
- attuned to new methods, and concepts
- firm in providing valid and complete information
- dexterous in thinking and bringing variant conditions together
- careful and caring in execution [more than 1 solution]
- AND overriding all, at all times— careful and caring in execution!

Obviously, there are details in every line of work, but the phrase really reflects more about how a person deals with information or techniques while performing the tasks. Most

work can be done, in an adequate manner with relatively little regard for detail. This quite often is satisfactory, but may be less than desirable in the long-term. Dealing with detail and resolving "loose ends" and other problems tends to provide a better, longer lasting product, and a higher level of client satisfaction. Adding "exactness" aids the effort.

Design professionals should ensure all details are carefully and clearly documented in the plans and specifications.

Details and loose ends should not be left to contractors, nor essential performance and reliability features to code authorities to assure compliance.

- "Consulting-Specifying Engineer"
magazine, May, 1997

In architecture and construction, though, a less than vigorous effort at detailing will directly result in suspect work, perhaps inadequate, or unsafe, and quite often not satisfactory to the client [and clients are, now, more demanding with each passing day]. In many projects, the level of client satisfaction has been raised to "precision". Yet construction remains as it always has been— "an imperfect science". With worker-developed skill levels diminishing, and with less worker dedication, self-esteem, pride-of-work, and productivity, construction is trending toward even more imperfection. There is an attitude in many projects that accept almost any quality of work, so long as the work is finished, on time!— with little regard for any level of quality above adequate. Also, there seems to be some correlation with larger, more costly projects that are pursued on almost impossible time lines. Obviously there is a strong element of attitude and perception in this, where motivation is low and the worker is simply working "for a pay check", and not to produce work to enhance self-pride and satisfaction. This is most unfortunate since it is a widely held situation, with, of course, some extremes which defy the norm.

Detailing do not come through flashes of genius, strikes of lightning, direct divine intervention, messages in bottles bobbing in the ocean, or sudden realizations. It is not pre-ordained, and often is really not all that clear prior to establishing the overall construction scheme and system[s]. It is not automatic, constant, predictable, or stock! Even checklists fall short of fully comprehensive listings of details— mainly these note those details that are the most common [to all projects], most mundane and routinely utilized. Neither is it calculated, but rather is responsive to the conditions and the specific

needs of the construction and/or the project. Rather details come from a full understanding of the construction currently required for the project, or that which is easily and reasonably anticipated for use. With this there is the application of a depth of construction knowledge that allows one to be most flexible and adaptive, and fully able to respond to changed conditions. No two projects are exactly alike. Even prototypical projects have some changes and nuances in them as they are set in new and different surroundings and circumstances.

Detailing may well be one of those proverbial situations where one must "feel" the approach and solution, without a known or specific path. In addition, one must be able to select from a host of proper and possible solutions, that one from the short list of possibilities that is "best" for the project's situation. It is here, often times, where the most innovative and ingenious solutions in detailing are done— creative, responsive, and contributive!

This trend has to be addressed, early-on and in a most positive manner on a project where the client and indeed the project itself demand near perfection because of both client and regulatory requirements. Every project needs to be perceived, by all participants, as a new opportunity to excel and to produce better work than before. Often the type of projects sets the demand for higher quality design and work. Projects where consumer goods, and particularly food products, medications, and similar human consumables are made or processed impose an elevated level of "perfection". This appears in sanitation, cleanliness, freedom from infestation, cleanability, wearability, etc.

However, in every project there is a need to establish a level of quality involving a search for near-perfection for proper construction and client satisfaction. No design professional should have, at any time, an attitude that "barely adequate" is the correct level of expertise and quality permitted. Even where building codes set out only "minimum" standards, providing better conditions, more substantial construction, etc. are in order to the point where they are still supportive and reflective of the budget and client demands. Doing more than required by code is admirable, extremely helpful, and certainly to the benefit of the client.

The trade worker too needs a renewed motivation to produce the highest quality work he/she is capable of, within the context of the project demands as expressed in the contract documents. While motivational talks, high-tone direction from supervisors, and firm instruction on the job site may induce some effort for increased quality-in-the-work, the work depicted and described on the contract documents also sets

the "tone" of the project. If these works are clear, direct, instructive, positive, informational, and in a format for easy assimilation, they set demands on the workers. There may be need for a reminder that work is to be done "in strict accord with drawings and specifications". Free-lancing and lackadaisical efforts simply will not produce the work required, and will, therefore, not be tolerated— no threat! Just fact!

Much of the "imperfection" in construction lies in the fact that professionals can draw details with great accuracy and "exactness". This is especially true even more now, with the CAD produced drawings. Often the precision seen in the drawing simply cannot be achieved, to the same degree in the field. Even with power tools and good worker skill, the actual work will contain slight variations, which in the end product are of no consequence. The imperfection are not a matter of unsafe or inadequate construction, but rather a lack of the precision which can be achieved in creation of the documents— a matter of the "theoretical" versus the "actual". It is noted here, though, to defuse any impression on young readers and professionals, that what they include or see on the drawings will exist exactly the same way in the actual construction. While quite similar, there will be normal and natural irregularities in the work. Realizing this is part of the experience that must be acquired to better understand construction as produced to meet the contract documents.

This also shows the direct impact that the professional has on the project by virtue of what is shown, and how well it is shown on the contract drawings. The drawings themselves set the level of quality the professional desires in the work [and by extrapolation, what is desired by the client in the finished project]. This is an aspect of the work that is not readily apparent to the casual observer, but which is a real and important part of the professional effort. In fact it is better called a very crucial part since it is here where the professional provides the linkage [sets out the scheme or format] for matching actual work with the final finished project anticipated by the client by virtue of the approved design concept. This "matching" is worked from the beginning of work and moves toward completion. It consists of doing the work, as depicted on the drawings in a manner whereby the unseen ["rough"] construction provides a proper backing for the finishes, and hence the complete, and finished project.

The fundamental concept here is that like a great many things and efforts— the underlying frame, structure, or construction— simply must be fashioned and installed correctly and soundly. If done, this then provides a base, matrix or substructure whereby the thinner, finished products can be installed or applied, forming the correct shapes, features, and planes. Much

like a photograph, if the negative [the fundamental "structure"] is faulty, the final print will be less than desirable. Misalignments, incorrect planes/shapes, lack of true/plumb/level work, improper sizing, weak construction, and other nuances in the underlying construction play havoc with the final appearance of the project. Therefore it is essential that the professional be well aware of these maladies.

Being so aware, it is incumbent on the professional to eliminate or prevent such conditions from occurring in future projects. The details of the projects may change, but the underlying principle in the details must survive and be accounted for, project by project. This is one of the considerations for determining whether a detail is a good candidate for storing and establishing as a "standard" repetitive detail. Obviously where variation is wide, and slight circumstantial conditions are variant, the detail will not be more than a "project-specific" detail, valid for a single use and project.

The responsibility and onus is squarely on the design professionals and their staffs [including, of course, EACH individual member!] to provide the necessary project information to the constructors and field personnel. Since the professional's design team is the sole entity who knows literally everything about the project and its construction, the responsibility to communicate clearly, completely, and properly to the field is unequivocal- and demanding!

As agent to the owner, the professional is contracted to act not only on behalf of the client, but also in the client's best interest. At a basic level, the client is saying that with little design and construction knowledge and experience, there is a need for someone else to perform these functions for the client. By hiring and contracting with a design professional, there is an "agency" relationship set up- a fiduciary relationship. This places a strong set of requirements and obligations on the professional, which is committed, by other instruments, to act legally, ethically, safely, correctly, and completely.

In spite of what project delivery system the client may choose to use, this relationship, and these obligations do not change. Many clients see no need for professional involvement after the documents are produced, and the project is ready for construction. When this very unfortunate decision is made, the obligation and onus is raked up in that the professional loses control of the project, and what could turn out to be perversion of the documents- and the project- at the hands of others. Thus, the documents produced simply must be the very best the professional is capable of producing, to protect the professional should any subsequent act regarding the project causes legal or safety issues.

It goes without saying that the professional is looking to her/his staff to support the effort to the limit, and that they, too, understand the full implications of their actions, products, and efforts. "Almost" and "not quite" are not acceptable answers. "Ask," "find out" and "ensure" are not just catch words, but rather they are valid and most important directions from the professional.

Drawing value

The key to successful execution of the burgeoning complexity in our projects is in simplification and clarity of the quite varied and innumerable parts. Even what may be called "normal", "familiar", or "traditional" materials, systems and methods of construction are now being stretched, stressed, re-configured, and made to perform in new ways, or in new roles. This, in turn, necessitates that the field personnel [trade workers, etc.] have all of the tools, both physical and mental, to cope with this new process. Ample information is required, of course, but in such "doses" as can be easily understood and assimilated, and executed by the trade workers. The information itself is becoming more complex as it now must be descriptive, illustrative, directional, crystal clear, and perhaps most importantly, quickly and easily assimilated and used.

The professional, and the "detailer" need to adapt and adjust their work and information to the audience they serve. Obviously, then, we also need to break the complexity down into smaller segments, and then fully depict and explain those segments. By installing these smaller portions in their proper sequence, we create a collage of both information [prior to the actual execution], and progressive, contributory construction during the actual construction work sequence.

This entire sequence is well-served, in the documentation phase, by properly conceived and executed detailing. The crux of this is carefully and thoughtfully selected locations, and production of quality details. The level of quality developed or incorporated into the details directly contributes to the value of the details, individually, as they become part of the actual construction work. Therefore there is an irrefutable need for objective evaluation of each and every detail, at every level of effort- job captain/project architect, person who identifies the need for a detail, person who chooses the solution to the problem, person who sketches and develops the detail, and those who create the final presentation of each detail.

Basically, there is need for all personnel, in the professional office [and removed from the academic setting] who utilize the CAD programs to fully understand that the products of their efforts are no longer dead-end, isolated, unrelated, "turn-it-in- and- get-a-grade" academic exercises.

In the professional office, the products instantly become vital communication tools, which convey a myriad of essential construction information and direction to the field. There, those invaluable communications are acted upon, and utilized in the actual work processes. Therefore, poor, marginal, and barely adequate detail drawings are simply unsatisfactory!

Dtlvalue

The overall value of a detail can be evaluated and quantified to some degree. Granted there are numerous mutations and

circumstances, but in general each detail can be "graded" as to its primary value to the project- a part of the communications sent to the field personnel. In the chart, these levels, or "grades", have been applied- good, fair and poor. Each of these has been noted under the Technical Solution, the Drawing itself and the Notations adjoining the drawing.

Since each of these values can vary, the chart shows how the various combination work to the produce details for working drawing set, and how they present themselves as communica-

EVALUATION OF DETAILS			
Technical Solution	Depiction	Documentation	Communication
Detail content; solution/ system/mat'l selection for problem	Drawings; clarity, line weights, accuracy, data separation; readability, mat'l symbols	Notations; number, location, brevity, correctness, tie to drawing	Overall quality and value of information, problem solving, and directions sent to field personnel
fair	fair	fair	marginal
fair	fair	good	usable
fair	fair	poor	poor
fair	good	fair	usable
fair	poor	fair	poor
fair	good	good	90%
fair	poor	poor	improper
fair	poor	good	poor
fair	good	poor	poor
good	good	good	good
good	good	fair	90%
good	good	poor	poor
good	fair	good	90%
good	poor	good	poor
good	fair	fair	marginal
good	poor	poor	poor
good	poor	fair	poor
good	fair	poor	poor
poor	poor	poor	recall
poor	poor	fair	recall
poor	poor	good	poor/recall
poor	fair	poor	recall
poor	good	poor	improper
poor	fair	fair	poor
poor	good	good	improper
poor	good	fair	improper
poor	fair	good	improper

Example of conclusion from chart [highlighted cells]: If you have FAIR technical content, with FAIR depiction, and POOR notations, you will have a detail that is POOR in its communication to the field personnel. Thus, the primary end-result is very questionable- perhaps the detail should not even be used!

Fig. 8-2

Chart assessing the variations in how project documentation is fashioned and how this effects the value of the documents as construction vehicles

tions tools. As the example in the chart notes [gray portion], reading across a line, left to right, gives the combination of values, which lead to the communications conclusion in the right hand column. Here, in each example, it is quite evident that the three elements—content, graphics, and notations—are mutually supportive, mutually dependent, and equally important. Failure or lack in just one element can drastically influence and downgrade the other two. In extrapolation, one can assess similar relationships between the knowledge required, the level and skill of effort expended, the time involved, and the direct value of the detail.

The primary lesson to be carried away from this chart is that of the 27 combinations, relatively few produce truly good, marginal or barely usable details. Surely this is conclusive that attention must be paid to each aspect of the detail— technical content, the graphics [drawing itself], and the notes used to support the drawing.

It can be agreed that detailing incorrect or inappropriate information even with good presentation techniques is wholly unacceptable; but we need always to assess the impact of detailing good and valid information with poor, substandard, murky, confusing or inappropriate presentation techniques.

Evaluation Issues	5 Excellent	4 Good	3 Average	2 Fair	1 Poor
Material Compatibility					
Aesthetics—Overall Design					
Corrosion Control					
Expansion Control					
Contraction Control					
Weathering Capability					
Constructibility					
Structural Capabilities					
Material Availability					
Thermal Characteristics					
Water Permeability					
Acoustical Qualities					
Fire Safety					
Maintainability					
Tolerances					
Total Points					

Detail Evaluation

- Acceptable
- Unacceptable
- Needs Refinement
- Requires Further Evaluation and Testing

Fig. 8-3

Grading Sheet to assist in understanding how a detail truly measures up as either a project-specific detail or one that can be retained as a standard detail [repetitive use]

The details

It's extremely valuable when you're able to see the big picture, having risen far above the mundane details. Yet it is just as important to know and understand the nature of those details. And for that, there is nothing that can replace actual hands-on experience. Most endeavors benefit from a competent manager, and managers become competent through intimate familiarity with what they're managing.

How can you direct someone to tend your garden if you're not regularly digging in the dirt yourself? How can you develop a successful customer service strategy if you're not regularly dealing with customer issues yourself?

If you consider yourself to be above the details, then those details will very likely bring you down at some point. Certainly delegate when you can, but be sure you know and fully understand what you're delegating.

Modern life is complex, and no one can be expected to understand all of the intricate complexities. Yet by the same token, it is essential to grasp the fundamental details upon which your world depends.

Be willing to get your hands dirty with the details of life. And you'll be well equipped to make the big picture even brighter.

Drawing preparation

There is an obvious, increasing, current and recurring need to review the use of CAD operations and techniques in the production of architectural and other working drawings. Thinking, in far too many instances, has been reduced to a matter of "how can we enter this information into the CAD process" – technical thinking has been reduced to a minimum as applied to the actual creation, development and refinement of the drawings themselves.

The point, here, is that it is extremely risky to continue to allow details [and other drawings] to be merely "dressed up" or "cloned", without really being analyzed, understood, and developed with workable solutions. Too often, drawings are being "thrown together", too quickly, and without really thinking through what they are to do, how they work, how they contribute, and perhaps more importantly, how they FAIL to work or do the job we intend for them! And this does not begin to address the issue of making a sketch drawing BETTER, and more complete by the addition of pertinent information, making a better presentation, correcting inaccurate information. Basically this involves converting a rough, manually drawn "sketch" into a fully presentable, usable CAD-produced working drawing,

truly valuable in the field. ALL of the foregoing carry a need for personal and individualized attention and resolution.

Without this type of rationalizing, analysis, and improvement, drawings going to the field contain too many flaws, too many "gaps", too many questionable aspects, misdirection, and too little true solutions to problems. This scenario is costly [either the contractors "guess" at our intent, ask numerous questions to ensure that they understand, or they make unfounded decisions on their own- any of this can add cost for extra work, etc.].

Where they guess, we are open to situations where problems that develop are traceable directly to our efforts. If the guess is wrong, and our work is faulty, then we have compounded problems. But if the work is executed as we depicted it, but includes the results of a bad guess, we still have unnecessary problems. Additionally, the project is at risk since the work may prove not to be fully workable or adapted to the correct project solution.

The remedy to much of this is to increase our diligence and sensitivity for upgrading our skills in thinking solutions through, calculating, uncovering risks and problems, and using the best collective knowledge available to depict correct, workable and positive solutions. This is not so much a matter of right and wrong, as it is one of slipping into easy, quick shortcut methods which seem to solve problems, but in reality create more problems than they solve. To remedy this, we must return to basics, to human involvement [devoid of CAD attributes] where the human elements of analysis, calculation, knowledge, insight, experience and innovation are the skills and techniques at hand, where pencil/pen and "bumwad" become the tools and instruments of choice. It, too, is a matter of choosing increased professionalism over status quo!

"....ultimately the use of the computer is the combining of the skillful hand with the reasoning mind. To relate directly to computerized drafting, isn't this, indeed, what our mind-set should be? To manipulate without direction or regard for the final product is a hollow, nonproductive waste of time, in regard to working drawings."

- Malcolm McCullough
Assoc. Professor of Architecture,
Harvard Graduate School of Design

Consider- No matter your current station in life (graduate, degreed- bachelor/associate/master; registered; co-op; designer/operator), the success of the project you are working on depends, DIRECTLY on how much YOU, as an individual,

care!!!! Caring is a form of commitment which requires you to strive for a high level of dedication to your work [and profession], and NOT just showing up to do a job! It is a drive to contribute in a meaningful manner, and not merely to function. It is a penchant for wanting to be better, to do better, and to make better- minute by minute; day by day; project by project; and, indeed, drawing by drawing!

You have been hired because of your knowledge and skills, and your experience in project production. This speaks to the fact that you know what has to be done, and at least in one way, you know how to accomplish the task. There is, though, a need to reach down deeper and utilize the other ancillary information, and knowledge that you have, and the education you have had, to bring forth not only more, but somewhat different information, and skill.

Even training/education in a "minor" aspect of a degree program is of value, and is part of what we are asking you to bring forth, develop further, and utilize. Even this effort calls for, first off, your renewed dedication and simple caring.

Caring has a direct impact on the project and the cost. For example, if you show a detail requiring work that is not normally done, or is not normally done as you show it, the cost of the project will go up. Simply because there is a question as to what will be required- if you insist on "your" way, the added cost is justified to your client's detriment. While it is true that staffers in document production are not always fully aware of the latest in intricate or unit pricing [cost per portion or item of work] cost is a consideration that must be kept in mind. There is a very delicate balance between cost and the need to do the right thing. That is, making a detail fit better to the project circumstances, may have an impact on project cost. Often contractors, without the depth of knowledge of individual project requirements tend to want to execute the work at the lower cost- but perhaps inadequate to the need. Here the detailing becomes crucial, and the individual detailer needs to have depth and flexibility of construction knowledge, and proper use of more experienced staffers and project leads [for advise, direction and analysis of proposed detailing]. Certainly, here is where there is need to overcome reliance on standard details, CAD or BIM- this all calls for human resolution based on correct analysis. Simply human care is critically important to prevent "over-detailing" and "under-detailing" where either too much is shown; it is too intricate; or not enough is shown, which allows for inappropriate free-lancing of the work.

You have to care about each line - what it does and doesn't do, and more importantly what it is SUPPOSED to do. So, too

with each note, word, dimension. Be aware and sensitive to condition- does the door open into a brick wall; why is a door opening "hatched?; misspellings; do your dimension add up to overalls?; do things look neat, controlled, and orderly?

Giving a damn - counts! "Blowing things off", forgetting, "sloughing off", glossing over, and simply not understanding (and being too proud to ask questions for fear of looking dumb) doesn't cut it. If you are charged with making changes noted on a check set or sketch, make absolutely sure that you make ALL of the changes, and in a correct manner. The same goes for any other assignment that you may feel is trivial or improper use of your talent and ability. IF you do not understand [try to learn something from every task] ask questions or for an explanation. This will add to your experience and serve you later in your career.

NEVER consider any assignment or work on the documents to be menial- your Project Architect knows what must be done, and is looking to you to help, assist, aid, and to contribute in a positive manner to completion of them.

It is your job to do the work assigned to you in the most complete, well-depicted, well-coordinated, and absolutely pertinent manner.

"Slopping" something together is indefensible, especially with the resources and people around you who can help. Besides being totally unprofessional, this attitude wins you no prize as detailer, team member, or valued staffer- and could lead you to the door! You need to remember that the office and all the members of the team have a common interest- producing a good, proper and profitable project. Hence EVERY team member must contribute to the best of their ability.

Thinking does NOT hurt, but gives you a world of pride, and makes you a valued employee.

There is NO such thing as a "dumb" question - ask, ask, and ask! (It's only dumb to think there is a dumb question!!!). If you feel you have a possible solution, bring it along, but be sure to ask, ask, and ask.

YOU MUST run, control, and think for the CAD system- YOU!!

From now on, consider CAD much as you do any other tool like a pencil or pen! This is not demeaning or casting dispersions on CAD but it correct perspective and recognizing that it is not a do-all-end-all- it has distinct limits and those limits rely on proper processing by human input. CAD and computers

do not contain or originate; they may generate or produce, but ONLY where data is introduced by human effort for the purposes of being processed by computerized functions.

It IS exactly that- a tool- it does no more than a pencil; OK so it's faster, but that in itself is meaningless, if content, intent and clarity are not present. Here values of the past are still in-place and most certainly valid. They are not based on the media involved, but rather of the quality of the information portrayed and how well it can be communicated to other users. A great many drafting values are seated in the past decades, generations and procedures- they endure because of their intrinsic value and their residual contribution to the best of documentation.

CAD is a marvelous, BUT inanimate machine- it cannot even turn itself on without you or another timing gadget. It doesn't know what to do, when or where; all it knows is what YOU tell it- tell it foolishness, it produces foolishness- who then is at fault? It doesn't know how to correct your mistakes, or how to do something you failed to do.

By the same token, CAD has great capabilities- granted- but there is NOTHING that says you have to use all of them, or all of any one of them. CAD will insert brick symbology until the cows come home- you give it the extent, and the command for the symbol and WOW, look at all those brick!!! [But have you, and CAD, contributed anything of value to the project? Don't allow yourself to become literally "a slave" to CAD, so engrossed that you become incapable of working without the machine- where your tremendous human capacities are negated and allowed to dwindle away from disuse. Don't allow IT to rob you of your talents outside use of the machine. Yes, there are others who will pressure for quicker solutions to meet cost and time considerations, but these can become problematic where your product is faulty- due to your inattention, inadequacy, or inability.

A simple, but common example, is the use of automatic CAD dimensioning which produces ridiculous sizing and distances, [7'-3 15/64" for example] which either complicate construction with untenable tolerance that are virtually unachievable, or add cost for the attempt, for no good reason. Your control of this one process is obvious- think! Make the machine do your bidding, based on your thoughts, and in a manner that you KNOW is right, and proper.

If it doesn't look right- it probably isn't! And, in addition, it is not right just because CAD produced it. By developing or regenerating your knowledge and experience, you can come to rely on your "gut feeling", and NOT on what a machine produces.

In none of this are you considered dumb or inadequate- you are either unprepared, inexperienced, or have allowed yourself to fall into "the easy way". There is no way to overcome this except by infusing yourself with new drive and new direction, and be getting field and office knowledge and guidance; in asking questions and advice; in seeking to better yourself through reading and educational courses that increase your insight to construction. It is easy to understand the feeling of accomplishment when one produces a very good drawing, even via CAD. But there is a similar and maybe even stronger feeling for developing the information, and solving the problems, which are depicted on the drawing. While literally "unseen", this work is more important than simply transferring the work from a mental to a real state.

Mentally walk yourself through your work- the details and other drawings. Ask yourself if there is enough information that YOU could build the work. Try to envision how the drawing solves the problem at hand- how it does [or does not] provide the protection, strength, or other attribute for which it is to be used. This is basis for simply understanding what your work and drawings are all about. It is not wholly and exclusively about pen sets, scales, plotting, schedule, and other aspects of the work which surround your effort. Focus! Keep your eye on the goal- remember your goal!

The IDP program proves, forthrightly, that the architectural schools are NOT teaching everything they should or could within the time you spend with them. Many academic priorities are wrong in that too much time is spent on some areas of instruction, at the expense of other equally necessary topics. There is need for curriculum reviews, and a determination what, exactly, the basic architectural course should contain. And with IDP in serious disarray, students and graduates are left in a precarious position. They have to engage OJT, and need to add to your knowledge and career status by asking, and finding out from others who have been "bloodied" and have also learned from those before them. All too many professional offices find an organized education/training to be merely a money-drain, and something they simply will not entertain. They do not wish to train new personnel, only to lose them too soon to better positions, or to higher salaries, elsewhere. This shortsightedness is most tragic for both young professionals and the offices.

In addition, this malaise and the cost of registration have soured many young professionals from taking the Architectural Registration Examination [ARE]. IN part this is a major disconnect between the graduates, the registration agencies [both states and NCARB] and the real needs of the profession. Stifling the flow of young professionals into the active

professional sequence in no way assists the growth, much less expansion of the profession— nor does it "refresh" it with valuable new "blood" , talent, and enthusiasm.

There is a great deal to learn, but don't fear this—it comes in steps or stages, and each project will add something to your personal storehouse of details, concepts, approaches, and solutions.

In the old days, ever so often, each day, we looked at our drawings upside down; you'll be amazed at how easy it is to spot errors every time you do this. Look at the drawings through half-closed eyes, and you'll see line work that is too light for proper readability and reproduction.

Remember, a line has a beginning and an ending- it goes "from" somewhere "to" somewhere!

Check and coordinate everything no matter how small. If each of us "makes sure", we'll do a much better job, quicker, and at less cost.

You will make mistakes! But make them in the office where they are easily changed. Do let things "slide" hopeful they will be caught or remedied in the field- only "bad" things happen that way.

KEEP CONTROL!! Only you can make things happen, including making the CAD machine do something. This means using the best information and the best technique(s) to get the project documented.

Don't be afraid to use resources. Most of what we use is shown or pictured somewhere; we use a lot of "standard" materials or systems. Look them up- reference books, other project drawings, Sweet's Catalogs, product reference manuals. Just be sure the drawings or details you use apply completely to your work- nothing is more distracting than a detail no one can figure out, or place in the job. If you need information, talk to your supervisor and suggest that the product representative be called, or that internet information be used or a product catalog be requested.

DETAILING HELPS

The time comes, via obvious need or request, where it is a matter of one detail and one person! Here the person must be able to call upon valid and reliable directions to produce the needed detail. Eventually in a career, these become mental processes that are automatically utilized without review. Until that time the following should reviewed and considered to ensure the highest level of detailing.

The following are checkpoints and general principles, which

of course, may be modified by office standards and requirements; the office requirements are, of course, mandatory, and thus require that all staffers adhere to them. This aspect has changed drastically with the increased use of CAD, since similar software is employed and little if any personal modifications occur; this also holds for CAD lettering that at one time had to be uniform even though hand done.

1. All lettering in notes should be the same size, and font. Titles are always larger than notes.

2. Turn on all layers, to ensure that notes and other information do not, 1) overlap each other, and 2) do not overlap portions of the drawing

3. Titles, section markers, door marks, wall type designators, targets, and all other such symbols shall be uniform (see attached), and the same size in all locations. Door marks should ALWAYS be within the door opening (move other "stuff" to miss them)

4. Dimension two thin, adjacent materials like this;

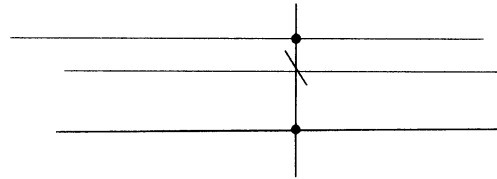

5. Run dimension lines THROUGH the wall [see above]. CAD likes to dimension just to the face of the wall, leaving a gap.

6. Run a line of dimensions between the column centerlines. Locate walls, partitions, and other landmarks (corners, bulkheads, etc.) from the nearest column centerline. Column centerlines are just that- long dash, dot or dash, then long dash, at close interval and continuous through the drawing, both ways.

7. Dimension lines which cross Match Lines require a definite termination; either to a column centerline, to a wall, and with a note showing the distance from the terminus to the landmark on the other side of the Match Line. DO NOT DIMENSION exactly to the match line as this is an invisible line, that is NOT located on-site (it is merely a drafting technique!).

Don't use Match Lines in wall sections. Think of wall sections as a series of details aligned one over the other. If the full height of the wall cannot be shown on the sheet, delete portions of the wall which just show repetitive construction (example- a brick wall), by using pairs

of break lines (and keep them small, too) through the width of the wall. Then merely space the detail work above and below the break lines closer together. DO, though make very attempt to show the very top and the very bottom of the wall.

8. Reflected ceiling plans should show walls, only, and with the same line weight for both new and existing; do not show door openings, etc. (remember these drawings are the view we would see if we looked down at the floor and it was mirrored).

Do not dimension borders of ceiling tiles (the rooms can vary in size and alignment, so the border may be altogether different from what you show). Spaces with no ceiling note as "exposed structure", not "open"; "unfinished" spaces should be shown as that.

In laying out ceiling grids, start at geometric center of room with an intersection of four (4) panels, OR with a panel centered both ways (see specification text examples).

9. Delete north arrows from section and detail sheets; use them on plan sheets ONLY.

10. Be aware of the need to vary line weight; new and existing work; work to be removed; materials that are "cut" in section. This adds readability to the drawings and makes things much clearer.

11. Do not rely on, or "allow" automatic CAD dimensioning to produce and control your dimensions (remember who is in control). Architectural drawings are NOT dimensioned down to the 1/16th's and usually not even to 1/8's. CAD programs often are set to do this, and some engineers tend to do this, but our work is too variable and there is no need for such precision, in view of the normal variation in our materials and systems. If a dimension is critical/necessary, mark it "HOLD"; if you are aware of a dimension that may vary several inches, add + to the number dimension. When changes are made, late in the production, using NTS (Not To Scale) is permitted.

12. When we add material symbols and other "hatching", on both plans and elevations, do this work only in relatively small areas- NOT throughout entire walls. Usually it is helpful to also do this at opening jambs, repaired work, offsets and corners, periodically along long walls, etc.

13. Notations ["Notes"]. It is very important to point out that details do not occur, in the Contract Documents, in isolation- they are supported and augmented [complemented and supplemented] by the specifications or written provisions for the work. Best notes are clear, cryptic, and direct and devoid

of any specifications information. "Roofing system" is sufficient as a drawing note, as it usually is supported by several pages of highly descriptive information about the system, in the specifications. Minimum use of words will aid readability of the drawings [more open space around the drawings] and will prevent confusion and errors. In fact, in the system called, "keynoting" just the specifications Section number and designator can be used to direct one from the detail to the written description. Wordy notations are time consuming, space "gobbling", unnecessary and hazardous!

14. Do some preliminary planning about sheet layout; never allow leader lines [from notes to drawings] to cross ("linear spaghetti" will result); locate notes close to the point of application; leader lines should touch the work, not merely point to, or "aim at" it.

15. Even though they may be applicable, use a separate set of notes for each drawing/detail; don't use one set of notes between closely located details [on the drawing sheets] and merely two sets of leader lines pointing to the two drawings.

Also, ensure that the same note for the same work, but on different drawings, say things identically. DO NOT include specification information on your drawing notes (this includes material information, and installation methods, etc.)

16. Use the "Detail Callout" only where a specific and unique location is involved. For example, every bollard does NOT need the "bubble", but can be noted as, "See Detail 12345", or "Typical bollard". Where other similar items repeat, are continuous, or wide-ranging work is done, use "typical" text in notes, etc., DO NOT repeat the entire callout.

17. Never use such large lettering that the drawing or object is obscured or made to "disappear". Just as with cartoons and comics use the words to aid and explain the drawing.

18. Be extra careful so you never transpose or otherwise "mess-up" a model number or other pertinent information. Don't misspell (Ensure there are no misspellings!).

19. Periodically, ask yourself (but you must be as harshly objective and detached as you can) if you have enough information, on the drawing, so you could build the work. Be careful not to move over things too quickly or "assume" something in your head that is not on the drawing(s).

The use of checklists, and "to do" lists is highly recommended, as well as a conscience effort to coordinate and

communicate your work, findings, solutions, and/or needs with others.

20. Oh, by the way-

ASSUME NOTHING!

Fig. 8-4

Strong express of the soundest of advice to those engaged in the detailing- and indeed the whole project-process. This, as attitude will carry forth as sound procedure and take one to better project documents.

Your work, to be purely professional, should be based on known facts, and not on guesses, hypothesis, or unsubstantiated information. Where so done, you will eliminate re-work work when the "bad" information is finally changed. This is NOT an excuse to be slow, but rather a warning sign to watch for bad information and attempt to avoid, or ask about it.

An area of detail work that is often overlooked, and is very susceptible to assumption, is cross-referencing. Not only must there be care in the creation and development of the detail, but also in setting a location[s] where the detail is applicable- i.e., a cross reference between the detail and its location elsewhere in the set of drawings [noting the actual location in the construction work]. Without due care, here, or in the face of an assumption, this referencing is often lost, and hence the detail languishes and confuses those who are trying to understand and build the project.

Cross-referencing in detailing is vital to the correct application of the details in their correct locations in the actual project work; without it, the value of the details is lost, and the work is confused and impaired.

21. "I guess that's OK"; "Oh, that'll be alright"; "Who cares?"; "No one will notice!"; "Who knows?"; "Let 'em work it out in the field"; "What I put down doesn't make any difference!"
 Wanna bet any of these thoughts are valid?

22. Be very wary of detailing or requiring work that you do not fully understand; your concept may be not only faulty,

but unbuildable; here, only experience is the remedy.

There often is a necessity for you to work out and even sketch out details and other drawings BEFORE you start your CAD operations. With the premise that CAD is a "vehicle" to getting things done, we must accept that the "WHAT IS TO BE DONE" belongs to us, our mental processes, our innovation, our creativity, our resolution of the problem.

There is no CAD key or operation called "Solve problem"! Intelligence in this entire process remains with us, and how we can gather information, perceive conditions and solutions, and create the designs and details to make things happen.

ALL OF THIS HAS BEEN SAID MANY TIMES- AND YOU MAY BE SICK OF HEARING IT- BUT UNTIL YOU AUTOMATICALLY, AND FIRST-OFF USE YOUR MIND AND MANUAL SKILLS, WHEN NEEDED [AND YOU MUST KNOW WHEN TO, AND WHEN NOT TO USE THEM] THINGS WILL GET INTO THE DOCUMENTS THAT ARE ERRONEOUS, UNRESOLVED, UNBUILDABLE, COSTLY, AND AT ODDS WITH THE TRUE INTENT AND NEED OF THE WORK. OUR DRAWINGS MAY NOT EVER BE "PERFECT" BUT WE SHALL NEVER STOP TRYING TO ACHIEVE THAT GOAL! NEVER!

23. You've heard of the "honor system" at the military academies; there is one in architecture also, and in document production. Precious little time is available, in any office, for a complete and comprehension review of every document, detail, etc. What you do or don't do could be overlooked.

You are, or will be a "professional" and with that comes the need to meet a standard of care (note- CARE) which meets doing the right thing, for the right reason, at the right time! Oddly enough, the standard of care that impacts you is part of the legal network which surrounds you.

AND, not to frighten you, but in this world today, you could find yourself in a witness chair in a court explaining why you drew what you did- don't be caught having only, "I thought that would be OK", as your only defense. Litigation is a nasty process (I hope you never engage it!) whose sole purpose is to point fingers and establish responsibility. Following set procedures, and working within the standard of care are of utmost importance.

24. Another important aspect to your "professional OJT and education" is your ability to understand the need to be flexible. Every office will have an office standards manual- the "ground rules" about how the office does things, or wants things done, consistently. Everything we do in one office is not, necessarily, the same way it is done by other offices.

In this, basic understanding of "why" something is done is far more important than how, or under what symbol it appears. We can best serve you, personally and professionally, by giving you some insight into this process.

25. It is very important, for your development, to think for yourself. However, understand that you cannot do this isolated from your colleagues and supervisors. What you put on the documents "commits" your firm. Therefore, take the initiative, do things, think, research, seek answers, ask questions, but at the same time keeping referencing back, and keep your supervisors informed. None of us know every way to do every thing; some of us have the experience to know, a little better, what works best, and what won't work- you need to gain this same information through your career.

26. A good amount of this is "heavy stuff", but is not intended to discourage or frighten you. We all like to have fun, and we want to enjoy our work- that is our goal here. Your satisfaction and ultimate success, as a professional, lies in doing things well, properly- and once!

READABILITY

Technically correct information, on construction contract drawings, is better portrayed when there is distinct separation between materials, devices, and other items. Only rarely does the architect utilize an "exploded view", which in essence is an assembly or installation guide. Normally, sections and details show the work in close proximity, as it will exist when finished.

Therefore, there is a need to be sensitive to, and to execute all drawings by;

- using variations in line weights, within a limited palate;
- treating similar edges in the same manner;
- following the principle that everything cut in section is depicted with dark lines for edges;
- distinguishing between edges of materials and thickness [of thin, sheet material such as sheet metal, floor coverings];
- understanding what the various parts are made of, and mentally visualize what they look like from an end or "cut" view;
- showing nothing on the interior of the drawings should

be darker than an outer object edge; the darkest line on a section or elevation is the grade line;

- ensuring that material symbols do not even approach the line weight of the material edges;
- finding, and understanding the use, delineation and weight of other lines, such as centerlines, dimension lines, extension lines, guide lines, etc.- these should never override any line within the body of the drawing.

All of this can be easily accomplished, IF you approach every drawing, from the outset, with the thought of using varied lines, and where you develop (in association with others, i.e., a fairly uniform system used by all) a single format for the lines. In this way we can direct, control, and prevent "free-lancing" which only makes for confusion and badly executed documents- none of us want that!

It is very interesting and quite telling that at one of the top ranked [2008] U.S. schools of architecture, that runs a co-operative program [school part of the year and work in offices the other part], that the following comments would be made by employers of the students-

Architecture co-ops excel at design, are considered highly creative and innovative, and quickly adapt to corporate work cultures. However, employers are concerned regarding students' ability in construction detailing (technical aspects of buildings) and would like to have the students stay with one co-op employer for a greater length of time.

REVIEW OF SAMPLE DETAILS

Reviewing and analyzing details is a valid and highly recommended exercise useful and productive both in educational value, and in the opportunity to review various approaches used to solving the problems.

The architectural details in this entire book were extracted from actual contact drawings of recently built buildings. They come from the working drawings produced by many architectural offices around the country and illustrate the great variety of approaches to solving similar design problems. The details each serves to illustrate one or more points about correct and proper mechanics for detailing. They serve to provide an opportunity to compare techniques and approaches; to assess relative concept and differing ways of doing the same thing; and to illustrate the vast flexibility available in presenting the information. Regional needs and considerations are also uniquely reflected in the drawings. This all is eminently important for all students, interns, and young professionals. And further significant because, to the author's knowledge, very little of such information is available to budding architectural design professionals.

The re-use of details, either project specific, or standardized, provides a basis for some conclusion, and provides some indication of how a construction problem can be resolved. The circumstances of projects are too diverse to ever declare that a certain detail is "an exact fit" for one project, as well as one or several others. Even when that appears to be the case [with repetitive or very similar projects] one simply must be careful to assess all of the circumstances, conditions and requirements of the project at hand and the details projected to solve its problems.

Design concepts, construction methods, building techniques, materials and project delivery systems are constantly being brought out, evolving or being adapted as the need arises. These all have developed innovations that changed the construction industry—radically and in a relatively short period of time. One way or another all of these changes are reflected in how buildings are put together. The product of this process of fitting the building parts together is the building's architectural details.

The strongest of cautions is given to all users of this book – details in this chapter and elsewhere herein are included solely for their educational and informational value. They are

not intended, suggested, or recommended for direct replication or re-use, even if modified or adapted, under any circumstances that can be envisioned. Needless to say, and as illustrated in this chapter, there is a wide variety in the need, type, style, production and depiction— all most important parts of detailing. This is seated in several sources: the mind and individual approach of the drafter, the demands of the office standard, the perspective of the different disciplines, and of course, the numerous "systems", too often presented as instruction in "the" way to detail. Lack of due consideration, careful analysis, and salient modification are the major factors in producing bad detailing, physically.

Therefore this chapter is not offered, and should not be perceived as or used as a "catalog" of available details, ready for direct use, incorporation or reproduction.

It is necessary to point out that there is a good amount of similar, duplicate and repetitive details. The work shown is common to many if not all projects, but conceived and documented in differing ways. These difference are design oriented; office philosophy, or changed to meet project circumstances— but all directed at solving the same problems. There is no intent to suggest or advocate usage; assess the propriety of right or wrong; or whether or not the detail should be included – nor rather the construction shown is correct for the project and standards applicable. This is plain and simply a small collection of the vast array of and variation in the project circumstances requiring details; they are here to merely provide some insight into the solution to certain problems, and to the motifs, formats, methods and techniques used to portray those solutions. All of these evaluations and ratings of success of failure are for others, including project managers, job superintendents, trade workers, construction instructors, manufacturers and suppliers— those who actually use and rely on the details.

Hence this collection is a purely academic offering and most certainly not one for "picking and choosing" a detail to re-use on a current project. These details are simply and blatantly "learning tools" and not a bank of details that one can directly "plug into" project circumstances.

Regardless [and importantly] there are innumerable ways to detail a single item or complex— and most all are valid. How

this is done, in the final analysis for a given project, must be part of the uniformity necessary in a set of drawings, and the overall presentation contained in the set itself. Hence the lack of absolutes is perpetuated since neither the solution, nor the presentation, is singular and without challenge in one way or another.

This is a matter of instilled technique, promulgated by the schools of architecture where they encourage individual expression, and refinement of presentation techniques on the part of each student. Unfortunately few schools have formal programs in the creation of the "nitty-gritty" working [contract] drawings, in favor of strong presentation-type drawings and virtual "tours". In addition, CAD obviously has blunted if not totally eliminated this effort to large degree. Truly a matter of glitz over the practicality of the true need in the office. Often student [graduates and interns] are left wanting for knowledge of detailing and some basic framework for what must be done and how]

The fact that these details are produced both by manual and computer drafting techniques is of no consequence and does not distract from their value as communication instruments and learning points. Neither does it relegate them to either current, modern or obsolete status. Also, note the wide variation in drafting techniques, reproduction value, and readability- what can and should be better? What is good as is? What can be learned from the perceived failures?

If a project were to be designed and produced by different offices, be it two or more, each final solution would be different- and so would the presentation of the design concept- and its detailing. Latitude in detailing is available, and constrained by the need for uniformity in a full set of drawings [the concept that all of the drawings were produced by a single drafter] Or rather within the production of each discipline contributing to a full set of drawings. Disciplines still do maintain their own perspectives and techniques. There more than likely will never be full resolution here. Although different in approach, now, there is a growing tendency to utilize the same CAD pen sets for all disciplines. This is not so much for anything but a computer systems decision eliminating the need to change the sets. This really inhibits individual design discipline techniques, readability, and presentation, which is more than merely "transmitting information in one way or another!" Unfortunately!

It is universally established, and well settled that architects take greater pride in the presentation of their drawings, than many other disciplines. Beyond "recording" the proper information in an accurate and complete manner, the architect

wants the actual drawing to be eye-catching, highly readable, and well executed. Perhaps this may be considered [unfairly!] as the "art" aspect of architecture shining through, but it does serve as a direction to produce drawings which do make a far better appearance, and places emphasis for highly communication value, along with easy and better understanding of those drawings, in a shorter period of time. All this, of course, is to the benefit of the project work.

Often the drawings of other disciplines are quite bland in appearance, little if any line weight variation, etc., but nonetheless accurate and informative. Adequate, one might say; does the job says another. But perhaps the workers who use these drawings may have become use to seeing similar drawings. There is direct benefit from drawings that are more expressive in their presentation, and to scotch comments, attention to appearance is not an added cost to the client, but merely an expression inherent in the architect, who has the responsibility in many projects to make presentations, and to produce presentation quality documents. The choice of a line width or intensity [or in manual drafting the pressure required to produce a darker line] in their working drawings are merely extensions of that presentation approach to the work- and the expertise and professional prowess of the architect.

These samples following are presented with no priority and no particular comment [for the most part]; case studies and comments follow in Chapter 10. No legends or captions were use to focus interest on analysis and the mechanics of producing the details- and how they communicate as an interchange of technical information. Individual architects rarely have the opportunity to review the working drawings of other architects. Currently there is no way for architects to exchange basic data relating to architectural detailing; discussion of software programs is far more prevalent.

The next 11 pages contain drawings that are representative of details, from various sources, but all illustrating only the installation of bollards [commonly called, "pipe guards"]. These details are typically used at large door openings where they protect the jambs of the openings from being damaged by vehicles. The lesson here is that this single, mundane and innocuous installation can be detailed in such a wide range of, and in numerous ways for both interior and exterior uses. Note the differences between them in the information provided; the scale of details; and the method of display; their placement [as shown in the plan views last in line; a problem if the location of the bollards causes inference with the building wall footings- in which case it is better to move the bollards outward slightly].

The lesson in these particular details carries over to all the others in this and other chapters— even with some standard details. These sample details only serve as isolated representatives of the innumerable ways to detail any one situation, and the variations that do occur both from office to office and from project to project [perhaps even within the same office].

This all strikes at the very heart of the task of detailing, the knowledge and flexibility required and the drawing principles and techniques that can be used, no matter what media of production is used. It is suggested that the highest value in the sample details that follow is seen by applying some simple evaluations to them. For example: overall readability [is it easy to find specific information?]; separation of line by

use of varied line weights; appropriate notations [or too verbose?]; highly unusual construction; ease of understanding the intent and the solution; what works and what does not; what needs to be done differently?; is there too much shown as to be confusing?

Also, readers are strongly encourage to take advantages of every opportunity afforded them to look at, review and learn from the details of others. The motives, motifs, and directions may differ, but in the end every detail has its place and can provide some added insight that each reader can retain mentally and call upon in the future.

To that end, this chapter is but a catalyst!

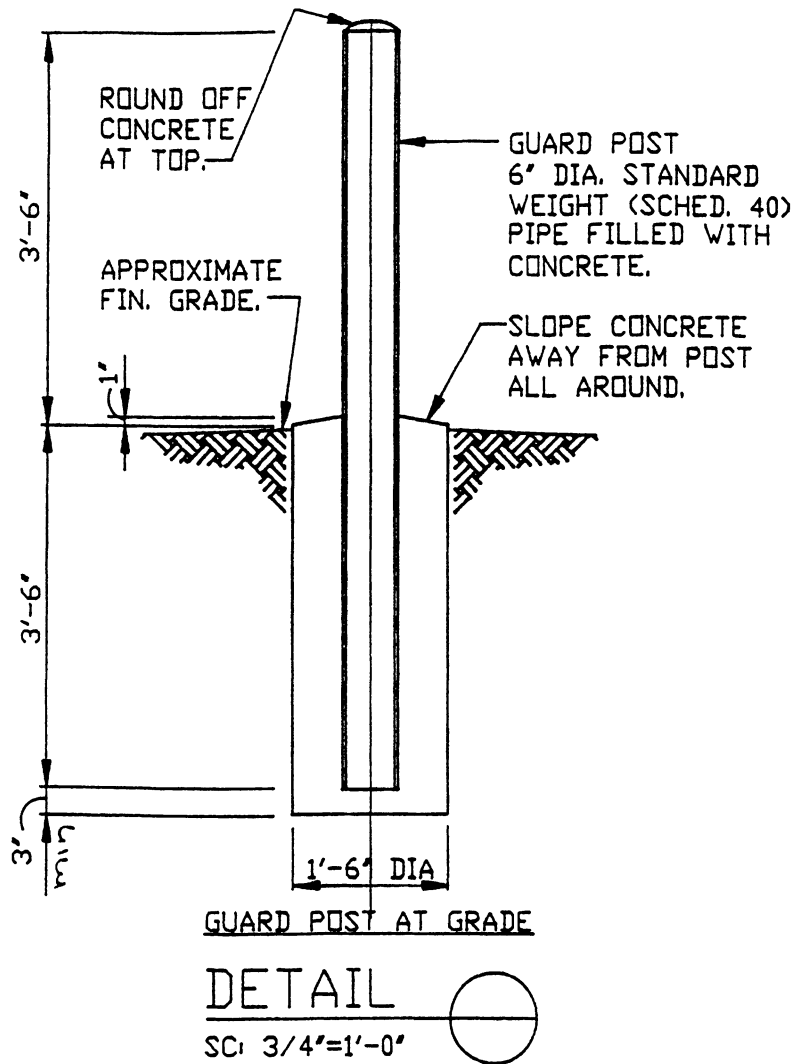

Fig. 9-1a

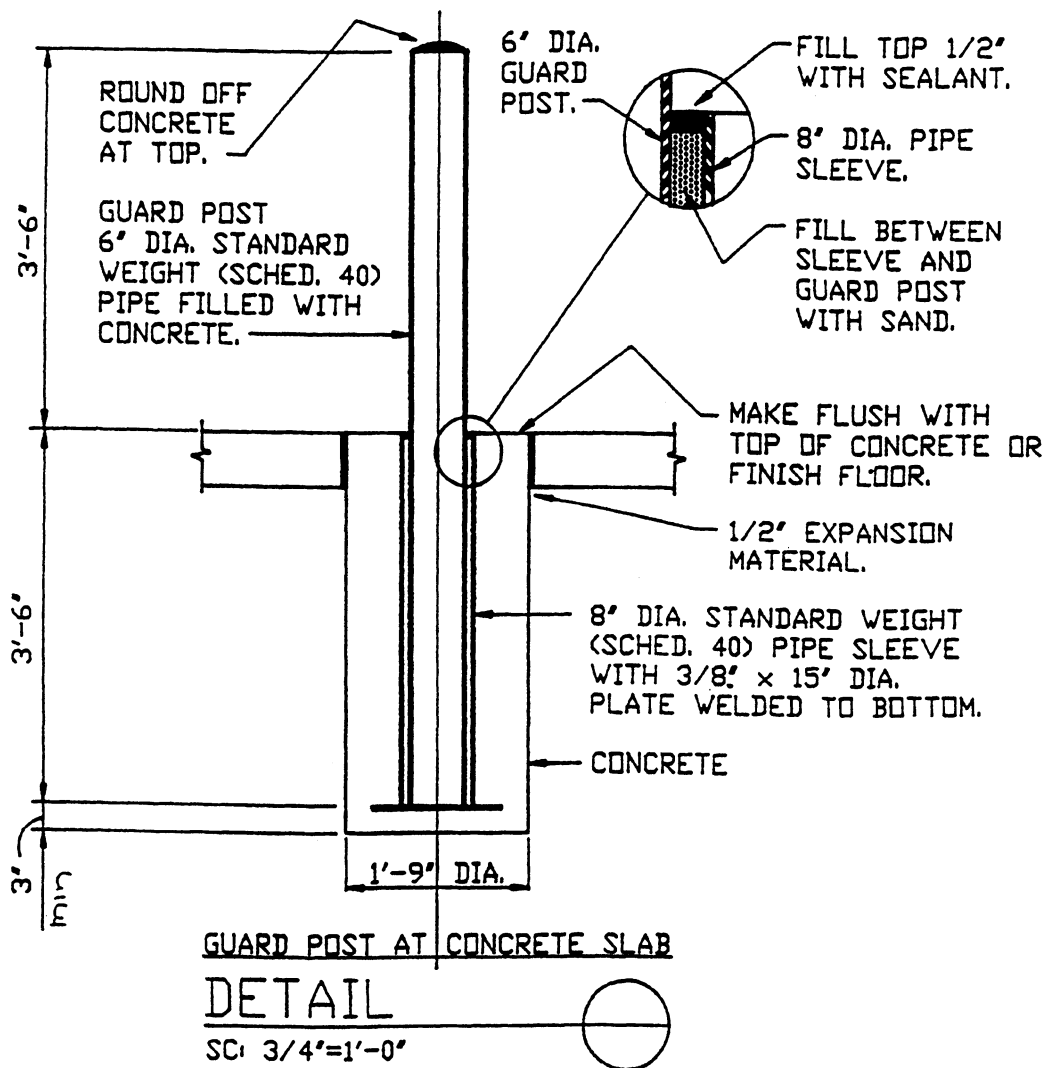
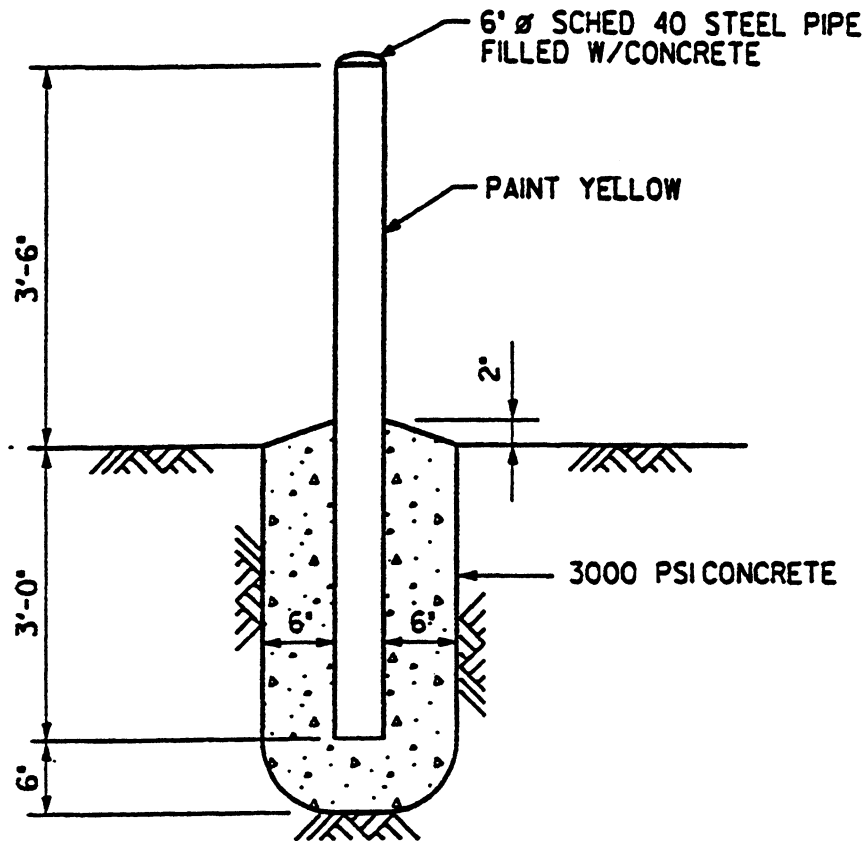

Fig. 9-1b



GUARD POST DETAIL

SCALE: NONE

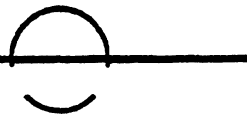

Fig. 9-1c

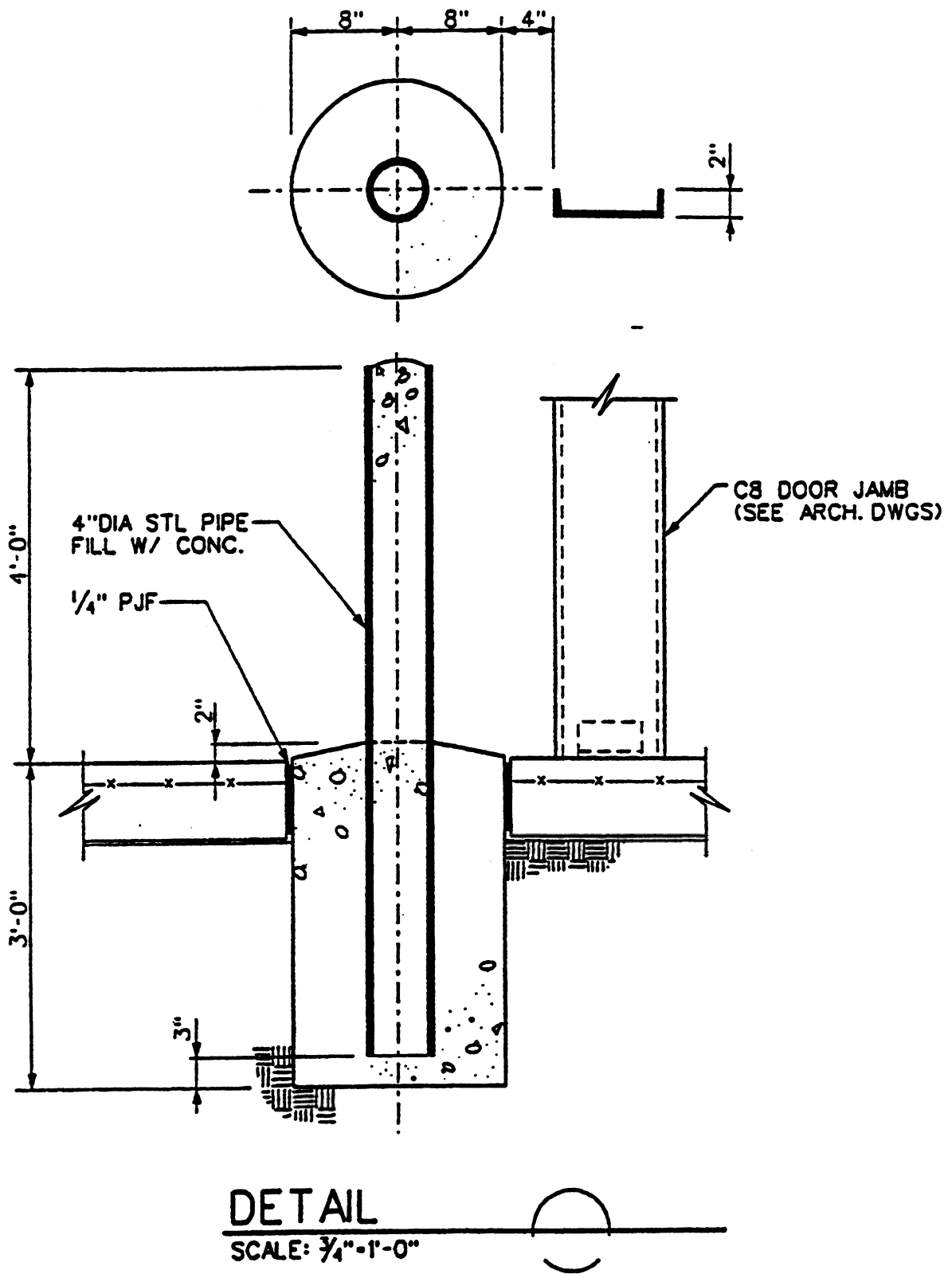

Fig. 9-1d

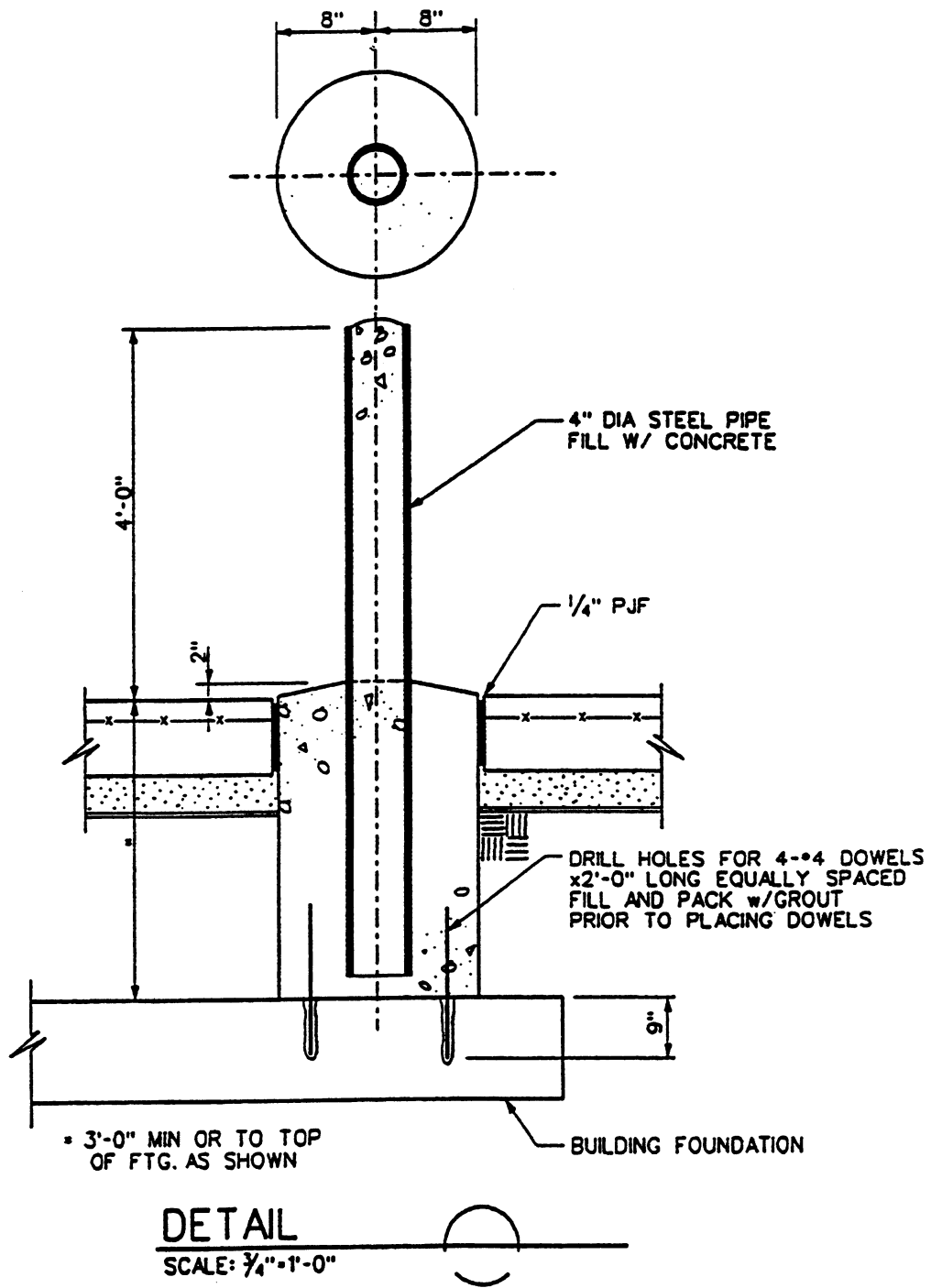

Fig. 9-1e

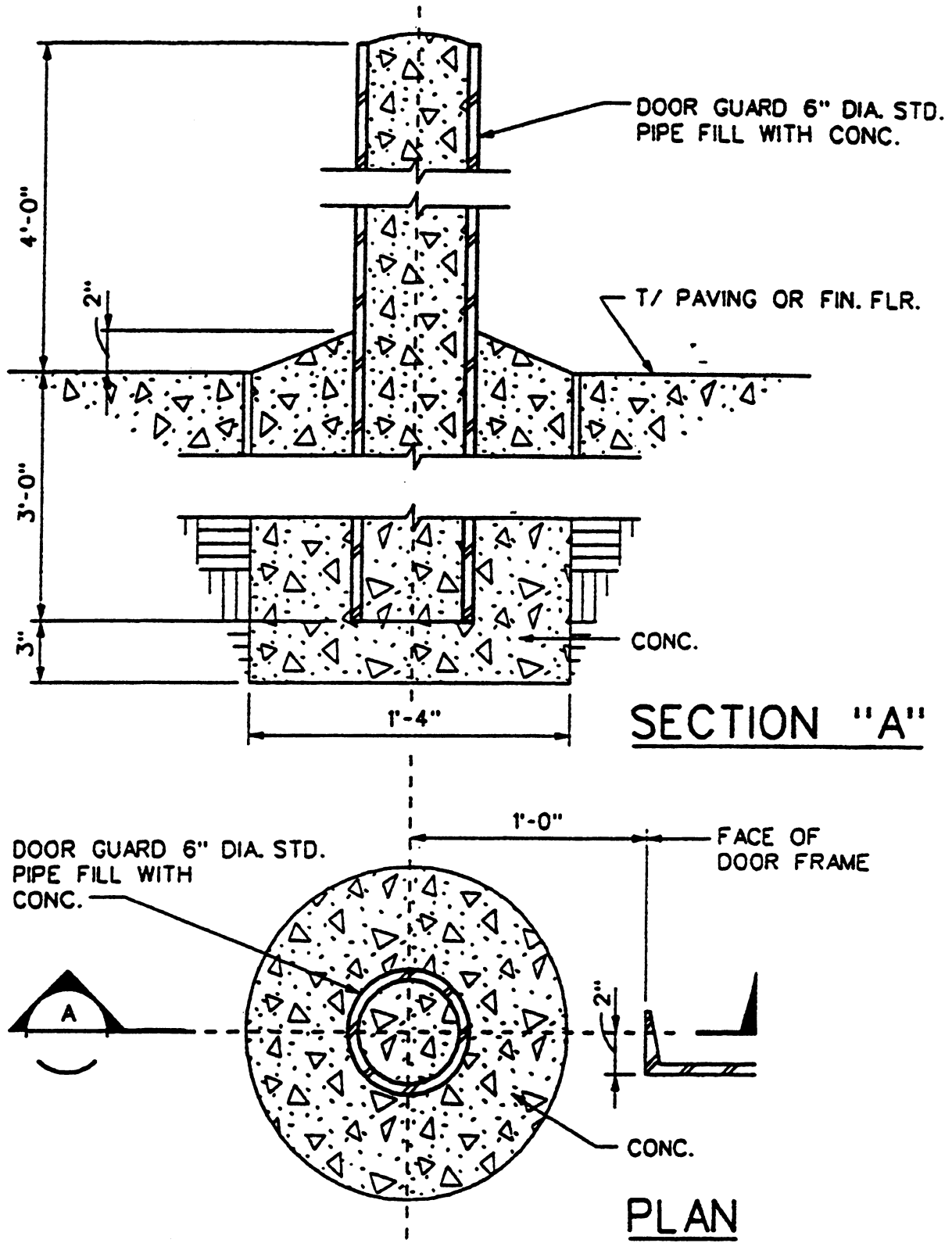

Fig. 9-1f

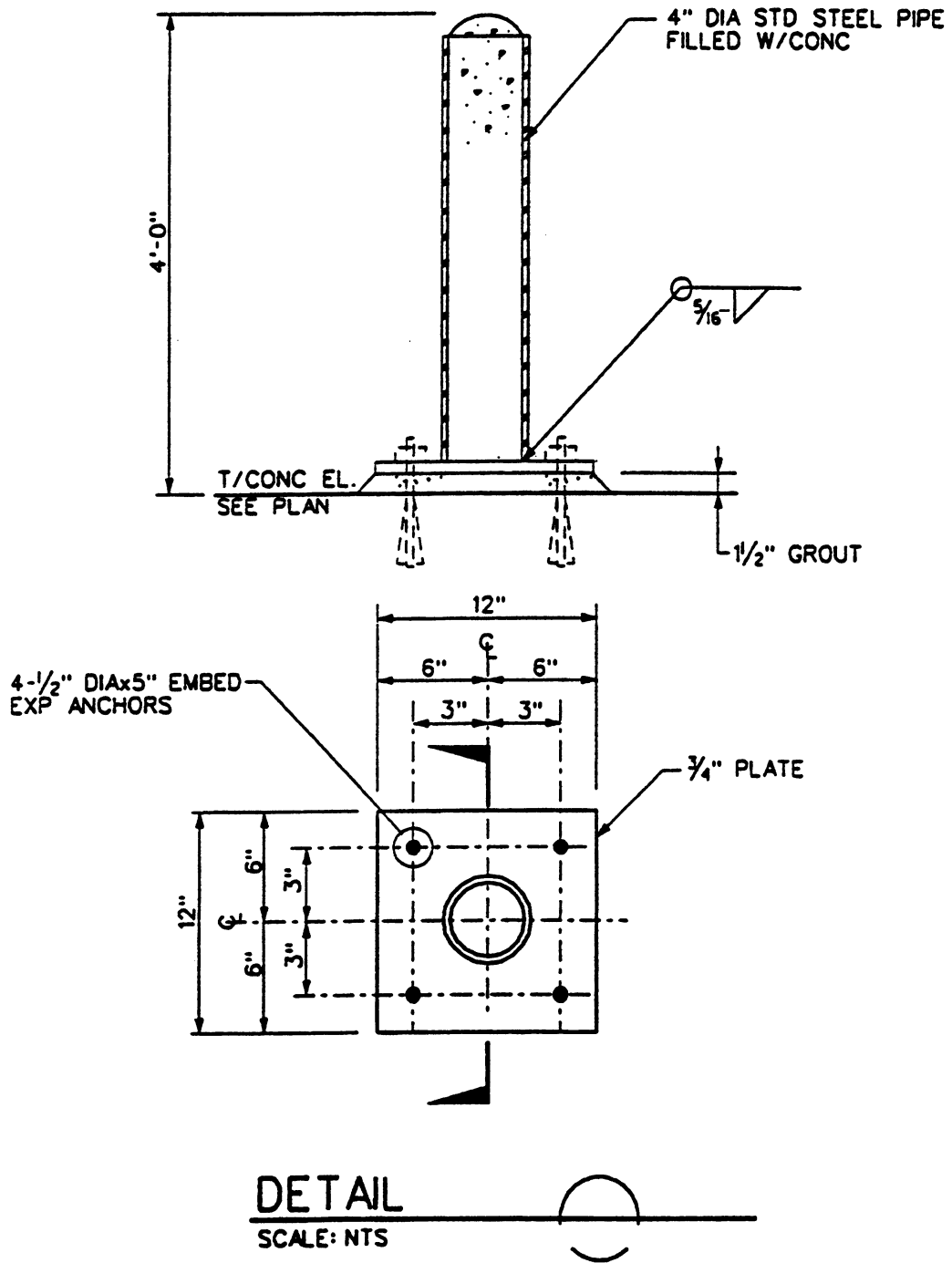

Fig. 9-1g

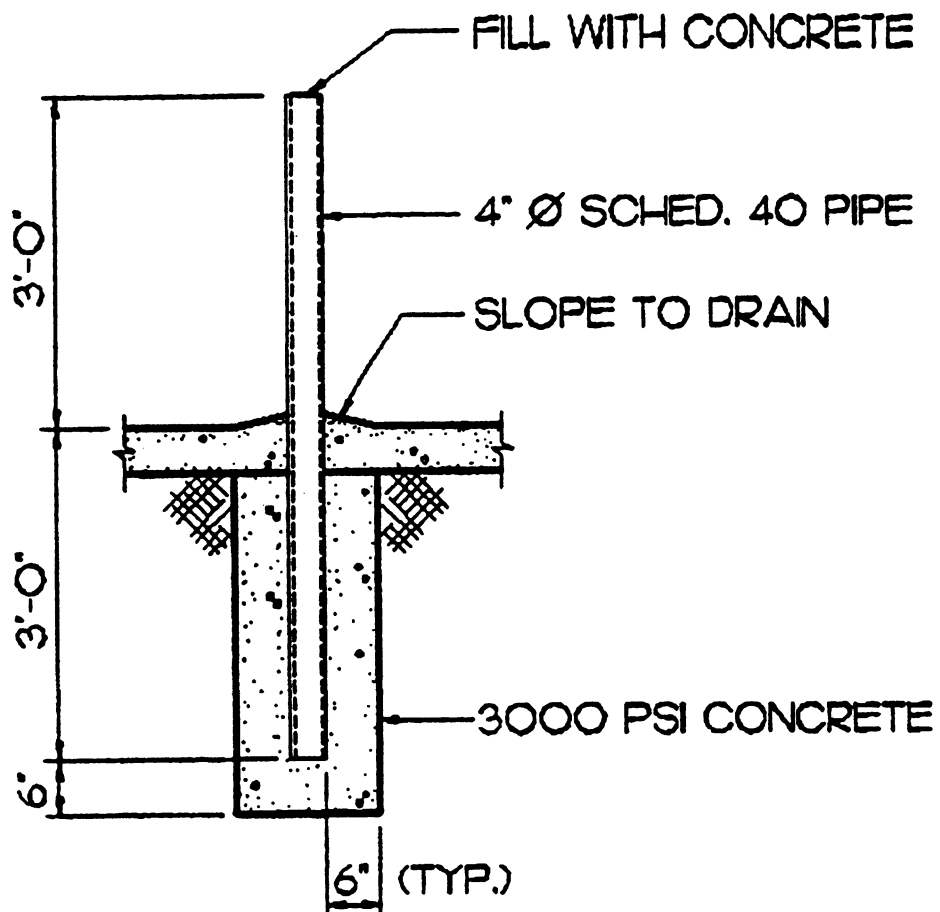
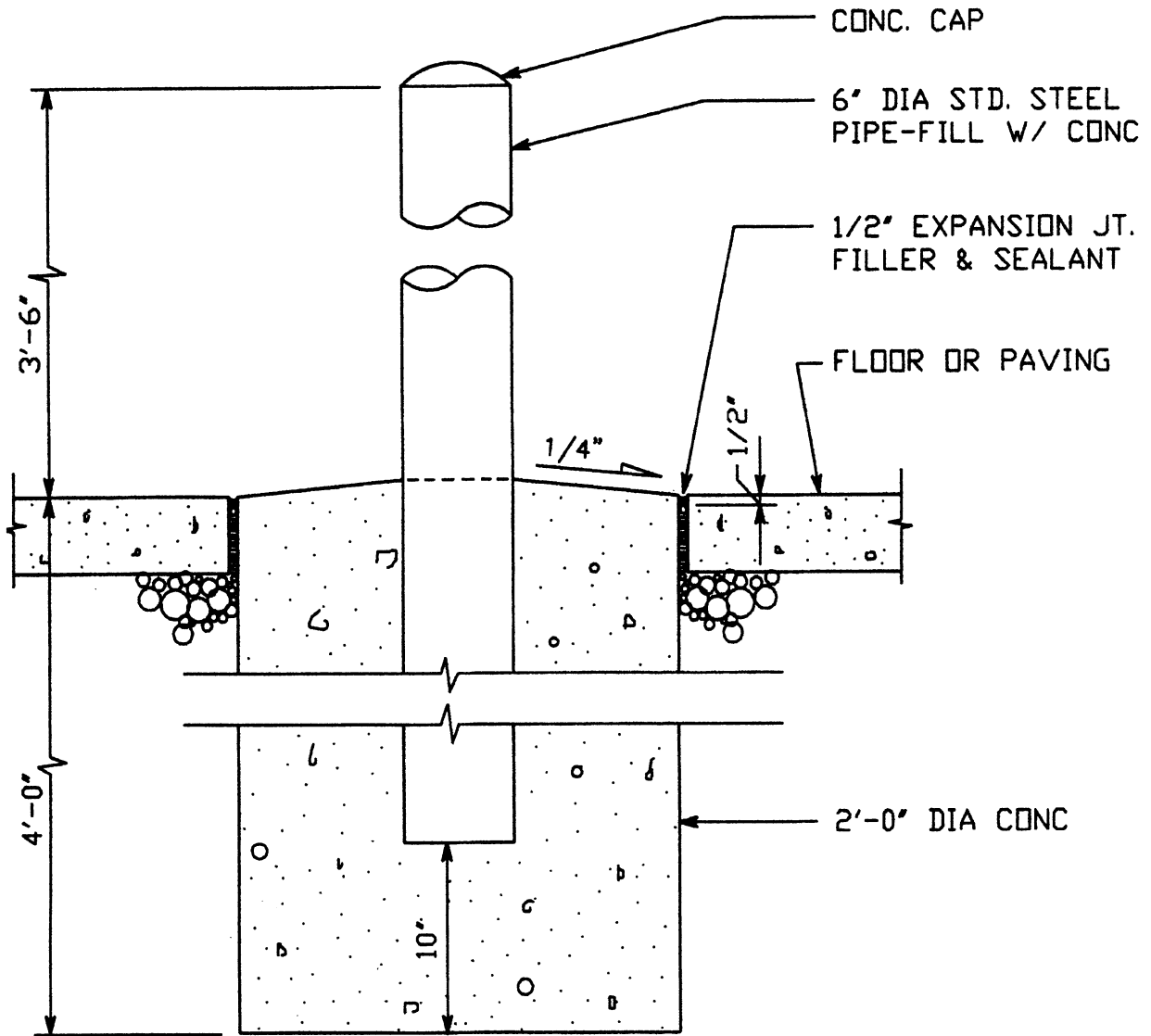

Fig. 9-1h



PIPE GUARD DETAIL

SCALE: 1 1/2"=1'-0"



XX-XX-X-X

Fig. 9-1i

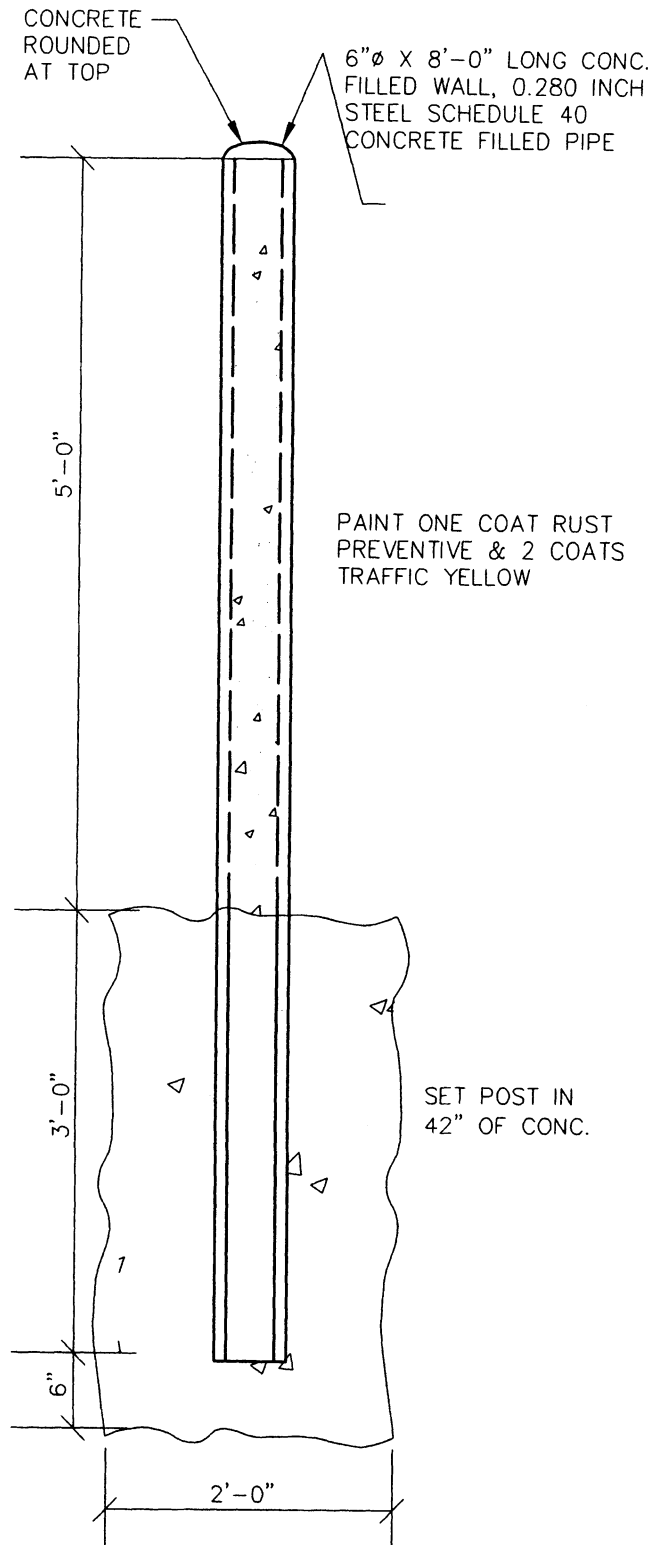
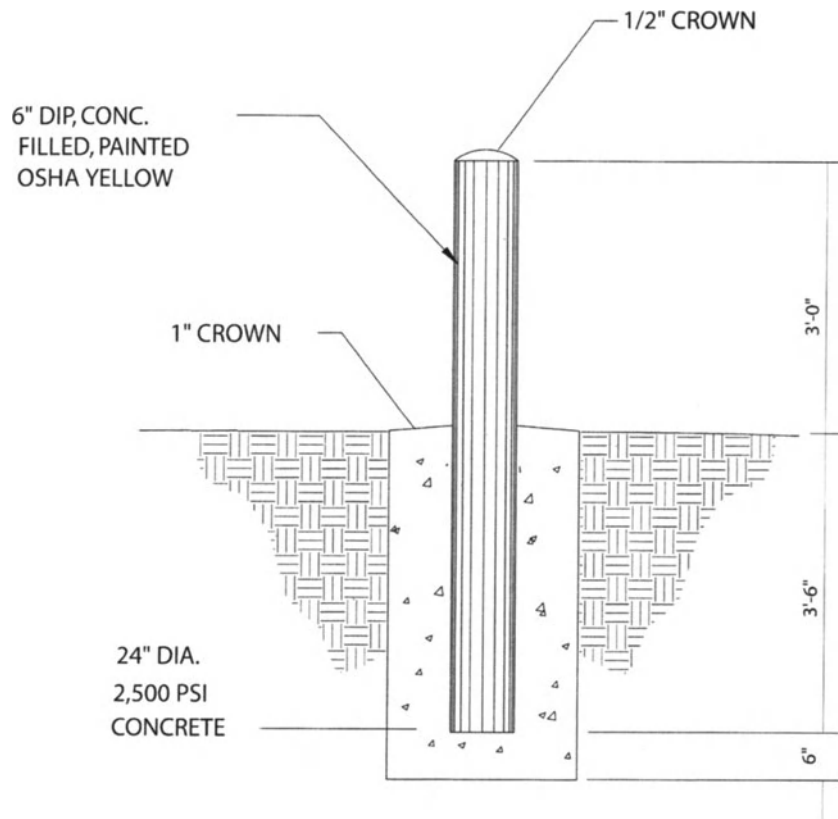
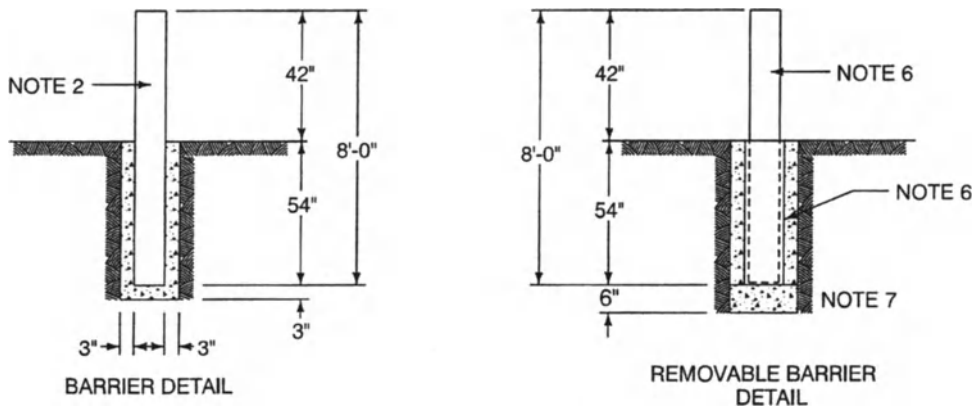

Fig. 9-1j



BOLLARD DETAIL

Fig. 9-1k



NOTES:

1. USE BARRIER TO PROTECT EQUIPMENT FROM POSSIBLE DAMAGE FROM VEHICLES.
2. USE 6" RIGID GALVANIZED STEEL CONDUIT, CUT TO 8' AND FILL WITH CONCRETE. ENCASE IN 3" OF CONCRETE, AS SHOWN.

Fig. 9-1l

DETAILER NOTES

- *1. GIVE DIMENSION - VERIFY AMOUNT OF DEFLECTION W/ STRUCTURAL DEPARTMENT
- *2. GIVE INSUL. TYPE OR NUMBER FOR CLOSURE MATERIAL AT TOP OF WALL AND AROUND JOIST (OR REMOVE FROM DETAIL IF NOT REQUIRED)

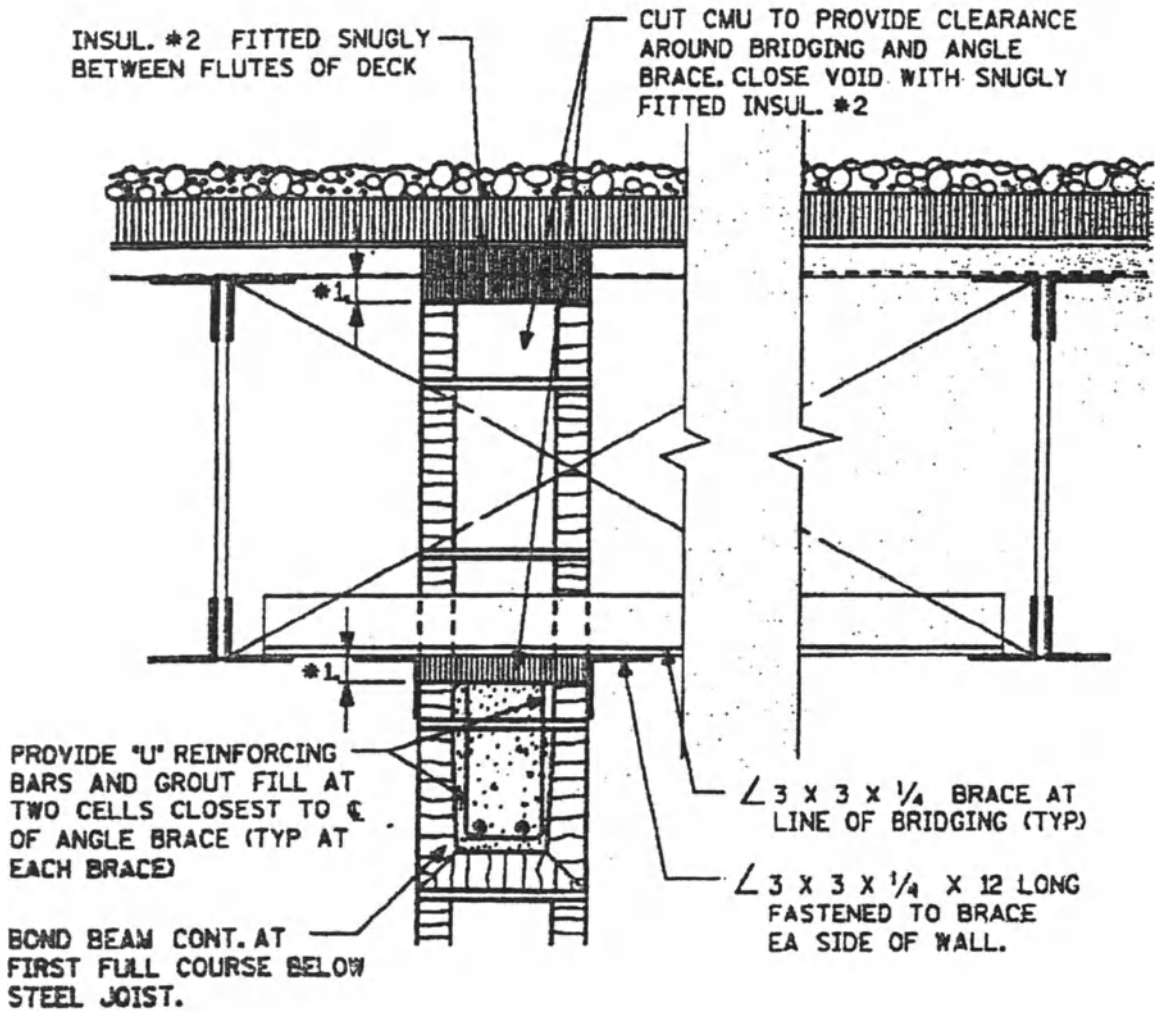

DETAIL

SCALE: 1/2"=1'-0"



TYP. LATERAL BRACING FOR TOP OF CMU WALL PARALLEL TO JOISTS (FOR SPECIALLY LOADED WALLS)

Fig. 9-2

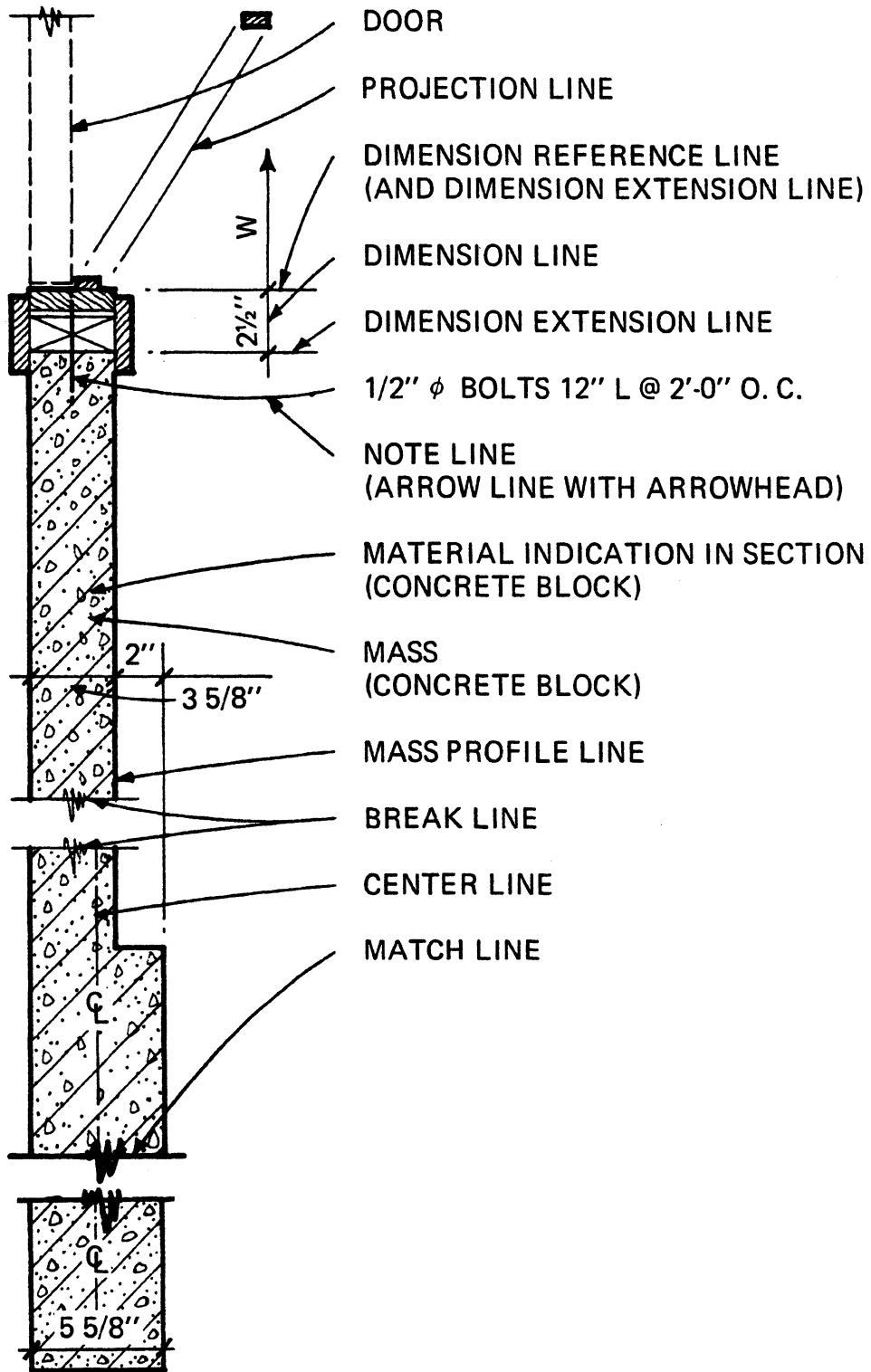

Fig. 9-3

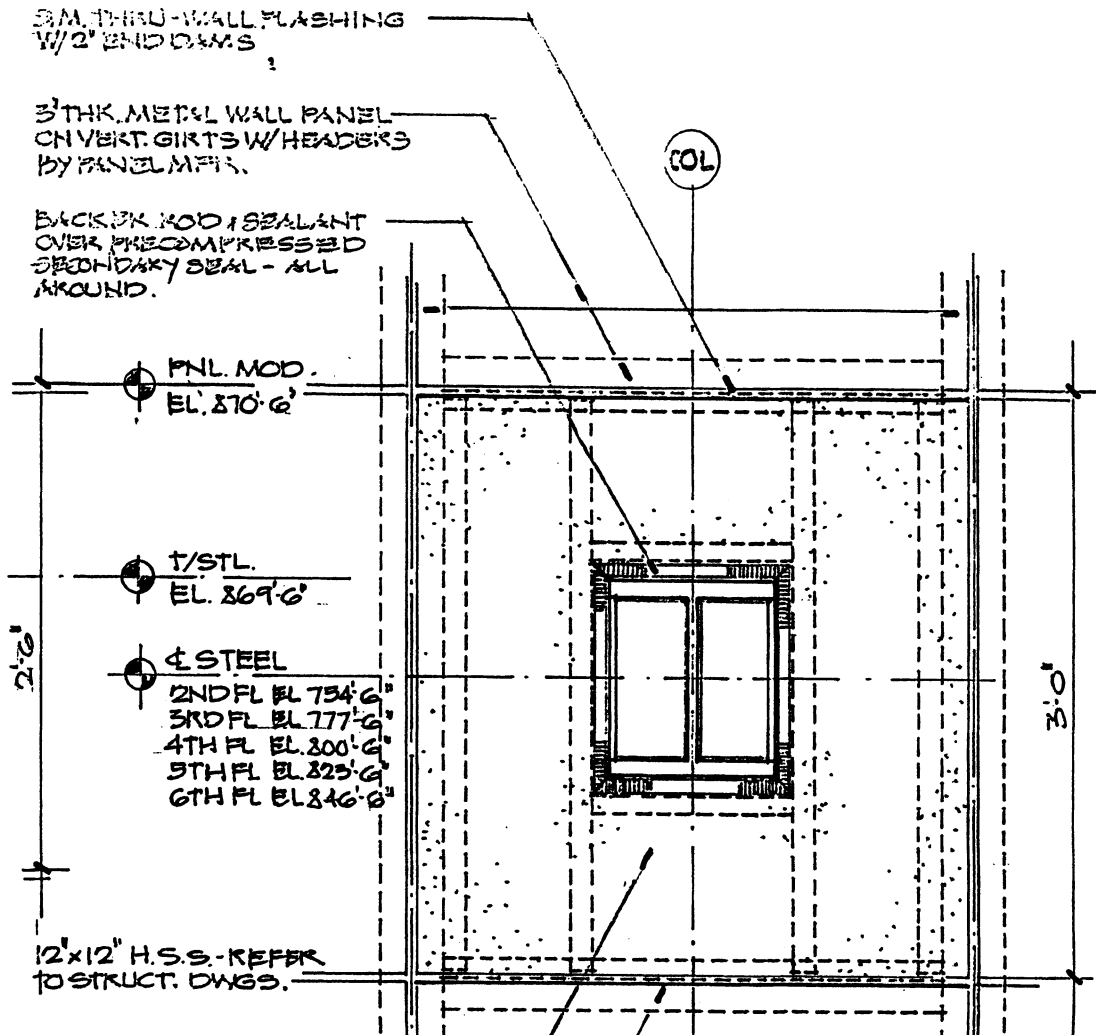

Fig. 9-4

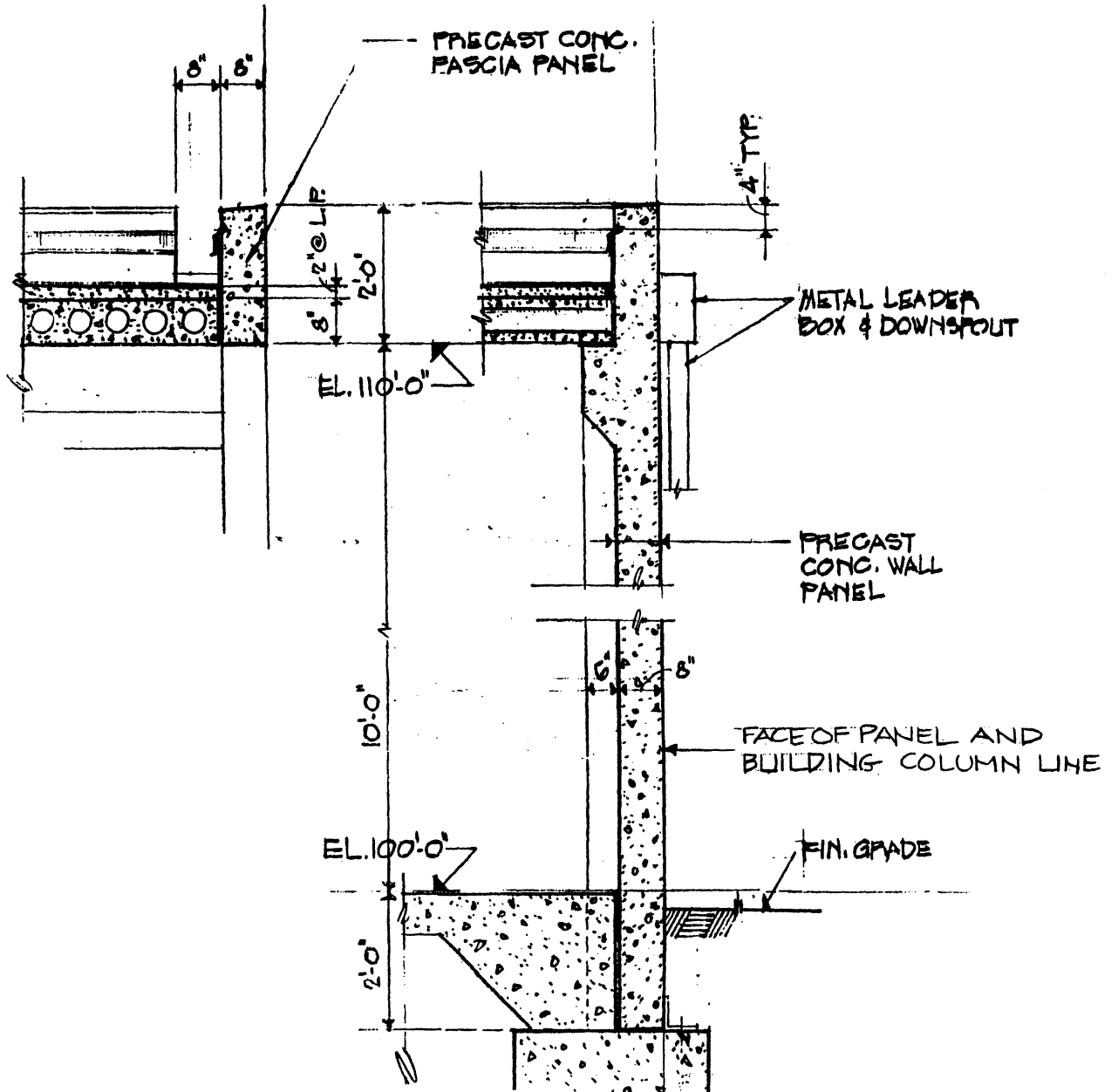

Fig. 9-5

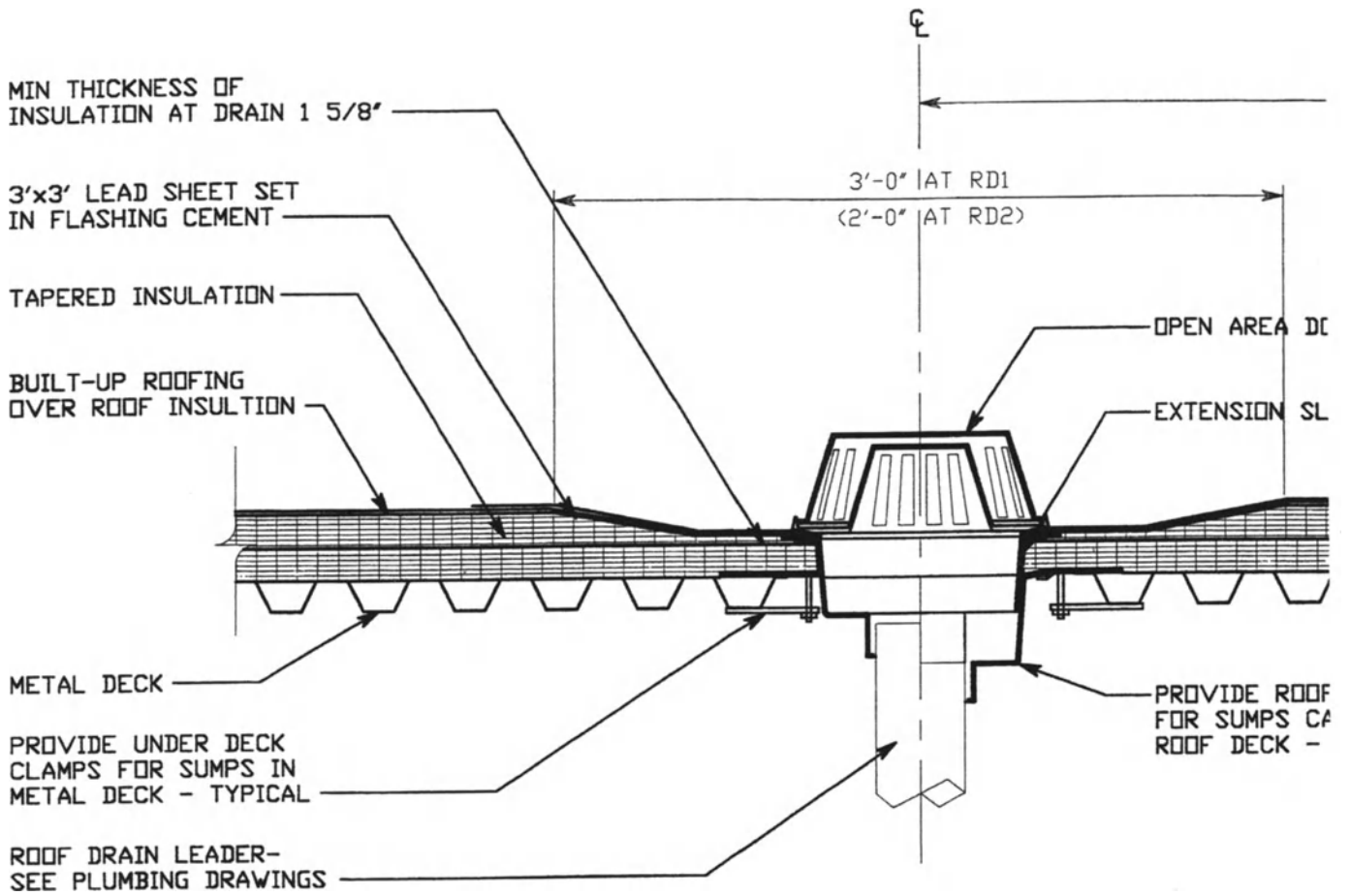

Fig. 9-6

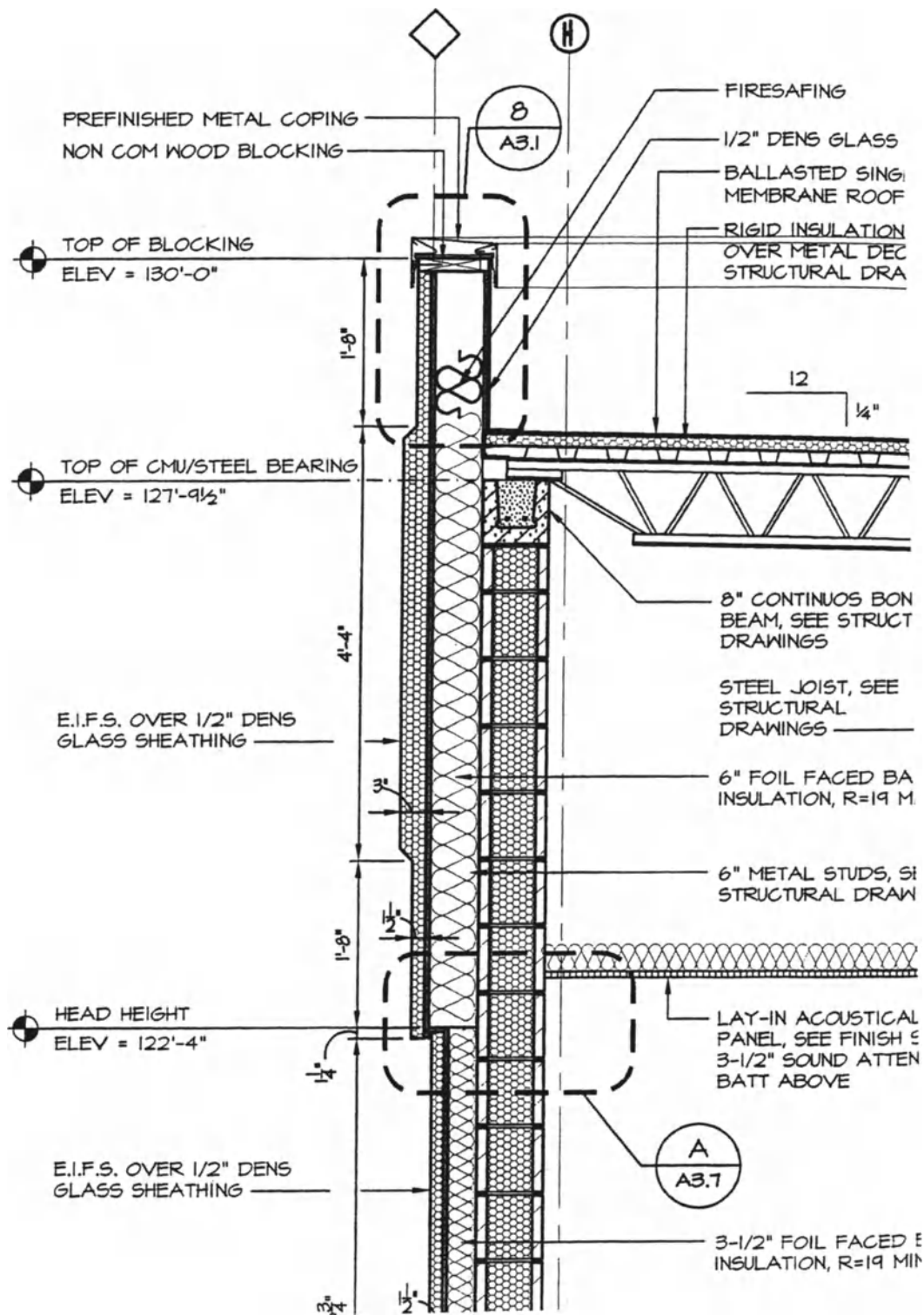

Fig. 9-7

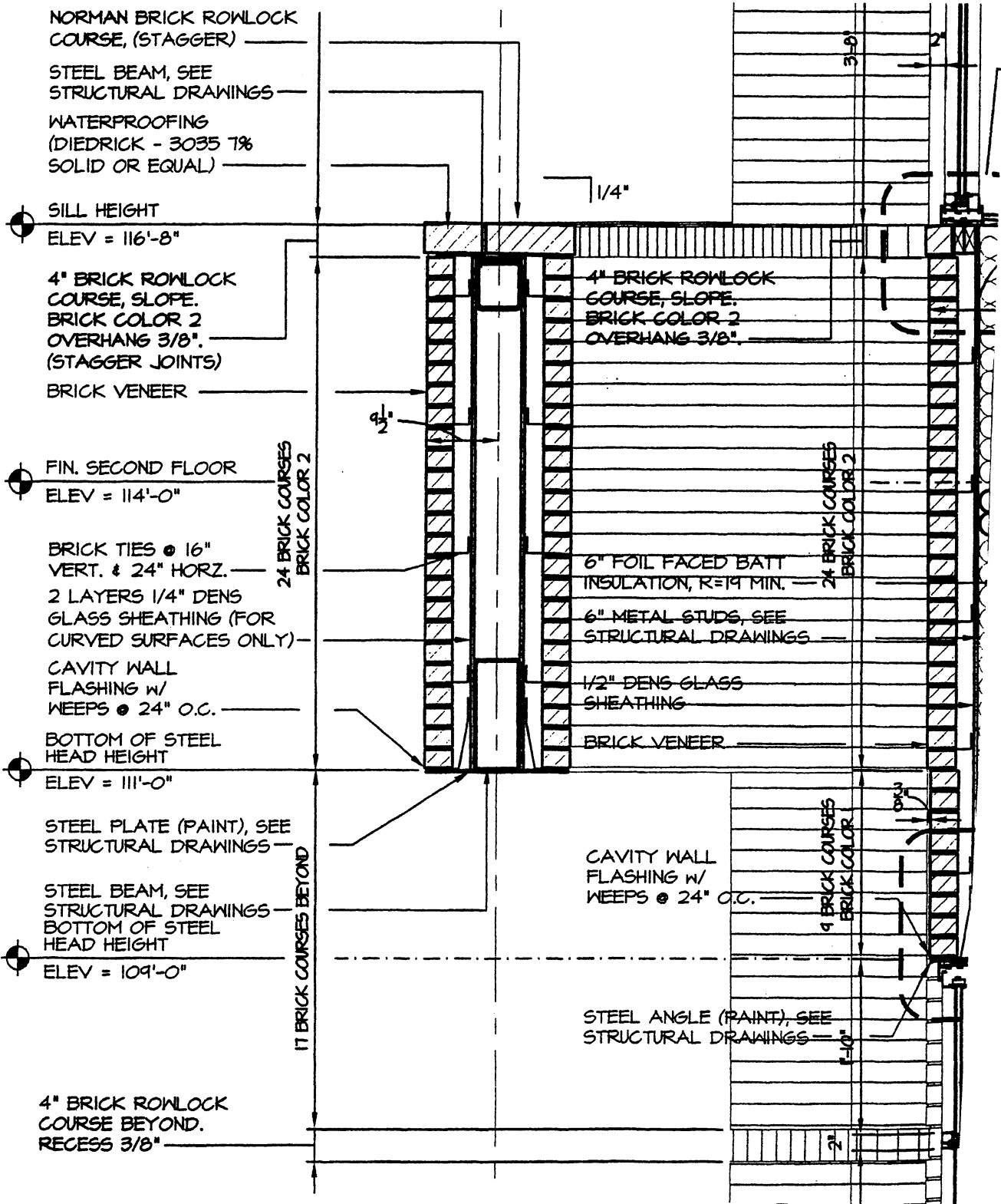
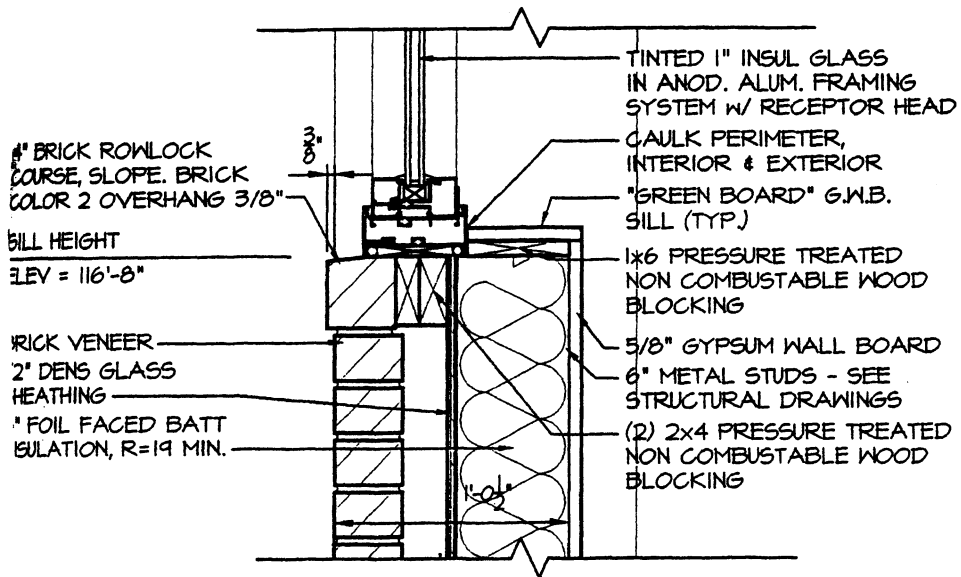

Fig. 9-8



DETAIL

SCALE: 1-1/2" = 1'-0"

6
A3.1

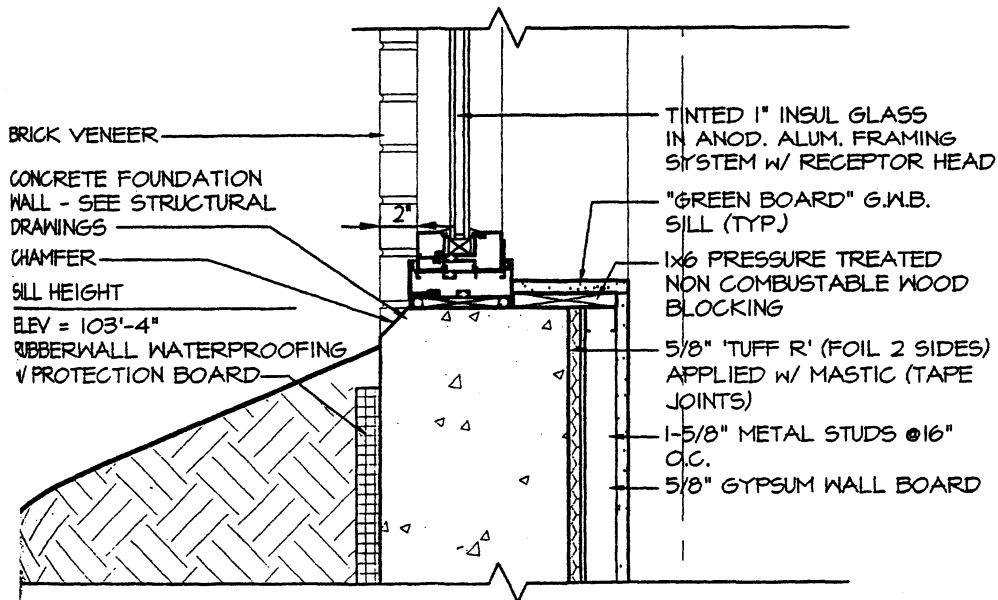

Fig. 9-9

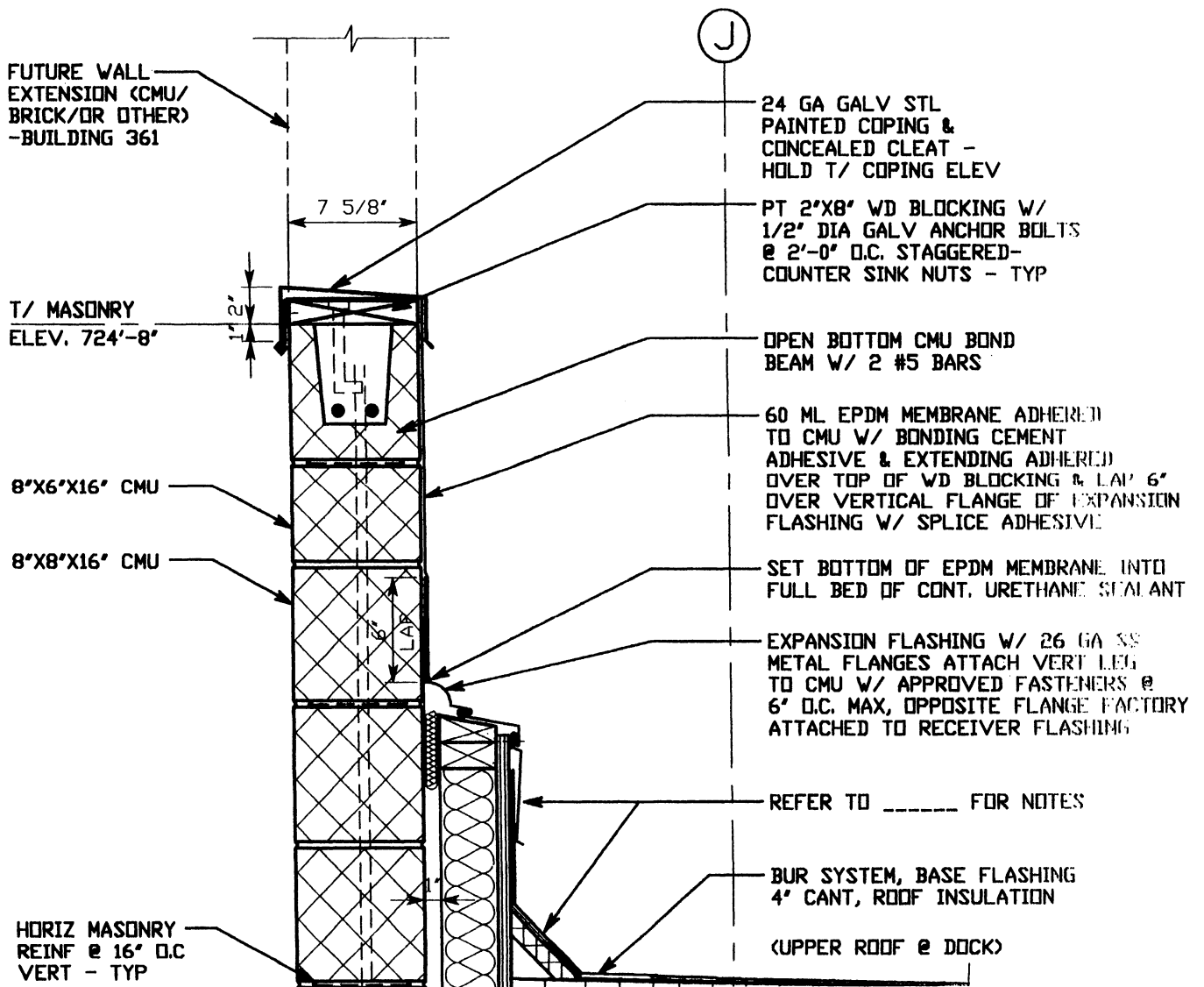

Fig. 9-10

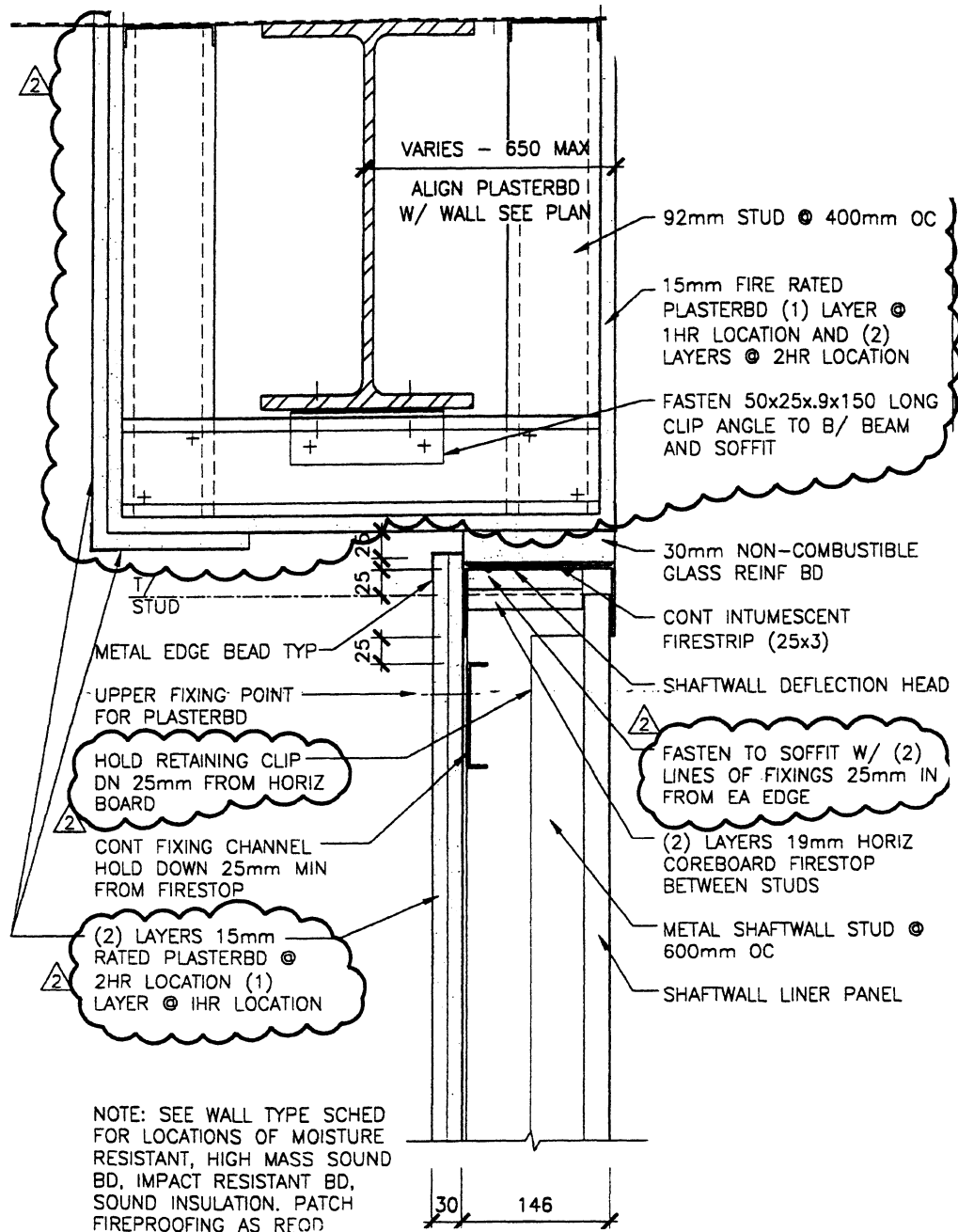

Fig. 9-11

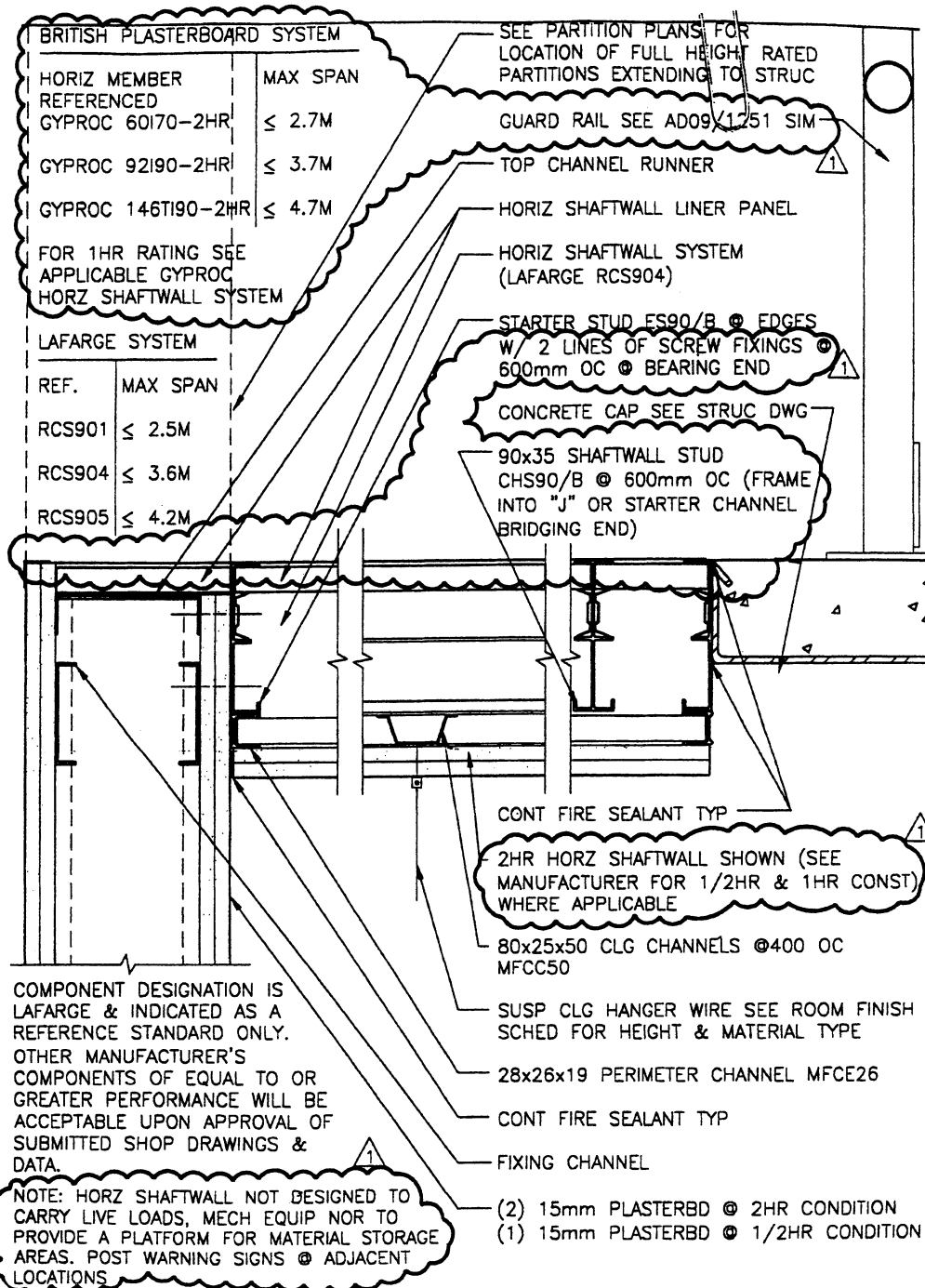
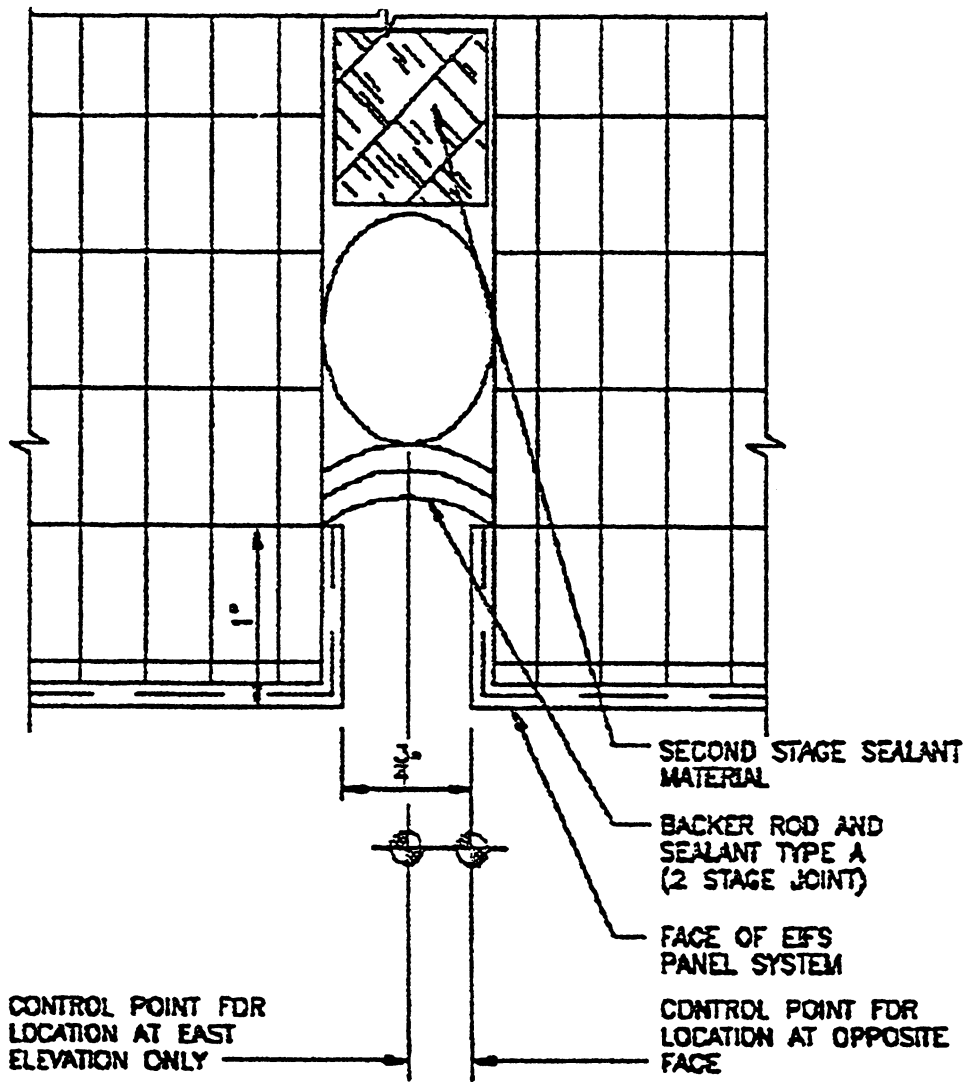

Fig. 9-12



TYP. VERT. EIFS PANEL JOINT

SCALE: FULL SIZE

168
E44104

Fig. 9-13

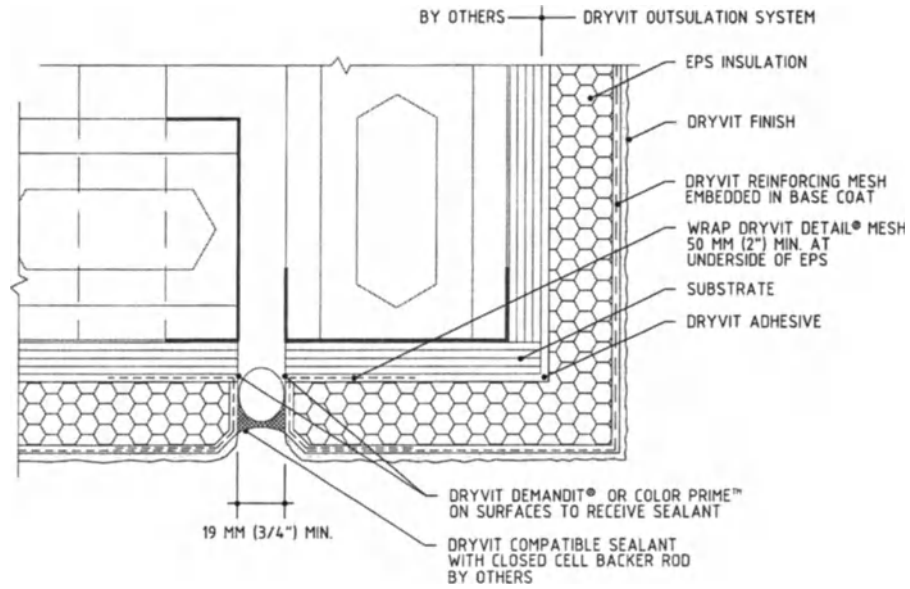

Fig. 9-14

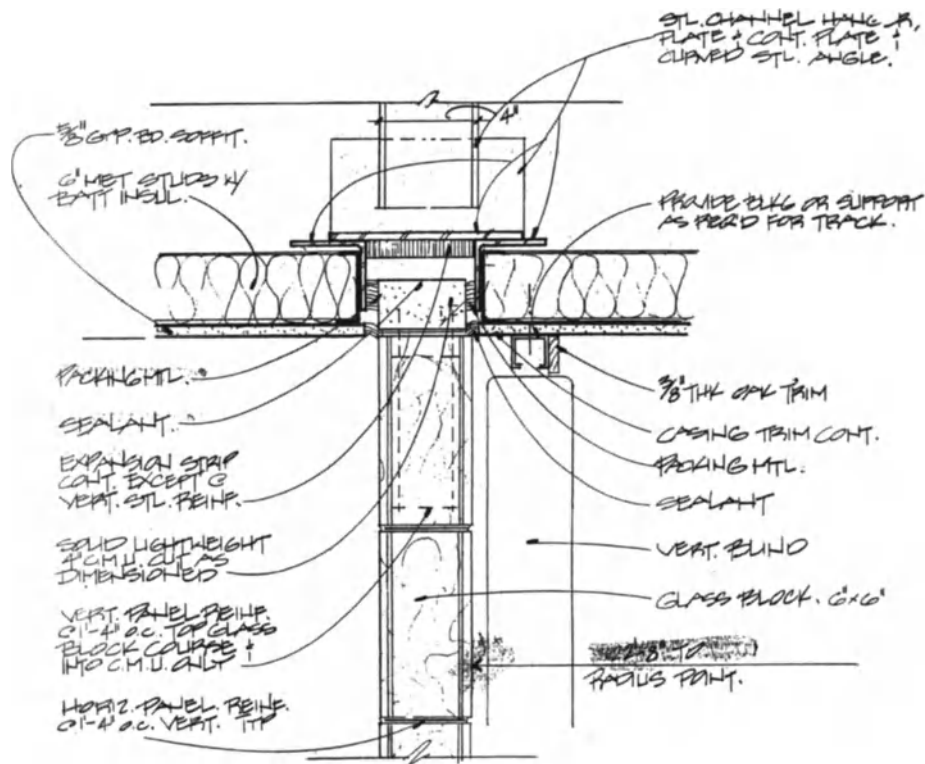

Fig. 9-15

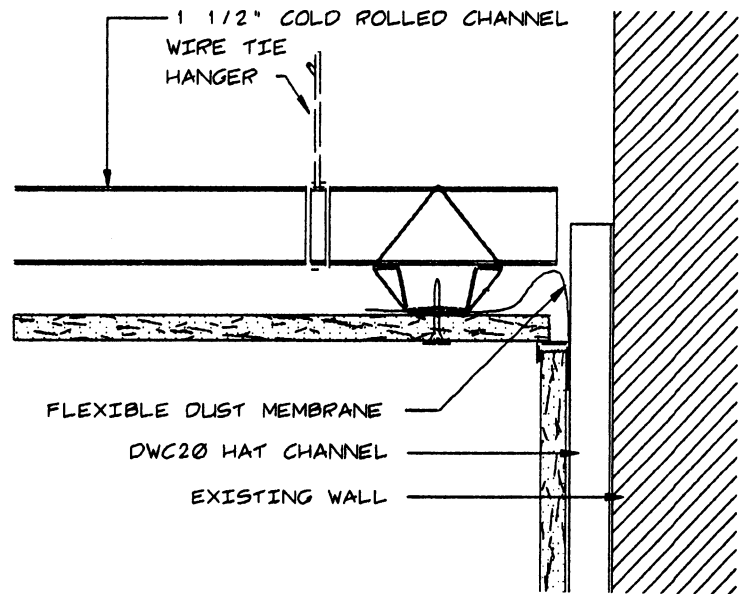

Fig. 9-16

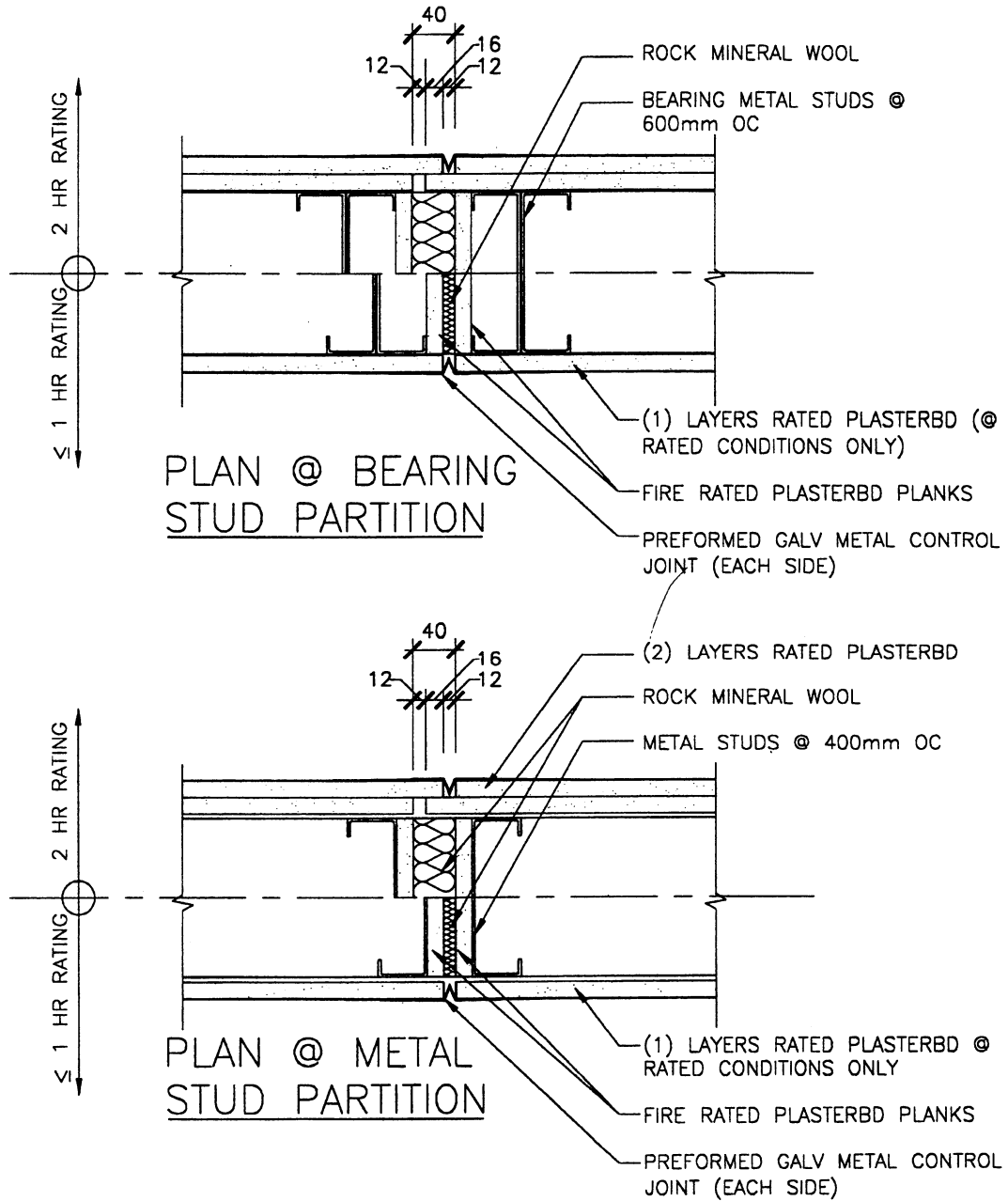

Fig. 9-17

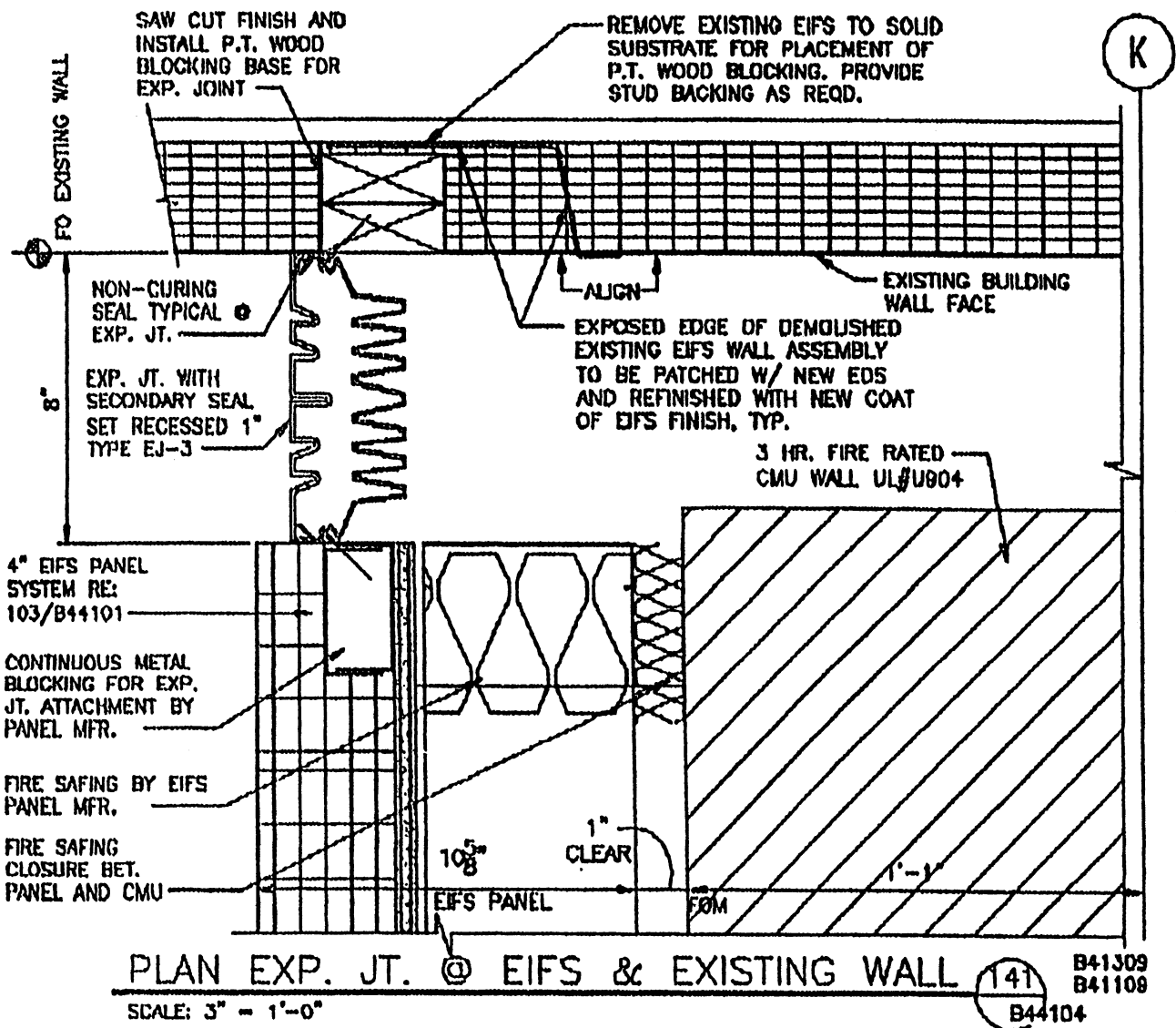
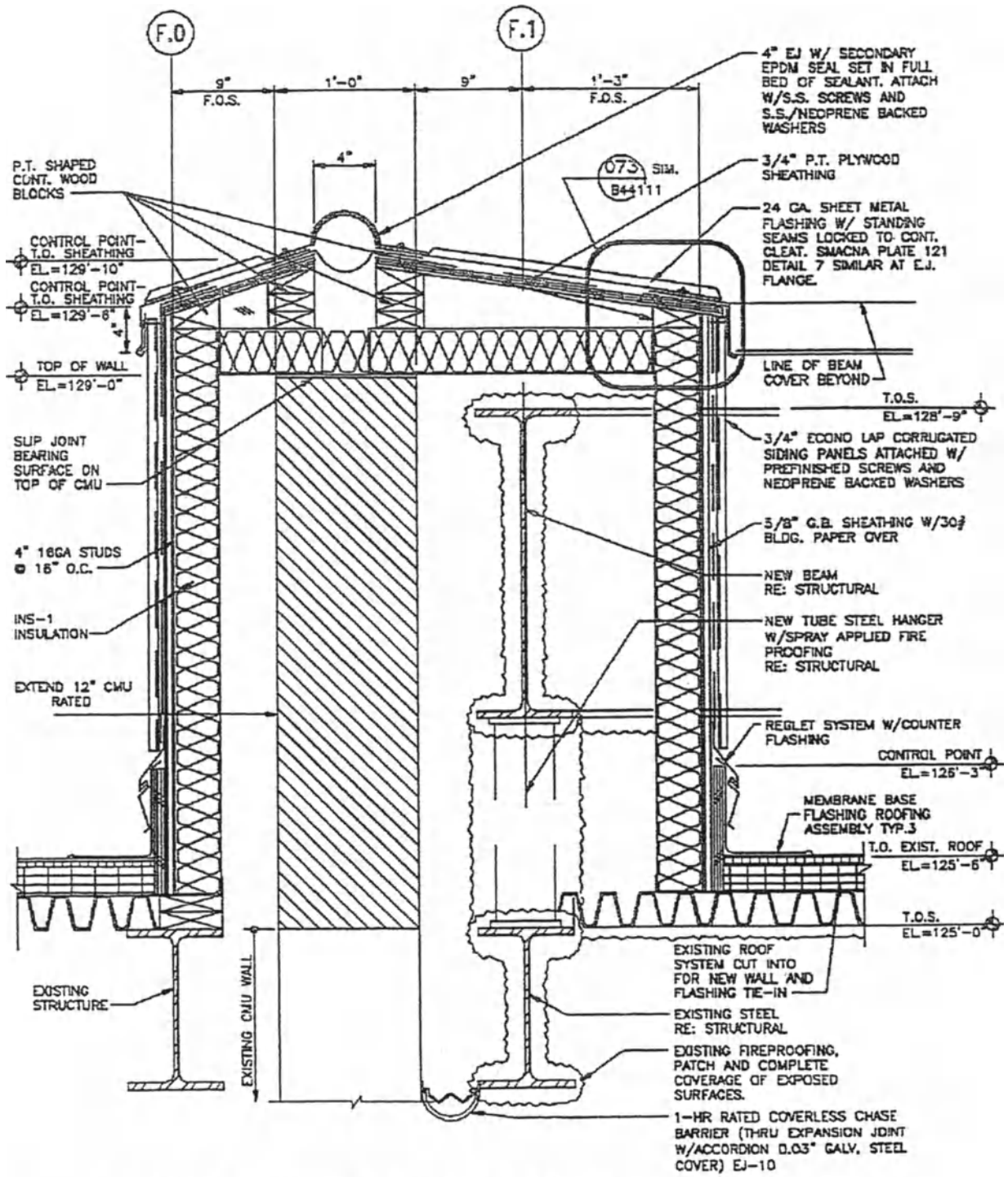

Fig. 9-18



BEAM/JOINT COVER @ SNOW ROOF 070 B41604
 1A22567401... 19-27-99 14-JLJ/1 S Jackson 125065
 SCALE 1/2" = 1'-0" B44112

Fig. 9-19

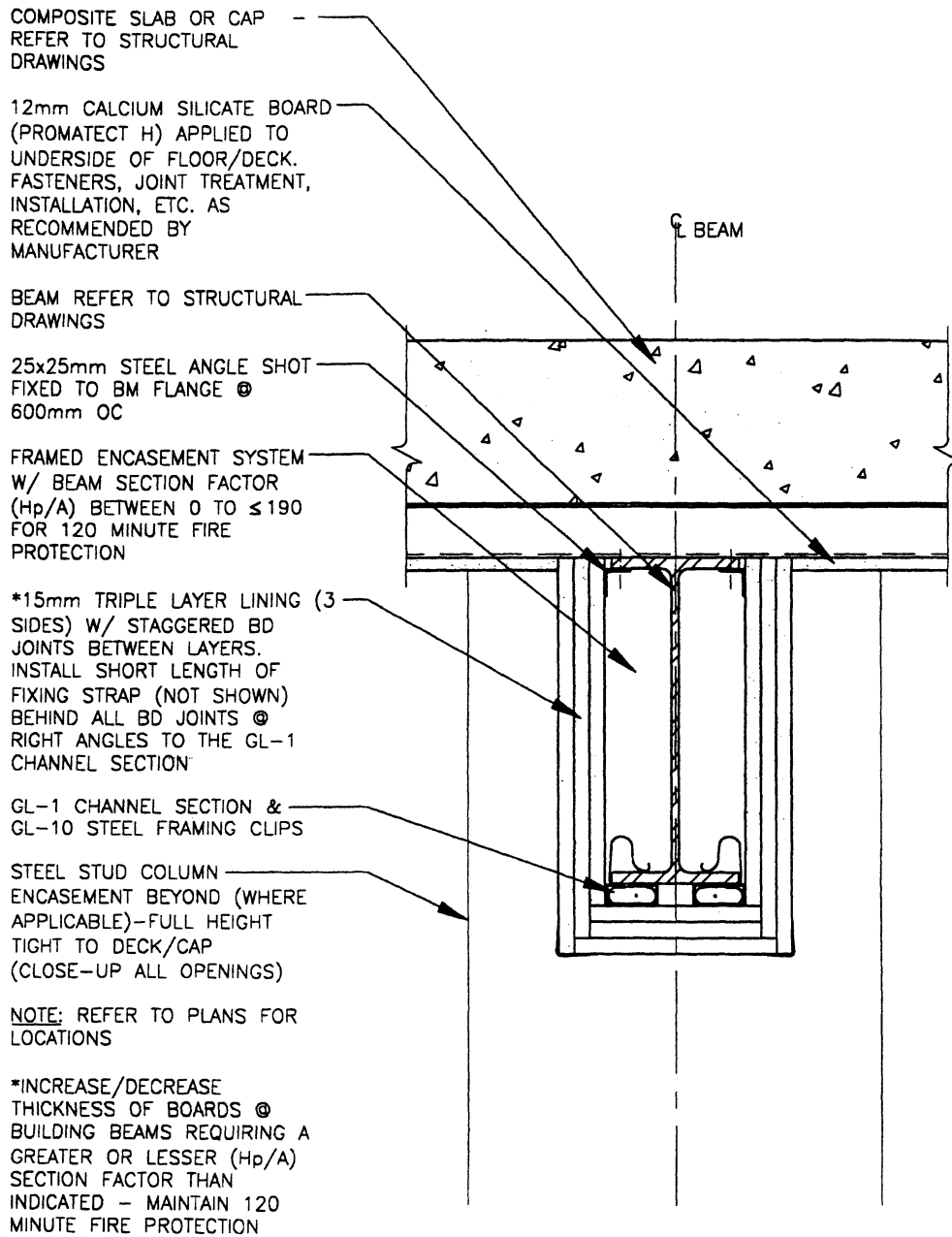

Fig. 9-20

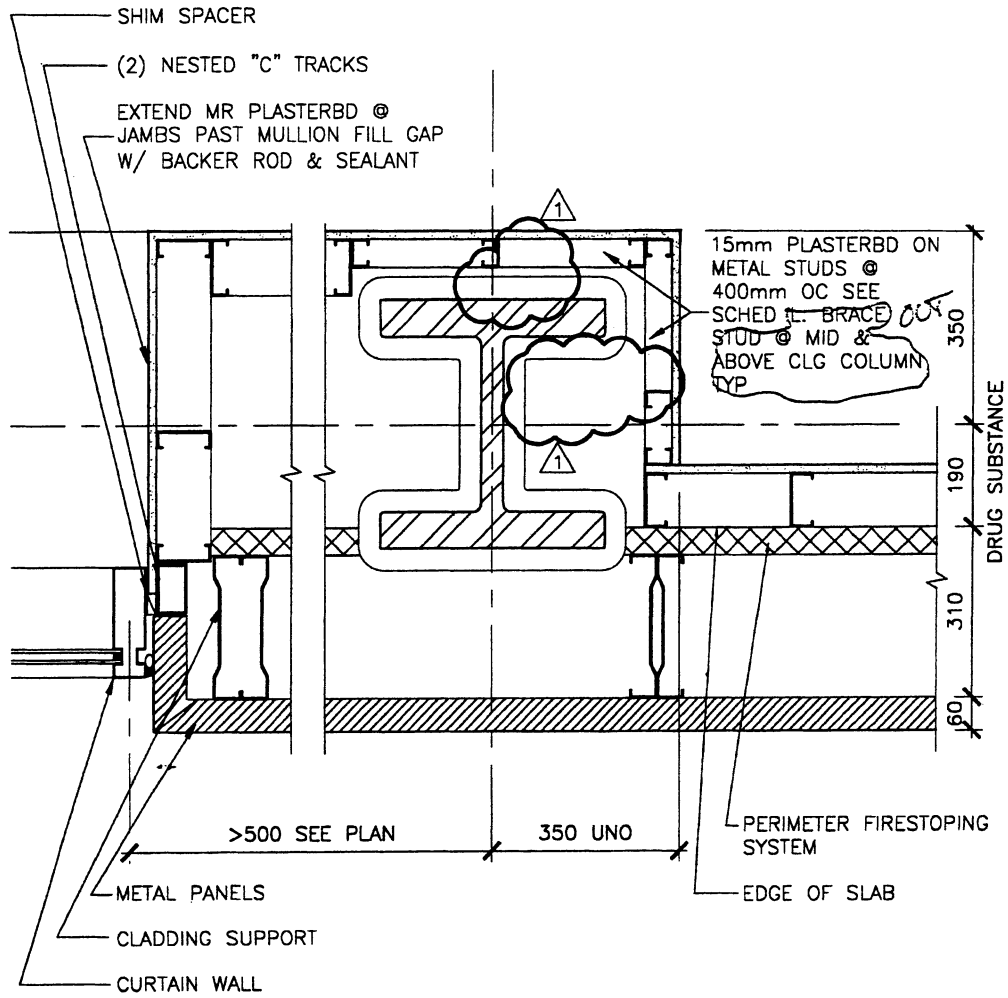

Fig. 9-21

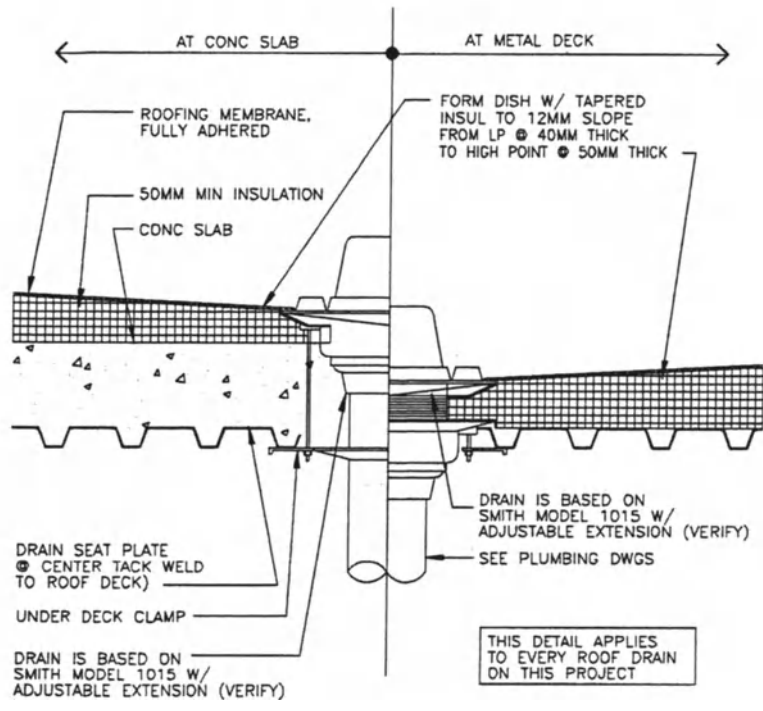
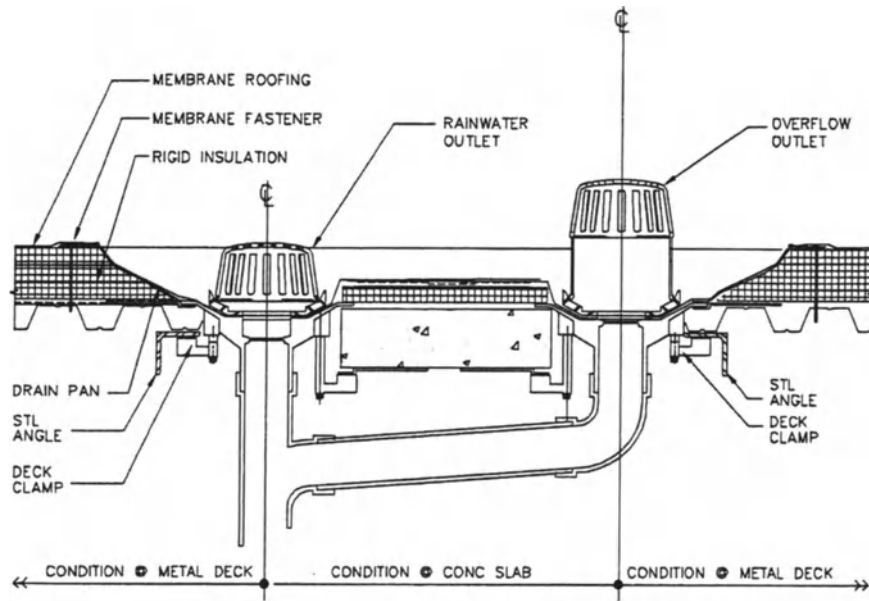

Fig. 9-22

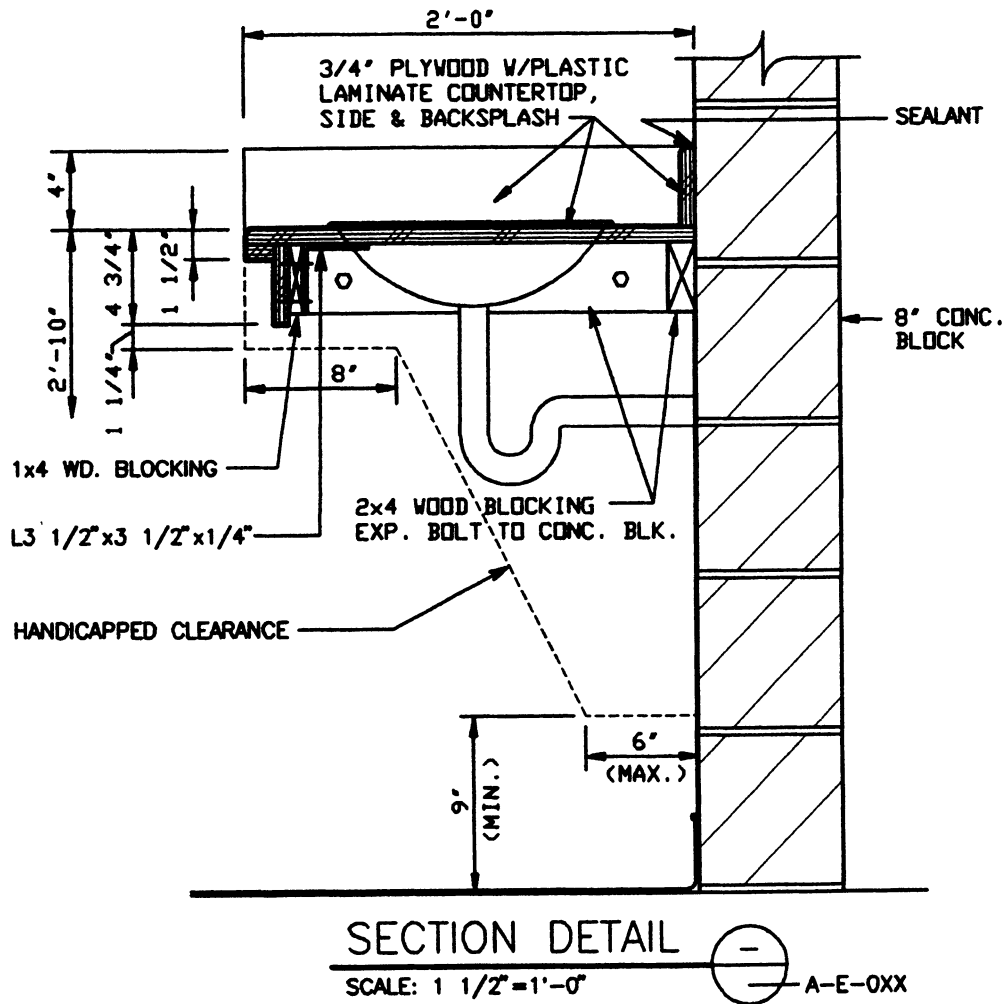
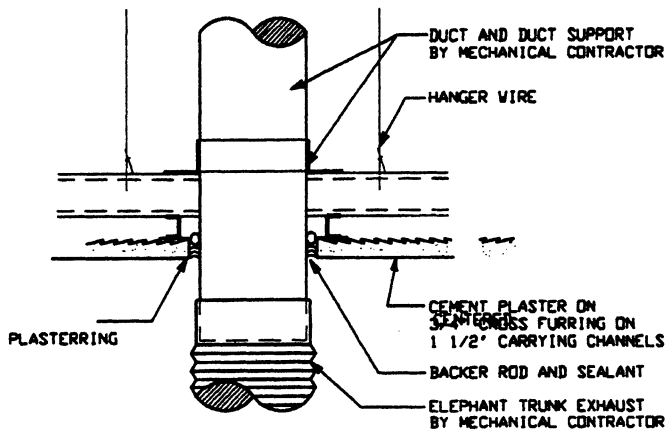
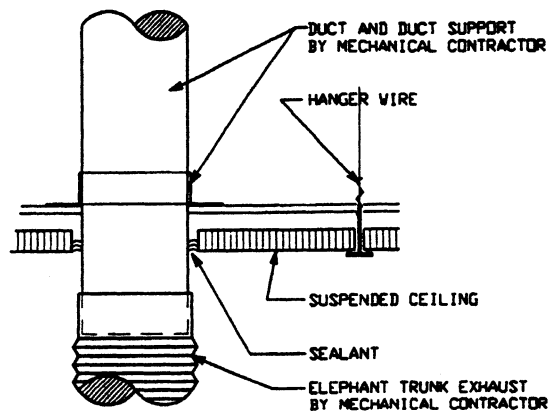

Fig. 9-23



DETAIL ?
 SCALE: 3"=1'-0" DVG#

NOTE: CONDITION AT CONDUITS PASSING THROUGH CLG. SIM.



DETAIL ?
 SCALE: 3"=1'-0" DVG#

NOTE: CONDITION AT CONDUITS PASSING THROUGH CLG. SIM.

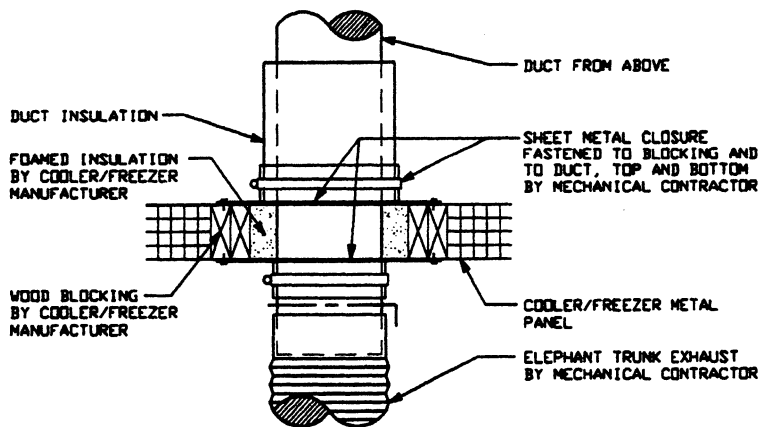

DETAIL ?
 SCALE: 3"=1'-0" DVG#

NOTE: CONDITION AT PIPES OR CONDUITS PASSING THROUGH INSULATED METAL PANELS SIMILAR. ALSO, REFER TO SPECIFICATIONS.

Fig. 9-24

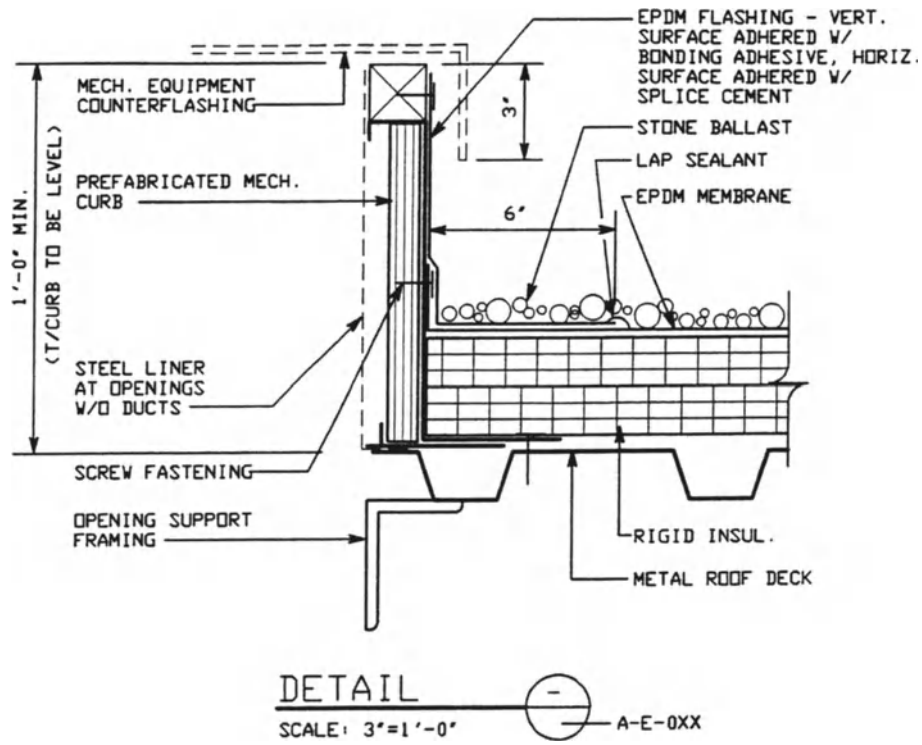

Fig. 9-25

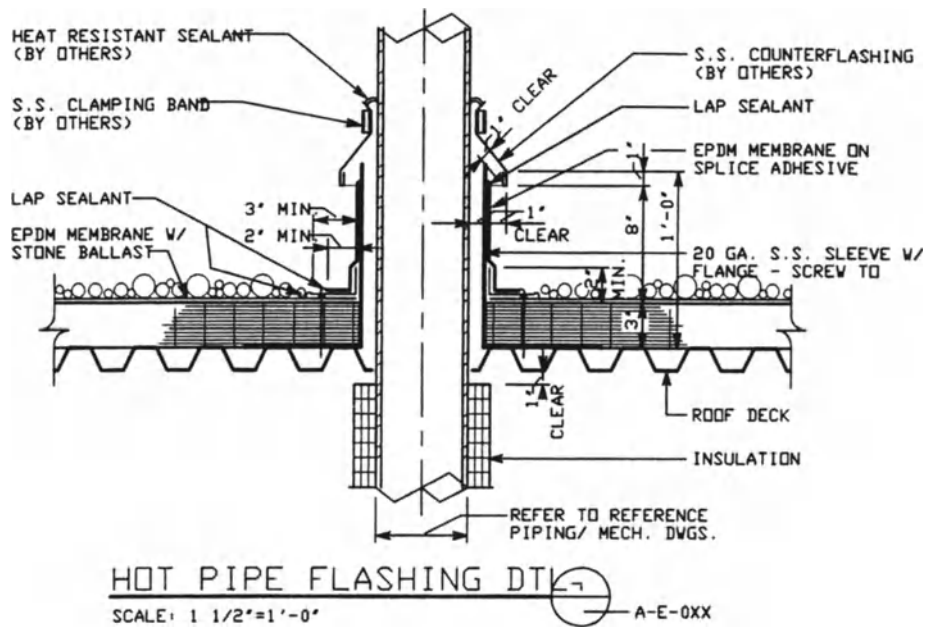

Fig. 9-26

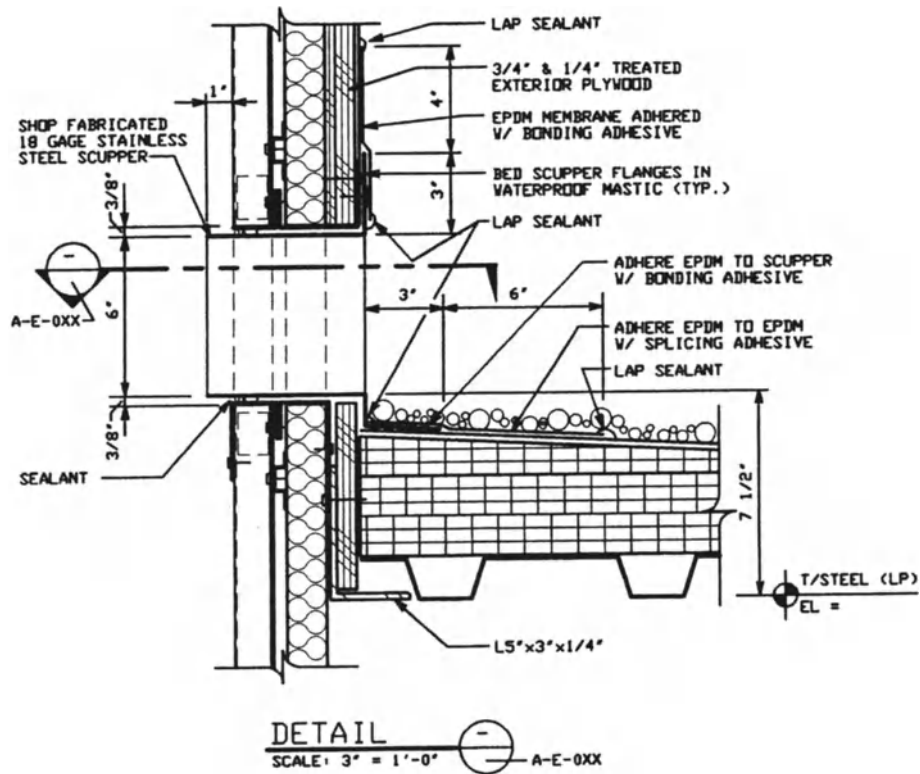

Fig. 9-27

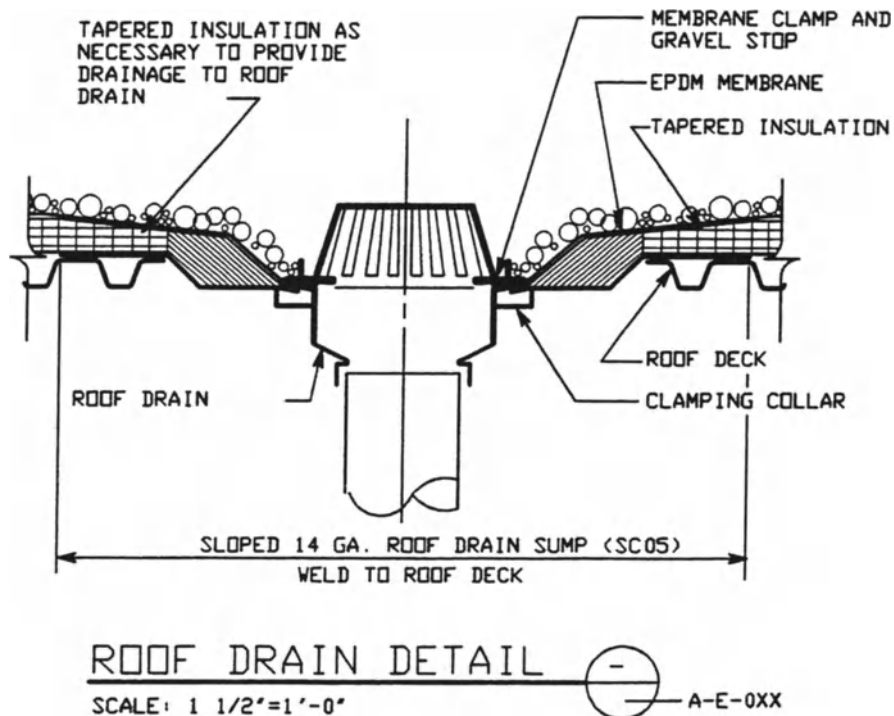

Fig. 9-28

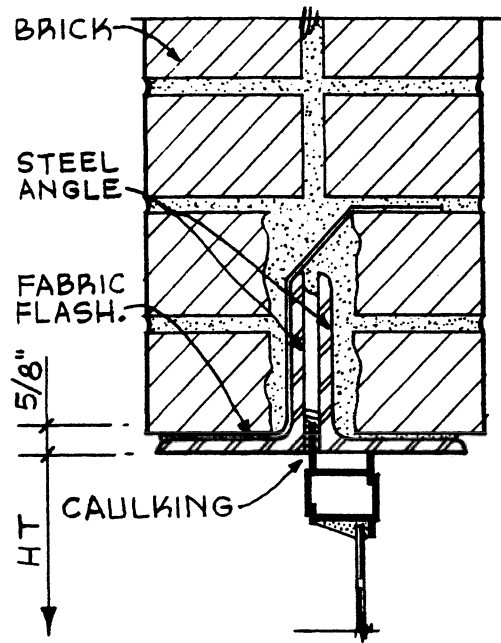

Fig. 9-29

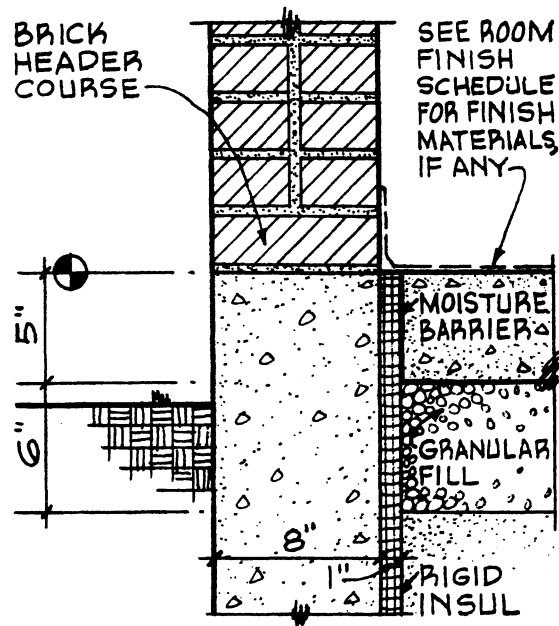

Fig. 9-30

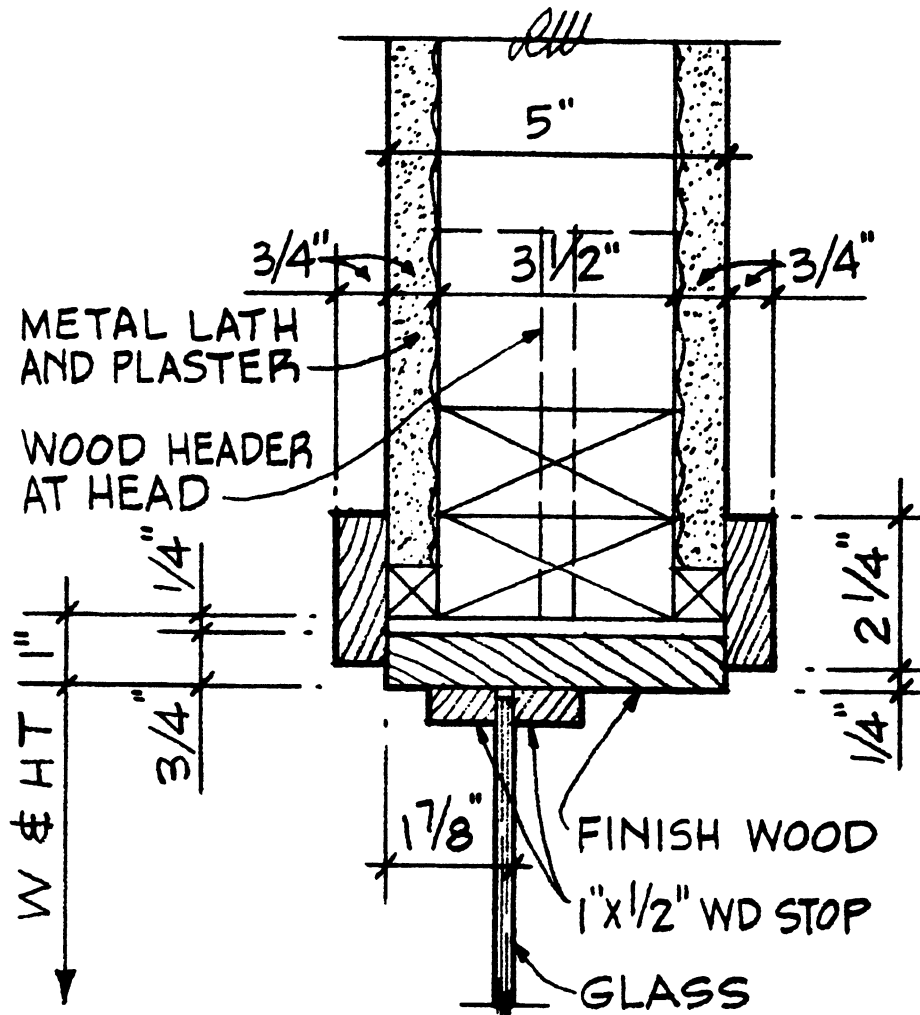

Fig. 9-31

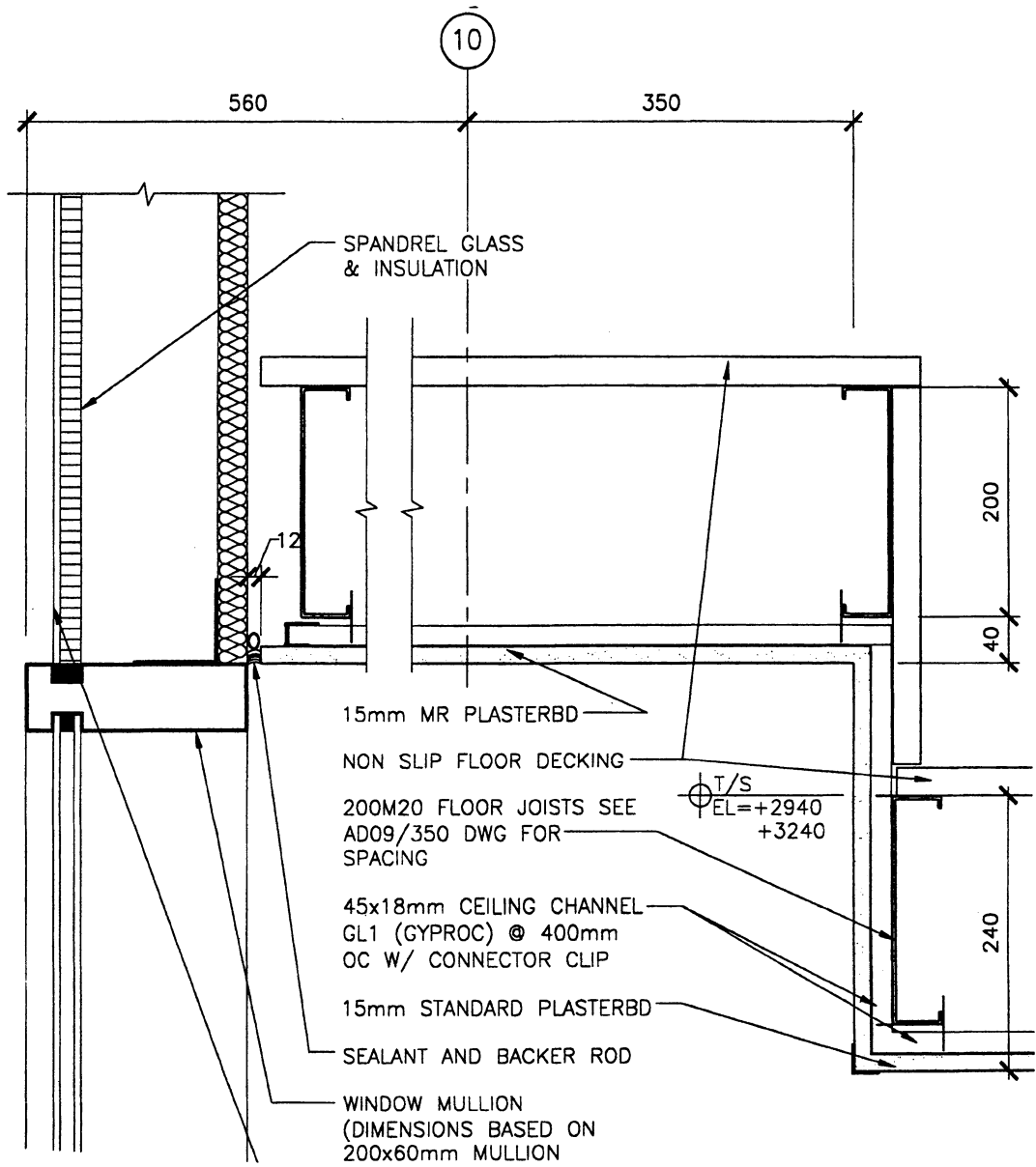

Fig. 9-32

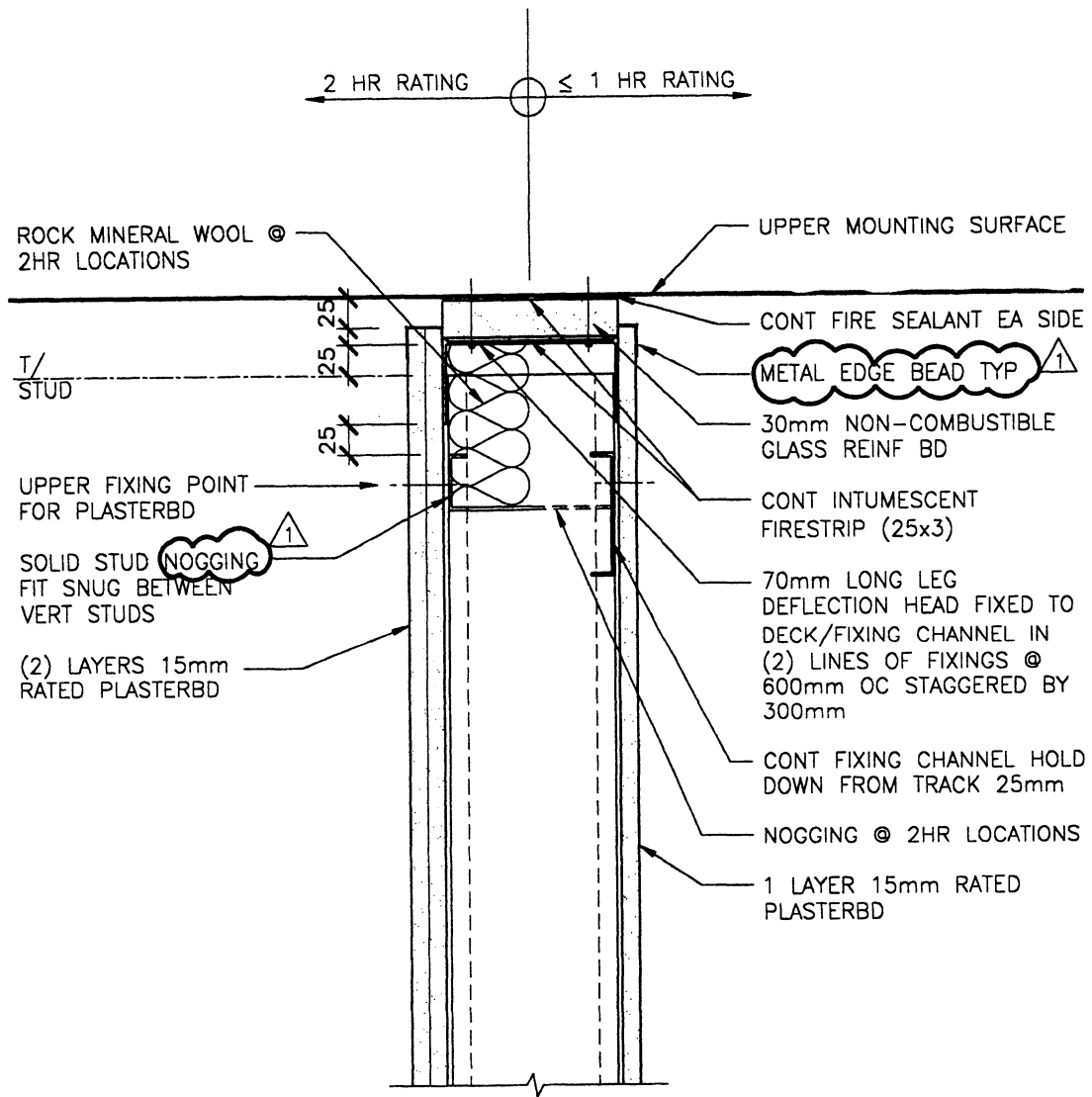

Fig. 9-33

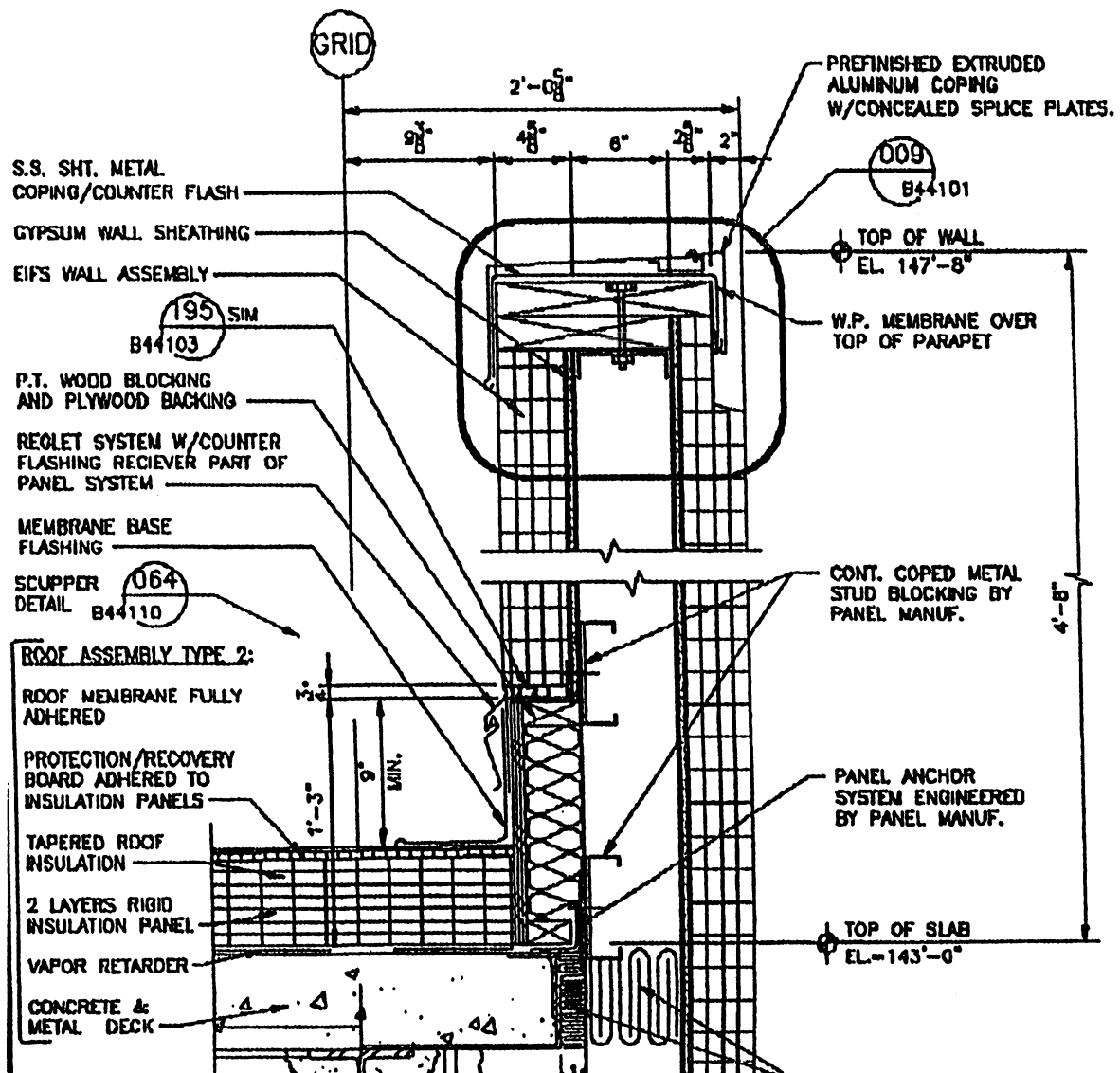

Fig. 9-34

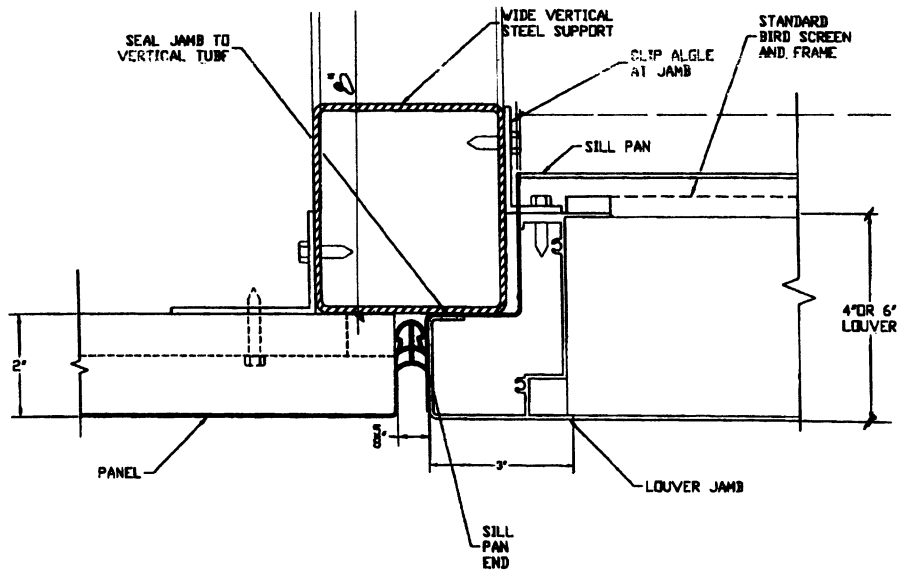

Fig. 9-35

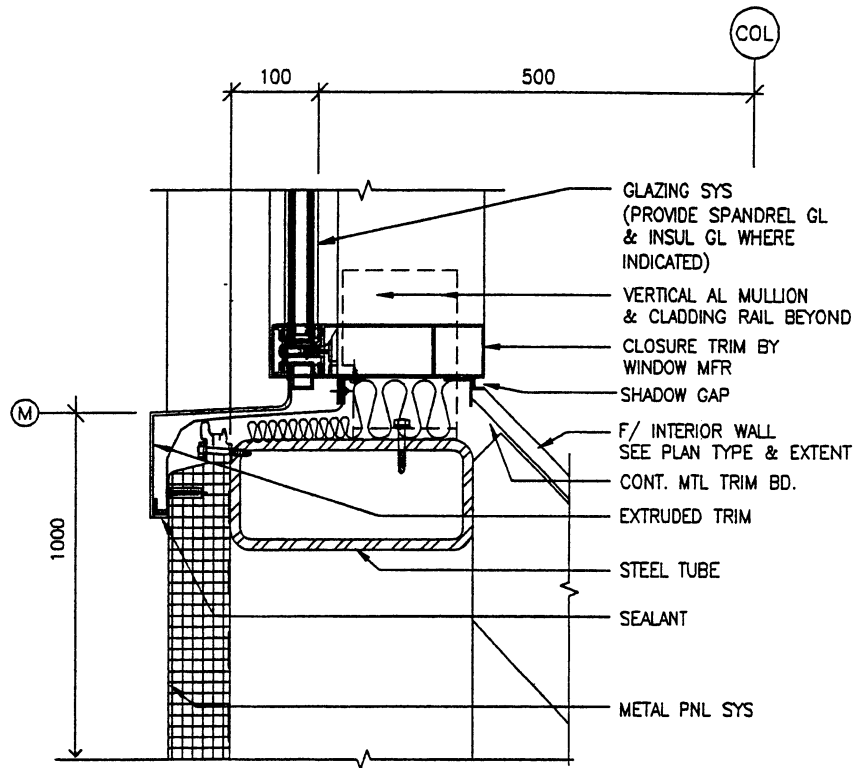

Fig. 9-36

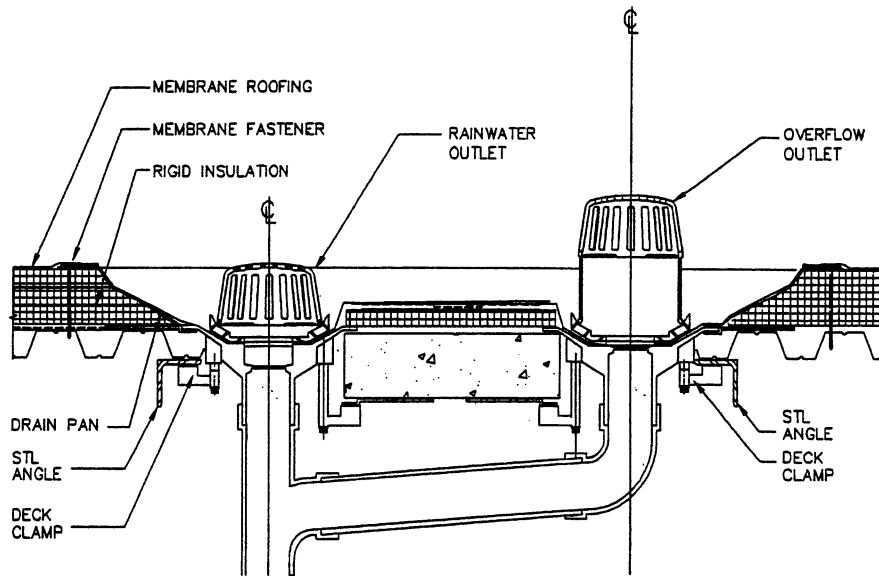

Fig. 9-37

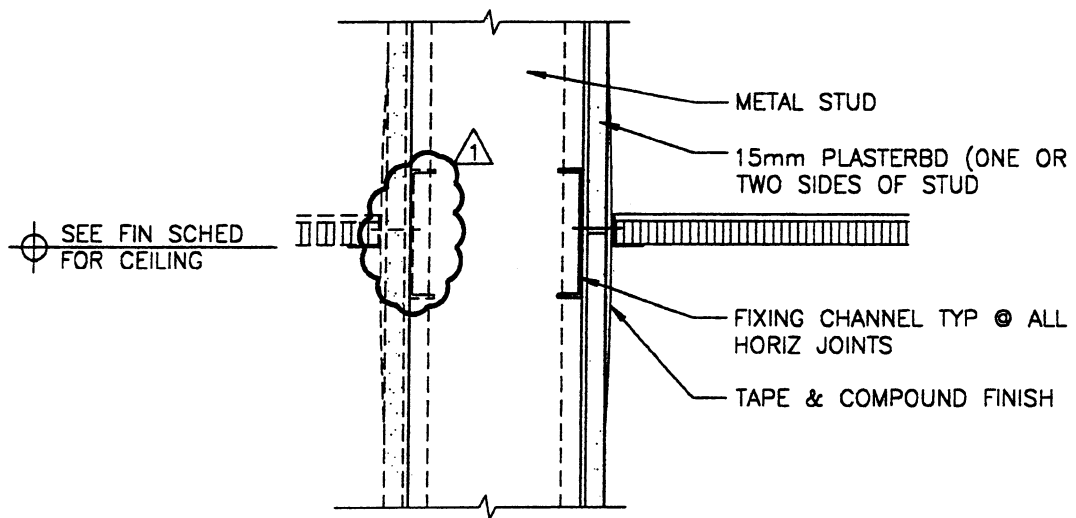

Fig. 9-38

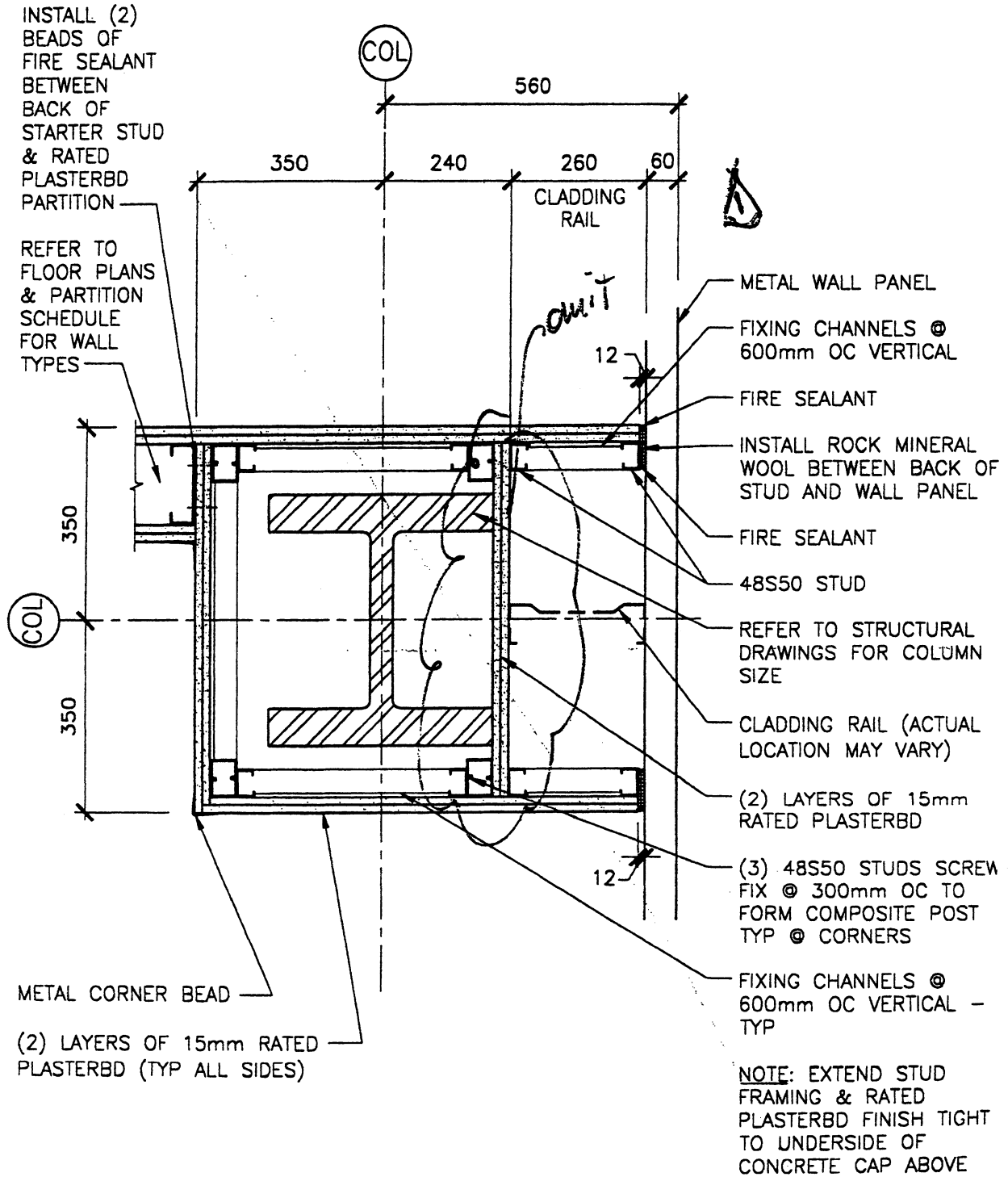

Fig. 9-39

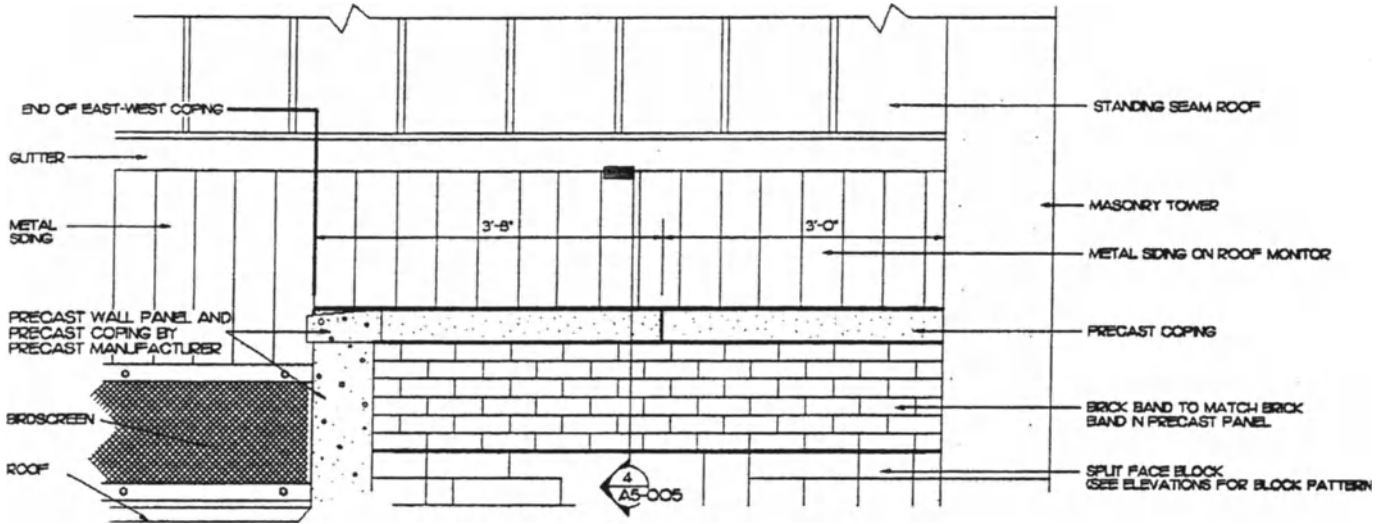

Fig. 9-40

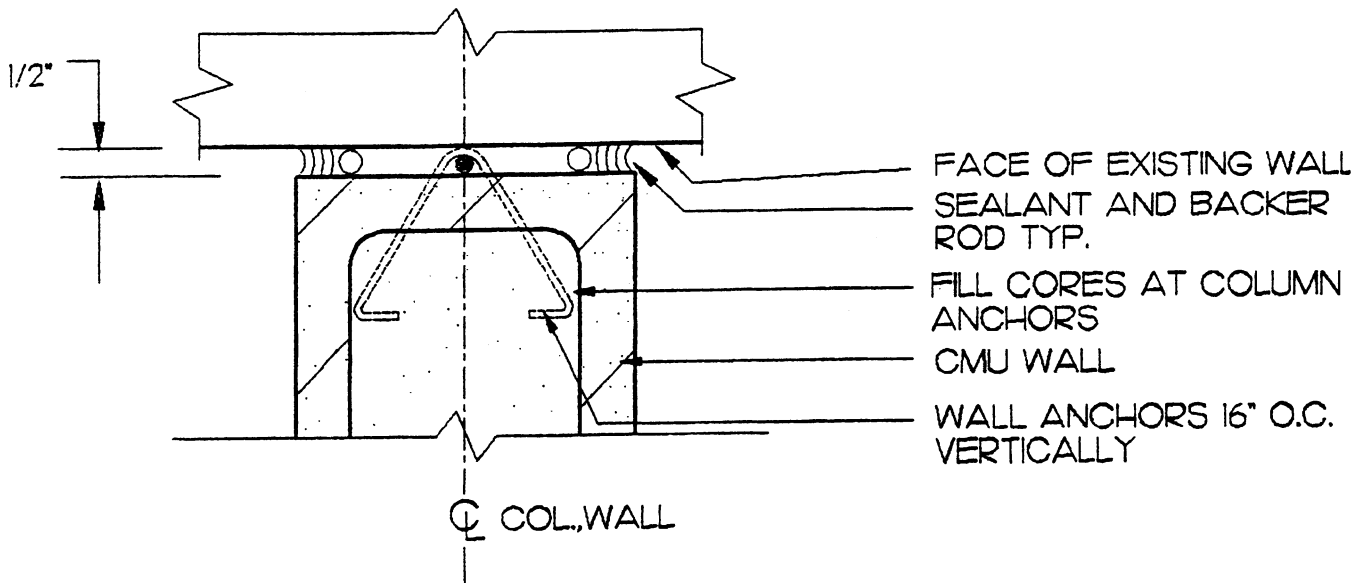

Fig. 9-41

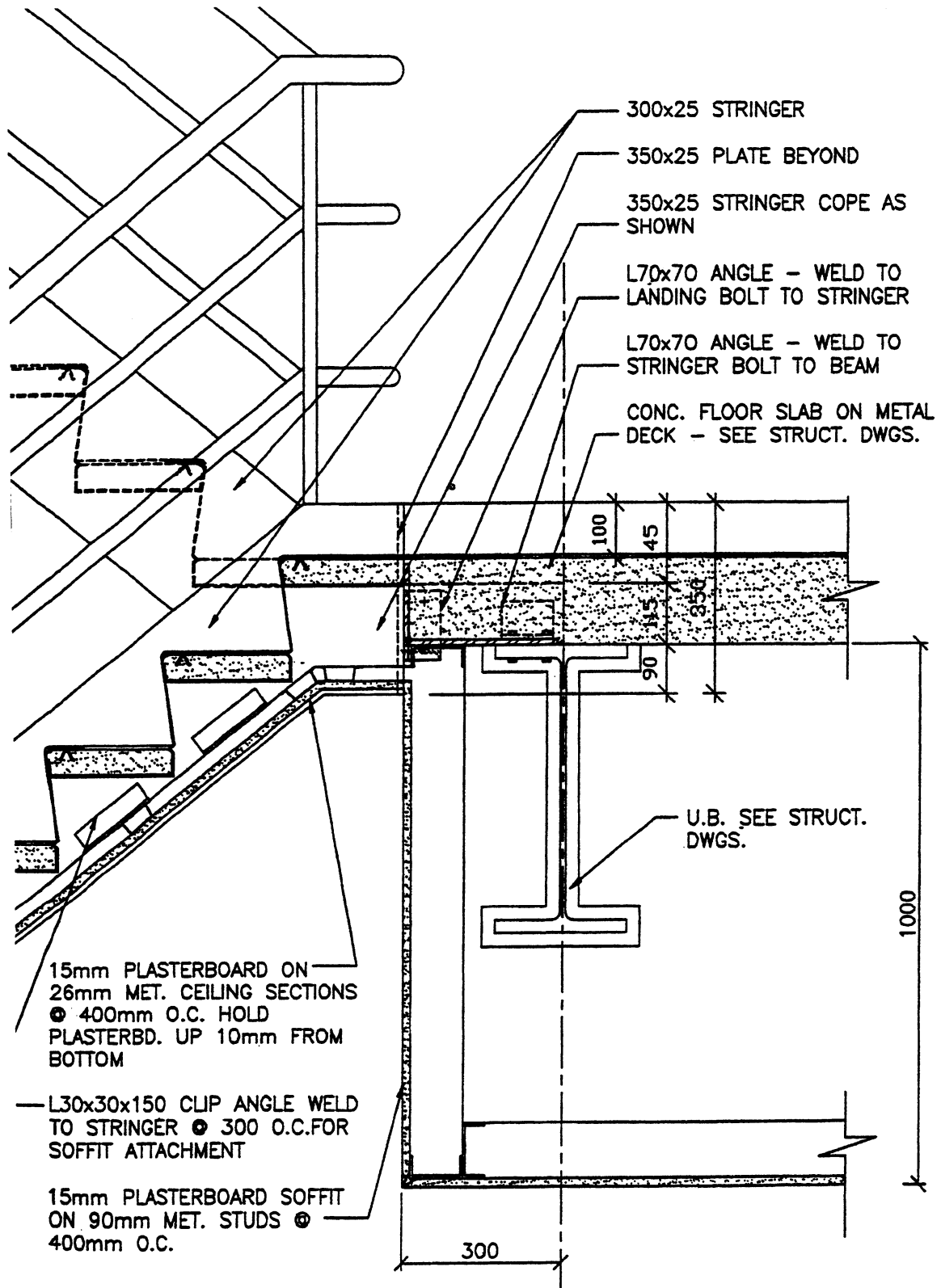

Fig. 9-42

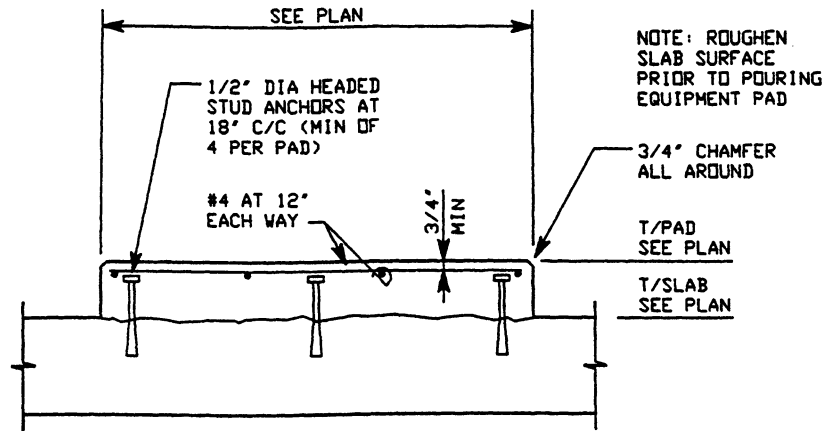

Fig. 9-43

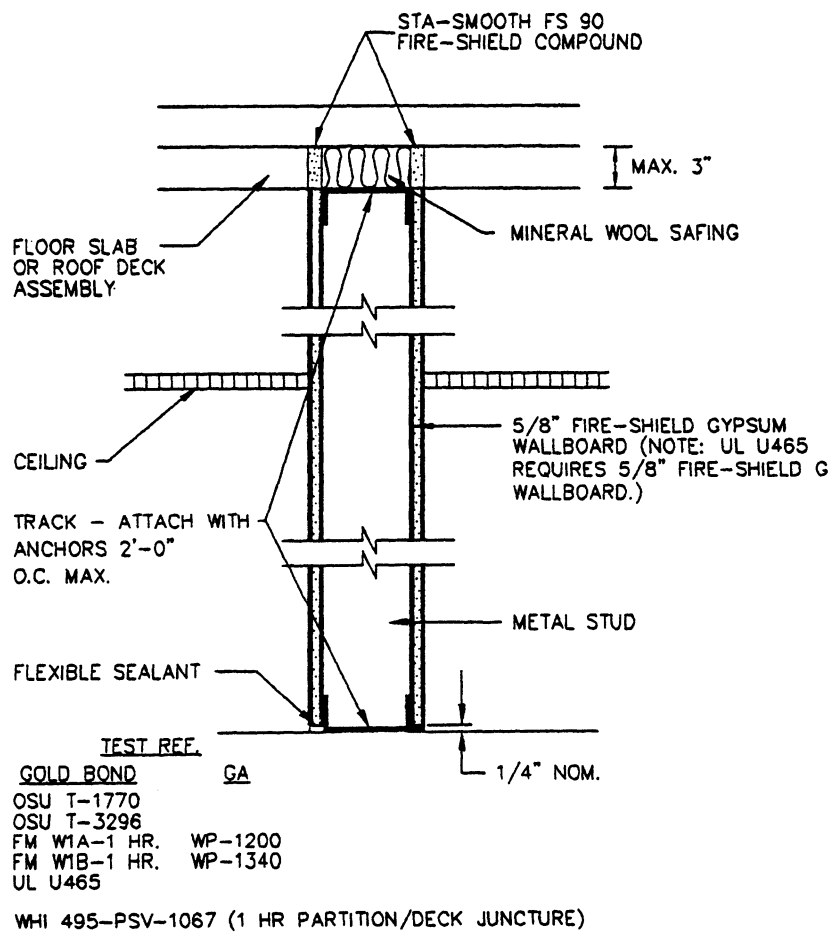
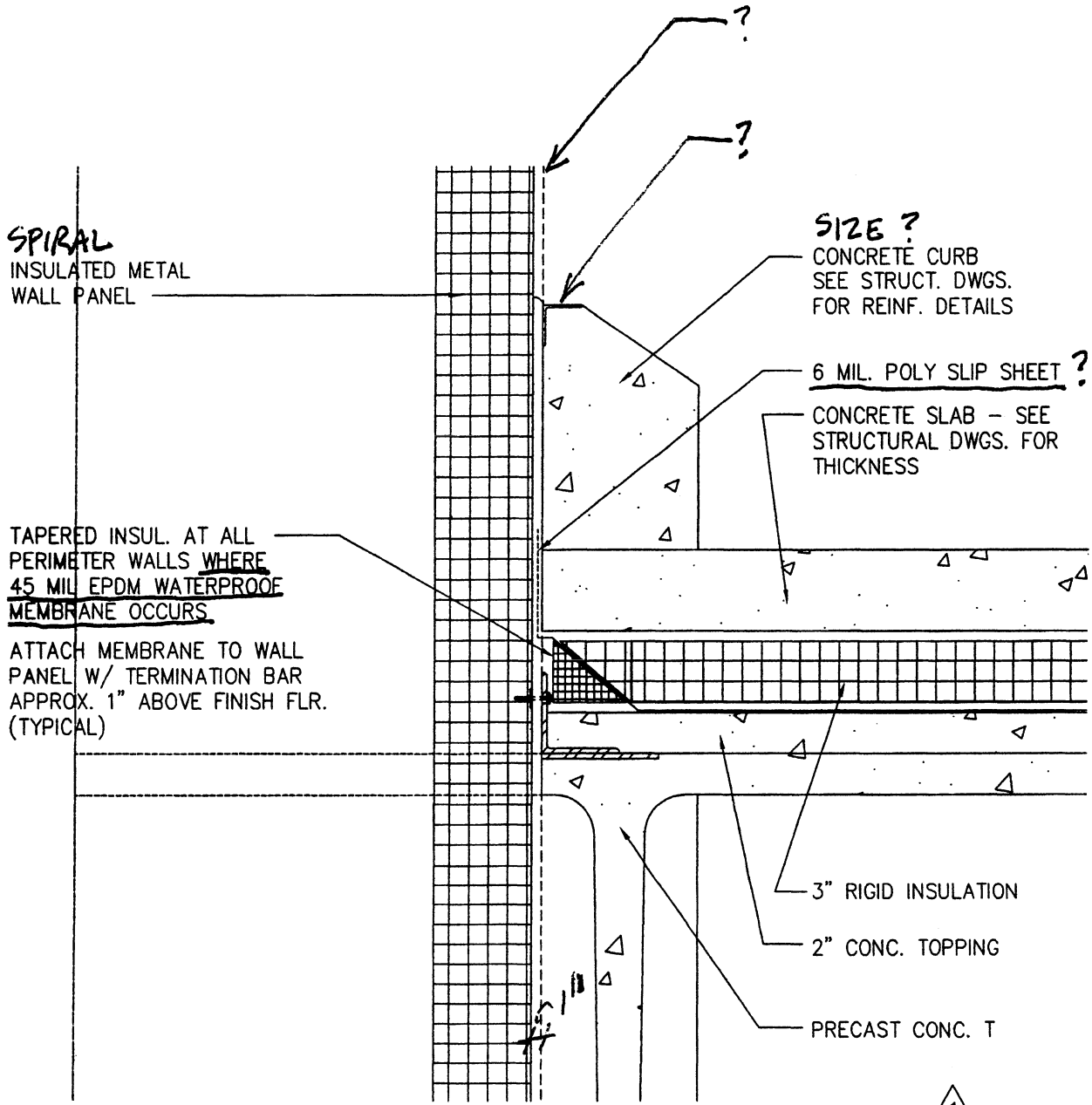

Fig. 9-44



1
A8.3

DETAIL

SCALE: 1 1/2" = 1'-0"
DWG REF: NONE

Fig. 9-45

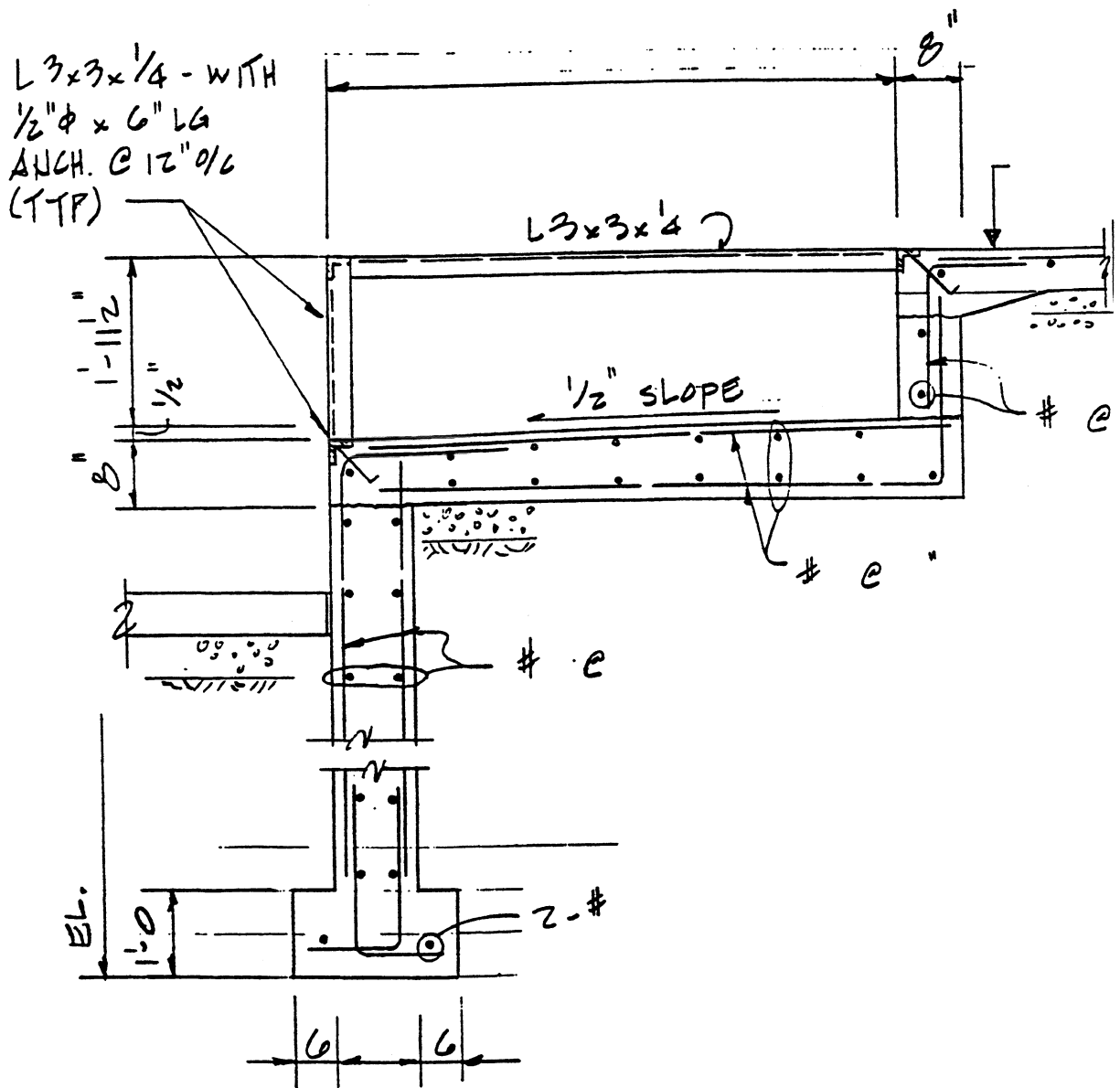

Fig. 9-46

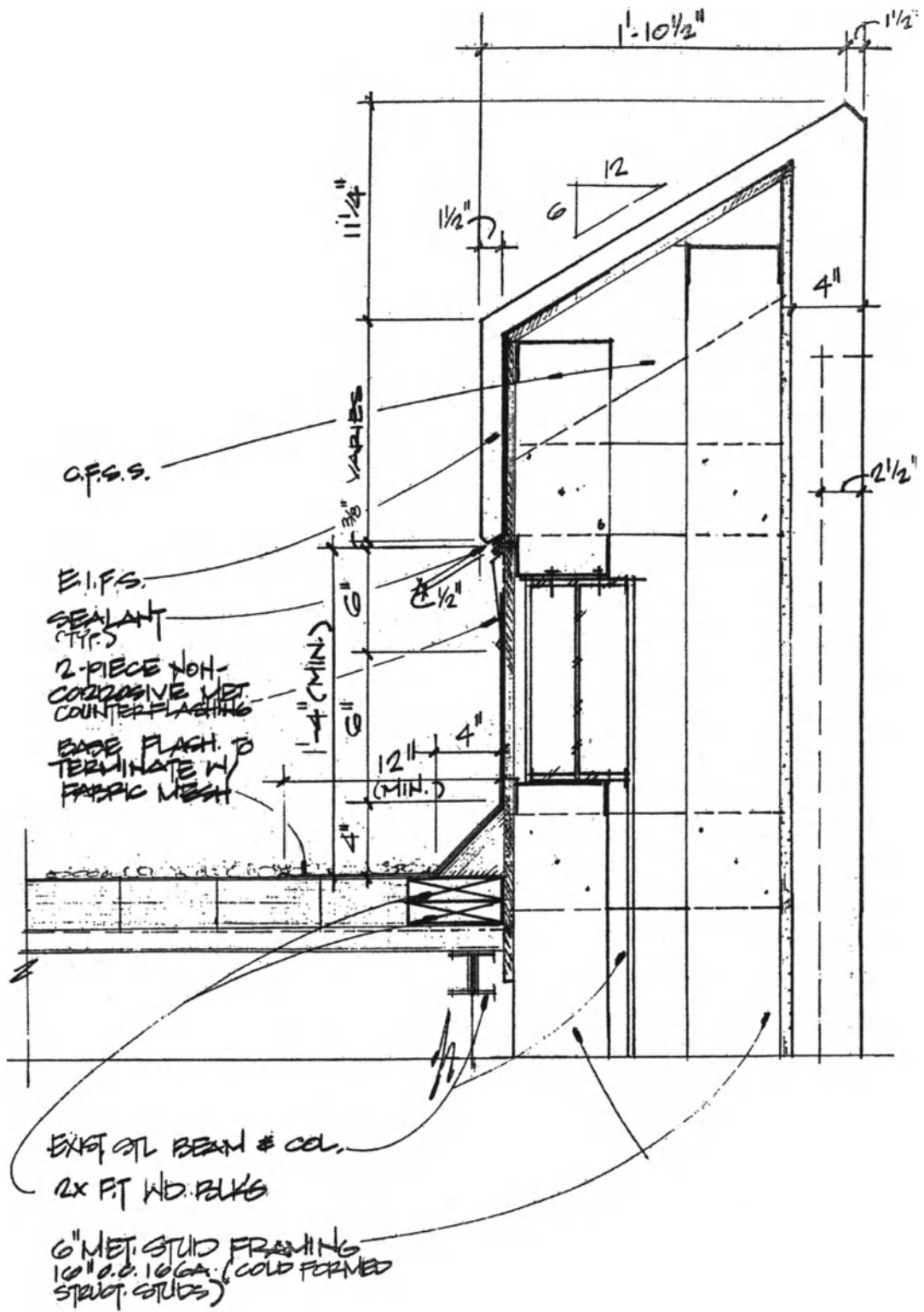

Fig. 9-47

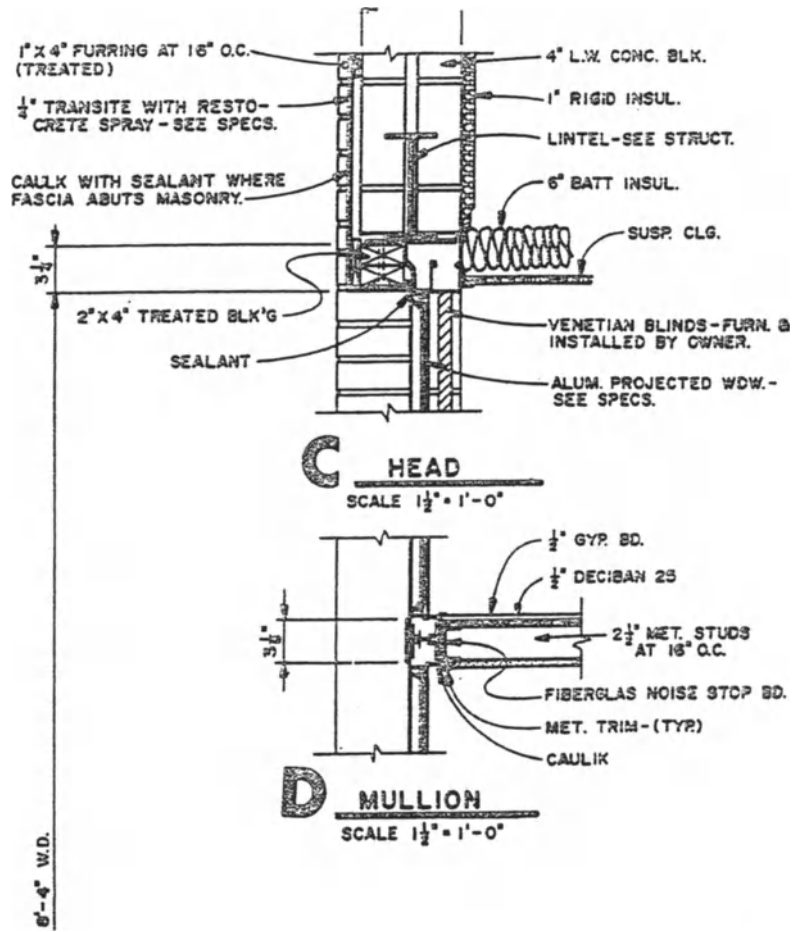

Fig. 9-48

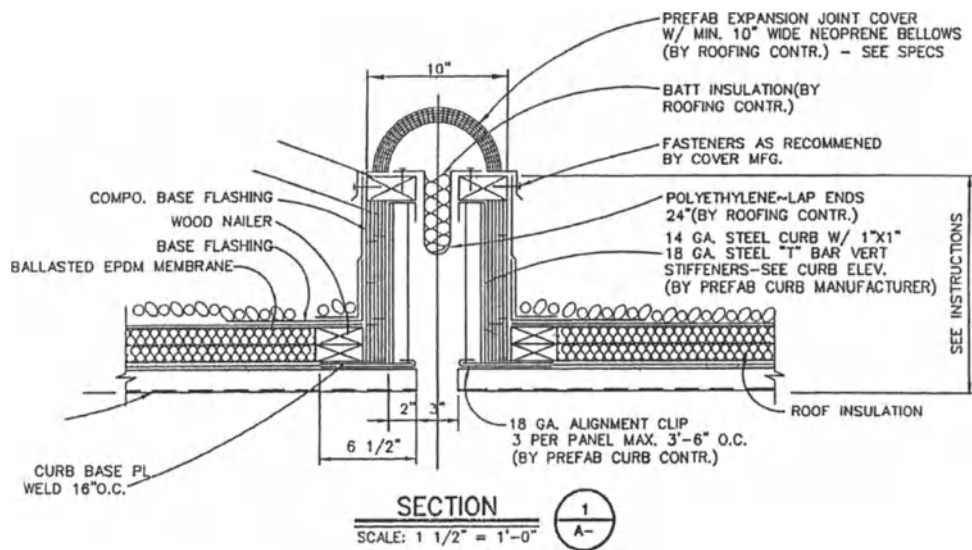

Fig. 9-49

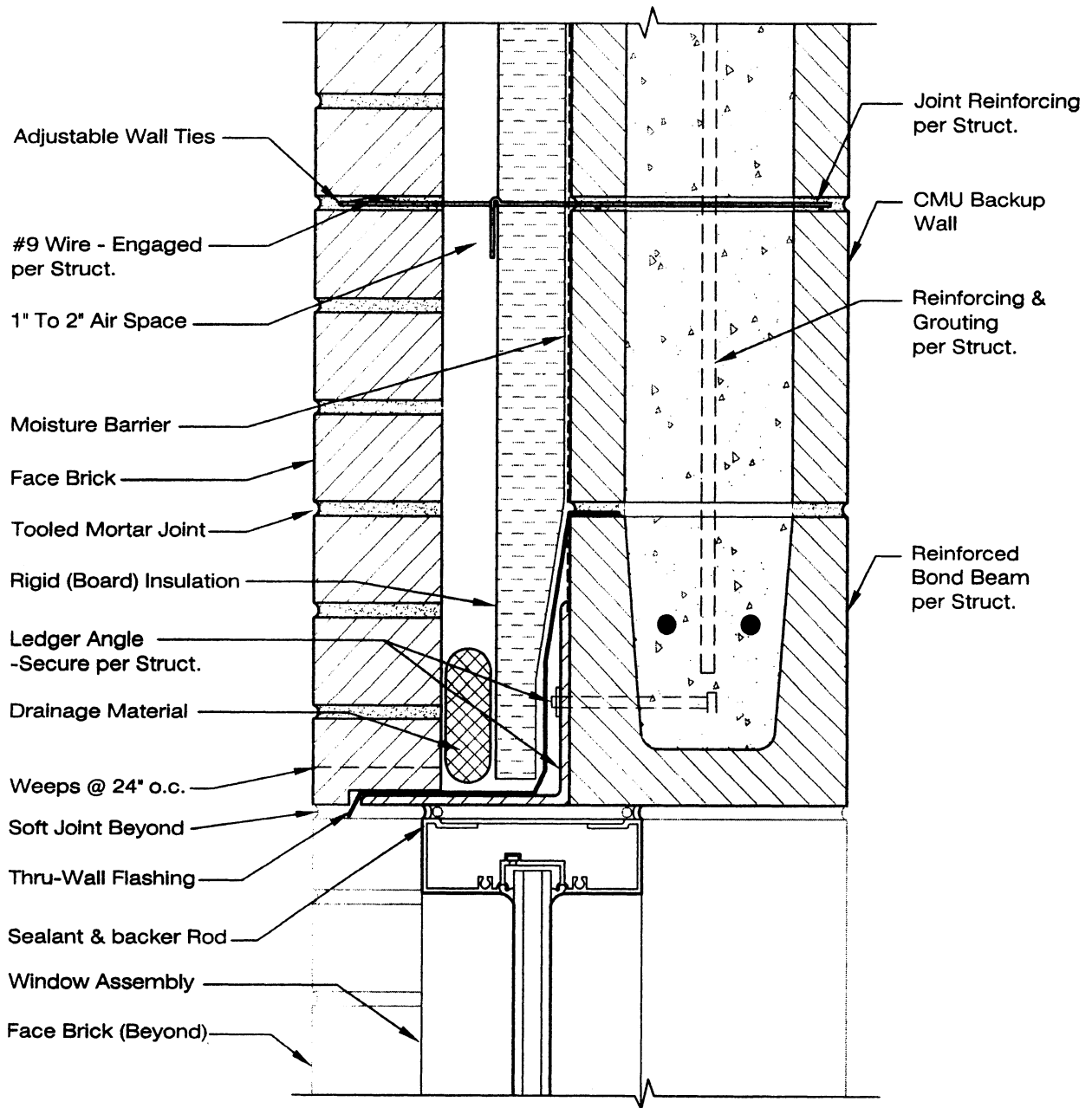

Fig. 9-50

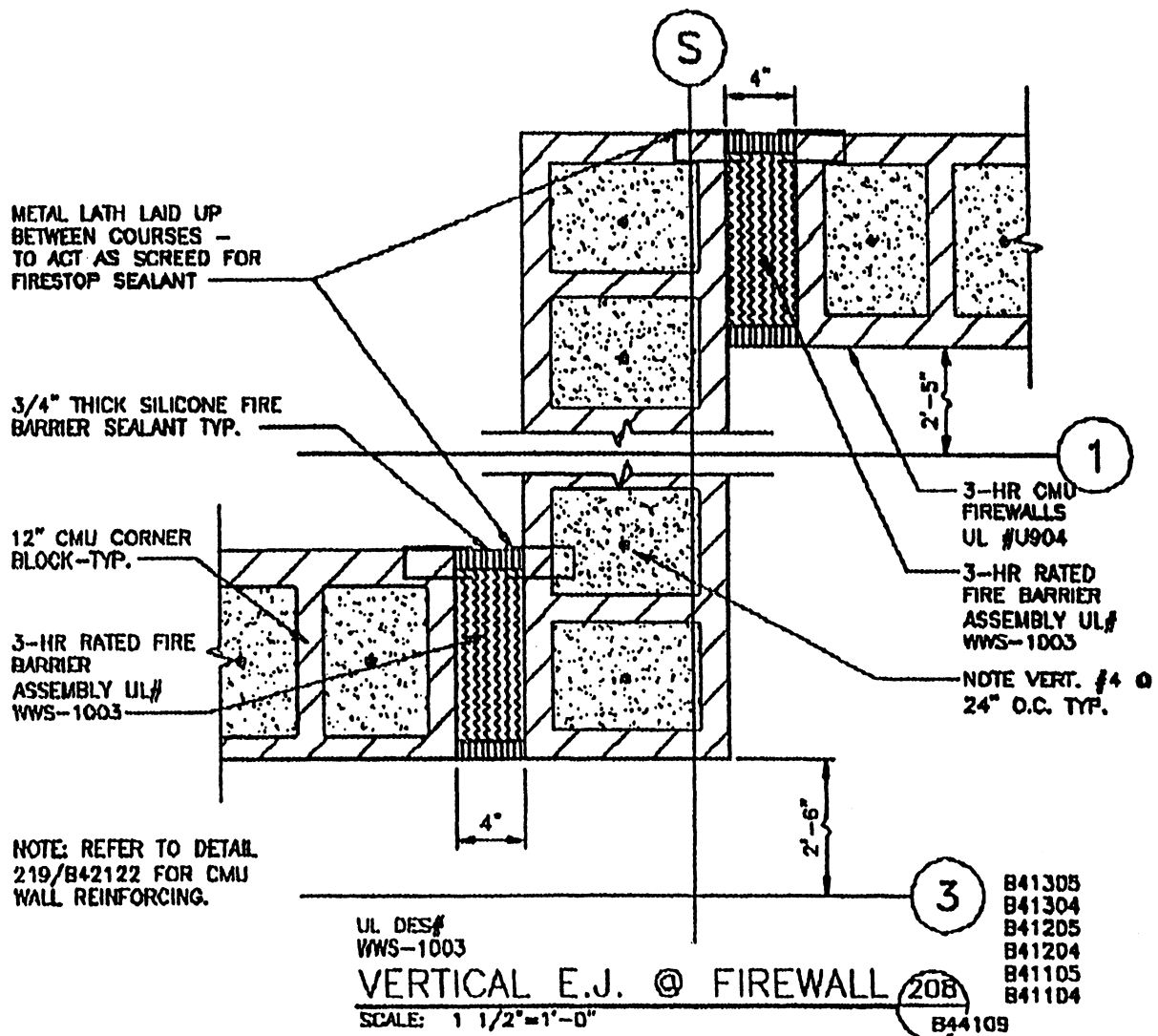

Fig. 9-51

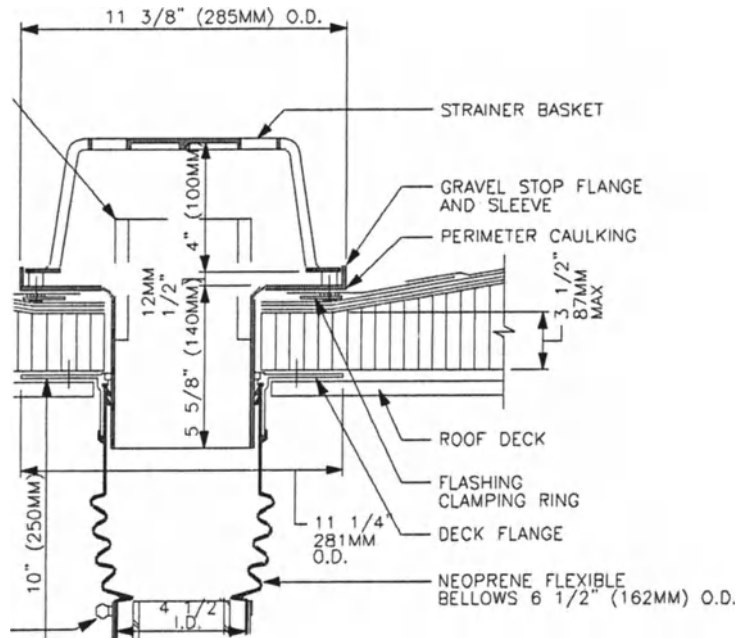

Fig. 9-52

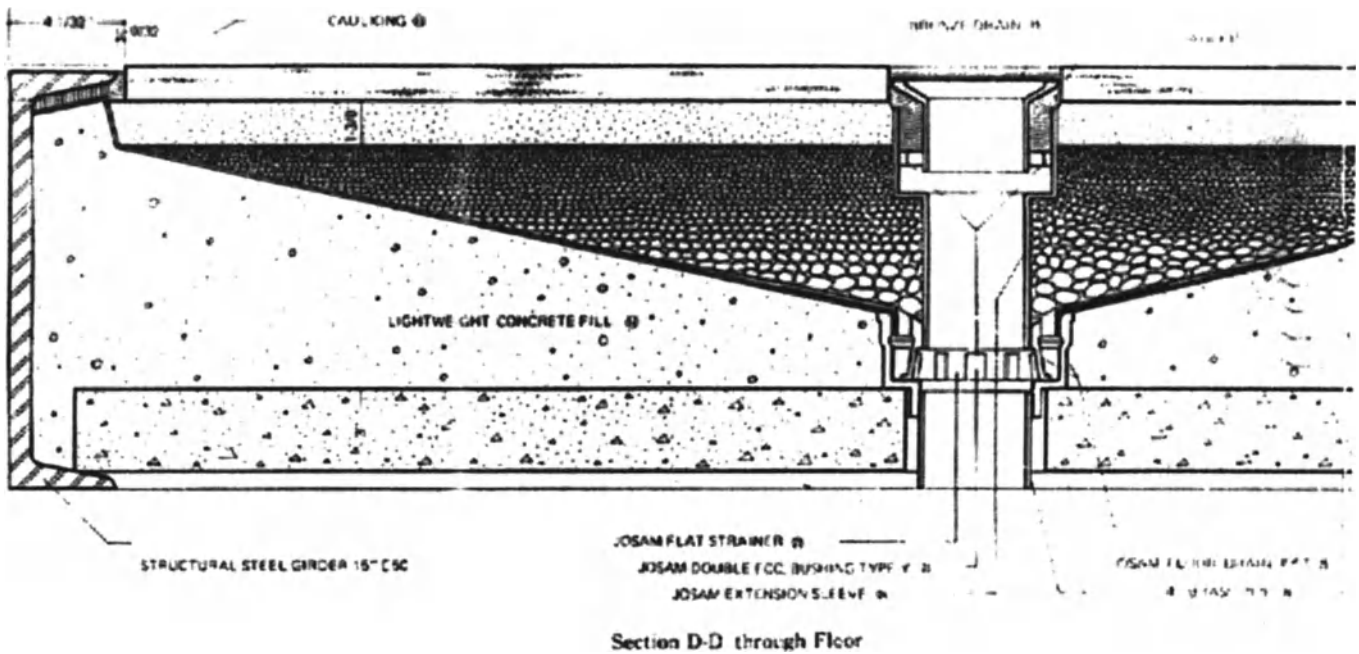

Fig. 9-53

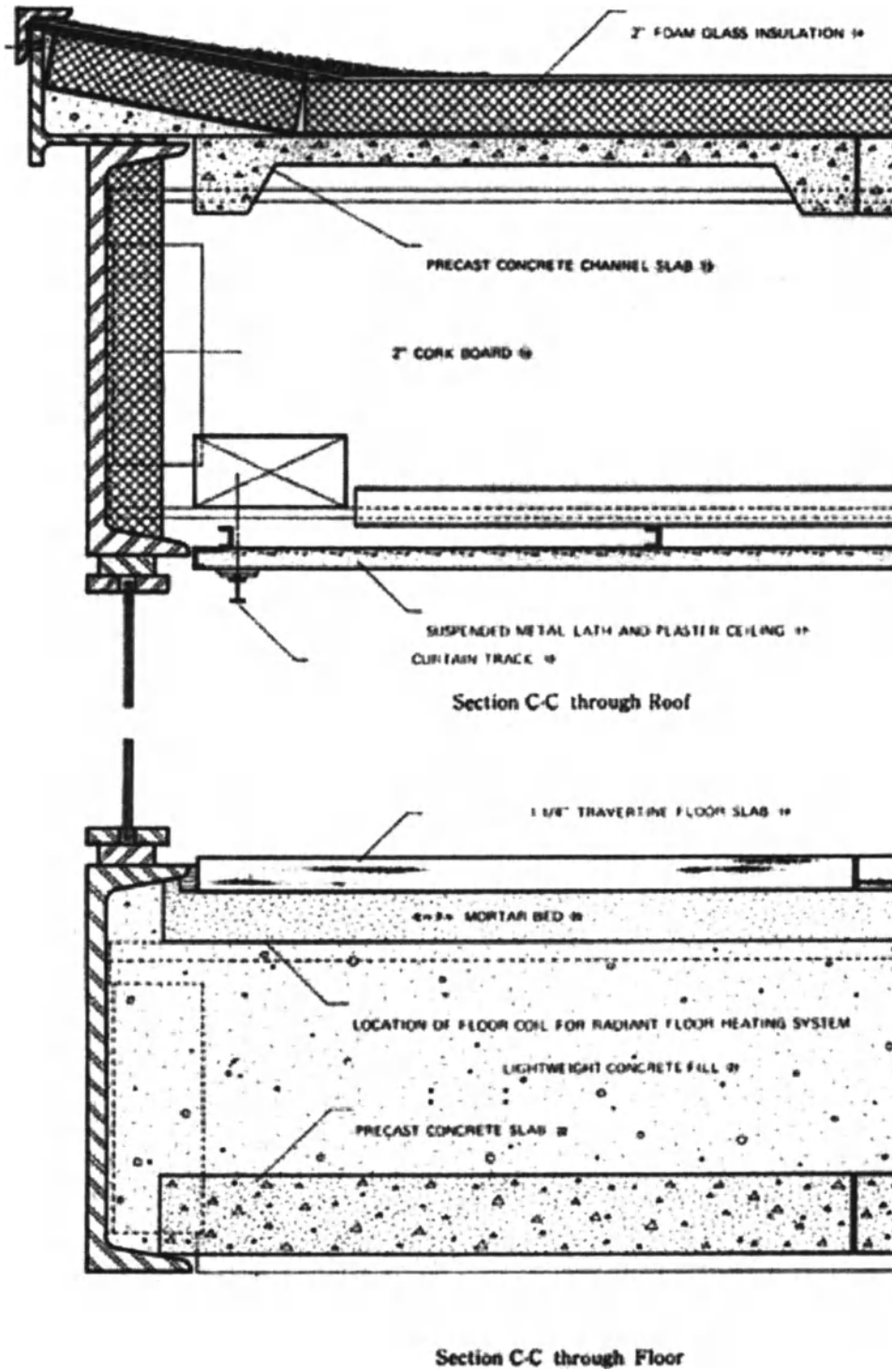

Fig. 9-54

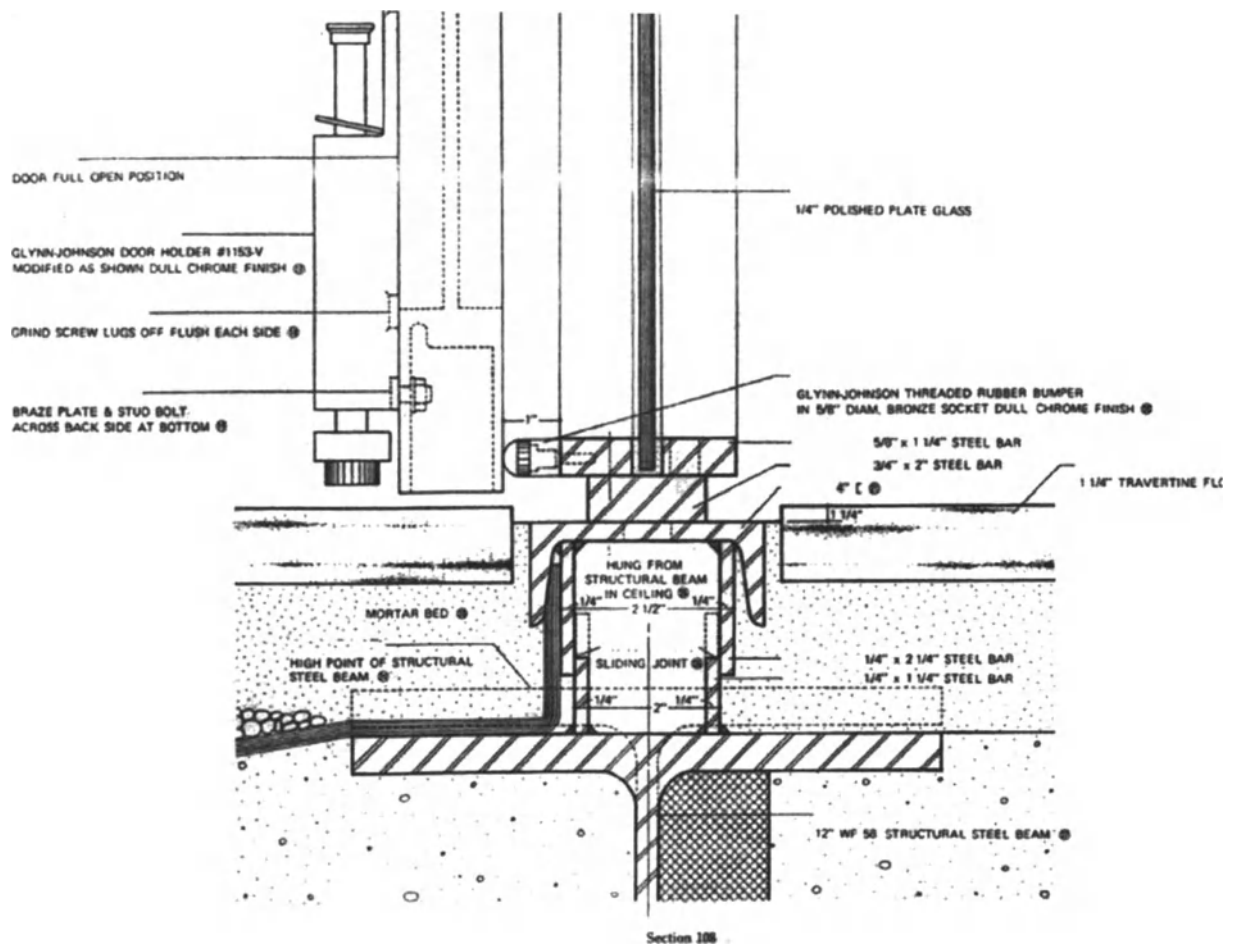

Fig. 9-55

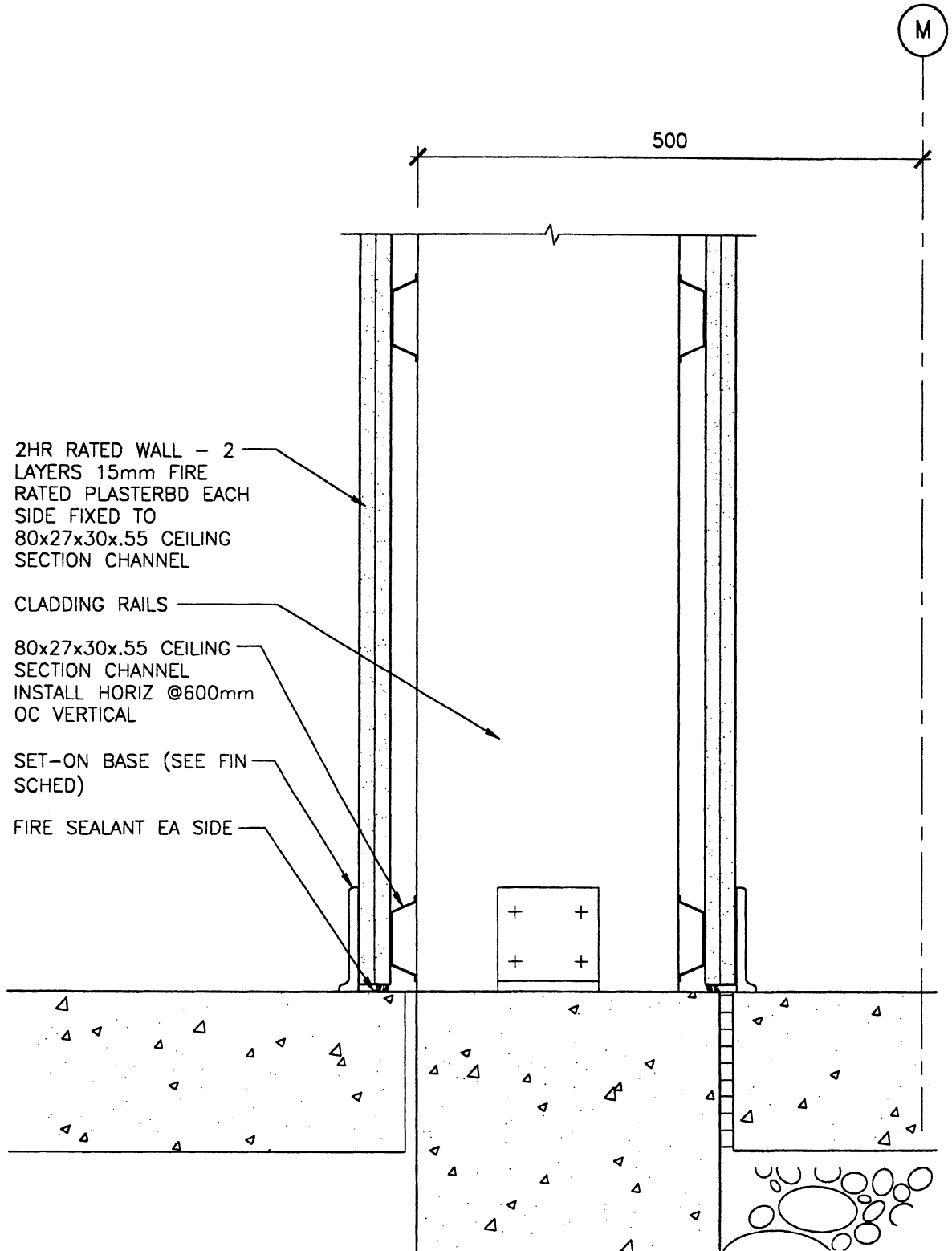

Fig. 9-56

2.03 A512 C CEILING Exterior 09111 Plaster Soffit, Incombustible

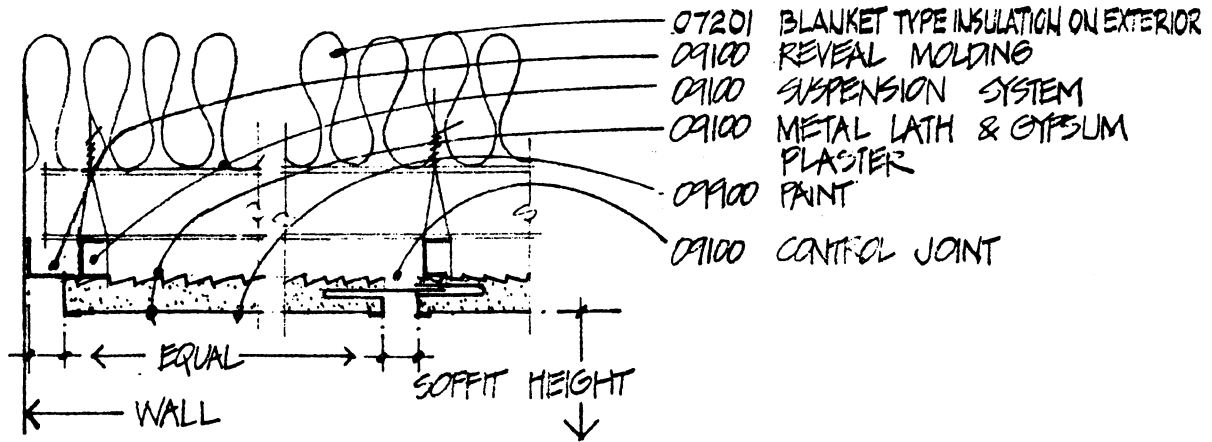
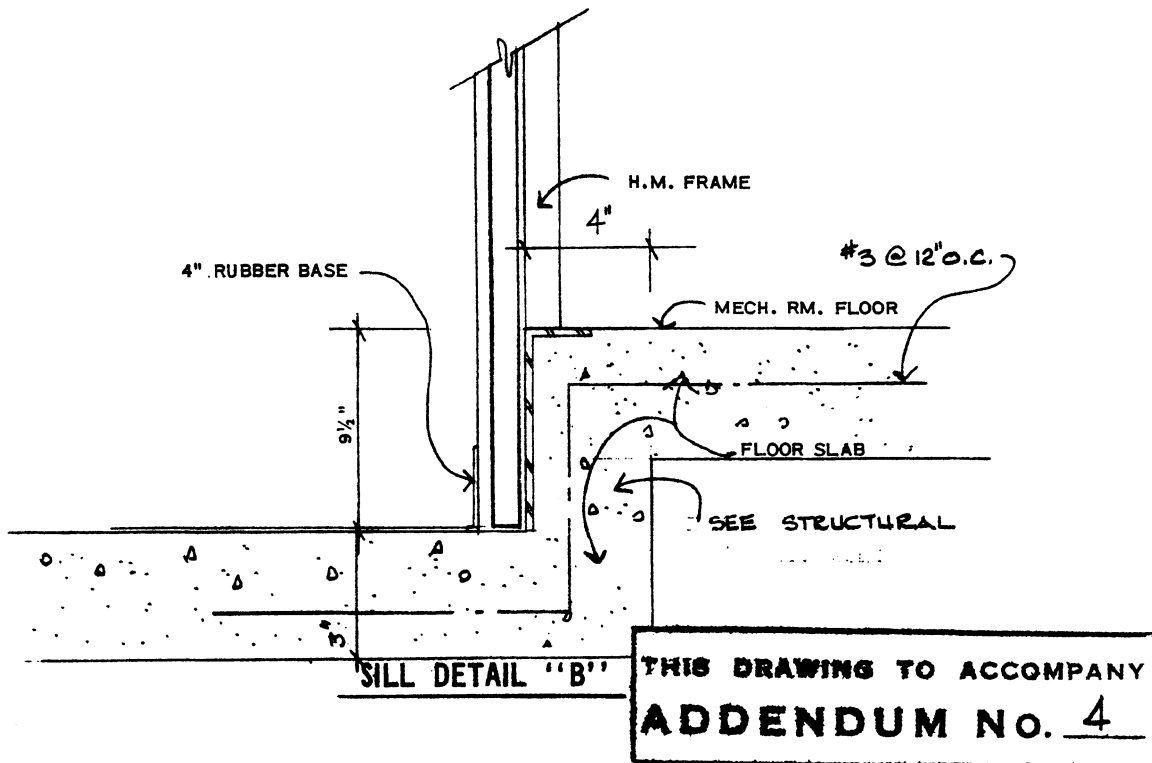
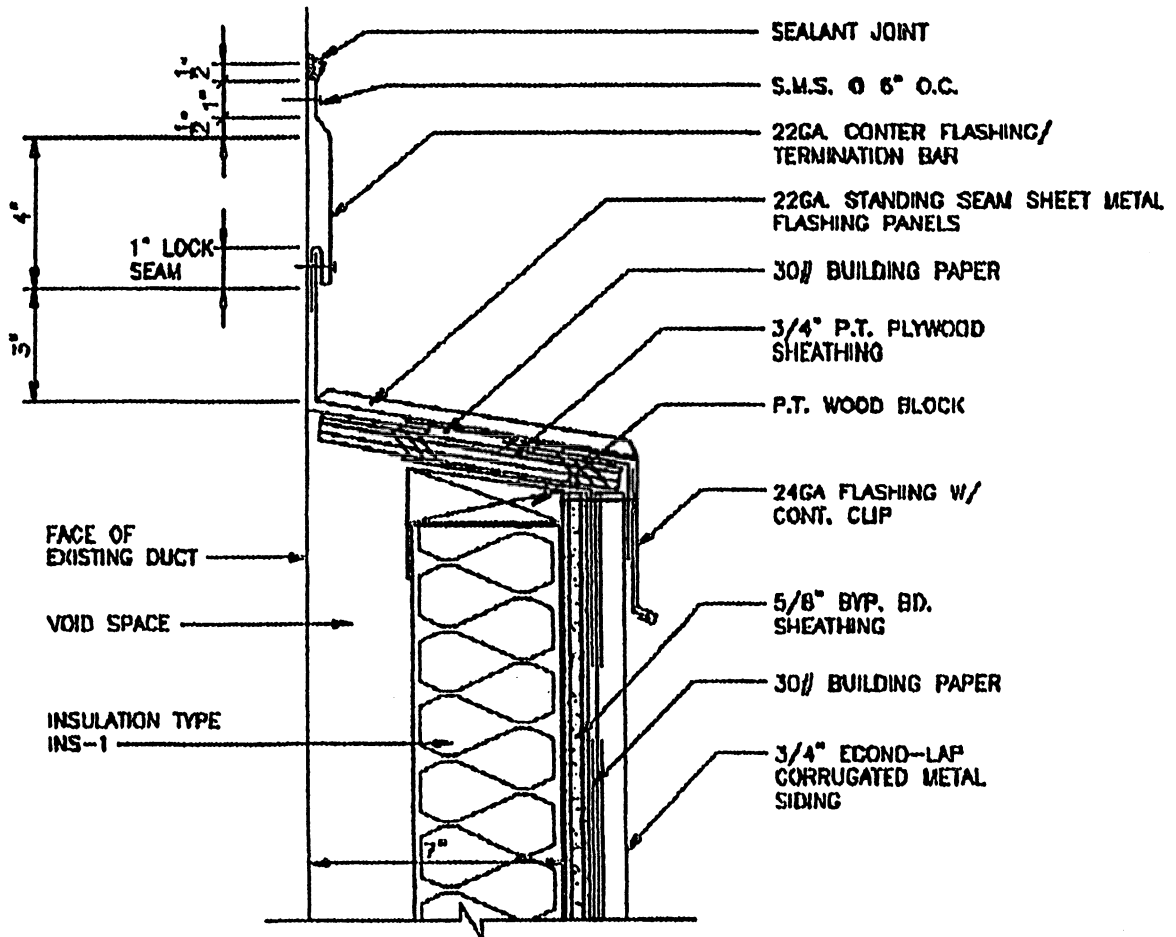

Fig. 9-57



SCALE: 3" = 1'-0"

Fig. 9-58



DUCT TO WALL FLASHING

SCALE: 3" = 1'-0"

078
B44113

Fig. 9-59

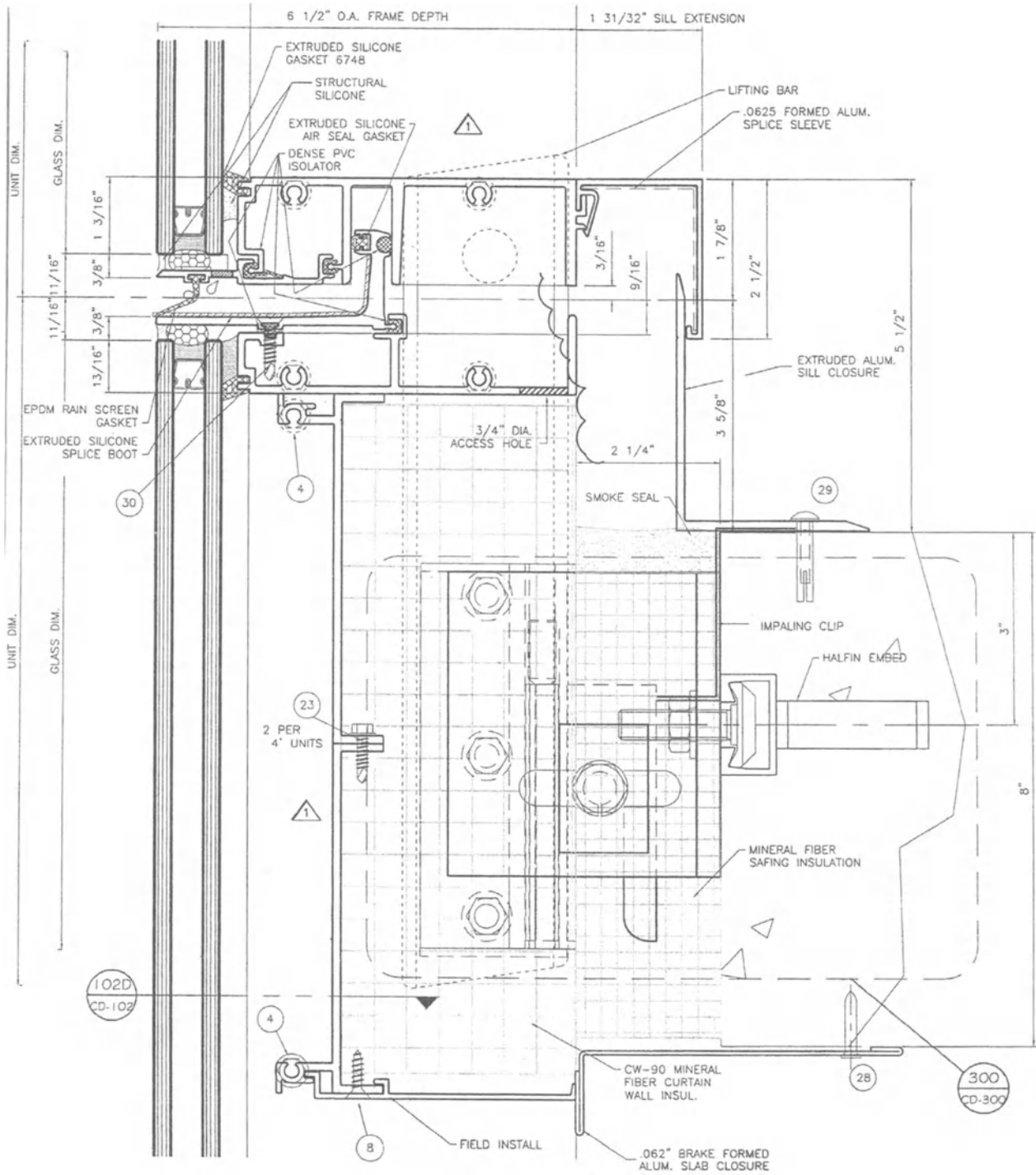

Fig. 9-60

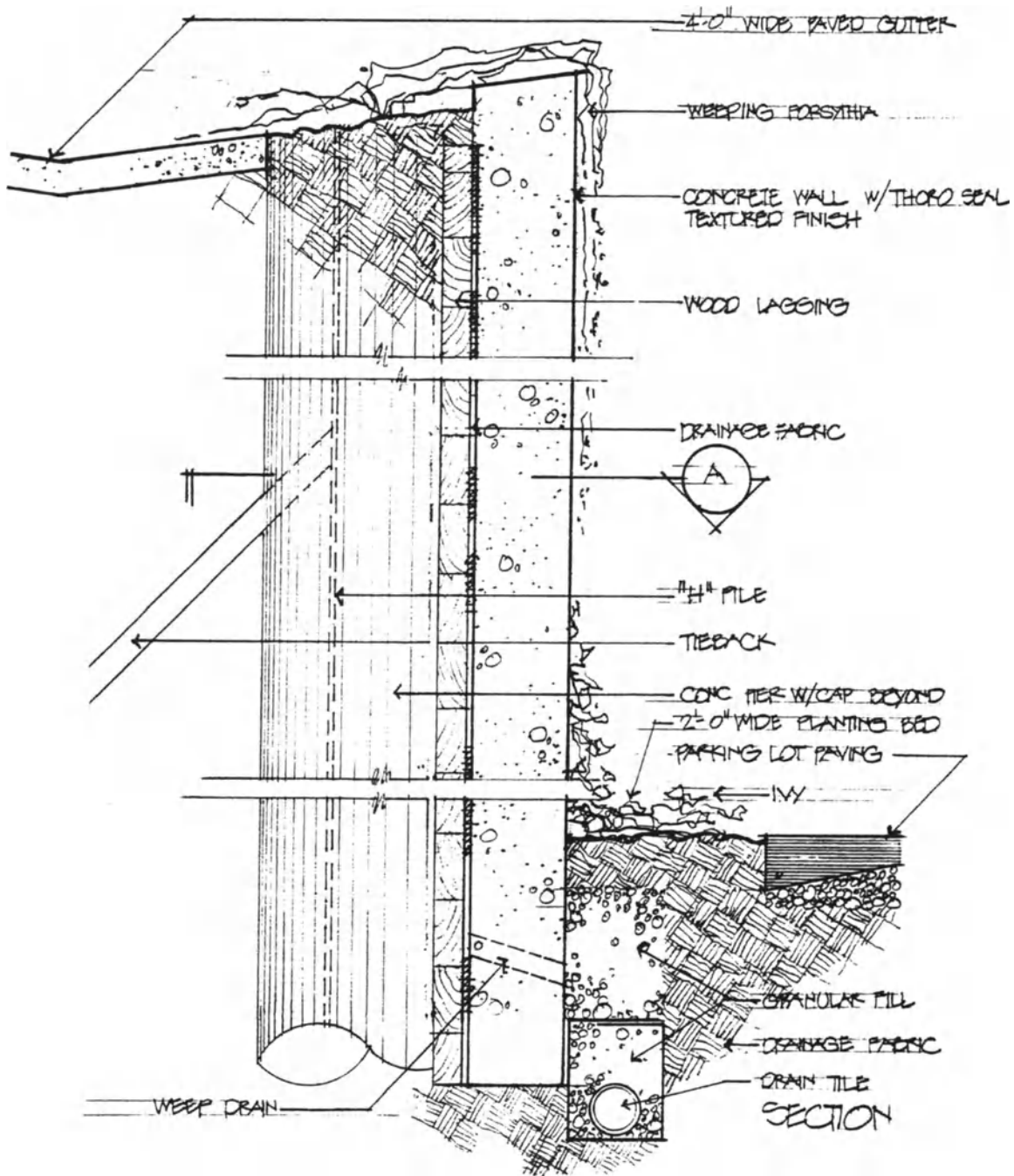

Fig. 9-61a

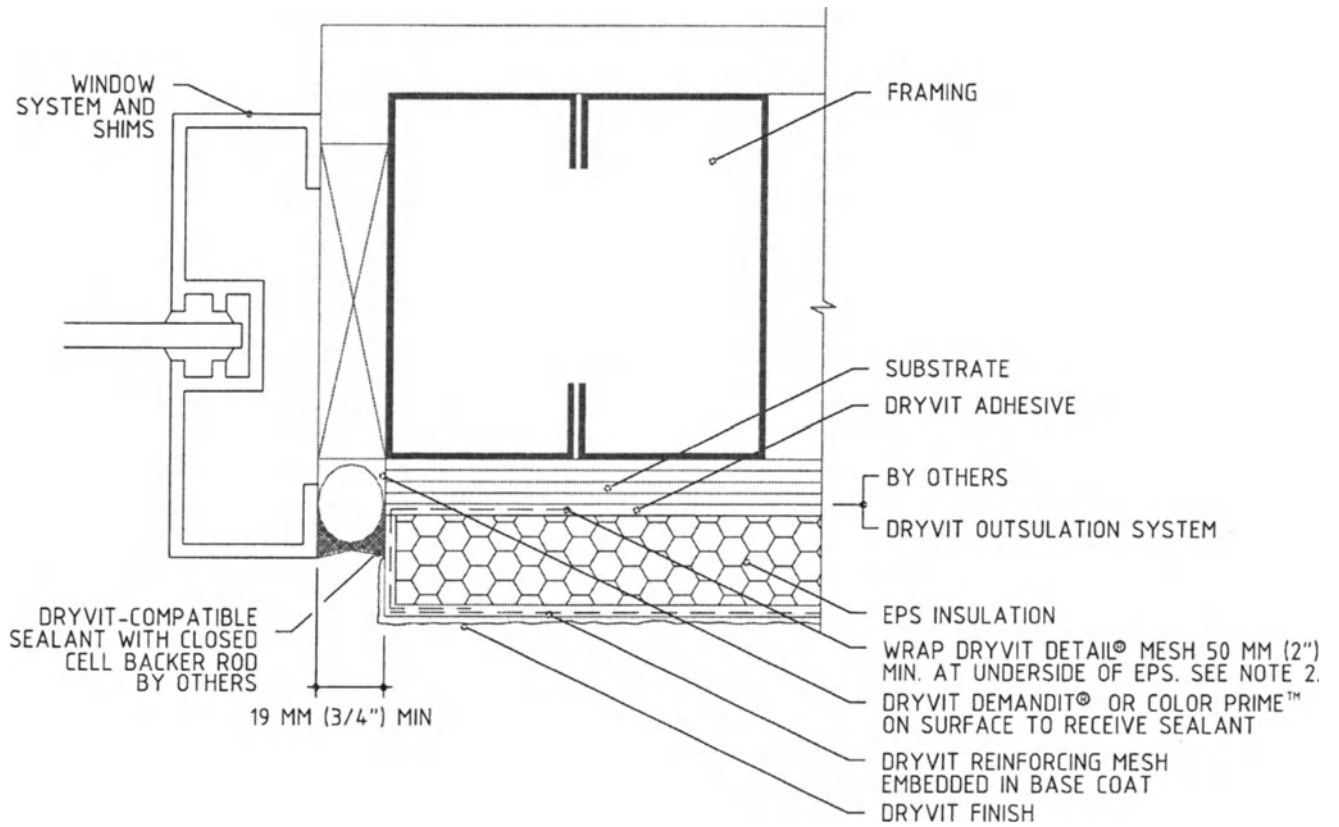

Fig. 9-61b

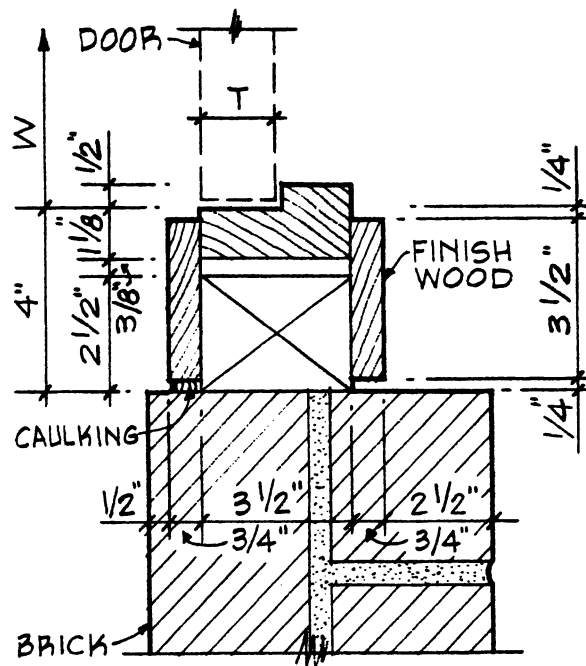

Fig. 9-62

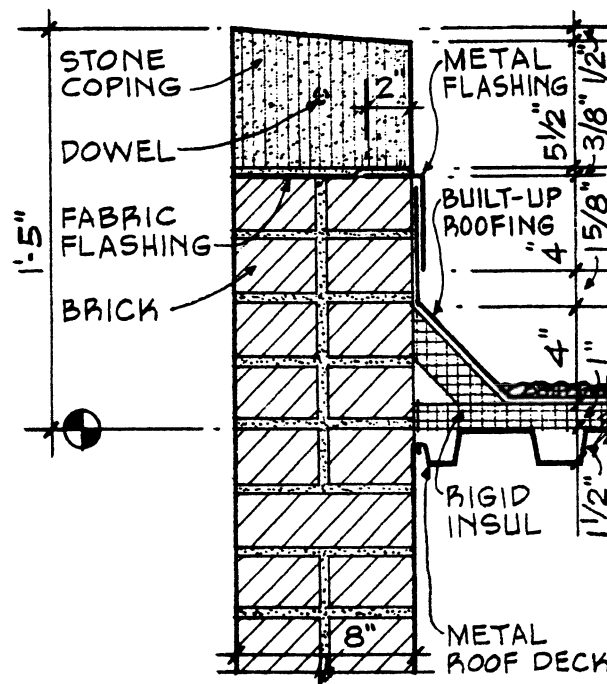
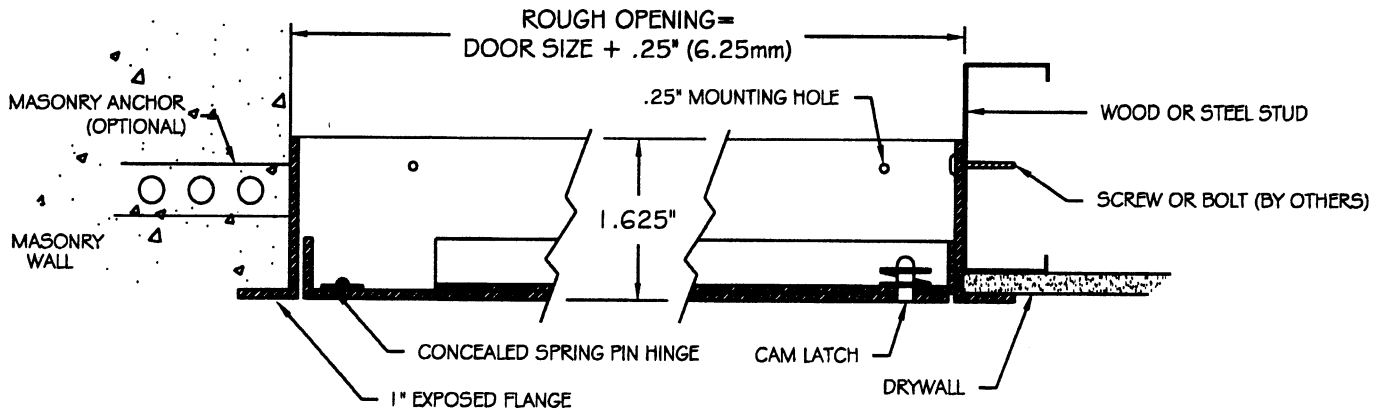

Fig. 9-63



A CUT-THRU SECTION
A NOT TO SCALE

Fig. 9-64

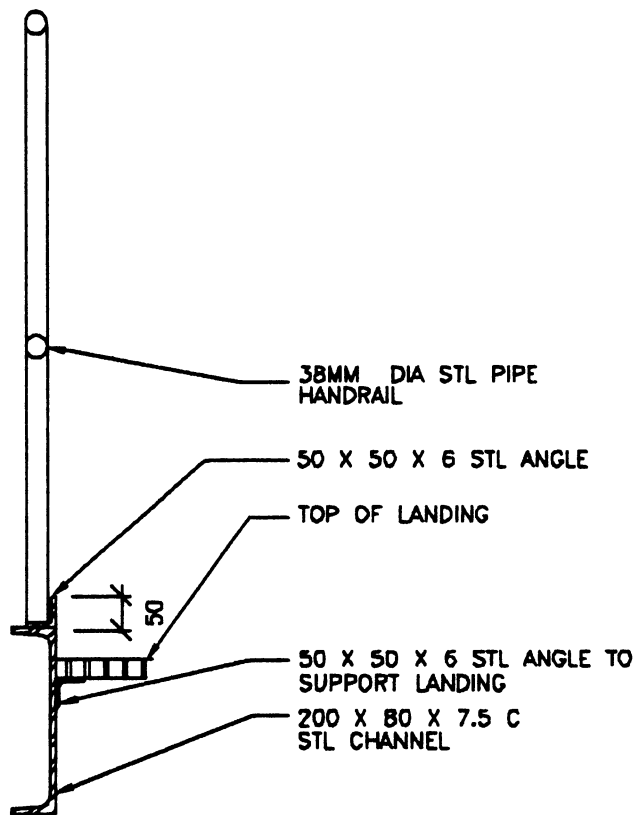
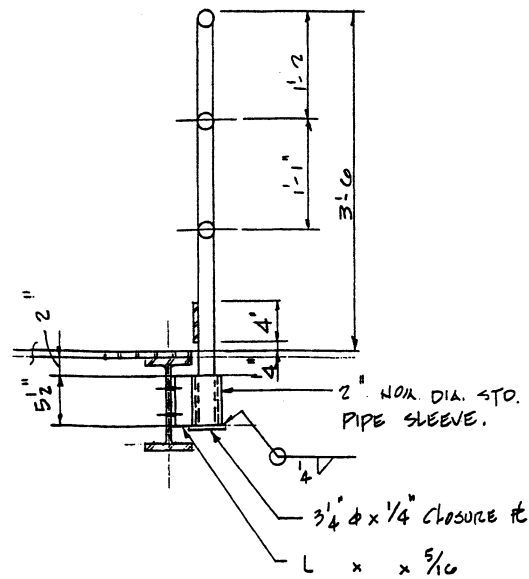

Fig. 9-65



REMOVABLE HANDRAIL DETAIL

Fig. 9-66

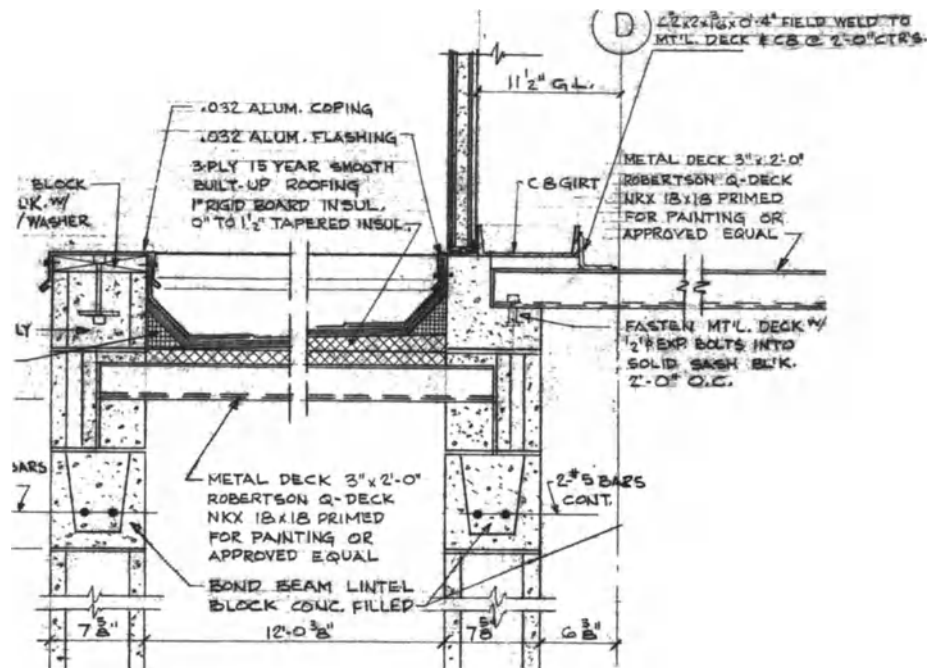

Fig. 9-67

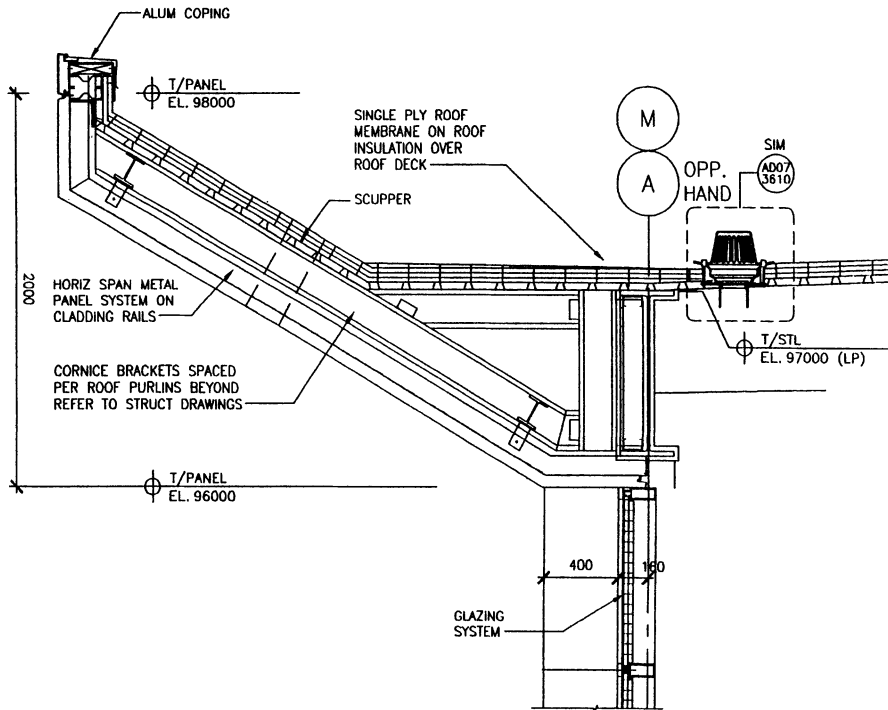

Fig. 9-68

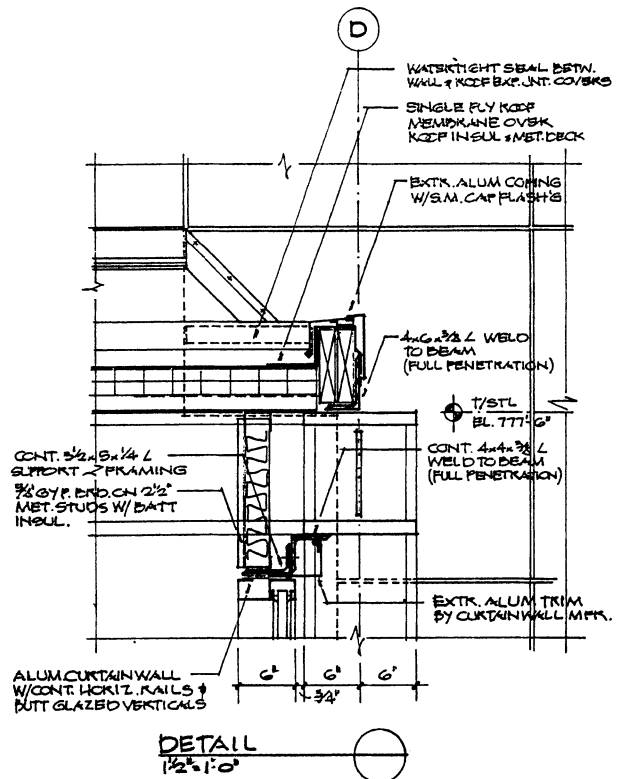

Fig. 9-69

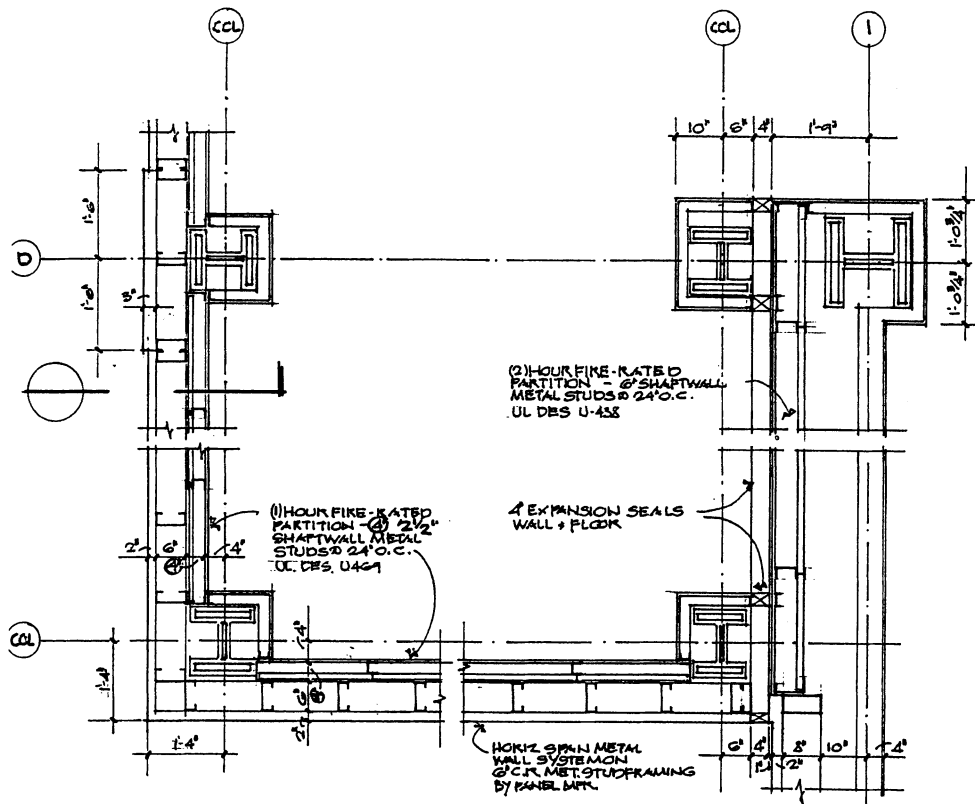
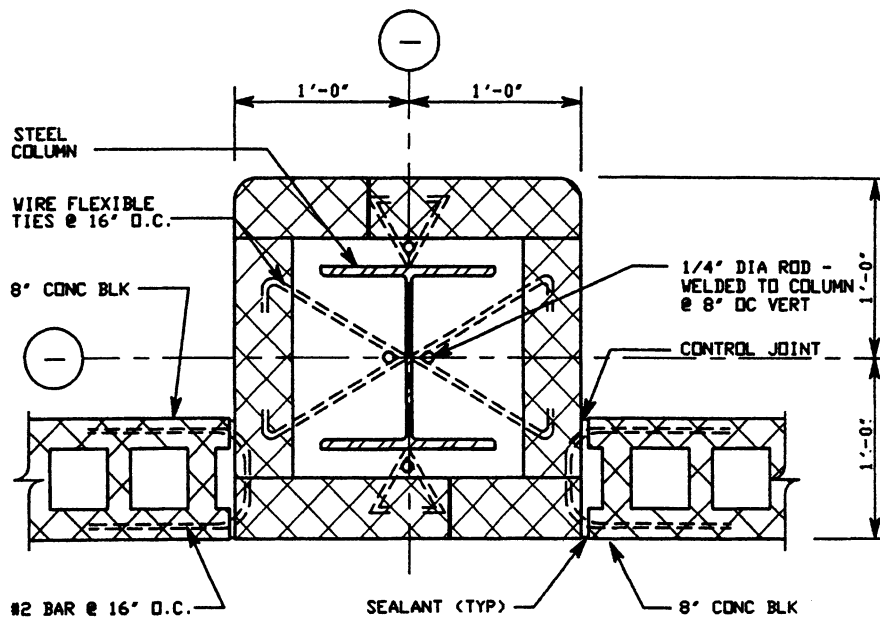

Fig. 9-70



DETAIL SCALE: 1 1/2" = 1'-0"

Fig. 9-71

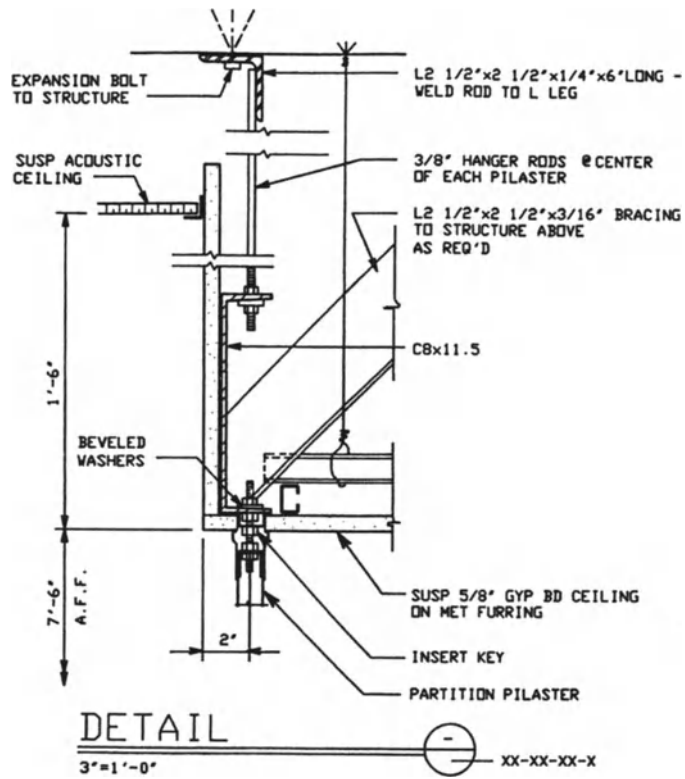

Fig. 9-72

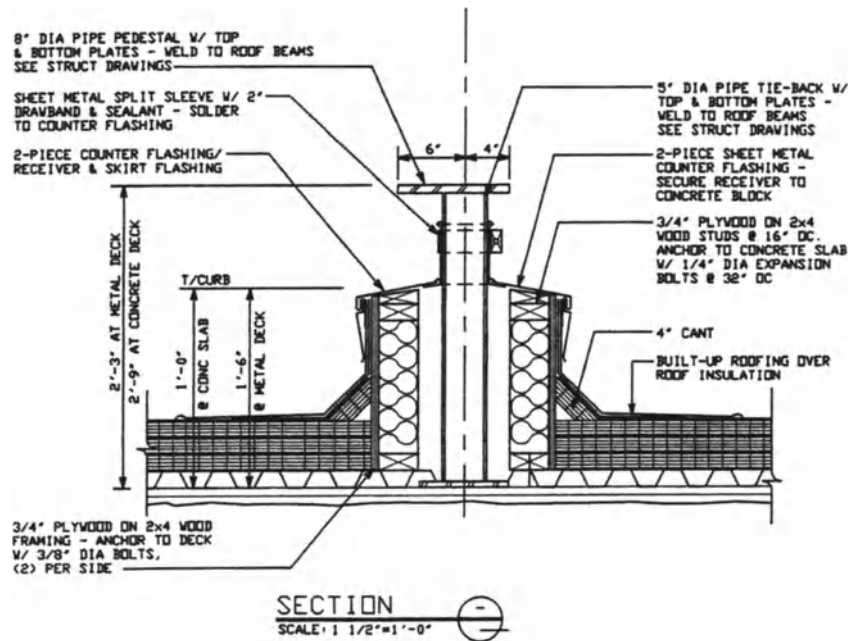

Fig. 9-73

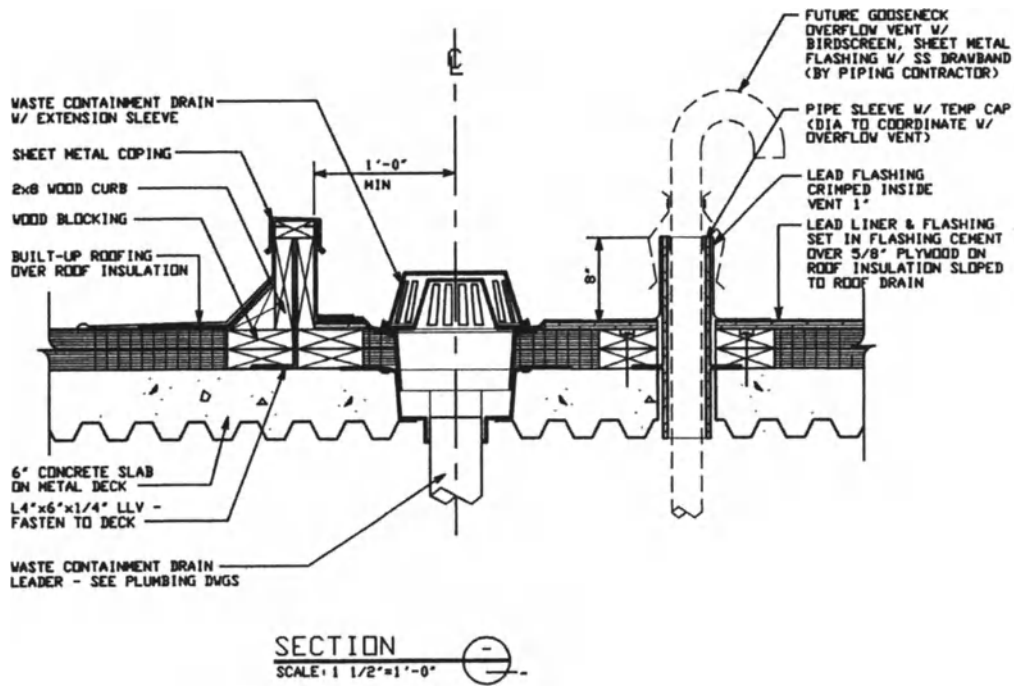

Fig. 9-74

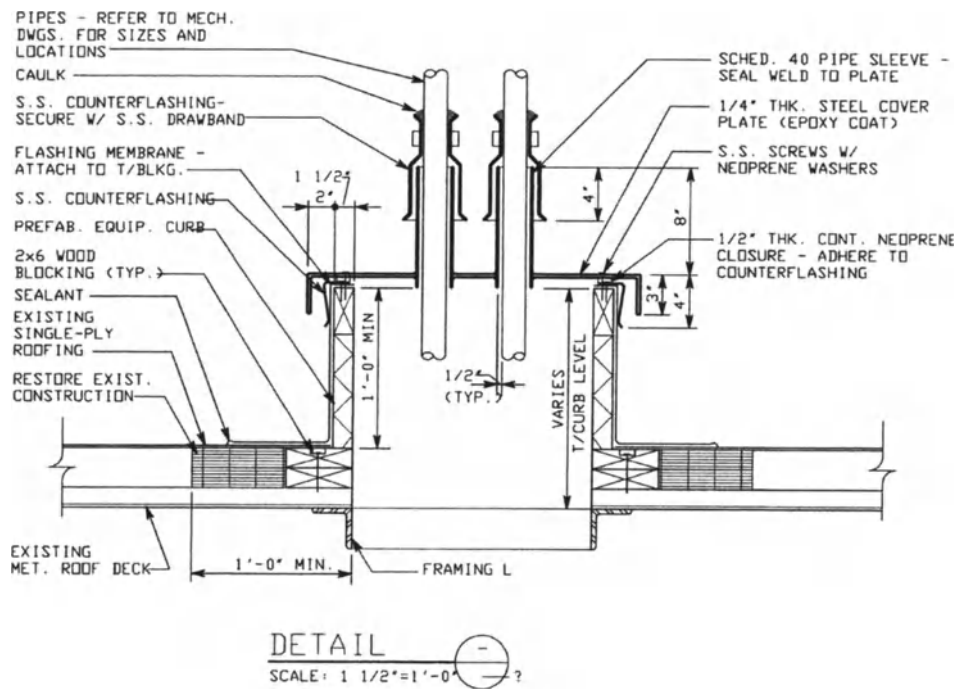

Fig. 9-75

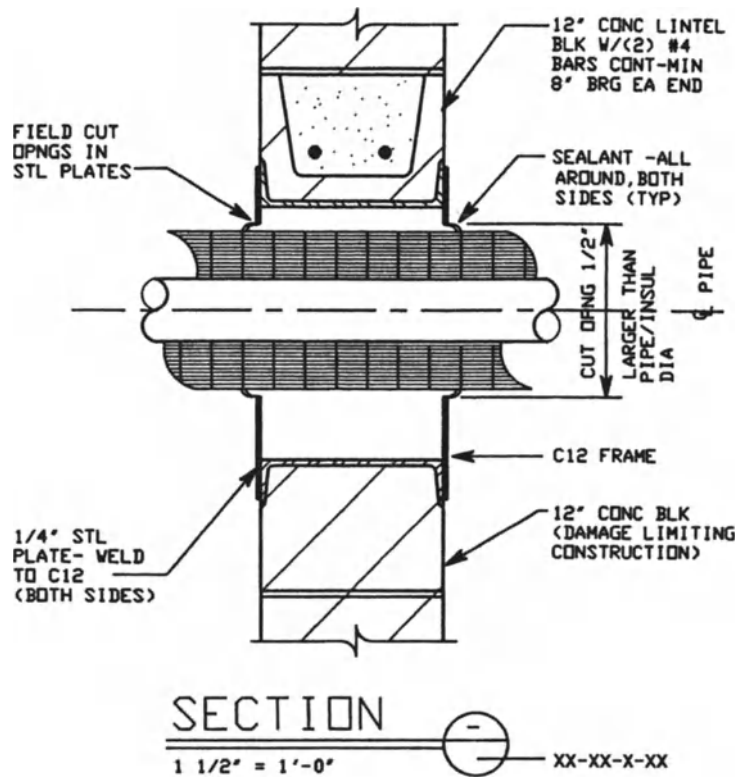

Fig. 9-76

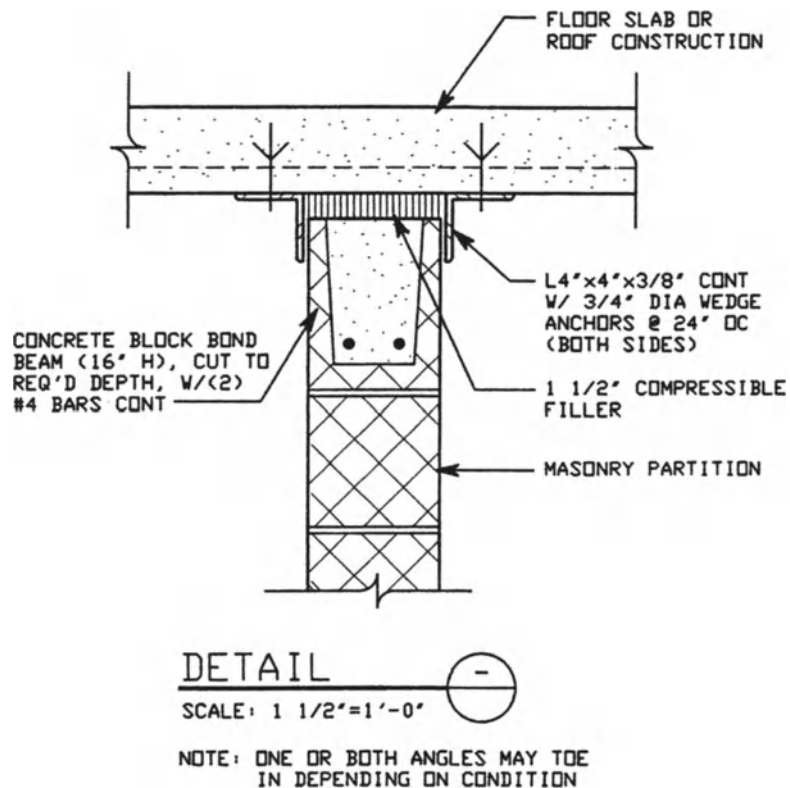

Fig. 9-77

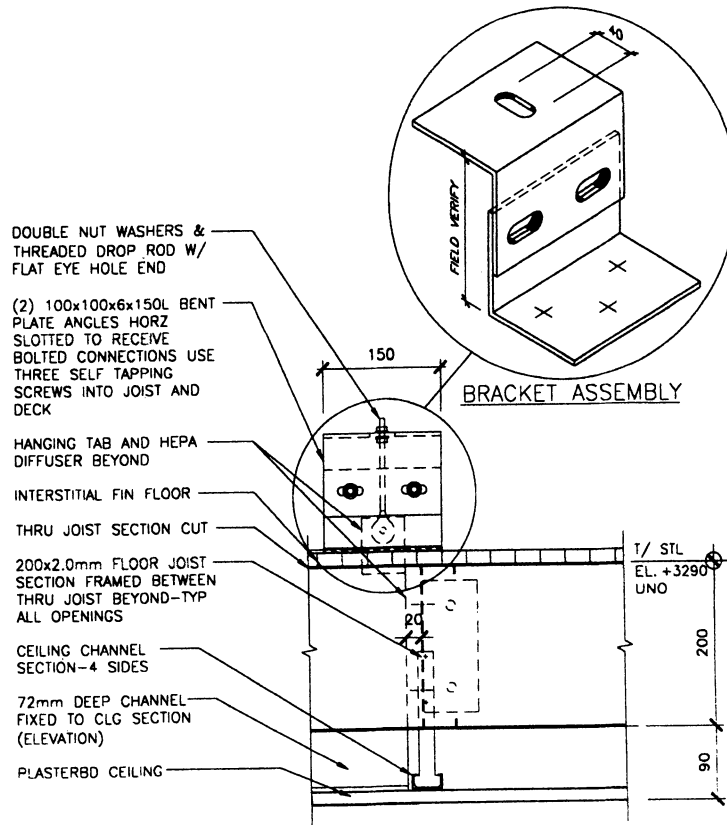

Fig. 9-78

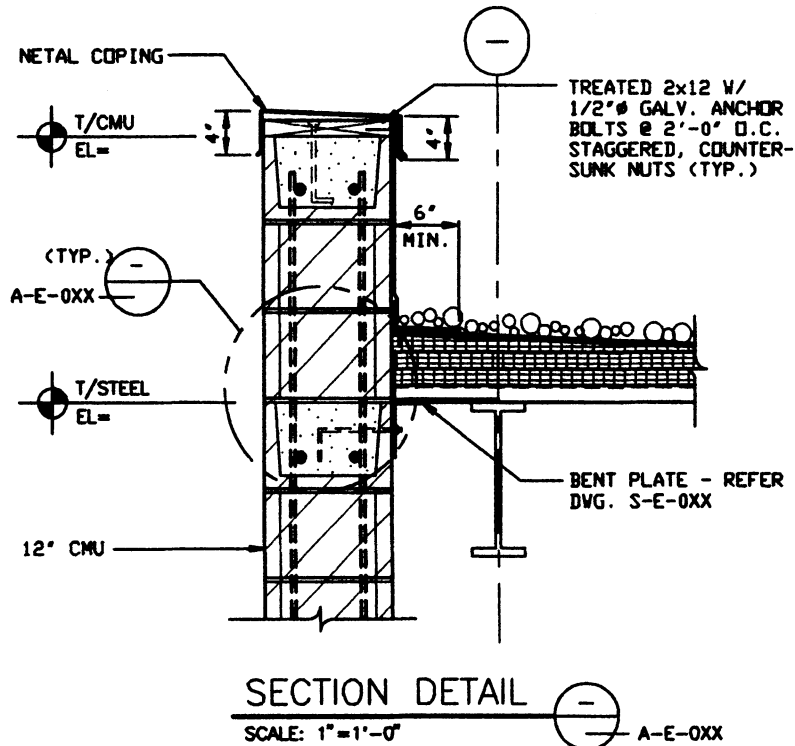

Fig. 9-79

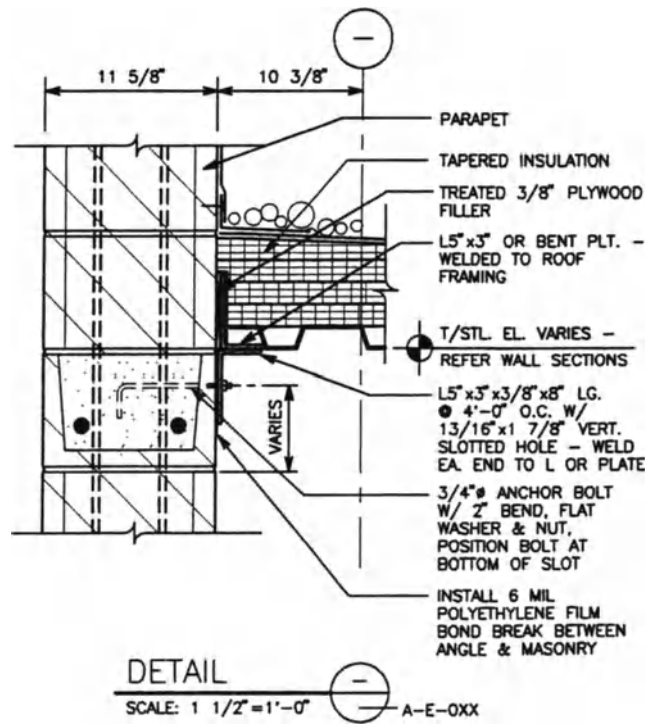

Fig. 9-80

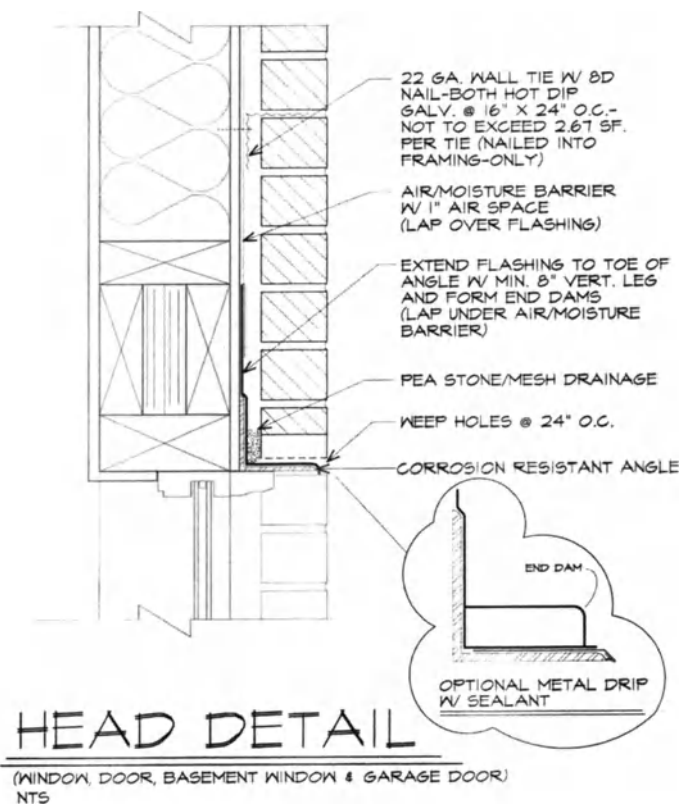
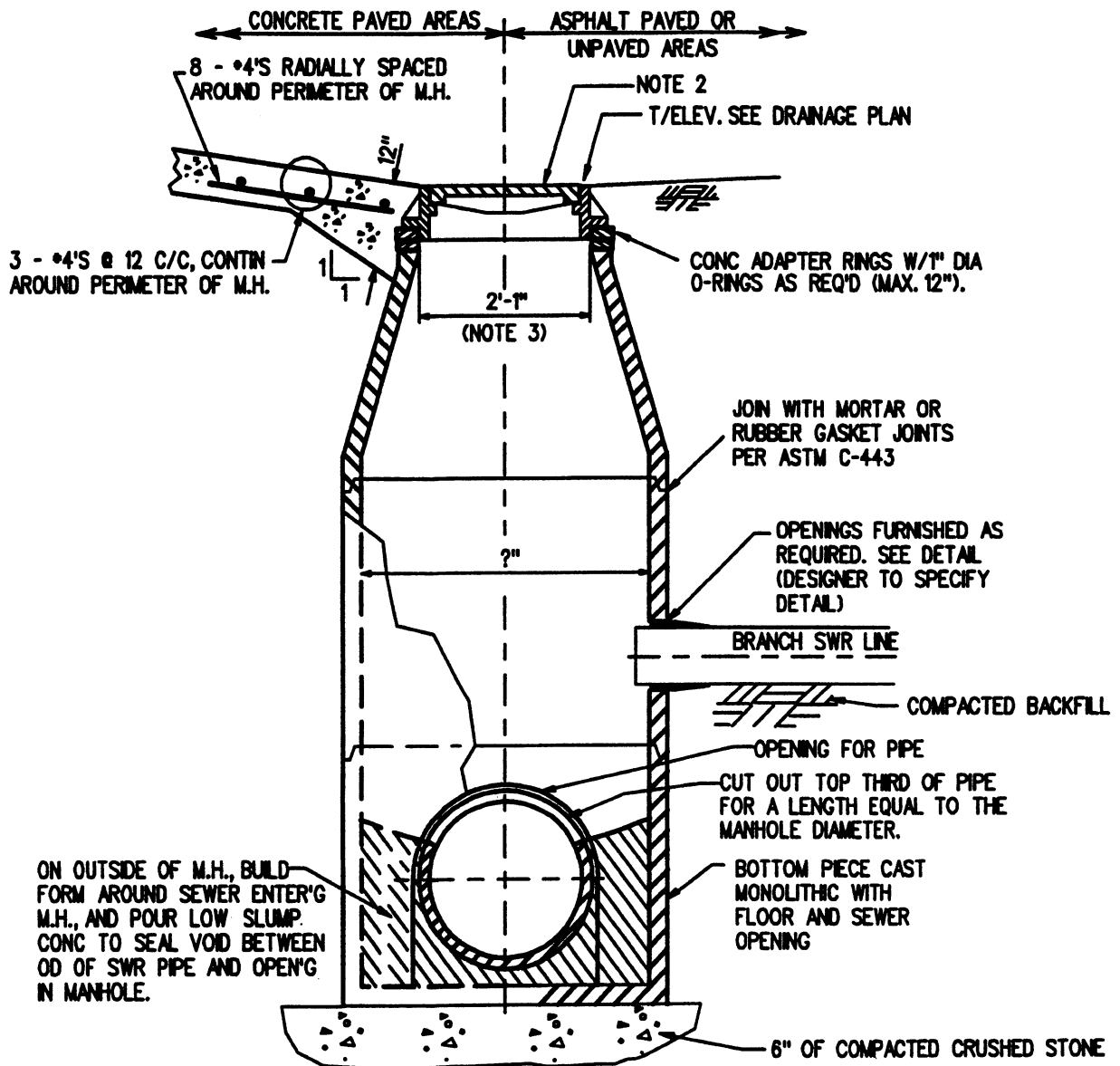

Fig. 9-81



- NOTES:**
1. MANHOLES SHALL BE REINFORCED PIPE, ASTM C-478 WITH INTEGRAL BOTTOM.
 2. GRATE AND FRAME TO BE (SEE DESIGNER NOTE 2)
 3. VERIFY OPENING WITH GRATE AND FRAME MANUFACTURER

PRECAST MANHOLE DETAIL

Fig. 9-82

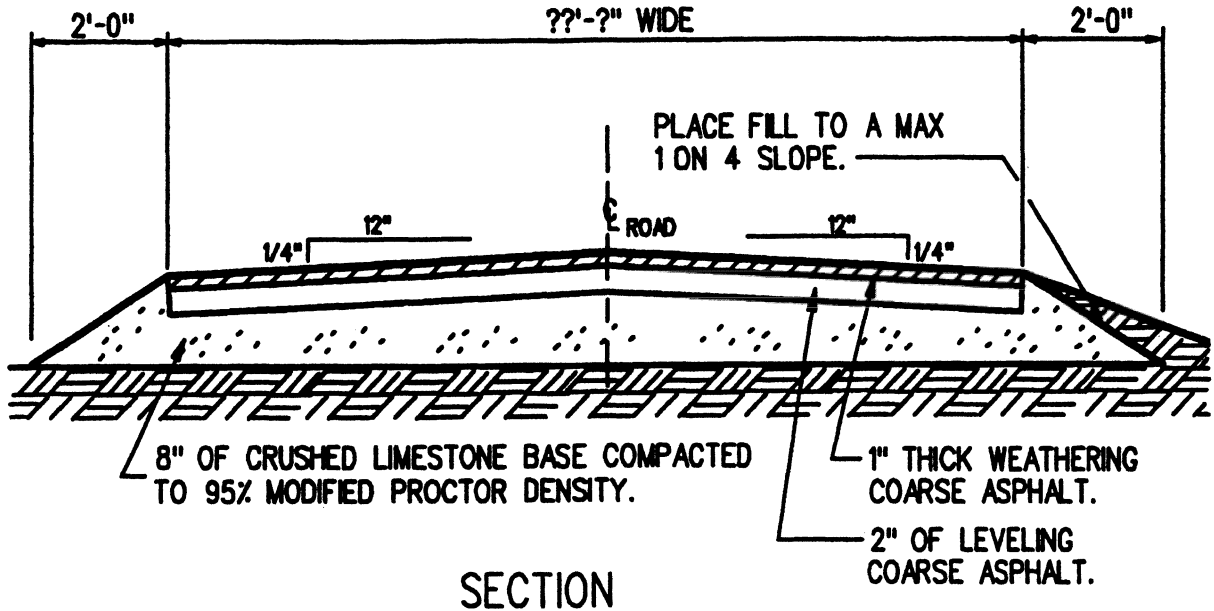

SECTION

NOTES:

1. MODIFIED PROCTOR DENSITY TO BE DETERMINED PER ASTM D-1557.
2. PRIME COAT TO BE TYPE SS-1H, PER MICHIGAN HIGHWAY DEPARTMENT SPEC 8.04.
3. CRUSHED LIMESTONE SHALL BE ONE HUNDRED PERCENT CRUSHED LIMESTONE FURNISHED BY WIRT STONE DOCKS, BAY CITY, MI. OR EQUAL. IT SHALL MEET MDOT NO. 23A (MODIFIED) SPECIFICATION.
4. BITUMINOS CONCRETE SHALL BE HOT-MIXED CONSISTING OF 5-7 % ASPHALT CEMENT (BY WEIGHT), AGGREGATE AND MINERAL FILLER AS REQUIRED.
5. ASPHALT CEMENT SHALL BE PER ASTM 09946 OR AASHTO M20, AC PENERATION GRADE 85-100.
6. MINERAL FILLER SHALL BE LIMESTONE DUST, PORTLAND CEMENT OR OTHER INERT FILLERS MEETING THE REQUIREMENTS OF ASTM D242 OR AASHTO M17.
7. WEATHERING COARSE SHALL BE BITUMINOUS MIXTURE NUMBER NO. 1100T
8. LEVELING COARSE SHALL BE BITUMINOUS MIXTURE NUMBER NO. 1100L

ASPHALT ROAD

Fig. 9-83

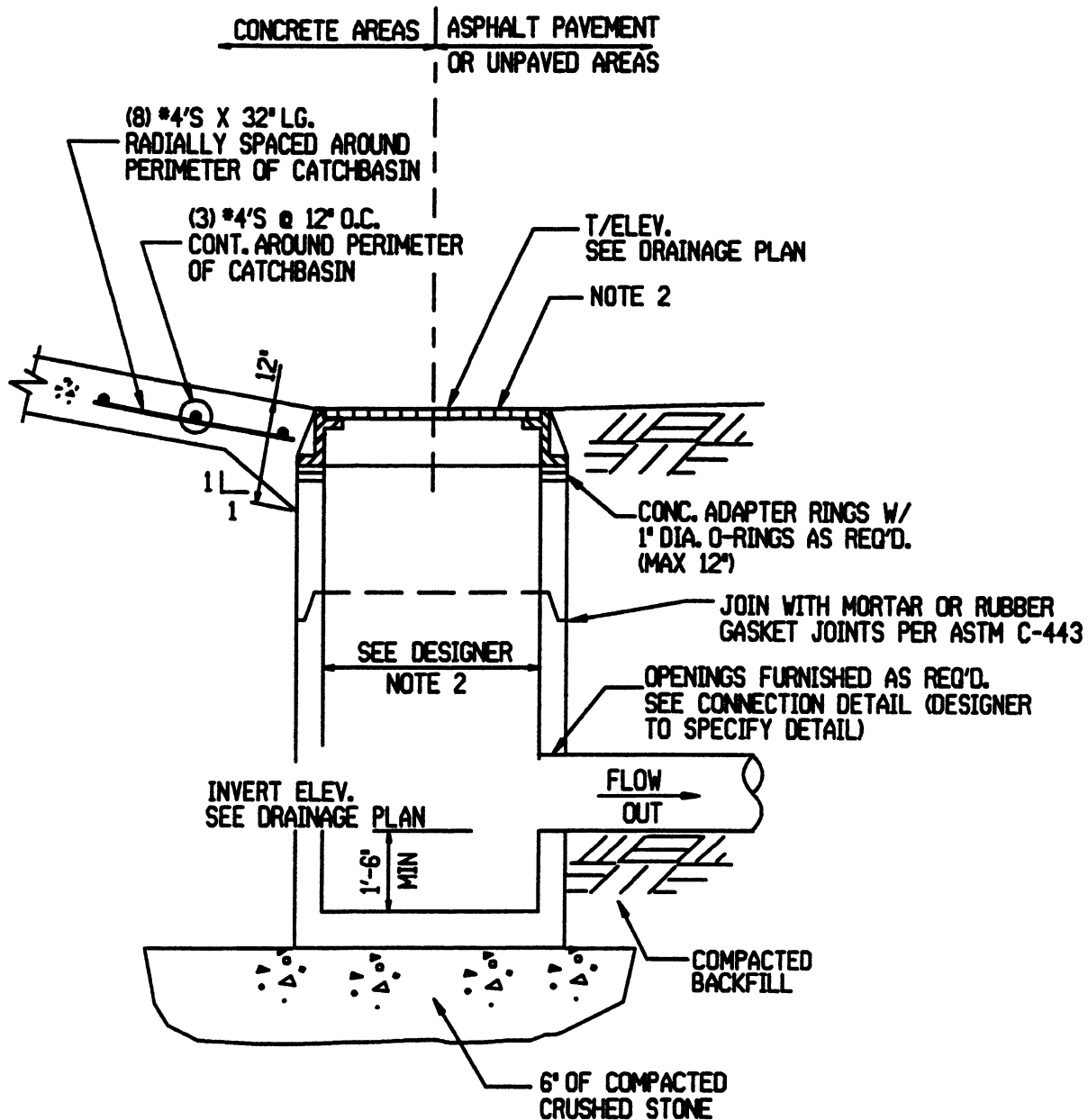

NOTES:

1. CATCHBASINS SHALL BE REINFORCED CONCRETE PIPE, ASTM C-478 W/ INTEGRAL BOTTOM.
2. GRATE AND FRAME TO BE (SEE DESIGNER NOTE 3)

PRECAST CATCHBASIN DETAIL

Fig. 9-84

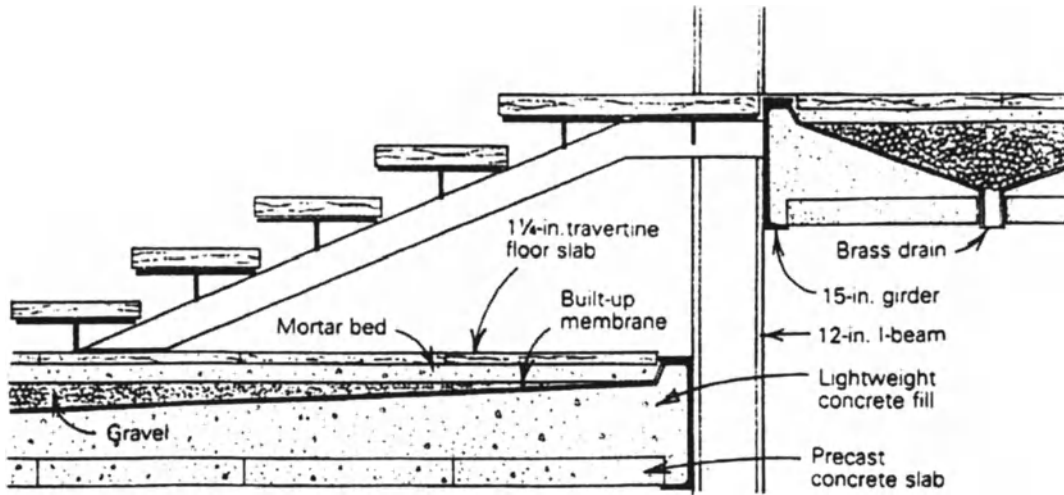

Fig. 9-85

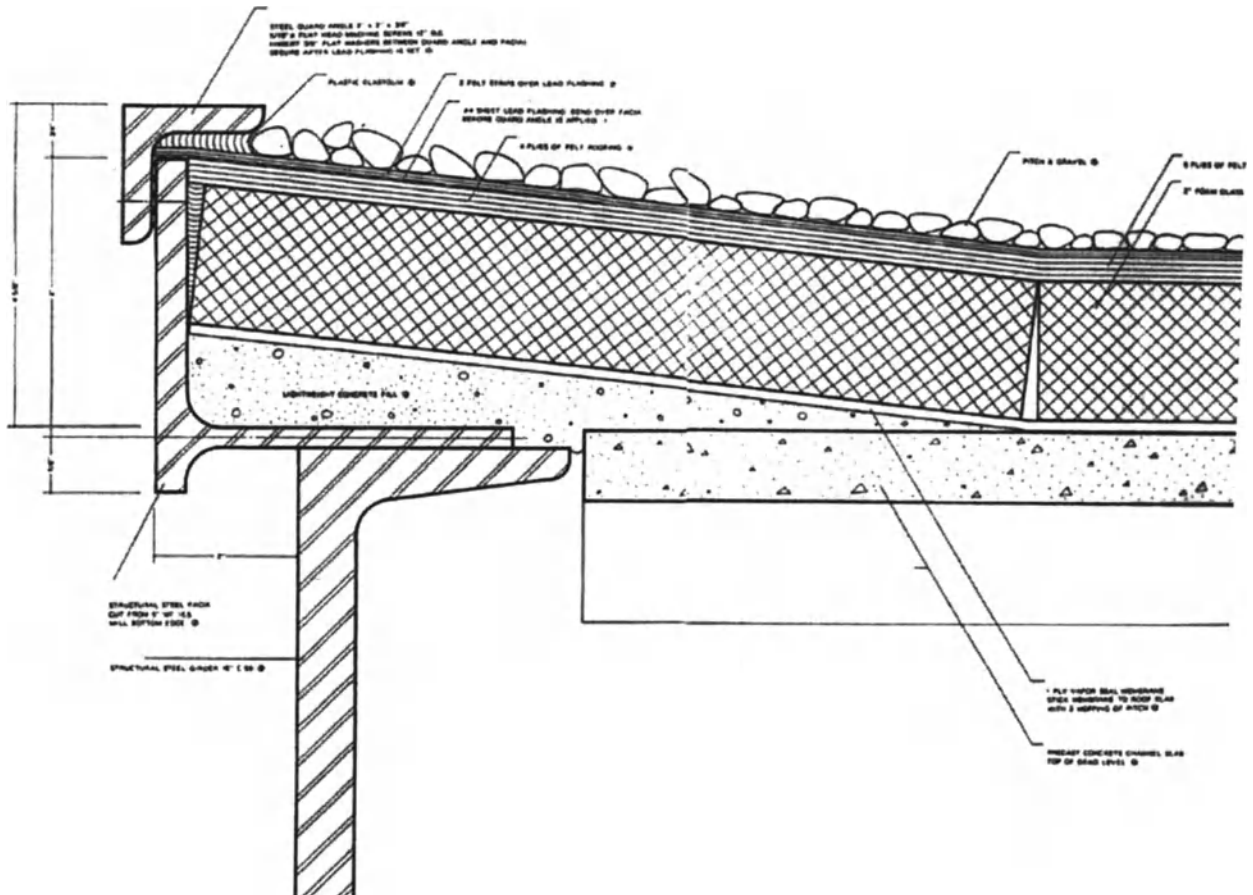

Fig. 9-86

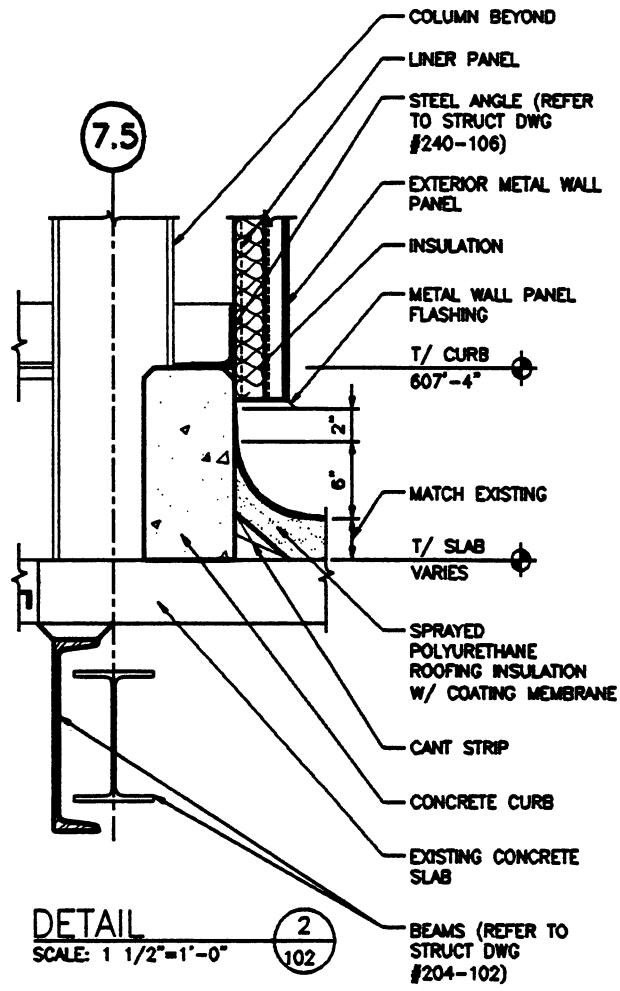

Fig. 9-87

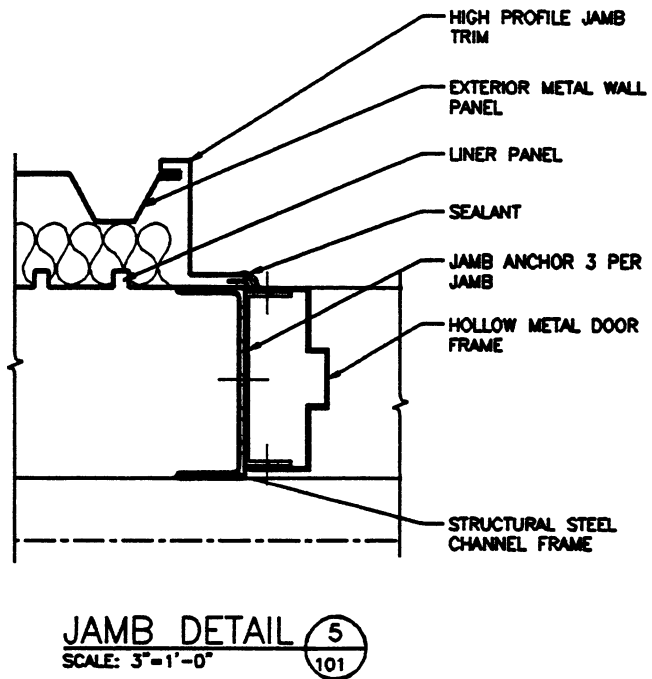
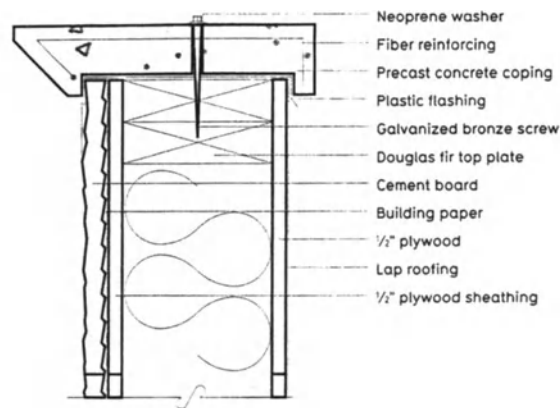
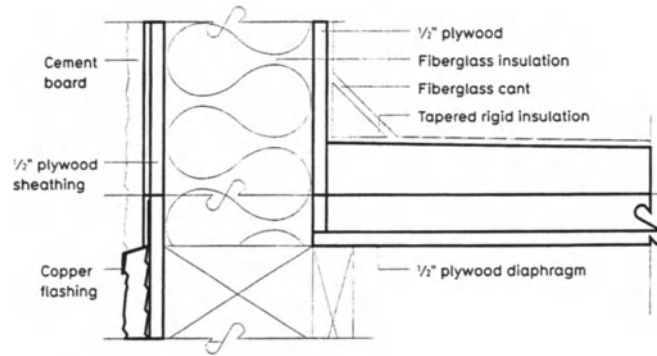

Fig. 9-88



Exterior wall at parapet



Exterior wall at roof

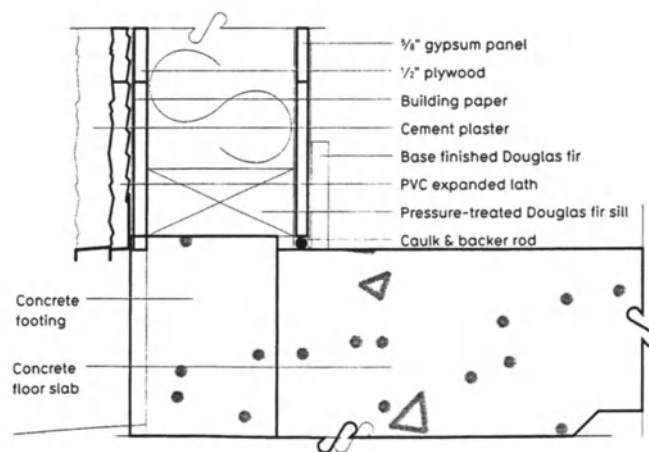

Exterior wall at foundation

Fig. 9-89

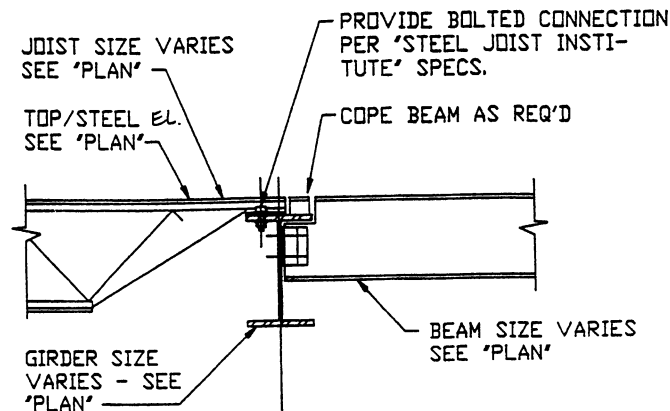

**BAR JOIST AND BEAM CONNECTION
AT INTERIOR GIRDER**

DETAIL
SC: 3/4"=1'-0"

Fig. 9-90

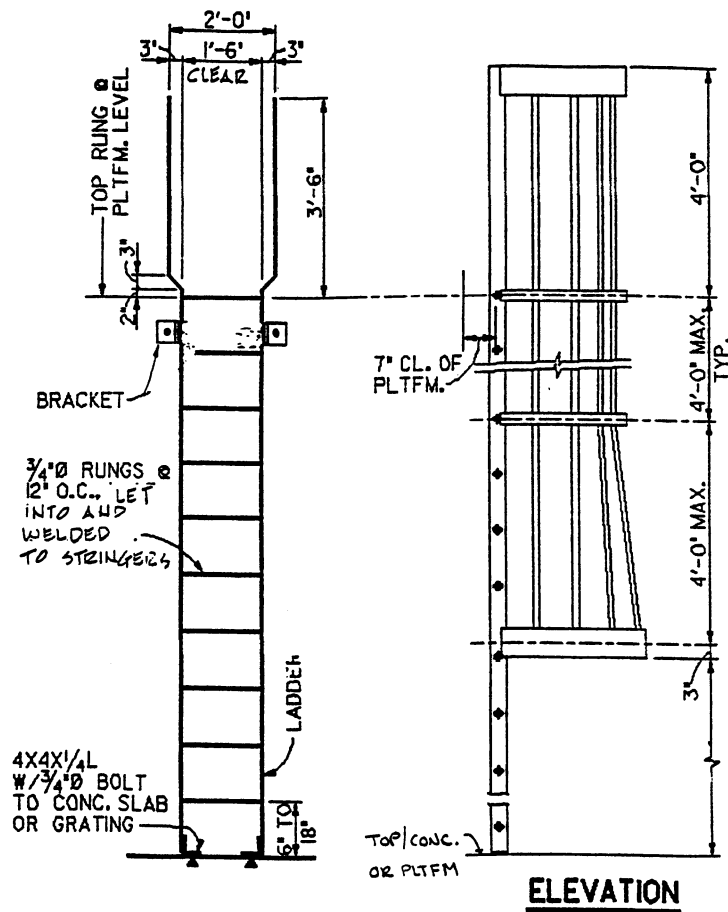

TYPICAL LADDER DETAILS

Fig. 9-91

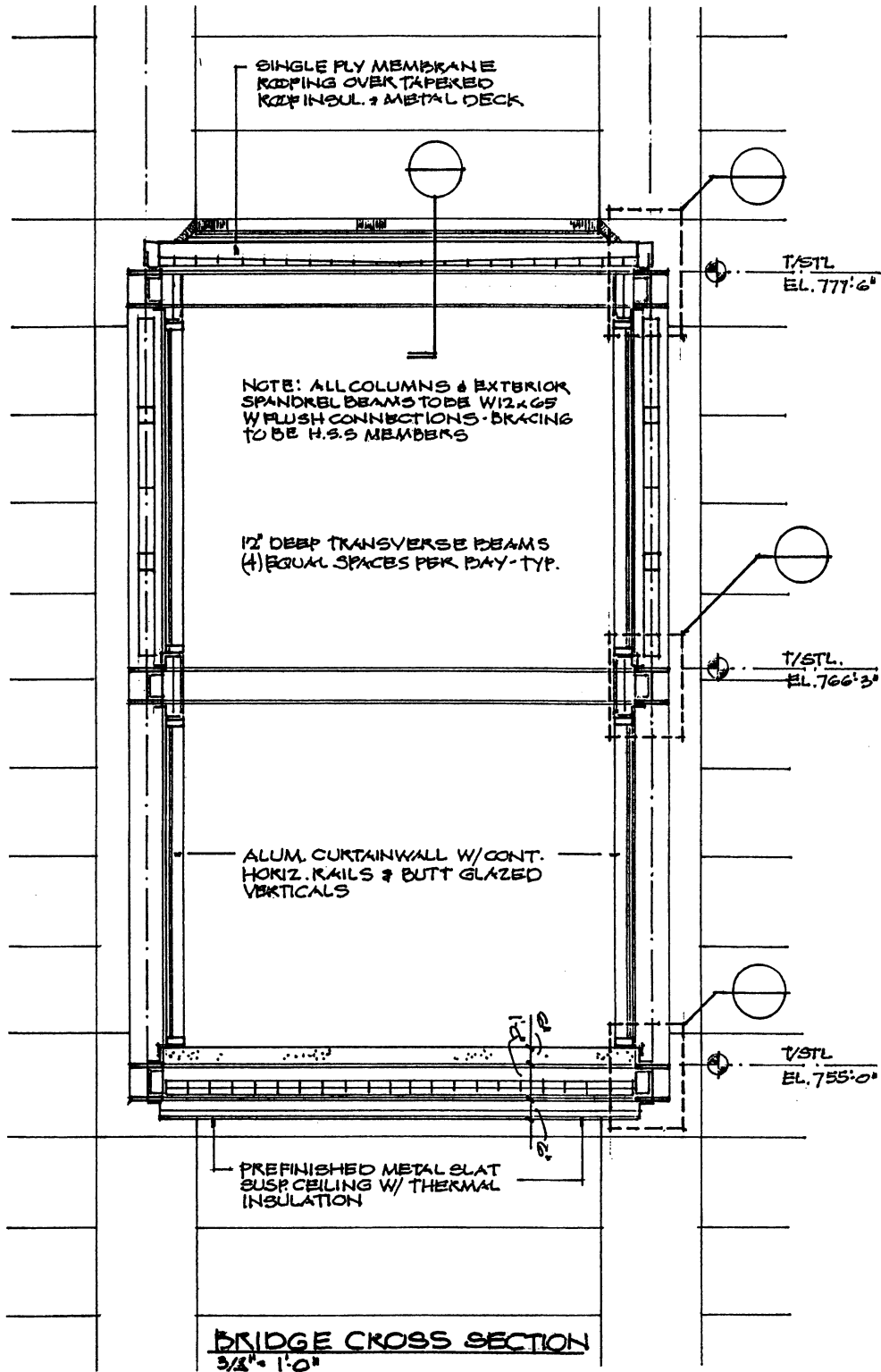
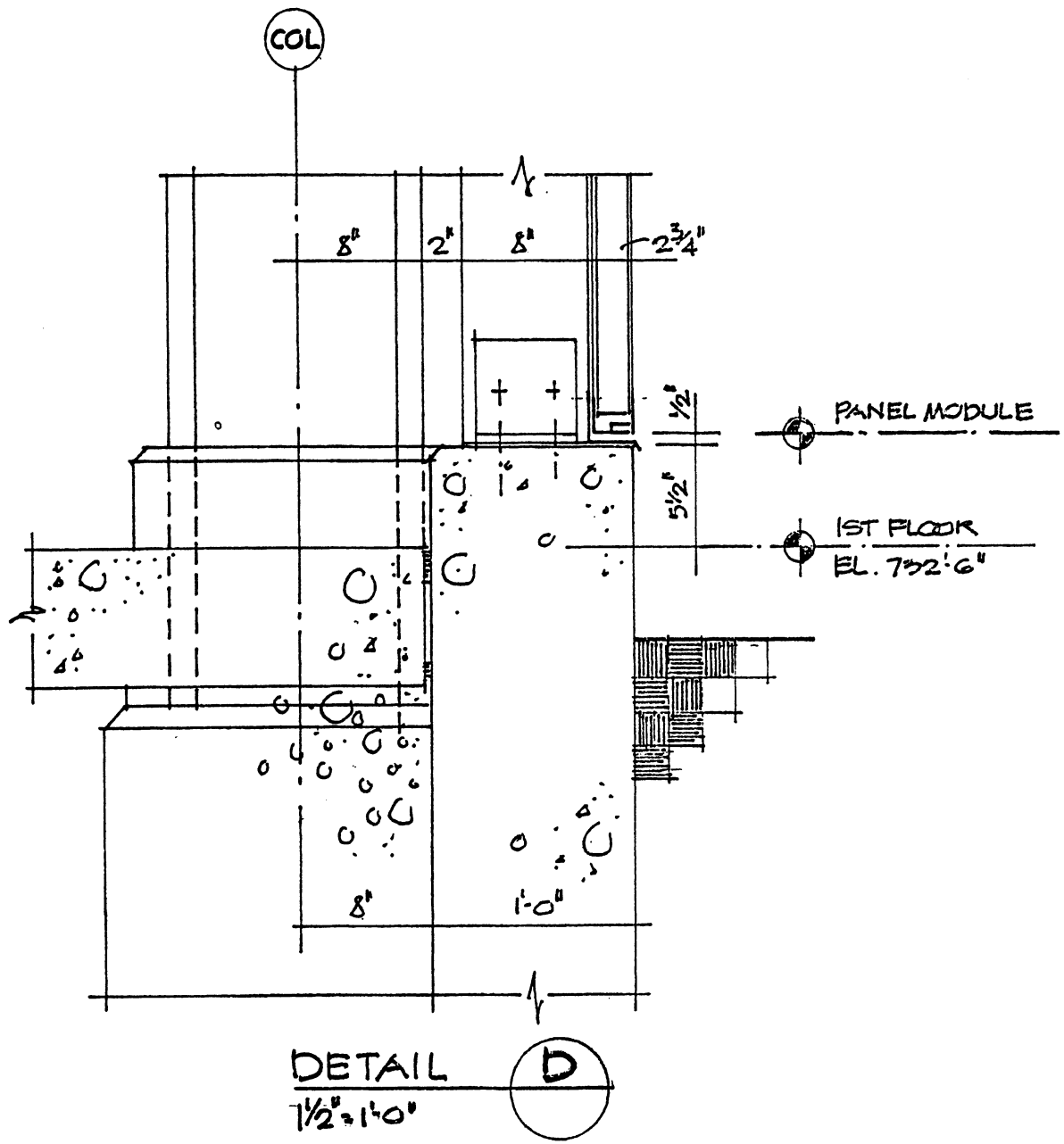

Fig. 9-92



EXPLOSION VENTING DETAILS

Fig. 9-93

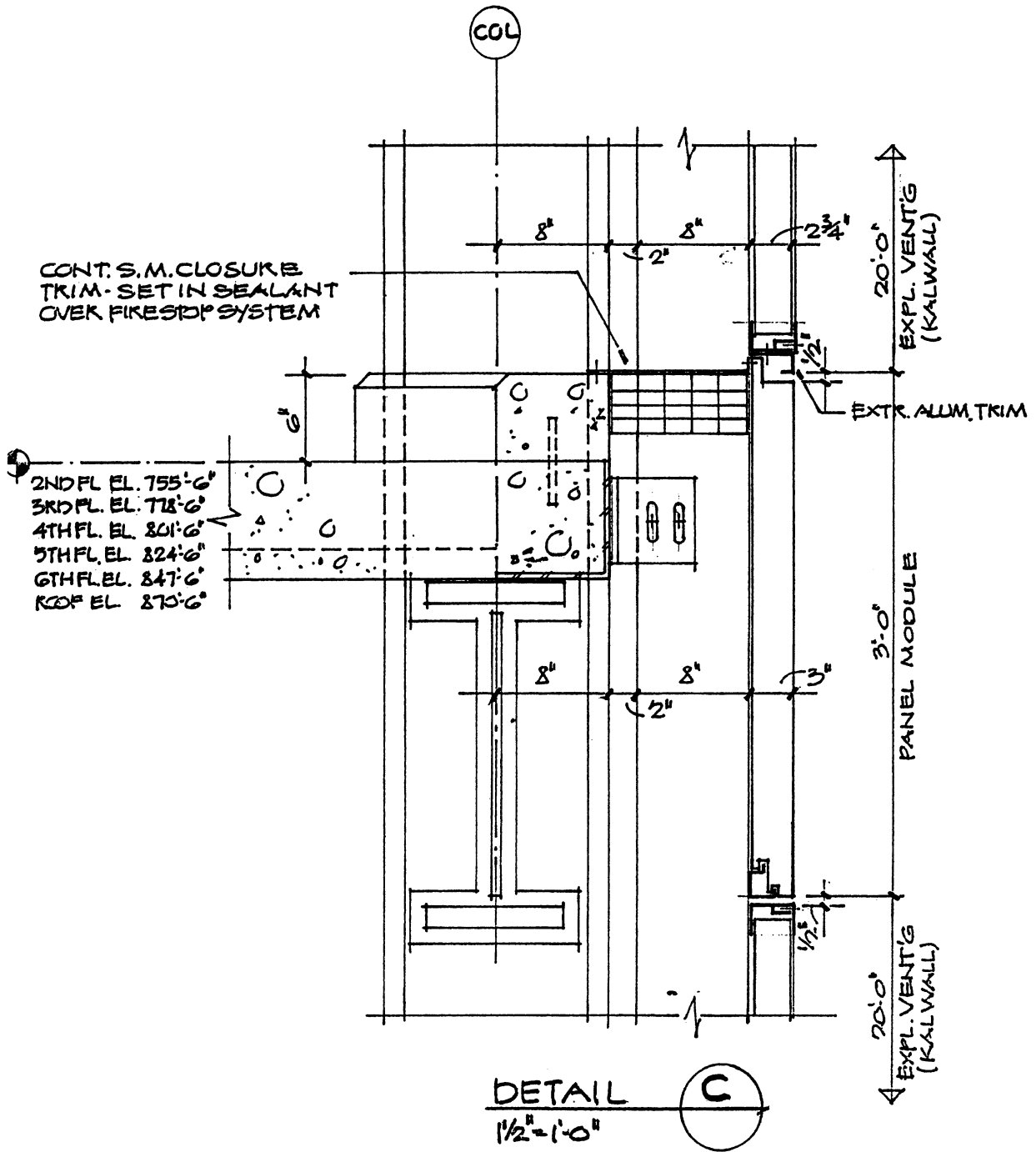

Fig. 9-94

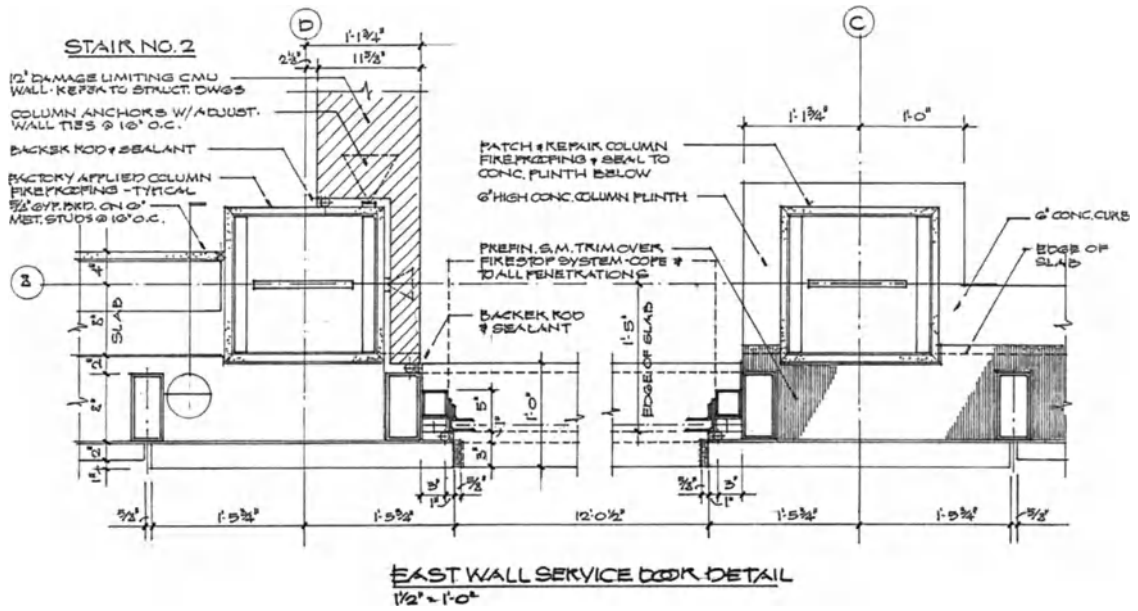

Fig. 9-95

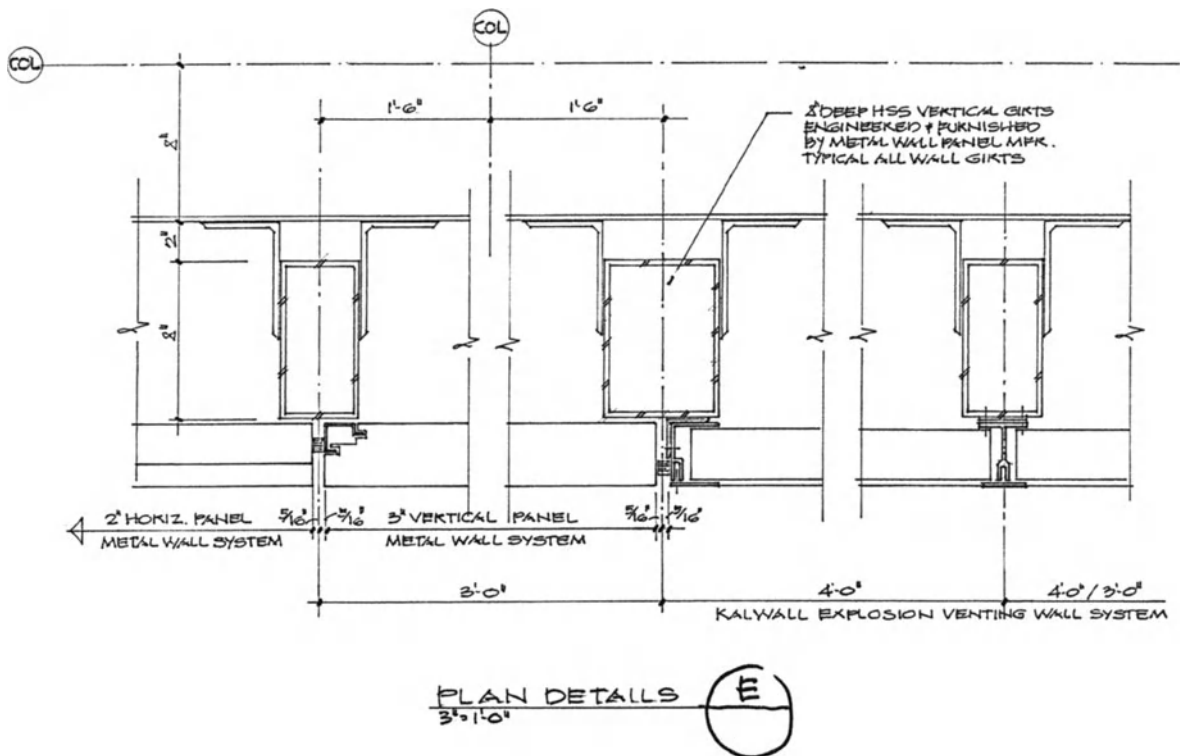

Fig. 9-96

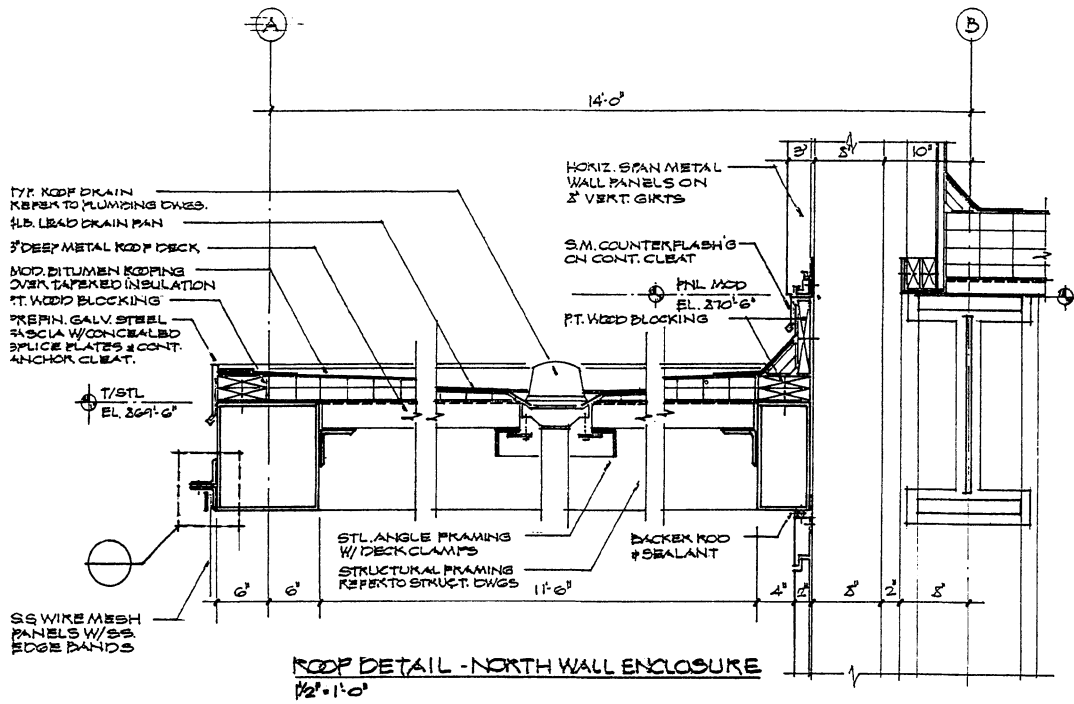

Fig. 9-97

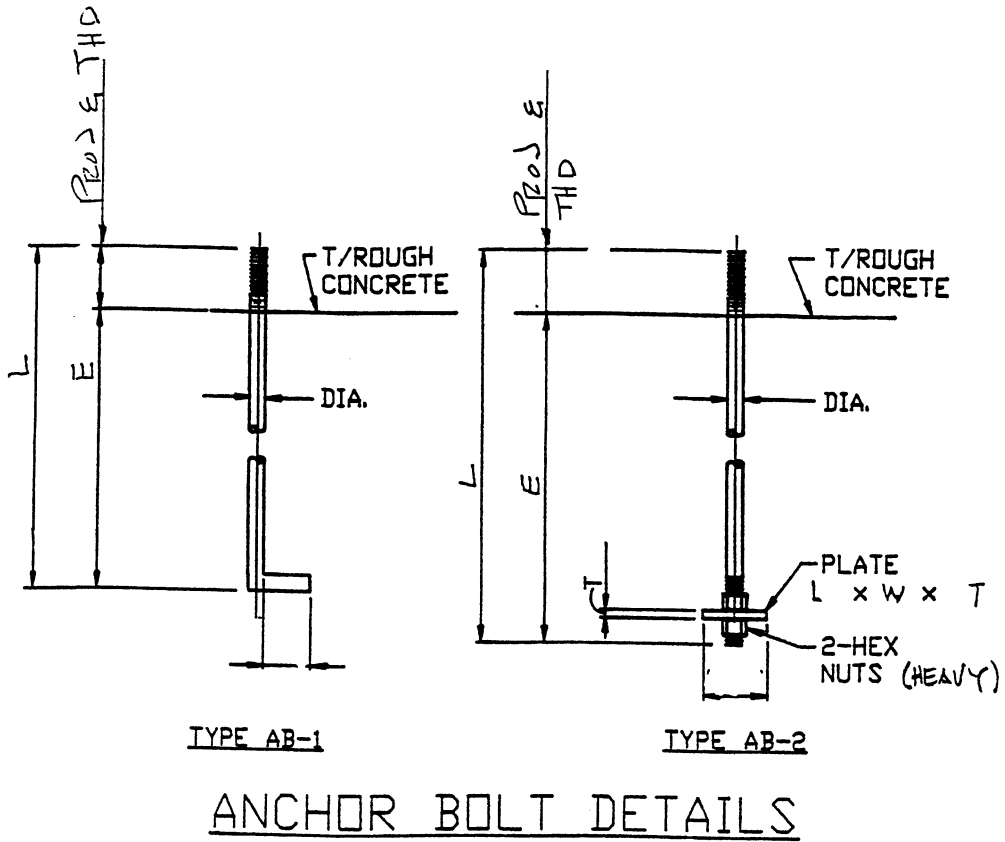
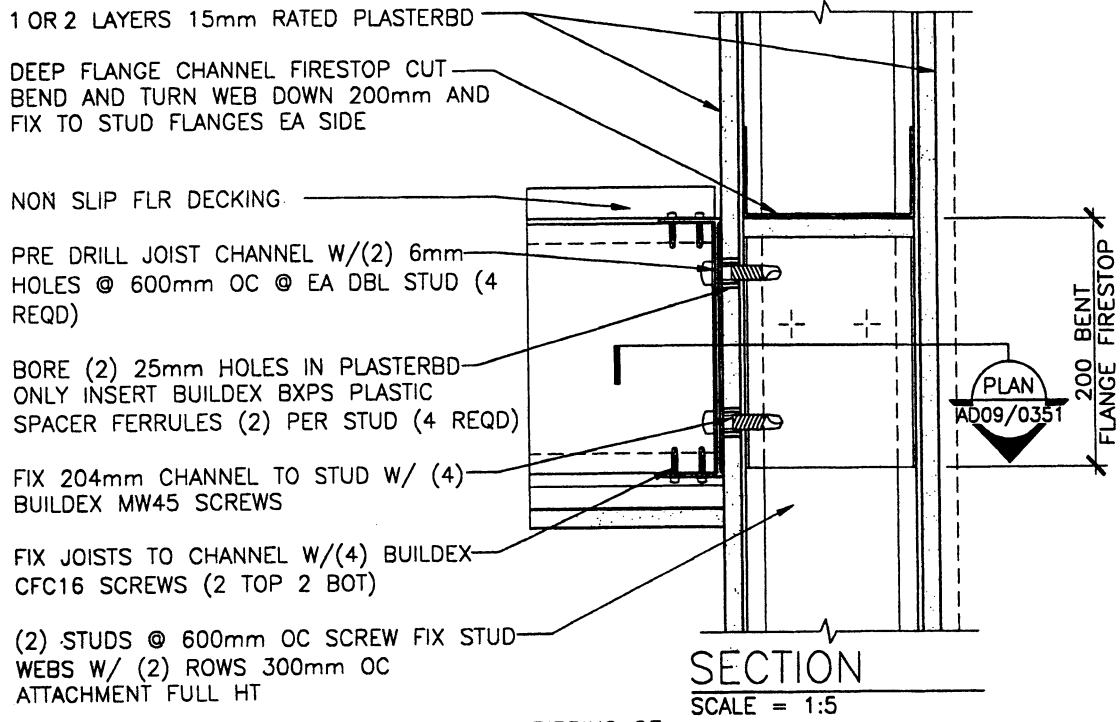

Fig. 9-98



NOTE LIMIT TORQUE APPLIED TO PREVENT STRIPPING OF SCREWS & DETERMINE IF CONNECTION WILL PERFORM AS REQD

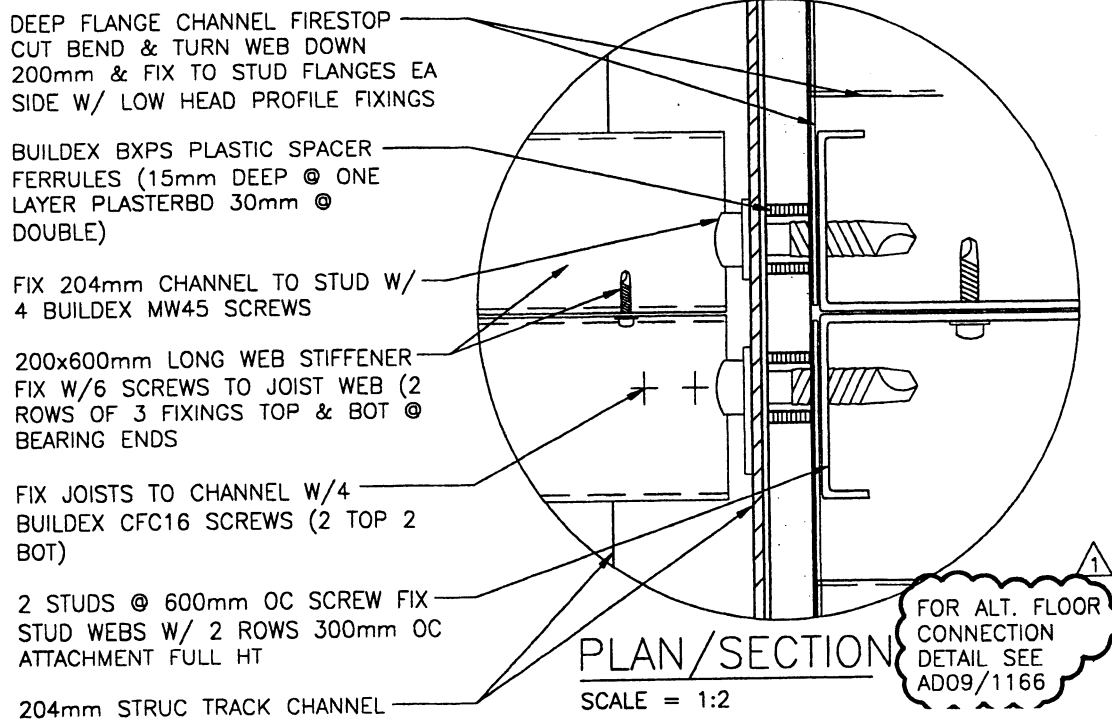
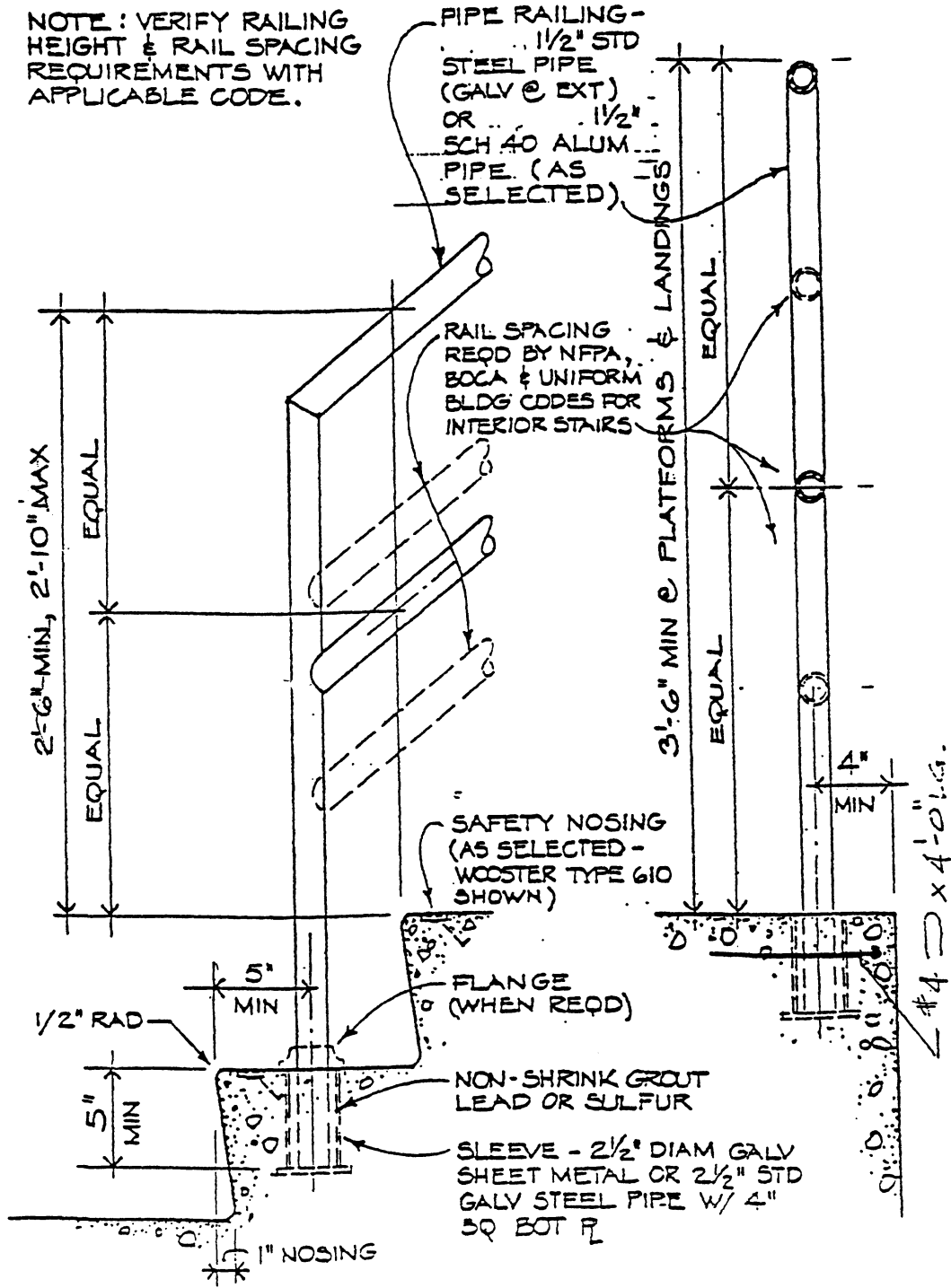

Fig. 9-99



SECTION
SCALE: 1 1/2" = 1'-0"

Fig. 9-100

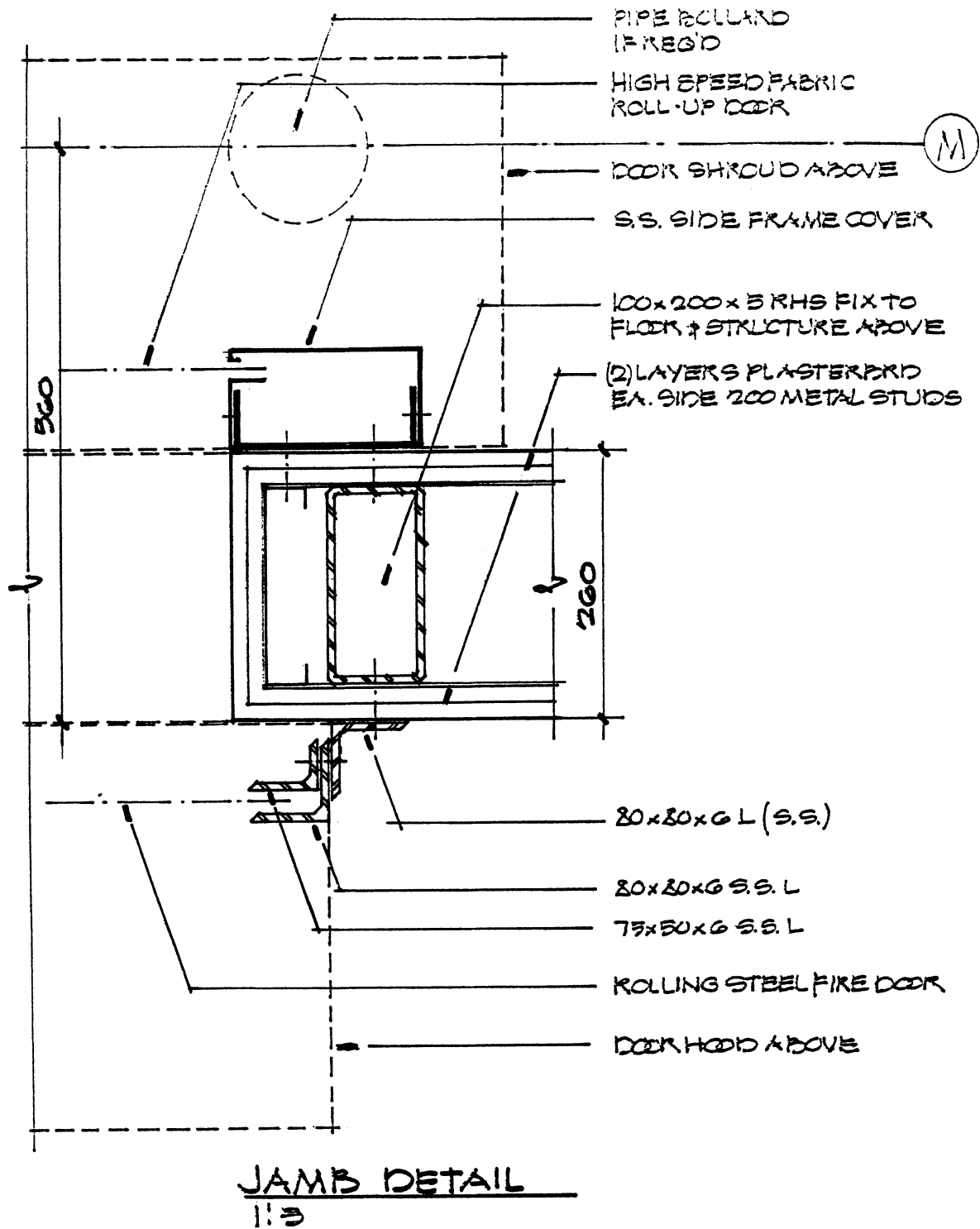

Fig. 9-101

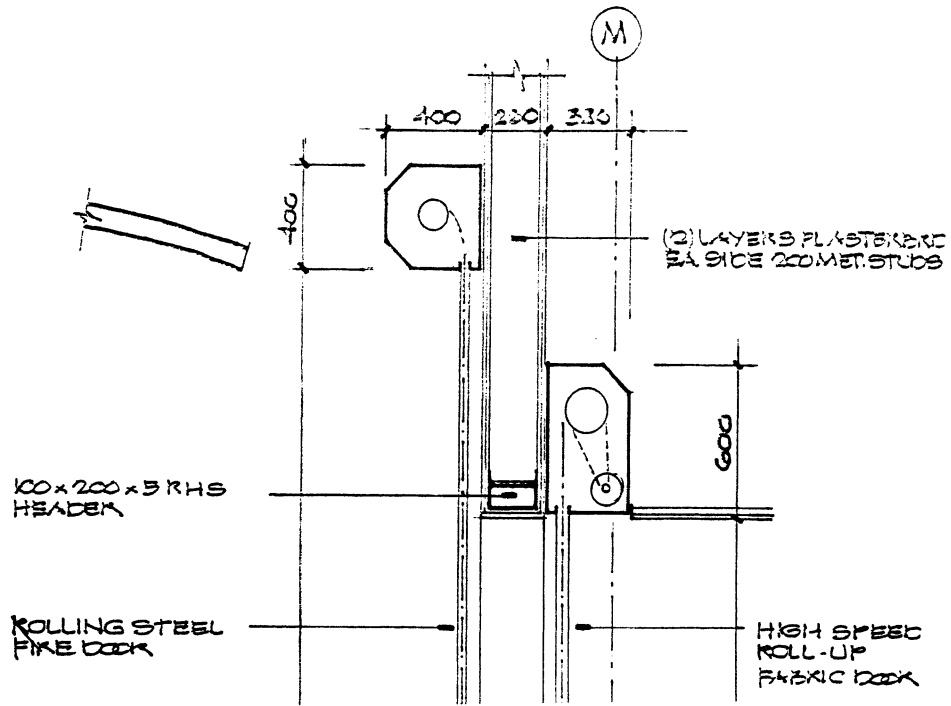

Fig. 9-102

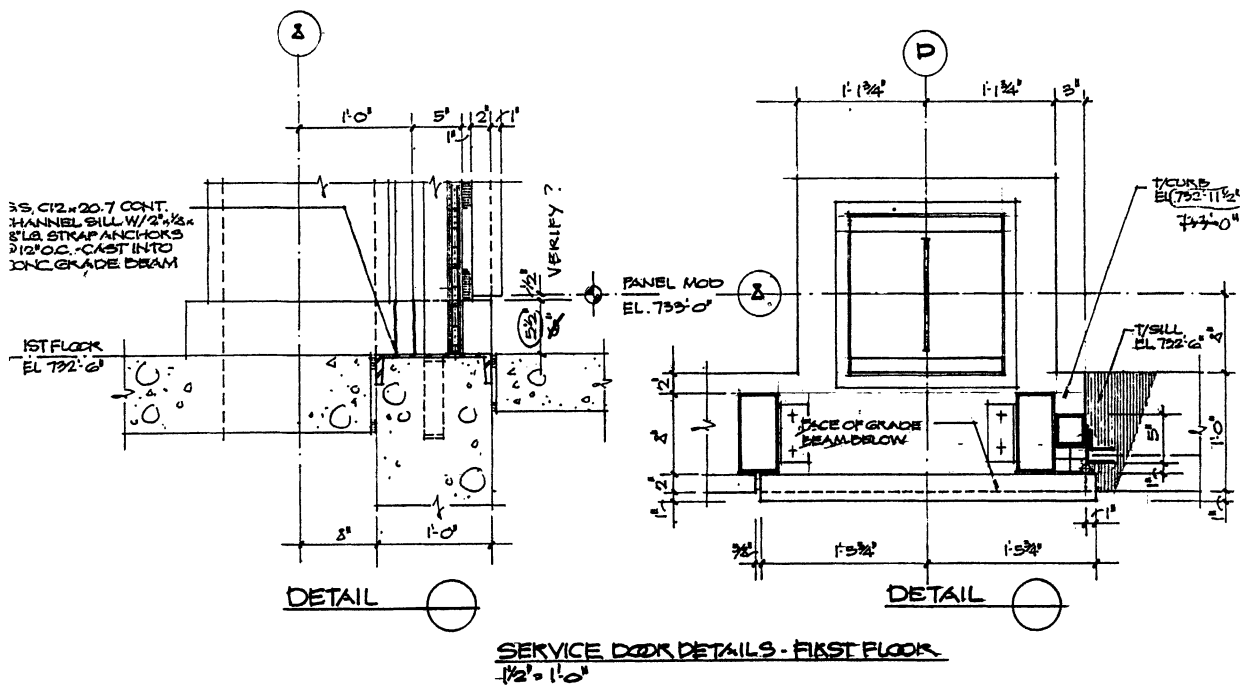

Fig. 9-103

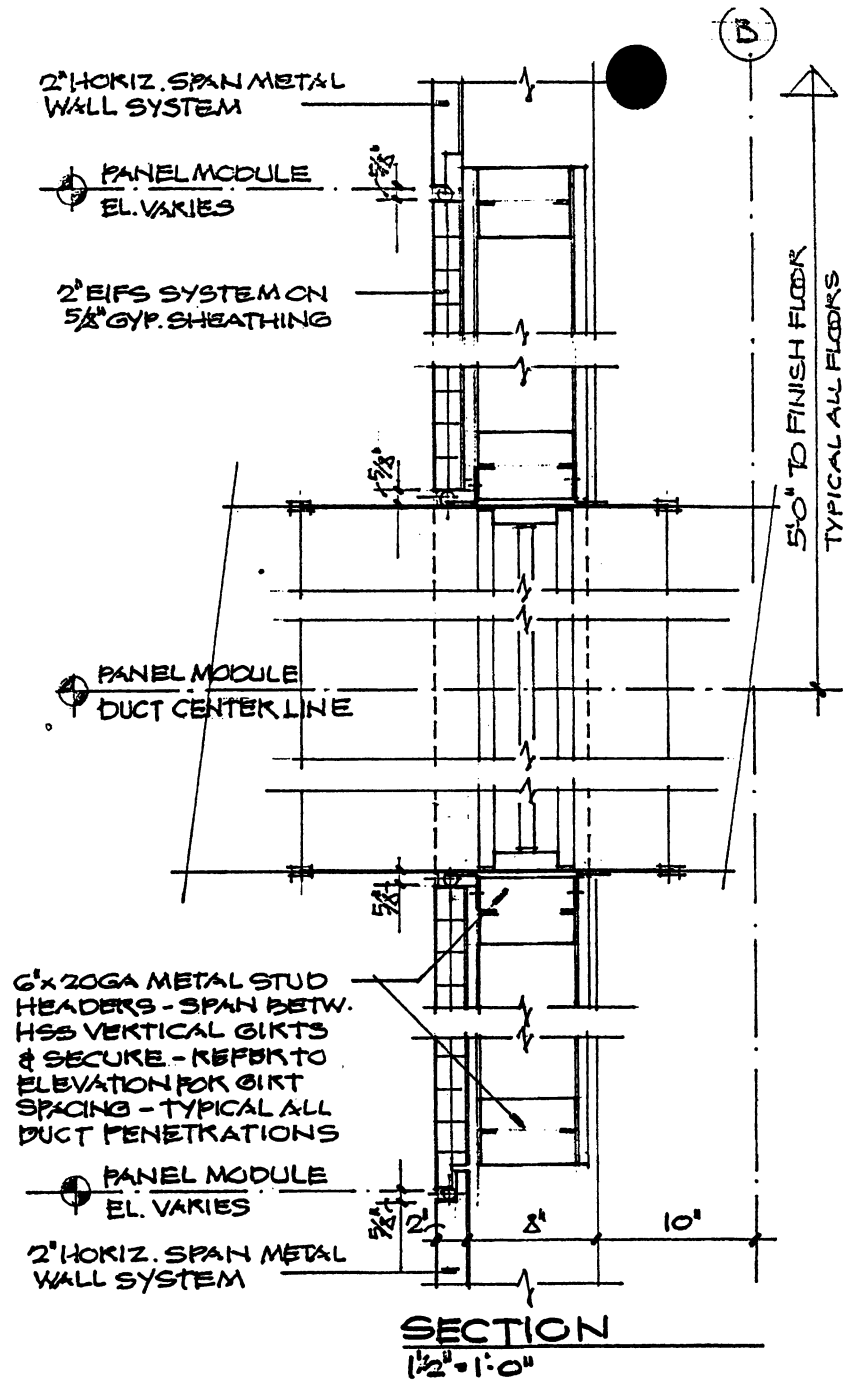

Fig. 9-104

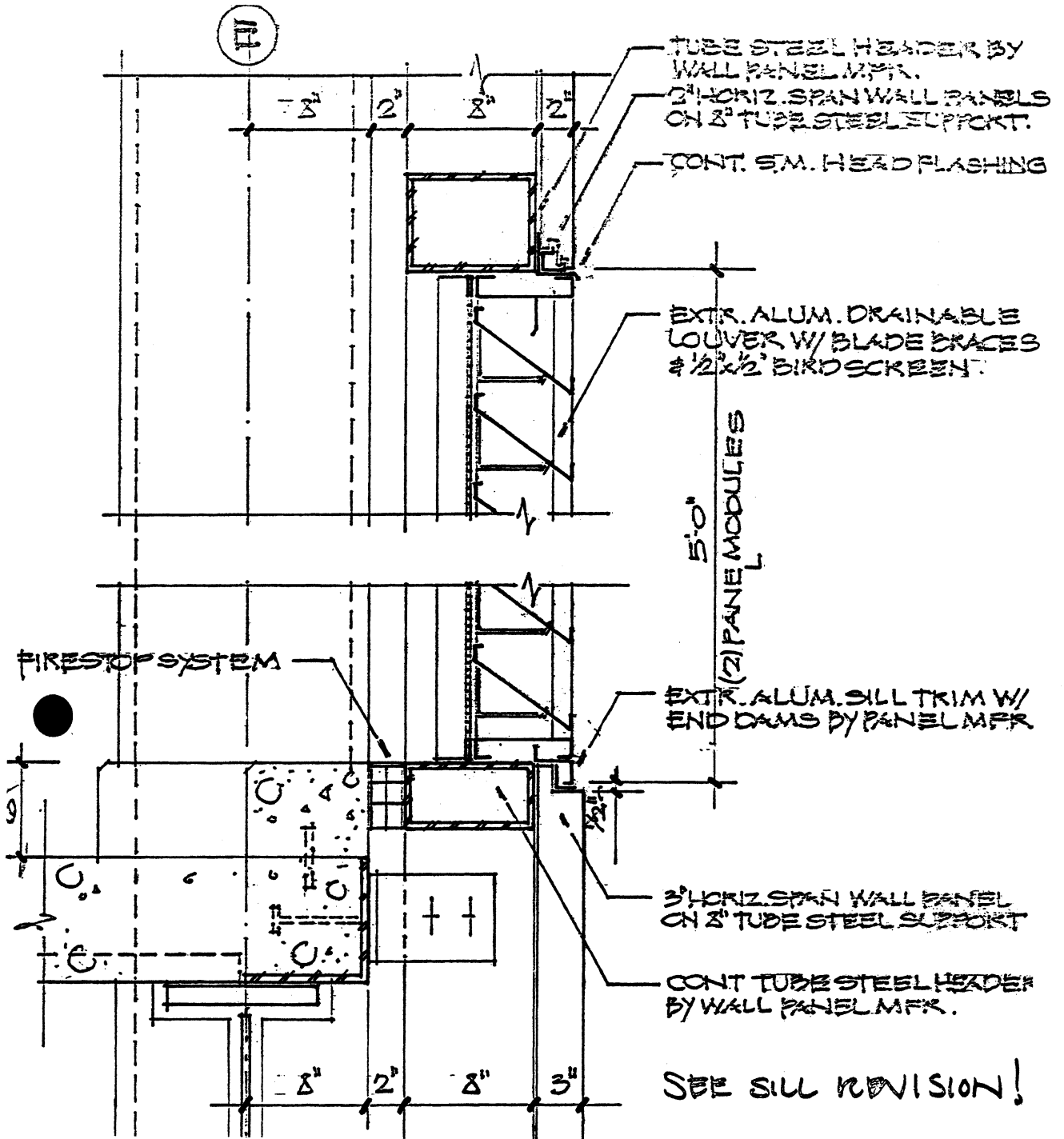

Fig. 9-105

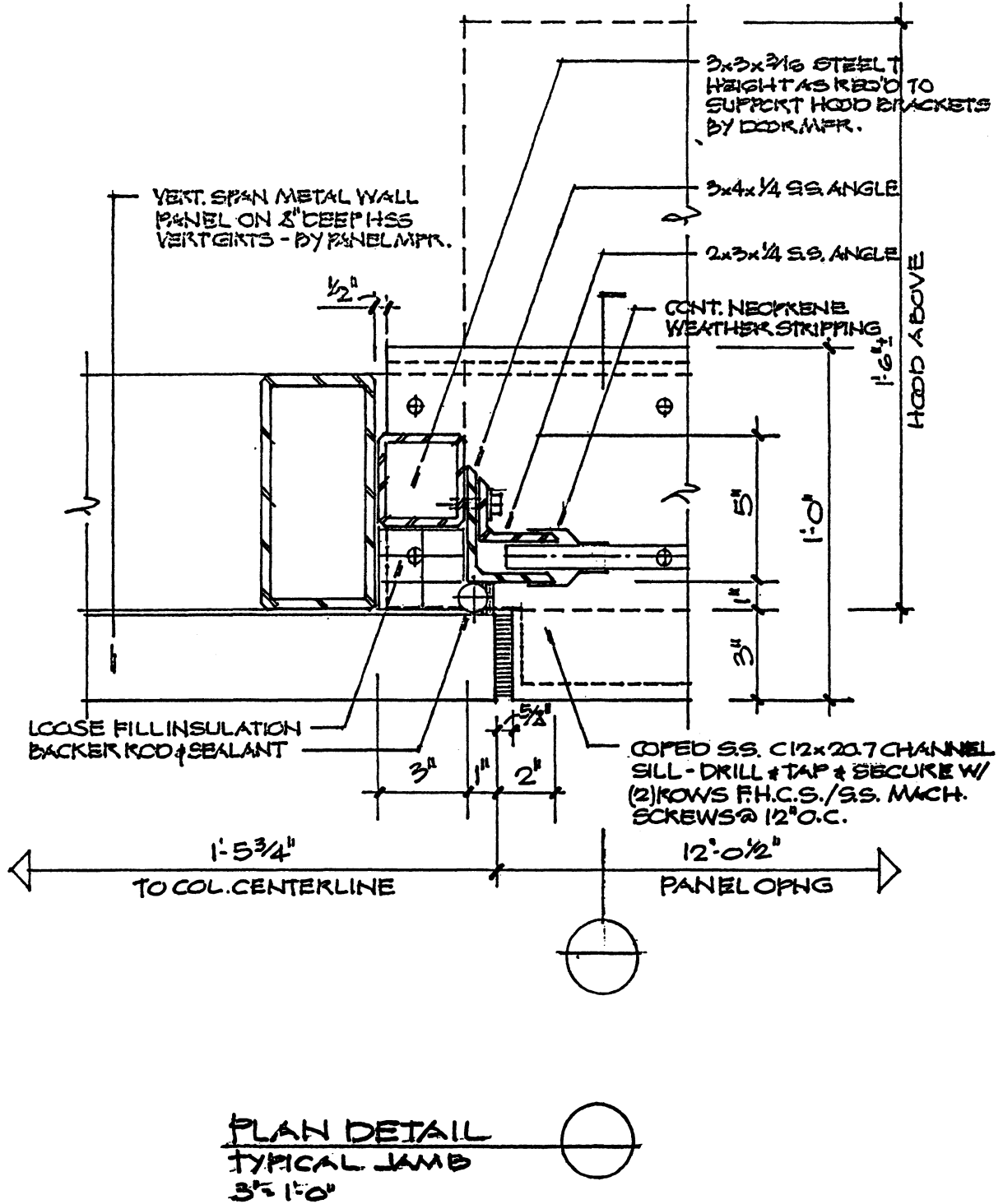

Fig. 9-106

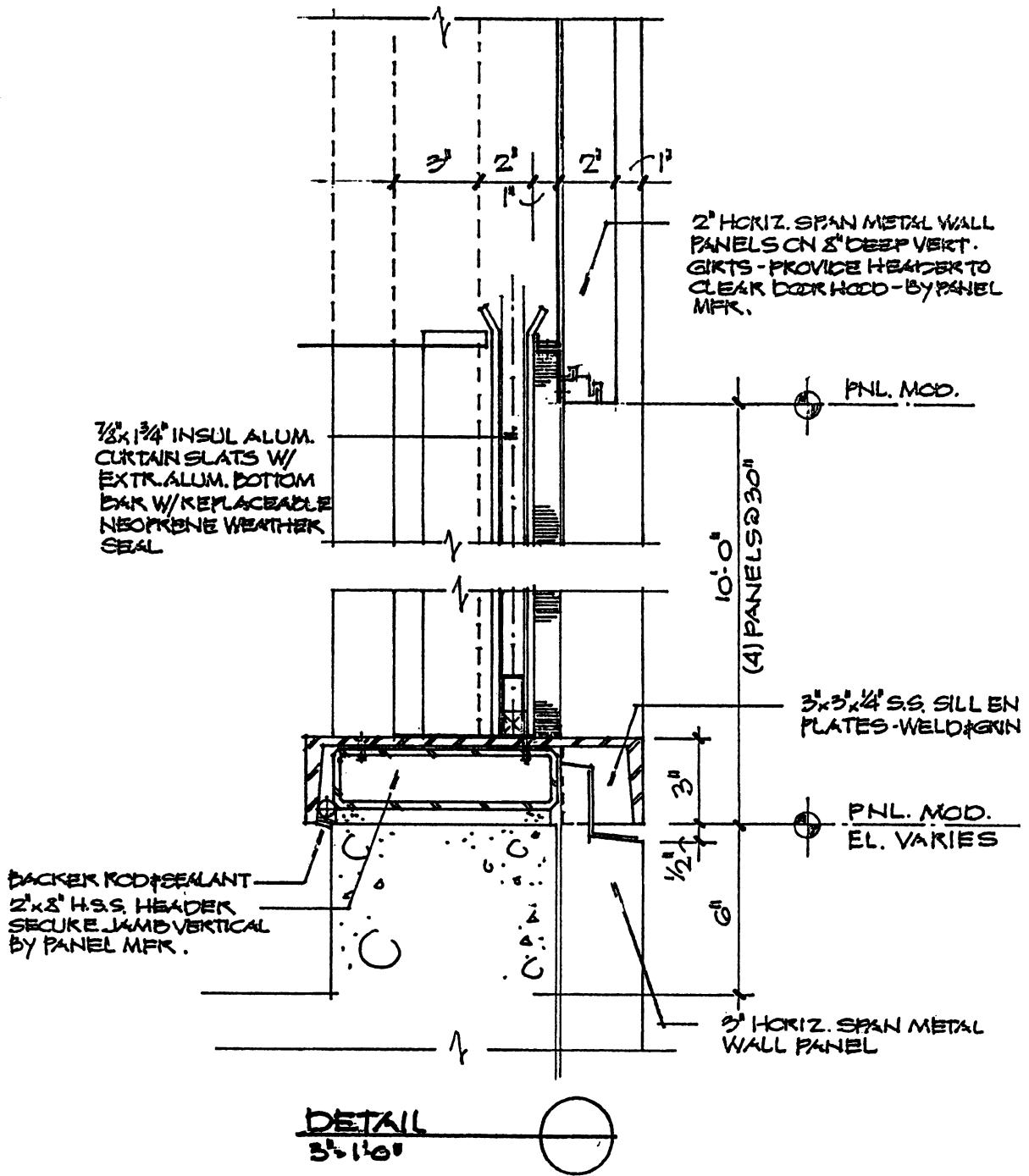

Fig. 9-107

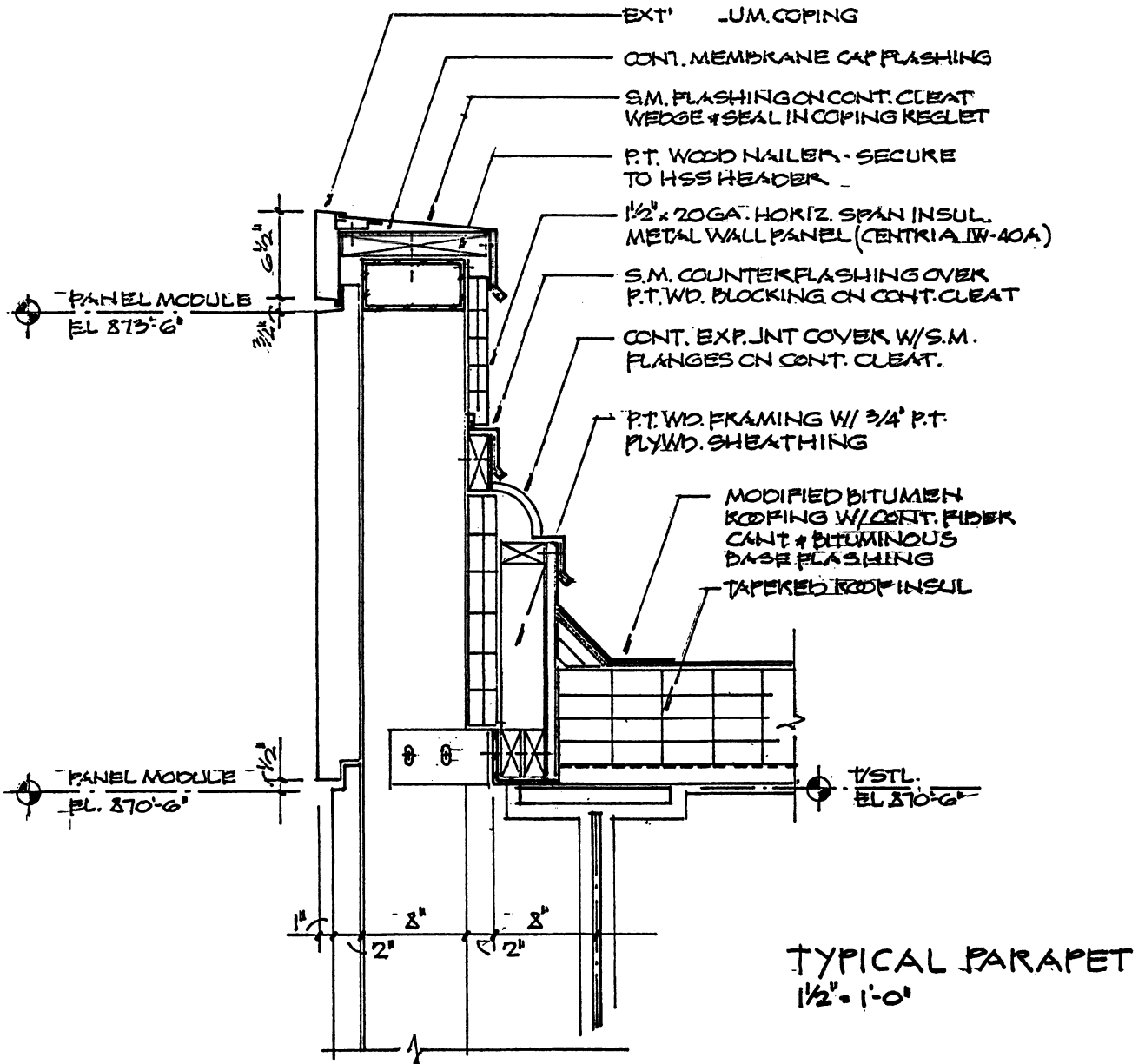

Fig. 9-108

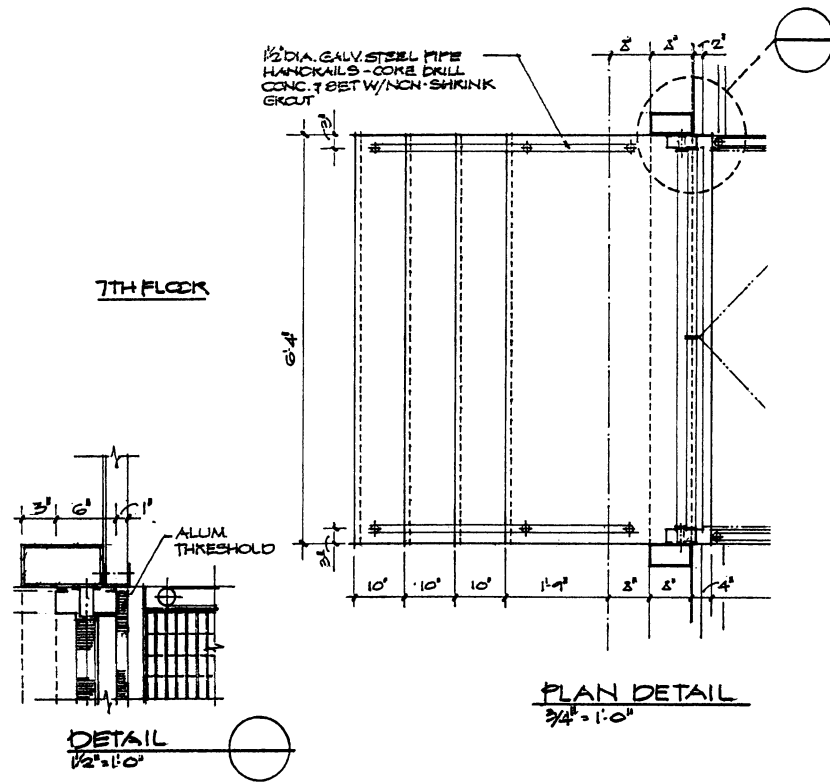

Fig. 9-109

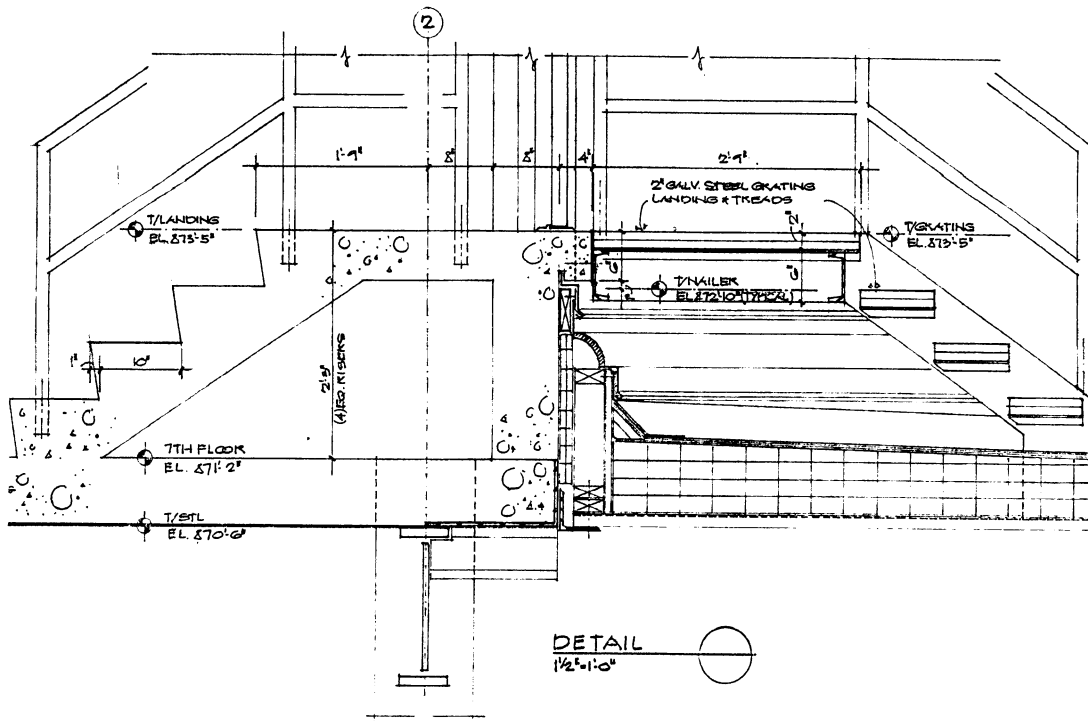
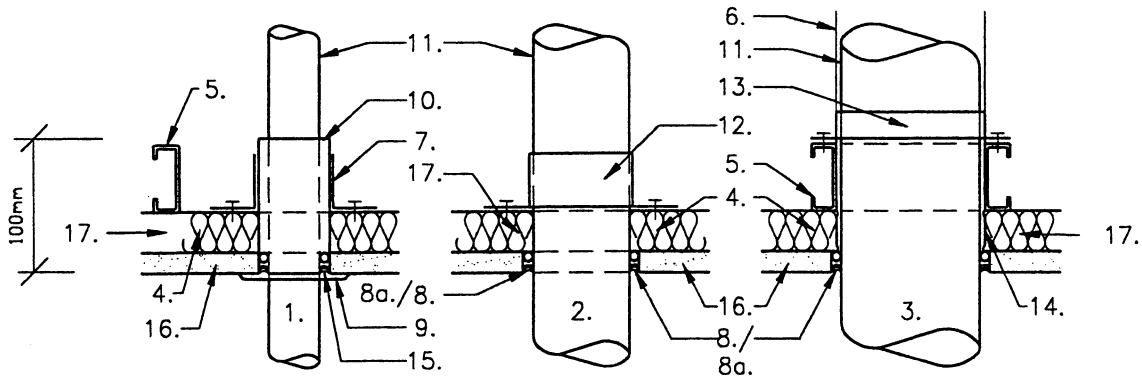

Fig. 9-110



SECTIONS SHOWN AT PENETRATIONS AT RIGHT ANGLES
TO CEILING SECTION CHANNELS, PENETRATIONS
PARALLEL TO CEILING CHANNELS ARE SIMILAR

- | | |
|---|---|
| 1. *SMALL PIPE OR CONDUIT | 11. FACE OF PIPE OR INSULATION |
| 2. *ROUND DUCT (SQUARE SIMILAR) | 12. DUCT FLANGE BY MECH. CONTR. DO NOT ATTACH TO DUCT. SUPPORT DUCT INDEPENDENT OF SUSPENDED CEILING TO ALLOW INDEPENDENT VERTICAL MOVEMENT. |
| 3. *LARGE PIPE / DUCT | 13. PIPE FLANGE BY PIPING CONTR. DO NOT ATTACH TO DUCT. SUPPORT PIPE INDEPENDENT OF SUSPENDED CEILING TO ALLOW INDEPENDENT VERTICAL MOVEMENT |
| 4. MAIN SUPPORT CEILING SECTION | 14. FRAME #4 ABOVE INTO PERIMETER CHANNEL FORMING A FRAMED OPENING-4 SIDES |
| 5. PRIMARY SUPPORT CHANNEL | 15. FS FIRESEAL MASTIC BETWEEN PIPE SLEEVE & PIPE @ RATED LOCATIONS. SEALANT & BACKER ROD @ NON-RATED LOCATIONS |
| 6. STRAP HANGER | 16. 15 mm PLASTERBOARD (RATED OR STANDARD) |
| 7. FRAME CEILING ANGLE AROUND FOUR SIDES OF OPENING & FIX TO #4 ABOVE SUPPORT PIPE AS DESCRIBED IN #13 BELOW | 17. ROCK MINERAL WOOL (80 kg/m ³) WRAPPED & INSULATED 150mm AROUND PIPE & BOUND W/ STEEL WIRE TO RETAIN IN PLACE @ RATED PENETRATIONS |
| 8. FS FIRESEAL MASTIC & SEALANT @ RATED LOCATIONS. SEALANT & BACKER ROD @ NON-RATED LOCATIONS | |
| 8a. INSTALL CONTINUOUS CASING BEAD FOLLOWING OPENING PROFILE AT ALL OPENING PENETRATIONS. KERF BEAD @ CIRCULAR OPENINGS & FINISH. | |
| 9. ESCUTCHEON PLATE (BY PIPING CONTRACTOR) | |
| 10. SS SLEEVE W/ FLANGE BY PIPING CONTRACTOR-SECURE TO #7 ABOVE | |

*SEE RELEVANT SECTIONS OF THE BS BRITISH STANDARDS & EN (1366-3) EUROPEAN STANDARDS INCLUDING TECHNICAL DOCUMENT PART B OF THE BUILDING REGULATIONS.

ALL DIMENSIONS IN MM
UP TO 2 HOUR RATING

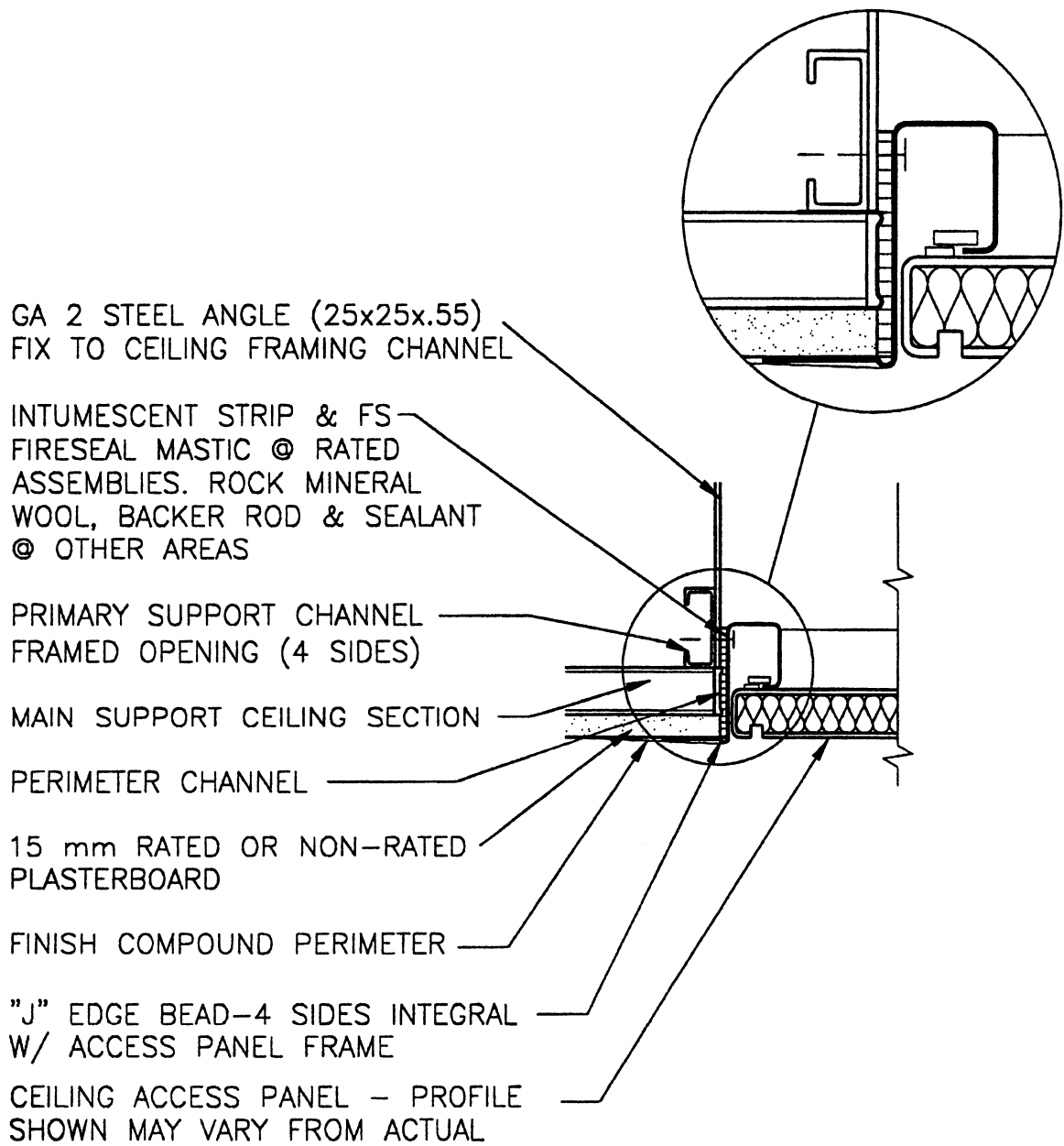

Fig. 9-112

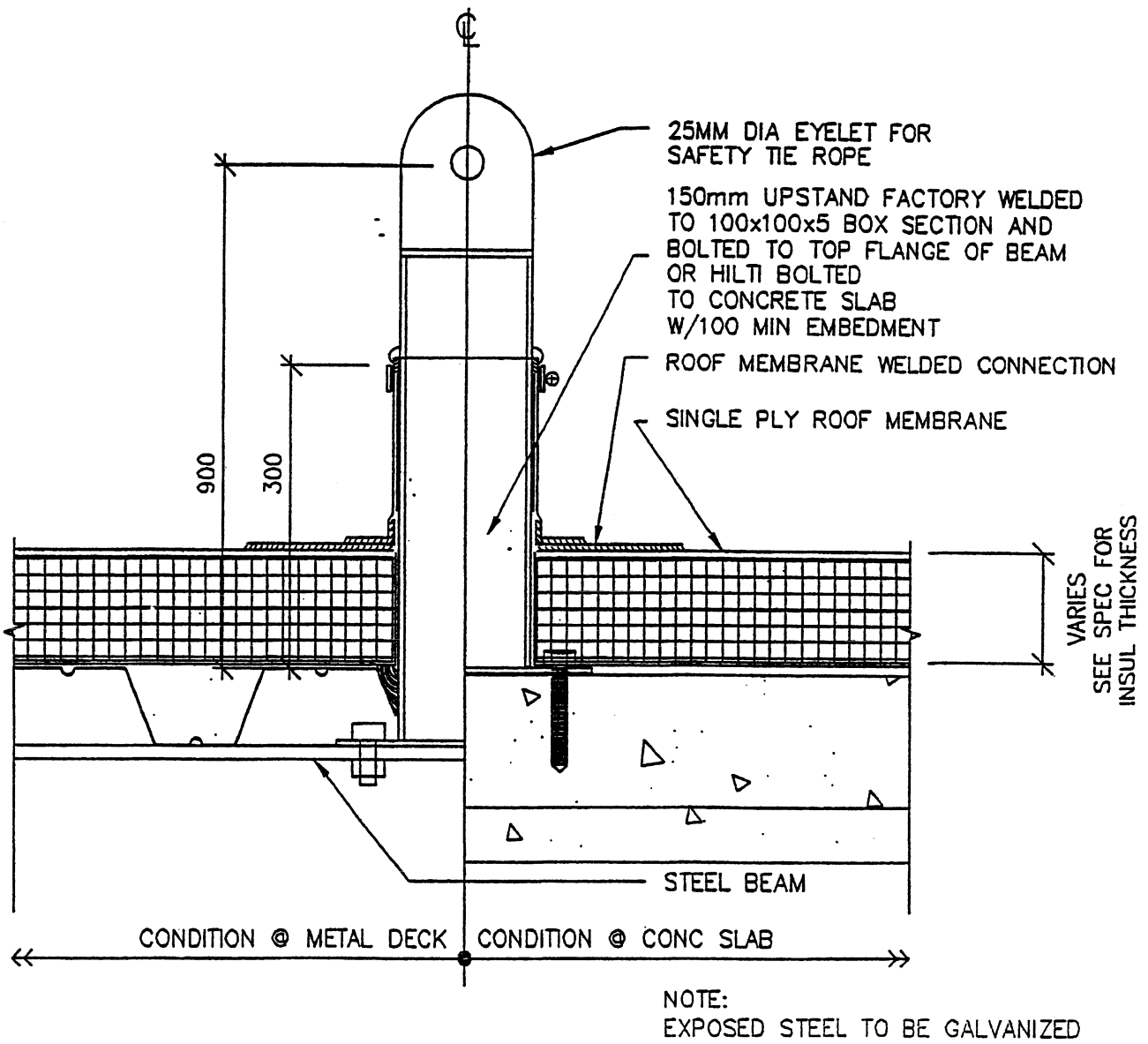

Fig. 9-113

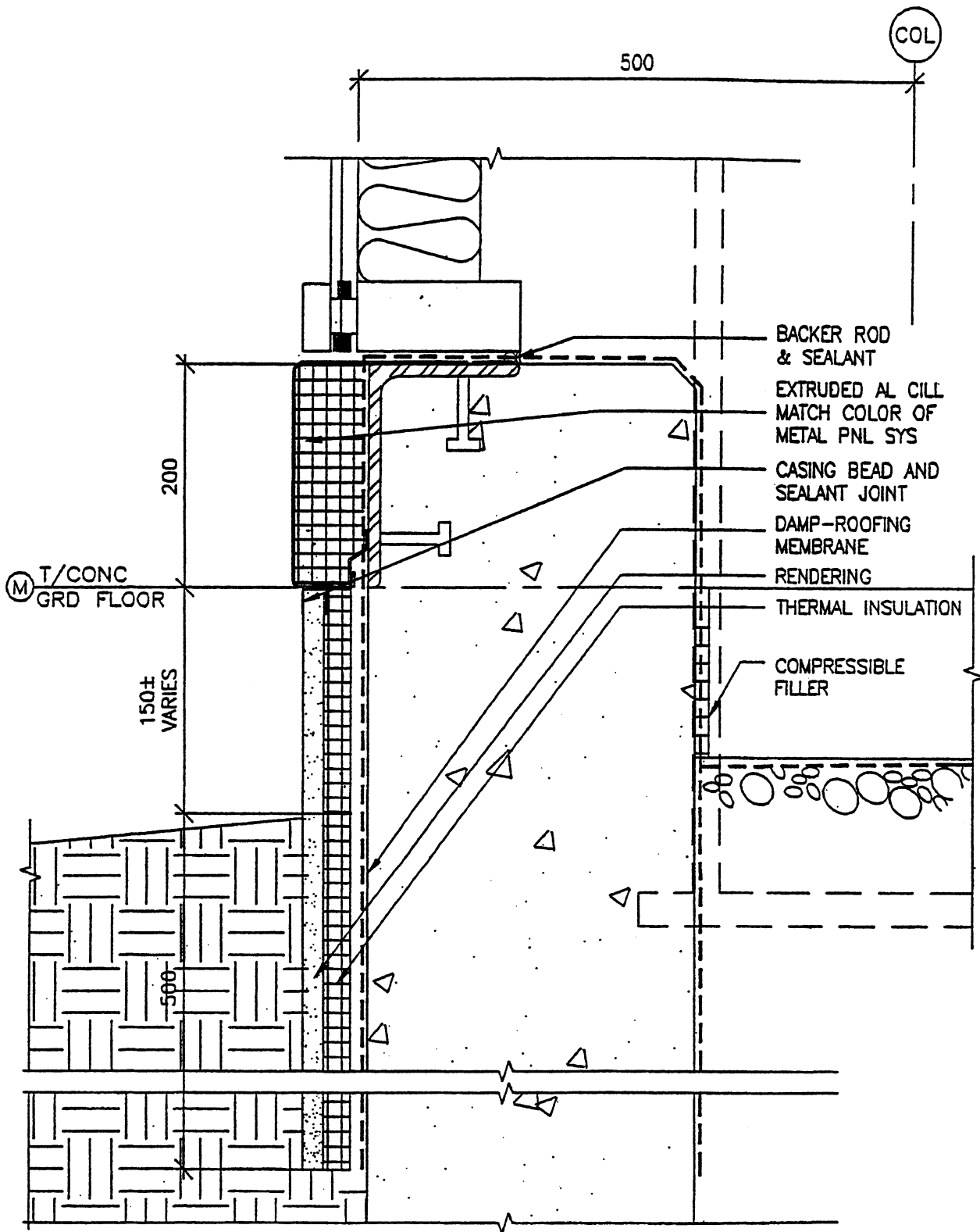

Fig. 9-114

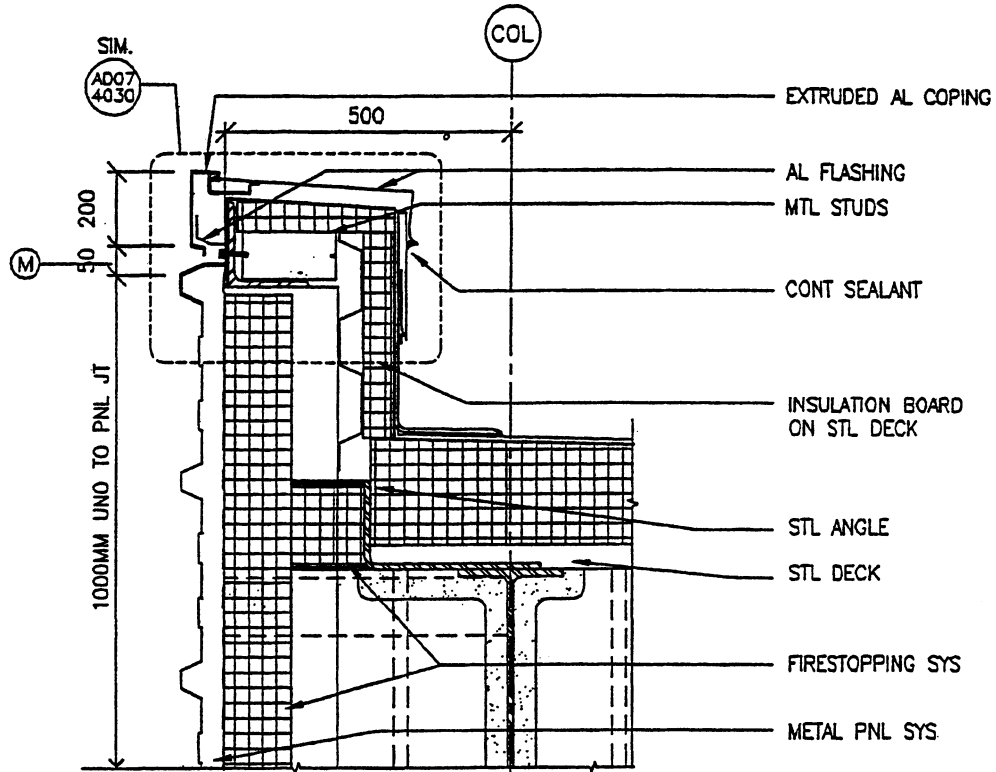

Fig. 9-115

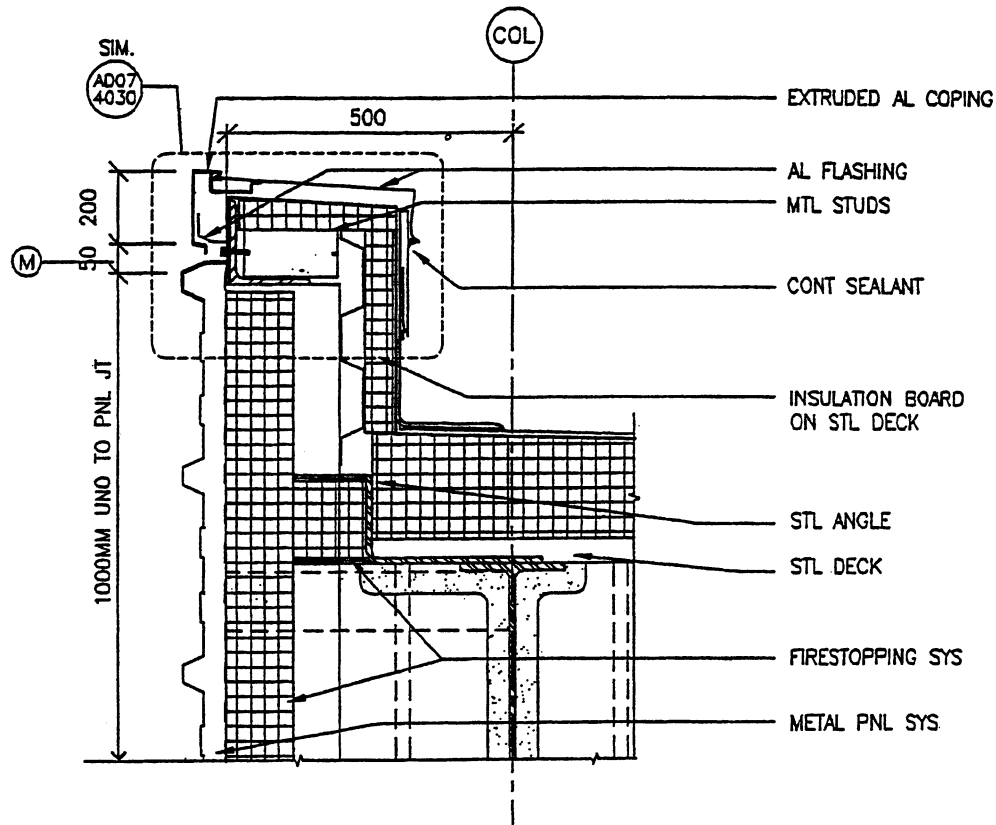

Fig. 9-116

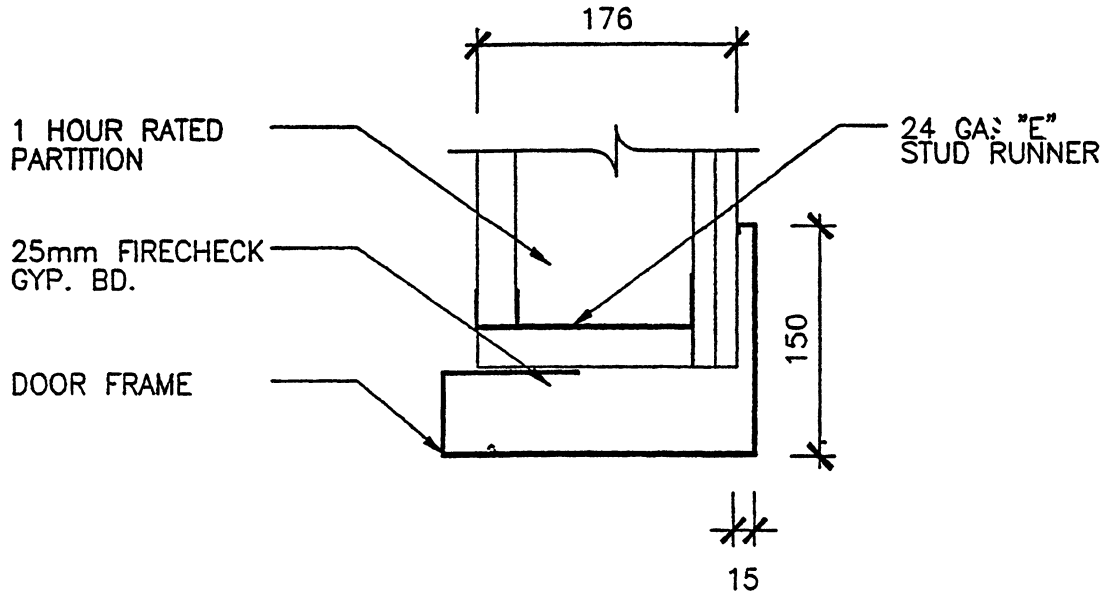

Fig. 9-117

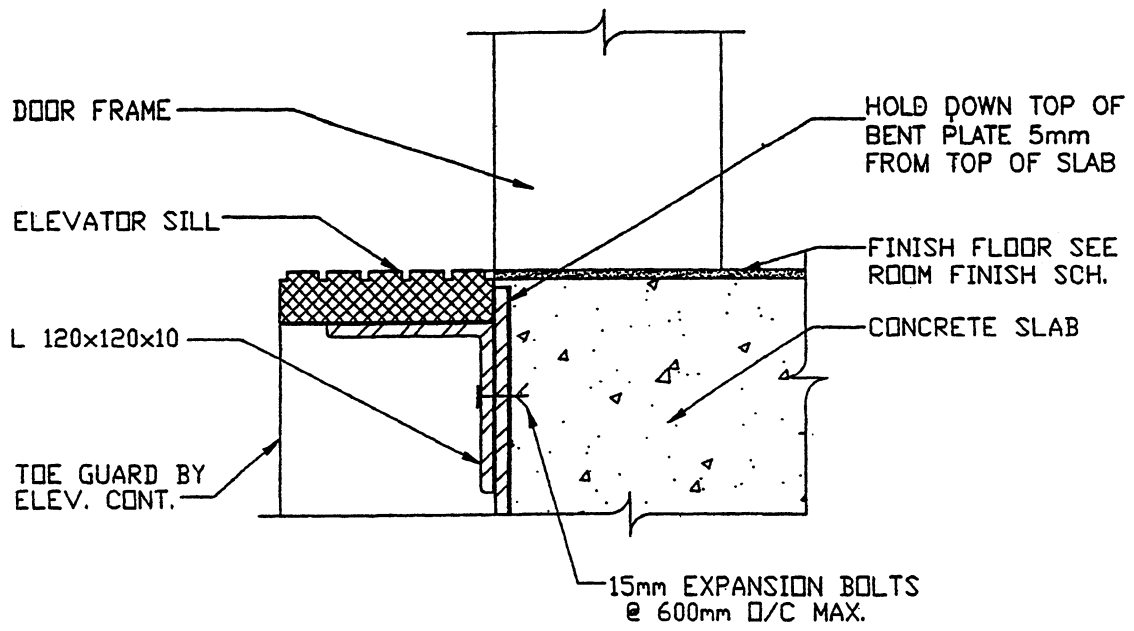

Fig. 9-118

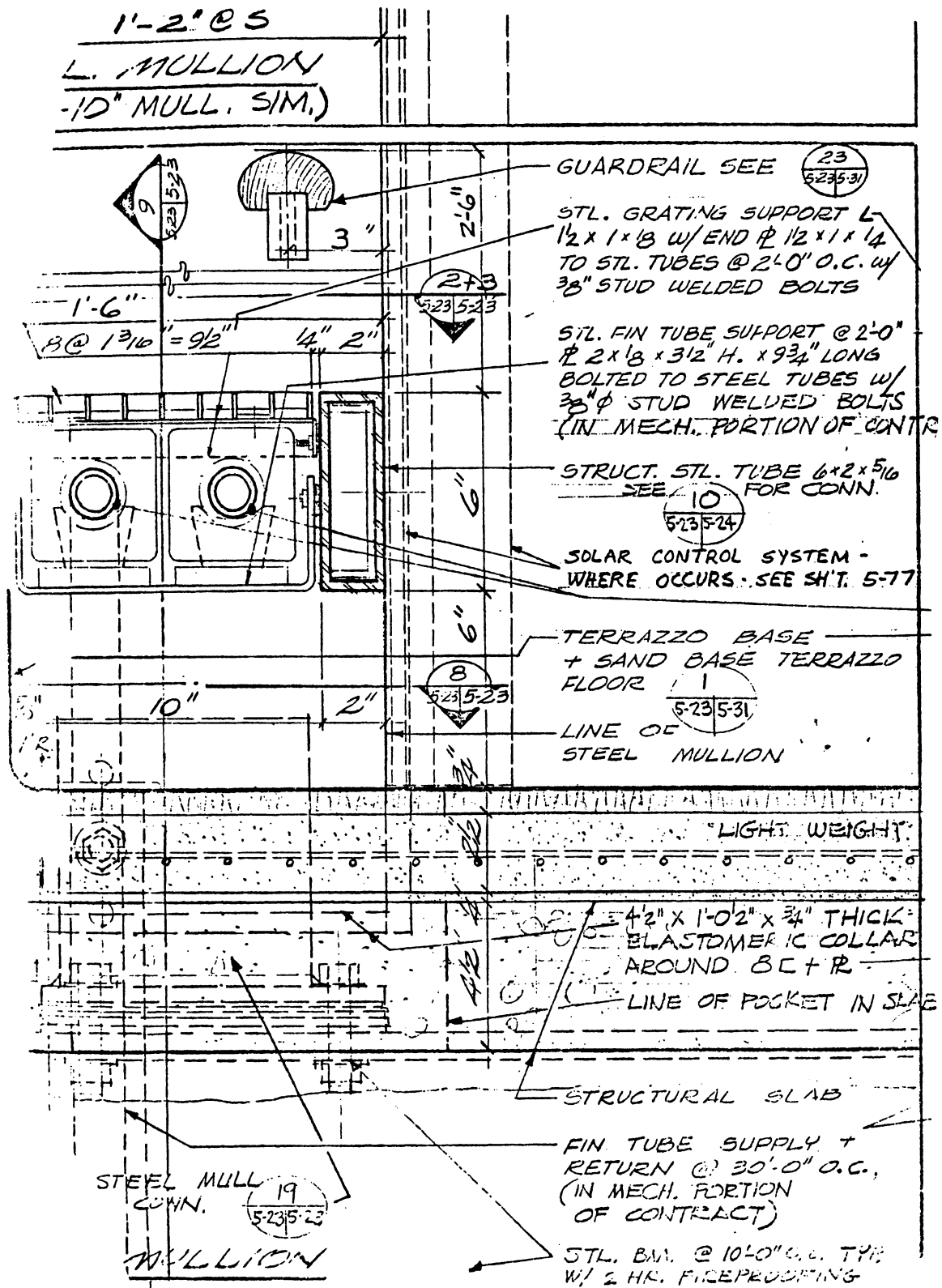

Fig. 9-119

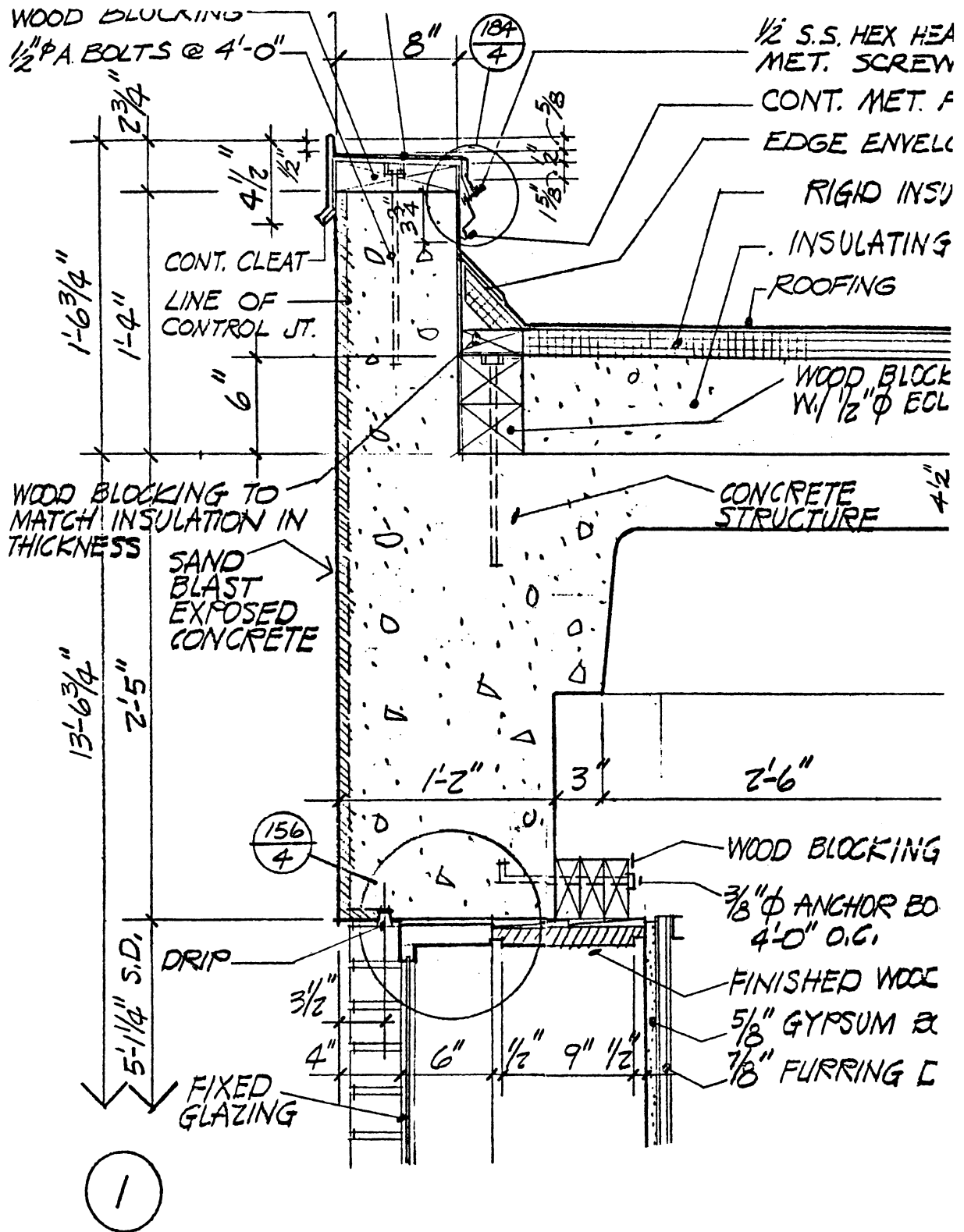

Fig. 9-120

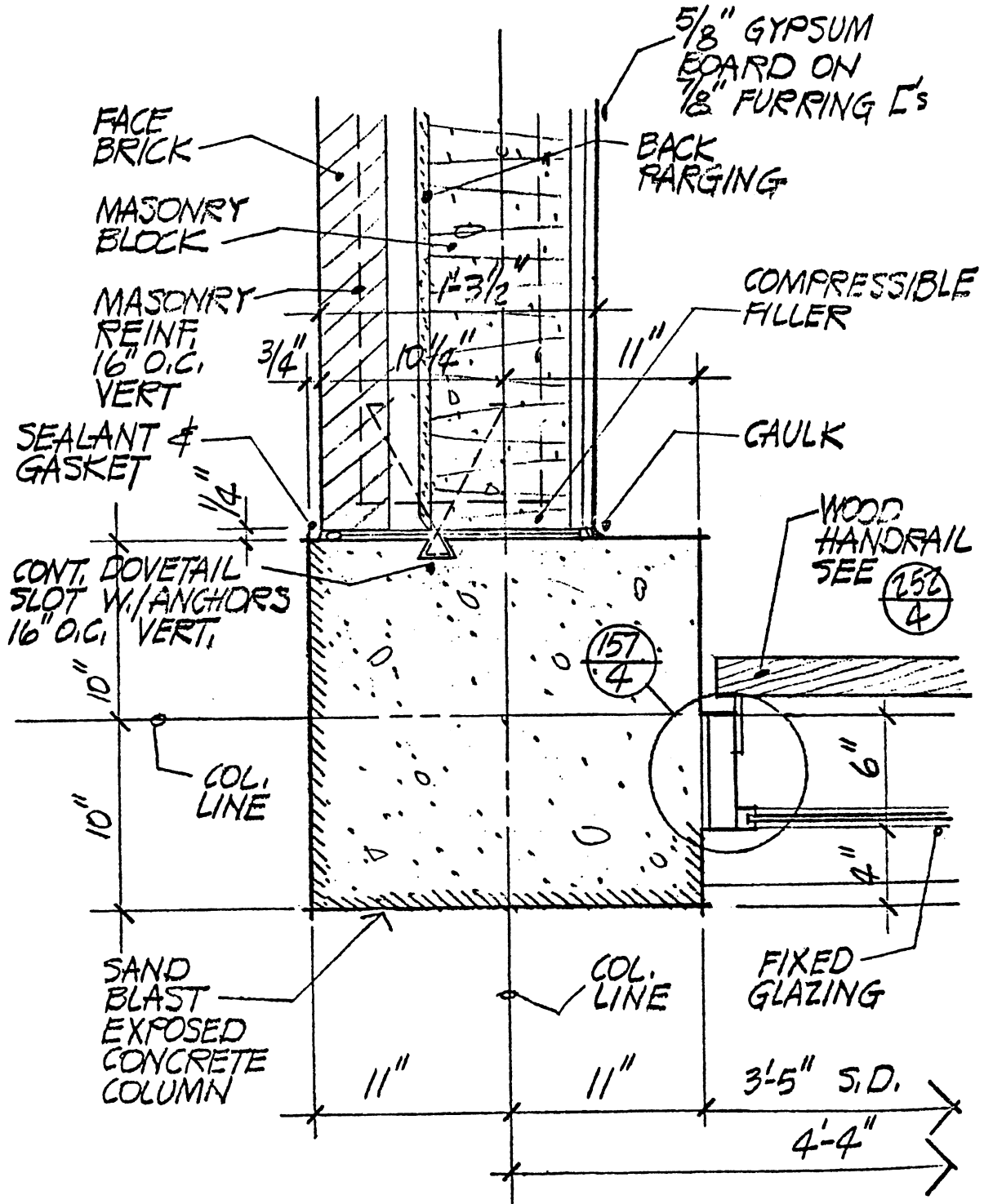

Fig. 9-121

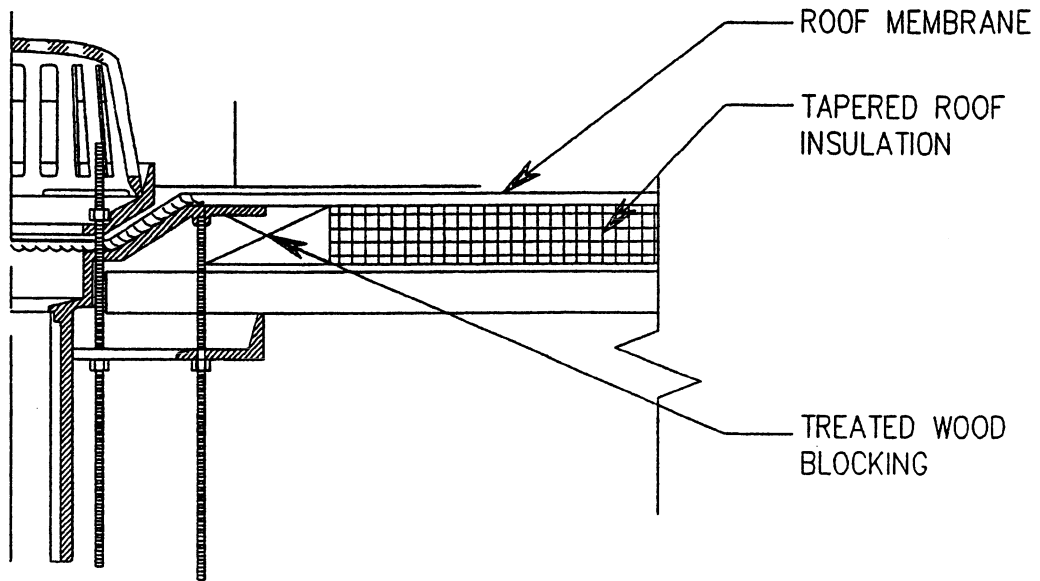

Fig. 9-122

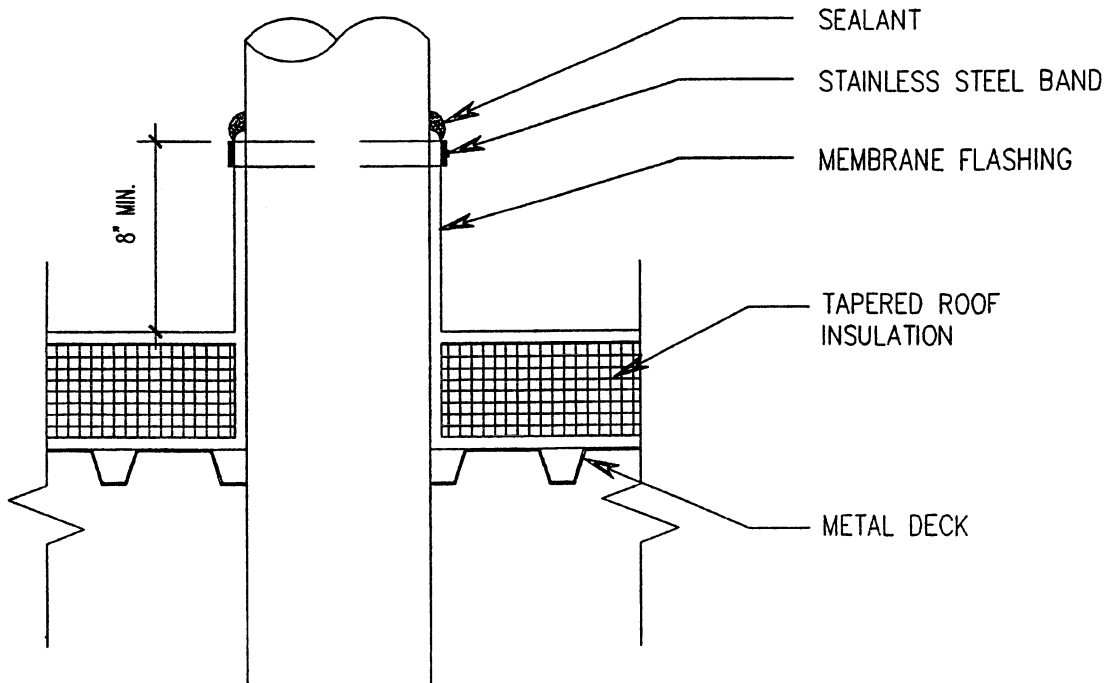

Fig. 9-123

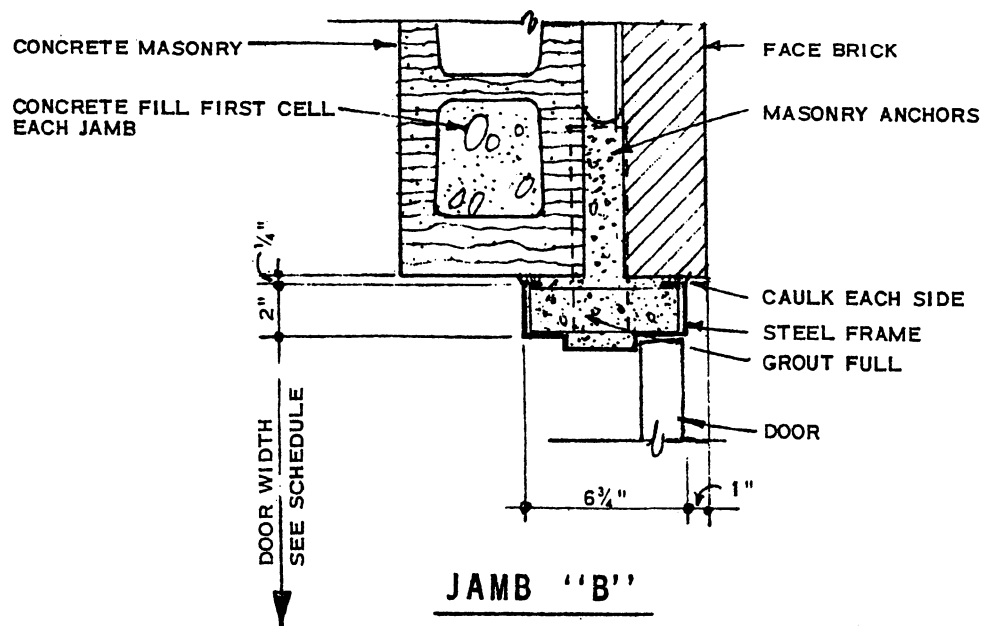
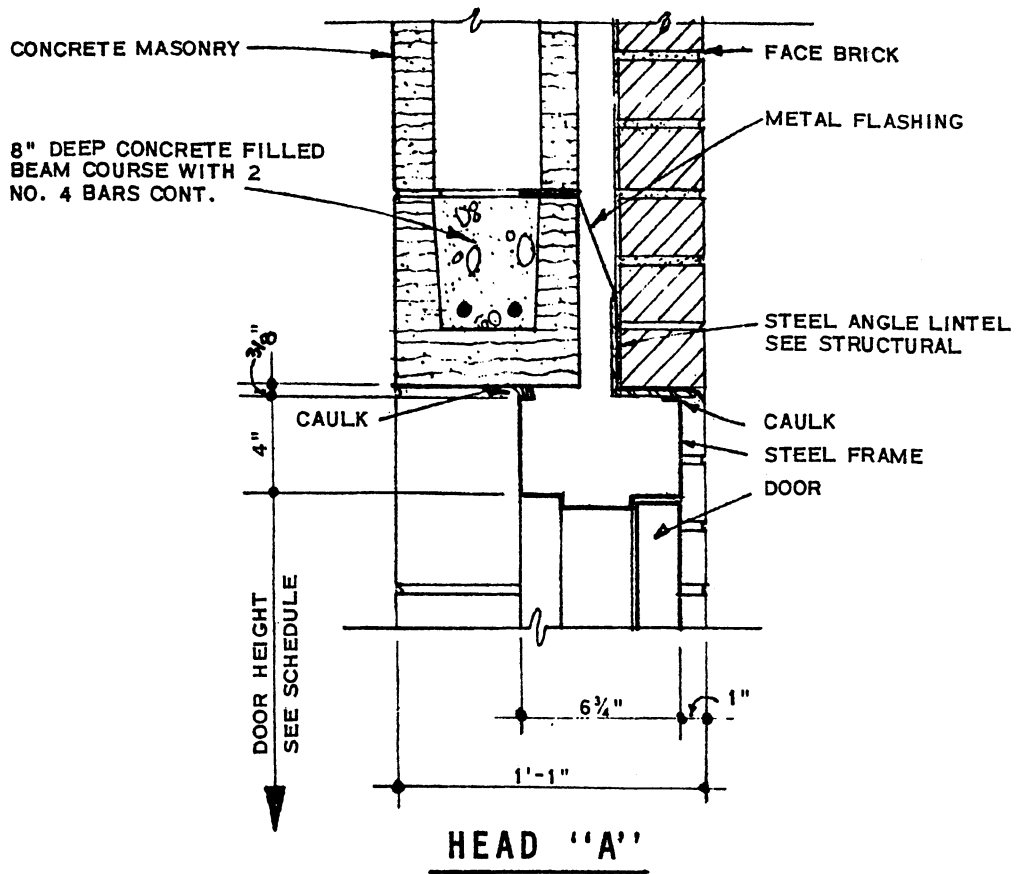

Fig. 9-124

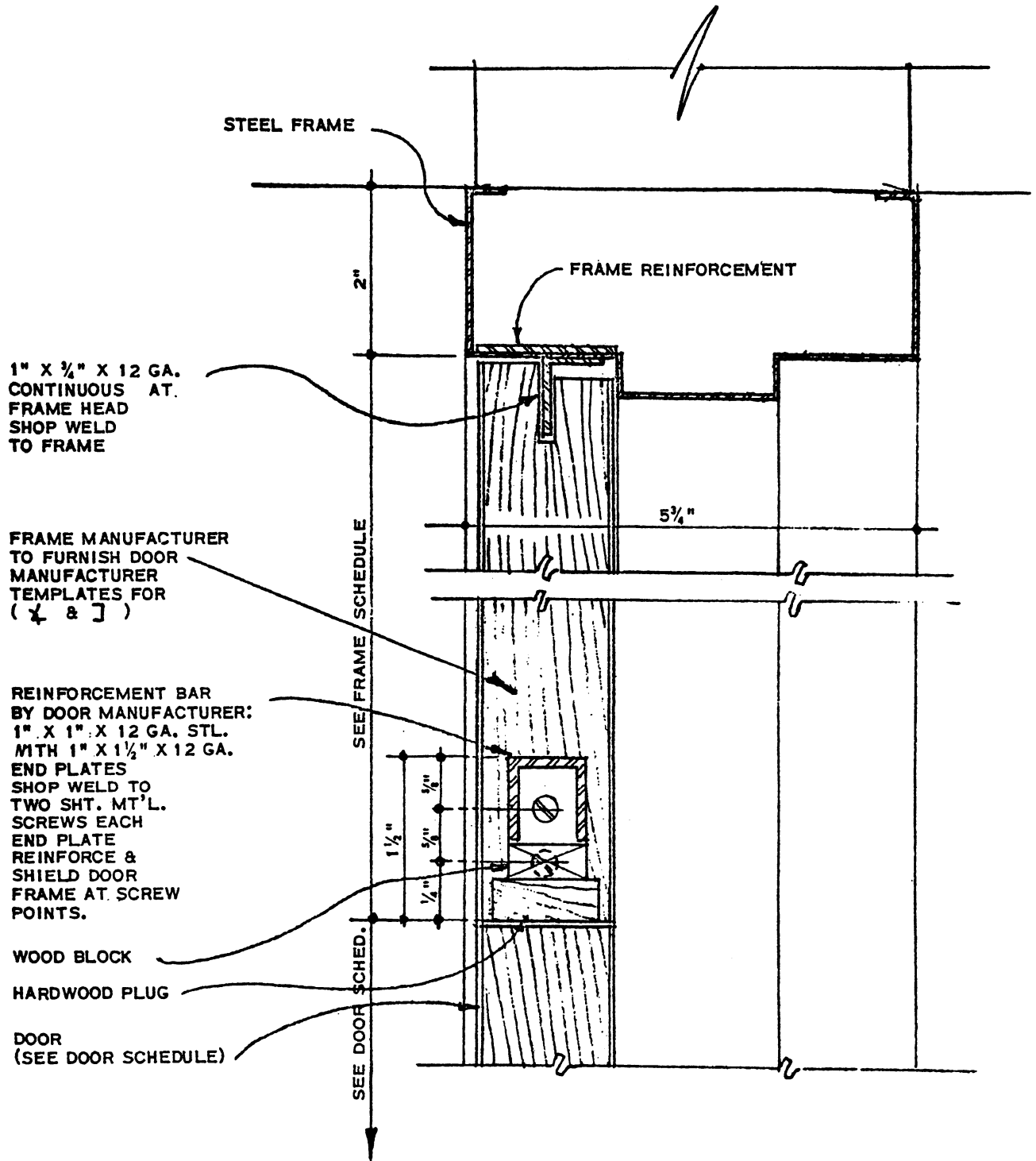

Fig. 9-125

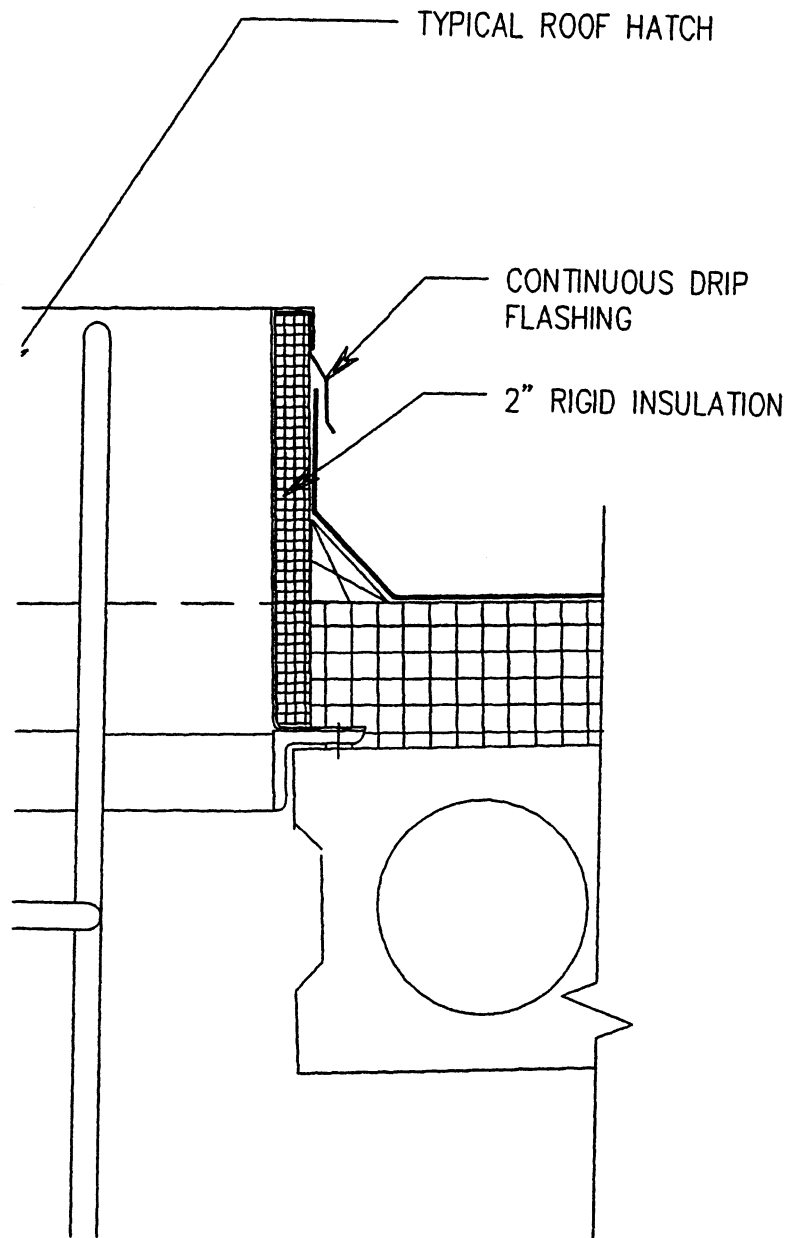

Fig.9-126

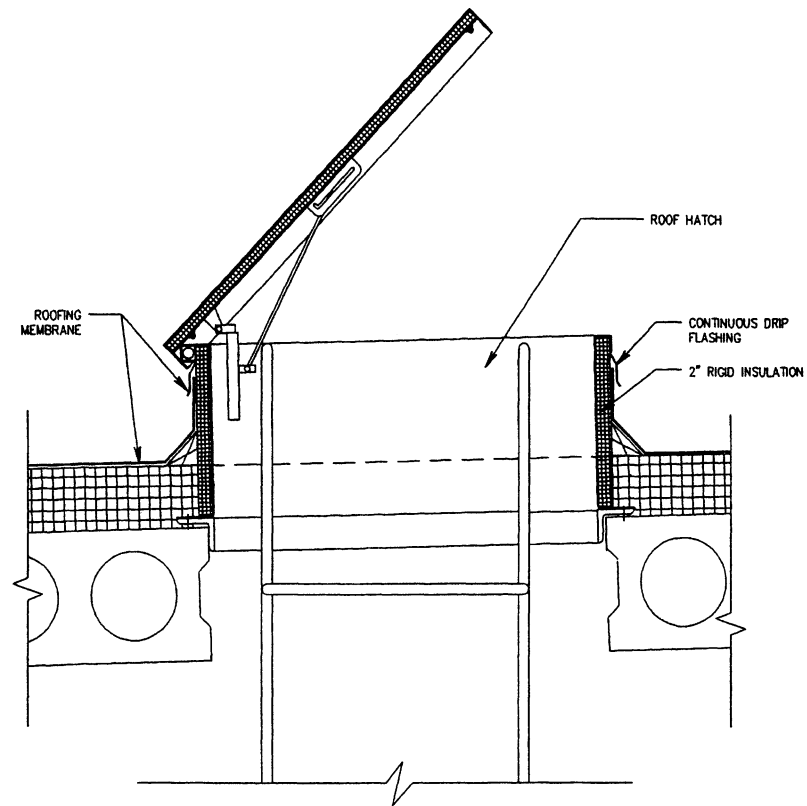

Fig. 9-127

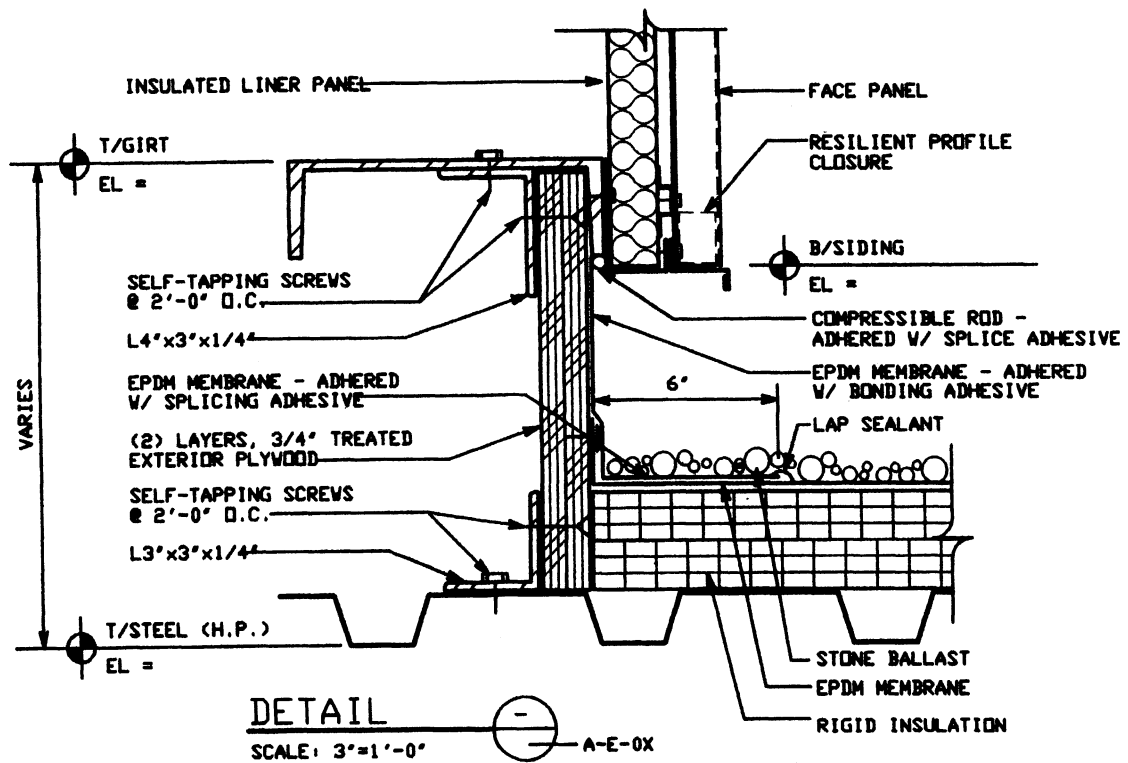

Fig. 9-128

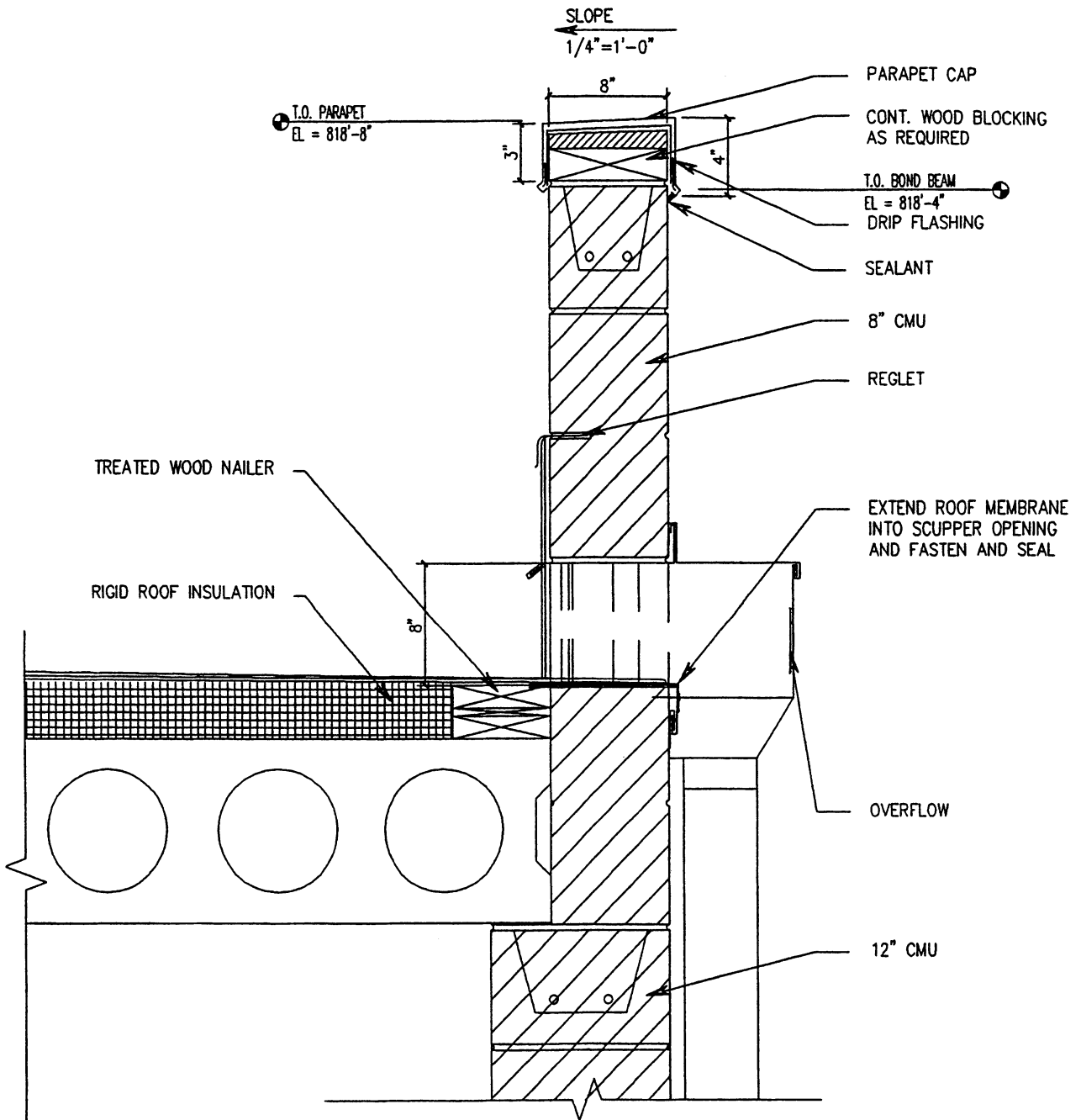

Fig. 9-129

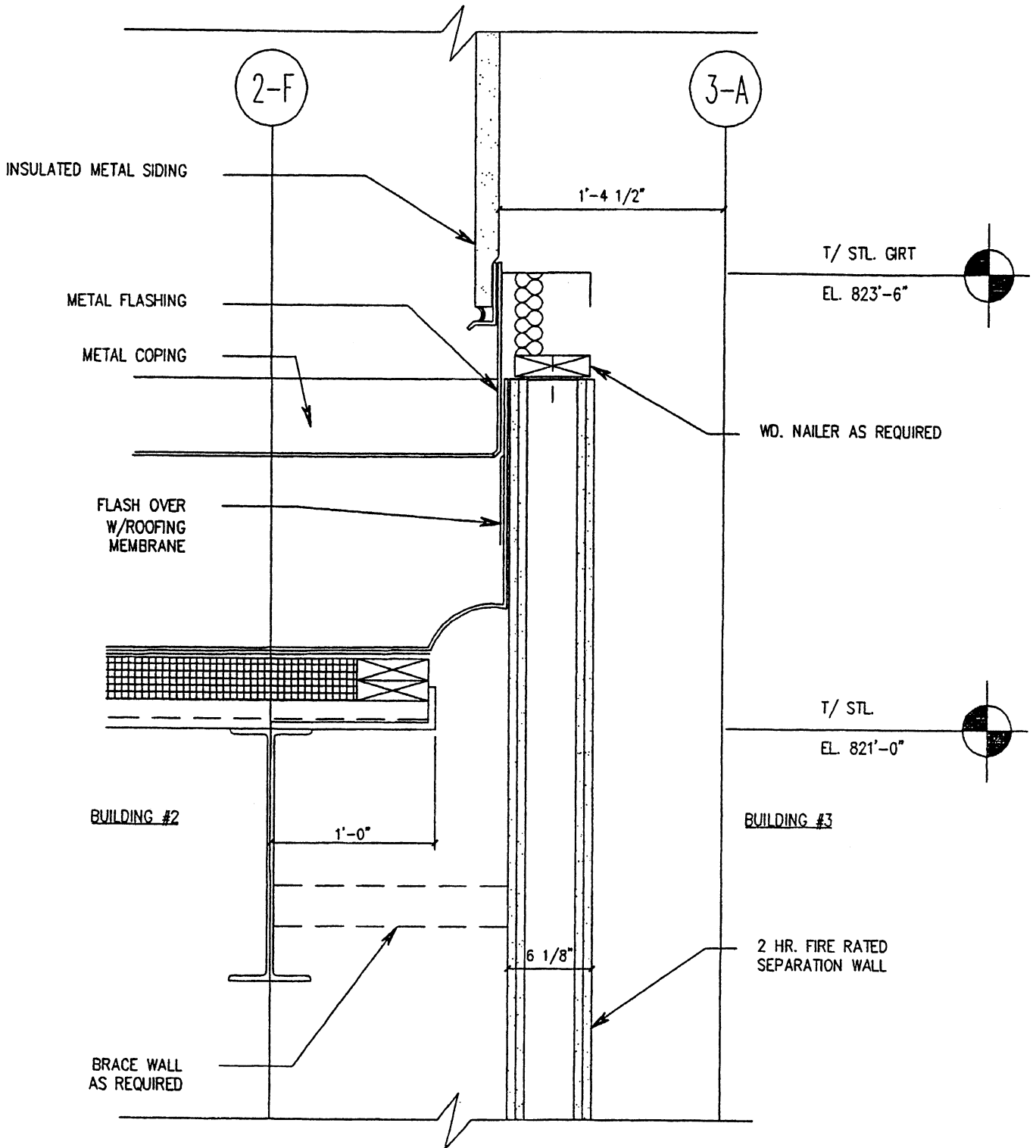

Fig. 9-130

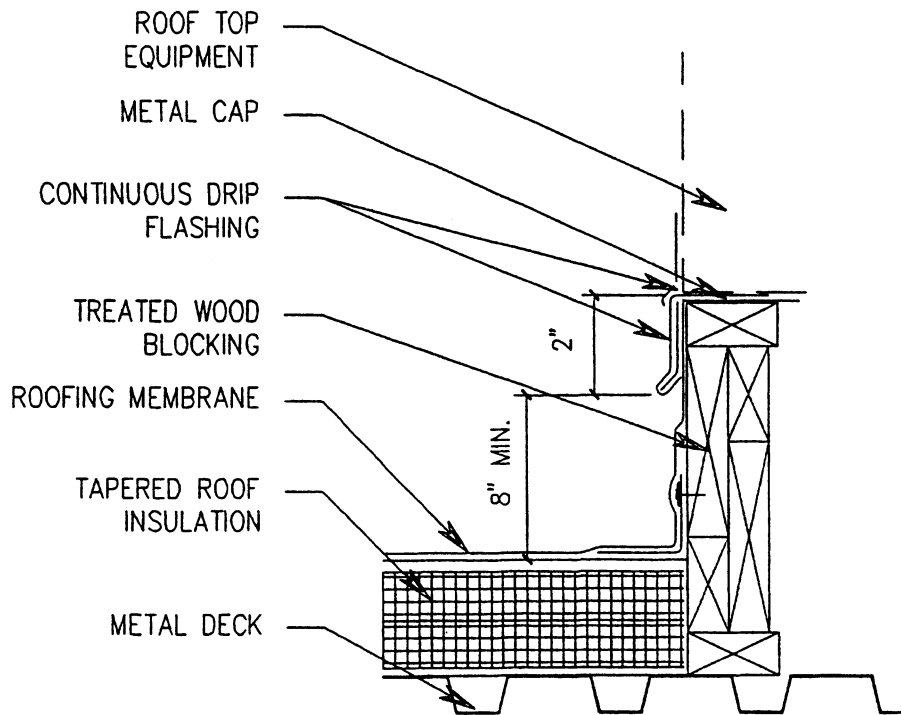

Fig. 9-131

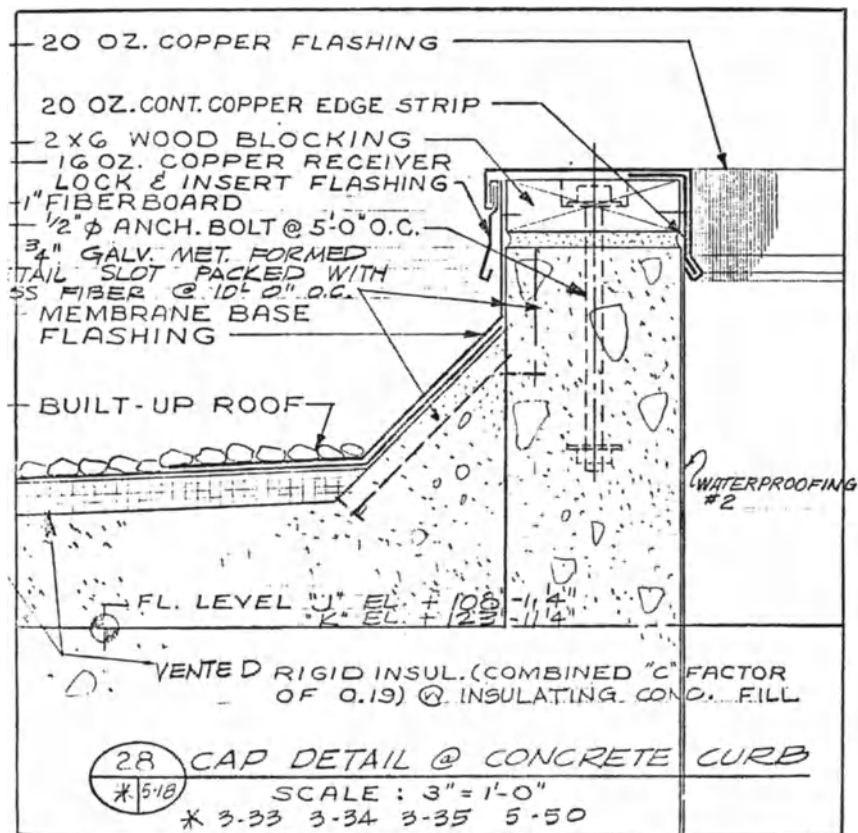
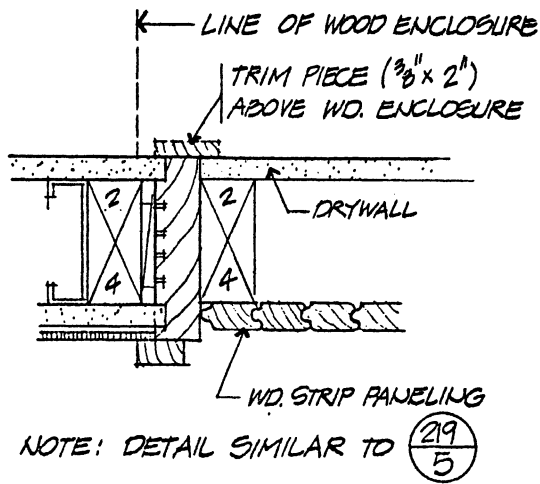
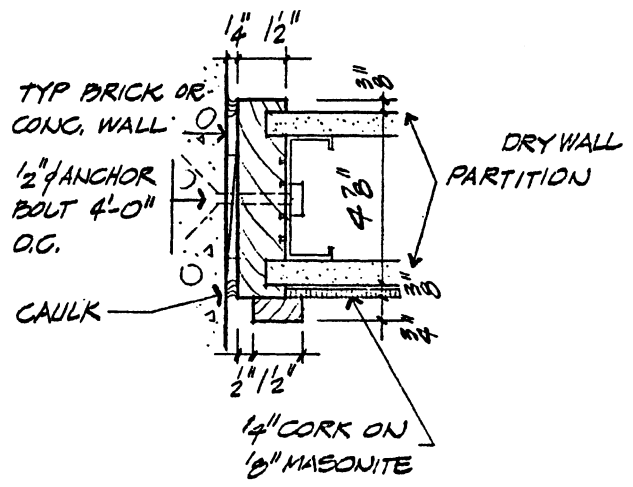

Fig. 9-132



NOTE: DETAIL SIMILAR TO 219
5

220 JAMB
SCALE 3"=1'-0"



221 JAMB

Fig. 9-133

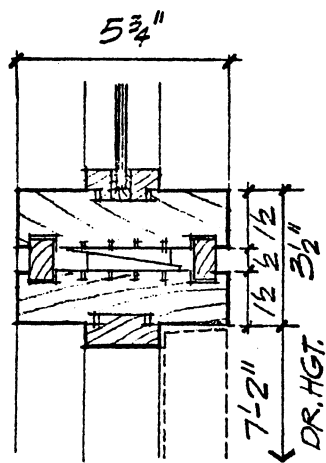

190 HEAD

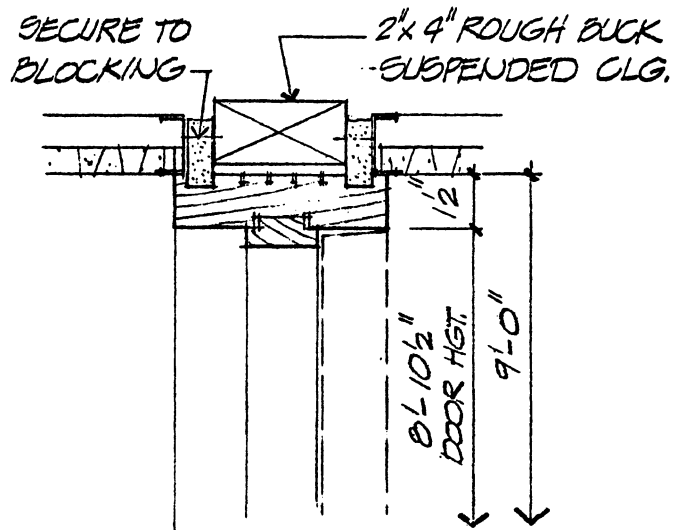

191 HEAD

Fig. 9-134

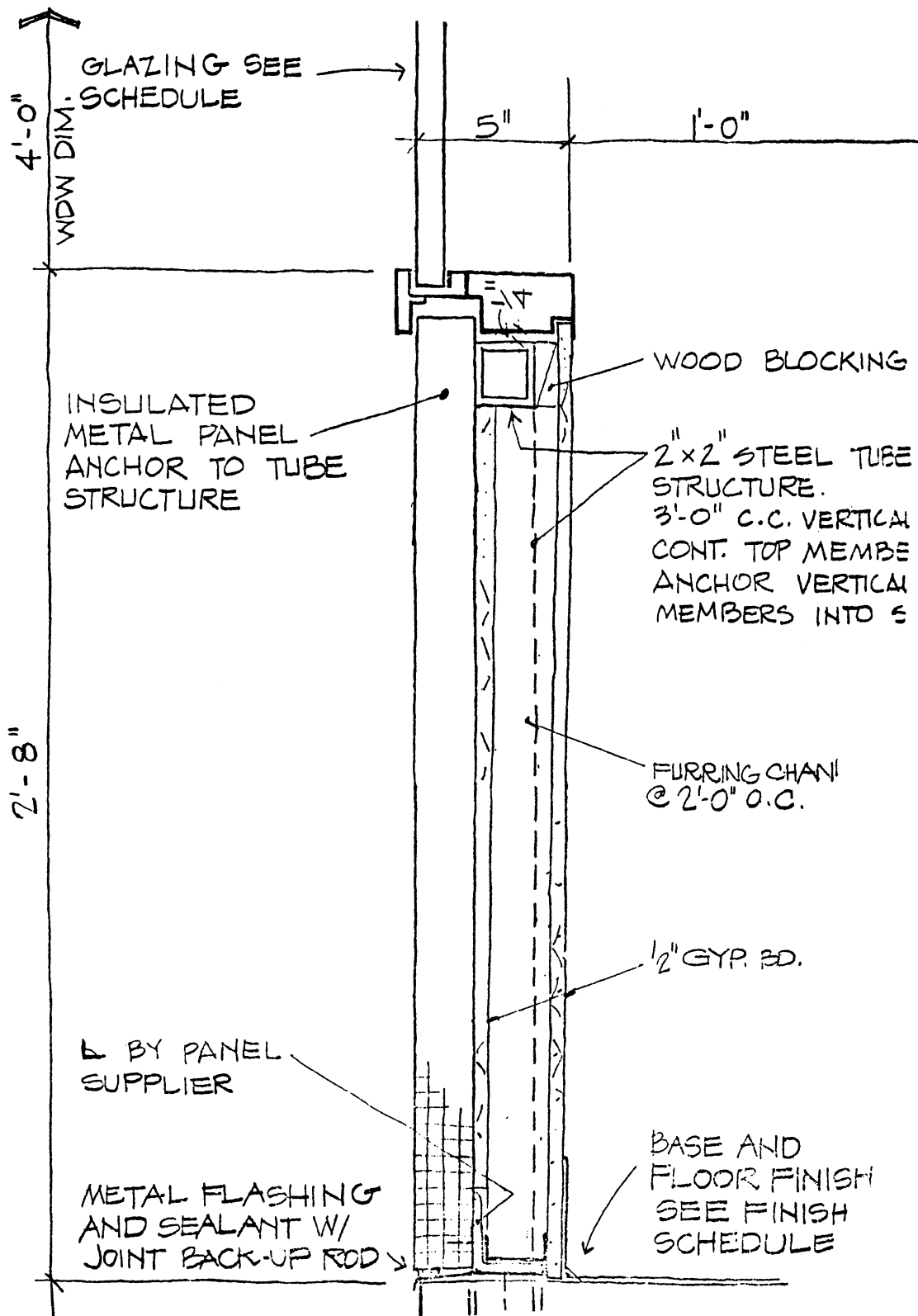

Fig. 9-135

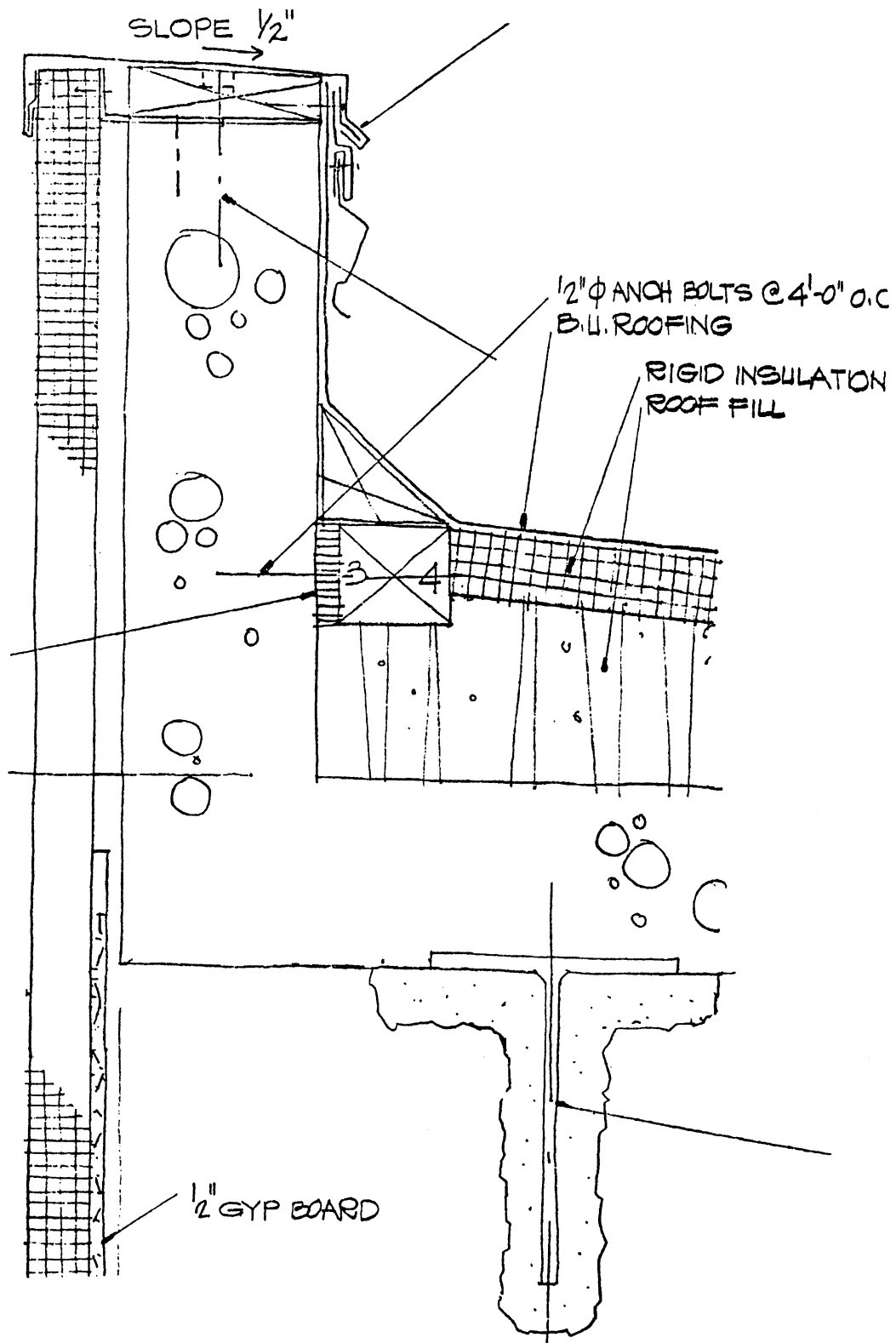

Fig. 9-136

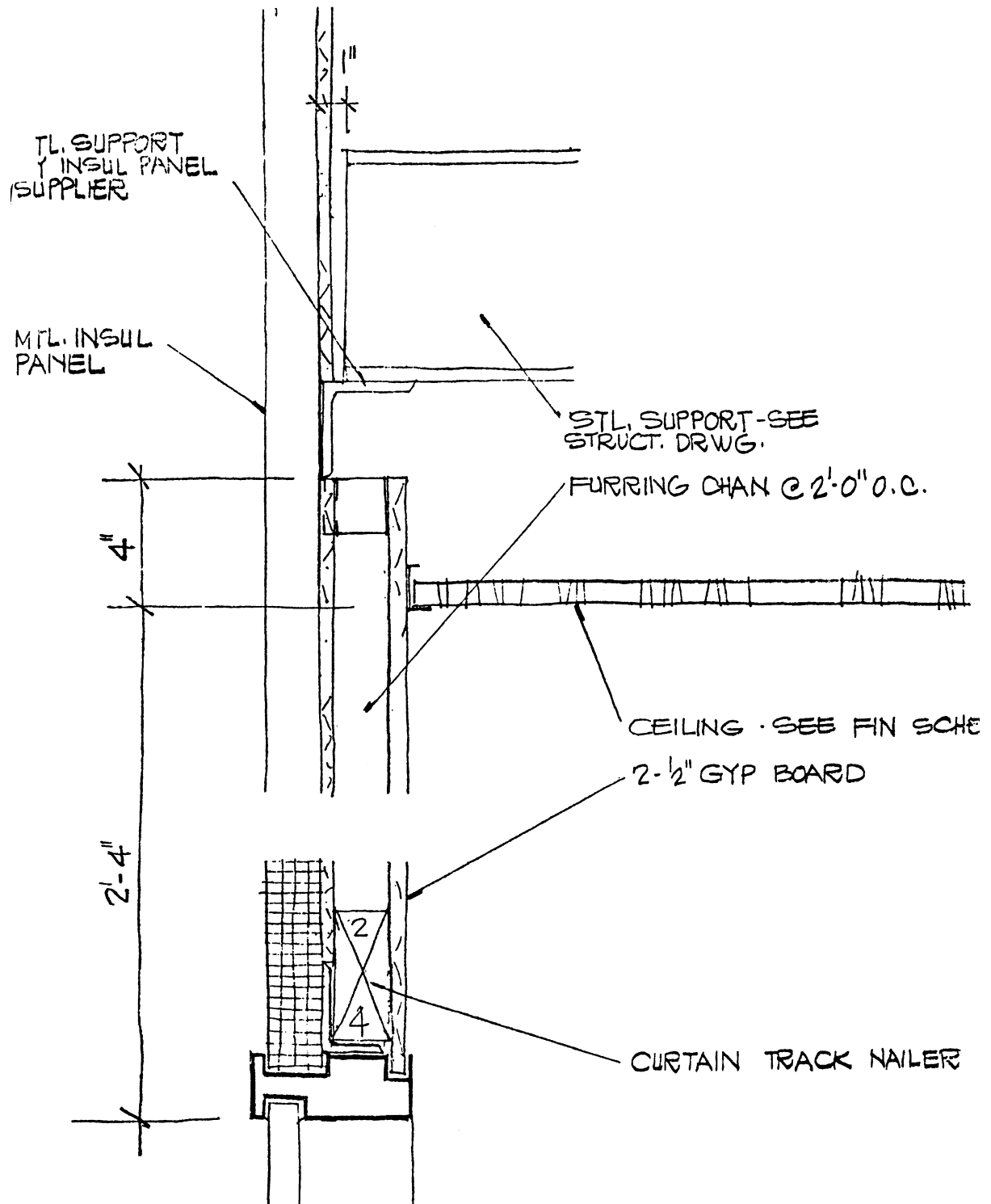

Fig. 9-137

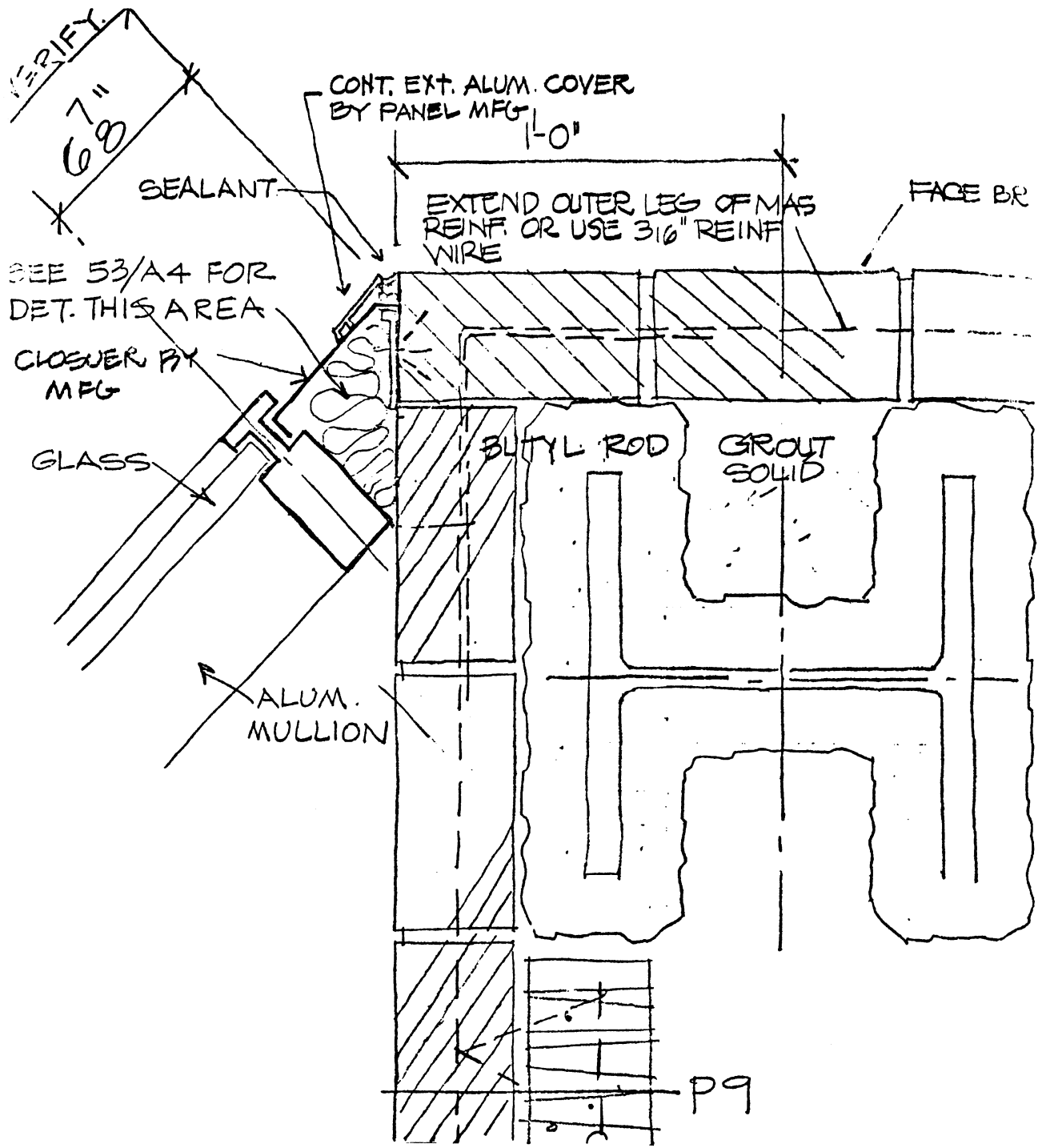

Fig. 9-138

LINTEL NOTES: WHEN FRAMES OCCUR IN MASONRY WALLS PROVIDE 12 GA. HAT SECTION FOR OPENINGS 3'-0" TO 3'-11". FOR LARGER OPENINGS SEE LINTEL SCHEDULE. NO REINF. FOR OPENINGS LESS THAN 3'-0"

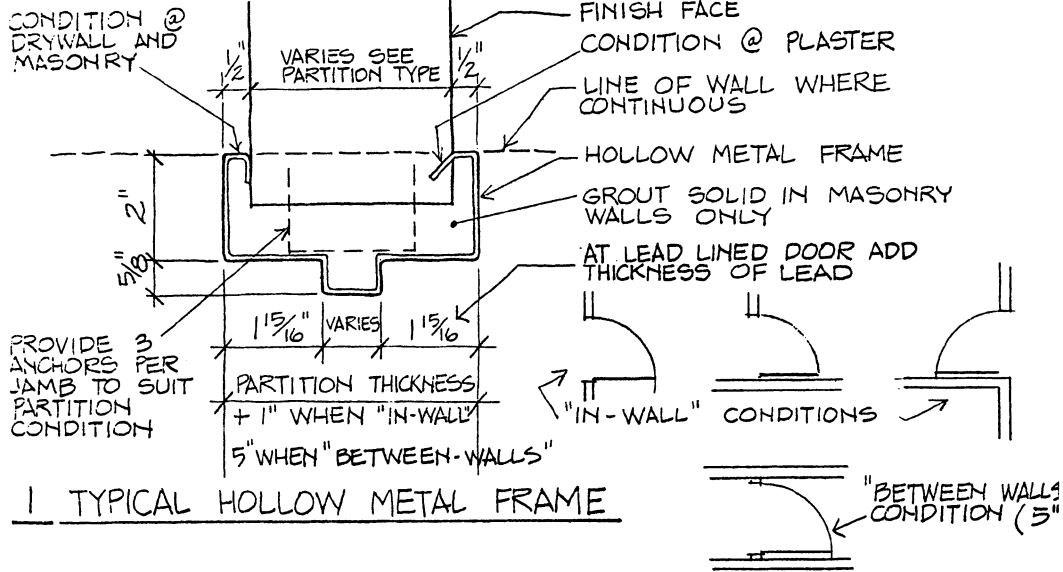

Fig. 9-139

<p>1 LAYER 1/2" DRYWALL</p> <p>3" METAL STUD @ 24" O.C.</p> <p>4"</p>	<p>STC RATING</p> <p>37</p>
<p>1 LAYER 1/2" DRYWALL</p> <p>3" METAL STUD @ 24" O.C.</p> <p>1 1/2" SOUND BLANKET</p> <p>4"</p>	<p>STC RATING</p> <p>43</p>
<p>1 LAYER 1/2" DRYWALL</p> <p>2 1/2" METAL STUD @ 24" O.C.</p> <p>2 LAYERS 1/2" DRYWALL</p> <p>4"</p>	<p>STC RATING</p> <p>41</p>

Fig. 9-140

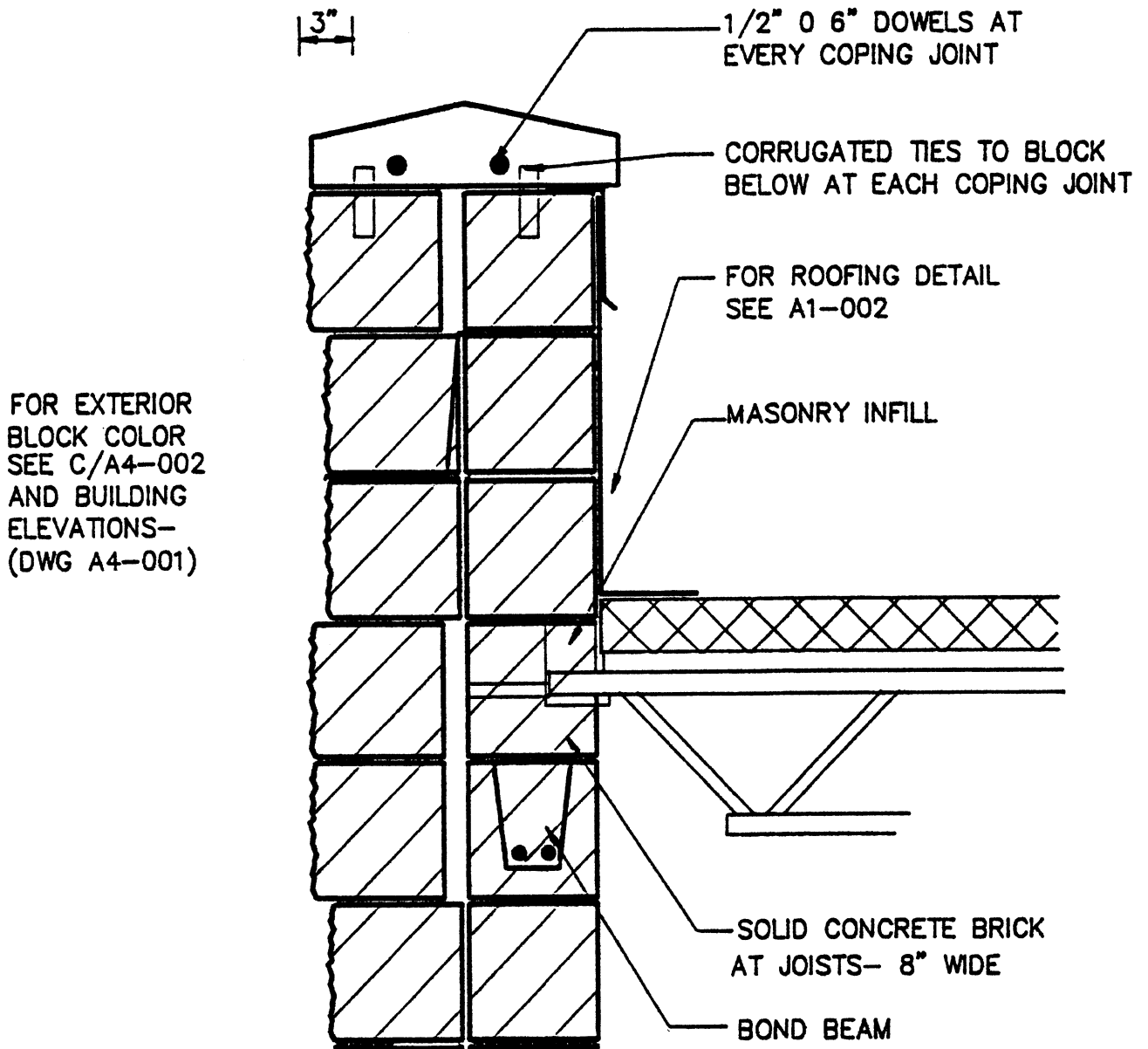

Fig. 9-141

DISCUSSION OF CASE STUDIES

One of the more effective educational tools is to present students with actual situations [in our case, detail drawings] and then to offer critique and analysis of the situations, pointing out both strong and weak points. Obviously, this process suffers to some degree from not being close to, or fully aware of the circumstances involved. Some portion of the solution or drawing may well have been driven by a hidden, remote, or curious requirement, which is not obvious or available now. Therefore comment on the case study details is a matter of "face value"- reflections on what is shown, with no direct insight into what caused the solution. Still much can be learned from these studies, which will assist the reader in understanding the underlying principles of detailing and the foibles that can befall one who is not careful and diligent.

In any event, the process is still extremely helpful in that student can experience first hand finished products that do not measure up to the other criteria set out. In this instance, it is helpful and instructive that there is some comment, on the "drafting" technique involved. Also, on the communicative aspects of the work, and the usefulness and constructibility of the work- essentially, "how" well the drafting work is done; "how" well the work communicates the necessary information; and "what" exactly is being required.

The details come from various projects and sources, but each serves to illustrate one or more points about correct and proper detailing. The fact that these details are produced both by manual and computer drafting techniques is of no consequence and does not distract from their value as communication instruments; neither does it relegate them to either current, modern or obsolete status.

Each detail included in this chapter is accompanied by a legend which assesses, analyzes, and critiques the detail, and its presentation. Sources of the details are not disclosed, since it serves no purpose to show that information, or to embarrass any professional or drafter involved.

The entire aim here is to instruct- not sniping or attempting to discredit- through the showing of items that are questionable, wrong, ambiguous, or that could be improved otherwise to make better details.

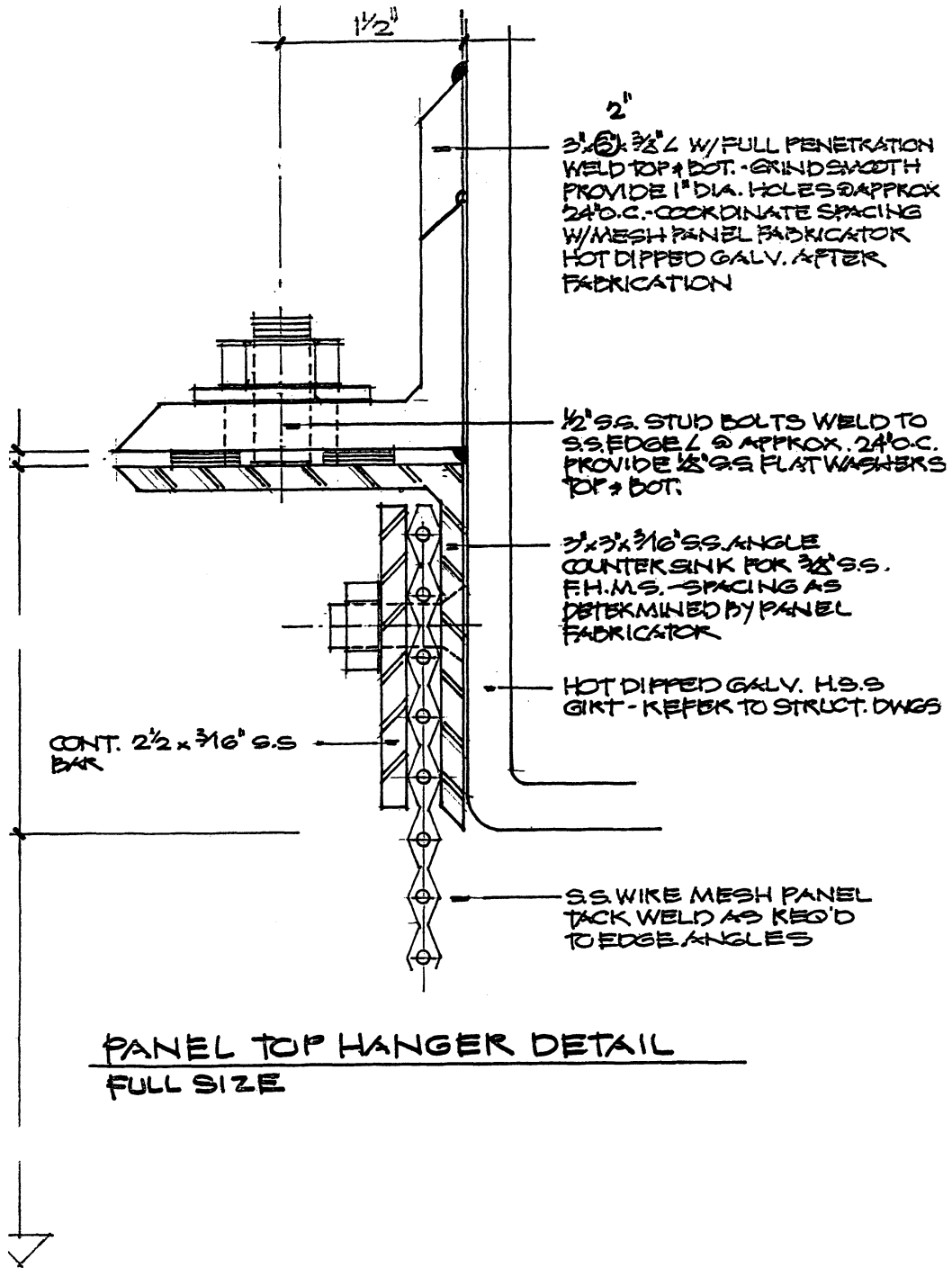
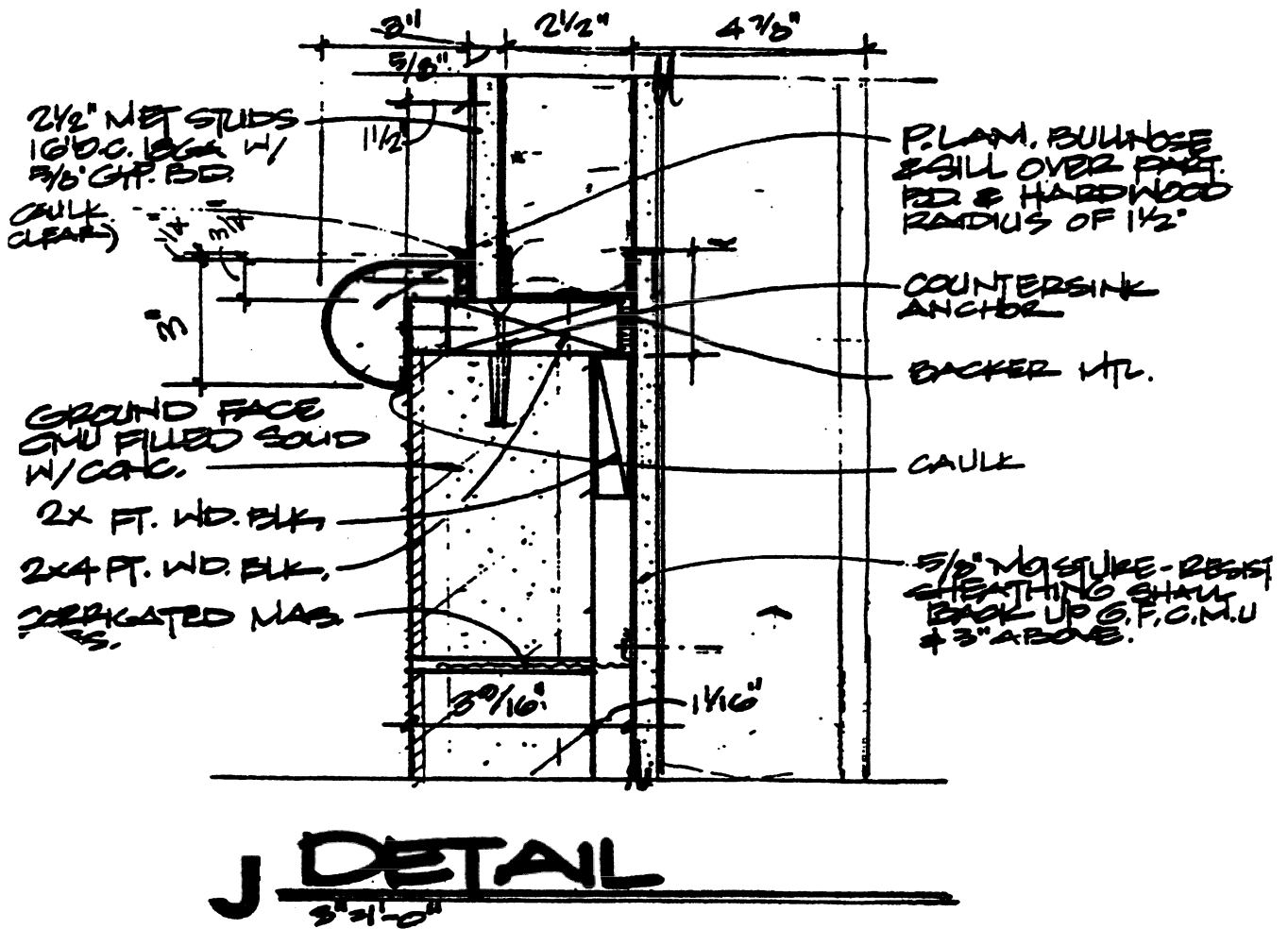

Fig. 10-0

This is an excellent, well illustrated detail, of a very small portion of a project - the connection of an enclosing metal mesh screen as the exterior facing of a project. Produced by manual drafting and shown here at full size [to clearly show all elements].



- CONSIDER:
1. How is the radius trim attached to the wall?
 2. How and when is the plastic laminate applied to the wood radius trim?
 3. Can you identify and note the use of the items not described in this detail?
 4. What alternative(s) can you offer for this detail to clarify these issues and to make a more workable detail?
 5. Do you understand the notes, etc. on this detail?

Fig. 10-1

A detail rather well done- but check the questions to see if the drawing really does its job.

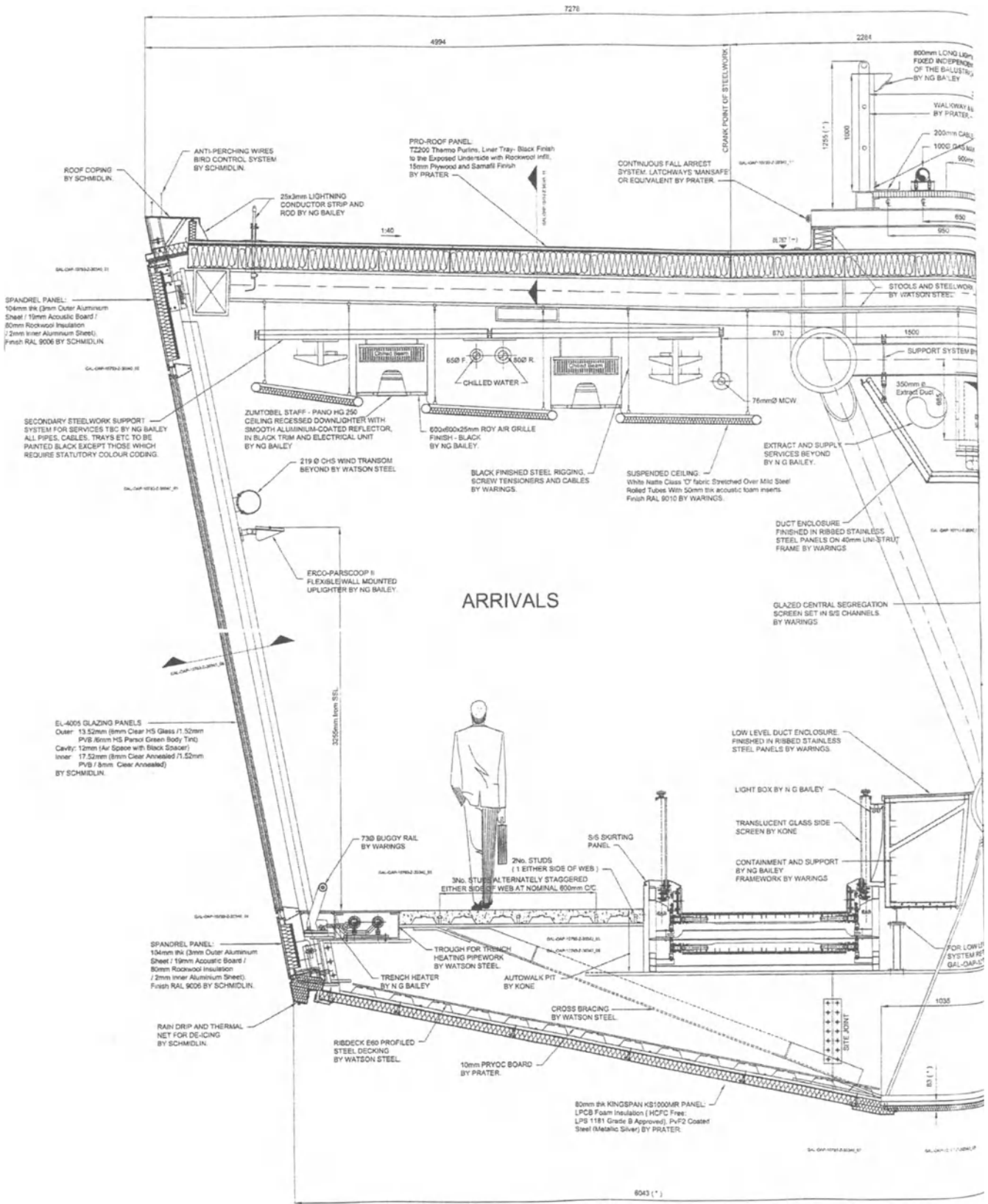

Fig. 10-2
A half-Section of the portion of a building to illustrate, the numerous instances where details will be required to show and communicate the work to be done.

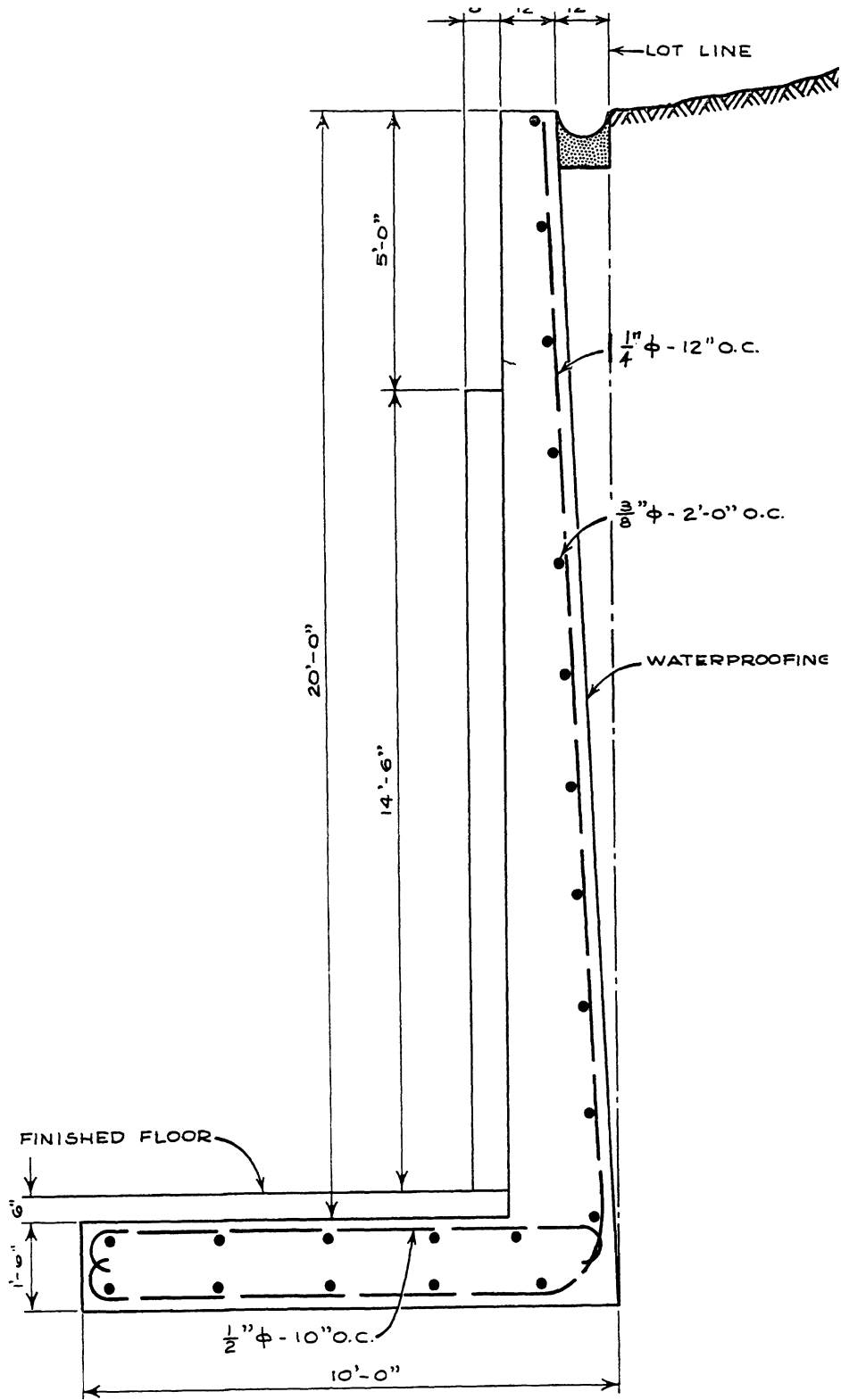

Fig. 10-3

A detail that led to failed work- can you find the problem. Follow the Lot Line down and noted how it runs through the note "1-1/4" ϕ ... The contractor missed this and installed 1/4" bars—the wall crumbled!

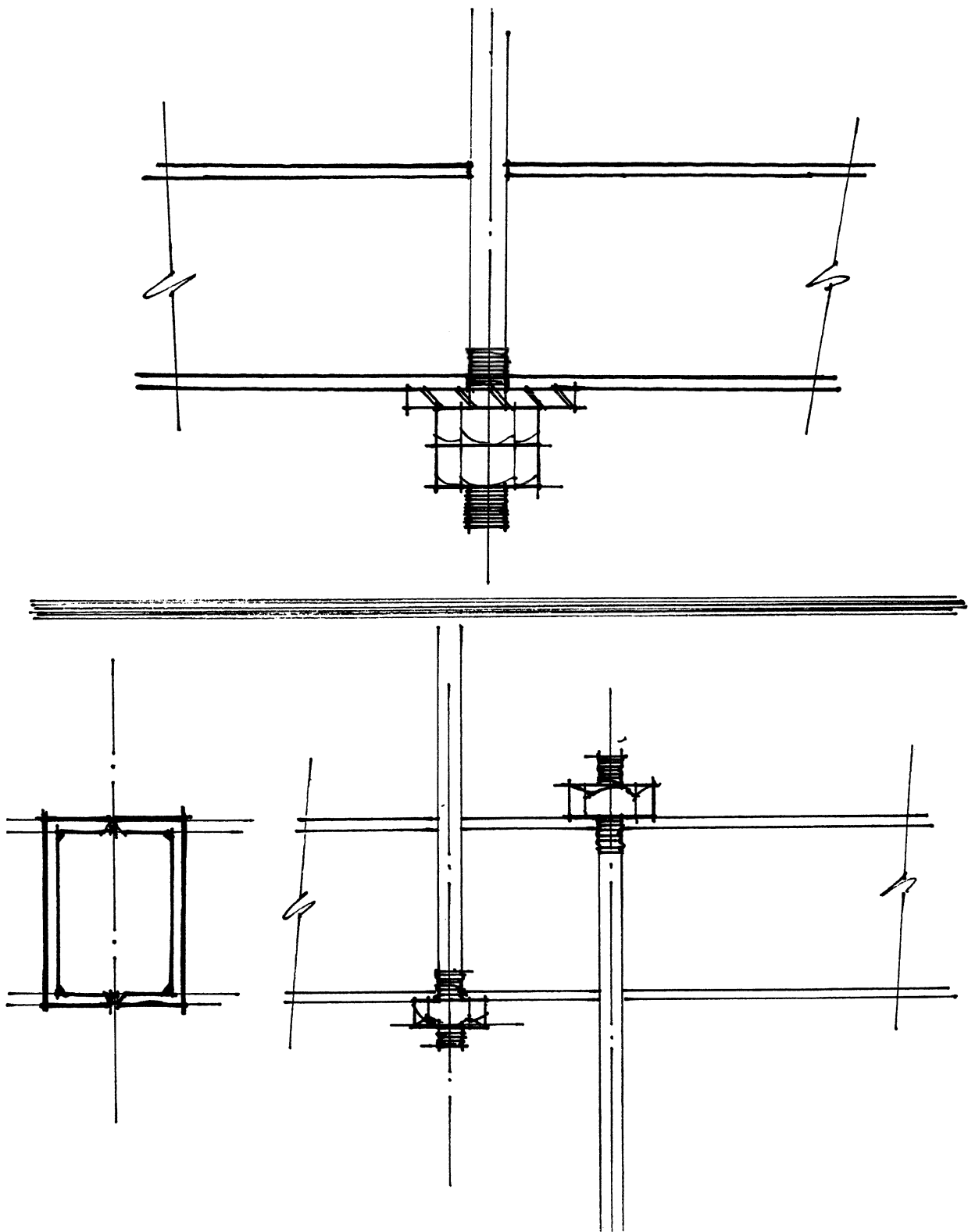

Fig. 10-4

Detail at another failure. Top is detail of hanger rod designed for hanging bridge in Kansas City Hyatt Regency Hotel- continuous rod with plates and nuts as shown. Lower the revised detail that failed- Back-to-back channels welded together used as beam failed when the separate rods broke the weld and the nuts pulled through leading to collapse and heavy lost of life.

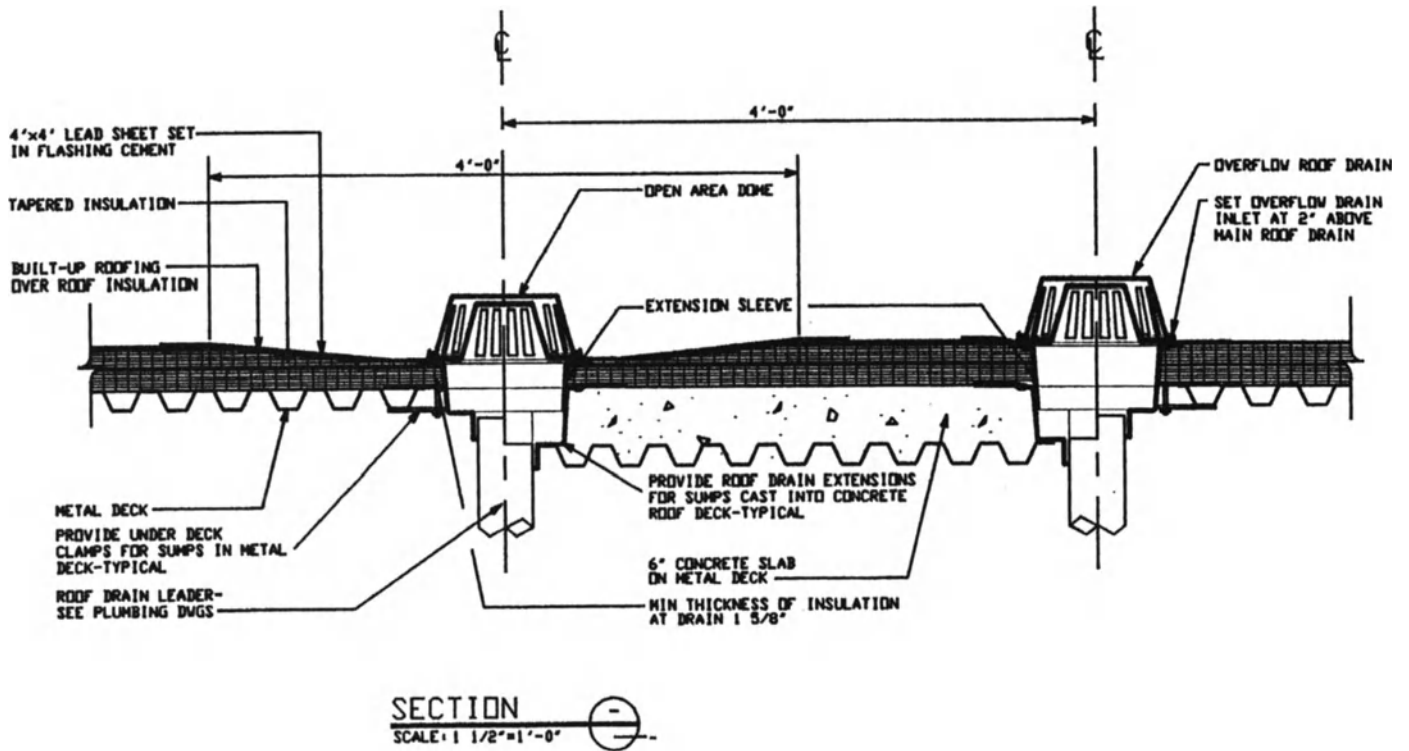

Fig. 10-5

Detail suffers from the small scale chosen; the "muddy" appearance of the roofing is a distraction that could have been avoided.

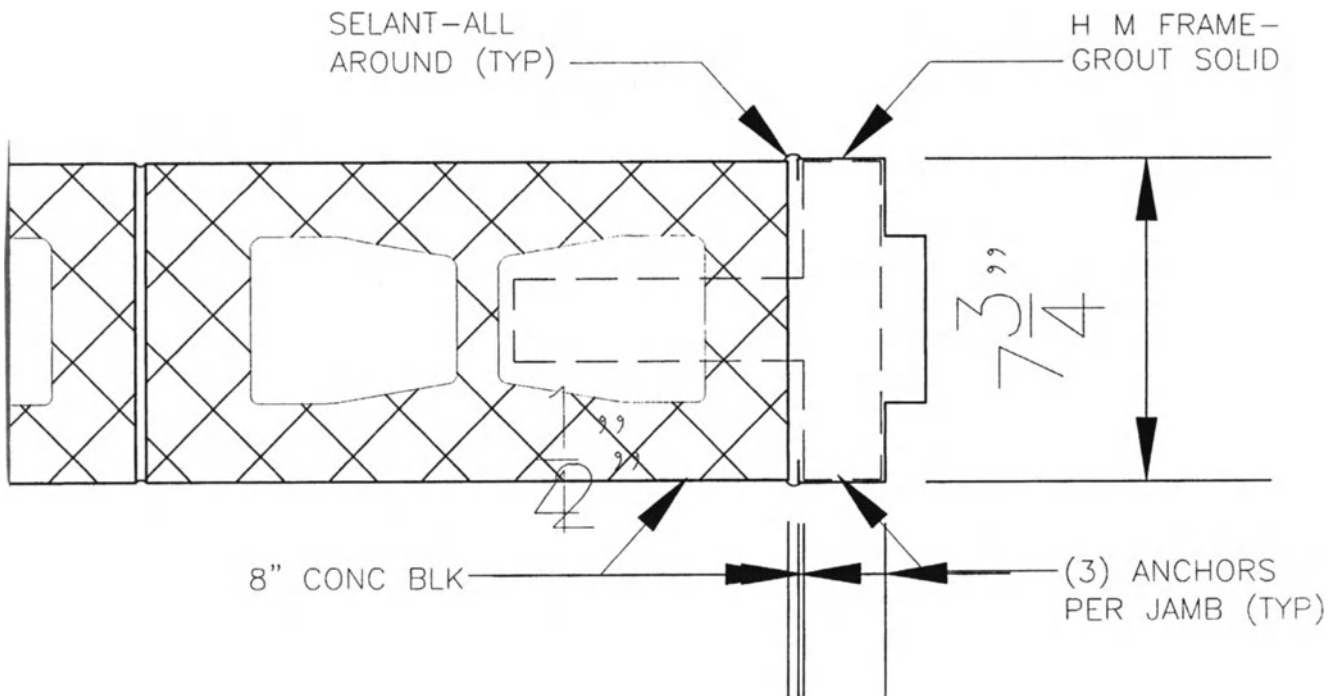
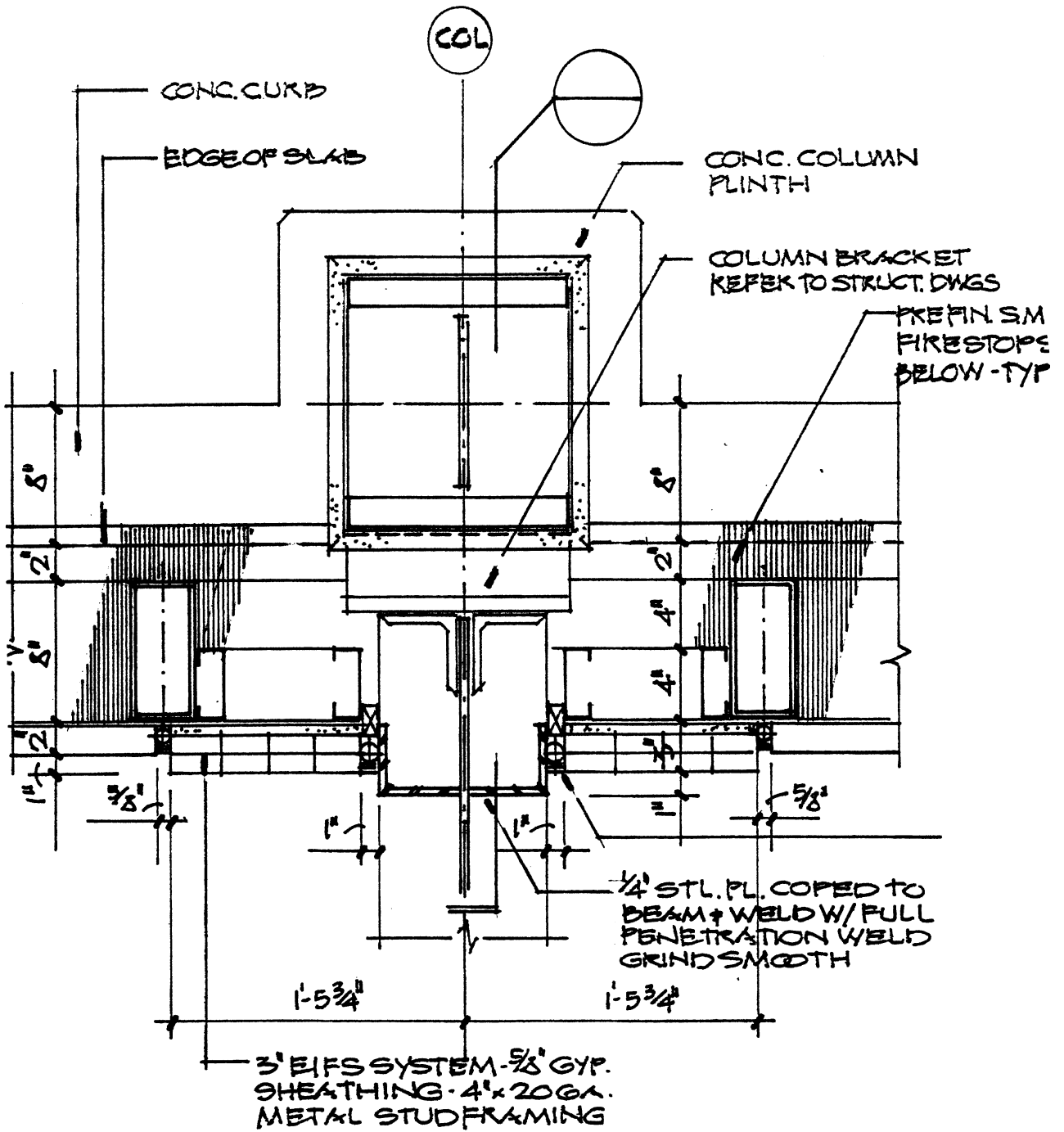

Fig. 10-6

This detail would be aided greatly by use of varied line weights. For example, the H.M. Frame, if darker, would better represent the thickness of the metal. And the outline of Conc. Blk should be darker than the material symbol used [but lighter than the frame]



PLAN DETAIL

1/2" = 1'-0"

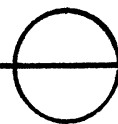

Fig. 10-7

The detail is of a bracket attached to a column into which a beam will be framed. Uses an unusual technique, where the series of line helps to define the vertical tubes involved. Those lines usually are used as a material symbol to indicate sheet metal in elevation— so use here is correct [detail in looking down onto the sheet metal] as noted, but also as a useful explanation.

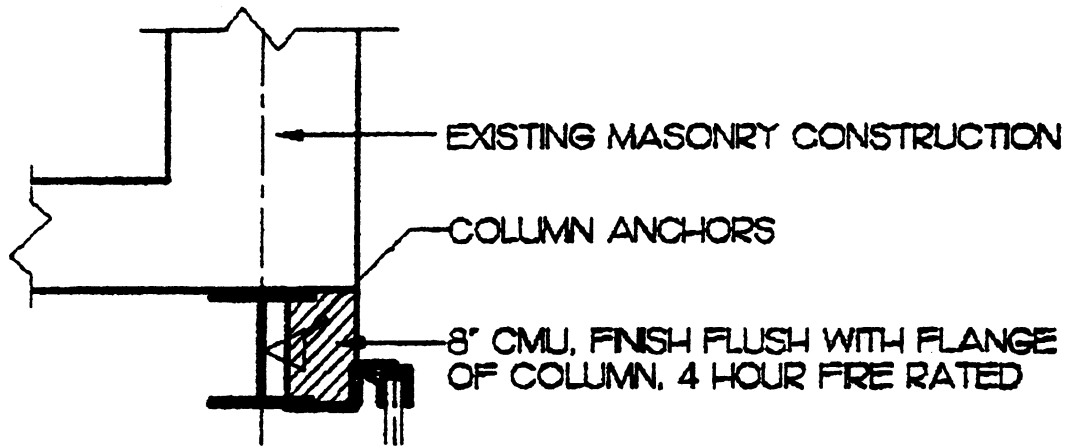

Fig. 10-8
Merely a problem of scale. Lot of information but difficult to read

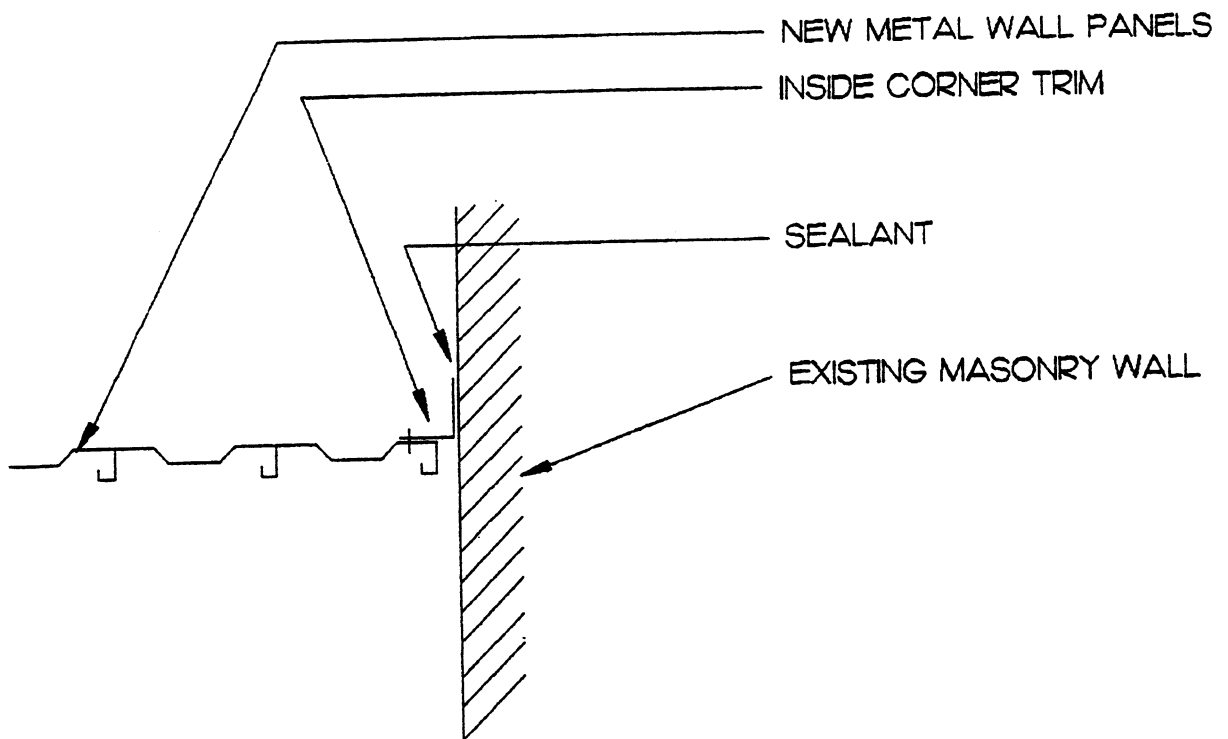

Fig. 10-9
Questionable detail- i.e., is it really necessary. Simply shows the trim between metal wall panels and masonry, and location of sealant.

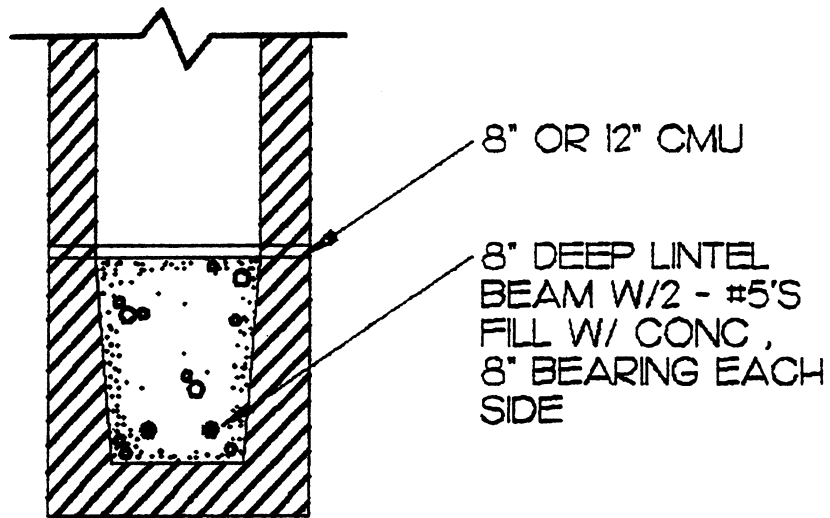

Fig. 10-10

Scale is a problem again, but here the material symbol hatching overwhelms the drawing improperly!
It is not the most important information in the drawing.

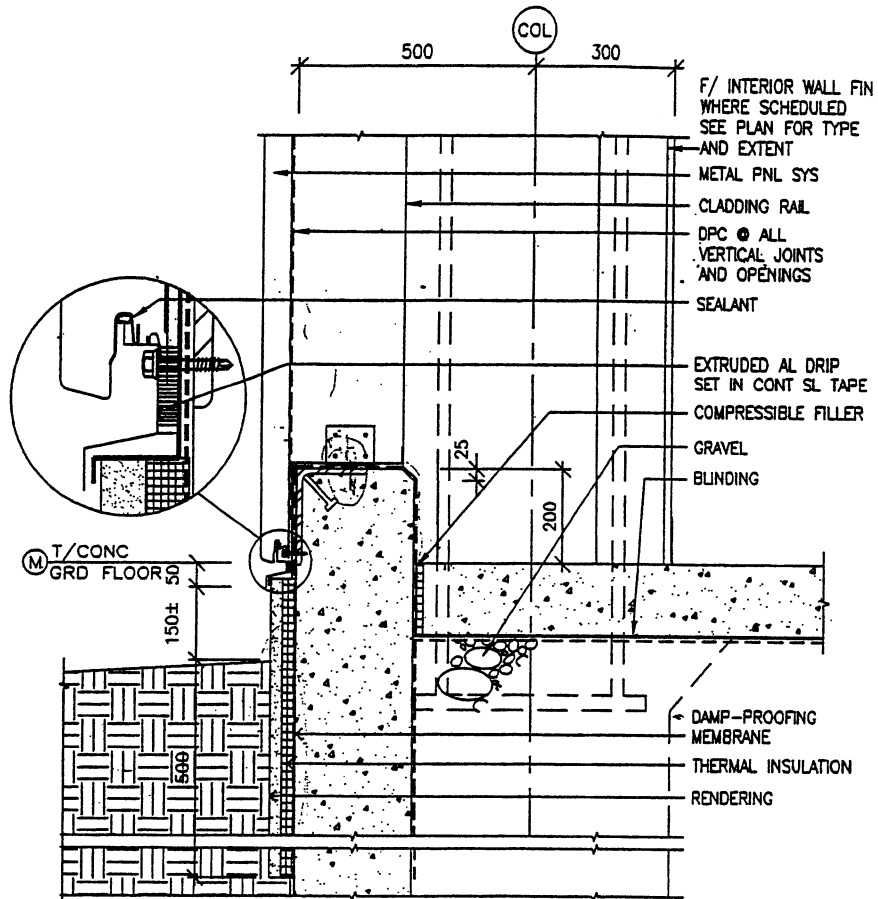

Fig. 10-11

Fairly good detail, overall, but well-conceived idea to "blow-up" the joint detail to a larger scale for readability and clarity

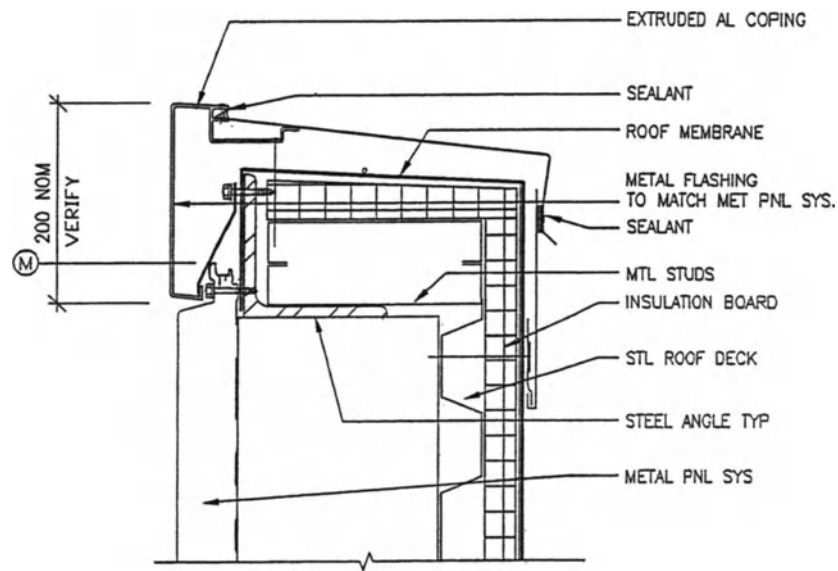

Fig. 10-12

Detail suffers from lack of varied line weights, but also note that what is called "Extruded AL Coping" in one note is called "Metal Flashing to match met pnl sys." in another [and note the leader line from this note through the entire drawing to the point of application- not good]

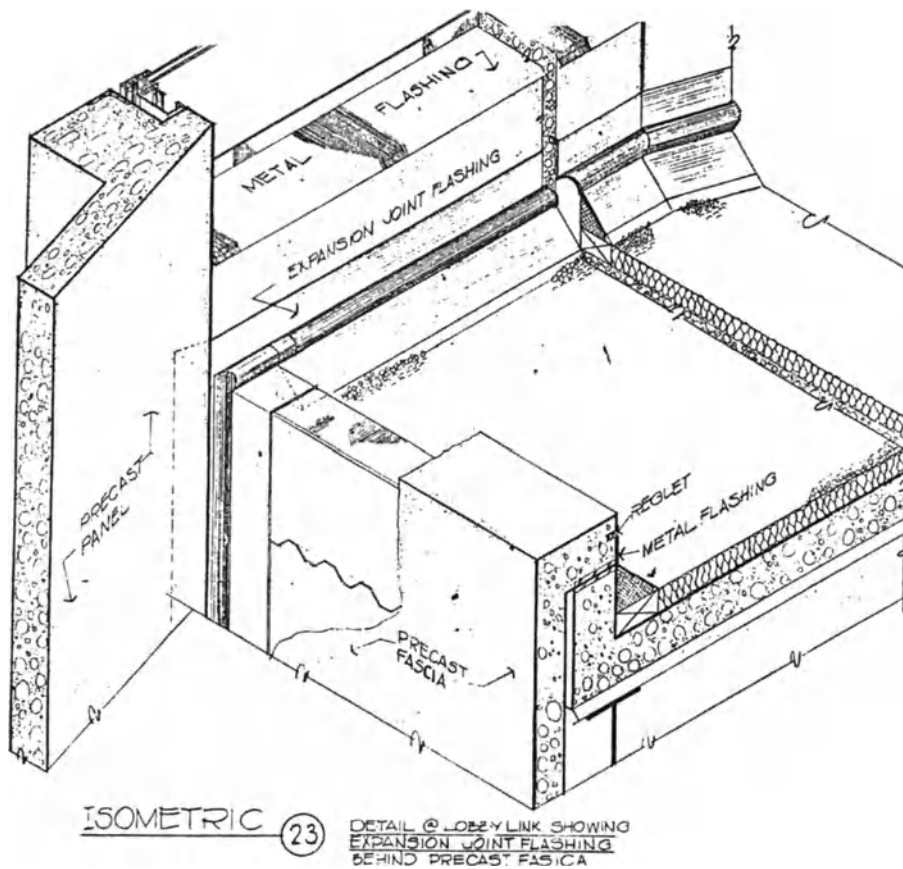

Fig. 10-13

Isometric projection of a detail. Often used in more complex situations for the sake of easier readability and clarity in the parts and interrelationships involved- and where 2-dimensional drawing is not able to do the job

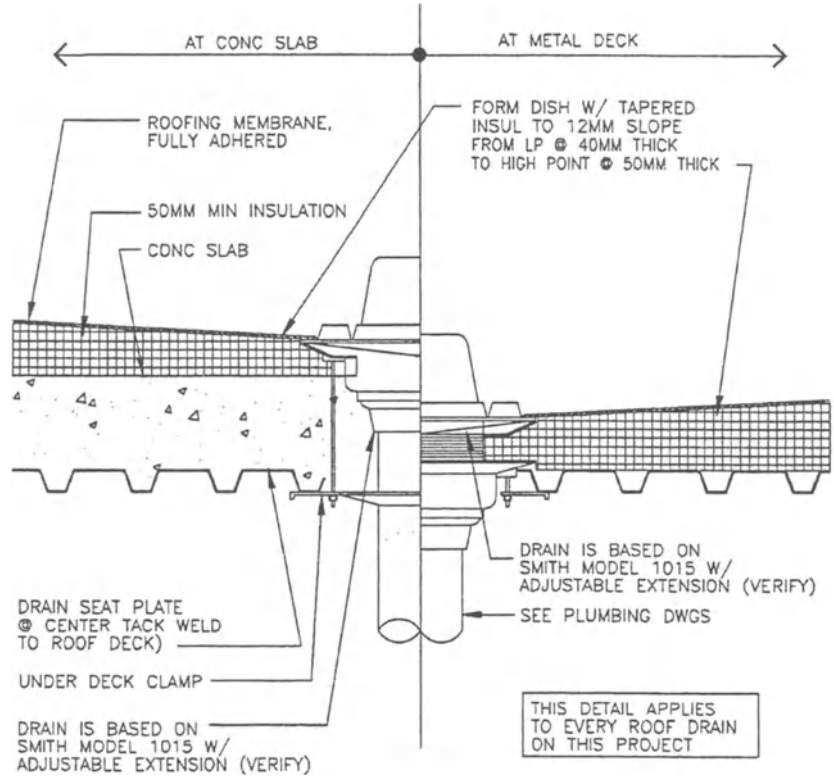
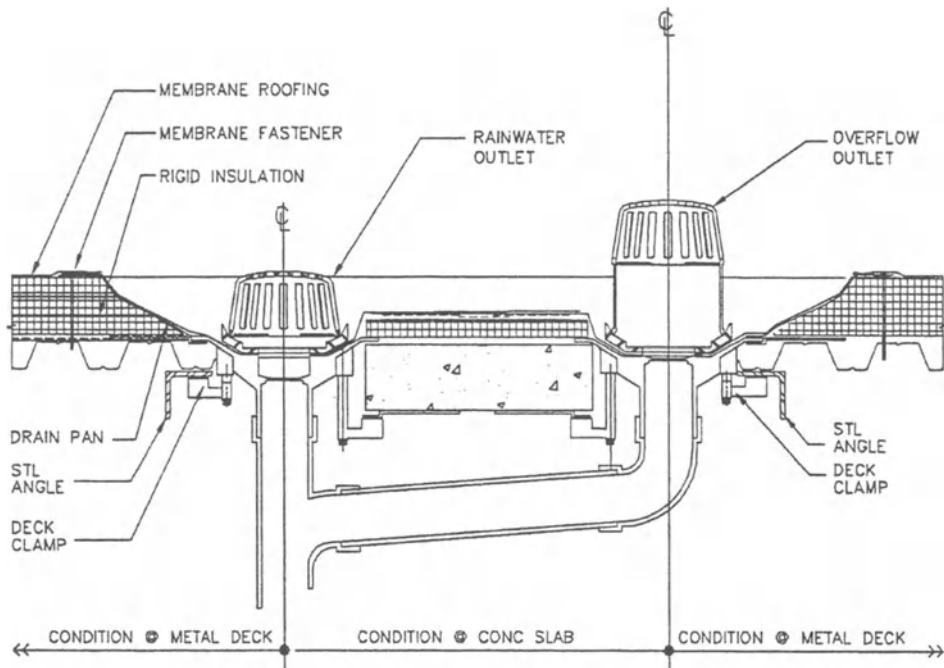

Fig. 10-14

Details that show differing conditions, one from another.
 Good idea, but does require all viewers to understand the direction of the drawing and the several variations involved

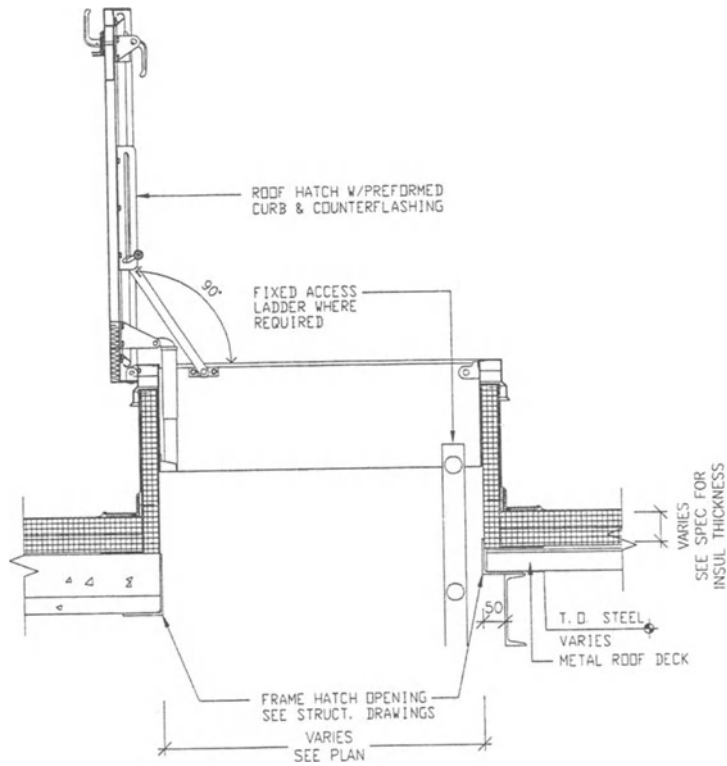

Fig. 10-15

Good detail, overall, but excessive in showing the hatch handle, hinges and other features—the detail is really about the curb and its fit into the roof work and opening

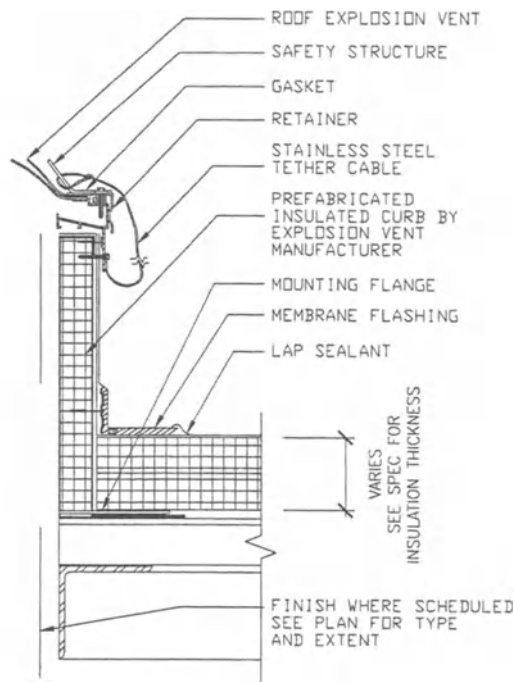

Fig. 10-16

Explosion vent detail that misses the point slightly. The important part is the connection of the vent to the curb [where a larger scale would help readability and understanding]

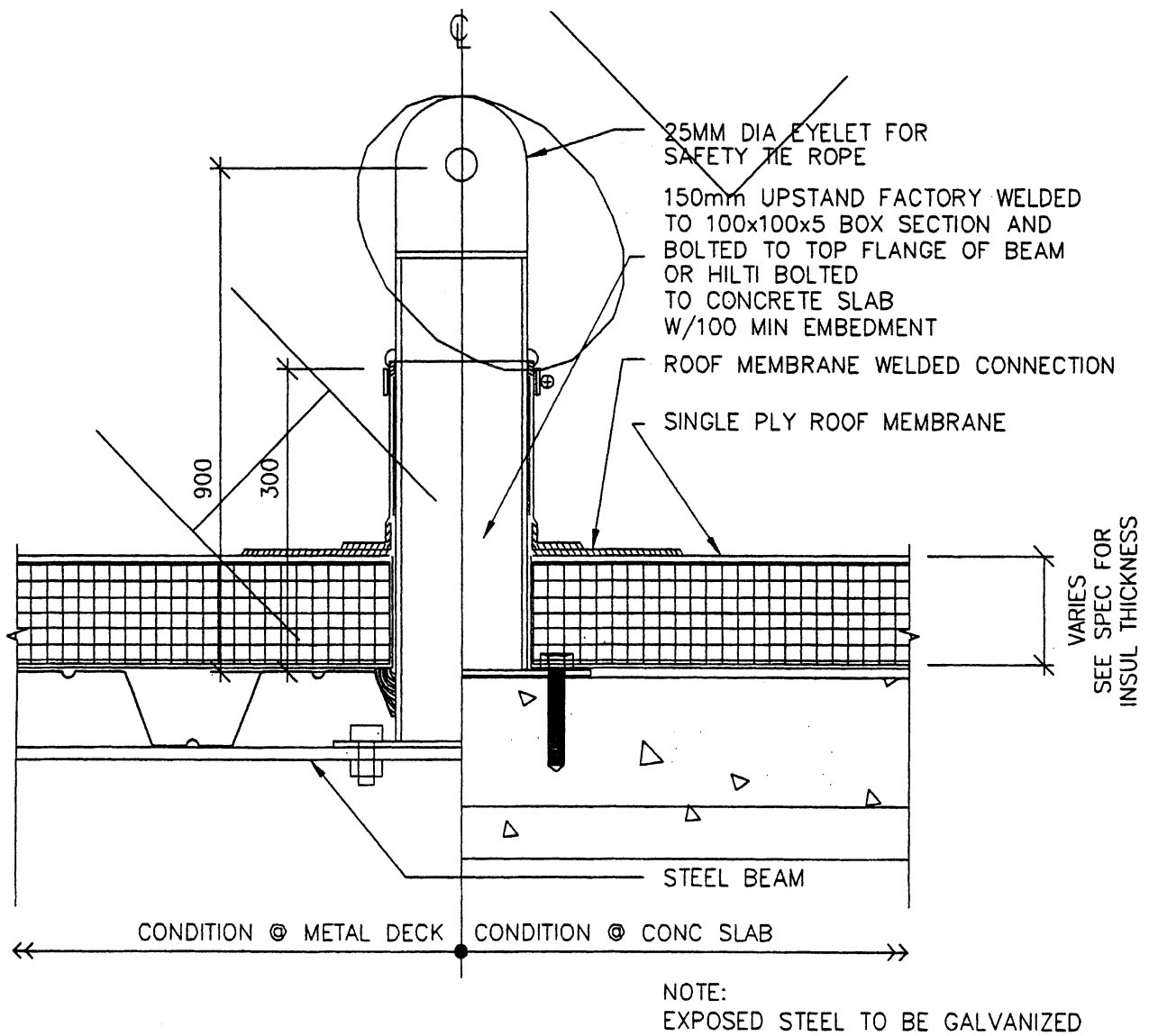
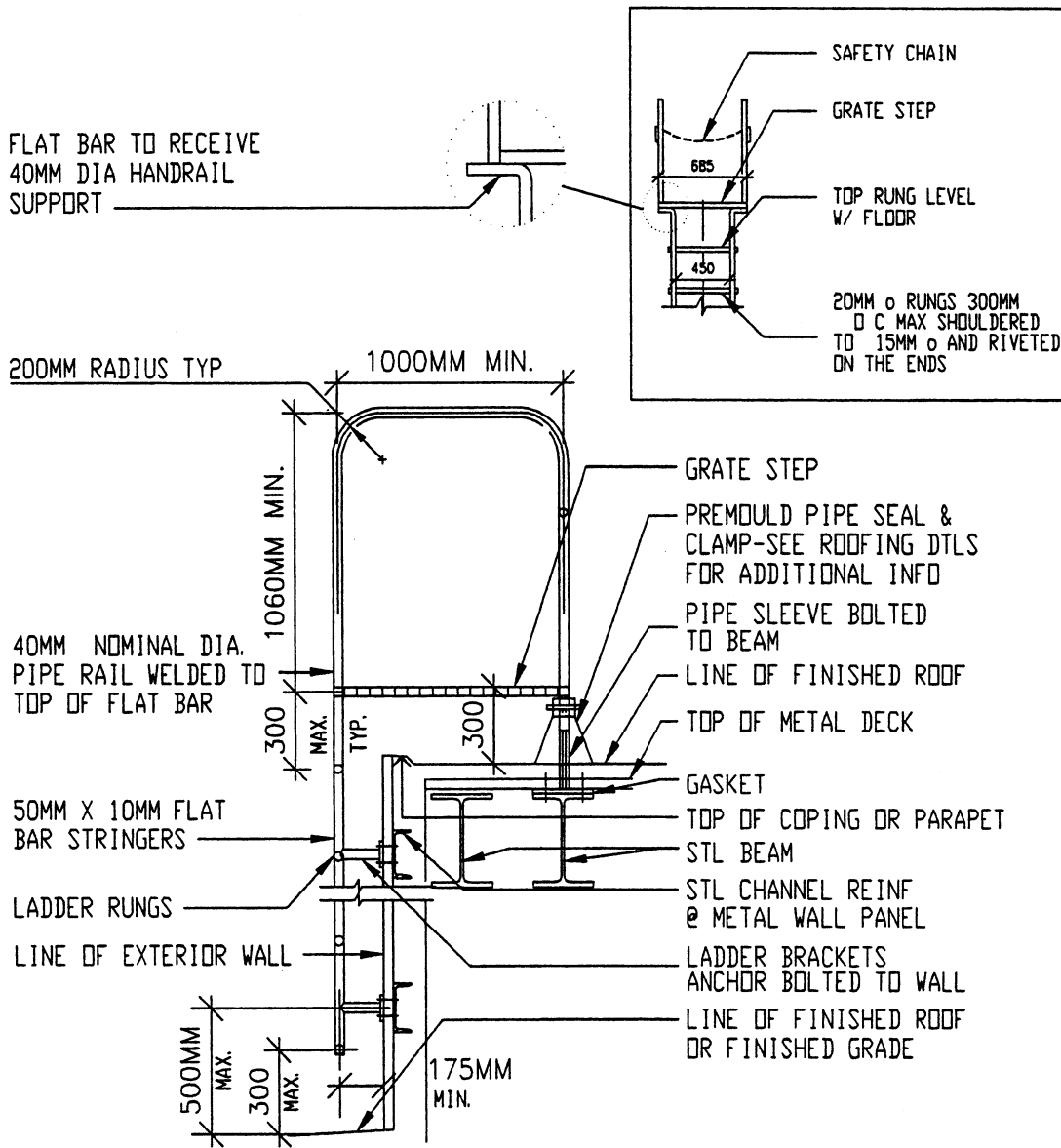

Fig. 10-17

Eyelet detail at varied conditions, but showing some work [undefined] that is over-detailing and needless. Unsure what the crude oval has to do with the drawing.



NOTES

- 1 CHECK PARAPET HEIGHT & DISTANCE TO ROOF. IF GRATE STEP HEIGHT EXCEEDS 300MM FROM ROOF LEVEL ADD ADD'L RUNGS TO ACCESS ROOF.
- 2 VERTICAL FOR RUN LESS THAN 6000MM
- 3 EXPOSED STEEL TO BE GLAVANIZED

Fig. 10-18

Details in need of better line definition. Also text almost overwhelms the drawing [too large]. Good to relate upper left detail to one in upper right, but is weakly done. Note misspelling in Note No. 3. Approaches being a standard detail

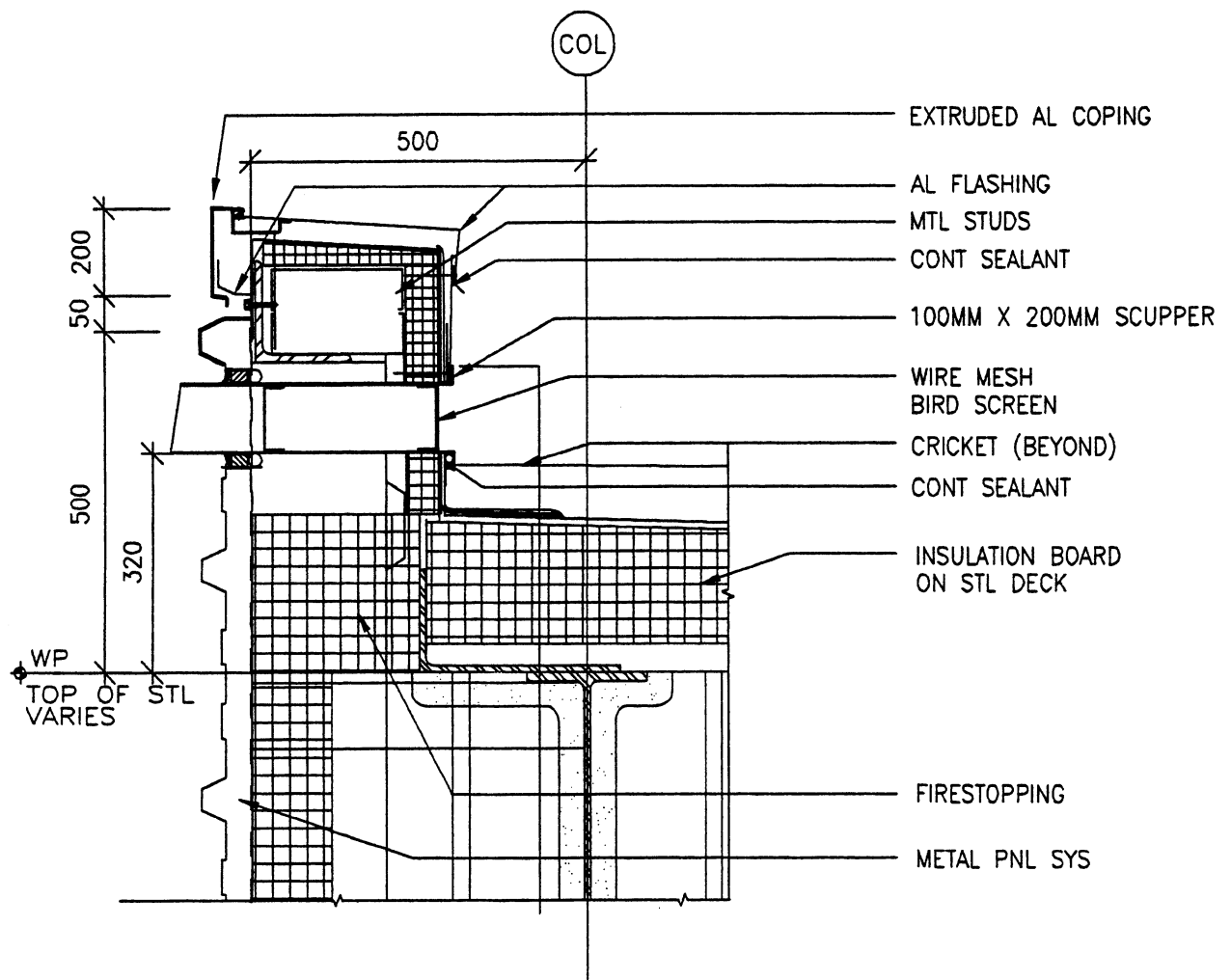

Fig. 10-19
Scupper detail with a lot going on, but somewhat murky because of the strong material symbol.
Parts of construction need to be stronger than that symbol for clarity

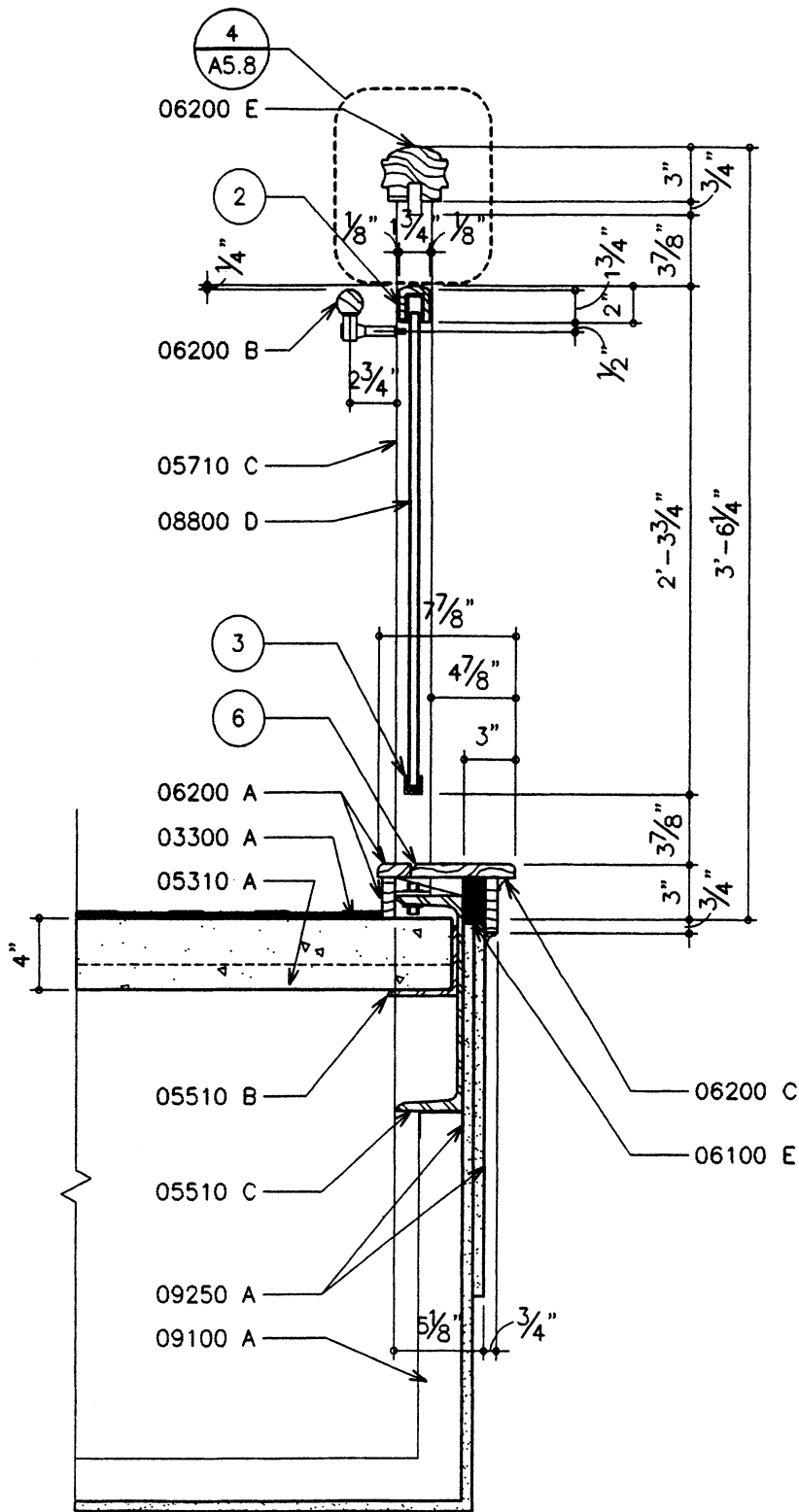

Fig. 10-20

Detail utilizing 2 types of keynotes: the circled numbers indicate notes that are included on the drawing sheet [usually these notes apply to several details and locations on the sheet. The 5-number and letter indication are keynotes that refer to information in the numbered specifications Section where the item/material is identified and described. The merit and use of this system is usually an office-by-office decision attuned to the practice and type of work involved. Also, noted cross reference [at the top of the detail] to a larger detail of the wood handrail

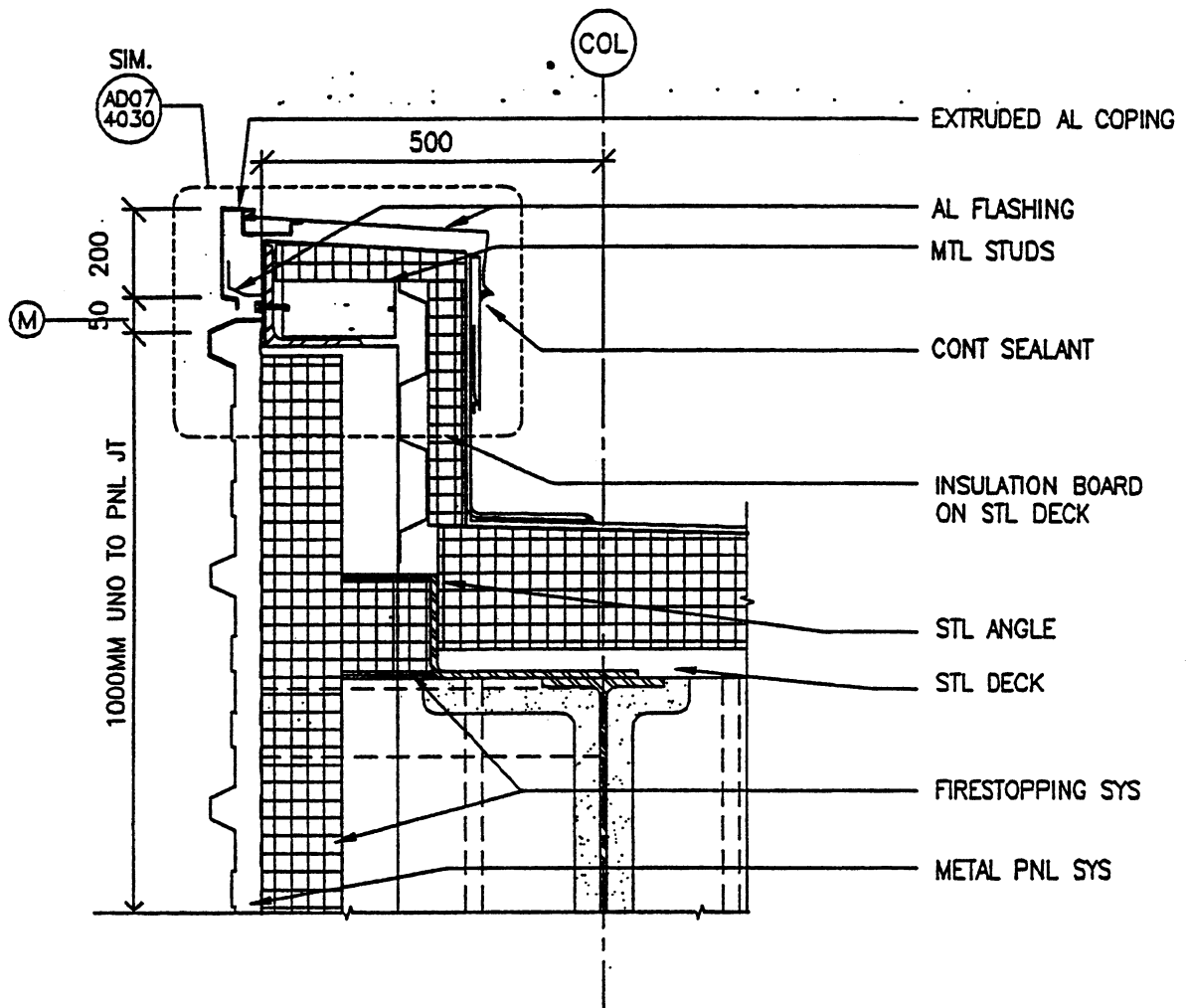

Fig. 10-21

Detail which uses a dotted reference box to refer the viewer to another detail of a more limited area of the construction-- good cross-referencing

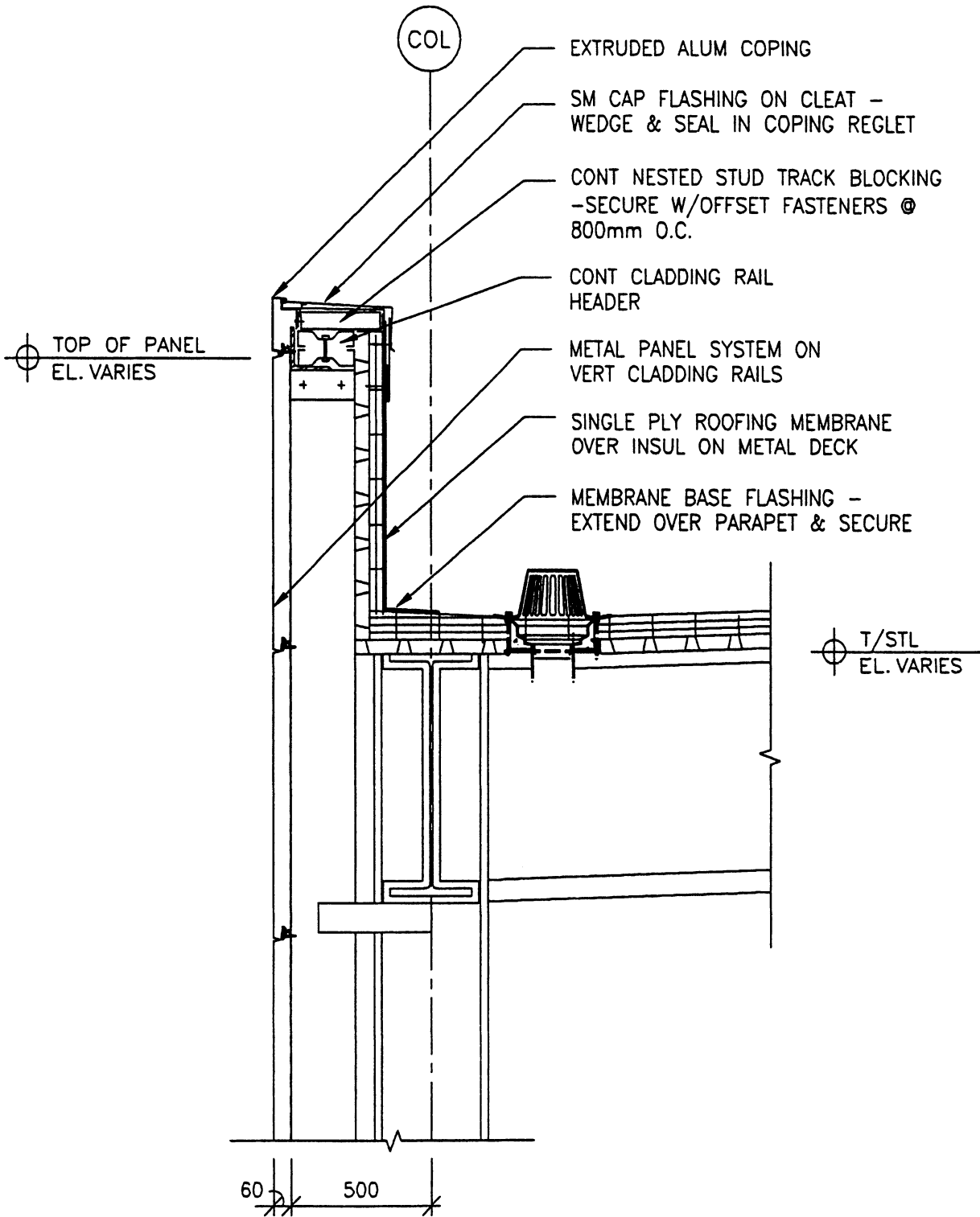

Fig. 10-22

Here it would have been better to delete the lower half of the drawing [useless] and increase the scale of the upper half for better reading—choose area of details with care

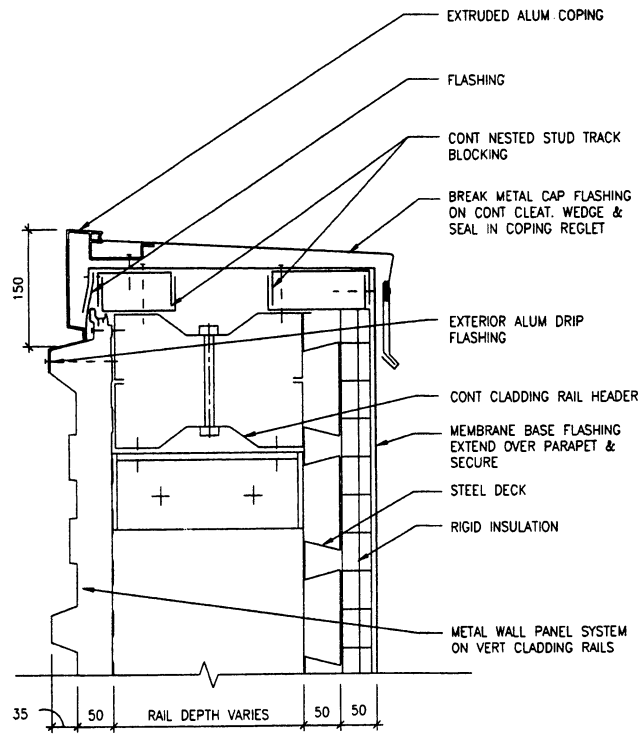

Fig. 10-23

Blow-up on coping detail from Fig. 10-22. Cross-reference would be helpful to interrelate the drawings.

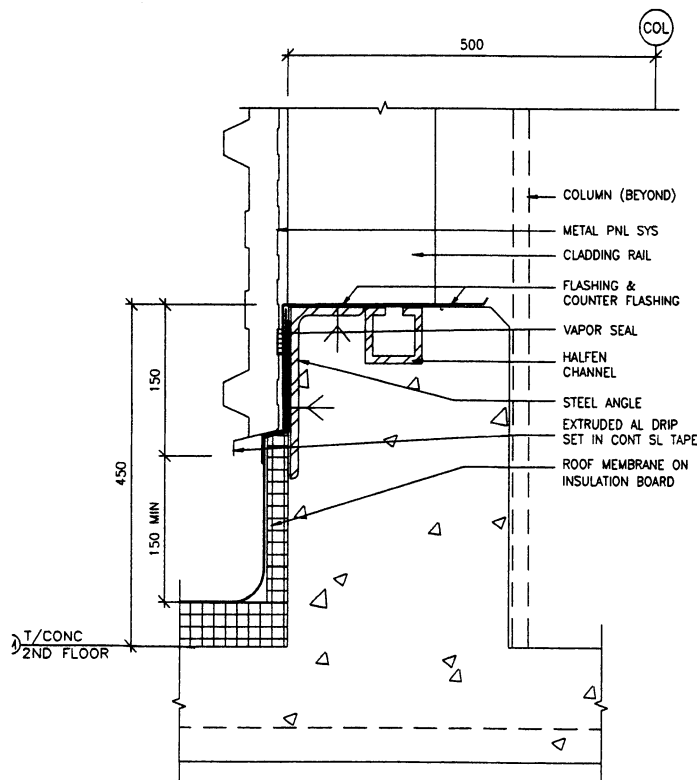

Fig. 10-24

The multiple layers of material on the curb [left face] needs better definition through use of larger scale drawing [for clarity]

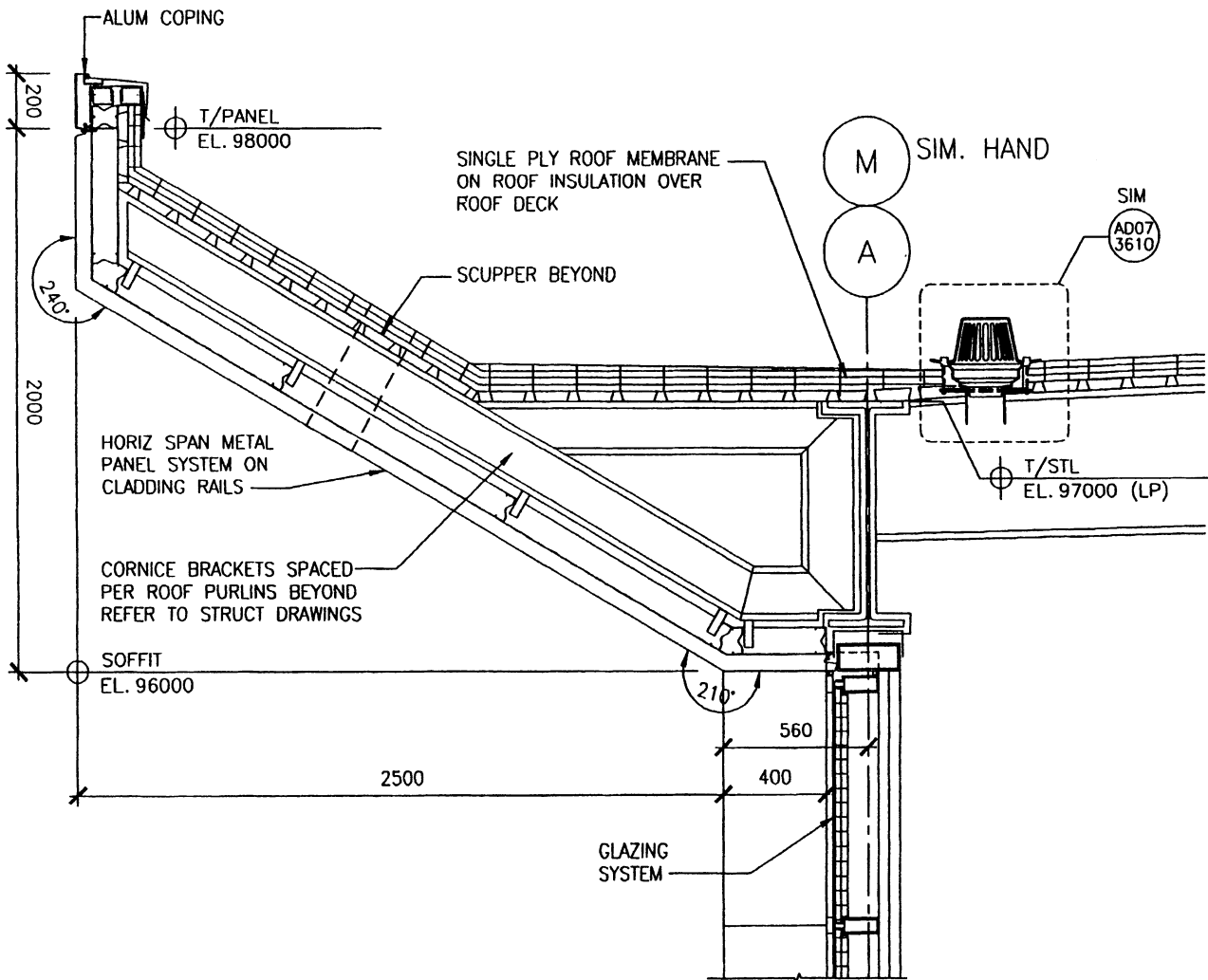

Fig. 10-25

Detail with a lot going on—note reference to other drain detail. Note similarity of Alum Coping to Fig. 10-23. Would have been a good idea to include scupper detail in lieu of reference to its location “beyond” [questionable reference]

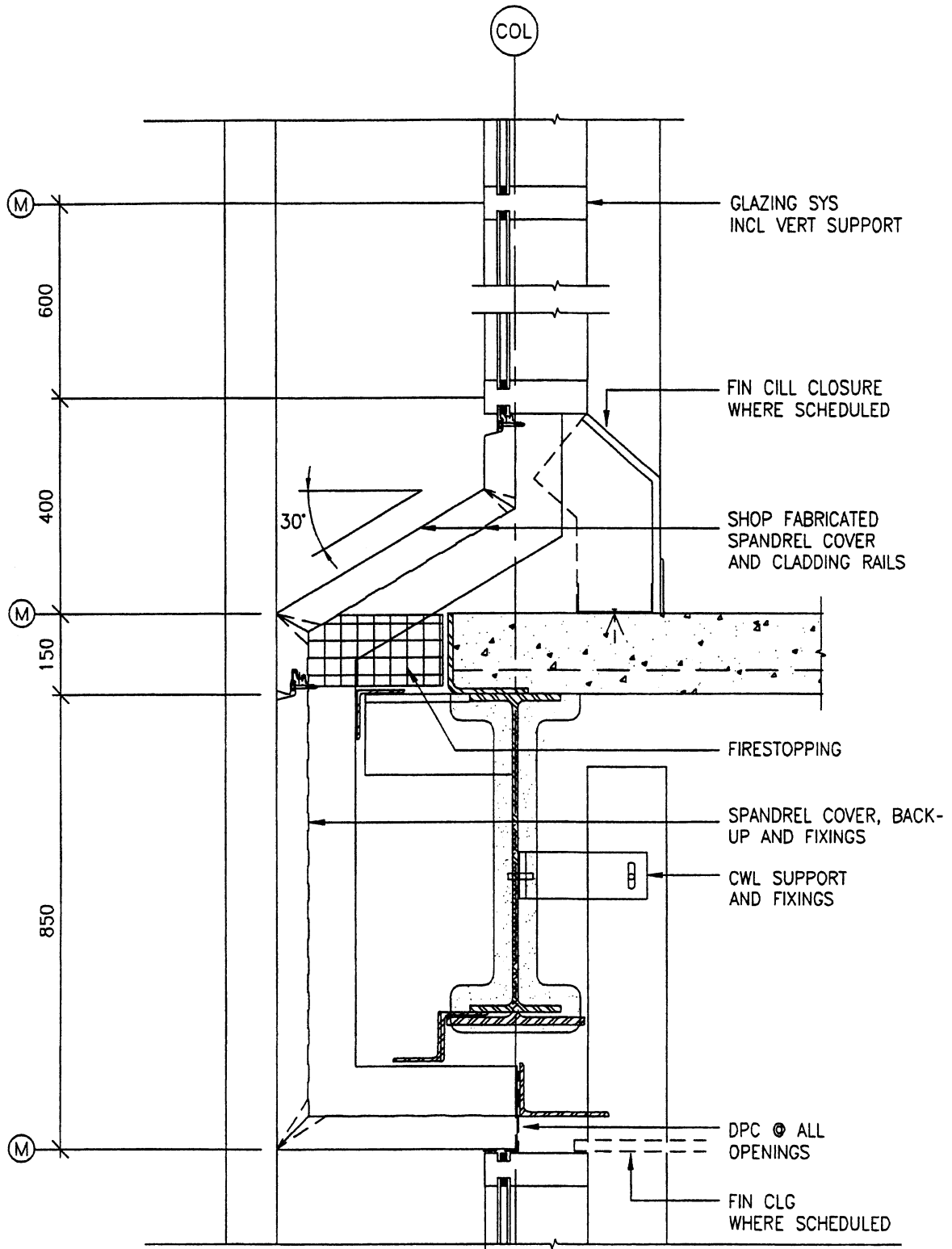

Fig. 10-26

Overall rather weak detail. Line work too light [does not well define parts].
Note that "Glazing Sys" is made up of hollow tubes that have more than a lie width thickness [better to show this for definition]

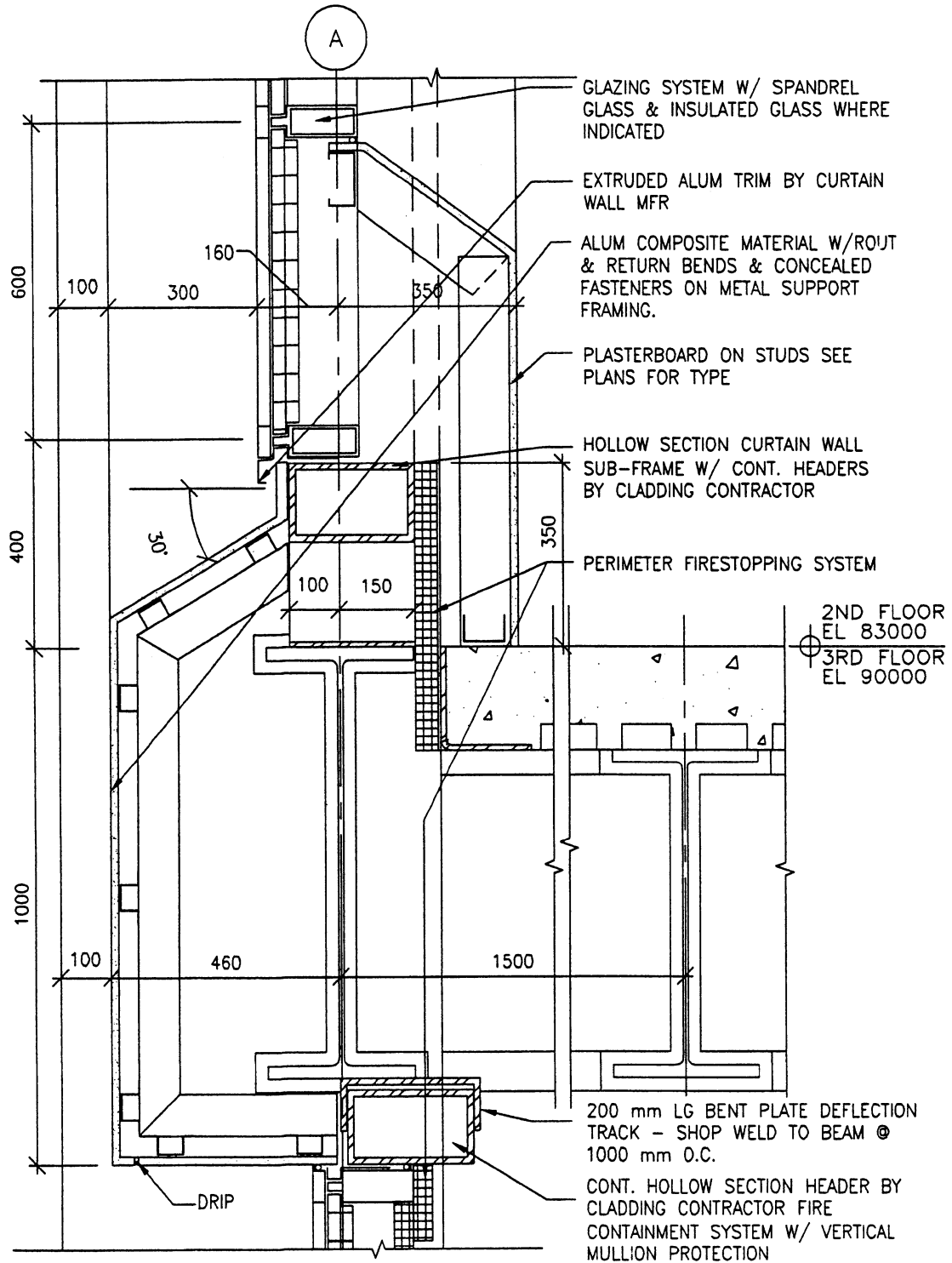

Fig. 10-27

Fair detail but would be far better with more varied line weighs which define edges of parts. Use of long leader lines from notes to point of application is distracting and confusing [relocate the notes]

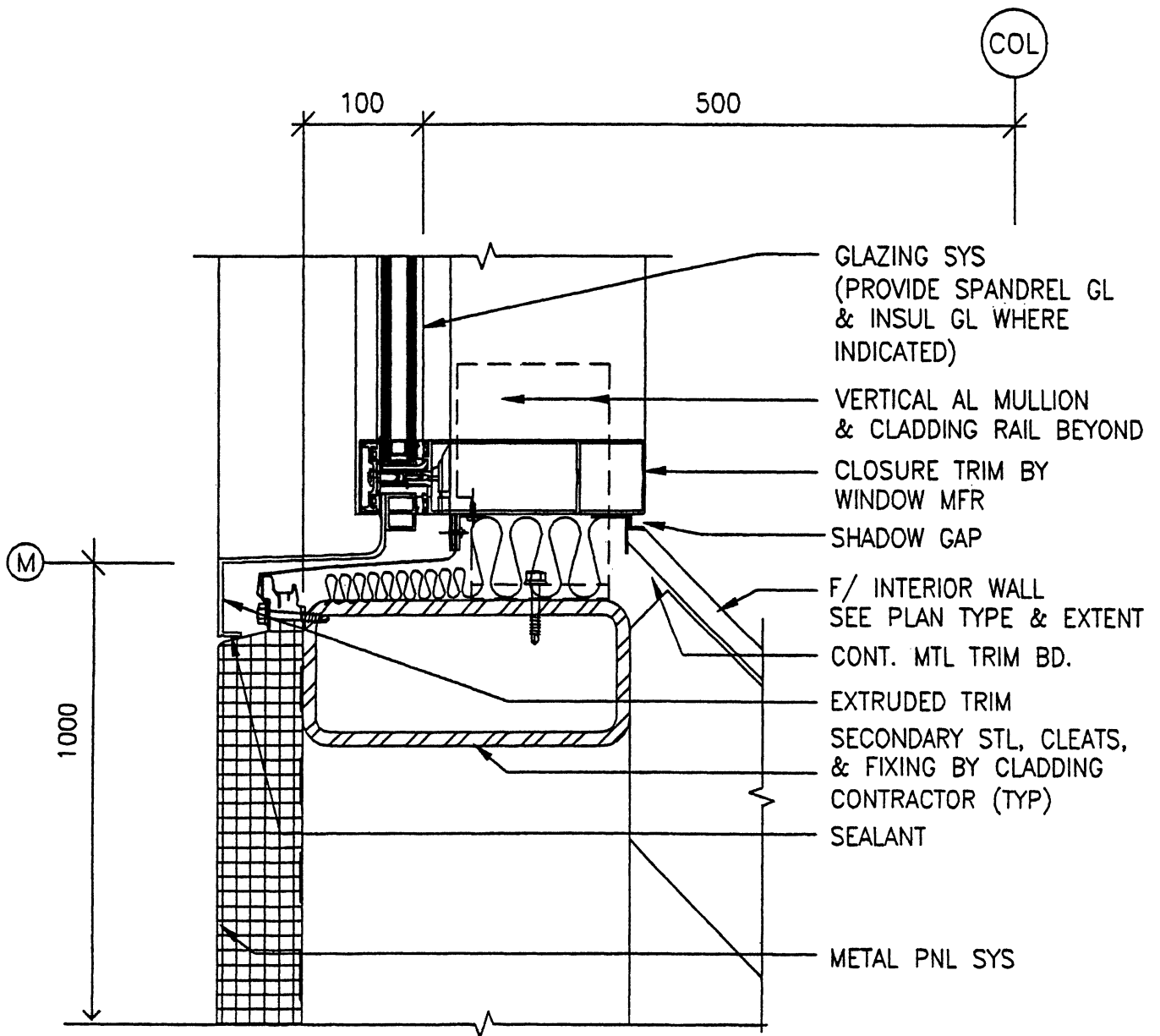

Fig. 10-28

Is the insulated glass unit [shown in the darkest work] really the most important part of this detail? No! Other parts and relationships need better definition

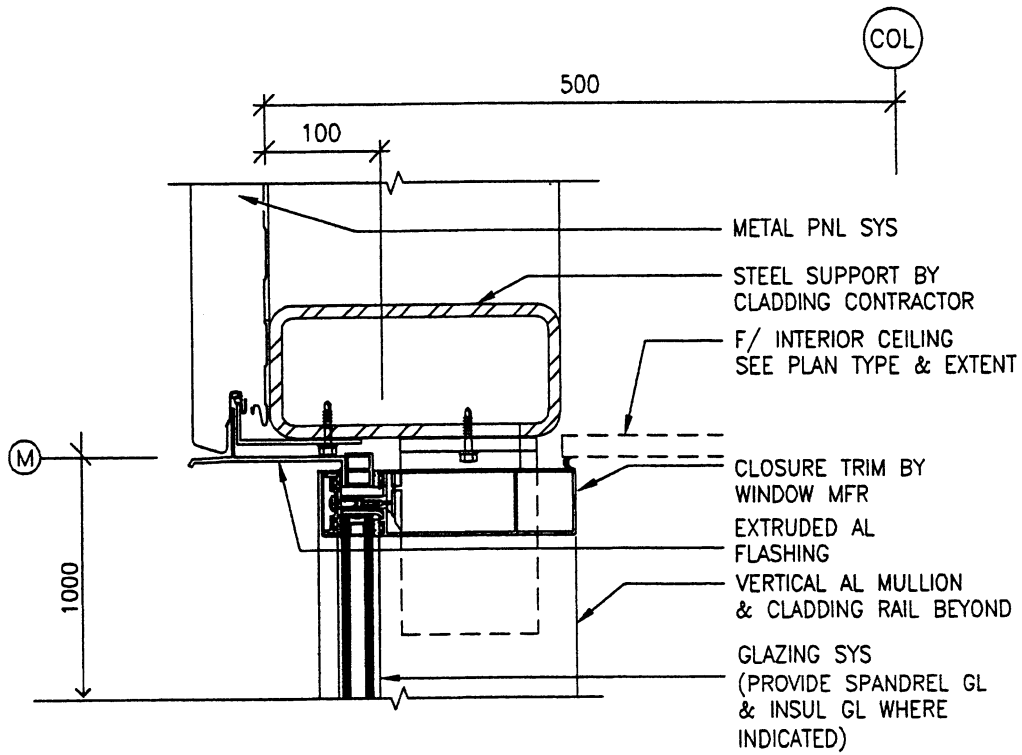

Fig. 10-29

Again, what is important her and worth spending time on? Surely not the glass unit, nor the threads on the fasteners!

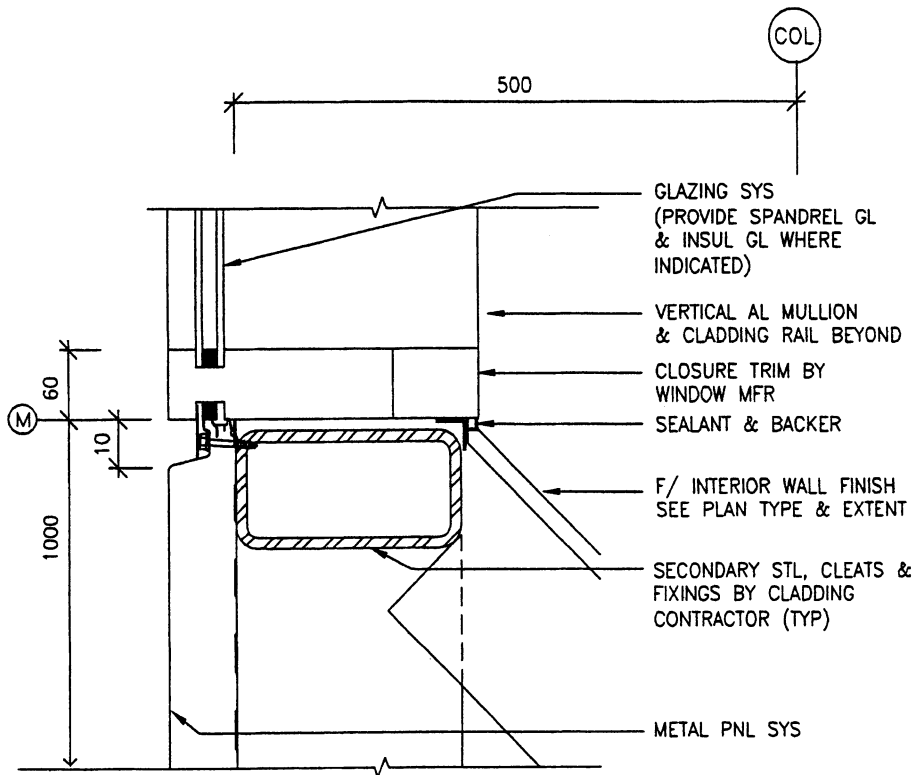

Fig. 10-30

Detail really suffers from use of single line to show items with thickness and the lack of identifying the significant parts [horizontal glazing tube, for example]

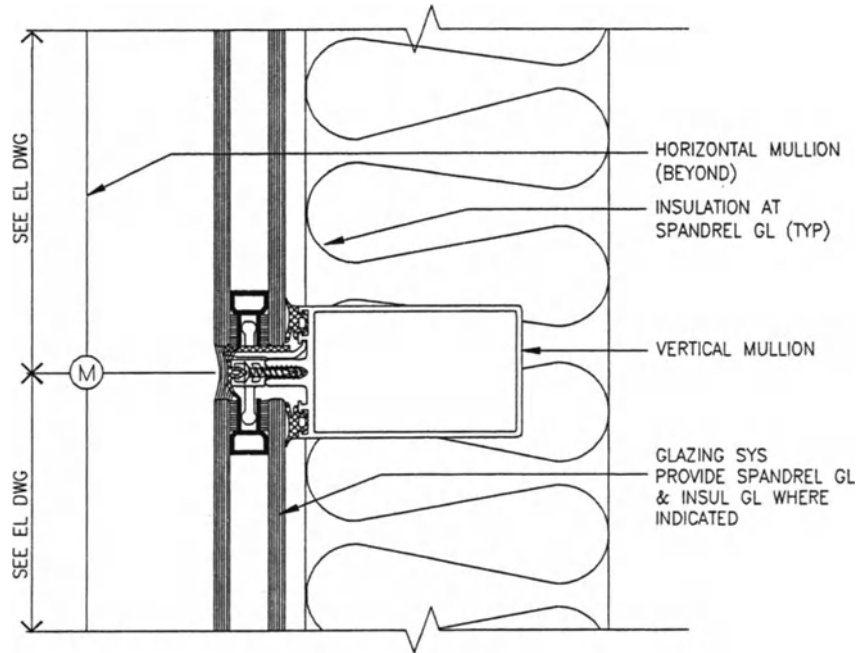

Fig. 10-31

Lot of work for no good return! Material symbols overwhelming and needless showing of threads, hatching in gaskets, etc.
The real story is the mullion, the fitting to it and the cover over the fasteners

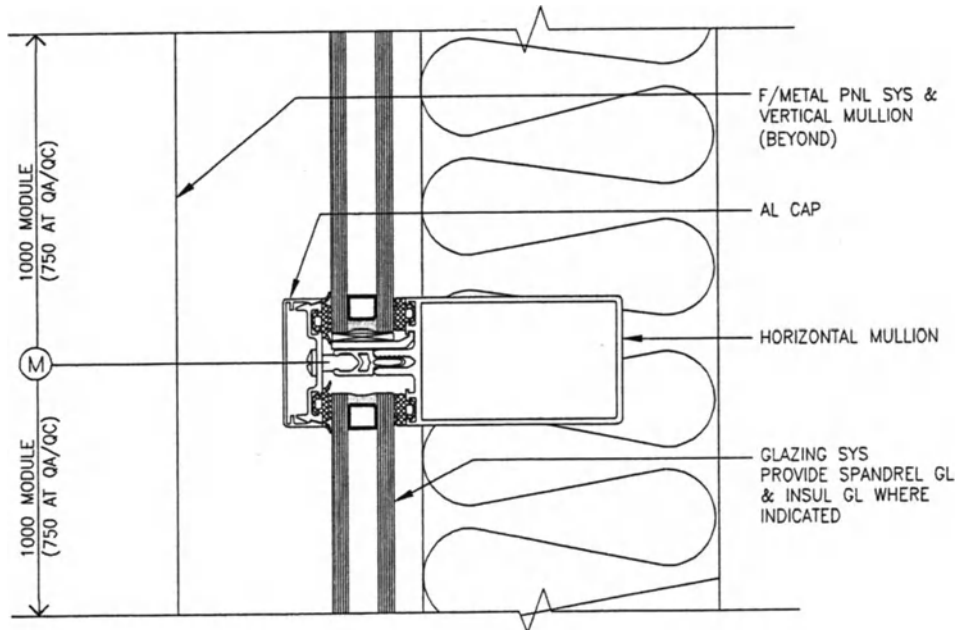

Fig. 10-32

Similar to Fig. 10-31, but with better system [mechanically] and less harshness in the line work [still needs adjusting here for even better reading]

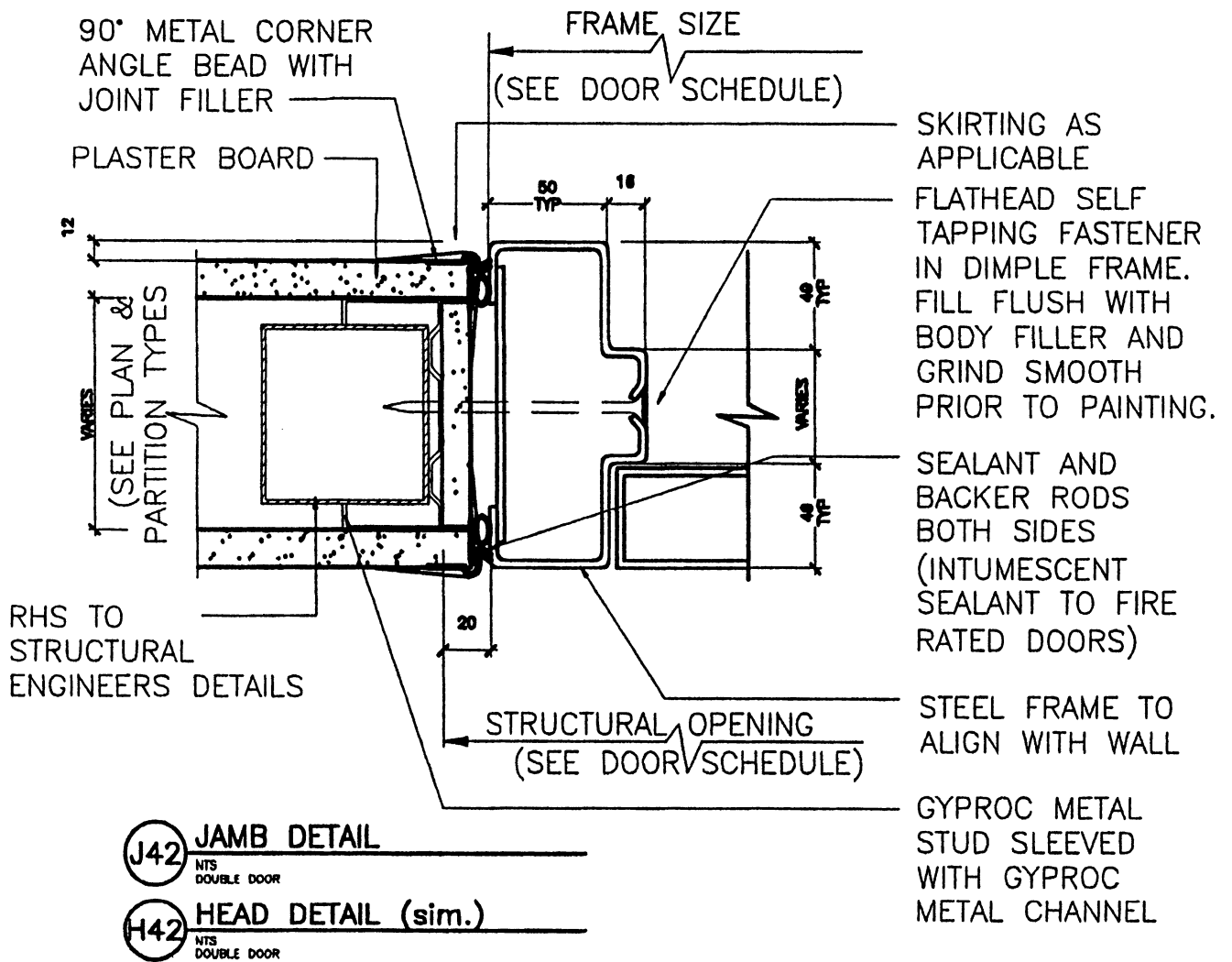

Fig. 10-33

Fairly good detail, but edges of plaster board are too dark as are the sealant and backer rod areas [isn't the structural member more important?] Text size too large for drawing. Note detail is used at both Jamb and Head of openings

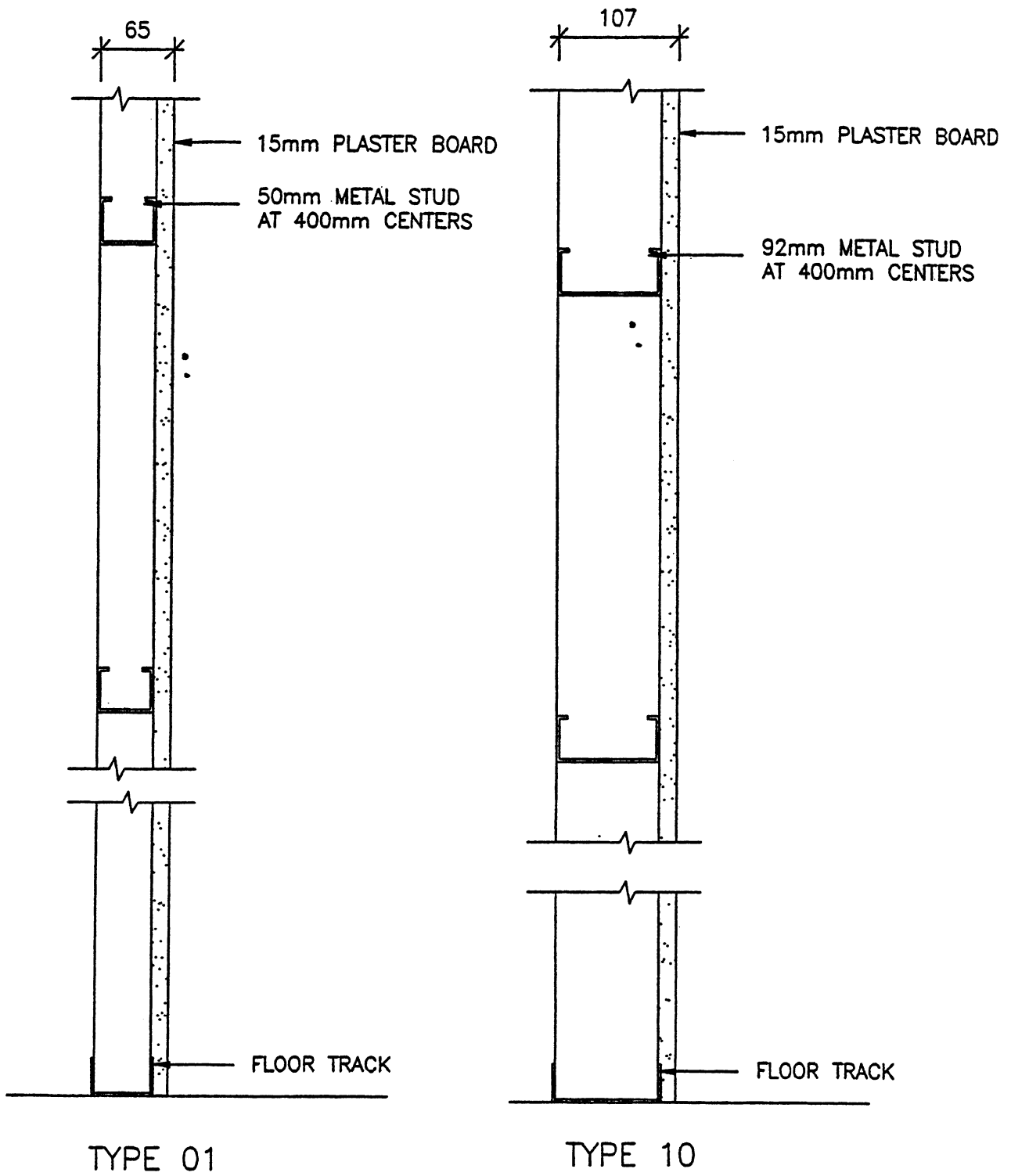

Fig. 10-34

Why? Question use of these details— and if deemed necessary surely can eliminate the area between the lowest upper notes and the floor track notes.

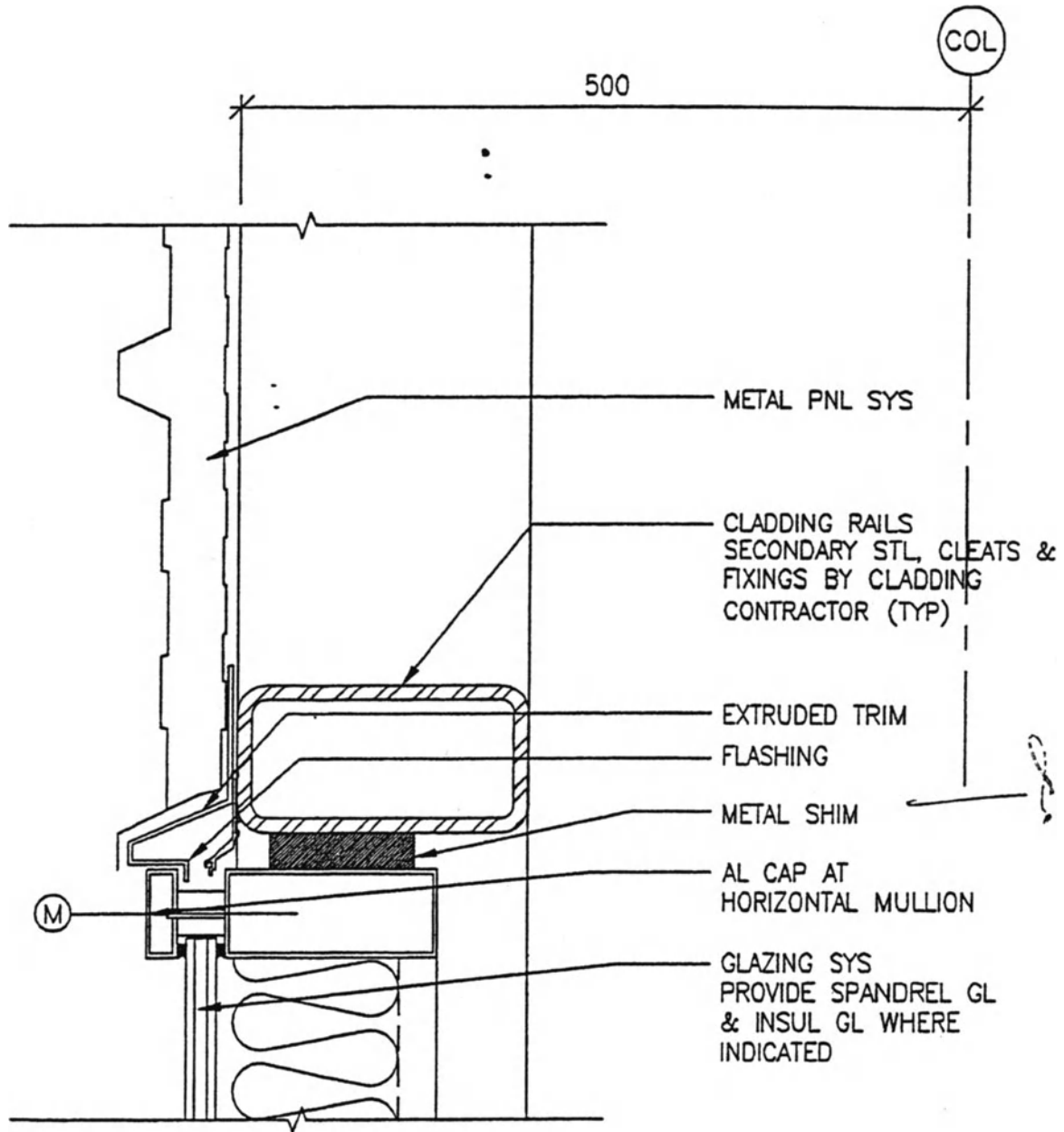

Fig. 10-35

A metal shim detail? Is the reason for this detail merely to show the shim? If so, question that decision

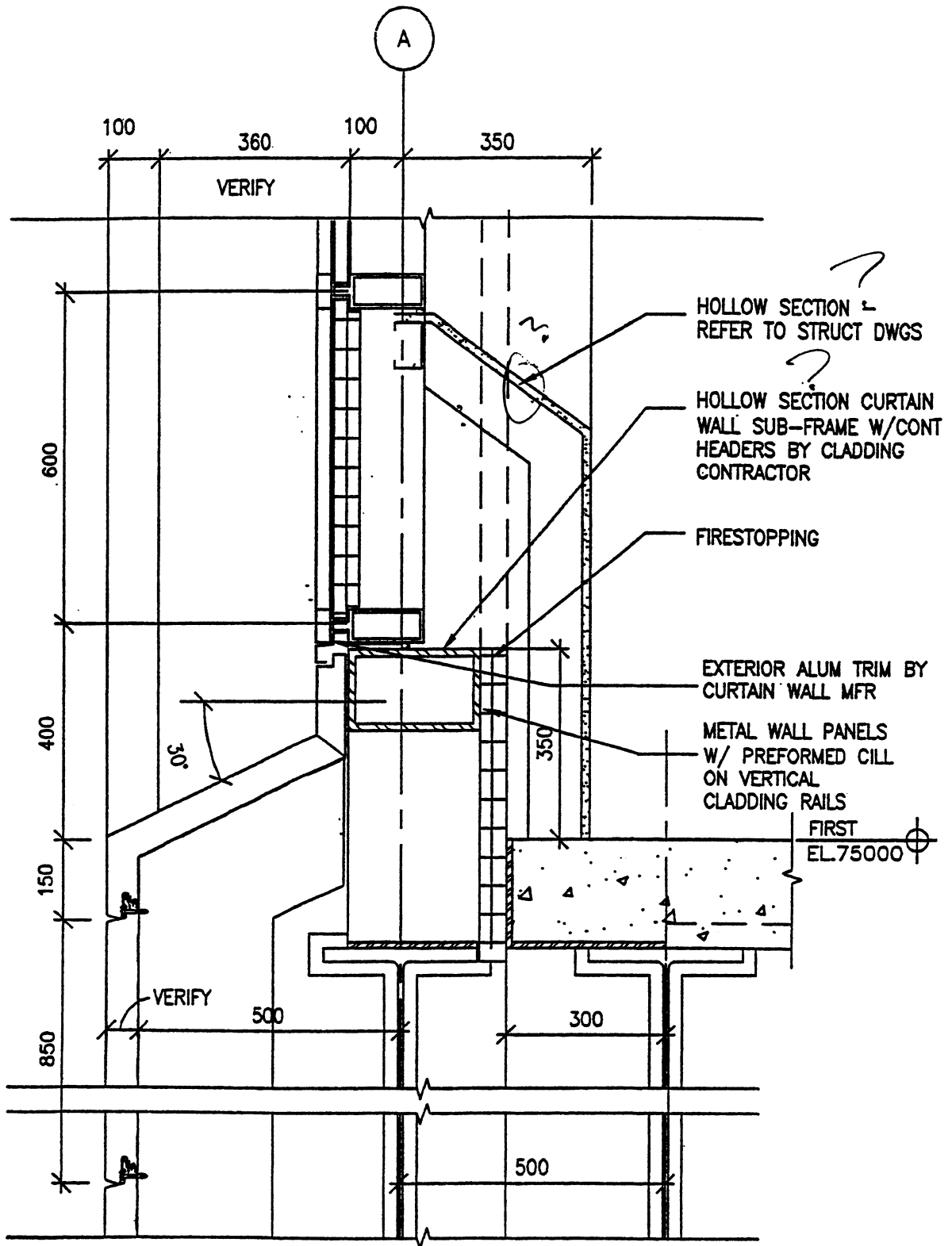

Fig. 10-36
Detail in question due to lack of clarity between notes and graphic drawing

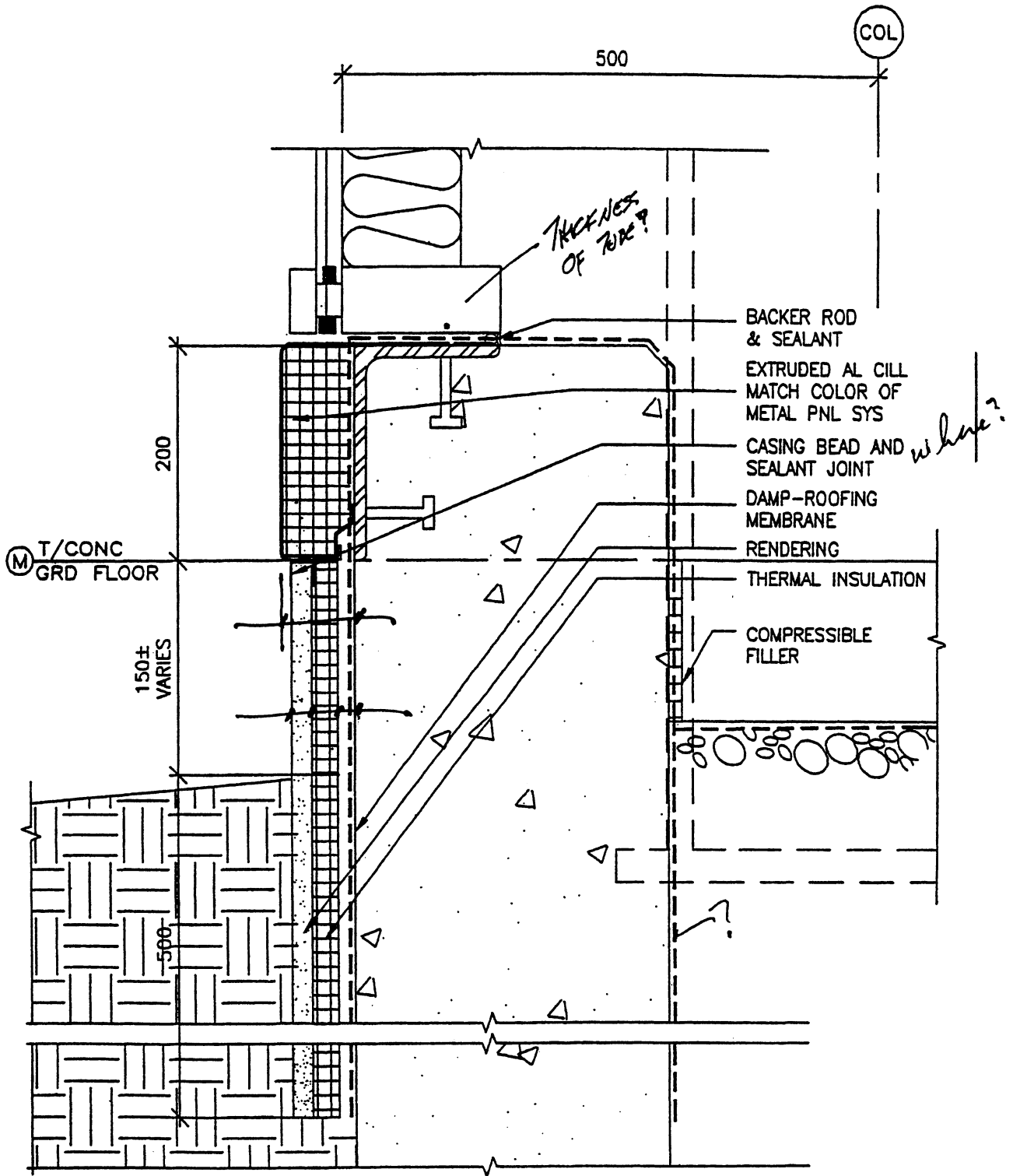

Fig. 10-37

Detail dominated by material symbols and long leader lines to the point of being distracting. Lot of work done for no good purpose while other more important parts are left with grave weaknesses

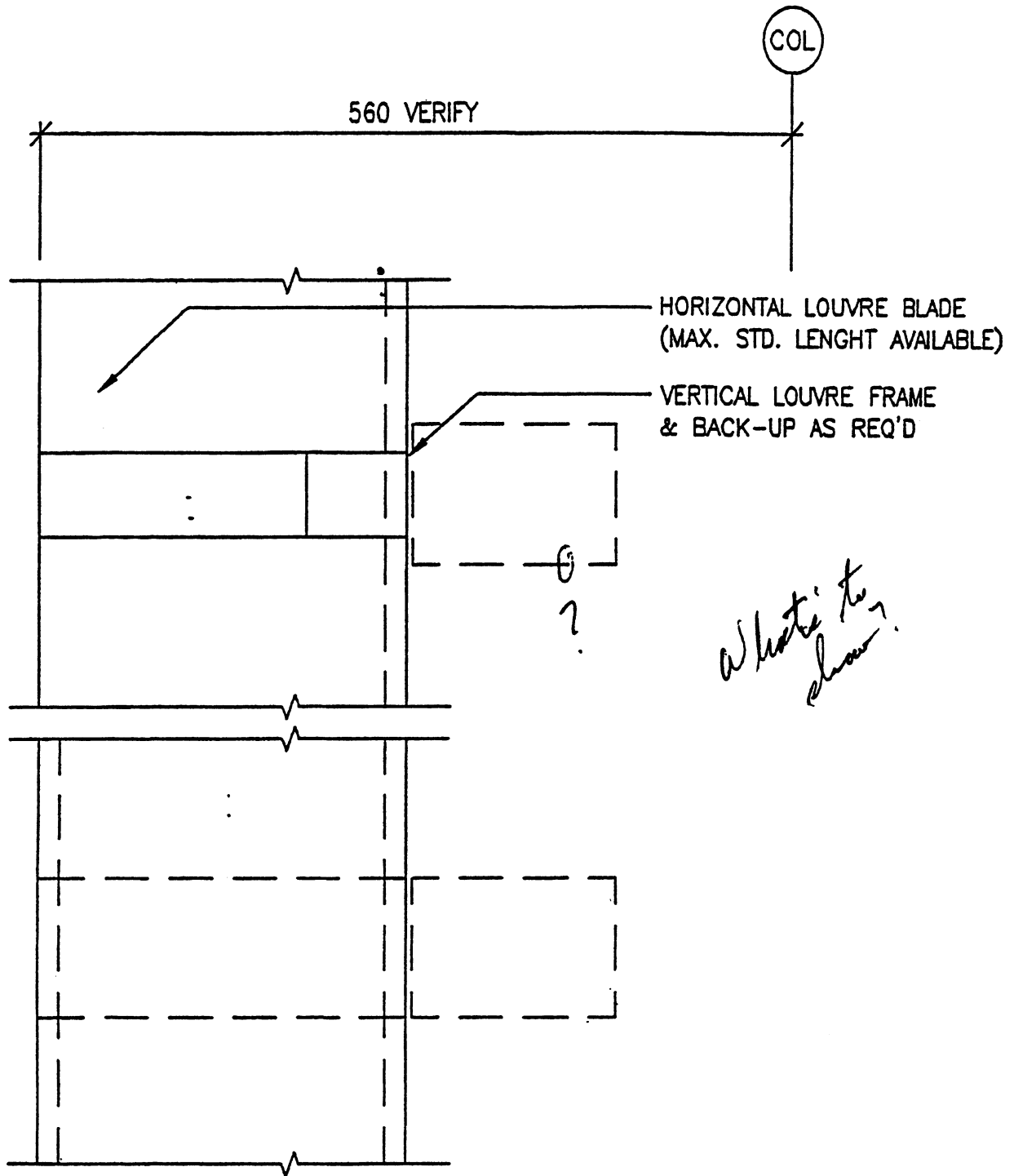
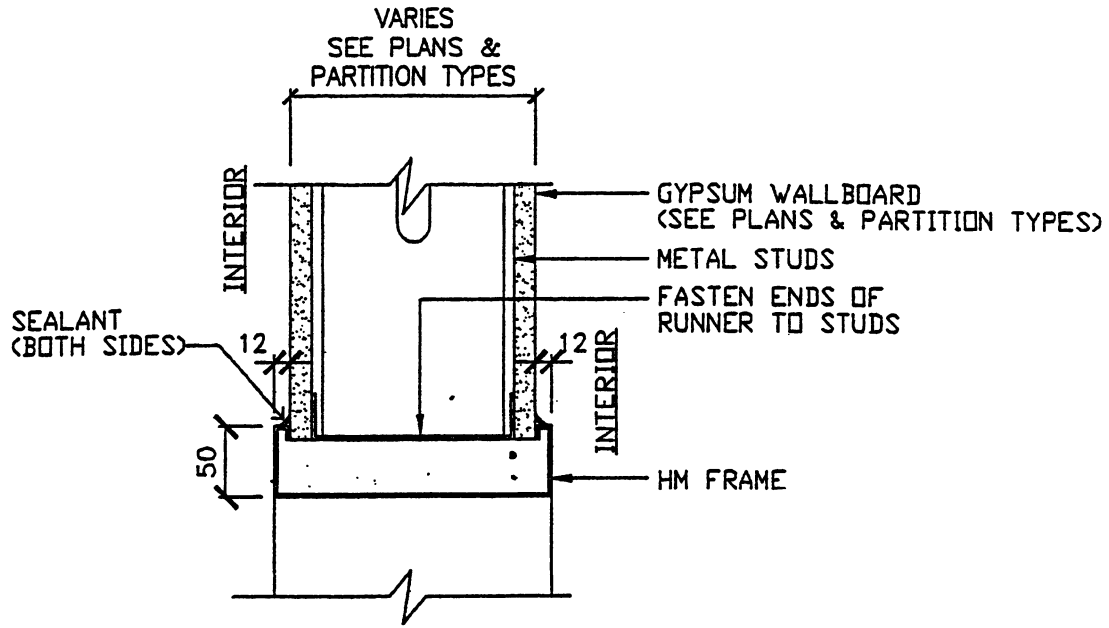

Fig. 10-38

It is not clear why this detail even exists- total lack of definition!



(TYP.)

B H4 FRAME HEAD
SCALE: 1/2"

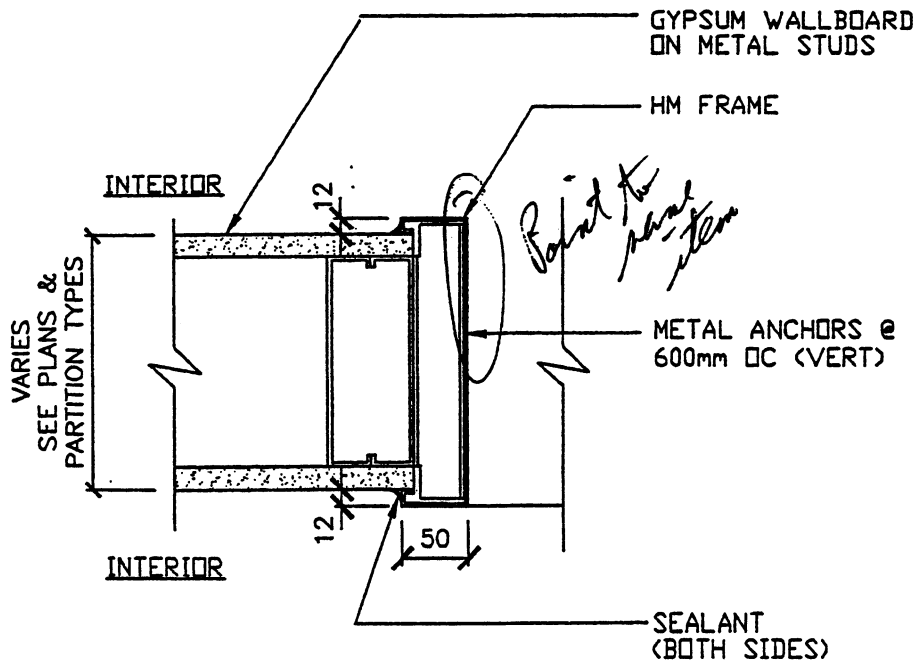

A J4 FRAME JAMB
SCALE: 1/2"

Fig. 10-39

Marginally good details, but main point is the notation of the same item as two different things

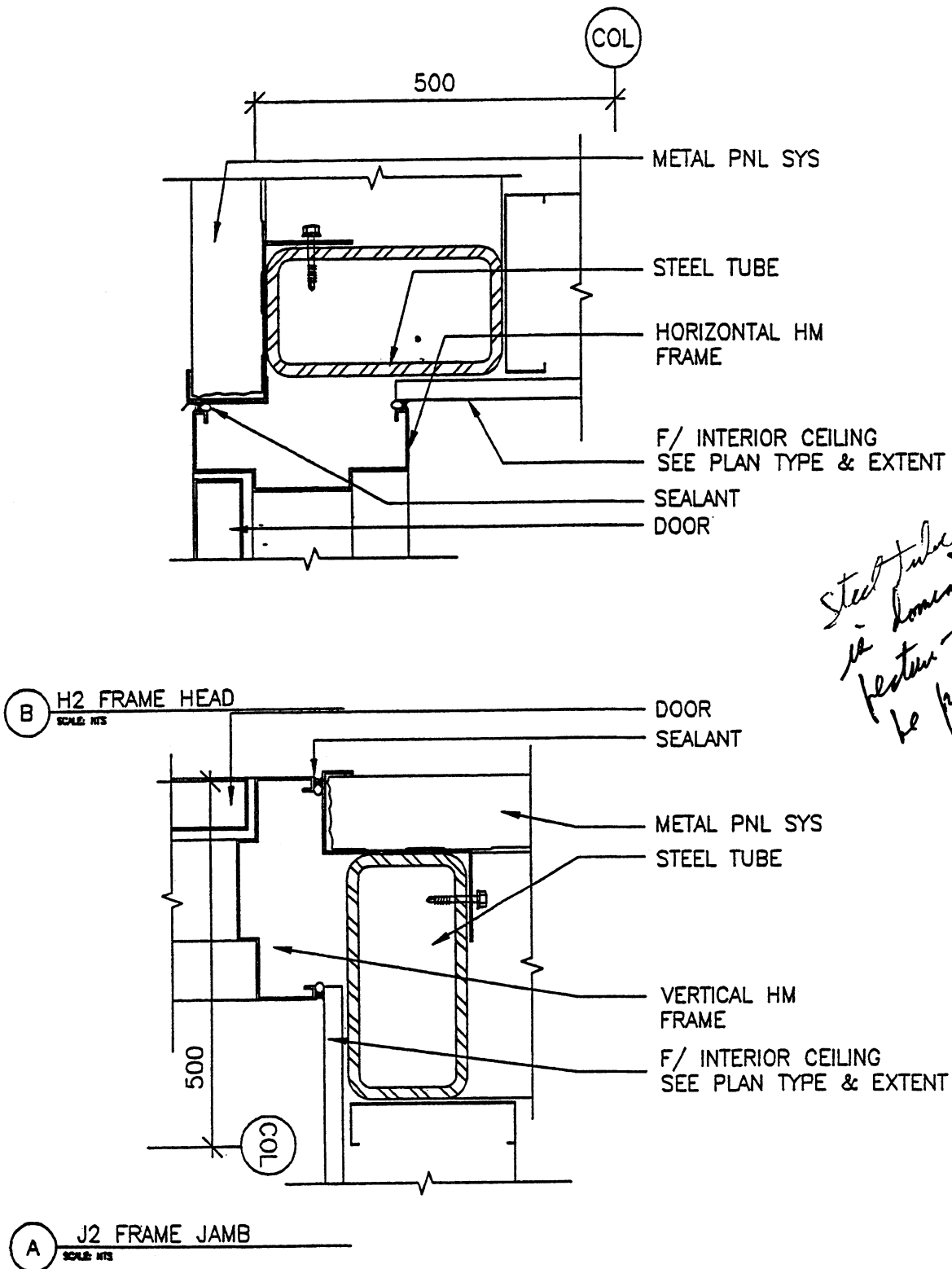

Fig. 10-40
These are door frame details and the fit into the walls, yet the frames are hardly distinguishable—
not the sign of a good detail; structural tube is too dominate

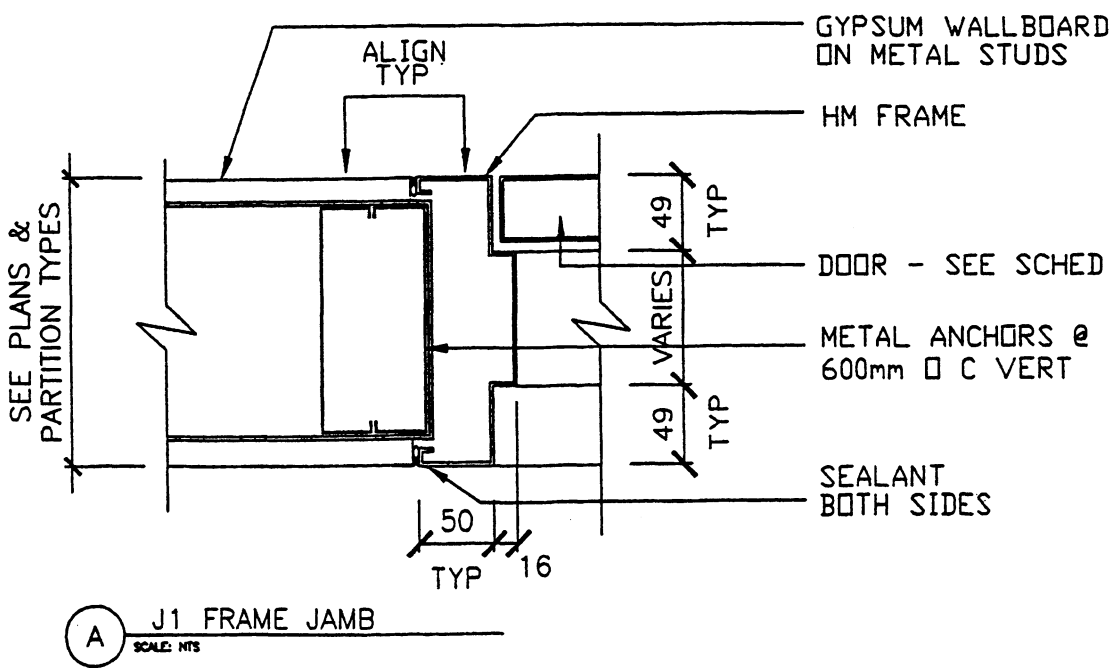
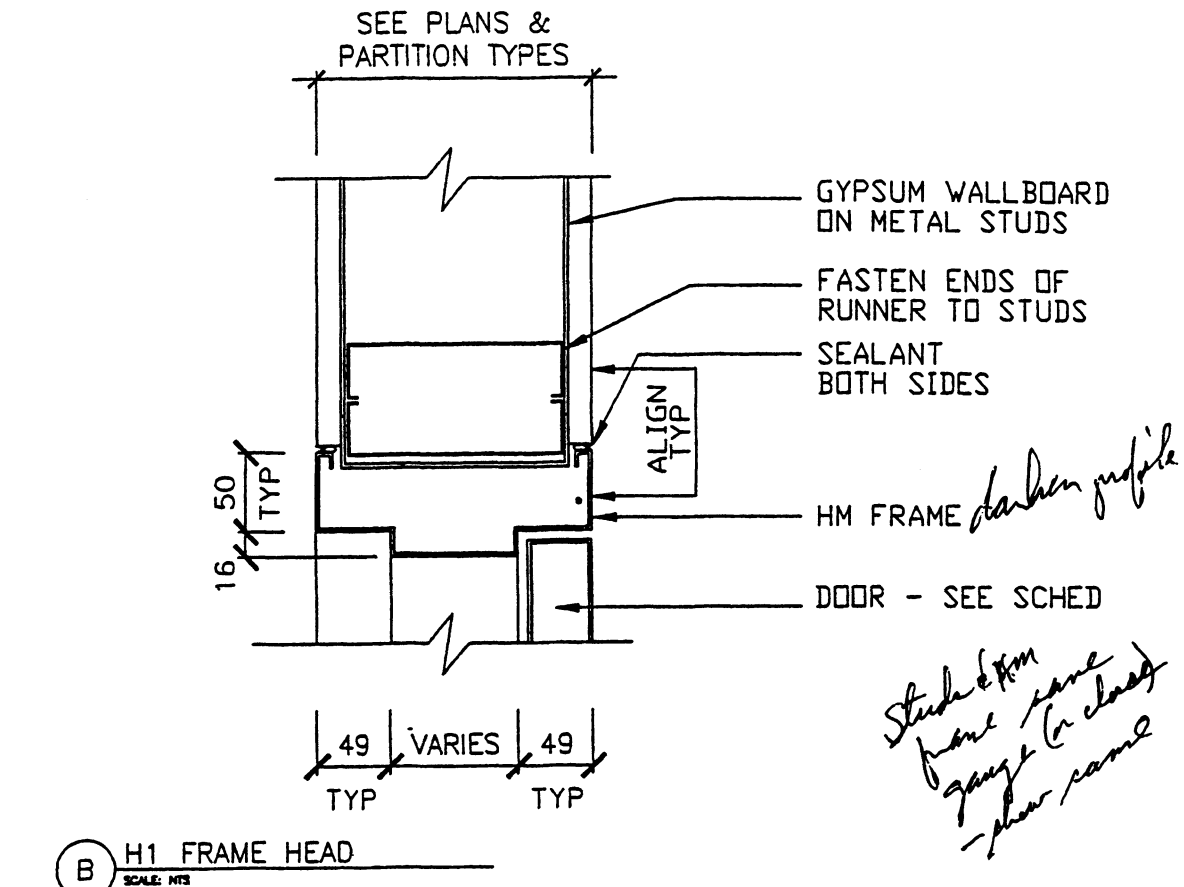

Fig. 10-41

Much the same as Fig. 10-40, except here the metal framing dominates and the detail has no focal point, i.e., the door frame

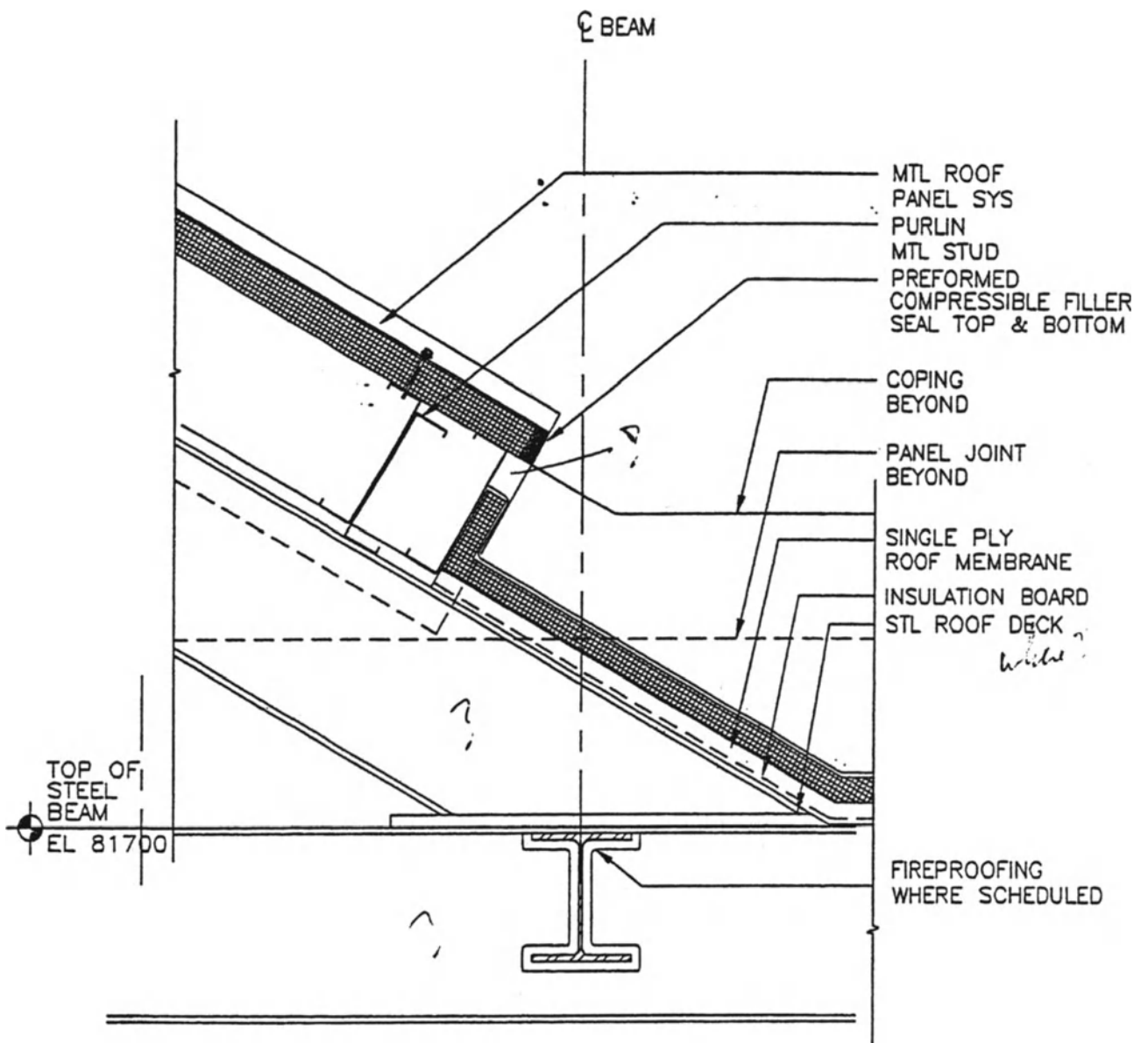

Fig. 10-42

Detail that leaves holes in information that are really necessary to its success. Showing work "beyond" is questionable [should be shown more lightly] and material symbol needs to be toned down

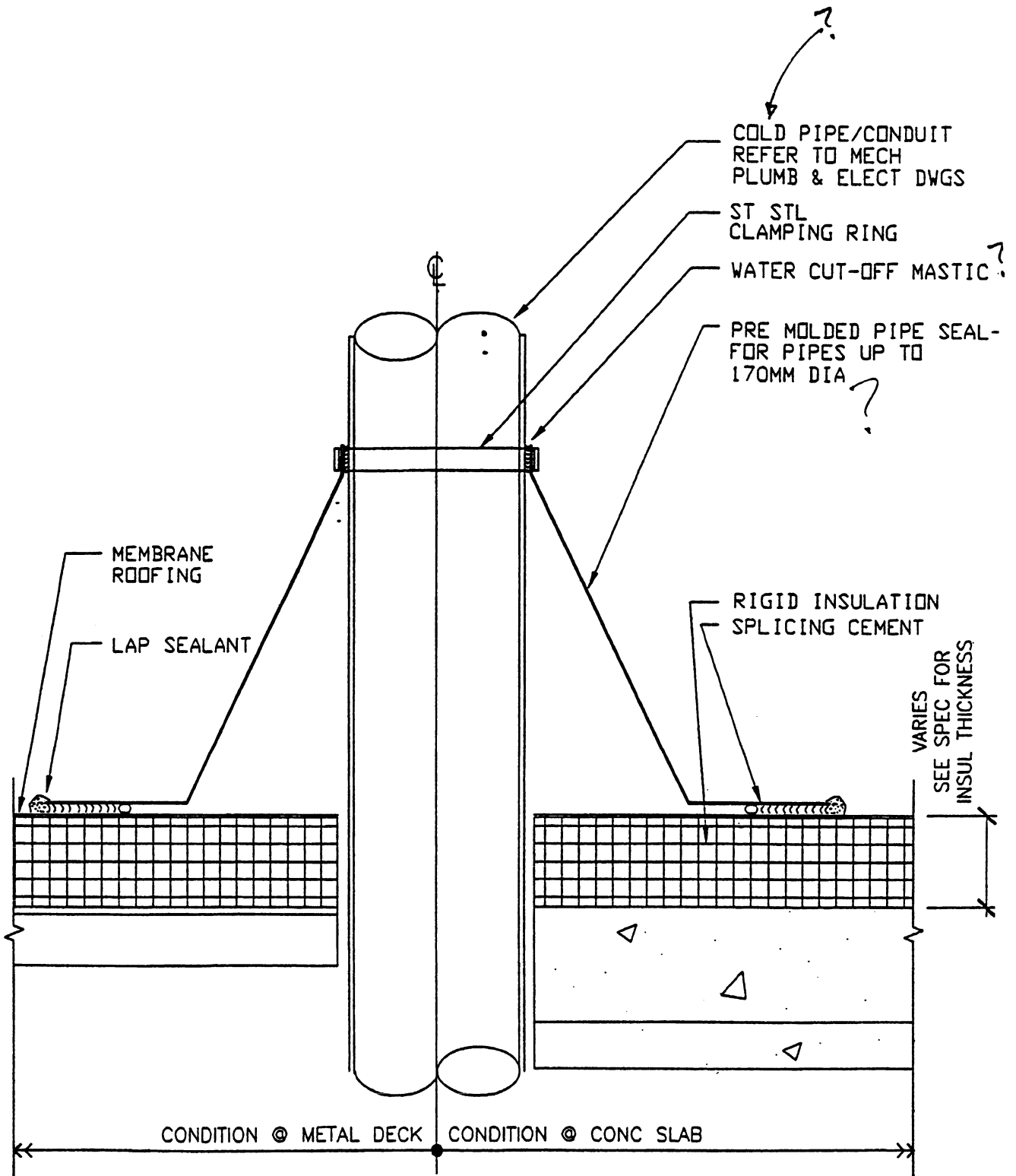

Fig. 10-43

Question value of entire detail. May be pertinent for detail of the clamping ring, if it is unique, but the lower information [even for noted differing conditions] provides no insight or added information. Pre-molded pipe seals are standard [and have thickness] and usually don't need special detailing.

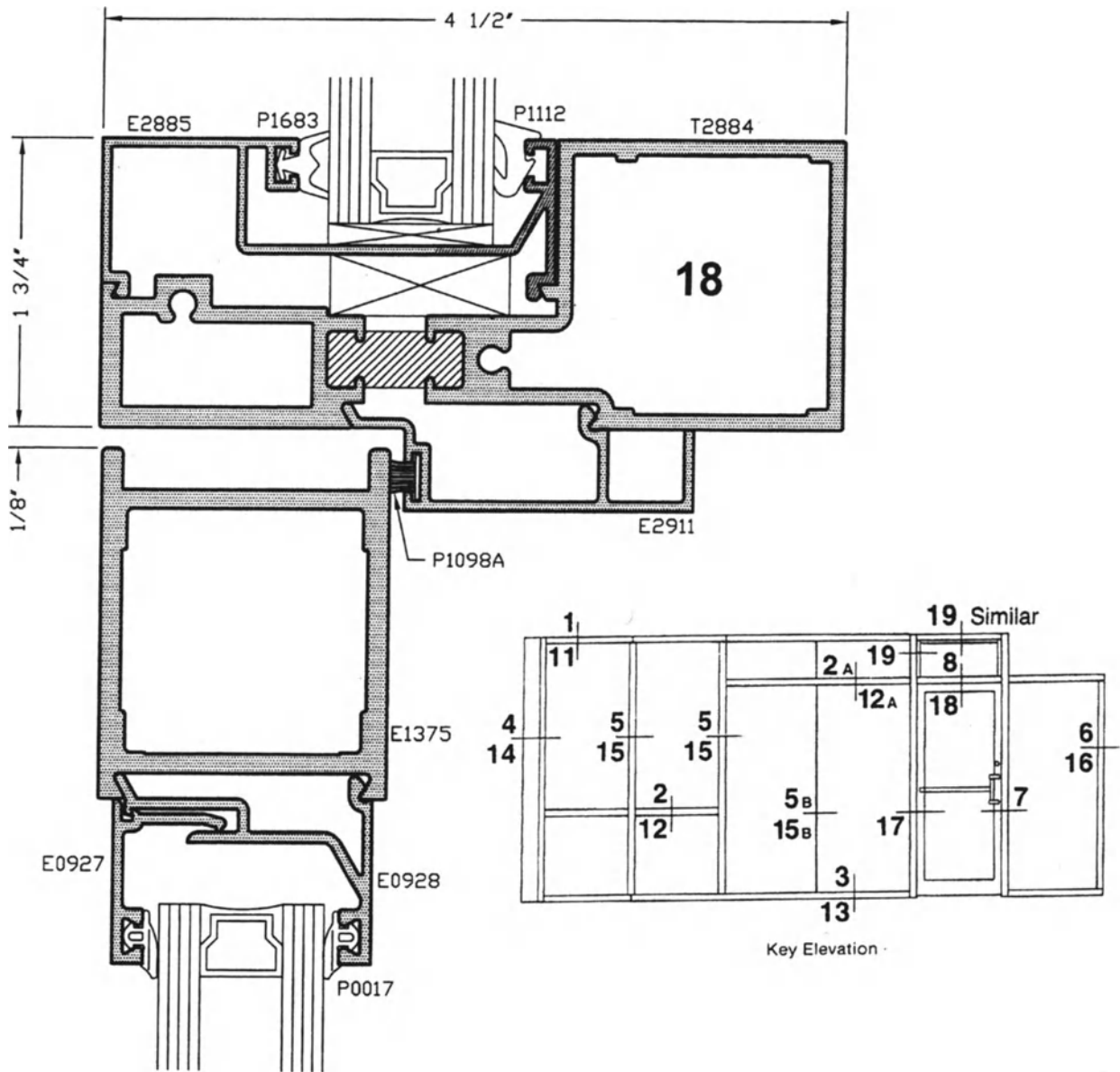

Fig. 10-44
Detail of a manufacturer that shows all of the quirks of the extrusions, but overall a very fine detail— clear and descriptive.
This is the head bar between the top of the door and the glass transom light [No. 18 in elevation].
Goes well beyond what the design professional needs to provide

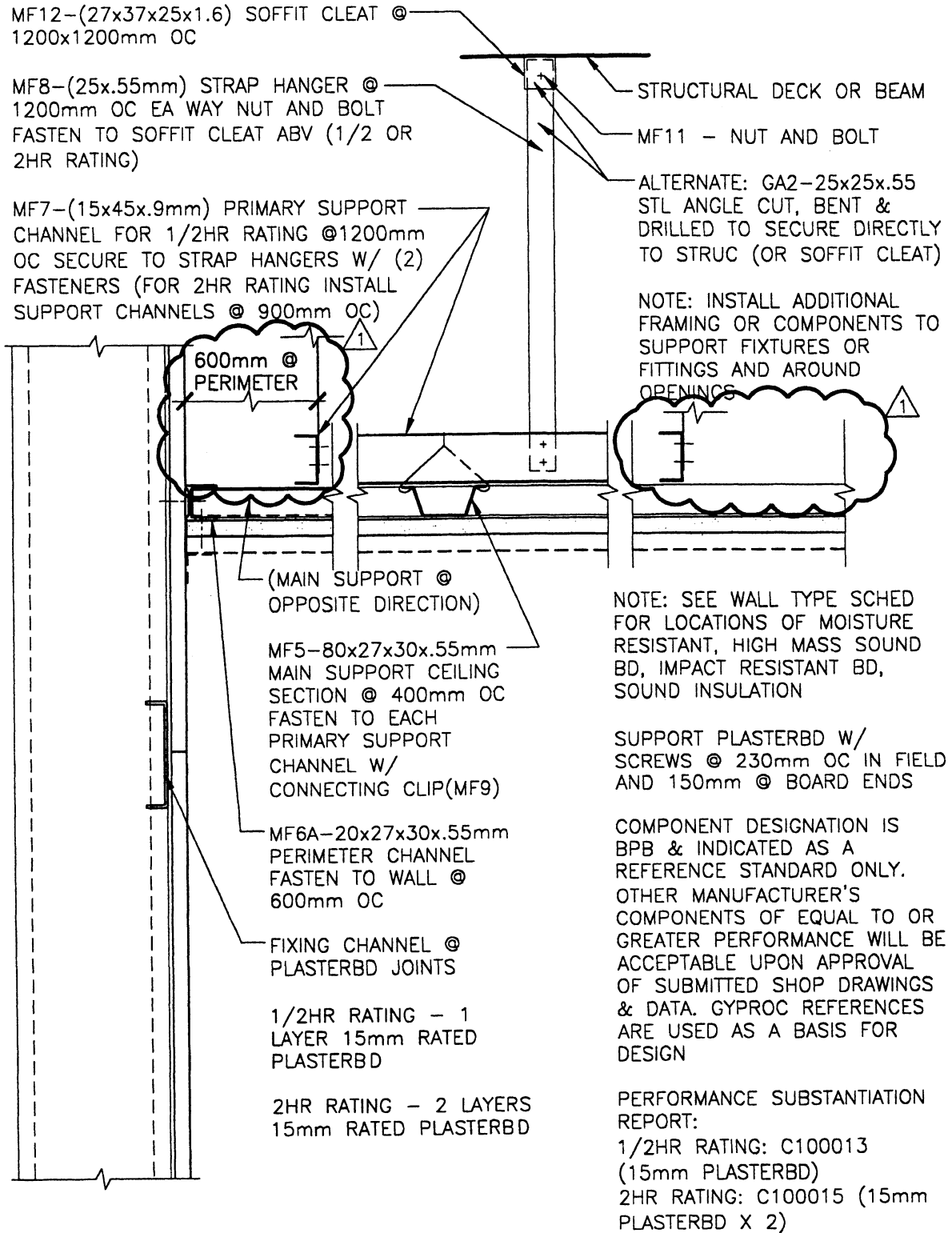

Fig. 10-45

In the main, a wrong-heads detail. Graphic is totally overwhelmed by text, much of which is specification information and needless here. Also, the revision "clouds" obscure and confuse the drawing. This all needs to be re-thought and re-directed for better detail production

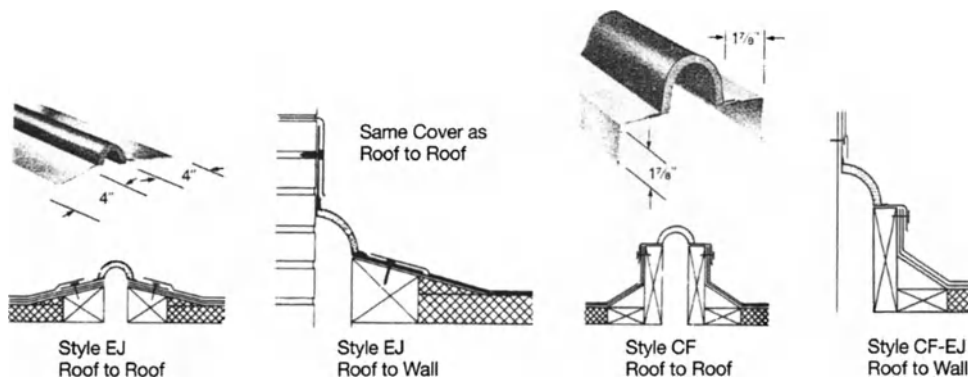

Fig. 10-46

Combination of pictorial [isometrics] and graphic images for clarity and explanation, and to indicate multiple types and styles of units noted [expansion joint covers for roofs]

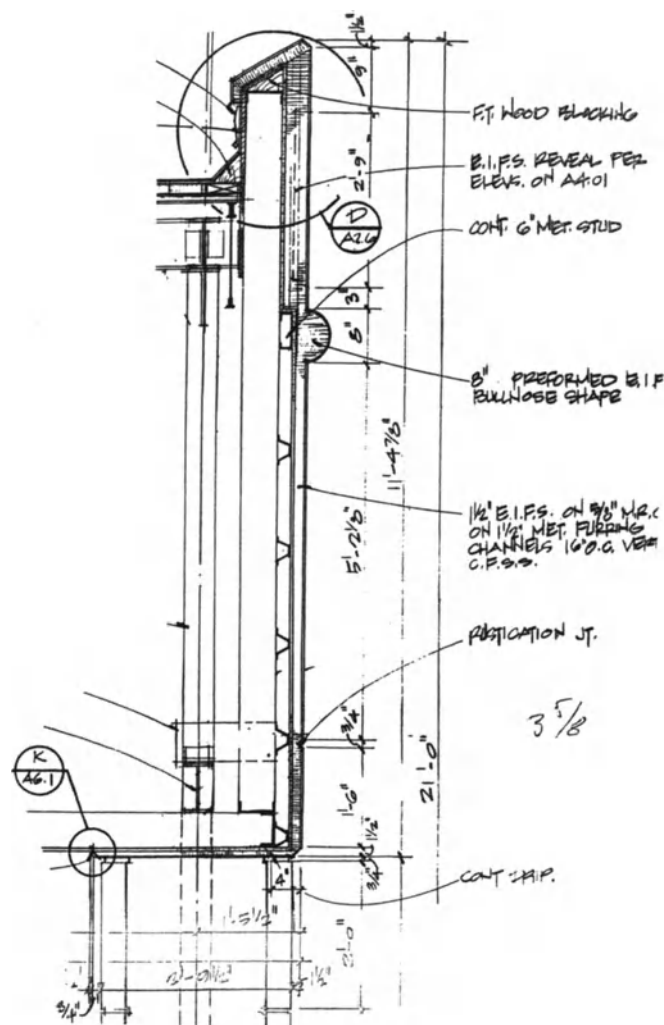

Fig. 10-47

Better than average detail. Some information lacking, but makes reference to other details that provide more insight and clarity

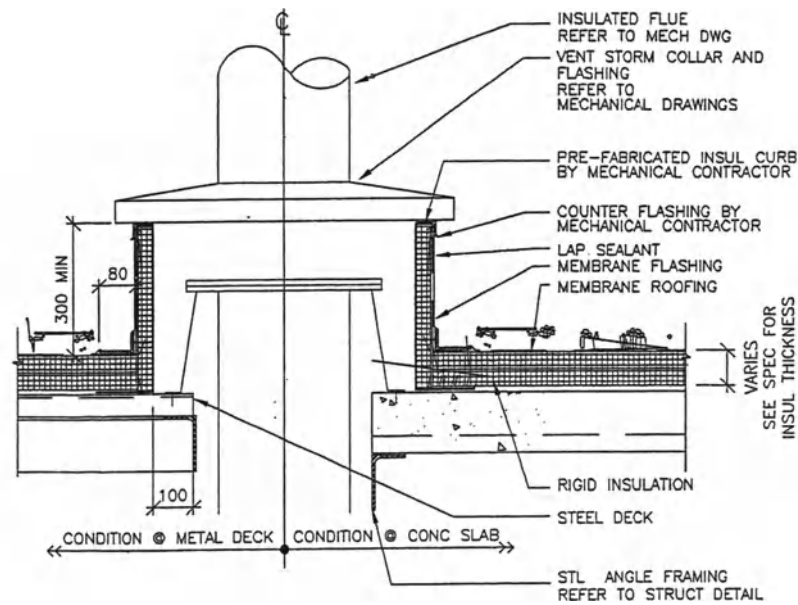

Fig. 10-48

Roof curb detail for varied roof construction. Insulation symbol too dominate, and "squiggles" above roof surface are unidentified, unclear and intent is absent. Detail should be more about fit of standard curb unit into specific roof configuration

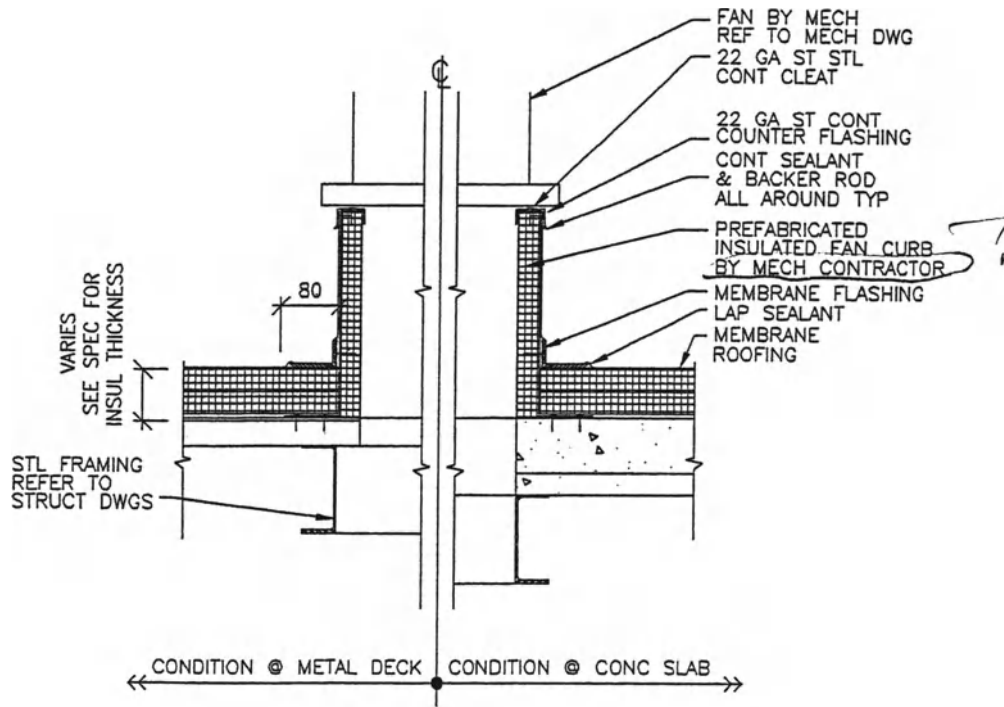

Fig. 10-49

Here as with Fig. 10-48, the unit is by others, and is standard implement, so detail needs to reflect how that unit is fitted into the roof surface and system; lot of unnecessary information is included

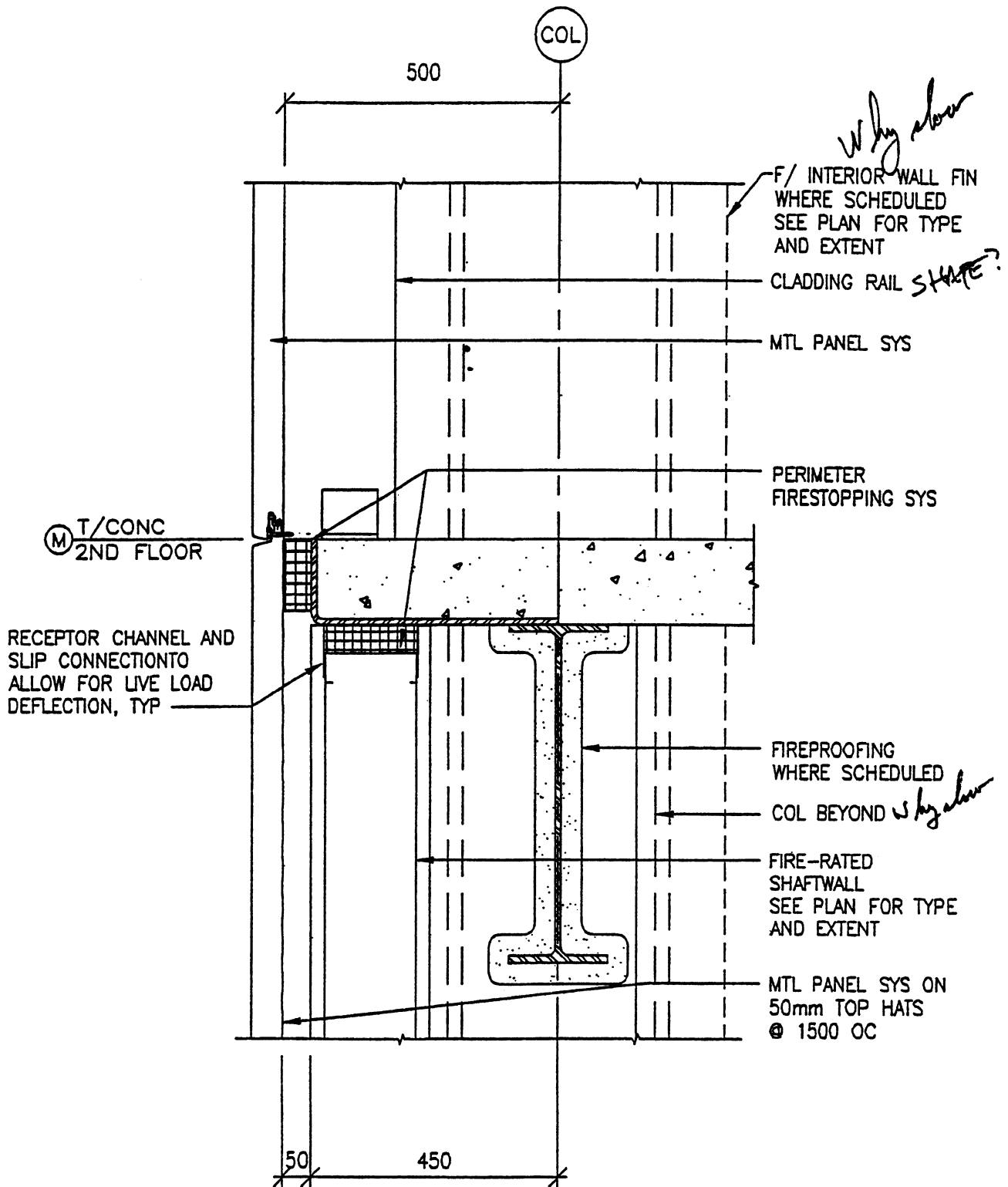

Fig. 10-50

A lot of superficial and background information is provided to no good end. This detail is centered about the firestopping at the floor-wall joint and should be adjusted to focus on that area, in more detail and at a larger scale.

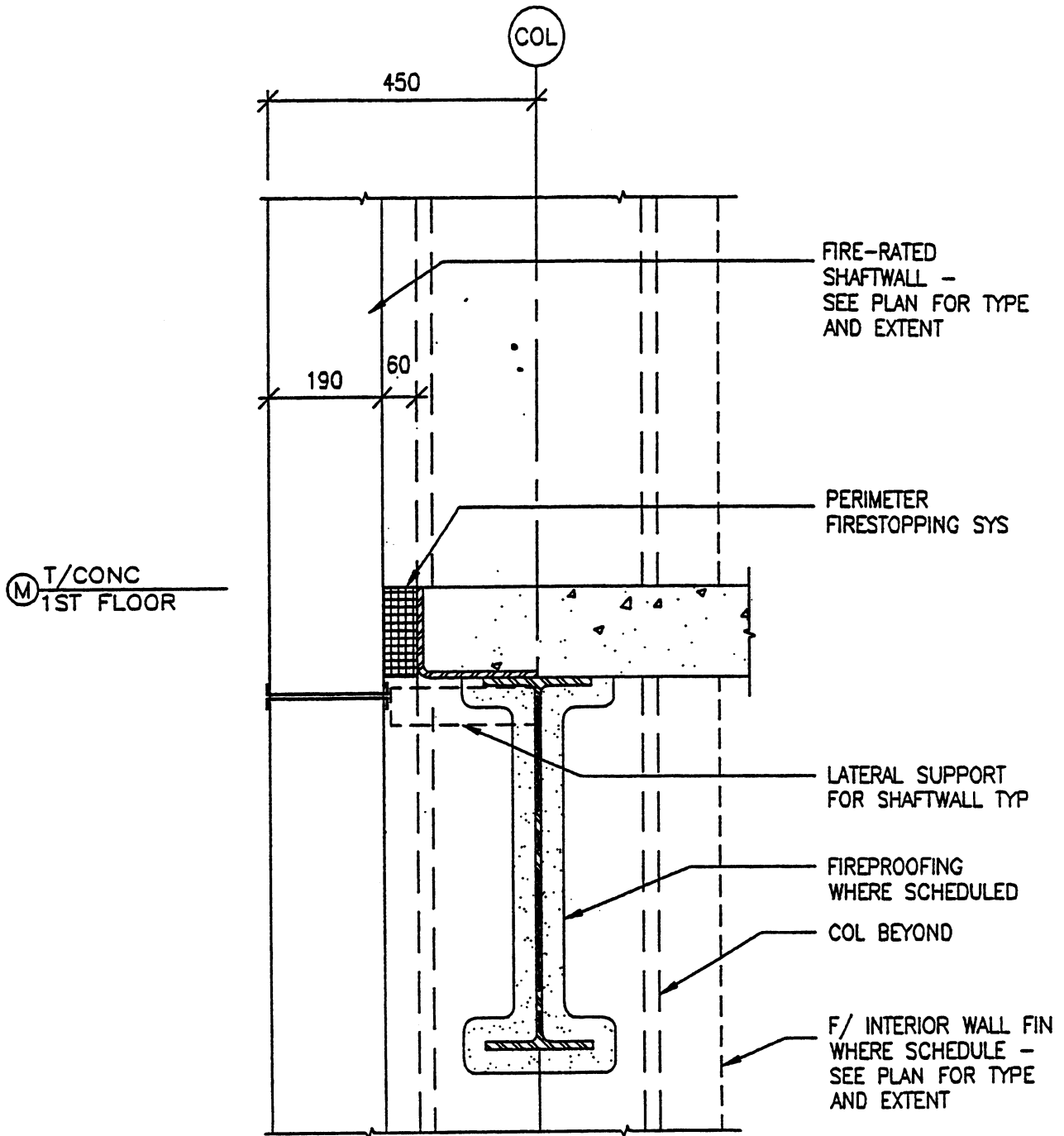

Fig. 10-51

Slightly different from Fig. 10-50, but better representation of the edge-of-slab condition

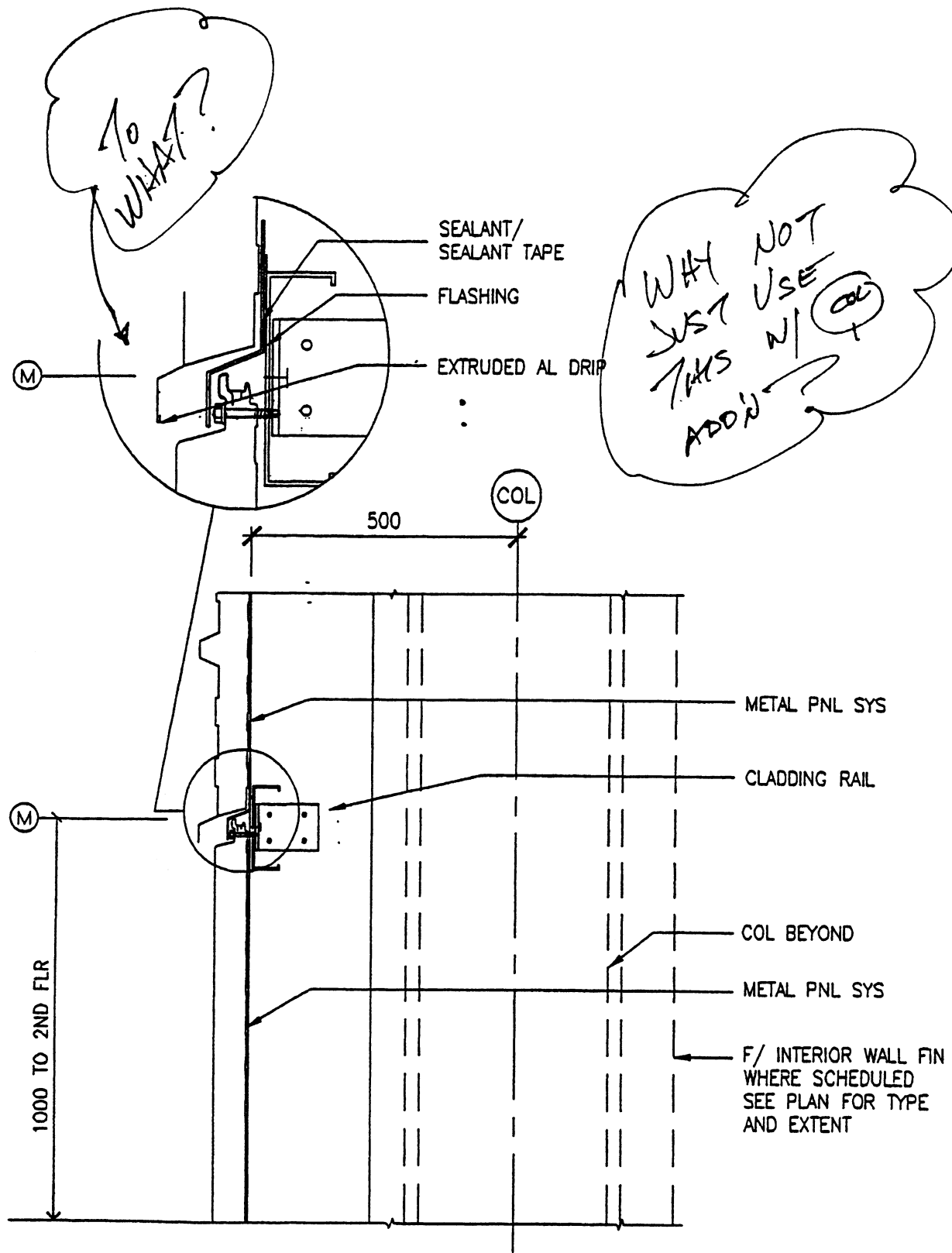

Fig. 10-52

The lower detail has virtually no value, but to place the smaller area detail—why not, then just use the augment the joint detail alone, by adding information, the column line indication and defining where the circled M target relates

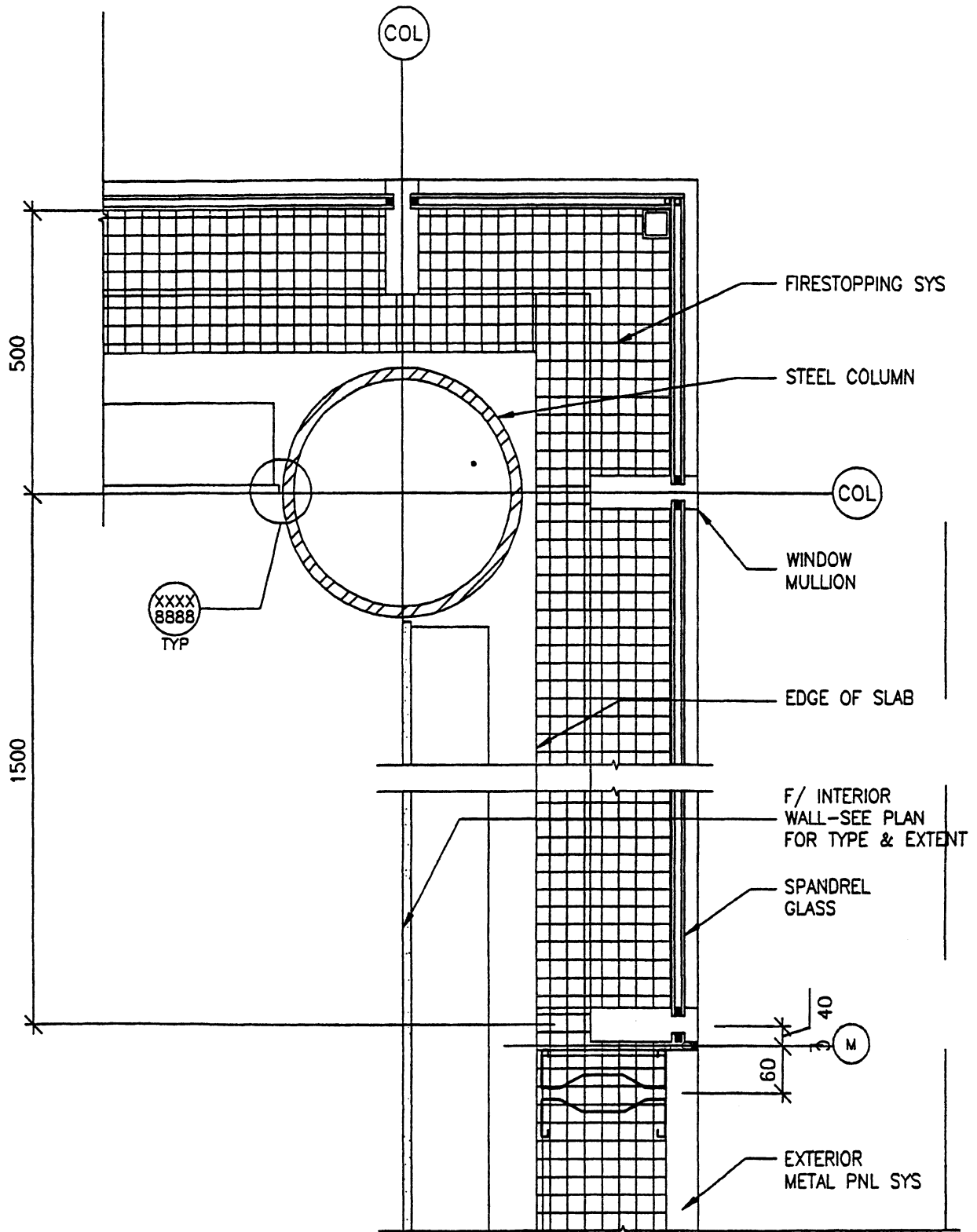

Fig. 10-53

Another detail where the lack of line weight allows the material symbol [insulation] overwhelmed the “guts” the detail—real shame to be so distracting through use of such an inconsequential piece of information

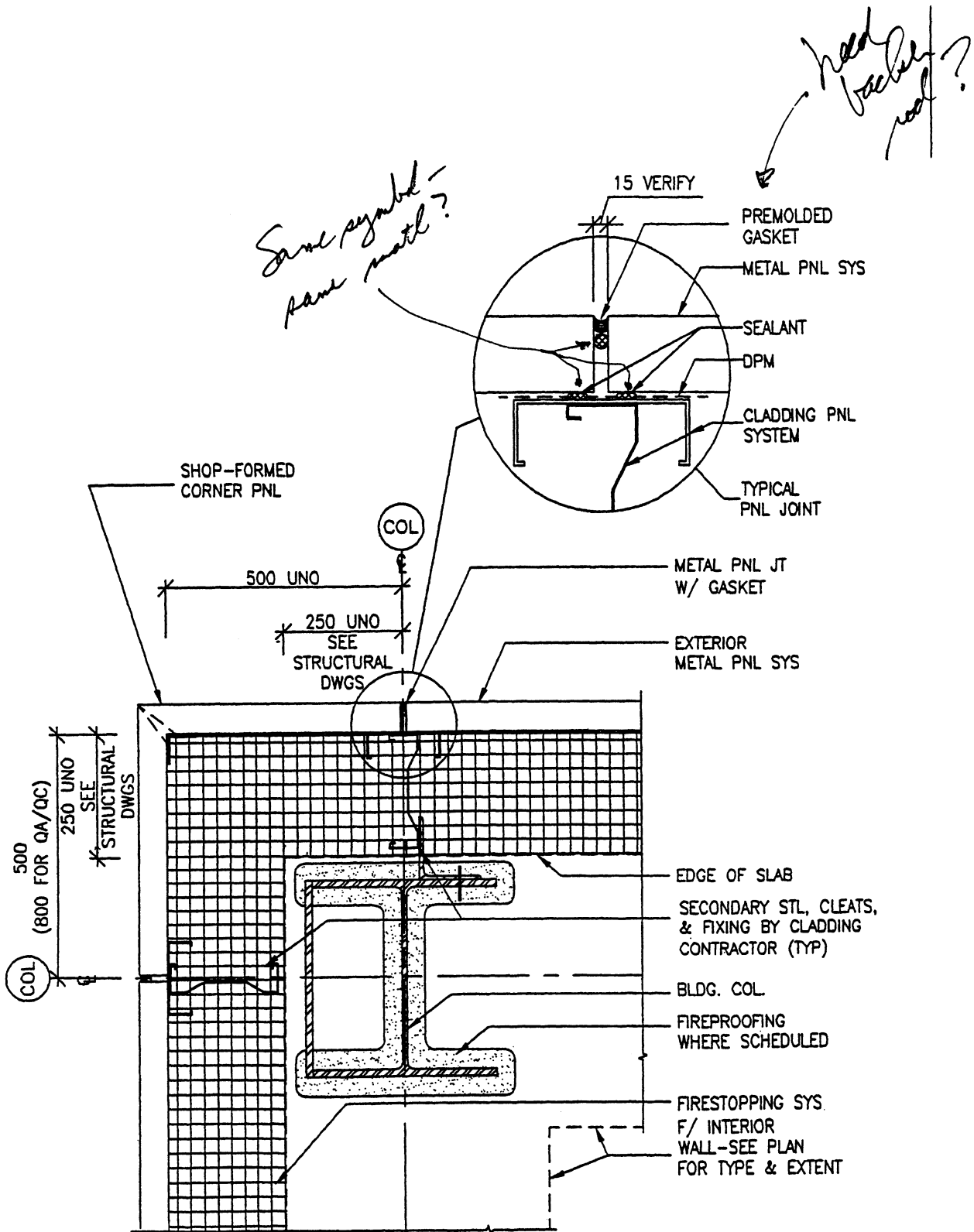

Fig. 10-54

Upper detail not totally responsive to situation. Is a backer rod, as shown, required behind a pre-molded gasket?

Why is the backer rod shown in the same symbol as the sealant?

Good idea to use 2 details here, but upper could be larger in size, and lower needs to reduce visual impact of insulation material symbol

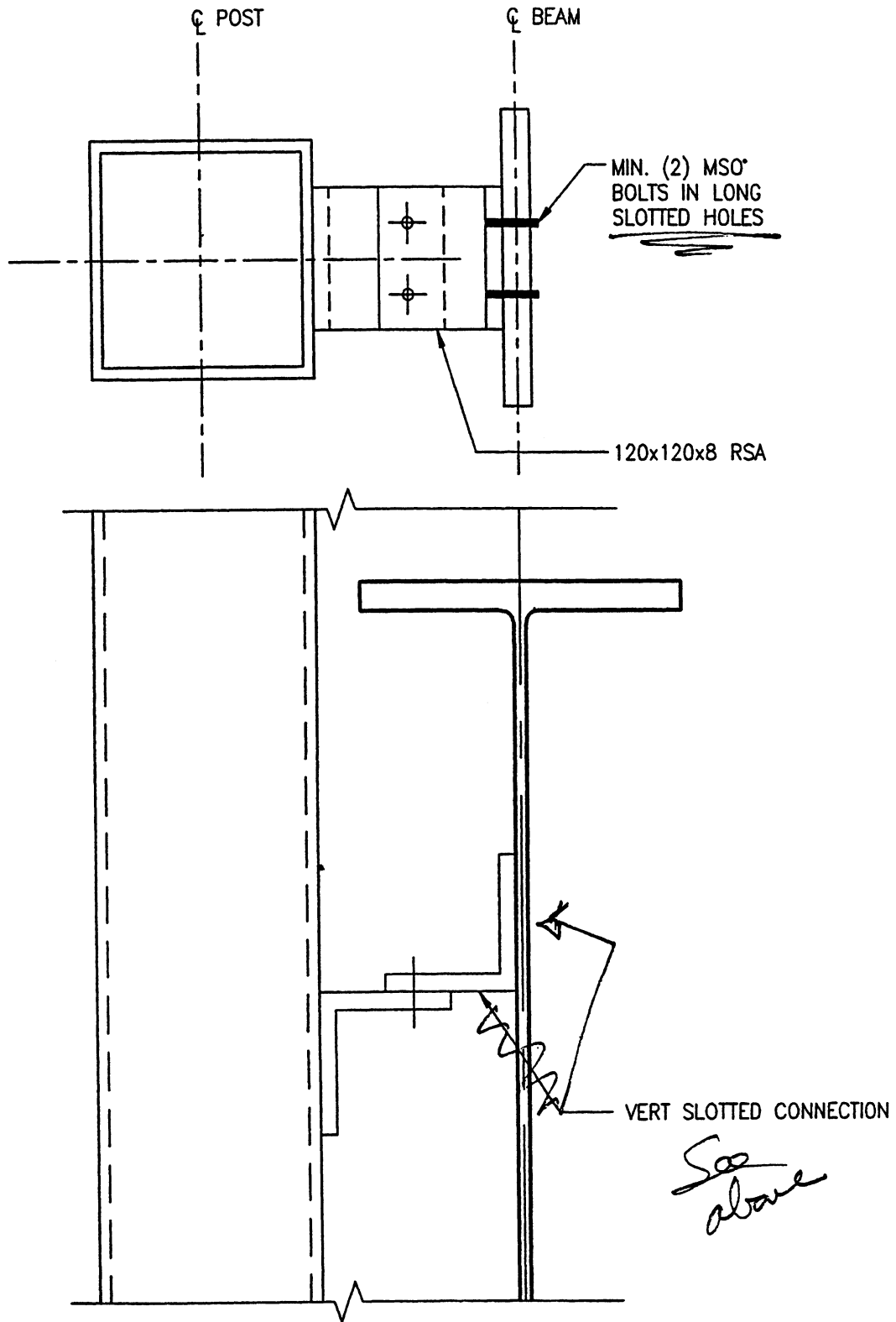

Fig. 10-55
Coordination problem, in that note in lower detail does not reflect condition shown in upper detail.
Holes in horizontal legs of angles are drilled round and are not slotted as called for in vertical leg

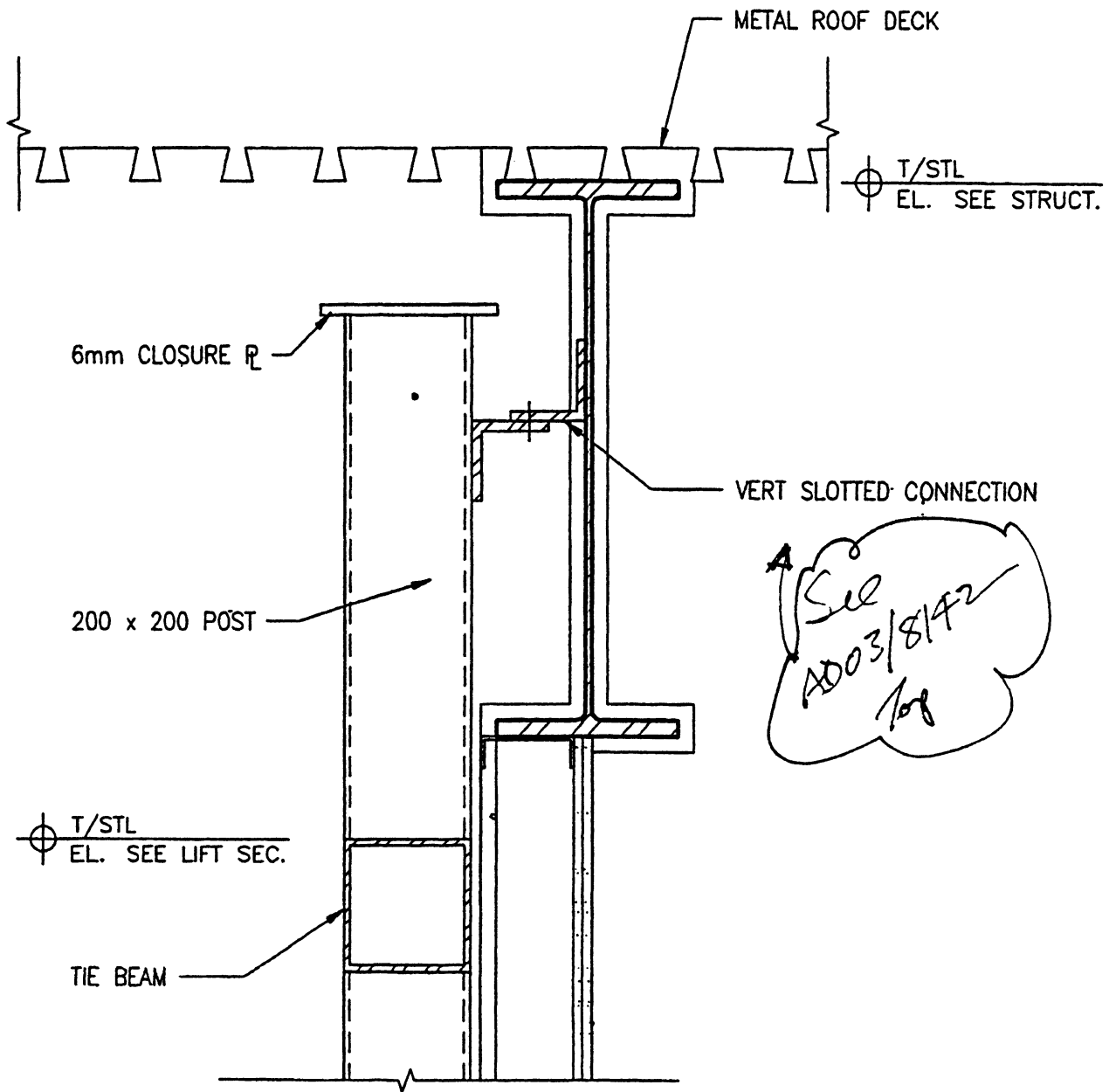

Fig. 10-56
Problem repeated here where Fig. 10-55 is applied

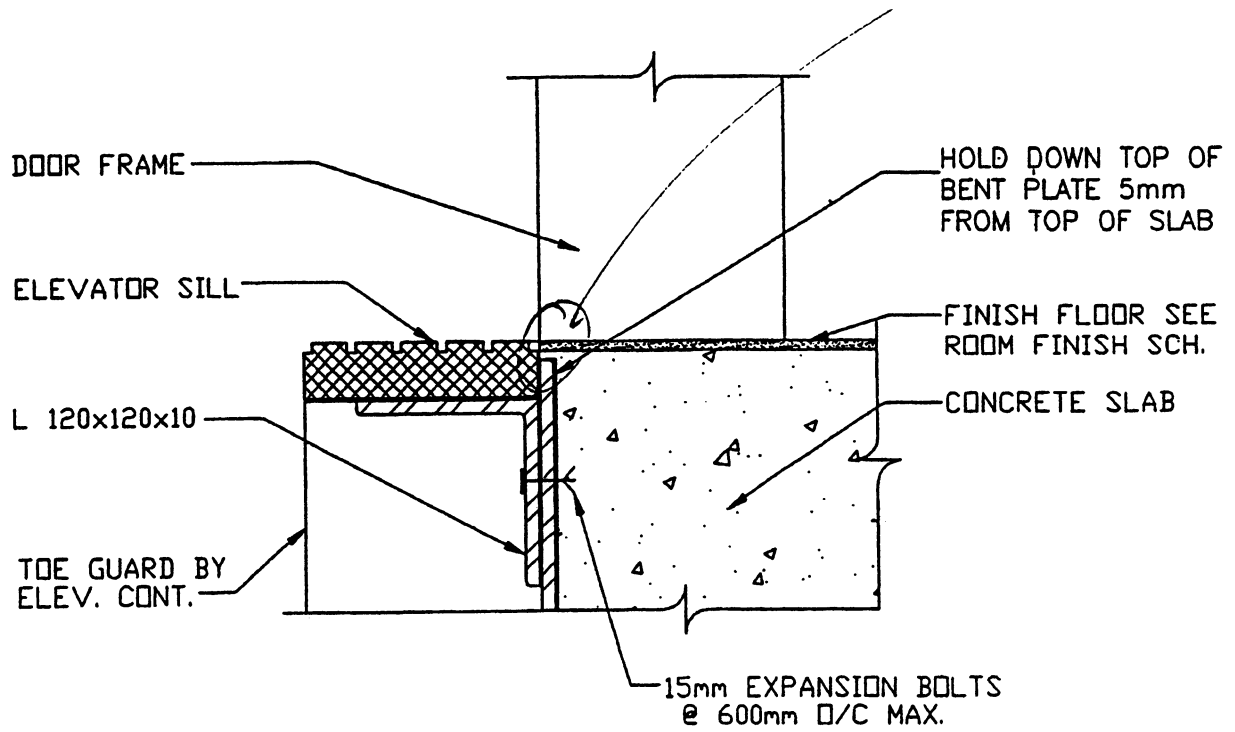

Fig. 10-57

Need to re-think holding the bent plate down "5 mm" from top of slab- can that really be done? Will that small strip of concrete hold in place? Or should it be filled just prior to installation of finish floor?

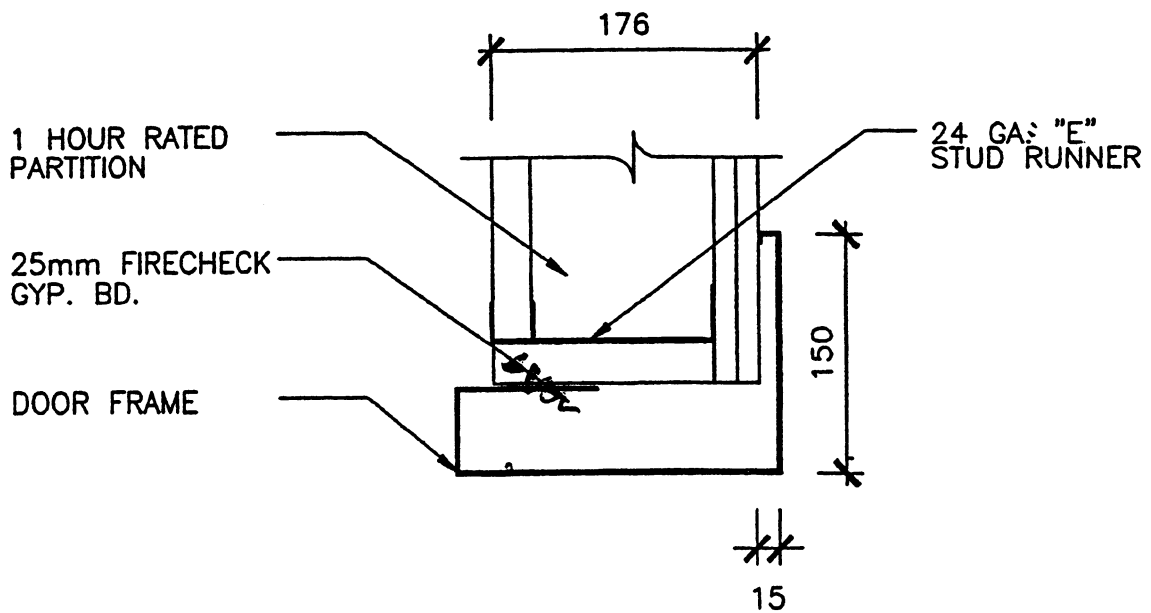

Fig. 10-58

Noted gyp bd. does not exist inside the door frame! Also line weight problems with "E" stud runner. Marginal detail overall.

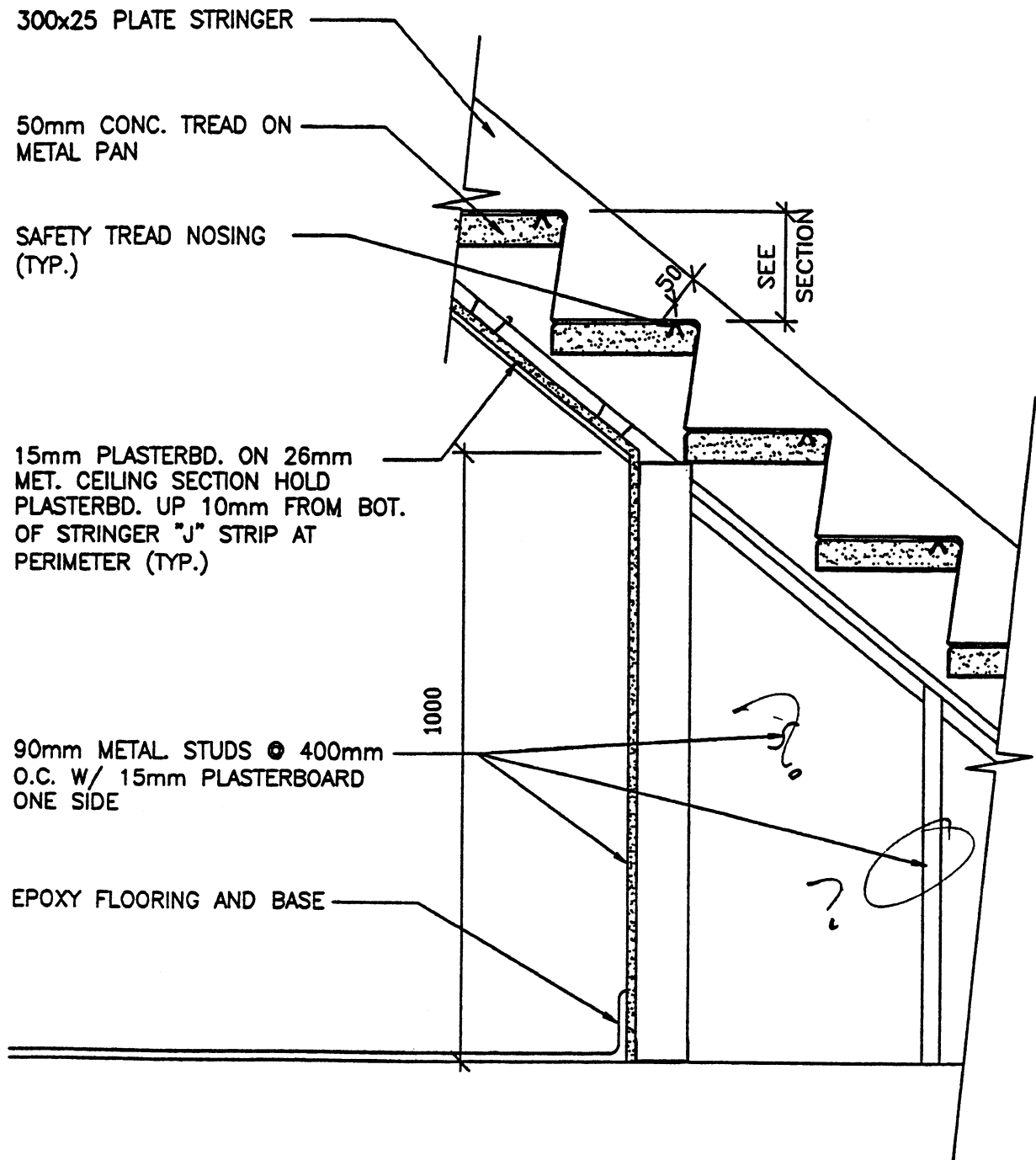

Fig. 10-59 Using multiple leader lines from one note to several areas/materials in differing locations and views is questionable—leads to confusion and unnecessary questions

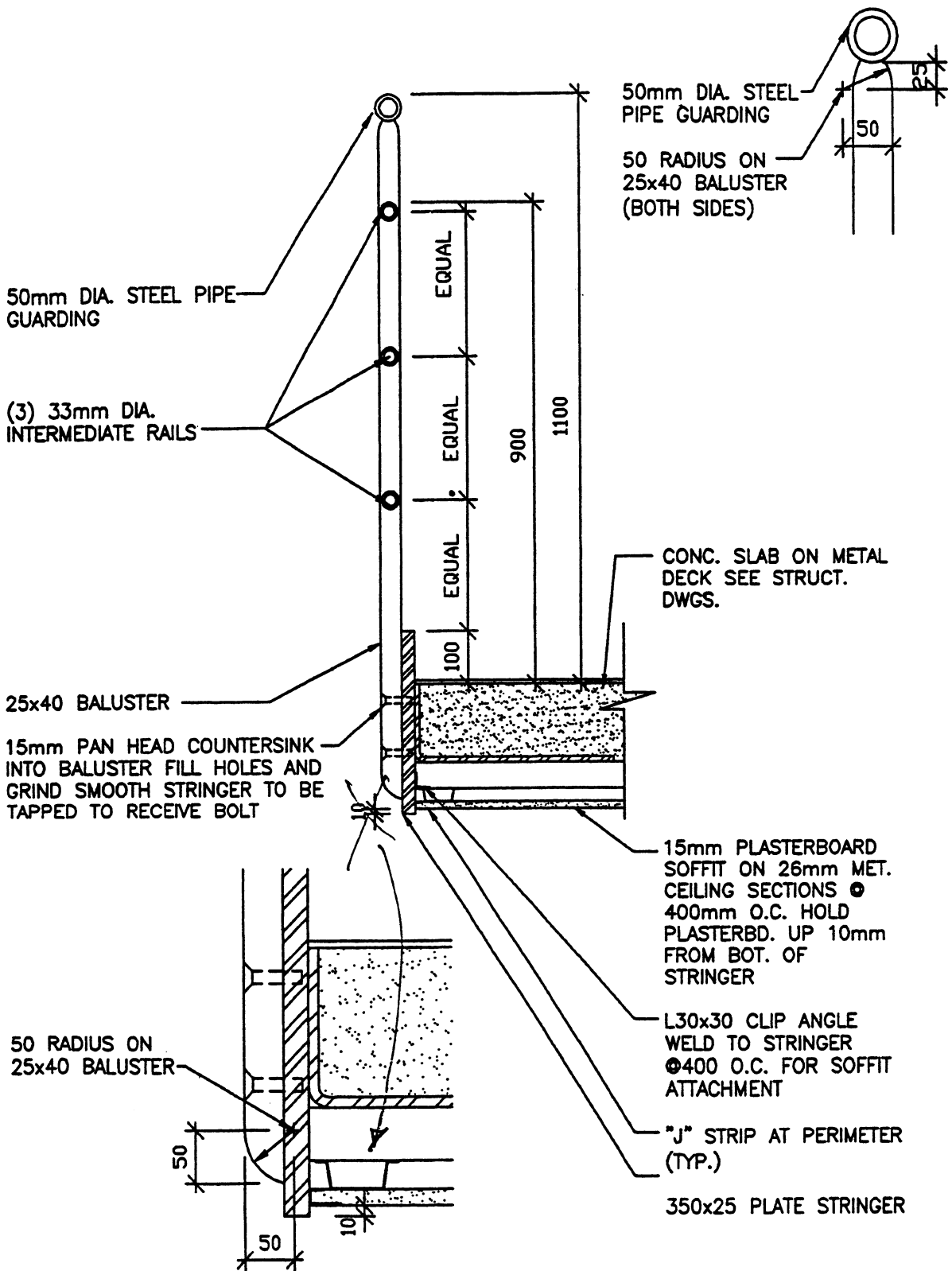

Fig. 10-60

Odd, but necessary "set" of details. Scale is the problem as it makes the drafter use additional views to depict the railing installation. Dimension shown at bottom of railing detail is unnecessary and is shown properly in the blown-up lower detail

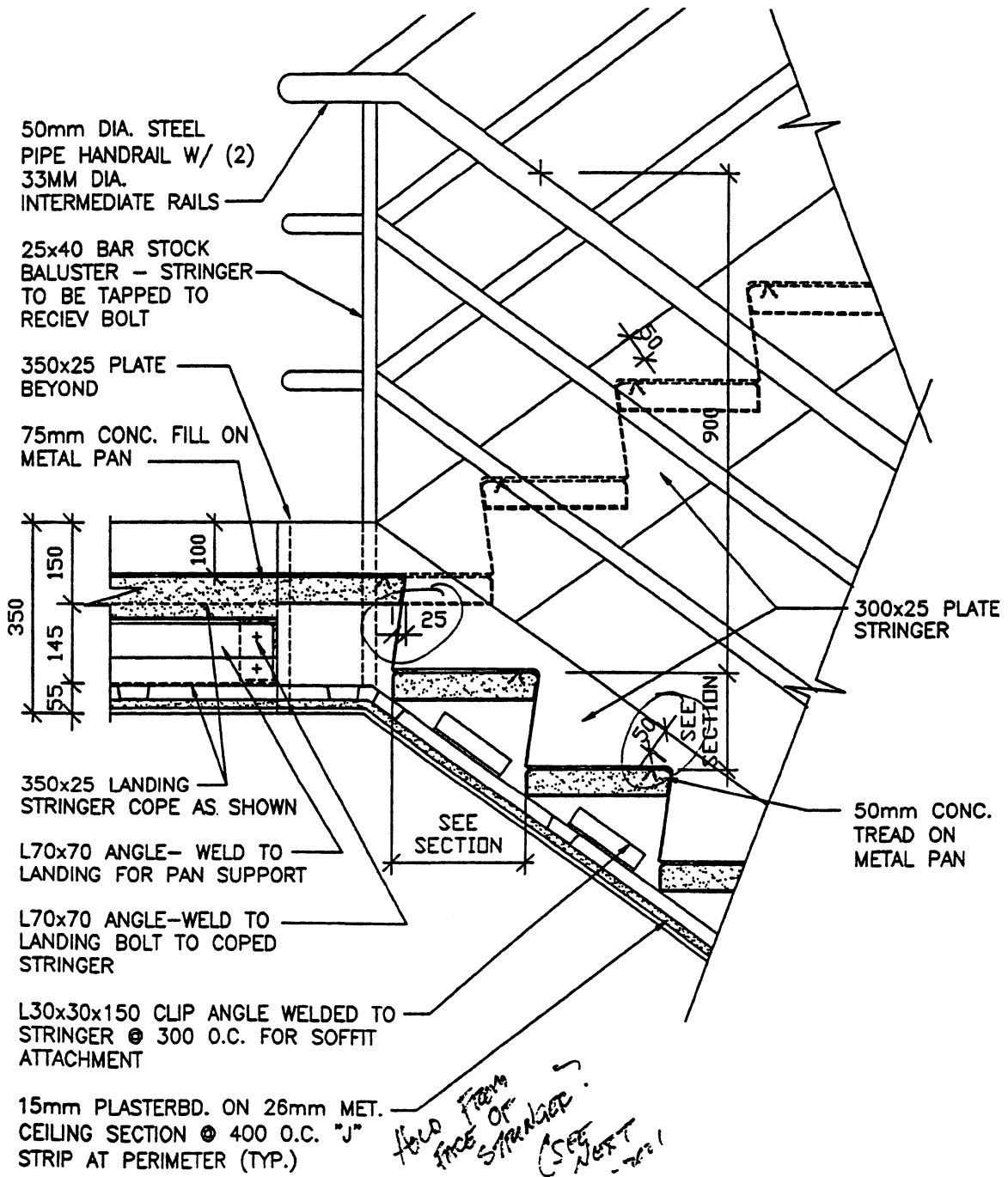

Fig. 10-61

A stair detail that works fairly well; better line weight variation would help. Note lower stairs are cut in Section [require darker outline], while the upper run of stairs are dotted [indicating their location on the other side of the stringer]

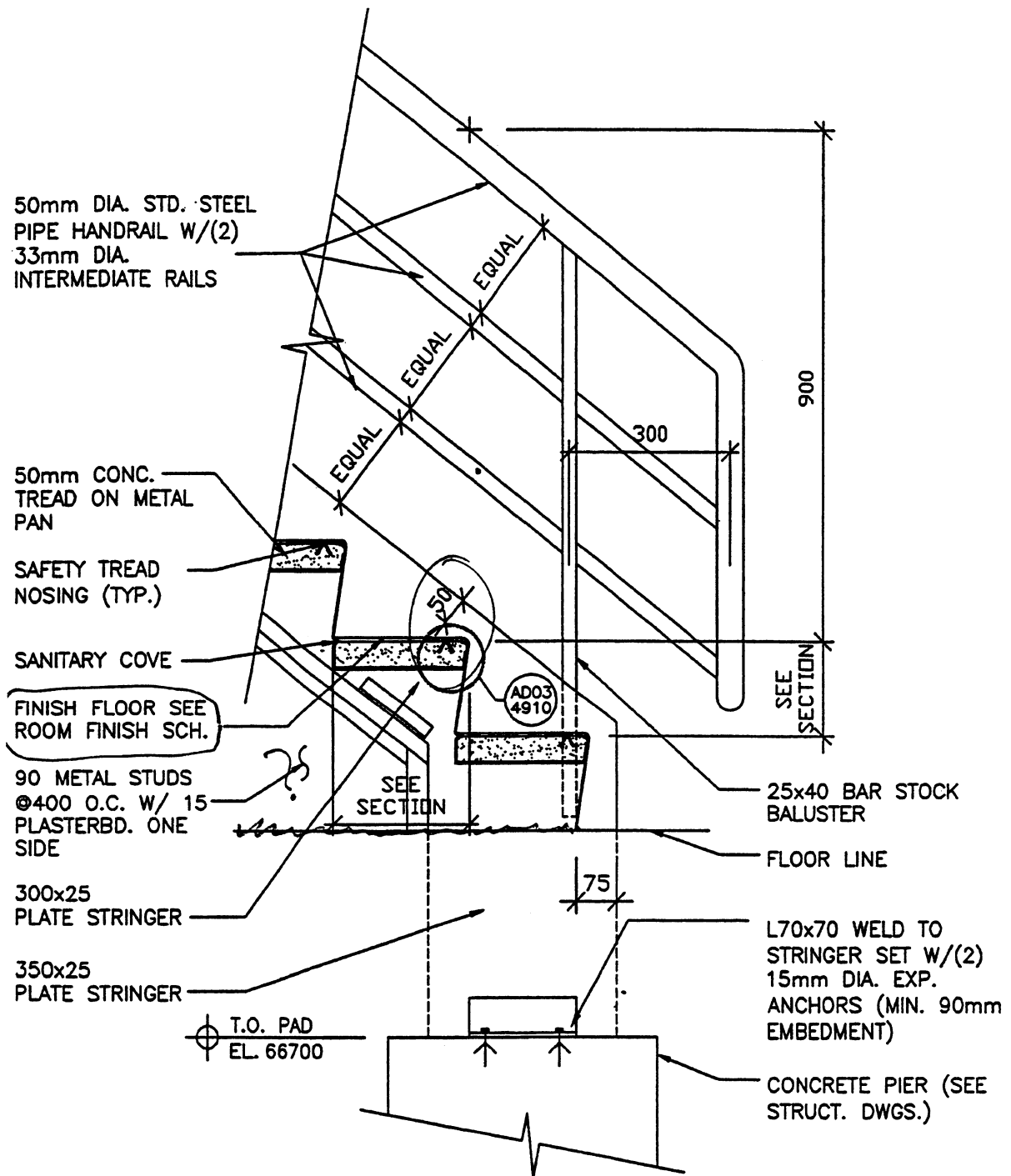

Fig. 10-62

Stair detail where stair terminates at floor [or perhaps an exterior grade line—why have a fire and footing otherwise?]. Nosing of stair is noted and referenced to another detail. “Finish floor” and “plasterbd.” notes are erroneous and unneeded.

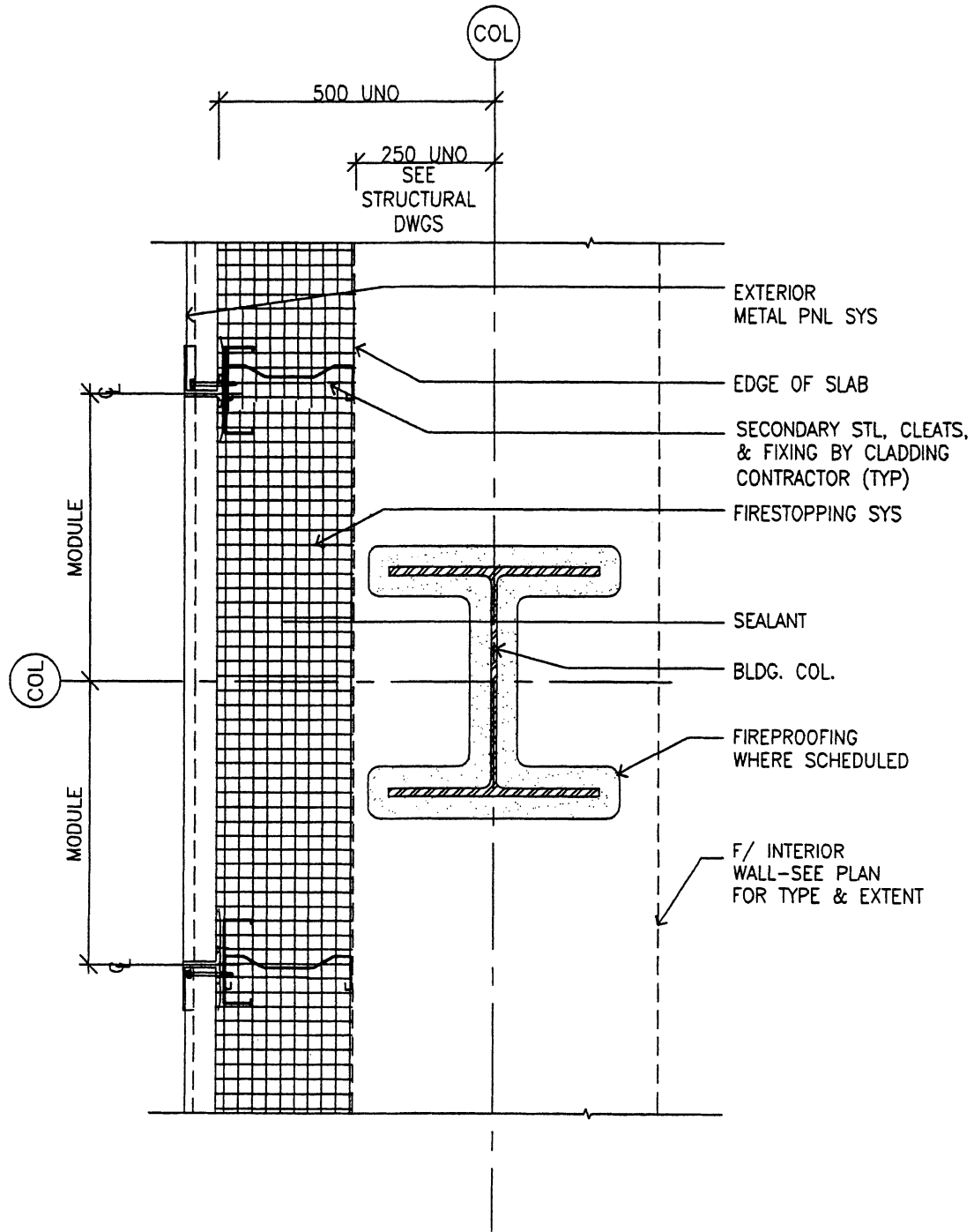

Fig. 10-63
Horizontal detail where major elements [edge of slab, exterior metal pnl sys, column, etc.] are not well-define and are overwhelmed by the least significant information [the insulation material symbol]

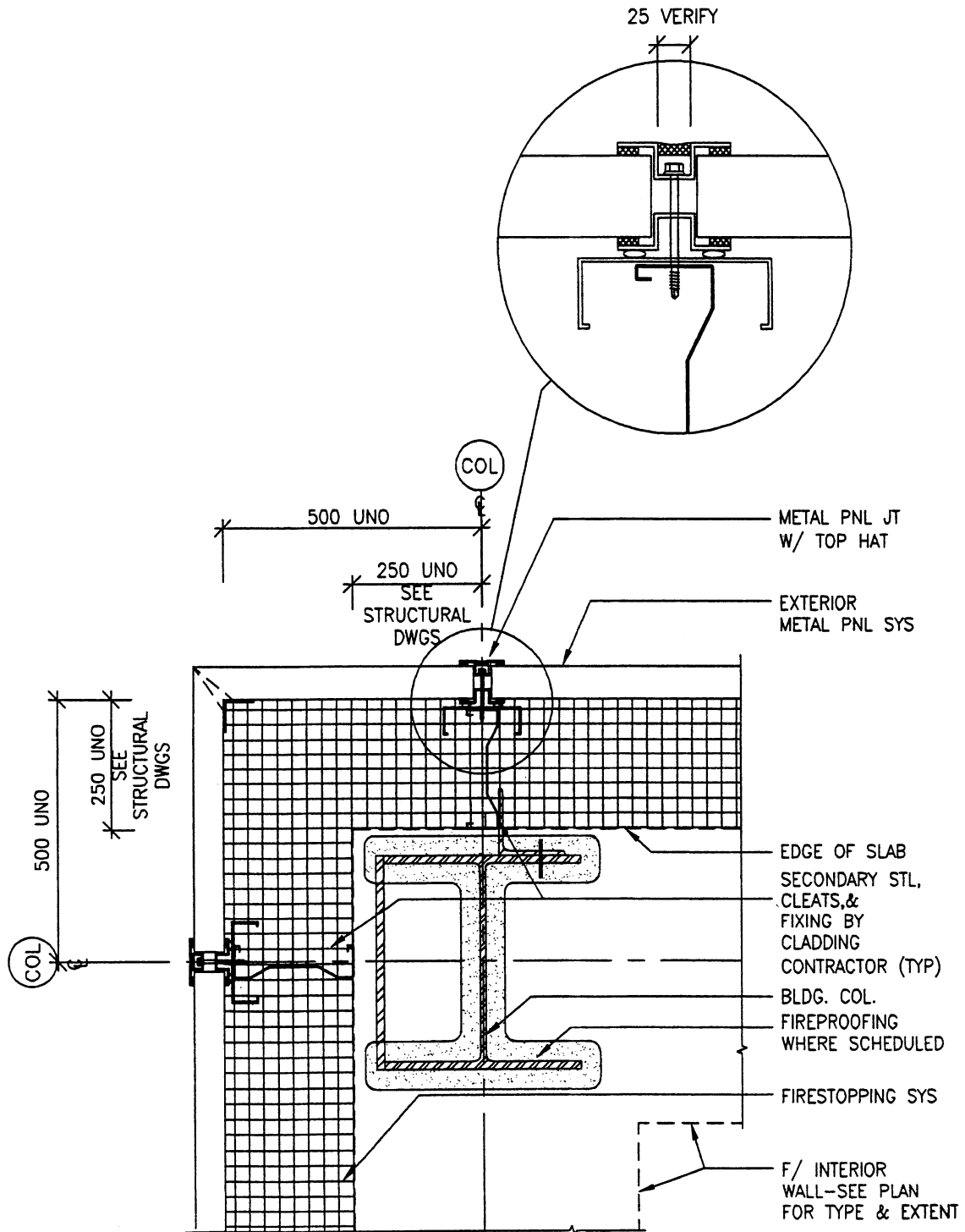

Fig. 10-64

A detail taken from another detail is a "dead-end"! The circled detail shows some work [which is helpful] but gives no information that would aid installers]. Shows the "pieces" involved but not what they are, etc. Larger detail suffers much as noted in Fig. 10-63

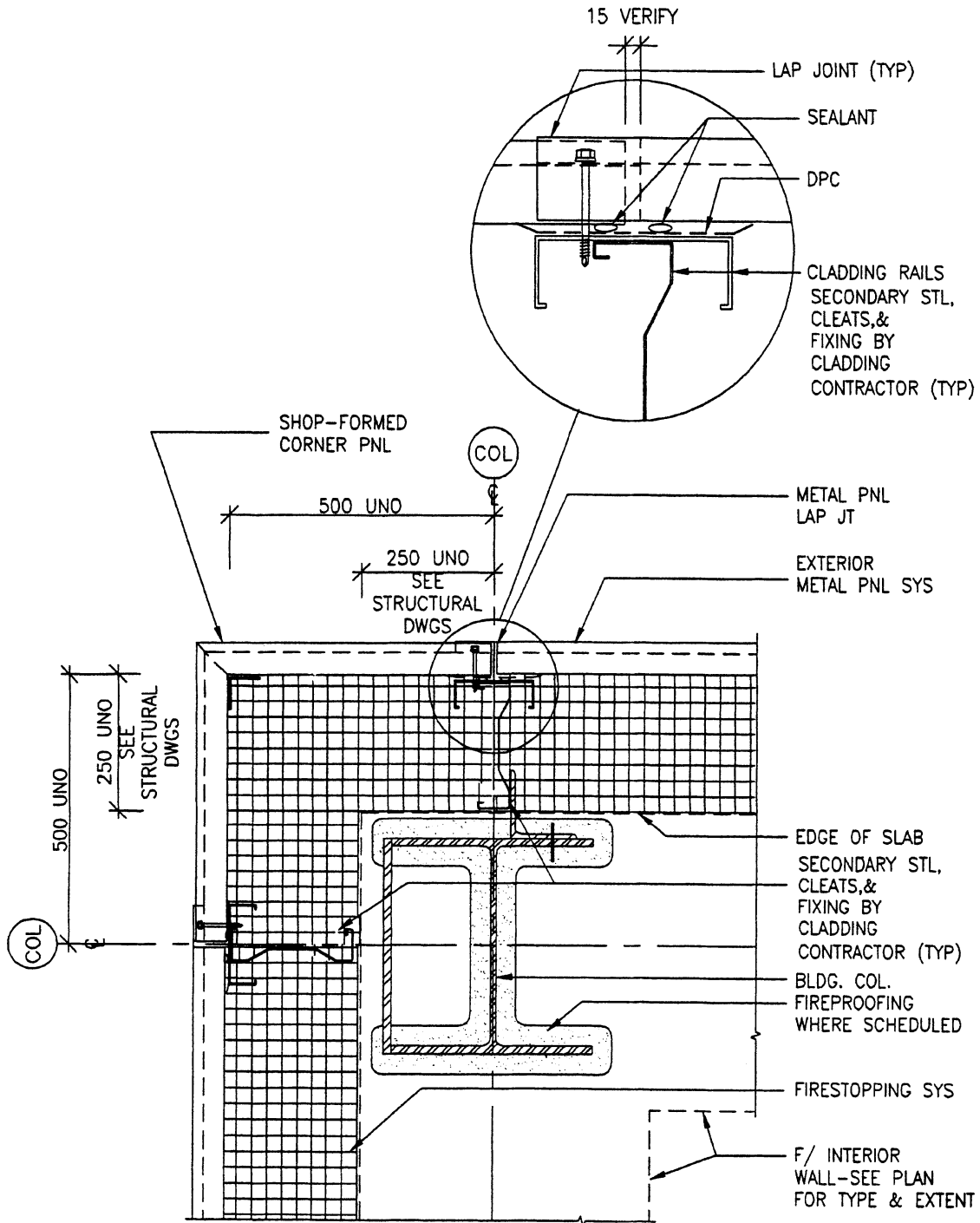

Fig. 10-65

Here the circled detail is of some added help, but both details suffer from lack of line weight variations and tend to be bland and confusing from readability standpoint.

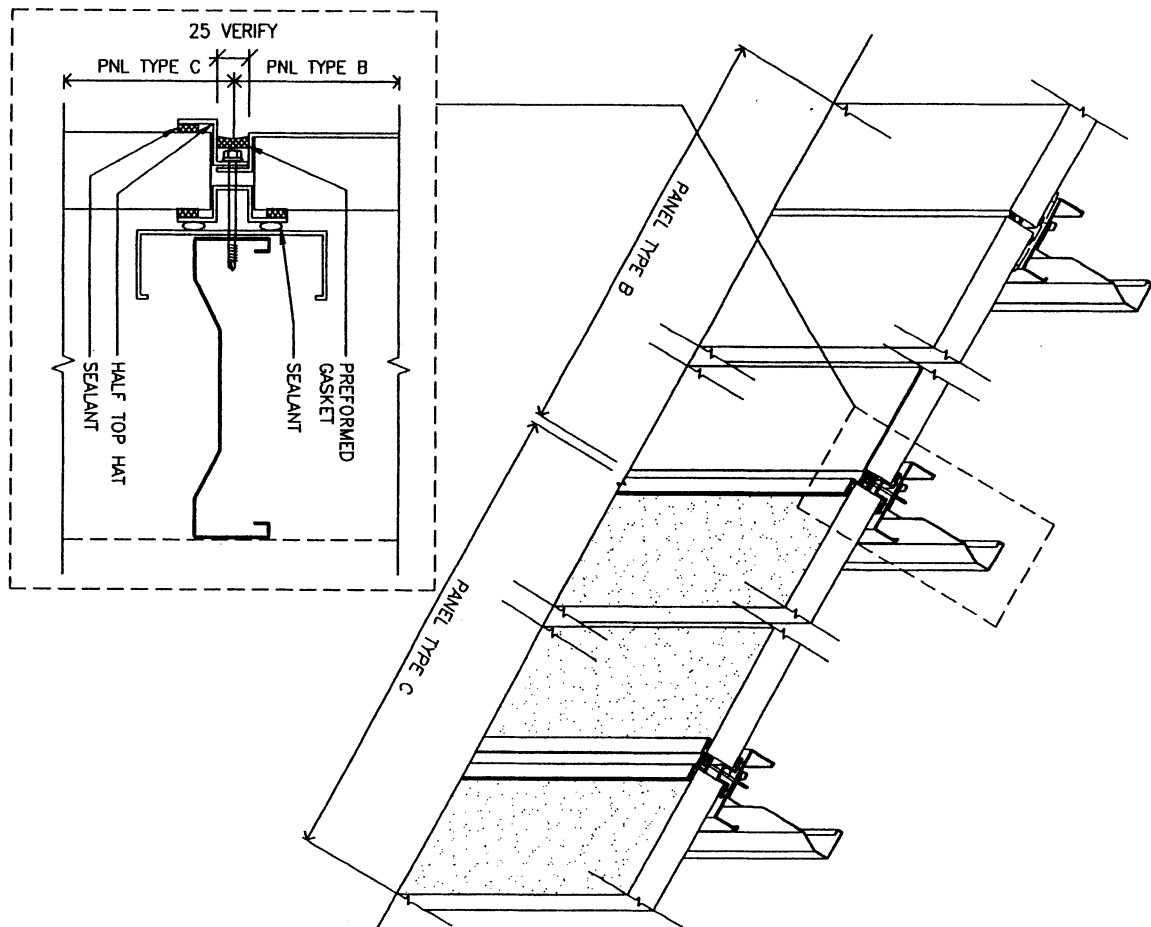

Fig. 10-66

Detail [perhaps from manufacturer] that shows the joint construction of wall panel system and its attachment to the supporting stud. Not sure isometric need be so extensive- perhaps detail in dotted box should be primary detail with mere reference to a single stud isometric- i.e., placing the emphasis on the more informational detail

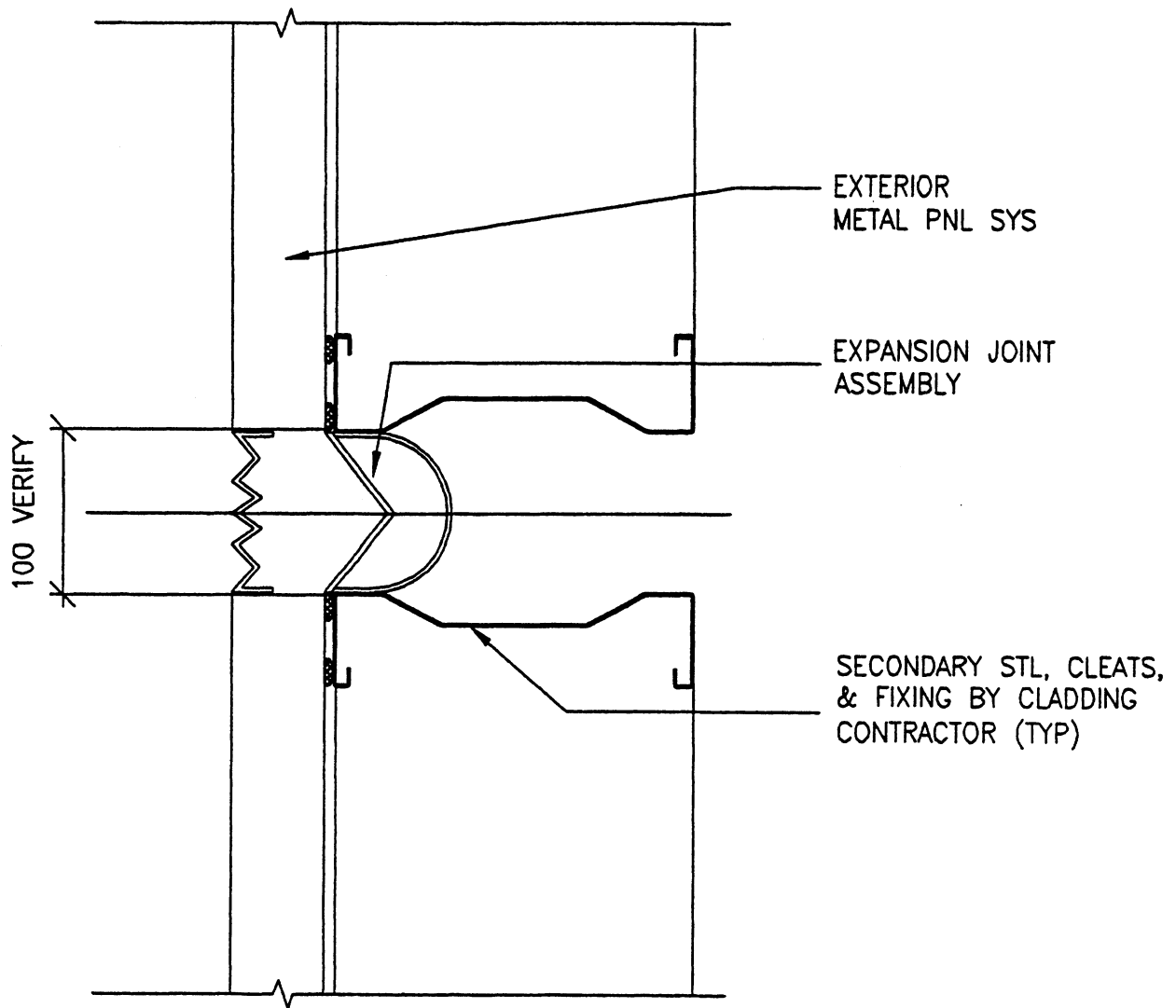

Fig. 10-67

A non-informational detail! Here the main element and cause for doing the detail is left with little information- i.e., the expansion joint assembly" note needs to be provide more information including the parts of the assembly, thicknesses perhaps, etc. Simply a lot of needed information is simply not here- if not why do the detail? Also, varied line weights would enhance detail

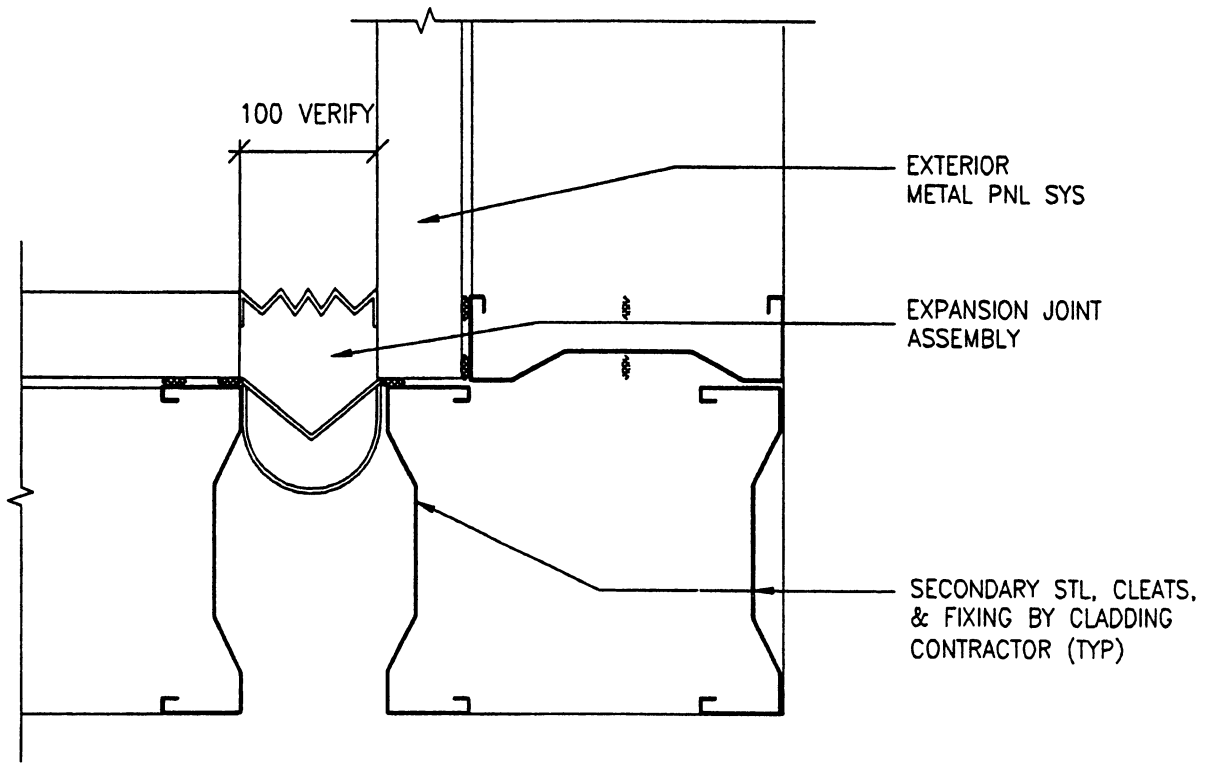

Fig. 10-68

Oops! Same problem repeated at detail at the corner of the metal panel system wall. Note total lack of information at left of detail

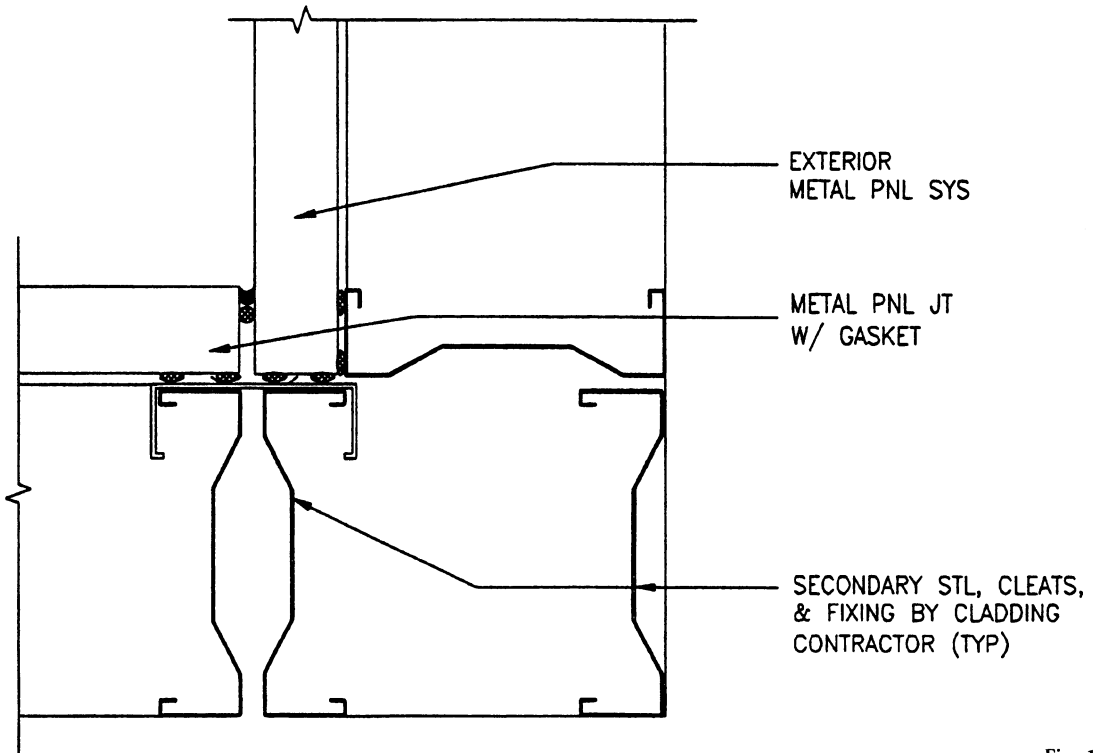

Fig. 10-69

Similar detail to 10-68 but with even less information about more construction parts and pieces

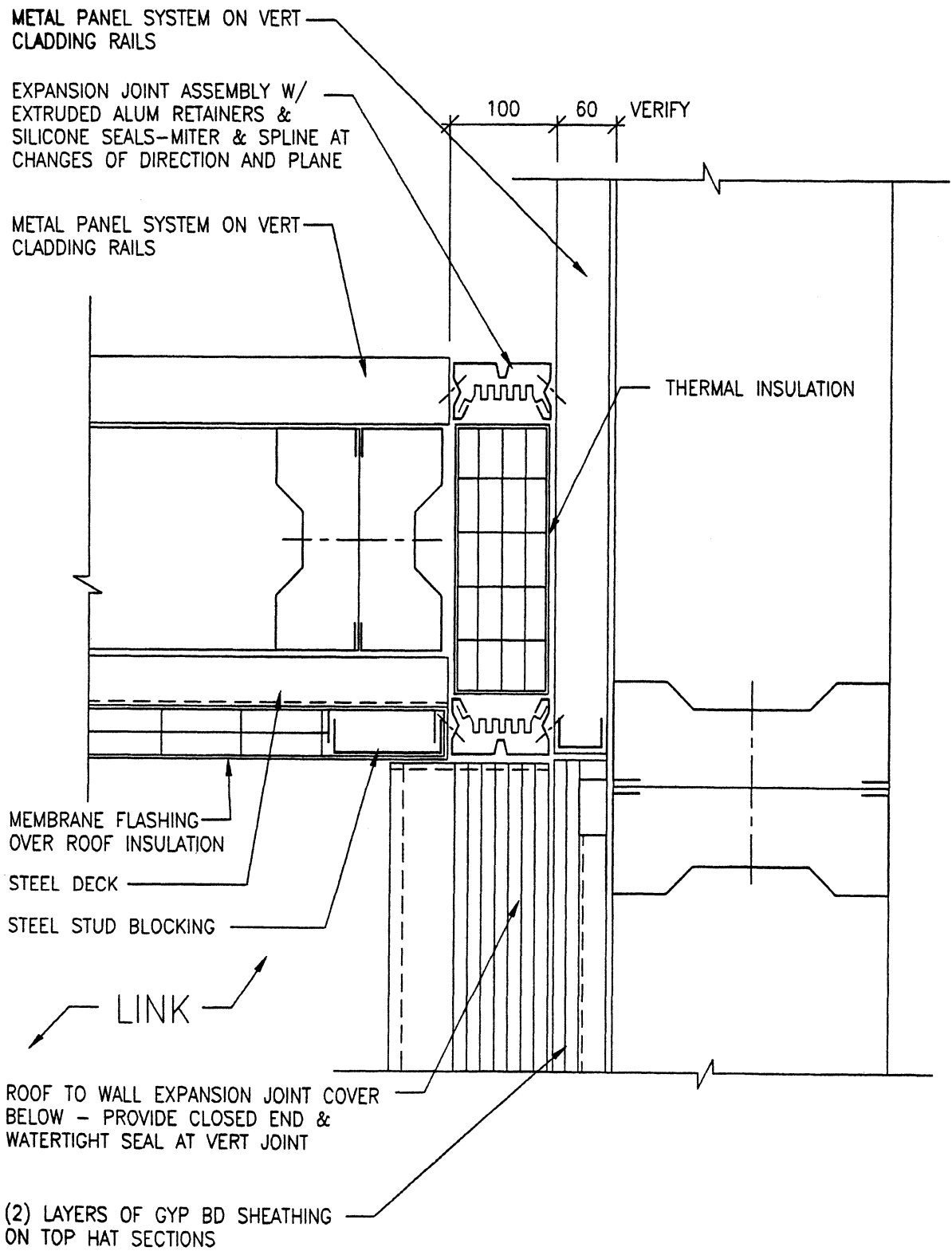

Fig. 10-70

A complex detail made even more complex and quite confusing [not easily read] by the simple lack of definition and the lack of the use of line weight variations. this is a typical example of "recording" information [i.e., just showing it] without any regard for making it easy to read and understand. Undue time will be required to simply decipher this detail.

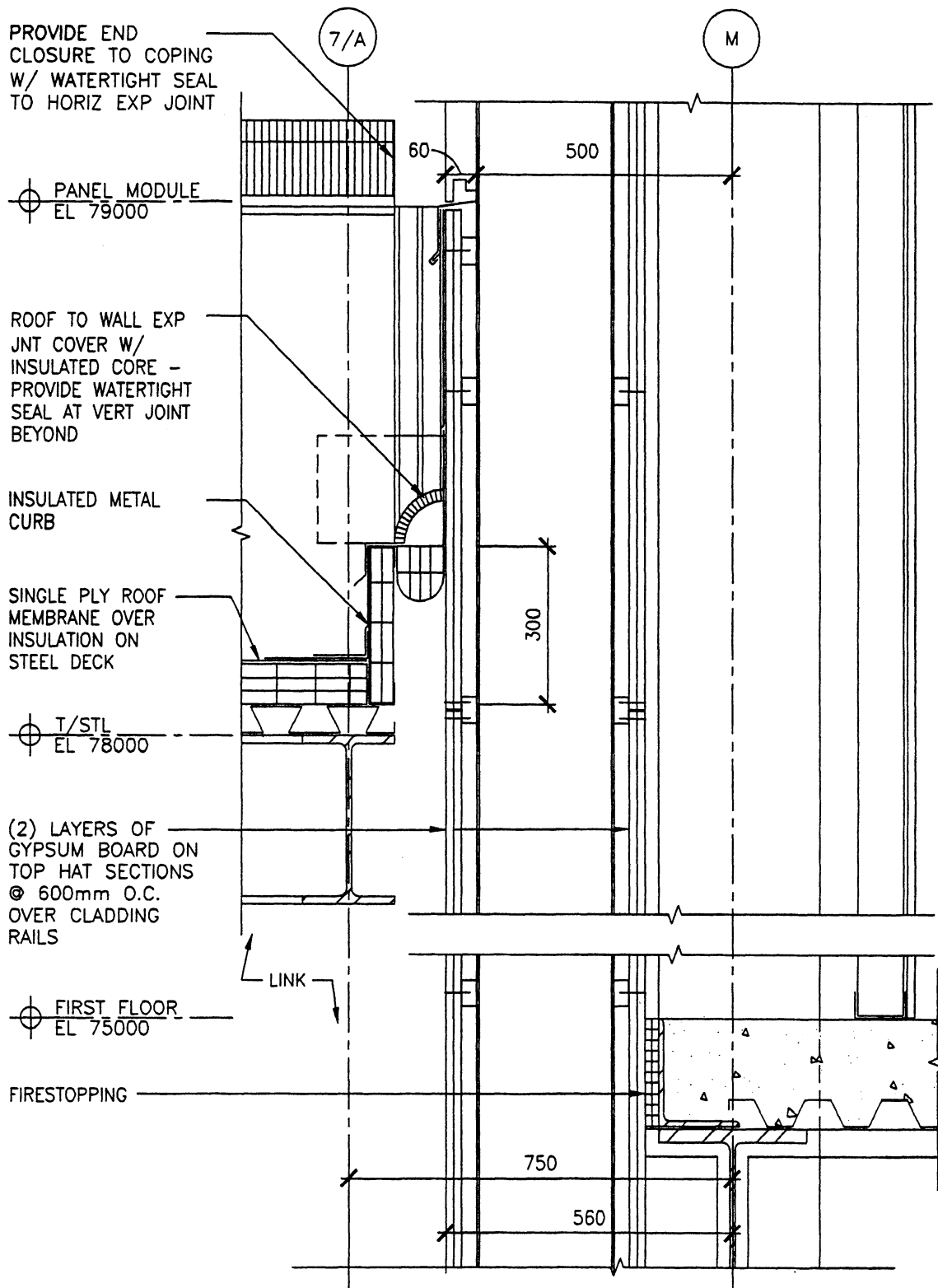

Fig. 10-71

A detail out of control and needs oversight! The primary issues if the expansion joint between roof area and wall. Too much needless, non-information on either side of Col. Line "M". And detail work below the break line is also needless [and other likely shown elsewhere]. Line work is weak and entire effort really needs some discipline- detail should never ramble like this one does involving use of too much time and space.

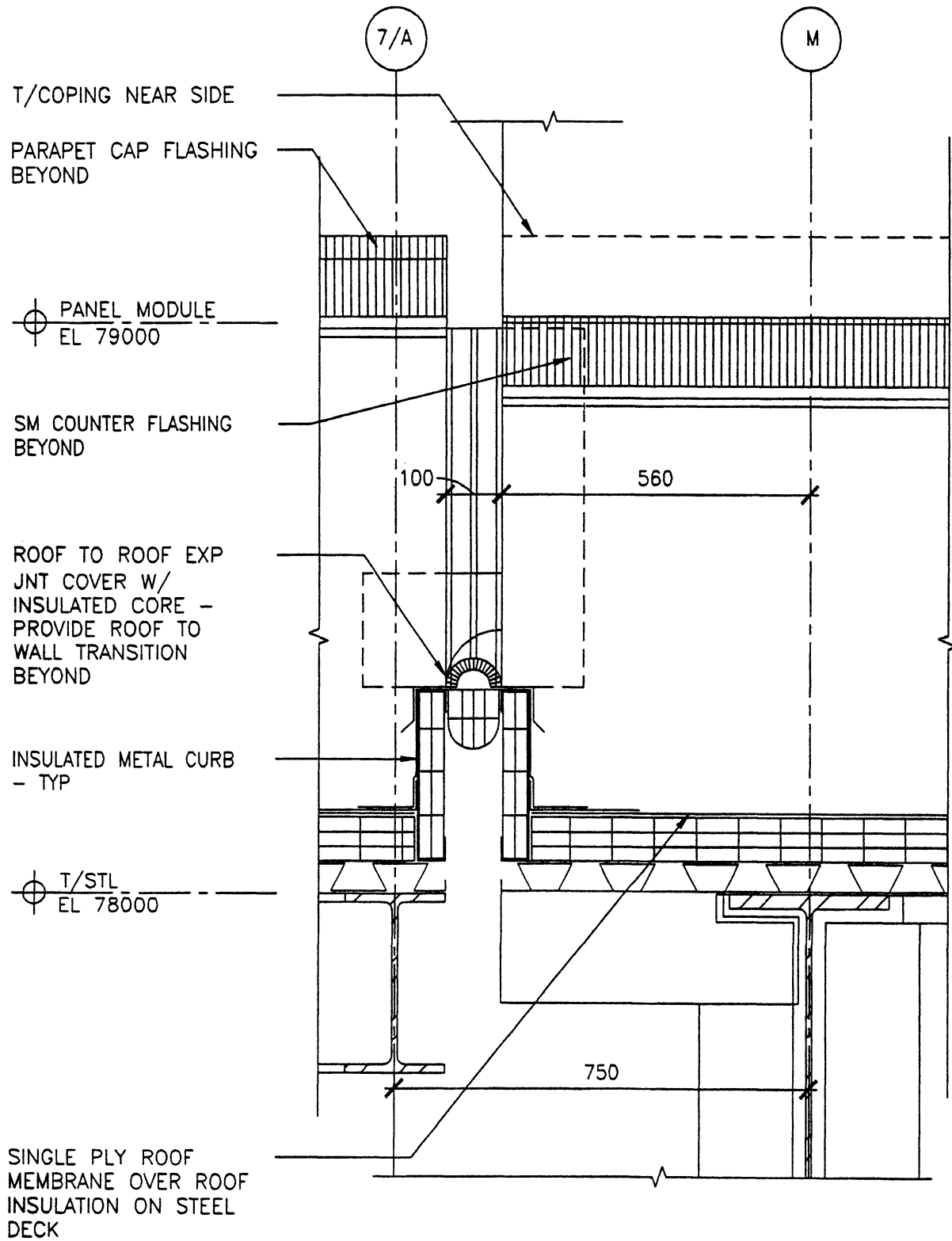

Fig. 10-72

Here, location of detail notes needs review. Long leader lines from notes to drawing that traverse the drawing need to be done rarely and then with great care. It appears that there was a decision [firm?; office standard?] to place all notes on the left of the drawing- and this proved to be ill-advised. Notes are best placed near point of application

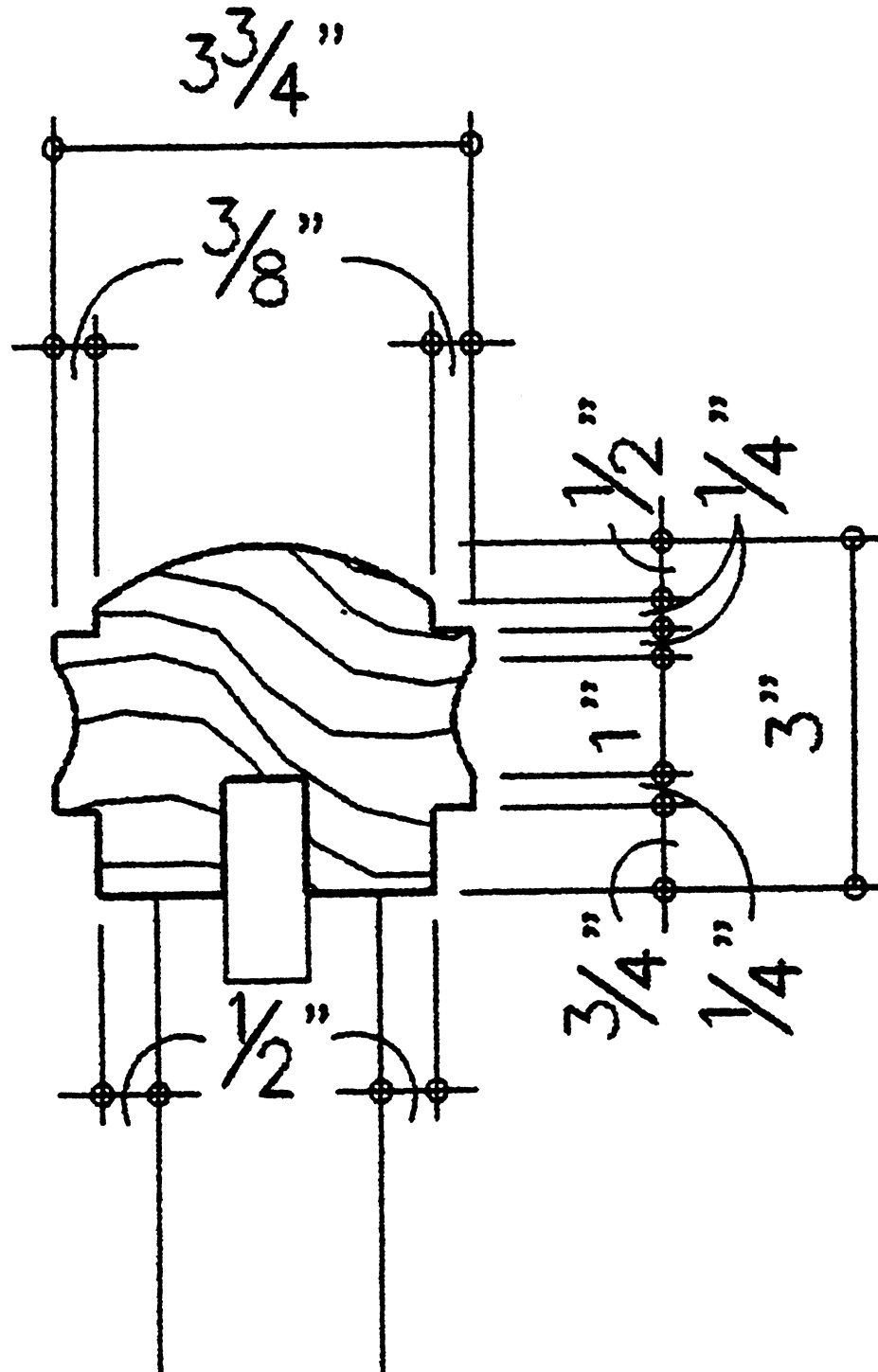

Fig. 10-73

Detail showing that no items is too small to merit some added information and distinction. Here a wood railing is detailed for a specific profile that is required to be fashioned out of larger pieces of wood stock; a reflection of a desired design feature [this profile can take any of a huge variety of railings]

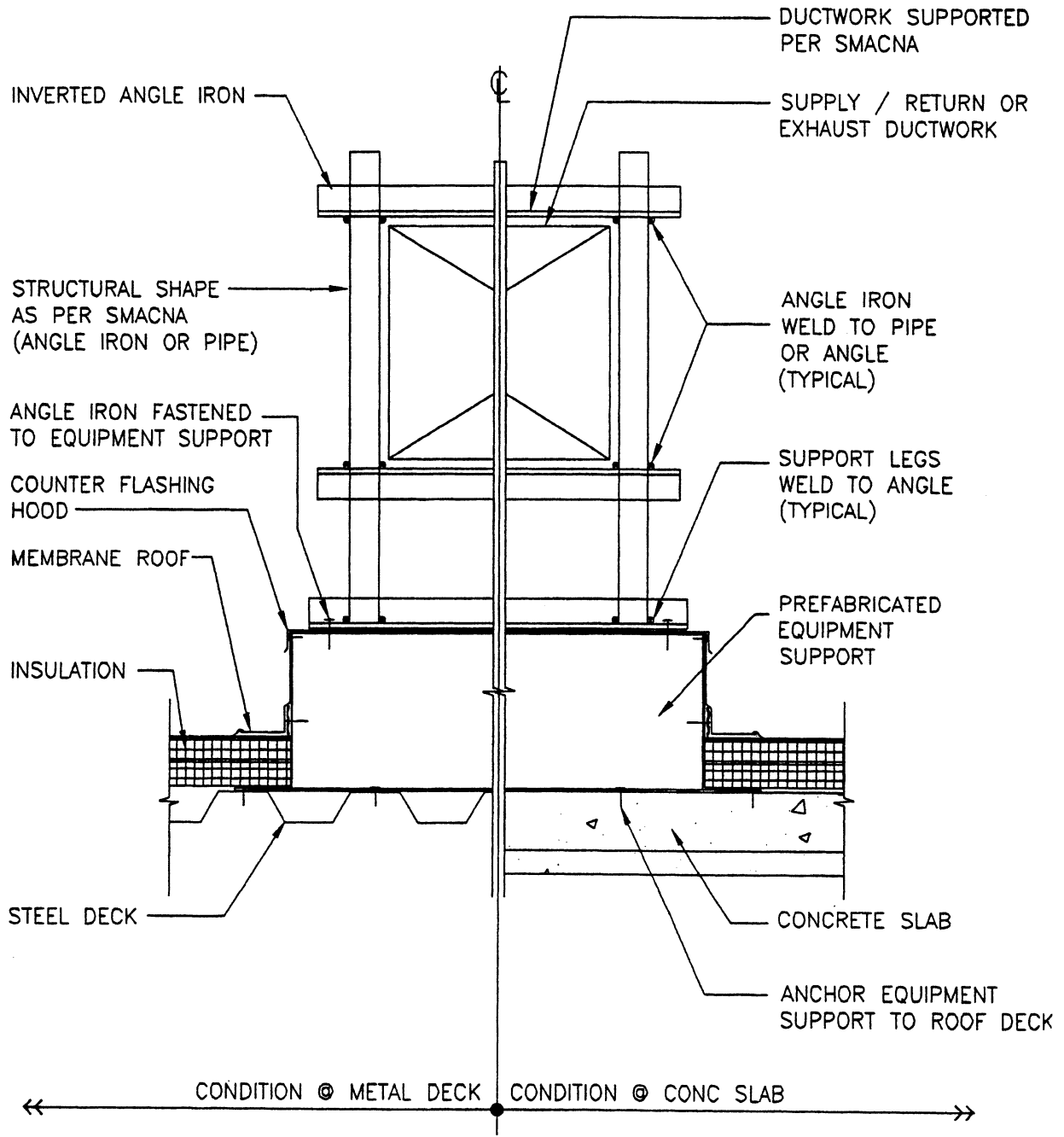

Fig. 10-74

Detail making an effort to eliminate need for multiple penetrations of the roof surface for legs of support. Only problem is the lack of detail in the note, "Prefabricate equipment support" and the lack of definition of what this is and its configuration [solid unit? some sort of hollow fabrication? materials? construction?, etc.]

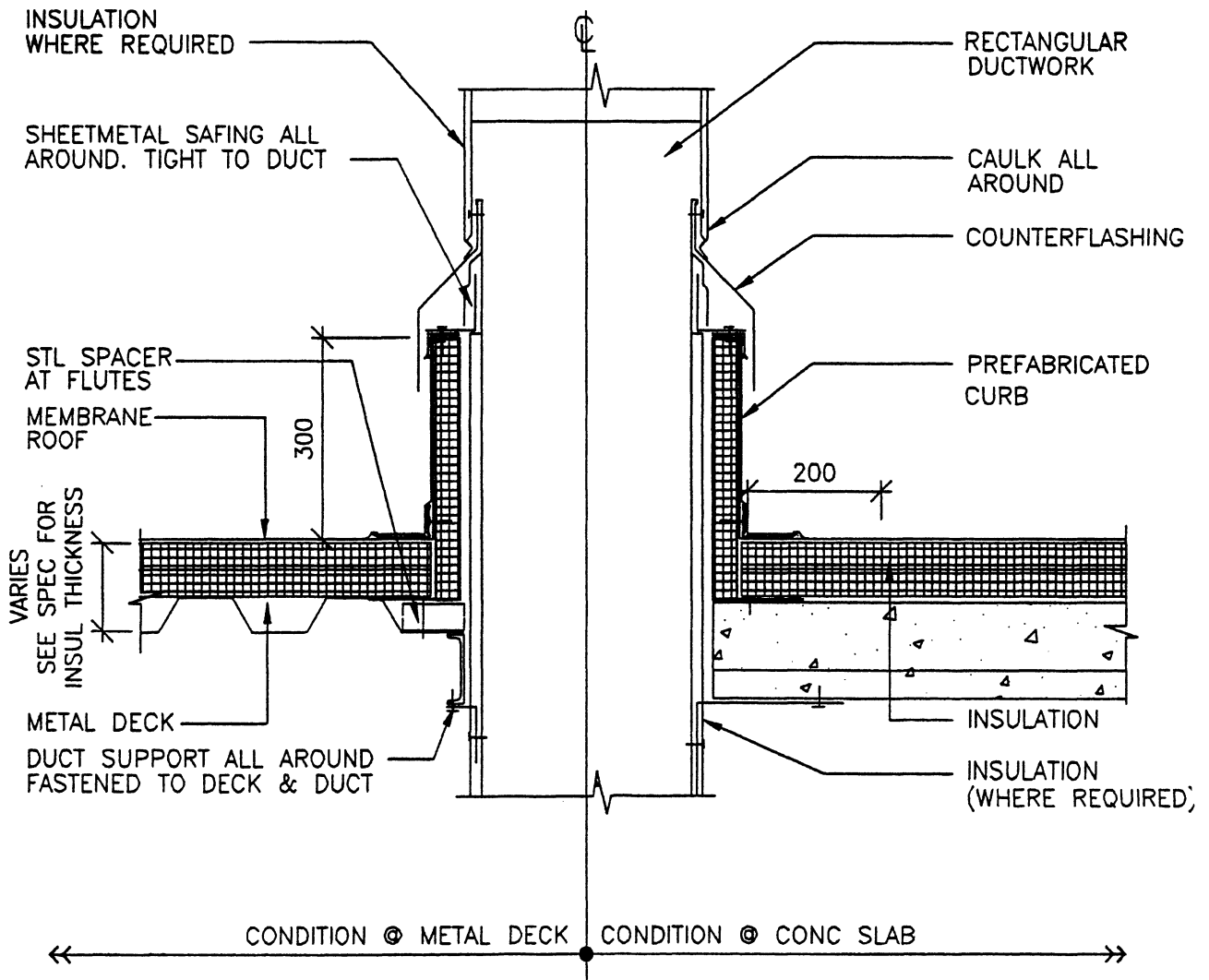

Fig. 10-75

If the insulation in the roof curb and that in the roof assembly warrant use of a material symbol [heavy-handed as it is] why is the insulation around the duct proper not also indicated by symbol? Line work generally weak.

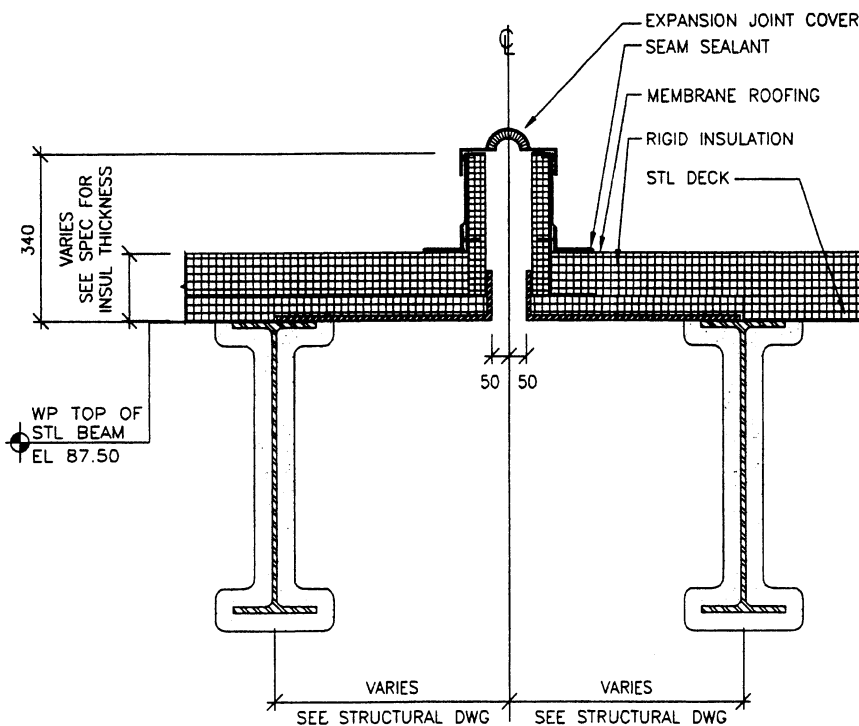

Fig. 10-76

A lot of detail for a very confined item. Why not eliminate all work to left of built-up curb assembly? Also, more information is required for that curb- if insulation is used vertically[?] then how is that covered; what is the turned-up piece under the roof system and running to the I-beam support? Bad decision to provide a lot of drawing and not enough information.

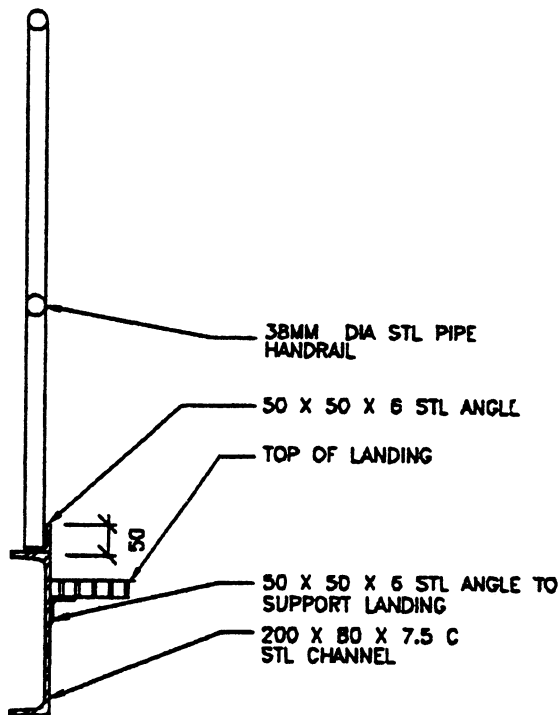

Fig. 10-77

Good example of thinking some work is so inconsequential that an unreadable detail is included- bad thought process! A grandiose detail is not necessary, but surely one should be provided that gives more information and a better chance for reading and use

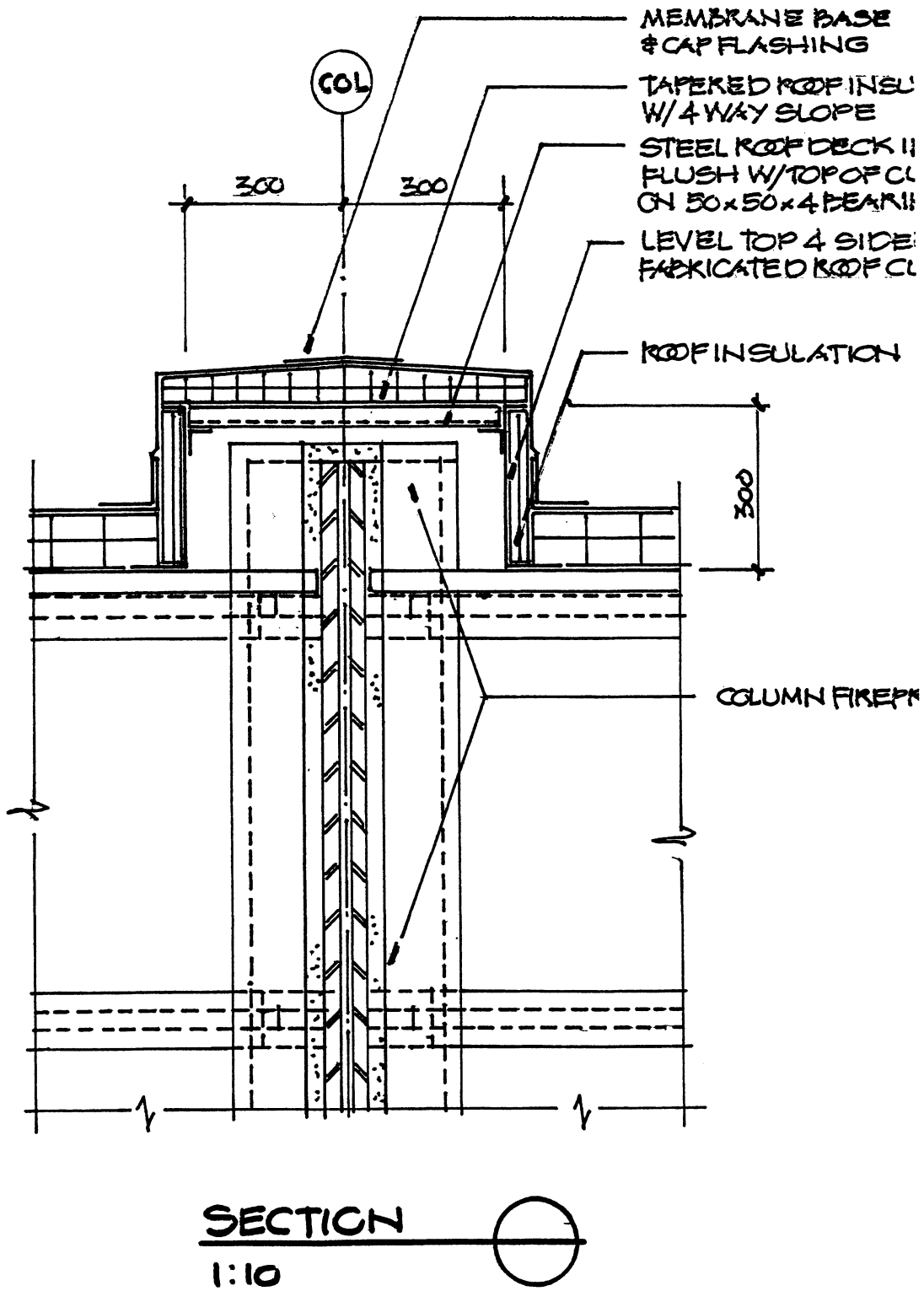

Fig. 10-78

Detail of the cover over a building column that penetrates the roof system [anticipating upward extension when building is expanded]. Good forethought but detail added needless cost. While a standard pre-fab curb is used, the cover can easily be fashioned by the curb manufacturer in lieu of the labor-time-heavy multiple layer construction shown that runs roofing up and over curb [the added cost]. The roof deck to be installed within the curb may be a safety factor that also may be resolved via the pre-fab curb cover; or may be is shown to support the tapered insulation. Further no need to run roof insulation around the curb; specify an insulated curb to start. Lower 1/3 of detail could be deleted.

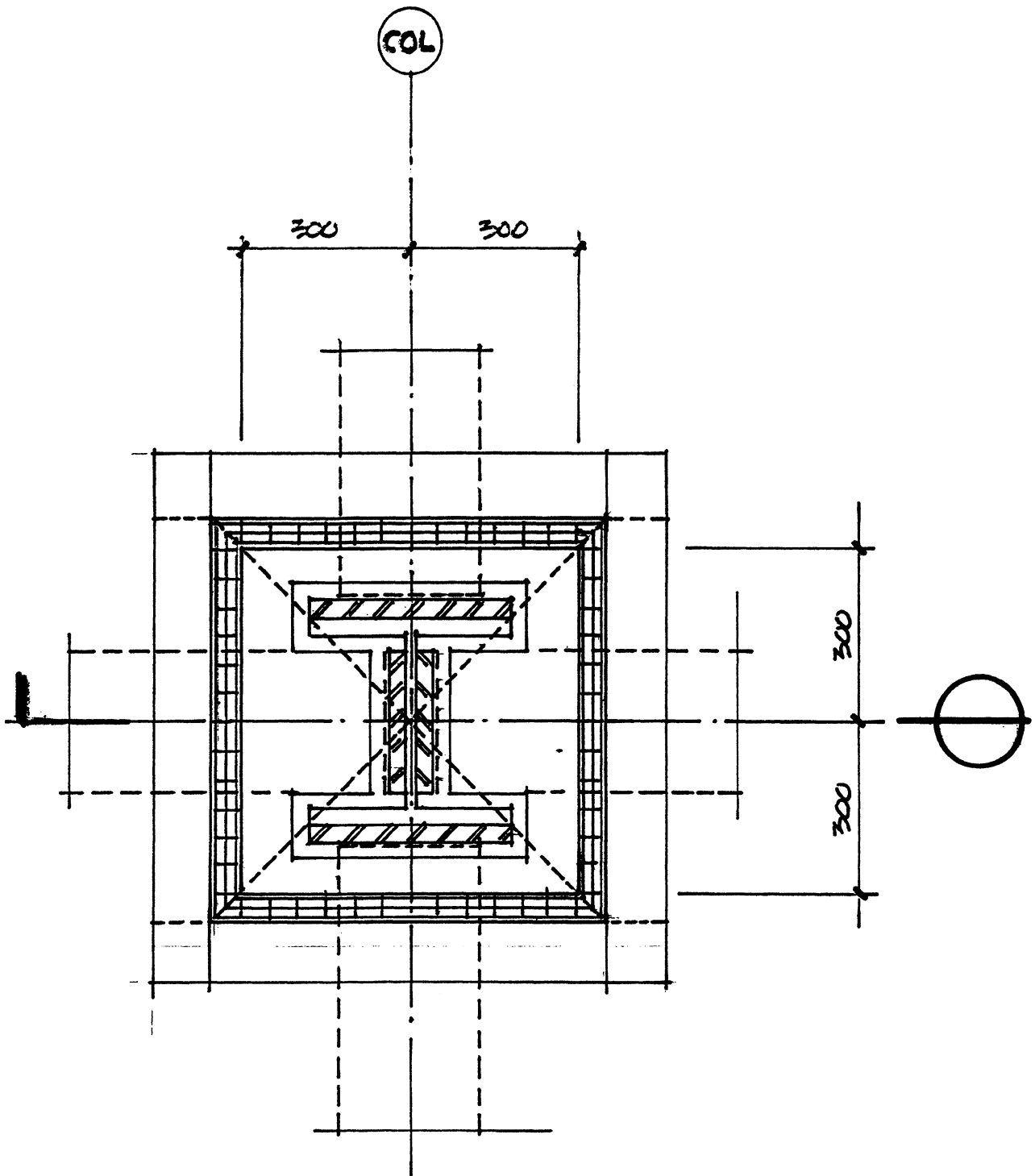

Fig. 10-79

Detail allied with Fig. 10-78 but obviously with no notations. The I-column is defined, but the applied material [using the two-chevron indication] is not identified and while may be necessary seems extraneous The larger box around the column is the fireproofing

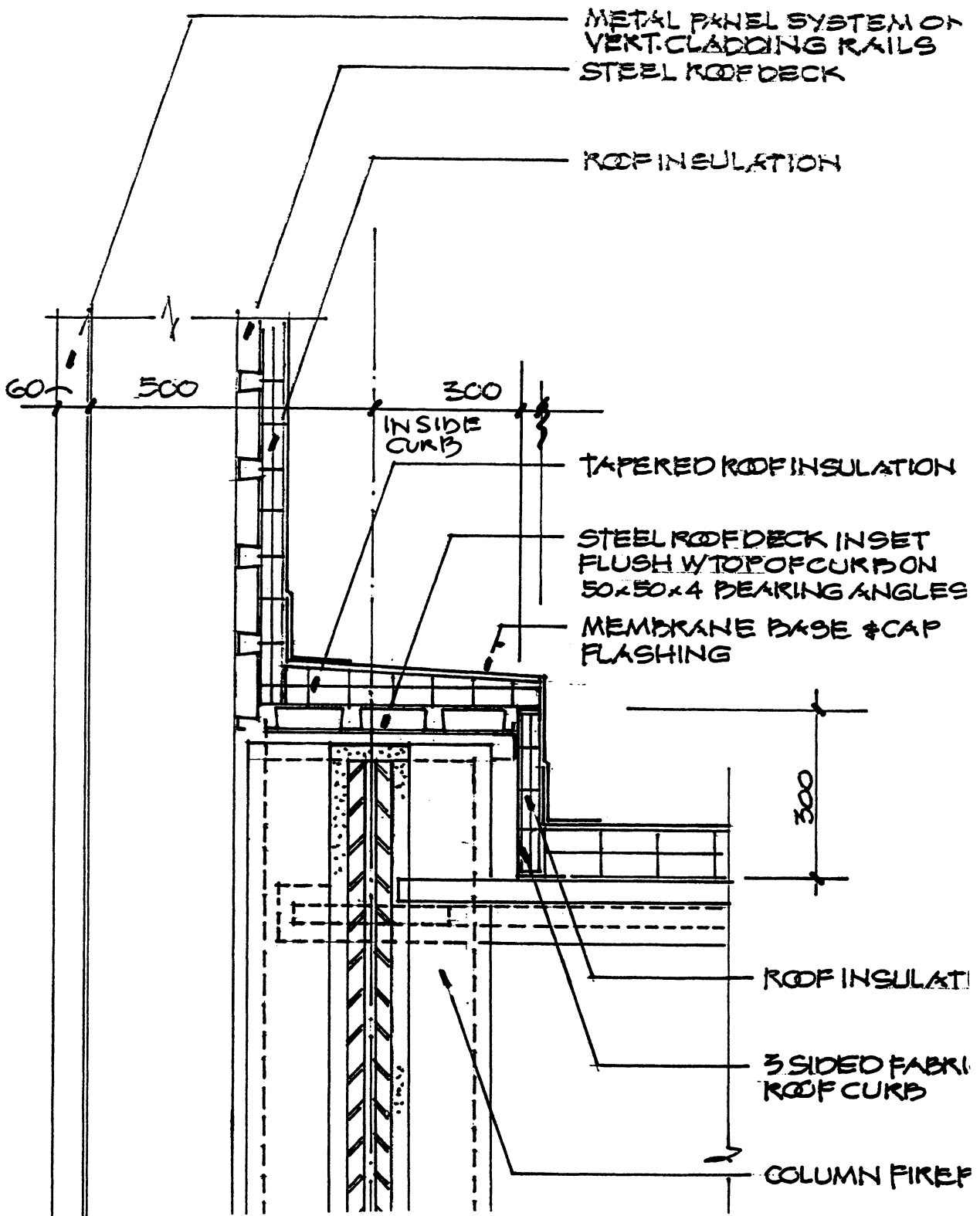

Fig. 10-80

A companion to Figures 10-78 and 10-79 but here wall is adjacent to column. Use of three-sided curb would seem to indicate the same type of metal curb cover could be provided and properly tied into the wall facing with flashing.

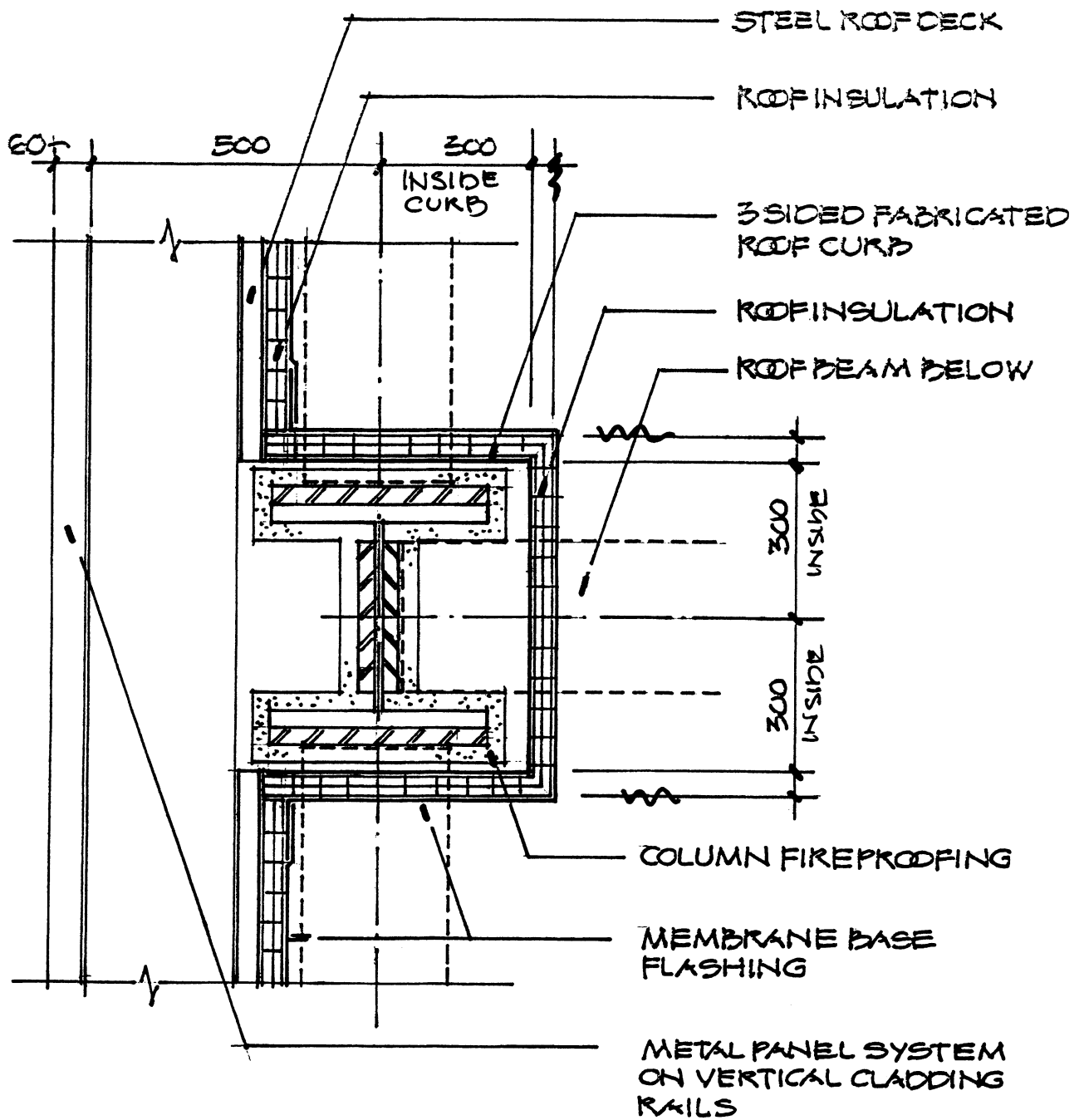

Fig. 10-81
Plan view Section associate with Fig. 10-80; see notes above

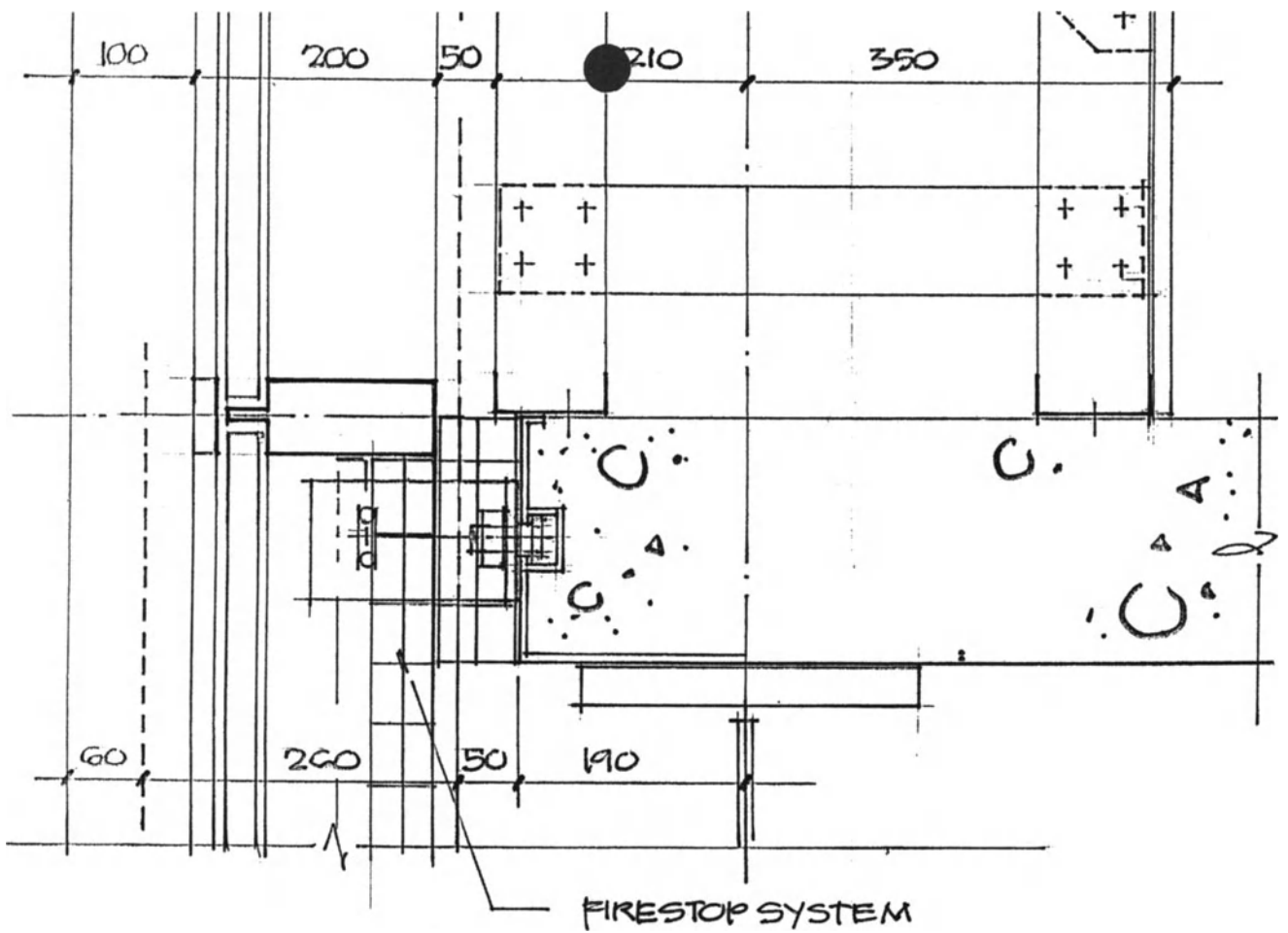

Fig. 10-82

Hopefully, a preliminary detail! The lack of notations is striking and leaves the effort as useless. In addition, some line work needs attention and the multiple parts and pieces need to be noted and related. Example of what should never get to the field!

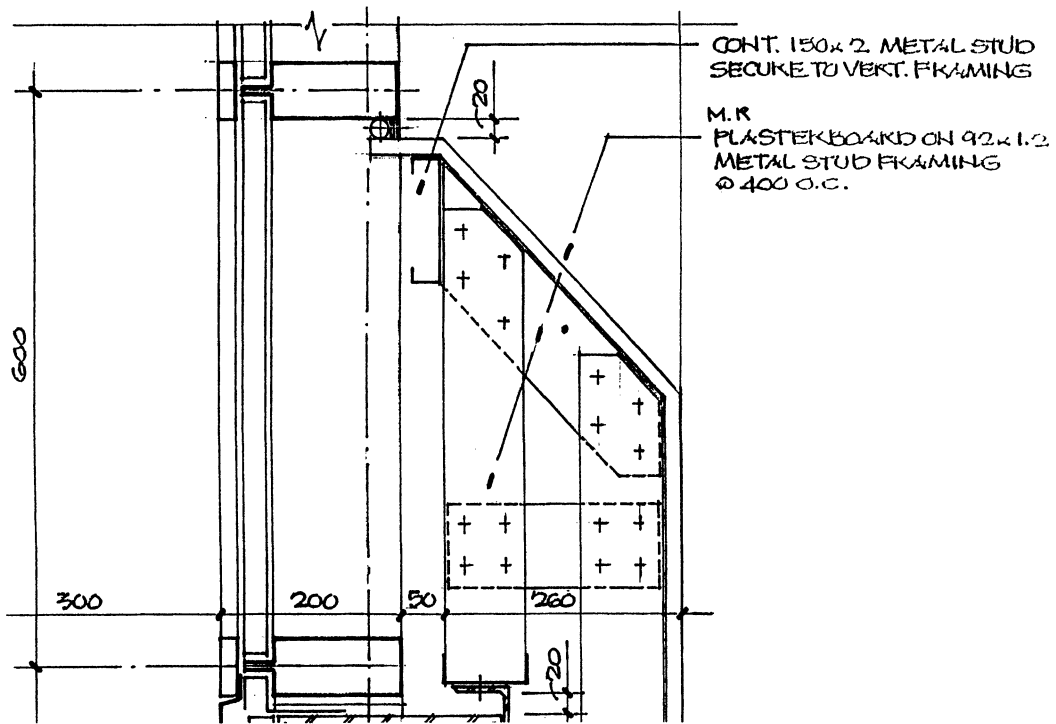

Fig. 10-83

Preliminary detail used here to show how one note can be used to indicate several materials [here in a sequence of construction]

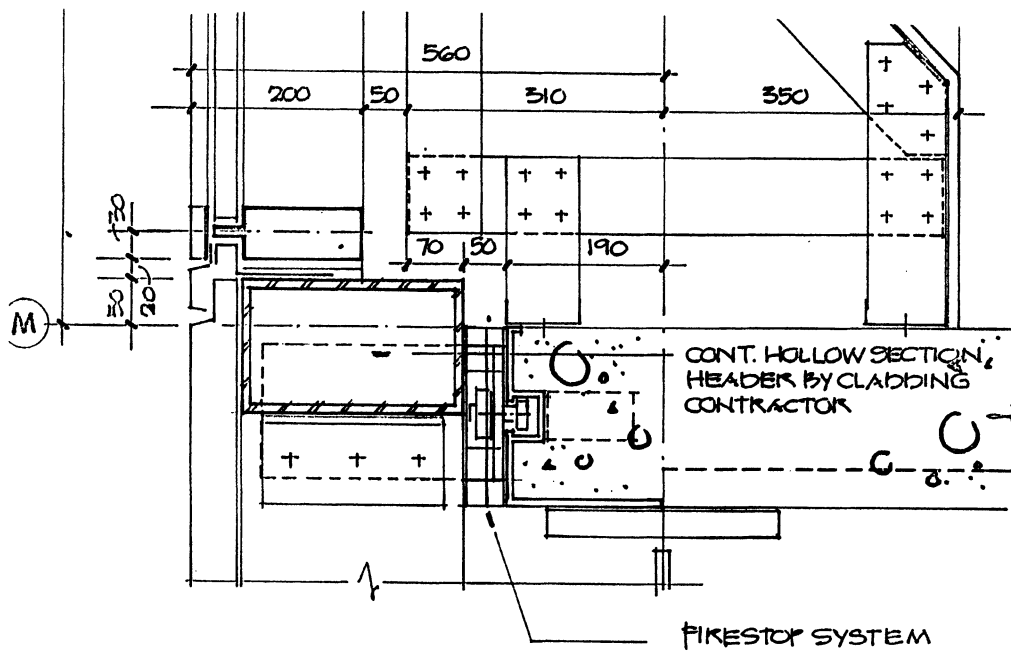

Fig. 10-84

Good start for a detail- how much can you locate that you feel needs attention or explanation [notes, etc./]? Also, the bigger challenge- what do you feel is missing?

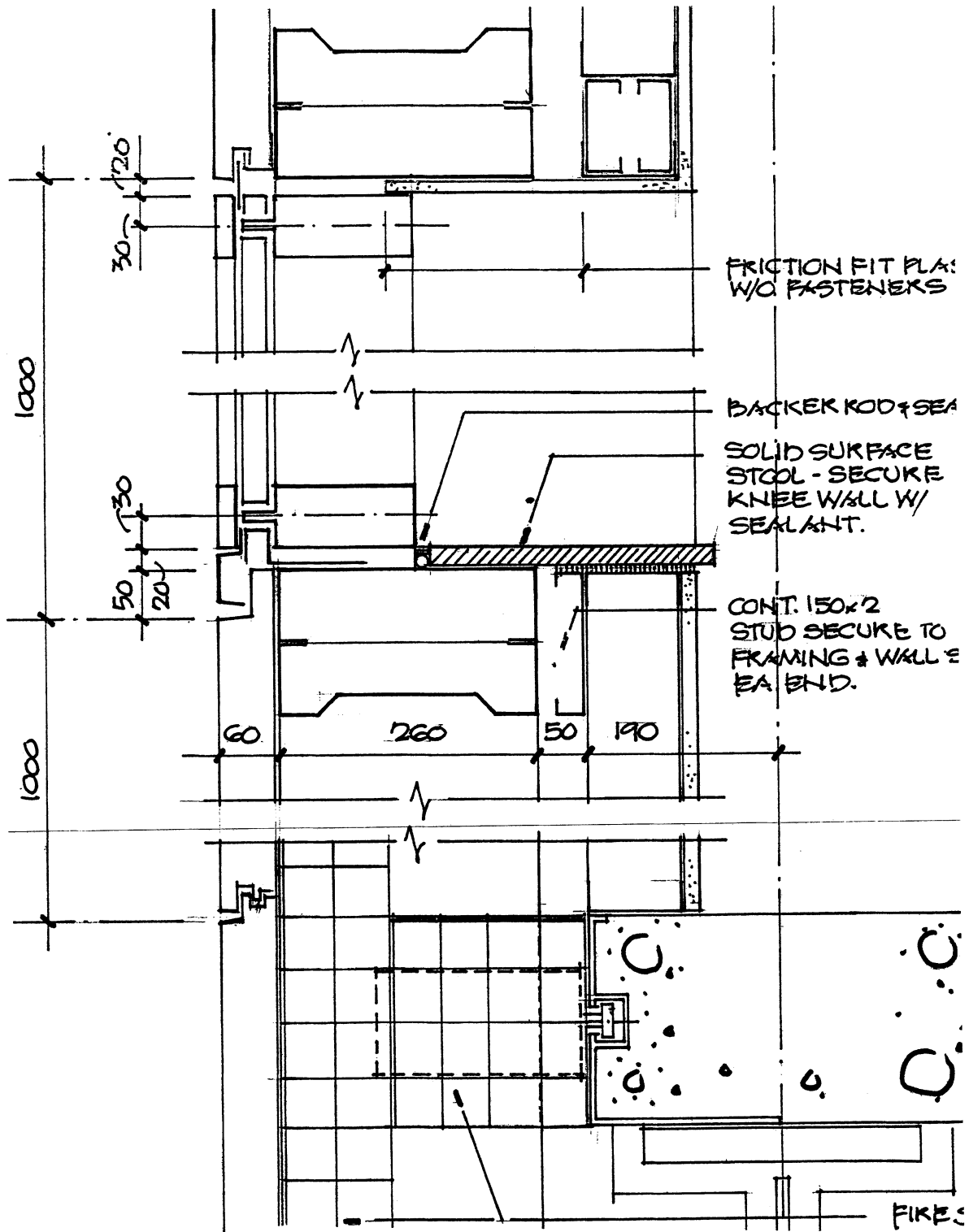

Fig. 10-85

This detail would be greatly enhanced and more readable if varied line weights were used. The sameness of the line work tends to blur the overall concept and presentation.

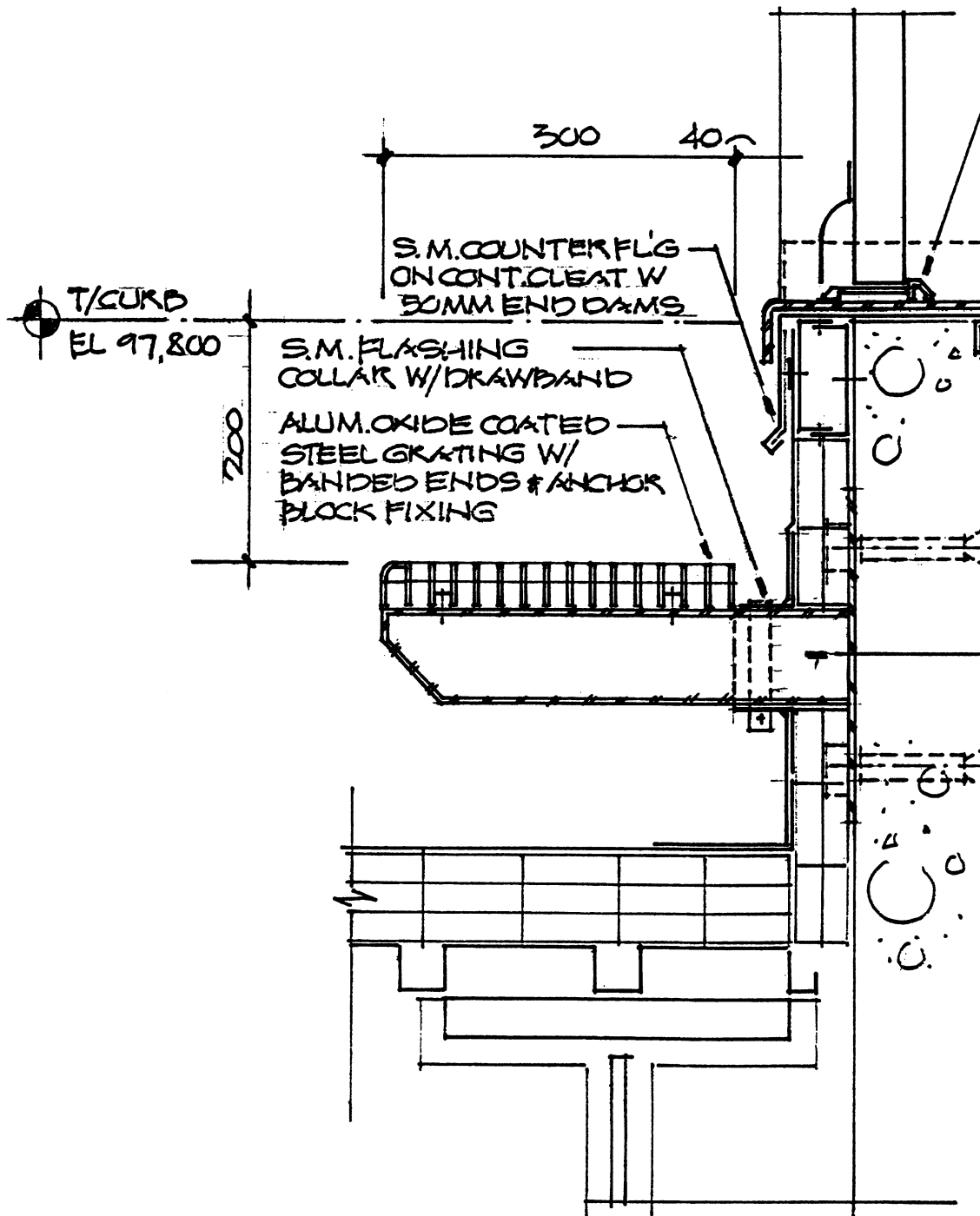

Fig. 10-86 Section detail of a metal grating step from a rooftop penthouse to the adjacent roof. Note how the line work draws the eye to the more important items being shown and lets the ancillary work regress [since it is not as important to this detail]

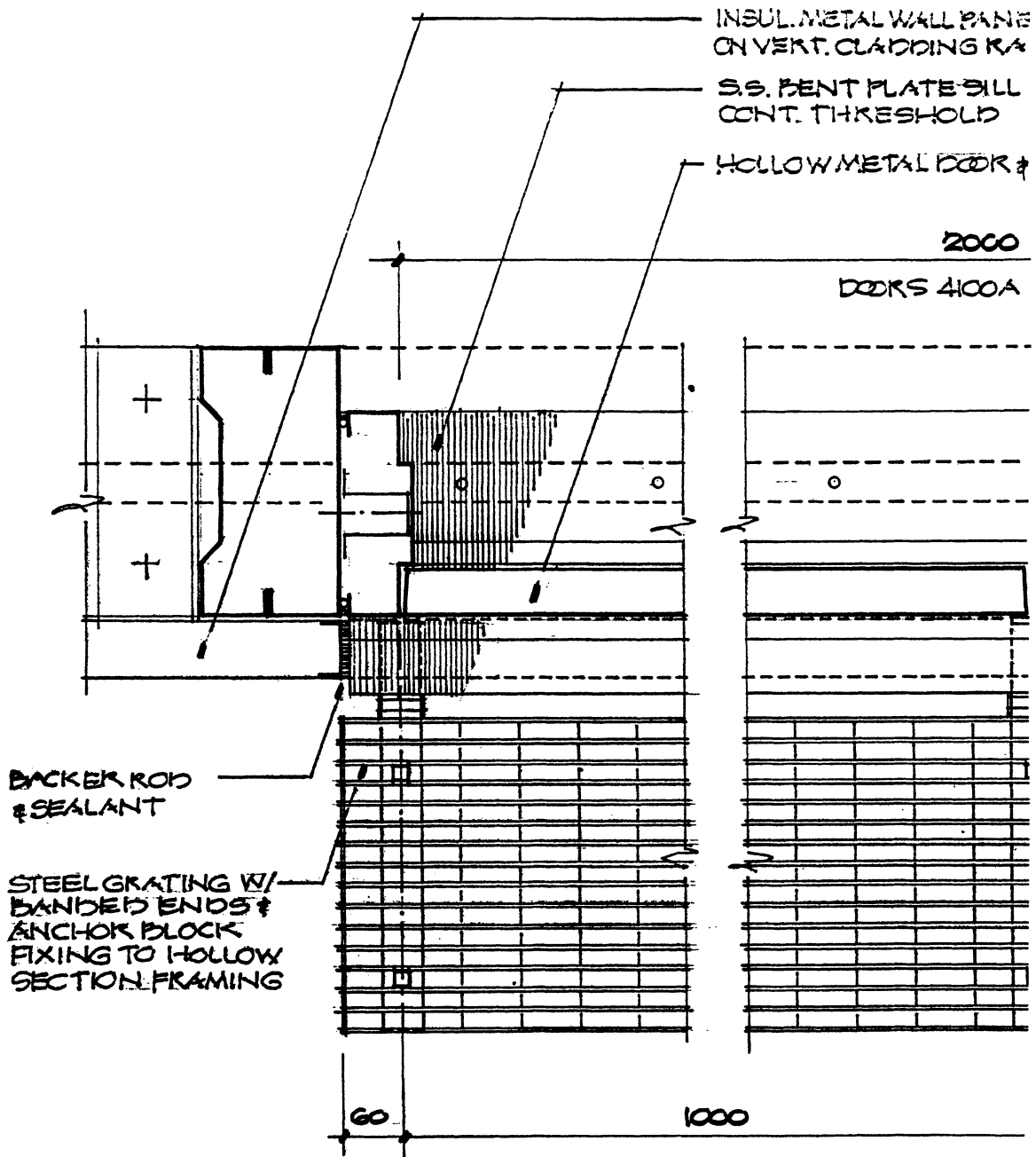

Fig. 10-87

Plan view of the step in Figure 10-86 used to relate how the step works to the area and construction around it. Again good variation in line work helps define detailed items and work.

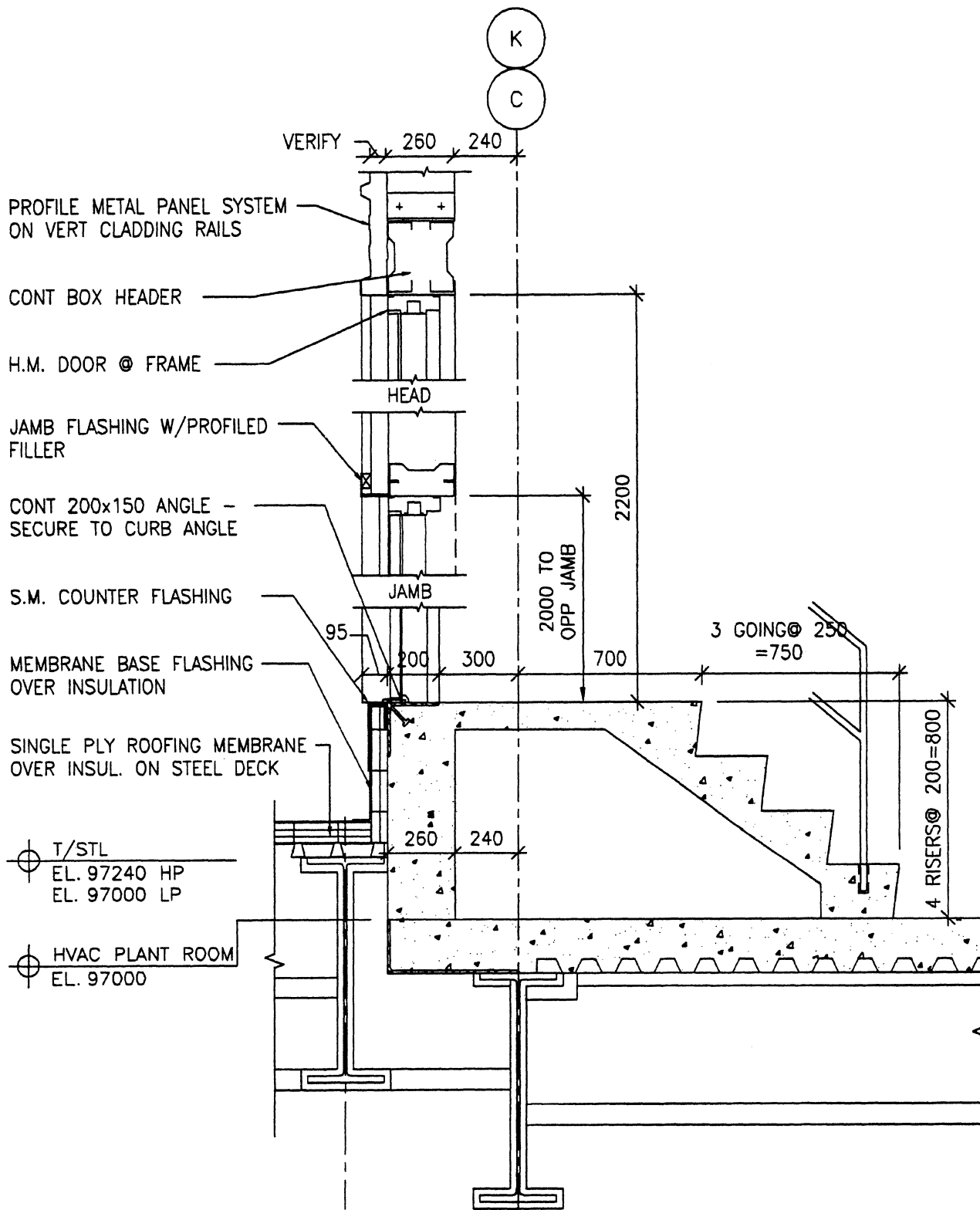

Fig. 10-88

Detail of concrete stair used in same way as steel is used in Fig. 10-86. Note blandness of detail; the lack of visual emphasis and the increased difficulty in reading the detail. Again, varied line work would help a good deal.

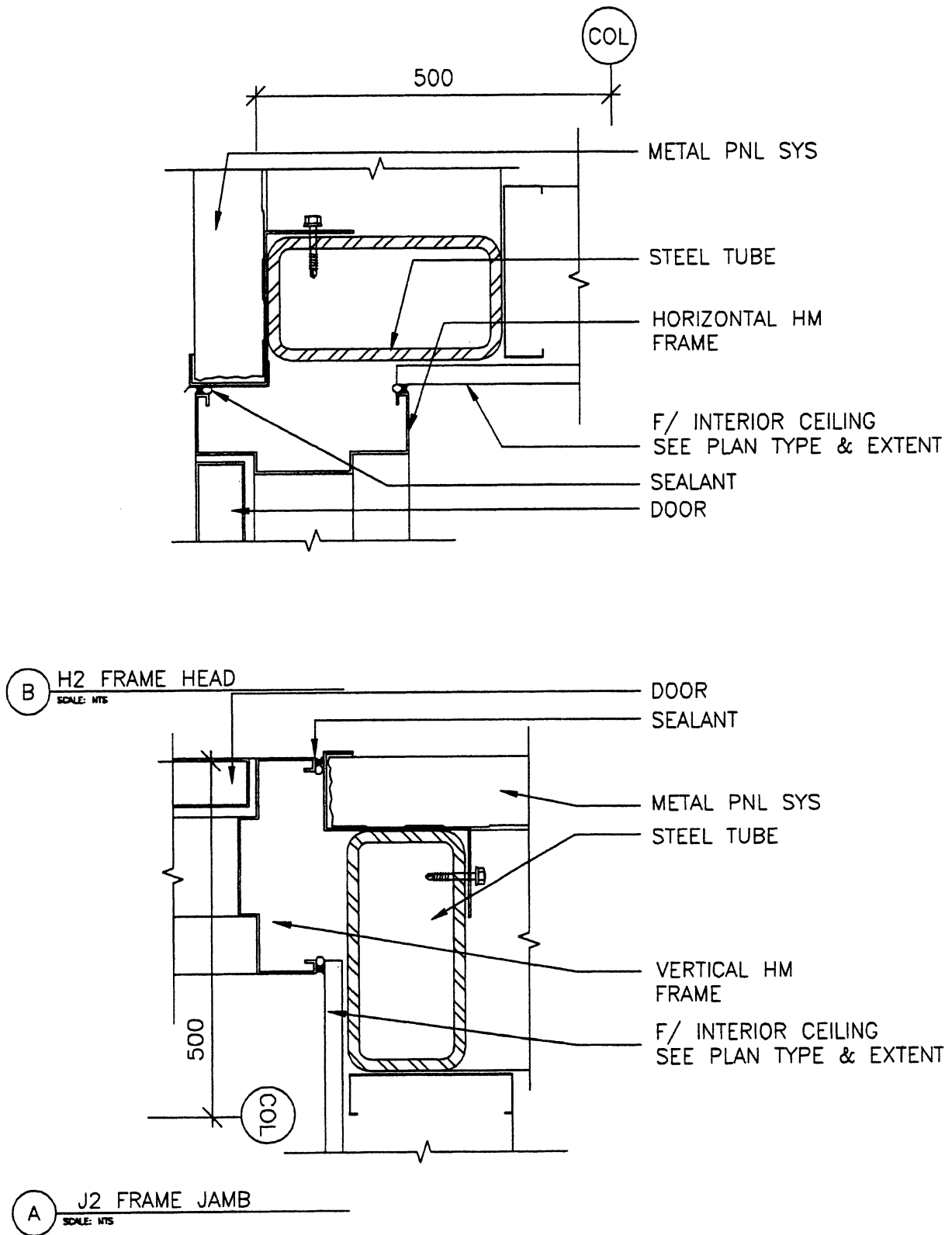

Fig. 10-89

By noting "Frame" and Head" these obviously are details of a door frame.

The problem is that it is difficult to identify the frame itself since all line work is similar and without emphasis. It is better to ensure that the primary item being detailed be shown clearly and distinctly from the surrounding ancillary work.

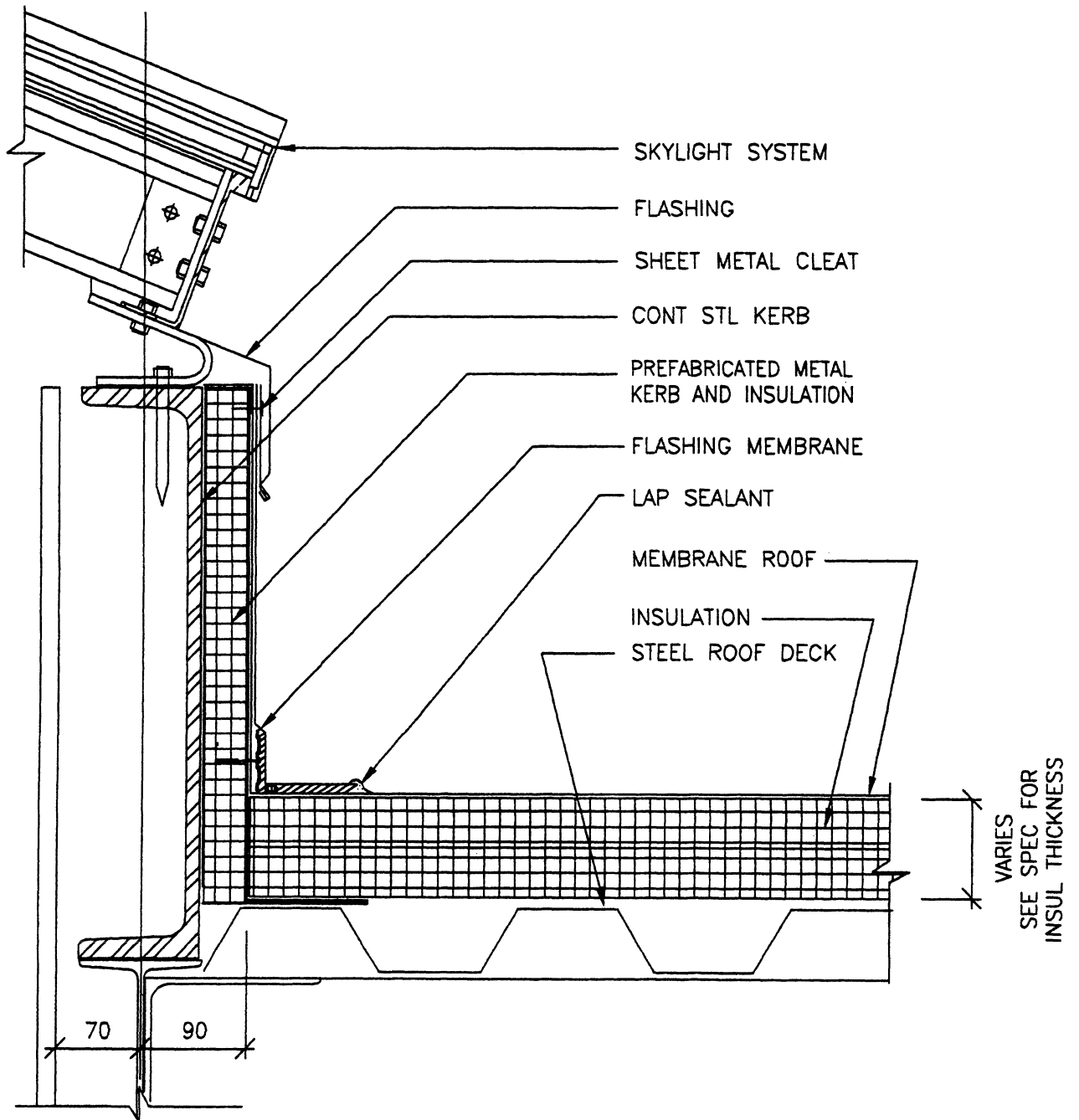

Fig. 10-90

A detail saved by the material symbols [to differentiate the material] and scale [large enough to show various layers and edges of materials].
But also over-detailed in that time has been taken to show configuration of bolts and fasteners needlessly.

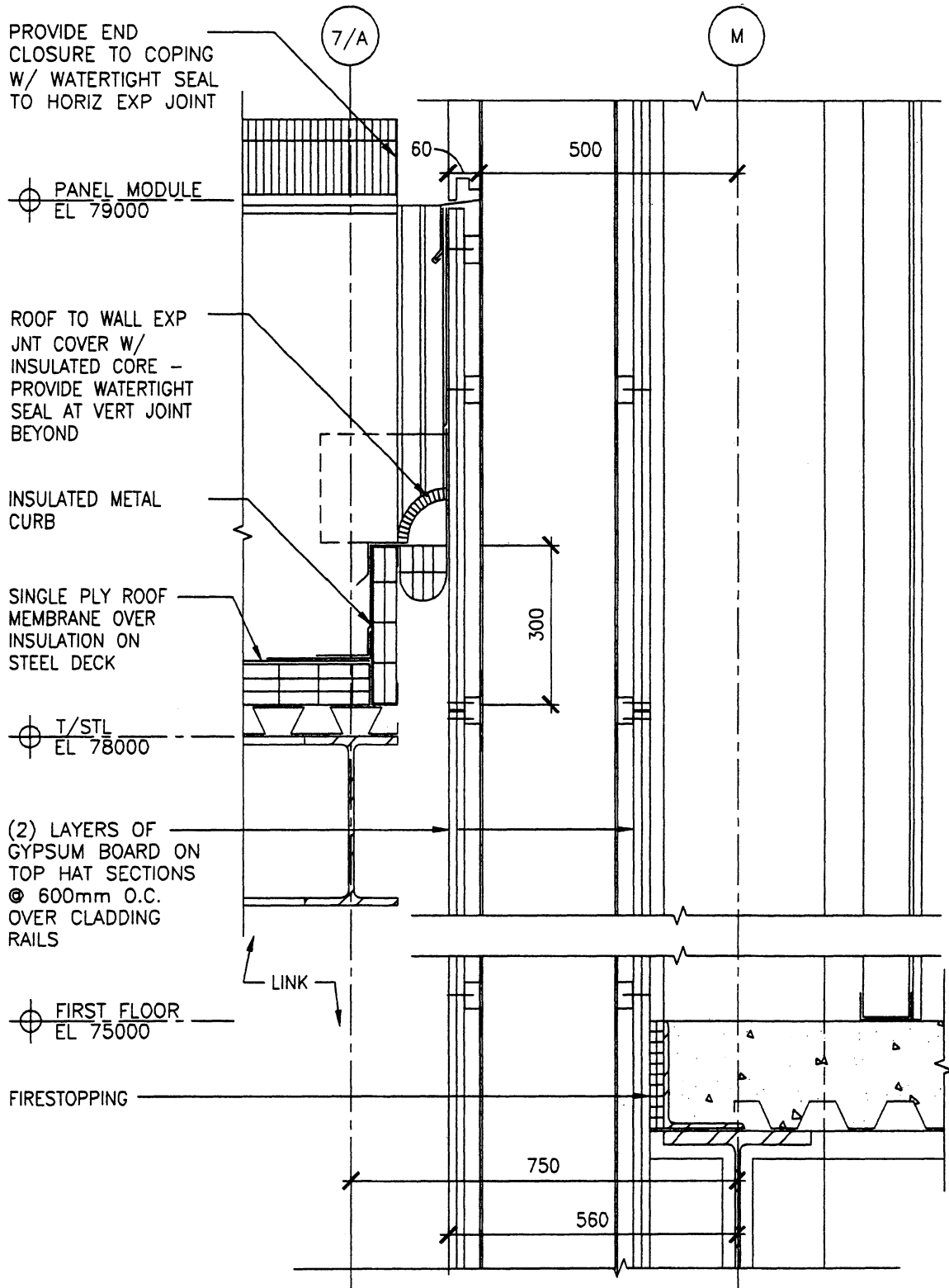

Fig. 10-91

A detail with a lot of work involved and a lot of lines all which show relatively nothing. What if this detail was confined to the upper left [above the T/STL note] and to the left of the "300" dimension? Would then show same information and could be done in better line work and perhaps a larger more readable scale.

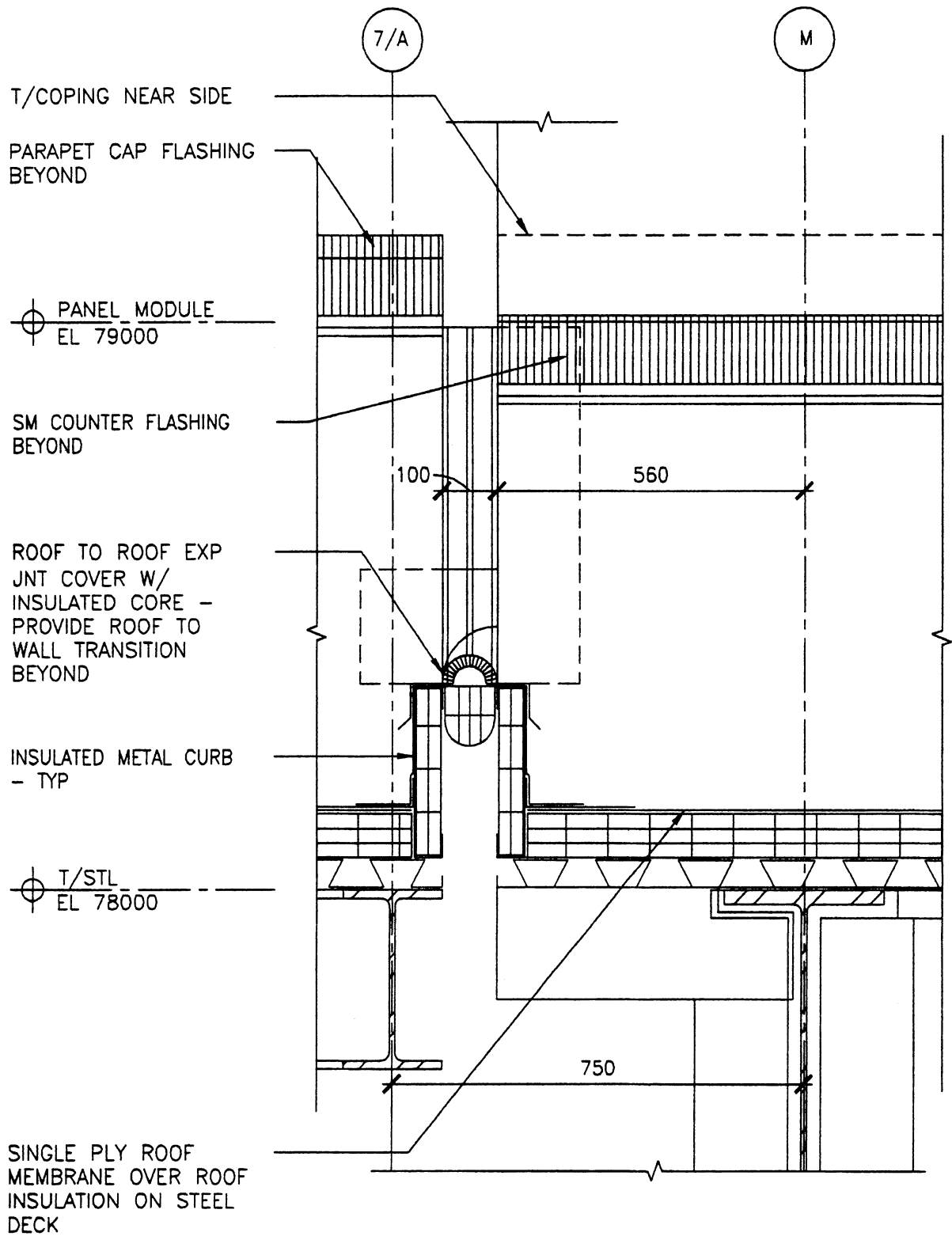

Fig. 10-92

This detail relates to Figure 10-91, and illustrates how using a smaller area overall allows for clearer detailing of similar work. Also line work somewhat improved.

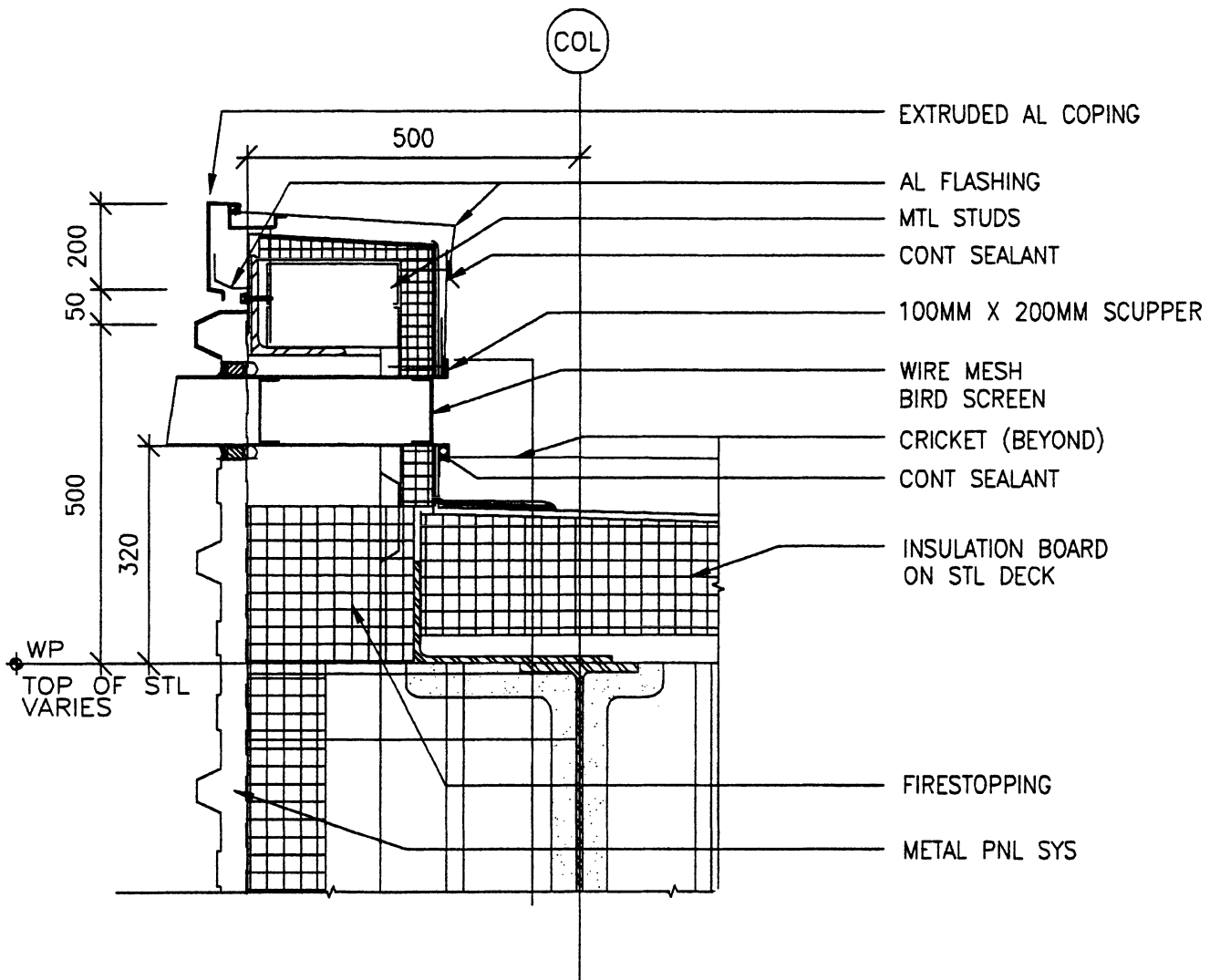

Fig. 10-93

Detail suffers from scale used. Small scale makes thin material become a blur and difficult to read.

Also note treatment of "metal pnl sys" immediately above and below scupper.

The primary feature here is the scupper box that penetrates the wall-- is that immediately apparent?

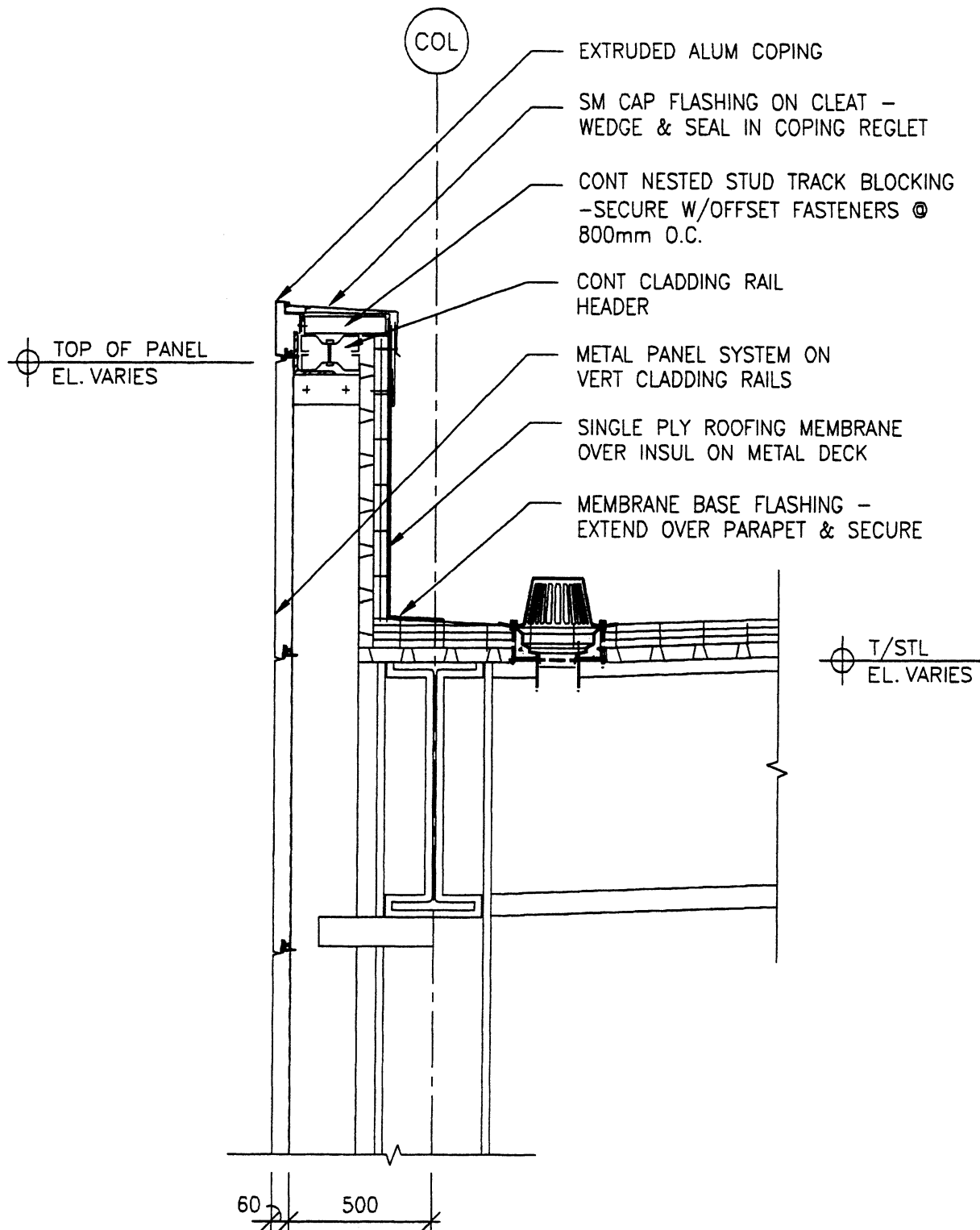
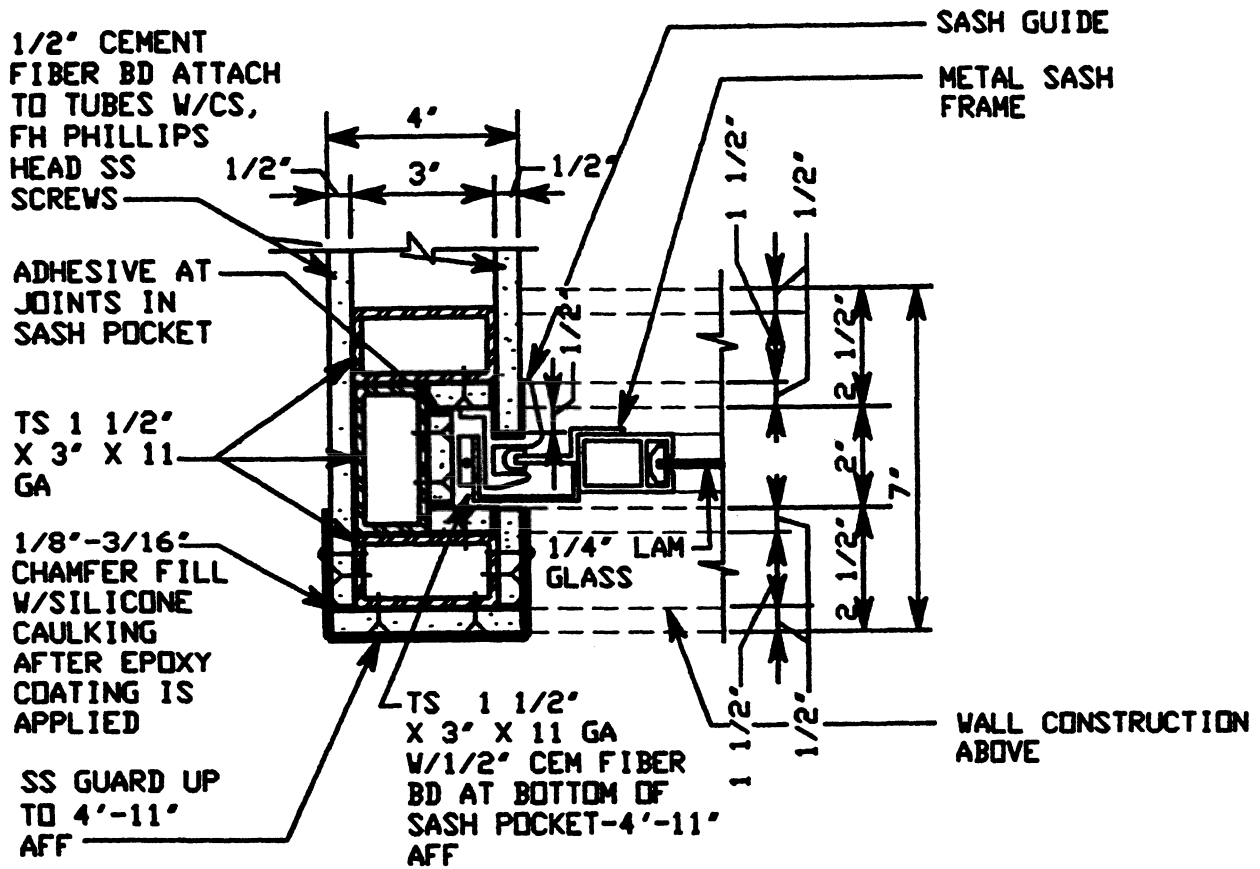

Fig. 10-94

This detail, by the notations is to show the construction of the top of a parapet wall. So why the inordinately elaborate detailing of such an innocuous items as the roof drain? Lot of work for no reason that contributes to the primary issue of the wall.



SASH JAMB
DETAIL

3"=1'=-0"

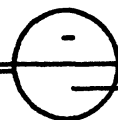

XX-XX-XX-X

Fig. 10-95

A detail with a lot of going on, and also to the point of being unreadable. Dark line work is good, but approaches smearing and indistinct lines.

Larger scale would be better to separate various items and read more easily.

Dimension arrow heads distractive, and thoroughly out of place on this detail.

ANALYSIS OF A DETAIL

The title of this chapter at one time was, "The Diagnostic Autopsy of a Detail: An Excursion in Forensic Architecture". While shortened, that title still conveys the reason for and the direction of the following discussion. Realizing the need for forensic analysis is not new to the architectural profession, but merely renamed to current vernacular and given more depth and meaning. A form of this process is an enduring element from years back—there has always been a need to be able to review, analyze and resolve any problems with details that may arise. Indeed, the detail is most expressive type of drawing in that it highlights exactly how things are to be located, used, built, connected, and otherwise related—the "bottom line" so to speak for how should be to properly executed the project work.

Overall, most all details work if only to a minimal degree. Often any failings of the details do not show up quickly, but rather tend to deteriorate over time [even short periods of time] or are aggravated by other conditions that accelerate the failing [for example, a bad roofing detail may not show itself for months until a heavy rain occurs]. Obviously, very short-term failures are annoying, perplexing, but in the end become "symptoms" that can still be remedied while workers are still on site.

However, where the time of construction is elongated [because of the size or complexity of the project] there usually are ample opportunities to experience failed details. Now this is not to indicate that every project has such details, but merely that the added time on-site allows the design professional and the constructors to experience, first-hand an failure in detailing. With this, there obviously is the further opportunity to analyze the problem and resolve it before the building is fully occupied and functional. By far the process of performing any require remedial work is greatly enhanced and the cost far lower.

It is obvious that in addition to skill in creating and developing details, the design professional must have a good level of forensic skills to investigation, find/uncover, analyze and draw conclusion about failed details. Even with the most insightful, far-sighted, and studious detailing, there is always a chance for conditions that fail in the actual construction. Some of these can be directed attributes to faulty detail design while others are due to improper execution of the details.

In either event, the fundamental problem is the lack of insight in developing or executing the control of the problem from the start—this could go all the way to improper conclusion in the initial assessment of what could and should be expected at the detail area. Simply, what was seen as the possible problem, and how was the solution developed?

Improper execution is, of course, another side of the situation. Here either inadequate oversight, or poor work has caused the problem to develop—i.e., the failure of the detailed work]. If the detail is not executed as shown, then the liability is with the contractor; if the work does comply, the liability may rest with the professional for improper detailing, and not thinking the situation through with all its ramifications. Of course, it is extremely difficult to assess and determine all of the "what-ifs" that could come into play, but part of basic design work is just that—creating solutions to as many of the possible circumstances as possible, through careful and insightful analysis, experience and construction knowledge.

Here it is again obvious that detailing requires both highly developed skill AND construction knowledge, and is not just work given over to junior and inexperienced staffers. This also reinforces the fact that many young professionals who rely heavily on CAD for their solutions [bad idea from the start as the solutions DO NOT reside there] need to gain adequate construction knowledge and insight and analytic skills. This may well hold true for BIM, but at this time this is not as clear as with CAD. BIM detailing would seem to very close to CAD in that the analysis will be lacking, since actual eye-ball observation and human brain analysis are not available.

It is obvious to say that everyone involved with detailing needs to have a knowledge level and skill well above mere mindless replication via CAD! This does not allude to high expertise at all levels, but rather intends to engender both the need and desire to become "involved" in detailing—in the conceptual stage, the development/documentation stage and at least in the bare rudiments in the analysis/ investigation stage [where required]. Simply, one must thoroughly understand detailing, in all its ramifications!

Still humans will forever be fallible, and failures will occur. No matter the basic source of the failure, there needs to resolution in the shortest time frame possible. There can be no

finger-pointing when, for example, a roof is leaking into the Owner's production area and causing ruined product and untenable conditions. Here quick knee-jerk analysis is inappropriate—concentrated and studious investigation is required, but in an expedited manner. Temporary measures may be taken to mitigate the problem at hand, but still final definitive remediation is necessary.

What follows is a series of details, specification excerpts and discussion gathered to both analyze a detail that became a problem, and were used as in-house instruction [deemed appropriate]—the last few sheets were proposed details to mitigate the problem. The latter was used to allow all staffers to be aware of both the problem, how it came to occur [differences between contract documents and actual construction], and the remedy which was proposed to resolve the problem. In addition, this is an excellent example of the reciprocal communication necessary between the field and the design office, both when details don't work, and when they do.

The detail in question was part of a project executed under a design/build delivery system, where the design professional was not an integral, on-going participant in the construction phase of the project. Indeed, the professional was called in only when problems arose and was not privy to a continual program of periodic observations which would have exposed the problem and offered solution before final installation. This "lack of control" was imposed on the professionals, but the construction arm of the same company was actually constructing the project work and did not pick up the slack and properly exercise control— or simply ask questions about the construction required even when it appeared to function improperly. Hence, the subcontractor was allowed to work outside the framework of the drawings and specifications [i.e. "free-lanced"]. The problems only began to occur well after the installation and at the point where an easy and inexpensive solution was no longer available.

Fundamentally, this is a matter of cast stone sills, which were improperly installed. This caused water leakage, of substantial proportion [for "leakage"], into the interior of the building. The investigation and discussion revolve around the improprieties in the work, which resulted in water being trapped under the sills, and not being allowed to flow outward, or evaporate. As the volume of water increased, the pressure and depth caused the water to seek relief [through the "weakest" point of the construction], which was found by flowing back through the wall, and into the building.

As noted in the following, there was also a built-in ambiguity in the specifications that was not caught, revealed and resol-

ved until the investigation was conducted. Handing off responsible from specifications to drawings if accepted procedure, so long as there is connection, understanding and resolution in both documents [i.e., the simple understanding where the final responsibility lies and where the base line instruction is set out for the contractors' use.

CAST STONE STILL FLASHING DETAIL

1. Revise Detail 105, Sheet B44101.
2. Dotted line under sill is the laminated copper flashing, as specified.
3. Hold outer edge 1/2" back from face of mortar [per specs 07600]
4. Set flashing in mortar bed [per specs]
5. Where anchors for sill penetrate the flashing, apply a generous bead of silicone sealant around each anchor.
6. Flashing shall be formed to create a pan [per specs]; at inner side, and at ends fold flashing up 3-inches; form corners [per specs] to form pan.
7. Set cast stone into flashing "pan"; adjust to tight, firm, secure fit in configuration detailed.

Fig. 11-1

Brief statement of situation with a detail that did not work properly when installed in the field

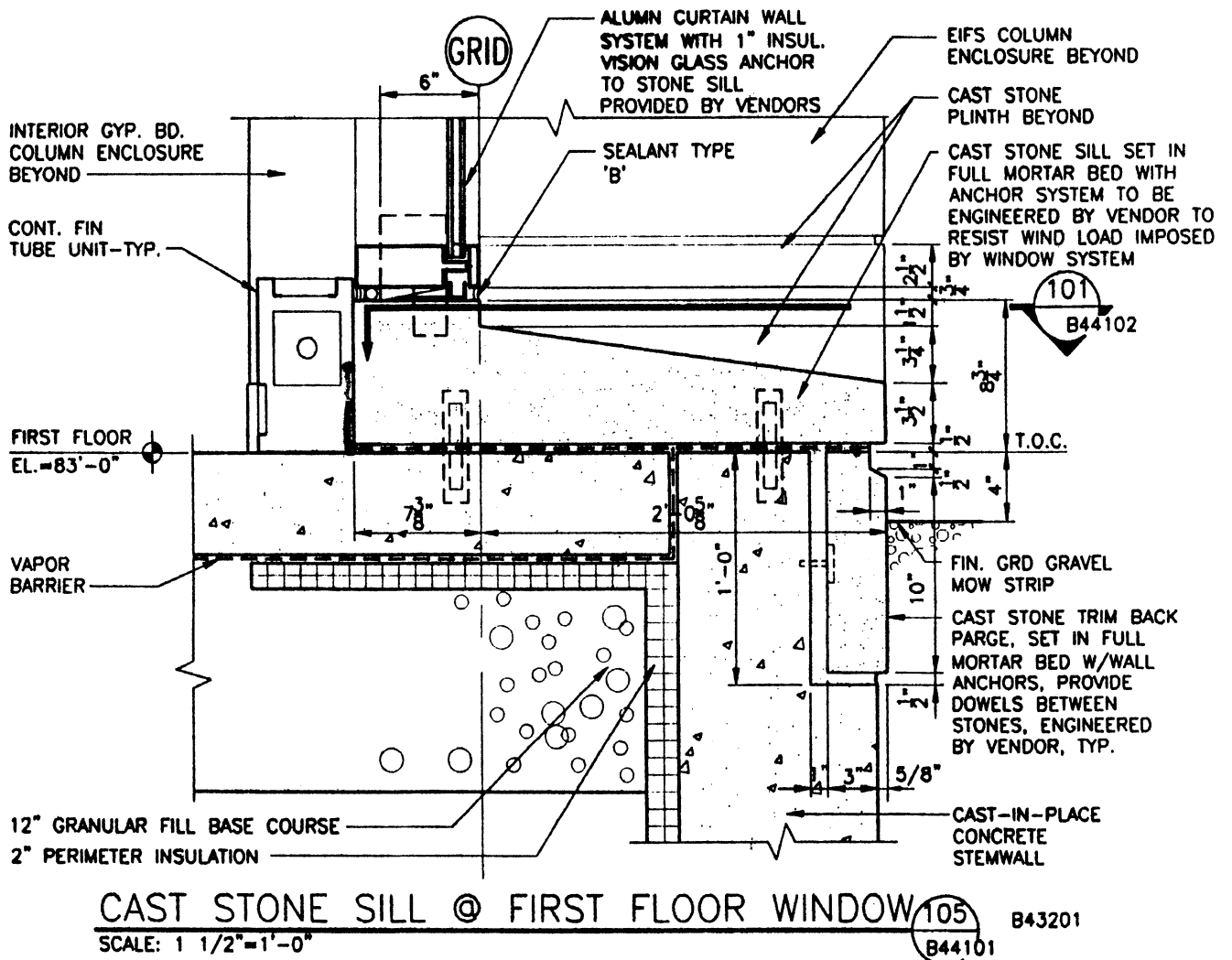
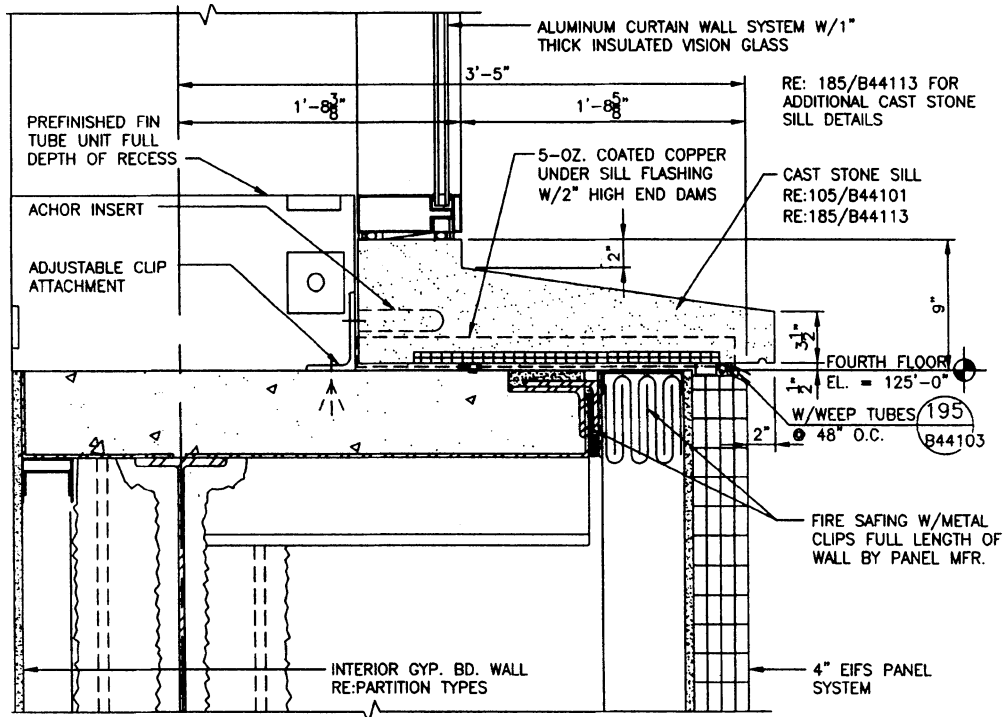

Fig. 11-2

The basic detail at fault- installation of cast stone window sills



WINDOW SILL @ STAIR #2

120 B43204
B44105

SCALE: 1 1/2" = 1'-0"

Fig. 11-3

Detail at another location but with same sill and added information

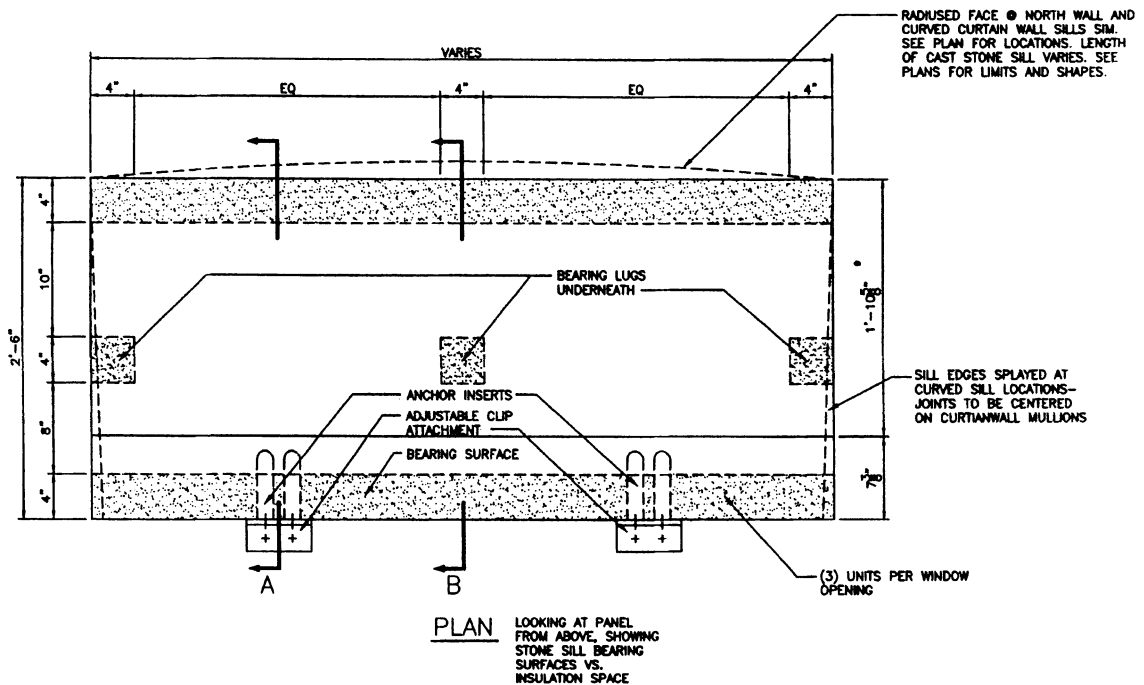

PLAN
LOOKING AT PANEL FROM ABOVE, SHOWING STONE SILL BEARING SURFACES VS. INSULATION SPACE

Fig. 11-4

Detail simplifying and explaining the minute information for forming of the sills

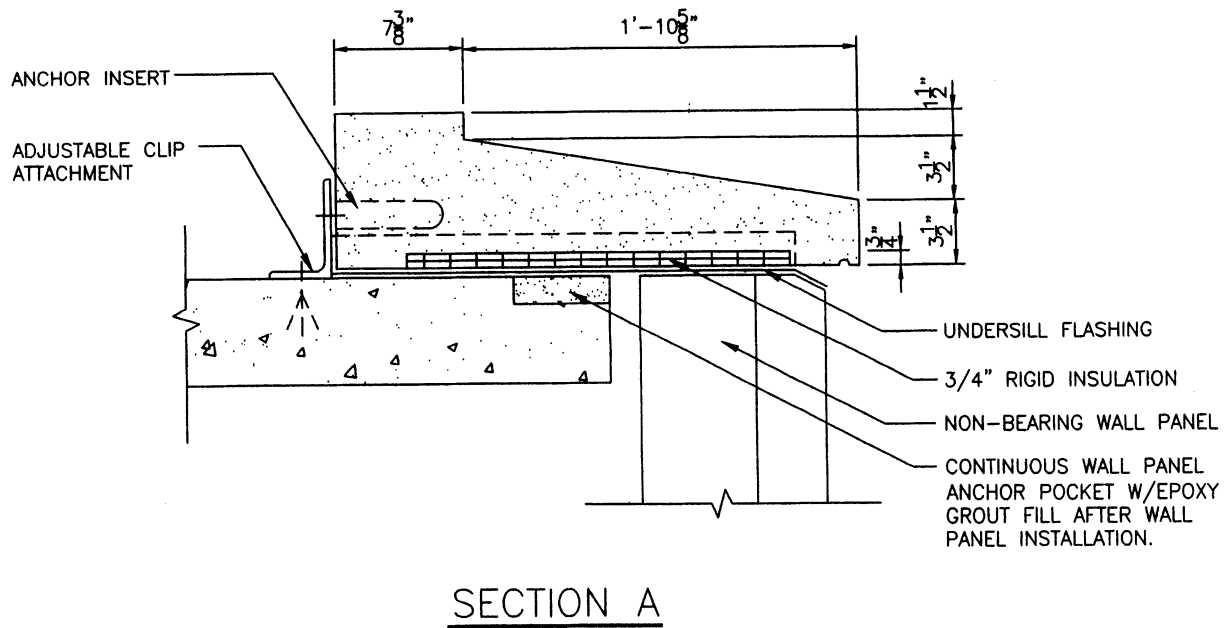

Fig. 11-5
Section A taken as noted on Fig. 11-4

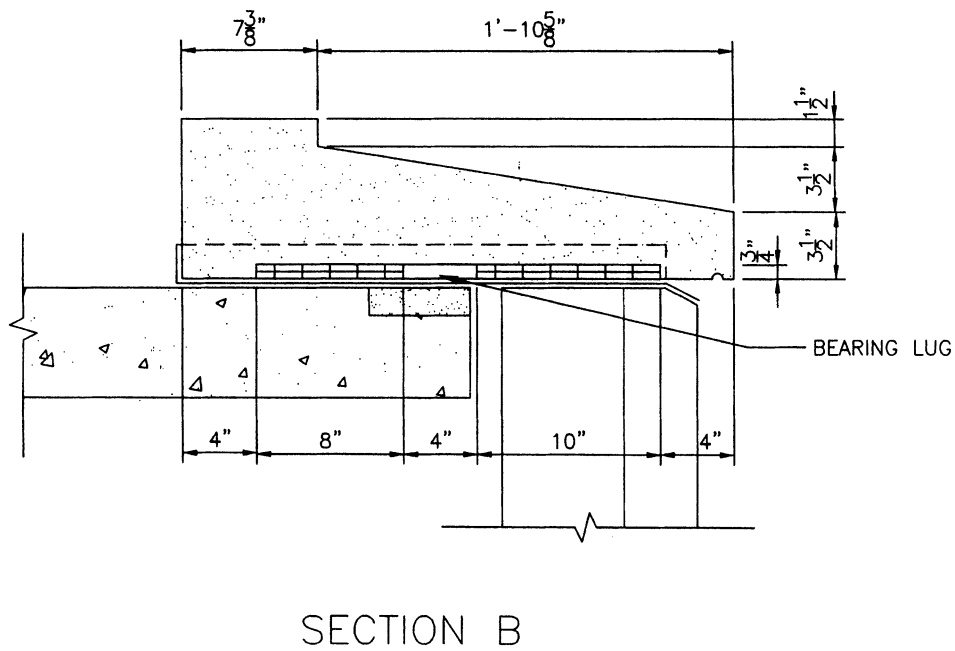

Fig. 11-6
Section B taken as noted on Fig. 11-4

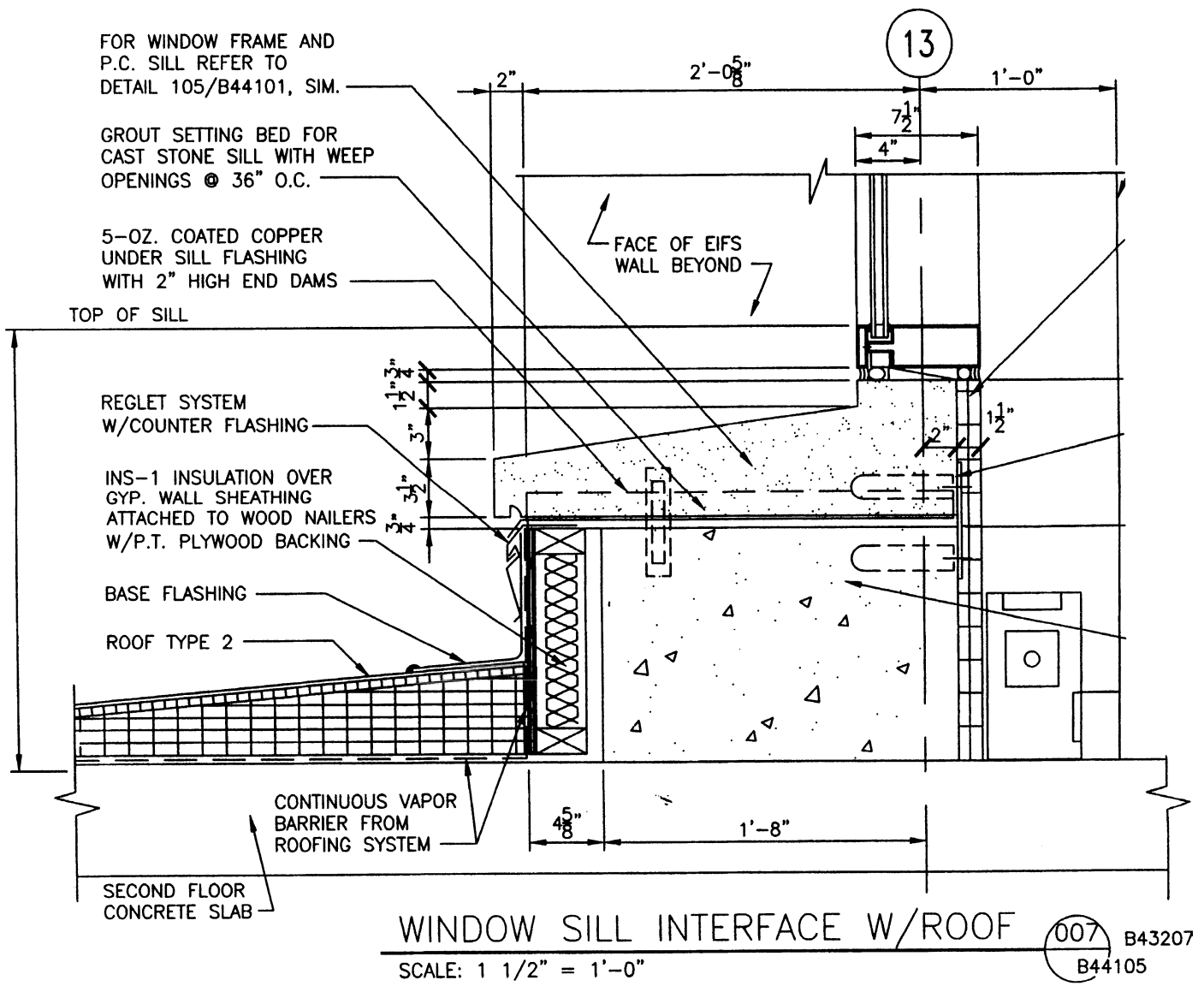

Fig. 11-7
Similar detail at another location

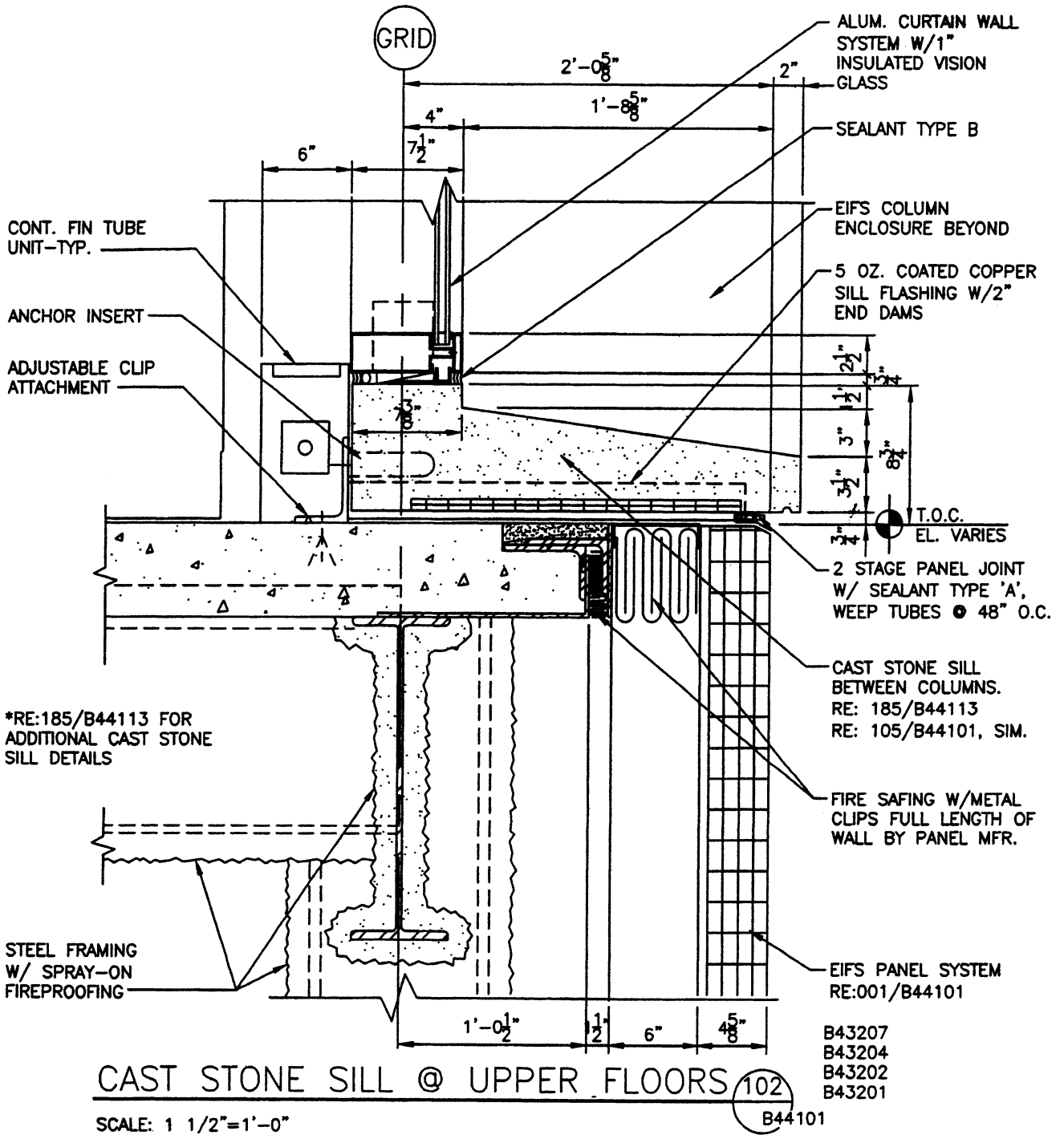

Fig. 11-8
Sill another location- same sill with some varied information

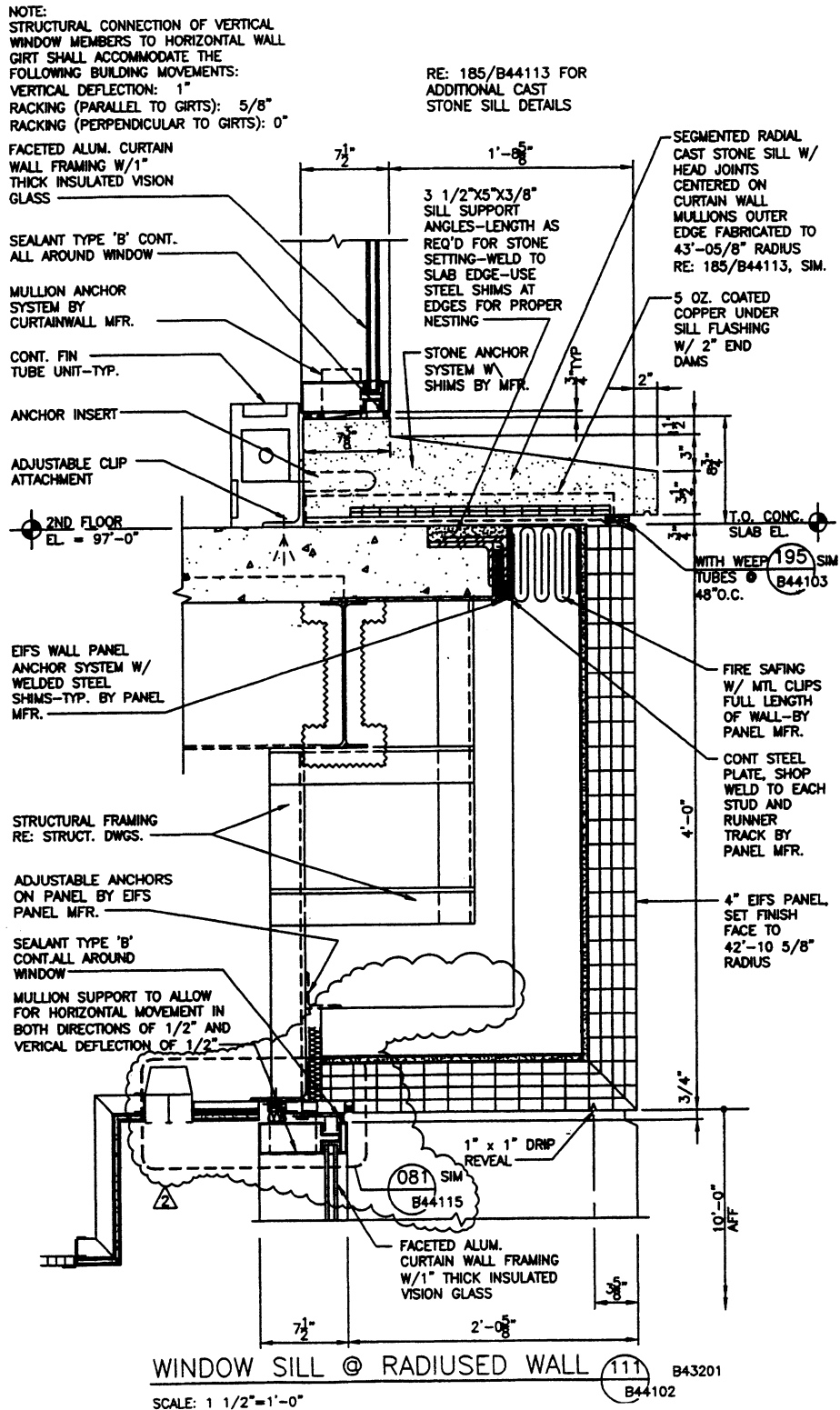

Fig. 11-9

Sill in a more complex construction location

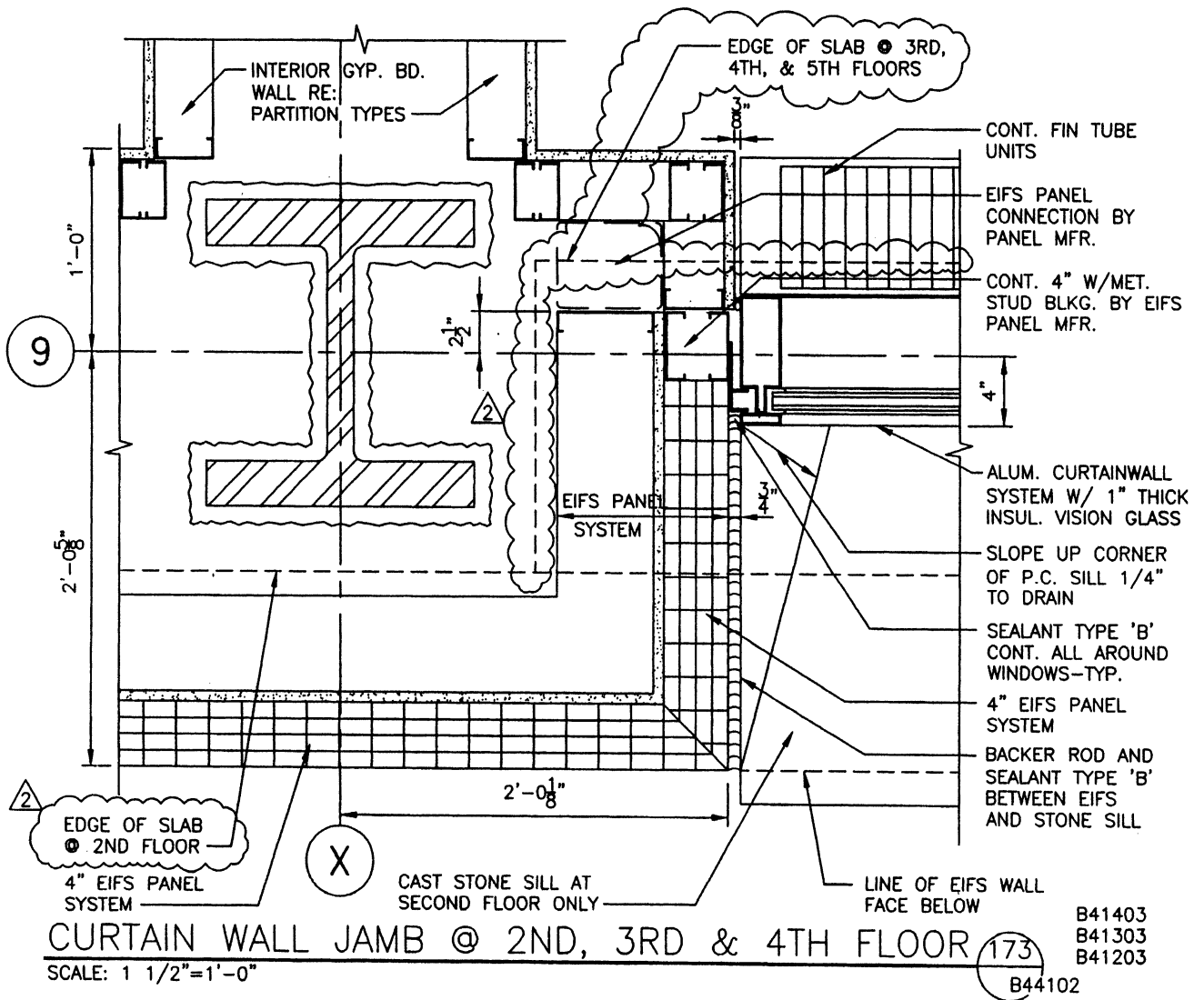
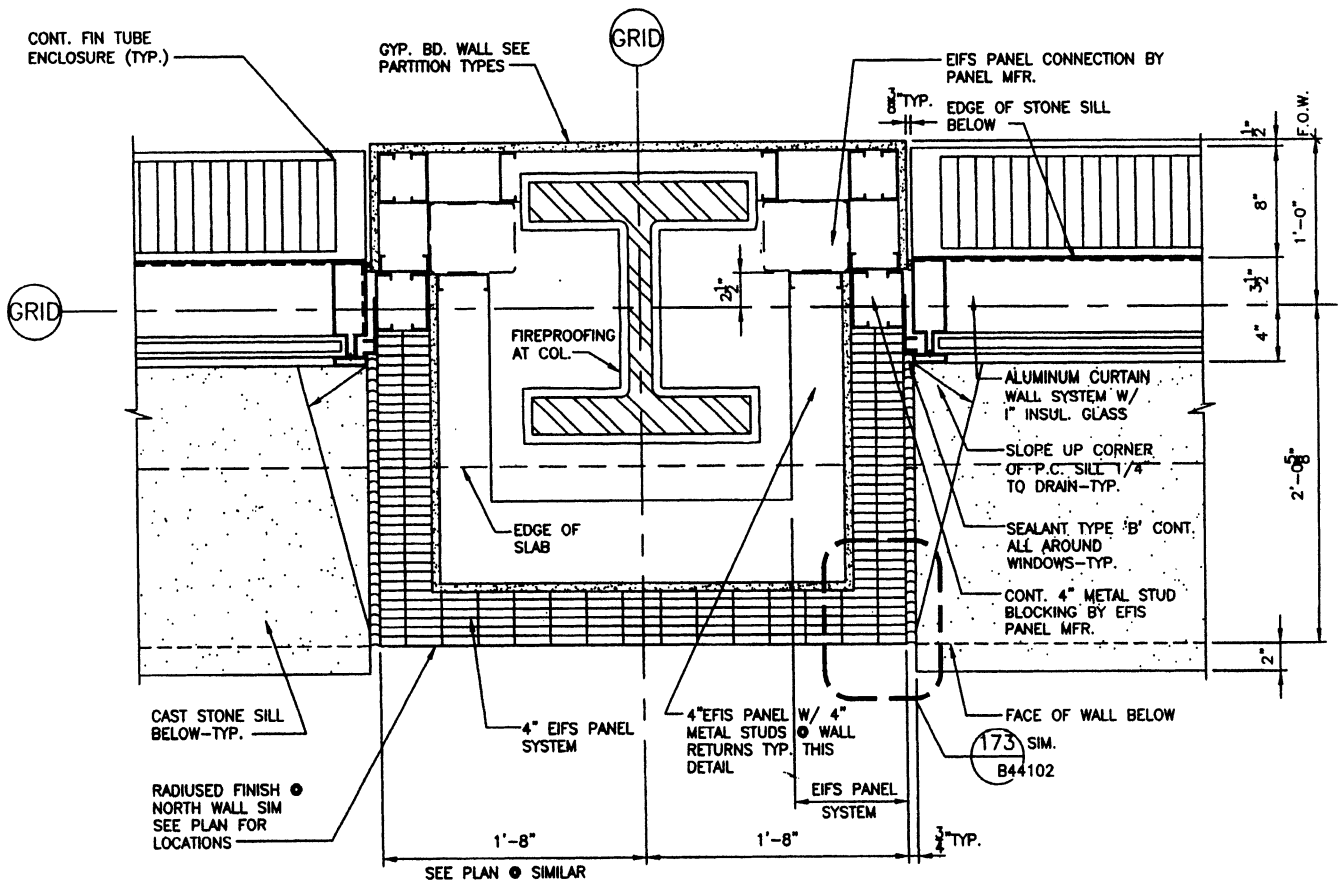

Fig. 11-10
Plan view of the jamb of the sill and fit to adjacent construction



TYPICAL COLUMN DETAIL

SCALE: 1 1/2"=1'-0" ● 2ND, 3RD, & 4TH FLOORS

SEE UPPER FLOOR PLANS

145 B44106

Fig. 11-11
Sill jambs at structural building column

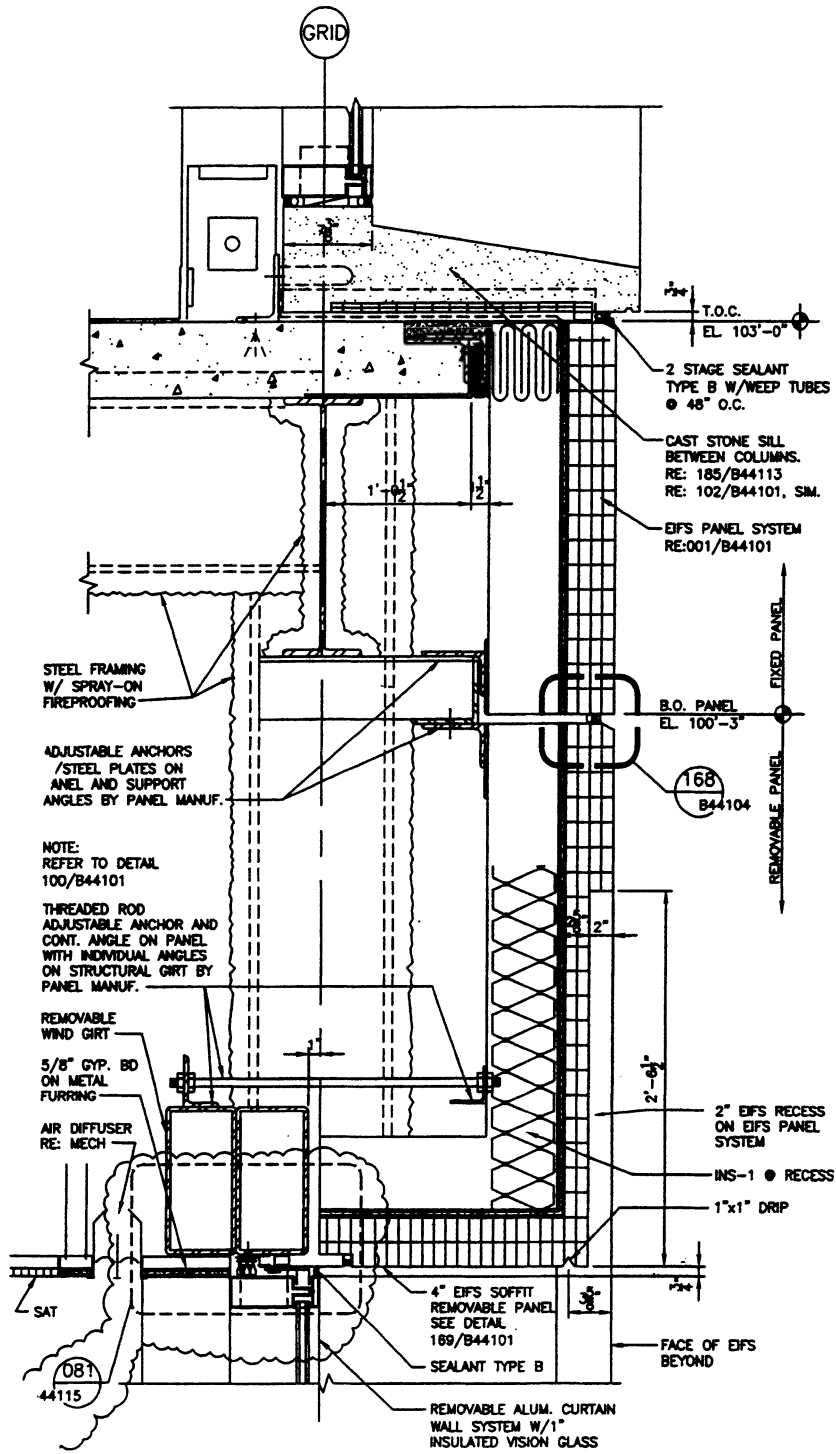

REMOVABLE SOFFIT PANEL

SCALE: 1 1/2"=1'-0"

223
B44109

B43202
B43201

Fig. 11-12

Sill in still another location; note references to other details

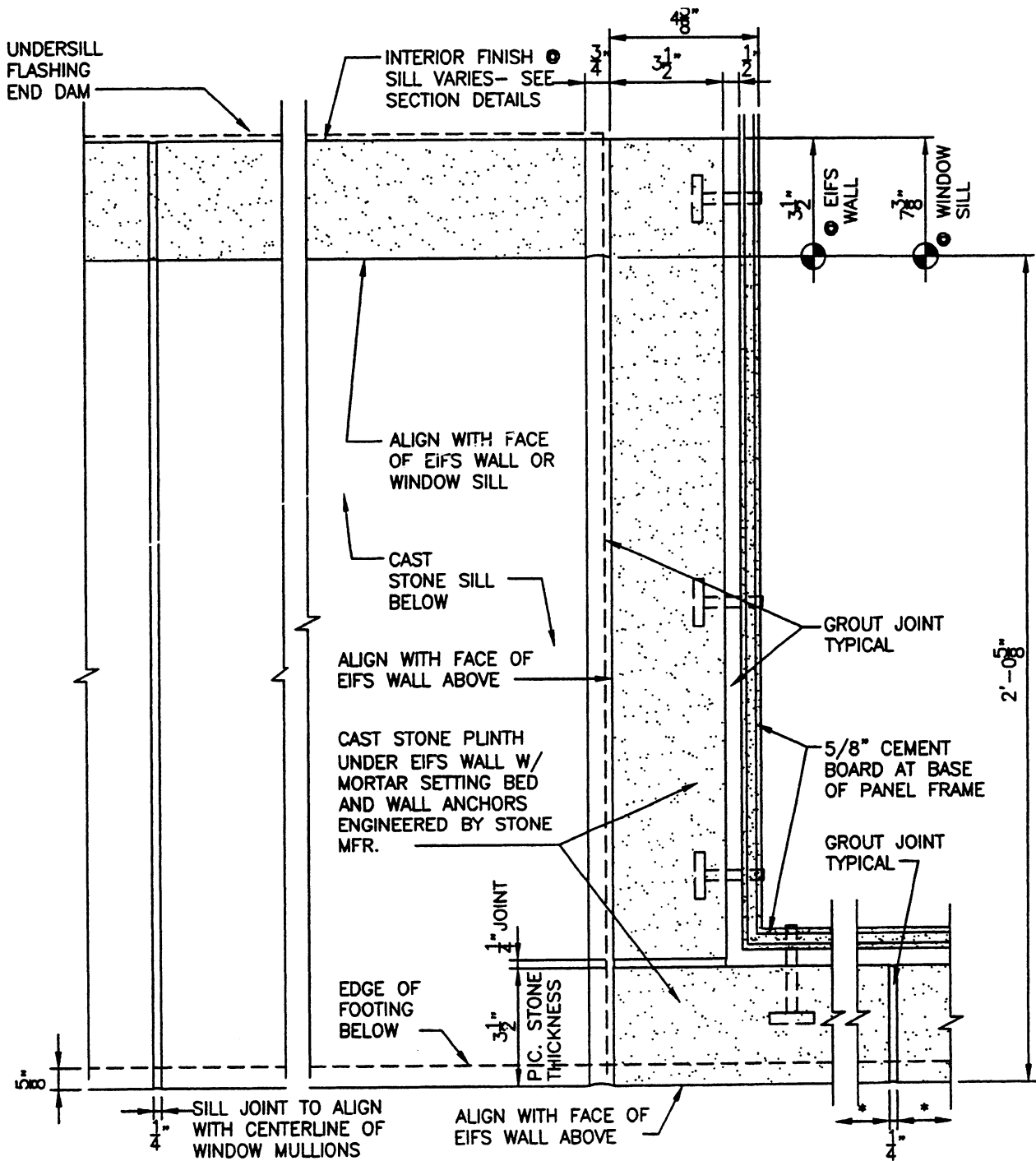

* REFER TO EXTERIOR ELEVATIONS FOR LOCATION OF CAST STONE PLINTH AND TRIM JOINTS ALONG PERIMETER OF BUILDING.

STONE PLINTH PLAN

SCALE: 3"=1'-0"

101
B44102

Fig. 11-13
Plan view looking down on sill at plinth

GUN APPLIED POLYURETHANE
PRIMARY SEALANT OVER
PRECOMPRESSED "POLYFILL B"
SECONDARY TYPE SEALANT.
SIZE ALL SEALANT DEPTHS
AS RECOMMENDED BY MFR.
FOR ACTUAL JOINT WIDTHS

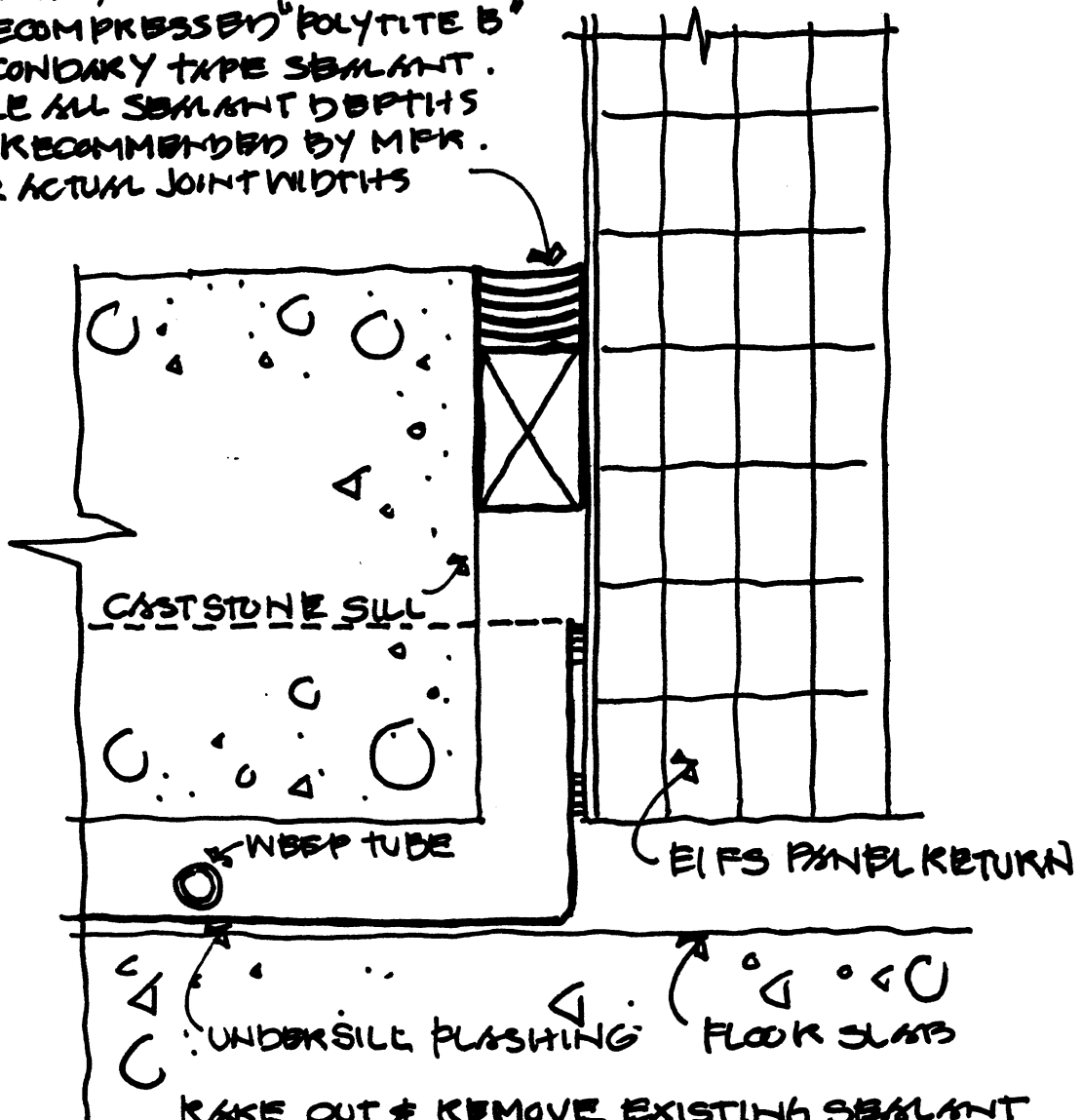

RAKE OUT & REMOVE EXISTING SEALANT
& BACKER ROD - THOROUGHLY CLEAN
CAVITY & PRIME ALL SURFACES BEFORE
INSTALLING SEALANT.

CAST STONE TYPICAL END JOINT

Fig. 11-14

Sketch by reviewer trying to remediate failure- section view at jamb; note additional of weep tube to evacuate water trapped under the sills

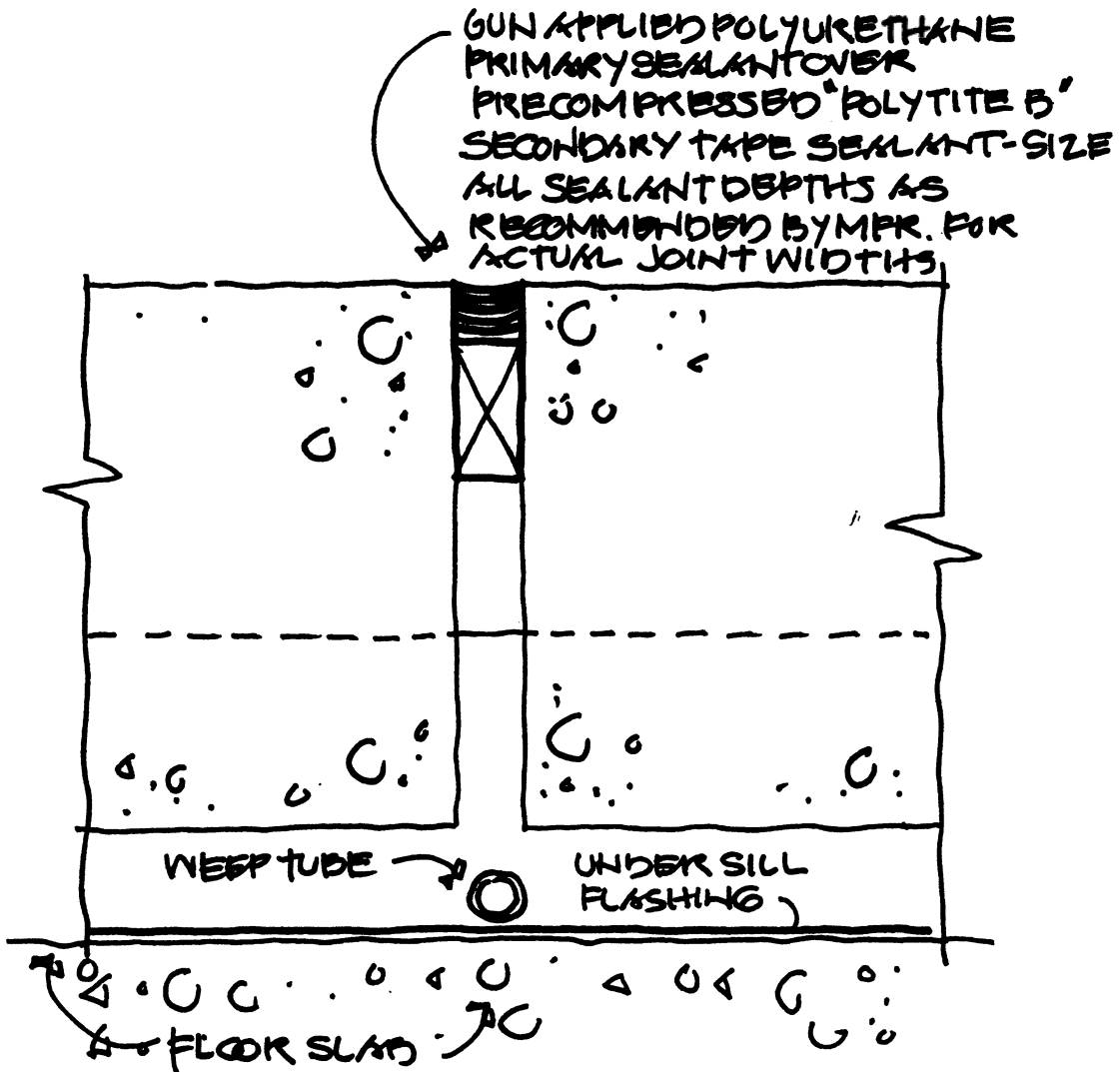

SAWCUT & CAREFULLY REMOVE MORTAR
 FROM ALL SILL HEAD JOINTS TO DEPTHS
 REQ'D - THOROUGHLY CLEAN & PRIME ALL
 SURFACES BEFORE INSTALLING SEALANT.

CAST STONE TYPICAL HEAD JOINT

Fig. 11-15

Reviewer's sketch at head joints between sections of sill

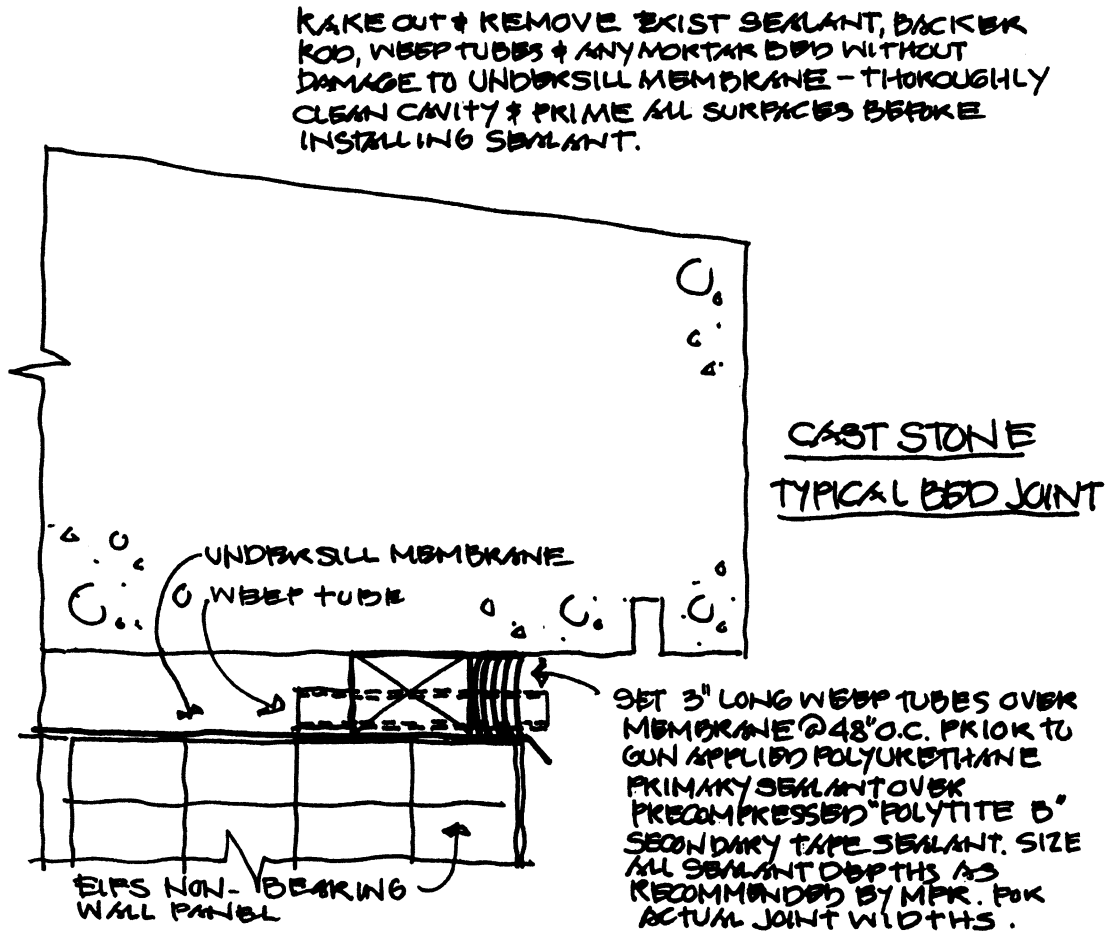

Fig. 11-16
Reviewer's vertical section showing bed joint under sills and added weep tubes

- E. Laminated Copper Flashing
1. Install laminated copper flashing rolls continuous without seams where possible. Where seams occur install in accordance with manufacturer's recommendations resulting in a watertight joint application.
 2. Start flashing $\frac{1}{2}$ -inch in from outside face of mortar. Carry through under cast stone sill and up interior face as indicated on drawings. Extend 6-inches beyond each side of sill in order to turn up ends forming a pan. All corners shall be folded, not cut.

Fig. 11-17

Portion of specifications for flashing required under the sills. Underscored text is part of the problem, since no turn-up was shown on the drawings. But even with this done correctly water would be trapped with no outlet [resolved via the added weep tubes]

DETAILS BY OTHERS

Other Sources

Although the design professional's staff is the primary source of project-specific details, there are other members of the design/construct team, who produce details, pertinent and necessary to the project.

Foremost among these are the manufacturers, suppliers, fabricators and subcontractors who provide materials, products, devices, implements, assemblies, systems and equipment to the project. Primarily, all of these parties have a far different perspective for producing details than the design professional. In the main, their details are intended to illustrate their materials or systems, in specific terms directly related to correct use or fabrication of their product, as they envision or recommend it. Some details are used to illustrate correct use of the products when utilized by other parties— and show examples of their flexibility and various installations. The better details show the true configuration and extent of the products involved, as they may be incorporated into other work.

This is important as information for the design professional, since many of these are standard [with each manufacturer, etc.] production products that must be customized to the specific needs and particular requirements of the project. Such data assists in the appropriate detailing [by the design professionals] of the specific project condition— i.e., adapting the generic manufacturers', etc. al. detail to a project specific detail. Overall, this type of detail drawing by others is directed toward selling the product by showing its attributes and possible adaptation.

It is commonplace for many of the drawings of the other parties to be projected in a format other than orthographic [2-dimensional] projection [where only height and width are shown]. Some will utilize isometric views— a projection showing the object tilted on one corner and showing three sides of the unit of item, but this is not the optically correct view that comes with perspective. This is a devised method to show more information in one drawing, and the better display of interrelationships. The motivation is to better show off the material or system and to provide added information and understanding of the product and its correct or possible fit and installation. It should be noted that the design professional is responsible for the correct fit into the project work, and may well utilize methods and configurations not always shown or

anticipated by the manufacturer— herein lies the lament of liability with both design professional and manufacturer.

For advertising and technical manual purposes, the details are often produced in more of a glitzy, usually photographic format, many using the 3-D aspects of isometric. Color may be used to separate portions of the drawings' material features. Also used is the "exploded" view, where the parts of the detail are slightly separated so one can more easily see how they fit together. These really are more generalized views and not meant for construction use [except perhaps for some submittals]. In all too many cases, the manufacturers' drawings come up short of showing everything involved with or the extent of what is contained within the product itself— hence the professional is left guessing at what will be supplied and what will not.

This is understandable to that point where it becomes murky as to who does what, who provides, or who supplies what. Often some manufacturers will "give over" as much work as possible to the proverbial "by others" [mainly items required but not part of the manufacturer's product line], when in fact it is far more appropriate for them to provide and do the work.

In the face of this situation, it is important that the design professional make it explicit as to what they need from the manufacturer [in regard to the specific product or device] and what will be executed or provided by others. This is important because of the wide variety of programs, techniques and levels of skills within the purview of the other parties. Some may have very sophisticated drawing processes— others may not. Some may try to incorporate their standard details, when in fact; the fit is inappropriate to actual or proposed project conditions [they hence require modification]. This setting of requirements is truly another of primary functions of good detailing. While not assigning or ascribing specific work to specific trades, it does serve to ensure that complete continuity, closure and weather-tightness is achieved [or other attribute that is appropriate]. And it gives added and proper credence to establishing responsibility for the whole of that portion of the work, and not some piece-meal, crazy-quilt and quite undefined circumstance.

This required process of customizing begins with the design professional who selects the item or material, and seeks to

Non-slip stair nosings that satisfy New York City Standard RS 6-1/1a and other building code standards for **photoluminescent exit path markings**. Profiled grooves with rubber or epoxy inserts provide durable, attractive surfaces that do not collect dirt or water. One inch wide photoluminescent tread is integrated in the outer 2 grooves along stair edges. Available in standard aluminum finish, Traction Tread nosings are designed for easy cutting and drilling onsite.

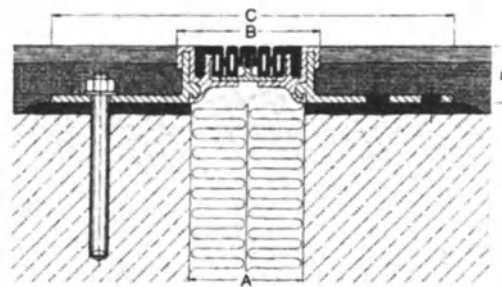
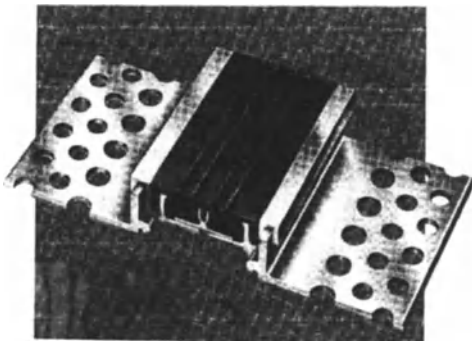
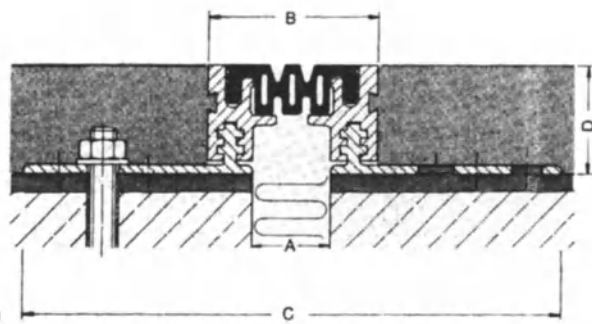
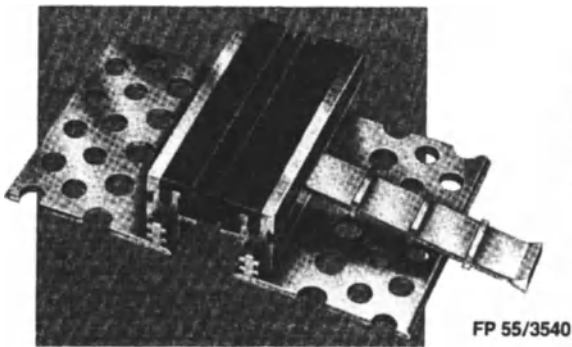
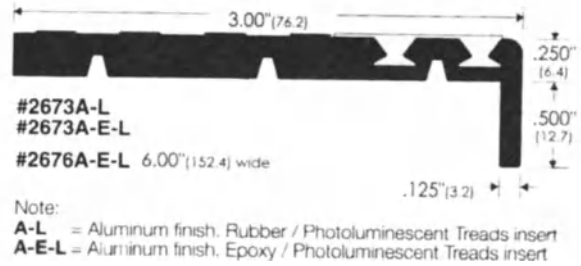
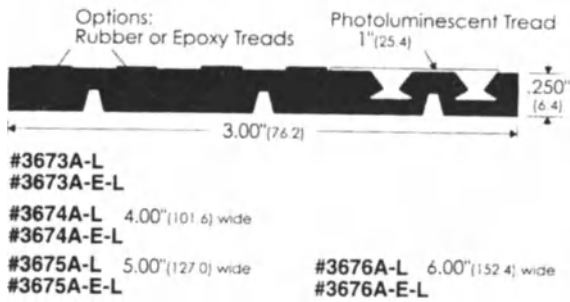
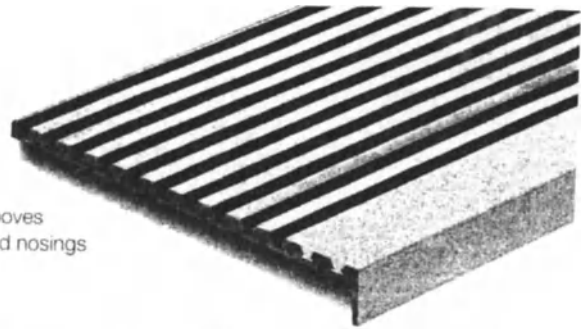

Fig. 12-1
Examples using a photographic image to display the device and drawings to provide more detailed information. A good presentation by the manufacturers of their products.

adapts and fit it to a specific general requirement or scheme of the project. This is a "collective" and generalized depiction of the project work as discerned and anticipated by the design professional. The work by the professionals does encompass the entire array of very careful and precise illustration and description required to design, locate, fashion and fit the various elements in a manner to fulfill the requisite customization. It is part of a progression of information that starts with the concept of the work involved, moves through this collective/generalized state that depicts the concept in more complete and defined terms. It remains, however, for the contractor and other parties to transform this information, to develop the minute portions of the work or fabrication and make specific assignments of the work to specific trades— basically instructions to their shop regarding how the item is to be built.

Submittals

There is an additional interface between the details of design professional and the others as related to the specific conditions and circumstances of the project work; this includes their responsibilities; and further illustrate, in a "checks-and-balance" format that the supplier, fabricator, or sub-contractors fully and correctly understands the work they are being required to perform— these documents are called "Submittals".

Submittal[s]:

Documents required, by project specifications, to be returned to the design professionals and contractors, by manufacturers, suppliers, and sub-contractors, showing and explaining, in precise terms, how fabrication and preparation of materials and systems will be done for the specific project; included are, 1] shop drawings, 2] product data, 3] samples, 4] certifications, 5] test results, 6] warranties, etc.; professionals and contractors check and approve these documents when in accord with general design concept.

In regard to detailing, the primary source is the shop drawings. These are prepared specifically for a project and combine manufacturer's details and project details. While details also exist in Product Data, these usually are the standard drawings of the manufacturer, very generic in nature and only specific to the project as noted in the associated printed matter. For example, wood paneling required in some selected rooms of the project. This will be documented by the design professional as to the species of wood desired, the general layout, profiles, general details and dimensions, the installation method and the overall appearance of the installation [location of joints, type of joints, sizes and profiles of various trim members, etc.]. While this information is complete and exact, to the level required of the design professional, there is a need for more specific and exacting information.

The work of fabrication and preparation of the various raw material elements of the paneling system is performed by the millwork subcontractor or supplier. Here each piece, member, and panel is detailed in a precise manner; exact lengths, profiles, joinery, matching, layout and cutting of panels, etc., from the "raw" unworked material [i.e., rectilinear boards are cut to length and profile, etc.] This task serves two ends— to show the shop workers not only what to use, and how to prepare it as required, but also to verify back to the design professional, exactly what will be provided, how it will be prepared [for "this" project], and how it will be installed. The level of this work goes further than that of the design professional, in that fabrication methods, cutting of material for economic use, and the fitting of the work on the job, all are solely the work of the subcontractor/supplier.

Basically this harkens back to the general trade concepts, the accepted and recognized practices, responsibilities, and needs of the contractors, and as normally noted in the AIA General Conditions [AIA Document A201]. These documents usually show that it is the Contractor who is responsible for the correct and accurate fit of the work, construction methods, techniques, fabrication, etc.; and this is fully distinct and separate from the responsibilities of the design professional. This is in keeping, too, with the generally accepted axiom of construction that the contractor is responsible for "the methods and means of construction", while the design professional is responsible for the concept, design and general configuration of the work.

This "separation" of tasks is significant in that the design professional is responsible for conveying the proper information, overall, about the required construction to all of the subcontractors, suppliers, fabricators, etc. This is best done through the process of detailing, so long as it is done within the confines of the authority— that is, that the professional does not impinge on or usurp the work of the contractors, et. al.. David J. Wyatt, CSI, CCS, Akron, OH, stated this clearly in his article, "Specifying Execution Requirements" [The Construction Specifier, July, 2001]. He noted that:

"Since they represent a key aspect of performance criteria— the final relationships of assembled products— drawings properly assume much of the burden for execution, while preserving the contractor's right and responsibility to control means and methods".

The unspoken crux of Wyatt's statement is that the performance criteria and the final relationships are items set out by the de-

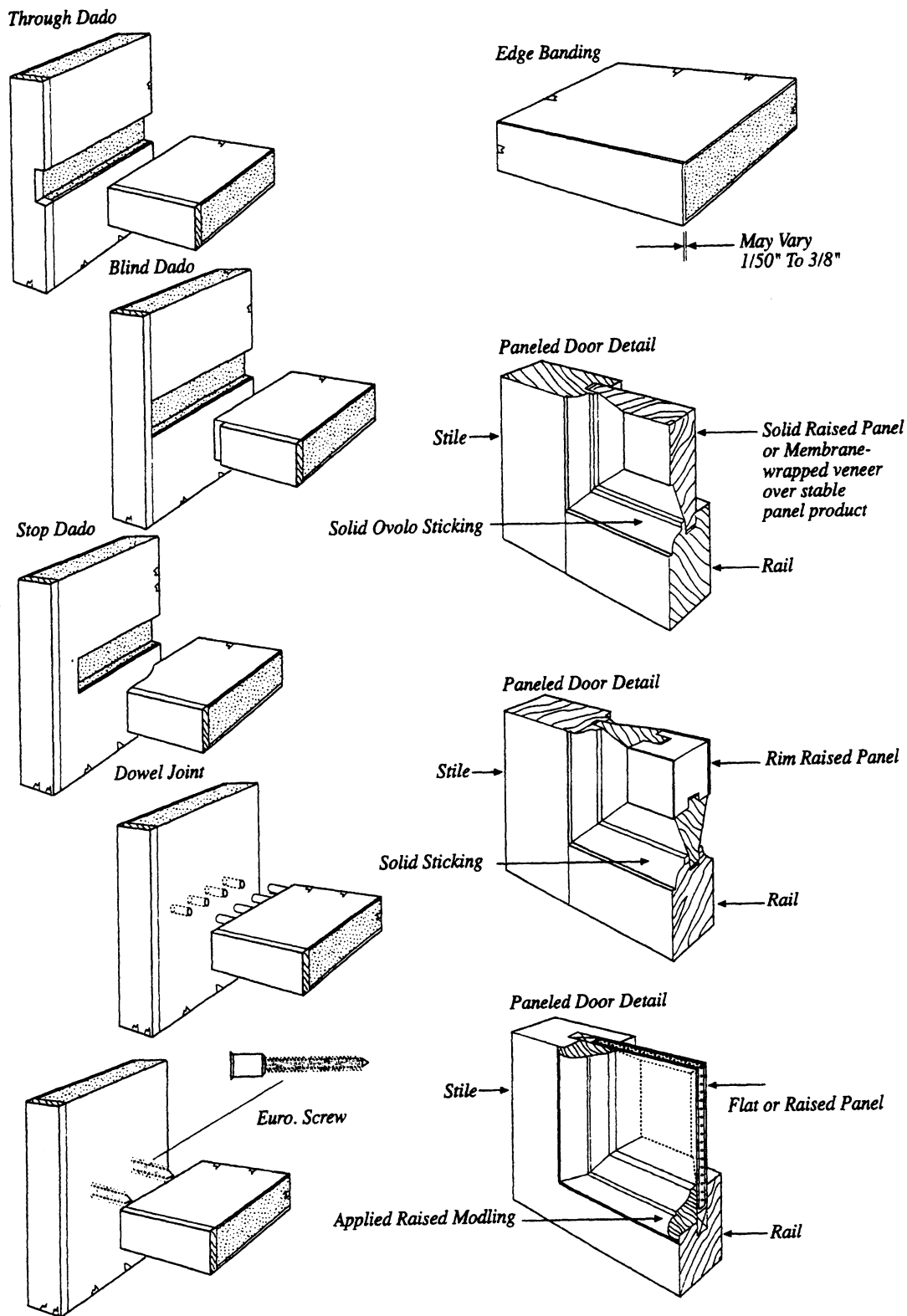

Fig. 12-2

Standard millwork joinery details that can be used and adapted to project specific installations. Provides suggested information so design professionals do not need to devise such details; also, these are familiar to millwork workers and forestall added labor and cost when more innovative details are used.

sign professional. Quality here sets the bar of quality required in the anticipated work of the others producing the shop drawings, etc. This process, though, depends on a good, valid, and candid exchange of information between design professional and the party producing the shop drawings. The professional must show and describe the work completely, noting its function and general construction [materials, configuration, attachment, etc.]. This should be done as discussed previously— in a manner that allows the expertise of the contractor/supplier to be interjected in resolving exactly how the work will be accomplished, i.e., the methods and means of construction.

In a true exchange of information, the parties commensurately contribute to the whole of the needed information. They supplement and compliment each other to produce drawings and descriptions/notations that allow the exact construction required. Although the work is to be produced in a shop, there is no difference in the amount or depth of information required from that transmitted to field personnel, for work done in the field. Usually, with shop produced work, there is a need for more exacting and precise information so the manufacturer or fabricator can incorporate the standards and devices they normally utilize. This all is based on the project-specific information [shown by the design professional in general terms] which in the main is interpreted, modified and contributed by the contractor/supplier [the fabricator/manufacturer being under contract for the work to one of those parties]. Here again the design professional needs to understand where her/his detailing should stop and where that of the fabricator/supplier should pick up.

The details come from various projects and sources, but each serves to illustrate one or more points about correct and proper detailing. The fact that these details are produced both by manual and computer drafting techniques is of no consequence and does not distract from their value as communication instruments; neither does it relegate them to either current, modern or obsolete status.

PRACTICE INSTRUCTIONS: SHOP DRAWINGS AND OTHER SUBMITTALS

Submittals

In most specifications and Project Manuals, there is a Section [usually in CSI Division 01], which deals exclusively with Submittals. Here the procedures for the transmittal of product data and fabrication information, to the Design Professional, are outlined, and the requirements set forth. In addition, in Part 1 of each of the technical Sections there will be a discussion, similar to the following, regarding the submittals which are specific to the work specified in the Section.

1.03 SUBMITTALS

- A. Refer to procedures for submittals in Section 013323, Shop Drawings, Product Data and Samples.
- B. Action Submittals: [for review, approval and return; action required]
 1. Product Data;
 2. Shop Drawings;
 3. Samples:
- C. Informational Submittals: [for collection of information for file only; action not required]
 1. Certificates;
 2. Test Reports:
- D. Design Delegation Submittals: [for verifying work of others; record only]
 1. Seismic Design Data: [as an example]
- E. LEED Submittals: [to verify a claim for LEED points]
 1. Verification Documents:
- F. O&M Manuals: The following submittals shall not be submitted to the Architect/Engineer, but shall be included in the O&M manuals required by Section 017823:
- G. To Owner; The following submittals shall not be submitted to the Architect/Engineer, but shall be submitted directly to the Owner:

The following are sample wording inserts that can be used for acquiring the correct information in the submittals; adjust and add provisions as necessary to properly reflect project needs:

- A. Product Data: Manufacturer's data sheets, and catalog cuts substantiating that products comply with requirements of the Specifications.
- B. Shop Drawings: Include details of each frame type, elevations of doors and frames, conditions at openings, details of construction, location and installation requirement of finish hardware and reinforcements, and details of joints and connections.
 1. Show anchorage and accessory items.
 2. Provide schedule of doors and frames using same reference numbers for details and openings as those used on the Drawings.
- C. Samples: Submit sample of Type 304 stainless steel with No. 4 finish [which is specified for door faces]. All items

manufactured with this finish shall match exactly regardless of stainless steel thickness.

- D. Certificates: Submit written forms which verify adherence to requirements for fire-rating of doors and frames.
- E. Warranty: Submit manufacturer's standard warranty covering doors and frames and associated items for a period of five [5] years from date of project Substantial Completion of the project.

The shop drawings, along with product data sheets [cuts, descriptions, and listing of product features] are all part of the submittal "package" required in various sections of the specifications. In some cases, actual samples of the material or device are also required, to first-hand assessment of quality, form, thickness, finish, or in some cases, for selection of color[s]. All of these submittals are not required for every project, and all of them need not be submitted at the beginning of the project.

These project requirements are set out, as necessary and appropriate, to provide for proper communication between the suppliers, sub-contractors, fabricators, manufacturers, and the project design professionals. The submittals are a method of "checks and balances" to ensure the best possible process to make the project a faithful result of the design concept. The process is exacting in that it is here where the "bottom-line", "nuts and bolts" information is presented. In the main, this is a major expansion and augmentation of the information the professional included in the contract documents. The information in the submittals allows for the manufacturer, fabrication, completion, installation, erection, etc., of the project's elements and work in the exact and correct manner required by the design concept.

In fact, while considered a nuisance by many professionals, submittals are vital to the success of the project. The submittals, in reality, are the necessary conduit of information that provides the complete array of data and directions required to address and resolve every detail of the project, as shown on the design and contract drawings. They are needed to verify full compliance with the professional's approved design concept—and most importantly, with the Owner's expectations! Therefore, submittals of various types are the last opportunity for the design professional to comment on, or adjust the various items, and how they will meet the requirements of the project.

In many instances there is need for judgment call on the part of the professional to accept the product as submitted [if in general conformance with the design concept], or to reject. Further, the professional can see the intent of the manufacturer

in constructing the work; an area of information NOT usually included in the design documents. In reality, if the item meets the intent and the appearance requirements of the project, and its design concept, the professional usually does not care about the internal unit construction and fabrication; the final result or product, its function and appearance are paramount. The implied warranties and guaranties of the manufacturer to the Owner, for long-term suitability and durability still remain in place, and cover any shortcomings that may develop—these are not areas of responsibility which lie with the design professional.

There is, however, a heavy legal onus on the design professionals and their handling and processing of submittals, particularly shop drawings. Extreme care and diligence is required to ensure that no added responsibility or liability is assumed by the professionals through their comments, changes, and added/modified requirements expressed on the submittals. Further, just as work in the field is "observed" and not "inspected, submittals are "reviewed", but never "approved" [See addition information and typical stamp at end of chapter]. Even with the recent change of attitude and information, this is still a crucial legal element. While these are merely words, when coupled with the legal considerations and nuances, they are valid concerns that can keep the professionals free of undue complications, added liability exposure, and confounding legal entanglements. In essence they maintain the proper level of responsibility for each party involved.

It is worth a minute to discuss this interplay of professional and contractor, and the parts they play regarding submittals, primarily shop drawings. Some may consider the interplay or exchange as a "game" or utter nonsense. However, it has serious consequences, and involves the responsibilities and liabilities of both. The contractor [via common acceptance as a result of AIA documents] has full and total responsibility for the "methods and techniques of construction", and for "the fit of work". Hence, it is totally out of place for the design professional to comment or change any such information submitted by the contractor. This is, of course, provided what is submitted is otherwise in conformance with the design concept. If or where this is done [except to identify non-compliance], the onus of liability for adequacy, cost, suitability, and appropriateness shifts, immediately and totally, to the contractor—it moves away from the professional. Where not done, this can lead to claims, disputes, change orders, added costs, and exposure to severe consequences should there be any type of failure, or shortcoming. The contractor, by following the professional's instructions, now has a viable defense [when needed] by saying that the professional's directions were followed, and the added cost, or the failure which has resulted is NOT something the contractor created—things were merely done as requested.

The same type of thing applies where the professional guarantees, verifies, field measures, or requires' certain work, or dimensions. Anything done under this scenario that is faulty will find solution usually and solely through the professional's resources. Hence, shop drawing review by the design professional [as well as review of the other submittals] is for general design conformance, and is not, in any way, unfettered approval of what the contractor has proposed. The explanatory text of the review stamp reflects the parameters of the review and thereby sets the limits of the professional's liability exposure.

It is important to understand, too, that this relationship and program of responsibility lies in the same context, and in the same format no matter what project delivery system is utilized— including design/build. While contracts for the project may be drawn in differing manners, there is virtually no change in the legal and mandated status of the design professional. Even though employment scenarios vary, there is no variation for the same in current law. Therefore, the legal status of the professional is unchanged— it may require added explanation, but still lies undeniable, and unmodified.

In a great number of instances on every project, the exact manufacturing or construction process or activity is irrelevant, and inconsequential. There are so many small operations that are required it is impossible to comment on and control each one. Professionals learn with experience that there is a time when the expertise of the contractor or manufacturer can be called into play, without jeopardizing any aspect of the project. Often, in fact, these parties know more about the operation than the professional, due to their training, research and experience. Utilizing such expertise is not shortchanging the client, and in fact, can be a method whereby the project is made better. No project participant is omnipotent, but mutual respect and acceptance of the knowledge of others can improve the project work. The great multitude of items and small operations are vital to success of the work, but their solution should emanate from those with the closest relationship and the highest level of expertise. Certainly, this should never be considered lackadaisical, improper, unprofessional, contract-breaching, or illegal.

Submittals usually entail a wide and vast variety of information depending on the work, material or equipment in question. In many instances, "cut" sheets, catalog pages, data sheets, and similar preprinted information is adequate. Quite often product information will include details illustrating common or anticipated uses of the materials or systems. These are very general in nature, but do give the manufacturer's concept to the "proper" utilization of the products. While these are not mandatory, they do serve as a guide to the professionals regar-

ding what is required to take proper advantage of the products, and how best to install them. The material, though, is NOT project specific and is intended purely as a guide or suggestion. This is true particularly when the item is a standard, manufactured piece of equipment or unitized work—it is completely built in a factory and merely shipped to the project site for correct installation. Little if any work, other than the normal installation is required.

With product data sheets and for other items [primarily pre-finished materials] there can be a need to submit color samples, or rather complete palettes of colors which are available from the product manufacturer. A selection is required [by Owner, design professional, etc.] before the unit or material will be fabricated. In essence the coloring and finishing of the product is part of the manufacturing process required before shipment is made to the site. Care must be taken that all of the required information, including answers to all inquiries, along with any color selections be returned to the submitting contractor, in a timely fashion.

Yet another process is started as material orders are placed. This is the activity known as shop drawing production. The vast majority of the items to be used in the project are made through various manufacturing processes. Quite often "standard" materials or devices are specified, but even these must be made proper for their fit into the project— minor adjustments and spacing may be involved. Other items will be fabricated specifically for the circumstances of the project, and must be made in special ways. For example, a countertop must be made to fit, exactly, between two end walls— obviously, its dimensions must be determined in the field, and then the shop must be total how to fabricate this work. Shop drawings are precisely that— drawings which indicate to the manufacturer's shop what is to be made, how many are required, and what special, different, or added features need to be made part of the material or apparatus. In many instances, the shop drawings will depict a specific arrangement of standard [stock] parts, pieces, items, etc., which matches the configuration or conditions in the project. While the individual items are common, and mass produced, their combinations and relationships vary from project to project; or even on the same project, but in different locations.

Shop drawings are literally interpretations of the work required on the working drawings. Architectural working drawings are not conceived or produced under the onus of showing "everything-there-is-to-know-about-the-work". Some information, primarily regarding methods and means of construction, is left to the contractor/supplier. The interpretations, then, are properly made by the manufacturer or fabricator of the material,

product, system or equipment in question. In essence, they are produced as "in-house" communications within the organization or "shop" where the raw materials and stock pieces work will be fashioned into those items specifically required on the construction project. Literally, they are instructions to the shop; they are submitted to the design professional mainly to show what is proposed, how it will be made, etc. The professional can then assess whether or not the planned work is in keeping with the overall design scheme of the project.

In the vain of being "instructions to the shop", these drawings can be quite detailed, and contain precise information, far beyond anything that is provided by the professional, but which is necessary for the proper manufacture or fabrication. They have a high "detail content" in that the producer wants to provide a good product, fully suitable for the project, but not in excess either in sizing, operation, or cost. This is not a struggle, but rather the manufacturer wants to sell the product, but does not want to lose money on it, nor does he/she seeks to be forced to do work not explicitly shown on the professional's working drawings. Exactness, then, is the best description of shop drawings; thus, they need to be based on sound and good information from the professional.

It is not unusual, though, for shop drawings to be executed in a manner that is quite different from the detail drawings of the professional. Even though they include a vast amount of information, the drawings many times are unrefined, and lack the polish of design professionals. In some limited case, shop drawings are produced by professionals or persons with professional training. Still there is a large volume of shop drawings executed by person with other background and expertise. To a good degree this is changing due to the introduction of CAD facilities, but still the agenda for shop drawings from the manufacturer/supplier/fabricator view point, is for the drawings to correctly show everything required for the product operations, no matter the drafting skill or refinement. Shop workers seeing similar drawings on a daily basis become accustomed to the drafting techniques. This is not true, though, of the trade workers on the project site, who see documents from various professional offices, which produce documents in quite varying formats and styles.

The task is reversed for the professional in that shop drawings varying widely from source to source, must be read, and understood for proper action can be taken. This requires a good eye, and skilled insight to both understand and assimilate the shop drawings in a timely and correct manner. This is quite vital to all concerned as the work will be produced in keeping with the shop drawings approved by the professional— errors left un-reconciled will survive in the final work.

There is a prevailing and widely used procedure for processing shop drawings. Before giving these drawings over to the fabricating/work shop, the manufacturer will submit them, to the design professional and contractor, for review, and to ascertain whether or not the proposed fabrication meets the intention and requirements of the contract documents. No manufacturer wishes to produce an item, only to have it rejected, or have it not fit the dimensions or purpose. Those required are usually submitted during the progress of the work, but always in a timely manner to allow for processing and approval, production, and shipping time, so the actual material or devices are on the site, ready for installation, at the right time.

The following is a work instruction which describes the process by which submittals are reviewed and returned to the contractor/supplier. Note in particular the involvement of the design professional, whose duties include review of the submittals, and adjustments where necessary. This involvement is crucial to ensuring that the work anticipated meets the requirements of the contract between constructor and owner.

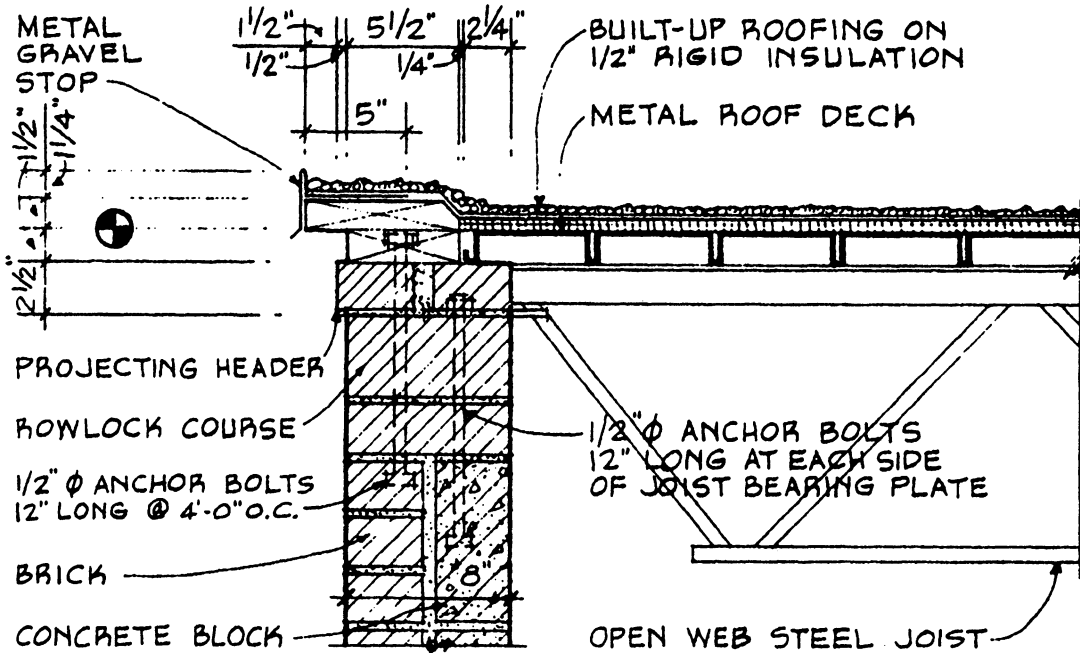

ARCH. WORKING DRAWING

ROOF-WALL SECTION

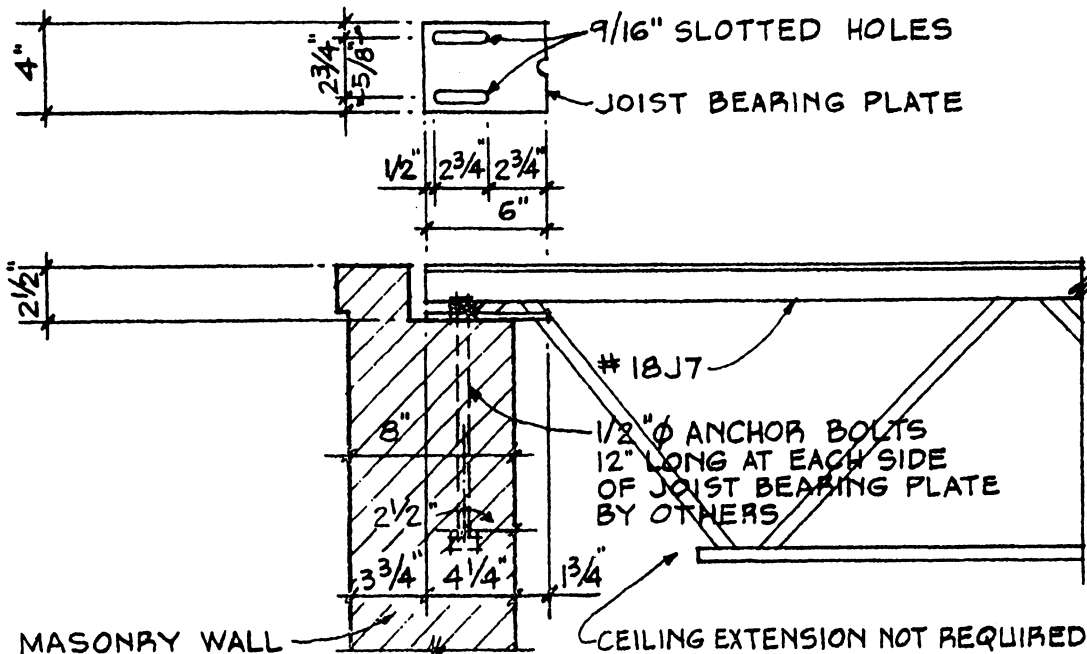

SHOP DRAWING

STEEL JOIST DETAILS

Fig. 12-3

Example of how an architectural drawing is converted or translated into a shop drawing

PRACTICE PROCEDURE: REVIEW OF SUPPLIER SUBMITTALS

PURPOSE

This practice establishes guidelines for the review of Supplier drawings, product data, samples, and requests for additional information (for example, color selection, type or model selections, etc.) by the design and engineering office responsible for the project.

SCOPE

This practice covers the following topics pertaining to the review process:

- Definition of responsibilities
- Identification of basic documents, and submittals
- Action taken by the Design Professional of Record (DPOR) and the associated discipline engineers

APPLICATION

This practice is applicable to all projects where specifications are generated for the purpose of selecting/designating products, equipment and other goods for installation, use, or providing to the project.

RESPONSIBILITIES

All suppliers and contractors required to submit shop, drawings, product data, and samples, and who need certain selections of color, model, etc. (prior to ordering items), shall make their submittals in a proper and timely manner. Such submittals shall be forwarded to the General Contractor, Construction Manager, or other on-site person designated.

The General Contractor, Construction Manager or other party responsible shall make a complete, thorough and proper review of all submittals, prior to forwarding them to the DPOR. Such review shall be in detail to augment the review of the DPOR (as noted below), and shall ensure proper fit and incorporation of the items reviewed into the project.

The final review of all Supplier furnished documents, drawings, product data, samples, and inquiries, for project items and work assigned to the engineering group, will be done by or through the DPOR, who may include review by the appropriate discipline engineer.

The DPR will be responsible for the following:

- Selecting which of the other disciplines should be involved in the review of each document; that

selection being based on the items involved and the content of the document.

- Coordination and communication with the respective disciplines to resolve any problems or conflicts regarding review comments.
- Notifying all affected disciplines of changes to the document.
- Reviewing the document to make sure the goods comply with the general intent of the Contract Documents.

ACTION

The DPOR upon receipt of the Supplier documents, shall log-in the submittal on a Supplier Submittal Log, and shall complete (when appropriate) a Supplier Submittal Routing Sheet. DPOR then routes the submittal, as necessary for proper review, to other discipline engineers.

The responsible discipline engineer, when involved, shall review the Supplier's documents in detail. This review is based upon the contract requirements for the item. The engineer also reviews the documents from the viewpoint of field installation, utility requirements, maintenance, safety, and any interfacing accessories that must be attached. In essence, the engineer's review is designed to ensure that the specified item will properly perform its intended task.

In addition, the discipline engineer shall communicate with the other disciplines in the review cycle to find, review, and resolve any conflicts or discrepancies, in a manner consistent with the requirements of the Contract Documents. Solutions are then routed back to the DPOR for final review, resolution, and disposition.

At the end of the review cycle, the DPOR shall accumulate the comments and solutions from other disciplines and either incorporates those comments, or notifies the appropriate discipline as to the status of its comment.

The DPOR, by utilizing the Supplier Submittal Log, shall ensure and verify that the Supplier has provided all drawings, product data, and samples required by the Contract Documents; and that all required selections, corrections and comments have been returned to the Supplier. This verification of products and their installation is required by Procurement to release final payment to the Supplier.

REFERENCES

Discipline specific requirements are contained in Practices, Supplier Drawing and Data Review, developed for each design discipline.

The design and engineering office shall adopt a standard form for;

- Supplier Submittal Log
- Supplier Submittal Routing Slip
- properly worded rubber stamp for imprinting submittals, listing disposition by the DPOR

Since the mid-1980s, when professional liability escalated in a chaotic manner, many legal opinions were issued to clarify and promote the correct configuration for that liability, and ways to stem undue increases in liability exposure for professionals. This was done, in response to case law where the liability of design professionals was being elevated unwittingly, needlessly, and dangerously. Stiff monetary awards were issued based on this issue. Many of the legal reviews and efforts included use of correct language in the shop drawing stamp used by architects and engineers.

In several articles in 1996 and 1997, the attorneys advised that the word "approved" should not be used in the stamp text. Rather the word "Reviewed" should be used. Basically, this was to eliminate the impression that the design professional was taking responsibility for the content and accuracy of the construction shown on shop drawings. This effort was a direct parallel to the use of the word, "observe", in lieu of "inspect", in regard to the work of the professionals on the job site.

The other text on the stamp was to properly list the parameters of the "review", in an attempt to specifically limit the liability exposure of the professional.

In many instances, instead of "review" the professionals used the phrase, "no exceptions taken", to indicate that the oversight made found no discrepancies with the general design concept. Unfortunately this did not work for long, in that judges, juries and arbitrators interpreted and decided that the phrase had the same meaning as "approved".

The issue and the thinking have now come full-circle. There is now a two-element approach noted in a new legal article. First, use of the word "approved" on the stamp, BUT strictly limited, via the text, the scope of the submittal review. The paragraph of text, on the stamp, is purposely written to define the limits of the "approval", which in turn clearly es-

tablishes what the design professional has reviewed- and has indicated accordingly. Since attorneys, engaged in construction law have brought this information forth, it carries the weight of a fully proper and effective system. [Fig. 12-4]

Following is a collection of details by various sources other than design professionals. These are presented to offer a small insight into the type, quality and wide variation of details available. It must be understood that there is a vast array [literally tens of thousands; commonly over 500,000 required for a modest sized project] of products available to the construction industry, and most all of them have similar information. The primary sources are the web sites, technical brochures and binders, and catalogs of the manufacturers, and their technical staffers and field/sales representatives. Also, there are web sites similar to www.4specs.com where listings of manufacturers are set out for use as reference and consultation.

[Figures 12-5 - 12-29]

SHOP DRAWING REVIEW

<u>A/E REVIEW</u>	<u>REQUIRED RESPONSE</u>
<input type="checkbox"/> APPROVED	<input type="checkbox"/> CONFIRM
<input type="checkbox"/> NOTE MARKINGS	<input type="checkbox"/> REVISE
<input type="checkbox"/> REJECTED	<input type="checkbox"/> RESUBMIT
<input type="checkbox"/> REQUIRES REVIEW AND APPROVAL BY GENERAL CONTRACTOR	

ARCHITECT/ENGINEER'S [A/E] REVIEW IS FOR GENERAL PERFORMANCE WITH THE DESIGN CONCEPT OF THE PROJECT, AND THE INFORMATION GIVEN IN THE CONTRACT DOCUMENTS.

THIS REVIEW DOES NOT INCLUDE, AND THE CONTRACTOR IS SOLELY RESPONSIBLE FOR: CONFIRMING AND CORRELATING ALL QUANTITIES AND DIMENSIONS; SELECTING FABRICATION PROCESSES AND TECHNIQUES OF CONSTRUCTION; COORDINATING THE WORK WITH THAT OF OTHER TRADES AND PERFORMING ALL WORK IN A SAFE AND SATISFACTORY MANNER.

CORRECTIONS OR COMMENTS MADE ON THIS SUBMITTAL DURING THIS REVIEW DO NOT RELIEVE CONTRACTOR FROM COMPLIANCE WITH THE REQUIREMENTS OF THE CONTRACT DOCUMENTS OR WITH ITS RESPONSIBILITIES LISTED ABOVE.

FIRM NAME: _____

BY: _____ DATE: _____

Fig. 12-4

Approval stamp used by design professionals indicating their review of shop drawings and their findings. Note context of this review in the text of the stamp.

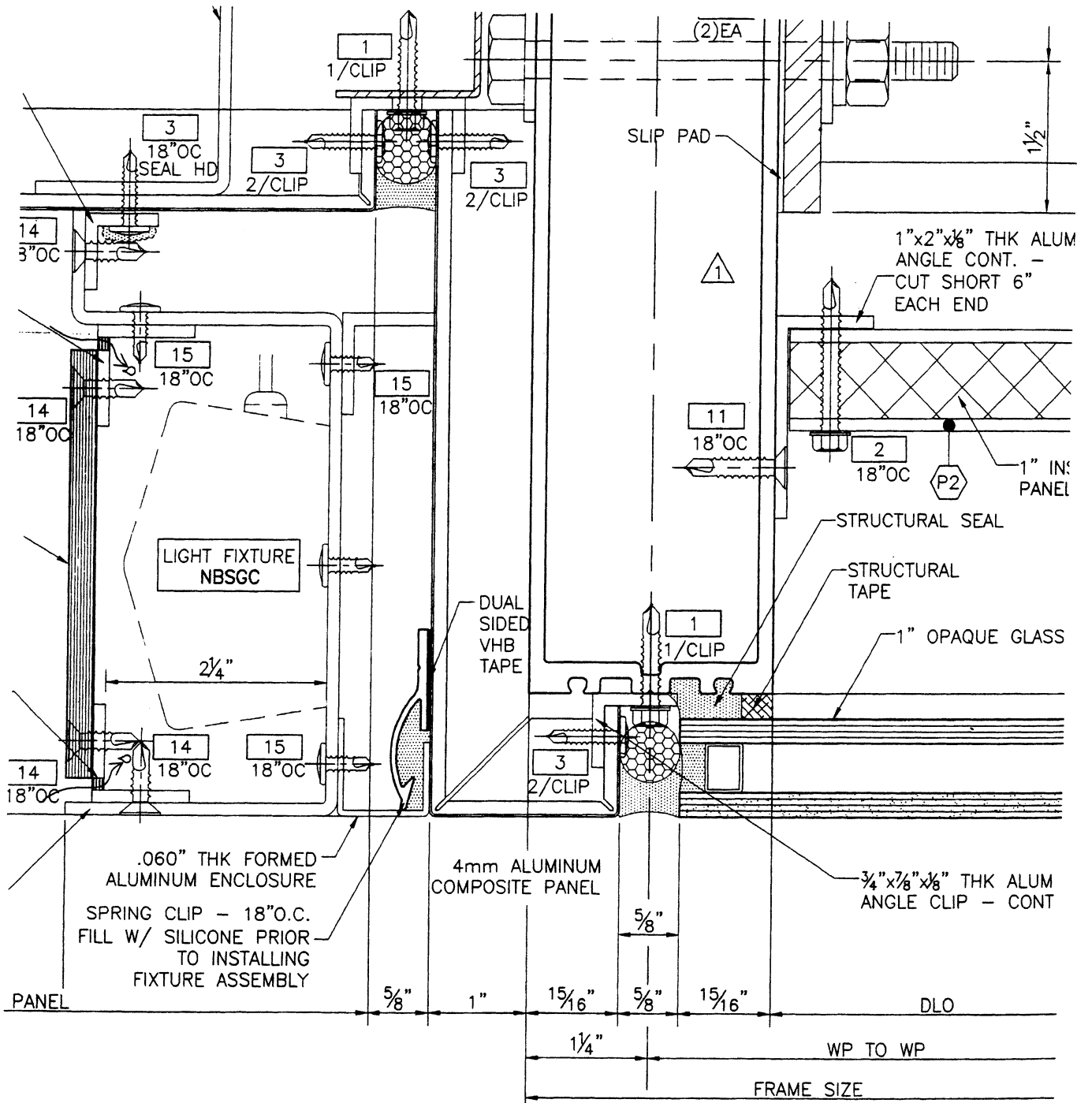

Fig. 12-5 Example of shop drawing for panel wall system. Extreme example that shows each device and part, precisely, so shop personnel can easily assembly the parts. originally drawn full size; reduced here.

UNREINFORCED EXPANSION JOINT FLOOR

F.

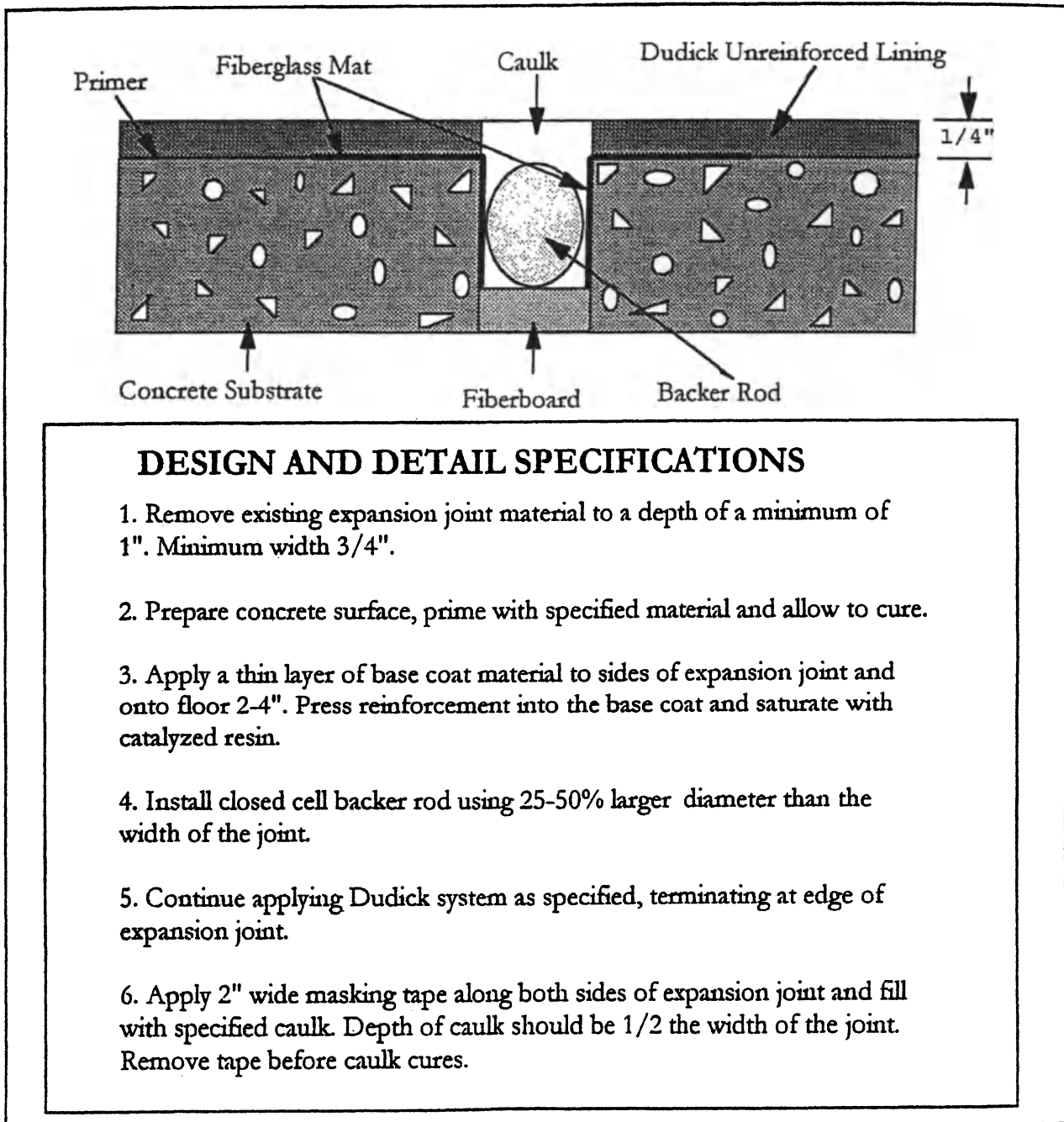

Fig. 12-6

Example of an expansion joint detail for a floor condition.

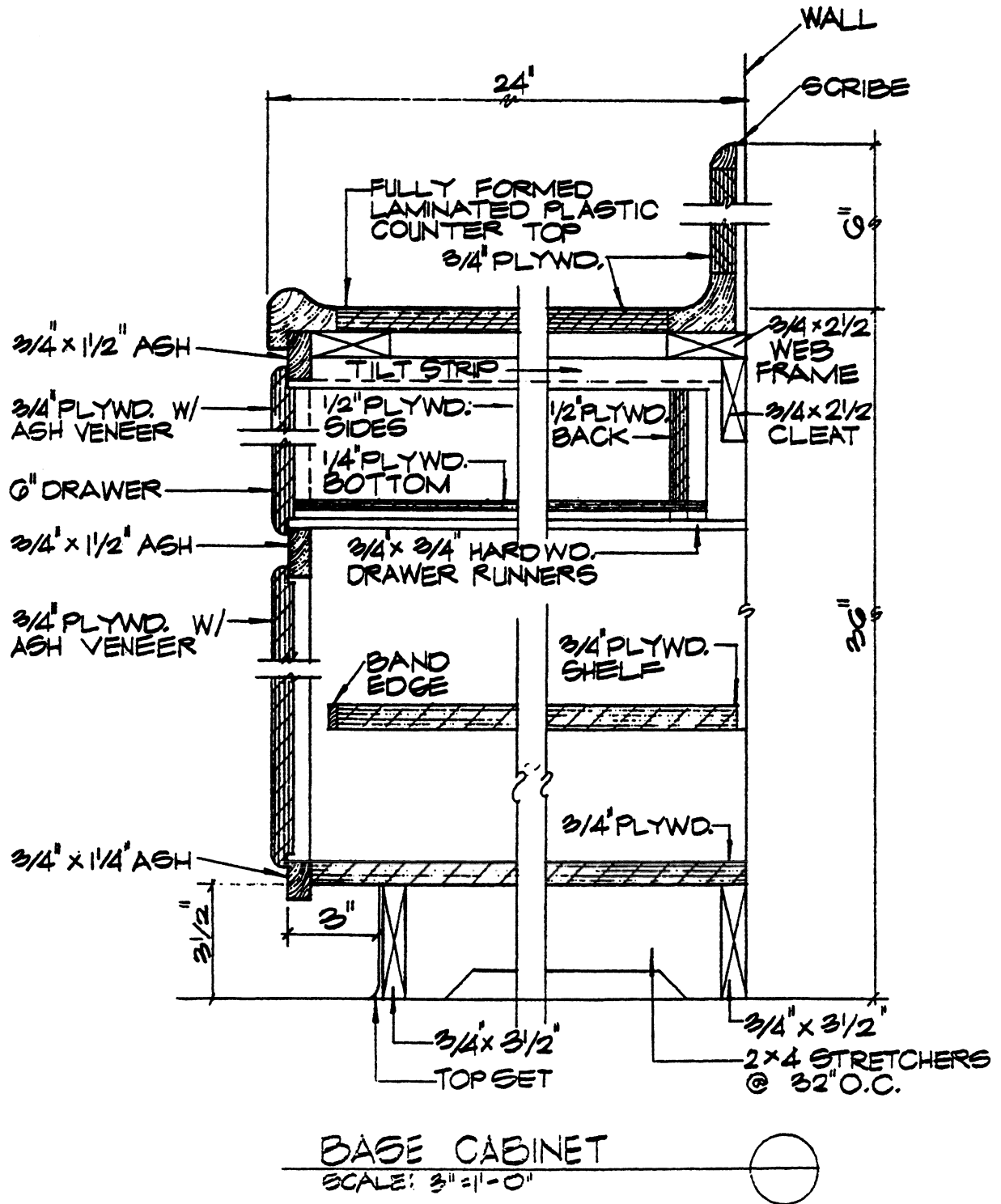

Fig. 12-7

Detail drawing, most probably a shop drawing [could be from design professional also] showing the construction of a typical bas cabinet.

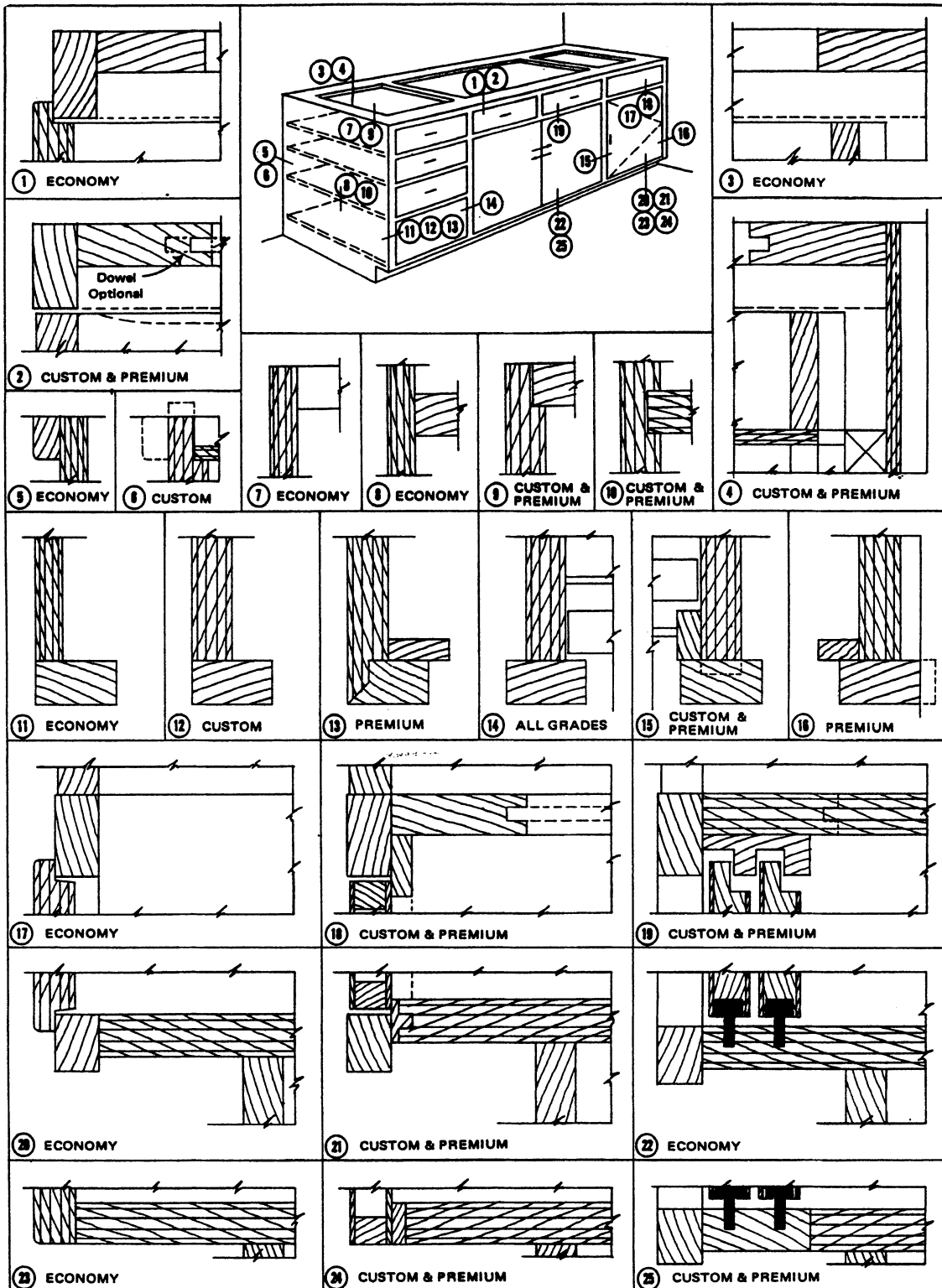

Fig. 12-8

Joinery details from an industry showing typical joints used for casework construction. Some of these details may be utilized in the construction shown in Fig. 12-7.

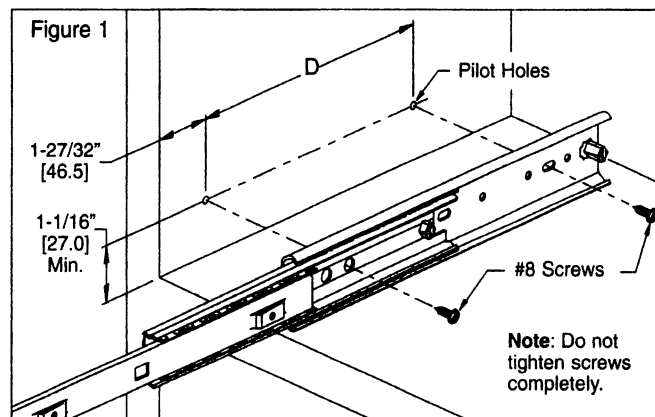
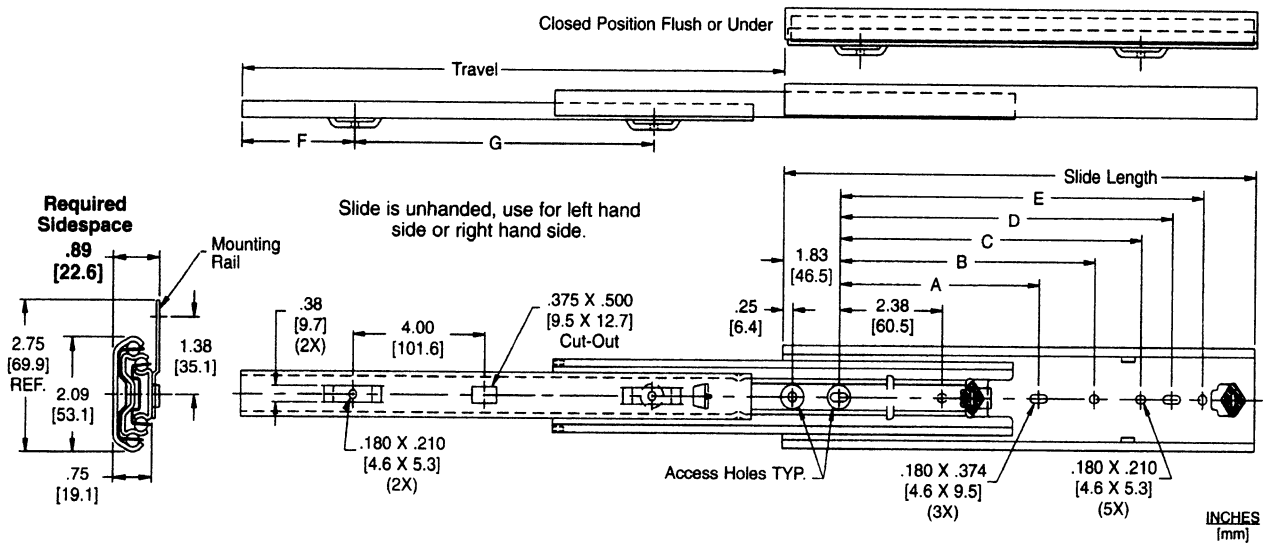
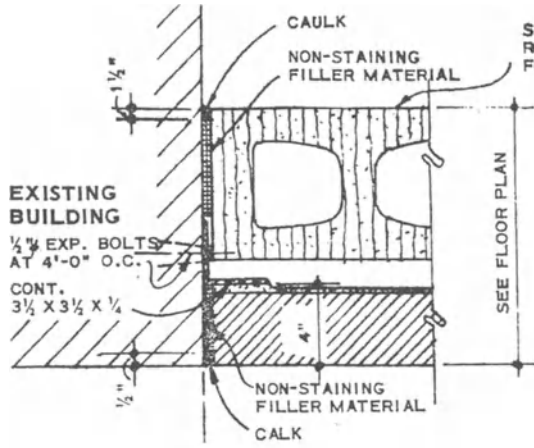
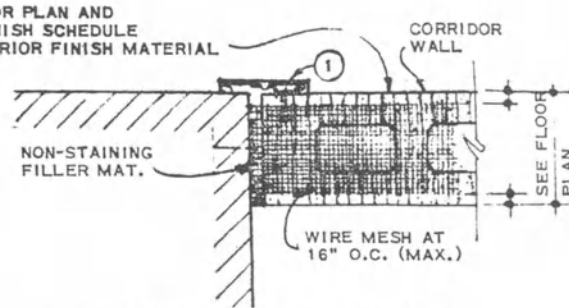

Fig. 12-9

Detail of drawer slide units using in casework construction. These devices are provided as finished units in various size, etc., and information includes proper installation procedure



A CONNECTION NEW EXTERIOR WALL TO EXISTING



C CONNECTION NEW INTERIOR WALL TO EXISTING AT CORRIDOR

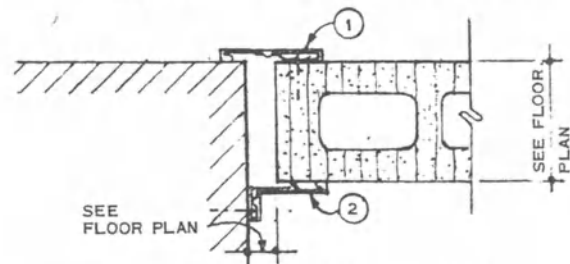

D EXPANSION JOINT AT CORRIDOR

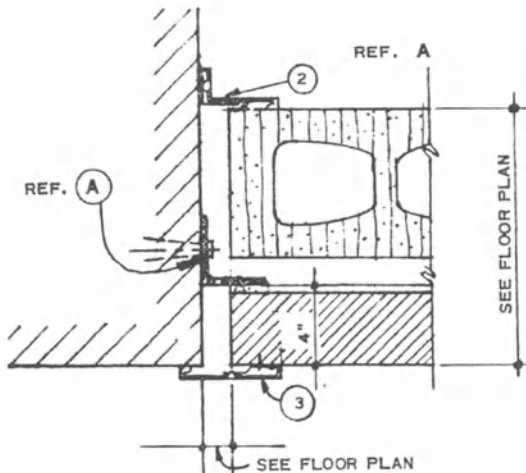

B EXPANSION JOINT CONNECTION AT EXTERIOR WALL

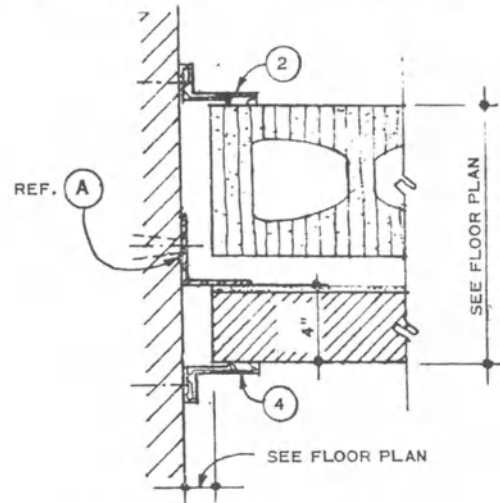

E EXPANSION JOINT CONNECTION AT EXTERIOR WALL

ALUMINUM COVER PLATE SCHEDULE

CODE	JOINT WIDTH	"METALINES" CATALOG NO.
1	0" TO 1"	503
	1 1/2"	703
2	0" TO 1"	603
	1 1/2"	803
3	0" TO 1"	500
	1 1/2"	700
	0" TO 1"	600
	1 1/2"	800

NOTE: ALL DETAILS THIS SHEET DO NOT NECESSARILY APPLY TO THIS JOB.

SCALE: 1/2" = 1'-0"

CONTROL JOINT AND EXPANSION JOINT DETAILS

Fig. 12-10

Industry source showing treatment of expansion joints in various ways, and using differing devices and closures

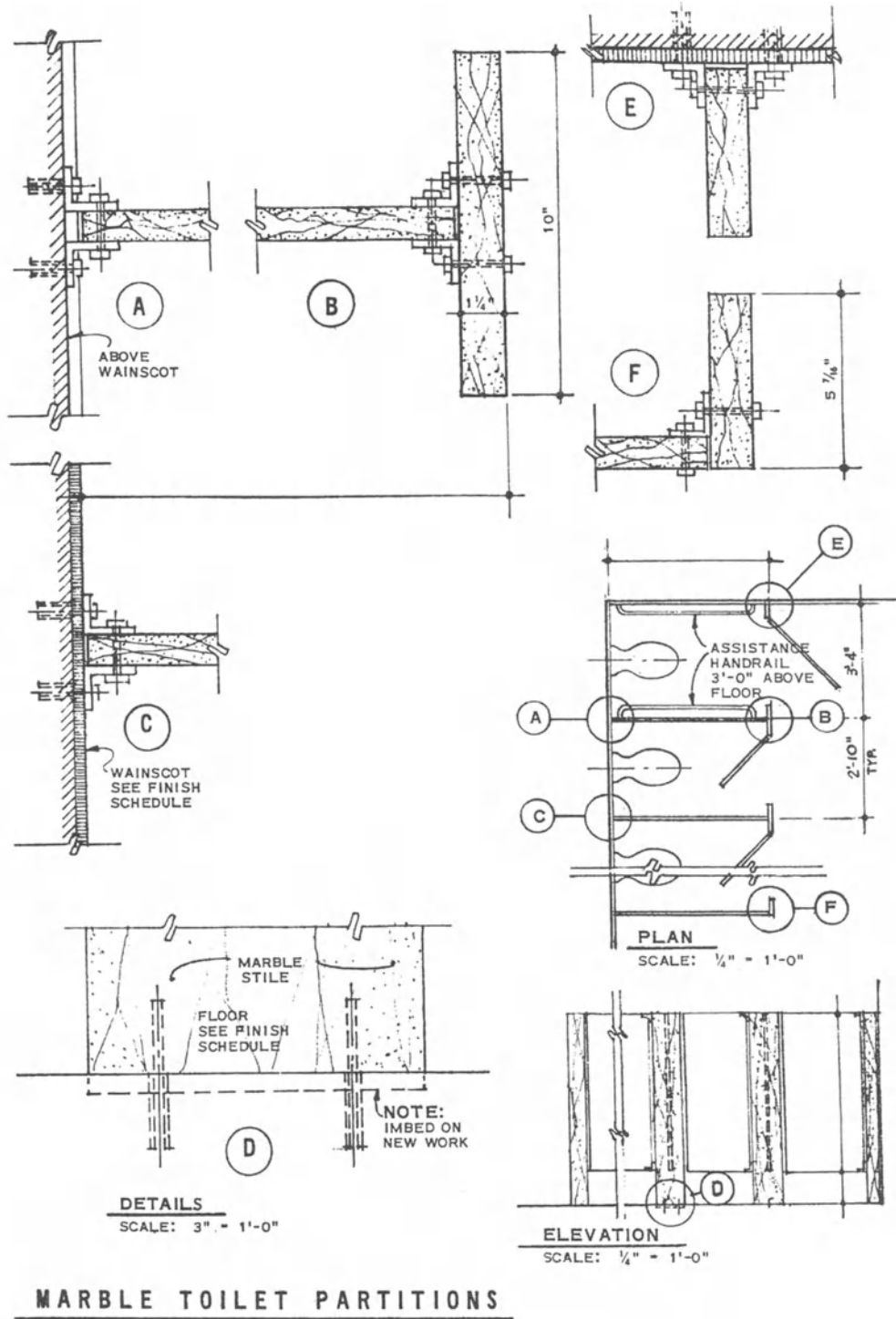

Fig. 12-11 Unusual details since stone or marble toilet compartments are used for high-profile, up-scale installations only. But nonetheless, details are required when the system is used, to ensure consistent high quality.

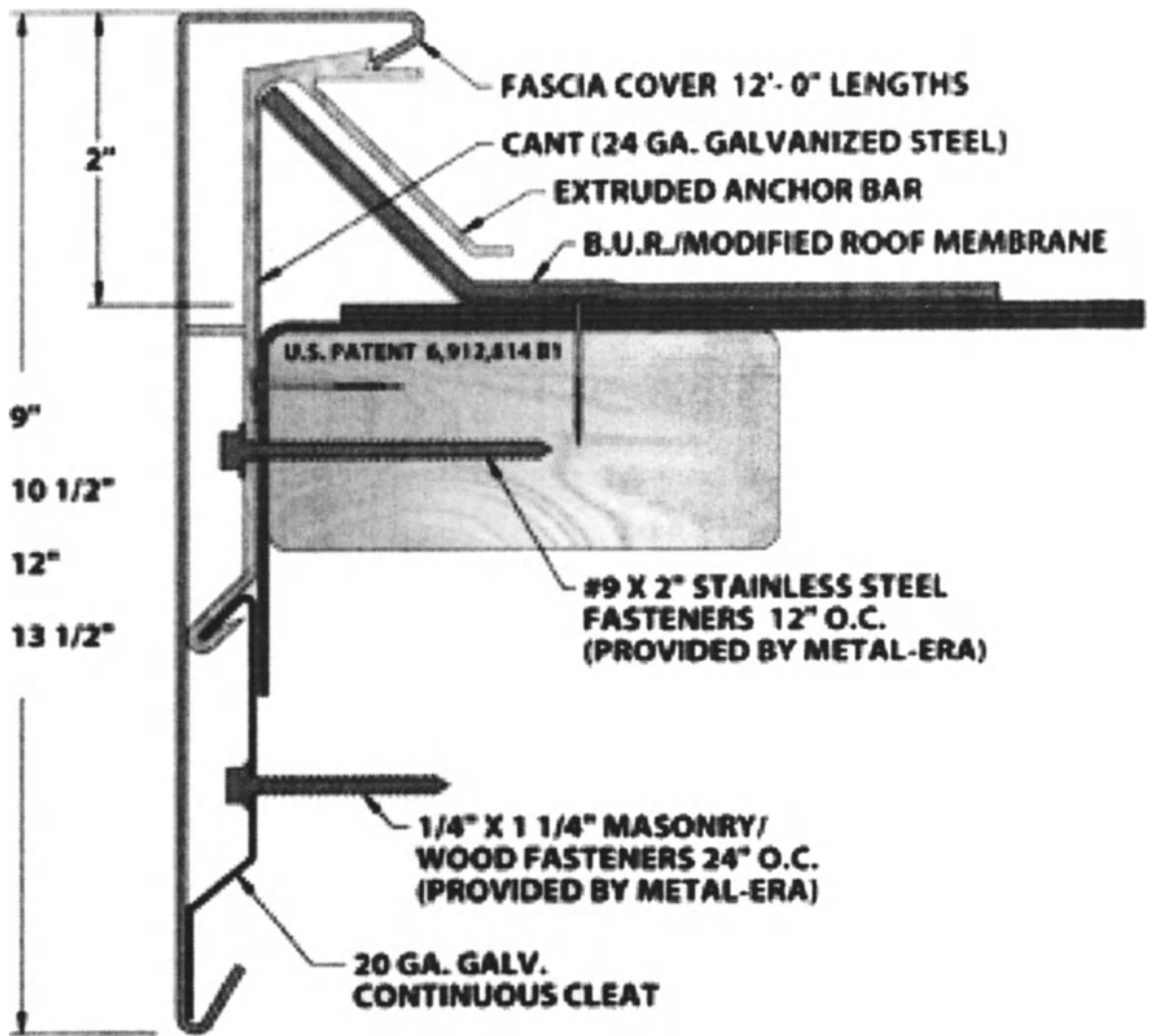

Fig. 12-12

Manufacturer's detail of a roof fascia system. Note the roof system but no information about the roof or wall construction— this is left to the design professional. Detail is intended to show how the fascia can be fitted to differing construction conditions [see options in text]

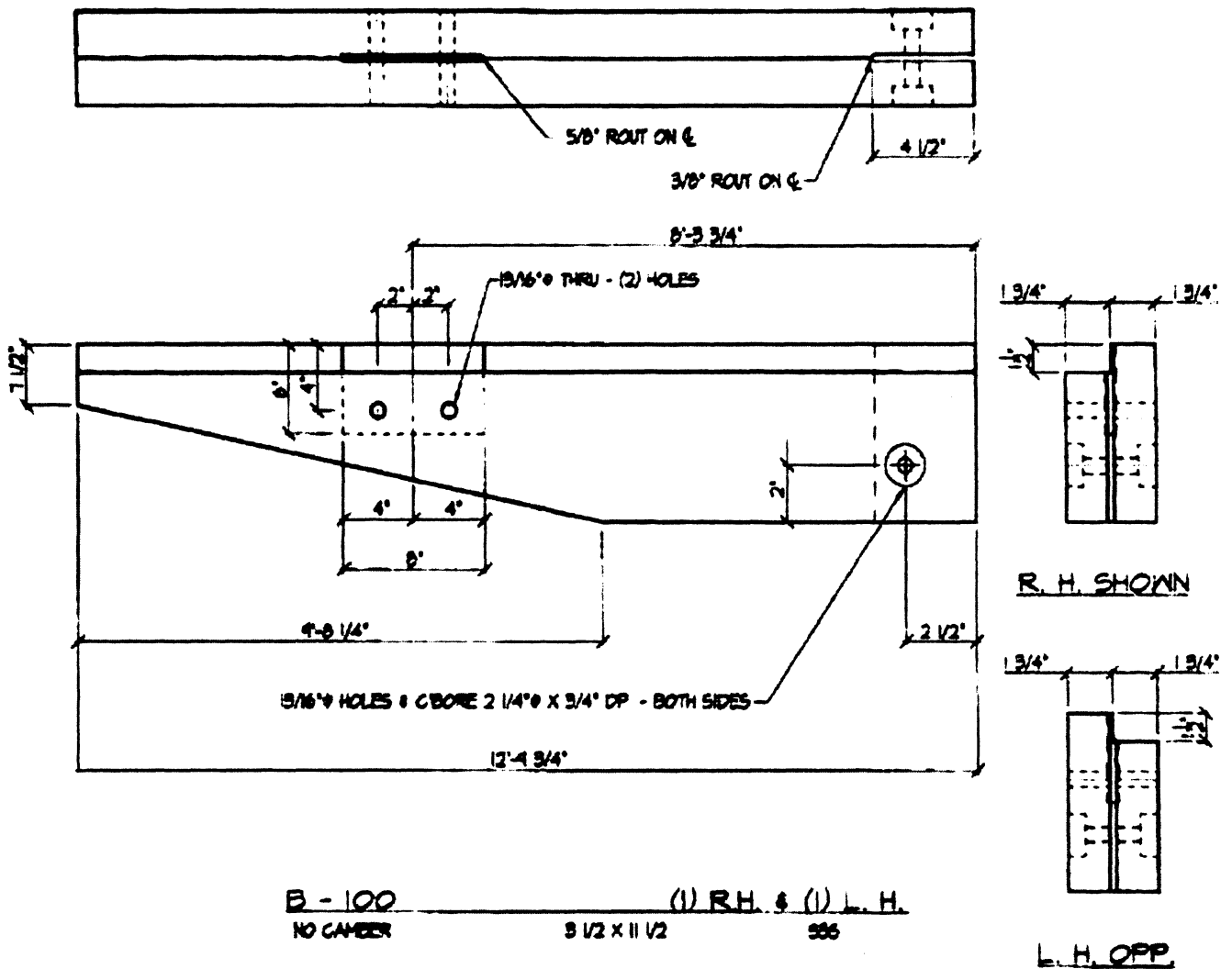
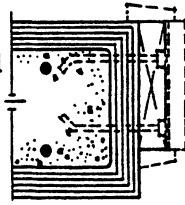

Fig. 12-13 Shop drawing showing the precise fabrication requirements for a large pre-fabricated wood beam.

DOORS

JAMB ANCHORAGE

- (1) Stagger bolts or place side by side. Buck may be installed with or after block work—
scale 1 1/2" = 1'-0"



- (2) Drive nails 3/4" thru buck bend over then drive flush. Nail heads and hooked ends embedded in grout will provide tight anchorage. Buck must be installed with block work. Frame can not be tightened after installation—

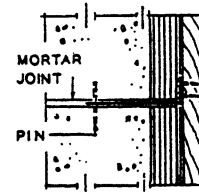
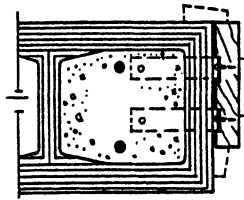
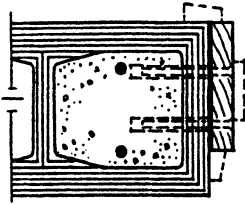
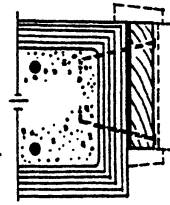

Vertical section

- (3) Flat head bolts used with conc. anchors or threaded (closed bottom) shield so that frame may be tightened after installation.

- (4) Metal anchors embedded in grout. Bend ends and screw to frame. Frame must be installed with block work. Frame can not be tightened after installation.

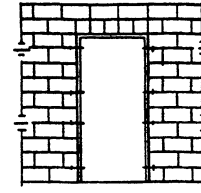
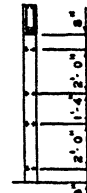
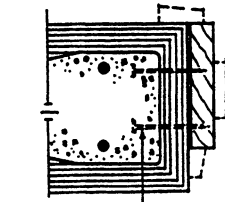
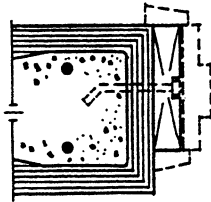

Section

Elevation

- (5) Single bolt will tend to wrap or split buck. Not recommended.

- (6) Jambs will work loose. Not recommended.

- (7) Anchorage spacing scale 1/4" = 1'-0"

METAL DOOR FRAMES — MODULAR

DOOR FRAME OPENING SIZES	
DOOR WIDTH DIMENSION	MASONRY OPG. FIN. DIM. - WIDTH
2'-0"	2'-0 3/8"
2'-4"	2'-4 3/8" (1)
2'-6"	2'-8 3/8"
2'-8"	2'-8 3/8"
2'-10"	3'-0 3/8" (1)
3'-0"	3'-0 3/8" (1)

DOOR HEIGHT 6'-6" & 7'-0" PLUS 3/16" FOR DOOR CLEARANCE.
MASONRY OPENING HEIGHTS 6'-8 3/8" AND 7'-0 3/8"

(1) REQUIRES 12" BLOCK BASED ON 4" MODULE

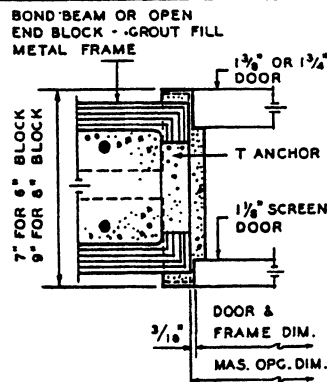

(1) Metal frame (typical)

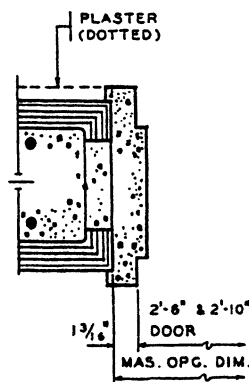

(2) 2'-6" and 2'-10" doors

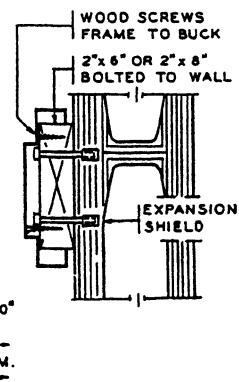

(3) Frame attached to block face scale 1 1/2" = 1'-0"

Fig. 12-14

Industry details for anchoring door frames to various wall conditions.

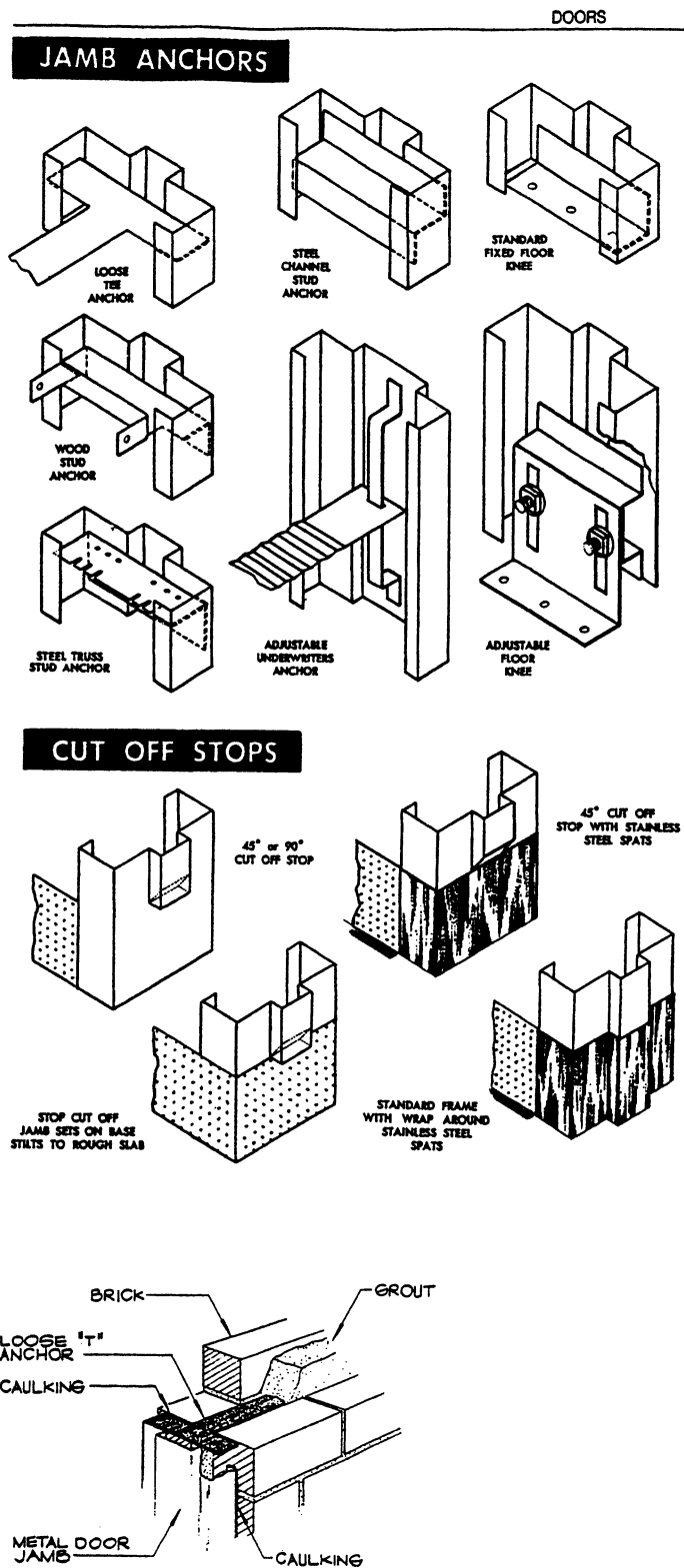
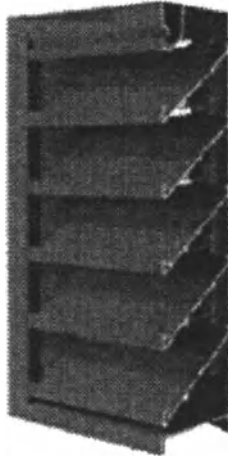

Fig. 12-15
Manufacturer's details showing anchors and stops available on hollow metal door frames



Description: Drainable

Material: Extruded Aluminum (Alloy 6063-T5)

Mullion: Visible Mullion

Louver Depth: 6" (152.4 mm)

Blade Thickness: 0.081" (2.06 mm)

Frame Thickness: 0.081" (2.06 mm)

Blade Angle: 35°

Standard Detail Drawing

View [full image](#) of drawing.

Download the CAD file. The drawing is in AutoCAD release 12 format.

[k6776.dwg](#) (96 kb)

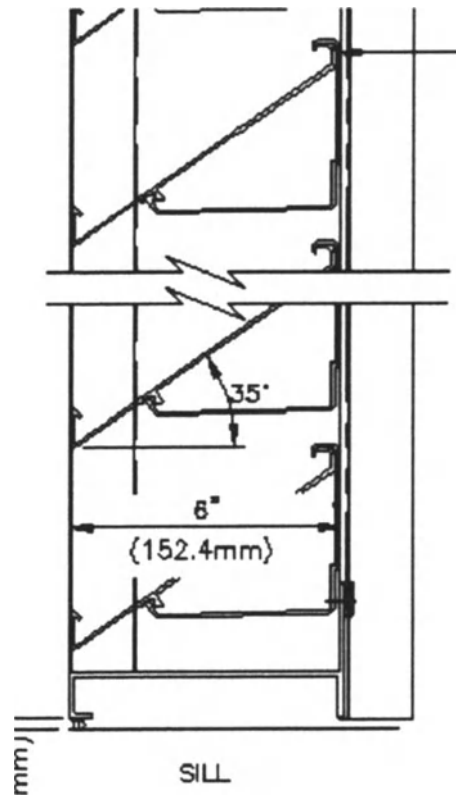

Fig. 12-16

Detail from the manufacturer of wall louver for one type of louver among many available

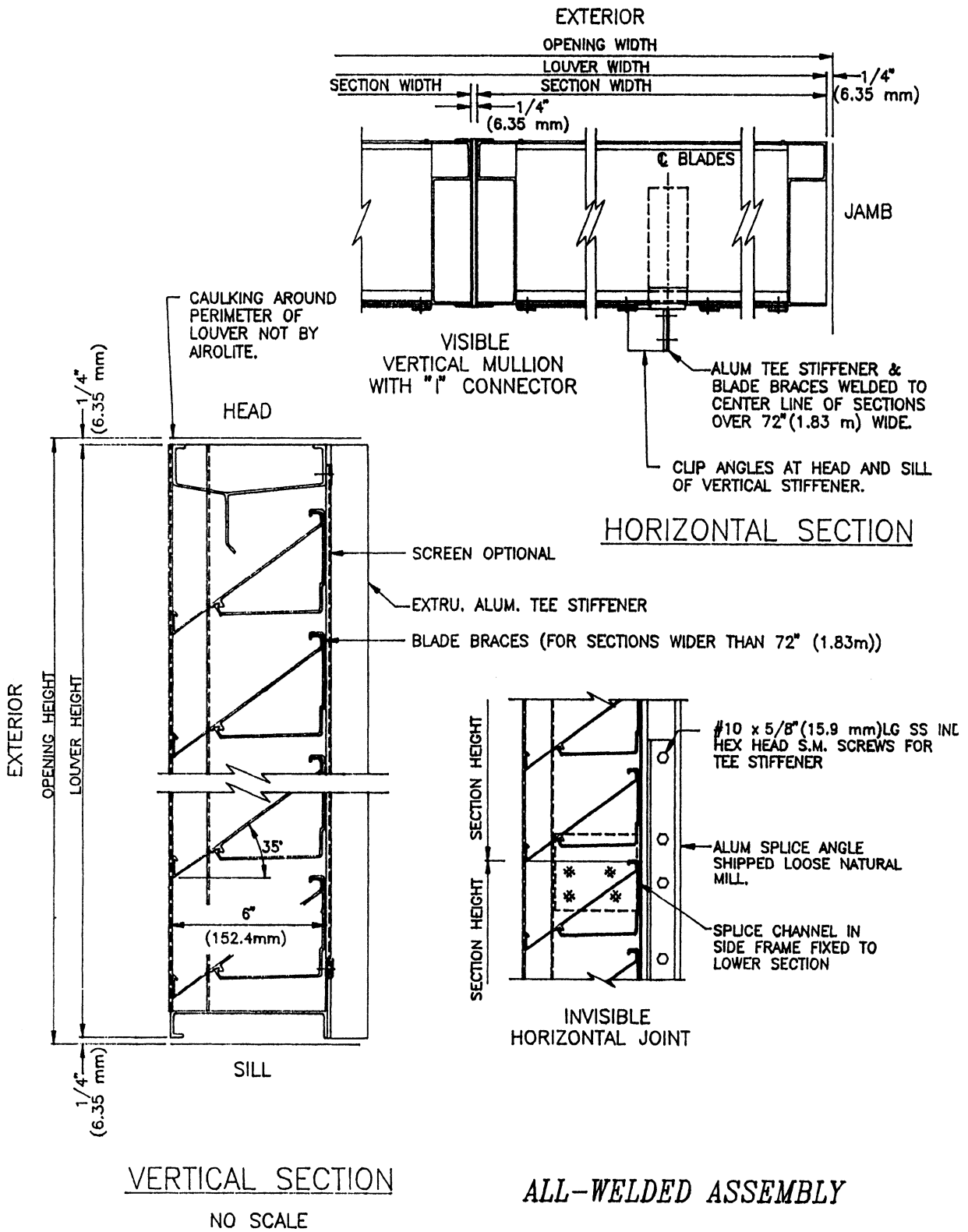
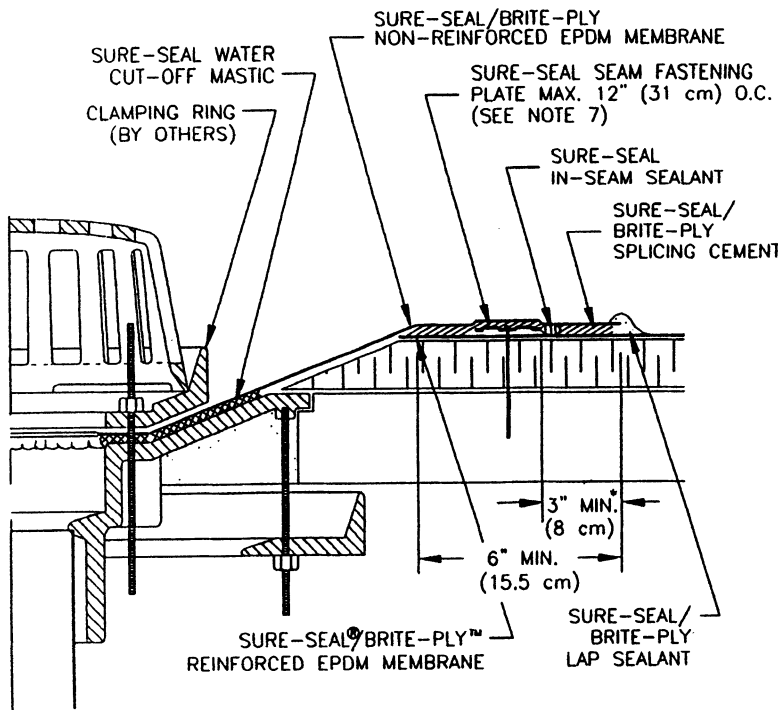

Fig. 12-17 Wall louver details from another manufacturer show various views of the unit

**FOR DRAINS WITH TAPERED INSULATION AT DRAIN
SUMP GREATER THAN 3 IN. (8 cm) TO 1 HORIZONTAL FOOT (31 cm)**



NOTES:

1. REINFORCED EPDM MEMBRANE MUST BE FASTENED WITH SEAM FASTENING PLATES NO MORE THAN 12" (31 cm) ON CENTER WHEN THE TAPERED INSULATION AT THE DRAIN SUMP IS GREATER THAN 3" (8 cm) TO THE HORIZONTAL FOOT (31 cm). CUT REINFORCED EPDM MEMBRANE EVEN WITH TOP EDGE OF DRAIN SUMP.
- WHEN TAPERED INSULATION AT THE DRAIN SUMP IS LESS THAN 3" (8 cm) TO THE HORIZONTAL FOOT (31 cm) REFER TO DETAIL U-6-B.
2. USE NON-REINFORCED EPDM MEMBRANE AS A SURFACE SPLICE AND EXTEND INTO DRAIN CLAMPING RING.
3. WHEN A SQUARE OR RECTANGULAR SECTION OF NON-REINFORCED EPDM MEMBRANE IS USED AS A SURFACE SPLICE, ROUND THE CORNERS OF THE NON-REINFORCED MEMBRANE FOR PROPER SPLICING.
4. LOCATE EDGE OF THE SURFACE SPLICE OUT OF THE DRAIN SUMP AT LEAST 6" (15.5 cm) IN ALL DIRECTIONS ONTO THE HORIZONTAL MEMBRANE.
5. INSULATION TAPER SHALL NOT BE STEEPER THAN 6" (15.5 cm) (VERTICAL) IN 12" (31 cm) (HORIZONTAL).
6. ROOF DRAIN SIZE AND NUMBER OF DRAINS SHALL BE IN ACCORDANCE WITH LOCAL CODES.
7. FASTENERS AND PLATES ARE REQUIRED FOR MECHANICALLY- FASTENED ROOFING SYSTEMS ONLY.

* FOR PROPER IN-SEAM SEALANT PLACEMENT REFER TO DETAIL U-2-A.

Fig. 12-18

Roofing detail showing how manufacturer's system fits into roof drain unit

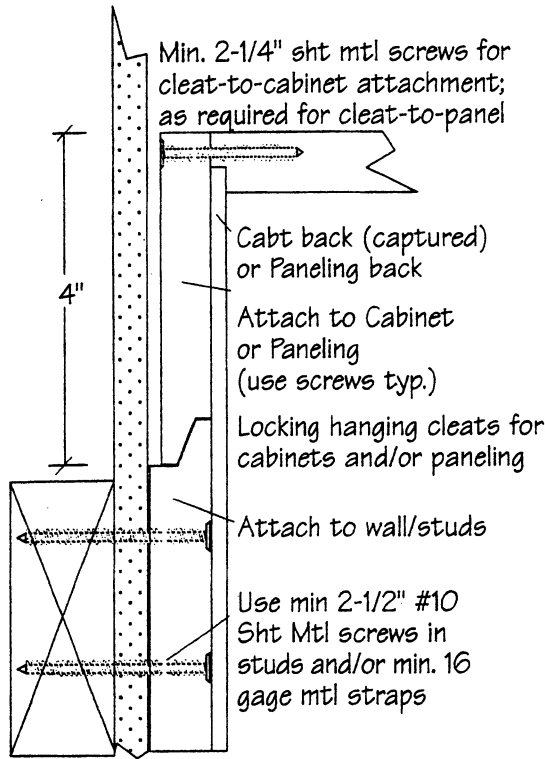

Figure 1700-01 - Cabinet or Panel Hanging

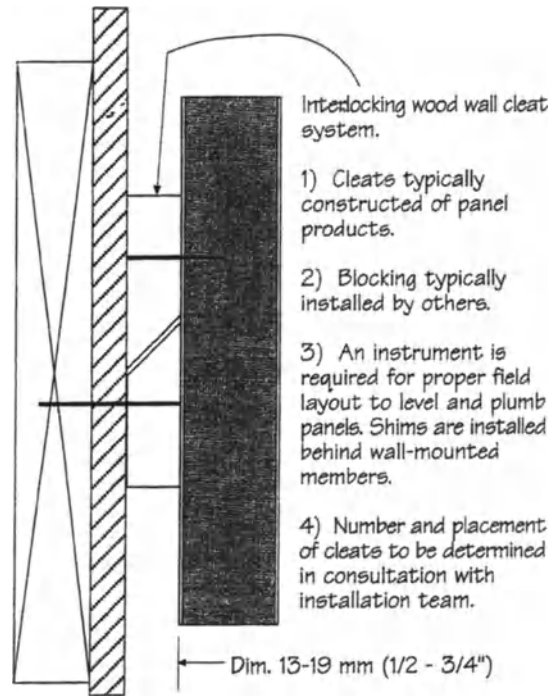

Figure 1700-03 - Wood Interlock

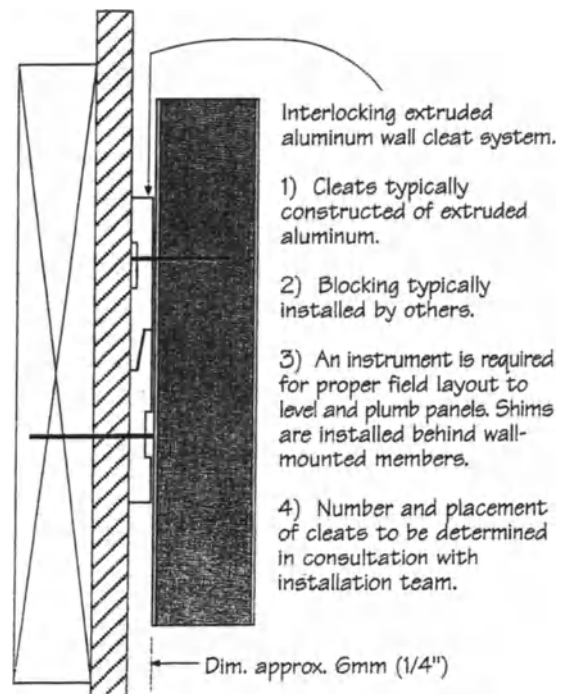
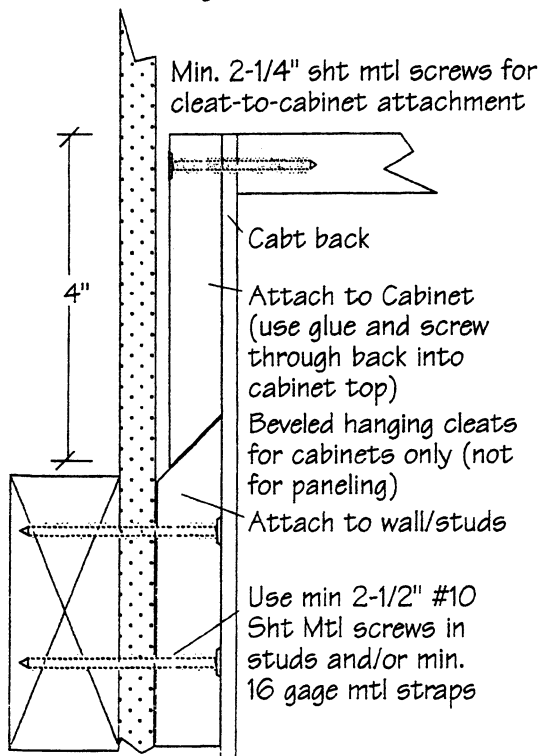

Fig. 12-19
Alternate details for the mounting [hanging] of panels and/or cabinets

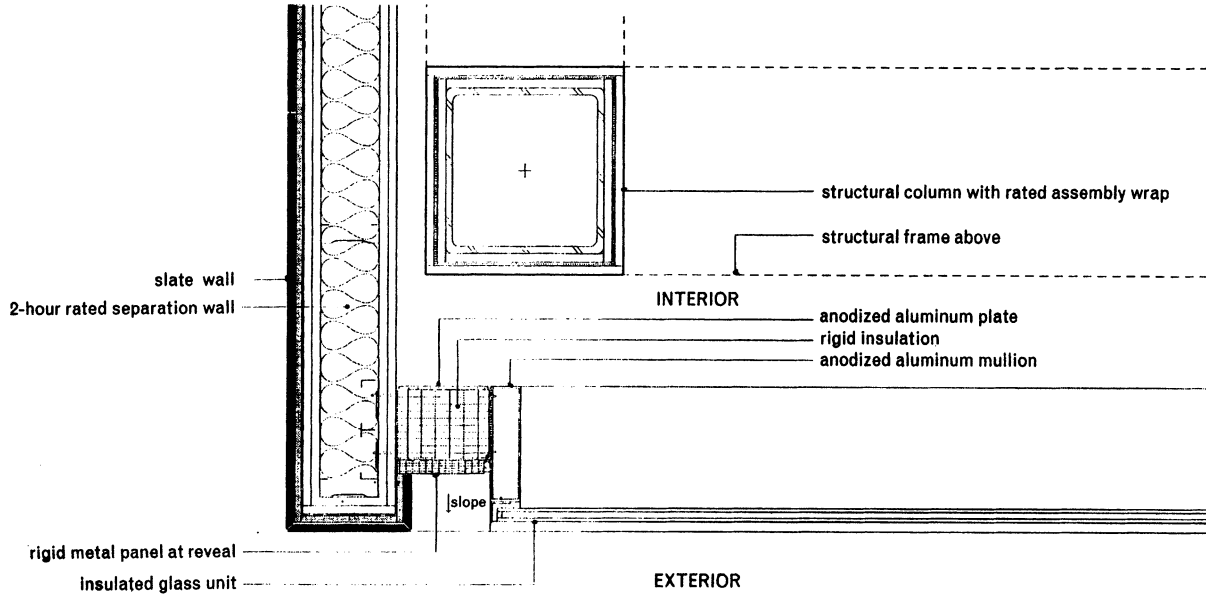

Fig. 12-20

Publication detail showing the closure between an solid end wall and a glazed wall of a building.
 Note difference in level of information, and no dimensions, provided

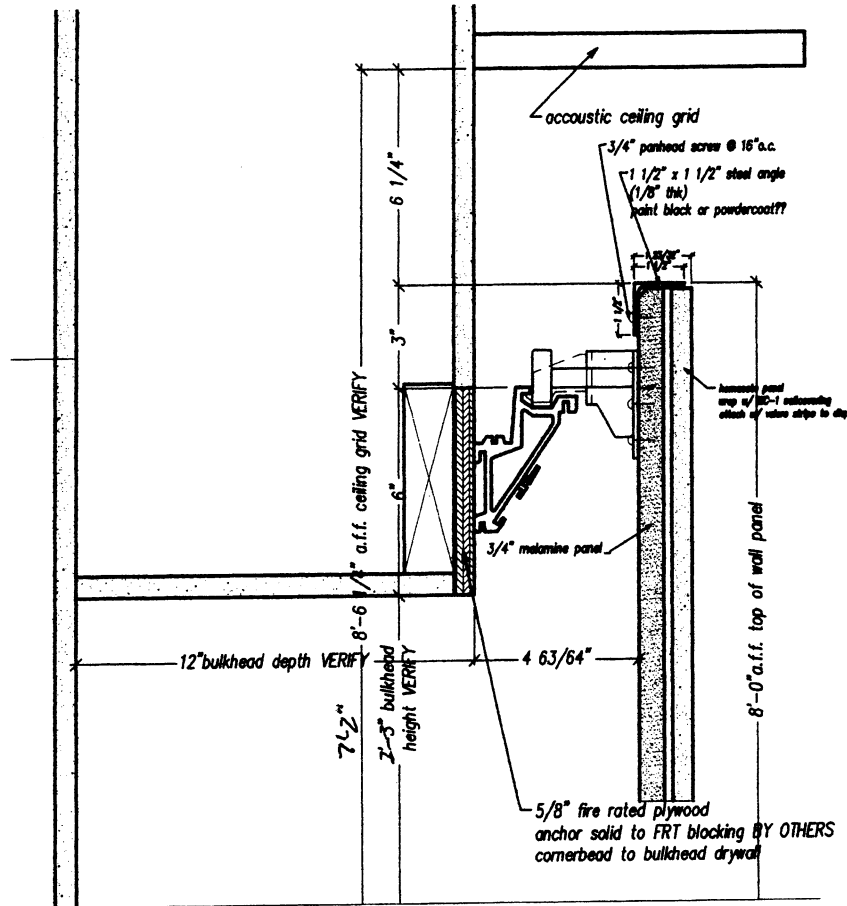

Fig. 12-21

Detail of manufacturer's mounting system for wall panels

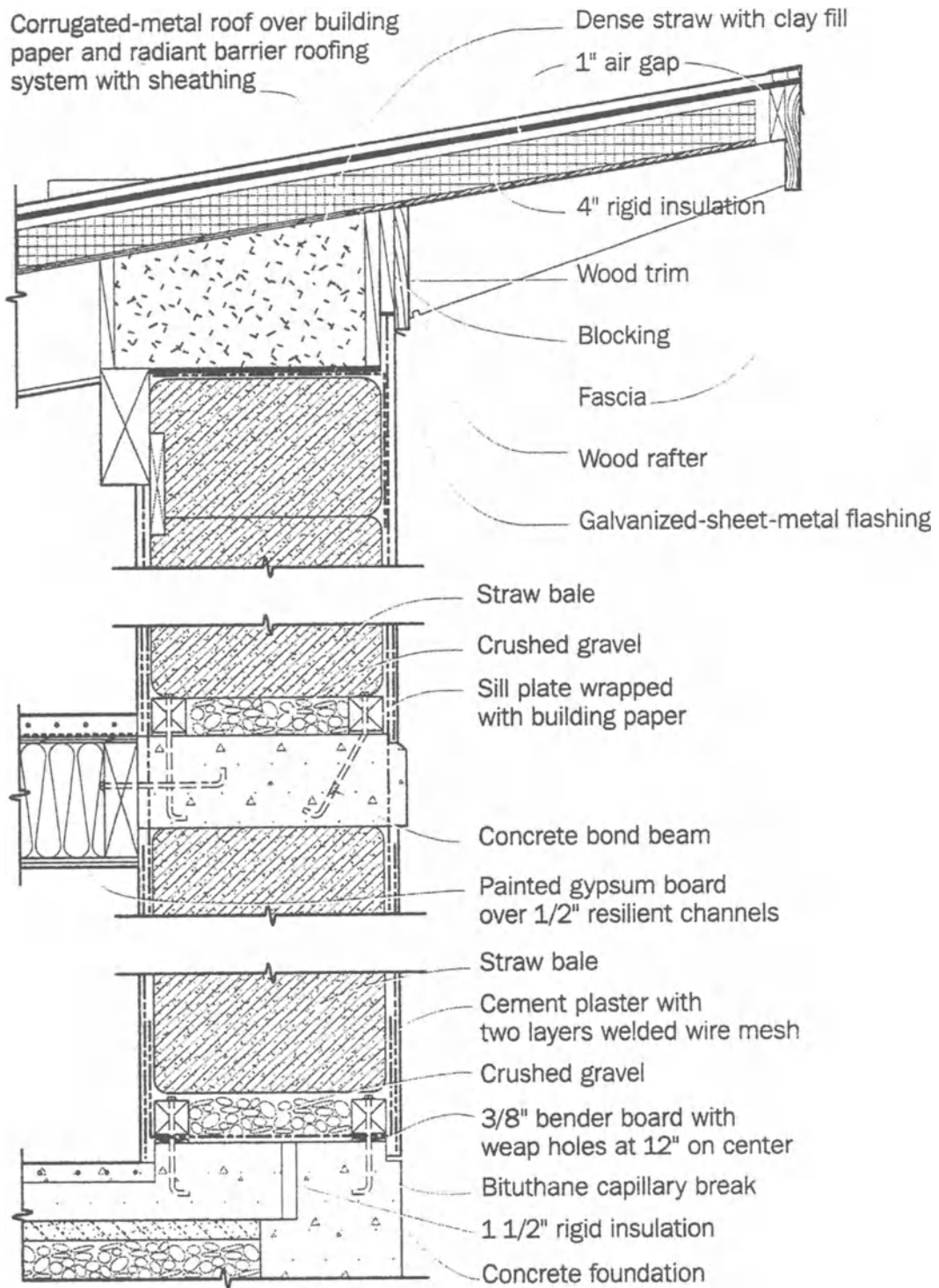
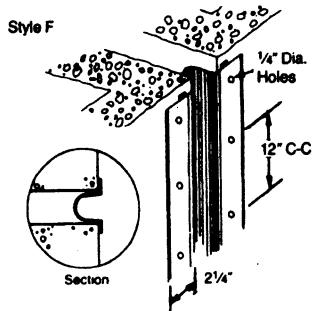

Fig. 12-22

Stylized detail [from publication] relating insight to construction but not at a level that could be used by the trade workers on the job site.

Abutment or Structural Expansion Joints



Sealant Transition for Abutment and Structural Joints

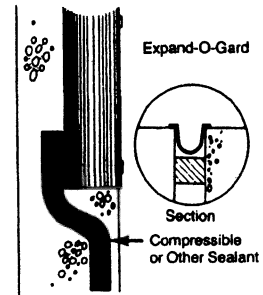

Behind Exterior Facade

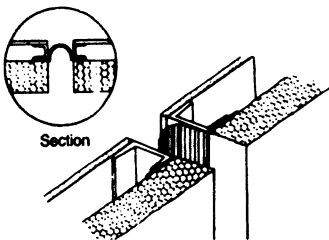

Curtain Wall to Dissimilar Material

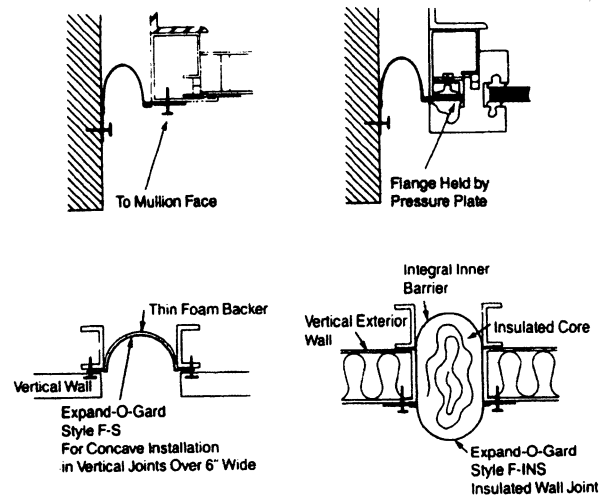

Fig. 12-23

Pictorial and detail views of various expansion joint systems [from manufacturer]

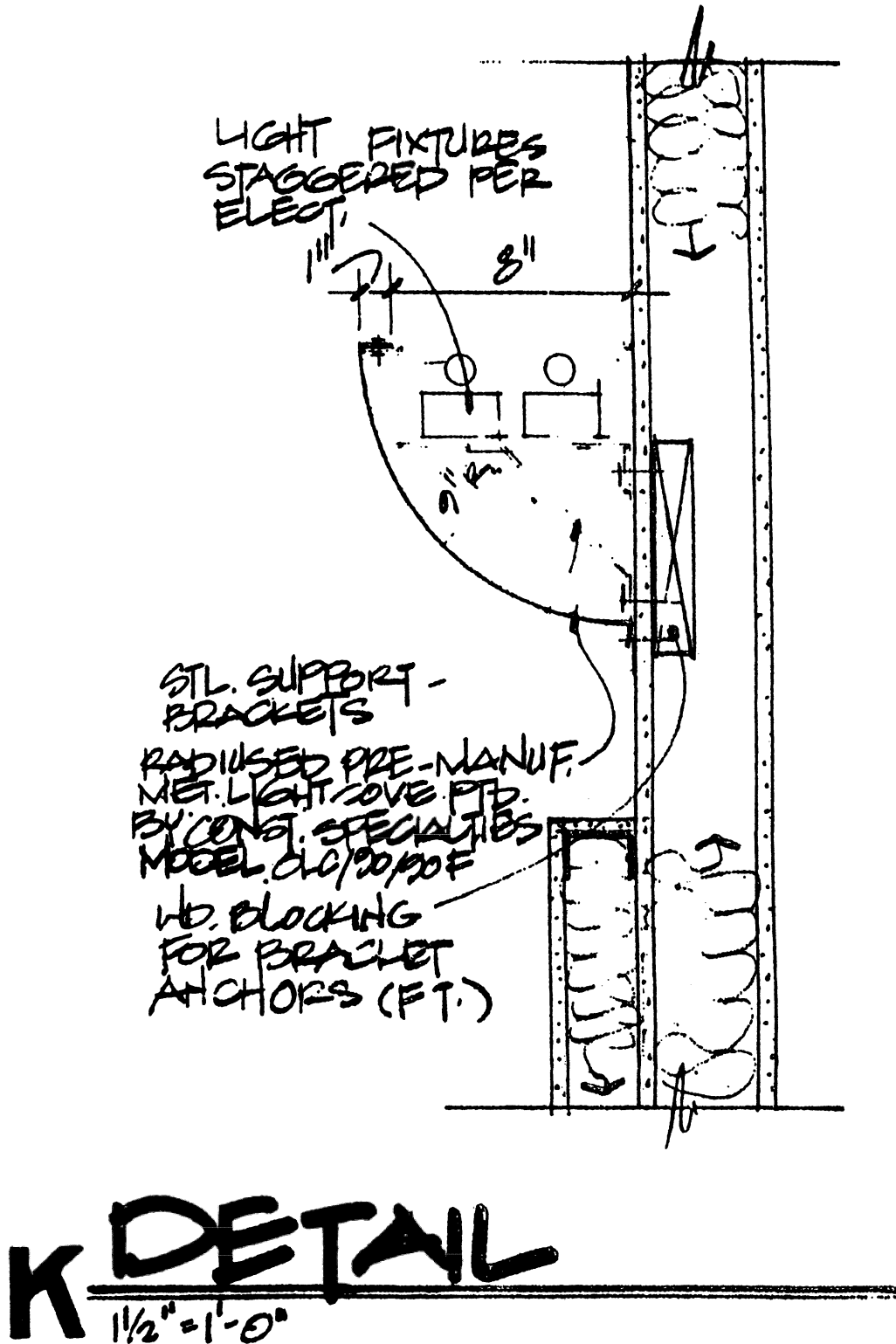

Fig. 12-24

Architect's detail using note to call out the type and model of the light cover; not the best practice, as the product information is much better contained in the specifications [note how "lost" information is in this view]

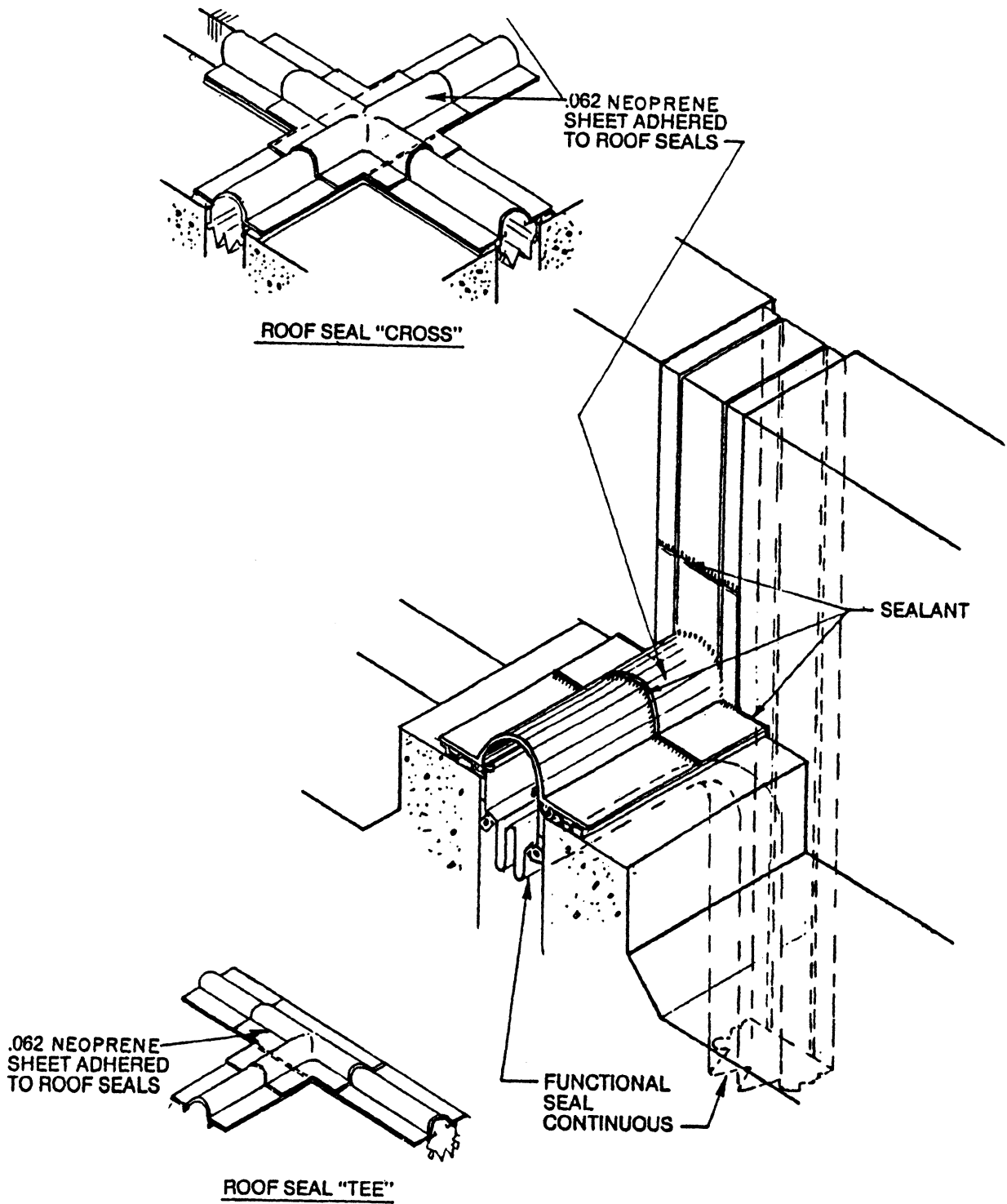
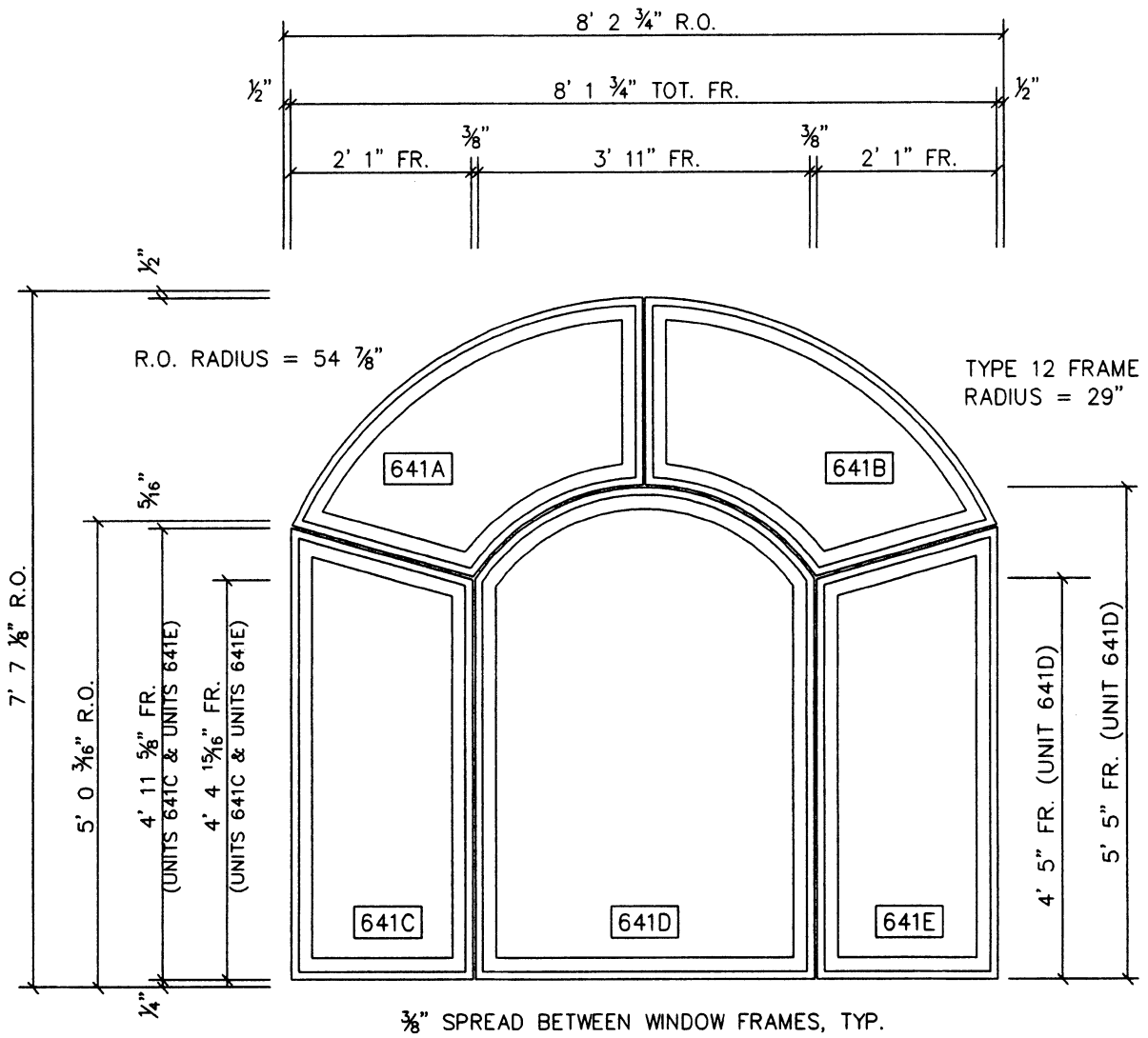

Fig. 12-25
Manufacturer's isometric views of the joint cover details



SEE PAGE 2 FOR
 CUSTOM-SHAPE UNIT
 DIMENSIONS

1 A 1 THUS
 LOCATION: OPEN TO LIVING ROOM
 PDQ ITEM #: 641

Composite ID	Unit ID	Product Code
A	641A	DCCCMFXZC1
A	641B	DCCCMFXZC1
A	641C	DCCCMFX2Z1
A	641D	DCCCMFX121
A	641E	DCCCMFX3Z1

Fig. 12-26
 Portion of shop drawing for a custom made residential window unit

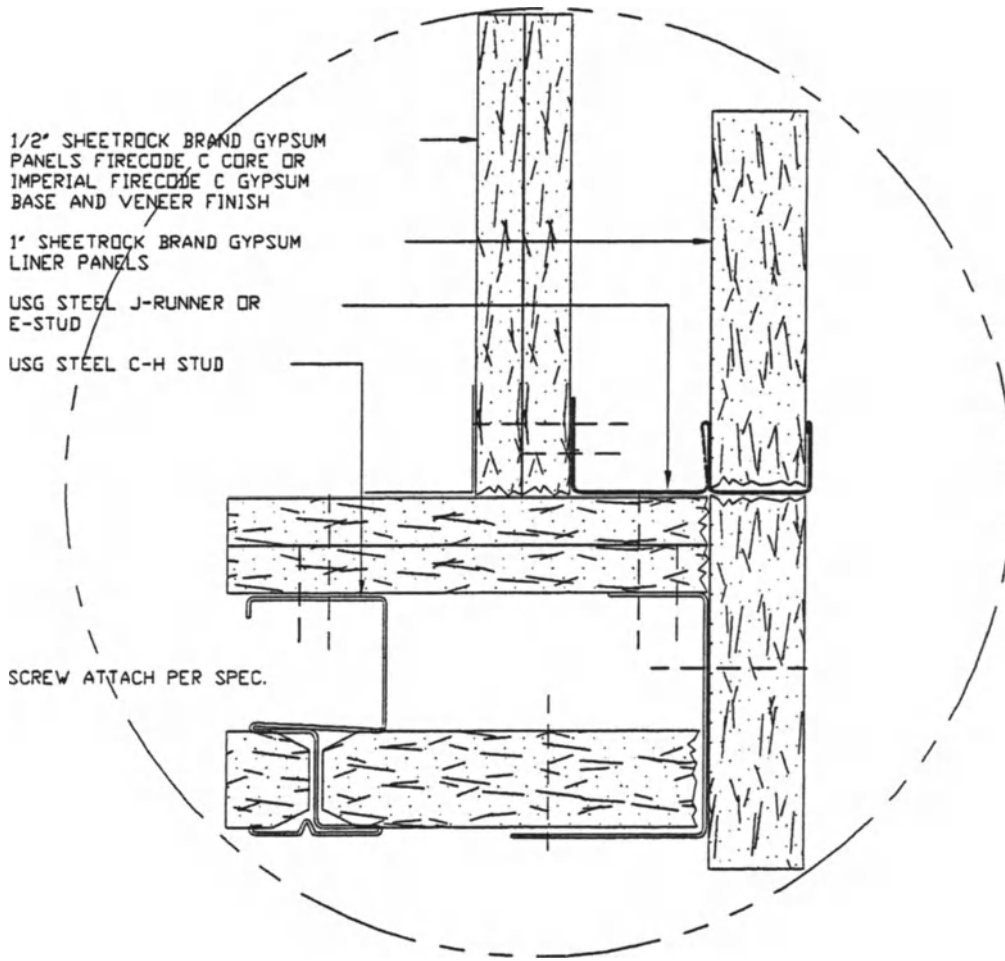

Fig. 12-27

Product manufacturer's detail of gypsum board partition intersection

GA FILE NO. WP 1082	PROPRIETARY 1	1 HOUR FIRE	45 to 49 STC SOUND
GYPSUM WALLBOARD, STEEL STUDS, MINERAL FIBER INSULATION, CEMENTITIOUS BACKER UNIT			
<p>One layer 5/8" proprietary type X gypsum wallboard or veneer base applied parallel to ONE SIDE of 3 3/8" 25 gage steel studs 16" o.c. with 1 1/4" Type S drywall screws 8" o.c. at vertical joints and 12" o.c. to intermediate studs. 3" mineral fiber insulation batts, 2.5 pcf, in stud space.</p> <p>OPPOSITE SIDE: One layer 1/2" proprietary cementitious backer units applied parallel or at right angles to studs with 1 1/4" Type S wafer head screws 8" o.c.</p> <p>Vertical joints staggered 16" on opposite sides. (NLB)</p>			
PROPRIETARY GYPSUM BOARD National Gypsum Company 5/8" Gold Bond® Brand FIRE-SHIELD® Gypsum Wallboard		Thickness: 4 3/4" Limiting Height: Refer to manufacturer Approx. Weight: 6 psf Fire Test: ITS J99-04001, 11-16-98 & 2-5-99, ITS Design NGC/WA 60-01 Sound Test: NGC 2099015, 8-19-99	

Fig. 12-28

Detail of fire-rated partition construction, from industry association source; one of several options available to design professionals for their selection.

Design No. U332
Bearing Wall Rating — 1 Hr.
Nonbearing Wall Rating — 2 Hr.
Finish Rating — 23 Min.
Load Restricted for Canadian Applications — See Guide BXUV7

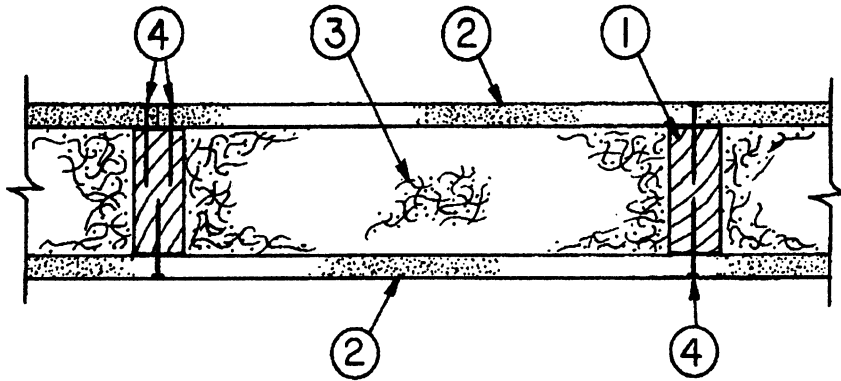

1. **Wood Studs** — Nominal 2 by 4 in. spaced 16 in. OC effectively fire-stopped.
 2. **Gypsum Board*** — Any Classified for Fire Resistance 5/8 in. thick wallboard applied horizontally or vertically, with beveled, square or tapered edges. Wallboard nailed to studs and plates with 8d coated nails spaced 8 in. OC. All joints staggered 2 ft with joints on opposite side of wall.
When used in widths other than 48 in., gypsum board to be installed horizontally.
See Gypsum Board (CKNX) Category for names of manufacturers.
 - 2A. **Gypsum Board*** — (As an Alternate to Item 2) - 5/8 in. thick applied either horizontally or vertically. Inner layers fastened to framing with 1-1/4 in. long Type W coarse thread gypsum panel steel screws spaced a max 8 in. OC, with last screw 1 in. from edge of board. When used in widths other than 48 in., gypsum board to be installed horizontally. All joints in face layers staggered with joints in base layers. Joints of each base layer offset with joints of base layer on opposite side.
AMERICAN GYPSUM CO — Type AG-C.
 3. **Spray-Applied Fire Resistive Materials*** — Sprayed with Type A-23 Adhesive in accordance with application instructions. The material is sprayed to completely fill the stud cavity. For wall assemblies having a fire rating of 1 hr, the fiber thickness may be reduced to 2 in. Minimum dry density of 12.0 pcf. For method of density determination, refer to Design Information Section.
AMERICAN SPRAYED FIBERS INC — Type DDM.
 4. **Nails** — 8d coated, 2-3/8 in. long. 0.113 in. shank diameter 1/4 in. diameter heads, spaced 8 in. OC.
 5. **Joints and Nailheads** — (Not shown) — Wallboard joints covered with tape and joint compound. Nailheads covered with joint compound.
 6. **Wall and Partition Facings and Accessories*** — (Not Shown) - (optional) — In lieu of Item 5 used to cover all wallboard joints and nail heads.
DWC L L C — "One Step Above Drywall Compound"
- *Bearing the UL Classification Mark

Fig. 12-29

Detail showing construction used in a test panel, by a testing agency, and which successfully passed the test. Assigned rating is reliable information that design professionals can rely on for building code compliance [provided construction used matches this information]

EPILOGUE

A FINAL WORD

Every student who enters a school of architecture or engineering wants to be an important and famed architect or engineer— few succeed! The lack of success is not a measure of their talent but rather it serves to show how the number of big name, renowned “starchitects” and celebrated engineers there are at any one time in the world, and the thousands of those professionals who also are actively practicing – only in other aspects.

No example of architecture or structural prowess is accomplished via design sketch to finished project! None succeed without a supporting cast of architects and other staffers who are capable of converting the first brilliance of the design concept into a buildable, enduring and stable building. There are those – in fact many of these– who revel in detailing and concocting ways for building the nuances of the design; how to accomplish the revolutionary look of the final project, on an item by item basis. They also practice architecture who do the detailing! That chore is not, should never be conceived as, or relegated to lower end of junior staffers in the context of busy work or information not all that consequential to the project work.

In September, 2001, the Twin Towers of the World Trade Center, in New York City, were attacked by terrorists. Each tower was struck by a hi-jacked commercial airliner, directed into the buildings by the terrorists on board and piloting the planes. Just an hour later, both towers [110-stories each] collapsed, in a “pancake” fashion, killing just fewer than 3,000 people, including several hundred fire-responding emergency personnel.

It is interesting to note, for comparison purposes, that in 1945, the Empire State Building in New York City was struck by a World War II bomber, a B-25. The building withstood that accident [the plane was landing in a dense Saturday morning fog]. There was limited loss of life, [the incident occurred on a Saturday] and the building was restored, and repaired– and of course remains in operation today. Mainly this can be attributed to a slower, lighter plane, less fuel on board, and the heavy masonry construction– as well as to a low number of occupants.

The Trade Center Towers, however, were devastated and both collapsed, as did several other buildings in the surrounding complex [hit, damaged and weakened by falling debris from the towers]. The loss of life was horrendous. This was not, however, a “construction accident or incident”. Neither was it a “design failure”– nor a “detailing failure”.

But for the sake of a review we offer the following analysis [from various sources] from the days immediately after the attack. They serve to show, very distinctly, how the design, engineering and construction was approached, and how, indeed, they might well have withstood even the impact of the planes under slightly different circumstances.

Tragically, the Trade Center towers were hit by fast moving, heavy commercial airliners, fully loaded with fuel. The basic construction of the towers, even though fully capable of withstanding a bomb [like that which exploded in one of the basements in 1993] and other major weather related incidents, was not able to withstand the extremes of both the aircraft intrusion on the structural system, and resulting conflagration. Just as things evolved greatly between 1933 when the Empire State was erected, and the plane accident in 1945, so too major changes occurred between 1971-3 and 2001– the life span of the towers. The message here is that in-place construction by its very nature is static, not evolutionary, and can be effected, and even destroyed by factors which do evolve, unfortunately in very threatening, and increasingly dangerous ways.

While these incidents are comparable, in part, they both are a tribute to the collective effort of construction designers and builders– and to the attention paid to detailing the construction, within the context of the expertise and knowledge available at their time of design!

Project Facts:

The World Trade Center, New York, New York; Built 1970 - 1977 Minoru Yamasaki & Associates, Architect, with Emery Roth and Sons.

The World Trade Center consisted of two 110-story buildings [known as the “Twin Towers”] and five smaller buildings. The buildings were light, economical structures designed to keep the wind bracing on the outside surfaces.

Architect Minoru Yamasaki studied over a hundred models before adopting the twin tower plan. Plans for a single tower were rejected because the size was cumbersome and impractical. Plans for several towers “looked too much like a housing project,” Yamasaki said. The final design was exquisite in its refined elegance and in its innovative structural design – obviously reflect in the detailing for both.

The World Trade Center Towers were among the tallest buildings in the world;

- *Tower One was 1,368 feet (414 meters) tall
Tower Two was 1,362 feet (412 meters) tall*
- *The Tower facades were constructed of aluminum and steel lattice*
- *The Tower floors were prefabricated trussed steel, 33 inches deep*
- *The Towers used tube construction with closely spaced columns and beams on the outer walls.*
- *There were no interior columns in the Tower office spaces*
- *The Towers rested on solid bedrock. The foundations extended more than 70 feet below ground.*
- *More than 1.2 million cubic yards of earth and rock were excavated to make way for the World Trade Center. The excavated material was placed in the Hudson River to create 23.5 acres of new land deeded to the City of New York. This landfill area is now Battery Park City.*
- *Contained nine million square feet of office space.*
- *Each tower contained 104 passenger elevators*
- *Each tower had 21,800 windows.*
- *About 50,000 people worked in the World Trade Center complex*
- *More than 200,000 tons of steel — far more than the amount required for the construction of the Verrazano Narrows Bridge — was used in the World Trade Center's construction.*
- *The 425,000 cubic yards of concrete used in building the World Trade Center; enough to build a five-foot wide side walk from New York City to Washington, D.C.*
- *At peak periods of construction, some 3,500 workers were on the site daily.*
- *There are 43,600 windows in the Twin Towers with over 600,000 square feet of glass window area cleaned by automatic window washing machines traveling on stainless steel tracks.*
- *With 60,000 tons of cooling capacity, the World Trade Center's refrigeration plant was the largest in the world.*
- *The 360-foot television mast atop One World Trade Center supports 10 main television antennas, numerous auxiliary antennas and a master FM antenna. Transmissions from the mast began in June, 1980. Ten television stations in the metropolitan area, including all the major networks, broadcast from the mast. In addition, six stations broadcast high-definition, digital television from the World Trade Center.*
- *The Tower's sky-lobby elevator systems separate express from local runs. There were 239 elevators and 71 escalators in the four buildings operated by the Port Authority at the complex. The sky lobby express elevators are capable of carrying 55 people/10,000 pound capacity, at speeds of 27 feet per second.*

Why is this discussion part of a book on detailing?

The answer is that while every project is not "jewel-like" in the Yamasaki tradition, there are inherent relationships in every project which function like jewels in a watch— they are honed, matched, coordinated, related and functionally interrelated. In addition, every project must be strong enough to withstand the prevailing conditions surrounding it.

How do they get that way? Through the details produced by the design professional! Those buildings served well and quite reliably during their life span, and posed no threat. Only an unthinkable act brought their end.

But, think for a moment, how many thousands of details were required to depict the construction, and appurtenances of the buildings!

It's that simple.

While the World Trade Center's exterior motif was Yamasaki's "jewel of jewels", the structure and the details of construction supported, contributed to, and functioned to allow the towers to exist and serve as they did. So impressive were these details, for the most part unseen, that the buildings were ravaged and destroyed only by the most extraordinary of attacks, and of unfathomable proportions.

Every life lost will be eternally mourned.

But the thousands of lives saved are a tribute to the wonderfully innovative design, the superior structural prowess— and yes, the details of all of the construction.

APPENDIX A

Excerpt from Speech by Professor Edward Allen on the occasion of being awarded the 2005 Topaz Medal by the AIA: March 4, 2005

"I believe that almost all students of architecture enter school wanting to acquire a broad technical competence in structures, materials and methods of construction, and environmental control systems for buildings. They want to learn to design elegant structures like those of Santiago Calatrava. They want to learn to use materials as creatively as Renzo Piano. They want to become masters of daylighting and natural heating and cooling.

By the end of their first year, we have educated this desire out of them. By the end of their first year, they believe that studio is all important, and technical classes are not.

Making Technical Subjects Irrelevant and Unattractive

How do we do this? How do we destroy students' desire to learn the technology of architecture? Let me count the ways.

1. We set up our curricula based on the fuzzy, fallacious notion that architecture is a combination of art and science; we slice the curricula neatly into two widely separated parts – art and science. The art we call "design," even though art and design are not synonymous. The science we call "technology," even though science and technology are not synonymous. We teach "design" in a studio, which makes sense; studio is the best place to teach design. We teach "technology" in a classroom, which makes no sense because technology is the design of useful things and is most naturally taught in a studio format.

2. Having erroneously divided the curriculum and decreed that technical courses be taught in a classroom format, we have decided which technical subjects to teach. Among the members of building professionals assembled to design a major building, the architect is expected to be the expert in just one technical area – detailing: detailing the building envelope, detailing interiors.

Detailing is the architect's sole means of turning dreams into built reality, the language by which we instruct workers on how to assemble a building to achieve the desired result. Skill in detailing is also the architect's best insurance against being sued

for buildings that leak, crack, or otherwise misbehave. Do we design our curricula to feature courses in the theory and practice of detailing? We do not. Few teach detailing in any organized way. NAAB says nothing about teaching detailing. We spend so much time teaching our students about the technical specialties of other professions, there's no time left to teach the specialty of our own. So we teach courses in structures, HVAC, acoustics, illumination — but not in detailing.

3. Having decided not to teach detailing, we then determined what to teach in each technical subject. For example, if we make a list of all the steps in designing the load-bearing structure of a major building, it will include explorations of site and soil conditions, choosing a structural material and a gravity-load framing system, laying out the framing system, adjusting the framing and floor plans to fit one another, designing and deploying a lateral load-resisting system, shaping long-span components, looking for opportunities to exploit the structural elements for architectural effect, detailing the structure, and checking assumed member sizes using mathematics to determine their adequacy. There is just one step in which the architect is almost never involved: checking member sizes using mathematics. Do we teach all the other steps? We do not. Instead we teach only the mathematics of checking member sizes. The saddest aspect is that force-feeding structural mathematics for the required number of terms turns off students of structures forever and still doesn't give them an arsenal of mathematical techniques sufficient to do a complete job of engineering a major structure.

To summarize: Based on a misconception of what architecture is, we have wrongly divided the curriculum into "design" and "technology." We have settled on the wrong technical areas to emphasize in our teaching. Within these areas, we teach the wrong stuff. Kafka could not have planned a more frustrating, ludicrous curriculum. It is no surprise that most students dislike most technical courses. They quickly lose their desire to become technically adept, to possess the skill of Calatrava and of Piano. It's a great loss, both to the students and to society.

Making Technical Courses Relevant and Attractive

What can be done about this situation? The Kafka-esque curriculum has accreted over an extended period into a rigid, unyielding structure. It is deeply embedded in the culture of the ARE and the requirements of NAAB. It is ossified in the

composition and preferences of the faculty members who teach technology at each school, most of whom are trying sincerely to do a good job, but who are not eager to change the way their subjects always have been taught.

We need to realize that architecture is neither art nor science—it is in a third realm of intellectual endeavor called design whose goal is to produce products to solve human problems, whose methods involve finding good-enough solutions to problems for which there is no best solution, but many that will suffice, any one of which might be developed into an inspired piece of artistry. The designer synthesizes and represents a potential solution, then applies simple tests and critical evaluations to determine whether it is good enough. This cycle of synthesis and analysis is repeated innumerable times, exploring new paths, re-exploring old ones, combining, discarding, and adapting until a sufficiently good solution has been reached.

All of architecture is created by this method, including the technical subsystems of buildings.

If the technical systems of buildings must be designed, then technical courses ought to be taught as design courses, preferably in a studio format. The most important principle is that mathematics and science should play supporting, not starring, roles. Math and science cannot generate good forms for things, they can only serve in the analytical phases of the design process to test proposed forms for conformation to the project's criteria. Students should design structures in every term of study, including the first. Ove Arup, one of the greatest structural engineers of the twentieth century said, "[Structural] design is not a science; it is a creative activity, involving imagination, intuition, and deliberate choice." The extent to which we teach creative activity, imagination, intuition, and deliberate choice in our structures classes is a measure of the appropriateness of our teaching.

It's important to show and discuss actual projects in technical classes, especially buildings that you have designed and built. Students appreciate learning the thoughts and intentions that went into a project, how these were translated into materials, details, and structure, what went wrong, what went right, and how a given result was achieved. They can visualize themselves in the same situations and say to themselves, "Yeah, I could do that." The technical curriculum should emphasize detailing in both structures and materials classes, for the reasons given earlier. It's good to show students how an inspired detail—such as the open connection in Fay Jones' Thorncrown Chapel or the multiple columns in Helmut Jahn's United Airlines Terminal – can make the difference between a good building and a great one.

Creating Magic

The most important thing about building technology is how to use it to create architectural magic. We may be able to visualize magic, but unless we have the ability to use materials and structure to make the magic real, we will fail to produce architecture. That's the major reason that good technology teaching is so important.

The biggest mistake we've made in our schools is to divide the architectural curriculum into "design" and "building technology," leaving a huge gulf between the two. Architecture is all one thing. Space, form, materials, structure, details, and environmental control systems all have roles in the making of a magical building. All must be designed, and all are designed by the same process. Therefore, for the sake of our students, we must learn to teach technology as design.

Edward Allen, FAIA

APPENDIX B

COMMON CONSTRUCTION ABBREVIATIONS

Following are construction abbreviations commonly used on drawings [and details] collected from various sources and are not universally used or required. For more current information refer to Module 5 - Terms and Abbreviations of the Uniform Drawing System (UDS) of the U. S. National CAD Standard (NCS) for more complete listing of terms and abbreviations. More information about the NCS can be found on the CSI website under Standards and Formats.

A.....	Area, Ampere; Acre; Alcove; Compressed Air Line	AMP.....	Ampere, Ampacity
AB.....	Anchor Bolt; Asbestos Board	AMPY.....	Ampere
ABV.....	Above	AMT.....	Amount
AC.....	Air Conditioning, Alternating Current, Acoustical	AN.....	Anode
ACC.....	Access	ANCH.....	Anchor, Anchorage
ACF.....	Architectural Concrete Finish	ANN.....	Annunciator
ACFL.....	Access Floor	ANOD.....	Anodized
ACI.....	American Concrete Institute	ANT.....	Antenna
ACL.....	Across the Line	AP.....	Access Panel
ACOUST.....	Acoustical	APPD.....	Approved
ACPL.....	Acoustical Plaster	APPROX.....	Approximate
ACR.....	Acrylic	APRVD.....	Approved
ACST.....	Acoustic	APT.....	Apartment
ACT.....	Acoustical Tile; Actual	APX.....	Approximate
AD.....	Access Door, Area Drain	AR.....	Acid Resisting
ADA.....	Americans with Disabilities Act of 1992	ARCH.....	Architect, Architectural
ADAAG.....	Americans with Disabilities Act	ARS.....	Asbestos Roof Shingles
.....	Architectural Guidelines	AS.....	Acoustic Sealant
ADD.....	Addendum; Addition	ASB.....	Asbestos
ADDL.....	Additional	ASC.....	Above Suspended Ceiling
ADH.....	Adhesive	ASCE.....	American Society of Civil Engineers
ADJ.....	Adjust, Adjustable, Adjacent	ASME.....	American Society of Mechanical Engineers
AF.....	Above the Floor	ASPH.....	Asphalt
AFF.....	Above Finished Floor	ASSEM.....	Assemble
AGA.....	American Gas Association	ASSOC.....	Association; Associate
AGG.....	Aggregate	ASSY.....	Assembly
AGGR.....	Aggregate	ASTM.....	American Society for Testing and Materials
AIA.....	American Institute of Architects	AT.....	Acoustical Tile; Asphalt Tile
AIC.....	Ampere Interrupting Circuit	ATC.....	Acoustical Tile Ceiling
AIEE.....	American Institute of Electrical Engineers	ATTEN.....	Attenuation
AISC.....	American Institute of Steel Construction	ATM.....	Atmospheric
AL.....	Aluminum	AUTH.....	Authorized
ALM.....	Alarm	AUTO.....	Automatic
ALT.....	Alternate, Alteration; Altitude	AVG.....	Average
ALUM.....	Aluminum	AW.....	Acid Waste
ALS.....	Ambient	AWG.....	American Wire Gauge
		AWS.....	American Welding Society
		AWWA.....	American Water Works Association
		AX.....	Axis
		B.....	Boiler, Bathroom, Bidet
		B TO B.....	Back to Back
		B & B.....	Balled and Burlapped, Bell and Bell
		B & F.....	Bell and Flange
		B & S.....	Bell and Spigot, Brown & Sharp
		B/.....	Bottom (of)

BBD	Bulletin Board	BT	Bathtub, Bolt
BA	Bulb Angle	BTR	Better
BAL	Balance, Ballast	BTU	British Thermal Units
BAF	Baffle	BTUH	British Thermal Units per Hour
BB	Ball Bearing, Bulletin Board	BUR	Built-up Roof
BBL	Barrel	BUZ	Buzzer
BC	Broom Closet	BV	Butterfly Valve
BD	Board, Blow Down (pipe)	BVL	Bevelled
BDL	Bundle	BW	Both Ways
BDY	Boundary	BWV	Back Water Valve
BDRM	Bedroom	BYP	By Pass
BEL	Below	C	Courses, Curb, Channel, Degrees Celsius, Clock Outlet
BET	Between	C/C	Center to Center
BETW	Between	C TO C	Center to Center
BEV	Bevel	CA	Compressed Air
BF	Board Foot, Back Face, Bottom Face, Both Faces, Boiler Feed	CAB	Cabinet
BG	Bag (e.g. of cement)	CAD	Cadmium, Computer-Aided Drafting
BHP	Brake Horsepower	CAIS	Caisson
BHD	Bulkhead	CAP	Capacity
BIT	Bituminous	CAR	Carpet
BJF	Bituminous Joint Filler	CARP	Carpenter
BKR	Breaker	CAT	Catalog
BL	Base Line, Building Line	CAV	Cavity
BLDG	Building	CB	Catch Basin, Cast Brass, Coal Bin
BLK	Block	CBX	Cast Box Strike
BLKG	Blocking	CC	Cubic Centimeter
BLO	Blower	CCT	Circuit
BLR	Boiler	CCW	Counter Clockwise
BLT	Borrowed Lite, Bullet Tips (Hinges)	CCTV	Closed Circuit TV
BLT-IN	Built-In	CD	Cold Drawn, Cadmium
BM	Beam, Bench Mark	CDS	Cold Drawn Steel
BMT	Butyl Mastic Tape Sealant	CEL	Cellar
BN	Bullnose	CEM	Cement
BNDG	Bending (re-bars)	CEM AB	Cement Asbestos Board
BNT	Bent	Cem P	Cement Water Paint
BO	Blow Off	CER	Ceramic
BOT	Bottom	CF	Cubic Feet
BP	Base Plate, Blueprint, Bypass	CFL	Counterflashing
BPL	Bearing Plate	CFM	Cubic Feet per Minute
BR	Bedroom, Brass, Boiler Room Branch	CFS	Cubic Feet per Second
BRDG	Bridge, Bridging	CFT	Cubic Foot
BRG	Bearing	CG	Corner Guard
BRK	Brick	CH	Coat Hook
BRKR	Breaker	CHB	Chalk Board
BRKT	Bracket	CHR	Chilled Water Return
BRS	Butyl Rubber Sealant, Brass	CHAM	Chamfer
BRZ	Bronze	CHAN	Channel
BRZG	Brazing	CHBD	Chalkboard
BS	Both Sides, Backset, Bluestone	CHS	Chilled Water Supply
BSMT	Basement	C.I.	Cast Iron
		CI	Cast Iron

CIP.....	Cast Iron Pipe, Cast-in-Place	CPE.....	Chlorinated Polyethylene
CIR.....	Circle, Circular, Circuit	CPL.....	Cement Plaster
CIRC.....	Circumference	CPP.....	Cement Plaster Painted
CISP.....	Cast Iron Soil/sewer Pipe	CPR.....	Copper
CITG.....	Clear Insulating Tempered Glass	CPT.....	Carpet
CJ.....	Control Joint	CR.....	Chromium (plated), Curtain Rod
CJF.....	Cork Joint Filler	CRPT.....	Carpet
CKT.....	Circuit	CRS.....	Course, Cold Rolled Steel
CL.....	Centerline, Clearance, Closing, Closure, Class, Closet	CS.....	Countersink, Cast Steel, Cast Stone, Commercial Standard
CLG.....	Ceiling	CSG.....	Casing
CLKG.....	Caulking	CSK.....	Countersink
CLL.....	Contract Limit Line	CSMT.....	Casement
CLO.....	Closet	CSN.....	Caisson
CLP.....	Clamp	CSS.....	Countersunk Screw
CLR.....	Clear	CSTG.....	Casting
CLR OPG.....	Clear Opening	CT.....	Ceramic Tile, Cork Tile,
CLS.....	Closure	CTD.....	Coated
CM.....	Center Matched, Construction Manager	CTR.....	Center, Counter
CMP.....	Corrugated Metal Pipe	CTSC.....	Communications Systems Terminal Cabinet
CMT.....	Ceramic Mosaic Tile	CTSK.....	Countersunk
CMU.....	Concrete Masonry Unit	CTWT.....	Counterweight
CMUP.....	Concrete Masonry Unit Painted	CU.....	Copper, Cubic, Coefficient of Utilization
CND.....	Condition, Conduit	CU. FT.....	Cubic Feet
CNDS.....	Condensate	CU. YD.....	Cubic Yard
CNTR.....	Center, Counter	CUR.....	Current
CNVR.....	Conveyor	CV.....	Check Valve
COAX.....	Coaxial	CW.....	Clockwise, Cold Water
C.O.....	Cased Opening	CWP.....	Circulating Water Pump
CO.....	Company, Cleanout, Cased Opening, Cut Out	CWR.....	Condensate Waste Return
COEF.....	Coefficient	CWS.....	Condensate Waste Supply
COL.....	Column	CY.....	Cubic Yard, Cycle
COM.....	Common	CYL.....	Cylinder
COMB.....	Combination, Combustion	CYL L.....	Cylinder Lock
COML.....	Commercial	D.....	Deep, Depth, Drop, Drain
COMM ED.....	Commonwealth Edison	D & M.....	Dressed & Matched
COMP.....	Composition, Compressed	DA.....	Double Acting
COMPO.....	Composition	DB.....	Decibel
COMPT.....	Compartment	DBL.....	Double
CONC.....	Concrete	DC.....	Direct Current
CONCP.....	Concrete Painted	DD.....	Driveway Drain, Deck Drain
COND.....	Condenser, Conduit	DEG.....	Degree
CONN.....	Connection	DEGC.....	Degree Celcius
CONST.....	Construction	DEGF.....	Degree Fahrenheit
CONSTR.....	Construction	DEMO.....	Demolition
CONT.....	Continuous, Continue, Control	DEP.....	Depressed
CONTR.....	Contractor	DEPT.....	Department
CONV.....	Convactor, Convenience	DET.....	Detail
COP.....	Copper	DF.....	Drinking Fountain
COR.....	Corner, Corridor	DH.....	Double Hung
CORR.....	Corridor, Corrugate	DIAG.....	Diagonal
COV.....	Cover		

DIA.....	Diameter	ENT.....	Entrance
DIFF.....	Diffuser	ENTR.....	Entrance
DIM.....	Dimension	EP.....	Electrical Panelboard, Explosion Proof
DISL.....	Disposal	EPDM.....	Ethylene Propylene Diene Monomer
DISP.....	Dispenser	EPJF.....	Expanded Polyethelene Joint Filler
DIV.....	Division	EQ.....	Equal
DL.....	Dead Load	EQPT.....	Equipment
DMH.....	Drop Manhole	EQUIP.....	Equipment
DMT.....	Demountable	ERP.....	Emergency Receptacle Panel
DN.....	Down	ESC.....	Escalator
DO.....	Ditto, or Door Opening	EST.....	Estimate
DP.....	Dampproofing, Dew Point, Distribution Panel	EVAP.....	Evaporator
DPR.....	Damper	EW.....	Each Way
DR.....	Door, Drain, Dining Room	EW C.....	Electric Water Cooler
DS.....	Downspout, Disconnect Switch, Door Switch	EW & C.....	Electric Wiring and Communication
DSP.....	Dry Standpipe	EWH.....	Electric Water Heater
DT.....	Drain Tile	EX.....	Exposed Construction, Exit
DTL.....	Detail	EXC.....	Excavate
DVTL.....	Dovetail	EXCAV.....	Excavate
DW.....	Dumbwaiter, Distilled Water	EXEC.....	Executive
DWG.....	Drawing	EXG.....	Existing
DWGS.....	Drawings	EXH.....	Exhaust
DWL.....	Dowel	EXH AIR.....	Exhaust Air
DWP.....	Drywall, Painted	EXIST.....	Existing
DWR.....	Drawer	EXP.....	Expansion, Exposed
DS.....	Downspout	EXPN.....	Expansion
DSP.....	Dry Standpipe	EXPP.....	Existing Patched and Painted
DX.....	Direct Expansion, Duplex	EXS.....	Extra Strong
E.....	East, Enamel, Exhaust	EXT.....	Exterior, Extinguish
E TO E.....	End to End	EXTR.....	Extrude
EA.....	Each	F.....	Degrees Fahrenheit, Fuse
EB.....	Expansion Bolt	F TO F.....	Face to Face
EC.....	Exposed Construction	FA.....	Fire Alarm, Fresh Air
ECP.....	Exposed Construction Painted	FAB.....	Fabricate
EE.....	Each End	FABR.....	Fabricate
EF.....	Each Face	FACP.....	Fire Alarm Control Panel
EFTS.....	Expanding Foam Tape Sealant	FAG.....	Fire Alarm Gong
EG.....	Edge Grain	FAO.....	Finish All Over
EIFS.....	Exterior Insulation and Finish System	FAR.....	Floor Area Ratio
EJ.....	Expansion Joint	FAST.....	Fastener, Fasten
EJECT.....	Ejector	FB.....	Flat Bar, Face Brick, Floor Box
EL.....	Elevation, Elevator	FBD.....	Fiberboard
ELB.....	Elbow	FBM.....	Foot Board Measure
ELECT.....	Electrical	FBP.....	Fabric Panel
ELEV.....	Elevator, Elevation	FBRK.....	Fire Brick
ELP.....	Emergency Lighting Panel	FC.....	File Cabinet, Foot Candle, Fault Current
EM.....	Emergency	FD.....	Floor drain
EMER.....	Emergency	FDC.....	Fire Department Connection
ENAM.....	Enamel	FDN.....	Foundation
ENCL.....	Enclosure	FE.....	Fire Extinguisher
ENGR.....	Engineer	FEC.....	Fire Extinguisher Cabinet

FF.....	Finished Floor, Factory Finish	GA.....	Gauge, Gage
FFE.....	Finished Floor Elevation	GAGE.....	Gauge
FF&E.....	Fixtures, Furnishings & Equipment	GAL.....	Gallon
FFL.....	Finished Floor Line	GALV.....	Galvanized
FGL.....	Fiberglass	GB.....	Grab Bar, Glass Block, Gypsum Board
FGR.....	Fiberglass reinforced	GC.....	General Contractor
FH.....	Flat Head, Fire Hose	GCMU.....	Glazed Concrete Masonry Unit
FHC.....	Fire Hose Cabinet	GD.....	Guard, Grade, Gutter Drain
FHMS.....	Flat head machine screw	GEN.....	General, Generator
FHR.....	Fire Hose Rack	GENL.....	General
FHS.....	Fire Hose Station	GF.....	Ground Face
FHWS.....	Flat Head Wood Screw	GFCI.....	Ground Fault Circuit Interrupted
FHY.....	Fire Hydrant	GFCMU.....	Ground-face Concrete Masonry Unit
FIL.....	Fillet	GFI.....	Ground Fault Interrupted
FIN.....	Finish, finished	GFRC.....	Glass Fiber Reinforced Concrete
FITG.....	Fitting	GI.....	Galvanized Iron
FIX.....	Fixture	GKT.....	Gasket
FIXT.....	Fixture	GL.....	Glass
FLASH.....	Flashing	GL BLK.....	Glass Block
FLG.....	Flooring	GLULAM.....	Glued-laminated
FLEX.....	Flexible	GMU.....	Glazed Masonry Unit
FLG.....	Flange, Flashing, Flooring	GND.....	Ground
FLR.....	Floor	GOVT.....	Government
FLUOR.....	Fluorescent	GP.....	Galvanized Pipe
FLX.....	Flexible	GPDW.....	Gypsum Drywall
FM.....	Fire Main, Factory Mutual Company	GPH.....	Gallons Per Hour
FND.....	Feminine Napkin Dispenser, Foundation	GPL.....	Gypsum Lath
FO.....	Finished Opening	GPM.....	Gallons Per Minute
FOB.....	Free On Board	GPP.....	Gypsum Plaster Painted
FOC.....	Face of Concrete	GPPL.....	Gypsum Plaster
FOF.....	Face of Finish	GR.....	Grade, Grille, Granite
FOS.....	Face of Studs	GRAN.....	Granular, Granite
FP.....	Fireproof	GRND.....	Ground
FPL.....	Fireplace	GRTG.....	Grating
FPM.....	Feet per minute	GSS.....	Galvanized Sheet Steel
FPRF.....	Fireproof	GSU.....	Glazed Structural Unit
FR.....	Frame, Front, Fire Riser	GT.....	Grout
FRG.....	Forged	GVA.....	Gate Valve
FRM.....	Frame	GVL.....	Gravel
FRPF.....	Fireproof	GYP.....	Gypsum
FRT.....	Fire Retardant	GYP BD.....	Gypsum Board
FS.....	Full Size, Federal Standards, Fused Switch	H.....	High
FSCW.....	Flush Solid Core Wood	HA.....	Hectare
FT.....	Foot, Feet, Fully Tempered	HB.....	Hose Bib
FTG.....	Footing, Fitting	HBD.....	Hardboard
FUR.....	Furred	HC....	Hollow Core, Handicapped (better called Accessible")
FURN.....	Furnish, Furniture	HCT.....	Hollow Clay Tile
FURR.....	Furring	HD.....	Head, Heavy Duty
FUT.....	Future	HDCP.....	Handicapped (better called "Accessible")
FVC.....	Fire Valve Cabinet	HDR.....	Header
G.....	Gas, Girder, Gutter, Gram	HDWD.....	Hardwood

HDWE	Hardware	INSUL	Insulation
HEX	Hexagonal	INT	Interior, Internal
HGR	Hanger	INTERM	Intermediate
HGT	Height	INTL	International
HH	Handhole	INTM	Intermediate
HHMB	Hex Head Machine Bolt	INV	Invert
HK	Hook or Hooks	IP	Iron Pipe
HKD	Hooked (re-bars)	IPS	Iron Pipe Size
HM	Hollow Metal	IW	Indirect Waste
HMP	Hollow Metal, Painted	J	Joist
HNCG	Hollow Neoprene Compression Gasket	J-BOX	Junction Box
HOR	Horizontal	JAN	Janitor
HORIZ	Horizontal	JB	Junction Box
HOSP	Hospital	JC	Janitor's Closet
HP	High Point, High Pressure, Horse Power	JCT	Junction
HR	Hour	JF	Joint Filler
HRS	Hot Rolled Steel, Hours	JST	Joist
HS	Heat Strengthened	JT	Joint
HSG	Housing	K	Kilopound (1000 pounds), Kelvin (temperature)
HT	Height, Heat, High Tension Duct	KAL	Kalamein
HTG	Heating	KCP	Keene's Cement Plaster
HTR	Heater	KD	Knocked-down, Kiln-dried
HTW	High Temperature Water	KG	Kilogram
HV	High Voltage	KIP	Kilopound (1000 pounds)
HVAC	Heating, Ventilating & Air Conditioning	KIT	Kitchen
HVY	Heavy	KM	Kilometer
HW	Hot Water, Heavy Wall	KO	Knockout
HWC	Hot Water Circulating, Heavy Wall Conduit	KP	Kickplate
HWD	Hardwood	KPL	Kickplate
HWH	Hot Water Heater	KS	Kitchen Sink
HWR	Hot Water Recirculating Return	KVA	Kilovolt-Ampere
HWS	Hot Water Supply	KW	Kilowatt
HWY	Highway	KWH	Kilowatt Hour
HYD	Hydraulic	KWHR	Kilowatt Hour
HYDRO	Hydrostatic	L	Angle, Left, Length, Lighting Panel, Long, Line
HZ	Hertz (Cycles Per Second)	LA	Landscape Architect, Lightning Arrester
I	Iron, Current (electrical)	LAB	Laboratory, Labor
ID	Inside Diameter	LAD	Ladder
IE	Invert Elevation	LAM	Laminate, Laminated
ILK	Interlock	LAT	Lateral
IMH	Inlet Manhole	LAV	Lavatory
IN	Inch	LB	Pound (weight), Lag Bolt
INC	Incandescent	LBL	Label
INCAND	Incandescent	LBR	Lumber
INCIN	Incinerator	LC	Light Control, Lead Covered
INCL	Incline, Include	LCL	Linen Closet
INCR	Increase	LD	Leader Drain
INFO	Information	LH	Left Hand
INS	Insulate, Insulation	LIB	Library
INSP	Inspect	LIBR	Library
INSTL	Install	LIN	Linear

LINO.....	Linoleum	MK.....	Mark
LIQ.....	Liquid	ML&P.....	Metal Lath & Plaster
LKR.....	Locker	MLDG.....	Molding
LL.....	Live Load	MM.....	Millimeter
LMS.....	Limestone	MMB.....	Membrane
LN.....	Length	MO.....	Masonry Opening
LNDG.....	Landing	MOD.....	Module
LNTL.....	Lintel	MONO.....	Monolithic
LOC.....	Locate	MOV.....	Movable
LOCS.....	Locations	MP.....	Metal Acoustical Panel
LP.....	Low Point, Low Pressure, Lighting Panel, Light Proof	MPS.....	Medium Pressure Steam
LR.....	Living Room	MR.....	Mop Receptor
LS.....	Limestone, Loud Speaker	MRD.....	Metal Roof Deck
LT.....	Light, Low Tension Duct, Laundry Tray	MT.....	Mount, Mounted
LTG.....	Lighting	MTD.....	Mounted
LTL.....	Lintel	MTL.....	Material, Metal
LT WT.....	Lightweight	MTR.....	Motor
LV.....	Low Voltage	MULL.....	Mullion
LVR.....	Louver	MWK.....	Millwork
LW.....	Light Weight	N.....	North, Nitrogen
LWC.....	Light Weight Concrete	NAT.....	Natural
LWDP.....	Lowered Wood Door, Painted	NATL.....	National, Natural
M.....	Meter, Motor, Thousand (brick), Bending Moment	NEC.....	National Electrical Code
MACH.....	Machine	NEUT.....	Neutral
MAINT.....	Maintenance	NFWH.....	Non-freeze Wall Hydrant
MAN.....	Manual	NI.....	Nickel
MAR.....	Marble	NIC.....	Not In Contract
MARB.....	Marble	NK.....	Neck
MAS.....	Masonry	NMT.....	Non-Metallic
MATL.....	Material	NO.....	Number, Normally Open
MAX.....	Maximum	NOM.....	Nominal
MB.....	Mail Box, Machine Bolt, Mop Basin	NRC.....	Noise Reduction Coefficient
MC.....	Medicine Cabinet, Mineral Core	NRP.....	Non-Removable Pin
MCC.....	Motor Control Center	NTS.....	Not To Scale
MDF.....	Medium Density Particleboard	O.....	Oxygen
ME.....	Mechanical Engineer	O TO O.....	Out to Out
MECH.....	Mechanical	OA.....	Outside Air, Overall
MED.....	Medium	OBS.....	Obscure
MED CAB.....	Medicine Cabinet	OC.....	On Center
MEMB.....	Membrane	OD.....	Outside Diameter
MERC.....	Mercury Vapor	OF.....	Outside Face
MET.....	Metal	OFF.....	Office
MEZZ.....	Mezzanine	OH.....	Overhead
MFD.....	Manufactured, Metal Floor Deck	OHD.....	Overhead Door
MFG.....	Manufacturer, Manufacturing	OI.....	Ornamental Iron
MFR.....	Manufacture, Manufacturer	OP.....	Opaque
MH.....	Manhole	OPNG.....	Opening
MI.....	Malleable Iron, Miles	OPP.....	Opposite
MIN.....	Minimum	OPP H.....	Opposite Hand
MIR.....	Mirror	OR.....	Outside Radius
MISC.....	Miscellaneous	ORN.....	Ornamental

OUT.....	Outlet	PRE.....	Prefinished
OVFL.....	Overflow	PREFAB.....	Prefabricated
OW.....	Open Waste	PRESS.....	Pressure
OZ.....	Ounce	PRF.....	Preformed
P.....	Pitch, Power Panel, Paint	PRFMD.....	Preformed
P. LAM.....	Plastic Laminate	PROT.....	Protection, Protective
P SL.....	Pipe Sleeve	PRSTR.....	Prestressed
PA.....	Public Address	PRTN.....	Partition
PAF.....	Powder Actuated Fasteners	PRV.....	Pressure Reducing Valve
PAR.....	Parallel	PS.....	Plumbing Stack
PARTN.....	Partition	PSC.....	Prestressed Concrete
PASS.....	Passage, Passenger	PSF.....	Pounds per square foot
PB.....	Pull Box, Push Button, Panic Bar	PSI.....	Pounds per square inch
PBD.....	Particle Board	PSIG.....	Pounds per square inch gage
PB STA.....	Push Button Station	PT.....	Paint, Point, Part
PC.....	Pull Chain, Piece, Precast Concrete	PTC.....	Post-Tensioned Concrete
PCF.....	Pounds per cubic foot	PTD.....	Painted, Paper Towel Dispenser
PCPL.....	Portland Cement Plaster	PTD/R.....	Combination Paper Towel Dispenser/Receptacle
PD.....	Pump Discharge, Plaza Drain	PTN.....	Partition
PDP.....	Paneled Door, Painted	PTR.....	Paper Towel Receptacle
PE.....	Porcelain Enamel, Professional Engineer	PVC.....	Polyvinyl Chloride
PED.....	Pedestal, Pedestrian	PVF.....	Polyvinylidene Finish
PERF.....	Perforate, Performance	PVG.....	Paving
PERIM.....	Perimeter	PVMT.....	Pavement
PERP.....	Perpendicular	PVT.....	Private
PFN.....	Prefinished	PW.....	Pass Window
PG.....	Pressure Gauge	PWR.....	Power
PH.....	Phase, Preheat, Phone	QUAL.....	Quality
PIV.....	Pivoted, Post Indicator Valve	QUANT.....	Quantity
PJF.....	Preformed Joint Filler	QT.....	Quarry Tile, Quart
PRKG.....	Parking	QTR.....	Quarter
PKWY.....	Parkway	QTY.....	Quantity
PL.....	Plate, Plan, Property Line, Plastic Laminate, Plastic	R.....	Riser, Radius, Resistance, Relay Panel
PLAS.....	Plaster, Plastic	R & S.....	Rod and Shelf
PLAS LAM.....	Plastic Laminate	RA.....	Return Air, Registered Architect
PLBG.....	Plumbing	RAD.....	Radius, Radiator
PLF.....	Pounds Per Lineal Foot	RB.....	Rubber, Rubber Base, Resilient Base
PLMBG.....	Plumbing	RBC.....	Rubber Base (Coved)
PLTF.....	Platform	RBS.....	Rubber Base (Straight)
PLYWD.....	Plywood	RBT.....	Rabbet
PLUMB.....	Plumbing	RCF.....	Raised Computer Floor
PNEU.....	Pneumatic	RCP.....	Reflected Ceiling Plan, Reinforced Concrete Pipe
PNL.....	Panel	RD.....	Roof Drain, Round, Receptacle Distribution Panel
PNT.....	Paint	REBAR.....	Reinforcing Bar
POL.....	Polish, Polished	REC.....	Receiver
PORC.....	Porcelain	RECEP.....	Receptacle
PORT.....	ortable	RECP.....	Receptacle
POT W.....	Potable Water	RED.....	Reducer
PP.....	Plaster, Painted, Power Panel, Precast Panel	REF.....	Refer, Reference, Refrigerator
PR.....	Pair	REFL.....	Reflected, Reflector
PRCST.....	Precast	REFR.....	Refrigerate, Refrigerator

REG.....	Register, Regular	SEC.....	Second, Secondary, Security System
REINF.....	Reinforcement, or Reinforce	SECT.....	Section
REM.....	Remove, Removable	SECY.....	Secretary
REQD.....	Required	SEL.....	Select
RES.....	Resilient	SERV.....	Service
RESIL.....	Resilient	SF.....	Square Foot
RET.....	Return, Retaining	SFGL.....	Safety Glass
RETG.....	Retaining	SGG.....	Structural Glazing Gasket
REV.....	Reverse, Revise, Revision	SGS.....	Silicone Glazing Sealant
REV DR.....	Revolving Door	SH.....	Shelf, Sheet, Shower
RF.....	Roof	SHR.....	Shower
RFG.....	Roofing	SHT.....	Sheet
RGTR.....	Register	SHTHG.....	Sheathing
RGH.....	Rough	SHWR.....	Shower
RGH OPNG.....	Rough Opening	SIG.....	Signal
RH.....	Right Hand, Reheat, Relative Humidity	SIM.....	Similar
RHR.....	Right Hand Reverse, Reheater	SJS.....	Silicone Joint Sealant
RM.....	Room	SK.....	Sink
RMV.....	Remove	SKL.....	Skylight
RO.....	Rough Opening	SL.....	Siamese Line
ROW.....	Right of Way	SLOT.....	Slotted
RPM.....	Revolutions Per Minute	SLV.....	Sleeve
RPT.....	Repeat (like "Ditto")	SND.....	Sanitary Napkin Dispenser
RR.....	Railroad	SNR.....	Sanitary Napkin Receptacle
RT.....	Rubber Tile, Right	SNT.....	Sealant
RTR/RR.....	Rubber Tread/Rubber Riser	SP.....	Soil Pipe, Standpipe, Soundproof, Single Pole
RVS.....	Reverse Side	SPC.....	Spacer
RVT.....	Rivet	SPD.....	Sump Pump Discharge
RW.....	Redwood	SPDT.....	Single Pole Double Throw
RWC.....	Rain Water Conductor	SPEC.....	Specification, Specifications
RWD.....	Redwood	SPECS.....	Specifications
RWL.....	Rain Water Leader	SPK.....	Speaker
S.....	South, Sealant, Supply, Sink	SPL.....	Special
S4S.....	Surfaced 4 Sides	SPLR.....	Sprinkler
S&M.....	Surfaced & Matched	SPM.....	Sprinkler Main
S&S.....	Stained & Sealed	SPP.....	Skim Coat Plaster Painted
S&V.....	Stain & Varnish	SPST.....	Single Pole Single Throw
SACT.....	Suspended Acoustical Tile	SQ.....	Square
SALV.....	Salvage	SS.....	Stainless Steel, Set Screw, Soil Stack, Service Sink, Slop Sink
SAN.....	Sanitary	SSD.....	Sub-soil Drain
SB.....	Setting Basin, Splash Block	SSGS.....	Silicone Structural Glazing Sealant
SC.....	Solid Core, Short Circuit, Self Closing, Sill Cock	SSK.....	Service Sink
SCD.....	Seat Cover Dispenser	SSS.....	Silicone Sanitary Sealant
SCFT.....	Structural Clay Facing Tile	SST.....	Stainless Steel
SCHED.....	Schedule	ST.....	Straight, Storm Water
SCR.....	Screen	STA.....	Station
SCUP.....	Scupper	STC.....	Sound Transmission Class
SCWD.....	Solid Core Wood	STD.....	Standard
SD.....	Soap Dispenser	STG.....	Storage, Seating
SE.....	Structural Engineer	STGG.....	Structural Glazing Gasket
SEAL.....	Sealant		

STGR.....	Stagger	TPH.....	Toilet Paper Holder
STIFF.....	Stiffener	TPTN.....	Toilet Partition
STK.....	Stack	TR.....	Tread, Transom
STL.....	Steel	TRANS.....	Transformer, Translucent
STM.....	Steam	TRAV.....	Travertine
STOR.....	Storage	TRD.....	Tread
STP.....	Standard Temperature & Pressure, Standpipe	TSL.....	Top of Slab
STR.....	Straight (re-bars), Strainer, Structural, Starter	TST.....	Top of Steel
STRL.....	Structural	TSTAT.....	Thermostat
STRT.....	Straight	TT.....	Terrazzo Tile, Traffic Topping
STRUCT.....	Structural	TV.....	Television
ST W.....	Storm Water	TW.....	Top of Wall, Thin Wall (conduit), Tempered Water
STWY.....	Stairway	TYP.....	Typical
SUCT.....	Suction	TZ.....	Terrazzo
SUPP.....	Supplementary, Supplement	UC.....	Undercut
SUPT.....	Superintendent	UH.....	Unit Heater
SUR.....	Surface	UL.....	Underwriters' Laboratories
SUSP.....	Suspended, Suspend	UNEXC.....	Unexcavated
SV.....	Safety Relief Valve	UNFIN.....	Unfinished
SW.....	Switch	UNO.....	Unless Noted Otherwise
SWBD.....	Switchboard	UP.....	Unpainted
SWGR.....	Switchgear	UR.....	Urinal
SY.....	Square Yard	USG.....	United States Gauge, United States Gypsum Company
SYM.....	Symmetrical	USS.....	United States Standard
SYN.....	Synthetic	UT.....	Utility
SYS.....	System	V.....	Volt, Valve, Vinyl, Vent, Ventilator
T.....	Tread, Thermostat, Tee	VA.....	Volt Ampere
T/.....	Top	VAC.....	Vacuum
T&B.....	Top and Bottom	VAR.....	Varnish, Varies
T&G.....	Tongue & Groove	VAT.....	Vinyl Asbestos Tile
TAN.....	Tangent	VB.....	Vapor Barrier, Valve Box, Vinyl Base, Vacuum Breaker
TB.....	Towel Bar	VBC.....	Vinyl Base (Coved)
TC.....	Top of Curb, Terracotta	VBS.....	Vinyl Base (Straight)
TCS.....	Terne Coated Stainless Steel	VCP.....	Vitrified Clay Pipe
TD.....	Trench Drain	VCT.....	Vinyl Composition Tile
TEL.....	Telephone	VENT.....	Ventilate, Ventilator
TEL CL.....	Telephone Closet	VERT.....	Vertical
TEMP.....	Temporary, Tempered, Temperature	VEST.....	Vestibule
TERR.....	Terrazzo	VF.....	Vinyl Fabric
TERM.....	Terminal	VIF.....	Verify In the Field
TH.....	Thermostat	VIN.....	Vinyl
THK.....	Thick, Thickness	VIT.....	Vitreous
THRESH.....	Threshold	VLT.....	Vault
THRM.....	Thermal	VNR.....	Veneer
THRMST.....	Thermostat	VOL.....	Volume
THRU.....	Through	VP.....	Vapor Proof, Vent Pipe
TKBD.....	Tackboard	VR.....	Vapor Retarder, Vacuum Return, Vertical Riser
TLT.....	Toilet	VRM.....	Vermiculite
TOL.....	Tolerance	VS.....	Vent Stack
TP.....	Top of Pavement	VT.....	Vinyl Tile
TPD.....	Toilet paper Dispenser	VTR.....	Vent Through Roof

VWC.....	Vinyl Wall Covering
W.....	West, Width, Wide, Watt, Waste, Water, Water Main
W/.....	With
W/O.....	Without
WAINS.....	Wainscot
WB.....	Wood Base
WC.....	Watercloset
WD.....	Wood
WDP.....	Wood, Painted
WDW.....	Window
WF.....	Wide Flange (structural steel)
WGL.....	Wire-Glass
WH.....	Water Heater, Wall Hung, Wall Hydrant
WI.....	Wrought Iron
WIN.....	Window
WM.....	Wire Mesh, Water Meter
WP.....	Waterproof, Working Point, Working Pressure, Weatherproof
WPR.....	Waterproofing
WPT.....	Working Point
WR.....	Water Resistant, Water Repellant, Waste Receptacle
WRSTP.....	Weatherstripping
WS.....	Weatherstripping, Water Stop
WSCT.....	Wainscot
WT.....	Weight, Water Table, Watertight
WVNR.....	Wood Veneer
WW.....	Window Wall
WWF.....	Welded Wire Fabric
XH.....	Extra Heavy
X HVY.....	Extra Heavy
X STR.....	Extra Strong
YD.....	Yard
YR.....	Year

APPENDIX C

CONSTRUCTION ORGANIZATIONS

(Selection USA and CANADA)

The following is a list of organizations that serve specific portions of the construction industry, and are sources for large amounts of specific construction related information, including details of various materials and construction systems. To verify or update information readers are advised to consult one of the following:

Encyclopedia of Associations, published by Gale Research Company.

National Trade and Professional Associations of the United States and Canada and Labor Unions, published by Columbia Books, Washington, DC.

ARCAT, published by The Architect's Catalog, Inc., Fairfield, CT. Sources of Information section of The Directory, published by the Sweet's Group of McGraw-Hill Construction Information Group.

Architectural Graphics Standards, 10th ed., manual published by John Wiley and Sons, Inc., New York, NY.

[Also, most larger public libraries have a directory service (free), which will locate addresses and telephone numbers in various cities]

- Academy of Certified Hazardous Materials Managers
- Accessible Design for the Blind
- Accessibility Equipment Manufacturers Assoc.
- Acoustical Society of America (ASA)
- Adaptive Environments
- Adhesive and Sealant Council
- Affordable Comfort
- Air Barrier Association of America
- Air Conditioning and Refrigeration Institute (ARI)
- Air Conditioning Contractors of America (ACCA)
- Air Diffusion Council (ADC)
- Air Infiltration and Ventilation Centre
- Air Movement and Control Association International (AMCA)
- Alliance to Save Energy
- Alliance for Fire and Smoke Containment and Control
- Alliance for Flexible Polyurethane Foam
- Alliance for Polyurethane Industry
- Aluminum Anodizers Council
- Aluminum Association Inc.
- Aluminum Extruders Council
- American Academy of Environmental Engineers
- American Arbitration Association (AAA)
- American Architectural Foundation
- American Architectural Manufacturers Association (AAMA)
- American Association for Laboratory Accreditation
- American Association of Automatic Door Manufacturers
- American Association of Botanical Gardens and Arboreta
- American Association of Engineering Societies
- American Association of State Highway and Transportation Officials (AASHTO)
- American Backflow Prevention Association
- American Boiler Manufacturers Association
- American Coal Ash Association
- American Concrete Contractors Association
- American Concrete Institute
- American Concrete Pavement Association
- American Concrete Pipe Association
- American Concrete Pressure Pipe Association
- American Concrete Pumping Association
- American Congress on Surveying and Mapping
- American Construction Inspectors Association
- American Consulting Engineers Council
- American Correctional Association
- American Council for Construction Education
- American Design Drafting Association
- American Electroplaters and Surface Finishers
- American Fence Association
- American Fiberboard Association
- American Fire Sprinkler Association
- American Floorcovering Alliance
- American Forest and Paper Association
- American Forest Foundation
- American Foundry Society
- American Galvanizers Association
- American Gas Association
- American Hardware Manufacturers Association
- American Hardwood Export Council
- American Institute for International Steel
- American Institute of Architects
- American Institute of Architecture Students
- American Institute of Building Design
- American Institute of Construction

- American Institute of Steel Construction (AISC)
- American Institute of Timber Construction
- American Iron and Steel Institute
- American Lighting Association
- American Lumber Standard Committee
- American National Standards Institute (ANSI)
- American Nursery and Landscape Association
- American Planning Association
- American Public Transportation Association
- American Public Works Association
- American Railroad Engineering and Maintenance-of-Way Association
- American Road and Transportation Builders Association
- American Rolling Door Institute
- American Seed Trade Association
- American Segmental Bridge Association
- American Shotcrete Association
- American Shutter Systems Association
- American Society for Engineering Education
- American Society for Nondestructive Testing
- American Society of Civil Engineers
- American Society of Concrete Contractors
- American Society of Consulting Arborists
- American Society of Furniture Designers
- American Society of Golf Course Architects
- American Society of Heating, Refrigeration and Air-Conditioning Engineers
- American Society of Healthcare Engineering
- American Society of Higher Education Facility Officers
- American Society of Home Inspectors
- American Society of Interior Designers
- American Society of Irrigation Consultants
- American Society of Landscape Architects
- American Society of Mechanical Engineers
- American Society of Plumbing Engineers
- American Society of Professional Estimators
- American Society of Safety Engineers
- American Society of Sanitary Engineering
- American Society of Theatre Consultants
- American Soil and Foundation Engineers
- American Solar Energy Society
- American Sports Builders Association
- American Subcontractors Association
- American Supply Association
- American Tree Farm System
- American Underground Construction Association
- American Walnut Manufacturers Association
- American Water Works Association
- American Welding Society
- American Wind Energy Association
- American Wire Producers Association
- American Wood Council
- American Wood-Preservers' Association
- American Zinc Association
- Amusement Industry Manufacturers & Suppliers
- APA - Engineered Wood Association
- Appalachian Hardwood Manufacturers
- Appraisal Institute
- Architectural Engineering Institute
- Architectural Precast Association
- Architectural Woodwork Institute
- Architectural Woodwork Manufacturers Assoc. of Canada
- Art Glass Association
- ASCR International - Association of Specialists
- ASIS International
- Asphalt Emulsion Manufacturers Association
- Asphalt Institute
- Asphalt Pavement Alliance
- Asphalt Recycling and Reclaiming Association
- Asphalt Roofing Manufacturers Association
- Associated Air Balance Council
- Associated Builders and Contractors
- Associated Construction Distributors International
- Associated Equipment Distributors
- Associated Floor Covering Contractors
- Associated General Contractors
- Associated Locksmiths of America
- Associated Schools of Construction
- Association for Bridge Construction and Design
- Association for Computer Aided Design in Architecture
- Association for Contract Textiles
- Association for Facilities Engineering
- Association for Preservation Technology
- Association for the Advancement of Cost Engineering
- Association for Women in Architecture
- Association of Asphalt Paving Technologists
- Association of Collegiate Schools of Architecture
- Association of Equipment Manufacturers
- Association of Energy Engineers
- Association of Energy Services Professionals
- Association of Home Appliance Manufacturers
- Association of Licensed Architects
- Association of Nonwoven Fabrics Industry
- Association of Professional Landscape Designers
- Association of Rotational Molders
- Association of State Floodplain Managers
- Association of Walls and Ceiling Industries
- ASTM International
- ATHENA Sustainable Materials Institute
- Audio Engineering Society
- Autoclaved Aerated Concrete Producers Association

- Automatic Fire Alarm Association
- Automotive Lift Institute
- BACnet Manufacturers Association
- Barre Granite Association
- Bath Enclosures Manufacturers Association
- BC Wood
- Blow-in-Blanket Contractors Association
- Brick Industry Association
- British Columbia Forest Information
- Builders Hardware Manufacturer Association
- Building Codes Assistance Project
- Building Commissioning Association
- Building Futures Council
- Building Owners and Managers Association
- Building Owners and Managers Institute
- Building Stone Institute
- Business and Institutional Furniture Manufacturer's Association
- Cable Tray Institute
- California Building Industry Association
- California Forest Products Commission
- California Industry Research Board
- California Manufactured Housing Inst.
- California Precast Concrete Pipe Association
- California Redwood Association
- Canadian Alarm and Security Association
- Canadian Carpet Institute
- Canadian Design Build Institute
- Canadian Hardwood Plywood & Veneer
- Canadian Institute of Plumbing and Heating
- Canadian Institute of Quantity Surveyors
- Canadian Institute of Steel Construction
- Canadian Plywood Association
- Canadian Precast / Prestressed Concrete Institute
- Canadian Restaurant & Foodservices Association
- Canadian Roofing Contractors' Association
- Canadian Sheet Steel Building Institute
- Canadian Society of Landscape Architects
- Canadian Solar Industries Association
- Canadian Standards Association
- Canadian Steel Producers Association
- Canadian Stone Association
- Canadian Window and Door Manufacturers Assoc.
- Canadian Wood Council
- Carpet and Rug Institute
- Carpet Cushion Council
- Cast Iron Soil Pipe Institute
- Cast Stone Institute .
- Cedar Shake & Shingle Bureau
- CEDIA
- Ceilings & Interior Systems Construction Association
- (CISCA)
- Cellulose Insulation Manufacturers Association
- Cement Association of Canada
- Center for Energy Efficiency and Renewable Energy
- Center for the Built Environment
- Center for Health Design
- Ceramic Glazed Masonry Institute
- Ceramic Tile Distributors Association
- Ceramic Tile Institute of America Inc.
- Certified Floor Covering Installers Assoc.
- Chain Link Fence Manufacturers Institute
- Chimney Safety Institute of America
- Collaborative for High Performance Schools
- Color Guild International
- Color Marketing Group
- Commercial Food Equipment Service Association
- Commercial Windows Initiative
- Composite Panel Association
- Compressed Air and Gas Institute
- Compressed Gas Association
- Concrete Anchor Manufacturer's Association
- Concrete Corrosion Inhibitors Association
- Concrete Countertop Institute
- Concrete Foundations Association
- Concrete Masonry Association of California & Nevada
- Concrete Reinforcing Steel Institute
- Concrete Sawing and Drilling Association
- Construction Estimating Institute
- Construction Financial Management Association
- Construction Industry Institute
- Construction Innovation Forum
- Construction Institute
- Construction Management Association of America
- Construction Materials Recycling Association
- Construction Owners Association of America
- Construction Science Research Foundation
- Construction Specification Institute
- Construction Specifications Canada
- Construction Writers Association
- Consumer Electronics Association
- Continental Automated Buildings Assoc.
- Conveyor Equipment Manufacturers Association
- Cool Metal Roofing Coalition
- Cool Roof Rating Council
- Cooling Technology Institute
- Copper Development Association
- Council for Masonry Research
- Council of Educational Facility Planners International
- Council of Forest Industries
- Council of Landscape Reg. Boards
- CSA America

- Daylighting Collaborative
- Decorative Plumbing & Hardware Industry
- Deep Foundations Institute
- Design Build Institute of America
- Design Management Institute
- Dietary Managers Assn.
- Door and Access Systems Manufacturers Association
- Door and Hardware Institute
- Dry Stone Conservancy
- Floodplain Management Association
- Floor Covering Installation Contractors Association
- Floor Installation Association of North America
- Foodservice Consultant's Society International
- Forest Products Society
- Forest Stewardship Council
- The Forest Guild
- ForestWorld
- Forging Industry Association
- Forest Certification Resource Center
- Forintek Canada Corp.
- Foundation for Design Integrity
- Foundation for Interior Design Education Research
- Galvalume Sheet Metal Roofing
- Gas Appliance Manufacturers Association
- Gas Technology Institute
- Geosynthetic Institute
- Geosynthetic Materials Association
- Geothermal Energy Association
- Geothermal Heat Pump Consortium
- Geothermal Resources Council
- Glass Association of North America
- Glass Packaging Institute
- Golf Course Builders Association of America
- Green Roofs for Healthy Cities
- Green Seal
- Greenguard Environmental Institute
- Gypsum Association
- Hardwood Manufacturers Association
- Hardwood Plywood & Veneer Association
- Health Facility Institute
- Hearth, Patio and Barbecue Association
- Heat Exchange Institute
- Heating, Air-conditioning & Refrigeration Distributors International
- Heating Refrigeration & Air Conditioning Institute of Canada
- Hollow Metal Manufacturer's Association
- Home Fire Sprinkler Coalition
- Home Furnishings International Association
- Home Ventilating Institute
- Human Factors and Ergonomics Society
- Hydraulic Institute
- Illuminating Engineering Society of North America
- Independent Electrical Contractors Assoc.
- Independent Office Products and Furniture Dealers Association
- Indiana Limestone Institute of America
- Industrial Fabric Association International
- Industrial Fasteners Institute
- Industrial Perforators Association
- Innovative Pavement Research Foundation
- Institution of Fire Engineers
- Insulated Cable Engineers Association
- Insulating Concrete Form Association
- Insulating Glass Certification Council
- Insulating Glass Manufacturers Alliance
- Insulation Contractors Association of America
- Integrated Building & Construction Solutions
- International Hurricane Protection Assoc.
- Institute of Clean Air Companies
- Institute of Electrical and Electronic Engineers
- Institute of Heating and Air Conditioning Industries Inc.
- Institute of Noise Control Engineering (INCE/USA)
- Institute of Store Planners
- Institute of Transportation Engineers
- Interior Design Educators Council
- Interlocking Concrete Pavement Institute
- International Association of Amusement Parks and Attractions
- International Association of Assembly Managers
- International Association of Electrical Inspectors
- International Association of Foundation Drilling
- International Association of Lighting Designers
- International Association of Lighting Management Cos.
- International Association of Plumbing and Mechanical Officials (IAPMO)
- International Association of Professional Security Consultants
- International Association of Structural Movers
- International Basketball Federation
- International Cast Polymer Association
- International Code Council
- International Communications Industries Association
- International Concrete Repair Institute
- International Dark Sky Association
- International Door Association
- International Electrical Testing Association (NETA)
- International Erosion Control Association
- International Facility Management Association
- International Firestop Council
- International Furnishings & Design Association
- International Groundsource Heat Pump Association

- International Institute for Lath & Plaster
- International Institute of Ammonia Refrigeration
- International Interior Design Association
- International Lead Zinc Research Organization
- International Masonry Institute
- International Parking Institute
- International Play Equipment Manufacturers Association
- International Safety Equipment Association
- International Sign Association
- International Slurry Surfacing Association
- International Society of Arboriculture
- International Society of Explosives Engineers
- International Solid Surface Fabricators Assoc.
- International Tropical Timber Organization
- International Wholesale Furniture Association
- International Window Cleaning Association
- International Window Film Association
- International Wood Products Association
- International Zinc Association
- Irrigation Association
- Joint Commission on Accreditation of Health Care Organizations
- Kitchen Cabinet Manufacturers Association
- Lean Construction
- Light Gauge Steel Engineers Association
- Light Right Consortium
- Lighting Controls Association
- Lighting Research Center
- Lightning Protection Institute
- Lightning Safety Alliance
- LonMark Interoperability Association
- National Construction Law Center
- National Corrugated Steel Pipe Association
- National Council of Acoustical Consultants
- National Council of Architectural Registration Boards
- National Council of Structural Engineers Associations
- National Council on Qualifications for the Lighting Professions
- National Council on Radiation Protection and Measurement
- National Electrical Contractors Association
- National Electrical Manufacturers Association
- National Elevator Industry
- National Environmental Balancing Bureau
- National Federation of State High School Associations
- National Fenestration Rating Council
- NFPA, International, Inc. [formerly National Fire Protection Association]
- National Fire Sprinkler Association
- National Fireplace Institute
- National Floor Safety Institute
- National Frame Builders Association
- National Glass Association
- National Ground Water Association
- National Guild of Professional Paperhangers
- National Hardwood Lumber Association
- National Home Furnishings Association
- National Institute of Building Sciences
- National Institute of Certified Floor-Covering Inspectors
- National Institute of Steel Detailing
- National Insulation Association
- National Joint Apprenticeship and Training Committee
- National Kitchen & Bath Association
- National Lighting Bureau
- National Lightning Safety Institute
- National Lime Association
- National Lumber Grades Authority
- National Multi Housing Council
- National One Coat Stucco Association
- National Onsite Wastewater Recycling Association
- National Ornamental and Miscellaneous Metals Association
- National Paint and Coatings Association
- National Parking Association
- National Pavement Contractors Association
- National Pest Management Association
- National Precast Concrete Association
- National Ready Mix Concrete Association
- National Restaurant Association
- National Roof Deck Contractors Association
- National Roofing Contractors Association
- National Rural Water Association
- National Sash and Door Jobbers Association
- National School Plant Management Association
- National School Supply and Equipment Association
- National Slag Association
- National Preservation Institute
- National Slate Association
- National Society of Black Engineers
- National Society of Professional Engineers
- National Spa and Pool Institute
- National Standards Systems Network
- National Stone, Sand and Gravel Assoc.
- National Sunroom Association
- National Systems Contractors Association
- National Terrazzo & Mosaic Association
- National Tile Contractors Association
- National Training Center for Stone & Masonry Trades
- National Trust for Historical Preservation
- National Utility Contractors Association
- National Wood Flooring Association
- Natural Stone Council

- Network of Executive Women in Hospitality
- Nickel Development Institute
- NOFMA - Wood Flooring Manufacturers Assoc.
- Non-Ferrous Founders Association
- North American Association of Food Equipment Manufacturers
- North American Association of Mirror Manufacturers
- North American Building Material Distribution Association
- North American Insulation Manufacturers Association
- North American Society for Trenchless Technology
- North American Wholesale Lumber Association
- Northeastern Lumber Manufacturers Association
- Northwest Wall and Ceiling Bureau
- NSF International
- Office Furniture Dealers Alliance
- Operative Plasterers' and Cement Masons' International Association
- Paint and Coatings Resource Center
- Paint Quality Institute
- Painting and Decorating Contractors of America
- Partnership for Advancing Technology
- Perlite Institute Inc.
- Petroleum Equipment Institute
- Pile Driving Contractors Association
- Pipe Fabrication Institute
- Plastic Lumber Trade Association
- Plastic Pipe and Fittings Association
- Plastics Pipe Institute
- Plumbing and Drainage Institute
- Plumbing Heating Cooling Contractors Association
- Plumbing Manufacturers Institute
- Polyisocyanurate Insulation Manufacturers Association
- Porcelain Enamel Institute
- Portland Cement Association
- Post-Tensioning Institute
- Powder Actuated Tool Manufacturers' Institute
- Powder Coating Institute
- Power & Communication Contractors Association
- Precast/Prestressed Concrete Institute
- Preservation Trades Network
- Professional Awning Manufacturers Association
- Professional Construction Estimators Association
- Professional Grounds Management Society
- Professional Landcare Network
- Professional Women in Construction
- Project Management Institute
- Protective Glazing Council
- Radiant Panel Association
- Redwood Inspection Service
- Reflective Insulation Manufacturer's Association
- Reflective Roof Coatings Institute
- Refrigeration Service Engineers Society
- Research Council on Structural Connections
- Residential Fire Safety Institute
- Resilient Floor Covering Institute
- Roof Coatings Manufacturers Association
- Roof Consultants Institute
- Royal Architectural Institute of Canada
- Safety Glazing Certification Council
- Scaffold Industry Association
- Scaffolding, Shoring & Forming Institute
- Scientific Equipment and Furniture Association
- Screen Manufacturer's Association
- Sealant Waterproofing and Restoration Institute
- Security Hardware Distributors Association
- Security Industry Association
- Sheet Metal and Air Conditioning Contractors National Association
- Siding and Window Dealers Association of Canada
- Silica Fume Association
- Single Ply Roofing Institute
- Slag Cement Association
- Slate Discover Center
- Smart Wood
- Society for Environmental Graphic Design
- Society for Marketing Professional Services
- Society of American Registered Architects
- Society of Architectural Historians (SAH)
- Society of Building Science Educators
- Society of Design Administration
- Society of Fire Protection Engineers
- Society of Glass and Ceramic Decorators
- Society of Hispanic Professional Engineers
- Society of Municipal Arborists
- Society of Women Engineers
- Society of Wood Science and Technology
- Soil and Water Conservation Service
- Soil Science Society of America
- Solar Energy Industries Association
- Solar Energy Society of Canada
- Solar Rating and Certification Corporation
- Southeastern Lumber Manufacturers Association
- Southern Cypress Manufacturers Association
- Southern Forest Products Association
- Southern Pine Council
- Southern Pine Inspection Bureau
- Southwest Research Institute
- Spancrete Manufacturers' Association
- Specialty Steel Industry of North America
- Specialty Tools and Fasteners Distributors Association
- Specifications Consultants in Independent Practice

- Spiral Duct Manufacturers Association
- Sports Turf Managers Association
- Spray Polyurethane Foam Alliance
- SSPC - Society for Protective Coatings
- Stained Glass Association of America
- Stairway Manufacturers' Association
- Standards Engineering Society
- Steel Deck Institute
- Steel Door Institute
- Steel Erectors Association of America
- Steel Framing Alliance
- Steel Joist Institute
- Steel Manufacturers Association
- Steel Plate Fabricators Association
- Steel Recycling Institute
- Steel Stud Manufacturers Association
- Steel Tank Institute
- Steel Truss and Component Association
- Steel Tube Institute of North America
- Steel Window Institute
- The Stone Foundation
- Stucco Manufacturers Association
- Structural Board Association
- Structural Building Components Council
- Structural Component Distributors Association
- Structural Engineering Institute
- Structural Engineers Association
- Structural Engineers of California
- Structural Insulated Panel Association
- Submersible Waste Water Pump Association
- Sump and Sewage Pump Manufacturers Association
- Surety Information Office
- Sustainable Building Information Centre
- Sustainable Buildings Industry Council (SBIC)
- Sustainable Forestry Initiative
- Telecommunications Industry Association
- Terrazzo Tile and Marble Association of Canada
- Testing, Adjusting and Balancing Bureau
- Textile Society of America
- Themed Entertainment Association
- Tile Contractors Association of America
- Tile Council of North America
- Tile Roofing Institute
- Tilt-Up Concrete Association
- Timber Frame Business Council
- Timber Framers Guild
- Tree Care Industry Association
- Tropical Forest Foundation
- Truss Plate Institute
- Tube & Pipe Association, Intl.
- Turfgrass Producers International
- Uni-Bell PVC Pipe Association
- United States Sign Council
- Urban Land Institute
- US Composting Council
- US Fuel Cell Council
- US Green Building Council
- Used Building Materials Association
- Valve Manufacturers Association
- Vent-Free Gas Products Alliance
- Vibration Isolation and Seismic Control Manufacturers Association
- Vinyl Institute
- Vinyl Siding Institute
- Wallcoverings Association
- Walnut Council International Office
- Water Environment Federation
- Water Quality Association
- West Coast Lumber Inspection Bureau
- Western Hardwood Association
- Western Red Cedar Lumber Association (WRCLA)
- Western States Clay Products Association
- Western States Roofing Contractors Association
- Western Wall and Ceiling Contractors Association
- Western Wood Preservers Institute
- Western Wood Products Association
- Window and Door Manufacturers Association
- Window Coverings Association of America
- The Wire Association International
- Wire Reinforcement Institute
- Wood Component Manufacturers Association
- Wood Moulding and Millwork Producers Association
- Wood Products Manufacturers Association
- Woodtruss Council of America
- Woodwork Institute
- World Energy Efficiency Association
- World Floor Covering Association
- World Green Building Council
- Woven Wire Products Association

APPENDIX D

READING RESOURCES

BOOK LIST

The following books, at least in part, provide different perspectives and added insight into the process of detailing:

- **Architectural Detailing: Function Constructibility Aesthetics** 2nd Edition by Edward Allen and Patrick Rand (2007)
- **Architectural Working Drawings** 4th Edition by Ralph W. Liebing (1999)
- **The Professional Practice of Architectural Working Drawings** by Richard M. Linde, Osamu A. Wakita (November 1994)
- **A Manual of Construction Documentation: An Illustrated Guide to Preparing Construction Drawings** by Glenn E. Wiggins (May 1989)
- **Working Drawings Handbook** by Keith Styles
- **Architectural Working Drawings: Residential and Commercial Buildings** by William Perkins Spence
- **Uniform Drawing Format Manual: New CADD and Drafting Standards for Building Design and Working Drawings** by Fred Stitt
- **Handbook of Architectural Details for Commercial Buildings** by Joseph De Chiara, [1980 or latest edition]
- **Construction Details for Commercial Buildings** by Glen Wiggins
- **Architectural Graphics Standards 10th Edition** by Ramsey and Sleeper [also several volumes are specific to various areas of work—site, interior, etc.]
- **Building Construction Illustrated** 4th Edition by Francis Ching
- **Guide to Contract Documents** 3rd Edition by William Poage

- **Fundamentals of Building Construction Methods and Materials** by Edward Allen
- **Time Saving Techniques for Architectural Construction Drawings** by Fred Nashed
- **Architectural Quality Control: An Illustrated Guide** by Fred Nashed
- **Construction Graphics** by Keith A. Bisharat
- **Time Savers Standards**, several volumes in series—, per Site Planning, Building Types and Building materials

Added Reading

Readers are advised, and strongly urged to take full advantage of the myriad books and other publications, which deal with construction, and ancillary work. There is a tremendous resource available, but it is not all that apparent. Normally, public libraries [even in large cities] do not carry a full range of publications on construction, mainly due to the large number that are available. They do have a fair cross-section of such publications. However, in many cases these are outdated and short of full coverage, but still provide some basic information. Things are constantly changing in construction, and new information coming out, so a comprehensive collection would be prohibitive.

There is, of course, a tremendous array of residential design books, self-help, do-it-yourself, and related information in book form. However, this does not address the full range of construction work. Construction information in the much broader range of non-residential design and construction falls into several categories;

- *general guide books and reference standards for design and construction;*
- *narrow scope books which deal with a particular type, or use of structure;*
- *"drafting" and CAD books regarding everything from basic drafting techniques to construction detailing, to renderings and other presentation drawings;*
- *theoretical discussions on method of construction and design;*

- *specific discipline discussions and handbooks*
[*structural steel design, for example*];
- *current informational and statistical data*
[*usually in periodicals*];
- *organization and association journals and periodicals*;
- *handbooks, booklets, catalogs, and pamphlets on specific materials, systems or devices and equipment published by manufacturers or trade organizations.*

This is not to indicate that each reader needs to acquire a large personal library, but a few, well-chosen books are quite often more convenient and handy for the users, in lieu of having to seek the same from another source. It is particularly important for students and new professionals to start a personal library, which they can build upon as their experience and interests widen. Regrettably many students sell off their textbooks, when they could become the foundation of a personal reference library. If a reader works in a particular area of construction, those reference items are best oriented toward both that work, and toward closely allied work. This allows for finding information, quickly, without lengthy searching.

The technical libraries in the offices of design professionals [and for the most part, contractors too] carry only a very limited array of pertinent handbooks and reference materials. Usually these facilities contain more material-, and systems-related technical information, which the staff can rely on for detailed information. Here it is important, though, that such libraries be refreshed and updated, frequently, to stay abreast of the most current products and information. A catalog of some 5 or 10 years standing is usually out of date and misleading if not totally obsolete.

Of course, times are changing, and the flow and availability of information is exploding. The Internet is an excellent resource, and reveals an ever-increasing number of resources and publications, provided the reader is familiar with the sources, such as major publishing houses, university publishing sources, trade organizations etc. Also, textbook publishers offer a good number of new information sources. Some of the major publishers devote entire series of books strictly to construction. Web searches, using a wide variety of keywords can be focused on any of these sources, and thousands of others for an amazing listing of information. One only has to be creative and flexible in initiating the search.

An Internet resource like www.amazon.com allows one to search through thousands of books that are available. One is cautioned to explore and search through a range of keyword entries to exercise this resource to the highest degree. Amazon, for example, lists almost 17,000 books under the

keyword, "construction"; almost 1,400 under "drafting", over 700 for "construction materials" and some 22,350 under "architecture"; with 32,000 under "engineering"-[incl. all types]. Of course, the more specific the keyword, the more focused and narrow the search results. Also, these numbers are on a continual increase as more and more authors offer their information and perspectives.

In this, though, there is a need for the desire to buy this information for easy access. That desire when carefully controlled and directed, can build both extensive and most valuable libraries. Mere numbers of books, though, could provide an expensive but little used asset. Care and discipline in selection is necessary. For example, there are numerous book clubs available, which send monthly flyers of available publications. One need not buy everything in every flyer, but using this method [and bonus offerings] can expand one's selection of books.

An incomplete listing of major publishing houses with large collections of construction-oriented books, includes:

Prentice-Hall
John Wiley & Sons
McGraw-Hill Book Co.
Watson-Guptill Publications
Von Norstand-Reinhold
Delmar Publishers, Inc.
Whitney Library of Design
MIT Press
Craftsman Book Company
Rizzoli International Publications
Goodheart-Willcox Company

Beyond the array of bound books [with hard or paper covers], there is a profusion of periodicals, which are available. These outlets, in particular, brings specific, usually narrow-scope and most timely information to the reader. Their precise purpose is to update and present the most current data and information, within their purviews. Their content comes in a variety of form. Some merely present reviews [with photos] of completed projects, showing how materials and systems were used. Other provide "papers" from various sources on technical topics, new findings, and innovative approaches.

Here again, the reader is open to choice— choosing those periodicals which best serve the need. Some of the periodicals have a recurring theme, like the CONSTRUCTION SPECIFER, of the Construction Specifications Institute. Its main theme each month is some aspect of specification writing. Always, no matter the format, there is information of value, be it new products, new techniques, professional direction, or open discussion.

Following is a partial listing of available periodicals. Many other, most very narrow in scope, also are available; there are numerous publishing houses which provide a wide variety and number of publications, usually within the bounds of a specific area of interest or work. For a fuller listing of periodicals, consult the listing of Trade Associations or Internet sites revealed by a search for "listing of periodicals".

Periodicals That Are Available Free of Charge

- **Modern Steel Construction:** American Institute of Steel Construction, One East Wacker Drive, Chicago IL 60601-2001, phone (312)670-5407. An excellent magazine on structural steel, featuring articles on current projects written by their architects and engineers.
- **Form & Function:** 125 South Franklin St., Chicago IL 60606-4678. A beautifully produced magazine on uses of USG Corporation gypsum products in current building projects.
- **Ascent:** Precast/Prestressed Concrete Institute, 175 West Jackson Boulevard, Chicago IL 60604, (312) 786-0300. A first-class quarterly journal that covers new buildings framed and/or clad in precast concrete.
- **Building Design and Construction:** Cahners Plaza, 1350 E. Touhy Avenue, Des Plaines, IL 60018-3358, (847) 390-2769. A general magazine of larger-scale building construction, with particular emphasis on the building team. Free subscription with evidence of professional qualifications as an active architect or engineer.
- **CMR Report:** National Concrete Masonry Association, 2302 Horse Pen Road, Herndon VA 20171. A newsletter from the Council for Masonry Research.
- **PCA Concrete Technology Today:** Portland Cement Association, 5420 Old Orchard Road, Skokie IL 60077-1083, (847) 966-6200. New developments in concrete research and practice.
- **Construction Metrication:** Construction Metrication Council, National Institute of Building Sciences, 1690 Vermont Avenue, N.W., Washington DC 20005-4905. A newsletter on metric practice in the construction industry.
- **Copper Topics:** Copper Development Association, Inc., 260 Madison Avenue, New York NY 1016. A newsletter about copper in building construction.
- **Metal Architecture:** Modern Trade Communications, Inc., 7450 N. Skokie Boulevard, Skokie IL 60077. A large-format, full-color journal of the metal package building industry, including structural metal roofing and cladding products.
- **Automated Builder:** 1445 Donlon Street, Suite 16, Ventura CA 93003, (805)642-9735. A monthly journal of the manufactured housing industry, available free with evidence of professional qualification.

Publications With Paid Subscriptions

- **Engineering News-Record:** Two Penn Plaza, New York NY 10121-2298, (888)867-6395. This is the weekly news magazine of the construction industry, with frequent articles of technical interest concerning projects currently under construction.
- **The Construction Specifier:** Construction Specifications Institute, 601 Madison Street, Alexandria VA 22314-1791, (800) 689-2900. This is the monthly journal of CSI. Every issue features summary articles on various areas of construction practice.
- **Magazine of Masonry Construction:** and **Magazine of Concrete Construction:** The Aberdeen Group, 426 South Westgate Street, Addison IL 60101, (888) 721-2402. Two of my favorites, these are down-to-earth, practical, richly illustrated monthlies on masonry and concrete that are aimed primarily at contractors.
- **Concrete International:** American Concrete Institute, P.O. Box 9094, Farmington Hills MI 48333, (248) 848-3700. This is the official journal of ACI and is an excellent source of the latest information on concrete technology. ACI also publishes the ACI Structural Journal and ACI Materials Journal, which are research journals that publish scientific papers.
- **PCI Journal:** Precast/Prestressed Concrete Institute, 175 West Jackson Boulevard, Chicago IL 60604, (312) 786-0300. An excellent, full-color, bimonthly magazine on precast, prestressed concrete construction research and practice.
- **The Journal of Light Construction:** Builderburg Partners, Ltd., 1025 Vermont Avenue, N.W., Washington DC 20005. Aimed at small builders, this is a superb monthly magazine on the practice of wood light frame construction.

- Wood Design and Building: 3380 Sheridan Drive, Suite 306, Amherst NY 14226. Both exquisite and practical, this full-color magazine features both fine color photography of new architecture in wood, and building code compliance information.
- Fine Homebuilding: The Taunton Press, Inc., P. O. Box 5506, Newtown CT 06470, (800) 888-8286. This lovely journal is aimed at the custom builder and advanced do-it-yourselfer. It features excellent articles on building techniques and technologies as well as design-oriented accounts of projects by architects.
- Architecture magazine: P.O. Box 2063, Marion, OH 43305, and Architectural Record, P.O. Box 564, Hightstown, NJ 08520; both standard journals for architects, are by subscription.
- Design/Build: telephone 1- [888] 867-6395; magazine devoted to the D/B delivery system and associated information and programs; also to Design/Build Institute of America [DBIA].
- CMeJOURNAL: % Construction Management Association of America [CMAA], 7918 Jones Branch Drive, McLean, VA 22101; magazine covering the CM project delivery system and various ancillary topics, document, and programs.

GLOSSARY OF CONSTRUCTION TERMS

Correct terminology, and knowledge of terms is critical in the production of contract documents, and especially in detailing. As a tool of communication, it is important to use terms which are widely used and commonly understood, within the mainstream construction lexicon.

This glossary has been compiled to be as comprehensive as possible for students in Architectural, Engineering, and Construction Technology programs. It is NOT, however, complete in that each construction phase, system, trade, and material has its own "jargon" and nomenclature; in many cases definitions, too. These number in the tens of thousands. Therefore, it is impossible to know and list them all; it is, however, well to become familiar with them as the need arises - always expanding the list. [Also, there is a need to caution that often things are called by familiar names which are not accurate - for example, it is plastic laminate, not Formica; it is concrete not cement; it is steel not iron, etc.]

The following is a short list of resources and references that may provide the definition of terms being sought by the student. Be advised that the latest editions should be verified with the publishers;

THE CONSTRUCTION DICTIONARY, 9th ed.
Greater Phoenix Chapter
National Association of Women in Construction
P.O. Box 6142, Phoenix, AZ 85005

DICTIONARY OF ARCHITECTURE AND CONSTRUCTION,
2d. ed.
by Cyril M. Harris
ISBN 0-07-026756-1
Published by McGraw-Hill Book Company

**BUILDING NEWS CONSTRUCTION
DICTIONARY ILLUSTRATED**, 2000 Ed.
ISBN 1557013268
Published by ENR/BNI Books
1221 Avenue of the Americas

CONSTRUCTION GLOSSARY, 2d. ed.
by J.S. Stein
ISBN 0-471-56933-X
Published by John Wiley and Sons, Inc.

MEANS ILLUSTRATED CONSTRUCTION DICTIONARY
ISBN 0-87629-218-X
Published by R.S. Means Co., Inc.
100 Construction Plaza
P.O. Box 800, Kingston, MA 02364

A VISUAL DICTIONARY OF ARCHITECTURE
By Francis D.K. Ching
ISBN D-28451-3
Published by John Wiley and Sons, Inc.

Also, many publications of the Trade and Professional organizations, listed in Appendix C, provide definitions and descriptions which are specific to their products or services.

A

A/C - An abbreviation for air conditioner or air conditioning.

A/C Circuit - (Alternating Current) The flow of current through a conductor first in one direction then in reverse. It is used exclusively in residential and commercial wiring because it provides greater flexibility in voltage selection and simplicity of equipment design.

A/C Condenser - The outside fan unit of the Air Conditioning system. It removes the heat from

A/C Disconnect - The main electrical ON-OFF switch near the A/C Condenser.

A/E - Architect/Engineer - the design professional hired by the owner to provide design and design-related services; a firm with personnel and expertise in both professions.

Above Grade - The portion of a building that is above ground level [see Grade].

Abrasives - Substances rubbed on wood to smooth the surface/ Flint; garnet, aluminum oxide, and silicon carbide are common abrasives; also, used in stair nosings, for non-slip surfaces; can be "seeded" into flat concrete surfaces and stair treads also for non-slip purposes.

ABS Pipe - ABS is abbreviation for Acrylonitrile Butadiene Styrene; type of plastic pipe frequently used in plumbing and drainage work. Black in color and usually in the form of Schedule 40 pipe.

Abut - To be immediately adjacent to, and touching on a side or end.

Accelerator - Any material added to stucco, plaster or mortar, which speeds up the natural set.

Access Floor - Raised floor system consisting of relatively small [24" square] individually removable panels, mounted on isolated pedestal supports, beneath which wiring, ductwork, cabling and other services may be installed; also called "computer floor" or "pedestal floor"

Access panel - Cover or door, of various sizes for openings provided to reach plumbing or other system, in/behind walls, floors, or ceilings; usually primed steel or stainless steel.

Accessories - Trim pieces, reinforcement, anchors and other similar devices that aid and enhance various material installations; vary in type but available for drywall, plaster, masonry, concrete, etc.

ACM - Aluminum composite material; usually sheet material for facings, etc. with aluminum face sheets laminated to various backing materials.

Acoustic Materials - Composition board installed on ceilings or walls for the purpose of reducing sound reflection (or echo); board is generally the same as that used for ordinary insulating purposes, or can be specially manufactured material for added acoustic capabilities; acoustical tile for ceilings is often perforated or fissured to increase the area of sound-absorbing surface; may be boards, batts, blocks, foam, spray-on, panel, sheets, pads or tile materials.

Acoustic(al) - Pertains to sound. In some buildings, it is necessary to include sound

control, i.e., acoustical treatment; generally smooth flat surfaces reflect sound; a soft, porous surface will absorb it. The finished surfaces of ceilings and walls are designed according to the need for acoustical treatment; floors may also be treated as well as doors, windows and mechanical systems.

Acre - A unit of land measurement equal to 43,500 square feet.

Activity - (1) A scheduling term (2) The smallest work unit within a project; the basic building block of a project. (see Project)

Actual dimension - Size of boards or lumber, distinguished from "nominal dimensions"; term "2x4" is nominal, while 1-1/2" x 3-1/2" is the actual size, which is that existing after machining, sanding and preparing the lumber.

ADA - The Americans with Disabilities Act which gives civil rights protection to individuals with disabilities similar to those provided to individuals on the basis of race, color, sex, national origin, age, and religion. It guarantees equal opportunity for individuals with disabilities in public accommodations, employment, transportation, State and local government services, and telecommunications; in construction, basically provides for full accessibility [barrier removal] for handicapped persons throughout various facilities in buildings and businesses; also contains minimum spacing, clearance requirements, and other physical protection.

Adapter - Fitting which makes transition between pipes and ducts which are not of the same size, or otherwise made to fit together.

Addendum (Addenda) - An addendum is generally issued by the owner to the contractor during the bidding process and as such, addenda are intended to become part of the contract documents when the construction contract is executed; written information [with drawings if necessary] adding to, clarifying or modifying bidding documents.

Adhesion - The property of a coating or sealant to bond to the surface to which it is applied.

Adhesive - A natural or synthetic material, generally in paste or liquid form, used to fasten or surface-attach material together; glues, cements, pastes, and mucilage are examples to install floor tile, fabricate plastic laminate-covered work, build up laminated structural members, or otherwise attach work items together.

Adhesive Failure - Loss of bond; or a coating or sealant from the surface to which it is applied.

Admixture - A substance other than Portland cement, water and aggregates included in a concrete mixture, for the purpose of altering one or more properties of the concrete; aids setting, finishing, or wearing of the concrete.

Aerator - The round, screened screw-on tip/nozzle of a sink spout. It mixes water and air for a smooth flow.

Aggregate - Hard, inert material, such as sand, water-worn gravel, slag and crushed stone, used as filler material combined with Portland cement and water to produce concrete; must be properly cleaned and well graded as required; also used alone as porous fill, substrate, or surfacing material; in a wide range of sizes that is used to surface built-up roofs.

AIA - The American Institute of Architects; a professional organization of registered architects; provides various membership services, documents, lobbying efforts, government interface, information education, and other professional services; national organization with regional/local chapters

Air-Dried Lumber - Lumber that has been piled and stored in outdoor yards or sheds for any length of time [in lieu of drying in a kiln]. For the United States as a whole, the minimum moisture content of thoroughly air-dried lumber is 12 to 15 percent and the average is somewhat higher. In the South, air-dried lumber may be no lower than 19 percent.

Air Duct - Formed conduit which carries conditioned air to rooms from an air-handling unit or furnace, and back again; varies in size and shape [rectangular, round]; usually sheet metal or fiberglass.

Air-entrained Concrete - Concrete suffused with tiny air bubbles, making it more workable and better able to withstand frost.

Air Filters - Adhesive filters made of metal or various fibers that are coated with adhesive liquid to which the particles of lint and dust adhere. These filters will remove as much as 90% of the dirt if they do not become clogged. The more common filters are of the throwaway or disposable type.

Air Infiltration - The amount of air leaking in and out of a building through cracks in walls, windows and doors.

Air Lock - Enclosure between sets of entrance doors to create a transition space; a vestibule, overheated to prevent flow of cold air into building; can be ceilingless, but duplicates entrance doors layout.

Air Space - A space or void in a wall or other enclosed part of a building between structural members.

Airway - A space between roof insulation and roof sheathing for movement of air.

Alligatoring - A condition of paint or aged asphalt which produces a pattern of cracks resembling an alligator hide, brought about by the loss of volatile oils and the oxidation caused by solar radiation. Coarse checking pattern characterized by a slipping of the new paint coating over the old coating to the extent that the old coating can be seen through the fissures; is ultimately the result of the limited tolerance

of paint or asphalt to thermal expansion or contraction; also a malady which occurs when roofing is deteriorating.

Alterations - (1) A term used to describe remodeling or renovations involving partial construction work performed within an existing structure (2) Remodeling without a building addition.

Anchor - Any of a number of devices/fasteners [usually metal] used to mechanically attach one item or material to another of the same or different qualities or composition.

Anchor Bolts - Bolts, placed/imbedded in concrete with threaded portion exposed, which fasten column base plates, sills, girders or other members to concrete or masonry such as bolts used to anchor sills to masonry foundation; bolts to secure a wooden sill plate to concrete, or masonry floor or wall in wood frame construction.

Angle (steel) - A section of rolled structural steel bent to form a 90 degree angle; may have equal or unequal legs; identified by the symbol "L"; used in miscellaneous ways or as part of structural frames- lintels to span openings and support masonry at the openings. In brick veneer, they are used to secure the veneer to the foundation. Also known as "shelf angle".

Approved - Term used to indicate acceptance of condition, material, system, or other work or procedure; reflects action by design professional or other authorized party, but does not relieve basic responsibility of party seeking such approval, as written in other binding documents and provisions

Apron - 1] The flat, vertical part of the inside trim of a window. It is placed against the wall directly beneath the window sill [stool]. 2] Also, concrete slab at the approach to a driveway or garage.

Arch - A curved structure that will support itself and the weight of wall above the opening, by mutual pressure.

Architect - Person trained in design and construction and registered by the state, who prepares architectural designs to meet the owner's requirements, and associated construction documents and observes construction of various types of building projects for a variety of types of structures.

Architect-Engineer (A/E) - An individual or firm offering professional services as both architect and engineer.

Architect's Scale - Three-sided "ruler" with two different scales on each side- one reads in one direction and is twice the other [e.g., 1/4-inch and 1/8-inch]; also can be beveled, two-sided versions.

Architectural Design - Process of assembling and developing stated project requirements, regulatory concerns and conceptual design principles into a coordinated program and associated sketches and drawings which depict the proposed project.

Architectural Drawing - Part of a set [series] of drawings created and compiled to depict the desired design configuration and details for the general construction of a project; does not address structural or building service systems; also, singly, a line drawing showing plan and/or elevation views of the proposed building for the purpose of showing the overall appearance of the building.

Areaway [wells] - 1] Concrete or metal barriers walls installed around a subgrade window to hold back the earth and allow light into a basement; also called "areaway". 2] An open subsurface space adjacent to a building used to admit light or air or as a means of access to a basement.

Ashlar - Squared and dressed stones used as a masonry wall facing; also, short upright wood pieces extending from the attic floor to the rafters forming a dwarf wall.

Asphalt - A mineral pitch insoluble in water and used extensively in building materials for waterproofing, roof coverings, shingles, floor tile, paints, and paving; A dark brown to black, highly viscous, hydrocarbon produced from the residue left after the distillation of petroleum. Asphalt is used on roofs and highways as a waterproofing agent. Most native asphalt is a residue from evaporated petroleum. It is insoluble in water but soluble in gas. line when heated. Used widely in building for waterproofing roof coverings of many types, exterior wall coverings, flooring tile, and the like.

Asphalt Expansion Joint Material - A composition strip of felt and asphalt material made to specified thickness and used to take up the expansion in concrete floor and sidewalks; in large part has given way to foam plastic material. [also see, Expansion joint material]

Asphalt Roofing - On a flat surface the roofing is composed of alternate layers of roofing felt and hot-applied asphalt (called built-up roof). [Asphalt is the most widely used material for covering roofs because it possesses the characteristics needed for protection against weather and is easily applied, at a relatively inexpensive cost]

Asphalt Shingles - Composition roof shingles made from asphalt impregnated felt covered with mineral granules, reinforced with strands of fiberglass; available in several weights.

Assemblies - Portions of a building in combination; for example, a roof/ceiling assembly, or a ceiling/floor assembly, where different materials are combined, installed, and interfaced to form protectives, and other aspects of construction for an entire building.

ASTM - Abbreviation for the organization, ASTM, International [formerly the American Society for Testing and Materials], an organization dedicated to developing and establishing the testing and standardization of building materials.

Astragal - A molding, attached to one of a pair of swinging doors, against which the other door strikes. French doors use this as the stop; trim piece that covers a joint between doors.

Attic - The accessible space located between the top of the ceiling and the underside of the sloped roof; usually accessed through a ceiling opening in the hallway or garage of a home.

Attic Ventilators - Fans or turbines in the roof or in gables for the purpose of moving air to circulate it through the attic; in houses, screened opening) provided to ventilate an attic space. They are located in the soffit area as inlet ventilators and in the gable end or along the ridge as outlet ventilators. They can also consist of power-driven fans used as an exhaust system. (See also Louver.)

Auger - In carpentry, a wood-boring tool used by a carpenter to bore holes; also large diameter screw-type tool to bore holes in earth for caissons

Awning - Shading device mounted above a window; usually canvas or metal, with some plastic

Awning window - A window unit that is hinged near the top so the bottom opens outward; can be single or multiple sections.

B

Back Nailing - The practice of nailing roofing felts to the deck under the overlap, in addition to hot mopping, to prevent slippage of felts.

Backer Rod - A flexible, compressible polyethylene or polyurethane foam rope or strip of plastic foam or similar material tightly wedged into a joint to limit the depth to which sealant can be applied; in glazing, a material installed under compression and used to control sealant joint depth, provide a surface for sealant tooling, serve as a bond breaker to prevent three-sided adhesion, and provide an hour-glass contour of the finished bead.

Backfill - Coarse earth or granular material used to fill in and build up the ground level around the foundation wall to provide a slope for drainage away from the foundation wall; (1) filling in any previously excavated area, i.e., The replacement of excavated earth into a trench around and against a basement foundation...

Backing - Added framing installed to allow secure installation of surface applied items, such as handrail brackets, towel bars, cabinets, countertops, shelving, lavatories, etc.

Backsplash - The raised or vertical lip/trim piece along the back and side edges of a countertop to close the joint at the wall; at a vanity, to prevent water from running down the backs of the cabinets.

Backup - A material, usually not in view, which acts as a support, filler, or rigidity reinforcement for another material (example- concrete masonry units act as "backup" to face brick).

Baffle - 1] Acoustical pads or panel to absorb sound, hung or attached to walls; 2] vanes in air ducts to divert flow of air; 3] any other device/material to preclude transfer of heat, sound, etc.

Balcony - A deck projecting from the wall of a building above ground or at floor level.

Ballast - 1] A heavy material (usually gravel or stone) installed over a roof membrane to prevent wind uplift and to shield the membrane from sunlight, and aids water evaporation. 2] Also, an electrical component in some fixtures to limit flow of electricity.

Balloon Framing - In carpentry, the lightest and most economical form of wood frame construction; system of light-wood or house framing characterized by the studding extending in continuous lengths from the foundation sill to the roof plate; not widely used because it requires applied fire blocking and a let-in ribbon for the second floor framing; utilizes long pieces of lumber, not readily available; also called Eastern Framing.

Balusters - Usually small vertical posts/members supporting a handrail in a railing used between a top rail and the stair treads or a bottom rail; more commonly known as banister spindles

Balustrade - A series of small vertical members [balusters], used between a top rail, and sometimes bottom rail, used on the edge of stair treads, balconies, and porches.

Bar - Small rolled or drawn steel shape, round, square or rectangular in cross section; a deformed steel shape used for reinforcing concrete.

Bar Joists - Structural steel framing units made from bar- and rod-shaped steel and other light weight members, for supporting moderate roof and floor loads; also known as "open-web steel joists", or "steel lumber".

Barge Board - A decorative board covering the projecting rafter (fly rafter) of the gable end. At the cornice, this member is a facie board.

Barrel Vault [Roof] - A roof design, which in cross section is an arched segment of a cylinder, lying horizontally, and that spans like an arch.

Barrier-Free Design - Providing layout and design that provides accessible route for all persons to all functions within a building, as noted; meet requirements of the Americans with Disabilities Act [ADA] regulations and local codes. etc.

Base - 1] The bottom part of any unit on which the entire thing rests; 2] can be a separate concrete pad under equipment; 3] A board placed against the wall around a room next to the floor to finish properly between floor and wall; 4] slang for "baseboard".

Baseboard - Interior wall trim at the floor line to cover the joint between wall and floor materials; strip of wood placed along the base of a wall or column to protect the finish from damage by shoe.

Base Cabinet(s) - The lower, floor mounted cabinets that support the work- or countertop, in offices, laboratories, kitchens or other work areas.

Base Flashing - The upturned edge of the watertight membrane formed at a roof termination point by the extension of the felts vertically over the cant strip and up the wall for a varying distance where they are secured with mechanical fasteners.

Base Molding - Molding used to trim the upper edge of interior baseboard.

Base Plate - A steel plate forming the bottom or base of a steel column; usually larger than the column to disperse the imposed load, to allow proper anchorage to the bearing surface.

Base Ply - An asphalt-saturated and/or coated felt installed as the first ply with 4 inch laps in a built-up roof system under the following felts which can be installed in a shingle-like fashion.

Base Shoe - Molding used next to the floor on interior base board. Sometimes called a carpet strip.

Bat - A half-brick [see Cull]

Batt - Strip of faced, or unfaced fiberglass insulation sized to fit snugly between framing members.

Batten - Narrow strips of wood or other material used to cover joints in sheets of wall materials or as decorative vertical members over plywood or wide boards.

Batten Plate - A formed piece of metal designed to cover the joint between two lengths of metal edge.

Batter Board - A pair of horizontal boards, set at 90 degrees to each other, nailed to posts set outside the corners of a building excavation, used to indicate the desired level, and serve as a fastening place for stretched cords used to mark building corners, and foundation lines during construction; to show the outlines of other building features and walls. Also, can indicate the proper level or grade elevation.

Batt Insulation - Strips of flexible blanket-like, or roll of insulating material (usually faced or unfaced fiberglass) used for thermal or sound insulation by being installed between framing members in walls, floors and/or ceilings.

Bay Window - Any fixed window space projecting outward from the walls of a building, either square or polygonal in plan.

Bead - In glazing, an applied sealant in a joint irrespective of the method of application, such as caulking bead, glazing bead, etc. Also a molding or stop used to hold glass or panels in position.

Beam - Structural support member (steel, concrete, lumber) transversely supporting a load that transfers weight from one location to another-- A structural member that is normally subject to bending loads, and is usually a horizontal member carrying vertical loads (an exception to this is a purlin); three types are-

1. Continuous beam- has more than two points of support.
2. Cantilevered beam- supported at only one end, and restrained against rotation and deflection by design and connection.
3. Simple beam- freely supported at both ends.

Beam pocket - A slot or recess left in a wall in which the end of a beam or joist is placed for bearing [support].

Bearing Partition - A partition that supports any vertical load in addition to its own weight.

Bearing Plate - Steel plate set on grout bed (non-shrinking) under the end of a beam or other structural member; distributes the load carried on the member over a greater area of the wall; may also be a "pad" made of a block of plastic or synthetic rubber which cushions point at which members meet.

Bearing Wall - A wall that supports any vertical load in addition to its own weight; wall or partition that supports all or part of the floors, roofs, or ceilings, in a building; partition that carries the floor joists and other partitions above it.

Bed joint - A horizontal mortar joint in brick or other masonry walls.

Bed Molding - A molding in an angle, as between the over hanging cornice, or eaves, of a building and

Bed or Bedding - In glazing, the bead compound or sealant applied between a light of glass or panel and the stationary stop or sight bar of the sash or frame. It is usually the first bead of compound or sealant to be applied when setting glass or panels.

Bed Rock - Unweathered [never exposed to air and light], and undisturbed solid stratum of rock; excellent bearing surface for foundation systems.

Below Grade - Element of item that occurs beneath the top of the earth [grade]; may be a portion of a building that is below ground level.

Bench Mark (B.M.) - A fixed point used as the basis for computing elevation grades; identified by marks or symbols on stone, metal or other durable surveying items/matter, permanently affixed in the ground and from which differences of elevation are measured; also referred to as a "datum", or "datum point".

Bent Glass - Flat glass that has been shaped while hot into curved shapes.

Berm [earth] - A low, artificially made mound of earth which adds height and depth to a flat landscape; often used in rock gardens, landscaped with rocks and plants. Also used against buildings to help insulate the walls [usually installed up to sill of windows].

Bevel [cut] - The angle of the front edge of a door usually from 1/8" to 2".

Bevel Siding (or Lap Siding) - A type of finish siding used on the exterior of a house. It is usually manufactured by re-sawing a dry, squared, surfaced board, diagonally, to produce two wedge-shaped pieces; used as horizontal siding in a lapped pattern. This siding varies in butt thickness from 1/2 to 3/4 inch and in widths up to 12 inches. Normally used over some type of sheathing.

Bi-fold doors - Doors panel hinged in the middle and fixed at the jamb; panels fold and slide to the jamb; ideal for achieving maximum opening.

Bi-pass doors - Track-mounted doors which slide by each other.

Bitumen - Any of various mixtures of hydrocarbons occurring naturally or obtained through the distillation of coal or petroleum. (See Coat Tar Pitch and Asphalt)

Bituminous Concrete - An asphaltic compound with small aggregate mixed in thick liquid asphalt, which hardens into a paving surface after being heated, spread and rolled; also, called "blacktop".

Blanket - Term referring to long rolls of fiberglass insulation, which are subsequent cut into batts.

Bleaching - A method of lightening the color of wood by applying chemicals.

Bleeding - A migration of a liquid to the surface of a component or into/onto an adjacent material; seeping of a stain or lower coat through the top coat, spoiling the appearance of the top coat.

Blend - Mixture of two or more elements to produce a different product: as of two pigments, to obtain a desired color in paint.

Blind Nailing - Nailing driven in such a way that the nail heads are not visible on the face of the work—usually at the tongue of matched boards for flooring, so the groove of the adjoining board conceals the nail head.

Blind Stop - A rectangular molding, usually 3/4 by 1-3/8 inches or more in width, used in the assembly of a window frame. Serves as a stop for storm and screen or combination windows and to resist air infiltration.

Blister - An enclosed raised spot evident on the surface of a building; Cloudy or milky-looking raised spots on finished surfaces. They are mainly caused by the expansion of trapped air, water vapor, moisture or other gases.

Blocking - Various wood members sized and cut to shape and used as fillers, backing, or nailing strips; Also, method of bonding two adjoining or intersecting walls not built at the same time.

Board Foot [Measure] - In carpentry, a system for specifying a quantity of lumber; one unit is one board foot, the equivalent of a board 12" x 12" and 1 inch thick.

Boards - Yard lumber less than 2 inches thick and 2 or more inches wide.

Bollard - Short stanchion used to inhibit vehicle access, to direct pedestrian traffic, and/or as decorative [and illuminated] markers [not part of a sign system]; also used as bumpers to protect building, fire hydrants, and similar features; also called "pipe guards".

Bolster - A short horizontal timber or steel beam on top of a column to support and decrease the span of beams or girders.

Bond - 1] The fusing together of materials through chemical action.

Bond Beam - Continuous, reinforced concrete block course in or around the top of masonry walls used to stabilize the walls.

Bond Breaker - A chemical coating, tape, or inert sheet divider to prevent adhesion of one material to another; primarily used in sealant joints to prevent sealant from adhering to backer rod.

Bond Plaster - In addition to gypsum, bond plaster contains 2-5% lime by weight and chemical additives which improve the bond with dense non-porous surfaces such as concrete. It is used as a base coat.

Bottom chord - The lowest or bottom horizontal or angled member in a truss.

Bottom or sole plate - Bottom framing member of a wall, usually either 2x4 or 2x6; plate is nailed to the bottom of the studs and to the floor joist or sheathing below it.

Bow - Distortion [curve, bend, warping] or other deviation from flatness in glass or wood so it is no longer flat.

Box sill - Wood frame sill construction where a header joist is nailed, vertically, across the ends of floor joists closing off the voids between joists; ensures proper joist spacing and stability; vertical board also called a "band board".

Brace - An inclined piece of framing lumber applied to wall or floor to stiffen the structure. Often used on walls as temporary bracing until framing has been completed.

Braced Framing - Supported framework of a house, especially at the corners; diagonal or let-in braces (wood or metal) form a triangular shape to make the frame rigid and solid; plywood sheets at corners provide the same function.

Bracing - Auxiliary members in framing that are used to make the major structural members more rigid; ties and rods used for supporting and strengthening various parts of a building used for lateral stability for columns and beams.

Bracket - A brace extending from a wall to support a weight, such as a shelf.

Brad - A small, fine finishing nail with a small head.

Brick - Masonry unit(s) composed of clay or shale with added ingredients and shaped into various size units; formed into a rectangular prism while soft, then burned or fired in a kiln; can have voids or recessed panel to reduce weight and increase bond to mortar; many types of brick, face brick being most familiar [can be exposed; many colors, textures and sizes]; also backup material; also a fire brick used for fire boxes in fireplaces; many colors available and a range of size for differing visual effects. Available in several grades, as follows:

Grade MW - Moderate Weather grade of brick for moderate resistance to freezing used, for example, in planters.

Grade NW - No Weather brick intended for use as a back-up or interior masonry.

Grade SW - Severe Weather grade of brick intended for use where high resistance to freezing is desired—Commonly called "Face Brick".

Brick ledge - Foundation feature, usually a continuous notch in the top outer corner, where the brick wythe is set, so the brick runs passed the face of the foundation wall.

Brick Mold - Standard wood molding used as outside casing around doors and windows; covers joint between window unit and adjacent wall.

Brick [wall] tie - Corrugated metal strip [approx. 1" w x 6-8" long] nailed to wall framing, bent and inserted into the mortar joints of brick veneer.

Brick Veneer - Single wythe (thickness) of brick facing applied over wood frame construction, or masonry other than brick; this facing is non-structural, and must be fastened to the framing or structural backup material for stability.

Bridging - 1) Method of bracing floor joists to distribute the weight over more than one joist; joins joists to act as a diaphragm unit and not individually; prevent displacement and wracking; usually two wood (1" thick) or light metal pieces crisscrossed between joists are inserted in a diagonal position between the floor joists at midspan to act both as tension and compression members for the purpose of bracing the joists a spreading the action of loads.; also can be wood stock same size as joists and is called "solid bridging"; must be installed continuously from end wall to end wall.

Broom finish - A slightly roughened, slip-resistant texture created by running a stiff broom across fresh concrete; commonly used on sidewalks.

Browncoat - The coat of plaster directly beneath the finish coat. In three-coat work, the brown is the second coat.

BTU - British Thermal Unit - The amount of heat energy required to raise the temperature of one pound of water through a change of one degree Fahrenheit [F].

Buck - Often used in reference to the assembly of rough frame opening members. Door bucks used in reference to metal door frame.

Buildability - Extent to which a design facilitates the construction of a building in accord with overall requirements for the project; collection of techniques and methods to ease construction.

Builder-grade - A trade term meaning a product of average quality normally found in production-built housing.

Building - (1) To form by combining materials or parts (2) A structure enclosed within a roof and within exterior walls housing, shelter, enclosure, business, and support of individuals, animals, their activities, or real property of any kind.

Building Brick - Brick for building purposes not especially treated for texture or color, formerly called "common brick." It is stronger than face brick.

Building Codes - Laws, ordinance, regulations and other legal requirements adopted by local governing jurisdictions to establish minimum acceptable safety standards for all types of construction; set safe building practices and procedures. The codes generally encompass structural, electrical, plumbing, and mechanical remodeling and new construction. Usually a building permit is required prior to the start of construction, and inspections are required during construction, to confirm compliance with the local codes.

Building Code Official - Department Head or chief of building regulations department; often a registered design Professional, and also certified as code official by state or code organizations. [see Building Inspector]

Building Envelope - (1) The waterproof elements of a building which enclose conditioned spaces through which thermal energy may be transferred to or from the exterior. (2) The outer structure of the building. (sometimes referred to as "Building Shell")

Building Inspector - A qualified government representative authorized to inspect construction in progress for compliance with applicable building codes, regulations and ordinances; works for the Building Code Official [see]; often certified by state or code organizations.

Building Line - Lines established and marked off by a surveyor which denote the exterior faces of a proposed building; used by trades-persons as guidelines; surveyors get their information from the plans, specifications and official records; building line is generally extended and marked on batter boards placed about 6 feet outside the corners/lines of the building excavation.

Building Paper - Heavy sheet material [e.g., papers, felts, etc.] used between sheathing and siding/facing for insulation and wind-breaking purposes; four types- 1) red rosin paper; 2) sisal paper; 3) plain asphalt felt paper (tar paper), and 4) plastic sheeting.

Building Permit - A written document issued by the appropriate governmental agency, to owner or contractor, prior to the start of construction on a specific project in accordance with drawings and specifications approved by the governmental authority; indicates proper review for compliance with various regulations; must be kept posted in a conspicuous place on the site until the job is completed and passed by the building inspector.

Built-Up Roof - A roof covering composed of 3 to 5 alternate layers [plies] of building (roofing) felt and laminated with hot liquid asphalt, coal tar or pitch, with a final surfacing of gravel or crushed slag; generally laid on a low slope or comparatively level roof.

Bull float - A large, rectangular, long handled float used for smoothing a large slab of concrete; can reach across or into the center of the slab. A tool used to finish and flatten a slab. After screeding, the first stage in the final finish of concrete, smooths and levels hills and voids left after screeding. Sometimes substituted for darbying. A large flat or tool usually of wood, aluminum or magnesium with a handle.

Bullnose - A radius or rounded corner on ceramic tile, CMUs, and drywall [using a metal trim piece]

Butt - Common type of door hinge that allows the edge of a door to butt into the jamb of the frame.

Butt Glazing - The installation of glass products where the vertical glass edges have butted vertical joints and no mullions or structural supporting mullions; joints are sealed with silicone sealant; used on interior or exterior for clean, sleek range of glass without struts.

Butt Joint - Joint The junction of two members in a square-cut joint, end-to-end, or side-to-side (edge-to-edge).

Butterfly Roof - A roof assembly, which pitches sharply from either side toward the center.

Buttering - In glazing, application of sealant or compound to the flat surface of some member before placing the member in position, such as the buttering of a removable stop before fastening the stop in place.

Butyl - Type of non-curing and non-skinning sealant made from butylene. Usually used for internal applications.

C

Cabinet - Shop or job-built unit for kitchens or office uses; often combination of drawers and shelves; can be wall-hung, or floor mounted.

Caisson - A deep shaft drilled into ground down to adequate bearing soil, then filled with concrete; used to support a column or to provide other structural foundation.

Callout - A note on a drawing with a leader line to the feature, location, material or work item involved.

Camber - A slight upward arch placed in a beam or girder to counteract deflection caused by loading.

Canopy - An overhanging roof.

Cant Strip - A board or strip installed on an angle at the intersection of the roof deck and a wall, curb, or other penetrating item to prevent bends and/or cracking of the roofing membrane at the intersection of the roof deck and wall used to avoid sharp right angles when the roof covering is installed; used with a base flashing to minimize breaking of the roofing felts.

Cantilever - A projecting beam or other structure supported at one end, only.

Cap - Upper/top trim or closure member of a column, pilaster, door cornice, molding or the like. The upper member of a column, pilaster, door cornice, molding, and the like.

Cap flashing - Portion of flashing attached to vertical surface to forestall water from migrating behind the base flashing.

Cap Sheets - In roofing, one to four plies of felt bonded and top coated with bitumen that is laid over an existing roof as a treatment for defective roofs.

Carriage - Center diagonal supporting member under and for stair treads; usually a 2" plank or steel member[s]; formed or notched to receive treads and risers; runs parallel to the stringers

Casement Window - A side-hinged window that opens outward by a crank device or push-bar; units of wood or metal sash, which may be opened by means of hinges affixed to the vertical edges.

Casework - Manufactured, or custom-built cabinetry, including shelves, cabinets (base and/or wall), countertops, and ancillary equipment; can be metal, wood, laminate covered, etc.

Casing - Trim/molding of various widths and thicknesses used to trim door and window openings at the jambs; also trim to finish a wall opening.

Cast-In-Place (Concrete) - Current and proper term for the placing of concrete into

its forms on the job site; also called "site-cast"; replaces the word "pour" which has negative connotations relating to a watery mix inappropriate for construction use.

Catch basin - Commonly, the drain in the curb or gutter of a street; in a stream or watercourse, a depression designed to hold water

Caulk - (v) The application of sealant to a joint, crack or crevice. (n) A compound used for sealing that has minimum joint movement capability; sometimes called low performance sealant.

Caulking - A waterproof adhesive filler material used to seal seams, cracks, and various types of joints between materials, or building parts; must remain flexible, non-drying and non-sagging; also see Sealants.

Cavity Wall - A masonry wall made of two or more wythes of masonry units joined with ties, but having an air space between them

Cellulose Insulation - Ground up newspaper that is treated with a fire retardant.

Cement, Portland [Types] - Portland cement is a finely ground, gray, powdery material which when mixed with water will harden; used with aggregate of various sizes in concrete and mortar; formed by crushing burned limestone clinkers [unburned material]; is available in a variety of types;

Type I Normal - is a general purpose cement suitable for practically all uses.

Type II Moderate - is used where precaution against moderate sulfate attack is important.

Type III High Early Strength - is used when high strengths are desired at very early periods

Type IV Low Heat - is a special cement for use where the amount and rate of heat generated during curing must be kept to a minimum; is intended in large masses of concrete such as dams.

Type V Sulfate Resisting - is a special cement intended for use only in construction exposed to severe sulfate action, such as western states having soils of high alkali content.

Cementitious - Attribute of inorganic substances that have cementing properties.

Centerline - Actual or imaginary line through the exact center of an object.

Center-to-Center - Measuring distance from centerline to centerline of similar, adjacent units; term meaning "on center", as in the spacing of joists, studding, or other structural parts.

Ceramic tile - Thin hand- or machine-made clay tile to act as facing or flooring where water or spillage is a problem; bathrooms, shower rooms, entries

Chain - Metal tape used by surveyors for measuring; unit of measure equal to 66 feet.

Chair Rail - Horizontal strip of wall molding installed at proper height and protruding enough to prevent top of chair backs from touching, scraping or marring the wall [see wainscoting]; In storefront, window wall, or curtain wall systems, a chair rail is an aluminum extrusion applied horizontally to the inside of the system 3 feet from the floor to create a barrier in floor-to-ceiling glazing applications.

Chairs - Metal, heavy wire, or plastic supports to hold reinforcing steel in place during placing of concrete in forms; allows concrete to surround bars, and provide proper [required] clear cover of concrete between bars and face of concrete member; available in single or multiple bar sizes, and in varying heights.

Chamfer - A beveled surface cut on the corner of a material; prevent chipped corners.

Channel Glazing - The installation of glass products into U-shaped glazing channels. The channels may have fixed stops; however, at least one glazing stop on one edge must be removable.

Channel - Structural section, steel or aluminum, shaped like a rectangle, but with one long side missing; "C"-shaped.

Chase - In masonry a recess or channel cut or built in the face of a wall to allow space for receiving pipes, conduits, etc.; also a recess in any wall to provide space for pipes and ducts, etc.

Checking - Fissures that appear with age in many exterior paint coatings, at first superficial, but which in time may penetrate entirely through the coating. It produces a pattern of surface cracks running in irregular lines. When found in the top pour of an asphalt built-up roof, checking is the preliminary stage of alligatoring.

Checkrails - Meeting rails sufficiently thicker than a window to fill the opening between the top and bottom sash made by the parting stop in the frame of double-hung windows. They are usually beveled.

Chimney - A vertical shaft for drawing smoke from a heating unit, fireplace, or incinerator, and venting it to the outside.

Chip board - Wood panels manufactured with small wood chips and glue; also called, Oriented Strand Board [OSB] and wafer board

Chord - Usually refers to uppermost [top chord] or lowermost [bottom chord] in a truss; also, a line drawn through a circle other than a diameter or radius.

Circuit Breaker - Simple switch-like device which automatically opens a circuit when the rated current is exceeded as in the case of a short circuit.

Cladding - Any of several materials or systems used as exterior wall enclosures for buildings; siding, metal

Claim - A formal notice sent by a contractor to an owner asserting the fact that the terms of the contract have been breached and compensation is being sought by the

contractor from the owner.

Clapboard - Type of siding which consists of narrow boards, usually thicker at one edge than the other.

Clear Dimension/Opening - Designation used to indicate the direct, unobstructed distance between opposing inside faces of an opening, frame, room, columns, etc.

Cleat - A wedge-shaped piece (usually of metal) which serves as a support or check. A strip fastened across something to give strength or hold something in position.

Clerestory - Portion of a building or room that extends above the adjoining roof, usually with glazing for light and ventilation.

Close-grained wood - Woods with narrow, inconspicuous annual rings; term sometimes used for wood having small, closely spaced pores.

Closer - Finish door hardware device which automatically pushes the door closed.

CMU - Abbreviation for concrete masonry unit [see]

Coal Tar Pitch - A bituminous material, which is a by-product from the coking of coal. It is used as the waterproofing material for tar and gravel built-up roofing.

Coarse-grained wood - Wood with wide, conspicuous annual rings indicating considerable difference between springwood and summerwood growth; term used for woods with large pores such as oak, ash, chestnut, and walnut.

Coating - A layer of any liquid product, of various compositions, spread over a surface for protection.

Coating/topping - Relatively thin material, such as paint, epoxy, etc. applied to surfaces for protection and/or decoration; topping is usually applied to floors to smooth irregularities, or to provide better wearing surface.

Codes - Variety of prevailing regulations, ordinances or statutory requirements set forth by governmental agencies associated with building construction practices and owner occupancy, adopted and administered for the protection of various aspects of public health, life safety and welfare.

Cold Applied - Products that can be applied without heating. These are in contrast to products which need to be heated to be applied.

Cold Patch - In roofing, a roof repair done with cold-applied material.

Collar - In roofing, a conical metal cap flashing used in conjunction with vent pipes or stacks usually located several inches above the plane of the roof, for the purpose of shedding water away from the base of the vent.

Collar beam - Horizontal member installed between opposing roof rafters about 1/3 of the way down from the ridge; to stiffen roof framing and prevent spreading of rafters when loaded.

Column - In architecture: A perpendicular supporting member, circular or rectangular in section, usually consisting of a base, shaft, and capital. In engineering: A vertical structural compression member which supports loads acting in the direction of its longitudinal axis; can also be purely decorative.

Combination Doors or Windows - Combination doors or windows used over regular openings. They provide winter insulation and summer protection and often have self storing or removable glass and screen inserts. This eliminates the need for handling a different unit each season.

Commissioning - The process at or near construction completion when a facility is put into use to see if it functions as designed. Usually applied to manufacturing type projects, and similar to Beneficial Occupancy in the commercial sector.

Common Bond - Brick laid in a pattern consisting of five (5) courses of stretchers, followed by one (1) "bonding" course of headers [tied to the backup wythe].

Common nail - Large diameter nail, with head, for rough framing; size indicated by "d", or penny designation [for example, 16-penny nail]

Common Rafter - Rafter extending from the top of the wall to the roof ridge.

Compatible - Two or more substances, which can be mixed or blended without separating, reacting, or affecting either material adversely.

Component - A part, member, unit or module of an assembly or building which is built or manufactured before being delivered to the project site for installation.

Composite Board - An insulation board, which has two different insulation types laminated together in 2 or 3 layers.

Composite Wall - A masonry wall that incorporates two or more different types of masonry units, such as clay brick, and concrete masonry units (CMUs).

Compound - A chemical formulation of ingredients used to produce a caulking, elastomeric joint sealant, etc.

Concave Joint - A mortar joint tooled and compacted into a curved, indented profile which sheds water.

Ce concealed Installations - Materials or equipment installed and subsequently covered by ceiling, wall or floor surfaces, or other enclosure to render it "out of view" and not readily visible.

Concrete - A thick, pasty (but "plastic/formable") mixture of Portland cement, sand, gravel, and water; can be formed into any shape which it retains when hardened and cured; mixes may be varied in proportioning, for strength, and other attributes or features.. e.g., 1 part cement, 2 1/2 parts sand, 5 parts coarse aggregate; an appropriate ratio of water produces a mix used for foundations, walls, abutments, piers, etc.

Concrete Block - Common term for masonry units of varying shapes and sizes, produced with concrete [see Concrete Masonry Units].

Concrete Brick - A solid concrete masonry unit the same size and proportions as a modular clay brick.

Concrete Cylinder Test - A compression test where wet [fresh from the delivery truck] samples of concrete are carefully placed in special cylinders, 6 inches in diameter and 12 inches high; cylinder is filled 1/3 full and concrete is then compacted by rodding, 25 strokes, with a bar; this is repeated at 2/3 full, and full. Two, or more such cylinders are prepared, some to be tested at 7 days and the remainder at 28 days after preparation; shells are stripped off and the concrete cylinders are lab-tested, in a hydraulic press that measures the pressure required to crush the cylinders to breakage; this determines the compressive strength of concrete, most commonly specified as 3,000 psi at 28 days.

Concrete Masonry Unit (CMU) - Units of hardened concrete formed to varying profiles, sizes, and strengths, some solid, others with hollow cores (voids); designed to be laid in same manner as brick or stone to form walls, partitions, etc. [commonly called "concrete block"]

Concrete, Plain - Concrete either without reinforcement, or reinforced only for shrinkage or temperature changes.

Concrete Slump Test - A test run on the job site to determine the plasticity of concrete. A sample of fresh concrete is placed in a cone-shaped container, 12" high. Concrete is compacted with 25 rod strokes at 1/3, 2/3, and completely full. The container is then slowly lifted; the concrete will "slump" as the form is removed. The flattened concrete is then measured to ascertain how much lower than the 12" original height remains, i.e., how much the concrete has "slumped" down from the 12" cylinder height. This "slump" will be specified and the actual test results note the acceptability of the concrete (for use in the project). This test is completely site-accomplished. Usually a slump of 3-5 inches is required or acceptable; it varies as required to meet the various job conditions.

Conduit - General term for an feature that carries or conveys some other substance.

Conduit, Electrical - Pipe-like tubing, usually metal or plastic, in which wire is installed for electrical service.

Conifer [coniferous] - A tree with needles in lieu of leaves that bears cones [pine for example]; also called "evergreen"]

Construct - To assemble and combine construction materials and methods to make a structure.

Construction Documents - Complete array of all drawings, specifications, addenda, change order, field instructions, bulletins, directives associated with a specific construction project. These documents delineate and graphically represent the physical construction requirements established by the A/E. [also, see Contract Documents]

Construction Phase - The fifth and final phase of the architect's basic services, which includes the architect's general administration (G&A) of the construction contract.

Construction Schedule - A graphic, tabular or narrative representation or depiction of the construction portion of the project-delivery process, showing activities and duration in sequential order.

Construction Specifications Institute [CSI] - Professional organization active in overall specification development, writing, production, and ancillary activities; established the original uniform 16-Division format which is standard and widely used today as the uniform basis for specifications and Project Manuals; provides information for upgrading of specifications content and production; adjusting to 50-Division format [2004] to meet need for more space specific to trades and professions, to clarify requirements, and provide for future additions

Contour Line(s) - Lines on a survey plat, site plan, or topographic map which connect points of like (same) grade elevation, referenced to above/below sea level or other appropriate datum point(s).

Contract - (1) An agreement for goods and/or services between two or more parties, especially one that is written and enforceable by law (2) The writing or document containing such an agreement.

Contract Administration - The contractual duties and responsibilities of the A/E, contractor or CM during the construction phase of a specific project for generally overseeing the actual construction and servicing the interactive provisions in the contract for construction.

Contract Bond - A written form of security from a surety company, on behalf of an acceptable prime or main contractor or subcontractor, guaranteeing complete execution of the contract and all supplemental agreements pertaining thereto and for the payment of all legal debts pertaining to the construction of the project.

Contract Documents - A term used to represent all executed agreements between the owner and contractor, any general, supplementary or other contract conditions, the drawings and specifications, all bidding documents less bidding information plus pre-award addenda issued prior to execution of the contract and post-award Change Orders, and any other items specifically stipulated as being included in the contract documents, which collectively form the contract between the contractor and the owner.

Contract Document Phase - The third phase of the architect's basic services wherein

the architect prepares working drawings, specifications and bidding information. Depending on the architect's scope of services the architect may also assist the owner in the preparation of bidding forms, the conditions of the contract and the form of agreement between the owner and contractor: phase of design for an architectural project when documents for construction are completed and bidding documents formulated.

Contract Document Review - A review of Bid and/or Contract Documents on a continuing basis, or at short intervals during the pre-construction phase, to preclude errors, ambiguities, and omissions.

Contractor - A properly licensed individual or company that contracts to perform a defined scope of work on a construction project and agrees to furnish labor, materials, equipment and associated services to perform the work as specified for a specified price; there are various types of contractors:

- *General*: responsible for execution, supervision and overall coordination of a project, and may also perform some of the individual construction tasks; not licensed to perform specialty trade work and hires special contractors for such tasks as plumbing, HVAC, electrical, etc.

- *Remodeling*: general who confines work projects to remodeling or renovation work exclusively

- *Sub contractor/Specialty contractor* is one who performs a limited amount of project work, usually in a special material or system.

Contractor's Option - A written provision in the contract documents giving the contractor the option of selecting certain specified materials, methods or systems without changing in the

Control Joint - An intentional, linear discontinuity which accommodates movement in a structure or component, designed to form a plane of weakness where cracking can occur in response to various forces so as to minimize or eliminate cracking elsewhere in the structure.

Coordinator - A person designated to assist a Control CM, Project Manager, or Level 2 Manager in executing the CM format.

Cope - Cutting one piece of material to allow connection to another, with a tight fit, such as removing the top and bottom flange of the end(s) of a metal I-beam, to fit within, and bolted to, the web of another I-beam in a "T" arrangement

Coped joint - Cutting and fitting woodwork to an irregular profile/surface [see scribing].

Coping - Cap or top covering of a masonry or other wall to close off the wall from moisture, etc. can be cut stone, formed metal, brick, or pre-cast concrete

Corbel - To build one or more courses of brick or stone, which extend beyond the face of the unit below or the wall in order to form a support for timber, or other member.

Core - A small section cut from any material to show internal composition.

Corner bead - A section of lightweight sheet metal angle used to shape and reinforce outside corners in drywall placed on outside corners of drywall before applying drywall 'mud'.

Corner Boards - Used as trim for the external corners of a house or other frame structure against which the ends of the siding are finished.

Corner Braces - Diagonal braces at the corners of frame structure designed to stiffen and strengthen the wall.

Cornerite - Product name for metal-mesh lath cut into strips and bent to a right angle. Used in interior corners of walls and ceilings on lath to prevent cracks in plastering.

Cornice - A horizontal projecting [overhanging] course on the exterior of a building, usually at the base of the parapet. In residential construction, the overhang of a pitched roof at the eave line, usually consisting of a fascia board, a soffit for a closed cornice, and appropriate moldings.

Cornice Return - That portion of the cornice that returns on the gable end of a house.

Corrosion - The deterioration of metal by chemical or electrochemical reaction resulting from exposure to weathering, moisture, chemicals or other agents or media.

Corrugated - Formed into a fluted, rippled, or ribbed profile; folded or shaped into parallel ridges or furrows so as to form a symmetrically wavy surface.

Counter Flashing - The formed metal secured to a wall, curb, or roof top unit to cover and protect the upper edge of a base flashing and its associated fasteners. Flashing that usually is installed downward over base or other flashing that rises from a surface [roof, etc.] to prevent entry of moisture

Coupling - In plumbing, a short collar with only inside threads at each end, for receiving the ends of two pipes which are to be fitted and joined together. A right/left coupling is one used to join 2 gas pipes in limited space.

Course - A single layer of brick or stone or other building material, or units such as brick, concrete block, shingles,

Cove base - Trim piece applied to walls, and resting on floor; radius bottom allows easier cleaning and more sanitary condition; flexible strip of vinyl, rubber, or plastic
Cove Molding - A molding with a concave face used as trim or to finish interior corners.

Crawl Space - A shallow open area between the floor of a building and the ground, normally enclosed by the foundation wall; space beneath a house or structure that lacks a basement, but which allows access to utilities; may also refer to the space in an attic that is too low to walk in, but high enough to crawl through or store in.

Crazing - A series of hairline cracks in the surface of weathered materials, having a web-like appearance. Also, hairline cracks in pre-finished metals caused by bending or forming. (see brake metal)

Cricket - A small drainage-diverting roof structure of single or double slope placed at the junction of larger surfaces that meet at an angle, such as above a chimney; also called a "saddle".

Cripple - Framing member that is cut off and used at less than full length [stud beneath a window sill, for example]

Cross-Bridging - Diagonal bracing between adjacent floor joists, placed near the center of the joist span to prevent joists from twisting; often lines of diagonal bracing placed in "X" fashion between floor joists.

Cross-Hatching - Indications, on working drawing sections, that indicate materials that have been cut by the cutting plane of the view; material symbols for example, to distinguish one from the adjacent. Can be solid infill on smaller scale or presentation drawings to simply identify the walls.

Crown Molding - A molding used on cornice or wherever an interior angle is to be covered especially at the roof and at wall/ceiling intersections

CSI - Abbreviation for the Construction Specification Institute [see]

Cubic Foot - Measure of volume that has three- 12" dimensions- width, height and depth; contains 1,728 cubic inches (12"x 12"x 12").

Cubic Yard - Measure of volume that is 3 feet on each side- width, depth, and height; contains 27 cubic feet

Cul-de-sac - A street or roadway with no outlet, but provided with a circular turnaround for vehicles.

Cull - Material [especially boards or brick] rejected for use because of marks, imperfections, defects, or of substandard grade; also pieces of brick broken or cut off from full unit, and unusable

Culvert - Round, corrugated drain pipe of various sizes as required, installed in a drainage course [ditch, stream] to allow water flow under an improvement like a road or street; commonly 15" or 18" in diameter installed beneath a driveway, parallel to and near the street.

Cupola - Small, decorative monitor or dome structure built on a roof of a building; often placed over an attached garage, at the peak of a gable roof; may be utilized for outside air intake for ventilation purposes.

Cupping - A type of warping that causes boards to curl up at their edges.

Curb - 1] Linear edging, raised or partially concealed around pave areas, at walks, around other areas; 2] also, a raised box installed around roof openings for passage of equipment, piping, devices, and the watertight mounting of same; 3] short wall or masonry built above the level of the roof that provides a means of flashing the deck equipment.

Curing - The slow chemical process that takes place in concrete after it is placed, in which mortar and concrete harden and as it attains its load-bearing strength over a period of time. The length of time is dependent upon the type of cement, mix proportion, required strength, size and shape of the concrete section, weather and future exposure conditions. The period may be 3 weeks or longer for lean concrete mixtures used in structures such as dams or it may be only a few days for richer mixes. Favorable curing temperatures range from 50 to 70 degrees F. Design strength is achieved in 28 days.

Curtain Wall - A thin, non-load bearing wall, supported by the structural steel or concrete frame of the building independent of the wall below; an exterior "skin"; Also a metal (most often aluminum) framing system on the face of a building containing vision glass panels and spandrel panels made of glass, aluminum, or other material.
Cutback - In roofing, basic asphalt or tar which has been "cut back" with solvents and oils so that the material become fluid.

Cut-in Brace - Nominal 2-inch-thick members, usually 2 by 4's, cut in between each stud diagonally.

Cut Off - A piece of roofing membrane consisting of one or more narrow plies of felt usually mopped in hot to seal the edge of insulation at the end of a day's work.

Cut Stone - Decorative, natural stone of various types, cut to given sizes and shapes (ashlar veneers, sills and copings, for example), but not including thin paving or facing sections.

D

d. - Designation of nail size [See Penny].

Dado - A rectangular groove or cut made across the width of a board, panel or plank intended to receive edge of connecting board or panel. In interior decoration, a special type of wall treatment.

Dampproofing - Layer of impervious material, spread or sprayed on walls usually,

to prevent moisture from passing through concrete, masonry or stone surfaces to repel water, the main purpose of which is to prevent the coated surface from absorbing rain water while still permitting moisture vapor to escape from the structure. (Moisture readily penetrates coatings of this type.) "Dampproofing" generally applies to surfaces exposed to moisture; "waterproofing" generally applies to surfaces exposed to standing water, and water with head pressure.

Datum (point) - An established, known, and fixed reference point from which grade elevations can be measured [See Bench Mark].

Dead Bolt - Finish hardware device for securing exterior doors; sliding square-ended bolt moveable by use of key or thumb-turn

Dead Load - The constant, design-weight/load on a structure imposed its own weight and any permanent fixtures attached above or below; the weight of the materials of which it is built, and other fixed loads.

Decay - Disintegration of wood or other substance through the action of fungi,

Decibel - Unit used to measure the relative intensity or loudness of sound; higher numbers indicate greater sound.

Deciduous - Trees which lose their leaves annually.

Deck - 1] "Deck" is also commonly used to refer to the above-ground floors in multi-level parking garage; 2] An elevated platform or exterior floor, similar to a concrete slab, patio, or porch; usually wood and extends out from building wall; usually slightly elevated above ground surface; also fluted metal sheets used as support for floors and roofs.

Deck Paint - An exterior enamel or stain with a high degree of resistance to mechanical wear, designed for use on such surfaces as porch floors.

Deflect - To bend or deform under weight.

Deflection - Amount of sag at the center of a horizontal structural member (between supports) when subjected to a load; amount of bending movement of any part of a structural member perpendicular to the axis of the member under an applied load.

Delamination - Separation of layers or plies of a built-up unit [e.g., plywood, laminate on underlayment] due to failure of adhesive

Demising Walls - The boundaries that separate your space from your neighbors' and from the public corridor.

Density - The mass of substance in a unit volume. When expressed in the metric system, it is numerically equal to the specific gravity of the same substance.

Dentil - An ornamental trim of repetitive, tooth-like blocks

Design - 1] The overall concept and configuration of a project developed to meet stated needs, desires and goals of the client; drawn showing the plans, elevations, sections, details and other features necessary for the construction of a new structure [as used by architect, the term "plan" denotes a horizontal projection; "elevation" applies to vertical exterior views. 2] A graphical representation consisting of plan views, interior and exterior elevations, sections, and other drawings and details to depict the goal or purpose for a building or other structure.

Design Professional - Term applied to one responsible for creation of a design scheme or concept for a portion of a building project; in particular, a properly registered architect or engineer.

Detail - (1) An individual part or item (2) A graphical scale representation, e.g., a drawing at a larger scale, of construction parts or items showing materials, composition and dimensions in a limited area of the project construction; type of sectional drawing showing special, in-depth information about a particular portion of the construction; usually drawn at larger scale than other views to show all construction required.

Dimension Lumber - Yard or framing lumber that is 2 inches thick [but less than 5"] and from 4 to 12 inches wide; includes joists, rafters, studding, planks, and small timbers.

Direct Nailing - To nail perpendicular to the initial surface or to the junction of the pieces joined. Also termed face nailing.

Directed - Term which reflects action[s] of design professional or other authorized party; used in same manner as "requested", "authorized", "selected", "approved", "required" and "permitted".

Distortion - Alteration of viewed images caused by variations in glass flatness or inhomogeneous portions within the glass. An inherent characteristic of heat-treated glass.

Door operator - Commonly a garage door opener, but also there are systems for the automatic operation of doors, which necessitate no human physical effort.

Door stop [bumper] - Floor or wall mounted device to prevent further opening of door; also wood strip of form on door frames against which the door closes.

Doorjamb - The vertical sides of the surrounding case into which and out of which a door closes and opens. It consists of two upright pieces, called side jambs, located under and attached to the horizontal head section.

Dormer - A rooftop projection built out from and above a sloping roof to provide greater headroom inside; opening in a sloping roof, the framing of which projects out to form a vertical wall suitable for windows or other openings.

Double Glazing - In general, any use of two lights of glass, separated by an air space, within an opening, to improve insulation against heat transfer and/or sound trans-

mission. In insulating glass units the air between the glass sheets is thoroughly dried and the space is sealed, eliminating possible condensation and providing superior insulating properties; also called "insulating glass".

Double Header - Two or more structural members joined together for added strength; also, the shorter framing, of two members, to create an opening in structural framing.

Double Plate - when two layers of 2 x 4's are placed on top of studs in framing a wall.

Double Strength - In float glass, approximately 1/8" (3 mm.) thick.

Double Tee - Refers usually to a pre-cast roof deck panel poured with two fins in its underside to impart flexural rigidity.

Double-hung Window - A window unit having a top and bottom sash, each capable of moving up and down, independently, bypassing each other.

Dowel - 1] Wood peg, "stick", or pin which fits into holes in abutting pieces to prevent slipping; 2] in concrete a re-bar extending from a member which permits attachment of other reinforcing in adjacent members, yet to be installed.

Downspout - A tube or pipe of plastic or sheet metal, for carrying rainwater from the roof gutter to the ground, or to a sewer connection; also called a "leader", or "conductor".

Drain [Footings] Tile - A perforated, corrugated plastic or clay pipe laid around the bottom of the foundation wall usually aside the footing] and used to drain excess water away from the foundation. It prevents ground water from seeping through the foundation wall. Sometimes called "foundation" or "perimeter" drain.

Drainage - Flow or removal of water.

Drawing - A graphical depiction of work to be performed to construct a project; conveys information as to construction, configuration, etc., with appropriate notations; each drawing addresses specific work, and usually there will be a set of drawings for a project.

Drawing Detail - A drawing done at a large scale, which shows a limited area of work- the fit of a door frame jamb into the adjacent wall, for example. Numerous views which provide increased amounts of information, relationships and construction items which cannot be easily shown on other types of drawings.

Drawings - (1) A term used to represent that portion of the contract documents that graphically illustrates the design, location, geometry and dimensions of the components and elements contained in a specific project in sufficient detail to facilitate construction. (2) A line drawing.

Dressed and Matched (Tongued & Grooved) - Boards or planks machined in such a manner that there is a groove on one edge and a corresponding tongue on the other.

Dressed Size Lumber - Actual size of lumber after shrinking from green dimension, and after machining and surfacing for pattern and construction use.

Drip - (a) A member of a cornice or other horizontal exterior finish course that has a projection beyond the other parts for throwing off water. (b) A groove in the underside of a sill or drip cap to cause water to drop off on the outer edge instead of drawing back and running down the face of the building.

Drip Cap - A molding placed on the exterior top side of a door or window frame to cause water to drip beyond the outside of the frame.

Drip Edge - A device designed to prevent water from running back or under an overhang.

Drop Siding - Usually 3/4 inch thick and 6 and 8 inches wide with tongued-and-grooved or shiplap edges.

Dry Glazing - Also called compression glazing, a term used to describe various means of sealing monolithic and insulating glass in the supporting framing system with synthetic rubber and other elastomeric gasket materials.

Dry Seal - Accomplishment of weather seal between glass and sash by use of strips or gaskets of Neoprene, EPDM, silicone or other flexible material. A dry seal may not be completely watertight.

Dry Sheet - A ply mechanically attached to wood or gypsum decks to prevent asphalt or pitch from penetrating the deck and leaking into the building below.

Dry-In - To make a building waterproof.

Drywall - Construction system that uses gypsum board used to cover the framing with taping, coating, and finishing to make the interior walls and ceilings of a building. Drywall is also used as a verb to refer to installation process. See Gypsum board, Wallboard.

Drywall "mud" - Common term for joint compound; substance used to fill/cover/ hide seams and nail/screw heads in finished gypsum board walls.

Dry-Wall Construction - A type of panelized interior wall construction in which the interior wall finish is applied in a dry condition, generally in the form of sheet materials or wood paneling as contrasted to "wet" plaster; usually referred to as "gypsum board, wall board, or plasterboard"; sheets of material are applied to a stud framework with threaded nails or screws.

Drywall Hammer - A special hammer used for nailing up gypsum board. It is also known as an ax or hatchet. Edges should be smooth and the corners rounded off. The head has a convex round & checkered head.

Drywall Nail - Nails used for hanging regular drywall that is to be taped and fi-

nished later must have adequate holding power and a head design that does not cut the face paper. They must also be of the proper depth to provide exactly 1 inch penetration into the framing member. Nails commonly used are chemically-etched and are designed with a cupped head.

Duct - A round or rectangular "tube" used to move air either from exhaust or intake, and for distributing warm air from the heating plant to rooms, or air from a conditioning device or as cold air returns; usually sheet metal or fiberglass; The installation is referred to as "duct work".

Dumbwaiter - An elevator with a maximum footage of not more than 9 sq. ft. floor area; not more than 4" headroom and a maximum capacity of 500 lbs. used for carrying materials only.

E

Earth-sheltered Building - A structure which is totally or partially underground [commonly, one face or elevation is exposed]; uses soil coverings to reduce heat loss (or gain).

Easement - Designated, and legally documented area of property where right or privilege, granted by the property owner, to another party that entitles the user to a specific, exclusive, but limited use of the property noted [access example; running of a utility line]

Eave - The projecting lower edges of a roof overhanging the side walls of the building, or the lower edge of the part of a roof that overhangs a wall.

Edge Clearance - Nominal spacing between the edge of the glass product and the bottom of the glazing pocket (channel).

Edge Grain (vertical) - Edge-grain lumber has been sawed parallel to the pith of the log and approximately at right angles to the growth rings; i.e., the rings form an angle of 45° or more with the surface of the piece.

Edge Metal - A term relating to brake or extruded metal around the perimeter of a roof.

Efflorescence - Undesirable chalky white stains on masonry walls created by water leaching soluble salts out of concrete or mortar and depositing them on the surface. Also used as the name for these deposits.

EIFS [Exterior Insulating and Finish System] - Exterior wall cladding system consisting primarily of polystyrene foam board with a textured acrylic finish material, usually a polymer, used as an exterior finishing material applied over insulation foam; stucco-like coating in several colors which conforms to any profile cut and constructed in the foam backing; adds thermal performance and decreases air infiltration.

Elastomer - An elastic rubber-like substance, such as natural or synthetic rubber.

Elastomeric - Of or pertaining to any of the numerous flexible membranes that contain rubber or plastic.

Elevation - 1] A side of a building; 2] Building drawing that shows vertical dimensions; 3] also the height of a point in reference to sea level; sometimes called "grade elevation"

Emulsion - In roofing, a coating consisting of asphalt and fillers suspended in water.

Encase - To fully enclose, such a totally covering an underground electrical conduit with concrete- top, bottom and sides.

End Dams - Internal flashing (dam) that prevents water from moving laterally within a curtain wall or window wall system.

End Lap - The amount or location of overlap at the end of a roll of roofing felts in the application.

Engineer (Professional) - Person trained and registered [by the state] to professionally engage in work of one of the areas of the engineering discipline; e.g. civil, structural, electrical, mechanical [HVAC, plumbing]; also referred to as a "design professional"; many types of engineers are not construction related.

Engineered Fill - Earth compacted by machine, in such a way that it has predictable physical properties, based on field and laboratory tests; produced using specified, supervised installation procedures.

English Bond - Pattern in brickwork consisting of alternate courses of headers and stretchers.

Entrance (Assembly) - Complex of construction, usually involving tubular wall framing (see Storefront)

EPDM - Ethylene Propylene Diene Monomer. A single-ply roofing membrane consisting of synthetic rubber; usually 45 or 60 mils. Application can be ballasted, fully adhered or mechanically attached.

Erect - To raise, construct a building frame; generally applied to prefabricated materials, such as structural steel, as they are installed on the job site.

Erector - The subcontractor who raises, connects, and accurately sets (plumb and level) a building frame from fabricated steel or pre-cast concrete members.

Escutcheon - Door hardware trim piece which surrounds and accommodates the knob and keyhole.

Ethics - Principles, rules or standards of performance for professionals set by the

organization or association to which the professional belongs or is associated by the public trust; guidelines for performance of professional services and duties.

Excavate - Dig the basement and or all areas that will need footings/foundations below ground.

Excavation - A cavity, hole or pit in the earth surface produced by digging and removing the earth in preparation for construction.

Exit - Egress facility whereby one may leave or "exit" a building; made up of exit access [corridors, etc. enroute to exit], the exit itself [enclosed fire-rated area], and the exit discharge.

Expanded metal lath - Thin sheet of metal with punched slits and then stretched to transform it into a diamond-shaped grid; used lath for plaster applications.

Expansion Bolt - A combination of a bolt and a sleeve used when an ordinary bolt is unsuitable; sleeve is inserted in pre-drilled hole, bolt is then inserted and turned to expand a "V" shaped piece into the sleeve and forces sleeve to become wider at bottom; tightened until assembly is firmly anchored in material.

Expansion Joint - 1] Joint in walls, floors other materials to permit and take up expansion caused by temperature changes without damage to surrounding surfaces; 2] a bituminous fiber strip used to separate blocks or units of concrete to prevent cracking due to expansion as a result of temperature changes. Also used on concrete slabs.

Expansion shield - Any of several types of inserts into wall materials to receive fasteners, i.e., a screw can be.

Expansive soil - Earth that swells and contracts depending on the amount of water present.

Exposed Aggregate Finish - Concrete surface in which the top of the aggregate (usually "pea gravel") is exposed; can be used in walks, or wall panels.

Exposed Installations - Materials or equipment, which is readily visible, within its location, without the removal or opening of any door, panel, or removal of any other cover or enclosure.

Extended Services - Dissimilar services included in a contract to be performed over and above those that are included as the principal services of the contract; applicable to design professionals, construction managers, etc.

Exterior - Area, space, or portion of project beyond the outer face of the structure or building; "outside"; direct opposite of "interior" [see]

Exterior Glazed - Glazing infills set from the exterior of the building.

Exterior plywood - Plywood with plies bonded together using exterior or waterproof adhesive; renders plywood more dampness resistant.

Exterior Stop - The molding or bead that holds the light or panel in place when it is on the exterior side of the lite or panel.

Exterior Wall - Outer wall of building or structure, which separates open air space from inside of building.

Extras - Common term for additional work requested of a contractor which was not included in the original contract; billed separately; may or may not impact time of completion of project.

Extrusion - An item formed by forcing a base metal (frequently aluminum) or plastic, at a malleable temperature, through a die to achieve a desired shape.

Eyebrow - A flat, normally concrete, projection which protrudes horizontally from a building wall; Eyebrows are generally located above windows.

F

Fabricator - Company that prepares, fashions, adapts standard materials or members (such as structural steel) for erection and installation to specific project conditions by cutting, fitting, punching, coping, and otherwise making ready for specific installations.

Facade - The face or front elevation of a building. Frequently, in architectural terms an artificial or decorative effort.

Face Brick - Brick of higher quality, and made specifically for exposure to weather; usually hard-burned and frostproof; available in large array of colors, textures, sizes, and combinations; brick made especially for exterior use with special consideration of color, texture and size, and used as a facing on a building.

Face Glazing - A system having a triangular bead of compound applied with a putty knife, after bedding, setting, and clipping the glazing infill in place on a rabbeted sash.

Face nailing - To nail perpendicular to the surface, or to the junction of the pieces joined; also termed "direct nailing".

Facing - Any material attached to the outer portion of a wall and used as a finished surface.

Factor of Safety - Ratio of ultimate strength of material to maximum permissible stress in use; unused capacity can be from two to five times or more that required.

Falsework - Temporary work that does not form a part of the final structure; concrete forms and scaffolding for example.

Fascia - The horizontal member on the edge of a roof or overhang; closes off ends

of rafters/trusses and is backing for gutter; flat board, band, or face, used sometimes by itself but usually in combination with moldings, often located at the outer face of the cornice. Any cover board or framed metal assembly at the edge or eaves of a flat, sloping, or overhanging roof, which is placed in a vertical position to protect the edge of the roof assembly.

Fast Track Construction - The process of designing portions of a project while portions already designed are under construction. A method of project management which involves a continuous design-construction Operation, where project work is carried on while drawings are being finished; as drawings are finalized they are incrementally released for construction [construction lags drawing production]; overall program reduces total time for design/construction sequence.

Fasteners - A general term covering a wide variety of metal devices, such as nails, bolts, screws, etc., which may be used for mechanically securing various components of a building.

Felt - A very general term used to describe composition of paper impregnated with asphalt used as underlayment for roof shingles, and in other ways as a building paper, roofing ply sheets; consisting of a mat of organic or inorganic fibers unsaturated, impregnated or coated with asphalt.

Fenestration - Arrangement, pattern and sizing of any glass panels, windows, doors, curtain wall or skylight units in exterior walls of buildings.

Ferrous - Refers to objects made of or partially made of iron, such as ferrous pipe.

Fiberglass - Glass spun into fine threads, and made into batting which is used as an insulation material; can also be pressed into rigid board insulation; and used for forms for, and can be fashioned into intricate shapes.

Field measure - Taking actual dimensions and sizes, during the construction work to ensure

Fill - A build-up land area/formation of new material such as clean sand, gravel, or loose earth used to bring a sub-grade up to desired level around a building, in a trench, etc.; [see Engineered Fill]

Fillet - A narrow concave strip connecting two surfaces that meet at an angle; adds both strength and beauty by avoiding sharp angles.

Fillet Bead - Caulking or sealant placed in such a manner that it forms an angle between the materials being caulked.

Fillet weld - Triangular shaped weld at the inside intersection of two metal surfaces set at right angles.

Finger joint - A series of matched V-grooves, and "teeth" cut in the ends of wood members to interconnect and fit them together to make longer pieces

Finish - 1] In hardware, metal fastenings on cabinets which are usually exposed such as hinges and locks. 2] Final, exposed surface texture of coating on a surface [paint, covering, etc.].

Finish Carpentry - 1] Carpentry work which will be exposed to view in the final project; casing of openings, running trim (base, chair rail, crown molds, etc.) bookshelves, paneling, and so forth. 2]The hanging of all interior doors, installation of door molding, base molding, chair rail, built in shelves, etc. [compare with Rough Carpentry].

Finish Coat - The last coat applied in plastering intended as a base for further decorating or as a final decorative surface. Finish coat usually consists of calcified gypsum, lime and sometimes an aggregate. Some may require the addition of lime or sand on the job. The three basic methods of applying it are (1) trowel (2) flat and (3) spray.

Finish Floor (covering) - The floor material exposed to view as differentiated from the sub-floor, which is the load bearing floor material beneath.

Finished Grade - Final, top level of earth/ground around a building; any surface which has been cut to or built to the elevation indicated for that point. Surface elevation of lawn, driveway or other improved surfaces after completion of grading operations.

Finish Hardware - Devices and features which allow installation and operation of doors; in particular, knobs, rosettes, escutcheons, push/pull plates, closers, hinges, etc., which are exposed and which have decorative finishes; also called "door hardware". (see Rough Hardware for comparison).

Finish Lumber - Good quality lumber used to form surfaces that will be finished (often in natural finish) and exposed to view.

Finish plaster - Final or white coat of plaster

Finished - 1] Completed; all required work is finalized, in-place, with nothing else required; 2] Material or equipment to which a decorative or protective material has been applied as a final decoration or protection [example, coat of paint, resilient flooring]

Finished Spaces - Rooms or areas, which in their final construction state, will have finishes or finished materials on the walls, floors, and ceilings.

Fire Cut - An angled cut made on the end of a joist or wood beam (where inserted into a masonry wall) to permit the member to rotate and drop away if burned through.

Fire Protection System - An interconnected system of devices and equipment installed throughout a structure [or in specific hazardous areas] to detect a fire, activate

an alarm, suppress or control a fire, or any combination thereof; fire alarm systems, sprinkler systems, and smoke detectors are examples.

Fire-Rated - Description of materials that has been tested for resistance to the passage of fire; doors, for example and materials for use in fire separation and other walls required to fire resistant.

Fire-Rated Doors - Doors designed to resist the passage of fire from one side to the other; constructed to match those tested in standard fire tests, and subsequently awarded an hourly rating and verification label; also called "labeled doors".

Fire-Rating - The comparative resistance of a material to failure, as stated in hours, when subjected to fire testing; ratings are standardized by fire underwriters (the Underwriters' Laboratories/UL for example), who publish full data on tests, results, and material performance.

Fire Retardant Chemical - A chemical or preparation of chemicals used to reduce flammability or to retard spread of flame.

Fire Wall - Any special wall designed and constructed to remain in place, despite collapse of structure on either or both sides of the wall, to stop the spread and passage of fire from one portion of a building to another for extended period of time (up to 4 hours); built to prevent the spread of fire in a building; such walls of solid masonry or concrete generally sub-divide a building and run from their own foundations to two or more feet above the plane of the roof.

Firebrick - A refractory brick that is especially hard and heat resistant; for use in fireplace fire boxes, and as smoke stack linings.

Fireproofing - Material to protect portions of buildings, primarily structural members against fire; can be stiff material (brick, concrete, tile, gypsum), or flexible (spray-on, wraps, paints).

Fire-Resistant - Basically, incombustible; slow to be damaged by fire; forming a barrier to the passage of fire.

Fire-Resistive - In the absence of a specific ruling by the authority having jurisdiction, applies to materials for construction not combustible in the temperatures of ordinary fires and that will withstand such fires without serious impairment of their usefulness for at least 1 hour.

Fire-Separation Wall/Partition - Fire-rated wall required by building codes to separate two areas of a building, into separate fire areas, as a deterrent to the spread of fire.

Fire-Stop - Any of a variety of material, even wood, placed in a solid, tight closure of a concealed space to prevent the rapid spread of fire and smoke through such a space. In a frame wall, this will usually consist of 2 by 4 cross blocking between studs; used to block the passage of flames or air currents upward, or across and in concealed building parts; includes draft-stops.

Fire-Stopping System - Installation of a tested combination of fire-resistant wraps, packing, collars, inserts, and sealants in annular areas around various penetrations in walls and floors, to preclude the passage of fire and smoke.

Fishplate - A wood or plywood piece used to fasten the ends of two members together at a butt joint with nails or bolts. Sometimes used at the junction of opposite rafters near the ridge line.

Fixed Window - Unit of glass mounted in an inoperable frame, mounted in a wall opening.

Flagstone (Flagging or Flags) - Flat stones, of various sizes and from 1 to 4 inches thick, used for rustic walks, steps, floors, and the like.

Flake - 1] scale-like particle. 2] To lose bond from a surface in small thin pieces. Sometimes a paint film "flakes".

Flange - Horizontal bottom and top portions of an I-beam, wide-flange beam, or channel member.

Flash Point - The critical temperature at which a material will ignite.

Flashing - Weatherproof material [sheet metal, or rubberized plastic] installed between roof sheathing (or wall sheathing) and the finish materials to ensure joints, openings, and connections in roofs and walls are watertight; used in roof valleys, at dormers, chimneys, and other vertical penetrations through roofs; Typically, sheet metal or a similar material is used in roof and wall construction to protect a building from water seepage; also at window, and door openings; usually covered, at least in part, by finished material such as siding or roofing so water is directed away from the areas in which leaks could occur.

Flat Glass - A general term that describes float glass, sheet, glass, plate glass, and rolled glass.

Flat Grain - Flat-grain lumber has been sawed parallel to the pith of the log and approximately tangent to the growth rings, i.e., the rings form an angle of less than 45° with the surface of the piece.

Flat Paint - An interior paint that contains a high proportion of pigment and dries to a flat or lusterless finish.

Flat Seam - A seam at the junction of sheet metal roof components that has been bent at the plane of the roof.

Flat-Slab Construction - Type of reinforced concrete floor/roof construction having no beams, girders of joists below the underside; requires thick slabs, moderate spans, and special reinforce-

ment at columns.

Flat work - Common term for large, horizontal concrete features such as floors, driveways, sidewalks, etc.

Flexible Metal Conduit - Conduit similar to armored cable in appearance but does not have the pre-inserted conductors.

Float Glass - Glass formed on a bath of molten tin. The surface in contact with the tin is known as the tin surface or tin side. The top surface is known as the atmosphere surface or air side.

Floor Plan - Horizontal sectional view, "cut through" a proposed building/structure, approximately 4 feet above floor line, and showing the basic layout of building or addition, which includes placement of walls, windows and doors as well as dimensions; includes all features, layout, configuration, and details of the design and construction; most important source of information for other contract documents.

Floor Plate - See Floor Plan.

Flue - The space or passage in a chimney through which smoke, gas, or fumes ascend. Each passage is called a flue, which together with any others and the surrounding masonry make up the chimney; each fuel burning appliance requires its own flue.

Flue Lining - Special, high-temperature fire clay or terra-cotta pipe, round or square, usually made in all ordinary flue sizes and in 2-3 foot lengths; used for inner lining of chimneys with brick or masonry work surrounding; runs from above the smoke chamber to the top of the chimney and several inches above top.

Flush Door - A door with two flat faces (no panels) and resembles a "slab"; can have a hollow or solid core; can have glass or louvered openings; can be fire-rated.

Flush Glazing - (Pocket Glazing) The setting of a light of glass or panel into a four-sided sash or frame opening containing a recessed "U" shaped channel without removable stops on three sides of the sash or frame and one channel with a removable stop along the fourth side.

Fly Rafters - End rafters of the gable overhang supported by roof sheathing and lookouts.

Folded Seam - In sheet metal work, a joint between sheets of metal wherein the edges of the sheets are crimped together and folded flat.

Foot Print - The imposed outline of a building or series of structures on a plot plan; area of land covered by buildings. See Floor Plan.

Footings - Lowest part of a foundation system for a structure, generally of reinforced concrete; spread out flat to distribute the imposed load of the wall, column, grade beam, chimney, foundation wall or other feature it supports, over sufficient area of earth to provide stability; wide pours of cement reinforced with re-bar (reinforcing bar) that support foundation walls pillars, or posts. Footings are part of the foundation and are usually poured before the foundation walls.

Foundation damp/waterproofing - Asphaltic mastic or special sheet materials applied to outer face of foundation walls, to prevent leakage of water or dampness into or through the wall; system used needs to be consistent with conditions anticipated [waterproofing being a far more imposing and expensive system].

Form Tie - Mesh, strap or heavy wire/rod used to hold wall forms in place, but of proper length to provide specified width; spaced at intervals over the entire area of forms, as necessary.

Form[work] - Temporary framing, basically, a "mold" into which concrete is placed; serves to give shape to cast-in-place concrete, and to support it and keep it moist as it cures; built of wood, plywood, or metal for holding and shaping concrete.

Foundation - The supporting portion of a structure below the first floor construction, or below grade, including the footings; lowest portion of structure, fully or partially below grade; substructure of building, consisting of foundation system (walls, grade beams, etc.) and supports (caissons, footings, etc.)

Foundation Drain - Piping or tile installed around the perimeter of a foundation wall (before backfill) and collects and diverts ground water away from the foundation. Generally, it runs to daylight or into a sump pit inside the home, and a sump pump is sometimes inserted into the pit to discharge any accumulation of water.

Frame Construction - A type of construction in which the structural parts are wood or depend upon a wood frame for support. In codes, if masonry veneer is applied to the exterior walls, the classification of this type of construction is usually unchanged.

Frame/Framing - The skeletal structural system (beams, columns, studs, etc.) of a building; rough lumber, steel or concrete frame including floors, roofs and partitions; in light wood framing there are "Platform" and "Balloon" systems.

Framing anchors - Variety of metal devices for connecting framing members together, in wood construction; plates, strips, angles, straps, etc.

Frieze - In house construction a horizontal member connecting the top of the siding with the soffit of the cornice.

FRP - Fiberglass reinforced plastic used for various shapes, doors and frames, grating sections, etc.

Frost heave - Movement or upheaval of ground surface due to the expansion of water in the ground below, when there is alternate freezing and thawing of water in soil; can cause cracks in concrete.

Frost Line - Lowest depth at which the ground will freeze; varies greatly by location and is listed in local building codes, since bottom of building footings must be placed well below this line; depth varies in different parts of the country; footings should be placed below this depth to prevent frost-heave movement which effects the building stability..

Fully Tempered Glass - Flat or bent glass that has been heat-treated to a high surface and/or edge compression to meet the requirements of ASTM C 1048, kind FT. Fully tempered glass, if broken, will fracture into many small pieces (dice) which are more or less cubical. Fully tempered glass is approximately four times stronger than annealed glass of the same thickness when exposed to uniform static pressure loads.

Fully-Adhered - A roof membrane fully adhered or attached over the entire surface area.

Fungi (wood) - Microscopic plants that live in damp wood and cause mold, stain, and decay.

Fungicide - A chemical that is poisonous to fungi.

Furnace - A heating system that uses the principle of thermal convection. When air is heated, it rises and as the air cools it settles. Ducts are installed to carry the hot air from the top of the furnace to the rooms. Other ducts, called cold air returns, return the cooler air back to the furnace.

Furnish - Means to "supply, and deliver to the job site, ready for unloading, unpacking, assembly, installation, and similar operations"; see "Install", and "Provide".

Furring - Narrow strips of wood or other material (metal channels) attached to a surface to provide an even, level, true to line, and plumb plane for attachment of finish wall or ceiling materials; provides some added insulation space.

Furr Out - To apply/install furring.

G

Gable - The end of a building where the roof slopes on only two sides as distinguished from the front or rear side. The triangular end of an exterior wall from the level of the eaves to the ridge of a double-sloped roof. In house construction, the portion of the roof above the eave line of a double-sloped roof.

Gable End - An end wall having a gable.

Galvanize - To coat steel members or sheets by dipping them into molten zinc after cleaning; to provide added protection against rusting.

Gambrel Roof - A type of roof which has its slope broken by an obtuse angle, so that the lower slope is steeper than the upper slope. A double sloped roof having two pitches.

Gang-nail plate - Steel plate with nail holes, or punched out "nails" applied to one or both sides of truss joints, to connect truss members together; placed in press after fasteners are installed.

Gaskets - pre-formed shapes, such as strips, grommets, etc., of rubber or rubber-like composition, used to fill and seal a joint or opening either alone or in conjunction with a supplemental application of a sealant.

Gauge - An outdated [but still widely used] uniform standard of measure for wire diameters, and thickness of sheet metal, plates, etc. [now use actual thickness sizes]; also a measure of other materials in regard to spacing or thickness.

Gauge Board - (Spot Board) Board used to carry grout needed to patch small jobs.

General Contractor [GC] - (or Prime Contractor) A contractor responsible for all facets of construction of a building or renovation; properly licensed individual or company having "primary" responsibility for the work; contracts to build a building, or a part of it for another party; hires, oversees and coordinates other contractors called sub-contractors, who perform specific specialized work on projects; often performs concrete and carpentry work in addition to general project supervision; GC can perform work with its own contractors or can perform the project work as an independent contractor, providing services to owners through the use of subcontractors when using the general contracting system. In the latter case, the GC is referred to as "Paper Contractor".

Girder - Larger of principle structural members of wood, steel, or concrete used to support concentrated loads at isolated points along its length, e.g., at the bearing points of a series of supported beams; used to support concentrated loads at isolated points along its length, usually made of steel or wood.

Girt - Horizontal strut which runs between structural members to brace the structure; also to provide for attachment of siding, cladding and other features to the building frame.

Glass - A hard, brittle substance, usually transparent, made by fusing silicates under high temperatures with soda, lime, etc.; also, variations which are translucent or even opaque [usually through an applied coating process]

Glass Block - Hollow masonry units made of glass; usually square, and made of diffused or molded glass; Translucent to permit passage of light, but not clear vision.

Glazing - (v) A generic term used to describe fitting/placing glass or other similar materials [acrylic plastic, for example] into windows and doors, or tubular grid curtain wall systems; the process of installing an infill material into a prepared opening

in windows, door panels, partitions, etc. (n) an infill material such as glass, panels, etc.

Glazing Bead - In glazing, a strip surrounding the edge of the glass in a window or door which holds the glass in place.

Glazing Channel - In glazing, a three-sided, U-shaped sash detail into which a glass product is installed and retained.

Glazing Compound - Mastic, similar to sealants, of various formulations to bed lights of glass in their frames.

Glue-Laminated (Glu-Lam) Timber - Timbers, large beams, and rigid frames (arches) built-up from a large number of small strip (laminations) of wood, glued together; used where solid wood timbers are not available for the loads and spans involved.

Government Anchor - V-shaped anchor, with open ends turned outward; usually 1/2" round bar, used to secure steel beams and joists to masonry walls which support them.

Grade - 1] construction/building trade term used in referring to the ground level around the building; 2] lumber term to denote the quality and classification of the pieces related to their adaptability for different uses; 3] the slope or gradient of a roof, piece of land, ramp, etc.

Grade Beam - Concrete foundation (wall) formed into a beam configuration (by pattern of reinforcement), which spans across isolated footings, piles, or caissons spaced at intervals; used where soil bearing pressure is inadequate for continuous support.

Grade of Wood - Designation given, after visual inspection, to indicate quality of manufactured lumber.

Gradient - Inclination or slope of a road, piping, ramp, ground level, etc.

Grain - In wood, the direction, size, arrangement, appearance, or quality of the longitudinal axes of wood fibers, or the figure formed by the fibers.

Granite - Fine to medium-coarse grained, Igneous rock with visible crystals of quartz and feldspar; dense, and water-resistant; can be used in thin panels, as stepping stones, or as thick pavers.

Granules - The mineral particles of a graded size which are embedded in the asphalt coating of shingles and roofing.

Gravel - Naturally rounded or mechanically crushed stones ranging in size from 1/4-inch to 1-1/2 inches; often used in sub-base, and surfacing for roads, paths, gardens, roofs, and as filler aggregate in concrete, or porous fills [for drainage] under slabs and around foundations; loose fragments of rock used for surfacing built-up roofs, in sizes varying from 1/8" to 1 3/4".

Gravel Stop - Metal (usually) strip or piece formed with a vertical lip used to retain the gravel on the roof surface around the edge of a built-up roof; can be enlarged to act as the fascia also.

Grid - [1] the assembly of main and cross tee members which form the support for a suspended ceiling; ceiling panels are fitted into or lay on the flanges of the tees; [2] Cross-pattern of centerlines of structural columns in a framing system, formed in both directions to define center points.

Grillage - System of steel beams set closely side-by-side, then crossed at 90 degrees by another set of beams. heavy support for large columns, located on top of footing.

Ground System - The connection of current-carrying neutral wire to the grounding terminal in the main switch which in turn is connected to a water pipe. The neutral wire is called the ground wire.

Ground-Faced Concrete Masonry Units (GFCMU) - Special concrete masonry units [CMU] made with variegated natural aggregates and with the faces ground to expose this aggregate; subsequently coated with an acrylic to accentuate the aggregate and seal the facing; ASTM units, generally produced in sizes same as other CMUs, plus special shapes as may be required for corners, coursing or special effects.

Grounds - Narrow strips of wood nailed to walls as guides for plastering, and as nailing base for interior trim; used around openings, at the floor line to strike off plaster, sub-jamb at interior doorways. They provide a level plaster line for installation of casing and other trim.

Grout or Grouting - (1) Mortar-like material made of such consistency (by adding water) that it will just flow into the joints and cavities of the masonry work and fill them solid; (2) material of non-shrinking, but plastic consistency used and placed as a spacer or shim to provide solid bearing [under column base plates for example]

Gun-Grade Sealant - A thickened liquid or mastic sealant material formulated in a degree of viscosity suitable for application by being extruded under pressure through the nozzle of a caulking gun.

Gunite - A spray applied, construction material composed of cement, sand or crushed slag and water mixed together and forced through piping and a spray nozzle/gun by pneumatic pressure onto metal mesh form work; used in the construction of swimming pools, artificial rock formations.

Gusset Plate - Plywood or metal plate used to overlay adjacent/intersecting members in a truss joint to connect and strengthen the joint; plate[s] is nailed, screwed, or bolted in place.

Gutter - [1] A U-shaped trough, along roof line of buildings, of metal or plastic to

receive and carry off various types of drainage, including rain water; usually non-sanitary drainage; [2] flat areas out from street curb for drainage.

Gutter Strap - Metal bands used to support the gutter.

Guy Wire - A strong steel wire or cable strung from an anchor on the roof to any tall slender projection for the purpose of support.

Gypsum [Wall] Board - Sheet material having a gypsum core laminated between layers of heavy paper (exposed face is manila in color; the back [concealed] face is gray); available in varying thickness, edge treatments, finishes [some pre-finished] and fire-ratings; overall usually 4'x8', 10', or 12'; also called "drywall", "plaster-board", and "gyp board" [see each].

Gypsum backer board - Board specifically manufactured to be located behind finish gypsum board in multi-layer drywall installations; can be water/moisture resistant for backing of ceramic tile installations; also called, "W/R", "Backer", or "Green" board.

Gypsum Board ["Gyp" board] - See Drywall and/or gypsum wall board

Gypsum Keene Cement - Material used to obtain a smooth finish coat of plaster, for use over gypsum plastic base coats only and in areas not subject to moisture. It is the hardest plaster.

Gypsum plaster - Powdered gypsum material combined with water and other ingredients to form a creamy applied coating that dries to a hard finish, i.e., plaster; can be applied in two, three or veneer coat systems; called "wet wall" as opposed to the drywall designation for panelized gypsum.

H

Hanger - Wire, rod or bar (or other shape required for loading) suspended from roof or other structural members used to support and carry piping, balconies, runways, etc.; stirrup-like drop support attached to wall to carry ends of beam; wire is used to hang a suspended ceiling grid system.

Hardware - A wide variety of items, in both rough and finished form, which provide various functions such as attachment, operation, etc. for doors and other features; also, can be applied to some accessories. see Rough Hardware, and Finish Hardware for further distinction.

Hardwood - Wood cut from broad-leaved trees, or trees that lose their leaves annually; examples include oak, maple, walnut, and birch; utilized in a number of construction and architectural items, primarily as finish carpentry.

Hatch - An opening in a deck; floor or roof. The usual purpose is to provide access from inside the building.

H-Beam - Another less-used name or designation for steel beam shapes; most often refers to an I-beam used as a column- "H-Column"; See I-Beam, and Wide-Flange.

H-clips - Small metal devices in shape of "H" that fit between edges of plywood panels to stiffen the joints; used primarily on roof decking.

H-column - Term commonly applied to columns which are steel I- or Wide Flange sections

Head - 1] The top of a frame at a door, window or other opening; 2] also, a standing depth of water which exerts downward pressure.

Header - 1] Framing members over windows, doors, or other openings; 2] Doubled members installed perpendicular to trimmer joists on each end of openings for stairs, chimneys, or other features for attachment of joists cut short to allow the opening; also wood lintels; 3] A beam placed perpendicular to joists and to which joists are nailed in framing for chimney, stairway, or other opening; 4] A wood lintel; 5] in masonry, units laid on the large flat face with small end exposed.

Head Room - Vertical clear space in a doorway, or in the height between a stair tread and the ceiling overhead.

Hearth - The inner [actual floor of firebox] or outer floor of a fireplace, usually made of brick, tile, or stone; also, incombustible floor or covering extension in front of a fireplace.

Heartwood - The wood extending from the pith to the sapwood, the cells of which no longer participate in the life processes of the tree.

Heat Strengthened Glass - Flat or bent glass that has been heat-treated to a specific surface and/or edge compression range to meet the requirements of ASTM C 1048, kind HS. Heat-strengthened glass is approximately two times as strong as annealed glass of the same thickness when exposed to uniform static pressure loads. Heat-strengthened glass is not considered safety glass and will not completely dice as will fully tempered glass.

Heel Bead - Sealant applied at the base of a channel, after setting the light or panel and before the removable stop is installed, one of its purposes being to prevent leakage past the stop.

Hidden work - Work performed which cannot be viewed in full which completed; e.g., underpinning, where back side cannot be viewed; risky work since final result is not viewable for evaluation.

High-Early Cement - Portland cement sold as Type III; sets up to its full strength faster than other types.

High-Strength [Tension] Bolts - Steel bolts designed to be tightened, with calibrated wrenches, to high tensile strength; used as a substitute for conventional rivets in steel frame construction.

Hip - The external angle formed by the meeting of two sloping sides of a roof.

Hip Rafter - A rafter that forms the intersection of an external roof angle.

Hip Roof - A roof that rises by inclined planes from all four sides of a building.

Hoistway - A vertical shaft or access way for the travel of one or more elevators.

Hollow Core Door - Door consisting of two wood veneer panels separated by a light weight core (grid, paper egg-crate, strips) installed to reinforce and stabilize the faces; solid wood framing members for stiles and rails.

Hollow Metal - Refers to doors and door frames fabricated from light-gauge carbon steel of various types. Similar work fabricated from stainless steel and other material usually identified by the material involved.

Honeycomb - (1) Areas in a foundation wall where the aggregate (gravel) is visible. Rough condition in concrete where voids are created in the surface and to some depth of the member; gravel is exposed and appears like "popcorn"; indicates poor mixing and consolidation of the concrete— a dry, stiff mix with inadequate water. Honeycombing can usually be remedied by applying a thin layer of grout or other cement product over the affected area. (2) Method by which concrete is poured and not puddled or vibrated, allowing the edges to have voids or holes after the forms are removed.

Hopper Window - Window with sash hinged or pivoted at the sill, and opens by tilting the top of the sash inward.

Horizontal masonry reinforcing - Long lengths of ladder- or truss-like configuration of heavy wires, laid in masonry joints, and extending from face to face of wall [slightly recessed from faces]; ties multi-wythe walls together so they act in unison..

Hose Bibb - A water faucet made for the threaded attachment of a hose; exterior bibbs should be frostproof.

House Wrap - A tough fabric-like material that lets moisture to pass through, but stops air from passing; installed To encase the entire building, from sill to eave under the siding or facing; for energy efficiency

Hurricane clip - Metal strap devices nailed to roof rafters and trusses, tying them to the top plate of the wall framing; also similar devices used to connect wall sill framing to foundations.

HVAC - Acronym for Heating Ventilation and Air Conditioning.

Hydraulic Elevator - An elevator where liquid is pumped under pressure directly into a cylinder by a pump driven by an electric motor without an accumulator between the pump and cylinder; piston in cylinder raises and lowers elevator car.

I-Beam - Rolled structural steel sections, of various sizes, with a cross section resembling the letter "I". (often called "H-beam" when used as a column It is used for various spans as support for smaller joists or over wide wall openings, such as a double garage door, when wall and roof loads are imposed on the opening; usually higher than it is wide; can be made of wood in similar profile; used for larger spans across openings, etc.

IBC- International Building Code - Code, with companion documents, first published in 2000; intention is for it to replace the three model codes used, but no longer promulgated in the U.S.; compilation of the model codes and fashioned so it is usable worldwide.

ICC- International Code Council - Organization for promulgation of the IBC, its distribution, revision and marketing worldwide; formed by and has three U.S. model code organizations as its major component/members.

I-joist - Wood framing members [joists and rafters] formed with solid vertical webs [plywood] inserted into top and bottom members of dimensioned lumber; lighter and cheaper than solid wood members.

Improvements - Improvements can be in the form of new construction or remodel work; alterations and additions to property which tend to increase value; buildings, utilities, streets, etc. in wood, glass, masonry, plaster, drywall, tile, brick, concrete, metal and other materials, and various types and configurations of construction.

Incombustible material - Material of various formulations which will not ignite or actively support combustion in a surrounding temperature of 1200 degrees F, during exposure of 5 minutes; will not melt when temperature is maintained at 900 degrees F for at least 5 minutes.

Incompatibility - Descriptive of two or more materials which are not suitable to be used together.

Indicated - Term refers to graphic representations, notes, or schedules on the drawings, or to paragraphs and schedules in the specifications; used to help locate references and information in manner similar to "shown", "noted", "scheduled", and "specified".

Infiltration - The process by which air leaks into a building. In either case, heat loss results. To find the infiltration heating load factor (HLF), the formula to account for

the extra BTU's needed to heat the infiltrated air is:

Inner Ply - Material or core located between two layers of material [such as roofing felts] that have been laminated together.

INR - (Impact Noise Rating). A single figure rating which provides an estimate of the impact sound insulating performance of a floor-ceiling assembly.

Insert - Devices, made of jute fibers compressed into a tubular form, lead, plastic; many sizes, lengths, etc., which are embedded in or surrounded by other material, concrete for example; exposed face creates an opening or anchorage for bolts, fasteners, other anchors, etc. which are then firmly held in place by the surrounding material.

Inside Drain - In roofing, a drain positioned on a roof at some location other than the perimeter. It drains surface water inside the building through closed pipes to a drainage system.

Inspection - (1) The act of inspecting [viewing, observing, or monitoring in a critical manner]. (2) An official examination or review of the work completed or in progress to determine its compliance with contract requirements.

Install - On site operations of "unloading, unpacking, assembling, erection, placing, locating, anchoring, applying, working to dimension, connecting, testing, finishing, curing, protecting, cleaning" and similar activities for proper and complete use/operation of area, equipment, appliance, surface, or item.

Insulating Board - Material, in rigid board form of various sizes and thickness, for insulating purposes; usually manufactured from vegetable fibers, or synthetic chemicals, and pressed or caused to "foam" into finished profile.

Insulating Concrete - Concrete with vermiculite added to produce lightweight concrete, with insulating properties, used for subfloor and roof fills.

Insulating Glass Unit - Two or more lights of glass separated by air spaces (for insulation purposes) and hermetically sealed to form a single-framed unit with an air space between each light.

Insulation - (1) A variety of materials designed and manufactured for protection from heat or cold, protection against fire, or reduction of sound transmission; usually paper, composition board, fiberglass, mineral/wood fiber wools, foam products are good insulators (poor conductors); produced as pliable batts and blankets, rigid boards, or loose particles; any material which slows down or retards the flow or transfer of heat. Building insulation types are classified according to form as loose fill, flexible, rigid, reflective, and foamed-in-place. All types are rated according to their ability to resist heat flow (R-Value). (2) In electrical contracting, rubber, thermoplastic, or asbestos wire covering. The thickness of insulation varies with wire size and type of material, application or other code limitations.

Insulation Board - A rigid structural building board made of coarse wood or cane fiber in 1/2- and 25/32-inch thickness It can be obtained in various size sheets, in various densities, and with several treatments.

Insulation Fasteners - Any of several specialized mechanical fasteners designed to hold insulation down to a steel or a nailable deck.

Interior - Within or "inside" of structure or building; direct opposite of "exterior" [see]; internal, confined and enclosed space within the exterior walls of the building; occupiable space usually with conditioned air source and artificial lighting.

Interior Finish - Term applied to the total effect produced by the inside finishing of a building; includes not only the material used, but the fashion of their installation and decoration; term used to represent the visible elements, materials and applications applied to cover the interior framed areas, or materials of walls and ceilings.

Interior Glazed - Glazing units or panels set in place from the interior of the building.

Interior Trim - General term for all finish moldings, casings, baseboards, cornices and other applied running and isolated trim pieces inside a building; installed by finish carpenters for fine fitting, finishing and decorative expression.

Interlayer - In glazing, any material used to bond two lights of glass and/or plastic together to form a laminate.

Intumescent Coating - Paint, mastic, or fireproofing substance that expands, when heated, to form a stable, foam-like, insulating char, when exposed to fire; and acts as an insulating agent (against the fire) for surfaces to which it is applied.

Isolated footing - Structural footing which stands alone in open area; primarily a footing for a column.

Jack rafter - Rafters cut to fit between the outside wall and a hip rafter, or the ridge and a valley rafter; rafter that spans the distance from the wall plate to a hip, or from a valley to a ridge. - A rafter that spans the distance from the wall plate to a hip, or from a valley to a ridge.

Jalousie - Type of window consisting of a number of long, narrow horizontally hinged glass panels, which operate in unison- out-swinging; can be used in doors, or a isolated window units.

Jamb - Sides of an opening; frame or lining mounted on the sides of a rough ope-

ning for installation of a door or window; also, sides members of windows, doors, or openings.

J-Channel/Bead/Mold - Metal trim piece, with unequal legs, applied to exposed edge [cut or uncut] of gypsum wallboard to provide a better finished edge appearance.

Joinery - General woodworking term used to describe creation of the joints where members/units are connected together, better execution of joints for better quality wood-joint construction; carefully done

Joint - Line, point, or position where two items meet, adjoin, or intersect each other; in masonry, the layer of mortar between the horizontal courses of units (tooled to raked, flush, weeping, concave, tooled, "V", etc. shape); The interfacing space between the adjacent surfaces of two members or components joined and held together by nails, glue, cement, mortar, or other means.

Joint compound - Pre-mixed gypsum-based material with the consistency of thick slurry used to fill the seams, and fastener depressions in drywall construction; also called "mud".

Joint filler material - Various material [asphalt impregnated felt, foam plastics, expandables, bellows, metal, synthetics] which are installed to fill the joints, and maintain closure during the flexing movement of the joint; to exclude air, water, fire, etc.

Joist - One of a series of parallel smaller framing members, usually 2 inches in thickness [wood], used to support floor and ceiling loads, and supported in turn by larger beams, girders, or bearing walls; also applicable to steel and concrete framing.

Joist hanger - One of a variety of metal framing anchors/devices shaped like a "U" used to connect two joists or joist and beam at right or other angles, to each other.

Junior Beam - Lightweight rolled structural steel sections similar to but smaller than an I-beam; used for short spans and light loads, bracing, etc.

K

Keene's Cement - A white finish plaster that produces a very hard, and extremely durable, moisture resistant wall surface; Because of its density, it excels for use in bathrooms and kitchens and is also used extensively for the finish coat in auditoriums, public buildings, and other places where walls may be subjected to unusually high traffic, hard wear or abuse; see veneer plaster and gypsum backing board.

Keeper - Metal plate set into doorframe, which retains the latch bolt of the door; holds door in closed position.

Kerf - Void created by the width of a saw blade as it cuts into wood surface, forming a groove or slot.

Key[way] - 1] Slot or deep groove formed in the top of concrete footings or other members, to receive concrete from adjoining members when placed; e.g., foundation wall concrete will fill slot; 2] hardware device for unlocking a lock and the slot into which the key is placed for its function.

Kicker - Diagonal brace, in concrete formwork for example, used to prevent side of form from springing out of alignment.

Kick Hole - A defect frequently found in perimeter flashings arising from being stepped on or kicked. A small fracture of the base flashing in the area of the cant.

Kick Plate - Brass, stainless steel, or plastic laminate plate fastened to the lower portion of a door to protect it from damage.

Kiln Dried Lumber - Artificially [oven] dried lumber; a method that produces lumber, because of the controlled conditions, superior to the more common air-dried product; lumber dried in this manner has a moisture content of 6 to 12 percent. Common varieties of softwood lumber, such as framing lumber are dried to a somewhat higher moisture content.

Kip [K] - A unit of measure equal to 1,000 pounds; used to simplify structural calculations; e.g., a 9,000 pound load is said to be "9 kips" in magnitude.

Kneehold - Open area in cabinet or casework which allows person to sit at counter-top with legs/knees in the recess under the top.

Kneewall - Short [usually 48" high] and often non-bearing, wall that extends from floor of an attic to the underside of the rafters.

Knife-Grade - Compound formulated in a degree of firmness suitable for application with a putty knife such as used for face glazing and other sealant applications.

Knocked-down (KD) - Unassembled construction unit requiring assembly after delivery to the job site.

Knot - Natural defect in lumber, where a branch or limb of a tree was located, that appears on the edge or face of the piece; weakens lumber [depending on size and location of knot]; should be located on top in framing members, and are prohibited in scaffolding planks.

Knurled - Having a surface texture of with striations or a grid of small knobs, or beads, as a nail which may have a surface for greater holding power; also texture on metal to allow better gripping as in door hardware for elderly or handicapped persons.

Kraft Paper - Strong, heavy, water-resistant, brown paper made of sulfate pulp, used for protection of surfaces, such as finished floors, and also in composition materials

[egg-crate grid in door cores. for example].

Kynar Coating - Architectural coating that is UV stable and suitable for exterior use on aluminum and other metal surfaces.

L

Lag Screw - Large diameter wood screw with hexagonal or square head for turning/tightening with a wrench.

Lally Column - A steel pipe column, with or without concrete/sand fill; used for loads up to moderate sizes, including residential floor loads.

Laminate - (1) To form a product by bonding together two or more layers of materials. (2) Also, the product so formed, such as plastic laminate [brand name example is Formica].

Laminated Glass - Two or more lights of glass permanently bonded together with one or more inter-layers.

Laminated Wood - Beams, arches, and other members formed by pressure gluing multiple thin layers or strips (laminations) together to form the shapes and size desired/required; substitute for solid wood members due to limited availability of same (see Glue-Laminated).

Landing - A platform, usually level, between flights of stairs, at changes in stair direction, or at the termination of a flight of stairs; also applicable to ramps; required to be placed on each side of door by building code.

Lap - To extend one material partially over another; the distance so extended.

Latch [bolt] - Spring-loaded metal cylinder/bar which moves horizontally and extends beyond the edge of a door; retracts and then engages the keeper for positive closure.

Lateral Bracing - Diagonal or other bracing in structural systems to counteract wind pressures, other loads, and to

Latex Caulk - A low-range sealant formulated of synthetic latex material; used on interior primarily; paintable.

Lath - A building material of wood, metal, gypsum, or insulating board that is secured to the framing on which plaster is applied; can be gypsum lath (solid or perforated), or metal lath, each providing a mechanical or chemical bond for the plaster.

Lattice - Framework of crossed wood or metal slats; lightweight, usually, but can be heavy where used as bracing in structures.

Lead - 1] A malleable metal once extensively used for flashings; 2] Professionally, the discipline head for a project work effort [e.g., Lead architect].

Leader - Vertical pipe-[see downspout - that carries rain water drainage from roof gutter to ground or storm sewer.

Lean-To Roof - The sloping roof of a building addition having its rafters or supports pitched against and supported by the adjoining wall of a building.

Ledger strip - A strip of lumber nailed along the bottom of the side of a beam or girder on which other supporting members [joists, for example] rest.

Let-in Brace - Nominal 1 inch-thick boards fitted into notched studs diagonally, so face of brace and studs are in same plane.

Level - 1) on a perfectly flat, horizontal line or plane; 2) tool used by workers to determine such level plane or line; 3) surveyor's instrument, similar to or a function of a transit, for establishing grade elevations; 4) term often used in place of floor, as in "4th Level".

Leveling Rod - A rod with graduated marks for measuring heights or vertical distances between given points and the line of sight of a leveling instrument, held by a survey crew member in a vertical position; usually made with telescoping sections for extreme height perhaps to 20 feet; also called a "Philadelphia Rod".

Lift Slab - System of construction where the various floor slabs are poured at ground level, and then subsequently lifted into proper position by hydraulic jacks, working simultaneously at each column; cast-in, steel collars are welded to steel columns to hold slabs in place.

Light - A single pane of glass or space in a window sash for a single pane of glass.

Light Steel Framing (LSF) - Construction method utilizing light gauge [20-25 gauge] sheet steel members for the framing of a structure; also called cold-formed metal [steel] framing.

"Like new" - Term applied to remedial work of modification or repair of existing work; replacement not required but care is required to make condition as noted.

Limestone - A fine to coarse-grained sedimentary rock; often used as ashlar or flagstone because it splits easily, limestone also serves as the preferred rock for constructing rock gardens; also good material for fashioning "cut stone" trim, such as copings, sills, etc.

Linear feet - Measure of length expressed in feet.

Linear measure - Measurement along a straight line.

Lintel - A horizontal structural member (wood, steel, concrete, stone, etc.) placed horizontally across the top of an opening [door, window, etc.], to support the wall above.

Liquid-Applied Membrane - Generally applied to cast-in-place concrete surfaces in one or more coats to provide fully-adhered waterproof membranes which conform to all contours.

Lite - see Light

Live Load - Loads produced by use and occupancy of the building or other structure and do not include construction or environmental loads such as wind load, snow load, ice load, rain load, seismic load, or dead load; includes all furniture, persons, and other movable loads not included as a permanent part of the structure.

Load - Weight imposed on buildings and structures by various elements, both natural and manmade; weight that must be properly and adequately supported by the building frame to prevent collapse or other failure.

Load-bearing Wall - Wall designed to support the weight (load) imposed on it from walls and structural members.

Loader - Self-propelled, wheeled or tracked, possibly articulated machine with "bucket" attachment for engaging and lifting loads, such as earth, or gravel; as opposed to the "pushing" action of the bulldozer.

Lockset - Complete complement of door hardware including the lock, knobs, trim, screws, and strike plates; also, "latchset" which is the same but with no locking function

Lookout - Framing extension, bracket or cantilever member which supports the overhead portion of a roof; also provides backing for soffit material; usually concealed from view

Loose Laid - In roofing, a membrane "laid loosely", without being adhered or otherwise fastened to the roof deck; system held in place by heavy ballast material; minimizes fastener holes in roofing system.

Lot - A parcel of land with boundaries determined by the county [or other local jurisdiction; part of the metes and bounds, and other land identification systems.

Louver - Unit with slanted slats of wood, plastic, or metal, used to permit air circulation [ventilation] but to exclude rain, and direct sunlight, or vision. See also Attic ventilators.

Lumber - The product of the sawmill and planing mill not further manufactured other than by sawing, re-sawing, and passing lengthwise through a standard planing machine, crosscutting to length, and matching and grading. 1" stock is sawed to 1" thickness then finished (planed) to final size of 3/4", 5/4" stock finishes out to 1" thickness, and 2"x stock finishes out to 1 1/2"; also referred to as "dimensioned lumber".

M

Mansard Roof - A roof style of steeply sloped sides sloping upward by inclined planes from all four sides of a building down from a flat top sections across the majority of the building area.; The sloping roofs on all four sides have two pitches, the lower pitch usually very steep and the upper pitch less steep; sides usually overhand walls below. Italian origin, popularized in France.

Mantel - The shelf mounted on a chimney, above a fireplace. Also used in referring to the decorative trim around a fireplace opening.

Manufactured Housing/Homes - Updated term for housing units totally factory-fabricated, with some portions unitized; built on a transportable chassis, which is not removable; should be equated to, and is another name for trailer-like construction [see mobile housing]; not controlled by local building codes and regulations [compare to Modular Home]

Manufactured Wood - Wood products such as a truss, beam, glu-lam, micro-lam or joist which is manufactured out of smaller wood pieces and glued or mechanically fastened to form a larger piece. Often used to create a stronger member which may use less wood. See also Oriented Strand Board.

Manufacturer - Organization, company, or person who designs, invents, formulates, makes or otherwise produces various products, including those for construction purposes, which are then provided to project via distributors, vendors, or suppliers.

Manufacturer's Instruction - The written installation and/or maintenance instructions which are developed by the manufacturer of a product and which provide useful information about product, its handling and installation; very important for proper use and installation and may have to be followed in order to maintain the product warrantee; often used to supplement and substitute for extensive specifications text.

Marble - A fine-grained metamorphic rock that is strong and weather-resistant; more often used in indoor than outdoor paving and walls because of its cost and its slipperiness when wet; grain can vary greatly in intensity as well as in a variety of colors, depending on the source.

Mason - A construction professional who builds masonry work using brick, stone, or concrete units.

Masonry - General term applied to construction formed with stone, brick, concrete, hollow-tile, concrete block, gypsum block, or other similar building units or materials or a combination of the same, bonded together with mortar to form a wall, pier,

buttress, or similar mass; sometimes called "unit masonry".

Masonry Cement - Factory-blended mixture of Portland cement and admixtures specially designed to increase the workability of mortar; usually better than site mixing, due to control available at plant.

Masonry Unit - A brick, stone, concrete masonry unit, glass block, or hollow clay tile intended to be laid in courses and embedded in mortar.

Masonry Veneer - A single wythe, non-load bearing facing installed over a structural frame, e.g., brick veneer applied to a wood frame house.

Mastic - A pasty material used as a cement (as for setting tile) or a protective coating (as for thermal insulation or waterproofing); Heavy-consistency compound that may remain adhesive and pliable with age. Is typically an adhesive or other coating material used for attachment, dampproofing, etc.

Matched Lumber - Lumber that is dressed and shaped on one edge in a grooved pattern and on the other in a tongued pattern.

Medium Dense Overlay - Plywood product with special paper facing laminated to panel; excellent weather-resistance for signs, etc.; readily paintable; called "MDO".

Meeting Attendance Form - A form consisting of three columns (individuals name, individuals title, and company the individual represents). This form is given to all persons attending any meeting. Each person attending the meeting will fill in their respective information. The date of the meeting should be included for reference.

Member - Individual element of structure such as a beam, girder, column, joist, piece of decking, stud, truss chord, brace, etc.

Membrane - 1] Sheet or mastic material which is impervious to water or water vapor.2] A generic term relating to a variety of sheet goods used for certain built-up roofing repairs and application.

Membrane roof - Roof covering consisting of a heavy, single ply of waterproof sheeting; usually a rubberized or other synthetic material such as EPDM, APP or PVC; alternative to multi-ply built-up roofing.

Metal Edge - Brake metal or metal extrusions which are secured at the perimeter of the roof to form a weather-tight seal.

Metal Lath - Expanded steel mesh created by slitting sheet steel and pulling it out until it forms a grid; used primarily for and provides an excellent plaster base due to mechanical "keying" of plaster around mesh wires.

Metal Wall Ties - Strips of corrugated sheet metal, usually galvanized, used to anchor (tie) brick veneer construction to the structural frame behind.

Micro-lam - Manufactured structural wood members, made using layers of 1-1/2" material laminated together; usually have higher strength than sawn lumber.

Mil - Unit of measure (thickness) for very thin sheets, and for paint and coatings thickness; one thousandth part of an inch [1 mil = .001 inch, 1/1000].

Mil Thickness - Measurement, in mils, used to determine Dry Film Thickness of paint or coating; also, used for other thin materials to indicate thickness.

Millwork - General term for interior woodwork and trim, made of finished wood which is machined to profile, size and finish; manufactured in millwork plants and planning mills; It includes such items as inside and outside doors, window and doorframes, blinds, porch work, mantels, paneling, stairways, moldings, and interior trim. It normally does not include flooring, ceiling, or siding material; part of finished carpentry work, as opposed to rough carpentry (framing).

Mineral Spirits - A by-product of petroleum, clear in color, a solvent for asphalt coatings.

Mineral Wool - Type of batt insulation consisting of many fine threads of a wood by-product; also used for fireproofing and acoustical treatment; some types are called "safing" insulation.

Miter Joint - The joint of two pieces at an angle that bisects the joining angle. For example, the miter joint at the side and head casing at a door opening is made at a 45° angle.

Mobile Home - Outdated term [now called Manufactured Home] for trailer-like unit, totally factory built on a transportable but permanent chassis.

Modular home - A factory-built, transportable building unit designed to be used by itself or with other, similar units, and site installed on a permanent foundation; produced complete with structural floor system; built with standard-size materials, and complete modules [kitchens/baths]; similar to manufactured housing, but requires some site construction; controlled by state regulations, and/or local building codes.

Moisture Barrier - Material, plastic or specially treated paper, that retards the passage of moisture or vapor into walls, and prevents condensation; see Vapor Barrier [Retarder].

Moisture Content of Wood - Weight of the water contained in the wood, usually expressed as a percentage of the weight of the oven dried wood.

Molding - Single strip/piece, or series of pieces of material cut, shaped, and finished with a distinctive profile, to serve as an ornament; can be made of various material- wood, stone, fiberglass, plaster, etc.; used for decorative purposes, e.g., door and window trim.

Monitor - A large structure rising above the surrounding roof planes, designed to give light and/or ventilation to the building interior.

Monolithic - Term used for concrete and other materials placed, or installed wi-

thout joints; as one-piece, or a unit.

Mopping - In roofing, a layer of hot bitumen mopped between plies of roofing felt. Full mopping is the application of bitumen by mopping in such a manner that the surface being mopped is entirely coated with a reasonably uniform coating. Spot Mopping is the procedure of applying hot bitumen in a random fashion of small daubs, as compared to full mopping. Sprinkle mopping is a special application of installing insulation to the decks. It is done by dipping a roof mop into hot bitumen and sprinkling the material onto the deck. Strip Mopping is the application of bitumen in parallel bands.

Mortar - A mixture of masonry cement, sand and water, used by masons as the bonding agent between masonry units; the "joint material" in masonry.

Mortar Types - Type M is suitable for general use and is recommended specifically for masonry below grade and in contact with earth, such as foundations, retaining walls and walks. Type M is the strongest type. Type S is suitable for general use and is recommended where high resistance to lateral forces is required. Type N is suitable for general use in exposed masonry above grade and is recommended specifically for exterior walls subject to severe exposures. Type O is recommended for load-bearing walls of solid units where the compressive stresses do not exceed 100 lbs. per square inch and the masonry wall not be subjected to freezing and thawing in the presence of excessive moisture.

Mortise - 1] Recess fashioned in wood or metal to receive a recessed device; commonly used in finish door hardware installation, to reduce surface mounting of devices. 2] A slot cut into a board, plank, or timber, usually edgewise, to receive tenon of another board, plank, or timber to form a joint.

Mosaic - Small colored tile, glass, stone or similar material, regular or irregular in shape but arranged to produce a decorative surface; used on walls or floors.

Mud Sill - Bottom-most horizontal member of an exterior wall frame; rests on top of foundation; commonly called "sill plate".

Mullion - A vertical separating member, bar or divider in the frame between windows/doors units or other openings that supports and holds several such in a single frame, as in sections of a curtain wall.

Muntins - Small horizontal or vertical bars that divide the sash frame into smaller areas to receive an individual light of glass; can be made as a grid set in the sash frame; Muntins are smaller in dimensions and weight than mullions.

N

Nail-base Sheathing - Sheathing material, such as wood boards, panels, or plywood to which siding can be attached by nailing; such nailing is not provided by fiberboard, or plastic foam materials used as sheathing (primarily for better insulation).

Nailer - Wood member, shaped to fit, in any of several places used to provide a nailing base for other members or materials; for example, member secured to non-nailable decks and walls by bolts or other means, which provides a suitable backing onto which roof components may be mechanically fastened; called "blocking" in some locations.

Natural Finish - Transparent finish on wood using sealers, oils, varnishes and preservatives; grain of wood is still exposed, and is often enhance by the coating; finish which does not seriously alter the original color or grain of the natural wood. Natural finishes are usually provided by sealers, oils, varnishes, water-repellent preservatives, and other similar materials.

Neat Plaster - A base coat plaster which does not contain aggregates and is used where the addition of aggregates on the job is desired.

NEC - National Electric Code; Standard No. 70 promulgated and published by the National Fire Protection Association [NFPA] and widely adopted and used as regulations for electrical work of all types; modified versions used for residential construction.

Needling - Series of steel or wood beams [called "needle beams"] threaded through a bearing wall to support it while its foundation is underpinned.

Neoprene - A synthetic rubber having physical properties closely resembling those of natural rubber. It is made by polymerizing chloroprenes, and the latter is produced from acetylene and hydrogen chloride.

New - Unused condition, fresh from manufacture, production, or fabrication [unless specifically noted otherwise] of all materials, devices, equipment, units and systems for projects; this meets owner's expectations and payment is based on this principle.

Newel [Post] - Large termination post at the end or turns in stair hand- and guard rails to which the end of a stair railing or balustrade is fastened; Also, any post to which a railing or balustrade is fastened.

Nominal Size - Size of material before final working and dressing; not the actual size; as a 2x4 (nominal) is 1-1/2" x 3-1/2" in actual size.

Nonbearing Partition/Wall - Term used for space dividing partitions or other walls, which carry no imposed floor or roof load; wall supporting no load other than its own weight.

Non-Drying (Non-Curing) - A sealant that does not set up or cure. See Butyl.

Non-Sag - A sealant formulation having a consistency that will permit application in vertical joints without appreciable sagging or slumping. A performance characteristic which allows the sealant to be installed in a sloped or vertical joint application without appreciable sagging or slumping.

Non-Skinning - Descriptive of a product that does not form a surface skin.

Non-Staining - Characteristic of a compound that will not stain a surface.

Nosing - 1] The projecting edge of a molding or drip. Usually applied to the projecting molding on the edge of a stair tread which projects over the riser; any similar projection. (2) A term applied to the rounded edge of a board.

Notch - 1] A three-sided slot, groove, or opening cut into a piece of material, usually along an edge. 2] A crosswise rabbet at the end of a board.

Nozzle - The tubular tip of a caulking gun through which the compound is extruded.

NRC - Noise Reduction Coefficient; term denoting noise reducing efficiency of individual acoustical materials

NSPE - National Society of Professional Engineers; professional association for registered engineers; national organization with regional/local chapters, and separate groups for different types of engineers [i.e., mechanical or civil engineers]

O

O.C. - "On Center". A measurement term meaning the distance between the center of one member to the center of the next adjacent member; studs rafters, joists, and the like in a building placed at 16 inches O.C. will be laid out so that there is 16 inches from the center of one to the center of the next.

O. G. (or ogee) - A molding with a profile in the form of a letter S; having the outline of a reversed curve. - A molding with a profile in the form of a letter S; having the outline of a reversed curve.

Oil-Canning - The term describing distortion of thin-gauge metal panels which are fastened in a manner restricting normal thermal movement.

On-Center (O.C.) - Method of indicating spacing of framing members or other items; measurement is from center of one object to the center of each of those adjacent; for example, "studs shall be 16" o.c."

Open Web (Steel) Joist - Prefabricated, light steel truss-like member with a welded lattice-like web; closely spaced for moderate spans; also called "bar joist" or "steel lumber".

Open-grained wood - Common term for woods with large pores such as oak, ash, chestnut, and walnut. Often preferred for decorative reasons; can be filled before finish. Also known as "coarse textured."

Orientation - 1) direction in which a building or structure faces; 2) relationship to a direction or bench mark/line; 3) relating contact drawings to the actual structure.

Oriented-Strand Board (OSB) - Newer engineered board that has the long axis of the strands of the wood chips aligned with the long dimension of the materials (such as the 8 foot measurement in a 4x8 sheet of OSB); bonded together with an adhesive matrix under pressure; previously old "chip board" was not structural while OSB is structural just like plywood.

Outcropping - Bare rock formations exposed and protruding from the surrounding soil.

Outtrigger - An extension of a rafter beyond the wall line. Usually a smaller member nailed to a larger rafter to form a cornice or roof overhang.

Overhang - Area or portion of upper story, building part or roof at the eave which extends horizontally beyond the vertical plane of the exterior walls of a building.

Oxidize - To combine with oxygen in the air.

P

Pad - 1] Extra usually isolated concrete slab installed on top of a floor slab, as the mounting surface for mechanical or other equipment; adds some strength, but merely provides a better, slightly elevated surface for mounting the unit(s); 2] landing area outside a door; 3] material installed under carpeting to add foot comfort, sound isolation, and to prolong carpet life [also called padding].

Paint - A combination of colored pigments with suitable binders, vehicle, thinners or oils to provide opaque, decorative, wearable, and protective coatings.

Panel - (1) A large, thin sheet of lumber, plywood, or other material. (2) A thin board with all its edges inserted in a groove of a surrounding frame of thick material. (3) A section of floor, wall, ceiling, or roof, usually prefabricated and of large size, handled as a single unit in the operations of assembly and erection. (4) a thin flat piece of wood, ply. wood, or similar material, framed by stiles and rails as in a door or fitted into grooves of thicker material with molded edges for decorative wall treatment.

Panel Door - Door constructed with thin panels installed between solid rails and stiles (perimeter frame).

Paneling - Thin sheet material of composite, synthetic or wood composition which is used as a lining or interior wall finish; can be nailed or glued into place over

various sub-surfaces.

Parapet Wall - That portion of a wall that extends above the top of the roof; usually in exterior walls, or interior fire walls.

Parging/Parge Coat - 1] A thin coat of Portland cement plaster used to smooth masonry walls. 2] A thin application of plaster, drywall compound for coating a wall.

Parquet floor - A floor made of a series of small panels or blocks [9-12 inches square] of flooring made with short pieces of hardwood laid in different design patterns, as opposed to long strip flooring.

Particleboard - A sheet material composed of compressed wood chips, flakes, or small wood particles such as sawdust, held together with special glues; non-structural.

Parting Stop or Strip - A small wood piece used in the side and head jambs of double-hung windows to separate upper and lower sash.

Parting stop or strip - A small wood piece used in the side and head jambs of double-hung windows to separate upper and lower sash.

Partition [wall] - An interior, full or part-high wall that subdivides space for directing traffic, separating or screening spaces one from another but plays no part in a building's structural integrity; non-bearing wall.

Party wall - Single wall common to two properties/ buildings owned by different owners; also common walls between row houses; straddles property line which separates two properties

Patio - Paved, open area outside a house; also called a terrace, and can be a structure such as a deck.

Patterned Glass - On type of rolled glass having a pattern impressed on one or both sides. Used extensively for light control, bath enclosures and decorative glazing. Sometimes call "rolled," "figured" or "obscure" glass.

Pavers - Clay masonry (brick) made specifically for finish floor surfaces, walks, drives, and terraces, etc.' must be frostproof and serviceable for heavy traffic; also, pre-cast concrete slabs used to create a traffic surface.

Paving - Asphaltic/bituminous material (or composites), or concrete installed as ground surfacing/cover, or as a hardstand for vehicle access or parking; usually asphaltic concrete (blacktop) or cast-in-place concrete over a compacted gravel fill; can be light-duty or heavy duty depending on traffic requirements and construction.

Pea gravel - A fine grade of naturally rounded stones approximately 1/4 inch in diameter; used frequently as the porous fill under floor and other slabs; used in gravel gardens, as flooring for children's play areas, as top finish in exposed aggregate sidewalks/slabs.

Penny - As applied to nails, it originally indicated the price per hundred. The term now series as a measure of nail length and is abbreviated by the letter d.

Penthouse - (not the magazine!) A relatively small structure/enclosure, usually roof mounted, to enclose mechanical and/or elevator equipment, without taking up valuable interior floor space.

Perimeter drain - Continuous line of 3" or 4" perforated plastic pipe or field tile that goes around the perimeter (either inside or outside)of foundation wall to drain off ground water or seepage; drains to open area, or basin/drain and may require a sump pump for draining.

Perlite - An aggregate formed by heating and expanding siliceous volcanic glass.

Perm - A measure of water vapor movement through a material (grains per square foot per hour per inch of mercury difference in vapor pressure).

Permanent Set - The amount by which a material fails to return to its original dimensions after being deformed by an applied force or load.

Permeability - A measure of the ease with which water penetrates a material.

Phased Construction - A unitized approach to constructing a facility by designing and constructing separate project elements. Each element is a complete project in itself.

Pier - Vertical structural member, usually rectangular in horizontal cross section, usually of concrete or masonry; used to support other structural members; also, short foundation columns, between window/door openings, and mass masonry supports such as for bridges, gates and girders.

Pigment - A powdered solid substance which when finely ground gives color, as in paint, enamel, dye, or lacquer.

Pilaster - Rectangular pier engaged in a wall, for the purpose of strengthening it; also can be decorative, or act as a beam support (expanded bearing area at the wall).

Pile (Piling) - Long concrete, wood or steel member driven into the ground to act as a below-grade column to support the building; used to carry building load to sufficient bearing soil.

Pitch - (a) The incline slope of a roof or the ratio of the total rise to the total width of a house, i.e., an 8-foot rise and 24-foot width is a one-third pitch roof. Roof slope is expressed in the inches of rise per foot of run. (b) A term frequently used to designate coal tar pitch.

Pitch Pocket - An opening extending parallel to the annual rings of growth, that usually contains, or has contained, either solid or liquid pitch

Pith - The small, soft core at the original center of a tree around which wood formation takes place.

Place[ing] [concrete] - More appropriate term for locating concrete in a project; as

opposed to "pour[ing]"; see Pour.

Plan - (1) A line drawing (by floor) representing the horizontal geometrical section of the walls of a building. The section (a horizontal plane) is taken at an elevation to include the relative positions of the walls, partitions, windows, doors, chimneys, columns, pilasters, etc. (2) A plan can be thought of as cutting a horizontal section through a building at an eye level elevation.

Plank - 1] A wide board, usually more than 1" thick; especially, one laid with its wide dimension horizontal and used as a bearing surface; 2] flooring section which is wider than regular strip flooring.

Plans - A term used to represent all drawings including sections and details; and any supplemental drawings for complete execution of a specific project. These graphic representations show the location, geometry, and dimensions of a project or its elements in sufficient detail to facilitate construction; See Blue Prints.

Plaster - A cementitious material, usually mixture of lime, sand, and water, applied to gypsum or metal lath or masonry surfaces; formed of a gypsum or Portland cement mixture; applied in paste form, which hardens into a hard smooth surface (or other finish desired); used for outside and inside wall surfaces [often called "wet wall" as opposed to "drywall"].

Plaster Grounds - Strips of wood used as guides or strike off edges around window and door openings.

"Plastic" concrete - Concrete that has not set or hardened, and can still be worked, moved, shaped; phrase has nothing to do with content of concrete.

Plastic Laminate - Composite material made from compressing Kraft paper into phenolic resin layers to form a decorative material; usually has a melamine exposed (decorated) surface; used for covering doors, countertops, wall paneling, cabinets, etc.

Plat - 1] Drawing or plat of a parcel or parcels of land based on and giving its legal description, and other survey data indicating the block numbers; the location, boundary lines, dimensions and number of each lot; and the location and names of the existing and planned streets.; 2] may be filed as an official record of the land via map of a geographical area as recorded by the county.

Plate - Horizontal members at top (doubled) and bottom of stud walls (sole plate); also, refers to bearing, top and base plates for structural steel members; examples- Sill plate: a horizontal member anchored to a masonry wall. Sole plate: bottom horizontal member of a frame wall. Top plate: top horizontal member of a frame wall supporting ceiling joists, rafters, or other members.

Plate Glass - Glass of high optical quality produced by grinding and polishing both faces of the glass sheet; glass with parallel faces and minimal distortion.

Plate Line - The top horizontal line of a building wall upon which the roof rests.

Platform Framing [Construction] - System of light-wood framing where floor joists of each story rest on the top plates of the story below but framed independently (upper story rests on flooring decking applied to top of first floor ceiling joists), or on the foundation sill for the first story, and the bearing walls and partitions rest on the subfloor of each story. (Usually one story constitutes a platform.); also, called "western framing"; See and contrast with Balloon Framing.

Plenum - (or Plenum Chamber) Chamber or container for moving air under a slight positive pressure to which one or more ducts are connected.

Plot - Lot, parcel, or other piece of land (real estate) with specific dimensions; potential building/construction site.

Plot Plan - An overhead, "bird's eye" view showing how a building sits on the building lot, typically showing setbacks (how far the building must sit from the road), easements, rights of way, and drainage; See Site Plan, and Survey

Plough/Plow - To cut a groove, lengthwise, in a board or plank.

Plumb - Exactly perpendicular; vertical; straight up and down; a plumb line is created when a weight ("plumb bob") is tied on a cord and held vertically.

Ply - A term to denote a single layer in a built up material or system; e.g. one layer of roofing in a built-up system, 1 layer of wood veneer in a built-up plywood panel, or in any finished piece of such material.

Plywood - Engineered wood panel, of many varieties and types, composed of a number of thin veneers bonded together, glued under pressure; Adjoining plies are usually laid with grains at right angles to each other, and almost always an odd number of plies are used; normally 4 feet wide by 8 feet although longer lengths are available; has various face finishes and can be used as a finish or rough material.

Poché - The infill color, pattern or material symbol within walls in architectural working drawings. [see cross-hatching].

Pocket (Channel) - A three-sided, U-shaped opening in a sash or frame to receive glazing infill. Contrasted to a rabbet, which is a two-sided, L-shaped sections as with face glazed window sash.

Pointing - The process where joints between masonry units, brick, etc., are filled with mortar.

Polished Wired Glass - Wired glass that has been ground and polished on both surfaces.

Polybutylene pipe - A modern type of flexible plastic pipe used for the distribution of potable water in a building.

Polymer - A substance consisting of large molecules which have been formed from smaller molecules of similar make-up.

Polysulfide Sealant - Polysulfide liquid polymer sealant which is mercaptan terminated, long chain aliphatic polymers containing disulfide linkages. They can be converted to rubbers at room temperature without shrinkage upon addition of a curing agent.

Polyurethane finish - A clear finish used for coating stained wood to provide it with protection and shine. It is durable and highly resistant to water.

Polyurethane Sealant - An organic compound formed by reaction of a glycol with and polyisocyanurate.

Polyvinyl Chloride (PVC) - Polymer formed by polymerization of vinyl chloride monomer. Sometimes called vinyl. Polyvinyl Chloride (PVC) A type of plastic formulation. Thin, flexible sheets of PVC plastic are used for vapor barriers, pond liners. Rigid PVC plastic pipe is used for plumbing, storm drainage, and water supply lines.

Ponding - A condition where water stands on a roof for prolonged periods due to poor drainage and/or deflection of the deck.

Pop Rivets - Fasteners used to join pieces of metal that are installed by either compressed-air-assisted or hand-operated guns. Unique in that they are installed from one side of the work.

Pop-Out - See stucco pop-out.

Pores - Wood cells of comparatively large diameter that have open ends and are set one above the other to form continuous tubes. The openings of the vessels on the surface of a piece of wood are referred to as pores.

Porosity - The density of substance and its capacity to pass liquids.

Portico - A covered entrance to a house, usually supported by decorative columns.

Portland Cement - Gray colored, finely powdered limestone material [crushed and pulverized] made from burning compounds of lime, silica, and alumina; used to coat and bond the aggregate together in concrete and mortar.

Post - A vertical member of wood, steel, concrete or other material that transfers weight from the top of the post to whatever the post is resting on; a column: a timber set on end to support a wall, girder, or other structural member.

Post & Beam Construction - Most common type of wall framing, using posts which carry horizontal beams on which joists are supported. It allows for fewer bearing partitions, & less material; system uses widely spaced posts and beams as the frame; plank decking applied transversely across the beams for stability and roof structure; a wood version of a rigid frame, in concept.

Potain - Name of French inventor, who designed first tower crane [single-masted, top-slewing] in 1928; known for large load capacity, and long reach [see Tower Crane].

Pot-Life - The time interval following the addition of an accelerator before chemically curing material will become too viscous to apply satisfactorily. See Shelf Life.

Pour - Outdated term, meaning to place concrete, casting concrete in place without interruption; not used, today, because of negative impression of a thin, watery inadequate substance.

Power - The energy rate, usually measured in watts. Power equals voltage times amps. or $W = E \times I$. The heavier the flow of amps at a given supply, the higher the rate at which energy is being supplied and used.

Pre-Bid Shopping - Negotiations between prime contractors (buyers) and trade contractors (sellers) to obtain lower prices prior to submitting prime contract proposals to owners.

Pre-cast Concrete - The shaping of structural members in a factory, then transported and installed in a building; includes concrete joists, beams, tee-slabs, as well as non-structural terrazzo, stair treads and risers, and miscellaneous trim, such as copings, sills, etc.

Pre-construction Meeting - Meeting convened to bring all parties to a project together to discuss mutual and project related topics, prior to actual start of construction; valuable to creating a good project atmosphere, and commonality of understanding on all aspects of the project.

Pre-construction Phase - All required phases prior to the start of construction.

Pre-Construction Planning - A team-building process used for the purpose of establishing below market dollar budget, overall project scheduling and design criteria; also identification and selection of the most feasible planning, design and construction team.

Precut - Cutting wood stock to exact dimensions at a mill, yard, or job site, before using/installation; for standardizing building components and minimizing errors.

Pre-Design Phase - The phase prior to the start of design where feasibility studies are done and conceptual project cost estimates are prepared.

Prefabrication - Building sections, or component parts of a building in a factory, or on-site, and installed/assembled as a whole on the job site; see Modular Housing.

Preservative - Any substance that, for a reasonable length of time, is effective in preventing the development and action of wood-destroying rot, fungi, borers of various kinds, insects that cause deterioration in wood. And similar destructive agents when the wood has been properly coated or impregnated with it.

Pre-Shaped Tape Sealant - A sealant having a pre-formed shape containing solids

or discrete particles that limit its deformation under compression.

Pressed wood products - A group of materials used in construction that are made from wood veneers, particles, or fibers bonded with an adhesive under heat and pressure; hardboard, for example.

Pressure-Treated Lumber - Lumber that is treated in such a way that the sealer is forced into the pores of the wood; Lumber that has been impregnated with chemicals/preservatives under pressure, for the purpose of retarding rot, decay, vermin, and/or fire.

Primer - (1) A material of relatively thin consistency applied to a surface for the purpose of creating a more secure bonding surface and to form a barrier to prevent migration of components, (2) The first coat of paint in a paint job that consists of two or more coats, (c) the paint used for such a first coat, used to provide good adhesion to the work being covered, and a good base for the finish coats.

Priming - Sealing of a porous surface so that compounds will not stain, lose elasticity, shrink excessively, etc. because of loss of oil or vehicle into the surround.

Product Data - Detailed information provided by material and equipment suppliers demonstrating that the item provided meets the requirements of the contract documents.

Professional Engineer - A professional firm and/or individual who is professionally trained and engaged in an engineering discipline.

Professional Services - Services provided by a professional, in the legal sense of the word, or by an individual or firm whose competence can be measured against an established standard of care.

Professionalism - Essentially; considerate, courteous, ethical behavior when dealing or communicating with others on a construction project.

Program - 1] Written list of needs and requirements, and regulatory obligations, set out by the owner [and law] for a specific project; 2] An ordered list of events to take place or procedures to be followed for a specific project.

Project - A word used to represent the overall scope of work being performed to complete a specific construction job.

Project Delivery System - A variety of contractual arrangements open to choice of owners, which create differing arrangements for the project team, sets specific responsibilities, and forms a general pattern for the conduct of the project.

Project Manager - A qualified individual or firm authorized by the owner to be directly responsible for the day-to-day management and administration, and for coordinating time, equipment, money, tasks and people for all or specified portions of a specific project.

Project Manual - A organized book setting forth the bidding requirements, conditions of the contract and the technical work specifications for a specific project that documents and augments the drawings. The Project Manual contains the General Conditions, Supplementary and Special Conditions, the Form of Contract, Addenda, Change Orders, Bidding Information and Proposal Forms as appropriate, and the Technical Specifications.

Project Representative - Qualified person authorized by owner and assigned to project [part- or full-time] to assist in administration of contract[s] to protect the owner's interest; may be owner's employee, or duly authorized employee of design professional, or both.

Project Site - Specific tract of land, lot or portion thereof which is dedicated to the project and its construction; the Physical location where a structure or group of structures was, or is to be located, i.e., a construction site.

Projection - In roofing, any object or equipment which pierces the roof membrane.

Protection Board - In roofing, heavy asphalt impregnated boards which are laid over bituminous coatings to protect against mechanical injury.

Public Sector - The domain where owners fund projects with monies that come in whole or in part from taxes.

Pulls - A knob or other form attached to the front of a drawer by which the drawer can be opened.

Punch List - A trade term referring to the document resulting from the process of inspecting, and listing completed work, to determine where there is need for correcting deficiencies and making minor adjustments at the end of the job; list prepared by the owner or his/her authorized representative of items of work requiring immediate corrective or completion action by the contractor.

Purlins - Smaller horizontal structural member spanning between rafters, beams or trusses to support a roof deck; in slope glazing, purlins are the horizontal framing members.

Push Stick - In hardware, a tool used when cutting a short board on a table saw.

Putty - A soft, pliable type of compound, having nearly the consistency of dough, usually made of whitening and boiled linseed oil, beaten or kneaded to the consistency of dough, and used in sealing glass in sash, filling small holes and crevices in wood, and for similar purposes.

PVC pipe - Pipe made from Polyvinyl Chloride plastic material; see.

PVDF - Architectural coating. See Kynar Coating.

Q

Qualified - An individual or firm with a recognized credentials, degree, certificate, or professional standing; or who by extensive knowledge, training and experience, has successfully demonstrated his/her abilities to identify and solve or resolve problems associated with a specific subject matter or project type.

Quality - The value levels of material and equipment selected by the A/E. Conformance to the technical specifications during construction.

Quality Assurance (QA) - The procedure established by the Project Team to inject and extract the level of quality designated by the owner.

Quality Control (QC) - That part of the Quality Assurance procedure that determines if specified quality is attained.

Quality Engineering - That part of the Quality Assurance procedure where the required level of quality is accurately inserted into the construction documents by the A/E.

Quarry Tile - Unglazed, machine-made tile used for floors with sanitary requirements and open to wet conditions; usually red or tan color, and 6"x6".

Quarter Round - A small molding with a cross section profile of a quarter circle.

Quarter Sawn - Lumber, usually flooring or veneer, that has been sawn so that the medullary rays showing on end grain are nearly perpendicular to the face.

Quarter-sawn Grain - Another term for edge grain.

Questionable Practices - Practices, standard or otherwise, that are not totally productive or are unfriendly or unfair to those parties that the practices interface.

Quoins - Large squared stone pieces, or slightly projected panels of brick, set in the corners of masonry walls for decorative purposes.

Quotes - Foreshortened or slang term for quotations which cite firm prices for work or material given by contractors and suppliers for labor and materials.

R

"R" value - A measure of a materials [incl. insulation] resistance to the passage of heat; high R value denoted better insulating "power" it has— e.g., typical new home's walls are usually insulated with 4" of batt insulation with an R value of R-13, and a ceiling insulation of R-30.

R.F.I. - (1) An abbreviation for Request for Information. (2) A written request from a contractor to the owner or architect for clarification or information about the contract documents following contract award.

Rabbet - A rectangular longitudinal groove cut in the corner edge of a board or plank; also, L-shaped groove cut into the edge of a board to receive the edge of another board and form a corner joint.

Radial - Extending out from the center, as the rays in a tree.

Radial Saw - A circular saw which hangs from a horizontal arm or beam and slides back and forth. The arm pivots from side to side to allow for angle cuts and bevels. When sawing finish plywood, the good side should face up as the saw cuts on the down stroke.

Radiant Heating - (1) A method of heating consisting of a forced hot water system with pipes placed in the floor, wall, or ceiling. (2) A method of heating with electrically heated panels.

Radiation - Any heated surface loses heat to cooler surrounding space or surfaces through radiation. The earth receives its heat from the sun by radiation. The heat rays are turned into heat as they strike an object which will absorb some or all of the heat transmitted.

Radiator - A heating unit which is supplied heat through a hot water system.

Radon - A colorless, odorless, radioactive gas that comes from the natural breakdown of uranium in soil, rock, and water; can create adverse conditions where it seeps into buildings.

Rafter - One of a series of sloped/inclined structural roof members running from the wall to the ridge or top of roof; designed to support the roof deck, roofing and other loading; such rafters for a flat roof are called "joists"; common rafter is one which runs square with the plate and extends to the ridge. A hip rafter extends from the outside angle of the plate towards the apex of the roof. They are 2" deeper or wider than common rafters. A valley rafter extends from an inside angle of the plates toward the ridge of the house.

Rafter cuts - A trade term for the angle cut s on rafters to fit into framing system when stick-building a roofing system.

Raggle Block - A specially designed masonry block having a slot or opening into which the top edge of the roof flashing is inserted and anchored.

Rail - The horizontal top, bottom, and center framing pieces of panel doors or of a sash. Also the upper and lower members extending over or between posts of a balustrade or staircase extending from one vertical support, such as a post, to another.

Raised grain - A roughened condition of the surface of dressed lumber in which the hard summerwood is raised above the softer springwood but not torn loose from it.

Rake - (a) Trim members that run parallel to the roof slope and form the finish

between the wall and a gable roof extension. (b) An incline or slope, as in a pitched roof, or the angle of slope of a roof rafter, or the inclined portion of a cornice.

Ramp - A sloped surface for walking, or rolling equipment for easier access, between floor levels, than stairs; required as access under the ADA regulations for disabled persons; can be utilized with stairs.

Rankin - Thermometer scale on which unit of measurement equals the Fahrenheit degree.

Raw Linseed Oil - The crude product processed from flaxseed and usually without much subsequent treatment.

Raze - To demolish, remove, dismantle or wreck existing work, usually to provide place for new construction.

Ready-mix concrete - Concrete prepared at an off-site "batching plant" [where all ingredients are initially combined], and continuously mixed while transported in a truck from the plant to the site, so it is immediately ready for placement; also, called "transit mixed".

Rebar - Contracted term indicating "reinforcing bars" (rods/steel); Reinforcing bar used to increase the tensile strength of concrete; see Reinforcing steel.

Record Drawings - A set of contract document drawings, marked up as construction proceeds to reflect changes made during the construction process, which show the exact location, geometry, and dimensions of all elements of the constructed project as installed. It is good practice to make As-Built Drawings by marking the changes on reproducible drawings such as mylar, vellum or sepias for the duplication purposes later.

Reflective Glass - Glass with a metallic coating to reduce solar heat gain.

Reflective Insulation - Sheet material with one or both sun faces of comparatively low heat emissivity, such as aluminum foil. When used in building construction the surfaces face air spaces, reducing the radiation across the air space.

Register - A fixture through which conditioned air flows. In a gravity heating system, it is located near the baseboard. In an air conditioning system, it is located close to the thermostat.

Reglet - A horizontal slot, formed or cut in a parapet or other masonry wall, into which the top edge of counter-flashing can be inserted and anchored. In glazing, a reglet is typically a pocket or keyway extruded into the framing for installing the glazing gaskets.

Reimbursable Expense - Charges to the owner covering costs for services that could not or intentionally were not quantified at the time the fee arrangement was made.

Reimbursable Expenses (or Costs) - Amounts expended for or on account of the project which, in accordance with the terms of the appropriate agreement, are to be reimbursed by the owner.

Reinforced Concrete - A composite material in which steel bars are encased in the concrete to reinforce its tensile strength using the best properties of each; material bonded together to act in unison with a combined capacity that exceeds that of either material alone; various designs utilize varying amounts of reinforcing. The steel consists of rebar or reinforcing bars varying from 3/8" to 2 1/4" in diameter and is installed before concrete is placed.

Reinforced Masonry - Masonry units, reinforcing steel, grout and/or mortar combined to act together to strengthen the masonry structure.

Reinforcing - Steel bars (rods) deformed with projecting ridges to ensure bonding, placed in concrete slabs, beams, and columns to add tensile strength; bars are bent or straight as required, and tied in shapes, grids or other configurations as required for concrete member; most are round, but some are square in cross section; diameter sizes vary from 3/8" to 2-1/4"; cut to proper length, and bent to shapes required by structural designer, to strengthen concrete framing members.

Reinforcing mesh - Steel wires welded into a grid of 6 or 10 inch squares and embedded in concrete; ties concrete pads/slabs together to reduce cracking; also called simply "mesh", or "welded wire fabric" [see].

Relative Heat Gain - The amount of heat gain through a glass product taking into consideration the effects of solar heat gain (shading coefficient) and conductive heat gain (U-value).

Relative Humidity - The amount of water vapor in the atmosphere, expressed as a percentage of the maximum quantity that could be present at a given temperature. (The actual amount of water vapor that can be held in space increases with the temperature.)

Release of Lien - A written action properly executed by and individual or firm supplying labor, materials or professional services on a project which releases his mechanic's lien against the project property.

Relief valve - A type of valve designed to open if it senses excess pressure or temperature.

Remodeling - The practice of altering, upgrading, renovating, rehabilitating, and/or re-decorating existing conditions and adding new space to existing structures.

Re-sawing - Sawing lumber again after the first sawing; specifically, sawing into boards or dimension lumber.

Resident Architect - An architect permanently assigned at a job site who observes the construction work for the purpose of protecting the owner's interests during

construction; also called project Representative.

Resident Engineer (RE) (inspector) - An individual permanently assigned at a job site for the purpose of representing the owner's interests during the construction phase, i.e., Owner's Rep.

Resilient flooring - Vinyl, vinyl-composition, rubber, cork, and other man-made floor coverings that are flexible yet provide a smooth surface; available in tile form [9x9 inches or 12x12 inches] and in sheets up to approx. 60" wide; installed with an adhesive.

Resistance - The internal structure of wires even in the best conductors opposes the flow of electric current and converts some current into heat. This internal friction-like effect is called resistance and is measured in ohms. Resistance equals Voltage divided by Amperage.

Resorcinol Glue - A glue that is high in both wet and dry strength and resistant to high temperatures. It is used for gluing lumber or assembly joints that must withstand severe service conditions.

Retaining wall - A wall that holds earth in place nearly vertically; a retaining wall can either be mortared, dry stacked, or of poured concrete, masonry units, or wood timbers.

Return - 1] In heating and cooling systems, a vent that returns cold air to be warmed. In a hot air furnace system, it is located near an inside wall. 2] Change in direction of a molding, cornice, or other design feature, without breaking the continuity of the profile.

Reveal - Side of an opening for a window or door in a masonry or wood structure; margin to which the casing is set on the jamb for appearance, and to accommodate the door hinges.

RFP - The abbreviation for "Request for Proposal; The second request for uniform detailed information from prospective CM practitioners being screened for a project.

Ribbon (or Girt) - Horizontal wood member [called "girt" in steel] to support other members, or for attachment of wall Normally a 1- by 4-inch board let into the studs horizontally to support ceiling or second-floor joists.

Ridge/Ridge Board - The top edge of a roof where two slopes meet; also, the horizontal board between, and to which opposing rafters are attached, running the length of the roof structure.

Rigid Insulation - Another name for insulation materials in a stiff, high density board form, as opposed to pliable batts or blankets; commonly dense fiberglass or foam-type insulations.

Rigid Metal Conduit - This conduit resembles plumbing pipe, protecting wires from damage.

Rise - 1] In stairs, the vertical height of a single step, or a full flight of stairs; also, distance from one floor to the next for stair design is called "total rise"; 2] also, vertical height of a roof above the surrounding walls.

Riser - 1] In general, the vertical part of a stair step closing the spaces between the treads of stairways. 2] in plumbing, a vertical water supply line.

Roll Roofing - Roofing material, composed of fiber and satin rated with asphalt that is supplied in 36-inch wide rolls with 108 square feet of material. Weights are generally 45 to 90 pounds per roll.

Rolled section - Term applied to steel structural shapes [Is, wide-flanges, angles, channels, etc.] which are formed by rolling super-heated steel [blooms/billets] through successive rolls to form the final required shape.

Roll-Out - A loose term used to describe the rapid succession (completion) of similar projects over a given time period.

Romex - A nonmetallic sheathed cable consisting of two or more insulated conductors having an outer sheath of moisture resistant, nonmetallic material. The conductor insulation is rubber, neoprene, thermoplastic or a moisture resistant flame retardant fibrous material. There are two types: NM and NMC - described earlier.

Roof Sheathing - Boards, or sheet material fastened to the roof framing (rafters/trusses, etc.) and to which the shingles or other roof covering is attached; also, called "roof deck or decking".

Roof System - General term referring to the waterproof covering, roof insulation, vapor barrier, if used and roof deck as an assembly or entity.

Rough Carpentry - That work of the carpenter trade which is, for the most part, concealed, such as framing, blocking, furring, etc.; usually involves dimensioned lumber, and rough hardware.

Rough Hardware - All devices such as nails, screws, bolts, hangers, etc., which aid in the construction of the framing and rough construction of the project; also called "Builders' Hardware"; see Finish Hardware.

Rough Opening - Opening in framing around a window or door opening that has been sized to accept the finished units with allowances for fitting, shimming and leveling of the door or window units.

Rough Plumbing - All plumbing that should be done before the finish trades (dry-wall, painting, etc.), including all waste lines and supply water lines that are in the walls or framing of the building. See also: Plumbing, Sub Rough, and Finish Plumbing.

Rough-in - A trade term referring to the installation of underground or material to be concealed, prior to being enclosed in the stud walls, or under floors; examples would be for plumbing, heating, and electrical systems; the bulk of these systems must be installed before the wall coverings are applied, so this is considered rough-in work. Also, the erection of the framing of the structure; portion of a system which does not include finishes and fixtures.

Rowlock - Laying brick on the long, narrow side, so the small ends are vertical in the face of the wall; a vertical header.

RPM - Revolutions per Minute.

Rubber Emulsion Paint - Paint, the vehicle of which consists of rubber or synthetic rubber dispersed in fine droplets in water.

Rubber-Tired Roller - A roller with rubber tires commonly used for compacting trimmed subgrade or aggregate base or clay type soils.

Run - (roofing) The horizontal distance between the eaves and the ridge of the roof, being half the span for a symmetrical gable roof (stairs). The net horizontal distance of a flight of stairs; also, the horizontal distance from the top of the sidewall to the ridge of a roof.

Running Bond - Most commonly used brick coursing/bonding pattern consisting entirely of stretchers overlapping by 1/2 brick; i.e., vertical joints centered over brick below.

R-Value - The thermal resistance of a glazing system. The R-value is the reciprocal of the U-value. The higher the R value, the less heat is transmitted throughout the glazing material.

S

Saber Saw - a saw that cuts on the upstroke, good side of wood faces down.

Saddle - Two sloping surfaces meeting in a horizontal ridge, used between the back side of a chimney, or other vertical surface, and a sloping roof feature to divert water around the vertical surfaces. Also called a cricket.

Safety Report - The Occupational Safety and Health Act (OSHA) of 1970 clearly states the common goal of safe and healthful working conditions. A Safety Report is prepared following a regularly scheduled project safety inspection of the specific project.

Safing Insulation - Fire-resistant insulating material inserted into space between piping, ducts, curtain wall, conduit, beam, column, wall, floor, etc. where fire might pass through; packing behind fire penetration sealant used to close top of such openings and retard passage of fire and smoke.

Samples - Limited size, physical pieces and examples or prototypes and detailed information provided by material and equipment suppliers demonstrating that the item provided meets the requirements of the contract documents.

Sand Float Finish - Lime mixed with sand, resulting in a textured finish.

Sanding - To make smooth by rubbing sandpaper or similar abrasive over a surface before applying a finish.

Sandstone - A fine to coarse-grained sedimentary rock that splits easily; often used in the construction of garden walls and paths.

Sandwich Panel - Panel consisting of two outer faces of wood, metal, or concrete bonded to a core of insulating material.

Sanitary fitting - Any of several connectors linking drain-waste-vent lines and designed to direct wastes downward.

Sap - Most of the fluids in a tree. Certain secretions and excretions, such as oleoresin, are excepted.

Sapwood - The outer zone of wood, next to the bark. In the living tree it contains some living cells (the heartwood contains none), as well as dead and dying cells. In most species, it is lighter colored than the heartwood. In all species, it is lacking in decay resistance.

Sash - Individual movable panels of window frames surrounding the glass; a single light frame containing one or more lights of glass.

Saturated Felt - A felt which is impregnated with tar or asphalt.

Scaffold - A temporary structure or platform for workers to sit or stand on when working at a height above the floor or ground.

Scale - Use of proportional measurements, i.e., using a small increment of measure to represent one foot (usually); also a drafting tool with markings at different intervals to permit measuring using different increments.

Scarf joint - A joint between two pieces of wood cut at an angle which allows them to be spliced and slide, one over the other, lengthwise without creating an open joint.

Schedule - A time-related plan for performing work or achieving an objective. 1] Written/graphic listing of various units of construction [doors, windows, toilet accessories, finish hardware, soil borings, room finishes, lintels, kitchen equipment, etc.], 2] activity to plan sequence or work, assignment of contractors, delivery of materials, etc. to meet stated completion date for project.

Schedule 40 pipe - This is a rating for the thickness and strength of a pipe; it is the standard weight of plastic pipe used for residential drainage and vent plumbing

systems.

Schedule of Values - (1) The breakdown of a lump sum price into sub-items and sub-costs for identifiable construction elements, which can be evaluated by examination for contractor progress payment purposes. (2) A statement furnished by the contractor to the architect or engineer reflecting the portions of the contract sum allotted for the various parts of the work and used as the basis for reviewing the contractor's applications for progress payments.

Schematic - A preliminary sketch or diagram representing the proposed intent of the designer.

Schematic Design Phase - The initial Design Phase on an architectural project: the first phase of the A/E design professional's basic services in which he/she consults with the owner to ascertain the requirements of the project and prepares schematic design studies consisting of drawings and other documents showing the scale, project components, and delineates the owner's needs in a general way for the owner's approval.

Scheme - (1) A chart, a diagram, or an outline of a system being proposed (2) An orderly combination of related construction systems and components for a specific project or purpose.

Scope of Work (SOW) - A written range of view or action; outlook; hence, room for the exercise of faculties or function; capacity for achievement; all in connection with a designated project.

Scotia - A hollow molding used as a part of a cornice, and often under the nosing of a stair tread.

Scratch Coat - The first coat of plaster, which is scratched to form a bond for the second coat.

Screed - The wood or metal straightedge or board used to strike off or level newly placed concrete immediately after it is placed, when doing concrete work. Screeds can be the leveling device used or the form work used to level or establish the level of the concrete. Screeds can be hand used or mechanical.

Screeding - Process of dragging a straight board across wet concrete to strike off excess concrete to achieve the desired thickness or grade elevation on the concrete.

Scribe - Fitting woodwork to an irregular surface or another section of wood trim by marking and cutting/coping wood or other materials so its edge matches the surface it butts up to, as the edge of a cabinet or paneling against a wall; in moldings, cutting the end of one piece to fit the molded face of the other at an interior angle to replace a miter joint.

Scupper - Opening through a wall for drainage of water from floor or roof into a downspout; requires careful and extensive flashing for watertight installation.

Scutch - A bricklayer's cutting tool used for dressing and trimming brick to a special shape. It resembles a small pick.

Scuttle - Opening and box-like unit with cover, in a ceiling or roof that provides access to an attic or roof.

Sealant - Thickened liquid, mastic, or paste substance, with adhesive qualities applied between components of a similar or dissimilar nature to provide an effective barrier against the passage of the elements; used to seal cracks, joints and porous surfaces; must adhere to surrounding material and permit expansion and contraction without rupture; many varieties, chemical compounds, types, colors and uses involved; may also be in tape or gasket form [see Caulking, and Gun-Grade Sealant].

Sealer - A finishing material, either clear or pigmented, that is usually applied directly over uncoated wood for the purpose of sealing the surface; also finish material [clear or pigmented] applied to reduce porosity or "dusting" of underlying material; e.g., concrete tends to create a dust as it dries.

Seasoning - Removing moisture from green wood in order to improve its serviceability.

Seismic Load - Added stresses/load on a structure caused by movement of the earth relative to that structure during an earthquake; varies by locale, and history of earthquake incidents; applicable to almost every project, if only to a limited degree; must be part of structural calculation and design for projects.

Select lumber - Lumber without knots or other deformities; it is the best lumber; in hardwood it refers to a specific grade.

Self-Healing - A term used to describe to a material which melts with the heat from the sun's rays, and seals over cracks that were earlier formed from other causes. Some waterproof membranes are self-healing.

Self-Leveling - A term used to describe a viscous material that is applied by pouring. In its uncured state, it spreads out evenly.

Selvage - The unsurfaced strip along a sheet of roll roofing which forms the under portion at the lap in the application of the roof covering.

Semigloss - Primarily a paint or enamel finish made with a slight insufficiency of nonvolatile vehicle so that its coating, when dry, has some luster but is not very glossy; can apply to other finished surfaces.

Separation - In concrete application, what happens to concrete when it is dropped directly with a flat chute causing the concrete to separate, usually occurring at a 1:2 slope.

Service Conductor - In electrical contracting, the supply conductors that extend

from the street main or from the transformer to the service equipment.

Service Drop - In electrical contracting, the overhead service conductors from the last pole or other aerial support to and including the splices, if any, connecting to the service entrance conductors at the building.

Set - 1] The change in concrete and mortar from a plastic (semi-liquid) to a solid (hardened) state; 2] Assemblage of drawings created and compiled to depict a complete construction project.

Setback - A required minimum distance from the property line to the line/point where construction may begin; open area also called a "required yard" where no constructed features may occur; applied to each section of a property line; usually required by zoning regulations.

Setting Blocks - Generally rectangular cured extrusions of neoprene, EPDM, silicone, rubber or other suitable material on which the glass product bottom edge is placed to effectively support the weight of the glass.

Settlement - Shift in structure caused reduction/shrinkage of soil beneath the foundation; usually uneven in nature, and can cause cracking in the upper walls.

Shading Coefficient - The ratio of the solar heat gain through a specific glass product to the solar heat gain through a lite of 1/8" (3mm) clear glass. Glass of 1/8" (3mm) thickness is given a value of 1.0, therefore the shading coefficient of a glass product is calculated as follows:

Shake - A thick hand-split shingle, re-sawn to form two shakes; usually edge-grained.

Sheathing - The rough structural covering, usually wood boards, plywood, gypsum or wood fiber, used over studs or rafters of framed buildings as the first layer of outer covering; installed under the exposed finished material.

Sheathing Paper - A building material, generally paper or felt, used in wall and roof construction as a protection to retard the passage of air and sometimes moisture.

Shed Roof - A roof having only one slope or pitch, with only one set of rafters which fall from a higher to a lower wall.

Sheet metal - Flat rolled metal less than 1/4-inch [6,35mm] in thickness.

Sheet Metal Work - All components of a house employing sheet metal, such as flashing, gutters, and downspouts.

Shelf-Life - Used in the glazing and sealant business to refer to the length of time a product may be stored before beginning to lose its effectiveness. Manufacturers usually state the shelf life and the necessary storage conditions on the package.

Shellac - A transparent coating made by dissolving lac, a resinous secretion of the lac bug (a scale insect that thrives in tropical countries, especially India), in alcohol.

Shim - A thin, tapered piece of wood used for wedging purposes to create level or plumb surfaces on materials.

Shingles - A covering applied in overlapping layers, for the roof or sides of a building; covering of asphalt, wood, tile, slate, or other material cut to stock lengths, widths, and thicknesses, which are laid in a series of overlapping rows, as a roof covering on pitched roofs.

Shiplap Lumber - Boards that are edge-dressed to make a close rabbeted or lapped joint, so they fit into or overlap each other.

Shop drawings - Drawings produced by manufacturers or fabricators which show, exactly, how items or equipment will be constructed so they meet the requirements of the contract drawings; literally, instructions to the "shop" for production of the item; used as submittals to the design professional as verification of how work will be accomplished.

Shore "A" Hardness - Measure of firmness of a compound by means of a Durometer Hardness Gauge. (A hardness range of 20-25 is about the firmness of an art gum eraser. A hardness of about 90 is about the firmness of a rubber heel.)

Shoring - The placing of shores [upright braces] under formwork as temporary supports; also refers to the bracing or sheeting used to hold back an earth bank.

Shutter - Usually lightweight louvered or flush wood or non-wood frames in the form of doors located at each side of a window. Some are made to close over the window for protection; others are fastened to the wall as a decorative device.

Sidelight - Usually a tall and fairly narrow glass panel on either or both sides of a door.

Siding - The finish covering of the outside wall of a frame building, whether made of horizontal weatherboards, vertical boards with battens, shingles, or other material; boards, panels or other sections of material placed over the outside wall of a frame building and nailed to the sheathing. Although wood or plywood is generally used, composition board is also popular. Wood siding is made in several different patterns, as are vinyl and aluminum.

Sight Line - The line along the perimeter of glazing infills corresponding to the top edge of stationary and removable stops. The line to which sealants contacting the glazing infill are sometimes finished off.

Signage - Modern term for the entire coordinated system or pattern of signs used on, around and throughout a building, interrelated and color-coded or coordinated.

Silicone - A polymer used for high range sealants, roof membranes, and masonry water repellent.

Silicone Sealant - A sealant having as its chemical compound a backbone consisting of alternating silicon-oxygen atoms.

Sill - The lowest member of the frame of a structure, resting on the foundation and supporting the floor joists or the uprights of the wall. Also, the member forming the lower side of an opening, as a door sill, window sill, etc.

Sill Plate - The framing member anchored to the foundation wall upon which studs and other framing members will be attached. It is the bottom plate of your exterior walls.

Sill Sealer - A material placed between the top of the foundation wall and the sill plate. Usually a foam strip, the sill sealer helps make a better fit and eliminate water problems.

Sill Step - The first step coming directly off a building at the door openings.

Single Family Dwelling (SFD) - A house built for the purpose of a single family as opposed to multi families such as a duplex or apartment complex.

Single Ply - A descriptive term signifying a roof membrane composed of only one layer of material such as EPDM, Hypalon or PVC.

Single Tee - The name given to a type of precast concrete deck which has one stiffening rib integrally cast into slab to form a member in the shape of the letter "T".

Sisal Kraft paper - A heavy, strong paper reinforced with strands of sisal fibers. The strands of sisal are placed between two layers of paper stuck together with a coat of pitch. This paper has many uses around construction because of its toughness and durability.

Site - The land area or real estate place where a structure or group of structures was, or is to be located, i.e., a construction, project or job site.

Site-cast (Cast-In-Place) Concrete - Concrete placed and cured in its final position in a building.

Site conditions - A term used when describing the attributes of a construction site. Examples would be: level, sloping, rocky, wet, etc.

Site-constructed - Built on the job or project location.

Site plan - The drawing that shows the boundaries of the property, existing features [natural and man-made], the layout of the proposed building, its location, site utilities, and other proposed improvements, also called a "site improvement" or "plot" plan.

Site work - Refers to the preparation of a site for building construction [clearing, grading, excavating, trenching, utility service lines].

Sizing - (1) Working material to the desired size. (2) A coating of glue, shellac, or other material applied to a surface to prepare it for wall covering, paint or other finish; similar to a primer.

Sky Dome - A type of skylight exhibiting a characteristic translucent plastic domed top.

Skylight - A glazed panel [window] in a box-like unit built into a roof or ceiling; designed to admit light and is somewhat above the plane of the roof surface.

Slab - 1] Term generally used when referring to a concrete floor; concrete pavements and sidewalks are also concrete slabs; 2] also, a thick slice of stone or other masonry material.

Slab-on-Grade - 1] A concrete floor slab/surface lying upon, and supported directly by, the ground beneath; 2] A term for a type of construction in which wall footings are needed but little or no foundation wall is poured, and the floor slab "floats" inside the foundation [not supported on the walls].

Slack Time - The flexibility with non-critical jobs that allows their start dates to be adjusted without affecting the project completion date. (also referred to as Float).

Slag - A by-product of smelting ore such as iron, lead or copper. Also overburden/dropping from welding which may burn, melt, or discolor adjacent surfaces.

Slate - A dark gray stratified stone cut relatively thin and installed on pitched roofs in a shingle like fashion.

Sleeper - Usually, a wood member embedded in concrete, as in a floor, that serves to support and to fasten subfloor or flooring.

Sleeve(s) - Tube or section of pipe installed under the concrete driveway or sidewalk, or through walls and floors that are used later to run piping, wiring or other utility equipment/devices.

Slope - Incline or pitch of roof surface; relationship between rises and run of a roof; amount of gradient on any non-level surface.

Sloped Glazing - Any installation of glass that is at a slope of 15 degrees or more from vertical.

Slump - A measure of the stiffness or "wetness" of concrete; see Slump Test.

Slump-Test - Measures the consistency of a concrete mix or its stiffness; differential between top of concrete and 12" high, test cone [used to form concrete, then removed]; 3-inch slump is dryer and stiffer than a 5-inch slump. If the tests results are high, one likely cause would be too much water. Low slump-not enough water. The test is measured in inches.

Smoke chamber - he portion of a chimney flue located directly over the fireplace.

Soffit - The area below the eaves and overhangs. The underside where the roof overhangs the walls. Usually the underside of an overhanging cornice extending out from the plane of the building walls.

Soft Costs - Soft Costs are cost items in addition to the direct Construction Cost. Soft Costs generally include architectural and engineering, legal, permits and fees,

financing fees, construction Interest and operating expenses, leasing and real estate commissions, advertising and promotion, and supervision.

Softening Point - The temperature at which a substance changes from a hard material to a softer and more viscous material.

Softwood - Wood produced from coniferous trees or trees that bear cone. Most commonly used are the pines, but also included such trees as fir, spruce, redwood, and cedar. The term has no reference to the actual hardness or softness of the wood.

Soil boring - Holes created by driving a hollow tube into the subsurface soil for the purpose of investigating the load bearing and stability characteristics of the earth under a building; tube fills with soil, and then is extracted so soil samples can be examined.

Soil Cover (or Ground Cover) - A light covering of plastic film, roll roofing, or similar material used over the soil in crawl spaces of buildings to minimize moisture permeation of the area.

Soil Stack - A general term for the vertical main of a system of soil, waste, or vent piping.

Sole Plate - bottom horizontal member of a frame wall.

Solid Bridging - A solid member placed between adjacent floor joists near the center of the span to prevent joists from twisting; structural bridging may also be "X" shaped, or horizontal.

Solid core door - A flush door with solid stiles and rails and a solid infill material with no internal cavities.

Sonotube - Large, round cardboard tubes used as forms designed to hold wet concrete in place until it hardens; forms are then easily stripped or torn away; used to form concrete columns.

Sound attenuation - Sound proofing a wall or subfloor, generally with fiberglass insulation to reduce transmission of sound through the construction assembly [see STC].

Spacers (Shims) - Small blocks of neoprene, EPDM, silicone or other suitable material placed on each side of the glass product to provide glass centering, maintain uniform width of sealant bead and prevent excessive sealant distortion.

Spalling - The chipping or flaking of concrete, bricks, or other masonry where improper drainage or venting and freeze/thaw cycling exists.

Span - The clear, unencumbered horizontal distance between structural supports such as walls, columns, piers, joists, beams, girders, and trusses.

Spandrel - The wall area above a window; the panels of a wall located between vision areas of windows, which conceal structural columns, floors, and shear walls.

Special Conditions - (1) Amendments to the General Conditions that change standard requirements to unique requirements, appropriate for a specific project. (2) A section of the conditions of the contract, other than the General Conditions and Supplementary Conditions, which may be prepared for a particular project. (3) Specific clauses setting forth conditions or requirements peculiar to the project under consideration, and covering work or materials involved in the proposal and estimate, but not satisfactorily covered by the General Conditions.

Special Consultants - Experts in highly specialized fields not inherent to an owner, A/E, or CM.

Specifications - A detailed, exact statement of particulars, especially statements prescribing the kinds and attributes of materials and methods, and quantitative and qualitative information pertaining to material, products, and equipment to be incorporated into a specific project. Detailed written instructions which, when clear and concise, explain each phase of work to be done, quality and level of workmanship required, and the general methods of installing and erecting the work; serve to complement, explain, and augment graphic information of working drawings.. The most common arrangement for specifications substantially parallels the Construction Specification Institute (CSI) format.

Splash Block - A small pan or block, of pre-cast concrete, or plastic, laid with the top close to the ground surface to catch roof drainage from downspouts and to direct, divert or carry it away from the building foundation.

Splice - The joining of two members to form one piece by attaching plates or boards and fastening to each of the members [spanning across the joint].

Splitting - The formation of long cracks completely through a membrane. Splits are frequently associated with lack of allowance for expansion stresses. They can also be a result of deck deflection or change in deck direction.

Spread footing - A concrete footing larger than the structural member it supports constructed for the purpose of spreading the load over the bearing soil; used under piers, columns, and foundation walls.

Sprinklers - A fire protection systems whereby water, foam or other extinguishing agents are disbursed from overhead or sidewall heads [spraying devices] when activated by the heat from a fire; first line of defense to extinguish fires in early and limited stages.

Spud - (not a potato!) The removal of gravel or heavy accumulations of bitumen from roof membranes by means of chipping or scraping.

Square - 1] A unit of measure, e.g., 100 square feet, usually applied to roofing material. Generally roof area estimates are expressed in the number of squares of mate-

rial required for application. Sidewall coverings are sometimes packed to cover 100 square feet and are sold on that basis. 2] Also indicates perpendicular, or at right [90 degree] angle.

Stack - The vertical pipe of a system of soil, waste or vent piping.

Stack Vent - Also called a waste vent or soil vent, it is the extension of a soil or waste stack above the highest horizontal drain connected to the stack.

Stain - A form of oil paint, very thin in consistency, intended for coloring wood with rough surfaces, such as shingles, without forming a coating of significant thickness or gloss.

Stair Carriage - Supporting member for stair treads. Usually a 2-inch plank notched to receive the treads; sometimes called a "rough horse."

Stair landing - A platform between flights of stairs or at the termination of a flight of stairs. Often used when stairs end, or change direction. Normally no less than 3 ft. X 3 ft. square.

Stair riser - The vertical member and distance from top of stair tread to top of next stair tread (and not to exceed dimension noted in building code, usually 7 to 7 1/2").

Stair stringer - Side supporting member for stair treads. Usually a 2 X 12 inch plank notched to receive the treads.

Stair well - A compartment extending vertically through a building, into which a stairway system is installed.

Standard Details - A detail drawing or illustration sufficiently complete and detailed, and generic enough for re-use on other projects with minimum or no changes.

Standard Dimension - A measurement unique to a specific manufactured item.

Standards of Professional Practice - A listing of minimum acceptable ethical principals and practices adopted by qualified and recognized professional organizations to guide their members in the conduct of specific professional practice.

Standing Seam - A type of joint often used on metal roofs.

Start Date - The date that an activity or project begins.

Start-Up - The period prior to owner occupancy when mechanical, electrical, and other systems are activated and the owner's operating and maintenance staff are instructed in their use.

Statement - A copy or summary of any account covering a stated period.

Static Decisions - Decisions that are made or can be made under the full influence of the project team's checks and balances.

Static Load - The total amount of permanent non moving weight that is applied to given surface areas.

Static Risks - Risks inherent to the project-delivery process which occur or can occur by accident and have no opportunity for gain in the manner of their disposal.

Statute of Limitations - The period of time in which legal action must be brought for an alleged damage or injury. The period commences with the discovery of the alleged damage or injury; or in construction industry cases with completion of the work or services performed. Legal advice should be obtained.

STC (Sound Transmission Class) - The measure of an assembly's [comprised of various materials] ability to inhibit the transmission of sound through that assembly. A single number rating derived from individual transmission losses at specified test frequencies. It is used for interior walls, ceilings and floors.

Steel joist - A light, steel truss made from small bars, rods, or angles welded into rigid units; sometimes referred to as "steel lumber", or "bar joists".

Steel Trowel - Tool used for non-porous smooth finishes of concrete. It is a flat steel tool used to spread and smooth plaster, mortar or concrete. Pointing trowels are small enough to be used in places where larger trowels will not fit. The pointing trowel has a point. The common trowel has a rectangular blade attached to a handle. For smooth finish, use trowel when concrete begins to stiffen.

Step Flashing - Individual small pieces of metal flashing material used to flash around chimneys, dormers, and such projections along the slope of a roof. The individual pieces are overlapped and stepped up the vertical surface.

Stick built - A structure built without prefabricated parts. Also called conventional building.

Stile - The side frame members of a panel door or window (not the jamb).

Stipulated Sum Agreement - A written agreement in which a specific amount is set forth as the total payment for completing the contract.

STL (Sound Transmission Loss) - The reduction of the amount of sound energy passing through a wall, floor, roof, etc. It is related to the specific frequency at which it is measured and it is expressed in decibels. Also called "Transmission Loss".

Stool - A flat horizontal molding fitted over the lower rough framing at a window sill, between jambs and contacting the bottom rail of the lower sash; commonly called "window sill".

Storefront Construction - System of light aluminum tubular sections interconnected to form a network of glass frames, utilizing large glass panels; usually includes the entrance complex, and acts as both wall and fenestration.

Storm Door - A panel or sash door placed on the outside of an existing door to provide additional protection from the elements.

Storm Sewer (Drain) - A sewer, pipe or other features (natural or man-made) used

to carry away rain-produced surface water drainage [but not sewage].

Storm Window - A glazed panel or sash placed on the inside or outside of an existing sash or window as additional protection against the elements.

Story - That space in a building from top of floor to top of floor next above.

Straightedge - Used to strike off the surface of a concrete slab using screeds and a straight piece of lumber or metal.

Strain - The percentage of elongation or compression of a material or portion of a material caused by an applied force.

Strap footing - Footing for two or more columns; columns so closely spaced, so it is easier to construct one common footing.

Striking Off - The operation of smoothing off excess compound or sealant at sight line when applying same around lites or panels.

String (or Stringer) - A timber or other support for cross members in floors or ceilings. In stairs, the support on which the stair treads rest; also stringboard.

String Line - A nylon line usually strung tightly between supports to indicate both direction and elevation, used in checking grades or deviations in slopes or rises. Used in landscaping to level the ground.

Strip Flooring - Finish flooring in the form of long, narrow, matched strips, or tongue and groove boards; wood or some synthetic materials.

Structural Design - A term used to represent the proportioning of structural members to carry loads in a building structure.

Structural Glazed (Clay) Tile - Hollow clay tile with glazed faces; used for constructing interior partitions where sanitation or cleanliness are concerns.

Structural Shapes - The "H", "I", "T" beams, angle, channel, and plate members for framing; steel, wood or concrete.

Structural Silicone Glazing - The use of a silicone sealant for the structural transfer of loads from the glass to its perimeter support system and retention of the glass in the opening.

structural steel - May be pre-cast.

Structural Systems - The load bearing frame assembly of beams and columns on a foundation. The beams and columns are generally fabricated off site and assembled on site. Other systems such as non load bearing walls, floors, ceilings and roofs are generally constructed within and on the structural system.

Structural Tubes - Usually welded seam, hollow tubular steel sections, of various sizes used as light columns, struts and bracing; also, other structural and sometimes decorative installations; can be square or rectangular.

Structure - (1) Something constructed (2) Building or other unit/facility erected or constructed in accord with specific drawings and specifications.

Stucco - A type of exterior finish. Most commonly refers to an outside plaster made with Portland cement as its base.

replaced by EIFS materials to some degree.

Stud - One of a series of wood or metal vertical structural members placed as supporting elements in walls and partitions, usually a piece of dimension lumber, 2 x 4 or 2 x 6, used in a series of spaced elements [commonly spaced 16 or 24-inches o.c.] to form the framework of a partition or wall.

Study and Report Phase - Principally applicable to engineering projects. Includes the investigation and determination of specific conditions and/or areas, activities or phases of the project and provides recommendations of design solutions to and owner's needs.

Sub - An abbreviation for Subcontractor.

Subcontract - A written form of agreement between the prime or main contractor and another contractor or supplier for the satisfactory performance of services or delivery or material as set forth in the plans and specifications for a specific project.

Subcontractor - A qualified subordinate contractor [individual or firm] who has a contract with the prime or main contractor. The subcontractor usually specializes in and agrees to do certain specific trade or skilled work on a building. Tile work, waterproofing plumbing, heating, electrical work, and other limited portions of construction work are sublet and perform by sub-contractors.

Subcontractor Bond - A written document from a subcontractor given to the prime or main contractor by the subcontractor guaranteeing performance of his/her contract and payment of all labor, materials, equipment and service bills associated with the subcontract agreement.

Subfloor - Carpentry term applied to flooring laid directly on the joists and serving as "temporary" decking during construction; Boards or plywood laid on joists over which a finish floor is to be installed; left in place when all rough construction work is completed, the finish floor is laid over the sub-floor.

Sub-grade - A fill or earth surface upon which concrete is placed; generally the area below the top of the earth surrounding a building.

Sublet - To subcontract all or a portion of a contracted amount.

Submittal[s] - Documents required, by project specifications, to be returned to the design professionals and contractors, by manufacturers, suppliers, and sub-contractors, showing and explaining, in precise terms, how fabrication and preparation of materials and systems will be done for the specific project; include shop drawings, product data, samples, certifications, etc.; professionals and contractors check and

approve these documents when in accord with general design concept.

Sub-Rough - That part of a building's plumbing system that is done before the cement is poured.

Substantial Completion - The stage in the progress of the work when the work, or designated portion of the work, is sufficiently complete in accordance with the contract documents so that the owner can occupy or utilize the work for its intended use.

Substantial Completion Date - The date on which a contractor reaches a point of completion, when subsequent interfacing contractors can productively begin work or the owner can occupy the project, in whole or in part, without undo interference.

Substitution - A proposed replacement or alternate offered in lieu of and represented as being equivalent to a specified material or process; must be fully equivalent to that specified.

Substrate - A part or substance which lies below and supports another; rough material similar to underlayment, which is installed under or behind a finish material for added support and strength.

Substructure - The supporting part of a structure, i.e., foundation system, and portion of structure/building below grade line; lowest support for superstructure; visible only in small part.

Sub-subcontractor - An individual or contractor who has a written contract with a subcontractor to perform a portion of the work; for example, a carpet laying service hired by a carpet supplier.

Sub-surface Investigation - (1) A term used to represent an examination of soil conditions below the ground. (2) Investigations include soil borings and geotechnical laboratory tests for structural design purposes.

Successor - (1) One that succeeds another (2) A scheduled activity whose start depends on the completion of one or more predecessors.

Superintendent - A job title usually reserved for the administrative level person who supervises the work of an on-site contractor.

Superstructure - The highly visible, major mass of the building, above ground level and the sub-structure and foundation.

Supervision - (1) The act, process, or function of supervising construction materials, methods and processes for a specific project (2) Hands on field direction of the contracted work by a qualified individual of the contractor.

Supplemental Conditions - Supplements or modifies the standard clauses of the general conditions to accommodate specific project requirements (synonymous with Supplementary Conditions).

Supplementary Conditions - A written section of the contract documents supplementing and qualifying or modifying the contracts general conditions.

Supplier - An individual or firm who supplies and/or fabricates materials or equipment for a specific portion of a construction project but does not perform any labor on the project. [see manufacturer].

Surety Company or Surety - A properly licensed firm or corporation willing to execute a surety bond, or bonds, payable to the owner, securing the performance on a contract either in whole or in part; or securing payment for labor and materials.

Survey - A procedure which examines and investigates the attributes of land areas; reviews legal descriptions, records, utility services, topography, physical features [natural and man-made] and overall state of the land area; also, drawing produced to depict investigation of documents and field observations; made to scale, by a registered land surveyor, showing the lengths and directions of the boundary lines of the lot; the surrounding lots and streets; the position of the house and all exterior improvements such as walkways, driveways, decks and porticos within the lot; and any existing encroachments.

Suspended Ceiling - A ceiling system supported by hanging it, by wire and light channel framing, from the overhead structural framing; may be solid drywall, or a series of acoustical panels laid in a grid.

Swale - A broad, shallow ditch or depression in the ground, either occurring naturally, or excavated for the purpose of directing water runoff.

Synergism - Actions by two or more persons to achieve an end result that could not be achieved as well by one of the persons.

T

T & G - Tongue and groove; a protrusion full length on edge of one piece of material fits into a groove in the next adjacent piece.

T&M - (1) An abbreviation for a contracting method called Time and Materials (2) A written agreement between the owner and the contractor wherein payment is based on the contractor's actual cost for labor, equipment, materials, and services plus a fixed add-on amount to cover the contractor's overhead and profit.

Tail Beam - A relatively short beam or joist supported in a wall on one end and by a header at the other.

Take-off - Process of measuring and otherwise ascertaining quantities of various materials for estimating purposes; associated more with materials than with labor.

Taper - A gradual and uniform decrease in size, as of a round or rectangular piece

or hole.

Taping - The process of covering the joints in drywall construction by applying joint tape over embedding compound in the process of joint treatment and filling over them with several coats of joint compound to produce a continuous smooth surface.

Team - The designated responsible project management of each trade contractor plus the Level 2 and Level 3 Managers of the owner, A/E, and CM, i.e., Project Team.

Tear-Off - In roofing, a term used to describe the complete removal of the built up roof membrane and insulation down to and exposing the roof deck.

Technical Inspection - Matching technical specification criteria with visual or mechanical tests on the project site, or in a remote location or laboratory, to ascertain conformance.

Technical Review - The critique of design solutions, or criteria used for design solutions, by a party other than the one providing the solutions or criteria, to determine adequacy and suitability of purpose.

Technical Specifications - Written criteria that augment the drawings pertaining to the technical construction of the project that cannot be conveniently included on the plans.

Tee - A pipe fitting, or pre-cast concrete member with a cross section resembling the letter T.

Tempered glass - Glass that has been cooled rapidly to produce surface tension. The result is a stronger-than-normal glass that shatters into relatively harmless cubical fragments when broken.

Template - A full-sized pattern from which structural or other work layouts are made. Templates may be of paper, cardboard, plywood, or metal.

Tenant's Rentable Square Feet - Usable square feet plus a percentage (the core factor) of the common areas on the floor, including hallways, bathrooms and telephone closets, and some main lobbies. Rentable square footage is the number on which a tenant's rent is usually based.

Tenant's Usable Square Feet - The square footage contained within the demising walls.

Tension - A stretching force; to stretch; a force that tends to pull apart.

Tenure - The duration, term, or length of time required by agreement or precedent for performance of services.

Termites - Insects that superficially resemble ants in size, general appearance, and habit of living in colonies; hence, they are frequently called "white ants." Subterranean termites establish themselves in buildings not by being carried in with lumber, but by entering from ground nests after the building has been constructed; they do attack and eat away wood members.

Termite Shield - A shield, usually of noncorrodible metal, placed in or on a foundation wall or other mass of masonry or around pipes to prevent passage of termites.

Terneplate - Sheet iron or steel coated with an alloy of about four parts lead to one part tin; primarily a roof covering.

Terra cotta - Ceramic material formed into masonry units- usually for decorative features.

Testing - Applying standard procedures to determine if prescribed technical criteria have been met in performance.

Testing Agencies - Entity, separate from any of the contractual parties on a project, engaged to perform inspections, tests, and analysis either at the site, in a laboratory or elsewhere; reports results to proper project party, and interprets results if required; may function to meet specifications, or to investigate problems which arise; building codes list some such agencies which are approved and acceptable due to impartiality, reliability, and past performance.

Texture Paint - One which may be manipulated by brush, trowel or other to give various patterns.

Thermal Insulation - Any material high in resistance to heat transmission that, when placed in the walls, ceiling, or floors of a structure, will reduce the rate of heat flow.

Thermal Movement - The measured amount of dimensional change that a material exhibits as it is warmed or cooled.

Thermal Shock - The stress built up by sudden and appreciable changes in temperature.

Thermoplastic Material - Solid material which is softened by increasing temperatures and hardened by decreasing temperatures.

Three-Phase - In electrical contracting, a wiring system consisting of 4 wires and used in industrial and commercial applications. This system is suitable for installations requiring large motors. It consists of three hot wires and one ground wire. The voltage in each hot wire is out of phase with the others by 1/3 of a cycle, as if produced by 3 different generators.

Threshold - A strip of wood or metal with beveled edges used over the joint between finish floor and the sill of exterior doors.

Thru-Wall Flashing - Flashing extended completely through a masonry wall. Designed and applied in combination with counter-flashings, to prevent water which may enter the wall above from proceeding downward in the wall or into the roof deck or roofing system.

THW - Moisture and heat resistant thermoplastic conductor. It is flame retardant, moisture and heat resistant and can be used in dry or wet locations.

Tie-In - In roofing, a term used to describe the joining of a new roof with the old.

Tile - A fired clay product that is thin in cross section as compared to a brick, either a thin, flat element (ceramic tile or quarry tile), a thin, curved element (roofing tile), or a hollow element with thin walls (flue tile, tile pipe, structural clay tile); also a thin, flat element of another material, such as an acoustical ceiling unit or a resilient floor unit.

Tilt-up construction - A method of constructing walls, and sometimes floors, by pouring concrete or putting wooden walls together in flat panels. When complete, they are moved to the building site where they are tilted into permanent place; units can be site built and then raised [tilted] into place.

Timbers - Yard lumber 5 or more inches in least dimension. Includes beams, stringers, posts, caps, sills, girders, and purlins Construction lumber larger than 4" x 6" (102 x 152 mm) in cross section.

Time is of the Essence - A provision in a construction contract by the owner that punctual completion within the time limits or periods in the contract is a vital part of the contract performance and that failure to perform on time is a breach and the injured party is entitled to damages in the amount of loss sustained. e.g., "time is of the essence in the completion of the construction contract".

Time of Completion - The date or number of calendar or working days stated in the contract to substantially complete the work for a specific project.

Time-and-a-half - A term meaning any individuals normal billing hourly rate is increased by a multiple of 1.5 following predetermined normal working hours.

Timeline - A synonym for scheduling of activities in the context of time.

Timely Completion - Completing the work of the contract before the date required.

Timely Performance - Compliance with a time requirement.

Tinted Glass - Glass that is colored with various formulations of pigments, dyes, or other admixtures added to the basic glass batch that give the glass color as well as light and heat-reducing capabilities. The color extends throughout the thickness of the glass; also, glass to which colored coatings have been applied.

TI'S (Tenant Improvements) - TI'S is a term used to define the interior improvements of the project after the Building Envelope is complete. TI'S usually include finish floor coverings; ceilings; partitions; doors, frames, hardware; fire protection; HVAC consisting of branch distribution duct work, control boxes, and registers; electrical consisting of lighting, switches, power outlets, phone/data outlets, exit and energy lighting; window coverings; general conditions; and the general contractor's fee. The cost of tenant improvements are generally born by the tenant and the costs of tenant improvements will vary with every building, and with tenant requirements.

Toe Bead - Sealant applied at the intersection of the outboard glazing stop and the bottom of the glazing channel; must be sized to also provide a seal to the edge of the glass.

Toenailing - Driving a nail at a slant, usually about 45 degrees with the initial surface in order to permit it to penetrate into a second member; used to attach joists to plates, etc.

Toe space - Recessed area at the bottom of cabinets and casework which allows person to stand close to face of units with toes in the recessed area.

Toilet Room Accessories - Various items of equipment such as towel dispensers, soap dispensers, waste receptacles, sanitary napkin and seat dispensers, robe hooks, tissue holders, etc. for installation in restrooms.

Tongue & Groove - A continuous projection on the edge of a board that fits into a groove formed on another board; also called "T&G" [see].

Tooling - The operation of pressing in and striking a sealant in a joint to press the sealant against the sides of a joint and secure good adhesion; the finishing off of the surface of a sealant in a joint so that it is flush with the surface.

Top chord - The top sloped or horizontal member of a truss.

Top Mopping - The finished mopping of hot bitumen on a built-up roof.

Top Plate - Top horizontal member of a frame wall; wood member laid horizontally on top of the studs to tie them together and form a base for the framing above which may be a floor or a roof. Most often two such plates are used - one over the other.

Topography - The configuration of the earth's surface, established by survey technique of taking grade elevation readings, and depicted by contour lines along with the locations of the natural or man-made monuments on survey plats.

Torching - Applying direct flame to a membrane for the purpose of melting, heating or adhering.

Total run - The overall horizontal measurement of a stair; horizontal distance from face of top riser to face of lowest riser.

Tower crane - Single-masted, top slewing cranes with up to 90-foot+ radius reach with 80-ton load; see "Potain".

Trade Association - Group, whose members have a common interest, and combine resources to promote products/services, establish standards, or otherwise enhance common good in lieu of individual efforts.

Trade Contractor - A contractor that specialized in providing/installing specific elements of the overall construction requirements of a project.

Trade Worker - Current term for a fully qualified construction worker; previously called "journeyman" under unionized format; capable of performing a specific range of required work [carpentry, for example] properly, but at less than a supervisory level.

Transit - A surveyors instrument used by builders to establish points and elevations both vertically and horizontally. It can be used to line up stakes or to plumb walls or the angle of elevation from a horizontal plane can be measured.

Transmittal - A written document used to identify information being sent to a receiving party. The transmittal is usually the cover sheet for the information being sent and includes the name, telephone/FAX number and address of the sending and receiving parties. The sender may include a message or instructions in the transmittal. It is also important to include the names of other parties the information is being sent to on the transmittal form.

Transom - A window or opaque panel installed above a door or permanent window, which is hinged for ventilation purpose.

Travel Time - Wages paid to workmen under certain union contracts and under certain job conditions for the time spent in traveling from their place of residence to and from the job.

Tread - The horizontal board, grating, plate, concrete fill, or surface in a stairway step on which the foot is placed.

Treated lumber - Wood products [including panels such as plywood] impregnated with chemicals to reduce damage from rot or insects; also, can be treated to become fire-resistant.

Tremie - A tube with removable sections and a funnel at the top used in concrete application. The bottom is kept beneath the surface of the concrete and raised as the form is filled and is used to pour concrete underwater.

Trim - 1) The finish materials in a building, such as moldings applied around openings (window trim, door trim) or at the floor and ceiling of rooms (baseboard, cornice, and other moldings); machined strips of wood used alone or in combination with molding; 2) also used in reference to painting and decorating where large areas or surfaces are decorated or highlighted by contrasting colors, textures or materials.

Trimmer - A beam or joist to which a header is nailed in framing for a chimney, stairway, or other opening.

True to plane - In the same plane, with no indentations or protruding elements; flat, vertical face.

Truss - Structural member formed with several smaller structural steel or wood members fastened together to make a lattice-like framework that will span long distances; utilizes principle of rigid triangular panels; designed to act as a beam of long span, while each member is usually subjected to longitudinal stress only, either tension or compression.

Tuck-Pointing - The re-grouting of defective mortar joints in a masonry or brick wall.

Turpentine - A volatile oil used as a thinner in paints and as a solvent in varnishes. Chemically, it is a mixture of terpenes.

Two-Part Sealant - A product composed of a base and curing agent or accelerator, necessarily packages in two separate containers which are uniformly mixed just prior to use.

Type-X Gypsum Board - One of a series of specially formulated fiber-reinforced gypsum boards which provide greater fire resistance; used where greater fire rating is required; fire-rated board.

U

UL/U.L. - See Underwriters' Laboratories

Ultraviolet - The invisible rays of the spectrum of light which are at its violet end. Sometimes abbreviated U.V.

Undercoat - A coating applied prior to the finishing or top coats of a paint job. It may be the first of two or the second of three coats. In some usage of the word it may, become synonymous with priming coat.

Underlayment - 1) Relatively thin, intermediate sub-floor material of plywood or fiberboard used to provide a smooth, level surface for finish materials such as carpet or other resilient flooring; usually installed over the structural sub-floor; 2) name of any substrate material.

Underpinning - The process of placing new foundations beneath an existing structure, to strengthen it and to allow deeper excavation immediately adjacent.

Underwriters' Laboratories - Highly regarded, independent testing agency that tests a wide variety of construction materials and assemblies, in addition to numerous other materials, equipment, devices, etc.

Underwriter's Laboratories (UL) Label - A label on a product or manufactured item showing the material is regularly tested by, and complies with the minimum standards of the Underwriter's Laboratories specification for safety and quality.

Unfinished Spaces - Rooms and areas, which in their final construction state, will have wall, floor and ceiling materials left in their natural state, without any applied decorative or protective materials. [It is possible to have finished work within these spaces—such as exposed piping—while the space itself is called, "unfinished"].

Uniform System - The CSI Master Format is a "uniform system" of numbers and titles for organizing construction information into a regular, standard order or sequence. By establishing a master list of titles and numbers Master Format promotes standardization and thereby facilitates the retrieval of information and improves construction communication. It provides a uniform system for organizing information in project manuals, for organizing project cost data, and for filing product information and other technical data.

Unit Price Contract - A written contract wherein the owner agrees to pay the contractor a specified amount of money for each unit of work successfully completed as set forth in the contract.

Unit Prices - A predetermined price for a measurement or quantity of work to be performed within a specific contract. The designated unit price would include all labor materials, equipment or services associated with the measurement or quantity established.

Up-Front Services - Free or reduced-rate services provided to prospective clients in the interest of obtaining a contract. Often rationalized as part of a firm's selling or public relations program.

Uprights - Vertical members supporting the sides of a trench.

U-Value - A measure of air-to-heat transmission (loss or gain) due to the thermal conductance and the difference in indoor and outdoor temperatures. As the U-value decreases, so does the amount of heat that is transferred through the glazing material. The lower the U-value, the more restrictive the fenestration product is to heat transfer. Reciprocal of R-value.

V

Valley - A depressed joint or seam formed in a roof where two areas of a roof at different slopes, and at an angle to each other, come together; must function as flashing between roof areas, and as a drainage conduit.

Valley Rafter - A rafter that forms the intersection of an internal roof angle. The valley rafter is normally made of double 2-inch-thick members.

Value - The intrinsic worth of something determine don an individual bases.

Value Engineer - A person, usually certified, who is qualified to perform value engineering services for a client.

Value Engineering - A technical review process; the close matching of engineering design to the value an owner derives from the design.

Value Management - The matching of project decisions and directions with the expressed requirements of the owner, from an owner value derived perspective.

Value Manager - A person qualified to perform value management services for a client.

Valve - A device to stop, start or regulate the flow of liquid or gas through or from piping.

Vapor - The gaseous form of any substance.

Vapor Barrier [Retarder] - A watertight sheet material used to retard the movement of moisture or water vapor into and through walls preventing condensation in them; usually plastic with or without reinforcing fibers. Usually considered as having a perm value of less than 1.0. Applied separately over the warm side of exposed walls or as a part of batt or blanket insulation; also, membrane which is placed between the insulation and the roof deck to retard water vapor in the building from entering the insulation and condensing into liquid water.

Varnish - A thickened preparation of drying oil or drying oil and resin suitable for spreading on surfaces to form continuous, transparent coatings, or for mixing with pigments to make enamels.

Vehicle - The liquid portion of a finishing material; it consists of the binder (non-volatile) and volatile thinners.

Veining - In roofing, the characteristic lines or "stretch marks" which develop during the aging process of soft bitumens.

Vendor - Supplier who provides manufactured products or units; one that sells materials or equipment not fabricated to a special design.

Veneer - 1. A thin sheet of wood or other material that overlay lesser materials to reduce cost; the visible sheet is generally of superior quality, chosen for its beauty; less costly veneers form the inner plies; plywood is made by gluing sheets of wood veneer together. 2. Brick/stone veneer consists of one row of units placed around a framework; most "brick" houses really just have wood frames covered by veneer.

Vent - A pipe or duct which allows flow of air as an inlet or outlet.

Vent Pipe - A vertical pipe of relatively small dimensions which protrudes through a roof to provide for the ventilation of gasses.

Vent Stack - A vertical vent pipe installed for the purpose of providing circulation of air to and from any part of a drainage system.

Vent System - In plumbing, a system to provide a flow of air to or from a drainage system or to provide circulation of air within such system to protect traps seals from siphonage and back pressure.

Ventilator - Device installed on the roof for the purpose of ventilating the interior of the building.

Venting - The process of installing roof vents in a roof assembly to relieve vapo pressure; The process of water in the insulation course of the roof assembly evaporating and exiting via the roof vents.

Verbal Quotation - A written document used by the contractor to receive a sub-contract or material cost proposal over the telephone prior to the subcontractor or supplier sending their written proposal via mail or facsimile.

Vermiculite - An aggregate somewhat similar to perlite that is used as an aggregate in lightweight roof decks and deck fills. It is formed from mica, a hydrous silicate with the ability of expanding on heating to form lightweight material with insulating quality. Used as bulk insulation and also as aggregate in insulating and acoustical plaster and in insulating concrete.

Vestibule - An open area at an entrance to a building; small area between sets of entrance doors.

Viscosity - The internal frictional resistance offered by a fluid to change of shape or to the relative motion or flow of its parts.

Visible Light Transmittance - The percentage of visible light (390 to 770) nanometers within the solar spectrum that is transmitted through glass.

Visual Mock-Up - Small scale demonstration of a finished construction product.

V-joint - Joint between two pieces of material, with corners beveled to form a joint profile resembling the letter "V."

Void - 1] Air space between material or between substance in material; 2] to cause to be, or to declare invalid, non-binding, or without power.

Volatile Thinner - A liquid that evaporates readily and is used to thin or reduce the consistency of finishes without altering the relative volumes of pigment and nonvolatile vehicles.

Voltage - The driving force behind the flow of electricity somewhat like pressure is in a water pipe.

Voltmeter - measures the voltage flowing through a circuit. The circuit must be closed to allow the voltage to flow.

W

Waferboard - An engineered building panel made by bonding together large, flat flakes of wood; by-product similar to plywood and oriented strand board, but using large "chips" or pieces of wood.

Waffle slab - A two-way concrete joist system (ribbed slab), formed with square pan forms; top of slab is flat, but underside contains pattern of voids similar to a waffle cake. see Two-way Ribbed Slab.

Wainscot - The decorative lower section of a wall [beneath chair rail height] made of different material from the upper part; usually composed of wood, tile, or wall covering.

Walkways - Designated areas for foot traffic; sidewalks, paths, walk-pads on roofs, scaffolding, bridges, etc.

Wallboard - Slang for gypsum wallboard as used in drywall construction [see].

Wall sheathing - Sheets of plywood, gypsum board, plastic foam, or other material nailed to the outside face of studs as a closure over and between spaced framing; may be base for exterior siding/facing if nailable.

Wall tie - A small metal strip or steel wire used to bind wythes of masonry in cavity-wall construction or to bind brick veneer to the wood-frame wall in veneer construction.

Wallboard - Short term for large, paper faced, rigid sheets of plywood, gypsum, or similar materials that may be fastened to the frame of a building, usually to form the interior wall surfaces; see gypsum wallboard.

Wane - Bark, or lack of wood from any cause, on edge or corner of a piece of wood.

Warp - To bend or twist out of shape.

Warranty - Assurance by a providing party that the work, material, and equipment under warranty will perform as promised or as required by contract.

Warranty Phase - The phase of a project where the agreement by which a party accepts responsibility for fulfilling an obligation and warrant that the work under warranty meets its intended use for a specifically established timeframe.

Water Repellant Coating - Transparent coating or sealer applied to the surface of concrete and masonry surfaces to repel water.

Water Repellent Preservative - A liquid designed to penetrate into wood and impart water repellency and a moderate preservative protection. It is used for millwork, such as sash and frames, and is usually applied by dipping.

Water table - The top level of water retained in the soil, or the natural underground water layer resulting from a nearby stream, drain, or shallow rock formation.

Water Vapor - Moisture existing as a gas in air.

Water-Cement Ratio - The strength of a concrete mixture depends on the water cement ratio. The water and cement form a paste. If the paste is made with more water, the concrete becomes weaker. Traditionally, concrete mixes have been identified in terms of the ratio of cement to fine aggregate to coarse aggregate. For example, the ratio 1:2:4 refers to a mix which consists of 1 cu. ft. of cement, 2 cu. ft. of sand and 4 cu. ft. of gravel. Cement and water are the two chemically active elements in

concrete and when combined, form a paste or glue which coats and surrounds the particles of aggregate and upon hardening binds the entire mass together.

Watercourse - An artificial or natural channel for intermittent drainage or a stream; constructed most often in formal gardens.

Waterproof - To render a material, or surface impervious to water; generally done by coating it with another material that will not let water pass through it.

Waterproofing - 1] Process whereby a building component is made totally resistant to the passage of water and/or water vapor. 2] Materials such as tar, asphaltic mastic or sprays, mortar parging, and heavy-body cementitious paints are common waterproofing agents.

Wattage - The electrical unit of power. KILOWATTS is 1000 watts and electric customers are billed on how many kilowatts of power they have used.

Weatherstrip - Narrower or jamb-width sections of thin metal or other material to prevent infiltration of air and moisture around windows and doors. Compression weather stripping prevents air infiltration, provides tension, and acts as a counter balance.

Weather-stripping - A strip of fabric or metal fastened around the edge of windows and doors to prevent air infiltration; can be interlocking or spring fit.

Weep Hole - Holes or slots [usually in vertical joints] in bottom courses of masonry veneer walls to allow the release of moisture accumulated in voids/cavities behind facing; important in brick veneer, other veneer work, and glazing structures.

Weep Screed - Tool used to drain moisture from concrete.

Weld - 1] The joining of components together by fusing. In thermoplastics, refers to bonding together of the membrane using heat or solvents. 2] A joint between two pieces of metal formed by fusing the piece together, usually with the aid of additional metal melted from a rod or electrode.

Welded-Wire-Fabric (WWF) - Heavy gauge steel wires welded together to form a grid for concrete slab reinforcing; wire size and spacing are available in variety; commonly called "mesh"; see Reinforcing mesh.

Wet Seal - Application of an elastomeric sealant between the glass and sash to form a weather tight seal, which are then firmly held in place by the surrounding material.

Wide-flange section - Any of a wide range of steel sections rolled in the shape of a letter I or H, with different dimensions than I-beams; usually width and depth are nearly the same dimension.

Wind brace - A diagonal structural member whose function is to stabilize a frame against lateral (wind) forces.

Wind load - Lateral forces acting against a building that, in particular, must be considered in the design of high-rise buildings.

Wind Uplift - The upward force exerted by wind traveling across a roof.

Wire Size - Conductors for building wiring are available in AWC (American Wire Gauge) sizes ranging from No. 14 to 4/0. The larger the number size, the smaller the diameter. For example #10 is smaller than #8. The larger the diameter of a wire, the lesser the resistance.

Wired glass - Glass in which a small-gauge wire mesh [similar to "chicken wire"] has been embedded during manufacture; used in fire-rated doors and windows, since glass is retained in opening by the wire.

Wood Filler - A heavily pigmented preparation used for fining and leveling off the pores in open-pored woods.

Wood members - Most commonly used at joints of wood trusses. They are fastened by nails, screws, bolts, or adhesives.

Wood Rays - Strips of cells extending radially within a tree and varying in height from a few cells in some species to 4 inches or more in oak. The rays serve primarily to store food and to transport it horizontally in the tree.

Wood Shakes (Shingles) - Individual wood roofing pieces, made of cedar (usually) which are hand split, or machined to useable size; can be fire-rated for added protection.

Woodfiber Plaster - Consists of calcified gypsum integrally mixed with selected coarse cellulose fibers which provide bulk and greater coverage. It is formulated to produce high-strength base coats for use in highly fire-resistant ceiling assemblies.

Work - The total of tasks, construction, installation, etc., that must occur to build, finish and produce the project anticipated and under contract; comprises the complete scheme of construction required by the contract documents including all labor, material, systems, tests, ratings, devices, apparatus, equipment, supplies, tools, adjustments, repairs, expendables, aids, temporary work and/or equipment, superintendence, inspection/approvals, plant, release, and permissions required to perform and complete the contract in an expeditious, orderly, and worker-like manner. The successful performance of the entire scope of the project. contract.

Work[ing] Day - Usually same as weekday [Mon. through Fri]; excludes weekends and holidays; describes the number of hours when work is performed during each calendar day.

Working Drawing - A drawing sufficiently complete with plan and section views, dimensions, details, and notes so that whatever is shown can be constructed and/or replicated without instructions but subject to clarifications. Working Drawing - One of a set of technical drawings intended for field use, by trade workers who actually

perform.

Work-Life - The time during which a curing sealant remains suitable for use after being mixed with a catalyst.

Work Letter - A written statement (often called Exhibit B to a lease or rental agreement) of the specific materials and quantities the owner will provide at his own expense. The work letter defines the building standards, including the type of ceiling, the type and number of light fixtures, the size and construction of the suite-entry and interior doors. Building standards define the quality of tenant spaces. Generally, a Work Letter is associated with the leasing or renting of office space by a tenant within a Building Envelope.

Work Order (WO) - A written order, signed by the owner or his representative, of a contractual status requiring performance by the contractor without negotiation of any sort.

Work Scope Description - A narrative description of the concise scope-of-work to be bid and performed by a specific contractor, subcontractor, etc.

Wythe - A section of a masonry wall which is one unit wide, in plan [most commonly, 4-inches wide for brick]; pertains to the number of such sections in the full width of a masonry wall [for example, 3 wythes wide yields a 12" wall].

X

XCM - An abbreviation for "Extended Services -CM"; A form of Construction Management (CM) where other services such as design, construction, and contracting are included with Additional Construction Management (ACM) services provided by the Construction Manager.

Y

Yard Lumber - Lumber of those grades, sizes, and patterns which are generally intended for ordinary construction, such as framework and rough coverage of houses.

Yard of concrete - Concrete unit measure denoting 1 cubic yard [3'x3'x3']in volume of 27 cubic feet; will provide 80 square feet of 3-1/2" thick flatwork.

Yard - [1] Commonly that area of a lot from the building to the property lines; [2] in zoning, redefined as that minimum prescribed distance and open area, back from the property lines where building cannot occur (also called "set-backs", or "required yards").

Z

Z-bar flashing - Bent, galvanized metal flashing that is installed in a horizontal joint, so one vertical leg fits behind the upper material, and the other leg fits over the lower material; for example, above a horizontal trim board of an exterior window, door, or brick run; also, where material is not available for the full height and must be spliced.

Zone - A designated portion of an entity divided for servicing reasons; for example, section of a building that is served by a separate heating or cooling loop because it has noticeably distinct heating or cooling needs. Also, the section of

Zoning - [1] Restrictions of areas or regions of land within specific geographical areas based on permitted building size, character, and uses as established by governing urban authorities. [2]Local government regulations, which control the use of land, so adjacent uses are similar, compatible, and not intrusive upon each other; also regulate access, open areas, setbacks; intended to create a positive, non-intrusive general atmosphere or environment in neighborhoods; prohibits nuisance and undesirable uses from locating in other areas devoted to less objectionable uses. [3] Creating separate sections of a building to be served by different systems or portions of system of mechanical services [for example, separate supply ducts carrying air conditioned air to different areas of building].

Zoning Certificate - Document issued by government zoning agency indicating acceptance or giving approval for proposed land use or project; used in association with [and usually in addition to] building permits.

Zoning Permit - A document issued by a governing urban authority permitting land to be used for a specific purpose.

Detailing

- American Institute of Architects, 30
- AIA Document A201, 34, 341
- architect not finished, 30
- basics
 - concept, 10, 42
 - definition, 43, 105
 - principles, good drafting, 54
 - service, 106
 - understanding, 10
- best answers, 24
- case law, 31
- collage, 29
- communication,
 - and project success
 - as key point
 - basic, 18, 49
 - create, 32
 - failure of, 52
- computerization, as culprit, 70, 114
- concept and implementation, 30
- construction industry, 93
- construction knowledge, 63, 106
- constructibility, 47, 94
- contracts, 62
- contract documents, 18
 - and details, 19
- control, 60
- conversion
 - of prelim info, 80
- correlation, documentation to quality, 55
- cost, of work, 94
- cross-referencing, 92
- details,
 - Arch. magazine, 99
 - best fit, 99
 - best view, 101
 - by others, 336
 - carefully conceived function 72, 89, 105
 - case studies, 236-317
 - convey pertinent info, 102
 - cost, 16
 - cross-reference, 104
 - development, 12
 - enough info, 103
 - evaluation of, 110, 111
 - example list, 36
 - expand another, 102
 - failure of, 91
 - good example, 27
 - historic arch trim/styles gloss
 - implement selected solution, 100
 - info not on sketch, 101
 - line weighs, 103
 - list of, 65
 - location, 99
 - make better const, 103
 - make detail better, 103
 - materials, 102
 - needs, 23
 - number req'd per project, 104
 - primary focus on area, 100
 - problem resolution, 99
 - procedure for, 40
 - production of, 34, 71
 - readable, 103
 - reduced effort, 39
 - repetitive, 36, 38
 - samples, 83, 86-87, 119-237
 - scale of, 101
 - show too much, 101
 - standard detail available, 102
 - standard, 35
 - surrounding area, 102
 - types of, 59
 - understand and explain, 104
 - viable, 37, 39, 41
 - w/ and w/o words, 69
 - weighty key, 99
 - well-executed, 26
 - what is needed, 100
 - what must be done, 100
 - what to show, 100
 - why is detail needed, 100
- detailer, 57, 107, 109
- detailing,
 - activities, 74
 - analysis, 81, 321-335
 - and architect, 44
 - appropriate, 16
 - architectural, 19, 24
 - aspects of, 66, 67

- basic concept, 107
- checklist, 76
- college course on, 45
- combination, 22
- convert, 11, 46
- creative, 26
- crucial, 11
- crux of, 77, 82
- defined, 17, 61, 72, 105
- develop skill 54, 79
- equation for, 25
- fallacious, 17
- formidable task, 24
- functions, 62
- fundamentals, 63
- goal of, 58
- guiding thought, 68
- helps in, 115
- historic, 50
- inability to, 14, 60
- inappropriate, 17
- indispensable, 43
- intent and content, 17
- level of skill, 10, 111
- need for, 23
- not option, 54
- no relationship to computerization, 64
- not new, 42
- not pre-eminent, 49
- perspectives, 43
- principles of, 54
- process of translation, 46
- project success, 55, 92
- readable, 118
- required perspective of, 45, 46
- scope, 20, 94
- sequence, 79
- specifications, 77
- start, 80
- stopping of, 89
- successful, 30
- three-tiers of, 91
- end result formidable task, 24
- end user, 53
- Harvard Five, 33
- Historic Perspective, 49
- Intern Development Program, 114
- information,
 - location, 85
 - progression of, 90
 - superfluous, 82
- over-detailing, 95
 - liability in, 96
- production techniques, 71
- professional
 - offices, 70
 - responsibility, abdicating, 58, 106
 - success, pre-requisite, 56, 98
- put bldg together, 14
- Questions & Answers, 99-104
 - quote on, 20
- quality
 - in Constructed Project, 26
- quotes:
 - Allen, Edward, 9, 10
 - Architecture magazine, 99
 - Carter, Tim, 61
 - Caudill, William, 10, 63
 - Consulting-Specifying Eng'r, 107
 - Cox, Robert, 16
 - Daniels, Chip, 14
 - Elwin, George, 93
 - Graves, Michael, 32
 - Hunt, Jr., William Dudley, 78
 - Jordan, J. Peter, 61
 - Marston, Ralph, 28
 - McCullough, Malcolm, 112
 - Novitski, B.J., 97
 - Noyes, Eliot, 33
 - Rand, Ayn [The Fountainhead], 53
 - Rand, J. Patrick, 30
 - Richardson, John B., 28
 - Stone magazine, 20
 - Weisbach, Gerald, 30
 - Whitacre, Anne, 17, 23
 - Wyatt, David J., 338
- Roggenbach, DeForrest, 73
- signature architects, 30, 31
- successful construction, 16
- trade worker, 45, 53, 56
- understandable by workers, 52
- working drawings,
 - as collage, 29
- World Trade Center, 370
- Wright, Frank Lloyd, 30