



Details in Contemporary Architecture

Christine Killory and René Davids

AsBuilt

Details in Contemporary Architecture

Details in Contemporary Architecture

Christine Killory and René Davids

AsBuilt

PRINCETON ARCHITECTURAL PRESS, NEW YORK

AsBuilt

A PRINCETON ARCHITECTURAL PRESS SERIES

AsBuilt features formal and material innovation in architecture, emphasizes structure and function, and explores the development and application of new technologies and materials.

Published by
Princeton Architectural Press
37 East Seventh Street
New York, New York 10003

For a free catalog of books, call 1.800.722.6657.
Visit our web site at www.papress.com.

© 2007 Christine Killory and René Davids
All rights reserved
Printed and bound in China
10 09 08 07 4 3 2 1 First edition

No part of this book may be used or reproduced
in any manner without written permission from the
publisher, except in the context of reviews.

Publication of this book has been supported by a
grant from the Graham Foundation for Advanced
Studies in the Fine Arts.

Every reasonable attempt has been made to identify
owners of copyright. Errors or omissions will be
corrected in subsequent editions.

Publication of this book has been supported by
a grant from the Graham Foundation for Advanced
Studies in the Fine Arts.

Editor: Jennifer N. Thompson
Design: Paul Wagner

Special thanks to: Nettie Aljian, Dorothy Ball,
Nicola Bednarek, Janet Behning, Becca Casbon,
Penny (Yuen Pik) Chu, Russell Fernandez,
Pete Fitzpatrick, Wendy Fuller, Sara Hart, Jan Haux,
Clare Jacobson, Mark Lamster, Nancy Eklund Later,
Linda Lee, Katharine Myers, Lauren Nelson Packard,
Scott Tennent, Joseph Weston, and Deb Wood
of Princeton Architectural Press
—Kevin C. Lippert, publisher

Library of Congress Cataloging-in-Publication Data
Details in contemporary architecture /
Christine Killory and René Davids, editors.—1st ed.
p. cm. — (AsBuilt)

ISBN-13: 978-1-56898-576-3
(hardcover : alk. paper)

1. Architecture—United States—Details.
2. Architecture—United States—21st century.
3. Architecture and technology—United States—
History—21st century. I. Killory, Christine, 1958-
II. Davids, René, 1949-
NA2840.D454 2006
721—dc22

2006024384

Contents

| | |
|-----|------------------------------------------------------------------------------------------------------------------------------|
| 6 | Preface |
| 12 | Sharp Centre for Design, Toronto, Ontario / Alsop Architects Ltd. and Robbie/Young + Wright Architects Inc. in Joint Venture |
| 18 | Greenwich Street Project, New York, New York / Archi-tectonics |
| 26 | Maximilian's Schell, Los Angeles, California / Ball Noguees |
| 30 | Genzyme Center, Cambridge, Massachusetts / Behnisch, Behnisch & Partner |
| 36 | Figge Museum of Art, Davenport, Iowa / David Chipperfield Architects |
| 40 | Arts Center College of Design, Pasadena, California / Daly Genik Architects |
| 50 | Nothstine Residence, Green Bay, Wisconsin / Garofalo Architects |
| 58 | BP Bridge and Great Lawn, Chicago, Illinois / Gehry Partners |
| 62 | Juan Valdez Flagship Café, New York, New York / Hariri & Hariri – Architecture |
| 68 | Walker Art Center, Minneapolis, Minnesota / Herzog & de Meuron |
| 76 | Hollywood Bowl, Los Angeles, California / Hodgetts + Fung Design Associates |
| 84 | Lake Whitney Water Treatment Plant, Hamden, Connecticut / Steven Holl Architects |
| 92 | South Mountain Community College Performing Arts Center, Phoenix, Arizona / Jones Studio, Inc. |
| 102 | Caltrans District 7 Headquarters, Los Angeles, California / Morphosis |
| 112 | Seattle Public Library, Seattle, Washington / OMA LMN: A Joint Venture |
| 124 | Delta Shelter, Mazama, Washington / Olson Sundberg Kundig Allen Architects |
| 128 | GKD-USA, Inc. Headquarters Building, Cambridge, Maryland / Dominique Perrault Architecture |
| 138 | The Solar Umbrella, Venice, California / Pugh + Scarpa Architecture |
| 144 | School of Architecture, Prairieview A&M University, Prairieview, Texas / RoTo Architects, Inc. |
| 154 | Shaw Center for the Arts, Baton Rouge, Louisiana / Schwartz/Silver Architects |
| 162 | Camera Obscura, Greenport, New York / SHoP Architects PC |
| 170 | Bengt Sjostrom Starlight Theater, Rock Valley College, Rockville, Illinois / Studio Gang Architects |
| 178 | Holy Rosary Catholic Church Complex, St. Amant, Louisiana / Trahan Architects |
| 188 | University of Chicago Graduate School of Business, Chicago, Illinois / Rafael Viñoly Architects |
| 198 | Museum of the Earth, Ithaca, New York / Weiss/Manfredi Architects |
| 206 | Acknowledgments |
| 207 | Illustration Credits |

Preface

Popular interest in architecture and the celebrity of architects has intensified in this media saturated age, but serious publications devoted to architecture are disappearing, while the quality of many that remain has declined. At a time when new knowledge and innovation are more important than ever, architects have fewer opportunities for intellectual exploration. *Details in Contemporary Architecture* is the first issue of *AsBuilt*, a new series from Princeton Architectural Press dedicated to formal and material innovation in architecture and the application of new technologies and materials. *AsBuilt* will present original solutions to problems of architectural detailing that demonstrate how complicated design problems have been handled by prominent architects, as well as those beginning their careers, to achieve beautiful, functional, and, where necessary, economical results. *AsBuilt* is dedicated to the proposition that architects learn best from other architects. Regularly calling attention to the details that go into works of contemporary architecture that are outstanding examples of art and technology will contribute to the creation of better buildings and strengthen the understanding and influence of architecture in society at large.

In each issue of *AsBuilt*, twenty-five projects will be selected from current architecture (in the United States and Canada), covering the whole range of building types, including works by architects from abroad collaborating with North American architectural and consultant teams. Since the Renaissance, when emphasis on the development of techniques for drawing propelled a shift away from construction toward representation and symbolic abstraction, critical theory has perpetuated a separation of building from architecture. The purpose of *AsBuilt* is to provide a continuing investigation into built architecture and the process of its realization, what they are now and what they are becoming; its larger objective is to revive the concept of building as the principal intellectual activity of architecture, to finally collapse the divide between theory and practice.

Whenever American architects gather in numbers, there are ritual lamentations about architecture's loss of respect, power, and influence, for which it is fair to say architects themselves have been largely responsible. The last fifty years have witnessed a systematic retreat at all levels of the profession as vast areas of the built landscape became architect-free zones, new materials, technologies, building types, and profound social change went unacknowledged, and market share was lost to canier, more pragmatic players. To lessen legal exposure, architects became cautious and risk-averse, demoting themselves from supervisors to observers on the job site. Some prominent architects assumed responsibility for the preliminary design of their projects only, staying on as project consultants but leaving the onerous, exacting, labor-intensive disciplines of construction documents, contract administration, and project delivery to others. As they became more preoccupied with architecture's scenographic qualities and responsive to noisy popular media, architects learned to market their work based on its value as image or entertainment, even as the overall quality of American buildings declined. Many abandoned the mundane purposefulness of everyday life altogether for the postmodern theory swamps, or virtual worlds where passion for architecture can be severed from reality. On many dysfunctional building teams, architects focus mainly on design while engineers, consultants, and contractors have little interest in it, if any.

Architecture is complex and difficult, as much a state of mind as an assembly of parts, but it is mainly about materials and the way they are put together. Images with the illusion of great accuracy and completeness can be generated almost as soon as they are imagined, but architecture is developed slowly, laboriously, through a continuing process of working back and forth from concept to detail, with increasing specificity and precision. For architects committed to innovation, design is an extended process that demands close collaboration with engineers, consultants, contractors, subcontractors, and

fabricators at every phase of a building project from inception to completion. The inevitable tension between concept and realization often generates fractious relationships among professionals with very different roles to play in putting a building together. Even when architectural intent survives the process intact, an architect is likely to reach completion feeling that he or she has borne a chalice safely through a throng of foes.

American building culture—traditionally risk averse, conservative, and confrontational—has lately shown signs of greater openness to material innovation and more collaborative relationships. As it has everywhere else, the digital revolution has forever changed American architectural design, practice, construction technology, buildings, and drawings. Whereas in the past architects translated an imagined three-dimensional conception of a building into two-dimensional drawings, they now create a computer model of the concept and generate the two-dimensional documents required to build it. Building information modeling (BIM)—based on the creation of intelligent three-dimensional models—and related information-sharing technology seem capable of realizing the earliest hopes for the role of computers in the making of architecture: a means of communicating and preserving architectural intent.

While many architects first turned to computers to realize new forms, they now recognize that by expanding their knowledge base and taking on additional risk, they can begin to regain control of the building process. As new technologies allow them to design in an ever more fluid fashion and to create forms not possible with less powerful tools, architects are also beginning to understand that they can minimize their own risk by becoming more familiar with the work of those who engineer and construct their buildings, and they are actively upgrading their skills.

Leading architecture firms such as Gehry Partners and Morphosis have used sophisticated modeling tools for years, not only to design and document their

buildings but also to digitally fabricate building components. By directly engaging the building process, architects can offer faster construction times, higher quality, and a control of the fabrication process to preserve the integrity of their concepts not possible with the traditional methods. Like many architects who have started practices in the last ten years, SHoP PC incorporates a workshop as an integral element of their design practice, allowing them to do fullscale modeling and prototyping, another step toward redefining the way architecture is practiced.

In response to the increased interest in fabrication techniques and rising demand from architects, many American craftsmen and a growing number of small companies are now cultivating specialties or reviving techniques of craftsmanship on the verge of extinction. The expanded metal mesh manufactured by Spantek Expanded Metal, a homely component of the basic American industrial shed traditionally used for vent covers and stair treads, was seen with fresh eyes by Swiss architects Herzog & de Meuron, and fabricated by architectural sheet metal contractor M. G. McGrath into three-dimensional box-like forms for the shimmering facade of the Walker Art Center. Studio Gang Architects worked with Uni-Systems, a Minneapolis-based firm specializing in moving structures, to create a kinetic, faceted roof for the Starlight Theatre, consisting of triangular stainless steel-clad panels supported by steel columns and trusses; when the roof opens, six movable panels rise in succession to form a six-pointed star revealing the sky. The business and reputation of A. Zahner of Kansas City, which had previously focused on more mundane metal work such as siding, decking, and heating ducts, has grown partly because it is the company that Frank Gehry usually depends on to determine how to color metal and make it bend to his challenging designs. A. Zahner fabricated the insulated stainless steel panels for the exterior of Steven Holl's Lake Whitney Water Purification Facility for the Connecticut Water Authority.

Americans are, as George Santayana once observed, idealists working on matter; imaginative, but the imagination is practical, and the future it forecasts is immediate. In this first issue of *AsBuilt*, there is evidence of a peculiarly American mix of an idealistic materialism, or a materialistic idealism: Olson Sundberg Kundig Allen Architects's contemporary riff on basic machine-age components, steel shutters that open and close simultaneously using a series of devices including a hand wheel, drive shafts, u-joints, spur gears, and cables; Pugh + Scarpa's thin film technology solar panels, usually relegated to an inconspicuous and utilitarian role, which become the defining formal element on the main facade; RoTo Architects curvilinear brick layouts, creating undulating surfaces to make the walls at Prairie View come alive; or the exquisite concrete work at the Holy Rosary Catholic Church, material expression elevated to a poetic and symbolic level.

As increasing numbers of prominent clients look abroad for celebrated architects, teams of consultants and construction professionals—headed by local architecture firms with appropriate experience—are assembled to realize their concepts using often unfamiliar American materials, technology, and construction practices. Over a third of the projects included in this first issue of *AsBuilt* are by architecture firms who have main offices in other countries, or principals who were born and trained overseas and have come to America to practice; many others have spent some time studying or working abroad. Foreign architects have to adapt their work to a building culture very different from their own, as well as unfamiliar technology and materials, but the reputations for excellence that got them hired usually translate into greater design freedom than is typically afforded local practitioners. Alsop Architects had already built a structure on giant legs in Britain when hired, in a joint venture with Toronto-based Robbie/Young + Wright Architects, to design an addition for the Ontario College of Art and Design. For a United States or Canadian-based

practice, the process of securing approval for such a bold proposal would probably have been much more difficult.

The shortcomings of American building practices have recently been the focus of unflattering comparisons with those of Europe and Japan, but there isn't another country on earth that has so many foreign architects working on commissions of every size. As a result, America is getting better architecture, greater access to more sophisticated technology and materials, and building construction is held to an increasingly higher standard. Whenever foreign architects build in America, different building traditions come together to produce a working process that is a hybrid, often created on the fly. Most of these projects are high-profile, high-budget commissions involving intensive research, innovations in physical technology, novel structural solutions, the introduction of new materials, or all of these, as with the Seattle Public Library, a joint venture between the Office for Metropolitan Architecture based in Rotterdam and local firm LMN Architects. The structural, mechanical, electrical, and plumbing engineering services were provided by Arup Engineering, a global firm of designers, engineers, and planners and the creative force behind several innovative projects in this book. When no locally available material served their purposes, Daly/Genik Architects began to research ethylene tetrafluoroethylene (ETFE) membranes, used extensively in Europe but which had yet to be installed in the United States, for the skylight system at the Art Center College of Design in Pasadena. The introduction of ETFE technology into the United States was eased because the Los Angeles office of Arup, with previous experience in ETFE systems in Europe, collaborated on the design of the delicate steel frames for the forty- and fifty-foot long skylights.

For the skin of the Shaw Center for the Arts in Baton Rouge, Schwartz/Silver Architects designed a wall system that used LINIT channel glass, a translucent linear structural glazing system with a depth and profile not found in conventional glass wall applications, distributed by

Bendheim Wall Systems, manufactured in Germany by Lamberts and used throughout Europe for decades. LINIT eliminates the need for most vertical and intermediate horizontal aluminum members. At the time it was completed, the Shaw Center was said to be the largest building in the United States to be completely clad in U-shaped cast glass, and the first to use the channel glass as the rainscreen for a wall system. GKD Gebrüder Kufferath, a German manufacturer of metal fabrics for architectural applications, hired Dominique Perrault Architecture, who has used their products extensively on various European projects, to design the new GKD-USA headquarters in suburban Maryland as a showcase for the products now manufactured there. GKD architectural metals are now readily available to the American market, where they are already in high demand. Hariri & Hariri—Architecture used a GKD woven stainless steel mesh for their building-sized screen on the Juan Valdez Flagship with an abstracted image of Juan Valdez sandblasted on it. Renowned glass manufacturer Cricursa of Barcelona manufactured forty-three panels of insulating laminated glass for Archi-tectonics's Greenwich Street Project, which curtain-wall fabricators UAD Group modeled and engineered using CATIA to precisely determine the geometries of each glass panel and its relationship to the underlying substructure. At the Figge Museum of Art, David Chipperfield Architects used a glass rainscreen for a multistory, impermeable, double-skinned exterior envelope incorporating passive ventilation in a 3-foot-wide cavity between the outer wall and inner skin structural wall where the thermal barrier is located—a technology developed in Scandinavia in the 1940s and used in Europe and Canada but unknown in the United States until recently.

Formal innovation in architecture is driven by social and technological change. In selecting material for *AsBuilt*, we are particularly interested in architecture that it would have been difficult—or impossible—to conceive and build without computers. Our aim is to include

project materials that reveal something of what actually lies behind the physical making of architecture: its structure, material, and form; the much misapplied image of minimal construction; buildings which seem to consist of skin alone; or those that aspire to have no details. It is our intention that *AsBuilt* will contribute to a continuing conversation about architecture-as-building and the process of its realization emphasizing the rationale and development of architectural detail and the significance of drawings, however generated, for the act of creation. Except for press releases, most architects are not accustomed to writing about their projects, or documenting them for publication beyond basic general arrangement drawings: plans, sections, and elevations. It is the purpose of *AsBuilt* to offer practicing architects an opportunity to review how others draw and present their work. Because it is a series, the focus is on the long term and it is our hope that the presence of a venue for technical, formal, and material exploration will stimulate more architects to document their design and construction processes for publication. The twenty-five projects included in this first issue add a dimension to the way American architecture and architects are perceived by the general public and present solid evidence that the most recent renewal of architecture in America is well underway.

Christine Killory

**Anti
Bullying
BAS**

Sharp Centre for Design, Toronto, Ontario

Alsop Architects Ltd. and Robbie/Young + Wright Architects Inc. in Joint Venture

Alsop Architects Ltd., London, United Kingdom

Robbie/Young + Wright Architects Inc., Toronto

The spectacular 80,000-square-foot addition to the extension of the Ontario College of Art and Design (OCAD) is a flying rectangle, or tabletop, on twelve steel columns housing art studios, lecture theaters, exhibit spaces, and faculty offices. The underside of the two-story volume is raised eight stories off the ground, unifying the existing brick structures underneath: Grange Park to the west and McCaul Street to the east. The rationale for raising the building 85 feet off the ground was to preserve views of Grange Park for OCAD's neighbors across McCaul Street. The void beneath the building also provides outdoor expansion space for the college's activities, a landscaped area that is an extension of Grange Park. Because the Sharp Centre is situated above the older main campus building, OCAD created an outdoor park space, connecting Grange Park to the McCaul Street neighborhood.

The tabletop is supported by a conventional concrete stair and elevator core as well as six pairs of tapering steel column legs, which touch the ground in an apparently random fashion. The core sits on twelve steel-reinforced caissons, 5 feet in diameter, extending 40 to 60 feet into the ground and an additional 5 feet into the bedrock. The six pairs of legs sit on five steel-reinforced caissons, each 8 feet in diameter. Also extending into the bedrock, the 100-foot-long hollow legs, originally fabricated for use as segments of a natural gas pipeline, are made of steel approximately 1 inch thick. Like all exposed steel in the Sharp Centre, the legs are covered with many coats of intumescent paint, a fireproofing material that swells when exposed to intense heat, increasing in volume and decreasing in density, to provide a protective cushion around each leg. Although all the

legs are the same size, seven are multicolored and five are finished in black to make them appear thinner, an even more persuasive optical illusion at night when the black legs become less visible and seem to disappear; the architects wanted the building to have a completely different nighttime look. The bright red steel tube that connects the new addition to the existing brick college building is used as an emergency exit. As a cost-saving measure, what was intended to be a multicolored translucent cladding is instead a corrugated aluminum skin painted in black and white to resemble pixilation, a visual effect intended to blur the scale of the building and affect the way it is perceived.

This page

Level 5 plan

Opposite

Top: McCaul Street view south

Bottom: West elevation from

Grange Park

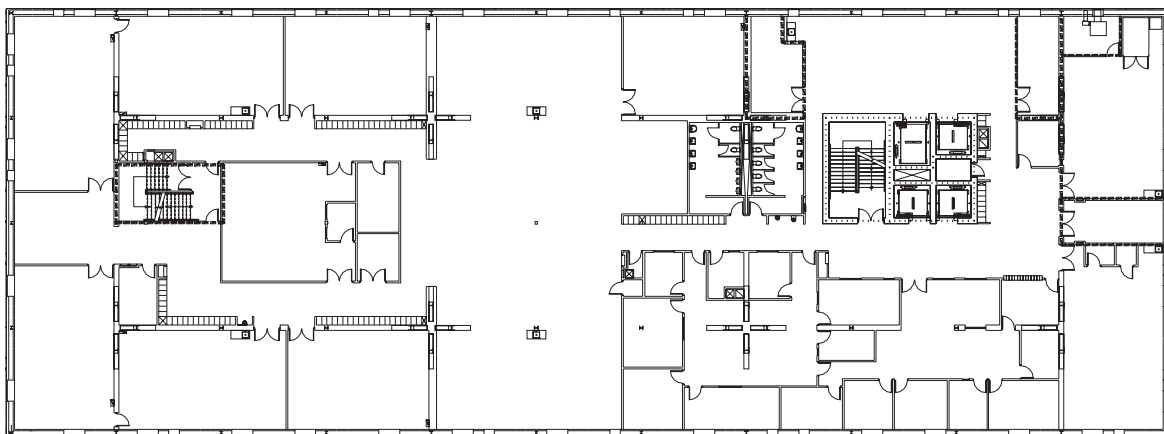



This page

Top: Tabletop cross section
east-west

Bottom: Last legs installation

Opposite

Top: Typical Classroom (left),
tabletop section detail

Bottom: View from McCaul Street
looking north

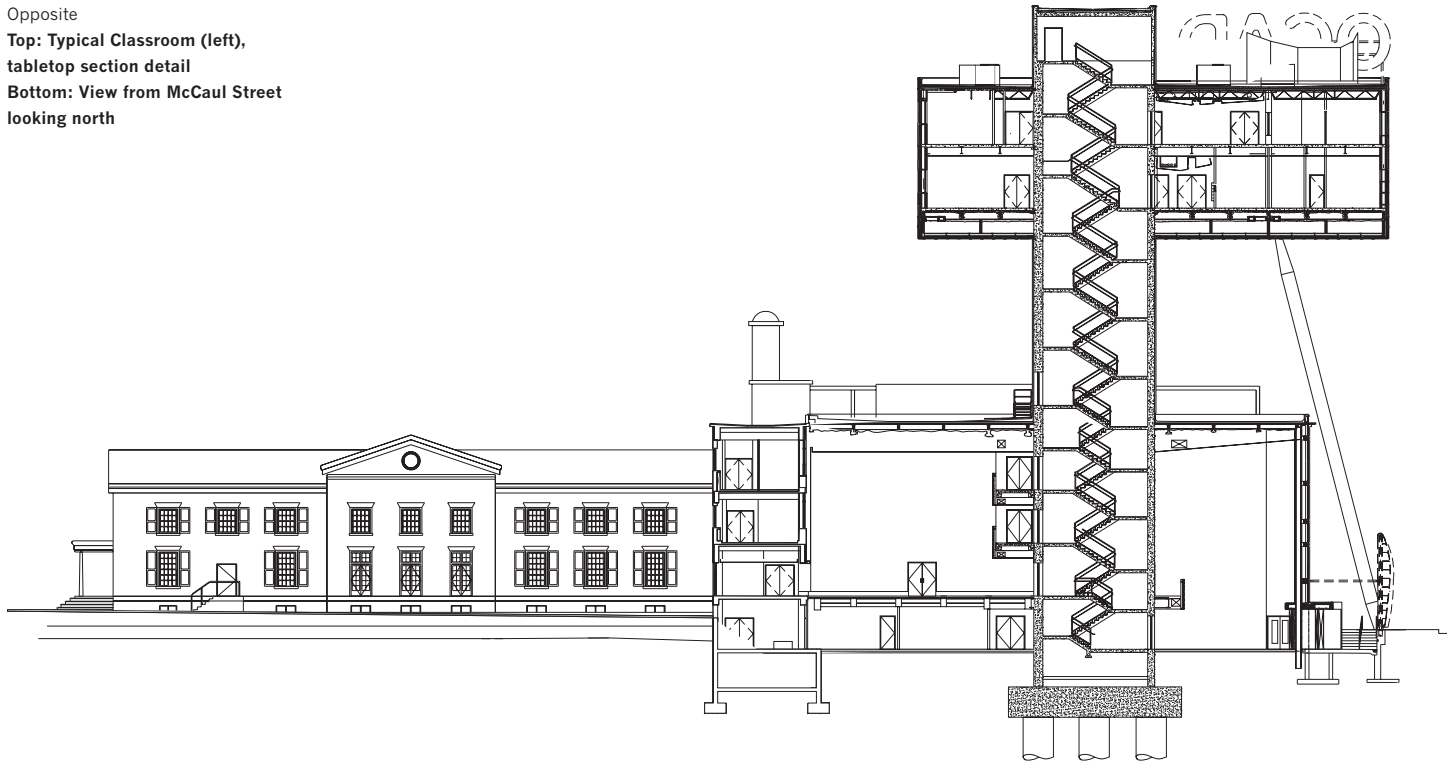

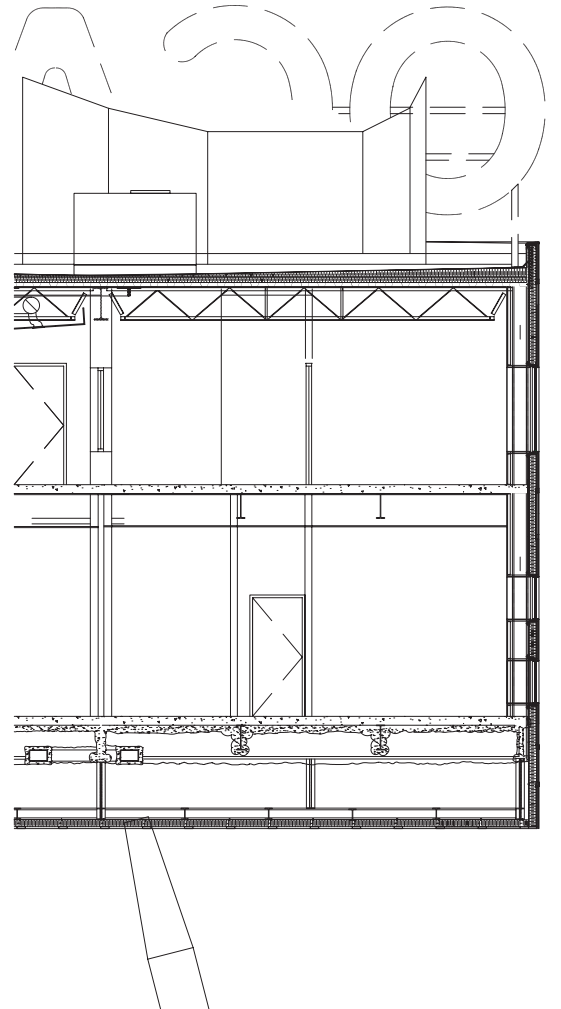
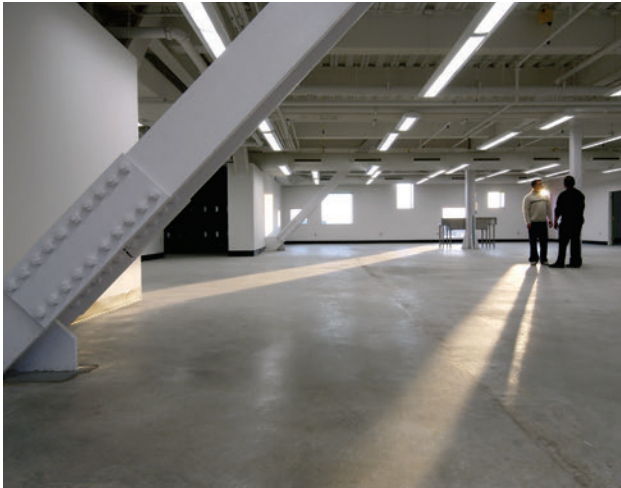

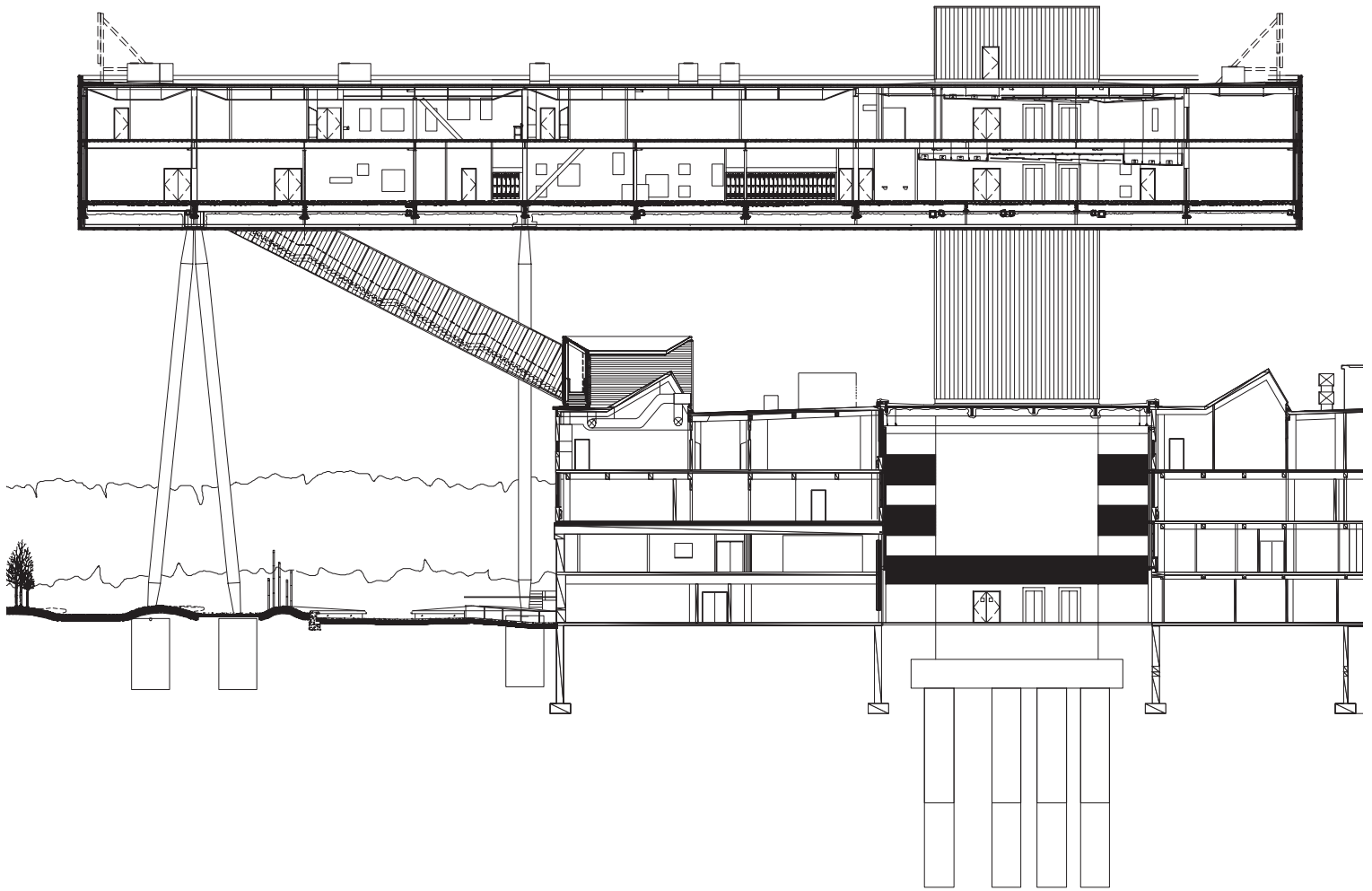

This page
Top: Tabletop, longitudinal section, north to south looking west
Bottom (left to right): Lower leg connection, upper leg connection, tabletop framing view south

Opposite
Top right: Lobby
Bottom: Tabletop section detail

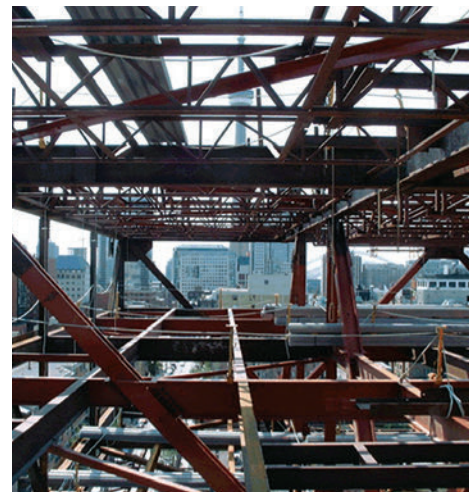

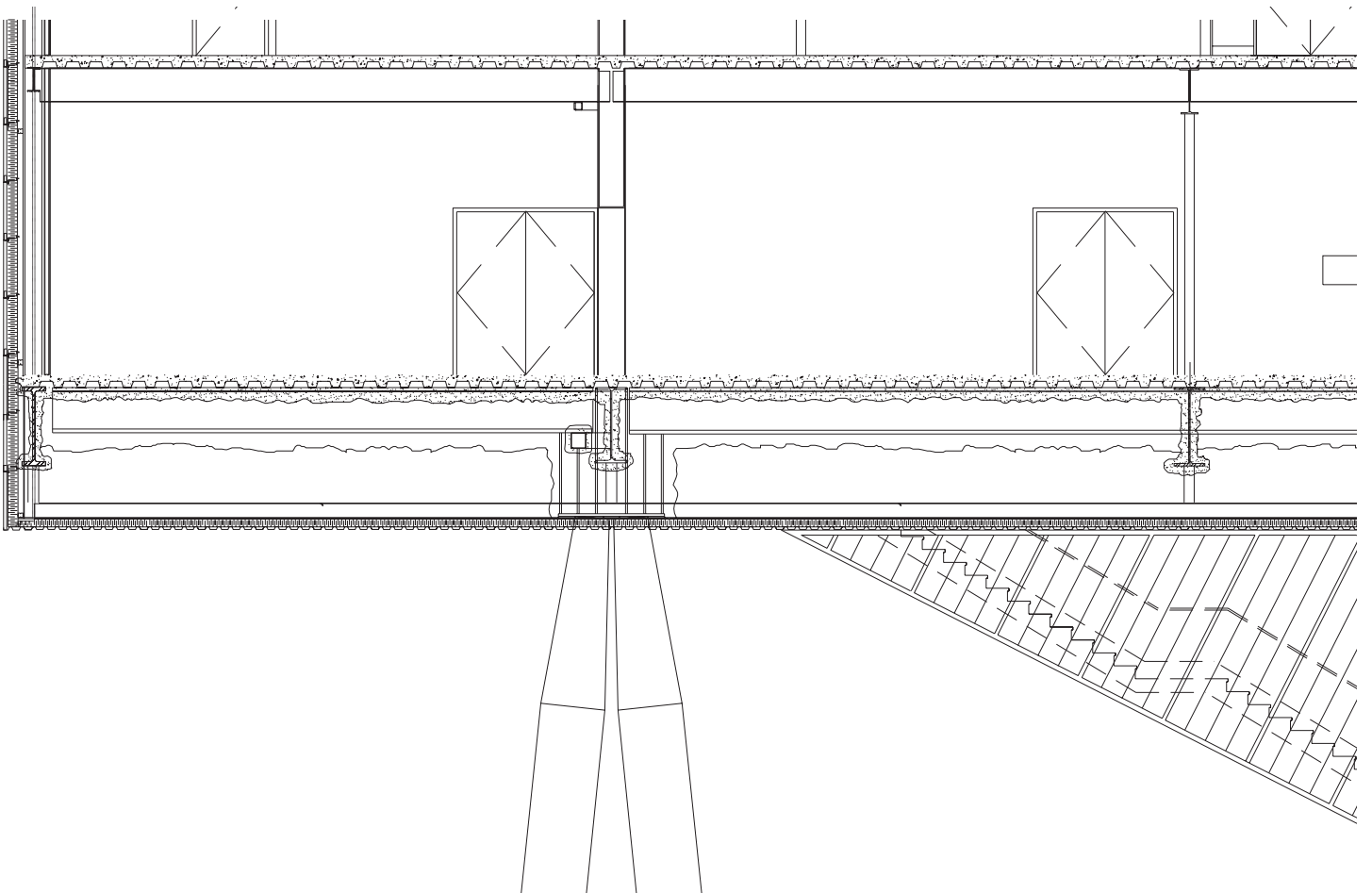
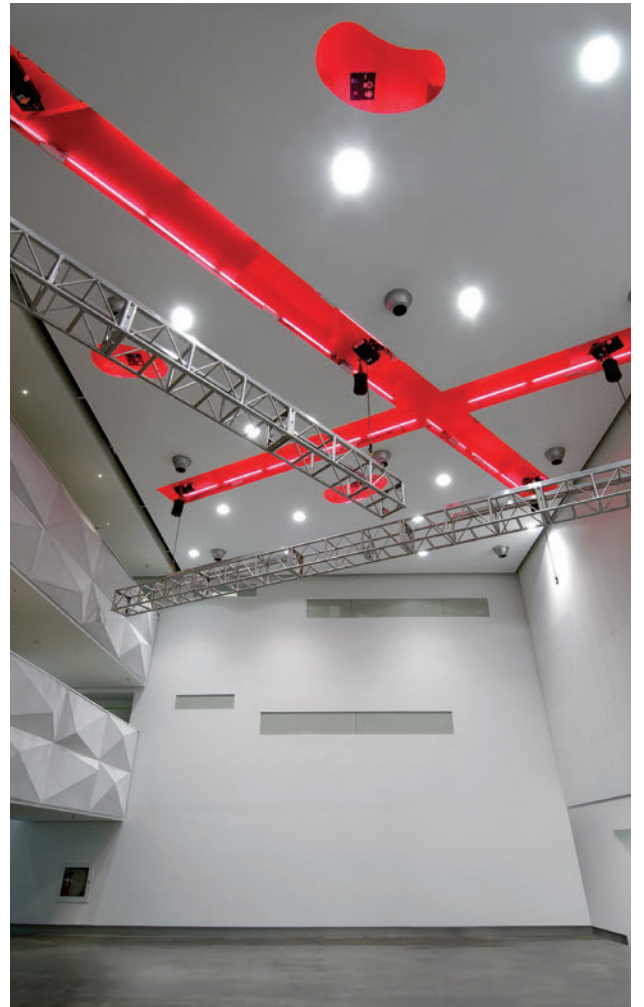
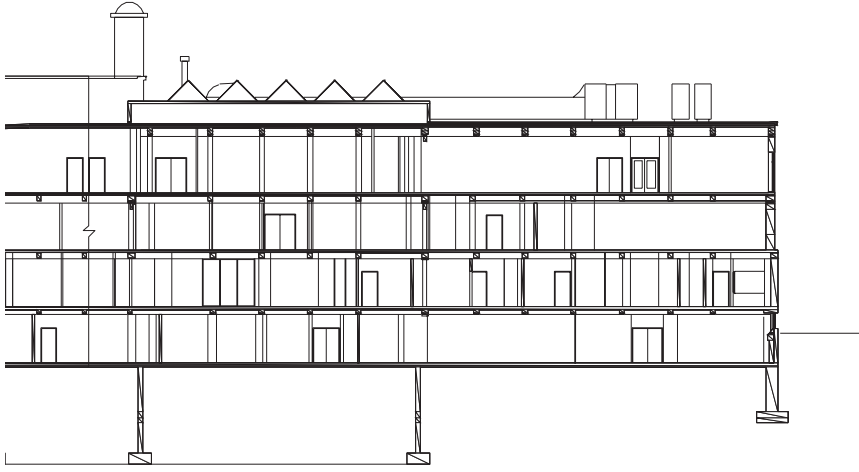

Greenwich Street Project, New York, New York

Archi-tectonics, New York

Architect of Record: David Hotson Architect, New York

The Greenwich Street Project includes the renovation of a six-story warehouse with a four-story penthouse added to the top, and the creation of a new eleven-story building, resulting in a total of twenty-three residential units as well as a commercial space on the ground floor. The west-facing main facade is a complex three-dimensional wall of transparent blue-green glass that cascades down the entire facade. The city building code allowed for a straight rise to a height of 85 feet and a building envelope setback of 1 foot from the street for every additional 2 feet-eight inches of height over 85 feet. Asymmetrical waves of glass move diagonally across the facade following the sloping profile of the setback angle.

The complex geometries of the glass wall provided an engineering and fabrication challenge. Cricursa of Barcelona manufactured forty-three panels of insulating laminated glass consisting of a 1/4-inch-thick layer of tempered blue-green glass, a 1/2-inch air gap, and one layer of laminated

glass comprised of two 1/4-inch-thick sheets of glass bonded together using a layer of polyvinyl butyral (PVB) film. The angled west-facing wall of glass has a low-E filter, a thin layer of metallic oxide applied to the third surface of the insulating glass to block radiant heat transfer and ultra-violet radiation. To create the folds in the glass, the manufacturer bent flat sheets of glass over molds, varying the temperature at which different areas of the glass were heated.

Curtain-wall manufacturer UAD Group and New York-based consultant Israel Berger & Associates modeled and engineered the complex curtain wall using CATIA to determine with precision the geometries of each glass panel and its relationship to the underlying substructure. Three principal groups of components were used to construct the curtain wall: sloping glass bend lines, three on the fourth, fifth, and sixth floors, and one on the ninth floor; inclined horizontal extrusions at four different

degrees, 8, 14.99, 23, and the typical 90; and cambered floor edges. The layered facade consists of aluminum fins covering the joints between the glass panels and thermal breaks between them, the bent glass panels and freestanding steel columns spaced 7 feet apart. The horizontal glass panels, all less than 3 feet wide, are supported by steel S4 I-beams on either side of the building and bolted to the vertical steel lattice. Stainless steel rods are used as cross-bracing tensile members, reducing the thickness and visual impact of the steel columns. Awning windows hinged at the top in the glass wall satisfy a code-related ventilation requirement for residential buildings. To prevent sound from traveling from loft to loft through the multistoried crystalline skin, insulated aluminum panels fill the space between the floor slabs and the curtain wall. To further reduce sound migration between lofts, drywall on party walls is extended to overlap the curtain wall mullions.

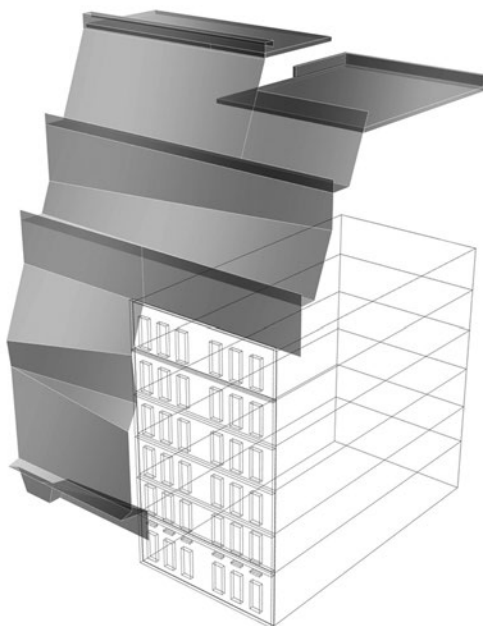

This page
Facade model

Opposite
Curtain wall detail



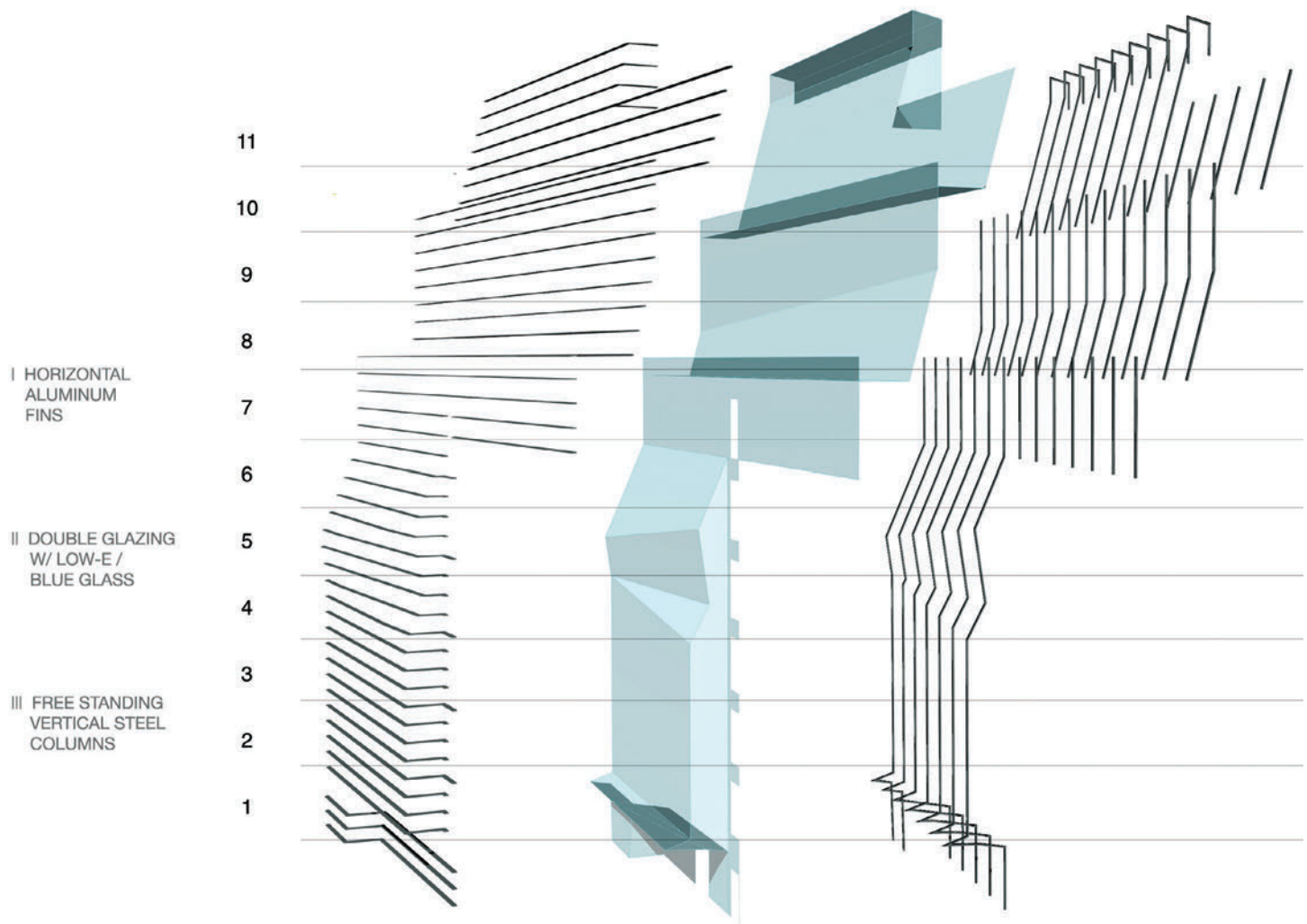

This page

Top: Curtain wall components

Bottom (left to right): Curtain wall roof framing, curtain wall framing detail, gallery entrance

Opposite

Facade axonometric



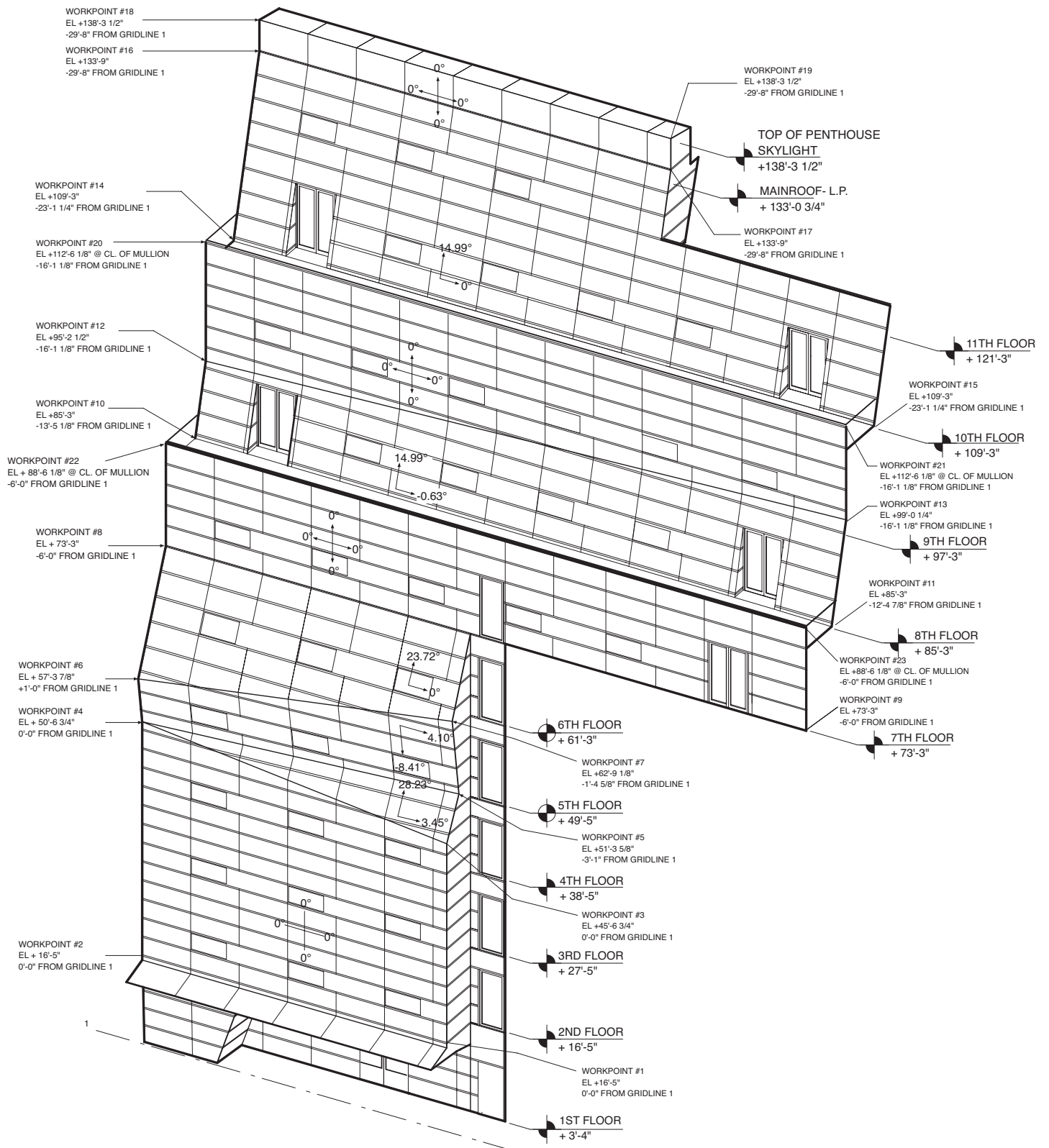



This page
Facade details

Opposite
**Bent panel axonometric view, Bent
mullion assembly (left),
horizontal mullions (middle
and right)
Bottom: Penthouse view west**



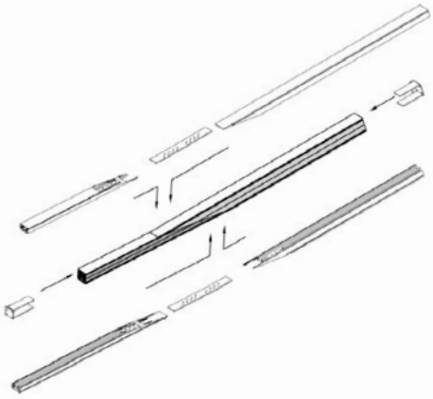
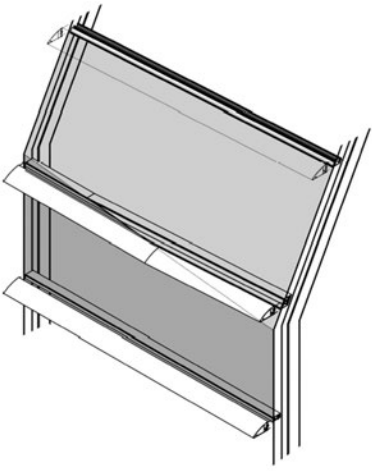

-8.41

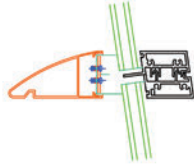

23.72

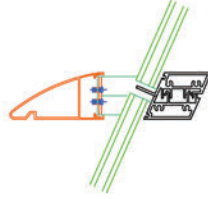

90

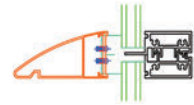

28.23

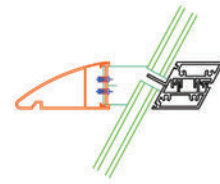

14.99

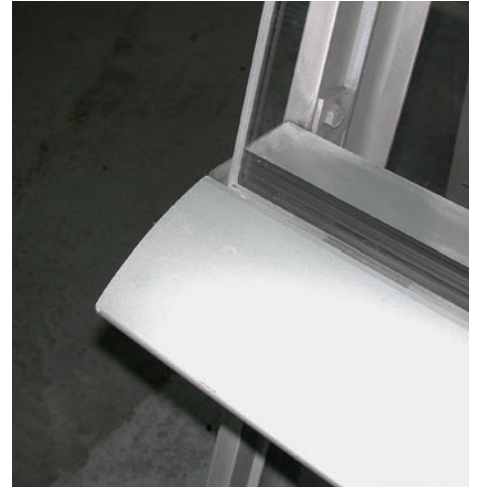
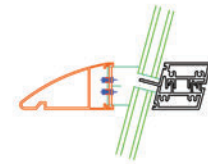

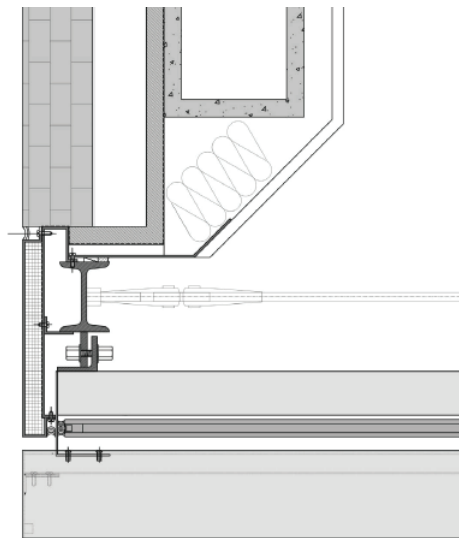
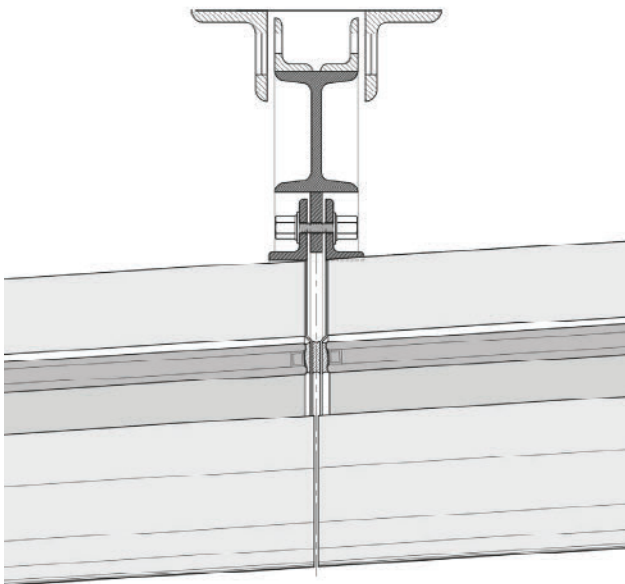
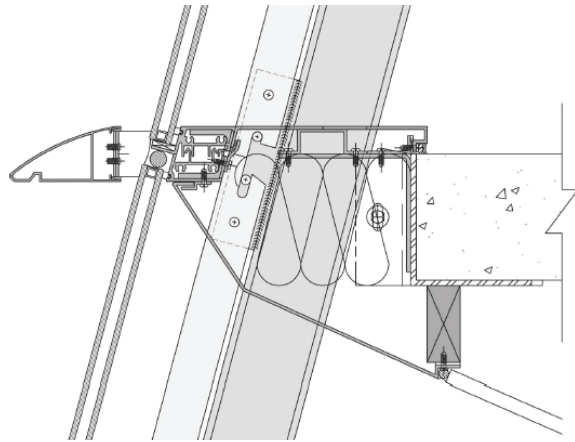
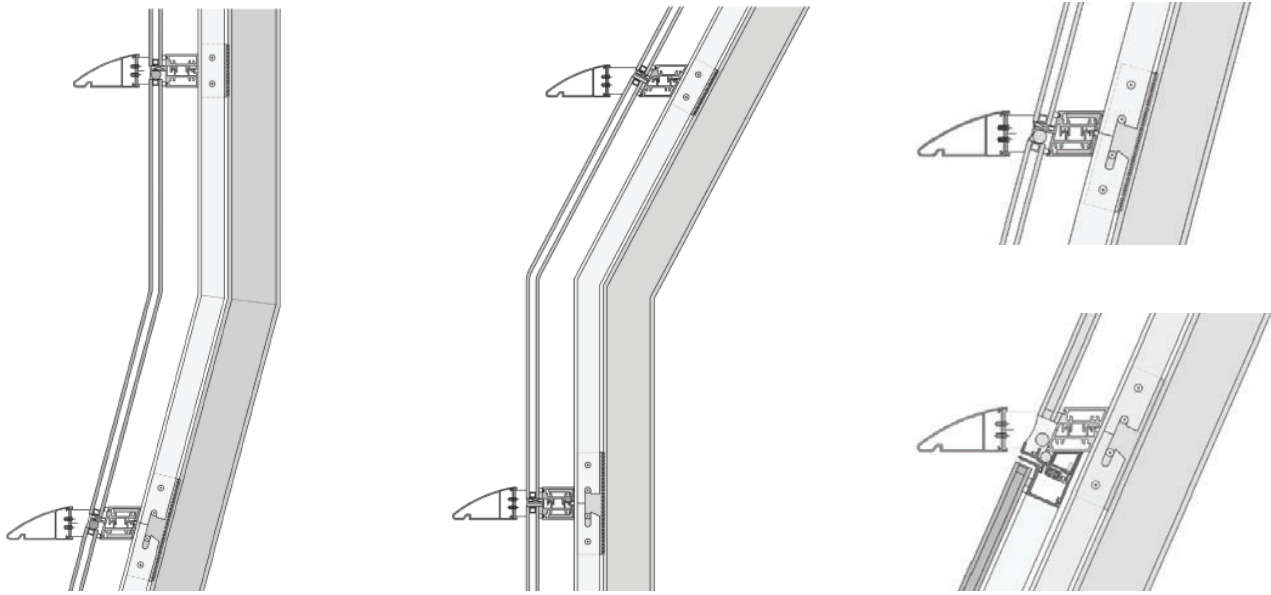



Opposite

Top: Bent panel sections (left and middle), section detail panel joint and detail through window top frame (right)

Middle: Detail section at horizontal mullion

Bottom: Jamb connection plan detail (left), corner plan detail

This page

Greenwich Street entrance with glass canopy

Maximilian's Schell, Los Angeles, California

Ball Nogues Design, Los Angeles

Maximilian's Schell, an outdoor installation of tinted Mylar simulating a celestial black hole by designers Benjamin Ball and Gaston Nogues, functioned as a temporary shade structure and outdoor room during the summer and fall of 2005. The interior of this experimental installation created an outdoor room for enhanced social interaction in the Materials & Applications courtyard on Silver Lake Boulevard. During the day as the sun passed overhead, the canopy cast colored fractal light patterns onto the ground. When standing in the center of the piece and gazing upward, the visitor saw only sky. In the evening when viewed from the exterior, the vortex warmly glowed, partially obscuring the building behind it.

The project required more than a year of development and involved several prototypes, although actual fabrication took only two weeks. The result was an installation that functioned not only as architecture and sculpture but also as a “made-to-order”

product through a unified manufacturing strategy. The designers achieved their aesthetic effects by manipulating Mylar—internally reinforced with bundled nylon and Aramid (a manufactured high-strength, high-modulus fiber, known commercially as Kevlar) with a sophisticated computer numerically controlled (CNC) cutting machine. Simultaneously reflective and transparent, the amber-colored film achieved UV-resistance from the application of a laminated golden metallic finish.

The result was neither a tent-type membrane nor a cable net structure in the manner of Frei Otto, but a unique tensile matrix comprised of 504 different iterations of a parametric component, or petal, each cut and labeled using the CNC system. Every petal connected to its neighbors at three points using clear polycarbonate rivets to form the overall shape of a vortex. As though warped by the gravitational force of a black hole, the petals continually changed scale

and proportion as they approached the center. An integration of structure and skin, the vortex behaved as a minimal surface: prestressed, always in tension, yet mathematically definable. Its origin lay in the soap-film surfaces modeled by Otto in the 1950s and 1960s, a process now typically accomplished using software that performs finite element calculations. After receiving hand sketches and computer models made by the designers, a structural engineer digitally created and refined the minimal surface model, quickly and precisely manipulating it during the form-finding process, while taking account of the distorting effects of gravity and enabling the finished vortex-shaped canopy to be in tension across its top surface. This gave the final form its purity and smooth appearance when viewed from the exterior. Seen from the interior, the piece resembled an enormous transparent flower with its petals lightly draping and curling downward.

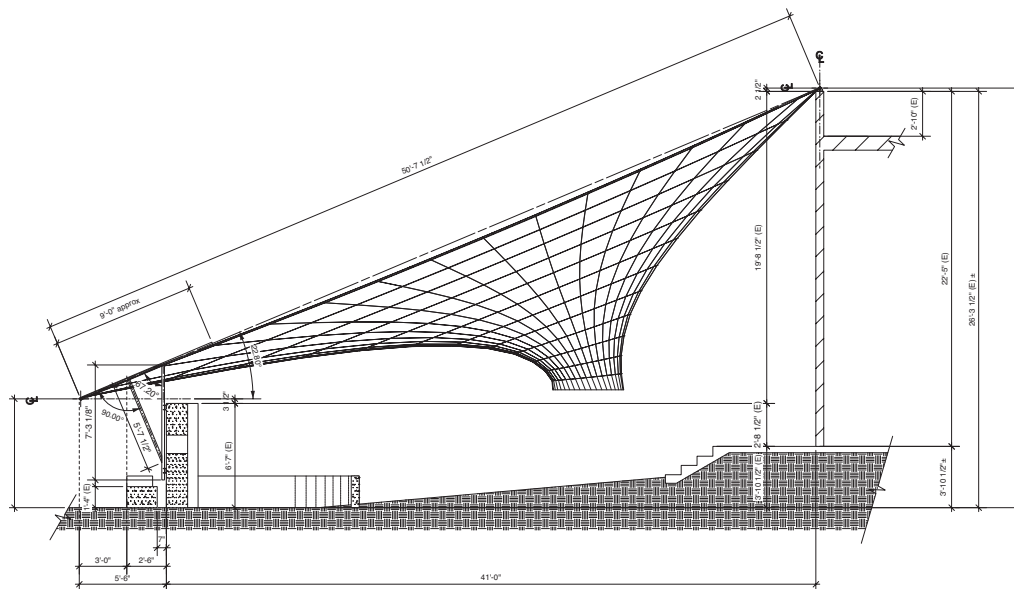

This page
Section

Opposite
Interior with canopy



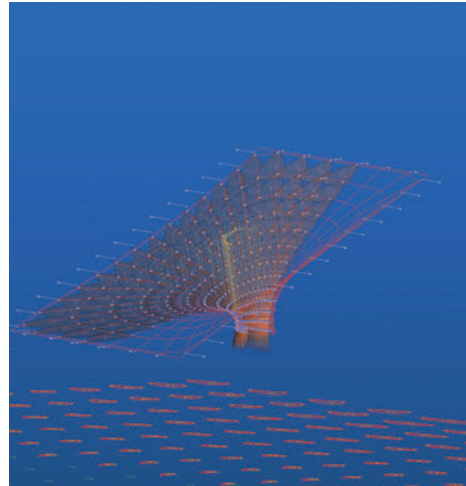
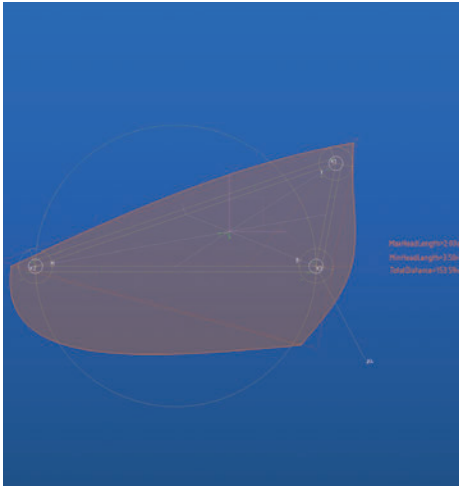
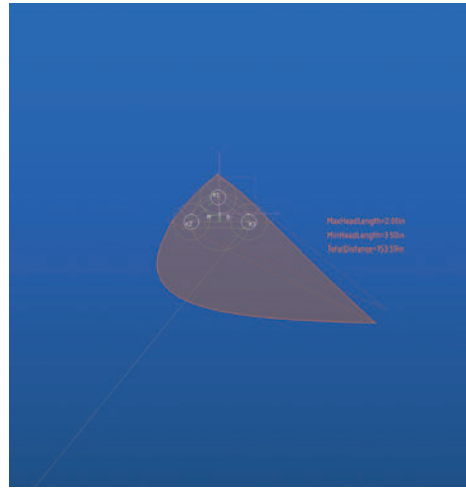
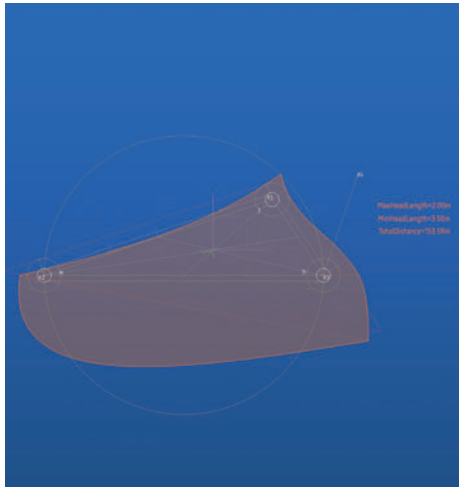
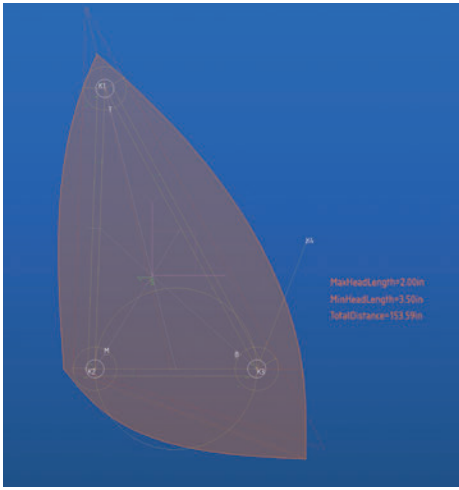

This page
Top: Section detail
Bottom: Cross section

Opposite
Silver Lake Boulevard elevation

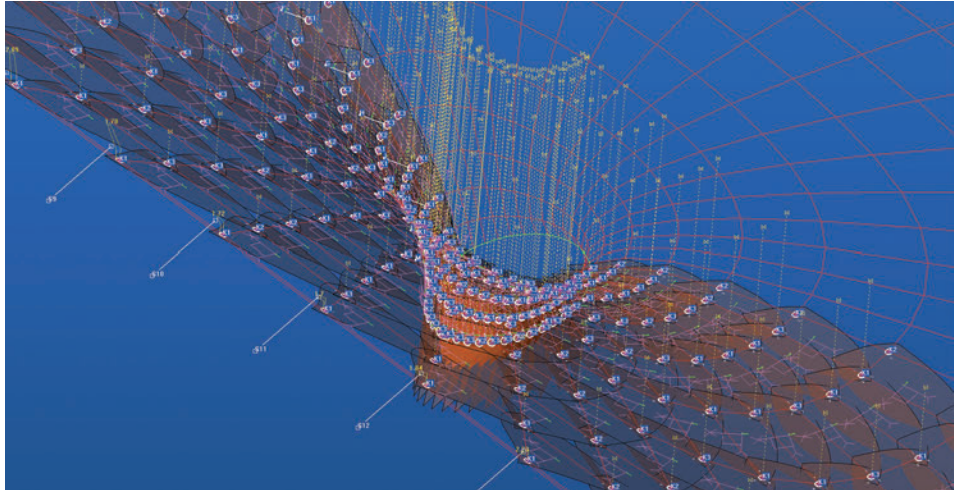



Genzyme Center, Cambridge, Massachusetts

Behnisch, Behnisch & Partner Inc., Stuttgart, Germany; Los Angeles, CA

The Genzyme Center is located on a brown-fields site originally part of the massive wetlands near the harbor in East Cambridge, which was polluted after various maritime and industrial uses and abandoned in the 1970s. The Genzyme Center itself is the largest of the seven new buildings in the mixed-use, high density development, their forms and envelopes largely predetermined by the site's master plan. Despite these constraints on the design process, Behnisch, Behnisch & Partner sought to create a landmark building that would exemplify the leading biotechnology company's spirit of innovation. The main goal of the design was to develop a building from the inside out, from the individual work environment—offices, meeting rooms, and team areas—to the overall structure of the building and the site. The environmental design features of the Genzyme Center encompass all parts of the building: the envelope, the full-height atrium, the central mechanical plant, the office lighting systems, and the site and storm water discharge systems. The building is organized around an interior oasis: an atrium flooded with daylight that branches out from the center to the facade. The layout offers a variety of different spatial situations and links the various areas of the building vertically and horizontally.

The building envelope includes a high performance curtain-wall glazing system with operable windows throughout all twelve stories linked to the building management system, allowing for automated control and night cooling. Thirty-two percent of the exte-

rior is a ventilated double facade with a 4-foot interstitial space for circulation that acts as a buffer zone by blocking the solar gain in summer and ventilating the heat away while introducing captured heat gains into the structure in winter, reducing thermal loss from the facade.

The atrium void acts as a huge ventilation and light shaft as fresh air is introduced to the occupied spaces by ceiling grills through the floor plates or operable facade openings; eased by pressure differentials, it then moves into the atrium, up and out through the heat recovery exhaust in the skylight. The central heating and cooling systems for the building also use exhausted steam from an adjacent power plant, which drives absorption chillers for summer cooling and is exchanged directly into heat in winter. This local energy cycle has no distribution losses, uses one of the most efficient cooling methods, has economies of scale from the power plant, and has emission filters to remove particulate matter. Automated light and occupant sensors detect conditions within the building's habitable areas and dim or eliminate artificial illumination as needed, resulting in significant energy savings. The high degree of automation built into the environmental controls combined with the adjustment options available to the occupants creates an appealing, customizable, and energy-efficient work environment. There are operable windows and lighting controls for perimeter workspaces, as well as permanent temperature and humidity monitors con-

nected to the building management system. Workspace layout and extensive use of glass on both interior and exterior walls permit views to the outside from all of the regularly occupied spaces.

The elaborate natural light enhancement system utilizes a series of roof-mounted heliostats (solar mirrors) on the north side of the building, which track the movement of the sun and reflect sunlight across the skylight to fixed mirrors on the south side. The fixed mirrors further reflect the light to a series of prismatic louvers located at the top of the atrium. The louvers also move with the sun's path and elevation and reflect glaring direct sunlight back to the mirrors, allowing diffuse light to enter the atrium. Once inside the atrium, the light is further reflected throughout the lower floors by a system of hanging prismatic mobiles, reflective panels, and a reflective light wall. On the outside glass walls, horizontal motorized blinds reflect light up to reflective ceiling panels (the first two in the ceiling grid), which in turn reflect the light through inner glass walls deep within the floor plate. The lighting system reduces energy use by about forty-five percent. There are two solar panel arrays on the roof of the mechanical penthouses, energy efficient features which, along with fans, motors, and an extensive building management system, significantly reduce the overall energy costs of the building. The light enhancement system provides sufficient natural light for at least seventy-five percent of the workspaces where critical tasks are performed.



This page
Top: Upper section
Bottom: Section, atrium

Opposite
Top: Atrium ceiling
Bottom: Ceiling detail

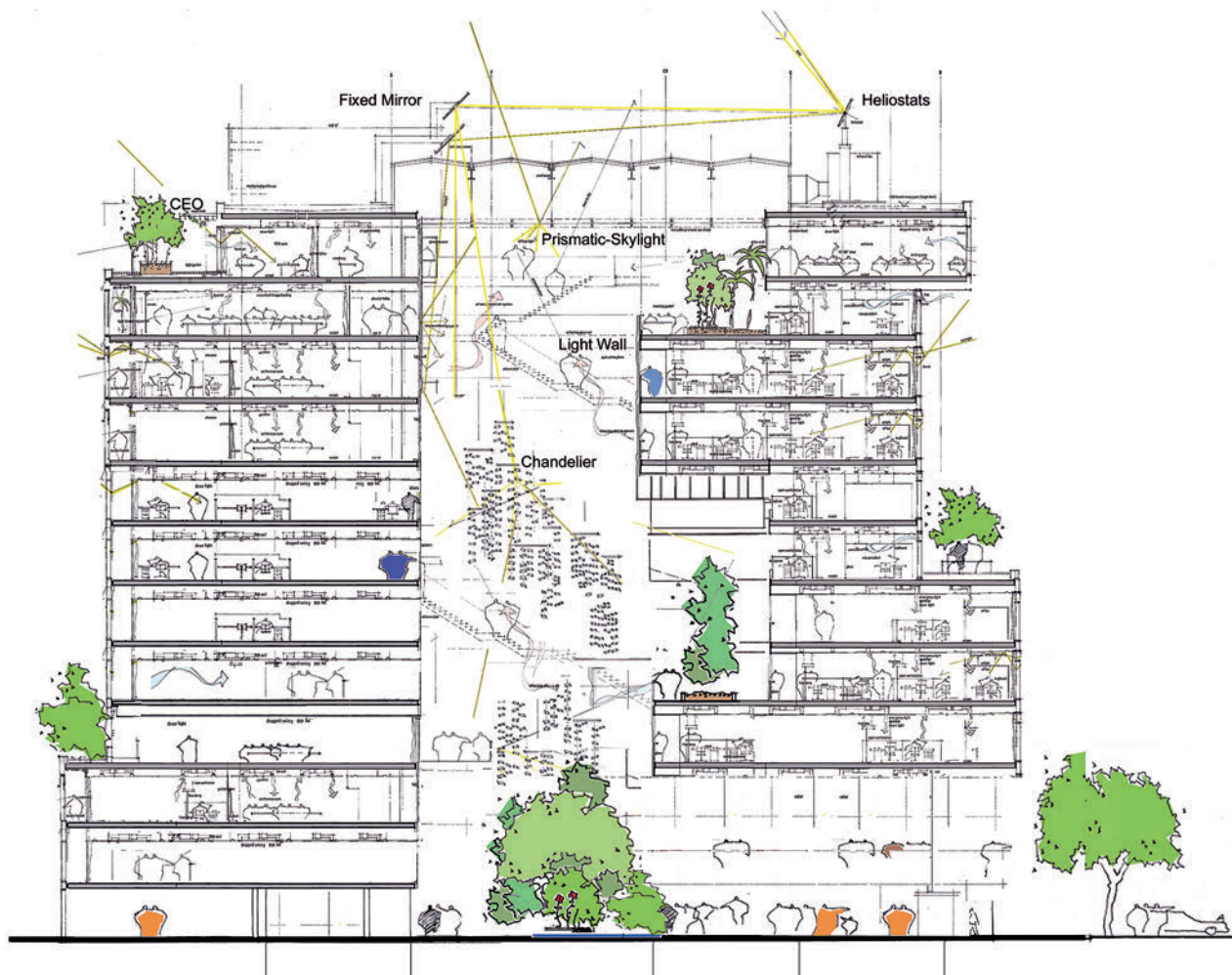
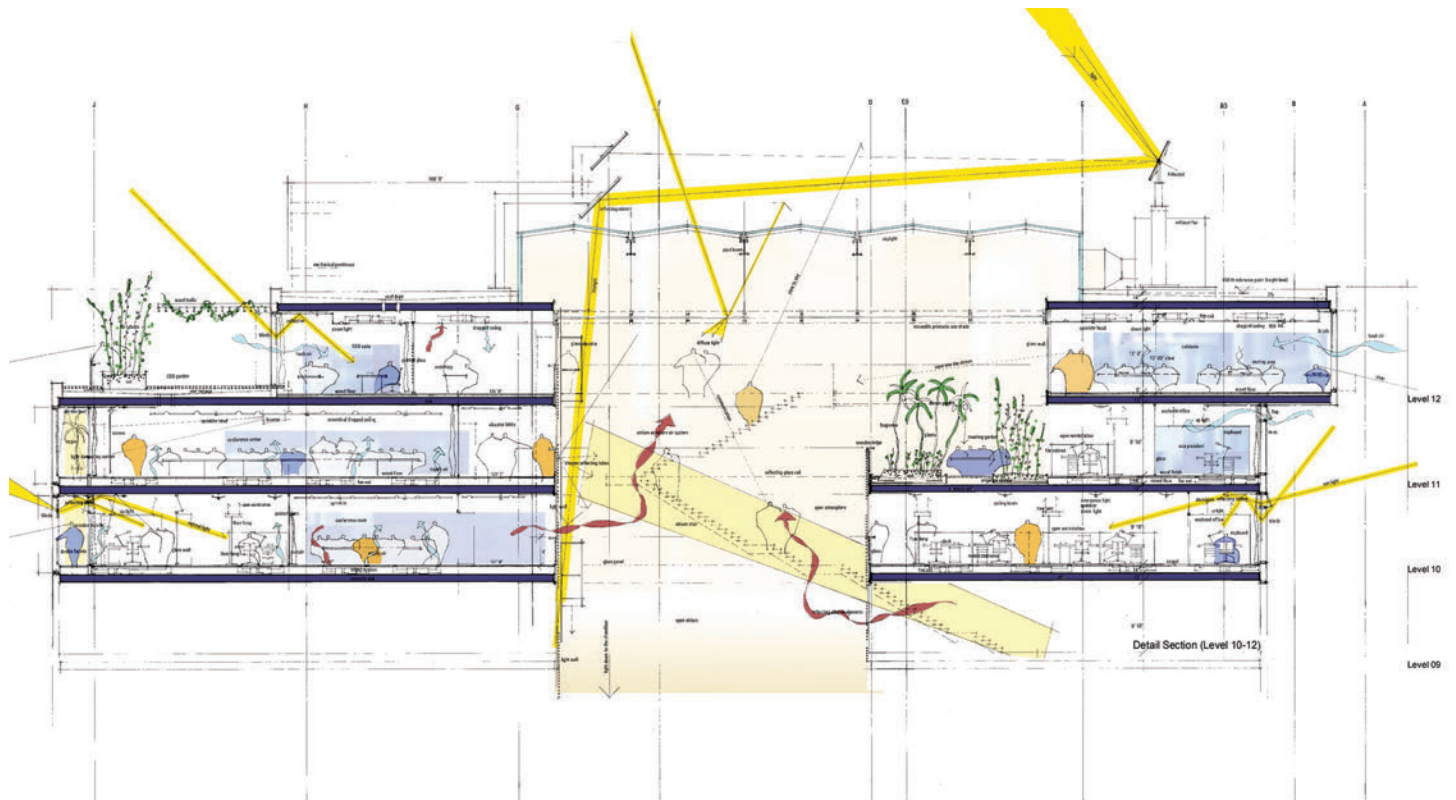



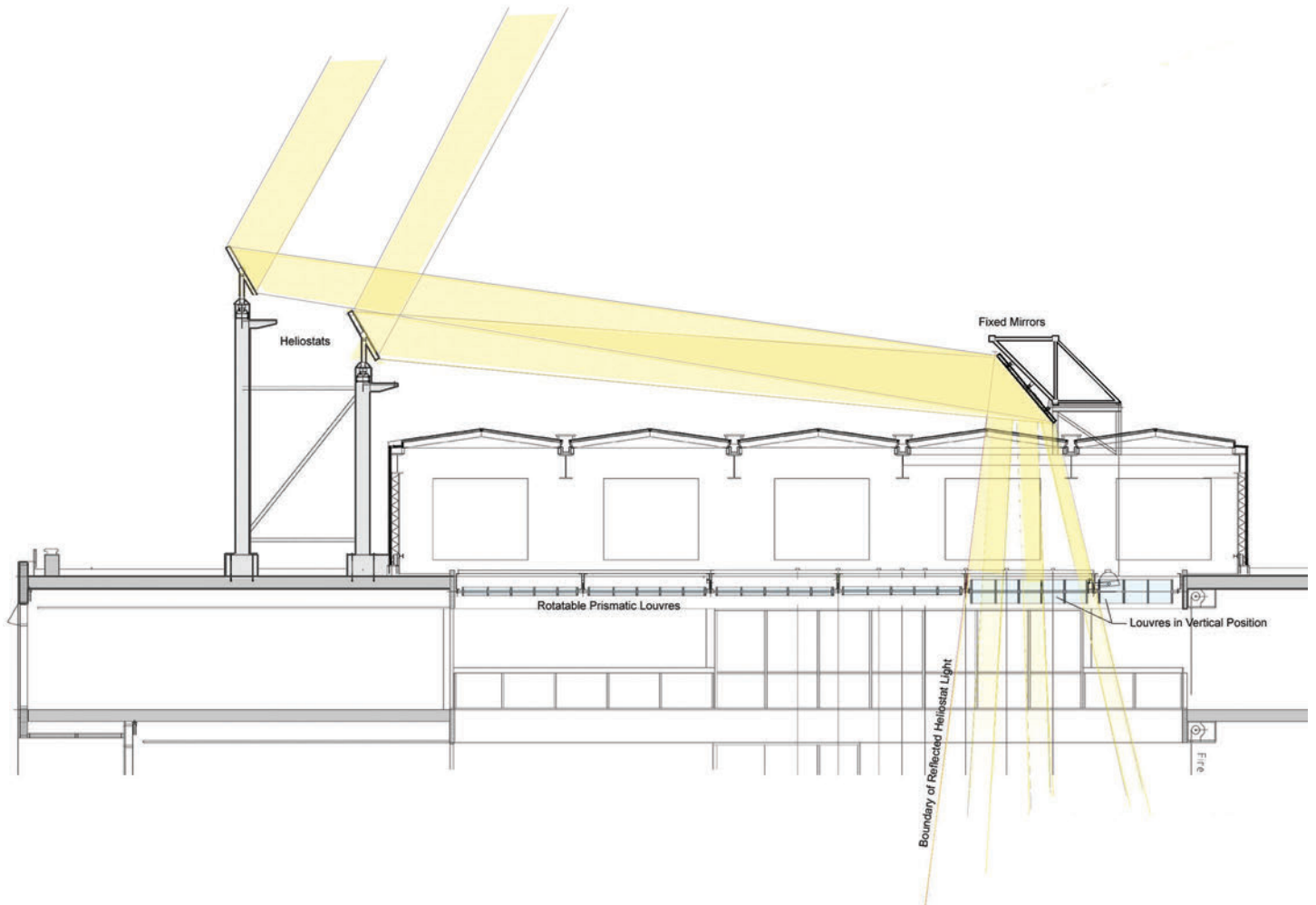

Opposite

Top: Atrium roof section

Bottom: Atrium roof exterior

This page

Top: Prismatic skylight plan

Middle: Prismatic skylight section

Bottom (left to right): Lightwall, chandelier detail, atrium looking up

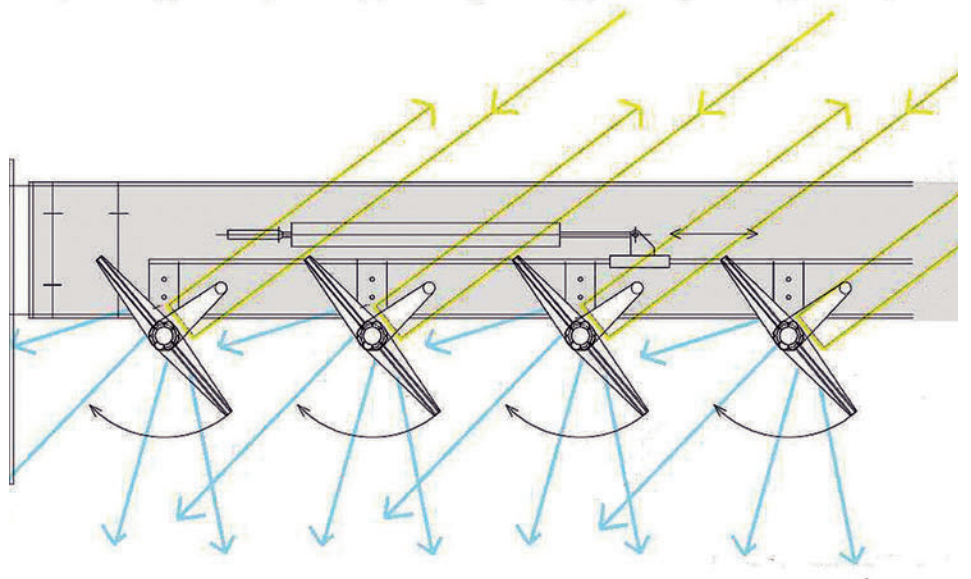
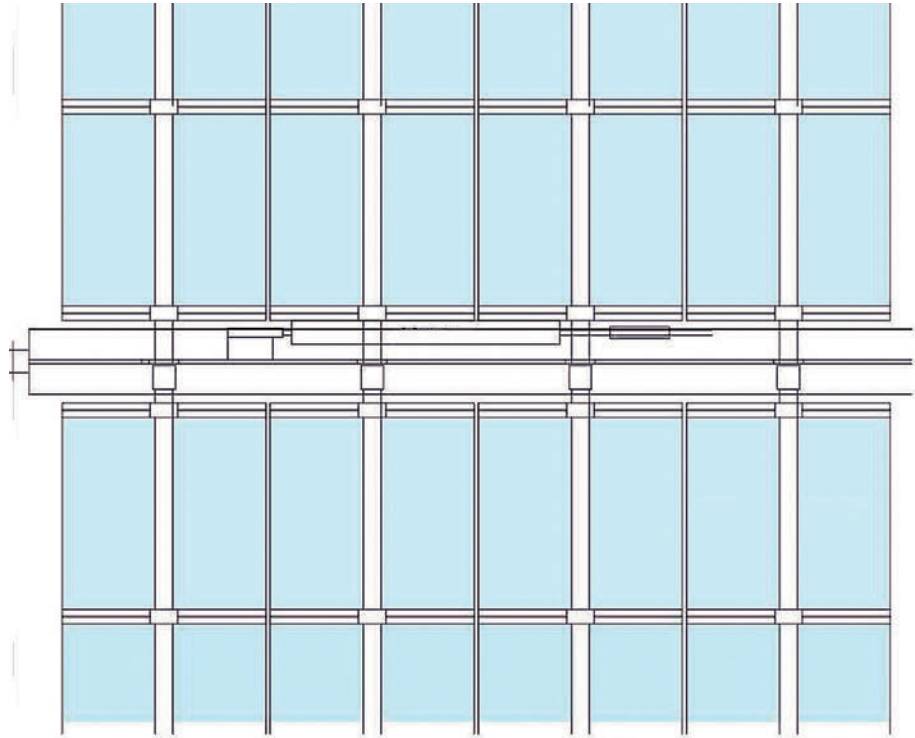

Figge Museum of Art, Davenport, Iowa

David Chipperfield Architects, London, United Kingdom

Architect of Record: Herbert Lewis Kruse Blunck Architecture, Des Moines, Iowa

The new Figge Art Museum was sited on the west bank of the Mississippi as the catalyst in a program to reinvigorate the center of Davenport and reestablish its historic connection to the river. David Chipperfield Architects intended the design of the new museum to simply but powerfully landmark Davenport's redeveloped waterfront. The building consists of a black base of integrally colored concrete supporting a monolithic block enveloped by opaque, transparent, and translucent glass; its simple form derived from the vernacular of local barns and agricultural sheds.

The museum is clad in a glass rainscreen, a multistory, impermeable, double-skinned exterior envelope, incorporating passive ventilation in a 3-foot-wide cavity between the outer wall and the inner structural wall where the thermal barrier is located. This buffer zone helps to moderate the disparities between the climate conditions inside and outside the building caused by the extreme temperatures of the local climate. Rainscreen technology results in a wall envelope that is both energy efficient and easy to maintain. In traditional construction, the vapor barrier is interrupted at floor and window lines and at any wall penetration. When there is a humidity imbalance between inside and outside, the water vapor from high concentration areas migrates to low concentration areas. If the

pressure within the wall cavity is lower than the external pressure, water vapor is actually drawn in through permeable wall materials and voids that occur wherever the vapor barrier is interrupted by windows, outlets, and other interfaces. Since the temperature within a building differs from that outside, gradients occur across the wall between the two zones. Adequate wall cavity airflow and drainage are not provided and the interior of the wall is inaccessible.

Because moisture occurs naturally within wall cavities, rainscreen technology provides a continuous thermal barrier integrated with the window system; airflow allows for evaporation of moisture and separate panels provide easy access if needed. Each panel of the rainscreen wall can be replaced individually without compromising adjacent portions of the exterior wall assembly. Wall cavities remain dry, insulated, and corrosion free. Because the outermost building layer no longer provides the thermal barrier, window and wall veneers require no caulking or sealants, corrosion within the wall is eliminated, the effect of insulation is optimized, its R-value is enhanced, and dependence on heating and cooling systems is reduced.

The inner skin of the museum consists of insulated stud-wall construction covered by perforated galvanized steel sheets and double-glazed windows. The rain screen's outer skin is composed of horizontal aluminum-

framed glazed units, measuring 4 by 10 feet. Openings at the base and horizontal joints located at every 4-foot interval of wall height increase air flow and drainage within the cavity. Veneer joints, covered by bug screens in the outer wall, are left open to allow air to circulate within the wall cavity, keeping the insulation dry by allowing moisture to evaporate. Mechanical shades located in this cavity in front of any windows further reduce solar gain within the building. The cavity also serves to moderate the effects of temperature and humidity differentials between the interior and exterior of the building.

The glass surfaces are fritted with horizontal banding that varies in density to define each of the museum's formal elements and help to reduce solar heat gain. There are two frit patterns on the inner and outer skins allowing varying levels of light transmission: 1/2 inch of clear spacing with either 14/16 inch or 1/2 inch of opaque frit strips. The patterns occasionally overlap to produce a moiré effect, created by two superimposed layers of repetitive semitransparent patterns. Although the museum has a transparent appearance, the glass is used mainly as a cladding material over a building with relatively few windows. Depending on the light conditions, the museum variously appears to be opaque gray, filmy white, reflective blue, or translucent green.

Opposite

Top: Mississippi riverfront elevation

Bottom: Southwest corner, River

Drive and Harrison Street



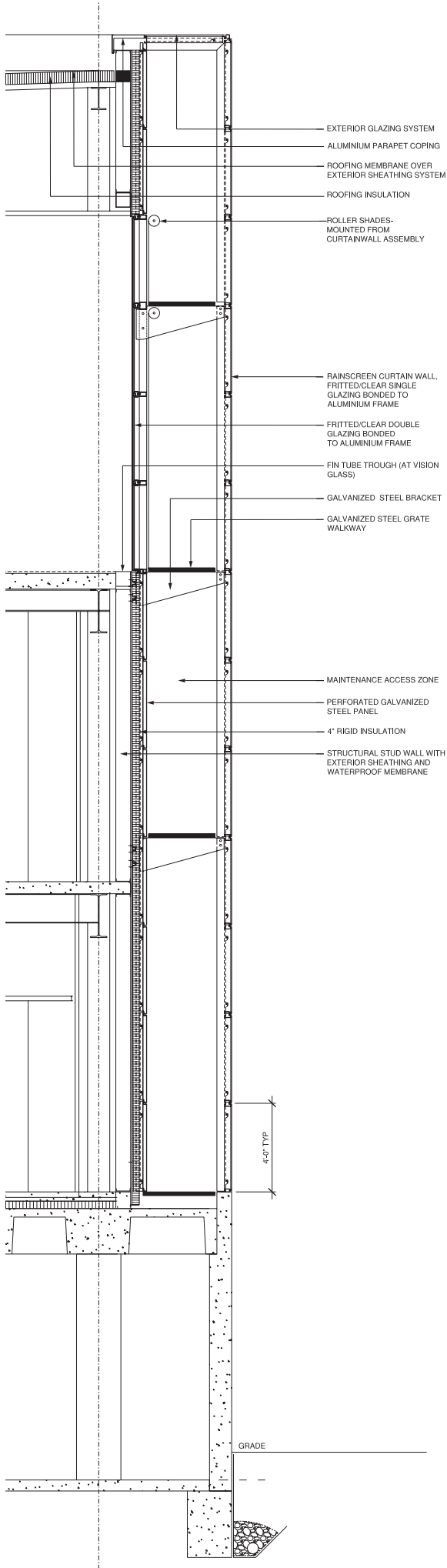



Opposite
Left: Rainscreen wall section
Top: Exterior view
Bottom: Rainscreen wall cavity



This page
Top: Rainscreen curtain wall
Bottom: Rainscreen wall cavity looking up (left), rainscreen and conventional walls

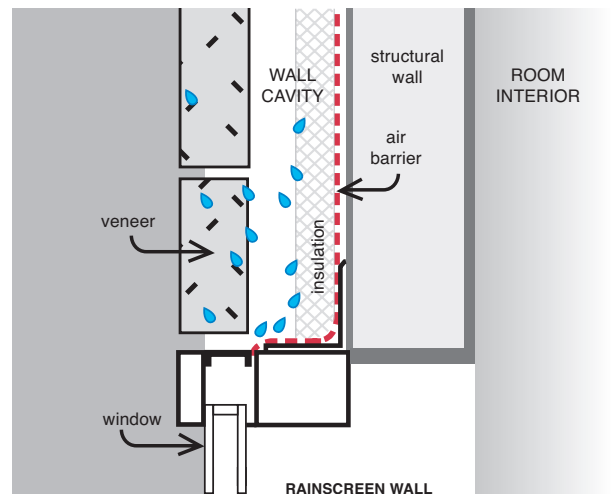
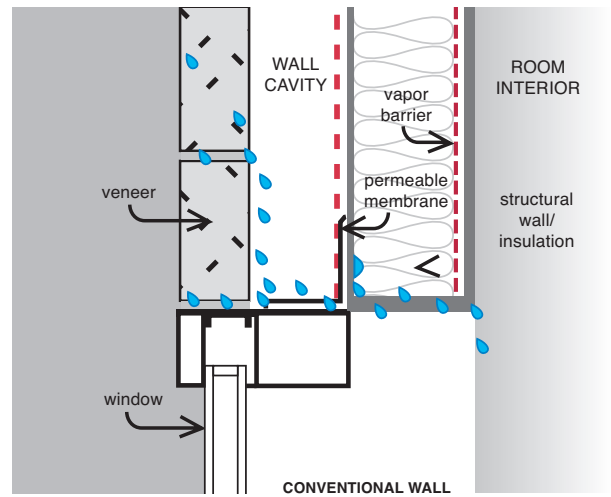

Art Center College of Design, Pasadena, California

Daly Genik Architects, Santa Monica, California

As the first building of its new south campus extension, the Art Center College of Design (ACCD) has taken over a large 100,000-square-foot concrete structure in downtown Pasadena, formerly a supersonic wind tunnel used by a consortium of aircraft companies to evaluate their planes throughout the mid- and late-twentieth century. As a result of its former use, the complex had large, dark, irregularly shaped spaces with few windows; the design challenge for its reuse by the ACCD was the creation of openings in the existing concrete shell that would allow light to penetrate the deepest recesses of the building. Through the installation of three large skylights in the roof—a sequence of interconnected light wells clad in layered lightweight plastic—and a series of cuts made in the exterior walls along the street, Daly Genik Architects transformed the 300-foot-long structure into a light-filled space suitable for galleries and arts instruction. The skylights have an emblematic significance for the renovated building: because ACCD also has a night school, it is as important for them to glow at night as to light the studios during the day.

The roof structure of the existing building is relatively fragile, consisting of concrete beams and purlins with a concrete deck. To lighten the load that would be concentrated on the roof, Daly Genik Architects agreed to cut away only the deck layer, leaving the beam structure intact. The new skylights and the cast concrete curbs which

distribute their weight evenly over the roof surface could weigh no more than the removed concrete decking, minimizing any additional load on the building's structure. Natural light for the studios was a critical consideration, but comparative analysis of various skylight solutions revealed that the amount of light admitted by the skylights was directly proportional to the weight of the framing required to support them. Daly Genik Architects began to research ethylene tetrafluoroethylene (ETFE) membranes—used extensively in Europe, but yet to be installed in the United States—ultimately choosing Foiltec NA as the primary contractor for the skylight system. The Los Angeles office of Arup Engineering, with previous experience of ETFE systems in Europe, collaborated on the design of the delicate steel frames for the 40- and 50-foot long skylights.

The Foiltec cladding system consists of a number of layers of the UV stable copolymer ETFE welded into pillows or foils, restrained around their perimeters by aluminum extrusions fastened to steel frames, and inflated with low-pressure air, providing insulation and resistance to wind loads. Because ETFE is an inflated system, it can only transmit tensile loads to the frame, and the higher the air pressure within the system, the higher the wind load and the greater the stress exerted by the system on the frame. Foiltec acts as a natural light control system, expanding and contracting



This page
First floor plan

Opposite
Top: Cross section
Bottom: Aerial view South
Raymond Avenue

to admit or block light as needed, which helps to reduce the heating and cooling loads within the building. The reinflation process can be controlled by a timer, a seasonal clock, or light and thermal sensors.

A Foiltec cushion consists of at least two layers but more can be added into the system to enhance the cladding's insulation properties. The range of transparency of the system is project-specific and determined by design intentions and desired building performance. Each foil can be designed to affect the appearance and performance of the roof, its visual transparency, and the levels of solar gain. One of the principal innovations by Foiltec is a valve system that allows an additional surface to be included in the pillow assembly. This surface can be printed with a pattern that is offset from the pattern printed on the exterior; when these surfaces are in contact with each other, light is excluded from the skylight. As the Foiltec layers expand and contract, the applied

pattern controls the amount of light that is admitted. Movement of the second or middle layer closer to the top or bottom of the system can alter its transparency. When the air is pushed in between the layers, they expand to look like pillows, allowing the maximum amount of light into the space; when the air is drawn out, the pillows flatten to bring the two surfaces of patterned Foiltec closer together, effectively blocking the light.

Daly Genik Architects intended the skylight installation to achieve an integration of design disciplines: structural engineering, architectural form, and graphic design. In collaboration with graphic designer Bruce Mau, they developed an original pattern for the three-layer Foiltec system, an integral part of the system's dynamic technology, which allows the skin to alter light transmission through visual transformation. Because ink will not adhere to its Teflon surface, the Foiltec had to be irradiated with a high frequency energy source and printed with

cut rubber rollers. The cost of the rollers was significant, but the larger investment was in optimizing the pattern so that correct amounts of light would be transmitted in the open or closed configurations. The architects originally specified criteria of forty percent open and ninety percent obscured. The Mau office produced a number of variations for the client's approval, and Foiltec evaluated the patterns for light transmission. Because reflections develop as light moves between the open layers, numerous iterations were required before the final design configuration was established. Throughout the course of the day, the Foiltec system responds like a respiratory system to changing levels of light, heat, and activity within the building. At night the skylights glow with a soft light and are transformed into iconic lanterns.

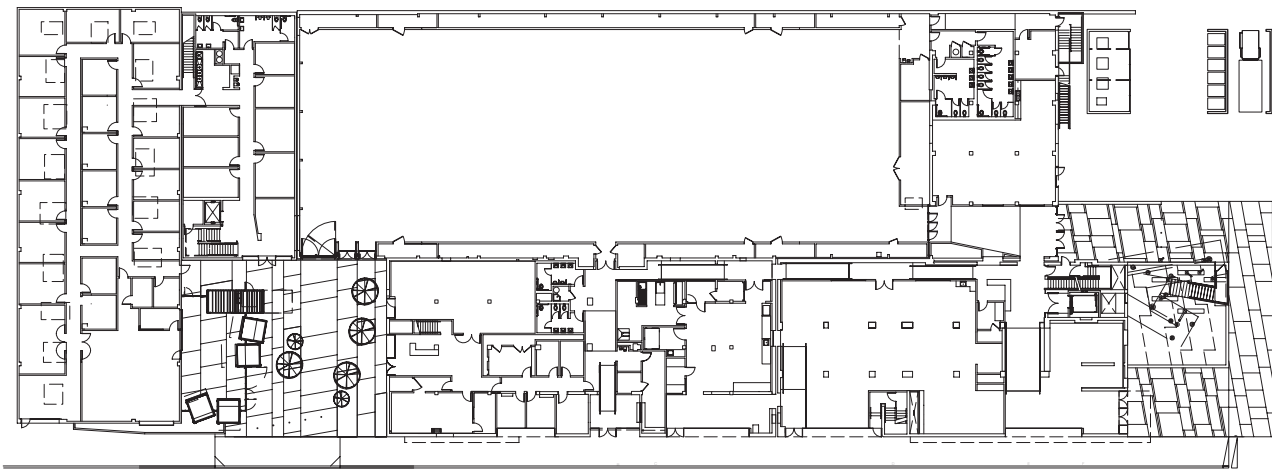

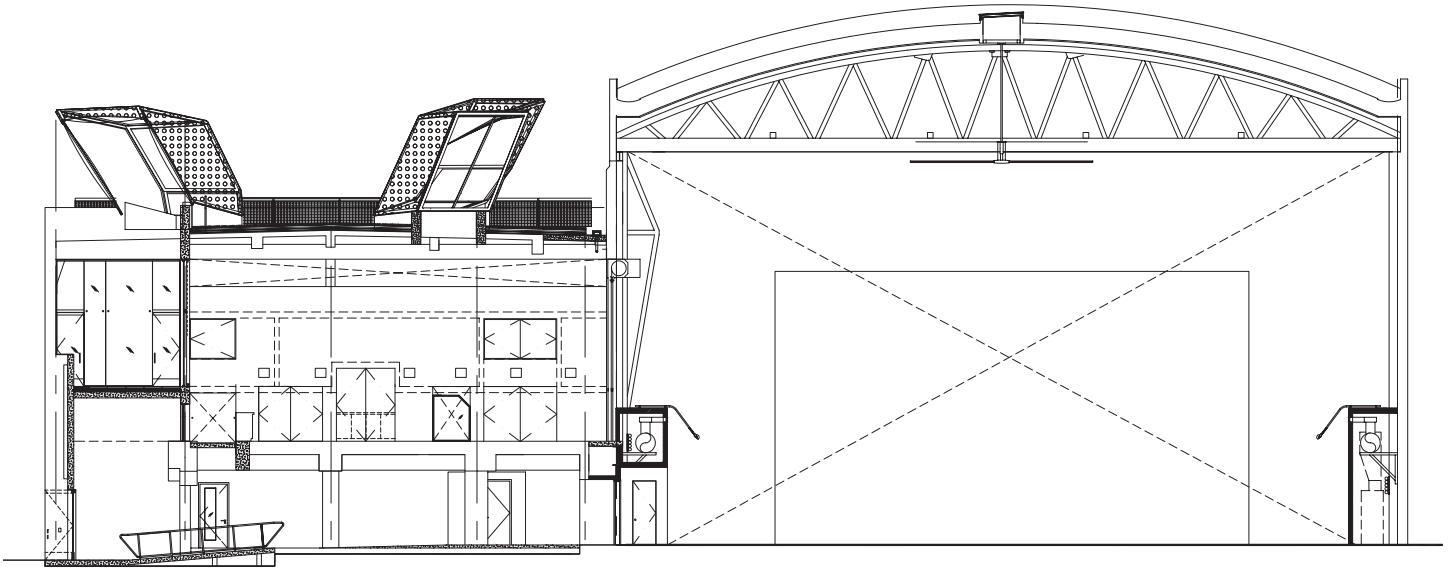

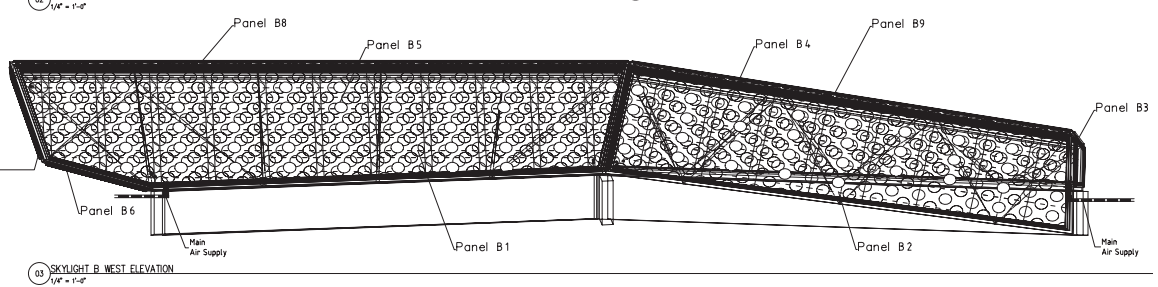
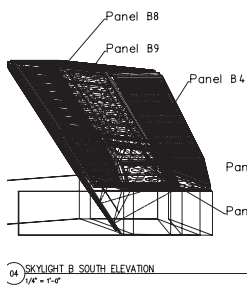
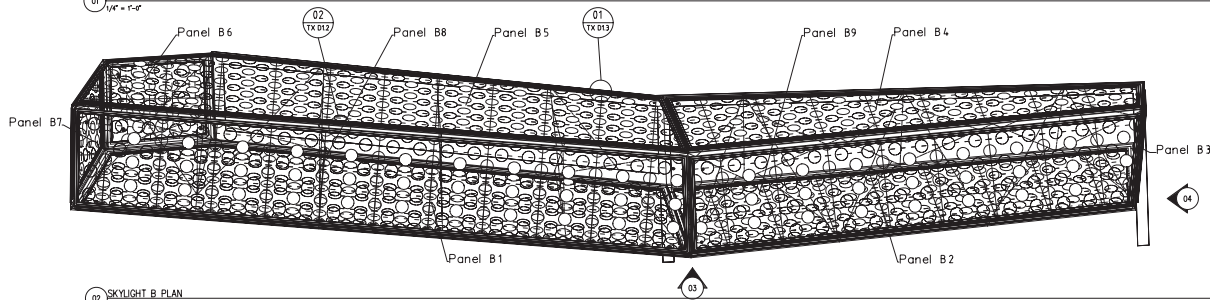
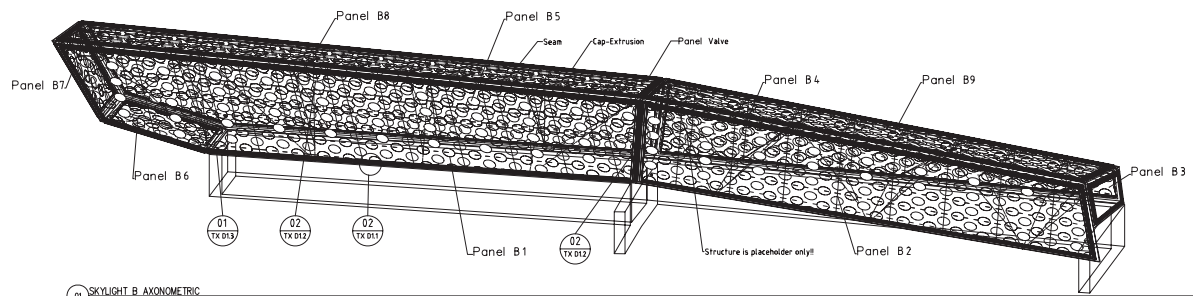
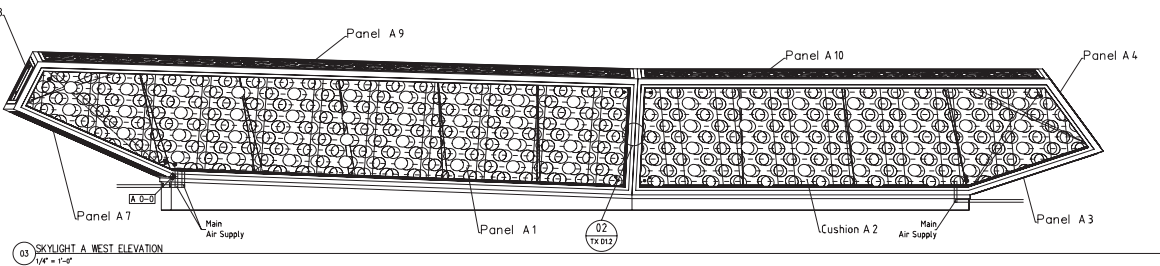
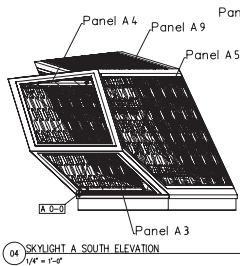
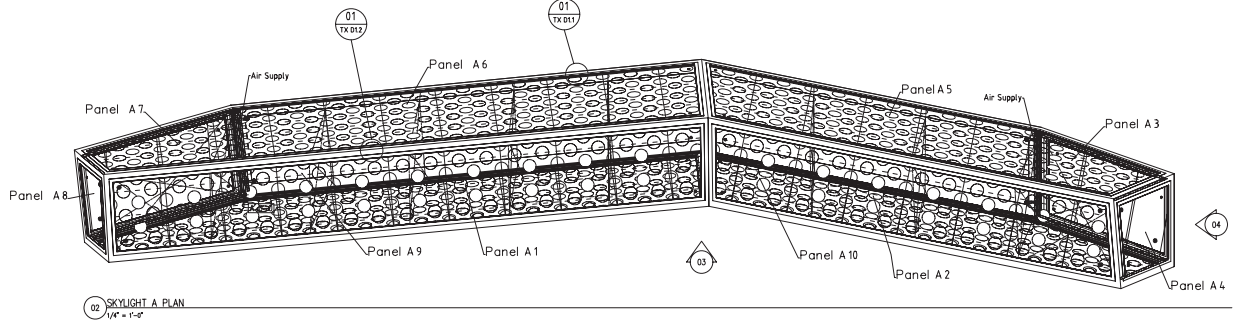
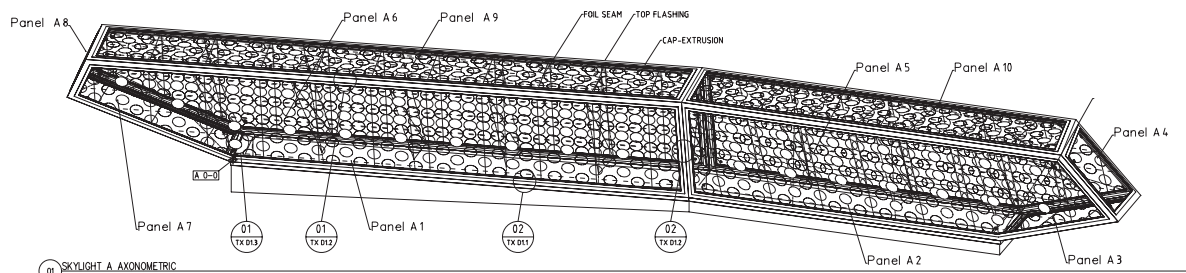

Opposite
Top: Skylight A
Bottom: Skylight B

This page
Top: Skylight C
Bottom: Skylight typical details

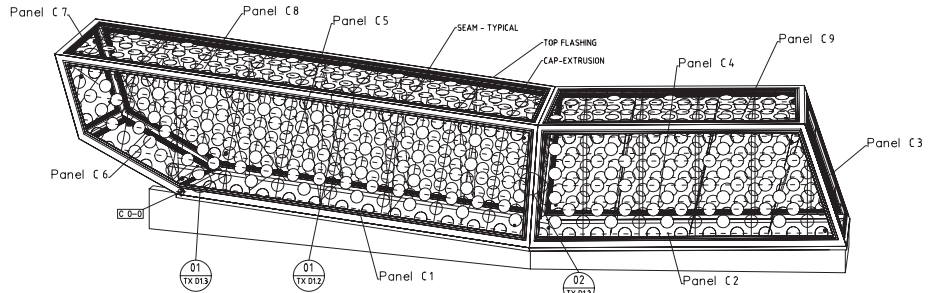

01 SKYLIGHT C AXO
 $\frac{1}{4}'' = 1'-0''$

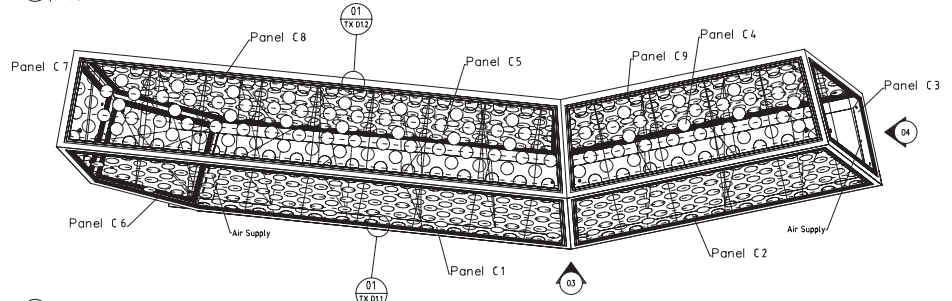

02 SKYLIGHT C PLAN
 $\frac{1}{4}'' = 1'-0''$

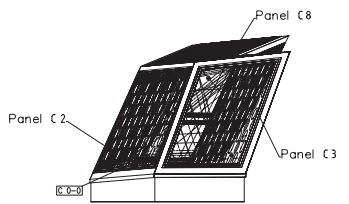

04 SKYLIGHT C SOUTH ELEVATION
 $\frac{1}{4}'' = 1'-0''$

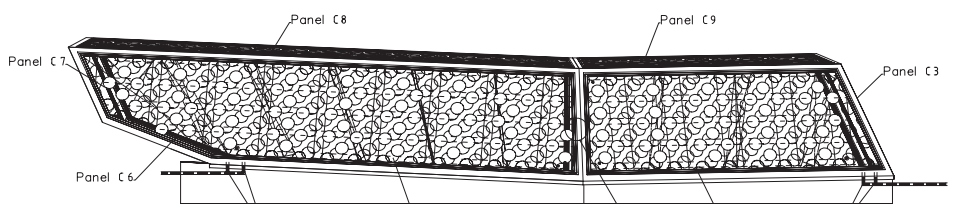

03 SKYLIGHT C WEST ELEVATION
 $\frac{1}{4}'' = 1'-0''$

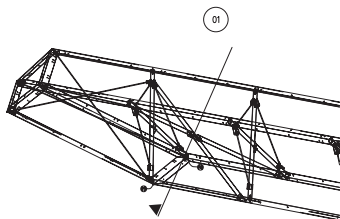

04 SKYLIGHT A - KEY AXON FOR TYPICAL SECTION CUT-LINE - 01 TYPICAL SECTION
 NOTE: SOUTH END OF SKYLIGHTS SIMILAR

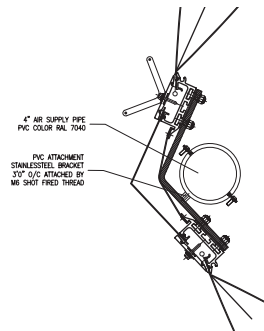

05 SECTION A - A
 $5'' = 1'-0''$

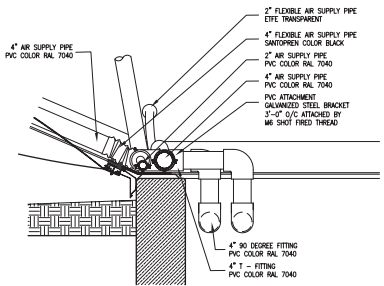

06 SECTION B - B
 $2'' = 1'-0''$

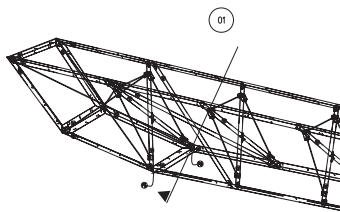

03 SKYLIGHT B - KEY AXON FOR TYPICAL SECTION CUT-LINE - 03 TYPICAL SECTION
 NOTE: SOUTH END OF SKYLIGHTS SIMILAR

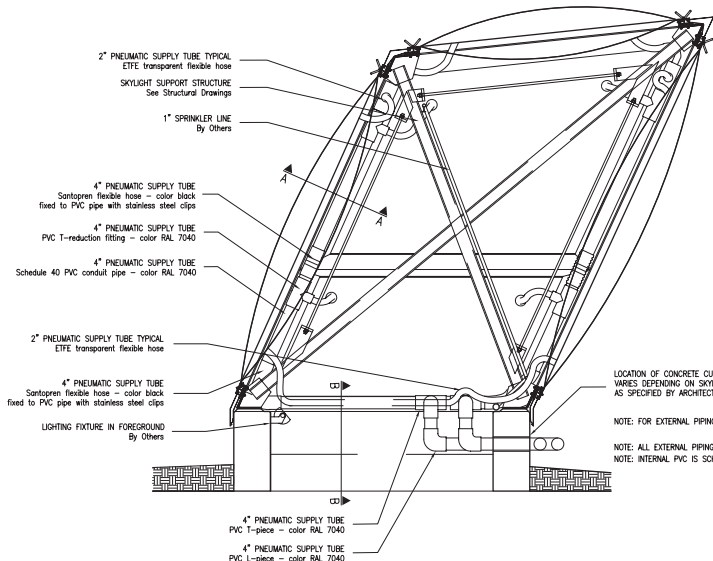

01 TYPICAL SECTION OF INTERNAL AIR SUPPLY PIPING
 $\frac{3}{4}'' = 1'-0''$

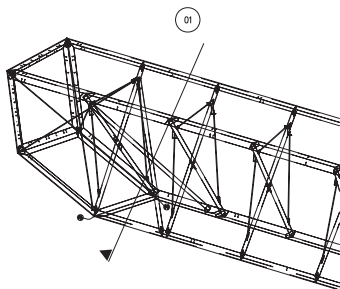

02 SKYLIGHT C - KEY AXON FOR TYPICAL SECTION CUT-LINE - 02 TYPICAL SECTION
 NOTE: SOUTH END OF SKYLIGHTS SIMILAR

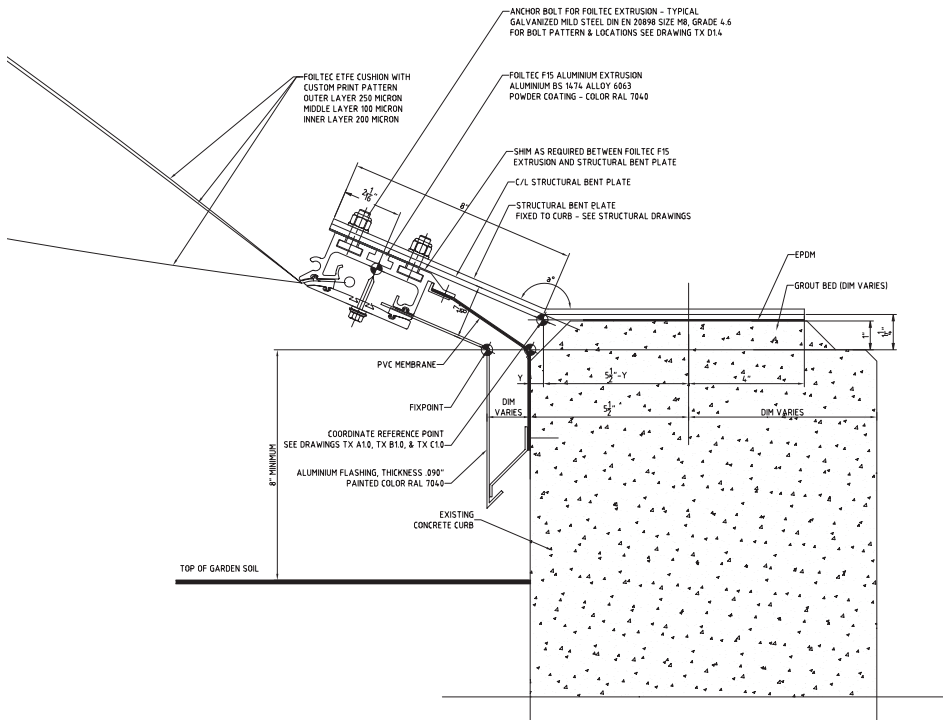
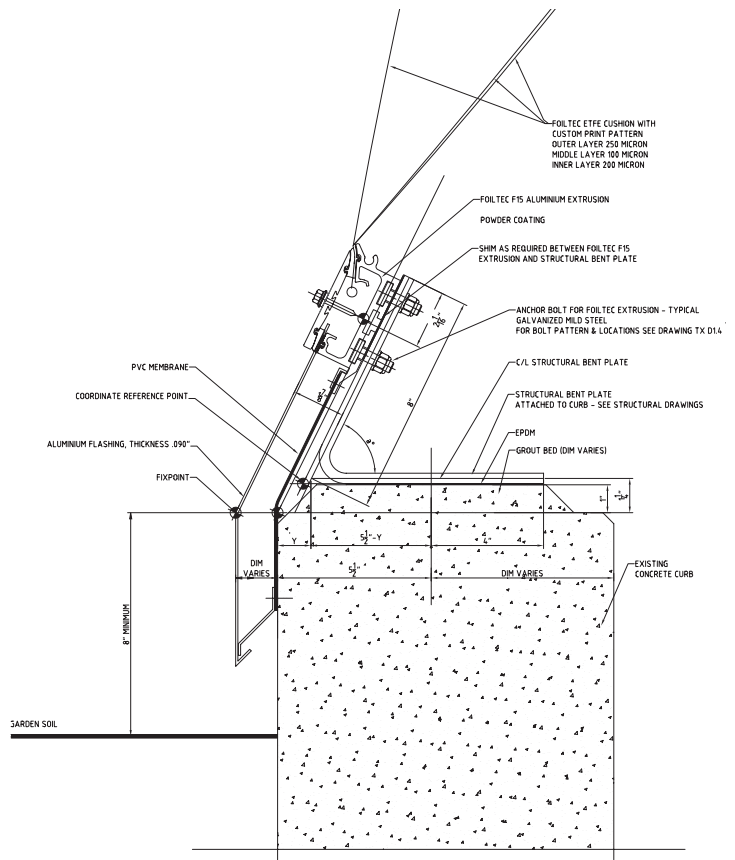
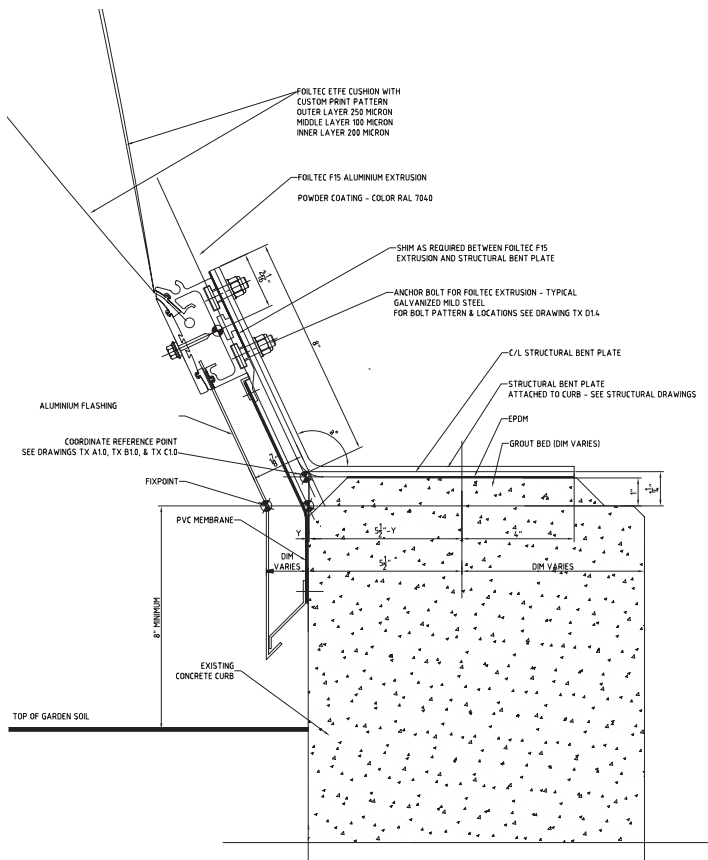

This page
Top and bottom: Skylight frame and curb details

Opposite
Top: Skylight frame detail
Bottom: Installation of skylight

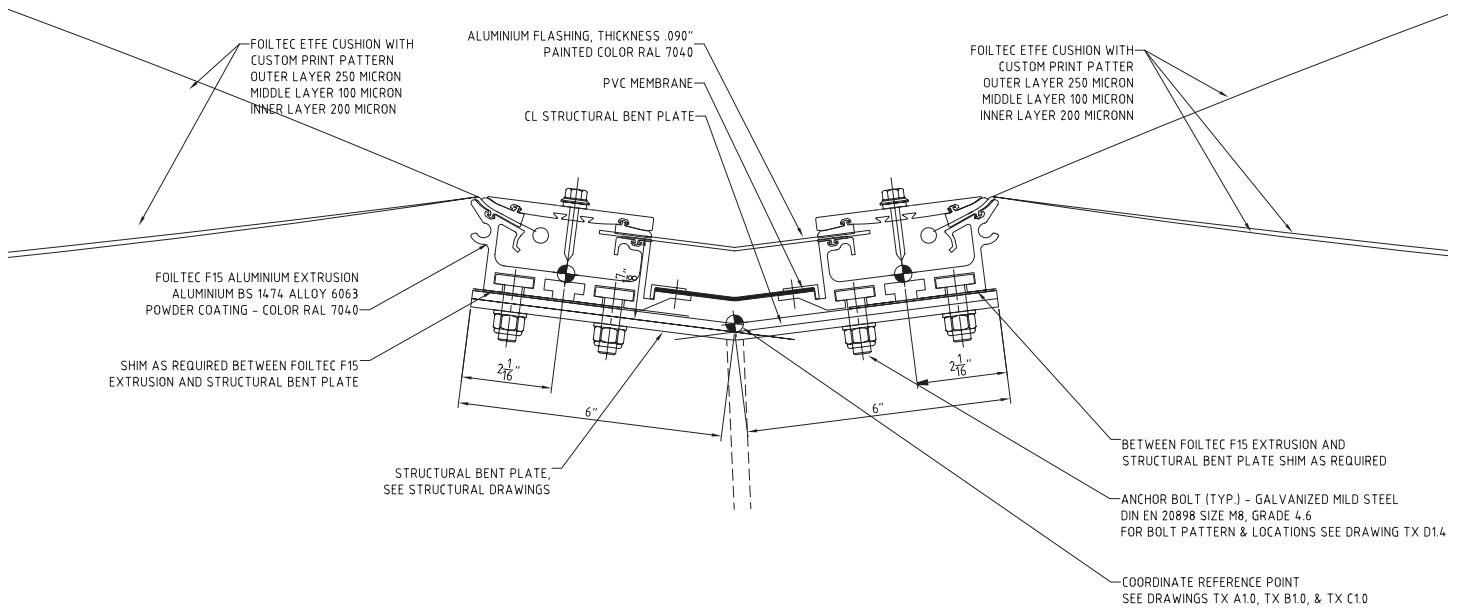

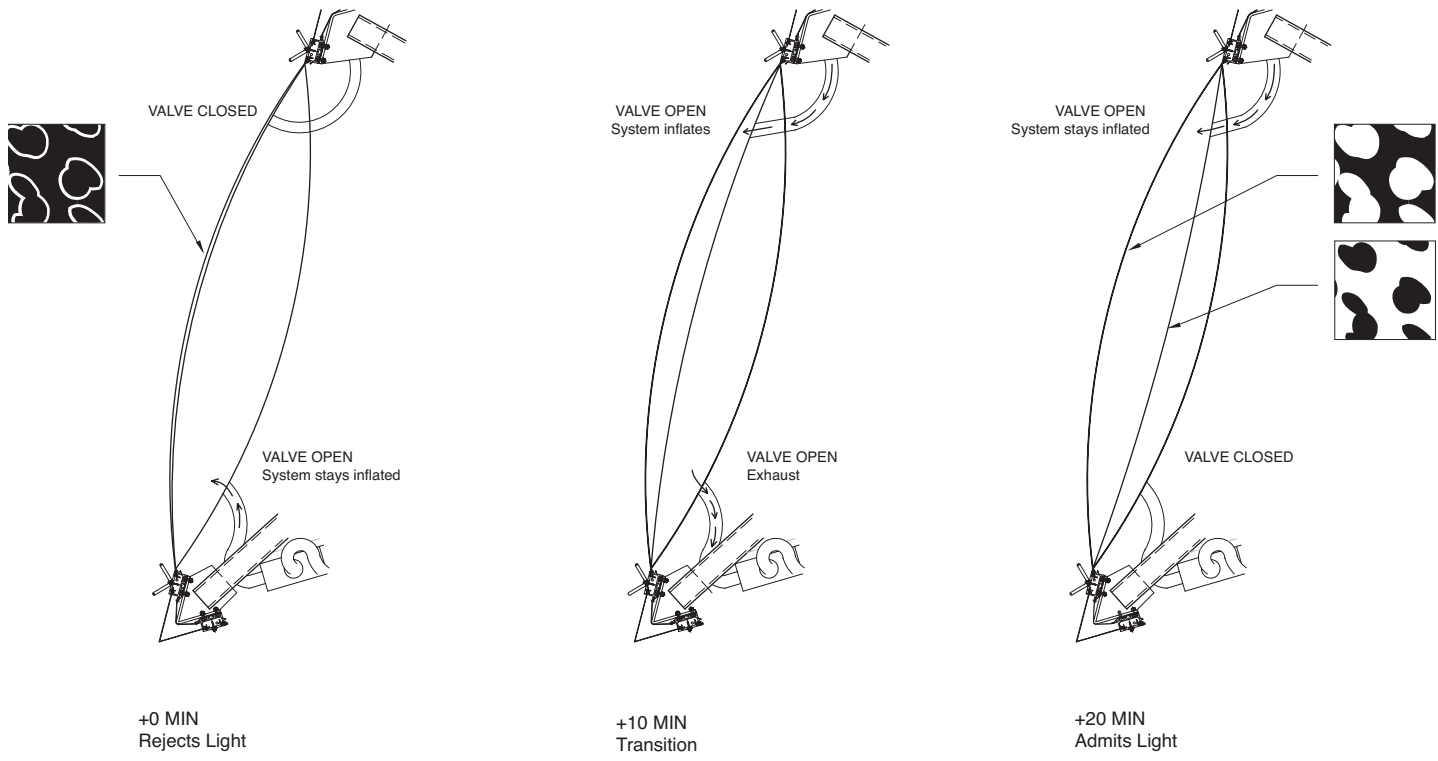

This page

Top: Foils open and closed

Bottom (left to right): Foils partially open, open, closed

Opposite

Top: Skylight, night

Bottom: South Raymond Avenue entrance

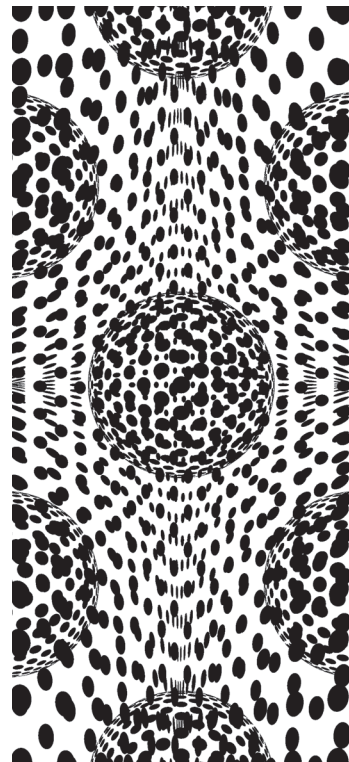
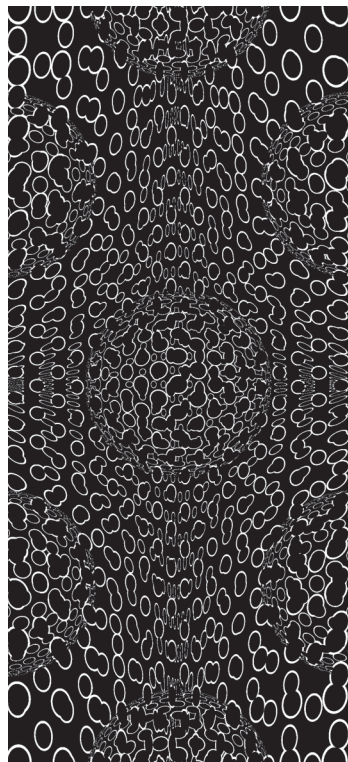
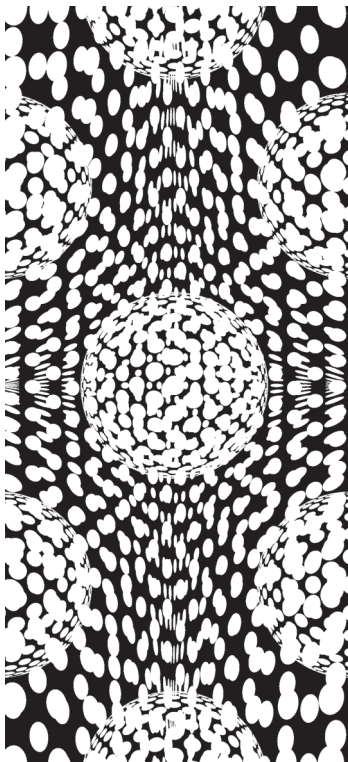



Nothstine Residence, Green Bay, Wisconsin

Garofalo Architects, Chicago, Illinois

Located on an acre of steeply sloped terrain, the Nothstine Residence consists of a series of additions and modifications to an existing wood frame structure on a site with panoramic waterfront views of Green Bay. The strategy for placement of these interventions was inspired by the clients' interest in horticulture, bird watching, and small-scale electric slot-car racing. The most striking feature of the house is the ribbon encapsulated in fiberglass that weaves along the southwest facade like a tortuous race-track, connecting the new additions. The hairpin turns and loop-the-loops include an extension of the living space, a master suite, a combination study and grow room (for indoor gardening), and a home theater, all organized along the continuously folding tectonic ribbon. A number of steel elements project from the house as bridges and platforms connecting the kinetic structure back to the landscape. The most dramatic of these is a slender bird-watching platform that is designed to sit at the tops of trees. A shored garden path and aqueduct system furthers the routing and tracking ideas of the architecture.

The continuously folding tectonic ribbons of the southwest addition are constructed with a structural system composed of steel trusses, engineered wood spanning members, and plywood. The trusses are back-to-back Ts that measure 3 1/2 by 5 by 1/2 inches with plates sized at 3/8 by 5 1/2 inches, which serve as connection points for the steel pipe cross members. Each connection is individually drawn to

provide for each eccentric weld length, determined by the changing angles of these members along continuous ribbons of space. A special router was used to cut the curved steel components that make up the truss assemblies. At the curved portions of the truss, the Ts are not bent but built up from CNC-cut plate steel. The precise production of these trusses facilitated the exact placement of the compression and tension members.

The completed truss became the guide for carpenters anchoring wood cross members, which are tapered at each end. As the roof joists lying on top of the truss curve around to a more vertical wall, small wood brackets hold the members in position until the plywood sheathing bonds them together into one system. As these in turn curve around to form the floor framing, the joists hang under the truss, held in place by joist hangers welded to the bottom chord. Careful placement of wood blocking allows for the entire steel truss to remain exposed on the interior of the project. The exposed steel elements are conceived to allude to the roll cages often fitted to high performance racing vehicles. The entire wood system becomes a rigid shell once two layers of plywood are glued and screwed to the outside edge of all the wood members. The bent plywood exterior surfaces of the ribbon are encapsulated in seamless fiberglass, which is applied directly to the plywood substrate through a spray nozzle in two coats; the second has the integral yellow color.

Opposite

Top: Rear elevation
Bottom: Side ribbon



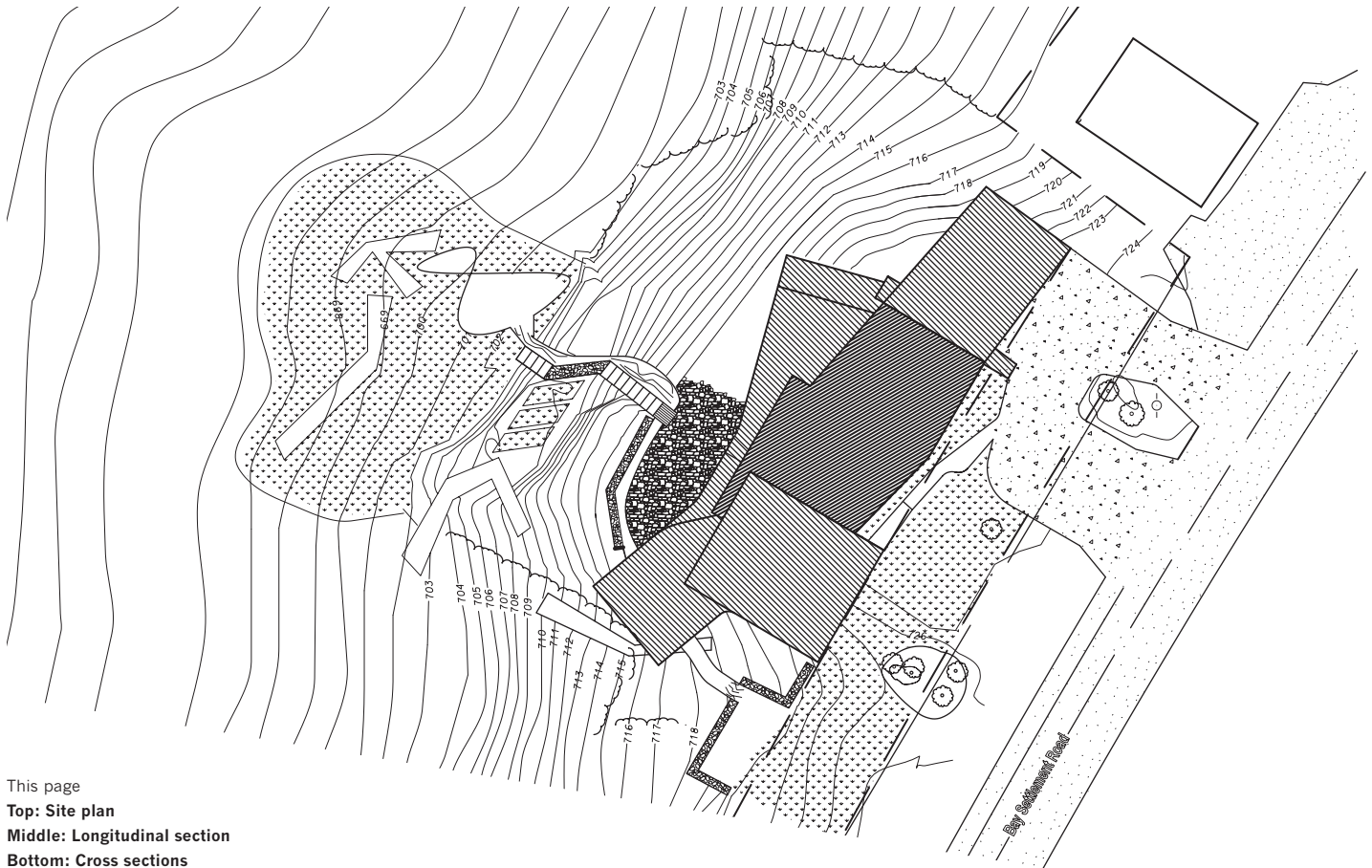

This page
Top: Site plan
Middle: Longitudinal section
Bottom: Cross sections

Opposite
Top: Third floor plan
Bottom: Framing details

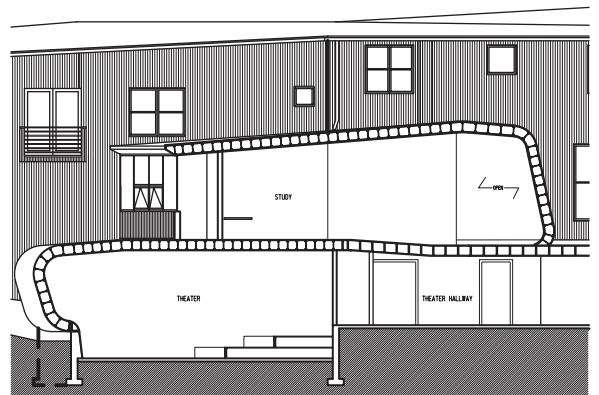
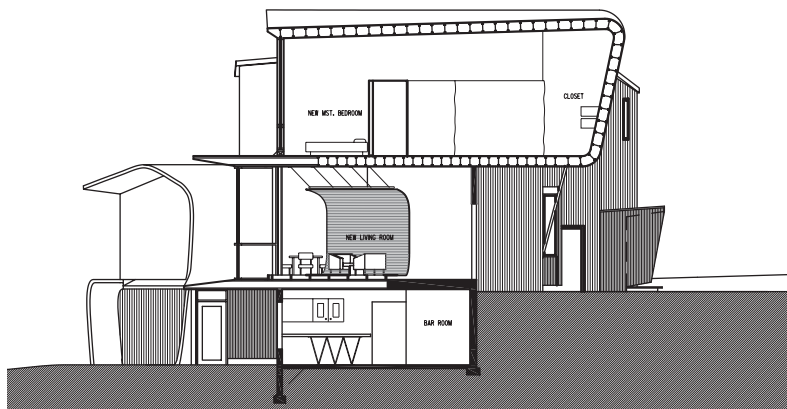

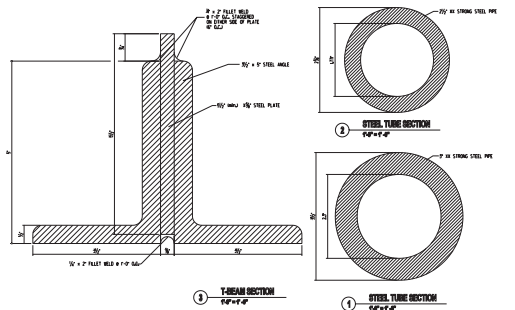
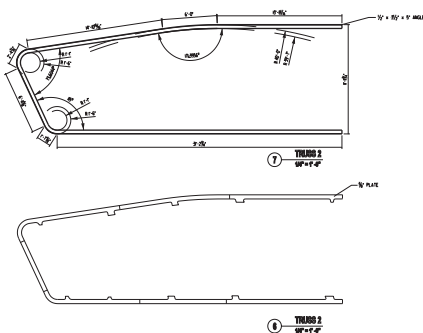
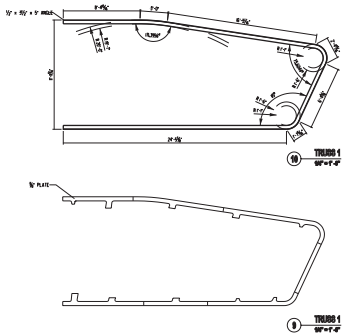
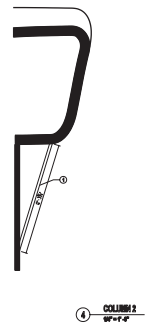
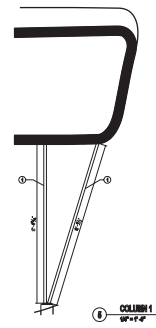
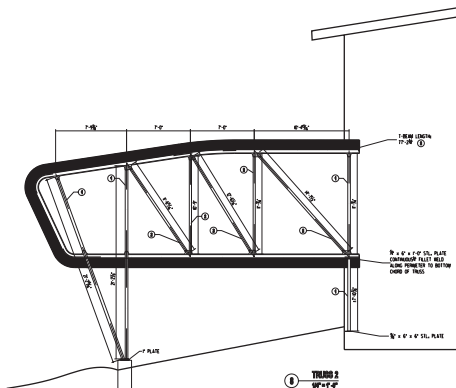
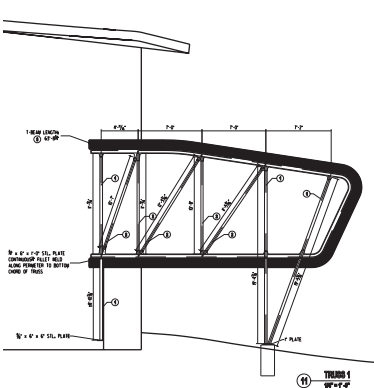
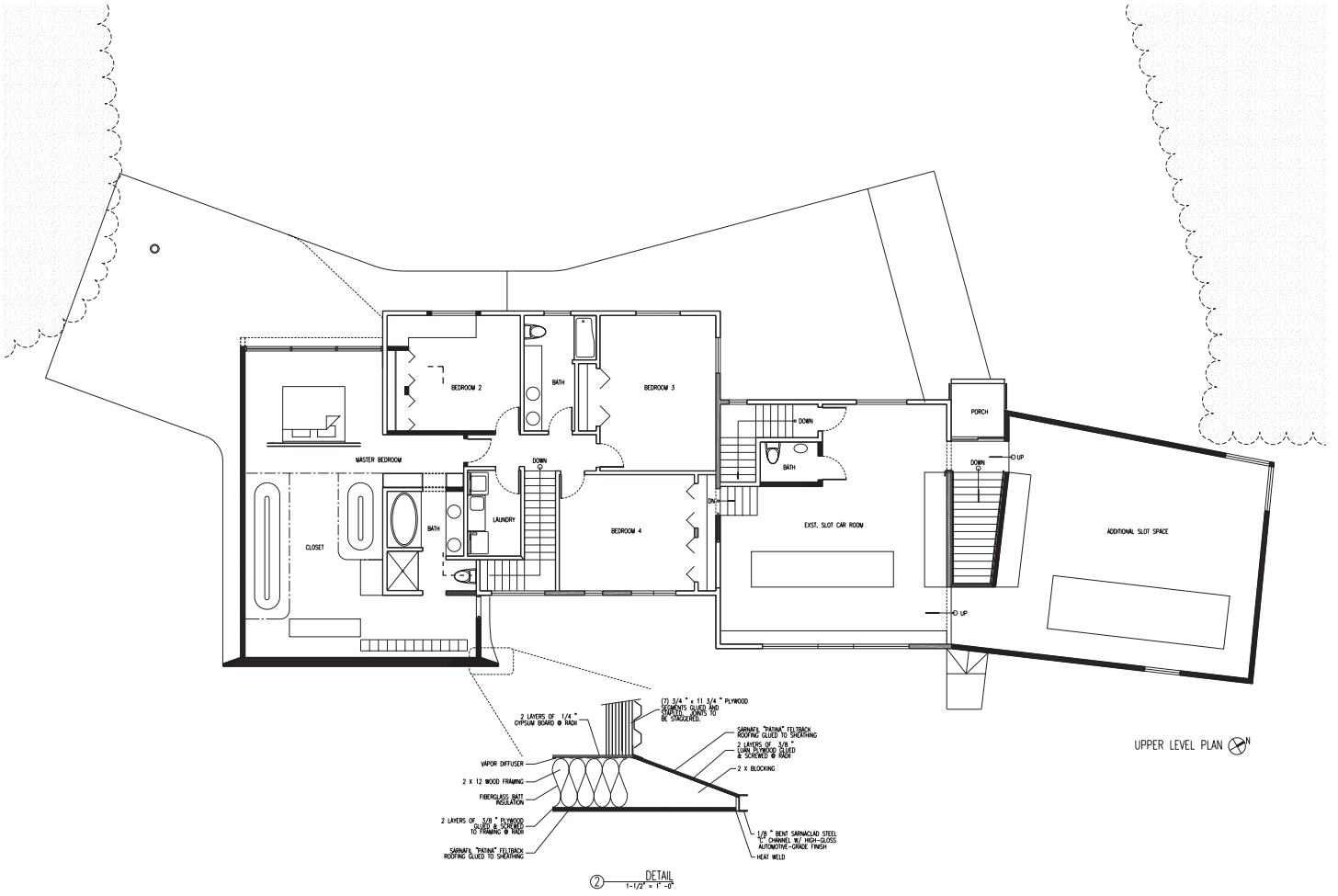

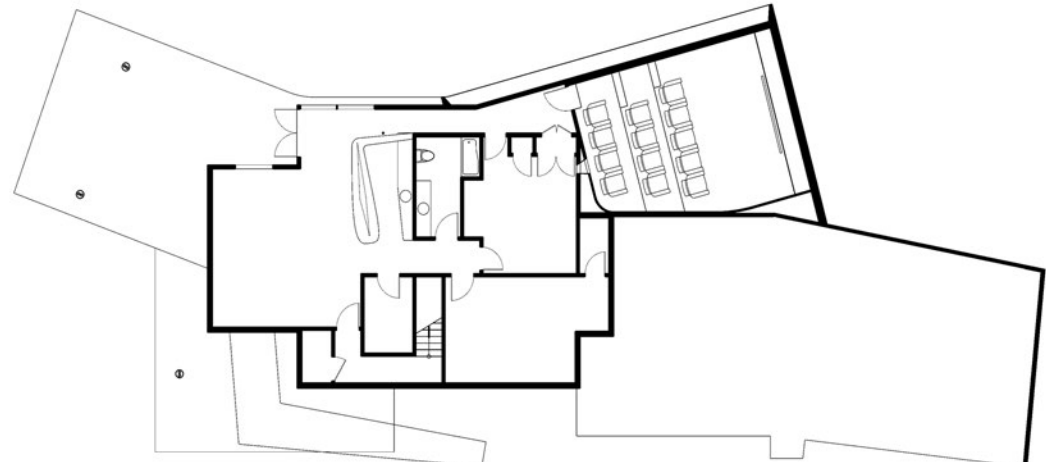
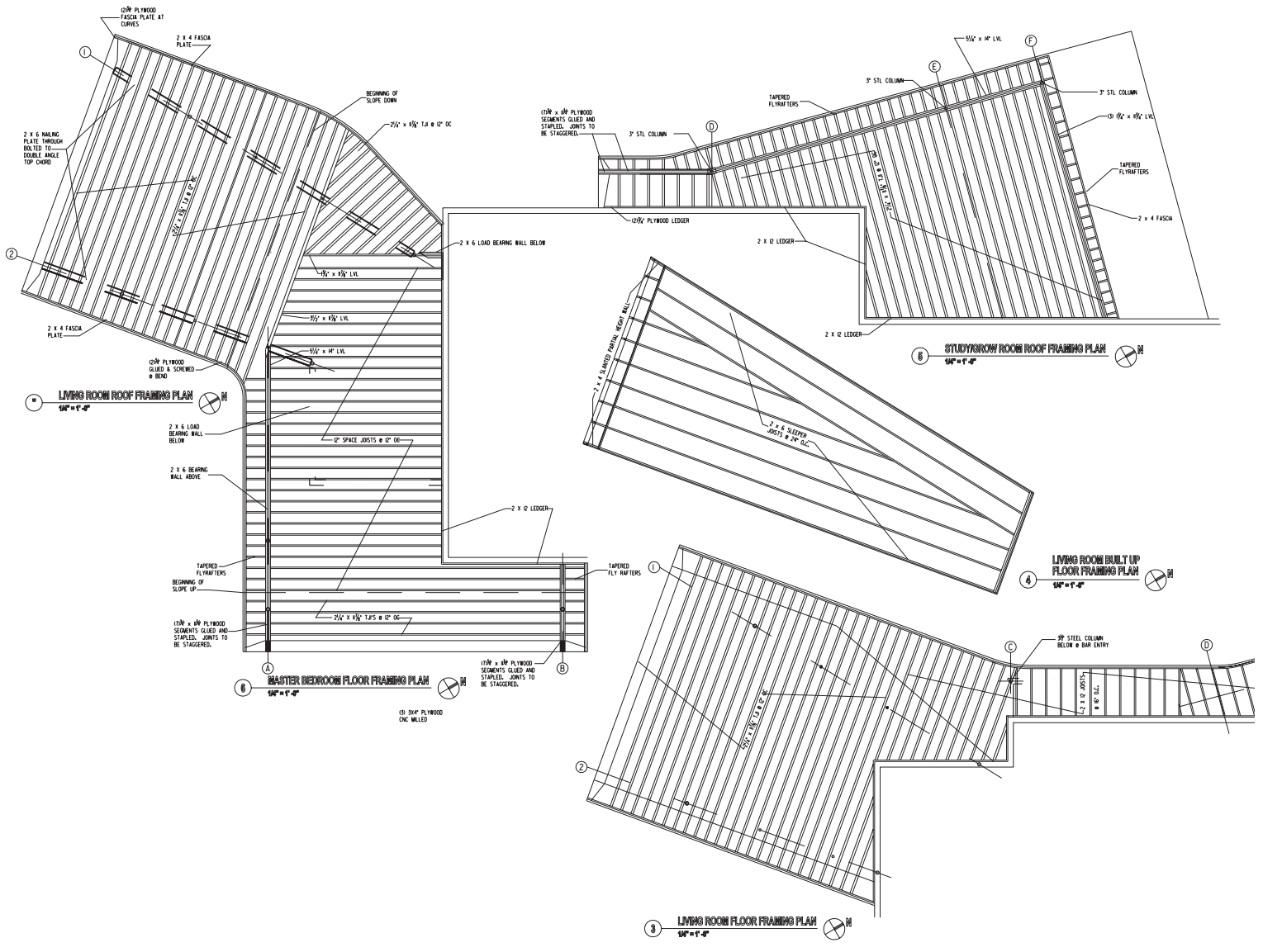

This page
 Top: Framing plans
 Right: First floor plan

Opposite
 Top: Platform detail
 Middle: Stair to rear yard
 Bottom: Second floor plan

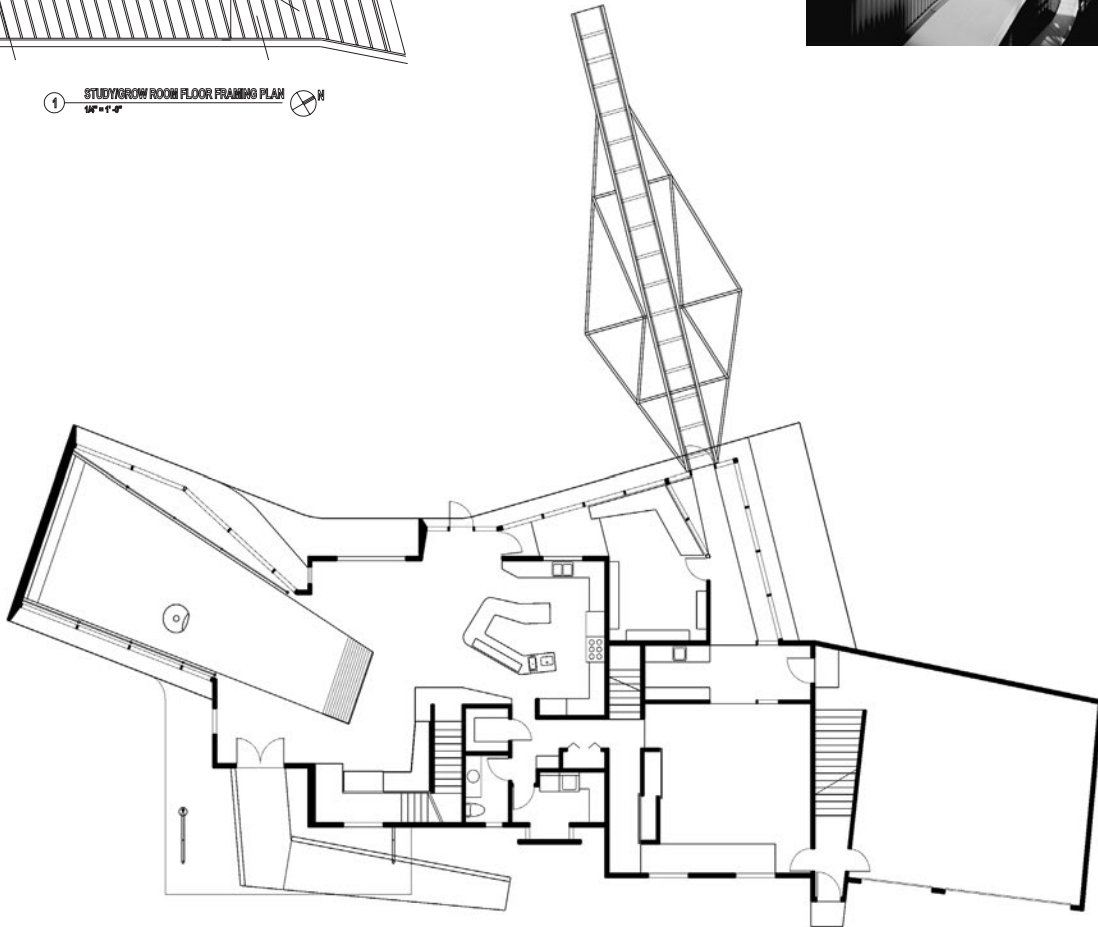
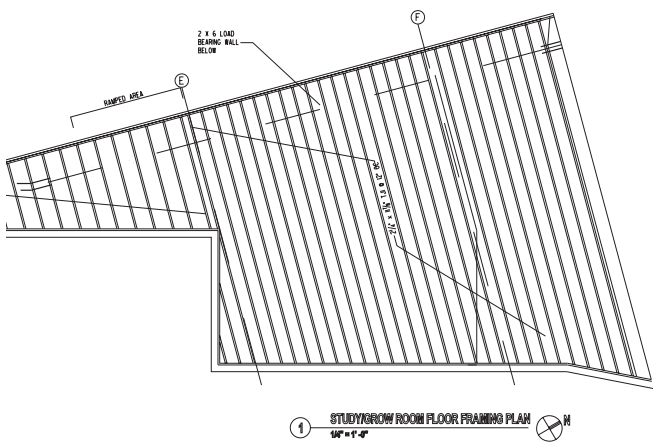
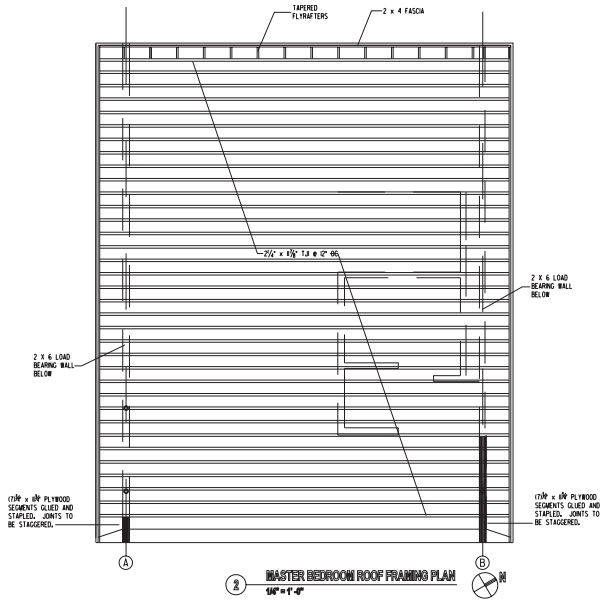

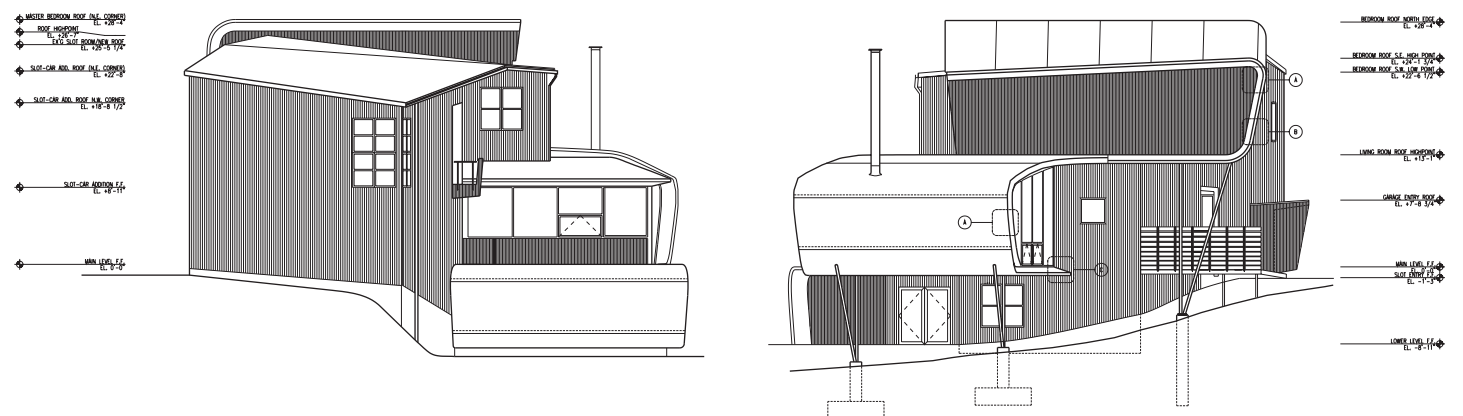
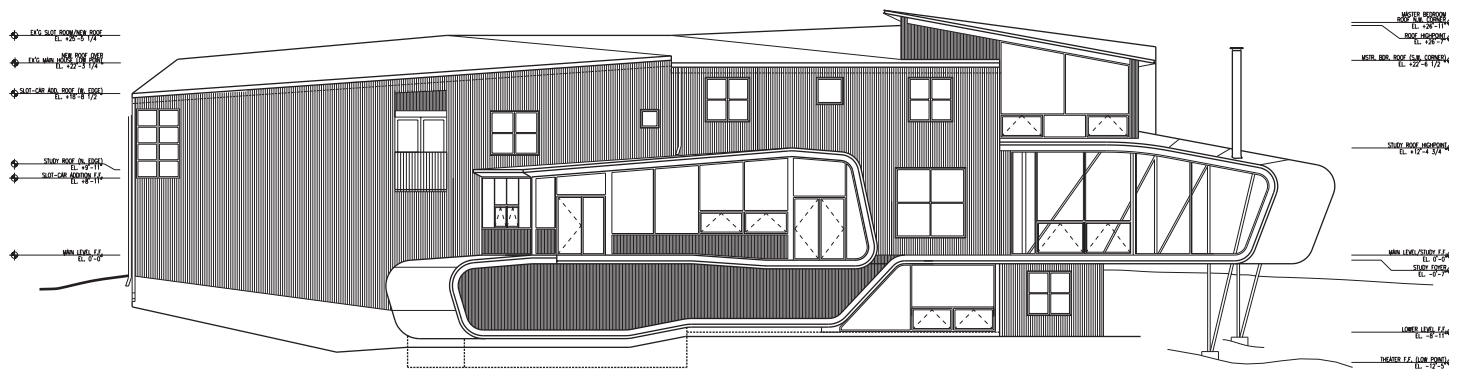
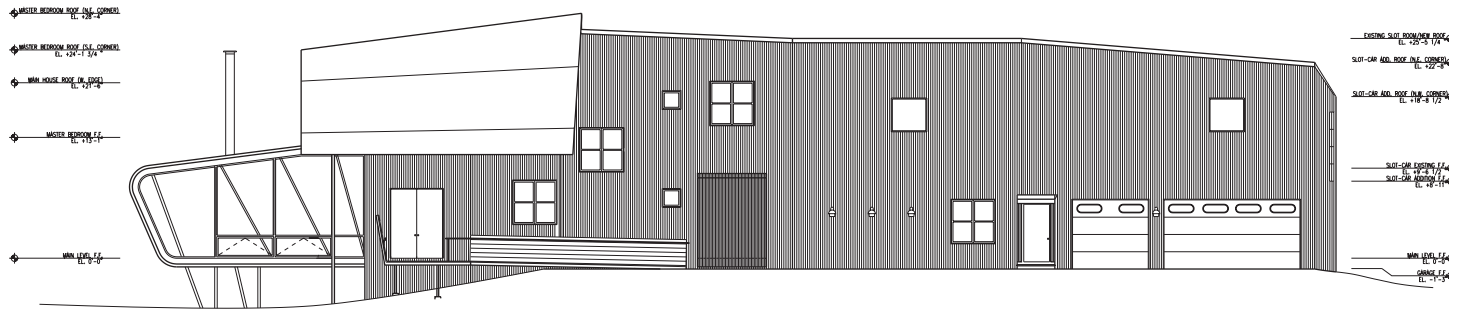

Opposite

Top: East elevation

Middle: West elevation

**Bottom: North elevation (left),
south elevation**

This page

Top: Ribbon models

Bottom: West elevation

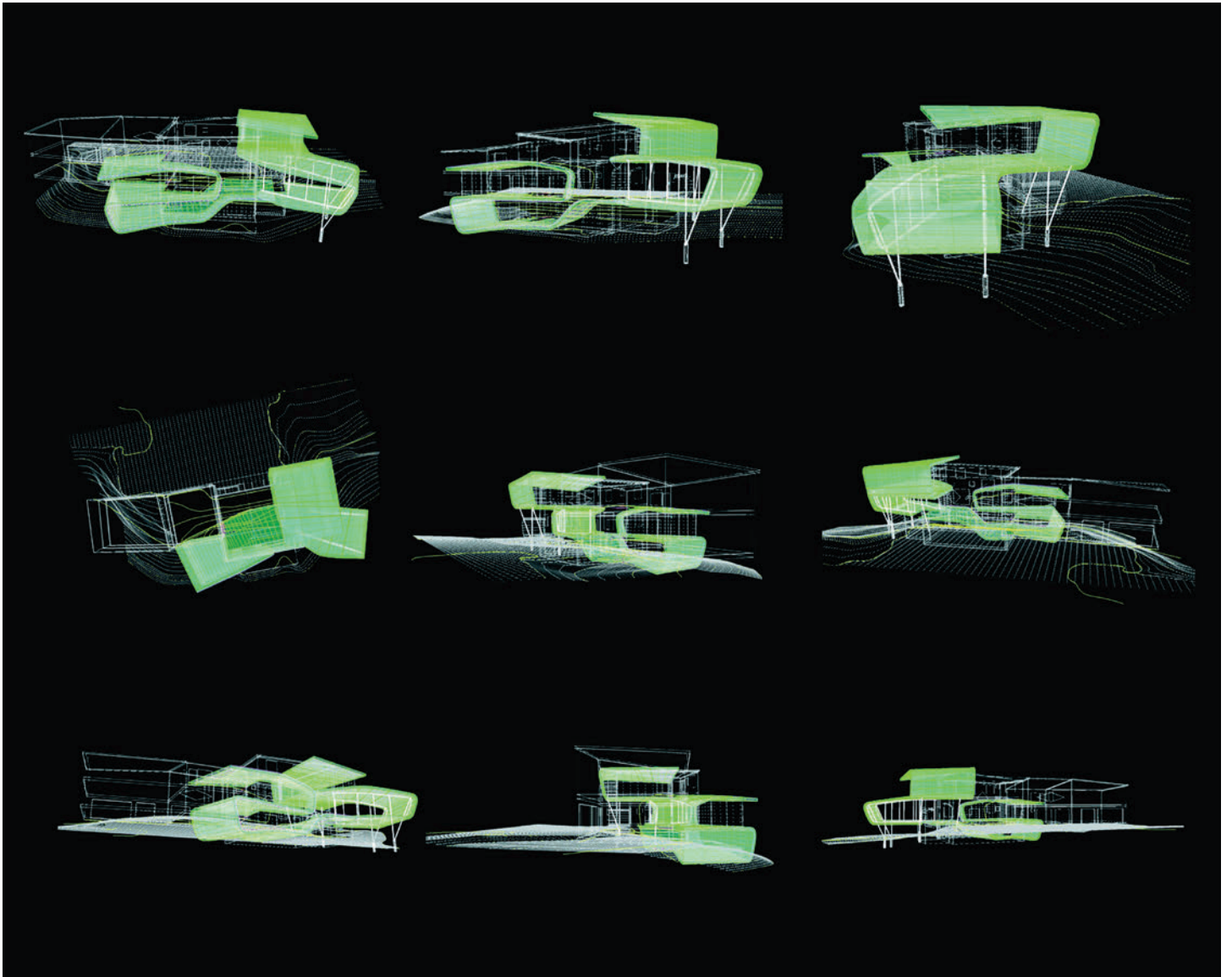

BP Bridge, Pritzker Pavilion, and Great Lawn, Millennium Park, Chicago, Illinois

Gehry Partners, LLP, Los Angeles, California

Chicago's Millennium Park is 16.5 acres and built over existing and expanded rail lines, bus lanes, and two new parking levels. The open area includes the four-thousand-seat Pritzker Pavilion, the Great Lawn with space for an audience of an additional seven thousand people, and the BP Bridge, all designed by Gehry Partners with structural engineering by SOM. The BP Bridge spans Columbus Drive to link Millennium Park with Daley Bicentennial Plaza and parkland on lakefront areas to the east. The 925-foot-long serpentine bridge provides views of the Chicago skyline, Millennium Park, and Grant Park along the shores of Lake Michigan. The extra length made possible by the bridge's sinuous curves allows for an overall slope of five percent, facilitating easy access and a comfortable path of travel for the physically challenged, while affording a shifting series of perspectives of Millennium Park and the Chicago skyline.

The bridge has a concrete and steel support structure and spans the roadway with a single supporting column. Its sharply angled side sections effectively minimize the overall appearance of the structure. Clad in more than nine thousand brushed stainless steel panels with an ipe hardwood deck, the BP Bridge acts as an acoustic barrier for the traffic noise on Columbus Drive and Michigan Avenue on the west side of the park. The Great Lawn is covered by a three-dimensional trellis of stainless steel, which supports lighting and many of nearly two hundred speakers positioned throughout the pavilion and lawn, efficiently amplifying sound without blocking views of the stage. The Great Lawn itself includes 95,000 square feet of reinforced natural turf lawn designed for extreme traffic use and runoff recovery through use of emerging turf technology, and a layered high performance drainage system. Because the structural

deck was designed to support 4 feet of growing medium, the planting design is not limited to the grid of the structural columns in the parking garage below. The result is varying profiles of growing medium with sand drainage throughout the project ranging in depth from 8 inches to 4 feet deep. The entire deck was waterproofed with a hot-applied rubberized membrane system. Styrofoam fill was used to create landforms, which do not exceed the designed load capacity of the structural deck. Two reinforced concrete cast-in-place garages support most of the roof deck, while a combination of steel structure and precast concrete structural tees span the railroad tracks.

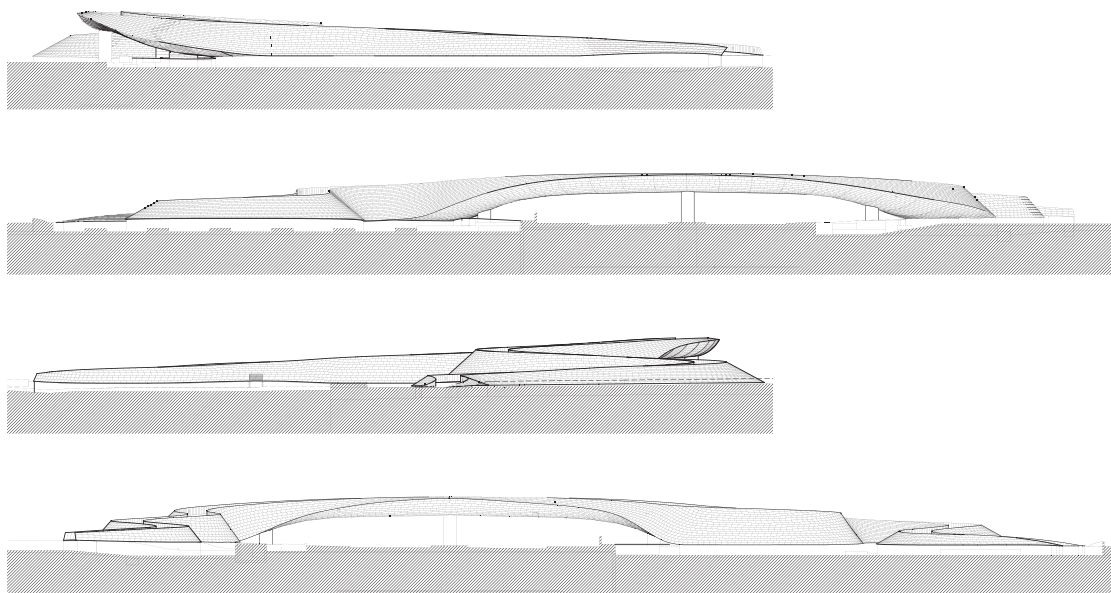

This page
Elevations

Opposite
Top: Overpass
Bottom: BP Bridge, Pritzker Pavilion, and Great Lawn aerial view



This page

Top: Concept drawing

Bottom: CATIA model (left),
bridge deck

Opposite

Top: Sections

Bottom: Section detail at
suspended portion

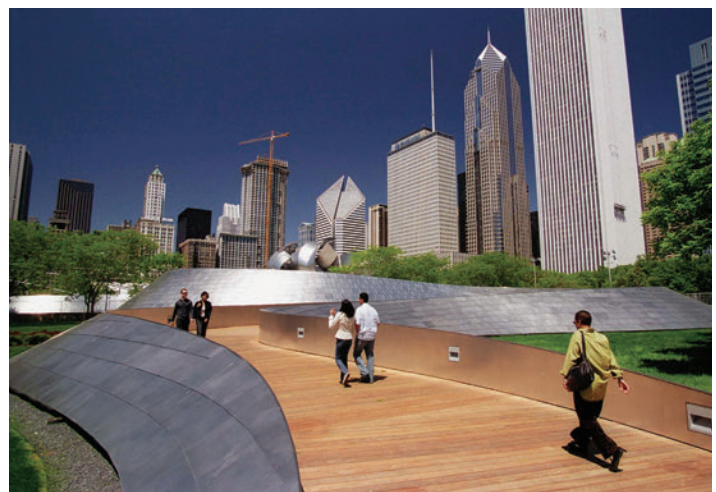
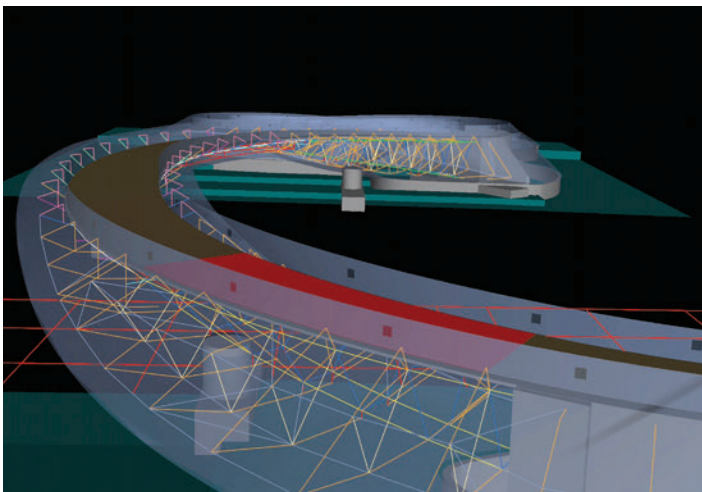
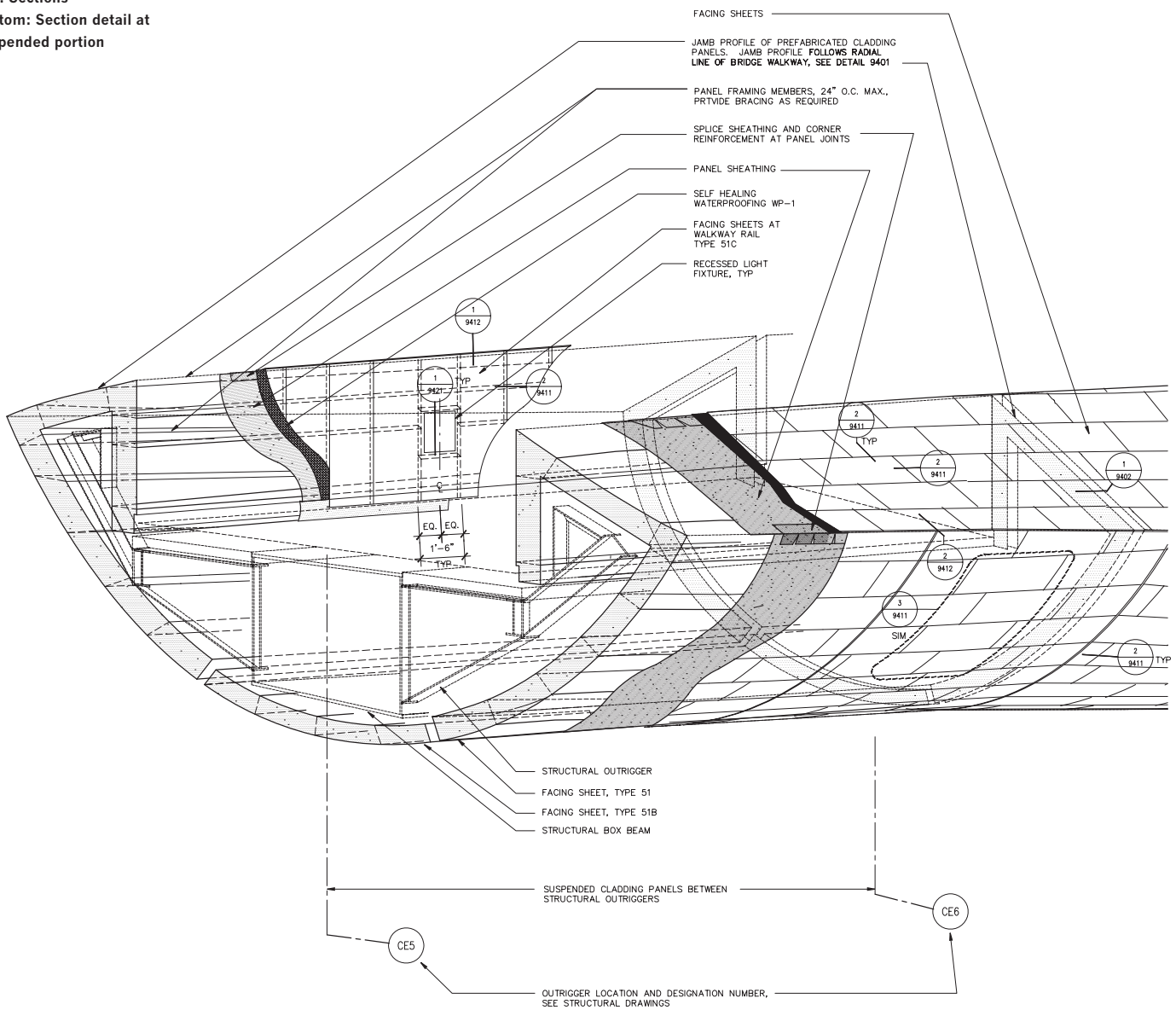

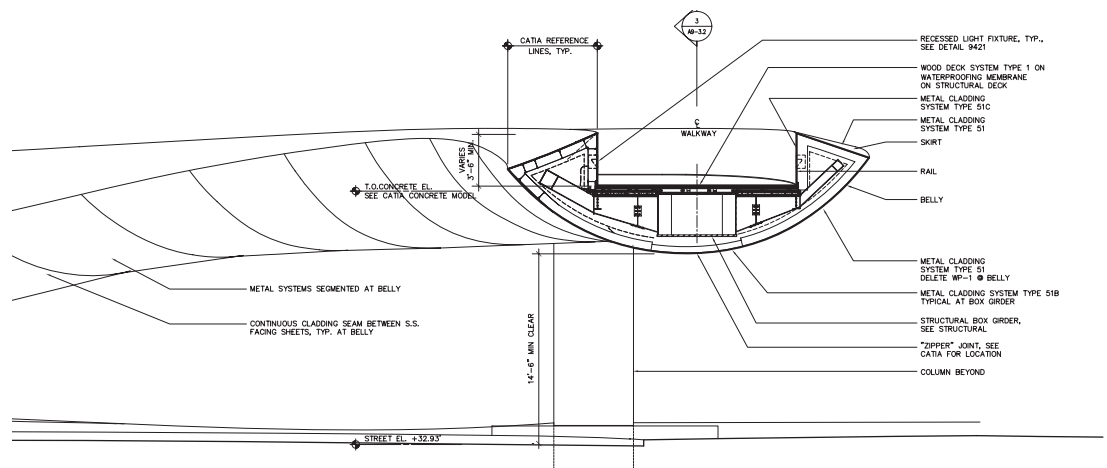

TYPICAL SECTION AT SUSPENDED PORTION

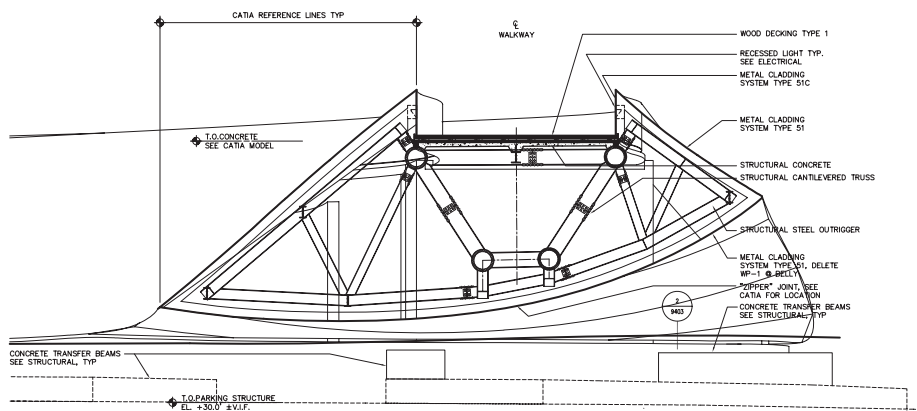

TYPICAL SECTION AT CANTILEVERED TRUSS

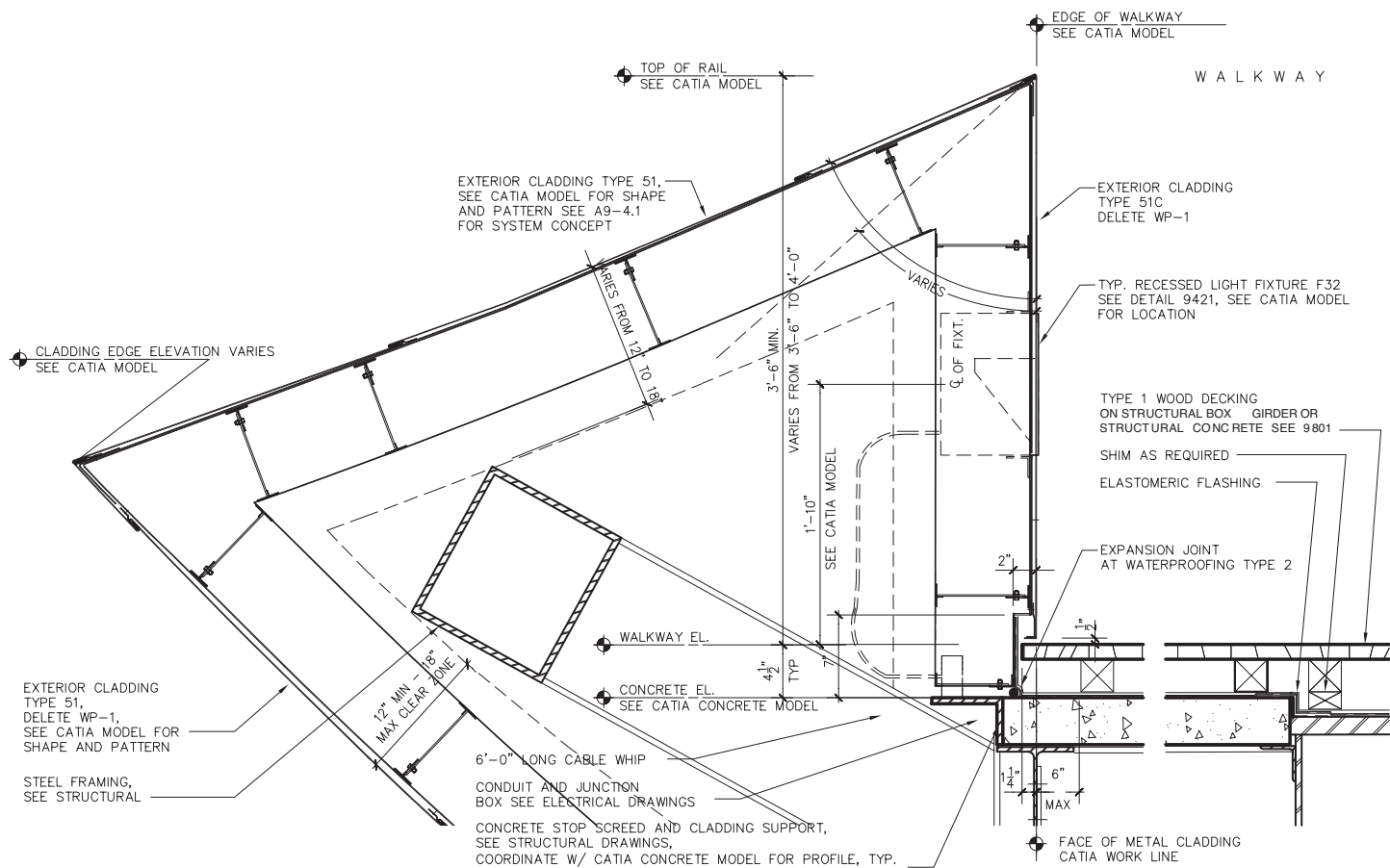

Juan Valdez Flagship Café, New York, New York

Hariri & Hariri—Architecture, New York

with RIR Arquitectos, Bogotá, Colombia

For the Colombian Coffee Federation's Juan Valdez Flagship in New York, Hariri & Hariri considered three different states of coffee—beans, powder, and liquid—and developed a palette of complementary architectural materials to reflect their various sensory qualities. The storefront itself is a folded plane of coffee-colored Brazilian ipe hardwood in the shape of a coffee bean, which then continues on through the interior of the café as the primary spatial organizer, containing the bar, counter, and coffee bean shop. Opposite the folded plane is the Liquid Wall, which runs along the entire length of the sales area and wraps around the lounge at the back of the shop with fluid seating forms carved out of its undulating volume. The Liquid Wall is 13 feet high and consists of 4-foot-wide styrene modules mounted on plywood backing joined together to form

larger panels. It was fabricated and assembled at the factory, then disassembled, and shipped in pieces to the café for installation. The styrene panels were then reassembled, sculpted with chainsaws, and sanded to a smooth finish. The surface of the entire wall was coated with a urethane hardener and a shiny white emulsion.

The facade of the four-story building is covered by a screen of GKDs Omega 1520 woven stainless steel mesh, which measures 30 by 35 feet tall, with an abstracted image of the Juan Valdez logo sandblasted on it. A protective plastic film was applied to the surface of the metal and selectively removed to form the logo. The screen is composed of three separate panels and stretches along the entire front of the building. At the top and bottom of the screen, every other cable extends beyond the edge of the screen to

form a loop fastened by a clamp. A stainless steel tensioning rod is threaded through the loops to stabilize the screen, and metal brackets secure it to the building. The frequency of the loop placement depends upon the overall weight of the screen as determined by the density of the stainless steel mesh, and the size of the loops is determined by the diameter of the tensioning bar required to stabilize the screen. Cables extend beyond the fabric edge to form a loop that is secured by a loop clamp. Both the frequency of the loops and the diameter of the tensioning bar are determined by the tension load on the screen and its overall weight, while the loop diameter is calculated based on the size of the tensioning bar. Springs added to the bottom edge of the screen anchor it to the building and hold the mesh screen in tension.

This page
Longitudinal section

Opposite
Top: Café view to East Fifty-Seventh Street
Bottom: Liquid Wall detail

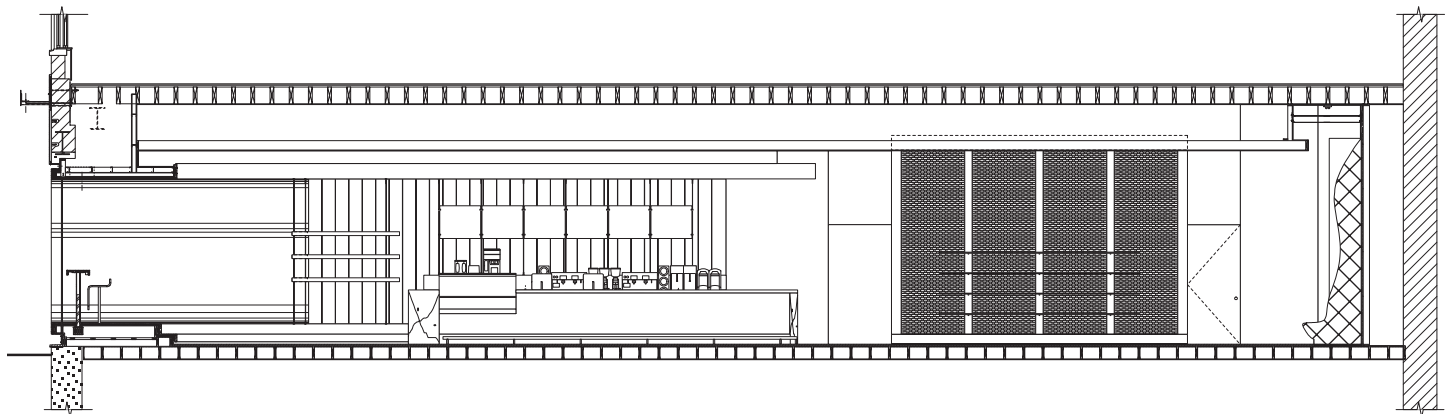



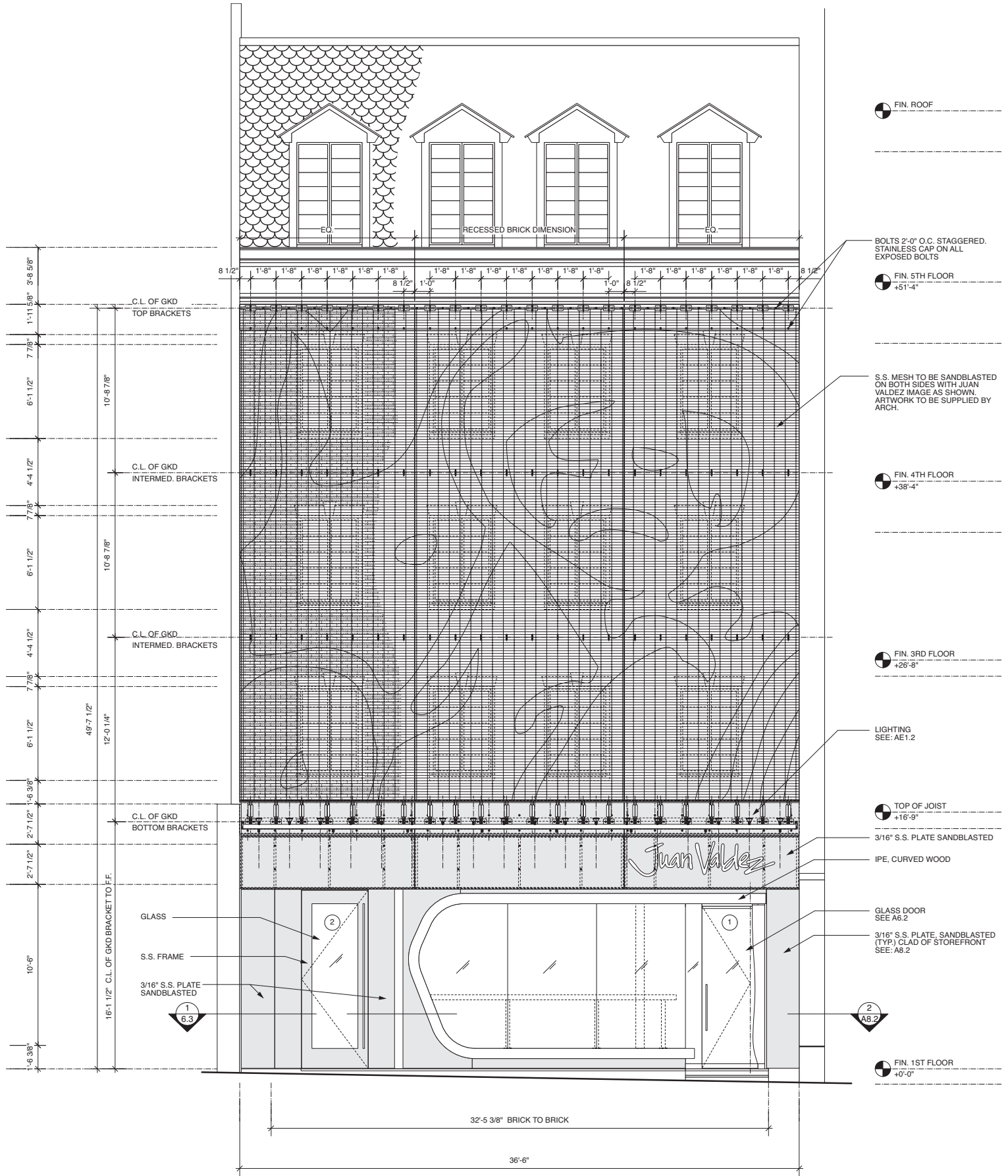

This page
East 57th Street elevation

Opposite
Top: Liquid Wall
Bottom: View from 57th Street

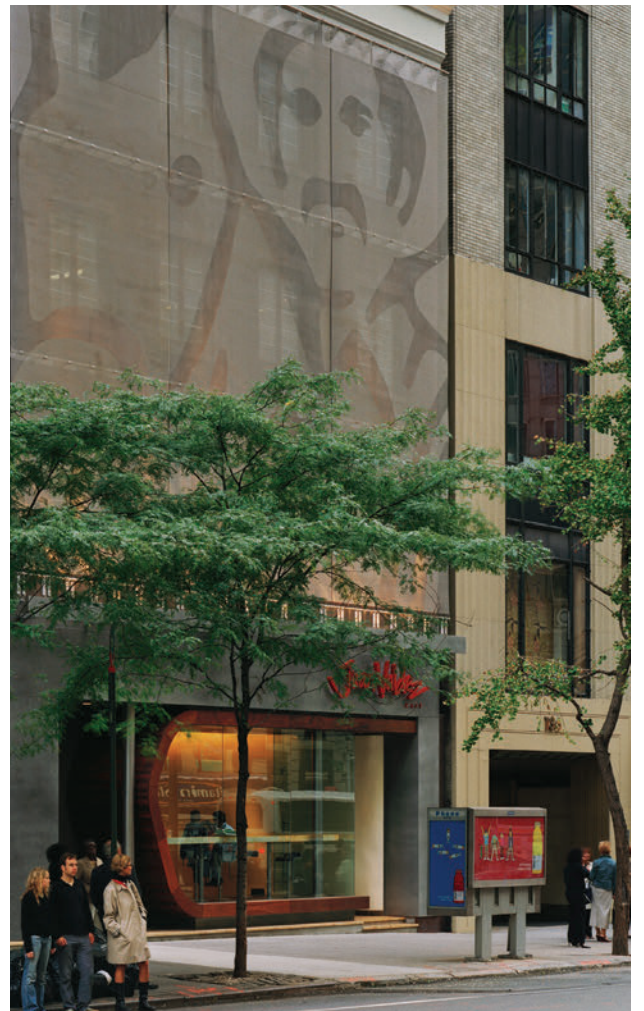
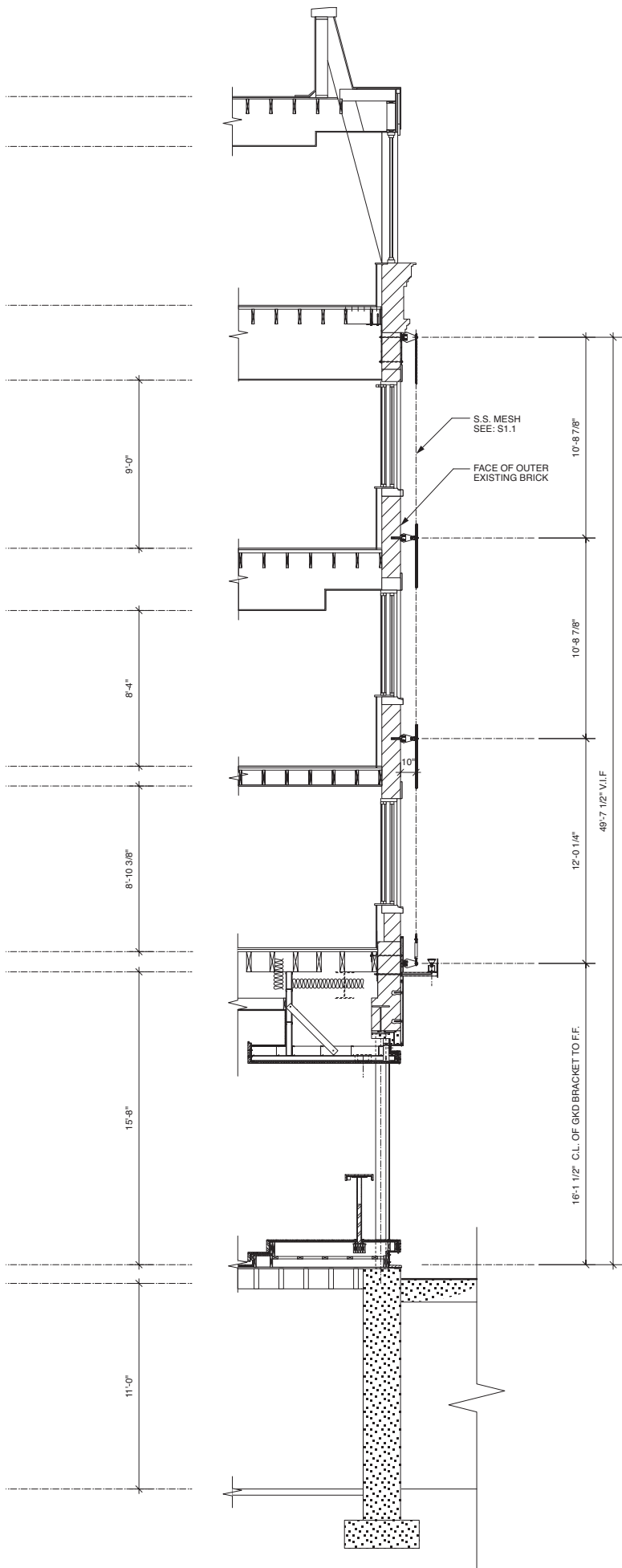



This page
Top: Liquid Wall installation
Middle: Liquid Wall plan
Bottom: Liquid Wall sections

Opposite
Top: Liquid wall Isometric
Bottom: Café panorama

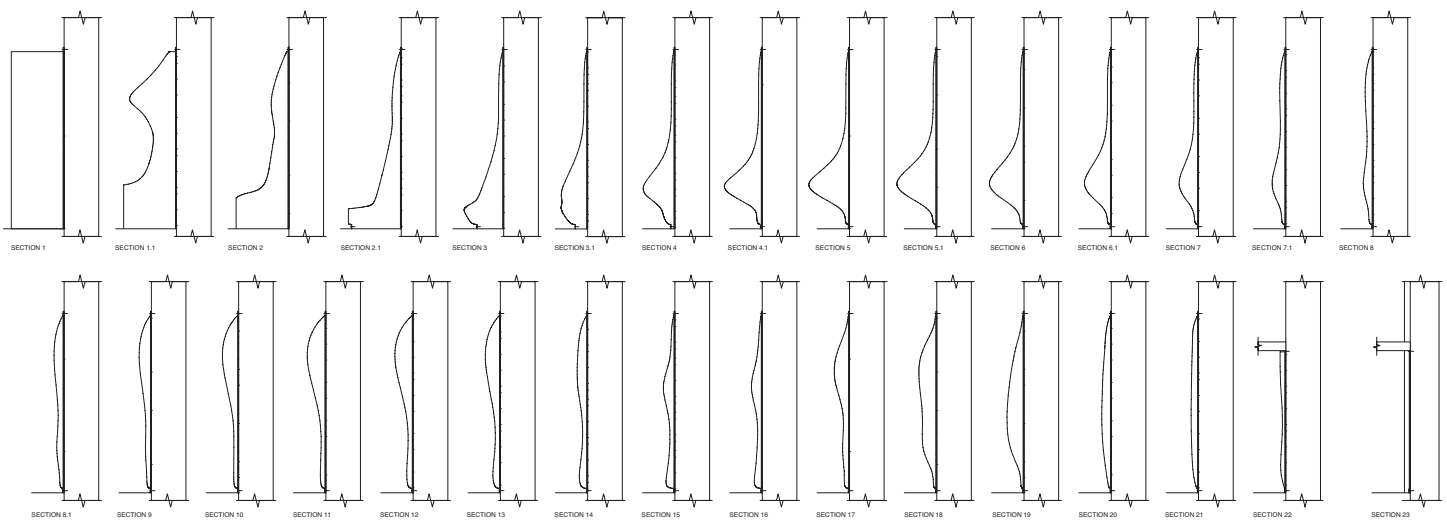
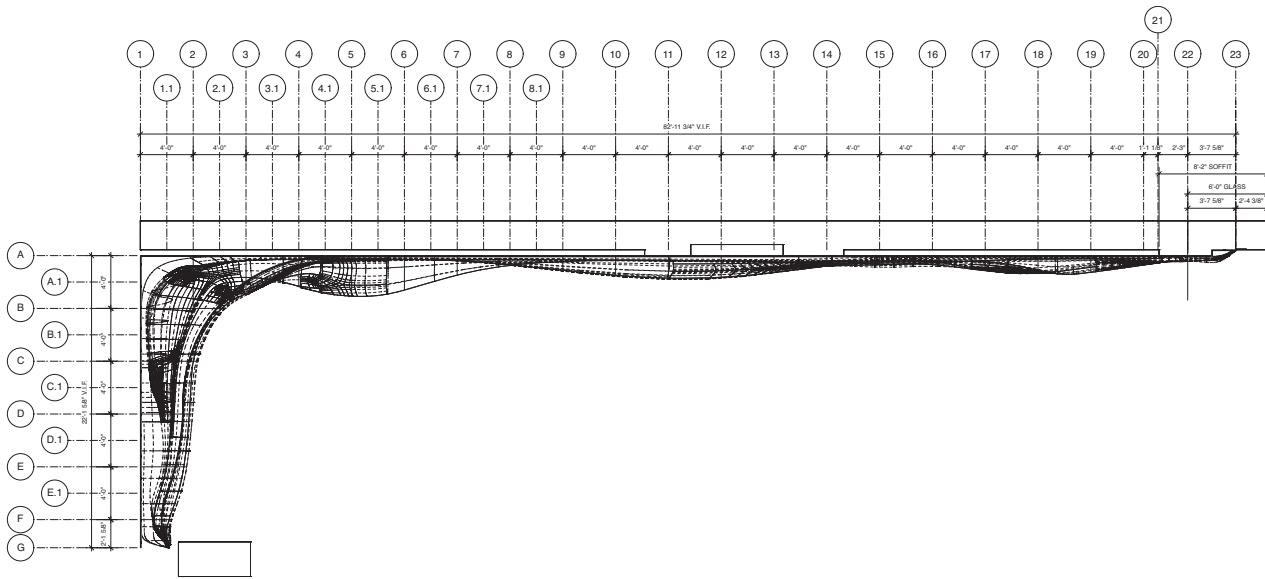

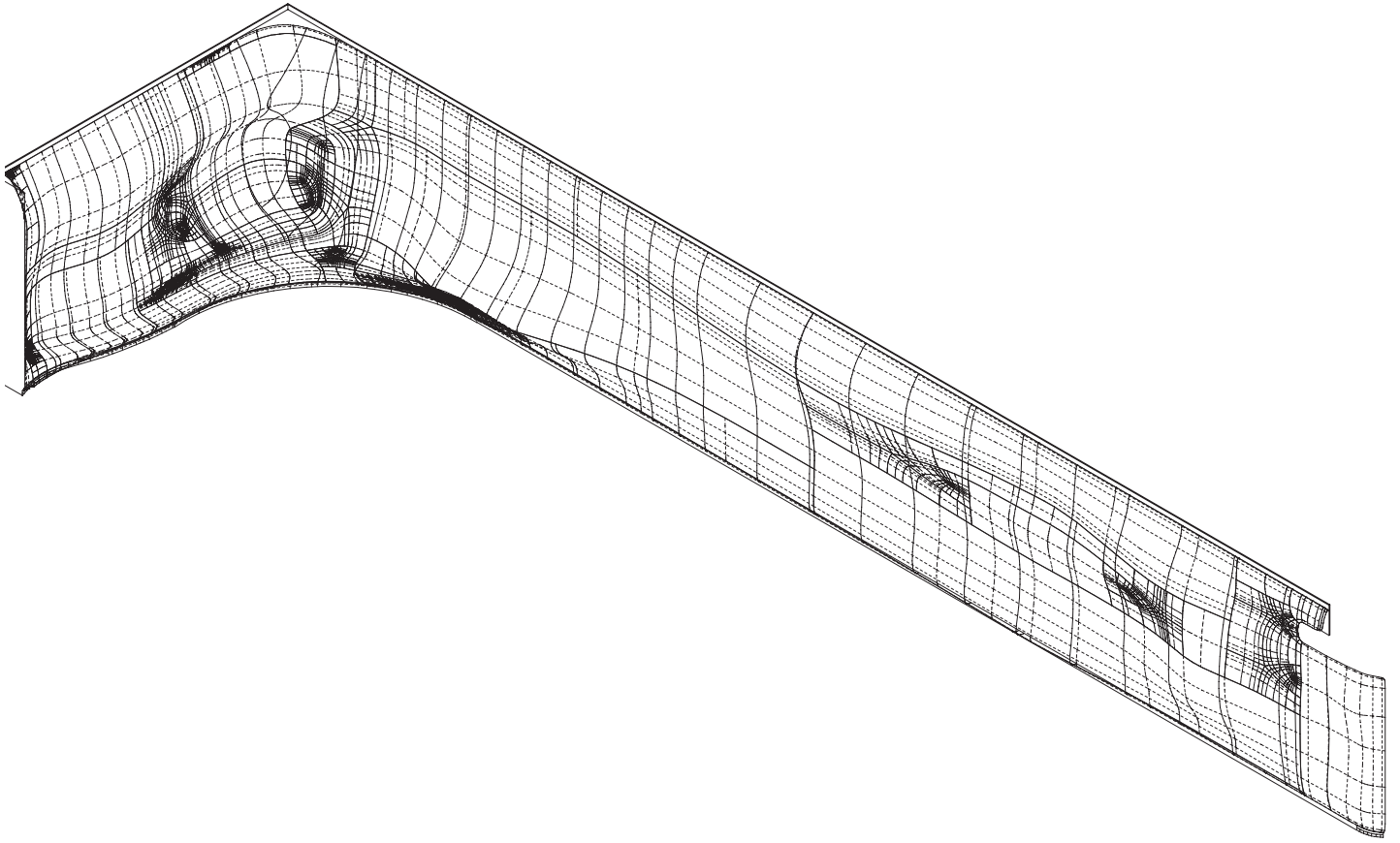

Walker Art Center, Minneapolis, Minnesota

Herzog & de Meuron, Basel, Switzerland

Architect and Engineer of Record: Hammel, Green and Abrahamson, Inc. (HGA), Minneapolis

For the new five-level expanded facility adjacent to the Walker Art Center in Minneapolis, architects Herzog & de Meuron wanted a building lighter, looser, and more open than the brick cubes of the existing museum. Originally they planned to cover the facade in a fabric-like material that could be folded up along the slanted profiles of the window openings so that the entire building would have a luminous translucence, like a paper lantern. The huge irregularly shaped windows are what the architects have termed “homologous forms,” which they compare to silhouettes. A number of cladding options were considered, including a Teflon-like fabric, as well as glass and copper, but all were eventually rejected because of formal and technical problems with full-scale mock-ups. The architects settled on expanded alumi-

num, produced by punching slits in and stretching sheet stock to create a surface of diamond-shaped voids. Because the perforated metal is formed into boxes, it has a transparency that gives the entire facade the appearance of depth, like translucent crumpled paper.

Three-dimensional models of the crumpled and creased forms desired for the facade were produced with creasing patterns detailed precisely to continue across adjacent units. After experiments to determine the size, thickness, and angles of the slots that would create the texture of the panels, a pattern of angled diamond meshing was designed by Spantek, a local manufacturer of expanded metals typically used for fan vents, gutter guards, and industrial filters. Large pounding machines slit and

stretched metal to make weblike sheets from 126,000 square feet of perforated aluminum stock. To achieve the desired texture architectural fabricator M. G. McGrath tooled stamping dies and rotated and creased the panels four times in different directions to produce a randomized undulating appearance. The panels were then anodized to maintain their shine. The geometry of the building required five sizes of panels, each one a 4-foot-square box with four sides and two open edges installed individually on the building. During the daytime, the panels reflect ambient light and create a shimmering, changeable facade. By night, the “homologous forms” of the windows placed irregularly throughout the aluminum facade give it the desired glowing effect.

This page
Model

Opposite
Top: Southeast elevation
Bottom: Northeast elevation

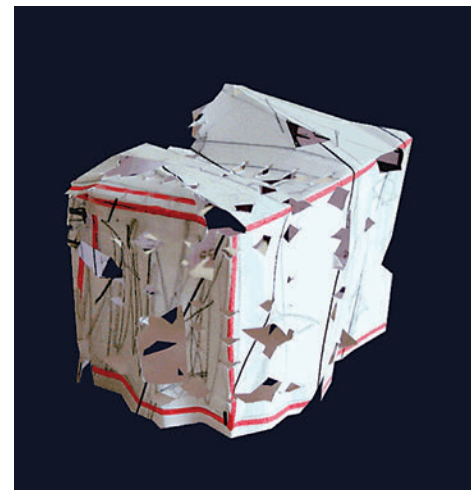

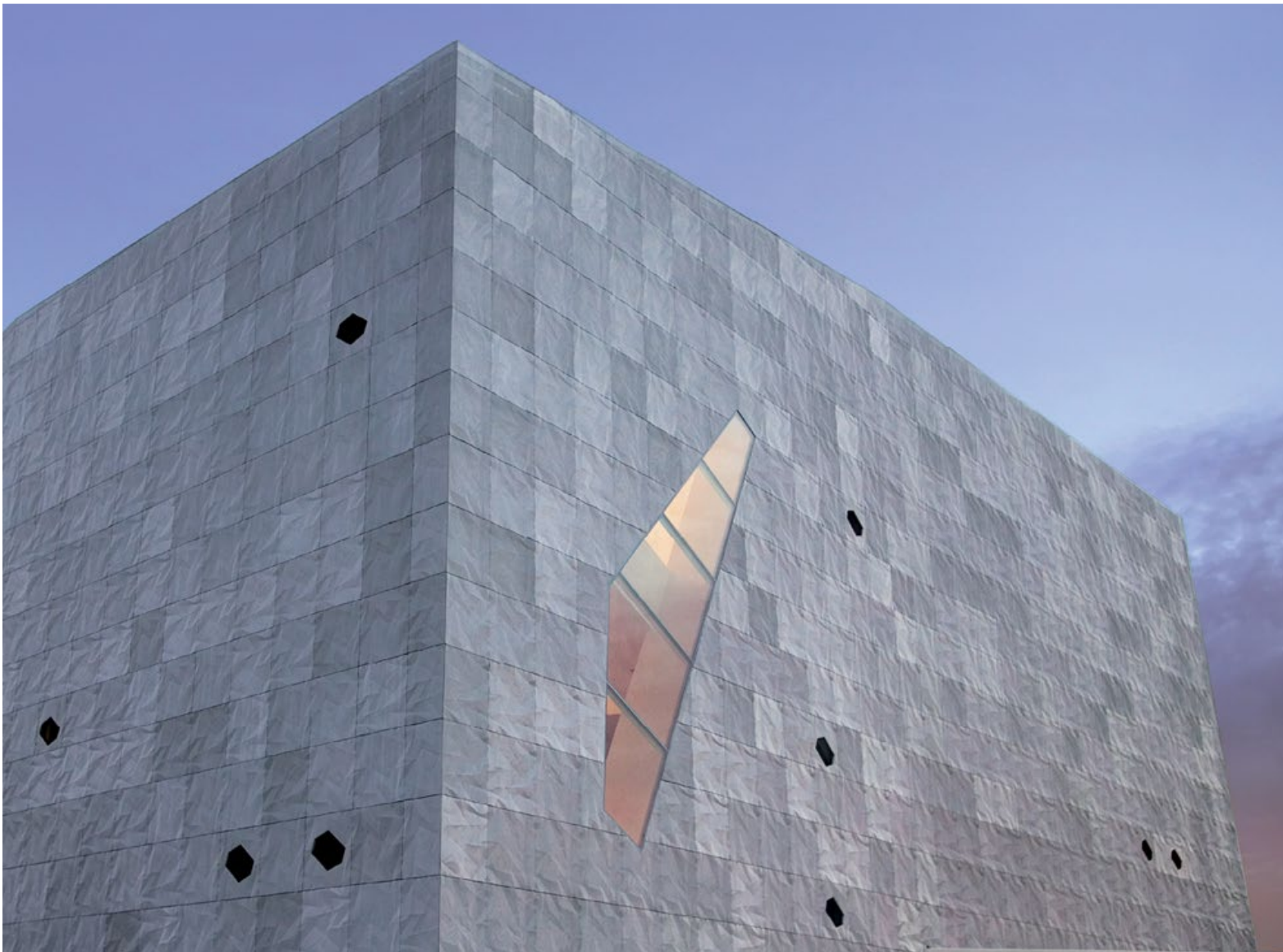

evolution of the homologous forms

ACTION
fold & cut

RESULT
unfolded
make pattern of repetition

ANALYSIS
selected forms

ABSTRACTION
homologous forms



multiple folds

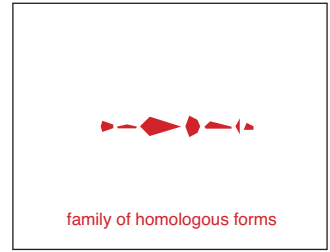
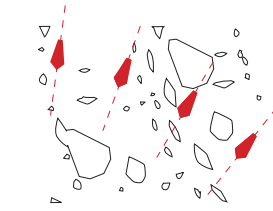

linear fold

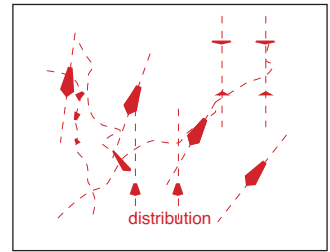
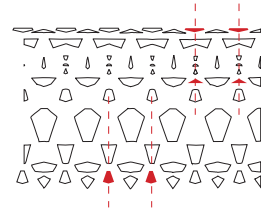

crumple

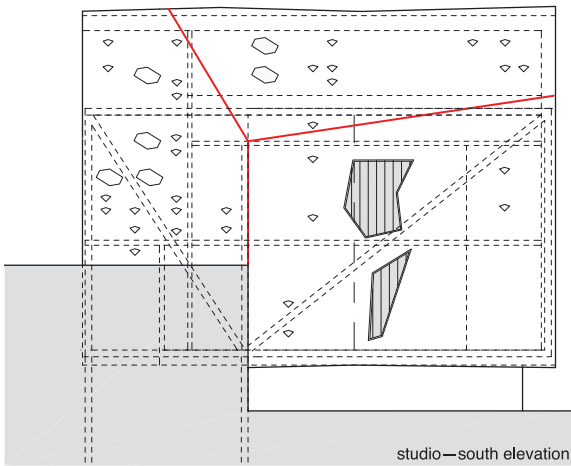
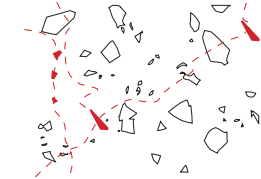

studio—south elevation

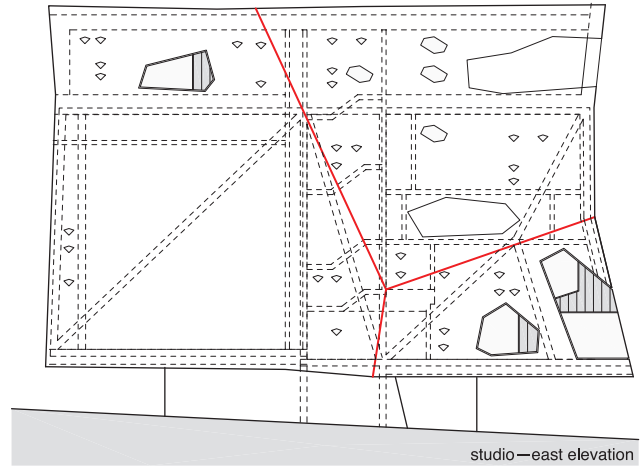

studio—east elevation

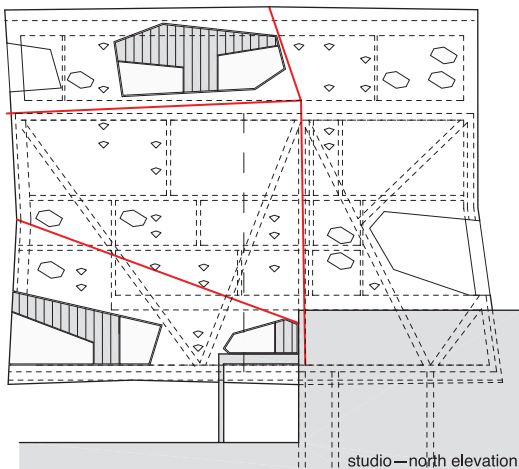

studio—north elevation

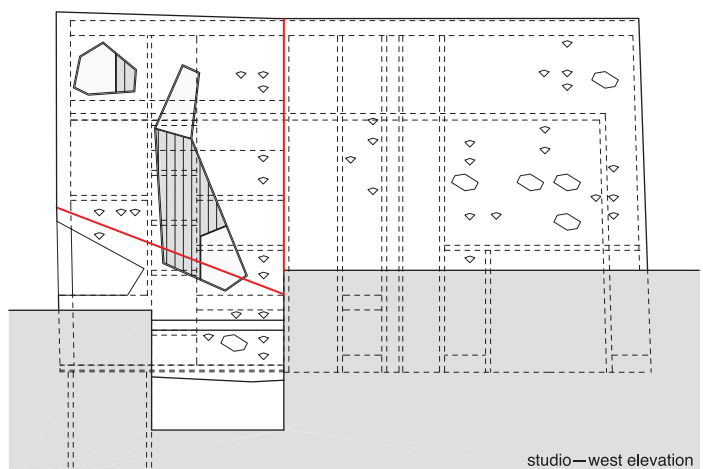

studio—west elevation

Opposite
Top: Analysis
Bottom: Exterior elevations

This page
**Top and middle: Aluminum panel
installation**
Bottom: Visitors entrance

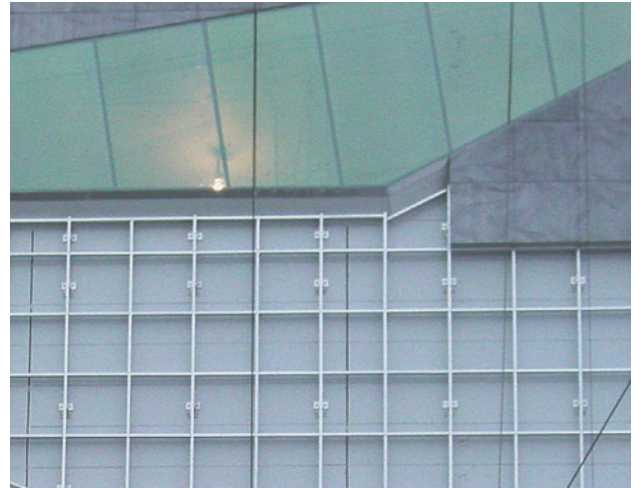

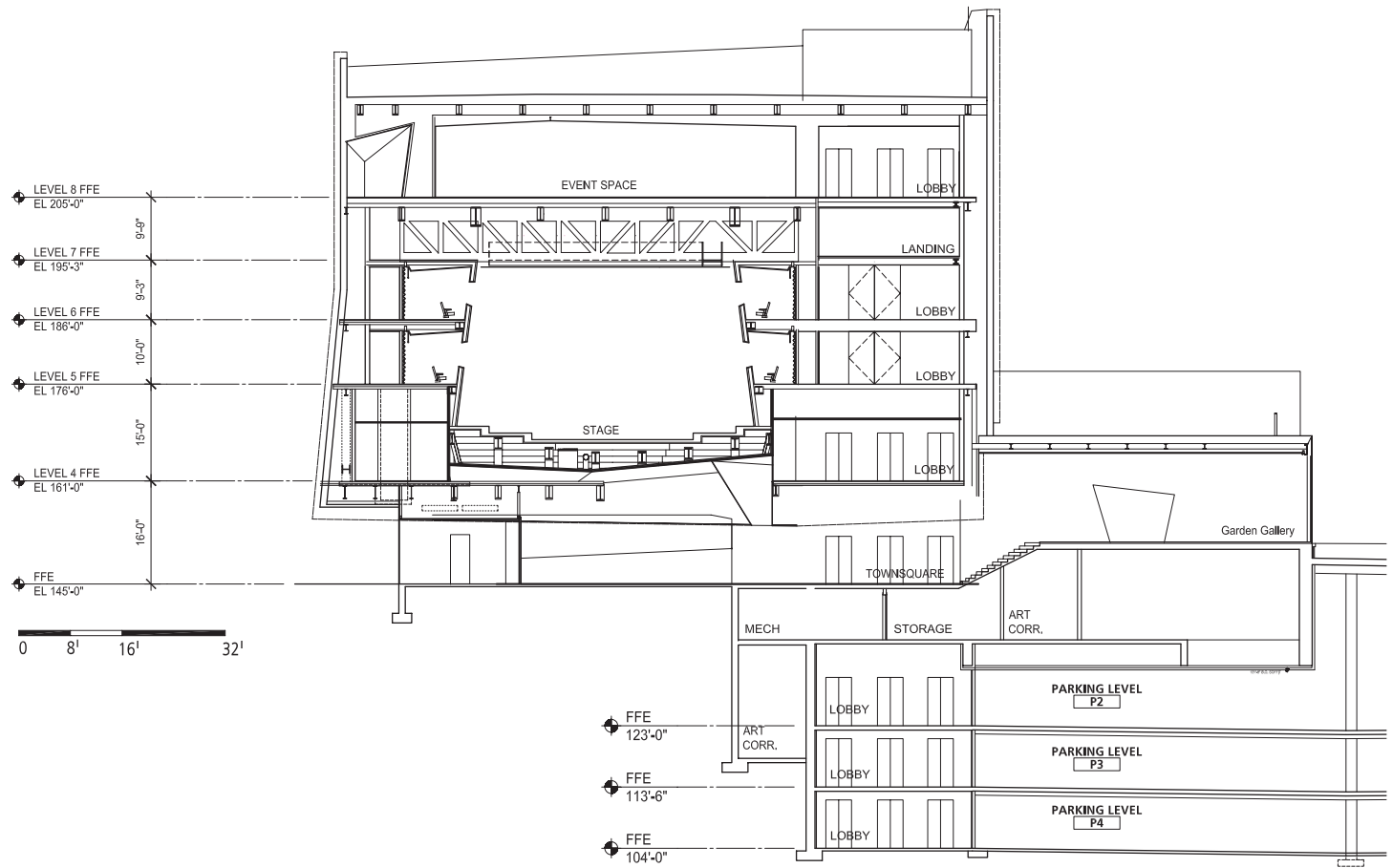

Opposite
Top: Cross section
Bottom: Aluminum panel
installation

This page
Right: Wall section
Bottom: Folded mesh box panel

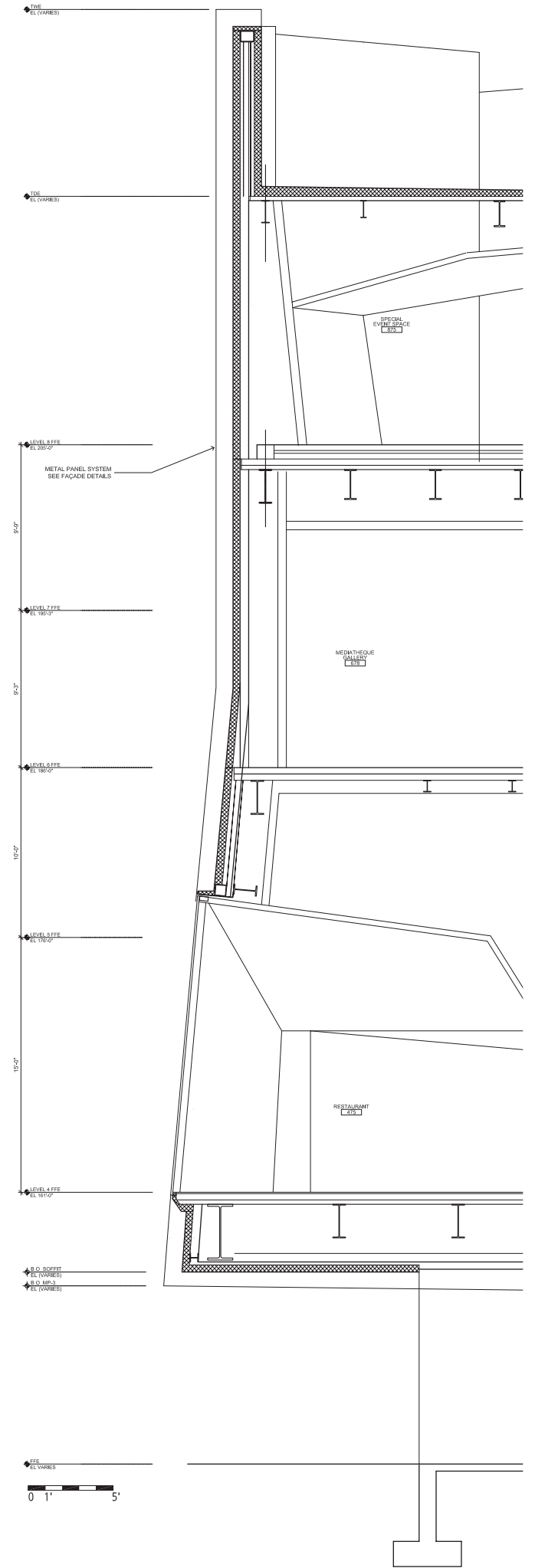

NOTE:

⊙ SIM-1 NO PANEL JT(SEE DTU FOR ALUM TUBE)

⊙ SIM-2 ALUM TUBE & PANEL JT-NO ANCHOR

TYP MP-2 HORZ. JT. ATTACH TO STEEL AND PROVIDE SLNT & BACK FLASHING

MP-3 PROVIDE FLASHING(TO MATCH MP-2 PANEL COLOR) ABOVE STAND OFF ASSEMBLY TO SET ON FULL SLNT BED OVER MP-2. TYP ⊙ ALL SIM COND

MP-3 MESH PANEL SEE 3/A470.5 FOR NOTES AND DIMS

PROVIDE ALUM ANGLE TO ATTACH HORIZONTAL MEMBERS

OUTER MOST FACE OF FOLDED EXPANDED ANOD ALUM MTL MESH

CONT. ALUM FRAME AT 3'-9" SPACING BOTH DIRECTIONS BY MP-3 PROVIDE SLIP JT

FILL W/ INSUL-35 BY MP-3 INSTALLER

PROVIDE 3/8" SIM AS REQ'D TO LEVEL

COMPRESSED SLNT CONT AROUND PERIMETER

FRJS-4 TYP ⊙ ALL SIM COND(MP-2 TO PROVIDE AS PANELS ARE BEING INSTALLED)

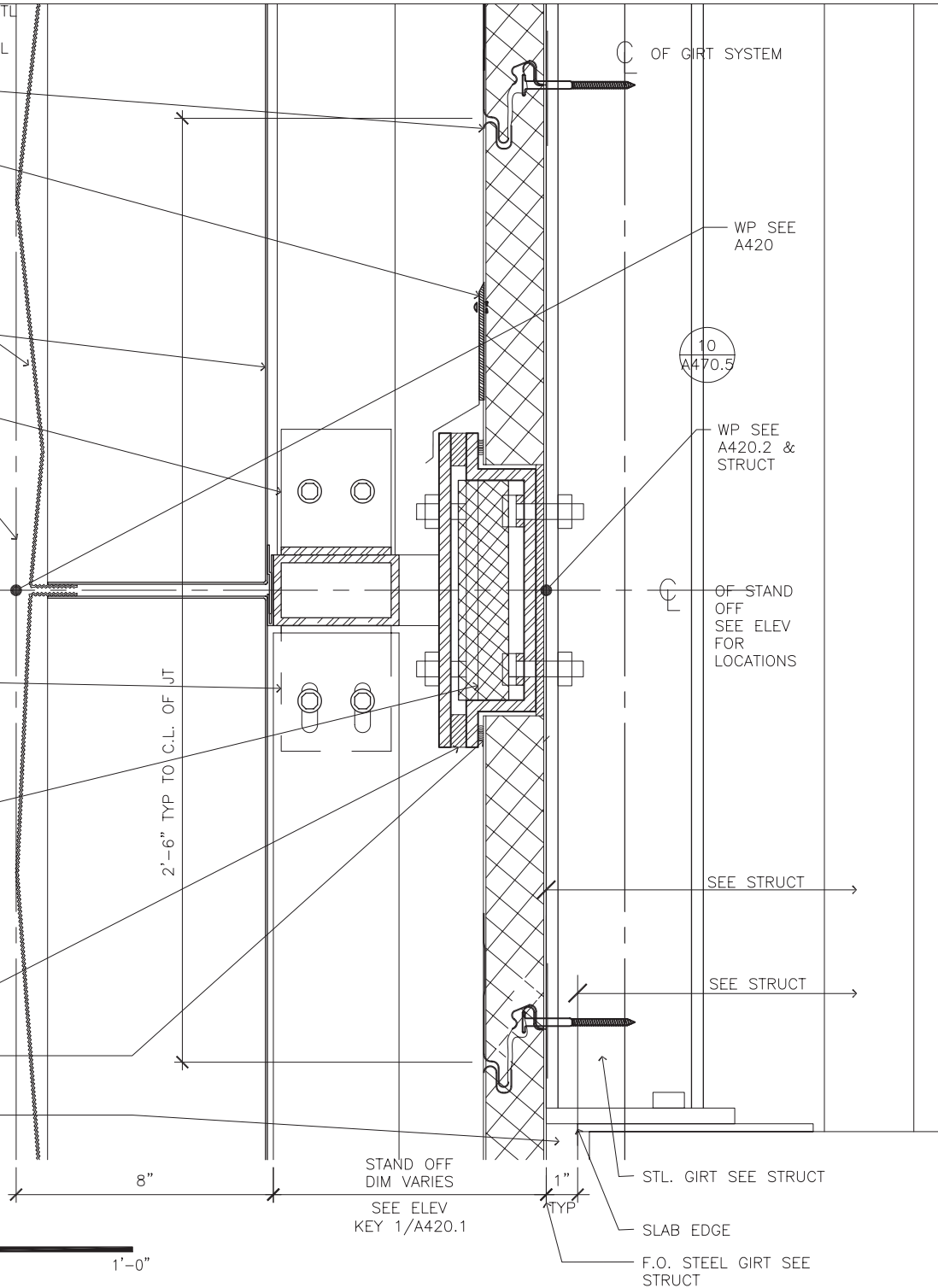
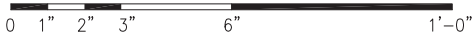

C OF GIRT SYSTEM

WP SEE A420

10
A470.5

WP SEE A420.2 & STRUCT

C OF STAND OFF SEE ELEV FOR LOCATIONS

SEE STRUCT

SEE STRUCT

STAND OFF DIM VARIES SEE ELEV KEY 1/A420.1

1" TYP STL. GIRT SEE STRUCT

SLAB EDGE

F.O. STEEL GIRT SEE STRUCT

2'-6" TYP TO C.L. OF JT

8"

1" TYP

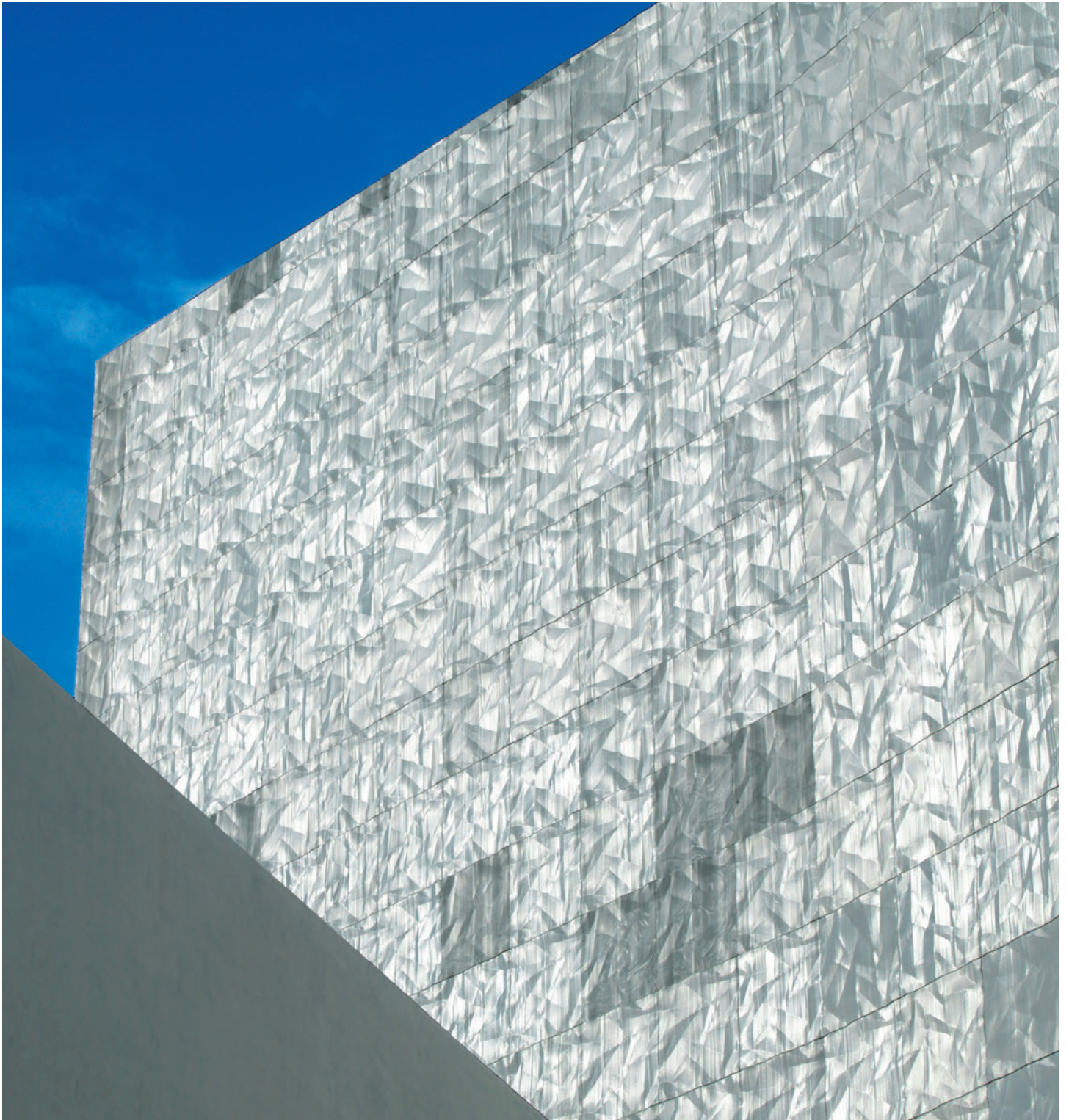

Opposite
Facade detail

This page
Elevation detail

Hollywood Bowl, Los Angeles, California

Hodgetts + Fung Design Associates, Culver City, California

Executive Architect: Gruen Associates, Los Angeles

Since its inauguration in 1923, the Hollywood Bowl has undergone a total of eight major renovations to resolve the inherent contradictions between form and function that have bedeviled it. Referencing the 1928 outdoor amphitheater whose acoustics were inherently impractical but whose shape is embedded in the memories of millions of patrons, the new shell designed by Hodgetts and Fung is based on a three-dimensional exploration of the geometry underlying the original. The architects' intent was to strike a balance between bringing the Bowl's acoustical and theatrical technology into the twenty-first century and preserving the look of an icon from Hollywood's early years.

The project involved the invention of a new type of acoustic device in which a largely invisible technology provides an unprecedented level of sound control for the outdoor amphitheater, a 60-by-90-foot aluminum and fiberglass ellipse spanned by folding translucent panels that form an adjustable reflecting surface to disperse sound among the performers, enabling them to achieve a musical balance. The

acoustic canopy, which floats as an elliptical ring above the stage and reflects sound waves to all parts of it, consists of a series of computerized translucent louvers extending across the ring programmed to shift into place according to the type of music being performed. The halo is designed to permit a nearly infinite range of adjustments to be made using a simple touch screen; it can be tuned in minute increments for each performance, like the ailerons on the tips of airplane wings, or folded up like butterfly wings to disappear into the canopy. Deployed for acoustic performances, the panels lie almost flat, displaying a progressively curved surface to disperse the sound pressure from the instruments below. The panels are then adjusted into vertical position for amplified or electronic performances. When deployed for a traveling show, the panels are flown by electric winches into docking stations between the baffles as the trusses themselves fold longitudinally to conform to the radius of the shell.

The underside of the aluminum halo is skinned in fiberglass, and the louvers are made of translucent polycarbonate plastic.

The rim of the halo itself consists of six segments fashioned from aircraft aluminum, containing the twenty movable louvers and the acoustic reflectors; a perimeter catwalk provides access to lighting fixtures. The reflector and catwalk assembly is inclined about ten degrees above horizontal in order to fit gracefully within the baffles, which line the shell walls, and to link geometrically with the furthest row of seating in the amphitheater. Behind the microphone line, the shell incorporates gantries able to handle even the largest speaker array at positions already determined in the field as most effective for the existing seating configuration. A substructure of ribs supports the acoustic panels. Driven by electric screw jacks, the panels are hinged to a backbonelike aluminum truss that carries the electronic controls. Lighting and sound equipment are stored above the acoustic canopy. The entire assembly is lightweight, kinetic, and controllable. Three towers stand above the exterior shell, supporting linear arrays of suspended speakers just below the proscenium to retain the seamless visual curve of the arch.

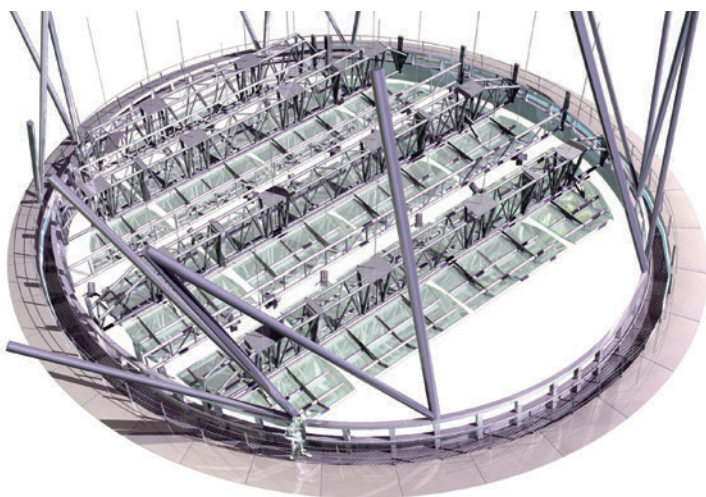

This page
Acoustic canopy

Opposite
Top: Dawn
Bottom: Sunset



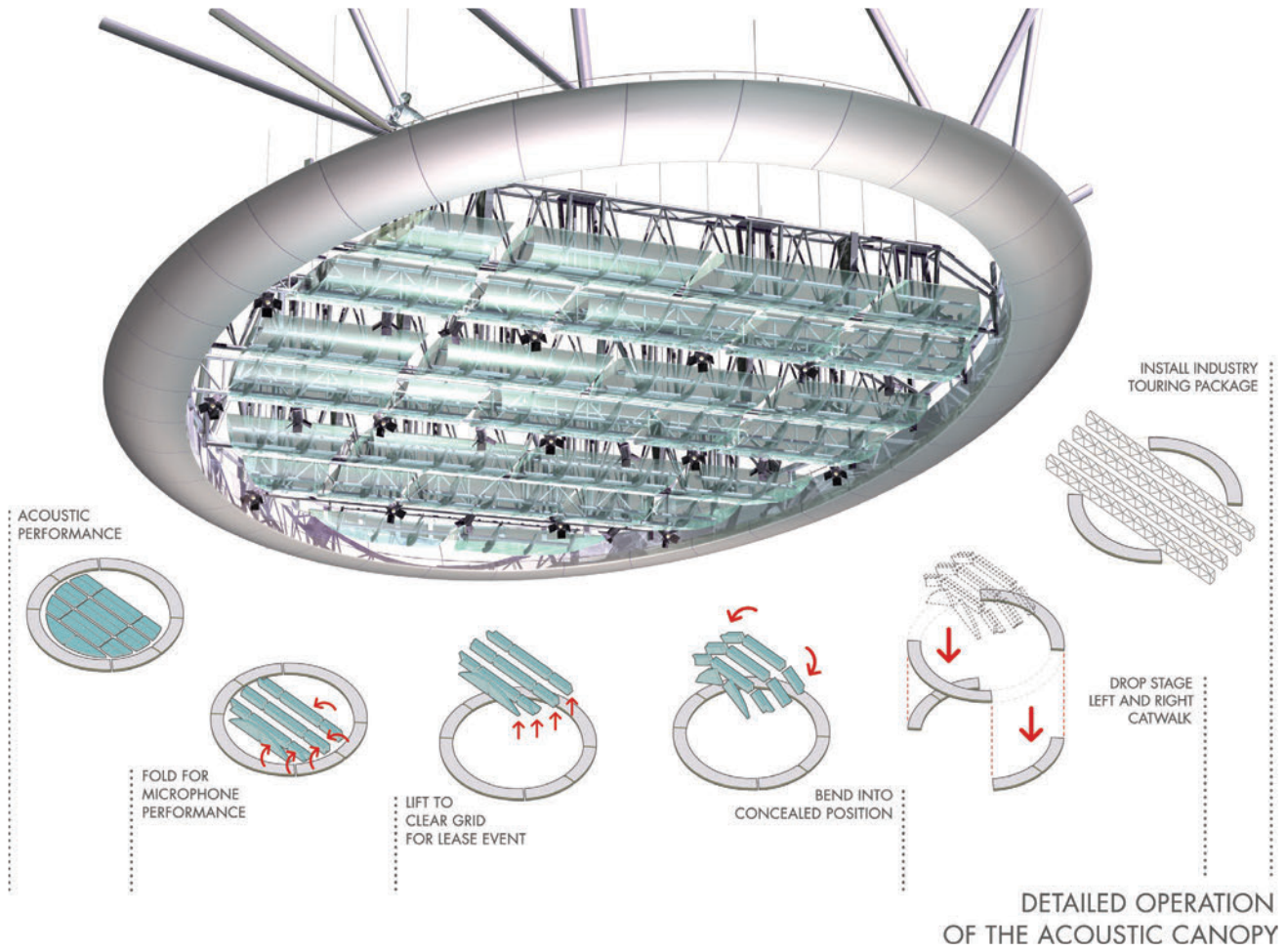

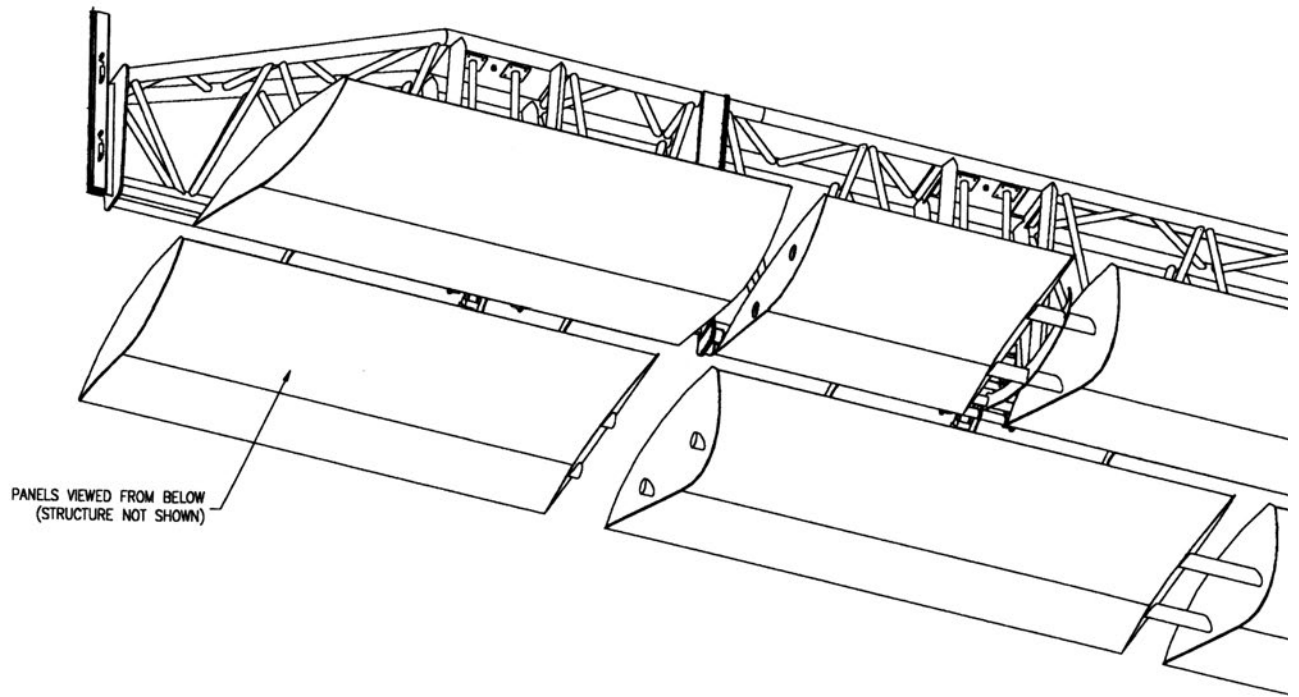

Opposite
Top: Acoustic canopy configurations
Bottom: Acoustic canopy installation

This page
Top: Acoustic canopy panel detail
Bottom: Acoustic canopy ring and panels detail

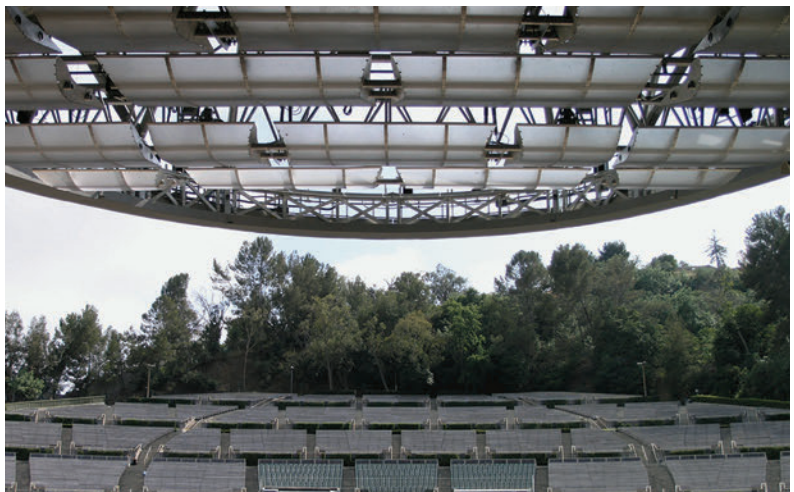
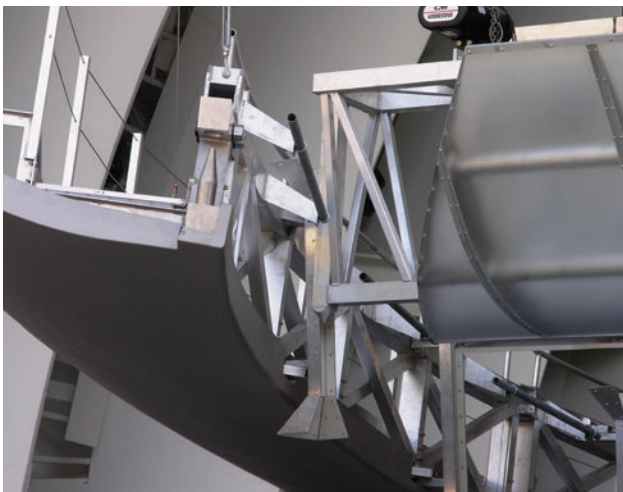
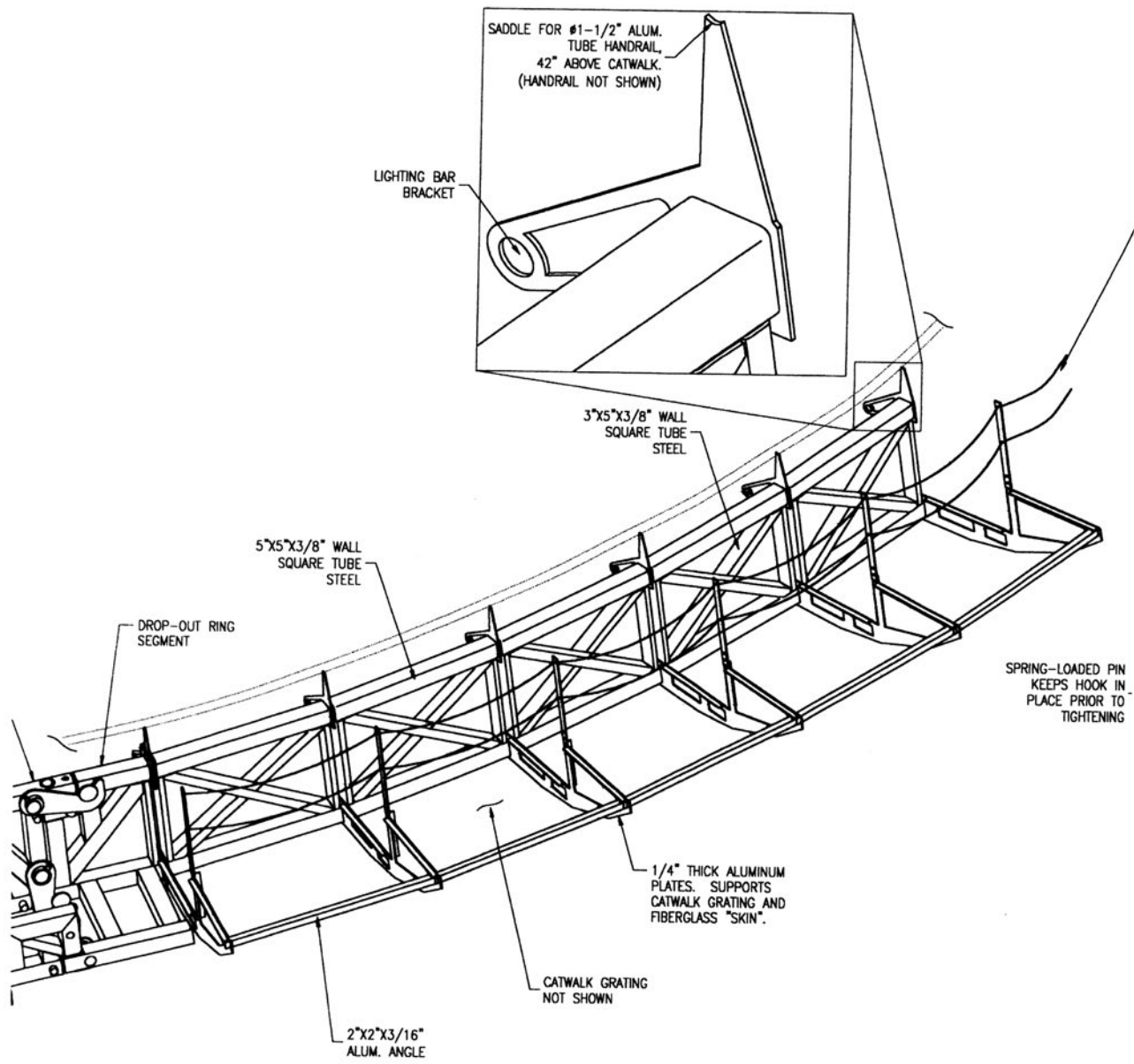

Opposite

Top: Acoustic canopy catwalk detail

Bottom: Locking device (left),
lighting battens

This page

Top: Computer control

Bottom: Truss details

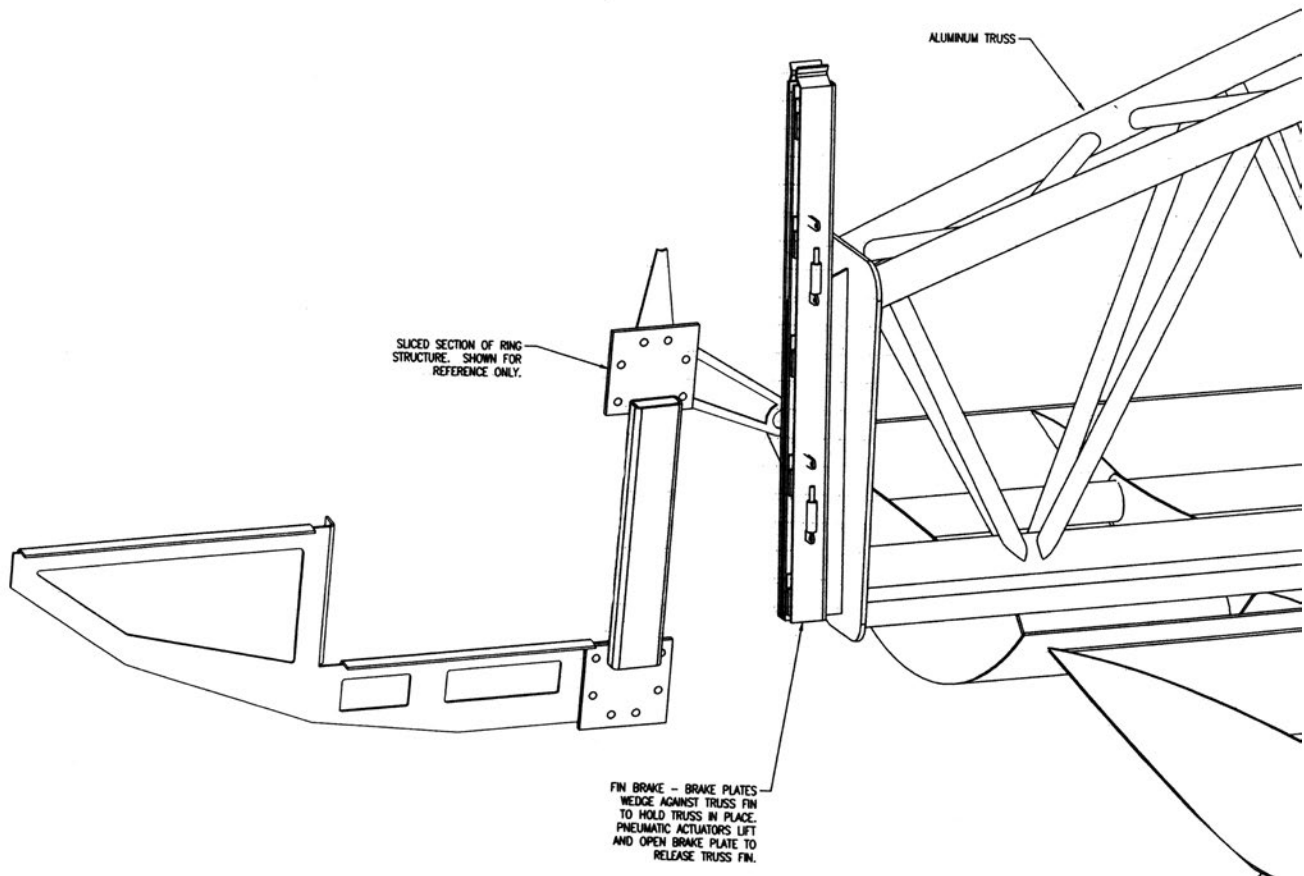
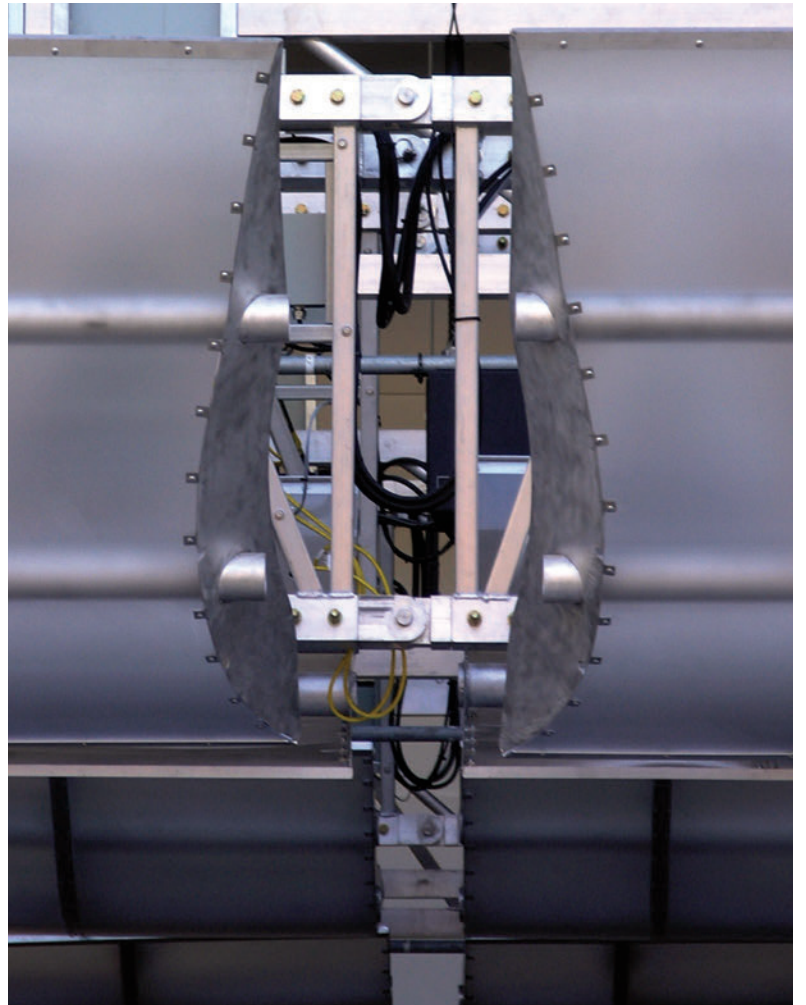

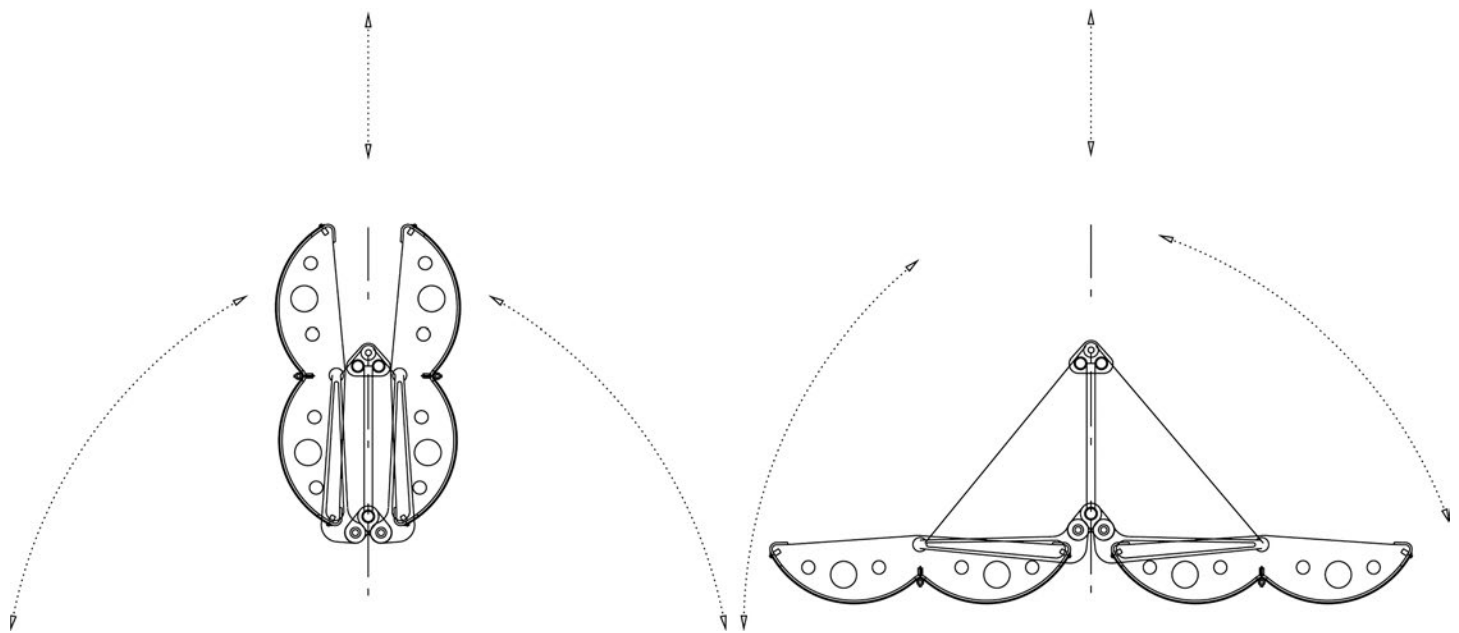
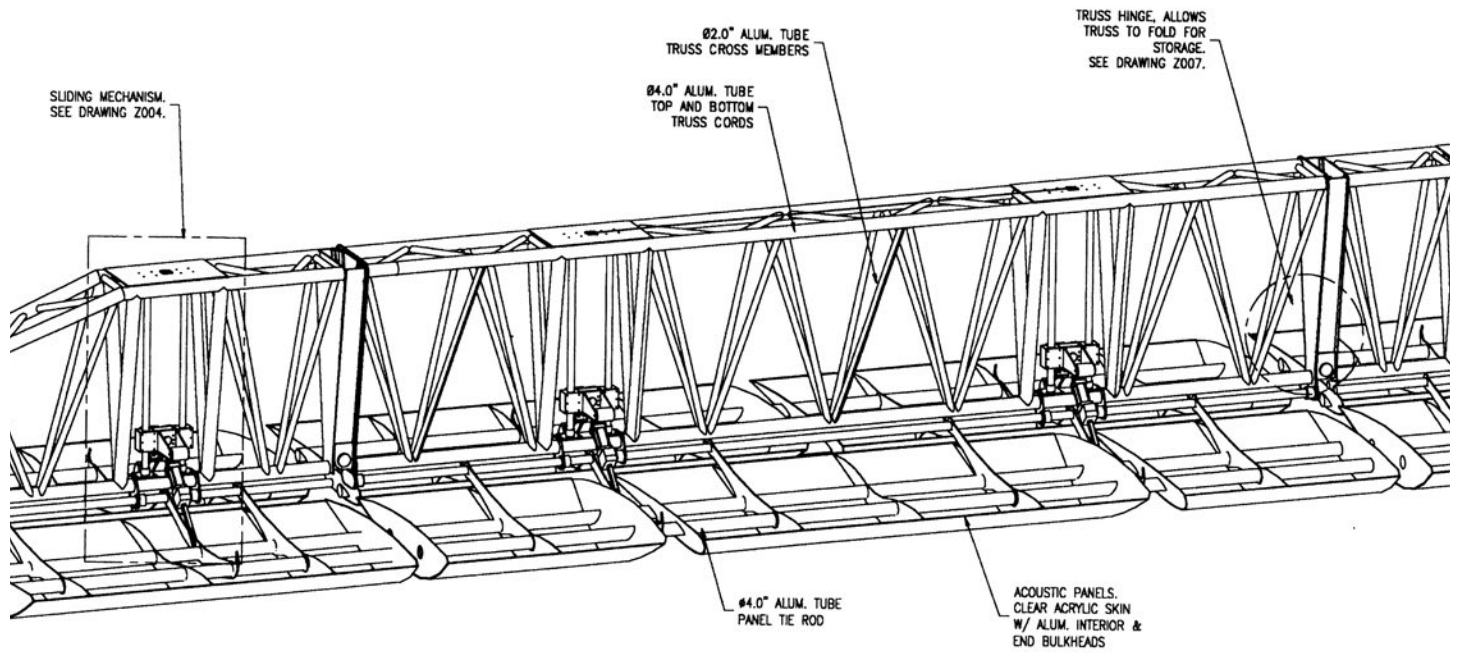

This page
Top: Light truss
Bottom: Louver detail

Opposite
Truss detail

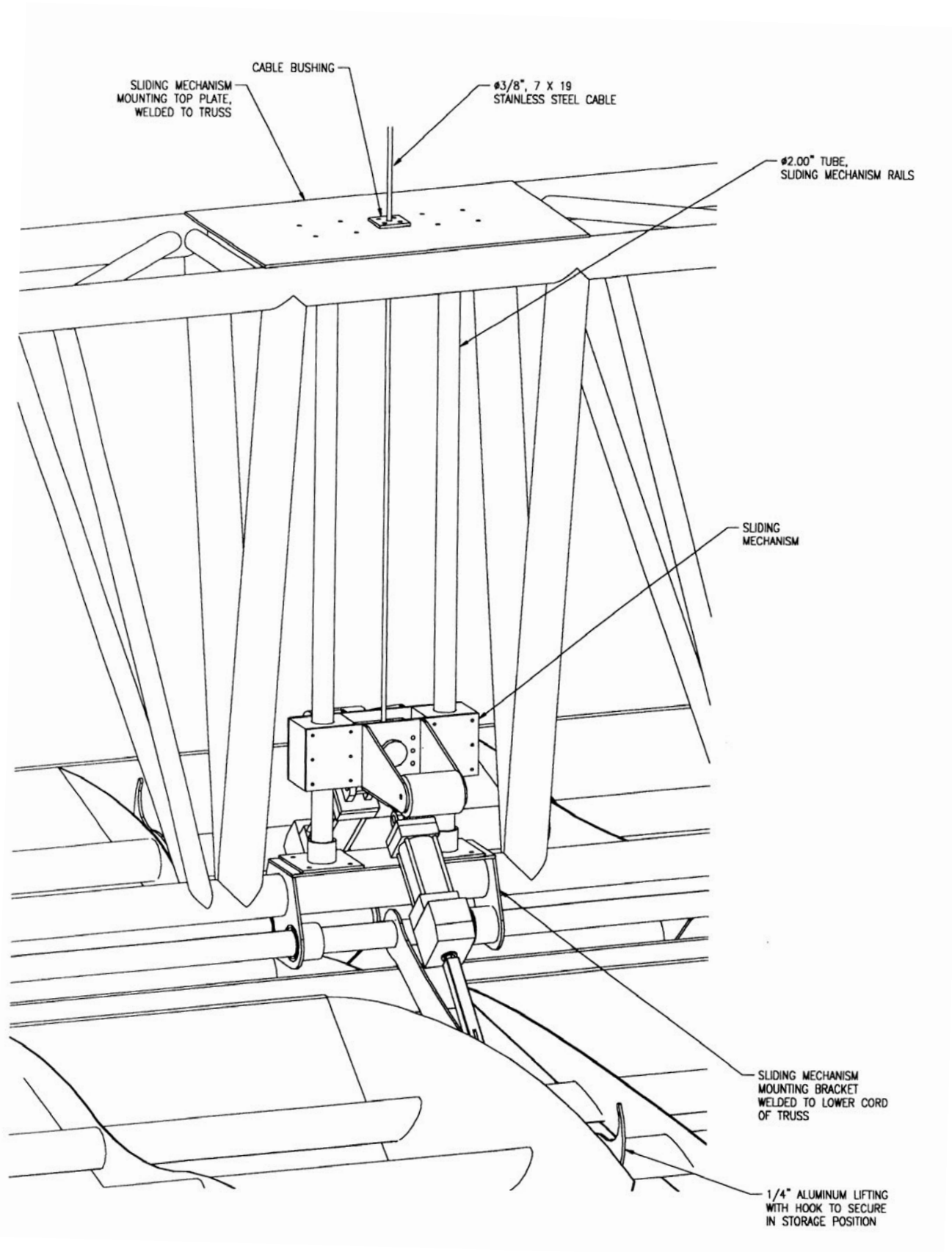

Lake Whitney Water Treatment Plant, Hamden, Connecticut

Steven Holl Architects, New York, New York

Landscape Architect: Michael Van Valkenburgh & Associates Inc., New York

The Lake Whitney Water Purification Facility is located in a public park, its water treatment processes housed underground in concrete boxes beneath a large, vegetation-covered roof with the exception of the pump room, where the equipment must be raised above grade to be serviced. That requirement led to the distinctive extruded form of the 360-foot-long stainless steel structure now called “the sliver,” resembling an upside-down water droplet in section. The sliver shape creates a curvilinear interior space that opens to a large window view of the surrounding park. There is a skylit lobby and rooms for public use on the ground floor and administrative offices and laboratories on the upper floors.

The new treatment facility operates at the molecular level, purifying millions of gallons of water each day. In the ozonation area of the plant, oxygen O₂ becomes ozone O₃ and is bubbled through the water to purify bacteria. By adding ozone to the water sup-

ply and then sending an electric charge through the water, the water treatment facility inactivates disease-causing microbes resistant to chlorine disinfection. The scale change from the molecular, in the purification process, to the panoramic in the landscape above is celebrated in the overall design of the park, which is comprised of six sectors, analogous to the six stages of the water treatment in the plant below. At the base of the sliver are water pumps which distribute the cleansed water throughout the region. Setting the plant in the ground places the treatment process below lake level; this enables the purification plant to be driven by the lake’s gravity pressure, eliminating the need for running energy-consuming pumps. A groundwater heat pump system of eighty-eight wells provides a renewable energy source for heating and cooling the building and avoids the environmental impact associated with fossil fuel energy use, saving 850,000 kilowatt hours annually.

The below-grade plant’s large thermal mass generates stable temperatures and minimizes the need for air conditioning. Gardens filter and store storm water to prevent runoff to neighboring sites.

The landscape of the water treatment facility is shaped and engineered to anticipate the dynamic interplay of water passing over and through it. Water flows naturally on the site from a high knoll covered with meadow grass at the top to a retention pond at the bottom, with spaces in between evoking formal gardens, a stream, and a farmyard. Unlike the design of a building that out of necessity resists change, the design of a planted landscape anticipates a slow and ongoing transformation of plant species and sizes that will be revealed over time. The landscape provides ecological benefits, filtering storm water that runs off the building roof and site pavements and storing the water on site. This design both eliminates the necessity for the project to increase

This page

South (top) and north elevations

Opposite

Top: Northeast elevation

Bottom: Entrance

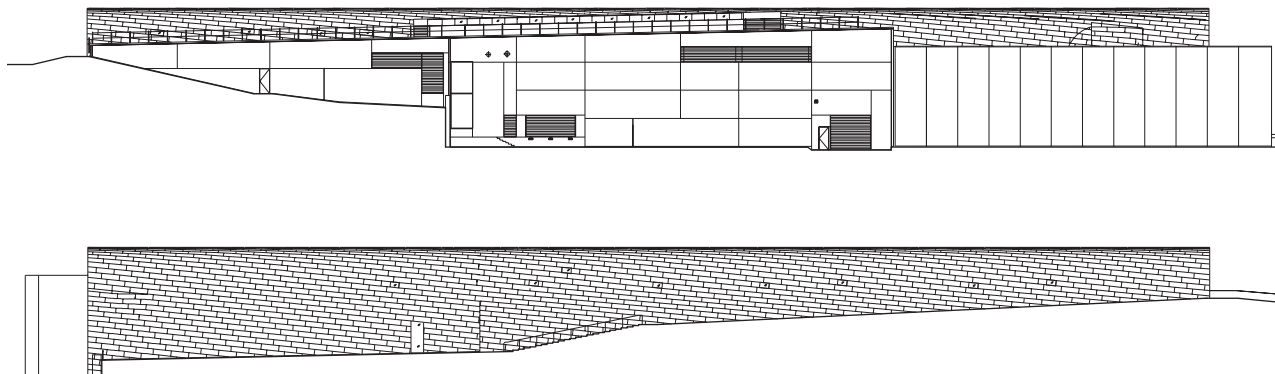

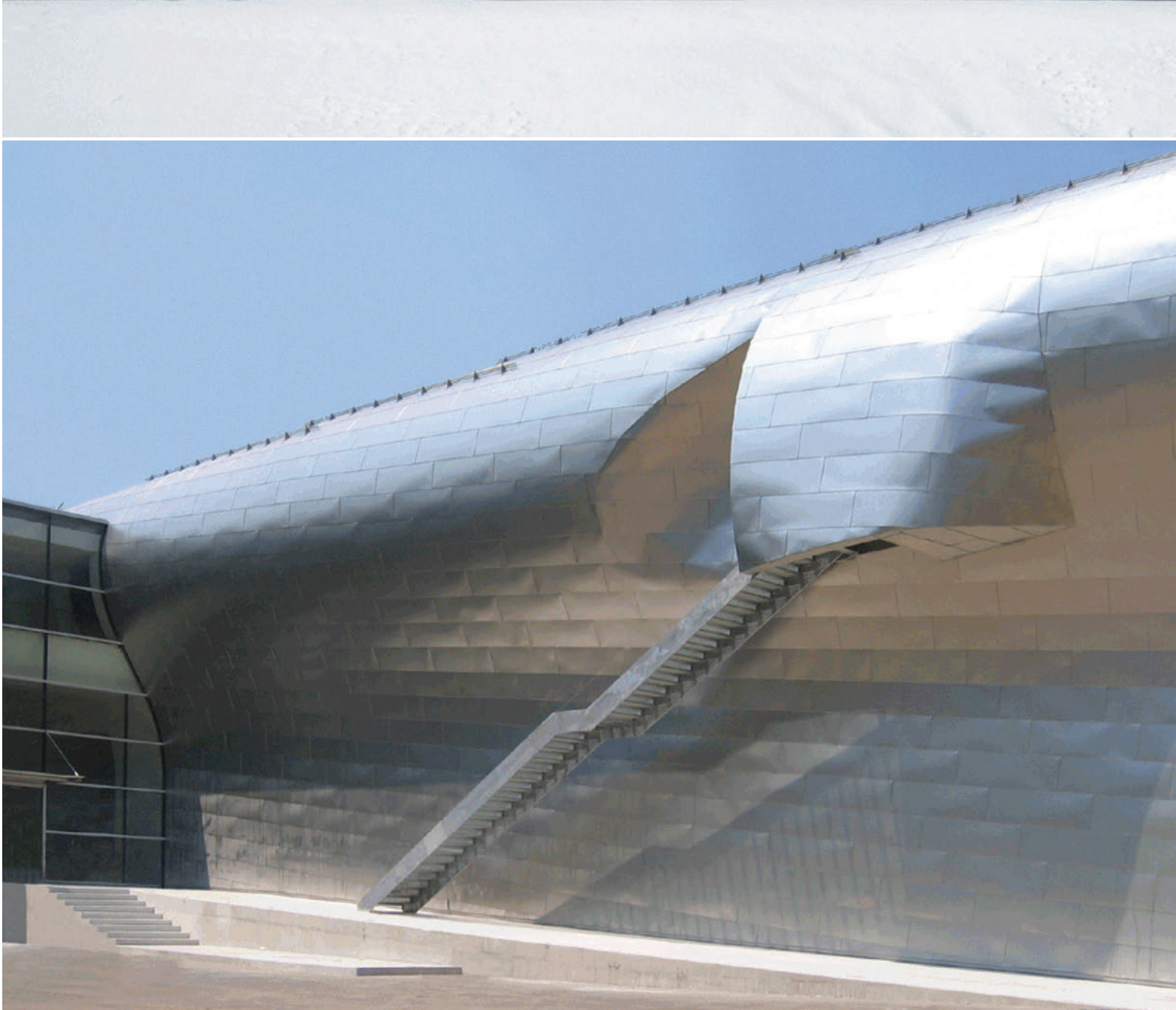

This page

Top: Cross section

Bottom: Longitudinal sections

Opposite

Top: Southeast elevation

Bottom: Stair detail

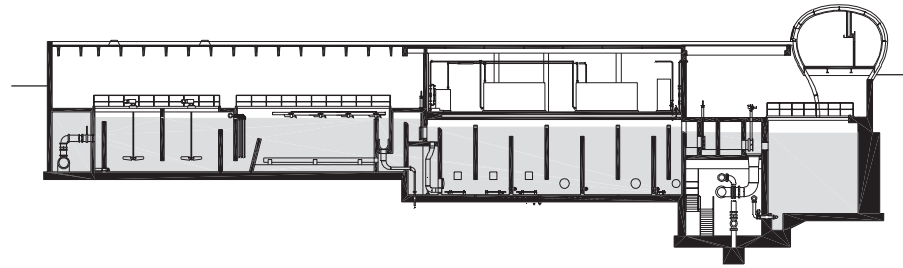

downstream storm flooding and provides a mechanism for rainwater to replenish the ground water supply. The green roof increases the thermal insulating capacity, or R value, by three points, prevents a heat island effect, and controls storm water runoff. The roof membrane is formed of a rubberized asphalt waterproofing system with an inverted roof membrane assembly (IRMA) configuration, in which the membrane is adhered in asphalt directly to the roof deck. A root barrier fabric was installed on top of the insulation to optimize moisture management in the planting layer and protect the insulation from water infiltration. The green roof, a low maintenance system

that requires no irrigation, is planted with species indigenous to alpine areas and rocky outcrops that thrive on shallow soils, wind exposure, and some foot traffic, all without dependency on artificial irrigation or fertilization. Most of the plants will grow to about 6 inches in height and will spread, offering full coverage within two growing seasons. The design is expected to prolong the life of the roof membrane and protect it from normal wear and tear by buffering it from the effects of extreme freeze-thaw cycles and peak summer temperatures, and allowing for possible abrupt cooling from rain showers.

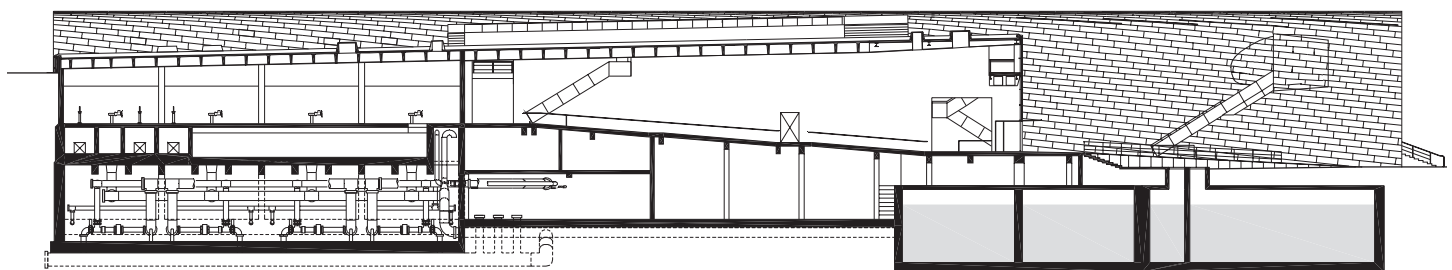
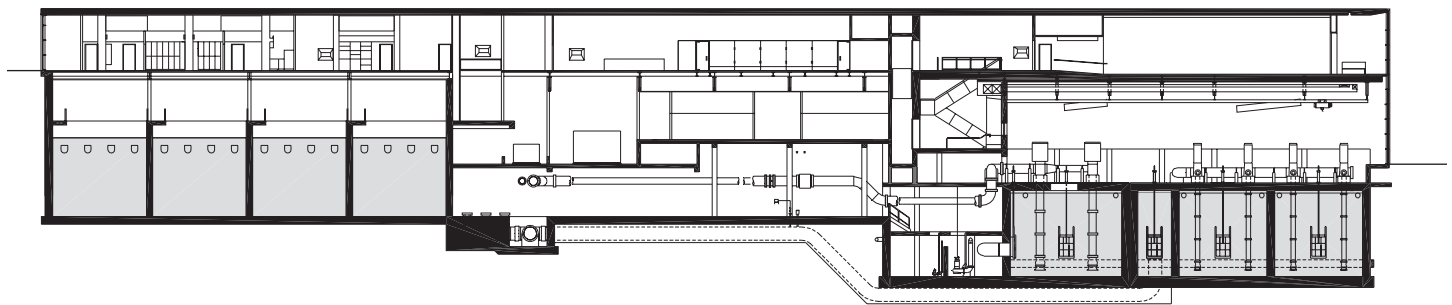



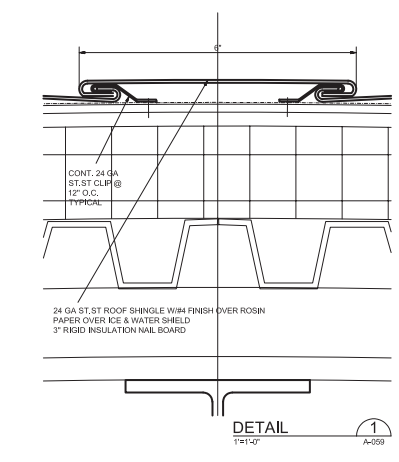
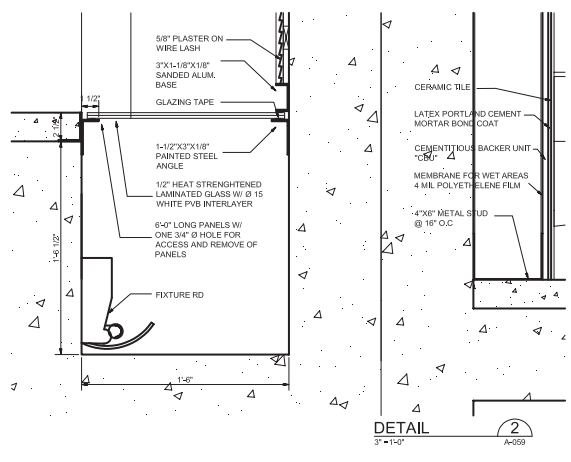
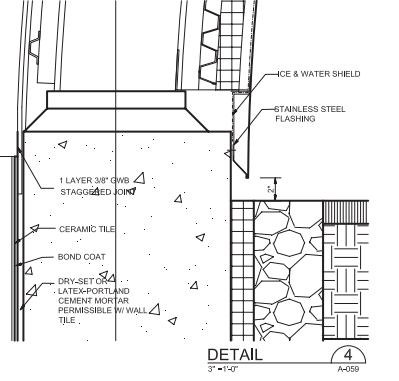
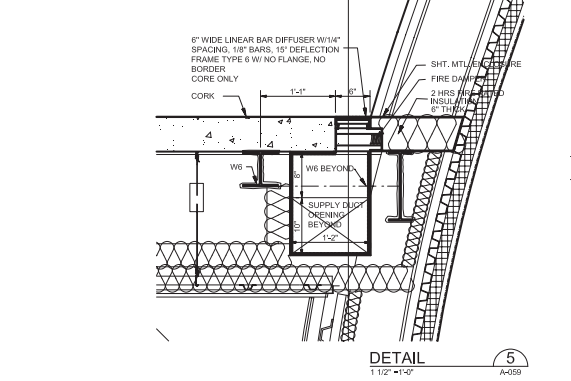
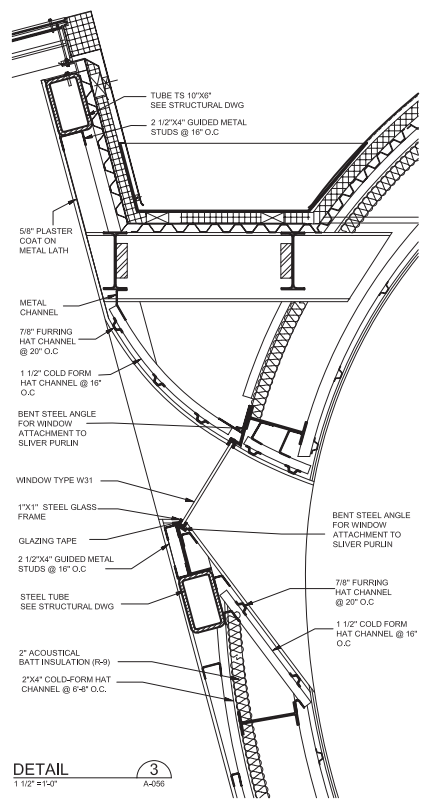
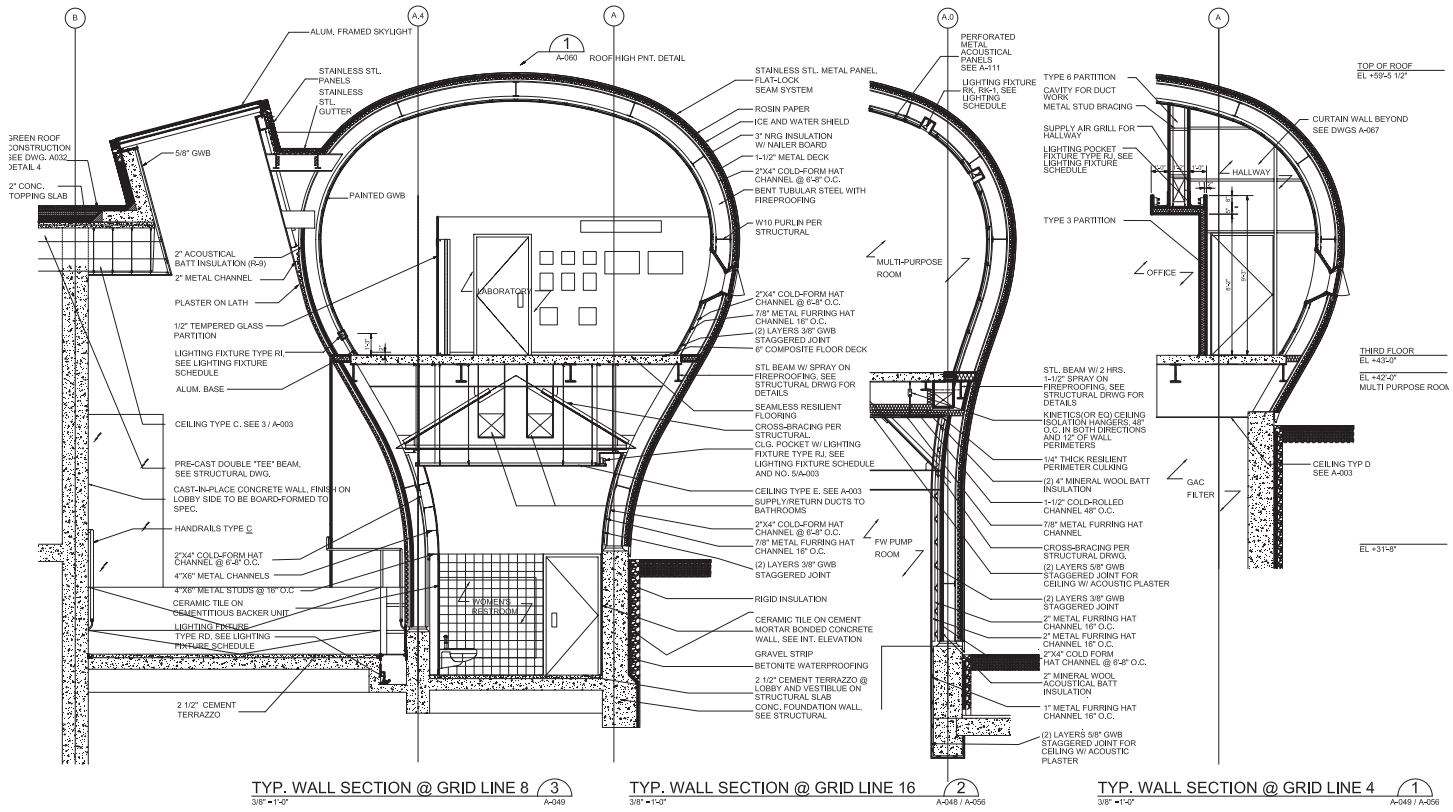

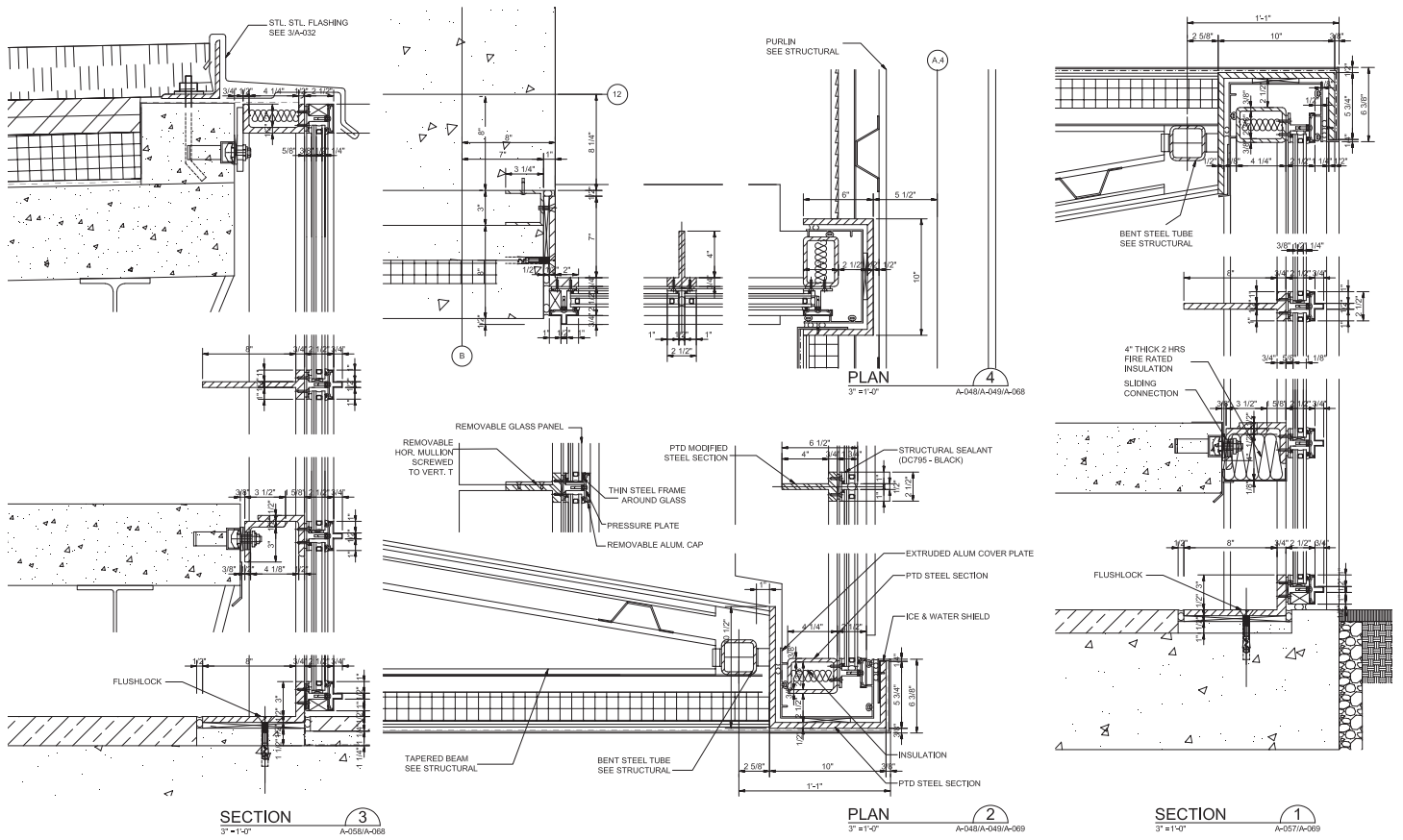

Opposite
Top: Typical wall sections
Bottom: Wall section details

This page
Top: Curtain wall details
Bottom (left to right): Steel framing, panel mock-up, installation

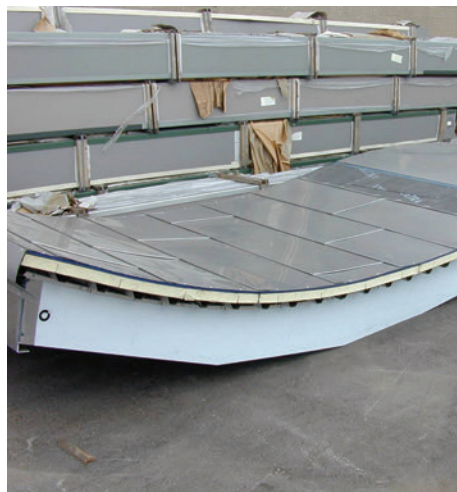

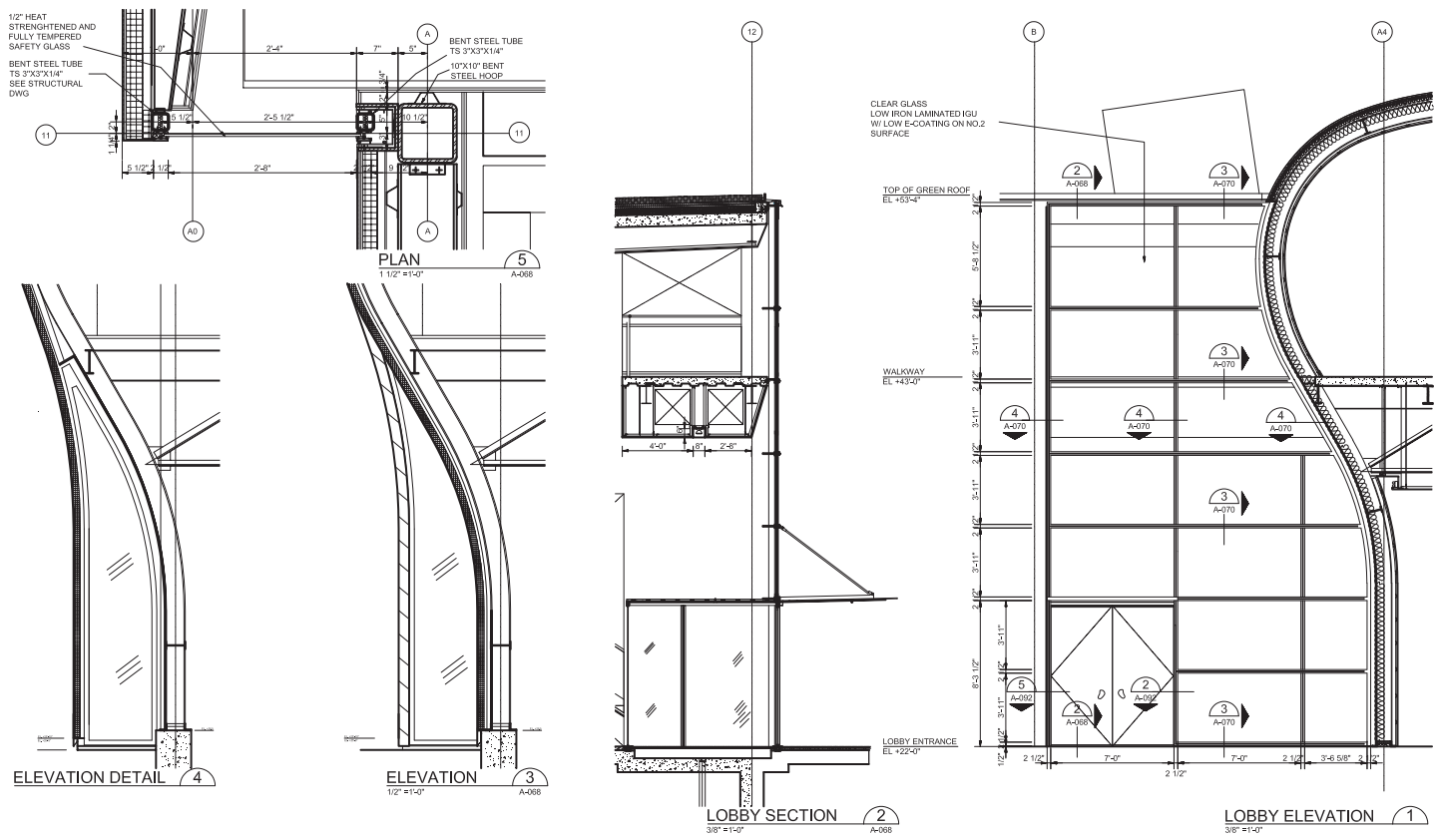

This page
Top: Lobby details
Bottom: Skylight detail

Opposite
Lobby

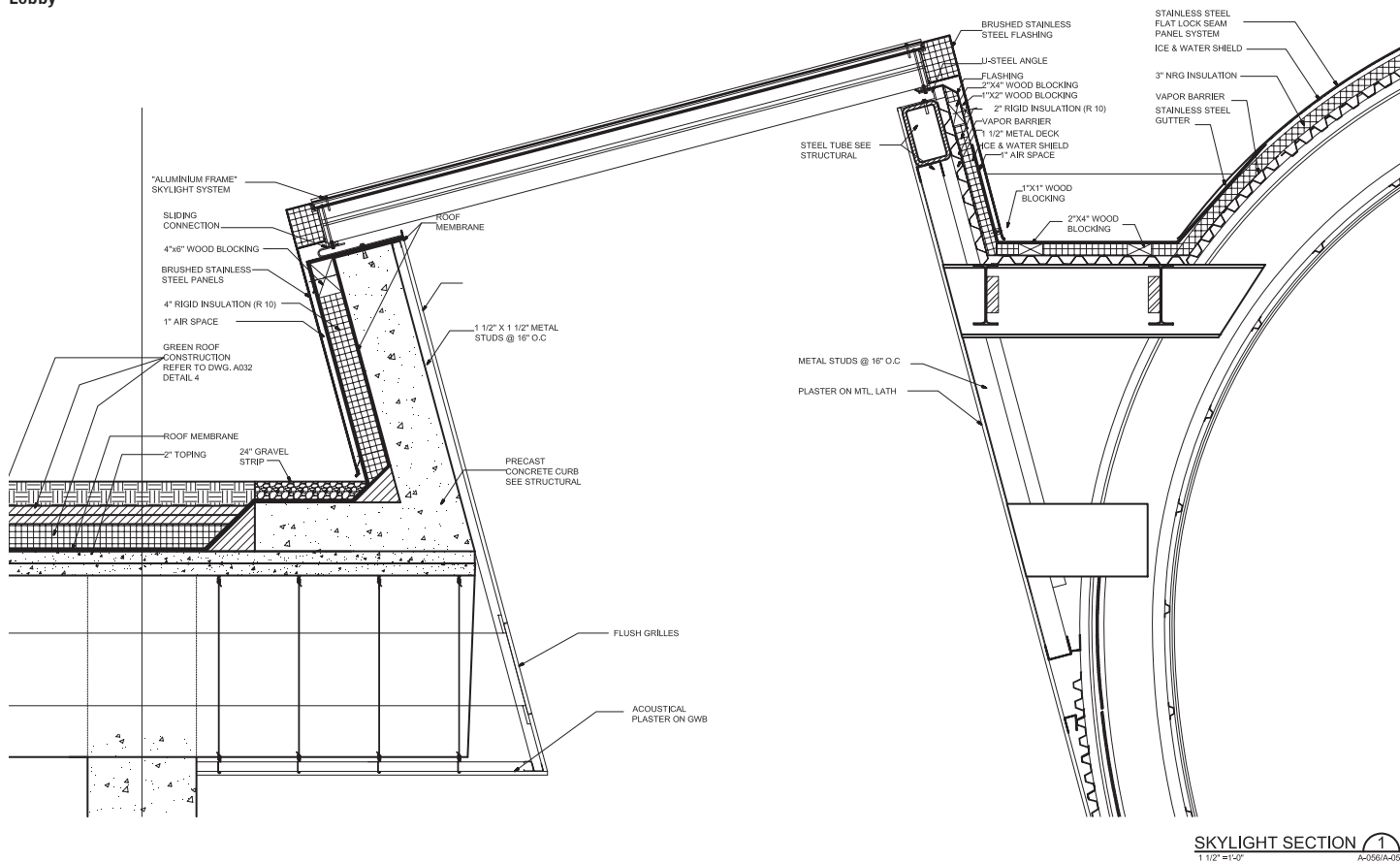



South Mountain Community College Performing Arts Center, Phoenix, Arizona

Jones Studio, Inc., Phoenix

The project site for the South Mountain Community College Performing Arts Center borders both the southern edge of Phoenix and the world's largest municipal park, South Mountain Park Preserve. The existing campus consists of simple stucco buildings arranged to create courtyards in the voids between buildings. The new 24,600-square-foot performance center required a 350-seat theatre, a 100-seat black box, a 75-seat dance studio, a recording studio, scene and costume shops, dressing and make-up areas, and a green room. The challenge of the site was to integrate the rich textures of the surrounding landscape—palo verdes, brittlebush, and gravel—into the new construction. The design team decided to produce an abstract box that would somehow change over the course of the day, using the college's philosophy of training students to recognize aspects of everyday life as performance opportunities to develop the building

concept. The performance hall, including the exterior lobby, house, and stage, is sited near the main entrance to the campus. The elevated exterior lobby, constructed of aluminum grating and galvanized purlins, puts members of the audience on stage before and after performances; lit like a lantern it announces to the community that an event is in progress.

The building is made up of two separate boxes: an outer box covered with rusted metal and glass, and an inner box that contains the theater itself. The lobby and circulation spaces occur in the space between. The building is constructed of sandblasted concrete masonry units with the exception of the screen in front of the performance hall, which is steel-framed and clad in overlapping weathering steel profiles that gradually peel away to reveal glazing in areas where light locks are not required. Like the needles of a saguaro cactus, the layered

folds of the steel sections act like louvers to dissipate heat, shade wall surfaces, and provide a tough outer shell for the sensitive area within, the sound chamber. To produce a seemingly random horizontal texture, the architects created a repeating panel system that could be easily and economically built by the contractor, a palette of four weathering steel profiles screwed into the plywood shell and moisture barrier, and four different horizontal course dimensions; the overlapping horizontal sections range in depth from 4 to 12 inches. The auditorium glows beaconlike at night, while during the day, the steel louvers create dappled patterns of sunlight and shadow throughout the lobby. The enclosure's transformation from opaque to semitranslucent signals the internal organization of building functions, from opaque around the stage area to translucent in the glass lobby at the opposite end of the building, where the steel is peeled away entirely.

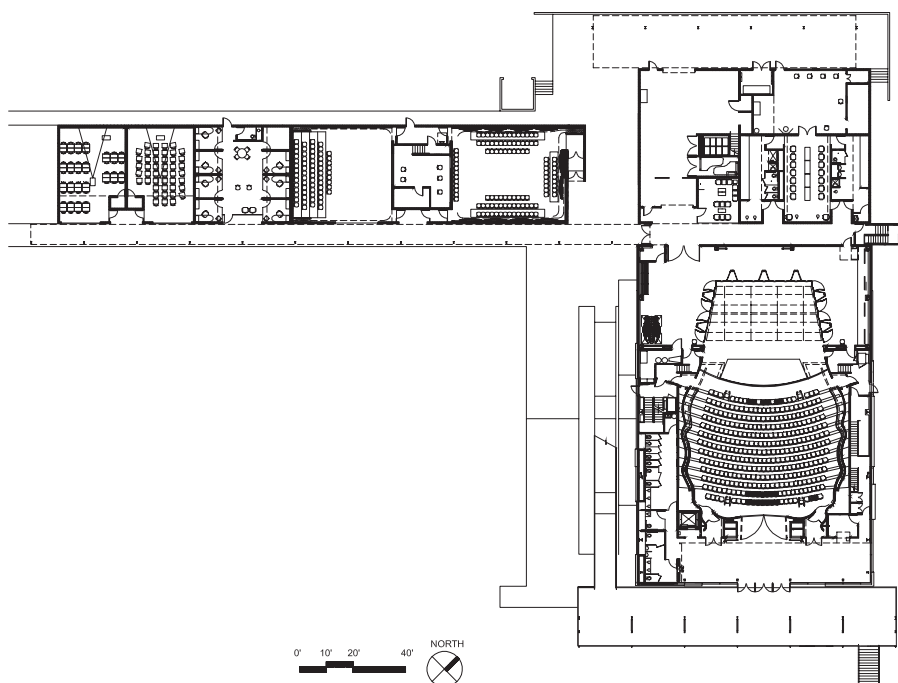

This page
Plan

Opposite
East elevation



performance hall



Opposite
 Top: Exterior from the south
 Bottom: Walkway detail

This page
 Below: Metal siding detail
 Bottom: Exterior wall detail
 Right: Wall sections

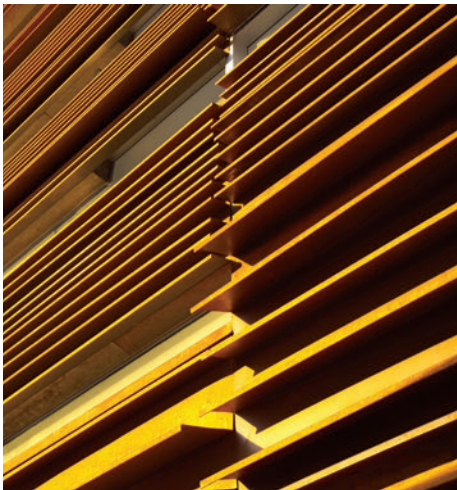
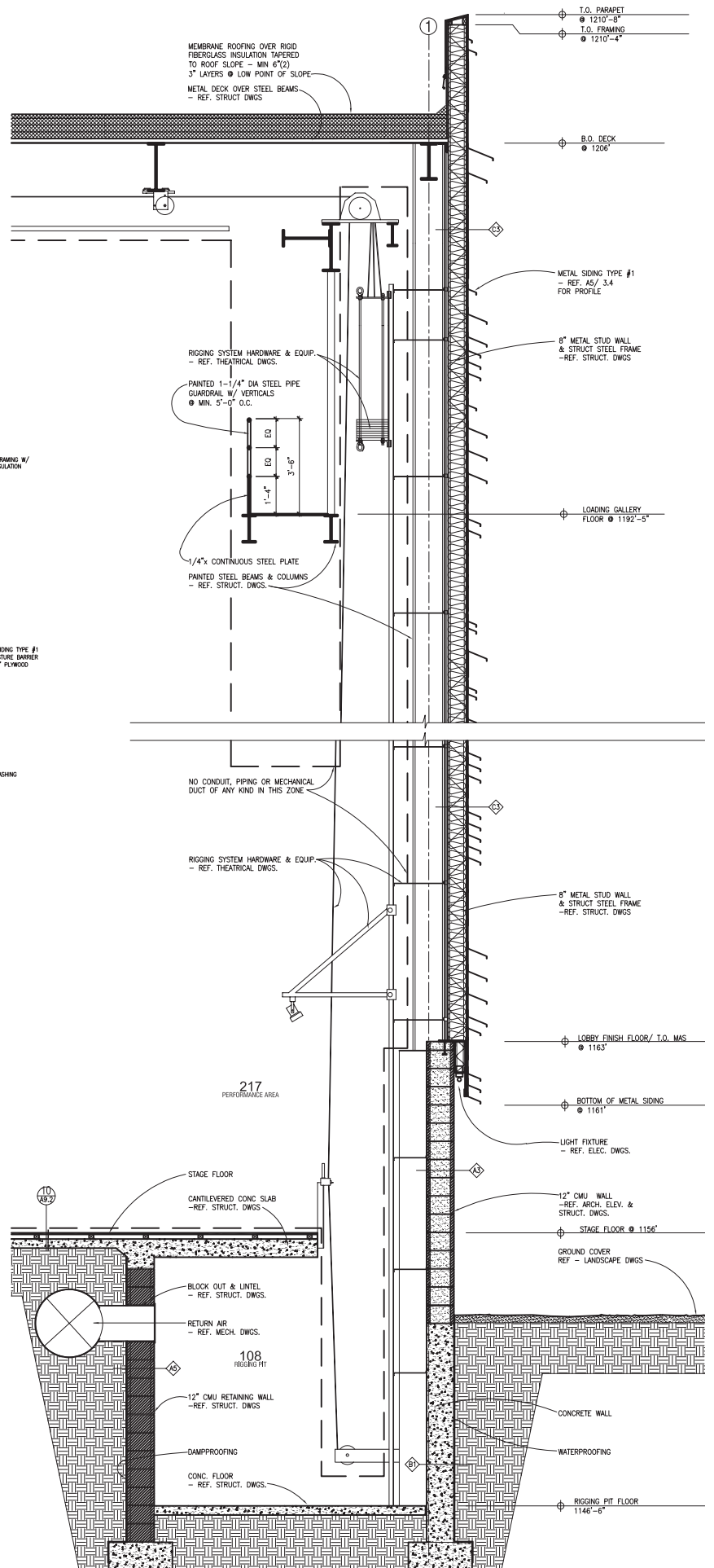
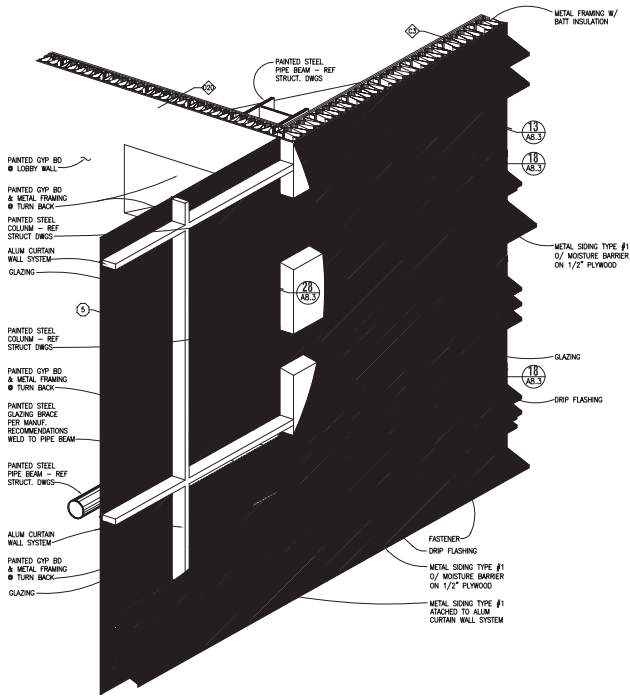

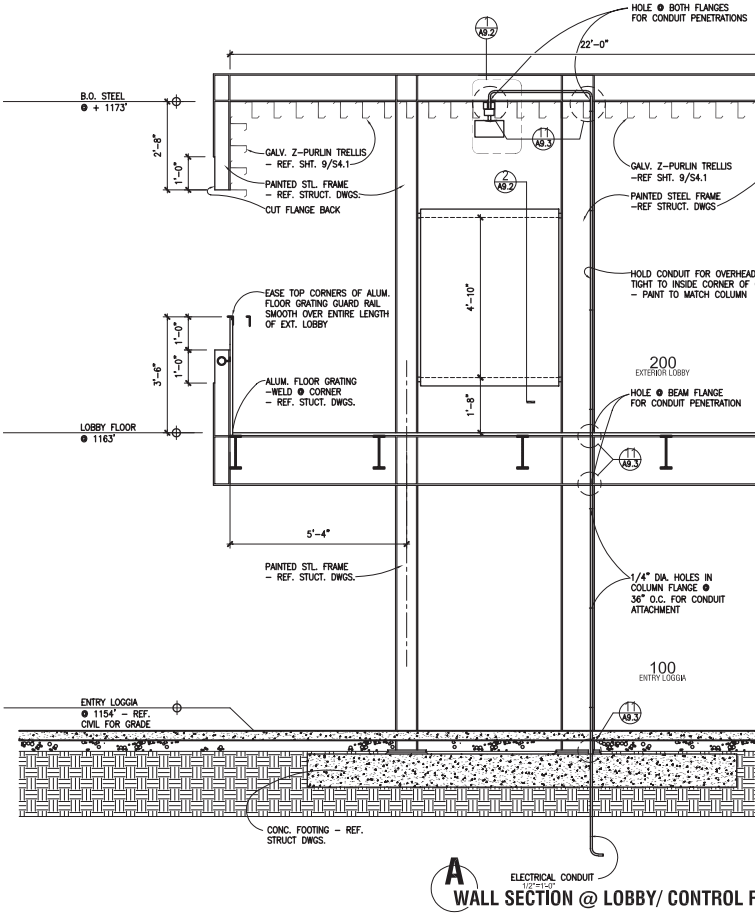
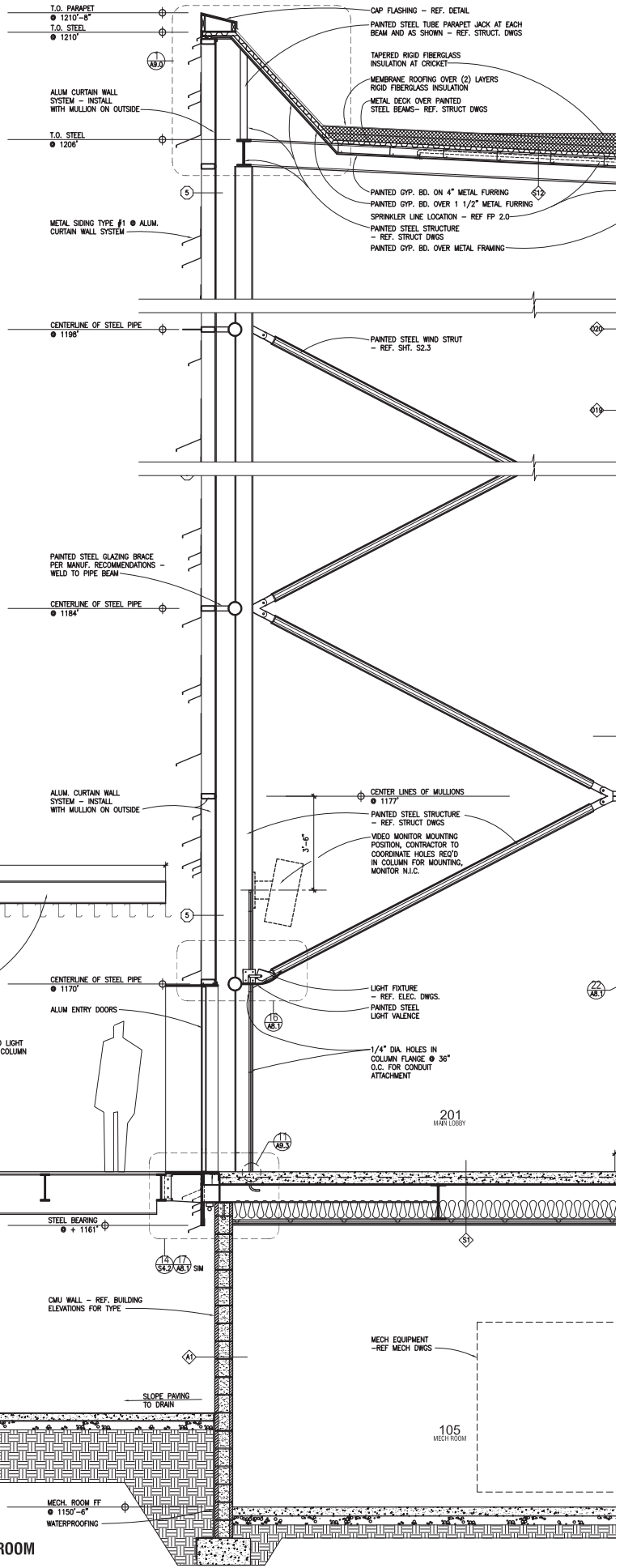

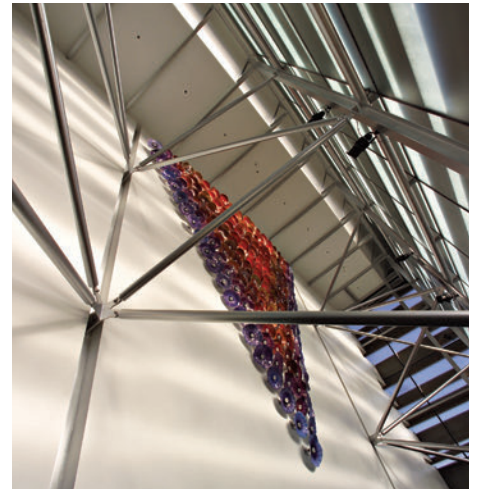
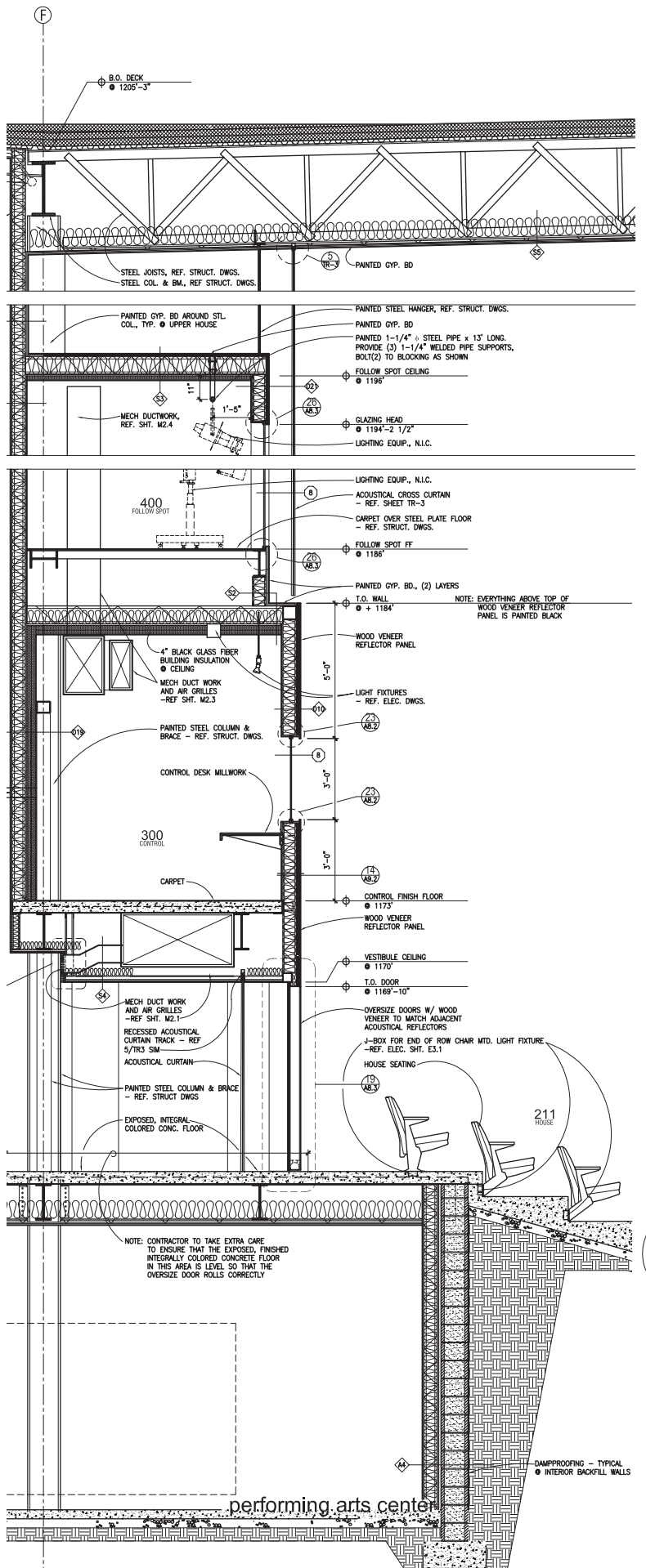

Opposite
 Left: Lobby detail
 Right: Wall section at lobby
 and control room

This page
 Top: Lobby details

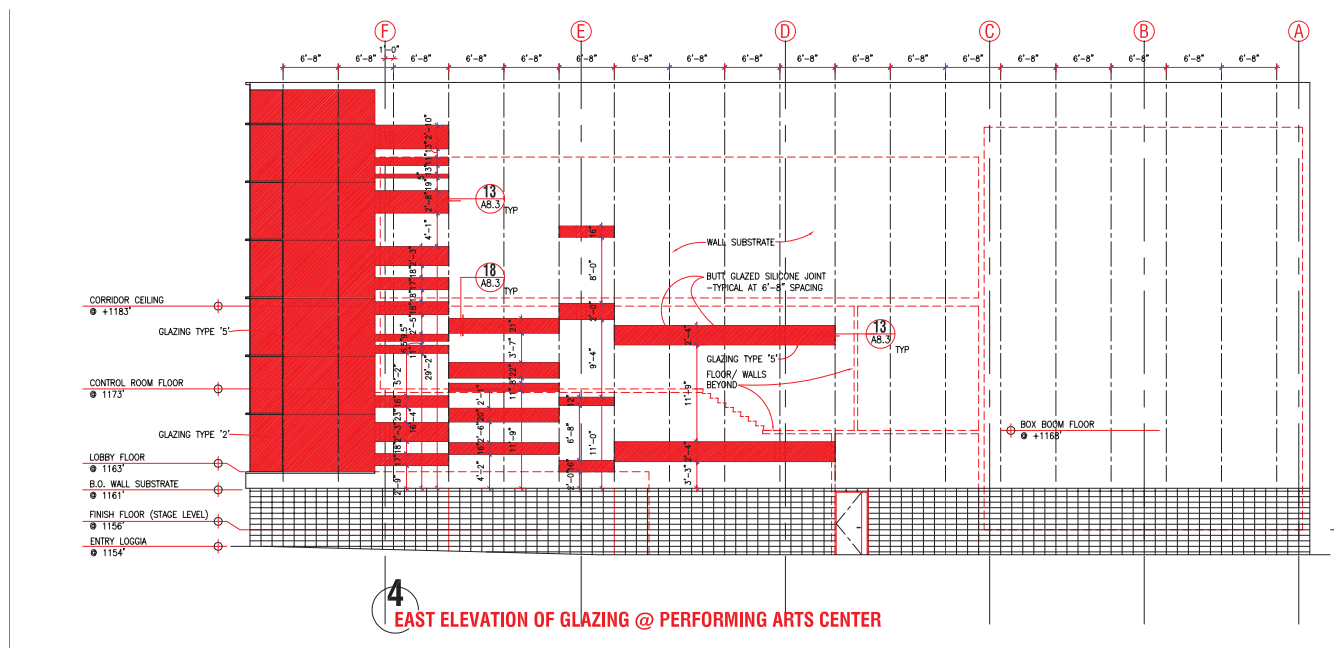
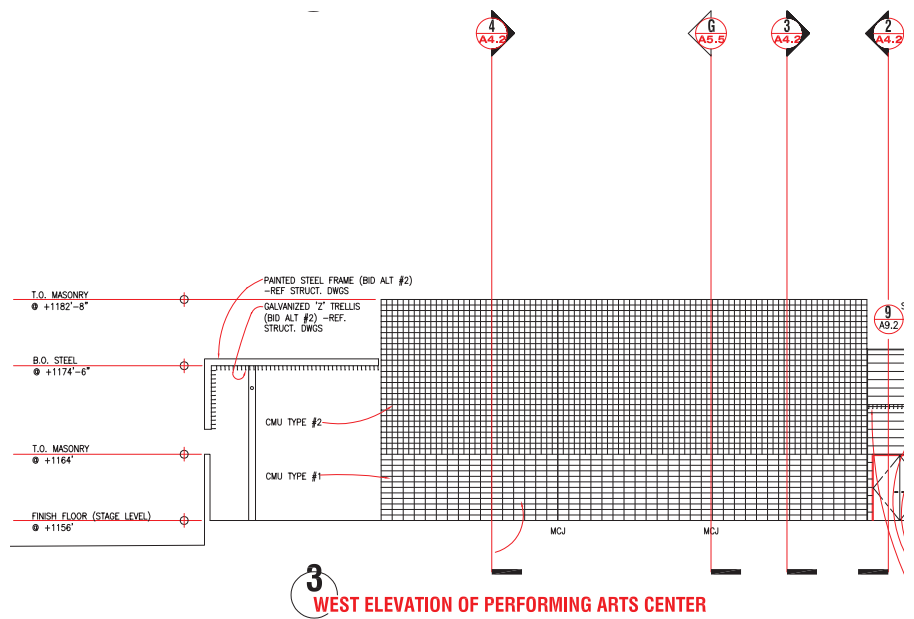
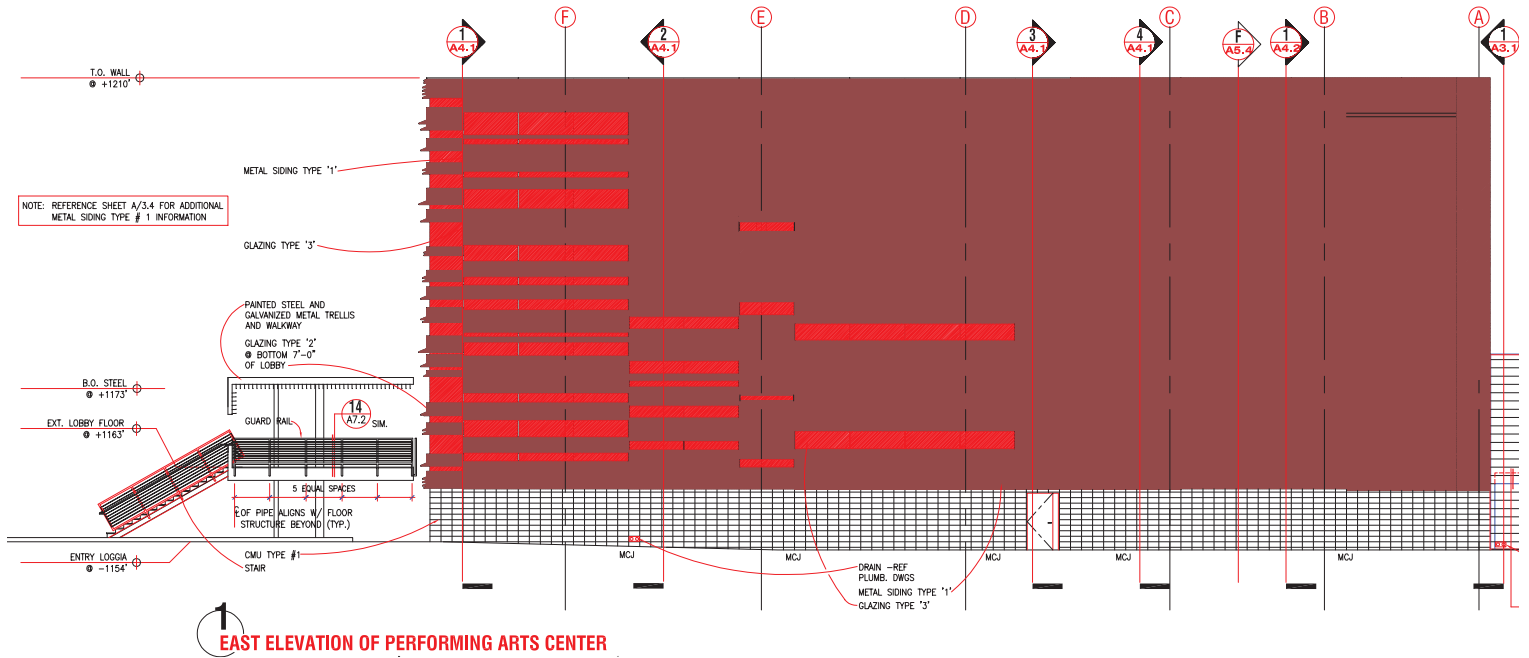

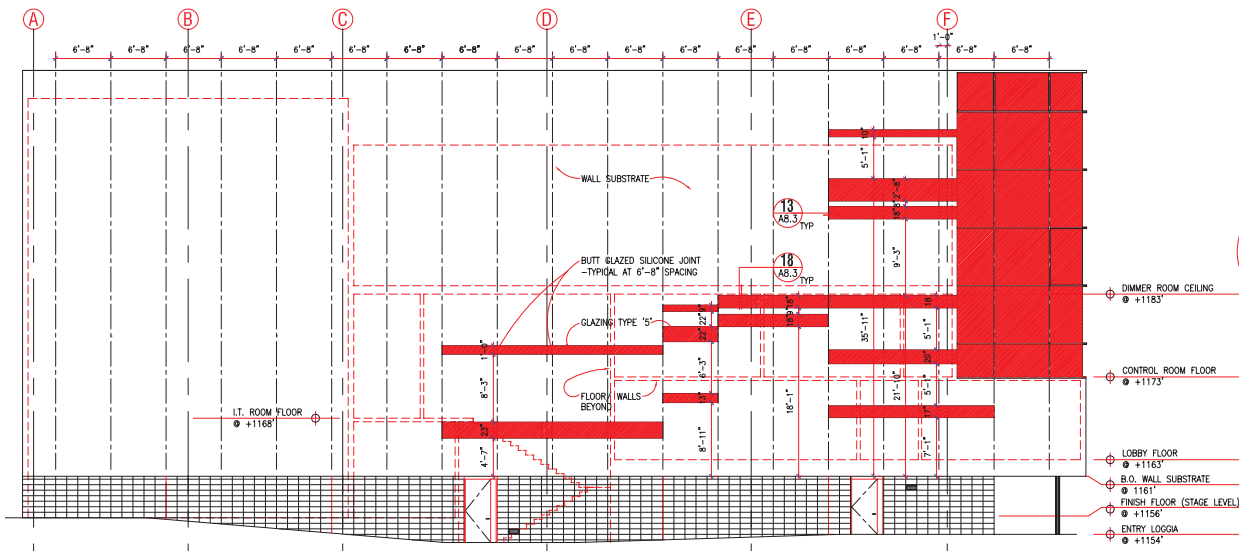
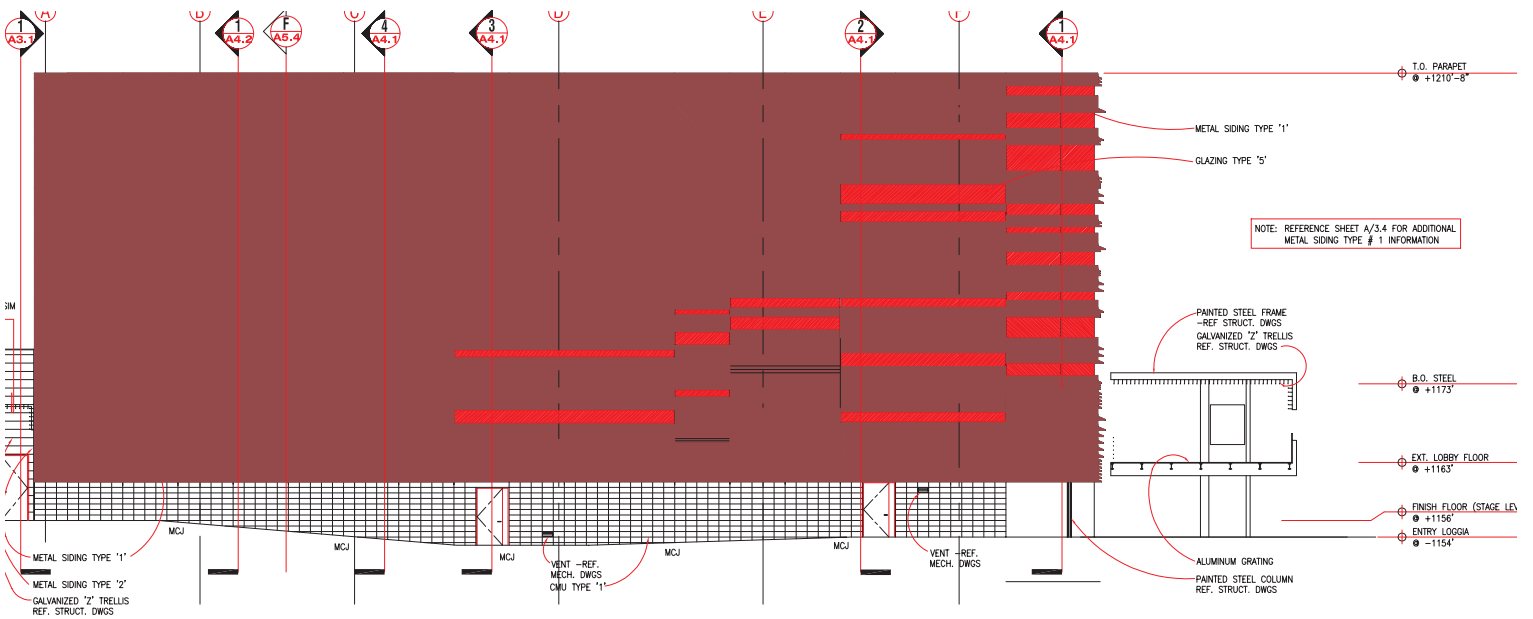
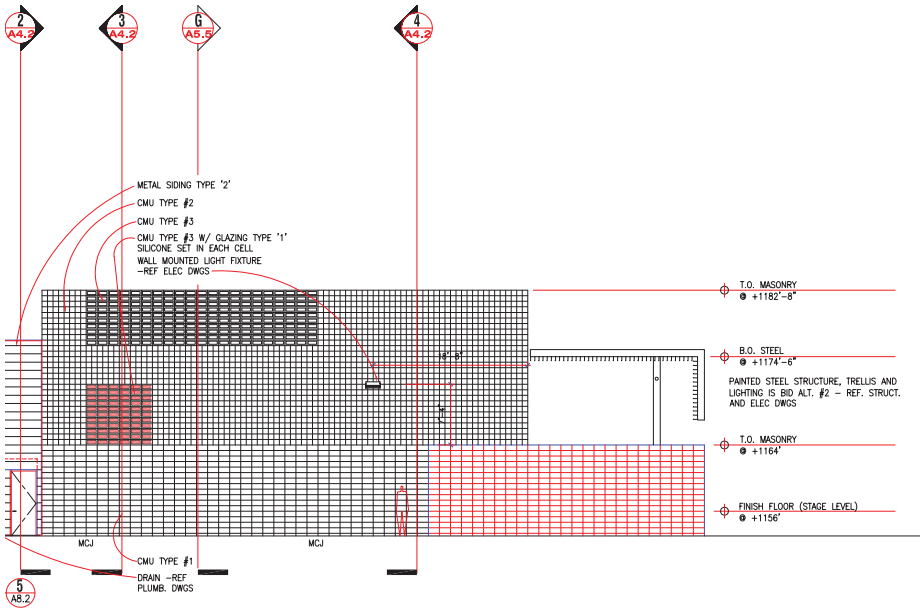

5 WEST ELEVATION OF GLAZING @ PERFORMING ARTS CENTER

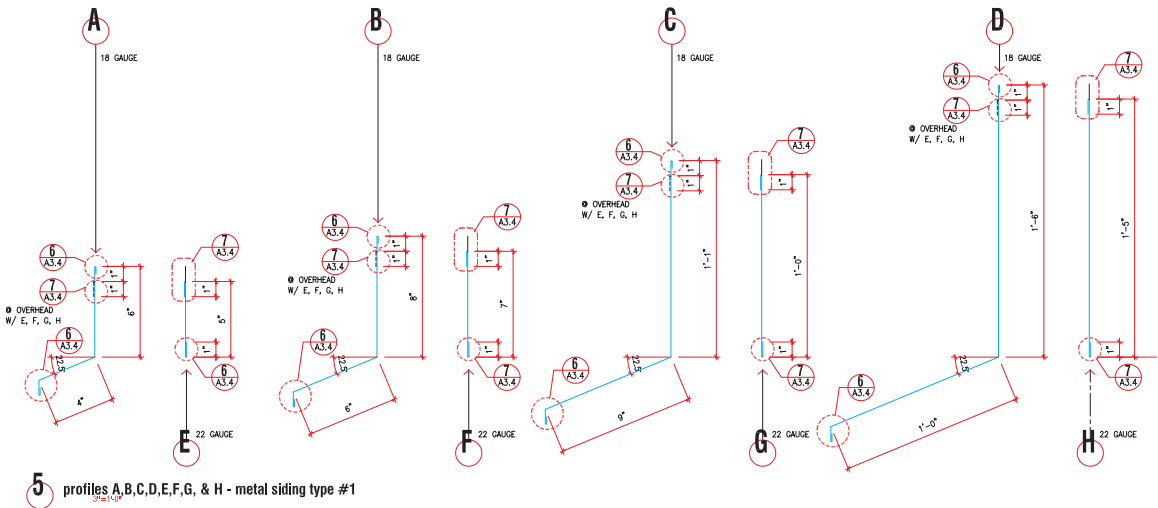
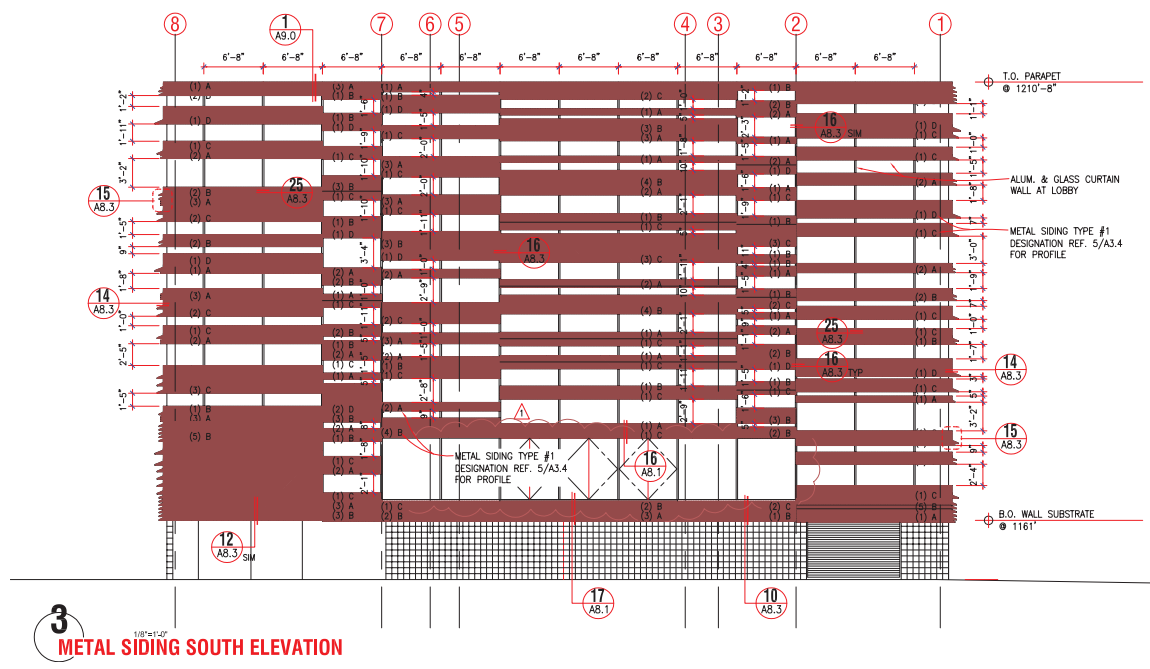
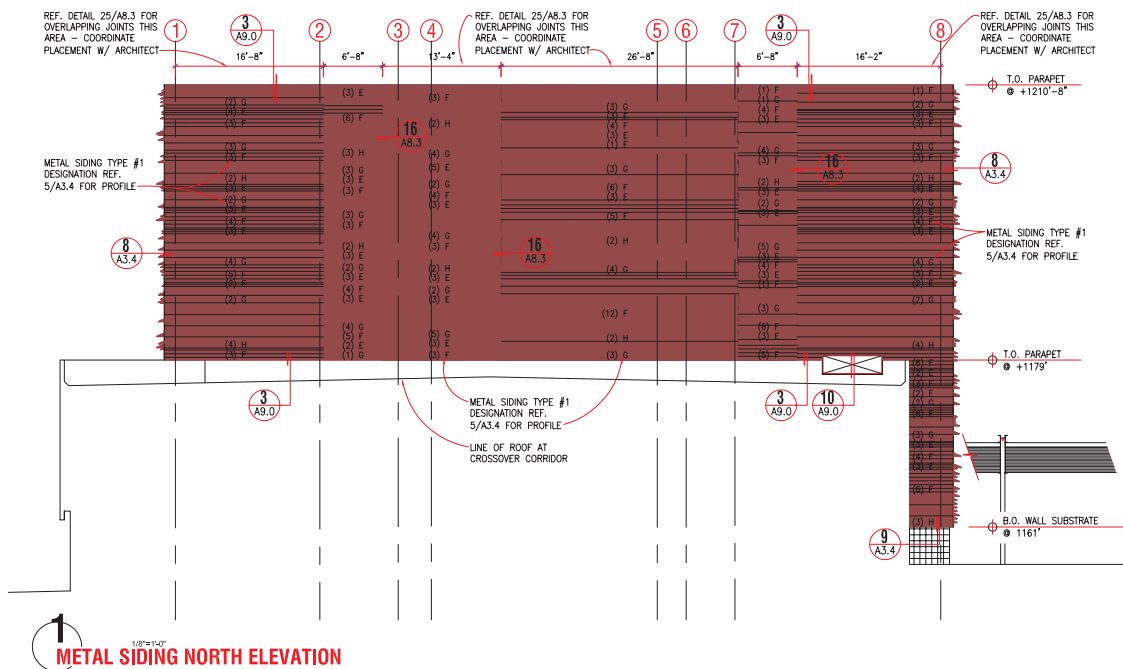

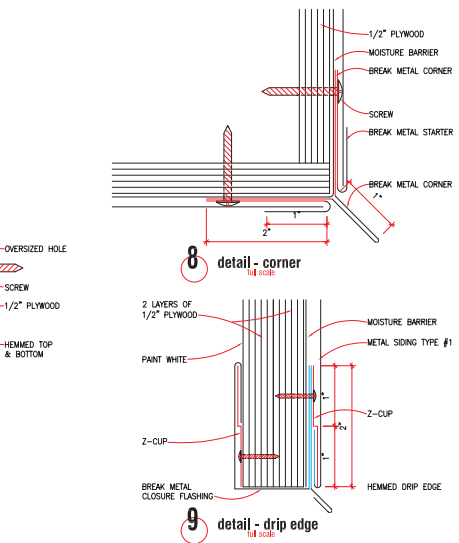
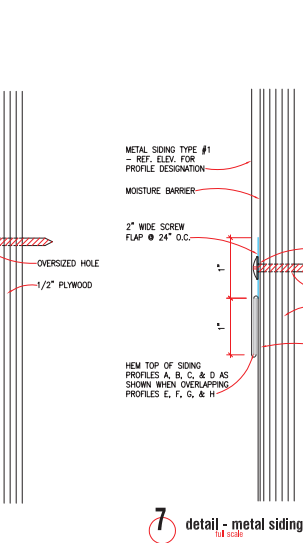
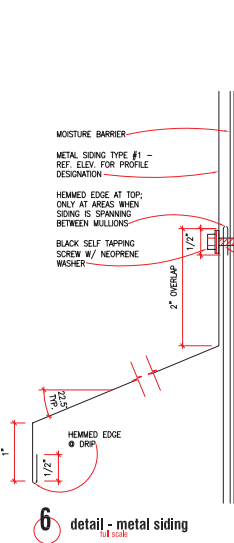
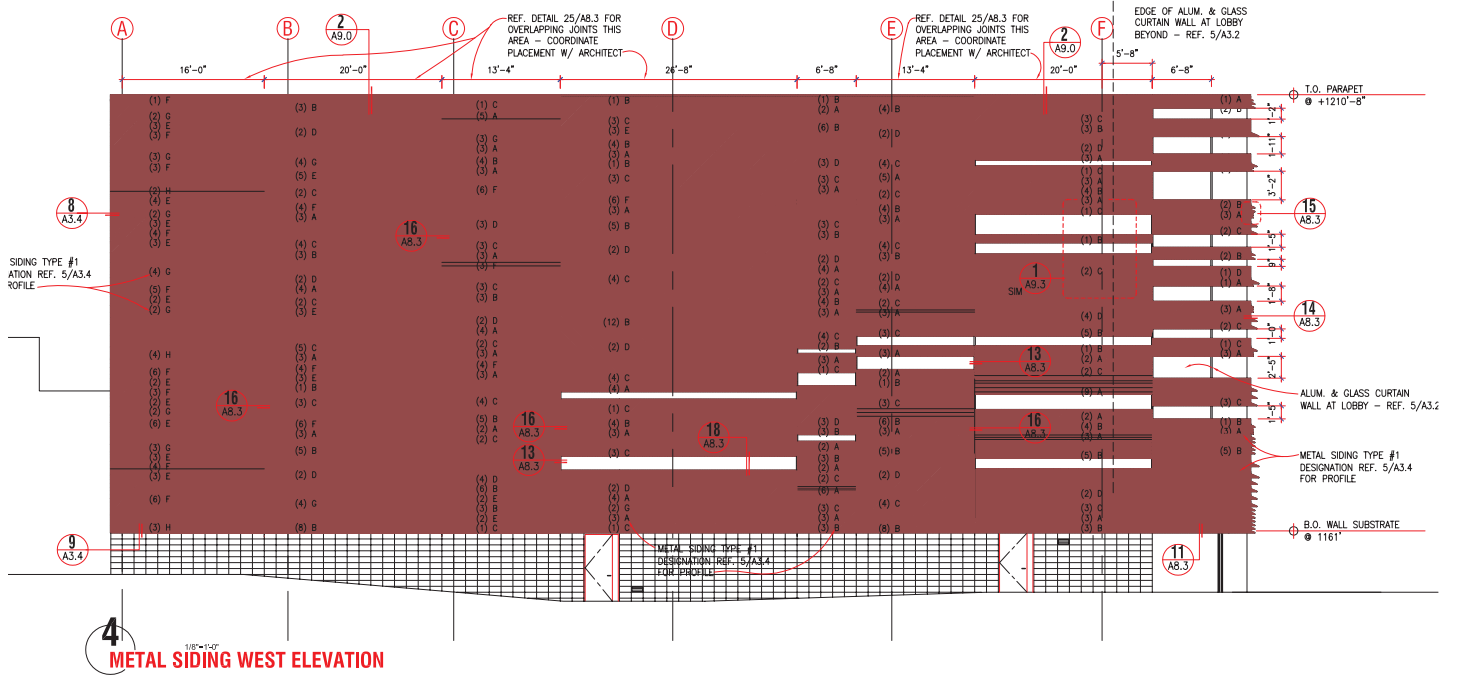
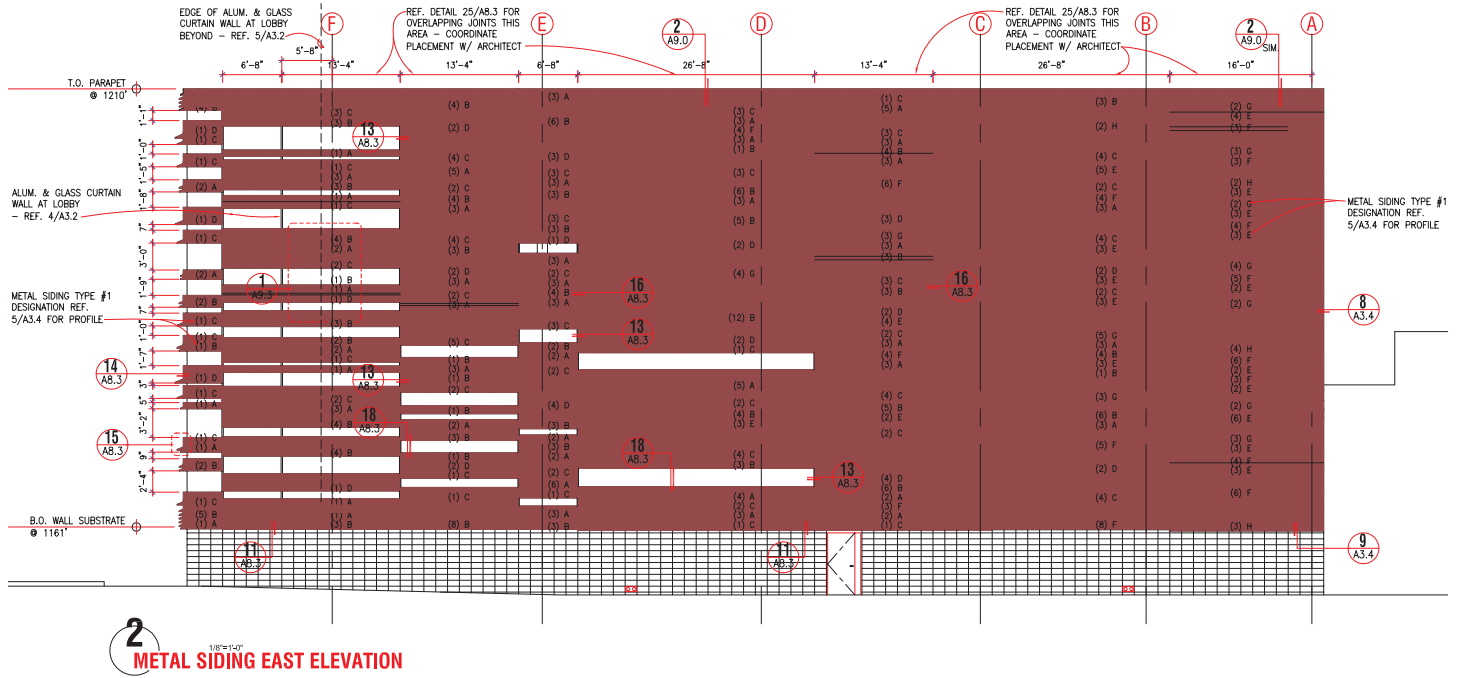

Caltrans District 7 Headquarters, Los Angeles, California

Morphosis, Santa Monica, California

Associate Architect: Gruen Associates, Los Angeles

The new Caltrans District 7 building in downtown Los Angeles is an office building for the state's freeway engineers and administrators at the edge of the fragmented civic center. The L-shaped facility spans an entire city block, creating floor plates roughly twice as long as those in conventional office buildings. The architects compare it to a horizontal highrise with two cores, one with an elevator that stops at every floor and another that operates on a "skip-stop" basis, opening onto minilobbies located on every third floor. To bring daylight into the center of the enormous floors, there are two twelve-story light wells that measure 30 feet square. With transparent curtain walls at its center and seemingly windowless walls on the facade, the building appears to be a conventional office building turned inside out. Floor plans also reverse the usual hierarchy of office space, with private closed-

door offices concentrated around the inner cores and large open work areas located around the perimeter.

Although no windows are visible, there are many windows hidden by the building's most distinctive element, a scrim wall with blue-gray coated perforated aluminum panels and operable windows, which are covered by a mechanical skin of many moving parts, alternately open or closed as they respond to changing temperature and light levels. Some of the three-dimensional panels are fixed, but over a thousand others open and close automatically, controlled by computerized light and temperature sensors on the west side of the building in the morning and on the east side in the afternoon, forming a ninety-degree angle with the facade. The appearance of the facades from the street depends on the time of the day; at dusk the building seems transparent,

translucent in midafternoon, and windowless and opaque at midday. At first, state officials were reluctant to install an electro-mechanical system to regulate the scrim's panels, but after extensive testing of at least five mock-ups, including a full-scale version subjected to wind, rain, and seismic movement, a pneumatic version with durable stainless steel actuator parts was accepted, providing the building with shading devices its occupants can control.

The facade system contains three different sizes of perforated aluminum panels: 1/4-inch holes on 11/32-inch centers, 1/2-inch holes on 11/16-inch centers, and 1-inch holes on 1 3/8-inch centers. The aluminum scrim walls also act as sunshades and create a microclimate in the interstitial space between them and the exterior curtain walls. The facade's panels are cooled as hot air rises upwards driven by colder air from

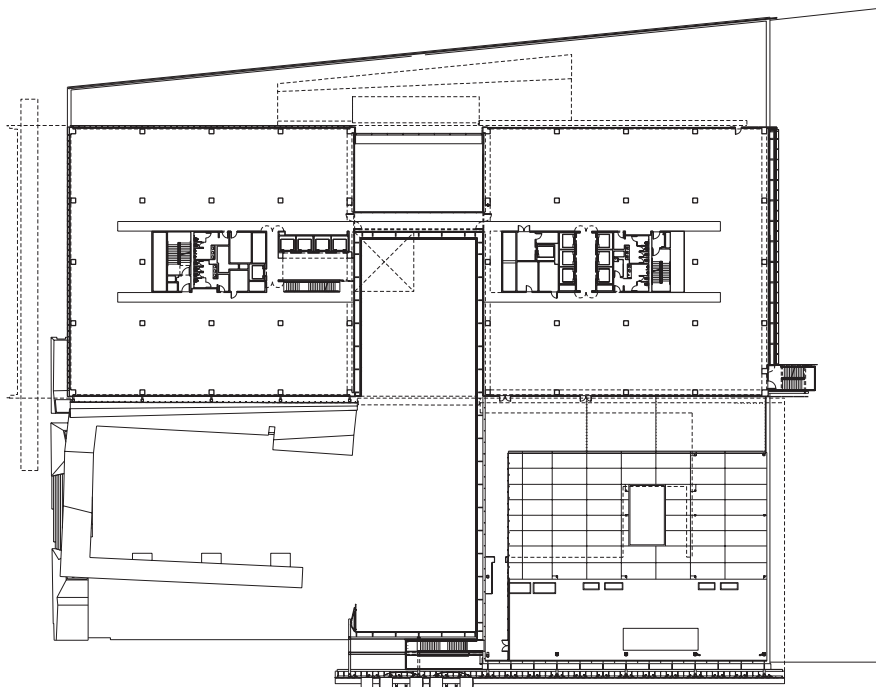

This page
Level 4 plan

Opposite
Top: Main Street elevation
Bottom: First Street elevation detail



This page

Top: Section looking west

Middle: Section looking south

**Bottom: Main Street elevation
passage section (left), Main Street
elevation passage detail**

Opposite

Passage

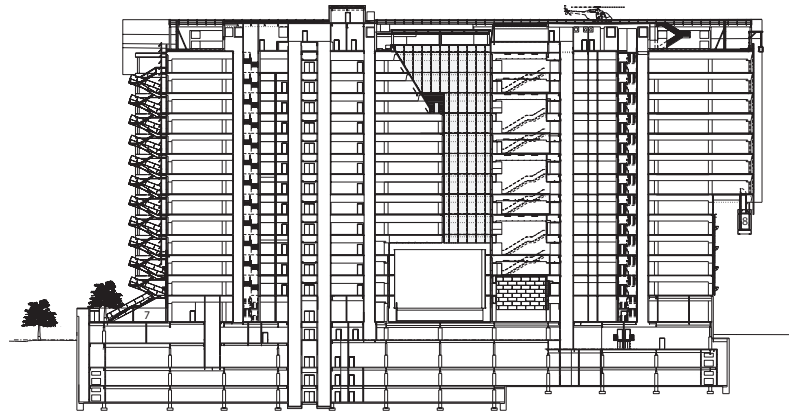

below. When the panels are closed, office workers retain views of the surrounding city. Over the entry courtyard, one aluminum panel continues on outward to form a canopy. The other scrim walls are attached to the building with metal brackets that secure them a foot off the building's primary exterior facade, consisting of an aluminum curtain-wall system with dual glazed panels with a heat strengthened outer face and a low-emissivity coating on the inner surface. The frames of the glass units, some as large as 71 1/8 by 125 7/8 inches, are coated with a dark gray waterproofing membrane to create the building's primary weather barrier. The building's equally innovative south facade is entirely surfaced with photovoltaic cells, which generate approximately five percent of the building's energy, and also act as a sunscreen to shade south-facing windows.

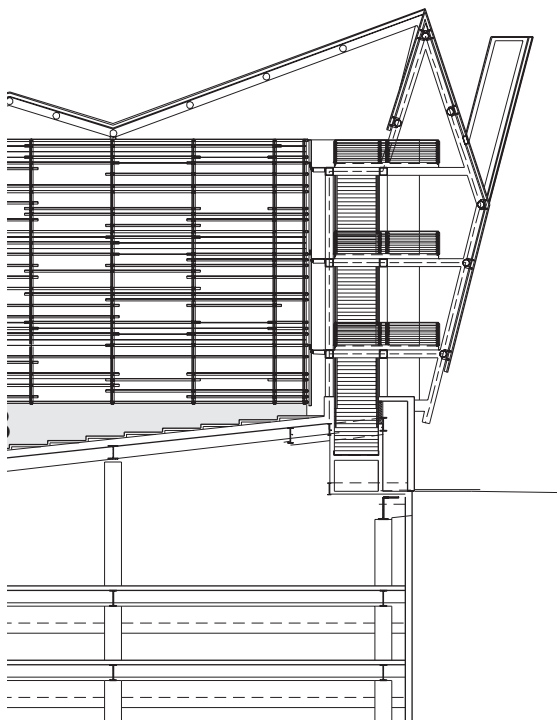
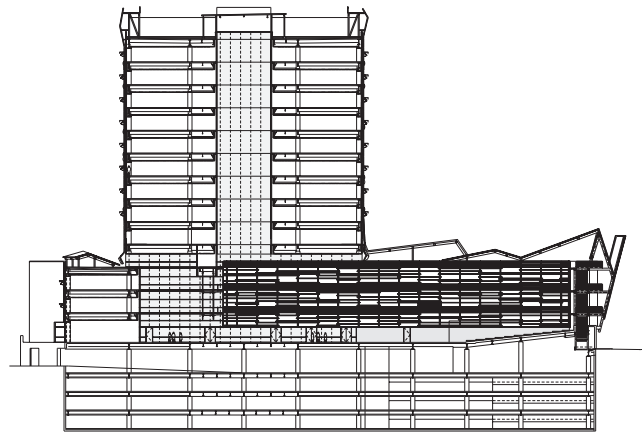

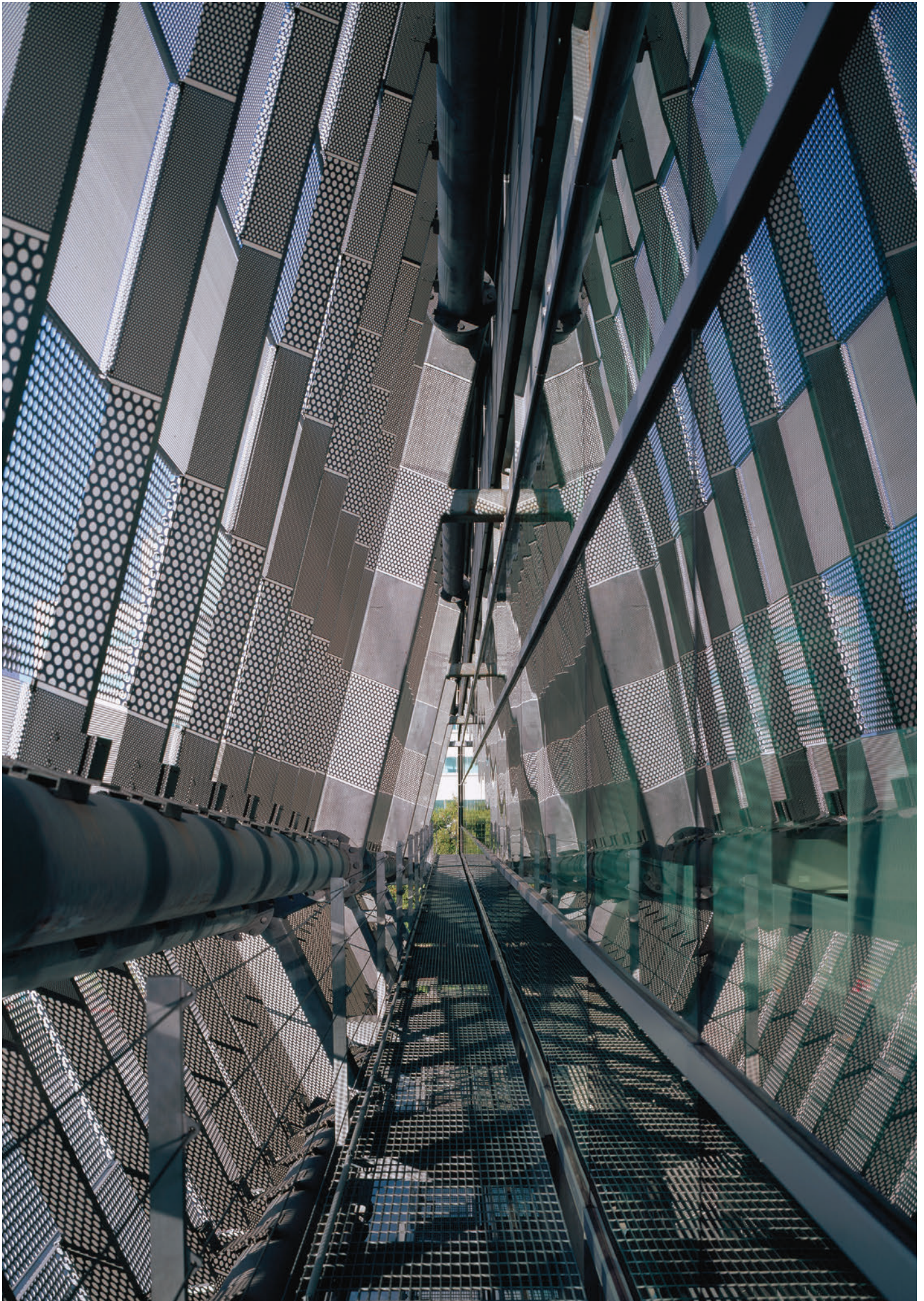

This page

Left: Exterior lobby, art wall system

Right: Solar elevation, interior

Bottom: Solar elevation panels

Opposite

Top: Photovoltaic wall system

Bottom: Light well wall system

Right: Light well and detail

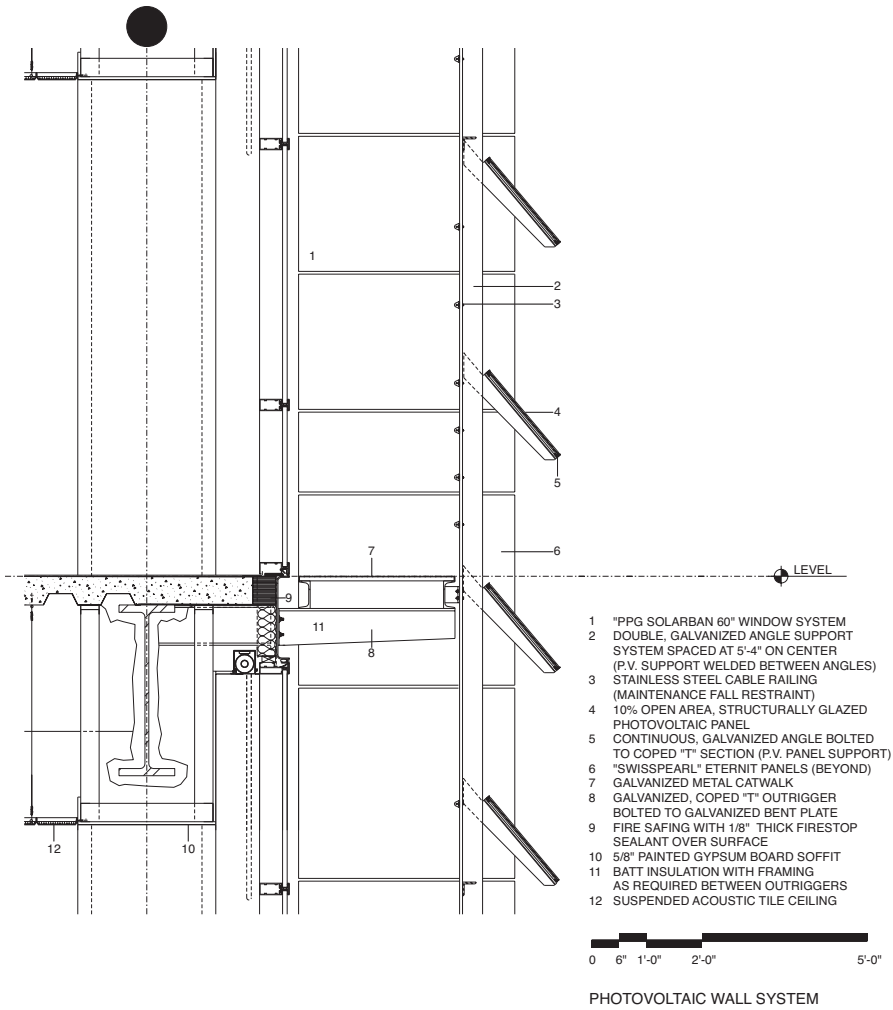

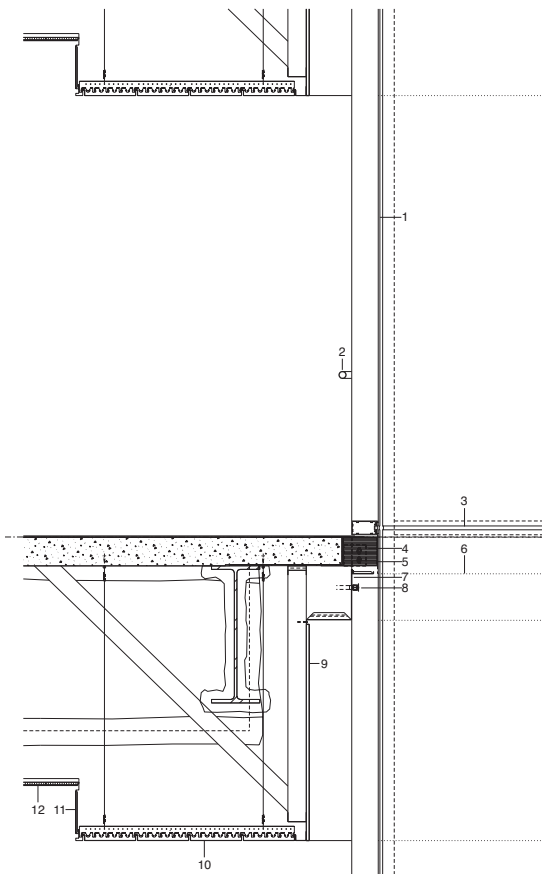

- 1 3/8" TEMPERED, STRUCTURALLY GLAZED CURTAIN WALL
 - 2 GUARDRAIL LOCATED AT 3'-0" TO TOP (PROVIDES OPEN SPACE TO GLAZING FOR PROPER SPRINKLER COVERAGE)
 - 3 CURTAIN WALL SYSTEM BEYOND
 - 4 FIRE SAFING WITH 1/8" THICK FIRESTOP SEALANT OVER SURFACE, SEALED TO BACK OF GLAZING
 - 5 FILM APPLIED IN STRIP TO SECOND SURFACE OF GLAZING TO HIDE SAFING AND FIRE SEALANT. (COLOR TO MATCH MULLION)
 - 6 LINE OF FILM BEYOND
 - 7 SHEET METAL, SNAP-IN CLOSURE (PAINTED TO MATCH MULLION)
 - 8 FIRE SPRINKLER (2 HOUR RATING)
 - 9 5/8" GYPSUM BOARD SOFFIT (PAINTED TO MATCH MULLION)
 - 10 PERFORATED METAL CEILING STRIPS (COLOR TO MATCH MULLION)
 - 11 SHEET METAL CLOSURE (PAINTED WHITE)
 - 12 SUSPENDED ACOUSTIC TILE CEILING
- 0 6" 1'-0" 2'-0" 5'-0"

LIGHTWELL WALL SYSTEM (2HR RATED)

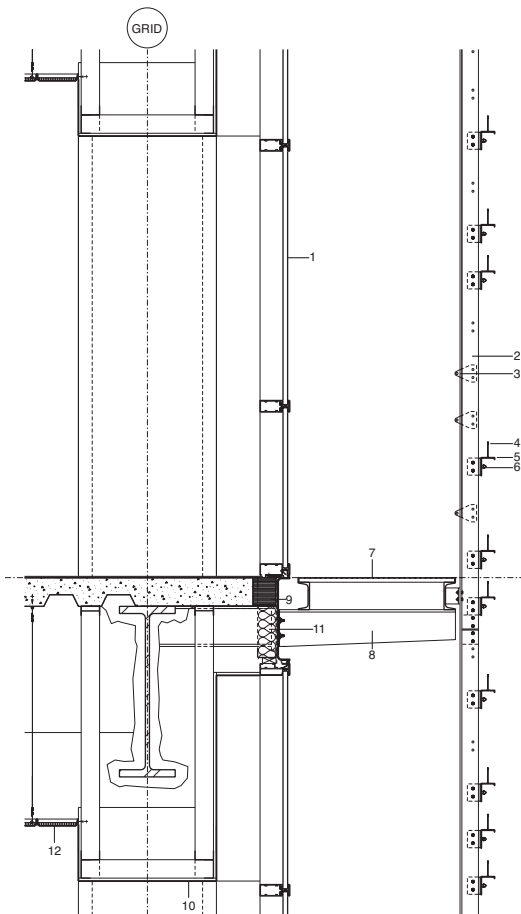
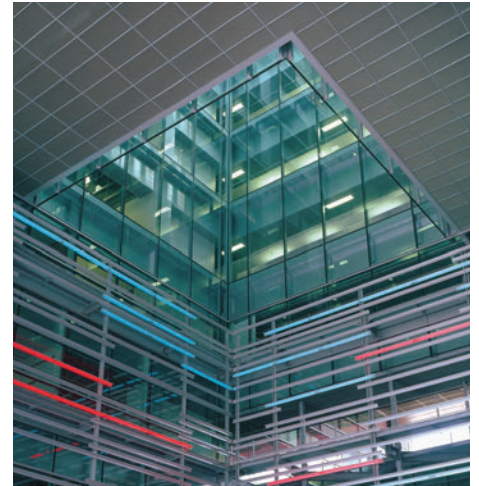

- 1 "PPG SOLARBAN 60" WINDOW SYSTEM
 - 2 DOUBLE, GALVANIZED ANGLE SUPPORT SYSTEM SPACED AT 6'-0" ON CENTER (ART SUPPORT BOLTED BETWEEN ANGLES)
 - 3 STAINLESS STEEL CABLE RAILING (MAINTENANCE FALL RESTRAINT)
 - 4 "BIRDWIRE" BIRD DETERRENT SYSTEM MOUNTED TO TOP OF ALUMINUM SECTION
 - 5 ALUMINUM SECTION WITH DRIP EDGE (STRUCTURE FOR NEON PUBLIC ART PIECE)
 - 6 NEON TUBE WITH GLASS MOUNTS
 - 7 GALVANIZED METAL CATWALK
 - 8 GALVANIZED, COPED "T" OUTRIGGER BOLTED TO GALVANIZED BENT PLATE
 - 9 FIRE SAFING WITH 1/8" THICK FIRESTOP SEALANT OVER SURFACE
 - 10 5/8" PAINTED GYPSUM BOARD SOFFIT
 - 11 BATT INSULATION WITH FRAMING AS REQUIRED BETWEEN OUTRIGGERS
 - 12 SUSPENDED ACOUSTIC TILE CEILING
- 0 6" 1'-0" 2'-0" 5'-0"

EXTERIOR LOBBY / ART WALL SYSTEM

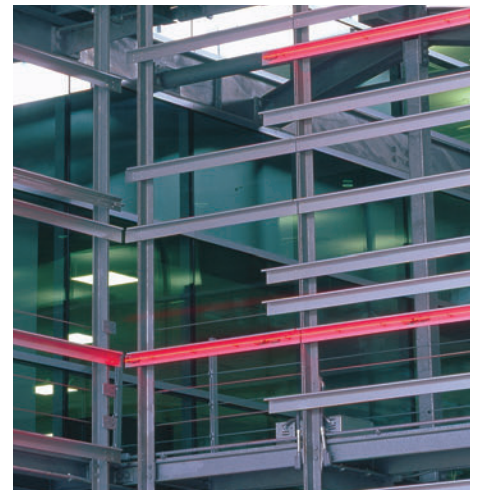

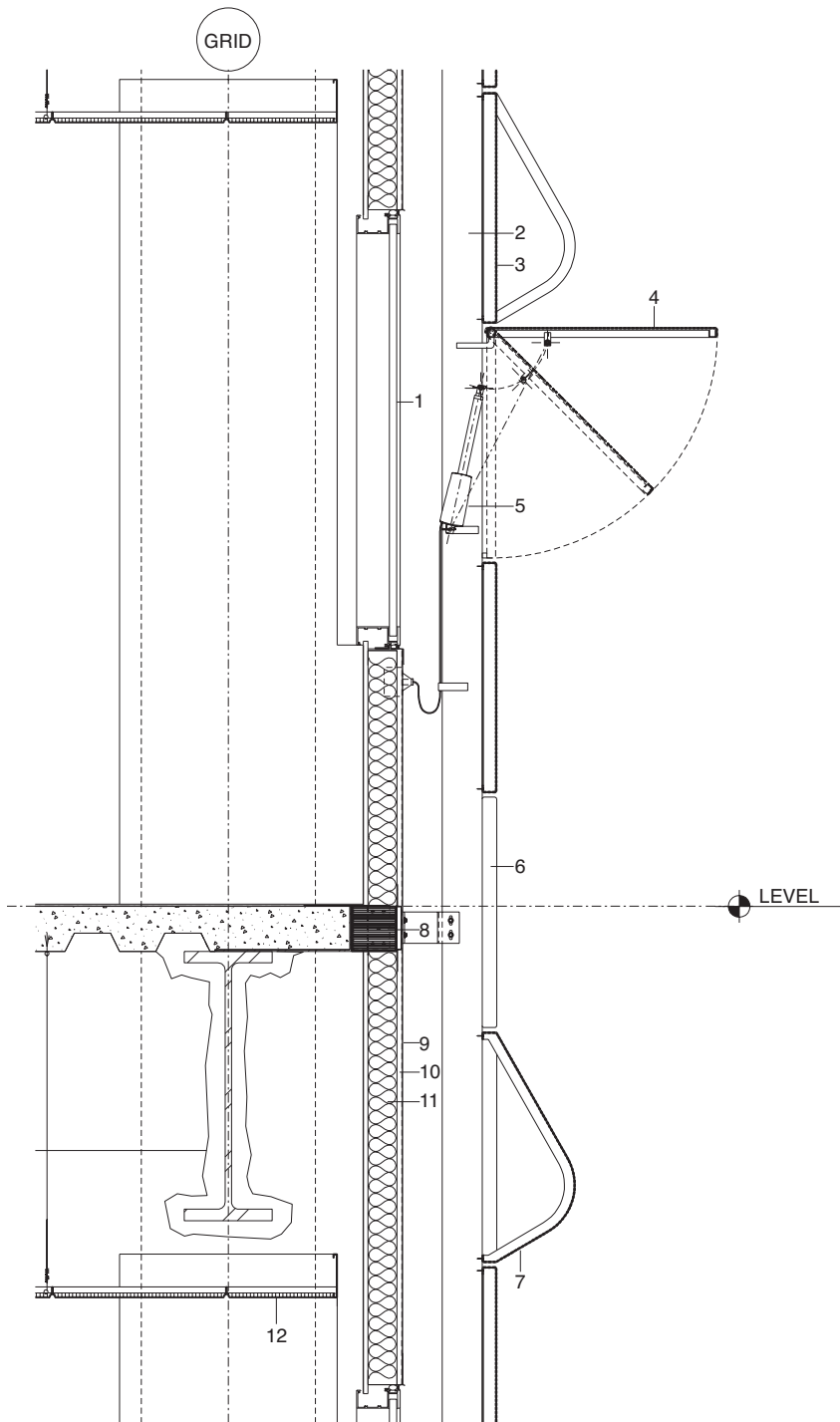

- 1 "PPG SOLARBAN 60" WINDOW SYSTEM
- 2 PERFORATED ALUMINUM PANEL SUB-STRUCTURE (PAINTED TO MATCH "SWISSPEARL")
- 3 FIXED PERFORATED ALUMINUM PANEL
- 4 OPERABLE PERFORATED ALUMINUM PANEL TO OPEN 90° TO VERTICAL
- 5 PNEUMATIC ACTUATOR CONTROLLED BY BUILDING MANAGEMENT SYSTEM
- 6 OPEN SLOT IN SKIN (PANELS REMOVED)
- 7 PRE-FORMED PERFORATED ALUMINUM PANEL WITH OPEN ENDS
- 8 FIRE SAFING WITH 1/8" THICK FIRESTOP SEALANT OVER SURFACE
- 9 "SARNAFIL" MEMBRANE WITH INTEGRAL COLOR TO MATCH "SWISSPEARL"
- 10 5/8" EXTERIOR SHEATHING
- 11 BATT INSULATION WITH FRAMING AS REQUIRED
- 12 SUSPENDED ACOUSTIC TILE CEILING



PERFORATED PANEL WALL SYSTEM

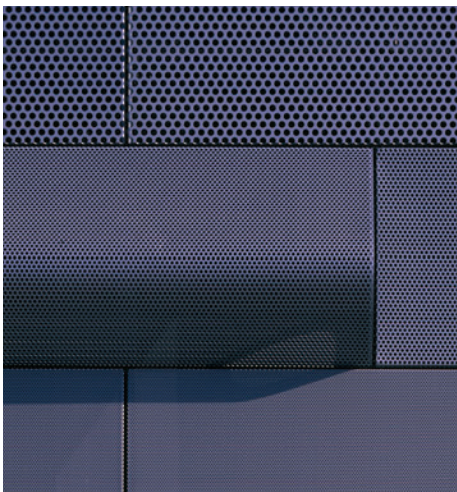

This page
Top: Perforated panel wall system
Left: Elevation window detail
Right: Window detail

Opposite
Elevation, operable windows

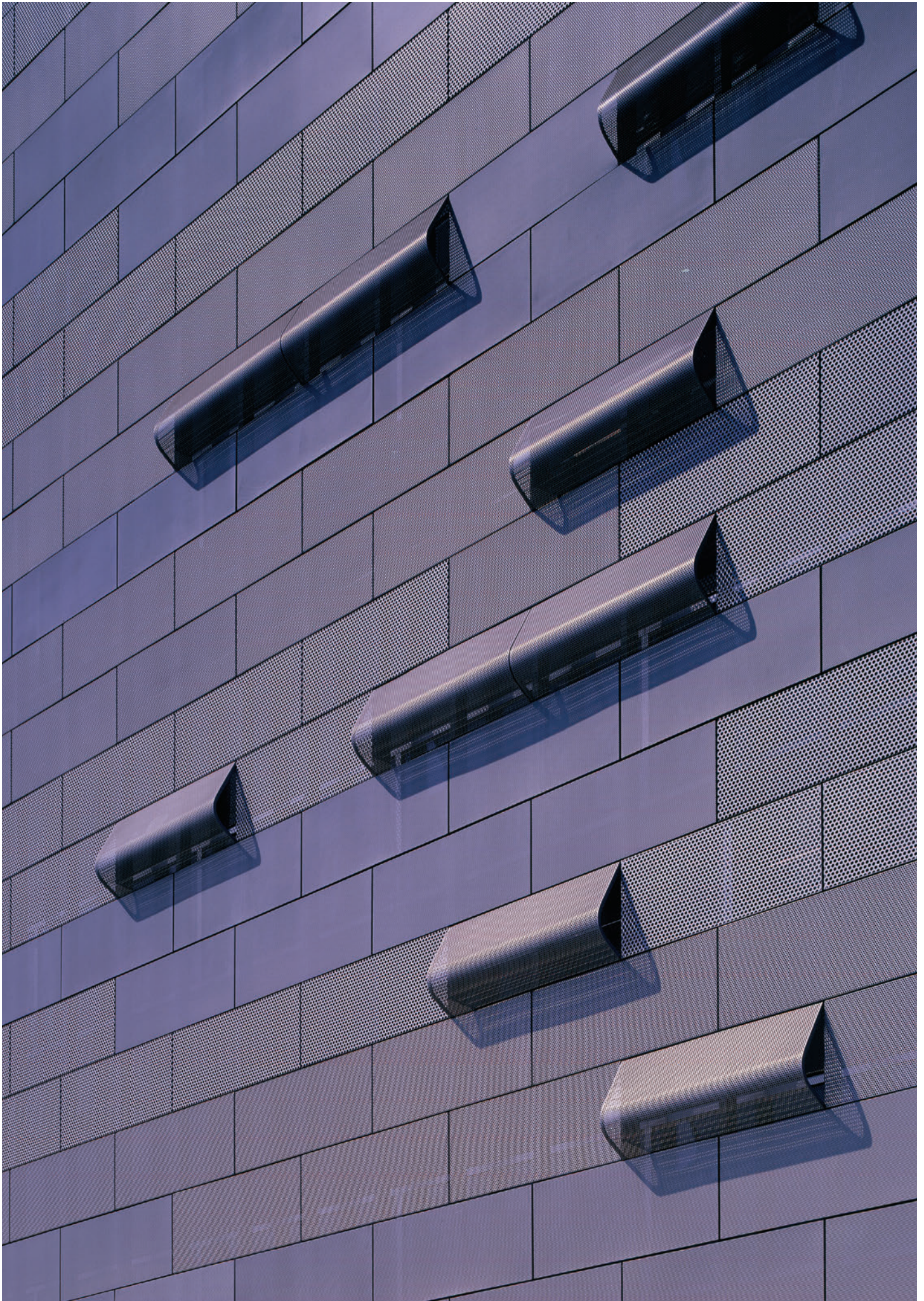

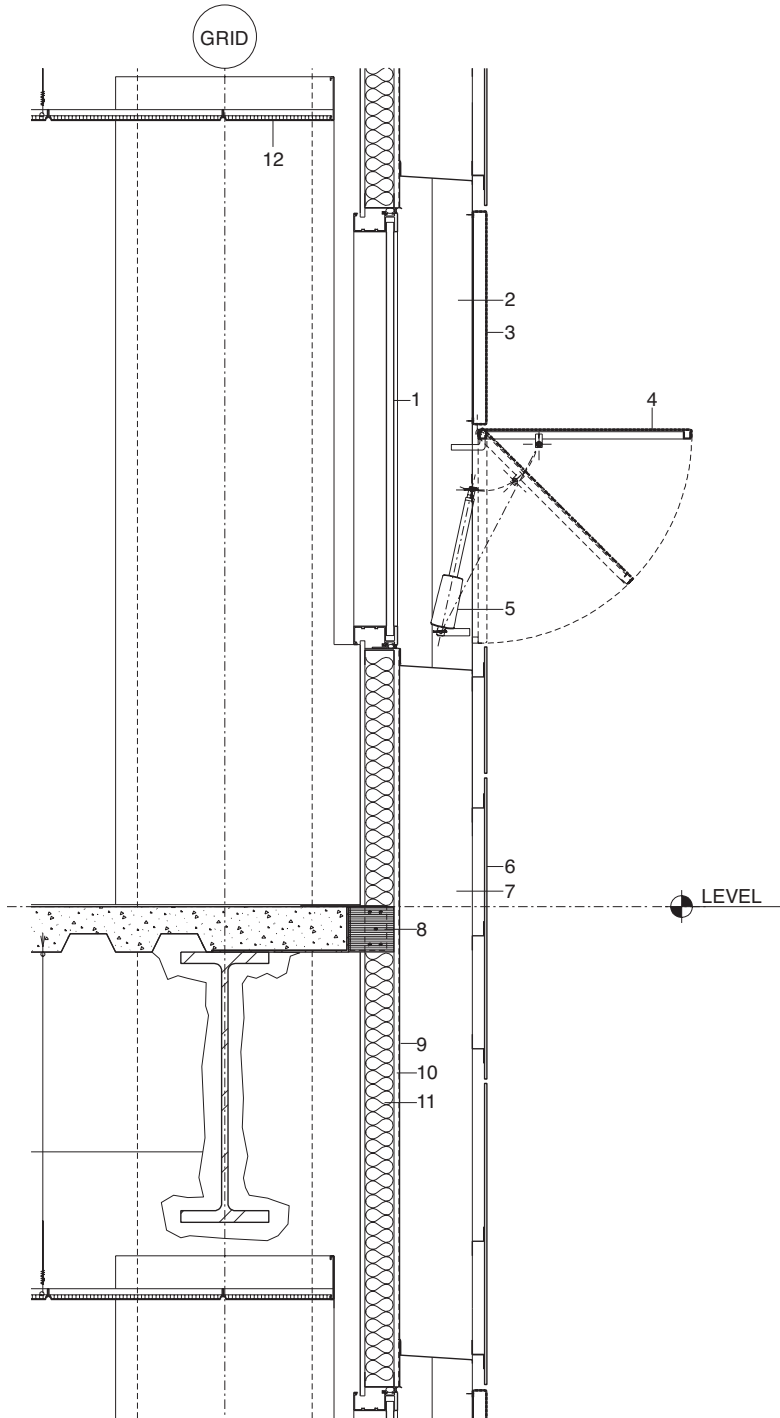

- 1 "PPG SOLARBAN 60" WINDOW SYSTEM
- 2 PERFORATED ALUMINUM PANEL SUB-STRUCTURE (PAINTED TO MATCH "SWISSPEARL")
- 3 FIXED PERFORATED ALUMINUM PANEL (PAINTED TO MATCH "SWISSPEARL")
- 4 OPERABLE PERFORATED ALUMINUM PANEL (PAINTED TO MATCH "SWISSPEARL")
- 5 PNEUMATIC ACTUATOR CONTROLLED BY BUILDING MANAGEMENT SYSTEM
- 6 "SWISSPEARL" ETERNIT PANELS
- 7 GALVANIZED, COLD FORMED METAL SUB-STRUCTURE
- 8 FIRE SAFING WITH 1/8" THICK FIRESTOP SEALANT OVER SURFACE
- 9 "SARNAFIL" MEMBRANE WITH INTEGRAL COLOR TO MATCH "SWISSPEARL"
- 10 5/8" EXTERIOR SHEATHING
- 11 BATT INSULATION WITH FRAMING AS REQUIRED
- 12 SUSPENDED ACOUSTIC TILE CEILING



CEMENT PANEL WALL SYSTEM



This page
Top: Cement panel wall system
Bottom: Operable window and sunshade

Opposite
Top: North facade, curtain wall system
Bottom: Canopy detail

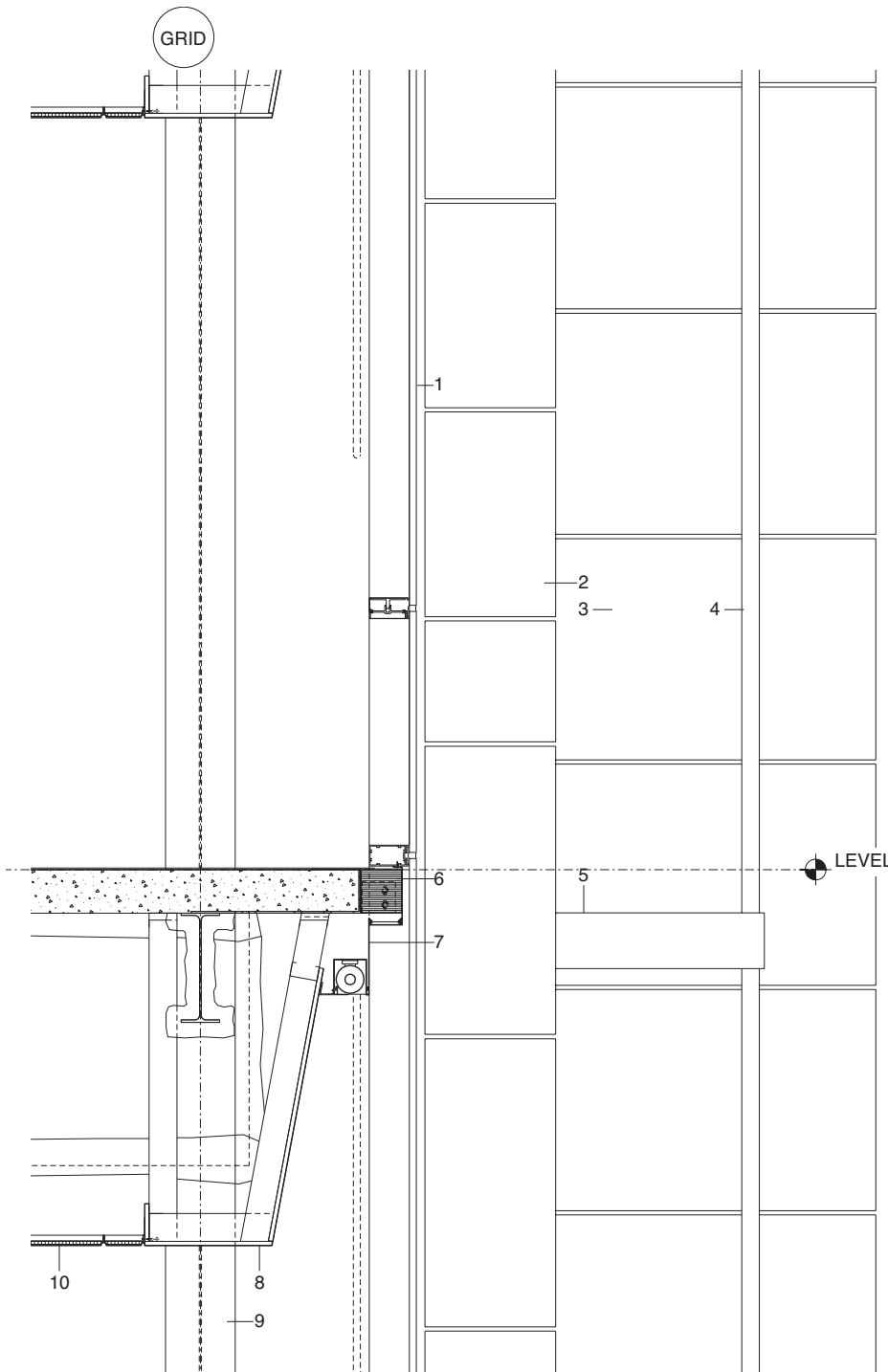

- 1 "PPG SOLARBAN 60," STRUCTURALLY GLAZED CURTAIN WALL SYSTEM
- 2 "SWISSPEARL" ETERNIT PANELS (AT END WALL BEYOND)
- 3 FIXED PERFORATED ALUMINUM PANELS BEYOND
- 4 PERFORATED ALUMINUM PANEL SUB-STRUCTURE (PAINTED TO MATCH "SWISSPEARL")
- 5 STEEL OUTRIGGER BEYOND, PROJECTING FROM CENTER OF ENDWALL TO SUPPORT PERFORATED ALUMINUM SKIN. (PAINTED TO MATCH "SWISSPEARL")
- 6 FIRE SAFING WITH 1/8" THICK FIRESTOP SEALANT OVER SURFACE
- 7 SHEET METAL, SNAP-IN CLOSURE (PAINTED TO MATCH MULLION)
- 8 5/8" GYPSUM BOARD SOFFIT (PAINTED TO MATCH MULLION)
- 9 EXPOSED STEEL COLUMN TO DAMPEN VIBRATION IN CANTILEVER (PAINTED TO MATCH MULLION)
- 10 SUSPENDED ACOUSTIC TILE CEILING



NORTH FACADE CURTAIN WALL SYSTEM



Seattle Public Library, Seattle, Washington

OMA | LMN: A Joint Venture

Office for Metropolitan Architecture (OMA), Rotterdam, Netherlands

LMN Architects, Seattle

The twelve-story 362, 987-square-foot Seattle Public Library sits on a steep urban site with a 29-foot height difference between its boundaries on Fourth and Fifth avenues. The library's distinctive exterior skin, a steel, glass, and aluminum diamond-shaped grid, began with the simple concept of wrapping the entire building in a continuous layer of transparency. This layer, with its faceted planes, outlines the elevated platforms on the exterior while creating a variety of interconnected spaces on the interior. Unifying these shifting planes of glass, a common diamond module has been utilized for the mullion framing across the entire envelope. Seemingly simple in concept, the curtain-wall glazing system is comprised of numerous components, each requiring extensive scrutiny by the design team and fabricator to function both separately and as a complete assembly. Realizing that a custom curtain-wall system would be required, the project team initiated an early bid package describing the scope and design intent of the general system. Using this delivery method, the design team, a joint venture between architect OMA and LMN, hoped to gain greater control over the system's final outcome by having technical expertise available during the design process. The bid was awarded to the German firm Seele GmbH under a design-build contract. This collaboration between architect and manufacturer helped the curtain-wall system develop from the initial design concepts into a constructible reality with little lost in translation. The team reviewed the design of the system and its components from many aspects, including aesthetics, structural capacity, thermal performance, weatherproofing, maintenance, and constructibility.

In order to understand the construction of the curtain-wall system, some understanding of the building's structural system is necessary. In general the structure is composed of both load-bearing and seismic systems. The load-bearing system, in the form of columns and beams, supports the elevated platforms containing program spaces. The seismic structure—l-beam steel arranged in latticelike geometry—connects platform to platform, providing bracing during a seismic event. While both systems exist to ensure the building's stability, they each create different conditions for the support of the curtain wall.

The predominant mullion system sloping in both an overslung (skylight) and underslung (reverse skylight) orientation became the basis for many design development studies. The final design incorporates a diamond module that marries the most efficient use of nonstandard glass panel shapes with adequate steel spanning capacity. Since it is directly supported on seismic steel, this particular system incorporates a thinner overall depth with a thickened aluminum section to allow for greater spanning ability and fewer support connections. As a result, the engineered mullion system relies on only two connection points per diamond. While adding efficiency to the curtain-wall system, the utilization of seismic steel for direct support also added much complexity. Due to its high cost, architectural grade steel could not be specified for the seismic structure; therefore, erection tolerance differences between the steel and curtain-wall system are considerable. To allow for these different tolerances, Seele developed setting blocks of various depths with hidden slots routed into them. The slots provide multiple planes of adjust-

ment, allowing holes connecting steel and aluminum to align. The mullion system's multiple components are attached using a screw-within-a-screw attachment, allowing for sequenced installation of each component while minimizing the number of connection points needed. To emphasize the component construction of the curtain-wall system, each of these stainless steel screw attachments is exposed to view.

A different mullion system had to be developed for the vertical glass facades. Unlike the sloping facades, seismic steel is not needed for structural support. For these areas the team designed a deeper aluminum mullion that would withstand lateral loading while spanning from floor to floor along a diagonal. When viewed from the exterior, the appearance of both the vertical and sloped mullion systems match. On the interior however, the deeper aluminum profile of the vertical mullion body adds sufficient strength to sustain lateral curtain-wall loads between floors. Originally designed as a rectangle profile, the mullion was later shaped to mimic the l-beam profile of the sloping seismic steel. A hollow void within the mullion section allows an aluminum splice plate to join mullions at tall facade sections. The void also provides space for aluminum plates to snap in at each floor edge, closing the gap between slab edge and glass. The vertical weight of each facet is supported from below on armatures connected back to the structure. Lateral bracing is transferred through threaded rod attachments located along the edge of each floor. The threaded rods provide tolerance adjustment and are sized to flex when responding to thermal movement of the curtain-wall system.

Opposite

Top: Fourth and Madison

Bottom: Entry passage



This page

Bottom: Unfolded elevation diagram (Darker diamonds indicate mechanical louvers); Fourth Avenue elevation (right)

Opposite

**Top: Third floor plan
Bottom: Living room**

Integral to the design development of the curtain wall was the envelope's thermal performance. Except for the roof, louvers, and exposed concrete foundation walls, the exterior envelope is comprised entirely of vision glass. This posed a considerable challenge to the design team given the current energy codes and the level of thermal performance the curtain-wall system would be required to achieve. The entire envelope, including all of its component parts, was included in the energy calculations. To help meet the required performance level, approximately half of the insulated glazing panels were fabricated with airspaces containing krypton gas and newly developed high performance low-E coatings. In addition, to combat increased solar heat gain experienced during the summer months, an aluminum expanded metal mesh interlayer was chosen for the glass panels receiving the most sun. The mesh's mini louvers provide shielding of direct sun as well as views

to the exterior through the mesh. Ideal for shading, the microdiamond pattern of the metal mesh also mimics the larger diamond pattern of the curtain-wall mullions. Originally envisioned as laminated between sheets of glass, the metal mesh floats within a 2-millimeter airspace in the final design. Clear low-iron glass is used in front of the mesh to brighten its appearance when viewed from the exterior.

To waterproof the building in Seattle's rainy climate, Seele designed three levels of defense into the system: the exterior aluminum mullion cap with premolded silicone gaskets; insulated glazing panels with flexible butyl tape applied along every joint between panels; and silicone gaskets molded to fit the interior surface of the mullion body. While the mullion cap, seals, and glass keep most of the water from entering the system, the next two layers channel any remaining moisture to weep holes along the lower edge of each facade. Even standing

water caught at the lower vertex of each diamond is addressed by tooling a slight ramp in the sealant joints of adjacent mullions allowing for the water's release. To verify these measures actually worked as designed, a portion of the building was built as a full-scale mock-up and forced to undergo extreme weather testing in controlled conditions.

The complicated geometry of the facade facets, including four that are nonplanar, meant increased scrutiny where adjacent surfaces meet to form a seam. Insulated aluminum closure panels were designed to transition across each seam while maintaining angle alignment with the adjacent planes of glass. Because the geometry for each facet needed to be precise, the position of the seismic steel was adjusted to the curtain wall's position in order to guarantee tight-fitting seams. A typical process would have the steel located first with the curtain wall layered over it. Each of the building's four

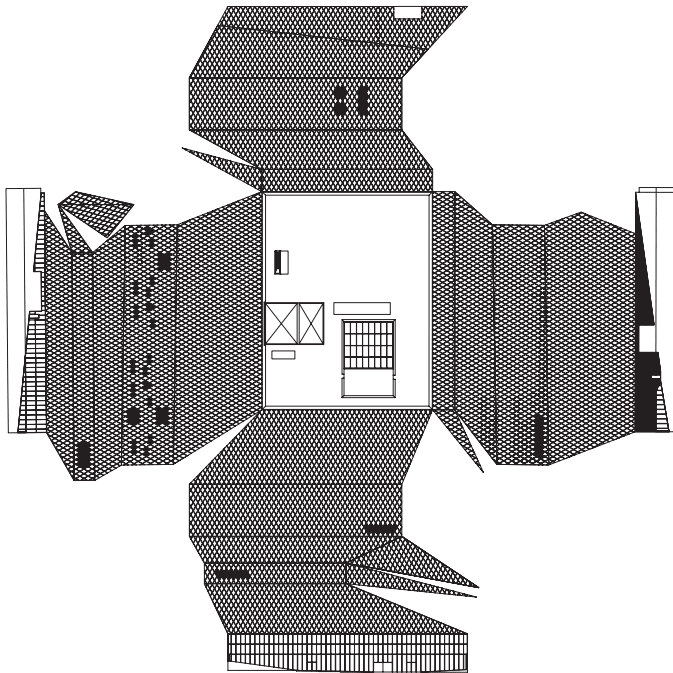

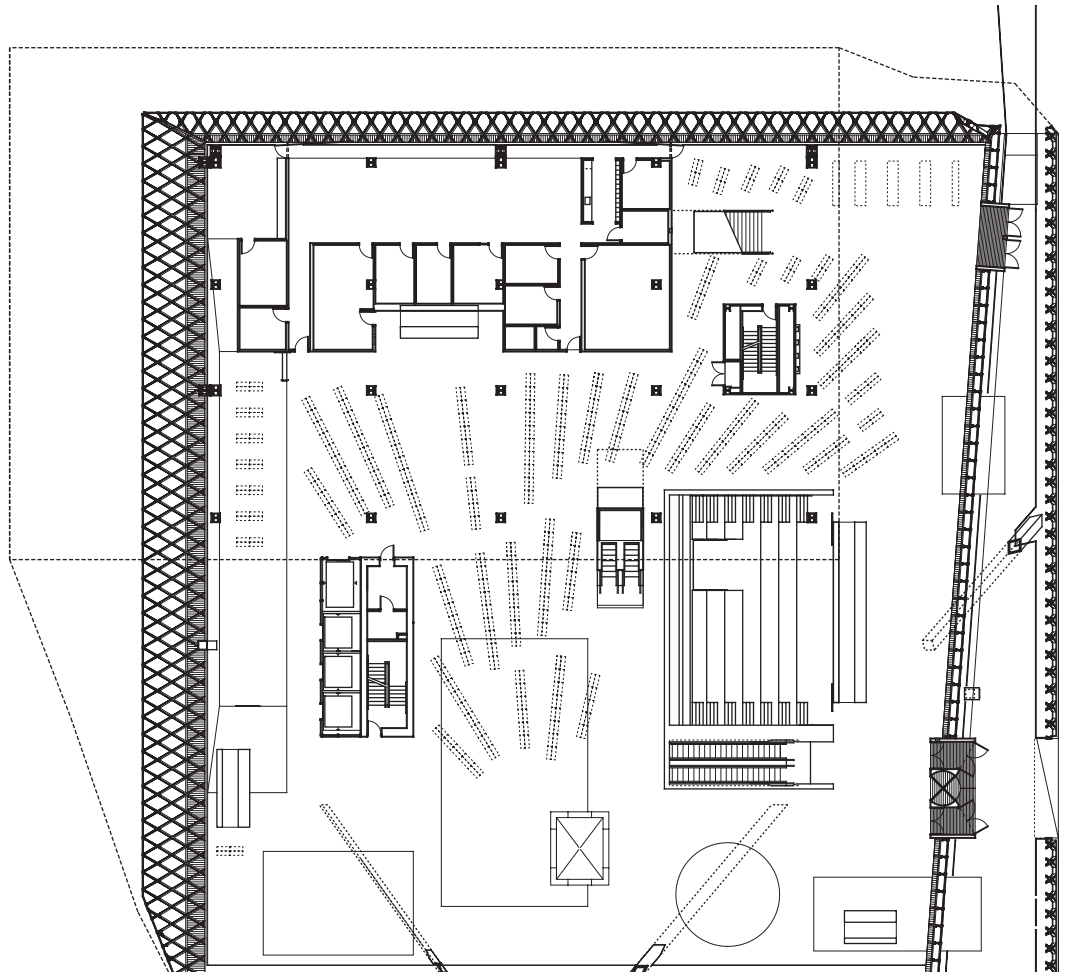

general street elevations has a diamond module continuous from top to bottom, bending at each horizontal seam; because of differing geometries, the diamond module is not contiguous around corners. This creates four vertical corner conditions, one at each elevation's edge. Corner panels having an inward profile accentuate the discontinuity of the diamond pattern. All other panels have an in-plane alignment from facet to facet where diamond patterns align. This geometry was tracked throughout the course of the project by use of an unfolded elevation diagram depicting the best overall view of the curtain wall's complexity.

Special attention was given to facets where water collection and snow retention were causes for concern. Gutters sized for the required capacity were incorporated as a thin trough across the lower edge of each facet. Since horizontal joints allowing for thermal movement could not be incorporated into the mullion's diamond pattern,

expansion space was provided at the leading edge of each gutter. Three stainless steel snow fences, 1/4 inch thick, are located in the gutter openings where necessary. Used to prevent snow and ice from sliding off the building's sloped surfaces, the fences are shaped to appear as if unfolded out of the adjacent gutter void. Steel armatures that penetrate the gutter's waterproofing layer and connect back to the structural steel support each fence.

To clean the expanses of exterior glass, a process inspired by mountain climbing is used. Traditional outriggers at the roof of the building allow window washers to descend each elevation from top to bottom on bosun chairs. While the skylight and vertical facades are scaled more easily, the underslung surfaces require additional measures to reach the glass. Stainless-steel eyebolts, which protrude through the mullion body and cap, are spaced at close intervals. Each eyebolt is attached back to seismic steel

members, providing load-carrying capacity. Window washers use carabiners to connect to these eyebolts in order to pull themselves within reach of the glass. These same eyebolts can also be utilized to support small work platforms should it be necessary to replace any underslung glass panels.

Fabricated entirely in Germany and shipped overseas to Seattle for installation, the library's curtain-wall system made a long journey both physically and metaphorically. From sketches to shop drawings, the collaborative design and engineering effort produced a working envelope that fulfills stringent functional requirements while still expressing its earliest conceptual intentions.

*Text contributed by Steve DeFraino,
LMN Architects*



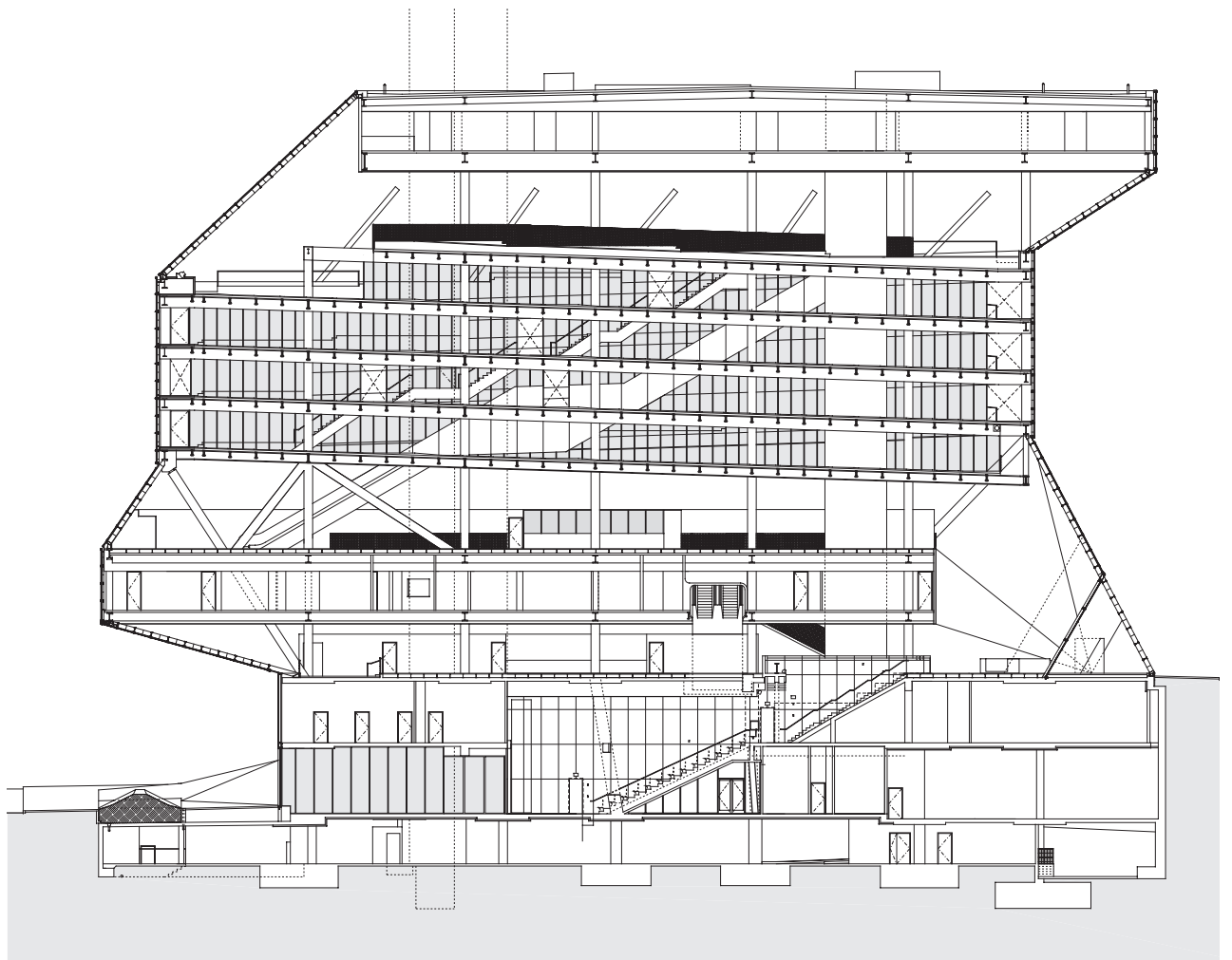
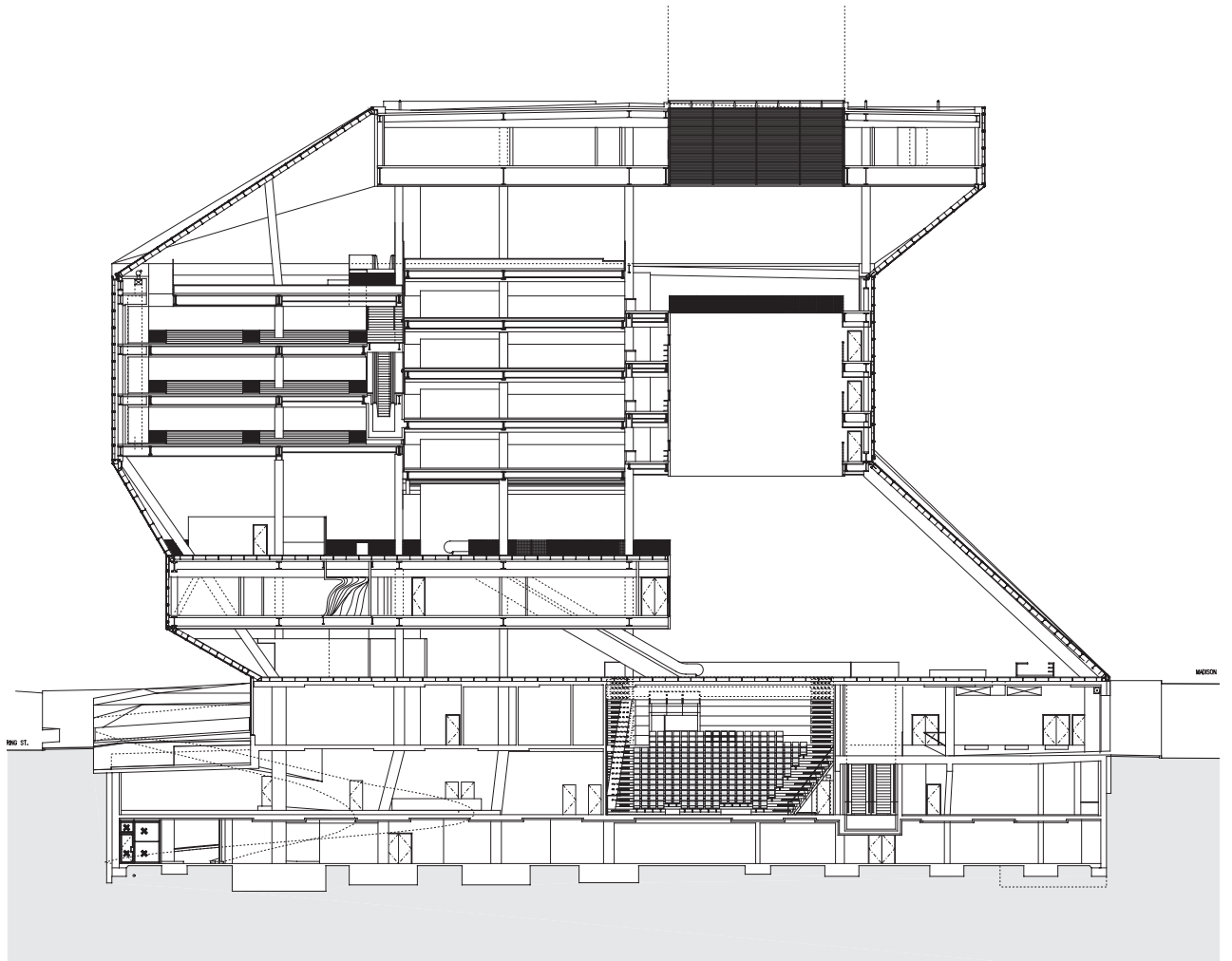

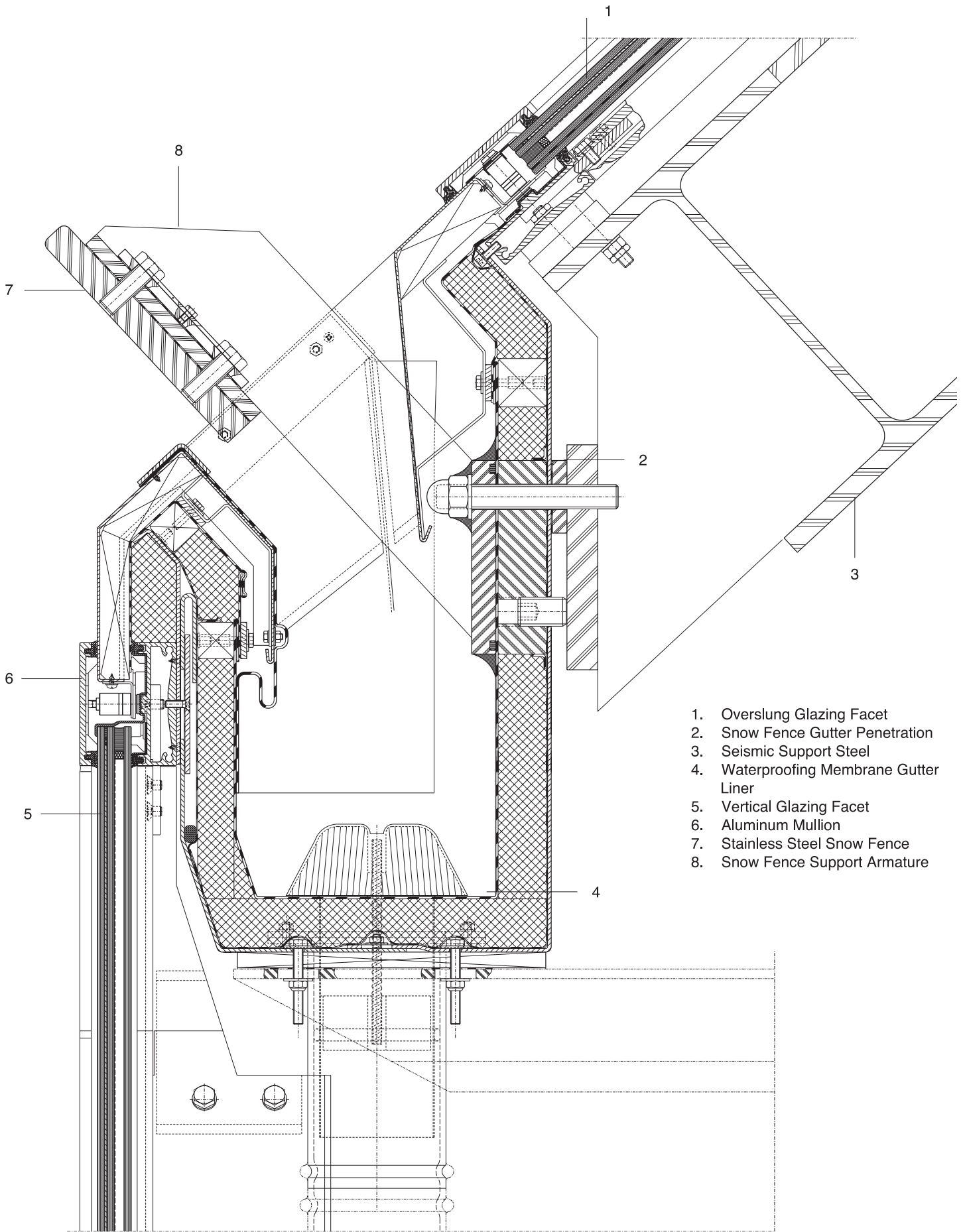

1. Overslung Glazing Facet
2. Snow Fence Gutter Penetration
3. Seismic Support Steel
4. Waterproofing Membrane Gutter Liner
5. Vertical Glazing Facet
6. Aluminum Mullion
7. Stainless Steel Snow Fence
8. Snow Fence Support Armature

Opposite
Gutter and snow fence detail

This page
Exterior wall section

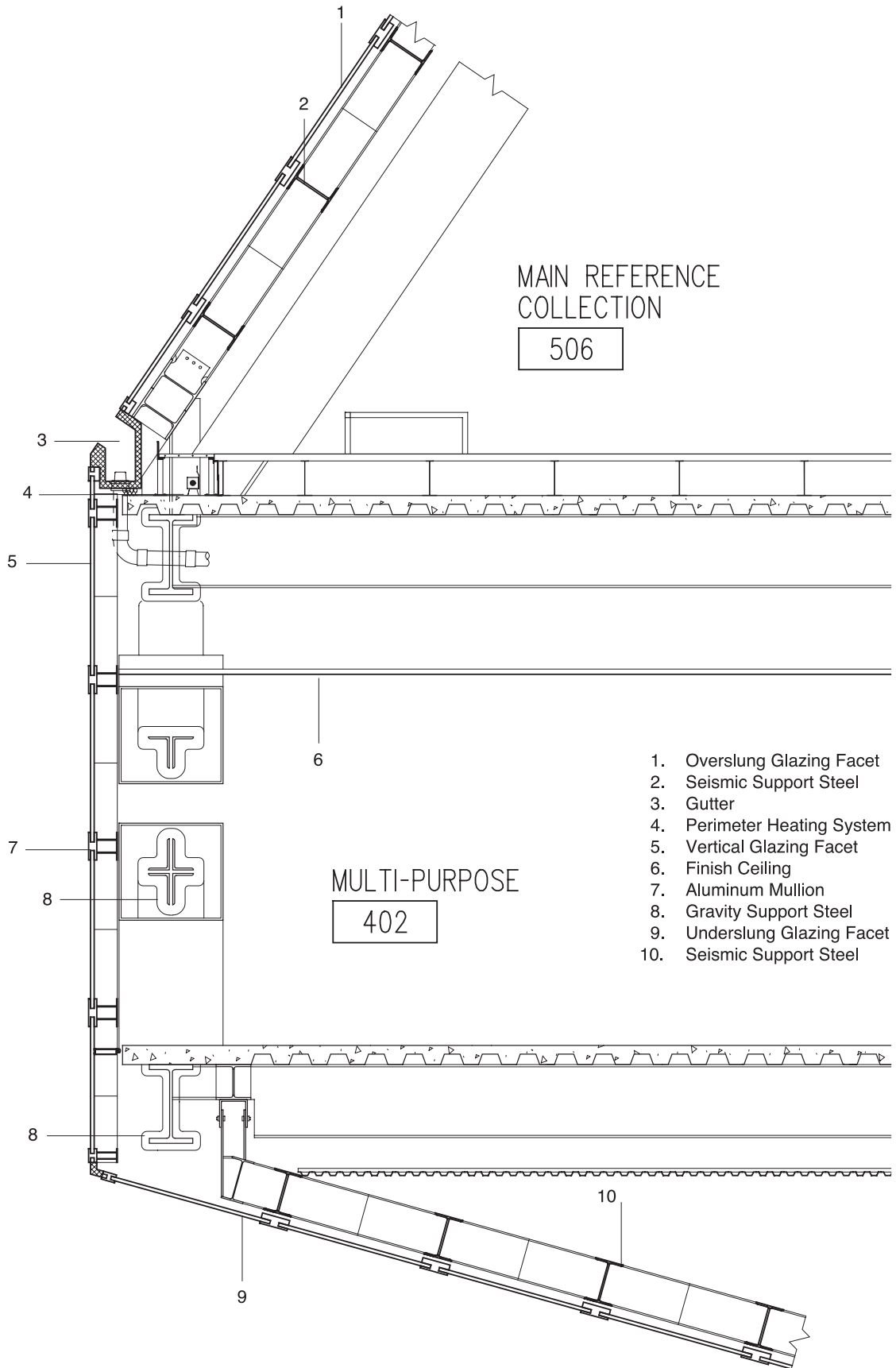

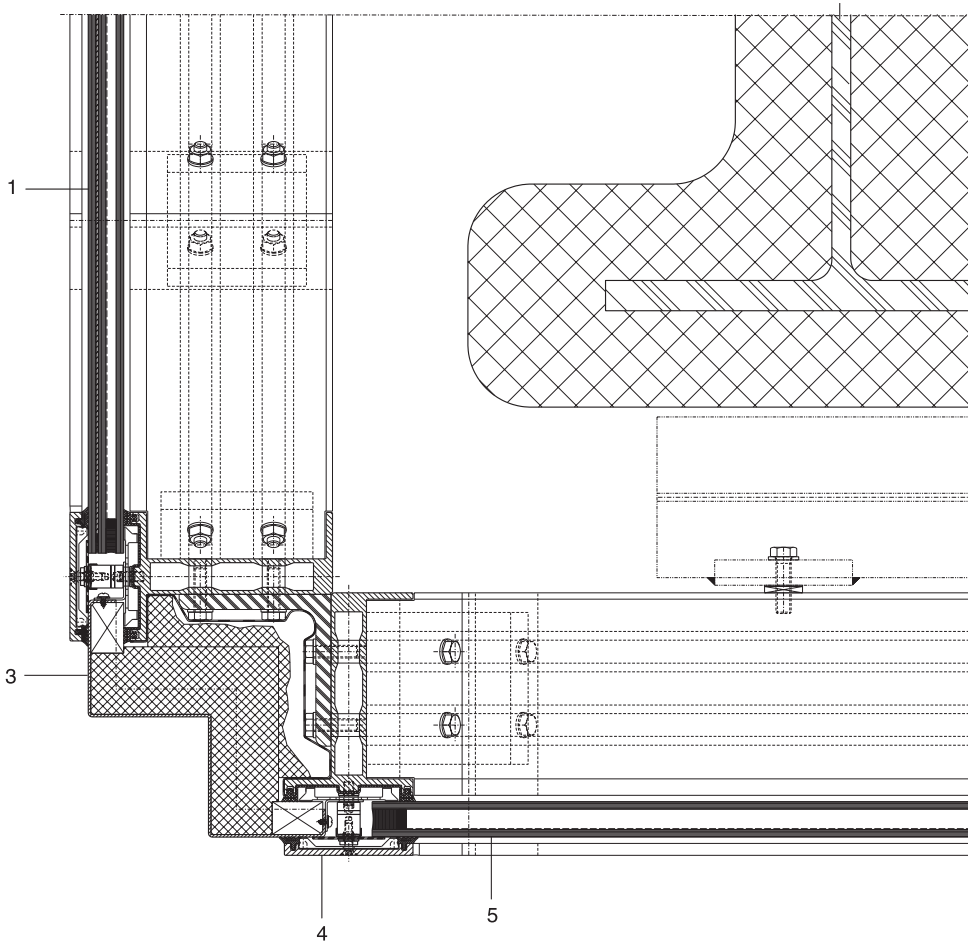

1. Expanded Metal Mesh Glazing at Vertical Facet
2. Gravity Support Steel
3. Insulated Aluminum Panel at Corner Condition
4. Aluminum Mullion at Vertical Facet
5. Vision Glass at Vertical Facet

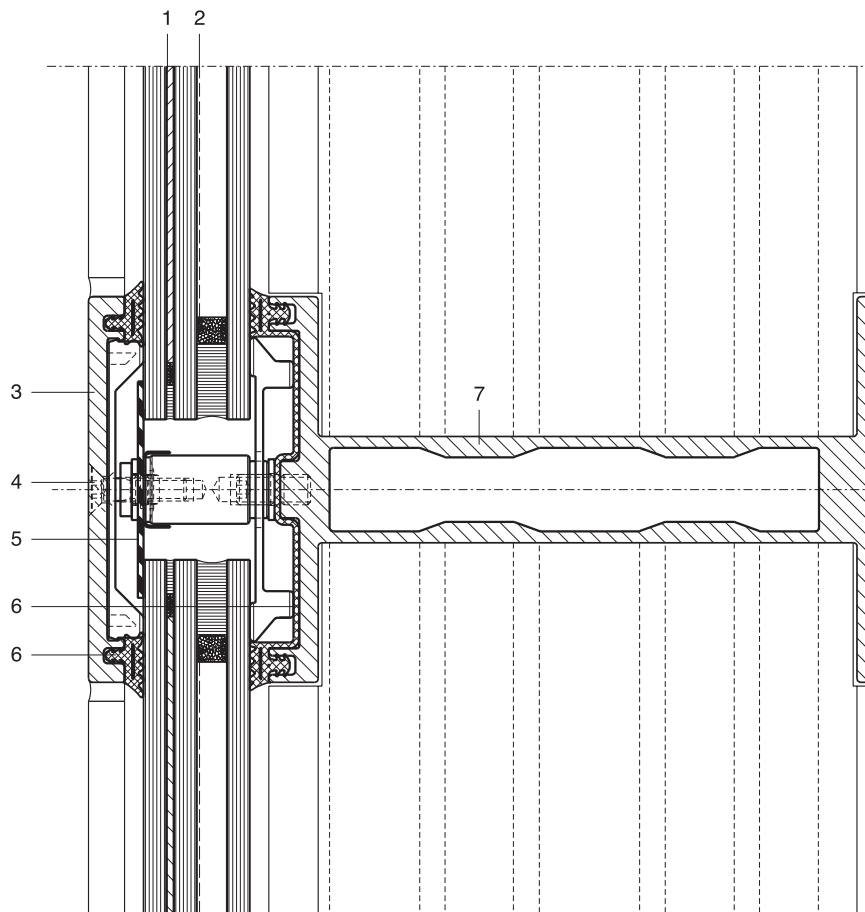

1. Expanded Metal Mesh Between 2 Layers of Glass
2. Low-E Coating
3. Aluminum Mullion Cap
4. Exposed Cap Fastener
5. Flexible Butyl Tape
6. Molded Silicone Gaskets
7. Deep Aluminum Mullion with Interior Void

Opposite

Top: Vertical corner detail

Bottom: Vertical mullion detail

This page

Top: Eyebolt section (left),
eyebolt elevation

Bottom: Fifth Avenue elevation

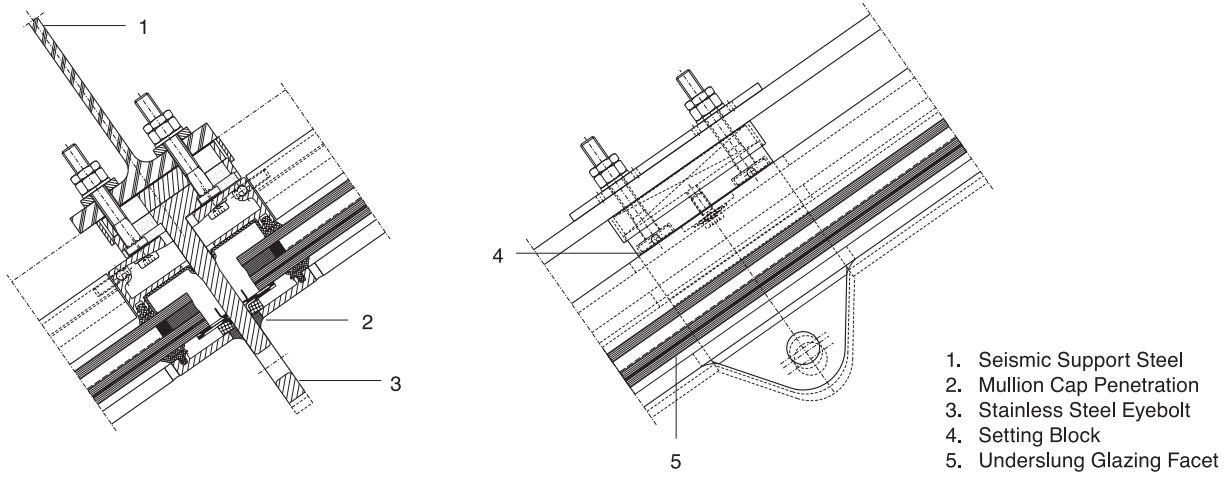

This page

Top left: Typical seam panel corner

Bottom left: Typical seam panel non-corner

Upper right: Curtain wall seismic grid module

Lower right: Middle panel has metal mesh interlayer

Opposite

Top: Typical sloping mullion

Bottom: Living room, curtain wall fills void between platforms

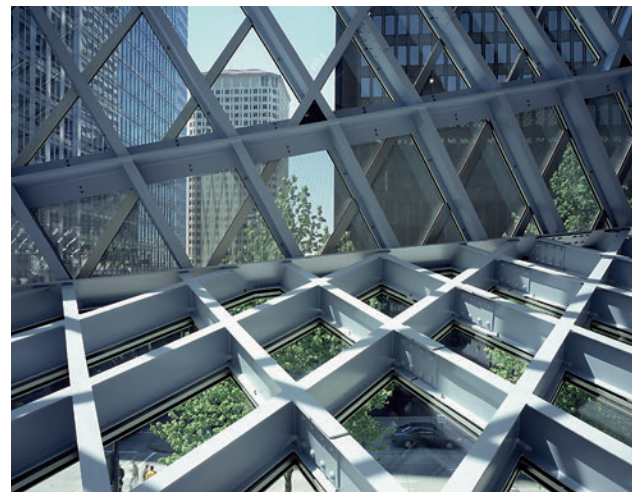
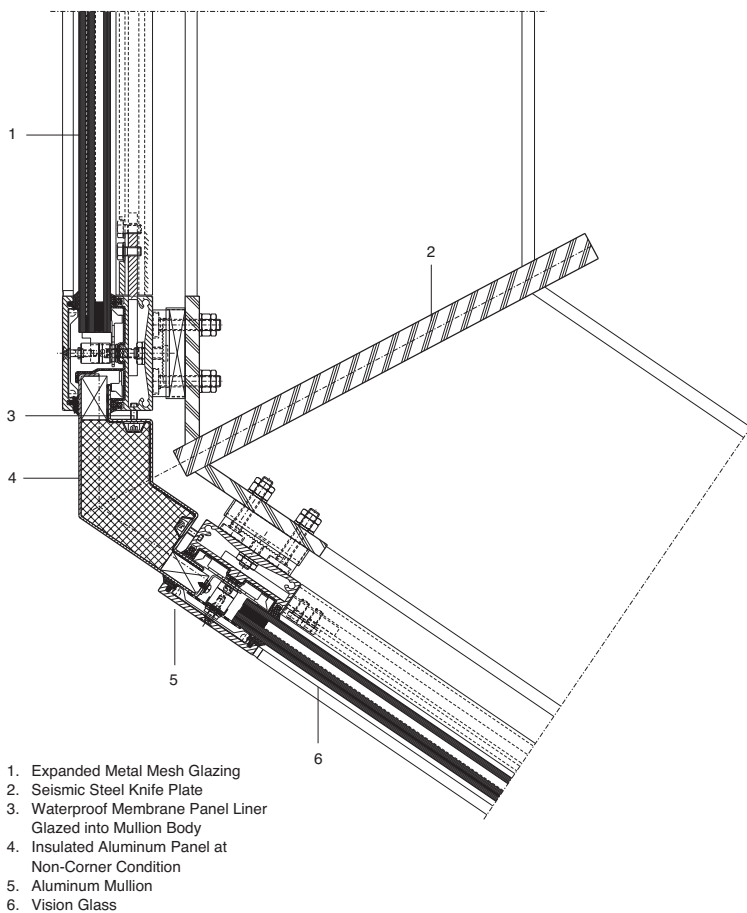
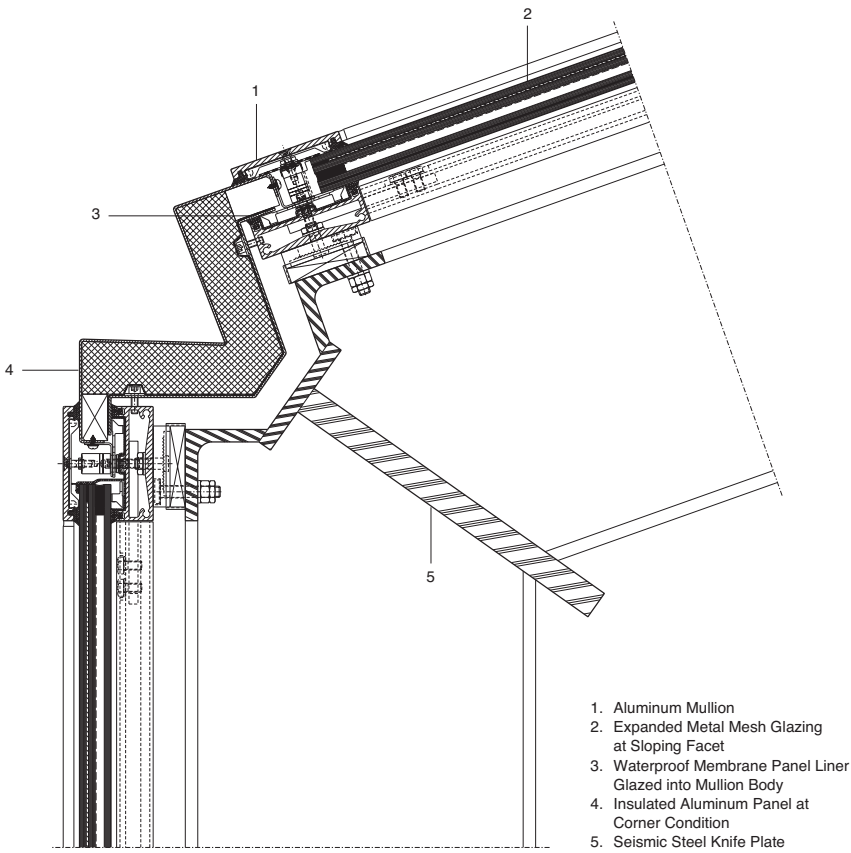

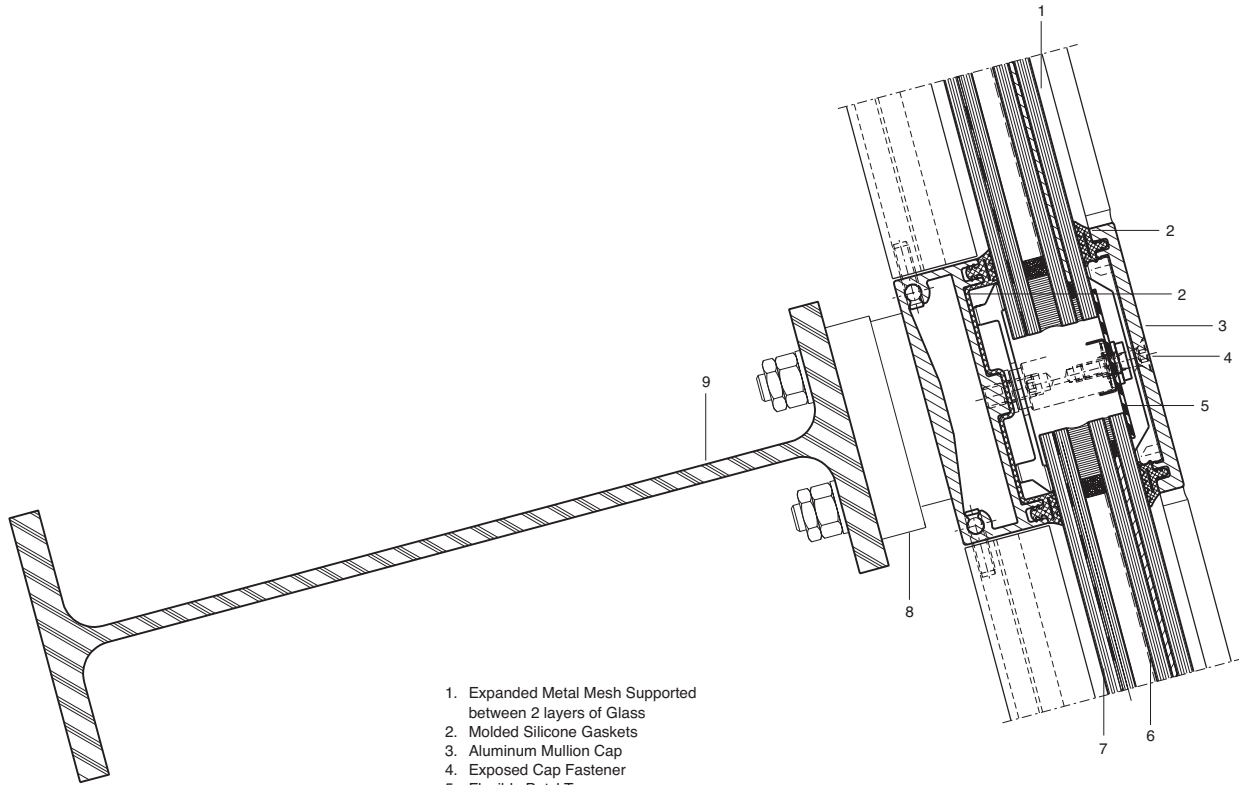

1. Expanded Metal Mesh Supported between 2 layers of Glass
2. Molded Silicone Gaskets
3. Aluminum Mullion Cap
4. Exposed Cap Fastener
5. Flexible Butyl Tape
6. Low-E Coating
7. Laminated Safety Glazing at Overslung Condition
8. Seismic Support Steel
9. Setting Block

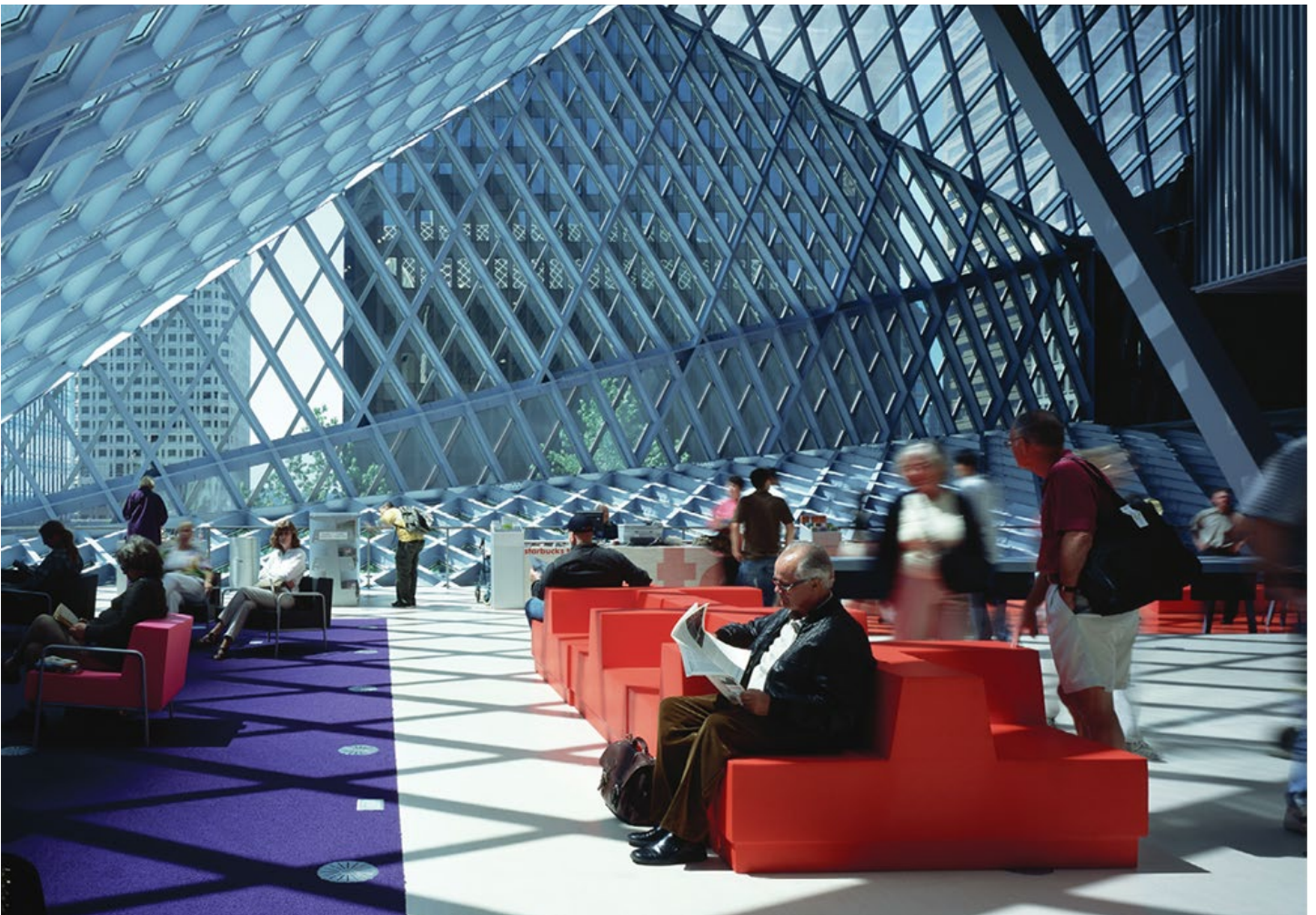

Delta Shelter, Mazama, Washington

Olson Sundberg Kundig Allen Architects,
Seattle, Washington

Set on a slight rise within a one-hundred-year flood plain in an alpine river valley, this 1,000-square-foot cabin, a 20-foot-square in plan, is essentially a steel-clad box on stilts that can be completely shuttered when the owner is away. Conceived as a low-tech, virtually indestructible weekend house, the cabin is raised above the ground to minimize potential flood damage and to take in 360-degree views of the surrounding forest and mountains. The cabin is composed of three levels: the lowest level is half carport, half utility and storage room; the middle level consists of the entry, the master bedroom, a small guestroom, and one and a half bathrooms; the top level is one large space that includes living, dining, and cooking areas. Cantilevered steel decks extend from the top and middle levels and provide space for outdoor sleeping and entertaining.

With substantial portions of the cabin prefabricated offsite—steel structure, roof, shutters, and stairs—the basic frame of the house was quickly constructed. The cabin is supported by four steel columns. Floors are 3-by-6-inch tongue-and-groove wood car decking; exterior wood infill walls are clad in 16-gauge hot-rolled steel sheets with exposed steel fasteners. One half of each exterior facade is glazed, the other half is clad in steel. All four 10-by-18-foot steel shutters can be opened and closed simultaneously by using a crank that moves the shutters over the glazed portions of each facade. The shutters are operated by a series of mechanical devices including a hand wheel, drive shafts, u-joints, spur gears, and cables.

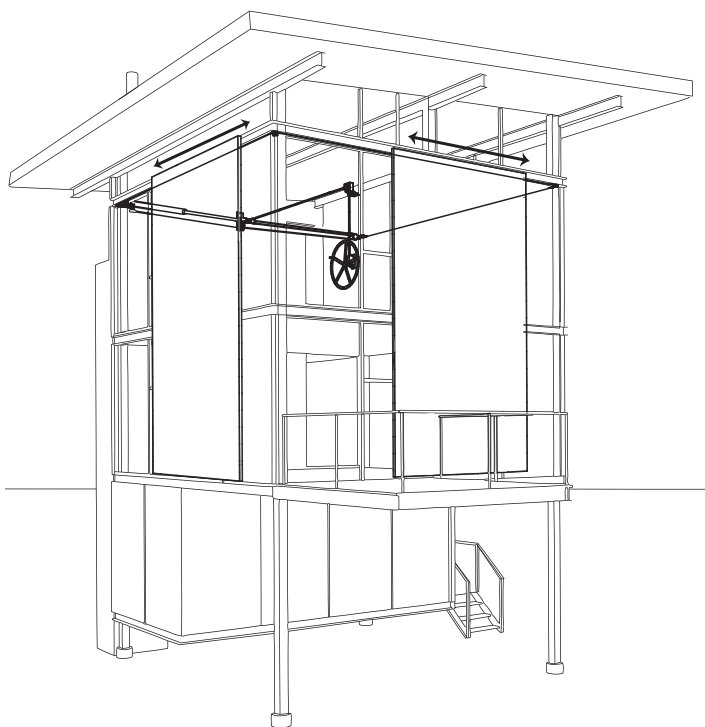

This page
Exterior perspective

Opposite
Shutters open



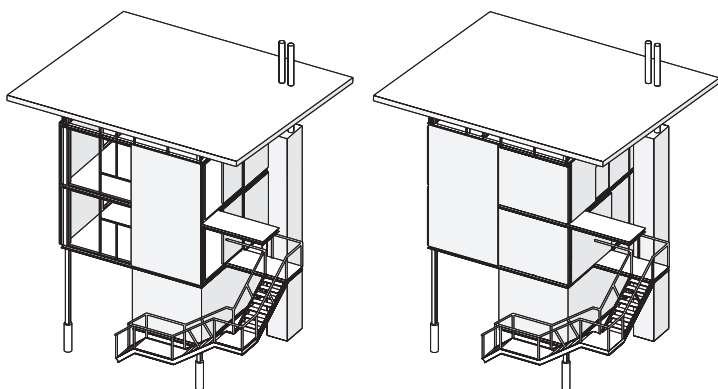
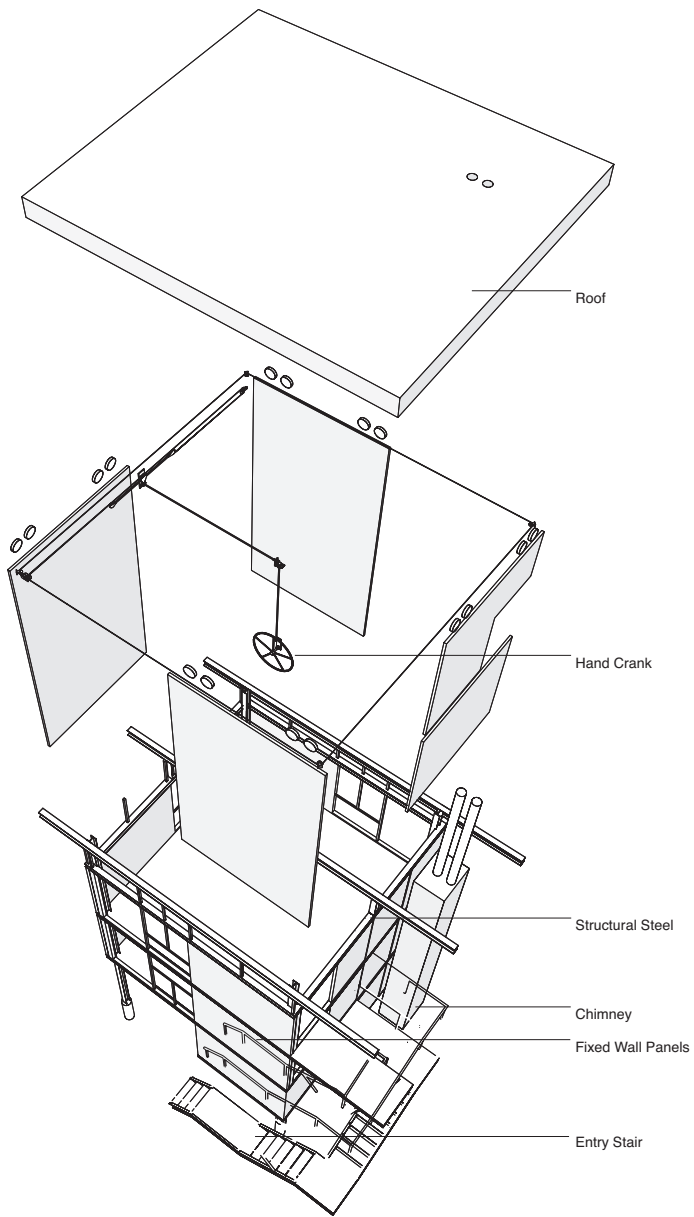

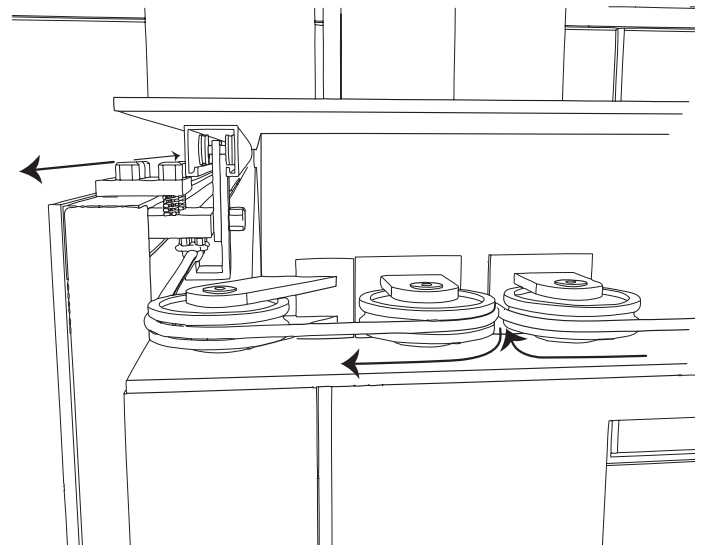
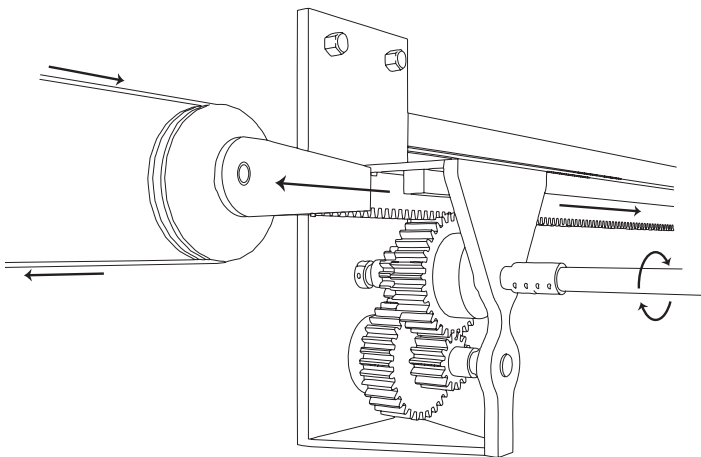
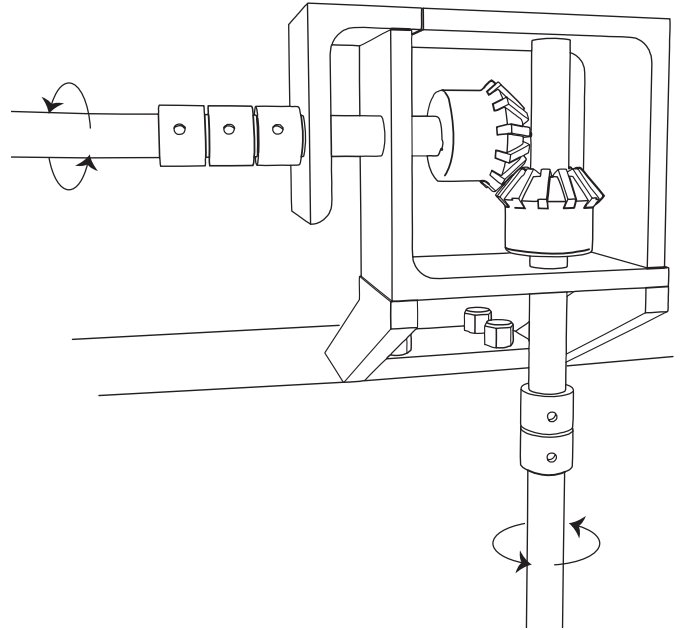
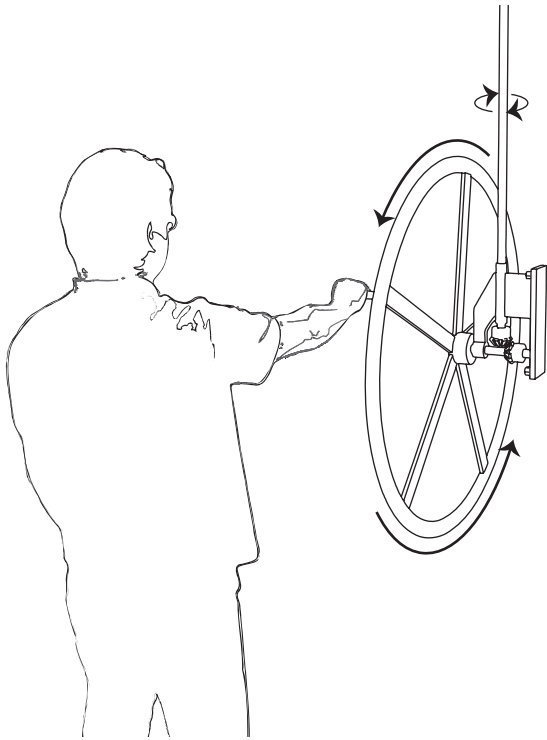

Opposite
**Top: Exploded view (left),
 wheel detail**
**Bottom: Shutters open and
 closed (left), shutters closed**

This page
**Top: Hand wheel (left) and
 shutter mechanism**
**Middle: Gear rack (left)
 and U-joint**
Bottom: Gears



GKD-USA, Inc. Headquarters Building, Cambridge, Maryland

Dominique Perrault Architecture, Paris, France

Executive Architect: Ziger/Snead LLP, Architects, Baltimore, Maryland

GKD Gebrüder Kufferath AG is a leading German weaving mill, supplying many types of woven metals and plastics for technically demanding applications: finely woven mesh for the filtration industry, process conveyor belting for the food industry, and decorative and functional metal fabrics for architectural applications. GKD metal fabrics are produced in various weights, textures, and degrees of transparency and flexibility. The fabrics are subdivided into product families focused on single elements in different densities, some of which have the light and flexible qualities of cables; others are characterized by the rigidity, mass, and durability of the rods; and hybrids possessing the elements and qualities of both types to varying degrees. The cables create flexibility lengthwise and the rods stability crosswise so that the material can be easily tensioned in one direction while remaining

stiff in the other direction. The meshes are fabricated in widths up to 25 feet and in lengths limited only by the weight of the material itself. GKD fabrics are manufactured with noncorroding, high-grade AISI Type 316 stainless steel, so little or no maintenance is required; alternative types of stainless steel are sometimes chosen for specific environments.

The new GKD-USA building includes a showroom, offices, and facilities for the production of woven meshes and metal fabrics. On a flat site in a suburban industrial park, the project consists of approximately 40,000 square feet and includes a double-height sky-lit manufacturing hall, flanked on the north and east sides by two levels of offices for administration and technical support staff. The entire volume is wrapped in reflective metal sheeting, allowing the factory to blend into its environment. Fifteen feet

beyond the face of the building, a 30-foot-tall freestanding woven metal mesh screen has been placed in the landscape. Located along the main access road, it partially screens the adjacent buildings from the offices while acting as a linear billboard to advertise the presence GKD and its metal mesh products. The remaining administrative spaces are located on the second level along the eastern facade where sliding mesh screens, which can be controlled individually by those inside, provide shade and animate the facade.

The showroom illustrates the aesthetics, functionality, and versatility of woven metal architectural design fabrics. The detailing and selection of materials is intended to reflect the qualities for which GKD's products are noted—durability, efficiency, and craftsmanship—as well as their visual and functional properties—reflectivity,

This page

Sections

Opposite

Top: Northwest corner

Bottom: Entrance

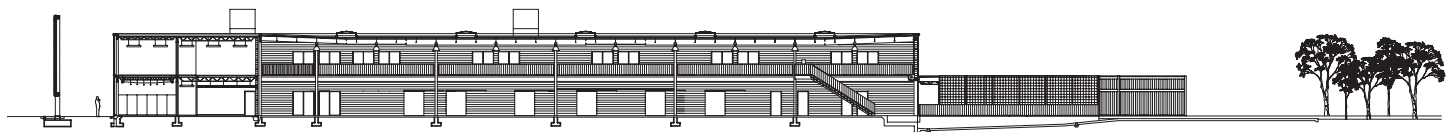
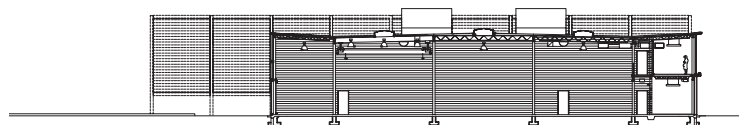
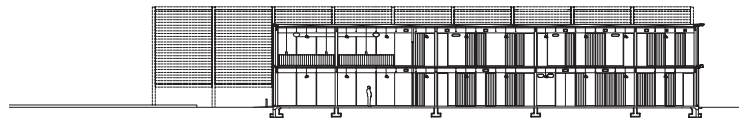



transparency, density, flexibility, and permeability to light and air. The taut, lean form of the building recalls the classic American industrial shed, transformed by applications of GKD metal fabric inside and outside to create a showcase for the company's products. The 150-foot-long wire mesh facade is an example of the design potential of the woven stainless steel fabric. The light bouncing off Chesapeake Bay is constantly in flux, and the surfaces of the building reflect the changing light so that its appearance changes according to the time of day, the weather, and even the season. Light bouncing off the wire mesh produces novel prismatic effects and, depending on the viewing angle, works to reveal or obscure the building behind it. There are movable sunscreen panels on the windows, suspended ceilings made of wire mesh, and stainless steel mesh floor coverings.

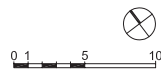
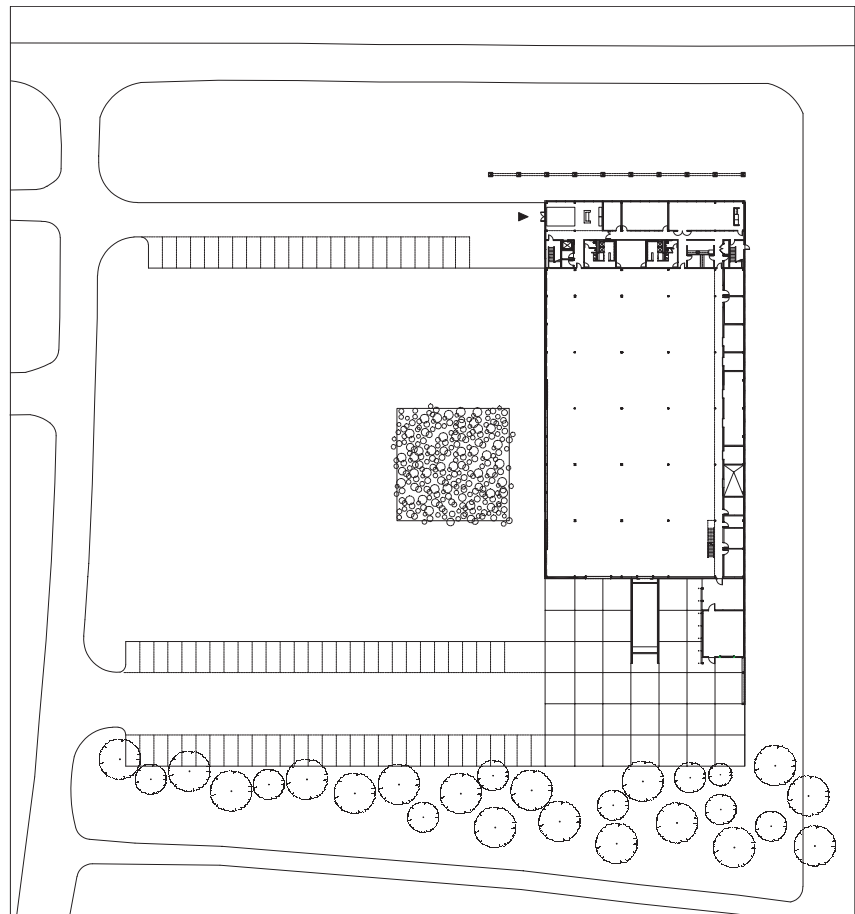

This page
Top: Site plan
Bottom: North elevation

Opposite
Manufacturing hall



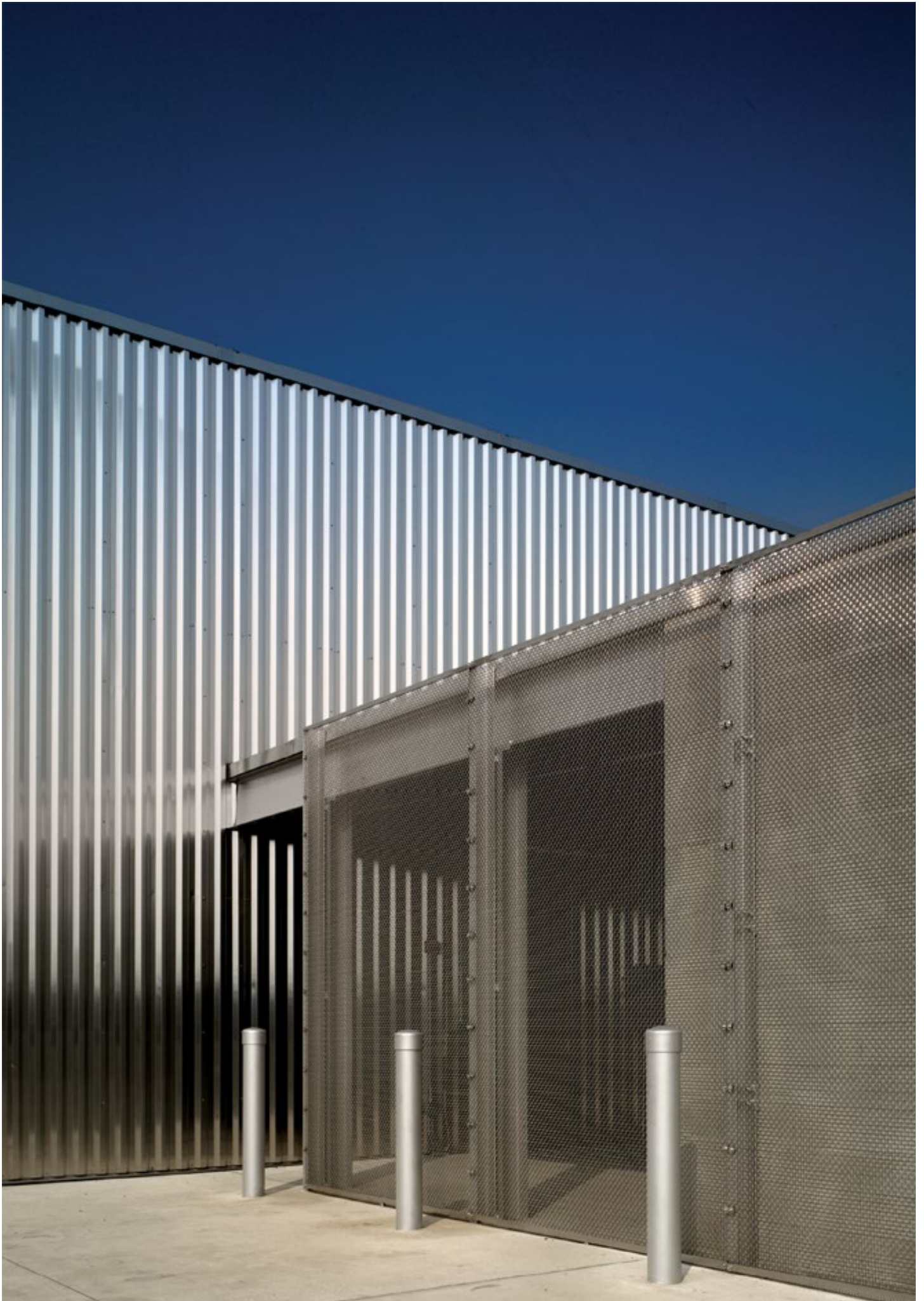

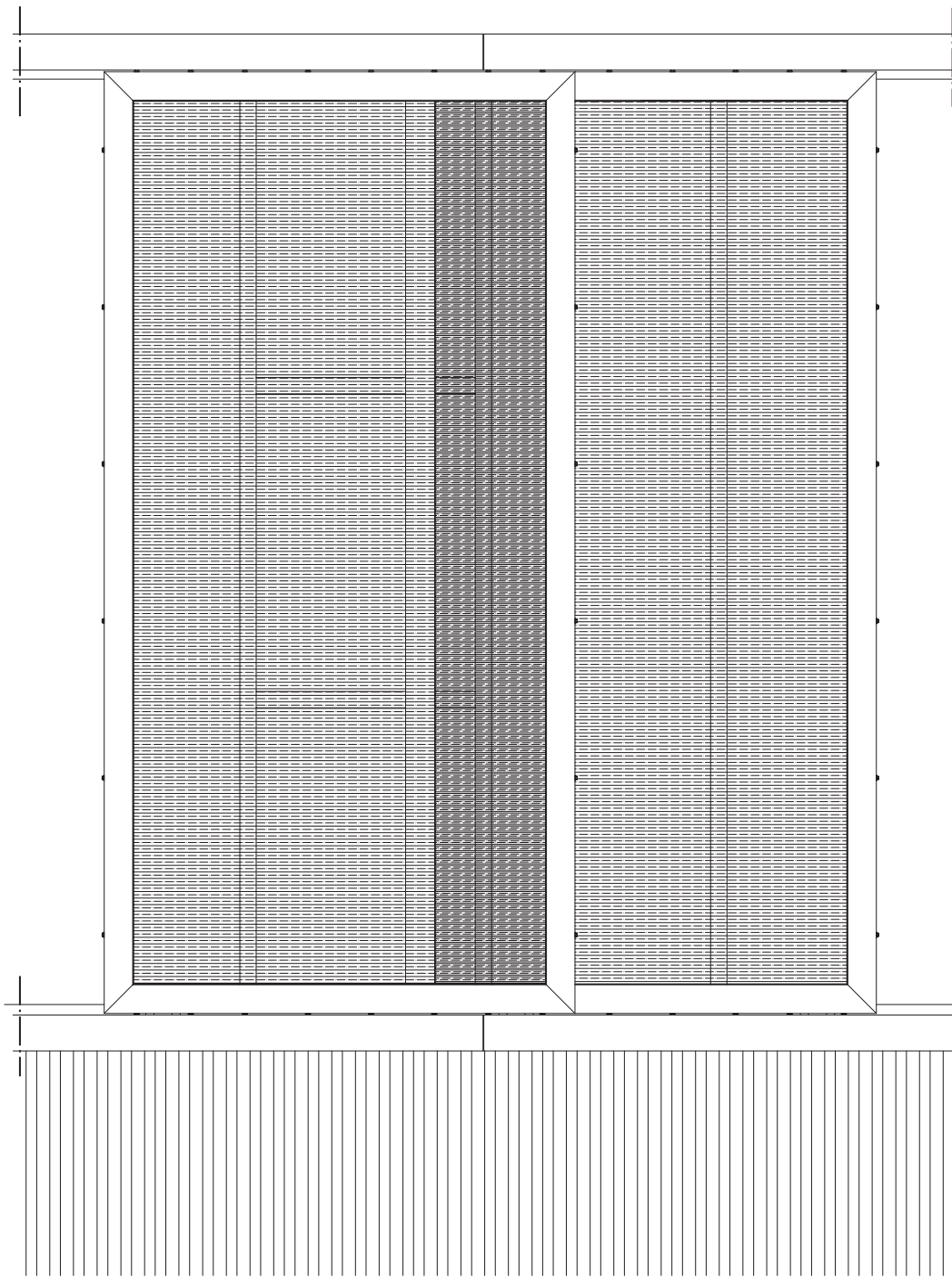

Opposite

Top: East screen elevation

Bottom: Northeast corner

This page

Top: East screen detail

**Bottom: Northeast corner (left),
east elevation detail**

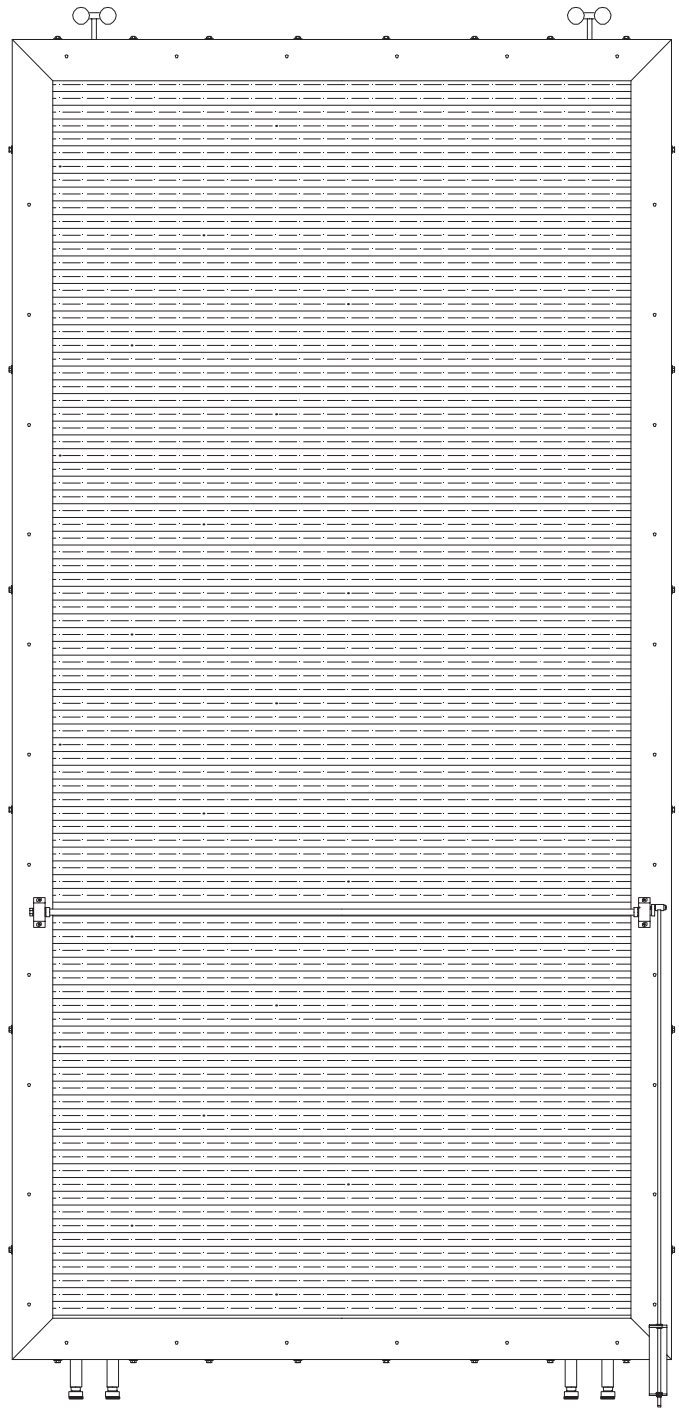

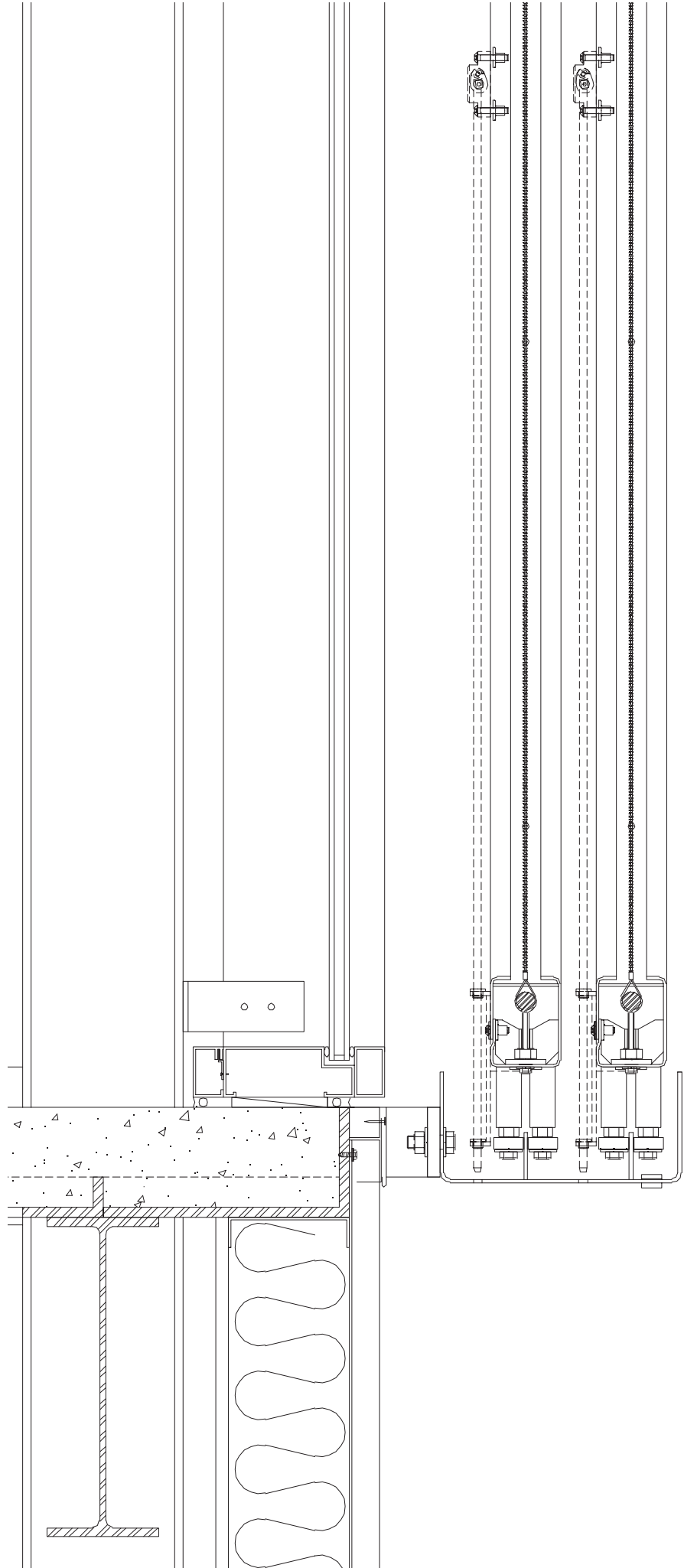
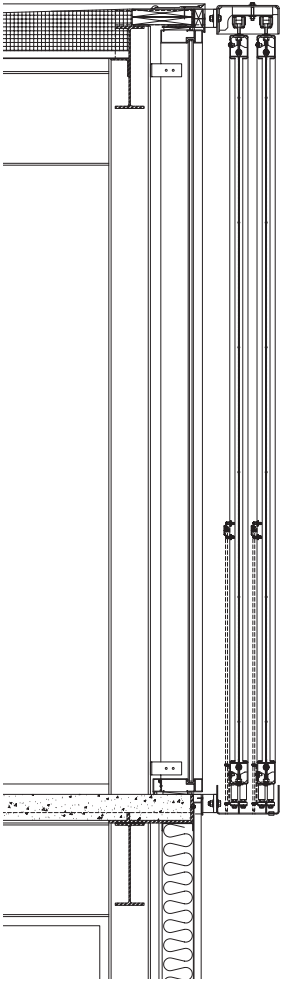

Opposite

Left: East screen section

Right: North screen inside

This page

Top: East screen, inside detail

Bottom: Lobby (left), northeast corner

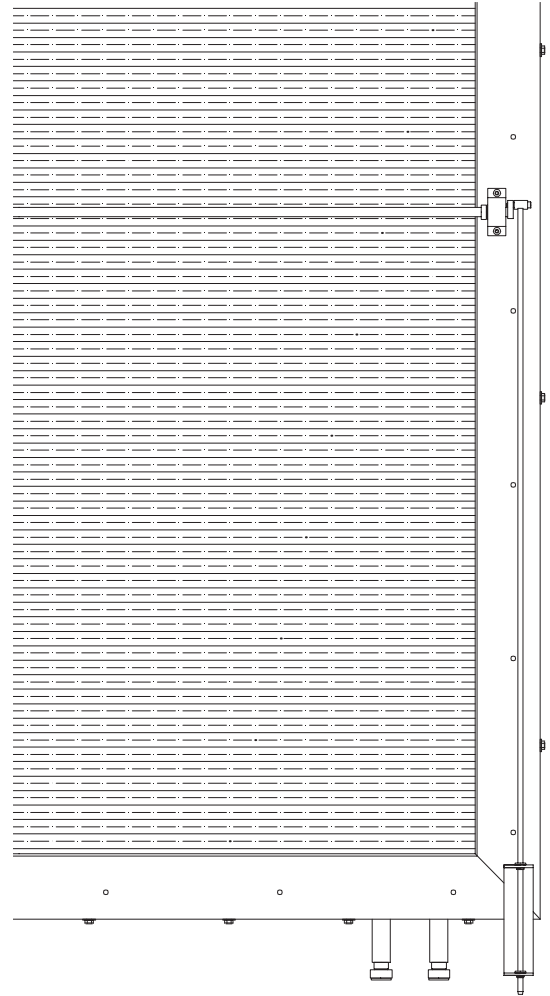

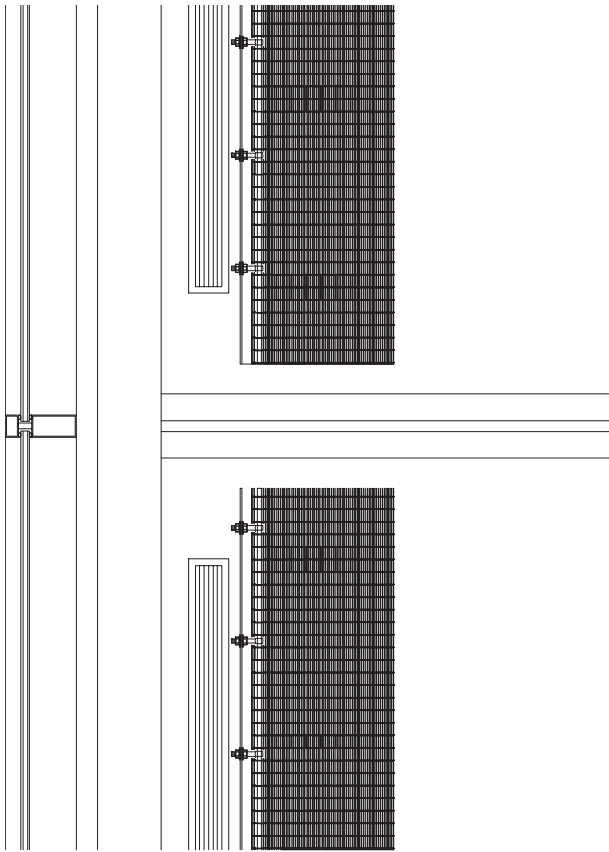

Horizontal Section
(Looking Up)
at Conference Room

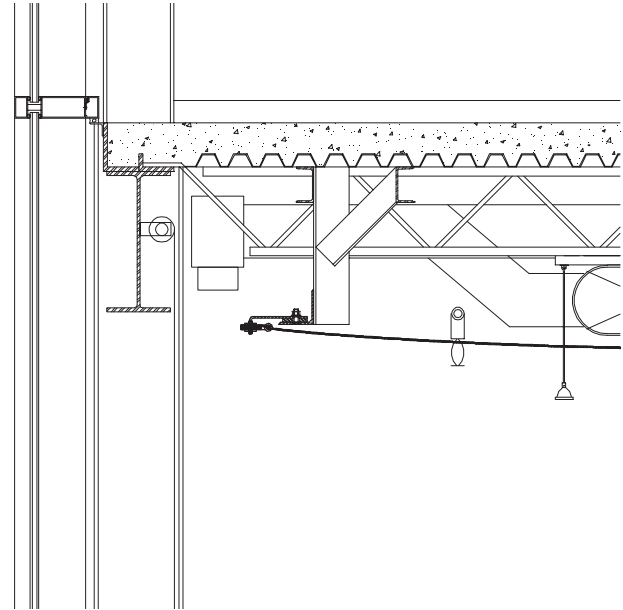

Vertical Section
at Conference Room

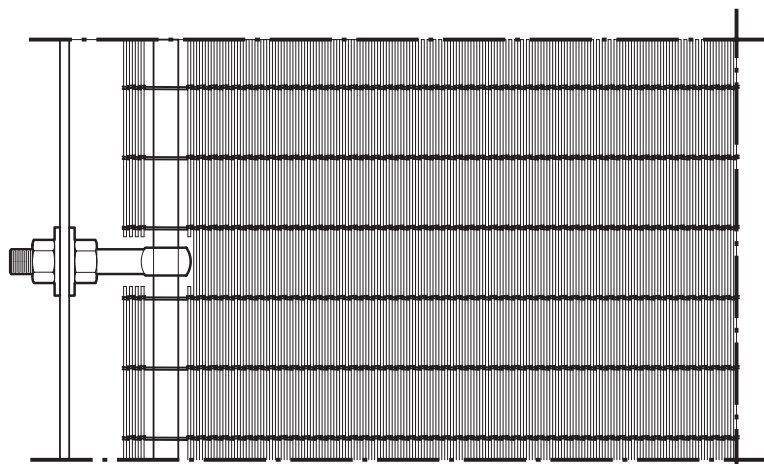
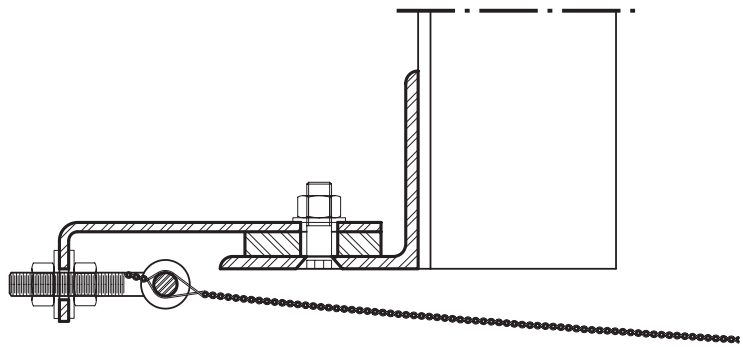

This page
Top: Conference room horizontal
section looking up (left),
conference room vertical section
at ceiling
Bottom: Meeting room ceiling
section and plan details

Opposite
Top: North screen elevation (left),
north screen detail
Bottom: North elevation
at night (left), north elevation
and exterior screen

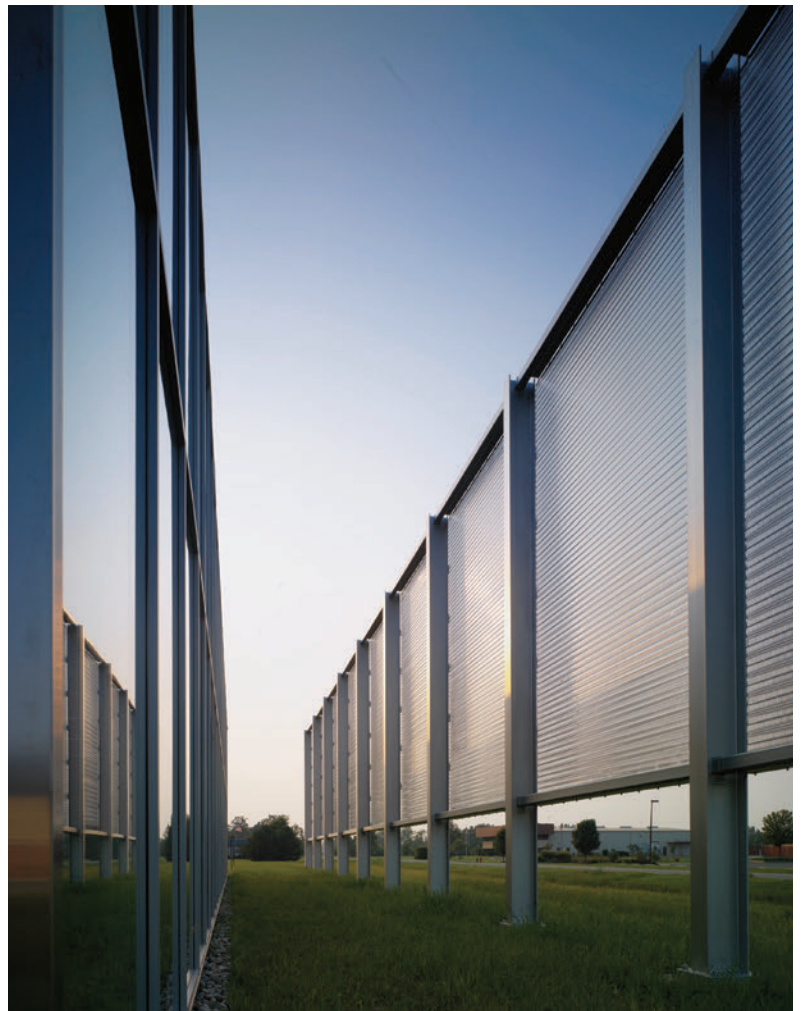
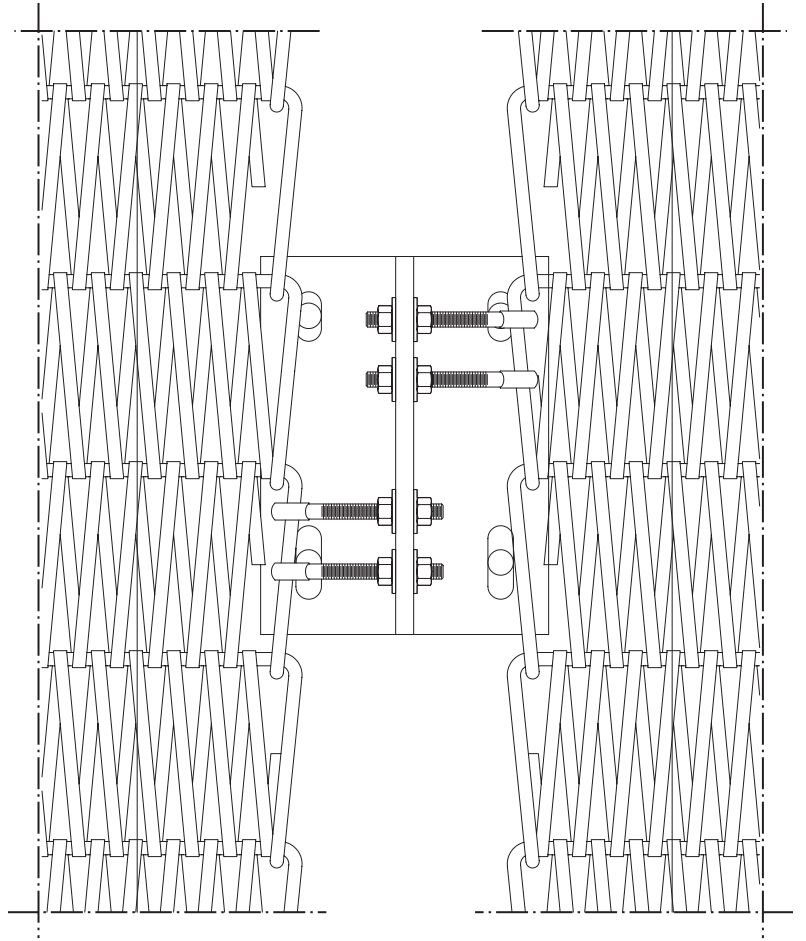
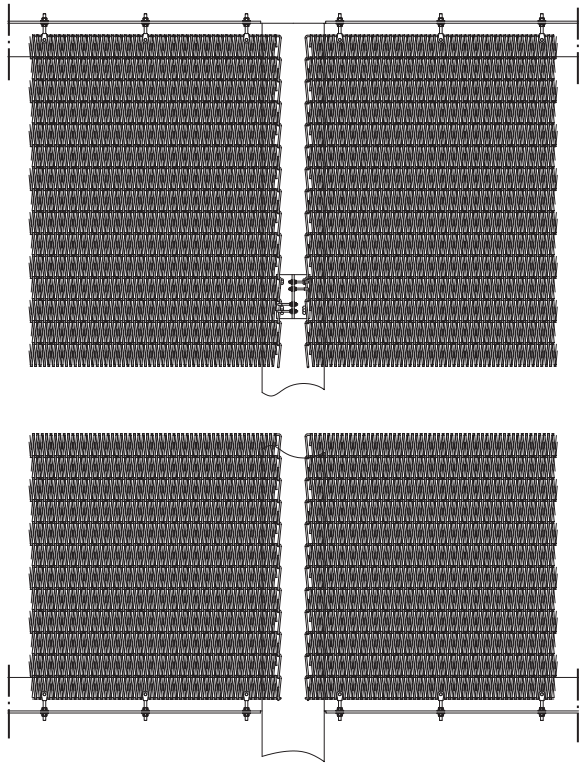

The Solar Umbrella, Venice, California

Pugh + Scarpa Architecture, Santa Monica, California

When enlarging their existing house in Venice, California from 850 to 2,200 square feet, Angela Brooks and Larry Scarpa selected materials based on technical performance as well as aesthetic qualities. Taking advantage of the unusual through-lot condition on the 41-by-100-foot site, the new floor plan shifts the residence 180 degrees south, allowing the architects to optimize the building's exposure to sunlight. Inspired by Paul Rudolph's Umbrella House in Lido Shores, Florida (1953), the roof is a reinvention of the solar canopy, a formal strategy that protects the house from exposure to intense sunlight while simultaneously absorbing and transforming it into usable energy, electricity.

Solar panels, usually relegated to an inconspicuous and utilitarian role, define the building envelope. A solar array is wrapped around the south elevation and the roof of the house becomes its defining formal element. The panels resemble tinted blue-black glass from the outside, but from below, incident light is filtered as through a prism, resulting in rainbows of illumination cast on

surfaces throughout the house. Using a process known as thin film amorphous silicon solar technology, the solar modules are created by laminating thin layers of semiconductor alloys directly onto heat-strengthened glass, then forming individual cells by a laser scribing process. Of the three main types of solar cells, crystalline, polycrystalline, and amorphous, the latter offer an opportunity for cost savings in building construction because they can replace other building components; the lower conversion efficiency of the amorphous silicon technology relative to crystalline and polycrystalline technology makes it otherwise less desirable. The silicon layers can be applied to glass, plastic, or metal in a variety of patterns and thicknesses to become part of a building's glazing or wall systems, unlike crystalline and polycrystalline panels that are added onto the building envelope without replacing any building components.

The modules used on the canopy and facade of the Solar Umbrella enhance efficiency by stacking two silicon solar cells vertically, with each cell tuned for optimum

conversion of different segments of the spectrum. A percentage of the light energy falling onto each solar module is then converted into direct current (DC) electricity for use at the place of generation, or an inverter can convert the DC electricity into alternating current (AC) and feed it back to the electricity grid. The noncombustible photovoltaic system consists of seventy-eight solar modules, fifty-seven on the roof and twenty-one on the south facade. Each module is equipped with an integral framing/mounting/wiring system for direct roof mounting; the interlocking frame assemblies enable fast installation and a seamless array appearance. Integral DC plug-together electrical connectors enable the array to be assembled quickly without tools. Once assembled, the connectors are concealed in channels in the anodized frame, providing an uncluttered appearance and easy access for troubleshooting. Both passive and active solar design strategies combined render the Solar Umbrella one hundred percent independent from the electrical utility grid.

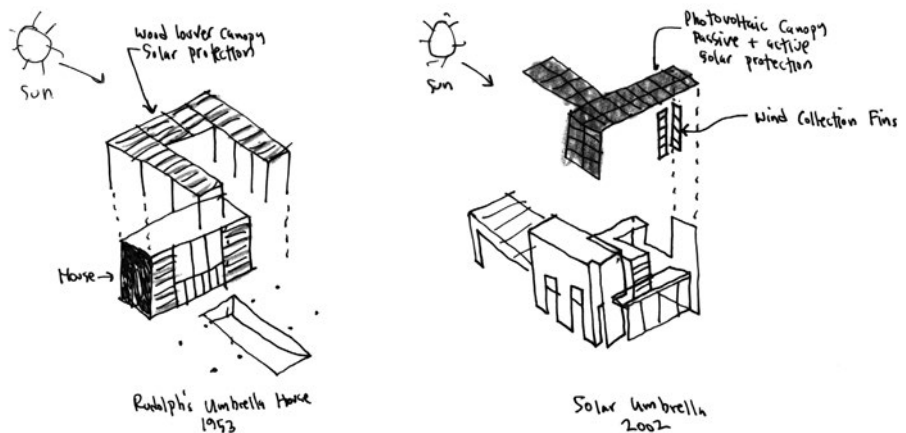

This page
Umbrella sketches

Opposite
Rear elevation





Opposite
Southeast corner

This page
Top: Second floor plan
Middle: First floor plan
Bottom: Roof plan with solar
panel layout

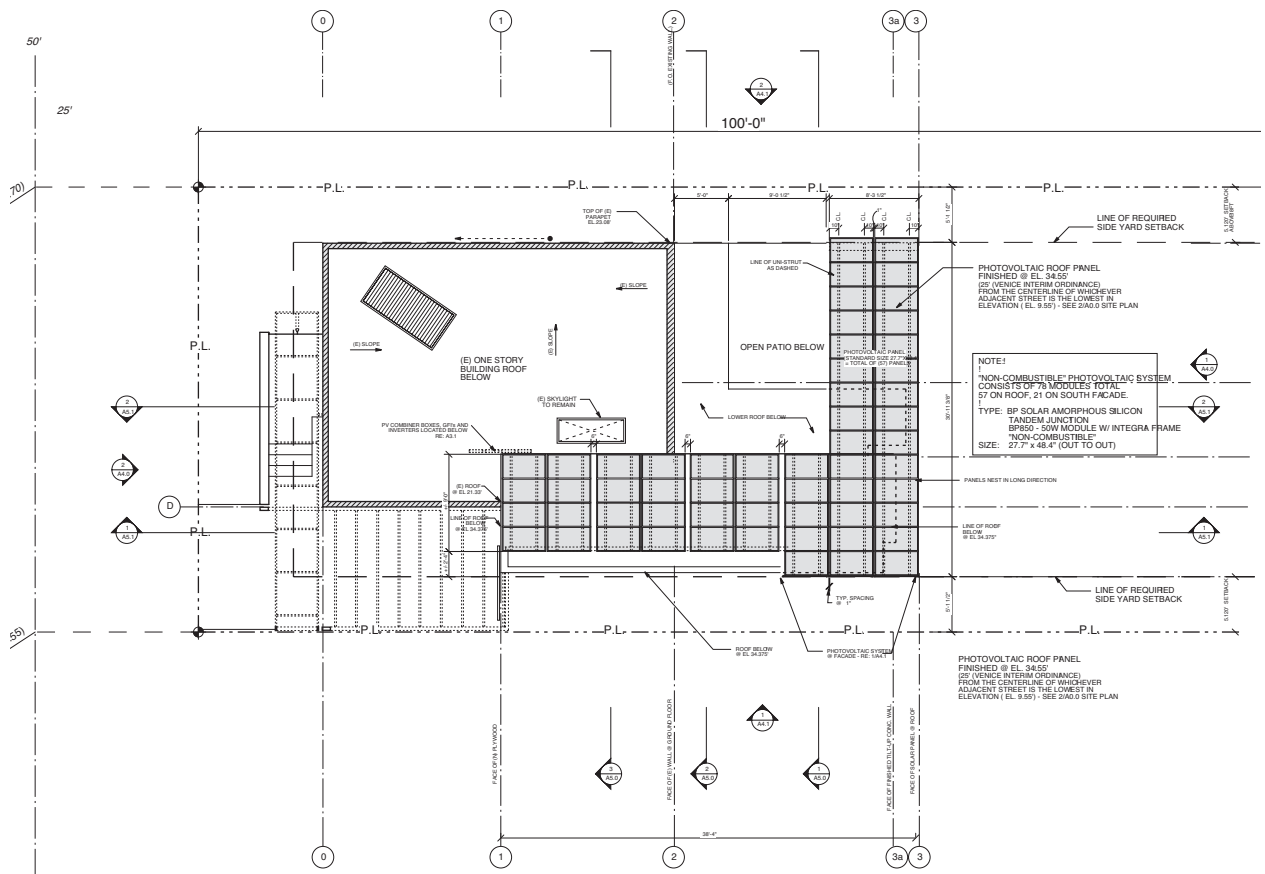
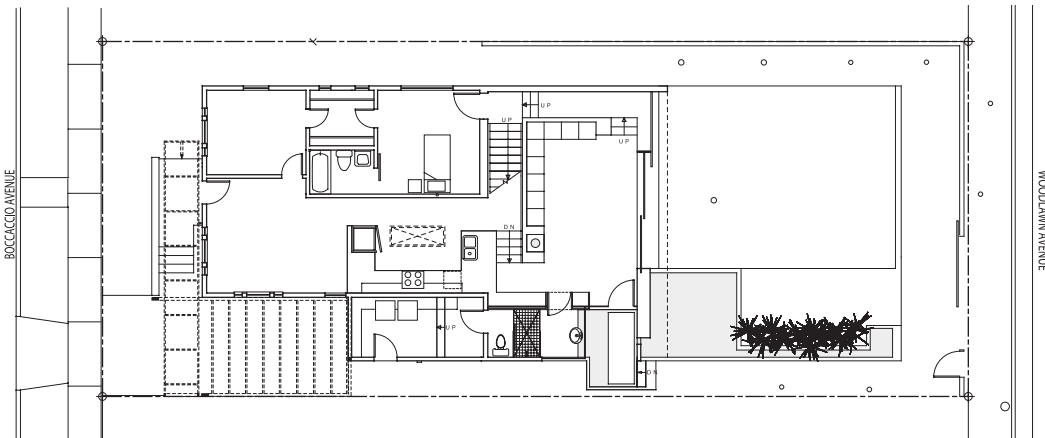
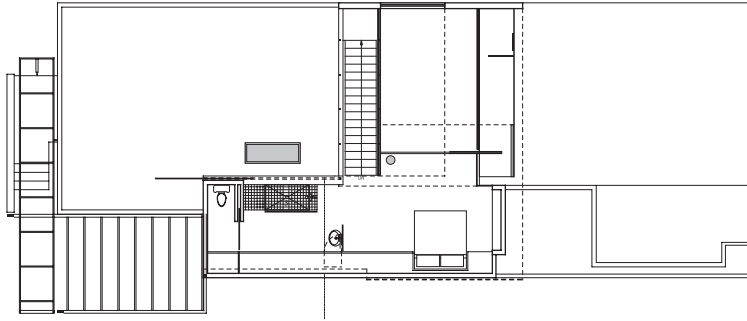

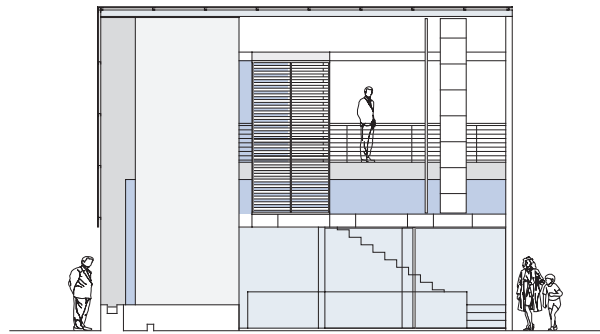
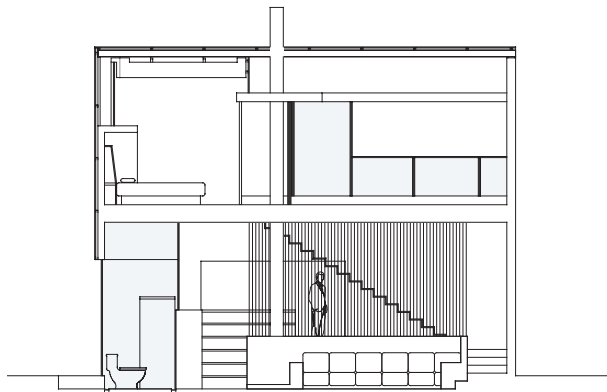
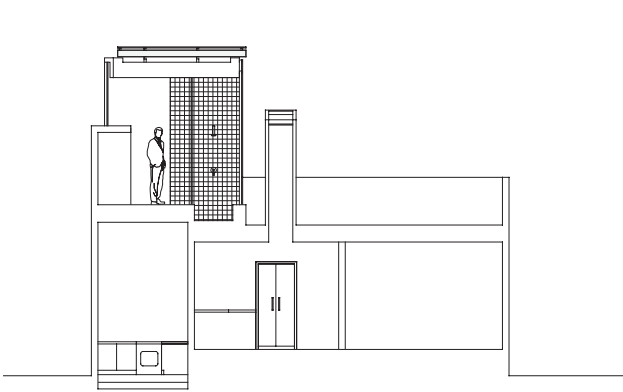
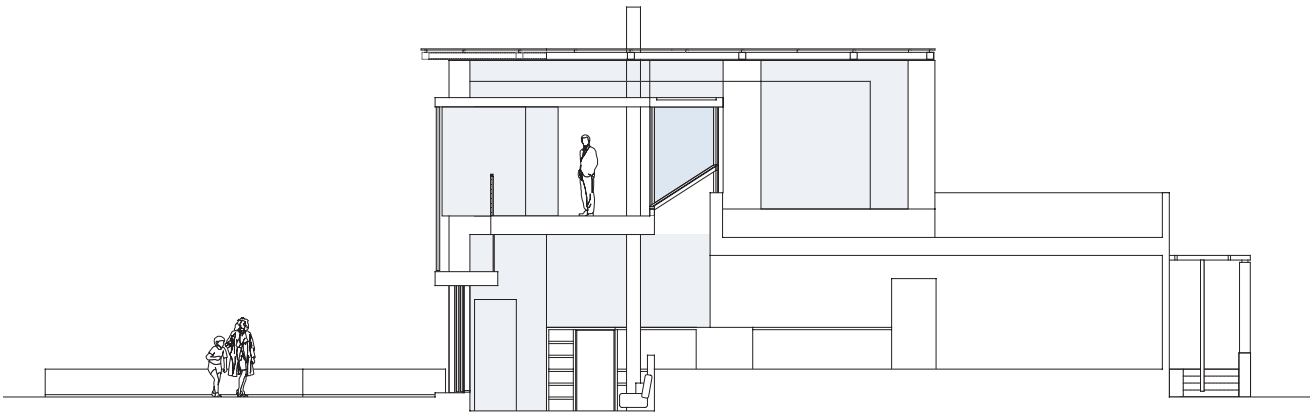

This page

Top: Longitudinal section

Middle: Cross sections

**Bottom: Front elevation (left),
rear elevation**

Opposite

Roof terrace with solar panels



School of Architecture, Prairie View A&M University, Prairie View, Texas

RoTo Architects, Inc., Los Angeles, California

Architect of Record: HKS, Inc., Dallas, Texas

The new College of Art and Architecture at Prairie View A&M University has sinuous, curtainlike brick walls that harmonize with the colors and textures of the surrounding native prairie grass landscape. On the north facade the brick peels away like curtains to allow slots of light into the classrooms and interior portions of the building. At the edge of the school is the new cultural center, another brick building linked to the rest of the complex by its use of the same structural module and proportioning system, thus remaining an identifiable element but also recognizable as part of the whole. RoTo Architects was particularly interested in the traditions and craft of brick-making and wanted the new building to exhibit the full range of the bricklayer's skills. Brick is naturally heavy and grounds a building literally and metaphorically; the architects wanted to make it lighter. In a departure from the conventional practices of bricklaying—bricks laid in straight lines, horizontally, and aligned flush vertically—the brick layouts at Prairie View are linear, but also curvilinear, circular, and angular, shifting progressively in and out, creating undulating surfaces that intercept sunlight throughout the day and cast dynamic shadow patterns, making the walls come alive. From a distance, these

walls appear to be lightweight and almost fabric-like but when seen close up, the profiles of each individual brick are visible.

The construction of the brick walls is a modification of a conventional brick curtain-wall system in which the bricks are self-supporting from floor to floor. At each floor, they are supported on a steel angle that is either tied into the primary concrete frame, or a steel frame, depending upon the location in the building. In order to use this system without extensive customization of the frame, supports, and brick detailing, two guidelines were established: the walls undulate in plan but are always straight, sloped lines in section; and the angle at which the brick vertical walls were allowed to slope was rigorously monitored so that their function as a watertight curtain wall would not be compromised.

The architects discovered that the selection of brick determined the size of the slope increment. The traditional brick veneer construction of the Architecture and Art Building where the brick wall is only one wythe thick could sustain one increment while the two-wythe, solid brick construction technology employed at the cultural center allowed that increment to be increased. The guidelines did not necessarily determine

the slope of the wall in every instance; rather, they helped to establish limits for the three-dimensional modeling of the facades.

The design team investigated traditional methods of animating the texture of brick walls by giving their surfaces greater three-dimensional plasticity, such as the techniques of corbelling, in which small projections are incrementally built out from a brick wall, each course extending out slightly farther than the one below, and rotation, where bricks are extended or turned to project slightly outward from the face of the wall. When construction began, the architects met with master bricklayers to investigate ways in which the building itself could be used as a vehicle for teaching by incorporating textbook examples of basic brick bonds and courses in its walls. Mock-ups were constructed, layouts and patterns tested, as well as grout profiles and depths, corners for acute and oblique conditions defined, and details developed for the construction of a four-story corner that was broadly curved at the bottom with a ninety-degree bend at the top. The collaborative hands-on exchanges were critical for the overall success of the project.

This page
South elevation

Opposite
Top: South elevation screen
Bottom: Breezeway, gallery, and entrance

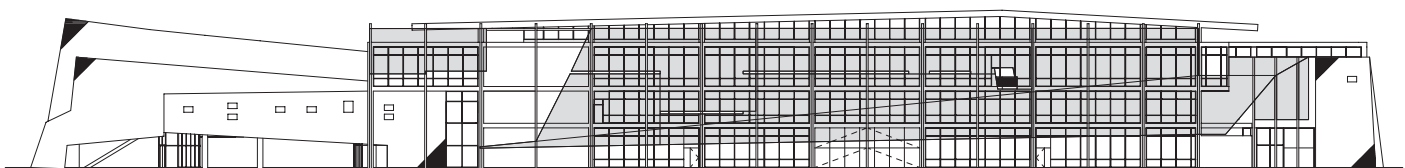



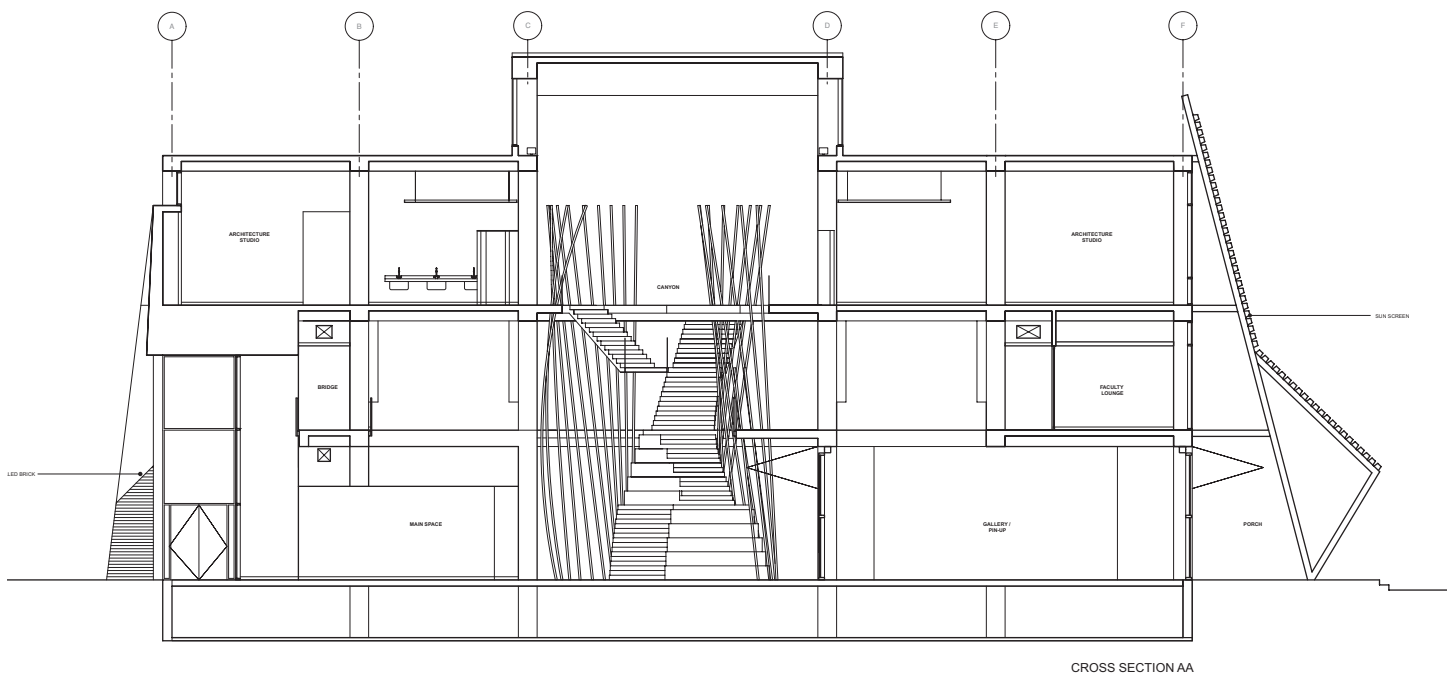
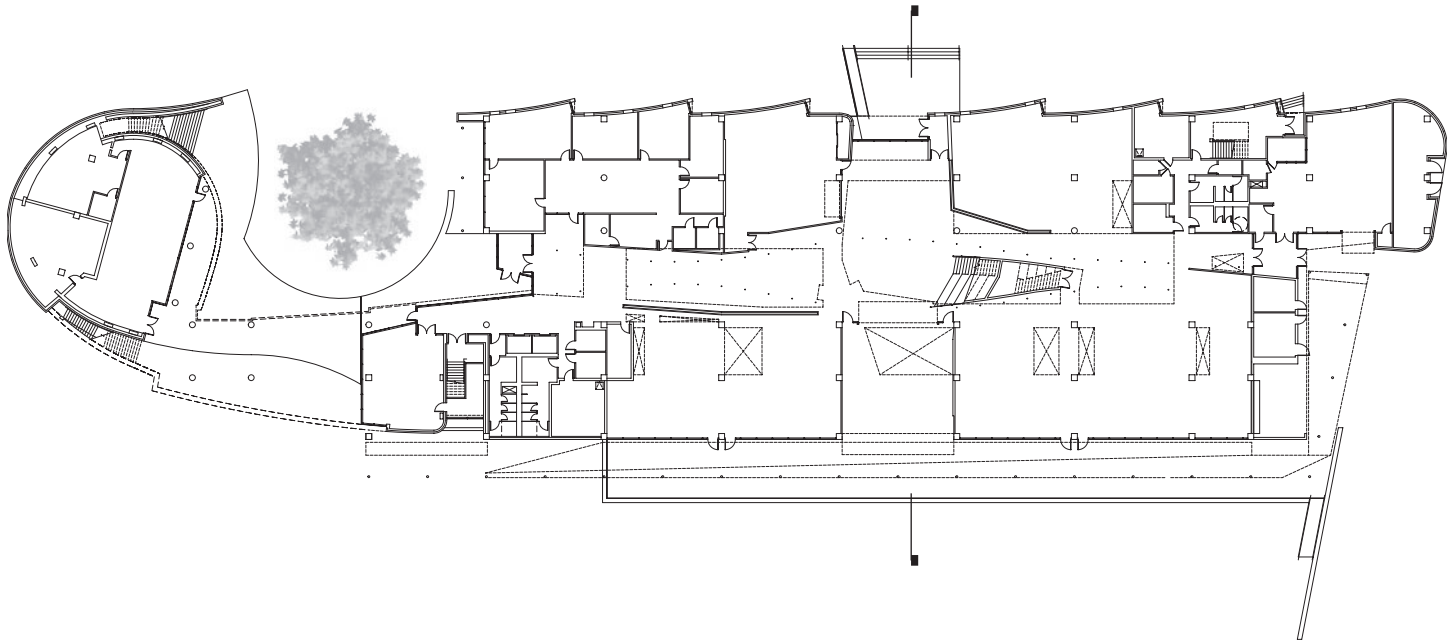

This page
Top: First floor plan
Above: Cross section

Opposite
Screen detail

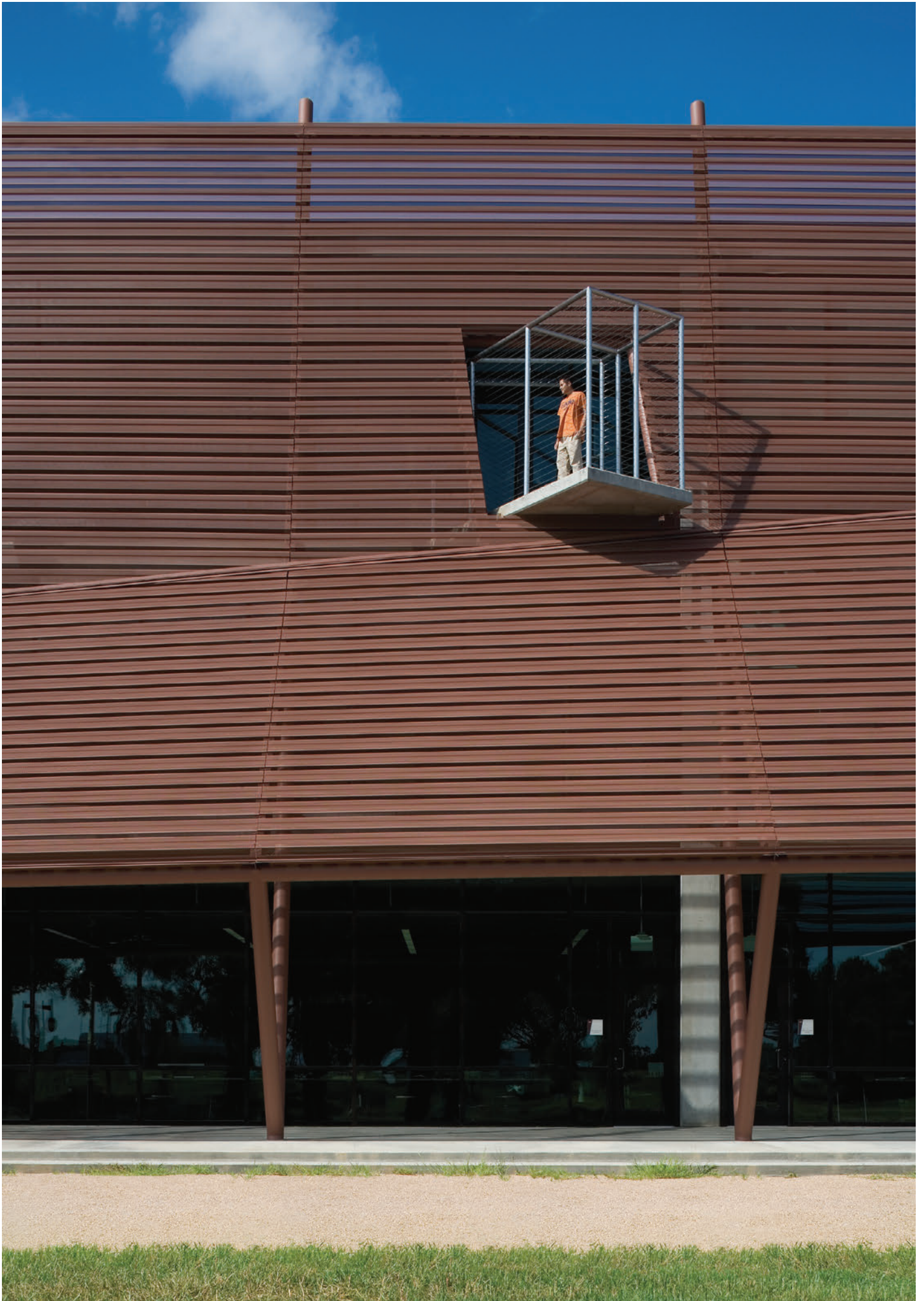



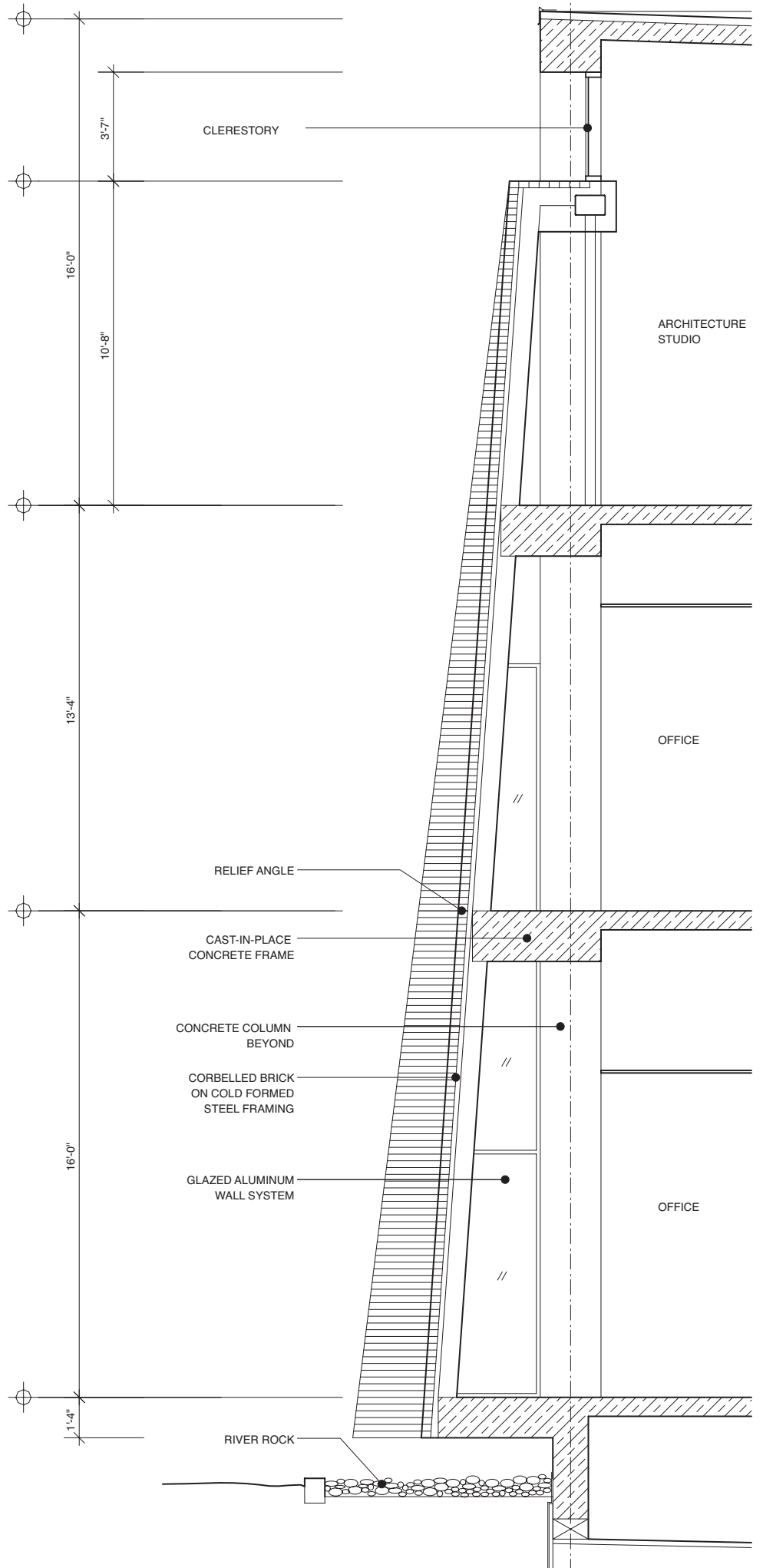

Opposite
Stair to courtyard

This page
**Typical section through
 brick skin**

(A)

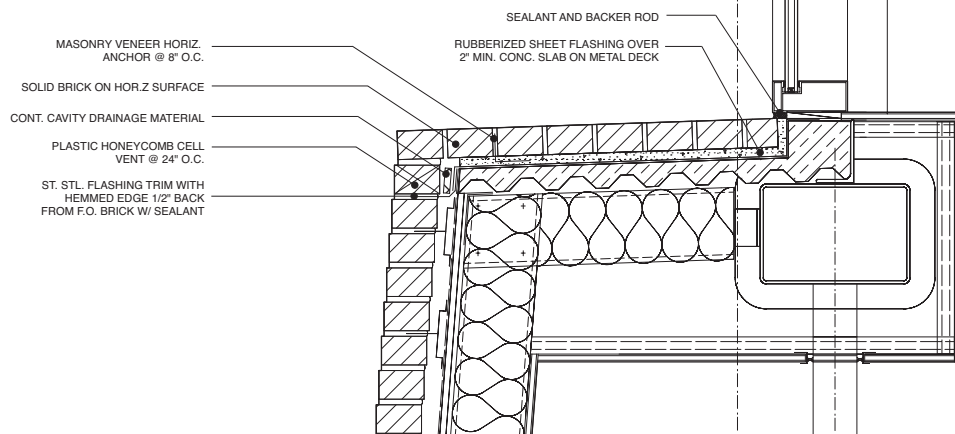

BRICK SECTION DETAIL AT CLERESTORY

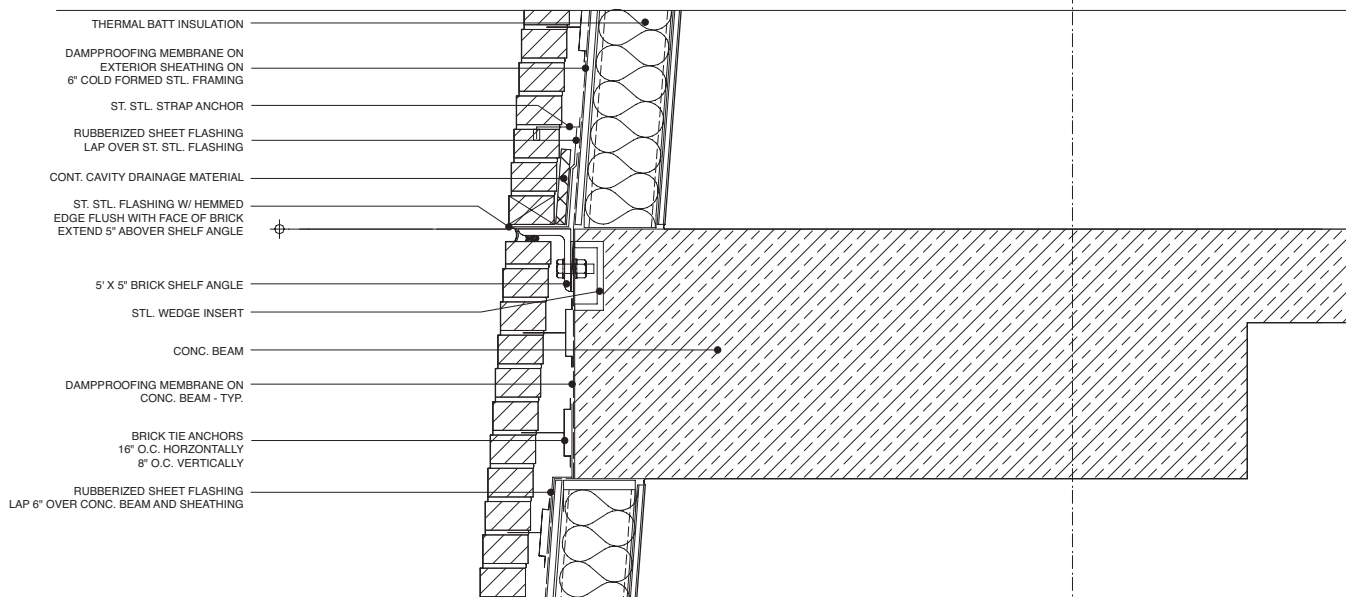

BRICK SECTION DETAIL AT FLOOR SLAB

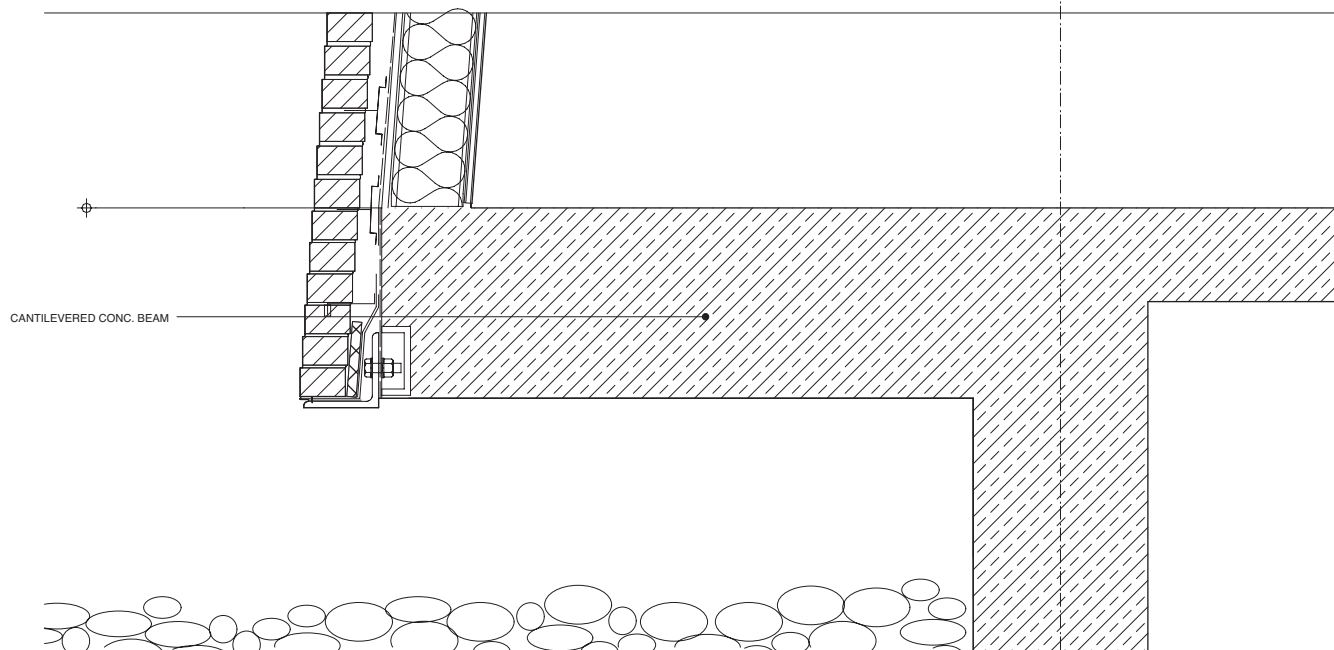

BRICK SECTION DETAIL AT WALL BASE

Opposite
Brick section details

This page
Below: North elevation
Right: Brick plan details

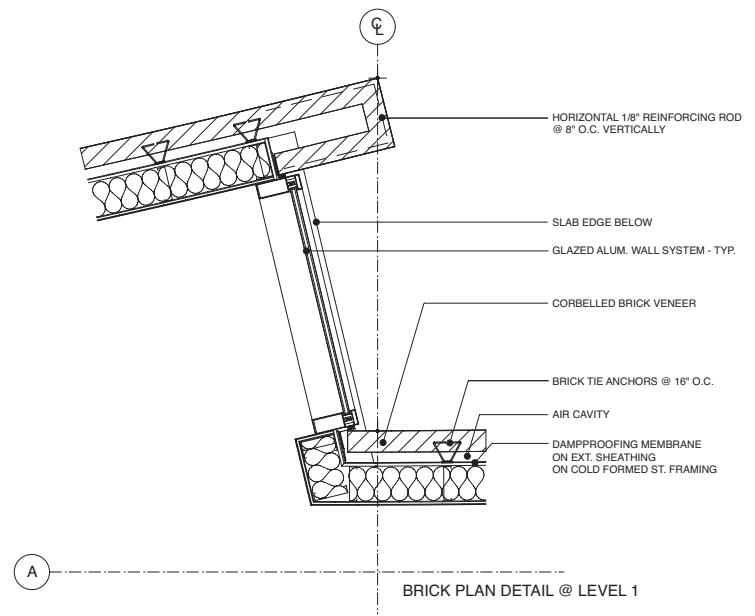
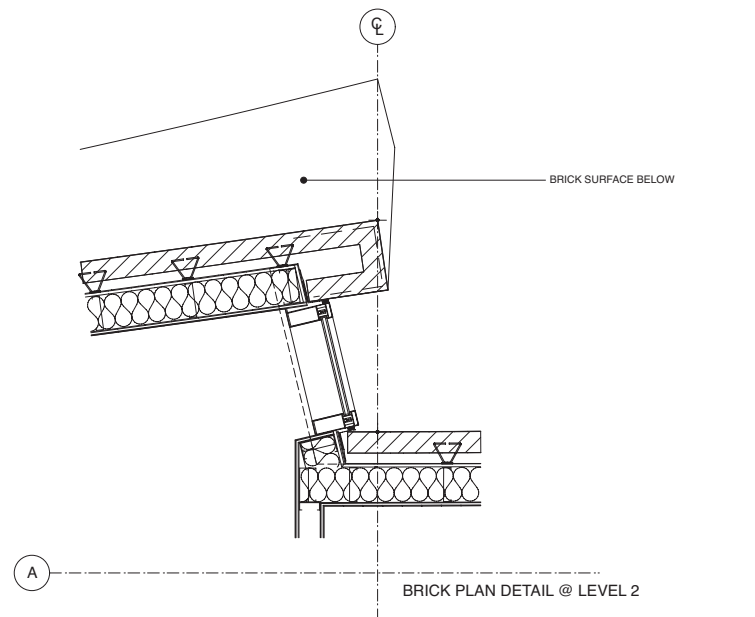
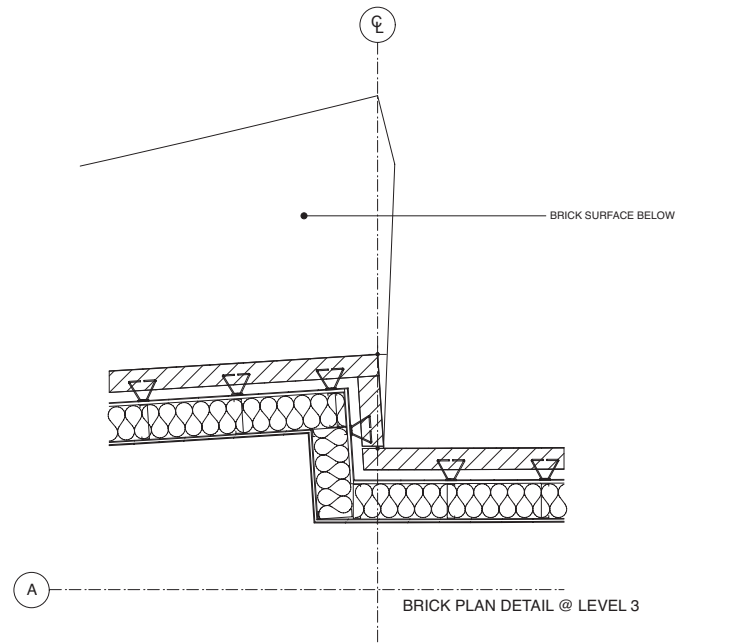

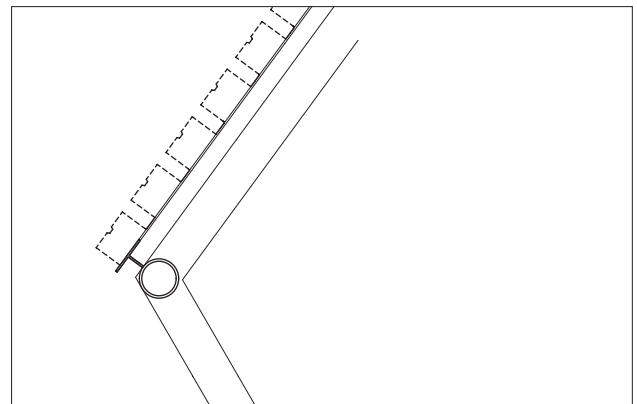
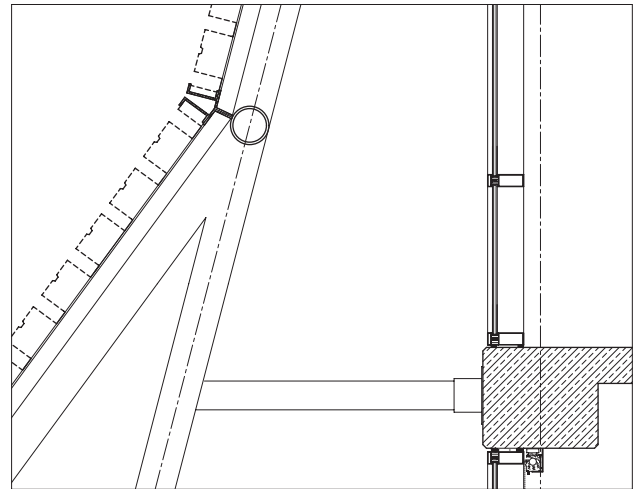
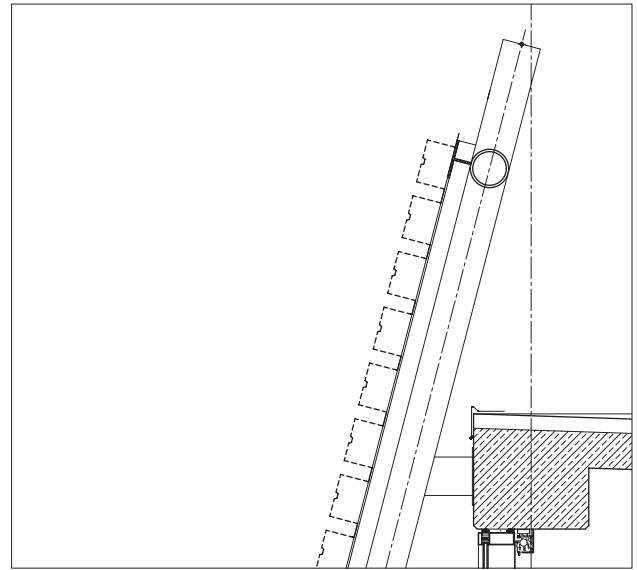
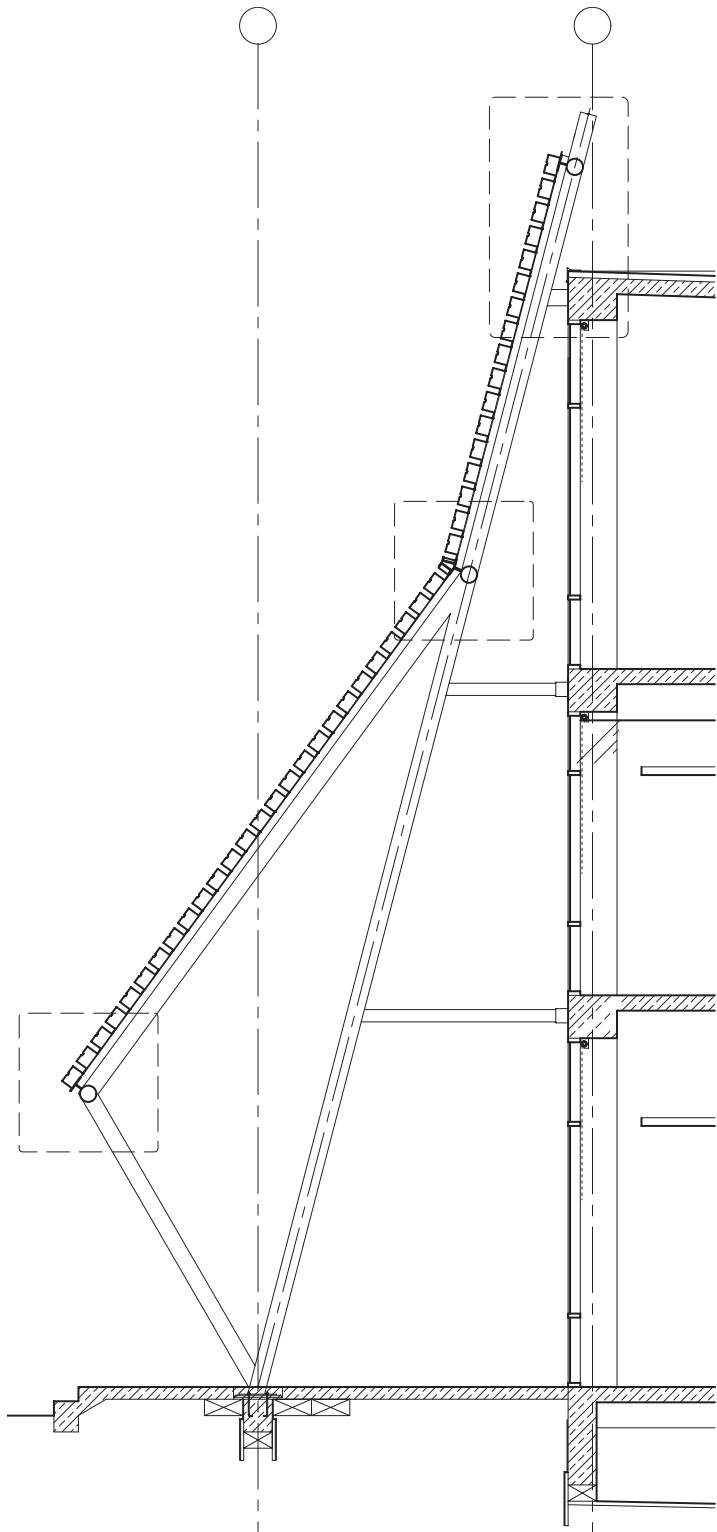

This page
Above: Screen section
Right: Screen details
(top, middle, bottom)

Opposite
South elevation screen
passage



Shaw Center for the Arts, Baton Rouge, Louisiana

Schwartz/Silver Architects, Boston, Massachusetts

Executive Architect: Eskew + Dumez + Ripple, New Orleans, Louisiana

Associate Architect: Jerry M. Campbell and Associates, Baton Rouge

The design of the Shaw Center was the result of a complex program that sought to accommodate the two anchor institutions, the Louisiana State University Museum of Art and the Manship Performing Arts Center. At one end of the building a theater with 322 seats is served by a fly loft at the upper reaches. The opposite end stretches north over the lobby and extends as a cantilever above the 1930s-era auto hotel parking garage and terminates with an upward thrust and the clerestory window of the museum's temporary exhibition gallery. A clear glazed central space serves as the main entrance for the entire complex. The building's exterior massing is emphasized by its cladding of hundreds of multi-length cast-glass channels. At the time of its completion, the Shaw Center was said to be the largest building in the United States to be completely clad in U-shaped cast glass, and it was the first to use the channel glass as the rain screen for a wall system. The building's facade was conceived to evoke a paper lantern, glass beading, and the meandering Mississippi. Although it seems counterintuitive to glaze an entire building that has relatively few windows, the glass envelope protects the valuable collections within while creating an active and luminous exterior surface, and a memorable silhouette on the city's skyline.

Early in the design process, Schwartz/Silver considered a number of cladding

systems, among them prepatinated copper and glass channel. Mock-ups were constructed on the site to demonstrate that channel glass would give depth and visual complexity to the building's surface while serving practical ends. The proposed facade was composed of two layers, an outer surface of channel glass and an inner layer of corrugated aluminum serving as the weather barrier, with an air gap between layers to create a rainscreen configuration. During the development of the cladding system, technical tests demonstrated that even in the heavy rains common in the region, the channels reduced the water to a mist in the cavity, thus functioning as a true rainscreen. To heighten the visual effect of the vertical channel glass, the architects specified channels in two different widths and various lengths. The channels are supported in the usual way, at top and bottom by horizontal aluminum members, but the horizontals are broken and sometimes overlapping, lending a syncopated rhythm to the exterior. To resist wind pressure, the channels are tied back to the structure with aluminum clips. Two-inch gaps between the glass channels perform the rainscreen function for the aluminum wall system, which is located 6 inches behind, and allow a cleaning wand to be inserted vertically to remove wind-blown debris.

U-shaped channel glass is most commonly used with the flanges facing inward

for applications where translucent natural light is desired within the building, for example in a hospital. However, Schwartz/Silver found that outward-facing flanges added more texture and visual complexity to the building's exterior, so the facades of the Shaw Center have channel glass with the flanges facing outward and capped with aluminum edging over most of their surface. At lower levels, the flanges are turned inward and sandblasted to prevent accidental damage. Small wires are embedded in the glass to reinforce it. To test the glazing system against hurricane-force winds, a mock-up was produced and placed in front of an old DC-3 airplane propeller to simulate wind-driven rain and a hundred-mile-per-hour wind pressure. Bendheim Wall Systems, the channel glass manufacturer in Germany, performed additional tests. Lengths, widths, and tints of the glass channels were varied. Narrower channels appear greener because the flanges are closer together, creating a denser concentration of greenish-tinted glass. A network of intermediate tubular supports punctuates the facade, separating it from and connecting it to the building's structure.

*Text contributed by James McCown,
Schwartz/Silver Architects*



SHAW CENTER

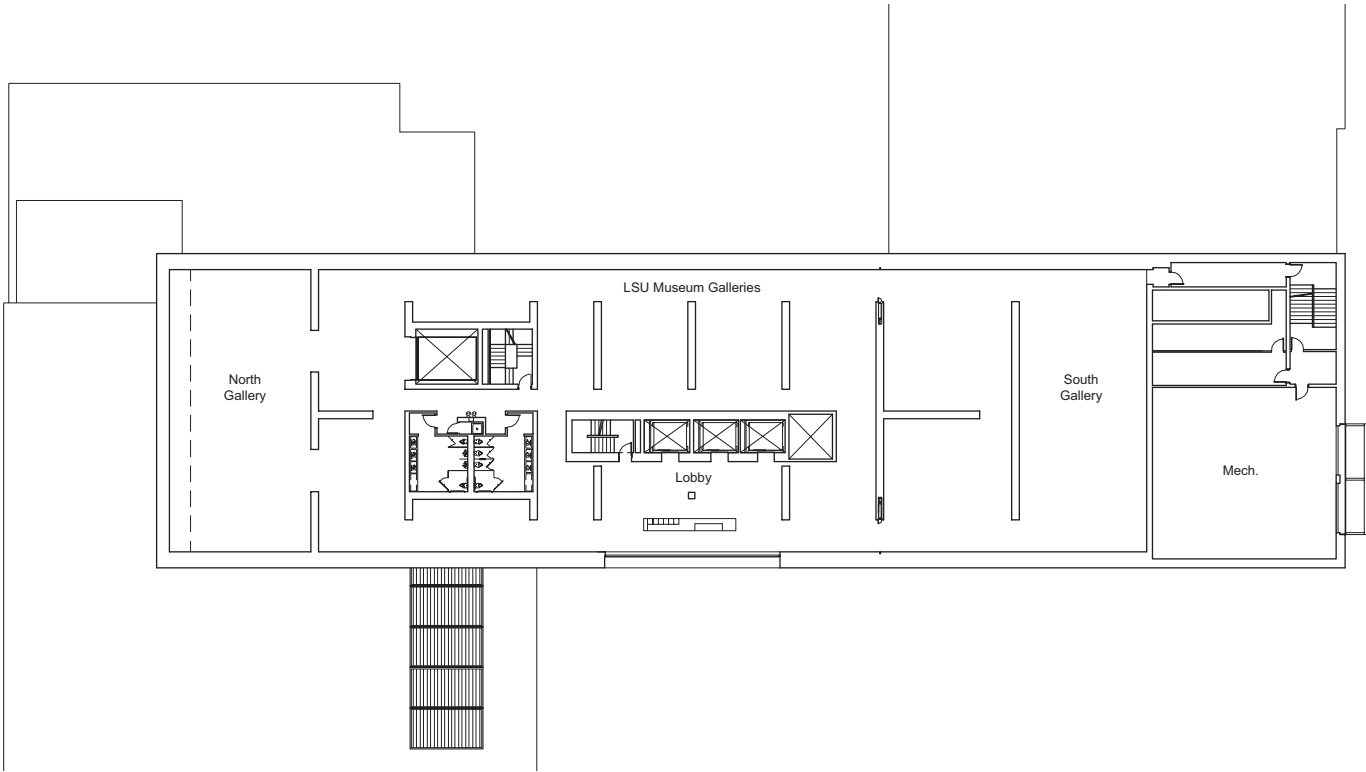
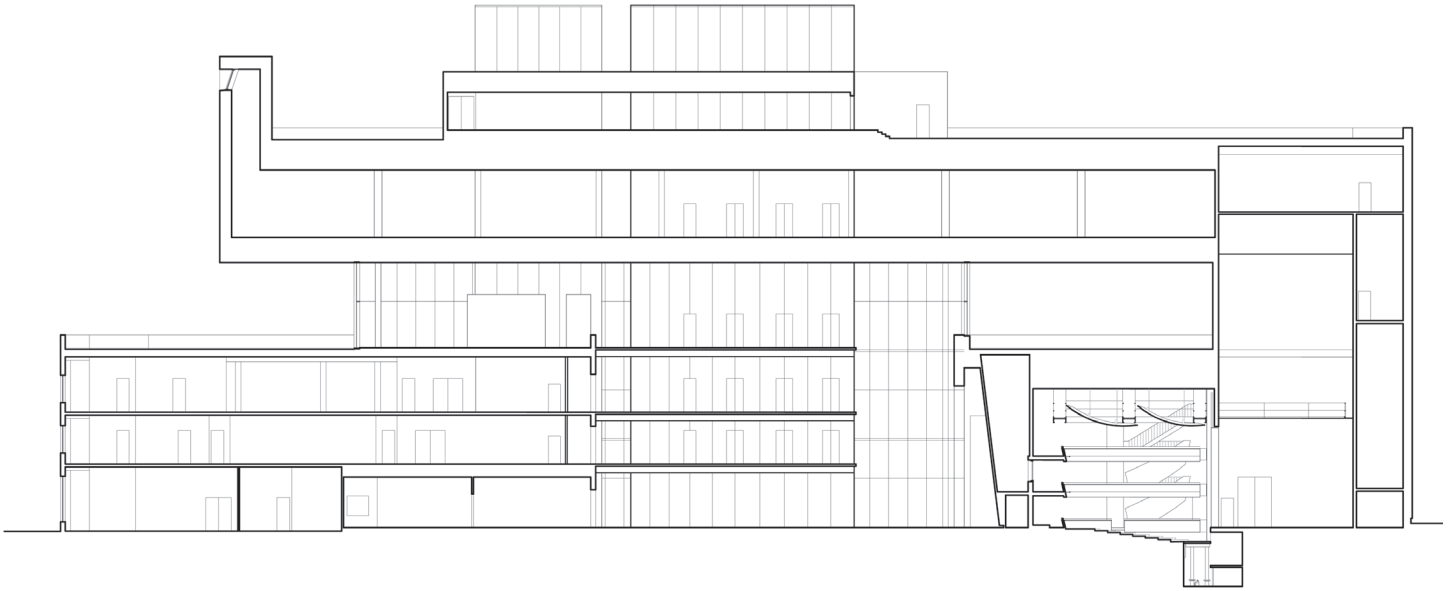

This page
Top: Longitudinal section
Above: First floor plan

Opposite
Top: East elevation
Bottom: West elevation
with auto hotel



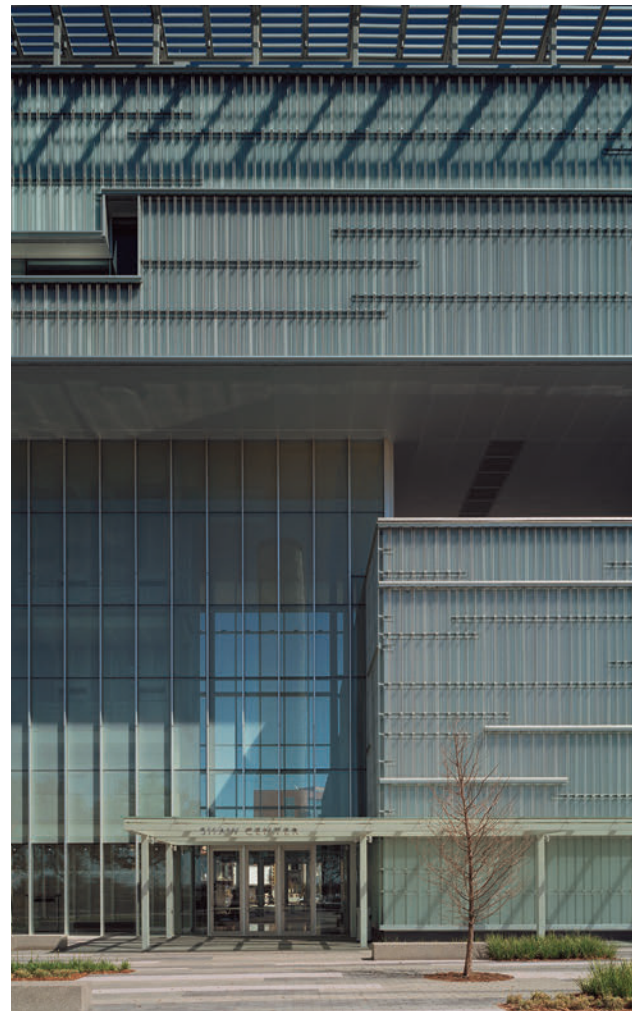

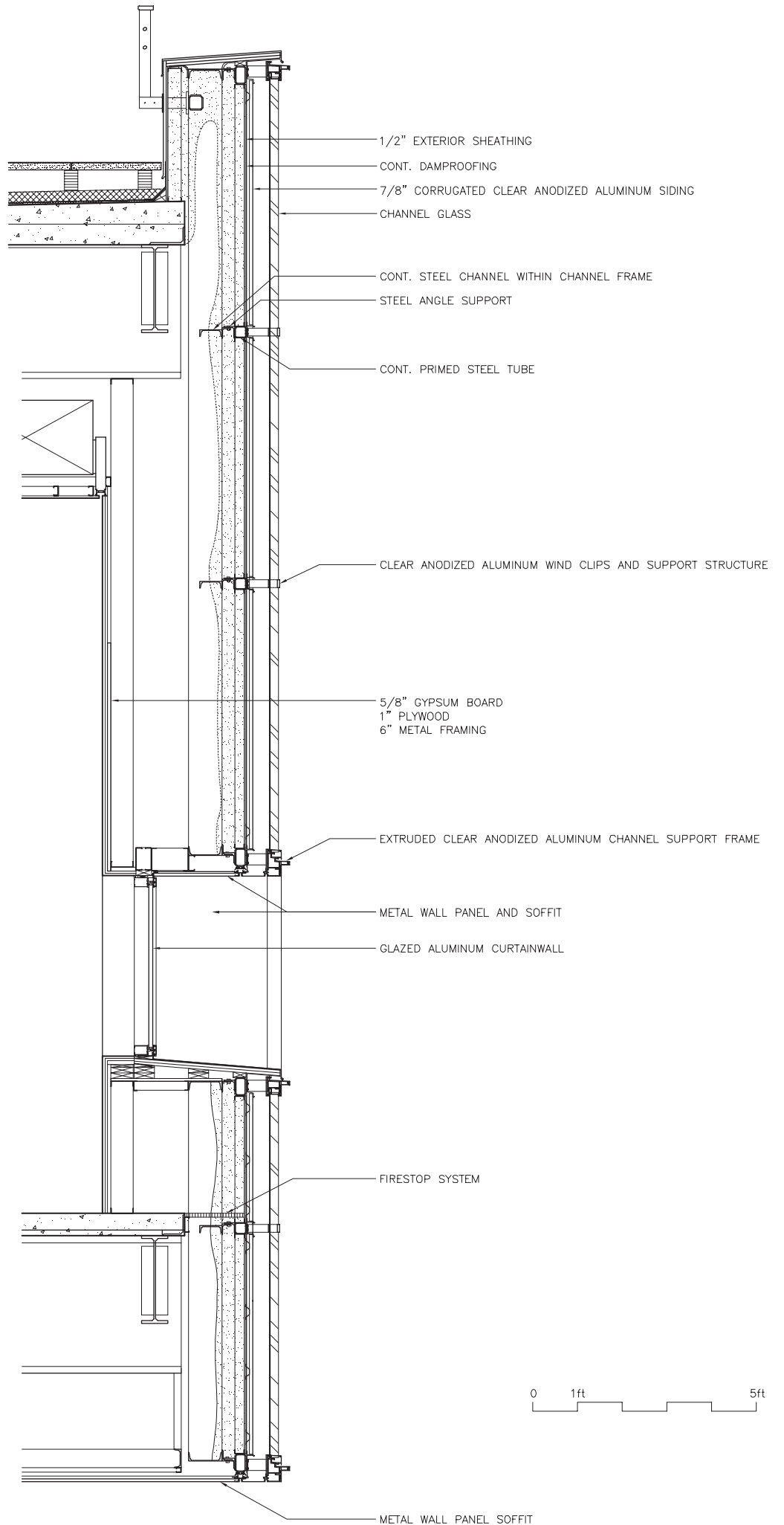

Opposite
Top: East elevation entrance
Bottom: Glazing detail (left),
entrance detail

This page
Wall section

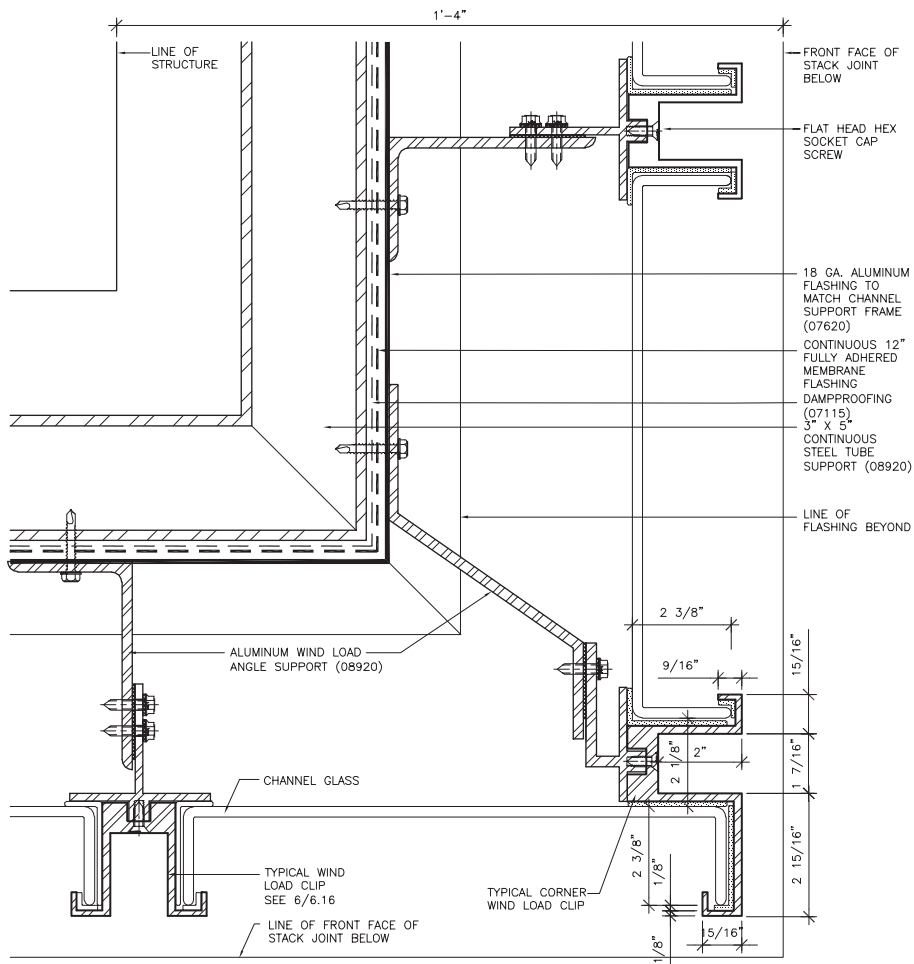

This page
Top: Corner detail plan
Bottom: Wind load clip plan and detail

Opposite
Top: Corner detail (left), wind load clip
Bottom: Glazing panels with wind load clips

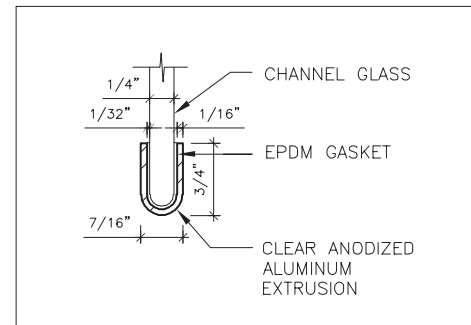
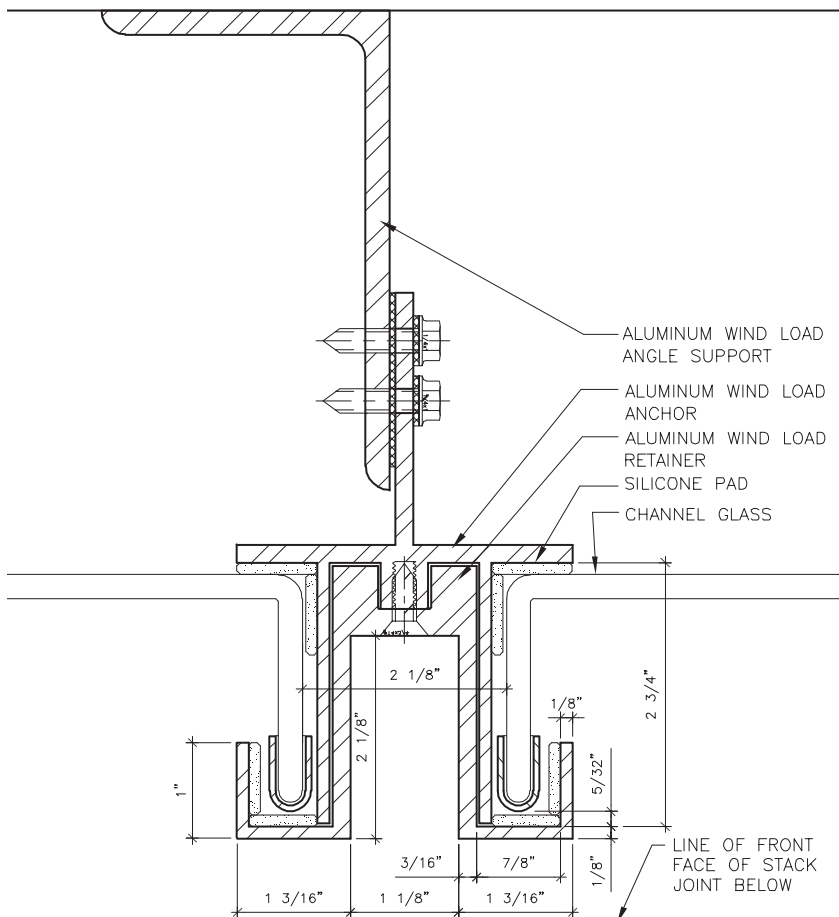

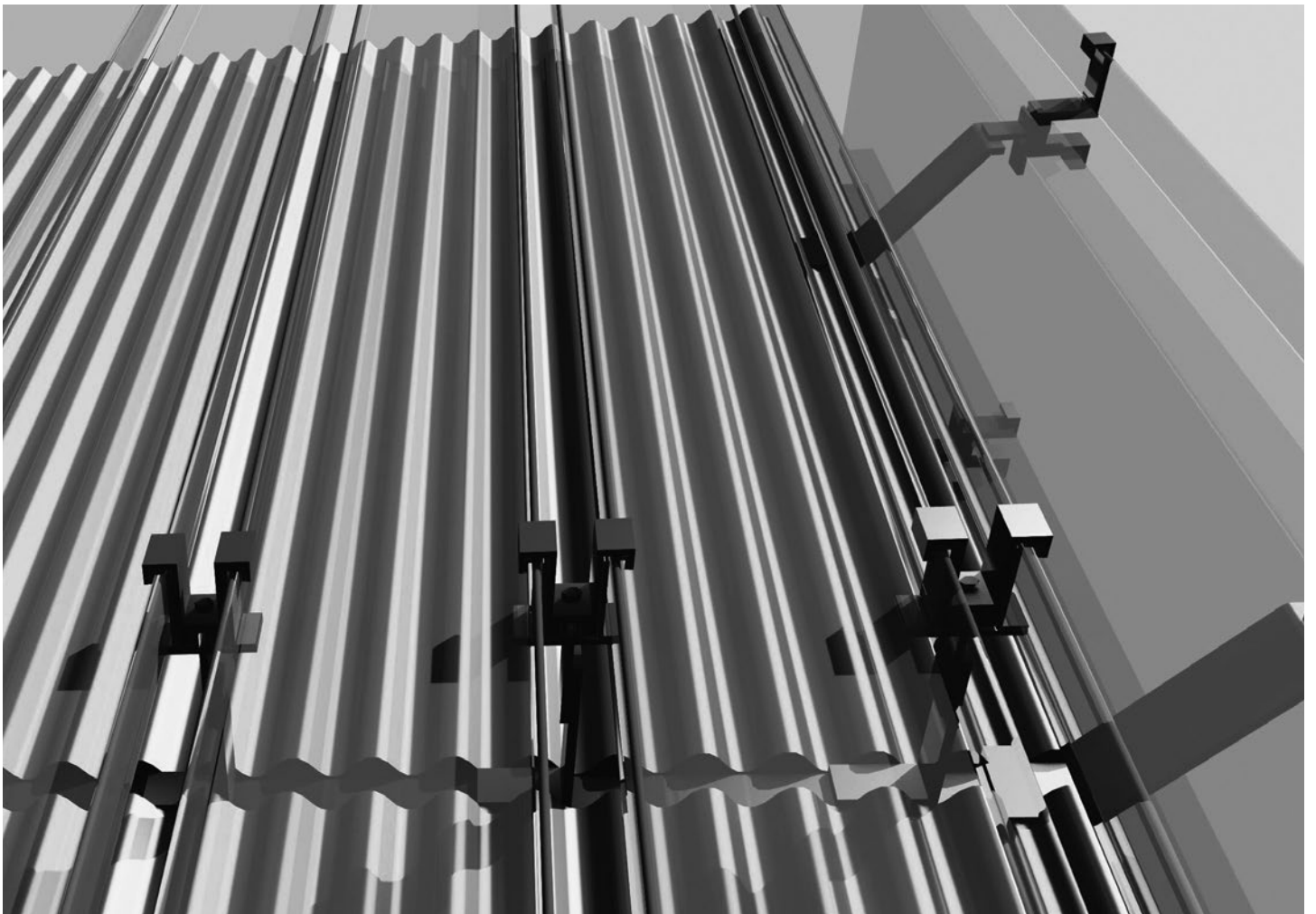

Camera Obscura, Mitchell Park, Greenport, New York

SHoP Architects PC, New York, New York

As part of its redevelopment project for the Greenport waterfront, SHoP built a camera obscura in which a mirror and lens project exterior imagery onto walls of the dark interior chamber. The camera obscura in Mitchell Park combines an historic optical device and program with contemporary building technology.

The building is composed of twenty-three hundred unique structural components, which were three-dimensionally modeled, laser cut, labeled as a kit of parts, bubble-wrapped, and shipped to the site to be fully assembled. SHoP has used this approach on parts of its other projects, but this is the first time an entire structure has been one hundred percent computer-modeled and fabricated. At the earliest stages of a building's creation, SHoP uses the same digital technology as its engineers and fabricators to reduce the amount of time, money, and material waste associated with conventional design, engineering, fabrication, and construction processes.

The camera obscura is made of ipe, a durable cultivated hardwood, combined with steel flitch beams at locations of particularly high stress. The interfaces between the steel and wood parts have been carefully detailed and play an important role in the overall aesthetic.

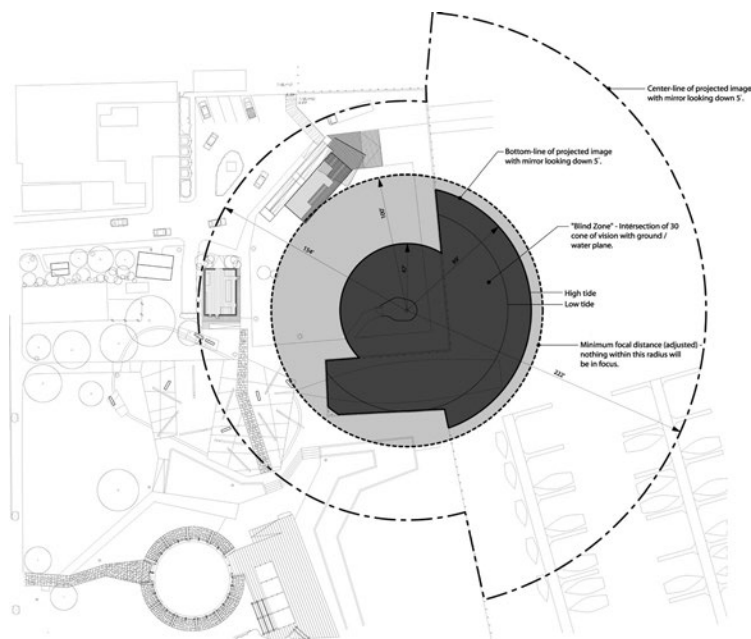
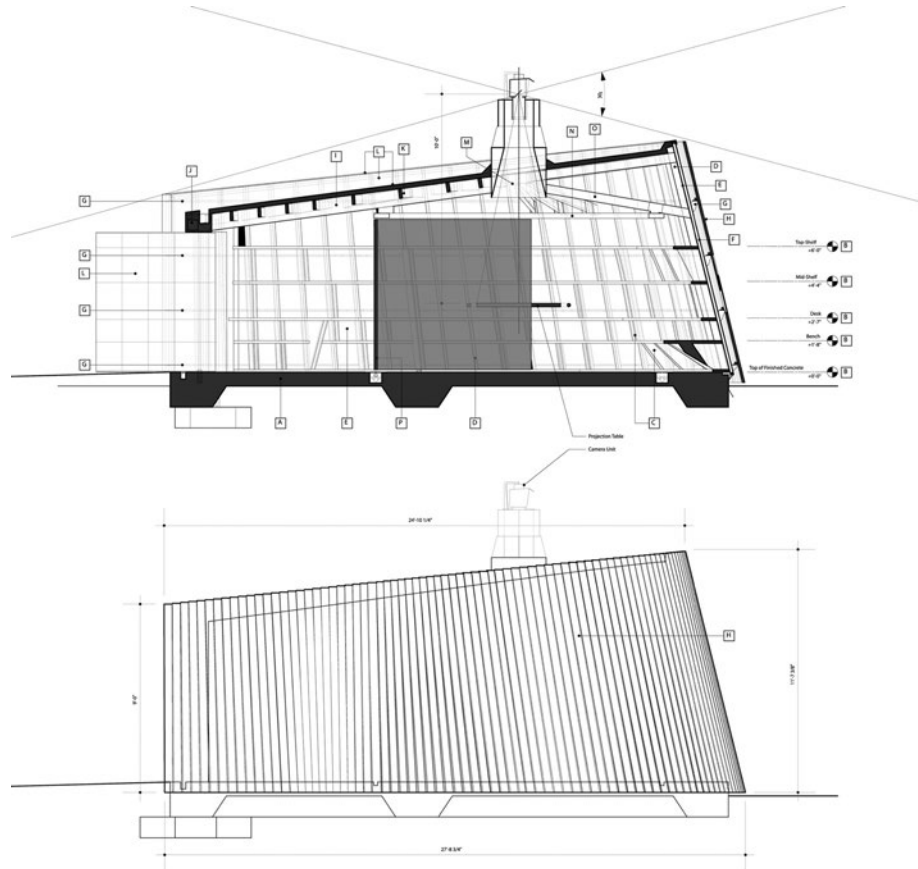

This page

Top: Longitudinal section
Middle: Side elevation
Bottom: Site plan

Opposite

Top: Rear elevation
Bottom: Camera obscura interior



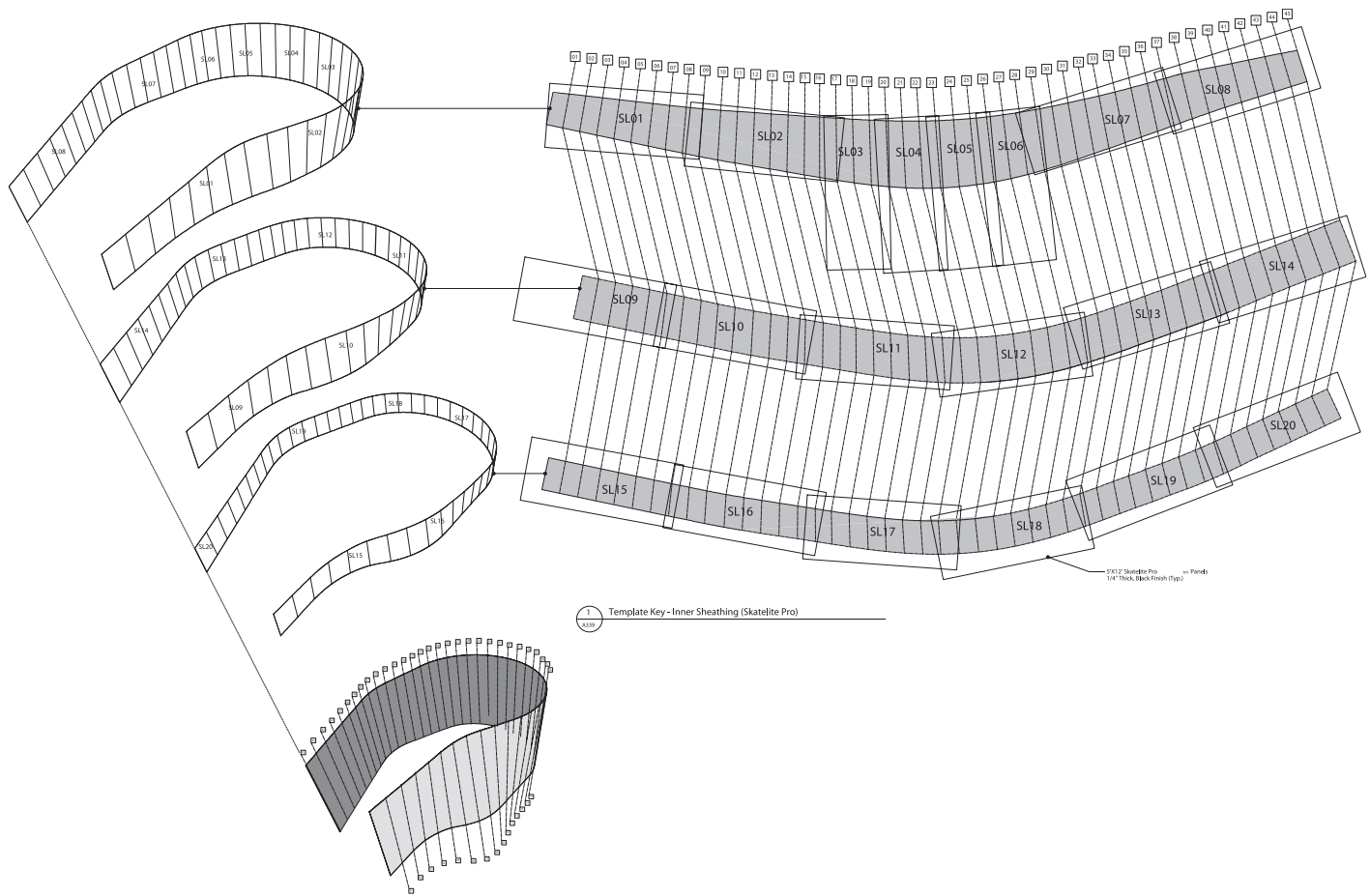

E Inner Sheathing - Skatelit

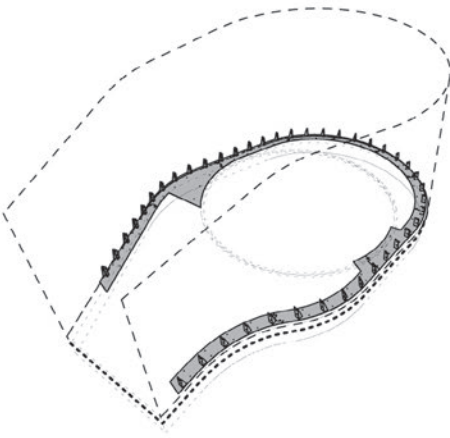

Steel Sill Plate Assembly

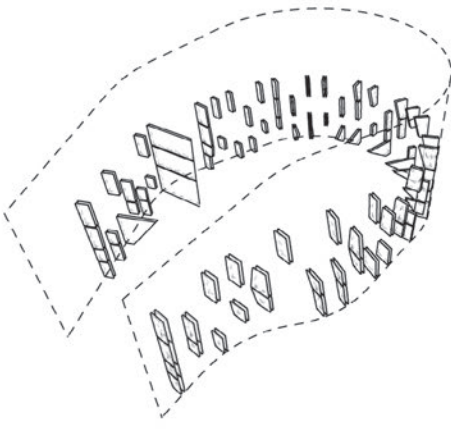

Aluminum Fins / Shelf Supports

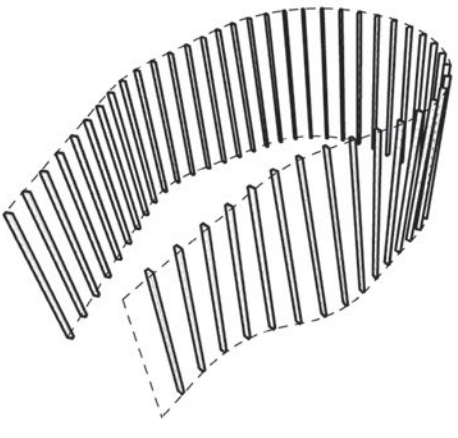

Ipe 2x4s

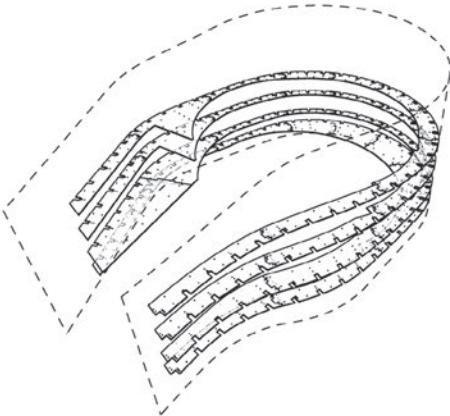

Aluminum Shelf Assemblies:
Bench, Desk, Display

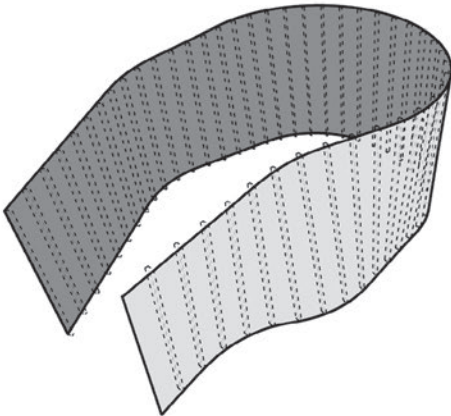

Sheathing Composite:
Skatelite Pro + Plywood

This page
Top: Inner sheathing
Bottom: Camera elements

Opposite
Top: Camera structure
Bottom: Frame (left), exterior sheathing

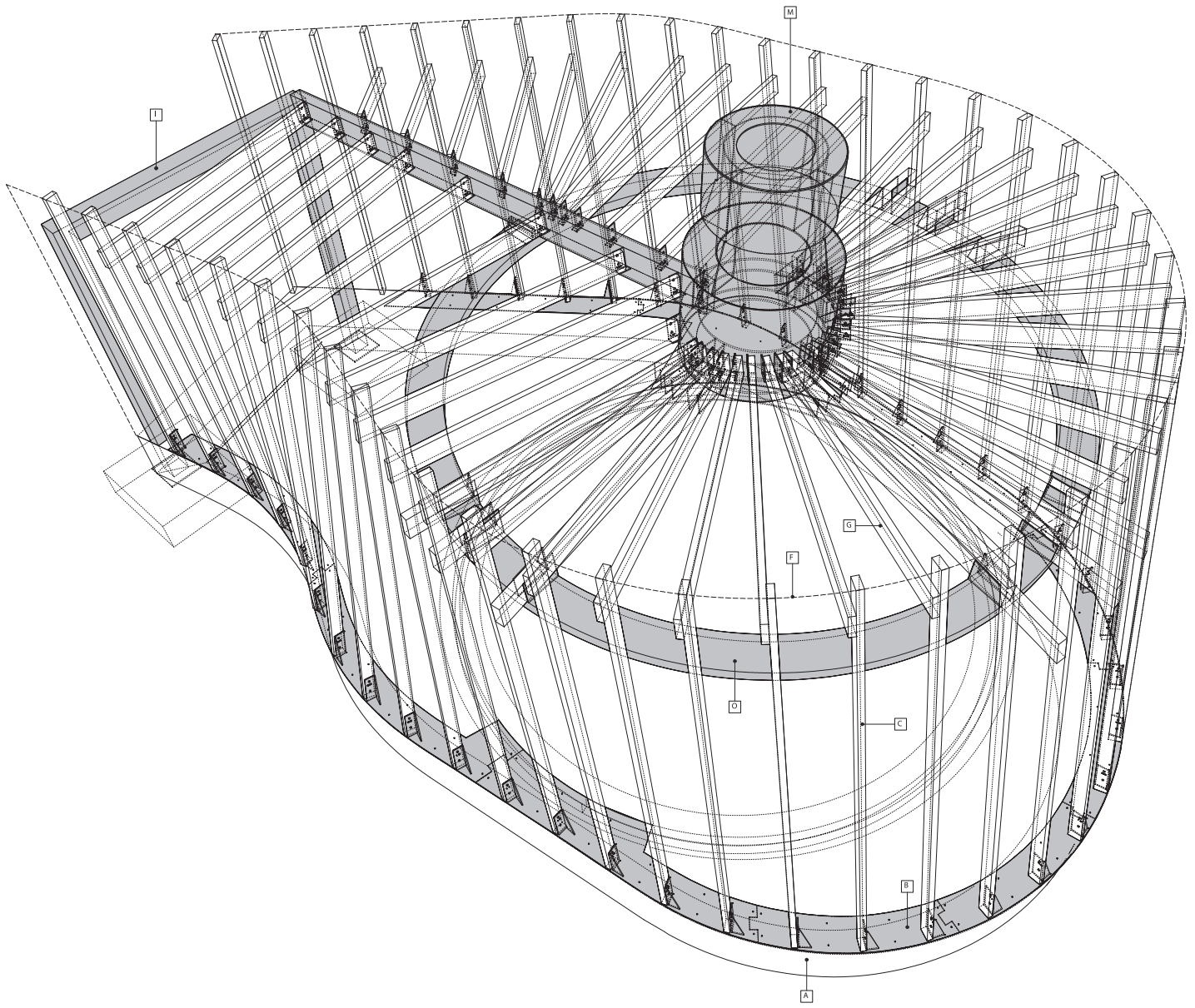

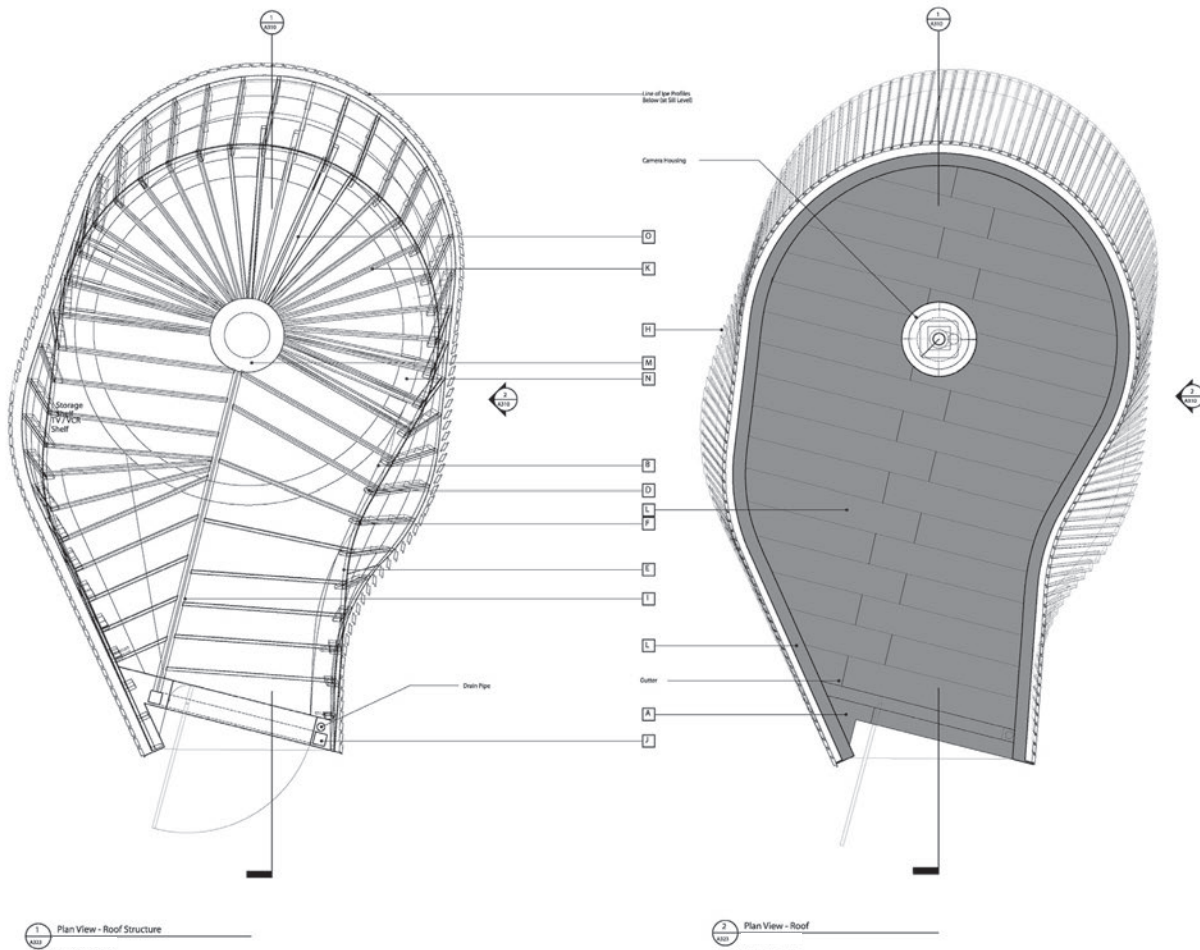

1 Plan View - Roof Structure

2 Plan View - Roof

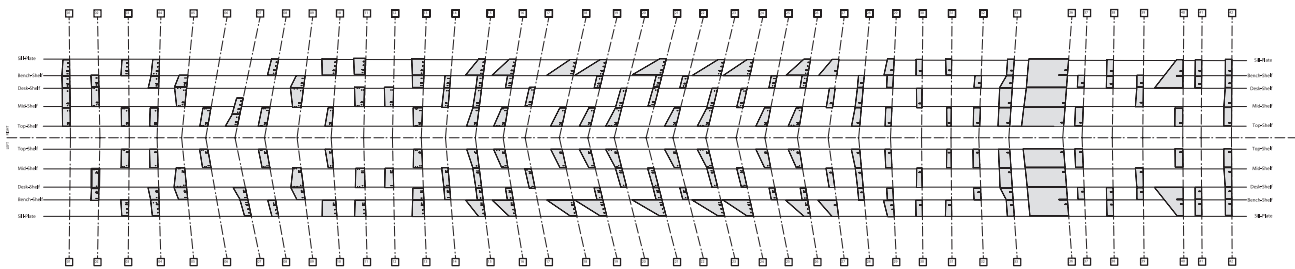

3 Component Schedule: Aluminum Fins / Shelf Supports

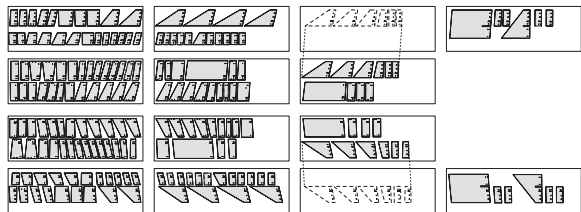

4 Nested Aluminum Fins / Shelf Supports

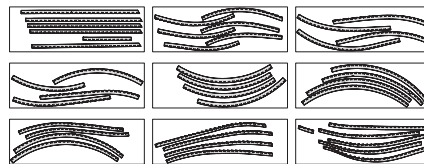

5 Nested Aluminum "Sawtooth" Ice Guide Components



6 Nested Aluminum "Sawtooth" Gussets



7 Nested Steel Tabs

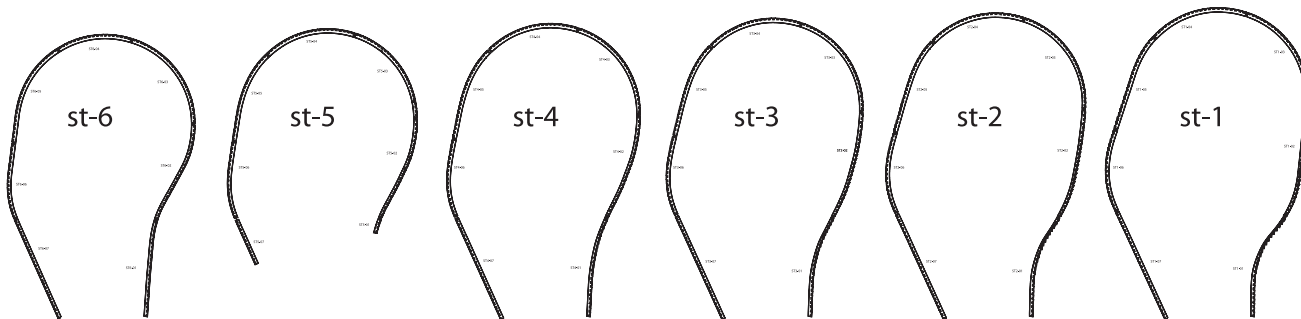

8 Component Schedule: Aluminum "Sawtooth" Ice Guides

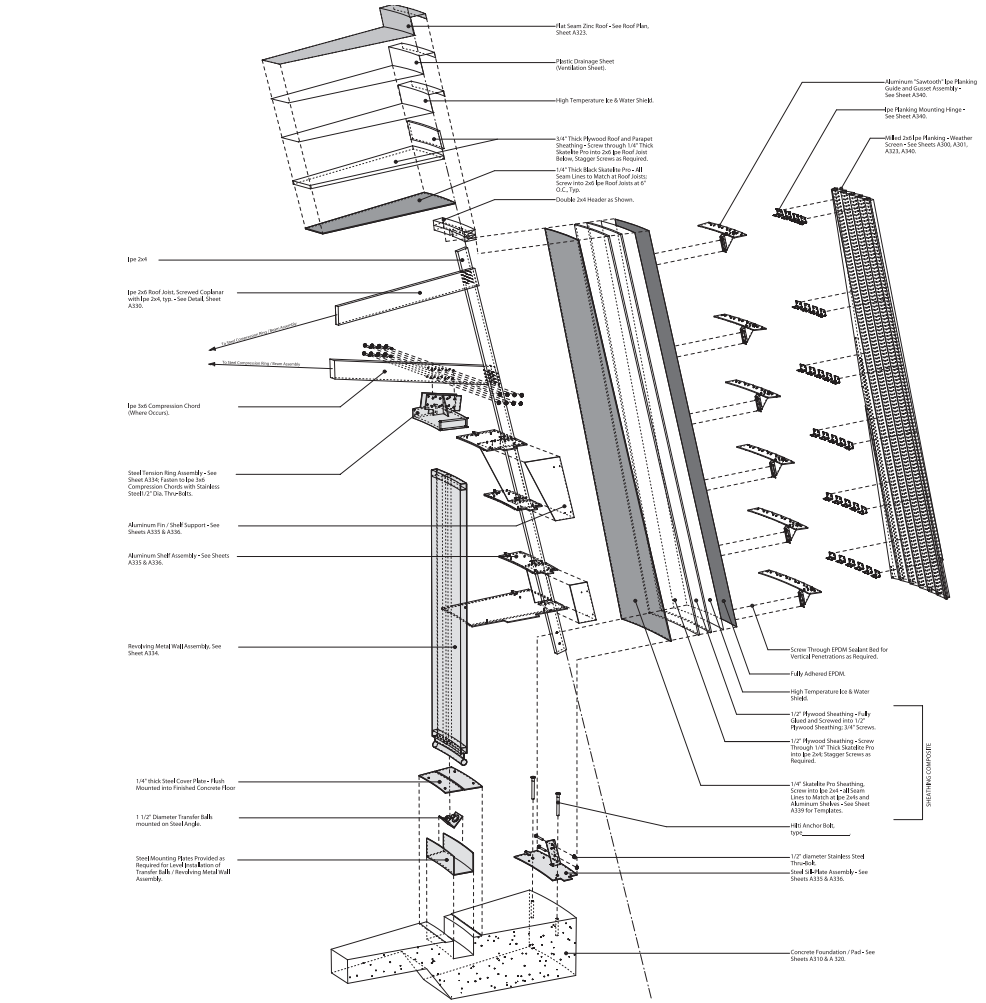
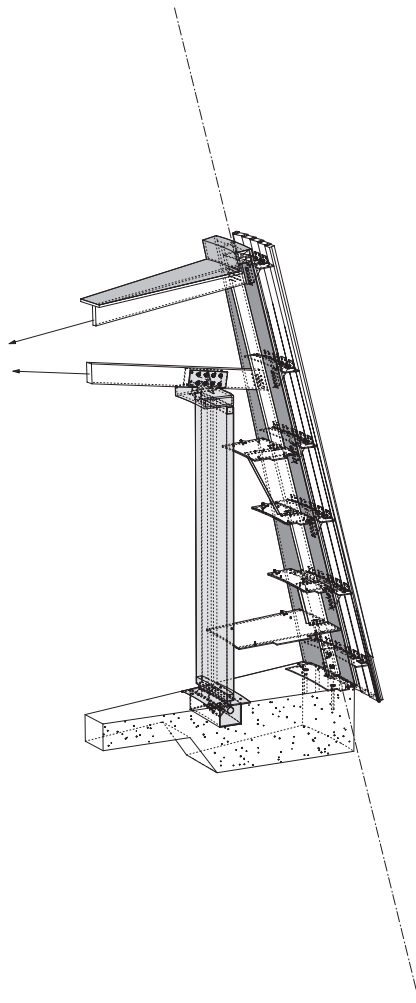



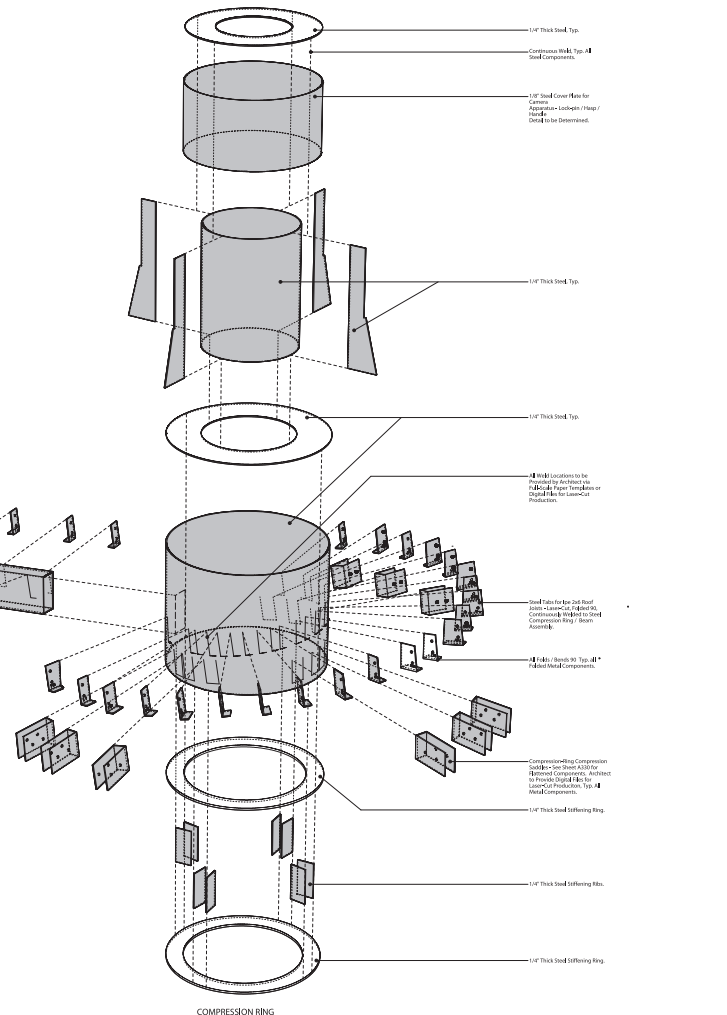
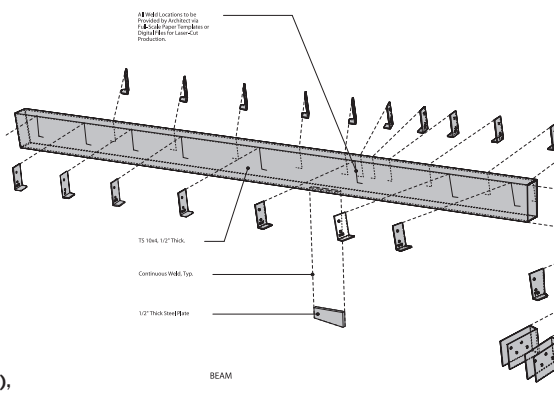



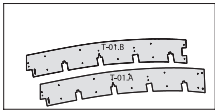
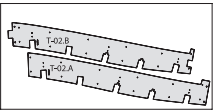
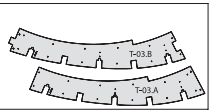
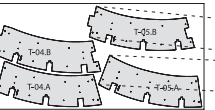

Note: Architect to provide 1/2" (12.5mm) and/or 3/4" (19mm) thick rigid foam insulation for the production of the roof composite.
 Note: 1/2" (12.5mm) and/or 3/4" (19mm) thick rigid foam insulation to be provided by the fabricator.
 Note: Steel Compression Ring to be fabricated to meet the thermal expansion requirements.

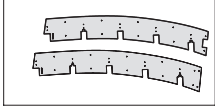
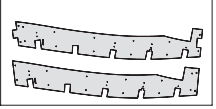
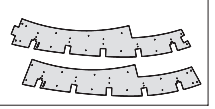
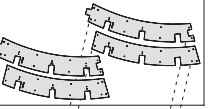
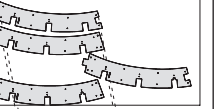
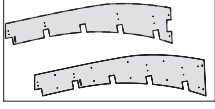
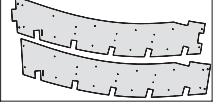
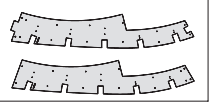

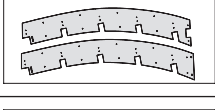
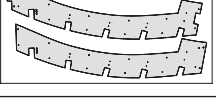
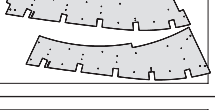
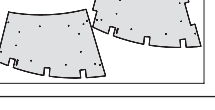
Opposite
Top: Roof structure plan (left), roof plan
Bottom: Nested pieces

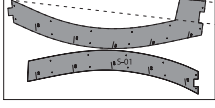
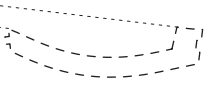
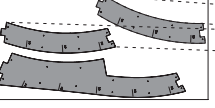
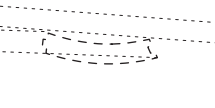
This page
Top: Completed assembly (left), assembly details
Bottom: Exploded isometric steel compression ring and beam assembly

| | 01 | 02 | 03 | 04 | 05 |
|-------------|-------------------------------------------------------------------------------------|-------------------------------------------------------------------------------------|--------------------------------------------------------------------------------------|---------------------------------------------------------------------------------------|---------------------------------------------------------------------------------------|
| top-shelf |  |  |  |  |  |
| mid-shelf |  |  |  |  |  |
| desk-shelf |  |  |  |  |  |
| bench-shelf |  |  |  |  |  |
| sill-plate |  |  |  |  |  |



| 06 | 07 | 08 | 09 | 10 | |
|----|----|----|----|----|--------------------------------------------------------------------------------------------------------------------------------------------------------------------------------------------------------|
| | | | | | |
| | | | | | |
| | | | | | |
| | | | | | |
| | | | | | |
| | | | | | |
| | | | | | |
| | | | | | |
| | | | | | <p>Bolt / Screw / Rivet Holes - See Note, This Sheet.</p> <p>4' x 12' x 1/4" Thick Milled Aluminum Sheet</p> <p>4' x 8' x 1/4" Thick Milled Aluminum Sheet</p> <p>4' x 8' x 1/4" Thick Steel Sheet</p> |

Note: All Screw, Rivet and Bolt Holes for all Steel and Aluminum Components / Assemblies to be Cut During Laser-Cut Production Process - No Manual Drilling required for Laser-Cut Steel or Aluminum On- and / or Off-Site.

Opposite
Top: Nested metal shelf and sill plate components for laser-cut production
Bottom: Shell (left), shell detail

This page
Bottom: Shelf detail (left), shell construction

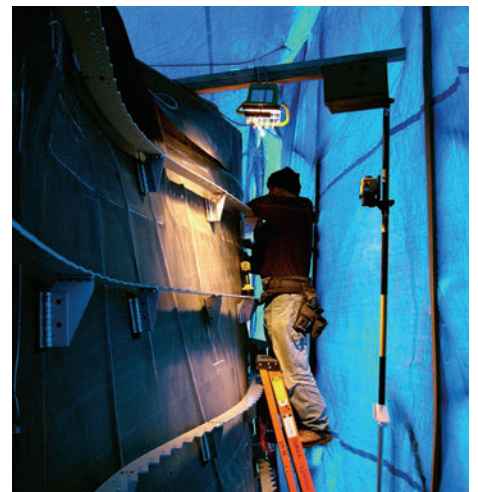

Bengt Sjostrom Starlight Theatre, Rock Valley College, Rockville, Illinois

Studio Gang Architects, Chicago, Illinois

Performances at the Starlight Theatre had always been susceptible to weather-related cancellations. Rock Valley College needed a roof for the popular outdoor venue that would guarantee their shows and maintain the open-air feeling of the existing theater. Studio Gang's solution was to develop a long-range renovation plan that could be constructed in phases over a three-year period, allowing the college to maintain the summer performance schedule. The first phase, completed in 2001, expanded the seating bowl from around six hundred to almost eleven hundred seats, and created a curving, 18-foot-high concrete structure at the back of the theater to house new bathrooms and ticket booths. The second phase, finished in 2002, consisted of an addition housing a 50-foot-tall fly tower and a proscenium stage house with sliding translucent doors. A copper-clad steel frame proscenium with 30-foot-high translucent all-weather doors faces the open-air seating bowl.

For the third phase, completed in 2003, the architect worked with Uni-Systems, a Minneapolis-based firm specializing in moving structures, to create a kinetic, faceted roof that consists of triangular stainless steel-clad panels supported by steel columns and trusses. When the roof opens, six of its panels rise in succession to form a six-pointed star revealing the sky. The theater's multi-pitched canopy has a lower fixed section of twenty panels 100 square feet in plan, and surrounds a higher 90-ton movable assembly over the seating area, a hexagon in plan with forty-foot sides, and six triangular panels that cantilever from steel trusses bearing on freestanding columns. Each panel weighs nearly 15 tons, opens to a sixty-eight-degree pitch and has a five-hp motor that drives a 50-ton-capacity screw jack. When closed, audience members see a hexagonal pitched roof. As the roof opens, each panel rotates up in sequence, in a clockwise motion over fifty-four degrees about the perimeter, quietly and quickly in

just over twelve minutes. There are no visible clues that indicate how the roof moves: the mechanical and structural systems are so seamlessly integrated that the panels appear to float open. The unusual design required that the roof components be installed in reverse order. Instead of beginning with the ridges and valleys, the main roof panels were installed first and then connected. Using 24-gauge type 316 stainless steel, each roof panel was fabricated as sections of tongue and groove planking, cut in standard lengths, and set on laminated wood beams covered with an ice-and-water protection compound, then cut to fit the roof angles on site. The panels have a gutter on each side, so that when they are down, the closed roof has a full gutter system. The panels raise and lower one by one in a specific order so the gutters can interlock and create a trough in between each panel. When it rains, the sophisticated roof seal system provides complete protection.

This page
**Building sections roof
closed (left) and open**

Opposite
Roof open

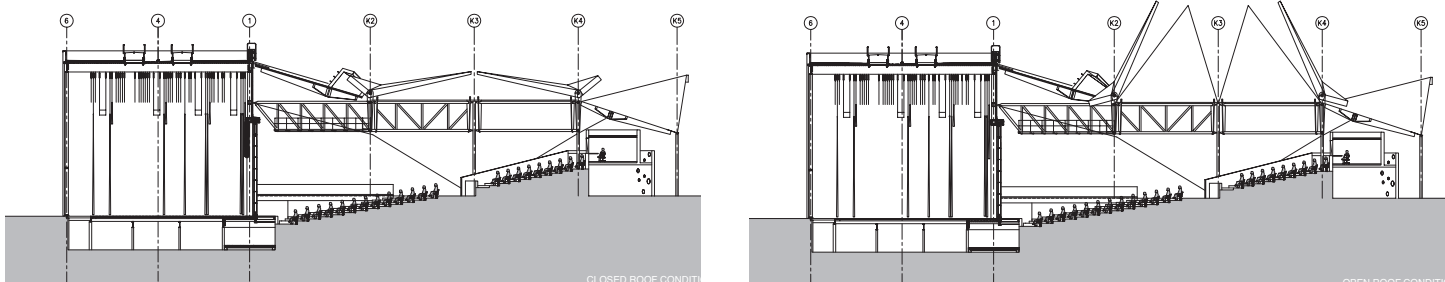



This page

Top: Roof panel

Middle: Panel structure

**Bottom: Theater entrance
(left), catwalk**

Opposite

Top: Entrance

Bottom: Roof, open

To operate the roof, the architects and engineers opted for electrical components with a back-up hydraulic operating system. Each panel was fitted with an ultra-quiet electronic gearbox so theater staff can smoothly and quietly rotate the panels up, one after another, in a clockwise movement with a single mouse click. Along with the drive mechanism, inside each panel is a hydraulic safety mechanism that serves as a redundant load path for the weight of the panel to accommodate the roof's gutter system. For clearance, the panels must be accurately positioned in relation to the interlocking system. Control software only activates after the operator clears digital security, including biometric thumbprint identification. A backup hydraulic circuit allows for manual operation.

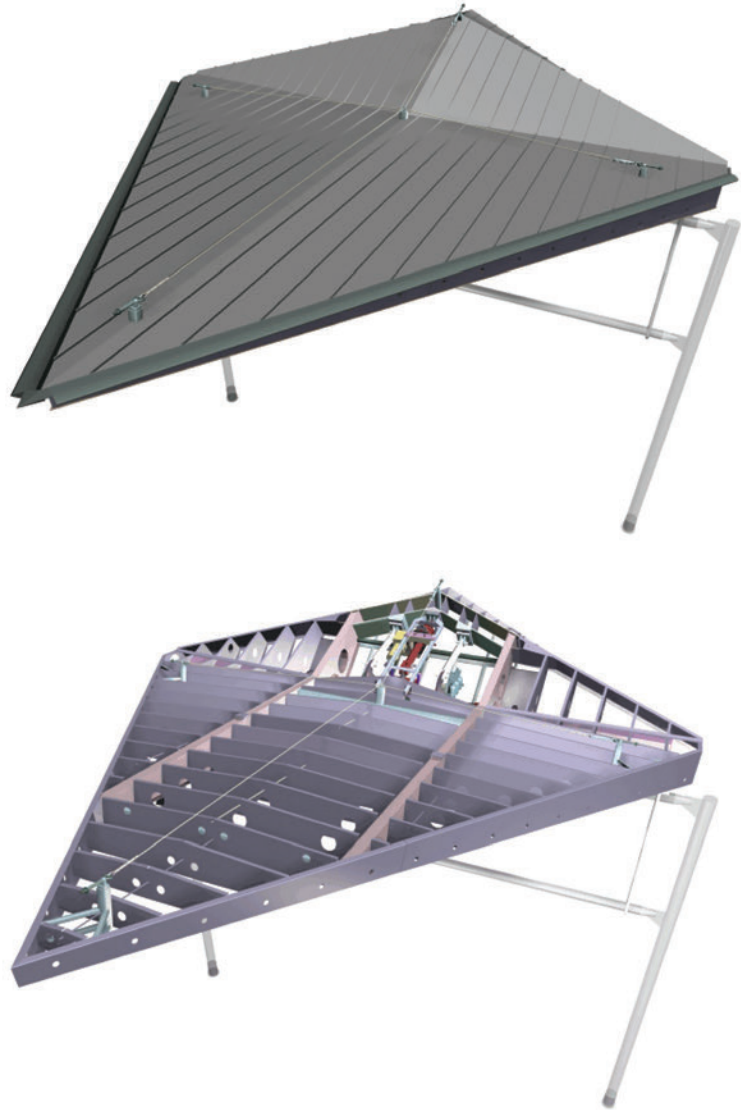



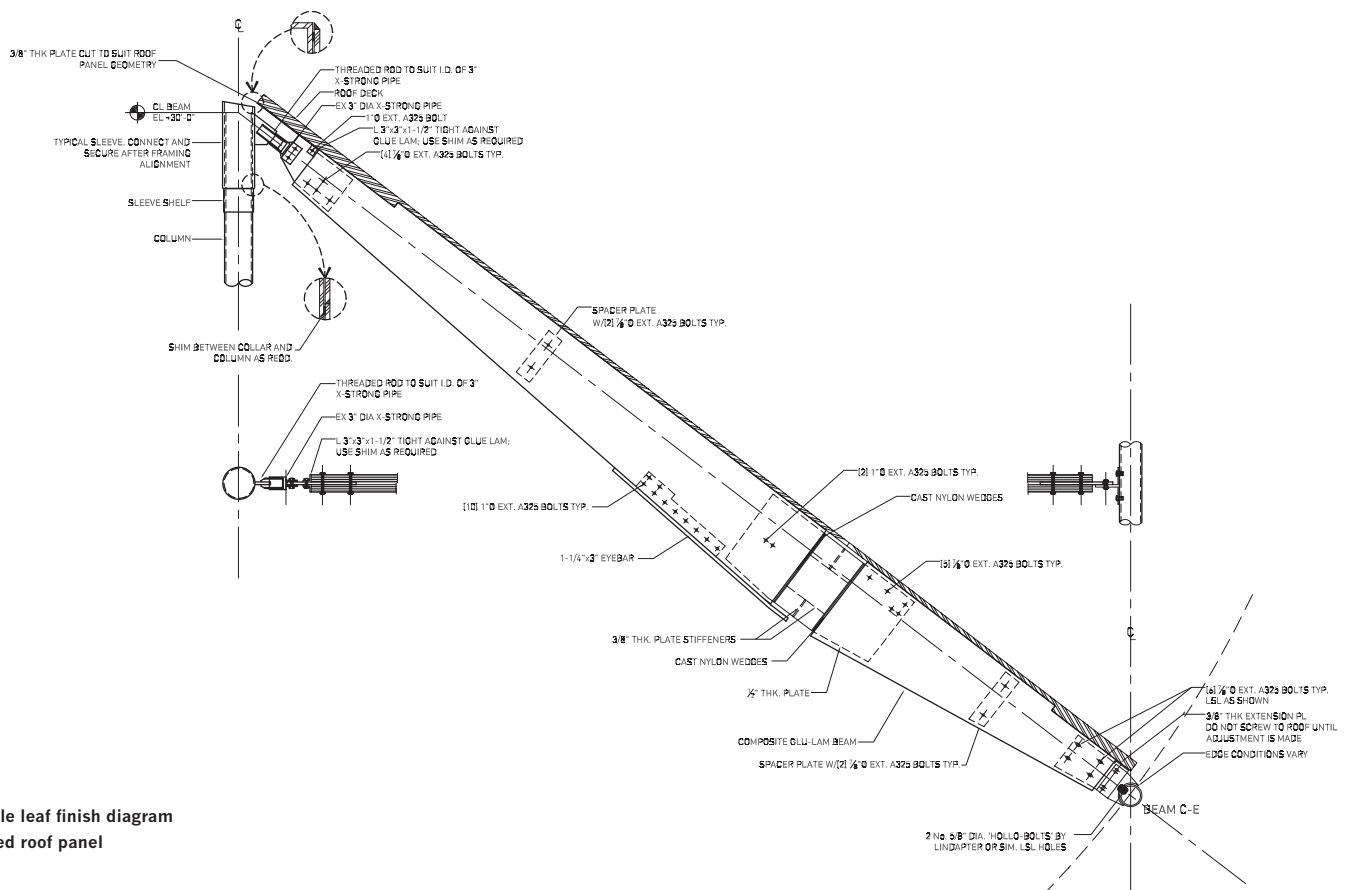
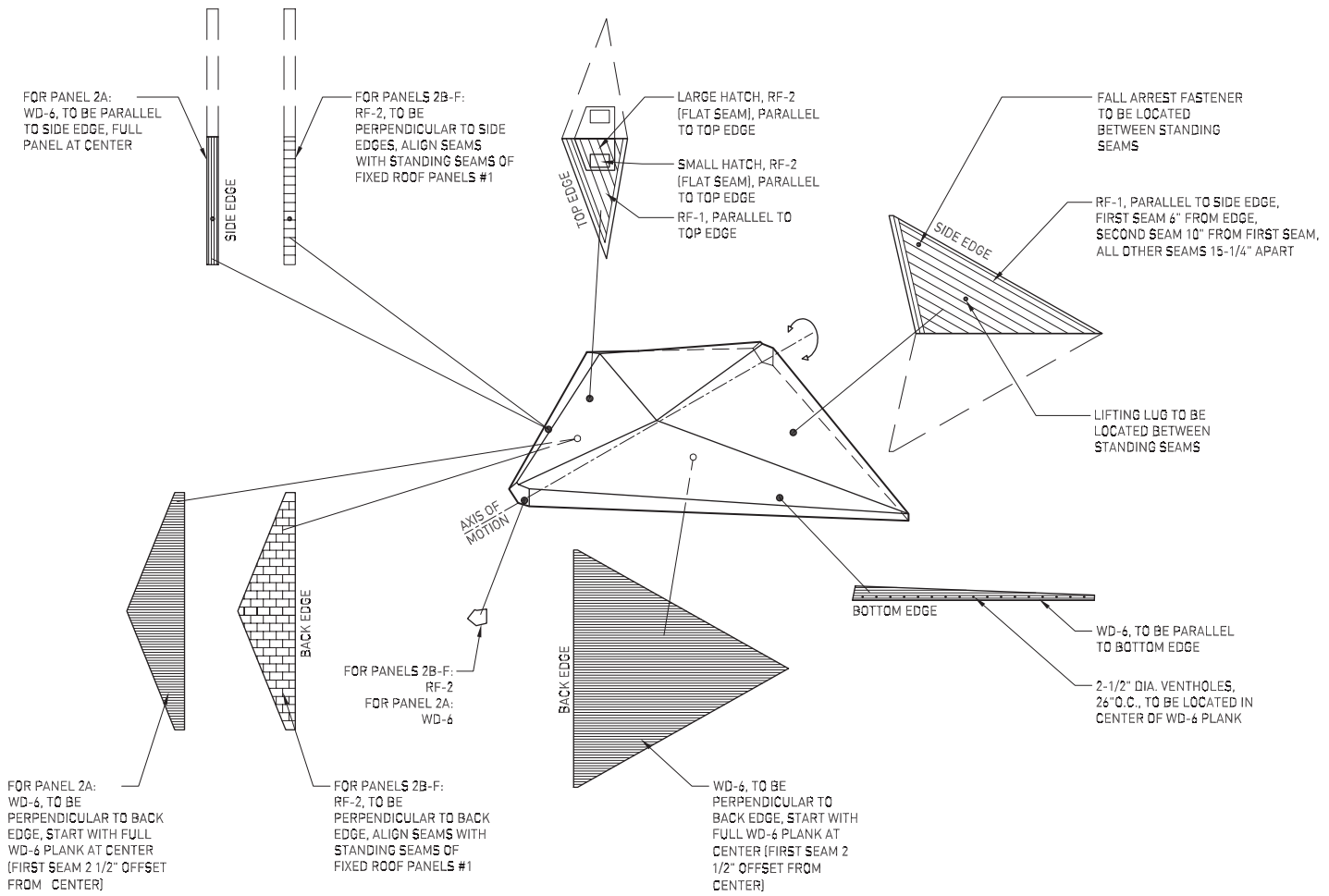

This page
Top: Operable leaf finish diagram
Bottom: Fixed roof panel connections

Opposite
Starlight roof opening sequence



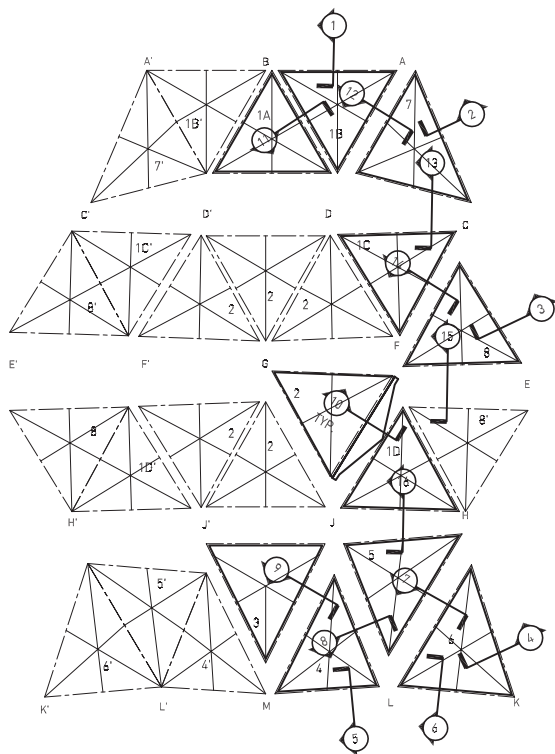
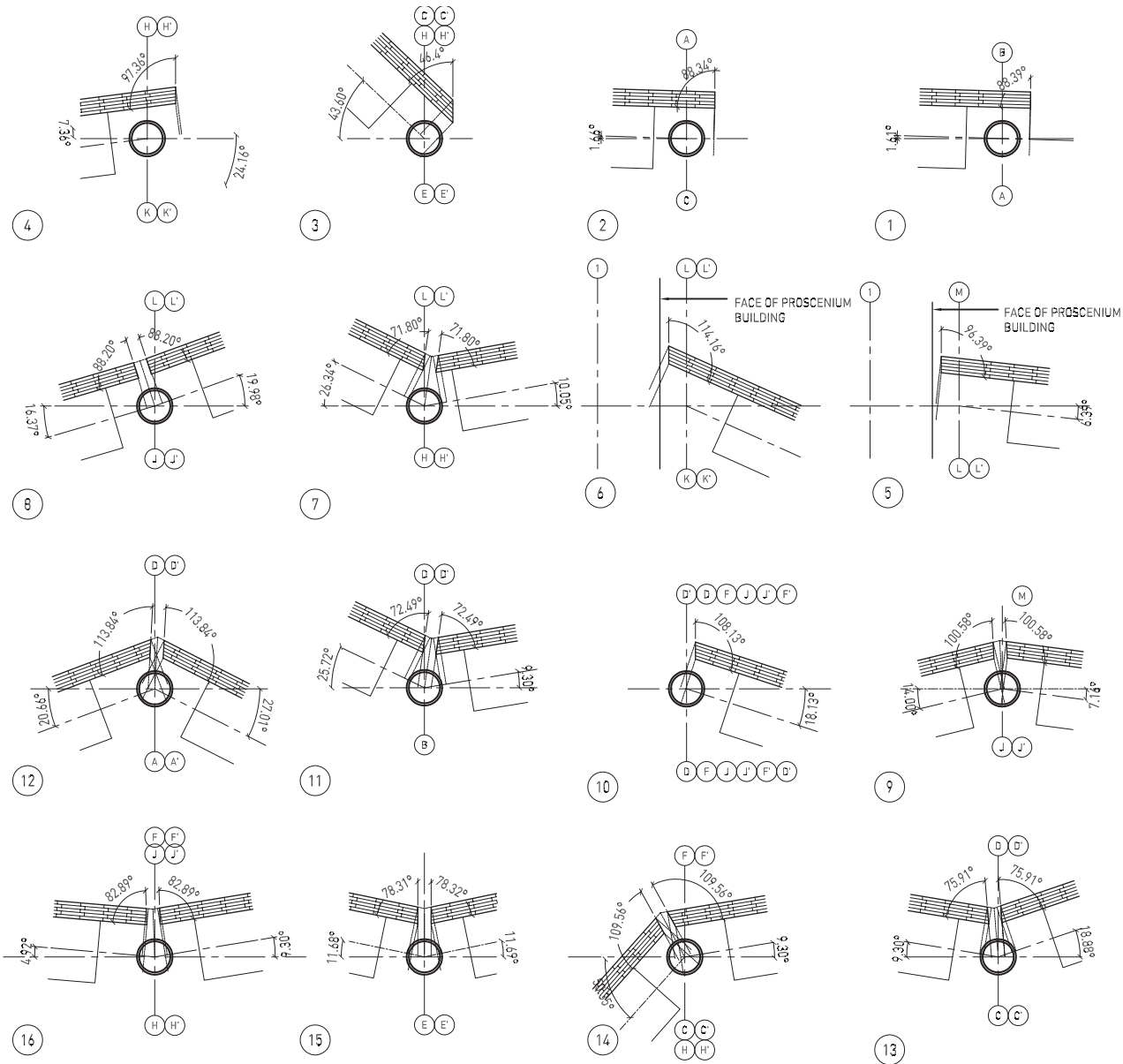

KEY PLAN

This page
Top and left:
Panel edge conditions

Opposite
Weather door

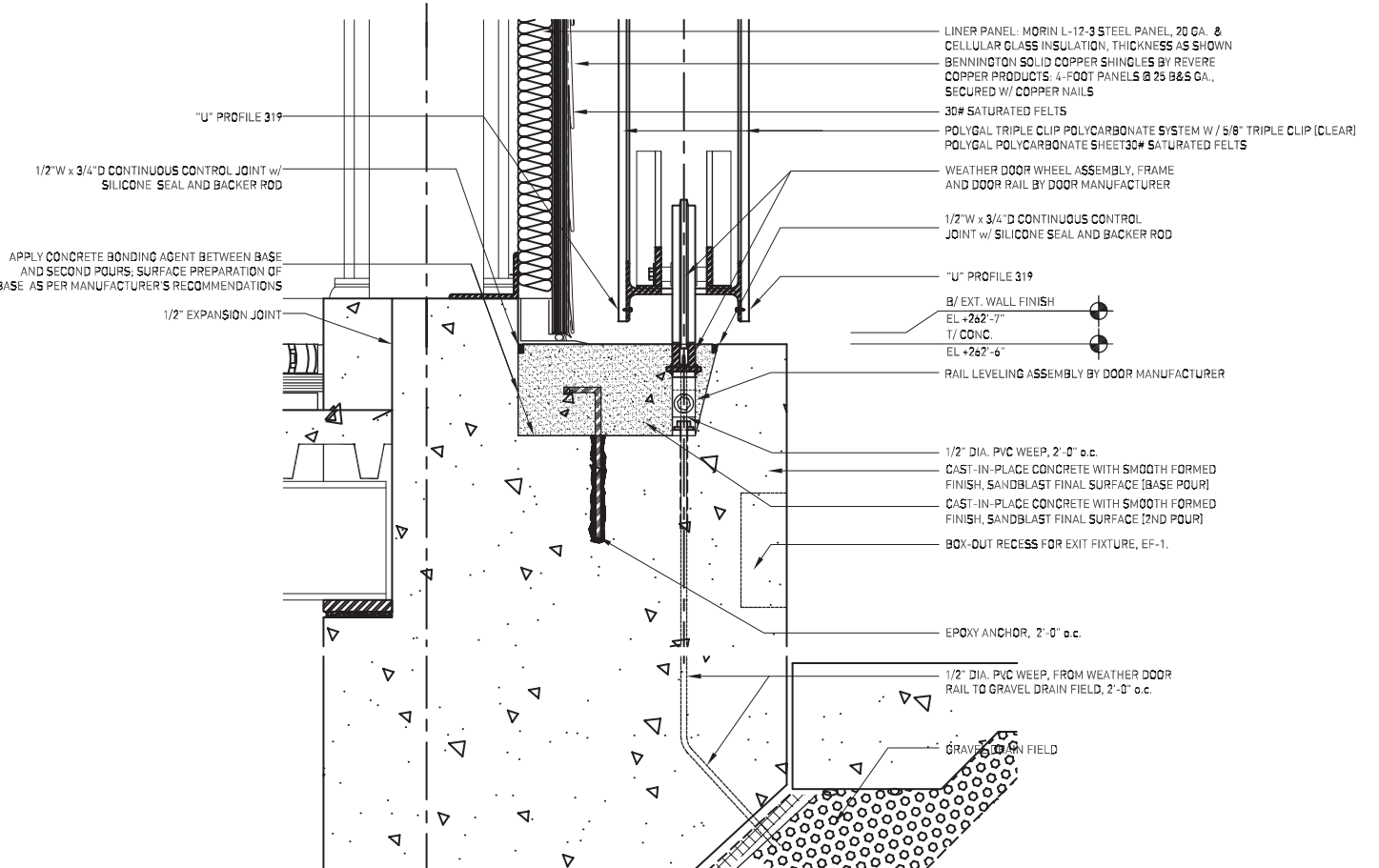
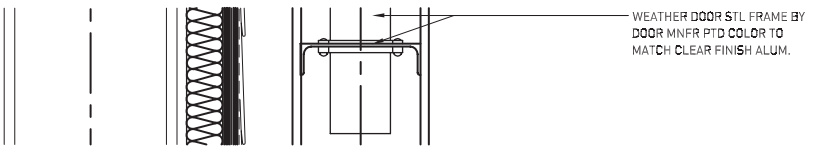
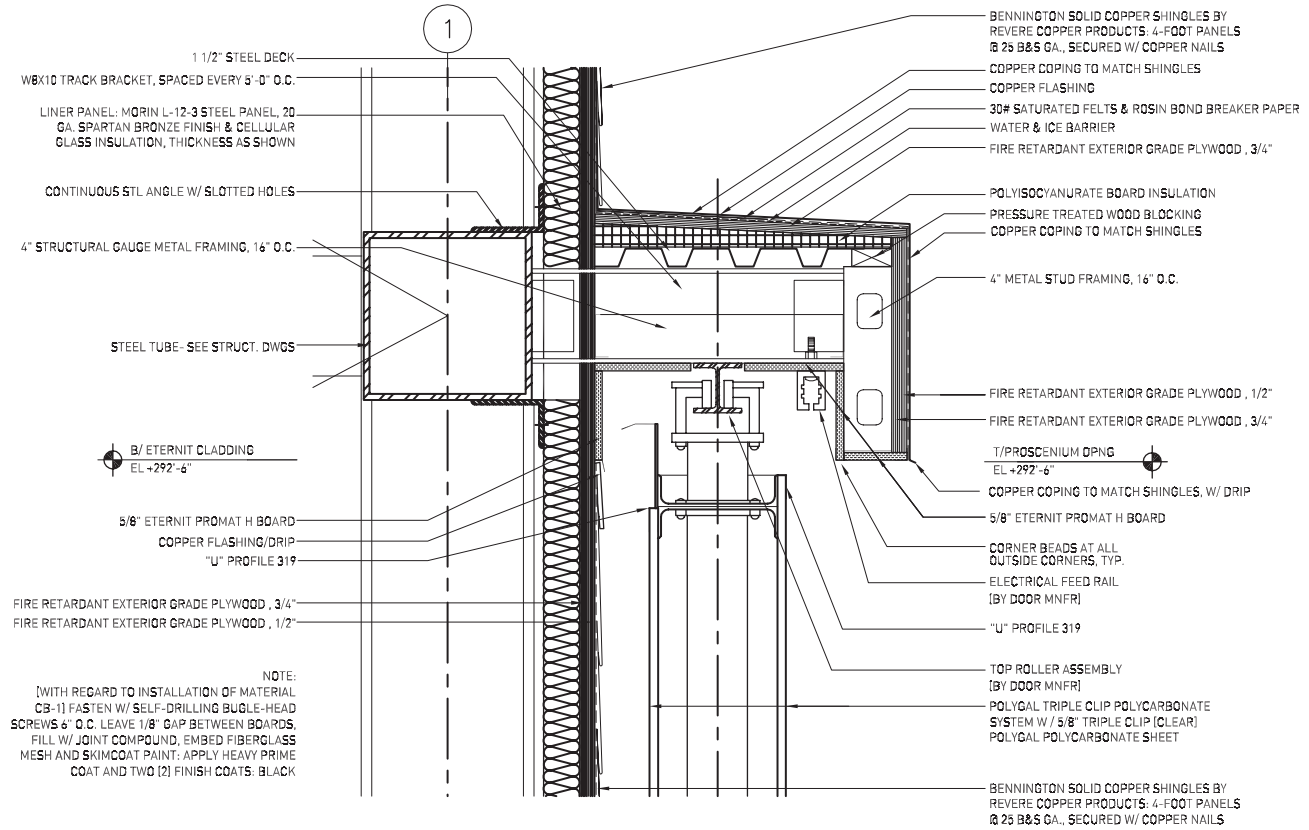

Holy Rosary Catholic Church Complex, St. Amant, Louisiana

Trahan Architects, Baton Rouge, Louisiana

The Holy Rosary Church site was a loose collection of historic vernacular church buildings and interim educational facilities overwhelmed by the surrounding rural landscape in southern Louisiana. Design objectives responded to these circumstances as well as to the church community's desire for a place with a heightened sense of spiritual purpose within the powerful natural setting. The new campus master plan unifies all parish functions while drawing a clear distinction between sacred and secular programs. Secular components of the campus take the form of linear edge pavilions arranged to frame a courtyard, or sacred precinct, where the oratory is located. Moving in a clockwise direction, the promenade around the interior lawn leads ultimately to the oratory. In the opposite direction, the path offers the complementary experience of gradual movement from the intensely spiritual center back into the community.

The perimeter pavilions define both an explicit and implicit boundary between the campus and its rural setting. These buildings, along with associated walkways and canopies, comprise an occupied frame, a thickened zone of space where a layering of elements and surface types gives depth

and weight to the experience of moving between the inner sanctuary and the territory beyond. The layering strategy is evident in both plan and building cross section, where parallel planes of concrete, glass, and canopy delineate degrees of enclosure from conditioned to semiconditioned space and open air. The architectural character of the composition is the product of an exploration of form, function, natural light, and materials. Visual understatement creates a quietness, focusing attention away from the architecture and toward the purpose of the church and its relationship to its setting. The deliberate effort to avoid decorative symbols or ornament directs attention to materials. In the context of striking simplicity, material expression is elevated to a poetic and symbolic level.

Initial focus on material was prompted by reforms of Catholic Church doctrine that emphasized the use of materials based on their capacity to suggest a sense of permanence and appropriateness. Costly or rare materials were avoided in favor of materials naturally abundant in the region that could be made radiant and expressive through proper use. Cast-in-place concrete provided an image of strength and was carefully

shaped and detailed to transcend its industrial stereotype. The density and mass of concrete contrasts with two types of glass: the transparency and crystalline clarity of plate glass and the translucent luminosity and sculptural properties of cast glass.

The unique role of each layer expressed in both materials and detailing is best illustrated in the wall sections. Cast-in-place concrete was chosen for the outer-most walls to give them mass and weight. While they appear two dimensional when approached from the exterior, these boundary markers reveal a space-defining role as the enclosing perimeter wall, generating a sense of stability and shelter in the academic and administrative pavilions. The edge-making function of this plane is asserted on the interior by a spatial separation of the roof and ceiling plane, allowing a wash of natural illumination to add warmth to the wall while intensifying its visibility. Careful detailing of the slot avoids compromising the purity of the relationship of the wall to roof plane by concealing the enclosure system.

By way of contrast, a glazed layer on the pavilion's courtyard face encourages a visual penetration of space. Self-supporting expanses of plate glass create a second

This page

Longitudinal section

Opposite

Top: Courtyard and oratory entrance

Bottom: Oratory rear elevation

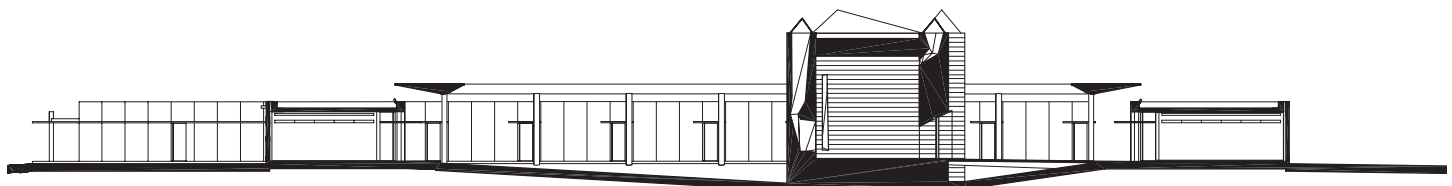



This page
**Bottom: Plan (left),
administration building**

Opposite
**Top: North-south section
view east
Bottom: Oratory east-west
section view south**

independent plane offset from the wall and roof edge, extending the full height of the building. This discrete plane of glass is associated equally with the pavilion enclosure and circulation path, a condition also expressed in the separation of building and glazing systems at the pavilion corner detail. The appearance of a continuous transparency from one glass panel to the next is achieved through silicone butt joint detailing.

The independent canopy system, inspired by the vernacular use of porches, creates semiconditioned protected space mediating between the courtyard and pavilions. In this application, the canopy shades the glazed wall and reinforces a directional movement around the courtyard. The canopy is shaped to express a secondary direction of movement perpendicular to the formal path and to appear light and floating in direct sculptural tension with its materiality and the massiveness of the adjacent buildings. This ultimate layer of the thickened frame is a wing shape, cantilevered in two directions from a procession

of columns coming to rest in the grassy edge of the courtyard.

The void between pavilions and oratory creates an outdoor room appropriate for large communal gatherings, smaller gatherings, or private meditation near the chapel. Seating on the lawn is facilitated by the gently depressed center of the courtyard that creates a slight bowl shape around the perimeter. Across this depression, a ramp leads to the chapel portal and marks the transition between secular and spiritual realms.

As the spiritual focus of the campus, the sacred space of the oratory is distinguished by its abstract purity, height, and placement. Off-center and rotated, the 30-foot cube of the chapel appears to float over the courtyard lawn, creating a deliberate break in the fabric of the complex. In direct contrast with the smooth, plywood-formed pavilion walls, the spare surfaces of the chapel are uninterrupted by tie holes, the concrete marked instead by the subtle texture of the narrow-board formwork, creating an inverse relationship with the wood lap

siding of the historic church. The rotation of the chapel exterior is accompanied by a reciprocal rotation of the sacred chamber, an internal 20-foot cube nested within the chapel's larger exterior cube—all six sides equal, to heighten the sense of mystery. This second rotation realigns the orientation of the sacred space with that of the main campus and symbolizes a union of spiritual and secular experience.

The geometric proportions of the oratory are derived from the Japanese four-and-a-half tatami mat configuration; tatami are usually 3 by 6 feet and rooms are built to contain a certain number of them—a formal Japanese tea room has the proportions of four and a half mats. The nonhierarchical organizational system of the tatami accommodates the greater flexibility required for liturgical purposes as parishioners are encouraged to play a more active role in the celebrations.

Splayed walls of the portal threshold mark the passage from the open courtyard to the intimate oratory chamber. Interconnected outer and inner openings are scaled

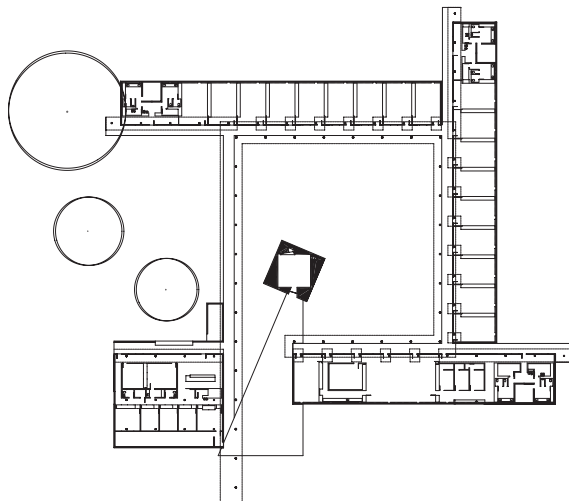

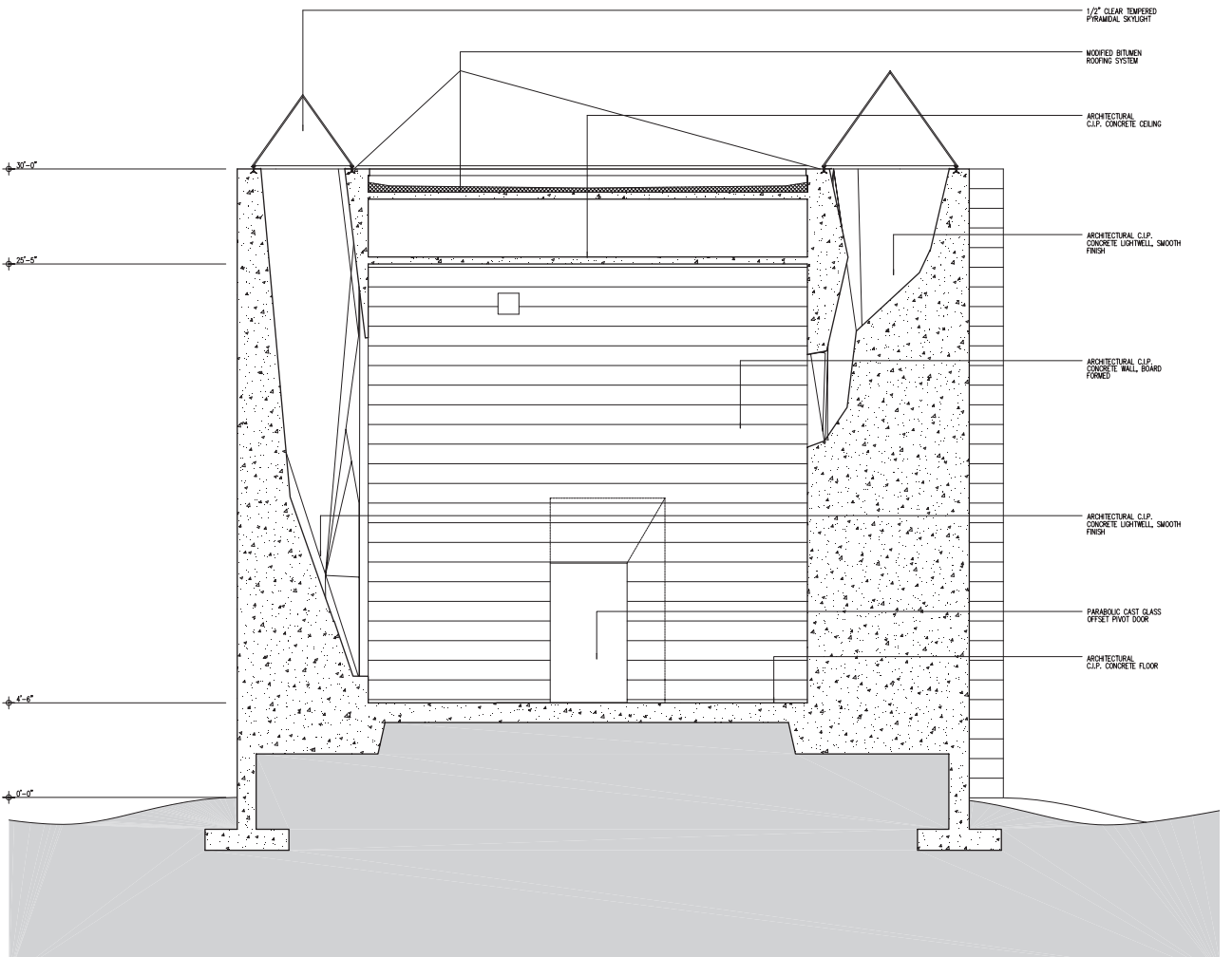
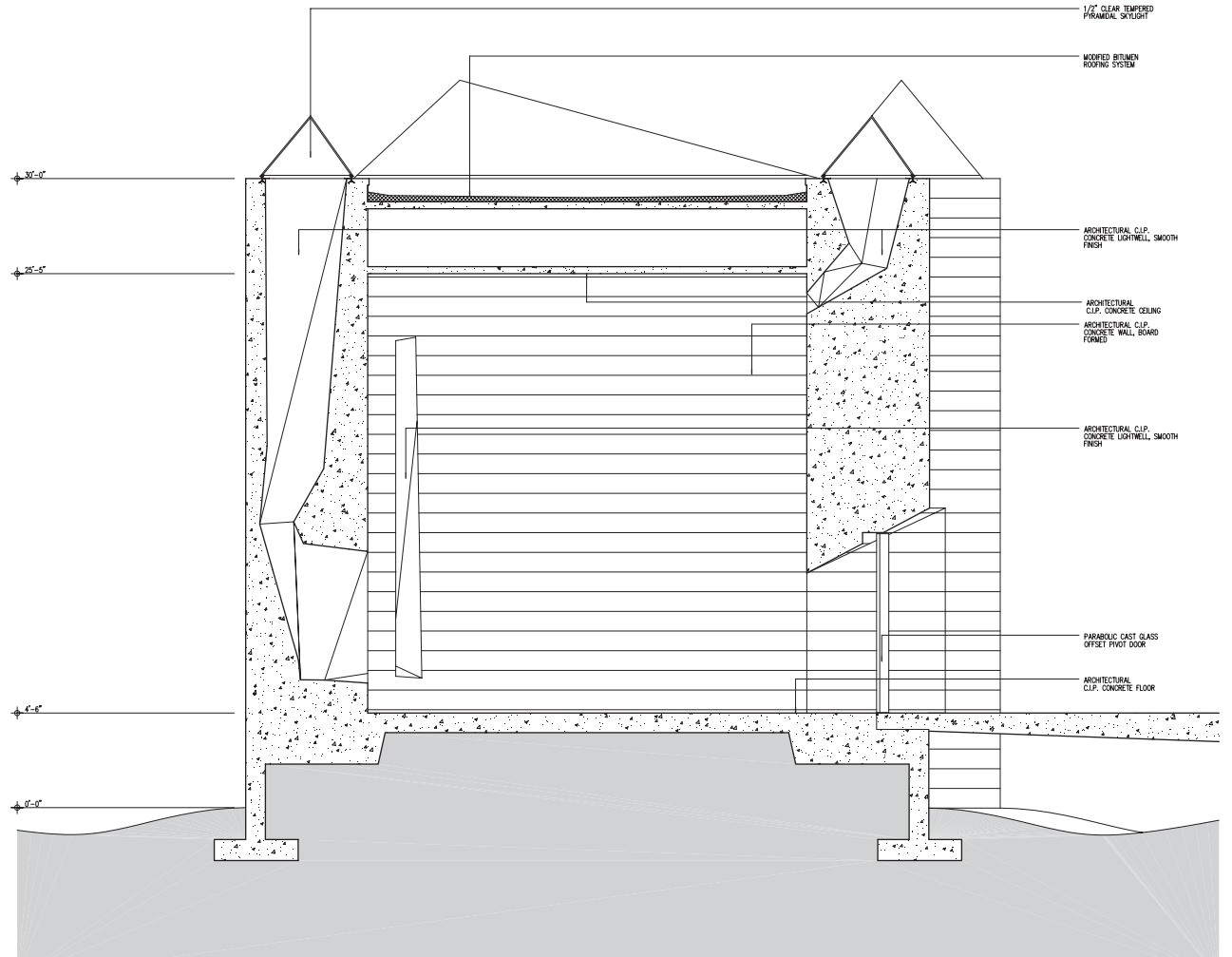

This page

**Bottom: Lavatory (left),
hand wash basin**

Opposite

**Top: Oratory interior, north
elevation (left), roof aperture**

**Bottom: Religious education
building entrance lobby**

proportionally to the outer and inner cubes. Consequently, passage into the oratory is experienced differently than passage out, a sequence of compression and release that gives physical form to the spatial and personal transformations taking place. A cast-glass door set within the threshold celebrates arrival and departure through the experience of light. The door is assembled from three stacked panels supported by narrow stainless-steel rails along the top and bottom edges. Lens shaped in plan, the panels vary in dimension across their widths, narrowest at the 12-millimeter edges and widest at its 75-millimeter centers. The parabolic shape of the door, fabricated by craftsman John Lewis, gathers and refracts light, glowing brightly at its edges and producing a soft luminosity at its center. In the process of pouring liquefied glass onto cooling layers, a texture of ripples and swirls was formed, creating a continuity between the appearance of the glass and concrete surfaces. Together, shape and texture serve to interrupt the line of sight, leaving only the obscured play of light, shadow, color, and

movement appropriate to the metaphysical experience of the inner chamber. A small stainless steel-lined recess scooped from the threshold wall allows the hand to grasp the door's narrow glass edge, rotating the door open on an offset concealed pivot.

As illustrated in the wall sections, light enters the interior of the chapel through a variety of openings in the varying wall thicknesses produced by the offset rotation of the interior and exterior cubes, drawing natural light into the oratory without revealing the source of light. Openings near the ceiling produce brilliant light; openings near the floor produce a soft, obscure light. Following the Catholic tradition of investing light with symbolism, each aperture is a meditation on a different aspect of the paschal mystery of Christ: death, resurrection, ascension, and eternal presence.





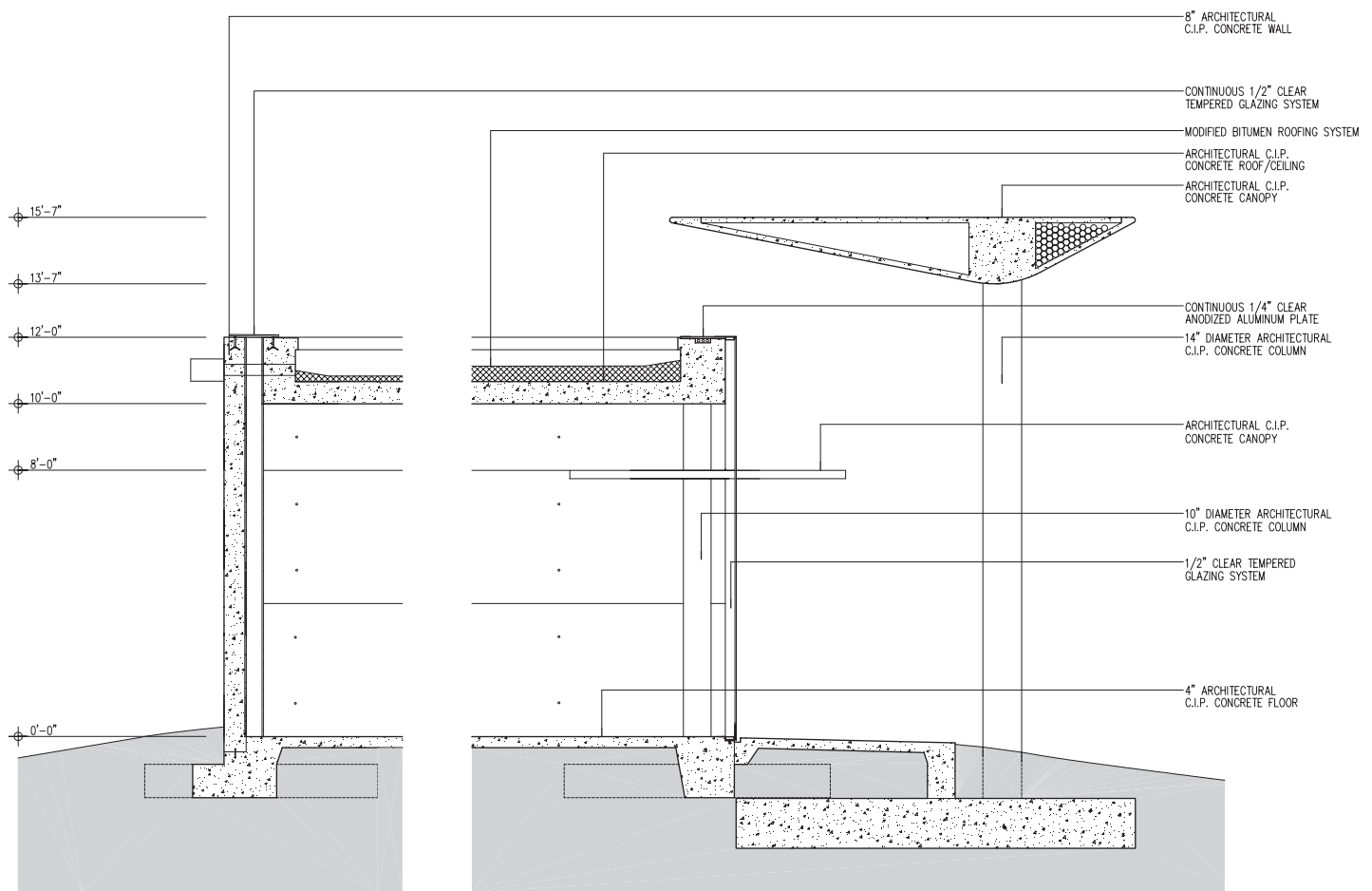

Opposite
Top: Colonnade and administration building section
Bottom: Office facing south

This page
Top: South pavilion section
Bottom: Lavatory lobby

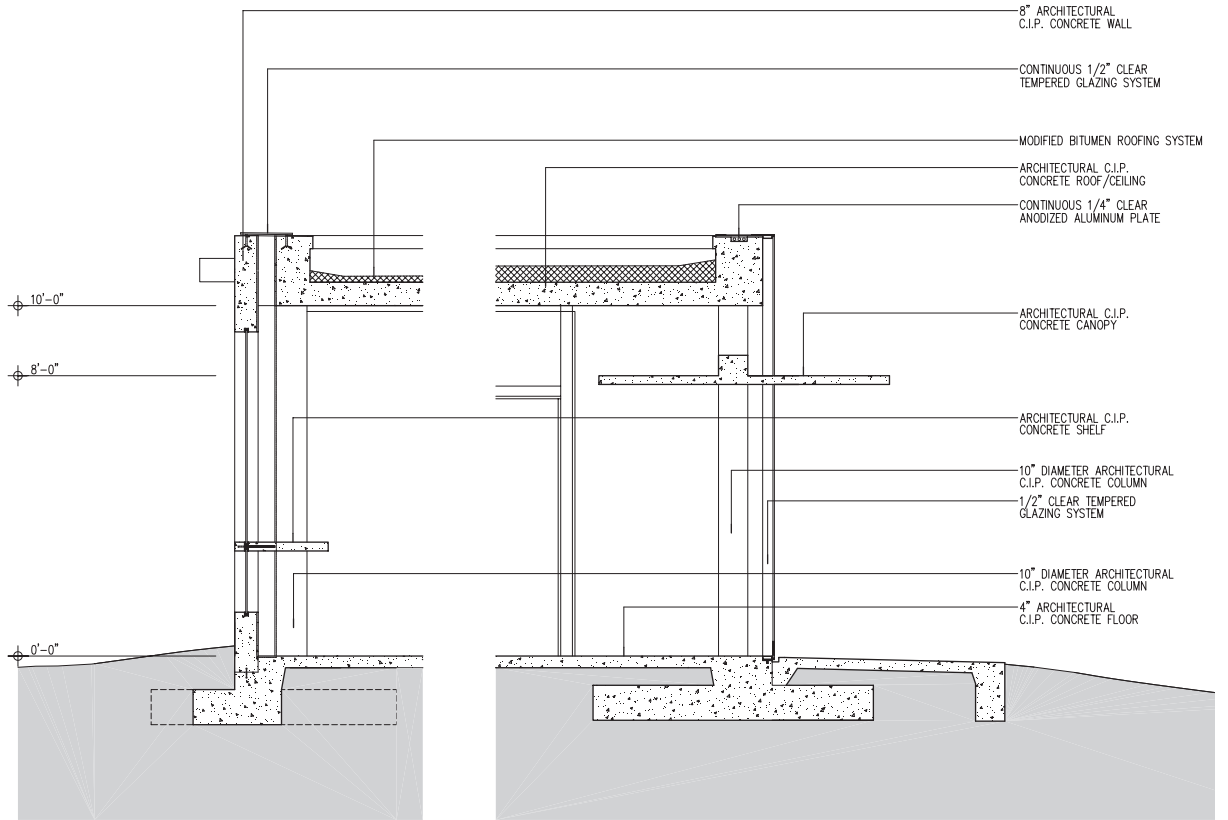

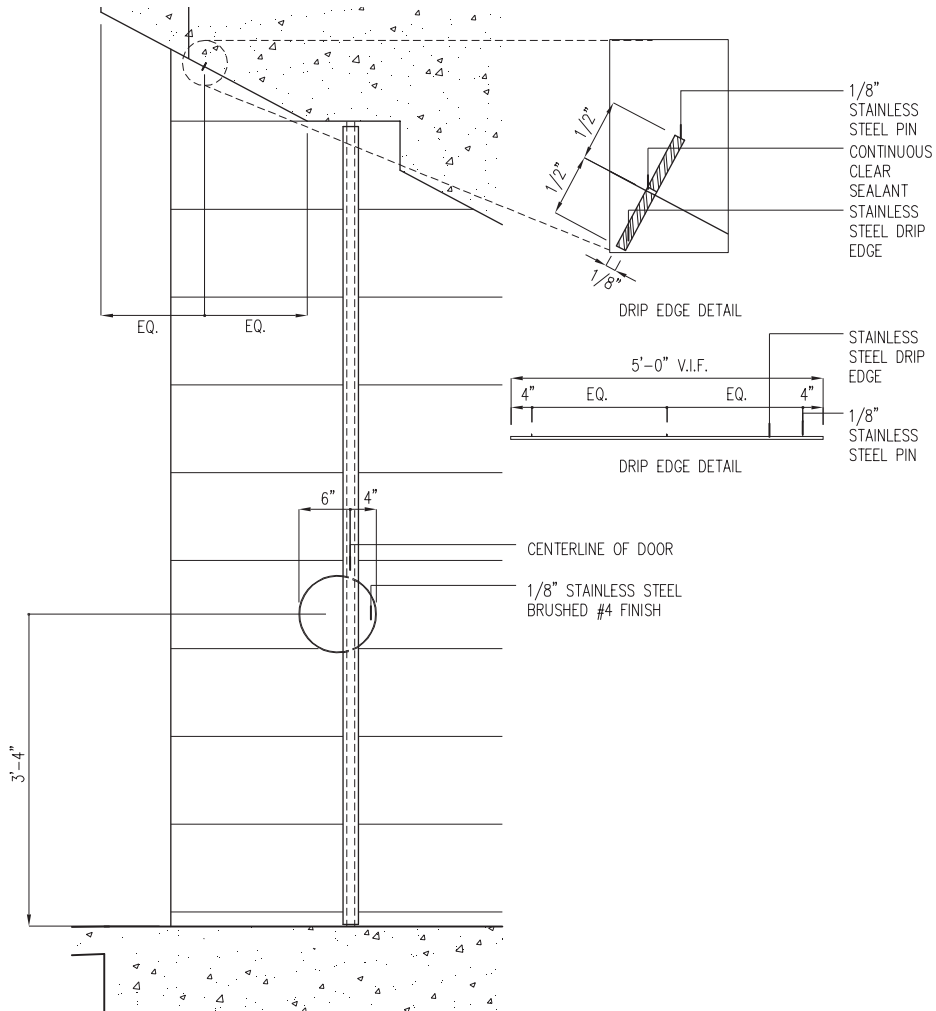

This page
Top: Oratory entry door section
Bottom: Oratory entry door plan, open (left)
Top right: Oratory entry door plan, closed
Bottom right: Oratory entry door, open

Opposite
Oratory entry door detail

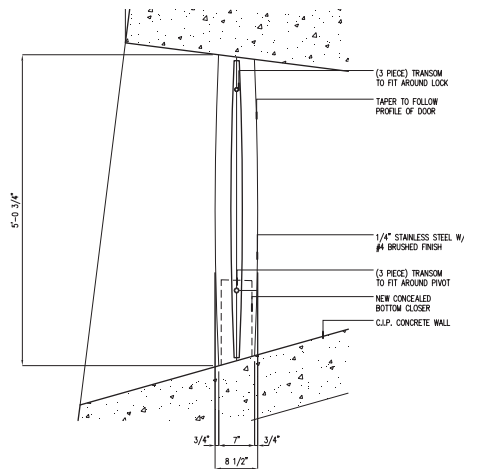
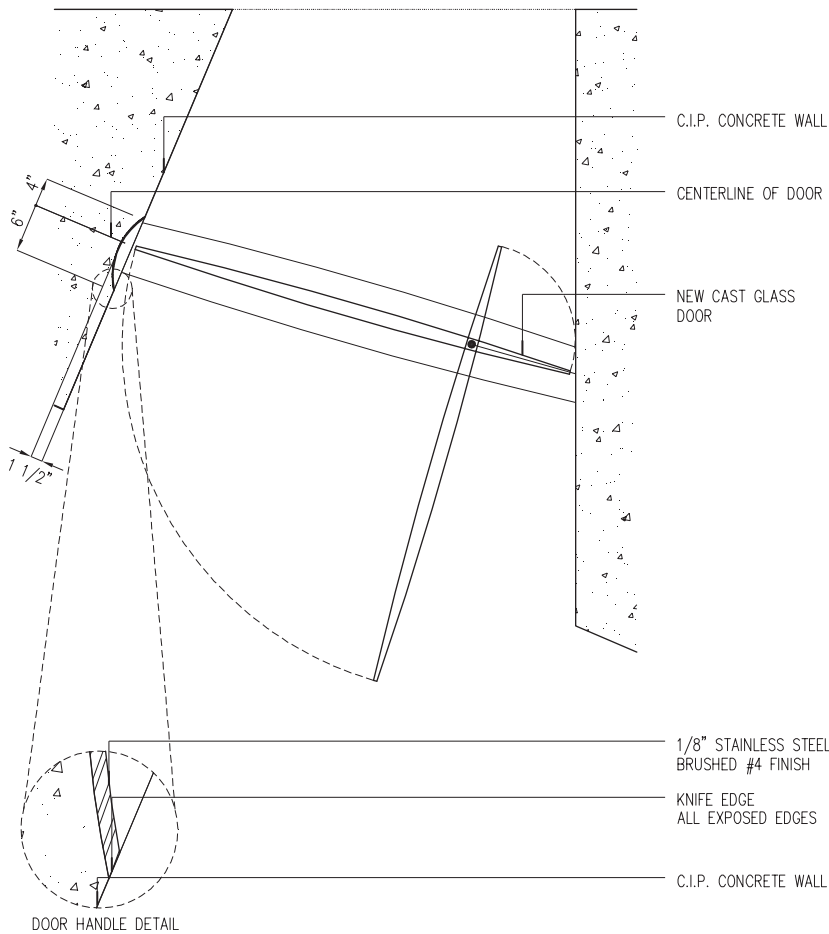



University of Chicago Graduate School of Business, Chicago, Illinois

Rafael Viñoly Architects, PC, New York, New York

The University of Chicago campus is organized around a sequence of quads that gives the institution its remarkable character; the architecture of the university is renowned for both its stylistic consistency and the quality of its public rooms. The design for the new Graduate School of Business is based on the idea that a quadrangle can be transformed into a public room—not another quadrangle in a campus of many extraordinary quadrangles, but an interior garden that functions year-round and becomes part of the school's identity, a space where people and ideas come together. The program had to integrate formal and informal learning space; provide plenty of opportunities for students and faculty to connect, collaborate, challenge, and create; and fit into an architecturally significant location bordering Frank Lloyd Wright's prairie-style Frederick C. Robie House and Bertram Goodhue's gothic Rockefeller Chapel.

The design for the Graduate School of Business makes the quad a public room enclosed in a winter garden, a six-story glass atrium that can be used year-round and functions as the main ceremonial space of the school. Natural light from the Winter Garden reaches the interior of the building through a ring of triple-height spaces surrounded by study rooms. Three circulation cores surrounding the Winter Garden connect all the levels of the building for use by the students, faculty, and the public at large.

In plan, the building recedes at the corner of Woodlawn Avenue and 58th Street to mirror the open space behind the

Rockefeller Chapel, anticipating the arrival at the main quadrangle of the university to the west. This green space allows the viewing of the horizontal composition of the Robie House as it was presented in Wright's original perspective. Cantilevered floors and horizontal limestone details on the facade are a nod to the building's celebrated neighbor. Curved steel beams that form Gothic arches—a key design motif of campus architecture and a major visual element of the Rockefeller Chapel—support the glazed roof of the Winter Garden. The roof is formed by quadripartite pointed vaults of tubular steel that transfer loads and forces through very thin structural members, an efficient structure that maximizes its transparency. Thin horizontal beams, which provide structural continuity to the curved surfaces, connect the narrow ribs of the vaults. The roof vaults also concentrate the snow load on the column centers rather than on the spans between them.

The convex surface of the glass ceiling accelerates the convection of hot air toward the top of the space where it is then exhausted, allowing the room to be naturally ventilated throughout the year. Mechanical shades shield the space below from heat gain and glare, and the flaring cylindrical forms of the columns resemble the silhouettes of trees in a garden. The funneled shapes of the roof vaults draw rainwater into and through the hollow centers of each of the four structural columns, then into a reservoir; Blair Kamin, architecture critic at the Chicago Tribune, described them as the world's most beautiful gutters.

Opposite

Top: Winter Garden elevation

Bottom: Graduate School of Business



This page
Top: Longitudinal section
Bottom: Elevation at quad

Opposite
Top: Winter Garden, geometry
layout
Bottom: Winter Garden (left),
Winter Garden from mezzanine

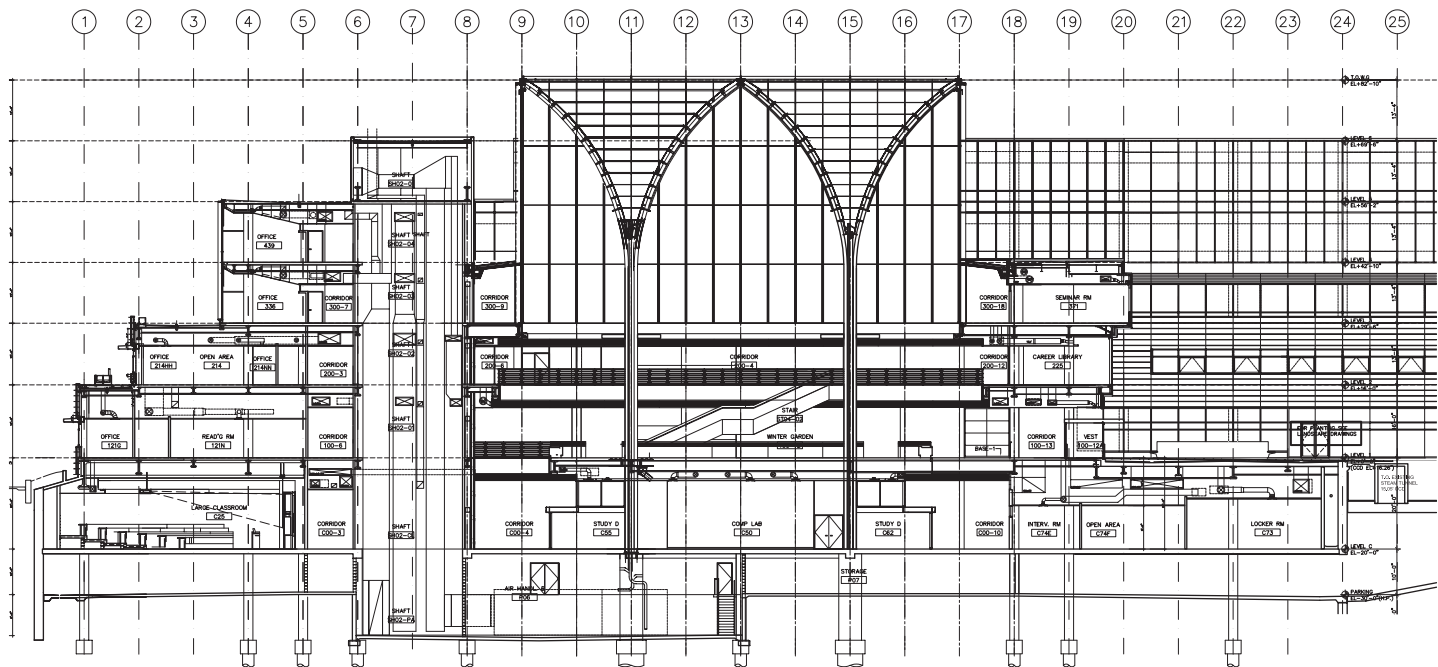

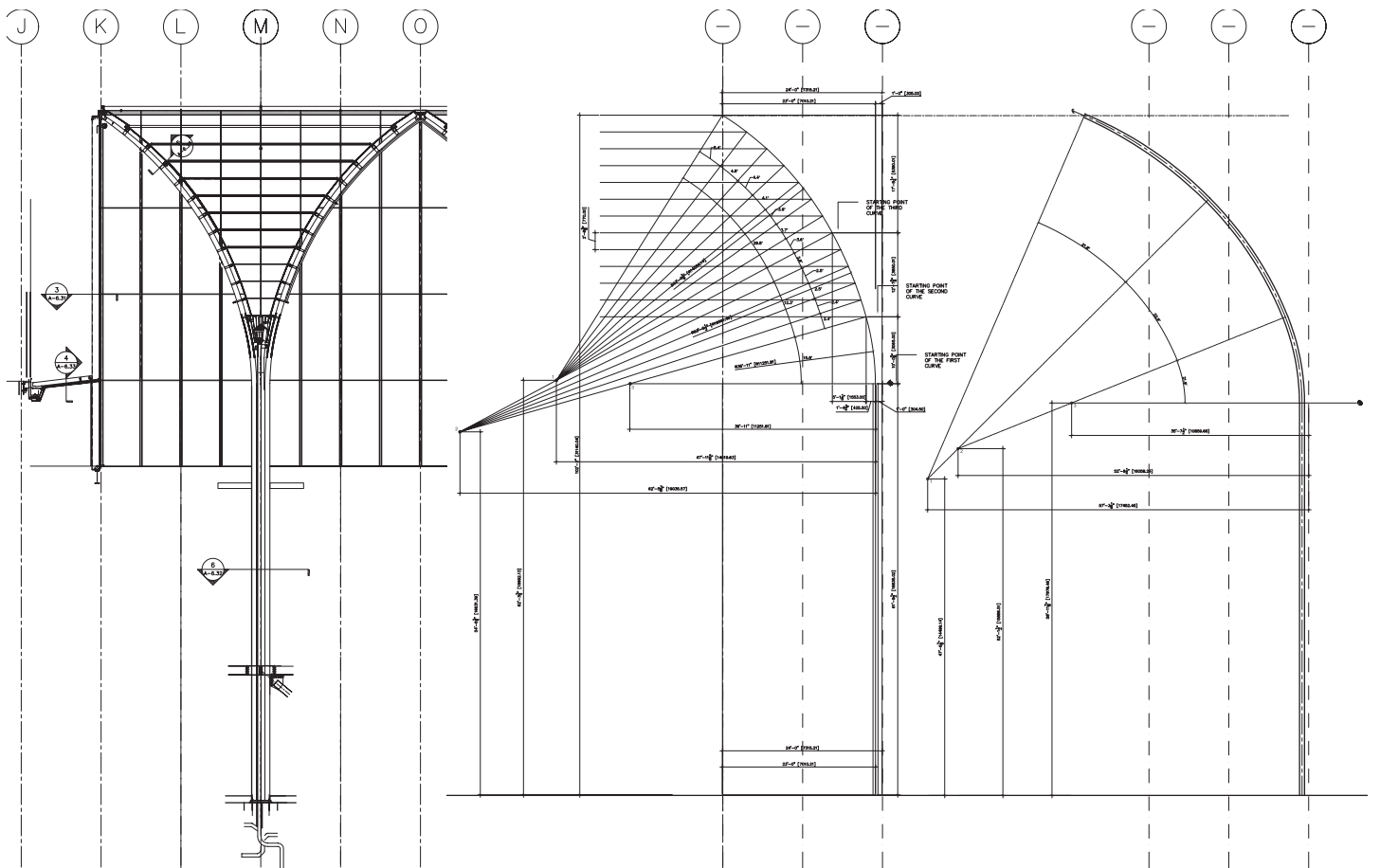



This page
**Winter Garden, roof
drain detail**

Opposite, Overleaf
Details

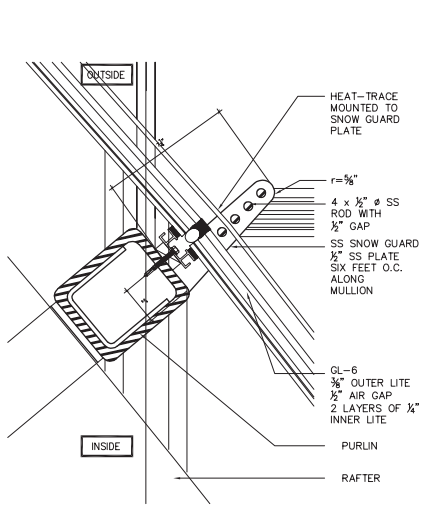

1 SNOW GUARD DETAIL
SCALE: 3"=1'-0"

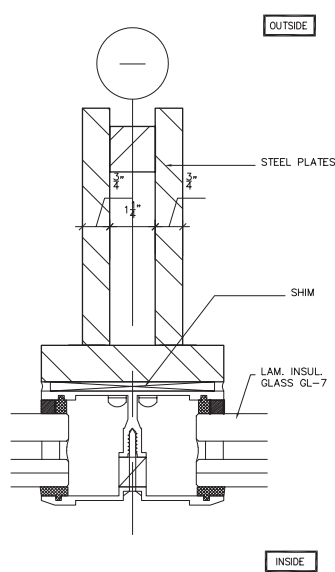

2 SKYLIGHT TYPE 2 DETAIL - SECTION
SCALE: 6"=1'-0"

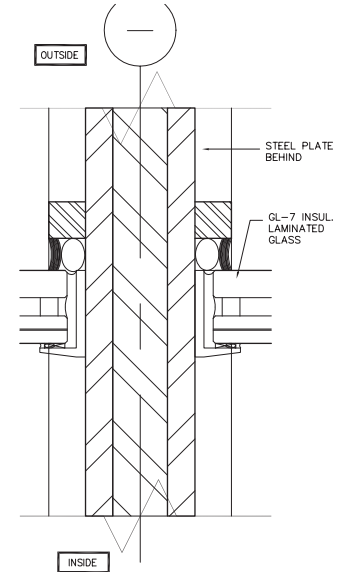

3 SECTION of SKYLIGHT
SCALE: 6"=1'-0"

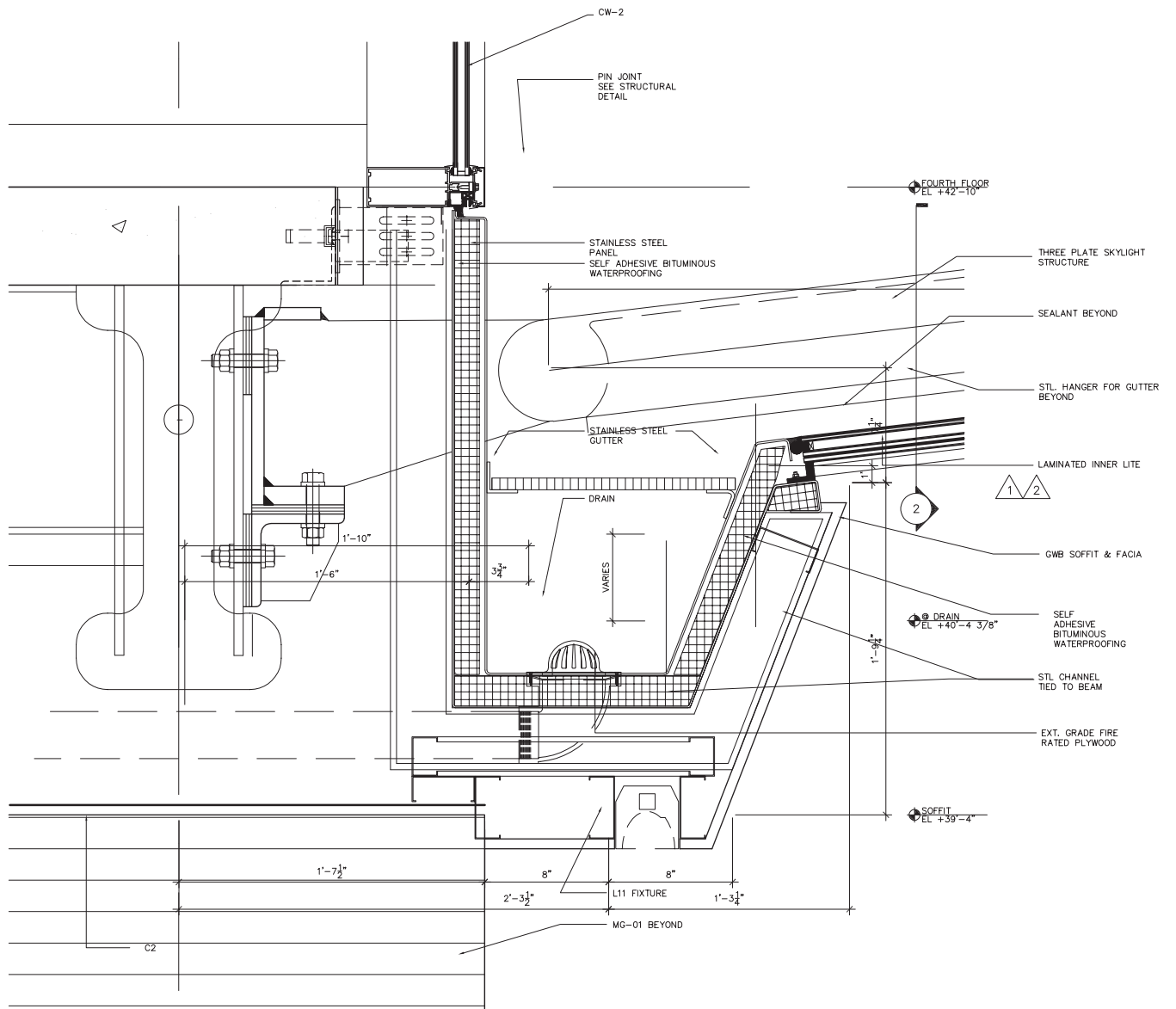

7 WALL GUTTER DETAIL
SCALE: 3"=1'-0"

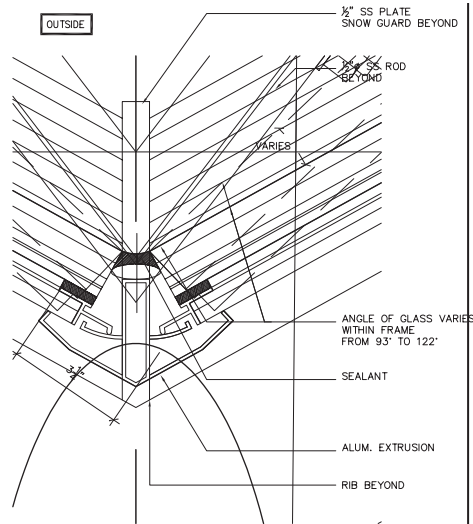

4 SK-1 VALLEY DETAIL (TYP.)
SCALE: 6"=1'-0"

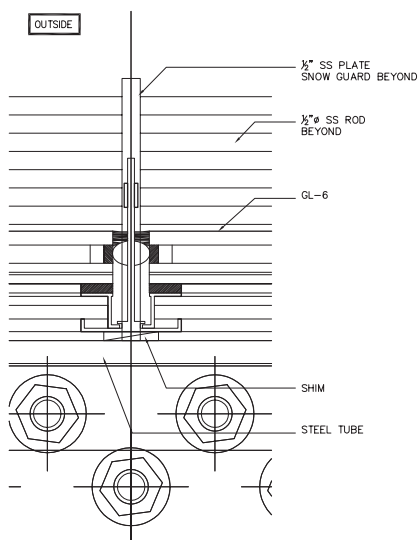

5 SK-1 DETAIL • RIB (TYP.)
SCALE: 6"=1'-0"

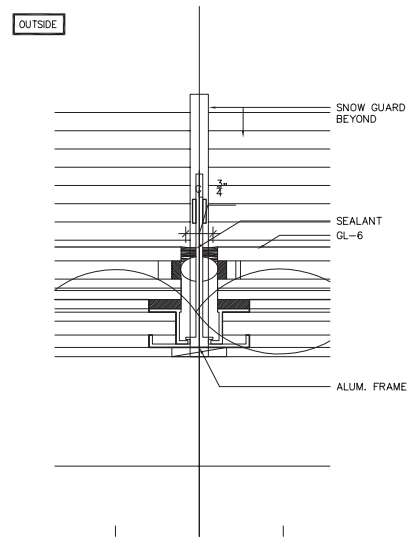

6 SK1 MULLION DETAIL (TYP.)
SCALE: 6"=1'-0"

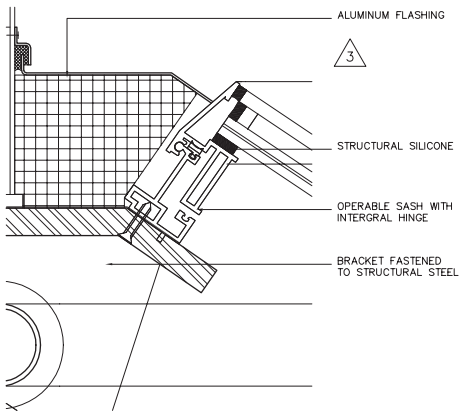

8 SMOKE VENT • HINGE SIDE
SCALE: 6"=1'-0"

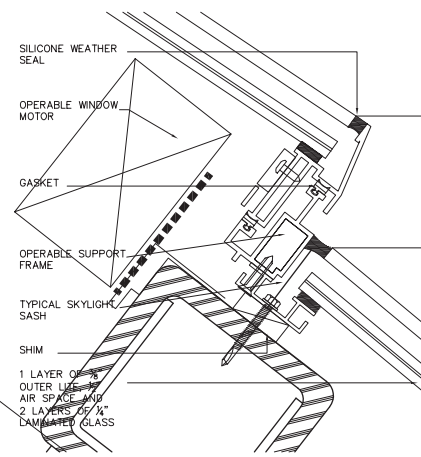

9 SMOKE VENT • SWING SIDE
SCALE: 6"=1'-0"

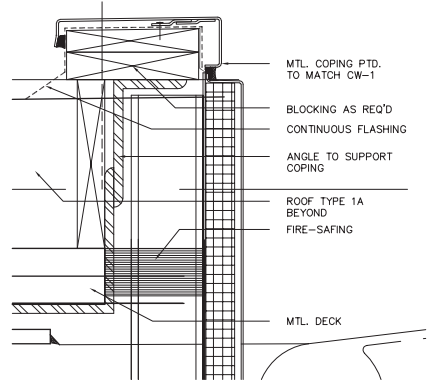

12 PARAPET DETAIL
SCALE: 3"=1'-0"

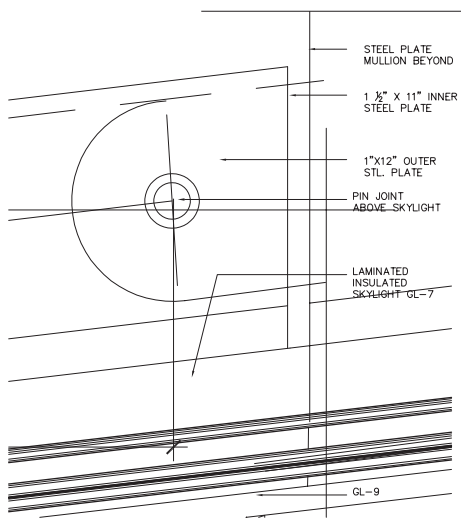

10 SKYLIGHT CONNECTION TO VERTICAL CURTAIN WALL
SCALE: 6"=1'-0" SECTION

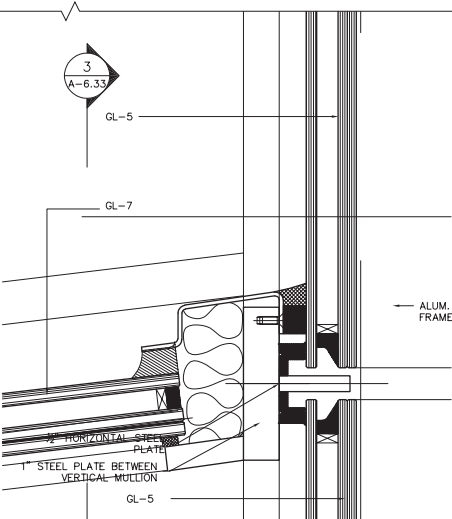

11 SKYLIGHT CONNECTION TO VERTICAL CURTAIN WALL
SCALE: 6"=1'-0" SECTION

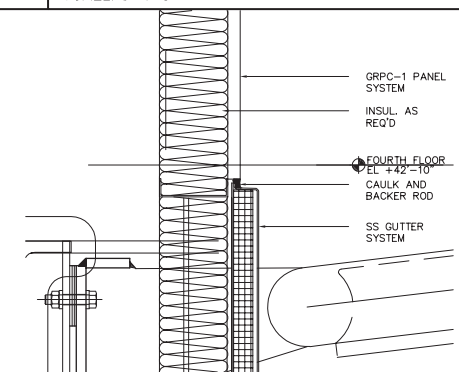

13 SK1 MULLION DETAIL
SCALE: 3"=1'-0"

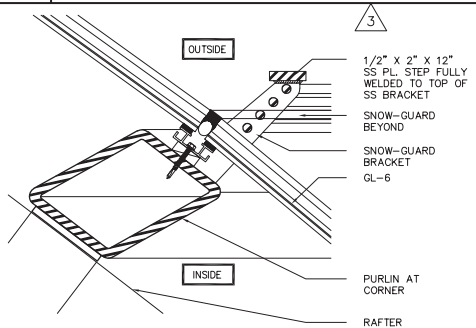

12 STEP ON SNOW GUARD DETAIL
SCALE: 3"=1'-0" SECTION



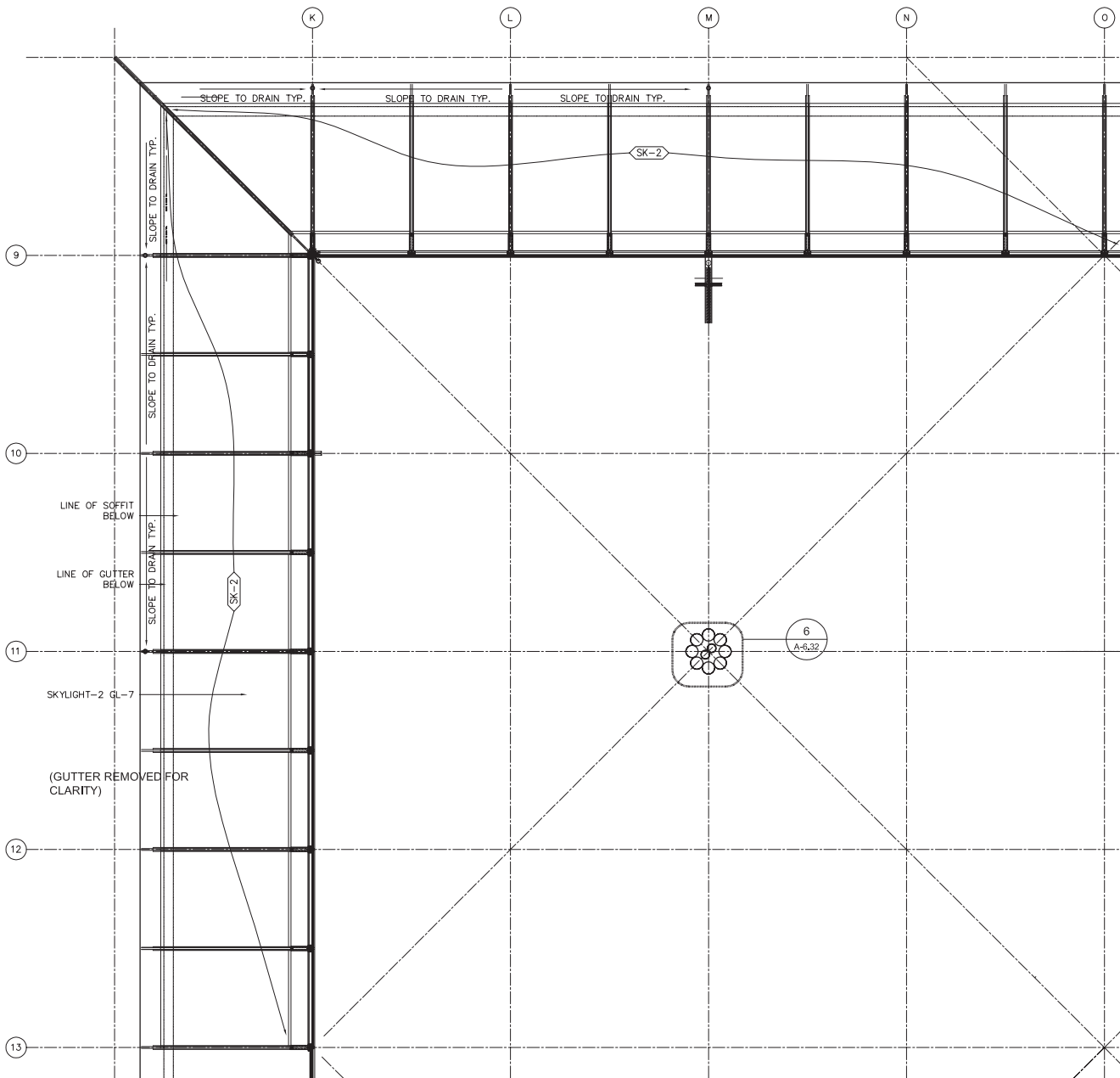

1 SKYLIGHT (SK-2) PART ROOF PLAN

SCALE: 1/4"=1'-0"

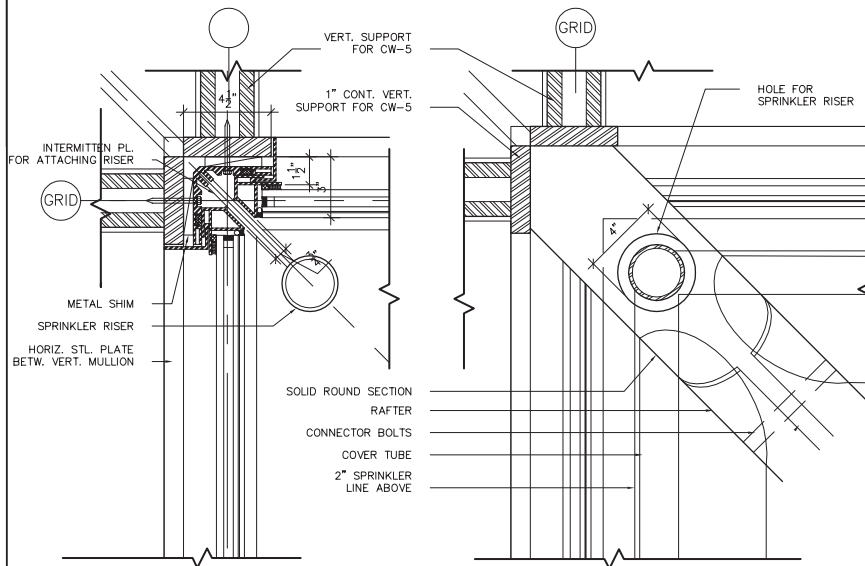

7 CORNER DETAIL
SCALE: 3/4"=1'-0"

10 CORNER DETAIL
SCALE: 3/4"=1'-0"

This page
Details

Opposite
Top: Winter Garden reflected ceiling plan
Bottom: Column and roof vault up (left), roof vaults overhead

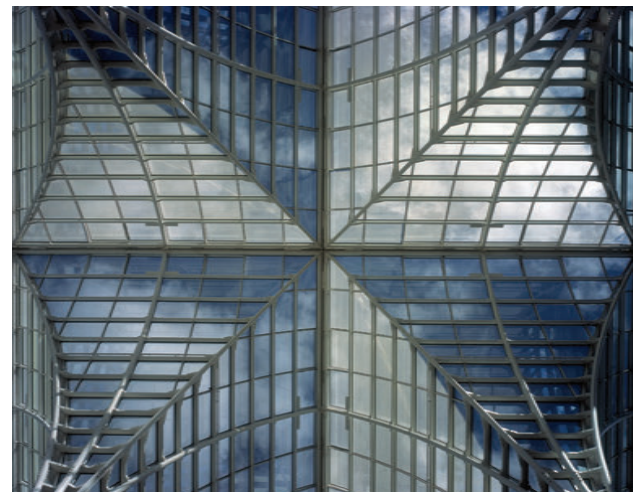
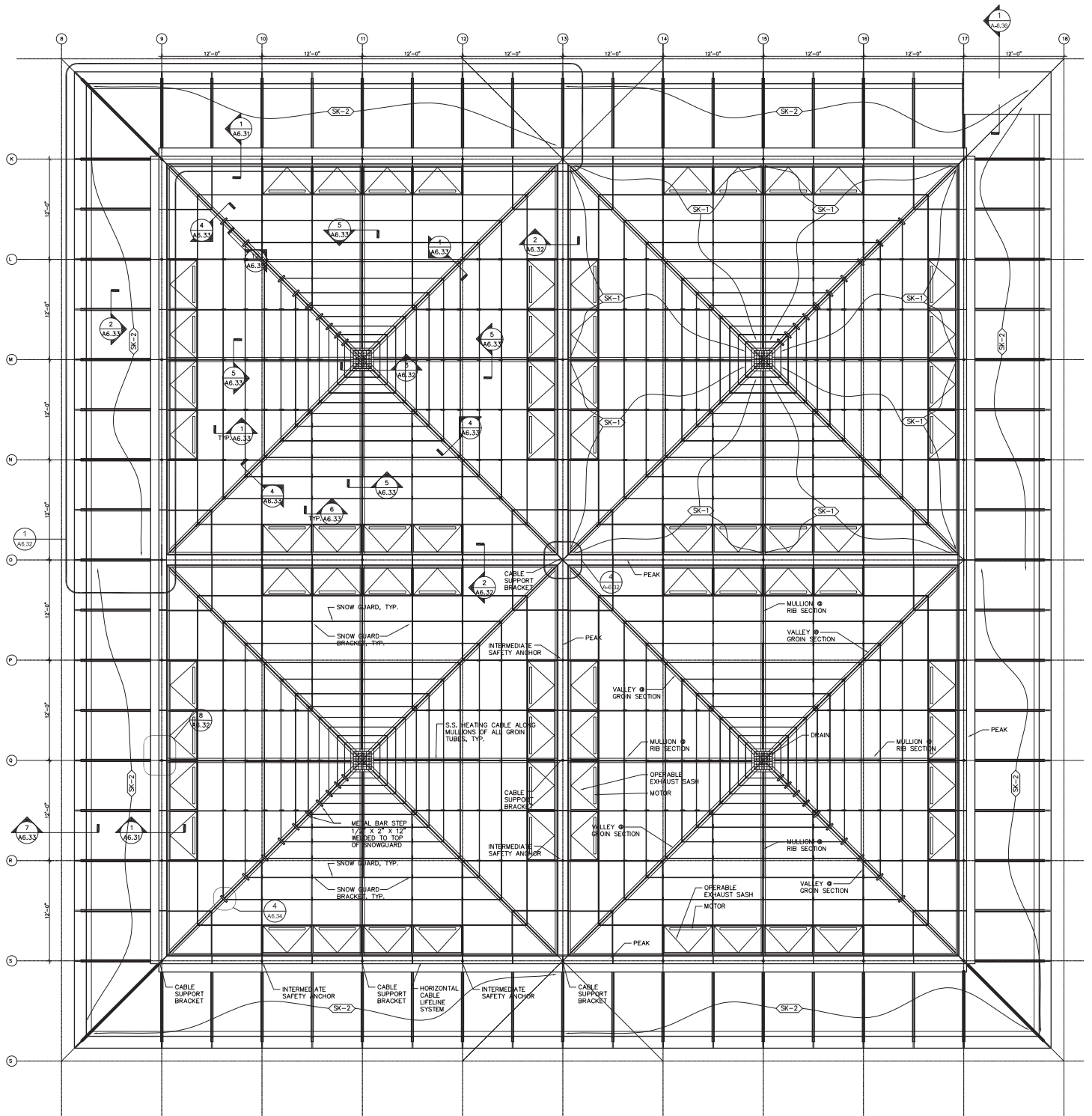

Museum of the Earth, Ithaca, New York

Weiss/Manfredi Architects, New York, New York

The new museum for the Paleontological Research Institution (PRI) houses one of the nation's largest fossil collections and demonstrates the intrinsic relationship between geological events and biological evolution. Shifted and carved by a receding ice sheet twenty thousand years ago, the site is currently marked by a gradual slope of 40 feet. The design concept for the addition to the PRI draws on the topographical features of the site and the dynamic interrelationship between biology and geology that is central to the mission of the museum: sedimentation, erosion, and the freeze and thaw cycles that created the glacially gouged landscape of the Finger Lakes region.

The new museum is set into the hillside adjacent to the existing research facility, forming a continuous terraced ground plane that fuses landscape, architecture, and geology into a cohesive whole. Built of reinforced poured-in-place concrete with aluminum curtain walls and large cantilevered standing-seam copper roofs, the museum is organized into two parallel buildings: a public education wing and a new exhibition wing, connected below grade. The partially buried structures define the edges of a cascading plaza, extending views to Cayuga Lake and the surrounding terrain. Approached from the south, a series of 10-foot-high planted berms and linear water terraces recalling glacial moraines conceals

four parking areas. Precisely graded, the parking areas divert ground water runoff to bioswales with gravel filters and reintroduced prehistoric grasses such as equisetum, which cleanse the ground water of chemicals and other pollutants. Water is then channeled onto the linear terraces, collected, and directed between the two parallel museum wings into a reflecting pool. Excess water overflows into a landscaped detention basin where it is slowly released into Cayuga Lake. The site is planted with ancient species of trees, grasses, and other plants native to the Finger Lakes region chosen for their educational, environmental, and aesthetic value.

The museum uses a geexchange system, which takes advantage of the earth's intrinsic energy storage capacity to heat and cool buildings, moving heat energy around rather than converting chemical energy to heat as does a furnace. Geexchange systems store the heat the earth absorbs from the sun at an efficiency approaching or exceeding four hundred percent, and return it as heat and/or cooling in a building. Because the systems transfer heat to and from the stable and relatively moderate temperatures of the ground, they are more energy efficient than other systems, reducing energy consumption and related emissions up to forty-four percent compared with air-source heat pumps and

up to seventy-two percent when compared with the electric resistance type heating standard in air-conditioning equipment.

The geexchange system has three major parts: a geothermal heat pump to move heat between the building and the fluid in the earth connection; a subsurface connection for transferring heat between the fluid and the earth; and a distribution subsystem for delivering heating or cooling to the building. A geothermal heat pump works much like a refrigerator, with the addition of a few extra valves that allow heat-exchange fluid to follow two different paths, one for heating and one for cooling. Pumps are attached to the ground either through a series of buried plastic pipes that circulate water or an environmentally safe antifreeze (closed loop), or water wells (open loop), often located beneath parking lots or landscaped areas. The system used in the Museum of the Earth makes use of two 1,550-foot wells. Groundwater circulating from these wells is transformed into radiant floor heating in the winter and fed into an air handling system for heating and cooling year round. The water absorbs heat from the ground during the winter and transfers it to the heat pumps inside the building. In the summer, the process is reversed as heat from the building is returned to the ground.

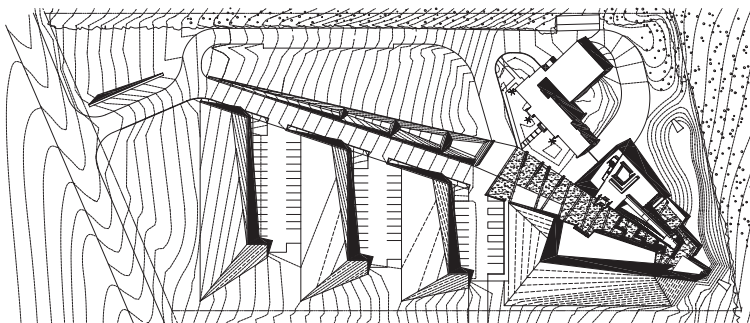

This page
Site plan

Opposite
Top: Entry plaza view south
Bottom: Entry plaza view north



This page

Top: Section

Bottom: Long site sections

Opposite

Bottom: View east

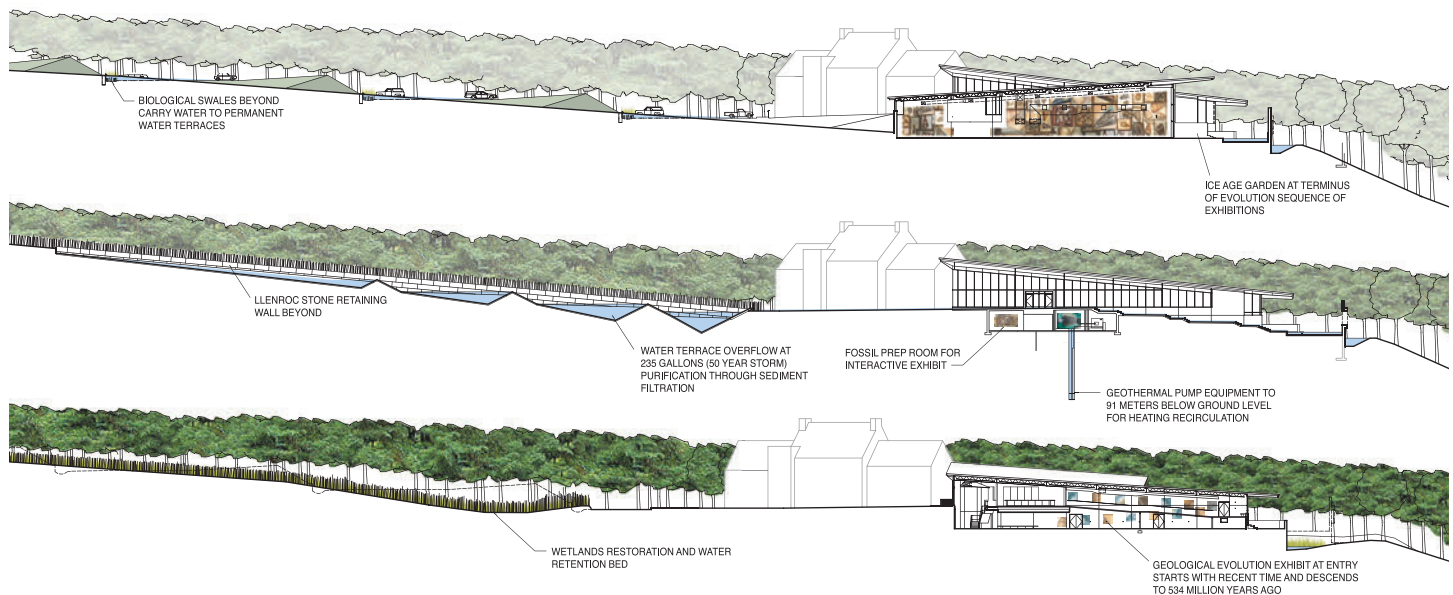
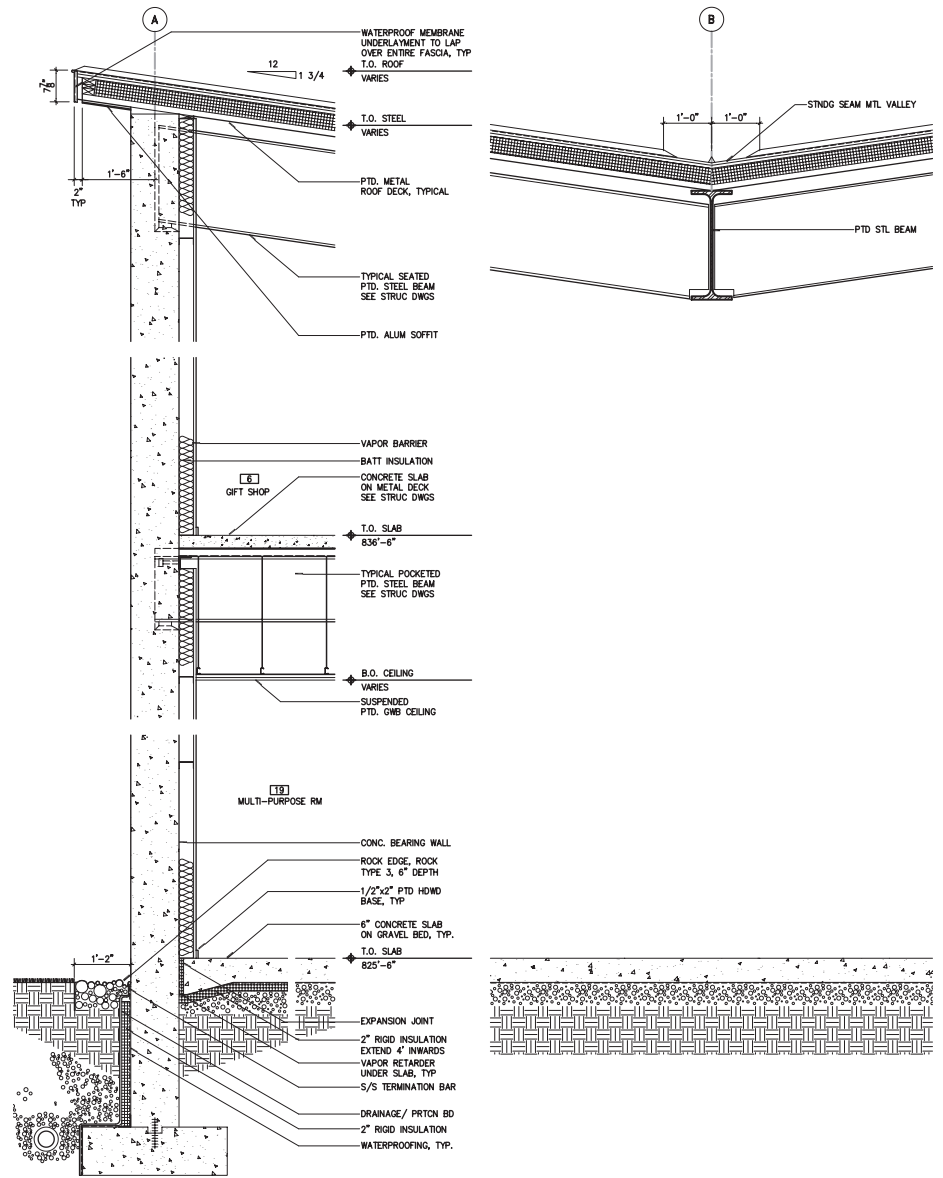

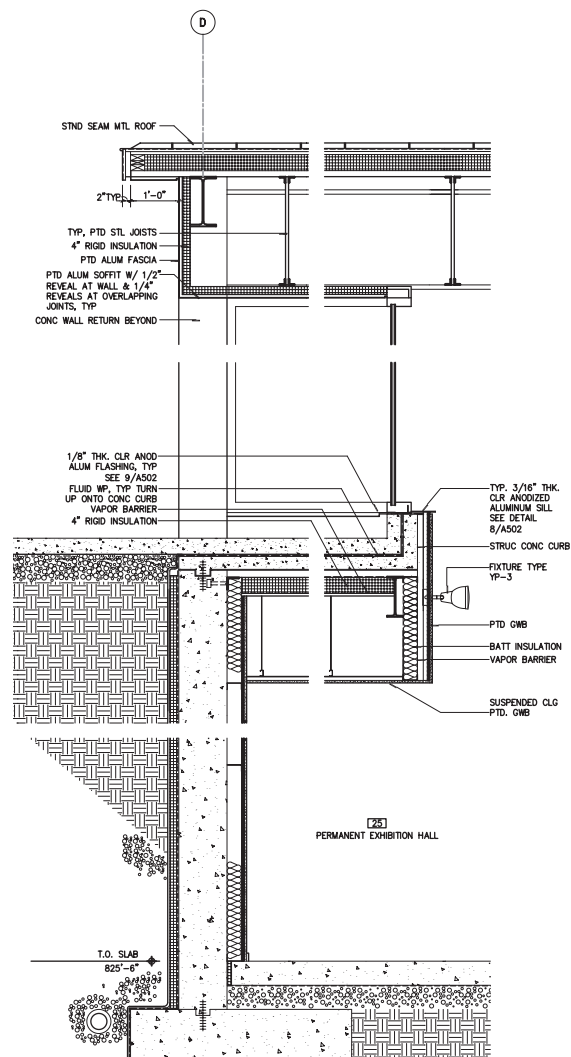
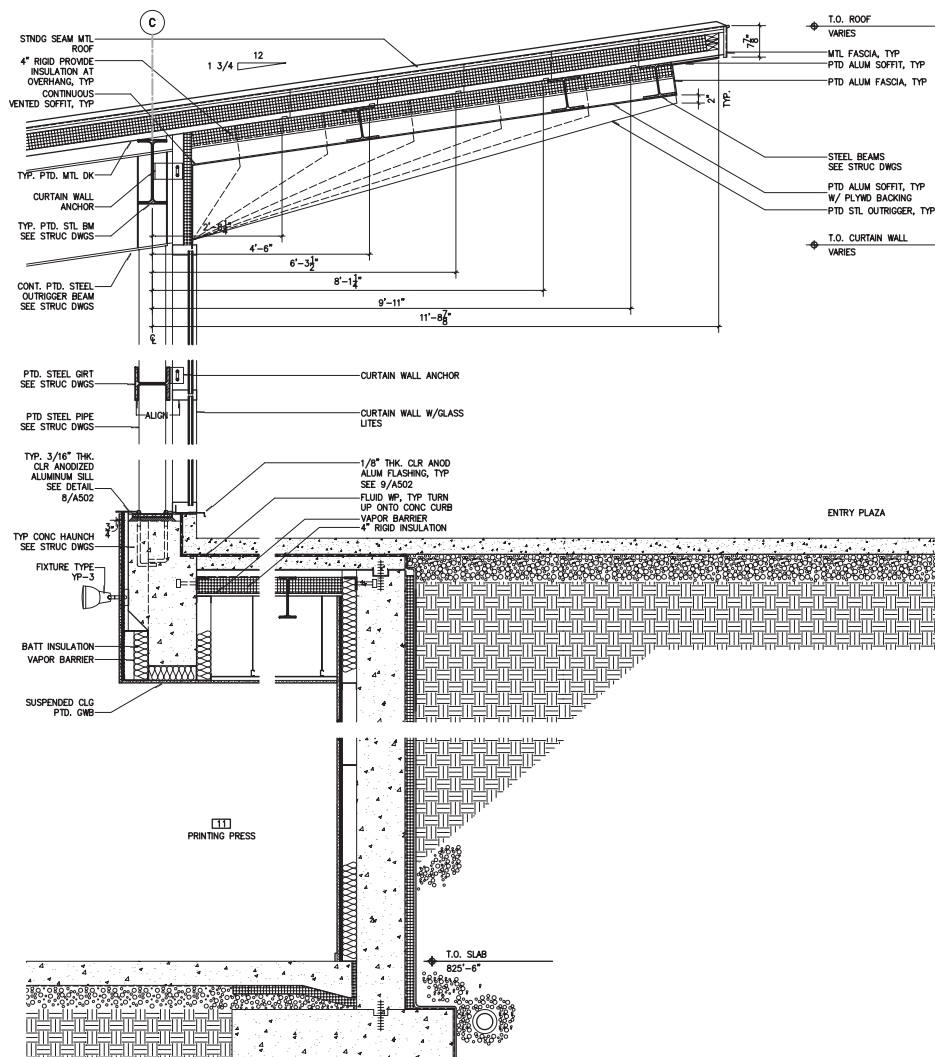

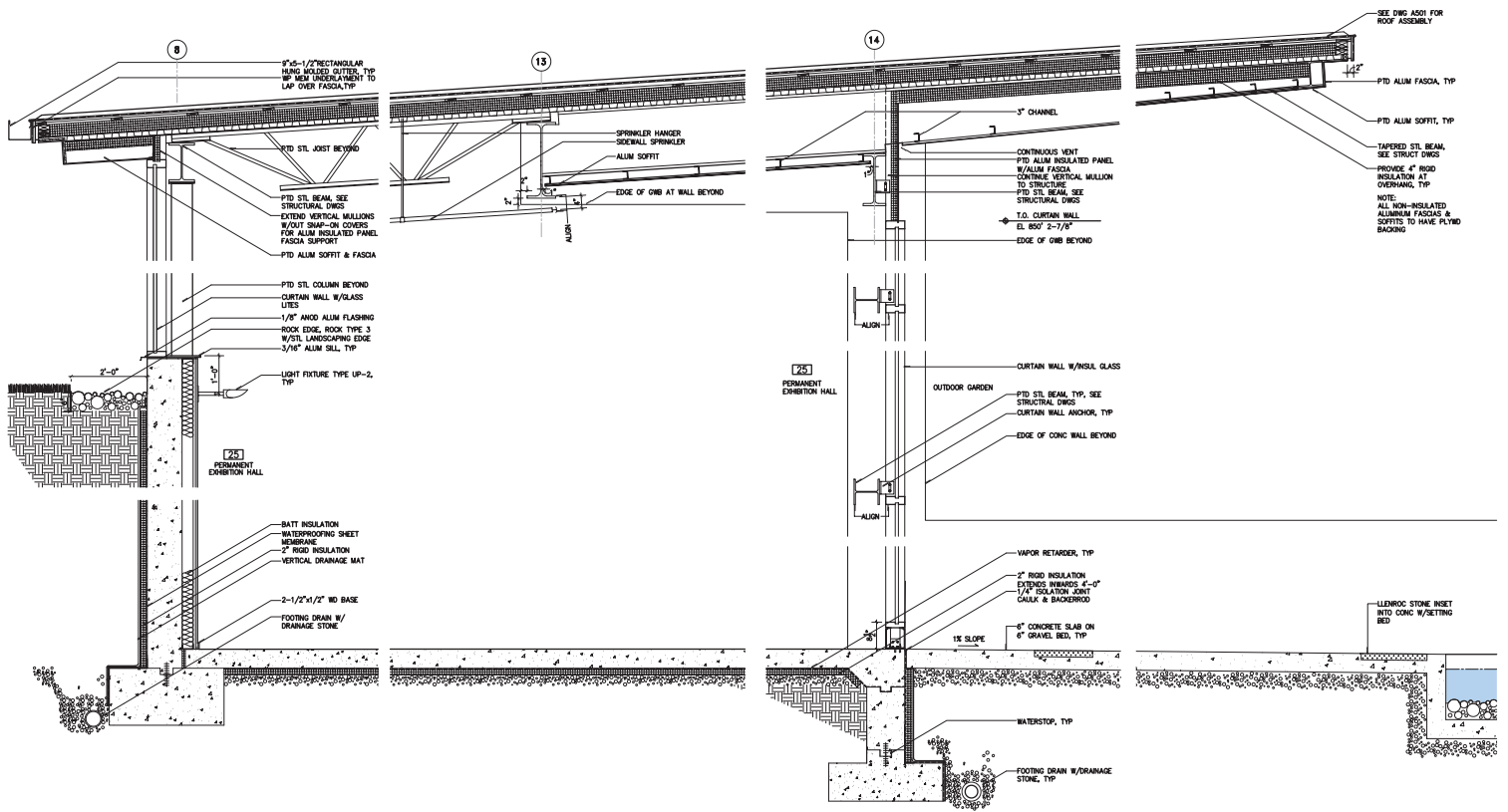

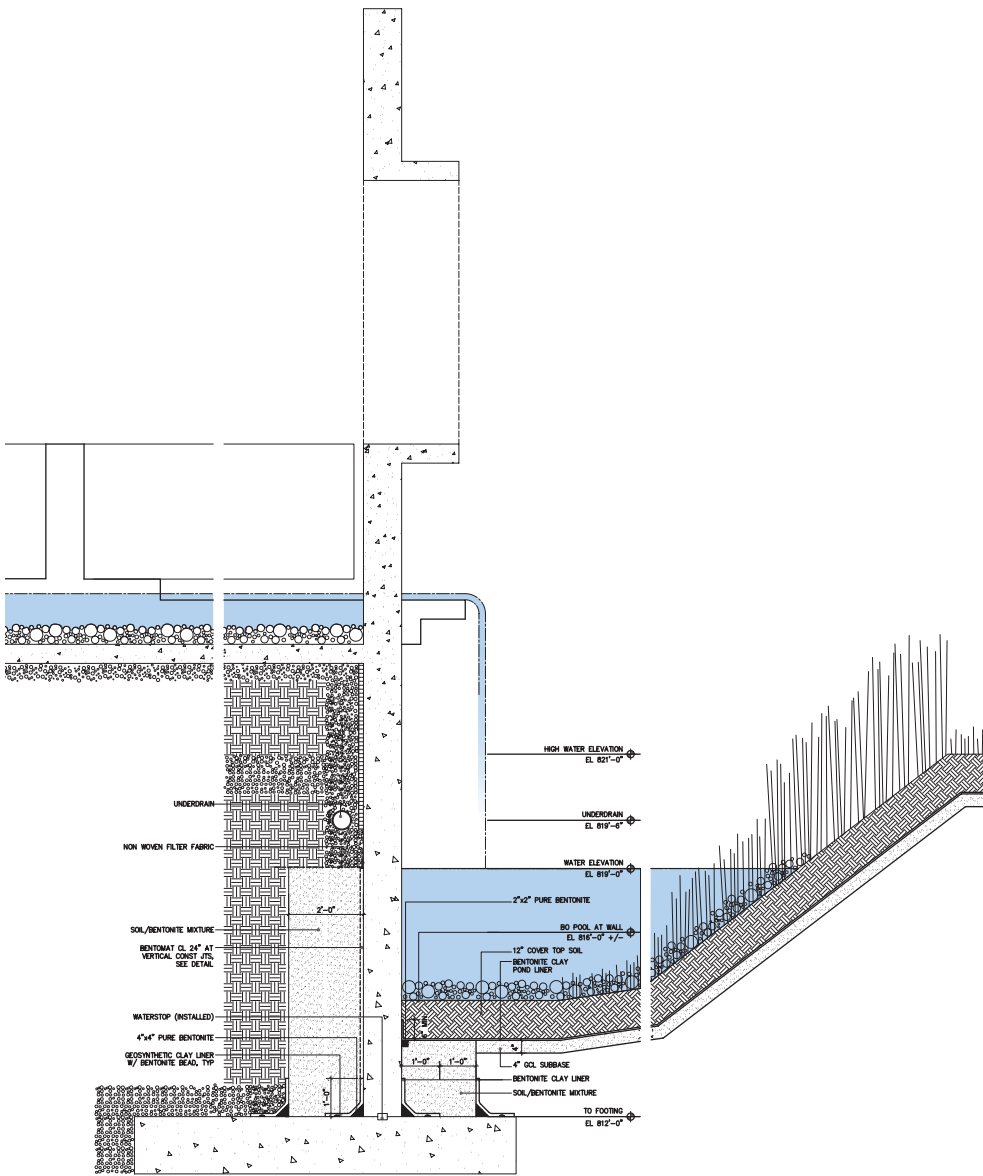

10-YEAR STORM
7,616 C.F. OF WATER

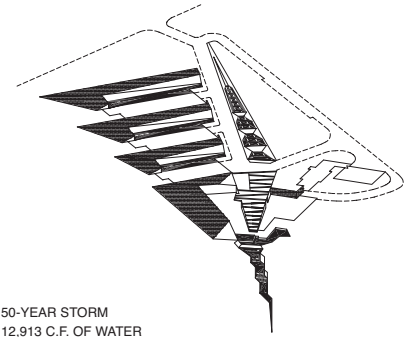

50-YEAR STORM
12,913 C.F. OF WATER

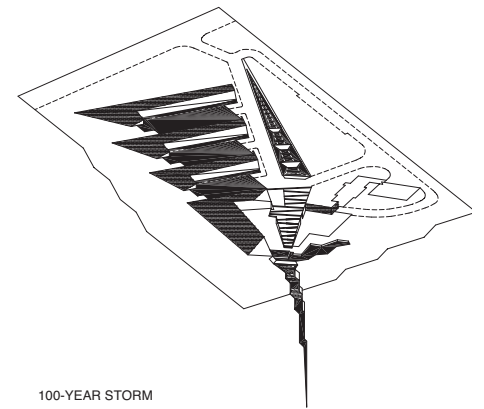

100-YEAR STORM
15,221 C.F. OF WATER

Opposite
Top: Longitudinal section
Bottom: Gallery (left), museum entrance

This page
Top: Storm water collection
Bottom: Finger Lakes region location map (left), perimeter stream

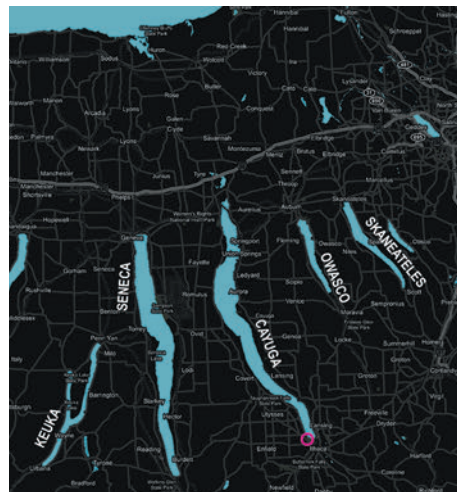

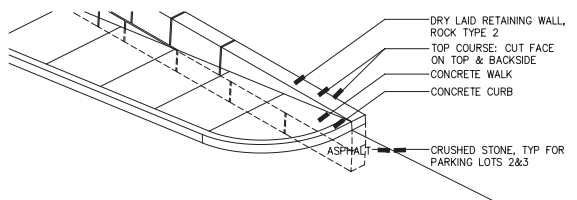
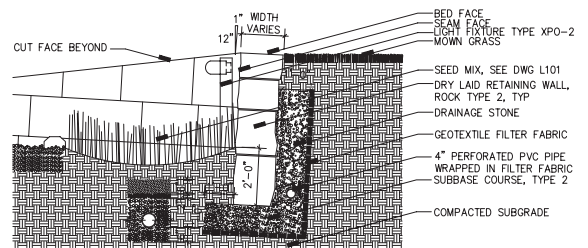
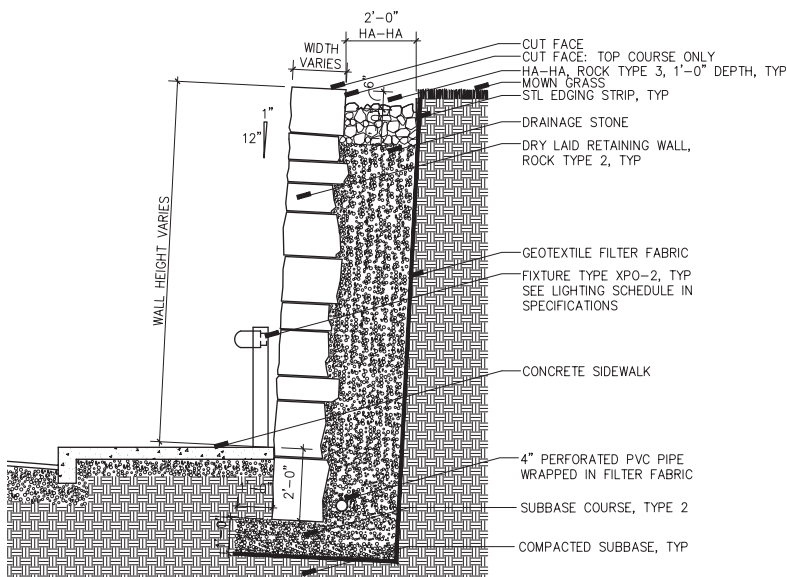
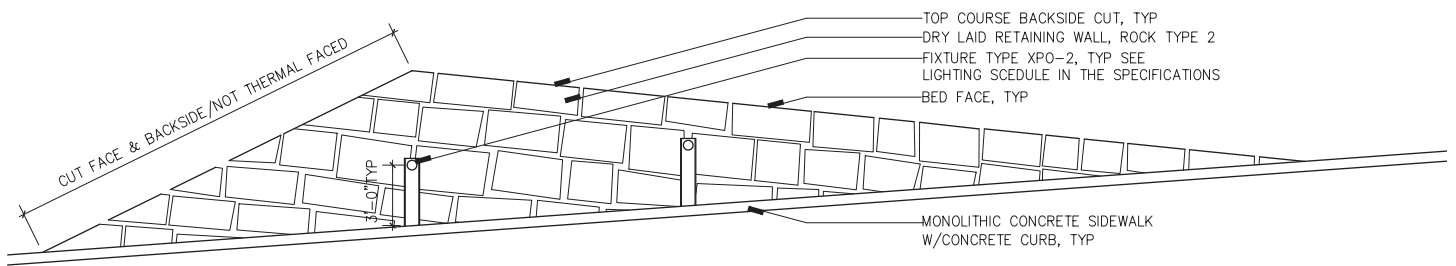
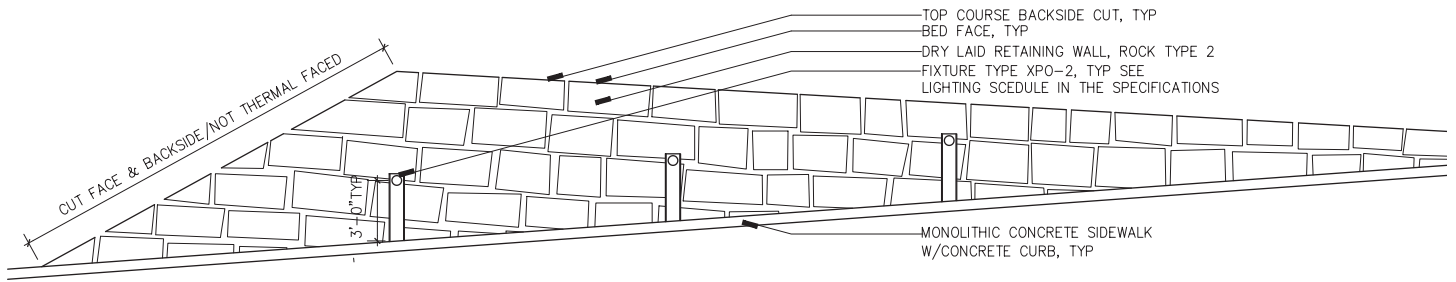
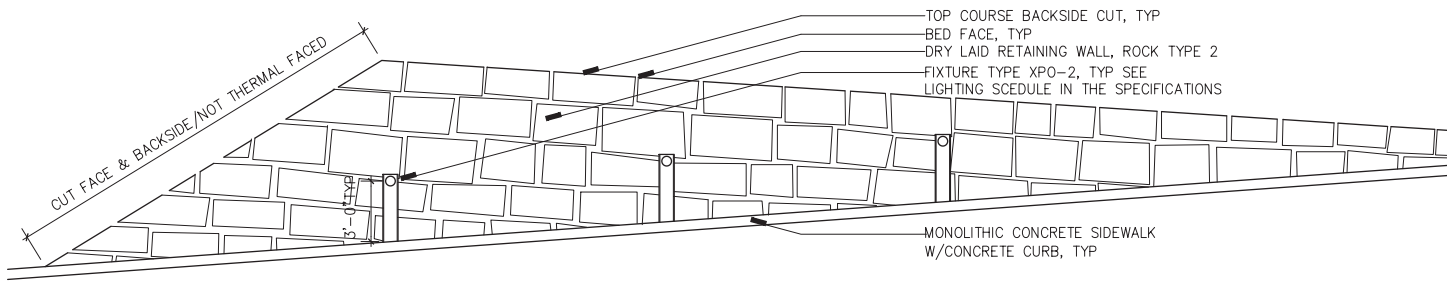

Opposite

Top: Berm retaining wall at parking lots 1, 2, and 3
Bottom left: Berm retaining wall at entry drive
Top right: Typical parking lot retaining wall
Bottom right: Sidewalk/retaining wall transition

This page

Top: Water terrace section
Middle: Bioretention basin cross section
Bottom: Bioretention basin detail

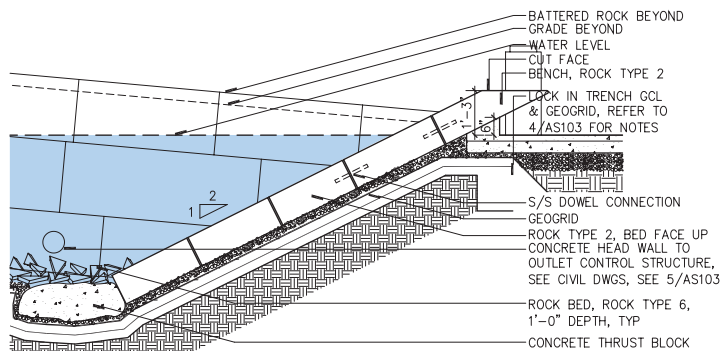
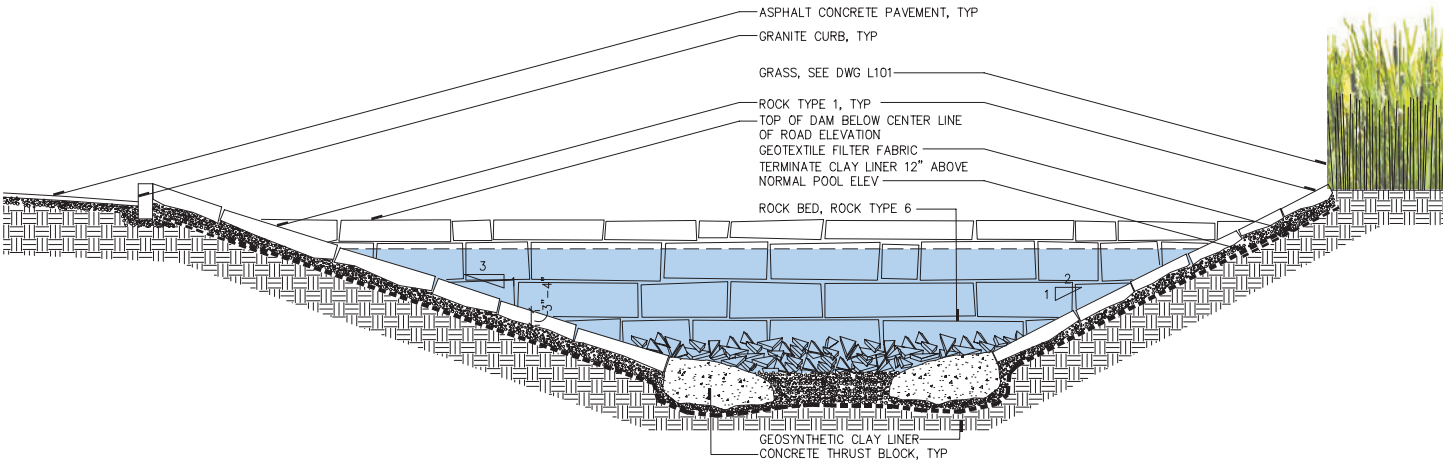
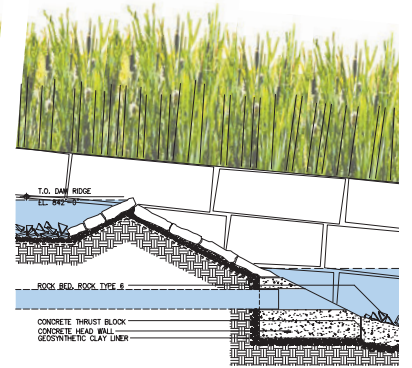
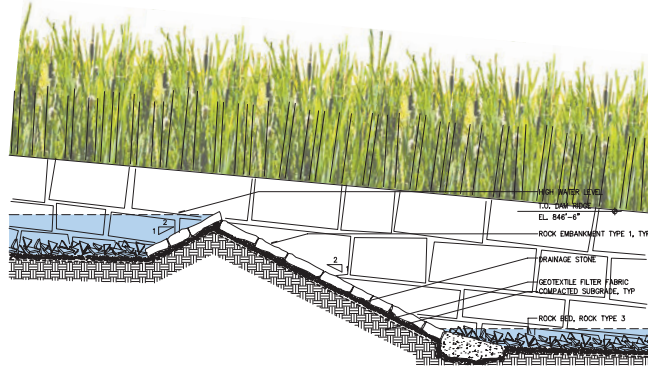
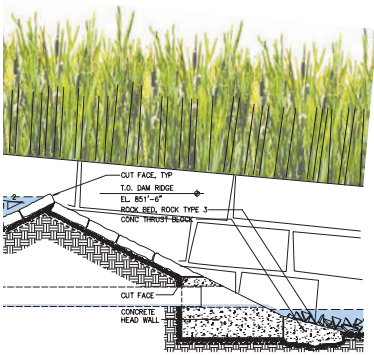

Acknowledgments

For assistance with the preparation of this first issue of *AsBuilt* we would like to thank the architects, engineers, consultants, manufacturers, and fabricators, as well as their technical and administrative staffs, who contributed drawings, images, and written material; the many excellent architectural photographers who have consented to the reproduction of their work; the Graham Foundation for Advanced Studies in the Fine Arts and Harrison Fraker, Dean of the College of Environmental Design at the University of California, Berkeley, for start-up support; and editors Jennifer Thompson and Sara Hart and Princeton Architectural Press for publishing the *AsBuilt* series.

Illustration Credits

Sharp

p. 13, p. 14 upper, p. 15, p.17 © Richard Johnson
p. 14 lower, p. 16 © Robbie/Young + Wright
Architects

Greenwich Street

p. 19, p. 20, p. 23 upper and lower right © UAD
Group Inc.
p. 22, p. 23 upper and lower left, p. 25 ©
Archi-tectonics

Maximilian's Schell

p. 27 © Joshua White
p. 29 © Scott Mayoral

Genzyme

p. 31, p. 33 top © Anton Grassl
p. 33 bottom, p 34, p. 35 © Roland Halbe

Figge

p. 37 © Ogy Blazevic
p. 38, p. 39 © W.J. Higgins & Associates, Inc.

ACCD

All photos © Benny Chan

Nothstine

All photos © Garofalo Architects

Millennium Park

All photo credits: "Photo courtesy of City of Chicago"

Juan Valdez

p. 63, p. 65, p. 67 © Paul Warchol
p. 66 © Hariri & Hariri - Architecture

Walker Art Center

p. 68, p. 73 © Herzog & de Meuron
p. 69, p. 71, p. 75 bottom: "Photo courtesy of
Walker Art Center"
p 71 top & middle, p. 72 © Alexander Sosa,
M.G. McGrath, Inc.

Hollywood Bowl

All photos © Hodgetts and Fung Design Associates

Lake Whitney

p. 85 top and bottom, p. 91 © Andy Ryan
p. 87 left © Chris McVoy
p. 87 right © Harold Shapiro
p. 89 top © Steven Holl Architects
p. 89 bottom © A. Zahner Co.

South Mountain

All images © Mark Boisclair Photography

Caltrans

All photos © Roland Halbe

SPL

p. 113, p. 114, p. 115, p. 116, p.121, p. 122 bottom,
p.123 © Philippe Ruault
p. 122 top © Pragnesh Parikh

Delta Shelter

All photos © Olson Sundberg Kundig Allen Architects

GKD

All photos © Alain Jamarillo

Solar Umbrella

All photos © Marvin Rand

Prairie View

All photos © Assassi Productions

Shaw Center

p. 155, p. 157, p. 158, © Tim Hursley
p 161 © Schwartz/Silver Architects

Camera Obscura

All photos © SHoP Architects PC

Starlight Theater

p. 171, p. 172, p. 173 top © Greg Murphy Studios,
Inc.
p. 173 lower, p.175 © Uni-Systems, LLC

Holy Rosary

All photos © Tim Hursley

UCBS

All photos © Brad Feinknopf

Museum of the Earth

p. 199 top © Jeff Goldberg/Esto
p. 199 bottom, p. 201, p. 202, p. 203, © Paul Warchol

