



In addition to providing the space needed for governors or leaders to conduct the community's affairs and transact business, municipal buildings serve multiple purposes. They are necessarily the centres of the community's political lives and the symbols of the whole community. Along with the social improvement, the relationship between government and the public, the role and functions of government in political activities also have got more or less development. Hence, this type of buildings' layout, environmental quality and characteristic of showing the administrative services has put forth their new requirements.

This book has selected many excellent municipal projects completed in recent years around the world, including Judicial Buildings, Administrative office buildings, Embassy Buildings, Fire stations and Emergency Operations Centre as well as Shelter Homes. Each of these projects is distinctive and creative, whose external form and internal quality have completely and perfectly presented the complex characteristics of the modern municipal buildings.

MUNICIPAL ARCHITECTURE

DESIGN
MEDIA
PUBLISHING
LIMITED

MUNICIPAL ARCHITECTURE

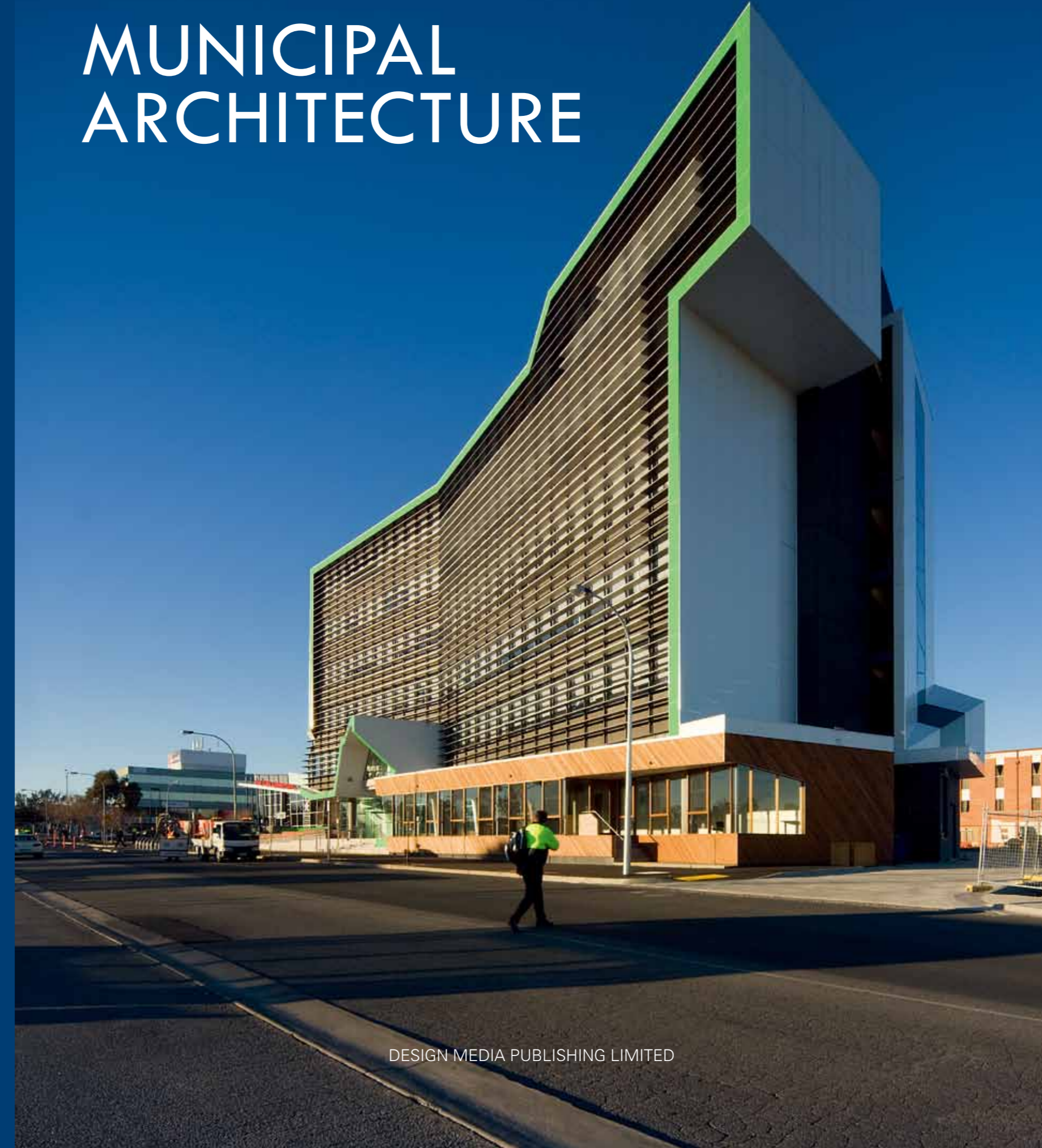

DESIGN MEDIA PUBLISHING LIMITED

MUNICIPAL ARCHITECTURE

Contents

Judicial Buildings

4	<i>Wilkie D. Ferguson, Jr. United States Federal Courthouse</i>	80	<i>KLPD (Traffic Squad of Dutch police services)</i>
10	<i>Justice and Administration Center</i>	84	<i>Mossos d' Esquadra Police Headquarters, Martorell</i>
16	<i>Durham Consolidated Courthouse</i>	90	<i>Commissariat De Grasse</i>
22	<i>Manchester Civil Justice Centre</i>		
26	<i>The Franklin County Courthouse</i>	96	<i>Town Hall Oss</i>
32	<i>Barcelona City of Justice and L'Hospitalet de Llobregat</i>	104	<i>Viborg Town Hall</i>
40	<i>Attunda District Court</i>	108	<i>Heemskerk Town Hall</i>
46	<i>Haifa Court House</i>	114	<i>City Hall Leyweg</i>
54	<i>Federal Arbitration Court of Moscow Region</i>	118	<i>City of Hume, Council Offices</i>
60	<i>Courthouse And Public Square</i>	122	<i>Ministry of Public Works</i>
66	<i>New Arezzo Courthouse</i>	128	<i>Bourne Hill Offices</i>
70	<i>Koninklijke Marechausse op de Marinekazeme te Amsterdam</i>	134	<i>Parliament Building Annexe</i>
76	<i>Center for Damage and Crisis Control</i>	140	<i>"La Cite Des Affaires" in Saint-Etienne</i>

Administrative office buildings

146 *Sarpi Border Checkpoint*

152 *Warroad Land Port of Entry*

Embassy Buildings

158 *French Diplomatic Campus – Beijing*

166 *House of Sweden*

170 *Canadian Embassy in Warsaw*

176 *New Chancery for the Singapore Embassy in Manila, Philippines*

182 *Canadian diplomatic Complex*

Fire stations and Emergency Operations Center

186 *Bergen Fire Station*

192 *Tromsø Fire Station*

198 *Brandon Firehall no.1*

202 *New Fire Station*

208 *New fire station in Dußlingen*

212 *Fire Station – Houten*

218 *Fire Station- Rijswijk*

226 *Mataró Fire station*

234 *Parc de Bombers*

240 *State Emergency Operations Centre*

246 *Fire Station Alkmaar*

Shelter Homes

250 *Omnicare, City Palace for the homeless*

256 *FPC De Oostvaarderskliniek*

262 *Shelter Home for the Homeless*

268 *Index*

Wilkie D. Ferguson, Jr. United States Federal Courthouse

Completion date: 2007 **Location:** Miami, USA **Designer:** Arquitectonica **Photographer:** Robin Hill, Norman McGrath, J Espana © Arquitectonica **Site area:** 26,305sqm **Total building area:** 53,678sqm **Award name:** 2007 AIA Academy of Architecture for Justice, Certificates of Citation

The building stands at the end of the axis created by the 4th Street Promenade. However, because the centre atrium space is approximately 20 metres above the plaza, both the physical and visual axes are maintained through the building. The design completes the judicial campus created by the old courthouse, the courthouse annex tower, the Lawrence King Building and the federal prison.

The planimetric design is based on a four-courtroom per floor layout. The two court towers are connected by a generous circulation lobby, which occurs on every floor, and rises dramatically throughout the entire height of the building. A dramatic conical glass atrium connects the floors by piercing through the lobbies and decreasing in size as it rises through the building terminating in a skylight.

The site plan is divided into two distinct zones. The first, at street level is comprised of densely planted native vegetation punctuated with seating and meandering walks which can be used for local art fairs and markets. The second zone is the lawn. It is raised approximately one metre above the sidewalk forming a natural and secure perimeter around the building. The walls of the plinth have seating. The two east quadrants of lawn areas were designated as the sites in which the artist Maya Lin developed her earthen installation, "Flutter." The hard-scape is primarily comprised of three-coloured pre-cast pavers, which coordinate, with the pre-cast panels of the building.

The building is composed of three individual elements: the opposing two towers and the glass crystal that spans between them.

The east and west curtain-wall elevations of the two towers are a blueprint for the interior functions within the building. The alternating rhythms, depths and colours of the horizontal and vertical sunshades delineate the primary office, circulation, chamber and courtroom functions located in the tower.

The north and the south façades of the tower are solid pre-cast with punched openings reinforcing the solidity of the envelope which then create the asymmetrical frame on the east and west elevations.

The signage is located on all four elevations of the tower. At the base, it welcomes pedestrian, at the top it acts as a banner for the vehicular traveller. The exterior expression is primarily transparent and open reflecting the integrity of the court while emphasizing equality before the law.

A monumental three-colour stone colonnade recalling the richness of traditional courthouses supports the south tower. The north tower sits upon the building garage clad in stone columns placed at irregular intervals and a metal grille. The crystal curtain-wall spanning the two towers contains an atrium that pierces through each floor.



South Elevation

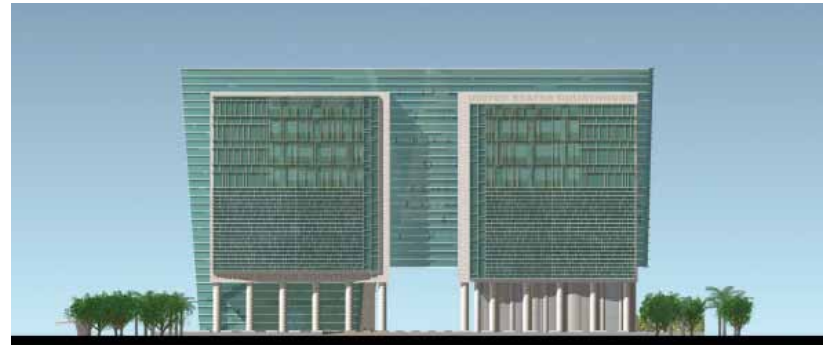

East Elevation



3

4

1. The three-colour stone colonnade
2. Pathways between the towers
3. The primary material for the north and the south façade of the tower is the same precast stone used to frame the curtain wall
4. The landscape surrounding the building



1



2





1



2



4



3

1,2. The main lobby and the elevator core are clad in a three-colour natural limestone
 3. The glass crystal that spans between the opposing two towers
 4. Far view of the corridor

- 1. Court Room
- 2. Library
- 3. Main Lobby
- 4. Parking





1



2

- 1. All millwork for the courtrooms are veneers of three different species of wood. Wood pew seating matches the walnut millwork
- 2. The ceiling is painted drywall in a custom designed "origami" shape

- 1. Court Room
- 2. Main Lobby



Site Plan

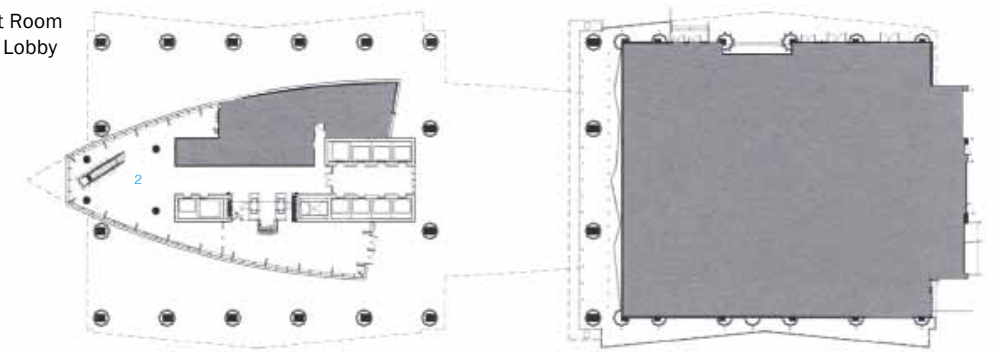

Ground floor plan

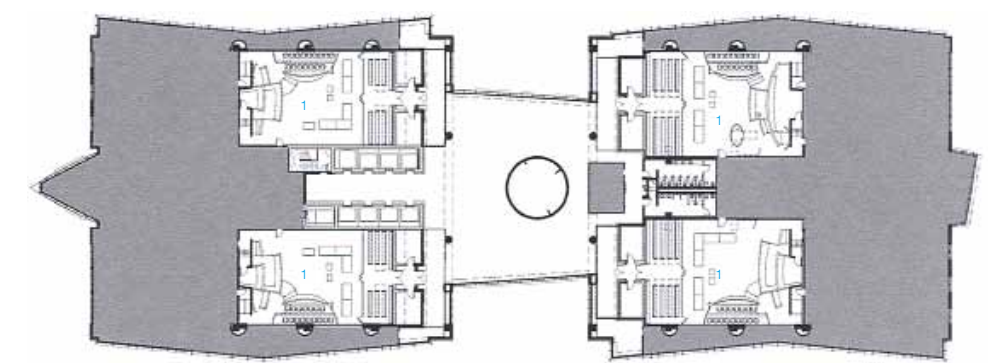

Courts floor plan

Justice and Administration Centre

Completion date: 2010 **Location:** Wiesbaden, Germany **Designer:** KSP Jürgen Engel Architekten GmbH **Photographer:** Jean-Luc Valentin **Site area:** 65,405 sqm



The ensemble on Mainzer Strasse is an important element in the restructuring of the heterogeneous urban planning to the south east of Wiesbaden Station. It comprises two buildings standing parallel to one another: the Justice and the Administration Centre.

The two main buildings are each divided up into one long block five and six storeys high, and on the courtyard side, into five elements at right angles. These border a green corridor that runs along the new ensemble from north to south, serving as a public area. The public has access to the Justice and Administration Centres both from the green corridor and from the street. Tall end carcasses border the main plaza in the quarter, accentuating the entrance on the courtyard side.

The Justice and Administration Centres follows a uniform system in terms of structure, whereas the individual façades feature different detailed designs: the long façades are structured by breaks, recesses and passageways. The upper storeys boast white plastering and, with different-colour window elements on the courtyard side, form a contrast to the anthracite of the plastered and natural stone façades of the three and five-storey blocks at right angles. Together with the public green corridor, this makes for a highly diverse appearance, creating an ensemble that is visitor and user-friendly.

The justice building houses all the courts domiciled in Wiesbaden and the state public prosecutor's offices. The administration building assembles in one location some 600 workplaces that were previously scattered over different locations throughout the city. All those facilities involving dealings with the public are located on the lower floors. With several seats outside, the cafeteria is a place for communication and enlivens the main plaza.



2



3

1. The main plaza accentuating the entrance on the courtyard side
2. The long façades are structured by breaks, recesses and passageways
3. The two main buildings are each divided up into one long block five and six storeys high



1

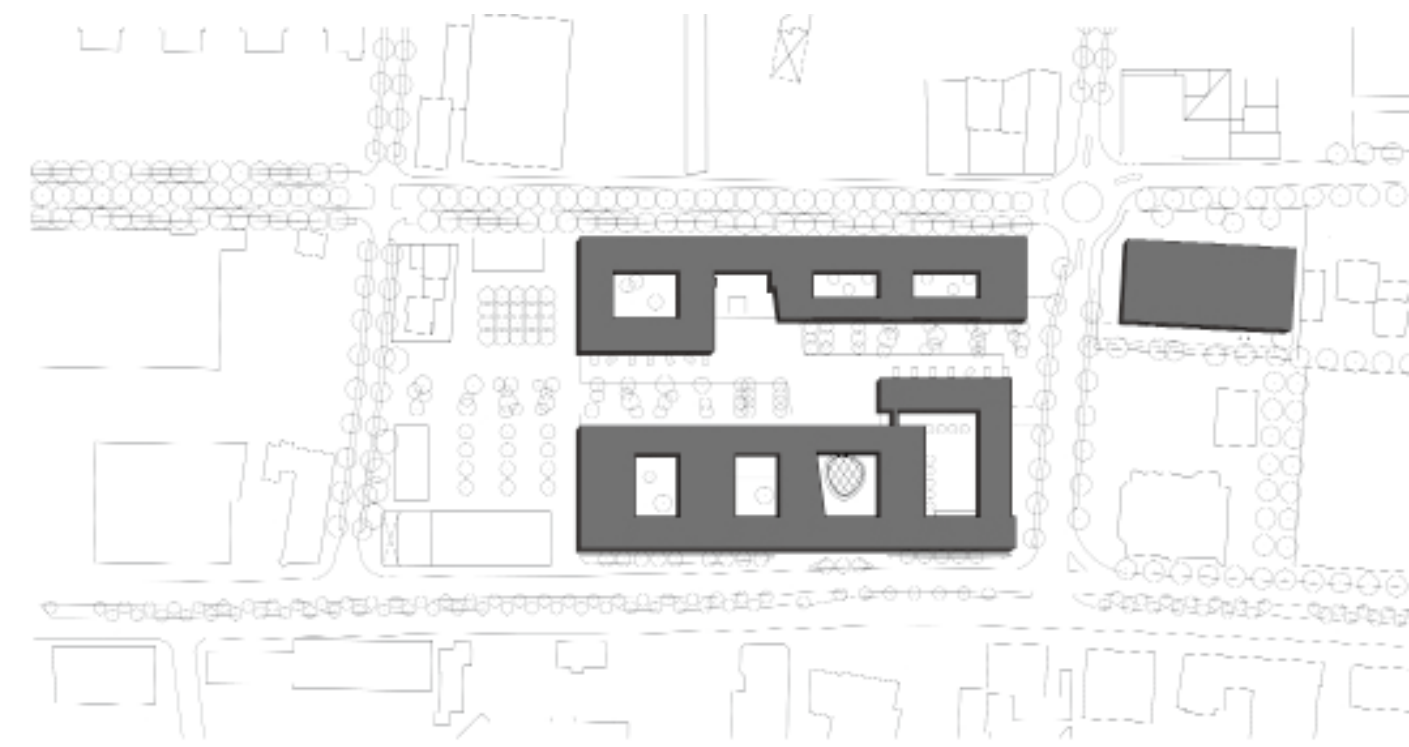

1, 2. The upper storeys boast white plastering and, with different-color window elements on the courtyard side, form a contrast to the anthracite of the plastered and natural stone façades of the three and five-storey blocks at right angles



1

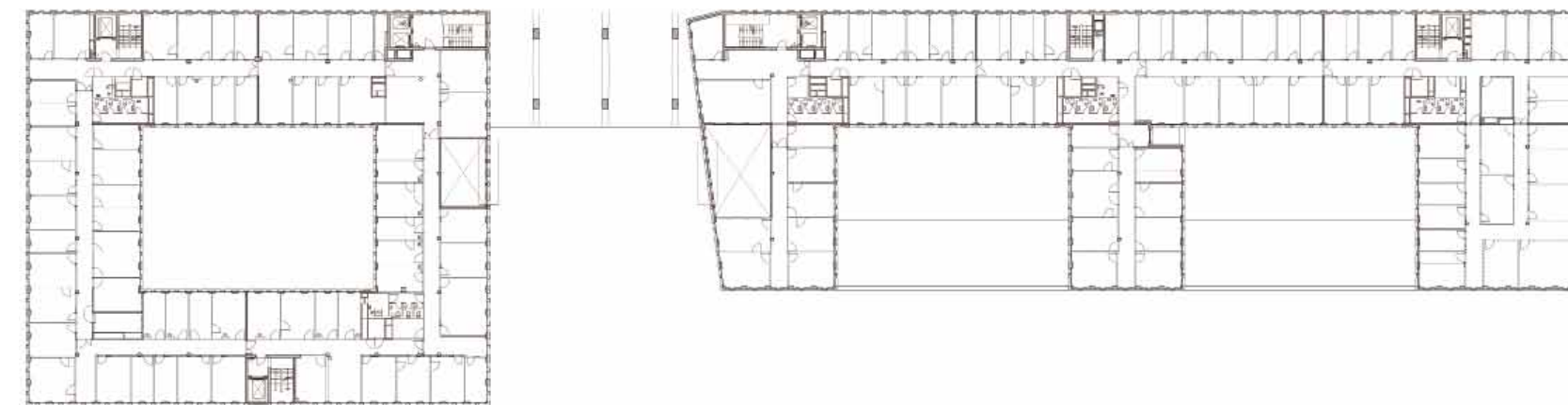

Ground floor plan
 1. Entrance
 2. Security centre
 3. Training area
 4. Public areas for the regional court
 5. Court cash
 6. Public areas for the local court



2

1. A unique skylight allows daylight to filter through the entrance hall
 2, 3. The predominant use of white enhances the light and airy feeling of the courtyards.



3

Durham Consolidated Courthouse

Completion date: 2010 **Location:** Oshawa, Ontario, Canada **Designer:** WZMH Architects **Photographer:** Shai Gil **Total building area:** 41,957 sqm

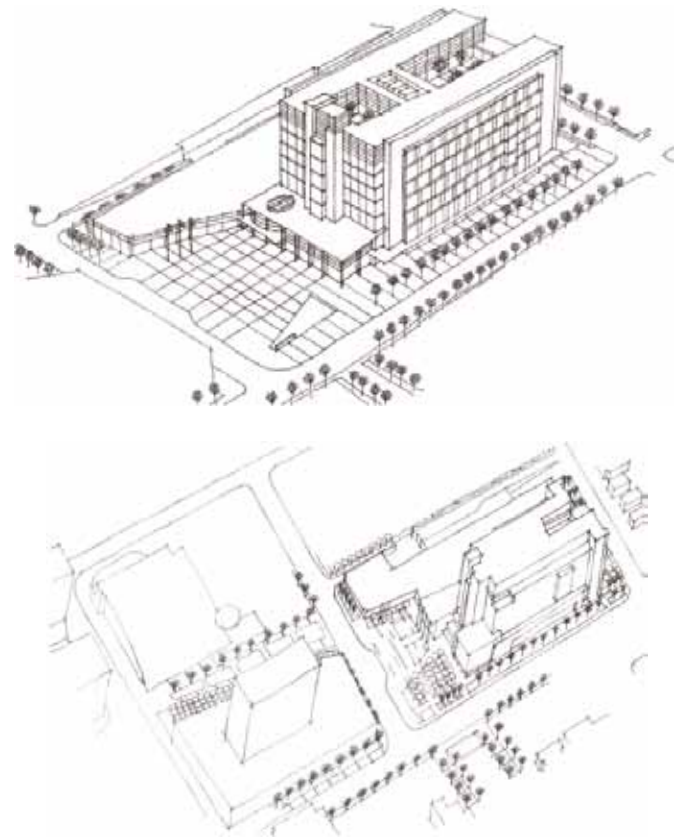

With its richly patterned cladding of spandrel, clear glass and carefully scaled massing, the Durham Consolidated Courthouse, completed in January 2010, makes a significant contribution to the emerging urban framework of downtown Oshawa. Its bold, modern vocabulary emphasizes transparency and openness both for users and passersby.

A large outdoor public space, Courthouse Square, is the forecourt to the building entrance. The scale of the main entrance pavilion on the square establishes a sense of dignity, appropriate for the front door of a courthouse. Providing badly needed space for the Province's judicial system, this six-storey, 40,000 metres structure houses 33 courtrooms, associated support space and prisoner-holding facilities. For planning efficiency, high-volume functions are located at or close to grade. The public circulation system is highly legible for first time users.

Exhibiting a new typology for a typical courtroom floor, the design has a "back to back" arrangement of courtrooms that results in short walking distances for judges and staff. For participants in court proceedings, the availability of natural light and outdoor views in the courtroom waiting areas will provide some stress relief.

The courthouse represents a physical embodiment of our justice system interpreted in a modernist language. Solid building elements serve to express the stability and permanence of the courts. Welcoming to the public, the courthouse elevations are highly transparent, using clear glass with a rich mosaic of white ceramic frit glass panels. The scale of the main entrance pavilion creates a formality and sense of dignity, appropriate for the front door of a courthouse.

The project is the first LEED NC Gold Provincial Government Building to be completed. It has a compact plan that minimises the exterior envelope, contributing to an overall building energy consumption that is 42per cent less than the Model National Energy Code for Buildings (MNECB).

This is the first project to be delivered using the Province of Ontario's Alternative Financing and Procurement framework and is a good example of how design excellence can be achieved by utilising private financing.

The courthouse is setback from Carriage Works Road to create a Courthouse Square of significant size that acts as a formal forecourt for the building. Providing over one acre of new landscaped open space, the project gives the City a significant new public amenity. The single public building entry is centrally located on the Square. The building mass parallels the street grid. Building setbacks serve to mediate between the surrounding properties and the large mass of the proposed building; a continuous 10metres high street wall creates a strong urban edge and pedestrian scale along Bond Street compatible with the existing adjacent low structures; above the second floor the building steps back. On the west, the main building core is raised to create a visual terminus, looking east from the proposed linear park. At the southeast corner of the site, a column of glass that is illuminated at night creates a strong gateway to downtown Oshawa.

1. Main entrance
2. Details of the side building
3. The front elevation of the courthouse is highly transparent, using clear glass with a rich mosaic of white ceramic frit glass panels
4. Side view and illumination effect
5. Night view of the main entrance



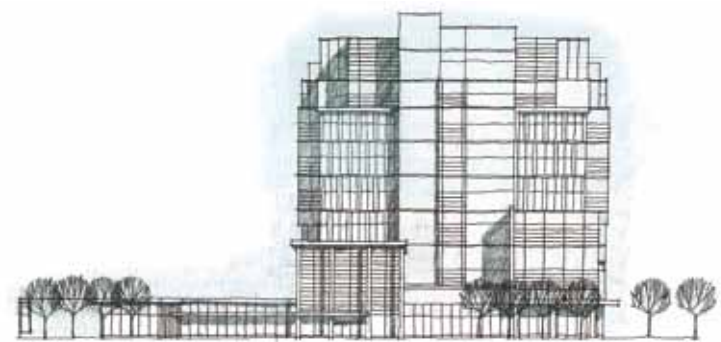

Courthouse Street Elevation

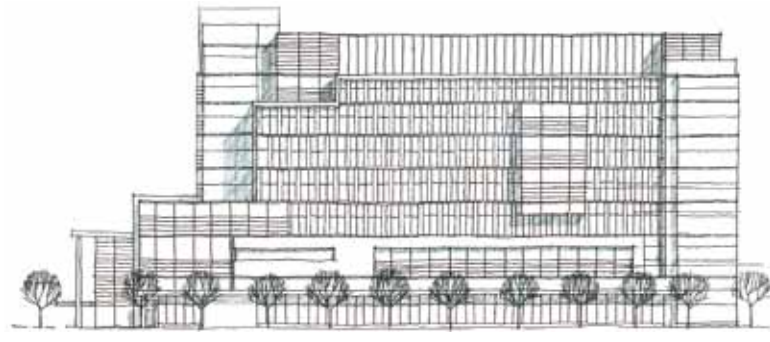

Bond Street Elevation

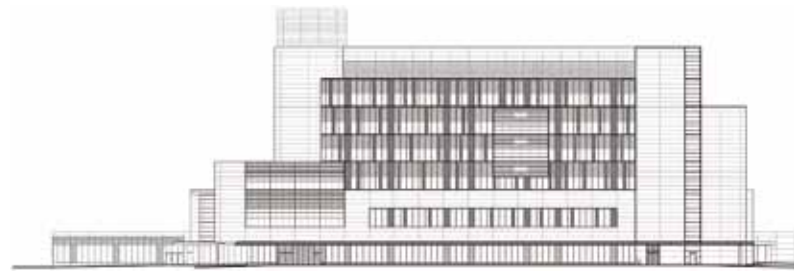

South Elevation



West Elevation



East-West Section

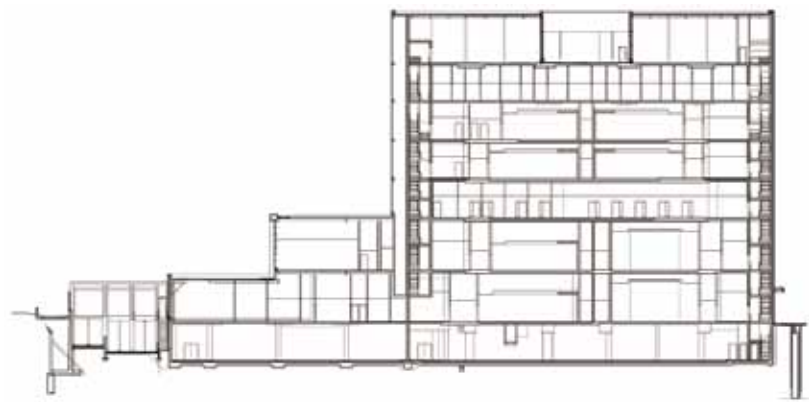

North-South Section



1. The open main entrance hall gives a sense of dignity
2. Reception area and far view of the lounge





1



3

- 1. Waiting area
- 2. Corridor
- 3. Court



2

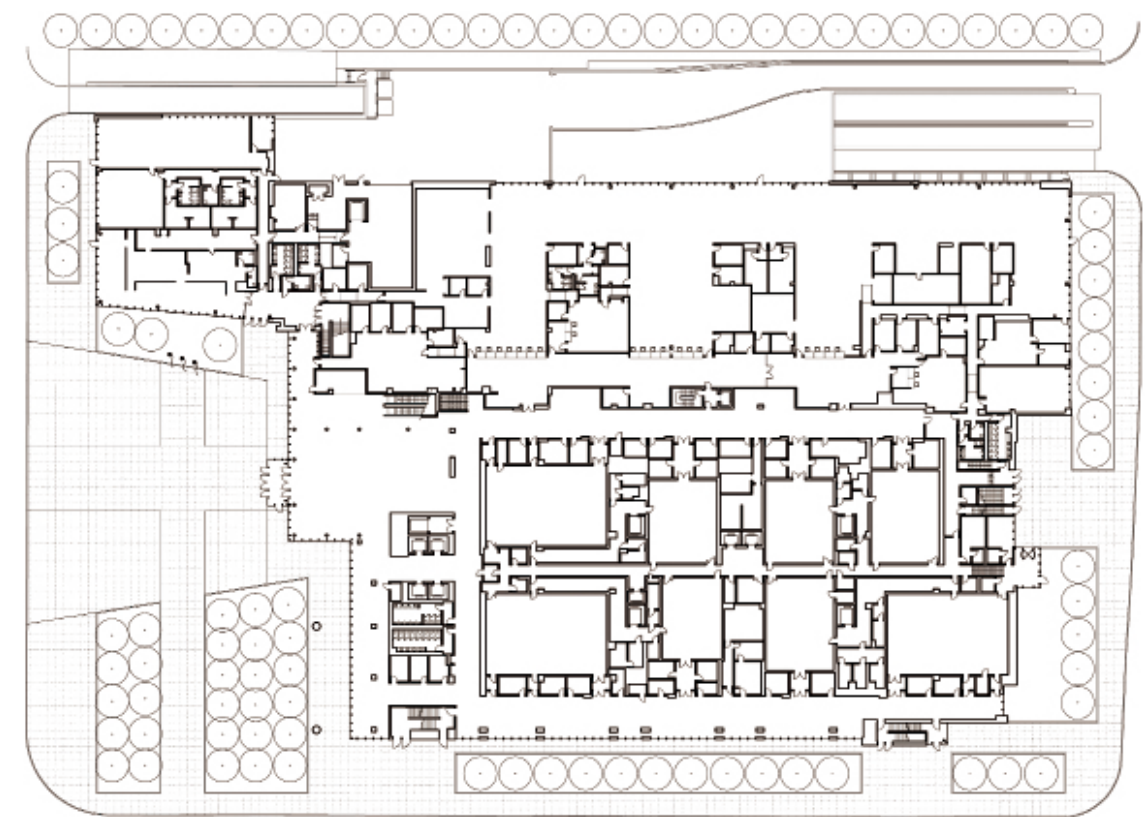

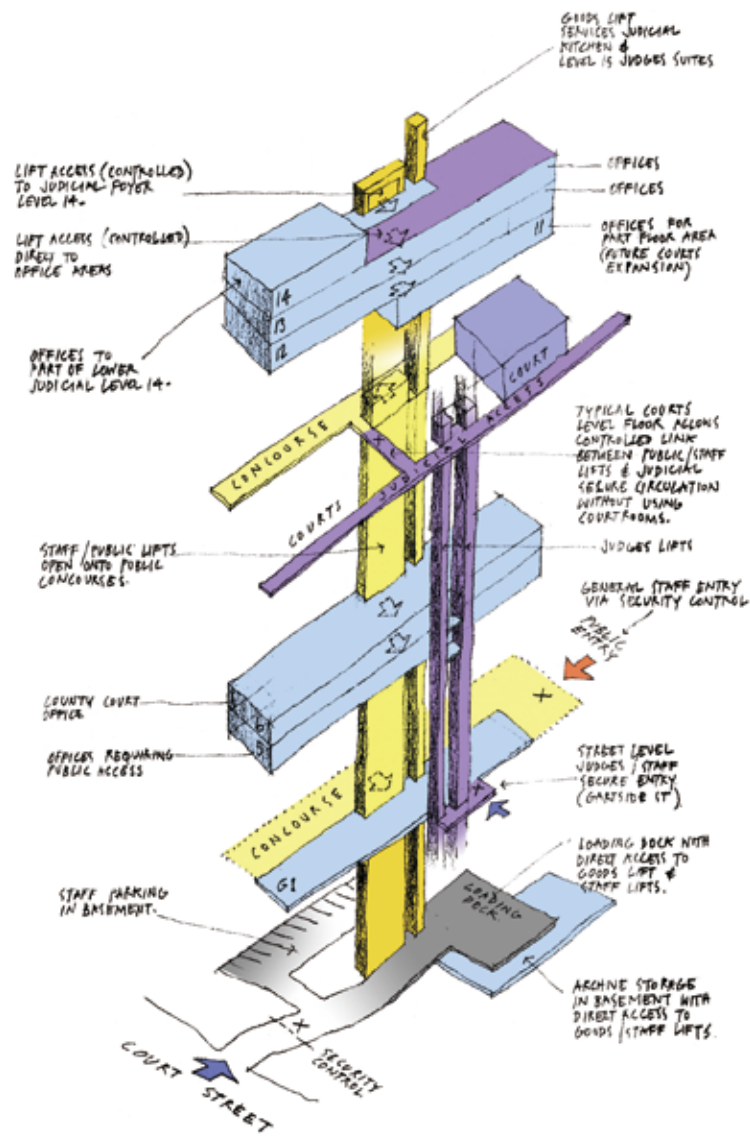

1. The building's projected court rooms. The striking profile and subtle use of glass and colour the city's skyline
2. Court
3. Each concourse is equipped with aluminum-faced meeting rooms strung out over the atrium

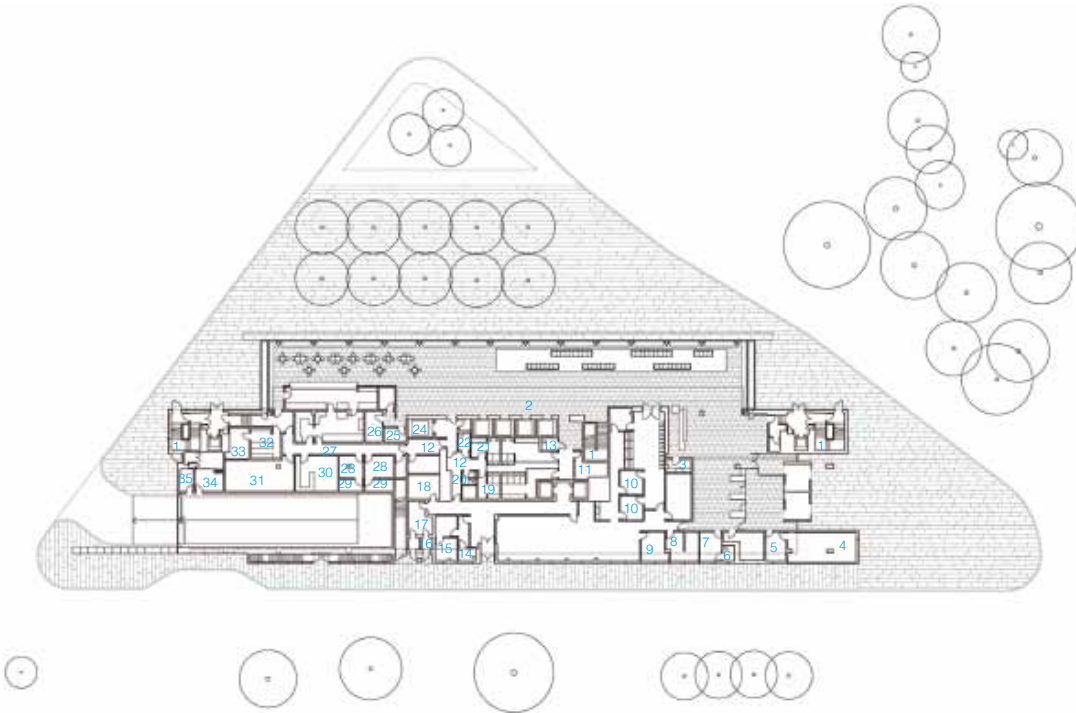
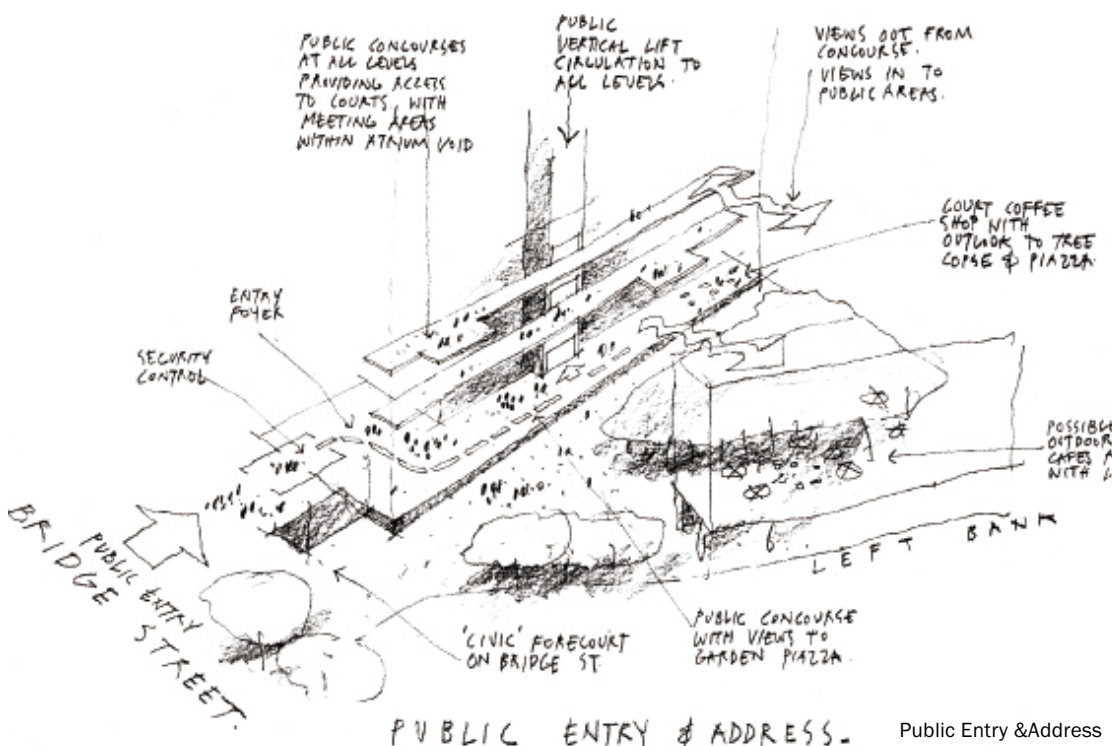

- | | | |
|-------------------------------|----------------------------|---|
| Ground floor plan | 12. Lobby | 24. Goods lift |
| 1. Stairs | 13. Public disabled toilet | 25. Baby feeding room |
| 2. Lift lobby | 14. Toilet | 26. Prayer room |
| 3. Reception store | 15. Video link room | 27. Services corridor |
| 4. Store / plant | 16. Secure letter box | 28. Cleaners assembly / locker room |
| 5. Store | 17. Post x-ray | 29. Store |
| 6. Disabled toilet | 18. Patching centre | 30. Kitchen staff / dry goods & refrigeration storage |
| 7. First aid room | 19. Staff female toilets | 31. Comms room |
| 8. District probate registrar | 20. Shower room | 32. Incident control room |
| 9. Probate manager | 21. Staff male toilets | 33. Lockers |
| 10. Interview room | 22. Staff disabled toilet | 34. Service area / secure temporary store |
| 11. Electrical room | 23. Cleaners store | 35. Security point |

The Franklin County Courthouse

Completion date: 2010 **Location:** Columbus, USA **Designer:** Arquitectonica **Photographer:** Dave Emery, Brad Feinkopf **Site area:** 30,658 sqm

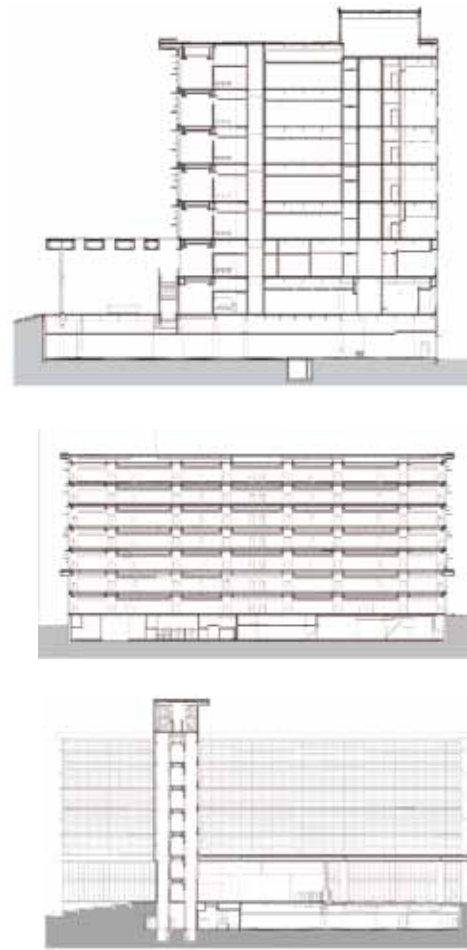

1. Far view of the building
2. Exterior Walls using glazed curtain walls with sun shading louvers and architectural pre-cast panels
3. Folding surfaces and planes set up a priority of scale at street level



A new county courthouse was designed as a modern expression of a traditional courthouse. A glass façade allows views to the interior and contributes to the LEED certification to which the city has aspired - the state's first green county courthouse. The \$105 million, 330,000 SF (30,658 Square metres) facility will accommodate 20 Common Pleas Courtrooms, 10 Magistrate Courtrooms, Special Proceedings Courtrooms, judge's chambers, offices and areas for support staff. High ceilings and an east/west orientation allow maximum light into courtrooms. The project includes a civic plaza, a green lobby canopy, and outdoor public spaces.

The building envelope allows the internal proceedings of the building to be observed from the outside, thereby increasing public awareness of the inner workings of the facility, while acting as a finely tuned, breathable membrane that increases efficiency and sustainability for the complex. Glazed curtain-wall systems with optimized louvers and screens are used to achieve the functionality of a high performance environment. Folding surfaces and planes set up a priority of scale at street level, which then go on to carefully contain the primary function of the project - its courtroom levels. This gesture is the key to identifying prominence on the main street as it strategically redirects to a civic building to the east, unifying the "court square."

The public areas are designed to reflect the professional and dignified nature of the courts and are made of high quality, durable, and easily maintained materials. Floors in the public lobby and public corridors are terrazzo. Walls are cherry wood paneling in the gallery corridor. The public lobby is enclosed by glass on two-sides, with skylights and precast columns. Public toilet facilities have porcelain tile floors and walls, GWB ceilings, stainless steel toilet partitions, granite vanities, and stainless steel accessories.

The courtrooms were designed to reflect the dignity of the court. High quality materials with durable, easily maintained finishes are used throughout. Courtrooms are carpeted with walls constructed of a combination of premium quality woodwork panels (6'-0" AFF), GWB, and acoustical wall panels. Various wood species and cuts were used. Ceilings are painted GWB with wood ceiling tile features. Spectator seating areas are fixed wood benches. Counsel tables, jury seating, lectern, and chairs are movable. Courtroom doors are 8'-0", flush, solid core, wood veneer doors with wood frames.

Chambers floors are carpeted, with ceramic tile at staff toilet and vinyl composition tile (VCT) at storage/file rooms and coffee galley. Each has painted GWB partitions with wood base and a wood chair rail. Staff toilets used painted GWB with ceramic tile wainscot. Ceilings are concealed spine ACT with painted GWB soffits. Doors are 8'-0", flush, solid core, wood veneer doors with wood frames.

Administrative areas reflect the professional, customer service side of the courts. Floors are carpeted, with ceramic tile at staff toilets and wet areas and VCT at storage/file rooms. Walls are painted GWB with vinyl wall base, and ceramic tile wainscoting for wet areas. Doors are wood with hollow metal frames. Furniture here is typical systems furniture with a mix of open office workstations and private office desks.





1. Side view of the building
 2. Sun shading devices to minimize solar gain and maximize views



2

- 1. Central Holding
- 2. Private Circulation
- 3. Clerk
- 4. Core/Mechanical
- 5. Public Circulation
- 6. Probations
- 7. Jury Commission
- 8. Building Support

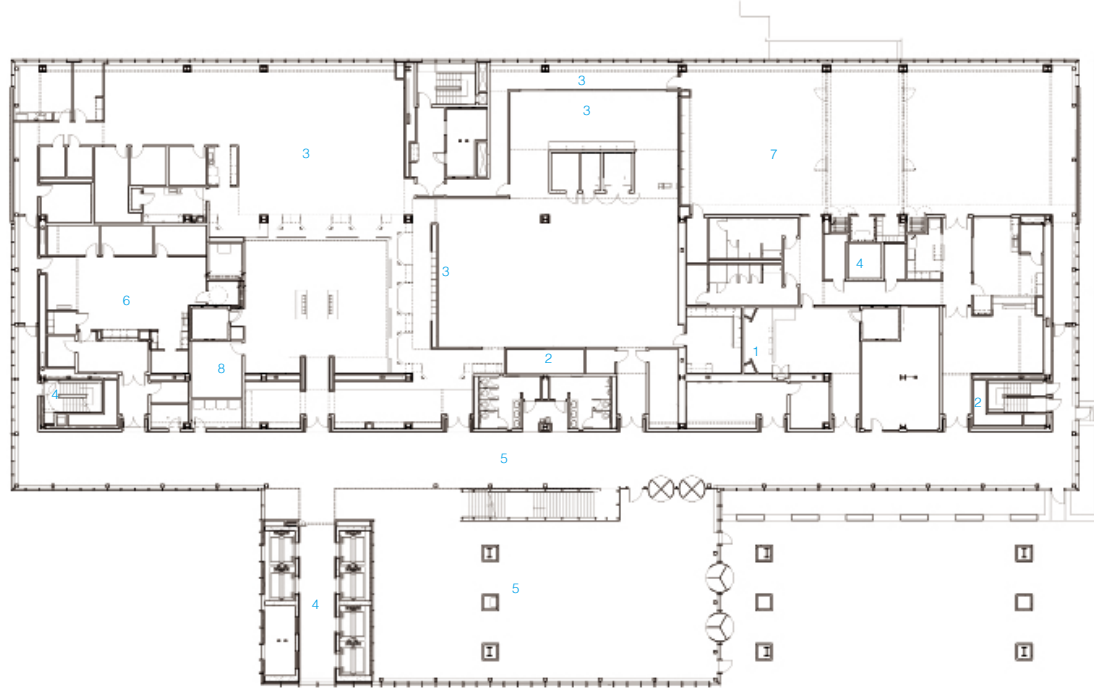



1



3



2

1. The entrance lobby with skylights and precast columns
 2, 3. Floors in the entrance lobby and public corridors are terrazzo

- 1. North Lawn
- 2. Service Drive
- 3. Service Court
- 4. Northeast Plaza
- 5. West Green
- 6. Rain Garden
- 7. Terraces
- 8. South Stairs
- 9. Fore Court

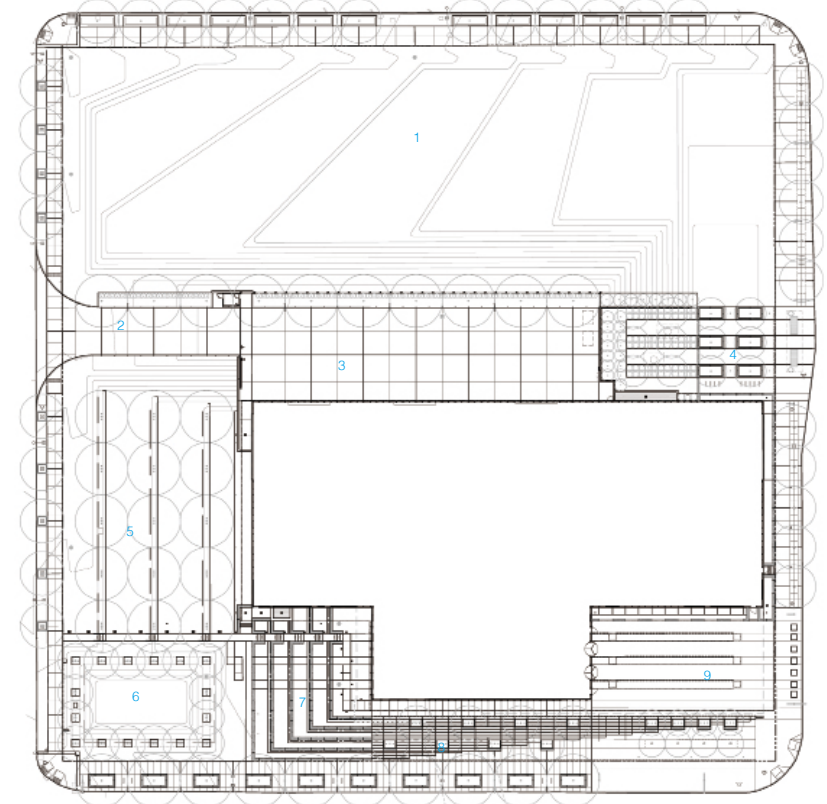

Barcelona City of Justice and L'Hospitalet de Llobregat

Completion date: 2009 **Location:** Barcelona, Spain **Designer:** David Chipperfield Architects (DCA), b720 Fermín Vázquez Arquitectos **Photographer:** Christian Richters, Joan Argelés **Site area:** 241519.92 sqm **Award name:** 2010 RIBA Award / 2010 FAD Architecture Award

The principle proposition of the project breaks down the massive programme requirements (241,519.92 Square metres of built surface area) into a series of separate but interrelated blocks on a public plaza, giving a spatial composition that attempts to break the rigid and monolithic image of justice. The proposal also attempts to provide equilibrium to the relationships between the different working areas, public areas and landscape.

A group of four large judicial buildings are situated around the perimeter of a linking concourse building: Building I (Lower Criminal Court), Building P (Criminal Courts), Building C (Civil Court), and Building F (Public Prosecutor's Office and Minors). They generally contain courtrooms at ground floor and a further three floors. All of these floors are accessed directly from the concourse building, which acts as a filter. The concourse building also gathers people at the start and completion of their judicial visit within a central public room, which overlooks the exterior plaza.

A second group of more autonomous buildings are used for a broader range of functions. Two of the buildings house various judicial services: Building G (the Institute of Legal Medicine) and Building H (Courts of L'Hospitalet de Llobregat). Buildings J and D are occupied by offices and retail facilities, while the remaining building is for complementary social uses.

The imposing façades are made of coloured concrete. Performed in situ, the pigment is added in the dosage (as part of the mass) and not afterwards. While the façades smooth texture is noticeable in a close perception, colour plays a key role at a global scale. The diversity of volumes and its homogeneous treatment are complemented by the colours that identifies each of the buildings: there are six colours to eight buildings. The pigments are basically iron oxide except green, which is chromium oxide. These pigments are stable (do not get altered with the effect of UV rays), insoluble and inert.

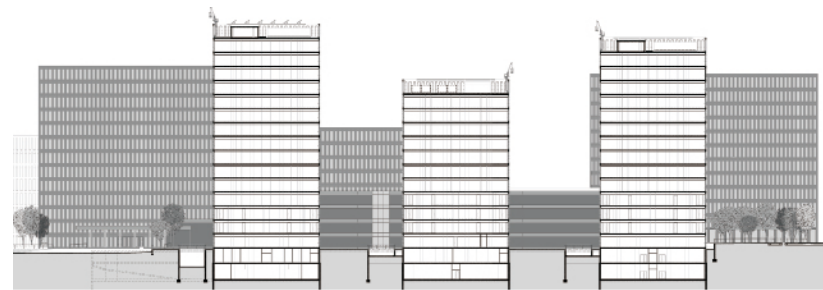
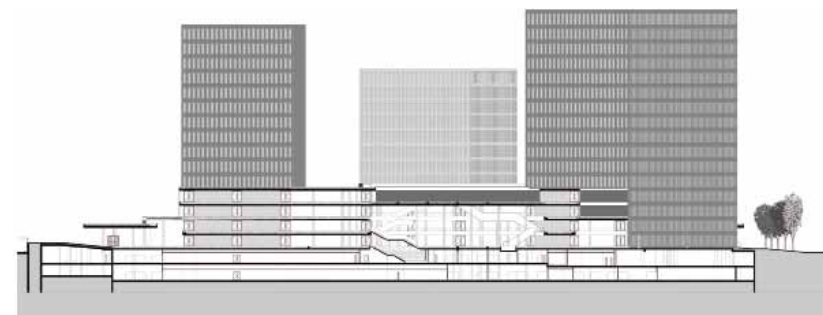

1. The project is composed of eight different volumes, breaking the previous rigid image of the judicial construction
2. Coloured concrete is the main material of the smooth external wall





1



2

- 1. The colourful external wall comes from the added chromium dioxide and iron sesquioxide
- 2. Top view of the reception hall

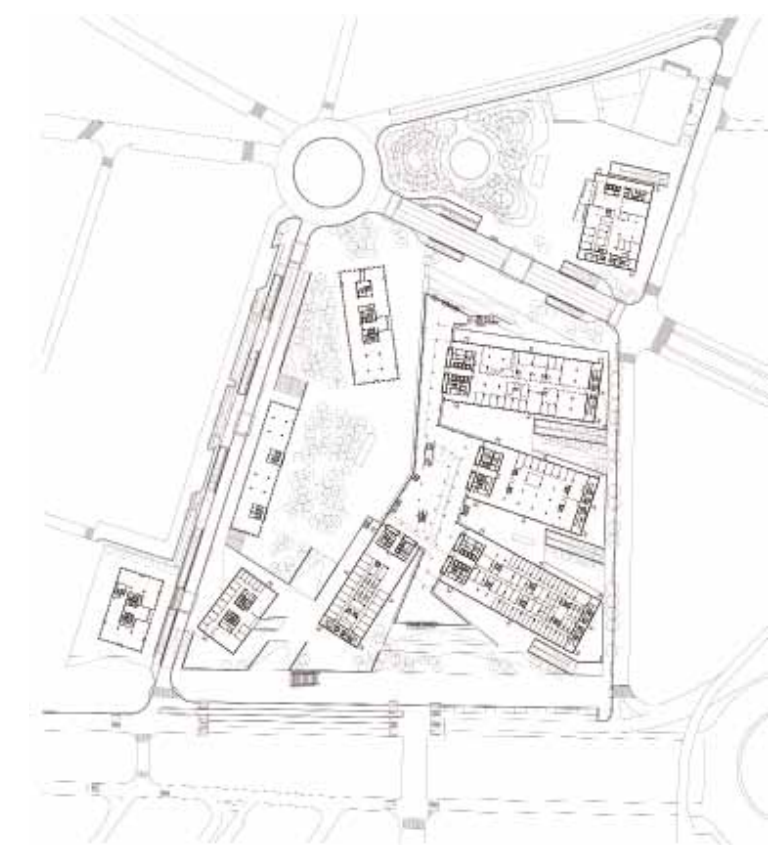



1

- 1. Far view of the reception area
- 2. Stairs
- 3. Public rest area on the second floor



2

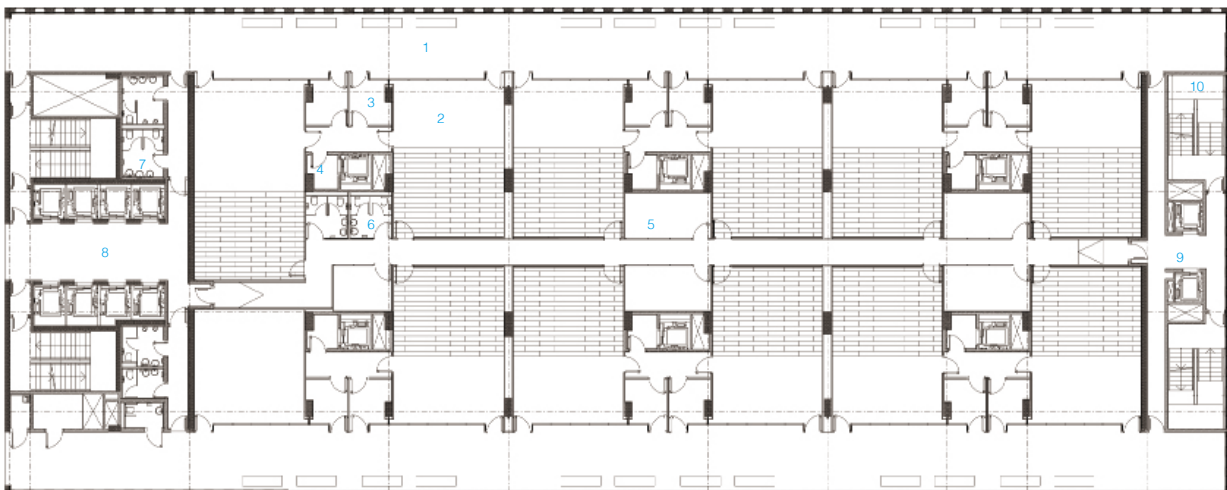

- Typical court plan
- 1. Waiting area
 - 2. Court room
 - 3. Witnesses waiting room
 - 4. Prisoners lifts
 - 5. Judges office
 - 6. Judges bathroom
 - 7. Public bathroom
 - 8. Public lifts
 - 9. Judges lifts
 - 10. Fire stairs



3



1



3



2

1. Office area
 2. Corridor of the office area
 3. Court space

Office Plan

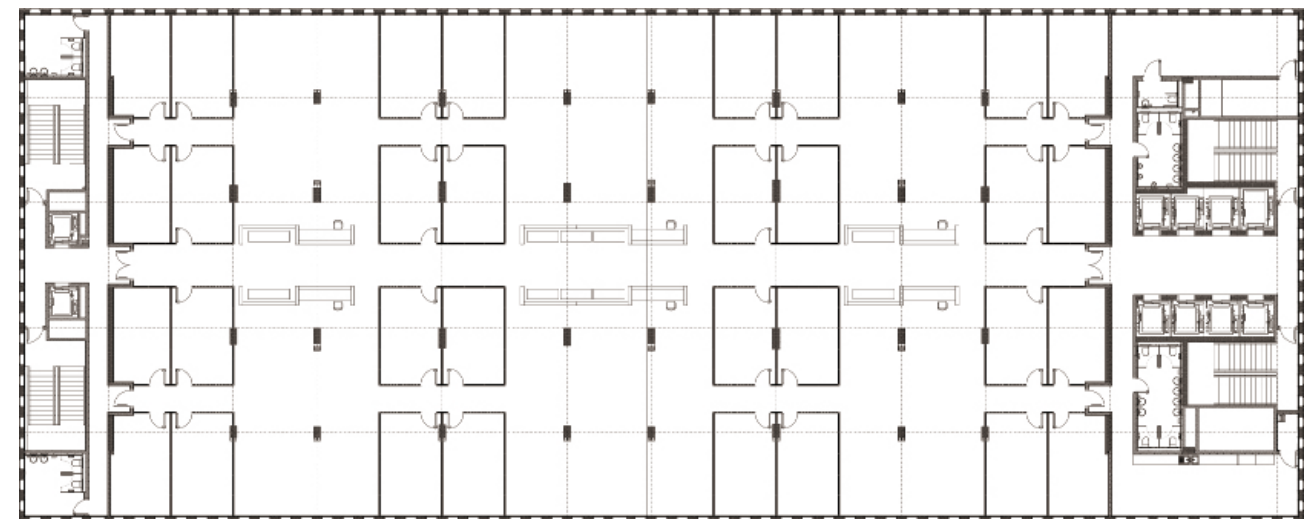

Attunda District Court

Completion date: 2010 **Location:** Stockholm, Sweden **Designer:** Svante Forsstrom Architects
Photographer: Daniel Hertzell, Holger Staffansson **Site area:** 3,500 sqm **Total building area:** 9,500 sqm

Transparency and Security of Justice

This district courthouse is part of a new efficient regional centre for justice in northern Stockholm, localizing police station, custody and district court next door to one another. The setting emphasizes the need for the contemporary courthouse to stand out with total integrity, announcing transparency, security of justice and serious dignity.

The entire building is organised by a logistic structure focusing on security issues and security of justice. This three-dimensional system facilitates separation of different parties to particular entrances to the building. The traditional courtrooms are also modern studios for audio and image recording as well as scenes for audio and image playback.

Working with transparency provides the opportunity to model light and contrast translucency to shimmering glass surfaces and dense wall parts. The courthouse faces the expansive local community centre and busy commuter train station with a largely glazed main façade. In three transparent axis light is let throughout the structure by large glazings and white atriums. The front façade corners are translucent by glazed stairwells. The dense wall parts of the main façade are precast white-on-white graphic concrete elements, the edge lines dissolved to merge wall and glazing. The wall parts float in the shimmering glass.

The front appearance is an accentuated contrast to the black plaster gables and rear façades. On the flat roof a smaller ship-like glass building stands like a lantern, lined with sunscreen louvers. The courthouse is based on a low platform of granite walls, planted with green grass and trimmed bushes. The public entrances are denounced with granite stairs and ramps and stout canopies made of steel and white precast concrete. The interior colour range is light and gentle with a prominent element of ash tree and white in the public spaces. Colour accents are concentrated to furnishings and public art.

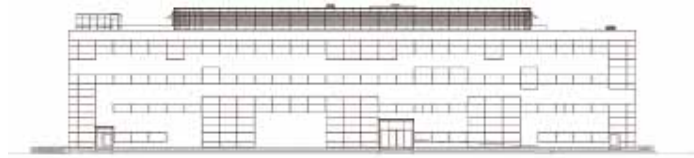

1. Night view of the façade
2. Side entrance
3. The glazed glass is the main material of the external walls





1. The back of the building is a black plaster external wall
2. Atrium
3. The public entrance hall

Ground floor plan (Floor plan court rooms)

- 1. Public entrance
- 2. Foyer area
- 3. Reception
- 4. Court room
- 5. Atrium
- 6. Stairway to upper floor
- 7. Protected area



Third floor plan (Floor plan office rooms)

- 1. Office room
- 2. Conference room
- 3. Meeting space
- 4. Copy room
- 5. Case room

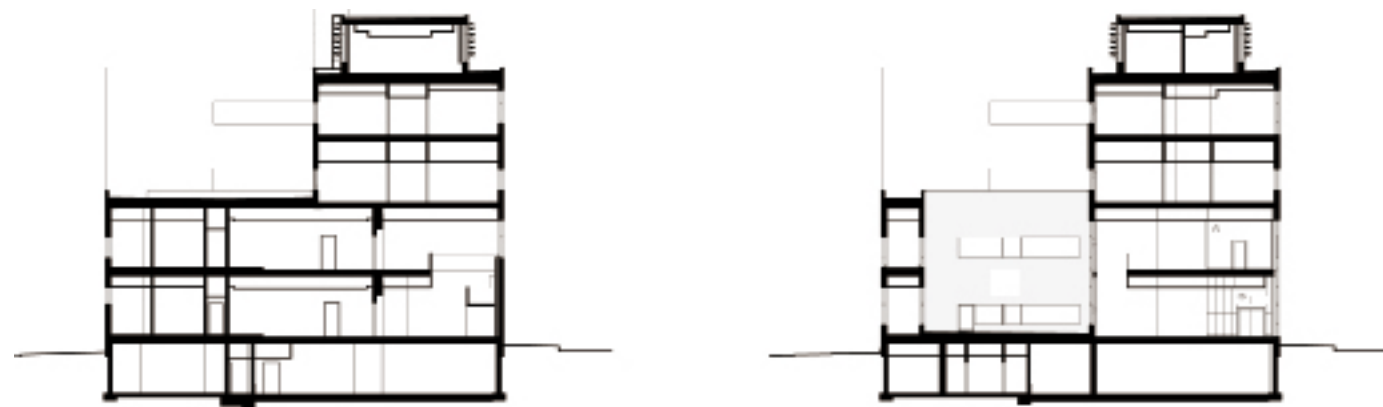



1. Foyer area, second floor
 2. Office
 3, 4. The court space is light and gentle with a prominent element of ash tree and white colour

Fourth floor plan (Floor plan roof lantern)
 1. Luncheon room
 2. Pantry
 3. Library
 4. Conference room
 5. Rooftop terrace

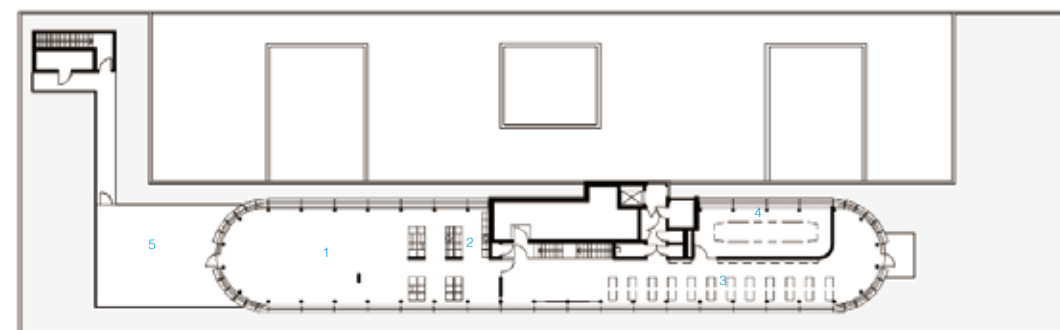

Haifa Court House

Completion date: 2008 **Location:** Haifa, Israel **Designer:** Chyutin Architects **Photographer:** Ardon Bar Hama **Site area:** 100,000 sqm

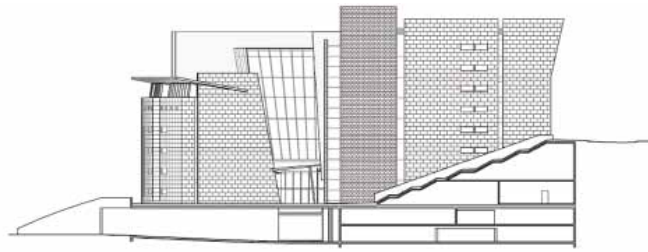

West Elevation

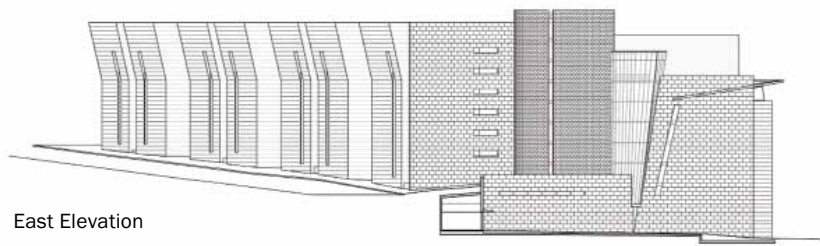

East Elevation

Haifa is the main northern city of Israel, situated on the shore of the Mediterranean Sea, on the slopes of Mount Carmel. The building site is located at Haifa's downtown area, between two roads that define its boundary. The lower avenue serves as a main city thoroughfare, linking the city of Haifa to the northern part of Israel. The topographical situation is unique as the topographical soaring of Mount Carmel begins at the site's longitude parallel. As a result, the building's positioning is "double faced," i.e., one side facing the mountain and the other facing the sea. The structure has two public entrances. The main entrance leads from the urban square in the west directly to the upper entrance level. The secondary entrance from the urban square on the eastern side of the structure leads to the lower entrance level. The building's entrance square from the west is a meeting point of main urban pedestrian routes.

The main concept pertaining to the building's functional plan is expressed in the systematic approach, which regards the structure as a "law factory." The functional effectiveness surpasses considerations related to prestige or status. The building is composed of two wings, with unique functional and spatial characteristics. The southwestern judicial wing, which is positioned along the length of the upper street, contains the courtrooms and judges' chambers. The northeastern administration wing, which is positioned along the lower main avenue, features the administration of the various courthouses. The two wings demarcate a monumental entrance hall, which constitutes the bridging and connecting link between them. From the entrance hall one enters the general service activity area including the law library, a restaurant and the judges' club. A sweeping and wide ceremonial stairway, designed in the entrance hall, leads to the main levels, and overpasses link the judicial and administrative wings on the various levels.

The interior of the structure is designed as a covered urban system. The courthouse's entrance space is the continuation of the external pedestrian street, which is defined by the office buildings and stores along its length. The space is designed as a covered street defined on its sides by the administrative and judicial wings. The public activities (the library and restaurant) face the main space, like the stores on the main road. The secondary roads and lanes lead perpendicularly from the main space to the judicial clusters and the administrative service areas. The traffic of the various groups in the building is based on the principle of separating the routes of the different groups of users: judges, staff, detainees and visitors.

The penetration of daylight into all of the courtrooms and the adjacent judges' chambers is a guiding principle in the choice of the architectural solution. This principle dictated the bloc-related split of the judicial wing into four "judicial clusters," each of which contains six courtrooms. The main entrance hall is illuminated through an upper skylight.

1. Details of the building's appearance
2. The southwest façade of the building orientates along the street
3. The main entrance plaza



1



2



3



4



1



2



3

1. The entrance hall connects the southeast and the northwest volume together
2,3. the atrium at the second floor



1



2



4



5



3

1. The overpass joints two volumes together
 2, 3. Details of the skylight
 4, 5. Details of the glazed glass curtain wall

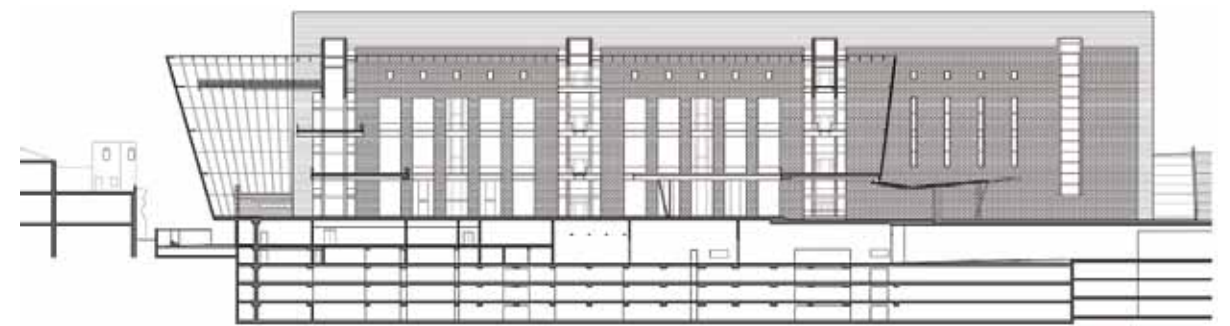

Section

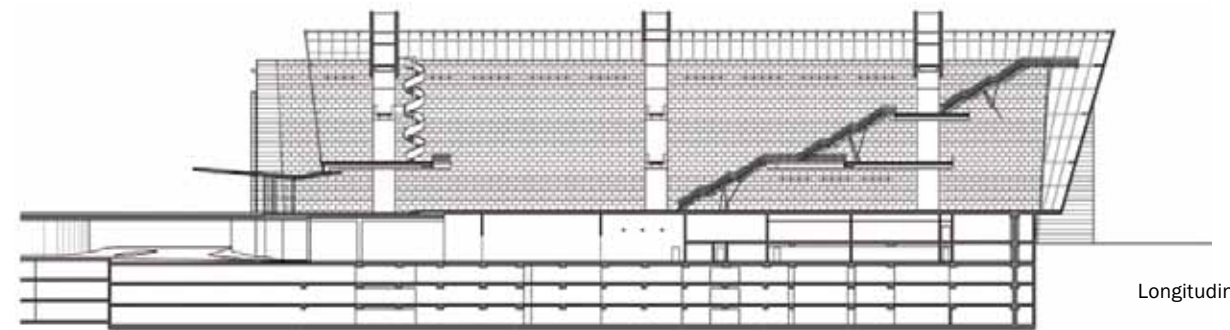

Longitudinal section



1



3



2

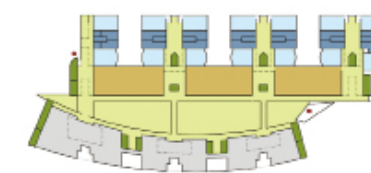

Ground Floor

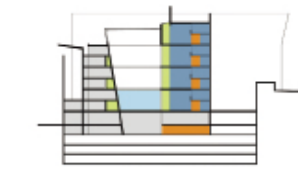

Functional Distribution Diagram

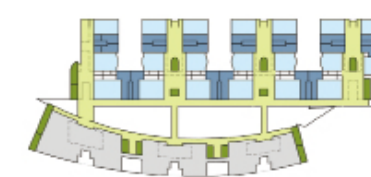

Main Floor

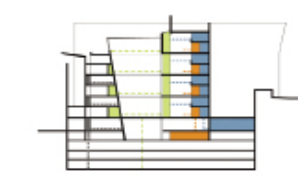

Circulation Diagram

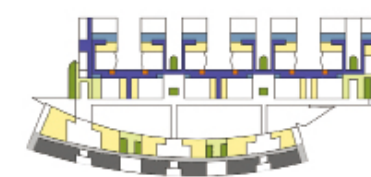

Gallery Floor

- Main/Secondary Entrance
- Courtrooms
- Judges' Chambers/Judicial Wing
- Judges' Corridor
- Administration Offices/Wing
- Administration Corridor
- Public Facilities/ Corridors
- Public Vertical Circulation
- Detainment
- Technical Facilities

1, 2. The starry auditorium
 3. The unique ceiling shape of the court

Federal Arbitration Court of Moscow Region

Completion date: 2007 **Location:** Moscow, Russia **Designer:** TPO Reserve **Architects:** V.Plotkin, I.Deeva, A.Borodushkin, D.Kazakov, A.Romanova, A.Logvinova **Photographer:** TPO Reserve **Site area:** 4,826 sqm **Total building area:** 24,426 sqm **Award name:** World Architecture Festival 2008 - Shortlisted **Award date:** 2008

The building is divided into two blocks: 7-storeyed ancillary building located in the depth of the site and 3-storeyed public building facing Seleznevskaya Street. Both buildings have separate entrances from the territory and are connected with each other by two passages on the second and the third floors. One of the passages is made in double light and houses a winter garden.

The underground part of the building is connected by a car park and car wash. The first floor of an ancillary building has a canteen for the staff and a complex for social and psychological rehabilitation with a gym, aerobic room, beauty salons, sauna and hair-dresser's salons. The upper levels are intended for lawyers' offices and departments with work stations. The sixth floor houses the office of the Arbitration Court Chairman with a view to Seleznevskaya Street and the historic building of the Museum of RF Ministry of Internal Affairs.

The public building is designed entirely for visitors. From the lobby a round staircase and elevator lead to the second and the third floors of the building where the court session rooms are located. The main technical areas of the building are situated the seventh floor of the ancillary building and in the underground part of the building.

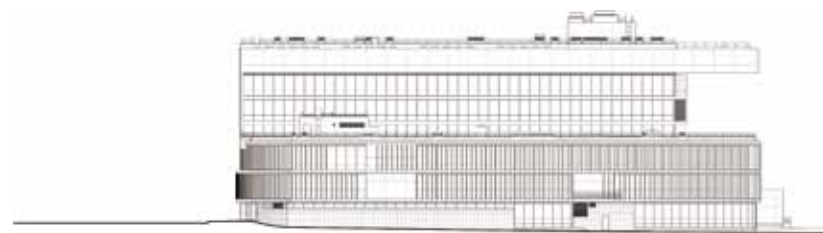

1. The panoramic view of the building
2. The graceful curve of the public building





1

1. The sweeping shutters installed on the public building could effectively filter the strong sunlight, and also give a sense of grace
 2. A seven-storey accessory building locates at the back of the building



2

- 1. Main entrance
- 2. Court room
- 3. Offices
- 4. Courtyard
- 5. Staircase

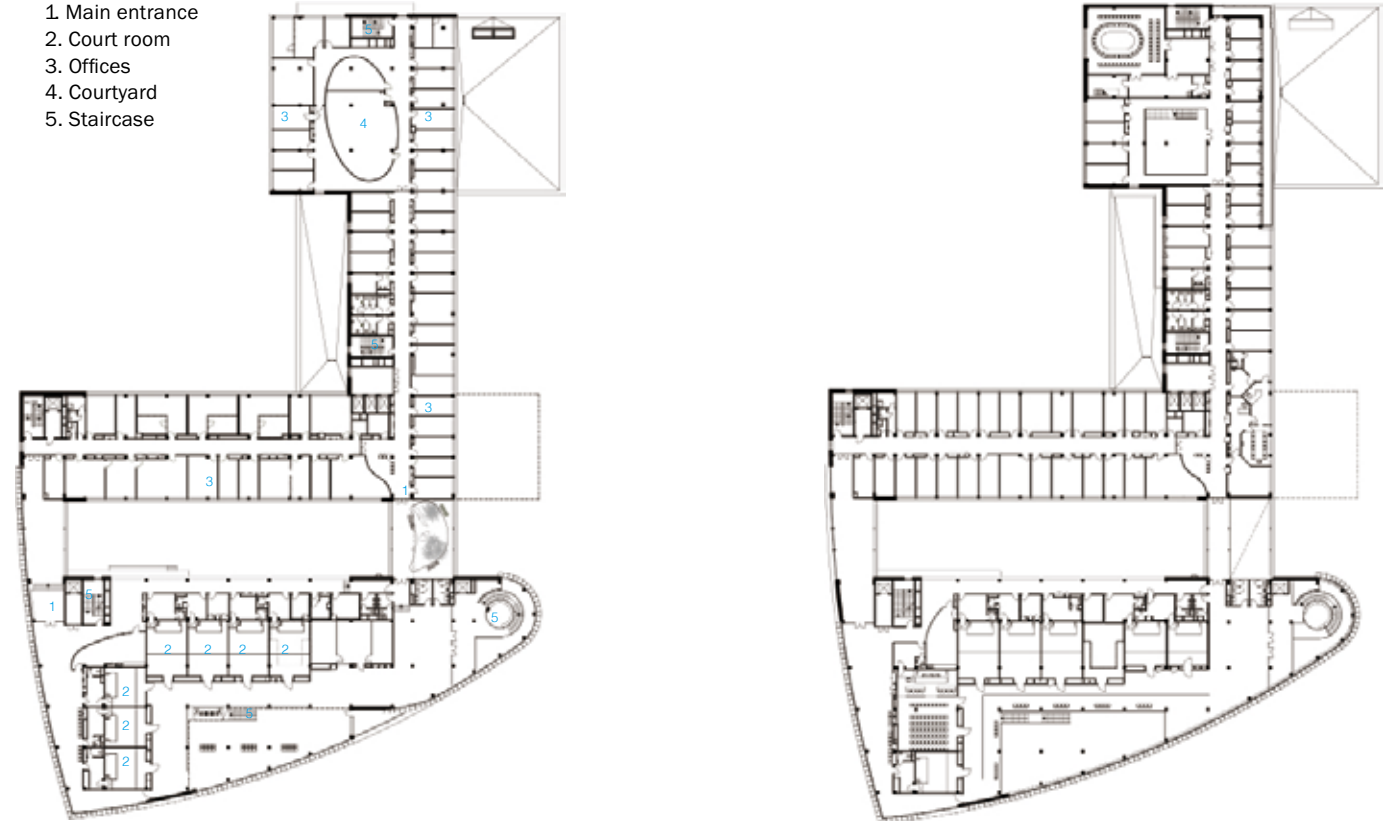



- 1. Both buildings are connected with each other by two passages on the second and the third floor
- 2. The cantilever structure of the building's façade
- 3. The spiral staircase in the public building



Courthouse And Public Square

Completion date: 2011 **Location:** Sankt Poelten, Austria **Designer:** Christian Kronaus + Erhard An-He Kinzelbach **Photographer:** Thomas Ott **Site area:** 600 sqm **Total building area:** 2,633 sqm

The project resulted from an open competition won by Architects Christian Kronaus and Erhard An-He Kinzelbach in collaboration with Vasko+Partner Engineers. The courthouse St. Pölten (Lower-Austria) asked for a building extension to house the higher regional court, district court and the state prosecutor's office. In addition, it required a redesign of the representative public square in front of the historic courthouse building with a new parking garage underneath.

At an urban scale, the new building closes the gap between the existing courthouse and the neighbouring prison. The former is a landmarked building with three floors. A key challenge in the design of the extension was to find a solution that would respect the historical context and coherently connect old and new while, at the same time, treat the new building as a structure in its own right, rather than as a mere annex. The mediation between the old and the new does not only function in formal terms but also on a spatial and organisational level. In particular, a system was developed that efficiently connects the three storeys of the courthouse building with the five storeys in the new building while, at the same time, mediating between the differing ceiling heights.

The overall design of the new project tries to extract as much as possible out of the organisational capacity of the existing building's façade. This particularly applies to the design of the square in front of the historic building. It replaces a previously hardly used forecourt, offering the city a new, attractive and programmed public space of urban quality and intensity. It is at once prominent, inviting yet protective towards the heavily used road. In order to integrate the building context into the square's design, the façade order is projected onto the square. This does not only establish a dialogue between the building and its immediate environment, but also conditions an urban field of elements with different additional functions. These urban furnitures as benches, planters at different heights and ventilation shafts form an artificial topography that caters to a multitude of urban activities and circulation patterns. The formerly determined forecourt with parking spaces thus transforms into a less determined and open field of urban furnitures that cater to more different uses and modes of appropriation. This renders the space as a lively, activated and differentiated urban public space as a place to stay, while it does not compromise on the given requirements for circulation and accessibility.

The programme of the extension building is divided into serving and served rooms. As a result, the building is composed of two distinct volumes, one holding the served spaces, offices and library, one holding all serving functions, such as stairs, elevators, bathrooms, server rooms and vertical shafts. The former has all flexibility, not least due to a exoskeletal structure with a minimum of internal columns and non-bearing partition walls, while the latter connects and mediates between the old and the new building. A performative folded wall divides the central corridor and the offices. It does not only separate spaces, but provides built-in file cabinets and closets for the office interiors, while adding value to the functional corridor by creating waiting and meeting areas in front of the office doors with integral benches and direct and indirect lighting fixtures.



East Elevation



North Elevation



Longitudinal section

1. Details of the benches at the citizen plaza
2. Panoramic view of the citizen plaza
3. The glossy golden colour of the new building's external wall gives the whole space a warm and active character
4. The distinctive windows create new lighting effects for the interior space



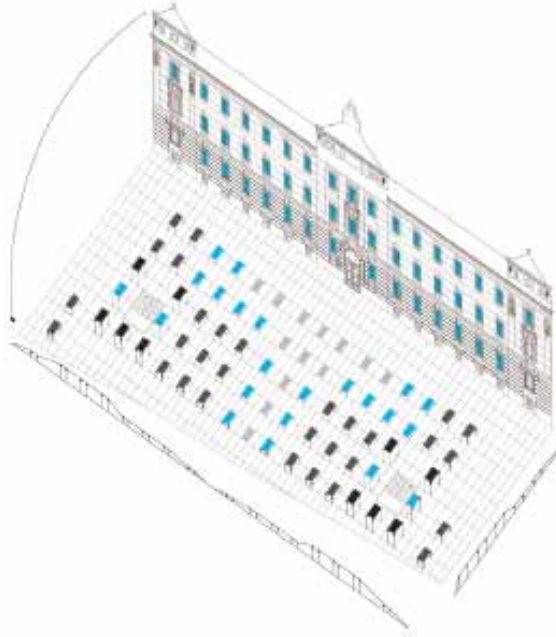
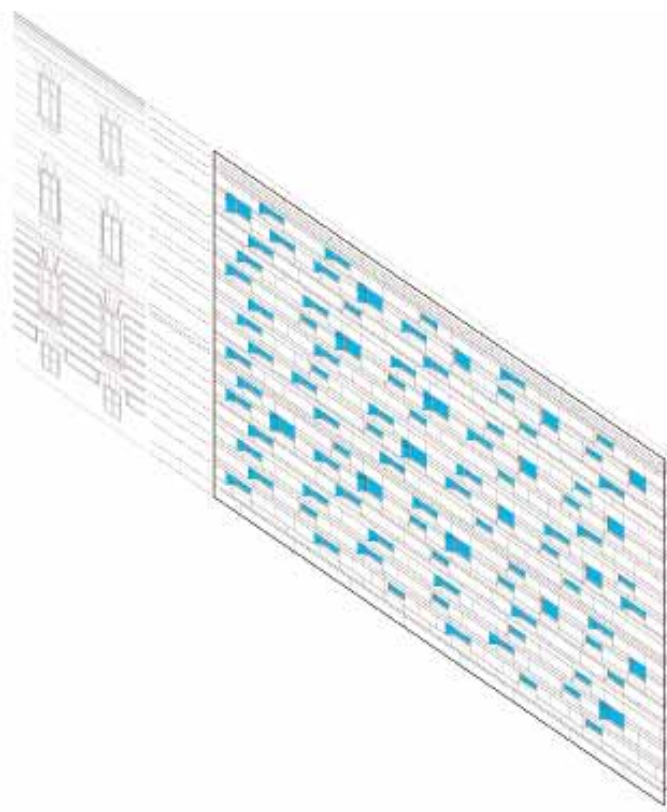

Façade and Square Diagramme

-  Ventilation
H=230
-  Tall Planter
H=230
-  Low Planter
H=90
-  Bench
H=45
-  Materials
H=0

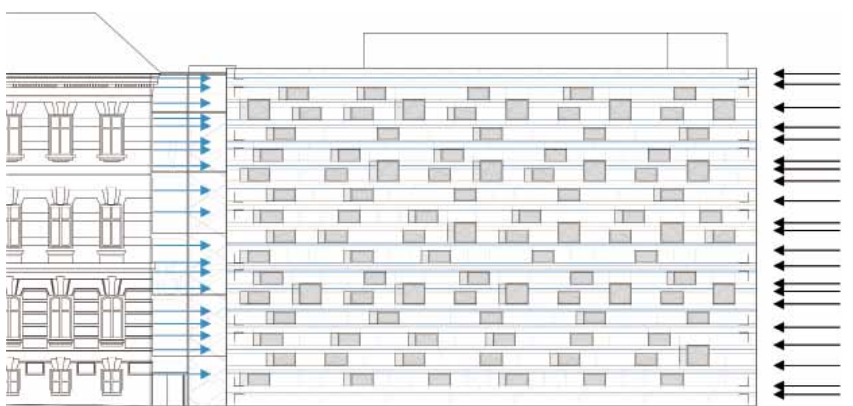

Longitudinal Section



1.View towards the new office building from the central staircase
2.Central staircase between the new and old buildings



2

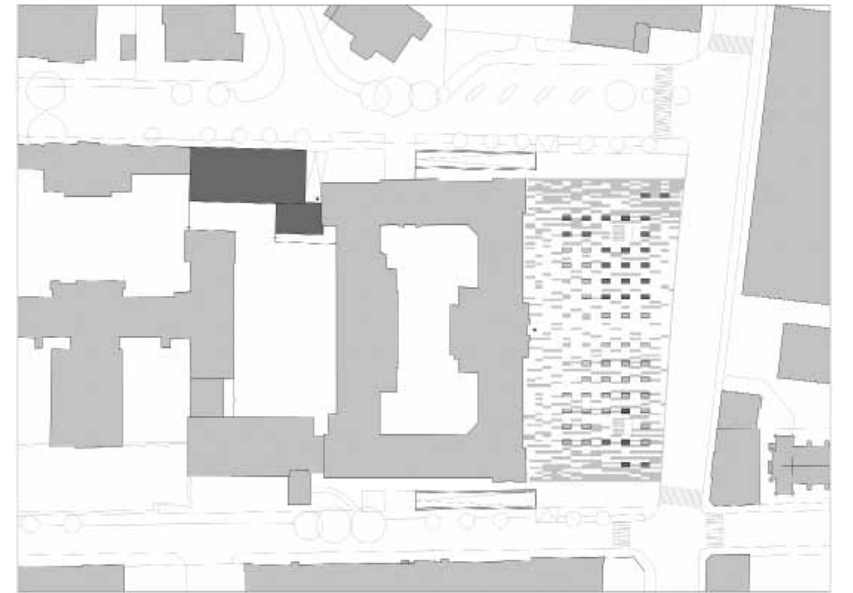

Site Plan



Ground floor plan
 1. Office
 2. Library
 3. Side entrance

- 1. Window perforations from the interior
- 2. A folded wall provides integral lighting and zoning for the corridor and built-in cabinets and closets for the office interiors
- 3. Seating benches are integrated into the folded wall



New Arezzo Courthouse

Completion date: 2007 **Location:** Arezzo, Italy **Designer:** Studio Nicoletti Associati **photographer:** Simone Levi – Studio Nicoletti Associati **Site area:** 23,000 sqm; new wing 5,000 sqm restored old building 18,000 sqm **Total building area:** 20,000 sqm

Near the Medici's Fortress, inside an historical park, the new building houses the main courtrooms and the Hall of Justice President headquarters and is linked to a neoclassical building, once a large hospital, to be restored and used for offices and archives.

The design of the New Wing, symbolises its environment: the rich vegetation of the park and the city's medieval structure, which was protected by a belt of conch walls on one side and, on the other, open to the squares, gardens and the territory. Also the New Wing is enclosed on the North side by a coved wall of black granite slabs whose surface is flamed, as to acquire a very elegant matted dark-grey tone. To the South, an undulating transparent sunscreen facade of stainless steel is shaped according to a geometrically warped geometrys which is characteristics of the skin of many living creatures, including leaves. Those complex curvilinear forms can be built using only rectilinear elements. Thus, a silver bioclimatic foliage protects the interior spaces by a luminous shadow and blends with the park without clashing with the neoclassical nearby architectural elements.

In the interior spaces, the astonishing reflection of the mirror-like polished black granite floor is contrasting with the greenish glazed envelop and the horizontal acoustic grey panel separated by narrow maple fascias. The three levels high entrance hall receives light from the roof, and is dominated by the vertical elevator case clad alike the floor by shining black granite panels.

A building osmosizes with surrounding landscape and with the pre-existing. The new building holds the courtrooms, and is connected directly to the pre-existing ex-Garbasso Hospital, restored and earmarked to house the office space. The project aims to evoke through the softness of the twisting surfaces the rich vegetation of the park, as well as the medieval structure of the city, which is protected by a walled boundary on one side and open towards the squares and the park on the other. Thus the new building reveals on the north side a continuous curving wall in scales of black streaked Chinese granite, part of a leaning cone on an elliptic base. On the southside it has a façade of aluminium held up by a weft of pillars of different inclinations in steel. The over-layering of the twisting surfaces creates a diaphanous and ambiguous space, that enables to open the imagination towards infinity, giving rise to a contemporary re-interpretation of a system of juxtaposed pulsing baroque, of architecture that breathes.

External solar shading is crucial to prevent solar gains from causing overheating and increasing the use of cooling requirements. That's why the buildings has a double skin to the south; this approach allows to provide efficient shading from the sun while allowing natural ventilation.

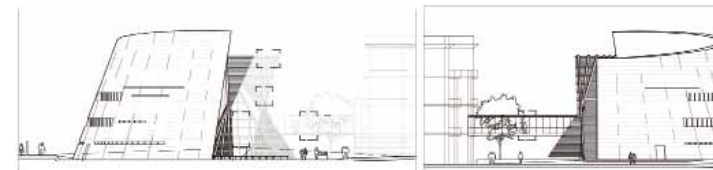

West Elevation

East Elevation

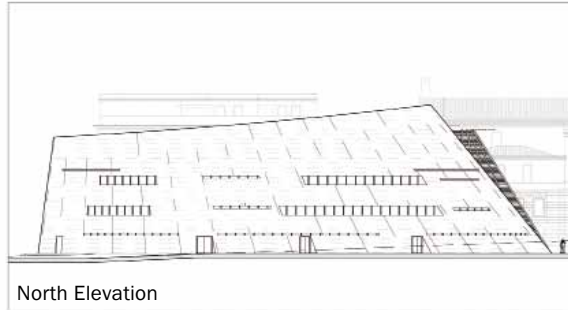

North Elevation

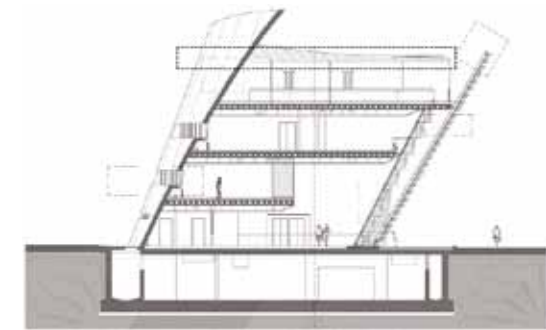

1. The joint of the new and the old buildings
2. Details of the stainless steel sunscreen
3. The external wall is composed of black granite slabs
4. The south of the building has a double skin, which provides efficient shading from the sun while allowing natural ventilation





1

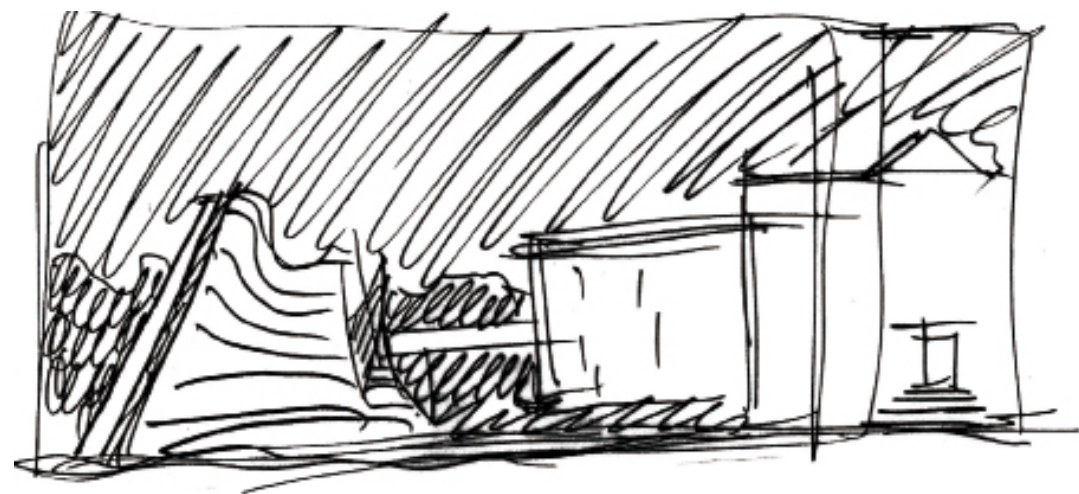

1. The three levels high entrance hall is dominated by the vertical elevator case
 2. The high entrance hall receives lights from the roof
 3. The exterior sunscreen ensures the interior court space get appropriate sunshine



2



3



Ground Floor Plan
 1. Foyer
 2. Court room No.1
 3. court room No.2
 4. Meeting room 1
 5. Meeting room 2
 6. Service room

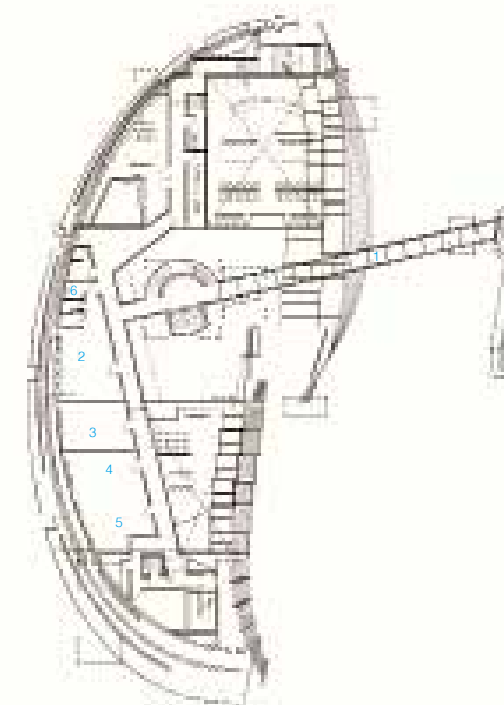

1st Floor Plan
 1. Connection with existing building
 2. Office No.1
 3. Office No.2
 4. Office No.3
 5. Office No.4
 6. Service room

Completion date: 2009 **Location:** Amsterdam, the Netherlands **Designer:** Wansleben-architekten, Norbert Wansleben **Photographer:** Thorsten Huempel / wansleben-architekten **Site area:** 2,000 sqm **Total building area:** 6,500 sqm

Koninklijke Marechaussee op de Marinekazerne te Amsterdam

The "KMAR - Koninklijke Marechaussee" can be described best as a police organisation with military status. Organisationally it is since 1998 beside the army, the navy and the air force the fourth independent organisation unity of the Dutch Ministry of Defense.

In this we see an expression for the ambivalent situation of the users, between the institution and the individual whom you serve, between the policeman as a function in the uniform and the person in it, between the society which demands security, but which looks at security forces doubtfully. Through this the building receives meaning and can step in a dialogue with the viewer and user. It speaks to the town which has produced it. It provides a message about its identity to veil this also at the same time.

One figures to understand the building very fast, how-ever, with closer looking the uncertainties rise again. Is the building dark or bright? Is it closed or transparent? How many floors does it have actually? These questions cannot be answered any more unambiguously. Additionally different lighting conditions and weather cause different impressions.

The viewer forms his own judgment which is valid however only for the moment. The next encounter, the second look, leads to other perceptions. To mark the project in his meaning of utilisation, the typology of the fortress was chosen. Characteristics like the access about a ramp by a folding gate on a higher situated court or the spiral staircases between the floors are to be led back here. Town planning it is a counterpart to the National Maritime Museum (Scheepvaart Museum) and thus forms the begin and the end of a spatial urban sequence.

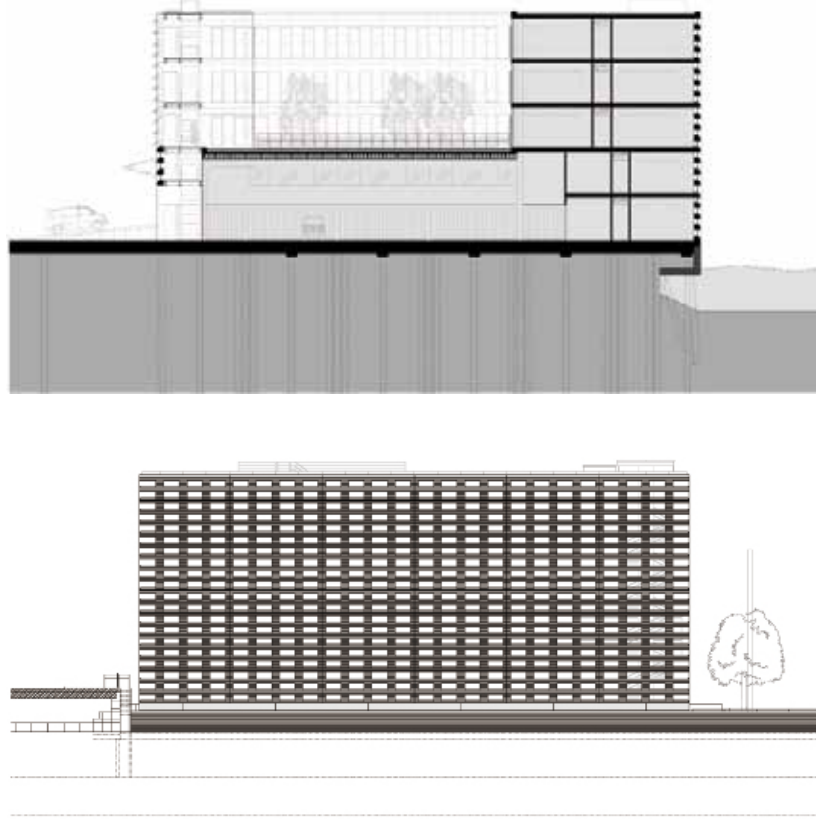

1. Detail of the wall
2. Main entrance and ramp – only access to the building
3. View from the south-west
4. View to the water front





1. Inner courtyard
2. Main stairs



2





1

- 1. Car parking
- 2. Interior view from the corridor at the first floor to the car parking
- 3. Shows a floor, the technical infrastructure is visible and shown in the space above



3



2

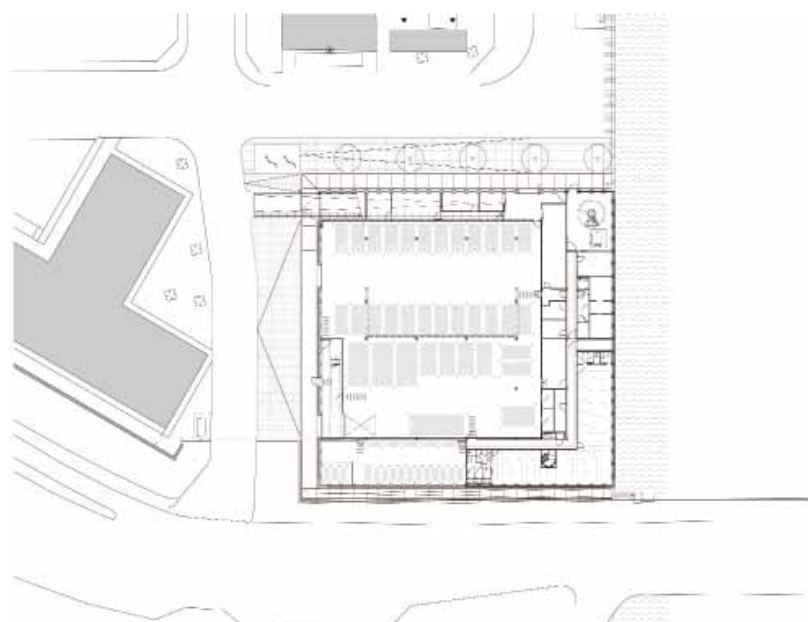

Ground floor plan

- 1. Parking area
- 2. Office
- 3. Elevator
- 4. Parking
- 5. Landscape

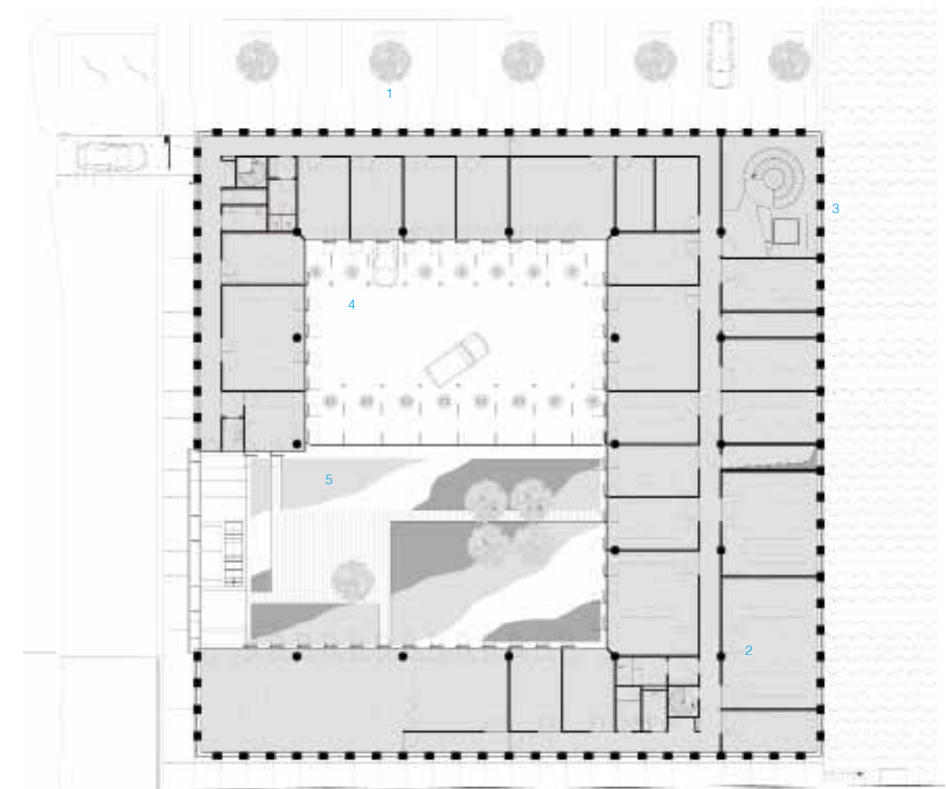

Completion date: 2010 **Location:** Maastricht, the Netherlands **Designer:** JHK Architecten
Photographer: Palladium Photodesign **Site area:** 8,500 sqm **Total building area:** 4,500 sqm

Centre for Damage and Crisis Control

On the site of the existing police-station at the Prins Bisschopsingel in Maastricht, JHK Architecten made a design for a new Centre for Damage and Crisis Control, the Meld- en Coördinatiecentrum (MCC = Centre for Damage and Crisis Control). This new MCC replaces a former sport and storage building. The technical area of this existing building has been integrated into the new building.

Situated in the Jekerdale, the building for MCC is part of a carefully considered ensemble. The ellipse shape of the MCC is fluently positioned in its characteristic surroundings. The façade of the existing police-station has been a starting point for the horizontal articulation of the new façade and connects the new building to the old. The shape of the MCC presents itself as a perfect starting point for possible future developments in this area.

Brought together in a compact volume of approximately 4,500 square metres, the emergency room, the call centre and the several office functions give shape to the nerve centre of crisis control in the South Limburg region. This volume is lifted above a solid base of storage and shed facilities. This base level can easily be adapted to a possible extension of offices in the future. The heart of the building, shaped as an atrium, unfolds itself as a spot for relaxation and communication as well as a central pivot point, which connects several functions with each other. The glass roof of the atrium provides enough daylight in the heart of the building.

The MCC is connected to the inner area of the existing police-station. The entrance of this building follows the path to get from the existing building to the MCC naturally and leads to the middle of the atrium.

The bigger and introvert areas are oriented towards the inner atrium, the offices are directed to the residential surroundings of the Jekerdale. The entire design contains a high level of flexibility and user-friendliness, which makes the building a pleasant place to work now and in the future. The materialisation of the upper and lower levels of the MCC has been inspired by the classical, rich detailed and refined masonry architecture in its surroundings. The upper level is specific because of its modern and light charisma.

The strong rhythm of high windows gives plenty of daylight to the offices and meanwhile its deep relief gives enough privacy in the crisis room and the call centre. Beside this, the relief of the prefab-elements made of aluminum generates a great natural shading device. The solid base is made of rough masonry. The firm basement guarantees protection of the vital functions of the crisis control centre without hiding the building.

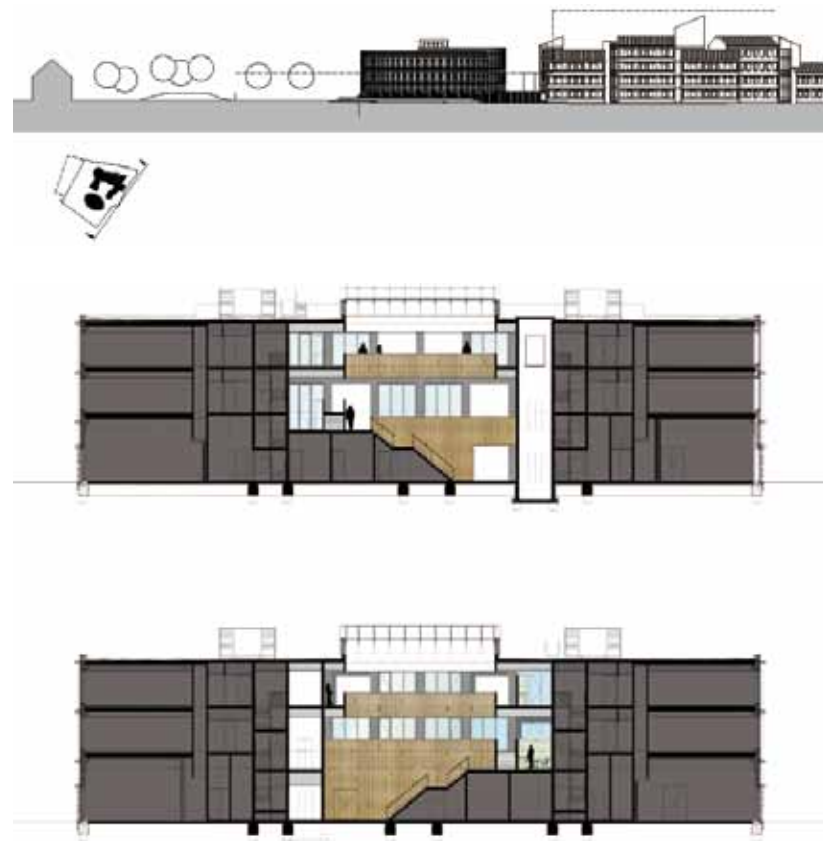

1. An artful aluminum shading device
2. Entrance
3. The ellipse shape of the building
4. The high windows give plenty of daylight to the offices and meanwhile their deep reliefs give enough privacy in the interior space





1. The glass roof of the atrium provides enough daylight in the heart of the building
 2. Call centre
 3. Corridor of atrium and tea room



2



3

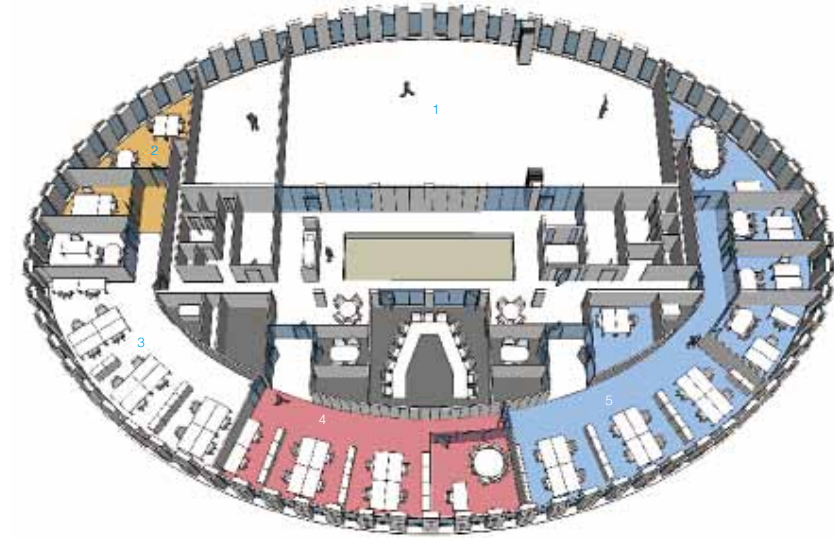

3D Impression Level 3

- 1. Head quarters
- 2. Municipal authorities
- 3. Acute care
- 4. Fire department
- 5. Police

KLPD (Traffic Squad of The Dutch Police Services)

Completion date: 2008 **Location:** Maasbracht + Assen, the Netherlands **Designer:** Joost Glisenaar (BAR architects), with Romain Muller, Anja Traffas, Carolina Contreras, Julia Schmid **Photographer building:** Rob 't Hart **Photographer Art work:** Tamar Frank **Site area Maasbracht:** 1,000sqm **Site area Assen:** 1,200sqm **Total building area:** 400 sqm new building + 600 sqm renovation of the existing building **Award name:** nomination Dutch Glass Award

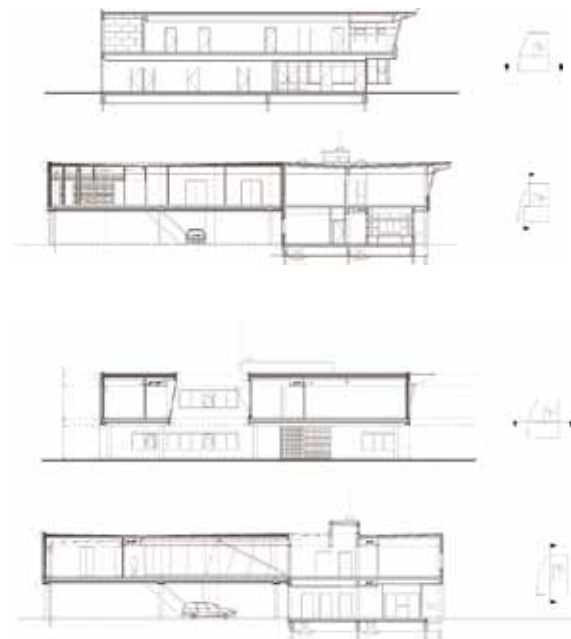

Following expansion of the package of tasks of the Traffic Squad of the Dutch Police Services, it became necessary to reorganise and expand the branches in Maasbracht and Assen.

Due to a lack of space, and the extra parking spaces required at the two locations, the extension needed to be raised, in order that the ground level would be fully available for parking purposes. And so an elevated building, in which the internal organisation of the offices can be optimized, is formed around a new, central patio which lets daylight into the car park. The ground floor of the existing building will be taken up entirely by the auxiliary functions within the premises. The upper floor and the extension will be used by the operations departments.

The existing office is built in a beige facing brick; the garage is clad with grey coloured metal sandwich panels. Due to the existing buildings already being constructed in two façade materials, the extension has been faced with a glazed brick, whose colour is in keeping with the existing buildings and whose gloss makes it distinctive. In order to enhance this distinction in a subtle manner, the windows and frame edges are made from silver coloured, mirrored glass and stainless steel. The window openings reflect the programme behind them: a panoramic window in the conference room, upright windows in the offices and compact windows in the changing rooms.

Unlike the neutral exterior, the heart of the building is expressive and inviting. The service stairs, balcony and oriel around the central patio are a crystalline, informal meeting place for breaks and quick meetings.

In Assen the Dutch 'light artist' Tamar Frank made an 'light artwork' around the staircase.



1. The extension needed to be raised, in order that the ground level would be fully available for parking purposes
2. The internal organisation is formed around a new, central patio which lets daylight into the car park
3. The existing office is built in a beige facing brick
4. The service stairs



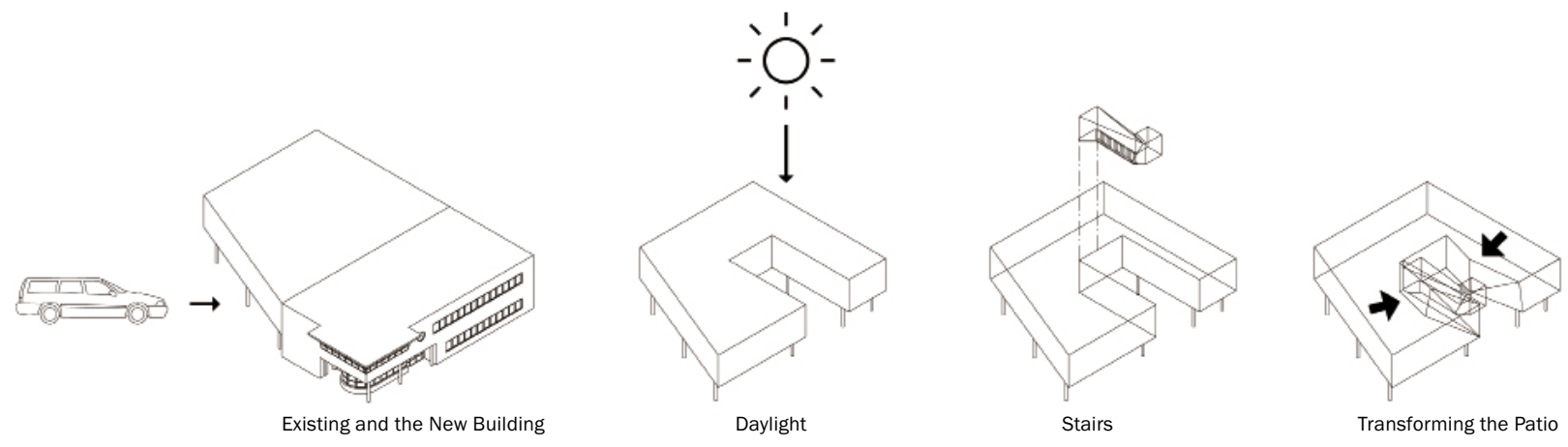

1. The central patio
2. The service stairs detail
3. Changing room

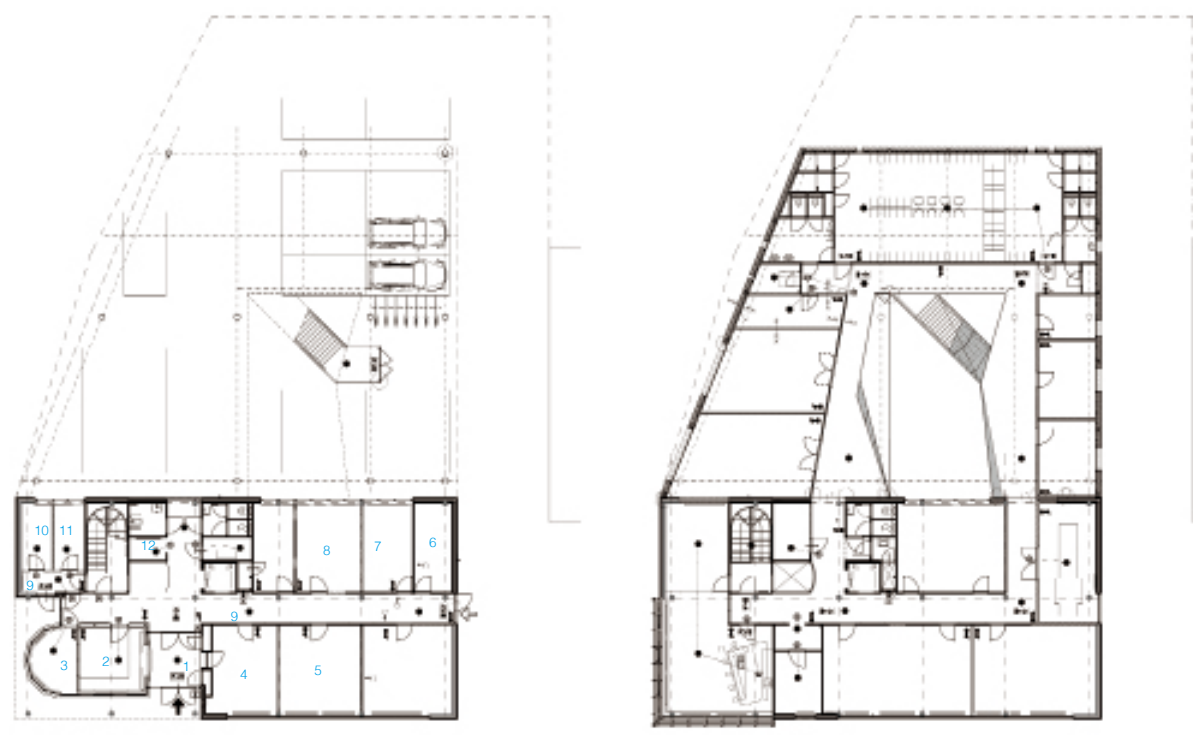

- 1. Entrance
- 2. Reception post
- 3. Declaration
- 4. Records
- 5. Head of unit
- 6. Salvage
- 7. Investigation
- 8. Information officer
- 9. Circulation space
- 10. Pasante room
- 11. Breath analysis room
- 12. Copy / print



Completion date: 2007 **Location:** Martorell, Spain **Designer:** Jordi Farrando **Photographer:** Adrià Goula
Total building area: 3,087.38 sqm

Mossos d' Esquadra Police Headquarters, Martorell

Both the urban implantation and the characteristics of the site suggest a compact building that exploits the lengthwise geometry of the plot and respects the planning determinants (maximum occupation and regulatory distances from adjacent properties). The inherent security requirements of the programme dictate this compactness.

The building comprises a basement and three above-grade floors and is laid out in keeping with the structural grid. Crosswise, the distance between columns is 4.80 metres; lengthwise, the two side bays are 4.80 metres wide, opposed to the 6 m of the central bay. On the basement floor, this arrangement produces a car park with a central passage (6 metres wide) with two side strips for parking (each 4.80 metres deep). On the other floors, the six-metre bay houses service spaces and circulations, whereas the 4.80-metres bays accommodate offices and public spaces.

The public area is in the building's entrance, with an information desk facing the door. One passage leads to the interview rooms, while another provides access to other areas. There is a separate entrance for the Mossos facing the communications shaft, which also provides direct communication between the public and the restricted areas. The custody suite is situated at the far end of the site. Its distribution repeats the logic of the public area, laying out custody cells to one side and the remaining spaces to the other. Once again, a two-corridor system separates circulations according to uses and prevents overlapping. There is only one point of access from the general distribution passage to the custody suite. A second communications shaft (stairs and lift) at the rear of the building provides direct access from the car park.

The custody suite and identification room act as a buffer between the cells for minors and adults, allowing separate direct access from both areas. They also allow visitor access without having to enter the rest of the area. The detained persons arrive by patrol vehicle and enter this buffer area via a metal security gate in the east façade. The technical services are located in the third bay on the ground floor, separate from the public area and custody suite, with their own entrance from the exterior if needed.

The first floor is where restricted activities take place. It comprises two bays: one houses the communications shaft, services and auxiliary spaces, and the other the offices. The entrance corridor is situated on the west side, enjoying a degree of transparency and exploiting natural lighting. The offices are situated in the east, with more discreet openings to prevent visual proximity to the exterior.

The second floor holds the most private spaces, the police officers' service area. The layout is similar to that of the first floor. One bay contains the entrance passage and services, and another houses staff spaces: changing rooms to the north, dining room and rest areas to the south (with views of the river Llobregat valley) and, at the centre, the briefing room and a protected terrace that provides indirect lighting for the hall and easy access to the exterior.

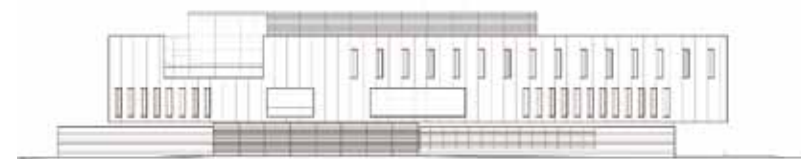

East Elevation



North Elevation

South Elevation



West Elevation

1. Main entrance
2. The offices are situated at the first floor, with more discreet openings to prevent visual proximity to the exterior
3. The building comprises a basement and three above-grade floors
4. The lengthwise geometry of the plot has greatly maximised the space



1



2



3



4



Longitudinal Sections

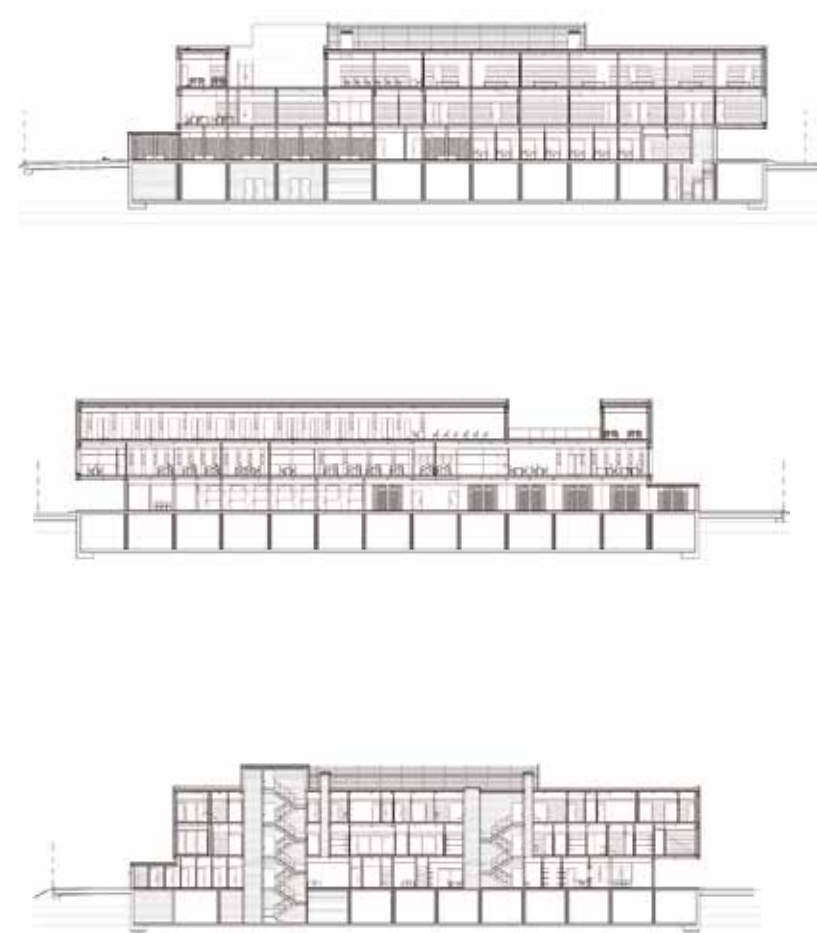

Cross Sections



Façade Details

1. Prefabricated concrete panel E: 120mm
2. Stainless steel railing, 50/3mm diameter handrail
3. 250mm Lacquered extruded aluminium slat Tamiluz Ducosun F+ Type
4. Fine grain terrazzo pavement, 30mm
5. Aluminium steel sheet on a waterproof panel
6. Ceiling. Heraklith Fiber 25mm plates
7. Lacquered aluminium frames. Various models
8. 4mm Steel sheet on a 22mm waterproof panel
9. Quartzite slat, black tone, 210x30mm, L: 1200mm subjected to the frame thanks with a L-shaped metallic sheet (30mm) and a 30.301,5mm tube
10. Exterior quartzite coating, black tone 250x30mm. L: Free
11. Concrete block wall 110mm
12. Thermal isolator. Extruded polystyrene rigid plates. E: 40mm
13. Concrete block wall 150mm

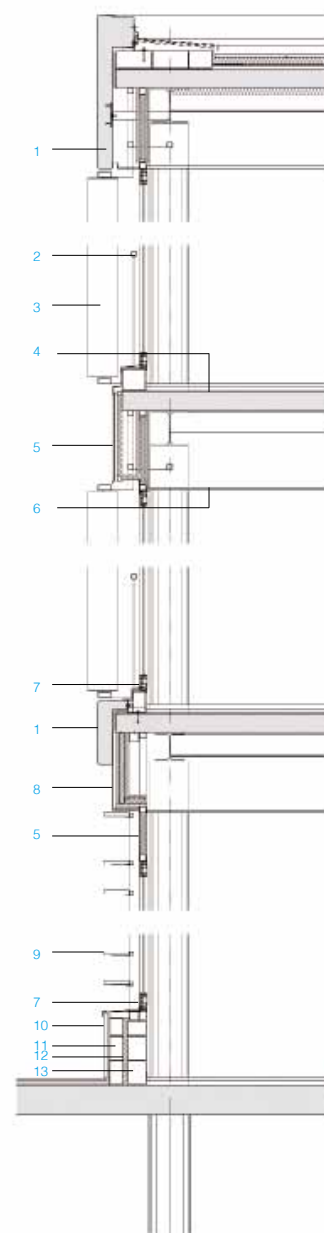

The second floor holds the most private spaces, such as the dining room and rest areas as well as a protected terrace



1

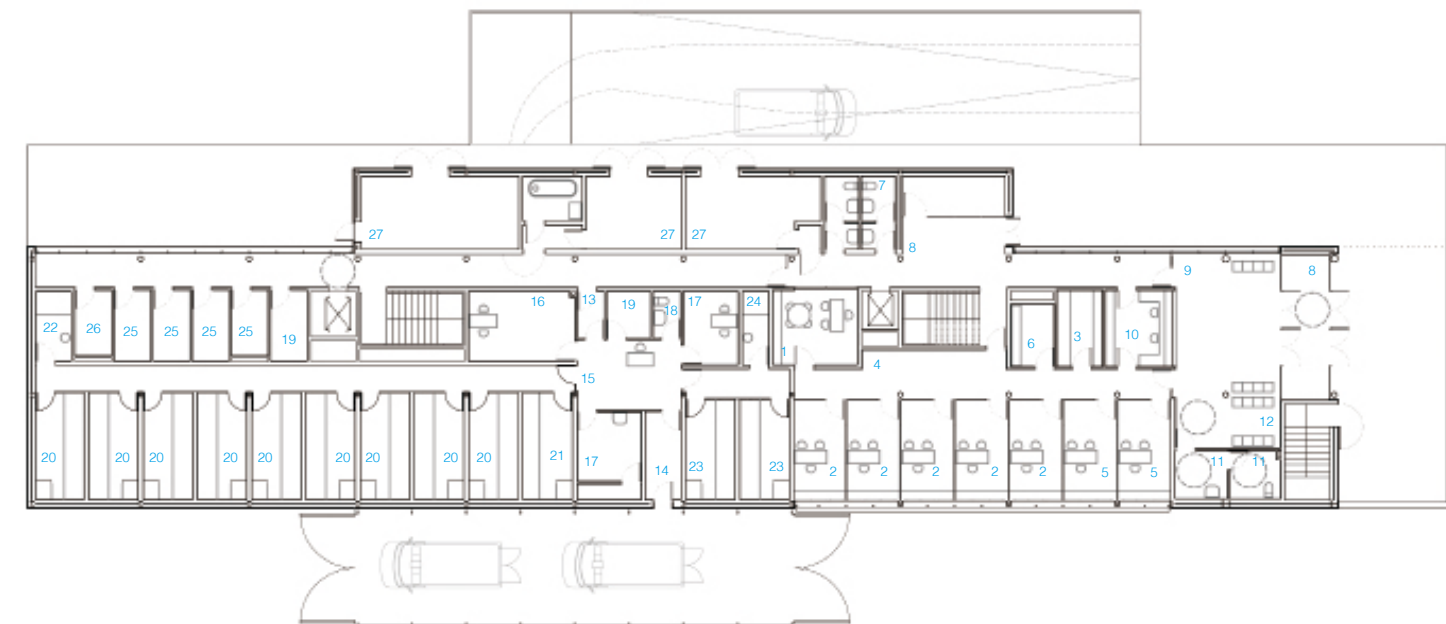

Ground floor plan

- Public Area
- 1. Head officer room
- 2. Visiting room
- 3. Archive
- 4. Fotocopies
- 5. Victim's attention
- 6. Victim's waiting area
- 7. On duty guards washroom
- 8. Entrance
- 9. Hall
- 10. Information and visitor's control
- 11. Public washroom
- 12. Waiting area

Detention Area

- 13. On duty guards hall
- 14. Detention hall
- 15. Custody hall
- 16. Identification room
- 17. Visiting room
- 18. On duty guards washroom
- 19. Storage
- 20. Adults detention cells
- 21. Public health detention cells
- 22. Adults shower room
- 23. Minors detention cells
- 24. Minors shower room

Other Services

- 25. Central archives
- 26. Cleaning room
- 27. Facility room



2

- 1. Leader's office
- 2. Corridor
- 3. Meeting room



3

Commissariat De Grasse

Completion date: 2008 **Location:** Grasse, France **Designer:** Jean Pierre Lott - architecte **Photographer:** Jean Michel Landecy **Total building area:** 3,500sqm

Situated on a completely exceptional site, the police station, the major public equipment, has an important urban role. The building is partly dedicated to the public, partly to the police corps. The public part (hall, public utilities) is shown by curves, and the building has a welcoming and bright character. The curved façades also serve as marks, visual from the city. The building is conceived on four levels.

By positioning the main entrance and the service access on two different levels, there is no view, no crossing between the public and the police officers. The public enters the building by a large staircase, visible from different angles. An elevator serves the public with walking difficulties.

On the ground floor there are two different entrances; one for the public and one for service. These two different entities do not cross. On the first floor the designer have situated the internal services of the police station. The public has access only on invitation or when accompanied by an officer. On the second floor, the designer have situated the fitness room for the police officers, with a breathtaking view on the valley. On the parking level, the designer have positioned, besides parking spaces, the changing rooms and a rest area.



Longitudinal section



3



4

- 1, 2. Details of the building's façade
- 3. The building is partly dedicated to the public, partly to the police corps
- 4. Façade of the building



1



2



1



3



2



4

1, 2. On the ground floor there are two different entrances; one for the public and one for service
 3. The public part is shown by curves
 4. Courtyard

- 1. The high eave of the back of the public entrance
- 2. Details of the piercing par
- 3. Inner corridor



Town Hall Oss

Completion date: 2010 **Location:** Oss, the Netherlands **Designer:** Architectenbureau De Twee Snoeken / Maarten Willems Tanja Lamers (Project architect), Bert Kaasjager (Project manager) **Photographer:** Norbert van Onna & Yvonne Lukkenaar **Total building area:** 18,500 sqm **Award name:** Nominaties Welstand 2008 **Award date:** 2008

The assignment was to renovate the old town hall of the city of Oss (The Netherlands). The town hall no longer fitted modern requirements for local government and work spaces. The old town hall was partly reused and a new wing was added to the existing building.

The renovation was executed in phases between 2006 and 2010. In this way civil servants could keep on working during the building process. The existing south block was extended with new offices. A larger public hall, combined with a new office building was built, and a conference centre was added. Also a new wedding room was designed, and a new city hall council chamber was built for meetings of local government officials. The interior design was part of the assignment, and was also executed by De Twee Snoeken.

The choice to partly renovate the existing building, and not to demolish it entirely, was the biggest contribution to a sustainable architectural solution. Further measurements were taken to enhance the sustainability of the building, and to increase energy efficiency. For example by means of the application of a geothermal heat pump. The surrounding 'ribbon' of the building functions like a skylight shade. Daylight is able to penetrate deep into the building, however without letting in the heat. The south façade of the building consists of narrow windows, covered with translucent solar panels. On the top of the building a green roof, solar panels and wind turbines are applied.

By means of these solutions the town hall has become a very sustainable building. The old town hall had energy label G (the worst possible score). Thanks to the renovation the building has now reached energy label A+, which is a very big improvement. The building is presently the most sustainable renovated town hall in the Netherlands.

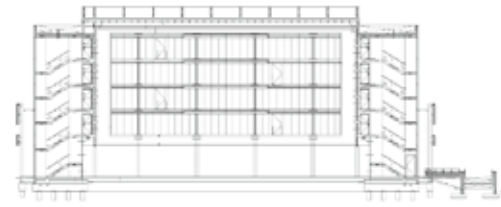

Elevation a

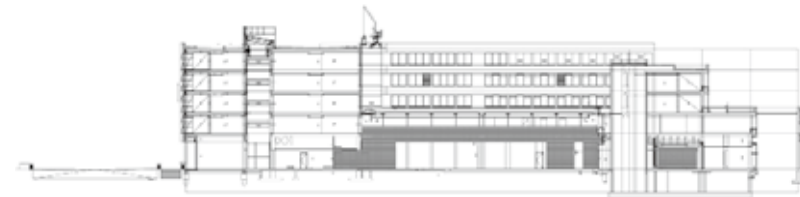

Elevation b

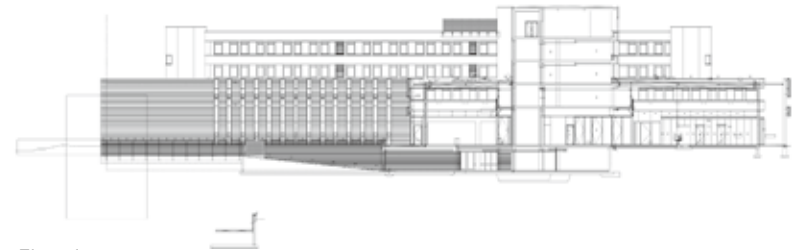

Elevation c

1. Details of the outer structure
2. Narrow windows could well control the daylight penetrate deep into the building
3. Narrow windows at the south façade are covered with translucent solar panels





1

- 1. The surrounding 'ribbon' of the building functions like a skylight shade
- 2. Public service window

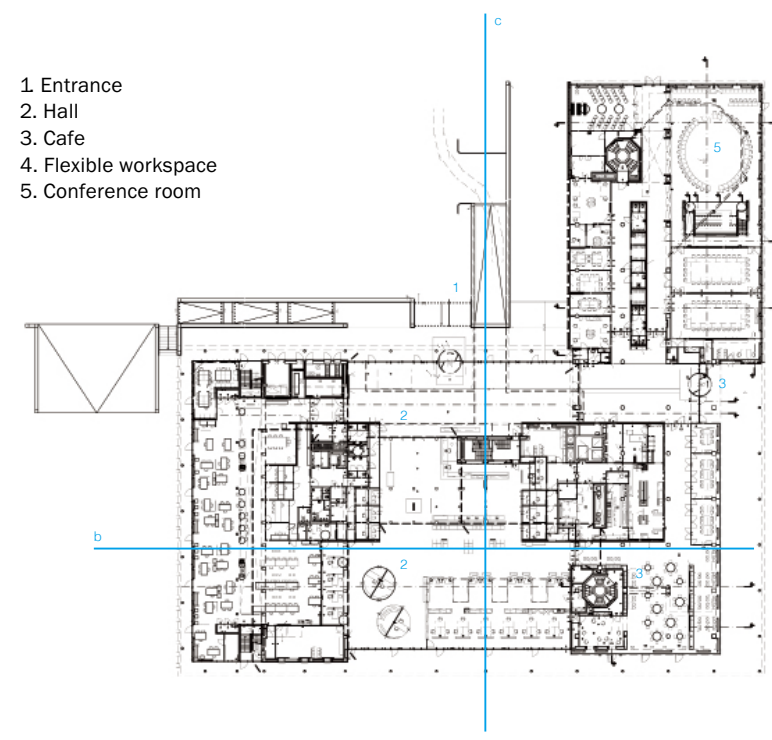

Ground floor plan

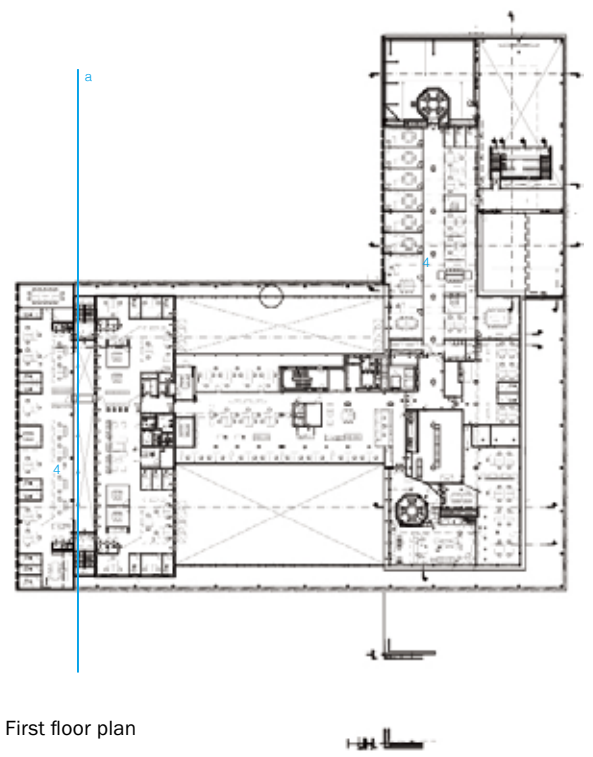

First floor plan



2



1



3



2

1. Waiting area
 2. Wedding room
 3. Lounge area

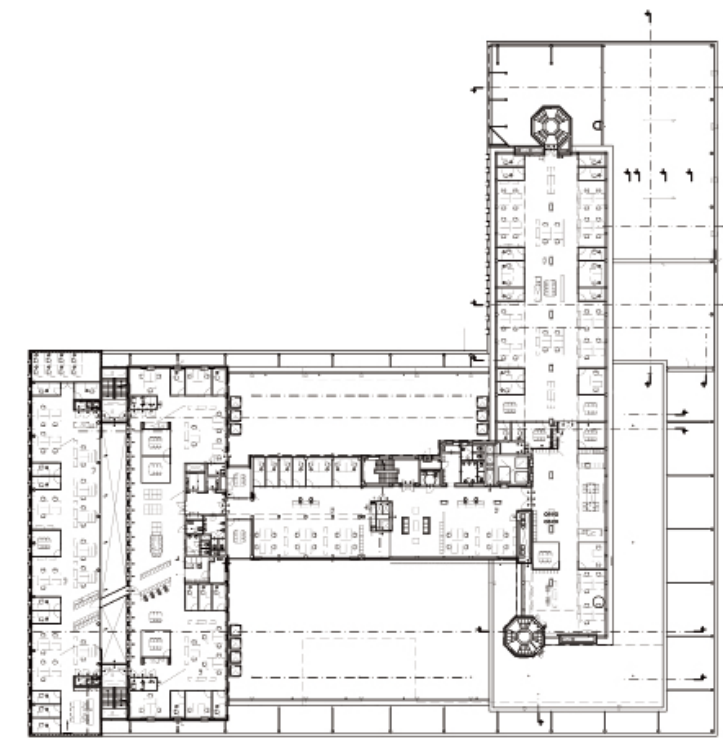

Second floor plan



1



3



2

1, 2. Conference room
 3. Restaurant
 4. Waiting area



4

Viborg Town Hall

Completion date: 2011 **Location:** Viborg, Denmark **Designer:** Henning Larsen architects **Photographer:** Thorbjørn Hansen Kontraframe **Site area:** 19,000 sqm **Award name:** First prize in international competition

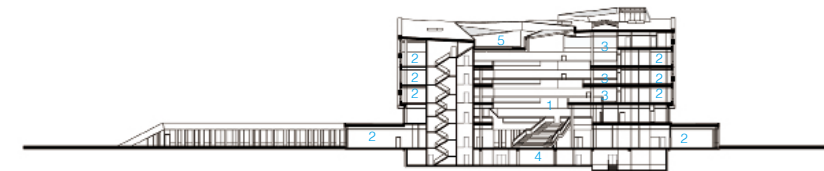
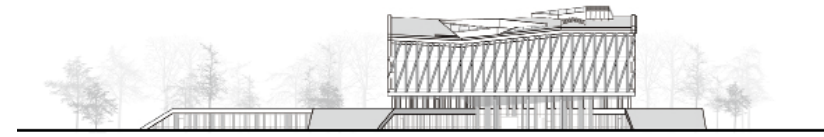

1. Atrium
2. Office
3. Kitchen
4. Technical Room
5. Roof



With its complex faceted shape Viborg Town Hall becomes a symbol of the new large municipal community that opens in the wake of the municipal merger.

The interplay between house and park creates a new place in the town where the large inner atrium is the heart that joins the town hall's professional community with the community of the citizens.

The town council hall is flexibly designed and together with the canteen, foyer and an adjoining meeting room it can be converted into a conference centre. The café on the top floor of the building has direct access to the roof garden with a view of Viborg Cathedral.

The energy consumption of Viborg Town Hall will meet the requirements for low-energy class 1 according to Danish building regulations (max 50 kWh/m²a / A) (A = the heated floor area).

A compact building geometry

- Treble glazing
- Natural ventilation (hybrid ventilation) - ensuring an energy-efficient ventilation of the building. An intelligent IT system measures the air quality and temperature and controls openings in the building envelope
- Mechanical ventilation in part of the building - requiring efficient heat recovery
- Absorption heat pumps powered by district heating
- Passive and active cooling of the building stock (concrete floor, open suspended ceilings)
- Groundwater cooling
- Daylight - the building has been designed to benefit the most from the daylight
- External solar protection
- Movement sensors and use of energy-efficient light sources to reduce electricity consumption
- Solar cells on the roofed parking spaces (approx. 1,265 mono-crystalline solar cells)
- Rainwater collection and percolation



1. With its complex faceted shape the building becomes a symbol of the new large municipal community
2. Solar cells on the roofed parking spaces
3. The northeast facade of the building





1



3



2

- 1 Atrium
- 2 Looking up to the ceiling from atrium
- 3. The central part of the atrium staircase has been flexibly turned into seats



First Floor Plan

- 1. Atrium
- 2. Office
- 3. Kitchen
- 4. Flex

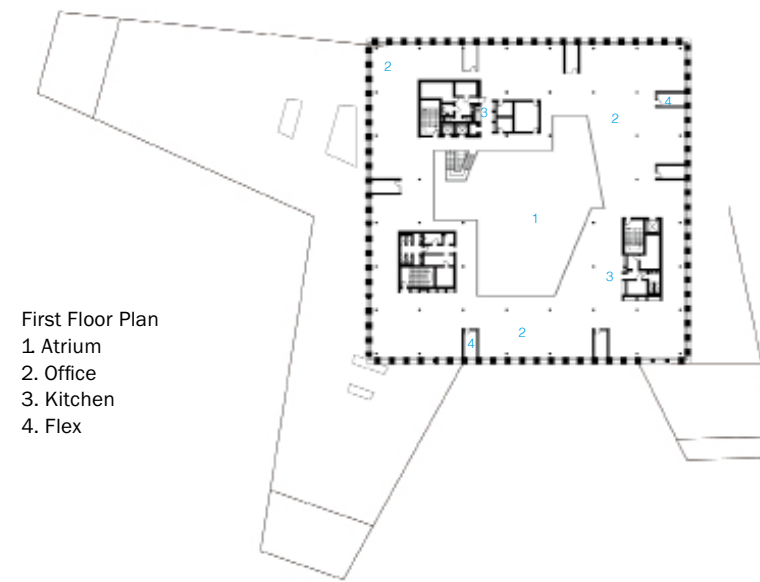

Ground floor plan

- 1. Main entrance
- 2. Atrium
- 3. Information / reception
- 4. Job shop
- 5. Conversation rooms
- 6. Multi-purpose hall
- 7. Office
- 8. Performance unit
- 9. Flex



Heemskerk Town Hall

Completion date: 2011 **Location:** Heemskerk, the Netherlands **Designer:** BD Architectuur Leiden/ Arnhem, Johan Meijer & Chris Hiep **Photographer:** Michel Kievits **Total building area:** 12,100 sqm

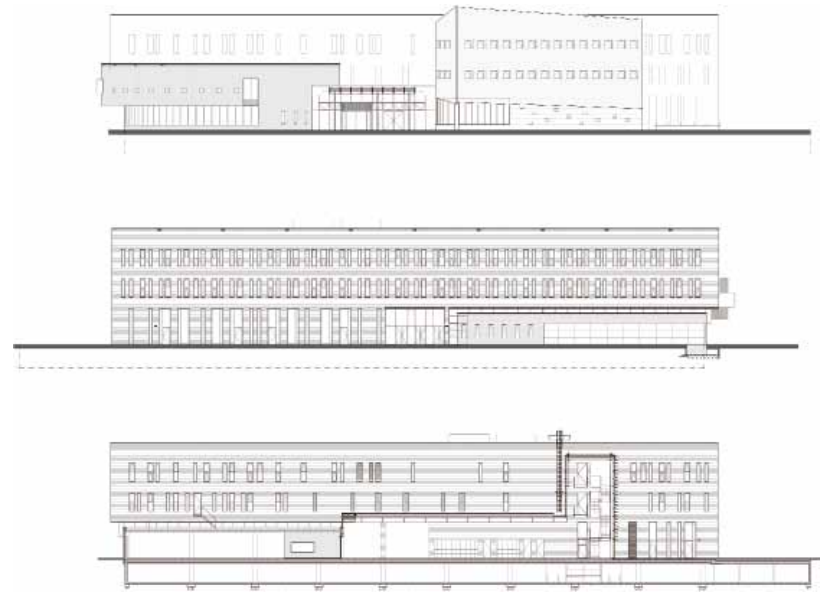

The new town hall and public library is situated near the centre of the Municipality of Heemskerk. The most important starting point in the design has been a durable and flexible building, appropriate in its surroundings. The architects of BD Architectuur chose to accommodate the programme in a composition of three recognizable building parts. Each building part has its own specific forms, materials and colour scheme. Applied façade materials are brick and stainless steel losange. Two parts constitute the Town Hall. The third section houses the library. In a natural way these volumes enclose the central hall. Here, the exterior and interior flow smoothly into one another, creating an inviting and hospitable welcome.

The building has an open and transparent character. The ground floor houses all public functions, including the library, the public counters, the boardroom and the internet cafe. On the floors the workstations are located. Underneath the building an underground parking garage is located.

The building was built with great care for the environment and sustainability. This has resulted in a sustainable building with the most optimum use of energy. In addition, the design is such that any future adjustments to office spaces can be achieved at minimal cost. This includes the use of moveable partitions and a flexible ceiling.

1. Office building part of the town hall locates at the back of the volume, with harmonious and strong colour, echoing with the surrounding waterscape
2. At the main entrance, applied façade materials are brick and stainless steel losange
3. The curve façade of the public library with unique colour scheme, goes harmoniously with other buildings





1. Overlooking the entrance from the central hall
 2. From the central hall, the exterior and interior flows smoothly into one another
 3. Population affairs

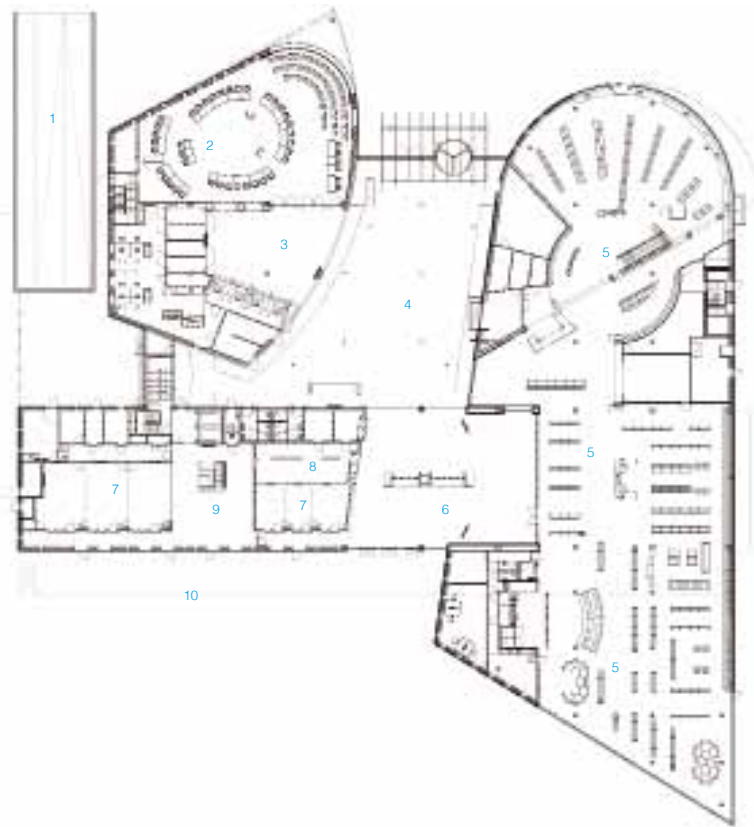

- Ground floor plan
- 1. Entrance parking garage
 - 2. Boardroom
 - 3. Population affairs
 - 4. Central hall
 - 5. Library
 - 6. Reading and interface
 - 7. Meeting rooms
 - 8. Kitchen
 - 9. Restaurant
 - 10. Terrace



1



2

1. Central hall of the public library
2. The ground floor houses restaurant, internet cafe and other public functions
3. Meeting room on the ground floor



3

City Hall Leyweg

Completion date: 2011 **Location:** Hague, the Netherlands **Designer:** Rudy Uytenhaak **Photographer:** Pieter Kers **Total building area:** 32,600 sqm

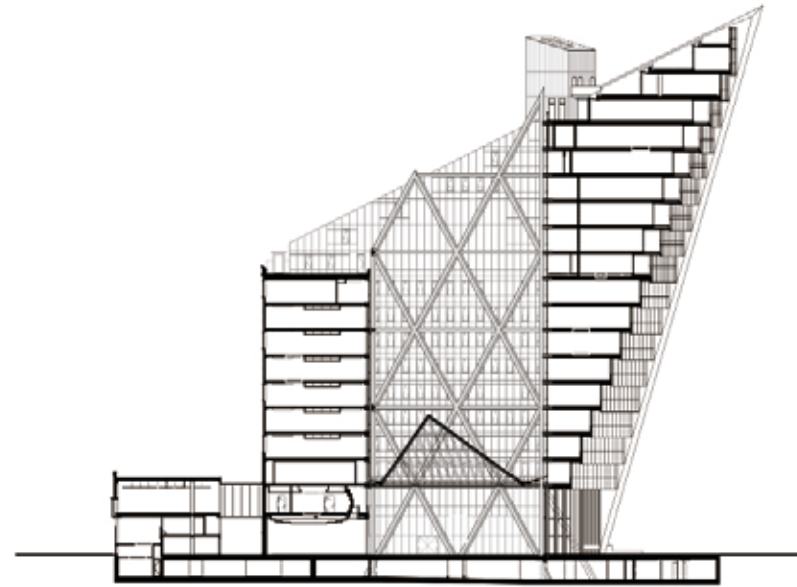

Longitudinal Section

As a result of the urban development plan for The Hague South West, the Escamp District of the city will experience a wave of renewal in the coming years. The main aim is to give the area a more varied and dynamic atmosphere. One element of this plan is the new municipal office, which as the social and administrative heart of the district deserves to become an icon for The Hague South West/Escamp. Inspired by the genius loci of the plan by Willem Marinus Dudok: an open city, in which primary volumes define the space of a spacious 'park city'. Buildings are placed like ships throughout the park city: objects standing free in space rather than walled-in streets.

The municipal office, with its robust prow, will acquire a strong role as an orientation landmark in the 'mental map' of the area. The independence of the municipal office is emphasised by the orientation of the upper section of the building as an object on a rising plane.

The design of the building has an autonomous form, but is in keeping with the existing buildings in its colouring and situation, representing a new interpretation of the original light and 'modern' architectural heritage. The service building on the rising plane has information square at its centre, opening up onto the various public functions and the collective office building.

On the ground floor, in addition to facilities functions, are the public service desks of the municipal services, information facilities and a library. The wedding hall, the staff restaurant and the meeting centre are located on the first floor. On a higher level, above the atrium roof, is the municipal health service, while the multi-purpose building unfolds around the triangular atrium. The upper nine storeys are made up of homes.

The Hague Municipal Council aims to be a transparent organisation. In this new municipal office, contact both with the outside world and within the organisation is enhanced by the building's triangular form. Because the workstations are placed in an open-plan office design around the atrium, staff has sightlines to each other and to other departments. By breaking open the corners of the triangular form, every department's area is provided with special points with outside views. There is a corridor circuit on each storey, so encouraging informal contact between employees and different departments. There are stairways at regular intervals in these corridors, so vertical circuits are also created.

In an inventive manner, the Leyweg municipal achieves a result that is expressive in its form, spatially surprising, flexible and functional, and in which the logic of sustainable construction has been optimally applied.

In the structural concept of the Leyweg municipal office, spaciousness, construction and installation technology are optimally attuned to one another, with sustainability and economic intelligence as the primary criteria. So, for example, all ducts and installations are integrated in a climate-control floor with concrete core activation, which also has acoustic and fire prevention functionality. Hanging ceilings are therefore not necessary, enabling a spacious total storey height. Using the principle of load-bearing exterior walls, the office areas are fully flexible in their layout, and therefore flexible in use. The meticulous fine-tuning of all these aspects with one another results in a businesslike and efficient office building that makes use of simple, 'proven' construction techniques.

1. The balcony details
2. Façade apartments from inside out
3. View of south side



1



2



3

- 1. View of north side
- 2. View of the facade from interior passage
- 3. View from back of hall towards entrance
- 4. Roof details



1



3



4



2



- Ground floor plan
- 1. Central hall
 - 2. Information desk
 - 3. Front office
 - 4. Back office
 - 5. Library
 - 6. Patio
 - 7. Goods
 - 8. Entrance to apartments
 - 9. Bicycle storage
 - 10. Entrance parking garage



- First floor plan
- 11. Meeting centre
 - 12. Wedding room
 - 13. Computer centre
 - 14. Meeting space
 - 15. Kitchen

City of Hume, Council Offices

Completion date: 2007 **Location:** Broadmeadows, Australia **Designer:** Lyons **Photographer:** John Gollings **Site area:** 77,602sqm **Award name:** 2008 Australian Institute of Architects, National Design Award - The Harry Seidler Award (Commercial Architecture) / 2008 Australian Institute of Architects, Victorian Chapter Award (Sustainability)

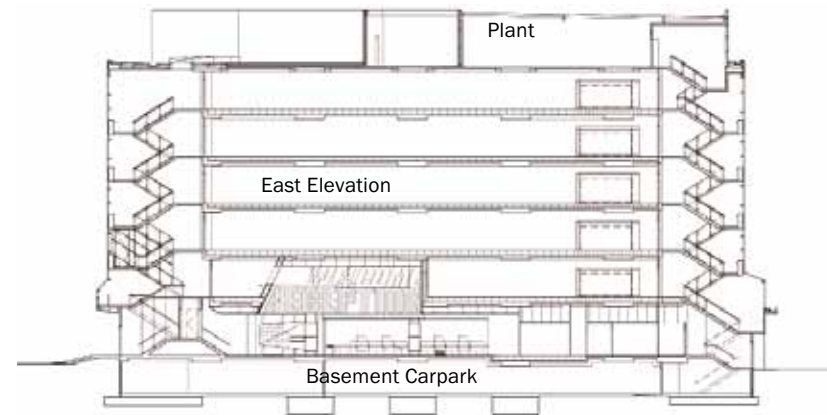

Hume City Council, based in Broadmeadows, is committed to the Transit City Vision articulated in the Melbourne 2030 planning framework. The Council proposed to consolidate their Sunbury and Broadmeadows offices into one united and seamless organisation, to build a sustainable city of higher density around a strong transit node.

This commission, won through a national design competition, provided a significant opportunity to design a 5-Green Star office building for a progressive organisation. Built opposite a major shopping centre the new Council office is an important civic marker in Melbourne's fastest growing suburb.

The design is a compact six-level form built up to the local planning scheme's height limit, creating a narrow footprint to allow natural light deep into the interior. The vertical scale of the building in contrast to the horizontal retail centre, is a precedent model for a suburban metropolis. The orientation of the site favoured a long floorplate facing northeast. Lifts, amenities and open circulation escape stairs are pushed to the east/west ends of the building allowing for the seamless occupation of office space. The open stairs create an internal circulation axis to encourage ease of access between departments. Meeting rooms are located adjacent to the stairs to encourage sharing.

Externally, an 'environmental' skin, rendered as a bright white skin and bright green line, wraps around the whole organisation. This singular and dynamic gesture attempts to express the ethos of the Council; equal measures civic and corporate. Expanding at top and bottom to accommodate the staff lounge and public meeting room, the envelope then folds over the foyer to form a generous public space.

The foyer is an extension of the external public realm, visually connected to the generous entry plaza. Recycled timbers contrast with 'Welcome' super graphics, mediating the relationship between public and private.

Our approach to sustainability was threefold; low energy usage, water conservation, and most importantly, occupant comfort. This was in response to the Council's understanding that motivated, happy staff provides better service to the public. Passive design principles - good orientation, sunshading, thermal mass and high performance glass - come as standard. A low energy subfloor displacement air-conditioning system delivers air at the occupant level, stratifying the hot air at a high level. Occupants can adjust the floor vent directions and locations. Ceilings are removed, exposing high concrete soffits to perform as thermal sinks. The higher floor to ceiling heights assist in the deep penetration of natural light and the up and down-lighting makes ideal occupant comfort lighting conditions.

- 1 Entrance
2. A bright white skin and the bright green line, wrap around the whole building





1



2



3

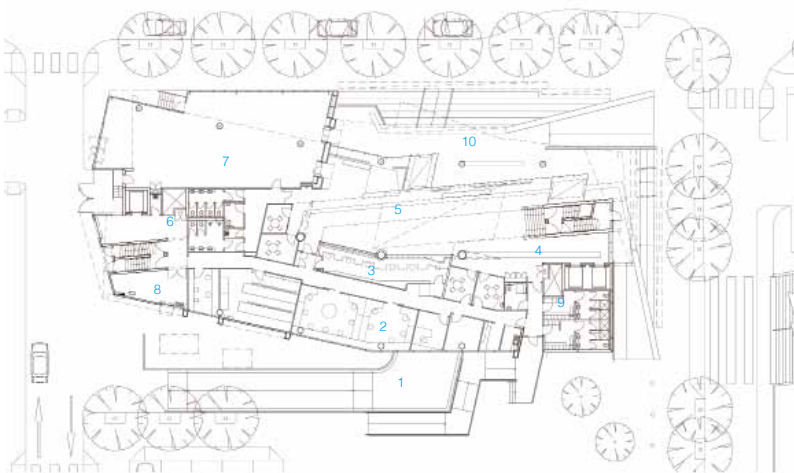

Site & Ground floor plan
 1. Carpark entry
 2. Callcentre
 3. Reception
 4. Lift lobby
 5. Foyer
 6. Lift lobby/loading
 7. Cafe
 8. Waste
 9. Staff amenities
 10. Forecourt

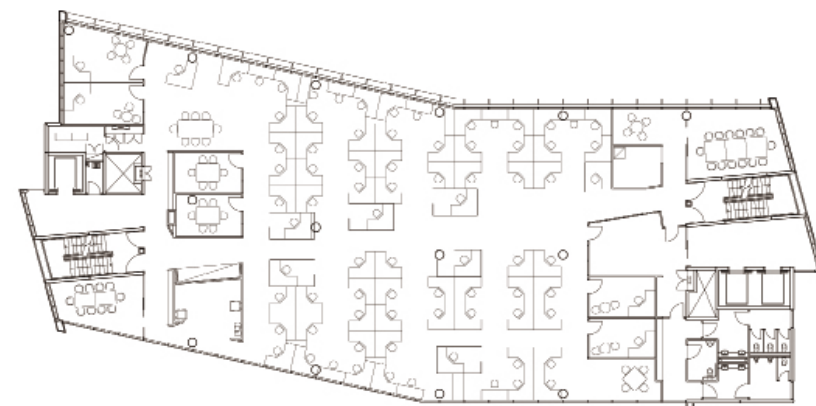

Typical office floor plan

- 1. Main face of the building and the entry plaza
- 2. Recycled timbers have decorated the foyer extensively
- 3. Details of the handrails at corridor
- 4. Conference room



4

Ministry of Public Works

Completion date: 2010 **Location:** La Coruña, Spain **Designer:** Arturo Franco **Photographer:** © Santos-Diez | BISIMAGES **Site area:** 1830,00 sqm **Total building area:** 4,696.89 sqm **Award name:** A+ Architecture Awards – Finalist



South Elevation

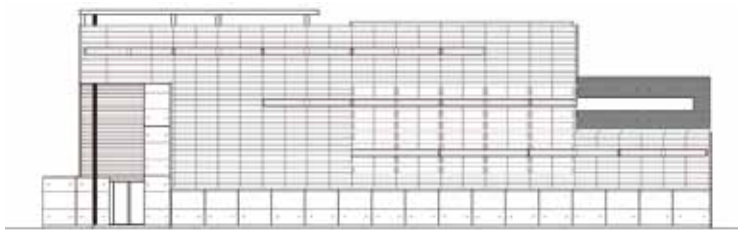

West Elevation



East Elevation

The building holds out the prospect of becoming a quiet functional part of the city which was designed for administrative purposes. The solemnity and rigorousness of a ministry requires a specific treatment that addresses both its effectiveness as an urban organisational focal point and reference, as well as its internal operations and its operations linked to strict public and private circumstances.

This outstanding achievement appears as a reference point in access to the city from one of its main thruways. The robustness of its volume is resolved through parallelepiped glass on a concrete base. A ventilated double-glass skin surrounds the interior spaces, covering its three main façades conceived in its eastern orientation. This piece is designed for vertical circulation and installations, with the back of the building facing a residential area in need of much repair.

The interior spaces were planned to soften the rigidity of the programme, unfolding to achieve distinct visual connections, being the central courtyard, the main spatial fracture that gives access to the three floors for public use and expands the Ministry from a functional standpoint. An intentional open space compensates for a busy schedule of administrative offices.

The building was constructed using concrete, steel and glass. Concrete for the structure and partitioning the load. Glass for the double panels of the façade and the interior layout of the offices and steel for the frames and construction details of the building.

In a city with 1,500 hours of sunlight per year, concrete and glass, in both their façades such as covered façades, seek to firstly, free up interior space and secondly, to provide a weightlessness and transparency that allows the passage of light in all directions.

With a programme designed to house the various offices of the engineers, a storage area for files, lounge areas, installations and services, rest rooms and a central courtyard, which distributes light, the building combines its mixed structure of columns and load-bearing walls, on one hand, to support the corresponding areas of the installations and vertical communications, and on the other hand, to free up the parts of the building designed for offices, lounge and reception areas.

As can be observed, a handicap that accompanied the design of the building over the course of its definition, as well as the various modifications undertaken since the beginning of the works, was to use the minimum number of materials for its construction with which to define each detail. These were mainly steel, glass and concrete.

Building facilities, driven vertically by the eastern side, are distributed over the surface of the different floors by using a micro perforated technical false ceiling, which enables both the inclusion of lighting fixtures, such as hiding the required pipes and cables, but leaving enough visibility to demonstrate they are there.

The main lounge area located on the second floor is not the only one. There are others located in different areas such as by exit doors to the outside of the building and a walkway outdoor terrace which is accessible from the third floor.

1. Concrete is the main material of the load bearing wall

2, 3. Glass for the double panels of the three façades gives a sense of transparent and lightness





1

In a building where the façades are mainly constructed of concrete, framework and carpentry, it was necessary to resolve any potential problems caused by thermal bridges which could occur along the frontage of the building. This can be resolved by placing special pieces in the steel frames and exterior columns, composed of steel and filled with insulation material to prevent the potential appearance of humidity on the concrete in the inside of the building.

The building's vertical communications occur in three different ways. Through the building's lifts, the interior emergency stairwell or cantilever cement stairs from the central courtyard. This layout allows flexibility in the circulations of the building, in the connection between all offices, private offices and meeting rooms in a fluid and effective manner.

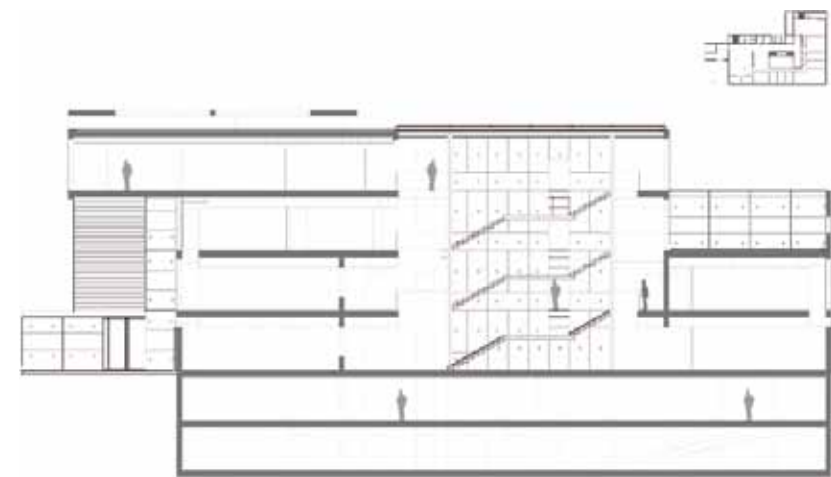

Longitudinal Section West



2

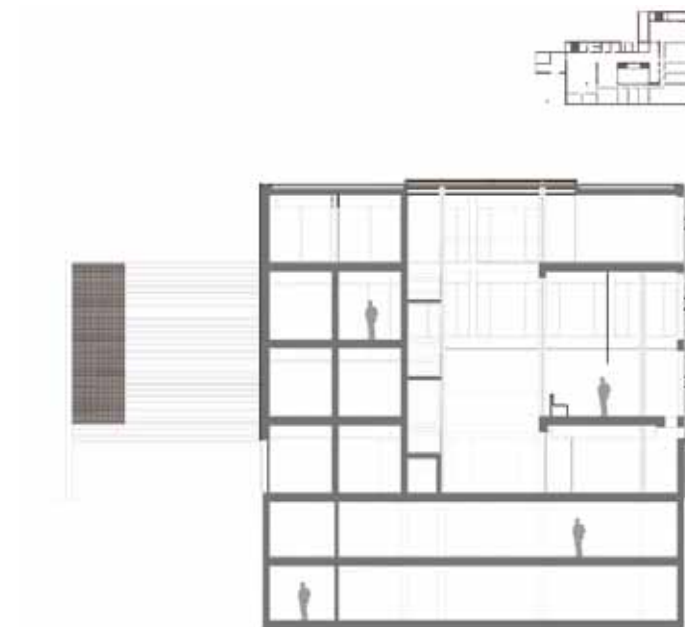

Cross Section Through Stairs

1. The integration of the concrete, steel and glass materials has interfused pliability with hardness
2. The organisation of the interior space mainly uses glass and steel material



1



2

- 1. The clear circulations of the inner space
- 2. Details of the inner corridor and staircase
- 3. Skylight brings the natural lights into the atrium



- Ground floor plan
- 1. Entry hall
 - 2. Principal entry
 - 3. Security zone
 - 4. Customer service & reception
 - 5. Service area & installations
 - 6. Central hollow
 - 7. Engineer offices
 - 8. Illumination void
 - 9. Management
 - 10. Emergency exit
 - 11. Garage entry



3

Bourne Hill Offices

Completion date: 2010 **Location:** Salisbury, United Kingdom **Designer:** Stanton Williams **Photographer:** Hutton & Crow **Total building area:** 2,600sqm New Build, 1,550 sqm Refurbishment **Award name:** 2010 Salisbury Civic Award; 2011 AJ100 Award - Finalist; 2011 RIBA Regional Awards; 2011 BCO Awards

Stanton Williams were commissioned following a RIBA competition in 2004 to develop proposals for the redevelopment of a sensitive historic site at Bourne Hill, Salisbury, as the head offices for the local council. Central to the project is an integrated vision that combines contemporary interventions with enhancement of the site's natural assets and recognition of its significant historic context, which includes attractive gardens, the remains of Salisbury's city walls, and St. Edmund's Church, now used as an arts centre.

The new building is set slightly apart from the historic house with a narrow glazed section delineating the boundary between the two. It comprises two interlocking cubic volumes, each reading as an L-shaped unit. One is of two storeys, the same height as the house itself, whilst the other is taller. The impression, therefore, is of a building stepping back as it meets its historic neighbour. Within, 2,600 square metres of flexible, open plan offices enjoy good views of the surrounding gardens.

Movement within the building is focused along a central route that links the mansion entrance to the new garden entrance via two triple-height glazed spaces. Adjoining this route, a central vertical circulation core in the new building gives access to all levels – including the 17 different levels of the old building.

Externally, the new building is given presence and scale through the use of a full-height colonnade set in front of its glazed elevations. The colour and texture of its Roach-bed Portland stone adds visual interest whilst also responding to the materials of St Edmund's Church and the historic city. Its use thus creates a striking visual link between old and new. The colonnade creates an attractive place in which to walk at the boundary between architecture and nature, with its columns framing glimpses of trees in the garden beyond that are reflected in the glazed behind. The result is a rich interplay of transparency, reflection, light and shadow.

There is a strong relationship between the architecture and the external landscape. Inside and outside spaces interlock. The colonnade is conceived as a "screen" and part of this landscape space. The reflective surfaces of the emphatically vertical glass façade replicate the surrounding trees and views, and bind the building to its context.



Longitudinal Section



Cross Section

1. Natural views of the surrounding
2. Salisbury Arts Centre
3. Externally, the new building is given presence and scale through the use of a full-height marble colonnade, which plays the role of screen, and creates an attractive place in which to walk at the boundary between architecture and nature





- 1. Trees in the garden reflected in the glazed behind which creates a beautiful visual effects
- 2. The new building comprises two interlocking cubic volumes. One is of two storeys, the same height as the house itself, whilst the other is taller



1



2



3

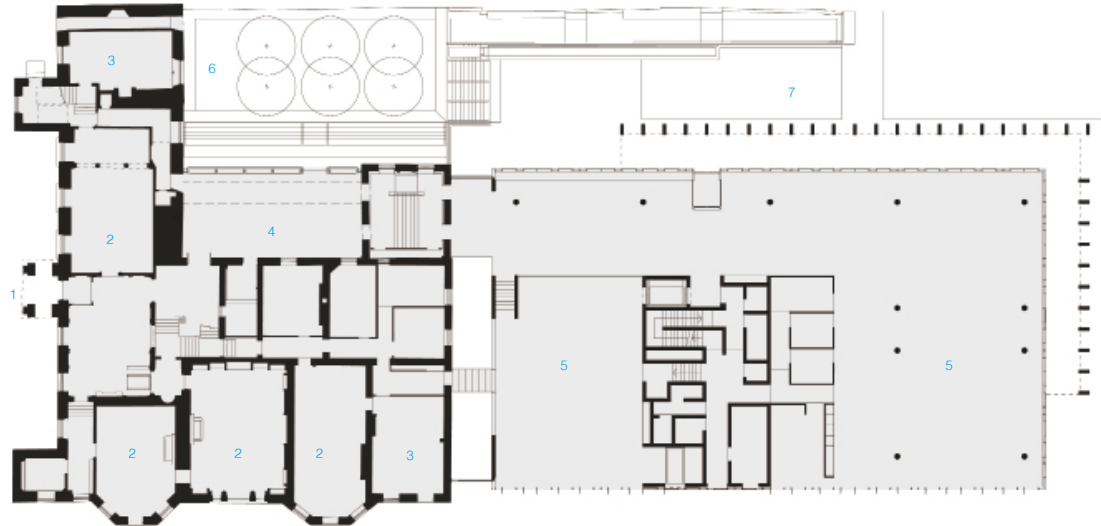

Ground floor plan
 1. Entrance
 2. Public rooms within house
 3. Office/meeting space within house
 4. Link structure
 5. New open plan office space
 6. New external courtyard
 7. New garden

1. High level link bridge
 2. Link structure
 3. New open plan office space

Parliament Building Annexe

Completion date: 2006 **Location:** Helsinki, Finland **Designer:** Pekka Helin, Peter Verhe, Mariitta Helineva, Seija Ekholm **Photographer:** Michael Perlmutter, Voitto Niemelä **Award name:** The Finnish Steel Construction Award **Award date:** 2006



Façades from the Main Road

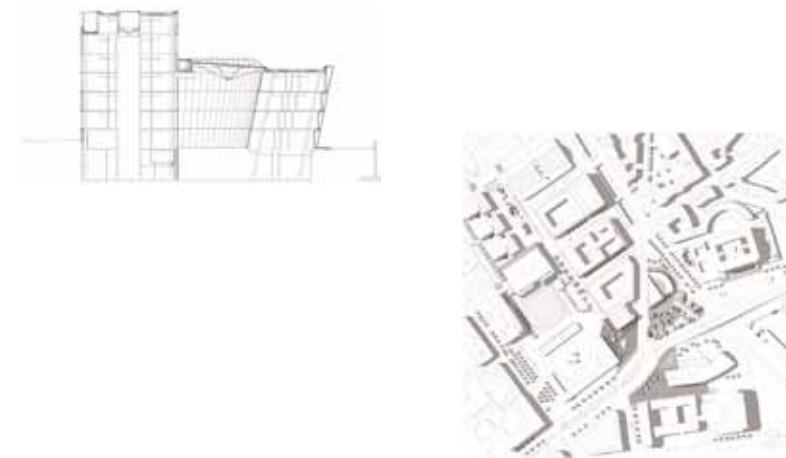

The two part visual image of this buildings fits well with the urban surroundings of the parliament building and the lines of Kamppi's building blocks. In the matter of room structure and practical usage this building is the most effective and complete of the proposals. The building is also the most energy efficient because of its compact size, well planned technical solutions and space structure.

The Annexe of Parliament House is situated at a nodal point in Helsinki's cityscape, where the system of coordinates shifts direction, at a site surrounded by buildings of string architectural character from different eras. Arkadiankatu Street intersects the east-west row of the city blocks of the Kamppi district, cutting a chunk out of it. This gap has been filled in by a building with an eave height that coincides with the cornice of the adjacent Hankkija building. The other visible part of the composition, a volume in the form of a partial cone, relates to the syntax of the existing parts of the Parliament building. Meeting and conference facilities, which for reason of security are not open to the public, are located underground.

Through architecture it is possible to express the ideals of the Nordic and Finnish practice of government; humanity, openness and understanding of the surrounding reality. The competition entry opens out the work of the Members of Parliament and their aides towards the city. The surfaces visible to the outside as well as those inside, the linings of rooms and the curtain-like sliding screens were of wood, which still - in a primitive way - is a material for which people have affinity.

After the competition in 1999 the openness was restricted on grounds of security and the townscape. The curved section is open as originally intended and technically executed as a double façade. The end of the building is clad with pink granite from Kalvola, like the old main building. In order to adapt it to the adjacent Hankkija building and the townscape, the surfaces of the triangular section are to be clad with dark-coloured, fired clay bricks with wide flush joints.

The crescent shaped atrium, which is enclosed by an upward-opening conical surface, is the main space of the building. The skin is formed of flat glass panels fixed in place like fish scales. The entity becomes a sort of fused chronological mapping device and kaleidoscope, it reflects and partly forms multiple images of people's movements in the building, the passing of clouds in the sky and the light of the moon or the sun - all depending on the position of the person observing, the time of the year and day.

One floor above are the main entrance, the office facilities and an information room and cafe for the public. On floors 1-6 are the offices of the MP's and their aides, the office of the Parliamentary Ombudsman, the international Department and the facilities of the different parliamentary committees.

Owing the required floor height, the interconnection of the different functions and the planned shape of the building, the design and execution of the structural components was a particularly demanding task. The frame consists mainly of in-situ RC columns and tensioned slabs without supporting beams. Steel is featured in the beams of the façades, the structural members of the double façade, the canopy, the gangways and the structural members of the conical interior surface and the glass roof.

1. At night, the transparent partial cone appears spectacle and charming
2. The nightview of the south façade
3. The south façade is clad with dark-coloured fired clay bricks
4. Two parts of the building go harmoniously with the surrounding environment





1



2



3



4

- 1. Steel is the structural element of the conical interior surface and the glass roof
- 2. Details of the staircase to atrium
- 3. Steel is also the structural element of the gangways

- 1. The international department of Parliament
- 2. MPs and their assistants, floors 3-6
- 3. The office of the Parliamentary Ombudsman
- 4. Visitor's centre
- 5. Restaurant in the atrium
- 6. Auditorium and meeting rooms



- 1. Ombudsman's office
- 2. Office room towards atrium
- 3. Grand committee meeting room

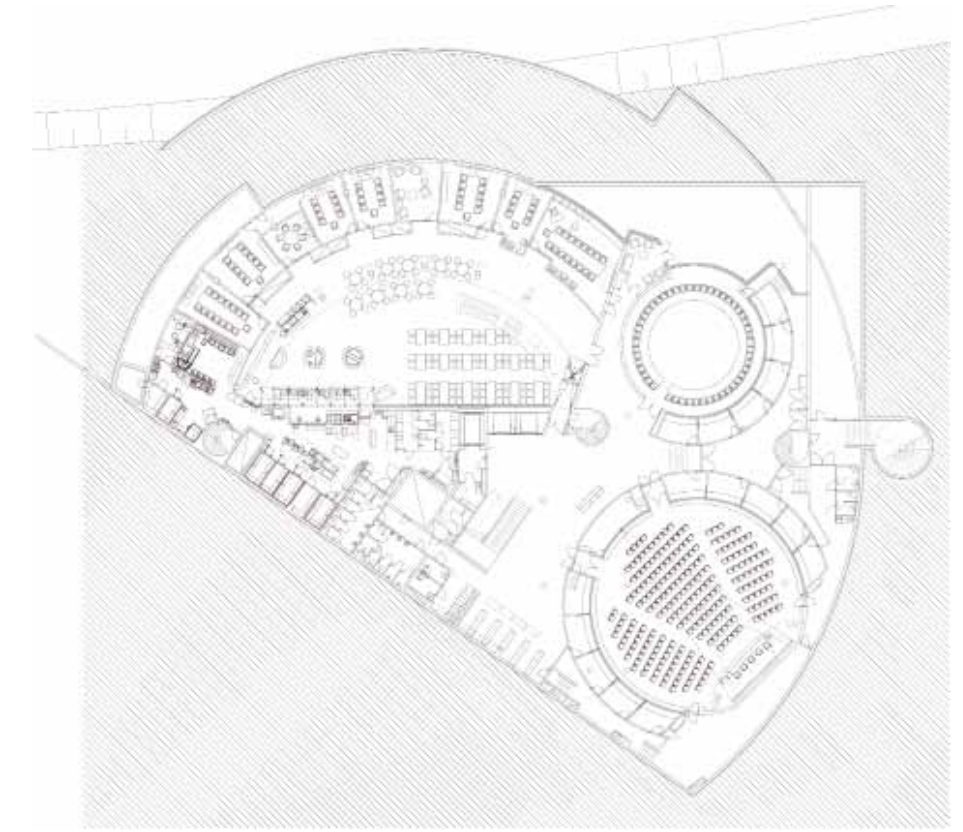

“La Cite Des Affaires” in Saint-Etienne

Completion date: 2010 **Location:** Saint-Etienne, France **Designer:** Manuelle Gautrand Architecture
Photographer: Philippe / Vincent **Site area:** 25,000sqm

The site is a vital liaison point between the centre of Saint-Etienne and the new Chateaucieux neighbourhood, to which it forms a major entranceway. It also constitutes a pole grouping several government bodies that will set up there: Regional Development Authority, Tax Services, Epora, Saint-Etienne Métropole, and so on. Service and leisure facilities will also be part of the mix: shared corporate restaurant, café, tourism bureau for the metropolitan area.

The idea is to develop a long built 'continuum' on the site to interact with adjacent streets. A linear construction that rears up and unfolds but also hugs the ground line to form a low accessible building - one that opens spacious courts and lifts bold overhangs. Each of its large bays serves an access route: the main portal opens to the concourse on avenue Grüner, which draws pedestrians into the project in a sliding movement. A high ceiling shelters and magnifies this entranceway, which is the finest and largest of three. The other two large 'ports' open the project to the streets that irrigate the lot, interconnecting pedestrian itineraries in the area.

The desire for continuity in construction does not simply reflect the idea of building a legible and unitary urban landmark, it also provides the flexibility that the project needs. In fact, the principle behind this continuum is to imagine a set of 'communicating parts' that enable the user-administrations to merge into a whole, one and all, and to evolve according to their needs in harmony with those of other tenants. The absence of breaks in surfaces will ensure that things remain open-ended, with the possibility of extending or reducing space.

The project is like a large 'Aztec serpent' rising on the lot. Its body has three identical outer faces, and an underside that is different: a skin of silvery transparent scales and a bright yellow 'throat', shiny and opaque.

This dual treatment of surfaces obeys a simple logic shared throughout, which aims at expressing clarity in folds. Depending on these movements, the yellow underside is either a floating canopy or an interior vertical wall, accompanying internal pedestrian movements with its rich luminous presence. The nearness of so much gorgeous yellow brightens up pavements and glazed elevations, casting golden washes over them like sunlight... This is a project that is about bringing together yellow and grey, silver and gold.

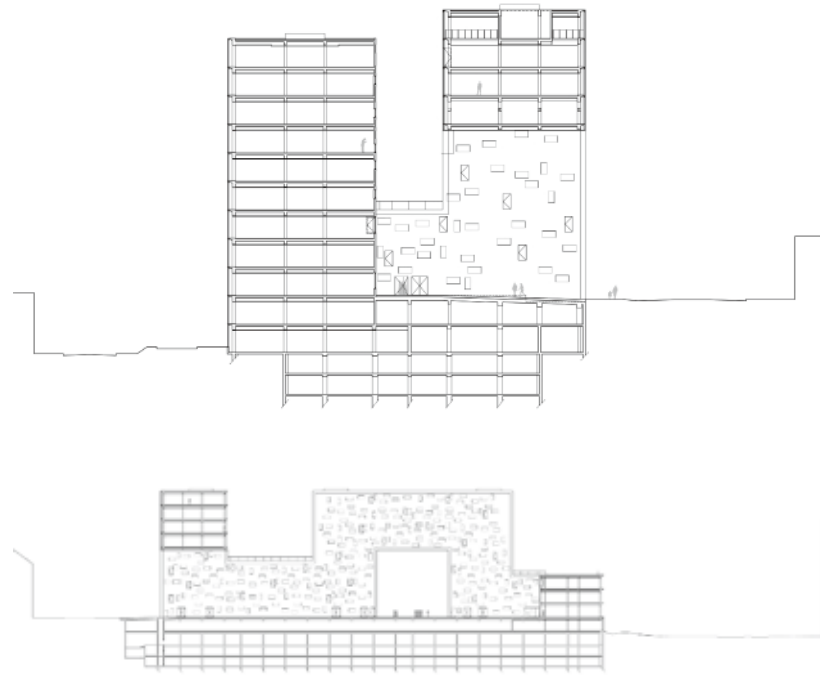

1. The idea is to develop a unique shape on the site to interact with adjacent streets. A linear construction forms a low accessible building - one that opens spacious courts and lifts bold overhangs
2. The low part forms a balcony
3. The bright yellow colour of the large bays brings a powerful visual impact
4. Varied shapes in different angles





1. Main entrance
2. The bay opens to the walking street



2

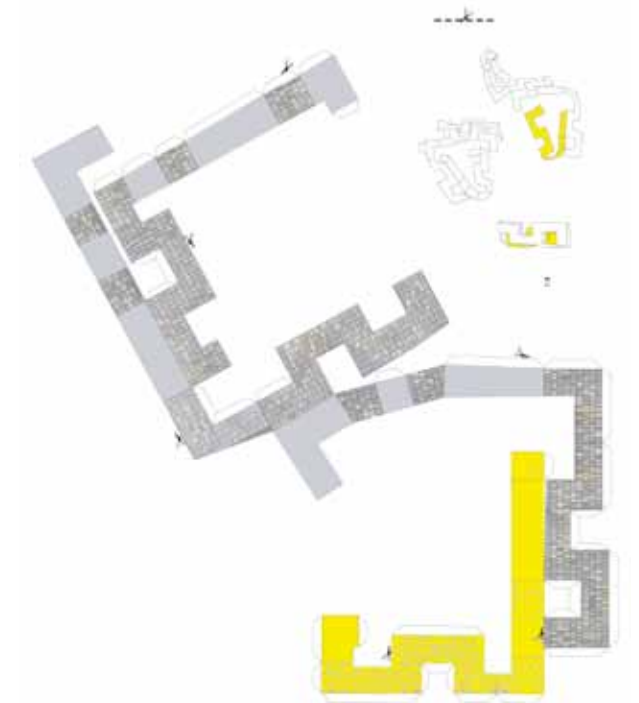
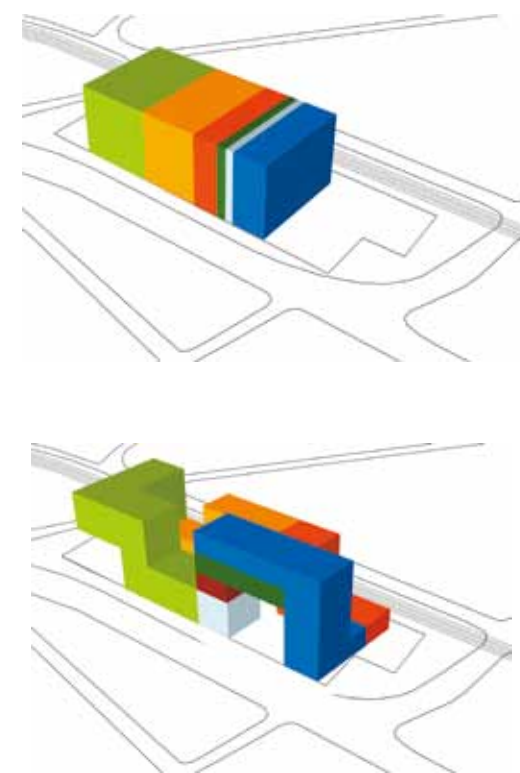



1



3



2

1.2. Plan of the office space
 3. Looking towards the balcony from window

- 1. Hall
- 2. Partitioned offices
- 3. Private entrance
- 4. Entrance

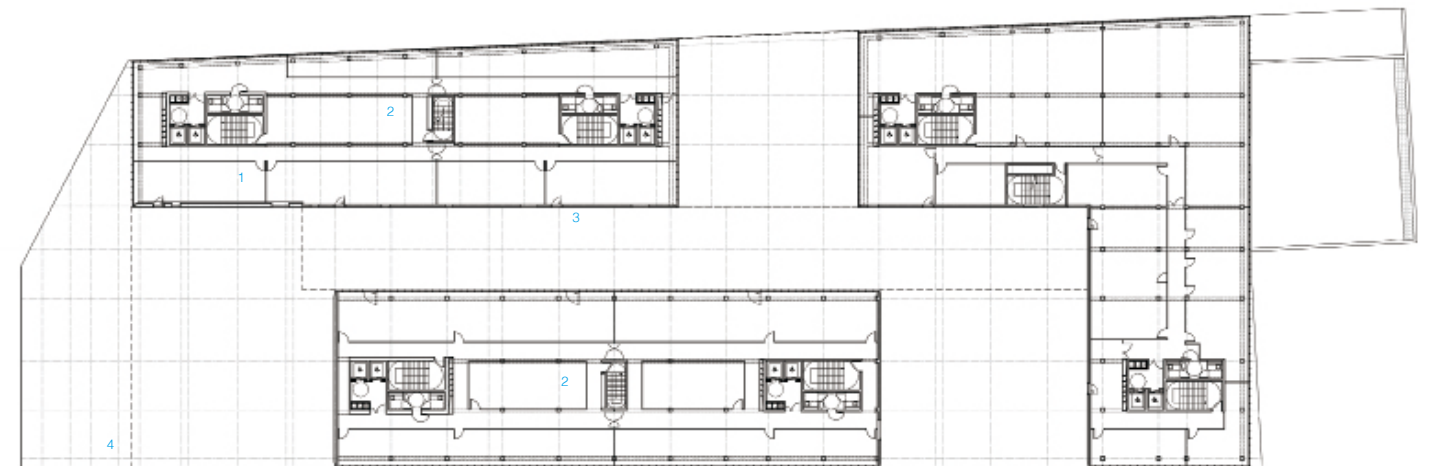

Sarpi Border Checkpoint

Completion date: 2011 **Location:** Sarpi, Georgia **Designer:** J. MAYER H. Architects **Photographer:** Jesko Malkolm Johnsson-Zahn, Beka Pkhakadze **Site area:** 16,500 sqm **Building area:** 4,443 sqm **Total floor Area:** 7,351 sqm



North Elevation



South Elevation

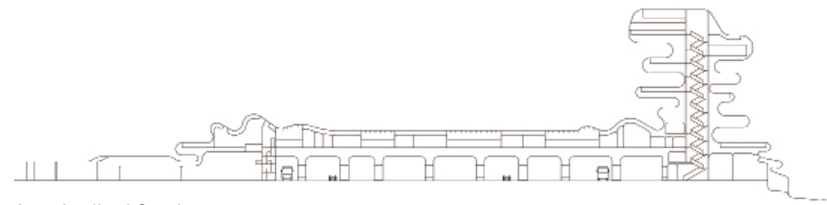

Longitudinal Section

The drivers crossing the coastal border between Turkey and Georgia will now pass below a knobby observation tower by Berlin architect J. Mayer H, situated at the Georgian border to Turkey.

The fascinating uniqueness of the Sarpi Border Checkpoint meets the undulating coast of the Black Sea in the small village of Sarpi, Georgia. The village is a major business travel checkpoint, and this required a contemporary iconic checkpoint building that would unite people and ideas in a unique customs headquarters. The bumpy tower, which sits atop the Sarpi Border Checkpoint building, houses a series of elevated terraces within its folds.

In addition to the regular customs facilities, the undulating structure also houses a cafeteria, staff rooms and a conference room on the two-storey building on the ground, while the tower's multiple floors allow it to be used as a viewing platform overlooking the steep part of the coastline and the calming stretches of water of the Black Sea.

The building welcomes visitors to Georgia, representing the progressive upsurge of the country. The client – Georgia's Ministry of Finance – needed the construction to welcome visitors in a way that would visually describe the country's "progressive upsurge", as the architects put it.

1. The checkpoint building that locates along the coast of the Black Sea is a contemporary landmark in the village
2. The bumpy tower houses a series of elevated terraces within its folds





1



3



2

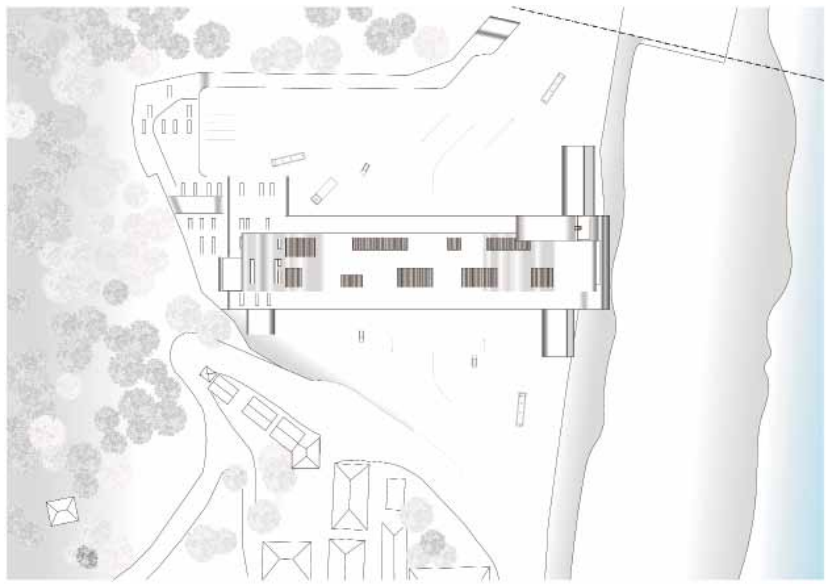

1. The bumpy structure of the Sarpi Border Checkpoint meets the undulating coast of the Black Sea
 2. Entrance of the customs hall
 3. Night view of the tower
 4. Details of the folding parts



4



1



2

- 1. Customs checking hall
- 2. The tower's multiple floors allow it to be used as a viewing platform overlooking the calming stretches of water of the Black Sea
- 3. Pedestrian tunnel for entering Georgia

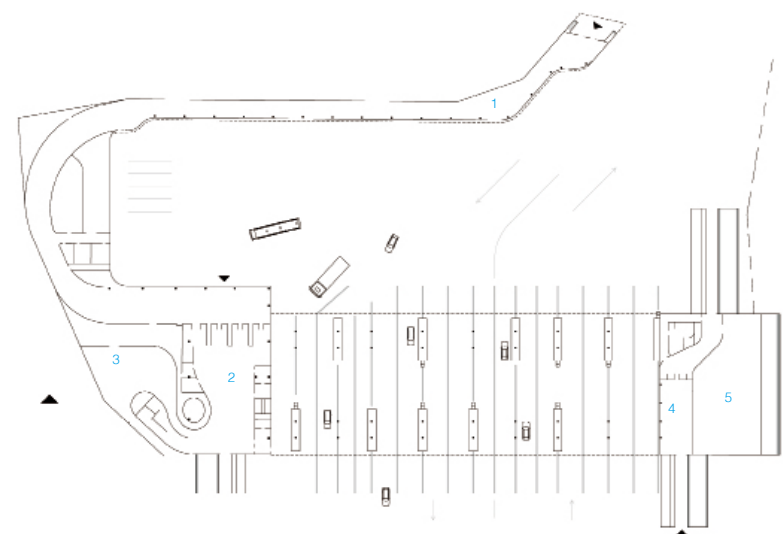

Ground floor plan
 1. Pedestrian tunnel for entering Georgia
 2. Customs hall for entering Georgia
 3. Baggage control
 4. Customs hall for leaving Georgia
 5. Duty free shop

Upper floor plan

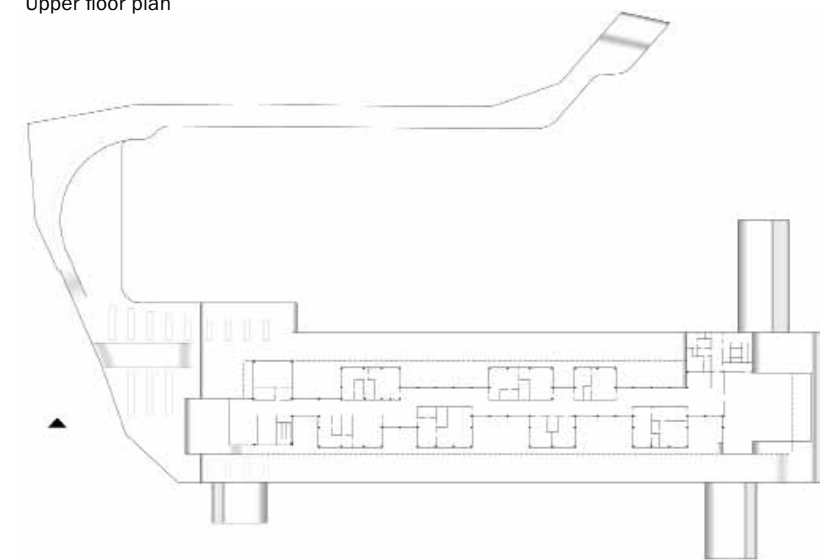

3

Warroad Land Port of Entry

Completion date: 2010 **Location:** Warroad, MN, USA **Designer:** Julie Snow Architects **Photographer:** Paul Crosby **Site area:** 3,726sqm

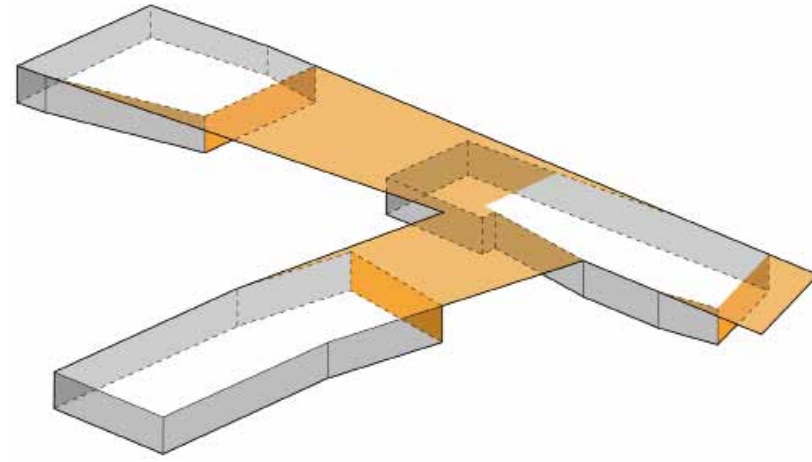

Wood Diagram Axon

The Warroad Land Port of Entry is a 40,108 square foot facility that supports the mission-driven demands of US Customs and Border Protection (CBP), the federal agency responsible for securing the nation's borders and promoting legal trade and travel. Conceived as a specific response to the vast open landscape along the Minnesota-Canadian border, its form reiterates the dominant horizon of the landscape while making reference to the East-West border. Inflected building forms facilitate intuitive use by visitors, the officers' ability to survey the entire site, and vehicle access to secondary and commercial inspection areas. The entire facility is clad in sustainably harvested cedar siding, embracing the "north-woods" identity of the region. Vehicular inspection areas (experienced primarily from the car) and the public spaces use expanses of glass and warm, stained cedar siding to create a transparent, welcoming presence. The exterior cedar siding is finished in a black stain, anchoring the building to its site. This strong contrast reinforces the threshold, creating a material warmth and richness in the cold winter months for officers and visitors through the port.

The port design manages a complex set of operational issues including site circulation of commercial, POV, and recreational traffic, state of the art vehicle inspection areas, holding areas, and officer training and work areas. All while integrating the latest technologies for securing the border and meeting the demands of an energy efficient and sustainable building. Life cycle cost analysis was used to ensure that long term cost and energy reductions were met and the project is in line to receive LEED Silver Certification. Geothermal heating and cooling, rain water capture, and daylight harvesting are among just a few of the strategies that allowed the design team to meet this certification. In addition to meeting these programmatic and operational issues, the port must also stand as a gateway to our nation, representing the open and democratic values of transparency, dignity, fairness and humaneness of the federal government.

The Warroad Land Port of Entry sets a new standard for remote, small ports in achieving the highest design standard for public buildings, conveying the ideals of the country while advancing the efficiency and comfort of federal officers. Its success is defined not only by the impact of its design, but also its open, timely, collaborative process that respects the nation's fiscal and natural resources. The design's success can be measured across all standards of design performance.



2

1. Far view of the Warroad land port of entry
2. Departure port
3. The entry port building and the annex use expanses of stained cedar siding



1



3



- 1. Vehicular inspection areas use expanses of glass and orange cedar siding to create a transparent, welcoming presence
- 2. Vehicle traffic area
- 3. Details of the black cedar siding





1. The orange colour of materials creates the building a sense of warmth and richness
 2. Work area

1



2

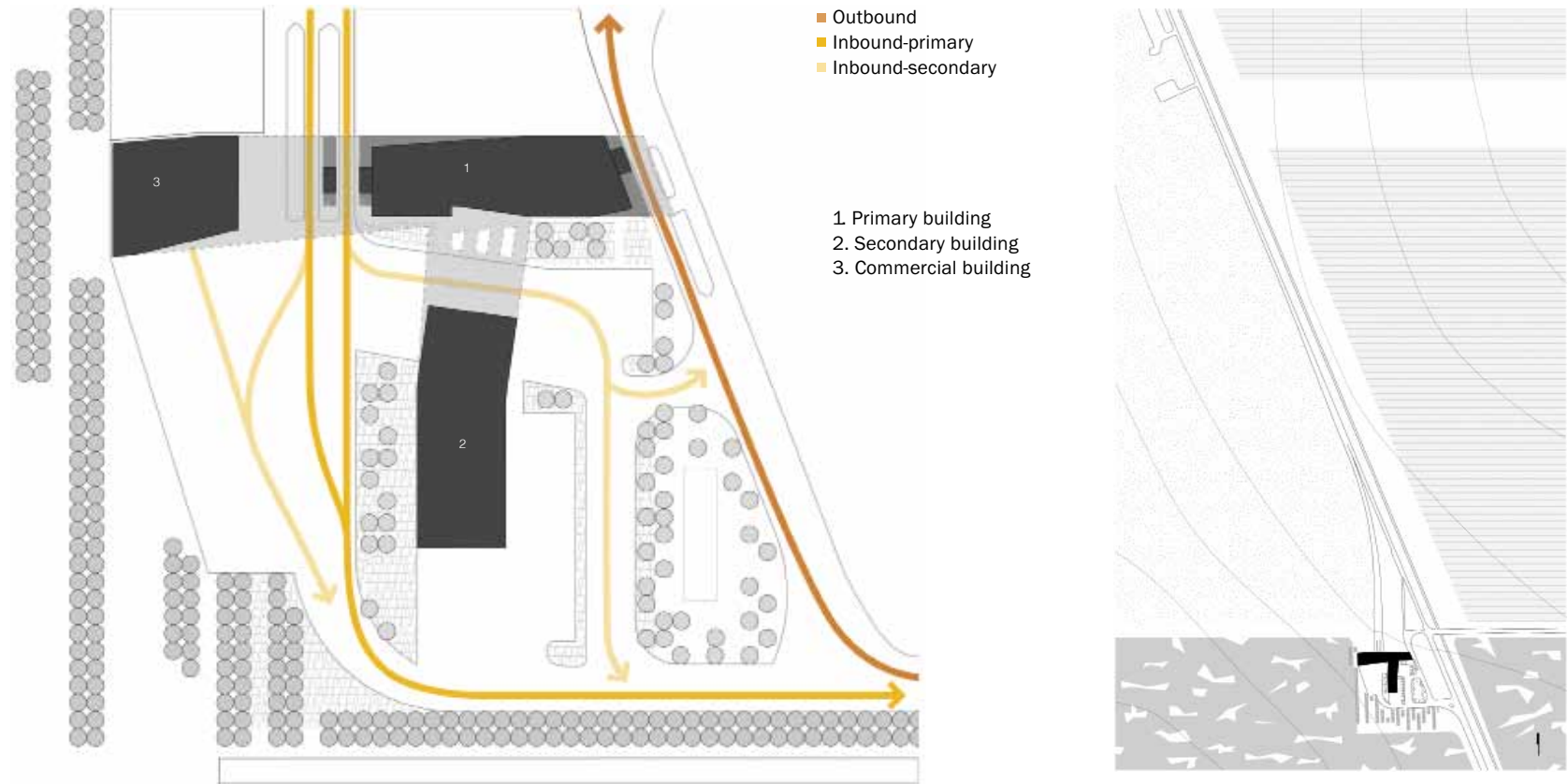

1

French Diplomatic Campus - Beijing

Completion date: 2011 **Location:** Beijing, China **Designer:** Alain Sarfati/SAREA Alain Sarfati Architecture **Photographer:** Noëlle Hoeppe / ADAGP ,François LAMARRE **Site area:** 19,500 sqm



West Elevation

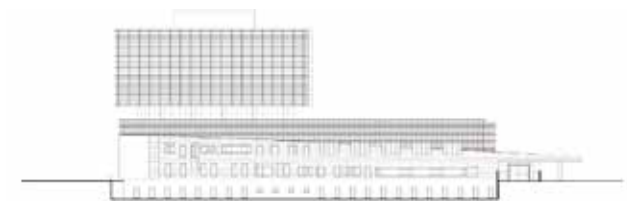

South Elevation

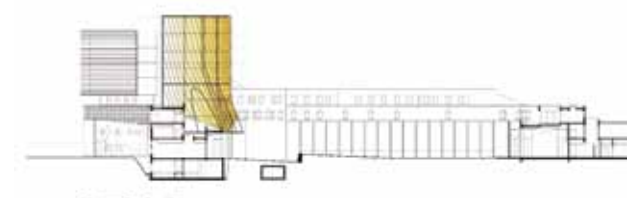

Longitudinal Section

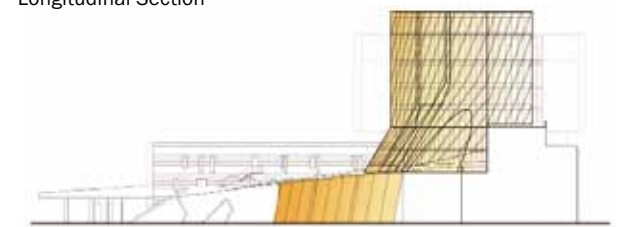

Cross Section

1. Entrance
2. Details of the building's external wall
3. Looking towards the external wall from streets
4. Panoramic view of the courtyard



Representing the country, an interior garden. Representing the home, a building designed in a square, surrounded by a forecourt, a service courtyard, a shallow moat and grassed alleys. Our embassy in Beijing is our backyard.

Superbly planted, this French enclave is protected by a symbolic rather than a defensive wall, almost an ornamental wall designed for the city and the passers-by of the third embassy zone of the Chinese capital. Third in terms of history, as new embassies move in, leaving their former sites. And third in terms of location, considering the distance from the centre and the proximity of Liangmaqiao to the third ring road, on the way to the airport. Located at the entrance of the compound, the French embassy acts as its watchtower.

Built with a concentric design, the empty spaces all over our embassy seem to increase its size. The embassy was born to encounter and dialogue. The focus on context and tolerance comes with a high opinion of the function of representation, strengthened by the universal values of French culture. The functional programme follows a very Cartesian tradition, arranging the parts around the interior garden to form a whole. A dash of French touch adds a little fancy, mixing elegance and grace.

Chancery, consulate and residence form 3 sides. The fourth side is made up by greenhouses, exhibition rooms or winter gardens, according to seasons and needs. The residence and the chancery respectively overlook the reception halls and the meeting rooms which give onto the garden. This piece of nature at the centre of the building is separated in two, for the officials and for the personnel. Chancery and Consulate are located in the Tower of services at the corner of Liangmaqiao avenue.

Smaller in size compared to its Chinese neighbours, it still is a remarkable landmark with its rotating sunblinds hiding the number of floors. Concealing its real scale, it stands, enigmatic, on the outside corner; its internal façade is covered with a cloud-like glass veil that blurs the surroundings. Two access ways run along the forecourt; one, official, leading to the reception rooms, the other, less formal, facing the tower on the ground level. Unique spaces, different atmospheres but harmony everywhere; and from all around the building, views on the interior garden, landscaped under the Beijing sky.

The general layout and openings ensure natural ventilation everywhere. It can also be boosted by the series of vents in the meeting rooms that act like chimneys. The residence can also get efficient natural ventilation from the patio.

The building being connected to district heating, the designers carefully chose the joinery and the glazing to obtain the best energy savings.

The materials were chosen keeping the environment in mind: stone. Wood and hard rubber are the main building materials. The greenhouses were designed with a Trombe wall: a black schist wall stores the heat during the day in order to turn it into additional heating.



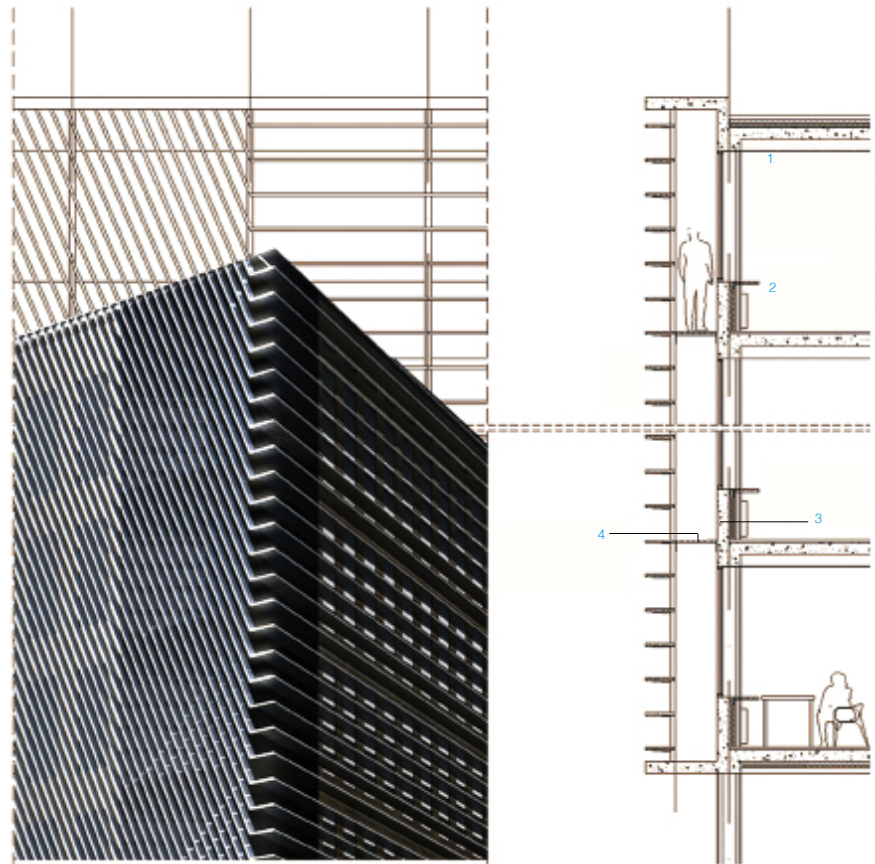

South and West Façade Details of Breezes Sun
 1. False ceiling
 2. Wooden shelf
 3. Concrete insulation coil
 4. Aluminum louver. Lacquered smooth mesh grating

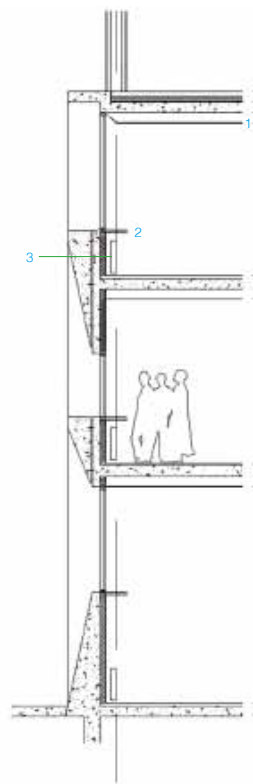
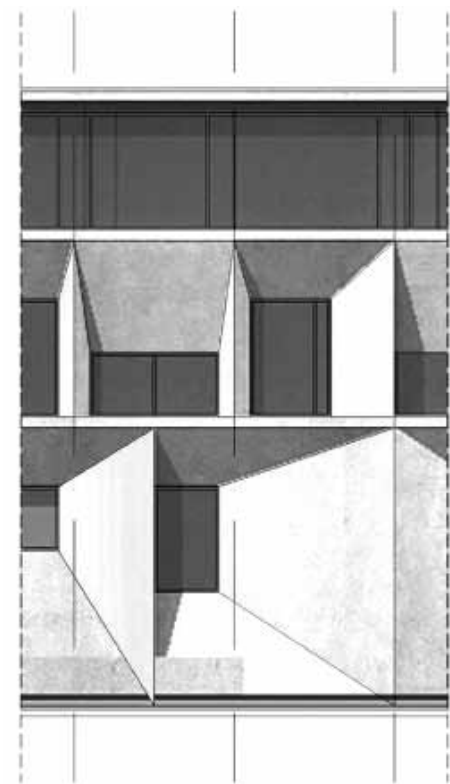

West Façade Bedrock Detail
 1. False ceiling
 2. Wooden shelf
 3. Stone seal glue reinforced concrete insulated coil



1. Details of the west façade of the building
 2. The stone was chosen to save the energy



1. North façade wrapped in a screen-printed glass
 2. Screen-printed glass details
 3. Corridor

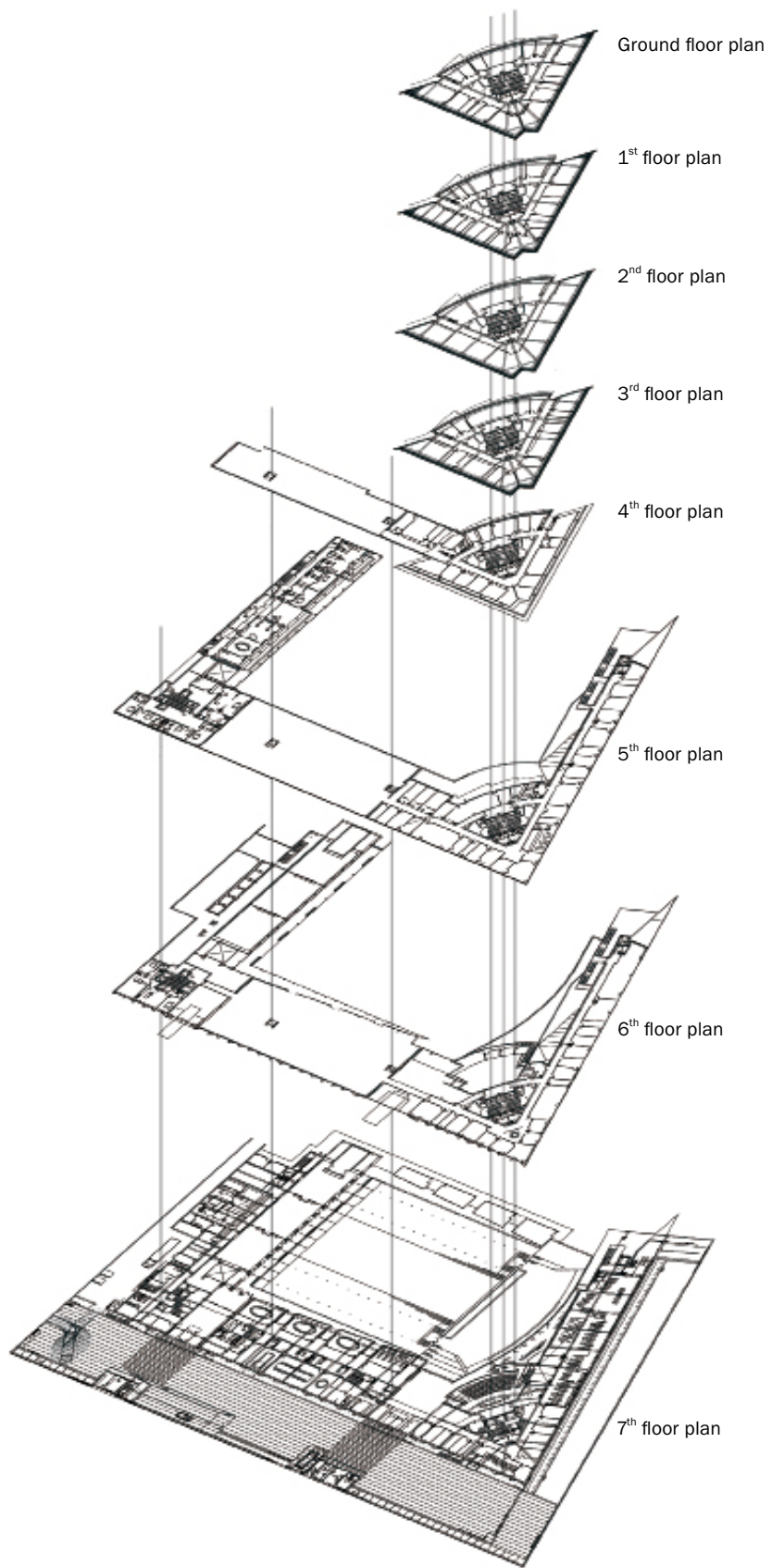

3



1



2



4



3

1, 3.Reception area and reception room
 2. Details of the doors
 4. Auditorium

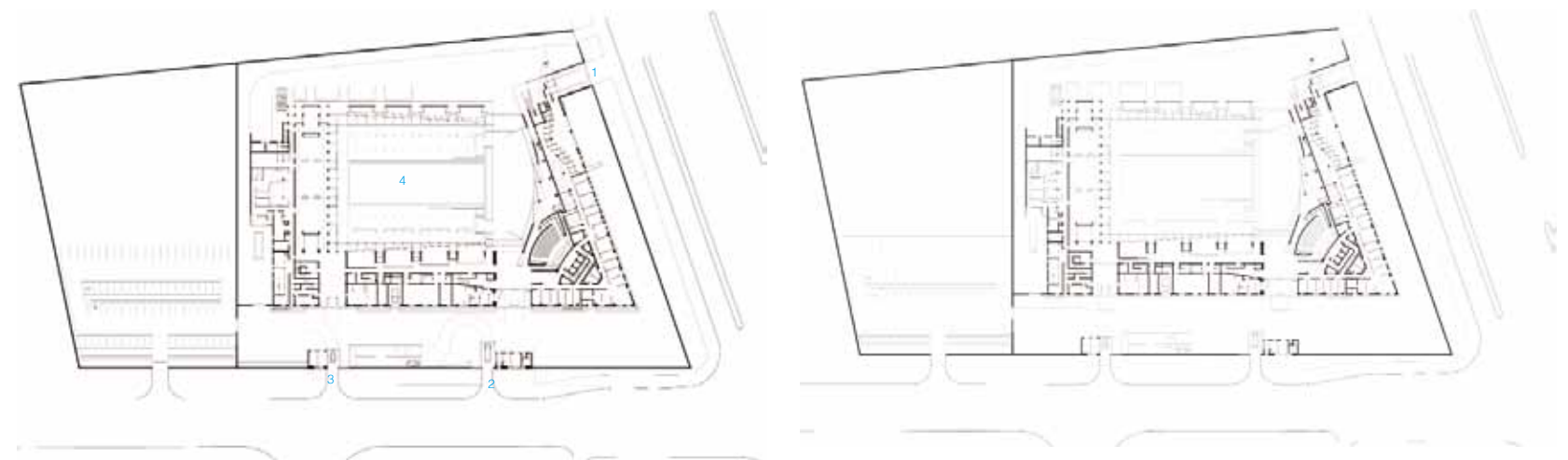

Ground floor plan
 1. Entrance
 2. Chancellery entrance
 3. Residence entrance
 4. Garden

House of Sweden

Completion date: 2006 **Location:** Washington D.C., USA **Designer:** Wingårdh Arkitektkontor AB **Total building area:** about 8,156 sqm, incl 1,561 sqm garage

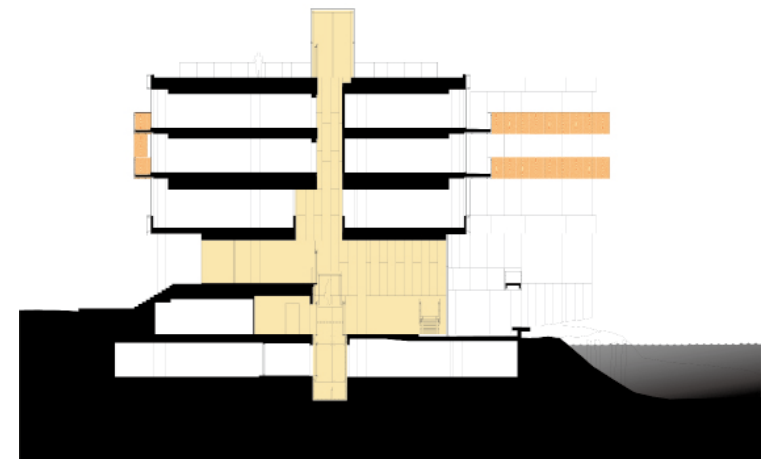
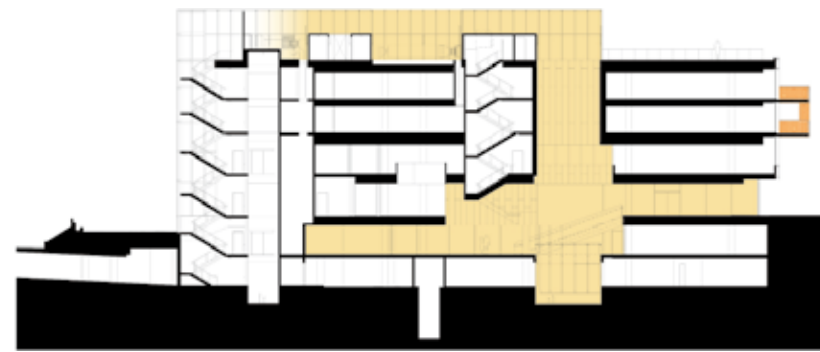

1. House of Sweden from the Potomac. The prominent location, on the conflation of Rock Creek and Potomac River, gives the building a unique position in Washington
2. The South façade. A belt provides privacy to the upper floors
3. The entrance from the 30th Street at night. The multi-task building combines apartments, offices and exhibition venues



Sweden has the chance to win a spectacular site – a peninsula surrounded by the Potomac and Rock Creek.

The National Swedish Property Board, with Jan Thews as its representative, has a clear goal. The city plan allows a certain volume and that has to be exploited to make the project financially reasonable. There is one drawback with this site, however – it floods regularly.

What the designer propose to do is to create a seven-level building, including a rooftop terrace and underground parking, and to build at least to the property boundary, except at entrance level. The entrance level lies at the highest point to which the Potomac River is expected to rise.

A large flight of steps and a ramp along the entrance side of the building leave the pillars exposed and create a loggia in a classicistic and classically modern style (compare this with Villa Savoie). Here, the cars will draw up and deliver the guests arriving at the embassy.

The Swedish Government has approved guidelines for how embassies should be designed and how they should act. One has to bear in mind that embassies should serve as display windows for Sweden where procedures are completely open and transparent and where exhibitions, talks and conferences are important and should be available to the general public.

The entrance floor is the hub of all operations. The part of the building used exclusively for the embassy is on the left with its reception area and with offices up on the next floor. The public part of the building has its reception on the right, with a large, glazed exhibition space (the Anna Lind Hall) facing the Potomac River and with a series of multi-purpose exhibition and conference rooms leading off a lower lobby.

Never before have the public areas been allowed to take up so much room, and the building really attracts the public. There are constant streams of people moving along the banks of the Potomac. Massive sliding doors make it possible to open up the Anna Lind Hall at both corners. The public is welcome to gaze from any side through the entrance hall, where interior and exterior walls made entirely of glass provide unobstructed views.

The top two floors of the building are a residential area, with 19 apartments. The two belts of balconies form a projecting box-like structure that encircles these two floors.

What is typically Swedish?

The answer is the red light that appears with the low setting sun at dusk. Sweden's northern latitude is radically different to Washington's geographical location. The designers wanted to create "the Nordic light in the dark Southern night". This was achieved by backlighting the panels cloaking the balconies around the building. The architects originally intended to use real wooden veneer on the balconies, enclosed between two sheets of glass. However, they decided instead to use computer-generated images, which were printed straight onto the laminated film. Six different patterns of exaggerated wood grain were combined to form an elegant façade around the private apartments. The whole of the façade is illuminated from behind in the evenings and at night, making the building glow like a huge lamp.





1

- 1. The entrance hall towards the reception. Glass works by Swedish artist Ingegerd Råman and sensitive woodworks were the visitor touches the building
- 2. The Concierge in the entrance hall, white lime stone flooring with black marble stripes, laminated ceiling in maple wood



2

- Entrance Floor
- 1. Entrance
 - 2. Main Lobby
 - 3. Concierge
 - 4. Art Work "March 6 A.M." / Ingegerd Råman
 - 5. Reception Embassy
 - 6. Embassy
 - 7. Exhibition Hall
 - 8. Void

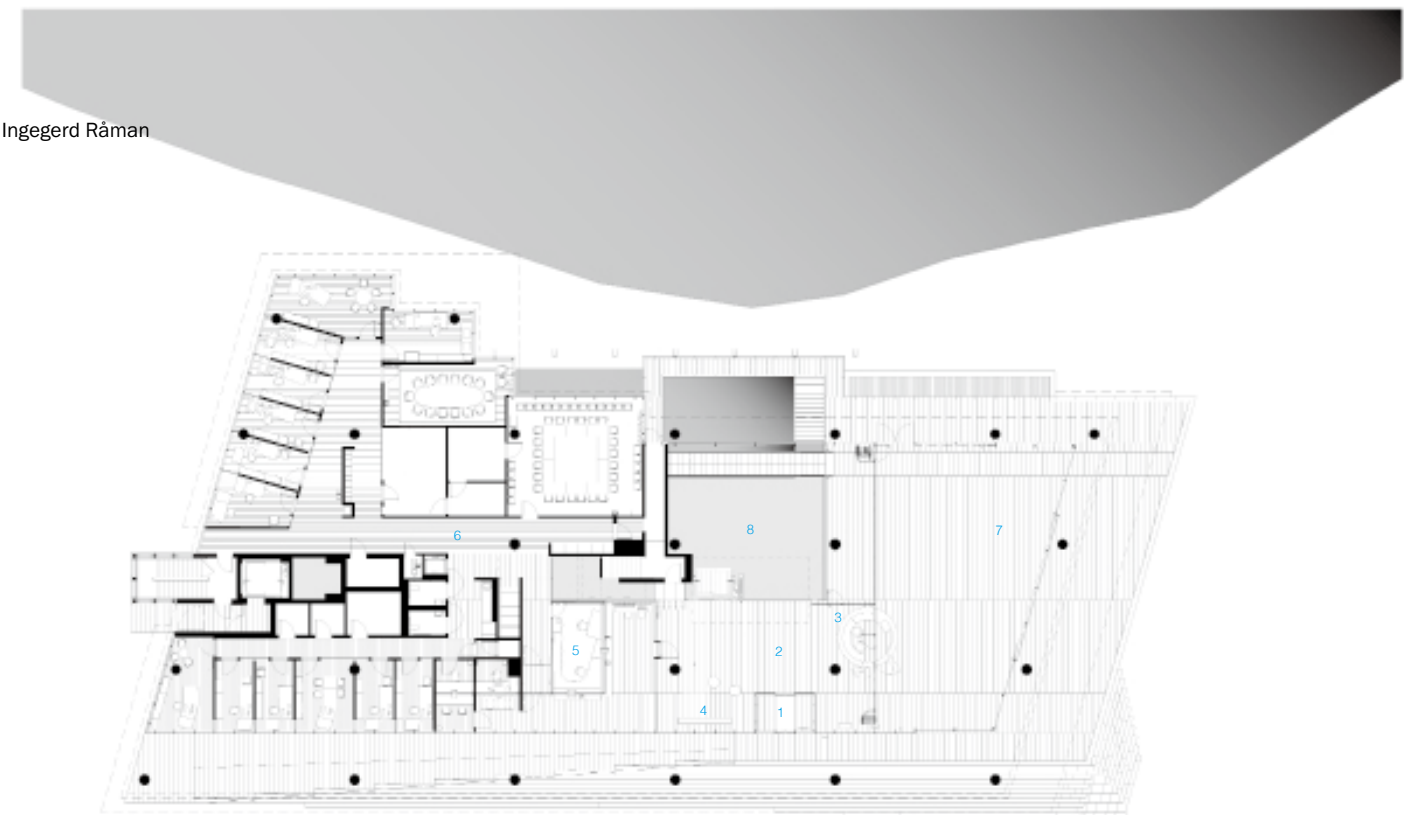

Canadian Embassy in Warsaw

Completion date: 2001 **Location:** Warsaw, Poland **Designer:** ABSTRAKT Studio Inc. / Voytek Gorczyński Architect Hady Lotfy, Paul Marcoccia, Natasha Djordevic, Kwang Kim, Rosmal Sereviratne
Photographer: Wojciech Krynski **Award name:** The Best Public Service Building - Mayor of Warsaw Award in Architecture. **Awarded description:** Organised by the office of the Mayor of Warsaw. The award is granted every year in three categories: The best office building; The best public service building; The best residential building **Award date:** 2007

Canadian Embassy in Warsaw has been officially opened at the end of October 2001. New building replaces 36-year-old technically outdated existing structure. It provides 3,800 square metres of new offices and exhibition spaces doubling the size of the original Embassy. It has been partially built on the foundations and the basement of the existing building.

Situated in Warsaw Embassy district in close proximity to Polish Parliament (Sejm), the Embassy is surrounded by city parks, French Embassy compound and the eighteenth century buildings. Detached from its immediate context the building affords uninterrupted views of the neighbouring parks and gave architects a rare opportunity in urban environment to integrate the building with the surrounding landscaping.

Canadian indigenous plants as well as large boulders emblematic of Canadian Shield have been used as the main "dry riverbed" landscaping elements replacing reflecting pools eliminated in the design process.

Two separate entrances to the Embassy have been maintained with the consular entrance accentuated by large cantilevered portion of the second floor, which also serves as a canopy. The immigration entrance on the opposite side of the building echoes consular entrance, and has been resolved in more subdued form.

The internal circulation in the building and clear duality of functions - the consular and commercial versus the immigration function - formed the basis of the architectural concept, focusing on the counter clockwise entrance movement sequence around the central, circular back-to-back main reception and culminating in three-storey skylit atrium of the consular area.

In the design process it was important for architects to maintain interplay between the openness and transparency of the publicly oriented functions, and the sense of security and impenetrability that is still very necessary in an embassy. This sense of security is most clearly expressed in the top floor of the Chancery with its solid stone cladding and horizontally slit windows.

Double height multipurpose room located near the immigration entrance opens up into the lobby, accessible from the Public Zone, thereby providing an opportunity to host a variety of public functions. On occasions when a reception or exhibition is taking place, the transparency of the glazed two-storey street elevation of this space conveys a sense of openness to the passerby. This space also has walk out access to a terrace and the Chancery garden beyond. The Embassy is clad in French limestone, anodized 4 millimetre aluminum panels and clear glass.



Longitudinal Section

- 1. Mechanical penthouse
- 2. Office
- 3. Garage

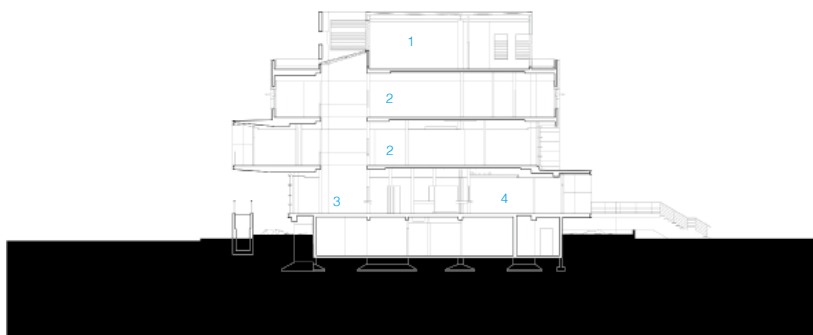

Cross Section

- 1. Mechanical penthouse
- 2. Office
- 3. Consular entrance lobby
- 4. Immigration entrance lobby

- 1, 2. Walk-out terrace and landscape
- 3. The Embassy is clad in French limestone, anodized 4mm aluminum panels and clear glass





1



2

- 1. The large cantilevered portion at the entrance also serves as a canopy
- 2. The transparency of the glazed two-storey street elevation of this space conveys a sense of openness to the passersby

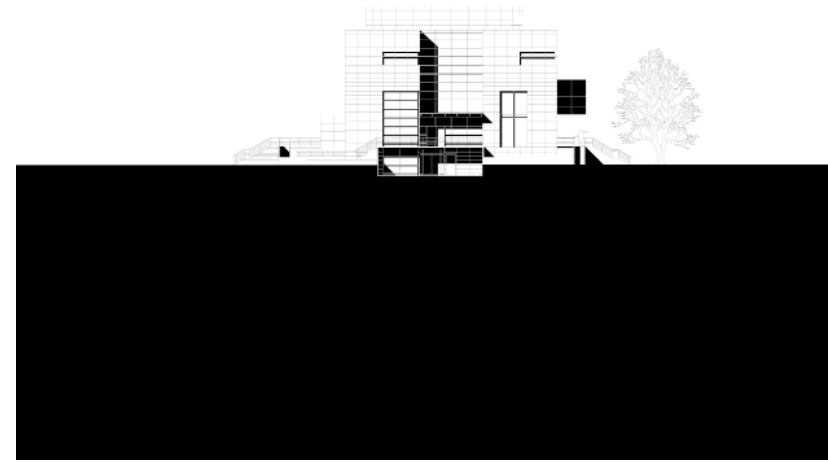

East Elevation

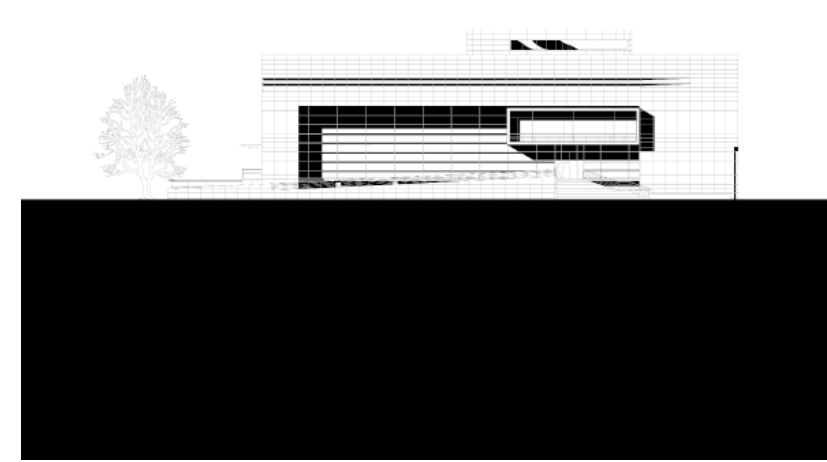

North Elevation

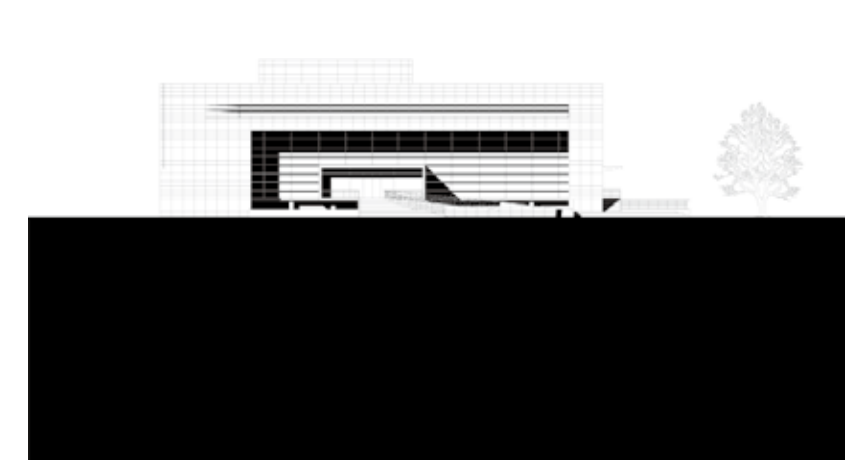

South Elevation

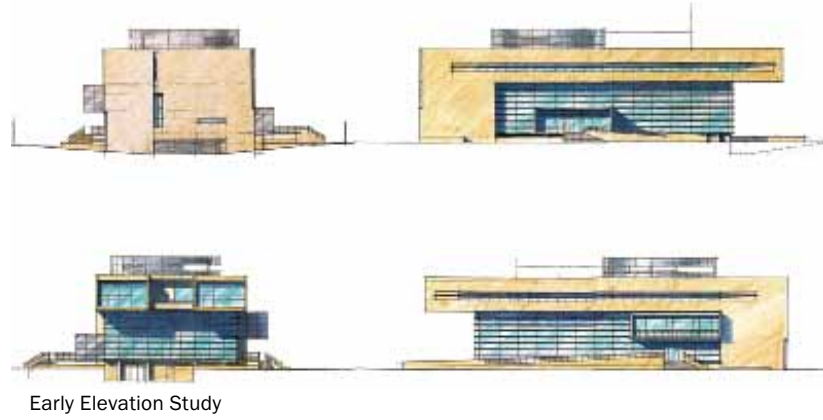
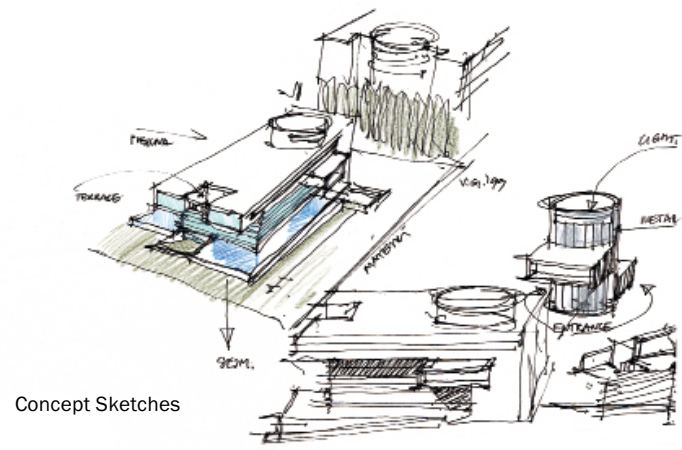

- 1. Stairs and "dry riverbed" landscaping elements below
- 2. Three-storey skylit atrium and central circular main reception



- Ground floor plan
- 1. Immigration entrance
 - 2. Immigration waiting/seated
 - 3. Reception
 - 4. Consular waiting and display
 - 5. Consular entrance
 - 6. Kitchen
 - 7. Multi-purpose room
 - 8. Terrace
 - 9. Garden
 - 10. Landscape area

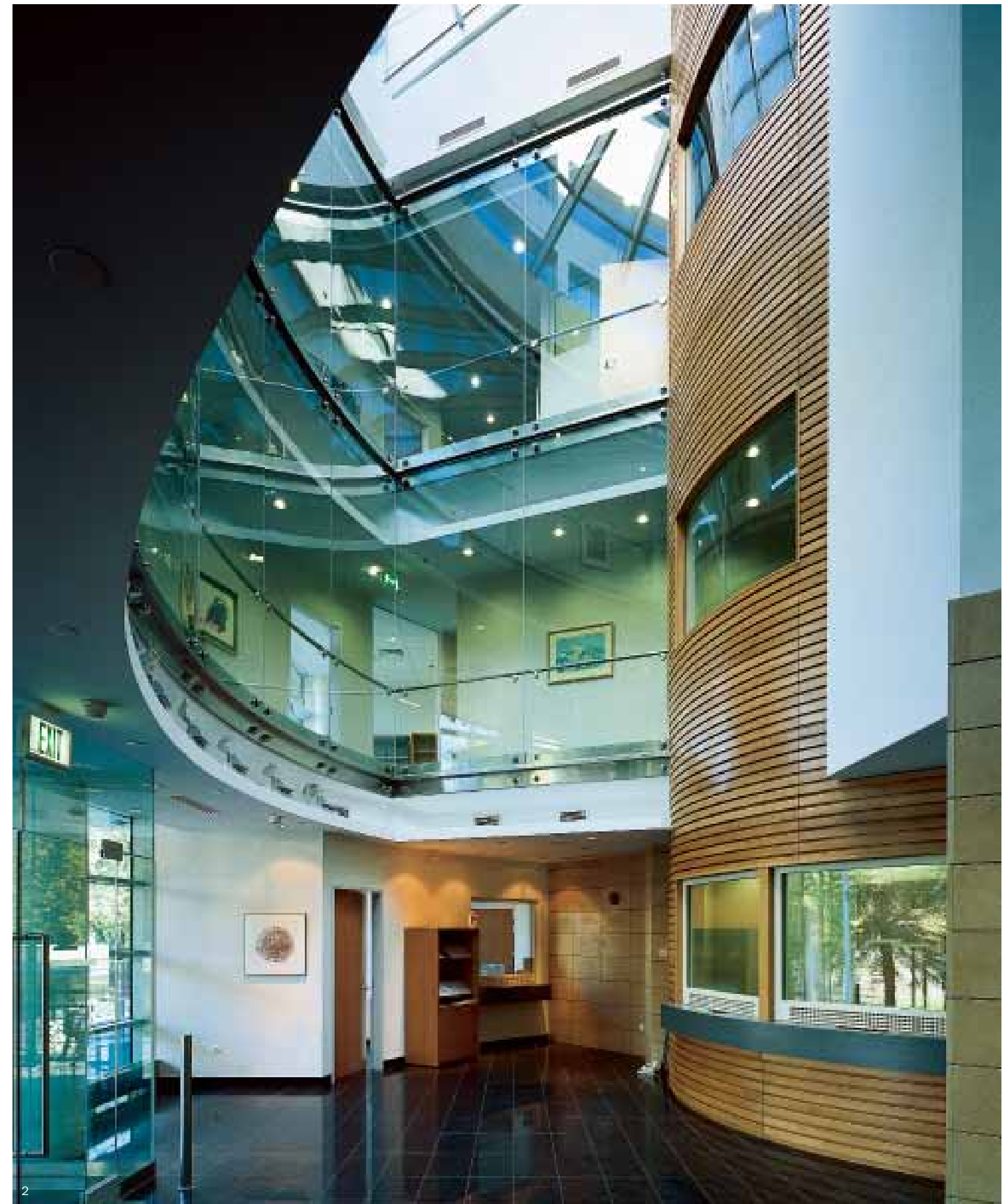

New Chancery for the Singapore Embassy in Manila, Philippines

Completion date: 2008 **Location:** Manila, the Philippines **Designer:** Forum Architects Pte Ltd
Photographer: Albert Lim **Site area:** 4,500 sqm **Total building area:** 4,130 sqm **Award name:** The 10th Singapore Institute of Architects (SIA) Architectural Design Award / - New Chancery for the Singapore Embassy in Manila (Honourable Mention - Community Category 2010)/ President's Design Award, Singapore / The Singapore Chancery In Manila, Philippines (Honourable Mention - Design of the Year 2008)

The challenge in the project was to derive an architectural image of the Chancery that would befit Singapore. The architects saw this in diplomatic terms rather than cultural ones. Singapore projects itself to its neighbours as a no-nonsense, efficient and well-mannered country. At the same time, it wants to be friendly and open. Its garden city image is also portrayed in the way the building sits amidst manicured landscape.

Large overhangs anchor the interplay of volumes to create large indoor and outdoor spaces. Both these types of spaces constantly relate to water, foliage and sky and conveys an imagery of a building set in a garden.

The lines of the buildings are slender and minimal conveying an efficiency, for which Singapore is so renowned for. Precision in the details and in laying of tiles, the modular considerations, as well as the overall control of building edges are all intended to lend the image of a crafted building.

Lifting the ground plane of the building gives the building a lightness, contrary to the reality as the building is practically surrounded by solid walls, a response to serious security threats. The floating elements of the entrance roof, the portal frame, the disabled access ramp as well as the cantilevered volume over the lobby of the main hall, contribute to the perception of lightness.

Spaces are layered to allow openness at the outer layer. As a Chancery, many areas are restricted beyond the first layer. The overhanging portal allows visual transparency, signaling a welcoming gesture. The entrance to the building is lined with reflective pools and a voluminous porte cochere.

To provide internal views, courtyards are created to allow its residents and users to have views outwards. These courtyards provide further security buffers for restricted areas.

As a mark of appreciation to the host country, patterns of the traditional fabric, the pina, (made from pineapple fibre) were graphitized and replicated as frit patterns on the glass cladding as well as the skylight. Shadows cast by these patterns can be seen in the lobby of the main conference room.

The attitude of precision and lightness continues in the aesthetic expression of the interiors.

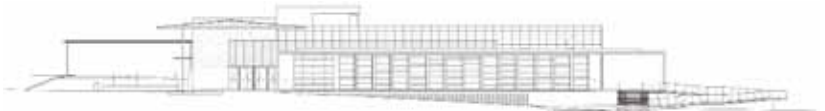

Front Elevation



Left Elevation



Rear Elevation



- 1, 2. The waterscape around the building
3. Large overhangs anchor the interplay of volumes to create large indoor and outdoor spaces
4. The solid wall clad with crafted tiles gives the building a lightness





- 1. Lighting effects of the entrance
- 2. The entrance to the building is lined with reflective pools
- 3. Singapore's garden city image is also portrayed in the way the building sits amidst manicured landscape



1, 2. The outside waterscape echoes with the interior sunlight that penetrates into the skylight
3. Entrance hall

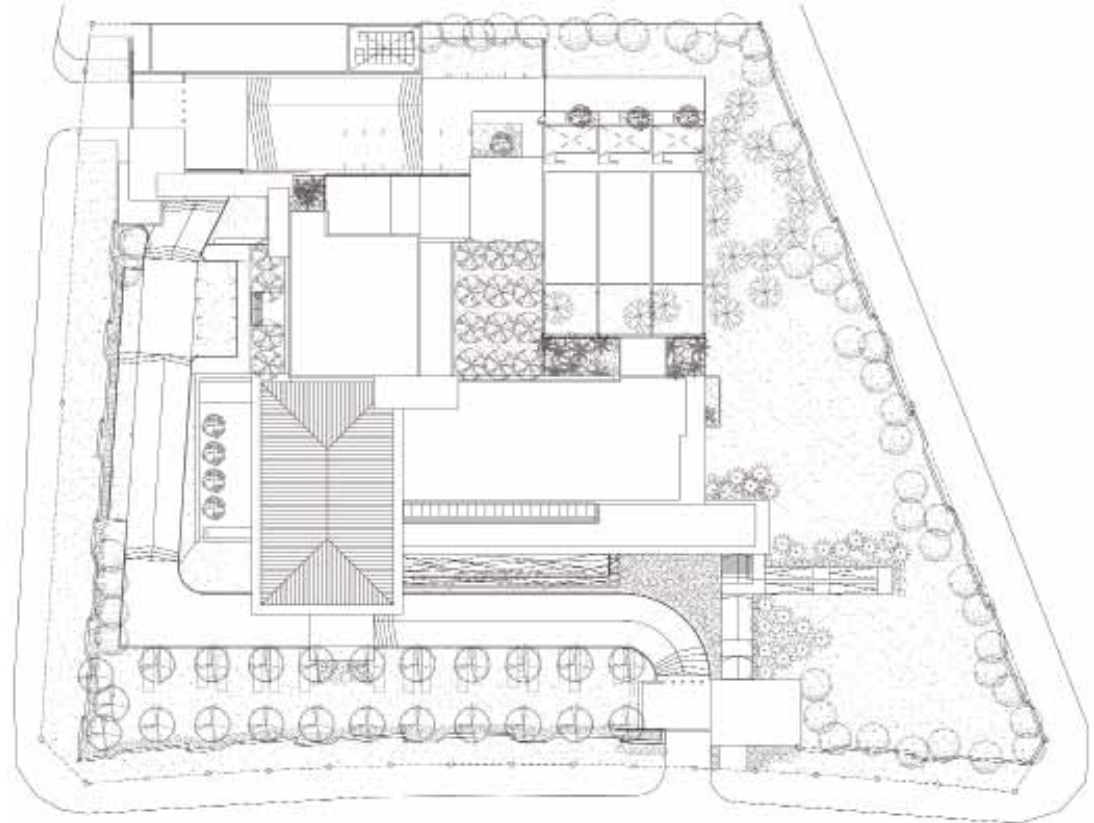

Canadian Diplomatic Complex

Completion date: 2007 **Location:** Seoul, Korea **Designer:** Zeidler Partnership Architects **Photographer:** Kim Yong Kwan **Site area:** 7,530sqm **Award name:** Canadian Society of Landscape Architects (CSLA), National Honour Award of Excellence **Award date:** March 2008

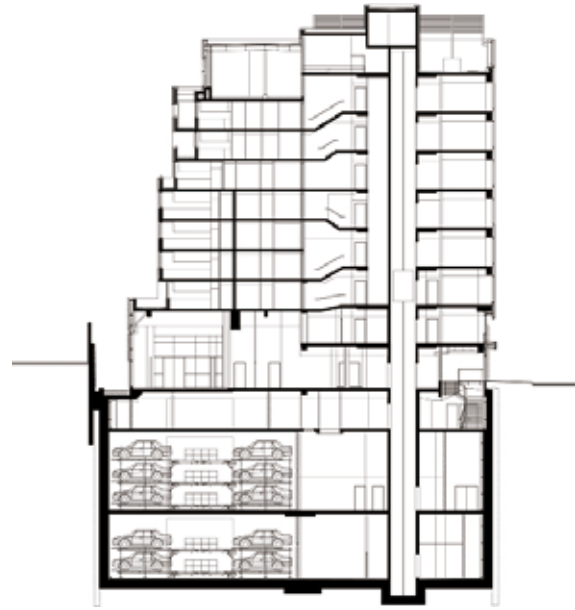

The design of the Canadian Embassy in Seoul creates a dialogue between Korean and Canadian cultures, expressing common links and in particular a shared reverence for nature. This unique site shares a "place" with a 520-year-old tree, a living symbol of nature, called Hakjasu or "scholar" tree in the historic Jeong-dong district near Deoksoo Palace.

The composition pulls back and suspends the two main building masses creating an entrance plaza and gathering place with this tree at its focal point. The building base ties together these two main blocks. This undulating mass is wrapped with a continuous wooden screen composed of western red cedar. Its soft curves frame the public space around the tree adding to the rich composition of textures and materials at the entrance to the building. The linear wood panels of the screen are hinged, allowing window cleaning. The wood will age to resemble the undulating walls surrounding Deoksoo Palace.

The historic Jeong-dong context plays an important part in the building materials and organisation of the embassy. Jeong-dong is built of stone, brick and wood in varying hues ranging from grey to red. Embassy materials have been chosen carefully to harmonise with these colours and textures and to extend the pedestrian walk that meanders along the undulating Deoksoo Palace's wall.

A protection plan for the 520-year-old tree was critical. The massing was designed for minimum impact on the tree root-ball. Using an existing urban site, directing drainage into landscaped areas, coordinating with local materials, minimizing parking through a high density automated system, providing open space, reducing light pollution by screening and curtain wall design, maximizing energy efficiency, commissioning - these were all measures taken to promote sustainability.

1. Entrance plaza
2. Reflective pool
3. The undulating mass is wrapped with a continuous wooden screen composed of western red cedar





1



2

1. Embassy materials have been chosen carefully to harmonise with the colours and textures of the surrounding buildings
2. The materials and textures of the flooring at the entrance hall go harmoniously with that of the entrance plaza
3. The tone and lines of the ceiling and floor as well as the wall give a sense of harmony and unity

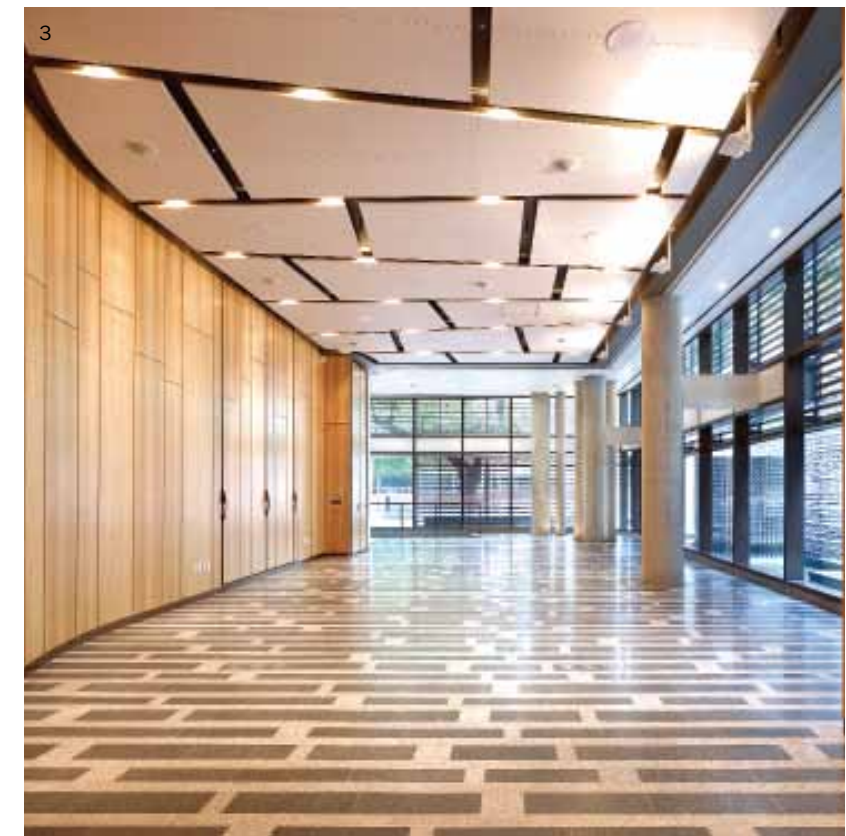
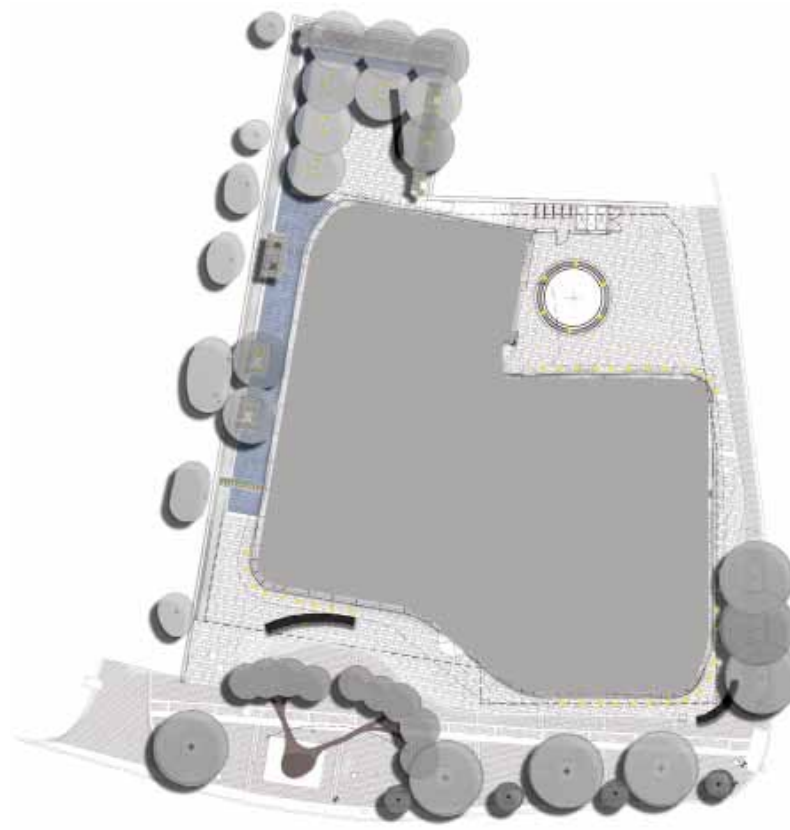

3

Bergen Fire Station

Completion date: 2007 **Location:** Bergen, Norway **Designer:** Stein Halvorsen Architects **Photographer:** Kim Miler **Award name:** First Prize, Architectural Competition **Award date:** 2007

The Fire station is located in the centre of Bergen, capital city of western Norway.

The aim was to create a functional and well-proportioned project, to establish good working conditions and to address the following main points:

- to incorporate the special qualities of the site; the lakeside view and the view towards the 7 mountains embracing the city of Bergen
- to minimise the negative effect of the neighbouring motorway
- to take into account future planned development –the fire station is located on the boundary of planned development

The building is curved. The outer curve -facing the motorway – forms the back of the building. It is solid and functions as protection towards the noise allowing the building to open up towards the courtyard facing the lake and the planned development. The shape of the building reflects the curved lines of the traffic machine and it follows the perimeter of the site in order to maximise the courtyard.

Four elements form the main architectural composition: the base, the shield, the tower and the bridge.

The 'base' (ground and the first floor) houses the garage and the heavy duty working areas. The main material is in-situ concrete.

The 'shield' is the dominating feature of the building covered with copper housing the offices, sleeping rooms, alarm centrals all within a singular shape opening up towards the courtyard away from the motorway.

The 'tower' is given an asymmetrical position to mediate between the courtyard and the main building. The tower is part of the fire station's training premises.

The 'bridge' spans from the 'shield'and connects the tower to the main building.

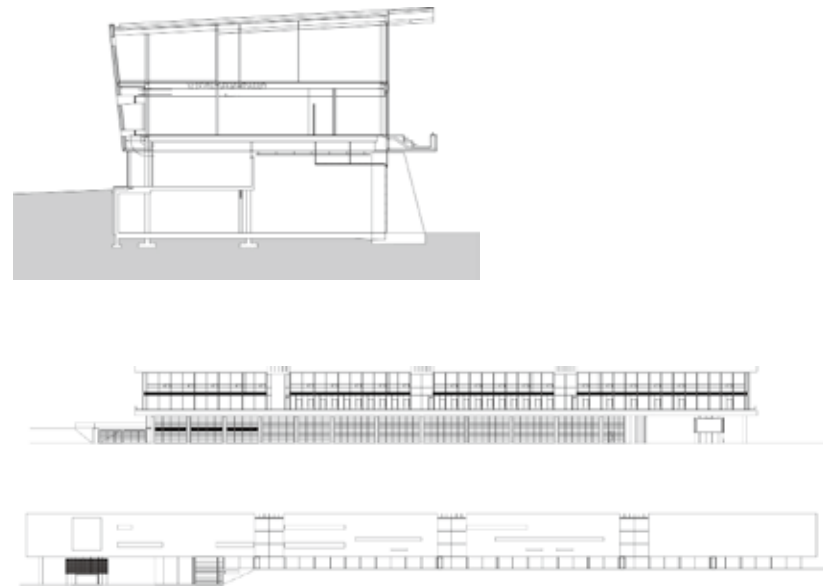

1. Aerial view of the building

2. The base, the shield, the tower and the bridge form the main architectural composition





- 1. Side view of the building facing the motorway
- 2. The curve shape of the building follows the perimeter of the site in order to maximise the courtyard
- 3. Far view of the tower and the rest area after training





1



2



3

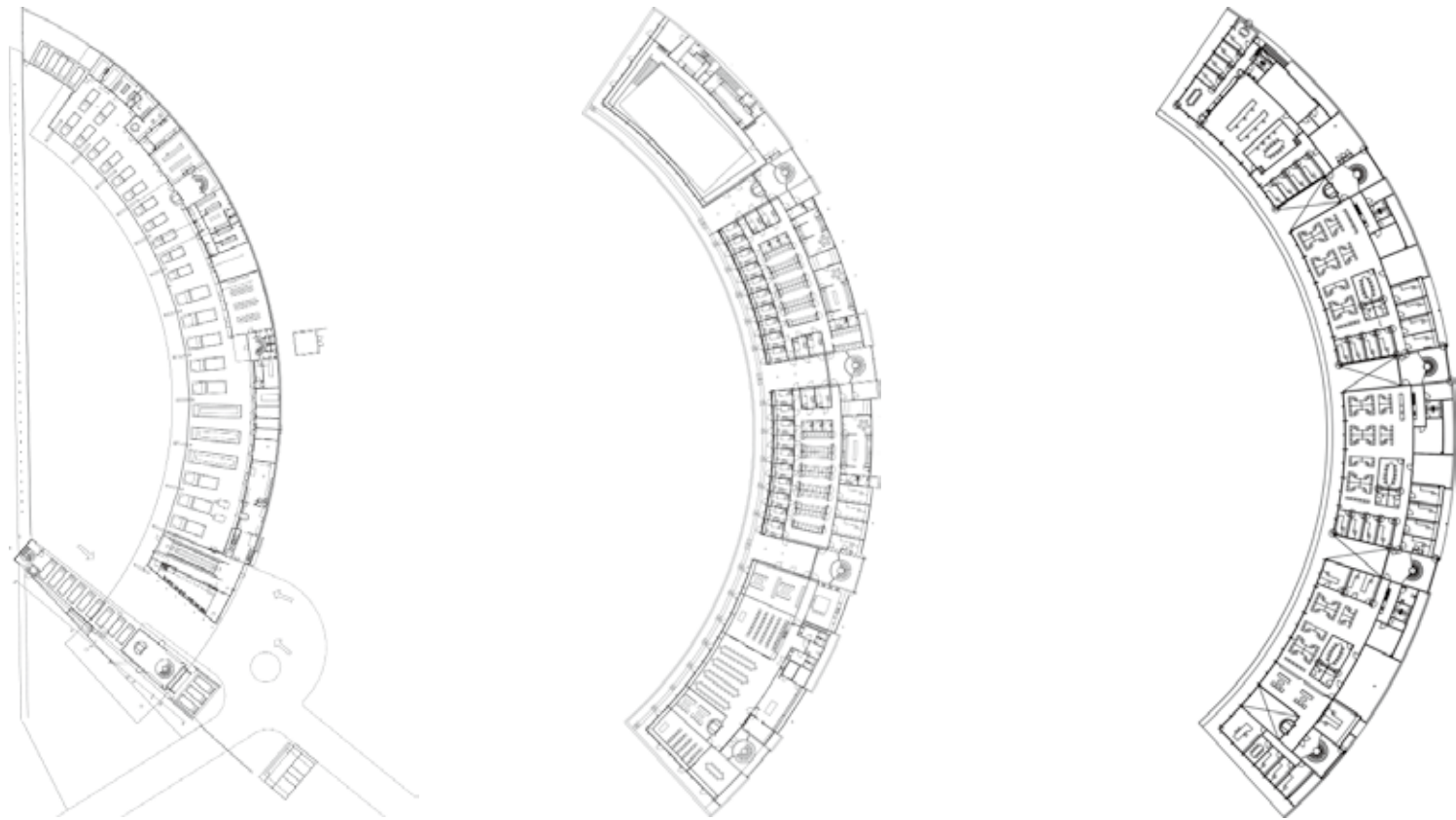

1. Fitness training hall
2. Pillar above the base
3. Climbing pole training area

Tromsø Fire Station

Completion date: 2010 **Location:** Tromsø, Norway **Designer:** STEIN HALVORSEN AS sivilarkitekter MNAL **Site area:** 5,300 sqm

Tromsø's new fire station marks the beginning of Stakkevollveien - a transformation area between Coal Crane Swing and Campus, and will hopefully set the standard for future developments.

On the site's lower level - addressing the Stakkevollveien - carriage hall and associated functions are located, while functions as public facilities, prevention division, monitoring room, administration, bedrooms for contingency crew and exercise room are on the top floor addressing Forsøket.

The topography of the site is exposed by a continuous wall that separates the lower and upper level. Large glazed garage doors penetrate the wall in order to expose the emergency vehicles, while the pavilion-like building literally floats above the wall. Façade cladding of the pavilion is orange insulating PC panels. The colour and materiality gives the building a distinctive character which highlights it in the cityscape. The combination enhances the signal effect the station has both in content and form.

Fire station is a two-storey building with a mezzanine in the carriage hall. The relatively low building is not dominating the neighbouring buildings, mostly residential, to the south and west.

The duality of the building is visible in both form and content; the emergency vehicles belong to roughness of the concrete walls and glass doors, while areas for crew and employees belong to the lightness of the pavilion.

The fire tower is a feature of great importance, and is given a distinctive design; the cantilever of the building towards the east gives tower a dynamic character. The interior of the fire station is designed with a high awareness of the building's function. Detailing and use of colour is toned down, and it was important to create a unified expression for the fire station in general and for the carriage hall in particular. Emergency area on lower level is clear and uncluttered plane. Functions on the upper level and vertical communication are linked to the "street" which runs through the entire building. Wherever you are in the building, you are close to the garages when the alarm goes off!

Fire station has one main and two secondary access doors on the upper level, all featured with open glass façades, but only the main entrance is characterized by a canopy.

Public areas are reached through the main entrance in the building's southern part and features large panoramic window overlooking the valey, Tromsdalen, while administration occupies middle section. Monitoring room, living room, bedrooms and gymnasium are situated in the building's northern section with quick access to the emergency units dressing room.

Canteen is located in the transition area between the daytime-only (administration) and the around-a-clock operations.

Transparency and visibility in the interior is emphasized in order to ensure overview and outlook at all times.

The interior is kept neutral and bright to a large extent, with light grey floors, white walls and simple white ceiling system. The main street of upper level is added an orange wall in order to emphasize the importance of the main communication route in the building.



East Elevation



North Elevation



West Elevation

1. Garage
2. The fire tower with a cantilever structure



1



2



1



3



2

- 1. The panoramic view of the tower
- 2. Façade cladding of the pavilion is orange insulating PC panels; the colour and the material give the building a distinctive character
- 3. Interior rock climbing training area



1. Vertical communication area
 2. Restaurant
 3. The emergency unit dressing room



Brandon Firehall No.1

Completion date: 2010 **Location:** Brandon, Canada **Designer:** Cibinel Architects **Photographer:** Mike Karakas **Size area:** 2,787sqm **Award name:** F.I.E.R.O. Fire Station Design Award of Merit **Award date:** 2009

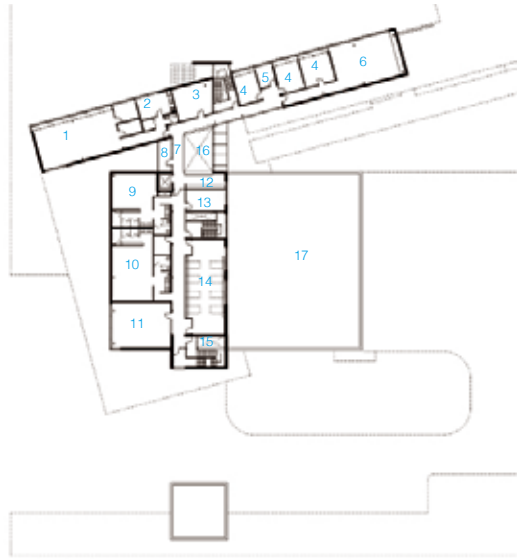

- | | |
|---------------------|---------------------------|
| First floor plan | 9. Female locker room |
| 1. E911 call centre | 10. Male locker room |
| 2. Kitchen | 11. Physical fitness room |
| 3. Store room | 12. Study |
| 4. Office | 13. Captains room |
| 5. Quiet room | 14. Sleeping quarters |
| 6. Classroom | 15. Hose tower |
| 7. Glulam bridge | 16. Open to below |
| 8. Exterior deck | 17. Roof |

The dynamic new 2,787 square metre Brandon Fire and Emergency Services Building validates the idea that a primarily utilitarian programme, which often times results in a prefabricated solution, can become a sophisticated architectural project that contributes to its surrounding community and landscape while still fulfilling its demanding functional requirements and modest budget.

The facility is divided into two formal components, a fire hall wing and an administrative wing. Severing the two components through the formal gesture of a pivot appropriately orients the fire hall wing with the street and aligns the administrative wing with the creek to the northwest. The separation allows daylight to penetrate the buildings on all sides, and a single-loaded corridor animates the façade with human movement and activity. A minimally detailed, non-programmed transparent volume situated between the two wings acts as a dramatic entry into both sections of the facility, mediating the two programmes with a thin hovering glulam bridge.

The public entry engages and welcomes the community with a generous landscaped public 'plaza' enclosed by the museum to the north, and the apparatus floor to the south. The museum features a "Bickle", an 80-year-old fire truck situated as if it is ready to take off to the next call, while the apparatus floor houses the current emergency fleet. Extensive glazing surrounding the plaza highlights the rich history of the fire department in the City, and allows visitors a glance into a state of the art facility.

A dramatic hose tower stands proud in the landscape and acts as an urban marker for people entering the City along the neighbouring street. Through a series of walls and fire separations, the tower also acts as a training facility and exit stair connecting the apparatus floor with the dorms on the second level. By integrating training facilities within the building, the availability of low ad no-cost training opportunities was expanded. Impervious dark brick cladding descends the tower and wraps around the building's horizontal walking surfaces, allowing for a natural runoff of water to be reabsorbed by the site's indigenous grasses.

The solution integrates functionality seamlessly into the aesthetics, giving appropriate expression to the demands of the facility while creating unique and effective civic presence in the community.



2

- The facility is divided into two formal components, an administrative wing and a fire hall wing, among which the dark brick cladding tower is the prominent part
- Night view of the building, the lights reflect training facility to the south and museum to the north
- Two formal components have naturally enclosed a public 'plaza'



1



3



1



3



2

1. Patio
2. Entrance of the main façade
3. Training facility
4. Meeting room



4

New Fire Station

Completion date: 2007 **Location:** Heidelberg, Germany **Designer:** Peter Kulka Architektur
Photographer: Lukas Roth **Site area:** about 15,000 sqm **Total building area:** 9,959 sqm **Award name:**
 1. distinction "Good Building 2008" Baden-Württemberg; 2. Recognition Gemany Façade Award 2009;
 3. Nominated Mies van der Rohe Award 2009

Situated at the transition between periphery and inner city the sculptural structure of the new fire station forms a distinct figure at the entry to Heidelberg.

On three sides the garage, where the fire engines are parked behind see-through foldable gates, wraps around a maintenance core. Together with the entry hall this constitutes the base of the building, sitting underneath the upper levels which are constructed according to the PassivHaus standard. On the eastern side the top floor continues as a bar that houses the administrative rooms on delicate v-shaped pillars. The 35-metre-high hose and training tower places emphasis on the vertical.

Through the combination of aesthetically and functionally sophisticated architecture with the energy standard of a PassivHaus entirely new opportunities are opened in the field of fire stations.

The whole structure is a steel and concrete frame construction that is thermically decoupled. The planning of the façade was of particular importance and consists of non-bearing aluminum panels, which make up the skin of the building together with lines of windows and thus increase the sculptural effect of the building. Photovoltaic cells were integrated into the façade of the tower following the same aesthetic specifications. In the process 135 monocrystalline solar modules were installed into a aluminum post-and-beam construction. The 350 square metres system blends in to the whole as an independent element. Another solar power plant was included in the planning for the office wing. Energy saving and resource-friendly performance makes the Heidelberg fire station an economically highly efficient building. Compared to a conventional fire station, for instance, 90% of the energy for space heating is saved and the integrated photovoltaic modules feed electricity into the municipal grid equal to what 14 three-person households use annually. By orientating the fire station and making sure that the solar-active components are not obscured by shade, the "passive" solar heat gain was optimized and became an essential heat source. The compactness of the building makes the PassivHaus-Standard possible even without a major south orientation. By using building material according to the "Guide for Healthy and environmentally sound building materials" of the city of Heidelberg and the application of diverse resource-friendly measures such as insulation, energy-efficient window glazing, earth heat exchanger, heat recovery and on site rainwater absorption, the fire station is a landmark example of sustainable architecture.

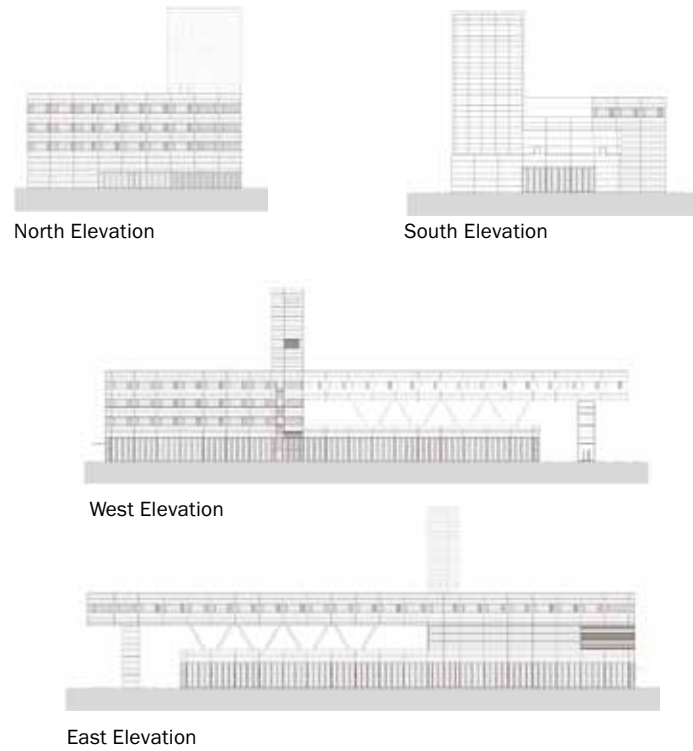

1. Panoramic view of the building
2. The 35-metre-high hose and training tower places emphasis on the vertical





1. On the eastern side the top floor continues as a bar that houses the administrative rooms on delicate v-shaped pillars
 2. South façade of the building
 3. Southwest façade of the building; the base mainly serves as the garage with folding doors

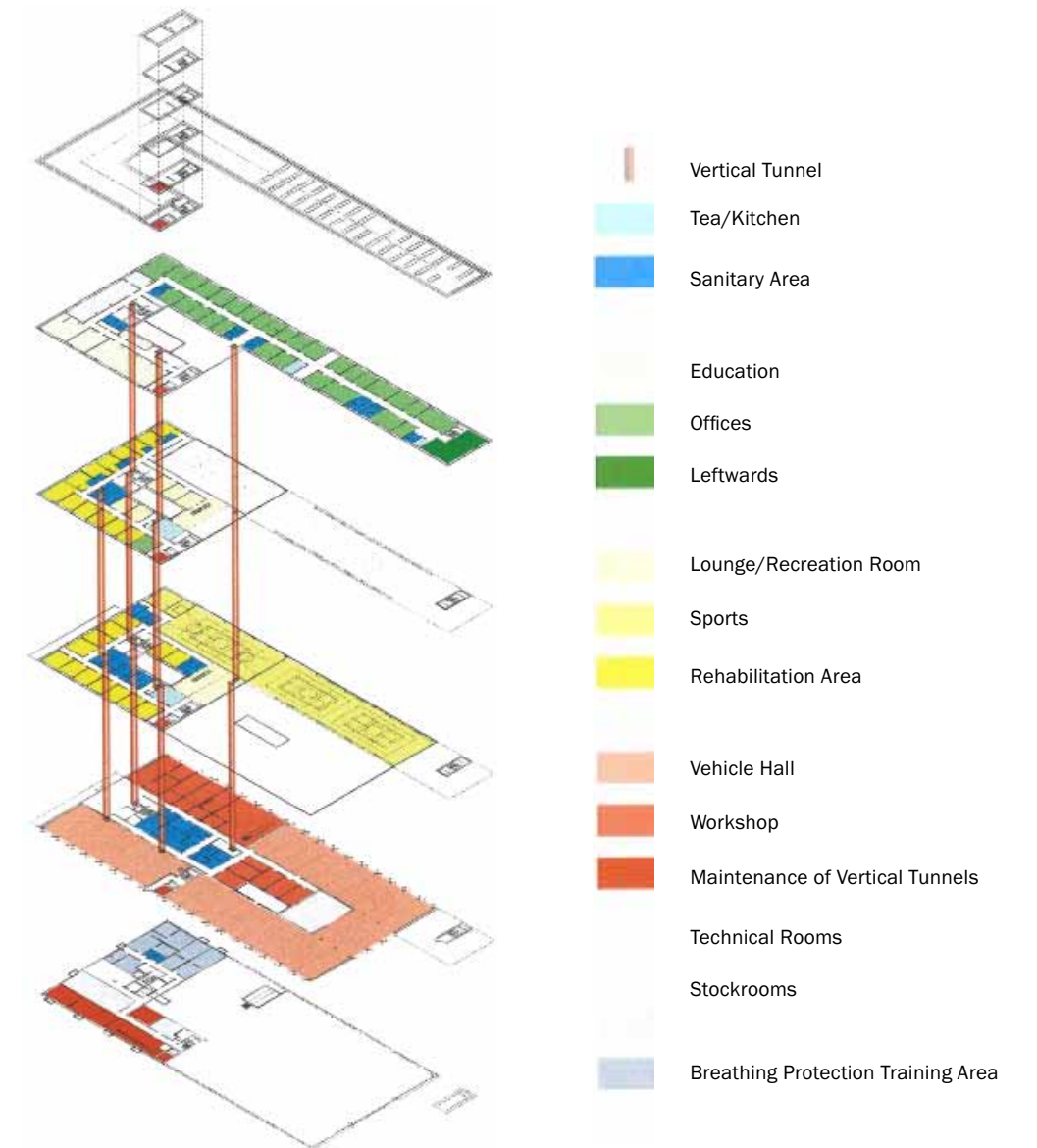



1



3



4



2

1. The inner space enclosed by the v-shaped pillars is a good training area
 2. A corner of the courtyard
 3, 4. Different colours of the ceiling at corridor play the role of signage

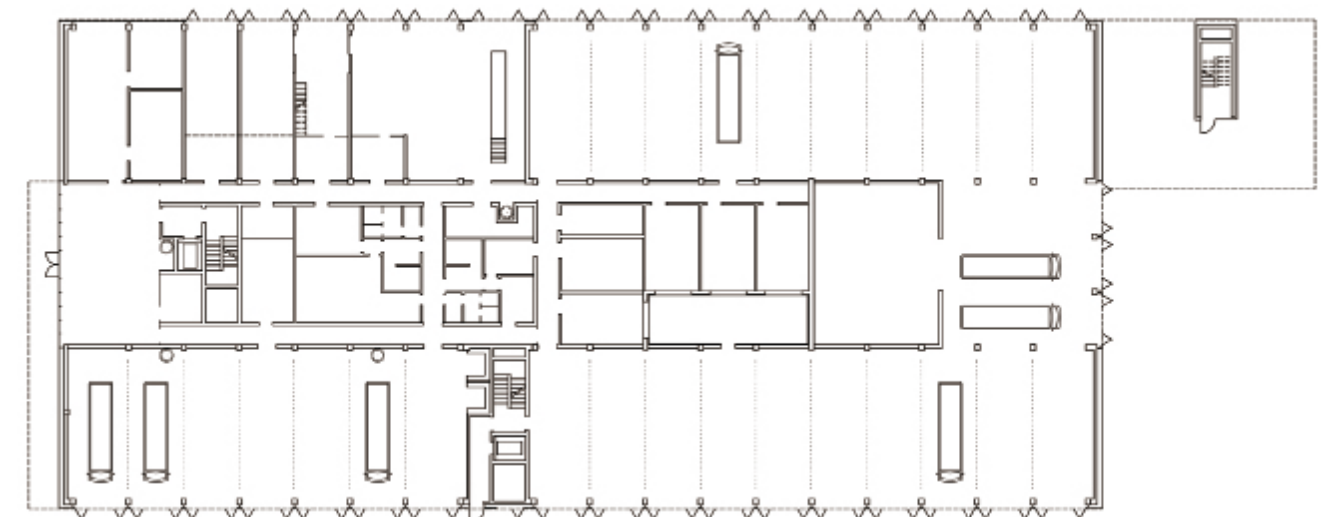

New Fire Station in Dußlingen

Completion date: 2010 **Location:** Dußlingen, Germany **Designer:** weinbrenner.single.arabzadeh / Architektenwerkgemeinschaft **Photographer:** Gerd Jütten - fotodesign.de **Site area:** 4,965sqm **Total building area:** Main building: 1195.00sqm; Annex: 46.40 sqm



East Elevation



North Elevation



Cross Section

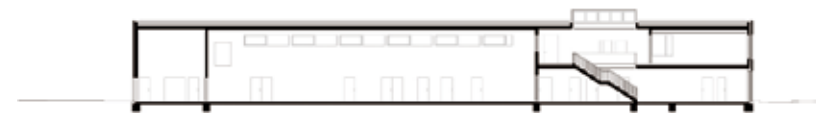

Longitudinal Section

The new fire station of the Volunteer Fire Department Dußlingen is located directly at the southern entrance of the community and is parallel to the main road B27. With its clear and confident architecture language, the solitaire building manages to appear as a "Namecard" of the community Dußlingen who drive past the main road.

This project has several challenges: on one hand there are meticulously structured processes of the fire department, and on the other hand there are spatial needs of the various technical equipments and vehicles. In addition, the cost limit of the three million Euro project has to be strictly followed.

An elongated building structure parallel to the main road forms the "exterior look" of the new building. A huge glazing in the entrance area and vehicle hall makes a significant contrast to the closed façade made of anthracite-coloured bricks.

The clarity of the building form continues as a design concept in all areas of the building and grants the new building a desired charm. The centre of the building is the radio room, which is centrally located between the vehicle hall and the entrance areas.

The foyer forms the heart of the building. It is accessed via the main entrance, the vehicle hall and the alarm entrance in the north. The staircase leads to the training and the Youth Room and their secondary rooms in upstairs. Additionally the foyer and the staircase areas are supplied by daylight by a huge skylight.

North of the new building are the parking lots for firemen. The changing rooms are directly located between alarm entrance and vehicle hall in order to make the shortest route for the firemen. This ensures that the vehicle hall can be reached immediately and the fire vehicle could get directly to the main road as soon as possible.

The wash hall - in the southern part of the new building - is used as an additional parking space in everyday life and thus increases seven of parking spaces.

1. An elongated building structure parallels to the main road
2. Alarm entrance
3. A huge glazing and the anthracite-coloured bricks make up the building's materials composition



1



2



3



1



4



2



3

- 1. Training room
- 2. Foyer
- 3. The foyer and the staircase areas are supplied by daylight by a huge skylight
- 4. Vehicle hall

Ground Floor Plan

- 1. Entrance
- 2. Room for Stand Duty
- 3. Alarm Entrance
- 4. Changing Room
- 5. Foyer
- 6. Radio Room
- 7. Vehicle Hall
- 8. Washing Hall

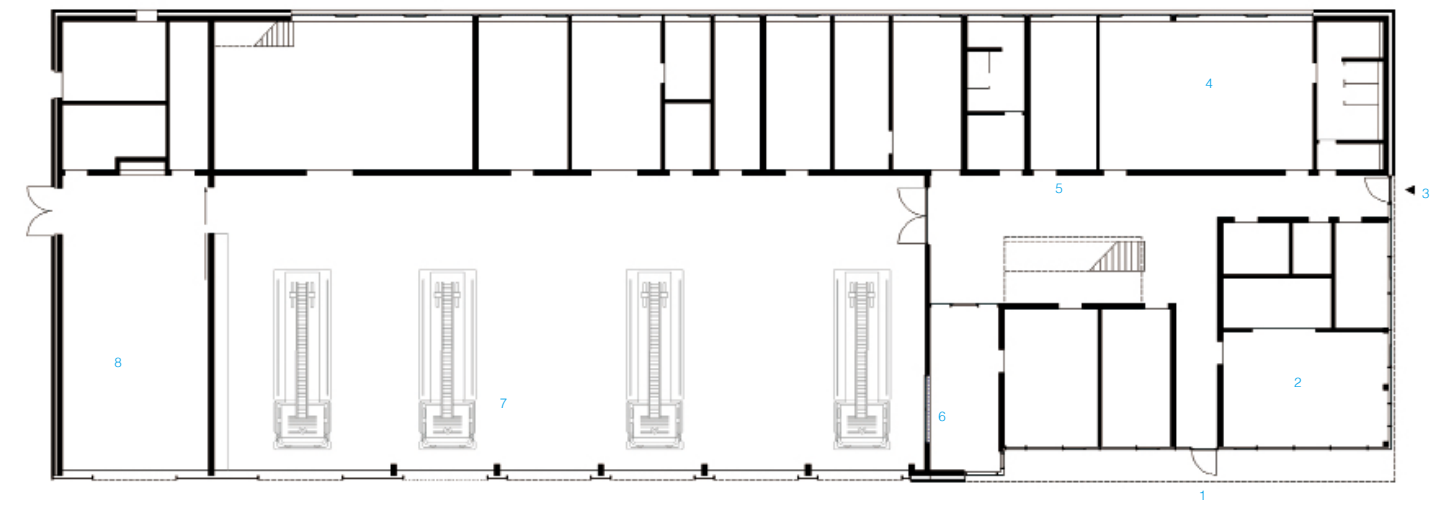

Fire Station - Houten

Completion date: 2010 **Location:** Houten, the Netherlands **Designer:** Jeanne Dekkers Architectuur
Photographer: Scagliola / Brakkee **Site area:** 600sqm **Total building area:** 260sqm

The fire station is situated on the edge of Houten, in an area of allotments along the De Kruisboog Road. It was the architecture of the allotments that served as an inspiration for Jeanne Dekkers Architectuur. Wood and transparent materials from the architecture of greenhouses were translated into the building in a contemporary manner, with an emphasis on the detailing. The reference to the name Houten (which means 'wooden' in Dutch) is not entirely coincidental.

The new fire station can accommodate one fire truck with additional room for about 20 volunteer firefighters. The simple brief included a changing room with showers and toilets, and a meeting / instruction room with a kitchenette. A clear design resulted from this programme, fully based on the logistics; the fire station runs like a machine.

The building has a timber supporting structure with double walls of transparent plastic sheets and a black recycled plastic, which, if necessary, makes it easy to demount and rebuild. The transparent façade elements are made up of polycarbonate sheets applied vertically over the whole height of the building. By using transparent materials, the inner workings of the fire station are made visible. Especially in the evening the transparency of the building ensures a luminous appearance like the greenhouses. The black recycled panels are horizontally orientated, contrasting with the transparent elements. Despite the fragile nature of the cladding material, the building is robust. This expresses the ruggedness of the fire brigade.

Since the building is not permanently in use, Jeanne Dekkers Architectuur developed a clever and optimized energy management, strategically designed for this use. An example is the relatively inexpensive heating system. Heating is most needed for drying the firefighters suits, so the dressing room is the most heated space. This warm air can also rise to the top floor because the floor is kept separate from the façade.

The design has a simple beauty; it not only looks attractive but is also extremely sustainable and durable. The choice of materials like wood and recycled plastic, with sober and clean detailing, resulted in significant savings in material usage and expenses. The ambition to make a landmark for the fire brigade of Houten has certainly succeeded.

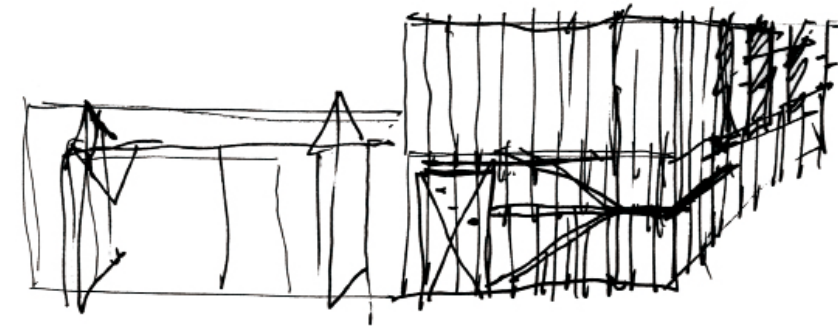
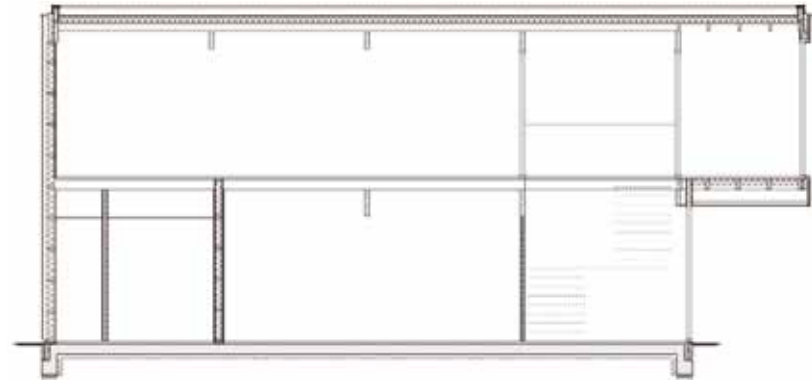

1. The transparent plastic sheets and a black recycled plastic make up the building's surface materials composition
2. The building has a timber supporting structure and the garage only accommodates a fire engine





1



3



2

- 1. The choice of materials like wood and recycled plastic resulted in significant savings in material usage and expenses, and also a simply beautiful appearance is created
- 2. Details of the garage inside
- 3. Meeting room/ instruction room

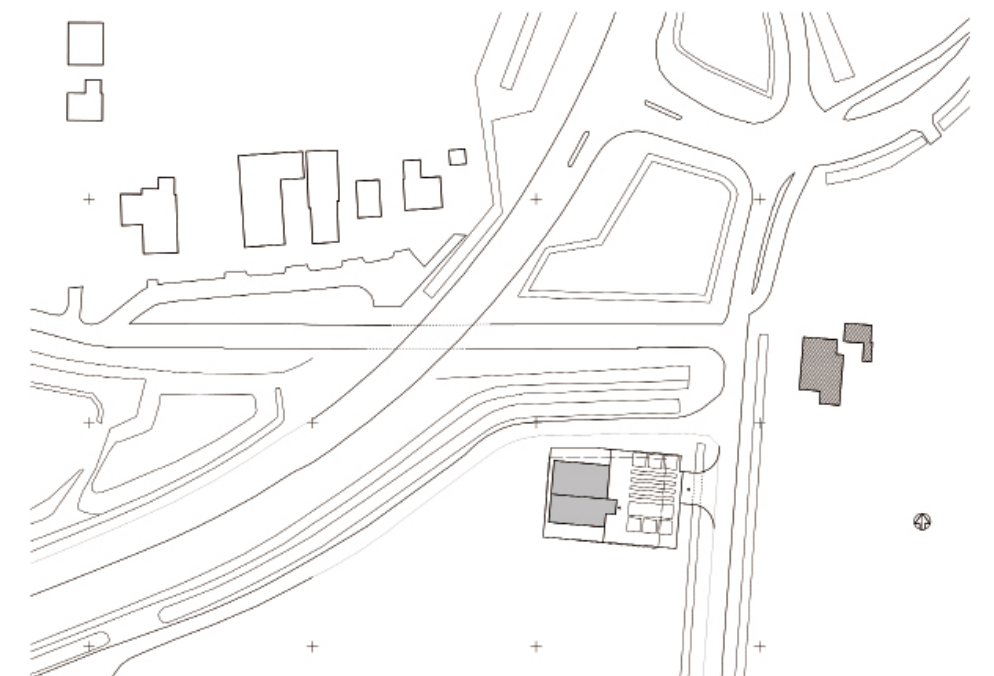



1



2

1 Stairs to the first floor from the ground floor
 2 The changing room on the ground floor

Ground floor plan
 1. Entrance
 2. Apparatus bay
 3. Toilet
 4. Utility room
 5. Changing room

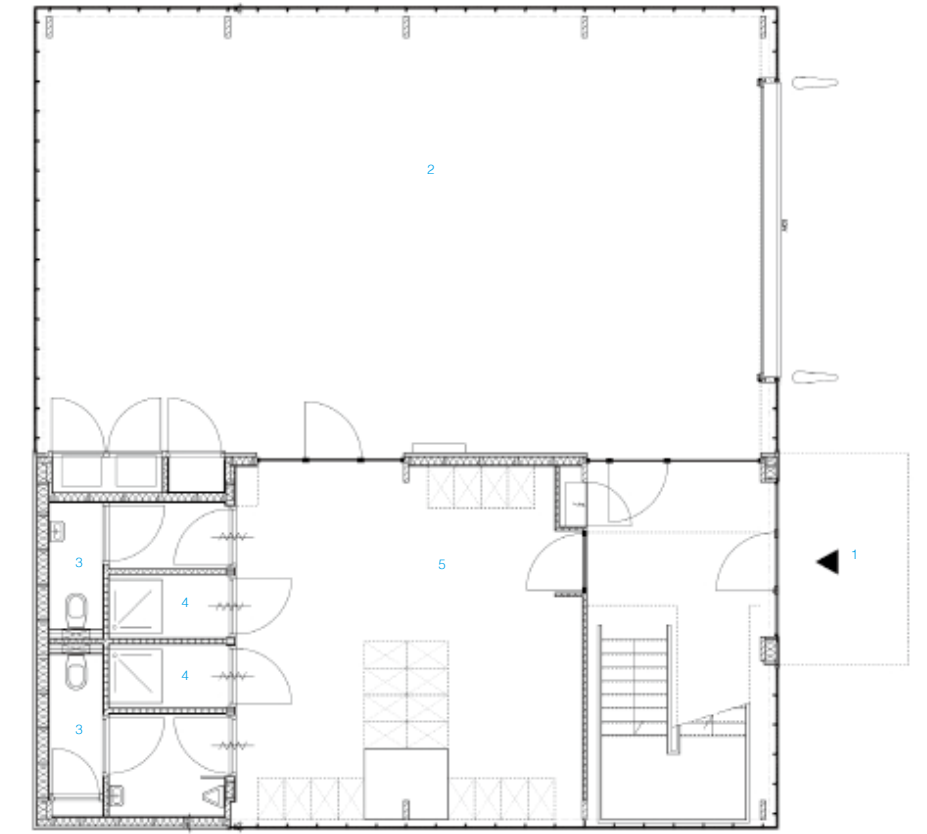

Fire Station- Rijswijk

Completion date: 2009 **Location:** Rijswijk, the Netherlands **Designer:** Jeanne Dekkers Architectuur
Photographer: Scagliola / Brakkee **Site area:** 4,300sqm **Total building area:** 3,400 sqm

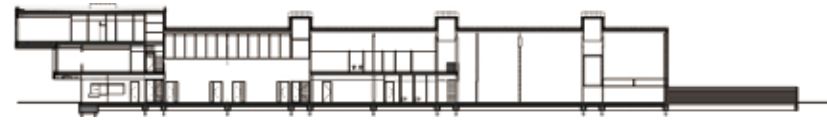

A new fire station was built at the intersection of the Churchilllaan and Beatrixlaan in Rijswijk. The building manifests itself as a show window for fire vehicles towards the broad, green avenue. Passengers can look into the huge hall through the transparent overhead doors. Especially at night when the lights are lit inside, this façade becomes the eye catcher of the building. Designed to provide around-the-clock accommodation, the station features a lounge, bedrooms and a gym.

The entrance, at the far end of the building, is accentuated by a series of floors that form gradually widening 'steps'. This end of the building is constructed of brick and glass surfaces. Thanks to the glazed façades, the living room, canteen and chief fire officer's quarters are visible from the street. The upper overhang seems to float because the lower floor has a storey high window strip, which goes around the corner. Because the corners are not supported by columns, the floating effect is dramatised.

The other side of the building connects with the underlying quiet residential area. The layout of the brick wall refers to the small scale of the opposite houses and the aluminum cap refers to the sloping roofs. Behind the façade next to the residential street are the bedrooms and classrooms located.

The most strikingly part of the exterior are four 'rafters', which are towering above the roof and stand at right angles to the interior network of corridors. Fitted with strips of glass, it seems like the volume is split open to allow light and air into the interior. It also creates beautiful 'light streets' inside and out.

The rafters also play a structural role in the floor plan, because they split the zone into public and private functions. Because of the architectural concrete and the visible structure, the building also has a sturdy appearance from the inside. But according to Jeanne Dekkers Architectuur firefighters are not only strong but they also have a soft side. To reflect both properties in the interior, pastel colours are applied in the traffic areas, panel curtains are hung in the living room and the cafeteria, and the kitchen are painted green.

Because of the combination of robust elements with soft colours and transparency, the building becomes a convincing effect of tension between sociability and machinery.

1. The building manifests itself as a show window for fire vehicles towards the avenue
2. The massive masonry structure echoes with the window strip that goes around the corner, creating a floating effect





1



3

3



2

- Ground floor plan
- 1. Entrance
 - 2. Reception
 - 3. Central hall
 - 4. Offices
 - 5. Instruction
 - 6. Practice room
 - 7. Storage
 - 8. Facilities
 - 9. Bicycles
 - 10. Control room
 - 11. Parking
 - 12. Garage

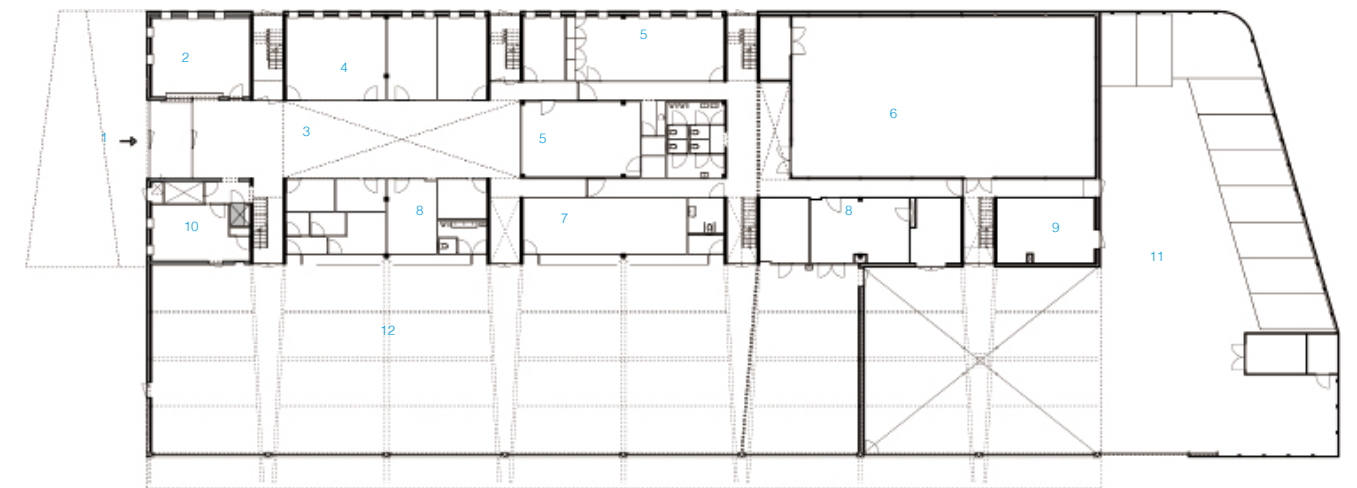



- 1. Overlooking the entrance hall from the corridor at the first floor
- 2. Details of the inner structure

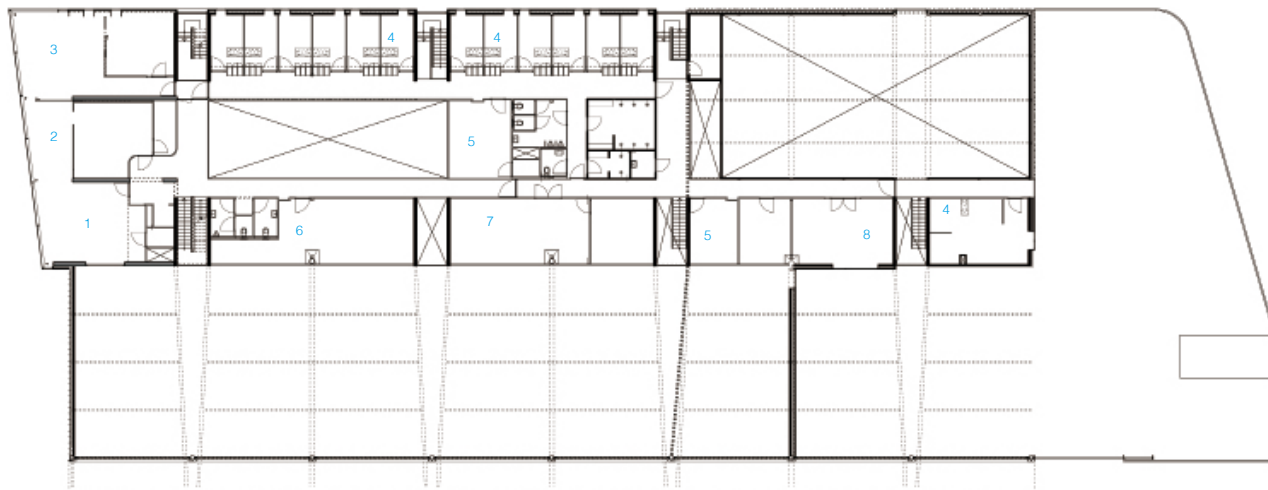
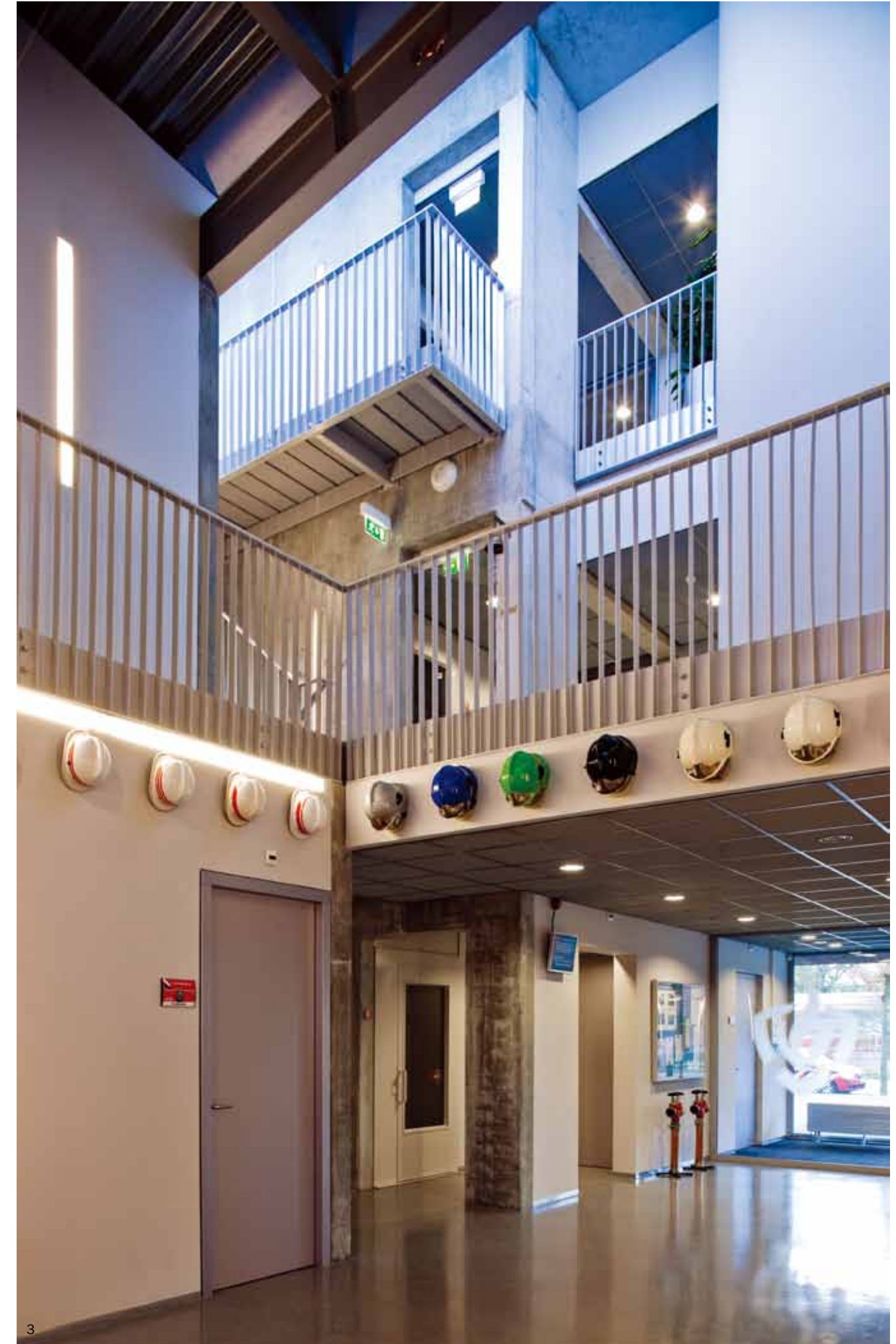

- First floor plan
- 1. Canteen
 - 2. Kitchen
 - 3. Living room
 - 4. Bedrooms
 - 5. Storage
 - 6. Computer room
 - 7. Plant rooms
 - 8. Gym



1



2

- 1. Garage
- 2. Fitness room

Mataró Fire station

Completion date: 2007 **Location:** Mataró, Spain **Designer:** Jordi Farrando **Photographer:** Adrià Goula
Total building area: 1,940.37 sqm



East Elevation

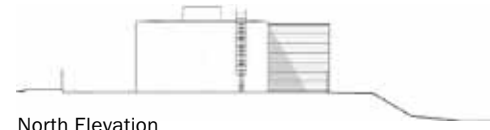

North Elevation



South Elevation



West Elevation

The specific requirements of the fire station and the volume of surrounding constructions constitute major constraints on the implantation of the building. Firstly, the garages had to be located to enable a quick exit for the fire engines in emergencies and easy entry when they return. Then a large open space was needed at the centre of the plot for exercises and drills, with space for a sports court. Finally, to continue the built characteristics of the area, the most appropriate solution was a two-storey building along Via Sèrgia.

For these reasons, the fire station is laid out in a long volume aligned with the street, and divided functionally into two parts: the garages and the living areas. The garage building is both high and deep to house the fire engines and all the annexed spaces (storehouse, compressor, workshop, drier for personal protective equipment). The garages face the street directly and open at the rear onto the yard.

The living area is laid out over two floors.

The ground floor houses administration (control, offices, filing system), a multipurpose hall used mostly for visitors (mainly school children), the changing rooms and associated washroom facilities, and the gym. These three main areas are clearly differentiated in the floor plan, with direct access to each from the foyer so that they can be used independently without causing inconvenience. At the same time, the distribution of the spaces in lengthwise strips allows for dual clean/dirty circulation and concentrates the bathroom and kitchen areas in a single strip.

The first floor houses spaces where the fire station staff spend most of their time when they are not drilling or out on call: the living-dining room, kitchen and bedrooms. Concentrated on the street side are circulation areas and the entrances to all the rooms and, on the opposite side, there is a large terrace opening up onto the inside of the plot.

The kitchen and living-dining room are separated by an intermediate space, the larder, which houses personal lockers and the industrial fridges. The dining room and living room are organised to be able to tell them apart. The bedrooms have more lockers opening onto the circulation space outside the sleeping area to prevent disturbing those who are sleeping.

1. The whole volume is divided functionally into two parts: the living areas and the garages
2. The living areas
3. The courtyard at the back of the building



1



2



3



1



3

- 1, 2. A large open space outside of the garages could provide a quick exit for the fire engines to go out and come in, and also serve as a space for exercises and drills
3. The annexed spaces



2

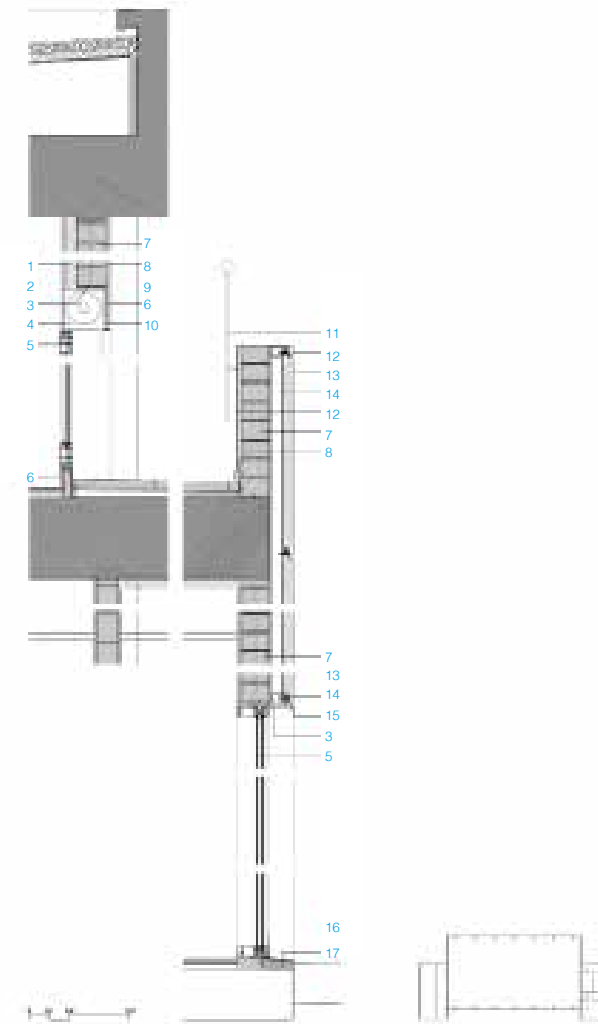

Façade details

1. Thermal isolator. Extruded polystyrene rigid plates E:50mm.
2. Vertical interior revetment of painted gypsum panels
3. Galvanised steel sheet lintel, 8mm thick
4. Aluminium "Monoblock" roll-up blind
5. Aluminium frames, "Technal" "MC Plus" type
6. "Mallatex"
7. Brick wall, 140mm
8. Mortar, 15mm
9. Galvanised and painted metallic sheet, E:40mm
10. Galvanised metallic U-shaped sheet 24x24x2.
11. Metal railing
12. Galvanised and pre-lacquered metallic sheet.
13. Galvanised and pre-lacquered aluminium sandwich panel E:50mm., W:1000mm
14. Painted substructure for subjecting sandwich panels
15. Pre-lacquered metallic piece with double folded runoff
16. Galvanised runoff metallic sheet
17. Waterproofing sheet



1



3



2

- 1. Corridor along the street side
- 2. Corridor to each room
- 3. Terrace opposites to the street side

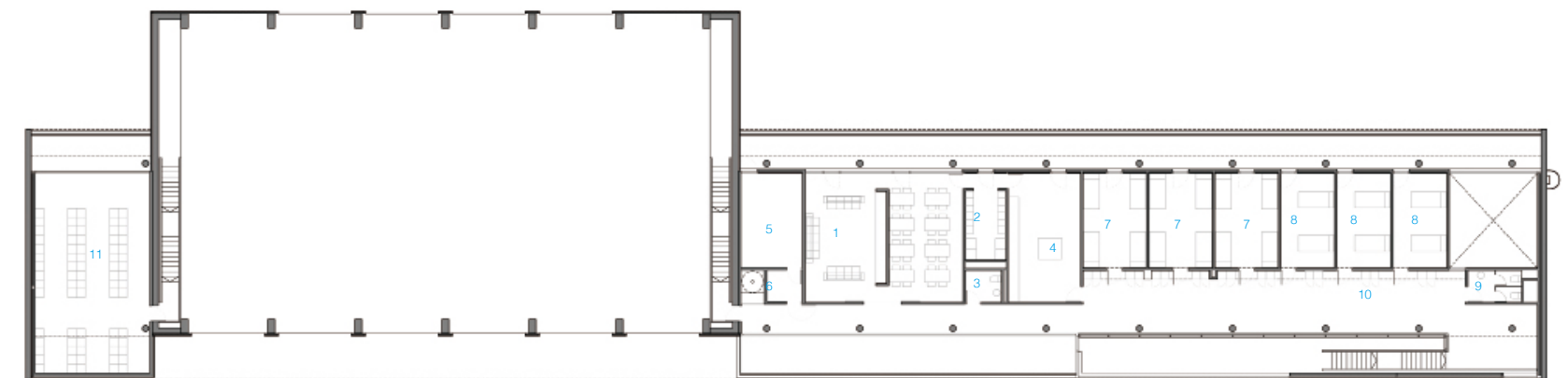

- First floor plan
- 1. Dining room
 - 2. Larder
 - 3. Washroom 1
 - 4. Kitchen
 - 5. Facility room
 - 6. Corridor 6
 - 7. 4 beds bedroom
 - 8. 3 beds bedroom
 - 9. Washroom 2
 - 10. Corridor 7

- Garage Area
- 11. Protective equipment area



1



1. Stairs to each room at the first floor
2. Training room

2

- | | | | |
|-------------------|------------------------------|-------------------------|----------------|
| Ground floor plan | 8. Multipurpose hall | 16. Officers washroom | Garage area |
| 1. Hall | 9. Accessible toilet | 17. Women changing room | 22. Garage |
| 2. Control room | 10. Cleaning room | 18. Women washroom | 23. Workshop |
| 3. Control office | 11. Men changing room | 19. Gym | 24a. Cleaner |
| 4. Small office | 12. Men washroom | 20. Corridor 2 | 24b. Drier |
| 5. Small office 2 | 13. Additional changing room | 21. Corridor 3 | 25. Storehouse |
| 6. Archive | 14. Additional washroom | | 26. Corridor 4 |
| 7. Corridor 1 | 15. Officers changing room | | |

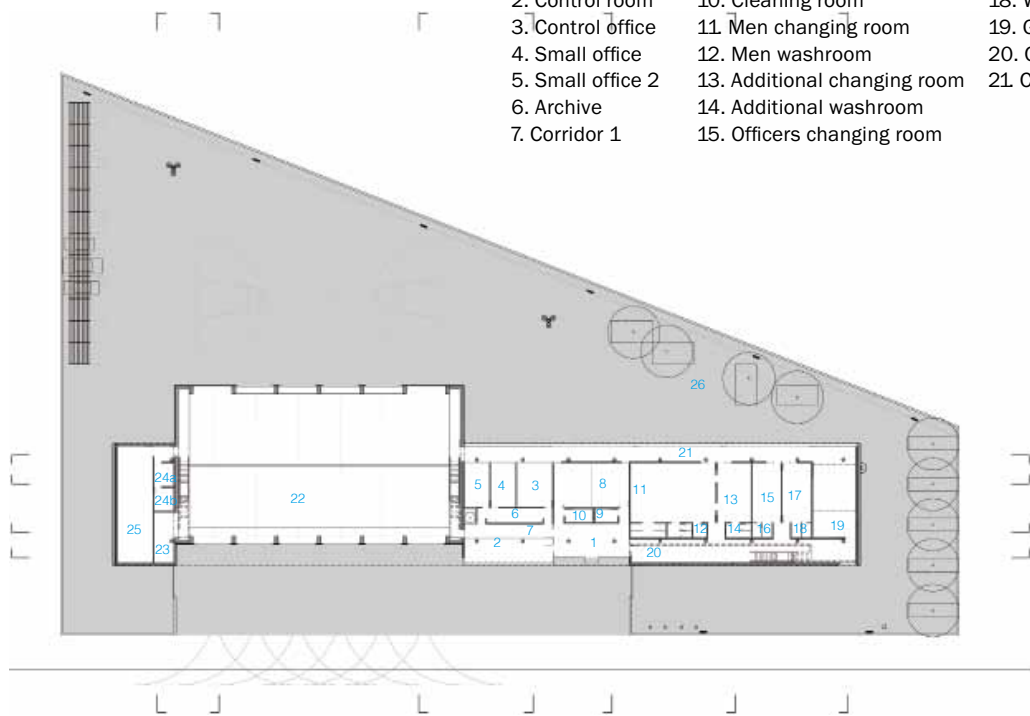

Parc de Bombers

Completion date: 2005 **Location:** Tarragona, Spain **Site area:** 893.37 sqm

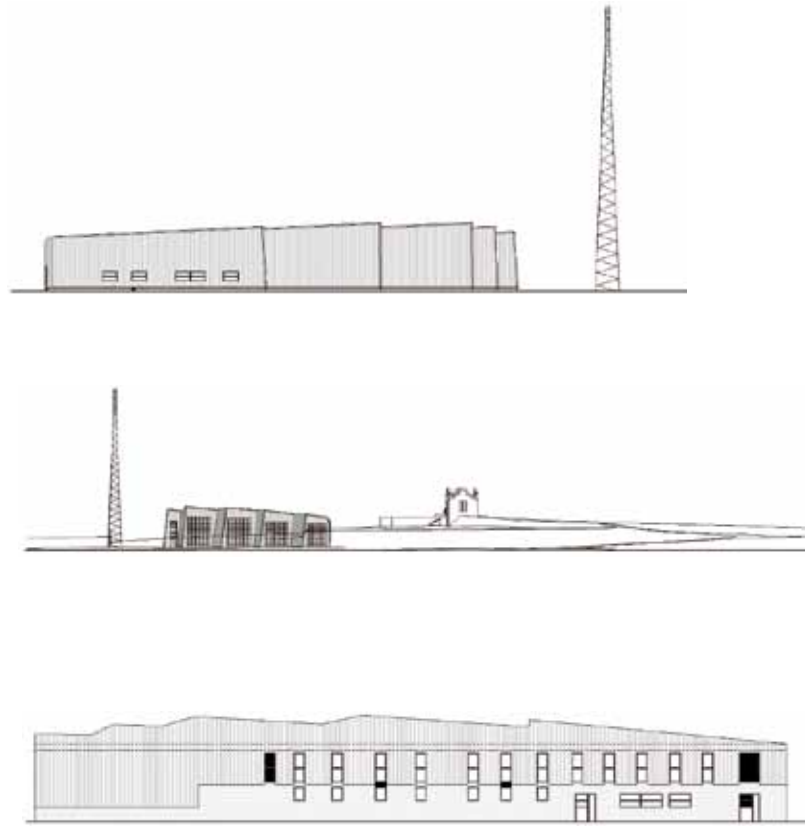

The project site is located in the town of Montblanc, in the industrial park located in the N-240, at the north of the village.

The fire station building is projected from the understanding that the fundamental part of the programme is the garage of the fire engines. This understanding is based on both the weight of the programme area (where it represents nearly 50% of all of this), the same load as representative of the vehicles in the same popular image of the fire fighters corp.

The proposed fire station in Montblanc could therefore be described as a proposed 'equipped garage' with annexes that will cover the other needs of the programme: stay, eat and sleep. This conception of the building is evident from the same shape and constructive solution of the station, where the roof of the garage's construction system solves almost all the façades of the building.

Also the disposition and the presence of the garage doors emphasize these features while reinforcing the dynamism and movement in and out of the fire engines. Finally, the outer envelope and serrated profile of the building look for an integration in the landscape of the Montsant mountain range, meaning that the best way to integrate the building is becoming an accident on the topographic landscape of the Conca de Barbera, more than only being a small warehouse in an industrial zone. The programme of the station is developed under a unique covering where the spaces on the ground floor are organised around the garage, and in the first floor are opened to the central room. In the garage level is paced the control room that separates it from the rest of the spaces located at the ground level, and controls the access from the same garage and from the outside.

From the same garage is given access to those parts of the programme that can be incorporated: laundry and cleaning equipment, cleaning, storage and garage. The staircase acts as a lobby-service distributor of the programme while it has direct access to the outside, to the most private part of the plot.

Separated from the garage, we can find the other dependencies at this level: changing rooms, toilets, dining room, kitchen and store. At the top level there are the bedrooms, the office of the chief, the gym and training room with a lift that solves the accessibility between the two levels. Both the bedroom and the dealer's head office and gym are open to the garage, establishing a direct visual relationship with the station's central activity. This level is understood as an upper level attic, a balcony above the ground floor.

1. The back of the building and the sports court
2. Details of the façade





1



2

- 1. The outer envelope and serrated profile of the building look for integration in the landscape of the surroundings
- 2. The ground floor is organised around the garage

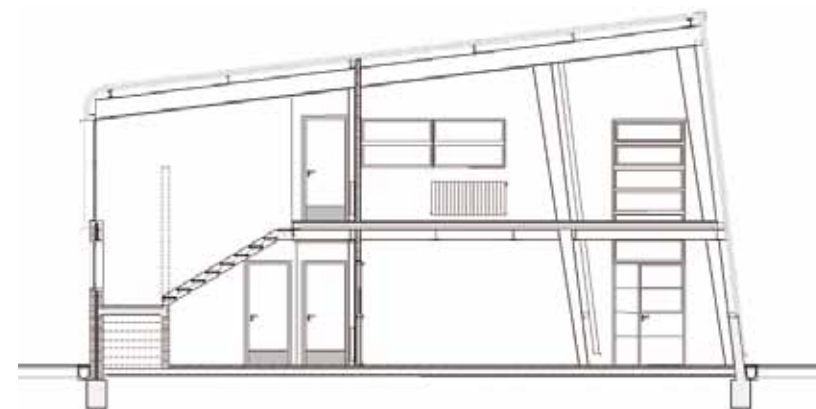



1 Garage
2. The Garage is connected with the cleaning room and the storage

1



2

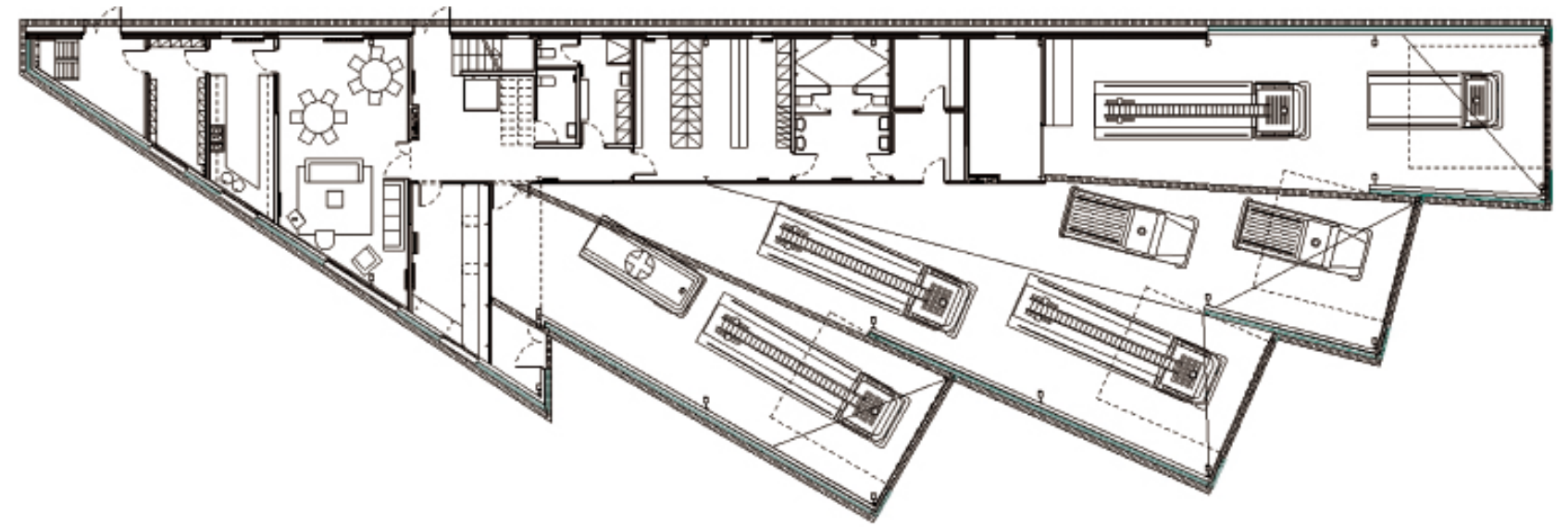

State Emergency Operations Centre

Completion date: 2005 **Location:** Springfield, USA **Designer:** DeStefano Partners **Photographer:** Barbara Karant (Karant + Associates) **Size area:** 5,575 sqm **Award name:** Association of Licensed Architects, 2006, Gold Medal; Metal Architecture, Design Award – Decorative Metal, 2006; Society of American Registered Architects, 2006, Design Award of Excellence

The State Emergency Operations Centre (SEOC), the new home for the Illinois Emergency Management Agency (IEMA), is among the first of a new generation of emergency operations facilities in the U.S. designed to coordinate responses to natural disasters and security or terrorist threats. Designing SEOC was an opportunity for the DeStefano Partners team and the State of Illinois to reinvent this type of facility with specific responses to both contemporary technology requirements and the human interactions that the technology supports.

This 5,575 square metres building houses meeting and conference spaces, offices, computer labs, data centres, and mission-critical audio-visual and telecommunications facilities to expedite the administration, coordination and monitoring of the emergency efforts of 27 state agencies. Several factors drove DP's design response: an extremely aggressive schedule, dictated by Department of Homeland Security funding deadlines; a desire to radically improve the working environment for the more than 50 IEMA employees, whose prior working conditions were located in a crowded basement, and create an environment where the permanent staff could work efficiently with the expanded staff of emergency responders. A desire to respond to demanding performance requirements in a creative, contemporary design. A goal to deliver a secure building and site based on input/directions from the client. The design incorporates a number of innovative strategies for securing the facility without making it look like a bunker or creating an inhospitable work environment for the centre's full time staff.

As the State's public face in an emergency, the SEOC also presents a highly visible image. Accordingly, another goal in the design process was to shape the SEOC as a symbol of government at its optimal efficiency. Security and technology were not only key functional elements of the SEOC, but also outward expressions of the degree of control and competence expected of emergency responders. With its contemporary look and frugal use of materials (many locally fabricated, such as limestone from nearby Bloomington, Indiana), the SEOC relays simultaneous messages about preparedness and judicious use of government funds. Cost estimating, though not unique to this job, was a critical exercise to keep this project on budget.

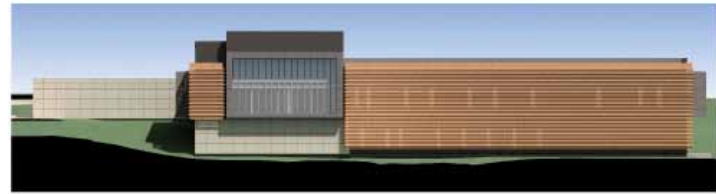
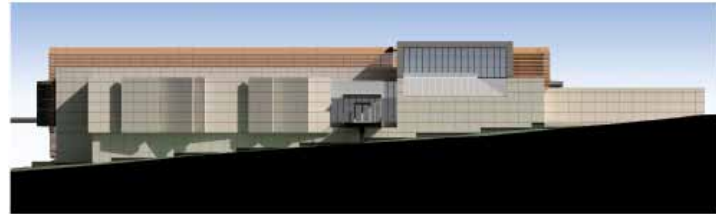

East and West Elevations



North and South Elevations

1. Building detail at copper screen wall
2. Detail of front façade
3. Front façade at public approach and parking area



3



1



2

- 1. View of entry façade showing layering of the limestone panels
- 2. Layering of limestone at public façade with the copper screen on the balance of the building

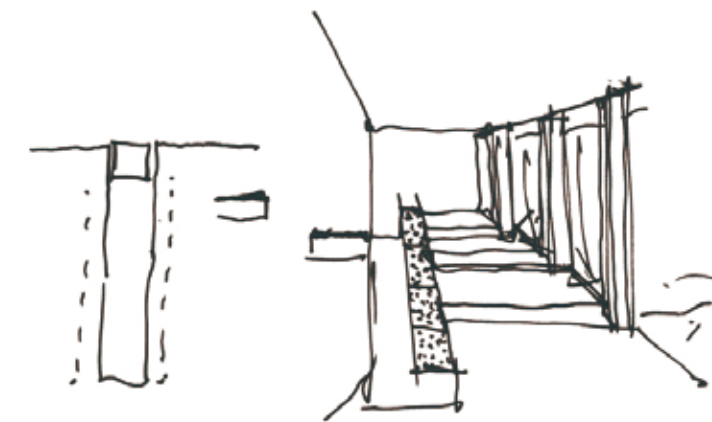
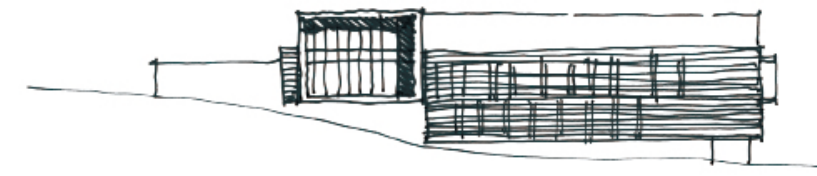



1



4



2



3

- 1. View of north façade
- 2. Detail of the rain screen showing all three of the material treatments coming together
- 3. Composite of aluminum panels, copper and limestone
- 4. View of building from the south

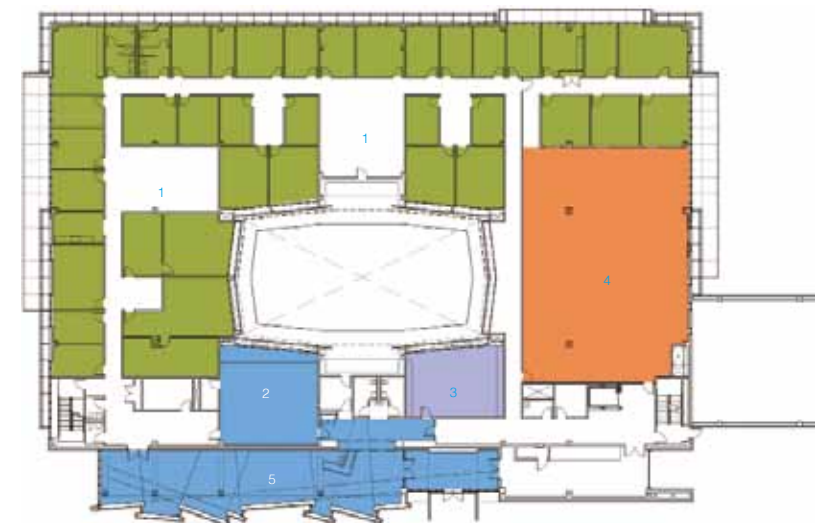

- Ground floor plan
- 1- Offices
 - 2- Media room
 - 3- Conference room
 - 4- Terrorism task force
 - 5- Public lobby

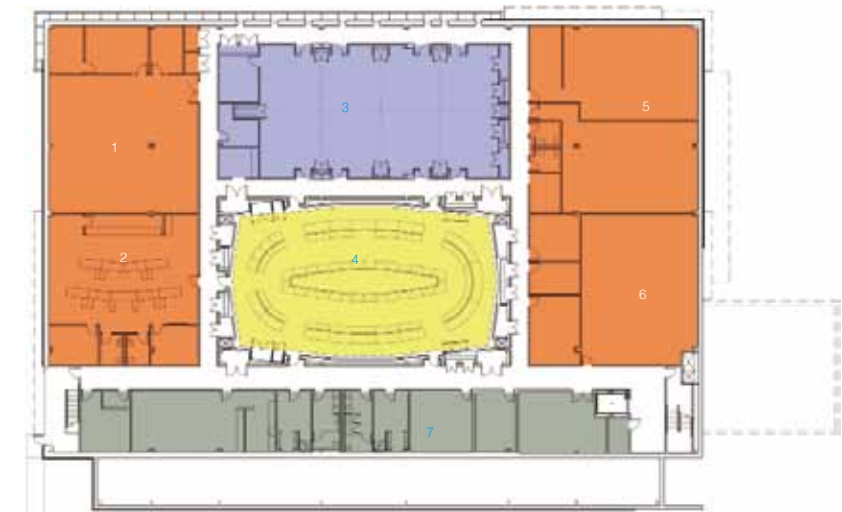

- First floor plan
- 1. Data centre
 - 2. Telecommunications
 - 3. Conference centre
 - 4. State incident response centre
 - 5. Radiological assessment
 - 6. Terrorism task force
 - 7. Support

Fire Station Alkmaar

Completion date: 2010 **Location:** Alkmaar, the Netherlands **Designer:** LIAG architects, Erik Schotte
Photographer: Bernard Faber, Wim Daneels **Site area:** 3,595 sqm **Total building area:** 8,515 sqm
 (ofce) + 3,300 sqm (parking on the roof) **Award name:** European Architecture Award 2011 Energy +
 Architecture (Honourable mention)

This new building is a collective building for the municipality of Alkmaar, which houses a fire station, a day-care centre for the care and treatment of drug addicts, a parking management centre, a video observation post and a facilities service department.

The building is characterised by a complex structure, partly the result of the necessary close proximity of the fireman's rooms to the depot in a volume that must conform to stringent town planning conditions. A design was chosen as a new addition to the council offices precinct, towards the railway tracks, rising to a height of about 20 metres, thereby accentuating the entrance to the city centre. The visible strong slanting line on the front and back of the building forms the access ramp for the parking on the roof.

The realisation of the building attracted much attention because of its ambitious approach with regard to its sustainable and energy-friendly way of building. Besides a well-balanced choice of materials, whereby the environmental consequences were taken into account when producing and recycling the materials, building elements were used that could be recycled easily as regards their dimensions and details, and which are in line with the principles of 'Cradle-to-Cradle'.

It was decided to use a heat/cold storage installation that provides the basic demand for heat and cold energy. Extra capacity is created by using the (parking) roof as a solar collector, so that the current offices also receive basic heating and coolness. Moreover, the parking level also functions as a collector for the greywater system. The level has underfloor heating with antifreeze and a green colour instead of black, in order to minimise shrinkage and in order to keep the working of dilatations as small as possible.

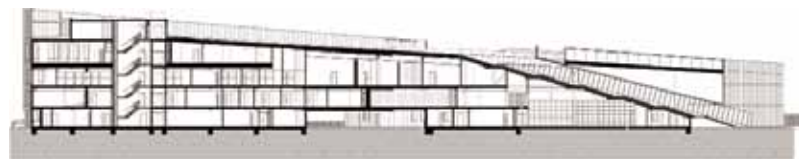
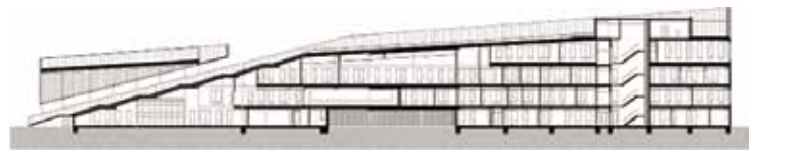

1. Far view of the building

2, 3. The visible strong slanting line on the front and back of the building forms the access ramp for the parking on the roof





1. The visible strong slanting line on the front and back of the building forms the access ramp for the parking on the roof

2. Details of the fire engine garage



2

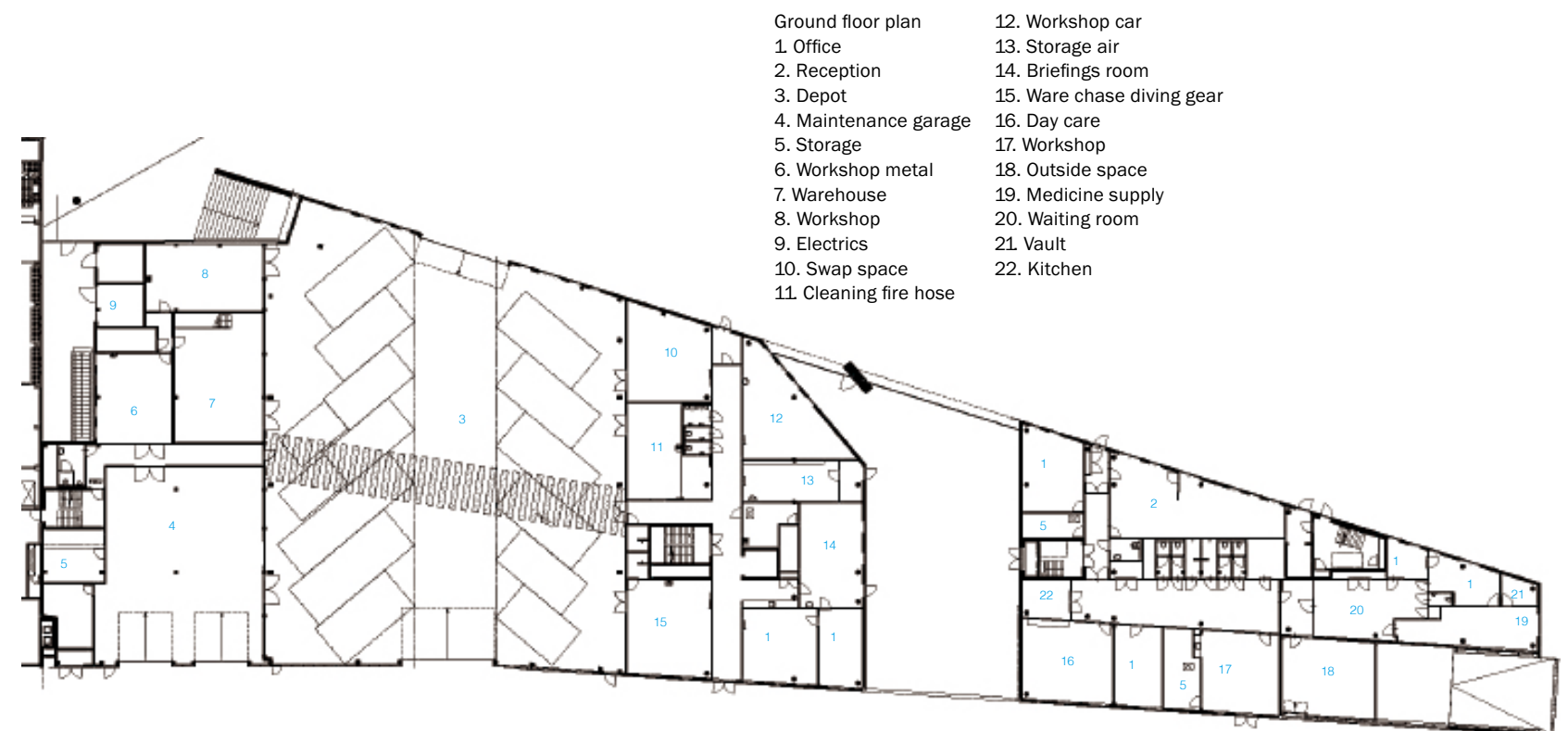

OmniCare, City Palace for the Homeless

Completion date: 2008 **Location:** Apeldoorn, the Netherlands **Designer:** FBW architecten
Photographer: Christian Richters **Site area:** 1,265 sqm **Total building area:** Total of 4,400 sqm, inclusive underground garage **Award name:** Apeldoorn Architecture Prize 2008, nominated; Winner of the Daas Brick Architecture Prize 2010; Winner of the Gelderland Provincial Prize 2010 voor Spatial Quality

OmniCare stands for rehabilitation and respect. A place where there is room for new initiatives, peace and order. OmniCare is not meant as a final destination but is seen as a temporary home. The first step on the road to a new life...

Homeless people and drug addicts hanging around cause a lot of irritation and nuisance in town. To divert this negative development the municipality, together with the involved care organisations in Apeldoorn, decide to come to an integrated care facility in the very hart of the city centre.

The location is chosen in an urban renewal area (Haven Centrum). Because the plot is very deep, it is possible to create an open courtyard in the middle. A courtyard that provides the clients with their own sheltered outside space, without giving hindrance in the public domain, in the streets.

The inner courtyard with the main entrance to the complex can be reached by a public passage. This passage connects the Stationsstraat to a future square and is surrounded by all kinds of facilities like a laundrette, a gift shop, an employment agency etcetera. On the first floor the most important spaces in OmniCare can be found: the Grand Café, with restaurant, atelier, and lounge all south orientated in the most sheltered corner of the building. On request of the clients a special space is created for contemplation, a room where you can be alone or make music. All upper storeys accommodate sleeping facilities organised along open galleries around the inner courtyard. The maximum capacity is 85 beds with all kinds of differentiation in time of stay and number of bedrooms (single rooms, rooms for groups, 2-bed rooms, 4-bed rooms, women etc). The outside façade of the building is in brick on a high transparent plinth. A special finish provides the bricks with a brilliant glow when sunlight hits the surface. The brick is meant as a neutral and warm background for the window openings with their shutters. These shutters are meant for privacy for the residents as well as the neighbours. The multi-colours of the shutters emphasize the individuality of the people that inhabit the building. The façades of the inner courtyard, in contrast to the more closed façades on the outside of the building, are as transparent as possible. All focus is on the sumptuous plants along the galleries and balustrades, to grow without restriction in all directions. A special tree, surrounded by art, is at the very heart of the complex. To complete the oasis, a waterfall is located in one of the green walls to provide the courtyard with a comforting sound. In the interior, rehabilitation and respect are translated in natural materials and quality. Colour is an important tool to provide the building with identity; we are in fact dealing with very colourful people. The colours chosen for the shutters determine the colours of the rooms behind. Every bedroom has its own sanitary unit. This unit is a standard product incorporated in a perforated iron sheet in a warm gold colour. The door to this unit is decorated with a print of African abstract textile art. This art is developed by the Kuba people of Zaire. The patterns they use are never boring to look at, because the supposed geometry never matches.



- 1 Entrance of the building
- 2 The various colours of the shutters emphasize the character of the building
- 3 The outside façade of the building is in brick. A special finish provides the bricks with a brilliant glow when sunlight hits the surface



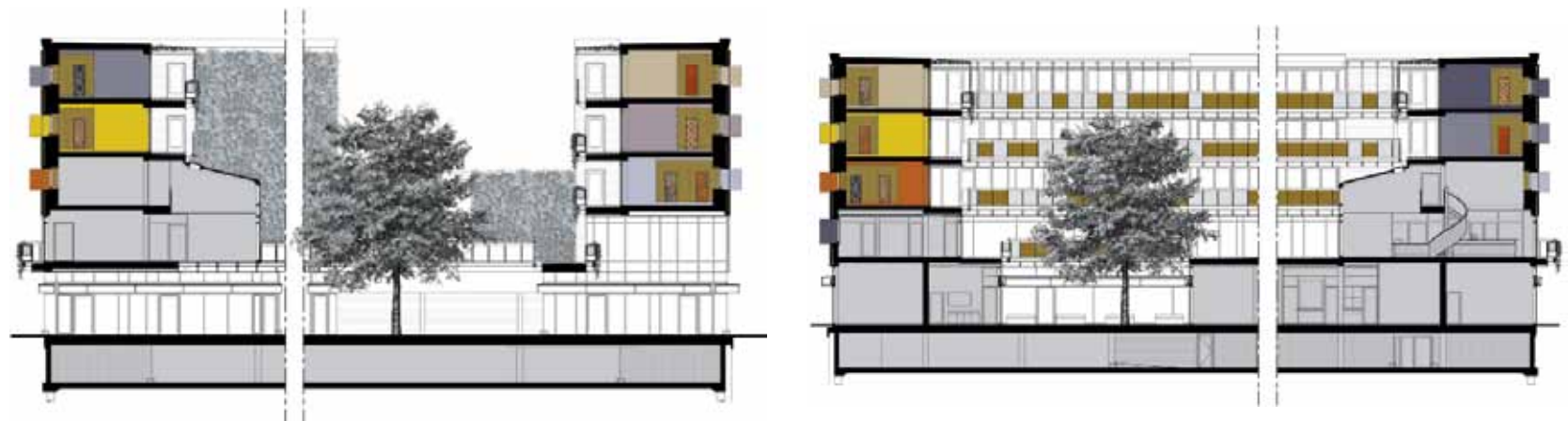

1. The painted colour creates an energetic façade
 2. The public passage leads to the inner courtyard



1



3

1. All focus is on the sumptuous plants along the galleries and balustrades, to grow without restriction in all directions
2. The façades of the inner courtyard are as transparent as possible
3. The public domain at the ground floor
4. Dining area



4



2

Ground floor plan

1. Courtyard
2. Passage
3. Project space (2nd hand store, (public) laundry, temporary employment agency, etc..)
4. Main entrance Omnizorg
5. Entrance Hall/ main staircase
6. Porter's lodge/security
7. User space carry in drugs (patients bring their own drugs and are allowed to use the drugs in this part)
8. Dispensary and user space heroin (patients who receive heroin on a doctor's prescription can collect and use the drugs in this part)

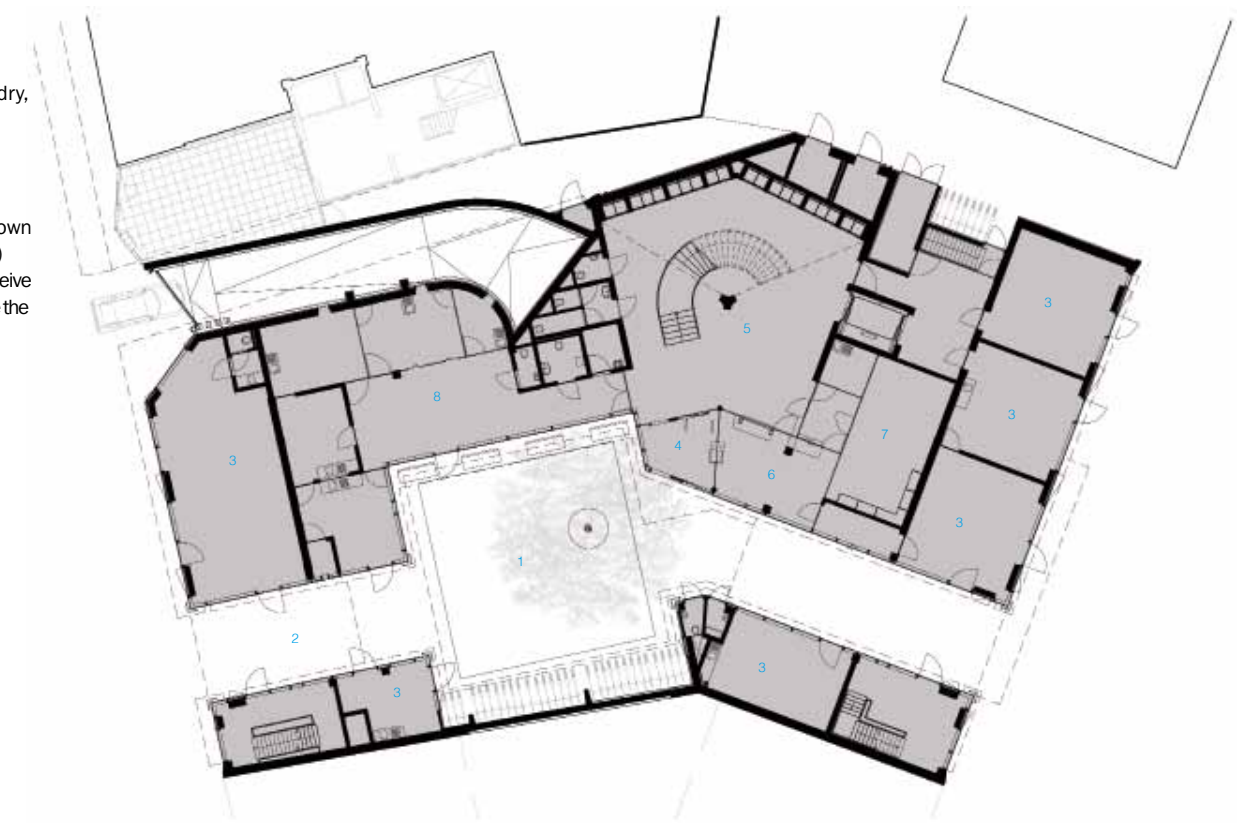

FPC De Oostvaarderskliniek

Completion date: 2008 **Location:** Almere Buiten – Oost, the Netherlands **Designer:** Studio M10 Architecture and Urban Design **Photographer:** René de Wit **Total building area:** 15,600 sqm **Award name:** National winner, BNA Building of the Year 2009; Daylight Award 2010

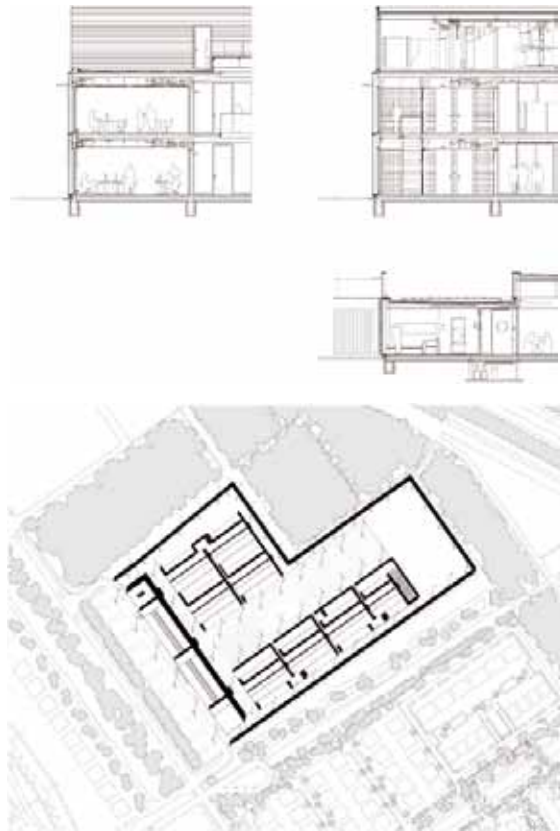

It has been decided to position the complex of buildings on the east side of the area 3T-9 at the Wijkverzamelweg, on a site measuring 5.4 hectares. The secure hospital is a large group of buildings for 174 patients and approx. 500 members of staff. The most representative side of the building complex, including the entrance and dispatch, lies along the neighbourhood's access road. The 154 parking spaces in front are easily accessible both from the north and south. Immediately south of the building complex lies the stop of the high-quality public transport line.

The multi-purpose building stands parallel to the neighbourhood's access road, and houses the treatment department (the 'therapy and training', 'learning and working', and 'leisure activities' clusters), the services department (staff and service rooms, management, administration and supporting services, and common areas), the entrance area (staff and visitors entrances, depot, reception and technical rooms) and the re-socialisation department.

The multi-purpose building is seen as an elongated building with a central 'street' across two floors that are interconnected in the public area by means of double-height atriums. The 'street' is the actual organisational principle. The building provides good accommodation and has been fitted with all facilities required for the functioning of the treatment and services sector. The aim was maximum flexibility from architectural, constructional and electrical and mechanical points of view, with a minimum of 'fixed' elements.

The stairwells, lifts and sanitary units of the multi-purpose building are evenly spread in coherence with the required compartmentation. The maximum and normal security residential areas are ground-oriented in the lower section of the building. They are situated on the west side, at right angles to the multi-purpose building. In between the residential areas mentioned above lies the outdoor accommodation for the normal secured sector (the courtyard, the market garden, sports area, etc.).

Staff, patients on leave and visitors all use the main entrance in the centre of the multi-purpose building. New patients and patients to be transported gain access via the DV&O garage along the entrance of the multi-purpose building. On the side wall on the northside, goods are loaded and unloaded via a transshipment area. The depot of the building complex (calamities, maintenance, etc.) also stands on this side of the building, between the side wall of the multi-purpose building and the ring wall. The civic amenity site lies along the ring wall, near the multi-purpose building. The bicycle and motorbike shed stands near the side wall on the south side of the multi-purpose building, against the ring wall.

The structural design of the buildings is based on unity and simplicity in its structural elements.

The structure of the multi-purpose building comprises a prefab concrete frame of two floor elements, i.e. columns and beams. The stability of this overall structure is provided by longitudinal walls and cross walls that absorb the wind load related eccentricities. They have been realised near the stairwells and sanitary units. The modular distances are based on a multitude of the modular distance of 3.60 metres. The building structures of the residential areas consist

1. Courtyard
2. The glazing exterior wall could help to well control the inner temprature
3. The glazing exterior wall also reduces the energy consumption of illumination





1



3



2

of prefab concrete floor walls. The modular distances are based on a multitude of 2.40 metres.

The infrastructure of the technical systems is clear and logical. With a view to the extensive layout of the building, a lot of attention has been paid to the infrastructure for heating, cooling, electrics, security, etc. In the design, the residential areas are fitted with underground system ducts. Principles with regard to reducing energy consumption also played a major role in the system set-up. Finally, a thorough security structure has been set up, taking into account the restriction and freedom of movement of residents and members of staff.

As for the treatment of the materials: the designers express the material, nothing more, nothing less. They have opted for durable materials. The building complex will have a distinguished light appearance, both inside and outside. The ring wall, bars and gates form an emphatic part of the architecture. The building complex will primarily consist of 'fair-face' concrete, steel, aluminium and glass.

1. The building complex primarily consists of 'fair-face' steel, aluminium and concrete, etc.
2. The building is composed of several modulars, and design of which is based on the principle of unity and simplicity
3. Dining area and corridor



1. Two floors and a central 'street' are interconnected by means of double-height atriums
2, 3. The structure of the multi-purpose building comprises a prefab concrete frame of two floor elements, i.e. columns and beams

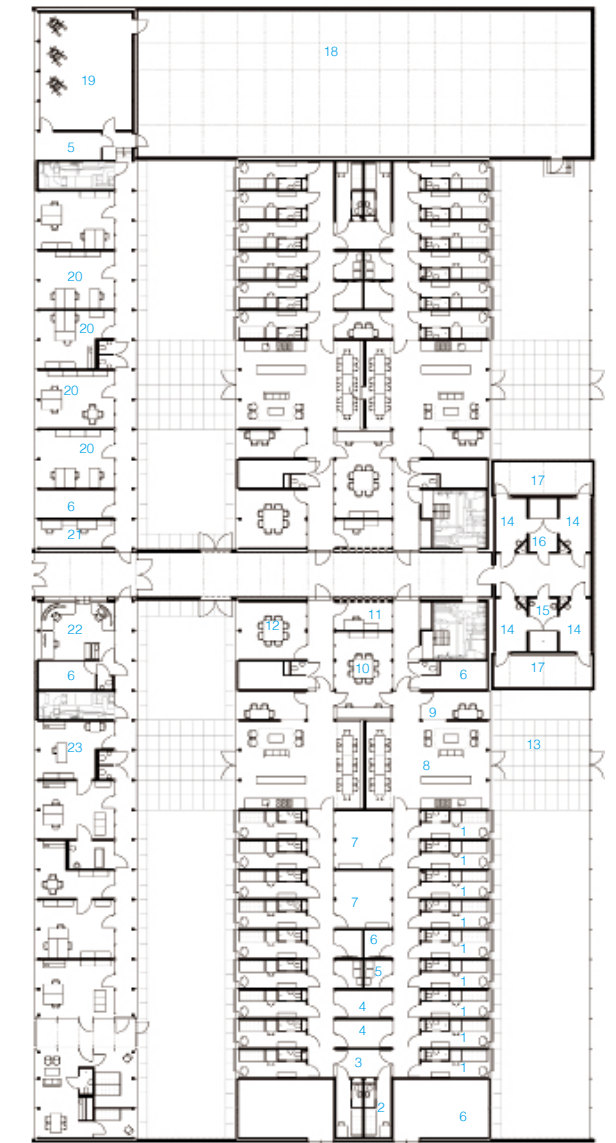

- | | |
|---------------------------|------------------------------------|
| Ground floor plan | 13. Patio |
| 1. Patient room | 14. Segregation unit |
| 2. Safe cell | 15. Consulting room |
| 3. Entrance security lock | 16. Bathing room |
| 4. Linen room | 17. Open-air-area |
| 5. Laundry room | 18. Outdoor exercise accommodation |
| 6. Storage | 19. Indoor exercise accommodation |
| 7. Activity room | 20. Treatment facility |
| 8. Living room / kitchen | 21. Team manager |
| 9. Consulting room | 22. Central security post |
| 10. Stm observation room | 23. Team room |
| 11. Section manager | 24. Medical service |
| 12. Meeting room | 25. Stay-over accommodation |

Shelter Home for the Homeless

Completion date: 2010 **Location:** Pamplona, Spain **Designer:** Javier Larraz Andia **Project Team:** Belén Beguristáin Lahuerta, Juan Miguel García **Photographer:** Iñaki Bergera **Size area:** 995.76 sqm (construction) + 460 sqm (development)

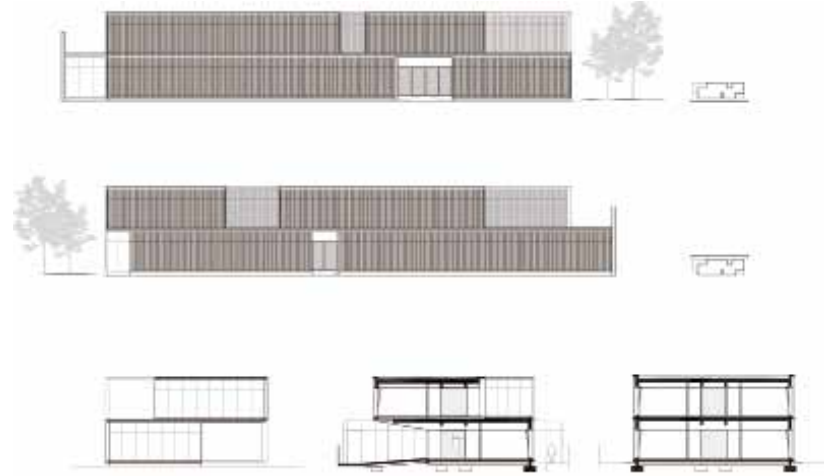

What the construction of the new Shelter Home for the Homeless offers, beyond satisfying the needs of shelter and food for the residents, is an opportunity for improving the quality of life of a socially excluded group, whose needs reach further than the simple fact of finding a place to sleep.

The proposal defines a sound volume, able to assume with personality the intensity of use to which it is going to be subjected to, and being at the same time flexible in its functioning, where the interior configuration facilitates the coexistence among the different groups of users, and allows for undertaking the different needs that are found in a relatively complex programme in spite of its limited space: bedrooms, dining rooms, occupational workshops, leisure rooms, etc.

A silent box is proposed, that protects its contents from the curiosity of the onlookers, and that adequately integrates its reduced scale in a semi-urban, bleak environment.

The project has undertaken an exercise of careful contention in various levels:
-Spatial: An extremely rational distribution is disposed, modulated and adjusted, where the programme of needs exhausts the meagre area at our disposal.

-Formal: A discreet, sensible and contained architecture is proposed, with no room for fancies.

-Economic and Temporal: The construction works were undertaken in the adjusted period of 6 months, at an amount of 870 per square metre.

-Energetic: the building holds an A level energetic qualification.

The centre offers shelter and food for its users. In exchange of these, they must get involved in the daily tasks of maintenance, such as cleaning, washing, gardening, painting,...searching in this way for a personal compromise and positively focusing the respect for the new installation.

The building integrates two different uses: a user hostage service and a medium stay centre for stable homeless persons in the city. Although both groups live together in the same volume, the project must avoid interferences amongst both programmes, facilitating its functional independence. For this reason two independent accesses are proposed, through each of two opposed longitudinal façades.



1. Panoramic view of the building
2. Unique shape of the volume with clear and logical layout
3. Panoramic view of the back of the building



1

2

3



1



3



4

- 1. Entrance
- 2. Entrance hall
- 3, 4. Details of the building's skin



2

- 1. Dining room
- 2. Rooms
- 3. Stairs
- 4. Washing room and lavatory

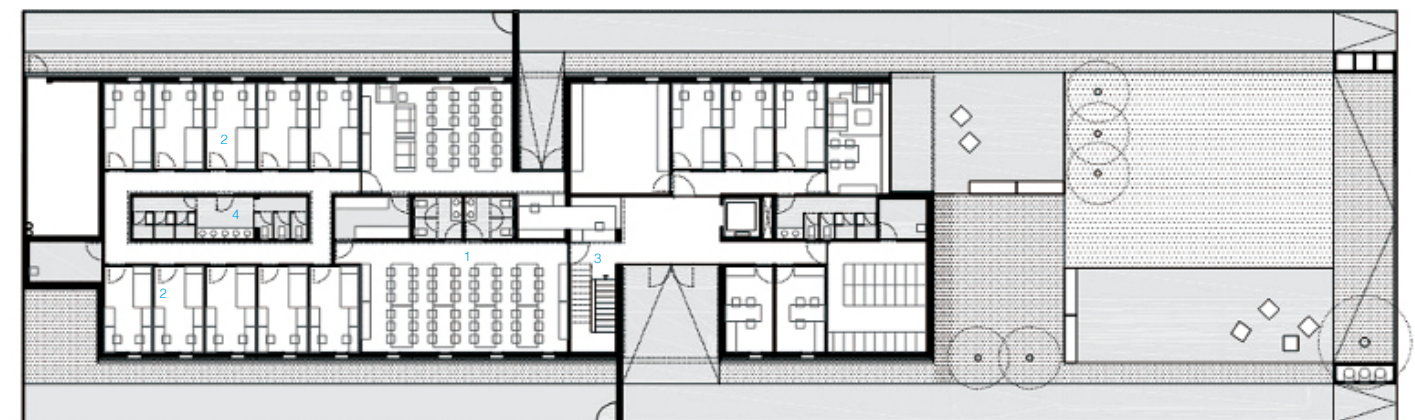



- 1. Leisure room
- 2. Corridor
- 3. Stairs
- 4. Occupational workshop



Index

ABSTRAKT Studio Inc.

180 Belsize Dr. M4S 1M1 Toronto ,Canada
Tel: + 416 830-3160
Fax: +416 484-6495

Architectenbureau De Twee Snoeken

Visiting Address
Postelstraat 49, DX 5211 's-Hertogenbosch
Mailing Address
PO Box 659, 5201 AR 's-Hertogenbosch
Tel: +0031 0 73 614 04 07

Arquitectonica

Arquitectonica Headquarters
2900 Oak Avenue, Miami, Florida, USA
33133
Tel: +1 305 372 1812

ARRIOLA & FIOL arquitectes

Mallorca 289 08037 Barcelona
Tel: +34 93 4570357
Fax: +34 93 2080459

Arturo Franco

C / Costa Rica 5 - 2º Cial. 15004 La Coruña
Tel: +981 27 29 19
Fax: +981 27 24 58

b720 Arquitectos

Josep Tarradellas 123, E-08029
Barcelona, Spain
Tel: +34 93 363 7979
Fax: +34 93 363 0139

BAR architects

543 Howard Street San Francisco, CA, 94105
Tel: +415 293 5700
Fax: +415 293 5701

BD Architectuur

Landjuweel 20, 3905 PG Veenendaal,
Postbus 1180, 3900 BD Veenendaal
Tel : +0318 502818
Fax: +0318 540436

Christian Kronaus

Schönbrunnerstr. 59-61 /B7, A-1070 wien
,Austria
Tel/Fax: +01 548 00 15

Chyutin Architects

12 Taiber Street, 53415 Givataim, Israel
Tel: +972 0 3 7320064
Fax: +972 0 3 7312760

Cibinel Architects

420-A Stradbrook Ave. Winnipeg, MB R3L
0J8 Canada
Tel: +204 989 8910
Fax: +204 989 8920

DCA

David Chipperfield Architects Ltd
11 York Road, London SE1 7NX, United
Kingdom
Tel: +44 20 7620 4800
Fax: +44 20 7620 4801

Denton Corker Marshall

49 Exhibition Street, Melbourne, VIC 3000,
Australia
Tel: +61 3 9012 3600
Fax: +61 3 9012 3601

DeStefano Partners

330 North Wabash Avenue, Suite 3200,
Chicago, Illinois, 60611 USA
Tel: +1 312 836-4321
Fax: +1 312 836 4322

Erhard An-He Kinzelbach

Zhidafangbo 8, Donghe Jiayuan 2-1-702,
310003 Hangzhou / P.R. China
office@knowspace.eu

FBW architecten

van Asch van Wijckskade 31, 3512 VR Utrecht
Tel: +31 30 254 08 51
Fax: +31 30 251 82 78

Forum Architects Pte Ltd

47 Ann Siang Road #06-01 Singapore 069720
Tel: +65 6224 2778
Fax: +65 6323 4603

Henning Larsen Architects

Vesterbrogade 76, Dk-1620 Copenhagen V
,Denmark
Tel: +45 8233 3000
Fax: +45 8233 3099

Javier Larraz Arquitectos

Miranda Yanguas 31002 Pamplona
Tel: +948 222 483

Jeanne Dekkers Architectuur

Papenstraat 7 ,2611 JB Delft
Tel: +015 2152969
Fax: +015 215 2960

Jean Pierre Lott - architecte

31 Rue Coquillière, 75001 Paris, France
Tel: +33 1 44 88 94 95
JHK Architecten
Hondiuslaan 44, 3528 AB Utrecht, Postbus
3328, 3502 GH Utrecht
Tel: +030 296 40 60

J. MAYER H. Architects

Bleibtreustrasse 54, Berlin, 10623, Germany
Tel: +49 0 30 644907700
Fax: + 49 0 30 644907711

Jordi Farrando

Enric Granados, 48, Barcelona, 08008, Spain
Tel: +34 93 323 45 35
Fax: +34 93 451



Julie Snow Architects

2400 Rand Tower 527 Marquette Avenue
Minneapolis, Minnesota 55402
Tel: +612 359 9430
Fax: +612 359 9530

KSP Jürgen Engel Architekten GmbH

Hanauer Landstraße 287-289 D-60314
Frankfurt, Germany
Tel: +49 0 69 944394 0
Fax: +49 0 69 944394 38

LIAG architects

Koninginnegracht 97, 2514 AK The Hague, The
Netherlands
Tel: +31 0 70 350 72 72
Fax: +31 0 70 354 55 98

Lyons

Level 3, 246 Bourke Street, Melbourne, Victoria
3000, Australia
Tel: +61 3 9600 2818
Fax: + 61 3 9600 2819

Manuelle Gautrand Architecture

36, Boulevard de la Bastille, 75 012 PARIS –
FRANCE
Tel: + 33 0 156 950 646

Pekka Helin

Helin & Co. Architects
P.O.BOX 1333, Urho Kekkosen Katu 3B, 00101
Helsinki Finland
Tel: +358 207 577 800
Fax: +358 207 577 801

Peter Kulka Architektur Köln GmbH

Werner-Hartmann-Straße 1, 01099 Dresden
Tel: +49 351 81 18 70
Fax: +49 351 81 18 720

Rudy Uytenhaak

Schipluidenlaan 4, 1062 HE Amsterdam, Nederland
Tel: +31 0 20 305 77 77
Fax: +31 0 20 305 77 78

SAREA Alain Sarfati Architecture

43 rue Maurice Ripoche 75014, Paris, France
Tel: +33 1 58 14 24 00
Fax: +33 1 58 14 24 13

Stanton Williams

36 Graham Street, London N1 8GJ, UK
Tel: +44 0 20 7880 6400

Stein Halvorsen AS

SIVILARKITEKTER MNAL, Sagveien 21 A, NO-0459
OSLO
Tel: +47 23 23 38 70
Studio M10 Architecture and Urban Design
PO Box 6015, 5600 HA Eindhoven, The Netherlands
Tel: +31 40 296 27 37

Studio Nicoletti Associati

Via di San Simone, 75, 00186 Roma(RM), Italia
Tel: +39 06 68 80 59 03
+39 06 45 47 94 98
Fax: +39 06 68 92 394

Svante Forsstrom Architects

Kungsbro Strand 29, 112 26, Stockholm, Sweden
Tel: +08 653 75 51
Fax: + 08 692 06 47

TPO Reserve

Tel: +7 495 755 69 60

Wansleben-architekten

Dipl. -Ing. Norbert Wansleben Machabäerstr. 5,
D-50668 Köln
Tel: +49 0 221 96 24 941
Fax: +49 0 221 96 24 942

Wingårdh Arkitektkontor AB

Kungsgatan 10A SE 411 19 Göteborg Sweden
Tel: +46 0 31 743 70 00
Fax: +46 0 31 711 98 38

WZMH Architects

95 St. Clair Avenue West, Suite 1500, Toronto,
Ontario, Canada M4V 1N6
Tel: +416 961 4111
Fax: +416 961 3176

Zeidler Partnership Architects

315 Queen Street West, Toronto, Ontario M5V 2X2
Tel: +416 596 8300
Fax: +416 596 1408

