

RAMSEY/SLEEPER

ARCHITECTURAL  
GRAPHIC  
STANDARDS



TENTH EDITION

THE AMERICAN INSTITUTE  
OF ARCHITECTS

---

ARCHITECTURAL  
GRAPHIC  
STANDARDS

---



JOHN WILEY & SONS

THE AMERICAN INSTITUTE OF ARCHITECTS

ROBERT C. GARRER  
Publisher

JOHN STEIN  
Editorial Director

BETH A. WEISBERG  
Associate Editor

ROBERT J. FLETCHER IV  
Production Manager

DEBBIE LYNN DAVIS  
New Media Director

CLAUDIA R. GUERRA  
Marketing Manager

ANTHONY LEWANDOWSKI  
Computer Consultant

JORDANI MULTIMEDIA  
Software Developer

JANET RUMBARGER  
Managing Editor

RICHARD J. VIJULLO, AIA  
Contributing Editor

PAMELA JAMES BLUMGART  
Assistant Editor

EDITORIAL ASSOCIATES

Melton E. Castro

Molly Cutting

Stacy Droneburg

Jenifer Tennant Dwyer

Christopher Keane

Elizabeth Laking

Elena Marcheso Moreno

Jennifer Taylor

Stephanie Vierra

Virginia Vitzthum

James V. Vose

INDEXERS

M. L. Coughlin

Jennifer Rushing-Schurr

L. Pilar Wyman

AGS TASK FORCE

Edward Allen, AIA

Ralph Bennett, AIA

William A. Brenner, AIA

Charles B. Goldsmith, AIA

McCain McMurray, AIA

Darrel Rippeteau, AIA

COMPUTER GRAPHICS ASSOCIATES

Liza Albano

Samir Ali

Kenneth R. Baetz

Gary Corey

Lawrence Dick

James M. Duda

Luke Fox

Mike Harris

Gordon M. Jensen

David Larson

Ann Lassetter

Anthony Lewandowski

Michael Lundberg

Jeffrey Madsen

Camille Mendez-Hordatt

Rene R. Moya

Tamra Ottesen

Scott Peterson, AIA

David Salela

Jerry L. Smith

Chuck Taylor

Renata Flecchia Tyler

Antonio Vercillo

Kenton Wesley Wingfield

Bradley E. Workman, AIA

THE AMERICAN INSTITUTE  
OF ARCHITECTS

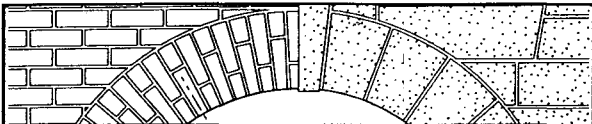

RAMSEY/SLEEPER

# ARCHITECTURAL GRAPHIC STANDARDS

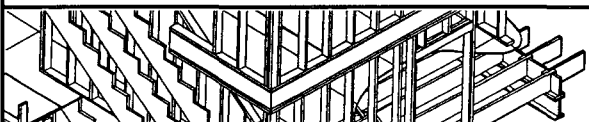

TENTH EDITION

JOHN RAY HOKE, JR., FAIA  
EDITOR IN CHIEF



JOHN WILEY & SONS, INC.

New York • Chichester • Weinheim • Brisbane • Singapore • Toronto

**SUBSCRIPTION NOTICE**

*Architectural Graphic Standards* is updated on a periodic basis to reflect important changes in the subject matter. If you purchased this product directly from John Wiley & Sons, we have already recorded your subscription for this update service.

If, however, you purchased this product from a bookstore and wish to receive future updates or editions billed separately with a 15-day examination review, please send your name, company name (if applicable), address, and the title of the product to:

Supplement Department  
John Wiley & Sons, Inc.  
One Wiley Drive  
Somerset, NJ 08875  
(800)-225-5945

This book is printed on acid-free paper. ∞

The drawings, tables, data, and other information in this book have been obtained from many sources, including government organizations, trade associations, suppliers of building materials, and professional architects or architecture firms. The American Institute of Architects (AIA), the Architectural Graphic Standards Task Force of the AIA, and the publisher have made every reasonable effort to make this reference work accurate and authoritative, but do not warrant, and assume any liability for, the accuracy or completeness of the text or its fitness for any particular purpose. It is the responsibility of users to apply their professional knowledge in the use of information contained in this book, to consult the original sources for additional information when appropriate, and, if they themselves are not professional architects, to consult an architect when appropriate.

Copyright ©2000 by John Wiley & Sons, Inc.

All rights reserved. Published simultaneously in Canada.

No part of this publication may be reproduced, stored in a retrieval system or transmitted in any form by any means, electronic, mechanical, photocopying, recording scanning, or otherwise, except as permitted under Section 107 or 108 of the 1976 United States Copyright Act, without either the prior written permission of the Publisher, or authorization through payment of the appropriate per-copy fee to the Copyright Clearance Center, 222 Rosewood Drive, Danvers, MA 01923, (978) 750-4744. Requests to the Publisher for permission should be addressed to the Permissions Department, John Wiley & Sons, Inc., 605 Third Avenue, New York, NY 10158-0012, (212) 850-6011, fax (212) 850-6008, E-Mail: PERMREQ@WILEY.COM.

To order books or for customer service call (800)-CALL WILEY (225-5945).

**Library of Congress Cataloging-in-Publication Data:**

Ramsey, Charles George, 1884-1963.

[Architectural graphic standards]

Ramsey/Sleeper architectural graphic standards/John Ray Hoke, Jr., editor in chief.—  
10th ed.

p. cm.

Includes bibliographical references and index.

ISBN 0-471-34816-3 (cloth: alk. paper)

1. Building—Details—Drawing. 2. Building—Details—Drawings—Standards. I. Title: Architectural graphic standards. II. Sleeper, Harold Reeve, 1893-1960. III. Hoke, John Ray, 1950-IV. Title.

TH2031 .R35 2000

721'.028'4—dc21

99-087348

Printed in the United States of America

10 9 8 7 6 5 4 3 2 1

---

# CONTENTS

---

Publisher's Note ix

Foreword x

Preface xi

*A View of Architectural Graphic Standards at the Beginning of the Twenty-First Century* xiii

Timeline xiv

*A Tribute to Architectural Graphic Standards* xv

Acknowledgments xvi

## 1 GENERAL PLANNING AND DESIGN DATA 1

- Human Dimensions 2
- Egress Planning 8
- Building Systems 13
- Seismic Design 37
- Lighting Design 47
- Acoustical Design 63
- Building Security 73
- Site, Community, and Urban Planning 81
- Flood Damage Control 101
- Automobiles, Roads, and Parking 103
- Trucks, Trains, and Boats 115
- Construction Information Systems 122

## 2 SITEWORK 143

- Subsurface Investigation 144
- Excavation Support Systems 145
- Piles and Caissons 146
- Water Distribution 147
- Sewerage and Drainage 148
- Paving and Surfacing 156
- Site Improvements and Amenities 159
- Retaining Walls 170
- Planting 177

## 3 CONCRETE 183

- Concrete Forms and Accessories 184
- Concrete Reinforcement 189
- Cast-in-Place Concrete 192
- Precast Concrete 201

## 4 MASONRY 209

- Masonry Mortar 210
- Masonry Accessories 212
- Masonry Units 218
- Glass Unit Masonry 244
- Stone 247

## 5 METALS 259

- Metal Materials 260
- Metal Fastenings 264
- Structural Metal Framing 266
- Metal Joists 273
- Metal Deck 275
- Cold-Formed Metal Framing 277
- Metal Fabrications 284
- Ornamental Metal 291
- Expansion Control 296

## 6 WOOD AND PLASTICS 297

- Introduction 298
- Design Load Tables 300
- Wood Treatment 314
- Wood and Plastic Fastenings 317
- Rough Carpentry 323
- Structural Panels 339
- Heavy Timber Construction 341
- Wood Decking 352
- Sheathing 355
- Wood Trusses 361
- Glued-Laminated Construction 373
- Finish Carpentry 378
- Architectural Woodwork 380

- 7 THERMAL AND MOISTURE PROTECTION 397**  
 Waterproofing and Dampproofing 398  
 Thermal Protection 402  
 Exterior Insulation and Finish Systems 404  
 Vapor Retarders 405  
 Shingles, Roofing Tiles, and Roof Coverings 406  
 Roofing and Siding Panels 413  
 Membrane Roofing 415  
 Flashing and Sheet Metal 429  
 Sheet Metal Roofing 434  
 Flashing 438  
 Roof Specialties and Accessories 450  
 Gutters and Downspouts 459
- 8 DOORS AND WINDOWS 463**  
 Fire Rating and Security 464  
 Door and Window Openings 467  
 Metal Doors and Frames 469  
 Wood and Plastic Doors 473  
 Specialty Doors 478  
 Entrances and Storefronts 482  
 Windows 486  
 Skylights 498  
 Hardware 503  
 Glazing 512
- 9 FINISHES 515**  
 Plaster and Gypsum Board 516  
 Tile 531  
 Stone Floor and Wall Coverings 534  
 Terrazzo 538  
 Special Ceiling Surfaces 539  
 Special Flooring 541  
 Unit Masonry Flooring 542  
 Wood Flooring 543  
 Resilient Flooring 546  
 Carpet 547  
 Wall Coverings 549  
 Special Wall Surfaces 551  
 Acoustical Treatment 552  
 Paints and Coatings 556  
 Special Coatings 561
- 10 SPECIALTIES 563**  
 Compartments and Cubicles 564  
 Service Walls 565  
 Wall and Corner Guards 567  
 Fireplaces and Stoves 570  
 Flagpoles 573  
 Identifying Devices 574  
 Lockers 576  
 Fire Protection Specialties 577  
 Protective Covers 579  
 Postal Specialties 583  
 Partitions 584
- 11 EQUIPMENT 587**  
 Security and Vault Equipment 588  
 Teller and Service Equipment 589  
 Instrumental Equipment 591  
 Commercial Laundry and Dry Cleaning Equipment 593  
 Vending Equipment 594  
 Audiovisual Equipment 595  
 Loading-Dock Equipment 598  
 Solid Waste Handling Equipment 599  
 Food Service Equipment 600  
 Residential Equipment 609  
 Darkroom Equipment 612
- 12 FURNISHINGS 613**  
 Lamps 614  
 General Use Furniture 615  
 School and Library Furniture 619  
 Residential Furniture 624  
 Classic and Contemporary Furniture 627  
 Ecclesiastical Furniture 635  
 Office Furniture 637  
 Interior Plants and Planters 641
- 13 SPECIAL CONSTRUCTION 643**  
 Air-Supported Structures 644  
 Special Purpose Rooms 645  
 Sound, Vibration, and Seismic Control 653  
 Radiation Protection 654  
 Pre-Engineered Structures 656  
 Building Automation and Control 660  
 Detection and Alarm 662  
 Fire Suppression 663
- 14 CONVEYING SYSTEMS 665**  
 Elevators 666  
 Escalators and Moving Walks 672  
 Material Handling 673

- 15 MECHANICAL 677**  
Mechanical Insulation 678  
Building Services Piping 679  
Plumbing 690  
Special Systems 704  
Heat Generation Equipment 705  
Refrigeration and Heat Transfer 710  
HVAC Systems 716  
Air Distribution 726
- 16 ELECTRICAL 737**  
Basic Electrical Materials and Methods 738  
Special Systems 745  
Transmission and Distribution 748  
Lighting 752  
Communications 758
- 17 SPORTS AND GAME FACILITIES 759**  
Field Sports 760  
Track and Field 770  
Court Sports 772  
Table and Bar Sports 780  
Aquatics 781  
Equestrian 790  
Ice and Snow Sports 791  
Target Shooting and Fencing 794
- 18 ENERGY AND ENVIRONMENTAL DESIGN 795**  
Climate 796  
Solar Radiation and Building Orientation 799  
Natural Ventilation 807  
Climate Response and Building Design 808  
Energy Conservation 813  
Passive Solar 819  
Active Solar 823  
Shading 826  
Thermal Transmission 829  
Environmental Construction 833
- 19 HISTORIC PRESERVATION 843**  
Introduction 844  
Historic Masonry 846  
Historic Wood 849  
Historic Architectural Metals 851  
Historic Roofs 852  
Historic Windows 853  
Historic Entrances and Porches 855

Historic Storefronts 857  
Historic Structural Systems 858  
Historic Interiors 860

**20 BUILDING TYPES AND SPACE PLANNING 863**

Residential Room Planning 864  
Nonresidential Room Planning 876  
Child Care 889  
Health Clubs 891  
Museums 892  
Airports 896  
Health Care 900  
Ecclesiastical 904  
Detention 907  
Justice Facility Planning 908  
Assembly 913  
Retail 922  
Animal Care 926  
Greenhouses 931  
Housing 932  
Waste Management 942  
Distribution Facilities 945  
Storage Facilities 948  
Processing Facilities 949

**21 ACCESSIBILITY 951**

Introduction 952  
Building Blocks 956  
Curbs and Parking 960  
Ramps 962  
Elevators 963  
Doors 966  
Communication 967  
Mobility Aids 968  
Furniture 970  
Toilets and Bathrooms 971  
Residential 974

**Appendix 977**

Graphic Symbols 978  
Drawing Methods 986  
Geometry 995  
Mathematical Data 1005  
Structural Calculations 1008  
Classical Architecture 1011  
Metric 1017

**Directory 1023**

**Index 1049**

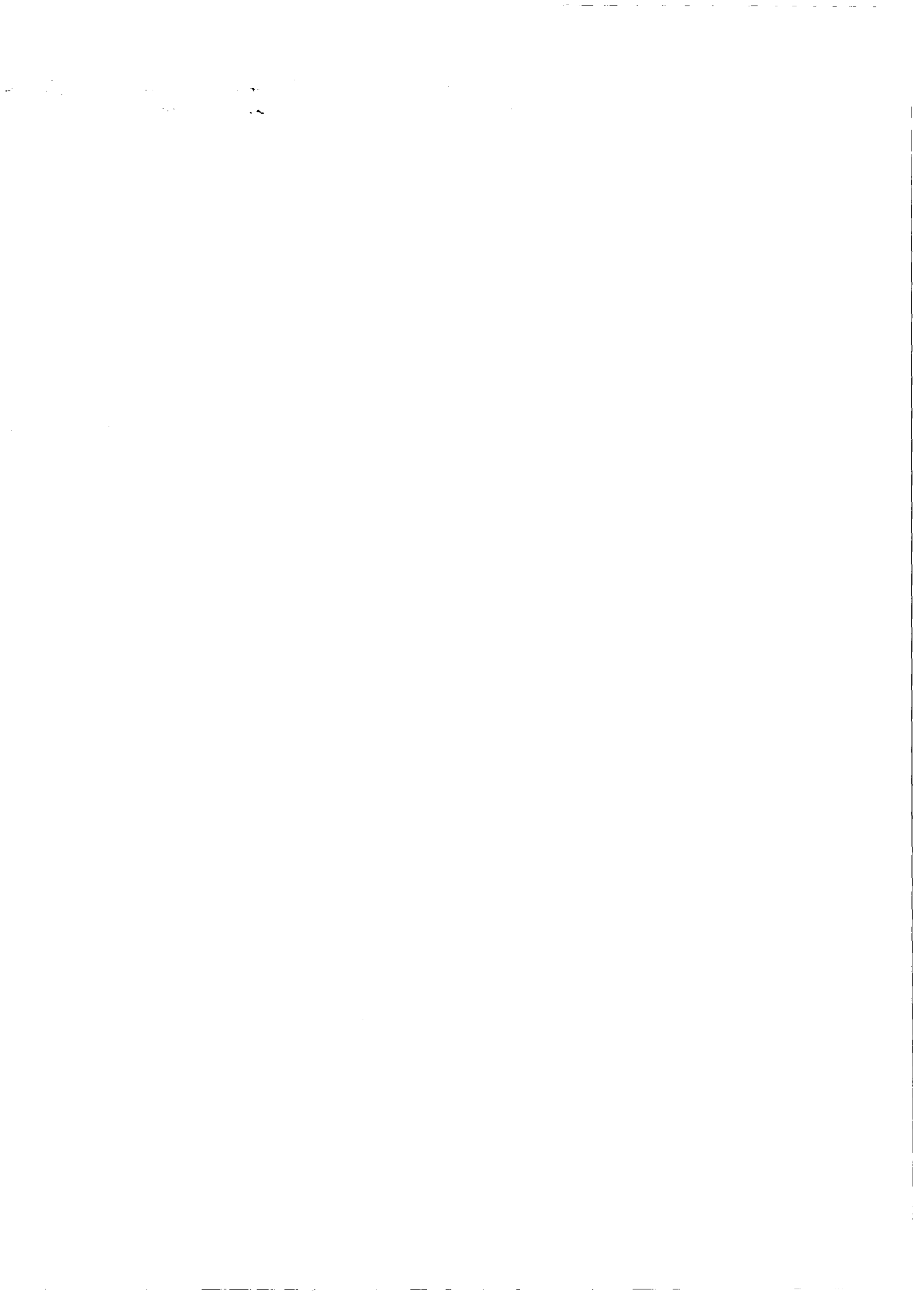

---

# PUBLISHER'S NOTE

---

Throughout most of the twentieth century, publication of a new edition of *Architectural Graphic Standards* has been a signal event at John Wiley & Sons. More than a million copies of Ramsey and Sleeper's book have influenced several generations of architects, engineers, and designers of the built environment, as noted by Robert Ivy and Philip Johnson in their respective essay and tribute to this tenth edition. For half of the life of *Architectural Graphic Standards*, Wiley has been proud to have The American Institute of Architects as its publishing partner in this great ongoing endeavor.

The release of the tenth edition of *Architectural Graphic Standards* is an unprecedented event even by the high standards set by this landmark publication. For the first time, revised print and digital versions are being released simultaneously. Also for the first time, both versions are fully integrated and contain the same content, in formats that are tailored to their respective media. This integration culminates a major investment of effort and resources, and ensures that *Architectural Graphic Standards* will continue to be not only a definitive reference but also a valuable design tool.

ROBERT C. GARBER  
Publisher  
Professional/Trade Publishing  
John Wiley & Sons, Inc.

In the fall of 1932, the lowest point of the Great Depression, my father W. Bradford Wiley joined John Wiley & Sons and soon learned that a promising new book had been published in May. Martin Matheson, then manager of marketing, had persuaded Charles George Ramsey, AIA, author of an earlier Wiley textbook, and his younger colleague, Harold Reeve Sleeper, FAIA, to develop their ideas and prepare the plates for what became *Architectural Graphic Standards*. Subsequently, Matheson directed the design and layout of the book and personally oversaw its production and manufacture.

The immediate acceptance and success of *Architectural Graphic Standards* extended far beyond its anticipated audience of architects, builders, draftsmen, engineers, and students. Interior designers, real estate agents and brokers, homeowners, insurance underwriters, and lovers of fine books all came to be among its users and admirers.

Soon after the publication of *Architectural Graphic Standards*, suggestions and requests came from many enthusiastic readers. These called for changes and additions and inevitably the decision was made to publish a second edition in 1936, which was almost 25 percent larger than the first. Recovery from the Great Depression had begun when the second edition came out, and with rising construction activity the demand for *Architectural Graphic Standards* increased. To serve its users' growing needs, work soon began on a third edition which, when published in 1941, was almost twice as large as the original edition.

World War II lengthened the interval between editions; the fourth edition, prepared by Sleeper, appeared in 1951 and had grown to 614 pages. The fifth edition (with 758 pages), Sleeper's last revision, was issued in 1956. The coauthors' achievements in the initial decade, followed by the efforts of Sleeper, provided untold thousands of users with an invaluable resource for almost 30 years.

Harold Sleeper's foresight led to his suggestion, which was heartily supported by John Wiley & Sons, that The American Institute of Architects be asked to assume the editorial responsibility for the sixth and subsequent editions. This was proposed at the June 1964 annual convention of The American Institute of Architects, and within a month a contract between John Wiley & Sons and the Institute led to the fulfillment of Harold Sleeper's wish.

Now, more than 60 years after publication of the first edition, we look back on a remarkable record. Each edition has surpassed its predecessors. The book has grown five-fold in length, immeasurably in depth, and is now packaged in a variety of formats designed for the changing information requirements of architects, their students, and their colleagues in the design and construction fields. The collected editions are a chronicle of twentieth-century architectural practice and reflect as well those times when progress has meant preserving (and hence respecting) our architectural heritage.

John Wiley & Sons takes pride in the part the company has played in the enduring success of *Architectural Graphic Standards* and in the association with The American Institute of Architects. Generations of readers have benefited from this work, and we look forward to meeting the needs of generations to come.

BRADFORD WILEY II  
Chairman  
John Wiley & Sons, Inc.



---

# FOREWORD

---

On behalf of The American Institute of Architects (AIA), I am delighted to celebrate with our partners, John Wiley & Sons, the publication of the tenth edition of *Architectural Graphic Standards*. Since 1964, this indispensable tool of the trade has been a resource in helping the AIA carry out its historic commitment to the architectural profession and the public we serve by helping to bring order to this nation's building design standards. What is remarkable about this work and the key, I believe, to its success has been the fact that *Architectural Graphic Standards* is the fruit of a thoughtful, cooperative process that makes every member of our industry an interested stakeholder.

This book has empowered and inspired generations of architects to create a better built environment. The collected editions are a chronicle of the best architectural practices of the twentieth century. Indeed, I would go so far as to make a claim that the very nature of modern practice is encapsulated in the pages of this splendid book. Each chapter, each page, and each detail assists the architect in the design process from programming through construction. Everyone at the AIA and every practicing architect is indebted to the founding authors, Charles George Ramsey, AIA, and Harold Reeve Sleeper, FAIA, for their leadership in creating this catalyst for coherence and coordination in a historically fragmented industry. Without it, modern practice would likely not be as advanced.

In this edition, there are so many contributions from talented AIA members and building design experts that it is impossible to acknowledge all of them here. These men and women gave unselfishly and creatively so that the whole profession will benefit from their knowledge and wisdom. Such generosity is at the heart of what it means to

be a professional. To that list, I would like to add the many individuals, firms, trade associations, professional societies, and manufacturers who have given this publication its authority. Their contributions are credited throughout this book on the appropriate pages.

I would also like to acknowledge and thank three Institute editors: Joseph N. Boaz, AIA (sixth edition); Robert T. Packard, AIA (seventh edition); and John Ray Hoke, Jr., FAIA (eighth, ninth, and tenth editions). John has led this project for the last quarter-century, defining the technical content essential to a new generation of architects. Because of the collective wisdom and dedication of the Institute's editors, the basic principles of service to the industry that were set forth in the original edition continue to be advanced.

I would also like to thank two gifted individuals who have enriched this new edition: Robert Ivy, FAIA, editor in chief of *Architectural Record*, for his inspiring essay, and AIA Gold Medal recipient Philip Cortelyou Johnson, FAIA, for his provocative tribute.

To each and every person associated with this special project I offer the words of Eero Saarinen, FAIA, who wrote in the foreword to the fifth edition: "Just as Vitruvius gives us understanding of the vocabulary of Renaissance architects, so *Architectural Graphic Standards* will show the future the dizzying speed and expanding horizons of architectural developments and practice in our time." (May 1956).

NORMAN L. KOONCE, FAIA  
Executive Vice President/CEO  
The American Institute of Architects  
Washington, DC

---

# PREFACE

---

The American Institute of Architects and John Wiley & Sons, Inc. are proud to offer to the building design and construction community the tenth edition of *Architectural Graphic Standards (AGS)*, for the first time in simultaneous release with a CD-ROM version. Since *AGS* was first published in 1932, more than a million copies of this comprehensive source of design data and details have helped shape twentieth-century buildings and cities. With the tenth edition, this influential volume, established by Charles George Ramsey, AIA, and Harold Reeve Sleeper, FAIA, will continue into the next millennium as a trusted companion to all who seek its guidance and reference.

Historically, the primary audience of *AGS* has been made up of architects, interns, and construction specifiers as well as civil, structural, and mechanical engineers and students in all these fields. In addition, however, a very important secondary market exists for *AGS*. This group is composed of general contractors, subcontractors, home builders, estimators, specialty contractors, developers, planners, landscape architects, interior designers, building code officials, building owners and building engineers, construction trade associations, historians and preservationists, facility space planners, librarians, homeowners, and lawyers.

Since the publication of the sixth edition in 1971, and under the care of The American Institute of Architects, *AGS* has generally been organized according to the principles of MasterFormat®, which is published by the Construction Specifications Institute. MasterFormat® organizes construction data and information into classifications based on building trade or specialty, reflecting the assembly-line character of the modern construction industry. In the tenth edition, an effort has been made to conform even more carefully to the MasterFormat® system. As a result, most pages have new and improved page titles and section names. Chapters 2 through 16 conform to MasterFormat®, while chapters 1, 17, 18, 19, 20, and 21 contain sections that are compatible with or complementary to MasterFormat®.

The tenth edition of *AGS* is the largest and most improved edition to date in terms of growth and content. It consists of approximately 11,000 illustrations in twenty-one chapters. Much of the core information, or about 50 percent of the book, has remained unchanged. The new edition has increased by 127 pages or about 14 percent. It now has 1,022 content pages, as compared to the 895 content pages in the ninth edition (one of the largest increases in

size for any edition yet). But in terms of real change, with revisions to old pages and new pages added, the book's growth in content is estimated to be about 63 percent. For those who keep records, we have omitted 232 ninth edition pages, revised 224 pages, added 333 new pages, and transferred 465 pages unchanged from the ninth edition.

The 232 ninth edition pages we have omitted constituted about 26 percent of that edition. This process of weeding out has helped enrich the book by making room for new material. Most of the pages that were eliminated were out of date or determined to be of little interest to today's professional. Because of the large number of new pages in this edition, I have not attempted to list them by name. Therefore, I encourage you to open the tenth edition and its CD-ROM product, located in the back cover of the book, and begin your journey.

An important new chapter titled "Accessibility" is based on the design standards of the Americans with Disabilities Act (ADA). Today, both existing buildings and new construction must comply with ADA requirements for accessibility. A special team of experts helped define and develop these new pages. My sincere thanks for their good work and dedication go to Thomas Davies, AIA; Mark J. Mazz, AIA; Lawrence G. Perry, AIA; and Kim Beasley, AIA.

The publication of a major new edition of *Architectural Graphic Standards* requires the time, energy, and expertise of many people. I would like to thank all of the great people at Wiley, but especially Robert C. Garber, publisher; Joel Stein, editorial director; Robert J. Fletcher IV, production manager; Debbie Lynn Davis, new media director; Beth A. Weiselberg, associate editor; and Jim Harper, editorial assistant, for their commitment to this immense and complex project. I would also like to thank two very important players at Wiley who continue to shape the future and the very nature of this important work. One is Stephen Kippur, executive vice president, and president, Professional/Trade Division. The other is Katherine Schowalter, vice president, Professional/Trade Division.

At the AIA, I am delighted with the dedication of our professionals. My special thanks go to three important people who make things happen. They are Janet Rumbarger, managing editor; Pamela James Blumgart, assistant editor; and Richard J. Vitullo, AIA, contributing editor. I am fortunate to have them as my friends and associates over three editions. I also want to thank Fred R. DeLuca, senior vice

president/COO, for his many years of service in the care of one of this Institute's most cherished programs.

I would like to thank two very special people who have joined our AGS celebration—my dear friend Robert Ivy, FAIA, editor in chief of *Architectural Record*, for his insightful essay on the historical context of AGS; and one of this nation's most prominent architects, Philip Cortelyou Johnson, FAIA, for his inspired tribute. We are grateful for their important contributions.

Finally, I want to pay tribute to the memory of the original editors, Charles George Ramsey, AIA, and Harold Reeve Sleeper, FAIA, who created the first five landmark editions. They made a wise decision in entrusting the future of their life's work to The American Institute of Architects, which has nurtured the book with great care and passion for its integrity. As the standard bearer of Ramsey's and Sleeper's original vision, *Graphic Standards* is poised at the beginning

of the new millennium, prepared for service for the next century and beyond.

In conclusion, I want to express my deep appreciation to the AIA members and other contributors for their good efforts in the making of the tenth edition. We honor them by acknowledging their contributions on the relevant page or pages, as well as on the acknowledgments page following the preface. Their valuable and inspired service to the Institute is a fine example of how the profession continues its undaunted support of *Architectural Graphic Standards* year after year.

John Ray Hoke, Jr., FAIA  
Editor in Chief  
Washington, DC

January 2000

---

# A VIEW OF ARCHITECTURAL GRAPHIC STANDARDS

AT THE BEGINNING OF THE TWENTY-FIRST CENTURY

---

The tenth edition of *Architectural Graphic Standards* arrives on the cusp of change, as both a century and a millennium tick into memory. It has been a period of extremes—scientific optimism tempered by overwhelming societal trauma, social improvement and two World Wars, Le Corbusier and Albert Speer, Einstein's cosmic vision and atomic weapons, Cold War and commerce.

Two houses built early in the twentieth century in Pasadena, California, illustrate divisions present early in the previous century. The first, Greene and Greene's Gamble house, represents the apotheosis of hand craft, a contemporary wooden temple on a hillside rubbed to near perfection, as open and forthright as the capitalist family it served. Just down the hill, Frank Lloyd Wright sounds a more complex chord at La Minatura, a sophisticated example of modular block construction, advanced for its moment, yet hinting at unresolved psychological forces. The two residences represent radically different ideals, prescient of clashes that would follow in succeeding years.

At the turn of the twenty-first century, our own models seem to be virtual ones, a galaxy of computer-generated, biomorphic shapes developed by architect Frank Gehry and his coterie. The cyber revolution seems to promise endless formal possibilities through easily calculated custom fabrication. We have traveled far from Wright and the Greenes. Bombarded by new information, which assaults us in an electronic torrent, we stand on an invisible divide with the sense that new ways of building are underway. Where can those of us concerned with shaping the built environment turn for help?

Throughout roughly two-thirds of the last hundred years, this encyclopedia of building convention and practice has offered succor and advice. *Architectural Graphic Standards* has been a repository of good ideas and a framework for constructing new ones; its content is singular, based on architecture's specific language, which is drawing. Since 1932, architects, engineers, and a host of others have turned to its pages as they would a knowledgeable mentor.

The representations in *Graphic Standards* are ideal, not specific, meant to embody the best thinking and applications in universal settings, allowing the reader to tailor details to the real world. As a source of ideal principles, the book stands with other seminal antecedents, such as the work of Vitruvius from the first century BC; as a comprehensive resource, it compares to the work of Sir Banister Fletcher almost two thousand years later, with a nod to Diderot and the encyclopedists of eighteenth-century France.

Part of this work's beauty is its organization. Its clear drawings; charts and graphs, and now its digital bits, offer information on a mind-boggling range of issues that mirror the design and building process. It answers the question, "How do you do that?," from site planning to building systems. *Graphic Standards* presupposes the interrelationship of parts to whole projects, a nineteenth-century notion articulated by Wright when he said, "The part is to the whole as the whole is to the part." Here, small details link into larger systems, ultimately joined into entire constructions embracing larger sites, a linked unity of great complexity, divisible into bite-sized chunks.

Physical wisdom is represented in graphic ways. Throughout the millennia, humankind has recognized subtle changes in dimensions that make big kinetic or aesthetic differences. Consider the lowly step. *Graphic Standards* presents tread/riser diagrams that acknowledge the enormous physical changes felt with minor shifts in width to height ratios. It remains to the architect to devise the actual stair, but all can appreciate the underlying facts.

You can read this book as social history as well. Sections on accessibility, ecology, town planning, and historic preservation all arose following specific movements in the larger civilization. Likewise, the exquisite renderings from earlier in this century, with their complicated analyses of shade and shadow, have disappeared: Software has rendered such knowledge almost arcane, as the electronic GPS system eclipsed dead reckoning.

However, the potential unlocked by the computer age only underscores our need for a resource like *Graphic Standards*. When all things are possible, we need to know what things are best. Great freedom on the screen will be well-served by rock-solid craft and a knowledge of materials. The editors and contributors to this body of knowledge have, in a sense, created their own architecture with *Architectural Graphic Standards*. It, and its complementary digital version, form a structure of firmness, commodity, and delight. Accessible and well-crafted, this sturdy and vast treasury of ideas allows us to study, adopt, and modify the accumulated wisdom of the past into our own new ideas. Thus armed, we step forward in time.

ROBERT IVY, FAIA  
Editor in Chief  
*Architectural Record*

# TIMELINE

The increase in size and complexity of *Architectural Graphic Standards* since its initial publication has mirrored the extraordinary accomplishments of architecture in the 20th century.

<i>Architectural Graphic Standards</i>	Architecture Landmarks
	1910 → <i>Pennsylvania Station</i> , New York (McKim, Mead and White)
John Wiley & Sons publishes <i>Architectural Details</i> , a prototype for <i>Architectural Graphic Standards</i>	1924
	1929 → <i>La Villa Savoye</i> , Poissy, France (Le Corbusier)
	1930 → <i>Chrysler Building</i> , New York (William Van Alen)
Wiley publishes first edition of <i>Architectural Graphic Standards</i>	1932
	1934 → <i>Fallingwater</i> , Bear Run, Pennsylvania (Frank Lloyd Wright)
10,000th copy sold	1936
100,000th copy sold	1947
	1949 → <i>The Glass House</i> , New Canaan, Connecticut (Philip Johnson)
Fourth edition published: changes in building technology trigger 80% increase in length over prior edition	1951
Fifth edition published: last edition prepared by Charles Ramsey and Harold Sleeper	1956
	1958 → <i>Seagram Building</i> , New York (Ludwig Mies van der Rohe)
	1966 → <i>Salk Institute</i> , La Jolla, California (Louis Kahn)
Sixth edition published: first edition edited by The American Institute of Architects; incorporates Unifomat organization	1970 → <i>John Hancock Center</i> , Chicago (Bruce Graham/Skidmore Owings and Merrill)
	1973 → <i>AIA Headquarters</i> , Washington, DC (The Architects Collective)
	1977 → <i>Centre Pompidou</i> , Paris (Richard Rogers and Renzo Piano)
	1978 → <i>National Gallery of Art East Wing</i> , Washington, DC (I. M. Pei)
	1982 → <i>Vietnam Veterans Memorial</i> , Washington, DC (Maya Lin)
Ninth edition published: incorporates ADA guidelines; new material on building systems and energy-efficient design	1994
First digital version of <i>Architectural Graphic Standards</i> released as CD v1.0	1996 → <i>J. Paul Getty Museum</i> , Malibu, California (Richard Meier)
	1997 → <i>Guggenheim Museum</i> , Bilbao, Spain (Frank Gehry)
1,000,000th copy sold	1999
Tenth edition of book and version 3.0 of CD published	2000

---

# A TRIBUTE TO ARCHITECTURAL GRAPHIC STANDARDS

---

In 1932, the same year Henry-Russell Hitchcock and I collaborated in writing *The International Style*, John Wiley & Sons brought out a little-known book titled *Architectural Graphic Standards*. Both of these books, in different ways, helped usher in the era of Modernism and contributed to my amazing journey in architecture. Sixty-eight years later and ten editions complete, *Architectural Graphic Standards*, or as I like to call it, *Graphic Standards*, has quadrupled in size and immeasurably in depth of content, thanks to the dedicated work of its gifted editors, architects, and contributors. I even understand that it is in digital form on CD-ROM located in the back cover of this book. What's next, a *Graphic Standards* website?

I can't think of another book published this century that has supported, taught, and delighted our profession as much as *Graphic Standards*. These ten editions are a chron-

icle of twentieth-century U.S. architectural practice standards. Furthermore, the book is one of the most unifying and focused reference works available in the world. I have always considered my *Graphic Standards* as important in design as is my pencil.

Every architect loves it, wears it out, and keeps it within arm's length. It is a combination of the *Encyclopedia Britannica* and the telephone book—or maybe it's the *Whole Earth Catalog* of architecture! No architect can be without *Graphic Standards*, and with it every architect is empowered and equipped to practice architecture.

PHILIP C. JOHNSON, FAIA  
The Glass House  
New Canaan, Connecticut

July 1, 1999

---

# ACKNOWLEDGMENTS

---

Edward Allen, AIA  
David Arkin, AIA  
Christopher Arnold, FAIA, RIBA  
Randall I. Atlas, AIA, Ph.D.,  
CPP  
Charles M. Ault  
Chip Baker  
Gordon B. Batson, PE  
Erik K. Beach  
Kim A. Beasley, AIA

Ralph Bennett  
Tedd Benson  
James Robert Benya, PE, FIES,  
IALD  
John Birchfield  
Reed A. Black  
Richard Boon  
Ben Brungraber, Ph.D., PE  
Robert D. Buckley, AIA  
Robert P. Burns, AIA

David Campbell  
Dennis Carmichael  
John Carmody  
David Collins, FAIA  
Mark Conroy  
Dean Cox, AIA  
Mark Knapp Crawfis  
Thomas O. Davies Jr., AIA  
Fred Davis, CLEP  
Larry O. Degelman, PE

Joseph Demkin, AIA  
Brent Dickens, AIA

Anthony DiGreggario  
Valerie Eickelberger  
Richard Eisner, FAIA  
John Eiker  
Dale Ellickson, FAIA  
Carrie Fischer  
Russell S. Fling, PE  
Robert P. Foley, PE

Mark J. Forma  
Kenneth D. Franch, PE, AIA  
Michael Frankel, CIPE  
Douglas J. Franklin  
Sidney Freedman  
J. François Gabriel  
Edgar Glock  
Ronald L. Gobbell, FAIA  
Paul Gossen  
Alfred Greenberg, PE, CEM

Walter T. Grondzik, PE  
Jeff Haberl, Ph.D., PE  
Tedd Hallinan  
Grant Halvorsen, SE, PE  
Don Hardenbergh  
Daniel F.C. Hayes, AIA  
Greg Heuer  
Richard F. Humenn, PE  
D.J. Hunsaker  
Mary K. Hurd

Robert Ivy, FAIA  
Hugh Newell Jacobsen, FAIA  
Kenneth D. Jaffe  
Philip Cortelyou Johnson, FAIA

Jacqueline Jones  
Philip Kenyon  
Don Klabin  
Thomas R. Krizmanic, AIA  
James W. Laffey  
Elin Landenburger

Michael G. Lawrence, AIA  
Grace S. Lee  
William T. Mahan, AIA  
Mark J. Mazz, AIA  
Keith McCormack, AIA  
Kevin R. McDonald, AIA  
McCain McMurray, AIA  
Joseph P. Mensch, PE  
Walter Moberg  
David Natella

Donald Neubauer, PE  
Paul Nimitz  
Beth Nixborf  
Thomas F. O'Connor, AIA,  
FASTM  
Pearse O'Doherty, ASLA  
Kathleen O'Meara  
Steven A. Parshall, FAIA  
Lawrence G. Perry, AIA  
Jessica Powell

Robert Prouse, IALD, IES  
Isabel Ramirez  
D. Neil Rankins  
Darrel Rippeteau, AIA  
Michael A. Ritter, PE  
Richard M. Roberts, AIA

Richard Rodgers  
Robert C. Rodgers, PE  
Carl Rosenberg, AIA  
Debbie Rathgeber Ryon, PE

Robert Sardinsky  
Christopher Savereid  
Michael Schley, AIA  
Thomas Schueler  
James E. Sekela, PE  
Stephen Selkowitz  
Neil Thompson Shade  
Robert W. Shuldes, PE  
Mary S. Smith, PE  
John Soltis

Stephen B. Soulé  
William W. Stewart, FAIA  
Kristie Strasen  
Doug Sturz  
Jim Swords  
Charles A. Szoradi, AIA  
Art Thiede  
Joel Ann Todd  
Charles B. Towles, PE  
Brian Trimble, PE

Thomas Turvaville, AIA  
James Urban, ASLA  
Jeffrey R. Vandervoort  
Richard J. Vitullo, AIA  
James W. G. Watson, AIA  
Ed Williams  
Stephen Wise

# GENERAL PLANNING AND DESIGN DATA

Human Dimensions 2

Egress Planning 8

Building Systems 13

Seismic Design 37

Lighting Design 47

Acoustical Design 63

Building Security 73

Site, Community,  
and Urban Planning 81

Flood Damage Control 101

Automobiles, Roads,  
and Parking 103

Trucks, Trains, and Boats 115

Construction Information  
Systems 122



## 2 Anthropometric Data: Adult

### INTRODUCTION TO ANTHROPOMETRIC DATA

The following anthropometric drawings show three values for each measurement: the top figure is for the large person or 97.5 percentile; the middle figure, the average person or 50 percentile; and the lower figure, the small person or 2.5 percentile. The chosen extreme percentiles thus include 95%. The remaining 5% include some who learn to adapt and others, not adequately represented, who are excluded to keep designs for the majority from becoming too complex and expensive. Space and access charts are designed to accept the 97.5 percentile large man and will cover all adults except a few giants. Therefore, use the 97.5 percentile to determine space envelopes, the 2.5 percentile to determine the maximum "kinetospheres" or reach areas by hand or foot, and the 50 percentile to establish control and display heights. To accommodate both men and women, it is useful at times to add a dimension of the large man to the corresponding dimension of the small woman and divide by 2 to obtain data for the average adult. This is the way height standards evolve. Youth data are for combined sex. Although girls and boys do not grow at the same

rate, differences are small when compared with size variations.

Pivot point and link systems make it easy to construct articulating templates and manikins. Links are simplified bones. The spine is shown as a single link; since it can flex, pivot points may be added. All human joints are not simple pivots, though it is convenient to assume so. Some move in complicated patterns like the roving shoulder. Reaches shown are easy and comfortable; additional reach is possible by bending and rotating the trunk and by extending the shoulder. Stooping to reach low is better than stretching to reach high. The dynamic body may need 10% more space than the static posture allows. Shoes have been included in all measurements; allowance may need to be made for heavy clothing. Sight lines and angles of vision given in one place or another apply to all persons.

The metric system of measurement has been included, since it is used in scientific work everywhere and is the most practical system of measurement ever devised. Millimeters have been chosen to avoid use of decimals. Rounding to 5 mm aids mental retention while being within the tolerance of most human measurements.

Disabilities are to be reckoned as follows: 3.5% of men and 0.2% of women are color blind; 4.5% of adults are hard of hearing; over 30% wear glasses; 15 to 20% are handicapped, and 1% are illiterate. Left-handed people have increased in number to more than 10%.

### SAFETY INFORMATION

Maximum safe temperature of metal handles is 50°C (122°F) and of nonmetallic handles, 62°C (144°F); maximum air temperature for warm air hand dryers is 60°C (140°F); water temperatures over 46.1°C (115°F) are destructive to human tissue. Environmental temperature range is 17.2 to 23.9°C (63 to 75°F). Weights lifted without discomfort or excessive strain are 22.7 kg (50 lb) for 90% of men and 15.9 kg (35 lb) for women; limit weight to 9.07 kg (20 lb) if carried by one hand for long distances. Push and pull forces, like moving carts, are 258 N (58 lbf) and 236 N (53 lbf) initially, but 129 N (29.1 lbf) and 142 N (32 lbf) if sustained. Noise above the following values can cause permanent deafness: 90 dB for 8 hr, 95 dB for 4 hr, 100 dB for 2 hr, 105 dB for 1 hr, and 110 dB for 0.5 hr.

Weight Kg & Lb (Includes Avg. Clothes). Data Are For Load Computations, Not Health Purposes.

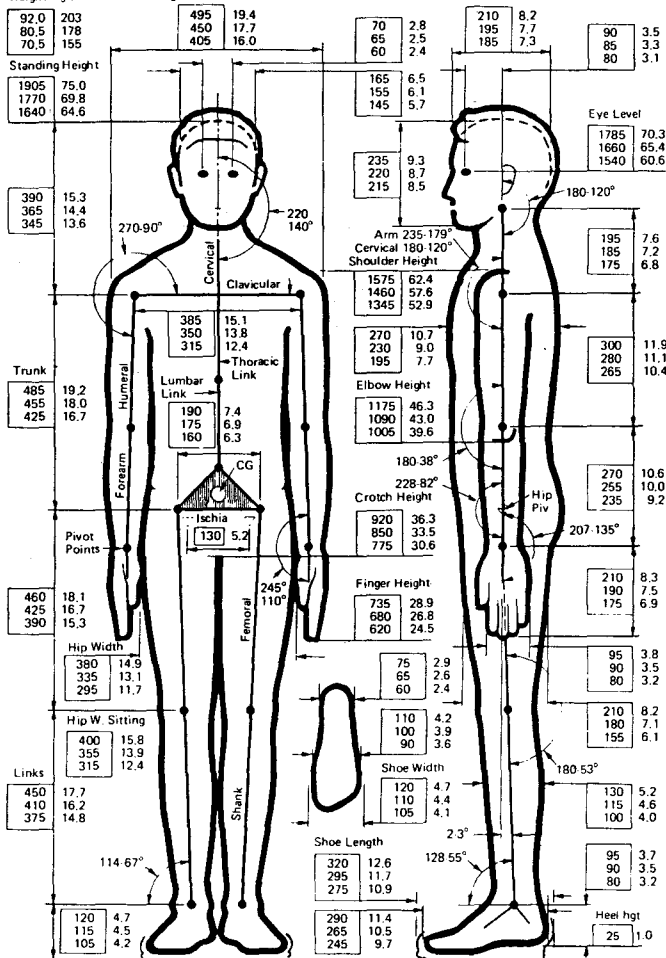

Standing Slump Can Be 30 1.2 For Men Or Women. C.G. Is Within Pelvic Link.

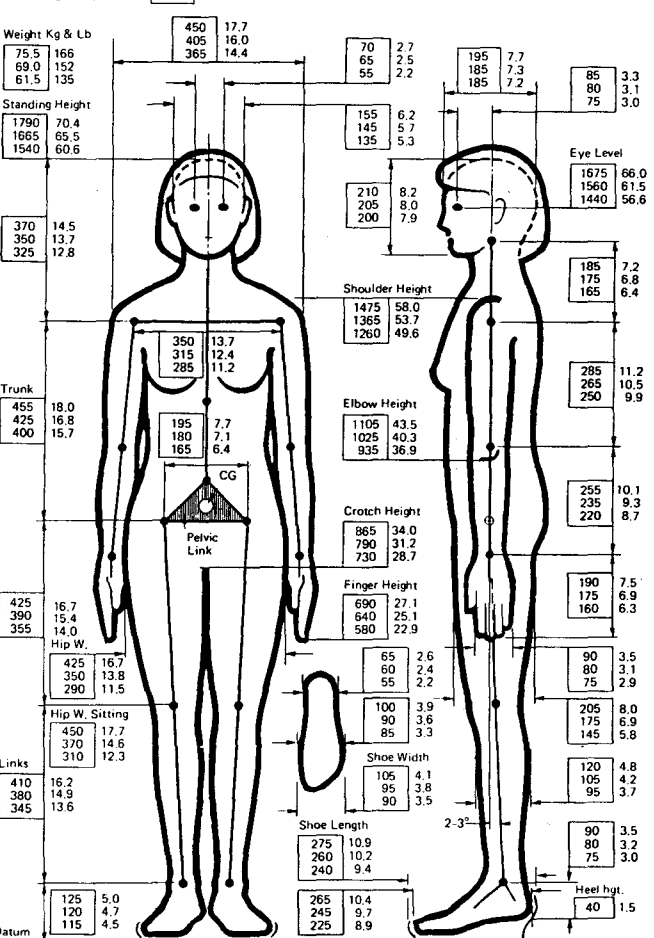

Male and	female standing heights (including shoes):	includes
1905	75.0	1790 70.4 large = 97.5 percentile
1775	69.8	1665 65.5 average = 50 percentile
1640	64.6	1540 60.6 small = 2.5 percentile

95% U.S. adults.

Dimensional notation system:

1000	39.3	Numbers appearing in boxes are measurements in millimeters. Numbers outside boxes are measurements in inches.
100	3.9	
25.4	1.0	

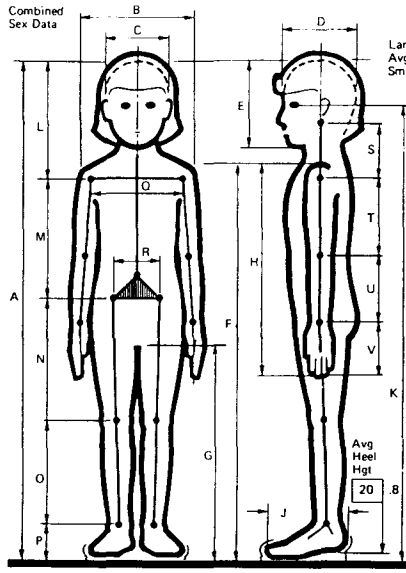

Ages	Standing Height A	Shoulder Width B	Head Width C	Head Length D	Head Height E	Shoulder Height F	Crotch Height G	Arm Length H	Foot Length J	Eye Level K	Weight Kg	Weight Lb
15	1800	70.8	465	18.2	155	6.2	200	7.9	225	8.8	1460	57.5
	1675	65.9	420	16.5	145	5.8	190	7.4	220	8.6	1370	54.0
	1545	60.8	375	14.8	140	5.5	185	7.2	215	8.4	1260	49.6
12	1625	63.9	395	15.6	155	6.1	200	7.9	215	8.5	1325	52.2
	1485	58.5	350	13.7	145	5.7	185	7.3	215	8.4	1205	47.5
	1350	53.2	300	11.9	135	5.3	170	6.8	210	8.2	1080	42.5
9	1440	56.6	350	13.8	150	6.0	200	7.8	210	8.3	1165	45.8
	1320	52.0	310	12.1	140	5.6	185	7.3	205	8.1	1065	42.0
	1200	47.3	265	10.5	130	5.2	170	6.7	205	8.0	960	37.7
7	1315	51.8	320	12.6	150	5.9	195	7.7	205	8.1	1060	41.8
	1220	48.0	285	11.3	140	5.5	180	7.1	205	8.0	970	38.2
	1125	44.2	250	9.9	130	5.1	165	6.5	200	7.8	890	35.1
5	1185	46.7	290	11.5	145	5.8	195	7.6	200	7.9	945	37.3
	1090	43.0	260	10.3	135	5.4	180	7.0	195	7.7	865	34.1
	995	39.1	230	9.1	125	5.0	165	6.5	190	7.5	780	30.7
3	930	36.7	240	9.5	135	5.2	175	6.9	195	7.7	735	28.9
	725	28.6	205	8.0	125	4.9	160	6.3	175	6.9	565	22.2
	505	19.9	150	6.0	95	3.8	100	4.0	125	5.0	375	14.9
Birth	505	19.9	150	6.0	95	3.8	100	4.0	125	5.0	375	14.9

	L	M	N	O	P	Q	R	S	T	U	V	
15	370	14.6	465	18.3	430	17.0	420	16.6	115	4.4	355	14.0
	350	13.8	430	17.0	400	15.7	390	15.3	105	4.1	325	12.7
	330	13.0	405	15.9	360	14.2	350	13.8	100	3.9	290	11.5
12	345	13.5	420	16.7	385	15.1	375	14.7	100	3.9	320	12.5
	320	12.6	390	15.3	345	13.6	335	13.2	95	3.8	280	11.1
	295	11.7	360	14.1	305	12.1	300	11.8	90	3.5	250	9.8
9	310	12.3	375	14.8	335	13.0	325	12.8	95	3.7	270	10.6
	290	11.4	350	13.8	300	11.9	290	11.4	90	3.5	245	9.6
	275	10.8	320	12.7	265	10.4	255	10.1	85	3.3	220	8.6
7	290	11.4	345	13.7	300	11.8	290	11.4	90	3.5	245	9.6
	280	11.0	325	12.8	270	10.6	260	10.3	85	3.3	220	8.7
	260	10.2	305	12.0	245	9.6	235	9.3	80	3.1	210	8.2
5	270	10.7	315	12.4	260	10.3	255	10.0	85	3.3	215	8.4
	255	10.0	300	11.8	235	9.3	220	8.8	80	3.1	200	7.8
	240	9.4	280	11.0	210	8.2	195	7.7	70	2.8	185	7.2

Ages	High Reach A	Low Reach B	Reach Distance C	High Reach D	Reach Radius E	Eye Level F
HS 15	2085	82.0	815	32.0	735	29.0
	1915	75.3	730	28.7	685	27.0
	1765	69.4	665	26.2	635	25.1
Jr. HS 12	1860	73.2	705	27.6	665	26.2
	1705	67.1	630	24.7	620	24.3
	1545	60.9	560	22.1	565	22.3
4th 9	1645	64.8	605	23.8	600	23.6
	1510	59.4	555	21.8	550	21.7
	1345	53.0	510	20.0	485	19.1
2nd 7	1505	59.3	545	21.5	550	21.7
	1370	53.9	510	20.1	495	19.5
	1245	49.0	485	19.0	445	17.5
KDG 5	1330	52.3	500	19.7	480	19.0
	1210	47.7	465	18.3	435	17.1
	1085	42.7	425	16.7	390	15.3

Up To Ages	Hat Shelf Height G	Lavatory Height H	Work Top J	Work Depth K	Table Height L	Seat Length M
15	1675	66.0	760	30.0	915	36.0
12	1485	58.5	685	27.0	795	31.3
9	1320	52.0	635	25.0	695	27.3
7	1220	48.0	585	23.0	635	25.0
5	1090	43.0	485	19.0	570	22.5

Ages	Seat Height N	Seat To Backrest O	Min Backrest Height P	Armrest Spacing Q	Seat Width R	Basic Table Width S
15	405	15.9	150	6.0	175	6.8
12	370	14.6	145	5.7	160	6.2
9	325	12.8	135	5.4	140	5.6
7	290	11.4	130	5.1	130	5.1
5	265	10.4	120	4.8	125	5.0

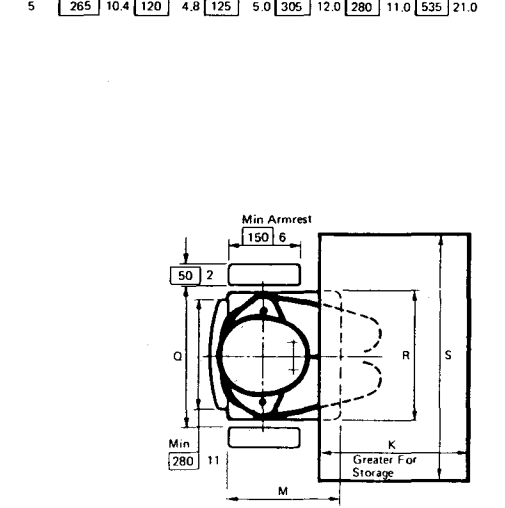
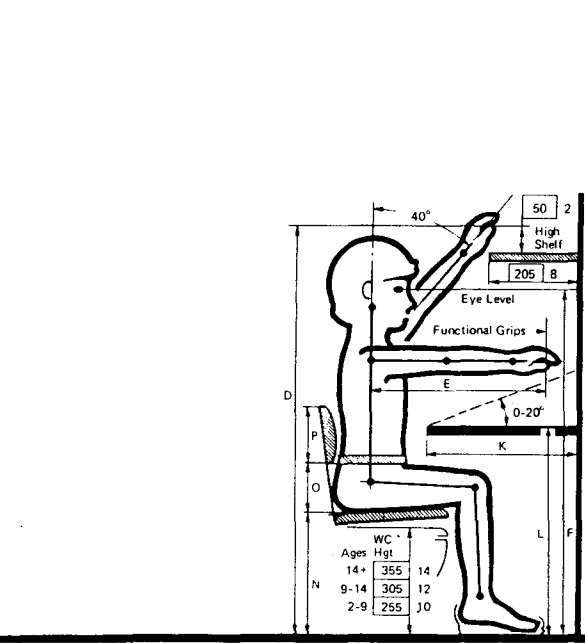
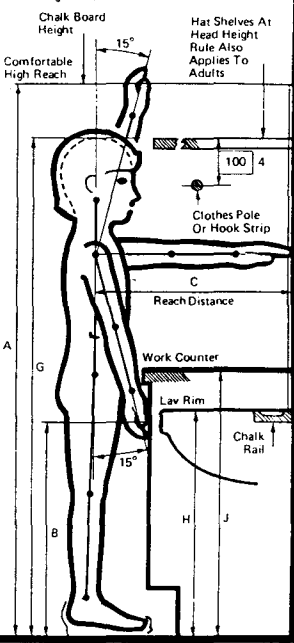

Standing heights (including shoes)—typical example:  
 1800 70.8 large 15 year youth = 97.5 percentile  
 1675 65.9 average 15 year youth = 50 percentile  
 1545 60.8 small 15 year youth = 2.5 percentile

Dimensional notation system:  
 1000 39.3 Numbers appearing in boxes are measurements in millimeters. Numbers outside boxes are measurements in inches.

Niels Driifrent, Alvin R. Tilley; Henry Dreyfuss Associates; New York, New York

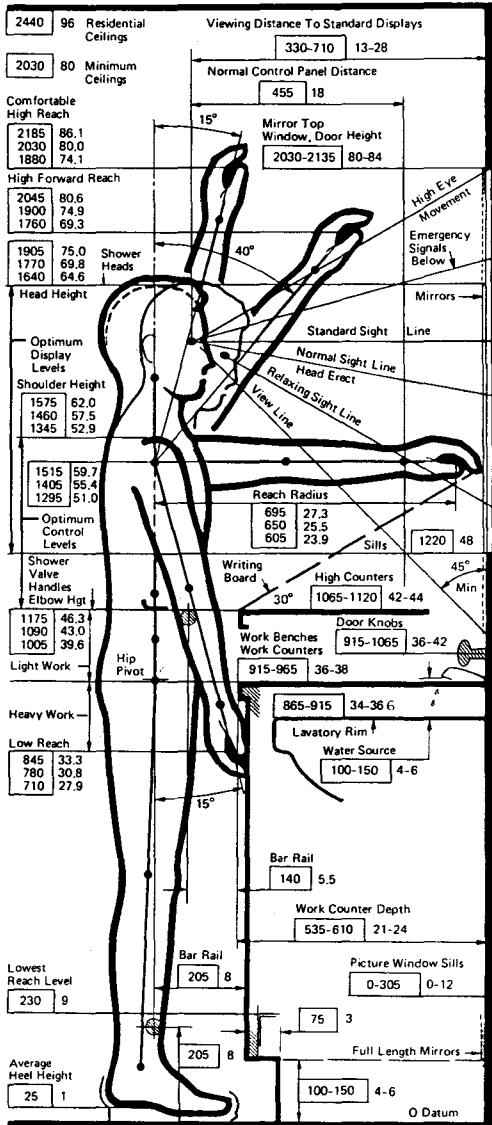
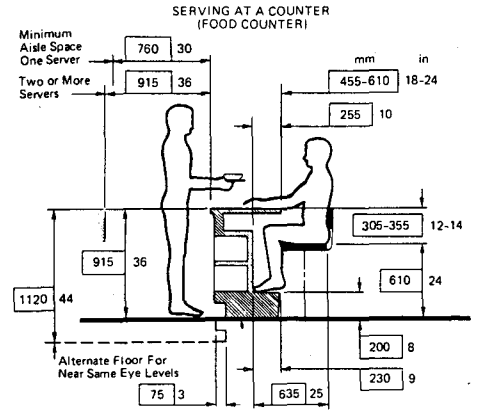
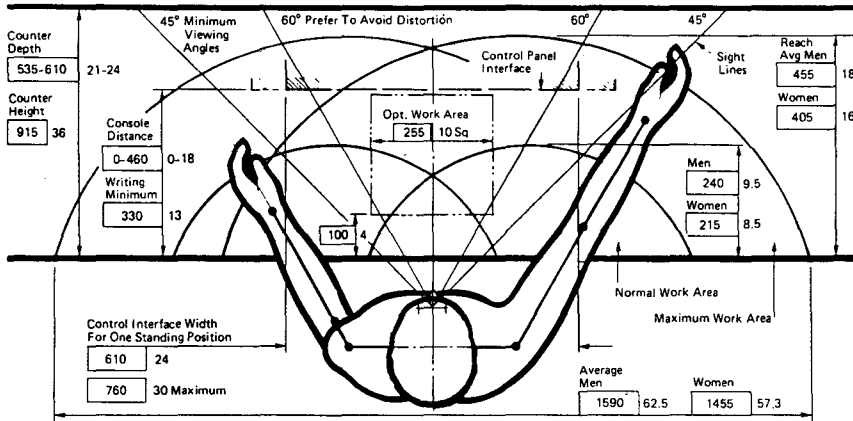

STANDING HEIGHT STDS. COMBINED ADULT SEX

2440	96	Residential Ceiling
2135	84	Office Doors
2030	80	Residential Doors
1980	78	Min Ceiling Chandeliers
1905	75	Shower Head (Max)
1880	74	Highest Head Top
1830	72	Clothes Line (Max)
1830	72	No See Over Hat Hooks (Max)
1830	72	Highest Shelf (Men)
1780	70	Shower Head Clear (Min) Rail For Evening Dresses
1730	68	Top Of Mirror
1600	63	Highest Shelf (Women)
1575	62	Catwalk Head Clear (Min)
1575	62	Avg Adult Eye Level
1475	58	Thermostats
1395	55	See Over
1370	54	Grab Bars
1320	52	Phone Dial Hgt
1320	52	Highest File
1270	50	Door Push Plates
1220	48	Shower Valves
1220	48	Wall Switch Plate
1145	45	Deal Plate
1120	44	Push Bar On Doors
1120	44	Bar (Hi)
1065	42	Counters, Doorknob (Max)
1065	42	Safety Handrails, Bars
1015	40	Entrance Lock (Max)
915	36	Ironing Board (Hi)
915	36	Handrails, Ironing Board (Hi)
840	33	Counters, Doorknob (Min)
840	33	Panic Bars
790	31	Lavatory Rim
760	30	Letter Slot, Rails On Steps
760	30	Ironing Board (Lo)
455	18	Wall Outlets
405	16	Highest Step
305	12	Rung Spacing
205	8	Bar Rails
190	7.5	Stair Riser (Opt)
150	6	Toe Space (Max)
75	3	Toe Clear (Min)
25	1	Threshold (Max)

ADJUSTMENTS FOR THE ELDERLY

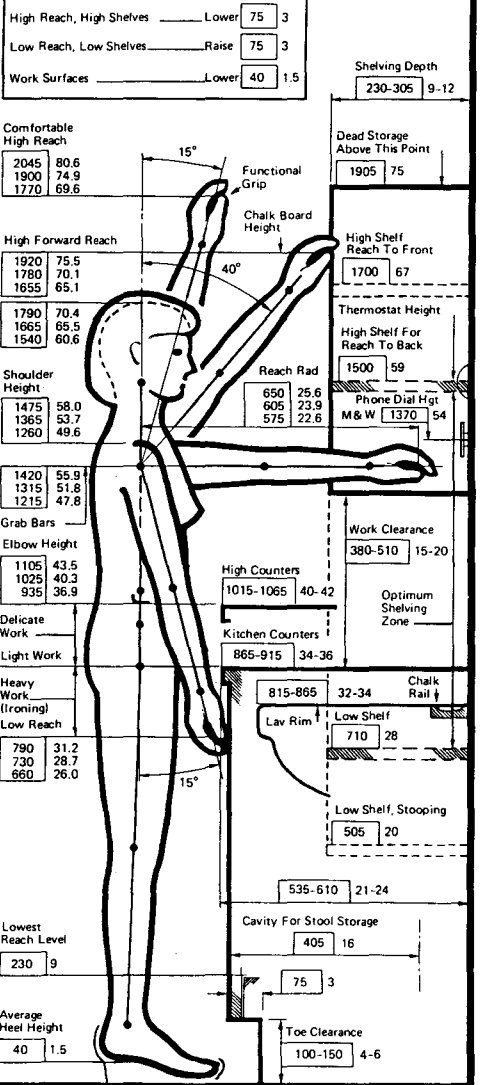

1905	75.0	1790	70.4	large = 97.5 percentile	includes 95% U.S. adults
1775	69.8	1665	65.5	average = 50 percentile	
1640	64.6	1540	60.6	small = 2.5 percentile	

Dimensional notation system:  
 1000 39.3  
 100 3.9  
 25.4 1.0  
 Numbers appearing in boxes are measurements in millimeters. Numbers outside boxes are measurements in inches.

Niels Diffrient, Alvin R. Tilley; Henry Dreyfuss Associates; New York, New York

1 HUMAN DIMENSIONS

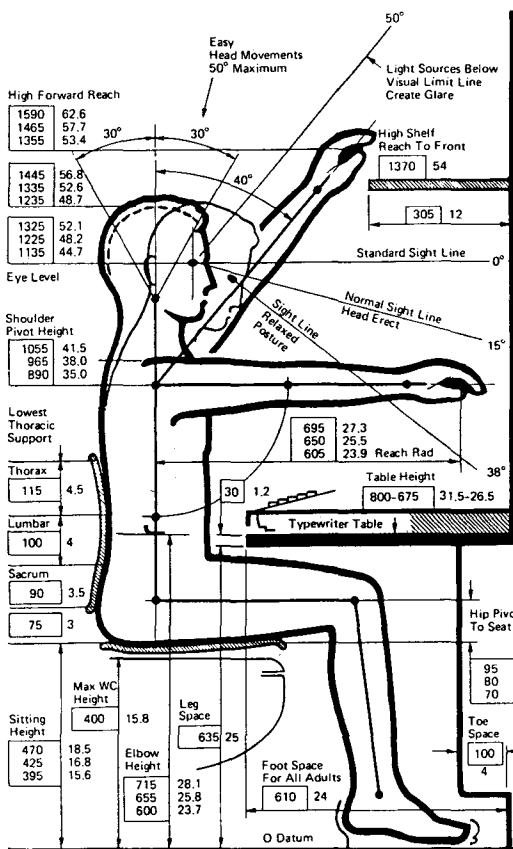
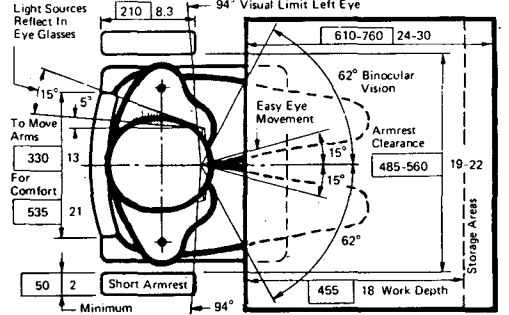
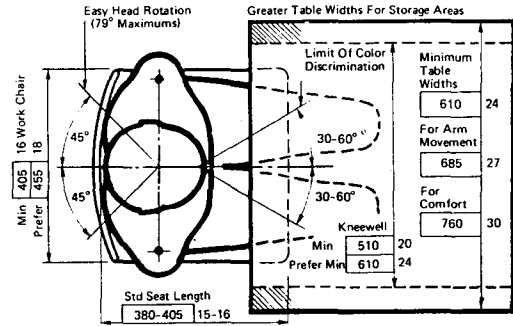
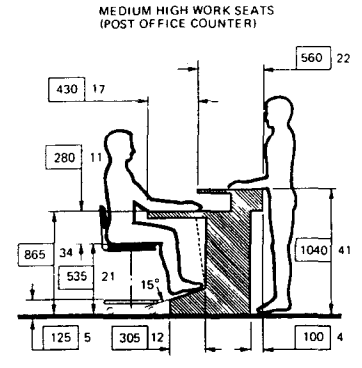
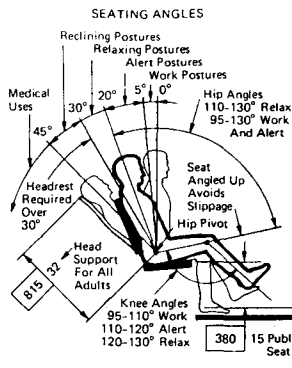
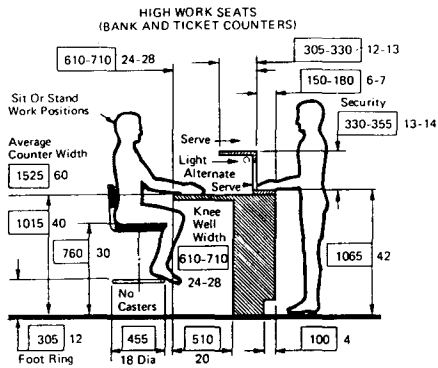

SITTING HEIGHT STDS. COMBINED ADULT SEX

1450	57	Highest Head Top
1420	56	Mirror Top
1370	54	No See Over
1370	54	Floor Lamp (Hi)
1270	50	High Shelf
1195	47	Avg Eye Level
1170	46	High File, Front Tab
1090	43	See Over Hgt
1065	42	Phone Dial Hgt
1015	40	Floor Lamp (Lo)
915	36	Lunch Counter
865	34	High File, Top Tab
790	31	Sewing Table
760	30	Stool For 42 Counter
735	29	Hosp. Bed (Hi) Work Table Desk
685	27	Iron Board
660	26	Typing Table
635	25	Table (Min) Knee Space
610	24	Side Tables Chair For 36 Counter
455	18	Coffee Table (Hi) Wall Outlets
455	18	Bed
445	17.5	Work Chair
400	15.8	Toilet Seat
380	15	Seat (Min) Park Seat
305	12	Foot Stool (Hi)
280	11	Coffee Table (Lo)
150	6	Foot Ring 24 Chair
150	6	Toe Space (Max)
75	3	Toe Clear. (Min)
50	2	Foot Stool (Lo)

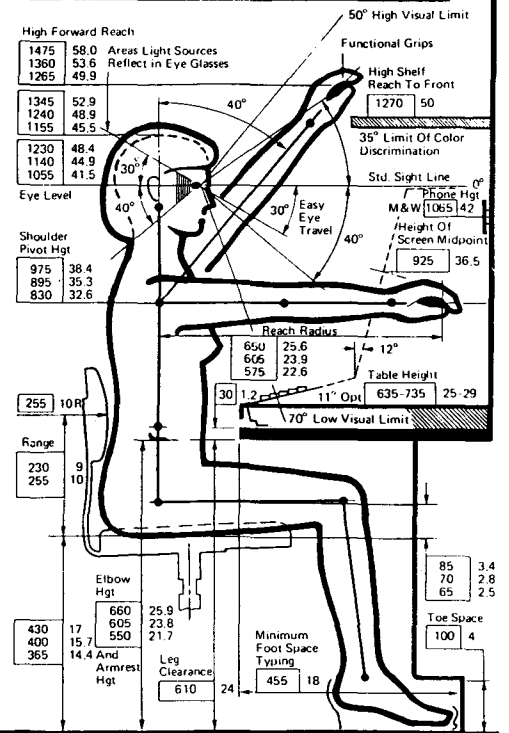
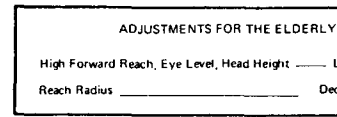

Male and	female standing heights (including shoes):	
1905 75.0	1790 70.4	large = 97.5 percentile
1775 69.8	1665 65.5	average = 50 percentile
1640 64.6	1540 60.6	small = 2.5 percentile
		includes 95% U.S. adults

**Dimensional notation system:**

1000 39.3, 100 3.9, 25.4 1.0

Numbers appearing in boxes are measurements in millimeters. Numbers outside boxes are measurements in inches.

Niels Diffrient, Alvin R. Tilley; Henry Dreyfuss Associates; New York, New York

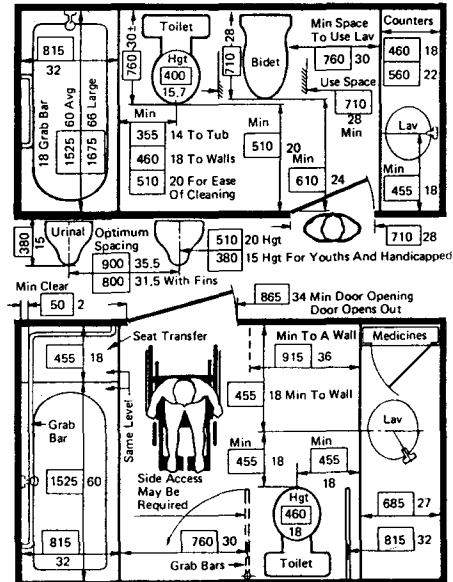
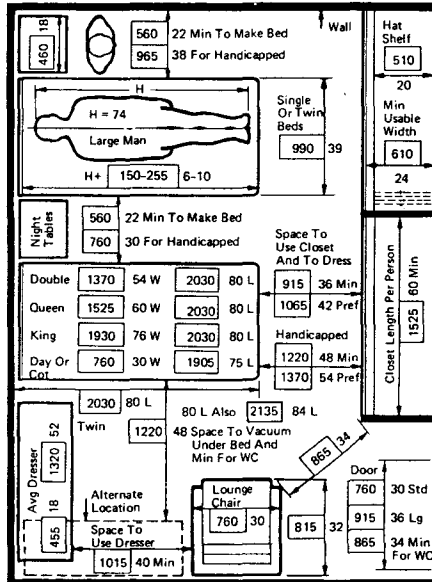
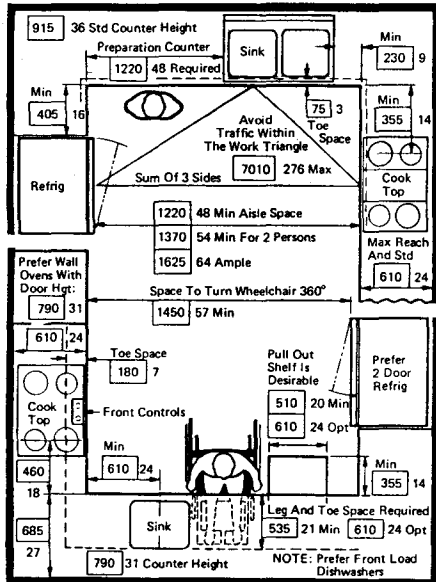
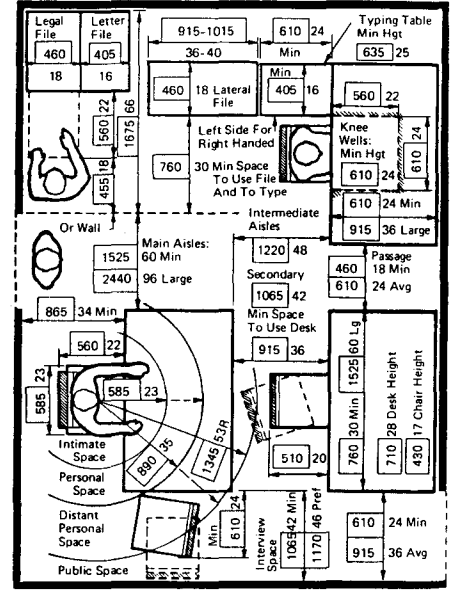
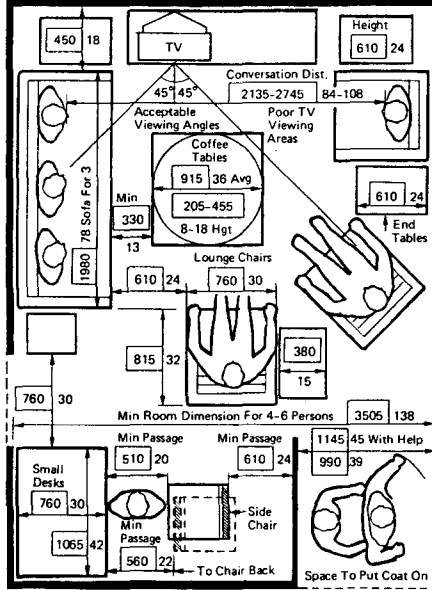
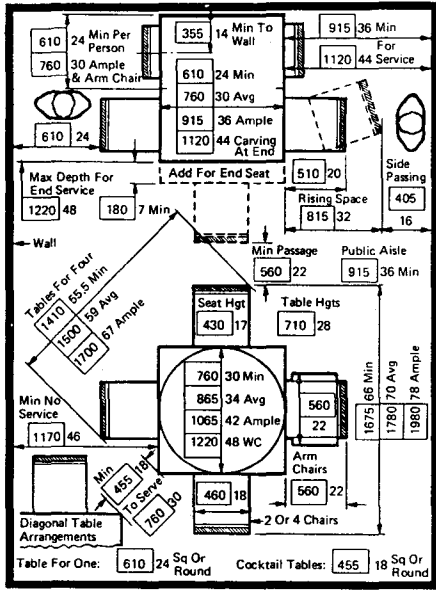
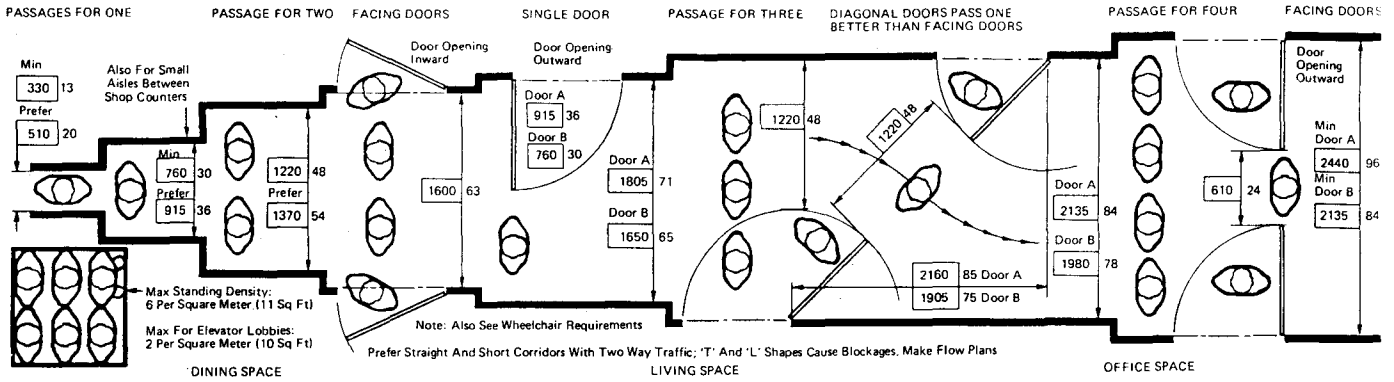

1905	75.0	1790	70.4	large = 97.5 percentile	includes
1775	69.8	1665	65.5	average = 50 percentile	95% U.S. adults
1640	64.6	1540	60.6	small = 2.5 percentile	

English Beds: Small Single 900 x 1900; New Std. Single 1000 x 2000; Small Double 1350 x 1900; New Std. Double 1500 x 2000

Dimensional notation system:  

1000	39.3	Numbers appearing in boxes are measurements in millimeters.
100	3.9	Numbers outside boxes are measurements in inches.
25.4	1.0	

Niels Diffrient, Alvin R. Tilley; Henry Dreyfuss Associates; New York, New York

# 1 HUMAN DIMENSIONS

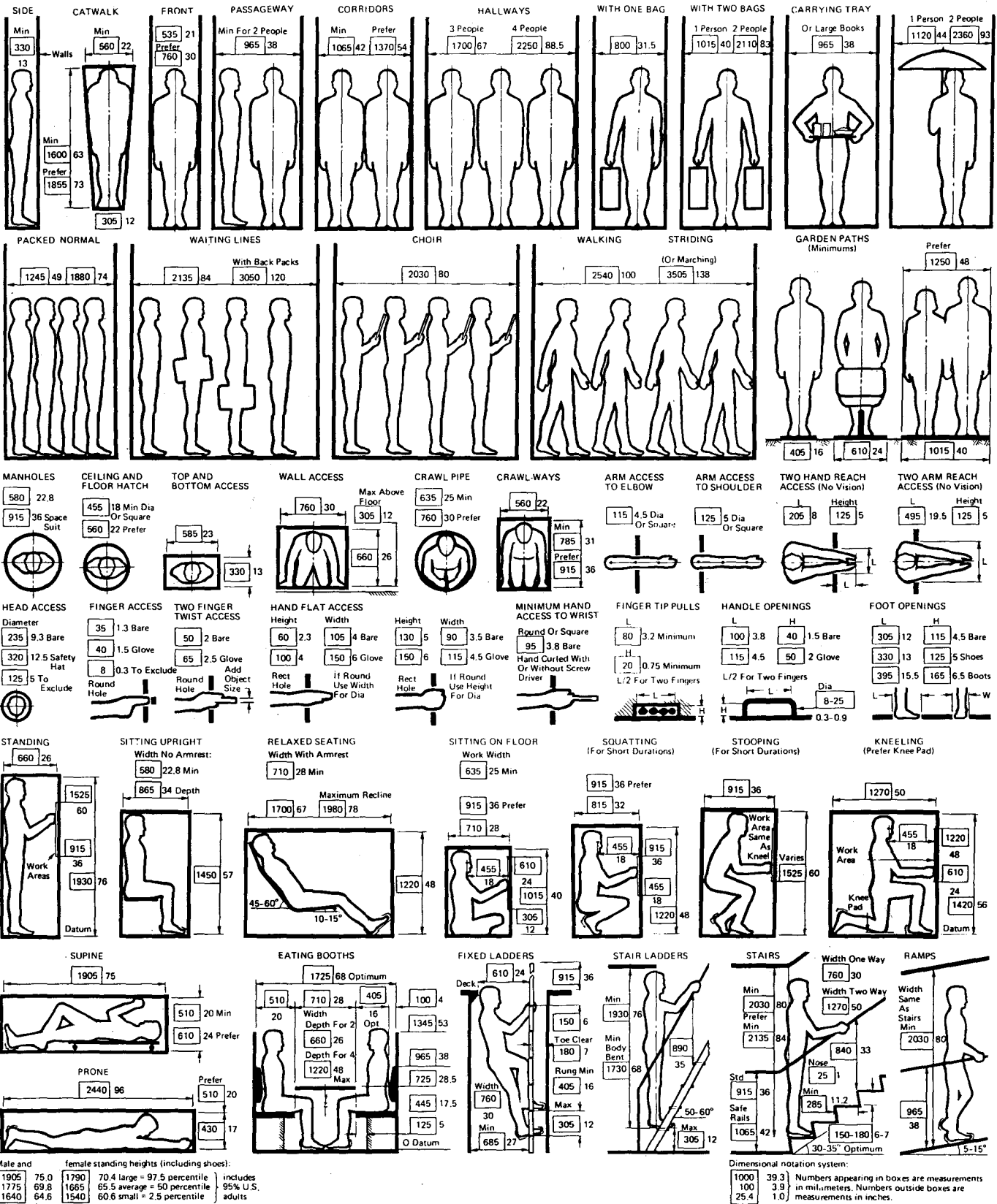

Niels Diffrient, Alvin R. Tilley; Henry Dreyfuss Associates; New York, New York

## 8 Occupant Load Calculations

### GENERAL

The information for determining occupant load shown in the table on this page comes from three model building codes in use in the United States:

1. BOCA National Building Code (BOCA), 1996 edition, with permission of the Building Officials and Code Administrators International, Inc., publisher.
2. Standard Building Code (SBC), 1997 edition, with permission of the Southern Building Code Congress International, Inc., publisher, with all rights reserved.
3. Uniform Building Code (UBC), 1997 edition, with permission of the International Conference of Building Officials, publisher.

Occupant load generally is defined as the maximum capacity of a building or room given as the total number of people present at any one time. For occupant loads, it is generally assumed that all areas of a building will be occupied at the same time, with some exceptions noted in specific codes. For example, the UBC states, "Accessory use areas, which ordinarily are used only by persons who occupy the main

areas of an occupancy, shall be provided with exits as though they are completely occupied, but their occupant load need not be included in computing the total occupant load of the building" [UBC Sec. 3302 (a)].

Most codes require that to determine multiple use building or area occupancies, the occupant load (OL) must be based on the use that produces the most occupants. For example, the occupant load for a school multiple use room, which will be used for classroom activities (OL factor 20) as well as assembly space (OL factor 15), is calculated using the 15 sq ft per occupant factor.

If buildings or areas contain two or more separate occupancies, the overall occupant load is determined by computing occupant loads for various areas and adding them together for an aggregate occupant load.

When calculating occupant load for areas with fixed seating in benches or pews, the number of occupants is based on one seat for each 18 in. of bench or pew space. In dining areas with booth seating, the number of seats is based on 24 in. for each seat.

### OCCUPANT LOADS

USE	MAXIMUM FLOOR AREA PER OCCUPANT (SQ FT)		
	BOCA	SBC	UBC <sup>1</sup>
Assembly areas <sup>2</sup> —concentrated use (without fixed seats): auditoriums, bowling alleys <sup>3</sup> , churches, dance floors, lodge rooms, reviewing stands, stadiums	7 net	7 net	7
Assembly areas—less concentrated use: conference rooms, dining/drinking areas, exhibit rooms, gymnasiums, lounges, stages <sup>4</sup>	15 net	15 net	15
Assembly areas—standing space	3 net	3 net	3
Business areas <sup>5</sup>	100 gross	100 gross	100
Courtrooms (without fixed seats)	40 net	40 net	40
Day care facilities	—	—	35
Dormitories	—	—	50
Educational			
Classroom areas	20 net	20 net	20
Shops and vocational rooms	50 net	50 net	50
Industrial areas <sup>6</sup>	100 gross	100 gross	200
Institutional <sup>7</sup>			
Children's homes, homes for aged, nursing homes, sanitariums, hospitals	—	—	80
Inpatient treatment areas	240 gross	240 gross	240
Outpatient areas	100 gross	100 gross	—
Sleeping areas	120 gross	120 gross	120
Kitchens (commercial)	—	—	200
Libraries			
Reading rooms	50 net	50 net	50
Stack areas	100 gross	100 gross	100
Lobbies (accessory to assembly area)	—	—	7
Locker rooms	—	—	50
Mechanical equipment areas	300 gross	300 gross	300
Mercantile <sup>8</sup>			
Basements	30 gross	30 gross	30
Ground floors	30 gross	30 gross	30
Upper floors	60 gross	60 gross	60
Storage, stockrooms, shipping areas	300 gross	300 gross	300 <sup>9</sup>
Parking garages	200 gross	200 gross	200
Residential <sup>10</sup>	200 gross	200 gross	—
Hotels and apartments	—	—	200
Dwellings	—	—	300
Skating rinks <sup>11</sup>	—	15 net	—
Rink area	—	—	50
Deck	—	—	15
Storage areas	300 gross	300 gross	300
Swimming pools			
Pool	—	—	50
Deck	—	—	15
All other areas	—	—	100

1. Both BOCA and SBC use net and gross floor areas to determine occupant load. UBC does not differentiate between net and gross areas.
2. Occupant loads for assembly areas with fixed seats are determined by the actual number of installed seats.
3. Occupant load calculations for bowling alleys under BOCA and SBC use 5 persons per alley in addition to the tabular values indicated.
4. Stages are considered assembly areas—less concentrated use (15 sq ft per occupant) in UBC, not separately classified in BOCA or SBC.
5. UBC classifies business areas as office occupancy.
6. UBC classifies industrial areas as manufacturing areas.

7. BOCA and SBC classify areas within institutional occupancies; UBC classifies by occupancy description only.
8. UBC classifies mercantile areas as store-retail sales rooms.
9. UBC considers storage and stockroom areas as storage occupancy (300 sq ft per occupant).
10. BOCA and SBC do not separate hotel/apartment and dwelling occupancies.
11. BOCA does not classify skating rinks separately from other assembly areas of less concentrated use (15 sq ft per occupant). SBC does not separate areas within skating rinks.

### EXITS

All three major codes use occupant loads to determine the size and number of required exits. Based on occupant loads and area uses, it is possible to determine the required number of exits and the arrangement and sizes of exit components.

All three codes (BOCA, SBC, and UBC) consider an exit to be more than merely a door. Although specific definitions vary with each code, exits usually are considered to be continuous and unobstructed means of egress to a public way and may include such building elements as doors, corridors, stairs, balconies, lobbies, exit courts, etc. Elevators are not considered exits. Requirements for arrangement, size, and operation of exits vary; consult applicable codes for specific information.

### MINIMUM EXITS BASED ON USAGE

USAGE	2 EXITS MINIMUM REQUIRED WHERE OCCUPANT LOAD IS AT LEAST:
Aged, homes for the	6
Aircraft hangars	10
Auction rooms	30
Assembly areas	50
Bowling alley	50
Children's homes	6
Classrooms	50
Congregate residences	10
Courtrooms	50
Dormitories	10
Dwellings	10
Exercise rooms	50
Health care facilities	
Sleeping rooms	8
Treatment rooms	10
Hotels and apartments	10
Kitchens (commercial)	30
Library reading rooms	50
Locker rooms	30
Manufacturing areas	30
Mechanical equipment rooms	30
Nurseries for children (day care)	7
Offices	30
Parking garages	30
School shops and vocational rooms	50
Skating rinks	50
Storage and stockrooms	30
Stores (retail sales rooms)	
Basements	2 exits minimum
Ground floors	50
Upper floors	50
Swimming pools	50
Warehouses	30
All other	50

ICBO; SBCCI; BOCA  
James O. Rose, AIA; University of Wyoming; Laramie, Wyoming  
Annica S. Emilsson; Rippeteau Architects, P.C.; Washington, D.C.

**GENERAL**

Stairways are an essential component in the circulation and egress systems of most buildings. They are also the site of accidents resulting in approximately 4000 deaths and one million injuries requiring hospital treatment annually in the United States. For these reasons, stairway design is strictly controlled by building regulations.

The information on this and the following page on stair design summarizes most common building code and access regulation requirements. Be sure to check local regulations as well.

**MINIMUM REQUIREMENTS:** Consult the table below on building code stairway requirements to determine dimensional limits for treads, risers, and stair width. Verify that local codes are not more restrictive.

**TREAD AND RISER SIZES:** Use the stair proportioning graph on the associated AGS stair design page to find the number of risers, riser height, and optimum tread depth.

**STAIR WIDTH:** In addition to the minimums shown on this page, stair widths must also meet occupant load requirements based on use group and floor area. Consult the local building code.

**LANDINGS:** Landings at least as wide as the stair itself are required at the top and bottom of the stair and at intermediate points if necessary to ensure that no single flight has a rise greater than 12 ft (3658 mm).

**STAIR LAYOUT:** A sample stairway plan and section are shown on the following page on stair design. Some tips for stair layout follow:

1. Maintain minimum headroom of 6 ft 8 in. (2032 mm) for non-residential and 6 ft 6 in. (1981 mm) for residential stairs.
2. Avoid flights with fewer than three risers to minimize tripping hazards.
3. The use of door alcoves is recommended to prevent stairway doors from obstructing the egress travel path.
4. For prefabricated stairs, the stairwell enclosure should be oversized by several inches for ease of stair installation and to avoid structural conflicts.

**TREAD AND RISER PROPORTIONING**

Most interior stairs are designed to the steepest limits permitted by code so as to occupy the least amount of space. However, tread and riser combinations that are less steep may be considered for exterior stairs, grand stairs, or stairs of just a few risers. The most common rule for the comfortable proportioning of stairs in these cases is 2 x riser height + tread depth = 25 in. (635 mm). Consider testing life-size mock-ups of stairs of unusual proportions to verify their ease of use.

**HANDRAILS**

The accompanying diagrams summarize most handrail requirements for nonresidential stairs. For residential stairs not covered by ADA, most codes permit handrails on only one side of the stair, without top and bottom extensions. In some cases a greater range of heights is also permitted. The ADA recommends (but does not require) additional handrails at lower heights where stairs are used by children.

**GUARDRAILS**

Guardrails 42 in. (1067 mm) in height are typically required on the open sides of nonresidential stairs. When handrails are used in combination with a guardrail, handrail heights

up to 42 in. (1067 mm) are permitted by some building codes. Intermediate rails or balusters must be spaced so that a sphere of either 4 or 6 in. (102 or 152 mm), depending on the code and use group, cannot pass through any part of the guard. Guardrail designs with horizontal rails that are easily climbed are not recommended and, in some cases, are restricted. For residential stairs, guardrails 36 in. (914 mm) in height are usually permitted.

**STAIR DETAILS**

Treads and risers within a flight must be uniform in size within close tolerances. Treads must be slip resistant. The shape of nosings and risers must meet the requirements shown below. Carpeting or other stair coverings should be applied securely and should not create a nosing radius greater than permitted. Handrails, guardrails, and stairways themselves must meet structural load requirements.

Access regulations in some localities require floor material strips of contrasting color located at the top approach to a stair and at the lowest tread. These markings are intended to aid the visually impaired in identifying the limits of the stair. The application of such markings may be appropriate even where not required, particularly where a high proportion of elderly or visually impaired users are anticipated.

**SPECIAL STAIR CONFIGURATIONS**

Winders (radiating risers) in stairs normally are permitted only in single-family residences. Minimum tread depth requirements at the inside of the winders may limit the inside radius of the stair. Spiral stairs typically are permitted in single-family residences and for access to mezzanines of limited area in other building types. With certain tread depth restrictions, circular stairways are permitted in most buildings. Alternating tread stairways are permitted for some mezzanines and for access to rooftops. The use of fixed ladders is limited to access to restricted areas, such as rooftops and elevator pits.

**REFERENCES**

*Metal Stairs Manual*. National Association of Architectural Metal Manufacturers, 1992.

Templer, John. *The Staircase*, 2 vols. Cambridge, Mass.: MIT Press, 1992.

**NOTE**

See pages in other *Architectural Graphic Standards* chapters for stair construction details in various materials and for other applications.

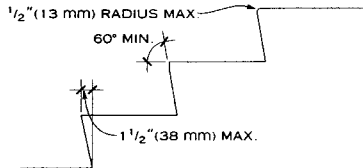

**ACCEPTABLE NOSINGS AND RISERS**

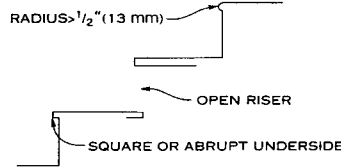

**UNACCEPTABLE NOSINGS AND RISERS**

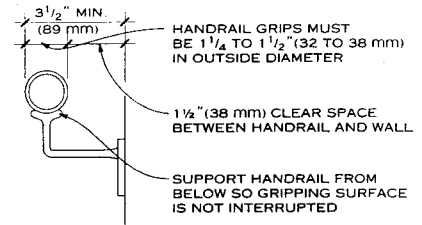

**SECTION**

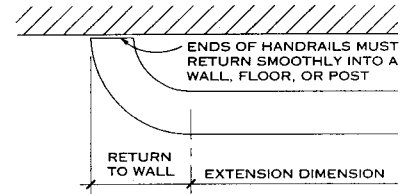

**PLAN**

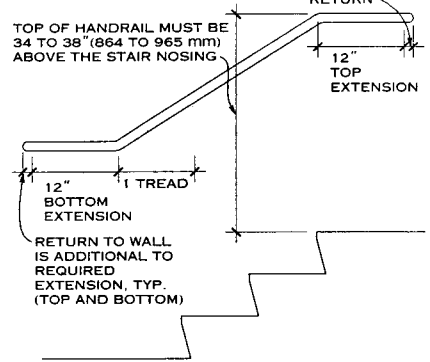

**ELEVATION**

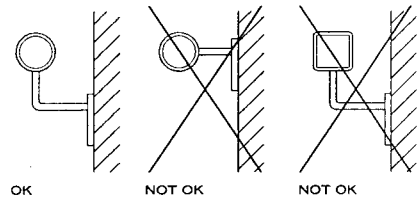

**NOTES**

1. When considering metal pipe rails, do not confuse the nominal size by which pipes are specified with the actual outside diameter of the pipe. The outside diameter is larger than the nominal size.
2. Handrails must be continuous on both sides of a stair. Ends of handrails must extend beyond the stair as shown above.
3. The gripping portion of a handrail must be equivalent to a 1 1/4 to 1 1/2 in. (32 to 38 mm) diameter round rail.

**HANDRAIL DETAILS CONFORMING TO ADA AND MOST BUILDING CODES**

**BUILDING CODE STAIRWAY REQUIREMENTS**

	BUILDINGS OTHER THAN SINGLE-FAMILY RESIDENCES			SINGLE-FAMILY RESIDENCES		
	MINIMUM TREAD DEPTH	RISER RESTRICTIONS	MINIMUM STAIR WIDTH	MINIMUM TREAD DEPTH	RISER RESTRICTIONS	MINIMUM STAIR WIDTH
1998 ADAAG	11" (279 mm)	No limits	48" (1219 mm) clear between handrails for stairs adjacent to an area of rescue assistance	No limits	No limits	No limits
1996 BOCA National Building Code	11" (279 mm)	7" (178 mm) maximum 4" (102 mm) minimum	44" (1118 mm) 36" (914 mm) for occupancy of 50 or fewer	9" (229 mm)	8 1/4" (210 mm)	36" (914 mm)
1997 Standard Building Code	9" (229 mm)	7 3/4" (197 mm) maximum	44" (1118 mm) 36" (914 mm) for occupancy of 50 or fewer in some cases	9" (229 mm)	7 3/4" (197 mm)	36" (914 mm)
1997 Uniform Building Code	11" (279 mm)	7" (178 mm) maximum 4" (102 mm) minimum	44" (1118 mm) 36" (914 mm) for occupancy of 49 or fewer 60" (1524 mm) for educational use group with occupancy of 100 or more	9" (229 mm)	8" (203 mm)	36" (914 mm)

Joseph Iano, Architect: Boston, Massachusetts  
Edward Allen, AIA: South Natick, Massachusetts  
Rippeteau Architects, P.C.: Washington, D.C.



STAIR PROPORTIONING GRAPH

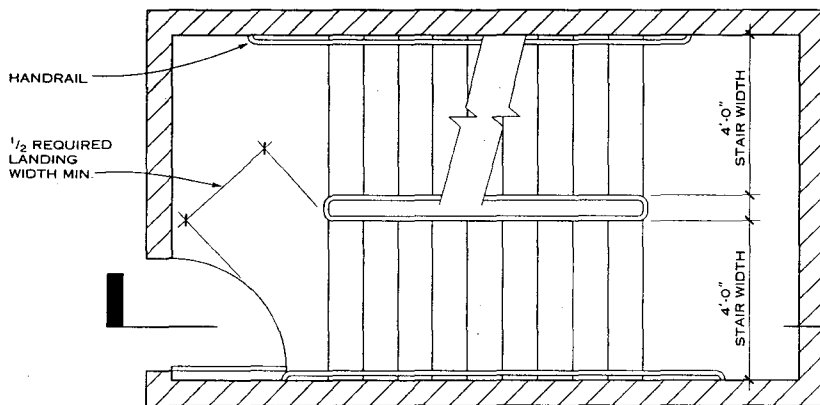
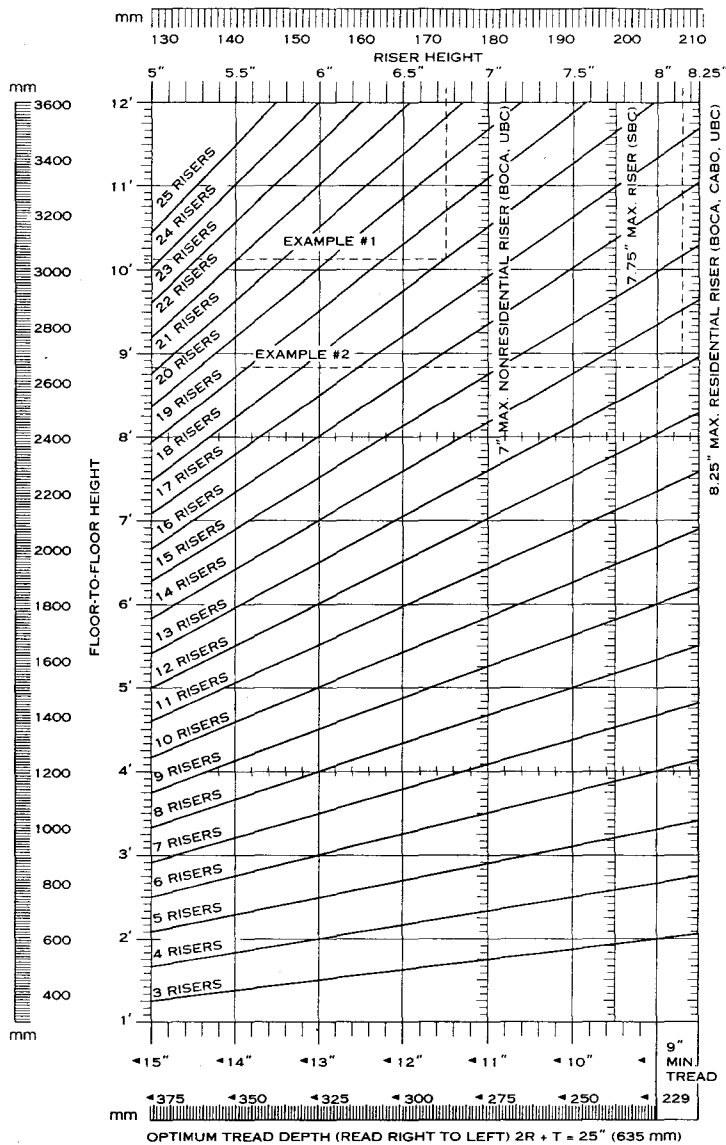

PLAN  
SAMPLE STAIRWAY

Joseph Iano, Architect; Boston, Massachusetts  
Edward Allen, AIA; South Natick, Massachusetts  
Rippeteau Architects, P.C.; Washington, D.C.

1 EGRESS PLANNING

STAIR DESIGN AND BUILDING CODES

Building codes are updated regularly, so it is best to consult the current copy of the applicable building code (the BOCA National Building Code, the Standard Building Code, or the Uniform Building Code) for tread and riser dimensions. The International Building Code will also offer a standard for these dimensions when it is published in 2000.

STAIR DESIGN EXAMPLE 1

An exit stairway in a theater rises a total of 20 ft 3 in. This dimension is off the graph shown at left, which means that at least one landing must be inserted in the stair. Select two flights of 10 ft 1 1/2 in. rise each. Looking for the highest possible riser, read across to the 18-riser sloping line (before crossing the 7 in. maximum riser height line), then upward to read a riser height of 6.75 in. Reading downward to the bottom horizontal axis, the optimum tread dimension is 11 1/2 in. This figure can be rounded down to the legal minimum of 11 in. to make the stair as compact as possible.

STAIR DESIGN EXAMPLE 2

A stairway in a single-family house rises 8 ft 10 in. and needs to be as compact as possible according to CABO requirements. Read across to the 13-riser sloping line, then upward to read a riser of 8.15 in.

NOTES

1. Stairs should be laid out in both plan and section. The dimensions shown on this page are samples only.
2. Landings must be at least as wide as the stair.
3. No single flight may rise more than 12 ft 0 in. (3658 mm) vertically.
4. In each flight, there is one more riser than tread.
5. Handrails may project up to 3 1/2 in. (89 mm) into the required stairway width. They must be continuous or the ends must extend beyond the top and bottom of the stair. Stairs serving areas of rescue assistance must have 4 ft clear between handrails.
6. Stairway doors must swing with the direction of egress travel and must not obstruct more than half of the required landing width at any point in the swing. When fully open doors must not strike handrails (including extensions) and not project more than 7 in. (178 mm) into the travel path.
7. See AGS page on areas of rescue assistance for more restrictive stair dimensioning requirements.

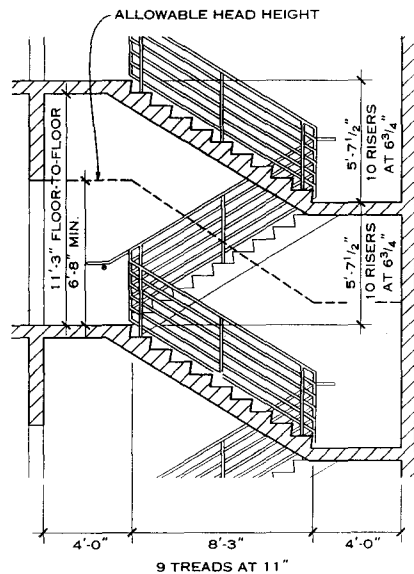

NOTE  
Measure allowable head height at nosings.

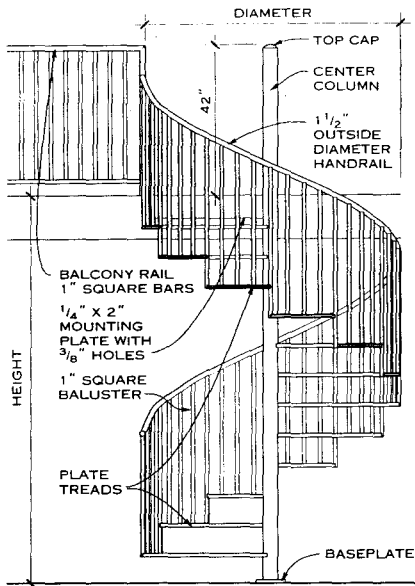

ELEVATION

FRAMING DIMENSIONS (IN.)

	STAIR DIAMETER								
	40	48	52	60	64	72	76	88	96
A	20	24	26	30	32	36	38	44	48
B	24	28	30	34	36	40	42	48	52
C	44	52	56	64	68	76	80	92	100

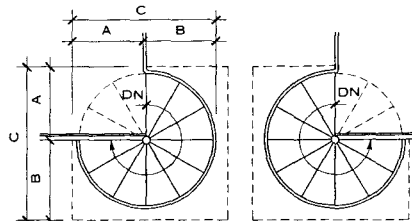

PLAN—RIGHT-HAND UP PLAN—LEFT-HAND UP  
NOTES

1. For spiral stairs, larger diameters increase perceived comfort, ease of use, and safety.
2. Tread and platform materials: The most common materials are steel (regular and galvanized), aluminum, and wood. Steel and aluminum can be smooth plate, checker plate, pan type, and bar. A variety of hardwoods can be used, although many manufacturers use steel substructures to support the wood finish surface.
3. Refer to local and national codes for dimension and construction requirements and allowable uses.

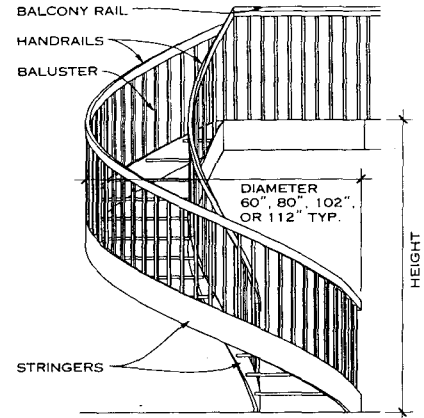

ELEVATION

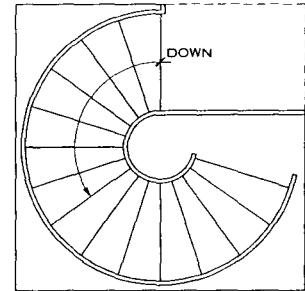

PLAN  
NOTE

Design considerations for circular stairs are similar to those for spiral stairs. A fabricated steel tube serves as a one-piece stringer to which treads are bolted or welded. Risers can be open or closed. Numerous finishes are available, and treads can be made of laminated wood.

CIRCULAR STAIRS

SPIRAL STAIRS

SPIRAL STAIR DESIGN DIMENSIONS (IN.)

Diameter	40	48	52	60	64	72	76	88	96
Center column	4	4	4	4	4	4	4	6 5/8	6 5/8
Lb/ft	205	220	235	250	265	310	325	435	485
Tread detail A	4	4	4	4	4	4	4	6 5/8	6 5/8
Tread detail B	18	22	24	28	32	34	36	42	48
27° tread detail C	9 1/4	11 1/8	12 1/8	13 15/16	14 7/8	16 3/4	17 5/8	20 1/2	22 5/16
27° tread detail D	7 5/8	8	8 1/4	8 3/8	8 1/2	8 5/8	8 3/4	10	10 1/2
30° tread detail C	10 1/2	12 9/16	13 5/8	15 3/4	16 3/4	18 7/8	19 7/8	23	25 1/2
30° tread detail D	8 1/2	8 5/8	8 3/4	8 7/8	9	9 1/4	9 3/8	11 3/8	11 1/2
Landing size	22	26	28	32	34	38	40	46	52

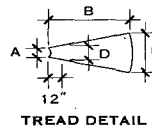

TREAD DETAIL

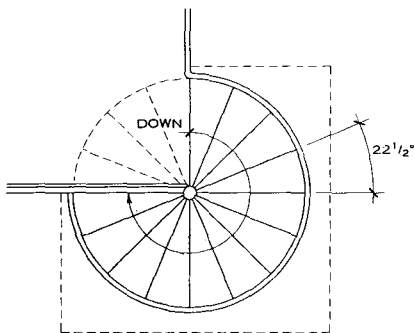

PLAN—RIGHT-HAND UP

FLOOR-TO-FLOOR TREAD COUNT

FINISH FLOOR HEIGHT (IN.)	NUMBER OF STEPS	CIRCLE DEGREE
84 to 91	12	270°
92 to 98	13	292 1/2°
99 to 105	14	315°
106 to 112	15	337 1/2°
113 to 119	16	360°
120 to 126	17	382 1/2°
127 to 133	18	405°
134 to 140	19	427 1/2°
141 to 147	20	450°
148 to 154	21	472 1/2°

NOTE

16 treads per circle. Riser height: 6 1/2 to 7 in.

22 1/2° TREAD SPIRAL STAIRS

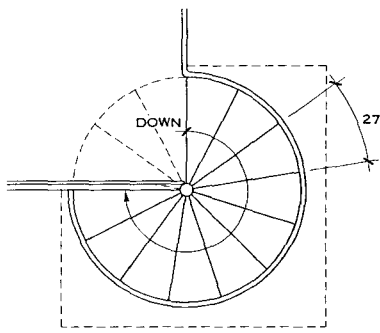

PLAN—RIGHT-HAND UP

FLOOR-TO-FLOOR TREAD COUNT

FINISH FLOOR HEIGHT (IN.)	NUMBER OF STEPS	CIRCLE DEGREE
90 to 96	11	297°
97 to 104	12	324°
105 to 112	13	351°
113 to 120	14	375°
121 to 128	15	405°
129 to 136	16	432°
137 to 144	17	459°
145 to 152	18	486°
153 to 160	19	513°
161 to 168	20	540°

NOTE

13 1/2 treads per circle. Riser height: 7 1/2 to 8 in.

27° TREAD SPIRAL STAIRS

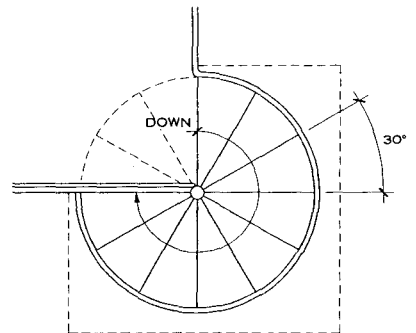

PLAN—RIGHT-HAND UP

FLOOR-TO-FLOOR TREAD COUNT

FINISH FLOOR HEIGHT (IN.)	NUMBER OF STEPS	CIRCLE DEGREE
85 to 95	9	270°
96 to 104	10	300°
105 to 114	11	330°
115 to 123	12	360°
124 to 133	13	390°
134 to 142	14	420°
143 to 152	15	450°
153 to 161	16	480°
162 to 171	17	510°
172 to 180	18	540°

NOTE

12 treads per circle. Riser height: 8 1/2 to 9 1/2 in.

30° TREAD SPIRAL STAIRS

David W. Johnson; Washington, D.C.

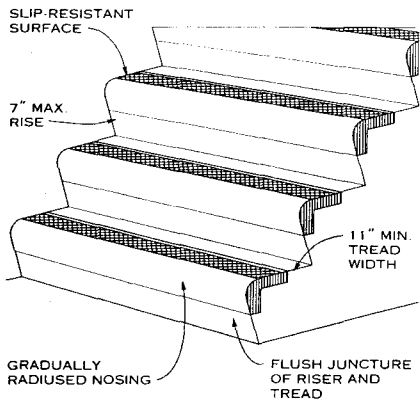

**TREADS AND RISER SIZES**

Riser and tread dimensions must be uniform for the length of the stair. ANSI specifications recommend a minimum tread dimension of 11 in., nosing-to-nosing and a riser height of 7 in., maximum. Open risers are not permitted on stairs accessible to persons with disabilities.

**TREAD COVERING**

OSHA standards require finishes to be "reasonably slip resistant" by using nosings of slip-resistant finish. Treads without nosings are acceptable provided that the tread is serrated or is of a definite slip-resistant design. Uniform color and texture are recommended for clear delineation of edges.

**NOSING DESIGN**

ANSI specifications recommend nosings without abrupt edges that project no more than 1 1/2 in. beyond the edge of the riser. A safe stair uses a 1/2 in. radius abrasive nosing firmly anchored to the tread, with no overhangs and a clearly visible edge.

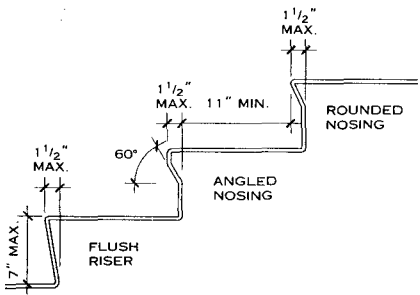

**RISER DESIGN**

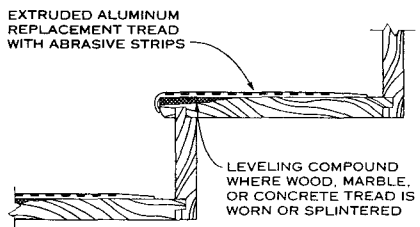

**NOTE**

Abrasive materials are used as treads, nosings, or inlay strips for new work and as surface-mounted replacement treads for existing work. A homogeneous epoxy abrasive is cured on an extruded aluminum base for a smoother surface, or it is used as a filler between aluminum ribs.

**REPLACEMENT OF TREAD**

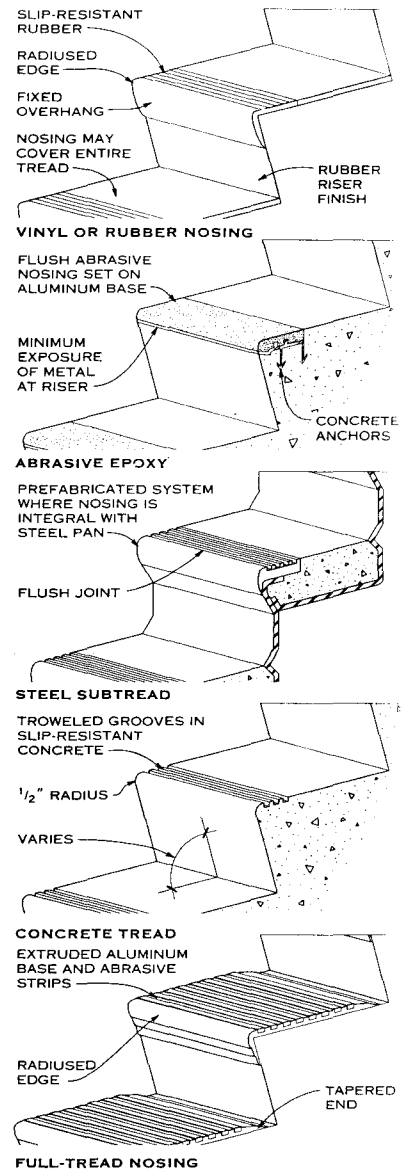
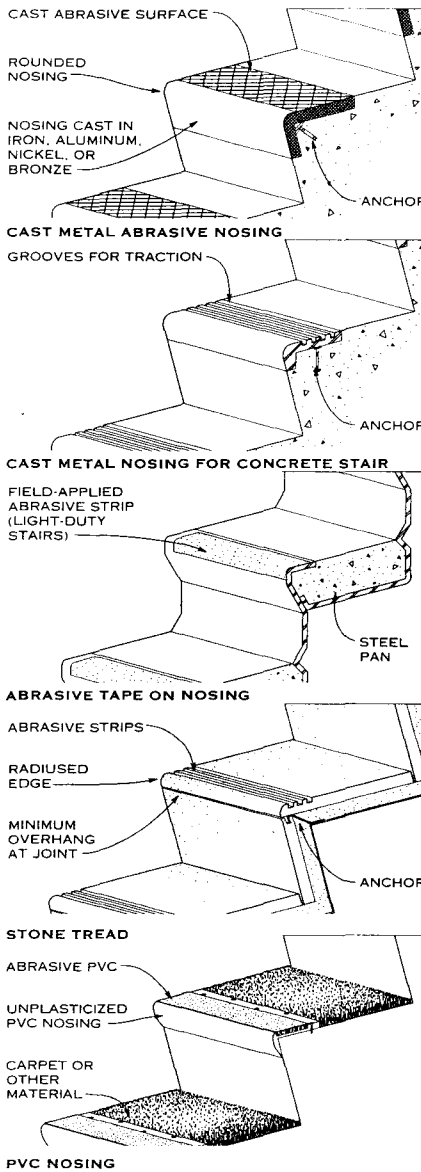

**ACCEPTABLE NOSING PROFILES (ANSI 117.1-86)**

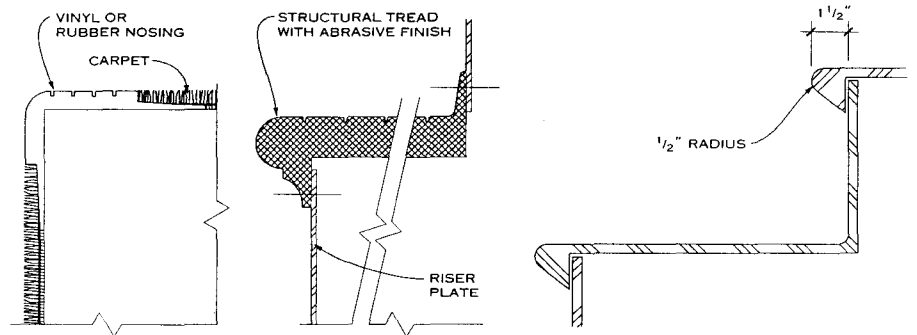

VINYL NOSING      STRUCTURAL TREAD      INTEGRAL METAL TREAD/RISER  
NOSING DETAILS

Eric K. Beach and Annica S. Emilsson, Rippeteau Architects, PC; Washington, D.C.

## INTRODUCTION

Combining a wide range of common building technologies, the building systems presented on this and the following pages reflect basic approaches to design, construction, and use of materials in response to a variety of occupancy requirements. Such building systems embody key integration issues that arise when components and subsystems are merged to produce complete buildings.

Each example includes a summary of the unique system features, a description of the system's most appropriate or particularly advantageous uses, and a discussion of the main opportunities and challenges for systems integration. The drawings stress the essential interconnectedness among design decisions, illustrating the design process as a fusion of the knowledge of many disciplines, each with an understanding of the value and import of the others' contributions.

The examples encompass structural, envelope, mechanical, and interior systems. In most examples one system (usually structural) or a pair of systems tends to dominate the integration potentials and priorities, clearly circumscribing the prudent and possible uses of the other systems. The examples represent common and reasonable combinations and variations, but they are not the only possibilities within a given building vocabulary.

## STRUCTURAL

Roof: Steel decking and open web steel joists (C)  
 Floor: Slab on grade (M)  
 Walls: Concrete masonry bearing wall and concrete footing (H)

Principal advantages and characteristics: Bearing wall and bar joist roof building systems employ masonry walls bearing on a turndown slab on grade or conventional spread footings. The walls support a roof structure of open web steel bar joists, through which mechanical distribution systems are threaded. Spans for J- and H-series open web joists generally may not exceed more than 20 times the joist depth, or more than 50 to 60 ft. Long-span joists are available, as are a wide variety of special shapes. By nature, open web joists spaced at even intervals are best suited to relatively light, uniform loads; joists may be doubled or tripled to accommodate heavier, concentrated loads or may be combined with other steel framing for roof openings and rooftop mechanical equipment. The roof deck may be precast concrete plank, tongue and groove wood decking, or, more commonly, steel decking. Small openings in the roof area can be framed between joists by means of specially designed headers.

In buildings with masonry bearing walls, each joist should be anchored to the masonry by means of a joist anchor embedded in the masonry. Steel joists can be designed to cantilever beyond the edges of the bearing walls. Continuous horizontal bracing of both top and bottom joist chords is possible with spot-welded connections at each joist and with the ends of the bracing members anchored to a bearing wall; this type of system is well suited to seismic risk zones.

## ENVELOPE

Roof: Built-up roofing and rigid insulation (B)  
 Walls: Window assembly (N), exterior insulation and finish system (EIFS) (D), and canopy assembly (K)  
 Floor: Vapor barrier and dampproofing (L)

Principal advantages and characteristics: The concrete masonry unit (CMU) bearing walls are insulated on the exterior to take better advantage of the wall's thermal mass by placing it toward the occupied side. Long-span open web steel joist roofs can deflect substantially, and the camber of the joists alone is often not sufficient to maintain the necessary slope to roof drains.

## MECHANICAL

HVAC: Rooftop unit (A) and ductwork (G)  
 Electrical: Surface-mounted conduit or behind furred-out walls  
 Plumbing: In partition walls, then through roof  
 Fire safety: Sprinkler system suspended from structure in ceiling plenum (E)

Principal advantages and characteristics: If ductwork is to be housed within the depth of the joist, headers or branches must be fed through the joist webs, perpendicular to the spanning direction. The webs of joists must be aligned, and bearing walls with projections must be worked around. Because beams running transverse to the joists may block the threading of piping, ductwork, and wiring, care must be taken that variations in the configuration of

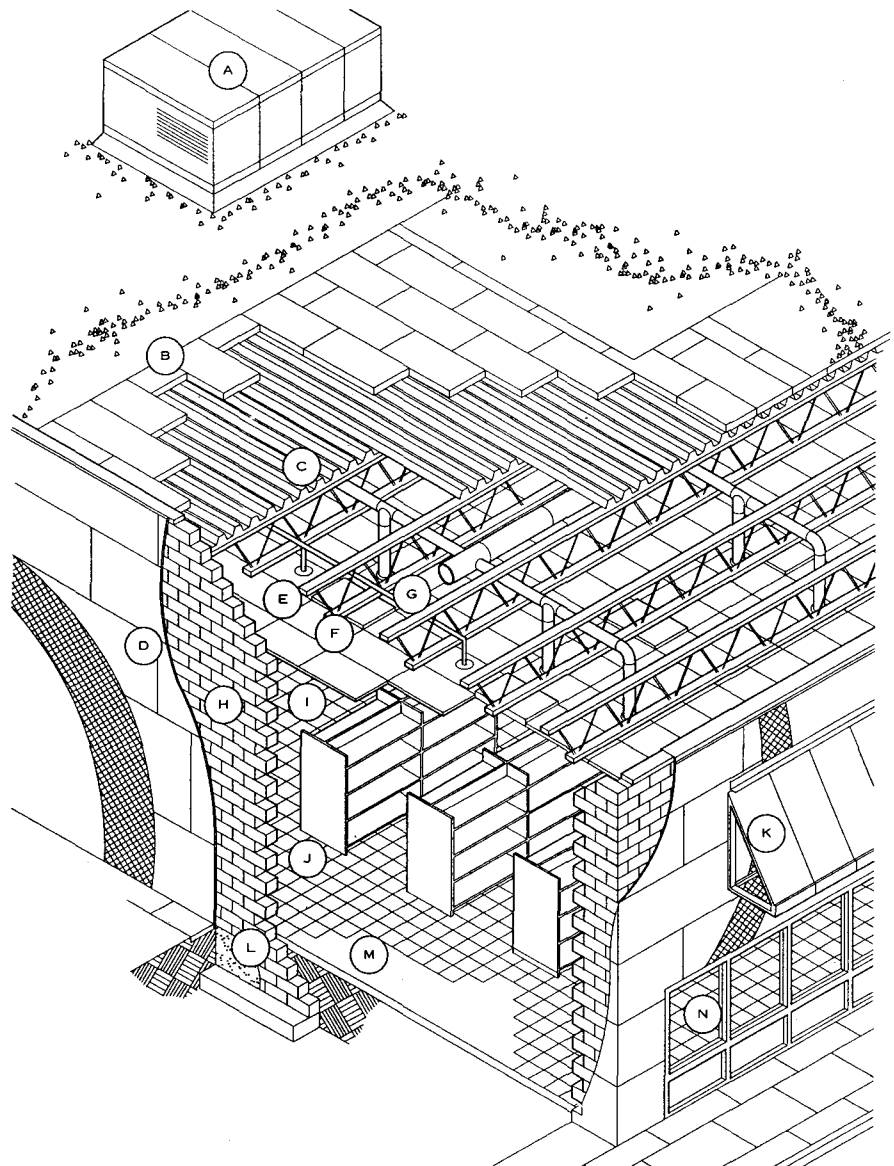

## STEEL BAR JOIST WITH BEARING WALL

perimeter walls do not disrupt the regular pattern of the joist web elements, interfering with straight runs for mechanical components. If the building owners will also be tenants, relatively fixed interior lighting and mechanical systems may be planned. Otherwise, overhead and in-floor systems should be laid out for maximum flexibility. If the joist depth is insufficient to carry the ductwork, such equipment can be suspended from the bottom chord of the steel joist.

## INTERIOR

Ceilings: Suspended acoustical tile (E)  
 Floors: Resilient tile (J)  
 Walls: Glazed interior face on CMU (I)  
 Lighting: Fluorescent light fixture in ceiling (F) and natural light (N)  
 Furnishings: Movable displays

Principal advantages and characteristics: Suspended interior ceilings are nearly always preferred to directly attached interior ceilings. Finished ceilings attached directly to the joist bottom chord are not only difficult to alter but must be designed to accommodate the high degree of deflection the roof assembly will experience.

## SYSTEM SUMMARY

Steel open web joist and bearing wall construction yields buildings that have relatively large interior clear spans and flexible interior layouts. The open webbing of the joists provides a lightweight structure that is easily penetrated by mechanical systems. The bottom chords of the joists are used for suspension of interior finishes, lighting fixtures, and air diffusers in finished areas, although they may be left uncovered. Masonry bearing walls and metal joist roofs are among the simplest and easiest to design and build. The relatively low cost of the system makes it attractive for speculative projects, as does the fact that contractors find this construction method familiar and easy to erect. Retail commercial facilities usually require flexibility in lighting, partitioning, and mechanical systems and large expanses of column- and wall-free space; the envelope and structural systems chosen often reflect these demands.

The height to which masonry bearing walls can be built without resorting to lateral bracing is limited, so they are used most frequently in one-story structures. Roof spans up to 60 ft can generally be accommodated. The spacing and depth of joists is related to the spanning capability of the roof decking material and the requirements for loads on the roof structure.

Richard J. Vitullo, AIA; Oak Leaf Studio; Crownsville, Maryland  
 Based on Richard D. Rush, AIA, *The Building Systems Integration Handbook* (John Wiley & Sons, 1986).

**STRUCTURAL**

Frame:	Steel, with welded and bolted connections (F)
Roof:	Steel decking welded to frame (A)
Floors, upper:	Steel decking welded to primary frame members, with cast-in-place concrete topping (M)
Floors,	Slab on grade, with concrete foundation (O)
Core:	Central service core of cast-in-place concrete

Principal advantages and characteristics: Core shear walls add rigidity to frame; composite action of structural steel framing and a steel and concrete floor diaphragm result in relatively long, uninterrupted clear spans with smaller depth of construction. Heights can range from one to more than 100 stories. System allows for off-site fabrication of frame components, easy shipping to site, and rapid assembly; corrugated steel deck becomes a working surface as soon as it is placed and provides formwork for concrete topping.

**ENVELOPE**

Roof:	Built-up roofing or single-ply membrane on rigid insulation (B)
Walls:	Curtain wall units of glass/frame assemblies (E) and insulated spandrel panels (I), attached to structural frame
Basement:	Waterproofing and protective board, with foundation drain (N); vapor barrier under slab (P)

Principal advantages and characteristics: The envelope is structurally independent of the steel frame, providing flexibility in weight, size, and configuration of the envelope system. Curtain wall units preassembled at the factory must be designed with shipping, storage, installation, and general handling in mind, emphasizing protection from damage at all stages.

**MECHANICAL**

HVAC:	Ducts, with diffusers, either suspended from structure in ceiling plenum or placed in floor plenum beneath access floor (D)
Electrical and	Electrical wires and cables placed mainly in access floor plenum and structural/electrified floor (H); can also be located in ceiling plenum, for lighting, and in interior wall at spandrel panel
Plumbing:	Most plumbing functions placed in core area for efficient vertical circulation of systems
Fire safety:	Sprinkler system suspended from structure in ceiling plenum

Principal advantages and characteristics: Mechanical systems, hidden in floor or ceiling plenums or both, can be accessed through removable panels in ceiling or floor systems.

**INTERIOR**

Ceilings:	Suspended acoustical tile (C)
Floors:	Carpeted access floor system (L) and structural electrified floor (H)
Walls:	Gypsum wallboard (J)
Lighting:	Fluorescent light fixture in ceiling (G) and natural light (E)
Furnishings:	Open office furniture (K)

Principal advantages and characteristics: Suspended ceiling provides space for distribution of internal services, but it tends to be used principally for overhead lighting and ductwork. Structural/electrified floors and access floor systems keep all wires and cables in space below finish floor, easily accessible by removable floor panels, allowing high degree of flexibility for interior environment. Buildup of static electricity and the ensuing risk of equipment damage and shocks need to be considered. Access floors are not suited to situations involving heavy point loads or shifting heavy equipment. Stringerless systems are among the most flexible and least costly varieties, but they lack the stability of fully gridded systems and depend on perimeter walls for restraint. Use of access floors as air plenum, requiring tight and uniform joints between access panels, may hinder access to wires, cables, and pipes; ductwork in floor plenums may eliminate the advantages of access floors by blocking the path for wiring, cables, and pipes.

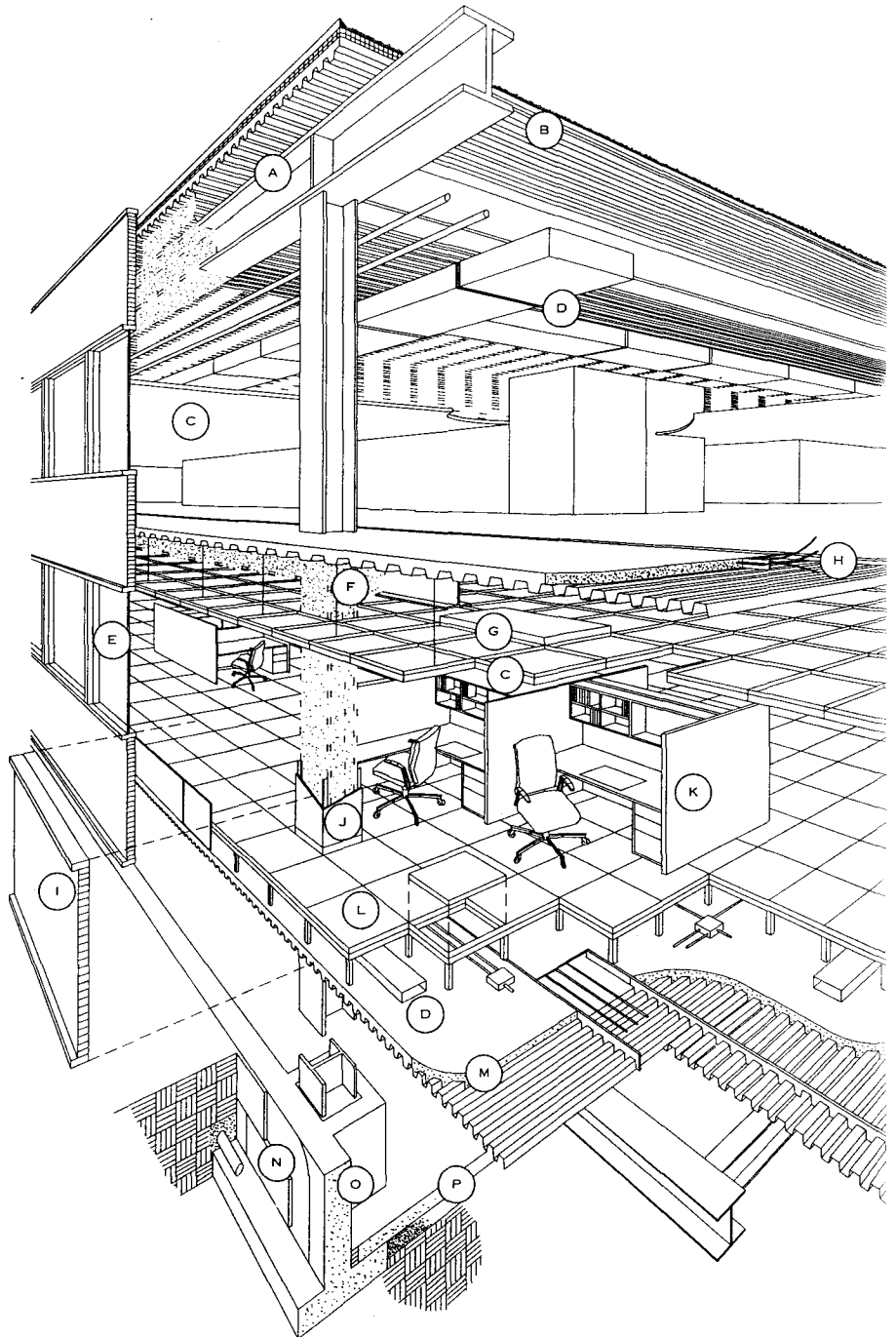
**STEEL FRAME WITH ACCESS FLOOR AND CURTAIN WALL****SYSTEM SUMMARY**

Steel frame and curtain wall construction allows for off-site fabrication of frame and envelope components, easy shipping to the site, and rapid assembly at the site. The steel and concrete in the floors are designed to act as a composite diaphragm, providing a thin, lightweight structural element with or without an access floor. The access floor

shown is advantageous in office environments that need especially flexible interior layouts. This system keeps all wires and cables in the space below the finish floor (generally not less than 4 in. deep) and out of wall cavities. Although access floors may add to overall floor-to-floor heights, the access floor conceals the most visually obtrusive distribution elements.

Richard J. Vitullo, AIA; Oak Leaf Studio; Crownsville, Maryland  
Based on Richard D. Rush, AIA, *The Building Systems Integration Handbook* (John Wiley & Sons, 1986).

**STRUCTURAL**

- Frame: Staggered story-high steel trusses (D) on steel columns (I) support floor slabs on both top and bottom chords
- Roof: Precast hollow-core concrete plank deck (C)
- Floors, upper: Precast hollow-core concrete plank deck (C)
- Floor, lowest: Slab on grade, with concrete foundation (M)
- Walls: Precast shear panels (H) and precast stiffener beams (O) stabilize structure

Principal advantages and characteristics: This system is best suited to multunit residential or hotel buildings of 7 to 30 stories with repetitive floor plans. Floor-height Pratt trusses are placed atop every other column in a staggered pattern, strengthening the structural system while reducing overall weight; precast hollow-core concrete planks serve as the floor without a topping slab, allowing for bays of approximately 60 x 60 ft (twice the truss spacing). A fire-resistant membrane, such as drywall, is usually added to each side of a truss to provide protection; these walls also serve to divide individual units. Lower floors in this system can be finished and trimmed while upper-level structural members are still being laid; the structure becomes rigid as soon as the precast exterior wall panels and the outer concrete deck elements have been installed.

**ENVELOPE**

- Roof: Rigid insulation, single-ply roofing and ballast (A)
- Walls: Window assembly (G), precast concrete panels (L), precast stiffener beams (O), and precast shear panels (H)
- Basement: Vapor barrier, and waterproofing and protective board (N)

Principal advantages and characteristics: Precast concrete wall members act as an envelope system as well as a structural system.

**MECHANICAL**

- HVAC: Ducts, with diffusers, and sprinkler system (B); separate unit-by-unit HVAC systems can be used
- Electrical: Conduit fed through vertical chases at outer walls (J)
- Plumbing: Pipes fed through vertical interior chases
- Fire safety: Sprinkler system supply at central corridor (B)

Principal advantages and characteristics: Because the Pratt-type trusses extend from floor to ceiling, with openings for corridors and elevator doors only, horizontal running of pipes, wiring, and ductwork can be difficult. For this reason separate unit-by-unit heating and air conditioning systems are often preferable; also, unitary HVAC systems offer economic and maintenance advantages in multifamily residential construction. Utilities are typically fed upward through chases and risers on outer walls, with service or supply units placed to either side on each floor; end wall stair enclosures are also used for this purpose. Most sprinkler systems are laid out in this fashion as well.

**INTERIOR**

- Ceilings: Underside of concrete planks is either painted or covered with acoustical ceiling tile; corridors may have suspended ceiling tile (B)
- Floors: Joints at floor planks are grouted and tops carpeted (K) or tiled (E)
- Walls: Gypsum wallboard (F)
- Lighting: Surface-mounted fixtures or suspended fluorescent fixtures at corridor (B)

Principal advantages and characteristics: The smooth surface of concrete deck planks can provide interior ceiling finishes, if desired.

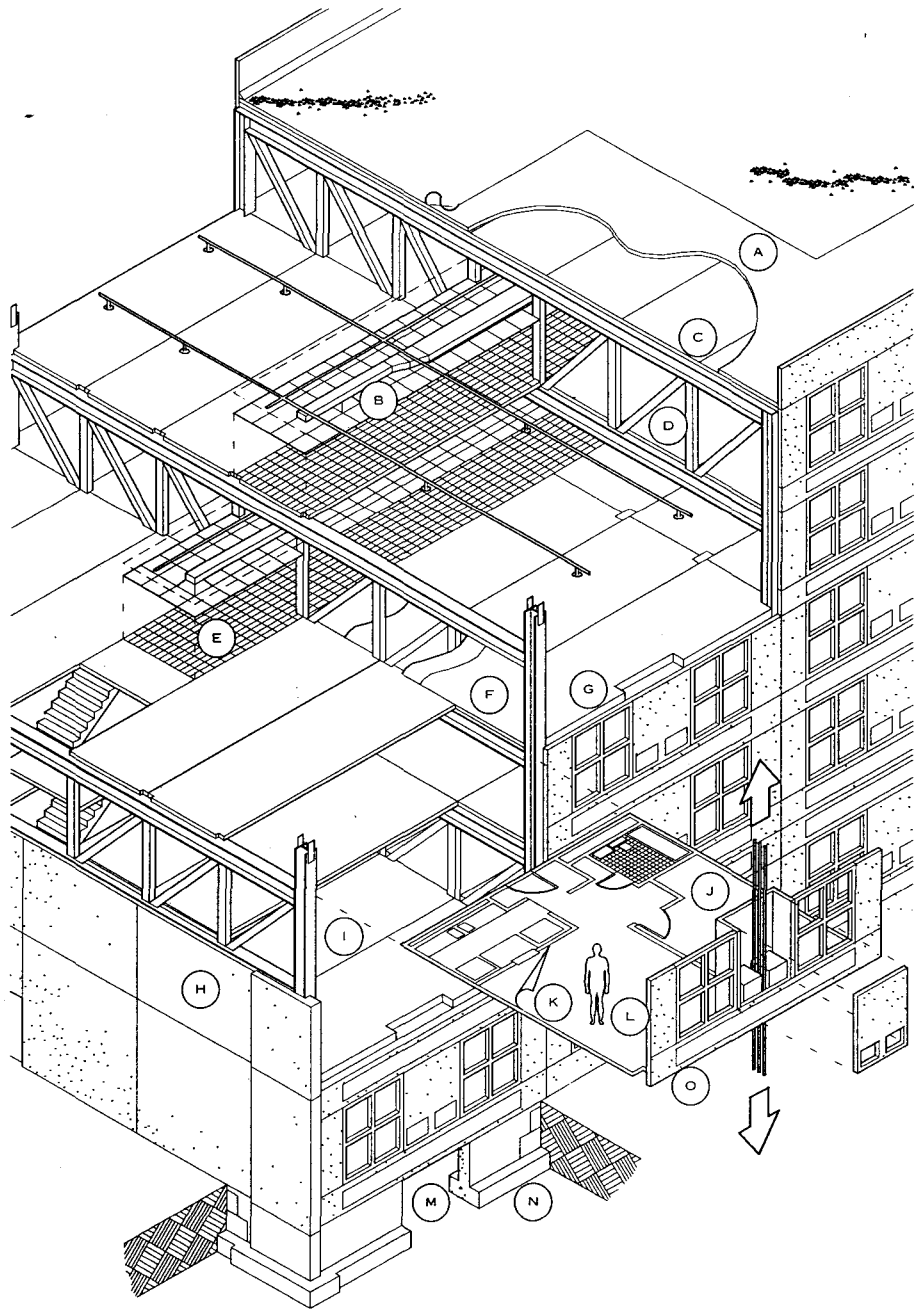

**STAGGERED STEEL TRUSS**

**SYSTEM SUMMARY**

Staggered truss construction is most often used for double-loaded residential-type occupancies, including hotels, high-rise apartments, nursing homes, and hospitals. Such building types usually have highly repetitive floor plans and can benefit from systems that integrate objectives regarding structure, interior unit separations, fire-compartmentalization, and acoustical privacy. The system is not generally

considered economical for low-rise buildings due to the manufacturing costs of the jigs for the trusses and the forms for the spandrel precasting. The system easily allows for long structural bays, permitting a high degree of flexibility in unit interiors. The ground floor is free of trusses and interior columns and thus suitable for parking or retail commercial use. The system's light weight reduces foundation size.

Richard J. Vitullo, AIA: Oak Leaf Studio; Crownsville, Maryland  
Based on Richard D. Rush, AIA, *The Building Systems Integration Handbook* (John Wiley & Sons, 1986).

**STRUCTURAL**

Roof:	Metal roof frame (C-stud brace, C-rafter, C-channel, C-joist) (C), with plywood sheathing
Floor, upper:	Metal floor frame (C-joist), steel deck, and concrete topping (L)
Floor, ground:	Slab on grade with concrete foundation (P)
Walls:	C-stud assembly (M)

Principal advantages and characteristics: The lightweight cold-formed steel members are load bearing, and beams, columns, channels, headers, and other elements can be built up from standard steel shapes and sections. The frame's rigidity depends on cross bracing, the distance from exterior corner to exterior corner, and the type and layout of fasteners used. Sheathing both sides of the frame also provides some lateral stability. Steel studs used for masonry backup should be cross braced with steel straps. Horizontal and diagonal bracing increases the frame's rigidity. Welded connections are stronger than self-tapping screws. The method of attachment can affect costs substantially. The positioning and types of fasteners for affixing both interior and exterior sheathing should be carefully specified, because these factors significantly affect lateral stability.

Cold-rolled steel framing is detailed and fastened quite differently than wood framing, and special noncarpentry tools and equipment are required. Advantages of cold-formed steel framing include its light weight, dimensional stability, speed and ease of assembly, resistance to moisture and decay, and, in some cases, readier availability than wood framing members. Also, steel framing members are frequently made from recycled scrap and can themselves be endlessly recycled.

**ENVELOPE**

Roof:	Shingles and roofing felt (B)
Grade:	Dampproofing (O) and vapor barrier under slab
Walls:	Batt insulation (K), window assembly (H), and brick veneer (G)

Principal advantages and characteristics: Deflection in lightweight steel frame construction can be several times greater than deflection in exterior masonry veneer; such differentials must be accommodated in anchoring details or overcome by adding structural rigidity to the wall frame. The masonry ties that anchor the veneer to the steel frame should permit free and independent movement of the two materials. Where the veneer depends on the steel frame for lateral stability, anchors should be flexible and should not resist shear; wire ties that allow independent movement are recommended. The framing design and method of fastening windows and doors should account for the differences in movement. In general, fenestration components should be attached to either the framing or the veneer, but not attached rigidly to both. When filled with batt insulation and fully sheathed, the lightweight steel frame wall is thermally isolated from the single wythe of masonry veneer. This results in greater differential thermal movement in the veneer than would occur with solid double-wythe masonry construction; the interior heat is not transferred as readily to the exterior masonry.

**MECHANICAL**

HVAC:	Ducts, with diffusers (D)
Electrical:	Wiring threaded through C-stud wall assembly (M)
Plumbing:	In partition walls, then through roof

Principal advantages and characteristics: Prepunched holes in the studs provide easy routing of plumbing and electrical lines. Most codes require the use of electrical conduit or sheathing of the prepunched stud opening to avoid stripping the insulation as wires are drawn through. Electrolytic action between framing members and nonferrous plumbing pipes must also be considered, and pipes on exterior walls must be adequately insulated.

**INTERIOR**

Ceilings:	Suspended acoustical tile (E)
Floors:	Ceramic floor tile (J), resilient floor tile (N), and carpet (I)
Walls:	Gypsum wallboard (F)

Principal advantages and characteristics: Interior gypsum wallboard, along with exterior sheathing, applied to steel studs provides additional lateral bracing and an interior finish.

Richard J. Vitullo, AIA; Oak Leaf Studio; Crownsville, Maryland  
Based on Richard D. Rush, AIA, *The Building Systems Integration Handbook* (John Wiley & Sons, 1986).

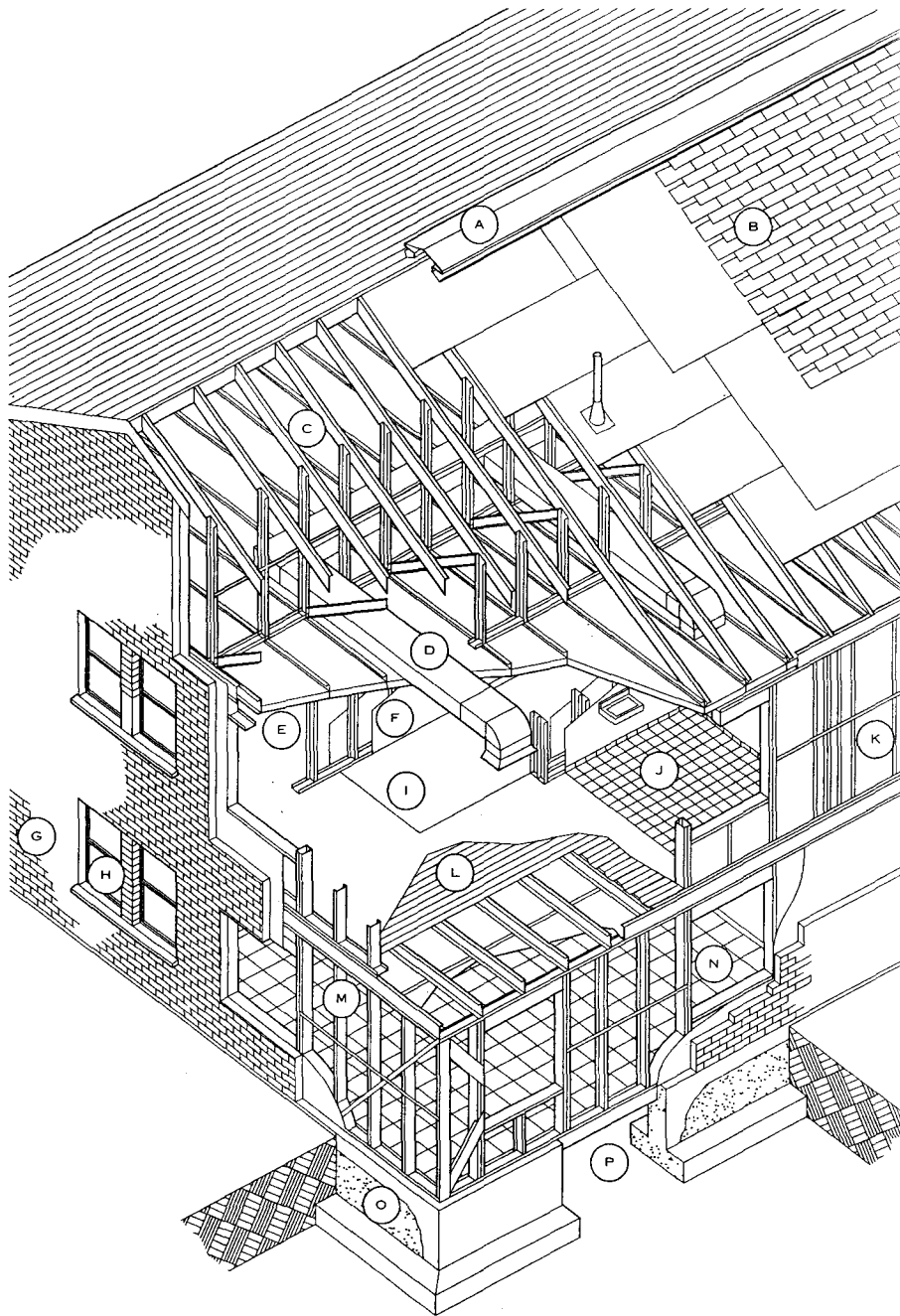
**LIGHTWEIGHT STEEL FRAME AND BRICK VENEER****SYSTEM SUMMARY**

Lightweight steel frame bearing wall construction is often used in low-rise commercial and residential buildings. The long-term performance of lightweight steel framing in structures over three stories is a concern. To date, its use in medium- and high-rise buildings has been mainly for exterior partitions or as nonbearing backup for exterior veneers.

Speed of construction, noncombustibility, and relative light weight are key advantages of this system. The space between studs eases insulation and accommodates piping

and electrical distribution. Because the framing can be completed independent of the masonry veneer, the interior is out of the weather quickly and can be finished while the exterior brick veneer is laid. In nonresidential construction, which is likely to have fewer bracing walls and longer vertical spans and horizontal runs, added cold-formed bridging or bracing of the frame increases lateral stability. This can also be accomplished by decreasing the stud spacing or increasing the stud gauge.

**STRUCTURAL**

- Roof: Wood roof truss and plywood sheathing (B)
- Floor, upper: Wood floor truss and plywood subfloor (G)
- Floor, ground: Slab on grade, concrete masonry foundation wall, and concrete footing (K)
- Walls: Wood frame and sheathing (F)

Principal advantages and characteristics: In this example, a standard wood framing system is employed with prefabricated roof and floor trusses and exterior sheathing. The trusses are built at the factory to engineering specifications. The exterior panels act in concert with wall studs as a structural skin and weathering surface. The wood frame system unifies envelope and structure when this external skin acts as a diaphragm over the studs, joists, and rafters. Often built of 2 x 4 elements, the floor trusses also provide a nailing edge nominally 4 in. wide along the top and bottom chords for subflooring and decking, an improvement over the thinner edges presented by dimension lumber. Because trusses are made up from commonly available dimension lumber, there is little chance that supply shortages will delay projects. Assuming proper factory quality control, the variations often seen in dimension lumber from different mill lots should not be a problem. Also, the smaller wood components are more readily available from sustainable forest reserves, as opposed to large dimension lumber sections, which are available only from older growth forests.

Bridging between floor trusses may be eliminated, depending on the depth of the truss and the application and rigidity of subflooring and ceiling finishes. If needed, bridging may be accomplished by running continuous 2 x 4s perpendicular to the truss chords within the open web and nailing them to truss struts. When such bridging is used, it should not block possible transverse duct runs. Most floor truss systems allow for a continuous-edge ribbon at the truss ends in lieu of a header. Before truss units are lifted into place, it is wise to inspect them for uniformity of depth and camber and for general tightness. If substantial field-work is contemplated, it may be desirable to use plywood I-trusses, which can be cut to length and drilled to allow threading of pipes and wires.

**ENVELOPE**

- Roof: Shingles, roofing felt, with metal flashing (A)
- Grade: Vapor barrier under slab, with dampproofing at foundation
- Walls: Batt insulation (E), window assembly (J), and lapped wood siding (I)

Principal advantages and characteristics: Wood components treated with fire retardants can now be used in many applications for which untreated wood is unsuitable. Some fire-retarding treatments may discolor wood, accelerate corrosion of metal fasteners, or alter the structural properties of the wood. For example, plywood can become delaminated, a particularly difficult problem when the plywood sheathing itself acts as the exterior finish surface.

**MECHANICAL**

- HVAC: Ducts and diffusers (H), with below-slab perimeter ducts (M)
- Electrical: Wiring threaded through holes drilled through wood studs
- Plumbing: Pipes set in partition walls, then through roof

Principal advantages and characteristics: Open web trusses allow threading of wiring, piping, and ductwork without on-site drilling or cutting, thus greatly speeding and easing the installation of heating, plumbing, and electrical systems.

**INTERIOR**

- Ceilings: Acoustical tile (C)
- Floors: Carpet (L)
- Walls: Gypsum wallboard (D)

Principal advantages and characteristics: The open web wood trusses permit longer clear spans than conventional timber framing, leaving greater flexibility for the location of interior partition walls that need not be load bearing.

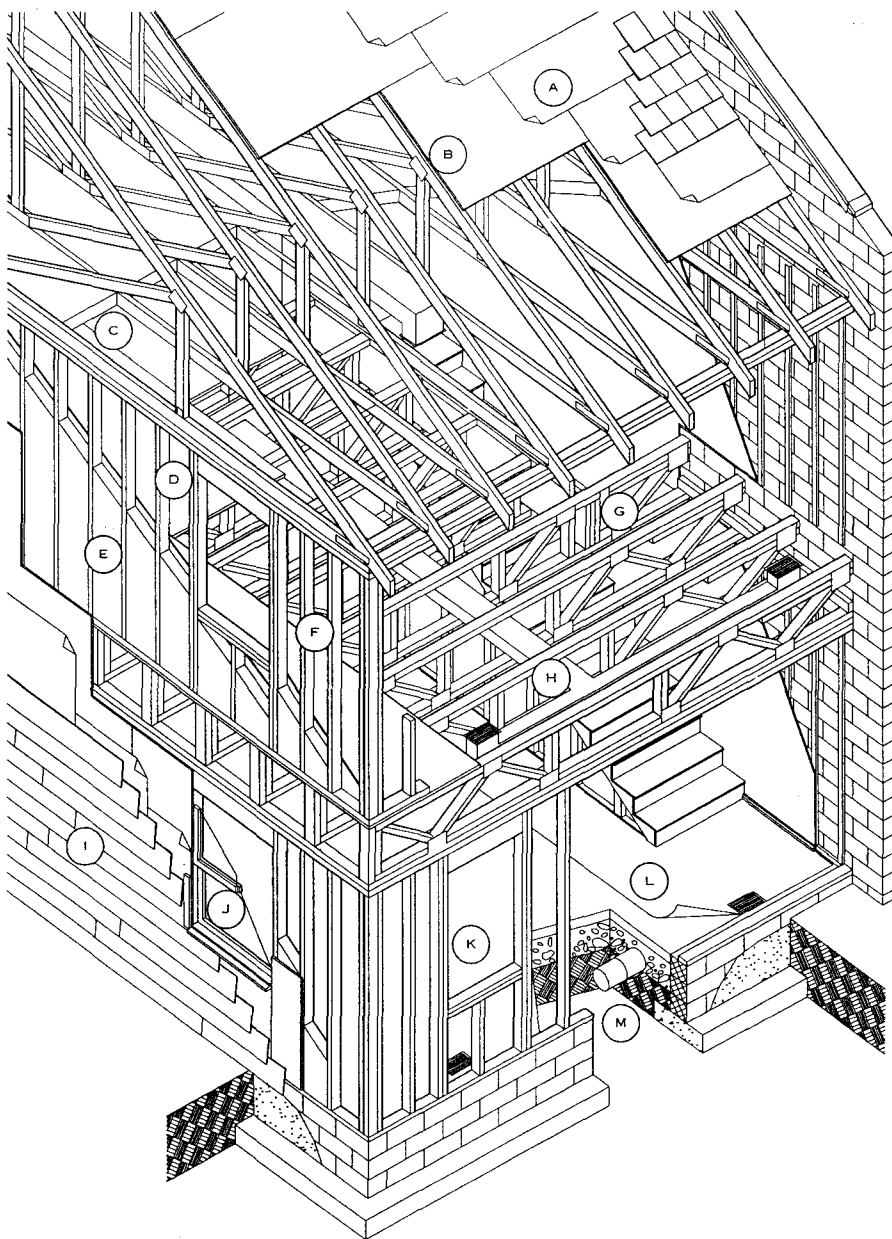

**WOOD ROOF TRUSS AND WOOD FLOOR TRUSS**

**SYSTEM SUMMARY**

Prefabricated roof and floor trusses eliminate much field labor, thus speeding on-site construction; help ensure dimensional stability; and may eliminate the need for intermediate load bearing partitions. Longer clear spans are possible with floor trusses than with generally available dimension lumber, and recent advances in manufacturing techniques make it possible to specify many special fea-

tures. Open web trusses are lighter in weight than dimension lumber and can be lifted easily in gangs by a small crane or lift. Trusses are available in standard configurations between 12 and 24 in. deep and allow threading of mechanical systems without cutting the members, speeding installation. The smaller wood components used in these trusses are more readily available from sustainable forests, as opposed to the older growth trees harvested for larger standard lumber sections.

Richard J. Vitullo, AIA; Oak Leaf Studio; Crownsville, Maryland  
Based on Richard D. Rush, AIA, *The Building Systems Integration Handbook* (John Wiley & Sons, 1986).



**STRUCTURAL**

Columns:	Cast-in-place concrete (K)
Roof:	Cast-in-place concrete flat plate (E)
Floors, upper:	Cast-in-place concrete flat plate (E)
Floors, basement:	Slab on grade and concrete pile foundation (N)
Core:	Central service core of cast-in-place concrete

Principal advantages and characteristics: Combines cast-in-place concrete columns with two-way concrete slab plates of uniform thickness. Two-way flat plate concrete floors are among the simplest concrete structures for reinforcing, formwork, and detailing. Exterior precast concrete panels can be attached on lower floors, even with flat plate shoring still in place, while concrete is being poured for upper-floor columns and plates. When crane hoists are used to lift concrete buckets or large equipment, a hole is generally left in a section of each plate to allow for passage of the hoist; this hole is filled later, when large components have been moved and concrete pouring is complete. Elevator shafts are not used for this purpose, as elevators are usually installed before construction work is complete. In this system, precast concrete or composite spandrel units are welded in place to a series of angle clips fastened into the concrete flat plates at their edges.

Flat plate concrete construction permits more stories to be fitted into a given building height than any other system. This is because its floor structure has minimum thickness, especially when post-tensioned. In addition, in many building types the underside of the floor plate can serve as the finish ceiling.

**ENVELOPE**

Roof:	Rigid insulation and ballast (C), on protected roof membrane (B)
Walls:	Window assembly (D) and precast concrete spandrel panels (M), batt insulation (I)
Basement:	Waterproofing and protective board at foundation, with vapor barrier under slab (O)

Principal advantages and characteristics: Exterior precast concrete panels can be attached on lower floors, even with flat plate shoring still in place, while concrete is being poured for upper-floor columns and plates. Window-framing elements and glazing are installed after the spandrels have been set. Tolerances within the system grow progressively tighter: the concrete structure requires the least attention; placement of steel angles for welding to the spandrels requires greater exactitude; and positioning the spandrels to accommodate framing and glass requires greatest care.

**MECHANICAL**

HVAC:	Ducts, with diffusers, suspended from structure in ceiling plenum (G)
Electrical and telecommunications:	Power and communication poles (H)
Plumbing:	Most plumbing functions in core area for efficiency in vertical circulation of systems
Fire safety:	Sprinkler system suspended from structure in ceiling plenum
Conveying system:	Elevator equipment in penthouse (A)

Principal advantages and characteristics: Centralized core permits relatively uniform, short horizontal runs for power, plumbing, lighting, and other systems.

**INTERIOR**

Ceilings:	Suspended acoustical tile (F)
Floors:	Carpeting (L)
Walls:	Gypsum wallboard, metal stud assembly (J)
Lighting:	Fluorescent light fixture in ceiling and natural light (D)

Principal advantages and characteristics: Workstations in unpartitioned interior offices can be serviced unobtrusively by ceiling height power and communications poles, in furred-out areas around columns, and in corridor partition walls. Office workstations require daylight exposure and views. Because the central core is farthest from perimeter zones, usable floor area in the perimeter can be maximized. On constrained urban sites, the central core may be moved against an unfenestrated wall and still retain this advantage.

Richard J. Vitullo, AIA; Oak Leaf Studio; Crownsville, Maryland  
Based on Richard D. Rush, AIA, *The Building Systems Integration Handbook* (John Wiley & Sons, 1986).

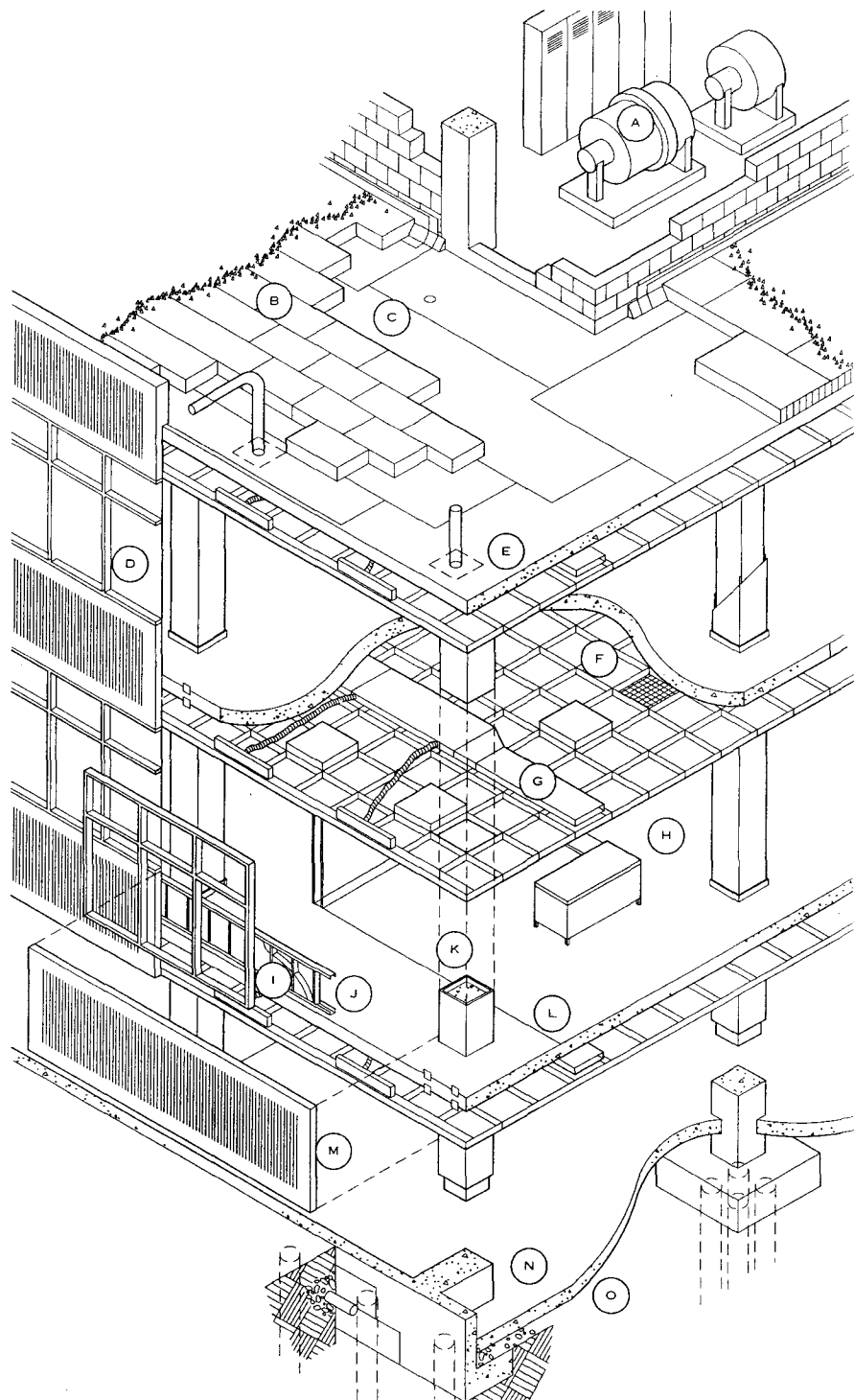
**FLAT PLATE CONCRETE****SYSTEM SUMMARY**

This example combines cast-in-place columns and two-way concrete flat plates of uniform thickness, with precast concrete spandrel panels. The system usually has a central core for vertical circulation and services, and it is typically employed for low- to medium-rise construction because of the costs and difficulties associated with placement of materials and labor in higher buildings. The central core also permits consolidation of vertical service risers, increasing

fire protection by reducing or eliminating through-floor penetrations in office areas.

Flat plate concrete construction is especially applicable to apartments, hotels, and dormitories, in which no suspended ceiling is required. Story height can be minimized in these applications by using the undersides of the slabs as finish ceiling.

**STRUCTURAL**

- Frame: Rigid concrete (J)
- Roof: Rigid concrete slab
- Floors, upper: Concrete slab (B)
- Floor, basement: Slab on grade and concrete foundation (L)

Principal advantages and characteristics: Post-tensioning is a highly sensitive integration of the compressive strength of concrete with the tensile strength of steel. Plastic-sheathed, high-strength steel tendons are cast in the slab and, after curing, are placed in the tubes, anchored, and jacked into tension from one end. After stresses are applied, the tendon channels may be grouted to bond the tendons to the slab. For lengths greater than 100 ft, stresses must be applied simultaneously from two ends. Integration of mechanical services is influenced greatly by the positioning of tendons, which controls the locations of through-slab penetrations. Post-tensioning permits the use of shallower beams and slabs, reducing overall building height and permitting longer spans with thinner structural members; structure is quite rigid and less subject to movement and creep, allowing use of masonry infill envelope. Alterations and demolition can be difficult due to potential forces latent in post-tensioned tendons.

**ENVELOPE**

- Roof: Built-up roofing or single-ply membrane on rigid insulation (A)
- Walls: Window assembly (I), and brick and concrete masonry with rigid insulation (K)
- Basement: Waterproofing and protective board at foundation (N), vapor barrier under slab

Principal advantages and characteristics: Envelope rests on the concrete frame by means of steel shelf angles attached to spandrel beams.

**MECHANICAL**

- HVAC: Ducts, with diffusers, suspended from structure in ceiling plenum (C)
- Electrical and tele-communications: Wires and cables placed in wall assemblies
- Plumbing: Most plumbing functions placed in centralized locations, avoiding tendons
- Fire safety: Sprinkler system suspended from structure in ceiling plenum

Principal advantages and characteristics: Mechanical systems hidden in ceiling plenums can be accessed through removable panels. This system is optimal for additions to hospitals and other medical facilities, which often require floor-to-floor heights that match those of the existing structure. Although contemporary standards for servicing and mechanical equipment require deeper interstitial spaces than are found in older medical buildings, the shallower slabs and beams of post-tensioned concrete construction can conserve such space.

**INTERIOR**

- Ceilings: Suspended acoustical tile ceilings (E)
- Floors: Resilient flooring (F)
- Walls: Metal stud and drywall assembly (H)
- Lighting: Fluorescent light fixture in ceiling (D) and natural light (I)
- Specialties: Operable partitions (G)

Principal advantages and characteristics: Suspended ceiling provides space for distribution of internal services but tends to be used only for overhead lighting and ductwork.

**SYSTEM SUMMARY**

Post-tensioned concrete construction is virtually identical to the flat plate concrete construction described on the preceding page. The major difference lies in the thickness of the concrete slab, which is slightly reduced in this type of construction.

Post-tensioning is a method of reinforcing concrete by stretching steel reinforcing tendons after placement and curing of the concrete structure. This prestressing reduces

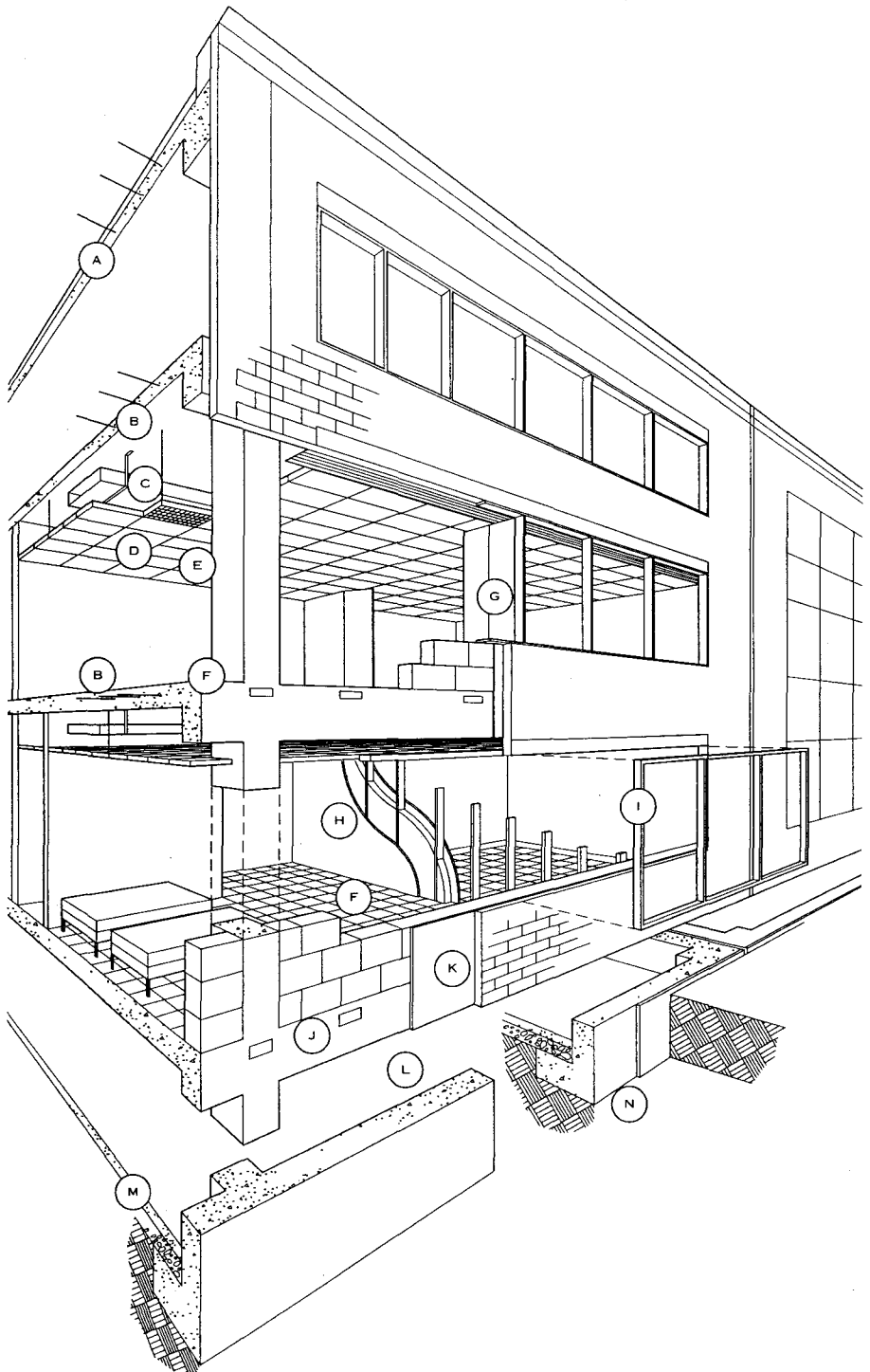

**POST-TENSIONED CONCRETE**

or eliminates tensile stresses on the concrete under use loading and strengthens the slab without increasing its thickness or adding the dead loads introduced by additional steel reinforcing rods. Post-tensioning is useful when the thickness is important to economical or functional design

aspects or when concentrated live loads are high and the building height must be kept to a minimum. It is also effective when project conditions require minimal floor-to-floor heights but maximum ceiling heights with generous space above the ceilings.

Richard J. Vitullo, AIA; Oak Leaf Studio; Crownsville, Maryland  
Based on Richard D. Rush, AIA, *The Building Systems Integration Handbook* (John Wiley & Sons, 1986).

**STRUCTURAL**

Frame:	Prestressed precast concrete columns and spandrel beams (D)
Roof:	Prestressed precast concrete double T (B)
Floors, upper:	Prestressed precast concrete double T (B)
Floors, basement:	Slab on grade, with cast-in-place concrete piles (F)
Core:	Cast-in-place concrete vertical circulation (E)

Principal advantages and characteristics: This system is most commonly used for parking garages. Double-T joists are generally 8 or 12 ft wide, at a depth of 18 to 36 in., depending on the spanning requirements; spans of 60 ft are considered maximum, due to the constraints of shipping and lifting the pieces, but longer spans and deeper sections are possible. It is advantageous to use as many similar elements as possible; that is, floors, inverted T girders, and columns should all be of the same length and design. Off-site precasting can conserve time and materials for concrete forming, and on-site erection time is considerably faster than for cast-in-place construction. Cast-in-place core provides lateral stability to frame. Adding final finishes and installation hardware to prestressed components before erection helps reduce on-site construction time. Temporary shoring and bracing may be required during construction, particularly (if the structure is composite) until the toppings have cured to service strength. Lifting loops are generally embedded in the precast pieces and then covered with the topping or cut off after installation.

**ENVELOPE**

Roof:	Concrete topping slab (A)
Walls:	Spandrel beams act as finish walls (D); no glazing in openings

Principal advantages and characteristics: For parking garages, the most common application of precast concrete frame, a weather-tight condition is not needed; therefore, structural components can be directly exposed to the elements. Some aesthetic treatments can be cast in or applied to surfaces but are not needed for moisture protection.

**MECHANICAL**

Electrical:	Conduit, exposed at underside of concrete structure
Plumbing:	Pipes from roof and floor drains, exposed to view throughout structure
Conveying system:	Elevator equipment for hydraulic elevator (G)
Fire safety:	Sprinkler heads dropped from supply lines set into channels at upper face of precast floor Ts

Principal advantages and characteristics: In parking structures the requirements for through-floor penetrations are minimal. However, holes or sleeves can be cast in the stems and flanges of the Ts, to allow for passage of conduit and piping. These holes and openings can be as great as one-third of the stem's total depth but must avoid the reinforcing tendons; openings toward the top of the stem in midspan and toward the bottom at the ends are most common. Preplanning of all openings is essential to minimize sitework and to realize the inherent economies of the system. Ts may be notched at the ends to permit passage of conduit along girders or bearing walls. Also, channels can be formed by chamfering mated edges of adjacent Ts at the upper surface, setting the conduit, then pouring a concrete topping slab.

**INTERIOR**

Floors:	Concrete topping acts as floor finish (A)
Walls:	Concrete structure surface acts as wall finish (D)
Lighting:	Fluorescent light fixtures attached to structure (C), and natural light between spandrel beams
Specialties:	Curbs, handrails, and signage

Principal advantages and characteristics: Most typical interior elements are not needed because of the open air nature of the building type; however, all elements provided are attached directly to the exposed structure. In parking garages, the depth of the structural Ts and concerns for minimizing floor-to-ceiling height present special challenges for the integration of lighting and signs.

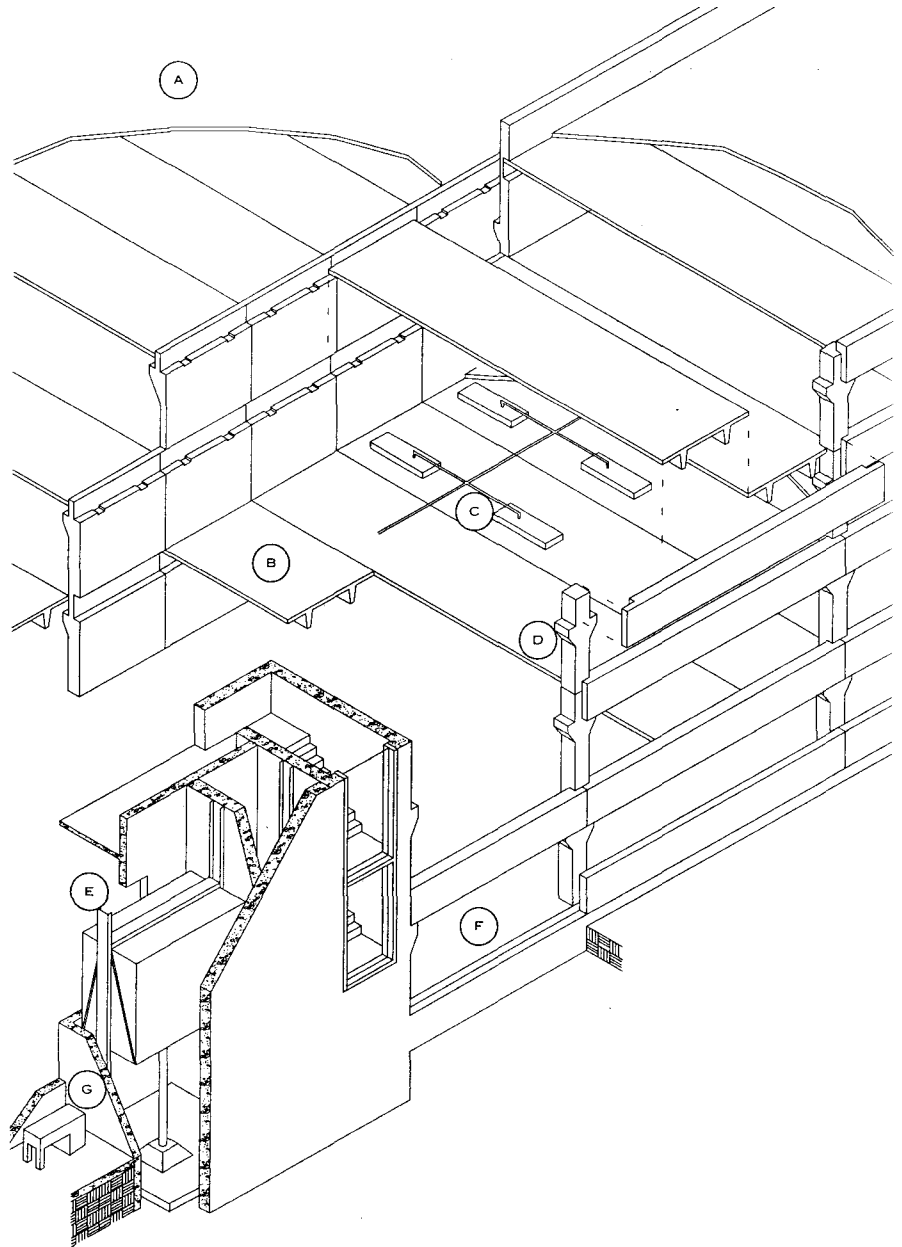
**PRECAST CONCRETE FRAME****SYSTEM SUMMARY**

Precast concrete components are usually pretensioned. Pretensioning is a method of prestressing concrete in which steel tendons are stretched prior to placement of concrete and maintained in tension until the concrete is cured. The external tension on the tendons is then released to compress the concrete. This example employs prestressed columns, inverted T girders, ledger girders, and double-T joists, all of the same length and design. Once the

floor and roof Ts are set, the surface is covered with a concrete topping that provides the finished, weather-exposed surface and a horizontal structural diaphragm. The precast components are fabricated off site and lifted in place by crane. A variety of finished surfaces is possible and the unity of materials presents an opportunity for natural visible integration of elements. Thin brick or tile can also be used as a surface material.

Richard J. Vitullo, AIA; Oak Leaf Studio; Crownsville, Maryland  
Based on Richard D. Rush, AIA, *The Building Systems Integration Handbook* (John Wiley & Sons, 1986).

**STRUCTURAL**

Frame: Rigid concrete (C)

Floors, upper: Flat plate (K)

Foundation: Slab on grade and concrete (M)

Principal advantages and characteristics: Flying form construction requires almost total regularity in structural bay widths. Flying forms can be used to construct flat slabs, pan-joint slabs, waffle slabs, and various types of beams-in-slab. They are also used to form spandrels of varying configuration. Flat plate or flat slab construction is preferred, as this eases movement of the flying form "table" and minimizes special additional forming. For flying forms to be economical, the building structural layout must be uniform and the beams and spandrels should be very shallow.

There are three principal types of flying forms: adjustable post shoring, manufactured truss forms, and column-supported forms. Adjustable post shoring uses scaffolding that rests on a wood sill and blocking and is raised by jacks. The forms are moved horizontally, usually by means of rollers, and are generally suitable for pours of up to 40 ft in length.

Manufactured truss forms, ranging up to 50 x 100 ft in side dimensions, use 4 to 6 ft deep trusses and are raised by a series of uniformly distributed jacks. The forms are moved by crane from one floor to the next, often in a staggered or stepped sequence. Greater widths in truss forms are made possible by the use of additional longitudinal trusses. Column-supported forms employ adjustable brackets that "climb" columns and are shored after initial positioning. This type is better suited to applications involving relatively close column spacing.

Usually the same work crew sets and strips the flying forms; half of the crew works below the deck level that has been cast, while the other half works above the previously cast area, setting the forms that have been removed. Conventional temporary shoring, separated from the surface forms, is set in place after removal of the flying forms. To speed the process of curing and to enable quicker removal of the forms, early high strength concrete is frequently used.

**ENVELOPE**

Roof: Built-up roofing and rigid insulation (B); concrete masonry parapet backup (A)

Walls: Window assembly (G) and precast concrete spandrel panels (L)

Basement: Vapor barrier (N)

Principles and characteristics: As in the case of conventionally cast-in-place flat plate concrete construction, the structural and mechanical systems are concealed from view, with the precast concrete envelope spandrel and glazing units connected to the structural frame. Flying form construction, which requires relatively uniform bay widths, can have an effect on visible integration because it produces regularity in the rhythm of structural elements.

**MECHANICAL**

HVAC: Ducts and diffusers (D)

Electrical and telecommunications: Under-carpet flat cable (J)

Principal advantages and characteristics: In office applications, the high quality of the slab's finished surface lends itself readily to the use of flat wiring for power, lighting, electronics, and communications. Because they are flat, these wiring systems increase the flexibility of open office planning; they are attached to the slab with steel tape prior to the installation of carpet tiles, with direction changes accomplished by folding the flat cable. Extra fire protection measures are unnecessary, as there are no through-slab penetrations to be sealed.

**INTERIOR**

Ceilings: Suspended acoustical tile ceiling (E)

Floors: Carpet tile (I)

Walls: Metal stud and drywall assembly (H)

Lighting: Fluorescent light fixture and natural light (F)

Principal advantages and characteristics: Flying form construction permits great flexibility in interior layouts and furniture arrangements. The use of flat wiring frees the electrical system from restraints imposed by the structure, permitting the furniture layout and power needs to remain variable until very late in the construction process.

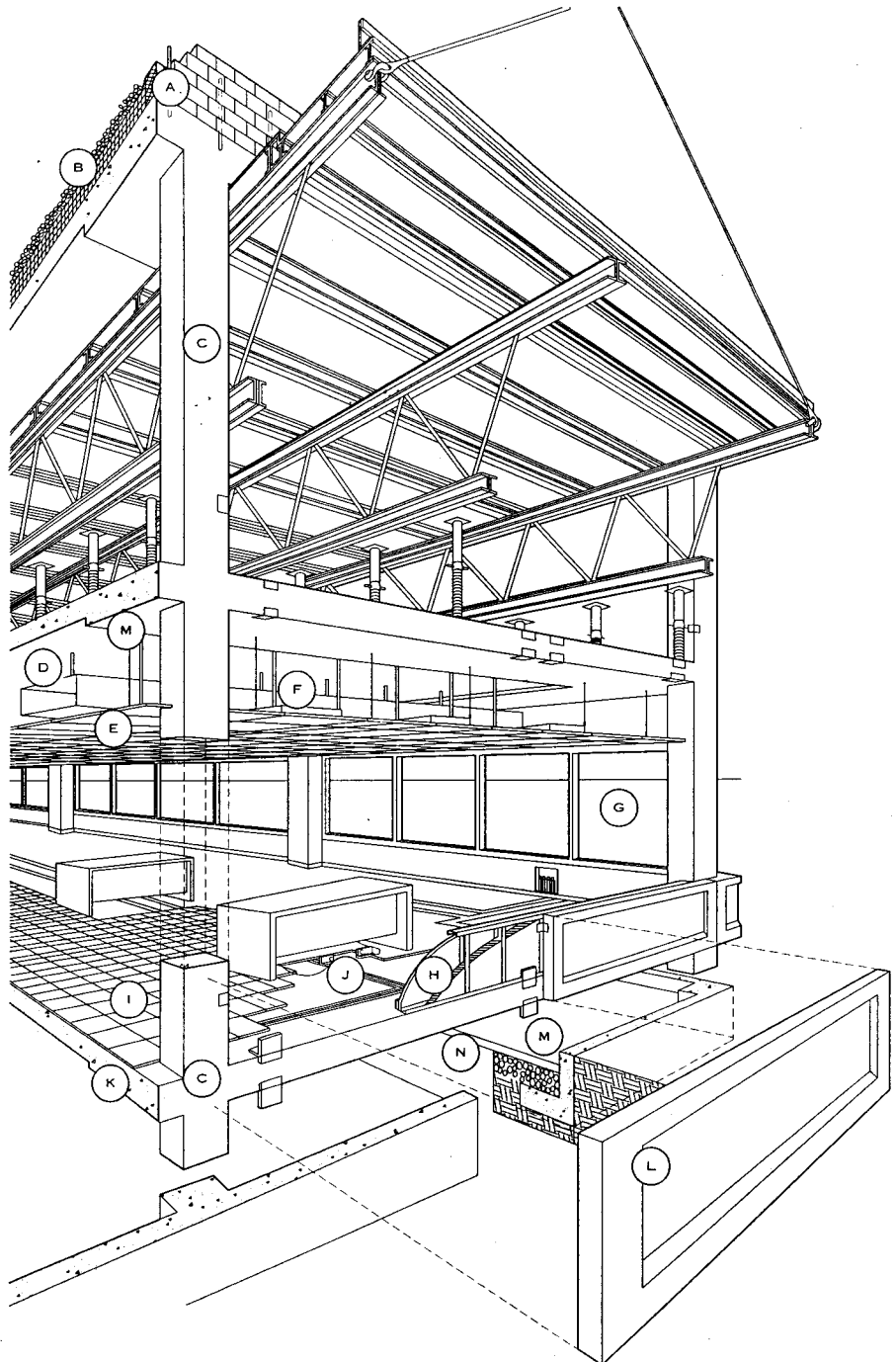
**FLYING FORM****SYSTEM SUMMARY**

Speed of construction, the economies realized through reuses of the forms, and the high quality of finished surfaces are among the most attractive features of this construction method. The systems employed with flying form construction do not differ substantially from those found in other types of reinforced concrete construction; the difference lies in the method of forming slabs and spandrels and in the sequencing of pours. A disadvantage of the flat plate construction system is the relative difficulty of punching through the slab or plate. An important consideration with the use of flying forms is the regularity of bay spacing and the absence of deep beams or spandrels.

During construction the forms are placed and removed in a sequence of related operations, with temporary shoring used after form removal under the slabs until they have cured. The repetitive use of the forms can lead to conservation of both time and, of course, the materials used in forming. Mechanical and interior systems are meshed in the suspended ceiling assembly. The use of flat wiring atop the floor slabs for internal distribution of power, lighting, electronics, and communications dictates the use of removable carpet tiles and yields a set of requirements for interfaces with furnishings and equipment.

Based on Richard D. Rush, AIA, *The Building Systems Integration Handbook* (John Wiley & Sons, 1986).

**STRUCTURAL**

Frame: Precast concrete panels (H)

Roof: Steel deck and open web steel joists (C)

Floor: Slab on grade and concrete footing (J)

Principal advantages and characteristics: Load-bearing tilt-up wall panels provide a unified vertical envelope, structure, and interior. The panels are precast on-site, generally using the floor slab or grade as the casting surface, and tilted or lifted into position. The floor slab used as a form must be level, smoothly finished, and treated with a bond-breaking agent to permit easy separation of the cast pieces. The wall panels, usually 6 in. in nominal thickness, may extend from one to several stories in height, and must be designed to withstand the bending loads involved in tilting and lifting, as well as loads that will be encountered once in place. They may be plain, reinforced, or prestressed and are often provided with temporary timber or steel "strongbacks" for tilting, particularly when there are large window openings.

The panels must be braced during construction until all wall and roof structural members are in place. Columns are usually cast in place following installation of the panels. In load-bearing tilt-up wall systems the roof and floor members are bolted or welded to plates and angles cast into a continuous ledge beam. Roofing systems may be steel open-web joists, precast concrete T's, or hollow-core planks. Flashing reglets and other roofing connection details can be cast with the panels. Regular inspection of casting and lifting operations is essential.

**ENVELOPE**

Roof: Built-up roofing and rigid insulation (B); skylights (A)

Walls: Precast concrete panels (H); window assembly (G); dampproofing and protective board (E)

Floor: Concrete slab (F)

Principal advantages and characteristics: Joints between panels should be designed to be concealed; this is easily accomplished where cast-in-place columns are designed to lap the panel edges, or where the panels insert at their edges into a precast column channel. Connections between panels should not be rigid, so caulks and sealants are important.

Foundation and slab detailing are key to preventing water infiltration at the panel bases. It is good practice to design the system so that the slab level is slightly above the bottom edge of the vertical tilt-up panel.

**MECHANICAL**

HVAC: Ductwork in open-web bar joists (G); radiant heat panels in suspended ceiling (E)

Electrical: Fluorescent light fixtures (F)

Principal advantages and characteristics: Because the slab on which the panels are cast must be smooth, utility raceways, pipes, and conduits that will penetrate the slabs must be stubbed below the finish slab level, covered during wall panel casting, and then uncovered for final connections.

The location and installation of angles, channels, weld plates, conduits, connectors, and other hardware should be carefully planned and detailed, with regular and careful inspections before placing the concrete. Lifting forces and special complications related to openings require exacting structural analysis and special erection hardware.

The suspended ceiling panels incorporate radiant heat panels. Ductwork for cooling and ventilation air is threaded through the open-web bar joists. In the open area, gas-fired heating units are suspended from columns and the structure is left exposed.

**INTERIOR**

Ceilings: Suspended acoustical tile ceiling (K)

Floors: Resilient tile flooring (I)

Walls: Precast concrete panels (H)

Lighting: Skylights (A) and fluorescent light fixtures (F)

Principal advantages and characteristics: The site-cast panels are the load-bearing elements for the roof members and provide both interior and exterior finish. The building shell can be erected quickly, permitting interior work to proceed along with final joining and sealing of the envelope panels.

The clear spans produced by the bar joist roof structure and option for hung ceiling allow interior partitions to be intro-

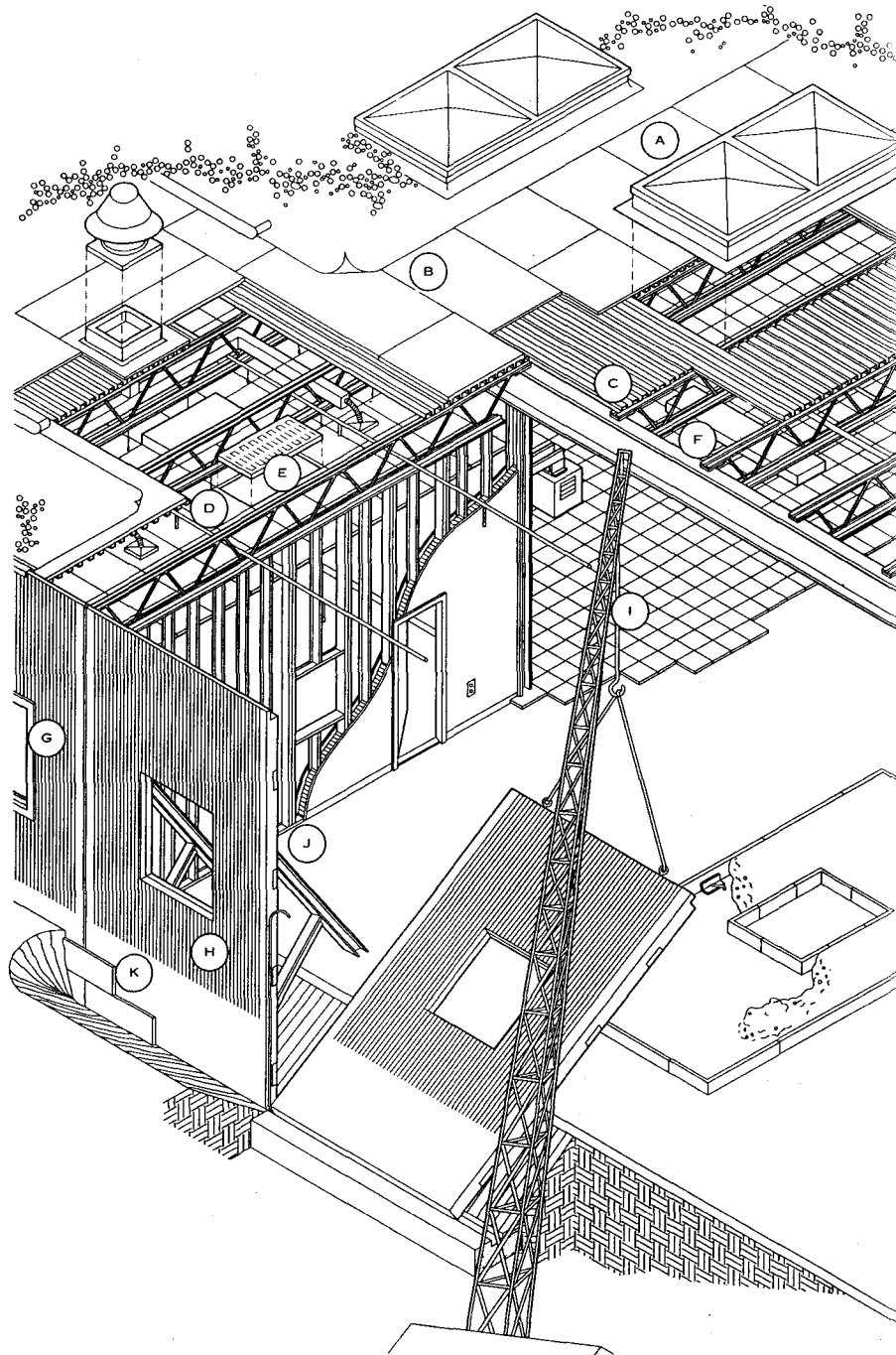
**TILT-UP WALL**

duced virtually anywhere, with meshed interior and mechanical systems provided by a ceiling-mounted radiant heat panel.

**SYSTEM SUMMARY**

Tilt-up walls have been used routinely in a variety of building types and heights, especially for single-story buildings with large, uncomplicated exteriors. The system is also increasingly used for multistory lowrise projects. Significant savings in time and formwork costs can be achieved, and long lead times required for precast or structural steel com-

ponents are often averted. Because most of the forming and erection work is done within the floor slab area, tilt-up systems work well in confined construction sites.

Conservation of time and forming material is realized when there is uniformity in panel design and when the floor surface can be used for forming. Careful planning of the forming, storage, and lifting sequence is essential, and early consultation with manufacturers and contractors is advisable. Regular inspection of casting and lifting operations is essential.

Based on Richard D. Rush, AIA, *The Building Systems Integration Handbook* (John Wiley & Sons, 1986).

1

BUILDING SYSTEMS

**STRUCTURAL**

Frame: Heavy glued laminated wood beams (H); exposed wood frame and plywood sheathing (J)

Roof: Plywood sheathing and wood roof, tongue-and-groove wood decking (C)

Floors: Slab on grade and concrete foundation (N)

Principal advantages and characteristics: Heavy glued and laminated beams and columns, which define the interior of the building, make up the frame in this example. The roof structure is laminated tongue-and-groove decking, nominally 2¼ in. thick, laid over the beams.

Considerable flexibility is available in selecting structural modules and bay sizes in heavy timber construction by varying the depth of beams and increasing the thickness of decking to span between beams. Columns are frequently oversized to give an appropriate appearance; if sized only to carry the loads transferred from above, they may appear too spindly in proportion to other framing elements.

Glued laminated beams, columns, and decking are generally preferred over dimensioned sawcut lumber. Appearance is easier to specify and ensure; a variety of custom shapes, sizes, and presawn joints can be obtained in glued laminated pieces; and they are drier and more resistant to twisting, checking, and shrinkage. All pieces should remain factory-wrapped until in place and out of the weather, as rain and snow will stain them.

If mill-cut lumber is used, it should be cut and dried well in advance and should be specified free of heart centers. Although well suited to pier foundation systems, post and beam framing is often more easily erected atop a perimeter masonry foundation.

Outside air infiltration is increased at endwall joints in tongue-and-groove timber decking and must be controlled through appropriate detailing. When components have been carefully ordered and weather conditions are favorable, erection of the structural system can proceed quickly.

**ENVELOPE**

Roof: Standing seam roof, roofing felt, and rigid insulation (B)

Walls: Wood siding (G); window assembly (F)

Floor: Vapor barrier under slab (O)

Principal advantages and characteristics: Lower portions of perimeter walls are framed conventionally with wood studs between main timber columns; a vapor barrier is placed toward the occupied side, and the voids are filled with batt or rigid insulation. Drywall covers interior walls; the exterior is sheathed in plywood and finished with diagonal wood siding. The roof deck is covered with a moisture barrier and insulated on top with rigid insulation board between sleepers. A standing seam metal roof is applied over the sleepers, which also provide diagonal bracing.

**MECHANICAL**

HVAC: Ducts, supply and return system (D)

Electrical: Rigid conduits run through decking (A)

Principal advantages and characteristics: Space heating and cooling is provided by air supply-and-return ducts. Kitchens, lavatories, and other areas requiring both odor removal equipment and greater amounts of fresh air are separated by walls and covered by suspended or furred ceilings.

As in any system with exposed components, cleanliness of details, finishing, and dimensional coordination are very important. If ductwork cannot be fed through voids in the floor structure into interior and exterior wall voids, layout, finishing, and suspension hardware must be skillfully designed and executed for compatibility, as must interior fire sprinkling systems. Overhead electrical service can be located in rigid conduits that run through the decking. During the application of roofing materials, puncturing these hidden conduits must be avoided.

**INTERIOR**

Floors: Carpeting (I) and clay tile flooring (M)

Walls: Drywall (L)

Lighting: Incandescent light fixtures (E) and natural light

Principal advantages and characteristics: The underside of the laminated tongue-and-groove decking is exposed to interior view and should be specified for appearance grade. Drywall covers interior walls.

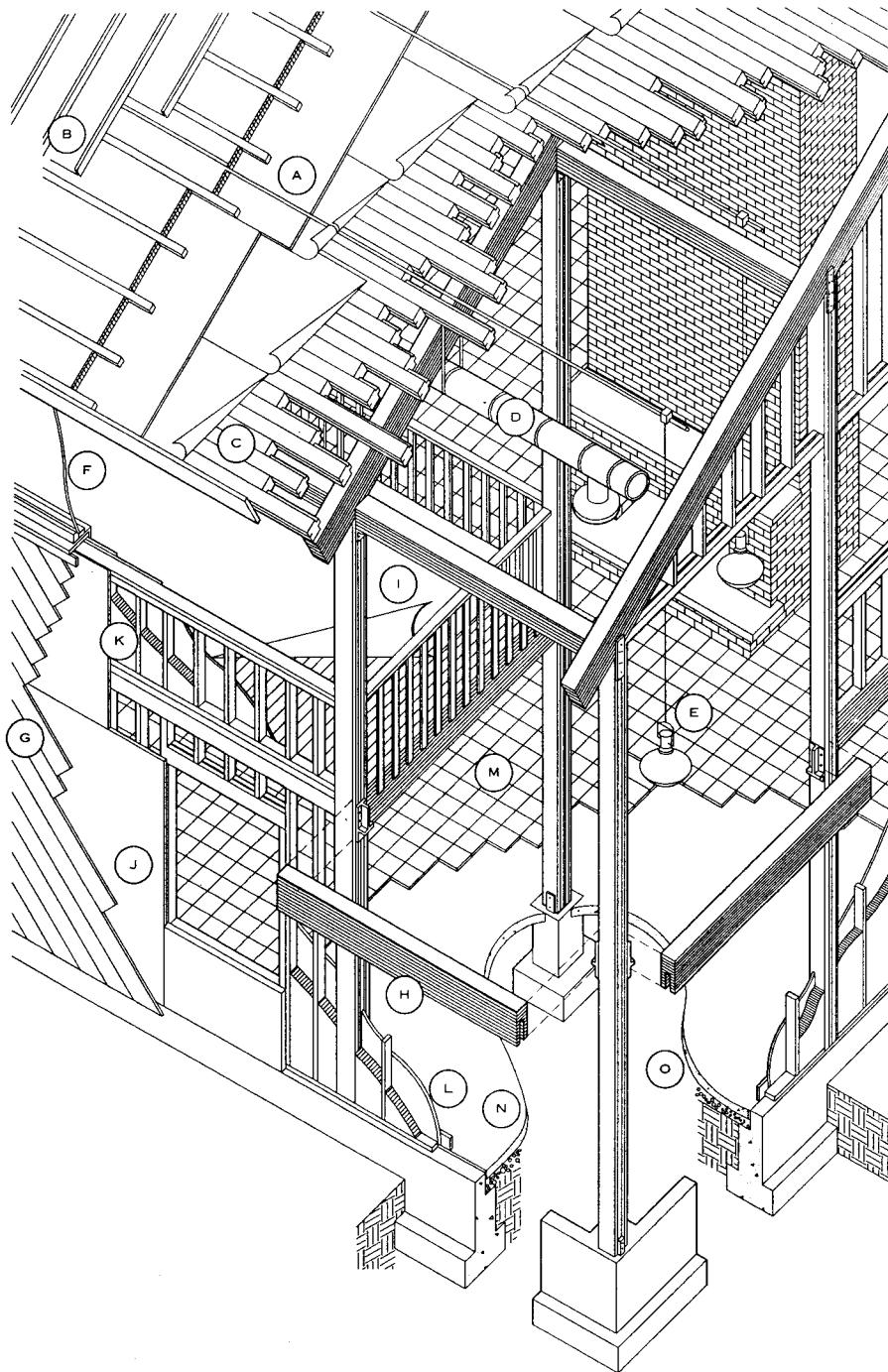
**LAMINATED WOOD POST AND BEAM****SYSTEM SUMMARY**

Although used historically for larger buildings, post and beam construction is now generally confined to buildings of three stories or fewer. Its main advantages are simplicity of elements and details, combined with the potential for visual integration and bold structural and architectural forms.

Structure and interior are unified in post and beam construction. Because the structural elements in this system are exposed to view in the finished buildings, as are portions of the mechanical system, care is required in the visual integration of these components and in the design

and appearance of hardware used for joinery of the wood members. Certain parts of the mechanical system can be meshed within interior partitions and exterior walls, leaving them concealed. The sizing of structural members and joinery details may be influenced more by considerations of visual proportion and appearance than strictly by the loading and stress conditions involved.

Based on Richard D. Rush, AIA, *The Building Systems Integration Handbook* (John Wiley & Sons, 1986).

**STRUCTURAL**

- Frame: Wood frame and sheathing (J)
- Roof: Glued laminated beams and wood deck (C)
- Floors: Plywood subfloor on lateral steel beams (N)

Principal advantages and characteristics: Modules are tied together through the concealment of joints and mating lines, accomplished by holding the cladding material back from the mating line, and spanning between two units with field-installed components to cover the area left unclad. They are then bolted to the steel frame, in addition to being anchored to the foundation. Stud framing, floor joists, and roof rafters are supported on steel I-beam frames until the unit is placed on its foundation.

**ENVELOPE**

- Roof: Sheet metal roofing and metal cap flashing (B)
- Walls: Aluminum siding (I) and batt insulation (D)
- Floor: Vapor barrier (O)

Principal advantages and characteristics: Openings in the envelope for doors and windows may present difficulty in mating units, due to differential movement of the units, which are normally placed on separate and less-than-permanent foundations. Entrance doors, for example, should not span between unit mating lines, even when the installation is not considered temporary. Exterior siding can be held back from the mating lines between units and then field-installed to span the joint lines. This technique improves visual integration and also helps tie units together structurally. At the roof, special curb caps are available or may be field-fabricated to span across low parapets on mated units. If a complex must mate some units at all four sides, mechanical system plants may be roof-mounted. Modular units are normally tied down by cable and earth-embedded anchors.

Skirting at the base of the units is often necessary for appearance and security, with field-set steps required at entrances. Plans for roof drainage and water carryoff should be resolved with the manufacturer.

**MECHANICAL**

- HVAC: Rooftop unit (A) and insulated ducts (E)
- Electrical: Electric baseboard heaters (L)
- Plumbing: Factory installed, hooked up on site (I)
- Fire safety: Fire sprinklers and fire/security systems may be factory installed

Principal advantages and characteristics: Wiring and plumbing, installed at the factory, are easily hooked up at the destination site. Nearly all system components are installed at the factory, including heating, cooling, and ventilation equipment. Site grading, foundation work, connection of utilities and services, landscaping, and interconnection of the modular units are the only on-site activities required. Mechanical systems are meshed within voids in the structure and envelope assembly and are basically self-contained within each unit; even when plans call for the linking together of units to form a complex, mechanical and electrical systems for the individual units remain independent. For occupancies that require substantial interior partitioning, HVAC supply and return registers should be planned for high wall or ceiling locations.

**INTERIOR**

- Ceilings: Suspended acoustical tile ceiling (F)
- Walls: Drywall (K); window assembly (H)
- Floors: Resilient flooring (M)
- Lighting: Fluorescent light fixtures in ceiling (G) and natural light

Principal advantages and characteristics: An interesting aspect of these low-cost buildings is that except for baseboard-mounted electric heat panels, there are no exposed structural or mechanical elements. The result is maximum interior flexibility.

Ordinarily floor plans are based on the relatively narrow dimension of the module and require great care in planning for interior layouts, although it is possible to obtain large clear-spanned floor areas. Claddings, exterior and interior wall finishes, door and window types, floor finishes, and envelope thermal insulation levels can be specified to order.

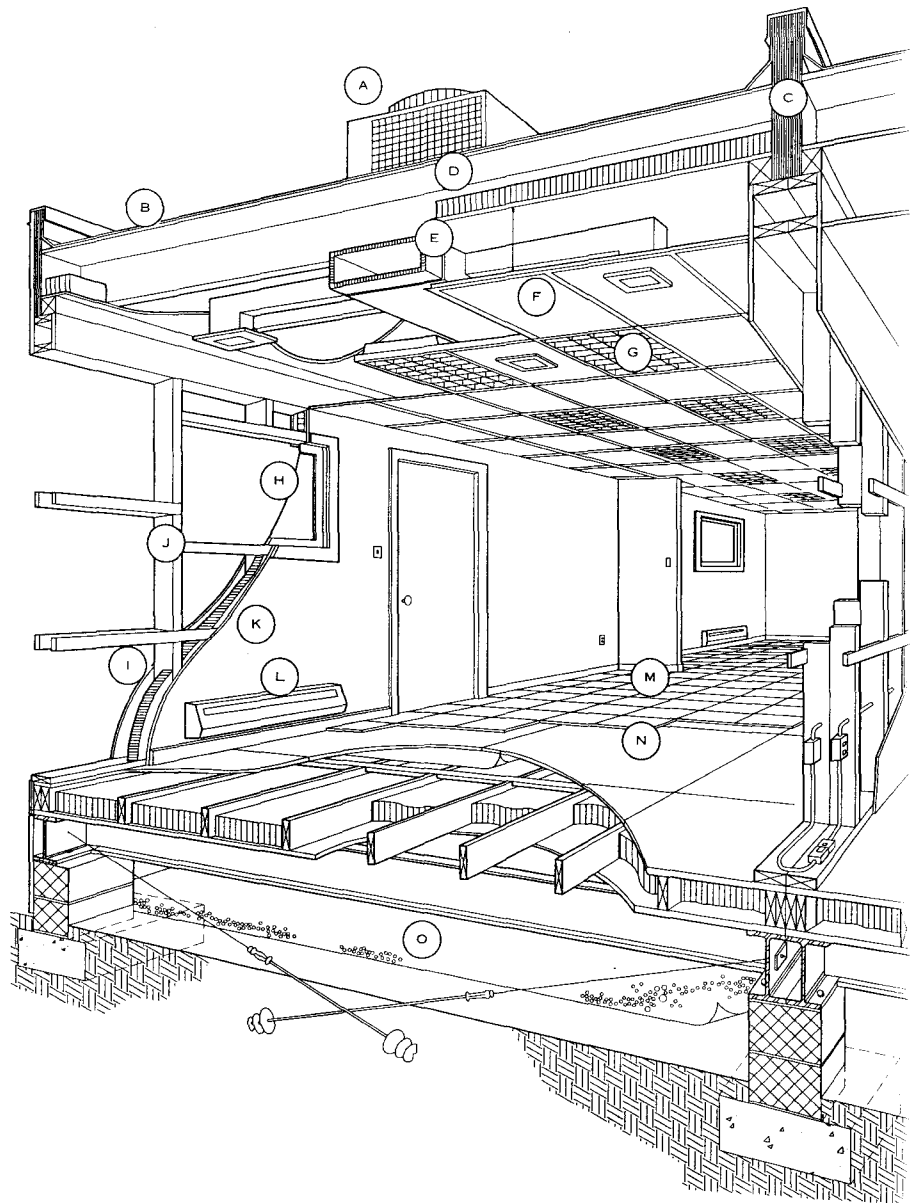

**LIGHTWEIGHT MOBILE MODULAR SYSTEM SUMMARY**

Lightweight mobile modular buildings consist of factory fabricated wooden structures. Although both smaller and larger dimensions are available, the most common size is 12 ft x 60 ft. Speeds of construction and low initial cost are the main advantages of mobile modules. On-site labor requirements are minimal. Where weather, labor, or site problems affect other options, or for emergency or temporary use, mobile modulars are often the appropriate solution. Mobile modular use has increased significantly in areas of rapid growth and development, especially in areas with large influxes of temporary population. Modules can be easily moved, even when assembled as a complex.

Modular units can almost always be combined. Door openings should not be placed at the mating lines between modules; such placement requires field installation of the doors and may result later in binding of the door due to differential movements between the mated modules. When planning the complex, the manufacturer should be apprised of the location of utilities and services on the site; any local building code requirements that differ from major codes; and handicapped access needs. Distance of the site from the manufacturing plant is a major cost factor, and any complications in shipping should be investigated.

Based on Richard D. Rush, AIA, *The Building Systems Integration Handbook* (John Wiley & Sons, 1986).



**STRUCTURAL**

- Frame: Metal space frame (B)
- Roof: Metal deck (B)
- Floor: Slab on grade and concrete foundation (I)

Principal advantages and characteristics: Space frames serve as both structural and interior systems, while providing a structure for envelope connections and space for meshing of mechanical distribution elements. A metal deck and built-up roof cover the space frame shown. Space frames may appear in horizontal, vertical, domed, vaulted, stepped, sloped, or tower configurations. In this example, the edges of the space frame are glazed to permit perimeter clerestory lighting of interior areas. Tubular high-strength extruded aluminum struts are joined by means of solid aluminum hubs, also designed to accommodate the hardware for fastening of clerestory glazing. The frame can also be cantilevered beyond the continuous perimeter masonry wall, which allows for effective plate structural action.

Space frames are increasingly common as atrium covers and have also been used as structures for entire building envelopes. In perimeter-supported applications, truss depth-to-span ratios of up to 1/30 are practical. Besides, their light weight and economy of materials, space frames have the quality control advantages of factory production.

Recent developments in strut and hub technology make space frames highly durable and well engineered. The lightweight frame components are easily shipped, quickly assembled on site, and then lifted into place. Sometimes the frames are factory assembled and shipped whole or in subsections to the site. Careful coordination and assembly instructions are important to keep pieces in sequence for field assembly. Field bolting is almost always preferred to field welding of frame components, because welding space frames is expensive, and quality control can pose problems.

Where a continuous perimeter wall will not support the space frame, the design of supporting points is crucial. Certain spanning and rigidity advantages are gained by the design of supports that extend the pattern of the space frame above or below the plane of the main truss.

**ENVELOPE**

- Roof: Built-up roofing and rigid insulation (A)
- Walls: Brick veneer and rigid insulation (G)
- Floor: Vapor barrier (J)

Principal advantages and characteristics: Structure and envelope are connected in this example, with the exposed nature of the space frame requiring a high degree of visible integration between the frame's structural components and parts of the mechanical system. The space frame permits very long column-free spans with minimal amounts of structural material. The visual properties can be destroyed if the frame is coated for fire protection and in many cases coating can be forgone if the frame is placed 20 ft or more above floor level.

**MECHANICAL**

- HVAC: Ducts suspended from hubs of the frame (C)
- Electrical: Electrical conduits (C)
- Fire safety: Sprinkler piping (C)

Principal advantages and characteristics: Because the space frame is a highly regular structure and is exposed to view in most applications, the coordination of service systems with patterns in the frame is essential for visible integration. Piping can be suspended from the hubs of the frame, but should correspond to the patterns of the frame. Utility runs generally follow the orthogonal grid, while the sprinkling apparatus and electrical conduits may be run diagonally. Fireproofing of space frames generally destroys their appearance, so sprinkling is usually a consideration unless the exposed frame is 20 ft or more above floor level.

**INTERIOR**

- Ceilings: Metal deck (B)
- Floors: Wood flooring (H)
- Walls: Glass block panel (E) and concrete masonry bearing wall (F)
- Lighting: Incandescent light fixtures (D)

Principal advantages and characteristics: The ceiling unifies interior and structural systems, and meshes them with unified mechanical and interior systems. The solid hubs in the

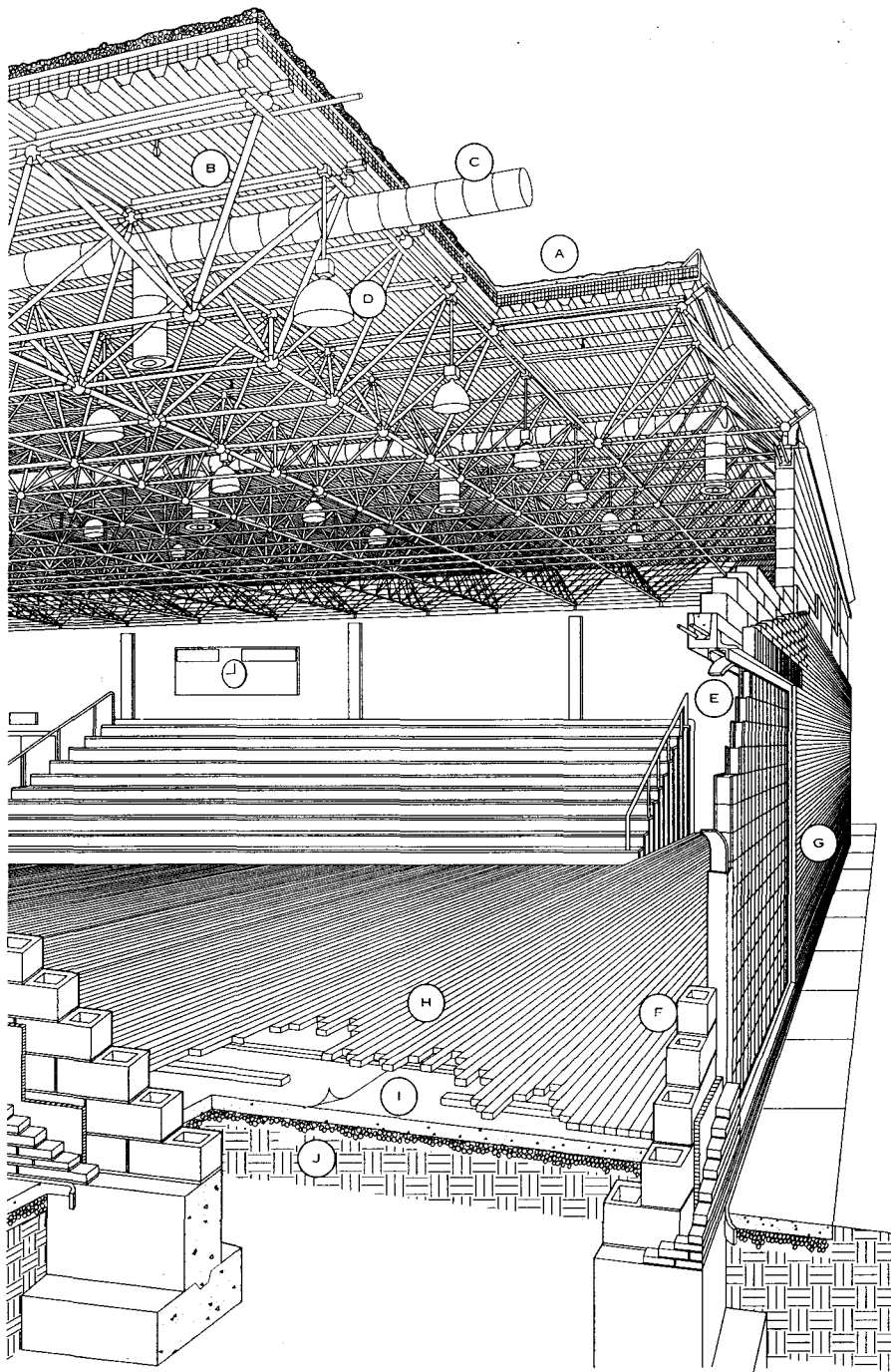

**SPACE FRAME**

frame serve to join the struts and can also accommodate mountings for the envelope system and various types of interior equipment.

**SYSTEM SUMMARY**

The triangulated space frame network is one of the strongest and most efficient structural configurations, permitting long column-free spans with lightweight, highly repetitive elements. Slender structural members make space frames advantageous in cases where high light permeability is sought, yet significant live structural loading may occur.

Typical applications include spans above entries, sports arenas, and convention centers.

The selection of a space frame module is governed by the integration of cladding systems, the spanning characteristics of decking, and the mullion spacing for glazings. A space frame may be enclosed with metal decking, glass, acrylic, membrane, or insulated paneling. Space frames must usually be engineered and fabricated by a specialty engineer and/or fabricator, although strut sections and hubs generally do not need to be specially designed for each application.

Based on Richard D. Rush, AIA, *The Building Systems Integration Handbook* (John Wiley & Sons, 1986).



**STRUCTURAL**

Frame: Rigid steel frame (C)

Roof: Standing seam metal roof (B); batt insulation (D)

Floors: Slab on grade and concrete foundation (L)

Principal advantages and characteristics: Pre-engineered primary frames and claddings are dominant in warehouse, agricultural, and light industrial buildings, and are increasingly used for office and retail facilities. Their use is generally confined to one-story construction, but there is growing experience with multistory buildings.

Metal frame and skin building systems take advantage of factory assembly techniques and quality control. The structural integration of frame components with the building skin, for strength and rigidity, permits major economies in the size and number of steel framing components. Primary and secondary framing members, fasteners, and panels interact to produce a light, stable building shell. All framing and cladding components are designed, engineered, and fabricated in a plant, then shipped to the site for erection. The same company often designs, engineers, and builds the system. Metal structural components are generally sized and deployed according to exact requirements of an application, permitting economies in materials and speed of construction.

**ENVELOPE**

Roof: Standing seam metal roof (B)

Walls: Window assembly (H); insulated metal wall panels (I)

Floor: Dampproofing (M) and vapor barrier (N)

Principal advantages and characteristics: The pre-engineered metal building integrates lightweight structural and envelope components, each of which adds strength and rigidity to the overall form. The floor slab, often left uncovered in warehouse and industrial applications, unifies the envelope, structure, and interior systems, and is normally the only major site preparation required for erecting the building. The light weight of the envelope system, which is valuable for shipping, is especially vulnerable to wind uplift and requires great care in design and layout of fastenings. For applications in which privacy or sound isolation is an issue, the thin sheet steel presents an acoustical problem.

The standing seam metal roof system requires less maintenance than other alternatives, and its long-term performance record is excellent. Most standing seam metal roofs provide a free-floating monolithic membrane, connected by a series of slotted clips that allow movement. This method freely accommodates expansion/contraction cycles caused by thermal changes. In addition, a variety of details, colors, and finishes is available.

**MECHANICAL**

HVAC: Ducts and diffusers (E); heat pump (J); ridge vent (A)

Plumbing: Stacks in roofing panels and seams

Principal advantages and characteristics: Although the structural and envelope systems of metal buildings are usually highly integrated, manufacturers rarely consider the mechanical and interior systems in any detail. When insulating metal sandwich panels are used for interior and exterior finishes, special care is required in detailing the power and signal wiring, and in providing for its protection once in place. The mechanical plant shown in this drawing is located on the ground adjacent to the building, but it could just as easily be roof mounted.

The standing seam metal roof presents several items of concern to architects: the modularity of roof panels and seams, important for locating plumbing stacks, skylights, and other roof apertures; proper expansion details at intersections with flashing, especially upper-roof ridge; and the critical importance of crickets, parapet caps, and other details to avoid buildup of standing water.

**INTERIOR**

Ceilings: Suspended acoustical tile ceiling (G)

Floors: Carpet (K)

Walls: Insulated metal wall panels (I)

Lighting: Fluorescent light fixtures (F) and natural light

Principal advantages and characteristics: This construction approach is particularly advantageous for applications requiring large interior clear-spans, the support of heavy overhead cranes, or substantial expanses of roof. More

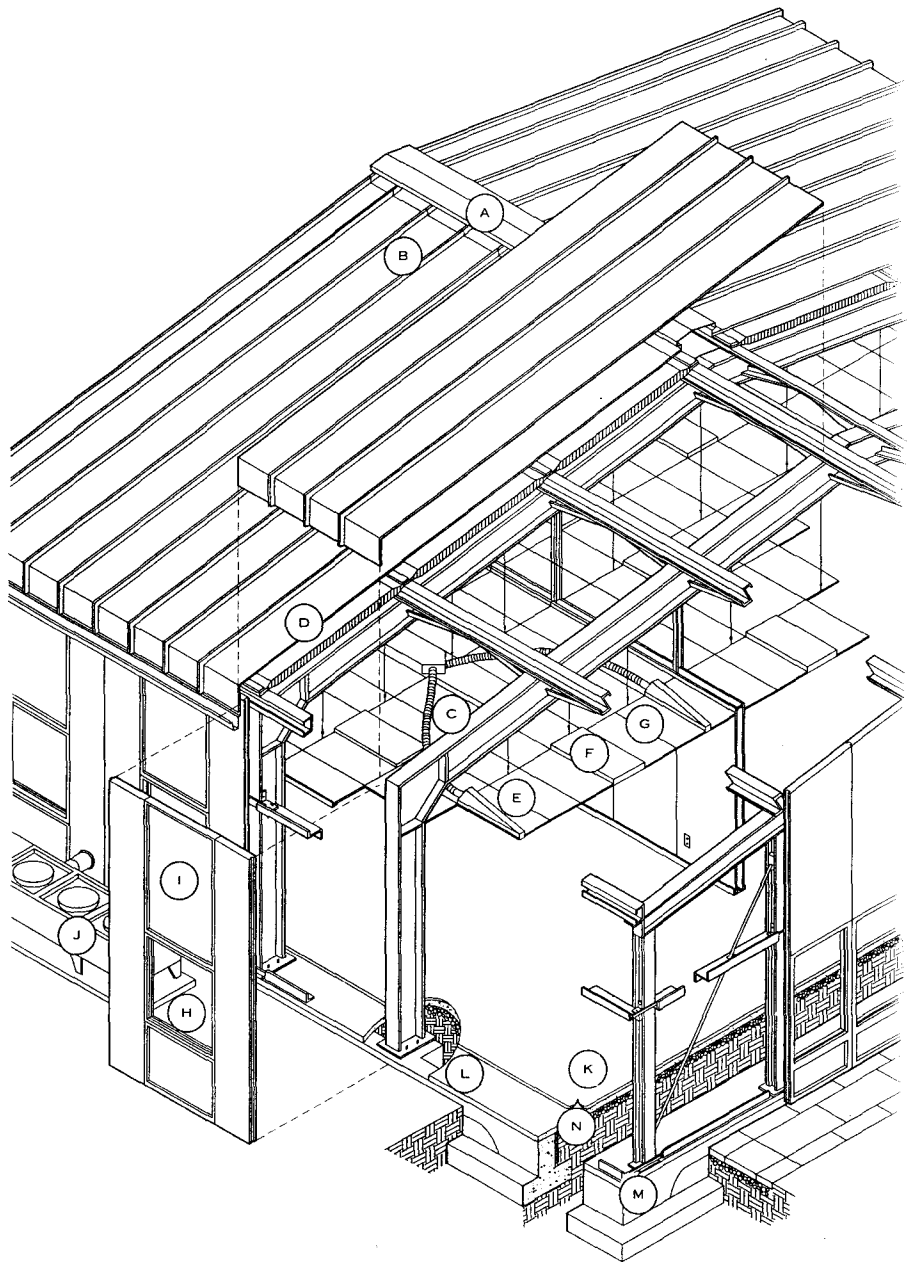
**METAL BUILDING SYSTEMS**

often associated with "standard" buildings components and even "standard" buildings, the metal buildings systems industry is able to respond to highly specialized needs, while still employing standardized structural components and factory fabrication.

**SYSTEM SUMMARY**

A variety of exterior cladding alternatives is available, ranging from lightweight corrugated metal skins to fully insulated sandwich panels that provide both interior and exterior finishes. Manufacturers also offer door, window, and skylight components that work as integral elements of the envelope and interior systems. Centralization of responsibility for engineering, fabrication, and construction permits close cost control and early assessment of building costs. Architects working with pre-engineered building systems can rely on technical support from the manufacturer,

including the preparation of fabrication and subsystem engineering documents.

The pre-engineered, cold-formed steel componentry is very flexible and can be used for a wide variety of building shapes and sizes. Such buildings can be rapidly dismantled and moved. The rectilinear nature of such systems usually results in buildings that are easily expanded in the longer dimension. Mechanical and interior systems are meshed in the ceilings, but the mechanical plant (here shown on the ground adjacent to the building, but just as easily roof mounted) is normally kept on the exterior, sometimes presenting difficulty with visible integration.

Metal systems are very lightweight. In areas subject to high winds, special care should be taken for wind bracing the structural frame and for fastening and design of exterior cladding details. Building corners and edges are particularly subject to wind-induced uplifting and suction.

Based on Richard D. Rush, AIA, *The Building Systems Integration Handbook* (John Wiley & Sons, 1986).

1

BUILDING SYSTEMS

**STRUCTURAL**

Frame: Steel cables in fabric sleeves (A); steel masts (C)

Floors: Slab on grade (E)

Principal advantages and characteristics: Structural, envelope, and interior systems are unified in tension-fabric structures. A fabric membrane, usually configured to follow an optimal structural shape, is anchored by steel cables attached to the fabric and is suspended from steel or aluminum masts to form a roof or total enclosure.

Fabrics for temporary use are typically composed of a polyester substrate with a polyvinyl-chloride-coated outer layer. A more expensive but longer-lasting fabric is either Teflon-coated or silicone-coated fiberglass. Cables are clamped to the fabric, which is cut and sewn according to patterns for the structural shape employed.

The rules of structural geometry that govern the design of tension structures impart a unique and particular form, which does not easily permit deviations. Working with an engineer, the architect often begins the design process with model studies and a computer analysis to verify load expectations and to guide pattern-making for the fabric.

**ENVELOPE**

Walls and roof: Noncombustible fabric membrane (B)

Floor: Vapor barrier (G)

Principal advantages and characteristics: In general the skin and cables of these structures are in tension, while columns and arches are subject to compression. Under dynamic loading conditions, an efficient tensile structure will adjust and allow slight deformation.

Unique aerodynamic properties assist open tension structures in overcoming the difficulties of wind-driven rain; wind conditions subject most of the fabric to negative pressure, "lifting" rain away from the skin. The use of vegetation or architectural barriers at ground-level openings also reduces wind and rain effects under the canopy.

**MECHANICAL**

Electrical: Lighting fixtures, receptacles, and sound system mounted on columns and masts (D)

Fire safety: Noncombustible or fire-retardant fabric membrane (B)

Principal advantages and characteristics: Because the fabric transmits light while blocking direct rays of the sun, it also assumes some functions normal to mechanical systems. Electrical lighting and other equipment are difficult to integrate because of the thinness of the structural envelope membrane, and are nearly always attached to the structural masts or placed on independent, freestanding structures.

Acoustical, thermal, and fire-safety considerations are difficult to accommodate in tension structures, although their light weight and dynamic properties under wind loading make them very safe from a structural point of view. If areas of fabric are placed close to the ground or in other easily accessible locations, vandalism becomes a concern, as most materials suitable for tensile structures are easily cut. Fabric-covered structures for the performing arts are generally equipped with electrical systems designed for safety in wet conditions. Sealing of the holes at the peaks of tensile structures where masts protrude is not usually necessary.

Several of the major building codes now contain provisions governing tensile structures, but it is advisable to consult local code officials early in the design process. The treatment of electrical wiring within or affixed to rigid columns and masts, which must be designed to permit some movement, may be a concern. Some fabrics are classified as noncombustible, and some are only fire retardant, so it is important to determine early on which fabrics are acceptable in a specific situation.

**INTERIOR**

Ceilings and walls: Noncombustible fabric membrane (B)

Floors: Pivoted mast base and concrete footing (F)

Lighting: Incandescent light fixtures (D)

Principal advantages and characteristics: Color is an integral element of fabrics and will have an effect on the quality of natural illumination beneath the canopy. Because the fabric provides both interior and exterior finished surfaces for the envelope, the columns and masts are typically the only

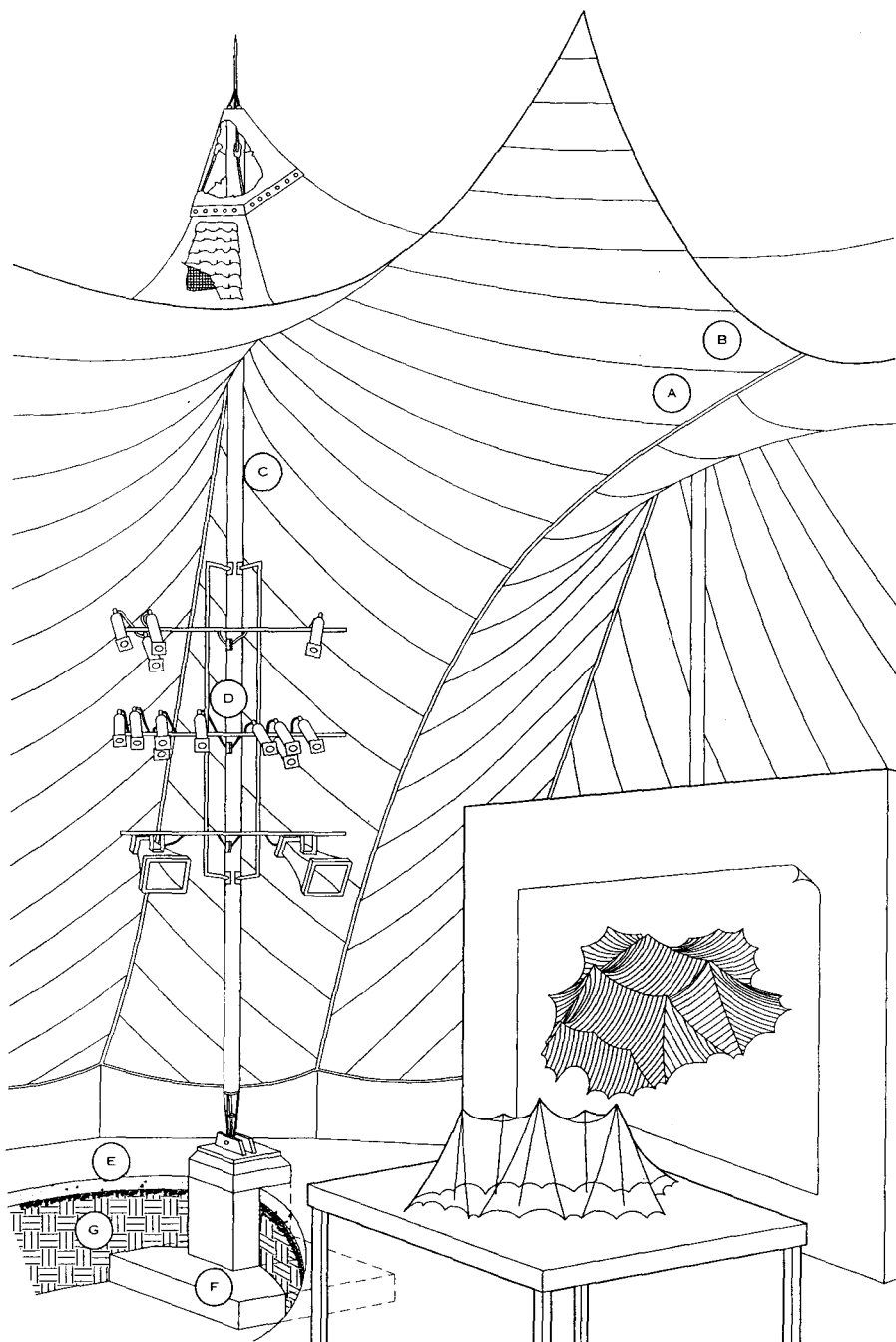

**TENSION FABRIC**

structural members used for mounting such items as lighting fixtures and power receptacles. Gantries hung from columns or masts provide additional service areas.

**SYSTEM SUMMARY**

Several features give tension structures an advantage over low-cost wood, metal, and concrete shelters. Fabrics can range in service life from a few years to several decades. If a lifetime of around 15 years is acceptable for the facility, a PVC-coated tension structure will suffice at a low initial cost. The usual solution for greater permanence is Teflon coated fiberglass. Clear spans of up to 100 ft are easily obtained with lightweight fabric structures.

Designers can consult with specialists on engineering and shop drawings. Design/build firms will produce complete shop drawings and often fabricate all components or erect the structure on the site. Careful detailing of steel and cable elements, joints, and attachments is critical to overall appearance, as most will be exposed to view. Steel and wire rope manufacturers can assist with detailing.

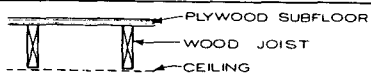
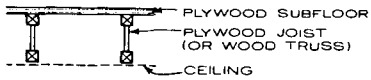
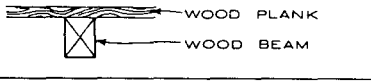
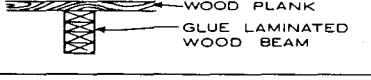
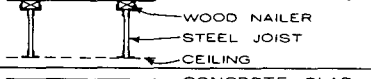
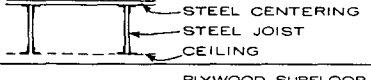
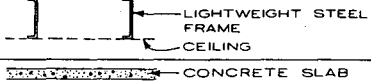
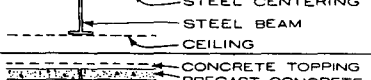
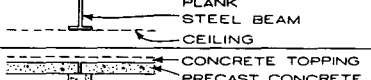
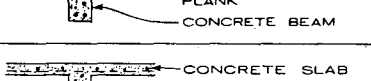
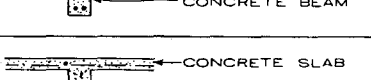
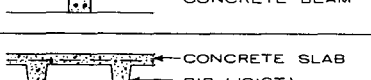
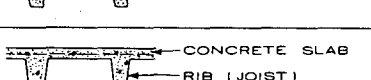
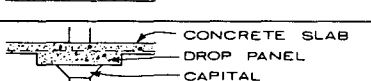
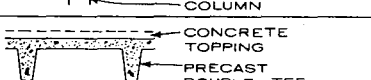
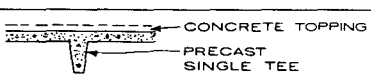
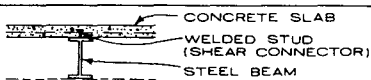
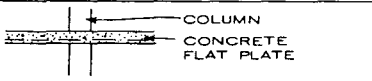
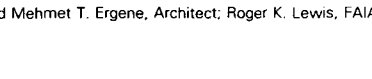

Based on Richard D. Rush, AIA, *The Building Systems Integration Handbook* (John Wiley & Sons, 1986).

FLOOR STRUCTURE ASSEMBLIES FOR ADDITIONAL INFORMATION CONSULT MANUFACTURERS' LITERATURE AND TRADE ASSOCIATIONS		DEPTH OF SYSTEM (IN.)	STANDARD MEMBER SIZES (IN.)	DEAD LOAD OF STRUCTURE (PSF)	ABLE LOAD RANGE (KIP/FT)	SPAN RANGE (FT)	DIMENSIONAL STABILITY AFFECTED BY
WOOD JOIST		7-13	Nominal joist 2 x 6, 8, 10, and 12	5-8	0-40	Up to 18	Deflection
WOOD TRUSS OR PLYWOOD JOIST		13-21	Plywood joists 12, 14, 16, 18, and 20	6-12	0-40	12-30	Deflection
WOOD BEAM AND PLANK		10-22	Nominal plank 2, 3, and 4	6-16	0-40	10-22	-
LAMINATED WOOD BEAM AND PLANK		8-22	Nominal plank 2, 3, and 4	6-20	0-40	8-34	-
STEEL JOIST		9-31	Steel joists 8-30	8-20	0-40	16-40	Deflection
STEEL JOIST		11-75	Steel joists 8-72	30-110	0-100	16-60 (up to 130)	Deflection
LIGHT-WEIGHT STEEL FRAME		7-12	Consult manufacturers' literature	6-20	0-60	10-22	-
STEEL FRAME		9-15	-	35-60	0-100	16-35	Deflection
STEEL FRAME		8-16	Concrete plank 16-48 W 4-12 D	40-75	0-150	Up to 50 Generally below 35	Deflection and creep
PRECAST CONCRETE		6-12	Concrete plank 16-48 W 4-12 D	40-75	0-150	Up to 60 Generally below 35	Deflection and creep
ONE-WAY CONCRETE SLAB		4-10	-	50-120	0-150	10-20 More with prestressing	-
TWO-WAY CONCRETE SLAB		4-10	-	50-120	0-250	10-30 More with prestressing	-
ONE-WAY RIBBED CONCRETE SLAB		8-22	Standard pan forms 20 and 30 W 6-20 D	40-90	0-150	15-50 More with prestressing	Creep
TWO-WAY RIBBED CONCRETE SLAB		8-22	Standard dome forms 19 x 19, 30 x 30 6-20 D	75-105	0-200	25-60 More with prestressing	Creep
CONCRETE FLAT SLAB		6-16	Min. slab thickness 5 without Drop 4 with panel	75-170	0-250	20-40 Up to 70 with prestressing	Creep
PRECAST DOUBLE TEE		8-18	4', 5', 6', 8', and 10' W 6-16 D	50-80	0-150	20-50	Creep
PRECAST TEE		18-38	16-36 D	50-90	0-150	25-65	Creep
COMPOSITE		4-6	-	35-70	0-200	Up to 35	Deflection
CONCRETE FLAT PLATE		5-14	-	60-175	0-200	18-35 More with prestressing	Creep

Roger K. Lewis, FAIA, and Mehmet T. Ergene, Architect; Roger K. Lewis, FAIA, & Associates; Washington, D.C

BAY SIZE CHARACTERISTICS	REQUIRES FINISHED FLOOR SURFACE	REQUIRES FINISHED CEILING SURFACE	SERVICE PLENUM	COMPARATIVE RESISTANCE TO SOUND TRANSMISSION		FIRE RESISTIVE RATING PER CODE AND UNDERWRITERS		CONSTRUCTION TYPE CLASSIFICATION	REMARKS
				IMPACT	AIRBORNE	UNPROTECTED HOURS	MAXIMUM PROTECTED HOURS		
-	Yes	Visual or fire protection purposes	Between joists -one way	Poor	Fair	-	2 (combustible)	4B (A) 3C (B)	Economical, light, easy to construct. Limited to lowrise construction
-	Yes	Visual or fire protection purposes	Between trusses and joists -two ways	Poor	Fair	-	2 (combustible)	4B (A) 3C (B)	Close dimensional tolerances; cutting holes through web permissible
Maximum beam spacing 8'-0"	Optional	No	Under structure -one way	Poor	Fair	-	2	3A 6" x 10" frame min. 4" planks min.	Most efficient with planks continuous over more than one span
-	Optional	No	Under structure -one way	Poor	Fair	-	2	3A 6" x 10" frame min. 4" planks min.	-
Light joists 16" to 30" o.c. Heavy joists 4'-12' o.c.	Yes	Visual or fire protection purposes	Between joists -two ways	Poor	Poor	-	1	3C (B)	-
Light joists 16" to 30" o.c. Heavy joists 4'-12' o.c.	No	Visual or fire protection purposes	Between joists -two ways	Poor	Fair	-	1-3	1, 2 and 3	Economical system, selective partition placement required. Cantilevers difficult
-	Yes	Visual or fire protection purposes	Under structure	Poor	Poor	-	1	3C (B)	-
-	No	Visual or fire protection purposes	Under structure	Poor	Fair	1-3	1-4	1, 2, and 3	-
-	Optional	Visual or fire protection purposes	Under structure	Fair	Fair	-	1-4	1, 2, and 3	-
-	Optional	No	Under structure	Fair	Fair	2-4	3-4	1 and 2	-
-	No	No	Under structure	Good	Good	1-4	3-4	1 and 2	Restricted to short spans because of excessive dead load
$L \leq 1.33 W$	No	No	Under structure	Good	Good	1-4	3-4	1 and 2	Suitable for concentrated loads, easy partition placement
-	No	No	Between ribs -one way	Good	Good	1-4	3-4	1 and 2	Economy through re-use of forms, shear at supports controlling factor
$L \leq 1.33 W$	No	No	Under structure	Good	Good	1-4	3-4	1 and 2	For heavy loads, columns should be equidistant. Not good for cantilevers
$L \leq 1.33 W$	No	No	Under structure	Good	Good	1-4	3-4	1 and 2	Drop panels against shear required for spans above 12 ft
-	Optional	Visual purposes; differential camber	Between ribs -one way	Fair	Good	2-3	3-4	1 and 2	Most widely used prestressed concrete product in the medium span range
-	Optional	Visual purposes; differential camber	Between ribs -one way	Fair	Good	2-3	3-4	1 and 2	Easy construction, lack continuity, poor earthquake resistance
-	No	Visual or fire protection purposes	Under structure	Good	Good	-	1-4	1, 2, and 3	-
$L \leq 1.33 W$	No	No	Under structure	Good	Good	1-4	3-4	1 and 2	Uniform slab thickness, economical to form, easy to cantilever



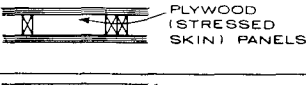
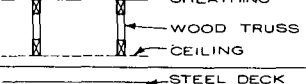
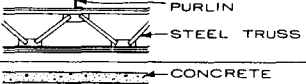
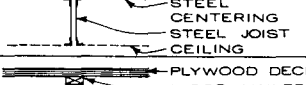
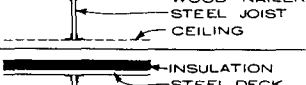
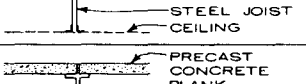
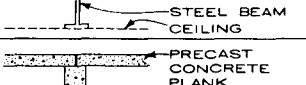
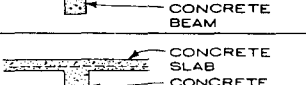
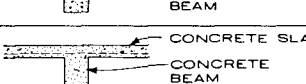
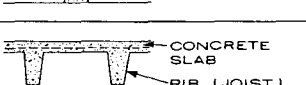
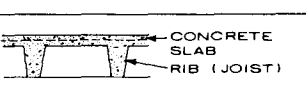
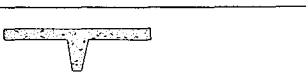
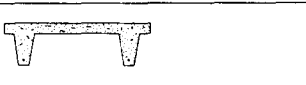
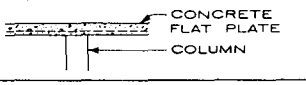
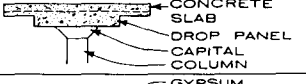
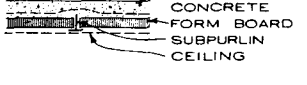
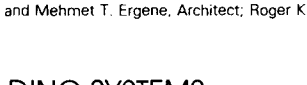







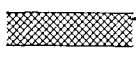

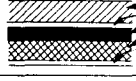

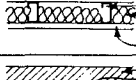

Roger K. Lewis, FAIA, and Mehmet T. Ergene, Architect; Roger K. Lewis, FAIA, & Associates; Washington, D.C

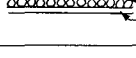
ROOF STRUCTURE ASSEMBLIES FOR ADDITIONAL INFORMATION CONSULT MANUFACTURER'S LITERATURE AND TRADE ASSOCIATIONS		DEPTH OF SYSTEM (IN.)	STANDARD MEMBER SIZES (IN.)	DEAD LOAD OF STRUCTURE (PSF)	SUITABLE LIVE LOAD RANGE (PSF)	SPAN RANGE (FT)	BAY SIZE CHARAC- TERISTICS	DIMENSIONAL STABILITY AFFECTED BY
WOOD RAFTER		5-13	Nominal rafters 2 x 4, 6, 8, 10, and 12	4-8	10-50	Up to 22	-	Deflection
WOOD BEAM AND PLANK		8-22	Nominal planks 2, 3, and 4	5-12	10-50	8-34	Maximum beam spacing 8'-0"	-
PLYWOOD PANEL		3 1/4 and 8 1/4	-	3-6	10-50	8-32	4'-0" modules	-
WOOD TRUSS		Varies (1'-12')	-	5-15	10-50	30-50	2'-8" between trusses	Deflection
STEEL TRUSS		Varies	-	15-25	10-60	100-200	-	Deflection
STEEL JOIST		11-75	Steel joists 8-72	10-28	10-50	Up to 96	Light joists 16"-30" o.c. Heavy joists 4'-12" o.c.	Deflection
STEEL JOIST		10-32	Steel joists 8-30	8-20	10-50	Up to 96	Light joists 16"-30" o.c. Heavy joists 4'-12" o.c.	Deflection
STEEL JOIST		11-75	Steel joists 8-72	6-24	10-50	Up to 96	-	Deflection
STEEL FRAME		4-12 plus beam depth	Concrete plank 16-48 W 4-12 D	40-75	30-70	20-60 Generally below 35	-	Deflection and creep
PRECAST CONCRETE		4-12 plus beam depth	Concrete plank 16-48 W 4-12 D	40-75	30-70	20-60 Generally below 35	-	Deflection and creep
ONE - WAY CONCRETE SLAB		4-10 slab plus beam depth	-	50-120	Up to 100	10-25 More with prestressing	-	-
TWO - WAY CONCRETE SLAB		4-10 slab plus beam depth	-	50-120	Up to 100	10-30 More with prestressing	L ≤ 1.33 W	-
ONE - WAY RIBBED CONCRETE SLAB		8-22	Standard pan forms 20 and 30 W 6-20 D	40-90	Up to 100	15-50 More with prestressing	-	Creep
TWO - WAY RIBBED CONCRETE SLAB		8-24	Standard dome forms 19 x 19, 30 x 30 6-20 D	75-105	Up to 100	25-60 More with prestressing	L ≤ 1.33 W	Creep
PRECAST TEE		16-36	16-36 deep	65-85	20-80	30-100	-	Creep
PRECAST DOUBLE TEE		6-16	4', 5', 6', 8', and 10' wide 6"-16" deep	35-55	25-60	20-75	-	Creep
CONCRETE FLAT PLATE		4-14	-	50-160	Up to 100	Up to 35 More with prestressing	L ≤ 1.33 W	Creep
CONCRETE FLAT SLAB		5-16	Min. slab thickness 5 w/o } Drop 4 w/ } panel	50-200	Up to 100	Up to 40 More with prestressing	L ≤ 1.33 W Equal column spacing required	Creep
GYPSUM DECK		3-6	-	5-20	Up to 50	Up to 10	Up to 8' between subpurlins	Deflection and creep

Roger K. Lewis, FAIA, and Mehmet T. Ergene, Architect; Roger K. Lewis, FAIA, & Associates; Washington, D.C

SUITABLE FOR INCLINED ROOFS	REQUIRES FINISHED CEILING SURFACE	SERVICE PLENUM	RELATIVE THERMAL CAPACITY	COMPARATIVE RESISTANCE TO SOUND TRANSMISSION		FIRE RESISTIVE RATING PER CODE AND UNDERWRITERS		CONSTRUCTION TYPE CLASSIFICATION	REMARKS
				IMPACT	AIRBORNE	UNPROTECTED HOURS	MAXIMUM PROTECTED HOURS		
Yes	For visual or fire protection purposes	Between rafters —one way	Low	Poor	Fair	—	2 (combustible)	4B (A) 3C (B)	
Yes	For fire protection purposes	Under structure —one way	Medium	Poor	Fair	—	2	3A 6" x 10" frame min. 4" plank min.	
Yes	No	Under structure only	Low	Poor	Fair	—	2	4B (A) 3C (B)	
Yes	For visual or fire protection purposes	Between trusses	Low	Poor	Fair	—	2 (combustible)	4B (A) 3C (B)	Truss depth to span ratio 1:5 to 1:10
Yes Pitched trusses usually used for short spans	For visual or fire protection purposes	Between trusses	Low	Fair	Fair	—	1-4	1, 2, and 3	Truss depth to span ratio 1:5 to 1:15
No	For visual or fire protection purposes	Between joists	Medium	Fair	Fair	—	1-4	1, 2, and 3	
Yes	For visual or fire protection purposes	Between joists	Low	Poor	Fair	—	1	1, 2, and 3	
Yes	For visual or fire protection purposes	Between joists	High	Excellent	Good	—	2	1, 2, and 3	
Yes	For visual or fire protection purposes	Under structure	High	Fair	Fair	—	1-4	1, 2, and 3	Easy to design; quick erection
Yes	No	Under structure	High	Fair	Fair	2-4	3-4	1 and 2	Provides finished flush ceiling. May be used with any framing system
No	No	Under structure	High	Good	Good	1-4	3-4	1 and 2	
No	No	Under structure	High	Good	Good	1-4	3-4	1 and 2	
No	For visual purposes	Between ribs —one way	High	Good	Good	1-4	3-4	1 and 2	
No	No	Under structure	High	Good	Good	1-4	3-4	1 and 2	Economy in forming; suitable for two-way cantilevering
Yes	For visual or fire protection purposes	Between ribs —one way	High	Fair	Good	2-3	3-4	1 and 2	Generally used for long spans
Yes	For visual or fire protection purposes	Between ribs —one way	High	Fair	Good	2-3	3-4	1 and 2	Most widely used prestressed concrete element.
No	No	Under structure	High	Good	Good	1-4	3-4	1 and 2	Uniform slab thickness; easy to form; suitable for vertical expansion of building
No	No	Under structure	High	Good	Good	1-4	3-4	1 and 2	Suitable for heavy roof loads
No	For visual or fire protection purposes	Under structure	High	Good	Good	—	2	1, 2, and 3	Provides resistance to wind and seismic loads

Roger K. Lewis, FAIA, and Mehmet T. Ergene, Architect; Roger K. Lewis, FAIA, & Associates; Washington, D.C.

EXTERIOR WALL ASSEMBLIES FOR ADDITIONAL INFORMATION CONSULT MANUFACTURERS LITERATURE AND TRADE ASSOCIATIONS		WALL THICKNESS (NOMINAL) (IN.)	WEIGHT (PSF)	VERTICAL SPAN RANGE (UNSUP- PORTED HEIGHT) (FT)	WIND RESIST. WIND RESIST.	RACKING RESISTANCE	SERVICE PLENUM SPACE	HEAT TRANS- MISSION COEFFI- CIENT (U-FACTOR) (BTU/HR · SQ FT · °F)
C. M. U.	 C. M. U. (GRAVEL AGGREGATE)	8 12	55 85	Up to 13 Up to 20	Wind resistance depends on geographical location and height of building; wind velocity; wall material thickness, strength; workmanship; axial loads; and horizontal span. Design walls for both inward and outward pressures	Good	None	0.56 0.49
C. M. U. (INSULATED)	 C. M. U. INSULATION INT. WALL FIN.	8 + 12 +	60 90	Up to 13 Up to 20		Good	Through insulation	0.21 0.20
C. M. U. AND BRICK VENEER (INSULATED)	 BRICK VENEER C. M. U. INSULATION INT. WALL FIN.	4 + 4 + 4 + 8 +	75 100	Up to 13 (w/filled cavity) Up to 20 (w/filled cavity)		Good	Through insulation	0.19 0.18
CAVITY	 BRICK VENEER CAVITY (MIN. 2") INSULATION (WATER REPELLENT) C. M. U. INT. WALL FIN.	4 + 2 + 4 4 + 2 + 8	75 100	Up to 9 Up to 13		Fair	None	0.12 0.11
C. M. U. AND STUCCO (INSULATED)	 STUCCO C. M. U. INSULATION INT. WALL FIN.	8 +	67	Up to 13		Good	Through interior insulation	0.16
WOOD STUD	 EXT. WALL FIN. SHEATHING WITH MOISTURE BARRIER WOOD STUD INSULATION WITH VAPOR BARRIER INT. WALL FIN.	4 6	12 16	Up to 14 Up to 20 (L/d ≤ 50)		Poor to fair	Between studs	0.06 0.04
BRICK VENEER	 BRICK VENEER SHEATHING WITH MOISTURE BARRIER WOOD STUD INSULATION WITH VAPOR BARRIER INT. WALL FIN.	4 + 4	52	Up to 14		Poor to fair	Between studs	0.07
METAL STUD	 EXT. WALL FIN. METAL STUD AT 16" O.C. INSULATION WITH VAPOR BARRIER INT. WALL FIN.	4 5	14 18	Up to 13 Up to 17		Poor	Between studs	0.06 0.04
BRICK VENEER	 BRICK VENEER SHEATHING WITH MOISTURE BARRIER METAL STUD AT 16" O.C. INSULATION WITH VAPOR BARRIER INT. WALL FIN.	4 + 4	54	Up to 15		Good	Between studs	0.07
INSULATED SANDWICH PANEL	 METAL SKIN AIRSPACE INSULATING CORE METAL SKIN	5	6	See manufacturers' literature		Fair to good	None	0.05 See manufacturers' literature
CONCRETE	 CONCRETE	8 12	92 138	Up to 13 (w/reinf. 17) Up to 20 (w/reinf. 25)		Excellent	None	0.68 0.55
CONCRETE (INSULATED)	 CONCRETE INSULATION INT. WALL FIN.	8 +	97	Up to 13 (w/reinf. 17)		Excellent	Through insulation	0.13
CONCRETE AND BRICK VENEER (INSULATED)	 BRICK VENEER CONCRETE INSULATION INT. WALL FIN.	4 + 8 +	112	Up to 13 (w/reinf. 17)		Excellent	Through insulation	0.13
PRECAST CONCRETE	 CONCRETE (REINFORCED) INSULATION INT. WALL FINISH	2 + 4 +	23 46	Up to 6 Up to 12		Fair to good	Through insulation	0.99 0.85
PRECAST CONCRETE SANDWICH	 CONCRETE INSULATION	5	45	Up to 14		Fair to good	None	0.14
GLASS	SEE INDEX UNDER "GLASS"			SIZE RANGE MAXIMUM ALLOWABLE GLASS AREA			SHADING COEFFI- CIENT S.C.	
SINGLE GLAZING	 1/4" GLASS	1/4	3.2	Four side supported 110 SF @ 10 PSF 20 SF @ 60 PSF Two side supported 40 SF @ 10 PSF 17 SF @ 60 PSF			Clear 0.94 Tinted 0.70	Clear/tinted 1.1 Reflective 0.8-1.1
DOUBLE GLAZING	 1/4" GLASS 1/4" CAVITY	3/4	6.4	Four side supported 55 SF @ 30 PSF 28 SF @ 60 PSF Heat strengthened 70 SF @ 80 PSF 30 SF @ 200 PSF			Reflective 0.44	Clear/tinted 0.5-0.6 Reflective 0.3-0.6
TRIPLE GLAZING	 1/4" GLASS 1/4" CAVITY	1 1/4	9.6					Clear/tinted 0.3-0.4 Reflective 0.2-0.4

Roger K. Lewis, FAIA, and Mehmet T. Ergene, Architect; Roger K. Lewis, FAIA, & Associates; Washington, D.C

RESISTANCE TO EXTERIOR AIRBORNE SOUND TRANSMISSION	HAZARD CLASSIFICATION (FIRE)	FIRE RESISTIVE RATING PER CODE AND UNDERWRITERS (HRS)	CONSTRUCTION TYPE CLASSIFICATION	SUBCONTRACTORS REQUIRED FOR ERECTION (PLUS FINISHES)	EXTERIOR MAINTENANCE REQUIREMENTS	REMARKS												
Fair to good	Classification provides data in regard to (1) flame spread, (2) fuel contributed, and (3) smoke developed during fire exposure of materials in comparison to asbestos-cement boards as zero and untreated red oak lumber as 100 when exposed to fire under similar conditions	2-4 4	1, 2, and 3	Masonry	Washing, re-pointing joints, painting, sand blasting	Properties of non-engineered masonry are drastically reduced												
Fair to good		2-4 4	1, 2, and 3	Masonry Carpentry Drywall	Washing, re-pointing joints, painting, sand blasting													
Excellent	<table border="1"> <tr> <td></td> <td>FUEL CONTRIBUTED</td> <td>SMOKE DEVELOPED</td> </tr> <tr> <td>FLAME SPREAD</td> <td></td> <td></td> </tr> </table> Paint on CMU 5-25      0-5      0-10		FUEL CONTRIBUTED	SMOKE DEVELOPED	FLAME SPREAD			3-4 4	1, 2, and 3	Masonry Carpentry Drywall	Washing, re-pointing joints, sand blasting							
	FUEL CONTRIBUTED	SMOKE DEVELOPED																
FLAME SPREAD																		
Excellent	Gypsum board surfaced on both sides with paper 15      15      0	4	1, 2, and 3	Masonry Drywall (Carpentry)	Washing, re-pointing joints, sand blasting	Cavity increases heat storage capacity and resistance to rain penetration												
Good	Gypsum board surfaced on both sides with paper, vinyl faced 25-35      0-10      15-45	2-4	1, 2, and 3	Masonry Drywall Lath and plaster (Carpentry)	Washing, painting, and restuccoing	The assembly is reversed for optimum energy conservation												
Poor to fair	Untreated wood particle board 180      75      190	1 (combustible)	4	Carpentry Drywall (Lath and plaster)	Washing, painting, and replacing exterior finish	Exterior wall finishes: • wood, plywood, • aluminum siding • stucco												
Good to excellent	Treated wood particle board with untreated wood face veneer 25-180      10-160      10-250	1-2 (combustible)	3B, C	Masonry Carpentry Drywall	Washing, re-pointing joints, sand blasting													
Poor to fair	Vermiculite acoustical plaster 10-20      10-20      0	1-2	1 (nonbearing) 2 and 3	Carpentry Drywall (Lath and plaster)	Washing, painting, and replacing exterior finish	Exterior wall finishes: • wood, plywood, • aluminum siding • stucco												
Good to excellent	Glass fiber batts and blankets (basic) 20      15      20  (foil kraft faced) 25      0      0	1-2	1 (nonbearing) 2 and 3	Masonry Carpentry Drywall	Washing, re-pointing joints, sand blasting													
Poor to good; see manufacturers' literature	Treated lumber (Douglas fir) 15      10      0-5	See manufacturers' literature	See manufacturers' literature	Curtain walls -erection	Washing, steam cleaning, painting, replacing joint sealers	Temperature change critical Minimize metal through connections												
Good	(Hemlock) 10-15      5-15      0	4 4	1, 2, and 3	Concrete work	Washing, sand blasting	Concrete walls have very high heat storage capacity												
Good	Laminated plastic (fr) 20-30      0-15      5-30	4 4	1, 2, and 3	Concrete work Drywall (Carpentry)	Washing, sand blasting													
Excellent	NFPA CLASSIFICATION: <table border="1"> <tr> <td>CLASS</td> <td>FLAME SPREAD</td> <td>SMOKE DEVELOPED</td> </tr> <tr> <td>A</td> <td>0-25</td> <td>0-450</td> </tr> <tr> <td>B</td> <td>26-75</td> <td>0-450</td> </tr> <tr> <td>C</td> <td>76-200</td> <td>0-450</td> </tr> </table> For lesser classifications, permitted in residential construction only, refer to regulating agency guidelines	CLASS	FLAME SPREAD	SMOKE DEVELOPED	A	0-25	0-450	B	26-75	0-450	C	76-200	0-450	4	1, 2, and 3	Concrete work Masonry Drywall (Carpentry)	Washing, re-pointing joints, sand blasting	
CLASS	FLAME SPREAD	SMOKE DEVELOPED																
A	0-25	0-450																
B	26-75	0-450																
C	76-200	0-450																
Poor to fair		1-3	1A (nonbearing) 1B, 2, and 3	Curtain walls -erection Drywall (Carpentry)	Washing, sand blasting, replacing joint sealers	Large size economical (fewer joints) units available with various finishes												
Fair		1-3	1A (nonbearing) 1B, 2, and 3	Curtain walls -erection	Washing, sand blasting, replacing joint sealers	8' x 20' max. size for concrete sandwich panels Plant quality control is very essential												
Poor	-	-	-	Curtain walls -erection (Glazing)	Washing, replacing joint sealers, gaskets	Anchorage to building is critical Anchors must isolate wall to limit building movement transmitted to glass												
Fair	-	-	-	Curtain walls -erection (Glazing)	Washing, replacing joint sealers, gaskets	Wall design must limit wall movement transmitted to glass Mullions should accommodate movement through gaskets, sliding connections, etc.												
Good	-	-	-	Curtain walls -erection (Glazing)	Washing, replacing joint sealers, gaskets													

Roger K. Lewis, FAIA, and Mehmet T. Ergene, Architect; Roger K. Lewis, FAIA, & Associates; Washington, D.C



**MINIMUM UNIFORMLY DISTRIBUTED LIVE LOADS**

OCCUPANCY OR USE	LIVE LOAD (PSF)
Armories and drill rooms	150
Assembly halls and other places of assembly	
Fixed seats	50
Movable seats	100
Platforms (assembly)	100
Attics	
Nonstorage	10
Storage	30 <sup>5</sup>
Bakeries	150
Balconies	
Exterior	60
Interior (fixed seats)	50
Interior (movable seats)	100
Bowling Alleys, poolrooms, and similar recreational areas	75
Broadcasting studios	100
Catwalks	25
Cold storage rooms	
Floor	150
Roof	250
Corridors	
First floor	100
Other floors, same as occupancy served except as indicated	
Dance halls and ballrooms	100
Dining rooms and restaurants	100
Dormitories	
Nonpartitioned	80
Partitioned	40
File rooms	
Card	125 <sup>1</sup>
Letter	80 <sup>1</sup>
High-density storage	150 <sup>5</sup>
Fire escapes on multifamily or single family residential buildings only	100
Foundries	600 <sup>2</sup>
Fuel rooms, framed	400 <sup>2</sup>
Garages (passenger cars only). For trucks and buses use AASHO <sup>3</sup> lane load	50
Grandstands	100 <sup>6</sup>
Greenhouses	150
Gymnasiums, main floor and balconies	100
Hospitals	
Operating rooms and laboratories	60
Private rooms	40
Wards	40
Corridors, above first floor	80
Hotels (see residential)	
Kitchens, other than domestic	150 <sup>2</sup>
Laboratories, scientific	100
Laundries	150 <sup>2</sup>
Libraries	
Reading rooms	60
Stack rooms (books and shelving at 65 pcf) but not less than indicated	150
Corridors, above first floor	80
Manufacturing	
Light	75
Heavy	125
Ice	300
Marquees	75
Morgues	125
Office buildings	
Office	50
Business machine equipment	100 <sup>2</sup>
Lobbies	100
Corridors, above first floor	80
File and computer rooms require heavier loads based on anticipated occupancy	
Penal Institutions	
Cell blocks	40
Corridors	100
Printing plants	
Composing rooms	100
Linotype rooms	100
Paper storage rooms	4
Pressrooms	150 <sup>2</sup>
Public rooms	100

Residential	
Multifamily houses	
Private apartments	40
Public rooms	100
Corridors	80
Dwellings	
First floor	40
Second floor and habitable attics	30
Inhabitable attics	20
Hotels	
Guest rooms	40
Public rooms	100
Corridors serving public rooms	100
Rest rooms and toilet rooms	40
Schools	
Classrooms	40
Corridors	80
Sidewalks, vehicular driveways, and yards subject to trucking	250
Skating rinks	100
Stairs and exit-ways	100
Storage warehouses	
Light	125
Heavy	250
Hay or grain	300
Stores	
Retail	
First floor, rooms	75
Upper floors	75
Wholesale	100
Telephone exchange rooms	150 <sup>2</sup>
Theaters	
Aisles, corridors, and lobbies	100
Orchestra floors	50
Balconies	50
Stage floors	150
Dressing rooms	40
Grid iron floor or fly gallery grating	75
Projection room	100
Transformer rooms	200 <sup>2</sup>
Vaults, in offices	250 <sup>1</sup>
Yards and terraces, pedestrians	100

**NOTES**

1. Increase when occupancy exceeds this amount.
2. Use weight of actual equipment when greater.
3. American Association of State Highway Officials.
4. Paper storage 50 lb/ft of clear story height.
5. Verify with design criteria.
6. Additional loads—120 lb/linear ft vertical, 24 lb/ft parallel lateral, and 10 lb/ft perpendicular to seat and footboards.

**LIVE LOAD**

Live load is the weight superimposed by the use and occupancy of the building or other structure, not including the wind, snow, earthquake, or dead load.

The live loads to be assumed in the design of buildings and other structures shall be the greatest loads that probably will be produced by the intended use or occupancy, but in no case less than the minimum uniformly distributed unit load.

**THRUSTS AND HANDRAILS**

Stairway and balcony railing, both exterior and interior, shall be designed to resist a vertical and a horizontal thrust of 50 lb/linear ft applied at the top of the railing. For one- and two-family dwellings, a thrust of 20 lb/linear ft may be used instead of 50.

**CONCENTRATED LOADS**

Floors shall be designed to support safely the uniformly distributed live load or the concentrated load in pounds given, whichever produces the greater stresses. Unless otherwise specified, the indicated concentration shall be assumed to occupy an area of 2 1/2 sq ft (6.26 ft<sup>2</sup>) and shall be located so as to produce the maximum stress conditions in the structural members.

**PARTIAL LOADING**

The full intensity of the appropriately reduced live loads applied only to a portion of the length of a structure or member shall be considered if it produces a more unfavorable effect than the same intensity applied over the full length of the structure or member.

**IMPACT LOADS**

The live loads shall be assumed to include adequate allowance for ordinary impact conditions. Provision shall be made in structural design for uses and loads that involve unusual vibration and impact forces.

1. ELEVATORS: All elevator loads shall be increased 100% for impact, and the structural supports shall be designed within limits of deflection prescribed by American National Standard Safety Code for elevators and escalators, A17.1 - 1981, and American National Standard Practice for the Inspection of Elevators, Escalators, and Moving Walks (Inspector's Manual) A17.2 - 1979.
2. MACHINERY: For the purpose of design, the weight of machinery and moving loads shall be increased as follows to allow for impact:
  - a. Elevator machinery, 100%.
  - b. Light machinery, shaft or motor driven, 20%.
  - c. Reciprocating machinery or power driven units, 50%.
  - d. Hangers for floors or balconies, 33%.
 All percentages to be increased if so recommended by the manufacturer.
3. CRANEWAYS: All craneways, except those using only manually powered cranes, shall have their design loads increased for impact as follows:
  - a. A vertical force equal to 25% of the maximum wheel load.
  - b. A lateral force equal to 20% of the weight of trolley and lifted load only, applied one - half at the top of each rail.
  - c. A longitudinal force of 10% of the maximum wheel loads of the crane applied at top of rail.
4. PARKING GARAGE GUARDRAILS: Guardrails and walls acting as impact rails in parking structures shall be designed for a minimum horizontal ultimate load of 10,000 lb applied 18 in. above the floor at any point of the guardrail.

**MINIMUM ROOF LOADS**

1. FLAT, PITCHED, OR CURVED ROOFS: Ordinary roofs - flat, pitched, or curved - shall be designed for the live loads or the snow load, whichever produces the greater stress.
2. PONDING: For roofs, care shall be taken to provide drainage or the load shall be increased to represent all likely accumulations of water. Deflection of roof members will permit ponding of water accompanied by increased deflection and additional ponding.
3. SPECIAL PURPOSE ROOFS: When used for promenade purposes, roofs shall be designed for a maximum live load of 60 psf; 100 psf when designed for roof garden or assembly uses. Roofs used for other special purposes shall be designed for appropriate loads, as directed or approved by the building official.

**LIVE LOAD REDUCTION**

In general, design live loads should not be in excess of 100 psf on any member, supporting an area of 150 sq ft or more, except for places of public assembly, repair garages, parking structures, and roofs. The reduction shall not exceed the value of R from the following formulas:

$$R = .08(A-150)$$

$$R = 23(1+D/L)$$

where R = reduction (%)  
 D = dead load per square foot of area supported by the member  
 L = live load per square foot of area supported by the member  
 A = area supported by the member

In no case should the reduction exceed 60% for vertical members, nor 40 to 60% for horizontal members.

For live loads in excess of 100 psf, some codes allow a live load reduction of 20% for columns only.

**CODES AND STANDARDS**

The applicable building code should be referred to for specific uniformly distributed live loads, movable partition load, special and concentrated load requirements.

In addition to specific code requirements, the designer must consider the effects of special loading conditions, such as moving loads, construction loads, roof top planting loads, and concentrated loads from supported or hanging equipment (radiology, computer, heavy filing, or mechanical equipment)

The live loads given in this table are obtained by reference to ASCE, UBC, BOCA, and SBCCI.

Charles W. Vanderlinden, PE; Hansen Lind Meyer, Inc.; Orlando, Florida

**GENERAL**

When selecting a long span roof system, it is appropriate to consider life safety of equal concern to cost. Egress must be carefully evaluated by simulating the most adverse conditions rather than simply complying with building codes. Fire safety begins by limiting the fire load, as codes rarely require fire protection or sprinkler systems. Auxiliary uses having any fire risk (e.g., food handling) should be carefully fire separated from the rest of the structure.

**DESIGN CONSIDERATION FACTORS**

Examples of long span structures shown in the table are rated for their ability to address the following design factor conditions.

**NATURAL CONDITIONS**

- a. Uneven or excessive snow and ice loads: Geometry, equipment, or exterior structure may contribute to snow drifting or ice buildup.
- b. Ponding: Provide positive drainage to remove water from the structure when roof drains clog.
- c. Wind: Evaluate potential of wind induced destructive vibration in members or connections.
- d. Thermal: Diurnal and seasonal temperature cycles can cause significant changes in structural shape and member stresses and may lead to fatigue failure.
- e. Freeze/thaw cycles or corrosive atmosphere: Evaluate long-term effects on structural performance, particularly for exposed concrete structures.

**PRIMARY STRESSES**

- f. Two or more load paths for all loads should be provided wherever possible. The greater the area a single member supports, the greater should be its safety factor.
- g. Compression failure: Resistance to lateral buckling of long members is crucial. Use members that assure initial and verifiable alignment.
- h. Tension failure: Dynamic stability under wind or other vibration loading should be carefully verified.

**SECONDARY STRESSES**

- i. Deflection: Changes in orientation of members at joints from loads can increase stresses destructively.
- j. Member interaction: Load flows through structures in such a way as to minimize strength. Check all possible load paths of complex geometric structures.
- k. Nonstructural connections: Assemblies attached to a structure will influence structural load flow and even become part of the load flow if the attachment changes the deflected shape.
- l. Scale: Most systems have a span beyond which self weight becomes a severe limit.
- m. Stress concentration: Check stresses at changes of cross sections, holes, and connections. High-strength materials are particularly sensitive.

**TOLERANCES**

- n. Erection alignment: True member length and spatial position are crucial for proper alignment and load flow.
- o. Creep: Length changes over time will influence both primary and secondary stresses.
- p. Supports and foundations: Supports must accept movements due to deflections from primary and secondary stresses and differential foundation settlement.

**QUALITY CONTROL**

- q. Engineering design must not be compromised by time, scheduling, design changes, or building codes. Computerized design must be carefully verified to resolve all primary and secondary stresses.
- r. Construction methods should be selected carefully to safely locate the structural components accurately in space.
- s. Site observation: Only when the structure is properly established in space should it be accepted. Changes in construction should be carefully checked.
- t. Structural building maintenance: Conditions and alignment of various members, especially crucial nonredundant members, should be verified on a regular schedule. Consider using equipment to detect excessive deflection.
- u. Nonstructural building maintenance: Condition of building components should not adversely affect the structure (e.g., keep roof drains open, prevent excessive equipment vibration, and maintain expansion joints).

**LONG SPAN SYSTEMS**

SYSTEM	MATERIAL (OR SHAPE)	ONE WAY	TWO WAY	FLAT SURFACE	PITCHED PLANE	CURVED PLANE	CURVED SURFACE	SPAN RANGE (FT)					SPAN/DEPTH RATIO	FACTORS STRONG AGAINST	FACTORS SENSITIVE TO
								50	100	150	300	600			
Joist	Steel	•		•				—	—	—	—	—	20 - 24	p,q,s	a,b,f,g
Truss	Steel	•	•	•	•			—	—	—	—	—	16 - 22	a,b,f	a,b,f,g,m,t
	Wood	•	•	•	•			—	—	—	—	—	9 - 12	a,b,f	m
Space frame	Steel		•	•				—	—	—	—	—	16 - 20	f	a,b,i,j,m,n,p,q,s,u
	Wood		•	•				—	—	—	—	—	9 - 12	b,f	a,b,f,g
Stressed skin	Steel	•		•				—	—	—	—	—	14 - 18	f	a,b,i,j,m,n,p,q,s,u
Beam	Steel	•		•				—	—	—	—	—	18 - 22	a,q	b,f,t
	Wood	•		•				—	—	—	—	—	16 - 20		b,f,t
	Prestressed concrete	•		•				—	—	—	—	—	22 - 26		b,f,t
Rigid frame	Steel	•		•				—	—	—	—	—	20 - 24	a,b	f
	Wood	•		•				—	—	—	—	—	18 - 22		f
	Prestressed concrete	•		•				—	—	—	—	—	24 - 28		f
Cable stayed							—	—	—	—	—		i,p	c,e,h,q,t	
Folded plate	Steel	•		•				—	—	—	—	—	18 - 22	b	a,f,m
	Wood	•		•				—	—	—	—	—	12 - 16	b	a,f,m
	Concrete	•		•				—	—	—	—	—	10 - 14	b	a,f,l,m
Cylindric shell	Concrete	•				•							10 - 14	b	a,l,m,o
Vault	Concrete	•	•			•		—	—	—	—	—	6 - 10	b	c,o
	Steel	•	•			•		—	—	—	—	—	4 - 8	b	a,d,f,g
	Wood	•	•			•		—	—	—	—	—	3 - 7	b	a,d,f,g
Arch	Concrete	•	•			•		—	—	—	—	—	3 - 7	b	a,d,f,g
	Steel	•	•			•		—	—	—	—	—	4 - 8	b	a,d,f,g
	Wood	•	•			•		—	—	—	—	—	3 - 7	b	a,d,f,g
Dome	Radial steel		•				•	—	—	—	—	—	4 - 8	b,c	a,d,f,g
	Geodesic dome		•				•	—	—	—	—	—	2 - 5	a,b,c,f,g	d,n,r
	Radial wood		•				•	—	—	—	—	—	3 - 6	b,c	a,d,f,g
	Lamella wood		•				•	—	—	—	—	—	3 - 6	a,b,c,f,g	d,n,r
Pneumatics	Steel		•				•	—	—	—	—	—	4 - 7	d	a,b,c,e
	Concrete		•				•	—	—	—	—	—	5 - 8	b,c,f,g	a,d,l,o
Cable	Parallel	•					•	—	—	—	—	—	8 - 16	d	a,b,c,f
	Radial		•				•	—	—	—	—	—	6 - 12	d	a,b,c,f
	Hyperbolic		•				•	—	—	—	—	—	4 - 8	b,d,f	a,c
	Tent		•				•	—	—	—	—	—	3 - 6	b,f	a,c
Hyperbolic	Concrete		•				•	—	—	—	—	—	3 - 6	f	a,d,l,o

**NOTES**

1. Steel is A-36; wood is laminated, sometimes heavy timber; concrete is reinforced with steel; prestressed concrete is prestressed with steel.
2. Cable-stayed system can give auxiliary support to trusses, beams, or frames, greatly reducing span and member sizes, but providing additional tensional strength.
3. Lamella arches provide two-way arch structures and improve redundancy.
4. Domes may also be constructed of aluminum.
5. Pneumatics are fabric roofs, pressurized, and stabilized with steel cables.
6. For each system the following notation applies:
  - is the typical configuration
  - is occasionally used

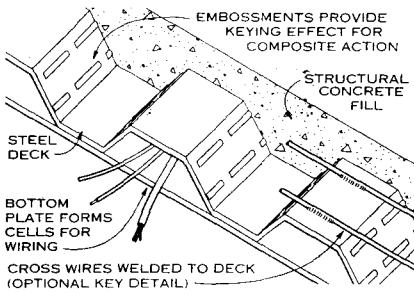

CONCRETE TOPPED STEEL DECK

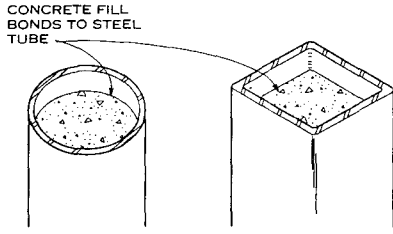

STEEL-ENCASED CONCRETE

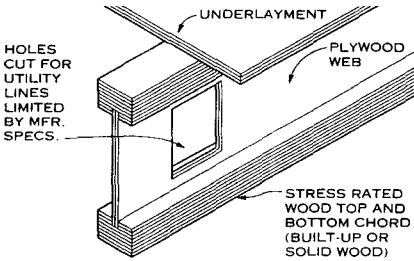

WOOD AND PLYWOOD COMPOSITE JOISTS

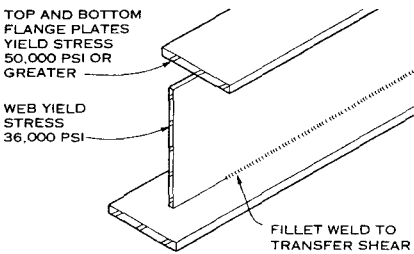

HYBRID STEEL GIRDERS USING STEELS OF DIFFERING STRENGTH

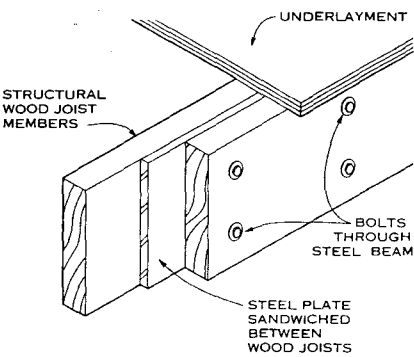

FLITCH BEAMS

Composite construction combines different materials, or different grades of a material, to form a structural member that utilizes the most desirable properties of each. Perhaps the earliest composite structural unit was the mud brick

Richard J. Vitullo, AIA; Oak Leaf Studio; Crownsville, Maryland

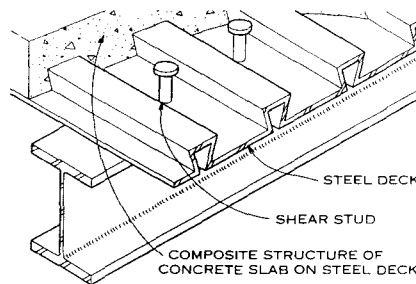

STEEL BEAM WITH STUD IN CONCRETE SLAB

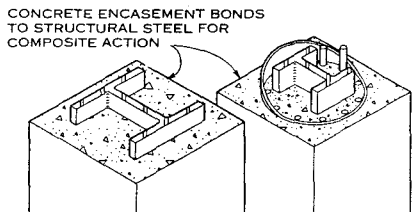

CONCRETE ENCASED STEEL COLUMNS

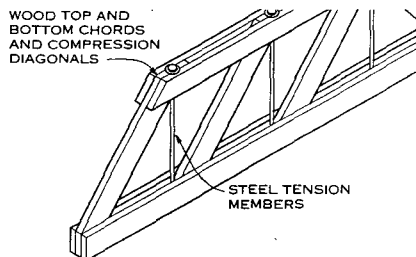

WOOD AND STEEL TRUSSES

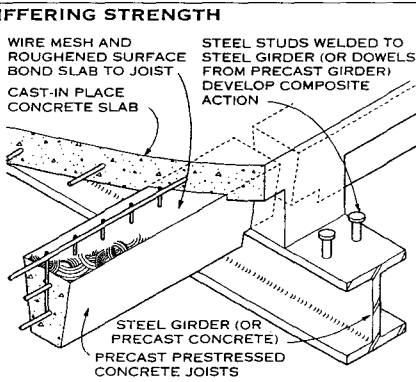
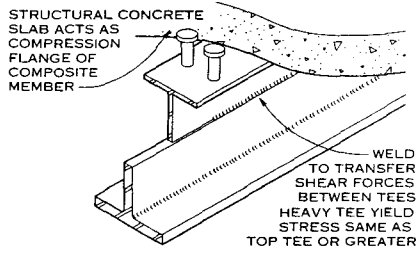

REINFORCED CONCRETE SLAB AND PRECAST JOIST

reinforced with straw. More recently fiberglass-reinforced plastics, wire-reinforced safety glass, and glued laminated plywood and wood beams have been used.

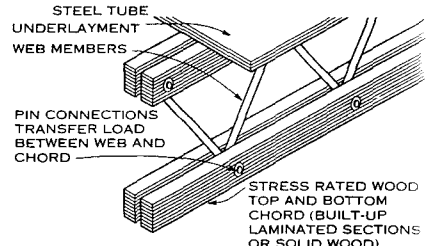
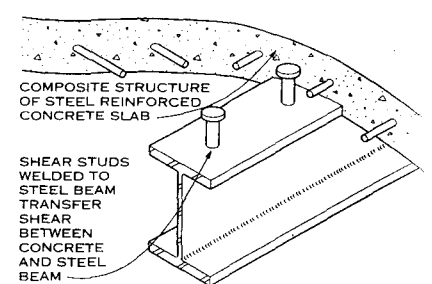

WOOD AND STEEL JOISTS

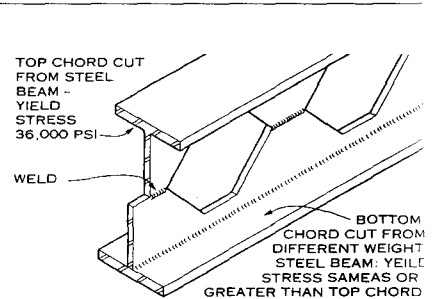
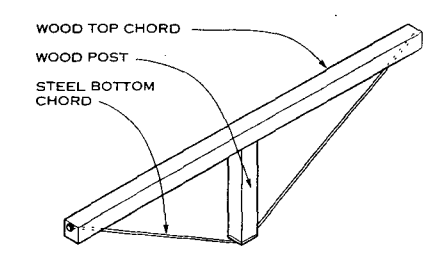

CASTELLATED BEAMS

NOTES

Individual elements of the composite unit must be securely fastened to prevent slippage, especially at points where load is transferred from one element of the composite member to another.

TYPES OF COMPOSITE ELEMENTS

1. Concrete topped composite steel decks.
2. Steel beams acting compositely with concrete slabs.
3. Steel columns encased by or filled with concrete.
4. Open web joists of wood and steel or joists with plywood webs and wood chords.
5. Trusses combining wood and steel.
6. Hybrid girders utilizing steels of different strengths.
7. Cast-in-place concrete slab on precast concrete joists or beams.

COMPARATIVE DESIGN

A 30 ft beam with a 2.25 kip/ft uniform load carrying 2 1/2 in. concrete fill on a 2 in. metal deck slab uses a W24x55 in a noncomposite design and only a W18x40 with 38 steel studs of 3/4 in. diameter in a composite design.

**GENERAL**

According to the theory of plate tectonics, the earth's crust is divided into constantly moving plates. Earthquakes occur when, as a result of slowly accumulating pressure, the ground slips abruptly along a geological fault plane on or near a plate boundary. The resulting waves of vibration within the earth create ground motions at the surface, which, in turn, induce movement within buildings. The frequency, magnitude, and duration of the ground motion, physical characteristics of the building, and geology of a site determine how these forces affect a building.

**DESIGN JUDGMENT**

In an earthquake, buildings designed to the minimum levels required by model codes often sustain damage. Early discussions with an owner should explore the need to limit property loss in an earthquake and the desirability of attempting to ensure continued building operation immediately afterward. To achieve these results, it may be necessary to make design decisions more carefully tuned to the seismic conditions of a site than code requires.

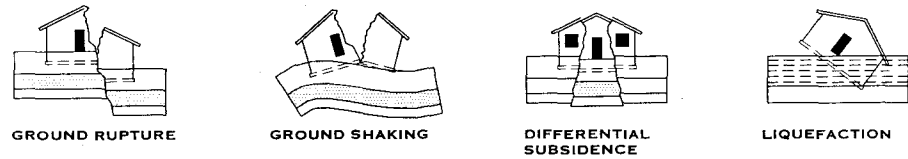

**MAIN CAUSES OF FOUNDATION FAILURE**

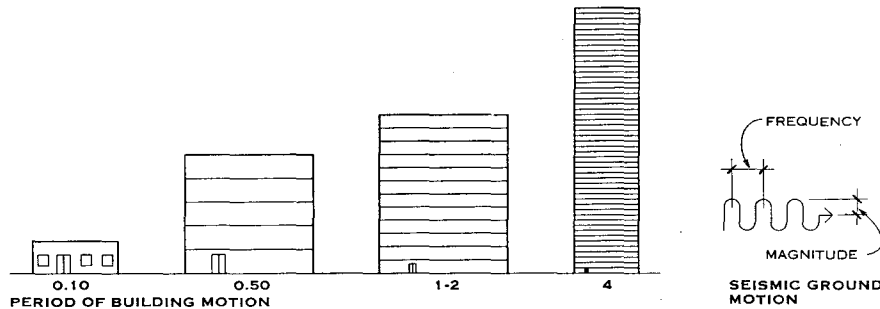

**NOTE**  
The relationship between the period of ground motion and the period of building motion is of great importance. Fundamental periods of motion in structures range from 0.1 second for a one-story building to 4.0 seconds or more for a high-rise building. Ground generally vibrates for a period of between 0.5 and 1.0 second. If the period of ground motion and the natural period of motion in a building coincide, the

building may resonate and the loads will be increased. Theoretically, one part of the seismic design problem is to "tune" the building so that its own period of motion falls outside the estimated range of ground motion frequency. In practice, this tuning is very seldom carried out. Rather, architects rely on increased load effects required by the applicable code to take care of the problem.

**FUNDAMENTAL PERIODS**

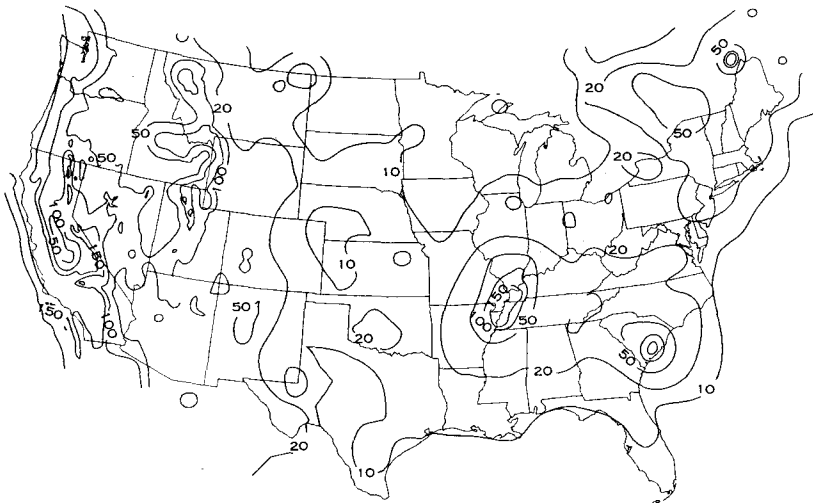

**SEISMIC ACCELERATION FOR LOW BUILDINGS EXPRESSED AS A PERCENTAGE OF GRAVITY**

William W. Stewart, FAIA; Stewart-Schaberg Architects; Clayton, Missouri  
Map courtesy of the U.S. Geological Survey, National Seismic Hazard Mapping Project (June 1996)

**SEISMIC CODES**

The seismic requirements in the Uniform Building Code have historically been based on Recommended Lateral Force Requirements, generally referred to as "The Blue Book," an earthquake design manual developed by the Structural Engineers Association of California. The seismic requirements in the National Building Code and the Standard Building Code are based on FEMA 222, the National Earthquake Hazards Reduction Program Recommended Provisions for Seismic Regulations for New Buildings. Since the Blue Book and the NEHRP provisions incorporate the expertise of many of the same engineers, and since the anticipated International Building Code will encourage convergence of the requirements, the seismic code development community intends to make the two codes similar.

The following information is based on the requirements expected to appear in the 1997 NEHRP provisions and in subsequent issues of all model codes. Detached one- and two-family dwellings will be exempt from seismic regulations in areas other than those with high seismicity. Seismic codes are constantly evolving, and architects should always consult the relevant code before beginning a project.

A recent, significant change in the seismic codes is the elimination of seismic zones as a basis for establishing design acceleration. Seismic maps have been redrawn (completely for the first time since 1976) to show building response periods as a percentage of gravity.

The map below, based on a building response period of 0.2 second, gives accelerations to be used for low buildings. A similar map based on a building response of 1.0 second is proposed for taller buildings. Before determining what level of ground shaking applies to a project, an architect must find out what type of earth the building will be built on. The maps are based on buildings built on soft rock, but ground motion increases as the soil becomes softer.

**TERMS**

The seismic community has an extensive set of terms with which to describe common conditions in the field. Following is a short list of these terms and their definitions:

**BASE SHEAR (static analysis):** calculated total shear force acting at the base of a structure, used in codes as a static representation of lateral earthquake forces; also referred to as "equivalent lateral force."

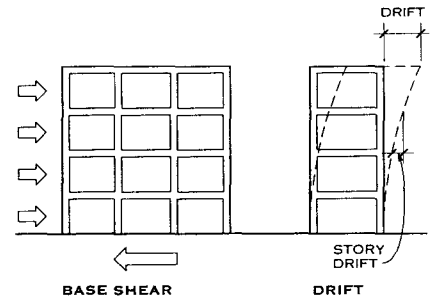

**BASE SHEAR AND DRIFT**

**DESIGN EARTHQUAKE:** earthquake ground motion for which a building is designed.

**DRIFT:** lateral deflection of a building or structure. Story drift is the relative movement between adjacent floors.

**DUCTILITY:** the ability of a structural frame to bend but not break. Its ductility is a major factor in establishing the ability of a building to withstand large earthquakes. Ductile materials (steel in particular) fail only after permanent deformation has taken place. Good ductility requires special detailing of the joints.

**DYNAMIC ANALYSIS:** a structural analysis based on the vibration motion of a building. Dynamic analysis is time-consuming and normally reserved for complex projects.

**FORCES, IN-PLANE:** forces exerted parallel to a wall or frame.

**FORCES, OUT-OF-PLANE:** forces exerted perpendicular to a wall or frame.

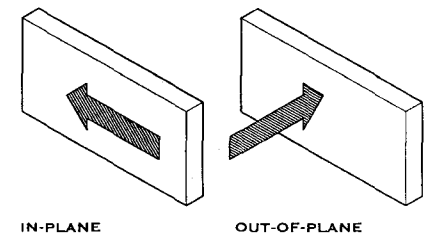

**FORCE DIAGRAMS**

**MAXIMUM CONSIDERED EARTHQUAKE:** the greatest ground shaking expected to occur during an earthquake at a site. These values are somewhat higher than those of the design earthquake, particularly in areas where seismic events are very infrequent. The code maps are based on earthquakes of this magnitude.

**RE-ENTRANT CORNER:** The inside building corner of an L-, H-, X-, or T-shaped plan.

**GENERAL**

Each building and site lies within a broader context of regional seismicity, localized geology, community vulnerability, and adjacent structures and land uses. Siting decisions, therefore, can have a significant impact on the overall seismic performance of a structure. This page focuses on the following criteria for siting a building:

1. Avoid unstable sites.
2. Avoid nonengineered fill.
3. Avoid or design for sites that can subside or liquefy.
4. Avoid building over surface faulting.
5. Avoid adjacent hazardous buildings.
6. Prevent battering from adjacent buildings.
7. Create safe areas of refuge when redeveloping older buildings.

Decisions on appropriate land uses for a specific site, separation from active ground faulting, site stability, and separation from adjacent buildings are critical to performance. Although many of these factors have traditionally been considered city planning issues, the designer must also incorporate them into the architectural development of a seismically resistant building.

**SEISMIC ZONATION TO REDUCE RISK**

RELATIVE RISK OF SITE	LAND USE
Low	High-density commercial/retail
	High occupancy and assembly
	Essential services (fire stations, hospitals, emergency operations centers, etc.)
Medium	Hazardous industrial processes
	Medium- and low-density residential
	Low-rise commercial/retail
High	Industrial uses
	Very low-density residential
	Nonhazardous industrial
	Recreation
	Public open space
	Public rights-of-way

**NOTE**

Land uses should reflect the relative risk of the location.

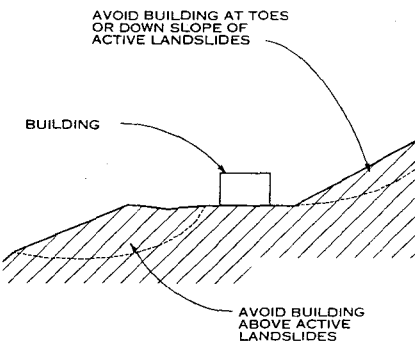

**SITE SECTION**

**NOTE**

On sloping sites, earthquakes can trigger landslides. Also, alluvium and unconsolidated soils can increase the violence and duration of ground shaking. In areas of young soil deposits, design for greater ground shaking. For example, during the 1989 Loma Prieta earthquake, ground shaking in San Francisco's marina district, on nonengineered fill, was more than twice as violent and lasted more than twice as long as ground shaking on adjacent bedrock sites.

**UNSTABLE SITES**

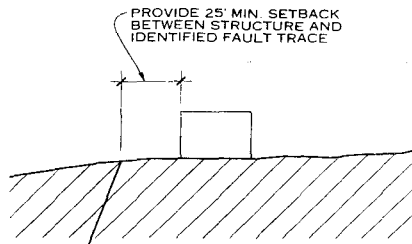

**SITE SECTION**

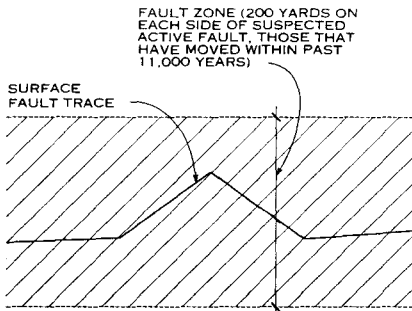

**SITE PLAN**

**NOTE**  
Within a fault zone, trench to determine the exact location of the fault trace. Development within a fault zone should be restricted to low-density land uses, open space, and other low-occupancy activities

**SURFACE FAULTING**

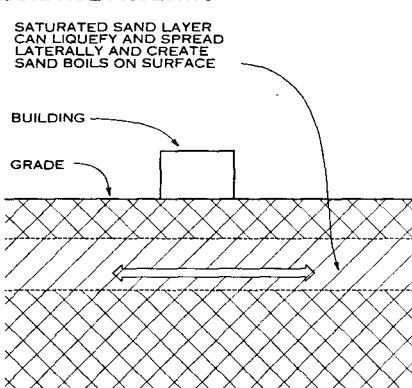

**SITE SECTION (BEFORE LIQUEFACTION)**

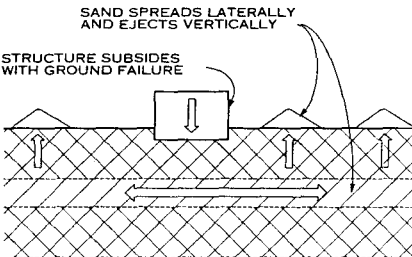

**SITE SECTION (AFTER EARTHQUAKE AND LIQUEFACTION)**

**NOTE**

Avoid sites subject to liquefaction (water saturated sandy soils), design foundation systems to withstand ground failure, drain water from the site, and change the composition of the soil and compact the site.

**SUBSIDENCE OR LIQUEFACTION**

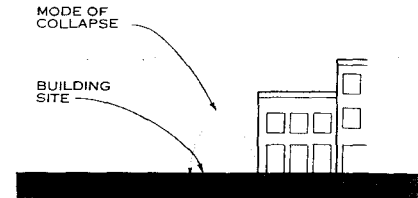

**SITE ELEVATION**

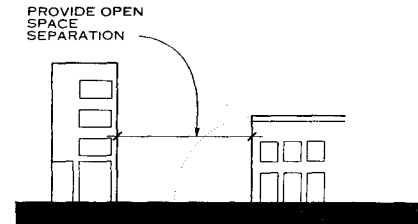

**SITE ELEVATION**

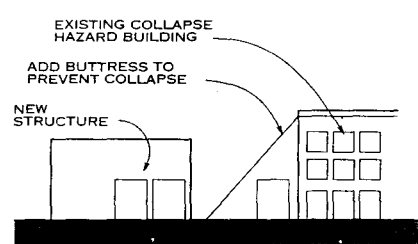

**SITE ELEVATION**

**ADJACENT HAZARDOUS BUILDINGS**

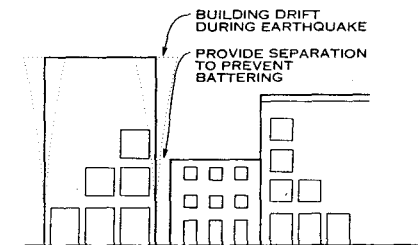

**BATTERING FROM ADJACENT BUILDINGS**

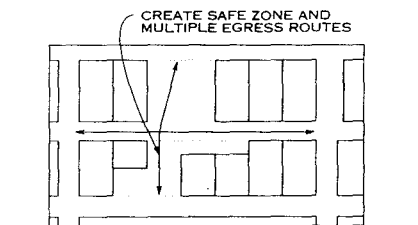
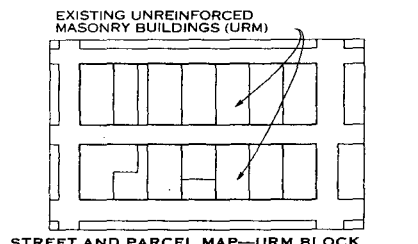

**SAFE AREAS OF REFUGE IN OLDER BUILDINGS**

Richard Eisner, FAIA; Governor's Office of Emergency Services; Oakland, California

**LOAD PATHS**

A load path is the path seismic forces take from the roof to the foundation of a structure. Typically the load travels from the diaphragms through connections to the vertical lateral force-resisting elements and on to the foundation by way of additional connections. This path should be direct and uninterrupted. Seismic design begins with, and codes require, the establishment of a continuous load path.

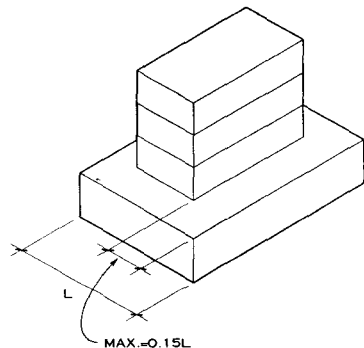

**PREFERRED**

**NOTE**

The base should not be too much larger than the tower above.

The seismic-resistant framing system selected for a structure must meet both architectural and seismic design requirements. Although most buildings can be made seismic resistant, some architectural configurations interrupt the load path or otherwise interfere with the seismic design process. Inappropriate design choices increase construction cost and make the seismic restraint system less effective. The examples on this page contrast configurations that probably would cause problems in areas with high levels of seismicity with variations that should avoid these problems.

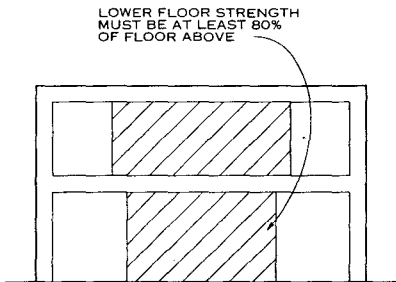

**PREFERRED**

**NOTE**

While it is best to have uniform stiffness, some variation is acceptable.

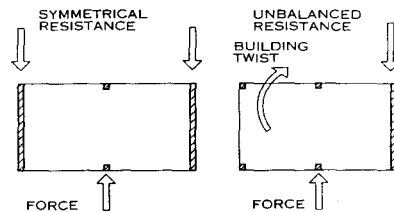

**PREFERRED NOTE**

The lateral force resisting system for a symmetrical building is much easier to design than that for an asymmetrical building. Because the source of an earthquake cannot be known, symmetry in both directions should be considered.

**DISCOURAGED**

**TORSION IN PLAN**

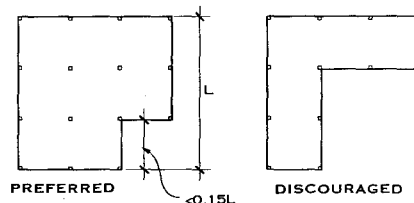

**PREFERRED**

**NOTE**

This is a variation of the symmetry issue. When the notch gets too big, the building tends to tear at the inside corner.

**DISCOURAGED**

**VERTICAL GEOMETRY IRREGULARITY**

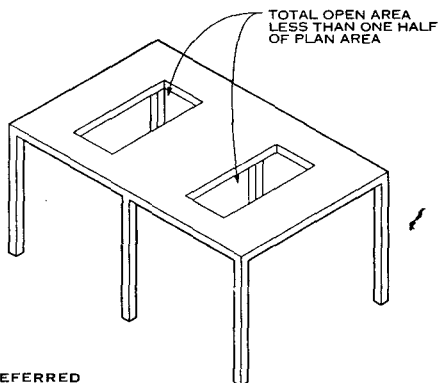

**PREFERRED**

**NOTE**

Horizontal diaphragms (floors and roofs) can more readily transfer earthquake loads to the vertical force resisting

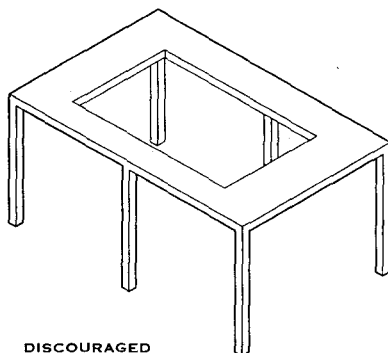

**DISCOURAGED**

system when the size and number of holes in the diaphragm are limited.

**DIAPHRAGM DISCONTINUITIES**

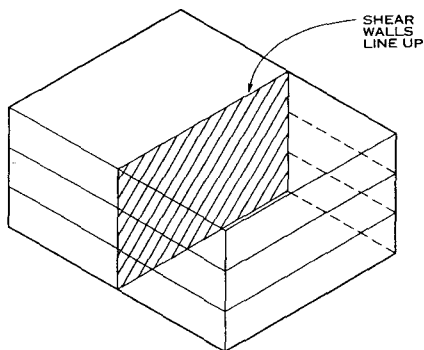

**PREFERRED**

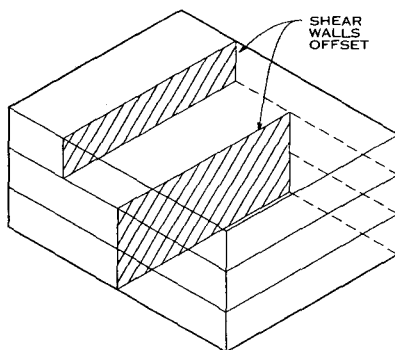

**DISCOURAGED**

**OUT-OF-PLANE VERTICAL OFFSETS**

**RE-ENTRANT CORNERS**

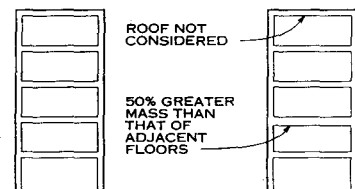

**PREFERRED**

**NOTE**

While all floors do not have to be the same, it is important that no floor has too much more mass than those adjacent.

**DISCOURAGED**

**MASS IRREGULARITY**

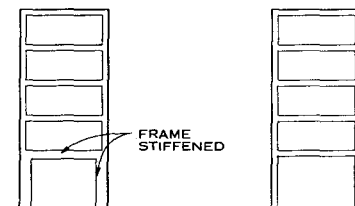

**PREFERRED**

**NOTE**

When a taller (inherently weaker) first floor is desired, anticipate using much heavier first floor framing to equalize the stiffness with that of the floors above.

**DISCOURAGED**

**SOFT STORY**

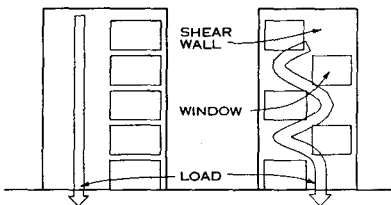

**PREFERRED**

**NOTE**

Although both drawings illustrate shear walls in the same plane, one arrangement is discouraged because the load path is not direct enough.

**DISCOURAGED**

**IN-PLANE DISCONTINUITY**

William W. Stewart, FAIA; Stewart-Schaberg Architects; Clayton, Missouri

**ESTABLISHING SEISMIC FORCES**

The equivalent lateral force procedure is the most common method of establishing seismic design forces. In it, the seismic load,  $V$  (base shear), is determined by multiplying the weight of the building by a factor  $C_s$  ( $V=C_sW$ ). The value of  $C_s$  depends on the size of the design earthquake, the type of soil, and the response modification factor (a variable corresponding to the type of lateral force resisting system used). This force is applied at the base of the structure then distributed throughout the building according to the mass and strength of the structure.

**DESIGN FOR RESISTING SEISMIC FORCES**

Shear walls are load-bearing or nonload-bearing walls that resist seismic forces acting in the plane of the wall. Shear wall design is simpler and more cost-effective than other lateral force resisting systems; however, the architectural design must be able to accommodate the locations of these walls and the small number of openings they permit.

Diaphragms are horizontal or nearly horizontal structural elements (usually a floor or roof) designed to transmit lateral forces to the vertical elements of a seismic resisting system. Diaphragms must be rigid enough and the connections strong enough to transfer the entire load to the lateral force resisting system.

Tall, narrow structures tend to tip over before they slide, while short structures slide rather than tip. Earthquake waves rock buildings, increasing overturning loads, and can act in any direction. Thus, resistance to overturning is best achieved at a building's perimeter rather than at its core.

Building foundations must be designed to resist the lateral forces transmitted through the earth and the forces transmitted from the lateral load resisting system to the earth. In general, softer soils amplify the effects of an earthquake.

**BUILDING FRAMES**

Braced frames depend on diagonal braces to resist lateral forces. Although cost-effective, most braces limit the number of openings possible in a wall. Eccentric bracing is a configuration that allows for more openings than are normally achievable. K-bracing used to be a common variation of X-bracing, but it was discovered that the forces at the intersection are very great, making the connection difficult.

A moment frame is one in which members and joints are able to resist lateral forces along the axis of the members as well as by bending. It is an alternative to solid shear walls that allows for openness and design flexibility.

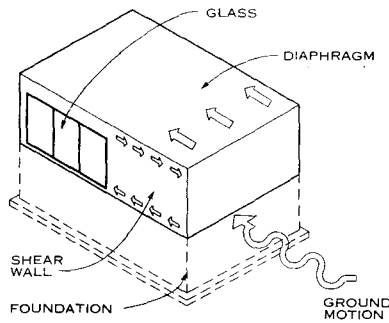

**SHEAR WALLS AND DIAPHRAGMS**

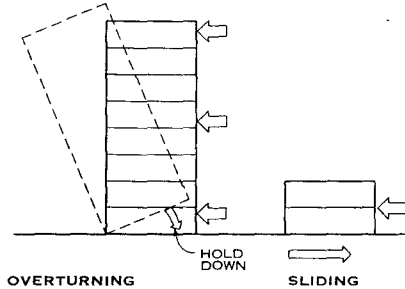

**OVERTURNING AND SLIDING**

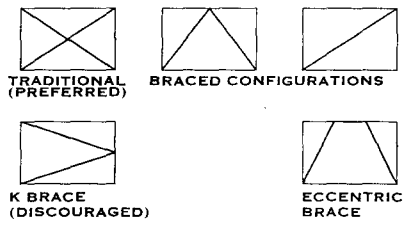

**BRACED FRAMES**

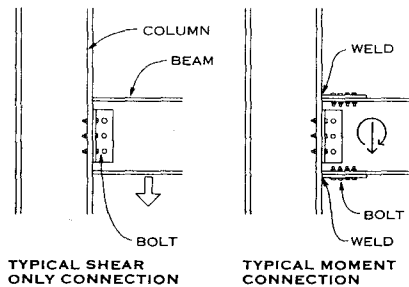

**CONNECTIONS**

**WOOD CONNECTIONS**

Connections are an important element of the lateral force resisting framing system. Wood connections come in a variety of types, many of which are not appropriate for seismic or wind loading conditions. End grain nailing performs poorly and should be avoided, and toe nailing as the sole means of attachment is inadequate. Positive connections using appropriate fasteners are necessary to establish a continuous load path. Shear walls must be fastened securely to the foundation. Diaphragms should be properly attached to the lateral force resisting system. Connector design and detailing should include proper use of connectors to achieve required load capacity and code compliance. Adequate size and placing of nails is necessary to minimize splitting and optimize the load carrying ability of the frame. (See AGS pages on wood seismic design and structural wood fasteners for details.)

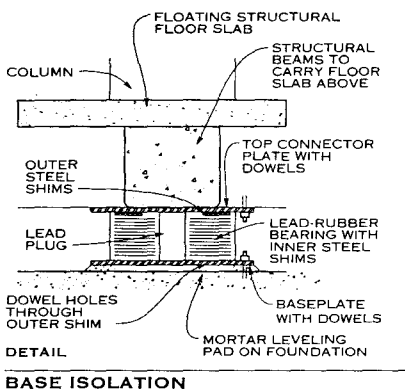
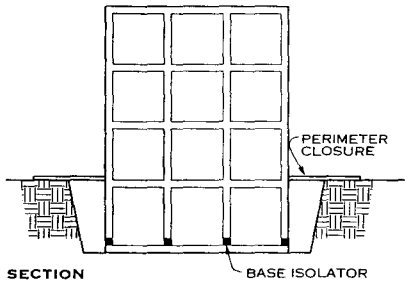

**BASE ISOLATION**

**ANCHORAGE**

Anchors are either cast-in-place or drilled in after placement of the concrete. When anchors can be precisely located before the concrete is poured, cast-in-place anchors are typically used. Post-installed anchors are usually employed when anchor locations cannot be predetermined with accuracy. Spacing between anchors, the distance to the edge of the concrete, embedment depth, stiffness characteristic, and the type of loading (e.g., dead, live, dynamic, seismic) all must be considered. For structural elements that require seismic design, only anchors tested under dynamic loading should be used. The preferred anchor types for seismic performance include cast-in-place bolts and inserts. Acceptable post-installed anchors are undercut anchors, heavy duty sleeve (torque-controlled expansion) anchors, and chemical anchors. J-bolts and L-bolts cannot be counted to resist much uplift.

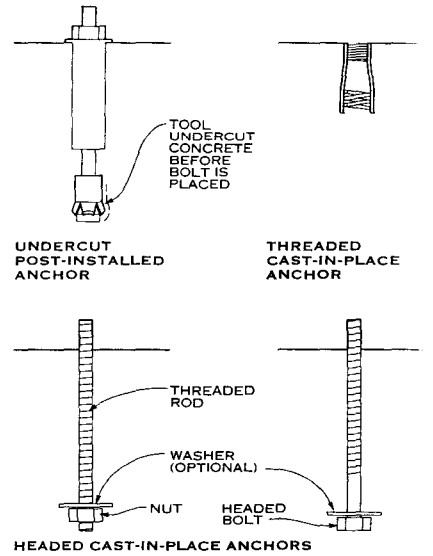

**ANCHORAGE**

**BASE ISOLATION**

Base isolation is a major seismic design innovation. Analogous to the suspension of an automobile, isolators separate the building from ground motion. Base isolation is most cost-effective for buildings in areas of high seismicity, buildings that must have an irregular shape, large historic buildings, and buildings that must remain in operation immediately after an earthquake.

When using base isolation, it is important to ensure that the isolators are the only place where the building touches the surrounding earth. This is normally accomplished by positioning the building in a large scooped out area and connecting it to the surrounding ground with flexible "bridges." The base isolators are usually located in a sub-basement dedicated to their use.

A recent variation of base isolation is offered by a family of devices that absorb or dissipate energy and change the response of a structure to seismic activity. These systems appear most useful for improving existing structures without the need for an entirely new structural system.

**REFERENCES**

AIA/ACSA Council on Architectural Research. Buildings at Risk: Seismic Design Basics for Practicing Architects.

Ceilings and Interior Systems Construction Association. Recommendations for Direct-Hung Acoustical Tile and Lay in Panel Ceilings. 5700 Old Orchard Rd., Skokie, IL 60077.

National Earthquake Hazards Reduction Program (NEHRP). Recommended Provisions for Seismic Regulations for New Buildings. 1994 ed. Part 1, "Provisions" (FEMA-222A); part 2, "Commentary" (FEMA-223A).

Handbook for the Seismic Evaluation of Existing Buildings (FEMA-178) and Handbook of Techniques for the Seismic Rehabilitation of Existing Buildings (FEMA-172).

Non-Technical Explanation of the 1994 NEHRP Recommended Provisions (FEMA-99).

William W. Stewart, FAIA; Stewart-Schaberg Architects; Clayton, Missouri

**GENERAL**

When detailing architectural and mechanical elements for seismic resistance, the architect's primary concerns are to minimize falling hazards and to maintain a normal egress route. Features such as masonry chimneys, parapets, light fixtures, suspended mechanical equipment, large ductwork, and heavy pipes are potential falling hazards. Cabinets and bookcases can block exits if they fall. An additional concern for architects designing for earthquake-prone areas is the need for a building to remain in operation after an earthquake.

Many resources that offer detailed solutions for seismic design only address areas with high seismic activity. However, no single detail is appropriate for all areas. This page is meant to guide architects through the philosophy of seismic design. Readers should use the references listed to develop the right solution for a particular site.

To determine seismic forces on architectural components, an importance factor (I) is introduced into the force equation. I is either 1.0 or 1.5. If the component is essential or might create a hazardous condition when falling or breaking, there is a 50% increase in the design load. The lateral force = 1.6 S<sub>AS</sub> IW. W is the weight of the part. S<sub>AS</sub> is the spectral acceleration. In reality the force decreases as the location (height) of the component within the building is lowered. A more complicated formula is available if it is necessary to reduce the loads.

**SEISMIC DESIGN CATEGORY FOR STRUCTURES**

VALUE OF S <sub>AS</sub>	SEISMIC USE GROUP		
	I	II	III
S <sub>AS</sub> ≤ 0.167 g	A	A	A
0.167 g ≤ S <sub>AS</sub> < 0.33 g	B	B	C
0.33 g ≤ S <sub>AS</sub> < 0.50 g	C	C	D
0.50 g ≤ S <sub>AS</sub> < 1.0 g	D	D	D
1.0 g ≤ S <sub>AS</sub>	E	E	F

**NOTES**

1. g—weight of object being analyzed; S<sub>AS</sub>—spectral response acceleration
2. Seismic use group classification is assigned to each building depending on the importance of maintaining function or protecting occupant safety. Buildings in seismic use group III are those that are required to function for post earthquake recovery. Seismic use group II buildings are buildings with relatively large occupant loads. Any remaining buildings fall into group I. The level of seismic detailing is expressed by letters A through F and is based on the relationship between the seismic use group and the level of design ground motion. This level of detailing is known as the seismic design category.

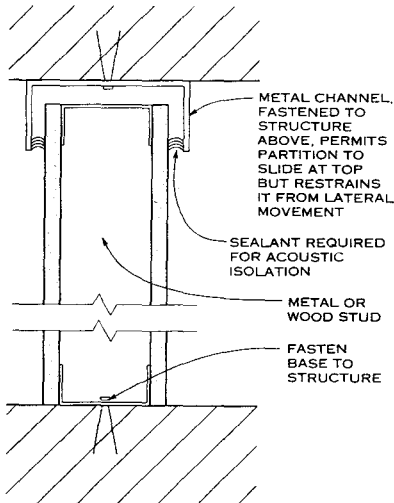

**NOTE**

This detail must be checked for acceptability when the partition is fire-rated. Partitions that extend to the structure above usually perform well if consideration has been given to potential building racking (i.e., being forced out of plumb).

**PARTITION DETAIL FOR SEISMIC AREAS**

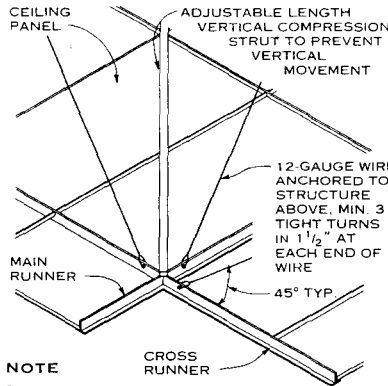

**NOTE**

Provide 4-way diagonal bracing and compression struts approximately every 12 ft each way.

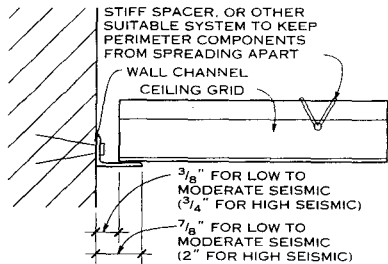

**WALL ATTACHMENT DETAIL NOTE**

For ceiling grids, pull-out capacity at the joints is a key to good seismic performance. Vertical (compression) struts prevent failure from wave-like or galloping motion. Solutions for all levels of seismic activity are addressed in the Ceilings and Interior Systems Construction Association standards.

**CEILING DETAILS FOR SEISMIC AREAS**

**LIGHT FIXTURES**

There are two ways to handle light fixtures that could shake free from the ceiling grid and create a falling hazard. One is to suspend the light fixture from the structure above with two to four wires (if two wires, they should be in opposite corners). The second method (not used in areas with high seismicity) is to brace the ceiling and clip the light fixtures to the grid. Pendant-mounted fixtures should be designed so they cannot swing and hit other building components.

**EXTERIOR CLADDING**

Exterior cladding must be secured to the building to prevent it from falling. Heavier veneers require more anchorage. When cladding is anchored to the structural frame, consideration must be given to how movement of the frame will affect movement in the cladding. A major concern is the difference in movement between floors and/or floor and roof (story drift), which is addressed with connections that permit the cladding to move independently of the structural frame. Commonly used are push-pull connections, caulked joints, slip joints, and covers that collapse.

**SPRINKLER SYSTEMS**

To brace sprinkler systems, architects must address three main problems: the falling hazard of heavy mains, separation of the mains at the joints (property loss is critical here), and breaking of the pipes where the heads pass through the ceiling. The latter problem is solved by enlarging the hole (with up to 1 in. clearance) and covering it with a large escutcheon plate. An alternative is to detail a swing joint in the sprinkler drop that will provide 1 in. movement in all directions. Another solution is to detail the grid and sprinkler drops as one integral unit. (See NFPA 13 for information on sprinkler bracing.)

**WATER HEATERS**

When a water heater overturns, a gas line can rupture. Depending on the level of seismicity, the common solution for residential water heaters is to use a flexible gas connection and/or a simple steel strap wrapped around the tank and securely anchored to a stud or solid wall.

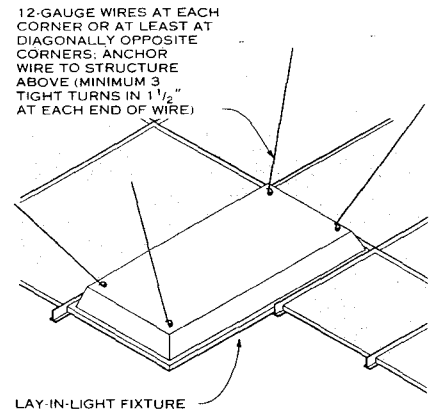

**LIGHTING FIXTURE DETAIL FOR SEISMIC AREAS**

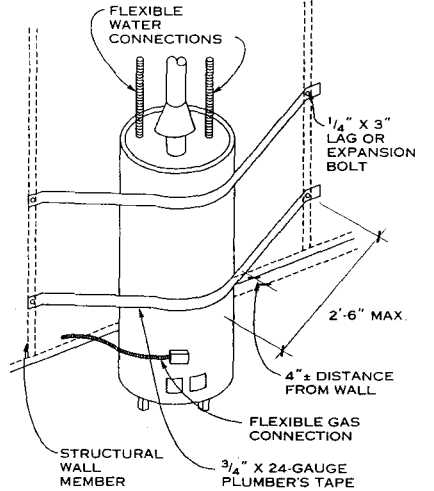

**NOTE**

Fill space between water heater and wall with 2x blocking with cushioned face.

**WATER HEATER SEISMIC REINFORCING**

**SHELVING AND CABINETS**

Shelves and racks can overturn during seismic activity, injuring building occupants or blocking exits. The hazard increases with the occupancy density and the height of the equipment. Fixtures should be bolted onto heavy-gauge studs above their center of gravity.

**ELEVATORS**

Traction elevators cause the most concern in regard to seismic activity. The main problem is that the counterweights may come loose and strike the cab. Current elevator standards address this problem, but older elevators may need to be upgraded.

**HVAC, ELECTRICAL, AND PLUMBING COMPONENTS**

HVAC equipment is often heavy, with large inertial forces; securely attaching such equipment greatly reduces damage. Piping systems generally perform well during seismic activity but are vulnerable at equipment connections.

Heavy electrical equipment such as switchgear, transformers, and batteries are the parts of the electrical system most vulnerable to seismic activity. Emergency systems depend on electrical power for fuel or control and so may fail even though the equipment remains functional.

Plumbing distribution systems are relatively flexible and can withstand a fair amount of shaking. Piping and equipment should be anchored so it will move with the structure, limiting differential movement at the joints.



## GENERAL

The greatest hazard in major earthquakes stems from older buildings that were designed under early seismic codes or before such codes were introduced. Seismic rehabilitation (or seismic retrofit) refers to design and construction intended to improve the seismic performance of an existing building.

Some cities have established seismic rehabilitation programs to reduce the risk caused by unreinforced masonry (URM) buildings, which are particularly hazardous in earthquakes. The City of Los Angeles, for example, passed an URM ordinance in 1981 that required all of the 8000 URM buildings in the city to be strengthened or demolished. San Francisco has a similar ordinance. Many buildings also have been voluntarily rehabilitated.

## REHABILITATION PROCESS

The first steps in rehabilitation are to identify the seismic deficiencies and determine a method of rehabilitation. Other steps involve budgeting, preparing contract documents, and selecting a contractor.

## EVALUATION PROCEDURES

Two procedures exist for evaluating buildings for seismic rehabilitation. The first, called rapid visual screening (RVS), is used to assess the rehabilitation needs of a number of buildings: a whole city, a few city blocks, a college campus, etc. RVS involves surveying the exterior of a building and recording its major features in a way that allows it to be rated for possible seismic risk. The evaluation takes about 30 minutes per building. The intent is not to provide a definitive seismic rating but rather to indicate which buildings should undergo a more detailed evaluation. This procedure is described in Federal Emergency Management Agency (FEMA) Publication 154.

The second, more detailed seismic evaluation process is described in FEMA Publication 178. The evaluation begins with collecting information about a structure and classifying it according to one of fifteen model building types. This qualitative investigation determines whether the building exhibits any of the defined life-threatening performance characteristics that similar structures have demonstrated in previous earthquakes. If such characteristics are identified, a detailed evaluation is recommended and permissible capacity/demand ratios are suggested. Although the detailed procedure generally takes several days to complete, it provides an evaluation of the building's threat to life and a list of the particular structural and nonstructural features that must be addressed.

Another aspect of the evaluation is establishing the benefit-cost ratio for seismic rehabilitation. FEMA Publication 227 describes such a procedure and provides computer software to perform the evaluation.

## HAZARDOUS BUILDING TYPES

Any building may be hazardous in an earthquake if it is not designed according to seismic codes and, perhaps more significant, the designer does not understand or have experience with seismic design. Many old buildings, designed before seismic codes existed, are well designed seismically and have stood the test of time. Other, newer buildings are unsafe because they were designed according to an obsolete code and without an understanding of seismic design issues.

A number of typical building types have been identified as hazardous because of their generally poor performance in earthquakes:

1. URMs: bearing wall buildings with unreinforced masonry walls, usually brick.
2. Nonductile concrete frame: typical of buildings constructed in the United States before about 1975, when new codes came into effect that recognized the problems caused by underreinforced concrete frame structures subject to brittle failure. (Ductility refers to the ability of structures, usually steel structures, to deform greatly under load without collapsing.)
3. Concrete or steel frame with unreinforced masonry walls (often hollow tile): popular for buildings constructed from the early 20th century until World War II.
4. Precast concrete tilt-up construction: common industrial building type that relies on the exterior concrete walls to act as shear walls against earthquake forces. Unless correctly detailed, the roofs are likely to pull away from the walls and collapse during earthquakes.

## REHABILITATION STRATEGIES

Although the unique characteristics of each building must be considered when devising a rehabilitation strategy, some fundamental concepts have been developed from experience:

1. Add strength.
2. Alter building stiffness.
3. Create structural continuity.
4. Add structural containment.
5. Rationalize existing capacity.
6. Isolate the building from the ground.
7. Add energy-dissipating details.

In addition to purely structural issues, architectural concerns influence rehabilitation design. For historic buildings, rehabilitation measures must be devised that respect the original architecture, and the addition of external strengthening components is not an option. For other buildings this may not be a concern, and affordable cost, safety, and preservation of building function may be the paramount objectives.

FEMA publication 172 provides conceptual design guidance on methods of rehabilitating all 15 model building types described in FEMA 178.

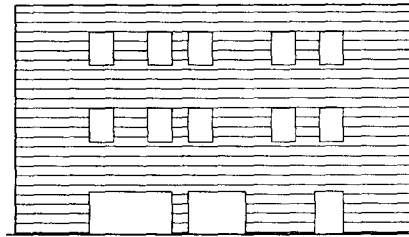

UNREINFORCED MASONRY BEARING WALL

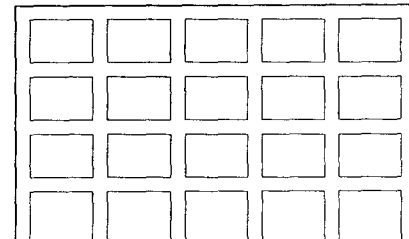

NONDUCTILE CONCRETE FRAME

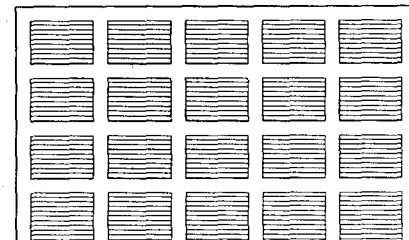

CONCRETE FRAME WITH UNREINFORCED MASONRY INFILL



PRECAST CONCRETE TILT-UP  
HAZARDOUS STRUCTURAL TYPES

## CODES AND REGULATIONS

At present a general code for seismic rehabilitation of buildings does not exist. For URM buildings, the City of Los Angeles Section 88 Code may be appropriate; for certain types of historic URM buildings, the Uniform Code of Building Conservation may be used. Following the Northridge earthquake, Los Angeles developed criteria for rehabilitating tilt-up buildings and nonductile reinforced concrete frame buildings.

The Building Seismic Safety Council/National Earthquake Hazard Reduction Program is developing the first comprehensive criteria (available about 1998) for the rehabilitation of all building types in any geographic region.

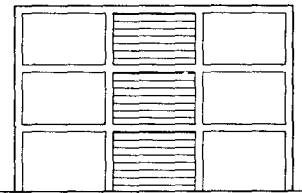

ADD REINFORCED INFILL WALLS TO INCREASE STRENGTH AND STIFFNESS

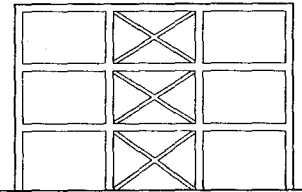

ADD BRACING TO INCREASE STIFFNESS

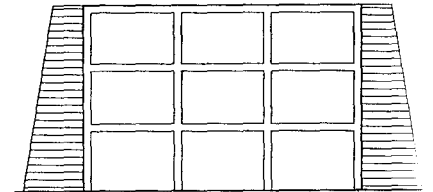

ADD BUTTRESSES FOR CONTAINMENT

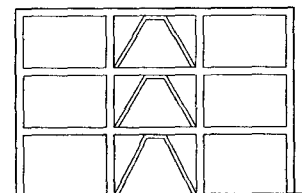

ADD ENERGY DISSIPATING BRACES TO REDUCE DRIFT AND INCREASE DAMPING

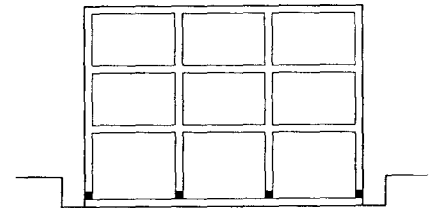

BASE ISOLATION TO REDUCE RESPONSE AND AID DAMAGE CONTROL  
REHABILITATING A CONCRETE FRAME

Christopher Arnold, FAIA, RIBA, Building Systems Development, Inc., Palo Alto, California

1

SEISMIC DESIGN

**GENERAL**

Empirical rules and formulas for the design of masonry structures resulted from the long history of masonry use and thus predate engineering and analysis. Empirical design is a method of sizing and proportioning masonry elements that depends on centering gravity loads over bearing walls, neglecting the effect of steel reinforcing.

For most masonry work, empirical design is conservative. It is generally appropriate for smaller buildings with interior masonry partitions and stiff floors, as well as buildings in

lower seismic exposure areas and walls not part of the lateral resisting system (even when other walls are engineered). Buildings that are in higher exposure areas or have walls that are part of the lateral resistance system require engineering design that conforms to local codes.

There are specific limits on masonry as to height, wind or other horizontal loads, and seismic loads. In many cases, design for wind and industry recommendations for crack control due to shrinkage or expansion may govern building reinforcement in areas with lower seismic activity.

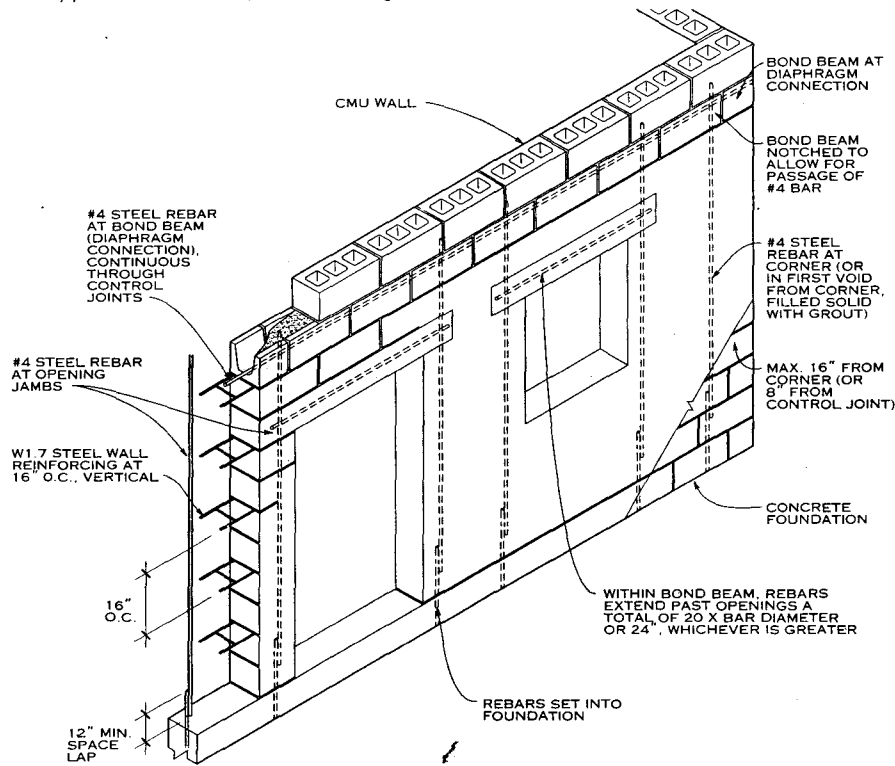

**NOTE**

Standard construction practice for masonry crack control requires W1.7 at 16 in. o.c., which would cover seismic

requirements as well. W1.7 steel reinforcement at 8 in. o.c. should be used in parapet locations.

**WALL REINFORCING FOR MASONRY WALL (EMPIRICAL DESIGN FOR MODERATE SEISMIC AREAS)**

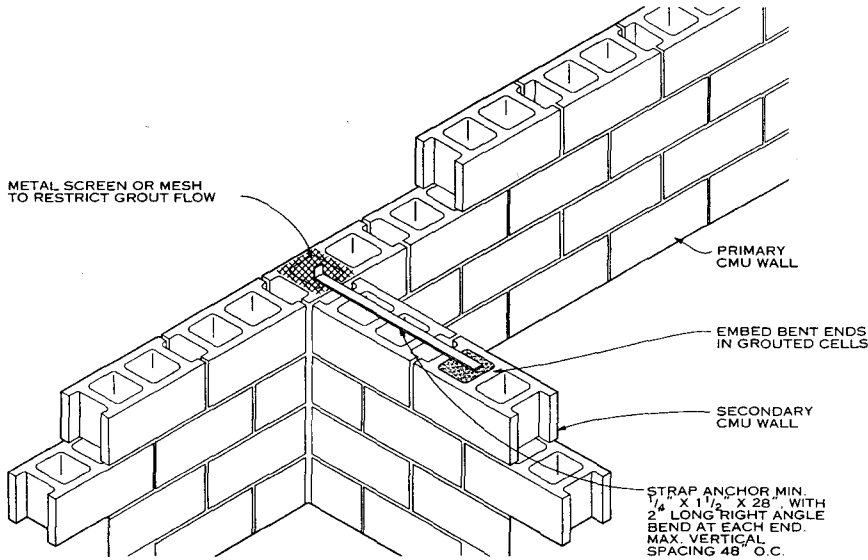

**INTERSECTING WALL DETAIL**

Edgar Glock, Masonry Institute of St. Louis; St. Louis, Missouri

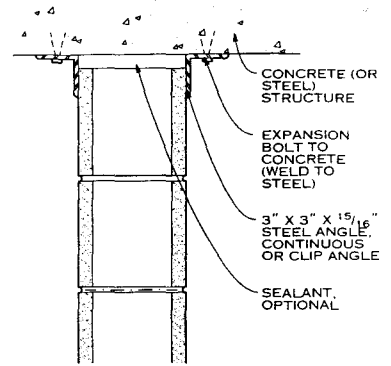

**NOTE**

This detail allows transfer of out-of-plane forces but isolates in-plane forces from the structure.

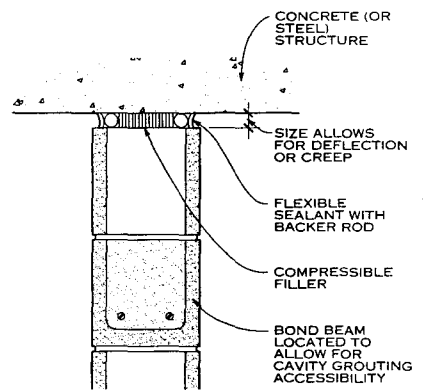

**NONBEARING WALL ISOLATION DETAILS**

**SHEAR WALL SPACING RATIO—EMPIRICAL DESIGN**

Bearing walls	Solid units	$l/t < 20$
	Fully grouted	$l/t < 20$
Others	$l/t < 18$	
Nonbearing walls	Exterior	$l/t < 18$
	Interior	$l/t < 36$

$l$ —wall length;  $t$ —wall thickness

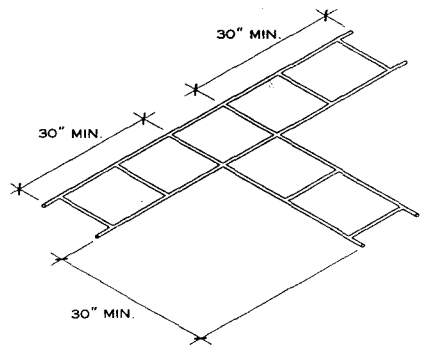

**NOTE**

Preformed, hot-dipped galvanized tees (W1.7 wire at 8 in. o.c., vertical for bearing; 16 in. o.c. for nonbearing) are used for reinforcing intersecting walls.

**INTERSECTING WALL REINFORCING**

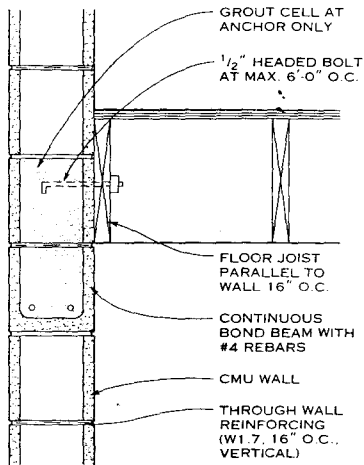

**NOTE**

Anchors should also be placed at cross-bracing for joists.

**DIAPHRAGM CONNECTION FOR WOOD JOIST/RAFTER PARALLEL TO WALL**

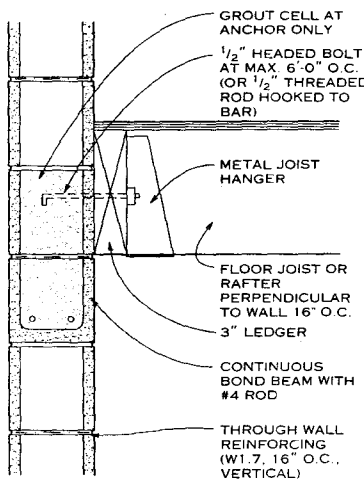

**DIAPHRAGM CONNECTION FOR WOOD JOIST/RAFTER PERPENDICULAR TO WALL**

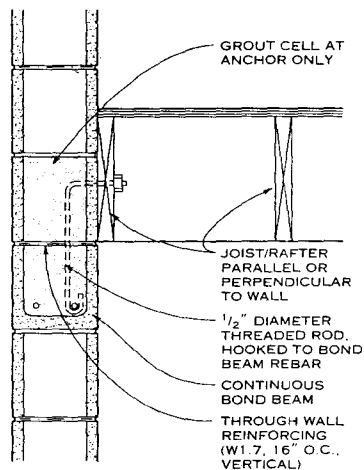

**ALTERNATE DIAPHRAGM CONNECTION FOR WOOD JOIST/RAFTER**

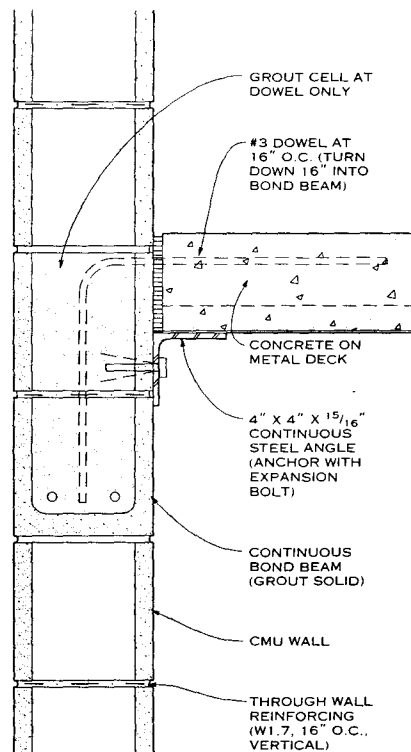

**DIAPHRAGM CONNECTION FOR STEEL JOISTS PARALLEL TO WALL**

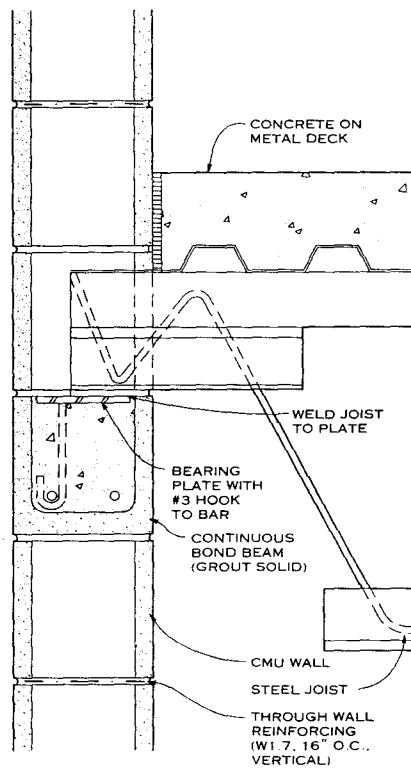

**DIAPHRAGM CONNECTION FOR STEEL JOISTS PERPENDICULAR TO WALL**

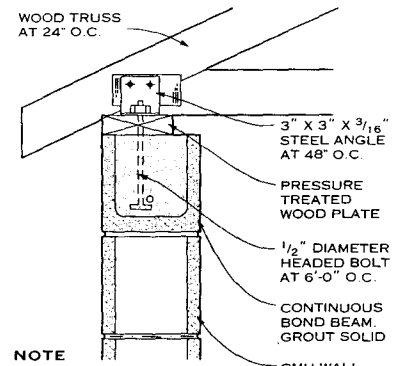
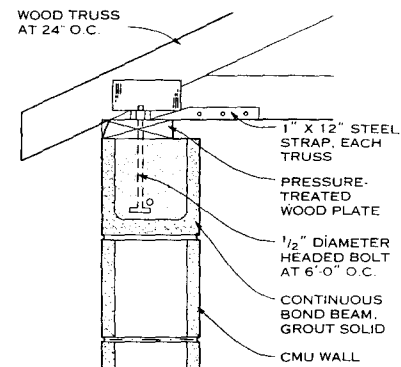

**NOTE**

For moderate seismic areas

**ROOF TIE DETAILS FOR MODERATE SEISMIC AREAS**

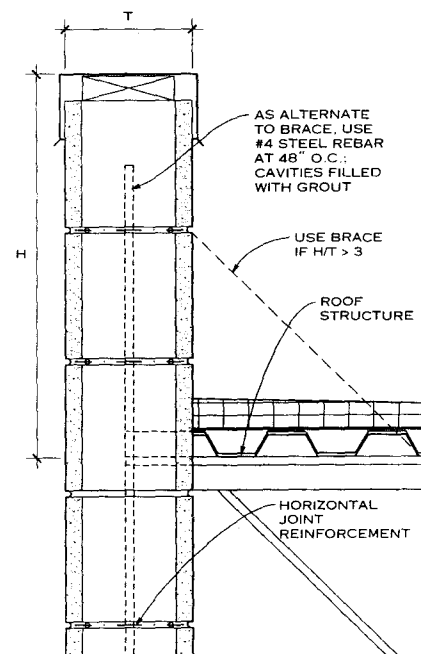

**NOTE**

Empirical design for masonry parapets should be used only in areas with low seismicity. Engineering analysis is required when the height-to-thickness ratio of three-to-one is exceeded and in areas of higher seismicity.

**MASONRY PARAPET DETAIL FOR SEISMIC AREAS**

**GENERAL**

Wood frame structures with a variety of solid wood and engineered wood products can be designed to resist seismic forces using many of the same principles used to resist wind forces. Wind-resistant design involves resolving loads assumed to be applied to the structure in one direction for a short time (monotonic loads). Wind load can induce shear that is both perpendicular and parallel with the structure, resulting in an overturning motion as well as uplift on the structure. Seismic loads, on the other hand, are cyclical, moving in different directions over a short period.

Seismic loading conditions on conventional construction are referenced in four main sources, which also provide information about the capacity of various materials: American Society of Civil Engineers 7-95, Section A9.9.10; the Building Code, Section 2326; the Standard Building Code, Sections 2308.2.2 and 2310; and the National Building Code, Section 2305.8. In general, these provisions are limited to buildings with bearing walls not exceeding 10 ft in height and gravity dead loads not exceeding 15 psf for floors and exterior walls and 10 psf for floors and partitions. Sheathing for braced walls must be at least 48 in. wide over studs spaced not more than 24 in. o.c.

Wood construction standards for all seismic areas include the following: wall anchorage must use a minimum of 1 o.c., maximum. Walls must be capped with double top plates. Uniform with end joints offset by at least 4 ft. Bottom plates must be 1 1/2 in. thick (2 in. nominal) and at least the width of the studs.

Forces must be transferred from the roof and floor(s) to braced walls and from the braced walls in upper stories to the braced walls in the story below, then into the foundation. Transfer must be accomplished with toe nails using three 8d nails per joist or rafter where not more than 2 ft o.c. or with metal framing devices capable of transmitting the lateral force. Roof to wall connections must be made at the exterior walls when the building is 50 ft or less in length. A combination of exterior and interior bearing walls is necessary when the building length exceeds 50 ft.

Connections designed for both lateral and vertical (uplift or overturning) loads must be used in conventional wood frame structures designed for seismic areas. Traditional nailing schedules are often adequate to handle lateral forces. Vertical forces can be addressed by lapping structural sheathing and/or strapping the roof, walls, and floors together at appropriate intervals. In addition, the overturning loads in walls must be restrained by anchoring the ends of the shear panels (whether traditional or perforated) to the structural wall below.

Nontraditional materials such as LVL, I joists, and structural composite lumber can be used in seismic design; the capacities and applicable connection types of these products are available from the manufacturers.

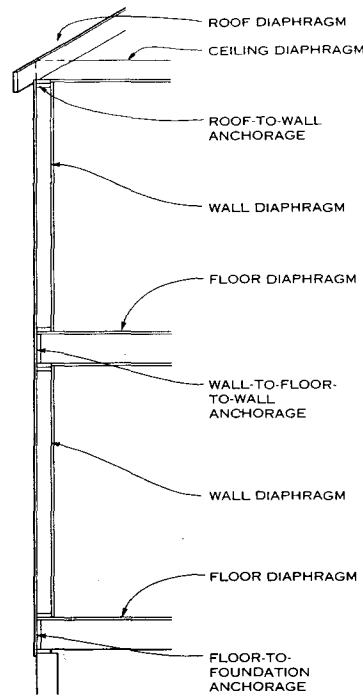

TYPICAL WALL SECTION FOR CONVENTIONAL WOOD FRAMING

**NOTES**

1. Diaphragms (the roof, floor(s), and shear panels in walls) must be designed to resist forces created by the dead load mass of the structure and applied seismic loads. In wood frame construction, a diaphragm is typically a structural "panel" made of a skin (sheathing) stretched over and fastened to ribs (wood members such as 2x4s). The resulting construction is stiff and strong enough to transmit forces to resisting systems such as the foundation. Connections must be designed to transfer lateral forces and restrain overturning motion. Lateral forces can be either perpendicular or parallel to the structure. The load from each part of a building that is created as the building shifts from the movement of the earth must be transferred to adjoining elements (roof sheathing to rafters to top plates to wall sheathing and studs to bottom plates to floor sheathing and framing and so on, until the lowest level of floor framing, from which the load moves to the foundation; in slab-on-grade construction, the load moves finally from the wall sheathing and studs to the bottom plates).
2. The roof diaphragm comprises roof sheathing, roof framing (rafters, top chord of truss, etc.), and blocking.
3. The ceiling diaphragm comprises ceiling finish material (for example, gypsum wallboard) and ceiling framing (joists, lower chord of trusses, etc.).
4. Roof-to-wall anchorage consists of hold-down anchors to resist uplift forces and nailing to resist shear forces.
5. The wall diaphragm comprises wall sheathing, wall framing, and sheathing fasteners.
6. The floor diaphragm comprises floor sheathing, floor framing (joists, trusses, etc.), blocking, etc.
7. Wall-to-floor-to-wall anchorage consists of hold-down anchors and shear connectors (for example, nails).
8. Floor-to-foundation anchorage consists of hold-down anchors to resist overturning forces and anchor bolts (1/2 in. diameter at 6 ft o.c.) to resist shear forces.

**SPACING FOR BLOCKED DIAPHRAGM\***

BOUNDARY PANELS (IN.)	OTHER PANELS (IN.)	CAPACITIES (LB/FT)
6	6	320
4	6	425
2 1/2	4	640
2	3	730

\*1 1/2-in. panel sheathing; 10d nails into 2X framing (Douglas fir, larch, southern pine).

**BRACED WALL SPACING**

SEISMIC PERFORMANCE CATEGORY	DISTANCE BETWEEN BRACED WALLS	MAXIMUM NUMBER OF STORIES
A	35 ft	3
B	35 ft	3
C	25 ft	2
D	25 ft	1*

\*Two stories for detached one- and two-family dwellings

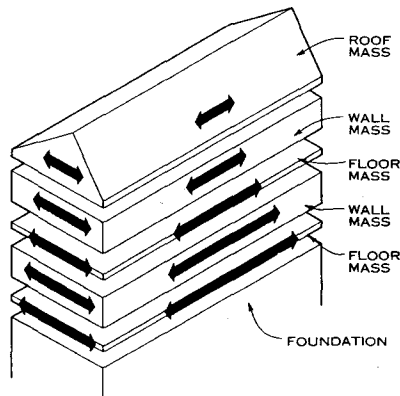

**NOTE**

Each diaphragm in a building must resist the seismic effects in both directions of all the mass above it as well as of its own mass. The seismic loads caused by the roof mass must be transferred to the wall, and the wall must be designed to resist both the effect of the mass of the roof and the mass of the wall. These combined loads must then be transferred to the floor below, which must be designed to resist the effect of both its mass and the load applied by the wall above. In turn, walls below must resist these loads, until the force reaches the foundation, which must be able to resist the combined loads from the rest of the building.

**SEISMIC LOAD TRANSFER**

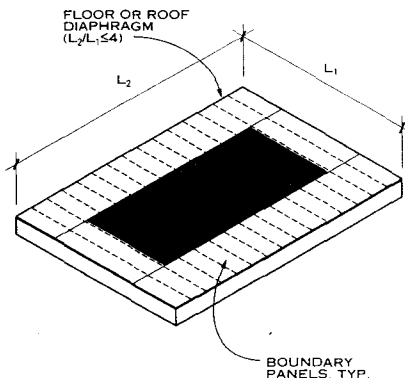

**NOTES**

1. Use 1 1/2 in. sheathing for the outside of shear panels, with 10d nails in 2x framing.
2. Capacities are based on structural I panels of Douglas fir, larch, or southern pine. For additional thicknesses or alternative wood species, consult the American Plywood Association.
3. The aspect ratio (the ratio of the longer dimension to the shorter) of a floor or roof diaphragm is limited to L2/L1 ≤ 4. Openings in the diaphragm are limited to either 12 ft or half the length of the diaphragm, whichever is smaller.

**FLOOR AND ROOF DIAPHRAGM**

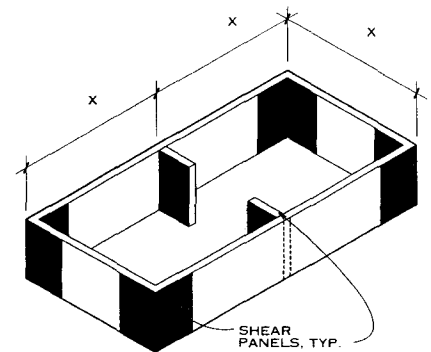

**NOTE**

The bracing element is typically a shear panel that is anchored against both shear and overturning.

**BRACED WALL SPACING**

David S. Collins, FAIA; American Forest & Paper Association; Cincinnati, Ohio

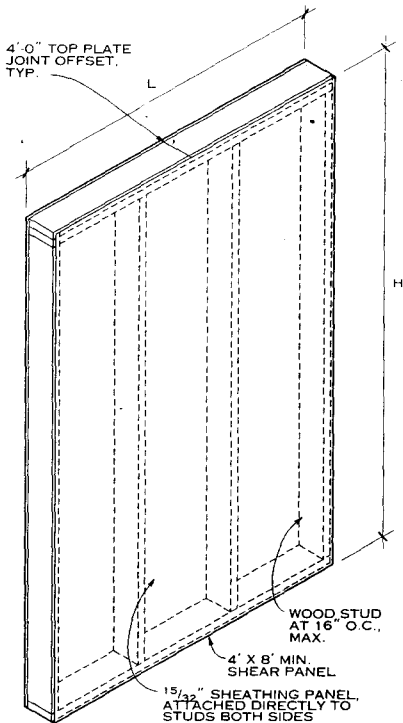

**NOTES**

1. Shear panels that consist of framing members and sheathing panel(s) or diagonal sheathing members provide the principal lateral resistance to shear loads. Sheathing panels are made of plywood and OSB (for structural panels), gypsum sheathing, or fiberboard. Diagonal wood sheathing boards or strapping can also be used. The shear capacity of the material depends on the quality of the framing and sheathing materials and on the connections. Building codes require a minimum aspect ratio of  $H/L \leq 2$  or  $3\frac{1}{2}$  for the panel. Sheathing both sides with the same material doubles the capacity of the shear panel. Tests have shown that sheathing each side with a different material adds capacity, although this concept is not accepted by all codes.
2. Use 10d nails at all edges and in field (center area) as follows: for edge nailing, 6 in. o.c. for 280 lb./lin. ft.; 4 in. o.c. for 430 lb./lin. ft.; 3 in. o.c. for 550 lb./lin. ft.; 2 in. o.c. for 730 lb./lin. ft.; and 12 in. o.c. for field nailing.
3. This drawing is based on use of structural I panels of Douglas fir, larch, or southern pine. For additional thicknesses or alternative wood species, consult the American Plywood Association.

**WOOD WALL SHEAR PANEL**

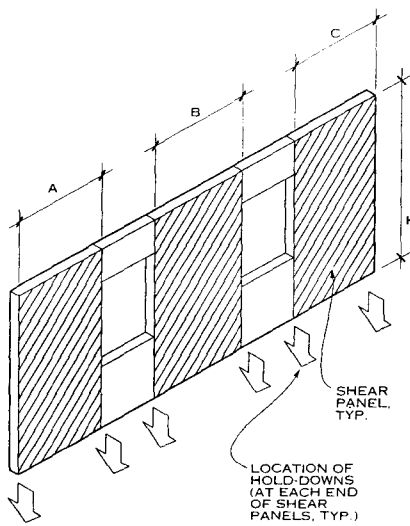

**NOTES**

1. In traditional shear wall design, parts of the wall that are sheathed from top to bottom without openings are considered individually as shear panels. Hold-down anchors are required at both ends of each of these panels. Each segment must be restrained against the overturning motion and the shear to which it will be exposed.
2. The capacity of a traditional shear wall is the sum of the capacities of the individual shear wall segments, which are determined by multiplying the length of each segment by the capacity of the sheathing (lb./lin. ft.). Example: Use  $1\frac{5}{32}$  in. sheathing for the outside of the shear panel, with 10d nails spaced 6 in. o.c. for 280 lb./lin. ft. The capacity of this shear wall would be equal to  $280 \times (A + B + C)$ ;  $280 \times H =$  uplift (hold-down capacity).

**TRADITIONAL SHEAR WALLS**

**MINIMUM LENGTH OF BRACED WALL**

STORY	SHEATHING TYPE*	LOW RISK	HIGH RISK		
			12'-0"	16'-0"	20'-0"
Top or only	G-P	8'-0"	12'-0"	16'-0"	20'-0"
	SW	4'-0"	8'-0"	8'-0"	12'-0"
Story below top	G-P	12'-0"	16'-0"	20'-0"	—
	SW	8'-0"	8'-0"	12'-0"	29'-0"
Bottom of 3 stories	G-P	16'-0"	—	—	—
	SW	8'-0"	Not permitted as conventional		

\*G-P—gypsum; SW—structural wood

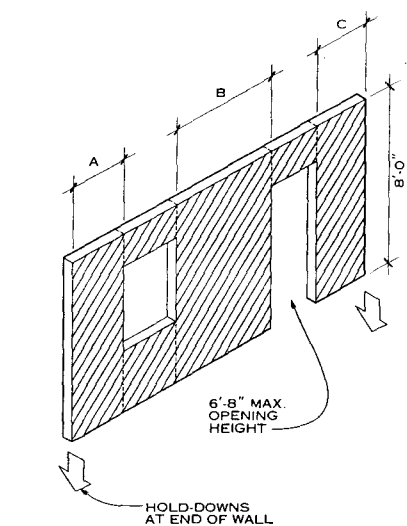

**NOTES**

1. For perforated shear walls, the whole wall is considered as a single shear panel without regard to wall openings. Hold-down anchors are required only at the ends of the wall. To determine the capacity of the wall, the lengths of the full-height sheathed areas are added together and the sum multiplied by the capacity of the sheathing.
2. Perforated shear walls may require higher capacity sheathing than traditional shear walls to compensate for the lack of intermediate hold-down anchors.
3. The sheathed walls above and below the openings in a perforated shear wall increase the capacity of the wall. The capacity of the shear wall must be adjusted by a factor derived from two variables: the maximum opening height and the percentage of full-height sheathing on the shear panel. In the following example, a factor of 0.49 is applied. The Wood Frame Construction Manual gives more examples. Example: Use  $1\frac{5}{32}$  in. sheathing for the outside of the shear panel, with 10d nails spaced 6 in. o.c. for 280 lb./lin. ft. Shear =  $280 \times (A + B + C) \times 0.49$ ;  $280 \times 8 = 2240$  lb uplift (hold-down capacity).

**PERFORATED SHEAR WALLS**

**LUMBER DESIGN VALUES FOR SEISMIC CONDITIONS**

DESIGN VALUE*	2 x 8	ADJUSTMENT FACTORS			ADJUSTED DESIGN VALUE (PSI)
		SIZE	REPETITIVE MEMBER 1.15	LOAD 1.6	
$F_b$	Douglas fir-larch no. 2; 875 psi	1.2 $F_b=1050$	1210	1930	1930
	SPF no. 1/no. 2; 875 psi	1.2 $F_b=1050$	1210	1930	1930
	Southern pine no. 2; 1200 psi	—	1380	2210	2210
$F_v$	Douglas fir-larch no. 2; 95 psi	—	—	150	150
	SPF no. 1/no. 2; 70 psi	—	—	110	110
	Southern pine no. 2; 90 psi	—	—	145	145
$F_c$	Douglas fir-larch no. 2; 625 psi	—	—	—	625
	SPF no. 1/no. 2; 425 psi	—	—	—	425
	Southern pine no. 2; 565 psi	—	—	—	565
$F_{c  }$	Douglas fir-larch no. 2; 1300 psi	1.05 $F_{c  }=1560$	—	2185	2185
	SPF no. 1/no. 2; 1100 psi	1.05 $F_{c  }=1320$	—	1850	1850
	Southern pine no. 2; 1550 psi	—	—	2480	2480

\*Additional design values for other species and grades of lumber can be obtained from the Supplement to the AF&PA National Design Specification.

**NOTE**

Design values for traditional solid wood products and connections are available in the American Forest and Paper

Association's National Design Specification. The values published for wood products must be adjusted by various factors, including size (except for southern pine), to determine the appropriate design values for a particular application. Repetitive members, consisting of three members spaced not more than 2 ft o.c. and sharing a load, must be increased by a factor of 1.15, while the adjustment for

seismic and wind conditions is a factor of 1.6. These factors are applicable only to solid wood products and glued laminated timbers. Connections have similar adjustment factors.

David S. Collins, FAIA; American Forest & Paper Association; Cincinnati, Ohio

**1 SEISMIC DESIGN**

## GENERAL

Lighting design involves selecting lighting fixtures (luminaires) and determining their locations and control devices to realize the desired effects. Basic lighting designs are fairly generic and require but a modest level of effort to achieve a workable result. Attractive and/or complex lighting designs, on the other hand, can require significantly more design work and detail in specifying products and locations. Typical steps in the process are these:

1. Establish project criteria: Determine the quantity and quality of illumination, color of light, and luminaire type (style, appearance) wanted. Check applicable codes and standards, and find out the cost and power limits.
2. Create design concepts: Select the types of luminaires to be used, outline desired controls, and propose locations. Test cost and power budgets.
3. Refine the design: Make calculations and adjustments, sketch details, draft specifications, and coordinate mechanical and structural work.
4. Prepare working drawings: Draw lighting plans, make fixture schedules, and plan layout and circuit controls. Determine emergency, life safety, and egress lighting.

As with all creative processes, it is not unusual to repeat steps until an acceptable result is achieved. With increasing enforcement of energy codes, traditional designs (especially those using incandescent lighting) will not meet energy code requirements. Reiterations involving different light sources or luminaires will often be necessary.

## SETTING DESIGN CRITERIA

Lighting design requires the definition of the following criteria for each application: quantity of illumination, quality of illumination, color of light, and suitable luminaire styles.

### QUANTITY OF ILLUMINATION

Standards for illumination are set by the Illuminating Engineering Society of North America (IESNA). Illumination is generally measured in the horizontal plane 30 in. above the floor. The units of illumination are footcandles (lumens per square foot) and lux (lumens per square meter). IESNA-recommended levels are summarized on the following page (Lighting and Lighting Systems)—more detailed and specific information is given in the IESNA Lighting Handbook and in other IESNA publications.

Specific lighting levels may be set by codes, such as life safety codes and health codes. For instance, NFPA 101 (National Fire Protection Association Life Safety Standard) recommends an average illumination of 1 footcandle (10 lux) along a path of emergency egress with an emergency power source. Some owners establish their own lighting level requirements for specific areas.

Choosing lighting levels involves thoughtful application of IESNA recommendations to meet the goals of the project. Too much light will lead to excessive energy use and failure to meet energy code limits. Use of high lighting levels (more than 200 footcandles) is rare and usually is associated with special purpose lighting systems like surgical lights.

The IESNA recommends exterior lighting levels for specific applications such as street lighting, sports lighting, and parking lot lighting. Although the IESNA makes some recommendations for exterior lighting applications that are more artistic, such as building facades or statuary, most of these are left to the designer's discretion.

The uniformity of lighting levels is also subject to IESNA recommendations. For interior lighting, IESNA generally recommends the following ratios of illumination for comfort:

1. Task proper: 100%.
2. Immediate surround: 33-100%.
3. Distant surround: 10-100%.

When light is designed to maintain these relationships, the human eye continually adapts to the light level and responds quickly to visual stimulus. However, visual interest is caused by contrast in which ratios between task and surround might be 100:1 or even greater. This is one of the greatest paradoxes of lighting design: The most appealing visual scenes are often uncomfortable.

## LIGHT SOURCE SELECTION GUIDE

LAMP CCT <sup>1</sup> (KELVINS OR K)	APPLICATIONS
<2500	Bulk industrial and security (HPS) lighting
2700-3000	Low light levels in most spaces (<10 FC); general residential lighting; hotels, fine dining and family restaurants, theme parks
2950-3200	Display lighting for retail and galleries; feature lighting
3500-4100	General lighting in offices, schools, stores, industry, medicine; display lighting; sports lighting
4100-5000	Special application lighting when color discrimination is very important; not commonly used for general lighting
5000-7500	Special application lighting when color discrimination is critical; uncommon for general lighting
MINIMUM LAMP CRI <sup>2</sup>	
<50	Noncritical industrial, storage, and security lighting
50-70	Industrial and general illumination when color is not important
70-79	Most office, retail, school, medical, and other work and recreational spaces
80-89	Retail, work, and residential spaces when color quality is important
90-100	Retail and work spaces when color rendering is critical

<sup>1</sup> CCT—correlated color temperature

<sup>2</sup> CRI—color rendering index

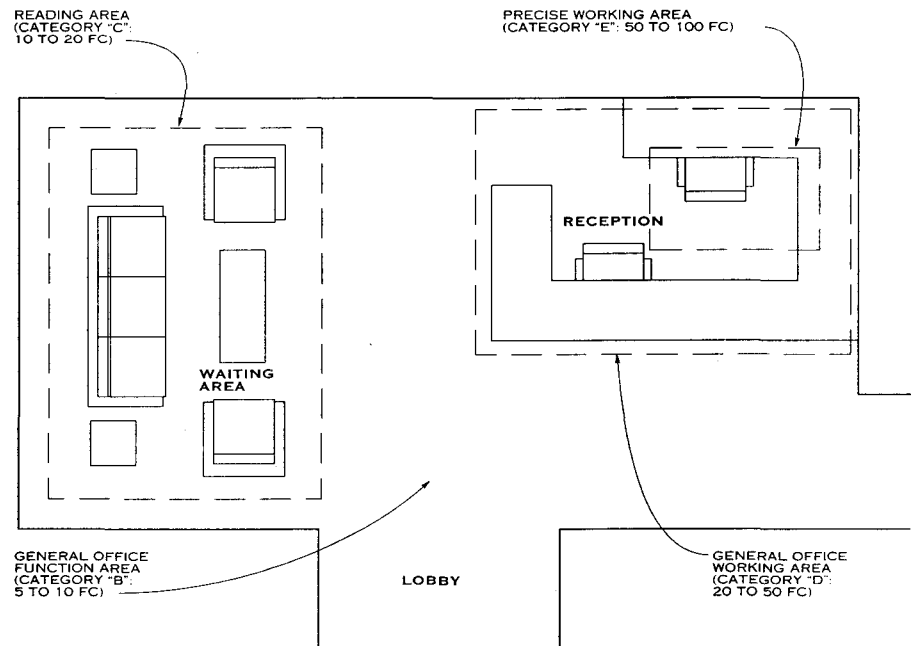

### NOTE

In this example, choosing the proper amount of light in each area not only meets visual needs but consumes only the minimum necessary energy. Use the high end of the

light level ranges for older people, where finishes are especially dark, or where the work is particularly important or requires great speed.

## LIGHTING LEVELS FOR TYPICAL OFFICE RECEPTION AREA

### QUALITY OF ILLUMINATION

Quality of illumination remains largely an aesthetic issue. However, a number of specific quality issues can be addressed objectively:

1. Eliminate flicker: Light sources should minimize or eliminate flicker caused by AC power or other influences.
2. Eliminate or minimize glare: Shield lamps from view. Minimize very bright and very dark surfaces. Illuminate walls and ceilings.
3. Use light sources with good color rendering: Halogen, high CRI (color rendering index) full size and compact fluorescent, and high CRI metal halide and white HPS lamps should be used whenever possible.

### COLOR OF LIGHT

Both the correlated color temperature (CCT) and color rendering index (CRI) for light sources should be used in choosing light sources. In general, try to match CCT when mixing sources, such as halogen and fluorescent.

### SUITABLE LUMINAIRE STYLES

Many design problems have reasonably obvious solutions determined by a combination of budget, energy code, and industry standards. For instance, most office lighting designs utilize recessed troffers because they are cost-effective and energy-efficient and they meet the standard expectations of owners and tenants. Choices among troffers require further consideration, although at that point style is a lesser issue.

Some situations call for uncommon or creative designs. In these cases, the distribution of the luminaire and its physical appearance become critical. In particular, luminaires that enhance the architecture are desired for residences, hotels, restaurants, and other nonwork spaces. Decorative styles range from contemporary to very traditional; lamp options may permit a choice between incandescent and more energy-efficient light sources, such as compact fluorescent or low watt high-intensity discharge (HID) luminaires. In fact, energy-efficient decorative lighting fixtures, both interior and exterior, are one of the fastest growing parts of the lighting fixture industry as the market for attractive luminaires that comply with energy codes grows.

James Robert Benya, PE, FIES, IALD, Pacific Lightworks; Portland, Oregon  
Robert Sardinsky, Rising Sun Enterprises; Basalt, Colorado

**GENERAL**

Most buildings are equipped with electric lighting systems for interior uses. Early in the history of lighting, illumination systems were designed for minimum use of interior space at night. Today, however, electric illumination systems generally are designed to be used in place of natural light.

**FUNCTIONS OF LIGHTING**

Light is one of many tools available to help in space design. In the beginning of any project, it is wise to recall the functions of lighting and to be certain each has been examined:

1. Performance of tasks: Lighting to perform work, whether it is reading, assembling parts, or seeing a blackboard, is referred to as task lighting. Visual work is a primary reason for providing lighting.
2. Enhancement of space and structure: It is only through the presence of light that spatial volume, planes, ornament, and color are revealed. For centuries, structural systems evolved partly in response to aesthetic as well as functional desires for light of a certain quality. The progress from bearing wall to curtain wall was driven by the push of newly discovered technologies (both in materials and in technique), by evolving cultural desires for certain spatial characteristics, and by a desire to admit light of a particular quality. These developments are reflected in the Gothic church window, the baroque oculus, and the Bauhaus wall of glass. With the advent of electric lighting systems, this connection of structure to light was no longer entirely necessary, but most architects continue to pay homage to this historical tie.
3. Focusing attention: The quality of light in a space profoundly affects people's perception of that space. The timing and the direction of an individual's gaze are often a function of the varying quality and distribution of light through the space. Lighting draws attention to points of interest and helps guide the user of a space.
4. Provision of security: Lighting can enhance visibility and thereby engender a sense of security. Lighting can also be used to illuminate hazards, such as a changing floor plane or moving objects.

**BASIC LIGHTING TERMS**

**LUMINAIRE:** a structure that holds an electric lamp and its socket, wiring, and auxiliaries, such as ballasts.

**PORTABLE LUMINAIRE (LAMP):** a luminaire equipped with a cord and plug and designed to be moved from space to space.

**LIGHTING FIXTURE:** a luminaire that is permanently attached ("hard wired") to a building.

**LIGHTING SYSTEM:** the lighting fixtures in a building, sometimes including portable lights, subdivided into smaller systems (e.g., the lighting system in a room or all luminaires of a particular type in a room or building).

**ILLUMINANCE:** the measure of light striking a surface, in footcandles (lumens per square meter). Illuminance can be measured and predicted using calculations; also illumination.

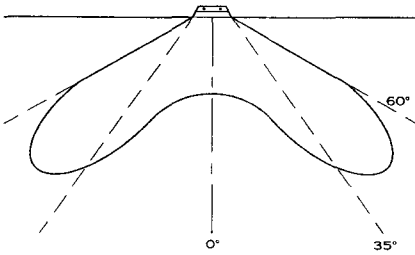

**NOTE**

Fixture manufacturers have developed luminaires (mostly fluorescent) that produce a light distribution that tends to reduce direct glare and veiling reflections if used in large, uniform arrays and typical open office geometries. This distribution pattern is called batwing.

**LUMINAIRE LIGHT DISTRIBUTION PATTERN**

James Robert Benya, PE, FIES, IALD, Pacific Lightworks; Portland, Oregon  
 Robert Sardinsky, Rising Sun Enterprises; Basalt, Colorado  
 Robert Prouse, IALD, IES; H.M. Brandston & Partners, Inc.; New York, New York

**1 LIGHTING DESIGN**

**ILLUMINANCE VALUES FOR VARIOUS INDOOR ACTIVITIES**

TYPES OF ACTIVITY	ILLUMINANCE CATEGORY	RANGES OF ILLUMINANCE		REFERENCE WORK PLANE
		LUX	FOOTCANDELES	
Public spaces with dark surroundings	A	20-30-50	2-3-5	General lighting throughout spaces
Simple orientation for short, temporary visits	B	50-75-100	5-7.5-10	
Working spaces used only occasionally for visual tasks	C	100-150-200	10-15-20	
Performance of visual tasks of high contrast or large size	D	200-300-500	20-30-50	Illuminance on task
Performance of visual tasks of medium contrast or small size	E	500-750-1000	50-75-100	
Performance of visual tasks of low contrast or small size	F	1000-1500-2000	100-150-200	
Performance of visual tasks of low contrast and very small size over a prolonged period	G	2000-3000-5000	200-300-500	Illuminance on task, provided by a combination of general and local (supplementary) lighting
Performance of very prolonged and exacting visual tasks	H	5000-7500-10000	500-750-1000	
Performance of very special visual tasks of extremely low contrast and small size	I	10000-15000-20000	1000-1500-2000	

**NOTE**

Standards for lighting and illumination in North America are established by the Illuminating Engineering Society of North America. IESNA recommendations are summarized in the

IESNA Lighting Handbook, 8th edition, from which this table is taken.

**LAMP:** the electric bulb or tube within a luminaire.

**PHOTOMETRY:** the measure of light, especially with respect to a luminaire.

**PHOTOMETRIC REPORT:** a written report that describes the manner in which light is emitted from a luminaire, presented in an industry standard format.

**ENERGY EFFICIENCY:** the measure of how a lighting system compares to standards, in the context of building size and function.

its lumens downward will have a higher CU (room cavity ratio and reflectance values being equal) than one that distributes light in any other direction. A higher CU is not necessarily a virtue; it only ranks fixtures according to their ability to provide horizontal illumination.

The lumen method/zonal cavity system is limited by the following:

1. It is based on a single number, average value.
2. It assumes a uniform array of lighting fixtures.
3. It assumes all room surfaces have a matte (Lambertian) finish.
4. It assumes the room is devoid of obstruction, at least down to the level of the work plane.

The light loss factor (LLF) is used to calculate the illuminance of a lighting system at a specific point in time under given conditions. It incorporates variations from test conditions in temperature and voltage, dirt accumulation on lighting fixtures and room surfaces, lamp lumen output depreciation, maintenance procedures (mainly frequency of cleaning), and atmospheric conditions. The LLF is also known as the maintenance factor.

To use a CU table, assumptions must first be made about the reflectance of major room surfaces. Then the room cavity ratio (RCR) can be determined according to one of the following formulas:

For rectangular rooms:  $RCR = [5 \times H(L + W)] / (L \times W)$ , in which H is the cavity height

For odd-shaped rooms:  $RCR = 2.5 \text{ wall area/floor area}$

**LUMEN METHOD**

Lighting design involves determining how many luminaires are needed for a particular application and where to locate them. The most accurate means of determining illumination performance is by computer; a number of point-by-point lighting programs are available with DXF and DWG file interfaces and other features. (See the annual computer issue of Lighting Design and Application, an IESNA publication, for a current list of commercially available programs.) It is also possible to estimate illumination results from a proposed lighting design using the lumen method and photometric report(s) from candidate luminaires.

The lumen method, also known as the zonal cavity system, is a calculation method that can be used to determine the horizontal illuminance that will result from a proposed lighting fixture selection and layout or the number of fixtures required by a proposed fixture selection and its horizontal illuminance value.

The lumen method is based on the definition of average footcandles over an area. The method modifies the fundamental equation of  $1 \text{ fc} = 1 \text{ lumen/sq ft}$  to account for room size and proportion; reflectance from walls, ceiling, and floor; fixture efficiency; and reduction in output over time due to dirt accumulation, deterioration of reflecting surfaces, and reduction of lumen output.

The lumen method requires the following information:

1. Room dimensions (to compute wall area and floor area)
2. Height of fixtures above work plane
3. Reflectance levels of major surfaces (ceiling, walls, floor)
4. An estimate of the light loss factor (LLF)
5. Initial lamp lumens
6. A target illuminance level

The coefficient of utilization (CU) is the percentage of total lamp lumens that reaches the work plane. As such, it has nothing to do with the intensity of the fixture but rather with the efficiency of the fixture (lumens emitted from the fixture divided by lamp lumens and the direction of the lamp output—this direction of output is graphically represented by the candlepower distribution curve). For purposes of this procedure, the plane of interest is invariably a horizontal plane (typically either the floor or desk level), therefore a fixture that throws the greatest percentage of

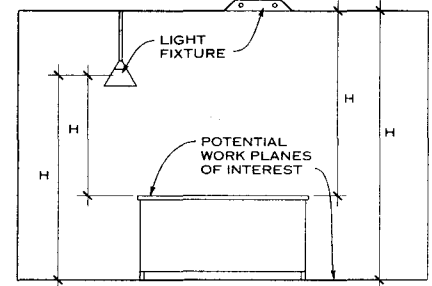

**NOTE**

Any one of these dimensions may be the cavity height (H), which is the distance from the light fixture to the work plane of interest.

**CAVITY HEIGHT DIAGRAM**

**GENERAL**

Lighting can be designed both to use minimum energy and to realize environmental benefits such as reduced air and groundwater pollution. Electric light sources more efficacious than traditional incandescent lamps have been developed to meet most lighting needs. The key to achieving efficient design is knowing how and when to choose efficient sources, luminaires, and controls.

**CODES**

The U.S. Energy Policy Act of 1992 requires states to develop codes that require efficiency in lighting design. Each code must meet or exceed the requirements of ASHRAE/IES 90.1-1989. In 1996, although in many states compliance was mandatory and enforced, some states had yet to adopt such a code, while others had not yet begun enforcement. For federal government buildings, a version of 90.1 with more stringent values was in force. Progress toward regulating energy efficiency in Canada was similar.

All codes presently calculate allowed watts based on building type and area. Codes generally determine allowed interior lighting watts in one of three ways—room by room, by area (groups of rooms), or for the entire building:

1. Room by room: Determine the specific use of each room and its net area. Multiply the area of each room by the allowed power density (watts/sq ft) adjusted for the room cavity ratio (RCR). Add the wattage for all rooms together.
2. Area: Determine the use of major portions of a building or renovation and the gross lighted area of each. Multiply the gross lighted area by the allowed power density (watts/sq ft) for each group of rooms by type. Add the figures for all areas together.
3. Whole building: Determine the building type and the gross lighted area for the entire building. Multiply the gross lighted area by the allowed power density (watts/sq ft) for the entire building by type.

To find the total allowed watts for the interior of a building, start with the total wattage as determined by one of the three methods above. Then subtract "credit" watts for lighting controlled by advanced automatic devices such as daylighting or motion sensing and add other allowed watts, if any.

An allowed lighting load can also be determined by using a building energy simulation program like DOE-2. However, because the program's algorithm is based on the same power density assumptions as the allowed amount given above, it is unlikely the value for lighting determined in this manner will be significantly different.

Exterior lighting is governed less than interior lighting, and under some codes it may not be governed at all. As well, energy codes in general do not regulate lighting watts in dwelling units.

**ADDITIONAL CODE REQUIREMENTS**

In addition to limiting lighting power in a building, lighting energy codes also have other requirements. These vary by state but may include the following:

1. Mandatory use of readily accessible switching in all enclosed spaces. (Exceptions are allowed for spaces in which this would be unsafe.)
2. Use of multilamp or electronic fluorescent ballasts whenever possible.
3. Separate switching for daylighted and nondaylighted spaces in building interiors.
4. Ability through switching or dimming to adjust lighting levels in a space exceeding 100 sq ft and 100 watts.
5. Automatic shutoff controls for lights in spaces in larger buildings (usually larger than 5000 sq ft).
6. Automatic shutoff controls for exterior lights.

**LIGHTING CONTROLS IN ENERGY-EFFICIENT APPLICATIONS**

While most energy codes require switching for all spaces, some switch types control energy use better through automatic switching and/or dimming. "Control credits" are often offered by codes that permit the designer to reduce the watts of all lights connected to certain automatic devices; this arrangement allows the design to employ more lighting watts and still comply with the energy code.

**COMPLIANCE STRATEGY**

To realize design compliance with local energy codes without significant redesign, observe the following process:

1. Choose a general lighting system that uses one of these sources: fluorescent T-8 with electronic ballasts, high-wattage compact fluorescent with electronic ballast, or metal halide or HPS (high-pressure sodium).
2. Make certain the luminaire and room are reasonably efficient. Use direct lighting for tasks whenever possible, and make room finishes light, especially ceilings.
3. Design to just barely meet IESNA recommendations for each space.
4. For downlighting, wallwashing, and other traditional incandescent applications, use compact fluorescent or HID (high-intensity discharge) sources.
5. Minimize the amount of track lighting by using recessed fixtures or monopoints when possible.
6. Use incandescent and halogen sources sparingly, confining them to necessary decorative lighting.
7. Add advanced controls such as motion sensors and daylighting dimming. These allow the reduction of actual lighting watts and can help bring a design into compliance with energy efficiency requirements.

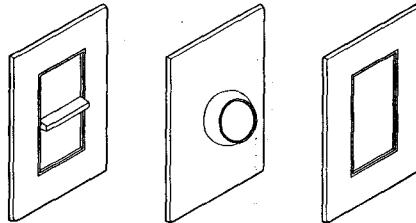

**LINEAR SLIDE CONTROL      ROTARY OR PUSH-ON/OFF CONTROL      TOUCH-PLATE CONTROL**

**DIMMING CONTROL DEVICES**

**TRADEOFFS**

Energy codes do not regulate lighting design or the amount of lighting in a particular space. For instance, a designer could slightly reduce the lighting loads throughout an office building by using efficient lighting equipment. With the energy saved, an important space like the main lobby could be illuminated in a less efficient manner, such as with incandescent chandeliers, and the project would still comply with the energy code.

Tradeoffs are allowed among interior spaces in the same building, but they are not allowed between interior and exterior lighting. In addition, tradeoffs are not allowed between buildings, even if they are owned by the same company and stand on the same site.

**ENERGY-EFFICIENT LIGHTING CONTROLS**

DEVICE OR METHOD	OPERATION	TYPICAL CREDIT*
Time clock (with manual override readily accessible)	Turns lights on and off at scheduled times	0-10%
Dimmer	Reduces lighting power by manual adjustment	0%
Motion sensor	Turns lights on and off based on space use	15% (>250 sq ft) to 30% (<250 sq ft)
Daylighting controls	Reduces interior lighting power based on amount of daylight in space	20% (stepped) to 30% (continuous dimming)
Scene preset dimming	Reduces average power by dimming combinations of lighting systems	10-20%
Tuning	Reduces lighting power by hidden adjustment	10-15%
Lumen maintenance	Reduces interior lighting power based on age of lamps and cleanliness of space	10-15%
Combined systems	Combinations of the above are not directly additive	Up to 45%

\*The credit offered varies from code to code and may not be available everywhere.

$$\text{NUMBER OF LUMINAIRES} = \frac{\text{footcandles desired} \times \text{room area}}{\text{CU} \times \text{LLF} \times \text{lamps/luminaire} \times \text{lumens/lamp}}$$

$$\text{AVERAGE FOOTCANDLES} = \frac{\text{lumens/lamp} \times \text{lamps/luminaire} \times \text{CU} \times \text{LLF}}{\text{area of room (sq ft)}}$$

$$\text{POWER DENSITY (W/sq ft)} = \frac{\text{design watts (including ballast)}}{\text{area of room}}$$

where:  
 CU = coefficient of utilization (percentage of light that actually reaches task)  
 LLF = light loss factor (time-dependent depreciation factors)

**NOTE**

See manufacturer's photometric tables or the Lighting Handbook of the Illuminating Engineering Society for tables of values for CU, LLF, lumens/lamps, etc.

$$\text{NUMBER OF FIXTURES} = \frac{50 \times 25 \times 40}{0.67 \times 0.7 \times 4 \times 2850} = 9.35 \text{ luminaires (use 9 or 10)}$$

$$\text{POWER DENSITY (W/sq ft)} = \frac{9 \times 111}{25 \times 40} \text{ or } \frac{10 \times 111}{25 \times 40} = 0.999 \text{ W/sq ft (9 luminaires) or } 1.111 \text{ W/sq ft (10 luminaires)}$$

**TYPICAL EXAMPLES**

Room size 25 x 40 ft; ceiling height 9 ft; illumination level 50 footcandles (IESNA category 10); 2 x 4 ft, recessed trofers with four 32-watt T8 lamps (2850 lm) each.

CU = 0.67 (plastic lens)  
 Electronic ballast input watts = 111  
 LLF = .70

**FORMULAS FOR AVERAGE LIGHTING CALCULATIONS**

James Robert Benya, PE, FIES, IALD, Pacific Lightworks; Portland, Oregon  
 Robert Sardinsky, Rising Sun Enterprises; Basalt, Colorado



**DETERMINING THE EFFECT OF PARTITIONS ON LIGHTING LEVELS**

The illumination that reaches a desk top in a direct lighting system is a combination of light arriving directly from the lighting fixture and indirectly via reflectance from various room surfaces. A partition not only interferes with this indirect component of light but can drastically reduce the potential direct component.

Consider the example shown in the accompanying diagrams. In diagram "A", the workstation is contained within 42 inch high panels. Extending "sightlines" (as if the desk top could "see" the ceiling) from the center of the station out to the ceiling over the top of the panels, it can be seen that in a 10 by 10 ft workstation, a ceiling area of 4,225 sq ft (65 x 65 ft) has the potential for contributing light to the workstation. If the lighting fixtures are installed 8 ft apart, there would be an average of 66 fixtures [4,225 sq ft ÷ (8 x 8 ft)] that could contribute light directly to the desk top.

If the same 10 x 10 ft workstation had partitions 60 in. tall, the projected lines would enclose a ceiling area of 676 sq ft (26 x 26 ft). This area would include only ten or eleven fixtures [676 sq ft ÷ (8 x 8 ft)]. This 80% decrease in the number of lighting fixtures that could possibly contribute light directly to the desk top does not translate into an 80% drop in light levels at the desk top. However, it will cause a significant decrease, the amount of which is influenced by factors such as the distribution pattern of the lighting fixtures and the finishes of the partitions.

Clearly, task lighting is important to consider when partitions are more than 42 in. high.

**LIGHTING CALCULATIONS FOR SPACES WITH PARTITIONS**

A rough approximation of the magnitude of the effect of partition height on lighting levels can be calculated using the following technique. (However, do not use this technique for totally direct lighting systems unless several luminaires directly contribute light to the cubicle.)

1. Use the coefficient of utilization (CU) table for the fixture to calculate the average illuminance at the top of the partitions. Use the distance from the luminaires to the top of the partitions as the cavity height, and use actual reflectance values except for the floor; use "0" for the floor cavity reflectance.
2. Determine the transfer coefficient of a virtual ceiling luminaire: Use the distance from the top of the partition to the desk top as the cavity height. Use the cubicle's partition reflectance as the wall reflectance, and use the effective ceiling cavity reflectance of the actual ceiling cavity above the top of the partitions. Use the table below to find the transfer coefficient.
3. Multiply the illuminance from the first step (at the top of the partitions) by the transfer coefficient to find the approximate average illuminance at the desk top.

**TRANSFER COEFFICIENTS**

CEILING	80			50		
	50	30	10	50	30	10
WALLS						
RCR*						
0	1.19	1.19	1.19	1.11	1.11	1.11
1	1.03	0.98	0.94	0.96	0.93	0.89
2	0.89	0.81	0.75	0.83	0.78	0.73
3	0.77	0.69	0.62	0.73	0.66	0.60
4	0.68	0.59	0.52	0.64	0.57	0.51
5	0.61	0.51	0.45	0.58	0.50	0.44
6	0.55	0.45	0.39	0.52	0.44	0.38
7	0.49	0.40	0.34	0.47	0.39	0.34
8	0.45	0.36	0.30	0.43	0.35	0.30
9	0.41	0.33	0.27	0.39	0.32	0.27
10	0.38	0.30	0.25	0.36	0.29	0.24

\*RCR—room cavity ratio

James Robert Benya, PE, FIES, IALD, Pacific Lightworks; Portland, Oregon  
Robert Sardinsky, Rising Sun Enterprises; Basalt, Colorado

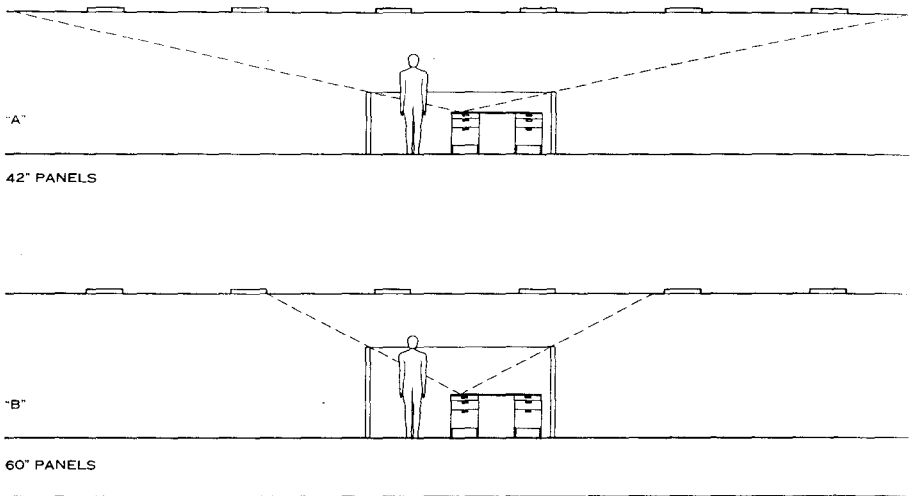

**PANEL HEIGHT COMPARISON**

**LIGHTING CONTROL CHOICES**

Energy codes require readily accessible switching for all electric lights. The National Electric Code requires switching at specific locations in houses. Traditional switches meet these requirements. Other lighting controls choices are discussed here:

**SWITCHING**

Standard toggle switches are the most commonly used lighting switches. Three-way and four-way switches permit control from several locations. Choices include standard toggle switches and the more modern "decora" or paddle switches. Electronic touch switches are also becoming more common.

**DIMMING**

Manual dimming is popular in homes and many other spaces. To dim fluorescent lighting, use modern high frequency electronic dimming ballast systems. An energy credit may be available for using manual dimming under some conditions.

**SCENE DIMMING**

Scene dimming or multichannel preset dimming systems are increasingly being used for spaces with four or more independent dimming channels, such as restaurants, custom-built houses, and boardrooms. Scene dimming systems are like modern theatrical dimming in that there is a cross-fade between scenes, which are combinations of preset dim light levels.

**TIME SCHEDULING**

Lighting controls that use clocks to switch lights on and off on predictable schedules are the most commonly used form of automatic lighting controls. Some energy codes require automatic controls of this type as a minimum standard. Controls may vary from individual "time clock" switches to programmable timers and large-scale energy management systems.

**OCCUPANCY SENSING**

Motion sensors can be used to control lights according to space occupancy. Passive infrared sensors are the most commonly used; ultrasonic sensors are also popular and work better in spaces with partitions. Sensors have sensitivity and timeout adjustments. Choose wallbox sensors with internal switches or dimmers for small rooms, ceiling-mounted sensors with remote relays for larger rooms. Multiple sensors can be used in the same room to ensure coverage.

Energy credits for using motion sensor systems are fairly substantial, as these systems save quite a bit of energy in most applications.

**DAYLIGHTING AND RELATED CONTROLS**

Daylighting systems use dimming or switching to reduce interior lighting when adequate daylight is present. In buildings with windows near the work area, savings can be significant, and most codes permit a substantial controls credit for daylighting.

Lumen-maintenance controls allow lighting to be dimmed automatically when it is new and, through photoelectric sensing, to be increased gradually as lamps age and luminaires get dirty. The equipment for these controls is similar to that for daylighting, and most systems do both.

Adaptation compensation controls (the opposite of daylighting) increase interior light as exterior light increases. Tunnels are classic applications for adaptation compensation, but the same principles can be used to save energy in supermarkets.

**DEMAND MANAGEMENT**

Lighting can be dimmed 10-20% with little effect on productivity but a profound impact on overall building load. By sensing incoming electric service for peaks, lighting can be dimmed when other building systems are peaking in load. The result is a "flattening" of the energy use curve, which lowers electric energy cost.

**APPLICATIONS FOR LIGHTING CONTROLS**

Office buildings, schools	Motion sensors in private offices, classrooms, and conference rooms
	Time scheduling systems for open office areas, corridors, halls, and lobbies
	Motion sensors in toilet rooms and storage
	Daylighting in areas adjacent to windows or skylights
	Combined systems (e.g., motion and daylighting) wherever logical
Retail	Time scheduling for store windows, general and display lighting
	Motion sensing for storage and dressing rooms
	Daylighting and lumen maintenance near skylights
	Adaptation compensation for general lighting
Industrial, institutional	Time scheduling in most areas
	Daylighting near windows and skylights
	Motion sensing in restrooms, little used storage areas
Outdoor	Choices include photoelectric switches, motion sensors, time switches, and manual switches

**GENERAL**

A luminaire is any device that includes a lampholder, a means of electrification, and a support. Lighting fixtures are luminaires that are permanently attached to a building. Luminaires are characterized by the manner in which light is distributed. Luminaire types are identified in the chart below.

**LUMINAIRE TYPES**

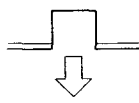
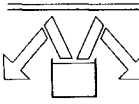
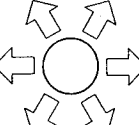
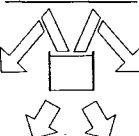
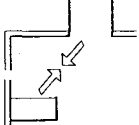
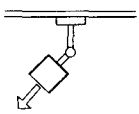
TYPE	LIGHT DISTRIBUTION
Direct	Emits light downward. Most recessed lighting types, including downlights and troffers, are direct luminaires. 
Indirect	Emits light upward, so it bounces from a ceiling into the space below. Many styles of suspended luminaires, sconces, and some portable lamps provide indirect lighting. 
Diffuse	Emits light in all directions uniformly. This type includes most bare lamps, globes, and chandeliers and some table and floor lamps. 
Direct/indirect	Emits light upward and downward but not to the side. Many types of suspended luminaires, and some table and floor lamps, offer this type of lighting. These luminaires can offer mostly direct or mostly indirect lighting. 
Asymmetric	For special applications. For instance, asymmetric uplights are indirect luminaires with a stronger distribution in one direction, such as away from a wall. Wall-washers are a form of direct luminaire with stronger distribution to one side to light a wall. 
Adjustable	Usually, direct luminaires that can be adjusted to throw light in directions other than down. Examples are track lights, floodlights, and accent lights. 

**CHOOSING LUMINAIRES**

**DIRECT** luminaires tend to be more efficient because they distribute light directly onto the task area. They generally create dark ceilings and upper walls, which can be dramatic but can create discomfort from the high contrast.

**INDIRECT** luminaires generally create comfortable low-contrast soft light, which psychologically enlarges space. They tend to be less efficient for task lighting.

**DIFFUSE** luminaires create broad general light that often is considered glaring due to the lack of side shielding. They are generally chosen for ornamental reasons or for utilitarian applications.

**DIRECT/INDIRECT** luminaires are often a good compromise between the efficiency of direct lighting and the comfort of indirect lighting.

James Robert Benya, PE, FIES, IALD, Pacific Lightworks; Portland, Oregon  
Robert Sardinsky, Rising Sun Enterprises; Basalt, Colorado

**LUMINAIRE STYLES**

Downlights and troffers are discussed below; commercial fluorescent fixtures, indirect and direct/indirect lighting systems, architectural lighting fixtures, and decorative lighting are discussed on the following page.

**DOWNLIGHTS**

Downlights are often called "cans" or "tophats." They are principally used for general illumination in a wide range of residential and commercial applications, especially in lobbies, halls, corridors, stores, and other finished spaces. Downlights can be equipped with incandescent, halogen, low-voltage, compact fluorescent, or HID (high-intensity discharge) lamps. There are several major types, which accommodate varying source types, ceiling heights, plenum heights, room types, and beamspreads. These include the following:

**OPEN CONE:** the cone of this type of downlight shields the lamp and develops a beam pattern.

**OPEN BAFFLE:** ridged baffles shield the lamp and minimize glare.

**OPEN ELLIPSOIDAL:** an elliptical reflector allows a small aperture only; this beamspread is highly efficient.

**LENSED (prismatic or fresnel):** generally used outdoors or in wet locations, the lens protects and seals the lamp compartment of this type of downlight.

**DIFFUSER:** a diffuser distributes light broadly, which is especially useful in closets and showers.

**ADJUSTABLE:** adjustable downlights can be used as a downlight or as an accent light.

**PULLDOWN:** this feature allows the light to be used as a downlight or an accent light and permits a wide aim.

**DOWNLIGHT RATINGS**

Choice of a downlight depends on the applications for which it is listed. The primary rating types are these:

**THERMALLY PROTECTED (T)** downlights are suitable for all applications except direct concrete pour.

**INSULATION-PROTECTED (IP)** downlights are used when the fixture may come in contact with insulation. They are designed to prevent fixture overheating.

**INSULATED CEILING (IC)** fixtures are used when the fixture is intended to be in contact with insulation.

**AIRTIGHT INSULATED CEILING (AIC)** downlights are for applications in which the fixture is in contact with insulation and air leaks in the ceiling must be prevented.

**DAMP LOCATION** fixtures can be exposed to moist air but not to direct water spray or rain.

**WET LOCATION** fixtures can be exposed to direct water spray or rain.

**SPA OR SHOWER** fixtures are designed to be used in a shower stall or over a spa.

**CONCRETE-POUR** fixtures are designed to be installed in direct contact with concrete.

**EMERGENCY** fixtures are equipped with a backup battery to produce light for at least 90 minutes during a power outage (generally available only for compact fluorescent luminaires).

**TROFFERS**

Troffers are widely used in offices, stores, schools, and other commercial and institutional facilities for general lighting in work and sales areas. They are the most common type of fluorescent luminaire.

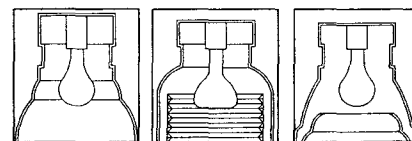

**OPEN CONE      OPEN BAFFLE      ELLIPSOIDAL**

**DOWNLIGHTS**

**LENSED** troffers use a plastic lens to refract light and distribute it in the desired area. The lens cuts off light distribution to minimize glare and protects lamps from breaking in food preparation and service areas. Lenses can contain internal RFI shields for use in hospital operating and laboratory rooms. Lens troffers equipped with highly polished internal reflectors offer very high efficiency.

**PARABOLIC** troffers have parabolically shaped aluminum or plastic louvers that shield the lamp to improve visual comfort. These troffers offer sharp cutoff, which makes some of them suitable for use in computer work spaces. "Parabolics" generally refer to deep-cell louvers 6 in. or larger across; "paracubes" are shallower troffers with smaller cells. Larger cells are more efficient, but smaller cells make it easier to hide the lamps.

Fixtures meeting IESNA recommendations for computer work spaces are generally identified.

Most troffers are recessed and designed to be laid into acoustic tile ceilings, with the fixture face matching the size of the tile. The most common troffer sizes are 2 x 4 ft, although 2 x 2 ft and 1 x 4 ft are also readily available. Other sizes exist, often to match a specific ceiling (such as 20 x 60 in. fixtures for a 5-ft ceiling grid system). Different mounting types are made, including the following identified by the National Electrical Manufacturers Association:

**NEMA "G":** for fixtures in a standard exposed inverted T grid.

**NEMA "F":** for fixtures furnished with a flange and designed to be installed in an opening in plaster or wallboard.

**NEMA "SS":** for fixtures in a screw-slot inverted T grid.

**NEMA "NFSG":** for fixtures in a narrow face slot T grid.

**NEMA "Z":** for fixtures in a concealed Z spline ceiling.

**NEMA "MT":** for fixtures in a metal pan ceiling system.

Some recessed troffers are also designed to interface with the building HVAC system: "Heat extraction" troffers have vents in the top of the fixture to allow return air to be pulled into the troffer, past the lamps, and into the ceiling plenum. "Air-handling fixtures" have slots around the lens or louvers to supply air to a room (by means of a special boot that can transfer air to the supply air system) or to remove it (by connection to a return duct).

Troffers can also be equipped with emergency battery packs to power some or all of the lamps during a power outage or emergency condition.

**TROFFER RATINGS**

Most troffers are rated for standard dry indoor applications and must not touch insulation. Some special types include

1. Gasketed: can be damp or even wet rated.
2. Fire-rated: can maintain up to one hour ceiling rating in certain rated ceilings.
3. Vandal-resistant: equipped with vandal-resistant lens.
4. RFI: lens troffers that are shielded from radio frequencies.
5. Specially gasketed: rated for clean room applications.

Troffers can be equipped with most fluorescent technologies, including dimming, magnetic or electronic ballasts, and T-12 or T-8 lamps. Special troffers are made for ceiling systems like the linear metal slat system (4 in. wide). Recessed troffer depth varies from 3 1/2 to more than 7 in., so troffers must be coordinated with other elements above the ceiling.

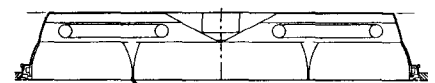

**ALUMINUM LOUVER**

**PARABOLIC LOUVERED**



**ACRYLIC LENS**

**LENSED**

**TROFFERS**

**LUMINAIRE STYLES**

Downlights and troffers are discussed on the previous page, where the subject of lighting equipment is introduced.

**COMMERCIAL FLUORESCENT FIXTURES**

Several types of fluorescent direct luminaires appropriate for general and utility lighting are employed as commercial fixtures. Most utilize wraparound lenses or diffusers in which the lamp is surrounded by the lens; either way, the lamp is hidden from direct view while radiating light downward and to the sides. Commercial luminaires are among the lowest cost lighting fixtures and are typically used for general and utility lighting in modest projects.

**COMMERCIAL RATINGS**

Most commercial fixtures are rated for dry locations. Some have damp labels. Most can be equipped with a battery pack for emergency power.

**INDUSTRIAL LIGHTING FIXTURES**

These fixtures generally have a utilitarian or functional appearance. Fluorescent industrials have strip lights and open fixtures with simple reflectors that are designed to be surface-mounted or hung by chains or rods. HID (high-intensity discharge) industrials include high bay downlights and low bay downlights. Industrial fixtures are generally used in factories and warehouses and increasingly in schools and retail stores where a less-finished appearance is desired.

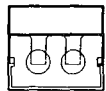

WRAPAROUND



STRIP



INDUSTRIAL FLUORESCENT

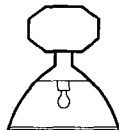

HIGH BAY HID LAMP

**COMMERCIAL AND INDUSTRIAL FIXTURES**

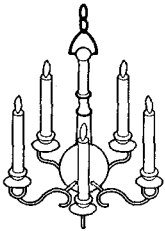

CHANDELIER



PENDANT



TRADITIONAL SCONCE

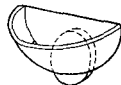

CONTEMPORARY SCONCE

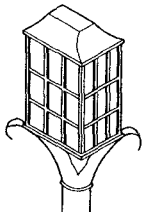

TRADITIONAL LANTERN

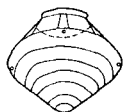

CONTEMPORARY CLOSE-TO-CEILING

**DECORATIVE FIXTURES**

**INDUSTRIAL RATINGS**

Most industrial fixtures are listed for dry locations. Some have finishes such as glass or porcelain that resist corrosion caused by airborne gases or particles; others are made of aluminum or plastic. Certain fixtures are specifically designed for demanding environmental applications ranging from wet or saltwater marine luminaires to explosionproof products for use in petrochemical plants, grain storage, and other unusual locations.

**INDIRECT AND DIRECT/INDIRECT LIGHTING SYSTEMS**

Most indirect and direct/indirect lighting systems are designed to illuminate offices and similar finished spaces. In almost all cases, the ceiling should be finished in white paint or white acoustical tile, as the reflectance of the ceiling plane is critical.

Indirect lighting systems only produce uplight. Generally they should be mounted at least 15-18 in. below the ceiling; longer suspension lengths can improve uniformity but potentially will decrease efficiency. To maintain adequate clearance, ceilings should be at least 9 ft high.

Direct/indirect lighting systems are intended to produce some indirect lighting for its comfort and balance and some direct lighting for efficient production of task lighting. Similar suspension length and ceiling height considerations apply. The percentage of uplight to downlight varies; generally the higher the ceiling, the greater the downlight percentage should be.



INDIRECT

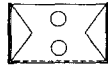

INDIRECT/DIRECT



DIRECT

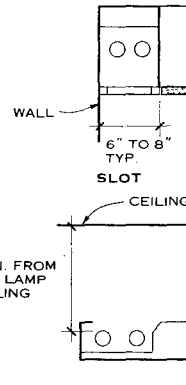

COVE

**SUSPENDED**

**INDIRECT, DIRECT/INDIRECT, AND DIRECT LUMINAIRES**



ROUND 4" TO 9" DIAMETER (UP, DOWN, OR UP/DOWN)



OVOID (UP, DOWN, OR UP/DOWN)



ELONGATED OCTAGON (UP, DOWN, OR UP/DOWN)



RACETRACK OVAL (UP, DOWN, OR UP/DOWN)



"V" OR WEDGE (UP ONLY)

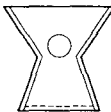

OPTIMAL FOR USE WITH VIDEO DISPLAY TERMINAL (UP/DOWN)

**SUSPENDED LIGHTING SHAPES**

**INDIRECT AND DIRECT/INDIRECT LIGHTING SYSTEM RATINGS**

Almost all indirect and direct/indirect luminaires are intended for dry, relatively clean indoor locations. Many of these systems are designed to meet IESNA recommendations for lighting computer workspaces and are rated as complying with either IESNA /ANSI RP-1-1993 or IESNA RP-24-1989. These ratings are based on ceiling brightness and uniformity criteria.

**ARCHITECTURAL LIGHTING FIXTURES**

Like downlights, architectural lighting fixtures are functional and inconspicuous rather than decorative. They are used to illuminate architectural shapes and forms.

WALLWASHERS come in several types. Eyelid wallwashers essentially are downlights with an eyelid-shaped shield on the room side. Recessed lens wallwashers resemble downlights but use an angled lens to throw light more to one side. Surface and semi-recessed lens and open wallwashers, which throw light onto an adjacent wall, generally work best; they can also be mounted to track. Downlight wallwashers are designed to illuminate rather than scallop an adjacent wall, although the light they provide is not good enough for display purposes.

WALL GRAZING FIXTURES, sometimes called "wall slots," are used to illuminate walls in lobbies, corridors, and core areas. They are especially suited for textured or polished surfaces.

ACCENT FIXTURES focus light on art and building surfaces. Recessed accent lights appear as downlights but internally permit rotation and elevation of the light beam. Eyeballs and pull-down accents resemble downlights that cannot be adjusted. Track lighting systems are specifically designed for accent lighting of art and retail displays, with easy relocation of lampholders along the track.

COVE LIGHTS provide uplighting from coves or other architectural elements more efficiently than strip lights and without socket shadows.

TASK LIGHTS are specifically designed to illuminate a desk area while minimizing veiling reflections.

**DECORATIVE LIGHTING**

Lighting is the "jewelry of architecture" and, in many building types, plays a significant role in building style, period, or motif.

CHANDELIERS are ornate luminaires that generally comprise many small incandescent lamps to simulate the effect of candle flames. Chandeliers are hung from the ceiling and are used for general illumination in dining rooms, foyers, and other formal spaces.

PENDANTS are also ceiling-hung decorative fixtures. In general, the term is used for luminaires that are less formal than chandeliers, such as those used in offices or restaurants. Most pendant luminaires also use incandescent lamps, although modern variations are available with HID and fluorescent sources.

CLOSE-TO-CEILING luminaires are similar to pendants but are mounted close to the ceiling to allow use in rooms with conventional ceiling heights.

SCONCES are ornate or decorative wall-mounted luminaires. Often they match an adjacent chandelier; in other cases, they are the sole decorative lighting element. Sconces generally exhibit the widest range of styles, from crystal sconces with flame-tip lamps to modern designs.

LAMPS are traditional portable luminaires generally used for table or floor mounting. Torchères are floor lamps designed for uplighting. Most portable lighting uses incandescent or halogen sources, although compact fluorescent options should be considered for commercial and hospitality applications.

LANTERNS are outdoor luminaires mounted to ceilings, walls posts, or poles.

**DECORATIVE LIGHTING RATINGS**

Lanterns are generally rated with wet labels. Most other decorative fixtures are rated for dry indoor use, although a few sconces also have damp or wet labels.

James Robert Benya, PE, FIES, IALD, Pacific Lightworks; Portland, Oregon  
Robert Sardinsky, Rising Sun Enterprises; Basalt, Colorado

**ILLUMINATION CRITERIA**

The lighting levels given are average figures:

1. Typical offices: 40-60 fc (400-600 lux) in an empty room.
2. Offices, mostly computer work: 20-40 fc (200-400 lux) in an empty room with task lighting as needed.
3. Offices, traditional paper tasks: 40-60 fc (400-600 lux) in an empty room with task lighting at work locations to provide 60-120 fc (600-1200 lux) for specific tasks.
4. Conference and meeting rooms: 30-50 fc (300-500 lux) in an empty room.
5. Lobbies and hallways: 10-20 fc (100-200 lux) in an empty room.

**OTHER RECOMMENDED CRITERIA**

**VISUAL COMFORT PROBABILITY (VCP):** This figure is only useful for comparing direct (troffer) lighting systems. A minimum of 70 is recommended. (Note that high VCP does not guarantee visual comfort.)

**CCT and CRI:** Correlated color temperatures (CCT) and the color rendering index (CRI) suitable for common office uses are shown in the accompanying table.

**LIGHTING POWER DENSITY:** Approximate design targets using T8 lamps and electronic high frequency ballasts (not including task lights) are shown in the accompanying table.

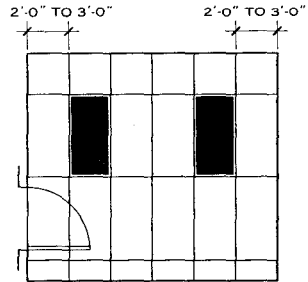

**REFLECTED CEILING PLAN**

**NOTE**

In this 10 x 10 ft office, two fixtures produce 50-60 fc on the work area at 1.18 watts/sq ft.

In small offices, maximize comfort and efficiency by having fixtures straddle the work area. Avoid placing a single overhead fixture. Partial symmetry is better than checkerboard or other asymmetrical layouts. Maintain approximately 2-3 ft from fixtures to side walls. Lensed fixtures and indirect lighting systems work best in small rooms.

**SMALL OFFICE LIGHTING LAYOUT**

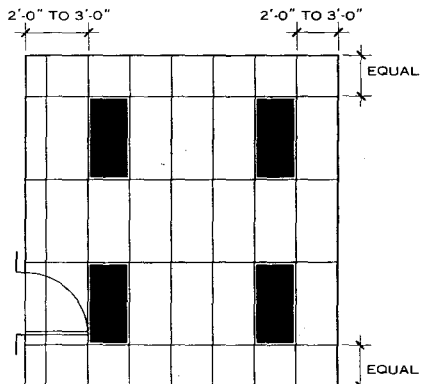

**REFLECTED CEILING PLAN**

**NOTE**

In this 14 x 16 ft room, four two-lamp fixtures produce 25-35 fc uniformly at 1.08 watts/sq ft. If higher lighting levels are needed, as in a mailroom, use three-lamp fixtures. In meeting rooms, consider adding task lights such as downlights or wall-wash luminaires.

In larger offices and work rooms, arrange fixtures as symmetrically as possible. Vary the spacing if necessary, for example, from the standard 8 x 8 ft to 6 x 8 or 10 x 8 ft. Keep the long sides of fixtures within 2-3 ft of the wall.

**LARGE OFFICE LIGHTING LAYOUT**

James Robert Benya, PE, FIES, IALD, Pacific Lightworks; Portland, Oregon  
Robert Sardinsky, Rising Sun Enterprises; Basalt, Colorado

**DESIGN CONSIDERATIONS**

**LENSED SYSTEMS** provide good basic light at the lowest cost, are the easiest to install, and tend to be the most efficient. Most are not suitable for computer work in large open rooms.

**PARABOLIC LOUVERED SYSTEMS** are more attractive and better for larger rooms where computer work is undertaken. Walls should not be too dark.

**INDIRECT LIGHTING SYSTEMS**, which provide a comfortable light, must be properly spaced to avoid light stripes on the ceiling. They require ceilings taller than 8 ft and generally require the use of task and/or accent lighting.

**DIRECT/INDIRECT LIGHTING SYSTEMS** must be properly spaced as well, but they offer a good balance between comfort and efficiency. They require ceilings taller than 8 ft and tend to be more complex and costly than other lighting systems.

Choose luminaires carefully, taking manufacturer's recommendations into account.

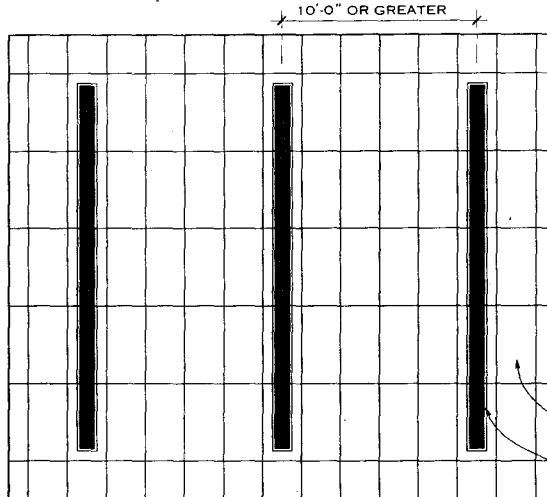

**REFLECTED CEILING PLAN**

**NOTE**

Using two lamps in every fixture, this layout produces 30-50 fc in an empty room at 1.22 watts/sq ft. Using one lamp, the design produces 15-30 fc at 0.6 watts/sq ft. The spacing between rows can be made wider. At 12 ft, the design delivers around 20-40 fc. Suspension length is critical.

**SUSPENDED INDIRECT AND DIRECT/INDIRECT SYSTEMS**

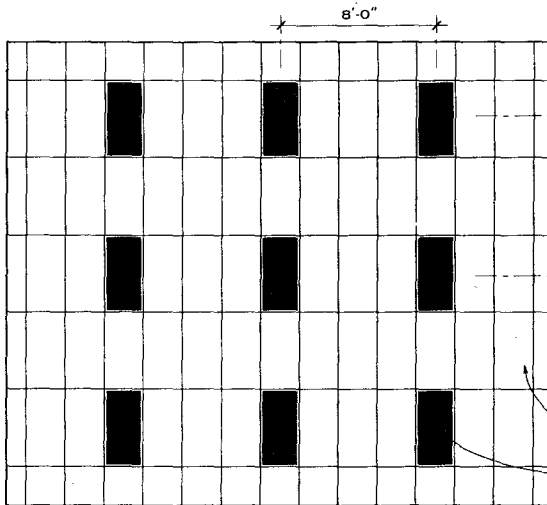

**REFLECTED CEILING PLAN**

**NOTE**

This layout produces 30-50 fc in an empty room using two F32T8 lamps in a lensed or parabolic luminaire at 0.92 watts/sq ft. With three lamps, it produces 50-75 fc at 1.38

**GENERAL DIRECT LIGHTING SYSTEMS**

**LIGHTING CRITERIA FOR OFFICES**

OFFICE TYPE	CCT <sup>1</sup>	CRI <sup>2</sup>
Most office space	3500 or 4100K	>70 CRI
Executive office	3000 or 3500K	>70 CRI
Medical/dental office	3500 or 4100K	>80 CRI
Art/graphics, dental operator	5000K	>90 CRI

**LIGHTING POWER DENSITY**

General office space	0.8-1.2 watts/sq ft
Executive office	1.1-1.4 watts/sq ft
Medical/dental office	1.0-1.8 watts/sq ft
Drafting/accounting space	1.4-2.0 watts/sq ft
Meeting rooms	1.0-1.6 watts/sq ft
Lobbies and hallways	0.4-0.8 watts/sq ft

<sup>1</sup>CCT—correlated color temperature

<sup>2</sup>CRI—color rendering index

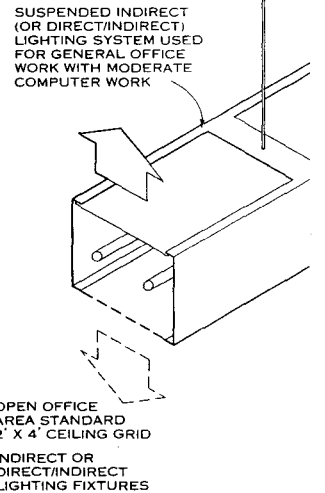

OPEN OFFICE AREA STANDARD 2' X 4' CEILING GRID  
INDIRECT OR DIRECT/INDIRECT LIGHTING FIXTURES

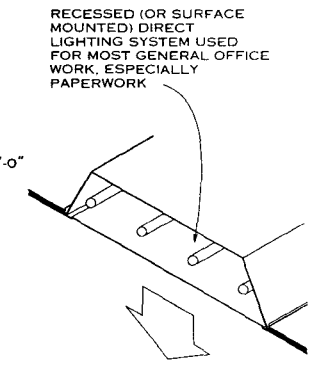

OPEN OFFICE AREA STANDARD 2' X 4' CEILING GRID  
DIRECT LIGHTING FIXTURE, TYP.

watts/sq ft. Increasing horizontal spacing to 10 ft with three lamps produces 40-60 fc at 1.22 watts/sq ft. Also consider 2 x 2 fixtures with two F32T8/U or four F17T8.

**CORRIDOR LIGHTING**

In office buildings, corridors require reasonably uniform illumination with minimum glare. Using ordinary troffers is tempting but generally creates too much light beneath the fixtures and not enough evenly distributed light.

Downlighting is easy but tends to create deep shadows and cave-like spaces. Mixing downlights and other lighting sources, such as sconces or wallwashers, creates a more attractive design with a better balance of brightness among walls, ceiling, and floor.

Wall lighting is an alternative to downlights and sconces for use in corridors. It enhances art and graphics and can reveal wall textures, such as those of stone and brick. Grazing lights can highlight polished or shiny surfaces such as granite or wood.

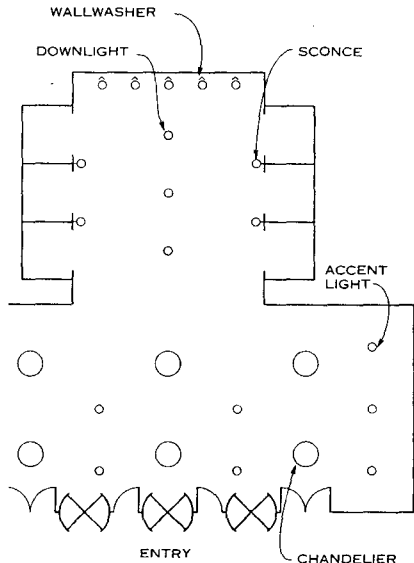

**PLAN**

**NOTE**

Fluorescent pendants and sconces produce general light. Compact fluorescent downlights and wallwashers and halogen art accent fixtures provide more specialized lighting that showcases the architecture and artwork and creates an atmosphere.

**MAIN AND ELEVATOR LOBBIES**

**LOBBY LIGHTING**

Lobbies offer a primary opportunity for use of creative or decorative lighting. Pendants, ceiling fixtures, and sconces are the primary lighting systems, supplemented by downlights, wallwashers, and other architectural light sources. To most easily meet energy code requirements, use fluorescent, compact fluorescent, and/or low wattage HID (high-intensity discharge) lamps instead of incandescent.

Main lobbies are a most important venue for ornamental and decorative lighting design. Wall lighting is especially useful for providing a sense of spaciousness and cheerfulness. Art objects such as paintings or sculpture may require accent lighting.

Architectural and decorative lighting sources are generally used in combination in lobbies. Incandescent and halogen lamps are often preferred for specific luminaire types, such as art display lights. However, whenever possible, use of more efficacious lighting sources such as fluorescent or HID fixtures is recommended.

**LIGHTING FOR CONFERENCE AND MEETING ROOMS**

A combination of lighting systems works best in meeting rooms. Uplights from sconces or pendants produce general, ambient light. Downlights illuminate the table. Wallwashers light presentation or art walls. Although the potential combined lighting power is high, preset control systems minimize simultaneous use.

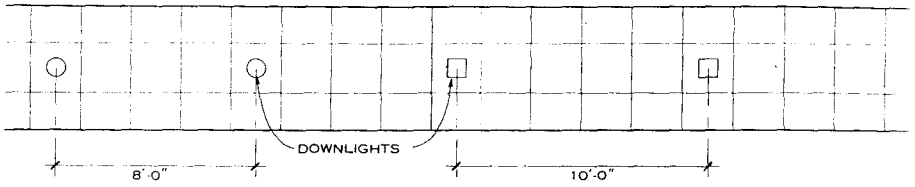

**NOTE**

In this scheme, each round downlight uses 26 watts of compact fluorescent light (either two 13-watt lamps or one 28-watt lamp). Square downlights use two 16-18-watt

lamps. Designs produce 10-20 footcandles (fc) at 0.6-0.7 watts/sq ft.

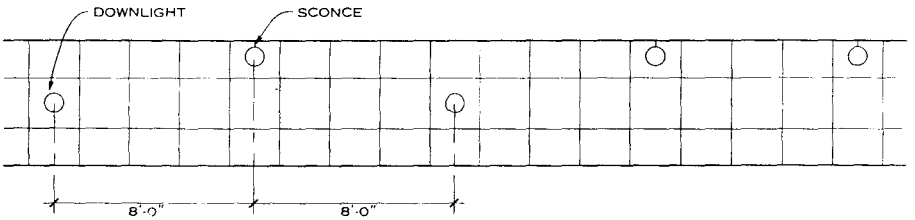

**NOTE**

In this arrangement, sconce quantity can be minimized by maintaining a nominal 8-ft either-or spacing. Sconces and

downlights each have two 13-watt lamps or one 26-watt lamp. Designs produce 10-15 fc at 0.6-0.7 watts/sq ft.

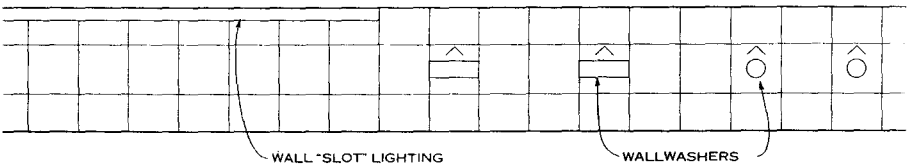

**NOTE**

Although asymmetric, lighting one wall of a hall or corridor can both provide effective light and be an attractive element, potentially highlighting art or graphics. A wall slot (shown at left) is best for textured or polished surfaces and

creates a floating ceiling; wallwashers (right) are better for lighting art or graphics. While footcandles are about the same as in the two schemes above, power use increases to 1.2-1.5 watts/sq ft to illuminate vertical surfaces.

**REFLECTED CEILING PLANS FOR CORRIDOR LIGHTING**

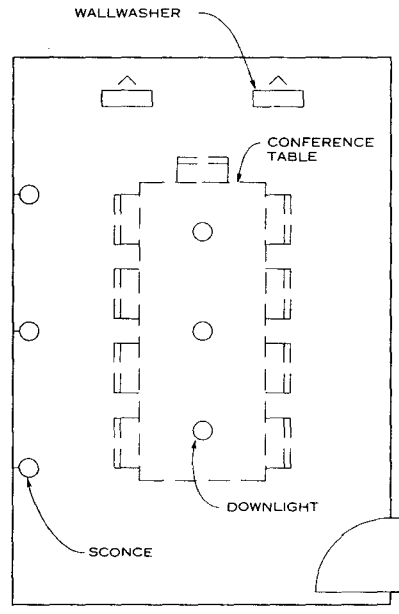

**AVERAGE CONFERENCE ROOM LIGHTING PLAN**

**NOTES**

1. The lighting load total in this plan of 2.75 watts/sq ft (5.25 watts/sq ft for halogen lamps) is not often reached because, in most cases, not all fixtures are used simultaneously.
2. Wallwashers produce vertical illumination at 30 footcandles (fc) on one short wall, using about 5 watts/sq ft with fluorescent lamps and 1.5 watts/sq ft with halogen lamps.
3. Downlights produce direct light at 10-15 fc that is concentrated downward, usually onto the table surface in a conference room. Compact fluorescent fixtures require 0.5 watts/sq ft, while halogen fixtures require about 1.25 watts/sq ft. The ability to dim lights is a requirement for most conference rooms.
4. Sconces produce indirect light at approximately 10-15 footcandles. Compact fluorescent lamps require 1 watt/sq ft to light a room, while halogen lamps require 2.5 watts/sq ft.
5. Incandescent and halogen light sources are often used in board and other meeting rooms. When a building houses a number of conference rooms, it is best to use fluorescent sources to avoid overspending in the overall building energy budget.

James Robert Benya, PE, FIES, IALD, Pacific Lightworks; Portland, Oregon  
Robert Sardinsky, Rising Sun Enterprises, Basalt, Colorado

**SPECIAL LIGHTING ISSUES FOR OFFICES**

Lighting for computer use, task lighting, and wall lighting are among the specialized lighting issues in office design.

**COMPUTER LIGHTING**

Lighting for computer workspaces is becoming increasingly specialized. There are four distinct approaches to this sort of design:

1. Parabolic troffers optimized for computer spaces: By meeting specific cutoff and distribution specifications, some parabolic and small-cell louvered direct lighting fixtures provide lighting acceptable for concentrated computer workspace applications. These lighting systems are generally fairly efficient but tend to create spaces with dark upper walls and ceilings.
2. Indirect suspended lighting: Indirect lighting systems that illuminate ceilings uniformly are also considered good for computer workspaces. General indirect lighting tends to be comfortable but bland. Supplemental task lighting is usually necessary.
3. Direct/indirect lighting: Some direct/indirect lighting systems have been optimized for illuminating computer workspaces, providing the advantages of the two lighting systems just described. The greatest disadvantage of these direct/indirect systems is cost.
4. Intensive CADD workspaces: CADD workspaces are the most demanding of all computer workspaces. Neither parabolic nor indirect lighting, even if optimized for computer workspaces, is acceptable. Task-only lighting systems or very low levels of general light are needed. The unusual requirements of these spaces are often resolved by creating a cave-like space and letting employees manipulate lighting levels and types with switches and dimmers.

**TASK LIGHTING**

For use under cabinets or shelves, continuous fluorescent task lights are generally the best choice. Good task lights offer the ability to dim or alter the distribution of light to minimize veiling reflections.

Table lamps and task lights produce localized task illumination using a portable luminaire. The area of influence is small but proper location can achieve a successful result. Use compact fluorescent lamps whenever possible.

**WALL LIGHTING**

Office spaces generally require supplemental wall lighting to compensate for the lack of wall lighting provided by most general lighting systems. Wall grazing and wallwashing are two methods used to accomplish this lighting task.

**FINAL TOUCHES**

Many offices are furnished with partition-style systems furniture. In this case, best results are obtained by coordinating lighting and furniture plans. Try to use fluorescent lamps of consistent color.

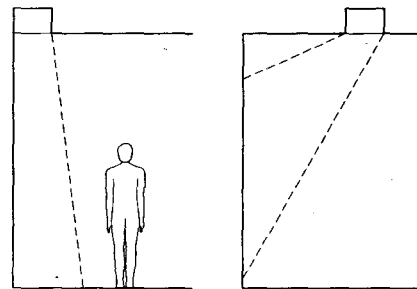

**WALL SLOT LIGHTING**

**WALLWASHER LIGHTING**

**NOTE**

A grazing light such as a wall slot is appropriate for illuminating interior core walls in open office spaces, but wallwashers or sconces can be used as well. Wall slot lighting accentuates the wall texture and enhances polished surfaces. Wallwashers accentuate wall pigment and work best for ordinary wall finishes with artwork hanging on them.

**WALL LIGHTING**

**ILLUMINATION CRITERIA FOR COMMERCIAL SPACES**

The lighting levels given are average figures for these commercial spaces:

1. Grocery store, general light: 70-90 footcandles (fc), or 700-900 lux, in an empty room, which will result in average center-of-aisle illumination of 50 fc.
2. Wholesale merchandise: 30-50 fc (300-500 lux) in an empty room with display lighting added as needed. For spaces with warehouse-style shelving, use 30-50 fc in aisles but take shelving into account.
3. General merchandise: 40-60 fc (400-600 lux) in an empty room with display lighting added at key locations to provide 70-100 fc (700-1000 lux) for secondary merchandise displays and 150-300 fc (1500-3000 lux) for primary displays.
4. Boutique and specialty retail stores: 20-30 fc (200-300 lux) in an empty room for general lighting. Display lighting is added throughout to provide 70-100 fc for most merchandise and 150-300 fc (1500-3000 lux) for primary displays.
5. Back-of-house storage and stock areas: 10-20 fc (100-200 lux) in an empty room.

**OTHER RECOMMENDED CRITERIA**

The correlated color temperature (CCT) and color rendering index (CRI) measurements for light can be used to help specify lighting fixtures:

Wholesale and grocery	3500 or 4100K > 70 CRI
Boutique/specialty	3000 or 3500K > 80 CRI
General merchandise	3500 or 4100K > 70 CRI
Jewelry, art	3000 or 5000K > 90 CRI

Lighting power density: Listed below are approximate design targets for whole stores, including back of house. These targets are based on HID (high-intensity discharge) systems of T8/compact fluorescent lamps and electronic high-frequency ballasts, including display lights.

Grocery	1.4-2.0 watts/sq ft
Wholesale	1.0-1.4 watts/sq ft
General merchandise	1.2-1.8 watts/sq ft
Department store	2.0-3.0 watts/sq ft
Specialty retail	1.8-3.5 watts/sq ft
Jewelry, china	2.5-4.5 watts/sq ft

**DESIGN OPTIONS FOR GENERAL COMMERCIAL LIGHTING**

FLUORESCENT STRIP LIGHTS AND LENS TROFFERS provide basic light for the lowest cost and are the easiest to install. They tend to be the most efficient, as well, but appear budget-minded.

HID INDUSTRIAL-STYLE FIXTURES also provide good basic light at low cost but appear budget-conscious. They can be used to create a warehouse motif in a retail outlet.

PARABOLIC LOUVERED SYSTEMS appear more expensive and suggest higher quality merchandise. They should be used in conjunction with valances and/or other perimeter and display lighting.

SUSPENDED DIRECT, DIRECT/INDIRECT, AND INDIRECT SYSTEMS require ceilings taller than 8 ft. These lighting types play a major role in the appearance and style of a space and are generally chosen to reinforce a specific marketing motif.

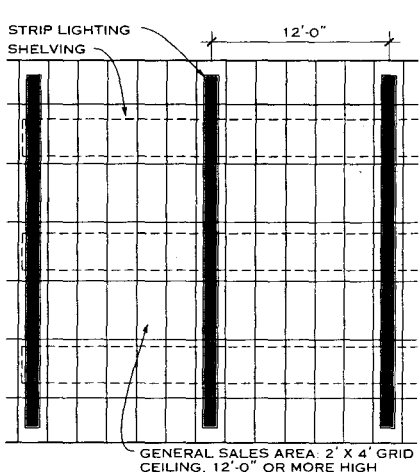

**STRIP LIGHTS/STRIP TROUGH LIGHTS**

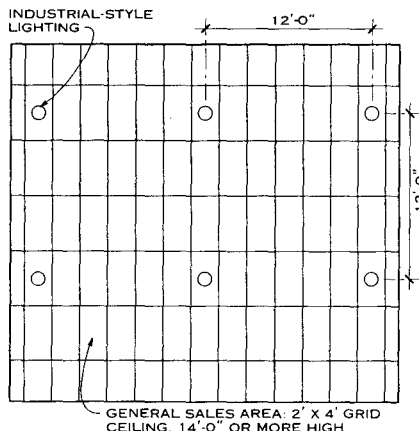

**INDUSTRIAL-STYLE LIGHTING**

**REFLECTED CEILING PLANS FOR WHOLESALE, GROCERY, AND MERCHANDISE STORES**

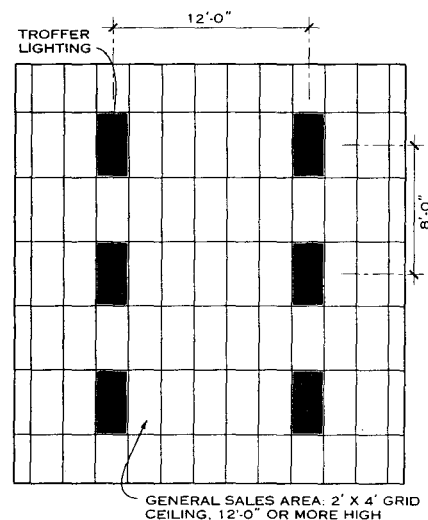

**TROFFER LIGHTING**

**NOTES**

1. Strip lights and strip trough lights are common in large retail grocery stores and many mass merchandise stores. The layout illustrated (above left) produces 60-80 fc in an empty room using two F96T8 lamps in a strip light or open trough in continuous rows at 1.15 watts/sq ft. Lights usually run perpendicular to shelving to allow rearrangement, but parallel lighting is preferable when shelves are fixed.
2. Industrial-style lights are commonly used for lighting warehouse-style discount stores. The layout shown at left produces 30-40 fc in an empty room using one 100-watt metal halide lamp in an industrial-style luminaire at 0.85 watts/sq ft. Using a 150-watt metal halide lamp, the lighting level is about 40-60 fc at 1.27 watts/sq ft.
3. Troffers in lay-in ceilings are common in the discount retail industry and serve as general purpose lighting for hardware and general merchandise. The layout above produces 60-70 fc in an empty room using four F32T8 lamps in a lensed or parabolic luminaire at 1.15 watts/sq ft. With high light level ballasts, this arrangement produces 80-100 fc at 1.58 watts/sq ft.

James Robert Benya, PE, FIES, IALD, Pacific Lightworks; Portland, Oregon  
Robert Sardinsky, Rising Sun Enterprises; Basalt, Colorado

**DESIGN OPTIONS FOR DISPLAY LIGHTING**

**TRACK LIGHTING** is the most popular and commonly used display lighting system. Use halogen, fluorescent, or high-intensity discharge (HID) display luminaires.

**RECESSED DISPLAY LIGHTS** are not as flexible as track lights but can be concealed better. This category includes adjustable accent lights and wallwashers. Sources include halogen, low-wattage HID, and compact fluorescent.

**DISPLAY MONOPOINT LIGHTS** are adjustable lights installed at fixed locations.

**VALANCE LIGHTING** is used for clothing and other displays in which a niche is created. Full-sized fluorescent lamps work best for the application.

**DISPLAY CASE LIGHTING** is similar to valance lighting except the light is built into the display cases to illuminate the task. Fluorescent, compact fluorescent, or low voltage incandescent or tungsten halogen lamps are used. Fiber-optic lighting systems may be useful in certain situations.

Among these options, track lighting offers the greatest versatility and the lowest installed cost. However, most energy codes count track light wattage by the foot rather than by the fixture. This makes it advisable to use other display lighting methods whenever possible so track lights can be used where really needed.

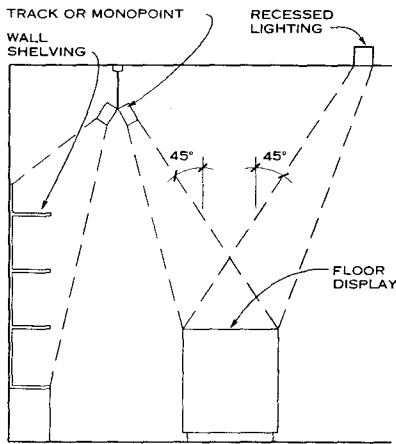

**NOTE**

The maximum angle of elevation for lighting is 45° except when walls are being lighted.

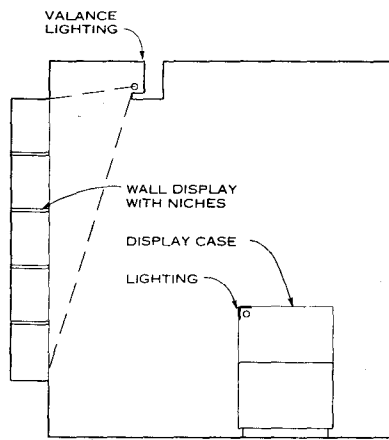

**NOTE**

Use wallwashers or accent lighting for walls and shelves, track lights or monopoints for floor displays, and valances in wall niches. Display case lighting is suitable for many applications, from jewelry cases to meat and produce counters.

**TYPICAL DISPLAY LIGHTING**

James Robert Benya, PE, FIES, IALD, Pacific Lightworks; Portland, Oregon  
Robert Sardinsky, Rising Sun Enterprises; Basalt, Colorado

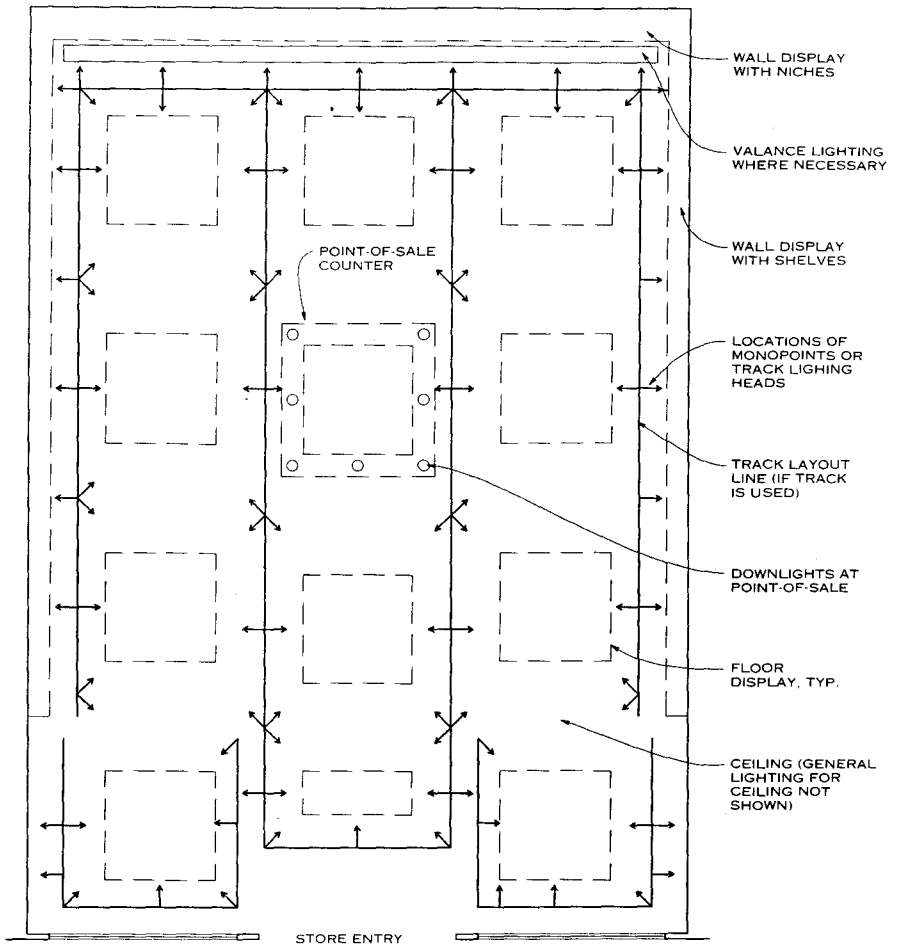

**REFLECTED CEILING PLAN LAYOUT OF DISPLAY LIGHTING**

**DRESSING ROOMS**

Good lighting helps sell clothing. For higher quality stores, provide attractive light with diffuse illumination of the customer; avoid downlights and track lighting. In lower cost and trendy stores, place the emphasis on fixture style and survivability.

**STORE WINDOWS**

Use high-wattage track lighting and/or low-voltage accent lighting. Run track vertically along the window sides, across

the top of the window, and possibly along the bottom of the window as well. Provide outlets for portable lighting inside the window.

**OTHER SPECIFIC APPLICATIONS**

Use high color rendering or special purpose fluorescent lamps for meat cases, fabrics, and similar demanding merchandise. For fine jewelry, consider high color rendering index, high color temperature fluorescent lamps and/or blue-filtered halogen lamps to achieve 4100-5000K.

**DISPLAY LIGHTING FOR STORES**

LIGHT SOURCE	ADVANTAGES	DISADVANTAGES	APPLICATIONS
Tungsten halogen (for greatest energy efficiency use halogen infrared reflecting [HIR] lamps)	Low cost, ready availability, excellent color, excellent beam control, dimmability, availability in wide range of sizes/wattages	Not energy-efficient, short lamp life	Recessed accent lights, track and monopoints, wallwashers of all types, portable lighting, low voltage lighting, showcase lighting, downlights
Full-size fluorescent lamps (primarily T8)	Low cost, ready availability, very good color, dimmability, energy efficiency, long lamp life	Very poor beam control, care required when used in cold environments	Valance lights, showcase lights, some types of wallwashers
Compact fluorescent (including high power T-5 twin tube)	Low cost, ready availability, very good color, dimmability, energy efficiency, long lamp life	Poor beam control, care required when used in cold environments	Wallwashers of all types, some types of floodlights, downlights
Compact hid (low-wattage metal halide and white high-pressure sodium are main choices)	Energy efficiency, very good beam control, long lamp life, good to very good color	High cost, not dimmable, limited range of sizes and wattages	Recessed accent lights, track and monopoints, wallwashers of all types, portable lighting, downlights

**ILLUMINATION CRITERIA**

The lighting levels given are average figures:

1. Classrooms with traditional paper tasks: 40-60 footcandles (400-600 lux) in an empty room.
2. Classrooms with mostly computer work: an average of 20-40 footcandles (200-400 lux) in an empty room with task lighting as needed.
3. Art, music, industrial, mechanics, and laboratory classrooms: 50-70 footcandles (500-700 lux) in an empty room, with task lighting as needed.
4. Lecture halls: 20-40 footcandles (fc) task illumination dimmable to 5 fc with cutoff for video/film presentation.
5. Hallways, commons (not including work spaces): 10-20 footcandles (100-200 lux) in an empty room.
6. Libraries: in active stacks, 20 footcandles minimum vertical illumination; for reading rooms, card files, and catalogs, 50-70 fc in an empty room; computer files and computer study/carrell areas, 20-40 fc in an empty room.
7. Gymnasiums: general illumination of 50 footcandles (500 lux) throughout; significantly higher levels may be required for high school or college sports that will be televised.
8. Typical administrative offices: 40-60 footcandles (400-600 lux) in an empty room.

**OTHER RECOMMENDED CRITERIA**

Visual comfort probability (VCP) is useful only for comparing direct (troffer) lighting systems. A minimum of 70 is recommended. (Note that a high VCP does not guarantee visual comfort.)

The correlated color temperature (CCT) and color rendering index (CRI) measurements for light can be used to help specify lighting fixtures:

Most classrooms	3500 or 4100K > 70 CRI
Commons, lunchrooms	3000 or 3500K > 70 CRI
Medical/dental classes	3500 or 4100K > 80 CRI
Art/graphics classes	4100-5000K > 80 CRI

Lighting power density: Listed are approximate design targets using T8 lamps and electronic high-frequency ballasts or high-intensity discharge (HID) systems (not including task lights):

Classrooms	0.8-1.2 W/sq ft
Lecture halls	1.2-2.0 W/sq ft
Arts and industrial education	1.2-1.8 W/sq ft
Gymnasiums (primary-secondary)	1.2-1.6 W/sq ft
Commons and hallways	0.4-0.8 W/sq ft

TROFFER SYSTEMS, lensed or parabolic, provide good, acceptable light at low cost and are commonly used in schools. Recessed lighting minimizes vandalism and is efficient.

SUSPENDED DIRECT/INDIRECT and INDIRECT SYSTEMS are favored for better lighting comfort and are suited for spaces with ceilings higher than 9 ft.

INDUSTRIAL-STYLE LIGHTING SYSTEMS are often used in industrial education, arts, gymnasium, and other spaces requiring plentiful, inexpensive, durable lighting. If using HID sources, provide quartz auxiliary lamps on some fixtures or an independent instant-on lighting system.

Choose luminaires carefully, considering manufacturer's recommendations.

**DESIGN OPTIONS**

More information about these lighting systems is available in the section on lighting for offices.

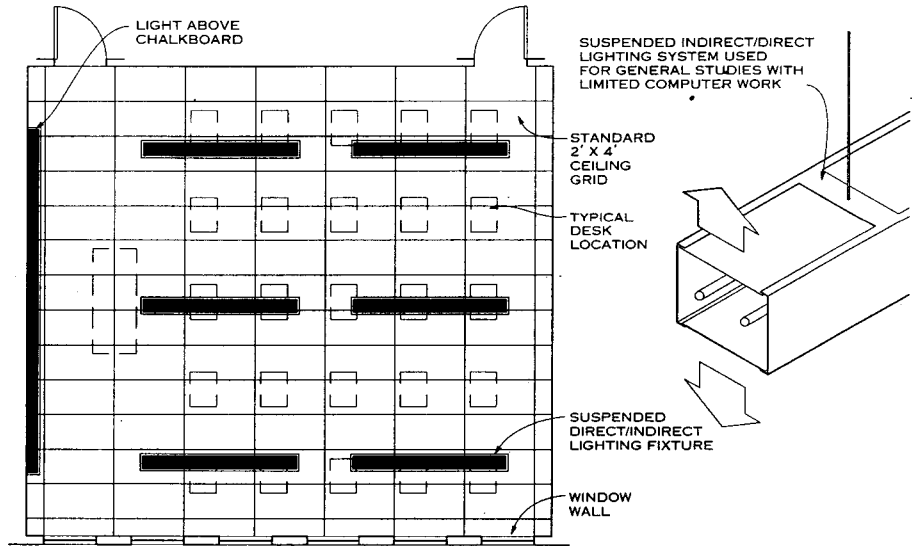

**REFLECTED CEILING PLAN**

**NOTE**

A layout with four F32T8 lamps and an electronic ballast in each suspended classroom fixture produces 40-50 fc in the seating area and 20-30 vertical fc on the chalkboard at 0.97

watts/sq ft. The direct/indirect fixtures are designed for traditional classrooms. An indirect lighting system might be used in a computer classroom.

**SUSPENDED DIRECT/INDIRECT LIGHTING SYSTEMS**

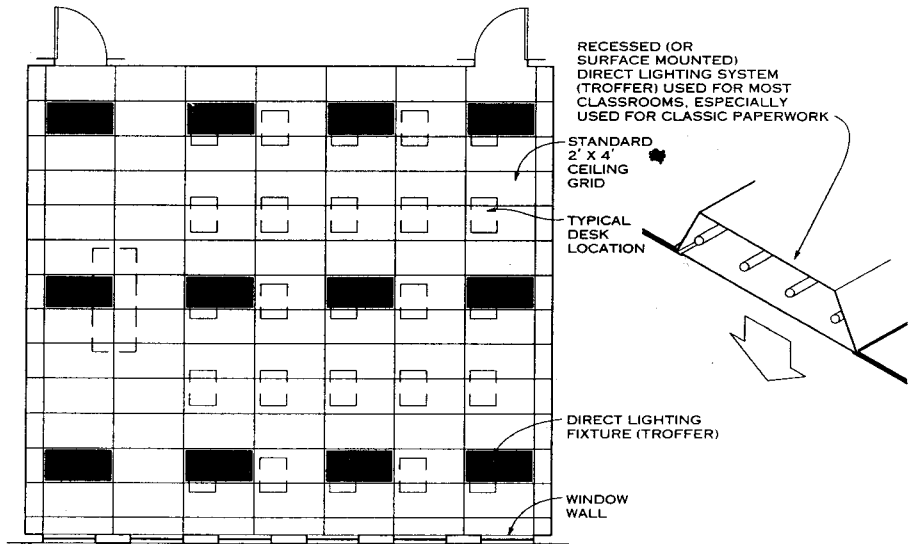

**REFLECTED CEILING PLAN**

**NOTE**

This layout, suitable for traditional classrooms, produces 50-60 fc in an empty room using three F32T8 lamps in a lensed or parabolic luminaire at 1.29 watts/sq ft. With a low

light level ballast, it can also produce 40-50 fc at 1.09 watts/sq ft.

For computer classrooms, use computer-optimized parabolics and dimming.

**CLASSROOM WITH TROFFERS**

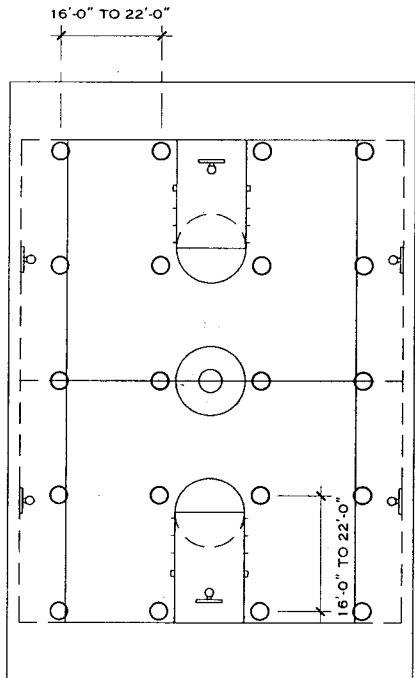

**REFLECTED CEILING PLAN**

**NOTE**

In a 10,000 sq ft gymnasium, average lighting would be 40-50 footcandles at 0.95 watts/sq ft provided by 400-watt metal halide fixtures.

**GYMNASIUM LIGHTING**

James Robert Benya, PE, FIES, IALD, Pacific Lightworks; Portland, Oregon  
Robert Sardinsky, Rising Sun Enterprises; Basalt, Colorado



**DESIGN OPTIONS**

INDUSTRIAL HID DOWNLIGHT SYSTEMS provide good acceptable light at low cost and thus are frequently used in industrial spaces. High-bay downlights are specifically suited for mounting heights greater than 20 ft. Low-bay downlights generally have lower wattage and are best for mounting heights less than 20 ft. Aluminum reflectors and prismatic glass or acrylic reflectors direct most light downward, although some light is directed upward in certain luminaires. Special aisle-lighters and other types are available.

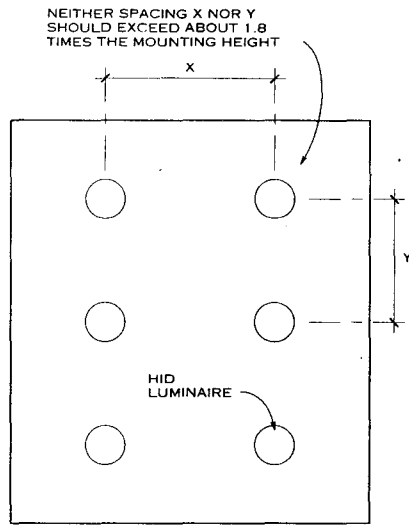

REFLECTED CEILING PLAN

**NOTE**

A low-bay layout using HID lighting requires the fewest luminaires. HPS offers the longest lamp life and lowest maintenance costs. Metal halide lighting is preferred for visibility and color rendering.

**HID LOW-BAY LAYOUT**

ROWS SHOULD BE SPACED (X) UP TO ABOUT 1.5 TIMES THE MOUNTING HEIGHT WITH GAPS UP TO ABOUT 1.0 TIMES MOUNTING HEIGHT

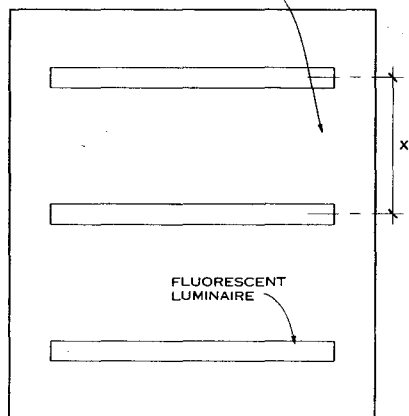

REFLECTED CEILING PLAN

**NOTE**

Fluorescent luminaires offer superior color and flicker-free operation with electronic ballasts. No warmup time, instant striking, and long lamp life are other advantages of this lighting type.

**FLUORESCENT LOW-BAY LAYOUT**

FLUORESCENT SYSTEMS are useful for mounting heights up to about 20 ft. They require more fixtures than HID systems but provide more uniform light with softer shadows; use electronic ballasts to eliminate stroboscopy. Fluorescent systems make good task lights for work stations.

SPECIAL APPLICATION LUMINAIRES come in hundreds of different types, each optimized for a specific job, work station, environment, or hazard. Examples include explosion-proof, vapor-tight, and paint booth luminaires.

Choose luminaires for specific applications carefully, taking into account manufacturer recommendations.

**ILLUMINATION CRITERIA**

The lighting levels given are average figures:

1. Industrial manufacturing—general: 30-50 footcandles (300-500 lux) in an empty room with task lighting as needed.
2. Industrial manufacturing—assembly and rough inspection: 50-70 footcandles (500-700 lux) in an empty room.
3. Industrial manufacturing—fine assembly and moderate inspection: 50-70 footcandles (500-700 lux) in an empty room with task lighting as needed to achieve 100-200 footcandles (fc) depending on type of work.
4. Industrial manufacturing—specialized: refer to the IESNA Lighting Handbook.
5. Lunchrooms and break areas: 20-30 fc (200-300 lux) in an empty room.
6. Hallways and circulation areas (excluding work spaces): 10-20 footcandles (100-200 lux) in an empty room.
7. Warehouses: with high stacks, 20 footcandles minimum vertical illumination on stacks; for general use, 20-40 fc in an empty room.
8. Storage areas: general illumination of 5-10 footcandles (50 to 100 lux).

**OTHER RECOMMENDED CRITERIA**

ATMOSPHERE/ENVIRONMENT: The amount and type of dirt and other airborne particles present in an application can affect luminaire selection. For spaces where hazardous, corrosive, or explosive vapors or dust are present, special lighting equipment is generally required.

SAFETY: Backup quartz auxiliary lamps are needed for high intensity discharge (HID) systems. Where rotating machinery is used, take precautions to prevent stroboscopic problems by using fluorescent lighting systems or rotating phases of power.

CCT and CRI: Correlated color temperatures (CCT) and the color rendering index (CRI) suitable for industrial uses are listed here:

Heavy industry, storage	2100 to 5000K >20 CRI
Most industrial	3000 to 5000K >50 CRI
Most warehouse	2100 to 5000K >20 CRI
Precise assembly	4100 to 5000K >70 CRI

LIGHTING POWER DENSITY: Listed are approximate design targets using HID systems or T8 lamps and electronic high-frequency ballasts (not including task lights):

Warehouse	0.2-0.5 W/sq ft
Light industrial	0.8-1.2 W/sq ft
Precision industrial and inspection areas	1.2-1.8 W/sq ft
Storage areas	0.1-0.3 W/sq ft
Lunchrooms and hallways	0.6-1.0 W/sq ft

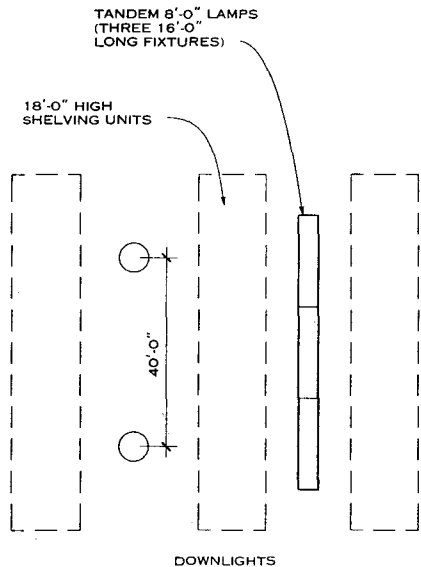

REFLECTED CEILING PLAN

**NOTE**

In the left aisle shown, two 250-watt HPS aisle lighter downlights illuminate the shelving units at 0.6 W/sq ft. In the right aisle, the task is performed by fluorescent F96T8/HO lamps at 0.5 W/sq ft. The fixture mounting height is about 18 ft above finished floor.

**ACTIVE AISLE LIGHTING FOR WAREHOUSES**

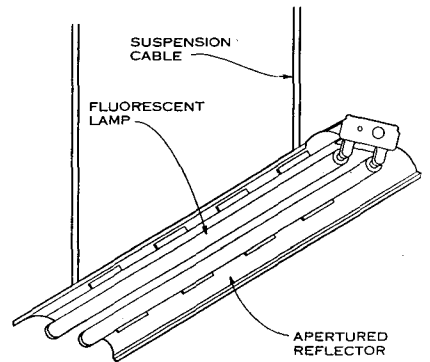

**FLUORESCENT DOWNLIGHTING**

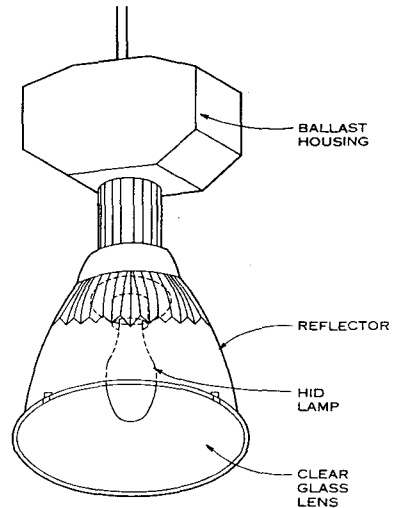

HID DOWNLIGHTING

James Robert Benya, PE, FIES, IALD, Pacific Lightworks; Portland, Oregon  
Robert Sardinsky, Rising Sun Enterprises; Basalt, Colorado

**GENERAL**

Outdoor lighting systems include a wide variety of lighting types used to illuminate buildings, parking areas, roads, landscapes, signs, and other outdoor areas.

**STREET AND ROADWAY LIGHTING**

Four significantly different lighting systems are used to illuminate roads and streets (and often large parking lots). All employ high-intensity discharge (HID) lamps:

1. Standard roadway lights, called cobraheads, are usually mounted to a mast arm and suspended over the roadway at mounting heights of 25-40 ft.
2. Sharp cutoff roadway lights, called shoeboxes, are specifically designed to minimize light pollution and trespass. They are typically mounted between 20 and 40 ft.
3. Traditionally shaped post lights often have a particular theme or design. They are usually less than 25 ft high.
4. High mast lights consist of multiple high-wattage lamps atop poles 60-120 ft high.

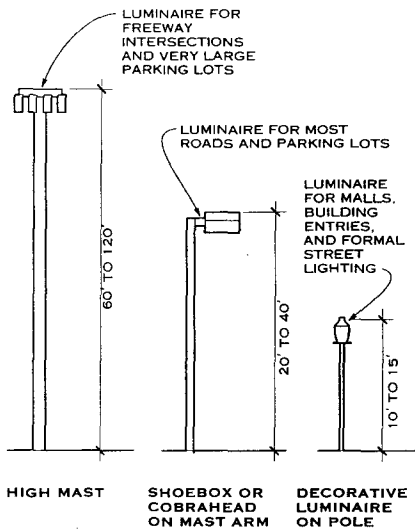

**STREET AND ROADWAY LIGHTING**

LAYOUT OF STREET AND PARKING LOT LIGHTING. Most luminaires for street and parking lighting are categorized according to the lighting patterns they create on the ground. Types I-V are described in the accompanying chart.

Computer point-by-point calculations are recommended. However, it is possible to lay out roadway and parking lot lighting using isolux curves (similar to those illustrated), making sure the overlapping footcandle lines achieve at least 25% of the intended average footcandle level.

**AREA FLOODLIGHTING**

Floodlighting is used to illuminate exterior fields, lots, yards, docks, and other similar areas. Special care is often needed to minimize light trespass and light pollution.

Floodlights are described by their light distribution. The National Electrical Manufacturers Association (NEMA) developed a system in which floodlight beams are measured in degrees of vertical and horizontal distribution, then rated from 1 (very narrow field angle) to 7 (very wide field angle).

GENERAL PURPOSE FLOODLIGHTS are usually made in rectangular boxes and typically have wide distributions (5V x 6H or 6V x 7H). Applications include work yards, general security and sports lighting, and building floodlighting. Lamps are usually HID from very low wattage (35 W) to 1,000 watts, but some floodlights use compact fluorescent and halogen lamps.

SPORTS LIGHTS are designed to throw narrow to medium wide beams (NEMA 2H x 2V to NEMA 4H x 4V). Most sports lights are round with standard 400-1500 watt HID lamps mounted in an axial position to create a round beam. Some advanced designs use special double-ended metal halide lamps (1500-2000 watts) for more precise optical control with less trespass.

James Robert Benya, PE, FIES, IALD, Pacific Lightworks; Portland, Oregon  
 Robert Sardinsky, Rising Sun Enterprises; Basalt, Colorado  
 Mark Rea, ed., IESNA Lighting Handbook (Illuminating Engineering Society of North America, 1993)

SHARP CUTOFF FLOODLIGHTS resemble shoebox parking lot luminaires with characteristics of Type IV distribution. These luminaires are designed to be elevated slightly in front to throw light farther. Sharp cutoff floods are especially good for car lots and sports lighting near residential districts where light trespass must be avoided.

**LIGHT TRESPASS AND POLLUTION**

LIGHT TRESPASS occurs when outdoor night lighting encroaches onto adjacent properties. Trespassing light is often annoying and can be quite offensive. Some cities have ordinances designed to prevent light trespass, although few of these are competently written.

LIGHT POLLUTION occurs when light is emitted upwards into the night sky. It both wastes energy and causes light pollution, a condition in which the upward light strikes dirt and airborne pollution and obscures the view of the night sky. Some municipalities and counties with important observatories have developed lighting ordinances that regulate light sources, cutoff, and hours of operation in an attempt to make astronomy more possible.

Both light trespass and light pollution can be minimized or prevented by using sharp cutoff equipment and careful design practices. For street and roadway lighting, this means using shoebox luminaires, including decorative luminaires that employ shoebox-style optics. For floodlighting, this means using sharp cutoff floodlights and special sports lights equipped with louvers and visors to prevent upward light. These high-performance lights require careful layout to meet design criteria.

**LUMINAIRE FOR STREET AND PARKING LIGHTING**

CATEGORY	USE
<p>Type I</p>	Roads and streets where the luminaire is mounted in the median or suspended over the road center. Spacing is 6-7 MH.*
<p>Type II</p>	Roads and streets where the luminaire is mounted above the road but to the side. Spacing is 5-6 MH.*
<p>Type III</p>	Roads and streets where the luminaire is to the side and not above the road; also used for parking lots. Spacing is 4-5 MH.*
<p>Type IV</p>	Parking lots and service areas requiring a forward throw distribution.
<p>Type V</p>	Parking lots. Spacing is 3-4 MH.*

\*MH—multiples of mounting height.

**OTHER COMMON TYPES OF EXTERIOR LIGHTING**

Exterior luminaires are designed specifically for many outdoor lighting applications. Some of the more common types are described in the accompanying chart.

Choose outdoor lighting with consideration for the elements and for the threat of vandalism or other damage. Some luminaires are composed of plastics or composite materials to resist damage and corrosion. Also keep in mind temperature extremes and the minimum starting temperatures of the lamp and ballast.

**LIGHTING INFORMATION SOURCES**

The best general purpose reference document for lighting information is the IESNA Lighting Handbook, published by the Illuminating Engineering Society of North America in New York. IESNA Recommended Practices provide in-depth information on specific applications, for example, office lighting, roadway lighting, and residential lighting.

Additional information on new and evolving lighting technologies is available from Advanced Lighting Guidelines, a publication of the U.S. Department of Energy from Battelle Pacific Northwest National Labs, and from Specifier Reports, published by the Lighting Research Center at Rensselaer Polytechnic Institute, Troy, New York.

Additional information on design and applications can be found in a number of textbooks on the subject of architectural lighting design, landscape lighting, and related topics. Popular lighting industry publications offering current projects and industry news include Lighting Design and Application, Architectural Lighting, Lighting Dimensions, and Architectural Record Lighting Supplement.

**COMMON EXTERIOR LIGHTING TYPES**

TYPE	USE
<p>Bollards</p>	Walkway and pathway lighting. A typical bollard is 42-48 in. high and uses a lamp ranging from about 35-watt to 100-watt HID (high-intensity discharge).
<p>Step lights</p>	Walkway and stairway lighting from adjacent retaining walls. The light is mounted at or below the rail height.
<p>Well lights, direct burial lights</p>	Illumination of trees and structures from below. These are concealed uplights.
<p>Landscape lights</p>	Includes a wide variety of low-level lights, such as path, planter bed, and wallwash lights and uplights in several styles. For residential landscapes, most lighting systems are low voltage (12V typically) for ease of wiring and safety.
<p>Parking garage lights</p>	Parking garages. These are a unique type of HID luminaire designed specifically for the low concrete ceilings of garages. They typically are 100- to 175-watt fixtures.
<p>Sign lights</p>	Illumination of signs. These are designed to be mounted below and in front of a sign and to illuminate upwards evenly.

**ILLUMINATION CRITERIA**

The lighting levels given here are average figures.

1. Parking lots with pedestrian cross-traffic: from 0.8 fc in places with low activity to 3.6 fc in places with a high level of activity; uniformity of 4:1.
2. Parking lots with minimum pedestrian cross-traffic: from 0.5 fc and uniformity of 4:1 in places of low activity to 2.0 fc with uniformity of 3:1 in places of high activity.
3. Sidewalks and bikeways: from 0.2 fc with 10:1 uniformity in residential areas to 1.0 fc with 4:1 uniformity in commercial areas.
4. Building entrances: from 1.0 fc near inactive entrances to 5.0 fc at active entrances.
5. Outdoor industrial areas: 0.2 fc for storage and dump areas; 2.0 to 5.0 fc for active loading, unloading, and rough work areas; 10 to 20 fc for work areas such as passenger loading, gas pumps, and railroad hump areas.
6. Outdoor sports: from 5 fc for recreational sport areas to 150 fc for major league baseball. Refer to the IESNA Lighting Handbook for more information.

**OTHER RECOMMENDED CRITERIA**

**COLOR OF LIGHT:** White light sources like metal halide, fluorescent, and compact fluorescent luminaires are recommended for sports, most applications involving pedestrians, and situations that require color discrimination. Light sources that provide poor color, such as high-pressure sodium fixtures, may be better suited for security lighting. Tungsten sources, including halogen fixtures, offer excellent color rendition but poor energy efficiency and short life.

**SURVIVABILITY:** Choose fixtures that are physically strong and resistant to vandals and the weather and environment.

**STARTING AND OPERATING TEMPERATURE:** Fixtures should be able to start and operate at the lowest expected temperature on a site. Minimum starting temperatures for common sources are shown in the accompanying table.

**LIGHT TRESPASS:** Minimize the light shining onto adjacent properties by using sharp cutoff lighting. Maximum mounting height for a fixture is a function of the cutoff angle.

**LIGHT POLLUTION:** Minimize light pollution by preventing stray upward light. Use cutoff luminaires.

**DESIGN CONSIDERATIONS FOR PARKING AREAS**

Poles between 12 ft and 40 ft high are most commonly used for parking areas because they provide good acceptable light at low cost. Pole spacing is generally about 4 times the mounting height; optimum pole heights are 15-20 ft for spacing along every aisle and 30-40 ft for spacing along every other aisle.

High mast poles higher than 40 ft (up to 100 ft) can be used to light large parking areas economically. Poles must be equipped with lowering devices for servicing luminaires.

Floodlights mounted onto buildings are often a low-cost alternative to mounting poles. To minimize light trespass, the farthest distance from the building to the edge of the lot or illuminated area is about 5 times the mounting height.

**DESIGN FOR WALKWAYS**

Walkways away from a building are usually illuminated by the parking lot lighting system. But near the building (or in areas like a park when there is no parking lot nearby) other lighting should be added. Consider these options:

1. Short "pedestrian" poles: similar to parking lot luminaires these poles are 8-15 ft high and use lower wattage lamps. Spacing is 4-6 times the mounting height.
  2. Low level "bollards": these are typically 42-48 in. high. Spacing is about 4 times the height of the bollards.
  3. Step lights recessed into retaining walls.
  4. Building-mounted wall brackets (wallpacks).
- Keep in mind the overhang of adjacent buildings. Canopies and soffits can serve as locations for recessed lighting to illuminate walks near the building foundation.

**MINIMUM STARTING TEMPERATURES**

COMMON LIGHT SOURCES	MINIMUM TEMPERATURE
Tungsten (incandescent, halogen)	No limit
MH, MV HID Lamps	-20°F
HPS lamps	-40°F
Fluorescent HO	-20°F
Fluorescent T12/T8	0°F*
Compact fluorescent amalgam (26-32-42 w)	-10°F*
Standard compact fluorescent	32°F

\*These temperatures are with specific low temperature ballast; with standard ballast, the temperature may be as high as 50°F.

**NOTE**

In a parking area, typical spacing of 17-ft fixtures is about 68 ft across by 60-70 ft across. Sides of buildings are good places to mount lights to illuminate side drives. Bollards are used near visitor parking to "dress up" the entry.

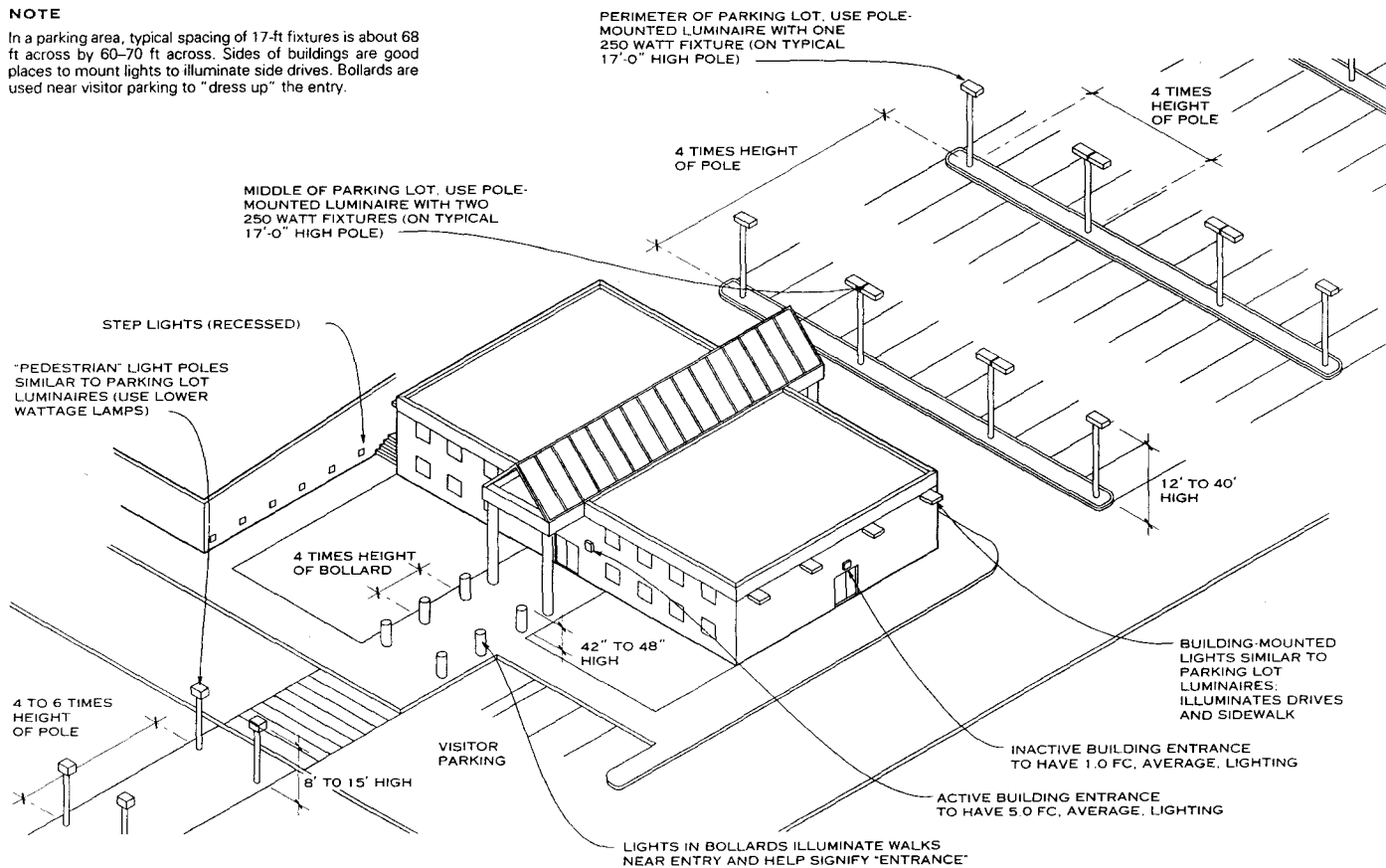

**DRIVES AND PARKING AREAS NEAR A BUILDING**

James Robert Benya, PE, FIES, IALD, Pacific Lightworks; Portland, Oregon  
 Robert Sardinsky, Rising Sun Enterprises; Basalt, Colorado

**GENERAL**

Ample daylight is available throughout most of North America for lighting interior spaces during a large portion of the working day. Daylight is often used for ambient lighting but may be used for critical visual tasks as well, in each case supplemented with electric light as needed. Daylight is thought by most to be psychologically desirable, and there is growing evidence that it is biologically beneficial and can contribute to enhanced task performance. The variability of the intensity and color of daylight over time stimulates the visual senses, and the view and visual connection with the outdoors that accompanies many daylighting designs is almost universally desired. Proper use of daylight can help reduce unnecessary energy use for electric lighting and cooling, if the electric lighting system is controlled with on-off switching or dimming.

**DESIGN STRATEGIES**

Daylight has always been an important element of architectural design, and in the era before cheap electric light it was often a major determinant of a building's form. In buildings today daylighting strategies are used in a variety of contexts, both as a strategy to define the quality of experience in an architectural space as well as in a more utilitarian role to reduce unneeded use of electric lighting.

Daylighting usually supplements or complements an electric lighting design, so it is essential that the two be fully integrated. For a given building program and climate, it may be feasible and desirable to create spaces in which the primary light source is daylight. In others, electric lighting will be the primary source, supplemented by daylight. The decision to make daylight the primary source will directly influence other design decisions such as the size of the floor plan, the arrangement of spaces within the floor plan, and the overall massing and configuration of the building. Designs intended to maximize daylight use will either provide perimeter access to each space or utilize low-rise designs that allow skylights to provide daylight. Atriums and light courts can provide some useful daylight in low-rise buildings of two to five stories. The best strategy for daylighting in high-rise buildings is to ensure that no spaces on the floor plan are more than 30 ft from a daylighting source.

**DESIGN PROCESS**

To be successful, daylighting requires the integration of all major building systems. Daylighting issues should be well defined in the programmatic or schematic phases of design and monitored through construction to occupancy. Early planning is essential, since it may be difficult and costly to add features later in design development. Many architects and lighting designers are skilled in resolving daylighting design issues and trade-offs. However, in designs that push the state of the art, present unusual conditions, or have quantitative performance expectations that must be met, it may be appropriate to use a daylighting consultant with expertise in many of the computer-based tools now available (see discussion below, Design and Analysis Tools).

Although critical design decisions related to plan and section will be determined early, many seemingly small decisions are made in the final stages of design and bid preparation that can influence the success of a daylighted space. These include issues such as interior finishes, furniture specifications, and installation details for controls. After construction is complete, most daylighting systems involving controls and operable systems should be calibrated and commissioned. The final step in the process is to ensure that facility managers and occupants understand the operation of the complete system.

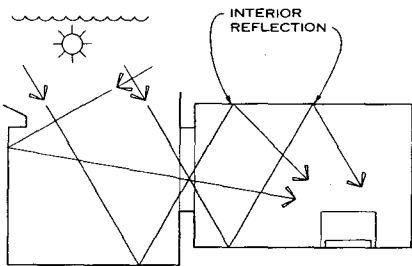

**LIGHT PATHS TO A WORK SPACE**

**SOURCE**

The origin of all daylight is the sun but the light may reach a work space via a number of paths. Direct sunlight is intense and varies substantially as the sun's position changes throughout the day (up to 10,000 footcandles (fc)). Daylight from a clear sky can be 10 to 25% of the intensity of direct sunlight (1000-2500 fc). Daylight under partly cloudy conditions can be highly variable; daylight under full overcast conditions can be 5 to 10% of sun conditions (500-1000 fc). Data on daylight availability for various cities and building orientations can be found in several references. Daylight availability at locations in the United States is influenced by latitude and weather patterns. Traditionally overcast climates such as Seattle may have sunshine only 40% of the year while regions like Palm Springs, California, have sunny conditions for 90% of the year.

Exterior conditions (ground, trees, water, adjacent buildings) can all influence interior daylight levels. In some cases the architect can control these conditions to enhance daylight levels. Nearby trees will filter daylight and adjacent buildings may obstruct the view of the sky and block direct sun. In built-up urban environments, windows on lower floors of buildings adjacent to multistory buildings will receive little useful daylight. The south facade of a light-colored building that is struck by direct sunlight can become a very bright light source for the north facing windows of an adjacent building.

Orientation has a major impact on available daylight and influences the degree of difficulty in controlling sunlight on a facade. North orientations in most North American locations receive direct sunlight only in the early morning or late evening in summer. South facades have the longest exposure to direct sun. Given the high altitude angle of the sun in summer, sun control on the south facade is readily addressed with properly sized overhangs. In winter low altitude sun must be controlled by shades, blinds, or other means. Low altitude direct sun on east and west orientations causes glare and cooling problems and is the most difficult to control. Exterior vertical fins or interior vertical blinds provide control but allow some view.

Not only does the intensity of daylight and sunlight vary but the color or appearance varies as well. The characteristic yellow-white of direct sunlight becomes redder as the sun moves lower in the sky and travels through more air mass. The north sky on a clear day can be deep blue, a result of scattering processes in the atmosphere. Cloudy and hazy skies typically have a uniform white appearance. Daylight is a full-spectrum source that, notwithstanding its variability, will faithfully render the color of most materials, something that not all electric lamps can do. The sun and sky are powerful sources of ultraviolet light that can damage pigments in paintings and furnishings. Design in light sensitive applications such as museums must pay particular attention not only to the UV characteristics of daylight but also to the visible light portions, which are responsible for some fading. Certain glazing options will reduce these negative effects of light to acceptable levels.

**ENVELOPE AND ROOM DESIGN**

Building envelope and room design details can be thought of as the light fixture that controls the distribution of daylight in a space. Envelope decisions include the size, shape, and location of the fenestration and the type of glazing and shading system. Room geometry, size, and surface properties also influence achievable daylight levels.

There are practical limits to room size beyond which conventional window systems are ineffective. The depth limitation of a daylighted zone with windows becomes a fundamental constraint and design determinant. For designs that use diffuse daylight from the sky, clouds, or surrounding environment, it is difficult to provide adequate daylight when the depth of the space is more than 1.5 or 2 times the height of the head of the window. (Designs that redirect daylight and sunlight to the ceiling using light shelves or light redirecting glazings might be able to extend this to 3 times the ceiling height.)

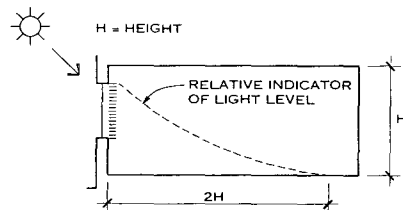

**DIFFUSE DAYLIGHT PENETRATION INTO A SPACE**

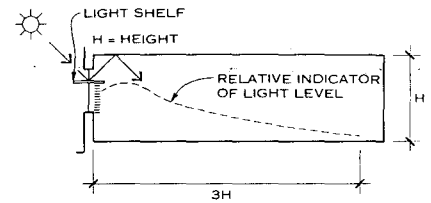

**REDIRECTED DAYLIGHT PENETRATION INTO A SPACE**

A window of a given size will provide the most daylight deep in a space when it is located as high as possible on the wall. Light-colored walls and ceilings maximize the daylight levels in the rear of a space. Deeper spaces need larger windows to provide more light but larger windows have other drawbacks. The uniformity ratio between the daylight level in the front and back of a room becomes larger as the room becomes deeper and should not exceed a ratio of 10:1. A splayed window reveal will reduce glare and ease the transition from bright exterior to darker interior. Sloped ceiling surfaces may improve daylight utilization but their biggest benefit is typically the greater ceiling height at the perimeter. Interior walls and partitions will reduce daylight levels. Use of light colors or glazed interior partition walls will help mitigate this undesired impact.

Distribution of daylight in a space can be greatly improved if it is introduced from multiple apertures—for example, windows on two sides of a space, or windows and clerestories, or windows and skylights. In low-rise buildings, diffusing skylights are an effective way to daylight a space. The skylights are diffusing and their spacing is optimized based on ceiling height. More elaborate toplighting systems can utilize a variety of roof monitors or clerestories.

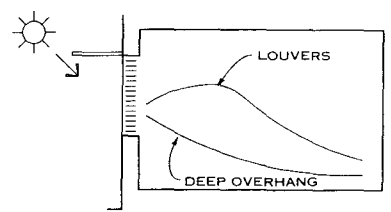
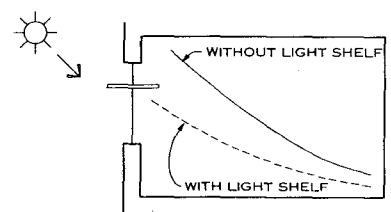
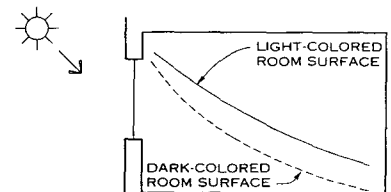
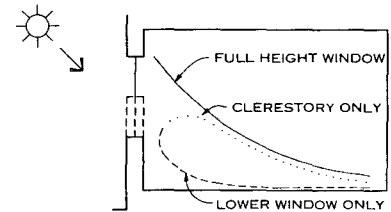

**RELATIVE INDICATOR OF LIGHT LEVELS WITH VARIOUS DESIGNS**

Stephen Selkowitz; Lawrence Berkeley National Laboratory; Berkeley, California

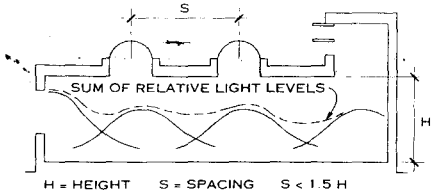

**LIGHT LEVELS WITH SKYLIGHTS**

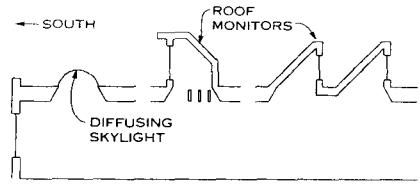

**TOPLIGHTING SYSTEM TYPES**

**GLAZING AND SHADING DESIGN**

Selection of a glazing system can have a tremendous impact on the performance of a daylighting system. The glazing controls the amount of light admitted, its intensity, and its directionality as it enters a space. The challenge is to admit adequate light to achieve illumination objectives without creating glare or causing overheating or large cooling loads. Numerous glazing systems are available to control solar gain and the transmittance, distribution, and color of light. Conventional clear and tinted glazings are still offered but low-E coated glass or plastic and spectrally selective low-E glazings are becoming more popular. These glazings reduce winter heat loss and reduce cooling load in summer with little additional loss of daylight. They are excellent for admitting daylight but glare control must be provided with shading systems. In an insulating glass unit, both low-E and tinted glazings can be used to optimize performance. Highly reflective glass with very low transmittance has a role in highly glazed facades with limited sun control options, but occupants complain about poor views through these glazings on overcast days or at night. Glazings with a frit layer provide some sun and glare control.

Some new options available to designers promise greater optical control capability. Prismatic glazings can redirect light, and between-glass elements can provide varying degrees of light control and solar control.

Adequate control of sun and glare is often difficult to provide with glazing selection alone. Architectural shading solutions are typically part of the exterior facade. Other shading devices can be positioned outside the glazing, between glazings, or at the interior surface. Shading systems can be static or operable, controlled either by occupants or with motorized, automated controls. Shading systems that are intended to block sunlight alone can be dark, but light-colored systems should be used if the intent is to provide diffuse daylight. Overhangs, fins, shade screens, venetian blinds, vertical blinds, miniature louvers, and roller shades are commonly used systems. Operable systems are often preferred because they can take advantage of the variability of sunlight and daylight. In open plan offices it may be desirable to use motorized, automated shading controls; in single-person offices it is likely that the occupant will use the shading controls as needed.

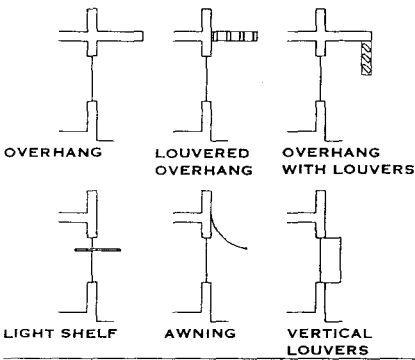

**WINDOW SHADING DEVICES**

New types of light redirecting systems such as prismatic glazings provide shading at a task location by redirecting the sunlight to the ceiling. Light shelves can also provide shading as well as some control of daylight levels and light distribution. Simple, flat light shelves with white, diffuse surfaces will provide some shading near the window and brighten the ceiling near the window but will not redirect light deep into a room. The size, shape, location, and surface properties of light shelves will have a significant influence on their ability to redistribute light in a space.

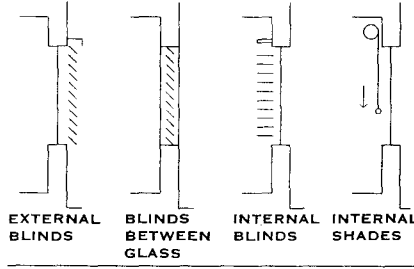

**SHADING DEVICES NEAR GLAZING SURFACE**

**SKYLIGHTS AND SLOPED GLAZING**

Light distribution from skylights is intrinsically more uniform than that from windows. Skylight solutions range from simple vacuum-formed plastic domes to sophisticated, multi-layer glazing products. Skylights in work areas with office tasks should provide diffuse light so that its distribution is relatively uniform. Nondiffusing glazings will result in visual hot spots and glare. Light diffusion can be achieved by using diffusing plastic bubble skylights, high transmission glazing with a diffusion screen below, some of the fritted glasses or laminates with diffusing layers, or exterior shading systems. Light wells provide a transition from the roof plane to the lower ceiling plane or the space below. The geometry and surface properties of the wells determine the total light loss. Light wells can reduce the amount of light entering a space from as little as 10% to as much as 85%. Splayed wells with high reflectance finishes are the best performers. Adequate daylight in most climates is provided with skylight areas of about 4 to 8% with relatively high transmittance glazing. Larger areas with proportionally lower transmittance will work as well. A completely glazed roof or sloped glazing may be used but the transmittance of the glazing should be about 5%. The importance of controlling heat gain depends in part on the occupancy of the space and the climate. In most skylight and sloped glazing designs, safety codes require laminated glass or alternative safety solutions; consult code authorities or manufacturers.

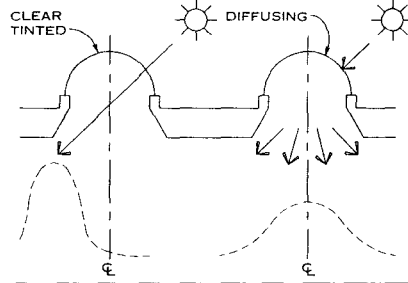

**DAYLIGHT DISTRIBUTION WITH SKYLIGHT TYPES**

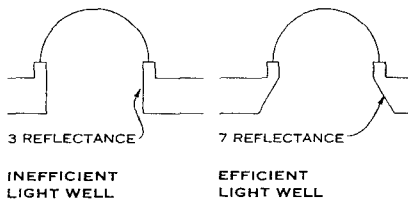

**LIGHT WELL DESIGN**

**ELECTRIC LIGHTING INTEGRATION AND CONTROLS**

Because people respond to the overall luminous environment, it is important that electric lighting and daylighting be designed and specified as a well-integrated system. The

overall lighting concept includes the controls used to manage the electric lighting system. Many designers believe that an indirect lighting system that illuminates the ceiling and wall surface is a better complement to a daylighted space than a direct lighting system. Such an indirect ambient system might be used with task lights to produce higher illuminance levels where needed. Electric lighting sources may be chosen for their compatibility with color temperature in a daylighted space, their ability to dim, and the ability to quickly restart if switched off.

A well-daylighted space will only save energy if lighting controls are used to turn off or dim electric lighting. For most systems the control options are on-off switching, multilevel switching, or dimming. Dimming is the preferred strategy because it changes light levels smoothly, often making changes in electric light levels unnoticeable in the space. Daylighting controls may also be combined with other forms of lighting control to achieve even greater energy savings. To guarantee energy and cost savings, automatic controls are preferable to manual controls, although occupants should be able to override any automatic system. Switching or dimming systems must be designed with care to capture daylighting savings. The layout of circuits for fixtures must be coordinated with the pattern of available daylight. These zoning issues are more important in open plan spaces than in perimeter single offices. Photocell sensors in automatic control systems must be properly located in the space, and the entire control system must be calibrated after installation. A users' manual for occupants is recommended.

**TOTAL BUILDING ENERGY CONSUMPTION**

Final daylighting design decisions must account for the interaction of other systems, such as heating and cooling impacts of the glazing and the cooling impacts of electric lighting use. Although the specifics vary with climate and other building design and operation details, the general trend of the lighting-HVAC trade-off is well known. It is useful to estimate the energy savings as a function of "effective aperture" (EA), defined as the fraction of the wall that is glazed (window-to-wall ratios, or WWR) times the visible transmittance (Tv) of the glazing system. An EA of .35 or greater is adequate to provide large daylighting savings; higher levels increase cooling loads with only minimal additional lighting energy savings. Optimal EA values for skylights are even smaller; an EA of .05 provides substantial energy savings.

**DESIGN AND ANALYSIS TOOLS**

Since many critical architectural decisions that affect daylighting solutions occur early in the design process, it is essential that the design consequences of those decisions be predictable. It is also important that the design intent of a daylighting solution be communicated to all members of the design team so that decisions made later in the process will support and reinforce the original intent. Relatively simple changes late in the process, ranging from a change in paint color to improper sensor position, can have a significant impact on the success of a daylighting plan. However, a number of tools are available to help predict the performance of a daylighting system.

**Physical Scale Models:** Since lighting scales perfectly, daylighting levels in a small-scale model placed outdoors will be the same as the full-size building space (assuming the model faithfully reproduces all of the parameters that influence light levels, such as geometry and surface reflectances). It is important to account for the effects of partitions and furnishings, which can significantly influence light levels. The continuous variability of the outdoor sky also must be accounted for when trying to compare results of successive measurements. One alternative is to use simultaneous measurements in side-by-side models. In all model measurements, care must be exercised in construction details, and accurate light measurement equipment must be used.

**Software:** Computer-based tools are increasingly used to estimate daylight levels and their impacts. Some calculate lighting and daylighting quantities only; others calculate daylighting as part of a complete building systems energy analysis. The most sophisticated lighting tools are linked to CAD software. They use either radiosity or raytracing techniques to produce photorealistic images that are not only quantitatively accurate but also assist the designer in understanding the qualitative aspects of daylighting design under a variety of sun and sky conditions. Some whole building energy simulation tools also model daylighting impacts. Those that can account for the hourly operational characteristics of light sensors and shading device operation can assist with understanding the lighting and thermal trade-offs involved in developing efficient building designs.

Stephen Selkowitz; Lawrence Berkeley National Laboratory; Berkeley, California

**GENERAL**

Sound is energy produced by a vibrating object or surface and transmitted as a wave through an elastic medium. Such a medium may be air (airborne sound) or any solid common building material, such as steel, concrete, wood, piping, gypsum board, etc. (structure-borne sound). A sound wave has amplitude and frequency.

The amplitude of sound waves is measured in decibels (dB). The decibel scale is a logarithmic scale based on the logarithm of the ratio of a sound pressure to a reference sound pressure (the threshold of audibility). The values of a logarithmic scale, such as the decibel levels of two noise sources, cannot be added directly. Instead, use the simplified method described in the table immediately below.

Difference between sound levels (in dB)	0-1	2-3	4-9	>10
Add this number to higher sound level	3	2	1	0

For example, 90 dB + 20 dB = 90 dB; 60 dB + 60 dB = 63 dB.

The frequency of sound waves is measured in Hertz (Hz, also known as cycles per second) and grouped into octaves (an octave band is labeled by its geometric center frequency). An octave band covers the range from one frequency (Hz) to twice that frequency (f to 2f). The range of human hearing covers the frequencies from 20 to 16,000 Hz. Human hearing is most acute in the 1000 to 4000 Hz octave bands.

The human ear discriminates against low frequencies in a manner matched by the A-weighting filter of a sound level meter, measured in dBA, or A-weighted decibels. This is the most universally accepted single number rating for human response to sound.

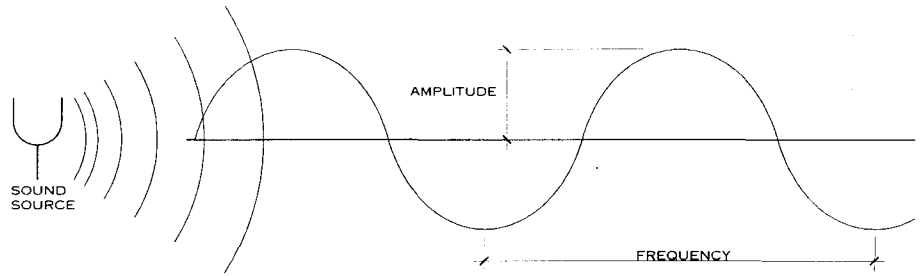

**SOUND AND FREQUENCY**

**FREQUENCY**

RANGE OF OCTAVE (Hz)	OCTAVE BAND CENTER FREQUENCY (Hz)
22-44	31.5
44-88	63
88-175	125
175-350	250
350-700	500
700-1400	1000
1400-2800	2000
2800-5600	4000
5600-11,200	8000

**SUBJECTIVE REACTIONS TO CHANGE IN SOUND LEVEL**

CHANGE IN SOUND LEVEL*	CHANGE IN APPARENT LOUDNESS
1 to 2	Imperceptible
3	Barely perceptible
5 or 6	Clearly noticeable
10	Significant change—twice as loud (or half as loud)
20	Dramatic change—four times as loud (or a quarter as loud)

\*Measured in decibels (plus or minus)

**FREQUENCY OF COMMON SOUNDS**

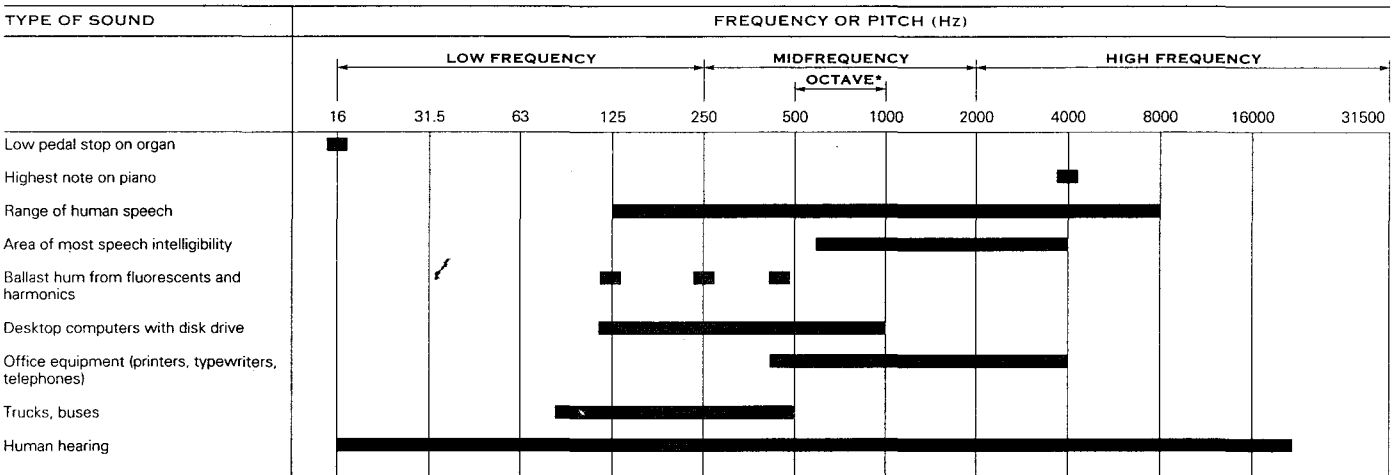

\*Octave—a frequency ratio of 2:1

**TYPICAL SOUND LEVELS**

SOUND LEVEL (dBA)	SUBJECTIVE EVALUATIONS	ENVIRONMENT	
		OUTDOOR	INDOOR
140	Deafening	Near jet engine and artillery fire	—
130	Threshold of pain	Jet aircraft departure (within 500 ft)	—
120	Threshold of feeling	Elevated train	Hard-rock band
110		Jet flyover at 1000 ft	Inside propeller plane
100	Very loud	Power mower, motorcycle at 25 ft, auto horn at 10 ft	Crowd noise in arena
90		Propeller plane flyover at 1000 ft, noisy urban street	Full symphony or band, food blender, noisy factory
80	Moderately loud	Diesel truck at 40 mph at 50 ft	Inside auto at high speed, garbage disposal, dishwasher
70	Loud	Heavy urban traffic	Face-to-face conversation, vacuum cleaner, electric typewriter
60	Moderate	Air-conditioning condenser at 15 ft, near freeway auto traffic	General office
50	Quiet	Large transformer at 100 ft	Large public lobby, atrium
40		Bird calls	Private office, soft radio music in apartment
30	Very quiet	Quiet residential neighborhood	Bedroom, average residence without stereo
20		Rustling leaves	Quiet theater, whisper
10	Just audible	Still night in rural area	Recording studio
0	Threshold of hearing	—	—

Carl Rosenberg, AIA; Acentech, Inc.; Cambridge, Massachusetts

**GENERAL**

All materials and surfaces absorb some sound greater than 0% and less than 100%. The percentage of incident sound energy that is absorbed by a material, divided by 100, equals the coefficient of absorption, designated  $\alpha$ , which ranges from 0 to .99. The coefficient varies as a function of frequency, Hz.

Any material can be tested in a proper laboratory to determine its  $\alpha$  values, as per ASTM C423. Some tests give values greater than 1.0, but this is an anomaly caused by the testing procedure; such values should be corrected to be not more than 1.0, since no material can absorb more than 100% of the incident energy that strikes its surface.

**SOUND ENERGY ABSORPTION MECHANISMS**

There are three mechanisms by which sound energy is absorbed or dissipated as it strikes a surface. In all cases, sound energy is converted to heat, although never enough heat to be felt.

**POROUS ABSORPTION** entails the use of soft, porous, "fuzzy" materials like glass fiber, mineral wool, and carpet. The pressure fluctuations of a sound wave in air cause the fibers of such materials to move, and the friction of the fibers dissipates the sound energy.

**TYPICAL VALUES FOR POROUS ABSORPTION**

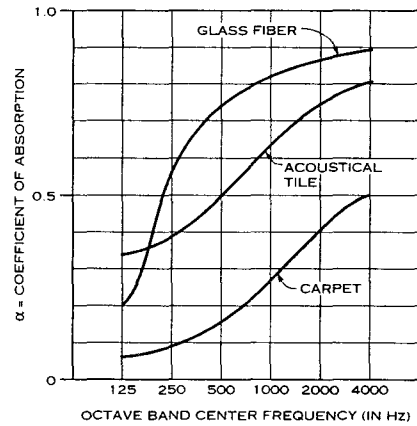

**PANEL ABSORPTION** involves installation of thin light-weight panels like gypsum board, glass, and plywood. Sound waves cause panels to vibrate. Sound absorption for a panel is greatest at that resonant frequency.

**TYPICAL VALUES FOR PANEL ABSORPTION**

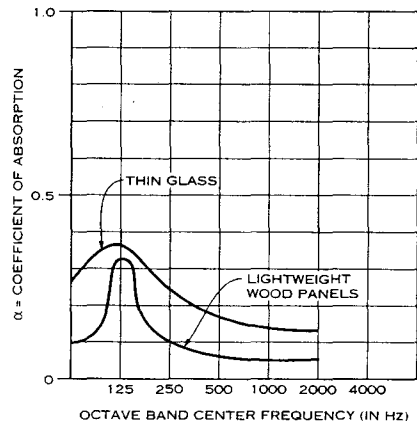

**CAVITY ABSORPTION** entails the movement of air pressure fluctuations across the narrow neck of an enclosed air cavity, such as a space behind a perforated panel or a slotted concrete masonry unit, also called a Helmholtz resonator. The natural frequency at which the resonator most efficiently absorbs sound is related to the volume of the cavity, the size of the neck opening, and the presence of any insulation in the cavity.

**NOISE REDUCTION COEFFICIENT**

The noise reduction coefficient (NRC) is the arithmetic average of the absorption coefficients,  $\alpha$ , at four designated frequencies: 250 Hz, 500 Hz, 1,000 Hz, and 2,000 Hz. These frequencies have been selected because they represent the middle range of most representative sound sources pertinent to architectural applications. Because the NRC value is meant to be only a general indication of a material's efficiency at absorbing sound, it is rounded off to the nearest .05 value and often represented as a .10 range (for example, .50 to .60). NRC ratings can never be less than 0 or greater than 1.00. The following formula can be used to compute the NRC for a particular application:

$$NRC = (\alpha_{250} + \alpha_{500} + \alpha_{1000} + \alpha_{2000})/4$$

**SAMPLE DERIVATION OF NRC**

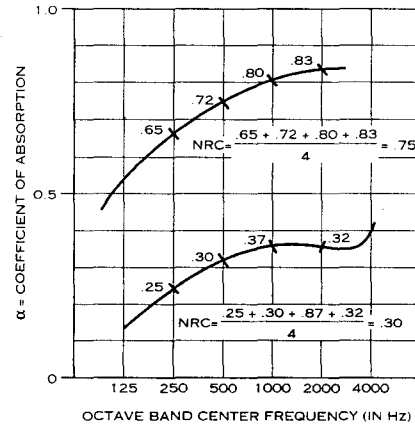

**SOUND-ABSORBING COEFFICIENTS FOR VARIOUS MATERIALS**

The sound-absorbing coefficients for a given material may vary depending on the thickness of the material, how it is supported or mounted, the depth of the air space behind the material, and the facing in front of the material. In general, thicker porous materials absorb more sound; the air space behind a material will increase the absorption efficiency, especially at low frequencies; and thin facings degrade high frequency absorption.

**MOUNTING ASSEMBLIES**

For consistency in comparing test results, there are set standards for the mounting assembly used in testing absorbent materials. These mounting conditions should be reported along with any and all test data so that the data accurately reflect field conditions. Mounting types A, D, and E are typical for standard sound-absorbing materials. A numerical suffix is used to specify the mounting depth in millimeters; for example, E-400 indicates mounting type E with a 400 mm airspace (a typical 16 in. plenum). Mounting types are specified by ASTM E795.

**SOUND-ABSORBING COEFFICIENTS FOR VARIOUS MATERIALS**

TYPICAL DATA/MATERIAL	125 Hz	250 Hz	500 Hz	1000 Hz	2000 Hz	4000 Hz	NRC
Marble	.01	.01	.01	.01	.02	.02	.00
Gypsum board, 1/2 in.	.29	.10	.05	.04	.07	.09	.05
Wood, 1 in. thick, with air space behind	.19	.14	.09	.06	.06	.05	.10
Heavy carpet on concrete	.02	.06	.14	.37	.60	.65	.30
Acoustical tile, surface-mounted	.34	.28	.45	.66	.74	.77	.55
Acoustical tile, suspended	.43	.38	.53	.77	.87	.77	.65
Acoustical tile, painted (est.)	.35	.35	.45	.50	.50	.45	.45
Audience area, empty, hard seats	.15	.19	.22	.39	.38	.30	.30
Audience area, occupied, upholstered seats	.39	.57	.80	.94	.92	.87	.80
Glass fiber, 1 in.	.04	.21	.73	.99	.99	.90	.75
Glass fiber, 4 in.	.77	.99	.99	.99	.99	.99	.95
Thin fabric, stretched tight to wall	.03	.04	.11	.17	.24	.35	.15
Thick fabric, bunched 4 in. from wall	.14	.35	.55	.72	.70	.65	.60

**NOTE**

This table gives representative absorption coefficients at various frequencies for some typical materials. To determine values not provided here, refer to manufacturer's data

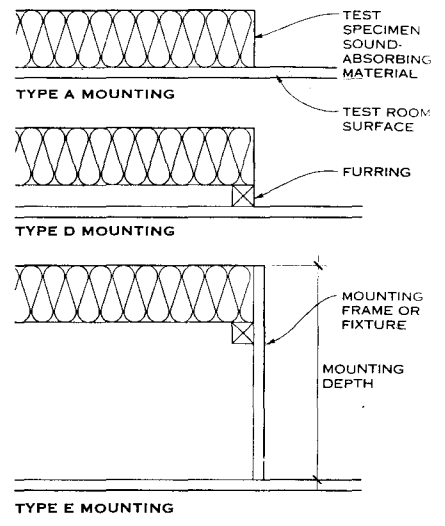

**TYPICAL MOUNTING TYPES ACOUSTICAL PERFORMANCE PER MOUNTING ASSEMBLY**

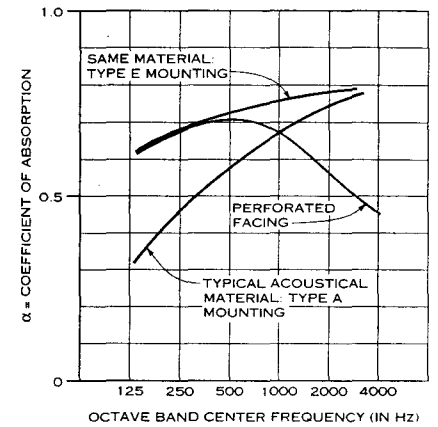

**NOTE**

Acoustical performance varies with mounting assembly and facing.

**SOUND-ABSORBING COEFFICIENTS FOR VARIOUS MATERIALS**

TYPICAL DATA/MATERIAL	125 Hz	250 Hz	500 Hz	1000 Hz	2000 Hz	4000 Hz	NRC
Marble	.01	.01	.01	.01	.02	.02	.00
Gypsum board, 1/2 in.	.29	.10	.05	.04	.07	.09	.05
Wood, 1 in. thick, with air space behind	.19	.14	.09	.06	.06	.05	.10
Heavy carpet on concrete	.02	.06	.14	.37	.60	.65	.30
Acoustical tile, surface-mounted	.34	.28	.45	.66	.74	.77	.55
Acoustical tile, suspended	.43	.38	.53	.77	.87	.77	.65
Acoustical tile, painted (est.)	.35	.35	.45	.50	.50	.45	.45
Audience area, empty, hard seats	.15	.19	.22	.39	.38	.30	.30
Audience area, occupied, upholstered seats	.39	.57	.80	.94	.92	.87	.80
Glass fiber, 1 in.	.04	.21	.73	.99	.99	.90	.75
Glass fiber, 4 in.	.77	.99	.99	.99	.99	.99	.95
Thin fabric, stretched tight to wall	.03	.04	.11	.17	.24	.35	.15
Thick fabric, bunched 4 in. from wall	.14	.35	.55	.72	.70	.65	.60

or extrapolate from similar constructions. All materials have some absorption values that can be determined from proper test reports.

Carl Rosenberg, AIA; Acentech, Inc.; Cambridge, Massachusetts

**GENERAL**

The total sound absorbing units (a) provided by a given material are a function of the absorptive properties ( $\alpha$ ) and surface area (S) of that material as defined by the formula

$$a = S\alpha$$

in which a = sabins (units of sound absorption), S = surface area (measured in sq m or sq ft), and  $\alpha$  = the coefficient of absorption.

The total sabins in a room can be determined by adding together the sabins of all the surfaces, which vary as a function of frequency. Since most materials absorb more high-frequency sound waves than low-frequency ones, it is typical to find more sabins in a room at high frequencies than at low frequencies.

In general, sound energy that is not absorbed will be reflected, thus surfaces with low coefficients of absorption can be used to encourage sound reflection when appropriate.

**PROPERTIES OF SOUND**

The sound properties distance and time are described here:

**DISTANCE**

Outdoors, sound drops off 6 dB each time the distance from a source is doubled (Inverse Square Law). Indoors, the reflecting sound energy in a room reaches a constant level as a function of the sound absorbing units (sabins) in the room. The noise level in a room can be reduced by adding more absorption, as shown in this formula:

$$\text{Noise reduction (NR)} = 10 \log a_2/a_1$$

**TIME**

Outdoors, sound ceases when the source stops. Indoors, sound energy lingers and this decay is called reverberation. The reverberation time (RT) is defined as the length of time, in seconds, it takes for sound to decay by 60 dB. Reverberation time is directly proportional to the volume of a space and inversely proportional to the units of absorption (sabins) in it, as expressed in this formula

$$RT = KV/a$$

in which RT = reverberation time in seconds, K = .161 (if volume is in m<sup>3</sup>) or .049 (if volume is in cu ft), V = volume in m<sup>3</sup> or cu ft, and a = total absorption in sabins (metric or English units).

Shorter reverberation times greatly enhance speech intelligibility and are imperative in listening environments for people with hearing impairments and for rooms with live microphones for teleconferencing.

**SOUND ABSORPTION**

Sound-absorptive materials (such as acoustic tile, glass fiber, wall panels, carpet, curtains, etc.) can be added to a room in order to control or reduce noise levels or shorten reverberation time. Noise control is especially helpful when the noise sources are distributed around a room, as in a gymnasium, classroom, or cafeteria.

While sound-absorptive materials can be added to any surface in a room, the greatest area available for coverage is usually the ceiling. Because many soft porous materials are fragile, they should not be located on surfaces that are susceptible to abuse. For these reasons, sound-absorptive materials are often installed on ceilings.

See the accompanying chart for guidelines on the use of sound absorption treatments.

**GUIDELINES FOR USE OF SOUND ABSORPTION**

ROOM TYPE	TREATMENT
Classrooms, corridors and lobbies, patient rooms, laboratories, shops, factories, libraries, private and open plan offices, restaurants	Ceiling or equivalent area; add additional wall treatment if room is quite high
Boardrooms, teleconferencing rooms, gymnasiums, arenas, recreational spaces, meeting and conference rooms	Ceiling or equivalent area; add wall treatments for further noise reduction and reverberation control and eliminate flutter or echo
Auditoriums, churches, etc. (list)	Special considerations and complex applications

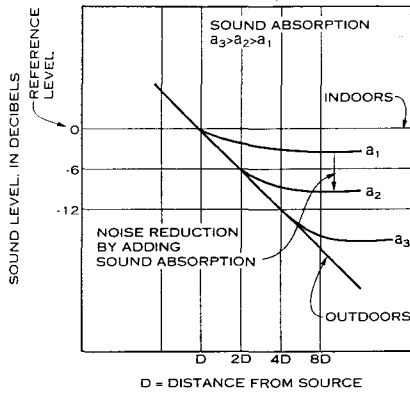

**SOUND OVER DISTANCE**

**NOTE**

The more sound absorption (sabins) inside a room, the lower the noise levels (approaching the drop-off with distance outdoors).

**PROPERTIES OF SOUND**

**AVERAGE COEFFICIENT OF ABSORPTION**

One measure of the quality of sound in a room is the average coefficient of absorption (or average noise reduction coefficient-NRC) for all surfaces combined, as determined by this formula:

$$\bar{\alpha} = a/S$$

in which  $\bar{\alpha}$  = the average coefficient (at a given frequency or average NRC), a = the total sabins (sound absorbing units), and S = the total surface area in the room (metric or English units; be consistent).

As determined by using the average coefficient of absorption, the quality of sound in a room can be evaluated as .1, .2, or .3. A room with an average coefficient of .1 is rather "live," loud, and uncomfortably noisy; one with an average coefficient of .2 is comfortable, with well-controlled noise; and one with .3 is rather "dead," suitable for spaces in which the emphasis will be on amplified sound, electronic playback, or a live microphone for teleconferencing.

**CALCULATION OF AVERAGE COEFFICIENT OF ABSORPTION**

(Sample at 1000 Hz)

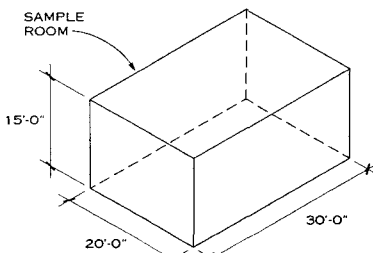

The volume of this sample room is 9000 cu ft (l x w x h).

**SAMPLE CALCULATION 1**

SURFACE	MATERIAL	AREA (SQ FT)	$\alpha$	a
Floor	Carpet	600 sq ft	.37	222
Ceiling	Gypsum board	600 sq ft	.01	6
All 4 walls	Gypsum board	1500 sq ft	.01	15
Total	—	2700 sq ft	—	243

The reverberation time for the sample room with a gypsum board ceiling is calculated as follows:

$$RT = .049V/a = .049 \times 9000 \text{ cu ft}/243 = 1.8 \text{ sec}$$

**SAMPLE CALCULATION 2**

SURFACE	MATERIAL	AREA (SQ FT)	$\alpha$	a
Floor	Carpet	600 sq ft	.37	222
Ceiling	Acoustical tile	600 sq ft	.77	462
All 4 walls	Gypsum board	1500 sq ft	.01	15
Total	—	2700 sq ft	—	699

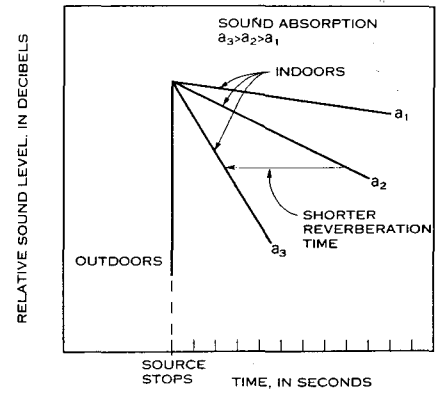

**SOUND OVER TIME**

**NOTE**

The more sound absorption (sabins) inside a room, the shorter the reverberation time.

The reverberation time for the sample room with an acoustical tile ceiling is calculated as follows:

$$RT = .049V/a = .049 \times 9000 \text{ cu ft}/699 = .63 \text{ sec}$$

The average coefficient of absorption ( $\bar{\alpha}$ ) in the sample room changes significantly from sample 1 to sample 2. The room with a gypsum board ceiling is rather live and noisy, while the room with an acoustical tile ceiling is comfortable, with well-controlled noise. The calculations that show this follow:

Before:  $\bar{\alpha} = a/S = 243/2700 = .09$   
 After:  $\bar{\alpha} = a/S = 699/2700 = .26$

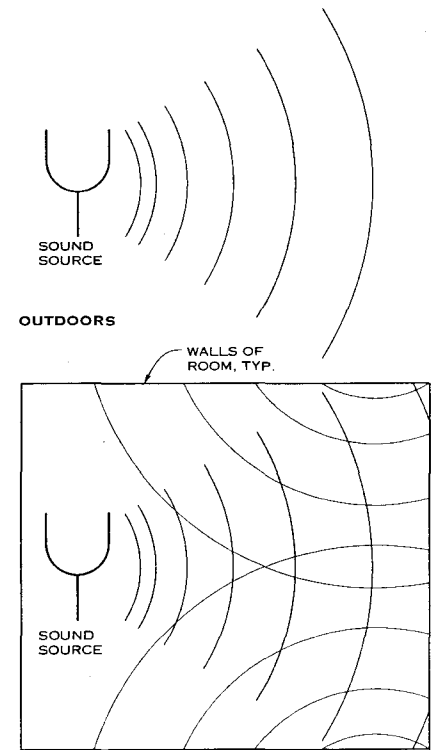

**INDOORS**

**NOTE**

Outdoors, sound waves expand spherically, becoming more dispersed (i.e., quieter) over distance and time. Indoors, sound waves reflect off surrounding surfaces, building up energy so sound drops off less quickly over distance or time.

**SOUND PATTERNS**

Carl Rosenberg, AIA; Acentech, Inc.; Cambridge, Massachusetts



**GENERAL**

The property of a material or construction system that blocks the transfer of sound energy from one side to another is transmission loss (TL), which is measured in decibels (dB). Specifically, TL is the attenuation of airborne sound transmission through a construction during laboratory testing according to ASTM E90. Transmission loss values range from 0 to 70 or 80 (or higher). A high TL value indicates a better ability to block sound; that is, more sound energy is "lost" as the sound wave travels through the material.

Sound transmission class (STC) is a single number rating system designed to combine TL values from many frequencies. STC values for site-built construction range from 10 (practically no isolation, e.g., an open doorway) to 65 or 70 (such high performance is only achieved with special construction techniques). Average construction might provide noise reduction in the range of STC 30 to 60.

It is very difficult to measure the STC performance of a single wall or door in the field because of the number of flanking paths and nonstandard conditions. Field performance is measured with noise isolation class (NIC) ratings, which cover effects from all sound transfer paths between rooms.

**DERIVATION AND USE OF THE STC CURVE**

To determine the STC rating for a particular construction, the STC curve shown in the accompanying figure is applied over the transmission loss (TL) curve for a laboratory test of the construction. The STC curve is then manipulated in accordance with prescribed rules to obtain the highest possible rating. The procedure states that the TL curve cannot be more than 8 dB less than the STC curve in any one-third octave band, nor can the TL curve be more than a total of 32 dB less than the STC curve (average of 2 dB for each of 16 one-third octave band frequencies). Any values from the TL curve that are above the STC curve are of no benefit in the rating. The object is to move the STC curve up as high as possible and to read the STC rating number from the point where the STC curve at 500 Hz crosses the TL curve.

The STC curve has three segments: the first segment, from 125 to 400 Hz, rises at the rate of 9 dB per octave (3 dB per one-third octave); the second segment, from 400 to 1250 Hz, rises at the rate of 2 dB per octave (1 dB per one-third octave); and the third segment, from 1250 to 4000 Hz, flat.

**TRANSMISSION LOSS**

Design of construction and materials for high transmission loss builds on three principles:

**MASS:** Lightweight materials do not block sound. Sound transmission through walls, floors, and ceilings varies with the frequency of sound, the weight (or mass) and stiffness of the construction, and the cavity absorption. Theoretically, the transmission loss increases at the rate of 6 dB per doubling of the surface weight of the construction. A single solid panel behaves less well than the mass law would predict, since the mass law assumes a homogeneous, infinitely resilient material/wall.

**SEPARATION:** Improved TL performance without an undue increase in mass can be achieved by separation of materials. A true double wall with separate unconnected elements performs better than the mass law predicts for a single wall of

**BENEFIT OF AIRSPACE IN IMPROVING TRANSMISSION LOSS (TL)**

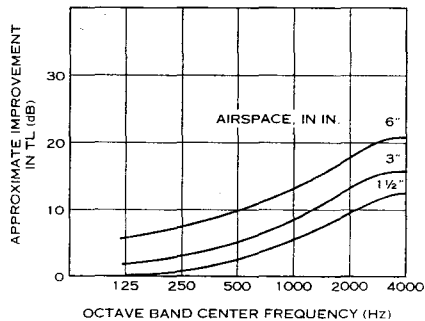

**NOTE**

If two layers of dense material are separated by an airspace (rather than being continuous), they create two independent walls. The improvement in transmission loss depends on the size of the airspace and the frequency of sound. Avoid rigid ties between layers in all double wall construction. The graph above indicates the approximate improvement in TL when a wall of a given weight is split into two separate walls.

the same weight. The transmission loss tends to increase about 5 dB for each doubling of the airspace between wythes (minimum effective space is approximately 2 in.). Resilient attachment of surface skins to studs or structural surfaces provides a similar benefit, as do separate wythes.

**ABSORPTION:** Use of soft, resilient, absorptive materials in the cavity between wythes, particularly for lightweight staggered or double stud construction, increases transmission loss significantly. Viscoelastic (somewhat resilient but not fully elastic) materials, such as certain insulation boards, dampen or restrict the vibration of rigid panels such as gypsum board and plywood, increasing transmission loss somewhat. Follow manufacturer-recommended installation details.

**NOISE REDUCTION**

Noise reduction (NR) depends on the properties of a room and is the actual difference in sound pressure level between

two spaces. It is the amount of sound blocked by all intervening sound paths between rooms, including the common wall but also the floor, ceiling, outside path, doors, etc.

Noise reduction also depends on the relative size of a room. If the noise source is in a small room next to a large receiving room (like an office next to a gymnasium), the noise reduction will be greater than the TL performance of the wall alone because the sound radiating from the common wall between office and gym is dissipated in such a large space. On the other hand, if the noise source is in a large room next to a small one (as from a gym to an office next door), the noise reduction will be far less than the TL of the wall alone because the common wall, which radiates sound, is such a large part of the surface of the smaller room. An adjustment for this ratio, plus the contribution of the absorptive finishes in the receiving room, enters into the calculation of actual noise reduction between adjacent spaces.

**GRAPHIC TECHNIQUE TO DETERMINE COMPOSITE TRANSMISSION LOSS (COMBINING TWO DIFFERENT CONSTRUCTION ELEMENTS)**

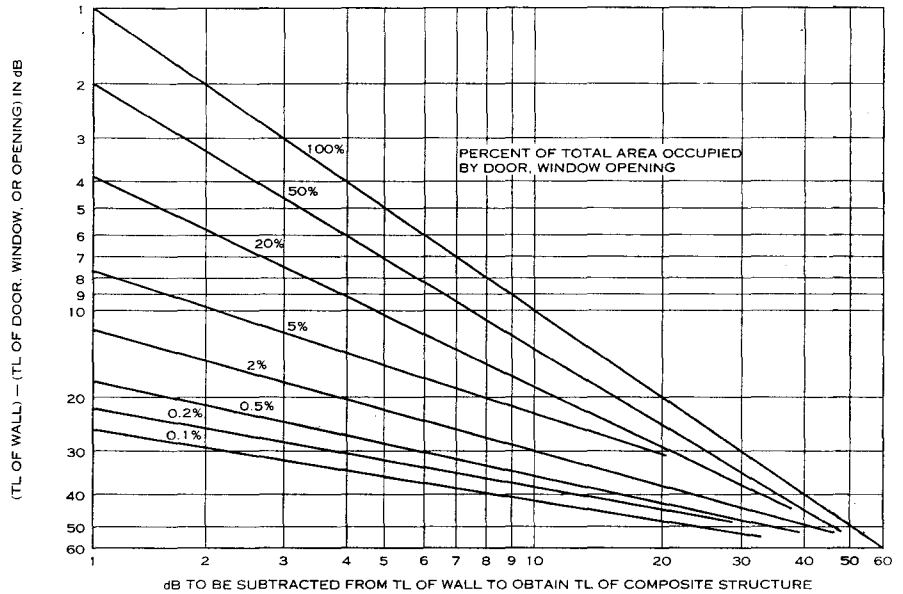

**NOTES**

1. When a wall or surface of a room is made up of two or more different structures (e.g., a window in an outside wall or a door in an office), the TL performance (or STC) of the composite construction should be evaluated by

combining the TL (or STC) values of the components of the wall alone, in accordance with the chart above.  
2. Note that small gaps and cracks such as the perimeter of an ungasketed door can dramatically degrade the performance of a high TL construction.

**SOUND TRANSMISSION CLASS (STC) RATING CURVE**

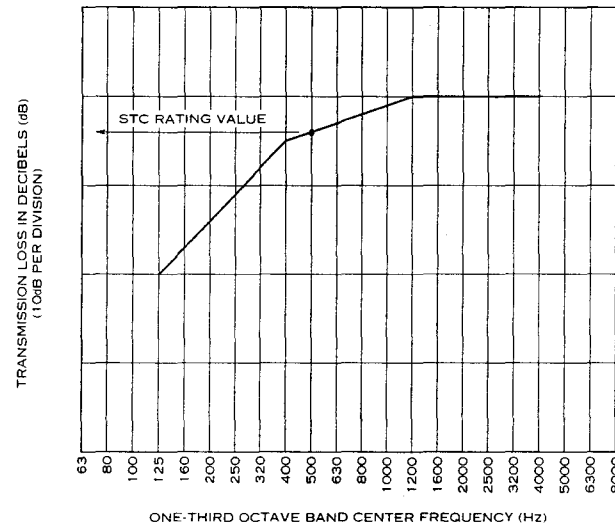

Carl Rosenberg, AIA; Acentech, Inc.; Cambridge, Massachusetts

**SOUND ISOLATION CRITERIA**

SOURCE ROOM OCCUPANCY	RECEIVER ROOM ADJACENT	SOUND ISOLATION REQUIREMENT (MIN.) FOR ALL PATHS BETWEEN SOURCE AND RECEIVER
Executive areas, doctors' suites, personnel offices, large conference rooms; confidential privacy requirements	Adjacent offices and related spaces	STC 50-55
Normal offices, regular conference rooms for group meetings; normal privacy requirements	Adjacent offices and similar activities	STC 45-50
Large general business offices, drafting areas, banking floors	Corridors, lobbies, data processing; similar activities	STC 40-45
Shop and laboratory offices in manufacturing laboratory or test areas; normal privacy	Adjacent offices; test areas, corridors	STC 40-45
Mechanical equipment rooms	Any spaces	STC 50-60+ <sup>1</sup>
Multifamily dwellings	Neighbors (separate occupancy)	
Bedrooms	Bedrooms	STC 48-55 <sup>2</sup>
	Bathrooms	STC 52-58 <sup>2</sup>
	Kitchens	STC 52-58 <sup>2</sup>
	Living rooms	STC 52-57 <sup>2</sup>
	Corridors	STC 52-58 <sup>2</sup>
Living Rooms	Living Rooms	STC 48-55 <sup>2</sup>
	Bathrooms	STC 50-57 <sup>2</sup>
	Kitchens	STC 48-50 <sup>2</sup>
School buildings	Adjacent classrooms	STC 50
Classrooms	Laboratories	STC 50
	Corridors	STC 45
Large music or drama area	Adjacent music or drama area	STC 60 <sup>3</sup>
Music practice rooms	Music practice rooms	STC 55 <sup>3</sup>
Interior occupied spaces	Exterior of building	STC 35-60 <sup>4</sup>
Theaters, concert halls, lecture halls, radio and TV studios	Any and all adjacent	Use qualified acoustical consultants to assist in the design of construction details for these critical occupancies

<sup>1</sup> Use acoustical consultants when designing mechanical equipment rooms to house equipment other than that used for air handling (e.g., chillers, pumps, and compressors) and heavy manufacturing areas that house equipment that generates noise at or above OSHA allowable levels or generates high vibration levels.  
<sup>2</sup> Ratings depend on nighttime, exterior background levels and other factors directly related to the location of a building. Grades I, II, and III are discussed in "Guide to Airborne, Impact, and Structureborne Noise Control in Multifamily Dwellings," HUD TS-24 (1974).  
<sup>3</sup> The STC ratings shown are guidelines only. These spaces typically require double layer construction with resilient connections between layers or, preferably, structurally independent "room-within-a-room" construction. The level of continuous background noise, such as that provided by the HVAC system or an electronic masking system, has a significant impact on the quality of construction selected and must be coordinated with the other design parameters.  
<sup>4</sup> Ratings depend on the nature of the exterior background noise—its level, spectrum shape, and constancy—as well as the client's budget and thermal considerations. Use qualified acoustical consultants for analysis of high noise outdoor environments such as airports, highways (especially those with heavy truck traffic), and industrial facilities.

connections between layers or, preferably, structurally independent "room-within-a-room" construction. The level of continuous background noise, such as that provided by the HVAC system or an electronic masking system, has a significant impact on the quality of construction selected and must be coordinated with the other design parameters.

Ratings depend on the nature of the exterior background noise—its level, spectrum shape, and constancy—as well as the client's budget and thermal considerations. Use qualified acoustical consultants for analysis of high noise outdoor environments such as airports, highways (especially those with heavy truck traffic), and industrial facilities.

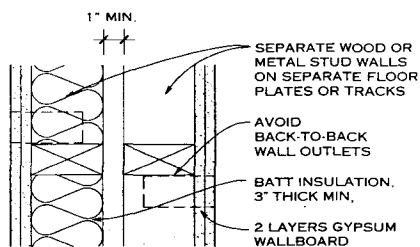

DOUBLE STUD WALL

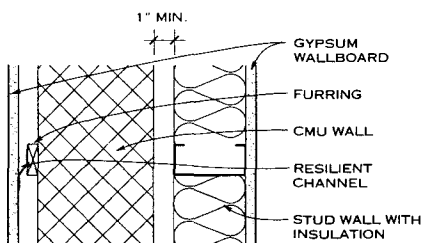

DOUBLE WALL—CMU AND STUD

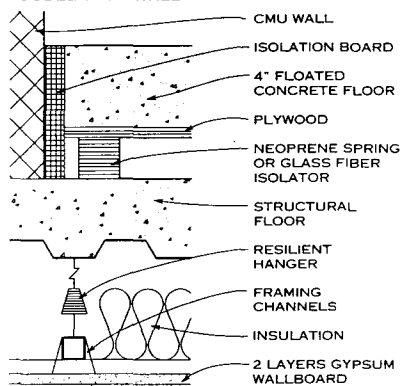

FLOOR/CEILING CONSTRUCTION—CONCRETE

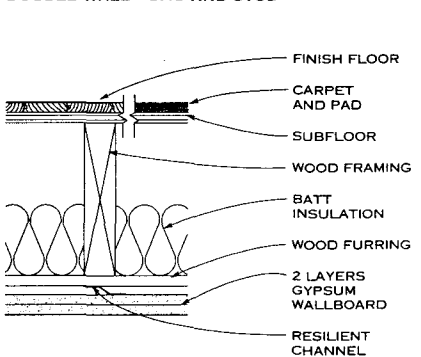

FLOOR/CEILING CONSTRUCTION—WOOD

**TYPICAL HIGH SOUND ISOLATION CONSTRUCTION**

**GENERAL**

One of the most common goals in the design of sound isolation construction is achievement of acoustical privacy from a neighbor. This privacy is a function of whether the signal from the neighbor is audible and intelligible above the ordinary background noise level in the environment.

Privacy index = noise reduction + background noise

Noise reduction is measured as a field performance where it is evaluated and given an STC value. Background sound levels from steady mechanical heating and ventilating systems, a constant part of our environment, are measured in accordance with ASHRAE standards by a set of uniform curves called noise criteria (NC) ratings. These NC curves are constantly refined, so check the latest ASHRAE guides.

Normal privacy, in which you are aware of a neighbor's activity but not overly distracted by it, can usually be achieved with a privacy index of 68 or higher. Confidential privacy, in which you are aware of the neighbor, usually requires a privacy index of 75 or higher.

A quiet environment with little or no natural background sound (from HVAC systems) between neighbors requires a higher degree of sound separation construction to achieve the same privacy as that in a noisier environment with louder background sound.

**IMPACT NOISE DESIGN CRITERIA**

Floors are subject to impact or structure-borne sound transmission noises such as footfalls, dropped objects, and scraping furniture. Parallel to development of laboratory sound transmission class (STC) ratings for partition constructions is the development of an impact insulation class (IIC). This is a single-number rating system used to evaluate the effectiveness of floor construction in preventing impact sound transmission to spaces beneath the floor. The current IIC rating method is similar to the STC rating.

Testing for IIC ratings is a complex procedure using a standard tapping machine. Because the machine is portable, it cannot simulate the weight of a person walking across a floor. Therefore, the creak or boom footsteps cause in a timber floor cannot be reflected in the single-figure impact rating produced from the tapping machine. The correlation between tapping machine tests in the laboratory and field performance of floors under typical conditions may vary greatly, depending on the construction of the floor and the nature of the impact.

Often the greatest annoyance caused by footfall noise is the low-frequency sound energy it generates, which is beyond the frequency range of standardized tests. Sometimes this sound energy is near or at the resonant frequency of the building structure.

Whenever possible, to stifle unwanted sounds use carpet with padding on floors in residential buildings and resilient, suspended ceilings with cavity insulation. For especially critical situations, such as pedestrian bridges or tunnels, hire an acoustical consultant.

Slamming doors or cabinet drawers are other sources of impact noise. If possible, bureaus should not be placed directly against a wall. Door closers or stops can be added to cushion the impact of energy from a door so it is not imparted directly into the structure. Common sense arrangements can help minimize problems in multifamily dwellings. For example, kitchen cabinets should not be placed on the other side of a common wall from a neighbor's bedroom.

**CONSTRUCTION NOTES**

- Edge attachment and junction of walls, partitions, floors, and ceiling can cause large differences in transmission loss (TL) performance. The transverse waves set up in continuous, stiff, lightweight walls or floors can carry sound a long distance from the source to other parts of the structure with little attenuation. Curtain walls, thin concrete floors on bar joists, and wood framed structures are particularly subject to this weakness.
- Properly designed discontinuities such as interrupted floor slab/toppings are helpful in reducing structural flanking.
- A resilient (airtight) joint between exterior wall and partition or partition and floor can appreciably improve TL.
- Continuous pipes, conduits, or ducts can act as transmission paths from room to room. Care must be taken to isolate such services from the structure.

**GENERAL**

Mechanical system noise, as a major component of acoustics in modern buildings, must be addressed in developing mechanical design and acoustical goals.

Background sound levels from mechanical systems are measured and evaluated by means of noise criteria (NC) ratings as well as by actual A-weighted decibel levels. The noise criteria curves provide a convenient way of defining the ambient noise level in terms of octave band sound pressure levels. The NC curves consist of a family of curves that relate the spectrum of a noise to the environment being specified. Higher noise levels are permitted at lower frequencies since the ear is less sensitive to noise at these levels. The complete octave band frequency of an acceptable ambient noise level can be specified with one NC number.

Mechanical equipment creates noise and vibration from the rotation of the equipment motor. Four aspects of the noise and vibration to be addressed are described here:

**MACHINE NOISE:** Sound isolation requirements for the walls and floors of a mechanical equipment room depend on the type of equipment to be housed and the sensitivity of adjacent spaces. Chillers can be extremely loud, requiring double walls and extra thick floor slabs. Air-handling units may only require regular wall construction, perhaps STC 50 systems. Major secondary sound paths are duct penetrations, open curbs under rooftop units, and doors; all potential sound paths must be controlled.

**FAN NOISE:** Rotation of the fan motor and the fan itself generates noise, which is transmitted along the duct path (both supply and return) to the listening space. Typical fan noise control elements include package silencers (inserted into a straight run of duct, often at the wall of the mechanical equipment room) and internal acoustical duct lining (glass fibers adhered to the duct walls). The degree of fan noise attenuation can be determined by calculations based on the size and sound power levels of the fan, the length and configuration of duct runs, the attenuation of the duct systems, the number and type of diffusers, and the room finishes in the listening space.

**AIR NOISE:** Movement of air through a duct generates turbulence, which creates noise. For sensitive spaces and quiet noise levels, the airflow must be at low velocity (hence the need for large ducts) with smooth inlet and outflow conditions. For extremely quiet noise levels, air velocities at diffusers or terminal devices may need to be below 400 fpm. Volume dampers to control flow for such spaces are critical; keep dampers 10 ft from diffusers, and avoid opposed blade dampers at diffusers. A simple duct layout that provides even distribution of air to all diffusers in a room can eliminate many problems (see preferred duct layout below).

**VIBRATION ISOLATION:** Rotating equipment generates vibration, which can travel through a structure and be radiated as noise in a distant location. Vibration isolation may entail use of neoprene pads, spring isolators, or inertia bases, depending on the size and power of the rotating equipment, the proximity of sensitive spaces, and the stiffness of the supporting structure. Piping attached to rotating equipment, especially chilled water piping, must also be isolated from the structure to prevent transmission of sound energy. The effectiveness of a vibration isolator depends on the static deflection of the isolator under load; lower frequency mechanical equipment rotation requires greater static deflection isolation to be effective.

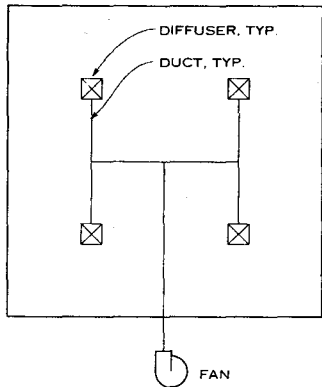

**NOTE**

All diffusers are equidistant from the fan. The system is self-balancing. The duct layout does not need volume dampers.

**PREFERRED DUCT LAYOUT**

Doug Sturz; Acentech, Inc.; Cambridge, Massachusetts

**1 ACOUSTICAL DESIGN**

**RECOMMENDED BACKGROUND NOISE CRITERIA FOR TYPICAL OCCUPANCIES**

TYPE OF SPACE	USES	NC RATING RANGE	A-WEIGHTED DECIBELS
Sensitive listening spaces	Broadcast and recording studios, concert halls	NC-15 to NC-20	25 dBA
Performance spaces	Theaters, churches (no amplification), video and teleconferencing (live microphone)	NC-20 to NC-25	30 dBA
General presentation spaces	Large conference rooms, small auditoriums, orchestral rehearsal rooms, movie theaters, courtrooms, meeting and banquet rooms, executive offices	NC-25 to NC-30	35 dBA
Quiet areas	Offices, small conference rooms, classrooms, private residences, hospitals, hotels, libraries	NC-30 to NC-35	40 dBA
Public spaces	Restaurants, lobbies, open plan offices and clinics	NC-35 to NC-40	45 dBA
Service and support spaces	Computer equipment rooms, public circulation areas, arenas, convention floors	NC-40 to NC-45	50 dBA

**NOISE CRITERIA SOUND PRESSURE LEVEL TABLE\***

NC CURVE	SOUND PRESSURE LEVEL (dB)							
	63 HZ	125 HZ	250 HZ	500 HZ	1000 HZ	2000 HZ	4000 HZ	8000 HZ
NC-70	83	79	75	72	71	70	69	68
NC-65	80	75	71	68	66	64	63	62
NC-60	77	71	67	63	61	59	58	57
NC-55	74	67	62	58	56	54	53	52
NC-50	71	64	58	54	51	49	48	47
NC-45	67	60	54	49	46	44	43	42
NC-40	64	57	50	45	41	39	38	37
NC-35	60	52	45	40	36	34	33	32
NC-30	57	48	41	36	31	29	28	27
NC-25	54	44	37	31	27	24	22	21
NC-20	50	41	33	26	22	19	17	16
NC-15	47	36	29	22	17	14	12	11

\*For convenience in using noise criteria data, the table lists the sound pressure level (SPL) in decibels for each NC curve.

**NOISE CRITERIA CURVES**

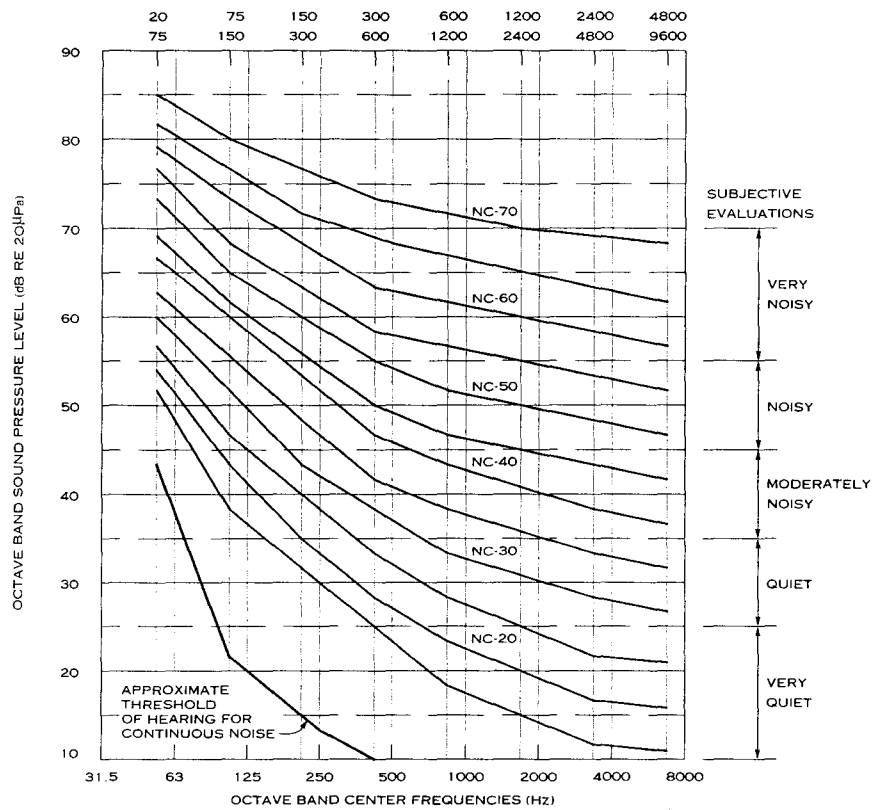

Doug Sturz; Acentech, Inc.; Cambridge, Massachusetts

**1 ACOUSTICAL DESIGN**

**GENERAL**

Performance spaces are rooms in which good hearing conditions are particularly critical to the use of the space and exchange of aural information. Such spaces include classrooms, lecture halls, recital halls, theaters, cinemas, concert halls, churches and synagogues. Critical design of a performance space may require assistance from an acoustical consultant, but the primary tools at the architect's direction are outlined here:

**LOUDNESS**

Audience and performers should be in the same space, and any sound generated by a speaker or musician should be projected efficiently to the audience and captured within the space. The "sending end" of the room (i.e., the stage) should be acoustically hard. Walls near the performer should be angled or splayed to enhance projection and prevent "flutter echoes" at the stage. Walls and ceilings where the audience sits should be hard so they can reflect sound, unless absorptive treatment is needed to eliminate problematic reflections or focusing or to reduce reverberation time (RT) for particular program needs.

**QUIET**

Good hearing environments should maximize the signal-to-noise ratio; in other words, in addition to the desired signal being well projected (see loudness), unwanted noise should be eliminated. To accomplish this requires very low background sound levels (NC-20 perhaps) from mechanical equipment. Sound lock vestibules eliminate intrusive noise from a lobby and allow latecomers to enter without acoustical interference to the show, and carpeted aisles help reduce footfall noise. Noise from exterior environmental sources should also be considered. Avoid lightweight roofs, which will transmit rain noise.

**SPACIOUSNESS**

Because of the lateral configuration of our ears, sound signals that are slightly different in each ear allow the listener to hear an acoustical quality called spaciousness, which is usually highly desired, especially for classical music. This sense of spaciousness can be enhanced if the distribution of sound through a large hall is diffused, and the ear literally hears reflections from many facets of the side and rear walls. This diffusion can be enhanced by protrusions and angled surfaces on the side walls.

**REVERBERATION TIME (RT)**

Refer to the accompanying charts on optimum reverberation times and preferred volume/seat ratios. Room volume and

area of absorption can be calculated to predict RT. The biggest design factor affecting RT is ceiling height. The relationship between the volume of a hall and the number of seats is often a good approximation of sound quality in the room.

In wide halls with high ceilings, seats in the center of the orchestra often suffer from lack of early reflections. Reflecting canopies or arrays over the front rows can bring reflected sound to these seating areas, which otherwise may suffer from poor articulation. Often, seating at the rear of the balcony does not experience this problem, and these seats have excellent acoustics.

**PREFERRED VOLUME/SEAT RATIOS**

VOLUME/SEAT		SOUND QUALITY OF SPACE
CU FT	M <sup>3</sup>	
Less than 200	Less than 6	Quite dead, suitable for speech and cinema
300 to 350	8 to 10	Good for music
Greater than 500	Greater than 14	Good for organ music only, too reverberant for speech

**ARTICULATION**

Much of the clarity of sound that audiences need for speech intelligibility and clear musical attacks comes from the sound reflected off hard surfaces that reaches listeners within 50 to 80 milliseconds of the direct sound (which always reaches the listener first). To enhance articulation of acoustics in a hall, the design must ensure there are enough surfaces to reduce the time gap between the initial (direct) sound and these early reflections; the initial time delay gap should be less than 50 milliseconds. Sound travels 1120 ft/second (in SI units, 333 m/second), so the initial time delay gap for prime seating locations should not exceed 50 ft (13 m).

**OTHER FACTORS**

Following are several other features to be considered when designing performance spaces.

**FOCUSING**

Focusing concentrates sound waves in one area, causing "hot spots" where the sound is louder or unnatural in quality. Concave surfaces either in plan or section can present major focusing problems if they are not identified and treated.

**SEATS**

The largest area of sound-absorbing surface in a performance hall is the seating. If the seats are made of a sound-reflecting material (wood, vinyl, plastic, etc.), their absorptive properties will change dramatically when they are occupied, since a person introduces about 5 sabins for each seat, which significantly affects reverberation time. Use of upholstered seats or pew cushions makes the RT similar whether the seats are empty or fully occupied and will never make the empty hall RT more dead than it would be when fully occupied.

**BALCONIES**

Balconies bring additional persons into a given volume and create more intimacy between audience and performer. However, seating under a balcony can be cut off from the main volume of sound if the balcony overhang is too great. A reasonable rule of thumb is that the overhang depth should not exceed the height of the opening (greater ratios are acceptable where live music is not part of the program).

**ORCHESTRA PIT**

The surface over the orchestra pit should be angled to project sound out to the audience but diffuse so that some energy is reflected back to the performers on stage. The front wall of the orchestra pit should be a hard surface so the front rows of the audience do not hear direct sound and so that more energy is reflected back to the performers on stage. Also, both the front and back walls may need to be treated with movable curtains to vary and control the degree of sound reflected off these surfaces.

**SOUND SYSTEM**

Electronic sound systems may be used for amplification (making the source louder for a big hall), for playback or recorded material, or for both. Depending on the source, the loudspeakers used to distribute the sound should be located at the center slightly in front of the speaker (for speech amplification) or on the left and right sides (for musical stereo playback or amplification of the orchestra pit). Additional loudspeakers may be needed under a balcony or at the rear of the hall to cover the upper balconies. Special effects loudspeakers are added around the hall as needed. The sound control location must be well placed within the audience area covered by the loudspeakers. Additional transmitters using infrared signals or FM radio signals can be used to meet ADA requirements.

**OPTIMUM REVERBERATION TIMES AT MIDFREQUENCIES (500-1000 HZ) FOR PERFORMANCE SPACES**

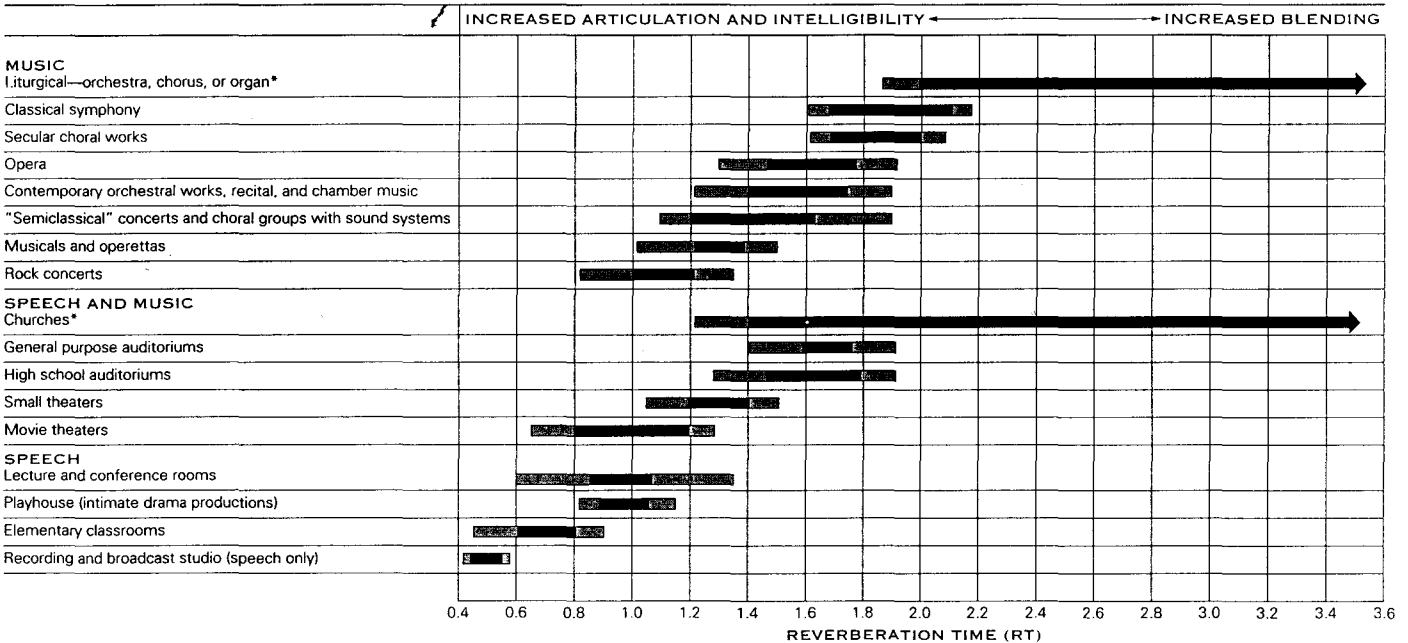

\*May go up to 8 seconds in reverberation time

**NOTE**

The breadth of RT range for each room type is a function of the room volume: the larger the room volume, the closer to the longer end of the range and vice versa.

Carl Rosenberg, AIA; Acentech, Inc.; Cambridge, Massachusetts

**GENERAL**

Open plan offices can provide great flexibility in office arrangements and work flow. However, because workstations or cubicles do not have full-height partitions, noise can be a major problem in such offices. The extent to which speech is distracting depends on the degree to which it is intelligible. An overheard conversation can be annoying or distracting, while an inaudible murmur is not. When designing open plan offices, the need for communication between workstations should be evaluated in light of work functions and practical separation.

Speech intelligibility and acoustics in an open plan office can be rated in terms of an articulation index (AI), which is a measure of the ratio between a signal (a neighbor's voice or intrusive noise) and steady background noise (ambient noise from mechanical equipment, traffic, or electronic sound masking). AI values range from near 0 (very low signal and relatively high noise; no intelligibility or good speech privacy) to 1.0 (very high signal and low noise; excellent communication or no speech privacy). When communication is desired (e.g., in classrooms or teleconference rooms), it is preferable to have a high AI so people can hear well. In an office, however, it is preferable to have a low AI so people can be freed from distraction and will be better able to concentrate. Average noise requirements for various office functions are shown in the accompanying chart.

**ARTICULATION INDEX (AI) FOR OPEN PLAN OFFICES**

AI VALUE	NOISE REQUIREMENTS	
>.65	Good communication	Necessary when communication is desirable (conference rooms, classrooms, auditoriums, etc.)
.35	Freedom from distraction	Reasonable work conditions not requiring heavy concentration or speech privacy; hear and understand neighboring conversations
.20	Normal speech privacy	Occasional intelligibility from a neighbor's conversation; work patterns not interrupted
<.05	Confidential speech privacy	Aware of neighbor's conversation but it is not intelligible

**DESIGN CONSIDERATIONS**

Low AI ratings for open plan office spaces can be achieved in three primary ways: by blocking sound, by covering (masking) sound, and by absorbing sound.

**BLOCKING SOUND**

Partial-height barriers or partitions are necessary to block direct sound transmission between workstations. The barriers must be high enough and wide enough to interrupt the line of sight between a source and a receiver; hence, the first 4 ft or so of barrier height do not help speech privacy at all. Barrier heights of 5 ft are a minimum requirement for acoustical separation, and heights of 6 ft are typical for normal privacy. The barrier should be able to block sound at least as well as the path for sound traveling over the barrier, which means a minimum laboratory sound transmission class value of 24. Barriers or screens should extend to the floor or leave only an inch or so open at the bottom. There should be no open gaps between adjacent panels. Barriers may need to have sound-absorbing facings to reduce reflections to the next workstation.

**COVERING SOUND**

The character and level of background sound is perhaps the most important acoustical design consideration for an open plan office. A modest level of background or ambient sound will cover, or mask, annoying, intrusive sounds. The masking sound must be pleasant and neutral with an even tonal spectrum (like the sound of a comfortable ventilation system) that drops off at the high end of the frequency range. There should be no pure tones or annoying characteristics (like the hum of a fluorescent light ballast).

**BACKGROUND SOUND LEVEL FOR OPEN PLAN OFFICES**

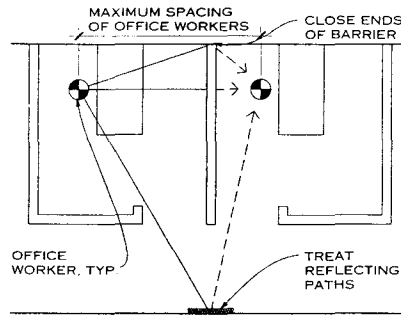
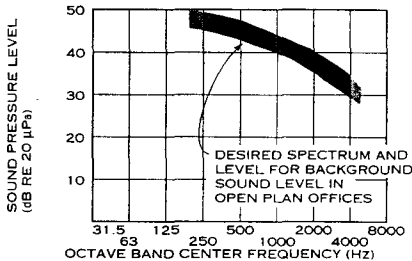

PLAN

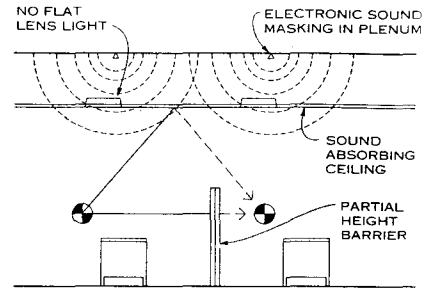

SECTION

**ARCHITECTURAL SOLUTIONS FOR SOUND CONTROL IN OPEN OFFICES**

The sound should be evenly distributed throughout the office so no areas are louder than others. In addition, the sound should not vary in the open plan area by more than 3 decibels in any octave band. Masking sound should be neither too loud nor too quiet, perhaps between 45 and 50 dBA. It should be loud enough to cover intrusive noises but never loud enough to be distracting in itself. Conference rooms and private offices, which require lower levels of background noise, should have plenum treatments so they are shielded from direct exposure to the masking sound.

Normal air conditioning and ventilation could generate enough background noise to mask sound between offices, but this sound source is not well designed for this purpose. Most office buildings use variable volume air distribution, so noise from the HVAC system may be erratic and uneven in distribution and change over time and season. The preferred solution is to install an electronic sound masking system.

Sound masking systems comprise a noise generator, an equalizer to shape the sound spectrum properly, amplifiers, and loudspeakers hidden above an accessible acoustical tile ceiling. Such systems generate a broadband, pleasant sounding, evenly distributed masking noise. The sound in the plenum filters down through the ceiling and provides an even blanket of sound that will mask the intrusive sound from a neighbor. Avoid untreated sound leaks in the ceiling such as openings for return air; these become noticeable "hot spots" and draw unwanted attention to the sound from the ceiling. Masking sound from two channels can improve spatial uniformity. Ceiling height and plenum conditions (fire-proofing, beams, ducts, etc.) will determine loudspeaker spacing and location. Electronic sound masking should be professionally designed and installed.

**ABSORBING SOUND**

The ceiling in an open plan office is the most important surface to treat with highly efficient sound-absorbing material. Glass-fiber ceiling panels often have NRC values of .85 or higher and are the preferred material for open plan spaces. Regular mineral-fiber acoustical panels have typical NRC values of about .55-.65. Hard sound-reflective materials such as exposed structure or gypsum board will dramatically reduce privacy and raise annoying sound levels in an office. Most ceiling tile manufacturers provide extensive NRC data for their products and have special products with high absorptive performance for use in open plan spaces. Materials must also be selected for their ability to reflect light.

Most sound-absorbing materials are measured in a reverberation chamber in accordance with ASTM C 423 to determine their random incidence sound-absorption coefficients ( $\alpha$ ) and from these data, manufacturers typically report the noise reduction coefficient (NRC). The NRC value is a good first approximation of the ability of a material to absorb sound from the human speech range. For office acoustics, however, a more useful value is the ability of a material to absorb sound at an incident angle of 40-60° from a flat ceiling and at frequencies weighted to reflect the relative contribution to speech intelligibility. Therefore, a more effective tool for evaluating the effectiveness of ceiling materials for sound absorption is the speech absorption coefficient (SAC), which can be calculated from standard sound absorption coefficients as follows:

$$SAC = \Sigma(0.06\alpha_{250} + 0.15\alpha_{500} + 0.24\alpha_{1000} + 0.32\alpha_{2000} + 0.23\alpha_{4000})$$

**OTHER FACTORS**

Arrange offices so that entrances are offset, and eliminate direct line of sight or an open view through doorways from one workstation to another. Workstations should be 8-10 ft apart so voice levels are adequately reduced over distance. Higher ceilings can help reduce noise transfer. Light fixtures in the ceiling plane should not have hard lenses or be placed directly above a partition because the fixture can then act as a mirror for sound across the barrier. Absorptive material

may be necessary on some barriers or reflecting surfaces (e.g., walls, file cabinets).

Carpet helps reduce footfall and impact noise and is a great benefit in open offices. Finally, voice levels should be kept to a minimum; even the best acoustical treatments cannot prevent disturbances caused by loud voices.

All the factors outlined in the paragraphs above are interrelated. For example, doubling the distance between adjacent workstations will reduce a nearby conversation by 5 dBA, while raising the height of a 5-ft barrier to 6 ft may reduce the sound path over the top by 3 dBA. Changing from a mineral-fiber acoustical ceiling tile to a glass-fiber ceiling tile may reduce reflected noise by 5 dBA. Adding sound masking may change the ambient level by 10-20 dBA.

An acoustics consultant can evaluate proposed layouts and materials as part of the design process. The acoustical outcome of a design should be analyzed before construction. As a rough initial guideline, offices in which freedom from distraction is the only criterion will require highly efficient sound-absorbing ceilings and an electronic background masking sound at levels between 45 and 50 dBA. For normal speech privacy, these conditions should be augmented by keeping workstations 8-10 ft apart and adding partial-height barriers at least 5 ft high, with increased attention to office layout and reflecting sound paths. Confidential privacy requires higher partitions and more attention to related details and is extremely difficult to achieve in an open plan.

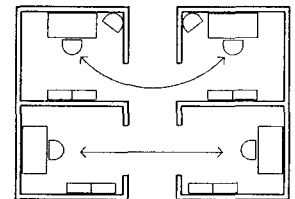

POOR LAYOUT

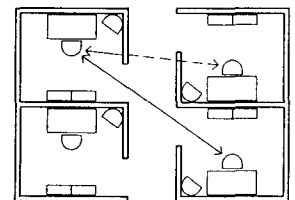

FAIR LAYOUT

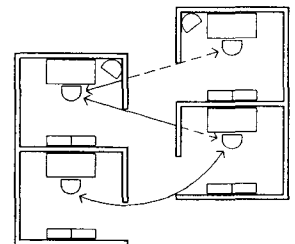

PREFERRED LAYOUT

**OPEN OFFICE CONFIGURATIONS**

Christopher Savereid, Acentech, Inc.; Cambridge, Massachusetts

**GENERAL**

Sound systems are used primarily to provide better listening conditions through sound amplification that increases the loudness of a sound source. Secondary uses of sound systems include recording and playback of audio signals, distribution of audio signals to remote locations, and satisfaction of ADA requirements for provision of assistive listening systems for hearing-impaired individuals.

Sound systems are recommended in all places of assembly, including auditoriums, churches, classrooms, and lecture halls with more than 60 seats; large conference rooms; courtrooms; legislative chambers; and sports arenas, particularly if these facilities will be used by inexperienced speakers. Sound amplification systems should not be used as a substitute for good room acoustical design. The sound system equipment chosen, its location in a space, and the reproduction quality it provides depend on the acoustical properties of that space.

Sound amplification systems should be used when one or more of the following conditions occur: (1) the room volume exceeds 50,000 cu ft; (2) the distance between source and farthest receiver exceeds 50 ft indoors and 25 ft outdoors; (3) the receiver is located beyond 70° horizontally from the source; (4) the room reverberation time exceeds 1.5 sec; and (5) the ambient noise levels are greater than NC-40 indoors or 55 dBA outdoors.

**TYPES OF SOUND SYSTEMS**

Sound systems are designed to serve a wide variety of functions, program types, and spaces. The primary functions are voice and music reinforcement, assistive listening, paging and emergency announcements, sound masking, and audio recording/playback.

**VOICE AND MUSIC REINFORCEMENT**

Voice and music reinforcement systems amplify the spoken word or a music program. Voice reinforcement systems are used in virtually all places of public assembly, but use of music reinforcement systems is usually restricted to auditoriums, amphitheaters, arenas, and churches. Loudspeaker locations are dictated by ceiling height and stage layout. Spaces with ceiling heights greater than 25 ft normally have a large "central cluster" loudspeaker system located above and forward of the stage. Low-ceiling spaces, such as classrooms or under balconies in a theater, normally have small (4- or 8-in. diameter) ceiling-mounted loudspeakers in a "distributed" speaker layout. Music reinforcement typically uses large loudspeakers located on either side of the stage, either set on the floor or hung from the building structure.

**ASSISTIVE LISTENING**

Assistive listening systems provide localized sound reinforcement to listeners who have difficulty hearing the program. These systems are used to comply with ADA requirements. An electrical output from the sound system is routed to a transmitter, either FM or infrared, which radiates a modulated audio signal that is picked up by a receiver carried by the listener. A small in-the-ear headset is connected to the receiver.

**PAGING AND EMERGENCY ANNOUNCEMENTS**

Paging and emergency announcement systems distribute voice or alarm signals. Codes may require that emergency announcement systems be dedicated, use equipment certified by Underwriters Laboratories (UL), or be capable of operating from emergency power sources. The audio program is transmitted via a distributed ceiling loudspeaker system in a 70.7-volt configuration.

**SOUND MASKING**

Sound masking systems radiate pink noise, the frequency content of which is adjusted to make speech less intelligible, thus increasing speech privacy. These systems are commonly used in open office environments, where partial-height workstations may make speech privacy difficult to achieve. Loudspeakers in a 70.7-volt configuration are located in the ceiling plenum, and the sound radiates through the ceiling tile into the space below. Precision adjustment and tuning of sound masking systems is crucial to their acceptance by employees.

**AUDIO RECORDING/PLAYBACK**

Audio media recording/playback systems provide for amplification of sources such as audiotape or compact disc (CD). These systems can function as an element of a larger sound system or they can stand alone. Recording systems use electrical output from the sound system to record the program content to cassette tape or digital audiotape (DAT). Reproducing systems amplify sound from signal storage media, such as cassette tape, DAT, CD, digital video disc (DVD), tape cars, message repeaters, or from a distant origin, such as radio or TV transmissions.

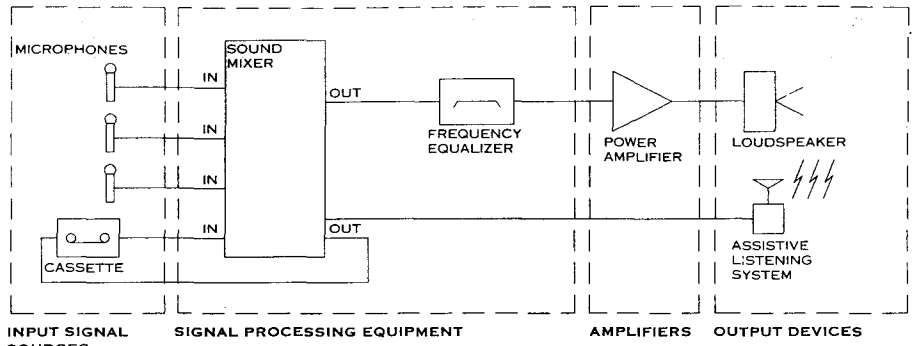

**BASIC SOUND AMPLIFICATION SYSTEM**

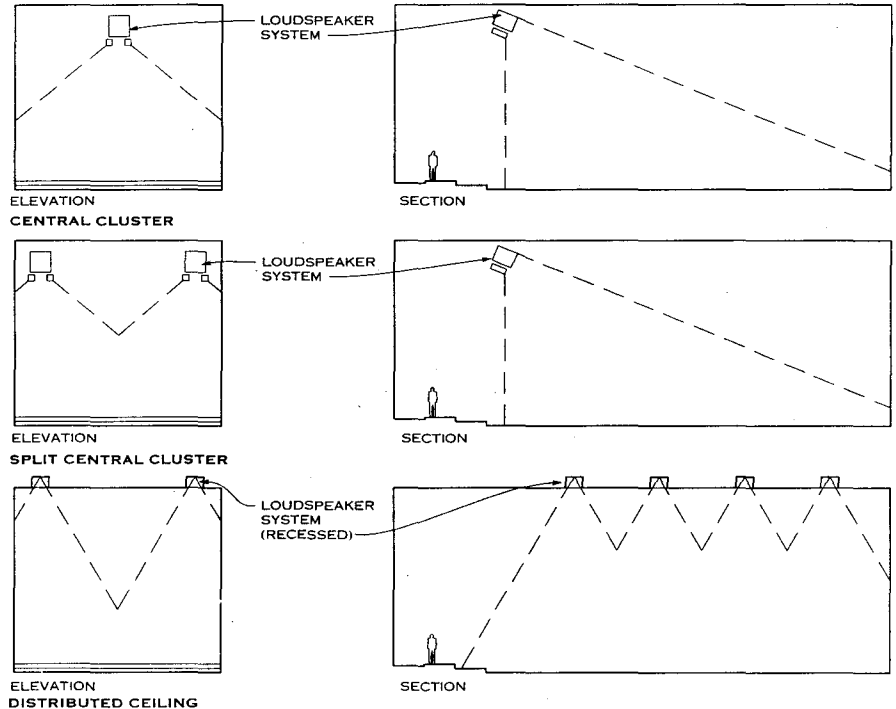

**LOUDSPEAKER SYSTEM TYPES**

**LOUDSPEAKER INSTALLATIONS**

To provide good sound coverage, loudspeakers must be properly integrated into the architectural design of a space. Most spaces have an optimum loudspeaker configuration that should be examined before exploring other options. Loudspeakers can be recessed behind architectural elements, assuming a suitably large opening with acoustically transparent grille cloth is provided.

The major loudspeaker installations include central cluster, split cluster, and distributed ceiling types.

**CENTRAL CLUSTER LOUDSPEAKER**

The central cluster loudspeaker system is located just forward of center stage and elevated a minimum of 20 ft above floor level. Separate low frequency and mid/high frequency loudspeaker components, either individual horn systems or multiway loudspeakers, are used. Listeners must have line-of-sight relationships to loudspeakers in order to receive good sound coverage.

Central cluster systems are not recommended for spaces with ceiling heights less than 20 ft due to sound level differences between the front and rear of the space. Advantages include low cost and naturalness of reproduction because of the inability of the ear to localize sound in the vertical plane.

**SPLIT CENTRAL CLUSTER LOUDSPEAKER**

The split central cluster loudspeaker system is similar in design and operational concepts to the central cluster system, but separate loudspeaker clusters are located at stage right and stage left locations, as might occur in a church with a separate pulpit and lectern or in a music reinforcement system. Each loudspeaker cluster is designed to cover the entire listener seating area. When the talker is at the stage right location, only that loudspeaker operates, likewise for the stage left location. This system provides greater source localization than the central cluster system since it uses the ability of the ear to localize sound in the horizontal plane.

**DISTRIBUTED CEILING LOUDSPEAKER**

Distributed ceiling loudspeaker systems use 4-, 8-, or 12-in. diameter, full-range, transformer-coupled cone loudspeakers, typically in a 70.7-volt configuration installed in the ceiling plane. These systems are normally used in spaces with a ceiling height less than 20 ft. The size of the loudspeaker depends on the ceiling height and whether the system will be used for voice or music reproduction. In spaces where the unamplified source to receiver distance exceeds 30 ft, it is often necessary to electrically delay the signal to the loudspeaker so the listener hears the unamplified sound first, followed in several milliseconds by the sound from the amplified ceiling loudspeaker. The signal processing technique of this system type helps to preserve source localization.

Neil Thompson Shade; Acoustical Design Collaborative, Ltd.; Falls Church, Virginia

**SOUND SYSTEM ELEMENTS**

Sound systems comprise input signal sources, signal processing equipment to alter the properties, of the signal, amplifiers to increase weak signal levels, and loudspeakers to convert electrical signals to acoustical signals.

**MICROPHONES**

A microphone is a transducer that converts sound waves into electrical AC voltage corresponding to the acoustical characteristics of the source. Microphones can be classified by type, transducer element, or polar pattern. The major microphone types are thin profile lectern, performer's handheld, boundary layer, and lavalier.

**LINE LEVEL SOURCES**

Line level signal sources include audio formats such as magnetic tape, audio and optical discs, video, telephonic devices, and radio. These sources are classified as recorded audio (magnetic tape, audio discs, and optical discs) or real-time audio (videoconferencing, telephone, and radio).

**SOUND MIXERS**

Sound mixers combine the electrical output of microphone and line level sources into a composite output signal for distribution to other components of the sound system. Sound mixers are classified as manually operated or automatic hands-off types. Manually operated mixers require placement in the same sound field the audience experiences so the operator can properly adjust the sound system. Automatic microphone mixers control turning on/off of microphones, adjusting gain, and routing of signals.

**SIGNAL PROCESSING**

Signal processing equipment provides the means for altering the frequency, magnitude, delay time, and distribution of audio signals received from the mixer. Signal processing equipment includes frequency equalizers, crossovers, signal delay lines, and distribution amplifiers. These items can be discrete components, or computer-controlled digital signal processing (DSP) can be used to execute their functions.

**AMPLIFIERS**

Amplifiers increase the voltage of the audio signals received from the signal processing devices and distribute the stronger signal to the loudspeakers. Amplifiers are configured as either low impedance output for driving 4, 8, or 16 ohm loudspeakers or as 25, 70.7, or 100 constant voltage output driving transformer-coupled loudspeakers.

**LOUDSPEAKERS**

Loudspeakers convert electrical AC voltage into sound waves. Sound reinforcement loudspeakers have either full-range cone drivers, commonly used for ceiling distributed systems, or multiway loudspeaker systems with separate low frequency and mid/high frequency drivers. Typically, mid/high frequency systems use compression drivers connected to a horn system to provide controlled directional sound coverage output.

**INFRASTRUCTURE**

Sound system equipment is normally installed in standard 19-in. wide equipment rack enclosures. Signal cables are

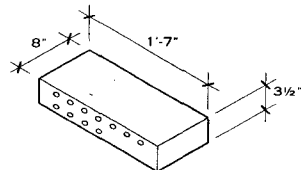

**AUTOMATIC MICROPHONE MIXER**

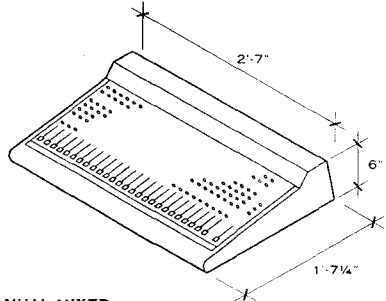

**MANUAL MIXER**

**SOUND MIXERS**

routed from these enclosures to audio wall plates that connect to input and output devices. Normally, metal conduit is used to minimize signal interference and to protect cables.

**ELECTRICAL POWER REQUIREMENTS**

Sound systems should have dedicated power circuits separate from other building electrical services. The major electrical power load comes from the amplifiers, which can easily exceed the power requirements of all other sound system components by a factor of 100. When computer-controlled sound systems are used, provide electrical power surge protection and a source of uninterruptible power.

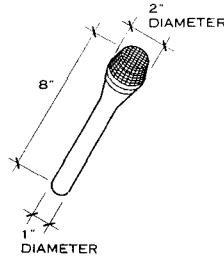

**HANDHELD PERFORMER'S MICROPHONE**

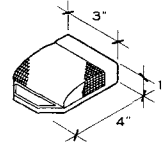

**BOUNDARY LAYER MICROPHONE**

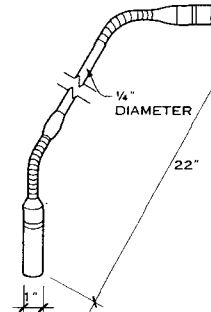

**THIN PROFILE LECTERN MICROPHONE**

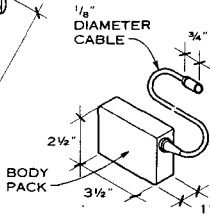

**LAVALIERE MICROPHONE**

**MICROPHONE TYPES**

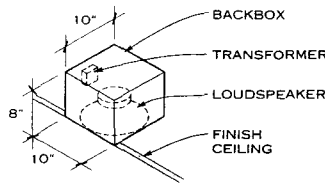

**FULL-RANGE CEILING LOUSPEAKER**

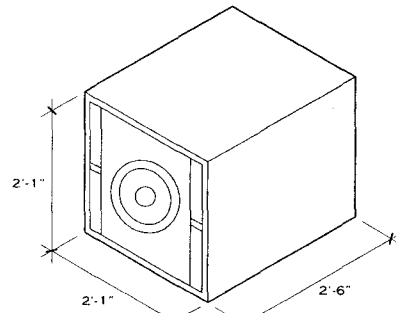

**HORN LOADED LOW-FREQUENCY LOUSPEAKER**

**LOUDSPEAKERS**

**AUDIO EQUIPMENT ROOMS**

Equipment rack enclosures are often housed in a dedicated audio equipment room. In this case, clearance should be left around the enclosures to permit maintenance work. When power amplifiers create a large sensible heat load, audio equipment rooms may require forced air cooling.

Locate audio equipment rooms as close as possible to the microphones and loudspeakers to minimize cable length. Often a separate equipment room is required so the power amplifiers can be located close to the loudspeakers.

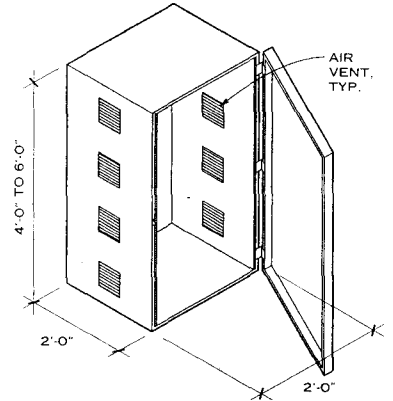

**AUDIO EQUIPMENT RACK**

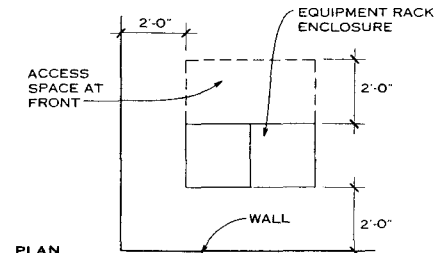

**PLAN NOTE**

Plan for space at each side, in front of, and behind equipment rack enclosures to allow for maintenance and access.

**AUDIO EQUIPMENT ROOM**

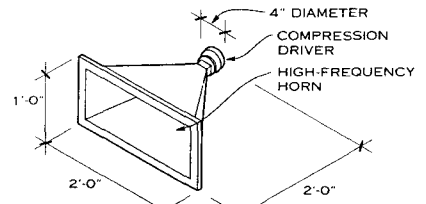

**COMPRESSION DRIVER WITH HORN**

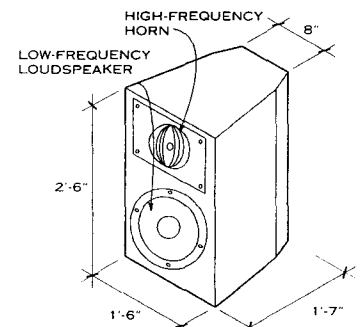

**MULTIWAY LOUSPEAKER**

Neil Thompson Shade; Acoustical Design Collaborative, Ltd.; Falls Church, Virginia

**GENERAL**

Crimes such as vandalism, terrorism, burglary, shoplifting, employee theft, assault, and espionage endanger lives and threaten the built environment. Despite this, security as a design consideration has often been inadequately addressed and poorly funded. Now, however, in many jurisdictions police authorities require security plan reviews as part of the building permit process in the same way they review life safety and fire prevention plans.

Security design is more than bars on windows, a security guard booth, a camera, or a wall. Security involves the systematic integration of design, technology, and operation for the protection of three critical assets—people, information, and property. Protection of these assets is a concern in all building types and should be considered throughout the design and construction process, from programming, schematic design, design development, preparation of construction documents, and bidding, through construction.

The most efficient, least expensive way to provide security is during the design process. Architects called on to address security and crime concerns must be able to determine security requirements, know security technology, and understand the architectural implications of security needs.

Designing without security in mind can lead to expensive retrofitting, which may require more security personnel than security equipment designed in from the start. As well, installation of retrofit security equipment can distort key building design elements and inhibit building function. Most important, planning without security can lead to successful claims against owners, architects, and building managers.

The process of designing security into architecture is known as crime prevention through environmental design (CPTED). It involves designing the built environment to reduce the opportunity for and fear of stranger-to-stranger predatory crime. This approach to security design recognizes the intended use of space in a building and is different from traditional crime prevention practice, which focuses on denying access to a crime target with barrier techniques such as locks, alarms, fences, and gates. CPTED takes advantage of opportunities for natural access control, surveillance, and territorial reinforcement. It is possible for natural and normal uses of the environment to meet the same security goals as physical and technical protection methods.

CPTED strategies are implemented by

1. **ELECTRONIC METHODS:** mechanical security products, target-hardening techniques, locks, alarms, CCTV, gadgets
2. **ARCHITECTURAL METHODS:** architectural design and layout, site planning and landscaping, signage, circulation control
3. **ORGANIZATIONAL METHODS:** manpower, police, security guards, receptionists, doormen, and business block watches

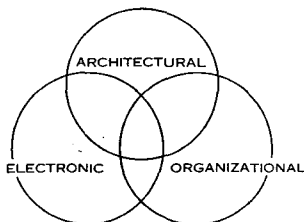

**CPTED STRATEGIES**

**CPTED CONCEPTS**

Concepts involved in crime prevention through environmental design are described below.

**DEFENSIBLE SPACE**

Oscar Newman coined the expression "defensible space" as a term for a range of mechanisms, real and symbolic barriers, strongly defined areas of influence, and improved opportunities for surveillance that combine to bring the environment under the control of its residents.

**NATURAL ACCESS CONTROL**

Natural access control involves decreasing opportunities for crime by denying access to crime targets and creating a perception of risk in offenders. It is accomplished by designing streets, sidewalks, building entrances, and neighborhood gateways to mark public routes and by using structural elements to discourage access to private areas.

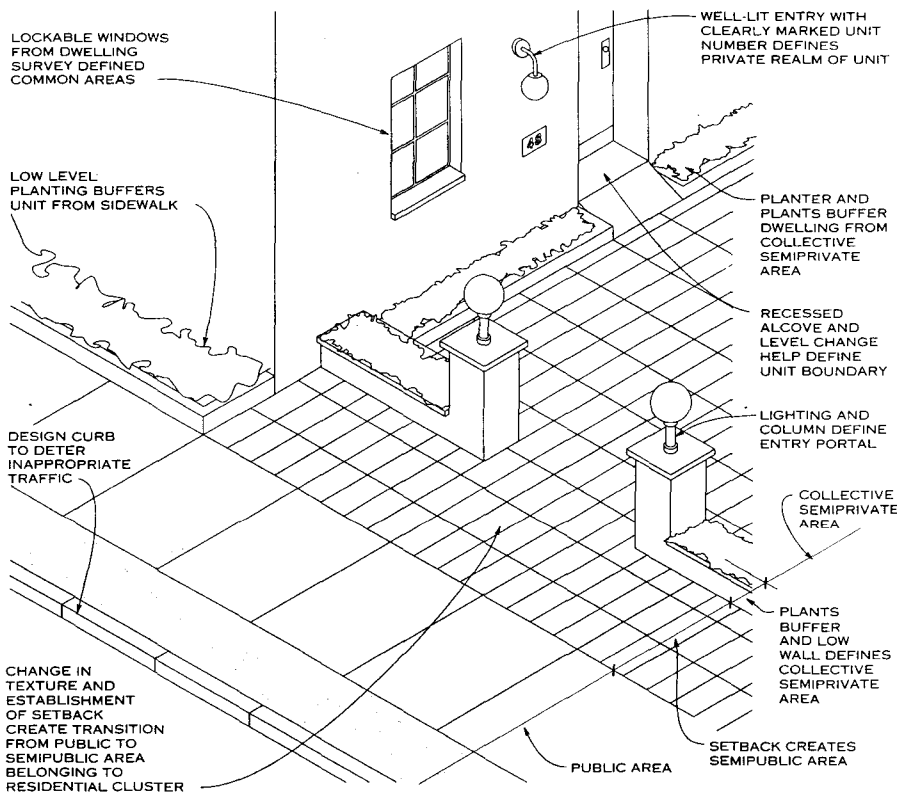

**SECURITY LAYERING OF SPACES**

**NATURAL SURVEILLANCE**

A design concept intended to make intruders easily observable, natural surveillance is promoted by features that maximize visibility of people, parking areas, and building entrances. Examples are doors and windows that look onto streets and parking areas, pedestrian-friendly sidewalks and streets, front porches, and adequate nighttime lighting.

**TERRITORIAL REINFORCEMENT**

Physical design can create or extend a sphere of influence. In this setting, users develop a sense of territorial control, while potential offenders perceive this control and are discouraged from their criminal intentions. Territorial reinforcement is promoted by features that define property lines and distinguish private spaces from public spaces such as landscape plantings, pavement design, gateway treatments, and fences.

**MANAGEMENT AND MAINTENANCE**

Operational and management concepts that maintain buildings and facilities in good working order and that maintain a standard of care consistent with national and local standards contribute to the security effort. Equipment and materials used in a facility should be designed or selected with safety and security in mind.

**LEGITIMATE ACTIVITY SUPPORT**

Legitimate activity for a space or building is encouraged through use of natural surveillance and lighting and architectural design that clearly defines the purpose of the structure or space. Crime prevention and design strategies can discourage illegal activity and protect a property from chronic problem activity.

**ADA AND BUILDING SECURITY**

The Americans with Disabilities Act of 1990 (ADA) affects architecture, life safety design, and building security technology dramatically. Sample regulations are listed below. For specifics, please see the act itself.

1. Instructions for access control card readers must be provided in braille for the visually disabled.

2. Door hardware, such as handles, pulls, latches, locks, and other operating devices, must be shaped so they are easy to grasp with one hand. Lever, push-type, and U-shaped mechanisms are acceptable, knobs are not.
3. Elevators must have visual signals to indicate when each call is registered and answered. Elevator doors must remain open for at least 3 seconds.
4. Regulations require counters to be 28 to 34 in. off the floor.
5. Alarm systems for evacuation must provide warnings for the blind, deaf, and nonambulatory staff of the building. Announcements must be louder than 15 dB but not exceed 120 dB for 30 seconds. Visual alarms must flash and be tied into the emergency power circuit. Fire alarms should also incorporate visual strobes to alert individuals who are hearing impaired.
6. ATM controls must be at least 15 to 54 in. high and have operating instructions in braille. Night deposit mechanisms must not require a tight grasp (no knobs).
7. Security vestibules must be accessible to individuals in wheelchairs. A maneuvering clearance of at least 4 ft must be provided.

Areas affected by ADA requirements for building security include vaults, safety deposit box rooms, front desk counters, security desk and information counters, control rooms, life safety equipment, safe-refuge areas, turnstiles and security screening checkpoints, all door and locking hardware, and access control devices.

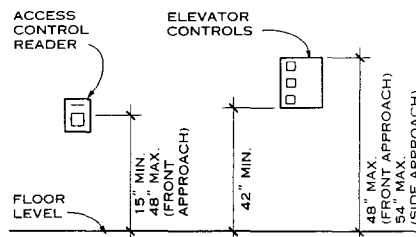

**SECURITY CONTROLS FOR ADA**

Randall I. Atlas, Ph.D., AIA, CPP; Atlas Safety & Security Design, Inc.; Miami, Florida



**PROJECT-RELATED SECURITY EVALUATION**

Security needs for an architectural project should be determined early, preferably as part of the programming and needs definition stage. Surveys of similar existing operations and interviews with personnel at these sites can help identify security concerns.

Once a client, owner, or security consultant has identified the security objectives of a project, the architect must ensure the design supports these objectives. Basic decisions about circulation, access, building materials, fenestration, and other design features can support or thwart overall security aims. The architect's role is to incorporate the basic security requirements and programmatic objectives into the project.

**PROJECT DESCRIPTION**

The first step in determining site-related security requirements is to identify the location, building type, style of operation, and economic aspects of the project. Security levels (high-low) can be defined by determining which areas, items of equipment, buildings, and activities and personnel are most sensitive or vulnerable.

**SITE SELECTION AND EVALUATION FOR THREATS AND VULNERABILITY**

Security objectives should be considered when choosing a site. For example, crowded sites can make it difficult to provide an adequate buffer around the perimeter or to control and check on-site circulation.

Once a site has been selected, the crime prevention through environmental design (CPTED) and security analysis process can identify measures to overcome any security deficiencies. The architect should consider conditions on and off the site, including topography; vegetation; adjacent land uses; circulation patterns; sightlines; potential areas for refuge or concealment; existing lighting conditions; and the types and locations of utilities, including their vulnerability to tampering or sabotage.

Steps for determining the threats to and vulnerability of a project and site are outlined here:

1. Identify a mission statement for the project.
  - a. Identify the assets to be protected.
  - b. Determine what is to be protected according to the categories of people, property, and information.
  - c. Determine the replacement value of the information and property to be protected.
2. Determine how critical security is to the design of the project.
  - a. Analyze the mission of the project.
  - b. Determine present posture/operation positions.
  - c. Determine the ease with which the property and information to be protected could be replaced.
  - d. Analyze the value of what is to be protected.

3. Determine the threats to the project.
  - a. Consider threats from sabotage, espionage, terrorism, street crime, disgruntled employees, workplace violence, among others.
  - b. Consider the value of the assets to be protected, the objectives of potential aggressors, the perceived deterrence of security measures, and the risk level at the site.
4. Determine what modes of attack may threaten the project. Among those to be considered are these:
  - a. Covert entry
  - b. Insider alone
  - c. Insider with others
  - d. Bombing
  - e. Surveillance
  - f. Demonstrations
  - g. Aerial attack
  - h. Standoff attack
  - i. Theft, burglary, robbery
  - j. Destruction
  - k. Contamination
  - l. Unauthorized entry
5. Determine the severity of the potential attacks. Which of the following would the perpetrators be most likely to use?
  - a. Tools
  - b. Weapons
  - c. Explosives
6. Determine the vulnerability of the site, considering the state of the following security measures at the site:
  - a. Security force capabilities
  - b. Penetration delay
  - c. Detection capabilities
  - d. Assessment capabilities
  - e. Access controls
  - f. Procedural controls
  - g. Mission requirements
7. Identify the constraints that will affect what security measures are implemented:
  - a. Financial
  - b. Operational
8. Determine the protection required for the project:
  - a. Where is security critical?
    - 1) At the outer perimeter?
    - 2) At the inner perimeter?
    - 3) At the asset?
  - b. What security measures will be implemented?
    - 1) Barrier/delay
    - 2) Detection
    - 3) Assessment
    - 4) Access control
    - 5) Command and control
    - 6) Manpower
    - 7) Security procedures

fications: organizational (people strategies), electronic (technology and hardware), and architectural (design and circulation patterns). These classifications should be considered for each level of defense or security layer:

1. First level—outer perimeter and site
2. Second level—building exterior
3. Third level—interior control and point security

In defensible space, these security layers are defined as public, semipublic, semiprivate, and private spaces.

**LIGHTING FOR SECURITY**

Security lighting does not prevent or stop crime, but it can help owners protect people and property. Good pedestrian lighting offers the natural surveillance people need to feel comfortable walking ahead or across a parking lot to their cars. Lighting can prevent surprises from jump-out criminals or give pedestrians the opportunity to request assistance, to turn and go another way, or to retreat.

Security lighting goals should be to achieve a uniform, consistent level of light on both pedestrian and vehicular paths of travel. Lighting is critical for the illumination of street and building names and numbers for effective response by police, fire, and emergency personnel. Design lighting to avoid light intrusion into residential settings.

The quality of lighting may be an important security feature. True-color, full spectrum light rendition can help with identification of vehicles and persons. Car lots and gas stations are examples of building types where metal halide luminaires are used for full spectrum light rendition.

**NOTES**

1. Proper beam control saves a system from glare, loss of light energy, and light intrusion.
2. Fixtures should be installed to cast a light pattern over a broad horizontal area rather than a tall vertical area.
3. Light surfaces reflect light more efficiently than dark surfaces.
4. Keep in mind the line of sight between the location of a light fixture and objects that may cast a shadow. Careful placement will avoid dark corners behind doors, trashcans, and other features.

**RECOMMENDED LIGHTING LEVELS (IN LUMENS) BY BUILDING TYPE**

	COMMERCIAL	INDUSTRIAL	RESIDENTIAL
Entrances	10	5	5
Interiors	30-100	30	10
Bathrooms	30	30	30
Elevators and stairs	20	20	20
Public spaces	30	30	—
Private spaces	20	20	20
Self-parking	1.0	1.0	1.0
Attendant parking	2.0	2.0	2.0
Sidewalks	0.9	0.6	0.2

**SECURITY LAYERING**

Once the risks, threats, and vulnerabilities of a project have been assessed, analyze the security measures that could be used for the project. The choices fall into three classification

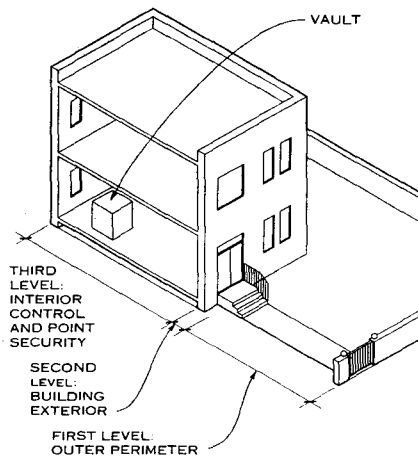

**CLASSIFICATIONS FOR VARIOUS LEVELS OF DEFENSE**

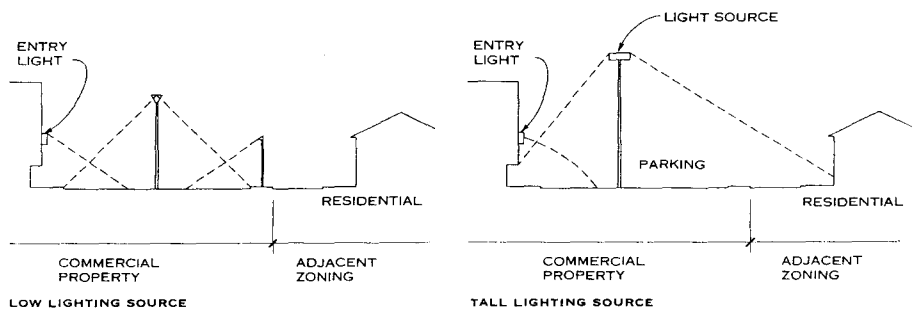

**SECURITY LIGHTING FOR COMMERCIAL PROPERTY**

Randall I. Atlas, Ph.D., AIA, CPP; Atlas Safety & Security Design, Inc.; Miami, Florida

**A SYSTEMS APPROACH TO SECURITY**

An interdependent arrangement of security barriers, technology systems, and security response capabilities yields a responsive and complete security delivery system.

The physical security process primarily consists of fences, building walls, inner walls and doors, and safes and vaults.

The proliferation of electronic security devices and systems, coupled with rapid and substantial advances in the capabilities of these systems, has resulted in a wide array of choices in security technology. To choose effectively among these, architects must gain a basic understanding of the principles and applications of crime prevention through environmental design (CPTED), security design, and operational security.

Use of alarmed surveillance systems can greatly reduce property loss. Reports have shown that even when actual breaking and entering incidents have increased, the amount of property stolen has decreased. This is due in part to the use of alarms, perimeter protection, and intrusion detection systems. However, integrated systems—those that employ the proper procedures, equipment, and people in combination—are the most effective.

In general, the security response capabilities at a particular facility depend on the efforts of the on-site security team. However, architects must design buildings that permit security staff to respond efficiently to incidents requiring their action.

**SENSOR SECURITY SYSTEMS**

Sensor security systems are commonly designed to protect perimeters or to monitor interior space.

PERIMETER SENSOR SYSTEMS may include the following features: continuous line of detection, in-depth protection, complementary sensors, alarm combination, priority schemes, clear zone, site specific system, sensor configuration, tamper protection, self-test compatibility, suitability for physical and environmental conditions, integration with video system, and integration with barrier delay.

Physical and environmental conditions that affect exterior sensors include topography, vegetation, wildlife, background noise, climate and weather, and soil and pavement.

The conceptual design stage of a perimeter sensor system involves identifying targets, defining threats, establishing security requirements, and developing basic security features.

The final design stage requires defining the clear zone surface, determining sensor locations, completing system engineering and specifications, locating perimeter fencing, and designing power and signal distribution.

Tasks in the construction stage include procuring materials, performing surveys, installing conduit and wiring, applying surface material, and installing outer fences and sensors.

Operation tasks are maintenance, testing, training, and documentation.

INTERIOR DETECTION SYSTEMS offer in-depth protection, detect intruders in time for adequate response, detect tampering, and are able to self-test. As well, they must be properly installed (no loose mountings, wiring in conduits, sensors in proper location for detection).

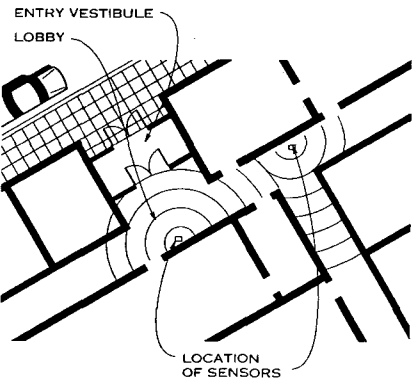

**SAMPLE LAYOUT OF INTERIOR SENSORS**

**TYPES OF SENSORS AND CONDITIONS OF USE**

ULTRASONIC MOTION DETECTORS are used when air turbulence is low and when there are external noise sources that could affect a motion detector that radiated energy outside of the protected area. Use low frequency detectors if audible noise is not objectionable.

MICROWAVE MOTION DETECTORS are used when air turbulence is present in the protected room and when there are no potential false alarm sources outside of the room and in the field of the detector.

PASSIVE INFRARED DETECTORS are used when air turbulence is present in an area or point to be protected. Temperature changes do not affect this type of device, but abrupt changes in light level may cause false alarms.

DETECTORS FOR ROOM BOUNDARIES are used when detectors are needed to give the earliest possible warning of an intrusion. They are used only in conjunction with space detectors for the interior of a room; vibration detectors, acoustic detectors, break beams, and breakwires are suggested.

MULTIPLE SPACE DETECTORS are used jointly when detectors are not affected in the same measure by external noise sources and when false alarm rates can be reduced drastically while still maintaining a reasonable probability of detection.

Multiple space detectors are used singly when one type of detector can protect one part of a room and another detector can protect another part of a room because external noise sources are specifically located.

VIBRATION DETECTORS are used when air turbulence, acoustical noises, and motion outside the room are present. These devices are best suited to protect room boundaries from penetration by drilling or hammering.

ACOUSTIC DETECTORS are used when light air turbulence, vibration, and motion are present outside the room. These devices are most effective in protecting room boundaries from penetration by drilling or hammering.

THERMAL DETECTORS are used to detect temperature rises in small enclosures such as vaults when an intruder uses a torch or burning bar to gain entrance. This device would normally be used in a system that includes other types of intrusion detectors.

**ENVIRONMENTAL EFFECTS ON SENSORS**

Environmental conditions that affect interior sensors include the electromagnetic energy, nuclear radiation, acoustic energy, thermal energy, optical effects, seismic phenomena, and meteorological conditions.

**ACCESS CONTROL SYSTEMS**

The following statements describe features of a good access control system:

1. They cannot be bypassed.
2. They allow observation by a protective force guard.
3. They protect the guard.
4. They block passage until access and material control procedures have been performed.
5. They provide secondary inspection of those who cannot pass the automated inspection.
6. They accommodate peak loads.
7. They accommodate vehicles and people.
8. They perform access and material control.
9. They are under surveillance by a central alarm station.
10. They are designed for both entry and exit.

**CARD TECHNOLOGIES**

BAR CODE cards have a series of vertical or horizontal stripes and spaces printed in a manner that represents coded data. The spaces between the stripes are read optically by a photodetector cell.

EMBOSSED CARDS exhibit pattern codes that are raised or indented in the card's surface and read by their relative position in the card reader.

HOLLERITH CARDS have a pattern of small holes punched into the card that presents specific data to the card reader. This card can be read optically or mechanically. The optical reader depends on the light patterns passing through the holes, while the mechanical reader uses electric read, brush, or switch contacts to read the coded patterns.

INFRARED CARDS depend on encoding information with varying density patterns that are read by infrared detectors. The patterns are optically detected and not visible to the human eye.

MAGNETIC SLUG CARDS have magnetic slugs or metal pieces embedded or layered in them; they are read by magnetic sensing devices. Also known as shim cards, they are generally limited to a single code, making them most suitable for parking operations.

MAGNETIC STRIPE CARDS have stripes or layers of a magnetic material embedded between layers or on a card's surface in vertical columns or horizontal rows. Areas or patterns on this magnetic material can be magnetized in coded patterns and read by magnetic sensing devices.

OPTICAL MEMORY CARDS depend on varied transparency densities arranged in rows, columns, or spots. These patterns are read by a system of light sources and photodetectors.

PROXIMITY CARDS incorporate embedded or laminated RF circuits that utilize electrically tuned circuits that resonate when activated by a transmitter sweeping through the RF range. A receiver picks up the resonating frequency and activates the code deciphering system. Unlike other access cards, the proximity card can be worn or carried and detected at various ranges depending on the design capabilities of the system.

SMART CARDS contain an onboard computer chip and a power supply, normally a lithium battery capable of storing up to six pages of text.

WATERMARK MAGNETIC CARDS contain small oxide particles physically oriented into zones of varying widths. The particles are set while the iron oxide slurry is still fluid; the binary structure spacing of this computer-generated pattern is then oven-cured to create an unalterable 10- or 12-digit code number but leaving another layer of the magnetic stripe available for encoding soft conventional data.

WIEGAND CARDS utilize magnetically embedded unstable ferromagnetic wires formed in a permanently tensioned helical twist. The Wiegand card reader uses a magnetic coil that picks up the flux reversal characteristics of the wires and converts them to binary pulses.

**VIDEO SURVEILLANCE SYSTEMS**

The major components of a video system are the camera, lens, and mount; lighting system; transmission system; synchronization system; video switching equipment; video recorder; video monitor; and video controller.

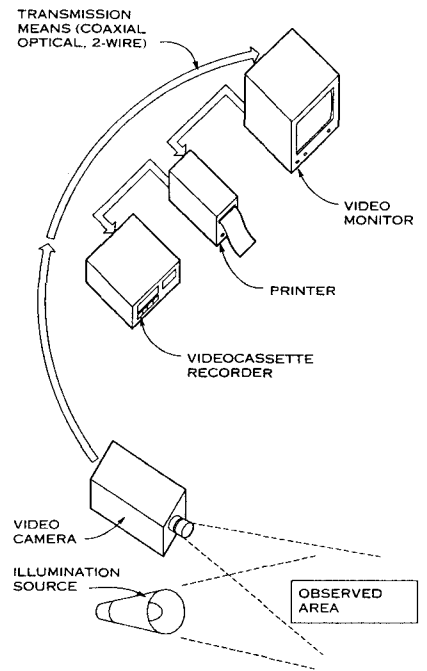

**MAJOR COMPONENTS OF A VIDEO SECURITY SYSTEM**

Randall I. Atlas, Ph.D., AIA, CPP; Atlas Safety & Security Design, Inc.; Miami, Florida

**GENERAL**

Basic security design strategies for building perimeters, interiors, lobbies, stairwells, loading docks, and roofs are outlined here. Also given are specific strategies for practicing crime prevention through environmental design (CPTED) and for addressing the need for bomb resistance.

**BUILDING PERIMETER**

1. Reduce the number of stairwells that exit to the outside.
2. Make the exit through the lobby whenever possible.
3. Entries should funnel people toward the control point.
4. Don't place any entries behind the control point.
5. Define public vs. private areas.
6. Project the image of a secure building.

**INTERNAL AREAS**

1. Place occupant services within protected floor space.
2. Control access to critical operation areas.
3. Provide buffer/reception zones in executive areas.
4. Provide multiple paths of entry/exit for executives.
5. Consider creating safe havens in senior executive offices.

**BUILDING LOBBY**

1. Position the control point between the entry and access to other floors.
2. Move flow past control point.
3. Place restrooms in public areas.
4. Make it possible to secure the lobby level.

**COMMON STAIRWELLS**

1. Designate stairways for emergency use only whenever possible.
2. Prevent access to floors from the garage and public areas.
3. Place stairs so they exit into the lobby.
4. Use internal stairwells for floor-to-floor transit.

**LOADING DOCKS**

1. Restrict access to authorized personnel.
2. Control access from the dock into the building.
3. Provide comfort area for drivers on the dock.
4. Make it possible to close off the dock.
5. Place dumpsters within controlled dock area.
6. Give vehicle staging a separate area.

**ROOFS**

1. Minimize entry points onto the roof.
2. Minimize entry via skylights by using multiple mullions. Solid or fixed diffusers in the light well can also prevent access.
3. Protect roof equipment, such as HVAC cooling towers, from vandalism with roof enclosures with lockable louvered doors spaced far enough from the equipment to allow proper ventilation.
4. Restrict the height of parapets to allow for surveillance from the ground.

**ENVIRONMENTAL SECURITY STRATEGIES**

1. Establish a physical boundary separating public from private property.
2. Design vehicular and pedestrian traffic patterns to maximize natural surveillance of arrivals and departures.
3. Clearly indicate primary and secondary entrances for employees, as well as a primary entrance for visitors.
4. Ensure that visitors will be processed at the main reception area before they proceed to secondary areas of the facility.
5. Erect physical barriers to separate public reception from private office areas.
6. Establish physical and electronic control over exterior and interior access points.
7. Compartmentalize and electronically control access to critical areas such as computer rooms, executive areas, power and telephone closets, and other restricted areas.
8. Physically separate shipping and receiving areas.
9. Restrict access to inventory storage areas.

10. Limit the number of facility exit doors based on operational necessity and fire loading regulations.
11. Clearly mark site entrances with signs that indicate visitor and vendor processing points.
12. Establish physical control over loading docks, equipment sheds, boiler rooms, and trashbins.
13. Provide adequate lighting and surveillance of employee and visitor parking lots.
14. If possible, separate employee and visitor parking.
15. Provide tenants with the means to control their own office areas.
16. Provide reception personnel with a means of covertly signaling duress situations.
17. Establish a uniform means of identification and access for multitenant sites.
18. Utilize primary and secondary authentication methods for access to highly sensitive areas.
19. Clearly delineate employee, visitor, vendor, and contractor status on badges along with the locations and times they are allowed access.
20. Design floor layout plans with security in mind.

**STRATEGIES FOR BOMB RESISTANCE**

Key defensive architectural design considerations for bomb resistance are listed here:

1. Establish a secured perimeter around the building as far from the building as possible.
2. Use poured-in-place reinforced concrete for all framing, including slabs, walls, columns, and roofs.
3. Roof and base slabs should be at least 8 in. thick, exterior walls 12 in. thick, and columns spaced no more than 30 ft apart.
4. Use seismic detailing at connection points.
5. Reinforce floor slabs and roofs using a two-way reinforcing scheme.
6. Design windows that comprise no more than 15% of the wall area between supporting columns.
7. Reduce the flying glass hazard by using a plastic mylar coating on the inside face of the windows.
8. Install specially designed blast curtains inside the windows to catch pieces of glass, while permitting the air-blast pressure to pass through the curtain.

9. Design artistically pleasing concrete barriers as planters or works of art and position them near curbs at a distance from the building.
10. Design buildings in a simple geometric rectangular layout to minimize the defraction effect when blast waves bounce off U-shaped or L-shaped buildings and cause additional damage.
11. Drastically reduce or eliminate ornamentation on buildings that could easily break away and endanger building occupants or pedestrians at street level. All external cladding should be of lightweight materials to minimize damage if they become flying objects after an explosion.

**PARKING GARAGES****NATURAL ACCESS CONTROL**

1. Garages should be attended or monitored openly with cameras and sound monitors marked with signs.
2. Place all pedestrian entrances adjacent to vehicle entrances.
3. Stairwells should be visible, without solid walls.
4. Place elevators close to the main entrance so the entire interior of the elevator is in view when the doors are open.
5. Elevators must not have permanent stop buttons.
6. Design the ground floor to provide a view of the garage: use wire mesh or stretch cable.
7. Limit access to no more than two designated, monitored entrances.

**NATURAL SURVEILLANCE**

1. All elevators should be monitored by cameras and sound or clear materials should be used for the entire car.
2. Replace retaining walls with stretch cable railings for maximum visibility.
3. Parking areas and driving lanes should be well lighted.

**MANAGEMENT**

1. Prohibit free access to adjacent buildings without direct monitoring.
2. Designate public and private parking spaces.
3. Operate during hours similar to those of local businesses.
4. Secure the garage when it is closed.

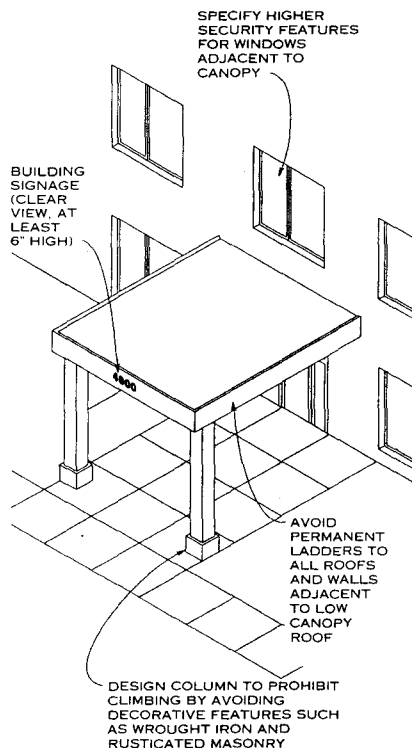
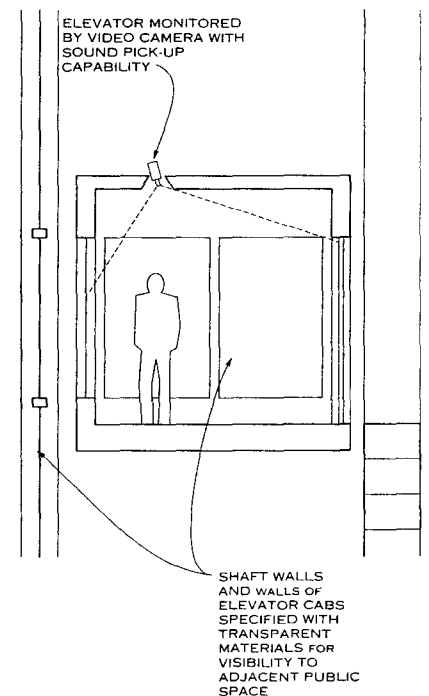
**ROOF AND CANOPY DESIGN****ELEVATORS**

Randall I. Atlas, Ph.D., AIA, CPP; Atlas Safety & Security Design, Inc.; Miami, Florida

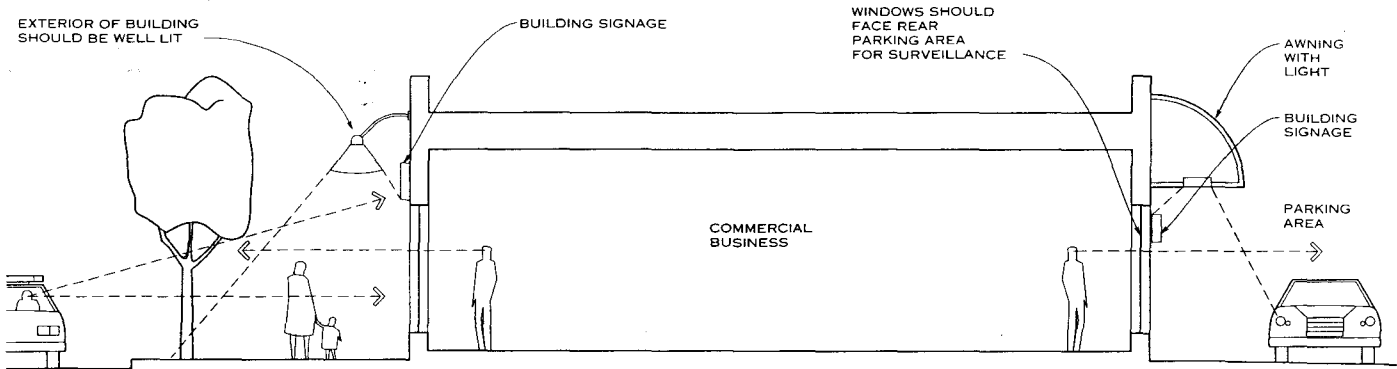
**NOTE**

Clear visibility should be maintained from store to sidewalk, street, parking areas, and passing vehicles. Window signs should cover no more than 15% of any window area.

**NATURAL SURVEILLANCE FOR COMMERCIAL PROPERTY****COMMERCIAL SECURITY**

Designing safe stores and malls is critical to ensuring strong business draw and retention. Commercial security measures and design must protect the patrons, property, and business information of a business.

**COMMERCIAL STOREFRONTS****NATURAL ACCESS CONTROL**

1. Locate cash registers in the front of the store near the main entrance.
2. Clearly mark public paths.
3. Signs should direct patrons to parking and entrances.
4. There should be no easy access to the roof.
5. Shops with rear parking lots should have rear entrances.

**NATURAL SURVEILLANCE**

1. Plan for good visibility: Windows should face rear parking lots. Signs in windows should cover no more than 15% of the window area. Interior shelving and displays should be no higher than five feet. Unobstructed views should be available from the store to the street, sidewalk, parking areas, and passing vehicles.
2. The building exterior should be well-lighted.
3. Loading areas should not create hiding places.
4. Drainage retention areas should be visual amenities, a landscaped pond or smaller waterway rather than a fenced area, but to be secure they should be visible from nearby buildings and streets.
5. All entrances should be under visual surveillance or monitored electronically.

**TERRITORIAL REINFORCEMENT**

1. Where possible, mark property boundaries with hedges, low fences, or gates.
2. Distinguish private areas from public spaces.
3. Identify shops with wall signs for those parking in the rear.
4. Specify awnings over rear doors and windows.

**COMMERCIAL SHOPPING MALL****NATURAL ACCESS CONTROL**

1. Use signs to mark public entrances clearly.
2. Clearly mark sidewalks and public areas with special paving and/or landscaping.
3. Separate loading zones from public parking zones; designate limited delivery hours.
4. The parking garage should provide no exterior access to adjacent rooftops.

**NATURAL SURVEILLANCE**

1. Make restroom doors visible from main pedestrian areas and keep them away from outside exits.
2. Parking areas should be well lighted. Use high-intensity lighting in parking garages to minimize hiding places. In addition, all levels of the parking garage should be visible from the street or ground floor.
3. Loading areas should not create dead-end alleys or blind spots.

**TERRITORIAL REINFORCEMENT**

1. Define property perimeters with landscaping, post-and-pillar fencing, and gates.
2. Keep the number of entrances as low as possible and make them obvious and celebrated.

**MANAGEMENT**

1. Assign close-in parking for nighttime employees.
2. Help business associations work together to promote shopper and business safety.

**COMMERCIAL DRIVE-THROUGHS****NATURAL SURVEILLANCE**

1. Locate ATMs in front of banks facing main roads or as a drive-through in the drive-in teller lanes.
2. Place the ordering station for a restaurant within sight of the restaurant interior.

**OFFICE BUILDINGS**

Office building security focuses on the safety and security of people, goods, and services. Office building security can assume a high or low profile based on the type and number of building users.

**NATURAL ACCESS CONTROL**

1. Clearly define public entrances with walkways and signs.
2. Accentuate building entrances with architectural elements, lighting, and landscaping and/or paving stones.

**NATURAL SURVEILLANCE**

1. Place restrooms where they can be observed from nearby offices.
2. All exterior doors and hallways should be well-lighted, as well as all parking areas and walkways.
3. Dumpsters should not create blind spots or hiding places.
4. Windows and exterior doors should be visible from the street or to neighbors.
5. All four facades should have windows.
6. Do not obstruct windows with signs.

7. Windows and doors should have views into hallways—including peepholes and vision panels.
8. Assign parking spaces to each employee and visitor.
9. Parking areas should be visible from the windows; side parking areas should be visible from the street.
10. Keep shrubbery below 3 ft and tree branches at least 10 ft above the ground for good visibility.

**TERRITORIAL REINFORCEMENT**

1. Define the perimeter with landscaping or fencing.
2. Design fences to permit visibility from the street.
3. Make exterior private areas easily distinguishable from public areas.
4. Position a security and/or a reception area to screen all entrances.

**INDUSTRIAL BUILDINGS**

Industrial enterprises need to protect the assets in their facilities. Special security consideration must be given to receiving and outgoing areas to reduce theft. Individual building tenants should have security technology availability for continuous monitoring and supervision of their space.

**NATURAL ACCESS CONTROL**

1. Avoid creating dead-end spaces.
2. Make site entrances easy to secure.
3. Control entrances to parking areas with fences, gates, or an attendant's booth.
4. Parking should be assigned by shifts and planned so late workers have the close-in spaces.
5. Restrict access to railroad tracks.
6. Plan storage yards for vehicular access by patrol car.
7. Avoid access to roofs via dumpster, loading docks, poles, stacked items, etc.
8. Delivery entrances should be separate, well-marked, and monitored.
9. Place employee entrances close to employee parking and work areas.
10. Separate nighttime parking areas from service entrances.
11. Avoid providing access from one part of the building into other areas.

**NATURAL SURVEILLANCE**

1. All entrances should be well-lighted, well-defined, and visible to public and patrol vehicles.
2. Parking areas should be visible to patrol cars, pedestrians, parking attendants, and/or building personnel.
3. Position the parking attendant for maximum visibility of the property.
4. Give reception areas a view of parking areas.
5. Use walls only when necessary.
6. Blind alleys, storage yards, and other out-of-the-way places should not offer hiding places.

**GENERAL**

Designing CPTED (crime prevention through environmental design) and security features into residential buildings and neighborhoods can reduce opportunities for and vulnerability to criminal behavior and help create a sense of community. The goal in residential design is to create safe dwelling places through limited access to properties, good surveillance, and a sense of ownership and responsibility.

**SINGLE-FAMILY DWELLINGS**

**NATURAL ACCESS CONTROL AND SURVEILLANCE**

1. Use walkways and landscaping to direct visitors to the proper entrance and away from private areas.
2. All doorways that open to the outside as well as sidewalks and all areas of the yard should be well-lighted.
3. Make the front door at least partially visible from the street and clearly visible from the driveway.
4. Windows on all sides of the house should provide full views of the property. The driveway should be visible from the front or back door and from at least one window.
5. Properly maintained landscaping should provide good views to and from the house.

**TERRITORIAL REINFORCEMENT**

1. Front porches or stoops create a transitional area between the street and the house.
2. Define property lines and private areas with plantings, pavement treatments, or fences.
3. The street address should be clearly visible from the street with numbers a minimum of 5 in. high and made of nonreflective material.

**SUBDIVISIONS**

**NATURAL ACCESS CONTROL**

1. Limit access to the subdivision without completely disconnecting it from neighboring areas. However, try to design streets to discourage cut-through traffic.
2. Paving treatments, plantings and architectural design features such as columned gateways can guide visitors away from private areas.
3. Locate walkways where they can direct pedestrian traffic and remain unobscured.

**NATURAL SURVEILLANCE**

1. Landscaping should not create blind spots or hiding places.
2. Locate open green spaces and recreational areas so they can be observed from nearby houses.
3. Use pedestrian-scale street lighting in areas with high pedestrian traffic.

**TERRITORIAL REINFORCEMENT**

1. Design lots, streets, and houses to encourage interaction between neighbors.
2. Accent entrances with changes in street elevation, different paving materials, and other design features.
3. Clearly identify residences with street address numbers that are a minimum of 5 in. high and well-lighted at night.
4. Property lines should be defined with post-and-pillar fencing, gates, and plantings to direct pedestrian traffic.
5. All parking should be assigned.

**MULTIFAMILY DWELLINGS**

**NATURAL ACCESS CONTROL**

1. Balcony railings should never be made of a solid, opaque material or be more than 42 in. high.
2. Define parking lot entrances with curbs, landscaping, and/or architectural design or a guard booth; block dead-end areas with a fence or gate.
3. Hallways should be well-lighted, and elevators and stairs should be centrally located.
4. Common building entrances should have locks that automatically lock when the door closes.
5. Limit access to the building to no more than two points. No more than four units should share the same entrance.

**NATURAL SURVEILLANCE**

1. Make exterior doors visible to the street or neighbors, and ensure they are well-lighted.
2. All four building facades should have windows. Site buildings so the windows and doors of one unit are visible from those of other units.

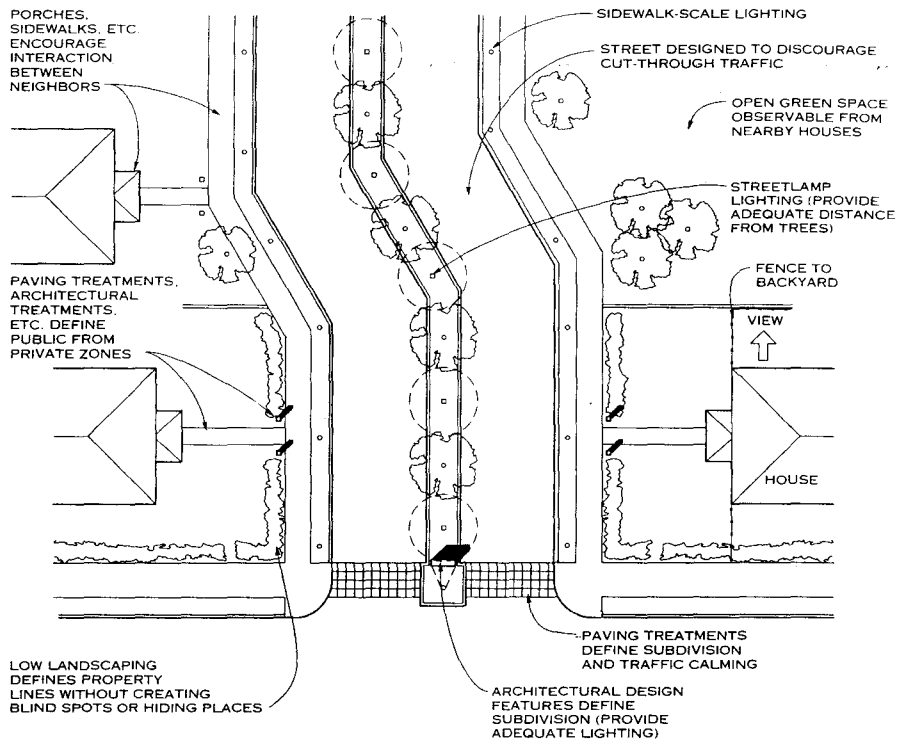

**CRIME PREVENTION THROUGH ENVIRONMENTAL DESIGN—PLANNING FOR SUBDIVISIONS**

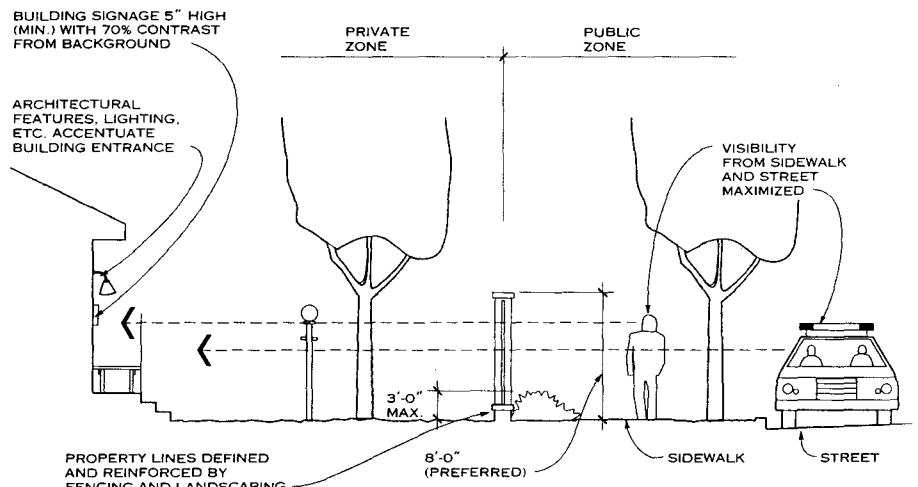

**CRIME PREVENTION THROUGH ENVIRONMENTAL DESIGN—PLANNING FOR RESIDENTIAL PROPERTY**

3. Assign parking spaces to each unit and locate them next to the unit. Designate special parking spaces for visitors.
4. Parking areas and walkways should be well-lighted.
5. Recreation areas should be visible from a multitude of windows and doors.
6. Dumpsters should not create blind spots or hiding places.
7. Elevators and stairwells should be clearly visible from windows and doors. In addition, they should be well-lighted and open to view—not hidden behind solid walls.
8. Shrubbery should be no more than 3 ft high for clear visibility and tree canopies not lower than 8 ft 6 in.

**TERRITORIAL REINFORCEMENT**

1. Define property lines with landscaping or post-and-pillar fencing, but keep shrubbery and fences low to allow visibility from the street.
2. Accent building entrances with architectural elements and lighting and/or landscape features.
3. Doorknobs should be 40 in. from window panes.
4. Clearly identify all buildings and residential units with well-lighted address numbers a minimum of 5 in. high.
5. Common doorways should have windows and be key-controlled by residents.
6. Locate mailboxes next to the appropriate residences.

Randall I. Atlas, Ph.D., AIA, CPP: Atlas Safety & Security Design, Inc.; Miami, Florida

**SITE SECURITY PLANNING AND DESIGN CRITERIA**

The safety and security of a building, its site, and its users should be an important design criteria, similar to such health and safety issues as structural integrity, accessibility, and fire safety. Increased threats to people and property from acts of terrorism, workplace violence, and street crime make it important to identify security issues and establish a plan to manage the risks.

**SECURITY ASSESSMENT**

An assessment of the security requirements should be made as early as possible, preferably as part of the programming phase and certainly before the design phase. Determining the security requirements is mainly a matter of managing the perceived risks. Although the assessment is the owner's responsibility, the architect should ensure that the security requirements have been identified before the design begins. Failure to identify security issues will surely result in design changes, delays, and cost increases for both the owner and the architect.

The security assessment will answer four questions:

1. What are the assets—persons, places, information, property—that require security protection?
2. What are the criminal or other threats—street crime, workplace violence, terrorism, sabotage—against which the assets must be protected?
3. How vulnerable are the assets to the threats (e.g., if workplace violence is identified as a threat, can unauthorized persons enter private work spaces unchallenged)?
4. What countermeasures are required to mitigate the threat (e.g., is the circulation pattern designed to channel visitors through controlled site-access portals)?

The cost of achieving the correct level of site-based protection may be very high, depending on the nature of the protected assets and the perceived threat to them. After the recommended countermeasures have been identified, organize them according to their priority and ask the owner to select those that are prudent and cost-effective for the project. In the case of federal projects (and many state and local government projects as well), the assessment results in the assignment of a defined level of protection (LOP), with specific countermeasures attached to each level. See the discussion below of the GSA Security Standards.

Risk assessment and security design are especially relevant in schools, hospitals, airports, office buildings, and multi-family apartment buildings. In recent years, terrorists have targeted such buildings because of their "architectural vulnerability," so it is clearly important to address security issues in their design.

**SECURITY LAYERING**

One way to think about security requirements is as a layering process. The first layer, the site perimeter of the property, is the first, not the last, line of defense. The U.S. Department of State seeks setbacks of at least 100 feet for new buildings, and even at that distance securing the perimeter is difficult in most urban settings. The building skin of the structure is the next layer. Sensitive areas within a building are deeper layers requiring protection, and, finally, at the center of all the layers, are the particular persons, information, or property that may require point protection.

**GSA RECOMMENDATIONS FOR SECURITY STANDARDS**

In response to bombings of federal office buildings, the federal government has developed security standards for all of its facilities, and an interagency security committee has recommended their adoption as government-wide standards. These standards, known as the GSA Security Standards, encourage a defensible space/crime prevention through environmental design (CPTED) approach that clearly defines and screens the flow of people and vehicles through various layers of public and private space. Edges and boundaries of a property should clearly define the desired circulation patterns and movements. Various screening techniques can be used to separate legitimate users of a building from those who are looking for opportunities to commit crime, workplace violence, or acts of terrorism.

The security standards also address the functional requirements and desired application of security glazing, bomb-resistant design and construction, landscaping and planting designs, site lighting, natural and mechanical surveillance opportunities (e.g., good sight lines, no blind spots, window placement, and proper applications of CCTV). The recommendations are further subdivided according to whether

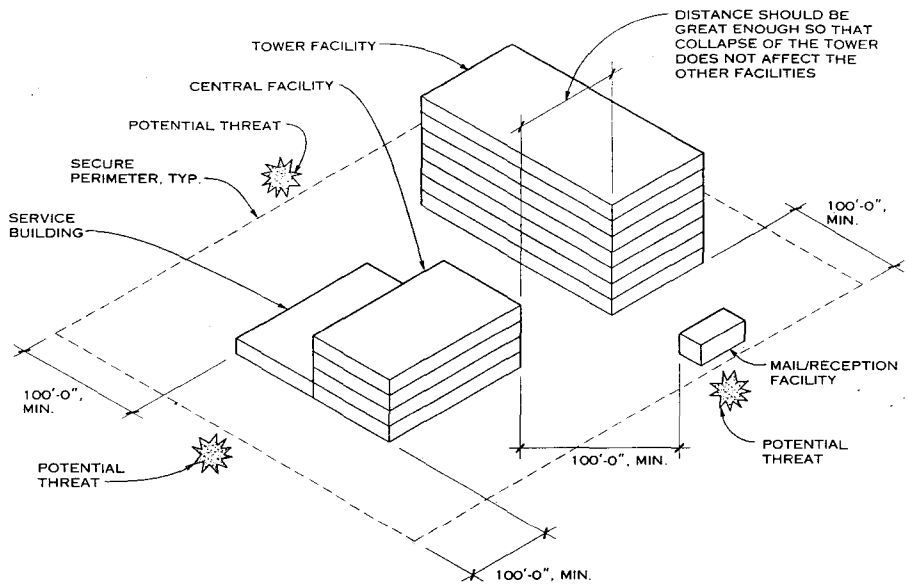

they should be implemented for various levels of security. For example, a level-one facility might not require an entry control system whereas a level-four facility would require electronic controls with CCTV assessment.

Several state and local governments also have reviewed the standards and applied them to new construction. Consult local and state authorities for specific requirements.

The standards take a balanced approach to security, considering cost-effectiveness, acknowledging acceptance of some risk, and recognizing that federal buildings should not be bunker- or fortress-like, but open, accessible, and attractive. Prudent, rather than excessive, security measures are appropriate in facilities owned by and serving the public.

The architecture and engineering team should address the following issues for renovations or new construction on any federal building (and often for state and local buildings):

**SECURITY PLANNING**

1. Security risks and needs of building tenants
2. Mylar film on exterior windows
3. Blast standards for current projects and new construction
4. Design standard for blast resistance and street setback for new construction

**PERIMETER AND EXTERIOR SECURITY**

1. Parking area and parking controls
2. CCTV monitoring
3. Lighting, including emergency backup
4. Physical barriers

**ENTRY SECURITY**

1. Intrusion detection system
2. Upgrade to current life safety standards
3. Screen persons as well as mail and packages
4. Entry control with CCTV and electric door strikes
5. High-security locks

**INTERIOR SECURITY**

1. Employee ID, visitor control
2. Access to utilities
3. Emergency power for critical systems
4. Location of day care centers

**APPLICATION OF GSA SECURITY STANDARDS TO ALL BUILDING TYPES**

Many of the issues addressed in the GSA standards apply to all building types. Among the important security design issues are establishment of (1) hierarchies of public and private spaces; (2) traffic patterns of the site and the building; and (3) opportunities for natural observation of surroundings. Hierarchies of space should proceed from open, pub-

lic areas, to semipublic, to semiprivate, to private spaces. Areas unassigned in the hierarchy become a sort of "no man's land," left unmonitored and unprotected. Traffic patterns of pedestrians and vehicles onto the site and into buildings should be carefully thought-out and controlled. And, finally, all buildings should be designed so that users have a good, unobstructed view of their surroundings.

The following design and planning considerations address both low- and high-threat situations. If neither a high nor a low threat is specified, then the design consideration applies to both situations.

**PLANNING**

1. Vehicular control
  - Low threat: not required
  - High threat: install barriers to stop a vehicle of a specified size
2. Perimeter vehicle inspection
  - Low threat: not required
  - High threat: install sally port with vehicle arrest device
3. Site lighting
4. Signage to control site circulation
5. Landscaping
  - Avoid dense landscaping in both low and high threat.
6. Minimize the number of entrances to a building.
  - Secure entrances when building is not in use.
  - Clearly identify the function of each entrance (e.g., employees only, deliveries, etc).
7. Install barriers on vulnerable openings such as ground floor windows, exterior fire stairs, roof openings, and skylights. Fence off problem areas to prevent unauthorized access and funnel movement along desired paths.
8. Control access for servicing and deliveries.
9. Use graffiti-resistant exterior finishes and/or landscape with creeping vines.

**PARKING**

1. Inside the building
  - Low threat: government vehicles, building employees.
  - High threat: government employees who need security
2. On-site controlled
  - Low threat: no restriction
  - High threat: 100-ft standoff
3. Parking on adjacent streets
  - Low threat: government and key employees only
  - High threat: use structural features to prevent parking
4. Parking on adjacent properties
  - Low threat: 5-ft standoff
  - High threat: 100-ft standoff

*Site Security Planning for Terrorism continues on the next page.*

Randall I. Atlas, AIA, Ph.D., CPP; Atlas Safety and Security Design, Inc.; Miami, Florida  
 Anthony DiGreggario; Applied Research Associates; Washington, D.C.  
 American Society for Industrial Security; Alexandria, Virginia

Site Security Planning for Terrorism is continued from the previous page.

**PARKING (CONTINUED)**

5. Parking facility security systems
6. Minimize the number of entrances to a building
  - Functions of the entrances should be clearly identified (e.g., employees only, deliveries, visitors)
  - Secure entrances when the building is not in use
7. Install barriers on vulnerable openings such as ground floor windows, exterior fire stairs, roof openings, and skylights. Fence off problem areas to prevent unauthorized access and funnel movement along desired paths.
8. Control access for servicing and deliveries.
9. Use graffiti-resistant exterior finishes and/or landscape with creeping vines.

**SITE**

1. Generous wiring and backup power
2. Intrusion detection devices
3. Boundary penetration sensors and motion detection systems
4. Access control systems
5. Contraband, weapons, and explosives detectors
6. Credential readers and positive personnel identification systems
7. Security control and information display systems

**EXTERIOR ENTRANCE**

1. Lobby
  - Protection from forced entry
2. Employee entrances
  - Same as lobby
3. Garage and service entrances
  - Vehicle arrest devices

**ELECTRICAL ENGINEERING**

Except for lighting (#5) and vehicle access control (#6), none of the following is necessary in low-threat projects.

1. Exterior connector for emergency power
2. Exterior surveillance
3. Emergency generator
4. Protected utilities and feeders
5. Adequate lighting (including site lighting)
6. Vehicle access control (parking)
7. Emergency communications (parking)
8. CCTV (parking)

**FIRE PROTECTION ENGINEERING**

1. Secured water supply
2. Dual fire pumps (electric and diesel)
  - Not required in low- or high-threat projects
3. Secured standpipe connection

**ELECTRONIC SECURITY**

1. Operational control center, fire command center, and security control center located together
  - Low threat: not required
2. Backup control center
  - Low threat: not required
  - High threat: locate in manager's or engineer's office
3. Electrical utility closets, mechanical rooms, and telephone closets
  - Low threat: entry with key should be maintained, with some method of noting times of entry and departure, such as marked by a watchman's clock system
  - High threat: access to mechanical, electrical, and telecommunication rooms should be authorized, programmed, and monitored at the security control center through preidentification of maintenance personnel
4. Elevator recall
5. Door lock
  - Low-threat: key-locked security keying system
  - High-threat: high-security keying system with electronic locks
6. Intrusion detection
  - Low threat: magnetic reed switches with optional sensor to detect breaking glass
  - High-threat: same as for low threat, with balanced magnetic contact switch set and sensor to detect breaking glass
7. Monitoring
  - Low threat: commercial central station
  - High threat: on-site, proprietary security control center; review roof intrusion detection
8. CCTV
  - Low threat: not required
9. Duress alarms
  - Low threat: install in key public contact areas, executive offices, and garages as needed
  - High threat: same as low threat

**SUMMARY OF KEY DEFENSIVE ARCHITECTURAL SITE DESIGN CONSIDERATIONS FOR BOMB RESISTANCE**

1. Establish a secured perimeter around the building that is as far from the building as possible. Setbacks of 100 ft are desired.

2. Design concrete barriers as flower planters; position them at curbs, spaced less than 4 ft apart.
3. Build new buildings in a simple, geometric, rectangular layout to minimize the "defraction effect" when blast waves bounce off U-shaped or L-shaped buildings causing additional damage.
4. Reduce or eliminate ornamentation on buildings, and use lightweight materials for exterior cladding. During a bomb blast (or even a hurricane), such ornamentation is likely to break away from the building and may injure building occupants or pedestrians at street level.
5. Eliminate potential hiding places near the facility.
6. Provide unobstructed views around the facility.
7. Site the building within view of other occupied facilities.
8. Locate assets stored on site but outside of the building within view of occupied rooms of the facility.
9. Minimize signage that indicates what assets are on the property.
10. Eliminate lines of approach perpendicular to the building.
11. Minimize the number of vehicle access points.
12. Eliminate or strictly control parking below buildings.
13. Locate parking as far from the building as practical (while still addressing ADA spaces and proximity), and place parking within view of occupied rooms or facilities.
14. Illuminate the building exterior and other areas where assets are located.
15. Secure access to power and heating plants, gas mains, water supplies, and electrical and phone service.

**CONCLUSION**

The design of a building can significantly affect how secure it is from acts of terrorism, workplace violence, and other crimes. The goal for architects is to use architectural design features and elements in a manner that enhances a building's security without compromising its aesthetics and functionality. While there are instances in which a fortress-like structure is the only solution to various security issues, in many cases a simple, well thought-out plan will yield the best results.

**MORE INFORMATION**

1. GSA security standards: [www.gsa.gov/pbs](http://www.gsa.gov/pbs)
2. American Society for Industrial Security: [www.asisonline.com](http://www.asisonline.com)
3. CPTED: [www.cpted-security.com](http://www.cpted-security.com)
4. National Criminal Justice Reference Service: [www.ncjrs.org](http://www.ncjrs.org)
5. Illumination Engineering Society of North America (security lighting): [www.iesna.org](http://www.iesna.org)

**ELECTRONIC SECURITY SELECTION MATRIX**

APPLICATIONS	OPERATING PRINCIPLES	DETECTION						MAJOR CAUSES OF NUISANCE ALARMS								CONDITIONS FOR UNRELIABLE DETECTION	TYPICAL DEFEAT METHODS
		PORTAL OPENING	BREAKING THROUGH WALL/FLOOR/CEILING	RADIAL MOTION	TRANSVERSE MOTION	TOUCHING OBJECT	AIR, HUMIDITY, TEMPERATURE	LOCALIZED HEATING	MOVEMENT OF OUTSIDE AIR	FLUORESCENT LIGHTS	LOOSE FITTING DOORS	MOUNT VIBRATION	AMBIENT ACOUSTICAL NOISE	RODENTS, ANIMALS	RADIO FREQUENCY INTERFERENCE		
BOUNDARY PENETRATION	Balance magnetic	X														Improper installation	Stay-behind intruder or entry through unprotected area
	Vibration		X					X			X						
	Infrasonic	X	X				X					X					
INTERIOR MOTION	Sonic	X		X	X		X				X	X	X		Air movement	Cover when sensor is in "access" mode	
	Ultrasonic	X		X			X				X	X	X				
	Microwave	X		X				X	X		X		X	X			
PROXIMITY	Infrared				X			X			X		X	X	Unstable thermal background	Gross changes in humidity, temperature, or pressure	Disable electronics
	Capacitance					X	X						X				
	Pressure dial					X							X				

Source: Basil J. Steele, American Society for Industrial Security, Alexandria, Virginia

Randall I. Atlas, AIA, Ph.D., CPP; Atlas Safety and Security Design, Inc.; Miami, Florida  
 Anthony DiGreggario; Applied Research Associates; Washington, D.C.

**DESIGN GUIDELINES**

Each commercial development project will have its own set of requirements. This outline is intended as an overview of the subjects the architect, engineer, and owner should consider when planning a small to medium commercial development.

**LOCAL PLANNING REGULATIONS**

As with all new projects, the designer should research the laws, codes, and ordinances that govern development in the jurisdiction. This may include municipal, township, county, state, and federal regulations as they pertain to land and building development.

**ZONING**

Confirm that the zoning classification of the property permits the intended use. For example, to build a warehouse the tract of land would have to be zoned for industrial use. The zoning classification also determines what level of development is allowed on a particular tract of land.

**BUILDING CODES**

The architect should find out what relevant codes/laws require in regard to life safety, welfare, and accessibility. These requirements should provide minimum criteria by which to measure the design and construction of a project. The intended use and type of construction will dictate allowable heights and areas.

Codes vary around the country, so architects must consult the local government for all applicable codes/laws and local amendments. Pertinent laws include the BOCA, UBC, SBCC, NFPA, ASHRAE, ANSI, and the ADA universal accessibility law.

**ENVIRONMENTAL ANALYSIS**

Environmental issues such as wetlands preservation, potential groundwater contamination, and preservation of native flora and fauna should be considered. Local groups can provide information regarding local environmental issues.

**GEOTECHNICAL ANALYSIS**

A geotechnical engineer should be retained at the inception of a project to provide a thorough subsurface investigation of the property. The key information provided by such a survey includes the following:

1. Soil quality/type: Soils are described, ranging from their composition to drainage.
2. Bearing capacity: A variety of field and/or laboratory testing, considered in conjunction with anticipated structural dead loads, goes into analyzing how a planned building will react to the soil conditions on a site. Settlement is one issue to be considered here.
3. Foundation recommendations: The geotechnical engineer uses analytical data about the soil quality/type and the bearing capacity of the soil to make recommendations regarding the most efficient/cost-effective foundation system.

**LOT COVERAGE**

Zoning laws regulate the amount of physical construction that can occur on a given piece of land. Physical construction covers buildings and paved, impervious surfaces (e.g., sidewalks, blacktop). Another measure affecting the allowable building footprint is building setback, the distance that must exist between a structure and the property line. Building setbacks are typically described in terms of front, rear, and side yards; rights-of-way; and property easements. Local municipal ordinances describe required setbacks, which vary based on location and intended use.

**PROPERTY SURVEY**

Property surveys verify the property boundaries, street lines, contours, pertinent landmarks, rights-of-way, and easements (construction restrictions) of a piece of property.

**DRAINAGE EASEMENT**

When properties share a common storm water basin, local authorities can hold easements to allow for storm water drainage across multiple properties. Drainage easements are not required when individual property owners are responsible for storm water management.

**MAXIMUM BUILDING HEIGHT**

The maximum height buildings on a particular site can reach is usually defined in terms of both stories and feet above the finished grade. These criteria are set by local ordinance and building code.

**PARKING REQUIREMENTS**

Parking requirements typically are a function of intended use and building size (e.g., one space per 250 sq ft of building area). In suburban office park planning, this is commonly the governing factor when maximizing buildable area on small and constricted sites.

**UTILITIES**

The architect must determine which utilities are required, which are available, how site access will be designed, and where the utility lines will enter the building. Utilities include water, sewer, gas, electric, and telephone.

**BUILDING ENTRANCE**

Public exposure, topography, orientation, and parking should be considered in designing and siting the main entrance. To maximize a building's presence on the site and help orient users, the main entrance should be obvious and easily visible. Site topography and the intended use of the building will determine orientation of the entrance, with consideration of sun angles and views. The main entrance should be readily recognizable from the main parking area.

**TRAFFIC SURVEY**

A typical traffic survey analyzes traffic patterns, densities, generators, and peak periods. This information is used to determine the guidelines/procedures required to provide safe and effective flows of vehicular and pedestrian traffic. Local governing agencies determine the scope and extent of survey required.

**SERVICE ACCESS**

Architects must consider vehicular service access to both the site and the building. Site design and building orientation must allow for maneuverability of service, delivery, and sanitary vehicles.

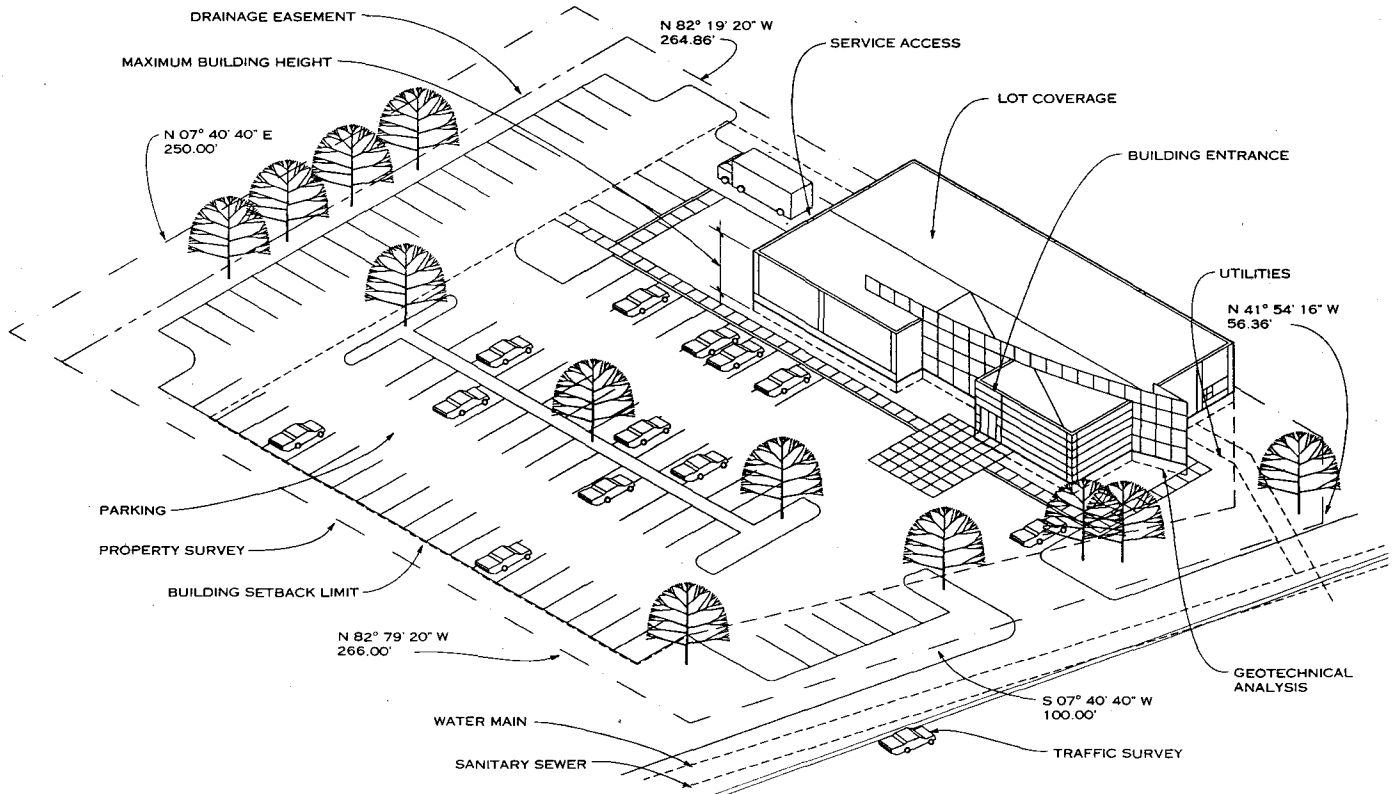

**SITE DEVELOPMENT DIAGRAM**

Greenfield Architects, Ltd.; Lancaster, Pennsylvania



**INTRODUCTION**

The following pages provide the essential elements of town design. Included are an abstract, a set of diagrams, and criteria for town and community design.

Site planning for development projects should be a sequential process that begins with information gathering and ends with detailed design drawings. The process involves three stages: analysis, design, and implementation. The chart below indicates a planning process; however, this can vary to accommodate the specifics of a particular project. Physical site characteristics, urban or suburban location, and community criteria modify the process. The site planning process includes both architect and landscape architect and, in some cases, biologists, civil engineers, and others. An integrated approach to site development and architecture helps create a quality environment. The text on this page is presented as a checklist for structuring a project.

**CLIENT CONTACT AND INPUT**

The first step is contact between the client and the site planner. The client may have some development objectives based on financial capabilities and market feasibility. It is important for the site planner to obtain all client data relative to planning the site.

**LITERATURE REVIEW**

Site planning covers a variety of situations from rural and suburban to high-intensity urban.

There is substantial literature on planning sites and designing neighborhoods of all densities. Recent publications demonstrate a return to the basic town planning principles that have produced orderly community design throughout history.

**COMMUNITY INVOLVEMENT**

Early in the planning process, contact community groups with an interest in the proposed project. Such efforts yield useful information for community design and are particularly important when a proposed project is adjacent to existing development. Compatibility issues are typically resolved with community participation.

One method of involving the community is the "charrette," a participatory planning process with a limited time frame, usually one day to a week, in which residents, municipal staff, elected leaders, and others participate in the physical design of a project. The planner receives local information useful for the design, and individuals and groups bring their interests to bear at the beginning of the design process, thereby expediting final approvals.

**REGIONAL, STATE, AND FEDERAL PLANNING**

Some areas of the country have established regional agencies for intercommunity issues, such as water management, transportation, population studies, and pollution control. Some communities have adopted regional planning guidelines.

State and/or federal criteria can also affect projects. State plans may address broad issues applicable to large sites or impose constraints on sites involving issues of statewide concern. Also, some states require environmental impact statements for large-scale projects. The U.S. Army Corps of Engineers is responsible for environmental review of proposed dredge and fill operations in navigable waters and wetlands. The Federal Flood Insurance Program establishes minimum elevations for potential flood areas. Other state, regional, and local authorities also may oversee the protection of air and water quality and other environmental issues.

**LOCAL PLANNING INFORMATION**

The planner must collect local planning information. Personal contact with planning and zoning agencies is important in order to comprehend local criteria. Following is a list of information to review.

**PLANNING DOCUMENTS**

Many communities have adopted comprehensive plans that indicate the particular land use and intensity of the site. In addition, information on the availability and/or phasing of public services and utilities, environmental criteria, traffic planning, and population trends can be found in most comprehensive plans. Some communities require that rezoning meet the criteria provided in their comprehensive plans.

In addition to the comprehensive plan, communities may also adopt neighborhood or area plans that refine the comprehensive plan as it relates to a particular locale. Many of these studies stipulate specific zoning categories for individual parcels of land.

**URBAN DESIGN PLANS**

Some communities have adopted urban design plans for creating a harmonious physical environment. These documents may range from conceptual to those that incorporate specific requirements. Some provide bonuses in land use intensities for incorporating urban amenities such as plazas and squares. There may also be criteria for retrofitting existing areas, a critical need in American cities where a substantial amount of urban area is deteriorated or developed incoherently.

**ZONING**

Land zoning prescribes the intensity and type of land use allowed. A zoning change is required if the planned project differs. Regulations often need to be modified to allow good community design. Common examples of regulations discouraging good urban form include excessive setbacks and restricted mixed-use development.

**PUBLIC WORKS STANDARDS**

Local public works criteria significantly affect the design of large sites. Roadway layout, cross sections, and drainage are typical requirements. Excessive roadway standards designed for automobile convenience, with little regard for

the pedestrian are typical of today's public works regulations. Such standards should be modified to allow coherent neighborhood design.

**PUBLIC SERVICES AND UTILITIES**

Other information that may require additional research includes

1. Availability of potable water, including local and state regulations on wells
2. Availability of public sewer service, access to trunk lines, and available increases in flow. If sewage lines are not immediately available, determine projected phasing of these services, as well as alternatives to sewage collection and treatment, including septic tanks.
3. Access to public roads, existing and projected carrying capacities, and levels of services of the roads. (State and local road departments can provide this information.)
4. Availability and capacities of schools and other public facilities, such as parks and libraries

**SITE ANALYSIS**

Site analysis is one of the planner's major responsibilities. All the on- and off-site design determinants must be evaluated before design begins. For details, see the following pages on environmental site analysis.

**PROGRAM DEVELOPMENT**

At the program development stage, background research, citizen input, and site analysis are combined with client input and synthesized into a set of program strategies. Basic elements for program development include market and financial criteria; federal, state, regional, and local planning information; local political climate development costs; the client's objectives; and site opportunities and constraints as developed in the synthesis of environmental site determinants. Balancing the various determinants will lead to an appropriate approach to site development. Consider dwelling unit type, density, marketing, time phasing, and similar criteria, as well as graphic studies of the site, to finalize the program. Develop clear graphic representations of design concepts to present to the client and others who may have input to the process. If the project cannot be accomplished under the existing zoning or public works requirements, requesting a regulatory change becomes a part of the program.

**ALTERNATIVE PLAN PREPARATION**

Once the program has been accepted by the client, develop several design solutions to meet the program objectives. When an alternative has been accepted, develop it into the preliminary plan. This plan should be relatively detailed, showing all spatial relationships, infrastructure, landscaping, and other relevant information.

**PUBLIC REVIEW**

A zoning change requires public review. Some communities require substantial data, such as impact statements and other narrative and graphic exhibits, while others may require only an application for the zoning change. Local requirements for changes can be complex, and it is imperative that the planner and the client's attorney are familiar with local criteria.

**FINAL DESIGN PLANS**

At this stage, the preliminary plans are refined into final site development plans that include fully dimensioned drawings, landscape plans, and site details. Final development plans also include drawings prepared by the engineer or surveyor, such as legal plats and utilities, street, and drainage plans. Upon approval, final design plans are recorded in the public records in the form of plats. Homeowner association agreements, deed restrictions, and similar legal documents must also be recorded, and they become binding on all owners and successive owners, unless changed legally. Bonding may be required for infrastructure and other public facilities. In some instances, the planner may develop specific design standards for the total buildout of the project.

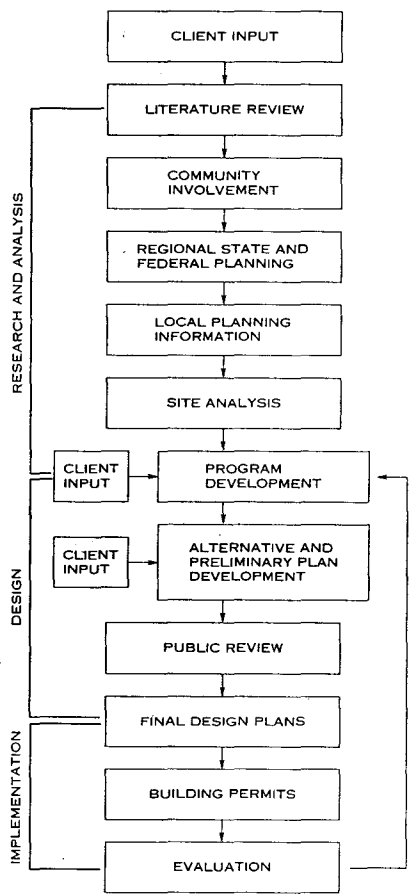

**TOWN PLANNING PROCESS**

Gary Greenan, Andres Duany, Elizabeth Plater-Zyberk, Kamal Zaharin, Iskandar Shafie; Miami, Florida

**1 SITE, COMMUNITY, AND URBAN PLANNING**

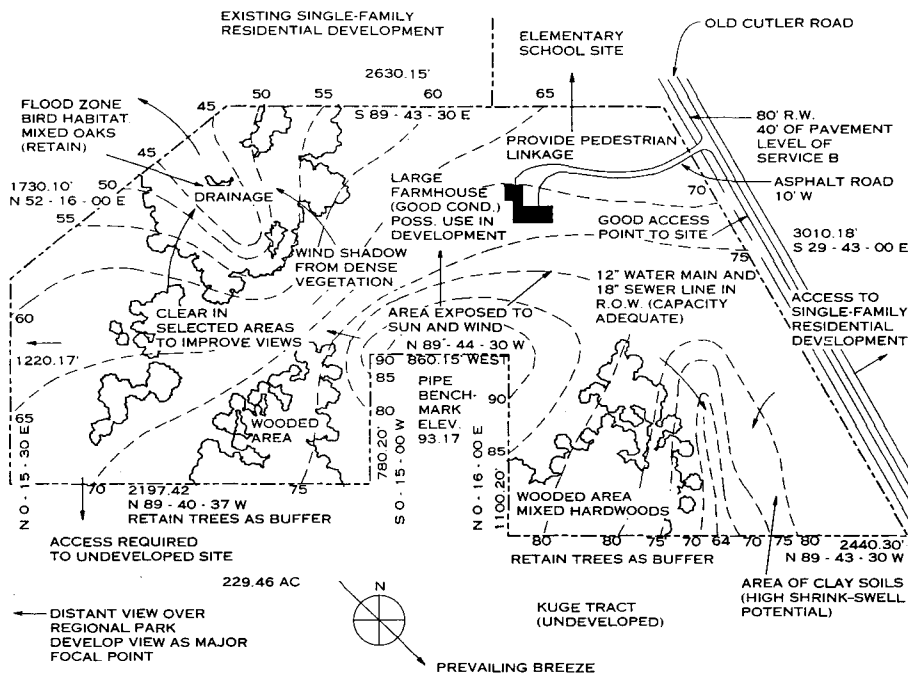

**TOPOGRAPHICAL SURVEY**

**SURVEY DATA**

The first step in any site analysis is the gathering of physical site data. An aerial photograph and an accurate survey showing the following information are basic to any site analysis process:

1. Scale, north arrow, benchmark, and date of survey
2. Tract boundary lines
3. Easements: location, width, and purpose
4. Names and locations of existing road rights-of-way on or adjacent to the tract, including bridges, curbs, gutters, and culverts
5. Position of buildings and other structures such as foundations, walls, fences, steps, and paved areas
6. Utilities on or adjacent to the tract—location of gas lines, fire hydrants, electric and telephone poles, and street lights; and direction, distance to, and size of nearest water mains and sewers and invert elevation of sewers
7. Location of swamps, springs, streams, bodies of water, drainage ditches, watershed areas, flood plains, and other physical features
8. Outline of wooded areas with names and condition of plant material
9. Contour intervals of 2 to 5 ft, depending on slope gradients, and spot elevations at breaks in grade, along drainage channels or swales, and at selected points as needed

Considerable additional information may be needed, depending on design considerations and site complexities such as soil information and studies of the geological structure of the site. Federal regulations for wetland mapping and conservation may also be relevant.

**SUBURBAN SITE ANALYSIS**

The site analysis is a major responsibility of the site planner. The physical analysis of the site is developed primarily from field inspections. Using the survey, the aerial photograph, and, where warranted, infrared aerial photographs, the site designer, working in the field and in the office, verifies the survey and notes site design determinants. These should include, but not be limited to, the following:

1. Areas of steep and moderate slopes
2. Macro- and microclimatic conditions, including sun angles during different seasons; prevailing breezes; wind shadows; frost pockets; and sectors where high or low points give protection from sun and wind
3. Solar energy considerations. If solar energy appears feasible, a detailed climatic analysis must be undertaken considering factors such as detailed sun charts; daily averages of sunlight and cloud cover; daily rain averages; areas exposed to the sun at different seasons; solar radiation patterns; and temperature patterns
4. Potential flood zones and routes of surface water runoff
5. Possible road access to the site, including potential conflicts with existing road systems and carrying capacities of adjacent roadways (usually available from local or state road departments)
6. Natural areas that from an ecological and aesthetic standpoint should be saved; all tree masses with name and condition of tree species and understory planting
7. Significant wildlife habitats that would be affected by site modification
8. Soil conditions relative to supporting plant material, areas suitable for construction, erosion potential, and septic tanks, if relevant
9. Geological considerations relative to supporting structures
10. Exceptional views; objectionable views (use on-site photographs)
11. Adjacent existing and proposed land uses with notations on compatibility and incompatibility
12. Potential noise sources, particularly noise generated from traffic that can be mitigated by using plants, berms, and walls and by extending the distance between the source and the receiver

**URBAN SITE ANALYSIS**

Although much of the information presented for suburban sites may apply equally to urban sites, additional site design criteria may be necessary. The urban environment has numerous design determinants in the form of existing structures, city patterns, and microclimatic conditions.

**ENVIRONMENTAL CONSIDERATIONS**

1. Air movement: Prevailing breezes characteristic of a region may be greatly modified by urban high-rise structures. Predominant air movement patterns in a city may be along roadways and between buildings. The placement, shape, and height of existing buildings can create air turbulence caused by micro air movement patterns. These patterns may influence the location of building elements such as outdoor areas and balconies. Also, a building's design and placement can mitigate or increase local wind turbulence.
2. Sun and shadow patterns: The sun and shadow patterns of existing structures should be studied to determine how they would affect the proposed building. This is particularly important for outdoor terraces and balconies where sunlight may be desirable. Sun and shadow patterns also should be considered as sources of internal heat gain or loss. Building orientation, window sizes, and shading devices can modify internal heat gain or loss. Studies should include daily and seasonal patterns and the shadows the proposed building would cast on existing buildings and open spaces.
3. Reflections: Reflections from adjacent structures such as glass-clad buildings may be a problem. The new building should be designed to compensate for such glare or, if possible, oriented away from it.

**URBAN CONTEXTUAL ANALYSIS**

1. Building typology and hierarchy: An analysis of the particular building type (residential, commercial, public) relative to the hierarchy of the various building types in the city is useful in deciding the general design approach of a new building. For example, public buildings may be dominant in placement and design, while residential buildings are subdominant. It is important to maintain any existing hierarchy that reinforces visual order in the city. Any predominant architectural solutions and details characteristic of a building type incorporated in the new building's design can help maintain a recognizable building type.
2. Regional character: An analysis of the city's regional architectural characteristics is appropriate in developing a design solution that responds to unique regional characteristics. Regional characteristics may be revealed through unique architectural types, through vernacular building resulting from local climatic and cultural characteristics, and from historically significant architecture. Historic structures should be saved by modifying them for the proposed new use or by incorporating parts of the existing structure(s) into the proposed design.
3. City form: The delineation of city form created by road layout, location of major open spaces, and architecture-created forms should be analyzed. Elements that delineate city form should be reinforced by architectural development solutions for a particular place within the city. For example, a building proposed for a corner site should be designed to reinforce the corner through building form, entrance, and design details. A building proposed for midblock may be a visually unifying element providing connection and continuity with adjacent buildings. Sites at the ends of important vistas or adjacent to major city squares probably should be reserved for important public buildings.
4. Building scale and fenestration: It is important to analyze building scale and fenestration of nearby structures. Reflecting, although not necessarily reproducing, such detailing in the proposed building can provide visual unity and continuity in the architectural character of the city. One example is the use and placement of cornice lines to define the building's lower floors in relation to adjacent buildings. Cornice lines also can define the building's relationship to pedestrians in terms of scale and use.
5. Building transition: Sometimes it may be appropriate to use arcades and porches to provide transition between the building's private interior and the public sidewalk. Including them may be especially worthy if adjacent buildings have these elements.
6. Views: Important city views of plazas, squares, monuments, and natural features such as waterfronts and parks should be considered. It is important to design the proposed structure to enhance and preserve such views for the public and for inhabitants of nearby buildings, as well as incorporating them as views from the proposed building.

Gary Greenan, Andres Duany, Elizabeth Plater-Zyberk, Kamal Zaharin, Iskandar Shafie, Rafael Diaz; Miami, Florida

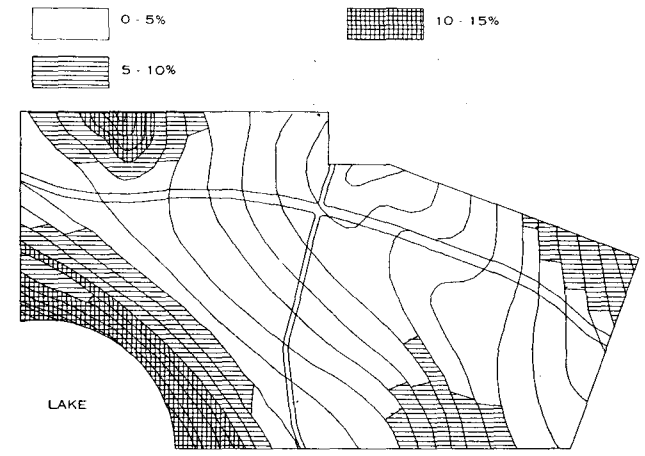

SLOPE

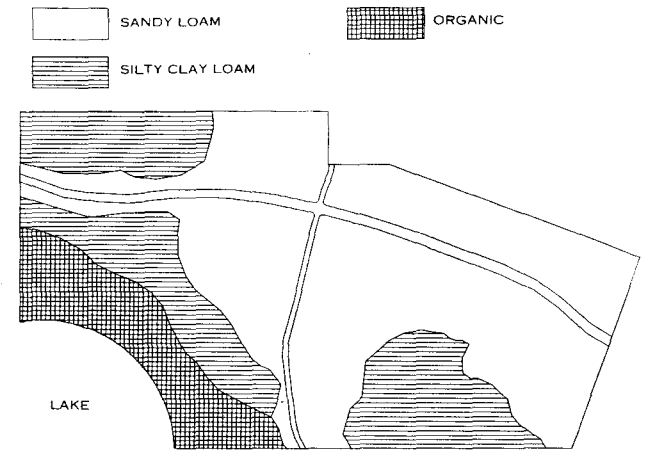

SOILS

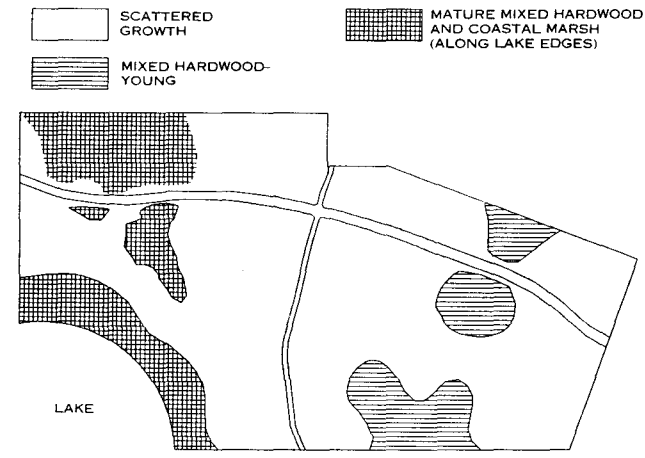

VEGETATION

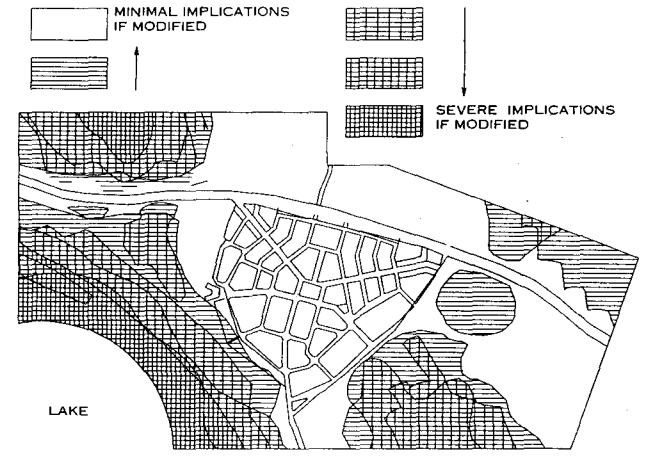

COMPOSITE

**ENVIRONMENTAL SITE ANALYSIS PROCESS**

If a site has numerous environmental design determinants, the site planner may analyze each environmental system individually in order to comprehend the environmental character of the site more clearly. This can be a complex process, and a site planner/landscape architect with expertise in environmental analysis should be retained to coordinate such an effort.

By preparing each analysis on transparencies, the site planner can use the overlay approach. Values are assigned to each sheet based on impact, ranging from areas of the site where change would have minimal effect to areas where change would result in severe disruption of the site. In essence, the separate sheets become abstractions with values assigned by the site planner and associated professionals. As each sheet is superimposed, a composite develops that, when completed, constitutes the synthesis of the environmental design determinants. Lighter tones indicate areas where modification would have minimal influence, darker tones indicate areas more sensitive to change. The sketches shown simulate the overlay process. The site planner may give greater or lesser weight to certain parameters depending on the particular situation. In assigning values that help determine the site design process, the site planner should consider such factors as the value of maintaining the functioning of the individual site systems, the uniqueness of the specific site features, and the cost of modifying the site plan.

Following is a list of the environmental design determinants that, depending on the particular site, may be considered and included in an overlay format:

1. **SLOPE:** The slope analysis is developed on the contour map; consideration should include the percentage of slope and orientation of slope relative to the infrastructure and land uses.
2. **SOIL PATTERNS:** Consideration may include the analysis of soils by erosion potential, compressibility and plasticity, capability of supporting plant growth, drainage capabilities, possible sources of pollution or toxic wastes, septic tank location (if relevant), and the proposed land uses and their infrastructure.
3. **VEGETATION:** Consideration of indigenous species (values of each in terms of the environmental system) includes size and condition, the succession of growth toward climax conditions, uniqueness, the ability of certain species to tolerate construction activities, aesthetic values, and density of undergrowth.
4. **WILDLIFE:** Consideration of indigenous species includes their movement patterns, the degree of change each species can tolerate, and feeding and breeding areas.
5. **GEOLOGY:** Consideration of underlying rock masses studies the depth of different rock layers and the suitability of different geological formations in terms of potential infrastructure and building.
6. **SURFACE AND SUBSURFACE WATER:** Consideration of natural drainage patterns covers aquifer recharge areas, erosion potential, and flood plains.
7. **CLIMATE:** Consideration of microclimatic conditions includes prevailing breezes (at different times of the year), wind shadows, frost pockets, and air drainage patterns.

**COMPUTER APPLICATION**

The above process is labor intensive when developed by hand on individual sheets of mylar; however, this particular method of environmental analysis is easily adaptable to the CAD (computer-aided drafting) system. Commercial drafting programs suitable for the overlay approach are readily available. Simplified, the method is as follows:

1. A map, such as a soil map, is positioned on the digitizer and the information is transferred to the processor through the use of the stylus. One major advantage to the use of a computer is that the scale of the map being recorded will be transferred to the selected scale by the processor. A hatched pattern is selected, with a less dense pattern for soil types that would have minimal influence and more dense patterns for soil types more sensitive to change. Once this information is programmed into the computer, it is stored.
2. The same process is repeated for development of the next overlay; for example, vegetation. Once again any scale map may be used. This process is repeated until all overlays have been stored. At any time one or all overlays can be produced on the screen.
3. The individual overlays or any combination of overlays can be drawn on mylar with a plotter. If appropriate for the particular analysis, the plotter will draw in color. The resulting overlay sheets take considerably less time than by hand and may be more accurate. Other benefits are that the site can be studied directly on the computer screen and any part of the overlay can be enlarged for greater detail.
4. The overlay process can be recorded by videotape or by slides from the screen for use in presentations.

Gary Greenan, Andres Duany, Elizabeth Plater-Zyberk, Kamai Zaharin, Iskandar Shafie, Rafael Diaz; Miami, Florida

1 SITE, COMMUNITY, AND URBAN PLANNING

**SITE ANALYSIS MAP**

Locate natural, cultural, and scenic features first. These include many buildable areas, such as farm fields, pastures, meadows, and mature woodland; special features, such as stone walls, springhouses, cellar holes, and views into and out of the site; and unbuildable areas, such as steep slopes, wetlands, springs, streams, and ice ponds.

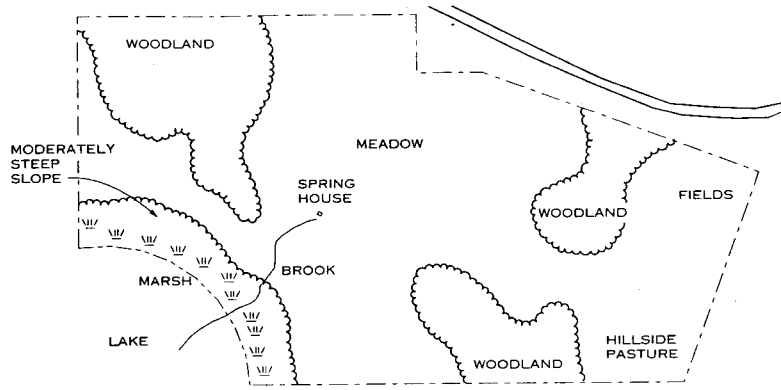

**CONVENTIONAL LAYOUT OR "YIELD PLAN"**

Sketch an unimaginative but legally correct conventional layout to demonstrate the density that could realistically be achieved on the site and, by comparison, to show local officials and abutters how different a rural village approach is. The sketch here shows how, under 1.5-acre zoning, a 520-acre site would ordinarily be checkerboarded into 300 lots, each with a required minimum area of 60,000 sq ft, leaving no open space whatsoever.

**SITE ANALYSIS MAP**



**VILLAGE PLAN**

Designing the development as a traditional village, with lots ranging from 5000 sq ft to 1 acre, achieves slightly greater density on less than one-quarter of the land and preserves nearly 400 acres. This layout is based closely on the site analysis map, with the village located to avoid disturbing the woodlands that provide the only natural habitat in this largely agricultural community. The most special site features are protected by designing around them. Nine "conservancy lots," varying in area from 20 to 60 acres, are limited to one principal dwelling plus two accessory units. This assures significant open space around the perimeter of this 300-lot village. Permanent conservation easements protect these lands from further subdivision and preserve the 150 acres of undivided open space and its trail system, which connects the old springhouse to the lakeshore and leads back to the schoolyard. This open space could be owned by the village government, a local land trust, or a homeowners' association (with automatic membership and authority to place liens on properties of members who fail to pay their dues). Rural views outward from three village streets have also been preserved, with open countryside terminating their vistas. Terminated vistas are also provided by three large public or semipublic buildings (churches, libraries, etc.) positioned at the ends of several streets.

**CONVENTIONAL LAYOUT**

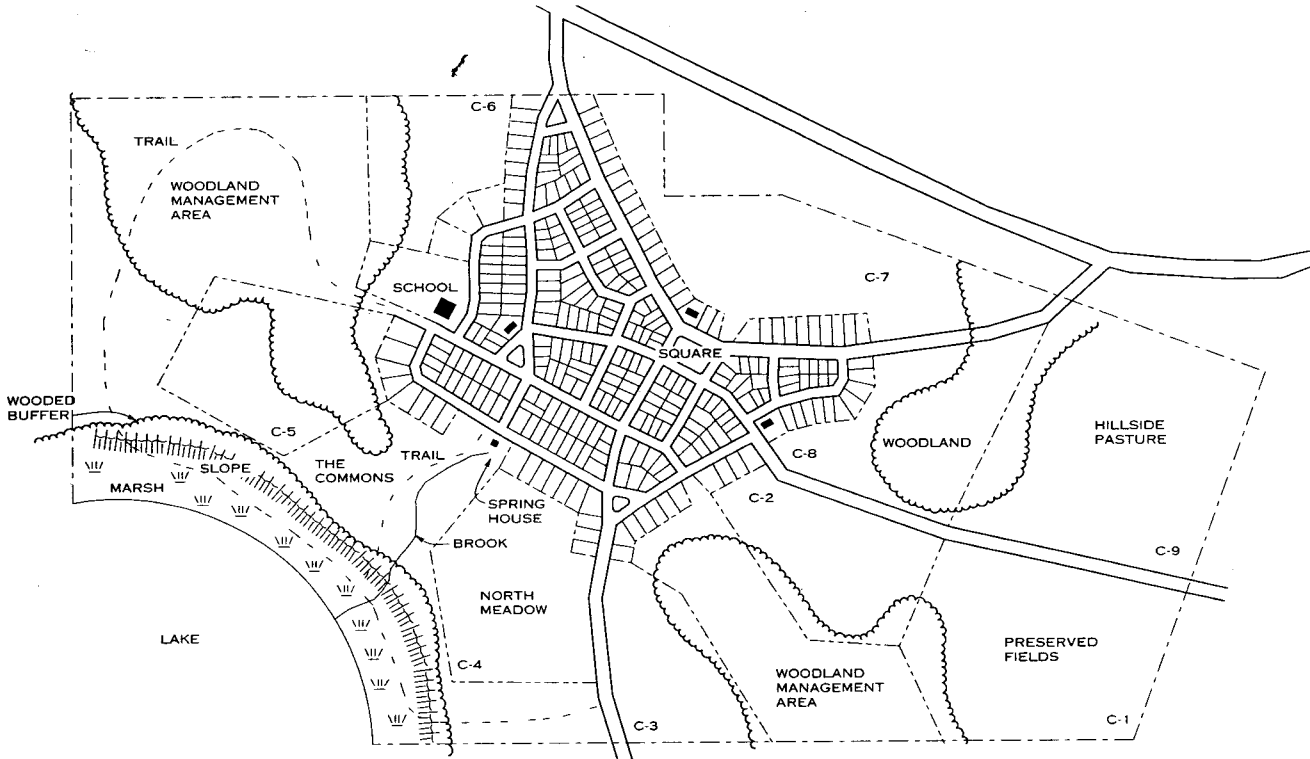

**RURAL VILLAGE DESIGN**

Randall Arendt, MRTPI; Natural Lands Trust; Media, Pennsylvania  
 Gary Greenan, Andres Duany, Elizabeth Plater-Zyberk, Kamal Zaharin, Iskandar Shafie; Miami, Florida

### THE NEIGHBORHOOD, THE DISTRICT, AND THE CORRIDOR

The fundamental elements of urbanism are the neighborhood, the district, and the corridor. Neighborhoods are urbanized areas with a full and balanced range of human activity. Districts are urbanized areas organized around a predominant activity. Neighborhoods and districts are connected and isolated by corridors of transportation or open space.

Neighborhoods, districts, and corridors are complex urban elements. Suburbia, in contrast, is the result of simplistic zoning concepts that separate activities into residential subdivisions, shopping centers, office parks, and open space.

#### THE NEIGHBORHOOD

Cities and towns are made up of multiple neighborhoods. A neighborhood isolated in the landscape is a village.

The nomenclature may vary, but there is general agreement regarding the physical composition of a neighborhood. The neighborhood unit of the 1929 New York Regional Plan, the *quarter* identified by Leon Krier, traditional neighborhood design (TND), and transit-oriented development (TOD) share similar attributes. The population, configuration, and scale may vary, but all of these models propose the following:

1. The neighborhood has a center and an edge. This combination of a focus and a limit contributes to the social identity of the community. The center is a necessity, the edge less so. The center is always a public space—a square, a green, or an important street intersection—located near the center of the urbanized area, unless compelled by geography to be elsewhere. Eccentric locations are justified by a shoreline, a transportation corridor, or a promontory with a compelling view.

The center is the locus of the neighborhood's public buildings. Shops and workplaces are usually here, especially in a village. In the aggregations of neighborhoods that create towns and cities, retail buildings and workplaces are often at the edge, where they can combine with others to draw customers.

The edges of a neighborhood vary in character. In villages, the edge is usually defined by land designated for cultivation or conservation of its natural state. In urban areas, the edge is often defined by rail lines and boulevards, which best remain outside the neighborhood.

2. The neighborhood has a balanced mix of activities: shops, work, school, recreation, and dwellings of all types. This is particularly useful for young, old, and low-income populations who, in an automobile-based environment, depend on others for mobility.

The neighborhood provides housing for residents with a variety of incomes. Affordable housing types include backyard apartments, apartments above shops, and apartment buildings adjacent to workplaces.

3. The optimal size of a neighborhood is  $\frac{1}{4}$  mile from center to edge, a distance equal to a five-minute walk at an easy pace. Its limited area gathers the population within walking distance of many of its daily needs.

The location of a transit stop within walking distance of most homes increases the likelihood of its use. Transit-oriented neighborhoods create a regional network of villages, towns, and cities accessible to a population unable to rely on cars. Such a system can provide the major cultural and social institutions, variety of shopping, and broad job base that can only be supported by the larger population of an aggregation of neighborhoods.

4. The neighborhood consists of blocks on a network of small thoroughfares. Streets are laid out to create blocks of appropriate building sites and to shorten pedestrian routes. An interconnecting street pattern provides multiple routes, diffusing traffic. This pattern keeps local traffic off regional roads and through traffic off local streets.

Neighborhood streets of varying types are detailed to provide equitably for pedestrian comfort and automobile movement. Slowing the automobile and increasing pedestrian activity encourage the casual meetings that form the bonds of community.

5. The neighborhood gives priority to public space and to appropriate location of civic buildings. Public spaces and public buildings enhance community identity and foster civic pride. The neighborhood plan creates a hierarchy of useful public spaces: a formal square, an informal park, and many playgrounds.

#### THE DISTRICT

The district is an urbanized area that is functionally specialized. Although districts preclude the full range of activities of a neighborhood, they are not the single-activity zones of suburbia. Rather, multiple activities support its primary identity. Typically complex examples are theater districts, capital areas, and college campuses. Other districts accommodate large-scale transportation or manufacturing uses, such as airports, container terminals, and refineries.

The structure of the district parallels that of the neighborhood. An identifiable focus encourages orientation and identity. Clear boundaries facilitate the formation of special taxing or management organizations. As in the neighborhood, the character of the public spaces creates a community of users, even if they reside elsewhere. Interconnected circulation encourages pedestrians, supports transit viability, and ensures security. Districts benefit from transit systems and should be located within the regional network.

#### THE CORRIDOR

The corridor is the connector and the separator of neighborhoods and districts. Corridors include natural and technical components ranging from wildlife trails to rail lines. The between is not the haphazardly residual space remaining outside subdivisions and shopping centers in suburbia. It is a civic element characterized by its visible continuity and bounded by neighborhoods and districts, to which it provides entry.

The transportation corridor's trajectory is determined by its intensity. Heavy rail corridors should remain tangent to towns and enter only the industrial districts of cities. Light rail and trolley corridors may occur as boulevards at the edges of neighborhoods. As such, they are detailed for pedestrian use and to accommodate building sites. Bus corridors may pass into neighborhood centers on conventional streets.

The corridor may also be a continuous parkway, providing long-distance walking and bicycling trails and natural habitat. Parkway corridors can be formed by the systematic accretion of recreational open spaces, such as parks, schoolyards, and golf courses. These continuous spaces can be part of a larger network, connecting urban open space with rural surroundings.

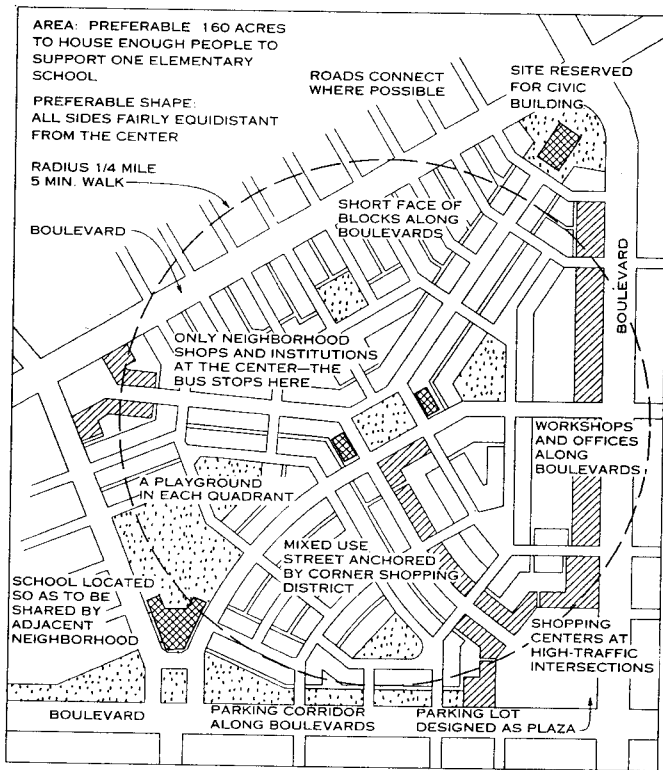

AN URBAN NEIGHBORHOOD (PART OF A TOWN)

Gary Greenan, Andres Duany, Elizabeth Plater-Zyberk, Kamal Zaharin, Iskandar Shafie, Miami, Florida  
The Cintas Foundation

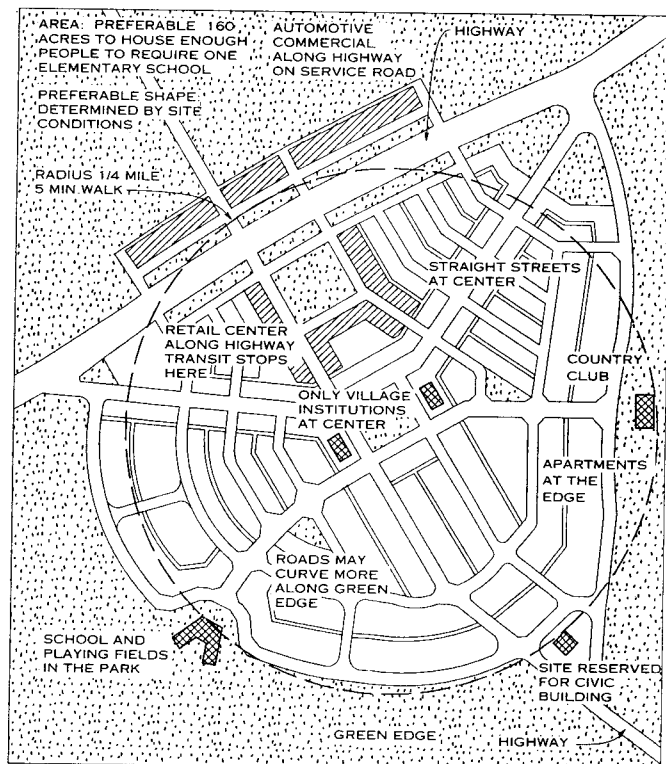

A RURAL NEIGHBORHOOD (A VILLAGE)

1

SITE, COMMUNITY, AND URBAN PLANNING

**GENERAL**

In its short history as a discipline, regional planning has generated a substantial number of models, usually presented as diagrams. Redrawing the main types in a standard graphic form reduces options to a few fundamental models. Most regional plans are hybrids of these few.

Most cities expand through incremental decisions, not by following clear regional plans. But even when followed closely, such plans tend to be implemented in distorted form, due to pressures from natural and man-made conditions. The diagrams of each planning model to the right are accompanied by examples of their application to actual places.

**GARDEN CITY/NEIGHBORHOODS, TOWNS AND VILLAGES**

This is the ancient natural pattern. A clearly defined core city, composed of neighborhoods, is surrounded by towns and villages that are separated by open landscape. Ideally, each element is relatively self-sufficient. This historical pattern has been overwhelmed as mechanical transportation has permitted the city to absorb the surrounding landscape and to erase its neighborhood structure.

A rationalization of this pattern, designating fixed greenbelts and creating independent new towns (garden cities), was proposed by Howard, and restructuring the core city into self-contained neighborhoods was proposed by Saarinen and Perry.

The garden city has been the underlying concept for suburban growth, although its current form is unrecognizably degenerated. With the late arrival of the office park into the residential/retail suburb, the functional elements of the city are now available in the suburb, and the core city has lost its importance. As conceptualized by Fishman and Garreau, this regional pattern is no longer centroidal. The automobile is able to move equally in all directions, although it tends to reinforce major intersections. These intensified points support commercial development, around which residential areas cluster.

This automobile model can be made pedestrian-oriented by traditional neighborhood development (TND), which reconfigures the activities of the shopping center, office park, and housing subdivision into the form of towns and villages. Of the three models described, this is the one most influenced by market conditions.

**LINEAR CITY/CORRIDORS AND WEDGES**

The linear city evolved with the advent of the streetcar. Moving along defined axes, the streetcar extended the boundaries of the centroidal city, creating corridors whose width was limited by the walking distance to the tracks. The arrival of the automobile, with its ability to go anywhere, destroyed the disciplined edges of the corridors, creating undifferentiated sprawl.

The remedial model (corridors and wedges) was conceptualized by Olmsted and MacKaye. Through legislation, the urban fabric is channeled along the transportation axes while wedges of open landscape are preserved between these corridors. The wedges are ideally continuous, formed by an irregular agglomeration of valuable natural features. This is the model most influenced by ecological concerns.

**TRANSIT-ORIENTED DESIGN**

This pattern emerged naturally with the advent of the railroad. Moving along a single axis like the streetcar, but unable to stop as frequently, the railroad creates nodal points of commercial development with residential settlement around them. The advent of the automobile permitted the expansion of these settlements beyond any limit, consuming the landscape.

This model was rationalized and modernized by Calthorpe and Kelbaugh as transit-oriented design (T.O.D.). The T.O.D. creates nodes at intervals most efficient for rail transportation. These mixed-use areas, limited in size by walking distance, are usually surrounded by a residential hinterland connected to the rail system by feeder bus. The commercial uses and other businesses at the nodes may not offer all the services that would make the area self-sufficient (i.e., a town). However, together, several areas linked by rail may be self-sufficient.

This is the model most influenced by the requirements of transportation.

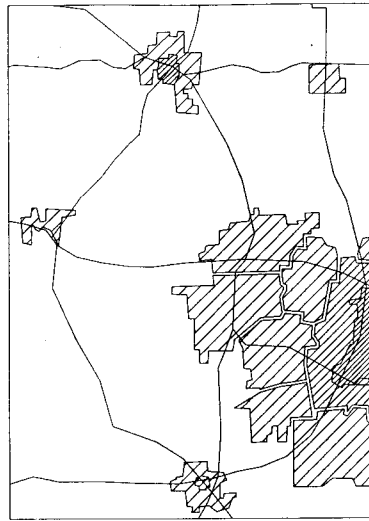

MADISON 1993

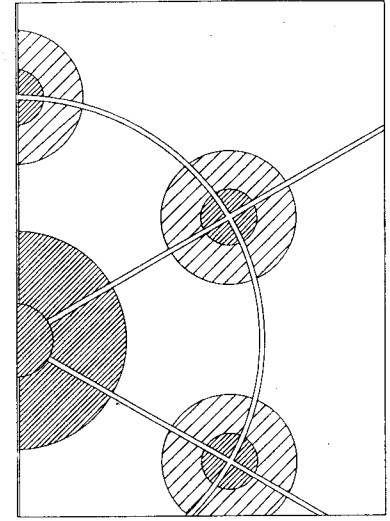

TOWNS AND VILLAGES

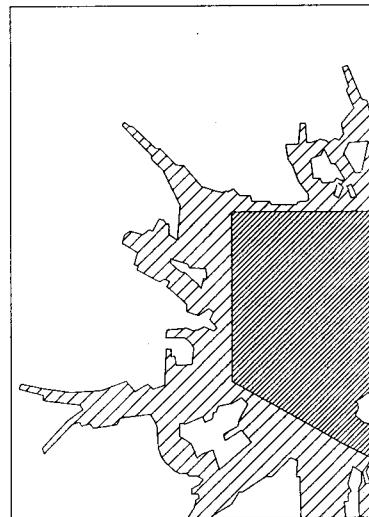

BALTIMORE 1950

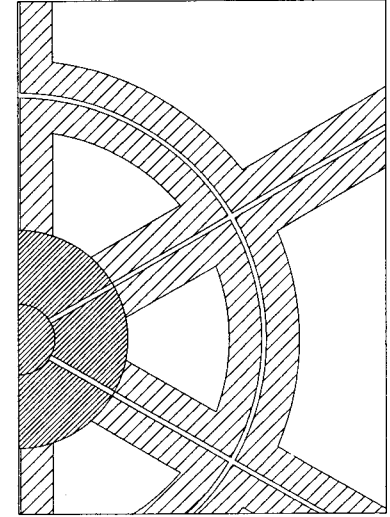

LINEAR CITY

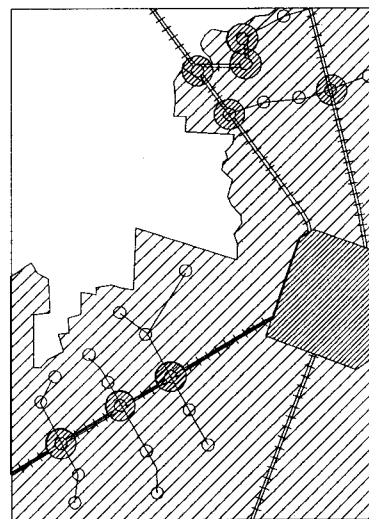

PORTLAND 2020

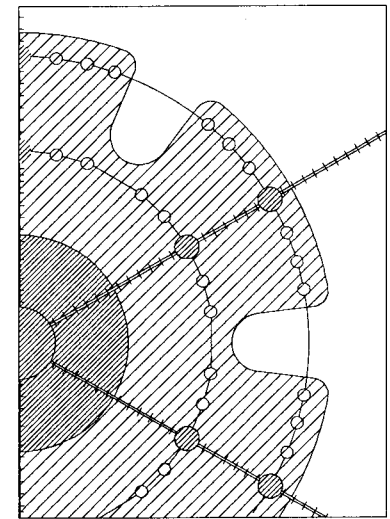

TRANSIT-ORIENTED DESIGN

Gary Greenan, Andres Duany, Elizabeth Plater-Zyberk, Kamal Zaharin, Iskandar Shafie, Rafael Diaz: Miami, Florida  
The Cintas Foundation

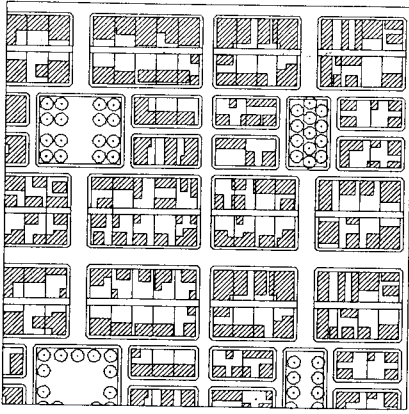

SAVANNAH

**ADVANTAGES**

1. Excellent directional orientation
2. Lot shape controllable
3. Street hierarchy with end blocks for through traffic
4. Even dispersal of traffic through the grid
5. Straight lines enhance rolling terrain
6. Efficient double-loading of alleys and utilities

**DISADVANTAGES**

1. Monotonous unless periodically interrupted
2. Does not accommodate environmental interruptions
3. Unresponsive to steep terrain

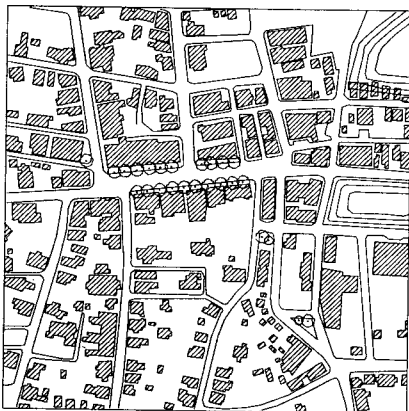
**ORTHOGONAL GRID**

NANTUCKET

**ADVANTAGES**

1. Street hierarchy with long routes for through traffic
2. Even dispersal of traffic through network
3. Intrinsically interesting by geometric variety
4. Responsive to terrain
5. Easily accommodates environmental interruptions
6. Short streets, terminated vistas

**DISADVANTAGES**

1. None

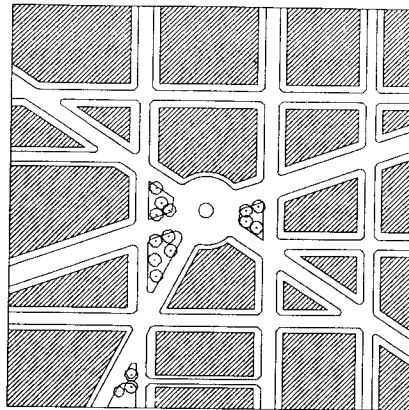
**ORGANIC NETWORK**

WASHINGTON, D.C.

**ADVANTAGES**

1. Street hierarchy with diagonals for through traffic
2. Even dispersal of traffic through the grid
3. Diagonals respond to the terrain
4. Diagonals interrupt monotony of the grid

**DISADVANTAGES**

1. Uncontrollable variety of blocks and lots
2. High number of awkward lot shapes
3. Diagonal intersections spatially ill defined

**GRID WITH DIAGONALS**

RIVERSIDE

**ADVANTAGES**

1. Intrinsically interesting by deflecting vistas
2. Easily accommodates environmental interruptions
3. Highly responsive to terrain
4. Even dispersal of traffic through the network

**DISADVANTAGES**

1. Little directional orientation
2. Uncontrollable variety of lots
3. No natural hierarchy of streets

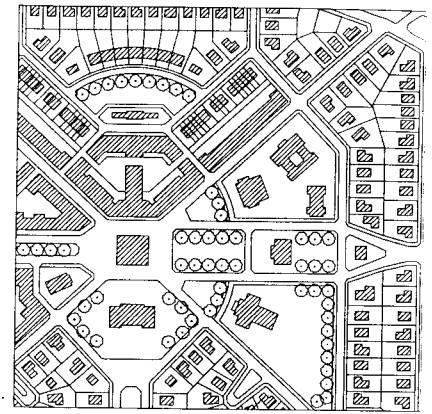
**CURVILINEAR NETWORK**

MARIEMONT

**ADVANTAGES**

1. Street hierarchy with diagonals for through traffic
2. Even dispersal of traffic through the network
3. Diagonals respond to terrain
4. Intrinsically interesting by geometric variety
5. Controllable shape of blocks and lots
6. Efficient double-loading of alleys for utilities
7. Diagonal intersections spatially well defined

**DISADVANTAGES**

1. Tends to be disorienting

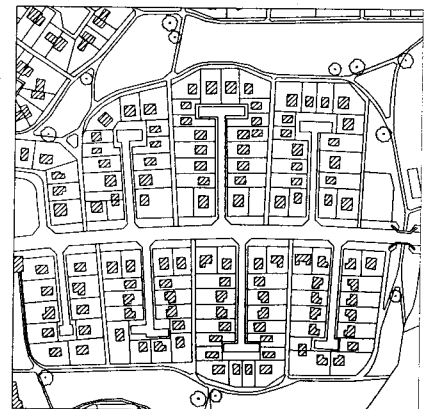
**DIAGONAL NETWORK**

RADBURN

**ADVANTAGES**

1. Street hierarchy with collectors for through traffic
2. Controllable variety of blocks and lots
3. Easily accommodates environmental interruptions
4. Highly responsive to terrain

**DISADVANTAGES**

1. Concentration of traffic by absence of network

**DISCONTINUOUS NETWORK**

Gary Greenan, Andres Duany, Elizabeth Plater-Zyberk, Kamal Zaharin, Iskandar Shafie, Rafael Diaz, Miami, Florida  
The Cintas Fountain



**GENERAL**

The urban plan must be assembled of blocks before building frontage and landscape types are assigned. The disposition of blocks has distinct socioeconomic implications.

**THE SQUARE BLOCK**

This type was an early model for planned settlements in America, particularly in Spanish colonies. It was sometimes associated with agricultural communities, providing four large lots per block, each lot with a house at its center. When the growth of the community produced additional subdivision, replatting created irregular lots (Fig. 1). While this may provide a useful variety, it is more often regarded as a nuisance by a society accustomed to standardized products. A further disadvantage is that discontinuous rear lot lines make alleys and rear-access utilities impractical. Despite these shortcomings, the square block is useful as a specialized type. When platted only at its perimeter, with the center left open, it can accommodate the high parking requirements of certain buildings. The open center, well insulated from traffic, may also be used as a common garden or a playground (Fig. 2).

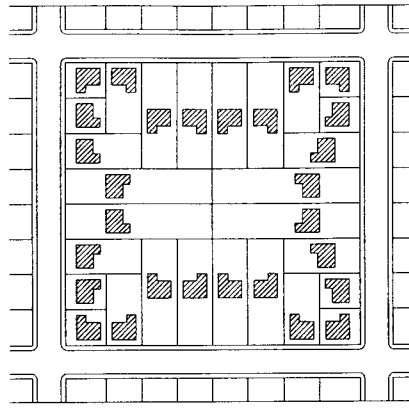

1. SQUARE BLOCK

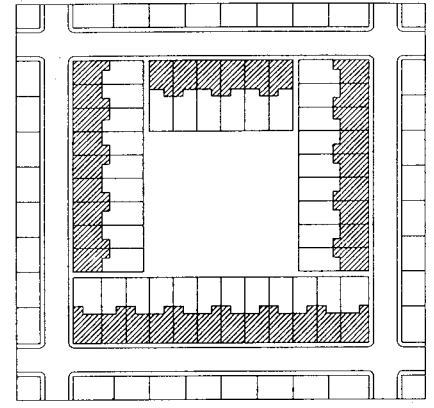

2. SQUARE BLOCK

**THE ORGANIC BLOCK**

This type is characterized by its irregularity; its variations are unlimited. The original organic block was the subdivision of residual land between well-worn paths (Fig. 3). It was later rationalized by Olmsted and Unwin to achieve a controllable, picturesque effect and to negotiate sloping terrain gracefully. The naturalistic block, despite its variety, generates certain recurring conditions that must be resolved by sophisticated platting. At shallow curves, it is desirable to have the facades follow the frontage smoothly. This is achieved by keeping the side lot lines perpendicular to the frontage line (Fig. 4-1). At the same time it is important for the rear lot line to be wide enough to permit vehicular access (Fig. 4-2). At sharper curves, it is desirable to have the axis of a single lot bisect the acute angle (Fig. 4-3). In the event of excessive block depth, it is possible to colonize the interior of the block by means of a close (Fig. 4-4).

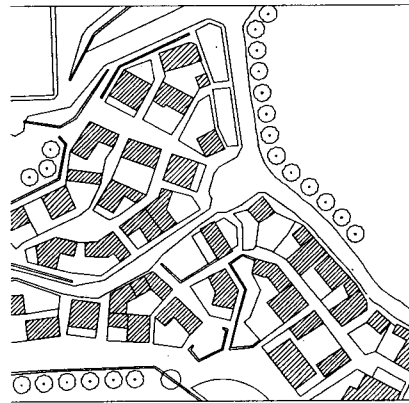

3. ORGANIC BLOCK



4. ORGANIC BLOCK

**THE ELONGATED BLOCK**

The elongated block overcomes some of the drawbacks of the square block. More efficient and more standardized, elongated blocks provide economical double-loaded alleys, with short utility runs, to eliminate the uncontrollable variable of lot depth and maintain the option of altering lot width. By adjusting the block length, it is possible to reduce cross streets toward rural edges or to add them at urban centers. This adjustment alters the pedestrian permeability of the grid and controls the ratio of street parking to building capacity. The elongated block can "bend" somewhat along its length, giving it a limited ability to shape space and negotiate slopes (Fig. 6).

Unlike the square block, the elongated block provides two distinct types of frontage. Residential buildings are placed on the quieter sides of the block (Fig. 5-1). Commercial buildings can be set on the short end of the block, platted to face the busy street; the amount of parking behind these properties is controlled by the variable depth (Fig. 5-2).

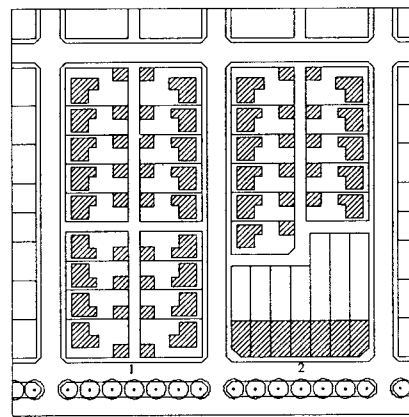

5. ELONGATED BLOCK

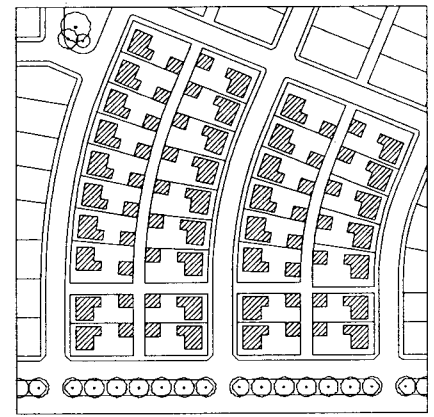

6. ELONGATED BLOCK



**GENERAL**

Public open space provides orientation, hierarchy, and communal structure to a neighborhood. The specialized open spaces shown here are derived from the elongated block types. They can also be adjusted to fit both square and organic block types.

**LANE**

Children often make lanes behind houses into informal playgrounds. The paved surface in front of garages is convenient for ball games. Lanes are particularly successful when they are designed to eliminate through traffic (right). Garage apartments provide supervision.

**PLAYGROUND**

Playgrounds can be easily extracted from any block by assigning one or several lots to this use. There should be a playground within 500 ft of every residence. The playground should provide both sunny and shaded play areas, as well as an open shelter with benches for parents. Playgrounds must be fenced, lockable, and lit, if they are not to become a nuisance at night.

**NURSERY**

A nursery can be inserted in the middle of a block, away from major thoroughfares. It requires a limited amount of parking but substantial vehicular drop-off space. The attached playground should be securely fenced and have both sunny and shaded areas. Children's games may be noisy, so it is advisable to locate nurseries where adjacent houses are buffered by outbuildings.

**CLOSE**

A close is a space shared by buildings inside the block. It may be pedestrian, or it may have a roadway loop around a green area. Its minimum width must coincide with emergency vehicle turning standards. The close is a superior alternative to the cul-de-sac, as the focus is a green rather than pavement. It is especially recommended for communal subgroups such as cohousing or assisted-living cottages. The close provides additional frontage for deep square and organic blocks.

**ATTACHED SQUARES**

Squares are green spaces that provide settings for civic buildings and monuments, which are located at the center or edge of the square. Buildings play a part, but the space is largely defined by formal tree planting. Squares should be maintained to a higher standard than playgrounds and parks.

**DETACHED SQUARES**

Squares detached on all sides by roads are particularly formal. Since adjacent buildings provide much of the population that uses a public space, detached squares are less likely to be used than other types. This separation also limits the amount of natural security provided by adjacent windows. The detached square remains appropriate as a means to symbolically enhance important places or institutions.

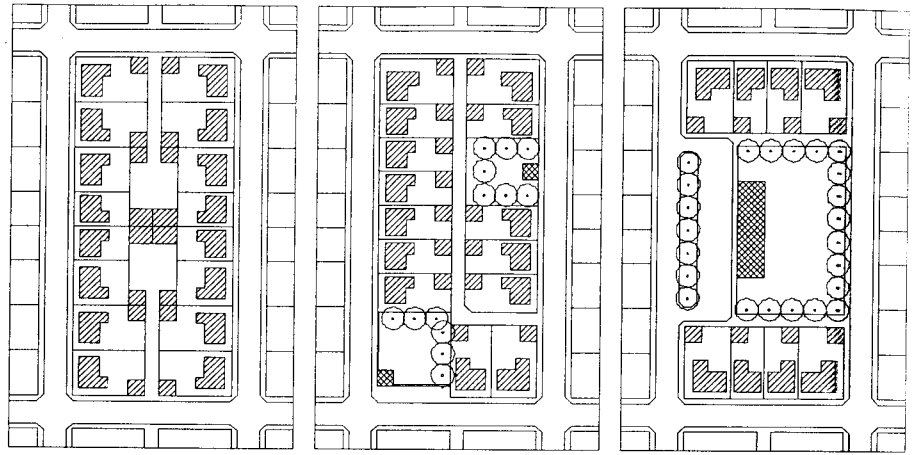

LANE PLAYGROUND NURSERY

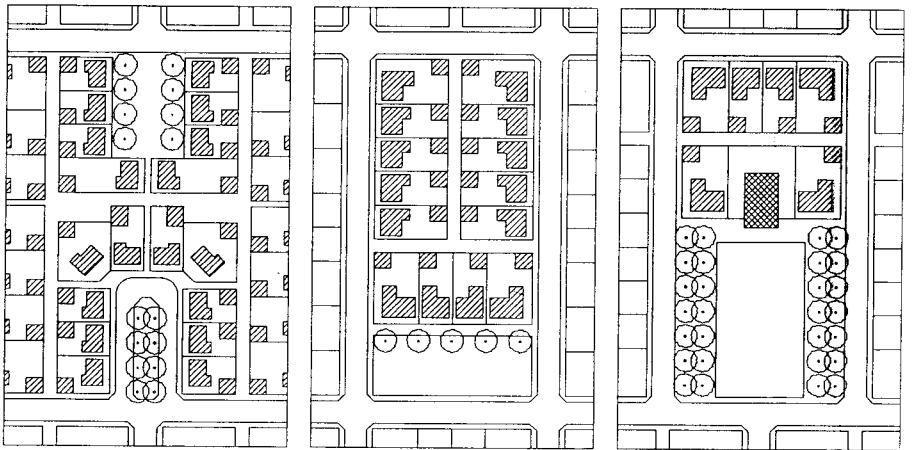

CLOSE ATTACHED SQUARES

**OPEN SPACE TYPES**

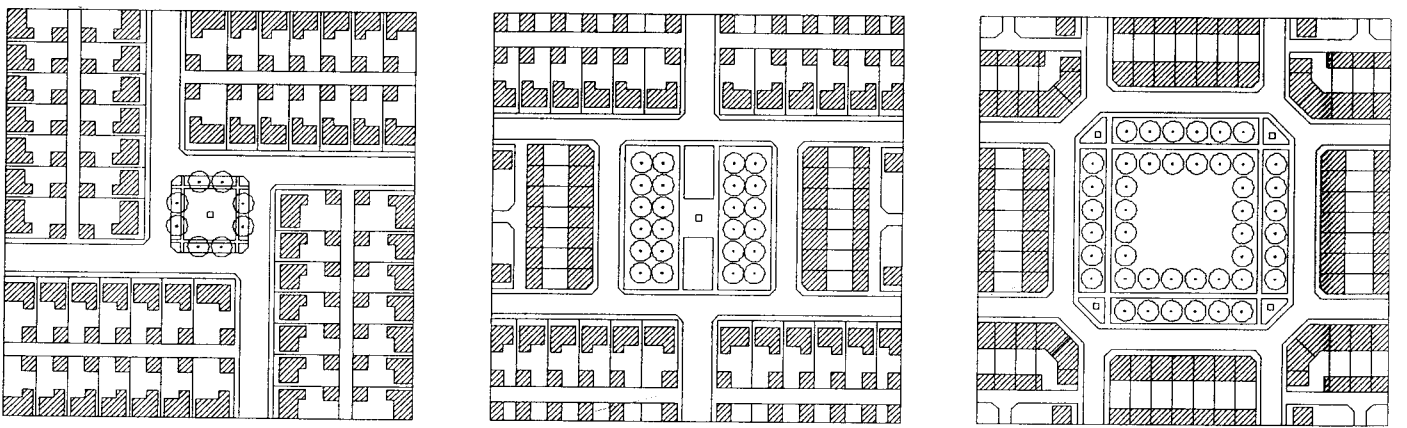

**OPEN SPACE TYPES—DETACHED SQUARES**

Gary Greenan, Andres Duany, Elizabeth Plater-Zyberk, Kamal Zaharin, Iskandar Shafie; Miami, Florida  
The Cintas Foundation

**MARKET PLAZA**

Plazas are public spaces that are primarily paved rather than green. They can sustain very intense use by crowds and even by vehicles. Parking lots should be designed as plazas that happen to have cars on them, rather than as single-purpose areas. A smaller shopping center can be transformed into a town center if it has been designed so it can be seamlessly attached to the block system and detailed as a plaza.

**CIVIC PLAZA**

Civic buildings are often no larger than the private ones that surround them, and their legibility as more important buildings cannot depend solely on architectural expression. Their setting within the block system must communicate their elevated status. Sites on squares or at the terminations of avenues are ideal but not always available. Thus the most dependable technique is to organize and detail the parking areas of civic buildings as plazas.

**GREEN**

The green is an urban, naturalistic open space. Like the square, it is small, civic, and surrounded by buildings. Unlike the square, it is informally planted and may have an irregular topography. Greens are usually landscaped with trees at the edges and sunny lawns at the center. Greens should contain no structures other than benches, pavilions, and memorials; paths are optional.

**PARK**

Parks are naturalistic open spaces, like greens, but larger and less tended. They are most successful when created from virgin woodland. Parks have grassy areas only periodically. A knoll or a pond can be used as an important organizing feature. Parks exist within the urban fabric of large cities, but their inherent size usually puts them at the edges of towns and villages. Parks may be edged by public drives, or by houses on very large lots, as long as connections to public paths occur at every block.

**BUFFER**

The buffer has the basic elements of a green, with the added purpose of buffering the impact of traffic from a highway or boulevard. Shown is a small lot development fronting a green. On the opposite side are larger lots on which houses are placed further back from the roadway edge as another buffer technique.

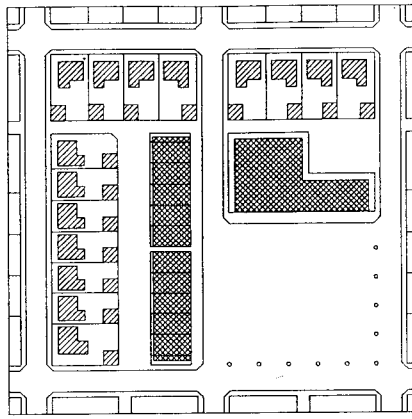

MARKET PLAZA

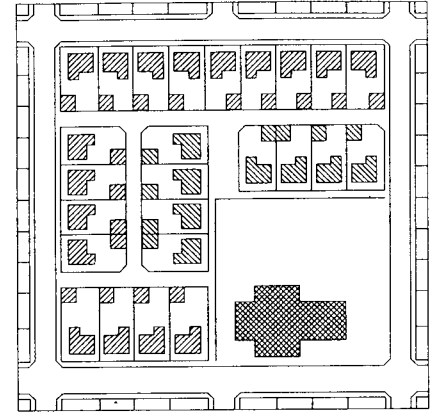

CIVIC PLAZA

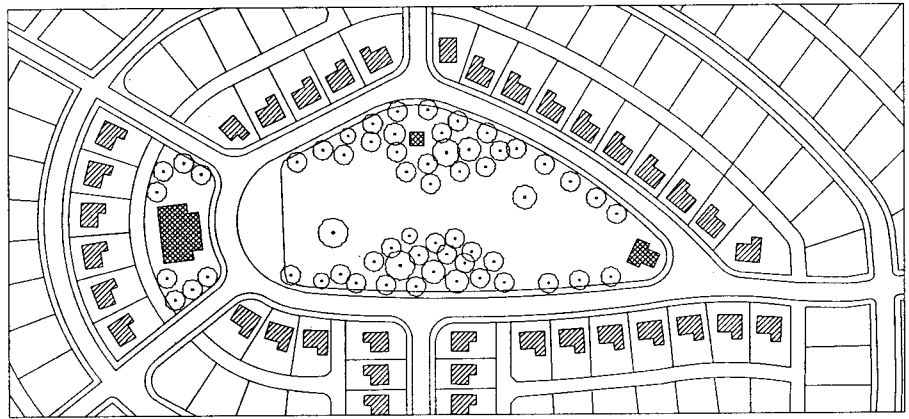

GREEN

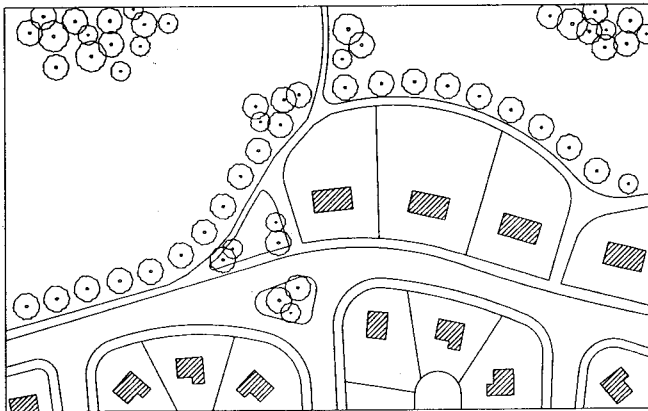

PARK

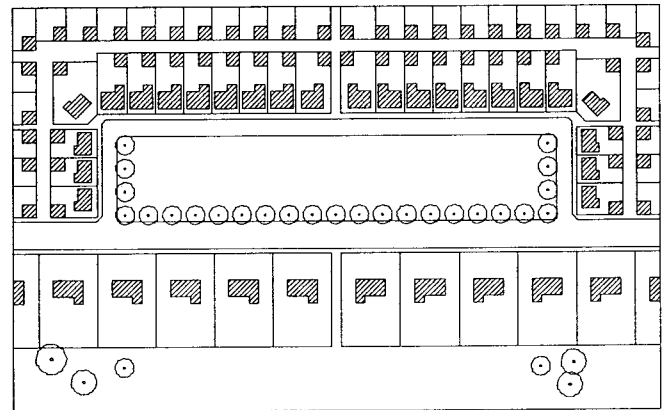

BUFFER

Gary Greenan, Andres Duany, Elizabeth Plater-Zyberk, Kamal Zaharin, Iskandar Shafie; Miami, Florida  
The Cintas Foundation

**GENERAL**

The traditional increment for platting lots in North America has been the 50-ft width. This subdivision dimension was efficient for many years, creating 25-ft rowhouse and shop-front lots, as well as 50-, 75-, and 100-ft lots suitable for houses. However, the advent of the automobile added a set of dimensional constraints that required new platting standards. The 50-ft width is wasteful, since the basic increment of efficient parking is the double row at 64 ft.

The 64-ft increment, when divided by four, provides the absolute minimum rowhouse lot of 16 ft, which allows one car to be parked with additional room for pedestrian passage. The minimum side yard lot is 32 ft. The minimum perimeter yard lot is 48 ft. The 64-ft lot efficiently provides for the high parking requirement of shopfronts, apartments, and office buildings.

The platting module of 16 ft corresponds to the traditional measure of the rod. Platting in rods, without knowing what building types will occupy the lots, maintains flexibility and ensures maximum density through parking efficiency.

Four building types accommodate the common residential, retail, and workplace uses of urban life. Some buildings, however, cannot be categorized typologically. Buildings dedicated to manufacturing and transportation may be distorted by large-scale mechanical trajectories. Civic buildings, which must express the aspirations of the institutions they embody, should also be exempt from the discipline of type.

**COURTYARD BUILDING**

This type of building occupies all or most of the edges of its lot and defines one or more private spaces internally. This is the most urban of types as it is able to completely shield the private realm from the public realm. It is common in hot climates, but its attributes are useful everywhere. Because of its ability to accommodate incompatible activities in close proximity, it is recommended for workshops, hotels, and schools. The high security the boundary provides is useful for recolonizing crime-prone urban cores.

**SIDE YARD BUILDING**

This type of building occupies one side of the lot, with the primary open space on the other side. The view of the side yard on the street front makes this building type appear freestanding, so it may be interspersed with perimeter yard buildings in less urban locations. If the adjacent building is also a side yard type with a blank party wall, the open space can be quite private. This type permits systematic climatic orientation, with the long side yard elevation facing the sun or the breeze.

**REAR YARD BUILDING**

This type of building occupies the front of its lot, full width, leaving the rear portion as a private space. This is a relatively urban type appropriate for neighborhood and town centers. The building facade defines the edge of the public space, while the rear elevation may reflect different functional purposes. In its residential form, this type is represented by the rowhouse with a rear garden and outbuilding. In its commercial form, the depth of the rear yard can contain substantial parking for retail and office uses.

**PERIMETER YARD BUILDING**

This building stands free on its lot, with substantial front and rear yards and smaller side yards. It is the least urban of the types, so it is usually assigned to areas away from neighborhood and town centers. This building type is usually residential, but when parking is contained within the rear yard it lends itself to limited office and boarding uses. The rear yard can be secured for privacy by fences and a well-placed outbuilding. The front yard is intended to be semipublic and visually continuous with the yards of neighbors. The illusion of continuity is usually degraded when garage fronts are aligned with the facades, as cars seldom pull in beyond the driveway. To avoid a landscape of parked cars, garages should be set back a minimum of one car's length from the facade or entered sideways through a walled forecourt.

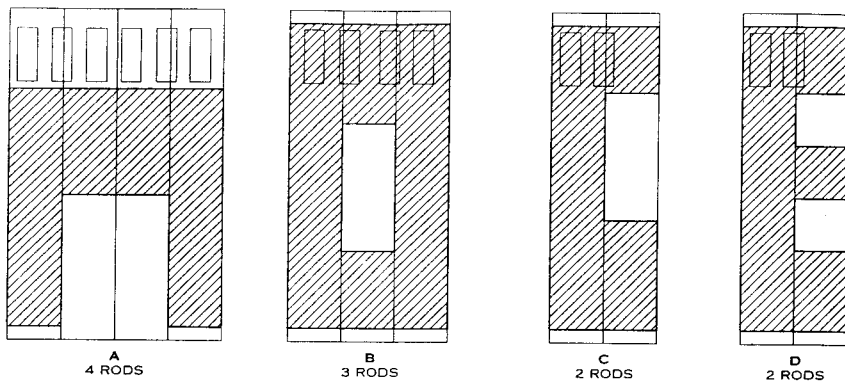

**COURTYARD BUILDING**

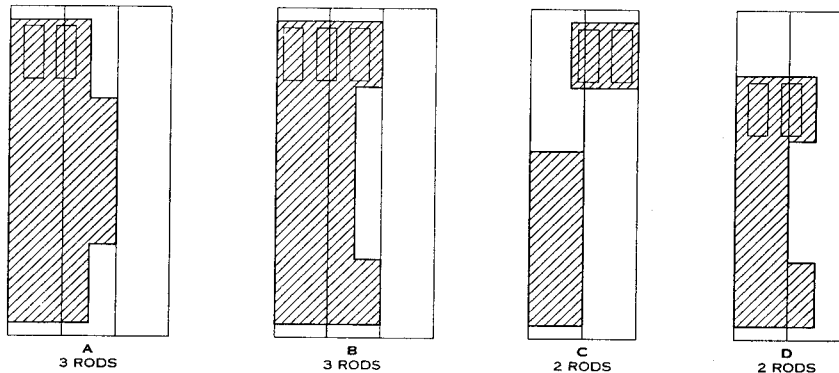

**SIDE YARD BUILDING**

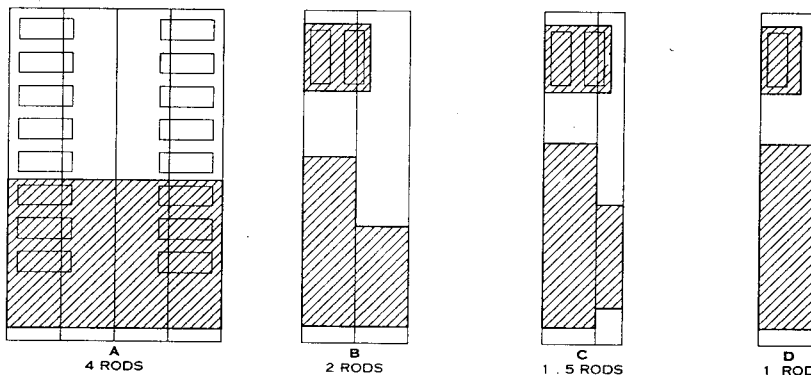

**REAR YARD BUILDING**

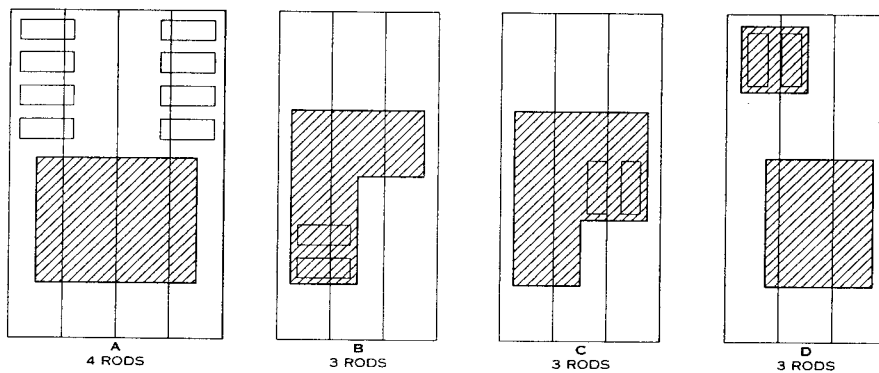

**PERIMETER YARD BUILDING**

Gary Greenan, Andres Duany, Elizabeth Plater-Zyberk, Kamal Zaharin, Iskandar Shafie; Miami, Florida  
The Cintas Foundation

**GENERAL**

Building delineates public space in an urban setting. Successful spatial definition is achieved when bounding buildings are aligned in a disciplined manner and the defined space does not exceed a certain height-to-width ratio.

Alignment occurs when building facades cooperate to delineate the public space, as walls form a room. Urban building articulation takes place primarily in the vertical plane or facade. If appendages such as porches, balconies, bay windows, and loggias do not obliterate the primary surface of the facade, they do not destroy alignment.

The height-to-width ratio of the space generates spatial enclosure, which is related to the physiology of the human eye. If the width of a public space is such that the cone of vision encompasses less street wall than sky opening, the degree of spatial enclosure is slight. The ratio of 1 increment of height to 6 of width is the absolute minimum, with 1 to 3 being an effective minimum if a sense of spatial enclosure is to result. As a general rule, the tighter the ratio, the stronger the sense of place and, often, the higher the real estate value. Spatial enclosure is particularly important for shopping streets that must compete with shopping malls, which provide very effective spatial definition. In the absence of spatial definition by facades, disciplined tree planting is an alternative. Trees aligned for spatial enclosure are necessary on thoroughfares that have substantial front yards.

**NOMENCLATURE**

**THE FRONTAGE LINE**

The lot boundary that coincides with a public thoroughfare or public space. The frontage line may be designed independently of the thoroughfare, to create a specific sense of place.

**FACADE**

The vertical surface of a building set along a frontage line. The elevation is the vertical surface set along any other boundary line. Facades are subject to control by building height, setback lines, recess lines, and transition lines. Elevations are only subject to building height and setback lines.

**SETBACK**

The mandatory distance between a frontage line and a facade or a lot line and an elevation.

**BUILDING HEIGHT**

The defined limit to the vertical extent of a building. The building height should be stated as a number of stories, rather than a prescribed dimension. This prevents the compression of internal ceiling heights. Height may be determined by density and view and not by the requirements of spatial definition, which are addressed by the recess line.

**RECESS LINE**

A line prescribed for the full width of the facade, above which the facade is set back. The recess line effectively defines the enclosure of public space. Its location is determined by the desired height-to-width ratio of that space, compatibility with the average height of existing buildings, or provision for daylighting at the street level.

**TRANSITION LINE**

A line prescribed for the full width of the facade, expressed by a variation of material or by a limited projection such as a cornice or a balcony. The transition line divides the facade, permitting shopfronts and signage to vary over time without destroying the overall composition.

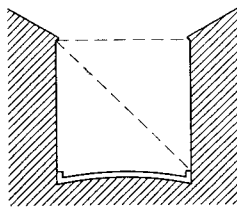

RATIO 1 : 1

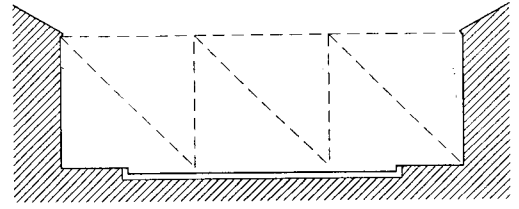

RATIO 1 : 3

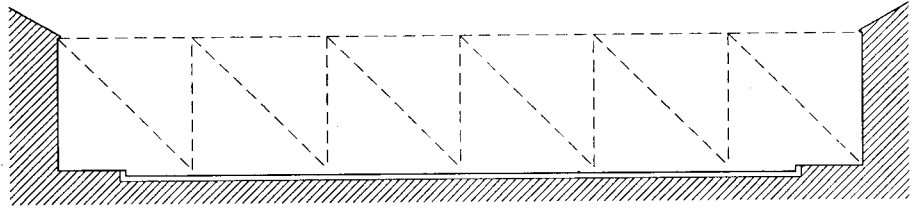

RATIO 1 : 6

**PROPORTIONS OF BUILDING HEIGHT TO PUBLIC SPACE**

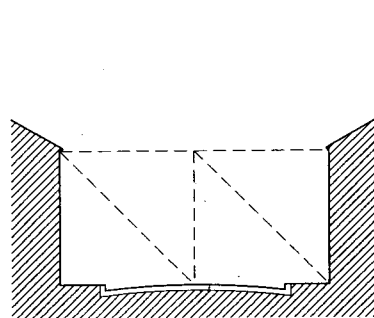

BY FACADE

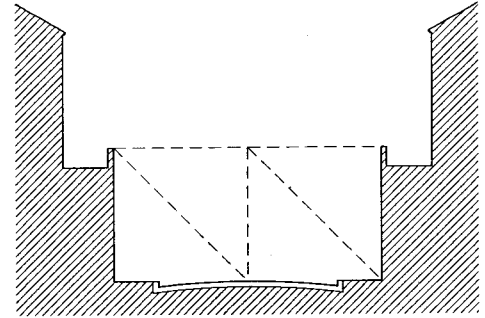

BY RECESS LINE

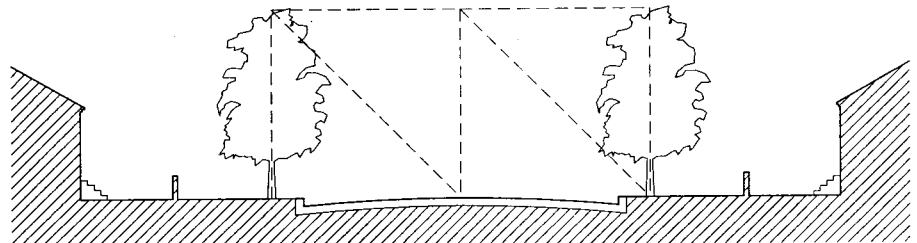

BY LANDSCAPING

**TECHNIQUES OF DELINEATING PUBLIC SPACE**

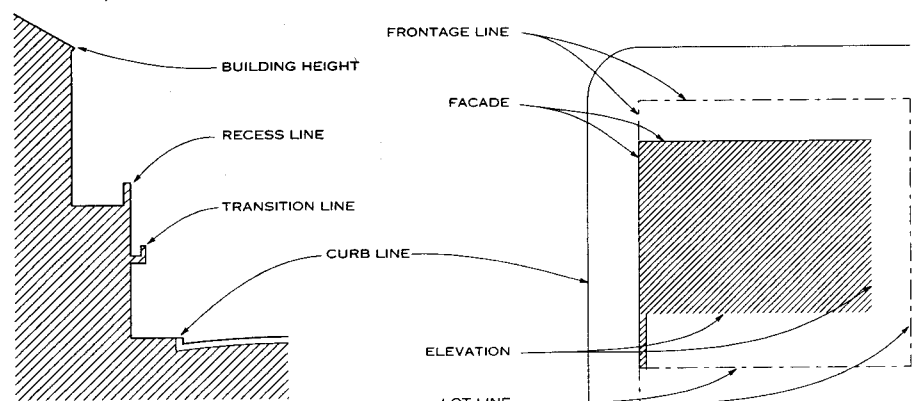

SECTION

PLAN

**DEFINITIONS**

Gary Greenan, Andres Duany, Elizabeth Plater-Zyberk, Kamal Zaharin, Iskandar Shafie; Miami, Florida  
The Cintas Foundation

**GENERAL**

Building type is independent of frontage type. For example, a courtyard building may have an arcade, a shopfront, a stoop, or a porch as its frontage type. Frontages can be ranked from most urban to most rural.

**ARCADE**

The facade overlaps the sidewalk, while the storefront remains set back. This type is excellent for retail use, but only when the sidewalk is fully absorbed so the pedestrian cannot bypass the arcade. An easement for public use of private property is required.

**SHOPFRONT**

The facade is aligned directly on the frontage line, with the entrance at grade. This type is conventional for sidewalk retail. It is often equipped with an awning or a porch. A transition line should separate the signage from the facade above. The absence of a setback and elevation from the sidewalk prevents residential use on the ground floor, although it is appropriate above.

**STOOP**

The facade is aligned directly on the frontage line, with the first floor elevated to achieve some privacy for the windows. This type is suitable for residential uses such as row-houses and apartment buildings. An easement may be necessary to accommodate the encroaching stoop. This type may be interspersed with the shopfront.

**FORECOURT**

The facade is set back and replaced by a low wall at the frontage line. The forecourt thus created is suitable for gardens, vehicular drop-offs, and workshop loading and storage. It should be used sparingly and in conjunction with the shopfront and stoop types, as a continuous blind wall is boring and unsafe for pedestrians. Tree canopies within the forecourt should overhang the sidewalk.

**DOORYARD**

The facade is set back from the frontage line, with an elevated garden or terrace between. This type can effectively buffer residential quarters from the sidewalk, while removing the yard from public use. The terrace, when roofed, is suitable for restaurants and cafes, as the eye level of the sitter is level with that of passersby.

**PORCH AND FENCE**

With an encroaching habitable porch, the facade is set back substantially from the frontage line. The porch should be within a conversational distance of the sidewalk. A fence at the frontage line marks the boundary of the yard.

**FRONT LAWN**

The facade is set back substantially from the frontage line. The front lawn this creates should be unfenced and visually continuous with adjacent yards. The ideal is to simulate buildings sitting in a rural landscape. A front porch is usually not appropriate, since no social interaction with the street is possible at such a distance. The large setback can provide a buffer from heavy traffic, so this type is sometimes found on boulevards.

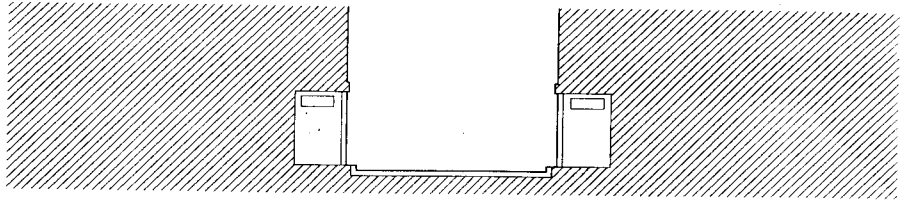

**ARCADE**

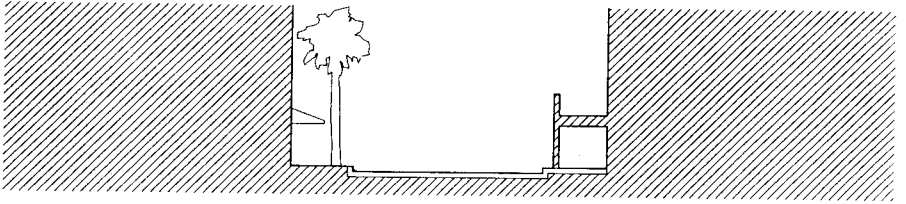

**SHOPFRONT**

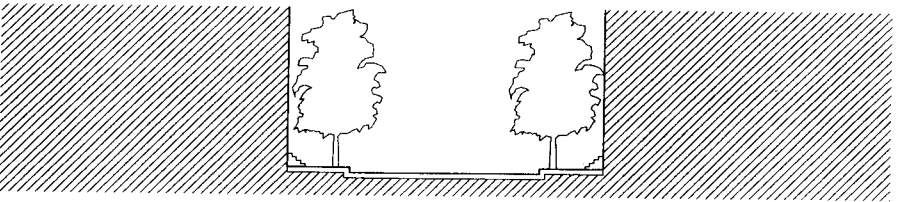

**STOOP**

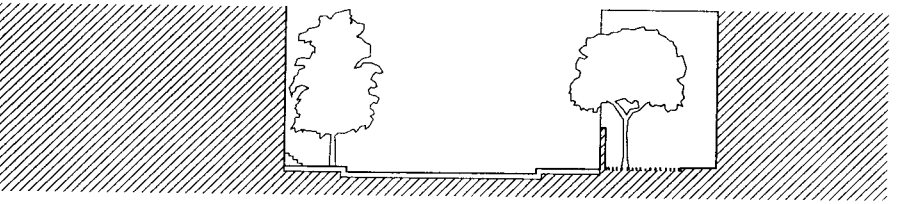

**FORECOURT**

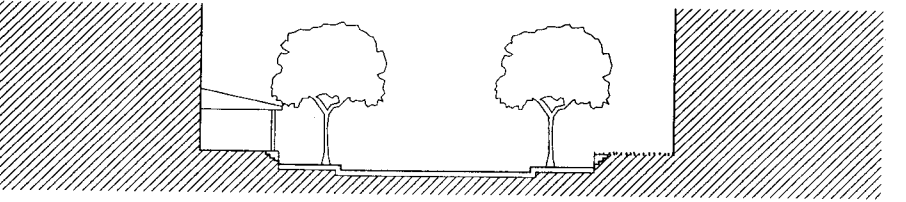

**DOORYARD**

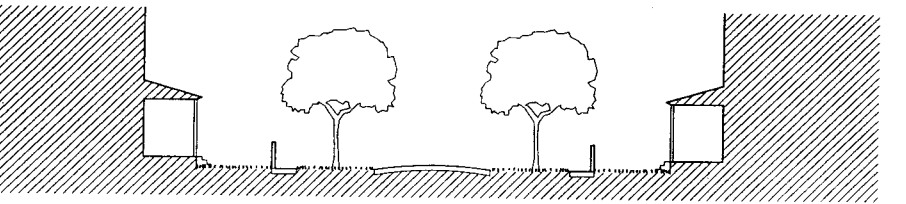

**PORCH AND FENCE**

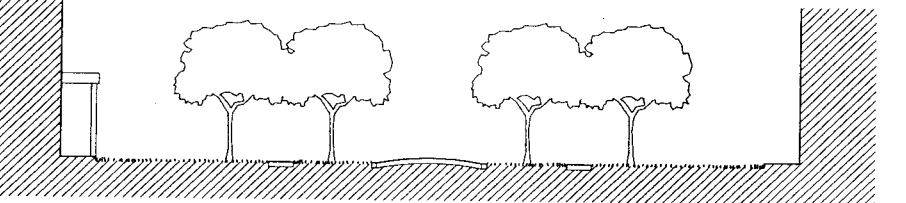

**FRONT LAWN**

Gary Greenan, Andres Duany, Elizabeth Plater-Zyberk, Kamal Zaharin, Iskandar Shafie; Miami, Florida  
The Cintas Foundation

## GENERAL

The urban landscape is a set of interdependent elements that creates a controlled sense of place. It includes thoroughfare type, building type, frontage type, and the form and disposition of landscape.

Public landscaping plays many roles above and beyond that of ornamentation:

1. To correct inadequacies of spatial definition caused by building frontages. Planting steady rows of trees at the edges usually reduces the height-to-width ratio of the street space. Grids of trees are used to fill gaps left by unbuilt lots and surface parking.
2. To adjust the microclimate by providing the appropriate level of shade or sun for buildings and sidewalks. For thoroughfares running east-west, this may involve the use of asymmetrical planting.
3. To support the intended urban or rural character of the public space. Selecting appropriate species and varying the species planted, as well as the regularity of their disposition, can alter the landscape significantly.
4. To create a pleasing visual composition, being careful to mask the aesthetic failure of certain buildings as well as to reveal the successes. Consider seasonal changes of each species.
5. To create a harmonious whole of specific character by coordinating public and private plantings. Selection should vary, to ensure resistance to pests, but not result in an incoherent collection of specimens. Native species should predominate to reduce maintenance, with an emphasis on species that support wildlife compatible with human settlement.

## RURAL ROAD

This type is appropriate for buildings at the edges of the neighborhood and along parks and greenbelts. There is no public planting line. The tree species should be episodic, but in coherent clusters. There are no curbs; the drainage is by open swales. Bicycle paths may be paved in asphalt.

## RESIDENTIAL ROAD

This type is appropriate for houses outside of neighborhood centers. Since the frontage usually includes a substantial setback, the tree canopy may be quite wide. The rural aspect may be supported by planting several species in imperfect alignment. Roads are detailed with open swales, and, where possible, drainage is through percolation.

## RESIDENTIAL STREET

This type is appropriate for residential buildings at neighborhood and town centers. Trees are in continuous planting strips, since the sidewalk does not require unusual width. Plant a single species of tree in steady alignment. A thin, vertical canopy is necessary to avoid nearby building facades. This type is dimensionally interchangeable with the commercial street type and may alternate in correspondence to the building facade. Streets are detailed with raised curbs and closed storm drainage.

## COMMERCIAL STREET

This type is appropriate for commercial buildings at neighborhood and town centers. Trees are confined by individual planting areas, creating a sidewalk of maximum width with areas accommodating street furniture. Plant a single species of tree in steady alignment. Clear trunks and high canopies are necessary to avoid interference with shopfront signage and awnings. Streets are detailed with raised curbs with closed storm drainage.

## AVENUE

This type is appropriate for approaches to civic buildings. The general principle is a thoroughfare of limited length, with a substantial planted median. At town centers, the median may be wide enough to hold monuments and even buildings. In residential areas, the median may be planted naturalistically to become a parkway or green.

## BOULEVARD

This type is appropriate for high-capacity thoroughfares at neighborhood edges. The detailing is similar to that of a commercial street. The effect of the medians is to segregate the slower traffic and parking activity, at the edges, from through traffic, at the center.

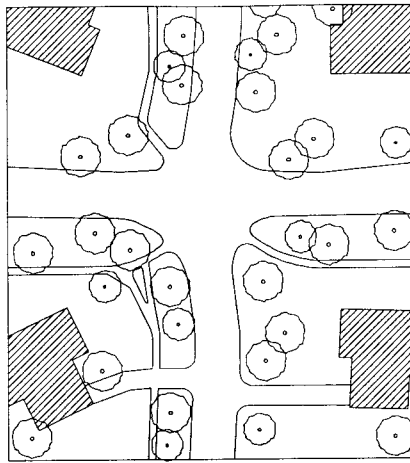

RURAL ROAD

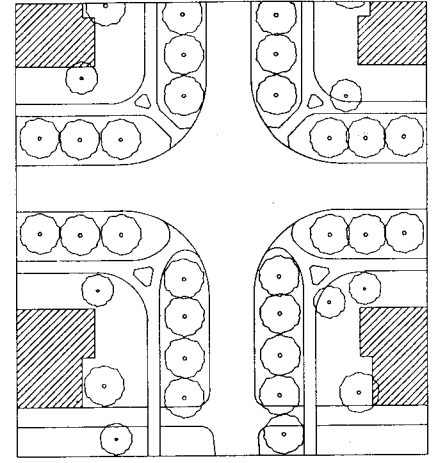

RESIDENTIAL ROAD

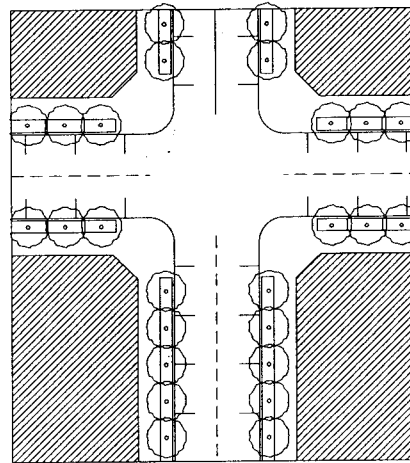

RESIDENTIAL STREET

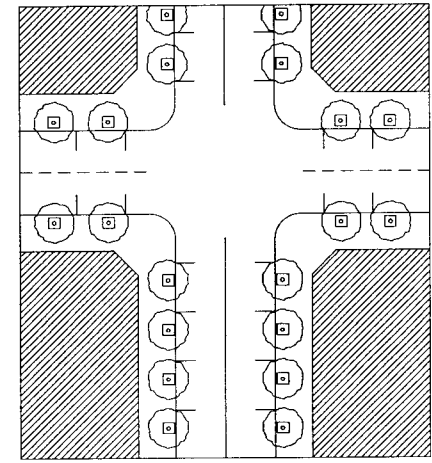

COMMERCIAL STREET

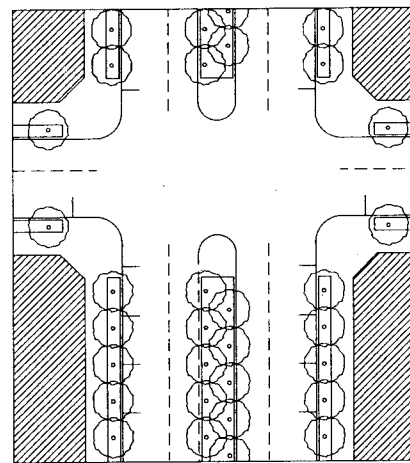

AVENUE

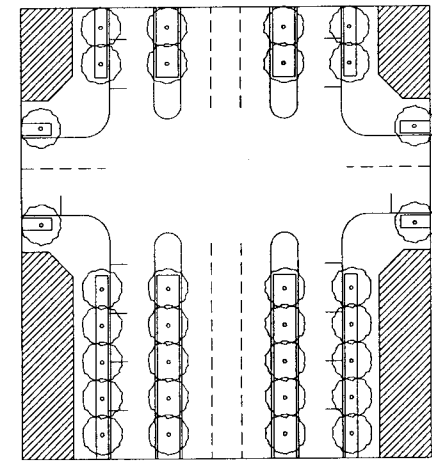

BOULEVARD

Gary Greenan, Andres Duany, Elizabeth Plater-Zyberk, Kamal Zaharin, Iskandar Shafie; Miami, Florida  
The Cintas Foundation

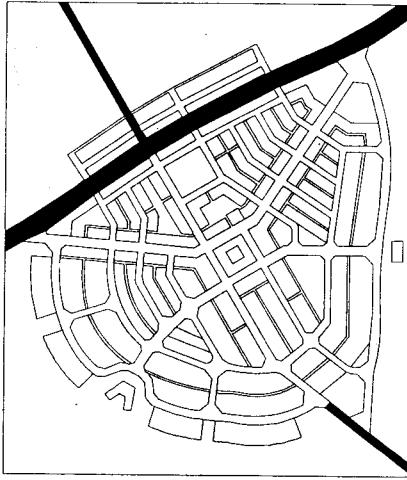

HIGHWAYS

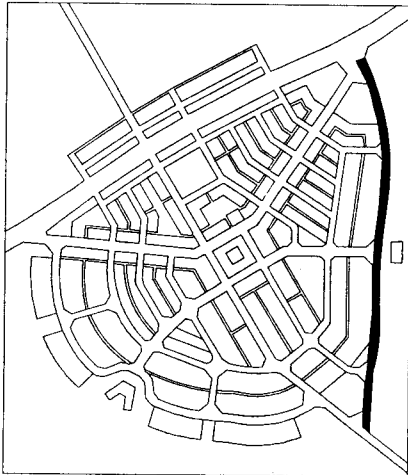

DRIVES

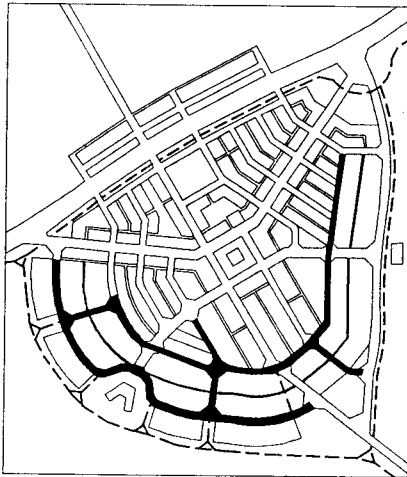

ROADS, LANES, PATHS  
MORE RURAL

**GENERAL**

Thoroughfares are endowed with two attributes: capacity and character. Capacity refers to the number of vehicles that can move safely through a segment within a given time. It is physically manifested by the number of lanes and their width and by the centerline radius, the curb radius, and the super elevation of the pavement. Character refers to a thoroughfare's suitability for pedestrian activities and a variety of building types. Character is physically manifested by the thoroughfare's associated building, frontage, and landscape types and sidewalk width.

Conventional traffic engineering practice uses terms such as "collector" and "arterial," which denote only capacity. This is too simplistic and tends to create an environment inhospitable for pedestrians. The following nomenclature more adequately describes the combination of capacity and character necessary to create true urbanism.

**NOMENCLATURE**

**HIGHWAY:** A long-distance, medium speed vehicular corridor that traverses open country. A highway should be relatively free of intersections, driveways, and adjacent buildings; otherwise it becomes a strip, which interferes with traffic flow. (Related terms include expressway, a high speed highway with intersections replaced by grade separation, and parkway, a highway designed with naturalistic landscaping, partially accommodated within a wide and varying median.

**BOULEVARD:** A long-distance, medium speed vehicular corridor that traverses an urbanized area. It is usually lined by parallel parking, wide sidewalks, or side medians planted with trees. Buildings uniformly line the edges.

**AVENUE:** A short-distance, medium speed connector that traverses an urban area. Unlike a boulevard, its axis is terminated by a civic building or monument. An avenue may be conceived as an extremely elongated square. (A related term is allée, a rural avenue spatially defined by trees aligned on either side but devoid of buildings except at the terminus.)

**DRIVE:** An edge between an urban and a natural condition, usually along a waterfront, park, or promontory. One side of the drive has the urban character of a boulevard, with sidewalk and buildings, while the other has the qualities of a parkway, with naturalistic planting and rural detailing.

**STREET:** A small-scale, low speed local connector. Streets provide frontage for high-density buildings such as offices, shops, apartment buildings, and rowhouses. A street is urban in character, with raised curbs, closed drainage, wide sidewalks, parallel parking, trees in individual planting areas, and buildings aligned on short setbacks.

**ROAD:** A small-scale, low speed connector. Roads provide frontage for low-density buildings such as houses. A road tends to be rural in character with open curbs, optional parking, continuous planting, narrow sidewalks, and buildings set well back. The rural road has no curbs and is lined by pathways, irregular tree planting, and uncoordinated building setbacks.

**ALLEY:** A narrow access route servicing the rear of buildings on a street. Alleys have no sidewalks, landscaping, or building setbacks. Alleys are used by trucks and must accommodate dumpsters. They are usually paved to their edges, with center drainage via an inverted crown.

**LANE:** A narrow access route behind houses on a road. Lanes are rural in character, with a narrow strip of paving at the center or no paving. While lanes may not be necessary with front-loaded garages, they are still useful for accommodating utility runs, enhancing the privacy of rear yards, and providing play areas for children.

**PASSAGE:** A very narrow, pedestrian-only connector cutting between buildings. Passages provide shortcuts through long blocks or connect rear parking areas with street frontages. Passages may be roofed over and lined by shopfronts.

**PATH:** A very narrow pedestrian and bicycle connector traversing a park or the open country. Paths should emerge from the sidewalk network. Bicycle paths are necessary along highways but are not required to supplement boulevards, streets, and roads, where slower traffic allows sharing of the vehicular lanes.

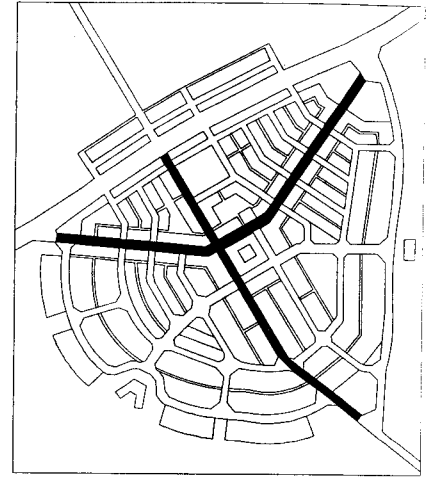

BOULEVARDS

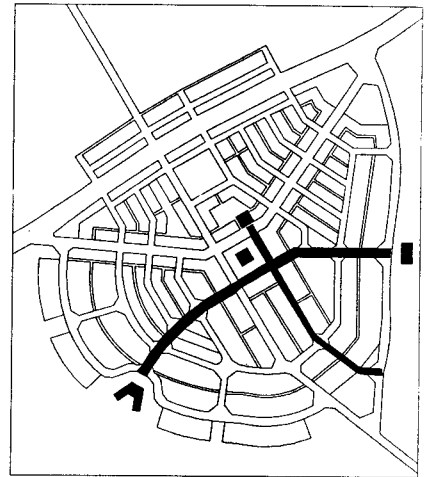

AVENUES

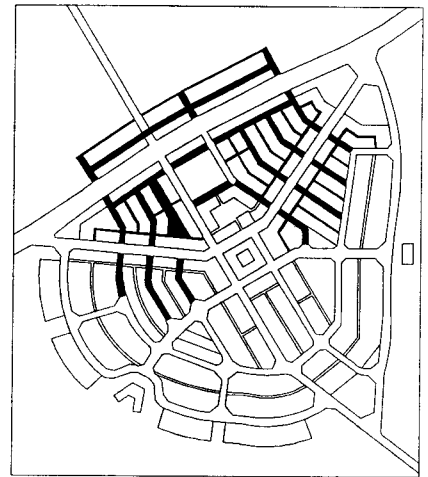

STREETS, ALLEYS, PASSAGES  
MORE URBAN

Gary Greenan, Andres Duany, Elizabeth Plater-Zyberk, Kamal Zaharin, Iskandar Shafie; Miami, Florida  
The Cintas Foundation

**GENERAL**

Capacity and character are combined and adjusted to achieve a complete series of useful thoroughfare types. The series is best regarded in pairs: keeping the right-of-way width (R.O.W) constant, each pair illustrates one type suitable in two ways, one for a relatively rural condition and another suitable for a more urban condition.

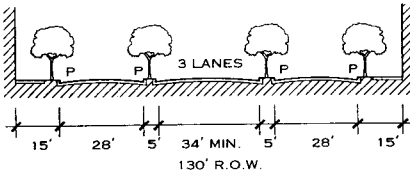

**BOULEVARD**

BOULEVARD		HIGHWAY
25-50 MPH	DESIGN SPEED	35-55 MPH
90 FT	MIN. CENTERLINE RADIUS	165-800 FT
15 FT	CURB RETURN RADIUS	35 FT
30 SEC	PEDESTRIAN CROSS TIME	N/A
ALWAYS	ON-STREET PARKING	NEVER
CLOSED	DRAINAGE	OPEN

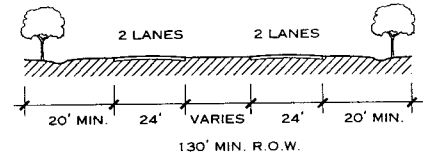

**HIGHWAY**

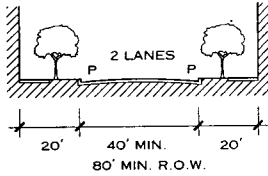

**MAIN STREET**

MAIN STREET		AVENUE
20-25 MPH	DESIGN SPEED	25-35 MPH
90 FT	MIN. CENTERLINE RADIUS	165 FT
15 FT	CURB RETURN RADIUS	25 FT
12 SEC	PEDESTRIAN CROSS TIME	15 SEC
ALWAYS	ON-STREET PARKING	ALWAYS*
CLOSED	DRAINAGE	OPEN/ CLOSED

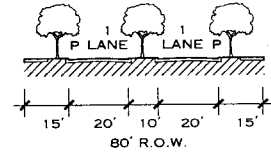

**AVENUE**

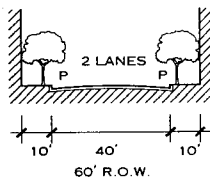

**STREET**

STREET		ROAD
20-25 MPH	DESIGN SPEED	25-35 MPH
90 FT	MIN. CENTERLINE RADIUS	165 FT
15 FT	CURB RETURN RADIUS	25 FT
12 SEC	PEDESTRIAN CROSS TIME	8.5 SEC
ALWAYS	ON-STREET PARKING	USUALLY*
CLOSED	DRAINAGE	OPEN/ CLOSED

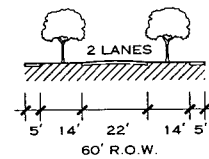

**ROAD**

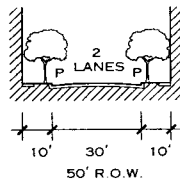

**MINOR STREET**

MINOR STREET		RURAL ROAD
20-25 MPH	DESIGN SPEED	25-35 MPH
90 FT	MIN. CENTERLINE RADIUS	165 FT
15 FT	CURB RETURN RADIUS	20 FT
8.5 SEC	PEDESTRIAN CROSS TIME	13 SEC
ALWAYS*	ON-STREET PARKING	NEVER
CLOSED	DRAINAGE	OPEN

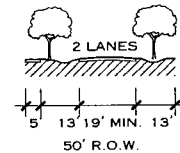

**RURAL ROAD**

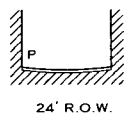

**ALLEY**

ALLEY		LANE
N/A	DESIGN SPEED	N/A
N/A	MIN. CENTERLINE RADIUS	N/A
5 FT	CURB RETURN RADIUS	20 FT
6.5 SEC	PEDESTRIAN CROSS TIME	3.5 SEC
USUALLY*	ON-STREET PARKING	USUALLY
CLOSED	DRAINAGE	OPEN

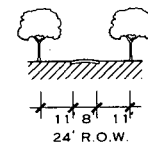

**LANE**

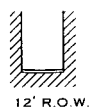

**PASSAGE**

PASSAGE		PATH
N/A	DESIGN SPEED	N/A
N/A	MIN. CENTERLINE RADIUS	40 FT
N/A	CURB RETURN RADIUS	5 FT
4.5 SEC	PEDESTRIAN CROSS TIME	4.5 SEC
NEVER	ON-STREET PARKING	NEVER
CLOSED	DRAINAGE	OPEN

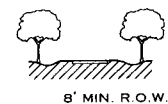

**PATH**

**MORE URBAN**

**MORE RURAL**

Chester Chellman, P.E.; Ossipee, New Hampshire  
 Gary Greenan, Andres Duany, Elizabeth Plater-Zyberk, Kamal Zaharin, Iskandar Shafie; Miami, Florida  
 The Cintas Foundation



## INTRODUCTION

The traditional neighborhood development (TND) ordinance produces compact, mixed-use, pedestrian friendly communities. It can be incorporated in municipal zoning ordinances as an overlay or as a separate district. It is intended to ensure the following conventions:

Traditional neighborhoods share the following characteristics:

1. The neighborhood's area is limited to what can be traversed in a 10-minute walk.
2. Residences, shops, workplaces, and civic buildings are located in close proximity.
3. A hierarchy of streets serves the pedestrian and the automobile equitably.
4. Physically defined squares and parks provide places for formal social activity and recreation.
5. Private buildings form a clear edge, delineating the street space.
6. Civic buildings reinforce the identity of the neighborhood, providing places of assembly for social, cultural, and religious activities.

Traditional neighborhoods pursue certain social objectives:

1. To provide the elderly and the young with independence of movement by locating most daily activities within walking distance
2. To minimize traffic congestion and limit road construction by reducing the number and length of automobile trips
3. To make public transit a viable alternative to the automobile by organizing appropriate building densities
4. To help citizens come to know each other and to watch over their collective security by providing public spaces such as streets and squares
5. To integrate age and economic classes and form the bonds of an authentic community by providing a full range of housing types and workplaces
6. To encourage communal initiatives and support the balanced evolution of society by providing suitable civic buildings

## SPECIAL DEFINITIONS

Terms used in a TND ordinance may differ in meaning from their use in conventional zoning ordinances:

**ARTISANAL USE:** Premises used for the manufacture and sale of items that are made employing only handwork and/or table-mounted electrical tools and creating no adverse impact beyond its lot.

**BLOCK:** The aggregate of lots and alleys circumscribed by public use tracts, generally streets.

**BUILDING HEIGHT:** The height measured in stories. Attics and raised basements do not count against building height limitations.

**CITIZENS' ASSOCIATION:** The organization of owners of lots and buildings associated under articles. The articles shall reference an approved master plan; set standards for building location, construction, and maintenance; provide for maintenance on public tracts; and provide for the construction of new civic buildings by an ongoing special assessment.

**FAÇADE:** The building wall parallel to a frontage line.

**FRONTAGE LINE:** The lot line that coincides with a street front.

**GREEN EDGE:** A continuous open area surrounding the neighborhood proper. The area shall be preserved in perpetuity as a natural area, golf course, or growing or playing fields, or it shall be subdivided into house lots no smaller than 20 acres each.

**LIMITED LODGING:** Residential premises providing no more than eight rooms for short-term letting and food services before noon only.

**LIMITED OFFICE:** Residential premises used for business or professional services, employing no more than four full-time employees, one of whom must be the owner.

**LOT:** A separately platted portion of land held privately.



## TND LAND ALLOCATION

**MEETING HALL:** A building designed for public assembly, containing at least one room with an area equivalent to 10 sq ft per dwelling, or 1300 sq ft, whichever is greater.

**NEIGHBORHOOD PROPER:** The built-up area of a TND, including blocks, streets, and squares but excluding green edges.

**OUTBUILDING:** A separate building, additional to a principal building, contiguous with the rear lot line, having at most two stories and a maximum habitable area of 450 sq ft. Outbuildings may be residential retail units. Outbuildings are exempt from building cover restrictions or unit counts.

**PARK:** A public tract naturalistically landscaped, not more than 10% paved, and surrounded by lots on no more than 50% of its perimeter.

**PROHIBITED USES:** Uses not permitted in the standard zoning ordinance, as well as automatic food, drink, and newspaper vending machines and any commercial use that encourages patrons to remain in their automobiles while receiving goods or services (except service stations).

**SHARED PARKING:** A parking place where day/night or weekday/holiday schedules allow the use of parking spaces by more than one user, resulting in a 25% reduction of the required spaces.

**SQUARE:** A public tract, spatially defined by surrounding buildings, with frontage on streets on at least two sides. Commercial uses shall be permitted on all surrounding lots.

**STORY:** A habitable level within a building no more than 14 ft in height from floor to ceiling.

**STREET LAMPS:** A light standard between 10 and 16 ft in height equipped with an incandescent or metal halide light source.

**STREET TREE:** A deciduous tree that resists root pressure and is of proven viability, in the region with no less than 4-in. caliper and 8-ft clear trunk at the time of planting.

**STREET VISTA:** The view, framed by buildings, at the termination of the axis of a thoroughfare.

**TRACT:** A separately platted portion of land held in common, such as a thoroughfare, a square, or a park.

Gary Greenan, Andres Duany, Elizabeth Plater-Zyberk, Kamal Zaharin, Iskandar Shafie, Miami, Florida  
The Cintas Foundation

**GUIDELINES FOR TRADITIONAL NEIGHBORHOOD DESIGN**

LAND USE	LAND ALLOCATION	LOTS AND BUILDINGS	STREETS AND PARKING
A1.GENERAL: (a) The TND shall be available as an overlay option for land development in all land use and zoning categories except industrial. (b) A TND requires a minimum parcel of 40 contiguous acres and a maximum of 200 acres. Larger parcels shall be developed as multiple neighborhoods with each individually subject to the provisions of the TND.	B1.GENERAL: (a) Similar land use categories face across streets; dissimilar categories abut at rear lot lines. (b) The average perimeter of all blocks within the neighborhood does not exceed 1300 ft. For block faces longer than 500 ft, an alley or pedestrian path provides through access.	C1.GENERAL: (a) All lots share a frontage line with a street or square. (b) The main entrances of all buildings except outbuildings are on a street or square. (c) Stoops, open colonnades, and open porches may encroach into the front setback. (d) The sides of buildings at corner lots are similar to their fronts.	D1.GENERAL: (a) All streets terminate at other streets. (b) Streetlights are provided along all thoroughfares at 35- to 50-ft intervals. (c) On-street parking is allowed on all local streets. (d) Parking lots are located behind or beside building facades. (e) Parking lots and garages are not adjacent to street intersections, civic use lots, or squares and do not occupy lots that terminate a vista. (f) Shared parking reduces local parking requirements.
A2.PUBLIC: (a) Includes streets, squares, parks, playgrounds, and the like. (b) Civic use lots may be placed within tracts designated for public use. (c) Large-scale recreational uses such as golf courses, schoolyards, and multiple game fields are located only at the edge of the neighborhood.	B2.PUBLIC: (a) A minimum of 5% of the neighborhood area or 3 acres (whichever is greater) is permanently allocated to public use. (b) Each neighborhood contains at least one square, not less than one acre in size, close to the center. (c) No portion of the neighborhood is more than 2000 ft from the square. (d) At least half the perimeter of squares, parks, and waterfronts face streets. (e) At least a quarter of the perimeter of waterfronts, golf courses, greenbelts, and other natural amenities face streets.	C2.PUBLIC: (a) Balconies and open colonnades are permitted to encroach up to 5 ft into thoroughfares and other tracts. Such encroachments shall be protected by easements.	D2.PUBLIC: (a) Parking shared between public and private uses is encouraged.
A3.CIVIC: (a) Contains community buildings such as meeting halls, libraries, post offices, schools, child care centers, clubhouses, religious buildings, recreational facilities, museums, cultural societies, visual and performance arts buildings, municipal buildings, and the like.	B3.CIVIC: (a) A minimum of 2% of the neighborhood area is reserved for civic use. (b) Civic lots are within or adjacent to squares and parks or on a lot terminating a street vista. (c) Each neighborhood has a minimum of one meeting hall and one child care facility.	C3.CIVIC: (a) Civic buildings have no height or setback limitations.	D3.CIVIC: (a) The majority (75%) of the off-street parking for civic structures is behind the buildings.
A4.COMMERCIAL: (a) Contains buildings primarily for business uses, such as retail, entertainment, restaurant, club, office, residential, lodging, artisanal, medical, etc. (b) At least 25% of the building area is designated for residential use.	B4.COMMERCIAL: (a) A minimum of 2% and a maximum of 30% of the neighborhood area is designated for commercial use. (b) Commercial lots have a maximum frontage of 32 ft. (c) A maximum of four lots may be consolidated to construct a single building.	C4.COMMERCIAL: (a) Buildings are built out to a minimum of 80% of their frontage at the frontage line. (b) Buildings have no required setback from the side lot lines. (c) Buildings do not exceed four stories in height and are no less than two stories in height. When fronting a square, buildings are no less than three stories in height. (d) Building coverage does not exceed 70% of the lot area.	D4.COMMERCIAL: (a) Lots front streets no more than four lanes wide; parallel parking and sidewalks minimum 15 ft wide. (b) Rear lot lines coincide with an alley. (c) Streets have curbs with a radius at intersections of 5 to 15 ft. (d) Street trees are aligned on both sides of the street at 35- to 50-ft intervals; when open colonnades are provided, no street trees are necessary. (e) The majority (75%) of the off-street parking is behind the buildings.
A5.HIGH RESIDENTIAL: (a) Contains buildings for residential use, limited office use, cafes, retail, lodging, and artisanal uses. (b) All of the building area above the ground floor is designated for residential use. (c) Outbuildings are permitted.	B5.HIGH RESIDENTIAL: (a) A minimum of 20% and a maximum of 30% of the neighborhood area is designated for high residential use. (b) High residential lots have a maximum frontage of 16 ft. (c) A maximum of eight lots may be consolidated for the purpose of constructing a single building containing one or more residential units.	C5.HIGH RESIDENTIAL: (a) Buildings are built out to a minimum of 70% of their frontage, at a continuous alignment no further than 10 ft from the frontage line. (b) Buildings have no required setback from side lot lines. (c) Buildings do not exceed four stories in height and, when fronting a square, are no less than three stories in height. (d) Building coverage does not exceed 50% of the lot area.	D5.HIGH RESIDENTIAL: (a) Lots front streets no more than three lanes wide, with parallel parking and sidewalks minimum 15 ft wide. (b) Street trees are aligned both sides of streets at 35- to 50-ft intervals. (c) Rear lot lines coincide with an alley. (d) All off-street parking is behind the buildings.
A6.LOW RESIDENTIAL: (a) Contains buildings for residential uses, including art studios, limited offices, limited lodging, and the like. (b) All of the building area above the ground floor is designated for residential use. (c) Outbuildings are permitted.	B6.LOW RESIDENTIAL: (a) A maximum of 60% of the neighborhood area is designated for low residential use. (b) Lots have a maximum frontage of 64 ft. (c) A maximum of two lots may be consolidated for the purpose of constructing a single building.	C6.LOW RESIDENTIAL: (a) Buildings are built out to a minimum of 40% of their frontage at a continuous alignment no further than 30 ft from the frontage line. (b) Side setbacks are no less than 10 ft in aggregate and may be allocated to one side. Buildings are set back no less than 20 ft from the rear lot line. Outbuildings have no required setback. (c) Buildings do not exceed three stories in height. (d) Building coverage does not exceed 50% of the lot area.	D6.LOW RESIDENTIAL: (a) Lots front roads no more than two lanes wide with optional parallel parking and sidewalks minimum 6 ft wide. (b) Street trees are installed on both sides of the street at no more than 50-ft intervals. (c) Rear lot lines may coincide with an alley. (d) All off-street parking is to the side or rear of the building. Where access is through the frontage, garages or carports are located a minimum of 20 ft behind the facade.
A7.WORKPLACE: (a) Contains buildings for uses such as corporate office, light industry, artisanal, warehousing, automotive, and the like.	B7.WORKPLACE: (a) A minimum of 2% and a maximum of 30% of the neighborhood area is designated for workplace use. (b) Lots have a maximum frontage of 64 ft. (c) A maximum of four lots may be consolidated for the purpose of constructing a single building.	C7.WORKPLACE: (a) Buildings are built out to a minimum of 70% of their frontage at a continuous alignment no further than 10 ft from the frontage line. (b) Buildings have no setbacks from side or rear lot lines. (c) Buildings do not exceed three stories in height. (d) Building coverage does not exceed 70% of the lot area. (e) Lots are separated from other use types at the side and rear lot lines by a wall of between 3 and 8 ft high.	D7.WORKPLACE: (a) Lots front streets as wide as necessary to accommodate truck traffic. (b) Street trees are aligned on both sides of the street at 35- to 50-ft intervals. (c) Rear lot lines coincide with an alley. (d) All off-street parking is to the side or rear of the building.

Gary Greenan, Andres Duany, Elizabeth Plater-Zyberk, Kamal Zaharin, Iskandar Shafie; Miami, Florida  
The Cintas Foundation

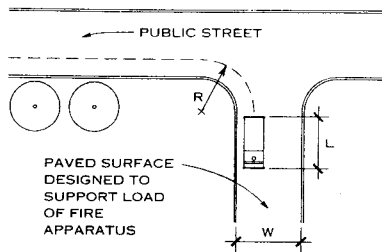

**FIRE APPARATUS ACCESS**

Fire apparatus (i.e., pumpers, ladder trucks, tankers) should have unobstructed access to buildings. Check with local fire department for apparatus turning radius (R), length (L), and other operating characteristics. Support systems embedded in lawn areas adjacent to the building are acceptable.

**RESTRICTED AREAS**

Buildings constructed near cliffs or steep slopes should not restrict access by fire apparatus to only one side of the building. Grades greater than 10% make operation of fire apparatus difficult and dangerous. Avoid parking decks abutted to buildings. Consider pedestrian bridge overs instead.

**FIRE DEPARTMENT RESPONSE TIME FACTOR**

Site planning factors that determine response time are street accessibility (curbs, radii, bollards, T-turns, culs-de-sac, street and site slopes, street furniture and architectural obstructions, driveway widths), accessibility for firefighting (fire hydrant and standpipe connection layouts, outdoor lighting, identifying signs), and location (city, town, village, farm). Check with local codes, fire codes, and fire department for area regulations.

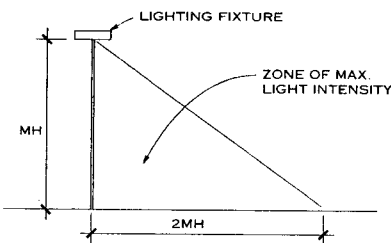

**OUTDOOR LIGHTING**

Streets that are properly lit enable fire fighters to locate hydrants quickly and to position apparatus at night. Avoid layouts that place hydrants and standpipe connections in shadows. In some situations, lighting fixtures can be integrated into exterior of buildings. All buildings should have a street address number on or near the main entrance.

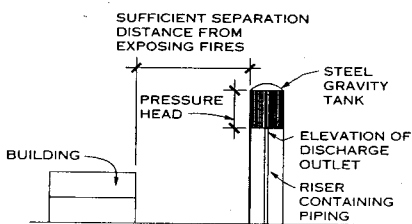

**GRAVITY TANK**

Gravity tanks can provide a reliable source of pressure to building standpipe or sprinkler systems. Available pressure head increased by 0.434 psi/ft increase of water above tank discharge outlet. Tank capacity in gallons depends on fire hazard, water supply, and other factors. Tanks require periodic maintenance and protection against freezing during cold weather. Locations subject to seismic forces or high winds require special consideration. Gravity tanks also can be integrated within building design.

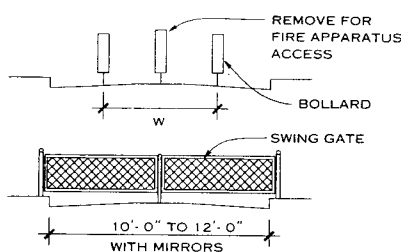

**ACCESS OBSTRUCTIONS**

Bollards used for traffic control and fences for security should allow sufficient open road width (W) for access by fire apparatus. Bollards and gates can be secured by standard fire department keyed locks (check with department having jurisdiction).

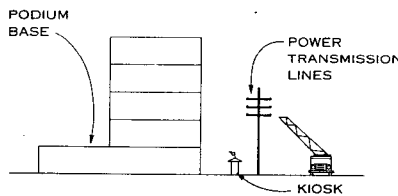

**STREET FURNITURE AND ARCHITECTURAL OBSTRUCTIONS**

Utility poles can obstruct use of aerial ladders for rescue and fire suppression operations. Kiosks, outdoor sculpture, fountains, newspaper boxes, and the like can also seriously impede fire fighting operations. Wide podium bases can prevent ladder access to the upper stories of buildings. Canopies and other nonstructural building components can also prevent fire apparatus operations close to buildings.

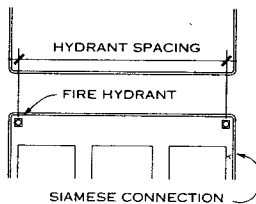

**FIRE HYDRANT AND STANDPIPE CONNECTION LAYOUT**

Locate fire hydrants at street intersections and at intermediate points along roads so that spacing between hydrants does not exceed capability of local fire jurisdiction. Hydrants should be placed 2 to 10 ft from curb lines. Siamese connections for standpipes should be visible, marked conspicuously, and be adjacent to the principal vehicle access point to allow rapid connection by fire fighters to the pumping engine.

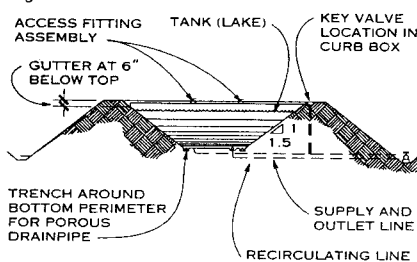

**ON-SITE LAKES**

Man-made and natural on-site lakes are used for private fire fighting in suburbs, on farms, and at resorts. A piped supply system to a dry hydrant is preferred for its quantity, flexibility, better maintenance, and accessibility. Man-made lakes with reservoir liners can be berm-supported or sunk in the ground. Lakes and ponds are natural water supplies dependent on the environment. See local codes, fire codes, and fire departments for on-site lake regulations.

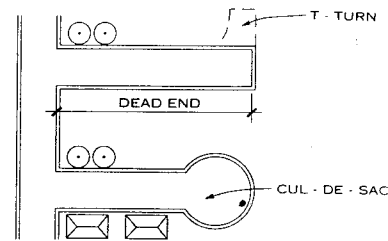

**DRIVEWAY LAYOUTS**

Long dead ends (greater than 150 ft) can cause time-consuming, hazardous backup maneuvers. Use t-turns, culs-de-sac, and curved driveway layouts to allow unimpeded access to buildings.

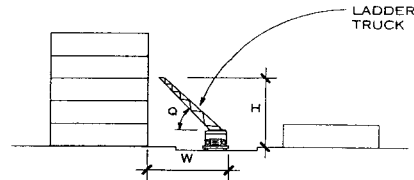

**DRIVEWAY WIDTHS**

For full extension of aerial ladders at a safe climbing angle (θ), sufficient driveway width (W) is required. Estimate the required width in feet by:  $W = (H-6) \cot \theta + 4$ , where preferred climbing angles are 60 to 80°. Check with local fire department for aerial apparatus operating requirements, including width of aerial device with stabilizing outriggers extended.

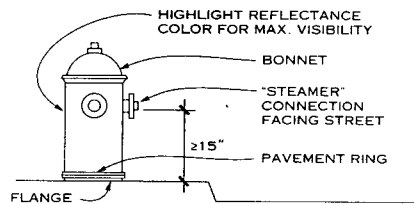

**FIRE HYDRANT PLACEMENT**

Fire hose connections should be at least 15 in. above grade. Do not bury hydrants or locate them behind shrubs or other visual barriers. Avoid locations where runoff water and snow can accumulate. Bollards and fences used to protect hydrants from vehicular traffic must not obstruct fire fighters' access to hose connections. "Steamer" connection should usually face the side of arriving fire apparatus.

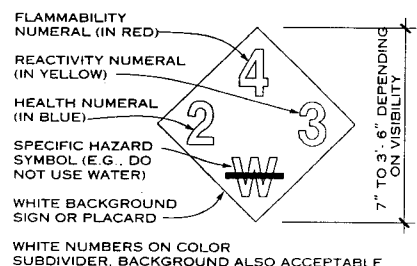

**NFPA 704 DIAMOND SYMBOLS**

Standard diamond symbols provide information fire fighters need to avoid injury from hazardous building contents. zero (0) is the lowest degree of hazard, 4 is highest. Locate symbols near building entrances. Correct spatial arrangement for two kinds of diamond symbols are shown. Consider integrating symbols with overall graphics design of building. (Refer to "Identification of the Fire Hazards of Materials," NFPA No. 704, available from the National Fire Protection Association.)

D. L. Collins and M. David Egan, P. E., College of Architecture, Clemson University; Clemson, South Carolina  
Nicholas A. Phillips, AIA; Lockwood Greene; New York, New York

**FLOOD DAMAGE MANAGEMENT**

Flood hazards are caused by building in flood-prone areas. Floods cannot be prevented, but the damage they wreak on man-made properties can be managed, either by altering the flood potential of an area or by avoiding construction in locations subject to flooding. Historically, flood damage management in the United States has focused on the former management technique, attempting to divert floods with structural flood controls—dams, levees, and channel modifications. However, such flood control measures have proved unsatisfactory over time.

Structural flood control projects have tended to encourage development in high hazard areas, often without appropriate land use planning. When a storm exceeds or violates the design parameters of a flood control structure, the damage that results from a flood can exceed what would have occurred if the structure had not been built. For example, floodplain invasion often occurs where levees have been built with the intention of reducing damage to agriculture. Although in some regions levees have reduced the number of high-frequency floods, in general they cause conditions favorable for their own failure by altering erosion patterns and increasing stages.

Recognition of the cost of development in high-risk areas, the uneven distribution of flood hazards on the landscape, and the natural and beneficial values of floodplains have led to more common adoption of nonstructural flood hazard management techniques. In particular, land use management and modified building practices are finding widespread acceptance.

Information on flood damage management and floodplain and wetland conservation is available from the Federal Emergency Management Agency (FEMA), the Natural Hazards Research Applications and Information Center, the U.S. Army Corps of Engineers, the Environmental Protection Agency, the National Park Service, and state and local agencies.

**FLOOD HAZARDS**

Most flood damage is caused by weather conditions such as hurricanes, fronts associated with midlatitude cyclones, thunderstorms, and melting snow packs. These conditions interact with surface features such as floodplains, coasts, wetlands, and alluvial fans, resulting in floods, mudslides, and erosion. Geologic phenomena such as earthquakes may also trigger floods.

Weather and climate information is available from the National Climate Data Center, regional climate research centers, and state climatology offices. Geologic and hydrologic information is available from the U.S. Geological Survey and state geological and geographical surveys.

**FLOOD-PRONE AREAS**

**FLOODPLAIN:** The relatively flat area within which a river moves and upon which it regularly overflows.

Rivers typically meander over their floodplains, eroding the cutbank and redepositing sediments in accretion zones such as point bars, meander belts, and natural levees. Channel shifting may be extreme in alluvial fans. Coastal floodplains, which include barrier islands, shores, and wetlands, have the same relationship to the sea that riverine floodplains have to rivers.

**WETLANDS:** areas characterized by frequent flooding or soil saturation, hydrophytic vegetation (vegetation adapted to survival in saturated areas), and hydric soils (soil whose chemical composition reflects saturation). Wetlands are often found in floodplains but are more restrictively defined.

**FLOOD TYPES**

Floods may be classified by their locations or physical characteristics.

**RIVERINE FLOOD:** great overflows of water from a river channel onto a floodplain caused by precipitation over large areas, melting snow, or both. Over-bank flow is a normal geophysical event that occurs on average every two years for most rivers.

**HEADWATER FLOOD:** a riverine flood that results from precipitation directly in a basin.

**BACKWATER FLOOD:** a riverine flood caused by high stages on downstream outlets, which prevent drainage from tributary basins or even reverse the flow.

**COASTAL FLOOD:** overflows onto coastal lands bordering an ocean, estuary, or lake. Coastal floods are caused by tsunamis (seismic sea waves), hurricanes, and northeasters.

**FLASH FLOOD:** a local flood of great volume and short duration. Flash floods differ from riverine floods in extent and duration. Flash floods generally result from a torrential rain or "cloudburst" covering a relatively small drainage area. Flash floods may also result from the failure of a dam or sudden breakup of an ice jamb.

**FLOOD RISKS**

Flood risk is usually expressed as the estimated annual frequency with which a flood equals or exceeds a specified magnitude. The flood risk for a future period of time is the joint probability of the occurrence of the annual flood risk. For example, if a house is situated at the "100-year flood" elevation (1% annual exceedance frequency), then its flood risk for a 30-year period is 26% or approximately a one in four chance it will be flooded to the specified depth or greater.

**STANDARD PROJECTED FLOOD (SPF):** a flood that may be expected from the most severe combination of meteorological and hydrological conditions characteristic of the geographic area in which the drainage basin is located, excluding extremely rare combinations.

SPFs are used in designing dams and other facilities with high damage potential.

**PROBABLE MAXIMUM FLOOD (PMF):** the most severe flood that may be expected from a combination of the most critical meteorological and hydrological conditions reasonably possible in a drainage basin. (This term is not a statistical concept.)

PMFs are used in designing high-risk flood protection works and in siting structures and facilities that must be subject to almost no risk of flooding.

**LAND USE IN FLOOD ZONES**

Land use management is the most effective method of managing flood damage. State control of land use in hazardous areas, authorized by the police-powers clause of the U.S. Constitution, is usually delegated to local planning and zoning boards. Local, state, and federal governments also regulate ecosystems essential for flood damage management, such as wetlands, coastal dunes, and mangrove stands. Land use management often includes setback regulations, which attempt to limit flood-related erosion damage. Regardless of regulations imposed by the government, developers should evaluate building sites for their intrinsic suitability for the intended use.

The National Flood Insurance Program (NFIP) requires that participating local governments adopt minimum floodplain management plans based on data provided by the federal insurance administrator. The NFIP does not require local governments to adopt land use or transportation plans that require preferential development of hazard-free areas or prohibit development of land in high-hazard areas. New construction in coastal zones is required to be located land-

ward of the reach of the mean high tide. Local land use and development or floodplain management plans that are more stringent than NFIP requirements supersede NFIP requirements. The NFIP divides riverine floodplains into floodway and floodway fringes for land use management. Coastal floodplains are divided into coastal high-hazard areas and coastal fringes. Land uses in these areas should always be verified with local agencies.

**FLOODWAYS**

Floodways include the channel of a watercourse and those portions of the adjoining floodplain required to permit the passage of a flood of specified magnitude at no more than a specified level above natural conditions. The NFIP requires floodways to be large enough to accommodate floods with a 1% annual exceedance frequency (100-year flood) without causing an increase in water levels of more than a specified amount (1 ft in most areas). Some localities object to the acceptability of increased flood levels this NFIP requirement implies. Instead, they define the floodway as the area inundated by floods with a 4% annual exceedance frequency (25-year flood).

Uses permitted in a floodway are those with low flood damage potential that do not obstruct flood flows or require structures, fill, or storage of materials or equipment. Fill is prohibited, and most structures are strongly discouraged. The following uses are generally permitted:

**FUNCTIONALLY DEPENDENT USES:** facilities and structures that must be located close to water in order to function, such as docking and port facilities and shipbuilding and repair facilities. Water supply and sanitary sewage treatment plants must be floodproofed if they must be located adjacent to bodies of water.

**AGRICULTURAL USES:** general farming, pasture, outdoor plant nurseries, horticulture, viticulture, truck farming, forestry, sod farming, and wild crop harvesting.

**RECREATIONAL USES:** golf courses, tennis courts, driving ranges, archery ranges, picnic grounds, boat launching ramps, swimming areas, parks, wildlife and nature preserves, game farms, fish hatcheries, shooting preserves, target ranges, trap and skeet ranges, hunting and fishing areas, and hiking and horseback riding trails.

**INCIDENTAL INDUSTRIAL-COMMERCIAL USES:** loading areas, parking areas, and airport landing strips (except in flash flood areas).

**INCIDENTAL RESIDENTIAL USES:** lawns, gardens, parking areas, and play areas.

**FLOODWAY FRINGES**

Floodway fringes are the portion of the regulatory floodplain outside of the floodway. Floodway fringes are treated as storage area for flood waters. Where permitted, property owners on each side of the floodplain may obstruct flood flows equally.

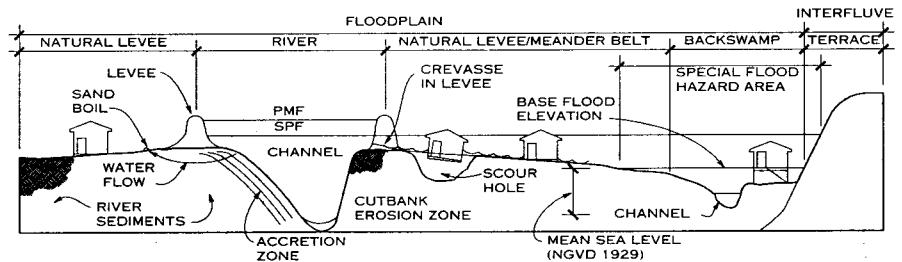

**INVERTED RIVER VALLEY**

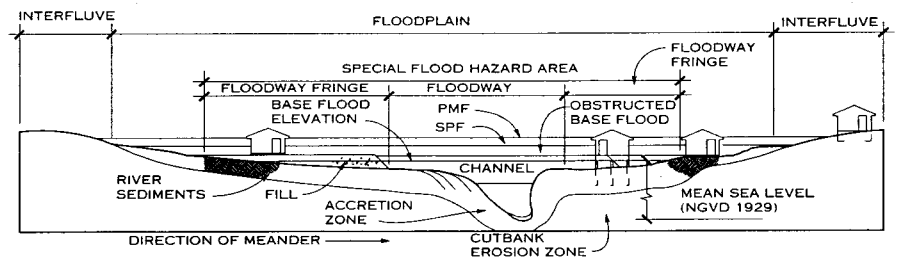

**V-SHAPED RIVER VALLEY**

Mattie Fincher Coxie; Baton Rouge, Louisiana

Uses permitted in floodway fringes include those permitted in floodways and elevated or otherwise flood-proofed structures for flood disaster relief. It provides flood damage insurance as an incentive for communities to adopt floodplain management regulations, especially those governing floodplain obstructions and building practices in floodplains. NFIP minimum standards require a low level of flood damage management based on historic conditions.

**FLOOD INSURANCE RATE ZONES**

The NFIP is a program intended to reduce federal expenditures for flood disaster relief. It provides flood damage insurance as an incentive for communities to adopt floodplain management regulations, especially those governing floodplain obstructions and building practices in floodplains. NFIP minimum standards require a low level of flood damage management based on historic conditions.

States and localities may establish standards higher than NFIPs, in which case these supersede NFIP standards. For example, other governments may control land use in hazardous areas, regulate runoff, have freeboard requirements, or base regulatory flood elevations on historic floods that exceeded the base flood or on the projected effects of future development. The NFIP Community Rating System provides insurance rate reductions as an incentive to adopt higher standards.

The NFIP bases Flood Insurance Rate Zones on the frequency of flooding and the presence of storm surge and waves. Local governments are typically required to regulate building practices in A and V zones as a condition of eligibility for flood insurance.

The most important requirement in A and V zones is that the first floor of new buildings be built equal to or higher than the base flood level, which has a 1% chance of being equaled or exceeded in any given year (100-year flood). The base flood is the still water height for riverine floods. For the Atlantic Coast and the Gulf of Mexico, the base flood includes storm surge plus wave crest height because of northeasters and hurricanes. The base flood for the Pacific Coast includes astronomical tides plus wave run-up caused by tropical cyclones and tsunamis. For major lakes, the base flood includes seiche (sloshing because of wind, seismic activity, and storm surge). The base flood elevation (BFE) is the height of the base flood in reference to mean sea level as defined by the National Geodetic Vertical Datum of 1929 (NGVD 1929).

Local communities may adopt regulatory flood datums (RFD) in place of base flood elevations. RFDs are the base flood plus a freeboard, a factor of safety expressed in feet and used to compensate for uncertainties that could contribute to greater flood height than that computed for a base flood. Freeboard allows for hazards excluded from consideration in figuring the base flood and uncertainties in analysis, design, and construction. Severe structural subsidence, increases in floods because of obstructions in the floodplain, urban runoff, or normal climatic variability, as well as long-term increases in sea level and storms, are often excluded from consideration in determining base flood levels. Urban conditions, low accuracy base maps, and unplanned development are other common sources of uncertainty that justify freeboard.

Some communities require up to a 3-ft freeboard to compensate for inaccurate flood insurance rate maps (FIRMs). The margin of error of base maps may be estimated as plus or minus one-half of the contour interval. Most FIRMs are developed from maps with a contour interval of 5 ft, and a margin of error of -2 1/2 ft. Field survey maps with a contour interval of 2 ft or less are used in some communities; the smaller interval reduces the uncertainty of the risk and the need for freeboard.

The NFIP classifies land either as special flood hazard areas (SFHA)—high-frequency flood, flood-related erosion, and mudslide zones—or low-risk and undetermined flood hazard zones. Zone names that include actuarial risk factors, such as A1-A30 and V1-V30, are being replaced by AE and VE designations with flood depths.

**A ZONES (A, AE, A1-A30, AO, AH, AR, A99)**

Zones A and AE (formerly A1-A30) are high-risk riverine areas susceptible to inundation by the still-water base flood. AO zones are areas of shallow flooding (1 to 3 ft) without defined channels, usually sheet flow on sloping terrain. AH zones indicate shallow flooding, usually with water ponding. AR zones are areas in which structural flood protection is deficient. A99 zones are areas in which structural flood protection systems are near completion.

The finished floor of the lowest habitable level of residences, usually including basements, must be elevated to the base flood elevation in zone A. Flood-resistant residen-

tial basements are permitted only in communities that meet special NFIP flood criteria and adopt special local standards for their design and construction. Commercial structures must be elevated or otherwise floodproofed to the BFE.

**B ZONES**

B zones indicate areas subject to inundation by floods with an annual exceedance frequency greater than the base flood with less than a 0.2% annual exceedance frequency (500-year flood). B-zone designations are not used on recent FIRMs because of the lack of statistical validity of most estimates of 500-year floods and the false perception that they are generally safe. On some maps B zones are shown as shaded X zones.

**C ZONES**

C zones, including all areas that are not in zones A, B, or V, are not necessarily flood free. They may include low-risk interfluvial regions (areas of a watershed above the natural floodplain), moderate-risk floodplain between the interfluvial and the regulatory floodplain, areas with localized nonriverine flooding, high-risk areas with small contributing drainage areas, and floodplains with structural flood protection that may be subject to low frequency catastrophic floods.

**D ZONES**

D zones are areas of possible but undetermined flood hazard.

**X ZONES**

X zones include all areas not in zones A or V, combining B and C zones found on older maps. On some maps, X zones that were formerly B zones and X zones within levee systems are shaded.

**V ZONES (V, VE, V1-V30, VO)**

Velocity zones V and VE (formerly V1-V30) are coastal high hazard areas identified as susceptible to inundation by the base flood, including storm surges with high velocity waves greater than 3 ft. Generally, zone V indicates the inland extent of a 3-ft breaking wave, where the still-water depth during the 100-year flood decreases to less than 4 ft. VO zones are proposed alluvial fan zones with high velocity shallow flow (1 to 3 ft) and unpredictable flow paths.

Elevation and structural requirements are most stringent in coastal high hazard areas. Fill below buildings is prohibited. If construction is permitted by the local government, the lowest horizontal structural member of the lowest habitable floor must be built above the base flood elevation. Rigid frames or semirigid frames with grade beams can resist the impact of storm surge and waves. Semirigid frames with-

out grade beams should be used only in areas not subject to potential scour. Freestanding pole structures are unsafe; large rotations develop at moment connections, causing deflection of pilings under sustained lateral loads that can lead to collapse.

Destruction of coastal dunes and wetlands dramatically increases the inland reach of storm surge and waves and increases the severity of flood damage. Buildings may be destroyed if dunes and wetlands are inadequately protected, even if they conform to legal building requirements.

**E AND M ZONES (E, M)**

E zones are areas adjoining the shore of a lake or other body of water that are likely to suffer flood-related erosion. M zones are areas with land surfaces and slopes of unconsolidated material in which the history, geology, and climate indicate a potential for mudflow. Setbacks and special building requirements are used in E and M zones.

**SOURCES**

*Coastal Construction Manual* (FEMA-55). Dames & Moore and Bliss & Nytray, Inc., 1986.

*Elevated Residential Structures* (FEMA-54). Washington, D.C.: American Institute of Architects, 1984.

*Elevating to the Wave Crest Level: A Benefit: Cost Analysis* (FIA-2). Shaeffer & Roland, Inc., 1980.

Federal Emergency Management Agency. *Answers to Questions About the National Flood Insurance Program* (FIA-2). Washington, D.C.: FEMA.

Federal Emergency Management Agency. *The Floodway: A Guide for Community Permit Officials*. Community Assistance Series No. 4. Washington, D.C.: FEMA.

Flood Loss Reduction Associates. *Floodplain Management Handbook*. U.S. Water Resources Council, 1981.

*Floodproofing Nonresidential Structures* (FEMA-102). Booker Associates, Inc., 1986.

Hayes, W. W., ed. *Facing Geologic and Hydrologic Hazards: Earth-Science Considerations*. Washington, D.C.: U.S. Geological Survey, 1981.

*Permit Officials' Handbook for the National Flood Insurance Program*. 3rd ed. Baton Rouge Louisiana Department of Transportation and Development, 1993.

**GENERAL LIMITS OF FLOODPROOFING**

METHOD	DEPTH	VELOCITY	WARNING REQUIREMENTS
Levees	4-7'	< 10'/sec	Advance warning required for installation of floodgates in openings
Floodwalls	4-7'	< 12'/sec	
Closures (24 hr maximum)	4-8'	< 8'/sec	5-8 hr advance warning required for installation of closures
Fill	10'+	< 10'/sec	Evacuation time required unless fill connects to higher ground
Piles, piers, and columns	10-12'	< 8'/sec	Adequate evacuation time required

**NOTE**

Information presented is general and warrants caution. Time available for warning may be severely limited by a flood's rate of rise.

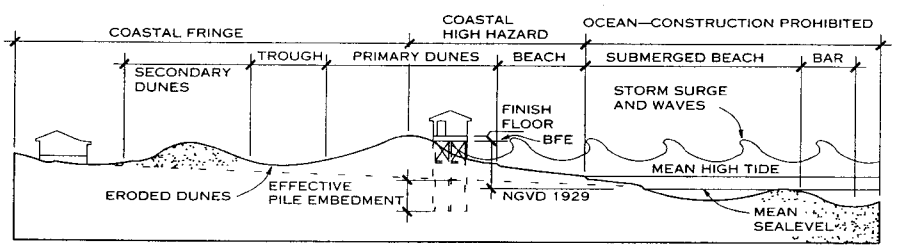

**COASTAL DUNES AND BEACHES**

Mattie Ann Fincher; Baton Rouge, Louisiana

**GENERAL**

In setting design parameters, the designer assumes that all vehicles present are "design vehicles." Design vehicles are selected to represent approximately the 85th percentile vehicle in a range from smallest to largest. In the recent past, small or compact car stalls were often separated from large or standard stalls in parking designs. However, a decline in smaller car sales and the increasing use of light trucks, vans, and utility vehicles (LTVUs) for personal transportation have made small-car-only stalls ineffective as a design tool. Therefore, while small car and large car design vehicles—as well as a composite encompassing both small and large—have been given here for reference, parking design must be based on a composite passenger vehicle that includes not only cars but light trucks, vans, and sport/utility vehicles.

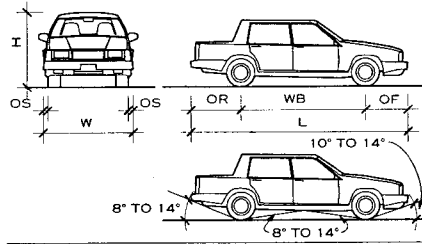

**PASSENGER CAR**

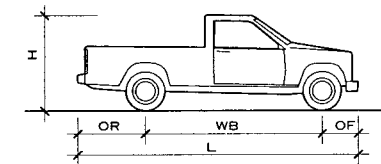

**LIGHT TRUCK**

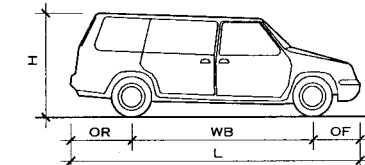

**VAN**

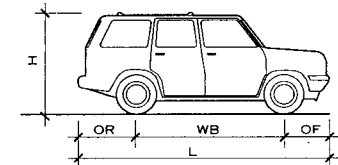

**SPORT/UTILITY**

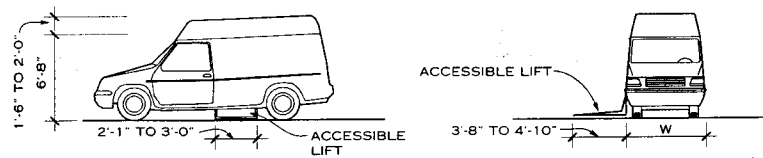

**WHEELCHAIR LIFT VAN**

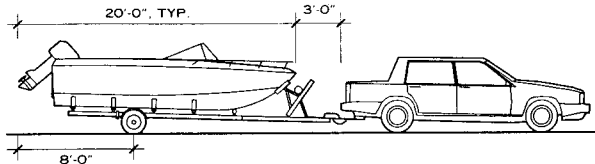

**BOAT TRAILER**

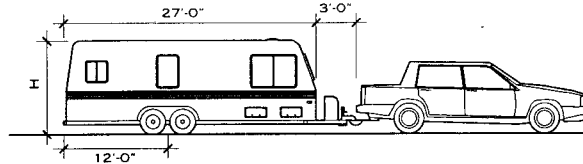

**RV—CONVENTIONAL TRAILER**

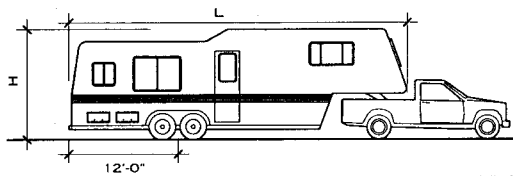

**RV—FIFTH WHEEL (PICKUP-BASE)**

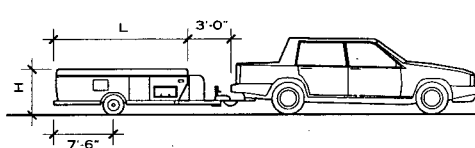

**RV—FOLDING TRAILER**

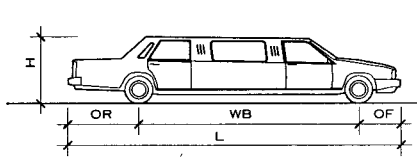

**STRETCH LIMOUSINE**

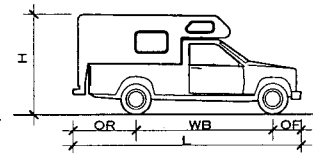

**SLIDE-IN CAMPER**

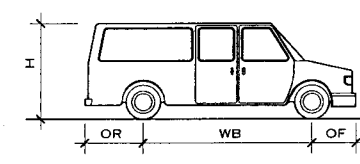

**SHUTTLE VAN**

**DESIGN VEHICLE DIMENSIONS**

VEHICLE	LENGTH (L)	WIDTH (W)	HEIGHT (H)	WHEELBASE (WB)	OVERHANG FRONT (OF)	OVERHANG REAR (OR)	GROSS WEIGHT
Small car <sup>1</sup>	15-0	5-7	4-8	8-6	2-0	4-6	2850
Composite passenger vehicle <sup>2</sup>	16-9	6-4	6-10	9-5	3-0	4-4	6000
Light truck	17-9	6-6	6-0	11-0	2-9	4-0	8600
Van	16-9	6-3	6-10	10-0	2-9	4-0	4600
Sport/utility vehicle	16-0	6-4	6-2	9-4	3-0	3-8	6000
Wheelchair lift van (personal use)	17-8	6-8	8-0	11-6	2-6	3-8	6000
Boat trailer	20-0	8-0	6-0	See detail	3-0	8-0	4000
RV—conventional trailer	27-0	7-0	9-0	See detail	3-0	12-0	5000
RV—fifth wheel (pickup-based)	34-0	8-6	12-0	8-0	22-0	12-2	3500
RV—folding trailer	16-0	7-6	5-0	—	8-6	7-6	1500
Slide-in pickup camper	18-11	10-0	7-3	—	—	—	2900
Stretch limousine	24-6	6-0	5-0	15-6	4-0	5-0	9000
Shuttle van (11 passengers)	20-0	6-6	6-10	11-6	3-0	5-6	11,000

<sup>1</sup> Small car classes 5 through 7 per Parking Consultants Council (PCC).

<sup>2</sup> A composite passenger vehicle is a design vehicle that encompasses passenger cars, light trucks, vans, and sport/utility vehicles. It is the vehicle for which a parking facility should be designed.

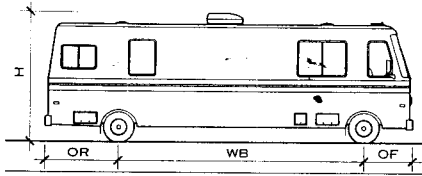

CLASS A MOTOR HOME

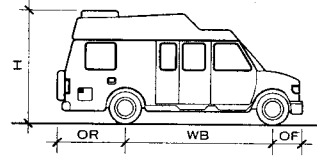

CLASS B MOTOR HOME

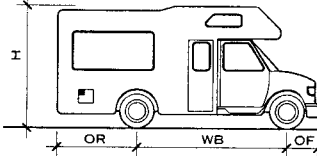

CLASS C MOTOR HOME

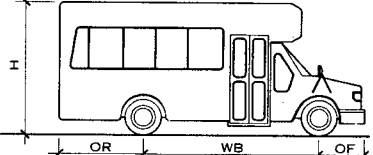

PARATRANSIT/SHUTTLE BUS

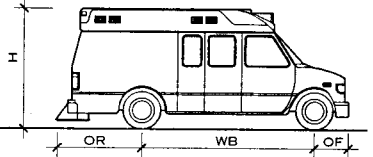

AMBULANCE VAN

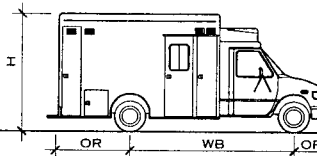

PARAMEDIC UNIT

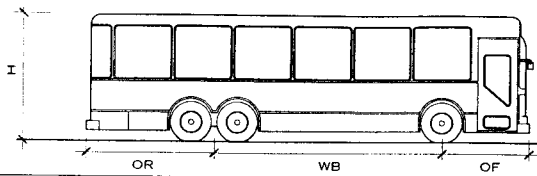

INTERCITY/CHARTER BUS

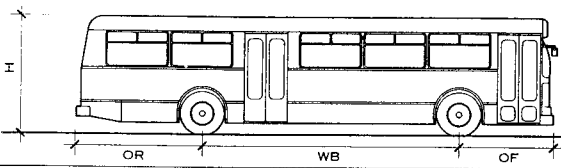

CITY BUS

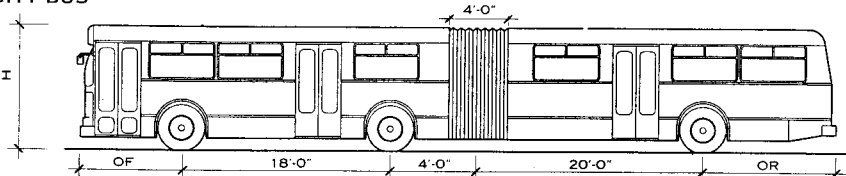

ARTICULATED BUS

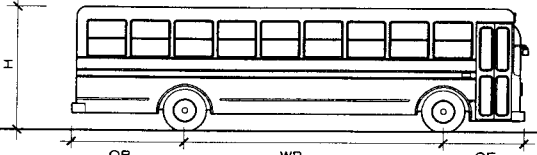

SCHOOL BUS

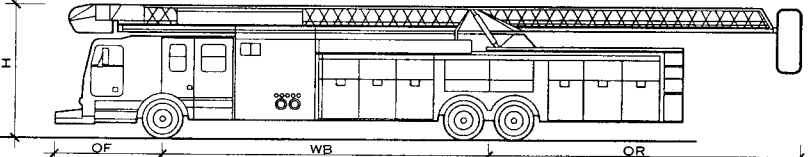

FIRE TRUCK—AERIAL

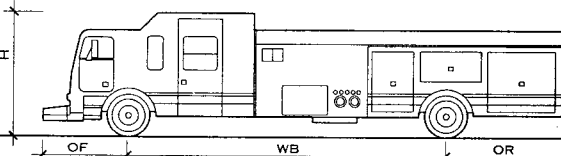

FIRE TRUCK—PUMPER

DESIGN VEHICLE DIMENSIONS

VEHICLE	LENGTH (L)	WIDTH (W)	HEIGHT (H)	WHEELBASE (WB)	OVERHANG FRONT (OF)	OVERHANG REAR (OR)	GROSS WEIGHT (LB)
Class A motor home (self-contained)	30-0	8-0	11-0	20-0	4-0	6-0	17,000
Class B motor home (van conversion)	20-0	6-8	8-6	11-6	2-6	6-0	9000
Class C motor home (van cutaway)	19-0	7-6	9-0	11-0	2-6	5-6	11,000
Paratransit/shuttle bus (20 passengers)	25-0	6-10	8-9	11-6	3-0	5-6	11,000
Intercity/charter bus	40-0	8-6	11-6	20-6	9-0	10-6	47,000
City bus*	40-0	8-6	11-2	25-0	7-0	8-0	47,000
Articulated bus*	60-0	8-6	10-4	See detail	8-6	9-6	50,000
School bus	40-0	8-0	10-0	22-0	8-0	10-0	47,000
Ambulance van	19-10	6-8	9-6	11-6	2-8	5-8	9400
Paramedic unit	22-6	7-8	9-6	13-2	2-8	7-0	11,500
Fire truck—pumper	31-0	8-0	9-8	18-8	5-0	7-5	35,000
Fire truck—aerial	45-9	8-0	10-2	20-3	6-2	19-4	52,000

\*Generally in conformance with standards of the American Association of State Highway and Transportation Officials (AASHTO).

Mary S. Smith, P.E.; Walker Parking Consultants/Engineers, Inc.; Indianapolis, Indiana

1 AUTOMOBILES, ROADS, AND PARKING

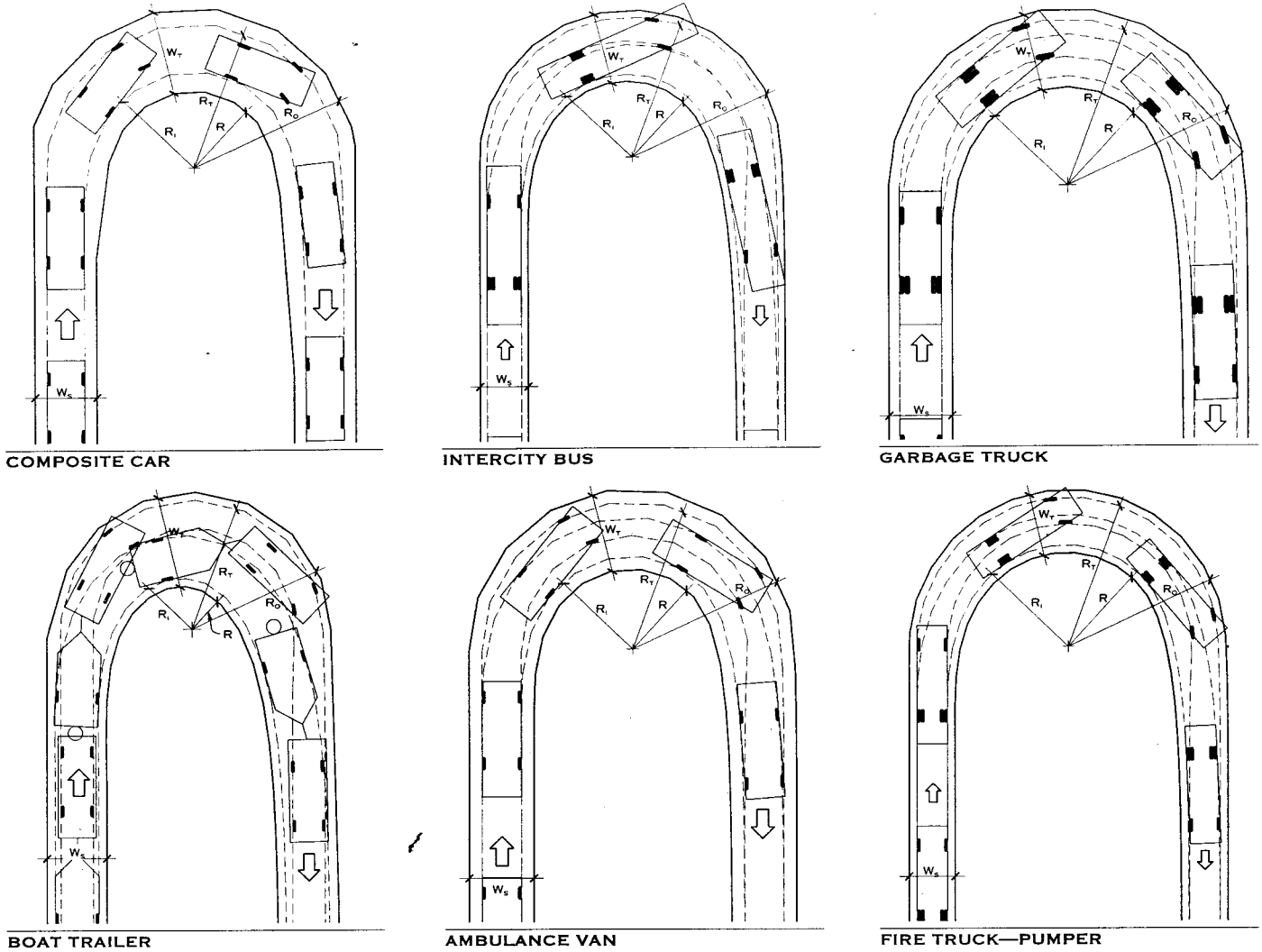

MINIMUM TURNING RADIUS FOR DESIGN VEHICLES (FT-IN.)

VEHICLE TYPE	MIN. TURNING RADIUS ( $R_T$ )	OUTSIDE FRONT RADIUS ( $R_O$ )	INSIDE REAR RADIUS ( $R_I$ )	STRAIGHT LANE WIDTH ( $W_S$ )	CURVED LANE WIDTH ( $W_T$ )	INSIDE CURB RADIUS ( $R$ )	TANGENT LENGTH (T)
Composite private vehicle	24-0	26-0	15-6	10-0	13-6	12-6	24-7
Wheelchair lift van	24-9	26-8	16-7	10-0	12-6	14-0	24-4
Boat trailer	24-0	24-11	8-5	11-0	16-11	6-10	60-9
RV trailer	23-10	25-4	5-7	11-0	18-4	4-1	83-3
Motor home	39-7	42-8	27-6	11-0	19-0	23-0	41-2
Stretch limousine	32-7	34-10	23-8	11-0	14-6	20-2	34-1
Shuttle van	24-10	26-11	16-5	11-0	13-6	13-4	29-7
Paratransit/shuttle bus	25-2	26-11	16-6	11-0	13-6	13-4	29-4
Intercity bus	35-3	36-10	23-5	12-0	17-10	18-7	60-0
City bus	42-0	46-6	24-0	12-0	27-0	21-0	60-0
Articulated bus	38-0	43-0	14-0	12-0	22-0	11-0	62-0
School bus	41-9	43-6	28-7	12-0	17-8	25-3	56-4
Garbage truck	31-0	33-4	20-8	12-0	14-6	18-6	38-0
Ambulance van	24-9	27-2	16-7	11-0	13-5	13-5	29-0
Paramedic unit	28-5	30-10	18-8	12-0	15-1	15-6	33-0
Fire truck-pumper	38-11	41-0	27-7	12-0	16-4	24-4	44-0

Source: American Association of State Highway and Transportation Officials (AASHTO).

NOTES

1. Minimum turn radii at less than 10 mph.
2. Obstructions (columns, walls, light poles, etc.) should be

held a minimum of 6 in. (2 ft preferred) from the edge of the lane given above. See details on the AGS page on driveways and roadways.

May S. Smith, P.E.; Walker Parking Consultants/Engineers, Inc.; Indianapolis, Indiana



**GENERAL**

Public streets and highways are designed to accommodate a variety of vehicles, up to and including semitrailer trucks. When private driveways and roadways will only serve passenger vehicles, it may be appropriate to use smaller dimensions in some instances. Nonetheless, be certain private roads are wide enough to allow passage of fire and emergency vehicles.

The "level of service" approach employed by traffic engi-

neers can be used as a tool for adapting designs to the specific needs of users. Level of service (LOS) A, which is the most comfortable, allows vehicle movement with little or no constraint. As the level of service decreases, from A to D, the comfort level decreases. LOS D is the minimum dimension for safe maneuvering of a vehicle at low speed.

The level of service selected for a particular application should reflect the needs of the users and of the owner of a property. Make adjustments according to the local vehicle size and mix and any concerns particular to the location.

**COMPARISON OF LEVELS OF SERVICE**

LEVEL OF SERVICE	LOS D	LOS A
Type of users	Familiar, young adults	Unfamiliar, elderly
Length of stay	Long-term	Short-term
Turnover	Less than 2 per day	More than 5 per day
Type of generator	Industrial	Retail
Location	Urban	Rural
Image	Spec office	Corporate headquarters
Percent small cars	High	Low
Percent light trucks, vans, and utility vehicles	Low	High

**RECOMMENDED DESIGN PARAMETERS FOR VEHICULAR CIRCULATION<sup>1</sup>**

	DRAWING KEY	LOS D	LOS C	LOS B	LOS A
Lane width, straight	$W_s$				
One lane <sup>2</sup>		10'-0"	10'-6"	11'-0"	11'-6"
Multiple lanes		9'-0"	9'-6"	10'-0"	10'-6"
Clearance to obstructions <sup>3</sup>	C	0'-6"	1'-0"	1'-6"	2'-0"
Radius, turning (outside front wheel)	$R_T$	24'-0"	30'-0"	36'-0"	42'-0"
Lane width, turning <sup>4,5</sup>	$W_T$				
One lane		13'-6"	13'-6"	13'-6"	13'-6"
Each additional lane		12'-0"	12'-0"	12'-0"	12'-0"
Circular helix <sup>4,6</sup>					
Single-threaded <sup>7</sup>					
Outside diameter	$D_o$	60'-0"	74'-0"	88'-0"	102'-0"
Inside diameter <sup>8</sup>	$D_i$	24'-0"	36'-0"	48'-0"	60'-0"
Double-threaded <sup>9</sup>					
Outside diameter	$D_o$	80'-0"	95'-0"	110'-0"	125'-0"
Inside diameter <sup>9</sup>	$D_i$	44'-0"	57'-0"	70'-0"	83'-0"
Express ramp slope	S	16%	14%	12%	10%
Transition length	$L_T$	10'-0"	11'-0"	12'-0"	13'-0"
Gated/controlled width <sup>10</sup>	$W_G$	8'-9"	9'-0"	9'-3"	9'-6"

Source: Mary S. Smith, *Parking Structures: Planning, Design, Maintenance and Repair*, 2d ed. (Chapman and Hall, 1996).

<sup>1</sup> The design parameters recommended are for design speeds ranging from 10 mph (LOS D) to 25 mph (LOS A). Additional dimensions for parking access aisles and turning bays are provided on the AGS page on parking design parameters.  
<sup>2</sup> For all levels of service, use a 15-ft lane to make room for passing a broken-down vehicle.  
<sup>3</sup> The clearance given is from the edge of a lane to a wall, column, parked vehicle, or other obstruction, as cited in American Association of State Highway and Transportation Officials, *A Policy on Geometric Design of Highways and Streets* (1990) [ASHTO 1990], figure 111-25.  
<sup>4</sup> The dimensions given for LOS D are from AASHTO 1990 figure 111-23, except the clearance cited in that figure has been reduced to 2 ft, per figure 111-25.

<sup>5</sup> For all levels of service, use a 20-ft lane to allow room to pass a broken-down vehicle, per AASHTO 1990 figure 111-23.  
<sup>6</sup> The diameters given measure from outside face to outside face of the walls (6-in. walls assumed).  
<sup>7</sup> Turning radii/lane width increased 3 ft because of multiple turns.  
<sup>8</sup> Decrease 3 ft 6 in. to provide 20-ft lane in order to leave room to pass broken-down vehicles.  
<sup>9</sup> Ramp slope, minimum lane width, and clearance to walls control dimensions for double-threaded helix.  
<sup>10</sup> The dimensions given assume a straight approach to lane; check turns into lanes with template.

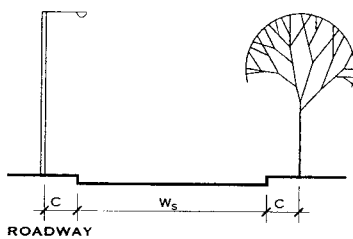

**ROADWAY AND RAMP WIDTHS**

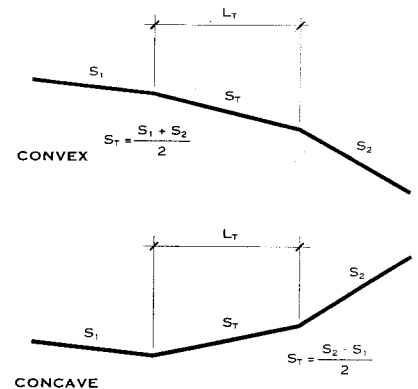

**TRANSITION SLOPES**

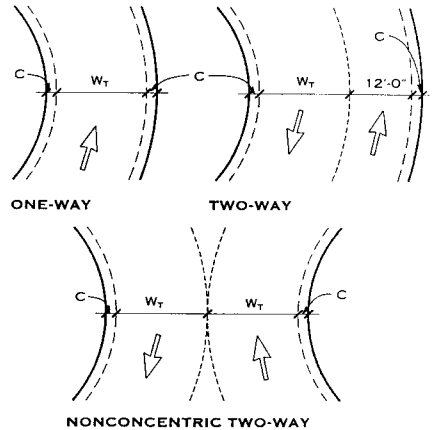

**LANE WIDTH (TURNING)**

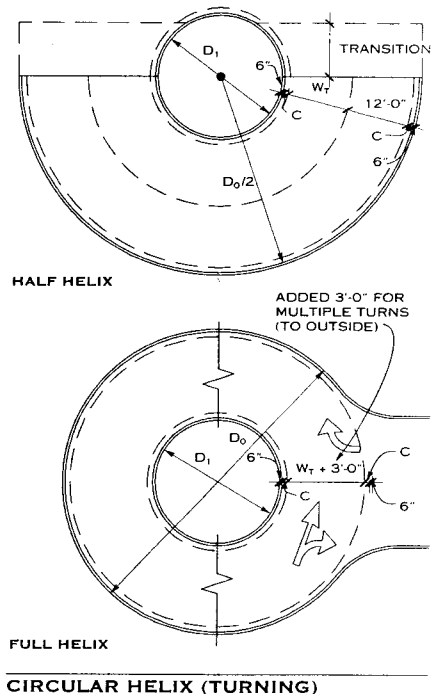

Mary S. Smith, P.E.; Walker Parking Consultants/Engineers, Inc.; Indianapolis, Indiana

**GENERAL**

Vehicle dimensions are shown on the AGS page on design vehicles. The U-shaped drive shown here illustrates a procedure for developing any drive configuration, given the design vehicle and its turning radii (R). The tangent (T<sub>G</sub>) dimension is an approximate minimum required for transition from one turn direction to another.

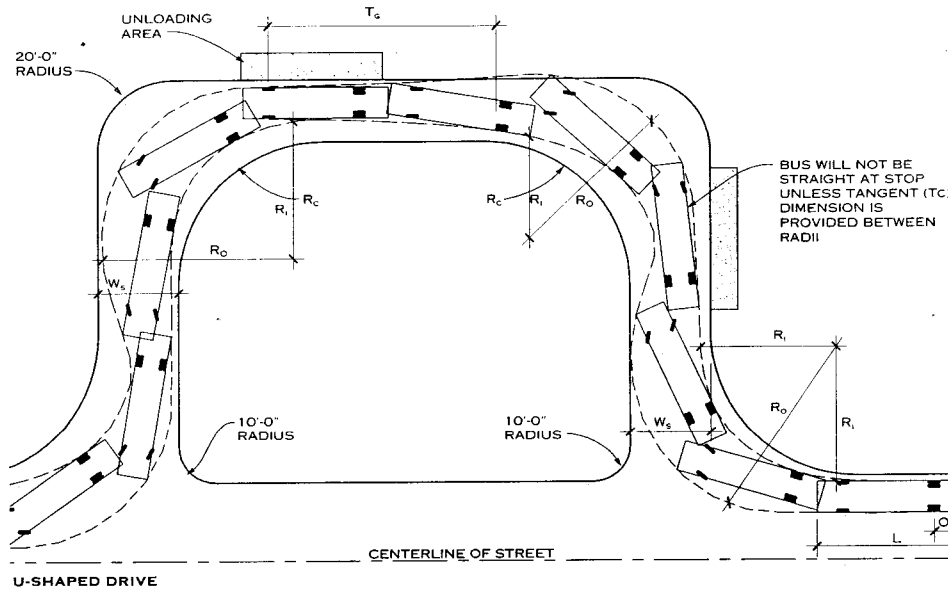

**NOTE**

For R<sub>C</sub>, R<sub>I</sub>, R<sub>O</sub>, W<sub>S</sub>, W<sub>T</sub>, and T<sub>G</sub>, see the AGS page on vehicle turning radii. For L, OR, and W, see the AGS page on design vehicles.

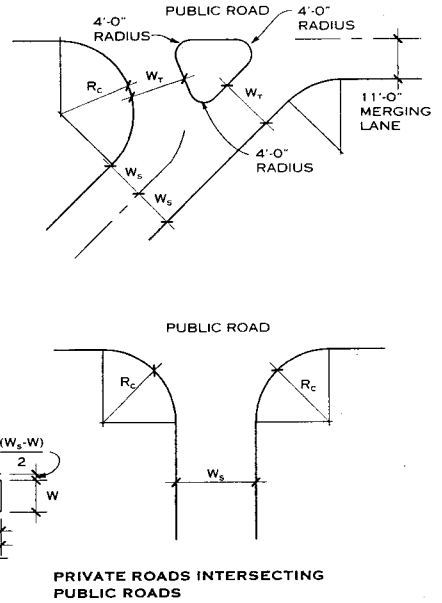

**INTERSECTIONS AND DRIVES**

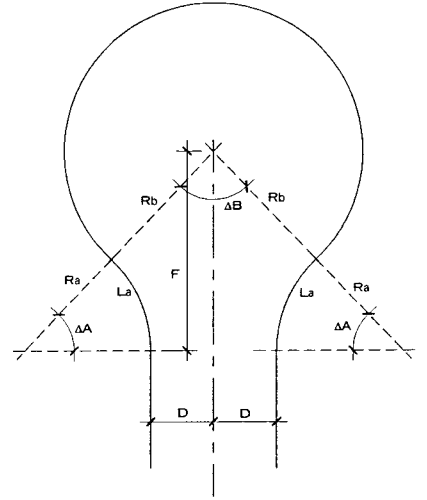
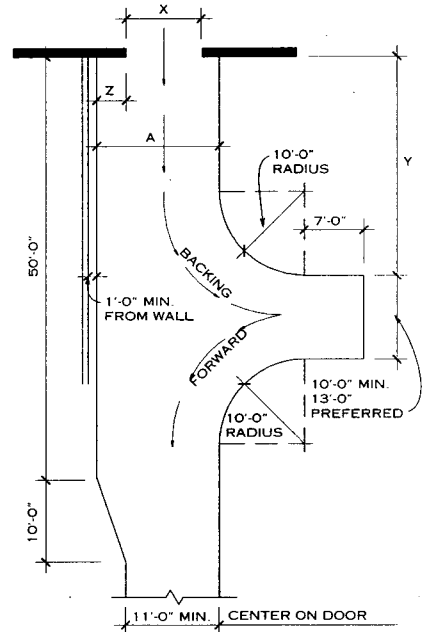
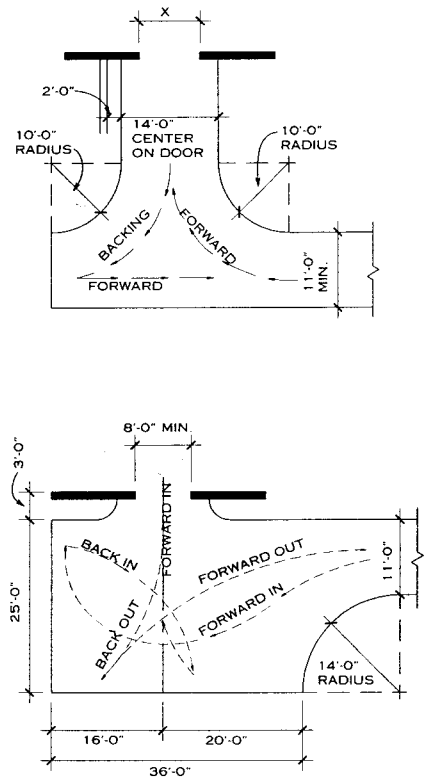

**SPACE REQUIREMENTS FOR DRIVEWAY LAYOUTS (FT-IN.)**

**90° IN-BACK OUT (1 CAR)**

X	8-9	9-0	10-0	11-0	12-0
Y	25-0	24-6	23-8	23-0	22-0

**STRAIGHT IN-BACK OUT**

X	9-0	10-0	12-0	16-0
Y	26-0	25-0	23-6	24-0
Z	3-4	3-1	2-0	3-0
A	14-4	14-5	14-8	20-0

**CUL-DE-SAC DIMENSIONS**

	SMALL	LARGE
D	16'-0"	22'-0"
F	50'-11"	87'-3"
ΔA	46.71°	35.58°
ΔB	273.42°	251.15°
R <sub>a</sub>	32'-0"	100'-0"
R <sub>b</sub>	38'-0"	50'-0"
L <sub>a</sub>	26'-1"	61'-8"
L <sub>b</sub>	181'-4"	219'-2"

**NOTE**  
Use this three-manuever entrance for single car garages only when space limitations demand it. The drawing is based on dimensions for a large car.

**PRIVATE DRIVEWAYS TO RESIDENTIAL GARAGES**

**NOTE**  
The R values for vehicles intended to use these culs-de-sac should not exceed R<sub>b</sub>.

Mary S. Smith, P.E.; Walker Parking Consultants/Engineers, Inc.; Indianapolis, Indiana

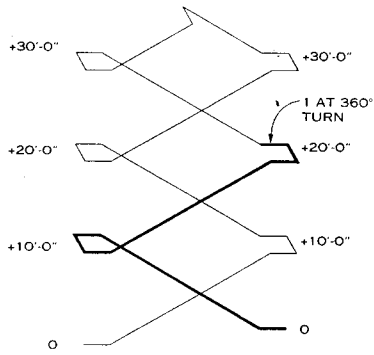

TWO TURNS AT 360° TO TOP  
TURNS IN PATH OF TRAVEL

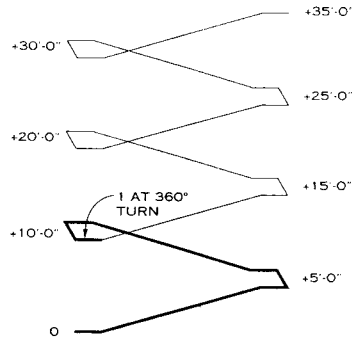

3 1/2 TURNS AT 360° TO TOP

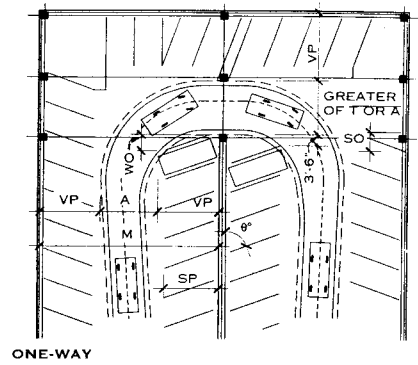

ONE-WAY

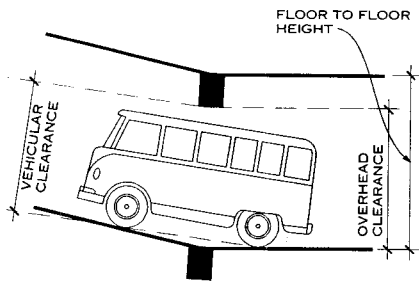

CLEARANCES FOR VEHICLES

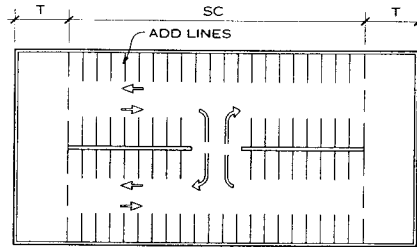

NOTE

If the bay run is greater than the "small car" dimension, provide a short circuit to help traffic flow.

SHORT CIRCUIT IN LONG BAY

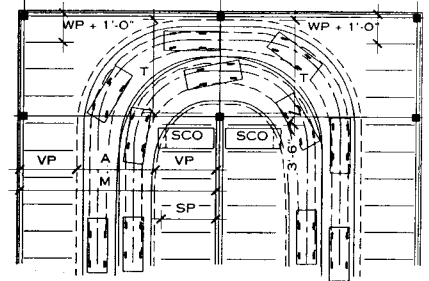

TWO-WAY

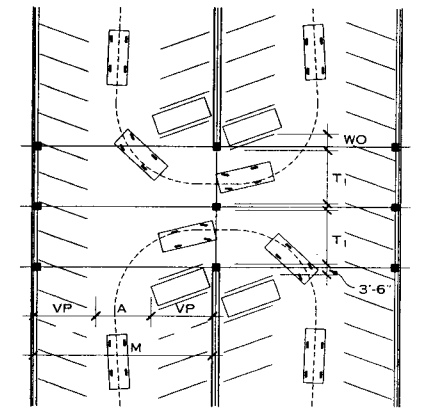

NONCONCENTRIC

TURNING BAYS

RECOMMENDED DESIGN PARAMETERS FOR WAYFINDING AND USER-FRIENDLINESS IN PARKING FACILITIES

DESIGN STANDARD FOR	LEVEL OF SERVICE (LOS)			
	D	C	B	A
Maximum walking distance				
Within parking facilities				
Surface lot	1400'-0"	1050'-0"	700'-0"	350'-0"
Structure	1200'-0"	900'-0"	600'-0"	300'-0"
From parking to destination				
Climate-controlled	5200'-0"	3800'-0"	2400'-0"	1000'-0"
Outdoors, covered	2000'-0"	1500'-0"	1000'-0"	500'-0"
Outdoors, uncovered	1600'-0"	1200'-0"	800'-0"	400'-0"
Height from floor-to-floor <sup>1</sup>				
Long span, posttensioned	9'-6"	10'-6"	11'-6"	12'-6"
Long span, precast	10'-6"	11'-6"	12'-6"	13'-6"
Percentage of parking spaces on flat floors	0%	30%	60%	90%
Parking ramp slope	6.5%	6%	5.5%	5%
Number of 360° turns to top	7	5.5	4	2.5
Short circuit in long run (SC) <sup>2</sup>	400'-0"	350'-0"	300'-0"	250'-0"
Travel distance to crossover <sup>3</sup>	750'-0"	600'-0"	450'-0"	300'-0"
Number of spaces searched or compartment				
Angled	1600	1200	800	400
Perpendicular	1000	750	500	250
Radius, turning (R <sub>T</sub> ) <sup>4</sup>	24'-0"	26'-0"	28'-0"	30'-0"
Turning bays, clear (T) <sup>5</sup>				
One lane	14'-6"	15'-9"	17'-0"	18'-3"
Two lanes, concentric <sup>6</sup>	26'-6"	28'-0"	29'-6"	31'-0"
Two lanes, nonconcentric	29'-0"	31'-6"	34'-0"	36'-6"

Source: Mary S. Smith, *Parking Structures: Planning, Design, Maintenance, and Repair*, 2d ed. (Chapman & Hall, 1996).

<sup>1</sup> Minimum vertical clearance for van accessibility is 8 ft 2 in., which requires minimum floor-to-floor heights per LOS C.

<sup>2</sup> A short circuit in a long run is used to shorten the exit path.

<sup>3</sup> In one-way designs, it is necessary to continue on the inbound travel path before connection to the outbound path.

<sup>4</sup> Due to lower design speeds, the turning radius in parking areas is less than that required for through-circulation elements.

<sup>5</sup> Clear between face of columns, curbs, or obstructions; check clearance at back of parking stalls with turning template.

<sup>6</sup> If flow is largely in one direction, the turning bay for a two-lane, concentric design can be reduced by 3 ft.

KEY TO DRAWINGS

ABBREVIATION	TERM
θ	Angle of park
A	Aisle width
M	Module
SC	Short circuit
SCO	Small car only space
SO	Stripe offset
SP	Stripe protection
T	Turning bay
VP	Vehicle projection
WO	Wall offset
WP	Width projection

Mary S. Smith, P.E.: Walker Parking Consultants/Engineers, Inc.; Indianapolis, Indiana

1 AUTOMOBILES, ROADS, AND PARKING

**PARKING SPACE DIMENSIONS (FT-IN.)<sup>1</sup>**

**ALL LEVELS OF SERVICE**

ANGLE OF PARK	VEHICLE PROJECTION	WALL OFFSET	OVERHANG	STRIPE OFFSET
45	17-1	10-7	1-9	16-3
50	17-8	9-4	1-11	13-8
55	18-1	8-2	2-1	11-5
60	18-5	7-1	2-2	9-5
65	18-7	6-0	2-3	7-7
70	18-8	4-11	2-4	5-11
75	18-7	3-10	2-5	4-4
90	17-6	1-0	2-6	0-0

**LEVEL OF SERVICE A**

ANGLE OF PARK	STALL PROJECTION	MODULE	AISLE	INTERLOCK
0	8-9	31-6	14-0 <sup>2</sup>	0-0
0	8-9	42-6	25-0 <sup>3</sup>	0-0
45	12-4	49-0	14-10	3-1
50	11-5	50-6	15-2	2-10
55	10-8	51-9	15-7	2-6
60	10-1	53-4	16-6	2-2
65	9-8	54-6	17-4	1-10
70	9-4	55-9	18-5	1-6
75	9-1	57-0	19-10	1-2
90	8-9	61-0	26-0	0-0

**LEVEL OF SERVICE B**

ANGLE OF PARK	STALL PROJECTION	MODULE	AISLE	INTERLOCK
0	8-6	30-0	13-0 <sup>2</sup>	0-0
0	8-6	40-0	23-0 <sup>3</sup>	0-0
45	12-0	48-0	13-10	3-0
50	11-1	49-6	14-2	2-9
55	10-5	50-9	14-7	2-5
60	9-10	52-4	15-6	2-2
65	9-5	53-6	16-4	1-10
70	9-1	54-9	17-5	1-5
75	8-10	56-0	18-10	1-1
90	8-6	60-0	25-0	0-0

**LEVEL OF SERVICE C**

ANGLE OF PARK	STALL PROJECTION	MODULE	AISLE	INTERLOCK
0	8-3	28-6	12-0 <sup>2</sup>	0-0
0	8-3	37-6	21-0 <sup>3</sup>	0-0
45	11-8	47-0	12-10	2-11
50	10-9	48-6	13-2	2-8
55	10-1	49-9	13-7	2-4
60	9-6	51-4	14-6	2-1
65	9-1	52-6	15-4	1-9
70	8-9	53-9	16-5	1-5
75	8-6	55-0	17-10	1-1
90	8-3	59-0	24-0	0-0

**LEVEL OF SERVICE D**

ANGLE OF PARK	STALL PROJECTION	MODULE	AISLE	INTERLOCK
0	8-0	27-0	11-0 <sup>2</sup>	0-0
0	8-0	35-0	19-0 <sup>3</sup>	0-0
45	11-4	46-0	11-10	2-10
50	10-5	47-6	12-2	2-7
55	9-9	48-9	12-7	2-4
60	9-3	50-4	13-6	2-0
65	8-10	51-6	14-4	1-8
70	8-6	52-9	15-5	1-4
75	8-3	54-0	16-10	1-0
90	8-0	58-0	23-0	0-0

<sup>1</sup> All dimensions are rounded to the nearest inch.  
<sup>2</sup> These are minimum aisle widths for one-way traffic at each level of service.  
<sup>3</sup> Figures given are widths for two-way traffic.

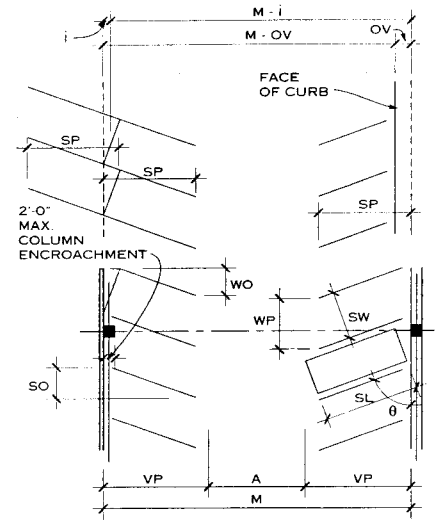

**KEY**  
 $\theta$  = angle of park  
 A = aisle width  
 i = interlock reduction  
 OV = overhang  
 M = module  
 SL = stall length  
 SO = stripe offset  
 SP = stripe projection  
 SW = stall width  
 VP = vehicle projection  
 WO = wall offset  
 WP = stall projection

**BASIC LAYOUT DIMENSIONS**

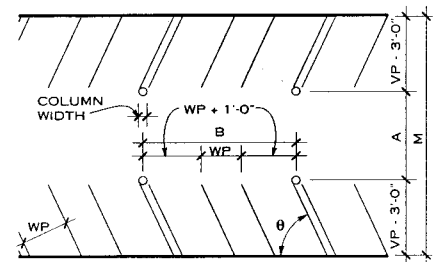

**NOTE**  
 Stalls adjacent to columns must be wider to provide the same level of service of turn.

**SHORT SPAN CONSTRUCTION DETAILS**

**NOTES**

1. Parking stalls for a design vehicle 6 ft 4 in. wide and 16 ft 9 in. long should have a stripe projection of 16 ft 3 in. and parallel stall length of 20 ft 9 in.
2. Small-car-only stalls (7 ft 5 in. wide by 15 ft long) should only be used at constrained locations or in remnants of space. The number of these stalls should not exceed 10% of total parking capacity at a site.
3. Angles between 76 and 89° are not recommended for one-way design because these angles permit drivers of smaller cars to back out and exit the wrong way.
4. Angled parking is not recommended for use with two-way aisles as drivers often attempt to make a U-turn into stalls on the other side of the aisle.
5. Add 1 ft to the module for surface parking bays without curbs or other parking guides (frequent poles or columns or walls) in areas with frequent heavy snowfall.
6. To maintain the same level of service (LOS), reduce the module (M) by 3 in. for each additional inch in stall width (SW) while maintaining minimum aisle width (see footnotes 2 and 3 to accompanying chart). For example,  
 8 ft 9 in. @ 90° on 61-ft module = LOS A  
 9 ft 0 in. @ 90° on 60-ft 3-in. module = LOS A
7. Columns and light poles may protrude into a parking module a combined maximum of 2 ft as long as they do not affect more than 25% of the stalls in that bay. For example, a 2-ft encroachment by a column on one side of the aisle or 1 ft each from columns on both sides is permissible.

**GENERAL**

ADAAG (Americans with Disabilities Act Accessibility Guidelines for Buildings and Facilities, 36 CFR 1191, July 26, 1991) requires all cashier booths in new construction (and in alterations that result in the removal of existing islands) to be accessible "to and through" the door. This mandate is found under the requirements for employee work areas or stations. A booth can meet this requirement if it is recessed in the pavement so the interior floor is at the same elevation as the driving lane. An accessible cashier booth can also have a curb ramp and appropriate latch-side clearance for the rear swinging door.

ADAAG recommends—but does not require—that at least one booth be a fully accessible workstation (have a 5-ft diameter wheelchair turning space, adjustable counter, accessible controls, etc.). A booth can meet this requirement with accessible doors on both sides, which allows T turning movements.

**KEY TO DRAWINGS**

TERM	ABBREVIATION	SYMBOL
Autogate	AG	
Ticket dispenser	TD	
Card reader	CR	
"Lot full" sign	LFS	
Detector loop	—	
Bollard	—	

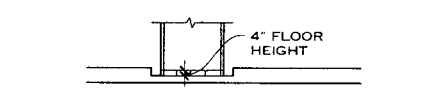
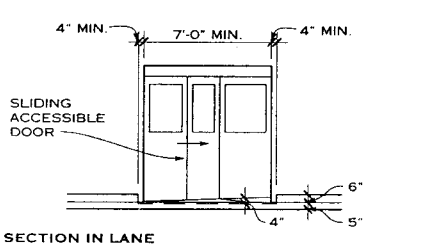
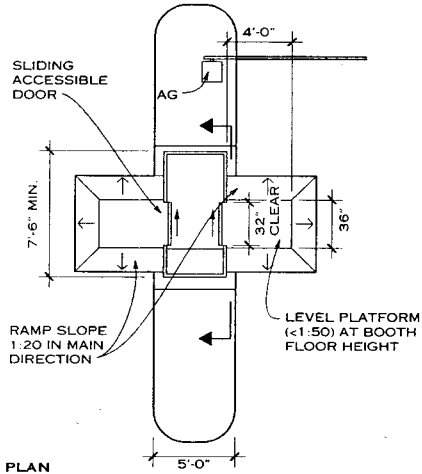

**EXIT WITH ACCESSIBLE CASHIER BOOTH**

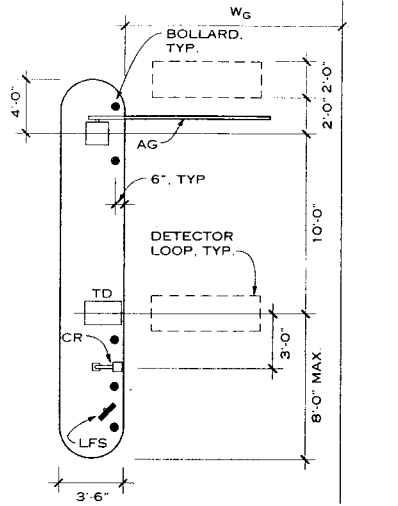

**ENTRANCE WITH TICKET DISPENSER**

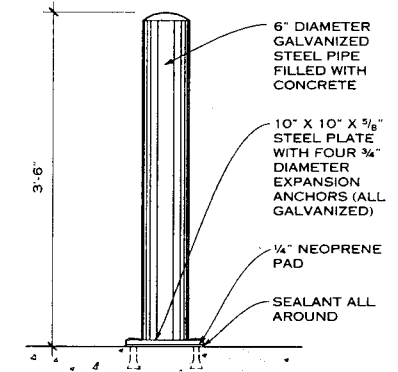

**NOTE**  
Place bollards so they are plumb.

**PIPE BOLLARD**

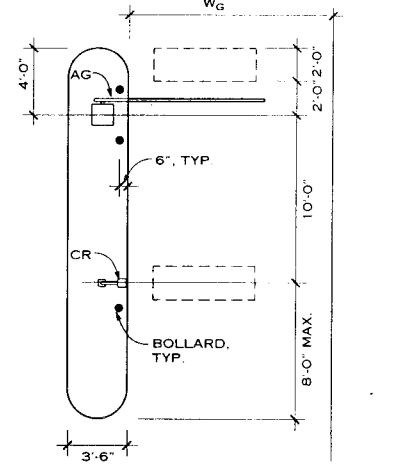

**ENTRANCE OR EXIT WITH CARD READER ONLY**

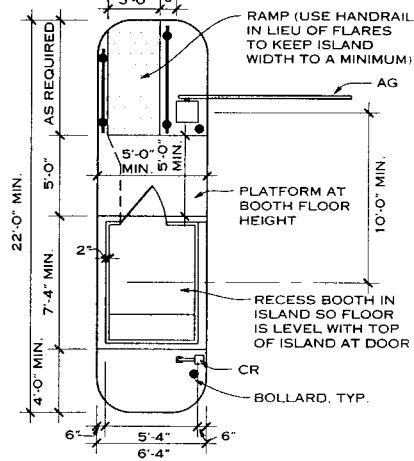

**EXIT WITH ACCESSIBLE CASHIER BOOTH AND CARD READER**

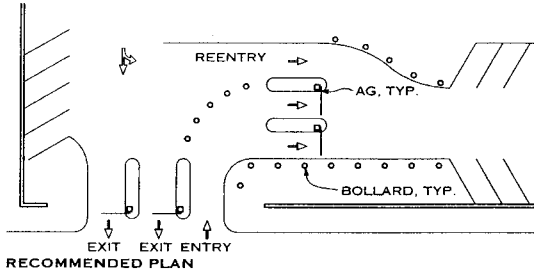

**RECOMMENDED PLAN**

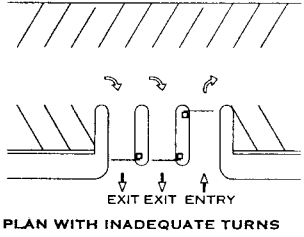

**PLAN WITH INADEQUATE TURNS**

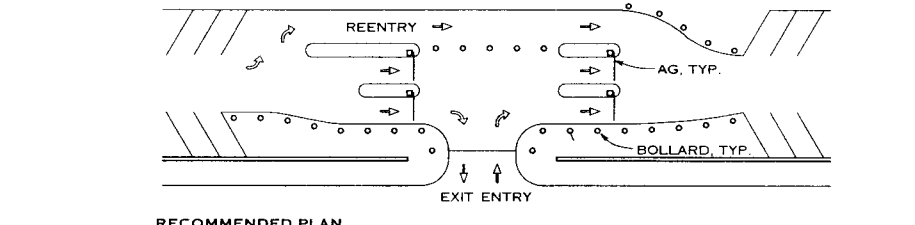

**RECOMMENDED PLAN**

**PARKING LOT ENTRY CONFIGURATIONS**

Mary S. Smith, P.E.; Walker Parking Consultants/Engineers, Inc.; Indianapolis, Indiana

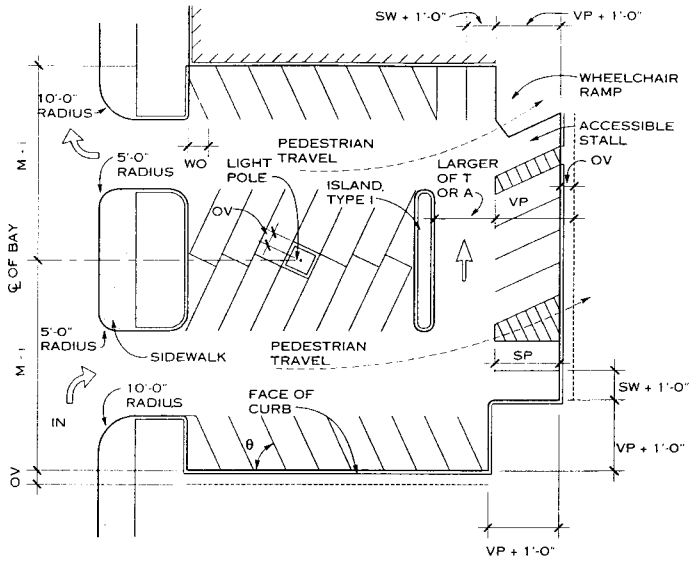

SMALL LOT WITH ONE-WAY TRAVEL

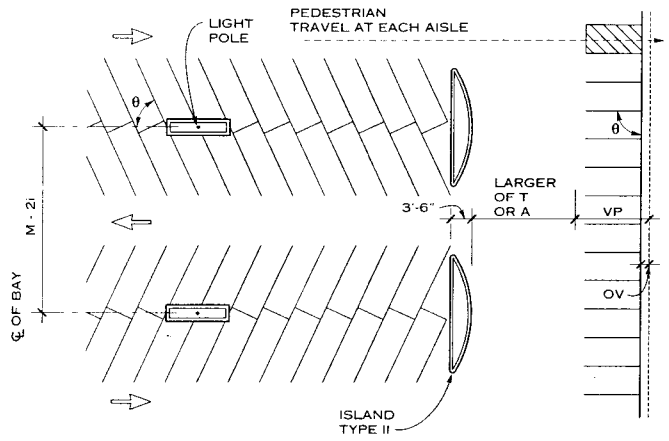

MULTIBAY LOT WITH TWO-WAY END AISLE

LOT DESIGNS WITH ISLANDS

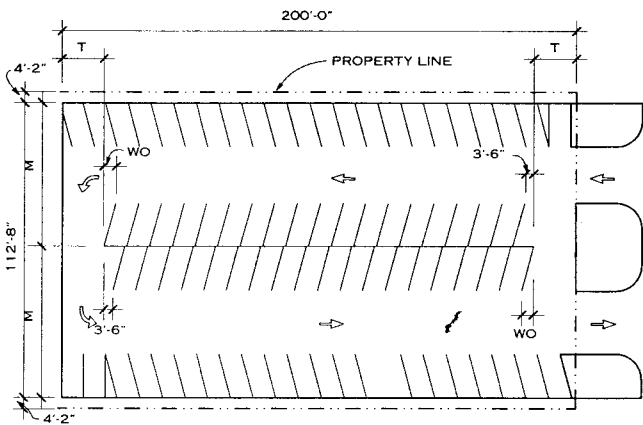

ANGLED PARKING

NOTES

1. GPA = 200 ft x 56.33 ft x 2 = 22,532 sq ft
2. Capacity = 80 vehicles
3. Efficiency = 22,532 sq ft/80 vehicles = 281.7 sq ft/space

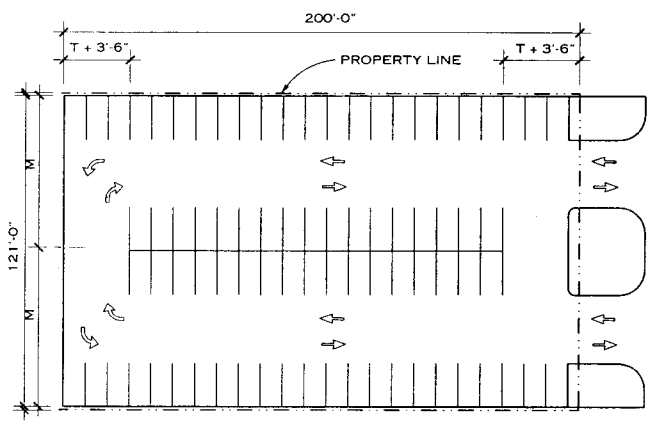

90° PARKING

NOTES

1. GPA = 200 ft x 60.5 ft x 2 = 24,200 sq ft
2. Capacity = 80 vehicles
3. Efficiency = 24,200 sq ft/80 vehicles = 302.5 sq ft/space

SMALL LOT DESIGNS

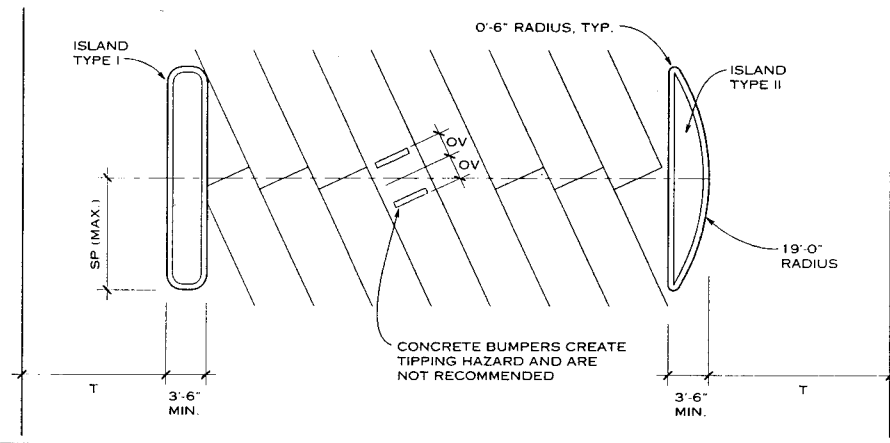

TYPICAL PARKING BAY WITH ISLAND TYPES

KEY TO DRAWINGS

ABBREVIATION	TERM
θ	Angle of park
A	Aisle width
i	Interlock reduction
GPA	Gross parking area
M	Module
OV	Overhang
R	Radius
SP	Stripe protection
SW	Stall width
T	Turning bay
VP	Vehicle projection
WO	Wall offset

Mary S. Smith, P.E.; Walker Parking Consultants/Engineers, Inc.; Indianapolis, Indiana

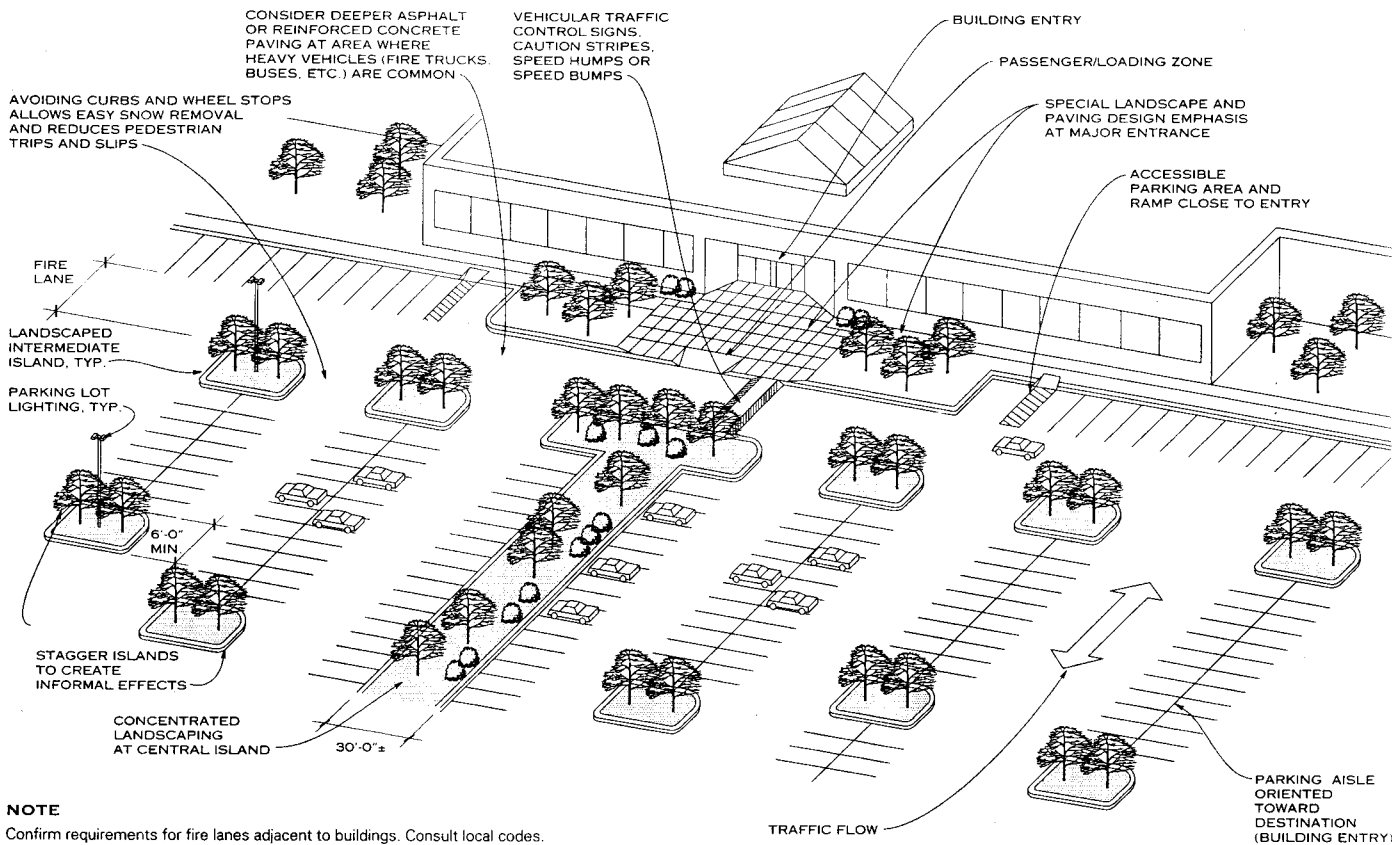

**NOTE**  
Confirm requirements for fire lanes adjacent to buildings. Consult local codes.

**COMMERCIAL PARKING ARRANGEMENT**

**NOTES ON DESIGN GUIDELINES**

1. Determine an efficient means of laying out the parking lot (see vehicle and parking space dimension data on other AGS pages on parking). A smaller paved area costs less to build and maintain, offers a shorter walking distance from car to building, lessens water runoff problems, and leaves more space for site landscaping.
2. Provide safe and coherent site circulation routes.
3. Provide access for fire rescue and mass transit vehicles. Consult local requirements.
4. Parking lots should offer direct and easy access for people walking between their vehicles and the building entrances. Pedestrians usually walk in the aisles behind parked vehicles; aisles perpendicular to the building face allow pedestrians to walk to and from the building without squeezing between parked cars. Walking areas should be graded to prevent standing water.
5. Accessible design is now mandatory, requiring designated parking spaces and curb ramps near building entrances. See AGS page on accessible curb ramps and passenger loading.

**LANDSCAPING**

Plants in parking areas can help relieve the visually overwhelming scale of large parking lots. To maximize the effect

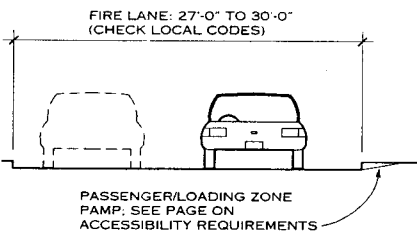

**FIRE LANE**

of landscaping, consider the screening capabilities of plants. Low branching, densely foliated trees and shrubs can soften the visual impact of large parking areas. High branching canopy trees do not create a visual screen at eye level but do provide shade. When possible, create islands large enough to accommodate a mixture of canopy trees, flowering trees, evergreen trees, shrubs, and flowers. Consider using evergreens, and avoid plants that drop fruit or sap.

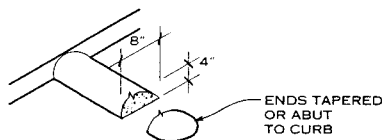

**SPEED BUMP**

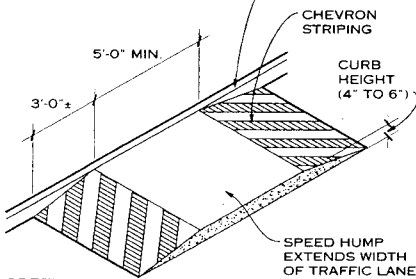

**SPEED HUMP NOTE**

Use of a speed hump eliminates the need for an accessible curb ramp.

**SPEED CONTROL DEVICES**

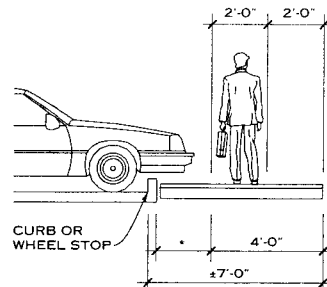

**AT SIDEWALKS**

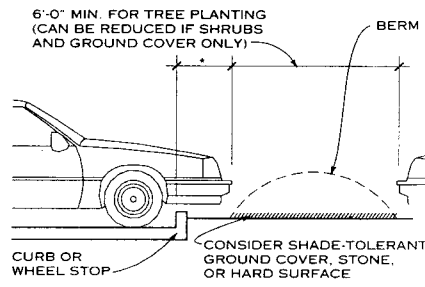

**AT PLANTING AREAS AND BERMS**

\*See the AGS pages on design vehicle dimensions for perpendicular dimension of overhang; adjust for angled parking.

**AUTOMOBILE OVERHANG REQUIREMENTS**

Mary S. Smith, P.E.; Walker Parking Consultants/Engineers, Inc.; Indianapolis, Indiana

**1** AUTOMOBILES, ROADS, AND PARKING

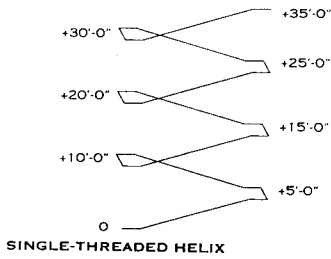

SINGLE-THREADED HELIX

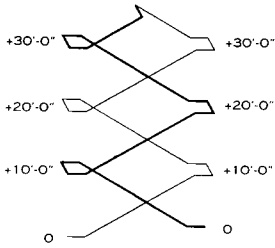

DOUBLE-THREADED HELIX

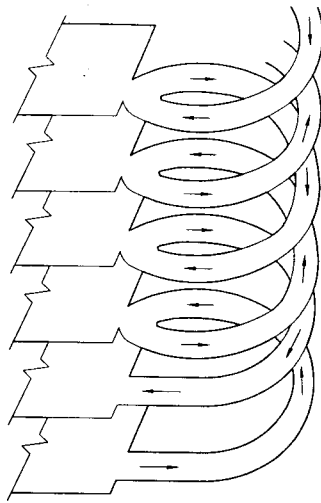

DOUBLE-THREADED CIRCULAR HELIX

NOTES

1. Floor-to-floor circulation in a parking structure is typically provided either by parking ramps or express ramps (those without parking) or a combination of both.
2. Almost all ramp systems are based on helical patterns, whether a fully circular express helix or a combination of straight runs and turning bays at the end.
3. The two fundamental helical patterns are the single-threaded helix, which rises one full floor in each 360° of revolution, and the double-threaded helix, which rises two floors with each complete revolution.
4. Express helices can be either single threaded or double threaded. Parking ramps can also be configured in single- and double-threaded patterns.
5. On a site that can accommodate two parking modules in width but is short (less than 200 ft), a single-threaded helix can be used only with two-way traffic flow and 90° parking.
6. Application of a two-bay single-threaded helix arrangement may be limited by the desirable number of turns, spaces passed, etc. of the selected level of service and/or by flow capacity considerations.

HELIX-SHAPED PARKING BAYS

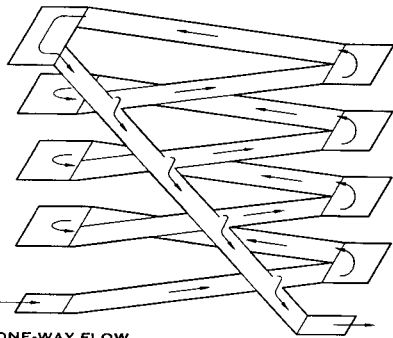

ONE-WAY FLOW

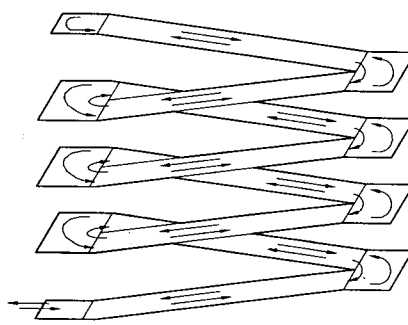

TWO-WAY FLOW

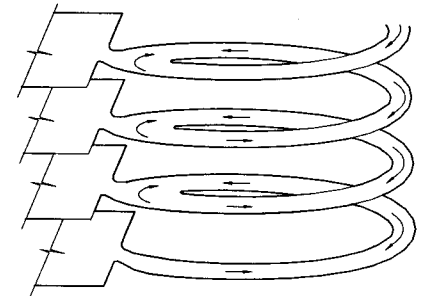

CIRCULAR FLOW

TWO-BAY SINGLE-THREADED HELIX

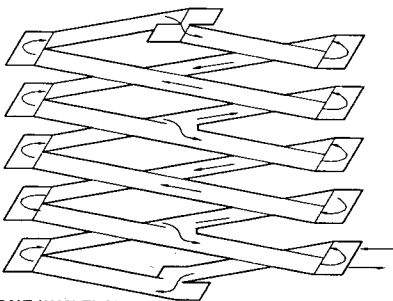

ONE-WAY FLOW

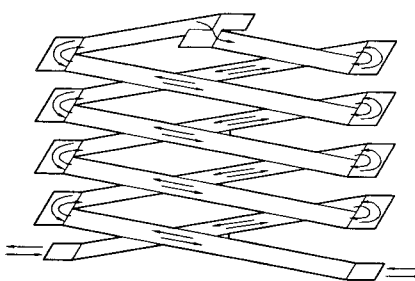

TWO-WAY FLOW

NOTES

1. The two-bay double-threaded helix can be taller and accommodate more spaces than the two-bay single-threaded model; however, it requires a longer site (typically more than 200 ft in length). Because this design may offer less desirable wayfinding and user-friendliness to unfamiliar users, it is most often used for predominantly employee parking.
2. A two-bay double-threaded helix may have either one-way or two-way traffic flow. The former has one up and one down route, while the latter provides two up routes and two down ones.

TWO-BAY DOUBLE-THREADED HELIX

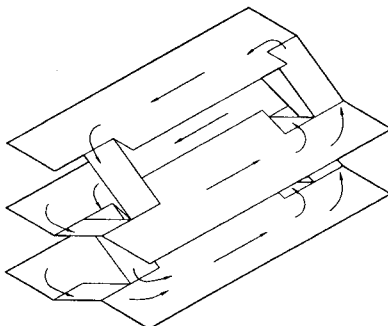

ONE-WAY FLOW

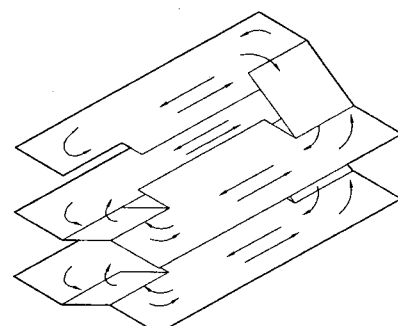

TWO-WAY FLOW

NOTES

1. The split-level design is a modification of the single-threaded helix in which the parking bays are flattened and speed ramps are used to accomplish a vertical rise. Split-level parking structures may have either two-way or one-way traffic flow.
2. Although they provide a level facade, split-level parking structures have a number of disadvantages. The main ones are loss of stalls (compared to a typical two-bay single-threaded helix), difficult design for turns and speed ramp, and poor efficiency (the square footage of parking area per stall is too high).

Mary S. Smith, P.E., Walker Parking Consultants/Engineers, Inc.; Indianapolis, Indiana  
William T. Mahan, AIA; Santa Barbara, California



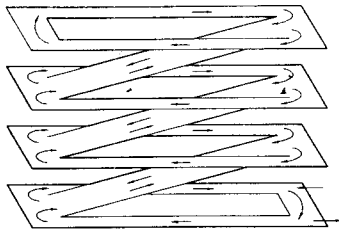

THREE-BAY SIDE-BY-SIDE

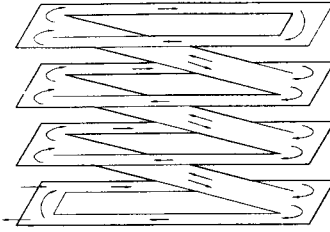

FOUR-BAY SIDE-BY-SIDE

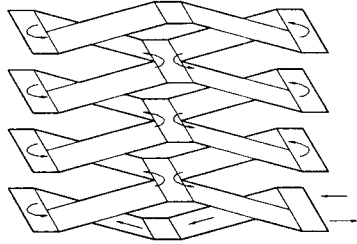

END-TO-END

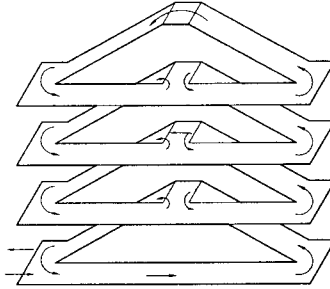

CAMELBACK

SINGLE-THREADED HELIX COMBINATIONS

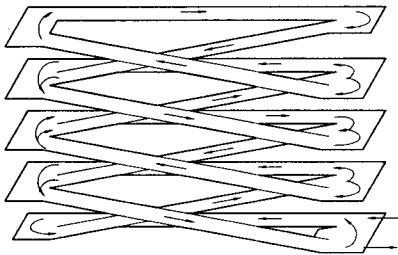

THREE-BAY DOUBLE-THREADED HELIX

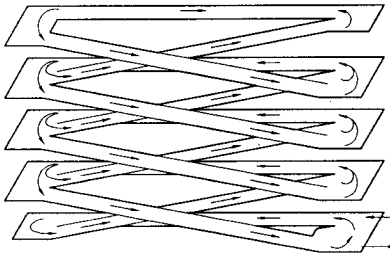

THREE-BAY SINGLE-THREADED INTERLOCKED HELIX

COMBINATION SLOPED AND FLAT BAYS

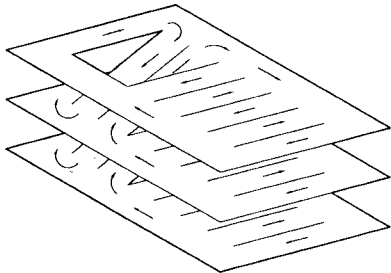

FOUR-BAY SIDE-BY-SIDE WITH SIDE FLAT BAYS

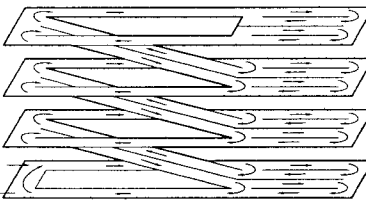

FOUR-BAY SIDE-BY-SIDE HELIX WITH END FLAT BAYS

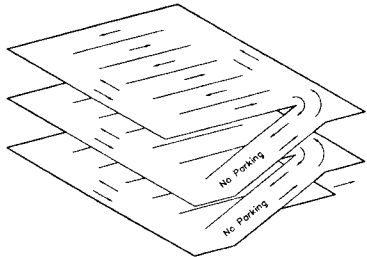

SINGLE-THREADED EXTERIOR EXPRESS RAMPS FLAT FLOOR PARKING

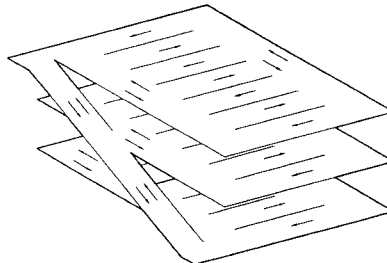

FLAT FLOOR WITH EXPRESS RAMP

NOTES

1. On wider sites, a combination of sloped parking bays and flat bays in single-threaded patterns can provide level facades with superior wayfinding and user-friendliness. These facilities may be limited primarily by height (too much height yields an excessive number of turns) or flow capacity (the number of spaces passed on the path of travel).
2. On longer sites, single-threaded helices can be combined in a camelback helix to provide one-way traffic flow. This one-way flow offers better wayfinding for unfamiliar users than a double-threaded helix. However, because there are more turning bays, the efficiency (sq ft/parking space) of the garage will be affected.

NOTES

1. Traffic can be routed in either a single-threaded or double-threaded pattern on the same configuration of flat and sloped parking bays.
2. The three-bay double-threaded helix option provides quicker vertical circulation and better flow capacity. However, because the flow is different on every other floor, making it confusing for unfamiliar users, this design works best for employee parking.
3. The interlocked helix offers better wayfinding (because it has the same flow pattern on every floor) but reduced flow capacity. The flow capacity is especially low during periods of high turnover because inbound and outbound traffic must merge at every floor.

NOTES

1. As a parking structure footprint becomes wider, it is generally preferable to add flat parking bays and keep the floor-to-floor circulation at the far end of the structure. Similarly, when a parking structure is longer than needed for floor-to-floor circulation, keep the ramps at one end and add flat areas close to the ultimate destination of those using the facility.
2. Totally flat floor parking combined with express ramps yields the best combination of wayfinding, user-friendliness, and security. Express ramps may be designed to require traffic to circulate through the floors or to allow vehicles to pass directly from floor to floor. The latter arrangement provides the greatest flow capacity and ease of access in very large structures (those with more than 2000 parking spaces).

Mary S. Smith, P.E.; Walker Parking Consultants/Engineers, Inc.; Indianapolis, Indiana

1 AUTOMOBILES, ROADS, AND PARKING

**DESIGN VEHICLE DIMENSIONS**

VEHICLE TYPE	LENGTH (L)	WIDTH (W)	HEIGHT (H)	WHEELBASE (WB)	OVERHANG FRONT (OF)	OVERHANG REAR (OR)	GROSS WEIGHT
Trash truck	25'-5"	7'-11"	10'-0"	13'-2"	4'-8"	7'-7"	20,000 lb
Single unit truck*	30'-0"	8'-6"	see table below	20'	4'-0"	6'-0"	20,000 lb
WB-40 truck*	50'-0"	8'-6"		13'/23'/4'	4'-0"	6'-0"	80,000 lb
WB-50 truck*	60'-0"	8'-6"		16'/4'/26'/4'	3'-0"	2'-0"	80,000 lb
WB-60 truck*	65'-0"	8'-6"		10'/20'/10'/18'	2'-0"	5'-0"	80,000 lb

\*Generally in conformance with AASHTO, A Policy on Geometric Design of Highways and Streets (1990).

**MAXIMUM ALLOWABLE HEIGHT AND WIDTH (FT-IN.)**

VEHICLE HEIGHT		VEHICLE WIDTH	
TOTAL HEIGHT	STATE	TOTAL WIDTH	STATE
13-6	In all states except those listed below	8-6	In all states except those listed below
13-0	CO	8-0	DC, GA, IL, KY, LA, MI, MD, MO, NC, PA, WV
14-0	AK, CA, HI, ID, KS, MT, NM, NV, ND, OR, UT, WA, WY		HI
14-6	NB	9-0	

**NOTE** Length and area restrictions vary by state and locale..Verify Width is 8 ft 0 in. or 8 ft 6 in. according to state regulations. exact dimensions and restrictions.

**MINIMUM TURNING RADIUS FOR DESIGN VEHICLES (FT-IN.)**

VEHICLE TYPE	MIN. TURNING RADIUS (R <sub>T</sub> )	OUTSIDE FRONT RADIUS (R <sub>O</sub> )	INSIDE REAR RADIUS (R <sub>I</sub> )	STRAIGHT LANE WIDTH (W <sub>S</sub> )	CURVED LANE WIDTH (W <sub>T</sub> )	INSIDE CURB RADIUS (R <sub>C</sub> )	TANGENT LENGTH (T)
Trash truck	31-0	33-1	21-2	12-0	14-11	18-4	38-0
Single unit truck	42-0	44-0	28-0	12-0	20-0	25-0	40-10
WB-40 truck	40-0	41-6	19-0	12-0	25-0	16-0	67-1
WB-50 truck	45-0	46-0	19-0	12-0	30-0	16-0	116-8
WB-60 truck	45-0	45-6	22-0	12-0	27-0	19-0	65-0

**NOTES**  
 1. Minimum turn radii at less than 10 mph.  
 2. Obstructions (columns, walls, light poles, etc.) should be held a minimum of 6 in. (2 ft preferred) from the edge of the lane given above. See details on the AGS page on driveways and roadways.

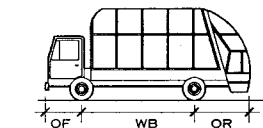

TRASH TRUCK

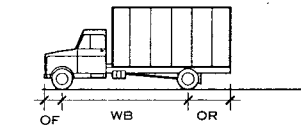

SINGLE-UNIT TRUCK

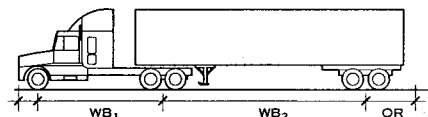

TRACTOR AND SEMITRAILER

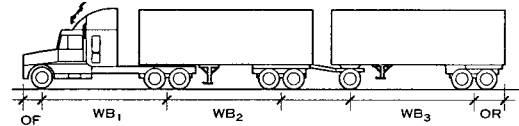

TRACTOR AND DOUBLE SEMITRAILER

**TRUCK TYPES**

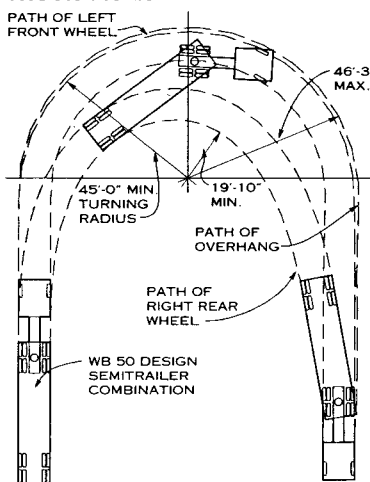

WB-50 SEMITRAILER DESIGN VEHICLE

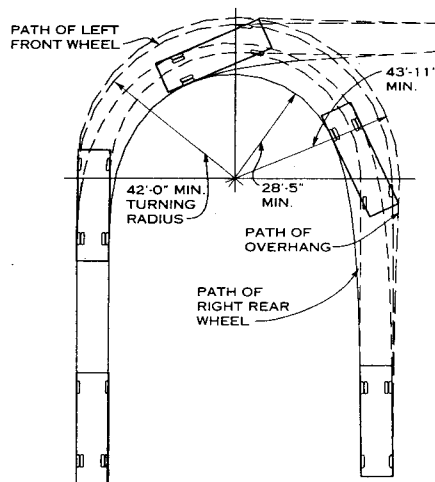

SINGLE-UNIT TRUCK DESIGN VEHICLE

**TURNING RADIUS**

**MAXIMUM ALLOWABLE LENGTH (FT-IN.)**

SEMITRAILER AND TRACTOR		
UNIT	EACH TRAILER	STATE
55-0	48-0	DC
60-0	45-0	HI
60-0	53-0	DE, GA
60-0	—	MO, NC, OR, WV
65-0	48-0	ME, NY, VT, WI
65-0	53-0	IL, KY
65-0	—	CA, LA, NM, VA
70-0	57-4	CO
75-0	48-0	ID
75-0	53-0	AK, MN, ND
92-0	53-0	UT
—	48-0	CT, FL, MA, NV
—	48-6	RI
—	50-0	MI, MS, TN
—	53-0	MD, MS, MT, NB, NH, NJ, IN, IA, OH, OK, PA, SC, SD, WA
—	53-6	AR
—	57-6	AZ
—	59-0	TX
—	59-6	KS
—	60-0	WY

**DOUBLE SEMITRAILER AND TRACTOR**

UNIT	EACH TRAILER	STATE
59-0	28-6	MI
60-0	29-0	DE
61-0	—	UT, WA
65-0	28-0	MD, MO
65-0	28-6	AR, IL
65-0	—	NB, NM, NY
70-0	28-0	OK
70-0	28-6	CO
75-0	28-0	ND, ID
75-0	28-6	CA, MN
75-0	—	AK, OR
80-0	28-6	SD
—	28-0	CT, DC, FL, GA, MA, NH, NJ
—	28-6	AZ, IN, IA, KS, MT, NV, OH, RI
—	30-0	MS
—	—	WY

**STRAIGHT BODY TRUCKS**

UNIT	STATE
40-0	In all states, except those listed below
35-0	NC <sup>1</sup> , SC <sup>1</sup>
42-0	IL
42-6	KS
45-0	CT, HI, ID, KY, OK, ME, SD, TX, UT
50-0	ND
55-0	MT
60-0	GA, WY
65-0	VT

**TRIPLE SEMITRAILER AND TRACTOR<sup>2</sup>**

UNIT	STATE
75-0	ID
85-0	AK
Each trailer 28-0	MO
Each trailer 28-6	AZ, CO, OH, MT, IN, SD
Each trailer 29-0	OK
105-0	OR, UT
110-0	ND
119-0	KS

<sup>1</sup> Two axles—35 ft; three axles—40 ft  
<sup>2</sup> Maximum allowable length not permitted, except in those states listed.

Mary S. Smith, P.E., Walker Parking Consultants/Engineers, Inc., Indianapolis, Indiana  
 William T. Mahan, AIA, Santa Barbara, California

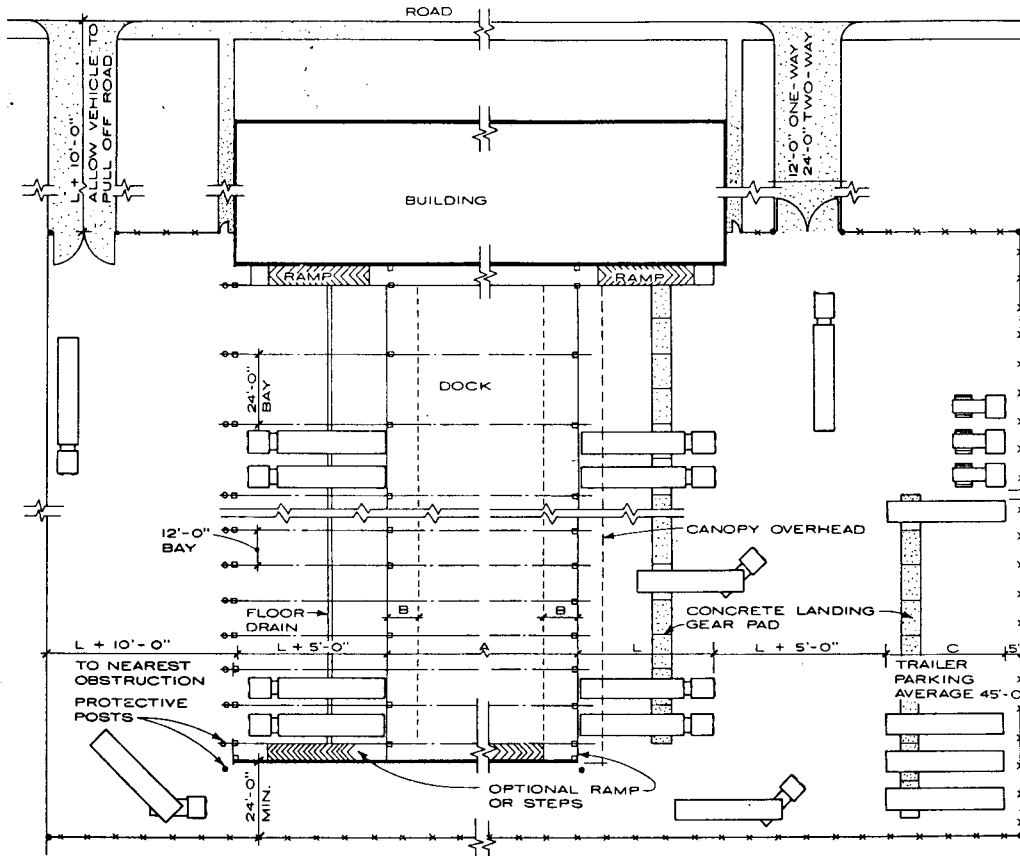

**TYPICAL PLAN OF CLOSED DOCK**  
 DOUBLE DOOR (PREFERRED) 22'-0" WIDE  
 X 14'-6" HIGH. SINGLE DOOR (OPTIONAL)  
 11'-0" WIDE X 14'-6" HIGH

**TYPICAL PLAN OF OPEN DOCK**  
 SINGLE DOOR (PREFERRED) 9'-0" WIDE X 10'-0"  
 HIGH. DOUBLE DOOR (OPTIONAL) 20'-0" WIDE  
 X 10'-0" HIGH

**NOTES**

1. Allow for off-street employee and driver parking.
2. Entrances and exits should be of reinforced concrete when excessive twisting and turning of vehicles are expected.
3. Average gate (swing or slide) 30 ft 0 in. wide for two-way traffic. People gate 5 ft 0 in. wide with concrete walkway 4 ft 0 in. to 6 ft 0 in. wide.
4. For yard security use a 6 ft 0 in. high chain link fence with barbed wire on top.
5. On-site fueling facilities are desirable for road units.
6. Provide general yard lighting from fixtures mounted on building or on 24 ft 0 in. high minimum poles at fence line. Mercury vapor or high pressure sodium preferred.
7. Tractor parking requires 12 ft 0 in. wide x 20 ft 0 in. long slot minimum. Provide motor heater outlets for diesel engines in cold climates.
8. Trailer parking requires 10 ft 0 in. wide slot minimum. Provide 10 ft 0 in. wide concrete pad for landing gear. Score concrete at 12 ft 0 in. o.c. to aid in correct spotting of trailer.
9. 4 ft 0 in. wide minimum concrete ramp from dock to grade. Slopes of 3 to 15% (10% average), score surface for traction.
10. Vehicles should circulate in a counter-clockwise direction, making left hand turns, permitting driver to see rear of unit when backing into dock.
11. Double trailers are backed into dock separately.

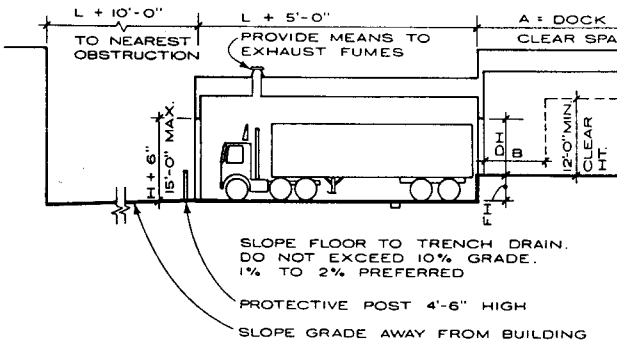

**TYPICAL SECTION OF CLOSED DOCK**

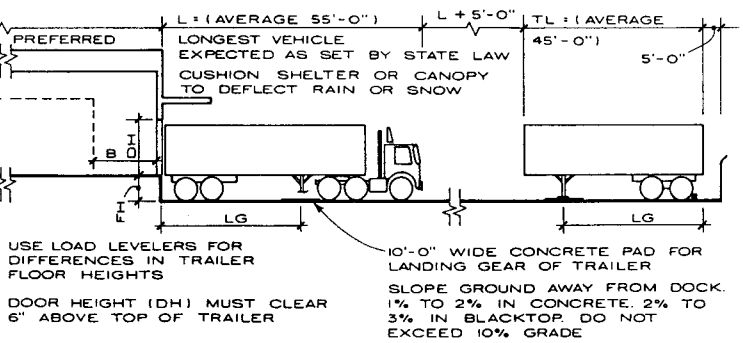

**TYPICAL SECTION OF OPEN DOCK**

**AVERAGE VEHICLE DIMENSIONS**

LENGTH OF VEHICLE (L)	FLOOR HEIGHT (FH)	VEHICLE HEIGHT (H)
60 ft tractor trailer	4'-0" to 4'-6"	14'-0"
45 ft trailer	4'-0" to 4'-2"	13'-6"
40 ft straight body	3'-8" to 4'-2"	13'-6"
18 ft van	2'-0" to 2'-8"	7'-0"

NOTE: Refer to other pages for truck and trailer sizes.

**AVERAGE WIDTHS OF DOCKS**

TYPE OF OPERATION	TWO-WHEEL HAND TRUCK	FOUR-WHEEL HAND TRUCK	FORKLIFT TRUCK	DRAGLINE	AUTO SPUR DRAGLINE
Dock width (A)	50'-0"	60'-0"	60'-0" to 70'-0"	80'-0"	120'-0" to 140'-0"
Work aisle (B)	6'-0"	10'-0"	15'-0"	10'-0" to 15'-0"	10'-0" to 15'-0"

Robert H. Lorenz, AIA; Preston Trucking Company, Inc.; Preston, Maryland  
 The Operations Council, American Trucking Association; Washington, D.C.

**1 TRUCKS, TRAINS, AND BOATS**

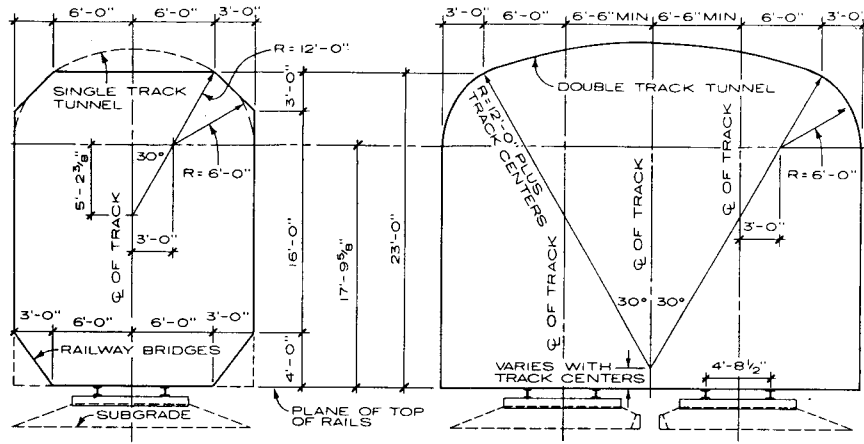

- NOTES**
1. Given clearances are the recommended minimums of the American Railway Engineering Association. Actual requirements vary from state to state.
  2. Clearances shown are for the tangent track and new construction. Clearances for reconstruction work or for alteration are dependent on existing physical conditions and, where reasonably possible, should be improved to meet the requirements for new construction.
  3. On curved track, the lateral clearances each side of track center line shall be increased 1 1/2 in. per degree of curvature.
  4. Common state requirement for lateral clearance of poles is 8 ft 6 in. (varies from 8 to 12 ft).
  5. Standard American railroad gauge of 4 ft 8 1/2 in. is measured between the inner faces of the rails.

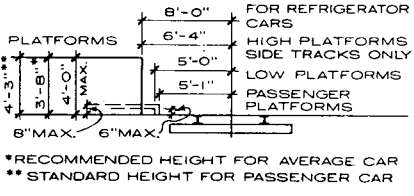
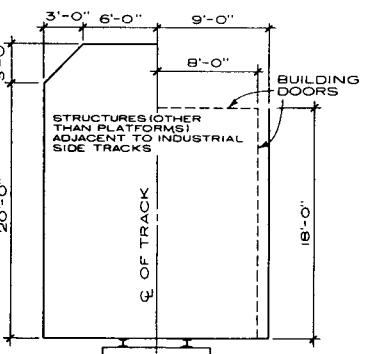

**NOTE**  
 The 6 ft 4 in. dimension will accommodate cars with either flush sliding doors or plug doors. Cars with hinged double doors require full clearance of 8 ft. Where 6 ft 4 in. platform is used, full clearance should be provided on opposite side, except inside buildings. (Several states allow a platform height of 4 ft 6 in. for refrigerator cars only, if the full lateral clearance of 8 ft is provided.)

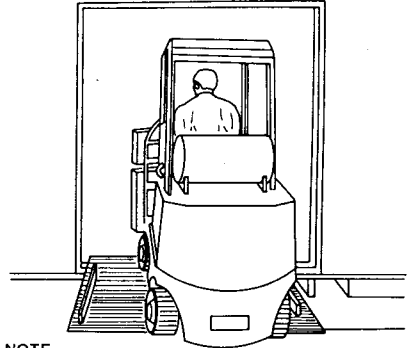

**NOTE**  
 Ramp travels laterally on rail mounted to edge of dock for positioning to rail car opening. It adjusts above and below dock level and locks to the rail when in the lowered position. Self-stores in vertical position when not in use. Available in varying lengths and widths.

**RAILWAY CLEARANCES**

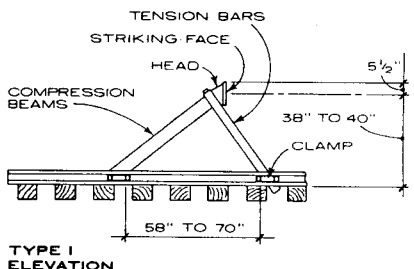
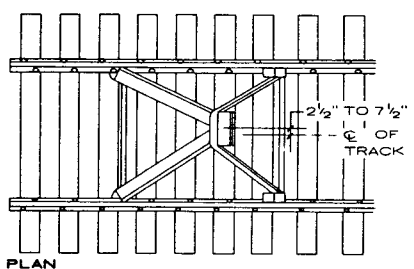

**RAIL DOCK RAMPS**

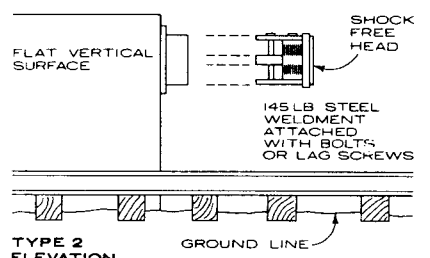

**TYPICAL BUMPING POSTS**

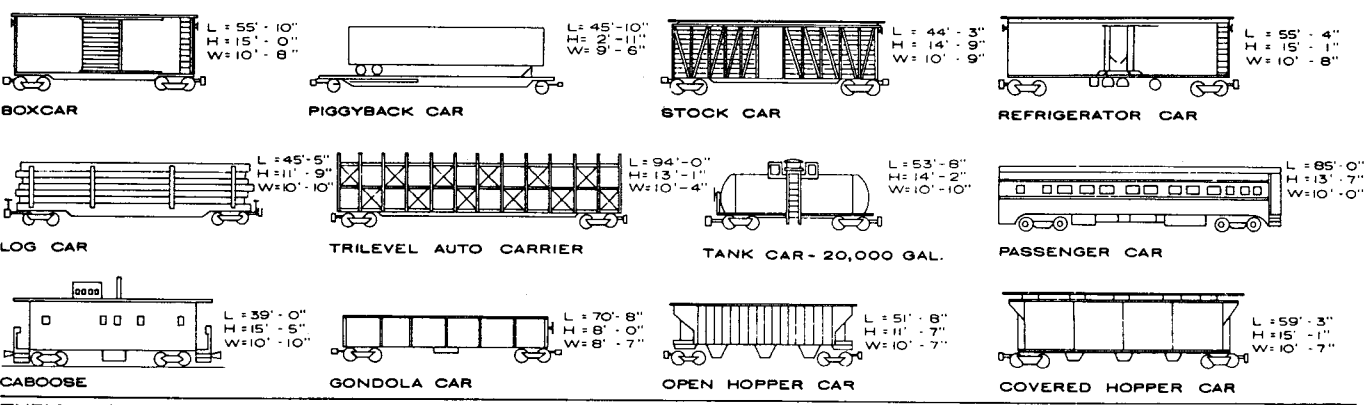

**TYPICAL RAILROAD CAR TYPES AND SIZES (ACTUAL CAR SIZES VARY GREATLY EVEN AMONG LIKE CAR TYPES)**

Ed Hesner, Rasmussen & Hobbs Architects; Tacoma, Washington  
 N. Claiborne Porter Jr., AIA; Anchorage, Alaska

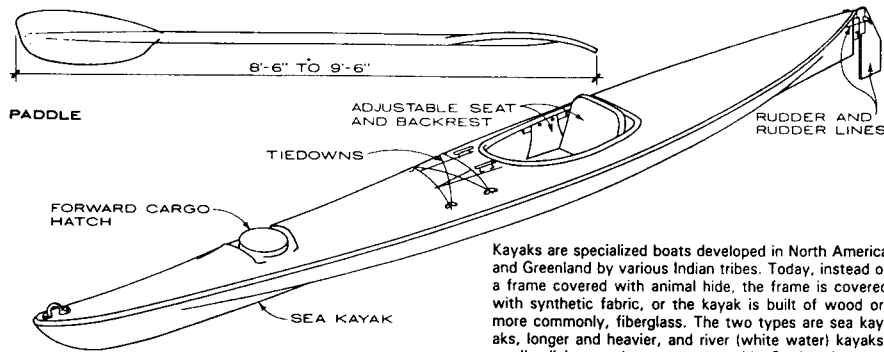

Kayaks are specialized boats developed in North America and Greenland by various Indian tribes. Today, instead of a frame covered with animal hide, the frame is covered with synthetic fabric, or the kayak is built of wood or, more commonly, fiberglass. The two types are sea kayaks, longer and heavier, and river (white water) kayaks, smaller, lighter, and more maneuverable. Sea kayaks range in length from 10 ft. 6 ins. to 23 ft. Their beam varies from 33 ins. to 17½ ins. White water kayaks are shorter and narrower to be more responsive in river rapids.

**KAYAK**

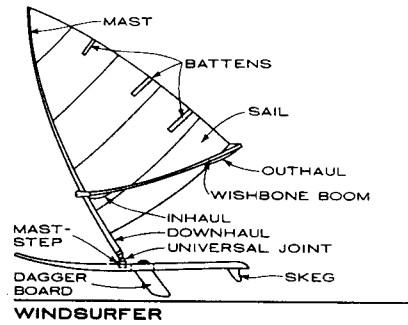

**WINDSURFER**

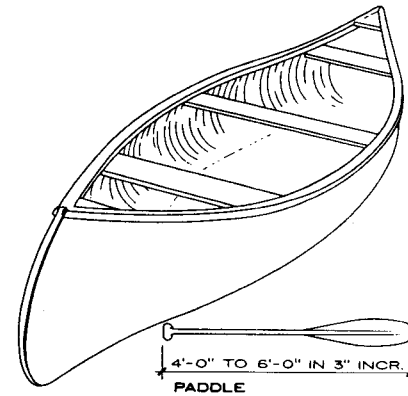

**CANOE**

Canoes have shallow draft, and they range in length from 12 ft. to 35 ft. They can be paddled, sailed, or motored, and they can be loaded with equipment. They are constructed of wood, fiberglass, or aluminum.

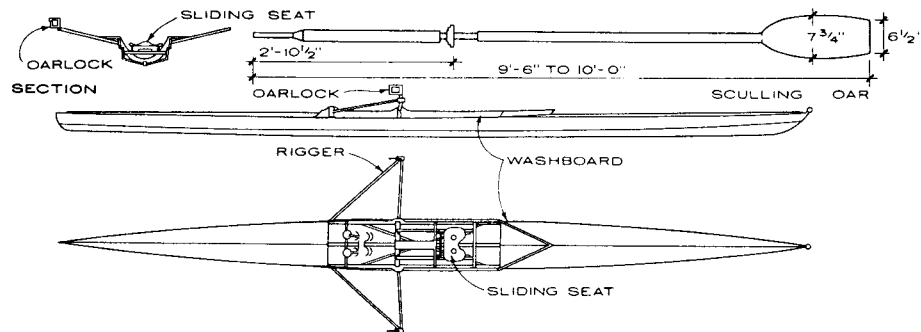

**ROWING SHELL**

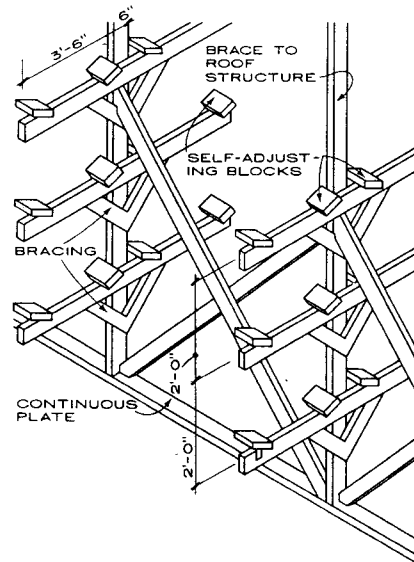

**ROWING SHELL STORAGE RACK**

Storage for rowing shells requires: two racks 8 feet apart for single and double; three racks 8 feet apart for eight-oared. Shells used daily should not be stored higher than 6 ft. Storage racks can be adapted easily to hold kayaks or canoes by adjusting the spacing between racks and the height between horizontal members.

Racing shells, built primarily of carbon fiber or plastic, are narrow and unstable in the water. There are two rowing styles: sweep rowing, where oarsmen work one oar with both hands; and sculling, where each oarsman works two oars, one in each hand. Sweeps are 12 ft. to 13 ft. long; sculling oars are 9 ft. 6 ins. to 10 ft. long.

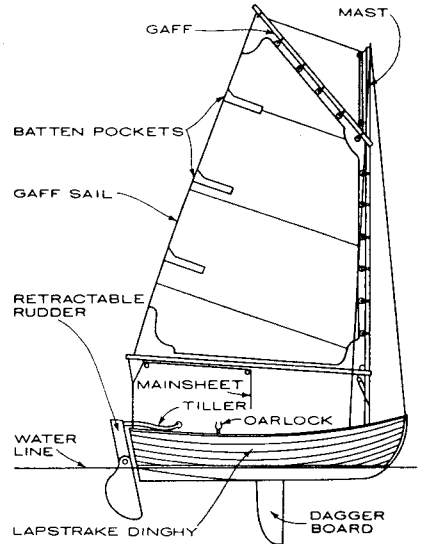

**DINGHIES**

Dinghies are small boats used as auxiliaries to larger craft. They also can be sailed and raced on their own. They vary in length from 6 ft. to 16 ft., and they are 2 ft. 10 ins. to 5 ft. 6 ins. in beam. They are constructed of wood or fiberglass, and they can be rigged for sail, rowing, or motoring.

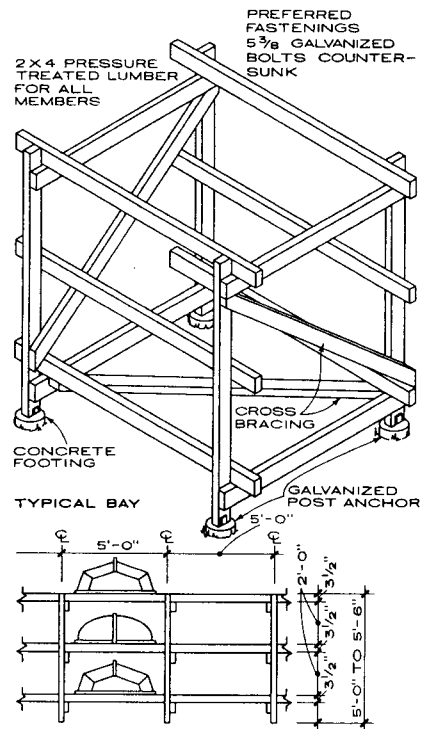

**DINGHY STORAGE RACK**

Dinghy racks store the small boats year round, and should be weather-treated. The rack members are fastened with countersunk bolts to avoid damaging dinghies. Racks must be able to support the weight of the boats and anyone climbing on the racks.

Timothy B. McDonald; Washington, D.C.

**1 TRUCKS, TRAINS, AND BOATS**

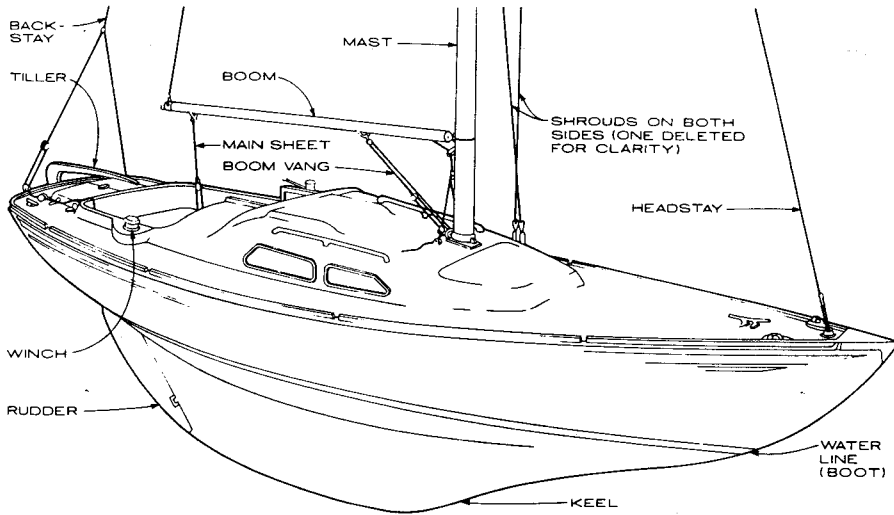

MONOHULL SAILBOAT

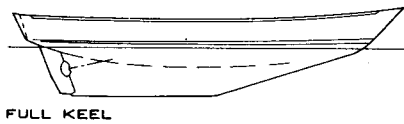

FULL KEEL

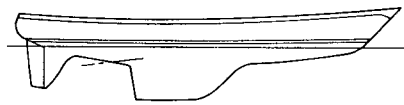

FIN KEEL

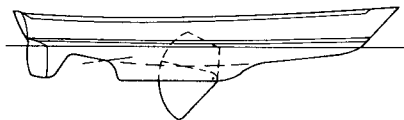

FIN KEEL / CENTER BOARD



CENTER BOARD

MONOHULL - BASIC UNDERWATER HULL SHAPES

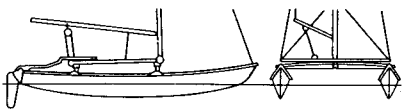

MULTIHULL

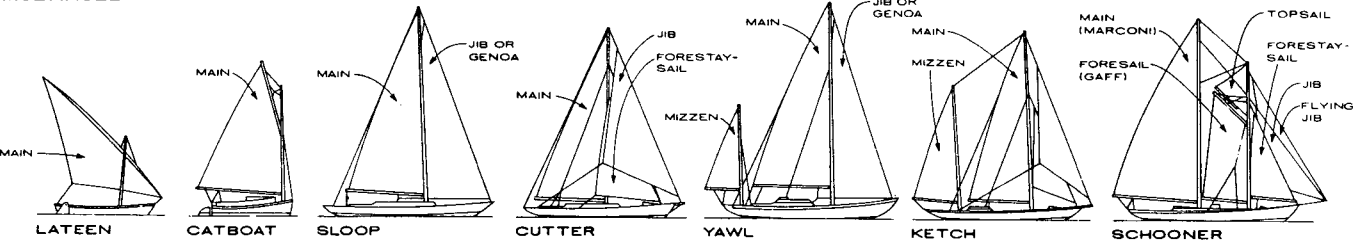

BASIC BOAT RIGS

CATBOAT RIG

Traditionally puts a lot of sail area on one short mast, as shown here, which is stepped far forward in the boat.

SLOOP

Design with two basic sails, mainsail and headsail; the latter, called a "fractional rig," is set either to the masthead or some distance below the masthead.

CUTTER

Like the sloop, a cutter rig has one mast carrying two headsails instead of one. The inner sail is the forestay sail and the outer sail is the jib.

YAWL

Unlike the sloop or cutter, the yawl is a two masted rig consisting of a mainmast and a mizzen mast that is stepped abaft (behind) the rudder post. The mizzen sail is much smaller than the main sail.

KETCH

Like the yawl, the ketch is also a two-masted rig; however, the mizzen mast is stepped forward of the rudder post and is larger than the yawl's mizzen. This placement dictates a smaller mainsail.

SCHOONER

Usually two-masted but can be three-masted. Commonly the foremast is the shorter of the two, and may be gaff or marconi rigged or at times a combination of both.

A combination of mast and rigging placement (where the mast is stepped), along with size, type and number of sails, make up the main differences in sailboat rigs. Today the most common is the marconi rig distinguished by a triangular mainsail, but it is not unusual for boats to be rigged with a traditional gaff, which is a four-sided sail that hangs from a spar called a gaff. In some instances marconi and gaff rigs are used together as shown on the schooner below.

Headsails are triangular sails set ahead of the mast. Basic headsails are the jib, working jib, staysail, and genoa. The working jib, unlike other jibs, does not overlap the mast and is often attached to a boom for easier control. Jibs and genoas do overlap the mast and mainsail. The forestaysail is combined with the jib to create a double-headsail and is used primarily on cutters and schooners.

Spinnakers, usually the largest sail set before the mast, come in several different shapes and sizes according to use.

DEFINITIONS

1. Length overall—LOA—boat's greatest length excluding bowsprits rudder or other extensions.
2. Length of water line—LWL—boat's greatest length at the water level excluding extensions such as rudders.
3. Beam—boat's maximum breadth.
4. Draft—distance from the waterline to the bottom of the boat's keel determining the least depth of water the boat can operate in: i.e., the amount it draws.
5. Displacement—weight of the water that the boat displaces.

NOTES FOR BASIC RIGS

LATEEN

Ancestor of the fore and aft rigs shown here. It dates back thousands of years and is still used in many parts of the world.

EXAMPLES

	LOA	LWL	BEAM	DRAFT	
<b>FULL KEEL BOATS</b>					
Folkboat	25'-10"	19'-10"	7'-4"	3'-11"	
Cape Dory 45	45'-3"	33'-6"	13'-0"	6'-3"	
<b>FIN KEEL BOATS</b>					
Tartan 28	28'-3"	23'-3"	9'-10"	4'-11"	
O'Day 35	35'-0"	28'-9"	11'-3"	5'-7"	
<b>FIN/CENTERBOARD</b>					
Cape Dory (270)	27'-3"	20'-9"	9'-5"	UP	DOWN
Tartan 37	37'-3"	28'-6"	11'-9"	4'-2"	7'-9"
<b>CENTERBOARD</b>					
Sunfish	13'-10"	13'-10"	4'-1/2"	3"	2'-8"
Laser	13'-10"	12'-6"	4'-6"	6"	2'-8"
El Toro	8'-0"	7'-0"	3'-10"	3"	1'-10"
<b>MULTIHULLS</b>					
Hobie 16	16'-7"	15'-9"	7'-11"	10"	

Timothy B. McDonald; Washington, D.C.

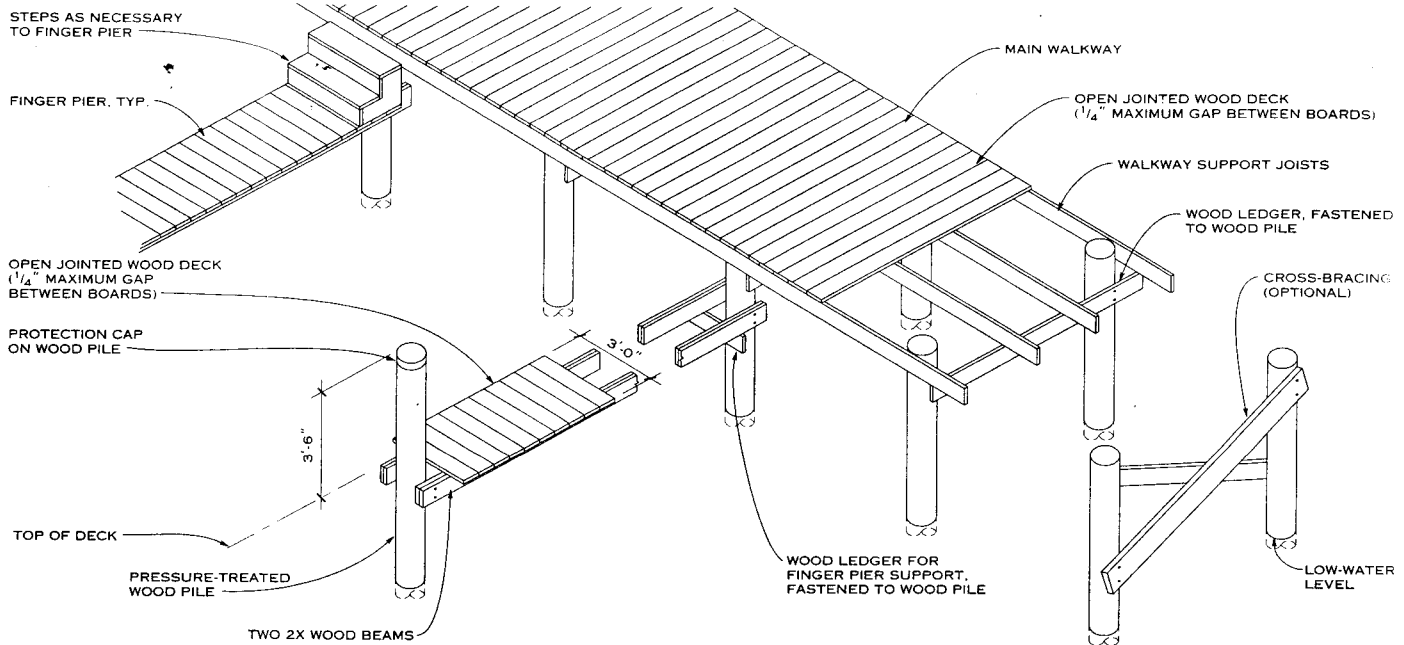

TYPICAL FIXED DOCK

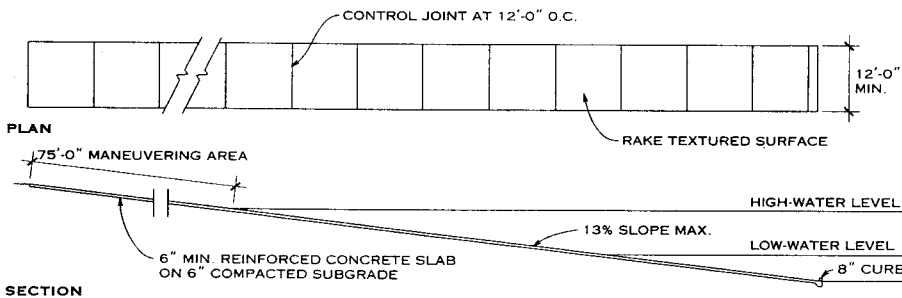

NOTES

1. Launching ramps are for sheltered waters only.
2. A finger pier or courtesy pier may be provided alongside the ramp. In tidal waters, these piers should be of floating construction.

BOAT LAUNCHING RAMP

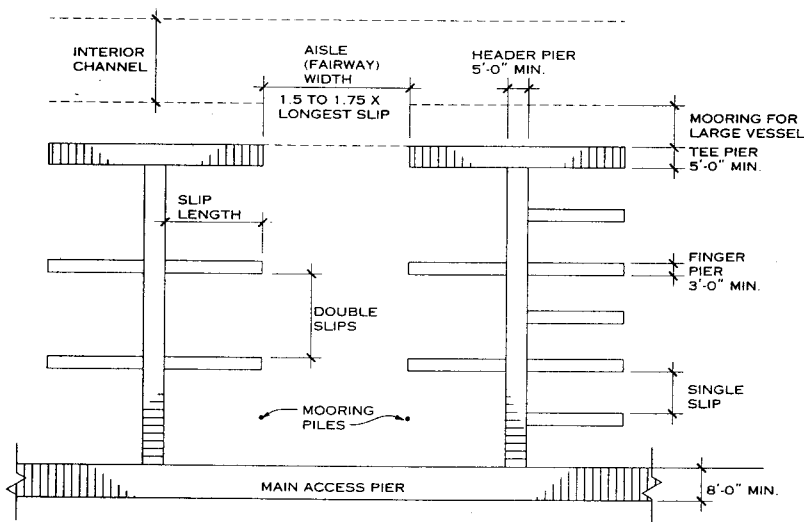

DOCKING PLAN

Stephen B. Soulé; Soulé and Associates, P.C.; Salisbury, Maryland

NOTES

1. Wood marine construction must be pressure treated with a preservative. Wood preservatives for use in marine applications fall into two general categories—creosote and waterborne. To select a specific preservative, the wood-attacking agents in local waters must be identified. A preservative may then be chosen based on the standards of the American Wood Preserver's Association. In some saltwater locations, wood construction may not be a viable option.
2. Waterborne preservatives are recommended for decks because creosote stains shoes and bare feet. Optional deck materials include untreated wood materials such as cedar and recycled plastic products.
3. The preservative selected should be approved by the Environmental Protection Agency.
4. Optional materials for piles include steel, concrete, and fiberglass. Wood, steel, concrete, aluminum, and vinyl may be used for bulkheads.
5. Deck height above water is determined by average deck levels and probable water level. Maintain a 12 in. minimum dimension between water and deck. Floating docks may be required in tidal waters. Consult manufacturers for construction information.
6. Cross-bracing should be minimized to avoid entanglement of swimmers.

DIMENSIONS FOR SLIPS AND FINGER PIERS (FT)

BOAT LENGTH	SLIP LENGTH	SINGLE SLIP WIDTH	DOUBLE SLIP WIDTH
20	23	10	20
25	28	12	25
30	33	14	27
35	38	15	31
40	43	18	34
45	48	19	36
50	53	20	38
55	58	22	42
60	63	23	44

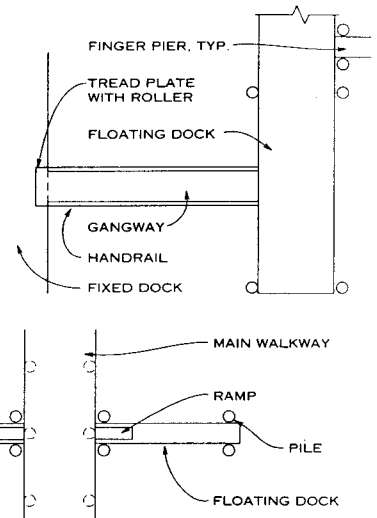
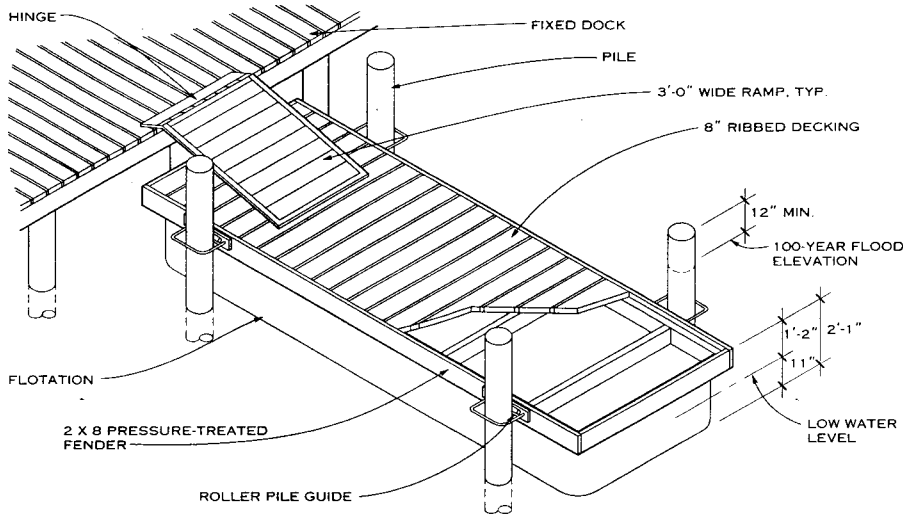

**FLOATING DOCK—DETAIL NOTES**

1. Floating docks must be engineered for the specific site and loading conditions. Docks can be designed to accommodate boats in a wide range of sizes as well as all utilities.
2. Docks can be anchored by pilings or by mooring chains and anchors. Piling material can be steel, concrete, or treated timber. Guide piles must be designed so that the top of all piles is above the 100-year flood elevation. Special consideration should be given to breakwaters for wave attenuation.

3. Flotation should be designed to provide minimum freeboard at full loading. Floats can be made of concrete, steel, aluminum, and plastic.
4. Docks may be constructed of steel, aluminum, concrete, or timber materials. Joints must be designed to withstand all applied forces.

**TYPICAL FLOATING DOCK ARRANGEMENTS**

5. Decking material can be timber, concrete, steel, plastic, or fiberglass.
6. All components should be designed in a manner that will minimize or eliminate corrosion.
7. Utility systems with accessible utility chases should be designed into the dock structure.

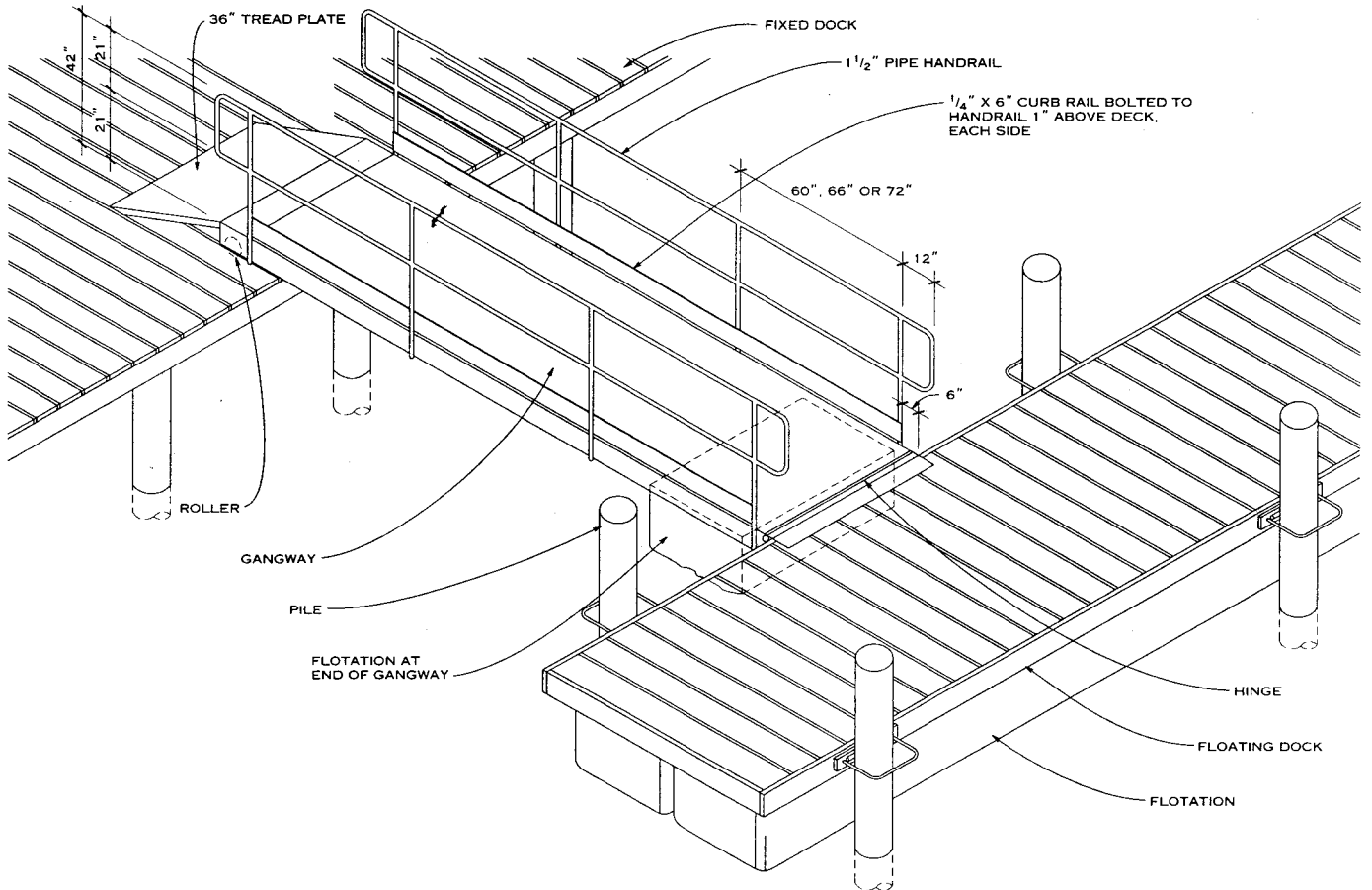

**GANGWAY—DETAIL**

Stephen B. Soulé; Soulé and Associates, P.C.; Salisbury, Maryland



## INTRODUCTION

More than 75 AIA contract and administrative forms are in print today. The ancestor of all of these was the Uniform Contract, an owner-contractor agreement first published in 1888. This was followed, in 1911, by the AIA's first standardized General Conditions for construction. The 1997 edition of AIA Document A201 is the fifteenth edition of those General Conditions.

Many practices common in the construction industry today became established through their inclusion in the AIA General Conditions for Construction and other AIA standardized documents. Arbitration, the one-year correction period, and the architect's role in deciding disputes are just three of these. While the AIA documents have had a profound influence on the industry, the influence also flows the other way. The AIA regularly revises its documents to take into account recent developments in the construction industry and the law. New standardized documents for design/build and for different types of construction management were published in the late 1990s, and documents for international practice are under consideration.

Because the AIA documents are frequently updated, users should consult an AIA component chapter or obtain a current copy of the "AIA Contract Documents Price List" to determine which are the current editions.

The relationship of the documents to the industry—influencing it, and in turn being influenced by it—is paralleled by the relationship of the documents to the law. AIA documents are intended for nationwide use and are not drafted to conform to the law of any one state. With that caveat, AIA contract documents provide a solid basis of contract provisions that are enforceable under the law existing at the time of publication. Case law on contracts for design and construction has for the past century been based largely on the language of AIA standardized documents and contracts derived from them. These court cases are listed in *The American Institute of Architects Legal Citator*, in which recent cases are summarized with all cases keyed to the specific provisions in the AIA documents to which they relate.

The AIA documents are organized in two ways: in a letter series and in cross-series families:

The document letter series is a system of classification that cuts across the various families and identifies the specific purpose of each document. The letter designations indicate the following:

- A Series—owner-contractor documents
- B Series—owner-architect documents
- C Series—architect-consultant documents
- D Series—architect-industry documents
- G Series—architect's office and project forms

Documents grouped in a family are coordinated to tie together the various legal and working relationships for the same project types. Documents within the same family may be in different series but are linked by common terminology and procedures. Documents in a family may adopt one another by reference. For example, the relevant terms of A201 are adopted by reference in A101, A111, A401, B141, B151, and C141.

The preceding paragraphs contain several references to "standardized documents," a term that covers most AIA documents. AIA standardized documents are intended to be used in their original, printed form. Much of the efficiency these documents bring to a transaction depends on this use. When people with experience in the construction industry see a standardized document, they are familiar with it and can quickly evaluate the proposed transaction based on the modifications made to it—if those modifications stand out. If modifications are blended into retyped or scanned document text, this advantage is lost.

Modifications used with AIA documents may themselves be derived from another type of document published by the AIA. These are model documents, the language of which is intended to be reproduced and adapted by users. One such repository of model text is A511, which is intended for use in developing supplementary conditions, an important component of the contract for construction. B511 serves a similar purpose with respect to owner-architect agreements.

AIA documents are currently available in both printed and electronic form. The software package AIA Contract Documents: Electronic Format for Windows™ enables users to access and print out the AIA documents. Modifications are clearly shown: deleted language appears with strike-throughs, and added language is underscored.

## DOCUMENT SYNOPSIS

These synopses are meant to be used as a quick reference for determining the appropriate uses for each of the contract documents and administrative forms published by the American Institute of Architects. That purpose naturally presumes independent judgment on the reader's part, as well as advice of counsel.

### A SERIES

The documents in the A Series of AIA documents relate to various forms of agreement between an owner and a contractor.

A101, STANDARD FORM OF AGREEMENT BETWEEN OWNER AND CONTRACTOR—STIPULATED SUM, is a standard form of agreement between owner and contractor for use when the basis of payment is a stipulated sum (fixed price). The A101 document adopts by reference and is designed for use with AIA Document A201, General Conditions of the Contract for Construction, thus providing an integrated pair of legal documents. When used together, A101 and A201 are appropriate for most projects. For projects of limited scope, however, use of AIA Document A107 might be considered.

A101/CMa, STANDARD FORM OF AGREEMENT BETWEEN OWNER AND CONTRACTOR—STIPULATED SUM—CONSTRUCTION MANAGER-ADVISER EDITION, is a standard form of agreement between owner and contractor for use on projects when the basis of payment is a stipulated sum (fixed price) and when, in addition to the contractor and the architect, a construction manager assists the owner in an advisory capacity during design and construction. The document has been prepared for use with AIA Document A201/CMa, General Conditions of the Contract for Construction—Construction Manager-Adviser Edition. This integrated set of documents is appropriate for use on projects when the construction manager serves only in the capacity of an adviser to the owner, rather than as constructor (the latter relationship is represented in AIA documents A121/CMc and A131/CMc). A101/CMa is suitable for projects when the cost of construction has been predetermined, either by bidding or by negotiation.

A105, STANDARD FORM OF AGREEMENT BETWEEN OWNER AND CONTRACTOR FOR A SMALL PROJECT, and A205, GENERAL CONDITIONS OF THE CONTRACT FOR CONSTRUCTION OF A SMALL PROJECT, are intended to be used in conjunction with one another. The two documents are only sold as a set, and they share a common instruction sheet. They have been developed for use when payment to the contractor is based on a stipulated sum (fixed price) and when the project is modest in size and brief in duration. A105 and A205 are two of the three documents that comprise the Small Projects family of documents. They have been developed for use with AIA Document B155, Standard Form of Agreement Between Owner and Architect for a Small Project. These documents are specifically coordinated for use as a set.

**Caution:** Although A105, A205, and B155 may share some similarities with other AIA documents, the Small Projects documents should not be used in tandem with other AIA document families without careful side-by-side comparison of contents.

A205 is considered the keystone document of the Small Projects family, since it is specifically adopted by separate reference into both A105 and B155. A205 is a vital document, in that it is used to allocate proper legal responsibilities among the parties, while providing both a common ground and a means of coordination within the Small Projects family. In order to maintain the condensed nature of this document, arbitration and other alternate dispute resolution (ADR) provisions have been omitted. ADR provisions may be included in A105 under Article 6.

A107, ABBREVIATED STANDARD FORM OF AGREEMENT BETWEEN OWNER AND CONTRACTOR FOR CONSTRUCTION PROJECTS OF LIMITED SCOPE—STIPULATED SUM. As an abbreviated form of agreement between owner and contractor, this document is intended for use when the basis of payment is a stipulated sum (fixed price). It is appropriate for construction projects of limited scope not requiring the complexity and length of the combination of AIA Documents A101 and A201. A107 contains abbreviated General Conditions. It may be used when the owner and contractor have already established a working relationship (e.g., a previous project of like or similar nature) or when a project is relatively simple in detail or short in duration.

A111, STANDARD FORM OF AGREEMENT BETWEEN OWNER AND CONTRACTOR—COST PLUS A FEE WITH A NEGOTIATED GUARANTEED MAXIMUM PRICE. This standard form of agreement between owner and contractor is appropriate for use on most projects requiring a negotiated guaranteed maximum price, when the basis of payment to

the contractor is the cost of the work plus a fee. A111 adopts by reference and is intended for use with AIA Document A201, General Conditions of the Contract for Construction, thus together the two documents offer an integrated pair of legal documents.

A121/CMc (AGC 565), STANDARD FORM OF AGREEMENT BETWEEN OWNER AND CONSTRUCTION MANAGER WHERE THE CONSTRUCTION MANAGER IS ALSO THE CONSTRUCTOR. This document represents the collaborative efforts of the American Institute of Architects and the Associated General Contractors of America. The AIA designates this document A121/CMc, while AGC calls it AGC Document 565. A121/CMc is intended for use on projects for which a construction manager, in addition to serving as adviser to the owner, assumes financial responsibility for construction. The construction manager provides the owner with a guaranteed maximum price proposal, which the owner may accept, reject, or negotiate. Upon the owner's acceptance of the proposal by execution of an amendment, the construction manager is contractually bound to provide labor and materials for the project.

A121/CMc divides the construction manager's services into two phases: the preconstruction phase and the construction phase, portions of which may proceed concurrently in order to fast track the process. A121/CMc is coordinated for use with AIA Document A201, General Conditions of the Contract for Construction and B141, Standard Form of Agreement Between Owner and Architect. Check Article 5 of B511 for guidance in this regard.

**Caution:** To avoid confusion and ambiguity, do not use this construction management document with any other AIA or AGC construction management document.

A131/CMc (AGC 566), STANDARD FORM OF AGREEMENT BETWEEN OWNER AND CONSTRUCTION MANAGER WHERE THE CONSTRUCTION MANAGER IS ALSO THE CONSTRUCTOR—COST PLUS A FEE, NO GUARANTEE OF COST. Similar to A121/CMc, this CM-constructor agreement is also intended for use when the owner seeks a constructor who will take responsibility for providing the means and methods of construction. However, the method of determining cost of the work diverges sharply in the two documents: A121/CMc allows for a guaranteed maximum price (GMP), while A131/CMc uses a control estimate. A131/CMc employs the cost-plus-a-fee method, which allows the owner to monitor cost through periodic review of the control estimate, which is revised as the project proceeds.

It is important to note that, while the CM-constructor is assuming varied responsibilities, there are still just three primary players on the project—the owner, the architect, and the CMc. The A201 General Conditions continue to apply, although they are modified (in part) by the A131/CMc agreement.

**Caution:** To avoid confusion and ambiguity, do not use this construction management document with any other AIA or AGC construction management document.

A171, STANDARD FORM OF AGREEMENT BETWEEN OWNER AND CONTRACTOR—STIPULATED SUM—FOR FURNITURE, FURNISHINGS, AND EQUIPMENT, is used for acquisition of furniture, furnishings, and equipment (FF&E) when the basis of payment is a stipulated sum (fixed price). A171 adopts by reference and is intended for use with AIA Document A271, General Conditions of the Contract for Furniture, Furnishings, and Equipment. It may be used in any arrangement between the owner and the contractor in which the cost of FF&E has been determined in advance, either through bidding or negotiation.

A177, ABBREVIATED OWNER-CONTRACTOR AGREEMENT FORM—STIPULATED SUM—FOR FURNITURE, FURNISHINGS, AND EQUIPMENT, is an abbreviated document that philosophically derives much of its content from a combination of the more complex and lengthy A171 and A271 documents. Its abbreviated terms and conditions may be used when a contractor for furniture, furnishings, and equipment (FF&E) has a prior working relationship with the owner or when a project is relatively simple in detail or short in duration.

**Caution:** This document is not intended for use with major construction work that may involve life safety systems or structural components.

A191, OWNER-DESIGN/BUILDER AGREEMENTS, contains two agreements to be used in sequence by an owner contracting with one entity serving as a single point of responsibility for both design and construction services. Design/build entities may be architects, contractors, or even businesspersons, as long as they comply with governing laws.

*continues on following page*

Dale Ellickson, FAIA; The American Institute of Architects, Washington, D.C.



CONSTRUCTION INFORMATION SYSTEMS

Document Synopses, A Series, *continued from previous page*

especially those pertaining to licensing and public procurement regulations. The first agreement covers preliminary design and budgeting services, while the second deals with final design and construction. Although it is anticipated that an owner and a design/builder entering into the first agreement will later enter into the second, the parties are not obligated to do so and may conclude their relationship after the terms of the first agreement have been fulfilled.

**A201, GENERAL CONDITIONS OF THE CONTRACT FOR CONSTRUCTION:** The General Conditions are an integral part of the contract for construction in that they set forth the rights, responsibilities, and relationships of the owner, contractor, and architect. While not a party to the contract for construction between owner and contractor, the architect does participate in the preparation of the contract documents and performs certain duties and responsibilities described in detail in the General Conditions. Because A201 is typically adopted by reference into certain other AIA documents (e.g., owner-architect agreements, owner-contractor agreements, and contractor-subcontractor agreements), it is often called the "keystone" document.

Since conditions vary by locality and by project, supplementary conditions are usually added to amend or supplement portions of the General Conditions as required by a particular project. Review the model language provided in A511 as a guide when creating supplementary conditions for A201.

**A201/CMa, GENERAL CONDITIONS OF THE CONTRACT FOR CONSTRUCTION—CONSTRUCTION MANAGER-ADVISER EDITION,** is an adaptation of AIA Document A201 developed for construction management projects with a fourth player—a construction manager—added to the team of owner, architect, and contractor. Under A201/CMa, the construction manager has the role of independent adviser to the owner, thus the document carries the CMa suffix. A major difference between A201 and A201/CMa occurs in Article 2, Administration of the Contract, which deals with the duties and responsibilities of both the architect and the construction manager-adviser. Another major difference implicit in A201/CMa is the use of multiple construction contracts directly with trade contractors.

**Caution:** It is vital that A201/CMa not be used in combination with documents that assume the construction manager will take on the role of constructor, give the owner a guaranteed maximum price, or contract directly with those who supply labor and materials for the project.

**A201/SC, FEDERAL SUPPLEMENTARY CONDITIONS OF THE CONTRACT FOR CONSTRUCTION,** is intended for use on certain federally assisted construction projects. For such projects, A201/SC adapts A201 by providing (1) necessary modifications of the General Conditions, (2) additional conditions, and (3) insurance requirements for federally assisted construction projects.

**A271, GENERAL CONDITIONS OF THE CONTRACT FOR FURNITURE, FURNISHINGS, AND EQUIPMENT:** When the scope of a contract is limited to furniture, furnishings, and equipment (FF&E), A271 is intended to be used in a manner similar to that in which A201 is used for construction projects. The document was jointly developed by the AIA and the American Society of Interior Designers (ASID). Because the Uniform Commercial Code (UCC) has been adopted in virtually every jurisdiction, A271 has been drafted to recognize the commercial standards set forth in Article 2 of the UCC and uses certain standard UCC terminology. Except for minor works, A271 should not be used for construction involving life safety systems or structural components.

**A305, CONTRACTOR'S QUALIFICATION STATEMENT:** An owner preparing to request bids or to award a contract for a construction project often requires a means of verifying the background, history, references, and financial stability of any contractor being considered. The time frame for construction and the contractor's performance history, previous experience, and financial stability are important factors for an owner to investigate. This form provides a sworn, notarized statement with appropriate attachments to elaborate on important aspects of the contractor's qualifications.

**A310, BID BOND:** This simple one-page form was drafted with input from the major surety companies to ensure its legality and acceptability. A bid bond establishes the maximum penal amount that may be due the owner if the selected bidder fails to execute the contract and provide any required performance and payment bonds.

**A312, PERFORMANCE BOND AND PAYMENT BOND:** This form incorporates two bonds, one covering the contractor's performance and one covering the contractor's obligations to pay subcontractors and others for material and labor. In

addition, A312 obligates the surety to act responsively to the owner's requests for discussions aimed at anticipating or preventing a contractor's default.

**A401, STANDARD FORM OF AGREEMENT BETWEEN CONTRACTOR AND SUBCONTRACTOR** is intended for use in establishing the contractual relationship between the contractor and subcontractor. It spells out the responsibilities of both parties and lists their respective obligations, which are written to parallel AIA Document A201, General Conditions of the Contract for Construction. Blank spaces are provided in which the parties can supplement the details of their agreement. A401 may be modified for use as a subcontractor-sub-contractor agreement.

**A491, DESIGN/BUILDER-CONTRACTOR AGREEMENTS:** This document contains two agreements to be used in sequence by a design/builder and a construction contractor. The first agreement covers management consulting services to be provided during the preliminary design and budgeting phase of the project. The second agreement covers construction. It is presumed that the design/builder has contracted with an owner to provide design and construction services under the agreements contained in AIA Document A191.

Although it is anticipated that a design/builder and a contractor entering into the first agreement will later enter into the second, the parties are not obligated to do so and may conclude their relationship after the terms of the first agreement have been fulfilled. Parties also may forgo entering into the first agreement and proceed directly to the second.

**A501, RECOMMENDED GUIDE FOR COMPETITIVE BIDDING PROCEDURES AND CONTRACT AWARDS FOR BUILDING CONSTRUCTION:** This guide outlines appropriate procedures in the bidding and award of contracts when competitive lump sum bids are requested in connection with building and related construction. The guide is a joint publication of the AIA and the Associated General Contractors of America (AGC).

**A511, GUIDE FOR SUPPLEMENTARY CONDITIONS** is a guide for modifying and supplementing A201, the General Conditions of the Contract for Construction. Although A201 is considered the keystone in the legal framework of the construction contract, it is a standard document and thus cannot cover all the particulars of a specific project. A511 provides model language with explanatory notes to help users adapt A201 by developing supplementary conditions that address local circumstances.

This document is printed with a column containing the model text and an adjacent column of explanatory notes. The AIA permits excerption of the model text under a limited license for reproduction granted for drafting supplementary conditions for a particular project.

**A511/CMa, GUIDE FOR SUPPLEMENTARY CONDITIONS—CONSTRUCTION MANAGER-ADVISER EDITION:** Similar to A511, the A511/CMa document is a guide to model provisions for supplementing A201/CMa, the General Conditions of the Contract for Construction, Construction Manager-Adviser Edition. A511/CMa should only be employed—as should A201/CMa—on projects for which the construction manager is serving in the capacity of adviser to the owner (as represented by the CMa document designation) and not in situations in which the construction manager is also the constructor (CMc document-based relationships).

Like A511, this document contains suggested language for supplementary conditions, along with notes on appropriate usage. In addition, many important distinctions are made to ensure consistency with other construction manager-adviser documents.

**Caution:** CMc documents are based on utilization of the A201 document, which in turn should be modified using A511 as a guide.

**A521, UNIFORM LOCATION OF SUBJECT MATTER,** is a joint publication of the AIA and the Engineers Joint Contract Documents Committee (EJCDC), which is composed of the National Society of Engineers, American Consulting Engineers Council, and American Society of Civil Engineers. By consensus of these organizations, the AIA and EJCDC documents follow the tabular guide in A521 with regard to the placement of subject matter among the various contract and bidding documents. A521 is a tabulation to guide the user in the proper placement and phrasing of information customarily used on a construction project. This document shows the importance of maintaining uniformity in location and language from document to document with respect to subject matter. Inconsistencies in either area may cause confusion, delay, or unanticipated legal problems.

**A571, GUIDE FOR INTERIORS SUPPLEMENTARY CONDITIONS:** Similar to A511, AIA Document A571 is intended as

an aid to practitioners preparing supplementary conditions for interiors projects. It provides information to help users address local variations in project requirements when A271, General Conditions of the Contract for Furniture, Furnishings, and Equipment, is used.

**A701, INSTRUCTIONS TO BIDDERS,** is used when competitive bids are to be solicited for construction of a project. Coordinated with A201 and its related documents, A701 contains instructions for procedures to be followed by bidders in preparing and submitting their bids, including bonding. Specific instructions or special requirements, such as the amount and type of bonding, are to be attached to A701 as supplementary conditions.

**A771, INSTRUCTIONS TO INTERIORS BIDDERS:** Similar to A701, A771 is used for projects dealing with furniture, furnishings, and equipment (FF&E). It parallels A701 but contains minor changes to maintain consistency with A271 and its related FF&E documents.

## B SERIES

The documents in the B Series relate to various forms of agreement between an owner and an architect for professional services.

**B141, STANDARD FORM OF AGREEMENT BETWEEN OWNER AND ARCHITECT WITH STANDARD FORM OF ARCHITECT'S SERVICES,** is a flexible contracting package that allows architects to offer a broad range of services to clients spanning the life of a project, from conception to completion and beyond. It is structured in a multipart format consisting of an agreement form—the Standard Form of Agreement, which contains initial information, terms and conditions, and compensation—and a services form—the Standard Form of Architect's Services: Design and Contract Administration, which defines the architect's scope of services. The scope defined approximates the level of services in the prior edition of B141. The separation of the scope of services from the rest of the owner-architect agreement allows users the freedom to choose alternative scopes of services. The AIA intends to publish additional scopes of services that correlate to the terms and conditions of B141.

**B151, ABBREVIATED STANDARD FORM OF AGREEMENT BETWEEN OWNER AND ARCHITECT,** is intended for use on construction projects of limited scope when the complexity and detail of AIA Document B141, Standard Form of Agreement Between Owner and Architect, are not required and when services are based on these five phases: schematic design, design development, construction documents, bidding and negotiation, and construction. This document may be used with a variety of compensation methods, including percentage of construction cost, multiple of direct personnel expense, and stipulated sum. B151 is intended for use in conjunction with A201, General Conditions of the Contract for Construction.

**B155, STANDARD FORM OF AGREEMENT BETWEEN OWNER AND ARCHITECT FOR A SMALL PROJECT,** is intended for use on a project that is modest in size and brief in duration. It adopts the A205 document by reference as it pertains to the architect's responsibilities in administering the construction contract between owner and contractor.

B155 is one of three documents that comprise the Small Projects family of documents. It has been developed for use with AIA Document A105, Standard Form of Agreement Between Owner and Contractor for a Small Project, and A205, General Conditions of the Contract for Construction of a Small Project. These documents are specifically coordinated for use as a set.

**Caution:** Although A105, A205, and B155 may share some similarities with other AIA documents, the Small Project documents should not be used in tandem with other AIA document families without careful side-by-side comparison of contents.

**B161, STANDARD FORM OF AGREEMENT BETWEEN OWNER AND ARCHITECT FOR DESIGNATED SERVICES,** has been replaced by AIA DOCUMENT B163.

**AIA DOCUMENT B162, SCOPE OF DESIGNATED SERVICES,** has been replaced by AIA DOCUMENT B163.

**B163, STANDARD FORM OF AGREEMENT BETWEEN OWNER AND ARCHITECT FOR DESIGNATED SERVICES,** is the most comprehensive AIA owner-architect agreement. This three-part document contains, among other things, a thorough list of 83 possible services divided among nine phases, covering pre-design through supplemental services. This detailed classification allows the architect to estimate more accurately the time and personnel costs required for a particular project. Both owner and architect benefit from the ability to clearly establish the

*continues on following page*

Document Synopses, B Series, continued from previous page

scope of services required for a project, as responsibilities and compensation issues are negotiated and defined. The architect's compensation may be calculated on a time/cost basis through use of the worksheet provided in the instructions to B163.

Part One of the document deals with variables typical of many owner-architect agreements, such as compensation and scope of services. The scope of services is delimited through use of a matrix that allows the parties to designate their agreed-upon services and responsibilities. Part Two contains detailed descriptions of the specific services found in the matrix. Part Three contains general descriptions of the parties' duties and responsibilities. The list of services in B163 has been expanded to include construction management and interiors services.

**B171, STANDARD FORM OF AGREEMENT BETWEEN OWNER AND ARCHITECT FOR INTERIOR DESIGN SERVICES**, is intended for use when the architect agrees to provide an owner with design and administrative services for the procurement of interior furniture, furnishings, and equipment (FF&E). Unlike B141, which is used for building design, this document includes programming of the interior spaces and requirements as part of the overall package of basic services. The authority to reject goods is left in the hands of the owner rather than the architect, since the procurement of goods is governed by the Uniform Commercial Code (UCC), which would in turn make the architect's mistaken rejection or acceptance of goods binding upon the owner. B171 is coordinated with and adopts by reference AIA Document A271, General Conditions of the Contract for Furniture, Furnishings, and Equipment. When B171 is used, it is anticipated that A271 will form part of the contract between the owner and the contractor for FF&E.

**B177, ABBREVIATED FORM OF AGREEMENT FOR INTERIOR DESIGN SERVICES**, is similar to B171 but has less complexity and detail. B177 may be used when the owner and architect have a continuing relationship from previous work together or when the project is relatively simple in detail or short in duration.

**B181, STANDARD FORM OF AGREEMENT BETWEEN OWNER AND ARCHITECT FOR HOUSING SERVICES**, has been developed with the assistance of the U.S. Department of Housing and Urban Development and other federal housing agencies. It is primarily intended for use in multi-unit housing design. B181 requires the owner, rather than the architect, to furnish cost-estimating services. B181 is coordinated with and adopts by reference AIA Document A201, General Conditions of the Contract for Construction.

**B188, STANDARD FORM OF AGREEMENT BETWEEN OWNER AND ARCHITECT FOR LIMITED ARCHITECTURAL SERVICES FOR HOUSING PROJECTS**, is a unique addition to the AIA Documents collection. Unlike its distant cousin B181, B188 is intended for use when the architect will provide limited architectural services in connection with a development housing project. It anticipates that the owner will have extensive control over management of the project, acting in a capacity similar to that of a developer or speculative builder of a housing project. As a result, the owner or separate consultants retained by the owner likely will provide the engineering services, specify the brand names of materials and equipment, and administer payments to contractors, among other project responsibilities. B188 is not coordinated for use with any other AIA standard form contract.

**B352, DUTIES, RESPONSIBILITIES AND LIMITATIONS OF AUTHORITY OF THE ARCHITECT'S PROJECT REPRESENTATIVE**: When and if the owner wants additional project representation at the construction site on a full- or part-time basis, B141 and other AIA owner-architect agreements reference B352 to establish the duties, responsibilities, and limitations of authority of the project representative.

The project representative is employed and supervised by the architect. In contrast, up until the early 1950s, B352 predecessor documents called the representative "the Clerk of the Works," because such persons were hired by the owner but supervised by the architect. The split between hiring and supervision caused numerous problems, which have been resolved under B352 by designating the architect as both employer and supervisor. B352 is coordinated for use with both B141 and B163, as well as with A201.

**B431, ARCHITECT'S QUALIFICATION STATEMENT**, is a standardized outline of information that a client may wish to review prior to selecting an architect for a particular project. It may be used as part of a request for proposals (RFP) or as a final check on the credentials of an architect. Under some circumstances, B431 may be attached to the owner-architect

agreement, for example, to show the team of professionals and consultants expected to be employed on the owner's project.

**B727, STANDARD FORM OF AGREEMENT BETWEEN OWNER AND ARCHITECT FOR SPECIAL SERVICES**, is the most flexible of the AIA owner-architect agreements in that the description of services is left entirely up to the ingenuity of the parties. Otherwise, many of the terms and conditions are very similar to those found in AIA Document B141. B727 is often used for planning, feasibility studies, and other services (such as construction administration) that do not follow the complete phasing sequence of services set forth in B141 and other AIA documents. If construction administration services are to be provided, care must be taken to coordinate B727 with the appropriate General Conditions of the Contract for Construction.

**B801/CMa, STANDARD FORM OF AGREEMENT BETWEEN OWNER AND CONSTRUCTION MANAGER WHERE THE CONSTRUCTION MANAGER IS NOT A CONSTRUCTOR**, is intended for use on projects for which construction management services are assumed by a single entity who is separate and independent from the architect and the contractor and who acts solely as an adviser (CMa) to the owner throughout the course of the project.

B801/CMa is coordinated for use with AIA Document B141/CMa, Standard Form of Agreement Between Owner and Architect—Construction Manager-Adviser Edition. Both B801/CMa and B141/CMa are based on the premise that there will be a separate, and possibly multiple, construction contractor(s) whose contracts with the owner are jointly administered by the architect and the construction manager under AIA Document A201/CMa, General Conditions of the Contract for Construction—Construction Manager-Adviser Edition.

*Caution:* B801/CMa is not coordinated with and should not be used with documents in which the construction manager acts as the constructor (i.e., contractor) for the project, such as AIA Documents A121/CMc or A131/CMc.

**B901, STANDARD FORM OF AGREEMENT BETWEEN DESIGN/BUILDER AND ARCHITECT**, contains two agreements to be used in sequence by a design/builder and an architect. The first agreement covers preliminary design, and the second covers final design. It is presumed that the design/builder has previously contracted with an owner to provide design and construction services under the agreements contained in AIA Document A191. Although it is anticipated that a design/builder and an architect entering into the first agreement will later enter into the second, the parties are not obligated to do so and may conclude their relationship after the terms of the first agreement have been fulfilled.

Design/build entities may be architects, contractors, or even businesspersons, as long as they comply with the governing laws, especially those pertaining to licensing and public procurement regulations. Prior to proceeding in this fashion or entering into either agreement contained in this document with any other entity, architects are advised to contact their legal, insurance, and management advisers.

#### C SERIES

The documents in the C Series relate to various forms of agreement between an architect and other professionals, including engineers, consultants, and other architects.

**C141, STANDARD FORM OF AGREEMENT BETWEEN ARCHITECT AND CONSULTANT**, establishes the respective responsibilities and mutual rights of the architect and the consultant. C141 is most applicable to engineers but may also be used for consultants in other disciplines who provide services to architects. The provisions of C141 are in accord with those of B151 and A201, General Conditions of the Contract for Construction.

**C142, ABBREVIATED ARCHITECT-CONSULTANT AGREEMENT**, adopts the terms of a prime agreement between owner and architect by reference.

**C727, STANDARD FORM OF AGREEMENT BETWEEN ARCHITECT AND CONSULTANT FOR SPECIAL SERVICES**, is intended for use when other C Series documents are inappropriate. It is often used for planning, feasibility studies, post-occupancy studies, and other services that require specialized descriptions.

**C801, JOINT VENTURE AGREEMENT FOR PROFESSIONAL SERVICES**, is meant to be used by two or more parties to provide for their mutual rights and obligations. It is intended that the joint venture, once established, will enter into a project agreement with the owner to provide professional services. The parties may be all architects, all engineers, a combination of architects and engineers, or another combination of professionals. The document pro-

vides a choice between two methods of joint venture operation. The "Division of Compensation" method assumes that services provided and the compensation received will be divided among the parties in the proportions agreed to at the outset of the project. Each party's profitability then depends on individual performance of preassigned tasks and is not directly tied to that of the other parties. The "Division of Profit and Loss" method is based on each party performing work and billing the joint venture at cost plus a nominal amount for overhead. The ultimate profit or loss of the joint venture is thus divided at completion of the project between the parties based on their respective interests.

#### D SERIES

The documents in the D Series, known as the Architect Industry documents, are applicable to a broad range of projects.

**D101, METHODS OF CALCULATING THE AREA AND VOLUME OF BUILDINGS**, establishes definitions for and describes methods of calculating the architectural area and volume of buildings. D101 also covers interstitial space, office, retail, and residential areas.

**D200, PROJECT CHECKLIST**, is a convenient list of tasks a practitioner may perform on a given project. This checklist will help the architect recognize required tasks and locate the data necessary to fulfill assigned responsibilities. By providing space for notes on actions taken, assignment of tasks, and time frames for completion, D200 may also serve as a permanent record of the owner's, contractor's, and architect's actions and decisions.

#### F SERIES

The F Series offered accounting forms for architects. With the exception of F5002, INVOICE FOR ARCHITECTURAL SERVICES, separate editions of F Series forms have been discontinued due to the preponderance of commercially available computer software on this subject. F1001 through F3002 are included in the book *Standardized Accounting for Architects* by Robert F. Mattox, FAIA.

#### G SERIES

The documents in the G Series relate to office administration, securing of goods and services, and administering and closing out of project agreements.

**G601, REQUEST FOR PROPOSAL—LAND SURVEY**, allows owners to request proposals from a number of surveyors based on information deemed necessary by the owner and architect. G601 also allows owners to fine-tune a request for proposal (RFP) by checking appropriate boxes and filling in project specifics to avoid costs associated with requesting unnecessary information. The document may also form the agreement between owner and land surveyor once an understanding is reached.

**G602, REQUEST FOR PROPOSAL—GEOTECHNICAL SERVICES**: Similar in both structure and format to AIA Document G601, G602 is an RFP that can evolve to form an agreement between owner and geotechnical engineer. G602 allows the owner to tailor the proposal request to address the specific needs of a project. In consultation with the architect, the owner establishes the parameters of service required and evaluates submissions based on criteria such as time, cost, and overall responsiveness to the terms set forth in the RFP. When an acceptable submission is selected, the owner signs the document in triplicate, returning one copy to the engineer and one to the architect, thus establishing an agreement between owner and geotechnical engineer.

**G604, PROFESSIONAL SERVICES SUPPLEMENT**, is intended to formalize procedures for authorizing supplemental professional actions, such as expanding the scope of basic services, incurring reimbursable expenses, or proceeding with certain additional services. The document should only be used in conjunction with an earlier agreement for professional services and is meant to provide a written record of such authorizations, with particulars of activities, time spans, and compensation involved.

**G612, OWNER'S INSTRUCTIONS REGARDING THE CONSTRUCTION CONTRACT, INSURANCE AND BONDS, AND BIDDING PROCEDURES**, is formatted as a questionnaire in three parts. Part A relates to the contracts, Part B covers insurance and bonds, and Part C deals with bidding procedures. The sections follow a project's normal chronological sequence to provide information when it will be needed. Because many of the items relating to the contract will have some bearing on the development of construction documents, it is important to place Part A in the owner's hands at the earliest possible phase of the project. The owner's responses to Part A will lead to selection of the

continues on following page

Dale Elickson, FAIA; The American Institute of Architects, Washington, D.C.

1

CONSTRUCTION INFORMATION SYSTEMS

Document Synopses, G Series, continued from previous page

appropriate delivery method and contract forms, including the general conditions. Part B naturally follows after the selection of the general conditions, because insurance and bonding information depends on the type of general conditions chosen. Answers to Part C will follow as the contract documents are further developed.

G701, CHANGE ORDER, may be used as written documentation of changes in the work, contract sum, or contract time that are mutually agreed to by the owner and contractor. G701 provides space for the signatures of the owner, architect, and contractor and for a complete description of the change.

G701/CMa, CHANGE ORDER—CONSTRUCTION MANAGER-ADVISER EDITION: The purpose of this document is essentially the same as that of G701. The major difference is that the signature of the construction manager-adviser is required along with those of the owner, architect, and contractor to validate the change order.

G702, APPLICATION AND CERTIFICATE FOR PAYMENT, and G703, CONTINUATION SHEET: These documents provide convenient and complete forms on which the contractor can apply for payment and the architect can certify that payment is due.

The forms require the contractor to show the status of the contract sum to date, including the total dollar amount of the work completed and stored to date, the amount of retainage (if any), the total of previous payments, a summary of change orders, and the amount of current payment requested. G703, Continuation Sheet, breaks the contract sum into portions of the work in accordance with a schedule of values required by the general conditions.

The form serves as both the contractor's application and the architect's certification. Its use can expedite payment and reduce the possibility of error. If the application is properly completed and acceptable to the architect, the architect's signature certifies to the owner that a payment in the amount indicated is due to the contractor. The form also allows the architect to certify an amount different than the amount applied for, with explanation provided by the architect.

G702/CMa, APPLICATION AND CERTIFICATE FOR PAYMENT—CONSTRUCTION MANAGER-ADVISER EDITION, and G703, CONTINUATION SHEET: Though the use and purpose of G702/CMa is substantially similar to that of G702, the construction manager-adviser edition expands responsibility for certification of payment to include both architect and construction manager. Similarly, both architect and construction manager may certify a different amount than that applied for, with each initialing the figures that have been changed and providing written explanation(s) accordingly. The standard G703, Continuation Sheet, is appropriate for use with G702/CMa.

G704, CERTIFICATE OF SUBSTANTIAL COMPLETION, is a standard form for recording the date of substantial completion of a work or a designated portion thereof. The contractor prepares a list of items to be completed or corrected, and the architect verifies and amends this list. If the architect finds that the work is substantially complete, the form is prepared for acceptance by the contractor and the owner. Appended to the form is a list of items to be completed or corrected. The form provides for agreement as to the time allowed for completion or correction of the items, the date when the owner will occupy the work or designated portion thereof, and a description of responsibilities for maintenance, heat, utilities, and insurance.

G705, CERTIFICATE OF INSURANCE, has been replaced by AIA Document G715.

G706, CONTRACTOR'S AFFIDAVIT OF PAYMENT OF DEBTS AND CLAIMS: The contractor submits this affidavit with the final request for payment, stating that all payrolls, bills for materials and equipment, and other indebtedness connected with the work for which the owner might be responsible have been paid or otherwise satisfied. G706 requires the contractor to list any indebtedness or known claims in connection with the construction contract that have not been paid or otherwise satisfied. The contractor may also be required to furnish a lien bond or indemnity bond to protect the owner with respect to each exception.

G706A, CONTRACTOR'S AFFIDAVIT OF RELEASE OF LIENS, supports AIA Document G706 in the event the owner requires a sworn statement of the contractor stating that all releases or waivers of liens have been received. In such event, it is normal for the contractor to submit G706 and G706A, along with attached releases or waivers of liens for the contractor, all subcontractors, and others who may have lien rights against the owner's property. The contractor is required to list any exceptions to the sworn statement provided in G706A and may be required to furnish the owner with a lien bond or indemnity bond to protect the owner with respect to such exceptions.

G707, CONSENT OF SURETY TO FINAL PAYMENT: By obtaining the approval of the surety for final payment to the contractor and the agreement of the surety that final payment will not relieve the surety of any of its obligations, the owner may preserve its rights under the bonds.

G707A, CONSENT OF SURETY TO REDUCTION IN OR PARTIAL RELEASE OF RETAINAGE, is a standard form for use when a surety company is involved and the owner-contractor agreement contains a clause whereby retainage is reduced during the course of the construction project. When duly executed, G707A assures the owner that such reduction or partial release of retainage does not relieve the surety of its obligations.

G709, PROPOSAL REQUEST, is used to obtain price quotations required in the negotiation of change orders. G709 is not a change order or a direction to proceed with the work; it is simply a request to the contractor for information related to a proposed change in the construction contract.

G710, ARCHITECT'S SUPPLEMENTAL INSTRUCTIONS, is used by the architect to issue additional instructions or interpretations or to order minor changes in the work. The form is intended to assist the architect in performing obligations as interpreter of the contract document requirements in accordance with the owner-architect agreement and the general conditions. This form should not be used to change the contract sum or contract time. If the contractor believes that a change in the contract sum or contract time is involved, other G Series documents must be used.

G711, ARCHITECT'S FIELD REPORT, is a standard form for the architect's project representative to use in maintaining a concise record of site visits or, in the case of a full-time project representative, a daily log of construction activities.

G712, SHOP DRAWING AND SAMPLE RECORD, is a standard form by which the architect can schedule and monitor shop drawings and samples. Since this process tends to be complex, the schedule provided in G712 shows the progress of a submittal, which in turn contributes to the orderly processing of work. G712 can also serve as a permanent record of the chronology of the submittal process.

G714, CONSTRUCTION CHANGE DIRECTIVE, replaces former AIA Document G713, Construction Change Authorization. G714 was developed as a directive for changes in the work that, if not expeditiously implemented, might delay the project. In contrast to a Change Order (AIA Document G701), G714 is to be used when the owner and contractor, for whatever reason, have not reached agreement on proposed changes in the contract sum or contract time. Upon receipt of a completed G714, the contractor must promptly proceed with the change in the work described therein.

G714/CMa, CONSTRUCTION CHANGE DIRECTIVE, CONSTRUCTION MANAGER-ADVISER EDITION, is designed to effect the same type of substantive changes in the work described in the synopsis of G714, above. The difference between the two lies not in purpose but in execution: Whereas the owner and architect must both sign the G714 in order for the directive to become a valid contractual instrument, G714/CMa requires execution by owner, architect, and construction manager-adviser.

G722/CMa, PROJECT APPLICATION AND PROJECT CERTIFICATE FOR PAYMENT, and G723/CMa, PROJECT APPLICATION SUMMARY: These documents are similar in purpose to the combination of G702 and G703 but are for use on construction management projects on which a construction manager serves as an adviser to the owner.

Each contractor submits separate G702/CMa and G703/CMa documents to the construction manager-adviser, who collects and compiles them to complete G723/CMa. G723/CMa then serves as a summary of the contractors' applications, with project totals being transferred to a G722/CMa. The construction manager-adviser can then sign the form, have it notarized, and submit it along with the G723/CMa (which has all of the separate contractors' G702/CMa forms attached) to the architect for review and appropriate action.

## REFERENCES

Information on the AIA documents may be obtained from the publications listed below. Information on the documents is also available on the AIA website at [www.aiaonline.com](http://www.aiaonline.com).

"AIA Contract Documents Price List." This publication is available free from AIA distributors or by calling (800) 365-2724. It lists the current edition of each AIA document.

American Institute of Architects. *The Architect's Handbook of Professional Practice*, 12th ed. Washington, D.C.: The AIA Press, 1994. The Handbook has been the architecture profession's premier manual of practice since it was first published in 1917. It contains sample copies of most of the AIA documents.

The Documents Supplement Service. This is a subscription service through which users of the Handbook can receive sample copies of new AIA documents as they are published. Subscribers also receive the *Supplement*, a newsletter of articles and comment on the AIA documents. Subscriptions may be obtained by calling (800) 365-2724.

"Promises, Promises: Forging Healthy Project Relationships." This is a series of continuing education manuals, each of which may be used either for seminar presentation or for self-study.

*Advanced Contract Concepts*. This manual covers the essentials of contract law: the elements of a contract, the fundamental principles of agency and negligence law, and the use of standard contract documents. It also includes an overview of the recent, major changes to two AIA standard contract documents: A201, General Conditions of the Contract for Construction, and B141, Standard Form of Agreement Between Owner and Architect.

*Design Service*. This manual addresses the general responsibilities of the architect and the owner in B141, Standard Form of Agreement Between Owner and Architect. Specifically, these responsibilities include establishing a program and budget, setting basic project parameters, and agreeing on the architect's scope of services. The manual also includes an overview of the Standard Form of Architect's Services: Design and Contract Administration, the first scope of services published with B141.

*Design and Contract Administration: Contract Conditions*. Contract conditions form the framework within which the owner and architect carry out their responsibilities to one another. This manual addresses the contract conditions that generally apply over the course of the owner-architect relationship, including compensation and billing, project timing and duration, responsibilities of the owner, and ownership and use of documents.

*Contract Administration Services*. This manual covers roles and responsibilities of owner, architect and contractor as a project moves into construction.

*Contract Administration—Office*. This manual addresses contract administration from the architect's perspective when "back in the office" and not in the field visiting the owner's site. It covers project initiation, submittals, changes, timing issues, suspension and termination, and special provisions, such as property insurance.

*Construction Contract Administration Conditions—Field*. This manual addresses construction contract administration conditions relevant to the architect's services on the job site, administering the contract, and evaluating the work as it progresses, as well as subcontractor relations, contractor's payments, claims, corrections to the work, and project closeout.

Sweet, Justin. *Sweet on Construction Industry Contracts: Major AIA Documents*. Vol. 1 of Construction Law Library. New York: John Wiley & Sons, 1996.

Sabo, Werner. *Legal Guide to AIA Documents*, 3rd ed. New York: John Wiley & Sons, 1992.

Stein, Steven G. M., ed. *The American Institute of Architects Legal Citator*. New York: Matthew Bender, 1997.

"You and Your Architect." This booklet, available free to AIA members, reviews issues to be considered by an owner preparing to retain an architect.

## INTRODUCTION

It is useful to have different ways of organizing construction information so the varying interests of those who view, use, and manipulate it can be accommodated. UniFormat and MasterFormat offer two commonly accepted ways of organizing information about construction projects and building operations.

MasterFormat emphasizes a view of construction focused on products, offering the perspective of product manufacturers, suppliers, specifiers, and contractors. MasterFormat names components (building materials, products, and activities) that have specifiable characteristics.

UniFormat focuses on performance requirements and coincides with the way users, owners, and designers view construction. UniFormat names systems and assemblies that have a determinable function.

### MASTERFORMAT

MasterFormat, with its list of products and activities, looks at construction in the way the parts are specified, purchased, and installed. The term products here means materials, components, and equipment that a contractor incorporates into the work of a project.

MasterFormat arranges information for project manuals into six major groups (introductory information, bidding requirements, contracting requirements, facilities and spaces, systems and assemblies, and construction products and activities). For details, see the AGS pages on MasterFormat.

Architects use MasterFormat in the following ways:

1. To arrange information in project manuals
2. To catalog product information with the numbers and titles used to specify those products and activities in construction documents
3. To arrange cost information and build a cost model for construction activities and associated products according to how they are specified in construction documents
4. To prepare keynotes for drawings that associate items with specifications in construction documents
5. To arrange facility management and construction market information in the way products and activities are specified in construction documents

### UNIFORMAT

UniFormat is a method of arranging construction information for a range of building types based on the physical systems and assemblies that make up a facility. Construction is viewed according to the way in which elements are used, thus systems and assemblies are characterized by their function with no identification of the products they comprise. Nine level 1 UniFormat categories and their associated classes and subclasses define the basic parts of a building, each characterized by its function.

Titles in UniFormat levels 1 through 3 can be applied to most project descriptions and preliminary cost estimates. Levels 4 and 5 are available for use on detailed, complex projects. Levels 4 and 5 titles and detailed lists provide a checklist to ensure comprehensive and complete application of UniFormat.

UniFormat is intended to help architects achieve consistency in economic evaluation of projects; enhance design program information reporting; and promote consistency in filing information for facility management, drawing details, and construction market data. More specifically, it is used to organize design descriptions, cost summaries, and performance specifications of systems and assemblies (e.g., HVAC systems and exterior wall assemblies).

Architects use UniFormat for these tasks:

1. Performing economic analysis of construction alternatives, particularly in early design stages
2. Building an evolving construction cost model arranged by the functional parts of a facility
3. Arranging descriptions of the functional parts of a project so they communicate how a design is intended to accomplish an owner's construction program
4. Arranging project manuals for applications when design-build delivery is employed
5. Filing drawing details
6. Filing facility management and construction market information

## APPLICATION OVERVIEW

On this and the following AGS page on UniFormat are basic strategies for numbering and titling information about systems and assemblies for uses other than construction doc-

uments. The methods described are not rigid; rather, they are meant to help UniFormat users develop an understanding of the system that will allow them to apply it consistently. Information is included about using UniFormat to organize cost information and preliminary project descriptions, arrange project manuals, and organize facility management and construction market information.

Level 1 UniFormat titles cover the major categories of construction information according to function. These letters and titles are fixed and should not be changed in application:

### PROJECT DESCRIPTION

- A—SUBSTRUCTURE
- B—SHELL
- C—INTERIORS
- D—SERVICES
- E—EQUIPMENT AND FURNISHINGS
- F—SPECIAL CONSTRUCTION AND DEMOLITION
- G—BUILDING SITEWORK
- Z—GENERAL

The category Project Description is a collection of basic information that introduces a project and includes bidding, proposal, and contract requirements. It can be used as a stand-alone contracting structure for construction projects and is especially suitable for design-build applications. The Project Description level does not have a letter designation, allowing it to appear first in the list of titles.

Like the Project Description, Category Z—General does not represent a building system or assembly. It is designated by the last letter of the alphabet to keep this category last if the system is expanded beyond building construction for a project.

Level 1 categories are divided into classes of information to make level 2 categories. These carry the letter of their parent category plus a two-digit number. Alphanumeric designations and titles of level 2 classes are fixed and should not be changed in application.

Levels 3 and 4 are created by further subdividing level 2 classes. These subclasses carry the alphanumeric designation of their parent category and class plus a two-digit number. Level 3 designations should not be changed in application. Alphanumeric designations for level 4 are unassigned within a group of level 3 subclasses and number extension are assigned by the user. The user-assigned number should carry the alphanumeric designation of the parent level 3 subclass plus a two-digit number or the corresponding MasterFormat number.

Titles presented below level 4 are level 5 subclasses, developed by presenting specialized design solutions of the level 4 parent subclasses. Particular materials may be identified to differentiate one specialized solution from another. Titles at level 5 are examples of information included in their level 4 subclass.

No alphanumeric designation is assigned. Users may assign extensions. Level 5 and some level 4 titles correspond to MasterFormat numbers and titles.

The UniFormat numbering system can expand to allow for additional numbers and titles at any level. User-defined numbers and titles that fit within the established framework of UniFormat can be added.

## SELECTING UNIFORMAT NUMBERS AND TITLES

Not all UniFormat titles will be used for every project. UniFormat is an expandable structure that can accommodate additional titles to meet specific requirements. However, designated numbers and titles should not be changed in order to maintain a consistent arrangement.

UniFormat titles are generic, descriptive titles independent of any design solution. They are the starting point for describing systems and assemblies. Be sure to incorporate these parent titles when creating a user-defined level 3, 4, or 5 title, so systems and assemblies titles are complete, clear, and descriptive. Users can add further systems and assemblies numbers and titles for projects that include items other than building construction, such as heavy civil engineering construction or process facilities.

Some users may want to add MasterFormat materials and methods information to a document organized according to UniFormat. MasterFormat numbers may be added throughout the design process as materials and methods are determined.

The transition from a document organized according to Uni-

Format to one organized according to MasterFormat may be easier if MasterFormat extensions are used. If these five-digit number extensions have been added, a document organized according to UniFormat can be searched or sorted according to a MasterFormat five-digit extension to regroup information according to MasterFormat.

## USING UNIFORMAT

Below and at the beginning of the next AGS page are explanations of several uses for UniFormat.

### ARRANGING COST INFORMATION

The list of elements or systems in UniFormat can be used as the basis of a system for organizing cost information which may be reported in varying degrees of detail. As design decisions are made, information about costs can be refined. This arrangement makes possible a comparison of cost information for various building elements, which may be particularly useful during early design phases.

A UniFormat cost model can be used in tandem with a cost model organized according to MasterFormat. The two models render a different view of a project and provide details appropriate for different requirements. For example, a cost model organized according to UniFormat can provide information about the cost of a concrete structure as compared to the cost of a steel structure. A cost model organized according to MasterFormat can provide information about the cost of all the concrete and steel on a project regardless of the structural system chosen.

Value analysis requires a consistent naming scheme carried throughout a project. UniFormat is particularly useful for this type of analysis, which requires attaching a cost to a particular use or facility function rather than to particular products and activities. Using MasterFormat numbers as suffixes to element designations helps the value analyst evaluate change proposals.

### ARRANGING PRELIMINARY PROJECT DESCRIPTIONS

Preliminary project descriptions are described in the CSI *Manual of Practice* in chapter FF/180, "Preliminary Project Descriptions and Outline Specifications." A preliminary project description helps an owner understand the various components and systems proposed by an A/E for a project. It also serves a requirement normally included in a design services agreement for which the A/E must submit a report after completing the schematic design but before proceeding to design development. These descriptions may serve as the basis for an estimate of probable construction costs.

UniFormat provides a logical sequence of systems and assemblies for describing a construction project before all materials and methods have been determined. UniFormat is used to organize, and serves as a checklist for preparing, preliminary project descriptions at various levels of detail. As a design progresses, both descriptions and estimates of probable construction costs can be refined.

### ARRANGING PROJECT MANUALS

Arranging project manuals, or portions of them, according to UniFormat is appropriate when performance specification is the method employed for all or some of the project. Performance specification can be used at many levels, from a single product to major subsystems or entire projects. It allows the owner to access a range of options, from existing technology to innovative systems and developing technologies. As well, performance specification encourages full bidding competition based on nonrestrictive requirements. Design-build projects make use of performance specification in its broadest application.

Whether an entire building or only a portion of it is specified using performance specifications, UniFormat can be used to organize this type of specification for elements crossing MasterFormat section and division boundaries. For conventional projects with project manuals organized according to MasterFormat, specifiers can include systems and assemblies before Division 1—General Requirements. According to UniFormat, systems and assemblies can be numbered and sequenced in this part of the project manual with the appropriate assignment of UniFormat numbers and titles. CSI *Manual of Practice* chapters FF/120, "Methods of Specifying," and SP/090, "Performance Specifying," provide detailed discussions about this application.

### ARRANGING CONSTRUCTION MARKET INFORMATION

Market information reporting agencies can use UniFormat to describe the facility being reported. UniFormat can also be used to assemble, store, and report information about elements separate from and in addition to reports on prod-

*continues on next page*

The Construction Specifications Institute; Alexandria, Virginia

1

## CONSTRUCTION INFORMATION SYSTEMS

continued from the previous page

ucts and activities. This helps show trends for major elements containing products and activities crossing MasterFormat section and division boundaries.

#### ORGANIZING DRAWINGS

UniFormat numbers and titles can be used as a file-naming convention for library files of standard details and schedules. The Uniform Drawing System (UDS) provides a detailed description for this application.

Library files are named differently from project files because the classification and indexing requirements are different. Library file naming should be grouped by building systems, assemblies, or use because that is the most natural way to search for them. Project detail files must also be organized to make it easy to produce project contract documents, record documents, and facility management documents from several files. Naming a detail file for a project requires the sheet identification, coordinates on the sheet, and a detail identifier.

UDS recommends an 8-character designator for naming library schedule files. A numbering system based on UniFormat can be used for preliminary phases of a project. UniFormat numbers can be used during the construction documents phase for schedules made up of assemblies of materials that might otherwise have separate MasterFormat numbers.

#### ARRANGING FACILITIES MANAGEMENT INFORMATION

UniFormat is used for preliminary project descriptions to communicate systems and assemblies concepts to a building owner. Once preliminary project descriptions have been refined, UniFormat can be used to communicate a building's functional systems and assemblies for real estate due-diligence reports and to organize maintenance and operation programs and data.

UniFormat can be used to document how systems and assemblies function; therefore, it is an organizational concept well-suited to describing systems design intent during facility commissioning. Project descriptions can be refined throughout the design process, making it easier to carry out the commissioning authority's performance testing and acceptance program. Facility personnel can then use the project descriptions to store information about systems maintenance and operations.

#### ARRANGING INFORMATION FOR DESIGN-BUILD APPLICATIONS

Design-build project delivery has created a need for an organizational structure that allows owners and design-build entities to communicate functional performance requirements. UniFormat provides this organizational structure.

#### UNIFORMAT AND MASTERFORMAT USED TOGETHER

UniFormat and MasterFormat can be used in all applications that have traditionally been the domain of MasterFormat. The 1998 edition of UniFormat includes cross-references to MasterFormat to help users apply both organizational principles. These applications include organizing project manuals; assigning specification numbers and titles; and organizing and filing cost information, drawing details, and facility management and construction market information.

Both systems can be characterized as "single," "serial," or "parallel":

1. Single applications use only UniFormat or MasterFormat exclusively throughout the application.
2. In serial applications, such as a project manual, a number and title are applied to each item based on either UniFormat or MasterFormat. Both organizational principles can be used in the same application.
3. Parallel applications are those in which each item is named with numbers and titles from UniFormat and MasterFormat. This is a powerful method in many applications, such as organizing cost information, in which information about a cost-estimate line item can be tracked to a product and to a system or assembly.

#### LEVELS 1 THROUGH 3 NUMBERS AND TITLES

##### PROJECT DESCRIPTION

- 10—PROJECT DESCRIPTION  
1010 Project Summary

- 1020 Project Program  
1030 Existing Conditions  
1040 Owner's Work  
1050 Funding

##### 20—PROPOSAL, BIDDING, AND CONTRACTING

- 2010 Delivery Method  
2020 Qualifications Requirements  
2030 Proposal Requirements  
2040 Bid Requirements  
2050 Contracting Requirements

##### 30—COST SUMMARY

- 3010 Elemental Cost Estimate  
3020 Assumptions and Qualifications  
3030 Allowances  
3040 Alternates  
3050 Unit Prices

#### CONSTRUCTION SYSTEMS AND ASSEMBLIES

##### ELEMENT A—SUBSTRUCTURE

- A10 Foundations  
A1010 Standard Foundations  
A1020 Special Foundations  
A1030 Slab On Grade

##### A20 Basement Construction

- A2010 Basement Excavation  
A2020 Basement Walls

##### ELEMENT B—SHELL

- B10 Superstructure  
B1010 Floor Construction  
B1020 Roof Construction

##### B20 Exterior Enclosure

- B2010 Exterior Walls  
B2020 Exterior Windows  
B2030 Exterior Doors

##### B30 Roofing

- B3010 Roof Coverings  
B3020 Roof Openings

##### ELEMENT C—INTERIORS

- C10 Interior Construction  
C1010 Partitions  
C1020 Interior Doors  
C1030 Fittings

##### C20 Stairs

- C2010 Stair Construction  
C2020 Stair Finishes

##### C30 Interior Finishes

- C3010 Wall Finishes  
C3020 Floor Finishes  
C3030 Ceiling Finishes

##### ELEMENT D—SERVICES

- D10 Conveying  
D1010 Elevators and Lifts  
D1020 Escalators and Moving Walks  
D1090 Other Conveying Systems

##### D20 Plumbing

- D2010 Plumbing Fixtures  
D2020 Domestic Water Distribution  
D2030 Sanitary Waste  
D2040 Rain Water Drainage  
D2090 Other Plumbing Systems

##### D30 Heating, Ventilating, and Air Conditioning (HVAC)

- D3010 Energy Supply  
D3020 Heat Generation  
D3030 Refrigeration  
D3040 HVAC Distribution  
D3050 Terminal and Packaged Units  
D3060 HVAC Instrumentation and Controls  
D3070 Testing, Adjusting, and Balancing  
D3090 Other Special HVAC Systems and Equipment

- D40 Fire Protection  
D4010 Sprinklers  
D4020 Standpipes  
D4030 Fire Protection Specialties  
D4090 Other Fire Protection Systems

##### D50 Electrical

- D5010 Electrical Service and Distribution  
D5020 Lighting and Branch Wiring  
D5030 Communications and Security  
D5090 Other Electrical Systems

##### D60 Basic Materials and Methods

#### ELEMENT E—EQUIPMENT AND FURNISHINGS

- E10 Equipment  
E1010 Commercial Equipment  
E1020 Institutional Equipment  
E1030 Vehicular Equipment  
E1090 Other Equipment

##### E20 Furnishings

- E2010 Fixed Furnishings  
E2020 Movable Furnishings

#### ELEMENT F—SPECIAL CONSTRUCTION AND DEMOLITION

- F10 Special Construction  
F1010 Special Structures  
F1020 Integrated Construction  
F1030 Special Construction Systems  
F1040 Special Facilities  
F1050 Special Controls and Instrumentation

##### F20 Selective Demolition

- F2010 Building Elements Demolition  
F2020 Hazardous Components Abatement

#### ELEMENT G—BUILDING SITEWORK

- G10 Site Preparation  
G1010 Site Clearing  
G1020 Site Demolition and Relocations  
G1030 Site Earthwork  
G1040 Hazardous Waste Remediation

##### G20 Site Improvements

- G2010 Roadways  
G2020 Parking Lots  
G2030 Pedestrian Paving  
G2040 Site Development  
G2050 Landscaping

##### G30 Site Civil/Mechanical Utilities

- G3010 Water Supply  
G3020 Sanitary Sewer  
G3030 Storm Sewer  
G3040 Heating Distribution  
G3050 Cooling Distribution  
G3060 Fuel Distribution  
G3090 Other Site Mechanical Utilities

##### G40 Site Electrical Utilities

- G4010 Electrical Distribution  
G4020 Site Lighting  
G4030 Site Communications and Security  
G4090 Other Site Electrical Utilities

##### G90 Other Site Construction

- G9010 Service Tunnels  
G9090 Other Site Systems

#### ELEMENT Z—GENERAL

- Z10 General Requirements  
Z1010 Administration  
Z1020 Quality Requirements  
Z1030 Temporary Facilities  
Z1040 Project Closeout  
Z1050 Permits, Insurance, and Bonds  
Z1060 Fee

##### Z20 Contingencies

- Z2010 Design Contingency  
Z2020 Escalation Contingency  
Z2030 Construction Contingency

The Construction Specifications Institute; Alexandria, Virginia



## INTRODUCTION

MasterFormat is a master list of numbers and titles for organizing information about construction requirements, products, and activities into a standard sequence. Many different delivery methods, products, and installation types are used on construction projects. Successful completion of projects requires effective communication among the people involved. Information retrieval is nearly impossible without a standard filing system familiar to each user. MasterFormat offers a standard filing and retrieval scheme applicable throughout the construction industry. It is a uniform system used for organizing information in project manuals, organizing cost data, filing product information and other technical data, identifying drawing objects, and presenting construction market data.

MasterFormat is produced jointly by the Construction Specifications Institute (CSI) and Construction Specifications Canada (CSC). It is updated periodically; the information on the pages in AGS comes from the 1995 edition.

## HISTORY

Since it was introduced in 1963, the 16-division CSI format has been widely accepted for standard practice in the United States and Canada. First published as part of the CSI Format for Construction Specifications, it was later used as the basis for the Uniform System for Construction Specifications, Data Filing and Cost Accounting—Title One Buildings, published in 1966. The Uniform System was developed and endorsed by the American Institute of Architects, American Society of Landscape Architects, Associated General Contractors of America, Council of Mechanical Specialty Contracting Industries (now the Associated Specialty Contractors), Producers' Council, National Society of Professional Engineers, and Construction Specifications Institute. In 1966 a similar effort in Canada produced the Building Construction Index (BCI), which was based on the 16-division format that had been introduced by the Specification Writers Association of Canada (renamed Construction Specifications Canada in 1974).

In 1972 the U.S. and Canadian formats were merged and published as the Uniform Construction Index (UCI). The UCI was a comprehensive framework for organizing information contained in project manuals, as well as a base of information for filing data and classifying project costs.

In 1978 Construction Specifications Canada joined with the Construction Specifications Institute to produce the first edition of MasterFormat, introduced by CSI as MP-2-1 and by CSC as Document 004E. This document incorporated a complete organizational format for project manuals, including bidding requirements, contract forms, and conditions of the contract in addition to the 16-division list of numbers and titles primarily used for specifications.

The first revised edition of MasterFormat, published in 1983, retained the basic principles of organization from the previous edition but added information to respond to the needs of the engineering disciplines. The 1988 edition, based on input from MasterFormat users, incorporated revisions and additions recognizing new products and developments in the construction industry.

The 1995 edition, the titles of which are published in the tenth edition of *Architectural Graphic Standards*, is the result of an extensive public review and coordination with industry users. It incorporates many minor revisions in numbers and titles and several changes in style and presentation. Some significant rearrangements of numbers and titles, particularly in divisions 1, 2, 13, 15, and 16, have been made.

## BASIC ORGANIZATION

The numbers and titles in MasterFormat are grouped under these general headings:

INTRODUCTORY INFORMATION (00001 to 00099)  
 BIDDING REQUIREMENTS (00100 to 00499)  
 CONTRACTING REQUIREMENTS (00500 to 00999)  
 FACILITIES AND SPACES (no numbering)  
 SYSTEMS AND ASSEMBLIES (no numbering)  
 CONSTRUCTION PRODUCTS AND ACTIVITIES (Divisions 1-16)

The first grouping, Introductory Information, is used for indexing. The second and third groupings, Bidding Requirements and Contracting Requirements, are for defining relationships, responsibilities, and processes for construction. The last three groupings, Facilities and Spaces, Systems and Assemblies, and Construction Products and Activities, are used to describe the physical aspects of construction.

## TITLES

MasterFormat arranges related construction products and activities into 16 level one titles, called divisions. The numbers and titles of the divisions are as follows:

Division 1—General Requirements  
 Division 2—Site Construction  
 Division 3—Concrete  
 Division 4—Masonry  
 Division 5—Metals  
 Division 6—Wood And Plastics  
 Division 7—Thermal And Moisture Protection  
 Division 8—Doors And Windows  
 Division 9—Finishes  
 Division 10—Specialties  
 Division 11—Equipment  
 Division 12—Furnishings  
 Division 13—Special Construction  
 Division 14—Conveying Systems  
 Division 15—Mechanical  
 Division 16—Electrical

The level two titles (formerly called broadscope titles) identify clusters of products and activities that have an identifying characteristic in common. Usually, the titles are a logical categorization of the division title. Sometimes, particularly in divisions 2, 13, 15, and 16, they are arbitrary breakdowns of the division to reduce it to a more manageable size. Level two titles are the highest level generally used in titling and arranging units of construction information. In MasterFormat, level two titles are presented as all uppercase letters and boldface type.

MasterFormat shows both numbers and titles at level three. Level three titles are presented as first letter uppercase and boldface type. Level three numbers are presented as the last three digits of the five-digit designation in boldface type.

MasterFormat suggests titles at level four but does not indicate numbers. Users should create numbers by interpolating between assigned numbers when using level four titles or creating new titles. Level four titles are presented alphabetically in regular (nonbold) type.

A key word index of requirements, products, and activities is included in MasterFormat to help find appropriate numbers and titles for construction subjects. Alphabetized entries may refer to either level two or level three numbers.

## RELATIONSHIP TO UNIFORMAT

CSI and CSC also publish UniFormat, which provides numbers and titles for the functional elements that make up construction product systems and assemblies. UniFormat can be used to organize project descriptions and preliminary specifications. It is particularly suited to organizing cost estimates for value analysis because its organization by function corresponds to value analysis techniques. MasterFormat and UniFormat are complementary for applications in which reference to both products and functional elements may be useful (e.g., project manuals and cost estimating).

The 1995 edition of MasterFormat establishes a location for these systems and assemblies but does not include the associated numbers and titles, deferring to UniFormat for these. In MasterFormat systems and assemblies fall immediately before the list of construction products and activities (Divisions 1-16) (see the list of level two MasterFormat titles on the accompanying AGS page).

## APPLICATION OVERVIEW

The following brief discussion is an overview of how to use MasterFormat numbers and titles for various applications. Refer to the CSI Application Guide for more detailed analysis.

### PROJECT MANUALS

MasterFormat is the fundamental standard for titling and arranging project manuals containing bidding requirements, contracting requirements, and specifications.

INTRODUCTORY INFORMATION: Indexing documents included in this grouping are found at the beginning of project manuals. They are not actual contract documents but may be incorporated in a contract document by reference.

BIDDING REQUIREMENTS and CONTRACTING REQUIREMENTS: Often referred to as Series (rather than Division) Zero documents, these documents are not specifications but definitions of the relationships, processes, and responsibilities for projects. The Bidding Requirements documents do not become a part of the construction contract. The Contracting Requirements documents are contract forms and conditions of the contract.

In these two groups, level two and level three MasterFormat numbers have been assigned to provide a consistent identification, but it is not necessary to renumber or retitling printed forms and standard documents published by various professional societies.

FACILITIES AND SPACES and SYSTEMS AND ASSEMBLIES: MasterFormat indicates a location but does not include standard numbers and titles for these groupings. Facility and space titles are often project specific, and neither CSI nor CSC has a master list of numbers and titles for these groupings. Refer to UniFormat for system and assembly numbers and titles.

CONSTRUCTION PRODUCTS AND ACTIVITIES: The heart of MasterFormat remains the 16 divisions defined by the level one specification titles. Divisions 1 through 16 remain a complete method of numbering and titling sections of specifications, both for arranging master guide specifications or for arranging a project specification.

### PRODUCT DATA

Identifying product data with MasterFormat numbers and titles is practical because of the relationship between products and specifications. Particular uses in this application include arranging publications in a technical library; filing information on products, methods, suppliers, and subcontractors; and inventorying construction products.

### COST ESTIMATING

MasterFormat is useful for identifying unit prices and cost report items for products and activities, arranging a database of product and activity unit costs, arranging and tabulating a project budget according to a product and activity breakdown, and relating cost items to specifications and drawings. MasterFormat is not particularly useful for value analysis, which requires assigning cost to particular functional elements, rather than to particular products and activities.

### DRAWING ELEMENTS

MasterFormat is used to keynote applications and has been found useful for linking drawing objects to specification sections. It is also used to identify CAD layer organizations.

### CONSTRUCTION MARKET DATA

Market data reporting agencies routinely use MasterFormat to list products for a project being bid. This practice allows users to quickly identify sales potential for their products and services on a particular project.

### FACILITY MANAGEMENT

Facility managers can identify data associated with products used in the building they manage with MasterFormat numbers. They can be used in filing systems for maintenance and operating instructions, procurement, maintenance work orders, shop drawings, warranties, operating histories, operating costs, and other data related to the life cycle of a facility.

## LEVEL TWO NUMBERS AND TITLES

The list of subordinate titles (level two) under each MasterFormat division title (level one) outlines the scope of each division.

### INTRODUCTORY INFORMATION

00001 Project Title Page  
 00005 Certifications Page  
 00007 Seals Page  
 00010 Table of Contents  
 00015 List of Drawings  
 00020 List of Schedules

### BIDDING REQUIREMENTS

00100 Bid Solicitation  
 00200 Instructions to Bidders  
 00300 Information Available to Bidders  
 00400 Bid Forms and Supplements  
 00490 Bidding Addenda

*continues on next page*

The Construction Specifications Institute; Alexandria, Virginia  
 Construction Specifications Canada

1

CONSTRUCTION INFORMATION SYSTEMS

continued from the previous page

#### CONTRACTING REQUIREMENTS

00500 Agreement  
00600 Bonds and Certificates  
00700 General Conditions  
00800 Supplementary Conditions  
00900 Addenda and Modifications

#### FACILITIES AND SPACES

#### SYSTEMS AND ASSEMBLIES

#### CONSTRUCTION PRODUCTS AND ACTIVITIES

##### DIVISION 1—GENERAL REQUIREMENTS

01100 Summary  
01200 Price and Payment Procedures  
01300 Administrative Requirements  
01400 Quality Requirements  
01500 Temporary Facilities and Controls  
01600 Product Requirements  
01700 Execution Requirements  
01800 Facility Operation  
01900 Facility Decommissioning

##### DIVISION 2—SITE CONSTRUCTION

02050 Basic Site Materials and Methods  
02100 Site Remediation  
02200 Site Preparation  
02300 Earthwork  
02400 Tunneling, Boring, and Jacking  
02450 Foundation and Load-Bearing Elements  
02500 Utility Services  
02600 Drainage and Containment  
02700 Bases, Ballasts, Pavements, and Appurtenances  
02800 Site Improvements and Amenities  
02900 Planting  
02950 Site Restoration and Rehabilitation

##### DIVISION 3—CONCRETE

03050 Basic Concrete Materials and Methods  
03100 Concrete Forms and Accessories  
03200 Concrete Reinforcement  
03300 Cast-In-Place Concrete  
03400 Precast Concrete  
03500 Cementitious Decks and Underlayment  
03600 Grouts  
03700 Mass Concrete  
03900 Concrete Restoration and Cleaning

##### DIVISION 4—MASONRY

04050 Basic Masonry Materials and Methods  
04200 Masonry Units  
04400 Stone  
04500 Refractories  
04600 Corrosion-Resistant Masonry  
04700 Simulated Masonry  
04800 Masonry Assemblies  
04900 Masonry Restoration and Cleaning

##### DIVISION 5—METALS

05050 Basic Metal Materials and Methods  
05100 Structural Metal Framing  
05200 Metal Joists  
05300 Metal Deck  
05400 Cold-Formed Metal Framing  
05500 Metal Fabrications  
05600 Hydraulic Fabrications  
05650 Railroad Track and Accessories  
05700 Ornamental Metal  
05800 Expansion Control  
05900 Metal Restoration and Cleaning

##### DIVISION 6—WOOD AND PLASTICS

06050 Basic Wood and Plastic Materials and Methods  
06100 Rough Carpentry  
06200 Finish Carpentry  
06400 Architectural Woodwork  
06500 Structural Plastics  
06600 Plastic Fabrications  
06900 Wood and Plastic Restoration and Cleaning

##### DIVISION 7—THERMAL AND MOISTURE PROTECTION

07050 Basic Thermal and Moisture Protection Materials and Methods  
07100 Dampproofing and Waterproofing  
07200 Thermal Protection  
07300 Shingles, Roof Tiles, and Roof Coverings

07400 Roofing and Siding Panels  
07500 Membrane Roofing  
07600 Flashing and Sheet Metal  
07700 Roof Specialties and Accessories  
07800 Fire and Smoke Protection  
07900 Joint Sealers

##### DIVISION 8—DOORS AND WINDOWS

08050 Basic Door and Window Materials and Methods  
08100 Metal Doors and Frames  
08200 Wood and Plastic Doors  
08300 Specialty Doors  
08400 Entrances and Storefronts  
08500 Windows  
08600 Skylights  
08700 Hardware  
08800 Glazing  
08900 Glazing Curtain Wall

##### DIVISION 9—FINISHES

09050 Basic Finish Materials and Methods  
09100 Metal Support Assemblies  
09200 Plaster and Gypsum Board  
09300 Tile  
09400 Terrazzo  
09500 Ceilings  
09600 Flooring  
09700 Wall Finishes  
09800 Acoustical Treatment  
09900 Paints and Coatings

##### DIVISION 10—SPECIALTIES

10100 Visual Display Boards  
10150 Compartments and Cubicles  
10200 Louvers and Vents  
10240 Grilles and Screens  
10250 Service Walls  
10260 Wall and Corner Guards  
10270 Access Flooring  
10290 Pest Control  
10300 Fireplaces and Stoves  
10340 Manufactured Exterior Specialties  
10350 Flagpoles  
10400 Identification Devices  
10450 Pedestrian Control Devices  
10500 Lockers  
10520 Fire Protection Specialties  
10530 Protective Covers  
10550 Postal Specialties  
10600 Partitions  
10670 Storage Shelving  
10700 Exterior Protection  
10750 Telephone Specialties  
10800 Toilet, Bath, and Laundry Accessories  
10880 Scales  
10900 Wardrobe and Closet Specialties

##### DIVISION 11—EQUIPMENT

11010 Maintenance Equipment  
11020 Security and Vault Equipment  
11030 Teller and Service Equipment  
11040 Ecclesiastical Equipment  
11050 Library Equipment  
11060 Theater and Stage Equipment  
11070 Instrumental Equipment  
11080 Registration Equipment  
11090 Checkroom Equipment  
11100 Mercantile Equipment  
11110 Commercial Laundry and Dry Cleaning Equipment  
11120 Vending Equipment  
11130 Audiovisual Equipment  
11140 Vehicle Service Equipment  
11150 Parking Control Equipment  
11160 Loading Dock Equipment  
11170 Solid Waste Handling Equipment  
11190 Detention Equipment  
11200 Water Supply and Treatment Equipment  
11280 Hydraulic Gates and Valves  
11300 Fluid Waste Treatment and Disposal Equipment  
11400 Food Service Equipment  
11450 Residential Equipment  
11460 Unit Kitchens  
11470 Darkroom Equipment  
11480 Athletic, Recreational, and Therapeutic Equipment  
11500 Industrial and Process Equipment  
11600 Laboratory Equipment  
11650 Planetarium Equipment

11660 Observatory Equipment  
11680 Office Equipment  
11700 Medical Equipment  
11780 Mortuary Equipment  
11850 Navigation Equipment  
11870 Agricultural Equipment  
11900 Exhibit Equipment

##### DIVISION 12—FURNISHINGS

12050 Fabrics  
12100 Art  
12300 Manufactured Casework  
12400 Furnishings and Accessories  
12500 Furniture  
12600 Multiple Seating  
12700 Systems Furniture  
12800 Interior Plants and Planters  
12900 Furnishings Restoration and Repair

##### DIVISION 13—SPECIAL CONSTRUCTION

13010 Air-Supported Structures  
13020 Building Modules  
13030 Special Purpose Rooms  
13080 Sound, Vibration, and Seismic Control  
13090 Radiation Protection  
13100 Lightning Protection  
13110 Cathodic Protection  
13120 Pre-Engineered Structures  
13150 Swimming Pools  
13160 Aquariums  
13165 Aquatic Park Facilities  
13170 Tubs and Pools  
13175 Ice Rinks  
13185 Kennels and Animal Shelters  
13190 Site-Constructed Incinerators  
13200 Storage Tanks  
13220 Filter Underdrains and Media  
13230 Digester Covers and Appurtenances  
13240 Oxygenation Systems  
13260 Sludge Conditioning Systems  
13280 Hazardous Material Remediation  
13400 Measurement and Control Instrumentation  
13500 Recording Instrumentation  
13550 Transportation Control Instrumentation  
13600 Solar and Wind Energy Equipment  
13700 Security Access and Surveillance  
13800 Building Automation and Control  
13850 Detection and Alarm  
13900 Fire Suppression

##### DIVISION 14—CONVEYING SYSTEMS

14100 Dumbwaiters  
14200 Elevators  
14300 Escalators and Moving Walks  
14400 Lifts  
14500 Material Handling  
14600 Hoists and Cranes  
14700 Turntables  
14800 Scaffolding  
14900 Transportation

##### DIVISION 15—MECHANICAL

15050 Basic Mechanical Materials and Methods  
15100 Building Services Piping  
15200 Process Piping  
15300 Fire Protection Piping  
15400 Heating Fixtures and Equipment  
15500 Humid-Generation Equipment  
15600 Refrigeration Equipment  
15700 Heating, Ventilating, and Air Conditioning Equipment  
15800 Air Distribution  
15900 HVAC Instrumentation and Controls  
15950 Testing, Adjusting, and Balancing

##### DIVISION 16—ELECTRICAL

16050 Basic Electrical Materials and Methods  
16100 Wiring Methods  
16200 Electrical Power  
16300 Transmission and Distribution  
16400 Low-Voltage Distribution  
16500 Lighting  
16700 Communications  
16800 Sound and Video

The Construction Specifications Institute; Alexandria, Virginia  
Construction Specifications Canada



**GENERAL**

The steps of the Problem Seeking® process cover both qualitative (establish the goals, uncover and test concepts, and state the problem statements) and quantitative (collect and analyze fact and determine needs) information.

The information index is a framework of key words used to seek information. These words are specific enough to cover the scope of major factors and universal enough to

be negotiable for different building types. The index establishes the interrelationship of information regarding goals, facts, concepts, and needs.

The Problem Seeking methodology covers four major categories of information: function refers to people, activities, and relationships; form includes site, quality, and social/psychological environment; economy addresses operating costs and life-cycle costs; and time entails historical aspects, present conditions, and future projections.

**PROGRAMMATIC CONCEPTS**

The programmatic concepts illustrated here and on the next page refer to abstract ideas intended mainly as functional solutions to clients' performance problems without regard to physical response. These diagrams briefly explain some of the concepts that recur on nearly every project, regardless of building type.

**INFORMATION INDEX**

FUNCTION	GOALS	FACTS	CONCEPTS	NEEDS	PROBLEM
People Activities Relationships	Mission Maximum number Individual identity Interaction/privacy Hierarchy of values Prime activities Security Progression Segregation Encounters Transportation/parking Efficiency Priority of relationships	Statistical data Area parameters Personnel forecast User characteristics Community characteristics Organizational structure Value of potential loss Time-motion study Traffic analysis Behavioral patterns Space adequacy Type/intensity Physically challenged guidelines	Service grouping People grouping Activity grouping Priority Hierarchy Security controls Sequential flow Separated flow Mixed flow Functional relationships Communications	Area requirements by organization by space type by time by location Parking requirements Outdoor space requirements Functional alternatives	Unique and important performance requirements that will shape building design
<b>FORM</b>					
Site Environment Quality	Bias on site elements Environmental response Efficient land use Community relations Community improvements Physical comfort Life safety Social/psychological environment Individuality Way-finding Projected image Client expectations	Site analysis Soil analysis FAR and GAC Climate analysis Code survey Surroundings Psychological implications Point of reference/entry Cost/sq ft Building or layout efficiency Equipment cost Area per unit	Enhancements Special foundations Density Environmental controls Safety Neighbors Home base/officing concepts On premise: fixed, free, group address Off premise: satellite, telecommuting, virtual office Orientation Accessibility Character Quality control	Site development costs Environmental influences on cost Building cost/sq ft Building overall efficiency factor	Major form considerations that will affect building design
<b>ECONOMY</b>					
Initial budget Operating costs Life-cycle costs	Extent of funds Cost-effectiveness Maximum return Return on investment Minimizing of operating costs Maintenance and operating costs Reduction of life-cycle costs Sustainability	Cost parameters Maximum budget Time-use factors Market analysis Energy source-costs Activities and climate factors Economic data Green building rating system	Cost control Efficient allocation Multifunction/versatility Merchandising Energy conservation Cost reduction Recycling	Budget estimate analysis Balance budget Cash flow analysis Energy budget (if required) Operating costs (if required) Green building rating Life-cycle costs (if required)	Attitude toward the initial budget and its influence on the fabric and geometry of the building
<b>TIME</b>					
Past Present Future	Historic preservation Static/dynamic activities Change Growth Occupancy date Availability of funds	Significance Space parameters Activities Projections Durations Escalation factors	Adaptability Tolerance Convertibility Expansibility Linear/concurrent scheduling Phasing	Escalation Time schedule Time/cost schedule	Implications of change and growth on long-range performance

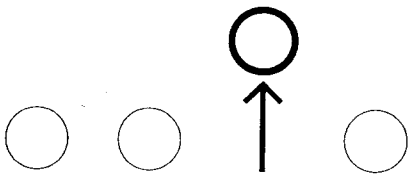

**PRIORITY**

The concept of priority evokes questions regarding order of importance, such as relative position, size, and social value.

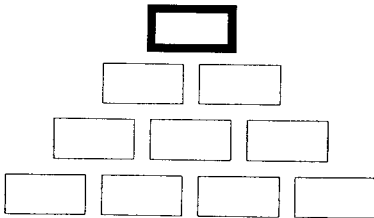

**HIERARCHY**

The concept of hierarchy is related to a goal about the exercise of authority and is expressed in symbols of authority.

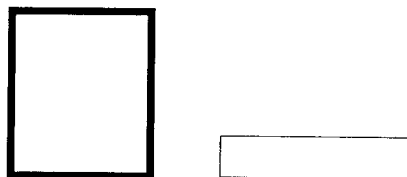

**CHARACTER**

The concept of character is based on a goal concerning the image the client wants to project in terms of values and the generic nature of a project.

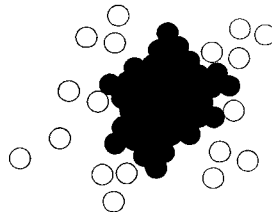

**DENSITY**

A goal for efficient use of land or space or for high degrees of interaction may lead to low, medium, or high density.

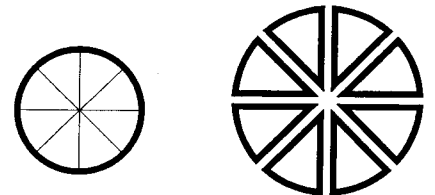

**SERVICE GROUPING**

Should services be centralized or decentralized? Each distinct service will be one or the other to implement a specific goal.

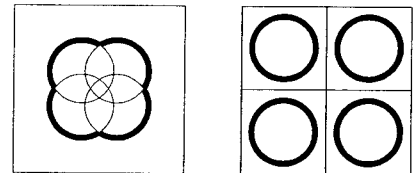

**ACTIVITY GROUPING**

Should activities be integrated or compartmentalized?

*Programmatic concepts continue on the next page*

Steven A. Parshall, FAIA; HOK Consultants; Houston, Texas

Programmatic concepts continued from the previous page

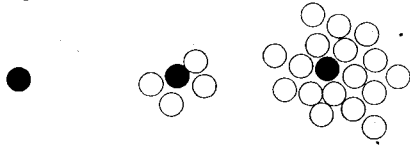

**PEOPLE GROUPING**

Look for concepts derived from the physical, social, and emotional characteristics of people—as individuals, in small groups, and in large groups.

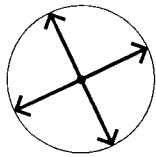

**HOME BASE**

Home base is related to the idea of territoriality—an easily defined place where a person can maintain his or her individuality.

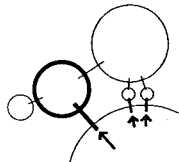

**RELATIONSHIPS**

The correct interrelation of spaces promotes efficiencies and effectiveness of people and their activities. This concept of functional affinities is the most common programmatic concept.

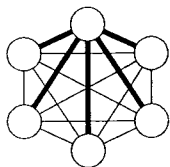

**COMMUNICATIONS**

A goal to promote the effective exchange of information or ideas in an organization may call for networks or patterns of communication: Who communicates with whom?

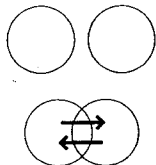

**NEIGHBORS**

Is there a goal for sociality? Will the project be completely independent or is there a mutual desire to be interdependent, to cooperate with neighbors?

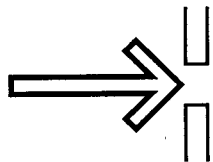

**ACCESSIBILITY**

Can first-time visitors find where to enter the project? The concept of accessibility also applies to provisions for persons with disabilities beyond signs and symbols. Do we need single or multiple entrances?

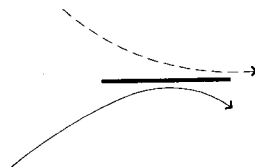

**SEPARATED FLOW**

A goal for segregation may relate to people (such as prisoners and the public), to automobiles (such as campus traffic and urban traffic), or to people and automobiles (such as pedestrian traffic and automobile traffic).

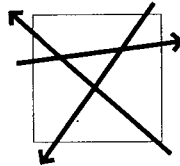

**MIXED FLOW**

Common social spaces, such as town square or building lobbies, are designed for multidirectional, multipurpose traffic. The concept of mixed flow may be apropos if the goal is to promote chance and planned encounters.

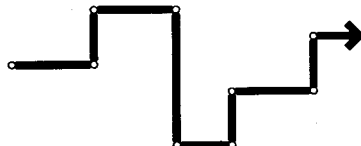

**SEQUENTIAL FLOW**

The progression of people (as in a museum) and things (as in a factory) must be carefully planned. A flowchart diagram will communicate this concept of sequential flow much more easily than words.

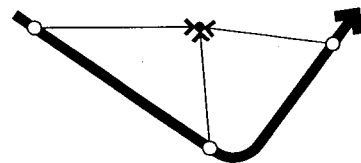

**ORIENTATION**

Provide a bearing, or point of reference, within a building, a campus, or a city. Relating periodically to a place, thing, or structure can prevent a feeling of being lost.

**EXPANSIBILITY CONVERTIBILITY VERSATILITY**

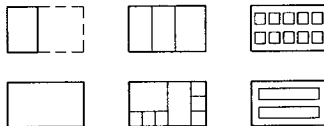

**EXTERIOR CHANGES**

**INTERIOR CHANGES**

**MULTIFUNCTION**

**FLEXIBILITY**

Flexibility covers the following three concepts: expansibility (accommodating growth through expansion), convertibility (allowing for changes in function), and versatility (providing the most for the money through multifunctional spaces).

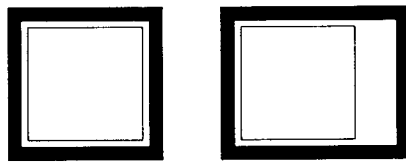

**TOLERANCE**

This concept may well add space to the program. Is a particular space tailored precisely for a static activity or is it provided with a loose fit for a dynamic activity—one likely to change?

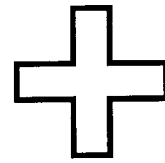

**SAFETY**

Which major ideas will implement the goal for life safety? Look to codes and safety precautions for form-giving ideas.

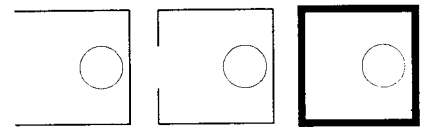

**SECURITY CONTROLS**

The degree of security control varies depending on the value of the potential loss—minimum, medium, or maximum. These controls are used to protect property and to control personnel movement.

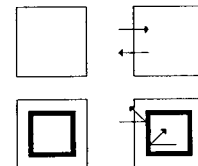

**ENERGY CONSERVATION**

There are two general approaches to achieving an energy-efficient building: (1) keep the heated area to a minimum by making use of conditioned but nonheated outside space, such as exterior corridors, and (2) keep heat flow to a minimum with insulation, correct orientation to sun and wind, compactness, sun controls, wind controls, and reflective surfaces.

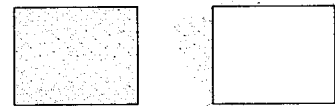

**ENVIRONMENTAL CONTROLS**

What controls for air temperature, light, and sound will be required to provide for people's comfort inside and outside the building? Look to the climate and sun angle analysis for answers.



**PHASING**

Will phasing of construction be required to complete a project on a time and cost schedule if the project proved infeasible in the initial analysis? Will the urgency for the occupancy date determine the need for concurrent scheduling or allow for linear scheduling?



**COST CONTROL**

This concept is intended as a search for economy ideas that will lead to a realistic preview of costs and a balanced budget to meet the extent of available funds.

Steven A. Parshall, FAIA; HOK Consultants; Houston, Texas

## INTRODUCTION

The MASTERSPEC® master specification system is a product of the American Institute of Architects and is published by Architectural Computer Services, Inc. (ARCOM). It includes libraries for architectural/structural/civil, structural/civil, mechanical/electrical, interiors construction, interiors FF&E, and landscape architecture and has small project, outline, short form, and full length versions. The MASTERSPEC system is endorsed or recommended by major design and construction documentation organizations in the United States.

MASTERSPEC® specification sections are used to produce project specifications for bidding and construction. These specifications describe materials and products, assemblies, and systems for a construction, as well as requirements for submittals, manufacture, installation, performance, and warranties. Bidding requirements, contract requirements, and project specifications are usually bound together in the project manual.

MASTERSPEC® sections are numbered and titled according to CSI MasterFormat and include all 16 of its divisions. Each section includes a broad range of products and options for each subject area. Users edit each section to tailor it to a specific project. When a firm does repetitive types of projects, MASTERSPEC sections may be edited to produce office masters that contain only those products and materials typically specified by the firm or by a particular client. These office masters are then edited to produce individual project specifications.

## MASTERSPEC SECTION DESCRIPTIONS

### DIVISION 1

**01000—GENERAL REQUIREMENTS**—This Section includes the Evaluations only. It contains background information on various subjects, including specification formats and contracting procedures, that apply to all Division 1 Sections.

**01013—SUMMARY OF WORK (FF&E)**—This Section summarizes the Work of the Furniture, Furnishings, and Equipment (FF&E) contracts and provides information to those who do not have access to the Agreement or bidding information. The Section includes the following:

**01023—ALLOWANCES (FF&E)**—This Section specifies provisions for lump-sum and unit-price allowances for Furniture, Furnishings, and Equipment (FF&E). It defines allowances, describing what is and is not included, and lists allowance quantities and amounts.

**01028—APPLICATIONS FOR PAYMENT (FF&E)**—This Section specifies administrative and procedural requirements governing the Furniture, Furnishings, and Equipment (FF&E) Contractor's Applications for Payment. It also contains requirements for preparing and submitting the Schedule of Values.

**01033—ALTERNATES (FF&E)**—This Section specifies provisions for proposed changes received before the Furniture, Furnishings, and Equipment (FF&E) Contract is awarded. The Section describes add alternates, deduct alternates, and alternates for the purpose of cost comparison.

**01038—MODIFICATION PROCEDURES (FF&E)**—This Section specifies procedures for changing the Furniture, Furnishings, and Equipment (FF&E) Contract Sum or Schedule.

**01043—COORDINATION (FF&E)**—This Section specifies coordination with the Work of construction contractors and other Furniture, Furnishings, and Equipment (FF&E) contractors.

**01100—SUMMARY**—This Section provides a framework in which to summarize the Work of the Project as covered in detail in the Contract Documents. It also provides general information to individuals who need to know general contract provisions.

**01125—SUMMARY OF MULTIPLE CONTRACTS**—This Section specifies the contractual responsibilities of each contract and the Project Coordinator relating to the Work, coordination, and temporary facilities and controls.

**01140—WORK RESTRICTIONS**—This Section specifies restrictions on the Contractor's use of the premises and requirements for continued Owner occupancy and Owner occupancy of the Project before Substantial Completion.

**01210—ALLOWANCES**—This Section specifies provisions for cash allowances, including lump-sum, unit-cost, contingency, and testing and inspecting allowances. It also specifies provisions for quantity allowances.

**01230—ALTERNATES**—This Section specifies provisions for change of scope and cost-comparison-type alternates. It also includes a sample "Schedule of Alternates" to help the specifier develop the Section.

**01250—CONTRACT MODIFICATION PROCEDURES**—This Section specifies administrative and procedural requirements for changes to the Contract Sum and the Contract Time, and the Contractor's preparation of Proposal Requests for changes to the Contract.

**01270—UNIT PRICES**—This Section specifies provisions for unit prices. It includes a sample list of unit prices and a sample unit-price schedule to help the specifier develop the Section.

**01290—PAYMENT PROCEDURES**—This Section specifies administrative and procedural requirements for the Contractor's Applications for Payment. This Section also contains requirements for preparing and submitting the Schedule of Values.

**01303—SUBMITTALS (FF&E)**—This Section specifies administrative and procedural requirements for processing Shop Drawings, Product Data, and Samples. The Section includes the following:

**01310—PROJECT MANAGEMENT AND COORDINATION**—This Section specifies administrative procedures required for Project management and coordination of construction operations and activities, including scheduling and conducting Project meetings.

**01320—CONSTRUCTION PROGRESS DOCUMENTATION**—This Section specifies administrative and procedural requirements for the Contractor's Construction Schedule, various schedules and reports required for performance of the Work, and construction photographs. It includes both Gantt-chart and critical path method (CPM) schedules.

**01322—PHOTOGRAPHIC DOCUMENTATION**—This Section specifies requirements for submitting construction photographs and videotapes. The services contained in this Section can vary extensively. For many projects, the few paragraphs in Division 1 Section "Construction Progress Documentation" may eliminate the need for this separate Section.

**01330—SUBMITTAL PROCEDURES**—This Section specifies Action and Informational Submittals, including Shop Drawings, Product Data, Samples, and other miscellaneous submittals.

**01400—QUALITY REQUIREMENTS**—This Section specifies general quality-assurance and quality-control requirements. Specific requirements for individual elements of the Work are specified in the appropriate Sections in Divisions 2 through 16. The Section Text is primarily for field tests and inspections of fabricated in-place construction rather than standard product testing.

**01403—QUALITY CONTROL (FF&E)**—This Section specifies provisions for product or material testing when it is the responsibility of the FF&E Contractor. The Section includes responsibilities for tests, inspections, and sample taking; written test reports; qualification of testing agencies; and repair and protection of the Work exposed to testing and sample taking.

**01420—REFERENCES**—This Section specifies general definitions for the Specifications and other Contract Documents including the Drawings. Definitions in this Section are not intended to intrude on legal and construction agreement matters; they supplement those definitions contained in AIA Document A201, 1997 edition. Most of the Section Text can be considered basic procedural requirements.

**01422—REFERENCE STANDARDS AND DEFINITIONS (FF&E)**—This Section specifies general definitions for Specifications and other FF&E Contract Documents including Drawings. Definitions in this Section are not intended to intrude on legal matters; they supplement those definitions contained in AIA Document A271, 1990 edition, and in ASID Document ID320, 1996 edition. Most of the Section Text can be considered basic procedural requirements.

**01500—TEMPORARY FACILITIES AND CONTROLS**—This Section specifies requirements of a temporary nature, including items not actually incorporated into the Work. It includes temporary utility services, construction and support facilities, and security and protection facilities.

**01600—PRODUCT REQUIREMENTS**—This Section specifies general requirements for products, materials, and equipment, including their delivery, storage, and handling, and selection of products by the Contractor. This Section also specifies administrative and procedural requirements for handling requests for substitutions made after award of the Contract, and general and procedural requirements for warranties.

**01613—DELIVERY, STORAGE, AND HANDLING (FF&E)**—This Section specifies requirements for handling goods on the Project Site.

**01623—INSTALLATION (FF&E)**—This Section specifies general requirements for Divisions 2 through 16 Sections. It includes requirements for examining the installation area, handling goods during installation, and disposing of unused materials.

**01633—SUBSTITUTIONS (FF&E)**—This Section specifies requirements for substitutions when specified goods are not available. It includes submittals required for proposed substitutions.

**01700—EXECUTION REQUIREMENTS**—This Section specifies administrative and procedural requirements for: examination of conditions, preparation for construction, construction layout, field engineering and surveying, general installation of products, coordination of Owner-installed products, progress cleaning, starting and adjusting, protection of installed construction, and correction of the Work.

**01703—CONTRACT CLOSEOUT (FF&E)**—This Section specifies administrative and procedural contract closeout provisions. It is primarily a summary Section; most of the provisions in this Section are the termination of requirements specified in other Sections. Basic contract closeout requirements are in the General and Supplementary Conditions.

**01731—CUTTING AND PATCHING**—This Section specifies administrative and procedural requirements for cutting and patching. It must be carefully coordinated with other Sections to avoid overlapping or conflicting requirements, such as those contained in Divisions 15 and 16.

**01732—SELECTIVE DEMOLITION**—This Section specifies the demolition of selected portions of existing buildings, structures, and site improvements, and the removal, salvage, and disposal of demolished materials.

**01770—CLOSEOUT PROCEDURES**—This Section specifies administrative and procedural contract closeout provisions. Most of the provisions in this Section cover the completion of requirements specified in other Sections. This Section specifies provisions for Project Record Documents, operation and maintenance manuals, and demonstration and training. If these subjects require more detailed treatment, delete them from this Section and use the applicable MASTERSPEC Supplemental Sections.

**01781—PROJECT RECORD DOCUMENTS**—This Section specifies procedures to be followed when developing Project Record Documents. It should be used when specific Project requirements are more extensive than requirements specified in Division 1 Basic Section "Closeout Procedures." The Section Text deals primarily with Record Drawings because they are the one type of Project Record Document most likely to be expanded beyond requirements in the Basic Section.

**01782—OPERATION AND MAINTENANCE DATA**—This Section specifies requirements for preparing and submitting emergency, operation, and maintenance manuals.

**01820—DEMONSTRATION AND TRAINING**—This Section specifies administrative and procedural requirements for instructing Owner's personnel in the operation and maintenance of systems, subsystems, and equipment. It should be used when specific Project requirements are more extensive than requirements specified in Division 1 Basic Section "Closeout Procedures."

### DIVISION 2

**02060—BUILDING DEMOLITION**—This Section specifies the demolition, removal, and disposal of existing buildings, structures, and site improvements; and the removal, salvage, and disposal of demolished materials.

**02080—UTILITY MATERIALS**—This Section specifies materials and methods for application with utility piping installations outside the building. Piping specialties, joining materials, joint construction, identification materials and devices, and installation requirements common to more than one Division 2 Section are included. This Section supplements other Division 2 Sections; it must be edited and used with other Sections for a complete piping system specification.

**02085—INTERCEPTORS**—This Section specifies interceptors used with sanitary sewerage and storm drainage systems. These interceptors are located outside the building and include metal and concrete types.

**02230—SITE CLEARING**—This Section specifies site clearing, including tree and vegetation removal and root grubbing, tree protection, topsoil stripping and stockpiling, capping and removal of site utilities, and removal of minor site improvements.

**02231—TREE PROTECTION AND TRIMMING**—This Section specifies the protection and trimming of trees that interfere with, or are affected by, temporary or new Work.

**02240—DEWATERING**—This Section specifies construction dewatering requiring more extensive treatment than that specified in other Division 2 Sections.

*MASTERSPEC continues on the next page.*

ARCOM: Salt Lake City, Utah, and Alexandria, Virginia

**02260—EXCAVATION SUPPORT AND PROTECTION**—This Section specifies general procedures and primary requirements for excavation support and protection systems.

**02300—EARTHWORK**—This Section specifies excavating, filling and backfilling, compacting, and grading inside and outside building limits. This Section also includes base and subbase materials for pavements; granular drainage course under slabs-on-grade; drainage and separation geotextile fabrics; and trench excavation and backfilling for utility and underground services.

**02361—TERMITE CONTROL**—This Section specifies initial soil treatment by applying chemical termiticides to the soil under and around susceptible structures during construction for preventive control of subterranean termites, and the option of using bait products to supplement soil treatment. According to the EPA-Registered Label, one manufacturer's bait product may be specified without also specifying soil treatment, if permitted by authorities having jurisdiction.

**02455—DRIVEN PILES**—This Section specifies Evaluations only for the following Sections covering types of driven piles:

**02456—CONCRETE-FILLED STEEL PILES**—This Section specifies concrete-filled steel shell and steel pipe piles.

**02457—PRESTRESSED CONCRETE PILES**—This Section specifies prestressed, precast concrete driven piles.

**02458—STEEL H PILES**—This Section specifies steel H-section piles and protective coatings.

**02459—TIMBER PILES**—This Section specifies preservative-treated round timber piles.

**02466—DRILLED PIERS**—This Section specifies drilled piers with straight or belled shafts and includes excavation, casings, slurries, reinforcement, concrete fill, and testing and inspecting.

**02510—WATER DISTRIBUTION**—This Section specifies water piping and specialties for potable-water service and fire-protection water service outside the building. This Section is not intended for municipal distribution systems.

**02511—HOT-MIX ASPHALT PAVING**—This Section specifies hot-mix asphalt paving for new and existing pavements and emulsified-asphalt surface treatments.

**02525—WATER SUPPLY WELLS**—This Section specifies cable-tool, rotary drilled, reverse-rotary drilled, and driven water wells with jet, line-shaft turbine, and submersible turbine well pumps and accessories.

**02530—SANITARY SEWERAGE**—This Section specifies sanitary sewerage outside the building.

**02535—PROCESS MATERIAL SEWERAGE**—This Section specifies process material sewerage outside the building and includes chemical-waste drainage piping, structures, and neutralization tanks; double-contained piping and structures; and chemical-waste force mains.

**02540—SEPTIC TANK SYSTEMS**—This Section specifies a sewage disposal system for use where a public sanitary sewerage system is not available.

**02551—HYDRONIC DISTRIBUTION**—This Section specifies piping for hydronic distribution systems outside the building. Piping includes pipes, fittings, valves, insulation, and specialties for the following:

**02553—NATURAL GAS DISTRIBUTION**—This Section specifies natural gas distribution piping and specialties outside the building to the point of delivery. The point of delivery is the service-meter assembly outlet. This may be only the service-regulator or service-shutoff valve if there is no meter.

**02554—FUEL-OIL DISTRIBUTION**—This Section specifies fuel distribution piping and specialties and fuel-oil storage tanks and accessories outside the building. Equipment in this Section is suitable for use with Grades No. 1 or No. 2 fuel oil.

**02555—STEAM DISTRIBUTION**—This Section specifies piping for low-pressure steam and condensate distribution systems outside the building. Piping includes pipes, fittings, valves, insulation, and specialties for the following:

**02584—UNDERGROUND DUCTS AND UTILITY STRUCTURES**—This Section specifies products used in underground electrical distribution for power and communications, including ducts, duct banks, handholes, and utility structures such as vaults and manholes.

**02630—STORM DRAINAGE**—This Section specifies gravity-flow and force-main storm drainage outside the building.

**02666—POND AND RESERVOIR LINERS**—This Section specifies impervious, flexible-membrane pond and reservoir liners for use with neutral aqueous solutions. Consult membrane manufacturers for proper membrane selection if required for lining or covering complex liquid toxic-waste holding ponds.

**02711—FOUNDATION DRAINAGE SYSTEMS**—This Section specifies foundation and underslab, subsoil drainage systems. It also includes in-plane wall drainage materials that work separately or in conjunction with other foundation drainage products.

**02751—CEMENT CONCRETE PAVEMENT**—This Section specifies cast-in-place concrete pavement construction including related formwork, reinforcement, concrete mix proportions, placement, and finishes.

**02764—PAVEMENT JOINT SEALANTS**—This Section specifies joint sealants, including backer materials, for concrete-to-concrete and concrete-to-asphalt pavement joints.

**02768—STAMPED CEMENT CONCRETE PAVEMENT**—This Section specifies cement concrete pavement, either integrally or surface colored, receiving a surface-imprinted stamped finish.

**02780—UNIT PAVERS**—This Section specifies paving for exterior applications using brick, concrete, rough-stone, and asphalt-block pavers installed by several methods. Installation methods include ungrouted, mortarless applications; portland cement mortar setting-bed methods; and bituminous setting-bed applications.

**02791—PLAYGROUND SURFACE SYSTEMS**—This Section specifies both loose fill and non-loose fill, impact-attenuating protective surfacing systems for outdoor use at ground-level locations, made from natural organic or inorganic materials or synthetic rubber-based formulations, and designed for use under and around public playground equipment. Surface systems that have and have not been determined to be accessible according to ASTM PS 83, *Specification for Determination of Accessibility of Surface Systems under and around Playground Equipment*, are specified.

**02813—LAWN SPRINKLER PIPING**—This Section specifies piping and valves, sprinklers and irrigation specialties, and controls and wiring for lawn sprinkler piping. Components in this Section will be downstream from the water distribution piping, valves, backflow preventers, and water meters specified in Division 2 Section "Water Distribution."

**02821—CHAIN-LINK FENCES AND GATES**—This Section specifies chain-link fence fabric, framing, fittings, swing and slide gates, privacy slats, gate operators, and access control for residential, commercial, and industrial applications according to ASTM standards and the Chain Link Fence Manufacturers Institute's (CLFMI) *Product Manual*. Residential fence and gate heights are limited to 6 feet (1.8 m) with fence line posts at a maximum spacing of 10 feet (3 m) o.c. Industrial fence and gate heights are limited to 12 feet (3.66 m) and less with fence line posts at a maximum spacing of 10 feet (3 m) o.c. Galvanized-coated, Zn-5-AL-MN alloy-coated (Zinc-5 percent aluminum-mischmetal alloy), aluminum-coated, and PVC-coated steel and aluminum-alloy fencing are included.

**02832—SEGMENTAL RETAINING WALLS**—This Section specifies freestanding retaining walls built from dry-laid concrete masonry units designed specifically for constructing segmental retaining walls. This Section includes both earth-reinforced retaining walls and gravity retaining walls. Alternate provisions are included to leave selection of the particular retaining wall unit design up to the Contractor, within some general appearance parameters, and to require that the Contractor provide structural design for the walls based on the units selected.

**02881—PLAYGROUND EQUIPMENT AND STRUCTURES**—This Section specifies public playground equipment suitable for children 2 through 12 years old and located in play areas at child-care facilities, institutions, multiple-family dwelling sites, parks, schools, recreational facilities, restaurants, and similar public areas.

**02900—LANDSCAPING**—This Section specifies trees, shrubs, ground covers, plants, and lawns. The Section includes preparation of planting pits and beds, topsoil, soil amendments, fertilizers, and mulches.

**02930—LAWNS AND GRASSES**—This Section specifies planting materials, including topsoil, soil amendments, and fertilizers for new seeded, sodded, sprigged, and plugged lawns and grassed areas. This Section also includes provisions for hydroseeding and reconditioning existing lawns.

**02955—TREES AND SHRUBS**—This Section specifies trees and shrubs and includes preparation of planting pits and beds, topsoil, soil amendments, fertilizers, and mulches.

**02956—GROUND COVER AND PLANTS**—This Section specifies ground covers and plants and includes preparation of planting beds, topsoil, soil amendments, fertilizers, and mulches.

### DIVISION 3

**03300—CAST-IN-PLACE CONCRETE**—This Section specifies cast-in-place, normal-weight and lightweight concrete for general building construction including related formwork, reinforcement, concrete materials and admixtures, vapor retarders, concrete mix requirements, placement, as-cast and applied finishes, curing, repairs, and field quality control.

**03301—CAST-IN-PLACE CONCRETE (LIMITED APPLICATIONS)**—This Section specifies cast-in-place concrete for projects using small quantities of concrete or noncritical applications of concrete. It is for simple projects where the Architect edits the Section Text with minimal or no direction from the structural engineer. The Section Text permits the setting of minimum quality standards for the Project by referencing ACI 301, *Specification for Structural Concrete*. For projects requiring detailed specifications and significant control of cast-in-place concrete, use Division 3 Section "Cast-in-Place Concrete."

**03331—CAST-IN-PLACE ARCHITECTURAL CONCRETE**—This Section specifies cast-in-place, formed, architectural concrete that requires special concrete materials, formwork, placement, and finishes.

**03361—SHOTCRETE**—This Section specifies requirements for pneumatically applied shotcrete work that may be used for repairing existing concrete structures or for new construction. Materials, mixes, and application procedures for both the wet- and dry-mix processes are included.

**03410—PLANT-PRECAST STRUCTURAL CONCRETE**—This Section specifies plant-precast, conventionally reinforced and prestressed, structural concrete units.

**03450—PLANT-PRECAST ARCHITECTURAL CONCRETE**—This Section specifies plant-precast, conventionally reinforced, architectural concrete units with conventional finishes, thin brick facings, or stone facings. Prestensioned or posttensioned, precast, prestressed concrete units and noncomposite insulated, precast concrete units are also included.

**03470—TILT-UP PRECAST CONCRETE**—This Section specifies tilt-up concrete wall panels that are site precast and finished, and tilted into place on-site. This Section specifies related formwork, reinforcement, concrete materials and admixtures, concrete mix requirements, placement, as-cast and applied finishes, bondbreakers, curing, repairs, and field quality control.

**03490—GLASS-FIBER-REINFORCED PRECAST CONCRETE**—This Section specifies plant-manufactured, glass-fiber-reinforced precast concrete units stiffened and supported by plant-attached framing panels produced from cold-formed steel studs or rolled carbon-steel structural shapes used primarily to clad building exteriors.

**03511—CEMENTITIOUS WOOD-FIBER DECK**—This Section specifies cementitious wood-fiber deck consisting of units composed of long strands of wood fibers combined with either portland cement or magnesium-oxysulfate hydraulic cement, and bonded under pressure. Monolithic, composite, and insulated composite tile or plank units are used to construct roof decks or form decks.

**03520—LIGHTWEIGHT CONCRETE ROOF INSULATION**—This Section specifies lightweight concrete roof insulation, with an oven-dry unit weight not exceeding 50 lb/cu. ft. (800 kg/cu. m), primarily used as fill over metal roof deck or structural concrete substrates.

**03532—CONCRETE FLOOR TOPPING**—This Section specifies factory-packaged, high-strength, iron-aggregate and emery-aggregate cementitious concrete floor toppings.

**03542—CEMENT-BASED UNDERLAYMENT**—This Section specifies cement-based, polymer-modified, self-leveling underlayment for application below interior finish flooring.

**03930—CONCRETE REHABILITATION**—This Section specifies concrete patching and repair including the removal of deteriorated concrete and reinforcement. Patching materials specified include job-mixed patching mortar, packaged-cementitious and polymer-modified patching mortars, cast-in-place concrete, and preplaced aggregate concrete. This Section also specifies floor joint repair, epoxy crack injection, corrosion-inhibiting treatments, polymer overlays and sealers, and structural reinforcement with both steel and composites.

MASTERSPEC continues on the next page.

## DIVISION 4

04410—STONE MASONRY VENEER—This Section specifies stone laid in mortar and applied either to concrete or masonry back-up or to frame construction. It includes stone installed in rubble, ashlar, and polygonal or mosaic patterns made from cut stone, split stone, or rough stone as extracted from the quarry or as collected from stream banks and similar deposits. It includes veneers mechanically attached to the back-up by anchors or ties built into the mortar joints and veneers adhered with mortar similar to the setting method used for ceramic wall tile. The Section is written primarily for exterior veneers for buildings and for concrete retaining walls, but could easily be modified to include interior facings of stone masonry.

04720—CAST STONE—This Section specifies cast stone building units used as architectural features, facing, trim, or site accessories. Cast stone is defined as architectural pre-cast concrete building units intended to simulate natural cut stone.

04810—UNIT MASONRY ASSEMBLIES—This Section specifies clay and concrete masonry for engineered and empirically designed applications.

04815—GLASS UNIT MASONRY ASSEMBLIES—This Section specifies glass unit masonry assemblies for wall, window, skylight, and floor applications. It includes exterior and interior applications and three installation methods. One method requires edges of glass-block assemblies to be retained by perimeter channel frames or chases. A second method allows edges of assemblies to be separated from perimeter construction but anchored to it by perforated metal strips (called *panel anchors*) embedded in horizontal mortar joints of glass-block assemblies and fastened to perimeter construction at ends. A third method uses a metal grid into which the glass block is inserted and adhesively secured with a silicone sealant.

04851—DIMENSION STONE CLADDING—This Section specifies dimension stone, set with mortar or sealant joints, for exterior cladding of buildings. Dimension stone cladding may be specified as field set, with or without mortar, and with individual anchors or a grid-type anchoring system. It may also be specified in the form of prefabricated assemblies. Dimension stone cladding systems may be specified to be engineered by the Installer to comply with performance criteria or may be fully designed and detailed.

04901—CLAY MASONRY RESTORATION AND CLEANING—This Section specifies requirements for quality masonry restoration. Some requirements are suitable for historic restoration projects, and some are more suited for ordinary rehabilitation and cleaning of nonhistoric structures. Because masonry restoration work can involve an assortment of materials and conditions, it is difficult to develop a master section that includes restoration and cleaning procedures other than those that are typical. The intent is to provide guidelines and information that can be adapted to fit individual cases.

04902—STONE RESTORATION AND CLEANING—This Section specifies requirements for quality stone restoration. Some requirements are suitable for historic restoration projects, and some for ordinary rehabilitation and cleaning of nonhistoric structures. Because stone restoration work can involve an assortment of materials and conditions, it is difficult to develop a master section that includes restoration and cleaning procedures other than those that are typical. The intent is to provide guidelines and information that can be adapted to fit individual cases.

## DIVISION 5

05120—STRUCTURAL STEEL—This Section specifies fabricating and erecting structural steel for building construction, including miscellaneous subframing units that may be part of the general framing system. Also included are extensive options for surface preparation and shop prime painting.

05210—STEEL JOISTS—This Section specifies open-web K-series steel joists, LH-series long-span steel joists, DLH-series deep long-span steel joists, and steel joist girders as defined by the Steel Joist Institute.

05310—STEEL DECK—This Section specifies steel roof and floor deck classified as roof deck, acoustical roof deck, cellular roof deck, composite floor deck, cellular metal floor deck with electrical distribution, noncomposite form deck, and noncomposite vented form deck.

05400—COLD-FORMED METAL FRAMING—This Section specifies cold-formed steel, load-bearing, and curtain-wall studs; floor and roof joists; rafters and ceiling joists; and roof trusses. This Section also includes gypsum sheathing and air-infiltration barriers.

05500—METAL FABRICATIONS—This Section specifies representative products made from steel and iron, including shapes, plates, bars, sheet, tubes, and pipe. It also includes selected fabrications made from aluminum, bronze, and

stainless steel, including nosings and tread plate. The Section includes miscellaneous steel framing for supporting overhead doors, ceiling hung toilet compartments, operable partitions, wood framing, countertops, and various equipment.

05511—METAL STAIRS—This Section specifies straight-run, steel-framed stairs with metal-pan, abrasive-coating-finished formed-metal, metal plate, and steel bar grating treads. It includes preassembled metal stairs for commercial applications, industrial stairs, and steel-framed ornamental stairs. It also includes steel tube railings for preassembled metal stairs.

05521—PIPE AND TUBE RAILINGS—This Section specifies pipe and tube handrails and railings fabricated from steel, aluminum, and stainless steel. While this Section specifies primarily functional, rather than ornamental, railings, it could also be used to specify ornamental railings made from pipe and tube shapes.

05530—GRATINGS—This Section specifies metal bar gratings, expanded metal gratings, formed-metal plank gratings, and extruded-aluminum plank gratings.

05580—FORMED-METAL FABRICATIONS—This Section specifies miscellaneous items that are shop fabricated from ferrous- and nonferrous-metal sheet to custom designs and that are not specified in other Sections. Products that could be included are sheet metal fabrications that 1) are brake formed to a custom or semicustom design; 2) are exposed to view where appearance is the primary concern; and 3) are not normally furnished as part of other work, such as window trim made by the window manufacturer. This Section includes only a limited number of examples of items satisfying the above criteria; other examples include mullion covers, miscellaneous boxes, counters, cabinets, and shelves.

05700—ORNAMENTAL METAL—This Section specifies products custom fabricated from various metals and used in building construction for functional, architectural, and decorative purposes where appearance is the primary concern. Ornamental metal includes both items made entirely from custom-fabricated components and those made entirely or partially from standard manufactured products that require some custom fabrication, finishing, and assembly. The emphasis in this Section is on custom metal that is fabricated, finished, and installed to exacting standards requiring high-quality materials and skillful workmanship. Where products meet these criteria and are not part of other assemblies and systems, such as window walls, doors and entrances, hardware, or prefabricated specialty items, they belong in this Section.

05715—FABRICATED SPIRAL STAIRS—This Section specifies metal spiral stairs with steel pipe or tube central supporting columns and radiating treads produced as standard manufactured products.

05720—ORNAMENTAL HANDRAILS AND RAILINGS—This Section specifies ornamental handrails and railings fabricated from aluminum, copper alloys, stainless steel, and steel and iron. It also includes glass- and plastic-supported railings, and illuminated railings. This Section covers railings assembled from standard shapes rather than those constructed from custom shapes. Ornamental railings made from custom shapes are specified in Division 5 Section "Ornamental Metalwork."

05811—ARCHITECTURAL JOINT SYSTEMS—This Section specifies exterior and interior building joint systems, with and without fire barriers, that accommodate movement resulting from one or more causes such as thermal changes, seismic forces, or wind sway.

## DIVISION 6

06100—ROUGH CARPENTRY—This Section specifies conventional wood framing for floors, ceilings, roofs, walls, and partitions as well as sheathing, subflooring, and underlayment. Also included is incidental rough carpentry required for support or attachment of other construction and not specified in another Section. Exposed items of rough carpentry included in this Section are limited, generally, to structural framing members. Timbers incidental to wood frame construction are included as well as engineered wood products.

06105—MISCELLANEOUS CARPENTRY—This Section specifies miscellaneous wood framing, incidental rough carpentry required for support or attachment of other construction, structural-use panels, underlayment, minor interior wood trim, shelving, and clothes rods. It is intended for projects that do not require wood framing or extensive use of other carpentry items. The Section includes pressure-preservative-treated and fire-retardant-treated wood. Miscellaneous concealed rough carpentry such as furring, blocking, grounds, and nailers can be specified using this Section. If the Project requires significant amounts of wood framing, sheathing, or subflooring, use 06100—ROUGH CARPENTRY instead.

06130—HEAVY TIMBER CONSTRUCTION—This Section specifies construction using rectangular solid-wood framing members 5 inches nominal (114 mm actual) and larger in both dimensions (timbers).

06150—WOOD DECKING—This Section specifies tongue-and-groove wood decking, both solid and laminated.

06185—STRUCTURAL GLUED-LAMINATED TIMBER—This Section specifies structural glued-laminated units including beams, purlins, arches, trusses, and columns.

06192—METAL-PLATE-CONNECTED WOOD TRUSSES—This Section specifies wood trusses factory fabricated from dimension lumber and metal connector plates.

06200—FINISH CARPENTRY—This Section specifies non-structural carpentry work that is exposed to view and is not specified in other Sections. Included are standing and running trim, stairs and railings, exterior siding, and interior paneling. Siding includes lumber, plywood, and hardboard siding. Paneling includes plywood, hardboard, and board paneling. Standard manufactured paneling is specified in this Section, while custom wood paneling is specified in

- 06402—INTERIOR ARCHITECTURAL WOODWORK and
- 06420—PANELWORK. In general, use this Section for work that is not shop fabricated and for siding and paneling types that are included only in this Section.

06401—EXTERIOR ARCHITECTURAL WOODWORK—This Section specifies fabricated wood products for use on the exterior of the building. Architectural woodwork is distinguished from other forms of wood construction by being manufactured in a woodworking plant and by complying with standards of quality for material and workmanship. It includes items of woodwork permanently attached to the building and exposed to view. Architectural woodwork generally involves items custom fabricated for an individual project, as opposed to mass-produced moldings or furniture. If required, woodwork can be specified to be shop finished rather than field finished.

06402—INTERIOR ARCHITECTURAL WOODWORK—This Section specifies fabricated wood products for use on the interior of the building. Architectural woodwork is distinguished from other forms of wood construction by being manufactured in a woodworking plant and by complying with standards of quality for material and workmanship. It includes items of woodwork permanently attached to the building and exposed to view. Architectural woodwork generally involves items custom fabricated for an individual project, as opposed to mass-produced moldings or furniture. Woodwork can be specified to be shop or field finished.

06420—PANELING—This Section specifies custom-manufactured paneling. Board paneling, flush wood paneling, laminate-clad paneling, and stile and rail paneling are included. Paneling fabricated from premanufactured sets of sequence-matched panels and custom-veneered paneling are included.

06605—INTERIOR PLASTIC ORNAMENTATION—This Section specifies molded- or extruded-plastic ornamentation for interior use, made of polystyrene, polyurethane, or fiberglass-reinforced polyester (FRP), including columns, moldings, chair rails, panel moldings, medallions, rosettes, domes, dome rims, stair brackets, niches, pilasters, pediments, window and door casings, plinths, wainscots, and custom shapes.

## DIVISION 7

07131—SELF-ADHERING SHEET WATERPROOFING—This Section specifies self-adhering, positive-side sheet waterproofing for concealed substrates, both vertical and horizontal, of plaza decks, below-grade walls, and planters. It also specifies plaza deck pavers.

07132—ELASTOMERIC SHEET WATERPROOFING—This Section specifies EPDM or butyl sheet waterproofing for concealed substrates, both vertical and horizontal, of plaza decks, below-grade walls, and planters. It also specifies plaza deck pavers.

07133—THERMOPLASTIC SHEET WATERPROOFING—This Section specifies PVC positive-side waterproofing for concealed substrates, both horizontal and vertical, of plaza decks, below-grade walls, and planters. It also specifies plaza deck pavers.

07141—COLD FLUID-APPLIED WATERPROOFING—This Section specifies cold fluid-applied polyurethane and latex-rubber waterproofing for concealed substrates, both vertical and horizontal, of plaza decks and below-grade walls. It also specifies plaza deck pavers.

MASTERSPEC continues on the next page.

ARCOM; Salt Lake City, Utah, and Alexandria, Virginia

1

CONSTRUCTION INFORMATION SYSTEMS

07142—HOT FLUID-APPLIED WATERPROOFING—This Section specifies hot fluid-applied, rubberized-asphalt waterproofing for concealed substrates, both vertical and horizontal, of plaza decks and below-grade walls. It also specifies plaza deck pavers.

07160—BITUMINOUS DAMPPROOFING—This Section specifies bituminous dampproofing for use above and below grade, including hot-applied asphalt and both emulsion- and cut-back- (solvent) type, cold-applied asphalt compounds of fibrated, semifibrated, or nonfibrated types.

07161—MODIFIED CEMENT WATERPROOFING—This Section specifies acrylic- and polymer-modified, cement-based waterproofing. It is usually applied on exterior, below-grade concrete and masonry walls, but may be applied on the interior of exterior walls and floors.

07162—CRYSTALLINE WATERPROOFING—This Section specifies cementitious waterproofing treatment with crystalline-type waterproofing. It is frequently applied on interior, below-grade concrete and masonry walls; may be applied on slabs below grade; and may be concealed behind or below applied finishes specified in other Sections. This product can also be used for waterproofing the exterior of walls below grade.

07163—METAL-OXIDE WATERPROOFING—This Section specifies metal-oxide waterproofing, which is an oxidizing iron and cement mixture. It is usually applied on interior surfaces of walls and slabs below grade, and may be concealed behind or below applied finishes specified in other Sections. This product can also be used for waterproofing the exterior of walls below grade.

07170—BENTONITE WATERPROOFING—This Section specifies panel and sheet membrane bentonite waterproofing systems used underground for types of construction where room to excavate beyond the walls is limited, where the walls are to be constructed against piling, or where the excavation must be backfilled over or against concrete before the concrete has had time to cure (such as a tunnel under a street).

07180—TRAFFIC COATINGS—This Section specifies cold liquid-applied, elastomeric, waterproof-barrier coatings with integral wearing surfaces for building areas housing equipment or subject to pedestrian and vehicular traffic.

07190—WATER REPELLENTS—This Section specifies clear, liquid-applied, penetrating, and film-forming water repellents for vertical and nontrafficked horizontal surfaces of brick, concrete unit masonry, concrete, portland cement plaster (stucco), and stone.

07210—BUILDING INSULATION—This Section specifies common types of general building insulation that are installed at the Project site as separate elements rather than as components of a prefabricated or field-assembled system specified in another Section. Exterior insulation and finish systems are examples of such assemblies. Also included is insulation that could be specified here or in other Sections. Examples of this include insulation used for masonry, gypsum board assemblies, and veneer plaster that are typically installed at the same time and by the same personnel performing noninsulation work.

07241—EXTERIOR INSULATION AND FINISH SYSTEMS—CLASS PB—This Section specifies Class PB exterior insulation and finish systems (EIFS) consisting of a decorative protective composite coating, or lamina, and an inner layer of rigid, cellular thermal insulation. Both field-applied systems and prefabricated panels are specified. Systems with molded, expanded polystyrene board (Type I) and glass-fiber-faced polyisocyanurate insulation are included. Exterior cement-board sheathing is included for both standard applications and prefabricated panels. Other types of sheathing and metal framing for prefabricated panels are included by reference to other Sections specifying those materials. An option is included for specifying joint sealants in Division 7 Section "Joint Sealants" or in this Section with reference to the "Joint Sealants" Section.

07242—EXTERIOR INSULATION AND FINISH SYSTEMS—CLASS PM—This Section specifies Class PM exterior insulation and finish systems (EIFS) consisting of a decorative protective composite coating, or lamina, and an inner layer of rigid, cellular thermal insulation. Only field-applied systems applied with extruded-polystyrene foam insulation (Type IV) are specified.

07311—ASPHALT SHINGLES—This Section specifies asphalt shingles for roofing applications. Shingles with fiber mats (fabric core) of either organic felt or fiberglass are included. A variety of generic shingles are specified in the Text, and other types can easily be added. This Section applies to roofs with a slope from 2 inches per foot (1:6) to very steep slopes, such as mansard roofs, when manufacturers' recommendations are considered.

07313—METAL SHINGLES—This Section specifies metal shingles, in both individual shingles and panel form. In most cases, shingle panels resemble hand-split cedar shakes.

07315—SLATE SHINGLES—This Section specifies natural-slate shingles for steep, sloped, standard-slate roofs including underlayment, flashing, and accessories for slate roofing.

07317—WOOD SHINGLES AND SHAKES—This Section specifies wood shingles and shakes for both roofing and wall applications. Western red cedar shingles and shakes, southern yellow pine shakes, western red cedar shingle panels, and fancy-butt western red cedar shingles are included.

07320—ROOF TILES—This Section specifies both hand-fired clay tile and concrete tile for roofing applications. A variety of shaped and flat tile units, including Spanish "S," Mission Barrel, Roman, French, and flat units, are included. Provisions for commonly used special shapes at eaves, rakes, ridges, and hips are also included, as well as underlayments, fasteners, and other accessories normally used with roof tiles.

07411—MANUFACTURED ROOF PANELS—This Section specifies factory-preformed metal roof panels for field installation without field forming. The Section includes panels of aluminum- and metallic-coated steel with and without applied finishes; and copper, stainless steel, and terne-coated stainless steel, which do not have applied finishes. Insulated roof panels and metal panel assemblies that are substantially preformed but require final mechanical seam closure in the field by means of a portable seaming machine are also included.

07412—MANUFACTURED WALL PANELS—This Section specifies factory-preformed metal wall panels for field installation without field forming. The Section includes panels of uncoated stainless steel and of aluminum- and metallic-coated steel with and without applied finishes. Insulated wall panels, both factory and field assembled, are also included.

07460—SIDING—This Section specifies vinyl, aluminum, and steel siding including commonly used accessories.

07511—BUILT-UP ASPHALT ROOFING—This Section specifies built-up asphalt roofing, including roofing insulation, base flashings, aggregate and paver ballast for protected membranes, roof walkways, and auxiliary roofing materials.

07512—BUILT-UP COAL-TAR ROOFING—This Section specifies built-up coal-tar roofing, including roofing insulation, base flashings, aggregate and paver ballast for protected membranes, roof walkways, and auxiliary roofing materials.

07531—EPDM SINGLE-PLY MEMBRANE ROOFING—This Section specifies EPDM single-ply membrane roofing, including roof insulation, base flashings, aggregate and paver ballast, walkways, and auxiliary roofing materials.

07532—CSPE SINGLE-PLY MEMBRANE ROOFING—This Section specifies CSPE single-ply membrane roofing, including roof insulation, base flashings, aggregate and paver ballast, walkways, and auxiliary roofing materials.

07533—THERMOPLASTIC SINGLE-PLY MEMBRANE ROOFING—This Section specifies thermoplastic single-ply membrane roofing, including roof insulation, base flashings, aggregate and paver ballast, walkways, and auxiliary roofing materials.

07546—COATED POLYURETHANE FOAM ROOFING—This Section specifies sprayed polyurethane foam insulation with an elastomeric protective coating for roofing applications.

07551—APP-MODIFIED BITUMINOUS MEMBRANE ROOFING—This Section specifies APP-modified bituminous membrane roofing, including roofing insulation, base flashings, aggregate and paver ballast for protected membranes, and auxiliary roofing materials.

07552—SBS-MODIFIED BITUMINOUS MEMBRANE ROOFING—This Section specifies SBS-modified bituminous membrane roofing, including roofing insulation, base flashings, aggregate and paver ballast for protected membranes, roof walkways, and auxiliary roofing materials.

07553—SELF-ADHERING MODIFIED BITUMINOUS MEMBRANE ROOFING—This Section specifies self-adhering, cold-applied, rubberized-asphalt composite sheet roofing for protected roof membrane applications. Roof insulation, mortar-faced roof insulation, aggregate ballast, and paver ballast are also included.

07561—HOT FLUID-APPLIED ROOFING—This Section specifies hot fluid-applied, rubberized-asphalt roofing for protected roof membrane applications. Roof insulation, mortar-faced roof insulation, aggregate ballast, and paver ballast are also included.

07610—SHEET METAL ROOFING—This Section specifies custom-fabricated (shop- or field-formed versus factory-roll-formed) metal roofing. This Section also includes prefinished, field-painted, and uncoated metal roofing.

07620—SHEET METAL FLASHING AND TRIM—This Section specifies sheet metal flashing and trim work related to or used in conjunction with roofing work and the general waterproof integrity of the building structure. This Section includes shop- and field-fabricated sheet metal accessories, trim, and flashing commonly used at the perimeter or penetrations of roofing or waterproofing work and where not integral with membrane systems. Metal waterproofing, flashing, and cap flashing are usually included in this Section.

07710—MANUFACTURED ROOF SPECIALTIES—This Section specifies manufactured roof specialties including copings, fasciae, gravel stops, gutters and downspouts, reglets, and counterflashing. This Section covers roof specialties listed in the 1995 edition of CSI's *MasterFormat*, except roof expansion assemblies.

07716—ROOF EXPANSION ASSEMBLIES—This Section specifies standard, factory-fabricated, roof expansion joint cover assemblies, including products designed to resist the effects of earthquake motions. This Section can be used alone, or provisions can be included in other Division 7 Sections.

07720—ROOF ACCESSORIES—This Section specifies accessory units installed on or in roofing, including curbs and equipment supports, relief vents in the form of gravity ventilators, ridge vents, roof hatches (also called *scuttles*), heat and smoke vents of both collapsible dome (gravity) type and pop-up (hatch) type, and snow guards.

07810—PLASTIC UNIT SKYLIGHTS—This Section specifies prefabricated skylights with formed, monolithic, single- and double-sheet plastic glazing, and integral curb or curb-mounted frame design.

07811—SPRAYED FIRE-RESISTIVE MATERIALS—This Section specifies sprayed fire-resistive materials for protecting structural steel for both concealed and exposed applications. It includes not only low-density cementitious and sprayed-fiber products used predominantly for concealed locations but also a variety of medium- and high-density products for exposed locations requiring a more finished appearance and greater resistance to physical abuse, deterioration from weather, air erosion, and high humidity.

07821—BOARD FIRE PROTECTION—This Section specifies calcium silicate and slag-wool-fiber boards used for fire protection of steel columns, steel beams, metal- and wood-framed walls, and solid walls. These materials form the encasing material for various assemblies with fire-resistance ratings. Another use for mineral-fiber board fireproofing is protection of HVAC ducts.

07841—THROUGH-PENETRATION FIRESTOP SYSTEMS—This Section specifies through-penetration firestop systems.

07920—JOINT SEALANTS—This Section specifies joint sealants including elastomeric sealants, solvent-releasing sealants, latex sealants, acoustical sealants, and preformed sealants for a variety of applications.

#### DIVISION 8

08110—STEEL DOORS AND FRAMES—This Section specifies standard steel doors and frames fabricated to comply with ANSI A250.8 and established Steel Door Institute standards.

08114—CUSTOM STEEL DOORS AND FRAMES—This Section specifies commercial hollow-metal doors and frames custom fabricated from steel, galvanized steel, and stainless-steel sheet to specific design requirements. This Section includes provisions for glazing, louvers, sidelights, and transoms of similar construction. Provisions are also included for fire-, sound-, and thermal-rated assemblies.

08125—INTERIOR ALUMINUM FRAMES—This Section specifies extruded-aluminum framing members for interior (usually) wood doors; glass sidelights, borrowed lights, clerestory glazing, and fixed windows; and gypsum wall-board partitions.

08163—SLIDING ALUMINUM-FRAMED GLASS DOORS—This Section specifies sliding aluminum-framed glass doors for exterior locations.

08211—FLUSH WOOD DOORS—This Section specifies non-fire-rated and fire-rated architectural flush wood doors. Both solid- and hollow-core units are covered, including those with face panels of wood veneer, plastic laminate, and hardboard.

MASTERSPEC continues on the next page

ARCOM; Salt Lake City, Utah, and Alexandria, Virginia



08212—STILE AND RAIL WOOD DOORS—This Section specifies stile and rail doors made from lumber, wood veneers, and wood composites including plywood, particle-board, fiberboard, and laminated-strand lumber. Doors of special design and construction, which may include custom-made doors, are specified along with doors of stock design and construction. Fire-rated doors with wood-veneered and -edged mineral-core stiles, rails, and panels are also included.

08263—SLIDING WOOD-FRAMED GLASS DOORS—This Section specifies sliding glass doors, bare- and primed-wood framed, and wood framed and clad with aluminum or vinyl on exterior exposed surfaces, for exterior locations.

08305—ACCESS DOORS—This Section specifies prime-painted steel, zinc-coated steel, and stainless-steel access doors installed in acoustical ceilings and masonry, concrete, gypsum board assemblies, and plaster walls and ceilings.

08314—SLIDING METAL FIRE DOORS—This Section specifies sliding metal fire doors of composite and hollow-metal construction. These doors are primarily intended for fire separation doors in industrial and commercial applications.

08321—INSULATING SECURITY DOORS—This Section specifies standard insulating security door assemblies, manufactured as a unit, complete with door, frame and hardware. Although intended primarily for fire and theft protection of documents in file rooms, they are also used for vault protection of other valuables.

08331—OVERHEAD COILING DOORS—This Section specifies flexible metal-curtain-type overhead coiling (rolling) service doors and counter doors, including fire-rated assemblies. Overhead coiling doors are fabricated from steel, stainless steel, and aluminum. Fire-rated doors are fabricated from steel and stainless steel.

08334—OVERHEAD COILING GRILLES—This Section specifies galvanized steel, stainless-steel, and aluminum overhead coiling (rolling) grilles with straight in-line pattern and with the option of glazed panels.

08343—ICU/CCU ENTRANCE DOORS—This Section specifies combination swing/slide manual ICU/CCU entrance door assemblies.

08346—SOUND CONTROL DOORS—This Section specifies non-fire-rated and fire-rated swinging steel door and frame systems with minimum sound transmission class (STC) ratings ranging between 43 and 52.

08351—FOLDING DOORS—This Section specifies non-acoustical and non-fire-rated accordion and panel folding doors with vinyl, wood, and other finishes; and bifold doors of wood, metal, and polyvinyl chloride (PVC) construction. These doors are intended as visual separation devices and primarily apply to commercial and institutional installations; however, by appropriate modification, they may accommodate light commercial and residential construction.

08361—SECTIONAL OVERHEAD DOORS—This Section specifies sectional overhead doors moved by a counterbalance mechanism and rollers along a steel track system and fabricated from flat steel or ribbed steel panel sections framed with steel members; paneled wood or flush wood panel sections framed with wood members; and aluminum, translucent (fiberglass-reinforced) plastic, and glass or plastic vision panel sections framed with aluminum members.

08410—ALUMINUM ENTRANCES AND STOREFRONTS—This Section specifies standard interior and exterior aluminum entrance and storefront systems. Entrance systems include swinging doors, framing, hardware, vestibule enclosures, transoms, and sidelights. Storefront systems include fixed glazing areas and framing.

08450—ALL-GLASS ENTRANCES—This Section specifies frameless tempered-glass entrances, including swing doors, sidelights, transoms, and related accessories.

08460—AUTOMATIC ENTRANCE DOORS—This Section specifies only the Evaluations for the following new Sections covering types of automatic entrance doors:

08461—SLIDING AUTOMATIC ENTRANCE DOORS—This Section specifies sliding automatic entrance door systems that include not only door operators and controls but also aluminum doors, sidelite and transom frames, and accessories.

08462—SWINGING AUTOMATIC ENTRANCE DOORS—This Section specifies swinging automatic entrance door systems that include not only door operators and controls but also aluminum doors, transom frames, and accessories. Bifolding operation is also included.

08470—REVOLVING ENTRANCE DOORS—This Section specifies conventional, circular, revolving entrance doors consisting of manual and power-assisted door leaves, or wings, rotating about a center post with a speed-control unit to limit rotation speed.

08510—STEEL WINDOWS—This Section specifies readily available stock and custom types of steel window units. It describes window types (operations) and window grades (classifications) in addition to performance requirements and finishes, and other options.

08520—ALUMINUM WINDOWS—This Section specifies various types of commonly used stock aluminum window units. The Section includes normally available options for window type, grade, and performance class. It also includes different glazing methods, finishes, and other options. The Section is primarily intended for generic specifying of competitive window types. When specific manufacturers' product names are inserted, the Text can be shortened to facilitate proprietary specifying.

08550—WOOD WINDOWS—This Section specifies various types of commonly used stock wood window units. The Section includes a variety of normally available options for window type and performance grade. It also includes different glazing methods, finishes, and other options. The Section is primarily intended for generic specifying of competitive window types. When specific manufacturers' product names are inserted, the Text can be considerably shortened to facilitate proprietary specifying.

08610—ROOF WINDOWS—This Section specifies venting and fixed insulating-glass units for installation on sloping roof surfaces.

08630—METAL-FRAMED SKYLIGHTS—This Section specifies aluminum-framed skylights with retaining-cap- or structural-sealant-glazing systems and glass or plastic glazing.

08631—TRANSLUCENT-INSULATING-PANEL SKYLIGHTS—This Section contains only the Evaluations for the following new Sections that specify aluminum-framed skylights glazed with different types of translucent, insulating panels:

- 08632—POLYCARBONATE-INSULATING-PANEL SKYLIGHTS
- 08633—FIBERGLASS-SANDWICH-PANEL SKYLIGHTS

08632—POLYCARBONATE-INSULATING-PANEL SKYLIGHTS—This Section specifies aluminum-framed skylights glazed with translucent, cellular-polycarbonate insulating panels.

08633—FIBERGLASS-SANDWICH-PANEL SKYLIGHTS—This Section specifies aluminum-framed skylights incorporating translucent, insulating, fiberglass-reinforced-polymer, sandwich panels.

08710—DOOR HARDWARE—This Section specifies Evaluations only for the following new Sections covering different specifying methods for door hardware:

08711—DOOR HARDWARE (SCHEDULED BY NAMING PRODUCTS)—This Section specifies hardware applied to doors, formally called *finish hardware*, *builder's hardware*, or *architectural finish hardware*. The Section uses manufacturers' product names or references to BHMA standards in the Door Hardware Schedule to indicate door hardware requirements.

08712—DOOR HARDWARE (SCHEDULED BY DESCRIBING PRODUCTS)—This Section specifies hardware applied to doors, formally called *finish hardware*, *builder's hardware*, or *architectural finish hardware*. The Section uses product descriptions in the Door Hardware Schedule to indicate door hardware requirements.

08716—POWER DOOR OPERATORS—This Section specifies power door operators normally furnished separately from doors and frames. These door operators are adaptable to a variety of door designs and sizes. Power door operators that aid the physically handicapped by acting as an automatic door operator and that comply with the requirements of BHMA A156.19, ADA accessibility guidelines, and ANSI A117.1 are also included.

08800—GLAZING—This Section specifies monolithic, laminated, and insulating glass along with the glazing materials required for their installation. This Section serves two primary purposes: 1) It covers glazing work normally subcontracted to installers of glazing; and 2) it is the Section that other Sections cross-reference to avoid repeating glazing requirements. In the latter case, edit this Section after the other Sections are substantially complete.

08801—SECURITY GLAZING—This Section specifies glazing products intended to resist abuse, physical attack, forced entry, and ballistics. Products included are laminated glass, glass/polycarbonate laminates, and laminated and monolithic polycarbonate sheets.

08814—MIRRORING GLASS—This Section, which is new to the Basic Version, specifies unframed and unbacked, fully silvered mirrored glass and pyrolytic mirrored glass for mounting on walls and ceilings.

08825—DECORATIVE GLASS—This Section specifies glass products for interior applications, including acid etched, sandblasted, silk screened, beveled, patterned, and laminated glass with integral decoration.

08840—PLASTIC GLAZING—This Section specifies light-transmitting plastic sheets that are glazed into openings as substitutes for glass. Included are acrylic glazing in the form of monolithic sheets and double-walled, structured sheets; and polycarbonate glazing in the form of monolithic sheets and double-walled, structured sheets.

08920—GLAZED ALUMINUM CURTAIN WALLS—This Section specifies standard and custom glazed aluminum curtain wall systems installed using stick, unit, and unit-and-mullion system methods.

08925—STRUCTURAL-SEALANT-GLAZED CURTAIN WALLS—This Section specifies standard and custom, 4-sided and 2-sided, structural-sealant-glazed curtain walls incorporating aluminum framing systems.

08960—SLOPED GLAZING SYSTEMS—This Section specifies standard and custom conventionally glazed and structural-sealant-glazed sloped glazing systems incorporating aluminum framing systems.

#### DIVISION 9

09210—GYPSUM PLASTER—This Section specifies gypsum lath and plaster; metal lath, furring, accessories, and support systems; and plastic accessories.

09215—GYPSUM VENEER PLASTER—This Section specifies gypsum-based veneer plaster on gypsum base, unit masonry, or monolithic concrete. Metal support systems, sound-attenuation insulation, thermal insulation, and cementitious backer units are also specified because they are integrated with veneer plaster construction. Veneer plaster materials and applications may be cross-referenced from other Division 9 Sections, such as "Gypsum Board Shaft-Wall Assemblies."

09220—PORTLAND CEMENT PLASTER—This Section specifies portland cement plaster including metal framing, furring, lath, and accessories; plastic accessories; job-mixed portland cement finish; and factory-prepared finishes such as stucco, acrylic based, and exposed aggregate.

09251—FACTORY-FINISHED GYPSUM BOARD—This Section specifies vinyl-film-faced, gypsum board panels and associated trim.

09253—GYPSUM SHEATHING—This Section specifies paper-surfaced and glass-mat gypsum sheathing attached to steel framing on exterior walls and air-infiltration barriers installed over the sheathing.

09260—GYPSUM BOARD ASSEMBLIES—This Section specifies gypsum board assemblies and metal support systems. Sound attenuation insulation and cementitious backer units for tile are also specified because they are often components of gypsum board assemblies.

09265—GYPSUM BOARD SHAFT-WALL ASSEMBLIES—This Section specifies non-load-bearing, steel-framed gypsum board assemblies that provide fire-resistance-rated enclosures for vertical shafts and horizontal enclosures.

09271—GLASS-REINFORCED GYPSUM FABRICATIONS—This Section specifies factory-molded products fabricated with glass-reinforced gypsum (GRG), for interior use.

09310—CERAMIC TILE—This Section specifies unglazed and glazed ceramic tile, including ceramic mosaic, quarry, paver, and wall tile; tile setting and grouting materials; accessories; and installation requirements.

09385—DIMENSION STONE TILE—This Section specifies natural stone tile for flooring, wall facing, and trim for commercial and residential installations. *Dimension stone tile* is defined as modular units less than ¾ inch (19 mm) thick fabricated from natural stone. Stone thresholds are also in the Section Text.

09400—TERRAZZO—This Section specifies cementitious, modified-cement-resin, and synthetic-resin terrazzo for flooring, base, stair treads, landings, and risers. Cementitious terrazzo includes standard and rustic cast-in-place systems and precast products. Resinous "thin-set" terrazzo includes cast-in-place, polyacrylate-modified-cement and epoxy-resin systems.

09451—INTERIOR STONE FACING—This Section specifies dimension stone used for interior wall facing, trim, moldings, base, countertops, and window stools.

09511—ACOUSTICAL PANEL CEILINGS—This Section specifies ceilings consisting of acoustical panels and exposed suspension systems, including special-use types for exterior locations, high-temperature and -humidity locations, and clean rooms.

MASTERSPEC continues on the next page.

ARCOM; Salt Lake City, Utah, and Alexandria, Virginia

1

CONSTRUCTION INFORMATION SYSTEMS

09512—ACOUSTICAL TILE CEILINGS—This Section specifies ceilings consisting of acoustical tiles and concealed suspension systems.

09513—ACOUSTICAL SNAP-IN METAL PAN CEILINGS—This Section specifies ceilings consisting of acoustical snap-in metal pans and concealed suspension systems. Types of metal pan ceiling units include both perforated and unperforated snap-in steel, stainless steel, or aluminum pans.

09547—LINEAR METAL CEILINGS—This Section specifies strip, decorative, linear metal ceilings.

09580—SUSPENDED DECORATIVE GRIDS—This Section specifies open-cell grid, plenum mask ceiling systems.

09600—STONE PAVING AND FLOORING—This Section specifies dimension stone paving and flooring installed on a thick, mortar setting bed. It also includes metal edging and stone thresholds.

09621—FLUID-APPLIED ATHLETIC FLOORING—This Section specifies polyurethane floorings, intended for use in athletic-activity areas, that are homogenous or installed over resilient underlayment.

09622—RESILIENT ATHLETIC FLOORING—This Section specifies rubber, vinyl, and thermoplastic-rubber-blend floor coverings in interlocking-tile or roll form and designed for use in athletic-activity or support areas.

09635—BRICK FLOORING—This Section specifies brick flooring for interior applications subject to pedestrian and light vehicular traffic. Three setting methods included for the specifier's choice are loose-laid brick flooring with sand-filled, hand-tight joints; thicket mortared brick flooring, with or without grouted joints; and thin-set mortared brick flooring, also with or without grouted joints. Where the same brick pavers are selected for both flooring (interior applications) and paving (exterior applications) and use either the same or different setting methods and beds, there can be advantages to combining them into one Section and choosing a section number that represents the major application. Brick flooring could also be included with unit masonry if the bricklayer's method is used for installation.

09636—CHEMICAL-RESISTANT BRICK FLOORING—This Section specifies chemical-resistant brick flooring installed with mortars, grouts, and setting beds that offer varying degrees of chemical protection based on specific user requirements. The Section may also include a protective membrane on the subfloor.

09640—WOOD FLOORING—This Section specifies solid- and engineered-wood flooring that is either factory or site finished.

09644—WOOD ATHLETIC-FLOORING ASSEMBLIES—This Section specifies hard maple, finish flooring and sub-flooring assemblies designed for use as athletic playing or exercising surfaces. Subflooring systems include those with enhanced shock-absorbing properties.

09651—RESILIENT TILE FLOORING—This Section specifies solid vinyl, rubber, and vinyl composition floor tile and resilient wall base and accessories typically installed with resilient floor tile.

09652—SHEET VINYL FLOOR COVERINGS—This Section specifies sheet vinyl floor coverings, with and without backings, for commercial projects.

09653—RESILIENT WALL BASE AND ACCESSORIES—This Section specifies rubber and vinyl wall base, stair treads, and accessories for use with resilient flooring and carpet.

09654—LINOLEUM FLOOR COVERINGS—This Section specifies linoleum tile and sheet floor coverings.

09671—RESINOUS FLOORING—This Section specifies decorative, general-use, and high-performance or special-application resinous flooring systems applied as self-leveling slurries or troweled or screeded mortars.

09677—STATIC-CONTROL RESILIENT FLOOR COVERINGS—This Section specifies static-dissipative vinyl composition, homogenous (solid) vinyl, and rubber floor tile; static-dissipative rubber sheet floor covering; conductive homogenous (solid) vinyl and rubber floor tile; and conductive vinyl and rubber sheet floor covering.

09680—CARPET—This Section specifies tufted, fusion-bonded, and woven carpet, as well as carpet cushion for commercial installations.

09681—CARPET TILE—This Section specifies carpet tile for commercial installations.

09771—FABRIC-WRAPPED PANELS—This Section specifies custom-fabricated, back-mounted, fabric-wrapped panels for ceilings and walls, in which the fabric is not adhered to the core material.

09772—STRETCHED-FABRIC WALL SYSTEMS—This Section specifies concealed-fastener, site-assembled, site-upholstered systems for ceilings and walls.

09841—ACOUSTICAL WALL PANELS—This Section specifies shop-fabricated acoustical panels that are wall mounted as opposed to freestanding or ceiling baffles. Both spline-mounted and back-mounted units are included.

09900—PAINTING—This Section specifies general surface preparation, materials preparation, and application principles for interior and exterior painting.

09920—INTERIOR PAINTING—This Section specifies general surface preparation, materials preparation, and application principles for interior painting.

09931—EXTERIOR WOOD STAINS—This Section specifies general surface preparation, material preparation, and application principles for exterior wood stains.

09945—MULTICOLORED INTERIOR COATINGS—This Section specifies polychromatic paint.

09950—WALL COVERINGS—This Section specifies vinyl, fiberglass, and textile wall coverings and wallpaper.

09960—HIGH-PERFORMANCE COATINGS—This Section specifies high-performance coatings for architectural and industrial applications.

09963—ELASTOMERIC COATINGS—This Section specifies a specially designed acrylic polymer containing elastomeric coatings for use on the exterior of masonry, concrete, and stucco structures. These coatings are dirt resistant, flexible in a range of temperatures, and very high-build materials that bridge small cracks and protect against deterioration resulting from moisture penetration of the substrate.

09967—INTUMESCENT PAINTS—This Section specifies intumescent-type, fire-retardant paint primarily for interior combustible and noncombustible substrates.

09975—HIGH-TEMPERATURE-RESISTANT COATINGS—This Section specifies general surface preparation, materials preparation, and application principles for high-temperature-resistant coatings used on the interior and exterior.

09980—WOOD-VENEER WALL COVERINGS—This Section specifies flexible wood-veneer wall covering.

09981—CEMENTITIOUS COATINGS—This Section specifies polymer-modified cementitious coatings to use above or below grade on the exterior or interior over masonry and concrete. After curing, these coatings produce a durable, hard, weather-resistant surface.

#### DIVISION 10

10100—VISUAL DISPLAY BOARDS—This Section specifies the most commonly used types of standard chalkboards, markerboards, and tackboards. Emphasis is placed on prefabricated units. Provisions are also included for traditional slate chalkboards and other field-assembled types.

10155—TOILET COMPARTMENTS—This Section specifies standard metal, plastic-laminate, and solid-plastic toilet compartments and screens.

10180—STONE TOILET COMPARTMENTS—This Section specifies marble and granite toilet compartments and screens, compartment doors, and associated fittings and hardware.

10190—CUBICLES—This Section specifies curtain and IV tracks and curtains and accessories for cubicles, dressing areas, tubs, and showers.

10200—LOUVERS AND VENTS—This Section specifies fixed and adjustable metal louvers, acoustical louvers, blank-off panels for louvers, and wall vents (brick vents). Louvers connected to ductwork, and those that are not, are properly specified in this Section. This Section specifies louvers made from extruded aluminum, formed galvanized steel, and formed stainless steel. Fixed-blade louvers specified include those with horizontal and vertical blades, drainable and nondrainable blades, and sightproof blades. Adjustable louvers specified include those with drainable and nondrainable blades, both fixed and adjustable blades combined in a single frame and single-blade units, and insulated units.

10265—IMPACT-RESISTANT WALL PROTECTION—This Section specifies various types of impact-resistant wall protection systems, including wall guards, handrails, and corner guards, as well as door and door frame protection systems. It also includes related impact-resistant wall covering products. The Section can be expanded to include any complete protection system or streamlined to specific wall and corner-guard applications only.

10270—ACCESS FLOORING—This Section specifies standard access flooring systems, including accessories. Not only does it include systems suitable for data centers, computer rooms, clean rooms, and other applications, but also those intended primarily for general office uses.

10350—FLAGPOLES—This Section specifies metal and fiberglass flagpoles, including ground-set, wall-mounted, and roof-mounted flagpoles. Metals include aluminum, steel, stainless steel, and bronze.

10405—BANNERS—This Section specifies banners of woven, nonwoven, and knit materials, for interior and exterior use.

10416—DIRECTORIES AND BULLETIN BOARDS—This Section specifies directories and bulletin boards fabricated from standard components common to several manufacturers. The Section can be used for specifying customized units by inserting additional requirements for materials and fabrication.

10425—SIGNS—This Section specifies panel signs, dimensional letters and numbers, and cast metal plaques. It includes typical materials and processes commonly used by a wide number of sign manufacturers.

10436—POST AND PANEL SIGNS—This Section specifies exterior, freestanding, illuminated and nonilluminated post and panel signs. It covers typical materials and processes used by a variety of sign manufacturers. The most commonly used panels, from the single-sheet variety to illuminated hollow-box-type units, are specified. Graphic image processes are also included.

10437—PYLON SIGNS—This Section specifies freestanding, illuminated and nonilluminated pylon signs. It covers typical materials and processes used by a variety of sign manufacturers. The most commonly used signs, from the upright-slab type to the tall, slender, square pylon-type unit, are specified. Graphic image processes are also included.

10505—METAL LOCKERS—This Section specifies standard, factory-fabricated wardrobe and athletic metal lockers. Commonly specified accessories and optional features, such as locker-room benches, are also included.

10520—FIRE-PROTECTION SPECIALTIES—This Section specifies portable fire extinguishers; their mounting brackets; and cabinets for fire extinguishers, hose valves, and rack and hose assemblies.

10550—POSTAL SPECIALTIES—This Section specifies standard mail chutes, receiving and collection boxes, horizontal- and vertical-type mailboxes, neighborhood delivery and collection box units, and parcel lockers.

10605—WIRE MESH PARTITIONS—This Section specifies standard- and heavy-duty wire mesh partitions, exterior (galvanized) partitions, wire mesh window guards, stairway partitions, and insert panels for railing systems.

10615—DEMOUNTABLE PARTITIONS—This Section includes only the Evaluations for the following Sections specifying demountable partitions:

- 10616—SITE-ASSEMBLED DEMOUNTABLE PARTITIONS
- 10620—DEMOUNTABLE UNITIZED-PANEL PARTITIONS

10616—SITE-ASSEMBLED DEMOUNTABLE PARTITIONS—This Section specifies reusable, demountable partition systems consisting of gypsum board panels or metal-faced gypsum board panels supported by concealed framing. This new Section replaces

- 10617—DEMOUNTABLE GYPSUM PANEL PARTITIONS and
- 10618—DEMOUNTABLE METAL PANEL PARTITIONS, both dated 11/92.

10620—DEMOUNTABLE UNITIZED-PANEL PARTITIONS—This Section specifies reusable, demountable, partition systems consisting of factory-assembled unitized panels.

10651—OPERABLE PANEL PARTITIONS—This Section specifies acoustically rated, manually and electrically operated, flat-panel partitions supported from an overhead track.

10653—FIRE-RATED OPERABLE PANEL PARTITIONS—This Section specifies acoustically rated, manually operated, flat-panel partitions, fire rated one hour or one and one-half hours, supported from an overhead track.

10655—ACCORDION FOLDING PARTITIONS—This Section specifies acoustically rated, manually and electrically operated, accordion folding partitions supported from a single overhead track.

MASTERSPEC continues on the next page.

ARCOM; Salt Lake City, Utah, and Alexandria, Virginia



10671—METAL STORAGE SHELVING—This Section specifies post and shelf storage units.

10680—MOBILE STORAGE UNITS—This Section specifies manually and electrically operated storage units consisting of carriages that glide on rails to open an aisle where access is required.

10750—TELEPHONE SPECIALTIES—This Section specifies prefabricated telephone specialties, including telephone booths and other enclosures, telephone housings, telephone-enclosure entrances for built-in telephone booths, and directory storage units. The Text is based on standard products of several manufacturers but can be adapted to specify similar standard and custom-designed units.

10753—WALL-MOUNTED TELEPHONE ENCLOSURES—This Section specifies prefabricated, wall-mounted, shelf-type telephone enclosures and wall-mounted, panel-type telephone housings. The Text is based on standard products of several manufacturers but can be adapted to specify similar standard and custom-designed units.

10801—TOILET AND BATH ACCESSORIES—This Section specifies standard toilet and bath accessories and mirror units commonly used in commercial and institutional applications.

#### DIVISION 11

11054—LIBRARY STACK SYSTEMS—This Section specifies stationary single-tier and multitier shelving for library materials.

11062—FOLDING AND PORTABLE STAGES—This Section specifies folding and portable stage platforms, seating-platform risers, standing choral risers, and acoustical shell systems that might be used indoors in schools, churches, banquet facilities, and multipurpose auditoriums.

11063—STAGE CURTAINS—This Section specifies examples of stage curtain fabrics and draw-travel curtain rigging commonly used in small- to medium-sized theater/auditorium installations without fly spaces.

11132—PROJECTION SCREENS—This Section specifies standard rear- and front-projection screens. It includes both manually and electrically operated, roll-up front-projection screens with almost any screen surface and rear-projection screens made of glass or acrylic plastic.

11150—PARKING CONTROL EQUIPMENT—This Section specifies basic parking control equipment for public and private installations including gate operators and controls and cashier's or parking attendant's booths.

11160—LOADING DOCK EQUIPMENT—This Section specifies dock bumpers, dock levelers, truck levelers, truck restraints, dock lifts, dock seals, dock shelters, and transparent strip door curtains. Dock bumpers include laminated-tread, molded- and extruded-rubber, and steel-face types. Both mechanical and hydraulic dock levelers are covered, including those permanently installed in pits and those attached at the edge of the dock. Truck restraints include both wall- and driveway-mounted types. Hydraulic dock lifts of the single-scissors type for permanent installation in pits are the only dock lift included. Dock shelters include rigid frame, flexible frame, and inflatable types.

11172—WASTE COMPACTORS—This Section specifies general-purpose, commercial, wet- or dry-waste compactor units for processing solid, nonhazardous, building-generated waste.

11307—PACKAGED SEWAGE PUMP STATIONS—This Section specifies small- and medium-size, factory-assembled, sewage pump stations.

11400—FOOD SERVICE EQUIPMENT—This Section specifies food service equipment for use in commercial, industrial, and institutional projects.

11451—RESIDENTIAL APPLIANCES—This Section specifies major residential appliances. It includes freestanding and built-in kitchen and laundry appliances, and both gas and electric equipment for residential and incidental nonresidential applications. Appliances included are restricted to units that may be purchased as standard manufactured items.

11460—UNIT KITCHENS—This Section specifies standard, factory-fabricated and -assembled unit kitchens including cabinetry, appliances, sinks, faucets, and accessories.

11610—LABORATORY FUME HOODS—This Section specifies standard laboratory fume hoods used for educational laboratories and research facilities. It includes conventional hoods, bypass hoods, and restricted bypass hoods; with or without airflow design, auxiliary air, and variable air volume (VAV) control. It also includes walk-in hoods, perchloric acid hoods, and radioisotope hoods. It includes hood stands and specifies casework supporting bench-type hoods by referencing

- 12347—METAL LABORATORY CASEWORK or
- 12348—WOOD LABORATORY CASEWORK.

11695—MAILROOM EQUIPMENT—This Section specifies equipment used to process incoming and outgoing mail. It replaces Section 11910—MAILROOM EQUIPMENT AND FURNITURE, dated 10/88, that is being withdrawn from the Interiors Library Construction Version.

#### DIVISION 12

12050—FABRICS—This Section evaluates fibers, textiles, and leather for use as wall coverings, vertical hangings, floor coverings, and furniture upholstery.

12100—ART—This Section evaluates the integration of art, both as a form of cultural expression and as decorative enhancement, into commercial interiors projects. Project coordination with work of other contracts and with a team of consultants is discussed.

12311—METAL FILE CABINETS—This Section specifies vertical and lateral metal file cabinets.

12320—RESTAURANT AND CAFETERIA CASEWORK—This Section specifies cashier counter, wait stations and other casework for food service facilities. This section can be modified to include more extensive custom display equipment by inclusion of additional detailed requirements.

12347—METAL LABORATORY CASEWORK—This Section specifies standard manufactured metal laboratory casework and common accessories, including cabinets, countertops, sinks, and service fixtures.

12348—WOOD LABORATORY CASEWORK—This Section specifies standard manufactured wood laboratory casework and common accessories, including cabinets, countertops, sinks, and service fixtures. The Text includes both wood-faced cabinets and plastic-laminate-faced cabinets.

12353—DISPLAY CASEWORK—This Section specifies manufactured cabinets and display cases for retail storage and merchandising.

12356—KITCHEN CASEWORK—This Section specifies stock-manufactured kitchen and vanity cabinets made from wood and wood products faced with wood, plastic laminate, vinyl, or a combination of these materials. Countertops made of plastic-laminate and solid-surfacing material are included so all components are in a single Section.

12359—METAL MEDICAL CASEWORK—This Section specifies standard manufactured metal medical casework and common accessories, including stainless-steel countertops, sinks, and shelving. It includes casework typically used in operating rooms, emergency rooms, x-ray rooms, central sterile supply, and similar spaces for the storage of instruments and supplies. It does not include laboratory casework, which is specified in Division 12 Section "Metal Laboratory Casework," or plastic-laminate countertops, which are specified in Division 6 Section "Interior Architectural Woodwork."

12361—MAILROOM CASEWORK—This Section specifies manufactured casework used in document distribution workrooms and to process incoming and outgoing mail.

12483—CUSTOM RUGS—This Section specifies custom-designed, 100 percent wool, hand-tufted area rugs installed over finish flooring.

12493—CURTAINS AND DRAPES—This Section specifies stationary and movable curtains and drapes, and window treatment hardware for commercial installations.

12496—WINDOW TREATMENT HARDWARE—This Section specifies hardware for manually operated and motor-operated draperies and curtains.

12510—OFFICE FURNITURE—This Section specifies desks, tables, and credenzas for office and computer-support applications.

12511—HORIZONTAL LOUVER BLINDS—This Section specifies manually operated and motor-operated venetian blinds.

12512—VERTICAL LOUVER BLINDS—This Section specifies manually operated and motor-operated vertical vane blinds.

12520—SHADES—This Section specifies manually operated and motor-operated roll shades, including blackout and mesh shades.

12521—CUSTOM UPHOLSTERED SEATING—This Section specifies specially designed, wood frame, upholstered seating.

12522—OFFICE SEATING—This Section specifies seating for office and computer-support applications.

12523—HEALTHCARE SEATING—This Section specifies patient and guest seating in hospitals and extended-care facilities. Sleeper chairs for guests and recliners and rockers for patients are also included.

12525—PLEATED SHADES—This Section specifies 2 basic types of pleated shades: accordion pleated shades with 1 fabric thickness and shades with multiple-fabric thicknesses forming air spaces (sometimes referred to as cellular shades).

12551—TRADING DESKS—This Section specifies modular desk units and equipment support for trading rooms for banks, insurance companies, and other financial institutions; trading support; data processing; reservation centers; 911 emergency facilities; and video production facilities.

12562—CLASSROOM FURNITURE—This Section specifies library seating and furniture for the display, storage, review, and checkout of library materials.

12563—DORMITORY FURNITURE—This Section specifies dressers, desks, chairs, nightstands, wardrobes, tables, beds, and other furniture items for residence hall rooms and lounge areas.

12567—LIBRARY FURNITURE—This Section specifies library seating and furniture for the display, storage, review, and checkout of library materials.

12571—AUDIO-VISUAL SUPPORT FURNITURE—This Section specifies lecterns, presentation equipment carts, and cabinets.

12574—OUTDOOR FURNITURE—This Section specifies movable, wood or metal tables and chairs designed to withstand temperature extremes and limited weathering.

12610—FIXED AUDIENCE SEATING—This Section specifies upholstered and nonupholstered interior assembly-space seating. Although exterior seating is not included, the Section Text could be modified to specify exterior fixed seating in stadiums.

12630—RESTAURANT FURNITURE—This Section specifies tables and seating for dining.

12634—CUSTOM FURNITURE—This Section specifies specially designed tables, desks, credenzas, etc.

12635—PATIENT ROOM FURNITURE—This Section specifies bedside cabinets, wardrobe units, desks, vanities, and chests of drawers designed specifically for healthcare applications.

12638—GUEST ROOM FURNITURE—This Section specifies guest room furniture sets including armoires (perhaps with a bar unit or other built-ins), credenzas, nightstands or bedside tables, writing desks, lounge chairs, and headboards. Also specified in this Section are mattresses and box springs, and guest bedroom seating.

12639—BANQUETTES—This Section specifies built-in, upholstered, custom seating.

12651—INTERLOCKING CHAIRS—This Section specifies multiple seating systems (ganged or tandem) with optional modular tabletops for waiting, reception, and lounge areas.

12677—ORIENTAL RUGS—This Section specifies antique, semiantique, and new, handmade imported rugs and rug pads.

12680—FOOT GRILLES—This Section specifies foot grilles, which are generally rigid sections of treads designed to remove foot traffic debris set in a recessed frame in the floor.

12690—FLOOR MATS AND FRAMES—This Section specifies commonly used types of recessed and surface installed floor mats for buildings other than single-family residential work.

12700—SYSTEMS FURNITURE—This Section specifies panel-hung-component systems, freestanding-component systems, desk systems supporting work-surface-mounted screens and other components, and beam systems.

12760—TELESCOPING STANDS—This Section specifies telescoping stands for interior applications consisting of multiple-tiered benches or chairs on interconnected, folding platforms. These systems are constructed of steel, wood and steel, or polyethylene plastic and steel, and can be operated manually or automatically.

12815—INTERIOR PLANTS—This Section specifies requirements for selecting, laying out, and placing plants provided by an interior landscape contractor.

12830—INTERIOR PLANTERS—This Section specifies movable, decorative planters with or without integral subirrigation systems.

MASTERSPEC continues on the next page.

ARCOM; Salt Lake City, Utah, and Alexandria, Virginia

1 CONSTRUCTION INFORMATION SYSTEMS

## DIVISION 13

13041—MODULAR VAULTS—This Section specifies modular vault panels and doors that are prefabricated and site assembled.

13052—SAUNAS—This Section specifies panel-built, or modular, saunas and custom-cut, or precut, saunas, furnished as complete units including heating, lighting, controls, and accessories.

13090—RADIATION PROTECTION—This Section specifies materials and methods for typical radiation protection systems used in medical x-ray rooms and radiation therapy rooms. It includes lead sheet, lead glass, and lead glazing plastic; lead-lined finish materials; and other lead-lined products, such as doors, frames, view windows, modular shielding partitions, and film transfer cabinets. The Section also specifies lead bricks, borated polyethylene, and neutron shielding doors and frames for radiation therapy applications. Signs indicating the thickness of the lead shielding provided are also included.

13100—LIGHTNING PROTECTION—This Section specifies lightning protection for buildings, building elements, and building site components.

13110—CATHODIC PROTECTION—This Section specifies passive cathodic protection systems that use magnesium or zinc sacrificial anodes to protect steel and iron piping and tanks. Modify the Section Text to include aluminum piping and tanks; include electrical conduit protection by adding "steel conduit" to "piping."

13125—METAL BUILDING SYSTEMS—This Section specifies metal building systems, complete with structural framing, roofing and siding panels, personnel doors, windows, and accessories.

13720—INTRUSION DETECTION—This Section specifies local intrusion detection equipment. It includes the detection devices and the central control and processing and equipment necessary for control. The Text of this Section specifies a system ready to be monitored by a remote station if required by a project. Various types of remote signaling systems are accommodated, but Specifications are not included for those external systems. The Section may also be edited to specify intrusion detection that can interface with an integrated building management system specified in another Section.

13810—CLOCK CONTROL—This Section specifies systems for displaying automatically adjusted time throughout a facility, for initiating time-scheduled audible and visual signals to announce events, and for initiating scheduled equipment operation via relays. The components specified use hard-wired or carrier-current distribution of time and program signals from a master unit. Equipment includes master clock- and program-control units, and various types of indicating clocks and audible and visual signal equipment, such as bells, horns, lights, and mechanical equipment. This Section covers a combination master clock- and program-control system. However, it can be modified to cover an independent master clock-control system or an independent program-control system.

13845—LIGHTING CONTROLS—This Section specifies wired, programmable, lighting control systems using low-voltage control circuits. Manual, low-voltage lighting controls are also specified.

13851—FIRE ALARM—This Section specifies local fire alarm and detection systems for buildings. It includes the panels necessary to control the systems and the various peripheral devices associated with detecting fires, initiating alarms, and indicating alarms with audible and visible signals. The Section also includes equipment for communicating alarm, supervisory, and trouble signals to a remote alarm receiving station.

13915—FIRE-SUPPRESSION PIPING—This Section specifies combined systems of standpipes and sprinklers for buildings and includes the following:

13916—FIRE-SUPPRESSION SPRINKLERS—This Section specifies wet- and dry-pipe, fire-suppression sprinklers for buildings and includes piping, sprinklers, specialties, and accessories. Use Division 13 Section "Fire-Suppression Piping" for preaction and deluge piping, sprinklers, specialties, and accessories; and combined (standpipe and sprinkler) systems.

13920—FIRE PUMPS—This Section includes only the Evaluations and Drawing Coordination and Specifications Coordination checklists for the following Sections covering fire pumps for building fire-suppression systems:

- 13921—ELECTRIC-DRIVE, HORIZONTAL FIRE PUMPS
- 13922—DIESEL-DRIVE, HORIZONTAL FIRE PUMPS
- 13926—ELECTRIC-DRIVE, VERTICAL-TURBINE FIRE PUMPS
- 13927—DIESEL-DRIVE, VERTICAL-TURBINE FIRE PUMPS

13921—ELECTRIC-DRIVE, HORIZONTAL FIRE PUMPS—This Section specifies electric-drive, horizontal fire pumps for building fire-suppression systems and includes the following:

13922—DIESEL-DRIVE, HORIZONTAL FIRE PUMPS—This Section specifies diesel-drive, horizontal fire pumps for building fire-suppression systems and includes the following:

13926—ELECTRIC-DRIVE, VERTICAL-TURBINE FIRE PUMPS—This Section specifies electric-drive, vertical-turbine fire pumps for building fire-suppression systems and includes the following:

13927—DIESEL-DRIVE, VERTICAL-TURBINE FIRE PUMPS—This Section specifies diesel-drive, vertical-turbine fire pumps for building fire-suppression systems and includes the following:

13956—FIRE-EXTINGUISHING FOAM PIPING—This Section specifies fixed, low-expansion, aqueous film-forming foam, fire-extinguishing systems for hydrocarbon-liquid fires. Foam systems are normally used on, but not limited to, Class B (flammable-liquid) fires.

13966—HALOGEN AGENT EXTINGUISHING PIPING—This Section specifies Halon 1301 halogen agent, fire-extinguishing systems.

13967—CLEAN-AGENT EXTINGUISHING SYSTEMS—This Section specifies clean-agent extinguishing systems. These systems use alternative agents that are substitutes for fixed, Halon 1301 extinguishing systems. Specified agents and related components in this Section are limited to those that are Factory Mutual approved and Underwriters Laboratories listed. Other agents are included in NFPA 2001, *Clean Agent Fire Extinguishing Systems*. See the Evaluations for further discussion.

13975—STANDPIPES AND HOSES—This Section specifies standpipes for buildings and includes the following:

## DIVISION 14

14100—DUMBWAITERS—This Section specifies preengineered electric dumbwaiter units, commonly used for floor-to-floor transfer of small-sized materials such as books, parts, food, etc., in a low- to medium-rise application. Car size is limited by the Code to 9 sq. ft. (0.84 sq. m) of platform and a height of 4 feet (1219 mm).

14210—ELECTRIC TRACTION ELEVATORS—This Section specifies preengineered electric traction elevators for either passenger or freight use. Substantial generic descriptions are included, however, to enable manufacturers to bid either custom or preengineered equipment. This Section can be modified to specify custom electric traction elevators.

14240—HYDRAULIC ELEVATORS—This Section specifies preengineered hydraulic elevators, including holess and roped hydraulic types, for either passenger or freight use. Substantial generic descriptions are included, however, to enable manufacturers to bid either custom or preengineered equipment.

14310—ESCALATORS—This Section specifies standard preengineered, heavy-duty, and exterior escalators.

14320—MOVING WALKS—This Section specifies moving walks as defined by ASME A17.1, which includes power-driven, continuous treadmill units used for conveying passengers along either a horizontal surface or an inclined ramp. It is intended for specifying preengineered units for normal installations, traveling either horizontally or between floors, rising one story at a time. The Section Text can be amplified to cover custom-engineered units and units with special requirements such as exceptionally long or curved runs or rises, custom profiles, or the use of custom materials in balustrade construction.

14420—WHEELCHAIR LIFTS—This Section specifies special-purpose lifts used to transport nonambulatory and semiambulatory persons from one level of a building to another. It includes vertical wheelchair lifts, inclined wheelchair lifts, and inclined stairway chair lifts. It also includes requirements for standard runway enclosures offered by manufacturers of vertical wheelchair lifts.

14512—TRACK VEHICLE SYSTEMS—This Section specifies self-propelled container systems that travel on electrified tracks.

14559—SELECTIVE VERTICAL CONVEYORS—This Section specifies vertical transport systems operated by a single motor that continuously moves a chain in a single direction, much like a ferris wheel. Containers hook into the chain as it passes their receiving station and are transported to other vertical locations.

14560—CHUTES—This Section specifies gravity-type, metal chutes used to convey waste and linen.

## DIVISION 15

15050—BASIC MECHANICAL MATERIALS AND METHODS—This Section specifies materials and methods for application with mechanical equipment and piping system installations inside the building. Piping specialties, joining materials, joint construction, identification materials and devices, and installation requirements common to more than one Division 15 Section are included. This Section supplements other Division 15 Sections. It must be edited and used with other Sections for a complete system specification.

15060—HANGERS AND SUPPORTS—This Section specifies hangers and supports for mechanical system piping and equipment.

15075—MECHANICAL IDENTIFICATION—This Section specifies identification materials and devices, and installation requirements. Use this Section for complex projects requiring comprehensive specifications for labeling and identifying mechanical installations. Use the Specifications in Division 15 Section "Basic Mechanical Materials and Methods" for simple projects.

15081—DUCT INSULATION—This Section specifies rigid and flexible duct, plenum, and breaching insulation and field-applied jackets for HVAC systems. This Section includes applications for indoor and outdoor ducts.

15082—EQUIPMENT INSULATION—This Section specifies blanket, board, and block insulation and field-applied jackets for HVAC equipment. This Section includes applications for indoor and outdoor equipment.

15083—PIPE INSULATION—This Section specifies preformed pipe insulation and field-applied jackets for plumbing and HVAC piping systems and for diesel-engine cooling piping and exhaust pipes. This Section includes applications for indoor and outdoor piping.

15100—VALVES—This Section specifies general duty valves common to most mechanical piping systems. Valves specified in this Section include gate, globe, ball, butterfly, plug, and check valves.

15121—PIPE EXPANSION FITTINGS AND LOOPS—This Section specifies pipe expansion fittings and loops for steel and copper piping for mechanical systems, and the following:

15122—METERS AND GAUGES—This Section specifies meters and gauges for mechanical piping systems; thermometers, pressure gauges, and test plugs; flow-measuring systems; flowmeters and flow indicators; thermal-energy flowmeters; and water meters.

15170—MOTORS—This Section specifies small and medium electric motors for use on ac power systems up to 600 V, according to NEMA standards. The Section includes the common requirements for referencing by other Sections where motors are integral components of the specified equipment. This Section does not include dc motors, synchronous motors, wound-rotor motors, and motors rated more than 600 V. Special motor types and features are also not included; these items may be covered in the individual equipment Sections or added to this Section. Previous Edition: Same Section number and title, dated 3/91. Related Sections: Refer to the Specifications Coordination checklist at the end of this Section. Summary of Changes: The following changes were made in this edition:

- SI (metric) units were added.
- "Submittals" Article was added to the Text.
- UL standard in "Quality Assurance" Article was deleted from the Text.
- Service factor was based on NEMA MG 1 requirements.
- List of unusual service conditions was added to "Basic Motor Requirements" Article in the Text.
- Specification for energy-efficient motors was updated.
- Terminology was changed to match NEMA MG 1.
- Specification for temperature rise and insulation class was added.
- Bearing specification and specification for motors applied on variable-frequency controllers were improved.
- Option for requiring thermal protection on motors above a certain size was added.
- "Source Quality Control" Paragraph was added to "Polyphase Motors" Article in the Text.
- Installation requirements were updated.
- "Commissioning" Article was deleted from the Text.

15181—HYDRONIC PIPING—This Section specifies piping systems for hot-water heating, chilled-water cooling, and condenser water. This Section includes pipes, fittings, special-duty valves, and hydronic specialties.

MASTERSPEC continues on the next page.

15182—STEAM AND CONDENSATE PIPING—This Section specifies steam and condensate piping and specialties for systems up to 125 psig (860 kPa), inside the building.

15185—HYDRONIC PUMPS—This Section specifies the following categories of hydronic pumps for hydronic systems:

15186—STEAM CONDENSATE PUMPS—This Section specifies steam condensate pumps for low-pressure steam systems.

15189—HVAC WATER TREATMENT—This Section specifies automatic and manual water-treatment systems for hot-water heating, steam and condensate piping, chilled-water, and condenser water systems; and water-treatment chemicals.

15191—FUEL OIL PIPING—This Section specifies fuel oil and diesel fuel piping, specialties, and accessories within the building. Equipment in this Section is suitable for No. 2 and lighter fuel oil and diesel fuel.

15194—FUEL GAS PIPING—This Section specifies natural and liquefied petroleum gas piping, specialties, and accessories within the building.

15212—LABORATORY AIR AND VACUUM PIPING—This Section specifies laboratory compressed-air and vacuum piping, designated as "laboratory air" and "laboratory vacuum"; laboratory gas alarm systems; and related specialties.

15221—CHEMICAL-WASTE PIPING—This Section specifies chemical-waste and vent piping, and specialties for laboratory systems.

15241—MECHANICAL VIBRATION CONTROLS AND SEISMIC RESTRAINTS—This Section specifies vibration isolators, vibration isolation bases, vibration isolation roof curbs, and seismic restraints and snubbers.

15252—LABORATORY AIR EQUIPMENT—This Section specifies compressed-air equipment and accessories for laboratory applications. Typical equipment applicable to this Section includes air compressors, receivers, dryers, air purification systems, and air-filter assemblies.

15253—LABORATORY VACUUM EQUIPMENT—This Section specifies vacuum equipment for laboratory applications. Typical equipment applicable to this Section includes vacuum pumps and receivers.

15411—WATER DISTRIBUTION PIPING—This Section specifies water distribution piping inside the building. Most piping specified is suitable for potable water, but some non-potable-water piping is included.

15420—DRAINAGE AND VENT PIPING—This Section specifies soil, waste, and vent piping and storm drainage piping inside the building.

15430—PLUMBING SPECIALTIES—This Section specifies plumbing specialties for water distribution systems; soil, waste, and vent systems; and storm drainage systems.

15440—PLUMBING FIXTURES—This Section specifies plumbing fixtures and related components, including the following:

15441—WATER DISTRIBUTION PUMPS—This Section specifies pumps for building potable-water systems.

15444—PACKAGED BOOSTER PUMPS—This Section specifies packaged booster pumps to maintain pressure in the building water distribution piping; compact, packaged booster pumps; constant-speed-drive, packaged booster pumps; and variable-speed-drive, packaged booster pumps.

15445—SEWAGE PUMPS—This Section specifies sewage pumps for the building sanitary drainage systems, and wet-pit-mounted, vertical sewage pumps; quick-disconnect-system, submersible sewage pumps; stationary, submersible sewage pumps; sewage-pump, reverse-flow attachment; submersible, grinder sewage pumps; submersible, cutter sewage pumps; sewage pump basins; packaged, sewage pump units; and packaged, wastewater pump units.

15446—SUMP PUMPS—This Section specifies sump pumps for building storm drainage systems, and wet-pit-mounted, vertical sump pumps; submersible sump pumps; compact, submersible sump pumps; sump pump basins; sump pump pits; and packaged, drainage pump units.

15450—POTABLE-WATER STORAGE TANKS—This Section specifies potable-water storage tanks for indoor installations. This Section may also be used for nonpotable-water applications.

15465—COMPRESSED-AIR EQUIPMENT—This Section specifies equipment and accessories for building compressed-air systems operating at 200 psig (1380 kPa) and less.

15466—MEDICAL AIR EQUIPMENT—This Section specifies medical and dental air equipment and accessories for healthcare facilities. Typical equipment applicable to this Section includes air compressors, dryers, air purification systems, and filter assemblies.

15467—MEDICAL VACUUM EQUIPMENT—This Section specifies medical and dental vacuum equipment and accessories for healthcare facilities. Typical equipment applicable to this Section includes vacuum pumps and vacuum exhausters (oral evacuation).

15469—WATER SOFTENERS—This Section specifies water softeners and accessories for water-supply systems.

15480—DOMESTIC WATER HEATERS—This Section specifies only the Evaluations for the following water heater Sections for domestic water systems:

15481—COMPRESSED-AIR PIPING—This Section specifies piping and piping specialties for building compressed-air systems operating at 200 psig (1380 kPa) and less.

15482—MEDICAL GAS PIPING—This Section specifies medical gas piping and specialties for healthcare facilities. Typical medical gas systems applicable to this Section are oxygen, air, vacuum, nitrous oxide, nitrogen, carbon dioxide, waste anesthetic gas evacuation, and dental vacuum (oral evacuation).

15485—ELECTRIC, DOMESTIC WATER HEATERS—This Section specifies electric water heaters and accessories for domestic water systems.

15486—FUEL-FIRED, DOMESTIC WATER HEATERS—This Section specifies fuel-fired water heaters and accessories for domestic water systems.

15487—DOMESTIC WATER HEAT EXCHANGERS—This Section specifies heat exchangers and accessories for generating hot water for domestic water systems, and the following:

15501—HEATING BOILERS AND ACCESSORIES—This Section includes Evaluations, Drawing Coordination, and Specifications Coordination only for the following Sections covering fuel-fired and electric boilers used for building heating systems:

- 15512—CAST-IRON BOILERS: Gas-fired, oil-fired, or combination gas/oil-fired boilers for hot water or low-pressure steam.

- 15513—CONDENSING BOILERS: Gas-fired boilers for hot water.

- 15514—FINNED WATER-TUBE BOILERS: Gas-fired boilers for hot water.

- 15515—STEEL WATER-TUBE BOILERS: Gas-fired, oil-fired, or combination gas/oil-fired, heating or power boilers for low-temperature and high-temperature hot water or low-pressure and high-pressure steam.

- 15518—FIRE-TUBE BOILERS: Gas-fired, oil-fired, or combination gas/oil-fired boilers for low-temperature and high-temperature hot water or low-pressure steam; and firebox boilers for hot water or low-pressure steam.

- 15519—ELECTRIC BOILERS: Electric-resistance boilers for hot water or steam.

15511—RADIANT HEATING PIPING—This Section specifies radiant heating piping, including pipes and tubes for embedded heat-transfer heating loops, manifolds, fittings, special-duty valves, and piping specialties.

15512—CAST-IRON BOILERS—This Section specifies gas-fired, oil-fired, or combination gas/oil-fired boilers for heating hot water or low-pressure steam.

15513—CONDENSING BOILERS—This Section specifies gas-fired boilers for heating hot water.

15514—FINNED WATER-TUBE BOILERS—This Section specifies gas-fired boilers for heating hot water.

15515—STEEL WATER-TUBE BOILERS—This Section specifies gas-fired, oil-fired, or combination gas/oil-fired heating or power boilers for low- and high-temperature heating hot water or low- and high-pressure steam.

15518—FIRE-TUBE BOILERS—This Section specifies gas-fired, oil-fired, or combination gas/oil-fired boilers; Scotch or Scotch marine boilers for low-temperature and high-temperature heating hot water or low-pressure and high-pressure steam; and firebox boilers for heating hot water or low-pressure steam.

15519—ELECTRIC BOILERS—This Section specifies electric-resistance boilers for heating hot water or steam.

15520—FEEDWATER EQUIPMENT—This Section specifies feedwater equipment used to return condensate and makeup water to both high- and low-pressure steam boilers. Feedwater units specified in this Section include vacuum units and those with cast-iron or steel receivers.

15530—REFRIGERANT PIPING—This Section specifies refrigerant piping used for air-conditioning applications, including pipes, tubing, fittings, specialties, special-duty valves, and refrigerants.

15550—BREECINGS, CHIMNEYS, AND STACKS—This Section specifies breechings, chimneys, and stacks for fuel-burning equipment, including double-wall metal vents, refractory-lined metal breechings and stacks, and fabricated breechings.

15560—FUEL-FIRED H&V UNITS—This Section includes only the Evaluations for the following new Sections specifying fuel-fired H&V units including direct- and indirect-fired units and destratification H&V units:

- 15561—DIRECT-FIRED, MAKEUP AIR UNITS
- 15562—INDIRECT-FIRED, PACKAGED H&V UNITS
- 15563—DESTRATIFICATION H&V UNITS

15561—DIRECT-FIRED, MAKEUP AIR UNITS—This Section specifies direct-fired, makeup air units that do not employ heat exchangers. Gas is burned in the airstream, and products of combustion are introduced to the space. These units include only those that are natural-gas and propane-gas fired and that are suitable for indoor and outdoor applications.

15562—INDIRECT-FIRED, PACKAGED H&V UNITS—This Section specifies indirect-fired, packaged H&V units factory assembled from standard components. Custom components and accessories can be added. Units typically include duct furnaces in parallel or series airflow, depending on heating requirements, with attached plenums housing fans, mixing sections, and other accessories. Units are suitable for indoor and outdoor applications.

15563—DESTRATIFICATION H&V UNITS—This Section specifies destratification H&V units that are large, fuel-fired units consisting of a fan, casing, and an industrial, fire-tube heat exchanger. These units are used to heat large areas of industrial buildings and warehouses. They are centrally placed in the space and circulate large volumes of air to distribute the heat throughout the space and to limit stratification. Accessories are limited.

15585—DEAERATORS—This Section specifies deaerators used to lead feedwater to steam boilers and to remove oxygen and other gases.

15610—FURNACES—This Section specifies gas- and oil-fired furnaces used in residential and light-commercial construction. It also specifies auxiliary equipment used with furnaces, including controls, filters, air cleaners, and humidifiers.

15620—FUEL-FIRED HEATERS—This Section specifies gas- and oil-fired unit heaters and duct furnaces and gas-fired, tube-type, infrared heaters. The unit heaters specified include the types normally mounted overhead indoors. The duct furnaces include both indoor and outdoor types. Tube-type infrared heaters covered include forced-draft and vacuum-vented-type units and multiple-burner, vacuum-vented systems.

15621—INDIRECT-FIRED ABSORPTION WATER CHILLERS—This Section specifies indirect-fired, hot-water and steam absorption chillers. One- and two-stage absorption chillers are specified. Single-stage absorption chillers are available from about 100- to 1700-tons (350- to 6000-kW) cooling capacity. Two-stage absorption chillers start at 350 tons (1230 kW), with the largest units providing 1500-tons (5275-kW) chilling capacity. They are used with air-conditioning systems applicable to public, institutional, commercial, and industrial buildings. The Section does not apply to chillers used for process chilling or other industrial purposes, nor does it apply to direct-fired absorption machines.

15622—DIRECT-FIRED ABSORPTION CHILLERS—This Section specifies direct-fired, two-stage absorption chillers. They range from 30- to 1100-tons (100- to 3870-kW) chilling capacity. Direct-fired, two-stage absorption chillers are used with air-conditioning systems applicable to public, institutional, commercial, and industrial buildings. Absorption chillers are not commonly used for process chilling or other industrial purposes where loads are more volatile.

15625—CENTRIFUGAL WATER CHILLERS—This Section specifies electrically driven centrifugal water chillers.

15628—RECIPROCATING WATER CHILLERS—This Section specifies reciprocating water chillers, including water-cooled, condenserless, and outdoor air-cooled types.

MASTERSPEC continues on the next page

ARCOM; Salt Lake City, Utah, and Alexandria, Virginia

1

CONSTRUCTION INFORMATION SYSTEMS

15640—PACKAGED COOLING TOWERS—This Section updated specifies factory-fabricated, mechanical-draft cooling towers.

15661—FLUID COOLERS—This Section specifies factory-fabricated, packaged, closed-circuit, mechanical-draft fluid coolers.

15663—EVAPORATIVE CONDENSERS—This Section specifies factory-fabricated, packaged evaporative condensers.

15671—CONDENSING UNITS—This Section specifies air- and water-cooled condensing units usually coupled to direct-expansion refrigerant coils in air-conditioning systems within buildings.

15672—AIR-COOLED CONDENSERS—This Section specifies air-cooled condensers used for air-conditioning systems.

15684—ROTARY-SCREW CHILLERS—This Section specifies rotary-screw chillers. Both single- and twin-screw compressors are included, along with air- or water-cooled condensers. This equipment Specification is based on capacities ranging from 20 to 1300 tons (70 to 4570 kW).

15710—HEAT EXCHANGERS—This Section specifies hydronic and steam heat exchangers for HVAC applications. Shell-and-tube heat exchangers and plate heat exchangers are also included.

15736—SELF-CONTAINED AIR-CONDITIONING UNITS (15 TONS AND SMALLER)—This Section specifies packaged air-conditioning units containing a refrigerant compressor and controls, with either integral water-cooled condensing or integral or remote air-cooled condensing. These units are designed for indoor installations, usually in the finished space, for capacities through 15 tons (50 kW).

15737—SELF-CONTAINED AIR-CONTAINING UNITS (LARGER THAN 15 TONS)—This Section specifies packaged air-conditioning units containing a refrigerant compressor and controls, with either integral water-cooled condensing or remote air-cooled condensing. These units are designed for indoor installations for capacities larger than 15 tons (50 kW).

15738—SPLIT-SYSTEM AIR-CONDITIONING UNITS—This Section specifies air-conditioning units consisting of two factory-made assemblies with a direct-expansion refrigeration system. The separate components include an evaporator coil and a fan, and a compressor and condenser. Units may be configured to operate as heat pumps.

15745—WATER-SOURCE HEAT PUMPS—This Section specifies water-source heat pumps used for air-conditioning systems in residential, commercial, industrial, and institutional buildings. The types specified in this Section are rooftop units to 25 tons (88 kW); vertical stack units to 2 tons (7 kW); concealed horizontal and vertical units to 25 tons (88 kW); exposed, floor-mounted console units to 1 1/2 tons (1.8 kW); and unit ventilator units to 4 tons (14 kW).

15752—HUMIDIFIERS—This Section specifies steam-injection, self-contained, heated-pan, and heat-exchanger humidifiers for application on ducted HVAC systems; and steam-injection and self-contained humidifiers for discharging vapor directly into conditioned space.

15761—AIR COILS—This Section specifies air coils using steam, hot water, electric resistance, chilled water, and refrigerants not integral to equipment.

15763—FAN-COIL UNITS—This Section specifies hydronic or direct-expansion cooling fan-coil units with or without supplemental hydronic, steam, and electric heat, including units for concealed installation with external duct connections and units with finished cabinets for surface and recessed mounting in ceilings or walls.

15764—RADIATORS—This Section specifies baseboard radiators, convectors, finned-tube radiators, and steel radiators for hot-water and steam heating systems.

15766—CABINET UNIT HEATERS—This Section specifies hydronic, steam, and electric cabinet unit heaters.

15767—PROPELLER UNIT HEATERS—This Section specifies hot-water, steam, and electric unit heaters.

15768—UNIT VENTILATORS—This Section specifies electric, hydronic, and steam unit ventilators.

15769—RADIANT HEATING PANELS—This Section specifies electric and hydronic radiant heating panels designed as surface-mounting units and for installing in lay-in ceilings with an exposed-grid support system.

15775—ELECTRIC HEATING CABLES—This Section specifies electric heating cables used for radiant heating, snow melting and ice stopping, pipe freeze protection, and hot-water-temperature maintenance.

15782—ROOFTOP UNITS—This Section specifies rooftop cooling units used for air-conditioning systems in commercial, industrial, and institutional buildings. Units contain air-cooled, direct-expansion refrigeration with heating options such as gas fired, hot water, and steam.

15783—COMPUTER-ROOM AIR-CONDITIONING UNITS—This Section specifies floor- and ceiling-mounted unitary air-conditioning units, and their accessories, intended specifically for computer-room applications.

15784—PACKAGED TERMINAL AIR-CONDITIONING UNITS—This Section specifies packaged, freestanding or through-the-wall, terminal air-conditioning and heat-pump units, including their accessories and controls.

15812—FIBROUS-GLASS DUCTS—This Section specifies rectangular and round fibrous-glass ducts for heating, ventilating, and air-conditioning systems.

15815—METAL DUCTS—This Section specifies rectangular, round, and flat-oval metal ducts; and duct fittings, supports, and liners for HVAC air-distribution systems. Applications include supply-, return-, outside-air, and exhaust ducts. Leakage testing, duct construction static-pressure classes, and leakage classes are specified in this Section.

15816—HVAC CASINGS—This Section specifies field-erected sheet metal casings used as equipment enclosures and plenums. HVAC casings can be field or factory fabricated; this Section allows for either method to be specified.

15820—DUCT ACCESSORIES—This Section specifies duct accessories, including dampers, actuators, duct silencers, turning vanes, duct-mounted access doors and panels, flexible ducts, flexible connectors, and duct accessory hardware.

15834—AIR CURTAINS—This Section specifies air curtains for insect and thermal protection of entranceways. Optional features for air curtains specified in this Section include heating coils and indirect-fired gas heaters, filters, intake louvers, and adjustable discharge nozzles.

15845—AIR TERMINALS—This Section specifies ducted air-control and distribution devices used in commercial air-distribution systems that control air volume and air temperature.

15846—AIR-TO-AIR ENERGY RECOVERY UNITS—This Section specifies energy recovery units designed for air-to-air energy transfer, including heat wheels, heat-pipe heat exchangers, and fixed-plate exchangers. Section includes devices for built-in air movement systems and those packaged as self-contained units.

15850—FANS—This Section includes the supporting documents (Evaluations, Drawing Coordination, and Specifications Coordination) for the following Sections specifying fans:

- 15851—CENTRIFUGAL FANS for indoor installations
- 15852—AXIAL FANS for indoor installations
- 15853—POWER VENTILATORS for indoor or outdoor installations

15851—CENTRIFUGAL FANS—This Section specifies centrifugal fans for indoor installations.

15852—AXIAL FANS—This Section specifies axial fans for indoor installations.

15853—POWER VENTILATORS—This Section specifies power ventilators for indoor or outdoor installations.

15854—CENTRAL-STATION AIR-HANDLING UNITS—This Section specifies central-station air-handling units with coils for indoor installations.

15855—DIFFUSERS, REGISTERS, AND GRILLES—This Section specifies outlet and inlet air terminals, including diffusers, registers, and grilles.

15861—AIR FILTERS—This Section specifies factory-fabricated air-filter devices and media used to remove particulate matter from air for HVAC applications.

15900—HVAC INSTRUMENTATION AND CONTROLS—This Section specifies control components, required for a complete control system, found in most HVAC control systems.

15940—SEQUENCE OF OPERATION—This Section specifies control sequences in HVAC systems. It includes examples of operation sequences that require editing to make them apply to the specific equipment and systems installed, desired operational intent, and Project conditions.

15990—TESTING, ADJUSTING, AND BALANCING—This Section specifies testing, adjusting, and balancing air and water distributions, measuring electrical performance of HVAC equipment, setting quantitative performance of HVAC equipment, verifying that automatic control devices are properly functioning, measuring sound and vibration, and reporting results of the activities and procedures specified in this Section.

## DIVISION 16

16050—BASIC ELECTRICAL MATERIALS AND METHODS—This Section specifies basic materials and methods for electrical installations, including basic Specifications for raceways, building wire, supporting devices, concrete bases, and electric identification. It also includes electrical demolition, electrical component touchup painting, cutting and patching for electrical construction, and electricity-metering equipment for Owner's and utility company's use.

16060—GROUNDING AND BONDING—This Section specifies grounding of low- and medium-voltage systems and equipment. It also covers minimum requirements for grounding electronic and other specialized systems and equipment, including those for data processing and telecommunications. This Section also provides options for specifying grounding requirements beyond the safety minimums for both power and electronic systems.

16071—SEISMIC CONTROLS FOR ELECTRICAL WORK—This Section specifies anchorage, fastening, and bracing devices used to prevent undesired movement of electrical components during earthquakes. It can be edited for use in any of the following Project situations:

16075—ELECTRICAL IDENTIFICATION—This Section specifies identification for electrical work, including raceways, cables, and equipment; warning and caution signs; and buried-cable warning tape. It is applicable on projects where identification requirements are more complex than can be covered by the basic electrical identification specifications included in Division 16 Section "Basic Electrical Materials and Methods."

16120—CONDUCTORS AND CABLES—This Section specifies low-voltage building wires and cables, including taps and splices.

16121—CONTROL/SIGNAL TRANSMISSION MEDIA—This Section specifies transmission media used for control and signal circuits for building projects. The Section includes copper conductor cables, optical fiber cables, and associated equipment for use in buildings, typically for interconnecting components of electronic data-processing, telephone, television, teleconferencing, building management and protection, and satellite communication systems.

16122—UNDERCARPET CABLES—This Section specifies flat cables for undercarpet installations in building projects. Undercarpet cables are available in two types to accommodate power and telecommunications branch circuits.

16124—MEDIUM-VOLTAGE CABLES—This Section specifies single-conductor and multiconductor cables, cable splices, and terminations for electrical distribution systems with voltages from 2001 to 35,000. This Section also specifies accessory products used directly with medium-voltage cables including splices, terminations, separable connectors, and fault indicators.

16130—RACEWAYS AND BOXES—This Section specifies electrical conduits, tubing, surface raceways, and wireways used for electrical power and signal distribution; electrical outlet, device, floor, pull, and junction boxes; raceway fittings; cabinets; and hinged-box assemblies.

16138—UNDERFLOOR RACEWAY—This Section specifies underfloor raceways, including conventional flattop, trench type, flush type, and cellular; service fittings; and junction boxes. It also specifies materials and labor for raceway connections to cellular metal deck specified in Division 5 and cellular concrete floor raceway specified in Division 3.

16139—CABLE TRAYS—This Section specifies metal cable trays used for supporting electrical wires and cables. Cable trays are also used for supporting electrical conduit and tubing systems and mechanical tubing and piping.

16140—WIRING DEVICES—This Section specifies electrical wiring devices including receptacles, snap switches, plugs, and plug connectors. This Section also specifies wall plates, floor service outlets, poke-through assemblies, telephone/power service poles, and multioutlet assemblies. Receptacle types specified include ground-fault circuit interrupters, integral surge suppression units, and isolated-ground receptacles. This Section also specifies simple dimmer switches but does not include dimmer systems. (See Division 16 Section "Lighting Control Equipment.")

MASTERSPEC continues on the next page.

ARCOM; Salt Lake City, Utah, and Alexandria, Virginia

- 16145—LIGHTING CONTROL DEVICES—This Section specifies devices for automatic control of lighting including time switches, photoelectric relays, occupancy sensors, and multipole lighting relays and contactors.
- 16215—ELECTRICAL POWER MONITORING AND CONTROL—This Section specifies an electronic interface with circuit protective devices in a power distribution system for both remote and local monitoring, metering, and control of individual circuits. It also specifies optional integration with the building automation system to extend the capabilities of that system.
- 16231—PACKAGED ENGINE GENERATORS—This Section specifies simple systems using a single diesel-engine generator set for emergency or standby electrical power applications. Use this Section to specify systems with standby ratings from 20 through 1500 kW, supplying systems rated 600 V and less.
- 16264—STATIC UNINTERRUPTIBLE POWER SUPPLY—This Section specifies 3-phase, on-line, static-type, uninterruptible power supply (UPS) units rated from 5 to 750 kVA for systems 600 V and less. This Section can be used to specify lower-rated units in this range that are suitable for location in a computer room or other finished space. Higher-rated units are usually installed separately from the loads served.
- 16265—CENTRAL BATTERY INVERTER—This Section specifies central battery inverters for supplying power to emergency and standby lighting and power circuits. These units combine a battery source with a charger and inverter. Units obtain power from a normal ac supply and are arranged to sense failure of that supply. When failure occurs, units transfer the load to the battery through the inverter. The approximate capacity range of equipment specified in this Section is from 0.5 to 20 kVA.
- 16280—POWER FACTOR CORRECTION CAPACITORS—This Section specifies capacitor-type, power factor correction equipment for use in electrical power systems rated 600 V and less. It also specifies fixed capacitors and automatic power factor correction units.
- 16288—VOLTAGE REGULATORS—This Section specifies voltage regulators and the power distribution units that often combine voltage regulators with other equipment for particular application in computer rooms and other environments.
- 16289—TRANSIENT VOLTAGE SUPPRESSION—This Section specifies transient voltage surge suppressors for application on low-voltage electrical power systems.
- 16312—SECONDARY UNIT SUBSTATIONS—This Section specifies indoor and outdoor secondary unit substations, including common types and configurations of incoming and transformer sections. This Section does not specify secondary distribution equipment directly but refers to other Sections for those requirements.
- 16315—OVERHEAD ELECTRICAL DISTRIBUTION—This Section specifies medium- and secondary-voltage overhead electrical power distribution up to 35 kV. It includes pole-mounting transformers and other equipment and materials used for upgrades or for extensions for projects associated with buildings or related construction.
- 16341—MEDIUM-VOLTAGE SWITCHGEAR—This Section specifies fusible metal-enclosed interrupter switchgear and metal-clad circuit-breaker switchgear used in indoor and outdoor equipment up to 34-kV class. This Section also specifies major accessory components used with medium-voltage switchgear, including grounding and test devices, fuses, emergency operating stations, and switchgear control batteries and chargers.
- 16350—MEDIUM-VOLTAGE TRANSFORMERS—This Section specifies transformers up to about 2500 kVA with medium-voltage primaries. Transformers in this Section are for both indoor and outdoor installation and are liquid-filled and dry-type distribution and power transformers.
- 16410—ENCLOSED SWITCHES AND CIRCUIT-BREAKERS—This Section specifies enclosed switches and circuit breakers rated 600 V and less where applied as individually mounted disconnecting means, service disconnecting means, and circuit overcurrent protection. Enclosed switches include fused and nonfused types rated 800 A and less. Circuit breakers include integrally fused circuit breakers and molded-case circuit breakers with thermal-magnetic and electronic trip units.
- 16415—TRANSFER SWITCHES—This Section specifies transfer switches and associated equipment rated 600 V and less for emergency and standby power systems. It specifies automatic transfer switches with and without bypass/isolation switches, and it specifies nonautomatic transfer switches. It also specifies the remote annunciator panels and annunciator and control panels sometimes used with automatic transfer-switch installations.
- 16419—FUSED POWER CIRCUIT DEVICES—This Section specifies bolted-pressure switches and other high-pressure contact switches rated 800 to 6000 A, 600 V or less, and accommodating Class L or Class T fuses.
- 16430—SWITCHGEAR—This Section specifies metal-enclosed, drawout, power, circuit-breaker switchgear rated 600 V and less, for use in ac systems.
- 16441—SWITCHBOARDS—This Section specifies dead-front distribution switchboards rated 600 V and less.
- 16442—PANELBOARDS—This Section specifies branch-circuit and distribution panelboards rated 600 V and less. It includes load-center-type and power-distribution panelboards with circuit-breaker or fused-switch devices. The Section also includes panelboards with integrally mounted transient voltage surge suppressor (TVSS) devices, panelboards with motor-starter branch devices, and panelboards with internal contactors and other features.
- 16450—ENCLOSED BUS ASSEMBLIES—This Section specifies standard low-voltage feeder and plug-in enclosed bus assemblies for power distribution in buildings.
- 16461—DRY-TYPE TRANSFORMERS (1000 V AND LESS)—This Section specifies dry-type distribution and specialty transformers rated 1000 V and less. Specialty transformers include buck-boost and control and signal units.
- 16481—MOTOR CONTROLLERS—This Section specifies general-purpose controllers rated 600 V and less used for starting, stopping, and controlling the speed of ac motors. This Section specifies manual controllers and magnetic and solid-state units. It also specifies auxiliary devices such as push buttons, selector switches, pilot lights, and control relays used with controllers. This Section specifies individually enclosed and mounted controllers. Basic controllers for use in group-mounted installations such as motor-control centers, switchboards, and motor-starter panelboards are specified in their respective Sections.
- 16482—MOTOR-CONTROL CENTERS—This Section specifies conventional, modular, freestanding motor-control centers operating at 600 V, ac and less.
- 16491—FUSES—This Section specifies cartridge fuses, rated 600 V and less, for use in switches, panelboards, switchboards, controllers, and motor-control centers. Use this Section with Sections specifying the above equipment.
- 16511—INTERIOR LIGHTING—This Section specifies factory-fabricated interior lighting fixtures and lighting fixtures mounted on exterior building surfaces used for general, supplemental, task, and emergency lighting applications.
- 16521—EXTERIOR LIGHTING—This Section specifies factory-fabricated exterior lighting fixtures, poles, and accessories.
- 16555—STAGE LIGHTING—This Section specifies stage lighting equipment for live performances in moderate-size auditoriums in schools, community centers, museums, and corporate centers. This Section also specifies stage lighting fixtures and control systems, including dimmer banks and a control console. Use this Section for limited-scope projects.
- 16570—DIMMING CONTROLS—This Section specifies three types of modular dimming systems and a range of wired, programmable, low-voltage lighting control systems. Time switches, photoelectric relays, and occupancy sensors are included. This Section also specifies relays and contactors required to execute on-off control commands for lighting circuits. Manual, low-voltage lighting control switches are also specified.
- 16715—PREMISES TELEPHONE WIRING—This Section specifies premises wiring for residential and light-commercial telephone distribution, with one to four service lines installed. Some projects may require that the cable and cable-terminating work for the system be provided under a separate telephone equipment contract. In such cases, delete those items and use this Section to specify the empty raceway system and the service provisions that will be required for the system.
- 16722—INTERCOMMUNICATION EQUIPMENT—This Section specifies direct-connected, manually switched and user-programmable, multichannel, microprocessor-switched, voice intercommunication equipment independent of telephone and other voice-data communication systems. This Section includes commercial, institutional, and industrial applications, but not residential systems, either single or multifamily.

16723—SCHOOL INTERCOM AND PROGRAM EQUIPMENT—This Section specifies voice intercommunication equipment for use in elementary and secondary schools. The Section permits the specifier to select between manually and microprocessor-switched equipment. The manually switched system is specified as the conventional, direct-connected, keyed system. The microprocessor-switched system is user programmable and can be upgraded in the future. Both systems are specified with the usual options for selective paging and for clock and program interface. The ability to transmit programmed audio material to classrooms and other spaces is also specified.

16725—NURSE CALL—This Section specifies basic visual and audiovisual patient-nurse communication equipment for healthcare facilities. Section organization permits the specifier to select between two equipment options: visual/ tone and audiovisual/voice. Both types of equipment are primarily used in small institutions. The selection is based on communication needs, existing equipment coordination requirements, staff preference, and budgetary planning.

16726—PUBLIC ADDRESS AND MUSIC EQUIPMENT—This Section specifies public address and music equipment. It can be used to specify equipment for background music, announcements, and paging and for giving instructions in such locations as stores, public places, waiting rooms, warehouses, offices, industrial plants, and schools. Features covered in this Section, such as the paging console, can be deleted for projects that do not require them. Other features may be added.

16727—SOUND-MASKING EQUIPMENT—This Section specifies electronic sound-masking equipment to help achieve privacy for normal conversation in indoor spaces, particularly in open office areas.

16740—COMMUNICATION AND DATA-PROCESSING EQUIPMENT—This Section specifies basic interior wiring for telecommunications systems in buildings. The communication wiring specified in this Section is suitable for local area networks (LANs) and telephone systems for voice and data communications. LAN media included in this Section support generic low- and high-speed LANs for data transmission rates up to 100 Mbps or more. System components included in this Section are items such as copper and fiber-optic cable, connecting blocks, outlet assemblies, cross connects, and patch panels.

16850—TELEVISION EQUIPMENT—This Section specifies closed-circuit television (CCTV) and master antenna television (MATV) systems. For MATV systems, this Section includes the options of off-air antennas, a community antenna television (CATV) service, a local CCTV system, and television receive-only earth stations as signal sources for television program material. Both fiber-optic and copper cabling are included for transmitting video signals.

ARCOM: Salt Lake City, Utah, and Alexandria, Virginia



CONSTRUCTION INFORMATION SYSTEMS

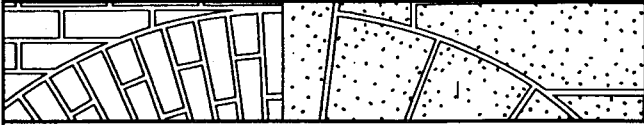

# SITWORK

Subsurface Investigation    144

Excavation Support  
Systems    145

Piles and Caissons    146

Water Distribution    147

Sewerage and Drainage    148

Paving and Surfacing    156

Site Improvements and  
Amenities    159

Retaining Walls    170

Planting    177

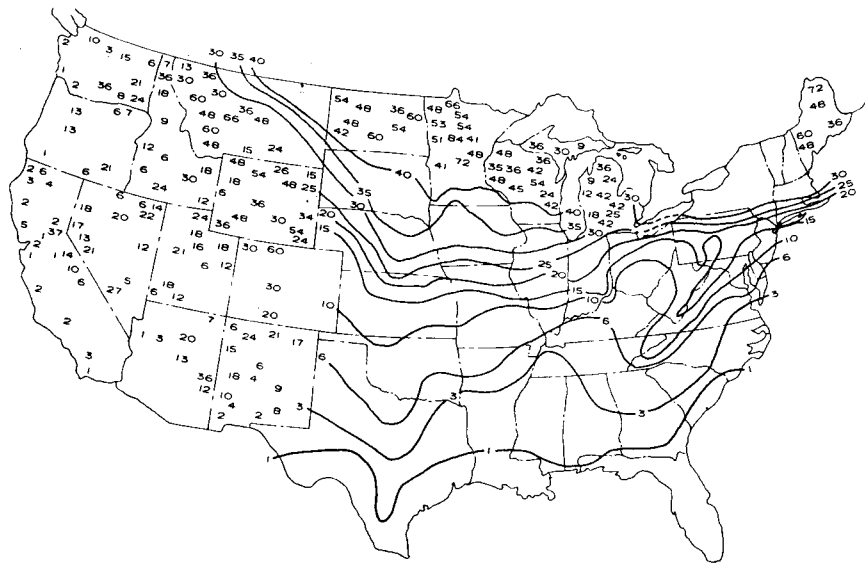

AVERAGE DEPTH OF FROST PENETRATION (IN.)  
SOURCE: U.S. DEPT. OF COMMERCE WEATHER BUREAU

**PRELIMINARY SUBSURFACE INFORMATION**

- A. Collect available information for soil, rock, and water conditions, including the following:
  1. Topographic and aerial mapping.
  2. Geological survey maps and publications.
  3. Local knowledge (history of site development, experience of nearby structures, flooding, subsidence, etc.).
  4. Existing subsurface data (boreholes, well records, water soundings).
  5. Reconnaissance site survey.
  6. Previous studies.
- B. Evaluate available information for site acceptability. If available data are insufficient, consult a geotechnical engineer to perform a limited subsurface investigation to gather basic information.
- C. Consult geotechnical engineer for potential foundation performance at each site as part of the selection process.

**DETAILED SUBSURFACE INFORMATION**

After selection of a potential site a subsurface and laboratory test investigation should be carried out by a qualified geotechnical engineer before design is undertaken.

The investigation should provide an adequate understanding of the subsurface conditions and the information should be assessed to determine potential foundation behavior.

The engineer should evaluate alternative foundation methods and techniques in conjunction with the architect.

The engineer or architect should provide inspection during construction to ensure that material and construction procedures are as specified and to evaluate unexpected soil, rock, or groundwater conditions that may be exposed by excavations.

**SOIL TYPES AND THEIR PROPERTIES**

DIVISION	SYMBOLS			SOIL DESCRIPTION	VALUE AS A FOUNDATION MATERIAL	FROST ACTION	DRAINAGE
	LETTER	HATCHING	COLOR				
Gravel and gravelly soils	GW		Red	Well-graded gravel, or gravel-sand mixture, little or no fines	Excellent	None	Excellent
	GP		Red	Poorly graded gravel, or gravel-sand mixtures, little or no fines	Good	None	Excellent
	GM		Yellow	Silty gravels, gravel-sand-silt mixtures	Good	Slight	Poor
	GC		Yellow	Clayey-gravels, gravel-clay-sand mixtures	Good	Slight	Poor
Sand and sandy soils	SW		Red	Well-graded sands, or gravelly sands, little or no fines	Good	None	Excellent
	SP		Red	Poorly graded sands, or gravelly sands, little or no fines	Fair	None	Excellent
	SM		Yellow	Silty sands, sand-silt mixtures	Fair	Slight	Fair
	SC		Yellow	Clayey sands, sand-clay mixtures	Fair	Medium	Poor
Silt and clays LL < 50	ML		Green	Inorganic silts, rock flour, silty or clayey fine sands, or clayey silts with slight plasticity	Fair	Very high	Poor
	CL		Green	Inorganic clays of low to medium plasticity, gravelly clays, silty clays, lean clays	Fair	Medium	Impervious
	OL		Green	Organic silt-clays of low plasticity	Poor	High	Impervious
Silt and clays LL > 50	MH		Blue	Inorganic silts, micaceous or diatomaceous fine sandy or silty soils, elastic silts	Poor	Very high	Poor
	CH		Blue	Inorganic clays of high plasticity, fat clays	Very poor	Medium	Impervious
	OH		Blue	Organic clays of medium to high plasticity, organic silts	Very poor	Medium	Impervious
Highly organic soils	Pt		Orange	Peat and other highly organic soils	Not suitable	Slight	Poor

- NOTES  
 1. Consult geotechnical engineers and local building codes for allowable soil bearing capacities.  
 2. LL indicates liquid limit.

Mueser Rutledge Consulting Engineers; New York, New York

**2** SUBSURFACE INVESTIGATION

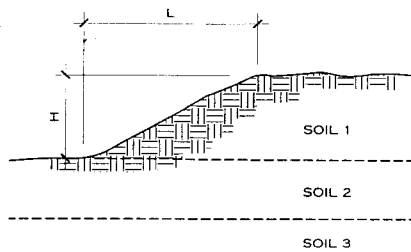
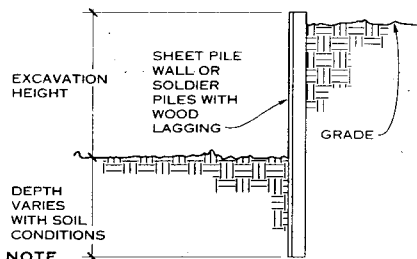

**EMBANKMENT STABILITY FOR OPEN EXCAVATION**

SOIL TYPES				REMARKS
1	2	3	L/H	
Fill	Rock	Rock	>1.5	Check sliding of Soil 1
Soft clay	Hard clay	Rock	>1.0	Check sliding of Soil 1
Sand	Soft clay	Hard clay	>1.5	Check lateral displacement of Soil 2
Sand	Sand	Hard clay	>1.5	
Hard clay	Soft clay	Sand	<1.0	Check lateral displacement of Soil 2

**CANTILEVER SHEET PILING**

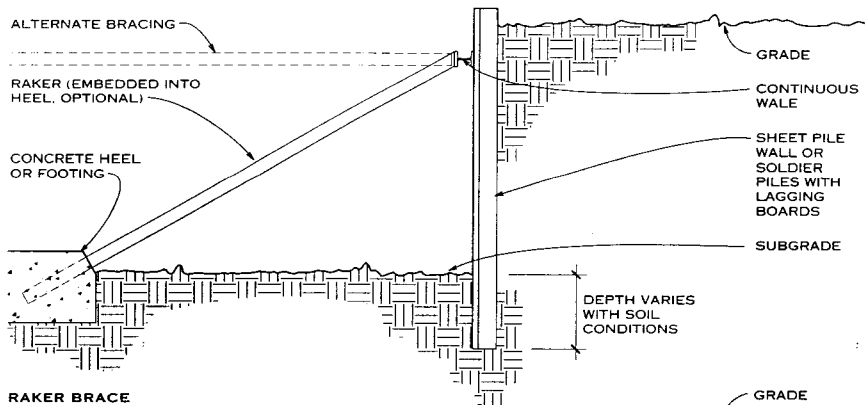

**RAKER BRACE**

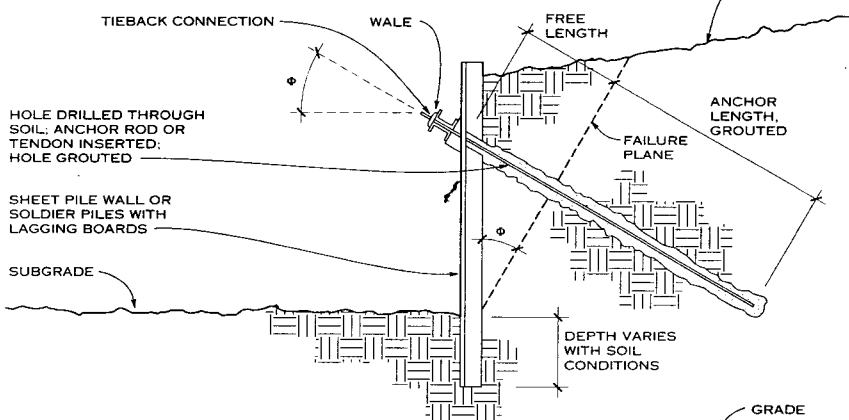

**EARTH ANCHOR BRACE**

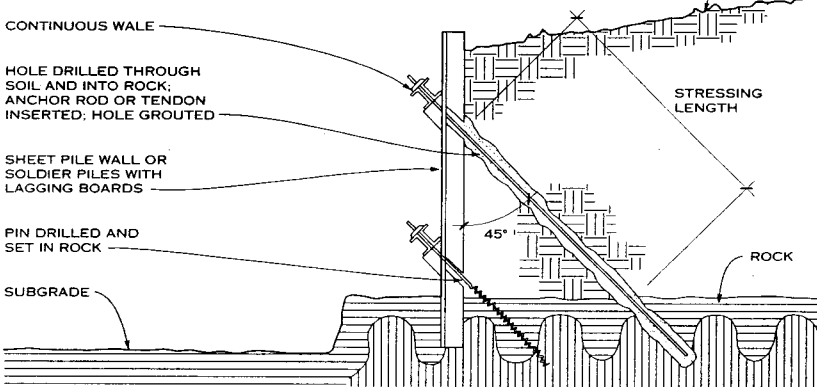

**ROCK ANCHOR BRACE**

**BRACED EXCAVATION DETAILS**

**OPEN EXCAVATION**

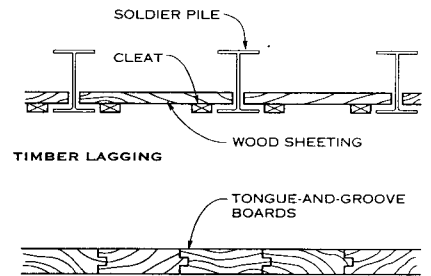

**TIMBER LAGGING**

**TIMBER SHEETING**

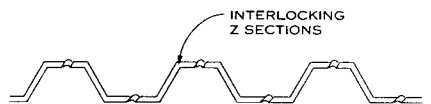

**STEEL SHEETING**

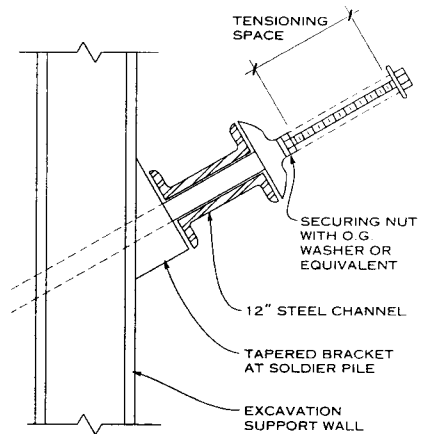

**CHANNEL WALER DETAIL**

**EXCAVATION SUPPORT COMPONENTS**

**NOTES**

1. For deep excavations, several tiers of bracing may be necessary.
2. If a subgrade of the excavation is used to install spread footings or mats, proper dewatering procedures may be required to avoid disturbing the bearing level.
3. At times, it may be possible to improve the bearing stratum by excavating compressible materials and replacing them with compacted granular backfill.
4. For evaluation of problems encountered with sheeting and shoring, consult a foundation engineer.
5. Local codes and OSHA regulations must be considered. Consult a foundation engineer for excavation design.
6. Proximity of utilities and other structures must be considered in excavation design.

Donald Neubauer, P.E.; Neubauer Consulting Engineers; Potomac, Maryland  
Mueser Rutledge Consulting Engineers; New York, New York



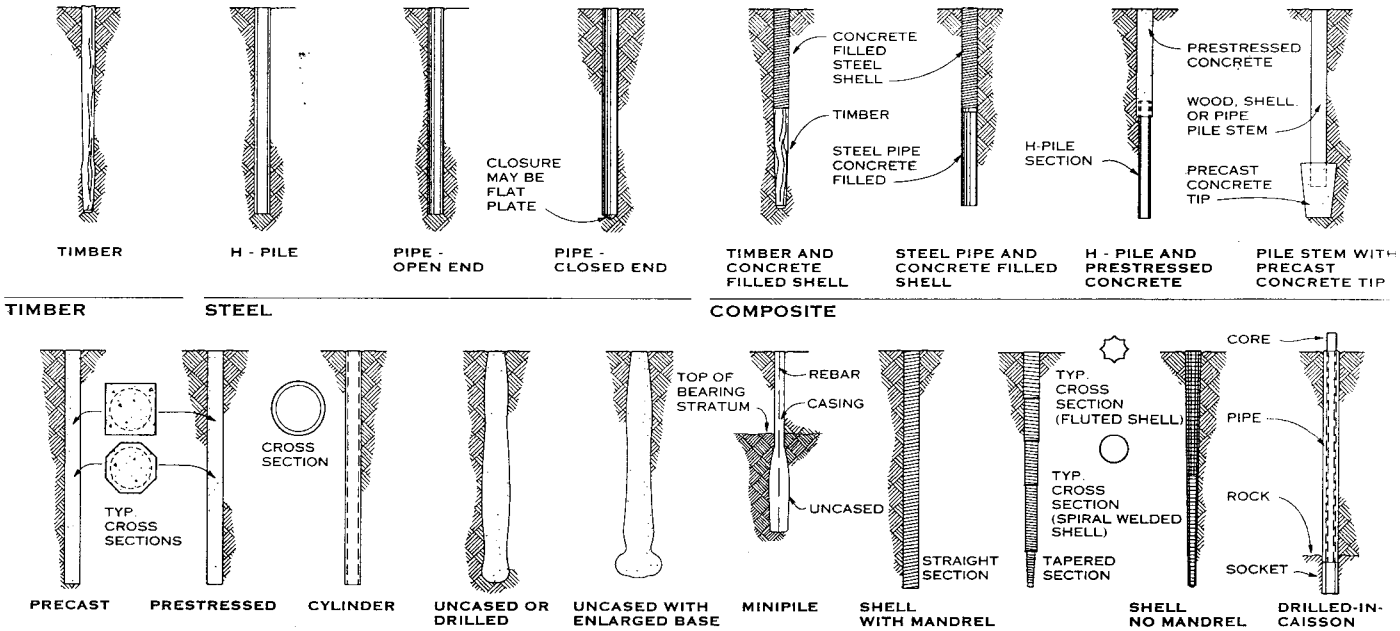

**CONCRETE**

**NOTES**

1. A mandrel is a member inserted into a hollow pile to reinforce the pile shell while it is driven into the ground.
2. Timber piles must be treated with wood preservative when any portion is above the groundwater table.
3. Uncased piles smaller than 30 inches should be installed using a continuous flight hollow stem auger with grout injected under pressure. Alternatively, a heavy wall casing is used to compact zero slump concrete to enlarge the base of the pile and assure pile continuity.
4. Uncased piers 30 inches in diameter and larger are installed using various types of augers and may be enlarged at the base using a belling tool in some soils. Refer to ACI 336.1 and ACI 336.3.

**GENERAL PILE DATA**

PILE TYPE	MAXIMUM LENGTH (FT)	OPTIMUM LENGTH (FT)	SIZE (IN.)	MAXIMUM CAPACITY (TONS)	OPTIMUM LOAD RANGE (TONS)	USUAL SPACING
<b>TIMBER</b>						
Timber	110	45 - 65	5 - 10 tip 12 - 20 butt	40	15 - 25	2' - 6" to 3' - 0"
<b>STEEL</b>						
H-pile	250	40 - 150	8 - 14	200	50 - 200	2' - 6" to 3' - 6"
Pipe—open end concrete filled	200	40 - 120	7 - 36	250	50 - 200	3' - 0" to 4' - 0"
Pipe—closed end concrete filled	200	30 - 80	10 - 30	200	50 - 70	3' - 0" to 4' - 0"
Shell—mandrel concrete filled straight or taper	100	40 - 80	8 - 18	75	40 - 60	3' - 0" to 3' - 6"
Shell—no mandrel concrete filled	150	30 - 80	8 - 18	80	30 - 60	3' - 0" to 3' - 6"
Drilled-in caisson concrete filled	250	60 - 120	24 - 48	3,500	1,000 - 2,000	6' - 0" to 8' - 0"
<b>CONCRETE</b>						
Precast	100	40 - 50	10 - 24	100	40 - 60	3' - 0"
Prestressed	270	60 - 80	10 - 24	200	100 - 150	3' - 0" to 3' - 6"
Cylinder pile	220	60 - 80	36 - 54	500	250 - 400	6' - 0" to 9' - 0"
Uncased or drilled piles or piers	120	10 - 50	12 - 120	500	30 - 200	3' - 0" to 8' - 0"
Uncased with enlarged base	120	25 - 50	14 - 20	150	40 - 100	6' - 0"
Minipiles	200	25 - 70	2.5 - 7	100	5 - 40	2' - 0" to 4' - 0"
<b>COMPOSITE</b>						
Concrete - timber	150	60 - 100	5 - 10 tip 12 - 20 butt	40	15 - 25	3' - 0" to 3' - 6"
Concrete - pipe	180	60 - 120	10 - 23	150	40 - 80	3' - 0" to 4' - 0"
Prestressed concrete H - pile	200	100 - 150	20 - 24	200	120 - 150	3' - 6" to 4' - 0"
Precast concrete tip	80	40	13 - 35 tip 19 - 41 butt	180	30 - 150	4' - 6"

**NOTE**

Applicable material specifications Concrete-ACI 318; Timber-ASTM D25: Structural Sections ASTM A36, A572, and A690. For selection of type of pile, consult a foundation engineer.

Mueser Rutledge Consulting Engineers; New York, New York

**2 PILES AND CAISSONS**

**TYPES OF WATER SUPPLY**

Water supply systems commonly employed for residential use are public water supply systems (mains); wells; cisterns/ rainwater catchments; natural springs; natural waterways (ponds, lakes, streams, rivers); and distillation.

**GENERAL NOTES**

- All water supply systems should be inspected, tested, and approved by local or state authorities, as required, before operation.
- Flush newly installed systems with fresh water, disinfect to remove contaminants, and perform bacteriological and chemical tests as required. Repeat testing on a regular basis, biennially or as recommended by health authorities.
- Surface contamination can extend to depths of 20 ft (or greater, depending on soil material). Seal casing/piping joints and voids surrounding the piping to prevent contamination seepage.
- Depending on the source, groundwater is generally cleaner and more pure than surface water. The ultimate use of the water (for toilet or laundry, irrigation, watering farm animals, human drinking and bathing) determines purity requirements. Consider disinfection and filtration systems to remove harmful bacteria and excessive impurities and minerals that affect water taste or quality.
- "Graywater" (water retrieved from bathing, laundry, or kitchen sources) can easily be filtered, stored, and recycled for nonpotable uses such as toilets, car washing, or irrigation. In addition, it can be processed through natural biological systems and returned to potable uses.

**WELLS**

Well details given here are generally from the *Manual of Individual Water Supply Systems* prepared by the Environmental Protection Agency's Office of Drinking Water (1982).

**WELL LOCATION:** Wells should be located at least 100 ft from (septic tank) sewage disposal. Check local codes.

**CAPACITY OF WELL, PUMP, AND PRESSURE TANK:** After drilling, test capacity for at least 4 hrs at a constant yield and drawdown. Determine minimum acceptable well capacity from the chart on this page titled "Determining Recommended Pump Capacity," then add a factor of safety and usage, preferably 100%. Use the same chart to determine the required pump capacity. The capacity of the pressure tank is figured by multiplying the pumping rate by 5 or 10 (42 gal minimum).

If a well does not have a pump capacity shown in the chart on this page, provide a smaller well pump and storage tank followed by a circulating pump and pressure tank.

**DISINFECTION:** Wells and associated piping should be disinfected before they are put into operation.

**TYPES OF WELL PUMPING SYSTEMS:** Pumping systems used for wells include a centrifugal pump with a motor aboveground and below the water level in the well; a jet pump, which has both pump and motor aboveground; and direct and reciprocating pumps in the well with a motor aboveground. (An artesian well is one in which the power of the water pressure elevates a column of water above the original water level without pumps.)

**CISTERNS**

Cisterns are man-made collection reservoirs (usually covered to stop evaporation) that store rainwater collected from roofs or paved areas called catchments. Cisterns are made of steel, polyethylene, concrete, and other chemically inert materials.

**TYPES OF WELLS**

TYPE	DEPTH	DIAM.	REMARKS
Dug	To 50 ft	3-20 ft	"Wishing well" type; masonry lining; can absorb surface contamination; susceptible to periodic dry spells
Bored	To 100 ft	2-30 in.	Bored with augers; vitrified tile or steel pipe casing; seal joints to 20-ft depth to prevent surface contamination
Driven	To 50 ft	1-2 in.	Driven by well-points; coupled pipe section casing; quick and cheap but shallow depth
Drilled	To 1000 ft	4-24 in.	Drilled by percussion or rotary bit; plastic or steel casing installed after full depth is drilled; expensive, large machinery required but greatest depths/water availability and constancy

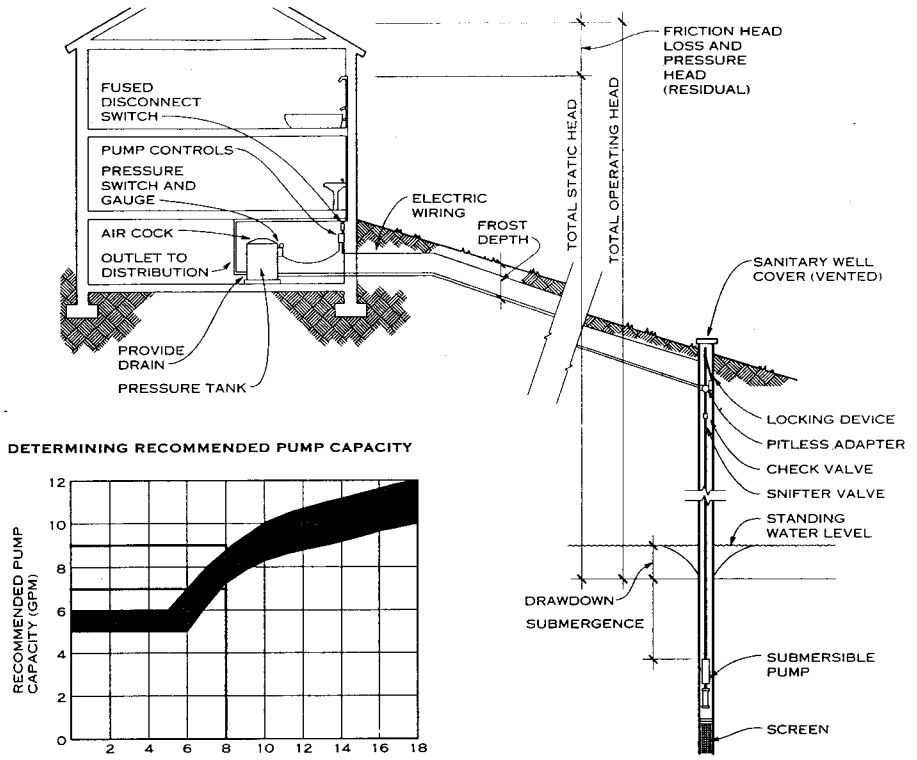

**DETERMINING RECOMMENDED PUMP CAPACITY**

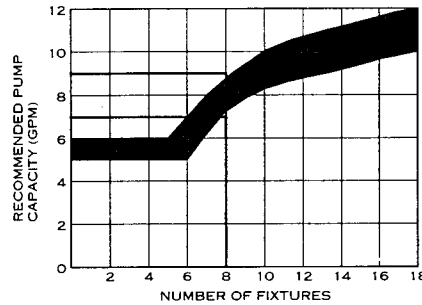

**TYPICAL DRILLED WELL AND DOMESTIC WATER DISTRIBUTION**

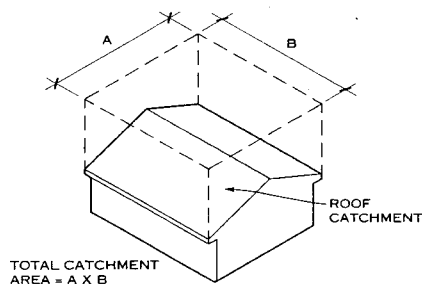

**ROOF CATCHMENT CALCULATION FOR CISTERN DESIGN**

Nonresistive materials are used for catchment areas and drainpipes. Water from cisterns may be used for emergencies only or for garden watering, cleaning, toilet flushing, bathing, laundry, dishwashing, or other, nonpotable uses.

Major factors used to estimate cistern capacity are amount of rainfall in the catchment area, effective collections surface, storage capacity, user water consumption per day, longest dry period for the region, and availability of other sources of water for emergencies. Basically, cistern size comes down to the relationship between how fast the tank is emptied and how fast it is filled and how much of a buffer is required. For residential use, consumption ranges from 30-50 gal/person/day. Water is produced at a rate between 0.4 and 0.6 gal/sq ft of catchment area per in. of rain. Consult local meteorological records and codes to determine cistern design.

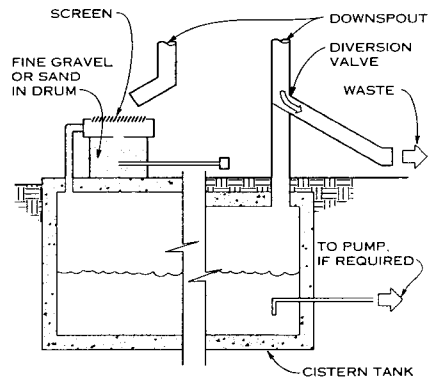

**SAND FILTER DIVERSION VALVE CISTERN TYPES FOR WATER PURIFICATION**

**NOTES ON CISTERNS**

- Locate cisterns as close as practical to the ultimate point of use and away from potential flooding to avoid contamination.
- Screen inlet and outlet piping to prevent the entrance of debris, insects, or animals.
- Provide sump, drainage, and lockable access for annual cleaning and disinfection of the storage tank.

**CAPACITIES OF TANKS AND CISTERNS (GALLONS)**

DEPTH (FT)	SQUARE TANK SIZES			ROUND TANK SIZES (DIAM.)			
	8 FT	10 FT	12 FT	8 FT	10 FT	12 FT	14 FT
4	1920	3000	4320	1500	2350	3380	4610
6	2880	4500	6480	2250	3520	5070	6920
8	3840	6000	8640	3000	4700	6760	9220
10	4790	7500	10,800	3760	5870	8460	11,520
12	5748	8976	12,960	4510	7040	10,150	13,830

Daniel F. C. Hayes, AIA; Washington, D.C.

**GENERAL**

Subsurface drainage systems are very different engineering designs than surface drainage systems. Surface drainage systems intercept and collect storm water runoff and convey it away from a building and site with the use of large inlets and storm drains. Subsurface drainage systems typi-

cally are smaller in size and capacity, designed to intercept the slower underground flows of a natural groundwater table, underground stream, or infiltration of soils from surface sources. Surface and subsurface systems typically require discharge either through a pumping station or by gravity drainage to an adequate outfall.

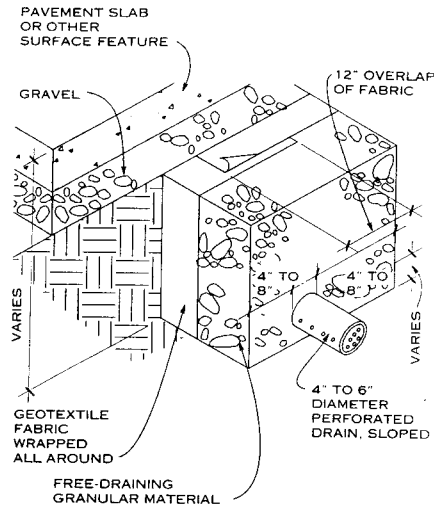
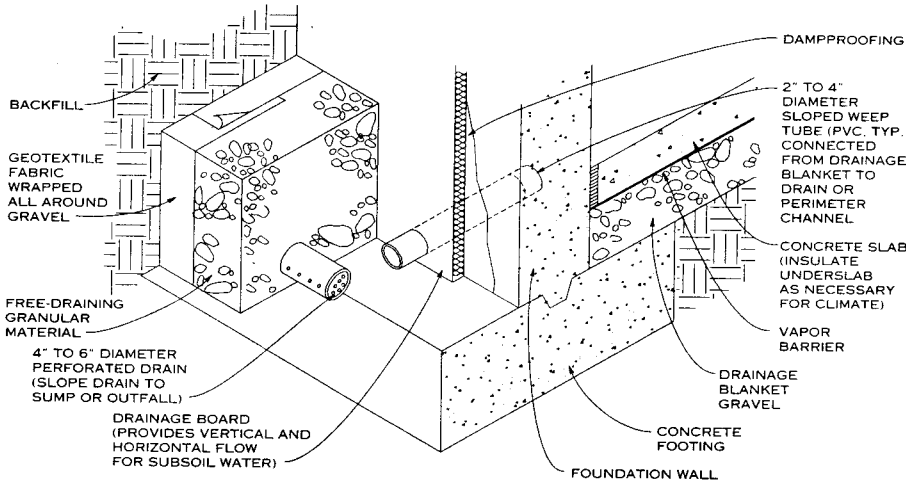

**NOTES**

1. The depth of a drain determines how much subsurface water levels will be reduced.
2. When a perforated drain is used, install it with the holes facing down.
3. When used to intercept hillside seepage, the bottom of a trench should be cut a minimum of 6 in. into underlying impervious material.

**TYPICAL PERIMETER FOOTING DRAIN**

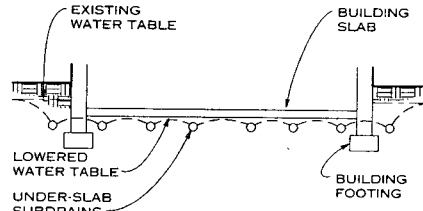
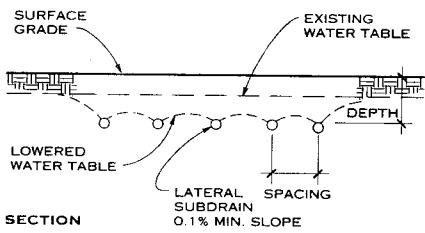

**TYPICAL SUBSURFACE DRAIN**

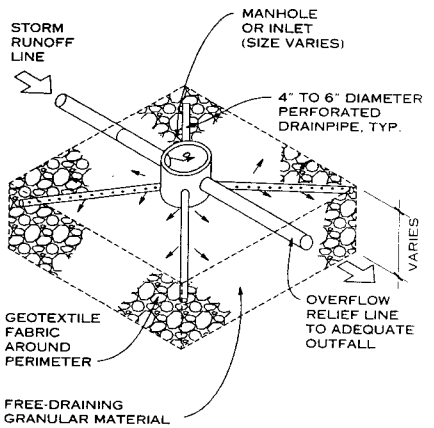

**NOTE**

Dry wells provide an underground disposal system for surface runoff, but their effectiveness is in direct proportion to the porosity of surrounding soils, and they are efficient only for draining small areas. High rainfall runoff rates cannot be absorbed at the rather low percolation rates of most soils, so the difference is stored temporarily in a dry well. Efficiency is reduced during extended periods of wet weather, when receiving soils are saturated and the well is refilled before it drains completely.

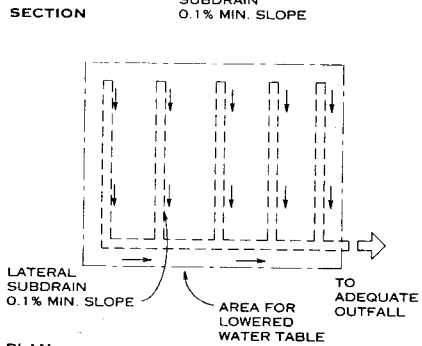

**PLAN NOTES**

1. Subsoil drainage systems are laid out to meet the needs of a site. A grid, parallel lines, or random pattern at low points in the topography is used to collect subsurface water.
2. Depth and spacing of subsoil drainage pipes depend on soil conditions. Geotechnical design may be required to ensure effective operation of a subsoil drainage system.

**UNDER-SITE SUBSOIL DRAINAGE**

**UNDER-BUILDING SUBSOIL DRAINAGE**

**DRY WELL**

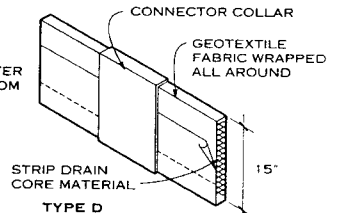
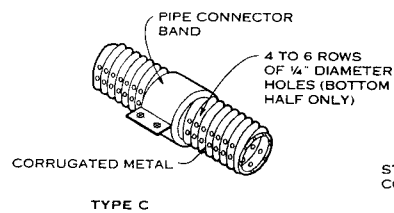
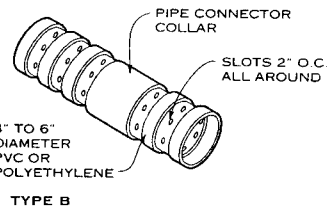
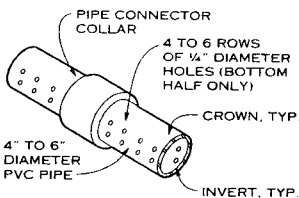

**SUBSURFACE DRAINPIPES**

Joseph P. Mensch, P.E.; Wiles Mensch Corporation; Reston, Virginia  
 Kurt N. Pronske, P.E.; Reston, Virginia  
 Harold C. Munger, FAIA; Munger Munger + Associates Architects, Toledo, Ohio

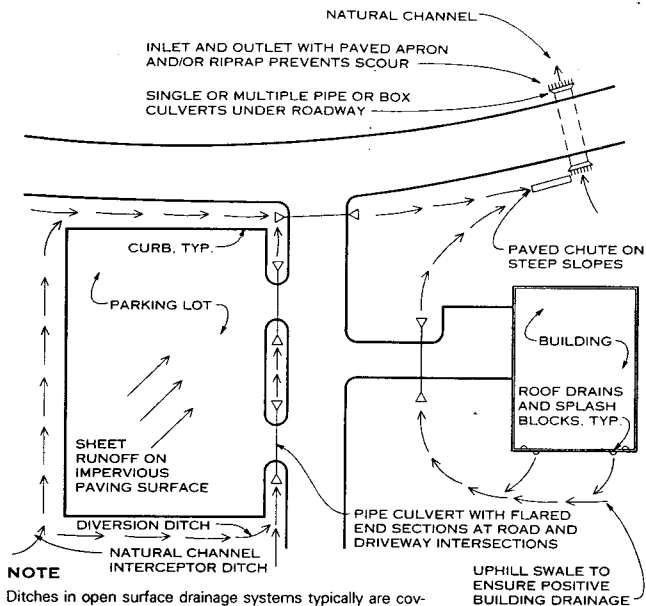

**NOTE**  
Ditches in open surface drainage systems typically are covered with grass, either seeded with a protective covering or laid with sod.

**OPEN SYSTEM**

**SURFACE DRAINAGE SYSTEM TYPES (IMPERVIOUS PAVING)**

**GENERAL**

Surface drainage systems are designed to collect and dispose of rainfall runoff to prevent the flow of water from damaging building structures (through foundation leakage), site structures, and the surface grade (through erosion). The two basic types of surface drainage are the open system and the closed system.

The open system, which utilizes a ditch/swale and culvert, is used in less densely populated, more open areas where the flow of water above grade can be accommodated fairly easily. The closed system, which utilizes pipes, an inlet/catch basin, and manholes, is used in more urban, populated areas, where land must be used efficiently and water brought below the surface quickly to avoid interference with human activity. The two systems are commonly combined where terrain, human density, and land uses dictate.

A pervious or porous paving system is often used for parking and other hard site surfaces. This drainage system allows water to percolate through the paved surface into the soil, similar to the way the land would naturally absorb water.

**NOTES**

- All slopes, grades, swales, and other drainage features must be laid out according to the ADA, without restricting accessible routes for persons with disabilities.
- Lay out grades so runoff can safely flow away from buildings. If drains become blocked, backed-up water should not accumulate around the foundation.
- An open system, or one in which water is kept on top of the surface as long as possible, is generally more economical than a closed system.
- Consider the effect of ice forming on the surface when determining slopes for vehicles and pedestrians.
- Consult local codes on such criteria as intensity and duration of rainstorms and allowable runoff for the locality.
- Formulas given on this page are meant for approximation only. Consult a qualified engineer or landscape architect to design a site-specific system.

**RUNOFF VELOCITY**

VELOCITIES (Channel)	MIN. (ft/sec)	MAX. (ft/sec)
Grass—athletic field	0.5	2
Walks—long.	0.5	12*
Walks—transverse	1	4
Streets—long.	0.5	20
Parking	1	5
Channels—grass swale	1	8
Channels—paved swale	0.5	12

\*8.3% maximum for handicapped access

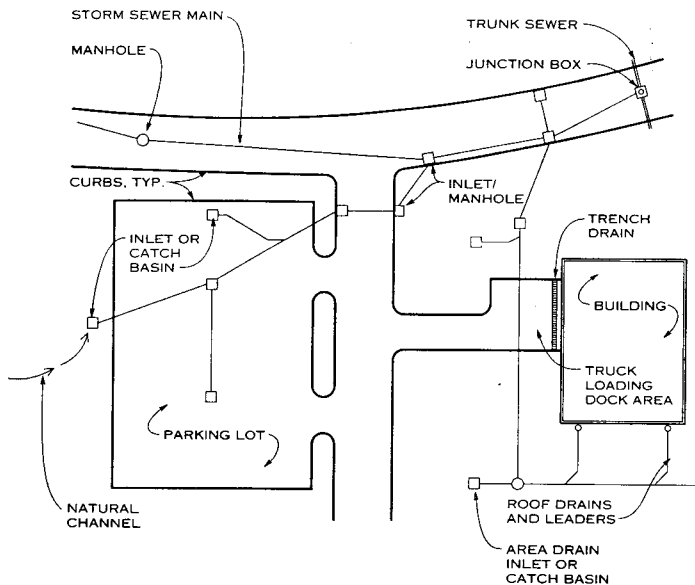

**CLOSED SYSTEM**

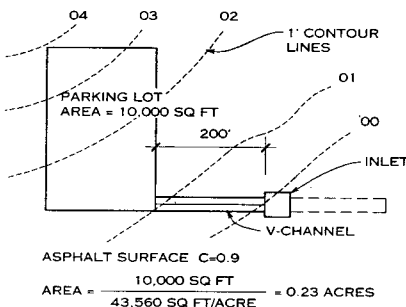

**NOTE**

Following is a simplified method for calculating the approximate runoff of areas less than 100 acres:

$$Q = C \times I \times A$$

Q = flow (cu ft/sec)  
C = surface runoff value (see table)  
I = intensity (in./hr; obtain from local codes)  
A = area of site (acres)

For example, assume the local code requires I = 5 in./hr:

$$Q = C \times I \times A$$

$$Q = 0.9 \times 5 \times 0.23$$

$$Q = 1.04 \text{ cu ft/sec}$$

Q = approximate volume of water per second entering the V-channel from the parking lot

**CALCULATION OF RUNOFF**

**SURFACE RUNOFF VALUES (C)**

SURFACE	VALUE
Roofs	0.95-1.00
Pavement	0.90-1.00
Roads	0.30-0.90
Bare soil—sand	0.20-0.40
Bare soil—clay	0.30-0.75
Grass	0.15-0.60
Commercial development	0.60-0.75
High-density residential development	0.50-0.65
Low-density residential development	0.30-0.55

**NOTE**

All values are approximate.

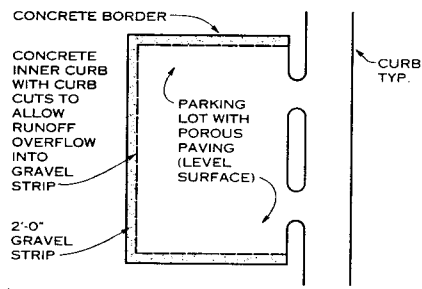

**POROUS PAVING SYSTEM**

**POROUS PAVING MATERIALS**

The two principal types of porous paving are a monolithic surfacing material and unit pavers. Monolithic porous paving is stone aggregate bound with asphalt or portland cement. The aggregate must be sorted to exclude the "fines" or sand-sized particles that normally fill the voids between larger pieces. Without the fines, the paving material allows water to run through it. Generally, porous asphalt and concrete are both strong enough for parking and roadway surfaces and pedestrian uses. Precast unit pavers, with shapes that allow water to flow through them, can also give surface stability for parking or driveways. Paver types are available for exposed placement or for burial just below the surface. In the latter case, the soil-pea gravel or vegetation in the pavers is exposed and can help percolate precipitation into the ground.

To reduce runoff and increase water absorption, porous paving must be underlaid with a bed of unbound aggregate. The unbound aggregate acts as a structural support and forms a reservoir to hold precipitation until it can percolate into the soil. Use of porous paving may permit use of a significantly smaller and simpler storm drainage system.

**SLOPES**

DESCRIPTION	MIN. %	MAX. %	REC. %
Grass—mowed	1	25	1.5-10
Grass—athletic field	0.5	2	1
Walks—long.	0.5	12*	1.5
Walks—transverse	1	4	1-2
Streets—long.	0.5	20	1-10
Parking	1	5	2-3
Channels—grass swale	1	8	1.5-2
Channels—paved swale	0.5	12	4-6

\*8.3% maximum for handicapped access

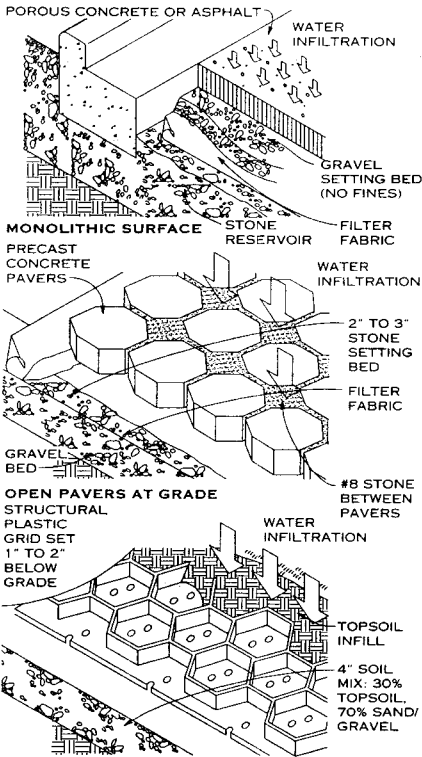

STRUCTURAL GRID/PAVERS BELOW GRADE  
 POROUS PAVING TYPES

**METHOD FOR SIZING CHANNELS**

Channels and pipes for handling water runoff may be sized by determining the flow of water (Q) with the formula  $Q = Va$ . V is the velocity of the runoff water in ft/sec as determined by the Manning formula, and "a" is the cross-sectional area of water given in square feet. For a given Q, adjust the channel or pipe shape, size, and/or slope to obtain the desired velocity (one that will not erode earth, grass ditches, or other features).

The Manning formula is  $V = 1.486/n \times r^{0.67} \times S^{0.5}$ , in which n = values relating to surface characteristics of channels (see table), r = hydraulic radius (see table), and S = slope (the drop in ft/length).

For example, assume a 200-ft concrete V-channel for which  
 W = 2 ft  
 h = 0.5 ft  
 S = 0.005 (1 ft/200 ft)  
 r = 0.37 (calculated using V-channel properties)  
 $V = (1.486/0.015) \times 0.25^{0.67} \times 0.005^{0.5}$   
 = 2.6 ft/sec (see runoff velocity table on first AGS surface drainage page).

To check flow, follow these steps:

$Q = Va$  ("a" from channel properties)  
 = 2.6 x 0.5 = 1.3 cu ft/sec.

Use the formula for calculating runoff ( $Q = C \times I \times A$ ; given on the first AGS surface drainage page) to determine the flow required for a site; compare it to the capacity of a channel sized according to the Manning formula to determine whether the channel design is satisfactory.

**n VALUES FOR MANNING FORMULA**

CHANNEL SURFACE	n
Cast iron	0.012
Corrugated steel	0.032
Clay tile	0.014
Cement grout	0.013
Concrete	0.015
Earth ditch	0.023
Cut rock channel	0.033
Winding channel	0.025

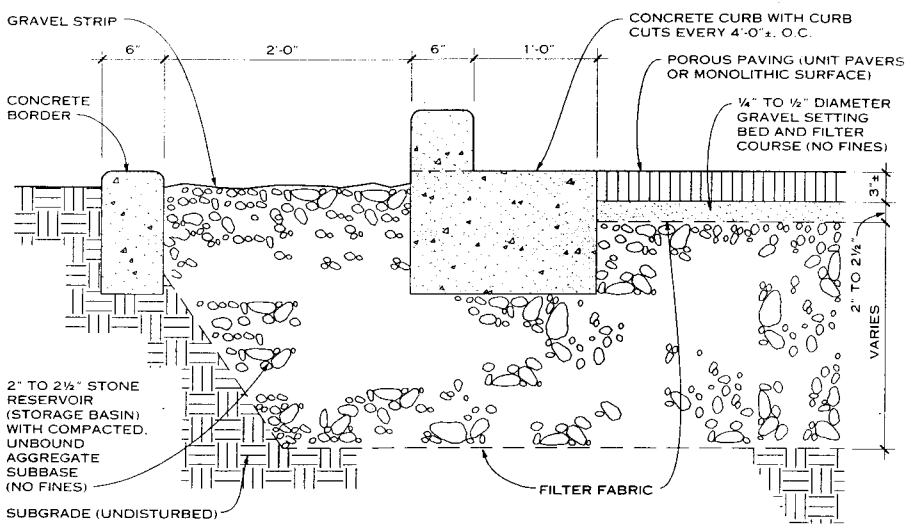

POROUS PAVING AND STONE RESERVOIR DETAIL

**NOTES ON POROUS PAVING**

1. Soils around porous paving installations must have a minimum percolation rate of about 1/2 in./hr and should not be more than about 30% clay. On sites where the slope is greater than 3%, terracing the paved areas allows the bottom of each reservoir to remain level.
2. Proper specification and supervision are important in the installation of porous paving materials. Soil under the reservoir must not be unduly compacted during construction.
3. Porous concrete can withstand heavier loads than porous asphalt. Because it does not soften in hot weather and may be more susceptible to freeze-thaw damage, it is better suited to warmer climates. Additives may be introduced to improve cold climate performance.

4. Porous asphalt has good freeze-thaw resistance but is best suited for areas in which traffic is limited, such as employee parking.
5. While clogging of monolithic porous paving is generally not a problem, recommended maintenance may include use of a hydrovac once or twice a year, as well as the prompt removal of leaves and windblown sand.
6. The reservoir below porous paving has no fixed depth but is designed according to the slope of the site, the soil percolation rate, and the size of the design storm. Consult a civil engineer or landscape architect.

**HYDRAULIC PROPERTIES OF TYPICAL CHANNEL SECTIONS**

TYPE SECTION	WIDTH (W)	BASE (b)	DEPTH (d)	AREA (a)	WETTED PERIMETER (P)	HYDRAULIC RADIUS (r)
RECTANGULAR	b or a/d	W or a/d	a/b	wd	W + 2d	$\frac{d}{1 + 2d/W}$
TRIANGULAR	2e	—	a/e	ed	$e\sqrt{e^2 + d^2}$	$\frac{ed}{2\sqrt{e^2 + d^2}}$
TRIANGULAR (curb and gutter)	2a/d	—	2a/W	Wd/2	$d + \sqrt{d^2 + W^2}$	$\frac{2Wd}{d + \sqrt{d^2 + W^2}}$
TRAPEZOIDAL (even sides)	b + 2e	W - 2e	a/b + e	d(b + e)	$b + 2\sqrt{e^2 + d^2}$	$\frac{d(b + e)}{b + 2\sqrt{e^2 + d^2}}$
PARABOLIC	a/0.67d	—	a/0.67W	0.67Wd	$W + \left(\frac{8d^2}{3W}\right)$	$\frac{a}{W + \left(\frac{8d^2}{3W}\right)}$

**NOTE**  
 0.3-0.5 ft recommended for freeboard (F).

Pearse O'Doherty, ASLA; Graham Landscape Architecture; Annapolis, Maryland

**GENERAL**

The grate design chosen for a particular application depends on the priorities assigned to each of the functions listed below. Local conditions may require inclusion of some or all of the performance features in a design.

**CAPACITY:** Interception of storm water is generally considered the most important function a grate can perform. The geometry and size of the openings affect this ability. Consult a civil engineer or hydrologist for individual grate capacities.

**SCREENING OF LARGE DEBRIS:** An inlet grate must act as a strainer to prevent harmful debris from entering sewer lines. A well-designed grate prevents objects such as branches, sticks, sheets of semirigid material, and chunks of wood, which can easily pass by large curb openings (such as open-throat type), from entering the catch basin.

**PASSING OF SMALL DEBRIS:** Organic material such as grass clippings, leaves, small stones, or twigs may be permitted to pass into the catch basin as they are not a hazard in sewer lines. Provide grate openings wide enough, long enough, or of special design to pass this debris and still meet requirements for roadway-safe grates.

**STRENGTH:** Inlet grates placed in roadways must be designed to withstand heavy traffic loads. The most generally accepted specifications for highway loading criteria come from the American Association of State Highway and Transportation Officials (AASHTO).

**PERMANENCY:** An inlet grate should be designed to match or exceed the expected life of the installation. Steel, aluminum, and cast iron are generally accepted materials for inlet grates, although other materials such as brass, chrome, and structural polyethylene are used in special applications.

**BICYCLE SAFETY:** Grates can be made safer for bicycle and pedestrian traffic through attention to design and installation. Options include diagonal bars set at a 45° angle; slotted grates, provided the slots are 1 1/4 to 2 1/4 in. wide and a maximum of 9 in. long and the transverse (cross) bars are spaced so a bicycle wheel cannot drop lower than about 1 in.; and bars transverse to the direction of traffic and storm water flow and slanted to conduct water into the catch basin. Grate design does not ensure safe usage; attention must be paid to usage patterns of probable users. Consult traffic engineers and local codes for more information.

Consider clogging hazards and the geometry of flow-through efficiency when designing for bicycle safety. Use of vane-shaped or sloped bars, rather than conventional vertical bars, may improve the capacity of a grate to pass storm water. Grates with these types of bars are safe for bicycles; consult manufacturers. Do not allow gutter slopes to be substantially swaled into the curb, which could create a pocket in the roadway affecting the safety of bicycles and other traffic.

**GRATE SIZING**

Most grates are oversized to prevent buildup of water; see manufacturers' catalogs for free area. The following formula for sizing grates is based on a given allowable depth of water over the grate.

$$Q = .66 CA (64.4 d)^{0.5}$$

- where A = free area (sq ft)
- d = allowable depth of water above grate (ft)
- C = orifice coefficient (0.6 for square edges, 0.8 for round)
- .66 = clogging factor

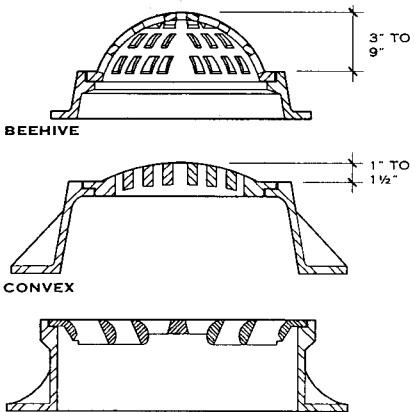

**MISCELLANEOUS GRATE DESIGNS**

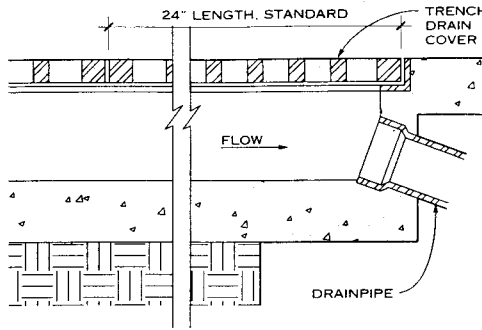

**LONGITUDINAL SECTION**

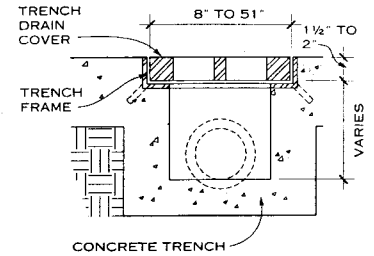

**CROSS SECTION**

**CONCRETE TRENCH DRAIN WITH GRATED COVER**

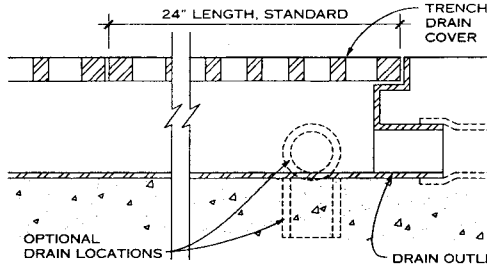

**LONGITUDINAL SECTION**

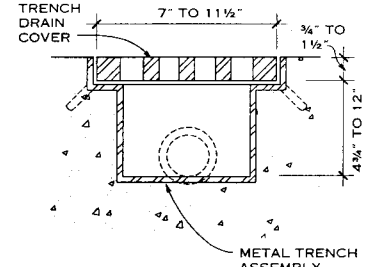

**CROSS SECTION**

**METAL TRENCH DRAIN ASSEMBLY**

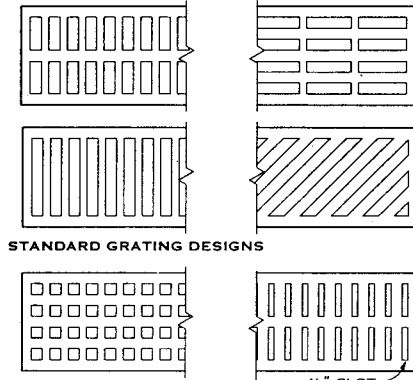

**STANDARD GRATING DESIGNS**

**GRATINGS FOR HEAVY PEDESTRIAN TRAFFIC**

**GRATING DESIGN TYPES**

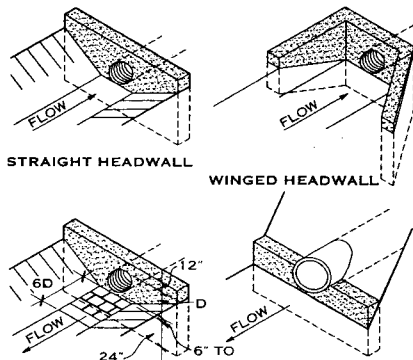

**HEADWALLS AND ENDWALLS**

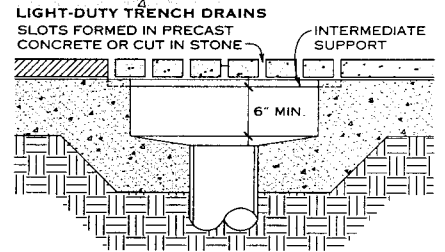
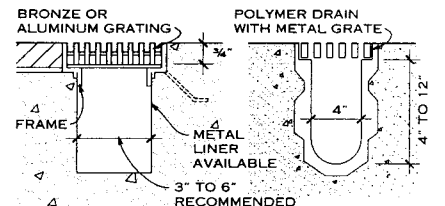

**CONCEALED DRAIN**

**MISCELLANEOUS DRAINS**

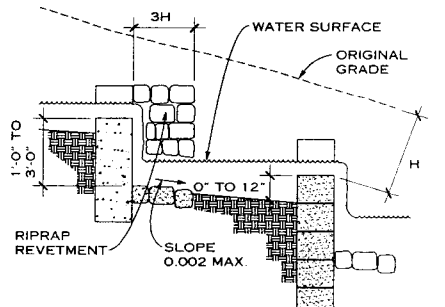

**NOTE**  
Use check dams where channel slope and velocity will cause erosion.

**CHECK DAMS**

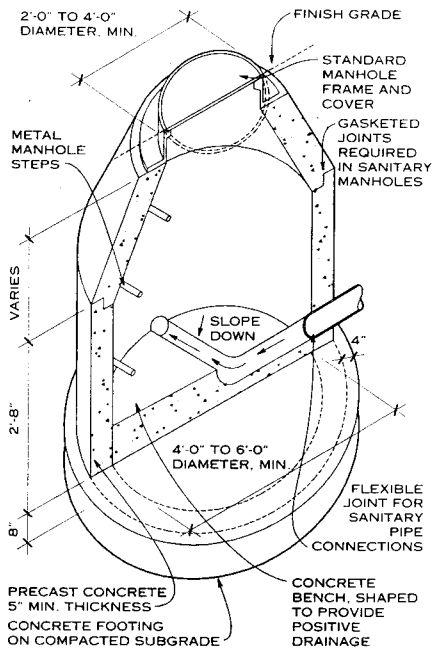

- NOTES**
1. Parging may be omitted in construction of storm sewer manholes.
  2. Wall thickness on precast concrete manholes increases with depths greater than 12 ft.
  3. Brick walls 8 in. thick may be used for manholes up to 12 ft deep. For that part of the manhole deeper than 12 ft, brick-and-block walls should be 12 in. thick. Manholes greater than 12 ft deep should have a base 12 in. thick.

**COMBINED OR SANITARY SEWER MANHOLE**

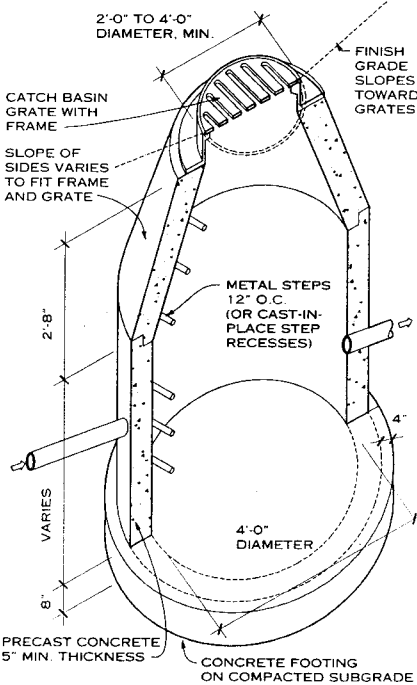

**NOTE**  
A pipe trap or hood is required for connections to combination sewers.

**CATCH BASIN**

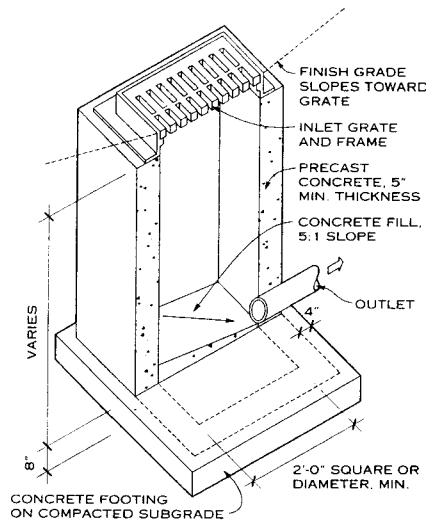

**INLET**

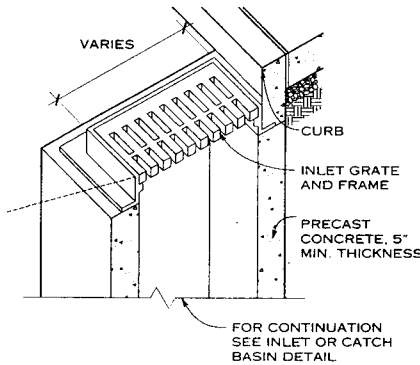

**GUTTER INLET**

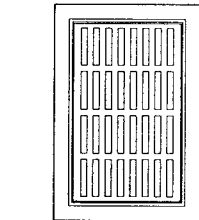

PLAN

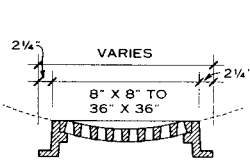

SECTION

**NOTES**

1. Frames and grates are available in many standard shapes and sizes. Constructed of cast or ductile iron, aluminum, and bronze, they are made for light- or heavy-duty loading conditions. Common shapes include round, rectangular, square, and linear. In addition, grates may be flat, concave, or convex. Consult manufacturers' catalogs for the full range of available castings.

**TYPICAL FRAMES AND GRATES**

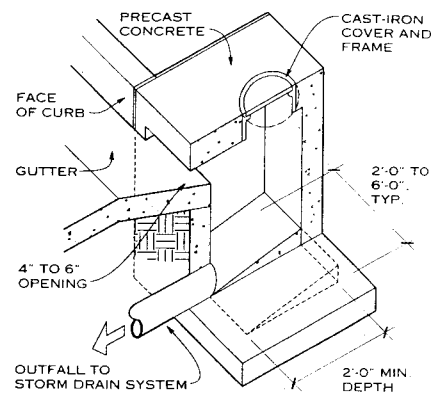

**CURB INLET**

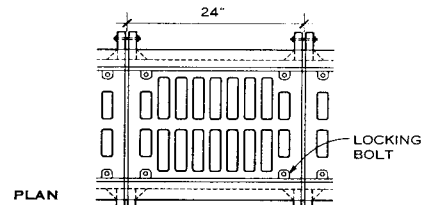

PLAN

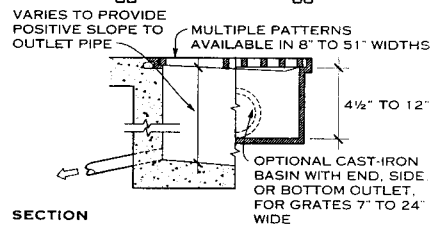

SECTION

**NOTE**

Grates without bolts are available.

**TRENCH DRAIN**

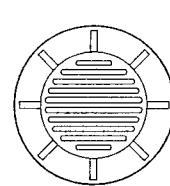

PLAN

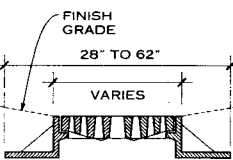

SECTION

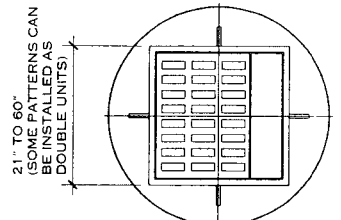

PLAN

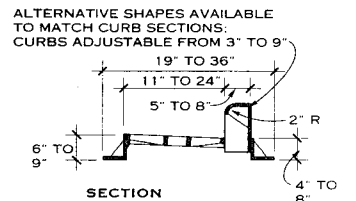

SECTION

ALTERNATIVE SHAPES AVAILABLE TO MATCH CURB SECTIONS. CURBS ADJUSTABLE FROM 3" TO 9"

2. Locate drainage structures with grated openings on or beyond the periphery of traveled ways to minimize contact with pedestrian or vehicular traffic. Grates that may come into contact with feet or narrow wheels must be constructed to prevent penetration by heels, crutch and cane tips, and slim tires but still have sufficient openings to pass the expected runoff.

Joseph P. Mensch, P.E.; Wiles Mensch Corporation; Reston, Virginia  
Kurt N. Pronske, P.E.; Reston, Virginia

**GENERAL**

Natural filtration devices in the environment retain and treat pollutants such as sediment, fertilizer, pesticides, and air pollutants before they can enter water bodies. Increasing development, however, compromises the ability of the landscape to prevent water resource contamination. Typically, when land is developed, trees that formerly intercepted rainfall and pollutants are felled; natural depressions that temporarily ponded water are graded, soil is compacted; and the thick leaf-litter humus layer of the forest floor, which had absorbed rainfall, is scraped off or erodes.

Once a site has been developed, it can no longer store as much water, and rainfall is immediately transformed into runoff and transported to rivers, lakes, wetlands, or other surface water systems. Once construction is complete and some vegetation has returned to the site, expansive impervious surfaces such as rooftops and parking lots prevent most runoff from percolating into the soil. Instead, it must be directed off site by a surface drainage system of curbs, culverts, gutters, and storm sewers.

Measures for managing pollutants include methods of construction and land development that replace natural pollution filtration pathways (e.g., forests, wetlands) with similar filtering mechanisms. Water detention systems retain water, provide for percolation to groundwater, and filter pollutants out of water runoff. These systems comprise detention basins, constructed wetlands, and other temporary and permanent erosion control measures.

When choosing appropriate runoff control measures for a site, consider the following factors: the sensitivity of the local ecosystem; slope of the site; depth of the water table; proximity to bedrock, foundations, and wells; land consumption; land use restrictions; high sediment input; and thermal impacts to downstream areas.

**NATURAL WETLAND SYSTEMS**

Wetlands naturally detain and filter water. Scattered throughout the United States, from tropical areas to tundra, they form in depressions in the landscape where the water table is near or at the surface of the soil. They may be as small as a tabletop or span tens of thousands of acres. There is no single, correct, ecologically sound definition for wetlands, primarily because of their diversity. These systems are an important part of the ecosystem because they produce food and timber, purify drinking water, absorb and store floodwater, suppress storm surges, and help maintain biodiversity. Water is supplied to a wetland either by surface sources (e.g., streams or rivers) or by groundwater.

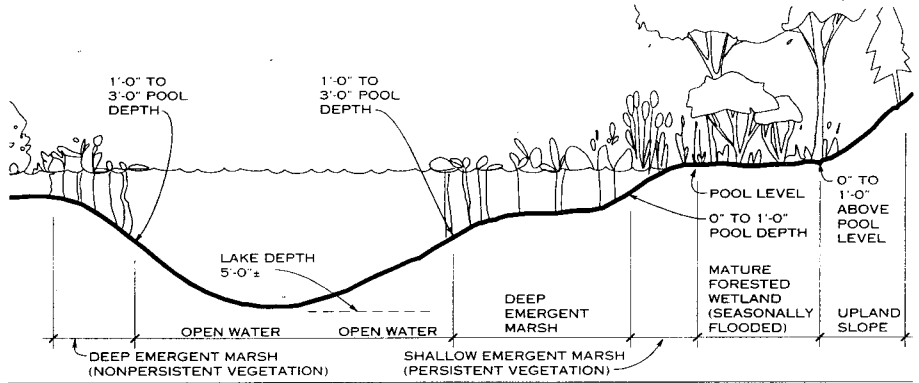

**CROSS-SECTION OF NATURAL FRESHWATER, NONTIDAL WETLANDS**

The sensitivity of wetlands determines appropriate buffer distances between them and developed areas. Buffers, which may range from 30 to 300 ft or more, should respond to the effect runoff may have on the wetland ecosystem. (Consult a wetlands scientist to formulate buffer distances.)

In general, four wetland sensitivity issues should be taken into account: hydrology—the wetland's source of water could be altered by development; vegetation—the plant species in a wetland have different levels of hardiness; ecological state—more pristine systems are more sensitive to development and runoff pollution; and animal species—for instance, nesting birds need greater buffer distances than wintering waterfowl.

**ON-SITE RUNOFF CONTROL MEASURES**

Architects can use several on-site measures to control runoff in development projects. One of the most commonly used is a simple open storage area for runoff. The configuration of such open systems varies, depending on the desired level of pollutant treatment. Typically called storage ponds, detention basins, or (when made to resemble a natural environment) a constructed storm water wetland, open systems generally operate more thoroughly with increased retention time.

Simple storage ponds are typically dry between storms after runoff has evaporated or infiltrated the groundwater. Dry

ponds sometimes include a wet lower area for additional runoff retention. Wet ponds are permanently wet, allowing pollutants to settle to the bottom. Wet ponds that extend runoff retention time with control devices can remove a very high percentage of particulate pollutants.

Constructed storm water wetlands (engineered, shallow marshlike areas) retain runoff for long periods, allowing pollutants to settle out of the water column and providing biological, chemical, and physical processes for breaking down pollutants. Wetland vegetation slows the velocity of storm water, reducing erosion and allowing pollutants to settle. Many organic and inorganic compounds are removed from wetlands by the chemical processes of absorption, precipitation, and volatilization.

Constructed storm water wetlands can also filter excess nutrients such as nitrogen and phosphorus contained in runoff from gardens and septic tanks. To correctly size a wetland used for storm water runoff control, consider the total volume and velocity of water entering and leaving the system.

Potential advantages of using constructed storm water wetlands are that they have relatively low capital and operating costs, offer consistent compliance with permit requirements, and greatly reduce operational and maintenance costs.

**COMPARATIVE ASSESSMENT OF THE EFFECTIVENESS OF URBAN BEST MANAGEMENT PRACTICES (BMPs)**

URBAN BMP OPTIONS	POLLUTANT REMOVAL RELIABILITY	LONGEVITY*	APPLICABILITY TO MOST DEVELOPMENTS	WILDLIFE HABITAT POTENTIAL	ENVIRONMENTAL CONCERNS	COMPARATIVE COSTS	SPECIAL CONSIDERATIONS
Storm water wetlands	Moderate to high, depending on design	20+ years expected	Applicable to most sites if land is available	High	Stream warming, natural wetland alteration	Marginally higher than wet ponds	Recommended with design improvements and with the use of micropools and wetlands
Extended detention ponds	Moderate but not always reliable	20+ years but frequent clogging and short detention common	Widely applicable but requires at least 10 acres of drainage area	Moderate	Possible stream warming and habitat destruction	Lowest cost alternative in size range	Recommended with design improvements and with the use of micropools and wetlands
Wet ponds	Moderate to high	20+ years	Widely applicable but requires drainage area of more than 2 acres	Moderate to high	Possible stream warming, tropic shifts, habitat	Moderate to high compared to conventional	Recommended, with careful site evaluation
Multiple pond systems	Moderate to high (redundancy increases reliability)	20+ years	Widely applicable	Moderate to high	Selection of appropriate pond option minimizes overall environmental impact	Most expensive pond option	Recommended
Infiltration trenches	Presumed moderate	50% failure rate within 5 years	Highly restricted (soils, groundwater, slope, area, sediment input)	Low	Slight risk of groundwater contamination	Cost-effective on smaller sites, rehab costs can be considerable	Recommended with pre-treatment and geotechnical evaluation
Infiltration basins	Presumed moderate, if working	60–100% failure within 5 years	Highly restricted (soils, groundwater, slope, area, sediment input)	Low to moderate	Slight risk of groundwater contamination	Construction cost moderate, but rehab cost high	Not widely recommended until longevity is improved
Porous pavement	High, if working	75% failure within 5 years	Extremely restricted (traffic, soils, groundwater, slope, area, sediment input)	Low	Possible groundwater impacts, uncontrolled runoff	Cost-effective compared to conventional asphalt when working properly	Recommended in highly restricted applications with careful construction and effective maintenance
Sand filters	Moderate to high	20+ years	Applicable for smaller developments	Low	Minor	Comparatively high construction costs and frequent maintenance	Recommended, with local demonstration
Grassed swales	Low to moderate but unreliable	20+ years	Low-density development and roads	Low	Minor	Low compared to curb and gutter	Recommended, with check-dams, as one part of a BMP system
Filter strips	Unreliable in urban settings	Unknown but may be limited	Restricted to low-density areas	Moderate if forested	Minor	Low	Recommended as one element of a BMP system
Water quality inlets	Presumed low	20+ years	Small, highly impervious catchments (less than 2 acres)	Low	Resuspension of hydrocarbon loadings, disposal of hydrocarbon and toxic residuals	High compared to trenches and sand filters	Not currently recommended as a primary BMP option

\*Based on current designs and prevailing maintenance practices

**NOTE**

The variety of urban BMPs available to remove pollutants from urban runoff differs widely in performance, longevity,

feasibility, cost, and environmental impact. As the matrix shows, storm water wetlands are an attractive BMP choice at many development sites.

Carrie Fischer, "Design for Wetlands Preservation," topic II.A.1 in *Environmental Resource Guide* (Washington, D.C.: The American Institute of Architects, 1992).  
 Thomas Schueler; Metropolitan Washington Council of Governments; Washington, D.C.



**STORM WATER WETLANDS**

Storm water wetlands can be defined as constructed systems explicitly designed to mitigate the effects of storm water quality and quantity on urban development. They temporarily store storm water runoff in shallow pools that create growing conditions suitable for emergent and riparian wetland plants. In combination, the runoff storage, complex microtopography, and emergent plants in the constructed wetland form an ideal matrix for the removal of urban pollutants.

Unlike natural wetlands, which often express the underlying groundwater level, storm water wetlands are dominated by surface runoff. Storm water wetlands can best be described as semitidal, in that they have a hydroperiod characterized by a cyclic pattern of inundation and subsequent drawdown, occurring 15-30 times a year, depending on rainfall and the imperviousness of the contributing watershed.

Storm water wetlands usually fall into one of four basic designs:

**SHALLOW MARSH SYSTEM:** The large surface area of a shallow marsh design demands a reliable groundwater supply or base flow to maintain sufficient water elevation to support emergent wetland plants. Shallow marsh systems take up a lot of space, requiring a sizable contributing watershed (often more than 25 acres) to support a shallow permanent pool.

**POND/WETLAND SYSTEM:** A pond/wetland design utilizes two separate cells for storm water treatment, a wet pond and a shallow marsh. The multiple functions of the latter are to trap sediments, reduce incoming runoff velocity, and remove pollutants. Pond/wetland systems consume less space than shallow marsh systems because the bulk of the treatment is provided by a deep pool rather than a shallow marsh.

**EXTENDED DETENTION WETLAND:** In extended detention wetlands, extra runoff storage is created by temporarily detaining runoff above the shallow marsh. This extended detention feature enables the wetland to occupy less space as temporary vertical storage partially substitutes for shallow marsh storage. A growing zone is created along the gentle side slopes of extended detention wetlands, from the normal pool level to the maximum extended detention water surface.

**POCKET WETLANDS:** Pocket wetlands are adapted to serve small sites (from one to ten acres). Because the drainage area is small, pocket wetlands usually do not have a reliable base flow, creating a widely fluctuating water level. In most cases, water levels in the wetland are supported by excavating down to the water table. In drier areas, a pocket wetland is supported only by storm water runoff, and during extended periods of dry weather it will have no shallow pool at all (only saturated soils). Due to their small size and fluctuat-

ing water levels, pocket wetlands often have low plant diversity and poor wildlife habitat value.

The selection of a particular wetland design usually depends on three factors: available space, contributing watershed area, and desired environmental function. However, storm water wetlands are not typically located within delineated natural wetland areas, which provide critical habitat and ecosystem services and are protected under local, state, and federal statutes. Storm water wetlands should also not be confused with constructed wetlands used to mitigate the permitted loss of natural wetlands under wetland protection regulations. The primary goal of wetland mitigation is to replicate the species diversity and ecological function of the lost natural wetland; whereas the more limited goal of storm water wetlands is to maximize pollutant removal and create generic wetland habitat.

Storm water wetlands are also distinguished from natural wetlands that receive storm water runoff as a consequence of upstream development. Although not intended for storm water treatment, wetlands influenced by storm water are common in urban settings. Storm water runoff that becomes a major component of the water balance of a natural wetland can severely alter the functional and structural qualities of the wetland. The end result is a storm water-influenced natural wetland that is more characteristic of a storm water wetland than a natural one.

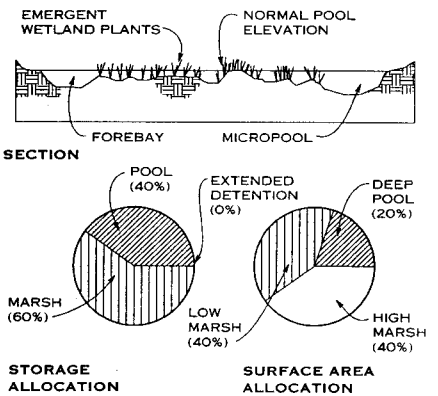
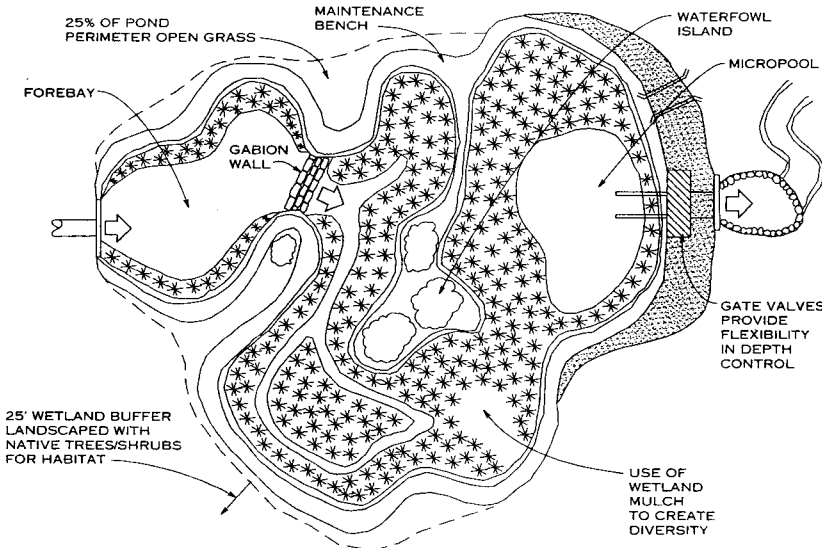

**NOTE**

Most of the shallow marsh system is 0-18 in. deep, a depth that creates favorable conditions for the growth of emergent wetland plants. A deeper forebay is located at the major inlet, and a deep micropool is situated near the outlet.

**SHALLOW MARSH SYSTEM**

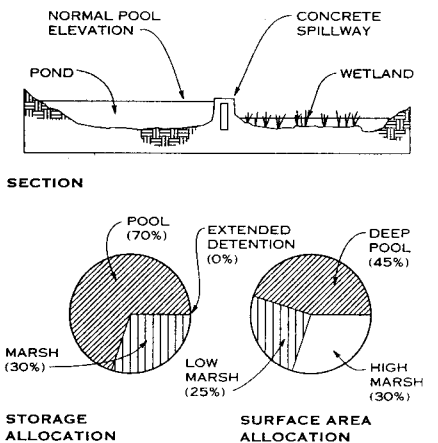
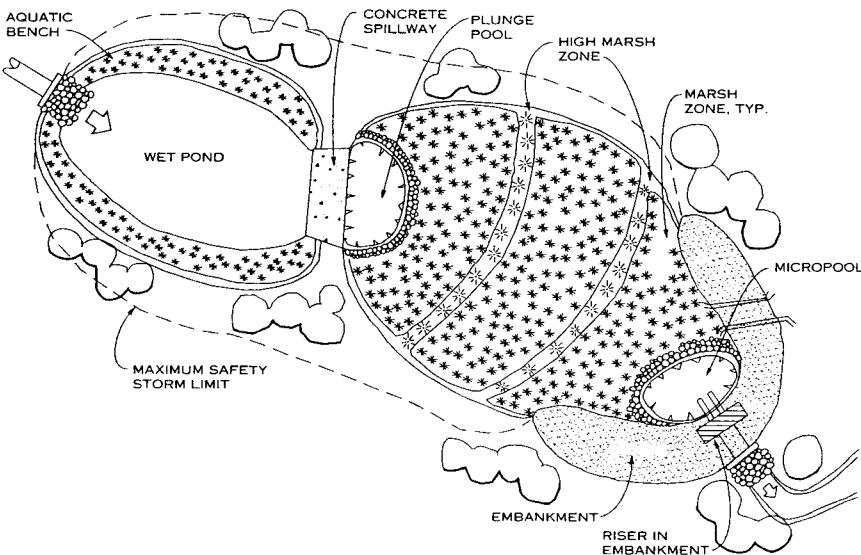

**NOTE**

The pond/wetland system consists of a deep pond that leads to a shallow wetland. The pond removes pollutants and reduces the space required for the system.

**POND/WETLAND SYSTEM**

Carrie Fischer, "Design for Wetlands Preservation," topic II.A.1 in *Environmental Resource Guide* (Washington, D.C.: The American Institute of Architects, 1992).  
Thomas Schueler, Metropolitan Washington Council of Governments; Washington, D.C.

COMPARATIVE ATTRIBUTES OF FOUR STORM WATER WETLAND DESIGNS

ATTRIBUTE	SHALLOW MARSH	POND/WETLAND	EXTENDED DETENTION WETLAND	POCKET WETLAND
Pollutant removal capability	Moderate; reliable removal of sediments and nutrients	Moderate to high; reliable removal of nutrients and sediment	Moderate; less reliable removal of nutrients	Moderate; can be subject to resuspension and groundwater displacement
Land consumption	High; shallow marsh storage consumes space	Moderate, as vertical pool substitutes for marsh storage	Moderate, as vertical extended detention substitutes for marsh storage	Moderate, but can be shoehorned into site
Water balance	Dry weather base flow normally recommended to maintain water elevations; groundwater not recommended as primary source of water supply to wetland			Water supply provided by excavation to groundwater
Wetland area/watershed area	Minimum ratio of .02	Minimum ratio of .01	Minimum ratio of .01	Minimum ratio of .01
Contributing watershed area	Drainage area of 25 acres or more, with dry weather Q*	Drainage area of 25 acres or more, with dry weather Q*	Minimum of 10 acres required for extended detention	1-10 acres
Deepwater cells	Forebay, channels, micropool	Pond, micropool	Forebay, micropool	Micropool, if possible
Outlet configuration	Reversed slope pipe extending from riser, withdrawn approximately 1 ft below normal pool; pipe and pond drain equipped with gate valve			Broad-crested weir with half-round trash rack and pond drain
Sediment cleanout cycle (approximate)	Cleanout of forebay every 2-5 yr	Cleanout of pond every 10 yr	Cleanout of forebay every 2-5 yr	Cleanout of wetland every 5-10 yr, on-site disposal and stockpile mulch
Native plant diversity	High, if complex microtopography is present	High, with sufficient wetland complexity and area	Moderate; fluctuating water levels impose physiological constraints	Low to moderate, due to small surface area and poor control of water levels
Wildlife habitat potential	High, with complexity and buffer	High, with buffer, attracts waterfowl	Moderate, with buffer	Low, due to small area and low diversity

\*Q—coefficient of runoff

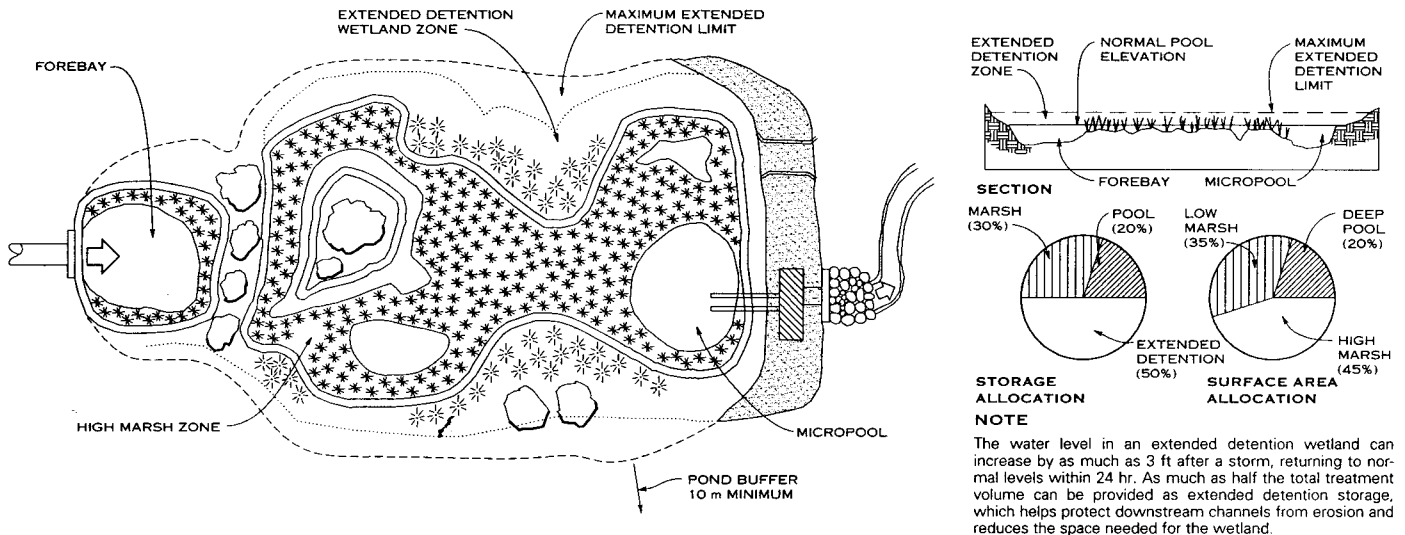

EXTENDED DETENTION WETLAND

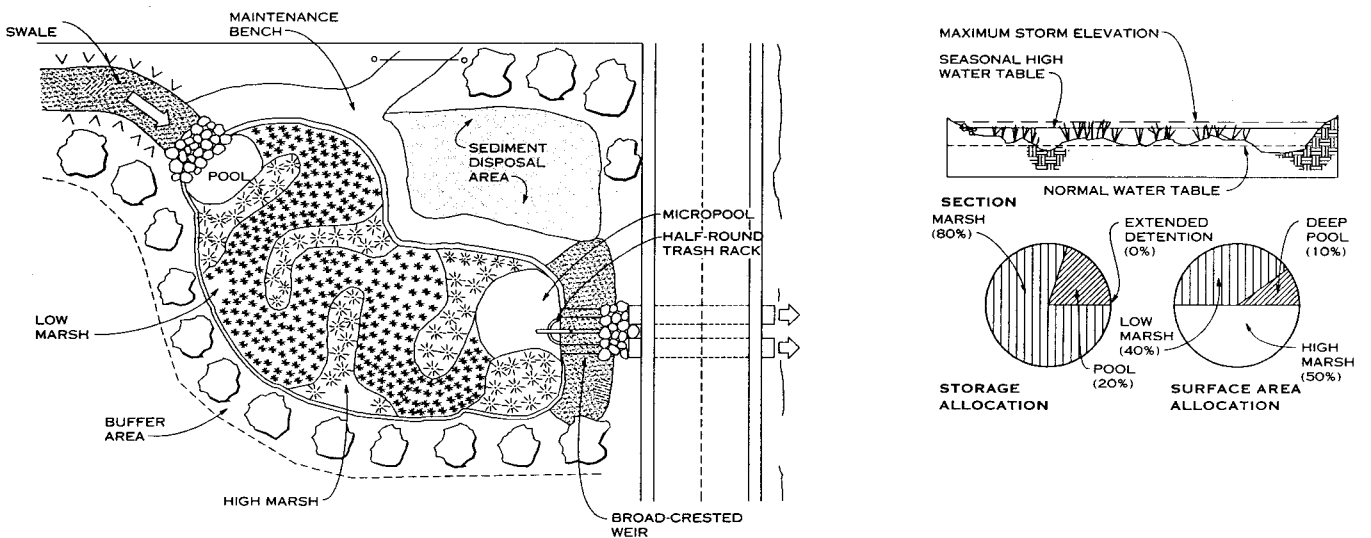

POCKET STORM WATER WETLAND

Carrie Fischer, "Design for Wetlands Preservation," topic II.A.1 in *Environmental Resource Guide* (Washington, D.C.: The American Institute of Architects, 1992).  
 Thomas Schueler; Metropolitan Washington Council of Governments; Washington, D.C.

**GENERAL**

Unit paving assemblies are principally used for applications such as shopping plazas, building entrances, walkways, patios, residential driveways, and residential parking areas. However, they may be used for streets with heavy vehicular traffic and for industrial floors or other special conditions. Consult with a landscape architect or engineer for appropriate design guidelines.

**NOTES**

1. Paver units are selected according to color, texture, abrasion resistance, and resistance to weathering. The texture of the unit affects slip resistance—the coarser the

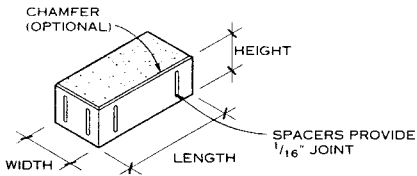

**RECTANGULAR**

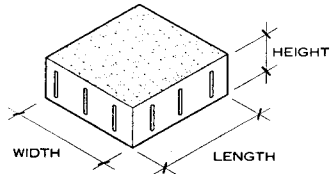

**SQUARE**

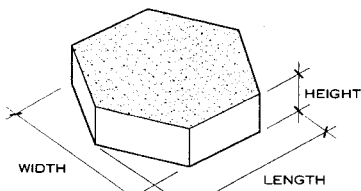

**HEXAGONAL**

**NOTE**

Rectangular, square, and hexagonal pavers are available in both brick and concrete.

**TYPICAL PAVER SHAPES**

**TYPICAL PAVER SIZES IN IN. (MM)**

RECTANGULAR*		SQUARE	HEXAGONAL	
W	L	W & L	W	L
4 (100)	8 (200)	4 (100)	6 (150)	6 (150)
3 5/8 (92)	7 5/8 (194)	6 (150)	8 (200)	8 (200)
3 1/2 (89)	7 1/2 (190)	8 (200)	12 (300)	12 (300)
7 5/8 (194)	7 5/8 (194)	12 (300)		
8 (200)	8 (200)	16 (400)		

\*Check with manufacturer for availability of chamfers.

**NOTE**

The height of pavers varies with the manufacturer and application but is usually 1 1/4 (32), 2 1/4 (57), 2 5/8 (67), or 2 3/4 (70).

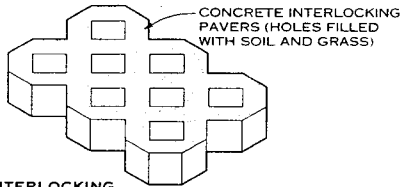

**INTERLOCKING**

**NOTES**

1. Voids may be filled with grass, ground cover, or gravel.
2. Grass pavers may be used to control erosion.

**GRASS PAVER TYPES**

texture, the better the slip resistance. Abrasion resistance refers to the wear and tear an assembly is subjected to under normal use. According to ASTM C902, "Standard Specification for Pedestrian and Light Traffic Paving Brick," an abrasion index classification determines the type of unit required for an intended exposure. A dense, hard-burned extruded brick with 8000 psi compressive strength that conforms to ASTM C902, Class SX, Type 1, resists both abrasion and weathering and is adequate for most heavy-traffic exterior applications. Molded brick with 4000 psi compressive strength that conforms to ASTM C902, Class SX, Type 2, is adequate for most exterior pedestrian applications. If materials other than brick are used for paving, consult the manufacturer to learn which products are suitable for use as pavers in a particular application.

2. Assess potential traffic loads when planning unit paving installations. Heavy vehicular loads require a rigid or semi-rigid continuous base, while a flexible base and flexible paving are suitable for light vehicular loads (residential-type). Use either base type for pedestrian traffic. Choose a bond pattern based on expected traffic patterns; traffic should travel perpendicular to the long dimension of the paving unit. For vehicular areas, use a gravel subbase

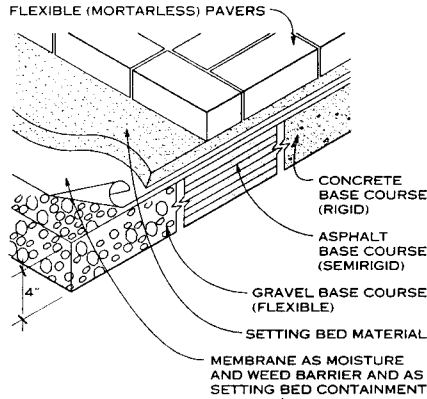

**FLEXIBLE (MORTARLESS) PAVER**

**NOTES**

1. Unit paving assemblies are classified according to the type of base supporting the paver, either rigid (mortared) or flexible (mortarless). Base types are a reinforced or unreinforced concrete slab on grade that accepts either rigid or flexible pavers (rigid); asphalt or bituminous concrete that accepts flexible pavers only (semirigid continuous); a compacted gravel, sand, or sand-cement mixture that accepts flexible pavers only (flexible); and suspended diaphragm or structural floor and roof assemblies, which vary by design and accept either rigid or flexible pavers.
2. Setting bed (cushion) material, placed between base and paving surface, functions as a leveling layer to help refine the finished grade and compensate for irregularities in the base and paver unit surfaces. Setting bed material can be a 1- or 2-in. layer of sand, pea gravel, stone screenings, roofing felt, asphalt (7% asphalt, 93% sand with a neoprene tack coat), or mortar. Sand for setting beds, bases, joints, and mortar should conform to ASTM C144, "Aggregate for Masonry Mortar." Use mortar setting or leveling beds only in conjunction with concrete and asphalt bases; the thickness of the bed may vary from 1/2 to 2 in.

**PAVER ASSEMBLY TYPES**

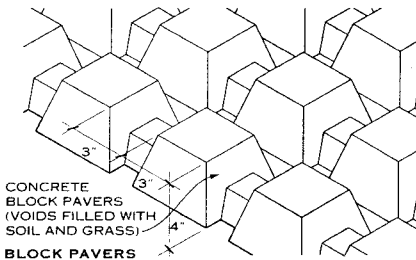

**BLOCK PAVERS**

3. Grass rings are available with close ring spacing for pedestrian use or with wide ring spacing for vehicular use.

(minimum 6 in. crushed gravel) compacted to 95% and paver sizes 8 in. square or smaller. Consult an engineer to accurately define paver sizes, shapes, gravel depth, concrete base depth, and concrete reinforcement requirements.

3. Proper subgrade preparation of areas to be paved is important. Remove all vegetation and organic material, and consider the location of existing or proposed underground utilities and storm drainage, as well as user convenience.
4. Plan for surface and subsurface drainage. Slope paving away from buildings, retaining walls, etc. at 1/8 to 1/4 in. per foot. Rigid paving always requires adequate surface drainage, with the long dimension of the mortar joints running parallel to the direction of runoff. Flexible paving requires both surface and subsurface drainage.
5. To prevent horizontal movement of flexible (mortarless) paving assemblies, use a curb of brick soldier coursing set in concrete, landscape timbers, or other edging material.
6. There are three major types of unit paver joint material: mortar, grout (portland cement and sand without hydrated lime), and a dry mixture of grout.

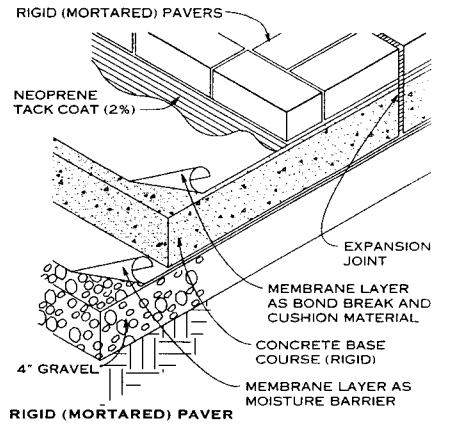

**RIGID (MORTARED) PAVER**

3. Membranes are installed in unit paving assemblies for several purposes: to control the passage of moisture, reduce weed growth, prevent the sand course from filtering into lower courses, and as a bond break. Consider using bond breaks between rigid paving and rigid bases to accommodate differential movement. Membranes are of sheet or liquid material that can resist moisture, rot, and decay. Sheet material includes asphalt roofing felt, polyethylene film, vinyl, neoprene, and rubber. Liquid types are asphalt, modified urethane, or polyurethane bitumen; these are preferred for irregular surfaces.
4. Use base materials, including gravel, concrete, and asphalt, for support, drainage, and/or ground swell protection. For maximum drainage efficiency and to prevent upward capillary action, specify clean, washed gravel.
5. Expansion joints can alleviate thermal and moisture movement, especially in rigid or mortared assemblies. Expansion joints are generally located parallel or adjacent to curbs and edgings, at right angle turns, around interruptions (e.g., manhole cover assemblies), at set distances in long runs of masonry, and where dissimilar materials meet.

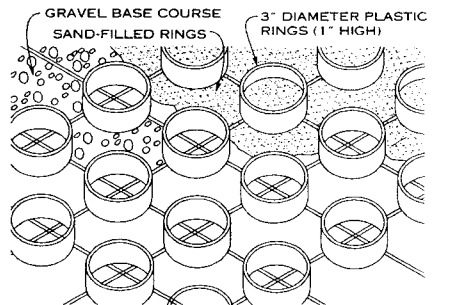

**GRASS RINGS**

Dennis Carmichael, EDAW, Inc., Alexandria, Virginia

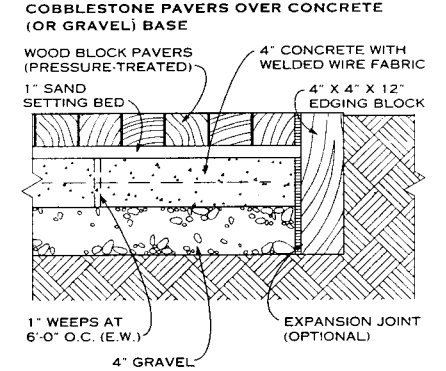
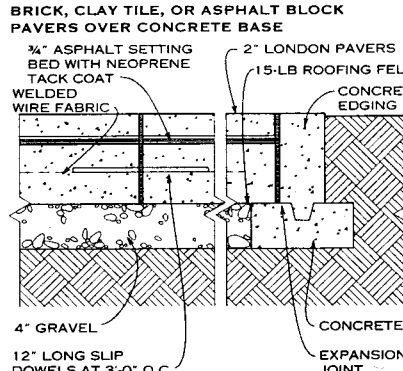
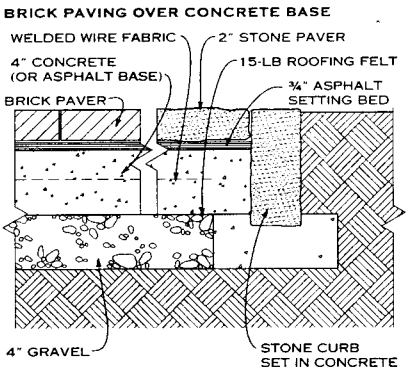
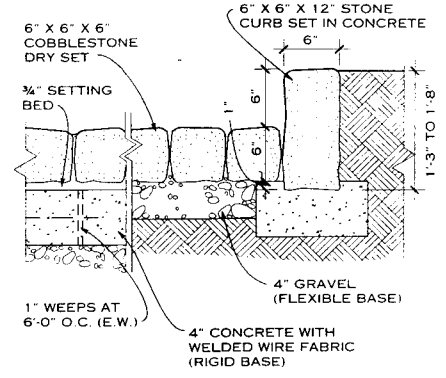
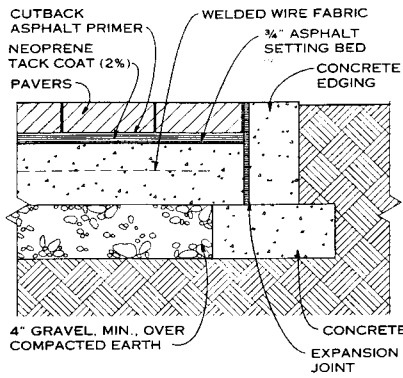
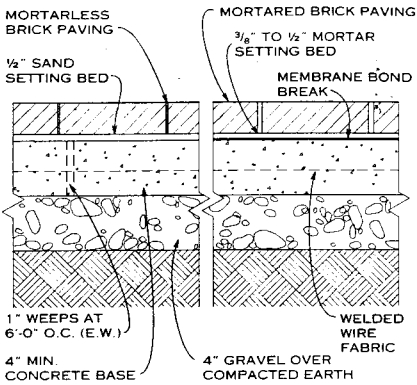

**BRICK OR STONE PAVERS OVER CONCRETE OR ASPHALT BASE**

**CONCRETE PAVERS OR LONDON WALKS OVER CONCRETE BASE**

**WOOD BLOCK PAVERS OVER CONCRETE BASE**

**PAVERS OVER RIGID BASE**

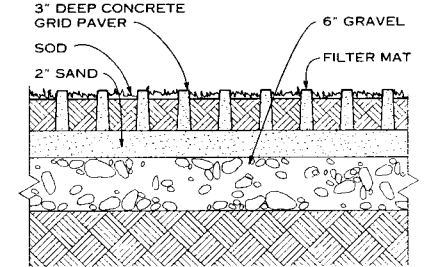
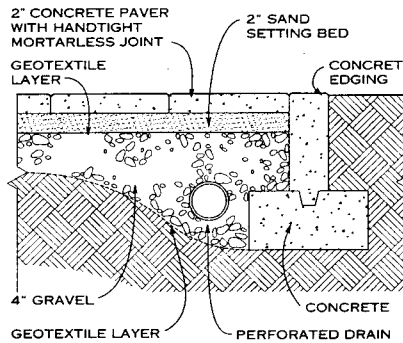
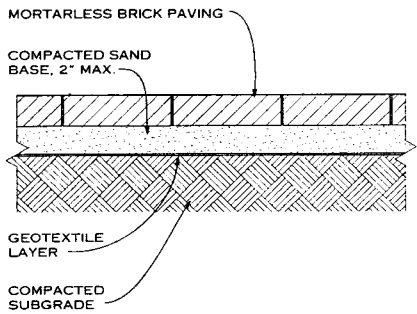

**NOTE**  
 Preformed lattice unit grids are used for storm runoff control, pathways, parking areas, and soil conservation.

**MORTARLESS (FLEXIBLE) BRICK PAVING OVER SAND BASE**

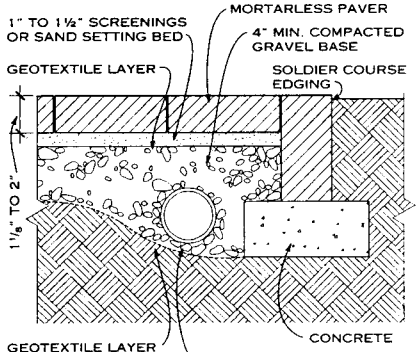

**CONCRETE PAVERS OR LONDON WALKS OVER GRAVEL BASE**

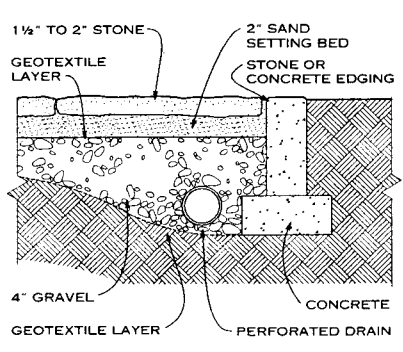

**GRID PAVING BLOCKS OVER GRAVEL BASE**

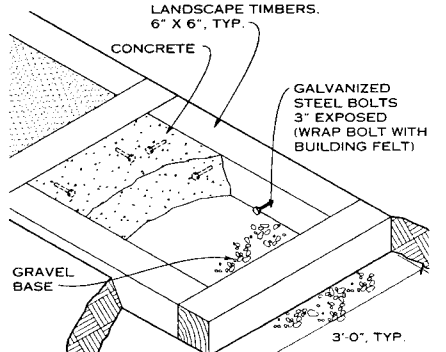

**BRICK, CLAY TILE, OR ASPHALT BLOCK PAVERS OVER GRAVEL BASE**

**CUT STONE PAVERS OVER SAND AND GRAVEL BASE**

**CONCRETE AND TIMBER SITE-FORMED PAVER WALK**

**PAVERS OVER FLEXIBLE BASE**

Dennis Carmichael; EDAW, Inc.; Alexandria, Virginia  
 Charles A. Szoradi, AIA; Washington, D.C.

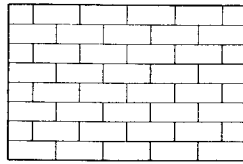

RUNNING BOND

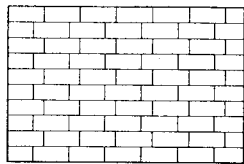

OFFSET BOND

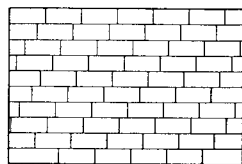

OFFSET BOND

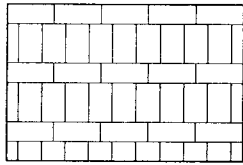

MIXED RUNNING AND STACK BOND

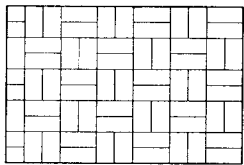

BASKET WEAVE

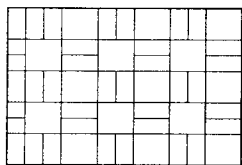

BASKET WEAVE

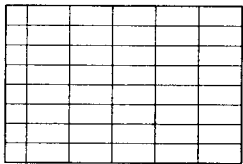

STACK BOND

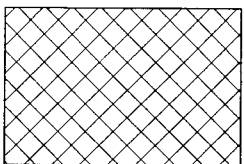

DIAGONAL STACK

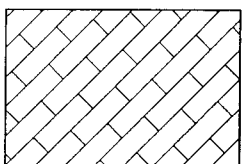

DIAGONAL BOND

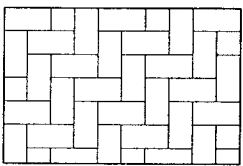

HERRINGBONE

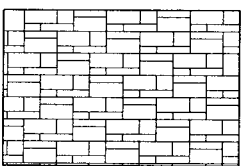

PATTERNED ASHLAR

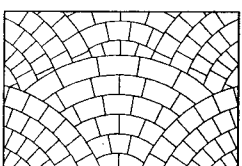

ROMAN COBBLE

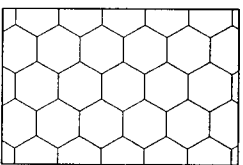

HEXAGON

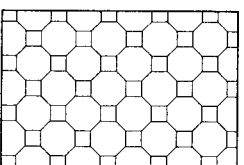

BASKET WEAVE OR PARQUET

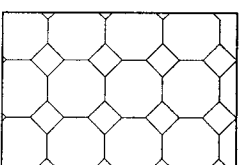

OCTAGON AND DOT

UNIT PAVERS

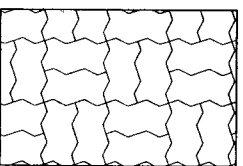

BASKET WEAVE

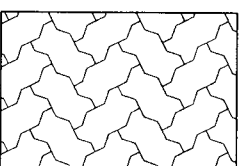

HERRINGBONE

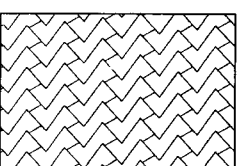

DIAGONAL RUNNING BOND

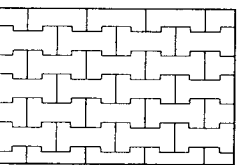

RUNNING BOND

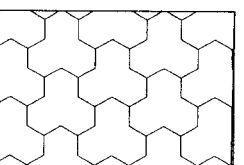

COMBINED HEXAGON

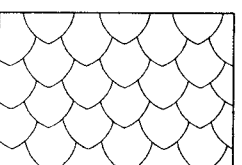

CATHEDRAL

INTERLOCKING UNIT PAVERS

Dennis Carmichael; EDAW, Inc.; Alexandria, Virginia

2 PAVING AND SURFACING

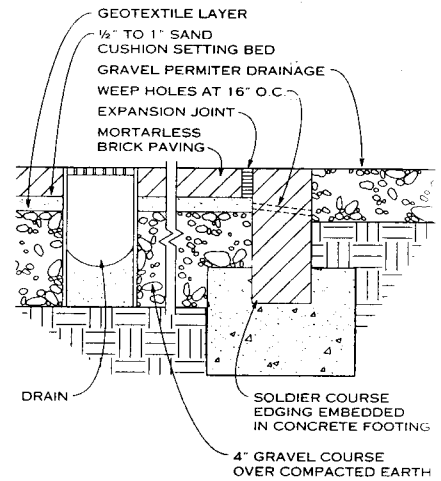

EDGE DRAINAGE AT FLEXIBLE PAVING

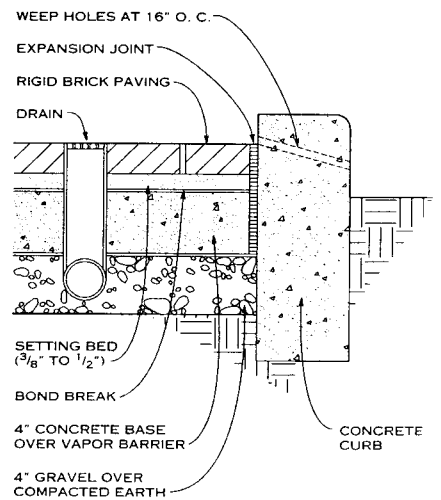

EDGE DRAINAGE AT RIGID PAVING

NOTES

1. Drainpipes may be omitted at well-drained areas.
2. Provide positive outflow for drainpipes.
3. Do not use unsatisfactory soil (expanding organic).
4. Satisfactory soil must be compacted to 95%.
5. Handtight paving joints are preferred over mortar joints. However, when mortar joints are required and freezing and thawing are frequent, use latex-modified mortar.
6. Concrete footing for edging should be 10 to 14 in. wide and 6 to 8 in. deep. It is preferable to place the bottom of the footing at freezing depth. If the freezing depth is deeper than the bottom of the footing, provide 4 in. of gravel below the footing.
7. Interlocking pavers are available in concrete, hydraulically pressed concrete, asphalt, and brick in different weight classifications, compressive strengths, surface textures, finishes, and colors. Consult local suppliers for availability.
8. Subject to the manufacturer's recommendations and local code requirements, interlocking concrete pavers may be used in areas subject to heavy vehicle loads at speeds of 30 to 40 mph.
9. Concrete interlocking paver sizes are based on metric dimensions.
10. When paver shape permits, the herringbone pattern is recommended for paving subject to vehicular traffic.
11. Continuous curb or other edge restraint is required to anchor pavers in applications subject to vehicular traffic.

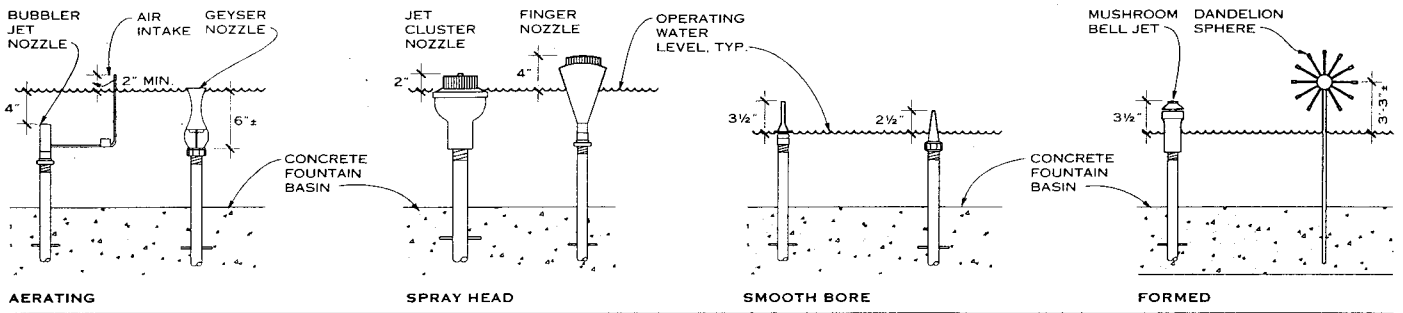

FOUNTAIN NOZZLE TYPES

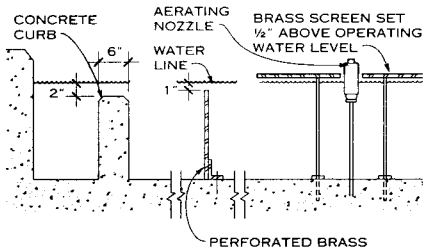

SURGE REDUCTION DEVICES

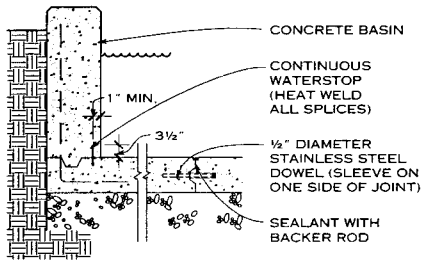

CONCRETE BASIN JOINT DETAILS

**GENERAL**

Materials used in fountain and pool design should be durable and resist damage caused by water, cracks, weather, stains, and freeze-thaw cycles. Suitable materials include stone, concrete, brick, tile, and metals such as copper, bronze, cast iron, and steel. Fiberglass, acrylic, and waterproof membranes such as PVC, EPDM, and butyl are commonly used.

**OVERALL DESIGN CONSIDERATIONS**

**SCALE:** Consider the size of the water feature in relation to its surroundings.

**BASIN SIZING:** For width, consider fountain height and prevailing winds. For depth, consider weight (1 cu ft water = 62.37 lb). Consider children playing near or in the pool. Allow space for lights, nozzles, and pumps. Local codes may classify basins of a certain depth as swimming pools. Nozzle spray may be cushioned to prevent excessive surge.

**BOTTOM APPEARANCE:** When clear water is maintained, bottom appearance is important. Enhance the bottom with patterns, colors, materials, three-dimensional objects, or textures. Dark bottoms increase reflectivity.

**EDGES OR COPINGS:** In designing the water's edge, consider the difference between the operating water level and the static water level. Loosely defined edges (as in a pond) make movement into the water possible both visually and physically. Clearly defined edges (as in a basin) use coping to delineate the water's edge.

**LIPS AND WEIRS:** A lip is an edge over which flowing water falls. A weir is a dam in the water that diverts the water flow or raises the water level. If volume and velocity are insufficient to break the surface tension, a reglet on the underside of the edge may overcome this problem.

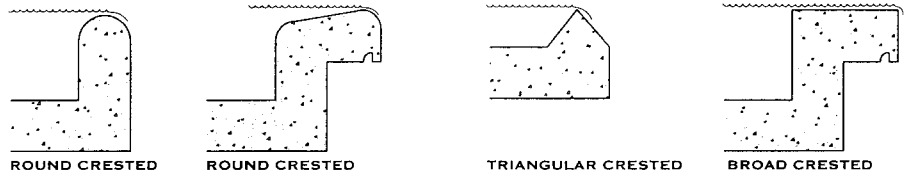

FOUNTAIN LIP SECTIONS

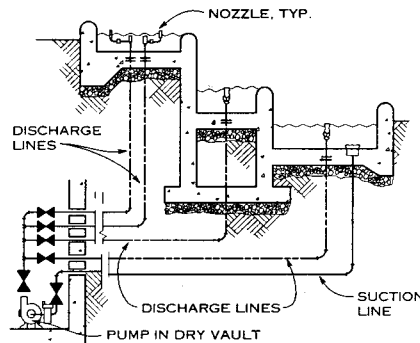

PIPE SCHEMATIC FOR DRY CENTRIFUGAL PUMP

**WATER FORM FOR FOUNTAINS**

**STATIC WATER:** Form and reflectivity are design considerations for water contained in pools and ponds.

**FALLING WATER:** The effect of falling water depends on water velocity and volume, the container surface, and the edge over or through which the water moves.

**FLOWING WATER:** The visual effect of a volume of flowing water can be changed by narrowing or widening a channel, placing objects in the path of the water, and changing the direction of the flow or the slope and roughness of the bottom and sides.

**JETS:** A pattern is created by forcing water into the air with a jet. Jet types include single orifice nozzles, tiered jets, aerated nozzles, and formed jets in a wide variety of forms, patterns, and types.

**SURGE:** A contrast between relatively quiet water and a surge (a wave or a splash) is made by quickly adding water, raising or lowering an object or moving it back and forth in the water, or introducing strong air currents to the water.

**WATER EFFECTS SYSTEM**

The water effects system comprises the pump, nozzles, and piping that move water through the fountain. The combination of nozzles, spray rings, eyeballs, pipes, weirs, and/or channels in a fountain or pool requires a pump system to generate water pressure, a suction line to bring water to the pump, and a discharge line to move water from the pump to the nozzles.

Fountain nozzles come in four basic types: aerating nozzles, spray heads, smooth-bore nozzles, and formed nozzles. Aerating nozzles (also known as bubbler jets, geyser nozzles, or foam nozzles) are characterized by white frothy water created by combining air and water. Spray heads are characterized by combinations of thin clear water jets coming from a distribution head in the shape of a fan or circle (suction or in-

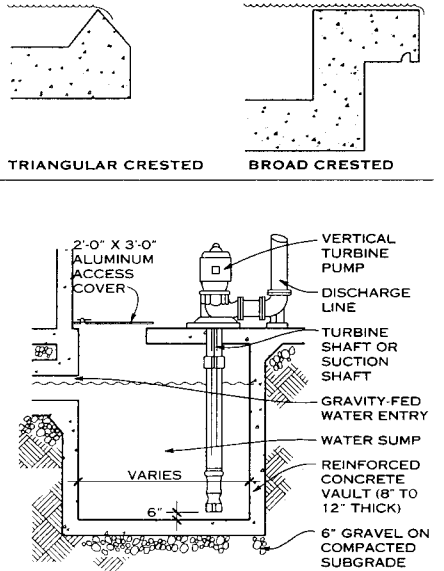

VERTICAL TURBINE PUMP

line strainer required). Smooth-bore nozzles are characterized by a clear, thin solid stream jet of water that breaks up into small droplets as it reaches its maximum height or distance. Formed nozzles are typified by a thin sheet of water that originates in a jet of varied size and shape. The thinness of the sheet of water makes the tolerances in the jet very tight (suction or in-line strainer required).

Fountains are usually closed water systems, i.e., the pump continuously cycles the water in the basin to the nozzles and back to the basin again. The pumps used to generate water pressure and operate the water effects of a fountain are largely powered by electric motors. Three types of pumps are commonly used: submersible, dry centrifugal, and vertical turbine pumps.

Submersible pumps, used for low volume fountains, are among the simplest pumping systems. A watertight electric motor and pump are set under the water of the fountain basin. The pump is usually equipped with a motor of 1/20 to 1 horsepower and moves a maximum of 100 gallons per minute (gpm). This type of pump requires fewer pipe penetrations in the basin wall than dry centrifugal or vertical turbine pumps.

Dry centrifugal pumps, most commonly used for larger water features, consist of an electric motor, a pump, a suction line, and a discharge line. This pump type ranges from 1/4 to 100 horsepower.

Vertical turbine pumps, used in large water features, are able to move tremendous amounts of water. They require a pump and motor, a water sump located in an equipment vault, a gravity feed mechanism to fill the sump, and a discharge line. These pumps are more energy-efficient than those with suction lines, as gravity moves water to the pump. The electric motor is not submerged in water, making a watertight seal less important. Vertical turbine pumps can move up to 5000 gpm.

**GENERAL**

Selection criteria to use when choosing a fence for a particular application include the degree of privacy or openness and sense of enclosure desired; the aesthetic and stylistic nature of the materials and setting; cultural and historical precedents; and security issues. Consider, as well, materials and maintenance requirements, soil conditions at the site and the foundations and anchorage required; topography, climate, and wind conditions at the site; the effects a design will have on neighbors and adjacent natural features; the size of the property; and the permanence and cost of the structure.

Local zoning and building codes often regulate the height of a fence and its relationship to the property line. Fences should not obstruct traffic sight lines at intersections but should prevent access to potential danger (e.g., unattended children at swimming pools or pedestrians at a construction site).

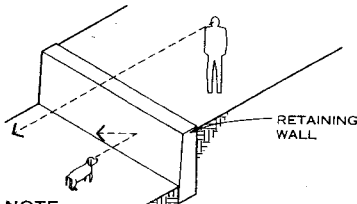
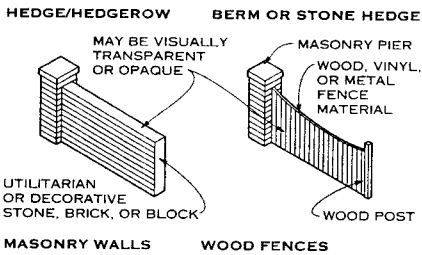
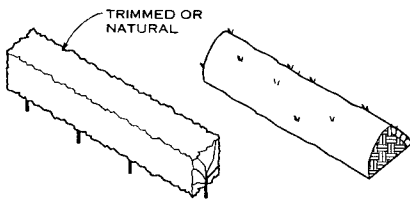
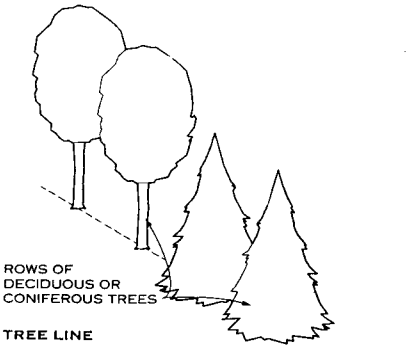

**NOTE**  
A retaining wall positioned to be invisible to the viewer (a "ha-ha") can prevent unwanted entry by outsiders.

**RETAINING WALL AS FENCE**

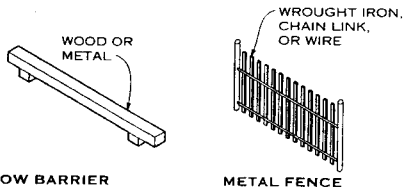

**PHYSICAL BARRIER TYPES**

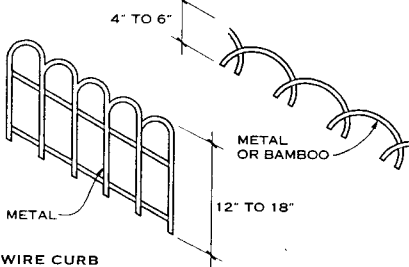
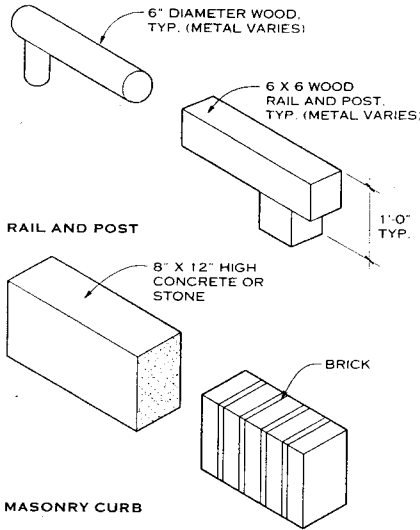

**LOW BARRIERS**

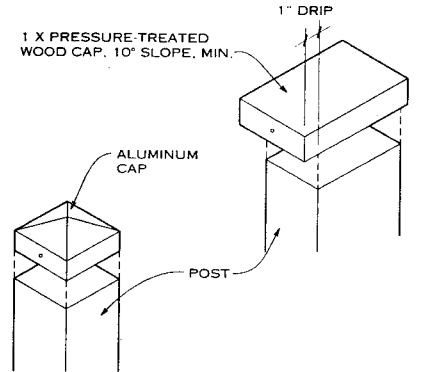
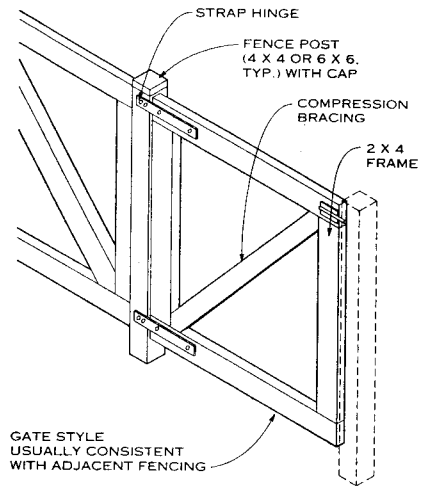
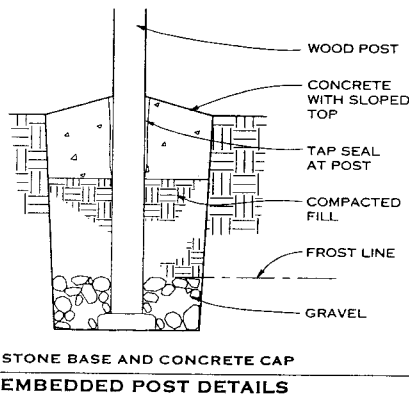
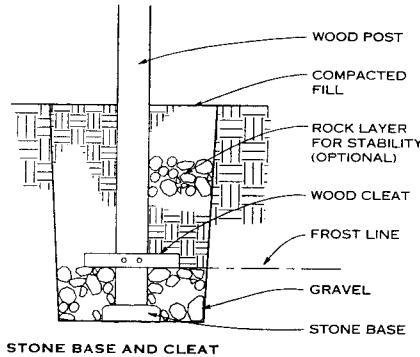

**NOTES**

1. Gates permit personnel and vehicles to pass through barriers. Construction techniques and operation of gates are similar to door methods; refer to AGS chapter 8 for further information on these subjects.
2. Compression bracing extending from the upper extremity to the lower connection point of a gate is often required; tension can be modulated through rods and turnbuckles to prevent warpage and sagging. Large or heavy gates can be fitted with rollers or wheels to aid operation; metal tracks mounted in paving prevent uneven surface wear.
3. Hardware should be made of noncorrosive materials. Latches with internal padlock hasps or locking mechanisms are available for security protection.

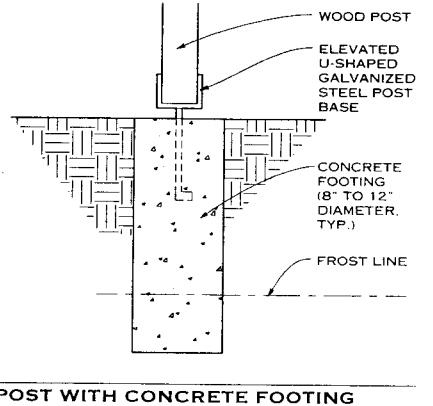

Daniel F. C. Hayes, AIA; Washington, D.C.

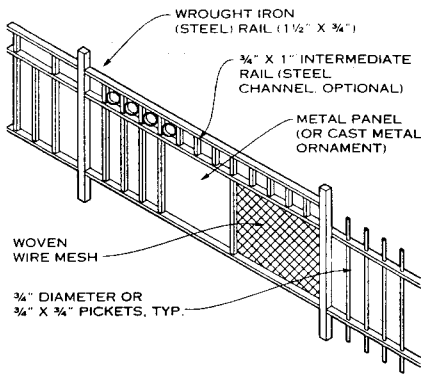

**NOTE**  
 Materials used for this type of fence are steel or aluminum in wrought or cast form.

**METAL BAR**

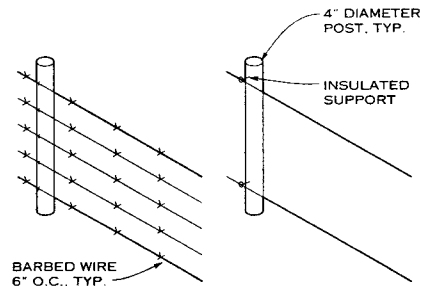

**BARBED WIRE**

**ELECTRIC WIRE**

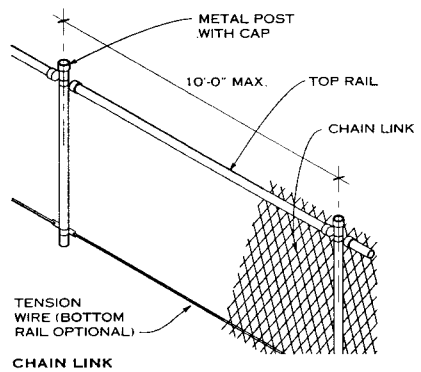
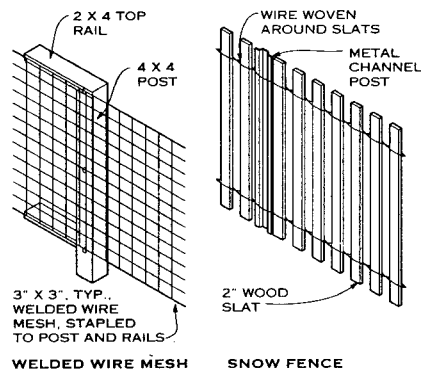

**METAL FENCE TYPES**

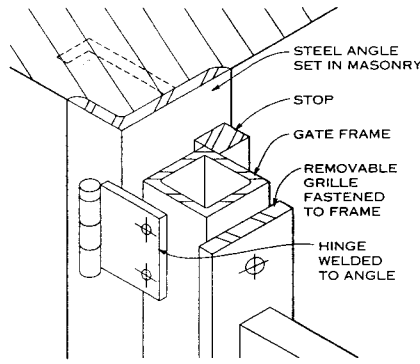

**SURFACE-MOUNTED HINGE**

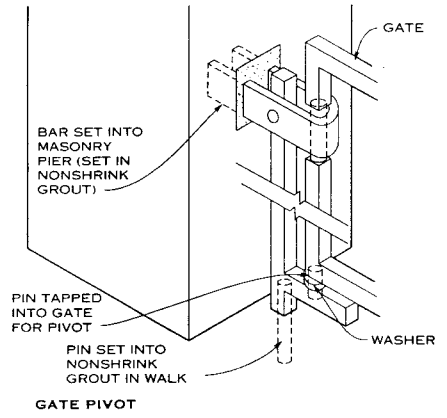

**GATE PIVOT**

**GATE DETAILS FOR WROUGHT IRON**

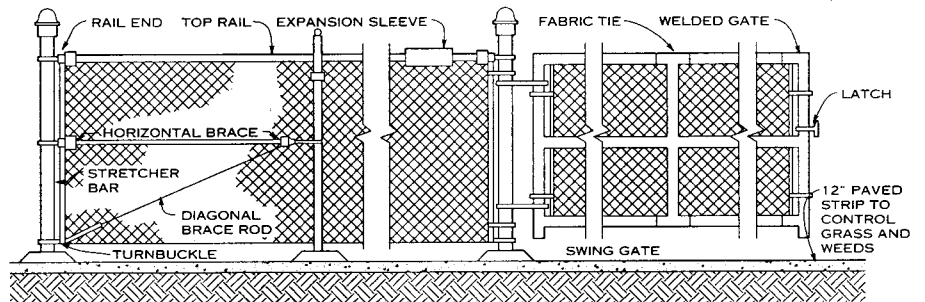

**CORNER POST**

**LINE POST**

**GATEPOST**

**NOTE**

For fences 5 ft and taller, a horizontal or diagonal brace, or both, is used for greater stability. Post spacing should be

equidistant and should not exceed 10 ft o.c.

**CHAIN-LINK FENCE AND GATE—ELEVATION**

**CHAIN-LINK FENCE MATERIALS**

MATERIAL	SIZES AVAILABLE*
Wire gauge	Usually no. 11 or no. 9 For especially rugged use, use no. 6 For tennis courts, no. 11 is generally used
Wire mesh	Usually 2" For tennis courts, usually 1 5/8" or 1 3/4" of chain-link steel that has been coated with hot dip galvanizing after weaving Top and bottom selvage may be barbed or knuckled
Corner and end posts	For lawn fences, usually 2" outside diameter For estate fences, 2 in. for low, 2 1/2 in. for medium, and 3" outside diameter for heavy or high For tennis courts 3" outside diameter
Line or intermediate posts	For lawn fences, 1 3/8" or 2" outside diameter round For estate fences, etc., 2", 2 1/4", or 2 1/2" H or I sections For tennis courts, 2 1/2" round outside diameter or 2 1/4" H or I sections
Gateposts	Same or next size larger than corner posts; footings should be 3'-6" deep
Top rails	1 3/8" outside diameter except some lawn fence may be 1 3/8" outside diameter
Middle rails	On 12'-0" fence, same as top rail
Gates	Single or double; any width desired Accessible routes require clear opening width of 32" min. and 18" latchside clearance; latches must be accessible
Post spacing	Line posts 10'-0" o.c.; 8'-0" o.c. may be used on heavy construction

\*Sizes given are not standard but represent the average sizes used.

**COATINGS**

Protective coatings, such as zinc and aluminum, can be used on metal fencing. Also available are various decorative coatings, including vinyl bonding and organic coatings; these are available from most manufacturers.

**VINYL-COATED WIRE FABRIC MESH**

Vinyl-coated wire fabric mesh is suitable for residential, commercial, and industrial applications. The mesh comes in five sizes—1, 1 1/4, 1 1/2, 1 3/4, and 2 in.—and in four gauges—11, 9, 6, and 3.

**SPECIAL FENCING**

**ORNAMENTAL:** This fencing type uses vertical struts only; no chain-link fabric is required. Ornamental fencing is ideal for landscaping or as a barrier fence.

**ELEPHANT FENCE:** This fence can actually stop an elephant, hold back a rock slide, or bring a small truck to a halt. Its size is specified as gauge 3 with a 2 in. mesh.

**SECURITY FENCE:** This fabric is nonclimbable and cannot be penetrated by gun muzzles, knives, or other weapons. It is suitable as a security barrier for police stations, prisons, reformatories, hospitals, and mental institutions. Mesh sizes available are 3/8 in. for maximum security, 1/2 in. for high security, 5/8 in. for super security, and 1 in. for standard security.

**POST SIZES FOR HEAVY-DUTY GATES**

ASA SCHEDULE 40 PIPE SIZES (IN.)	SWING GATE OPENINGS (FT)	
	SINGLE	DOUBLE
2 1/2	Up to 6	Up to 12
3 1/2	Over 6 to 18	Over 12 to 26
6	Over 13 to 18	Over 26 to 36
8	Over 18 to 32	Over 36 to 64

Daniel F. C. Hayes, AIA; Washington, D.C.



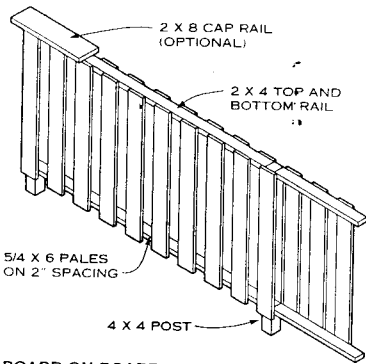

BOARD ON BOARD

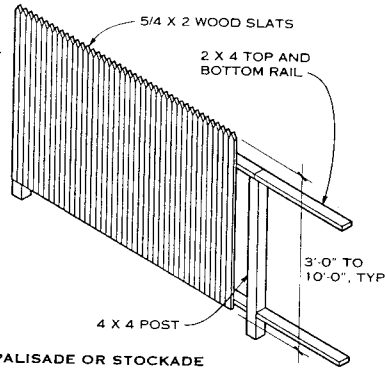

PALISADE OR STOCKADE

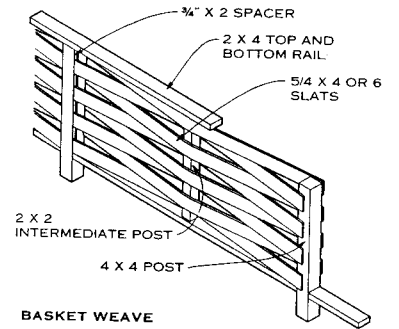

BASKET WEAVE

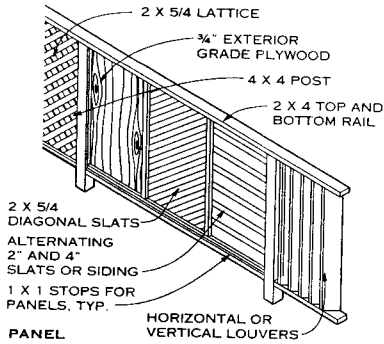

WOOD PRIVACY FENCES

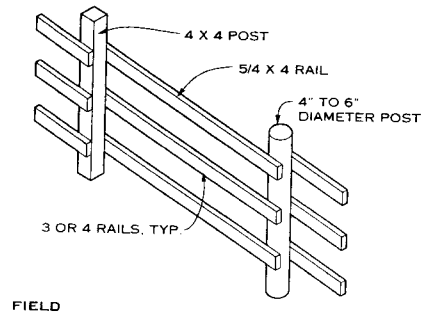
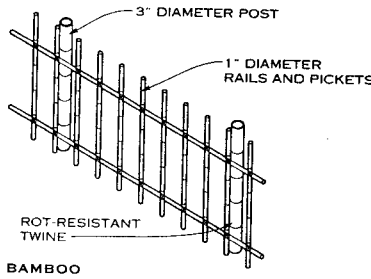
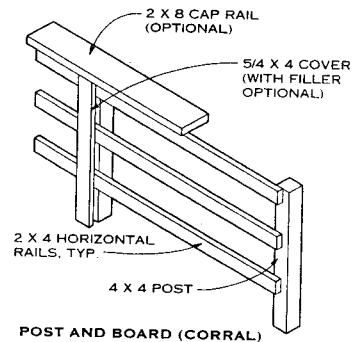
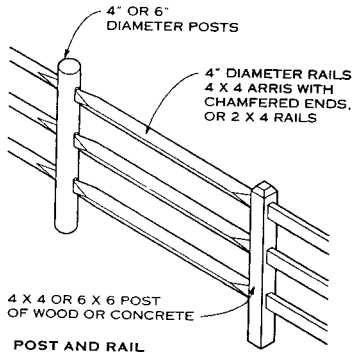
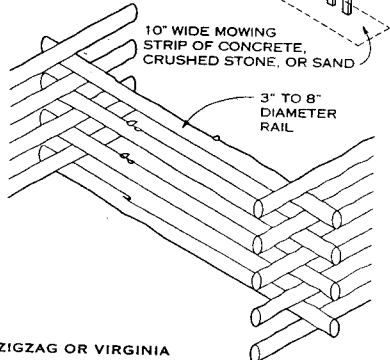
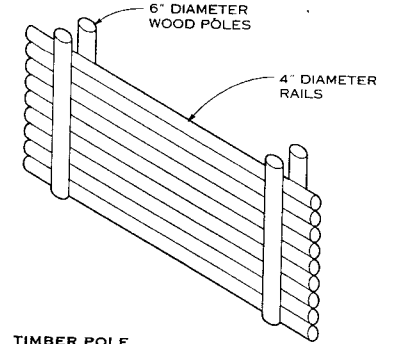
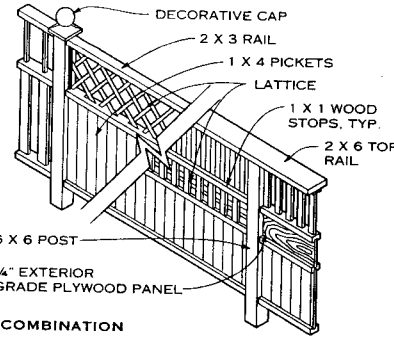
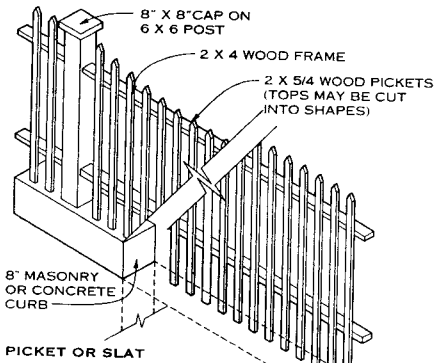

WOOD BOUNDARY FENCES

NOTES

1. Untreated wood materials such as white oak or tamarack can last up to 10 years; cypress, redwood, and sassafras up to 15 years; red and white cedar up to 20 years; and black locust and osage orange up to 25 years. Weather and insect preservative treatments can extend the useful

life to 25 to 30 years for most species. Verify life expectancies and compatibility with finishes and hardware with manufacturers.

2. Fasteners should be made of noncorrosive materials such as aluminum alloys or stainless steel; high quality hot-

dipped galvanized steel is acceptable. Metal flanges, cleats, bolts, and screws are preferable to common nails.  
3. Virgin or recycled plastic may be used as an alternative material for the fences illustrated on this page.

Daniel F. C. Hayes, AIA; Washington, D.C.

**GENERAL**

Consistent with the philosophy of crime prevention through environmental design (CPTED), architects use a combination of design and operational tools to address projects requiring site security. These tools include access control of pedestrians on the site, natural and mechanical surveillance of occupants of the property, and clear definition of public and private space through a combination of real and symbolic barriers.

When terrorism, workplace violence, or street crime is possible on a site, the U.S. General Services Administration recommends the following for all government buildings:

1. Eliminate potential hiding places near the facility.
2. Provide an unobstructed view around the facility.
3. Place the facility within view of other occupied facilities.

4. Locate assets stored on site but outside the facility within view of occupied rooms in the facility.
5. Minimize the signage or indication of assets on the property.
6. Set the facility a minimum of 100 ft from the facility boundary, if possible.
7. Eliminate lines of approach perpendicular to the building.
8. Minimize the number of vehicle access points.
9. Eliminate or strictly control parking beneath facilities.
10. Locate parking as far from the building as practical,

11. Illuminate the exterior of the building and/or exterior sites where assets are located.
  12. Secure access to power/heat plants, gas mains, water supplies, and electrical and phone service.
- Design elements commonly used to create real and symbolic barriers to increase site security include bollards/planters, curbs, vehicle barriers, gates, security lighting, and signage.

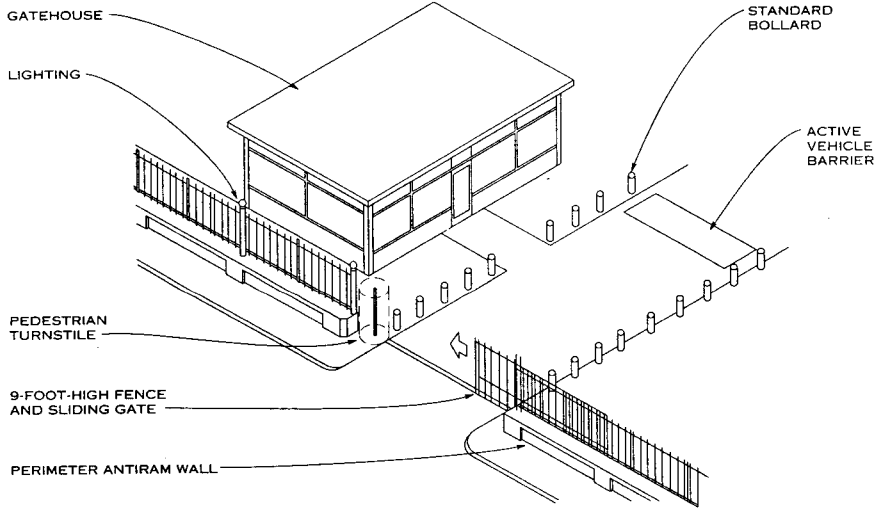
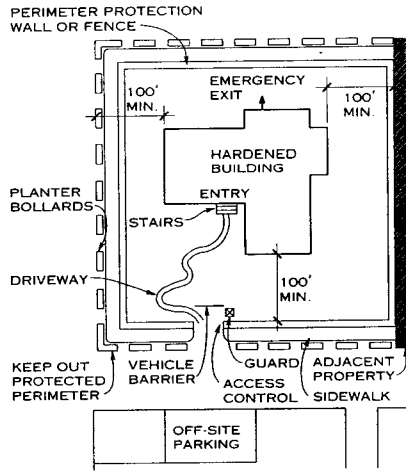

**SECURED SITE PLAN**

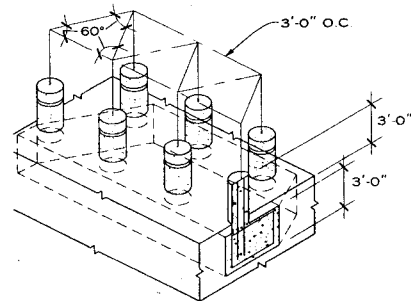

**CONCRETE BOLLARDS WITH CONTINUOUS FOOTING**

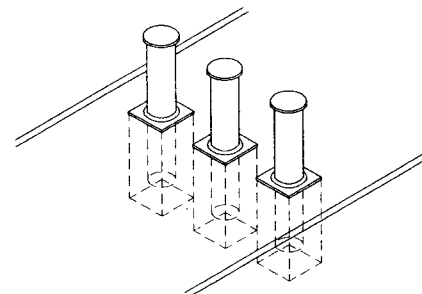

**RETRACTABLE BOLLARDS**

**TYPICAL SALLY PORT**

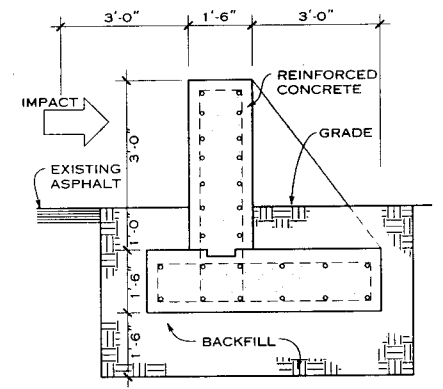
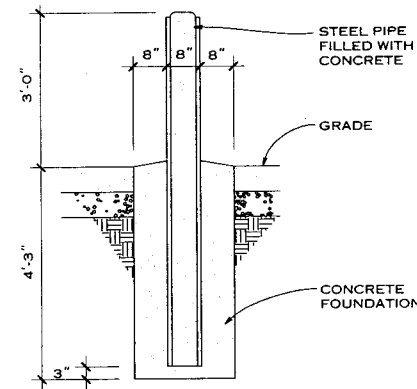

**BOLLARD DETAIL**

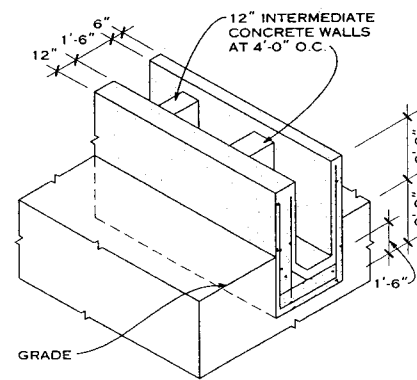

**CONCRETE PLANTER BARRIER**

**TYPICAL RETAINING WALL FOR SECURITY**

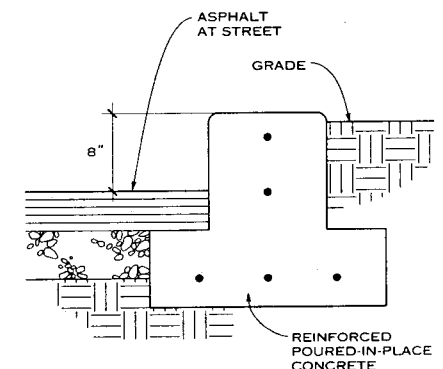

**NONMOUNTABLE CURB DETAIL**

Randall I. Atlas, AIA, Ph.D., CPP; Atlas Safety and Security Design, Inc.; Miami, Florida

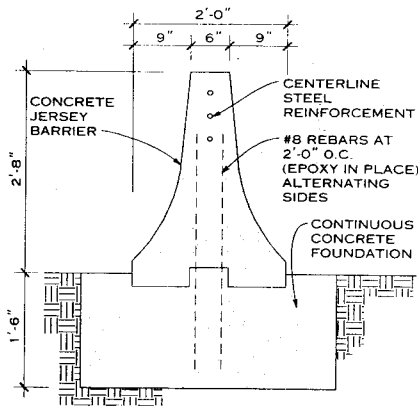

CONCRETE JERSEY BARRIER

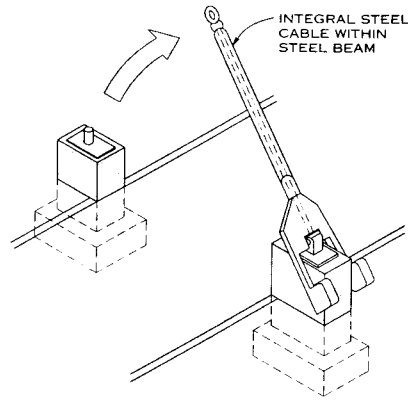

CABLE CRASH BEAM

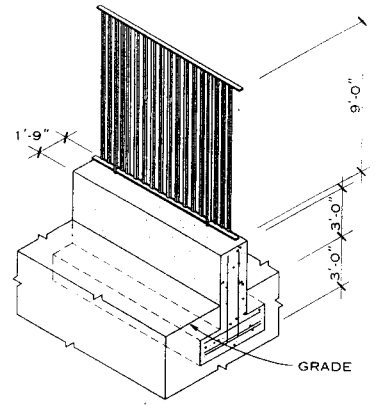

FENCE ON BARRIER WALL

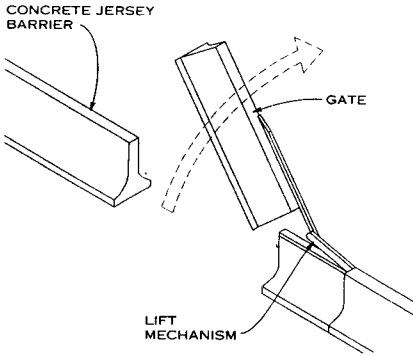

**NOTE**

This reinforced steel gate has the same cross-sectional profile as the concrete barrier. It is usually controlled remotely.

GATE AT JERSEY BARRIER

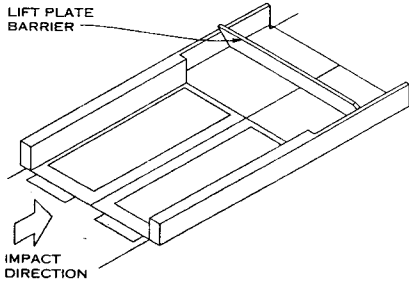

PORTABLE LIFT PLATE

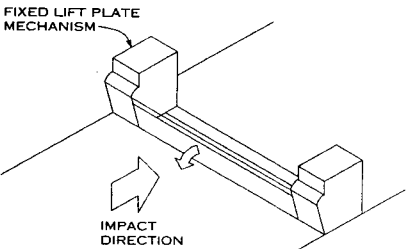

FIXED LIFT PLATE

LIFT PLATE BARRICADE SYSTEMS

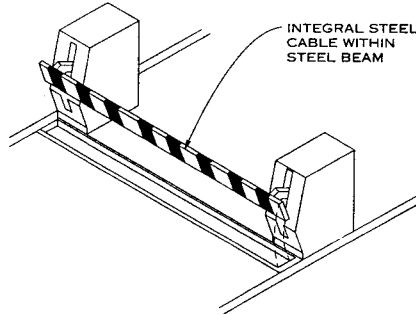

LIFT CRASH GATE

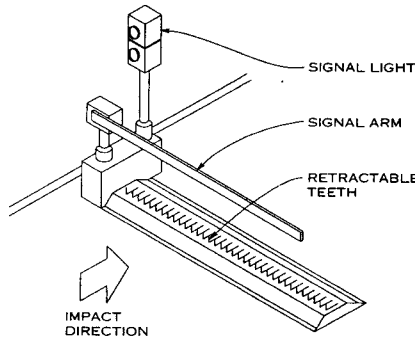

TRAFFIC CONTROLLER

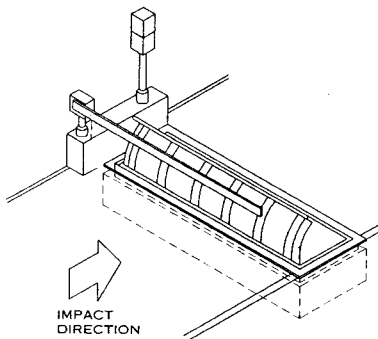

RETRACTABLE BARRIER

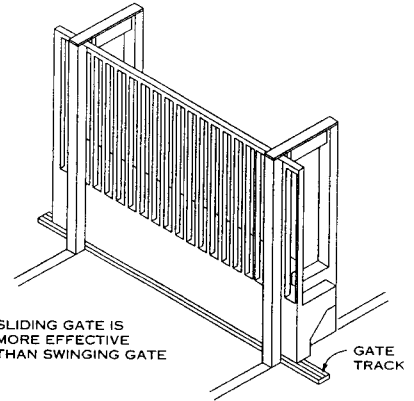

SLIDING GATE IS MORE EFFECTIVE THAN SWINGING GATE

SLIDING CRASH GATE

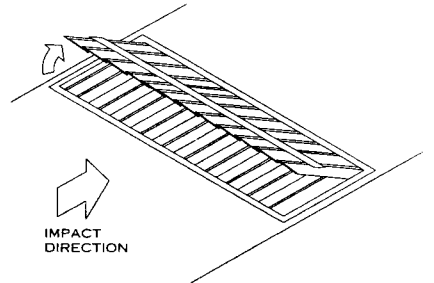

BEAM-TYPE BARRICADE

**NOTE**

Active barriers at access/egress points in high security areas should be fully engaged until vehicles are cleared for passage. A visible signal light or drop arm should indicate the status of the barrier to approaching vehicles. Operating time should not exceed 3-4 seconds. In case of power failure, the barrier system must be able to maintain its position to prevent access but be capable of manual operation; it also should be connected to emergency power. Remote controls should include a status indicator.

Edwin Daly, AIA, and Ellen Delaney; Joseph Handwerger, Architects; Washington, D.C.  
 William G. Miner, AIA; Washington, D.C.  
 Randall I. Atlas, AIA, Ph.D., CPP; Atlas Safety and Security Design, Inc.; Miami, Florida

**INTRODUCTION**

Playing is vital to the physical, emotional, and social growth of children. To encourage healthy growth, the play environment must challenge children at their level of development yet reassure them as they investigate their physical limits. Each stage of development results in different types and levels of interaction and activity. The outdoor play environment becomes increasingly important as the boundaries of the child's world stretch beyond the home and primary care. Play equipment should be selected and designed to attract, fascinate, and sustain the interest of the age groups who will use it, while promoting agility, strength, and balance.

Playing may consist of imitation, role play, and fantasy play, as well as more active pursuits. Space and equipment must be provided to encourage jumping, climbing, swinging, sliding, crawling, hanging, running, building, sitting, and meeting. Designs should provide opportunities for children to be imaginative and to interact socially. Think of the equipment as a flexible, three-dimensional system that allows children to move in every direction and challenges them with a consistently changing space.

Three age groups must be considered in designing playgrounds. Toddlers (3 to 5 years) should be separated from older children by a fence they can see through. This makes it easier for caregivers to supervise the younger children but allows the toddlers to feel part of things. Early elementary (6 to 9 years) and late elementary (9 to 12 years) children have traditionally been separated, but another option is to design equipment that has several levels of difficulty, allowing use by both groups.

Most traditional play equipment is designed to stand alone as single units, although these may be linked together. Where space or other conditions limit the scope of development, such equipment is useful. However, because a child's play activity tends to proceed in a continuous flow, integrated play areas have proved more successful than arrangements of individual items. Combining several materials, colors, and textures also makes the play space more inviting. A variety of options is available to the designer in both custom and manufactured products.

**DESIGN SUGGESTIONS**

The design of a playground should meet the needs and sustain the interest of the children who will use the site. Using nonrepetitive elements and semitransparent features creates mystery and surprise. Dynamic, movable components

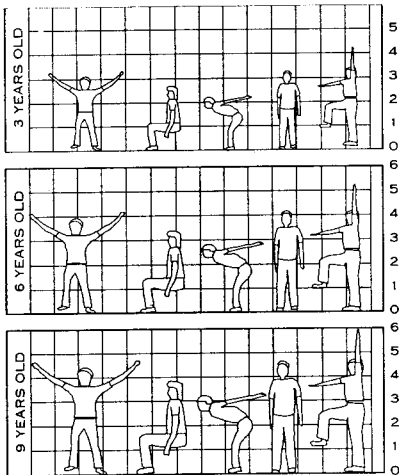

**GROWTH AND DEVELOPMENT**

**NOTES**

Two methods of expanding the capabilities of an integrated playground are:

1. **LINKING OF EQUIPMENT:** Connecting activity centers with links that are in themselves play structures, thus multiplying the possible uses of all of the structures involved.
2. **JUXTAPOSITIONING EQUIPMENT:** Placing units close enough together to generate interaction from one to the other; also increases the play potential and interest of the area.

allow more creative opportunities for children, and a variety of textures stimulates the sense of touch. Children never tire of playing with sand and water. Manufacturers offer a wide variety of water features for the playground, including wading pools and fountains. Water elements also encourage adult interaction. Space for congregating can be provided as semienclosed refuge or open areas. Bridges add interest to equipment and can provide connections between structures; they also create more climbing and refuge space. In addition to traditional plank bridges, there are arched, rope, suspension, or tire bridges. Suspension bridges may be designed to meet specifications provided in the Americans with Disabilities Act (ADA).

If a theme such as a ship, castle, or fort is incorporated in the playground, the equipment will automatically encourage the child's imagination. However, don't replicate these themes too closely. Leave most of the creation to the child.

Adults should not be separated from the play area. Ample seating should be provided, and the equipment should be interesting to adults, too, since their presence gives security, instruction, and approval.

Practical concerns should be taken into account in designing a playground: how does the equipment appear from the surrounding area? What are the views from the site? How much noise will travel to and from the playground? The design should consider the time of day the equipment will be used and be suitable for use all year. Drainage is important, especially around swings and berms, and shade is especially desirable over metal slides.

**SAFETY AND MATERIALS**

No playground is completely safe. The potential for accidents is inherent in the element of risk involved in most play. Nonetheless, playground equipment should provide challenging activities in the safest way possible.

Round, square, and rectangular timber should be pine or fir (oak warps, redwood splinters). Color should be in the form of stain, not paint, and all edges should be beveled or rounded. Steel pipe, sheets, chain, and drums can be vinyl coated. Chain, rope, and tires are available in plastic. Use of concrete and stone should be kept to a minimum. Hardware should be galvanized, and joints and connections covered or recessed.

Most important, a bed of absorbing ground cover, such as pine bark or wood chips (12 in. deep), pea gravel (10 in. deep), or sand (10 in. deep), should be installed beneath the equipment. Hardwood chips and rubberized surfacing are easier for persons with disabilities to travel over. Asphalt, packed dirt, and exposed concrete are not acceptable play surfaces.

A safety zone of at least 4 ft should surround the entire play area, with 7 ft in front of slides, 9 ft in front of swings, and 4 to 5 ft on the sides of the swings. Allow 65 to 70 sq ft of play space per child.

**EQUIPMENT FOR CHILDREN WITH DISABILITIES**

The ADA has raised a new understanding of the need to include children with disabilities in play activity wherever possible. Several elements will encourage the participation of children with disabilities. Bump stairs, transfer platforms, accessible suspension bridges, and slides (provided there is enough traction), as well as components that can be manipulated from a wheelchair, are all useful. Many persons with disabilities have some upper-body mobility, and horizontal ladders and rings can help children strengthen the upper body. Ramps and handrails should be used wherever possible.

**MANUFACTURED VERSUS CUSTOM EQUIPMENT**

Manufacturers of playground equipment offer products in timber, plastic, or powder-coated steel. Available as either individual items or in predesigned arrangements, these products are durable and easy to install and offer a variety of accessories. Because they are designed as modular units, they can be used to create a limitless number of compositions and can be expanded at a later date. Some have no need for foundations. All products must conform to the Consumer Product Safety Code.

Custom-designed equipment has the advantage of being site and situation specific. In addition, the manipulation of landforms by the designer can result in a much more interesting and creative site. Most of the materials used by manufacturers are readily available to designers, making custom design of equipment an affordable option.

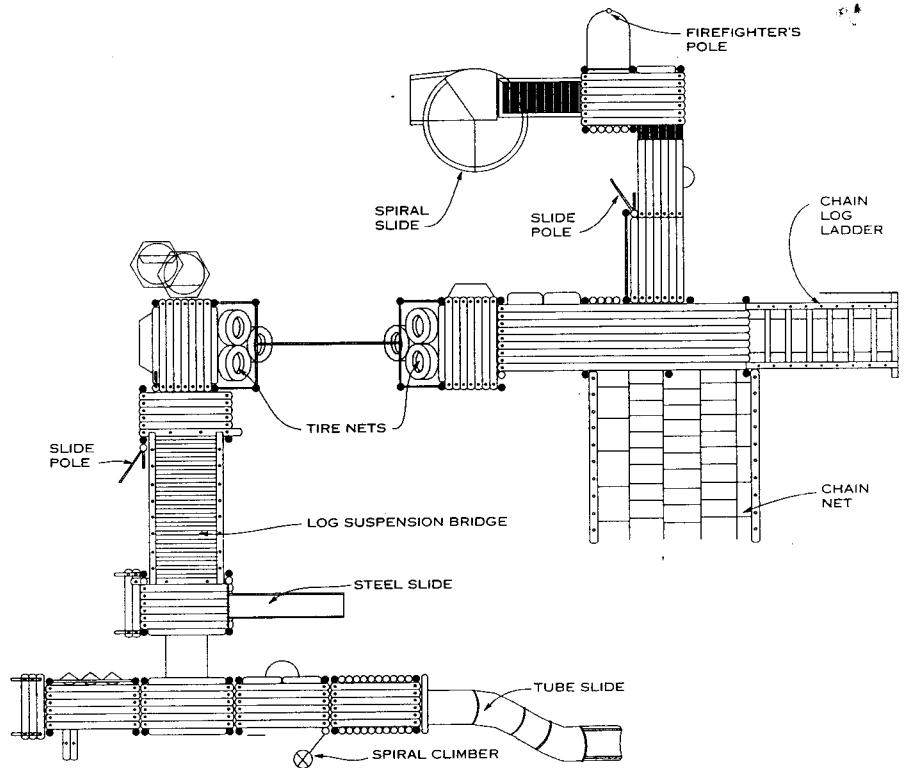

**INTEGRATED PLAY AREA**

Andrew Sumners; University Park, Maryland

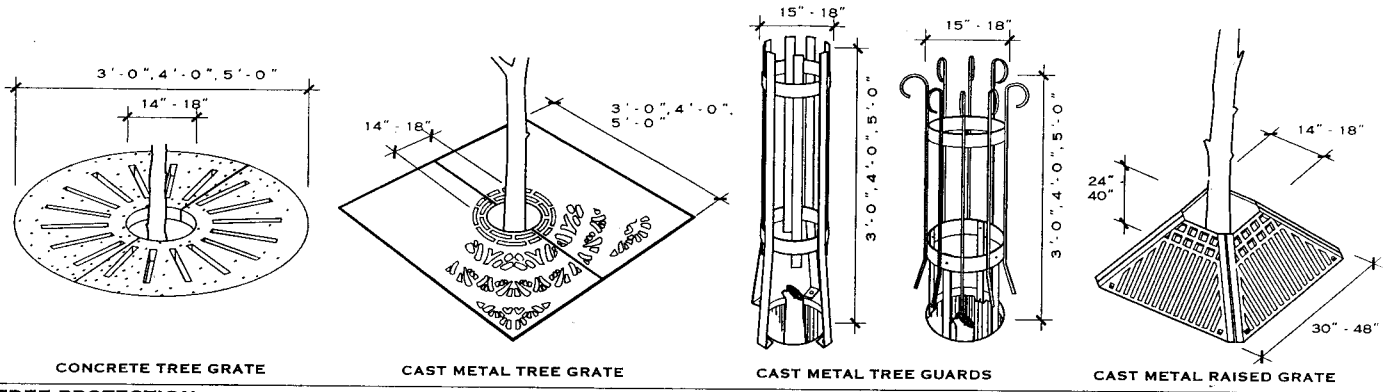

TREE PROTECTION

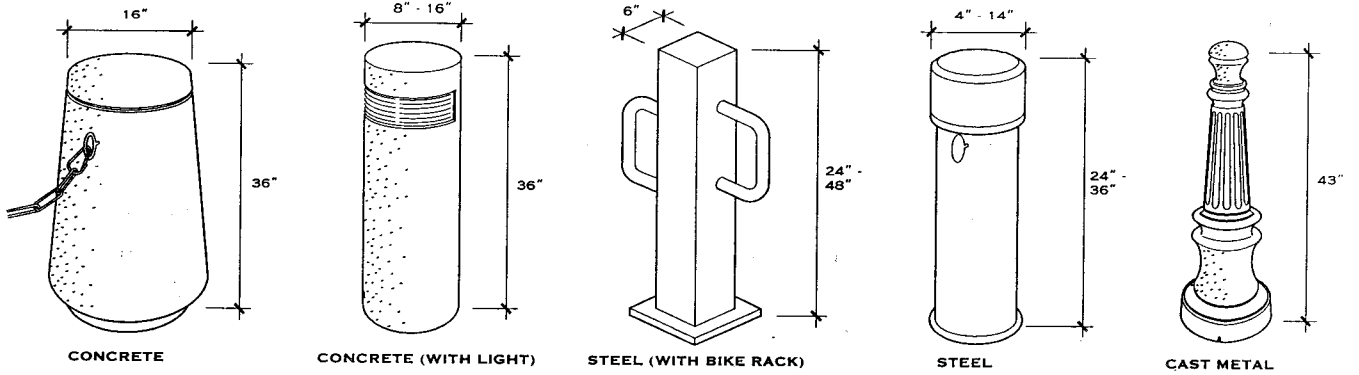

BOLLARDS

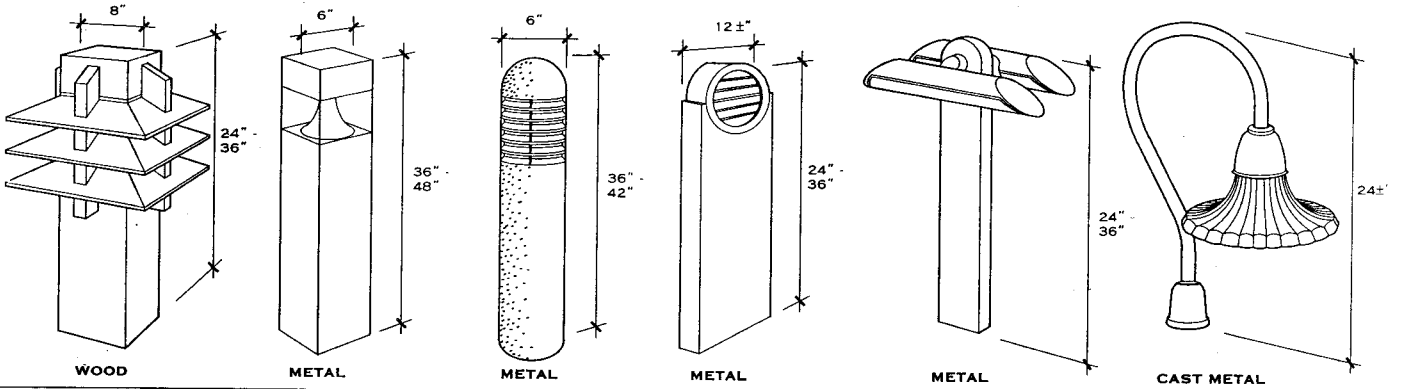

LANDSCAPE LIGHTS

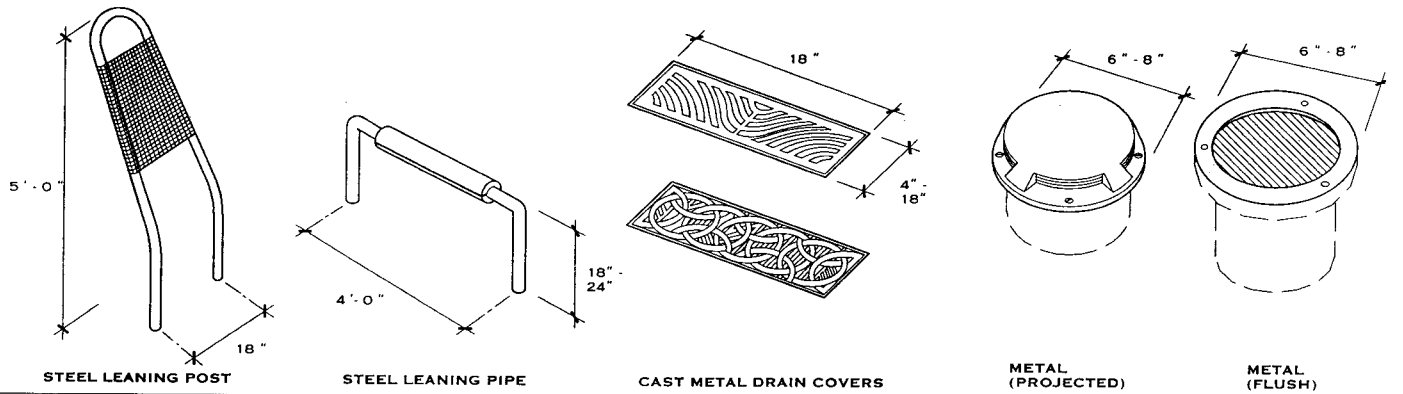

MISCELLANEOUS

DRIVE / WALKOVER LIGHTS

Richard J. Vitullo, AIA; Oak Leaf Studio; Crownsville, Maryland

2 SITE IMPROVEMENTS AND AMENITIES

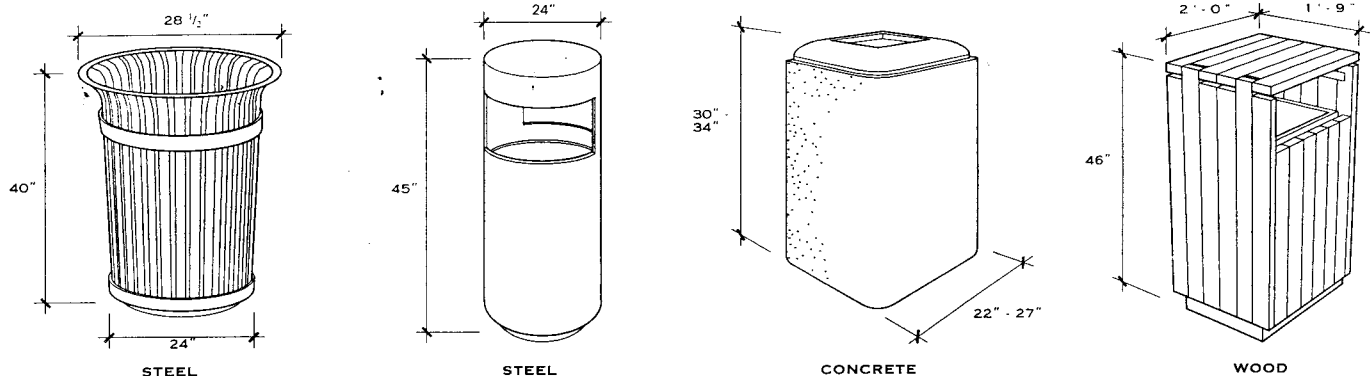

STEEL

STEEL

CONCRETE

WOOD

TRASH RECEPTACLES

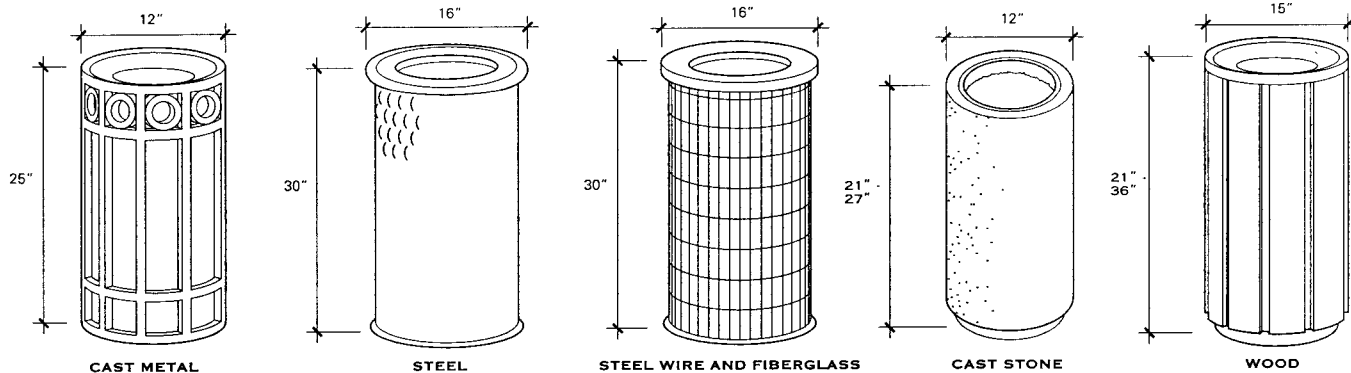

CAST METAL

STEEL

STEEL WIRE AND FIBERGLASS

CAST STONE

WOOD

ASH URNS

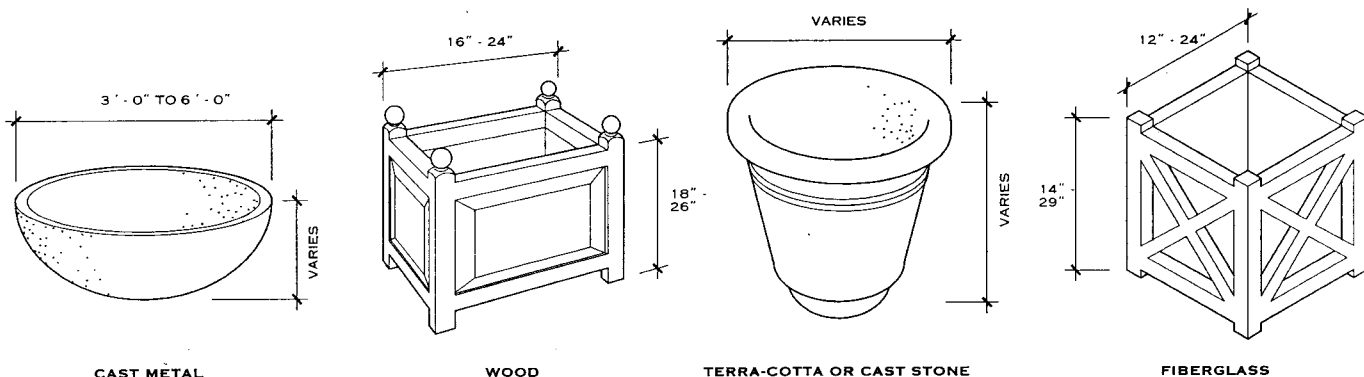

CAST METAL

WOOD

TERRA-COTTA OR CAST STONE

FIBERGLASS

PLANTERS

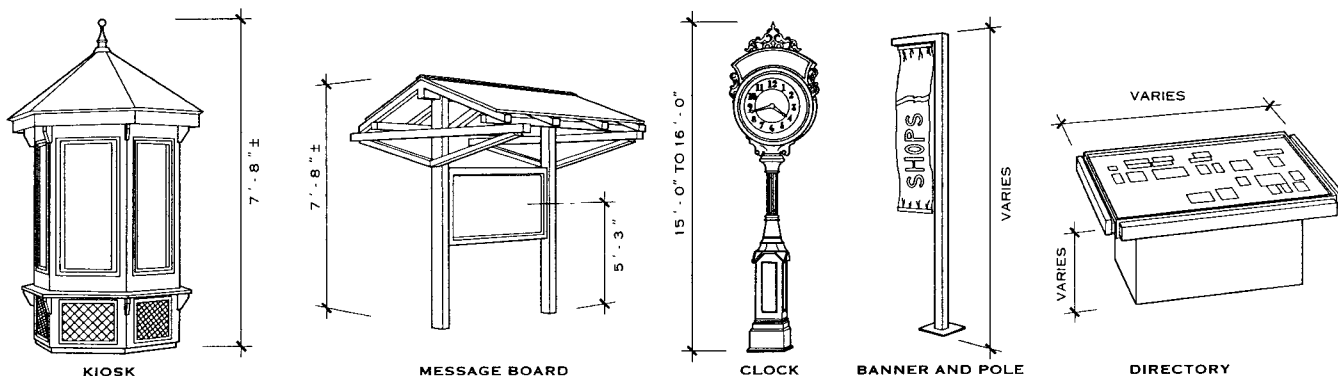

KIOSK

MESSAGE BOARD

CLOCK

BANNER AND POLE

DIRECTORY

INFORMATION-RELATED FURNISHINGS

Richard J. Vitullo, AIA; Oak Leaf Studio; Crownsville, Maryland

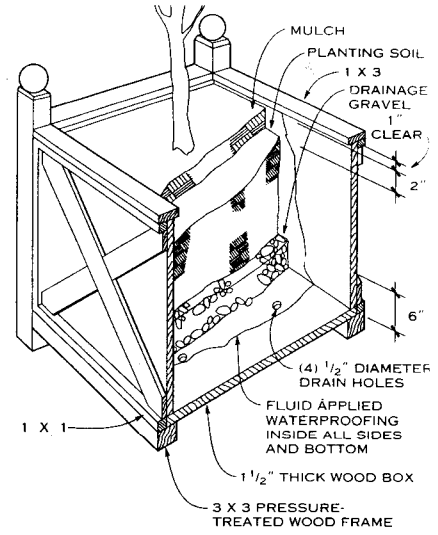
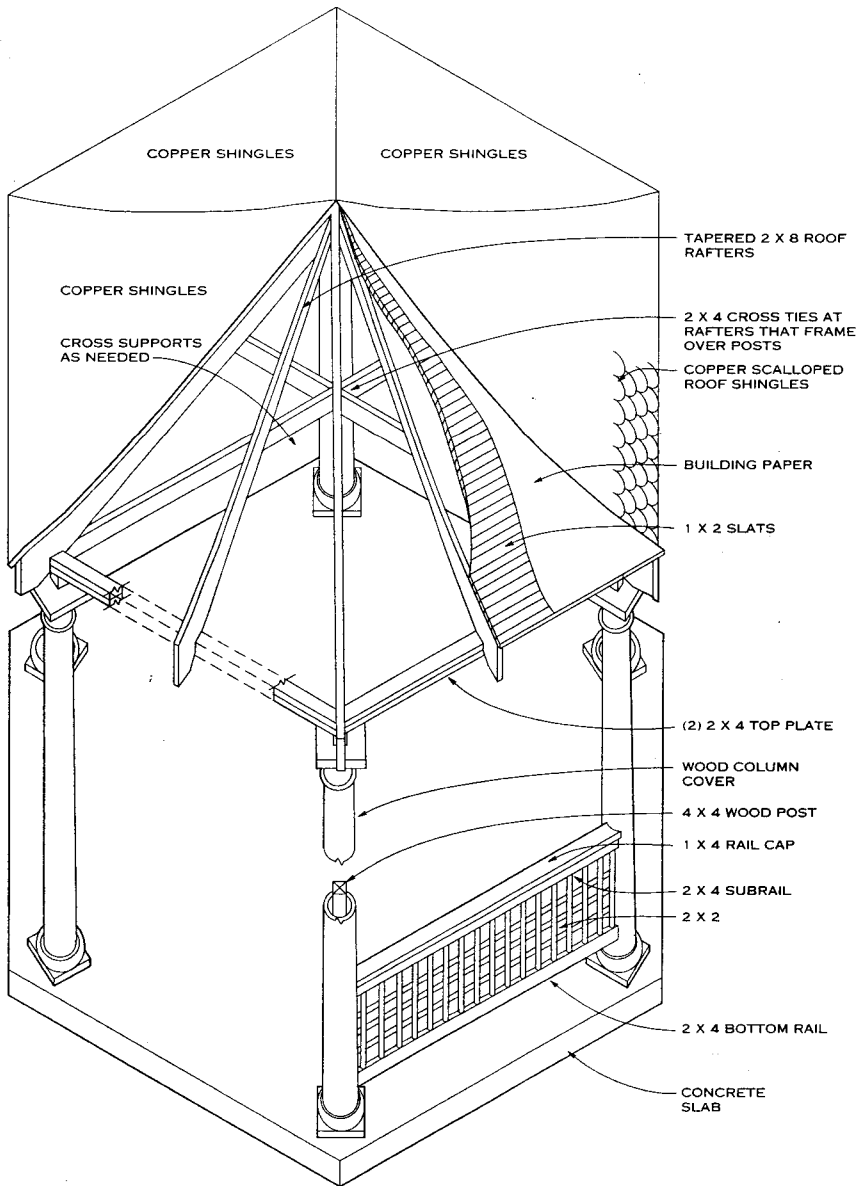

**WOOD PLANTER**

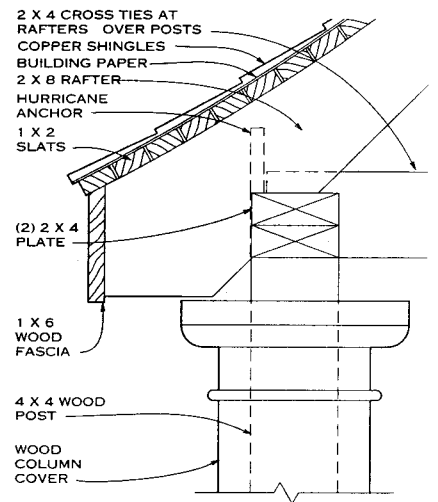

**GAZEBO DETAIL**

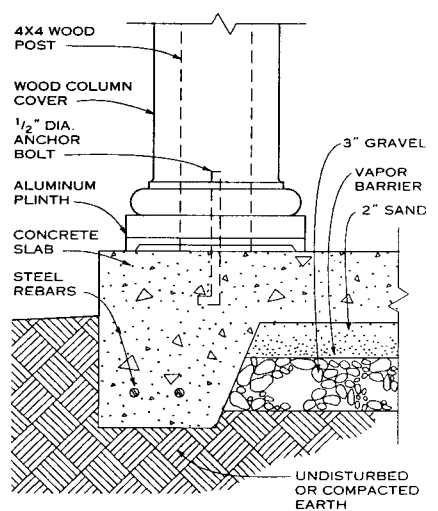

**GAZEBO DETAIL**

**GAZEBO**

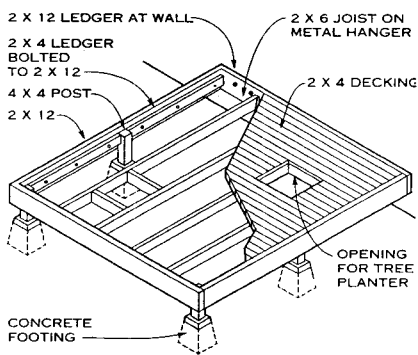

**WOOD DECK PLATFORM**

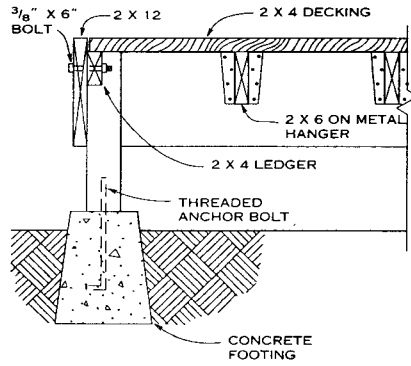

**PLATFORM FOOTING DETAIL**

Gary Greenan; Miami, Florida  
Richard J. Vitullo, AIA; Oak Leaf Studio; Crownsville, Maryland

**2 SITE IMPROVEMENTS AND AMENITIES**

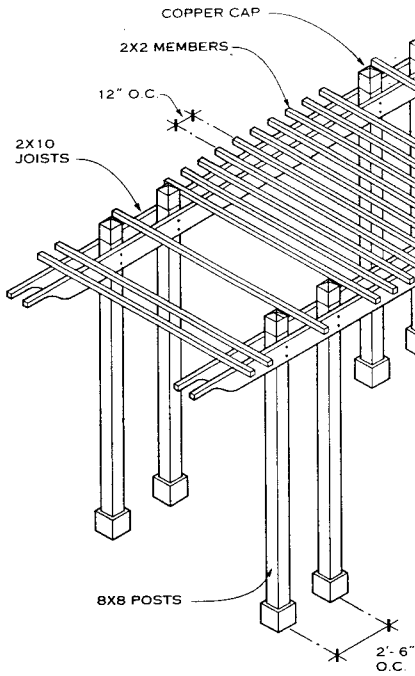

**NOTE**  
All wood is pressure-treated pine.

**WOOD TRELLIS**

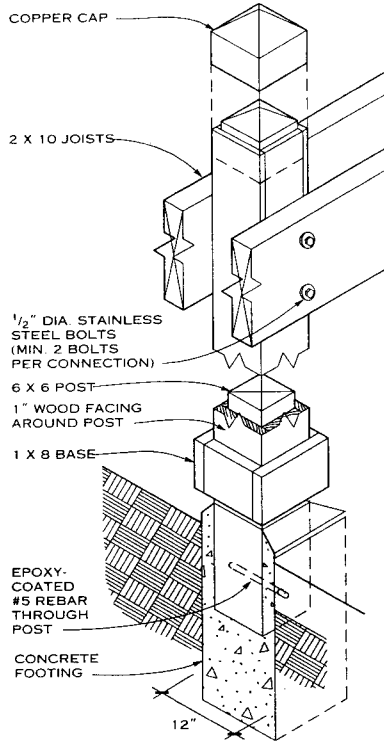

**TRELLIS DETAIL**

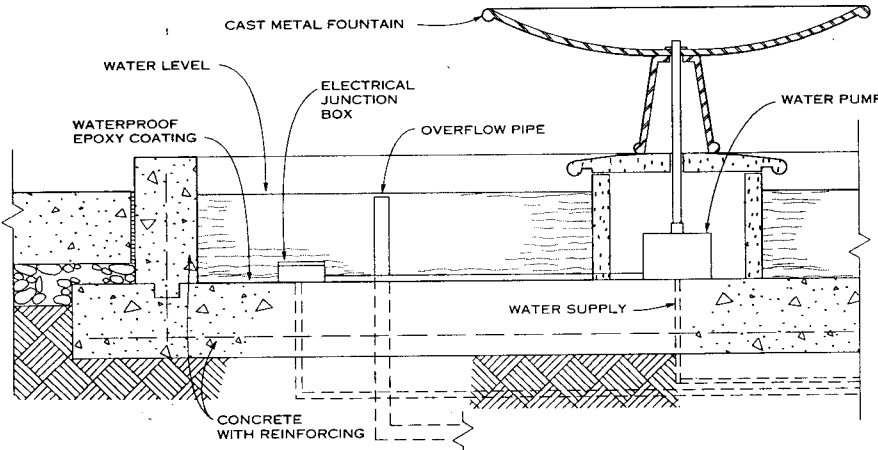
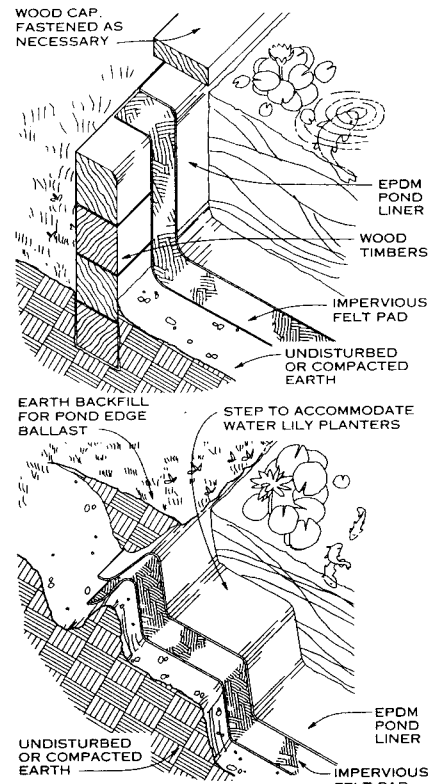

**FOUNTAIN SECTION**

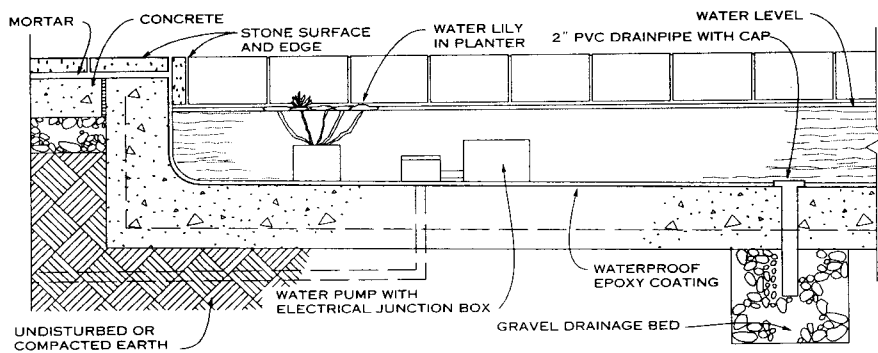

**POND SECTION**

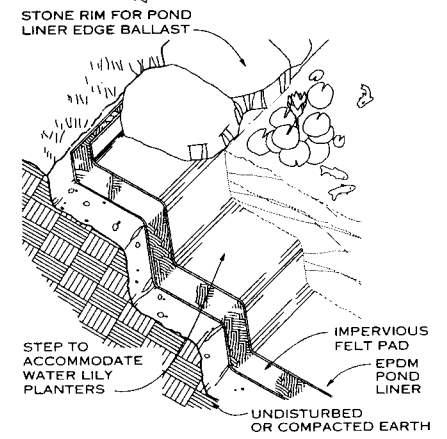
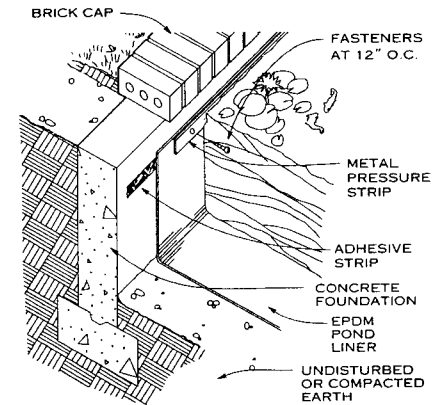

**POND DETAILS**

Gary Greenan; Miami, Florida  
Richard J. Vitullo, AIA; Oak Leaf Studio; Crownsville, Maryland



**GENERAL**

Embankment stabilization is required when steep slopes are subject to erosion from stormwater runoff or flowing streams. Erosion can damage the site and pollute waterways with sediment.

The need for mechanical stabilization can be reduced through careful site gradings that divert or slow the velocity of runoff. Avoid disturbing stable, natural stream banks. Check with regulatory agencies before planning to grade stream banks, wetlands, or floodplains.

Numerous proprietary products are available for stream bank stabilization and erosion control; consult manufacturers.

**NOTES**

1. Control erosion during construction with silt fences, straw bales, sediment ponds, and seeding and mulching. Follow local and state guidelines and regulations.
2. Line channels with erosion-resistant material (sod, stone riprap, erosion-control blanket). Channel dimensions and lining should be designed for expected runoff.
3. At the bottom of the slope drain channel, the flow should be conveyed to a storm sewer, detention pond, constructed wetland, or other control method that meets regulations.

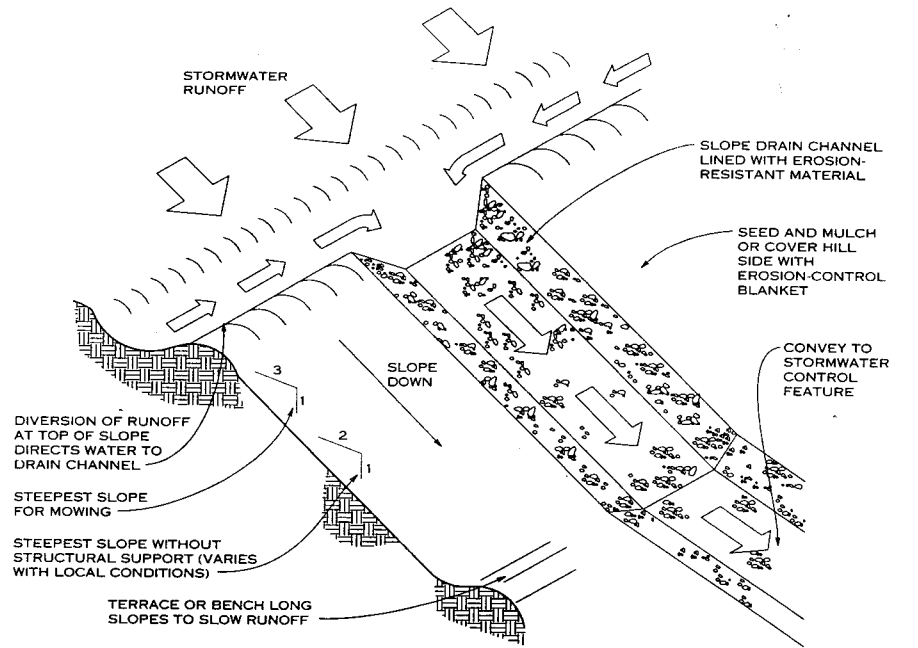

**GRADING AND EROSION CONTROL**

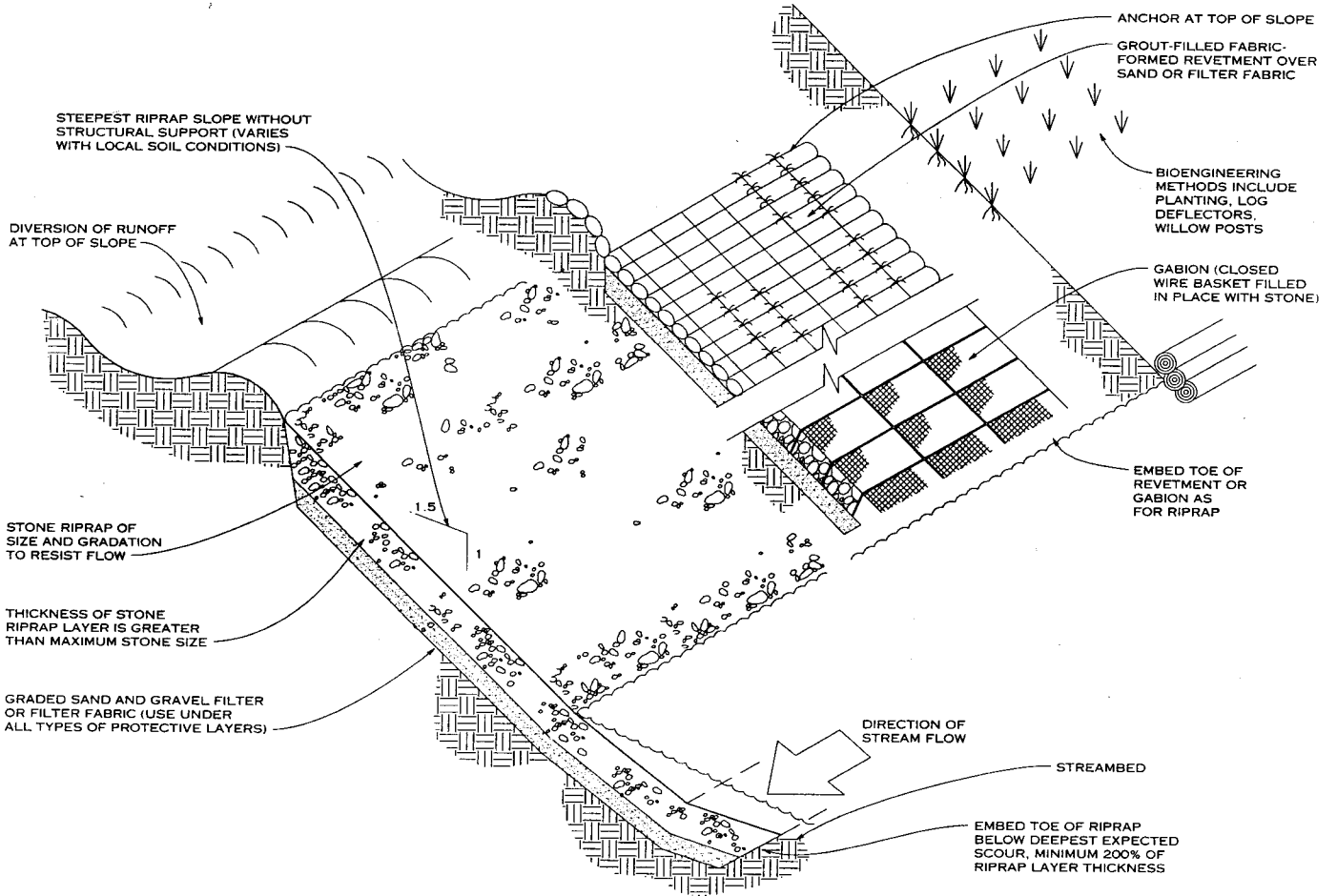

**STREAM BANK STABILIZATION**

James E. Sekela, P.E.; Pittsburgh, Pennsylvania

**2** RETAINING WALLS

**GENERAL**

Retaining walls are designed and constructed to resist the thrust of the soil, which can cause the wall to fail by overturning, sliding, or settling. In stone walls, resistance to soil thrust can be helped by battering the stonework (that is, recessing or sloping the masonry back in successive courses).

Garden-type retaining walls, usually no higher than 4 ft, are made from small building units of stone, masonry, or wood. For higher walls, reinforced concrete is more commonly used. Terracing may be built with walls of wood, stone, brick, or concrete.

Walls less than 2 ft high do not require drains or weep holes. Pressure-treated wood is recommended for any design in which wood is in contact with the ground. Redwood may be substituted if desired.

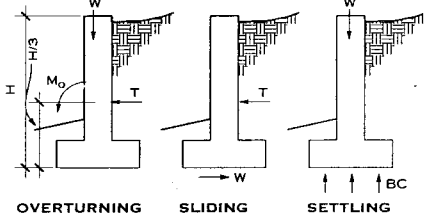

- NOTES**
1. H = height of wall, A = area of footing, W = composite weight of wall; T = lateral thrust of soil on wall; d = width of base of wall;  $M_O$  = overturning moment of a retaining wall;  $M_R$  = resisting moment; w = lateral force on wall in psf; BC = bearing capacity of soil.
  2. The overturning moment of a retaining wall (equal to  $T \times H/3$ ) is resisted by the resisting moment of the wall. For symmetrical sections, the resisting moment equals  $W \times d/2$ . Using a safety factor of 2,  $M_R \geq 2 \times M_O$  (assume  $33^\circ$  angle of repose of soil).
  3. The lateral (sliding) thrust of soil on a wall must be resisted. The resisting force is the weight of the wall multiplied by the coefficient of soil friction. Using a safety factor of 1.5,  $W \geq 1.5T$ , where  $T = (w \times H^2)/2$ .
  4. The bearing capacity of the soil must resist vertical forces (settling)—the weight of the wall plus any soil bearing on the base plus any vertical component of the soil thrust for a wall with any surcharge. Using a safety factor of 1.5,  $BC \geq 1.5W/A$ .

**FORCES RESISTED BY RETAINING WALLS**

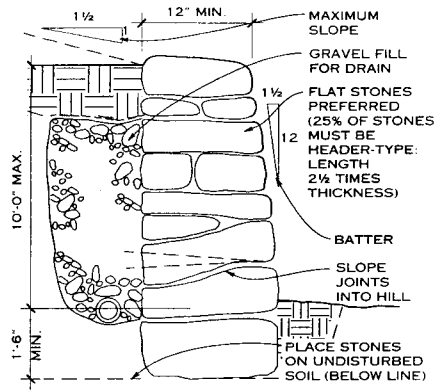

**NOTE**  
Stagger vertical joints from course to course 6 in. horizontally. The thickness of the wall at any point should not be less than half the distance from that point to the top of the wall.

**DRY STONE WALL**

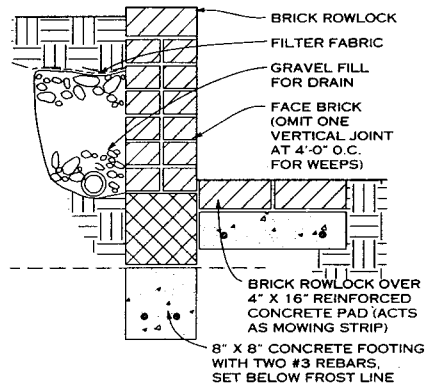

**BRICK WALL**

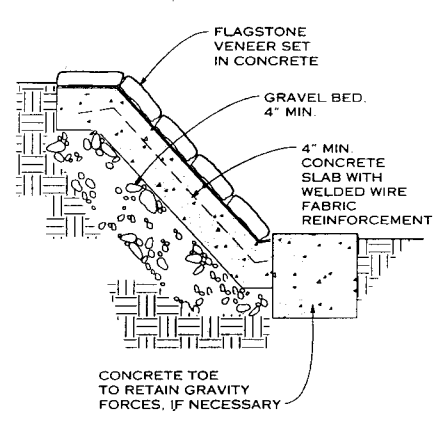

**STONE BANK**

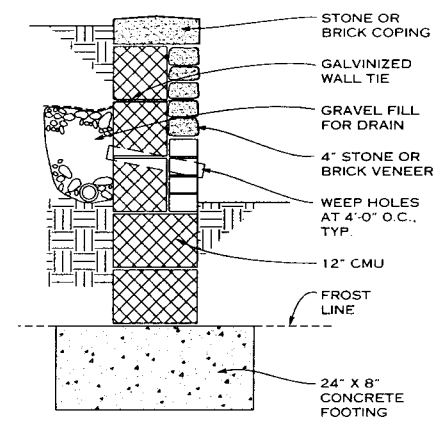

**STONE/BRICK VENEER WALL**

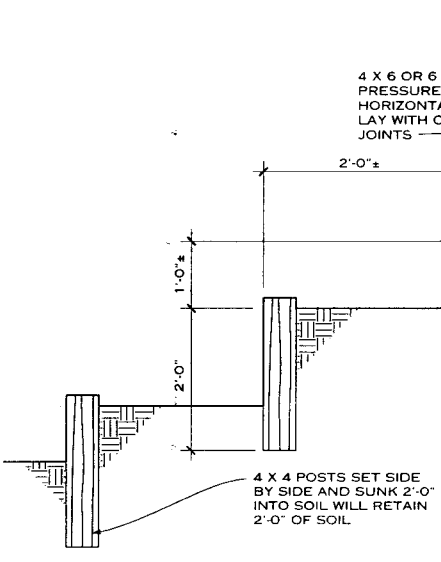

**SOIL TERRACING NOTE**  
A structural engineer should be consulted for the final design.

**WOOD RETAINING WALL**

Donald Neubauer, P. E.; Neubauer Consulting Engineers; Potomac, Maryland

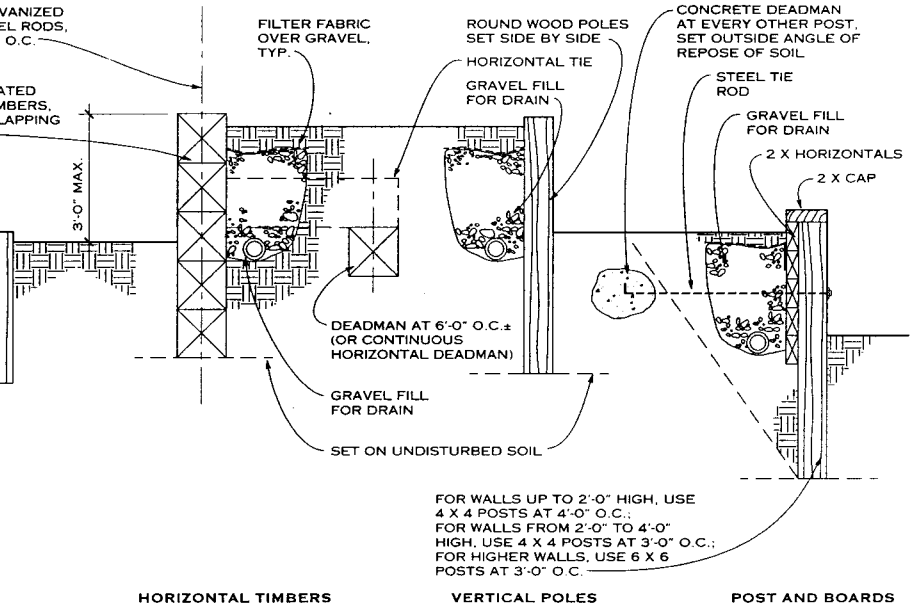

**HORIZONTAL TIMBERS**      **VERTICAL POLES**      **POST AND BOARDS**

FOR WALLS UP TO 2'-0" HIGH, USE 4 X 4 POSTS AT 4'-0" O.C.; FOR WALLS FROM 2'-0" TO 4'-0" HIGH, USE 4 X 4 POSTS AT 3'-0" O.C.; FOR HIGHER WALLS, USE 6 X 6 POSTS AT 3'-0" O.C.

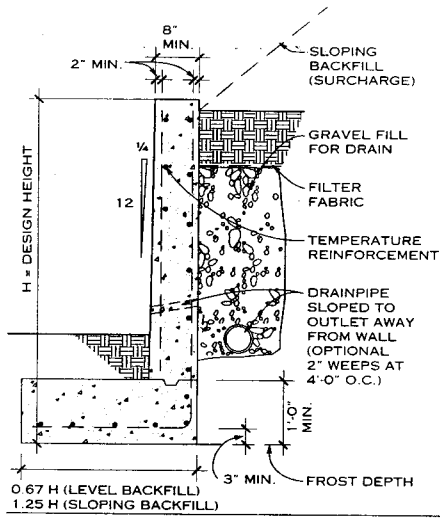

L-TYPE RETAINING WALLS

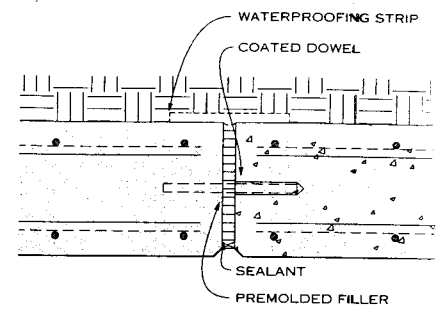
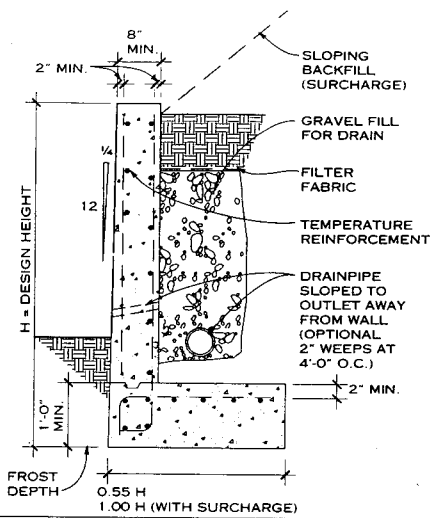

VERTICAL EXPANSION JOINT

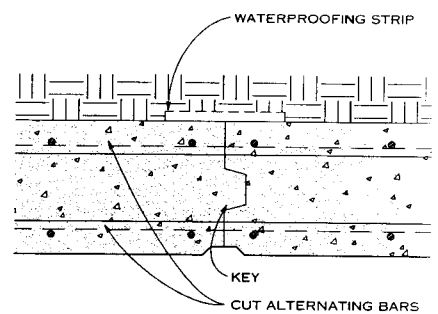

VERTICAL CONTROL JOINT

RETAINING WALL JOINTS

NOTES

1. Provide control and/or construction joints in concrete retaining walls about every 25 ft. Every fourth control and/or construction joint should be an expansion joint. Coated dowels should be used if average wall height on either side of a joint is different.
2. Consult with a structural engineer for final design of all concrete retaining walls.
3. Concrete keys may be required below retaining wall footing to prevent sliding in high walls and those built on moist clay.
4. T = the lateral thrust of the soil on the wall in the drawing of a gravity retaining wall.

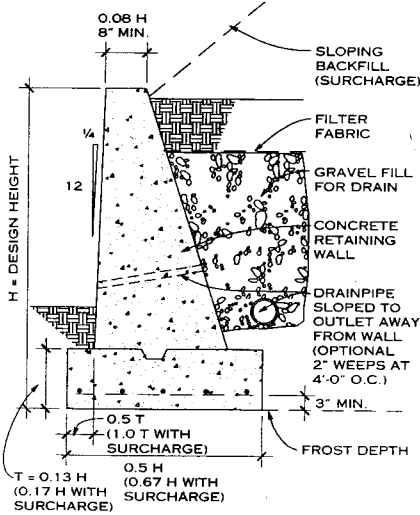

GRAVITY RETAINING WALL

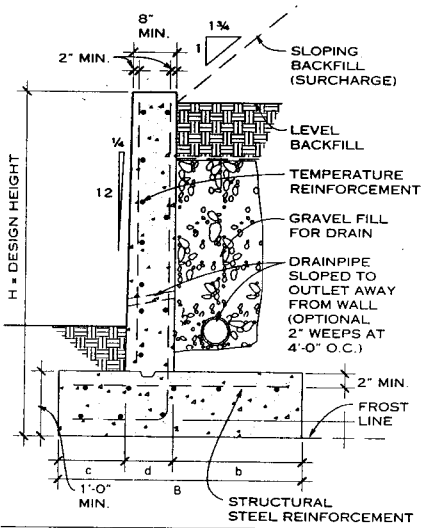

T-TYPE RETAINING WALL

PRELIMINARY DIMENSIONS FOR CONCRETE RETAINING WALLS

APPROXIMATE CONCRETE DIMENSIONS (FT-IN.)									
BACKFILL SLOPING DIA. = 29° 45' (1 1/2:1)					BACKFILL LEVEL—NO SURCHARGE				
HEIGHT OF WALL (H)	WIDTH OF BASE (B)	WIDTH OF WALL (a)	HEEL (b)	TOE (c)	HEIGHT OF WALL (H)	WIDTH OF BASE (B)	WIDTH OF WALL (a)	HEEL (b)	TOE (c)
3-0	2-8	0-9	1-5	0-6	3-0	2-1	0-8	1-0	0-5
4-0	3-5	0-9	2-0	0-8	4-0	2-8	0-8	1-7	0-5
5-0	4-6	0-10	2-6	1-2	5-0	3-3	0-8	2-2	0-5
6-0	5-4	0-10	2-11	1-7	6-0	3-9	0-8	2-5	0-8
7-0	6-3	0-10	3-5	2-0	7-0	4-2	0-8	2-6	1-0
8-0	7-0	1-0	3-8	2-4	8-0	4-8	1-0	2-8	1-0
9-0	7-6	1-0	4-2	2-4	9-0	5-2	1-0	3-2	1-0
10-0	8-6	1-0	4-9	2-9	10-0	5-9	1-0	3-7	1-2
11-0	11-0	1-1	7-2	2-9	11-0	6-7	1-1	4-1	1-5
12-0	12-0	1-2	7-10	3-0	12-0	7-3	1-2	4-7	1-6
13-0	13-0	1-4	8-5	3-3	13-0	7-10	1-2	5-0	1-8
14-0	14-0	1-5	9-1	3-6	14-0	8-5	1-3	5-5	1-9
15-0	15-0	1-6	9-9	3-9	15-0	9-0	1-4	5-9	1-11
16-0	16-0	1-7	10-5	4-0	16-0	9-7	1-5	6-2	2-0
17-0	17-0	1-8	11-1	4-3	17-0	10-3	1-6	6-7	2-2
18-0	18-0	1-10	11-8	4-6	18-0	10-10	1-6	7-1	2-3
19-0	19-0	1-11	12-4	4-9	19-0	11-5	1-7	7-5	2-5
20-0	20-0	2-0	13-0	5-0	20-0	12-0	1-8	7-10	2-6
21-0	21-0	2-2	13-7	5-3	21-0	12-7	1-9	8-2	2-8
22-0	22-0	2-4	14-4	5-4	22-0	13-3	1-11	8-7	2-9

Donald Neubauer, P.E.; Neubauer Consulting Engineers; Potomac, Maryland

**NOTES**

1. Materials and construction practices for concrete masonry retaining walls should comply with "Building Code Requirements for Concrete Masonry Structures (ACI 531)."
2. Use fine grout when grout space is less than 3 in. in the least dimension. Use coarse grout when the least dimension of the grout space is 3 in. or more.
3. Steel reinforcement bars should be clean, free from harmful rust, and in compliance with applicable ASTM standards for deformed bars and steel wire.
4. Alternate vertical bars may be stopped at the mid height of the wall. Vertical reinforcement is usually secured in place after the masonry work has been completed and before grouting.
5. Designs shown are based on an assumed soil weight (vertical pressure) of 100 pcf. Horizontal pressure is based on an equivalent fluid weight for the soil of 45 pcf.
6. The walls illustrated are designed with a safety factor against overturning of not less than 2 and a safety factor against horizontal sliding of not less than 1.5. Computations in the table for wall heights are based on level backfill. One method of providing for additional loads from sloping backfill or surface loads is to consider them as additional depth of soil. In other words, an extra load of 300 psf can be treated as 3 ft of extra soil weighing 100 psf.
7. The top of masonry retaining walls should be capped or otherwise protected to prevent water from entering unfilled hollow cells and spaces. If bond beams are used, steel is placed in the beams as the wall is constructed. However, horizontal joint reinforcement may be placed in each joint (8 in. o.c.) and the bond beams omitted.
8. Allow 24 hrs for masonry to set before grouting. Pour grout in 4 ft layers, with one hour between each pour. Break long walls into panels 20 to 30 ft long with vertical control joints. Allow seven days for finished walls to set before backfilling. Prevent water from accumulating behind walls by means of 4 in. diameter weep holes spaced 5 to 10 ft apart (with screen and graded stone) or by a continuous drain with felt-covered open joints combined with waterproofing.
9. When backfill height exceeds 6 ft, provide a key under the footing base to resist the tendency of the wall to slide horizontally.
10. Heavy equipment used in backfilling should not come closer to the top of the wall than a distance equal to the wall height.
11. A structural engineer should be consulted for the final design.

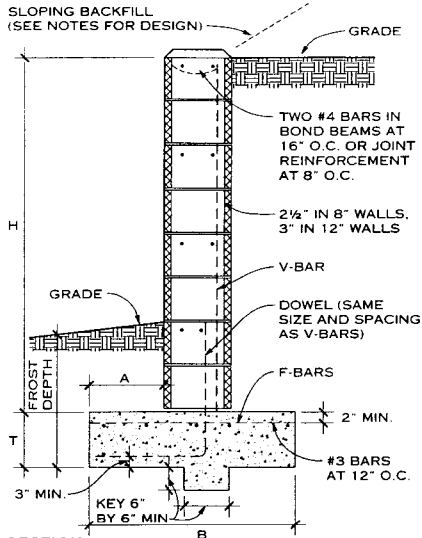

**DIMENSIONS AND REINFORCEMENT FOR CMU RETAINING WALLS**

WALL	H	B	T	A	V-BARS	F-BARS
8"	3'-4"	2'-4"	9"	8"	#3 @ 32"	#3 @ 27"
	4'-0"	2'-9"	9"	10"	#4 @ 32"	#3 @ 27"
	4'-8"	3'-4"	10"	12"	#5 @ 32"	#3 @ 27"
	5'-4"	3'-8"	10"	14"	#4 @ 16"	#4 @ 30"
12"	6'-0"	4'-2"	12"	16"	#6 @ 24"	#4 @ 25"
	5'-4"	3'-8"	10"	14"	#4 @ 24"	#3 @ 25"
	6'-0"	4'-2"	12"	15"	#4 @ 16"	#4 @ 30"
	6'-8"	4'-6"	12"	16"	#6 @ 24"	#4 @ 22"
	7'-4"	4'-10"	12"	18"	#5 @ 16"	#5 @ 26"
8'-0"	5'-4"	12"	20"	#7 @ 24"	#5 @ 21"	
8'-8"	5'-10"	14"	22"	#6 @ 8"	#6 @ 26"	
9'-4"	6'-2"	14"	24"	#8 @ 8"	#6 @ 21"	

**TYPICAL CANTILEVER RETAINING WALL**

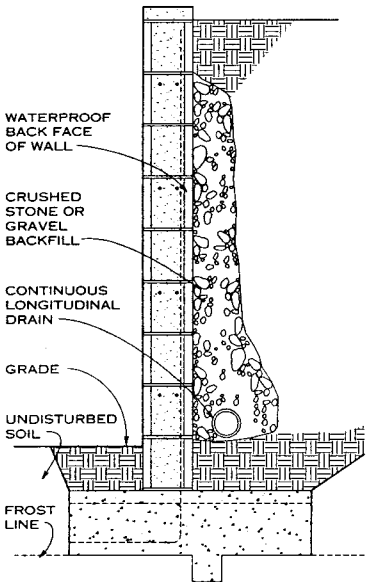

WITH IMPERMEABLE BACKFILL

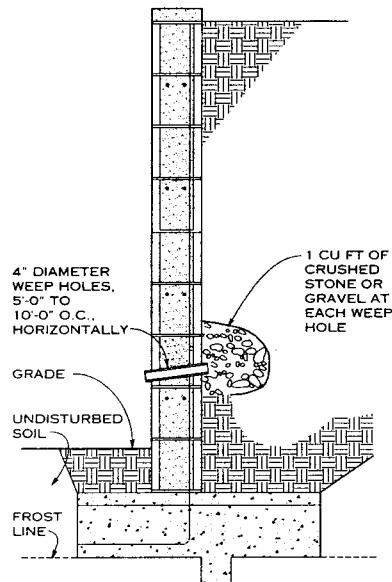

WITH PERMEABLE BACKFILL

**DRAINAGE DETAILS FOR RETAINING WALLS**

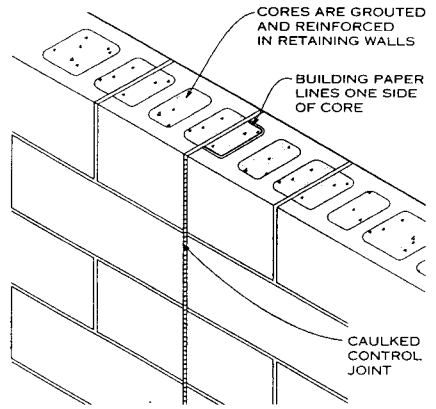

**NOTE**

Long retaining walls should be broken with vertical control joints into panels 20 to 30 ft long. These panels must be designed to resist shear and other lateral forces while permitting longitudinal movement.

**Shear-Resisting Control Joint**

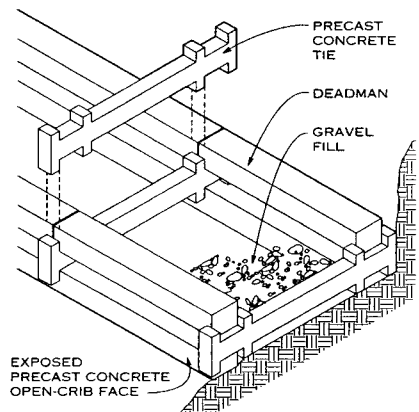

**DETAIL**

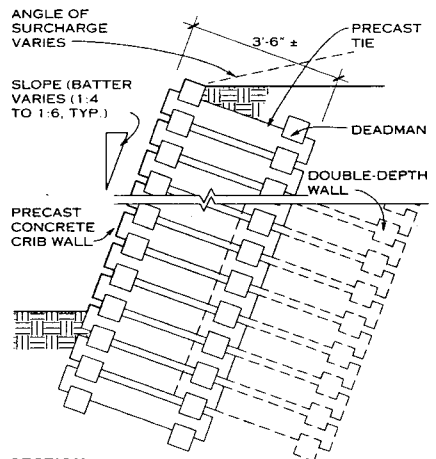

**SECTION**

**NOTE**

For retaining walls taller than a certain height, double- or triple-depth walls may be needed. Fill composition varies from crushed stone to granular soil, according to conditions. Consult a structural engineer.

**PRECAST CONCRETE CRIB WALL SYSTEM**

Donald Neubauer, P.E.; Neubauer Consulting Engineers; Potomac, Maryland

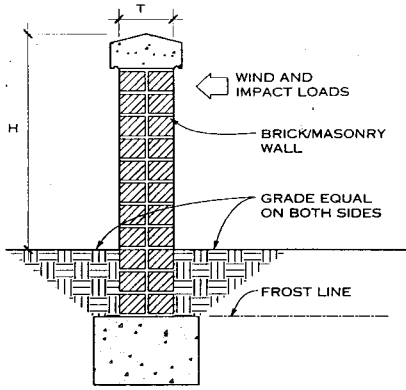

**NOTES**

1. Design straight garden walls (without piers) with sufficient thickness to provide lateral stability.
2. To resist 10 psf wind pressure, the height above grade (H) and thickness (T) should relate as follows:  $H \leq .75T^2$  (H and T are in inches).

**STRAIGHT GARDEN WALLS**

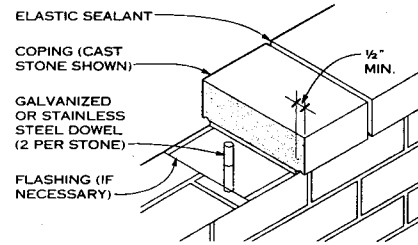

**STONE**

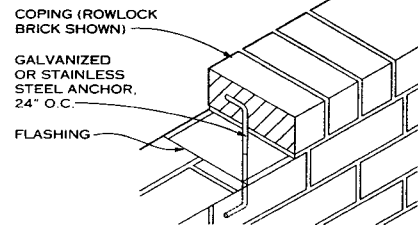

**BRICK (NO DRIP SHOWN)**

**NOTE**

In general, through-wall flashing should be used immediately under the coping of garden walls. However, this decision depends on several factors, including the type of coping used, the number of joints used, and the climatic conditions of the area (whether there is high or low precipitation and the number of freezing and thawing cycles).

**COPING DETAILS**

**REQUIRED EMBEDMENT FOR PIER FOUNDATION\***

WALL SPAN (FT)	WIND LOAD (10 PSF)			WIND LOAD (15 PSF)			WIND LOAD (20 PSF)		
	4	6	8	4	6	8	4	6	8
8	2'-0"	2'-3"	2'-9"	2'-3"	2'-6"	3'-0"	2'-3"	2'-9"	3'-0"
10	2'-0"	2'-6"	2'-9"	2'-3"	2'-9"	3'-3"	2'-6"	3'-0"	3'-3"
12	2'-3"	2'-6"	3'-0"	2'-3"	3'-0"	3'-3"	2'-6"	3'-3"	3'-6"
14	2'-3"	2'-9"	3'-0"	2'-6"	3'-0"	3'-3"	2'-9"	3'-3"	3'-9"
16	2'-3"	2'-9"	3'-0"	2'-6"	3'-3"	3'-6"	2'-9"	3'-3"	4'-0"

\*For wall sizes shown within heavy lines, a 24-in. diameter foundation is required. All other values have been obtained using an 18-in. diameter foundation.

**NOTE**

To figure the vertical spacing and size of reinforcing steel required for panel walls, consider the probable wind load and the wall span between piers. Consult a structural engineer for assistance.

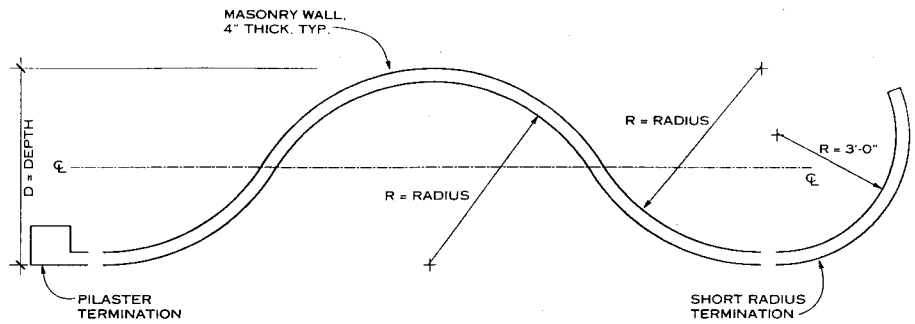

**NOTES**

1. The radius of curvature (R) of a 4-in. thick serpentine wall should be no more than twice the height of the wall above finished grade.
2. The depth (D) of curvature of a serpentine wall should be no less than half the height of the wall above grade (max. height = 5 ft 0 in., typical).

**SERPENTINE GARDEN WALLS**

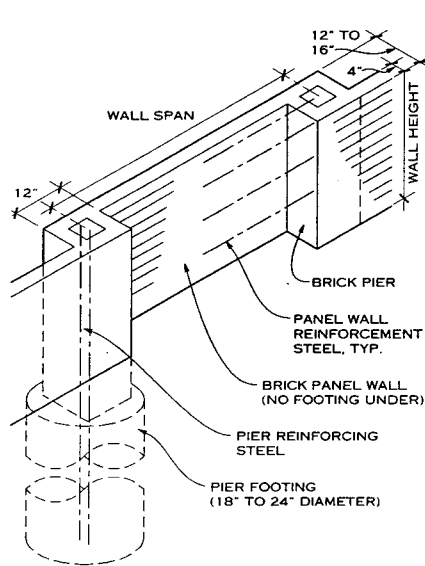

**PIER-AND-PANEL SYSTEM**

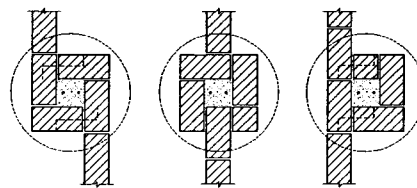

**PIER TYPES**

**NOTE**

The pier-and-panel wall is composed of a series of relatively thin (4-in. thick) reinforced brick masonry panels, which are braced intermittently with masonry piers. This wall is relatively easy to build and is economical because of the narrowness of the panels. It is also easily adapted to varying terrain conditions.

**PIER-AND-PANEL GARDEN WALLS**

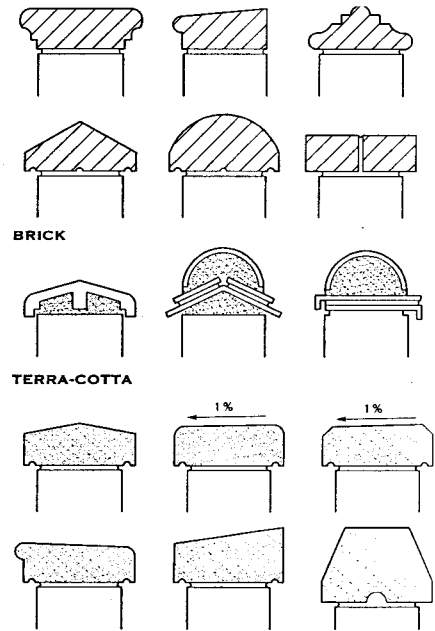

**CAST STONE/CONCRETE**

**NOTES**

1. Copings and caps prevent water from entering the inner wall from above by shedding water to the sides, where it is thrown clear of the wall, usually by means of a drip edge.
2. Anchor coping as necessary. If the coping material is different from the wall material, compare their thermal and moisture expansion characteristics and make provisions for differential movement.

**COPING TYPES FOR WALLS**

**PIER REINFORCING STEEL\***

WALL SPAN (FT)	WIND LOAD (10 PSF)			WIND LOAD (15 PSF)			WIND LOAD (20 PSF)		
	4	6	8	4	6	8	4	6	8
8	2#3	2#4	2#5	2#3	2#5	2#6	2#4	2#5	2#6
10	2#3	2#4	2#5	2#4	2#5	2#7	2#4	2#6	2#6
12	2#3	2#5	2#6	2#4	2#6	2#6	2#4	2#6	2#7
14	2#3	2#5	2#6	2#4	2#6	2#6	2#5	2#6	2#7
16	2#4	2#5	2#7	2#4	2#6	2#7	2#5	2#6	2#7

\*For wall sizes shown within heavy lines, 12 x 16 in. piers are required. All other values have been obtained with 12 x 12 in. piers.

Dennis Carmichael; EDAW, Inc.; Alexandria, Virginia

2 RETAINING WALLS

**FREESTANDING GARDEN WALLS**

Freestanding garden walls provide a physical or visual barrier to outdoor areas. Walls higher than eye level (approximately 5 ft 6 in.) provide both a physical and visual barrier; typically they are situated near and designed to blend with an adjacent architectural structure. Walls designed under eye level provide a sense of partial enclosure while maintaining a view, which is sometimes framed by the wall design.

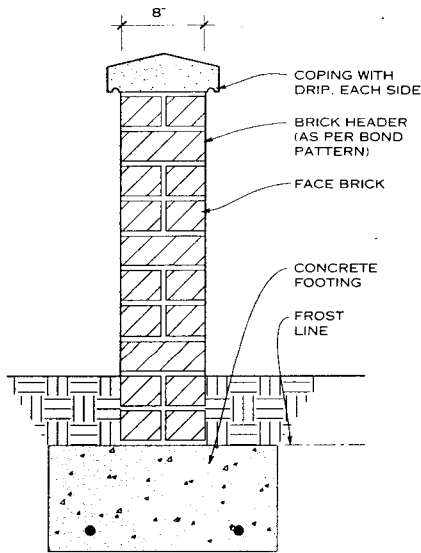

**SOLID MASONRY**

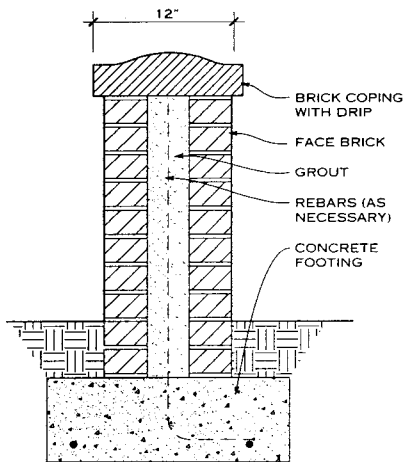

**GRAOUTED REINFORCED MASONRY**

**FREESTANDING MASONRY GARDEN WALLS**

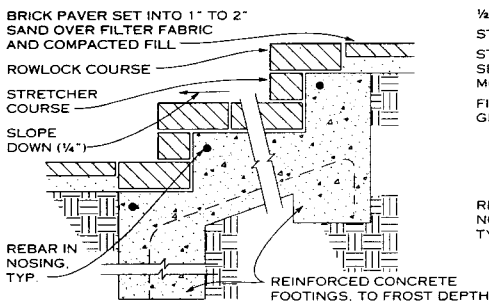

**BRICK MASONRY SITE STEPS**

Dennis Carmichael; EDAW, Inc.; Alexandria, Virginia

Design factors that should be addressed when designing freestanding garden walls include these:

1. Quality and durability of materials (unit material, mortar, and reinforcement) and detailing when exposed over time to rain, wind, sun, thermal movement, and degradation
2. Appearance of both sides of the wall
3. Foundation design
4. Adjacent plantings

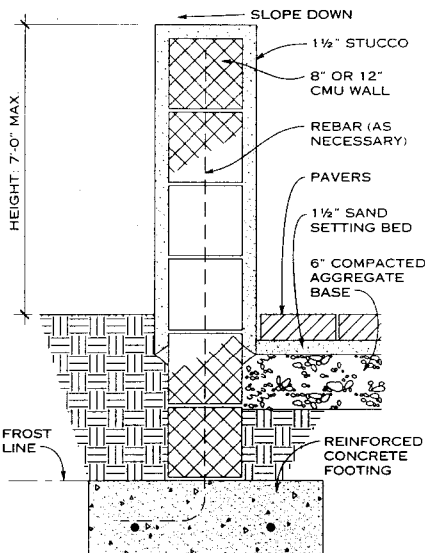

**STUCCO OVER CMU**

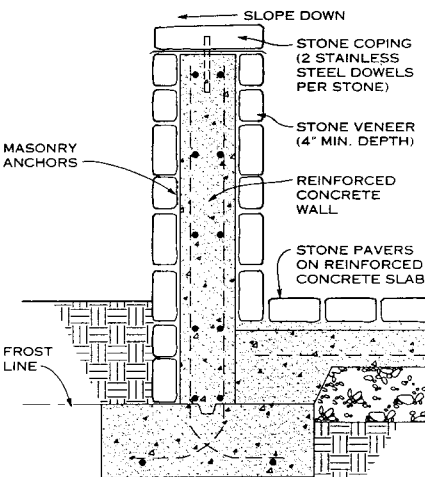

**STONE VENEER OVER REINFORCED CONCRETE**

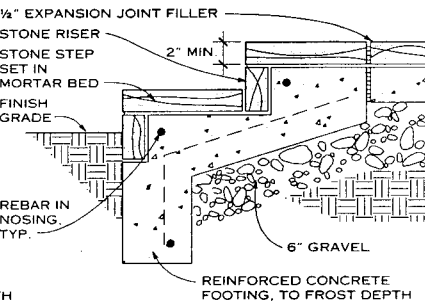

**STONE**

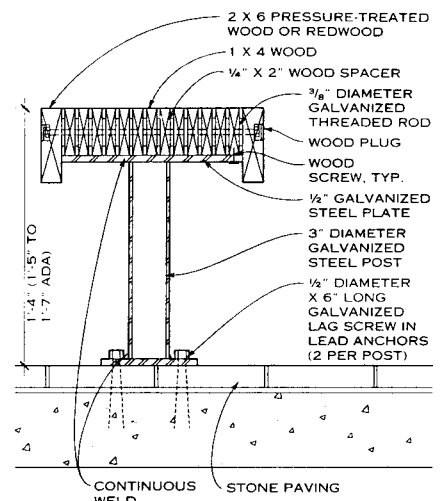

**WOOD SITE BENCH**

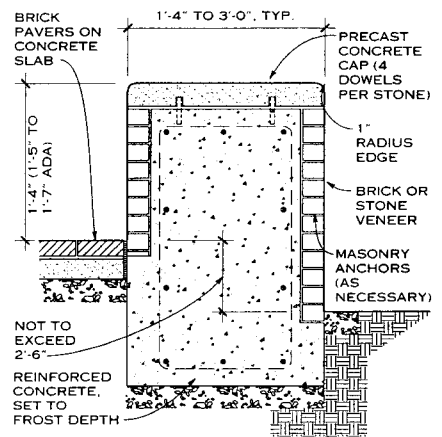

**BRICK VENEER SEAT WALL**

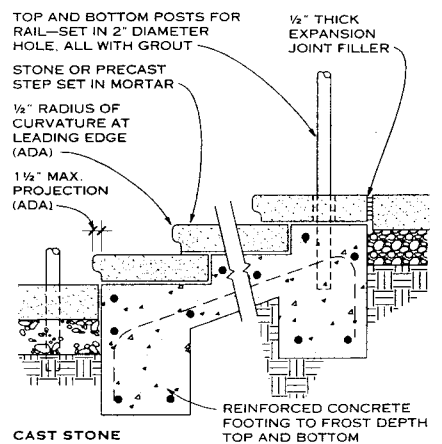

**NOTES**

1. Provide handrails on both sides of all stairs along accessible routes.
2. Step surfaces should be sloped so water will not accumulate on the walking surface.
3. These details are for reference only. Consult ADAAG for tread and handrail requirements for specific applications and BOCA for riser-to-tread ratios.

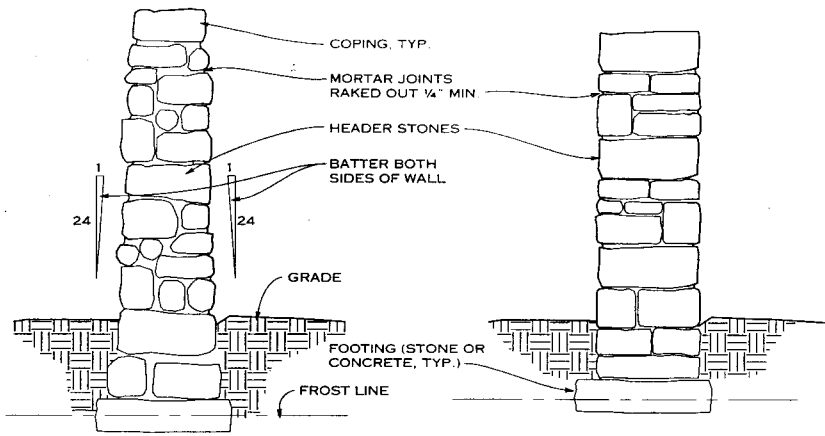

NATURAL FIELDSTONE (UNCOURSED) ASHLAR (COURSED)  
MORTARED STONE WALLS

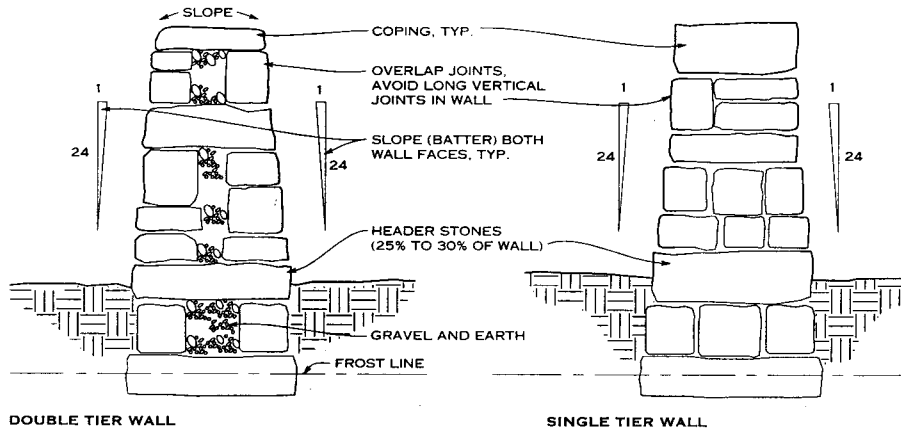

DOUBLE TIER WALL SINGLE TIER WALL

DRY STACK STONE WALLS

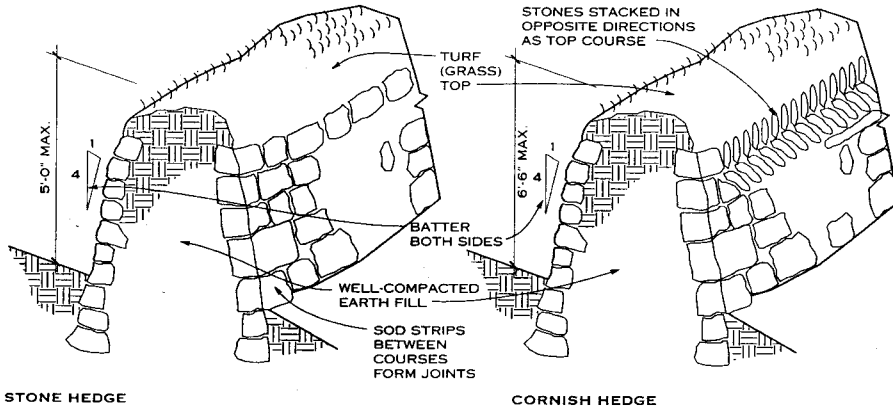

STONE HEDGE CORNISH HEDGE

STONE HEDGES

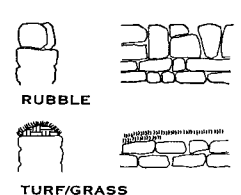
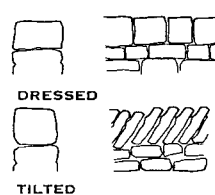
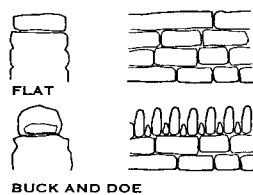
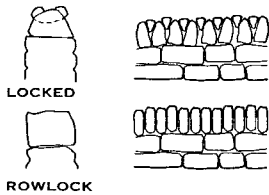

STONE WALL COPINGS

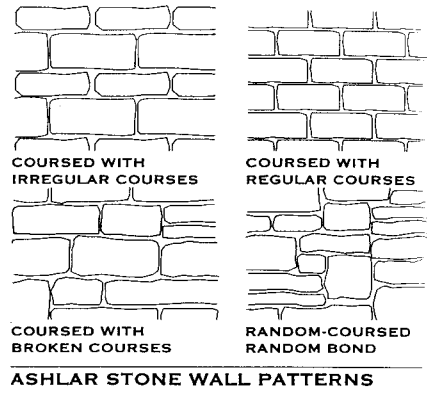

ASHLAR STONE WALL PATTERNS

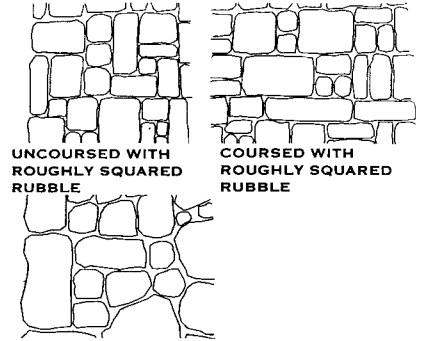

RANDOM RUBBLESTONE WALL PATTERNS

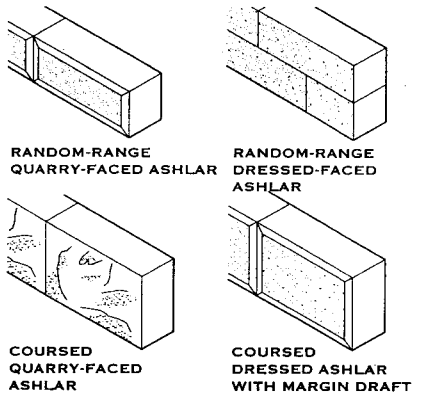

**NOTE**  
Most types of stone can be used for stone walls, but granite, limestone, sandstone, and slate are preferred. Ashlar and rubble are the main types of stonework used for walls. Ashlar is stone that has been cut and squared and can be laid in straight courses to create a uniform, stable wall; its surface can have any texture. Rubblestone has not been cut or dressed, and stability is largely achieved by using header stones that run through the wall, binding it together.

STONE TYPES FOR WALLS

Dennis Carmichael; EDAW, Inc.; Alexandria, Virginia

**GENERAL**

The physical environment of the site, the design needs of the project, and the design character of the trees are all factors that must be considered in selecting trees and preparing a landscape plan for a building.

Soil conditions (acidity, porosity) at the site, the amount and intensity of sunlight and precipitation, and the seasonal temperature range in the area create the physical environment in which trees must be able to survive. As well, consider how the location and topography of the site will direct the wind, resulting in cold winds and cooling breezes that can affect the health of trees.

Trees can be used to address the design needs of a project by directing pedestrian or vehicle movement, framing vistas, screening objectionable views, and defining and shaping exterior space. Trees can also be used to modify the microclimate of a site and to help conserve building energy use from heating, cooling, and lighting systems.

The design character of the trees themselves plays a part in which species are best suited for a particular application. The shape of a tree can be columnar, conical, spherical, or spreading, and the resulting height and mass will change over time as the tree matures. Some trees grow quickly and others more slowly, and their color and texture varies from coarse to medium to fine, affecting their character. The appearance of deciduous trees changes with the seasons, while the effect of an evergreen remains relatively constant.

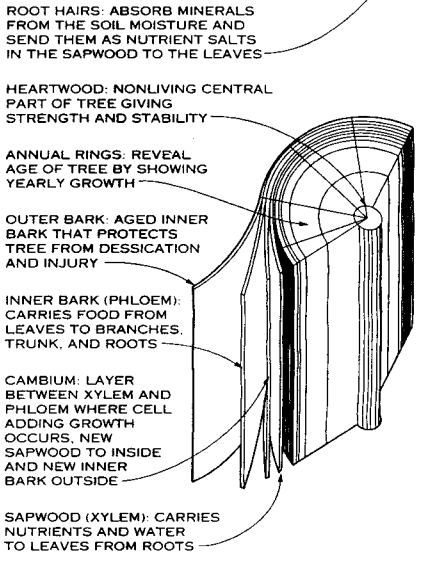
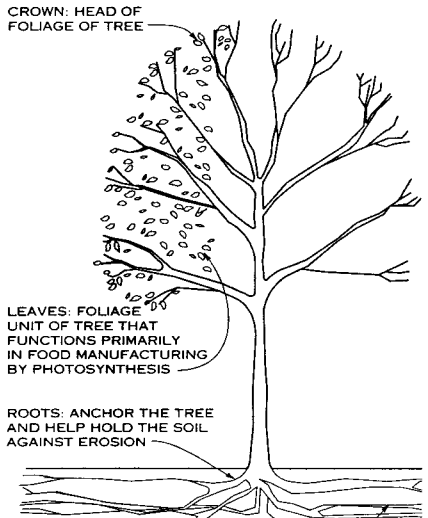

**PHYSICAL CHARACTERISTICS OF TREES**

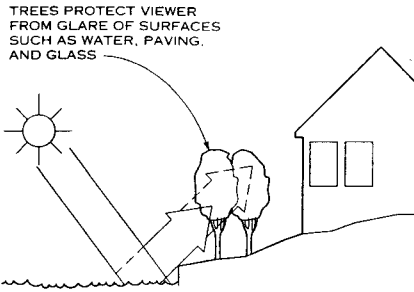

**NOTE**  
The vertical angle of the sun changes seasonally; therefore, the area of a building subject to the glare of reflected sunlight varies. Plants of various heights can screen sun (and artificial light) glare from adjacent surfaces.

**GLARE PROTECTION**

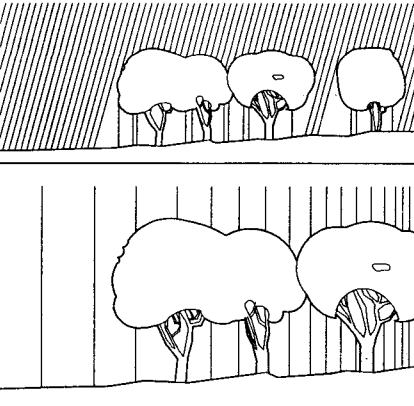

**NOTE**  
Large masses of plants physically and chemically filter and deodorize the air, reducing air pollution. (Top) Particulate matter trapped on the leaves is washed to the ground during rainfall. Gaseous pollutants are assimilated by the leaves. (Bottom) Fragrant plants can mechanically mask fumes and odors. As well, these pollutants are chemically metabolized in the photosynthetic process.

**AIR FILTRATION**

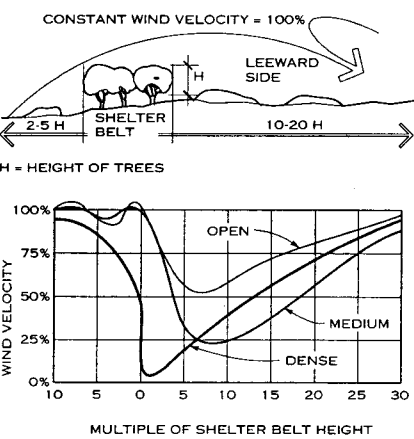

**NOTE**  
Shelter belt wind protection reduces evaporation at ground level, increases relative humidity, lowers the temperature in summer and reduces heat loss in winter, and reduces blowing dust and drifting snow. The amount of protection afforded is directly related to the height and density of the shelter belt.

**WIND PROTECTION**

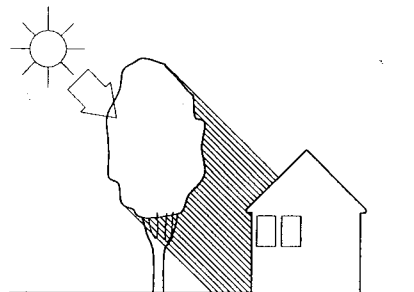

**NOTE**  
In summer, trees obstruct or filter the strong radiation from the sun, cooling and protecting the area beneath them. In winter, evergreen trees still have this effect, while deciduous trees, having lost their leaves, do not.

**SHADE PROVISION**

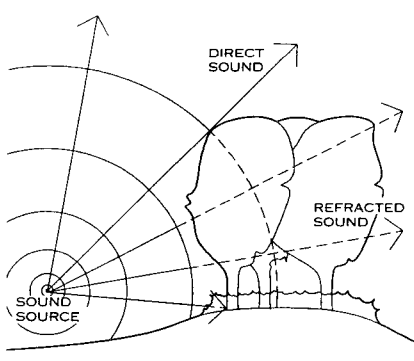

**NOTE**  
A combination of deciduous and evergreen trees and shrubs reduces sound more effectively than deciduous plants alone. Planting trees and shrubs on earth mounds increases the attenuating effects of a buffer belt.

**SOUND ATTENUATION**

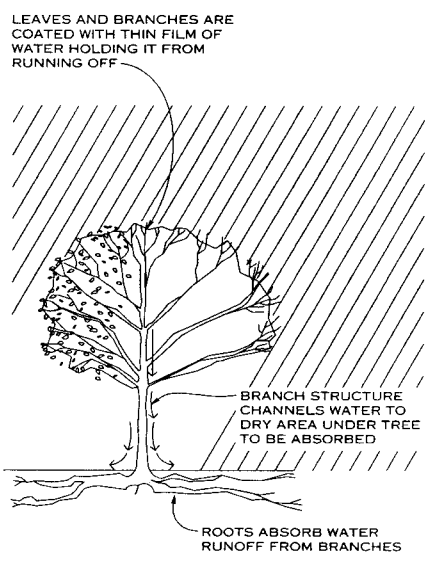

**NOTE**  
Mature trees absorb or delay runoff from stormwater at a rate 4 to 5 times that of bare ground.

**RUNOFF REDUCTION**

James Urban, ASLA; James Urban Landscape Architecture; Annapolis, Maryland



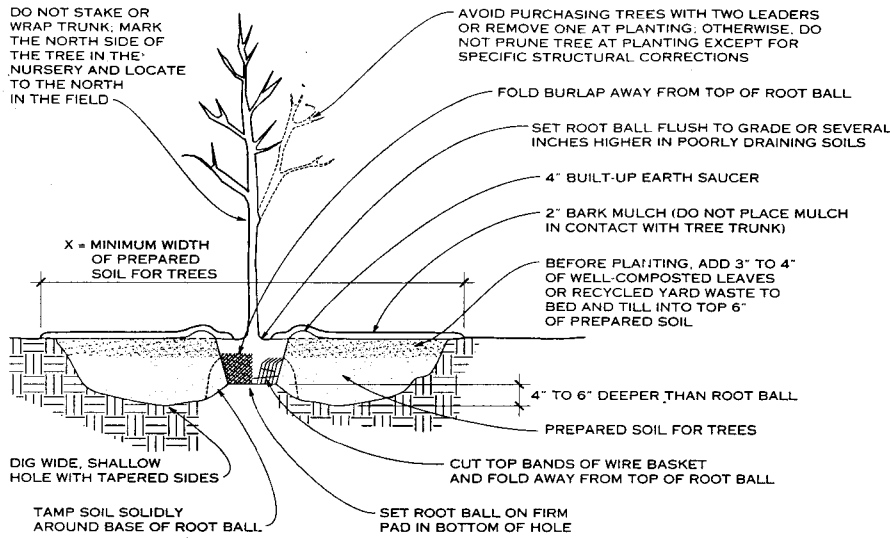

**NOTES**

- For container-grown trees, use fingers or small hand tools to pull the roots out of the outer layer of potting soil; then cut or pull apart any roots circling the perimeter of the container.
- Incorporate commercially prepared mycorrhiza spores in the soil immediately around the root ball at rates specified by the manufacturer.
- During the design phase, confirm that water drains out of the soil; design alternative drainage systems as required.
- Thoroughly soak the tree root ball and adjacent prepared soil several times during the first month after planting and regularly throughout the following two summers.
- The planting process is similar for deciduous and evergreen trees.

**TREE PLANTING DETAIL (BALLED AND BURLAPPED PLANTS)**

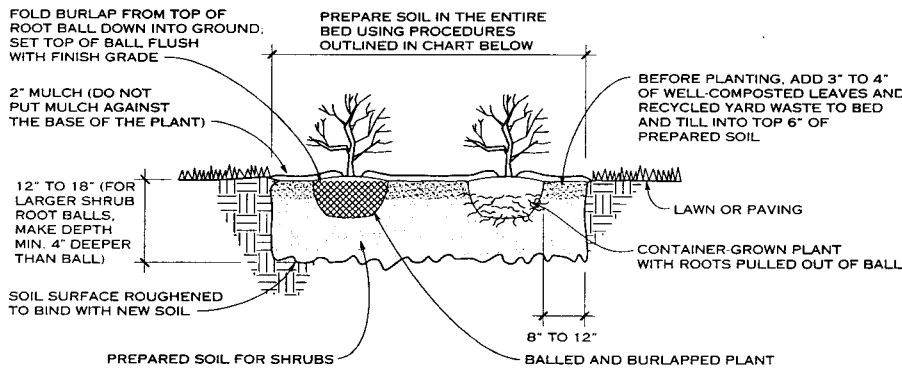

**NOTES**

- For container-grown shrubs, use fingers or small hand tools to pull the roots out of the outer layer of potting soil; then cut or pull apart any roots that circle the perimeter of the container.
- Incorporate commercially prepared mycorrhiza spores in the soil immediately around the root ball at rates specified by the manufacturer.
- Confirm that water drains out of the soil during the design phase; design alternative drainage systems as required.

**SHRUB PLANTING DETAILS**

**GENERAL RANGE OF SOIL MODIFICATIONS AND VOLUMES FOR VARIOUS SOIL CONDITIONS**

POSTCONSTRUCTION SOIL CONDITION	MIN. WIDTH PREPARED SOIL FOR TREES (X)	TYPE OF PREPARATION
Good soil (not previously graded or compacted, topsoil layer intact)	6 ft or twice the width of the root ball, whichever is greater	Loosen the existing soils to the widths and depths shown in details above.
Compacted soil (not previously graded, topsoil layer disturbed but not eliminated)	15 ft	Loosen the existing soils to the widths and depths shown in details above; add composted organic matter to bring the organic content up to 5% dry weight.
Graded subsoils and clean fills with clay content between 5 and 35%	20 ft	Minimum treatment: loosen existing soil to widths and depths shown, add composted organic matter to bring organic content up to 5% dry weight. Optimum treatment: remove top 8-10 in. or the existing material, loosen existing soils to the widths and depths shown, add 8-10 in. of loam topsoil.
Poor quality fills, heavy clay soils, soils contaminated with rubble or toxic material	20 ft	Remove existing soils to the widths and depths shown, replace with loam topsoil.

James Urban, ASLA; James Urban Landscape Architecture; Annapolis, Maryland  
American Nursery & Landscape Association (formerly AAN); Washington, D.C.

**2 PLANTING**

**SOIL IMPROVEMENT**

The quality of soil available for planting varies widely from site to site, especially after construction activity has occurred. The nature of construction results in compaction, filling, contamination, and grading of the original soil on a site, rapidly making it useless for planting. Previous human activity at a site can also affect the ability of the soil to support plants.

During the design phase, assumptions must be made regarding the probable condition of the soil after construction is complete. The health of existing or remaining soil determines what types of soil preparation will be required and the volume of soil to be prepared. Conditions will vary from location to location within a project, and details must be condition-specific. For large projects or extreme conditions, it is useful to consult an expert experienced in modifying planting soils at urban sites.

**NOTES**

- If site or design constraints prohibit use of the dimensions shown on this page, follow the guidelines for planting in urban areas.
- Whenever possible, the soil improvement area should be connected from tree to tree.
- Always test soil for pH and nutrient levels and adjust these as required.
- Loosen soil with a backhoe or other large coarse-tilling equipment when possible. Tilling that produces large, coarse chunks of soil is preferable to tilling that results in fine grains uniform in texture.
- The bottom of planting soil excavations should be rough to avoid matting of soil layers as new soil is added. It is preferable to till the first lift (2 to 3 in.) of planting soil into the subsoil.

**STANDARD ROOT BALL SIZES FOR NURSERY-GROWN SHADE TREES**

CALIPER* (IN.)	HEIGHT RANGE (FT-IN.)	MAX. HEIGHT (FT)	MIN. BALL DIA. (IN.)	MIN. BALL DEPTH (IN.)
1/2	5-6	8	12	9
3/4	6-8	10	14	10-1/2
1	8-10	11	16	12
1-1/4	8-10	12	18	13-1/2
1-1/2	10-12	14	20	13-1/2
1-3/4	10-12	14	22	14-1/2
2	12-14	16	24	16
2-1/2	12-14	16	28	18-1/2
3	14-16	18	32	19-1/2
3-1/2	14-16	18	38	23
4	16-18	22	42	25
5	18-20	26	54	32-1/2

\*Up to and including the 4-in. caliper size, the caliper measurement indicates the diameter of the trunk 6 in. above ground level. For larger sizes, the caliper measurement is taken 12 in. above ground level.

**NOTES**

- See American Standard for Nursery Stock, ANSI Z60.1, for complete list of nursery standards for other types and sizes of trees and shrubs.
- See International Society of Arboriculture's "Principles and Practices of Planting Trees and Shrubs," 1997.

**CONSTRUCTION AROUND EXISTING TREES**

Great care should be taken not to compact, cut, or fill the earth within the crown area of existing trees. Most tree roots are located in the top 6 to 18 in. of the soil and often spread considerably farther than the drip line of the tree. Compaction can cause severe root damage and reduce the movement of water and air through the soil. To avoid compacting the earth, do not operate equipment or store materials within the crown spread.

Before construction begins, inject the soil within the crown area of nearby mature trees with commercially prepared kelp-based fertilizer and mycorrhizal fungus developed to invigorate tree roots. Prune tree roots at the edge of the root save area, as roots pulled during grading can snap or split well into the root save area. Rot and disease that enters dying roots in compacted or filled areas can move into the tree if root pruning has not been carried out. Install tree protection fencing and silt protection at the limits of construction activity near trees.

During construction, apply additional water in the canopy area to compensate for any root loss beyond the crown spread. Have all mature trees inspected by a certified arborist before construction begins to identify any special problems. Remove all deadwood and treat all trees for existing insect and disease problems. When possible, begin fertilization and problem treatments at least one full growing season before construction.

Removal of significant portions of the crown will affect the health of a tree by reducing its ability to photosynthesize in proportion to the mass of its trunk. Younger, healthier trees withstand construction impacts better than older trees.

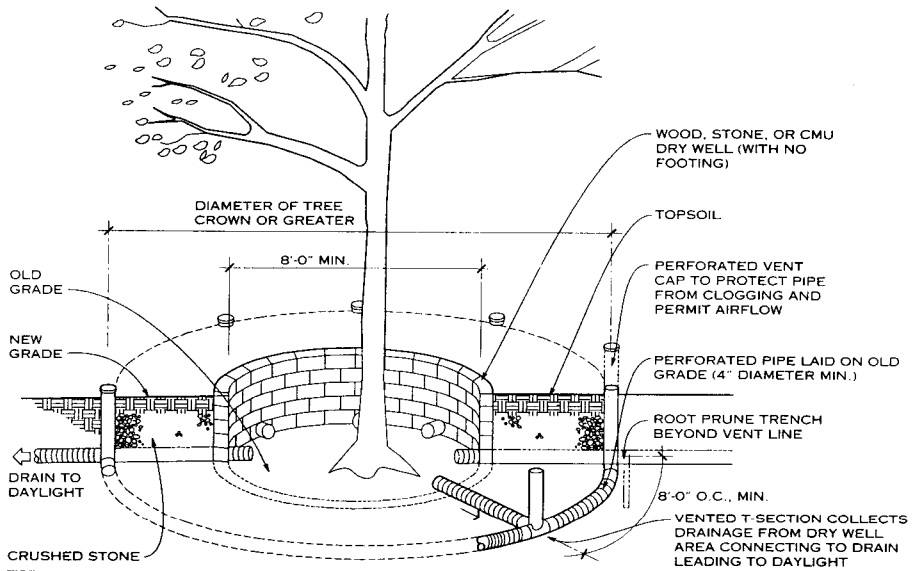

**FILLING AROUND EXISTING TREE**

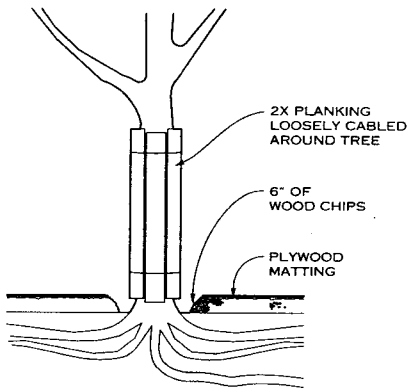

**NOTE**

If construction operations must take place within the crown spread area, install 6 in. of wood chips on top of the soil to protect it. Use plywood matting over mulch in areas where equipment must operate. Protect the trunk of the tree with planking loosely cabled around the tree to reduce scarring by equipment. Remove planking, matting, and mulch as soon as operations are finished.

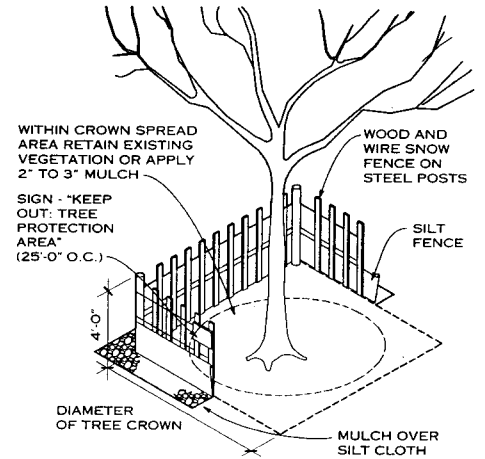

**NOTE**

A barrier such as that illustrated can keep construction equipment and personnel from compacting the soil around tree roots.

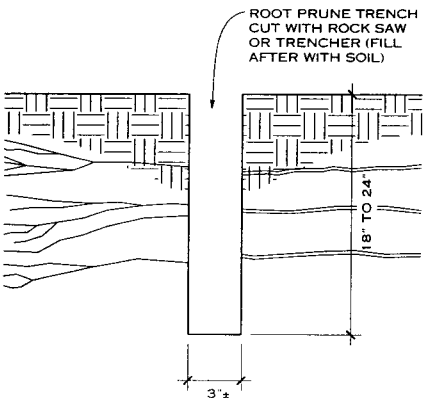

**NOTE**

A root prune trench severs roots with a clean cut, protecting remaining roots from cracking, rot, and disease.

**ROOT PRUNE TRENCH**

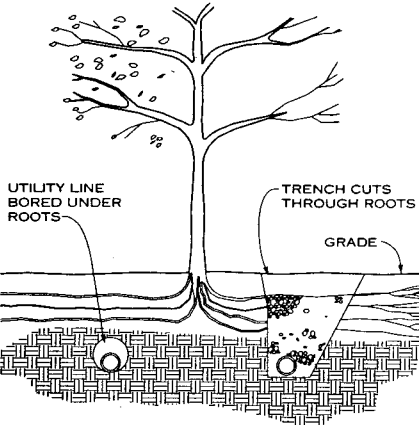

**NOTE**

Fewer roots are severed by tunneling under a tree than by digging a trench beside it.

**UNDERGROUND UTILITY LINE NEAR EXISTING TREES**

**TREE AND ROOT PROTECTION**

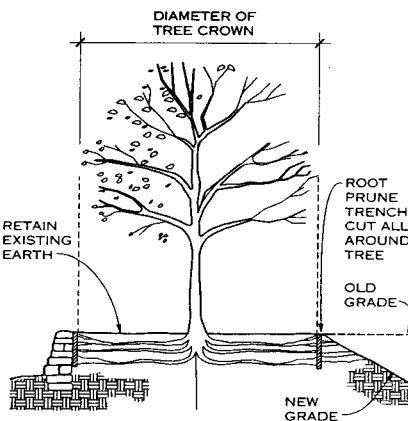

**CUTTING GRADE AROUND EXISTING TREE**

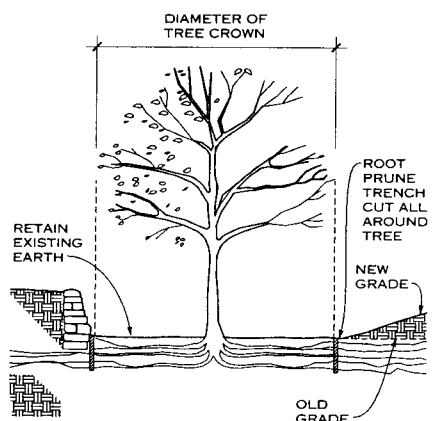

**FILLING GRADE AROUND EXISTING TREE**

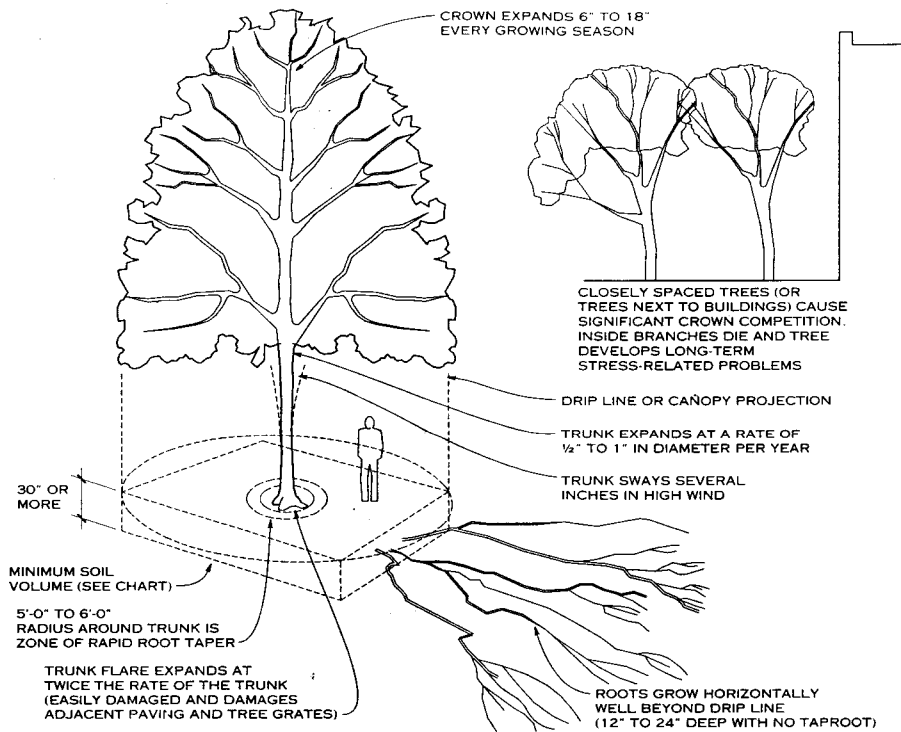

**TREE STRUCTURE—PARTS AND GROWING CHARACTERISTICS**

**GENERAL**

Areas of dense urban development leave little room for tree roots to develop. Large areas of pavement, competition with foundations and utilities for space below ground, and extensive soil compaction and disruption limit the amount of soil available for trees. When the area of ground around the tree open to the rain and sun is less than 400 to 500 sq ft per tree, the following design guidelines should be followed to encourage the growth of large healthy trees.

Five major parts of the tree structure must be accommodated in the design process:

**CROWN GROWTH:** The tree crown expands every growing season at a rate of 6 to 18 in. per year. Once the crown reaches a competing object such as a building or another tree canopy, the canopy growth in that area slows and then stops. Eventually the branches on that side of the tree die. As the canopy expansion potential is reduced, the overall growth rate and tree health are also reduced.

**TRUNK GROWTH:** The tree trunk expands about 1/2 to 1 in. per year. As the tree increases in size, the lower branches die and the trunk lengthens. Tree trunks move considerably in the wind, especially during the early years of development, and are damaged by close objects.

**TRUNK FLARE:** At the point where the trunk leaves the ground, most tree species develop a pronounced swelling or flare as the tree matures. This flare grows at more than twice the rate of the main trunk diameter and helps the tree remain structurally stable. Any hard object placed in this area, such as a tree grate or confining pavement, will either damage the tree or be moved by the tremendous force of this growth.

**ZONE OF RAPID ROOT TAPER:** Tree roots begin to form in the trunk flare and divide several times in the immediate area around the trunk. In this area, about 5 to 6 ft away from the trunk, the roots rapidly taper from about 6 in. in diameter to about 2 in. Most damage to adjacent paving occurs in this area immediately around the tree. Keeping the zone of rapid taper free of obstructions is important to long-term tree health. Once a tree is established, the zone of rapid taper is generally less susceptible to compaction damage than the rest of the root zone.

**ROOT ZONE:** Tree roots grow radially and horizontally from the trunk and occupy only the upper layers (12 to 24 in.) of the soil. Trees in all but the most well-drained soils do not have taproots. A relationship exists between the amount of tree canopy and the volume of root-supporting soil required (see the accompanying chart). This relationship is the most

critical factor in determining long-term tree health. Root-supporting soil is generally defined as soil with adequate drainage, low compaction, and sufficient organic and nutrient components to support the tree. The root zone must be protected from compaction both during and after construction. Root zones that are connected from tree to tree generally produce healthier trees than isolated root zones.

**SOIL MODIFICATIONS**

Thoroughly till organic matter into the top 6 to 12 in. of most planting soils to improve the soil's ability to retain water and nutrients. (Do not add organic matter to soil more than 12 in. deep.) Use composted bark, recycled yard waste, peat moss, or municipal processed sewage sludge. All products should be composted to a dark color and be free of pieces with identifiable leaf or wood structure. Recycled material should be tested for pH and certified free of toxic material by the supplier. Avoid material with a pH higher than 7.5.

Modify heavy clay or silt soils (more than 40% clay or silt) by adding composted pine bark (up to 30% by volume) and/or gypsum. Coarse sand may be used if enough is added to bring the sand content to more than 60% of the total mix. Improve drainage in heavy soils by planting on raised mounds or beds and including subsurface drainage lines.

Modify extremely sandy soils (more than 85% sand) by adding organic matter and/or dry, shredded clay loam up to 30% of the total mix.

**SOIL VOLUME FOR TREES**

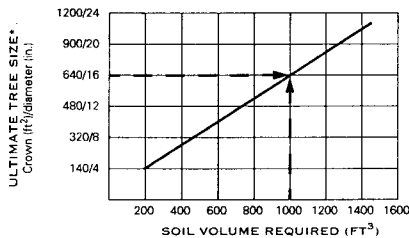

\*The ultimate tree size is defined by the projected size of the crown and the diameter of the tree at breast height.

**NOTE**

For example, a 16-in. diameter tree requires 1000 cu ft of soil.

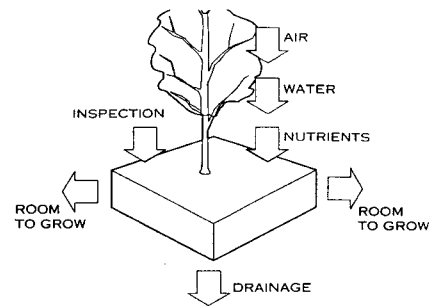

**NOTE**

Soil volume provided for trees in urban areas must be sufficient for long-term maintenance.

**SOIL VOLUME—REQUIREMENTS FOR TREES**

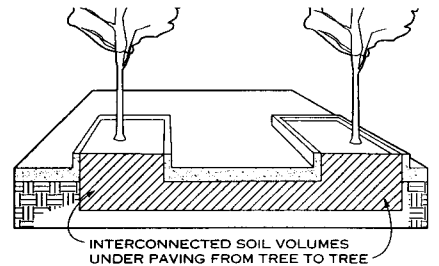

**NOTE**

The interconnection of soil volumes from tree to tree has been observed to improve the health and vigor of trees.

**SOIL VOLUME—INTERCONNECTION**

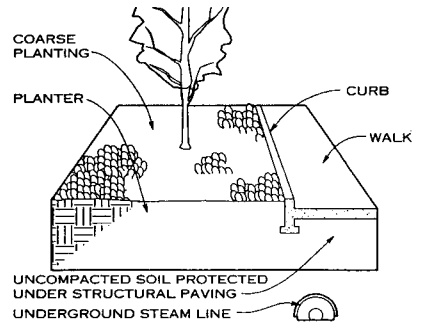

**NOTES**

1. Coarse plantings keep pedestrians out of planters.
2. Curbs protect planters from pedestrians and deicing salts.
3. Underground steam lines must be insulated or vented to protect planter soil.

**SOIL PROTECTION FROM COMPACTION AND DEGRADATION**

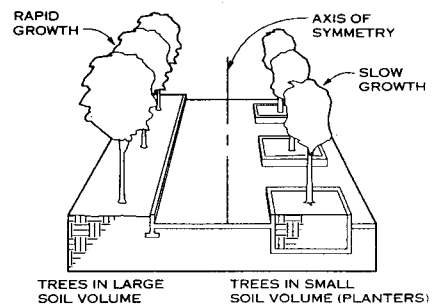

**NOTE**

If visually symmetrical tree planting is required, symmetrical soil volumes are also required to produce trees of similar crown size.

**VISUALLY SYMMETRICAL TREES**

James Urban, ASLA; James Urban Landscape Architecture; Annapolis, Maryland

2 PLANTING

**GENERAL**

Traditional urban designs in which trees are regularly spaced in small openings within paved areas generally result in poor tree performance. This is because such designs generally do not provide adequate soil for root growth and ignore the fact that trees must significantly increase trunk size every year. As well, competition for space, both at ground level and below, is intense in urban areas.

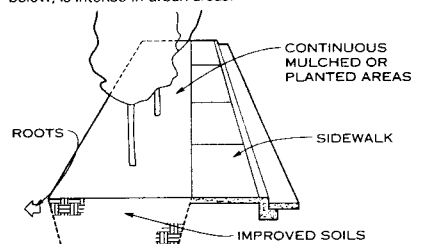

**NOTE**  
Best design option: Planting trees between sidewalks and buildings creates the fewest conflicts between roots and paving by permitting rooting activity on adjacent property.

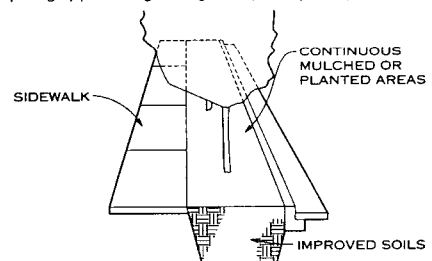

**NOTE**  
Acceptable design option: Planting between curbs and sidewalks in a continuous unpaved planting bed provides good soil levels for trees but contributes to root/paving conflicts as trees mature.

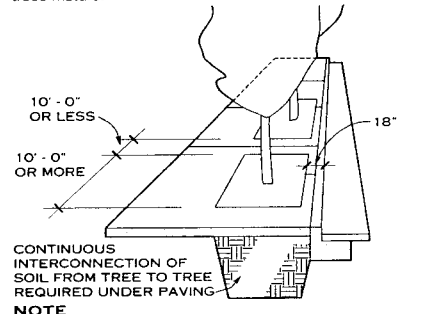

**NOTE**  
Difficult design option: In highly developed areas with parking adjacent to the curb, planting in long narrow tree openings with an 18-in. wide walk along the curb accommodates pedestrians exiting cars. Root/paving conflicts are probable.

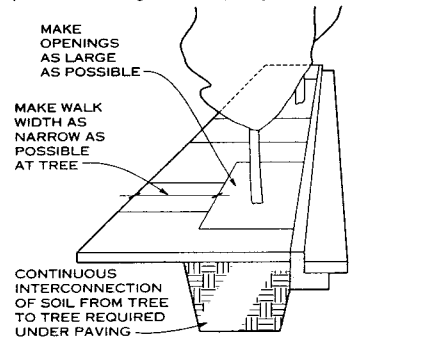

**NOTE**  
Most difficult (and most expensive) design option: Tree openings are undersized for future trunk/root development. Severe root/paving conflicts are very likely.

**SIDEWALK PLANTING OPTIONS**

Although it is possible to design uncompacted soil volumes for trees under pavement, this is very expensive and the soil is never as efficient as that in open planting beds. Increasing trunk size can only be accommodated by using flexible materials that can change configuration over time. Urban designs that have flexible relationships between trees, paving, and planting beds and large areas of open planting soil offer the best opportunity for long-term tree health and lower maintenance costs.

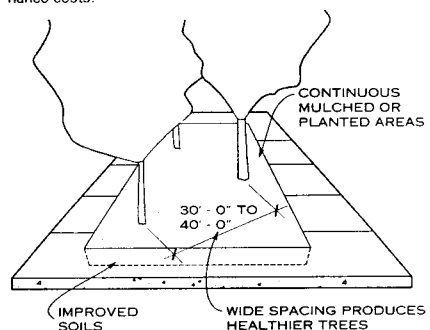

**NOTE**  
Best design option: Separate planting and walking areas. Avoid small disconnected soil volumes to minimize root/paving conflicts.

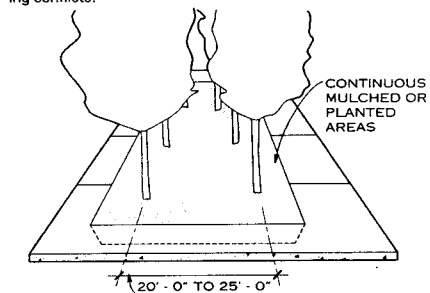

**NOTE**  
Acceptable design option: Each tree has a smaller canopy with less yearly growth. More disease and insect problems are likely. Ground plantings eliminated by shade over time.

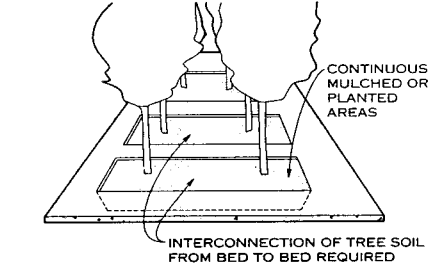

**NOTE**  
Difficult design option: Shading, slow tree growth, and poor health are problems. Root/paving conflicts are likely.

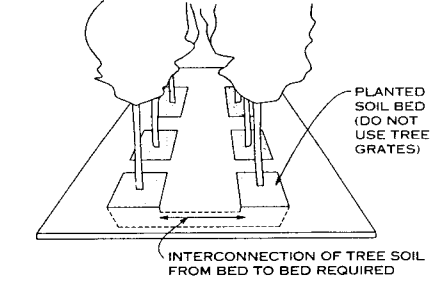

**NOTE**  
Most difficult (and most expensive) design option: Slow tree growth and severe root/paving conflicts are to be expected.

**PLAZA TREE PLANTING OPTIONS**

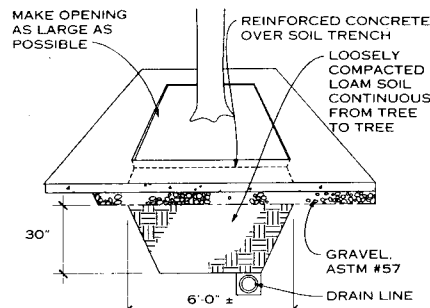

**CONTINUOUS SOIL TRENCH NOTE**  
A continuous soil trench provides very good soil but in limited quantity. Use in areas where adjacent backfill is compacted soils or fills.

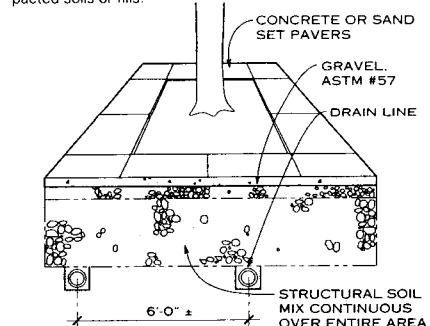

**STRUCTURAL SOIL NOTE**  
Structural planting soils replace subgrade material with a fill that can be compacted to meet normal engineering compaction requirements and still support root growth below the pavement. The principle is that when the gravel is compacted, the soil is not because the amount of soil in the mix is insufficient to fill all the voids. Hydrogel, a cross-linked potassium copolymer, is used to help bind the mixture during the mixing process. The soil mix includes ASHTO #4 gravel (100 lb calculated dry weight), shredded clay loam (15-18 lb), hydrogel (0.03 lb), and water ±10 (including the water calculated in the gravel and the soil). For further information, contact the Urban Horticulture Institute at Cornell University (Ithaca, NY).

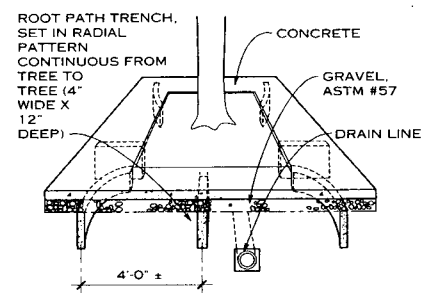

**ROOT PATH TRENCH NOTES**

1. In urban areas where the pavement subgrade is compacted soil that is free from rubble, toxic, or poorly drained fills, a system of root paths can be installed to guide roots under the pavement, where they have room to grow. These roots grow deeper in the soil, causing fewer root/paving conflicts than roots left to exploit the normal minor weaknesses in paving and subgrades.
2. A root path trench is made by installing a length of strip drain material (a 12-in. wide x 1-in. thick plastic drain core wrapped in filter fabric) in a narrow trench and backfilling with loam topsoil. This allows air and water to flow more freely into the soil under the pavement. Install geotextile fabric and the gravel base material and then the paving.
3. Root paths cannot replace larger soil trenches or structural planting soil in areas in which existing soil conditions are extremely poor for root exploration.

**TREE SOIL INTERCONNECTION OPTIONS UNDER PAVING**

James Urban, ASLA; James Urban Landscape Architecture; Annapolis, Maryland

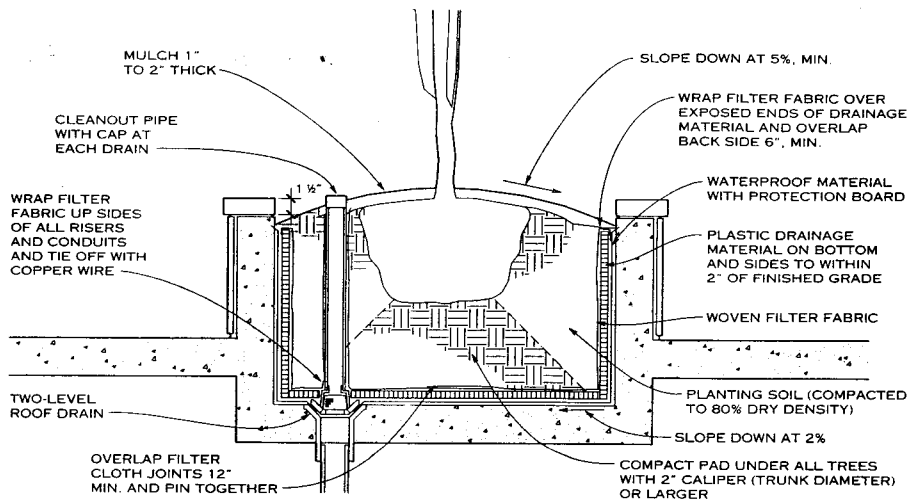

**ROOFTOP PLANTER**

**SELECTING PLANTS FOR ROOFTOP PLANTING**

When choosing plants for a rooftop setting, consider the factors outlined below:

**WIND TOLERANCE:** Higher elevations and exposure to wind can cause defoliation and increase the transpiration rate of plants. High parapet walls with louvers can reduce wind velocity and provide shelter for plants.

**HIGH EVAPORATION RATE:** The drying effects of wind and sun on the soil in a planter reduce soil moisture rapidly. Irrigation, mulches, and moisture-holding soil additives (diatomaceous earth or organic matter) help reduce this moisture loss.

**RAPID SOIL TEMPERATURE FLUCTUATION:** The variation in conduction capacity of planter materials results in a broad range of soil temperatures in planters of different materials. Cold or heat can cause severe root damage in certain plant species. Proper drainage helps alleviate this condition.

**TOPSOIL:** Improve topsoil in planters to provide optimum growing conditions for the plants selected. A general formula calls for adding fertilizer (determined by soil testing) and one part peat moss to five parts sandy loam topsoil. More specific requirements for certain varieties of plants or grasses should be considered.

**ROOT CAPACITY:** Choose plant species carefully, considering their adaptation to the size of the plant bed. If species with shallow, fibrous roots are used instead of species with a coarse root system, consult with a nursery advisor. Consider the ultimate maturity of the plant species when sizing a planter.

**PLANTING DETAILS**

**SOIL DEPTH:** Minimum soil depth in a planter varies with the plant type: for large trees, the soil should be 36 in. deep or 6 in. deeper than the root ball; for small trees, 30 in. deep;

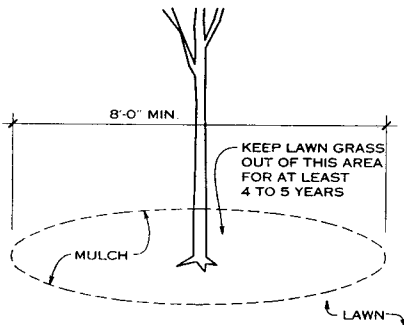

**NOTE**

Young trees planted in lawn areas face substantial competition from the roots of grasses.

**TREES PLANTED IN LAWNS**

for shrubs, 24 in. deep; and for lawns, 12 in. deep (10 in. if irrigated).

**SOIL VOLUME:** To determine sufficient soil volume, see chart on Soil Volumes for Trees (on another AGS page in this section).

**SOIL WEIGHT:** The saturated weight of normal soil mix ranges from 100 to 120 pcf, depending on soil type and compaction rate. Soils can be made lighter by adding expanded shale or perlite. Soils lighter than 80 pcf cannot provide structure adequate to support trees.

**DRAINAGE FABRIC:** Plastic drainage material should be a minimum of 1/2 in. thick. Most drainage material comes with a filter fabric attached, but the overlap joints provided are not wide enough for the unconsolidated soils found in planters. A second layer of woven filter fabric, delivered in rolls greater than 10 ft in width, should be installed. Tuck the fabric over the exposed top of the drainage material to keep soil out of the drainage layer.

**INSULATION:** Most planters do not require insulation; however, in colder climates planters with small soil volumes located over heated structures may require insulation. Consult local sources for a list of cold-hardy plants.

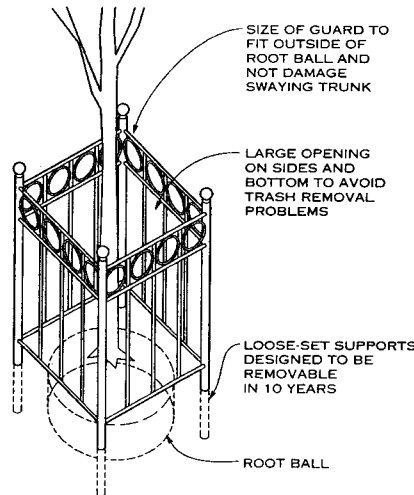

**NOTE**

Tree guards can protect young trees from trunk damage caused by bicycles. If made too small, however (less than 30 in. in diameter), they can damage the tree as it grows and are difficult to remove. The high cost and potential harm to trees outweigh the minor protection tree guards afford a trunk. They should only be used in areas with particularly high traffic.

**TREE GUARDS**

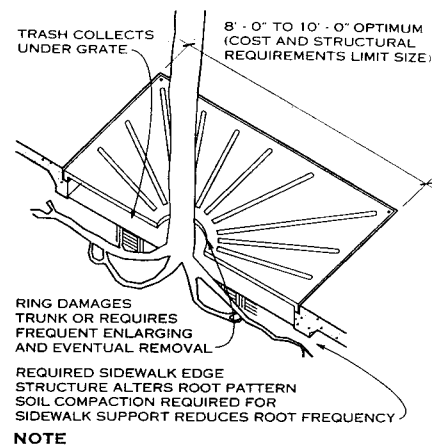

**NOTE**

Tree grates decorate the base of a tree but provide no significant benefit. Many aspects of tree grates can damage a tree or reduce its potential for growth.

**TREE GRATES**

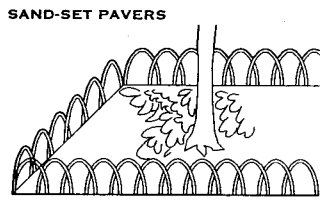
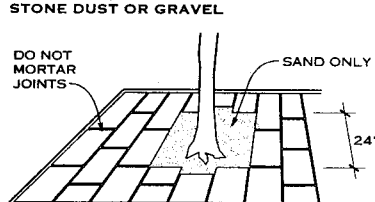
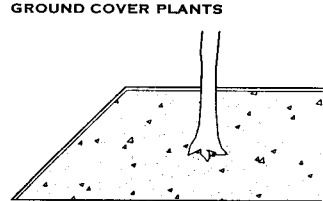
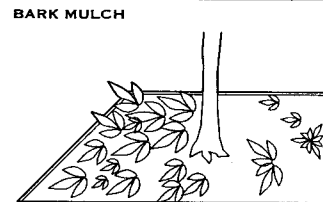
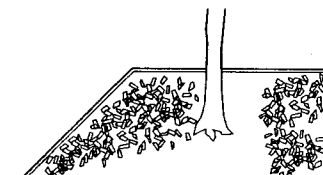

**NOTE**

Alternatives to tree grates (and guards) include softer, organic coverings that suit the purpose better, are less expensive, and require less maintenance over the life of the tree.

**TREE BASE PROTECTION**

James Urban, ASLA; James Urban Landscape Architecture; Annapolis, Maryland

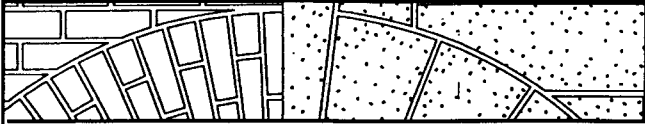

# CONCRETE

Concrete Forms and  
Accessories 184

Concrete Reinforcement 189

Cast-in-Place Concrete 192

Precast Concrete 201

**GENERAL**

Formwork costs are a substantial part of the total cost of putting concrete in place—anywhere from 35 to 60 percent. Thus, by developing design elements and details that simplify or standardize form requirements, the architect can help contain overall costs:

1. Reuse forms: This is crucial to economy of construction. The designer can facilitate form reuse by standardizing the dimensions of windows, columns, beams, and footings, using as few different sizes of each as possible. Where columns must change size, hold one dimension (e.g., width) constant, while varying the other (depth). This enables at least half of the form panels to be used many times. Repeat the same floor and column layout from bay to bay on each floor and from floor to floor. This improves labor productivity and permits reuse of many forms.
2. Use a preconstruction mockup: The architect and builder should agree on the location and desired appearance of architectural surfaces before any of the exposed concrete work begins. Specify a full-scale preconstruction mockup to help achieve this and to avoid postconstruction disagreements.
3. Handle forms in large panels: This also reduces construction costs. Wherever possible, make uninterrupted formed areas the same size. Increasing the size of such areas enables the builder to combine form panels into gangs for efficient crane use.
4. Simplify design details: Intricacies and irregularities cost more and often do not add proportionately to the aesthetic effect.

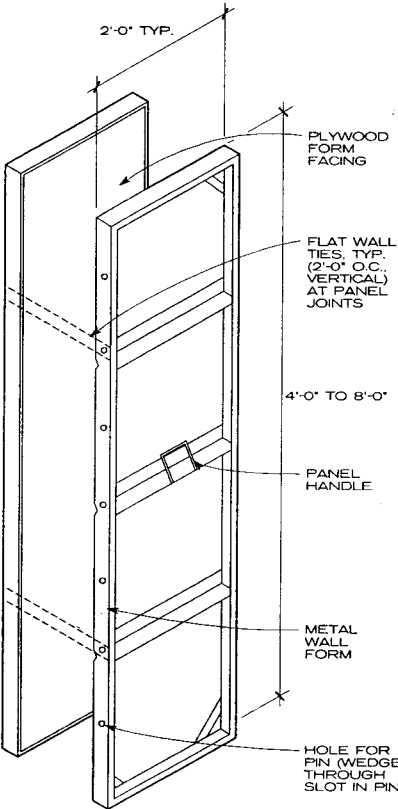

**NOTES**

1. Commonly made of steel-framed plywood, panels are also available in aluminum. Wall ties (typically flat ties) and wall forms are held together by slotted pins that run through adjoining holes. A wedge pushed down into the slot alongside the wall form tightens the joint. Service life can be extended by turning or replacing the plywood face.
2. Reusable plastic liners may be attached to inner surfaces to produce patterned concrete.
3. For maximum economy, panels can be assembled in large gangs and set in place by crane.

**HAND-SET MANUFACTURED WALL FORMS**

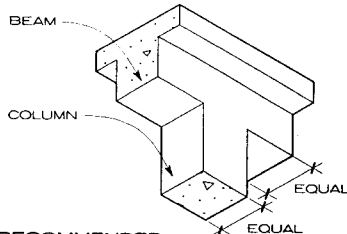

**RECOMMENDED LOW-COST FORMWORK**

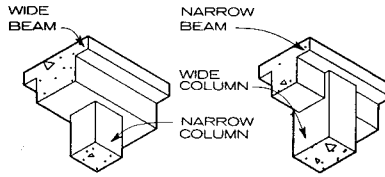

**MID-COST FORMWORK**

**HIGH-COST FORMWORK**

**NOTE**

In general, the least costly design to form has columns the same width or narrower than the beams they support, allowing the beam form to be erected in a continuous line. In mid-cost formwork design, the beam bottom forms are cut to fit around the column tops. In high-cost formwork design, the beam forms are fitted into pockets on both sides of the column forms.

**BEAM-TO-COLUMN FORMWORK ECONOMIES**

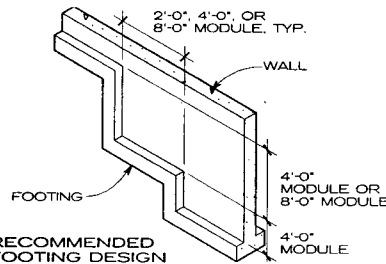

**RECOMMENDED FOOTING DESIGN**

**NOTE**

When stepped footings are required, use fewer steps and design them to standard lumber and plywood dimensions or modular divisions of these dimensions.

**WALL FOOTINGS**

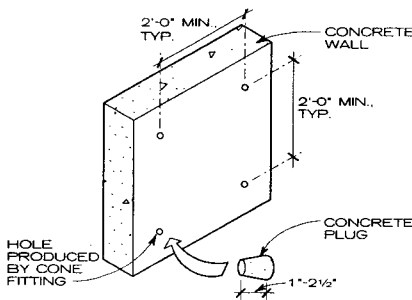

**NOTE**

Installing and removing ties and patching tie holes are some of the most labor-intensive operations in forming walls. Also, getting a durable, inconspicuous patch often proves difficult. Avoid this problem by specifying smooth cone fittings at the tie ends, then either leaving the resulting uniform tie holes exposed or plugging them with pre-formed concrete plugs and a bonding agent. Leave no exposed corrodible metal within 1 1/2 in. of concrete surface. Contractors may propose tie spacing wider than 2 ft o.c. to reduce the total number of ties to save money, but this calls for stronger ties and heavier form supports.

**FORM TIE PATTERN**

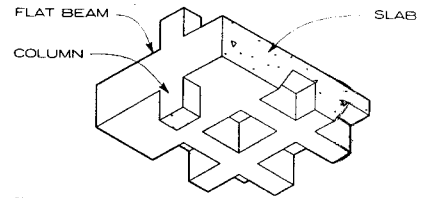

**RECOMMENDED LOW-COST FORMWORK**

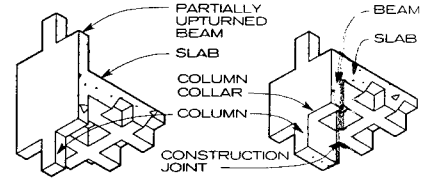

**MID-COST FORMWORK**

**HIGH-COST FORMWORK**

**NOTE**

Flat beams designed to be equal in depth to the floor assembly are the least costly, since they most efficiently accommodate flying form construction. Deeper, narrower beams cost more, but if deeper beams are needed, costs can be controlled by making the beam the same thickness as the column depth and at least partially upturned. The most costly option is a column thicker than the beam, since this requires a column collar with construction joint.

**SPANDREL BEAM FORMWORK ECONOMIES**

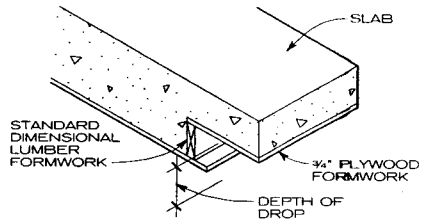

**SLAB FORMWORK**

**NOTE**

Adapting design elements to the modular sizes of formwork lumber and plywood and dimensioning parts of the structure to fit the modules can save the expense of custom formwork. For example, to save the waste and time of sawing and piecing together the edge form, make the depth of the drop in a slab equal to the actual size of standard lumber plus 1/4 in. for the plywood's thickness.

**STANDARD LUMBER FORMS**

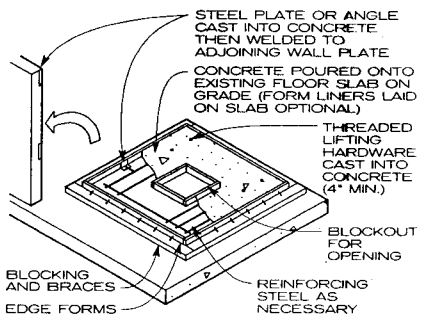

**TILT-UP WALL FORMWORK**

**NOTE**

In tilt-up construction, walls are cast on the completed floor slab, which must be level, smoothly finished, and treated with a bond-breaking agent to permit easy separation. The wall is then tilted or lifted into vertical position and fastened to the adjoining wall piece. This method reduces formwork and labor and eliminates transportation requirements that may limit panel size.

**TILT-UP WALLS**

Mary K. Hurd; Engineered Publications; Farmington Hills, Michigan

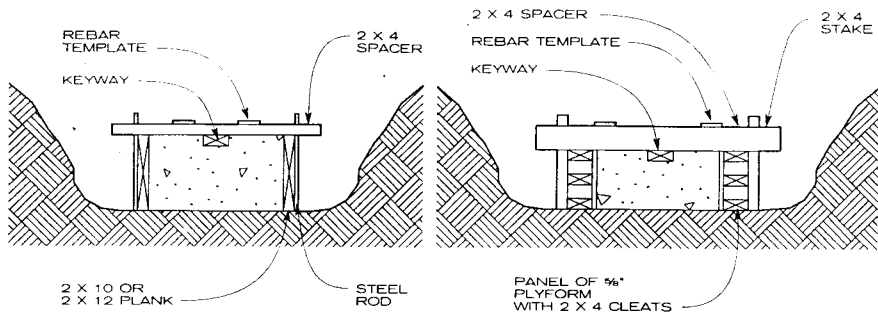

WALL FOOTINGS

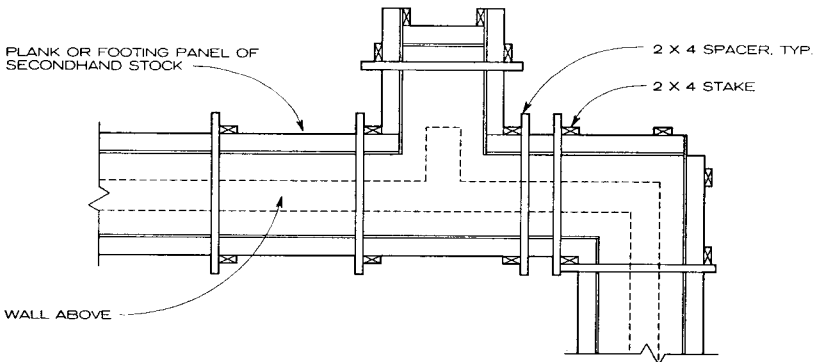

WALL FOOTING PLAN

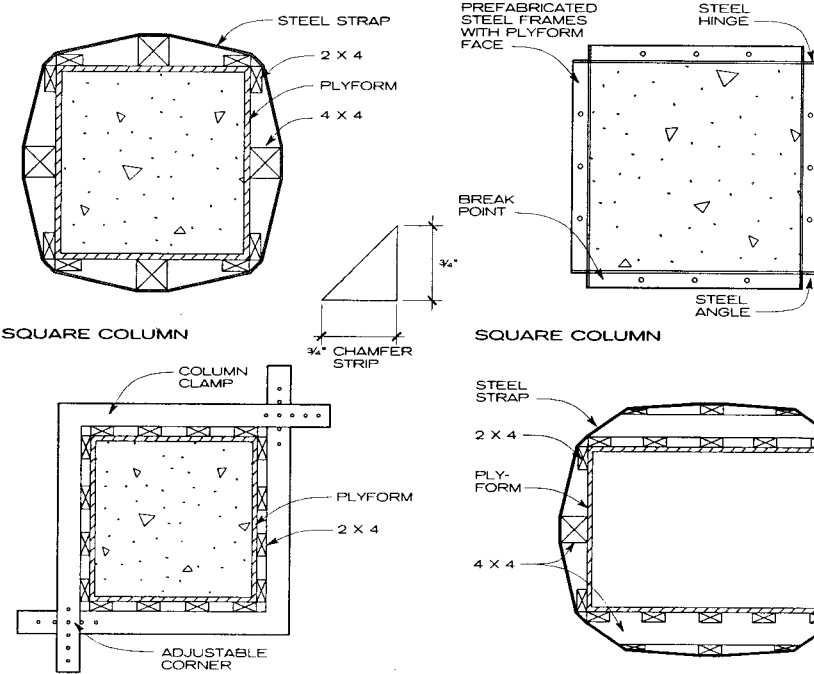

SQUARE COLUMN NOTE

LARGE COLUMN PLAN

It is recommended that chamfer strips be used at all outside corners to reduce damage to concrete when forms are removed. Consult manufacturers' guides and catalogs for ideal materials, pour rate (ft/hr), and outside temperature (°F).

COLUMN PLANS

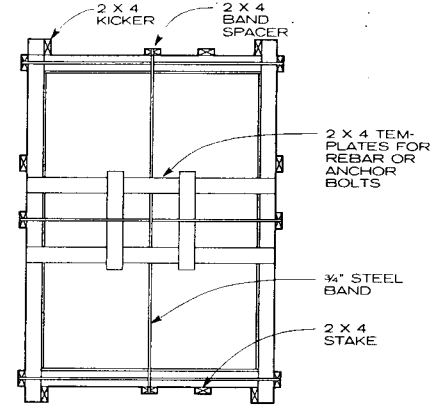

PLAN

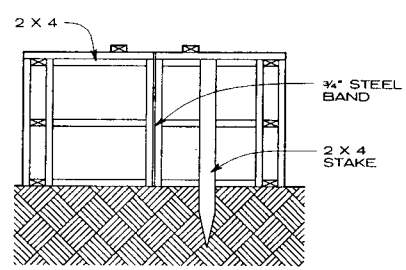

ELEVATION COLUMN FOOTINGS

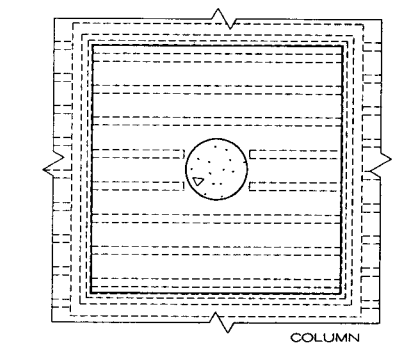

PLAN

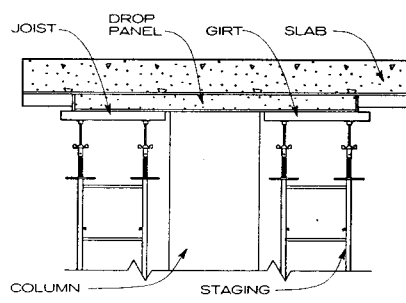

SECTION

DROP PANELS AT COLUMN TOPS

Tucker Concrete Form Company; Stoughton, Massachusetts



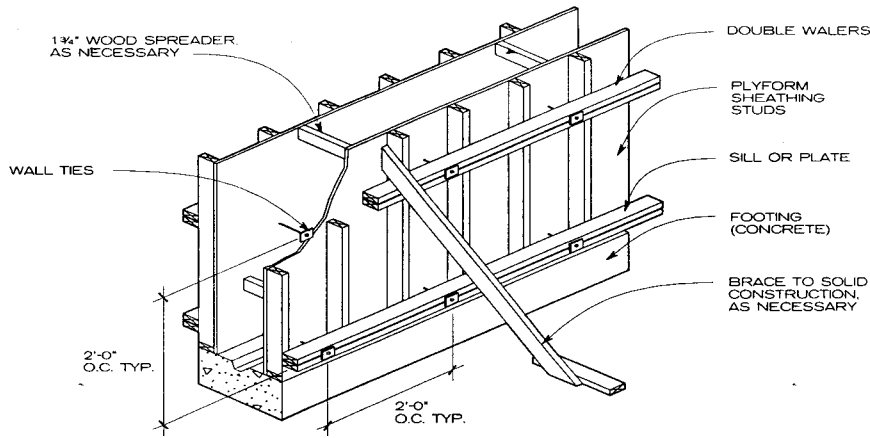

TYPICAL SITE-BUILT WALL FORMWORK

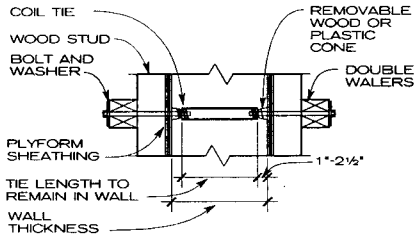

SECTION AT WALL TIE  
SITE-BUILT WALL FORMS

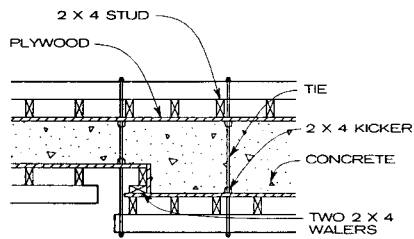

TYPICAL WALL WITH OFFSET

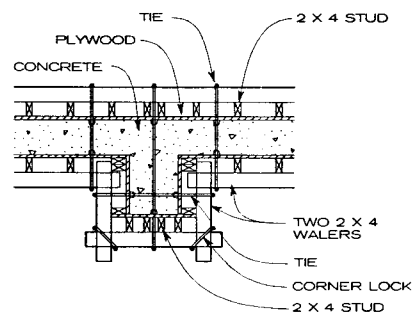

PLAN  
PILASTER

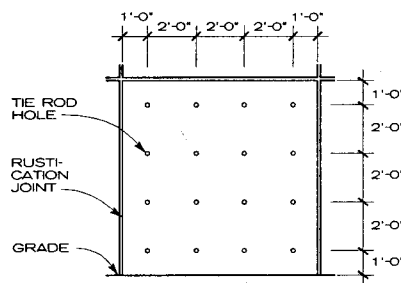

TYPICAL EXPOSED CONCRETE ELEVATION

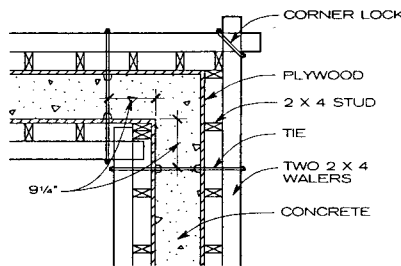

PLAN  
TYPICAL CORNER

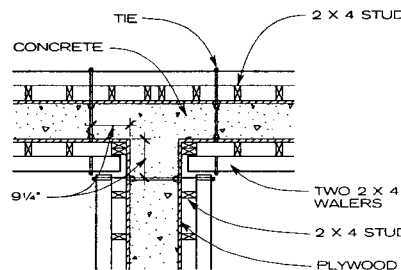

PLAN  
TYPICAL T WALL JUNCTION

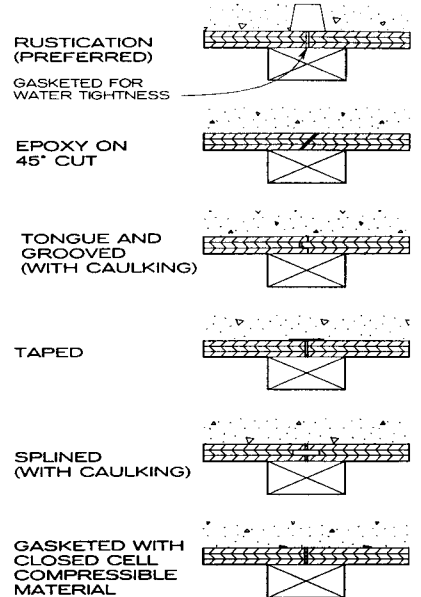

FORM SHEATHING JOINT DETAILS

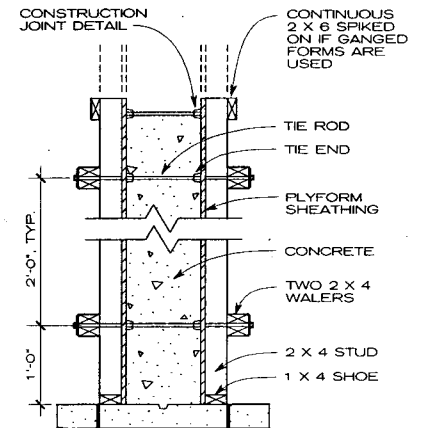

NOTE

Verify size and spacing of components for each job. The combination of plyform sheathing, studs, walers, and ties must be chosen carefully to safely resist concrete pressure and limit deflection of the form face. Steel and aluminum studs and walers may be used in place of wood.

TYPICAL JOB-BUILT WALL SECTION

NOTES

1. The typical wood and plywood framing details shown must be modified as necessary to accommodate the lateral pressure of fresh concrete on the forms. Studs and walers of aluminum or steel are frequently used. Lateral pressure varies depending on the rate at which the form is filled, the temperature of the concrete, vibration procedures, and the type of admixtures used in the concrete.
2. Consult manufacturers' recommendations for safe working loads on ties. Consult the American Concrete Institute's *Formwork for Concrete* (SP-4) for detailed design recommendations.
3. A great variety of form ties are commercially available (see AGS page on concrete formwork hardware). For architectural surfaces exposed to weather, choose a tie that leaves no corrodible metal closer than 1 1/2 in. from the concrete surface. Ties should be tight fitting and sealed as necessary to prevent leakage at holes in the forms.
4. Ties fitted with wood or plastic cones should leave depressions at least as deep as the surface diameter of the cone. The holes may be filled with recessed plugs or left unfilled if noncorroding ties are used.
5. Provide cleanout doors at the bottom of wall forms.

Tucker Concrete Form Company; Stoughton, Massachusetts  
Mary K. Hurd; Engineered Publications; Farmington Hills, Michigan

**GENERAL NOTES**

1. Scaffolding, steel shores, or wood posts may be used under stringers depending on loads and height requirements.
2. For flat slabs of flat plate forming, metal "flying forms" are commonly used.

3. Patented steel forms or fillers can be special ordered for unusual conditions; see manufacturers' catalogs. Fiber forms are also on the market in similar sizes. Plyform deck is required for forming.
4. Plyform is usually  $\frac{5}{8}$  in. minimum thickness, Exposure 1.

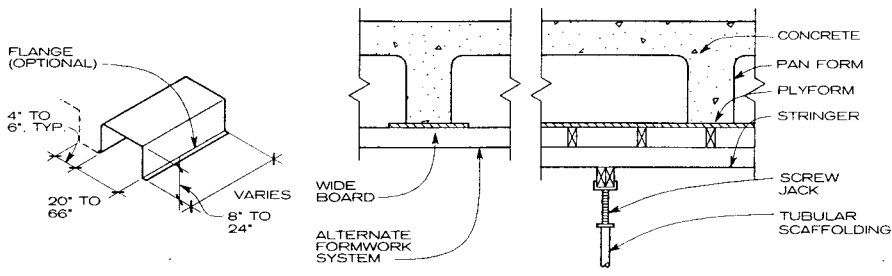

TYPICAL PAN FORM

TYPICAL CENTERING

**NOTES**

1. Forms are available in steel and lightweight fiberglass. Consult manufacturers for forms with different dimensions and rib-form variations. Typically three types are available: nail-down flange (simplest, but produces rough, nonarchitectural surface); slip-in type (based on

nail-down form but with board insert for smooth appearance); and adjustable (without flanges; produces smooth rib).

2. Consult ANSI A48.1-1986 for complete pan form standards.

**TYPICAL PAN FORM FOR ONE-WAY SLAB**

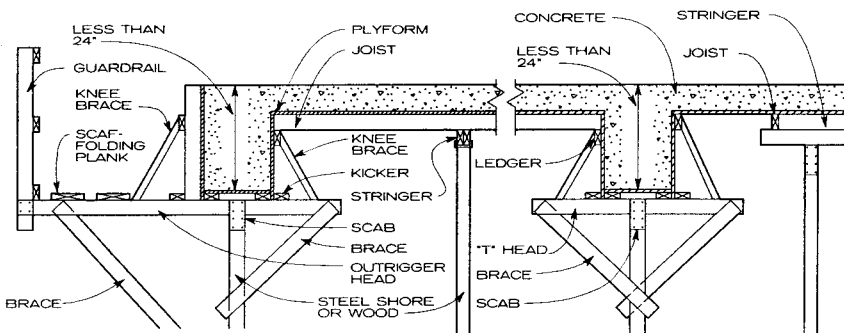

**TYPICAL SLAB AND SHALLOW BEAM FORMING**

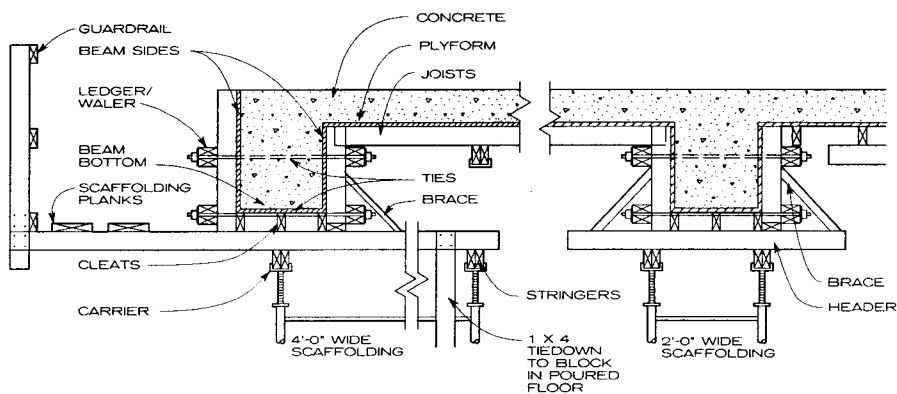

**TYPICAL SLAB AND HEAVY BEAM FORMING**

Tucker Concrete Form Company; Stoughton, Massachusetts

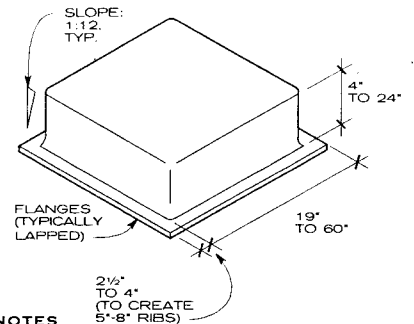

**NOTES**

1. Standard waffle slab forms are square for ease of use and economy. Dimensions vary slightly from manufacturer to manufacturer. Consult ANSI A48.2-1986 for complete dome form standards.
2. Forms are available in steel and lightweight fiberglass. Consult form manufacturer for options in material, textures, and dimensions.

**TYPICAL DOME FORM FOR WAFFLE OR TWO-WAY SLAB**

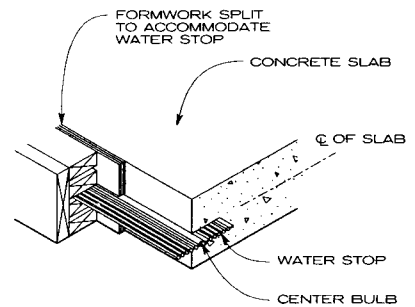

**NOTE**

Waterstops are flexible barriers used to prevent the passage of liquids and gasses under pressure through joints in concrete slabs. Waterstops are typically made of polyvinyl chloride, and their shapes vary according to application. If a center bulb is specified, it must remain unembedded in the center of the joint.

**SLAB FORMWORK WITH WATER STOP**

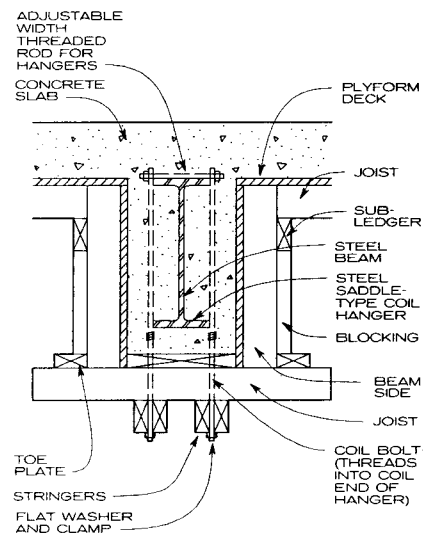

**NOTE**

This type of formwork is used to fireproof structural steel beams by wrapping them in concrete.

**TYPICAL SUSPENDED FORM WITH COIL SADDLE-TYPE HANGERS**

**GENERAL**

Concrete formwork hardware includes ties, anchors, hangers, and spacers used to hold forms and reinforcements in place against the forces of unhardened concrete and other loads applied during construction. Concrete ties are tensile units adapted to hold concrete forms together and may be classified by use or by load-carrying capacity. Classified by use are two main concrete tie types: "continuous single member," in which the entire tie rod extends through the wall and through both sides of the formwork (this can be a pull-out tie or a snap-off tie), and "internal disconnecting," in which the tensile unit has an inner part with threaded connections to removable external members. Classified by load-carrying capacity are light-duty (safe working loads of up to 3750 lb) and heavy-duty (loads of more than 3750 lb) concrete ties. Safe working load should be set at no more than half the tie's ultimate strength. Other hardware systems and configurations may be available; consult manufacturers for complete details.

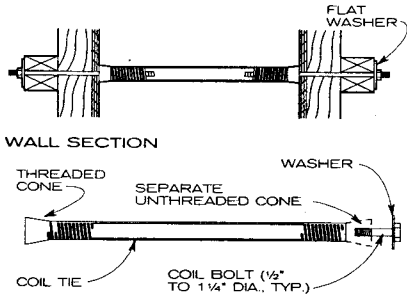

**NOTE**  
Coil ties are medium- to heavy-duty ties fabricated to accept a threaded bolt, which passes through the formwork lumber.

**COIL TIES**

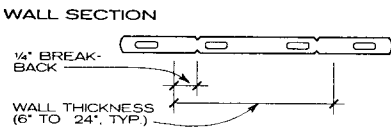
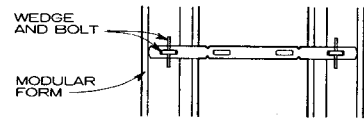

**NOTE**  
Flat ties are light-duty ties used with a wedge and bolt to secure and space modular wall forms.

**FLAT TIE**

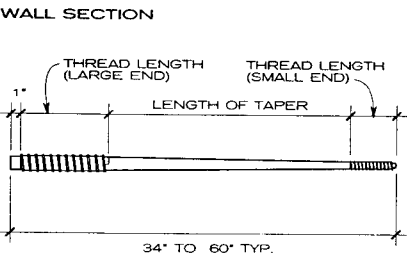
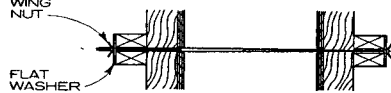

**NOTE**  
Generally used for heavy-duty loads of up to 50,000 lb, the taper tie system is a versatile forming system whose parts are removed after the concrete sets and may be reused. Ties may be installed after forms are in place.

**STEEL TAPER TIE**

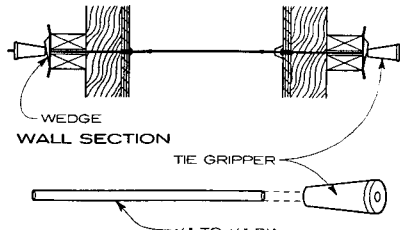

**NOTE**  
Fiberglass form ties, straight rods secured with reusable external metal grippers, have safe working loads ranging from 2250 to 25,000 psi. The ties are readily broken off or cut at the concrete surface, then ground flush.

**FIBERGLASS FORM TIE**

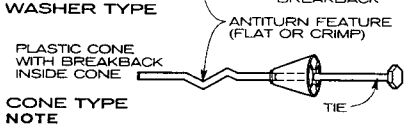
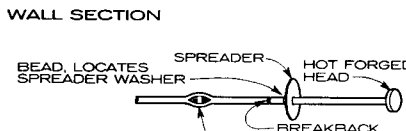
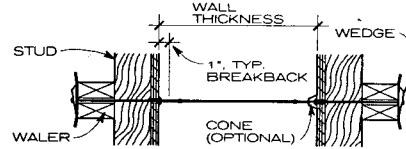

**NOTE**  
Snap ties are a type of through tie for light-duty use, fabricated so the exposed ends of the tie can be snapped off at the breakback (a notch in the rod). The antiturn device makes it easier to break off the exposed end.

**SNAP TIES**

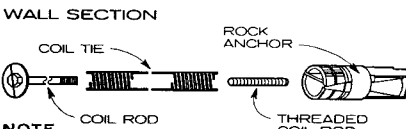
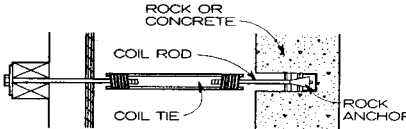

**NOTE**  
Rock anchors are used with coil ties to facilitate one-side forming of walls.

**ROCK ANCHOR**

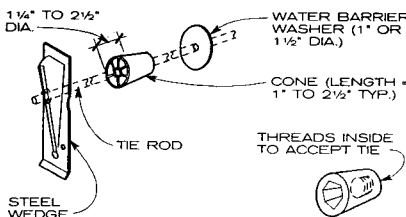

**NOTE**  
Steel wedges are placed at the outside threaded ends of pull-out or snap tie rods, holding the formwork in place. Plastic or wood cones may be placed on the tie rod at the formwork wall surface, so that when the formwork is removed the tie rod ends are set back for subsequent finishing (with plugs, etc.).

**TIE ROD ACCESSORIES**

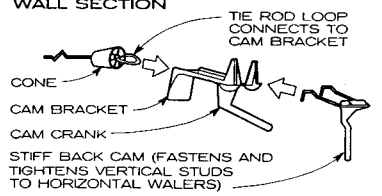
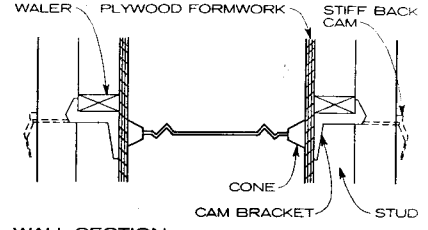

**NOTE**  
This light-duty system is suitable for job-set forms.

**CAM LOCK BRACKET/TIE SYSTEM**

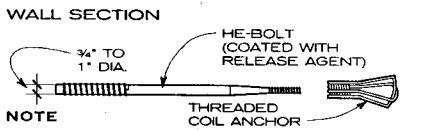
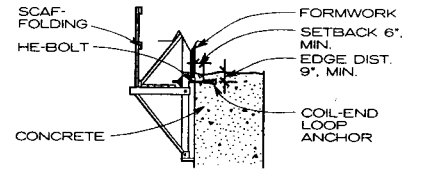

**NOTE**  
The coil anchor is embedded near the top of a concrete lift to support the formwork of the succeeding lift. The reusable he-bolt is threaded into the coil.

**HE-BOLT WITH COIL ANCHOR**

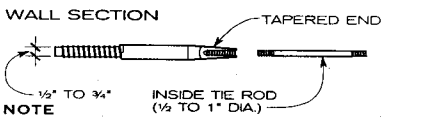
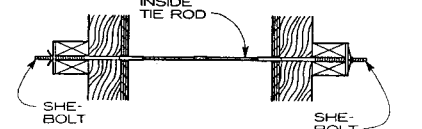

**NOTE**  
She-bolts are reusable heavy-duty tie components threaded onto an internal tie rod permanently embedded in the concrete. They are typically used with crane-handled forms.

**SHE-BOLT/TIE ROD**

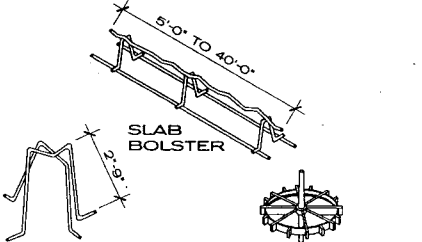

**NOTE**  
Bar supports are used to maintain the reinforcement's design distance from the wall sides or slab bottom. They are typically made of stainless steel or epoxy- or plastic-coated steel.

**REINFORCING BAR AND MESH SUPPORTS**

Mary K. Hurd; Engineered Publications; Farmington Hills, Michigan

**GENERAL**

Steel reinforcement for concrete consists of reinforcing bars and welded wire fabric. Bars are manufactured by hot-roll process as round rods with lugs, or deformations, which inhibit longitudinal movement of the bar in the surrounding concrete. Bar sizes are indicated by numbers. For sizes #3 through #8, the numbers are the number of eighths of an inch in the nominal diameter of the bars. Numbers 9, 10, and 11 are round and correspond to the former 1 in., 1 1/8 in., and 1 1/4 in. square sizes. Sizes #14 and #18 correspond to the former 1 1/2 in. and 2 in. square sizes. The nominal diameter of a deformed bar is equal to the actual diameter of a plain bar with the same weight per foot as the deformed bar. Epoxy-coated, zinc-coated (galvanized), and stainless steel reinforcing bars are used when corrosion protection is needed; stainless steel also has nonmagnetic properties. In some instances, a fiber-reinforced plastic (FRP) rebar is used for highly specialized concrete reinforcement because of its high tensile strength and light weight, corrosion resistance, and dielectric (nonconductive) properties. FRP rebars are manufactured in the same sizes as steel rebars and also have deformations on the surface. Consult manufacturers for further information.

Welded wire fabric is used in thin slabs, shells, and other designs in which available space is too limited to give proper cover and clearance to deformed bars. Welded wire fabric, also called mesh, consists of cold drawn wire (smooth or deformed) in orthogonal patterns; it is resistance welded at all intersections.

Wire in the form of individual wire or groups of wires is used in the fabrication of prestressed concrete.

**ASTM STANDARD REINFORCING BAR SIZES**

ASTM SIZE DESIGNATION	AREA (SQ IN. ACTUAL)	WEIGHT (LB/FT. ACTUAL)	DIAMETER (IN. ACTUAL)
#18	4.00	13.600	2.257
#14	2.25	7.650	1.693
#11	1.56	5.313	1.410
#10	1.27	4.303	1.270
#9	1.00	3.400	1.128
#8	0.74	2.670	1.000
#7	0.60	2.044	0.875
#6	0.44	1.502	0.750
#5	0.31	1.043	0.625
#4	0.20	0.668	0.500
#3	0.11	0.376	0.375

**NOTE**

Metrication of reinforcing bars is being considered in the United States; as of October 1995, a decision had not been made about what metric rebar sizes would apply in the United States. Metrication may result in a reengineering of reinforced concrete structures using the new bar sizes.

**SHRINKAGE AND TEMPERATURE REINFORCEMENT FOR STRUCTURAL CONCRETE**

REINFORCEMENT		PERCENT OF CROSS-SECTIONAL AREA OF CONCRETE, ONE WAY
GRADE	TYPE	
40/50	Deformed bars	0.20
—	Welded wire fabric	0.18
60	Deformed bars	0.18

**COMMON STOCK STYLES OF WELDED WIRE FABRIC**

NEW DESIGNATION (W-NUMBER)	OLD DESIGNATION (WIRE GAUGE)	STEEL AREA (IN. / SQ FT)		WEIGHT (LB/100 SQ FT)
		LONG.	TRANS.	
<b>SHEETS AND ROLLS</b>				
6 x 6 - W1.4 x W1.4	6 x 6 - 10 x 10	.028	.028	21
6 x 6 - W2.0 x W2.0	6 x 6 - 8 x 8	.040	.040	29
6 x 6 - W2.9 x W2.9	6 x 6 - 6 x 6	.058	.058	42
6 x 6 - W4.0 x W4.0	6 x 6 - 4 x 4	.080	.080	58
4 x 4 - W1.4 x W1.4	4 x 4 - 10 x 10	.042	.042	31
4 x 4 - W2.0 x W2.0	4 x 4 - 8 x 8	.060	.060	43
4 x 4 - W2.9 x W2.9	4 x 4 - 6 x 6	.087	.087	62
4 x 4 - W4.0 x W4.0	4 x 4 - 4 x 4	.120	.120	85

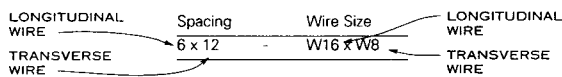

**METHOD OF DESIGNATION FOR WELDED WIRE FABRIC**

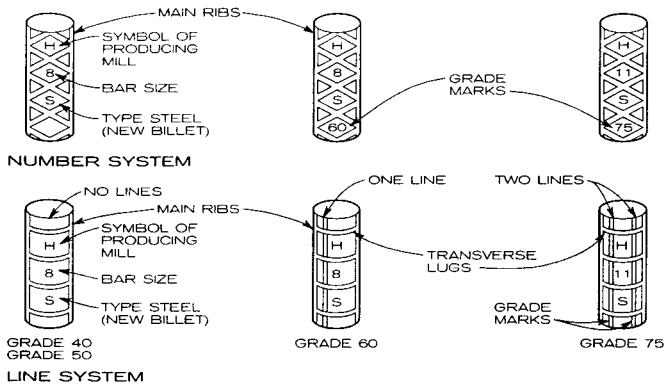

**NOTE**

Steel type grade marks: S—billet (A615), I—rail (A616), IR—rail meeting supplementary requirements, S1 (A616), A—axle (A617), W—low alloy (A706).

**REINFORCING BAR GRADE MARK IDENTIFICATION**

**STANDARD STEEL WIRE SIZES AND GAUGES**

PLAIN WIRE NUMBER	DEFORMED WIRE NUMBER	ASW GAUGE NUMBER	FRACTIONAL DIAMETER (IN.)	DECIMAL DIAMETER (IN.)	AREA (SQ IN.)	WEIGHT (LB/ LIN. FT)
W20	D20	—	1/2	.505	.200	.680
—	—	7/16	31/64	.490	.189	.642
W18	D18	—	15/32	.479	.180	.612
—	—	9/16	5/32	.462	.168	.571
W16	D16	—	29/64	.451	.160	.544
—	—	5/8	7/16	.431	.146	.496
W14	D14	—	13/32	.422	.140	.476
—	—	4/8	17/32	.394	.122	.415
W12	D12	—	25/32	.391	.120	.408
W11	D11	—	3/8	.374	.110	.374
W10.5	—	—	3/8	.366	.105	.357
—	—	3/8	23/64	.363	.103	.350
W10	D10	—	23/64	.357	.100	.340
W9.5	—	—	11/32	.348	.095	.323
W9	D9	—	11/32	.338	.090	.306
—	—	7/16	11/32	.331	.086	.292
W8.5	—	—	21/64	.329	.085	.289
W8	D8	—	21/64	.319	.080	.272
W7.5	—	—	5/16	.309	.075	.255
—	—	1/2	5/16	.307	.074	.251
W7	D7	—	19/64	.299	.070	.238
W6.5	—	—	19/64	.288	.065	.221
—	—	1	19/64	.283	.063	.214
W6	D6	—	9/32	.276	.060	.204
W5.5	—	—	17/64	.265	.055	.187
—	—	2	17/64	.263	.054	.183
W5	D5	—	1/4	.252	.050	.170
—	—	3	15/64	.244	.047	.160
W4.5	—	—	15/64	.239	.045	.153
W4	D4	—	7/32	.226	.040	.136
W3.5	—	—	7/32	.211	.035	.119
—	—	5	13/32	.207	.034	.115
W3	—	—	3/16	.195	.030	.102
W2.9	—	—	3/16	.192	.029	.098
W2.5	—	6	5/16	.178	.025	.085
W2.1	—	7	5/16	.162	.021	.071
W2	—	8	11/64	.160	.020	.068
—	—	9	5/32	.148	.017	.058
W1.4	—	—	9/64	.124	.014	.048

**REINFORCING BAR GRADES AND STRENGTHS**

ASTM SPEC	MIN. YIELD STRENGTH (PSI)	MIN. TENSILE STRENGTH (PSI)	STEEL TYPE
<b>Billet steel ASTM A 615</b>			
Grade 40	40,000	70,000	S
Grade 60	60,000	90,000	
Grade 75	75,000	100,000	
<b>Rail steel ASTM A 616</b>			
Grade 50	50,000	80,000	R
Grade 60	60,000	90,000	
<b>Axle steel ASTM A 617</b>			
Grade 40	40,000	70,000	A
Grade 60	60,000	90,000	
<b>Low-alloy ASTM A 706</b>			
Grade 60	60,000	80,000	W
<b>Deformed wire ASTM A 496</b>			
Welded fabric	70,000	80,000	—
<b>Plain wire ASTM A 82</b>			
Welded fabric < W 1.2	56,000	70,000	—
Size ≥ W 1.2	65,000	75,000	

Concrete Reinforcing Steel Institute; Schaumburg, Illinois  
Gordon B. Batson, P.E.; Potsdam, New York

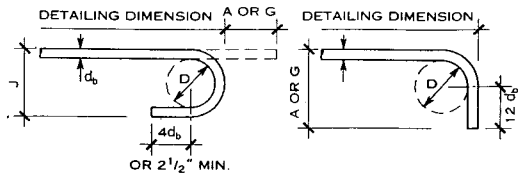

**STANDARD HOOK**

BAR SIZE	180° HOOK			90° HOOK	
	A OR G	J	D	A OR G	D
#3	5"	3"	2 1/4"	6"	2 1/4"
#4	6"	4"	3"	8"	3"
#5	7"	5"	3 3/4"	10"	3 3/4"
#6	8"	6"	4 1/2"	12"	4 1/2"
#7	10"	7"	5 1/4"	14"	5 1/4"
#8	11"	8"	6"	16"	6"
#9	15"	11 3/4"	9 1/2"	19"	9 1/2"
#10	17"	13 3/4"	10 3/4"	22"	10 3/4"
#11	19"	14 3/4"	12"	24"	12"
#14	27"	21 3/4"	18 1/4"	31"	18 1/4"
#18	36"	28 1/2"	24"	41"	24"

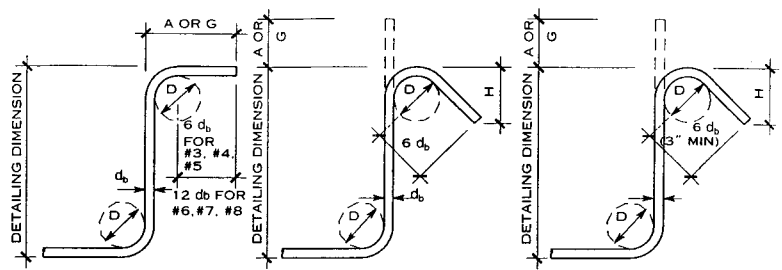

**STIRRUP HOOKS AND TIES**

BAR SIZE	90° HOOK/TIE		135° HOOK/TIE			135° SEISMIC HOOK/TIE		
	A OR G	D	A OR G	D	H	A OR G	D	H
#3	4"	1 1/2"	4"	1 1/2"	2 1/2"	4 1/4"	1 1/2"	3"
#4	4 1/2"	2"	4 1/2"	2"	3"	4 1/2"	2"	3"
#5	6"	2 1/2"	5 1/2"	2 1/2"	3 3/4"	5 1/2"	2 1/2"	3 3/4"
#6	12"	4 1/2"	7 3/4"	4 1/2"	4 1/2"	7 3/4"	4 1/2"	4 1/2"
#7	14"	5 1/4"	9"	5 1/4"	5 1/4"	9"	5 1/4"	5 1/4"
#8	16"	6"	10 1/4"	6"	6"	10 1/4"	6"	6"

**STANDARD REINFORCING BAR HOOK DETAILS**

**COMPRESSION LAP SPLICES AND ANCHORAGES FOR REINFORCING BARS**

STEEL GRADE (FY-KSI)	CONCRETE COMPRESSION STRENGTH (F'c)	LAP SPLICE IN db ≥ 12 IN.	DOWELS, IN db (8 IN. MIN.)
40	3000	20	15
	4000	20	13
	5000	20	12
50	3000	25	18
	4000	25	16
	5000	25	15
60	3000	30	22
	4000	30	19
	5000	30	18
75	3000	44	28
	4000	44	24
	5000	44	23

**NOTES**

- db = reinforcing bar diameter.
- Reinforcing bars #14 and #18 may not be used in lap splices except when lapped to #11 bars or smaller. To find the lap dimension, take the larger figure of either 22 db of the larger bar or 30 db of the smaller bar.
- Consult Concrete Reinforcing Steel Institute (CRSI) for tension splices and anchorages.

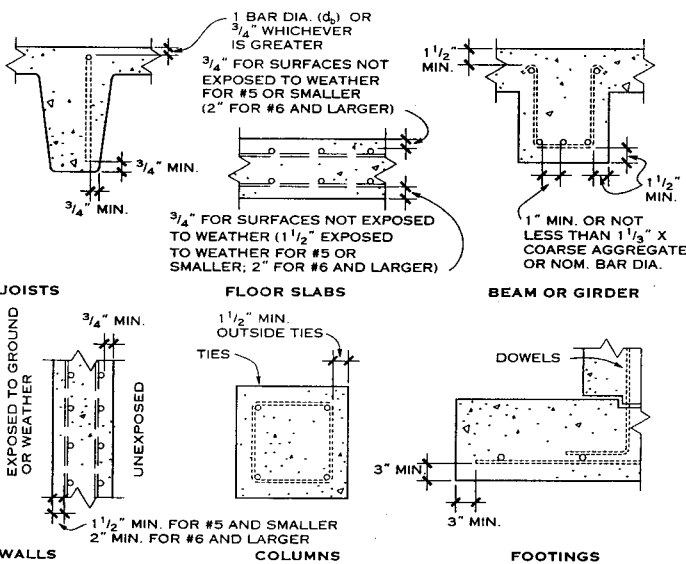

**PROTECTION FOR REINFORCEMENT**

Concrete Reinforcing Steel Institute; Schaumburg, Illinois

**TENSION LAP SPLICES AND ANCHORAGE F'c = 3000 PSI, NORMAL WEIGHT**

BAR SIZE	LAP CLASS	TOP BARS CATEGORY						OTHER BARS CATEGORY					
		1	2	3	4	5	6	1	2	3	4	5	6
#3	A	16	16	16	16	16	16	13	13	13	13	13	13
	B	21	21	21	21	21	21	16	16	16	16	16	16
#4	A	23	22	22	22	22	22	18	17	17	17	17	17
	B	30	28	28	28	28	28	23	22	22	22	22	22
#5	A	36	29	27	27	27	27	27	27	21	21	21	21
	B	46	37	35	35	35	35	36	29	27	27	27	27
#6	A	50	40	35	32	32	32	39	31	27	25	25	25
	B	65	52	46	42	42	42	50	40	35	32	32	32
#7	A	69	55	48	39	38	38	53	42	37	30	29	29
	B	89	71	63	50	49	49	69	55	48	39	38	38
#8	A	90	72	63	51	45	43	70	56	49	39	35	33
	B	117	94	82	66	59	56	90	72	63	51	45	43
#9	A	114	91	80	64	57	48	88	70	62	49	44	37
	B	148	119	104	83	74	63	114	91	80	64	57	48
#10	A	145	116	102	81	73	58	112	89	78	63	56	45
	B	188	151	132	106	94	76	145	116	102	81	73	58
#11	A	178	142	125	100	89	71	137	110	96	77	69	55
	B	231	185	162	130	116	93	178	142	125	100	89	71
#14	N/A	242	242	170	170	121	121	187	187	131	131	93	93
#18	N/A	356	356	250	250	178	178	274	274	192	192	137	137

**NOTES**

- Lap splice lengths are multiples of tension development lengths; Class A = 1.0 lb, Class B = 1.3 lb (ACI 12.15.1) Values of lb for bars in beams or columns are based on transverse reinforcement meeting minimum requirements for stirrups in ACI 11.5.4 and 11.5.5.3, or meeting tie requirements in ACI 7.10.5; and are based on minimum cover specified in ACI 7.7.1.
- Conditions that require Category 1 or Category 2 lap splice lengths should be avoided if at all possible for the larger bar sizes. These inordinately long lengths present possible construction problems due to placing, congestion, etc. Options available in trying to avoid Category 1 or 2 conditions include:
  - Increasing the concrete cover to more than one bar diameter and/or increase the bar c-c. spacing to more than three bar diameters.
  - Utilizing the Av allowance in ACI 12.2.3 (b) for beams or columns. Note that if ties or stirrups meet the minimum Av requirement, Category 1 lengths are reduced to Category 5 lengths and Category 2 lengths are reduced to Category 6 lengths.
- The ACI 318-89 code does not allow lap splices of #14 or #18 bars. The values tabulated for those bar sizes are the tension development lengths.
- Top bars are horizontal bars with more than 12 in. of concrete cast below the bars.
- #11 and smaller edge bars with c-c. spacing not less than 6db are assumed to have a side cover not less than 2.5db. Otherwise, Category 5 applies rather than Category 6.
- For lightweight aggregate, multiply the values above by 1.3.
- For epoxy-coated reinforcing bars, multiply the values above by one of the following factors:
  - Cover < 3db or c-c. spacing < 7db multiply top bars by 1.31 and all other bars by 1.50.
  - Cover > 3db and c-c. spacing > 7db multiply top bars and all other bars by 1.20.
- See CRSI's *Reinforcement: Anchorages, Lap Splices and Connections* manual for tables of tension development and lap splices for other concrete strengths and epoxy-coated rebars.

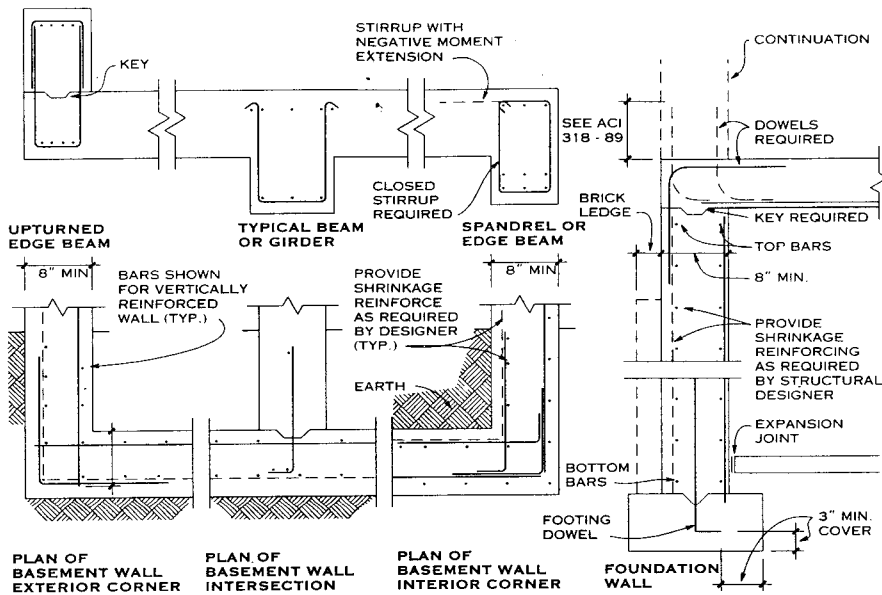

REINFORCING DETAILS

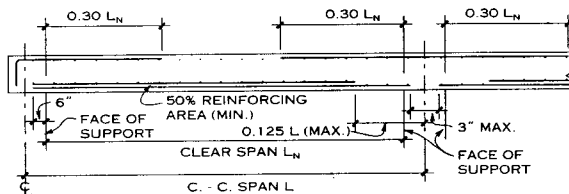
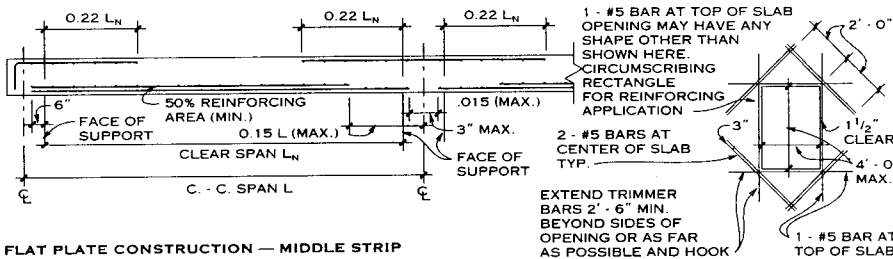

LONGITUDINAL SECTION—ONE WAY CONCRETE JOIST CONSTRUCTION

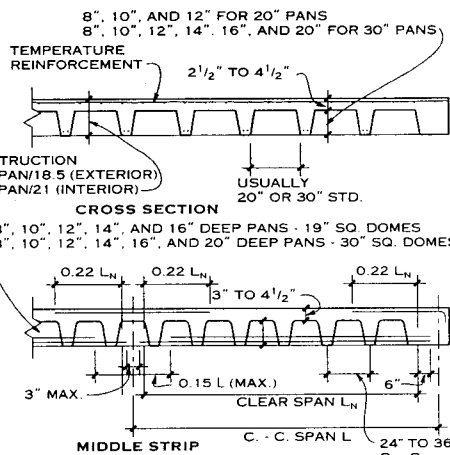
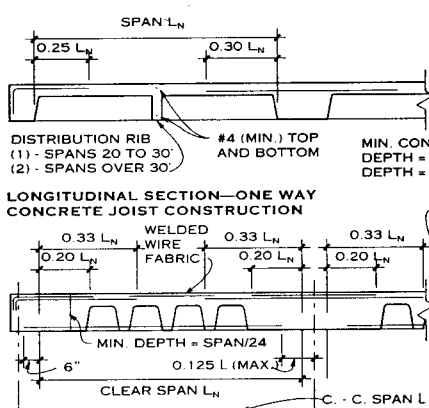

CONCRETE FLOOR SYSTEMS

Anthony L. Felder; Concrete Reinforcing Steel Institute; Schaumburg, Illinois  
Kenneth D. Franch, AIA, PE; Phillips Swager Associates, Inc.; Dallas, Texas

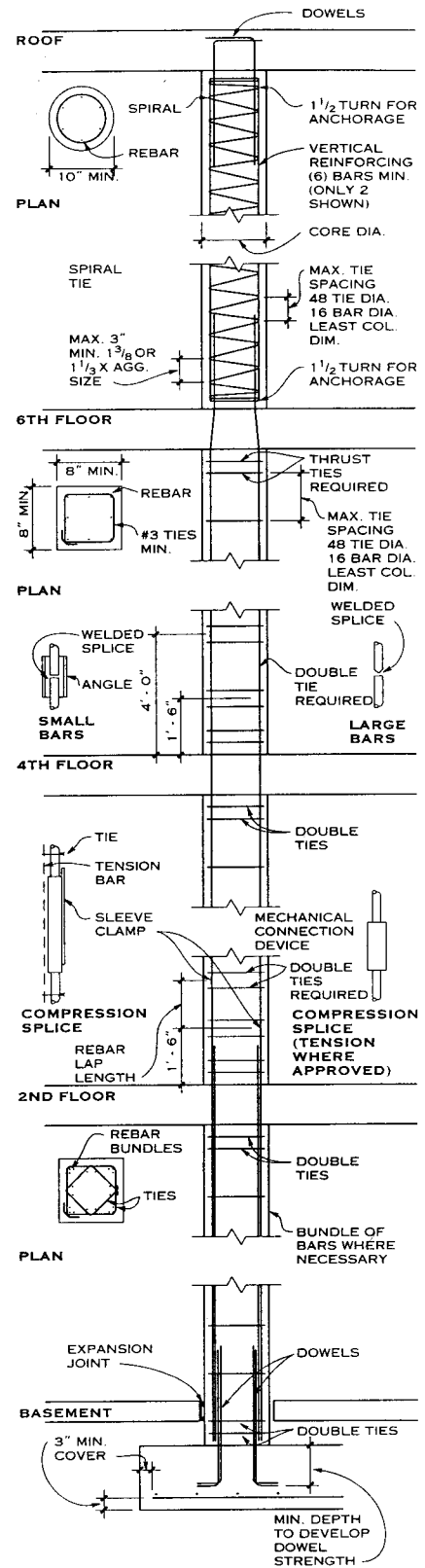

COLUMN REINFORCEMENT

**GENERAL**

Admixtures are those ingredients in concrete other than portland cement, water, and aggregates that are added to the mixture immediately before or during mixing. Admixtures can be classified by function as follows: air-entraining admixtures; water-reducing admixtures; retarding admixtures; accelerating admixtures; superplasticizers; finely divided mineral admixtures; miscellaneous admixtures that aid workability, bonding, dampproofing, gas-forming, grouting (nonshrink), and coloring and help reduce permeability and inhibit corrosion.

Concrete should be workable, finishable, strong, durable, watertight, and wear-resistant. These qualities can usually be achieved by selecting suitable materials or by changing the mix proportions. Sometimes air-entraining admixtures are necessary, but in most cases admixtures can be forgone. No admixture can substitute for good concreting practice.

The major reasons for using admixtures are to reduce the cost of concrete construction; to achieve certain properties in concrete more effectively; to ensure the quality of concrete during mixing, transporting, placing, and curing in adverse weather conditions; and to overcome certain emergencies during concreting operations.

**NOTES**

1. The effectiveness of an admixture depends on such factors as type, brand, and amount of cement; water content; aggregate shape, gradation, and proportions; mixing time; slump; and concrete and air temperatures.
2. Trial mixtures should be made with the admixture and the job materials at temperatures and humidities anticipated on the job to ensure compatibility with other admixtures and job materials and to allow observation of how the properties of the fresh and hardened concrete are affected by local conditions.
3. The cost of using admixtures should be compared with the cost of changing the basic concrete mixture. Determine how using an admixture will affect the cost of transporting, placing, finishing, curing, and protecting the concrete.
4. Recommended total air contents for different exposure conditions are shown for different aggregate sizes in the table below.

**TOTAL TARGET AIR CONTENT FOR CONCRETE<sup>1</sup>**

NOMINAL MAXIMUM AGGREGATE SIZE (IN.)	AIR CONTENT (PERCENT) <sup>2</sup>		
	SEVERE EXPOSURE <sup>3</sup>	MODERATE EXPOSURE <sup>3</sup>	MILD EXPOSURE <sup>3</sup>
3/8	7 1/2	6	4 1/2
1/2	7	5 1/2	4
3/4	6	5	3 1/2
1	6	4 1/2	3
1 1/2	5 1/2	4 1/2	2 1/2
2 1/2	5	4	2
3	4 1/2	3 1/2	1 1/2

<sup>1</sup> Experience shows that hardened concrete with the air contents specified in this table, as sampled and tested in the plastic state, performs satisfactorily. The air content of hardened concrete may be somewhat different.

<sup>2</sup> Project specifications often allow the air content of the delivered concrete to be within several percentage points of the table target values.

<sup>3</sup> Severe exposure is an environment in which concrete is exposed to wet freeze-thaw conditions, de-icers, or other aggressive agents. Moderate exposure is an environment in which concrete is exposed to freezing but will not be continually moist, not exposed to water for long periods before freezing, and will not be in contact with de-icers or aggressive chemicals. Mild exposure is an environment in which concrete is not exposed to freezing conditions, de-icers, or aggressive agents.

**CONCRETE ADMIXTURES BY CLASSIFICATION**

TYPE OF ADMIXTURE	DESIRED EFFECT	MATERIAL
Accelerators (ASTM C 494, Type C)	Accelerate setting and early-strength development	Calcium chloride (ASTM D 98); Triethanolamine, sodium thiocyanate, calcium formate, calcium nitrate, calcium nitrite
Air detrainers	Decrease air content	Tributyl phosphate, dibutyl phthalate, octyl alcohol, water-insoluble esters of carbonic and boric acid, silicones
Air-entraining admixtures (ASTM C 260)	Improve durability in environments of freeze-thaw, de-icers, sulfate, and alkali reactivity; Improve workability; segregation and bleeding are reduced or eliminated	Salts of wood resins (Vinsol resin); some synthetic detergents; salts of sulfonated lignin; salts of petroleum acids; salts of proteinaceous material; fatty and resinous acids and their salts; alkylbenzene sulfonates; salts of sulfonated hydrocarbons
Alkali-reactivity reducers	Reduce alkali-reactivity expansion	Pozzolans (fly ash, silica fume), blast-furnace slag, salts of lithium and barium, air entraining agents
Bonding admixtures	Increase bond strength	Rubber, polyvinyl chloride, polyvinyl acetate, acrylics, butadiene-styrene copolymers
Coloring agents	Colored concrete	Modified carbon black, iron oxide, phthalocyanine, umber, chromium oxide, titanium oxide, cobalt blue (ASTM C 979)
Corrosion inhibitors	Reduce steel corrosion activity in a chloride environment	Calcium nitrite, sodium nitrite, sodium benzoate, certain phosphates of fluosilicates, fluoaluminate
Dampproofing admixtures	Retard moisture penetration into dry concrete	Soaps of calcium or ammonium stearate or oleate; butyl stearate; petroleum products
Finely divided mineral admixtures		
Cementitious	Hydraulic properties; partial cement replacement	Ground granulated blast-furnace slag (ASTM C 989); natural cement; hydraulic hydrated lime (ASTM C 141)
Pozzolans	Pozzolanic activity; improve workability, plasticity, sulfate resistance; reduce alkali reactivity, permeability, heat of hydration; partial cement replacement; filler	Diatomaceous earth, opaline cherts, clays, shales, volcanic tuffs, pumicites (ASTM C 618, Class N); fly ash (ASTM C 618, Class F and C), silica fume
Pozzolanic and cementitious	Same as cementitious and pozzolan categories	High calcium fly ash (ASTM C 618, Class C); ground granulated blast-furnace slag (ASTM C 989)
Nominally inert	Improve workability; filler	Marble, dolomite, quartz, granite
Fungicides, germicides, and insecticides	Inhibit or control bacterial and fungal growth	Polyhalogenated phenols; dieldrin emulsions; copper compounds
Gas formers	Cause expansion before setting	Aluminum powder; resin soap and vegetable or animal glue; saponin; hydrolyzed protein
Grouting agents	Adjust grout properties for specific applications (i.e., non-shrink grout for setting steel on masonry or concrete, fill reglets and cracks)	See air-entrained admixtures, accelerators, retarders, workability agents
Permeability reducers	Decrease permeability	Silica fume; fly ash (ASTM C 618); ground slag (ASTM C 989); natural pozzolans; water reducers; latex
Pumping aides	Improve pumpability	Organic and synthetic polymers; organic flocculents; organic emulsions of paraffin, coal tar, asphalt, acrylics; bentonite and pyrogenic silicas; natural pozzolans (ASTM C 618, Class N); fly ash (ASTM C 618, Classes F and C); hydrated lime (ASTM C 141)
Retarders (ASTM C 494, Type B)	Retard setting time to offset effect of hot weather, to delay initial set for difficult placement, or for special finishing, such as exposed aggregate	Lignin; borax; sugar; tartaric acids and salts
Superplasticizers* (ASTM C 1017, Type 1)	Flowing concrete; reduce water-cement ratio	Sulfonated melamine formaldehyde condensates; sulfonated naphthalene formaldehyde condensates; lignosulfonates
Superplasticizer* and retarder (ASTM C 1017, Type 2)	Flowing concrete with retarded set; reduce water	See superplasticizers and water reducers
Water reducer (ASTM C 494, Type A)	Reduce water demand at least 5%	Lignosulfonates; hydroxylated carboxylic acids; carbohydrates (also tend to retard set so accelerator is often added)

\* Superplasticizers are also referred to as high-range water reducers or plasticizers. These admixtures often meet

both ASTM 494 and C 1017 specifications simultaneously.

Robert W. Shuldes, P.E.; Portland Cement Association; Skokie, Illinois

**3 CAST-IN-PLACE CONCRETE**

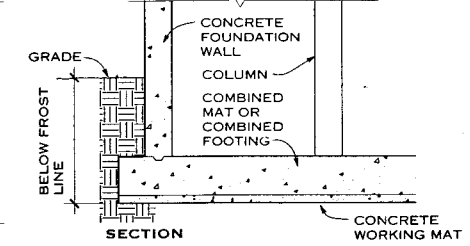
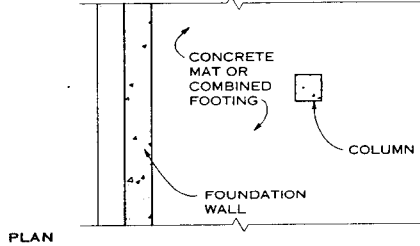
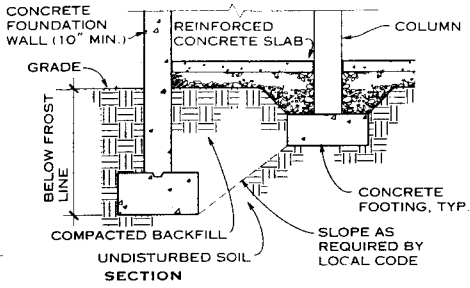
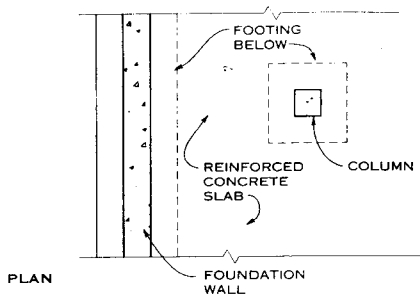

**SPREAD FOOTINGS**

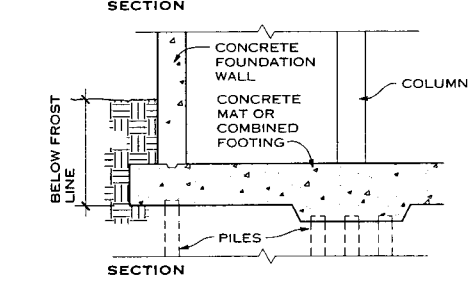
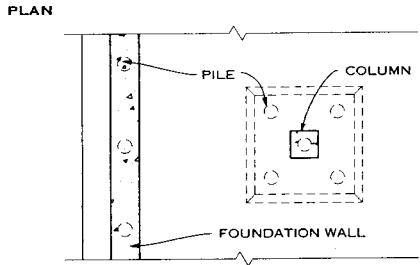
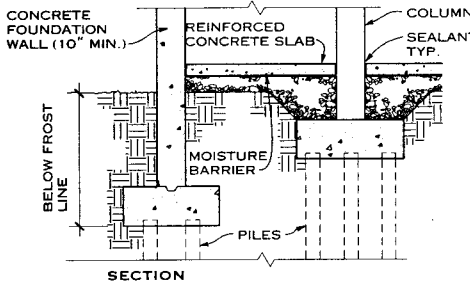
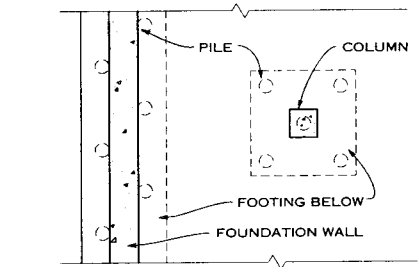

**PILE-SUPPORTED FOUNDATIONS**

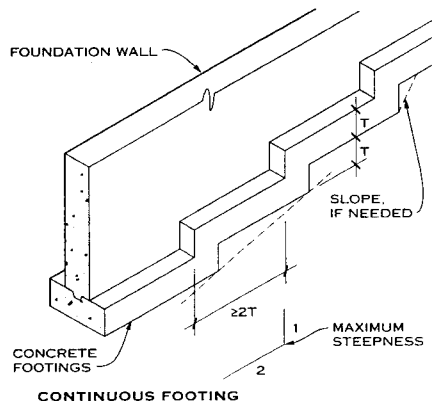
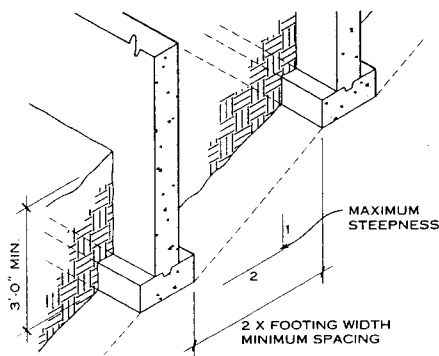

**DISCONTINUOUS FOOTINGS**

**STEP FOOTINGS**

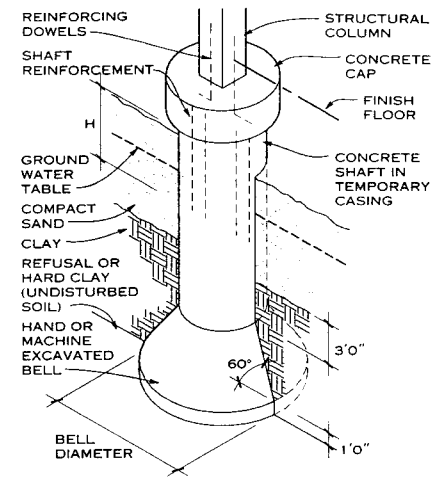

**NOTES**

1. Test soils to determine their allowable bearing capacity. Refer to local building codes.
2. "H" is a function of the passive resistance of the soil, generated by the moment applied to the pier cap.
3. Piers may be used under grade beams or concrete walls. For very heavy loads, pier foundations may be more economical than piles.

**BELL PIER FOUNDATION**

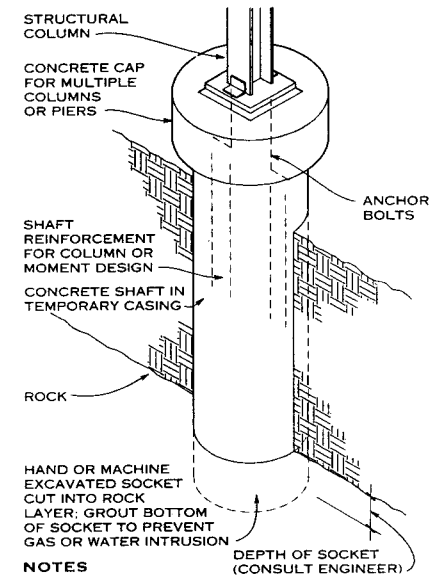

**NOTES**

1. Set pier into a socket in rock to transmit high compression or tension loads into rock by bond.
2. Pier shaft should be poured in dry conditions if possible, but tremie pours can be used.

**SOCKET PIER FOUNDATION**

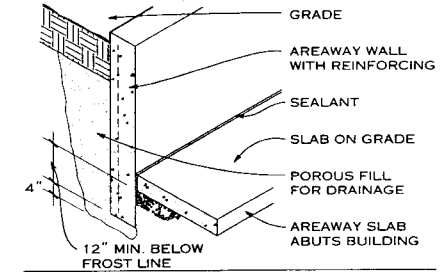

**AREAWAY WALL**

Donald Neubauer, P.E.; Neubauer Consulting Engineers; Potomac, Maryland  
 Mueser Rutledge Consulting Engineers; New York, New York



**GENERAL**

Factors to consider in the design and construction of all slabs on grade include the intended use of the slab or slab section, the condition and preparation of a uniform subgrade, quality of concrete, adequacy of structural capacity, type and spacing of joints, finishing, curing, and application of special surfaces. The subgrade support must be reasonably uniform and the upper portion of the subgrade (called the base) should be of uniform material and density. Both should be properly compacted. A thin layer of compactable granular fill may be placed immediately beneath the slab to act as a percolation barrier.

Wear resistance (abrasion) is directly related to the condition of the top portion of the concrete slab. Surface hardness and abrasion resistance may be provided by special additives or hardeners to the surface. The quality of the overall concrete slab will be enhanced by proper water-to-cement ratio, reasonable slump limits, and well-graded aggregates with the maximum size of the coarse aggregate as large as placing will permit. Exterior concrete subjected to freeze-thaw cycles should have 4 to 7% entrained air.

Reinforcement in concrete slabs is unnecessary where frequent joint spacings are used. Where less frequent joint spacings are used, reinforcement is placed in the slab, at or above the mid-depth (generally 1/2 down from the top surface) to act as crack control. Common contraction joint spacing is 15 to 25 ft, depending on the thickness of the slab and the construction type. Checkerboard placement of slabs is no longer recommended by American Concrete Institute (ACI) 302.1 "Guide for floor and slab construction," where strip placement of slabs is recommended for large areas.

Three types of joints are recommended:

1. ISOLATION JOINTS (also called expansion joints): Allow movement between slab and fixed parts of the building such as columns, walls, and machinery bases.
2. CONTRACTION JOINTS (also called control joints): Induce cracking at preselected locations.
3. CONSTRUCTION JOINTS: Provide stopping places during floor construction. Construction joints also function as control and isolation joints.

Sawcut control joints should be made as early as is practical after finishing the slab and should be filled in areas with wet conditions, hygienic and dust control requirements, or con-

siderable traffic by hard wheel vehicles, such as forklifts. A semirigid filler Shore Hardness "A" of at least 80 should be used in joints supporting forklift traffic.

Concrete floor slabs are monolithically finished as a general procedure by floating and troweling to a smooth and dense top surface finish. ACI 302 provides specific guidance for appropriate finishing procedures to control the achievable floor flatness. ACI 302, ACI 360, and ACI 117 provide guidance for flatness selection and the techniques by which flatness and levelness are produced and measured. Two systems are used. The preferred method of measuring flatness and levelness (documented in ACI 302 and ACI 117) is the F-Number System. Special finishes are available to improve appearance as well as surface properties. These include sprinkled (shake) finishes or high-strength toppings, either as monolithic or separate (two-stage floor) surfaces. Where propagation of water vapor is undesirable, a water-proof vapor barrier, with permeance not to exceed 0.20 perms, can be used.

**THICKNESS DESIGN**

In general, the controlling loading to a slab on grade is the heaviest concentrated loading that it will carry. This is frequently the axle loading of an industrial lift truck or the set of post loadings from heavy rack storage shelves. The concrete slab thickness required will depend on the loading itself, the modulus of rupture of the concrete (usually based on the compressive strength of the concrete), the selected factor of safety used in the design, and the modulus of subgrade reaction (k) of the soil support system (subgrade). Procedures and examples are shown in ACI 360, ACI 330, and ACI 302. Class 1, 2, and 3 floors should be no thinner than 4 or 5 inches. Loading and usage frequently require floors thicker than 6 inches.

**DOWEL SIZE AND SPACING (IN.)**

SLAB DEPTH	DOWEL DIA.	TOTAL DOWEL LENGTH	DOWEL SPACING CENTER TO CENTER
5-6	3/4	16	12
7-8	1	18	12
9-10	1 1/4	18	12

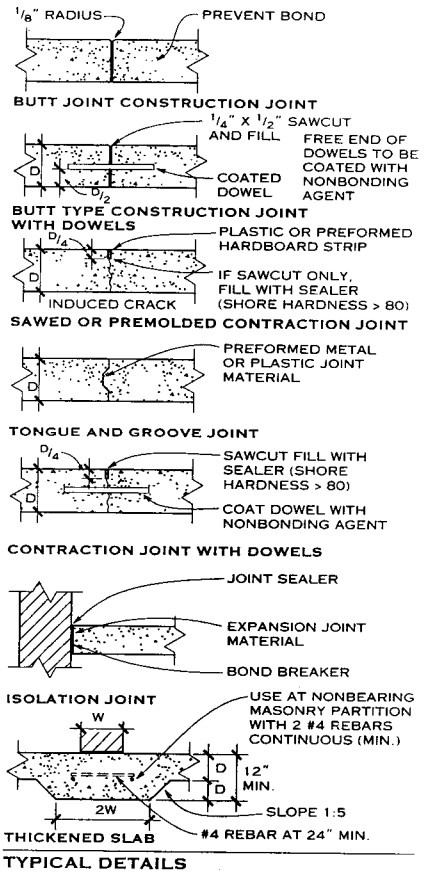

**CLASSIFICATION OF CONCRETE SLABS ON GRADE**

CLASS	RECOMMENDED SLUMP (IN.)	RECOMMENDED 28-DAY COMPRESSIVE STRENGTH (PSI)	USUAL TRAFFIC	USE	SPECIAL CONSIDERATIONS	CONCRETE FINISHING TECHNIQUE
1	5	3000	Light foot	Residential surfaces; mainly with floor coverings	Grade for drainage; level slabs suitable for applied coverings; curing	Single troweling
2	5	3500	Foot	Offices and churches; usually with floor covering  Decorative	Surface tolerance (including elevated slabs); nonslip aggregates in specific areas  Colored mineral aggregate; hardener or exposed aggregate; artistic joint layout	Single troweling; nonslip finish where required  As required
3	5	3500	Foot and pneumatic wheel	Exterior walks, driveways, garage floors, and sidewalks	Grade for drainage; proper air content; curing	Float, trowel, or broom finish
4	5	4000	Foot and light vehicular traffic	Institutional and commercial	Level slab suitable for applied coverings; nonslip aggregate for specific areas and curing	Normal steel trowel finish
5	4	4000	Industrial vehicular traffic—pneumatic wheel	Light-duty industrial floors for manufacturing, processing, and warehousing	Good uniform subgrade; surface tolerance; joint layout; abrasion resistance; curing	Hard steel trowel finish
6	4	4500	Industrial vehicular traffic—hard wheels	Industrial floors subject to heavy traffic; may be subject to impact loads	Good uniform subgrade; surface tolerance; joint layout; load transfer; abrasion resistance; curing	Special metallic or mineral aggregate; repeated hard steel troweling
7	4	Base 3500	Industrial vehicular traffic—hard wheels	Bonded two-course floors subject to heavy traffic and impact	Base slab—Good uniform subgrade; reinforcement; joint layout; level surface; curing Topping—Composed of well-graded all-mineral or all-metallic aggregate; Mineral or metallic aggregate applied to high-strength plain topping to toughen; surface tolerance; curing	Clean-textured surface suitable for subsequent bonded topping Special power floats with repeated steel trowelings
8	2	Topping 5000-8000	As in classes 4, 5, and 6	Unbonded toppings—Freezer floors on insulation, on old floors, or where construction schedule dictates	Bond breaker on old surface; mesh reinforcement; minimum thickness 3" (nominal 75mm) abrasion resistance, and curing	Hard steel trowel finish
9	5	4000 or higher	Superflat or critical surface tolerance required. Special materials-handling vehicles or robotics requiring specific tolerances	Narrow-aisle, high-bay warehouses; television studios	Varying concrete quality requirements. Shake-on hardeners cannot be used unless special application and great care are employed. Proper joint arrangement	Strictly follow finishing techniques as indicated in section 7.15 of ACI 302

Boyd C. Ringo; Cincinnati, Ohio

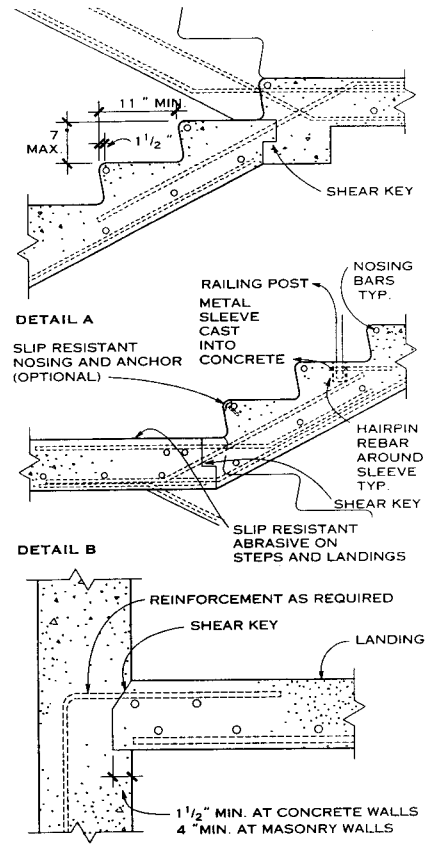
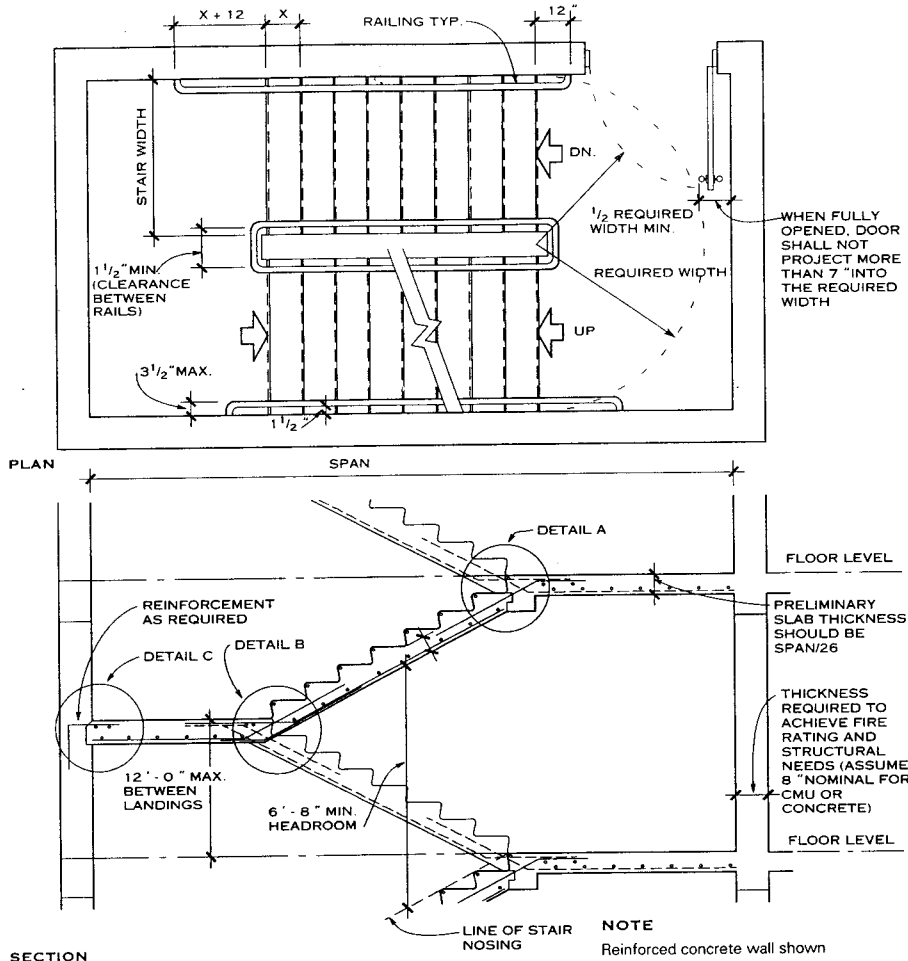

- NOTES**
1. Structural engineer to determine reinforcement specifications and specific placement in stairs.
  2. Check codes for dimensions and clearances for accessibility standards.

**U-TYPE CONCRETE STAIRS**

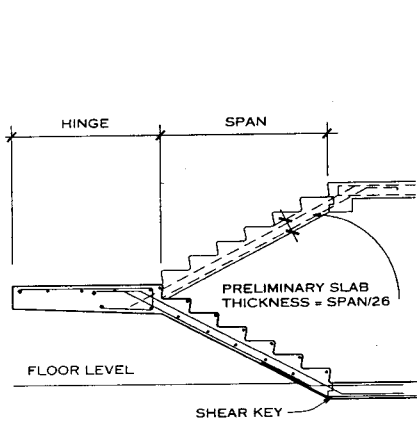

**NOTE**  
Extend hinge only as required by stair width, unless otherwise permitted by structural engineer.

**FREESTANDING CONCRETE STAIR**

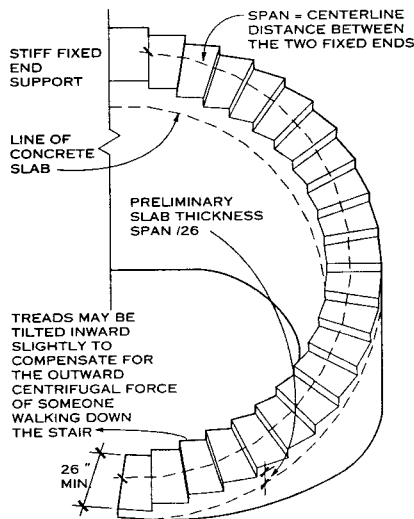

**NOTE**  
Use of helicoidal concrete stairs depends on very stiff fixed end support and small support deflection.

**HELICOIDAL CONCRETE STAIR**

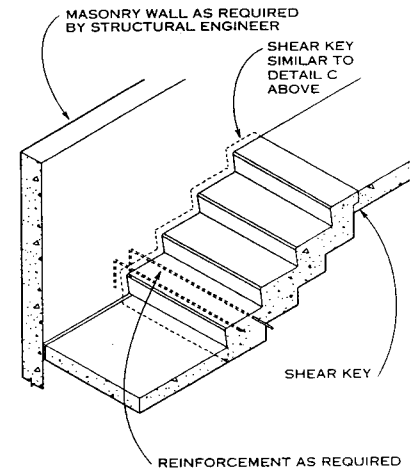

**NOTE**  
Reinforcement must develop full bond in masonry walls and have full development length in concrete walls.

**CANTILEVER CONCRETE STAIR**

Krommenhoek/McKeown and Associates; San Diego, California  
Karlsberger and Companies; Columbus, Ohio

**GENERAL NOTES**

1. The information presented on these pages is intended only as a preliminary design guide. All structural dimensions for slab thickness, beam and joint sizes, column sizes, etc., should be calculated and analyzed for each project condition by a licensed professional engineer.

2. Spans shown are approximate and are based on use of mild reinforcing steel. Spans may be increased 25 to 50% with the use of prestressing. For spans greater than 40 ft, consider posttensioning.

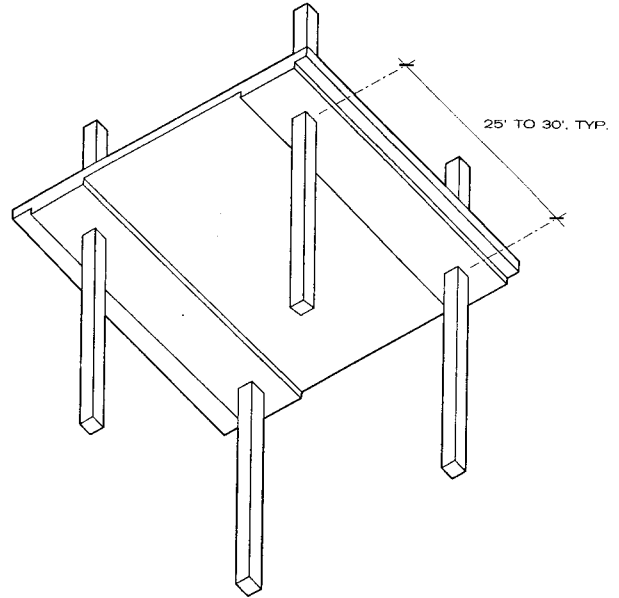
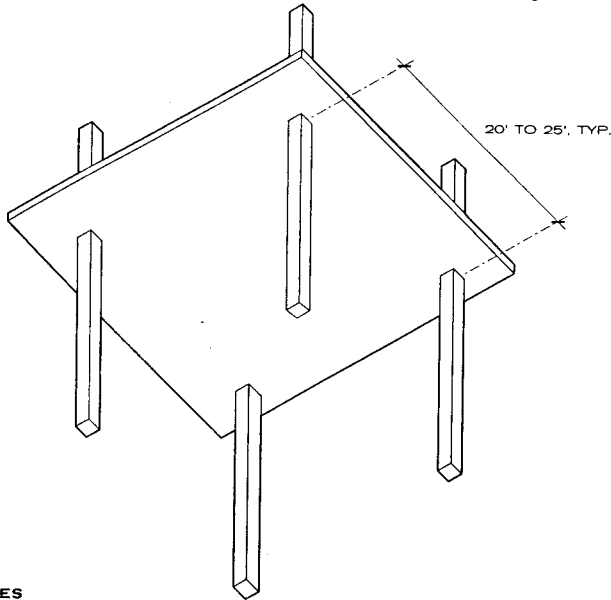

**NOTES**

1. Advantages: Inexpensive formwork; ceilings may be exposed; minimum thickness; fast erection; flexible column location.
2. Disadvantages: Excess concrete for longer spans; low shear capacity; greater deflections.
3. Appropriate building types: Hotels, motels, dormitories, condominiums, hospitals.
4. A flat plate is best for moderate spans because it is the most economical floor system and has the lowest structural thickness. Avoid penetrations for piping and ductwork through the slab near the columns. Spandrel beams may be necessary.

**NOTES**

1. Advantages: Longer spans than flat plate; typically posttensioned; minimum thickness.
2. Disadvantages: Must reuse formwork many times to be economical.
3. Appropriate building types: High-rise buildings; same use as flat plates if flying forms can be used more than 10 times.
4. A banded slab has most of the advantages of a flat plate but permits a longer span in one direction. It can resist greater lateral loads in the direction of the beams.

**FLAT PLATE**

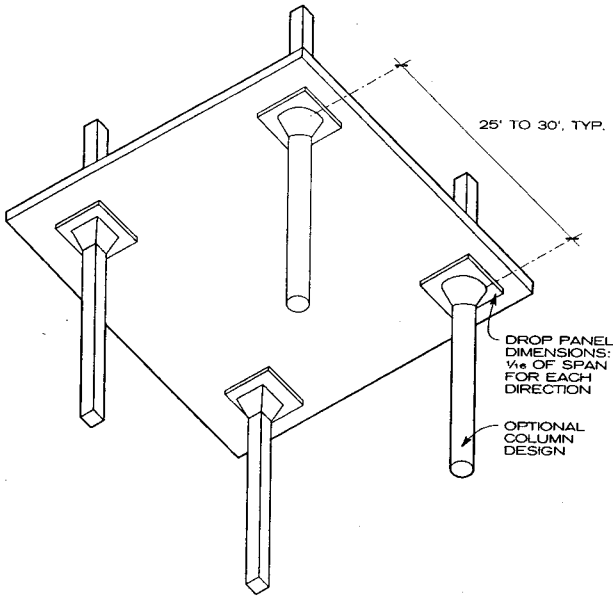

**BANDED SLAB**

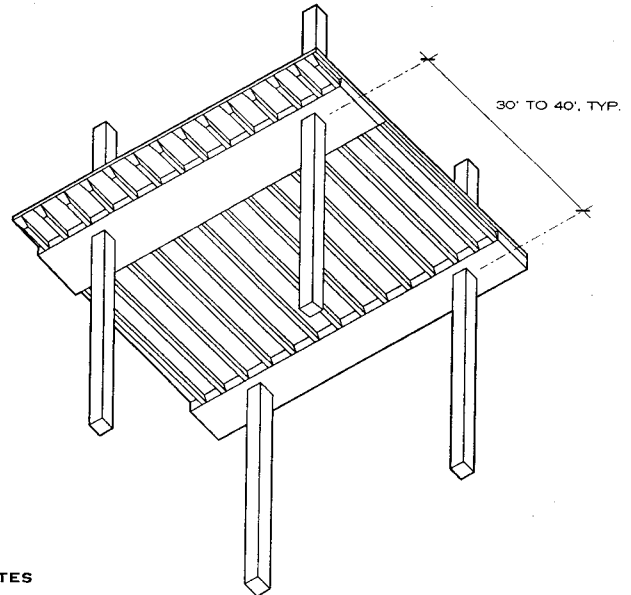

**NOTES**

1. Advantages: Economical for design loads greater than 150 psf.
2. Disadvantages: Formwork is costly.
3. Appropriate building types: Warehouses, industrial structures; parking structures
4. Flat slabs are most commonly used today for buildings supporting very heavy loads. When live load exceeds 150 lb per sq ft, this scheme is by far the most economical.

**NOTES**

1. Advantages: Minimum concrete and steel; minimum weight, hence reduced column and footing size; long spans in one direction; accommodates poke-through electrical systems.
2. Disadvantages: Unattractive for a ceiling; formwork may cost more than flat plate.
3. Appropriate building types: Schools, offices, churches, hospitals, public and institutional buildings, buildings with moderate loadings and spans.
4. This is the best scheme if slabs are too long for a flat plate and the structure is not exposed. The slab thickness between joints is determined by fire requirements. Joists are most economical if beams are the same depth as the joists. Orient joists in the same direction throughout the building and in the long direction of long rectangular bays.

**FLAT SLAB**

**JOIST SLAB**

Russell S. Fling, P.E., Consulting Engineer; Columbus, Ohio

**3 CAST-IN-PLACE CONCRETE**

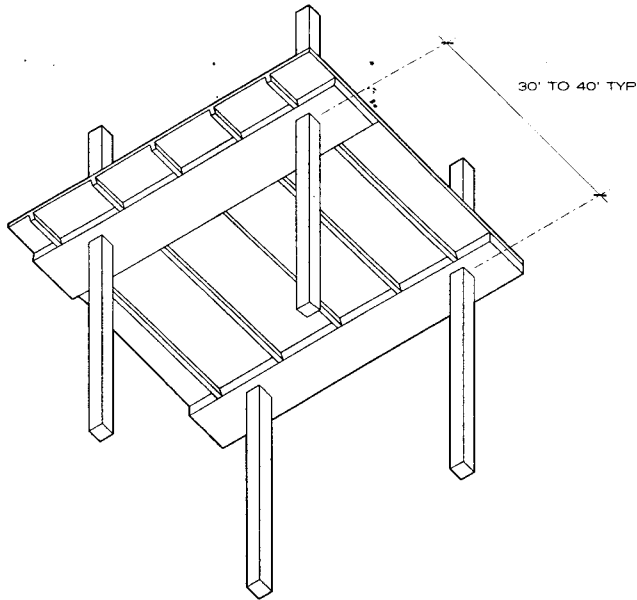

**NOTES**

1. Advantages: Uses less concrete than joist slab; lower rebar placing costs; joist space used for mechanical systems. Permits lights and equipment to be recessed between joists.
2. Disadvantages: Similar to joist slab; joists must be designed as beams; forms may require special order.
3. Appropriate building type: Same as for joist slabs, especially for longer fire ratings.
4. Ensure the availability of formwork before specifying skip joists. For larger projects, a skip joist slab should be less expensive than a joist slab, and it permits lights and equipment recessed between joists.

**SKIP JOIST**

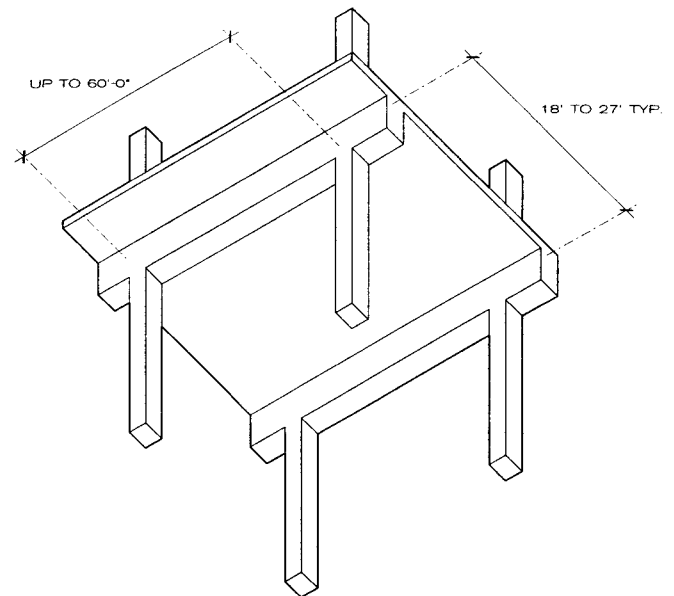

**NOTES**

1. Advantages: Long span in one direction.
2. Disadvantages: Beams interfere with mechanical services; more expensive forms than flat plate.
3. Appropriate building types: Parking garages, especially with posttensioning.
4. This scheme is most favored for parking garages, but the long span of about 60 ft must be prestressed unless beams are quite deep. Shallow beams will deflect excessively.

**ONE-WAY BEAM AND SLAB**

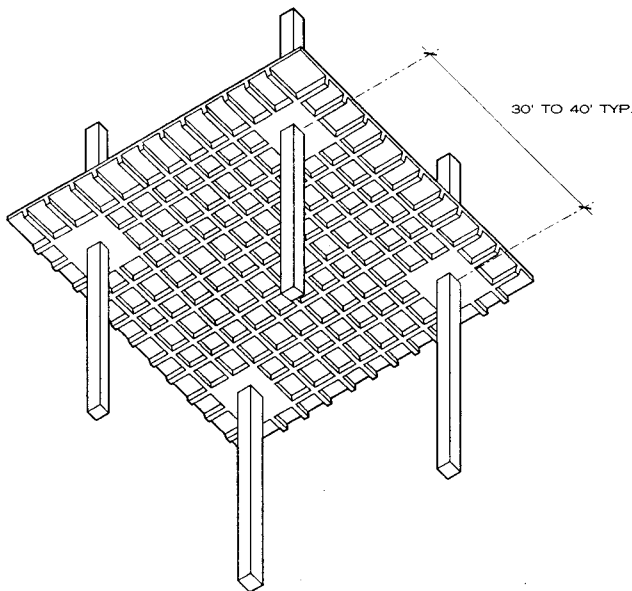

**NOTES**

1. Advantages: Longer two-way spans; attractive exposed ceilings; heavy load capacity.
2. Disadvantages: Formwork costs more and uses more concrete and steel than a joist slab.
3. Appropriate building types: Prominent buildings with exposed ceiling structure; same types as are suitable for flat slab but with longer spans.
4. Column spacing should be multiples of pan spacing to ensure uniformity of drop panels at each column. Drop panels can be diamond-shaped, square, or rectangular.

**WAFFLE SLAB**

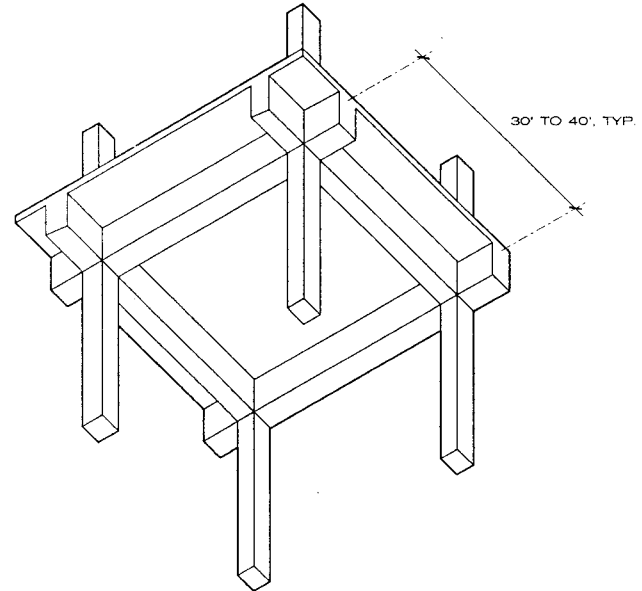

**NOTES**

1. Advantages: Long span in two directions; small deflection; can carry concentrated loads.
2. Disadvantages: Same as for one-way beams, only more so.
3. Appropriate building types: Portions of buildings in which two-way beam framing is needed for other reasons; industrial buildings with heavy concentrated loads.
4. The high cost of the formwork and structural interference with mechanical systems make this scheme unattractive unless heavy concentrated loads must be carried.

**TWO-WAY SLAB AND BEAM**

Russell S. Fling, P.E., Consulting Engineer; Columbus, Ohio

**GENERAL**

Architectural concrete and structural concrete are both made from portland cement, aggregate, and water, but they have entirely different concrete mix designs. A variety of architectural finishes and colors can be achieved by changing the mix of these three simple ingredients. The cost of production usually determines the limit of finish choices. There are three basic ways to change the appearance of a concrete surface finish:

**MATERIAL VARIATION** involves changing the size, shape, texture, and color of the coarse and fine aggregate, particularly in exposed aggregate concrete, and choosing white or gray cement.

**MOLD OR FORM VARIATION** involves changing the texture or pattern of the concrete surface by means of form design, form liners, or joint/edge treatments.

**SURFACE TREATMENT** involves treating or tooling the surface after the concrete has cured.

Design drawings for architectural concrete should show form details, including openings, joints (contraction, construction, and rustication), and other important specifics. Other factors that affect concrete surfaces are mixing and placing techniques, slump control, curing methods, and release agents.

**NOTES**

1. Choosing a placing technique (pumping vs. bottom drop or other bucket type) is an important step toward achieving a desired architectural concrete surface and finish. Evaluate whether architectural concrete forms can also be used for structural concrete. Verify that the vibrators used are of the proper size, frequency, and power.
2. Shop drawings should be carefully checked to determine form quality and steel reinforcement placement. Require approval of forms and finishes; field mockup is advised to evaluate the appearance of the concrete panel and the quality of workmanship.
3. Release agents are chemical treatments applied to the liner or face of the form that react with the cement to prevent it from sticking to the form. The safest way to select a release agent is to evaluate several products on a test panel under actual job conditions. The curing compound, used to retard or reduce evaporation of moisture from concrete or to extend curing time, is typically applied immediately after final finishing of the concrete surface. Consult manufacturers and the American Concrete Institute for more detailed information about the compatibility of these treatments and the form surface material or other finishes and surfaces to be applied to the concrete.

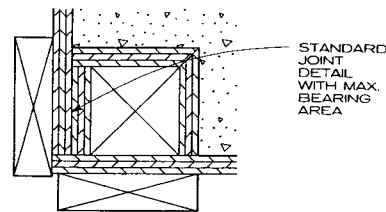

STANDARD JOINT DETAIL WITH MAX. BEARING AREA

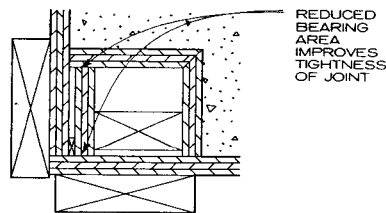

REDUCED BEARING AREA IMPROVES TIGHTNESS OF JOINT

**EXPOSURE METHODS FOR ARCHITECTURAL CONCRETE SURFACES**

METHOD	FINISH EFFECT	COLOR SOURCE	FORM SURFACE	CRITICAL DETAILS
1. As cast	Remains as is after form removal, usually exhibits board marks or wood grain	Cement first influence, fine aggregate second influence	Smooth and textured	Slump = 2 1/2 to 3 1/2" Joinery of forms Proper release agent Point form joints to avoid marks
2. Abrasive blasted surfaces				
a. Brush blast	Uniform scour cleaning	Cement and fine aggregate have equal influence	All smooth	Scouring after 7 days Slump = 2 1/2 to 3 1/2"
b. Light blast	Blasted to expose fine and some coarse aggregate (sand blast, water blast, air blast, ice blast)	Fine aggregate primary, coarse aggregate and cement secondary	All smooth	10% more coarse aggregate Slump = 2 1/2 to 3 1/2" Blasting between 7 and 45 days Water and air blasting used where sand blasting prohibited 1500 PSI concrete compressive strength, min.
c. Medium exposed aggregate	Blasted to expose coarse aggregate (sand blast, water blast, air blast, ice blast)	Coarse aggregate	All smooth	Higher than normal coarse aggregate Slump = 2 to 3" Blast before 7 days
d. Heavy exposed aggregate	Blasted to expose coarse aggregate (sand blast, ice blast) 80% visible	Coarse aggregate	All smooth	Special mix coarse aggregate Slump = 0 to 2" Blast within 24 hours Use high-frequency vibrator
3. Chemical retardation of surface set	Chemicals expose aggregate Aggregate can be adhered to surface	Coarse aggregate and cement	All smooth, glass fiber best	Chemical grade determines etch depth Stripping scheduled to prevent long drying between stripping and washoff
4. Mechanically fratured surfaces, scaling, bush hammering, jack-hammering, tooling	Varied	Fine and coarse cement and aggregate	Textured	Aggregate particles 3/8" for scaling and tooling 2 1/2" minimum concrete cover over reinforced steel 4000 PSI concrete compressive strength, minimum
5. Combination/fluted	Striated/abrasive blasted/irregular pattern Corrugated/abrasive Vertical rusticated/abrasive blasted Reeded and bush hammered Reeded and hammered Reeded and chiseled	The shallower the surface, the more influence fine aggregate and cement have	Wood or rubber strips, corrugated sheet metal, or glass fiber	Depends on type of finish desired Wood flute kerfed and nailed loosely
6. Grinding and polishing	Terrazzo-like finish	Aggregate and cement	All smooth	Surface blemishes should be patched 5000 PSI concrete compressive strength, minimum

**ARCHITECTURAL FEATURE AT CORNER**

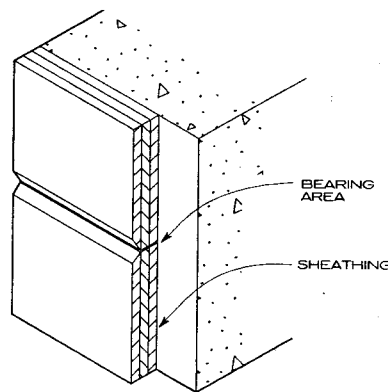

BEARING AREA  
SHEATHING

**HORIZONTAL FORMWORK JOINT**

**NOTE**

A notch at the joint between two form members reduces the bearing area at the point of contact, improving the tightness of the joint. A non-notched joint is acceptable, but a notch is recommended.

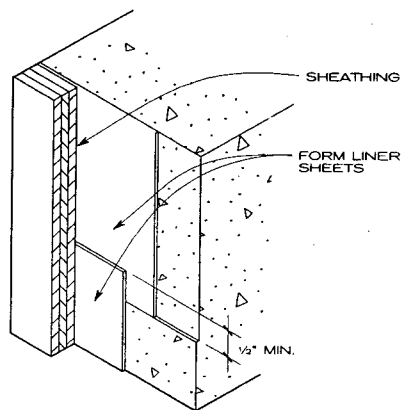

**FORM LINER JOINT**

**NOTE**

Placing the inner sheet above the outer sheet reduces shadows, particularly on smooth surfaces.

**JOINTS IN FORMWORK**

D. Neil Rankins; RGA/Virginia; Richmond, Virginia

**3**

**CAST-IN-PLACE CONCRETE**

**AGGREGATE**

Aggregate is one of three components of concrete and greatly affects the final appearance of the concrete surface. Aggregate should be selected on the basis of color, hardness, size, shape, gradation, method of exposure, durability, availability, and cost. Aggregate hardness and density must be compatible with structural requirements and weathering conditions.

Sources for coarse and fine aggregates should be kept the same for an entire job to avoid variations in the final surface appearance, particularly in light-toned concrete. Following are the common types of aggregate available:

**QUARTZ** is available in clear, white, yellow, green, gray, and light pink or rose. Clear quartz is used as a sparkling surface to complement other colors and pigmented cements.

**GRANITE** is known for its durability and beauty and is available in shades of pink, red, gray, dark blue, black, and white. Traprock such as basalt can be used for gray, black, or green.

**MARBLE** probably offers the widest selection of colors—green, yellow, red, pink, gray, white, and black.

**LIMESTONE** is available in white and gray.

**MISCELLANEOUS GRAVEL**, after being washed and screened, can be used for brown and reddish-brown finishes. Yellow ochers, umbers, buff shades, and pure white are abundant in riverbed gravels. Check local supplies.

**CERAMIC** exhibits the most brilliant and varied colors when vitreous materials are used.

**EXPANDED LIGHTWEIGHT SHALE** may be used to produce reddish-brown, gray, or black aggregate. Porous and crushable, this shale produces a dull surface with soft colors. It should be tested for iron staining characteristics and must meet ASTM C 330.

**RECYCLED CONCRETE** aggregate is produced when old concrete is crushed. Primarily used in pavement work, this material generally has a higher absorption rate and lower density than conventional aggregate. It should be tested for durability, gradation, and other properties, as with any new aggregate source.

**EXPOSED AGGREGATE**

An exposed aggregate surface is a decorative finish for concrete work achieved by removing the surface cement to expose the aggregate. Aggregates suitable for exposure may vary from 1/4 in. to a cobblestone more than 6 in. in diameter. The extent to which the pieces of aggregate are revealed is largely determined by their size. Size is generally selected on the basis of the distance from which it will be viewed and the appearance desired.

Aggregates with rough surfaces have better bonding properties than those with smoother surfaces; bond is important, particularly when small aggregate is used. For better weathering and appearance, the area of exposed cement matrix between pieces of aggregate should be minimal, which makes the color of cement in exposed aggregate concrete less important.

**SUGGESTED VISIBILITY SCALE**

AGGREGATE SIZE, IN. (MM)	DISTANCE AT WHICH TEXTURE IS VISIBLE, FT (M)
1/4-1/2 (6-13)	20-30 (6-9)
1/2-1 (13-25)	30-75 (9-23)
1-2 (25-50)	75-125 (23-38)
2-3 (50-75)	125-175 (38-53)

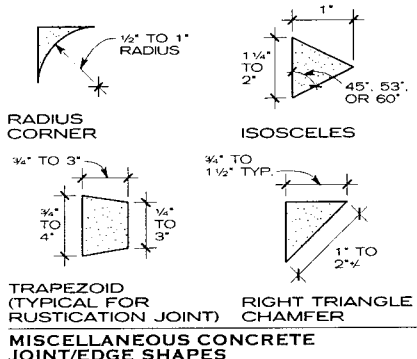

D. Neil Rankins; RGA/Virginia; Richmond, Virginia

**SURFACE TEXTURE/FORM LINER**

Patterned forms and liners make it possible to simulate in concrete the textures of wood, brick, and stone at a lower cost. The texture and resulting shadow patterns conceal minor color variations or damage that would be conspicuous and unacceptable on a smooth surface. Use of rustication strips at joints in textured liners simplifies form assembly work.

**NOTES**

- The choice of liner material may depend on whether the work is precast, cast-in-place, or tilt-up. Thin liners that work well for horizontal casting may wrinkle and sag in vertical forms, where sturdier liner materials are required. Form liners such as plastic foams can usually be used only once, while many elastomeric liners are good for 100 or more uses with reasonable care.
- Reusable aluminum wall forms, textured with various patterns, can also be used; sections are held together with metal pins. Typical sizes are 3 x 8 ft and larger.
- Making a preconstruction mock-up is helpful in choosing patterned liner materials. If built on site, the mock-up can be used as a reference standard for inspectors and workers. If ribbed liners are specified, the largest aggregate particle should be smaller than the rib.
- Typical form liner materials are
  - Plyform: Sandblasted, wire-brushed, or striated plyform can be used as form sheathing or as a liner inside other structurally adequate forms.
  - Unfinished sheathing lumber: Used to produce rough, board-marked concrete, this lumber can be used as form sheathing or liner. Ammonia spray on wood will raise grain and accentuate the wood pattern.
  - Rigid plastics: ABS, PVC, and high-impact polystyrene sheets can be molded or extruded to produce nearly any pattern or texture. Although typically supplied in sheets of 4 x 8, 4 x 10, and 4 x 12 ft, they can be special ordered in lengths up to 30 ft or longer.
  - Glass fiber-reinforced plastics (GFRP): These look much like other plastics but are stronger and more durable, particularly laminated GFRP. Extruded GFRP is less expensive (and less durable). Custom lengths up to 40 ft are available.
  - Elastomeric plastics: These rubbery liners, typically polyurethane, are the most costly, but they are very strong and durable and flexible enough to accommodate finer details. Standard sheets in sizes up to 4 x 12 ft are available, as are larger custom sheets. Typically attached to form sheathing with adhesive, they are sensitive to temperature change and may deform; consult manufacturers.
  - Polystyrene foam: Single-use liners are used to produce unique patterns for specific jobs.
- Joints in the forms and liners must be executed carefully and the liners handled properly to achieve high-quality workmanship. Check liners for compatibility with release agents and adhesives.

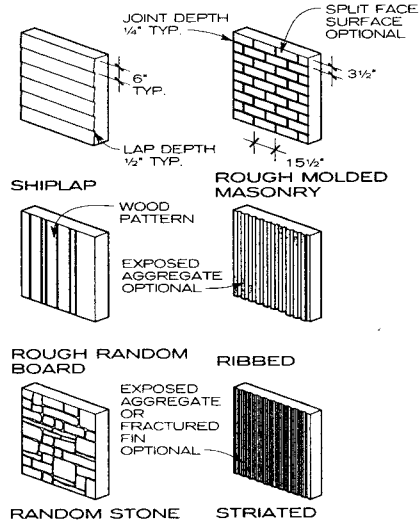

**NOTE**

Consult manufacturers for other available patterns.

**REUSABLE FORM LINER PATTERNS**

**INTEGRALLY COLORED CEMENT**

Colored concrete can provide a cost-effective simulation of natural stone or other building materials. Two standard types of cement are available, offering different shades of color: standard gray portland cement and white cement. Integrally colored concrete is made by adding mineral oxide pigments to concrete mixes made with one of these two types. Fine aggregates should be selected carefully, since they can enhance the color effect. The amount of coloring material should not exceed 10% by weight of the cement; any excess pigment may reduce concrete strength, and strong colors can be achieved with less than 10% pigment. White cement is used when lighter, more delicate shades of concrete are desired, although it is more expensive; darker hues can be produced using gray cement.

**NOTES**

- Variations in all components of the concrete mix make color formulas only approximate. After a basic color is selected, the exact shade may be determined by preparing a number of small panels, varying the ratio of pigment to cement, with aggregate playing a more important role in exposed aggregate mixes. To evaluate panels properly, store them for about five days under conditions similar to those on the construction site. Panels lighten as they dry.
- Batching, mixing, placing, and curing practices must be uniform, and sources of ingredients must be constant throughout a job to maintain color uniformity. Avoid admixtures that contain calcium chloride, since it can cause discoloration. Clean forms and nonstaining release agents are vital. Consult pigment manufacturers' recommendations.
- Pigments should meet the quality standards of ASTM C979. Finely ground iron oxides are the most widely used pigments for coloring concrete. Colors and their sources include blue (cobalt oxide), brown (brown iron oxide), buff (yellow iron oxide), green (chromium oxide), red (red iron oxide), gray/slate (black iron oxide).
- Color-conditioning admixtures offer integral color and have additives that improve workability, better disperse color and cement, and reduce color bleeding for improved uniformity. Consult manufacturers.

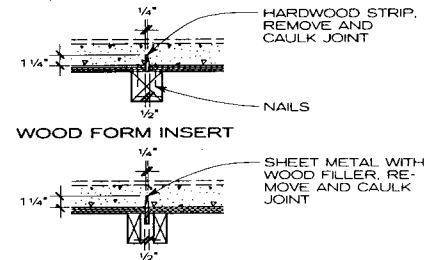

**SHEET METAL FORM INSERT**

**NOTE**

In flat concrete work, a rotary saw may be used to make a contraction joint.

**CONTRACTION JOINTS**

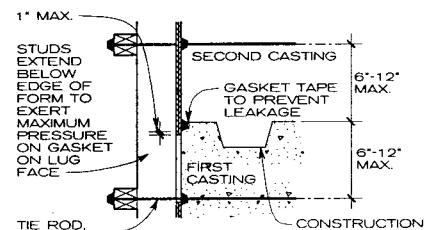

**TYPICAL CONSTRUCTION JOINT**

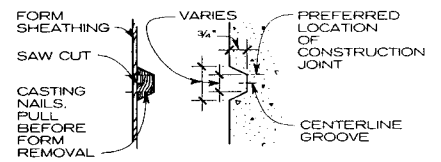

**RUSTICATION AT CONSTRUCTION JOINT**

**CONCRETE REPAIR**

Damage or deterioration of concrete can occur at any time during service life. Minor repairs may be required during initial construction, for example, filling form tie holes; patching lifting loops on precast concrete; or repairing broken edges on beams, walls, and columns. Distress may result from inadequate design or construction, or deterioration, natural effects, or exposure to aggregate chemicals. Most repairs improve appearance, blending adjacent surfaces by matching texture and color. The repair area should be permanently bonded to the adjacent concrete and sufficiently impermeable to liquid penetration to keep it from shrinking or cracking. Repairs should withstand freeze/thaw cycles as well as surrounding concrete does.

The American Concrete Institute defines generally acceptable architectural concrete surfaces as those with minimal color and texture variation and minimal surface defects when viewed at 20 ft. Most architectural concrete contains some irregularities, such as blowholes or bugholes. Criteria for acceptability should be defined in advance, but patches should match the surrounding area as much as possible.

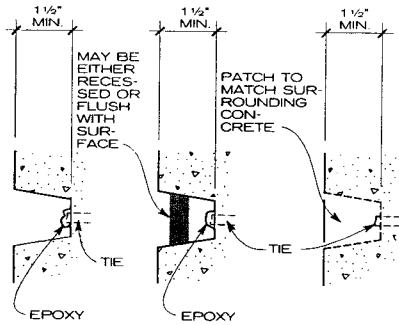

**EPOXY OVER TIE    SOLID PLUG    PATCH**

**NOTE**

Solid plugs may be made of precast mortar, plastic, or lead. Mortar of a drytamp consistency will be less likely to smear on surrounding concrete. If surrounding concrete is smooth, recess plug or patch.

**TIE HOLE TREATMENT OPTIONS**

**REPAIR MATERIALS**

Prepackaged cementitious and latex-modified cementitious repair materials are available, with formulations for thin or thicker repairs. Where aesthetics are important, use the same cement and aggregates as in the surrounding work. Most types of Portland cement are acceptable, but match the original type, if possible. Certain prepackaged mixes must conform to ASTM C 928. Aggregates should match the existing concrete aggregate, if possible. For exposed aggregate, matching the texture and color may require special mixtures to meet the specifications. Any admixture used in concrete work can be used in repair mixtures. Bonding agents may be required for some repairs, especially thin ones; they are typically either cement-based, latex-based (ASTM C 1059), or epoxy-based (ASTM C 881). Acrylics, methyl methacrylates, and polymers are less expensive than epoxy bonding agents but are more likely to shrink. Repaired areas should be sealed or coated to the same specifications as the surrounding concrete work to protect against natural forces, corrosives, and chemicals.

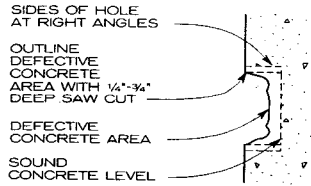

**NOTE**

Larger and thicker patches should be anchored mechanically to the surrounding concrete.

**PATCHING OF DEFECTIVE CONCRETE SURFACES**

**GUIDELINES FOR PATCHING**

1. Design patch mix to match original, with small amount of white cement; may eliminate coarse aggregate or hand-plate it. Trial and error, the only reliable match method, should be performed on a mock-up first.
2. Remove defective concrete down to sound concrete; for exposed aggregate concrete, chip slightly deeper than maximum size of aggregate.
3. Clean area; saturate with water and apply bonding agent to base of hole and to water of patch mix.
4. Pack patch mix to density of original.
5. Place exposed aggregate by hand.
6. Bristle-brush after setup to match existing material.
7. Moist-cure to minimize shrinking.
8. Use form or finish to match original.

**PROTECTIVE AND DECORATIVE COATINGS**

Concrete surfaces may require a sealer or coating to protect against severe weather, chemicals, or abrasions; to prevent dusting of the surface layer; to harden the surface layer; or to add a decorative finish.

Sealers are usually clear and are expected to penetrate the surface without leaving a visible film. Coatings are clear or opaque and, while they may have some penetration, they leave a visible film on the surface. Sealers and coatings should allow vapor emission from the concrete but at the same time keep moisture from penetrating after curing.

Decorative coatings usually protect as well and are formulated in a wide selection of colors. Decorative coatings include water-based acrylic emulsion; elastomeric acrylic resin; liquid polymer stain; solvent-based acrylic stain; portland cement-based finish coating; and water-based acidic stain (a solution of metallic salts).

**PROTECTIVE COATINGS AND SEALERS**

FINISH	USE
Cementitious acrylic polymeric coating	Aesthetic treatment
2-component epoxy coating	Protects damp or under-water surfaces
Solvent-based aliphatic urethane coating	Resists graffiti, chemicals, abrasion
Epoxy coal tar-based coating	Waterproof, resists corrosion
Coal tar-modified epoxy resin coating	Nonskid waterproof surface membrane
Water-based epoxy coating	Chemical, abrasion resistance for interiors
Vinyl ester-based coating	High chemical resistance
Aliphatic urethane coating	Chemical, abrasion
Solvent-based acrylic methacrylate copolymer sealer	Reduces water penetration
Silane/siloxane sealer penetrating water repellent	Protects from deicers and freeze/thaw damage

**NOTES**

1. Floor-hardening agents are applied to reduce dusting and increase hardness slightly at the surface.
2. Consult a qualified specialist to determine the correct coating or sealer for a particular application.
3. There may be restrictions on the use of solvent-based coatings and sealers in some areas due to the presence of VOCs (volatile organic compounds).

**CRACKING IN CONCRETE CONSTRUCTION**

	SLABS ON GRADE				BEAMS, WALLS, COLUMNS, AND STRUCTURAL SLABS			
	SURFACE CRAZING	PLASTIC SHRINKAGE	EARLY CONCRETE VOLUME CHANGES	OTHER CRACKING		SETTLEMENT CRACKS	OTHER CRACKING	
Cause	Shrinkage of cement paste at exposed concrete surfaces due to concrete mix, too-wet excessive bleeding, over-troweling surface, rapid drying of surface	Water at the concrete surface evaporates too rapidly due to job site conditions such as low humidity, high wind speeds, high concrete temperatures, high to moderate air temperatures	As concrete cools and hardens, concrete volume shrinks; cracking will occur if slab is restrained at any point	Subgrade settlement	Premature excessive loading on slab	Same as for slabs on grade; also, heavier amounts of reinforcement and nature of formed or shored construction	Flexible forms and insufficient vibration can increase likelihood	Subgrade or formwork settlement, early volume changes, construction overloads, errors in design and detailing
Effect	Unightly cracking of surface layer although surface is probably sound	Parallel cracking, fairly wide at the exposed surface but shallow; doesn't typically extend to slab edge; crack spacing and length vary greatly	Random or regularly spaced cracks, usually passing completely through slab; during sawcutting of joints, crack may jump ahead of sawcut	Slab will bend and crack	Punch-through at edge by heavy equipment, etc.	Longitudinal cracks develop over reinforcement bars; can cause reinforcement bar corrosion		General cracking
Preventive measures	Reduce amount and rate of shrinkage at concrete surface by avoiding wet mixes, limiting bleeding by increasing sand or air content, limiting troweling/not troweling too early, curing as soon as possible	Reduce rate at which surface moisture evaporates by erecting windbreaks or building walls before slab, avoiding wet mixes, dampening subgrade before concrete pour, curing as soon as possible, avoiding vapor barrier under slab unless necessary	Not always preventable; careful joint design or reinforcement may help; other measures: tool or sawcut joints 1/4 of slab thickness, min., time sawcut according to concrete curing rate; locate contraction joints at columnlines, min.; for unreinforced slabs, space joints at 24 to 36 times slab thickness, max.; posttension at slab; isolate slabs from adjoining structures with preformed joint filler or if continuity is required, increase slab reinforcement	Compact subgrade well	Generally, curing periods of 4 to 7 days, followed by 1 to 2 days of drying	Proper form design and sufficient vibration or re-vibration; use lowest possible slump, increase concrete cover		Consult with structural concrete engineer or consultant to prevent

**NOTE**

Expect some cracking in concrete construction. Generally, cracking is controlled with joints and reinforcement; how-

ever, not all cracks indicate errors or performance problems, and not all cracks need to be repaired.

Grant Halvorsen, S.E., P.E.; Wheaton, Illinois

**3**

**CAST-IN-PLACE CONCRETE**

**GENERAL CONSIDERATIONS**

- Concrete strength is usually 5000 psi at 28 days and at least 3,000 psi at time of prestressing. Use hardrock aggregate or lightweight concrete. Low slump controlled mix is required to reduce shrinkage. Shrinkage after prestressing decreases prestress strength gains.
- Post-tensioning systems can be divided into three categories depending on whether the tendon is wire, strand, or bar. Wire systems use 0.25 in. diameter wires that have a minimum strength of 240,000 psi and are usually cut to length in the shop. Strand systems use tendons, made of seven wires wrapped together, that have a minimum strength of 270,000 psi and are cut in the field. Bar systems use bars ranging in diameter from 3/8 to 1 3/8 in. in diameter, with a minimum strength of 145,000 psi; they may be smooth or deformed. The system used determines the type of anchorage used, which in turn affects the size of breakout required, in the edge of slab or beam, for the anchorage to be recessed.
- Grease and wrap tendons, or place in conduits to reduce frictional losses during stressing operations. Limit length of continuous tendons to about 10 ft if stressed from one end. Long tendons require simultaneous stressing from both ends to reduce friction loss. Tendons may be grouted after stressing or left unbonded. Bonded tendons have structural advantages that are more important for beams and primary structural members.
- Minimum average prestress (net prestress force per area of concrete) = 150 to 250 psi for flat plates, 200 to 500 psi for beams. Exceeding these values by much causes excessive prestress losses because of creep.
- Field inspection of post-tensioned concrete is critical to ensure proper size and location of tendons and to monitor the tendon stress. Check tendon stress by measuring elongation of the tendon, and by monitoring gauge pressures on the stressing jack.
- Make provisions for the shortening of post-tensioned beams and slabs caused by elastic compression, shrinkage, and creep. After the post-tensioning is complete, build shearwalls, curtain walls, or other stiff elements that adjoin post-tensioned members and isolate them with an expansion joint. Otherwise, additional post-tensioning force will be required to overcome the stiffness of the walls and prevent cracking.
- Fire tests have been conducted on prestressed beam and slab assemblies according to ASTM E119 test procedures; they compare favorably with conventionally reinforced concrete. There is little difference between beams using grouted tendons and those using ungrouted tendons.
- References for further study:  
 Post-Tensioning Institute, "Post-Tensioning Manual."  
 Prestressed Concrete Institute, "Design Handbook for Precast and Prestressed Concrete."  
 Lin, T.Y., "Design of Prestressed Concrete Structures."  
 American Concrete Institute, "Building Code Requirements for Reinforced Concrete" (ACI-318-83).

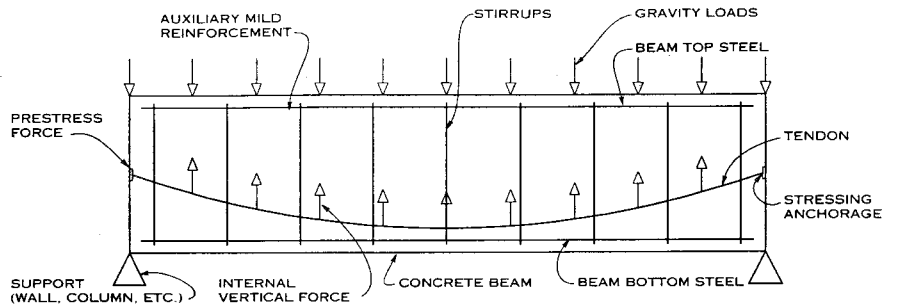

**PRESTRESSED OR POST-TENSIONED BEAM**

**NOTES FOR DIAGRAM ABOVE**

- Prestressing force compresses entire cross-section of the beam, thereby reducing unwanted tension cracks.
- Permanent tension is introduced into tendon and "locked in" with the stressing anchorage in one of two ways. The principle in both cases is the same. In prestressed concrete, the tendon is elongated in a stressing bed before the concrete is poured. In post-tensioned concrete, the tendon is elongated after concrete has been poured and allowed to cure by means of hydraulic jacks pushing against the beam itself. Post-tensioned beams permit casting at the site for members too large or heavy for transporting from factory to site.
- Internal vertical forces within the beam are created by

- applying tension on the tendon, making the tendon begin to "straighten out." The tension reduces downward beam deflection and allows shallower beams and longer spans than in conventionally reinforced beams.
- Auxiliary mild reinforcement provides additional strength, controls cracking, and produces more ductile behavior.
- Use stirrups to provide additional shear strength in the beam and to support the tendons and longitudinal mild reinforcement. Stirrups should be open at the top to allow the reinforcing to be placed before the tendon is installed. After the tendons are placed, "hairpins" that close the stirrups may be used when required.

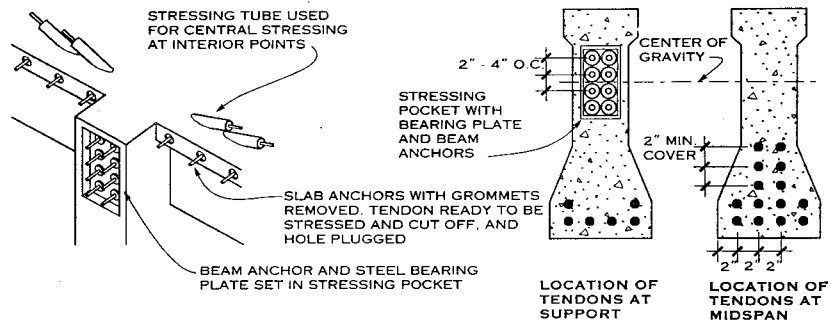

**PRESTRESSED BEAM**

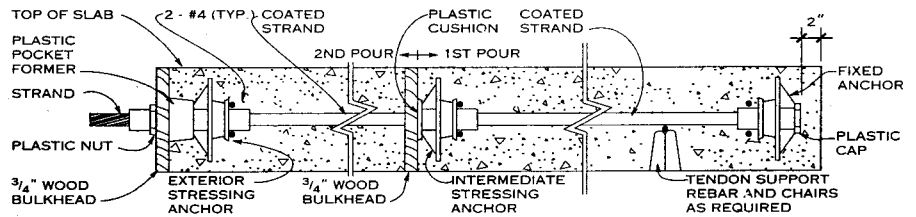

**UNBONDED SINGLE STRAND TENDON INSTALLATION AT SLAB**

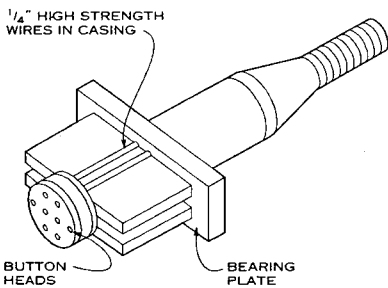

**8 WIRE BBRV POST-TENSIONING ANCHOR (GROUTED)**

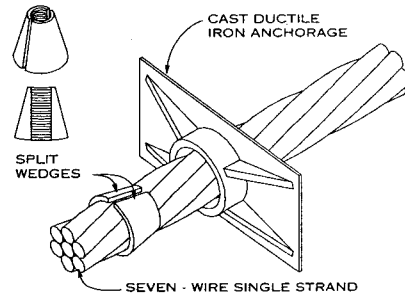

**SINGLE STRAND TENDON ANCHORAGE (UNBONDED)**

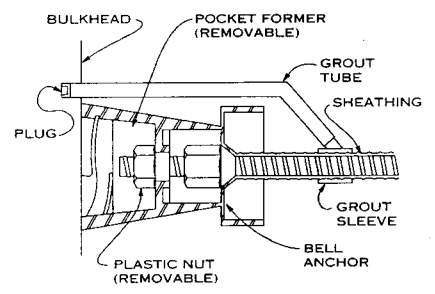

**THREAD BAR ANCHORAGE (GROUTED)**

Leo A. Daly, Planning/Architecture/Engineering/Interiors; Omaha, Nebraska



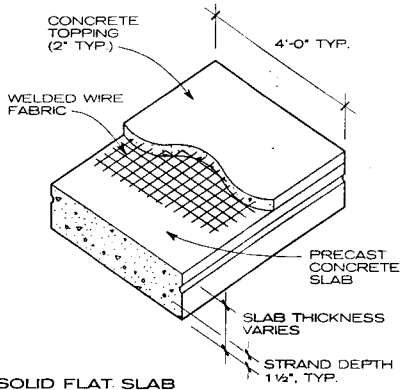

SOLID FLAT SLAB

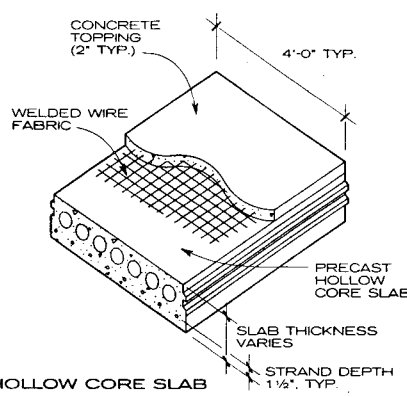

HOLLOW CORE SLAB

NOTES

1. Normal weight (150 pcf) or lightweight concrete (115 pcf) is used in standard slab construction. Topping concrete is usually normal weight concrete with a cylinder strength of 3000 psi. All units are prestressed with strand release when concrete strength is 3500 psi.
  2. Strands are available in various sizes, strengths and placements according to individual manufacturers.
- Strand designation code (SDC):  
 78 - S  
 — straight  
 — diameter of strands in sixteenths  
 — number of strands
3. Camber varies substantially depending on slab design, span, and loading. Nonstructural components attached to members may be affected by camber variations. Calculations of topping quantities should recognize camber variations.
  4. Safe superimposed surface loads include a dead load of 10 psf for untopped concrete and 15 psf for topped concrete. The remainder is live load.

FLAT DECK MEMBERS

SAFE SUPERIMPOSED SERVICE LOADS (PSF) FOR SOLID FLAT SLABS (4-FT WIDTH, 5000 PSI)

SLAB THICKNESS (IN.) (150 PCF CONCRETE)	SLAB DESIGNATION	TOPPING THICKNESS (IN.)	SPAN (FT)																																	
			10	11	12	13	14	15	16	17	18	19	20	21	22	23	24	25	26	27	28	29	30	31	32											
S.D.C. : 68-S	FS4	None	300	252	214	180	152	127	105	88	73	60	50	40	32																					
	FS4+2	2				335	268	213	169	132	101	74	52	32																						
S.D.C. : 78-S	FS6	None					396	351	303	261	225	195	168	146	126	109	94	81	69	59	49	41	33													
	FS6+2	2								371	323	281	239	201	169	140	115	93	73	56	40															
S.D.C. : 68-S	FS8	None									358	311	271	237	207	182	159	138	120	103	88	75	63	53	43	34										
	FS8+2	2										395	344	301	264	231	199	167	140	115	94	74	57	41												

SAFE SUPERIMPOSED SERVICE LOADS (PSF) FOR 6- AND 8-IN. HOLLOW-CORE SLABS (4-FT WIDTH, 5000 PSI)

SLAB THICKNESS (IN.) (150 PCF CONCRETE)	SLAB DESIGNATION	TOPPING THICKNESS (IN.)	SPAN (FT)																																			
			15	16	17	18	19	20	21	22	23	24	25	26	27	28	29	30	31	32	33	34	35	36	37													
S.D.C. : 78-S	4HC6	None	364	317	277	243	214	189	168	150	134	120	107	96	87	78	70	62																				
	4HC6+2	2			382	335	294	260	231	205	181	157	137	119	102	88	75	63																				
S.D.C. : 88-S	4HC8	None	360	335	311	290	272	256	242	229	215	205	188	170	154	141	128	117	106	97	89	81	74	67														
	4HC8+2	2				346	325	306	286	271	252	227	205	186	168	152	138	124	111	98	86	76	66	56														

SAFE SUPERIMPOSED SERVICE LOADS (PSF) FOR 10- AND 12-IN. HOLLOW-CORE SLABS (4-FT WIDTH, 5000 PSI)

SLAB THICKNESS (IN.) (150 PCF CONCRETE)	SLAB DESIGNATION	TOPPING THICKNESS (IN.)	SPAN (FT)																																						
			20	21	22	23	24	25	26	27	28	29	30	31	32	33	34	35	36	37	38	39	40	41	42																
S.D.C. : 97-S	4HC10	None	298	278	264	248	237	223	214	203	193	179	164	150	138	126	116	106	98	90	82	75	69	63	57																
	4HC10+2	2				295	278	265	250	239	226	218	201	184	168	154	138	124	111	98	87	77	67	58	49																
S.D.C. : 78-S	4HC12	None									194	185	177	169	162	155	148	142	137	131	126	121	120	112	104																
	4HC12+2	2				280	264	249	236	223	212	201	195	185	177	169	161	154	147	141	135	129	126	116	107																

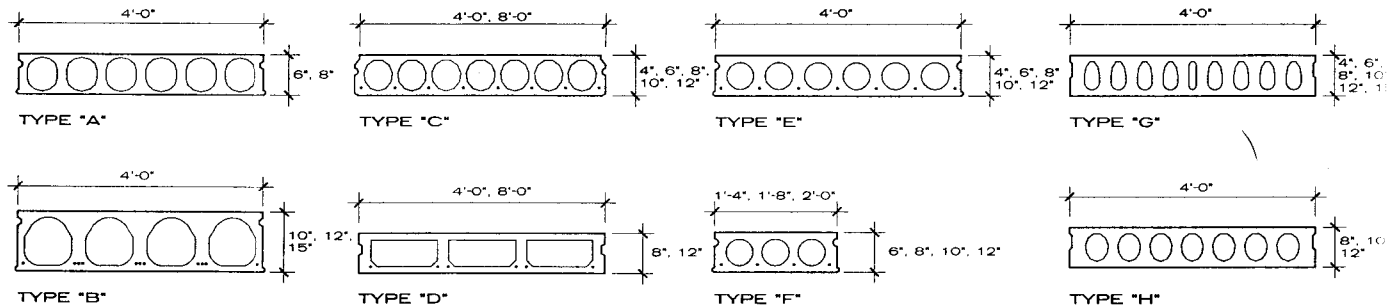

NOTE  
 All sections are not available from all producers; check availability with local manufacturers.

HOLLOW CORE SLAB TYPES

Sidney Freedman; Precast/Prestressed Concrete Institute; Chicago, Illinois

APPROXIMATE MAXIMUM SPAN FOR STEMMED DECK SECTIONS

DECK TYPE	DEPTH (IN.)	CONCRETE WEIGHT	DESIGNATION	TOPPING DEPTH (IN.)	STRAND DESIGNATION	MAX. SPAN (FT)	SAFE LOAD (PSF)
A	12	Normal weight	8DT12	0	88 D1	44	32
			8DT12+2	2	68 D1	34	50
		Lightweight	8LDT12	0	68 D1	42	33
			8LDT12+2	2	68 D1	38	33
A	18	Normal weight	8DT18	0	108 D1	60	34
			8DT18+2	2	88 D1	48	47
		Lightweight	8LDT18	0	108 D1	64	34
			8LDT18+2	2	88 D1	52	39
A	24	Normal weight	8DT24	0	148 D1	74	45
			8DT24+2	2	128 D1	64	49
		Lightweight	8LDT24	0	148 D1	80	42
			8LDT24+2	2	108 D1	68	46
A	32	Normal weight	8DT32	0	228 D1	94	52
			8DT32+2	2	208 D1	80	72
		Lightweight	8LDT32	0	228 D1	100	50
			8LDT32+2	2	208 D1	86	65
B	32	Normal weight	10DT32	0	228 D1	88	53
			10DT32+2	2	208 D1	76	66
		Lightweight	10LDT32	0	228 D1	98	42
			10LDT32+2	2	208 D1	82	58
C	26	Normal weight	10DT26	0	148 D1	68	33
		Lightweight	10LDT26	0	148 D1	72	37
C	34	Normal weight	10DT34	0	228 D1	90	34
		Lightweight	10LDT34	0	228 D1	90	51

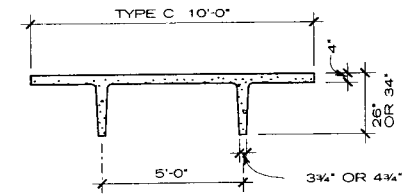
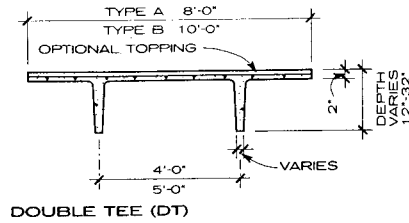

- NOTES**
- Safe loads shown indicate dead load of 10 psf for untopped members and 15 psf for topped members. Remainder is live load.
  - Contact manufacturers in the geographic area of the proposed structure to determine availability, exact dimensions, and load tables for various sections.
  - Check camber for its effect on nonstructural members (partitions, folding doors, etc.), which should be placed with adequate allowance for error. Calculations for topping quantities should also recognize camber variations.
  - Normal-weight concrete is assumed to be 150 lb/cu ft; lightweight concrete is assumed to be 115 lb/cu ft.

**STEMMED DECK MEMBERS**

**NOTE**

Strand pattern designation:  
 — Number of strands (20)  
 S = straight, D = depressed  
 208 D1 — Number of depression points  
 — Diameter of strand in sixteenths

Topping concrete = 3000 psi

150 lb/cu ft lc = 5000 psi for normal or lightweight deck

**SAFE SUPERIMPOSED SERVICE LOAD (PLF)\* FOR PRECAST BEAM SECTIONS**

TYPE	DESIG-NATION	NO. STRAND	H (IN.)	H1/H2 (IN.)	SPAN (FT)																		
					16	18	20	22	24	26	28	30	32	34	36	38	40	42	44	46	48	50	
RECTANGULAR	12RB24	10	24		8884	6957	5578	4558	3782	3178	2699	2312	1996	1734	1514	1328	1170	1033					
	12RB32	13	32					8238	6859	5785	4933	4246	3683	3217	2826	2495	2213	1970	1760	1576	1415	1272	
	16RB24	13	24			9278	7439	6079	5044	4239	3600	3084	2662	2313	2020	1772	1560	1378	1220	1082	961		
	16RB32	18	32						9145	7713	6577	5661	4911	4289	3768	3327	2951	2627	2346	2010	1886	1697	
	16RB40	22	40									9010	7839	6867	6054	5365	4777	4271	3832	3449	3113	2817	
L - SHAPED	18LB20	9	20	12/18	6675	5211	4164	3389	2800	2341	1978	1684	1444	1245	1080								
	18LB28	12	28	16/12			8387	6857	5694	4789	4071	3491	3017	2624	2295	2017	1781	1578	1402	1249	1114	995	
	18LB36	16	36	24/12					9617	8117	6927	5966	5180	4529	3983	3521	3126	2787	2493	2236	2011	1813	
	18LB44	19	44	28/16								9039	7866	6893	6078	5389	4800	4293	3854	3471	3153	2838	
	18LB52	23	52	36/16										9798	8658	7694	6871	6162	5548	5012	4542	4127	
	18LB60	27	60	44/16														9292	8349	7532	6819	6193	5641
INVERTED TEE	24IT20	9	20	12/8	7078	5515	4404	3582	2957	2470	2084	1773	1518	1307	1130	980							
	24IT28	13	28	16/12			8874	7247	6013	5053	4292	3677	3175	2758	2409	2113	1861	1644	1456	1292	1147	1020	
	24IT36	16	36	24/12						8594	7327	6305	5469	4776	4199	3710	3293	2934	2623	2352	2114	1904	
	24IT44	20	44	28/16									9554	8306	7272	6409	5680	5057	4520	4056	3650	3295	2981
	24IT52	24	52	36/16											9164	8137	7261	6507	5853	5283	4786	4348	
	24IT60	28	60	44/16														9863	8857	7986	7226	6559	5970

\* Safe loads shown indicate 50% dead load and 50% live load; 800 psi top tension has been allowed, therefore additional top reinforcement is required.

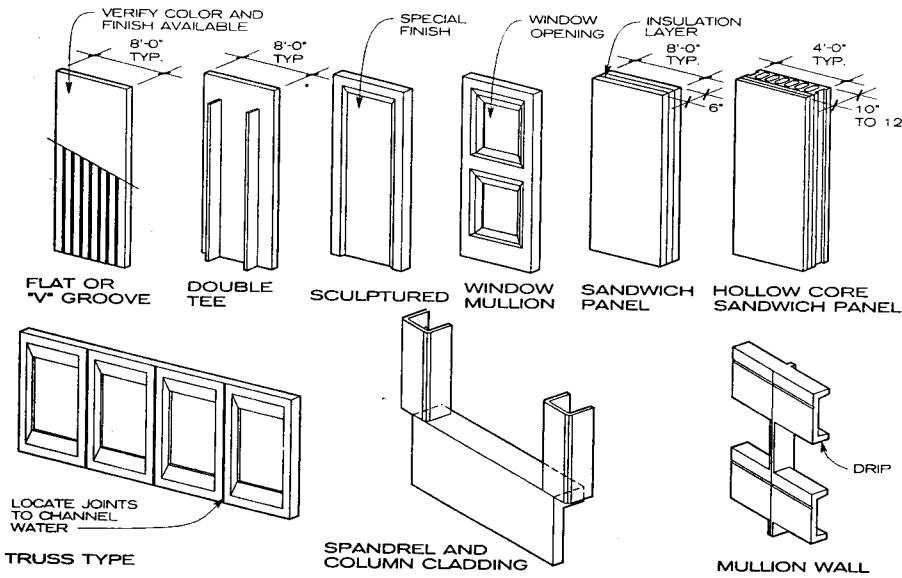

PANEL VARIATIONS

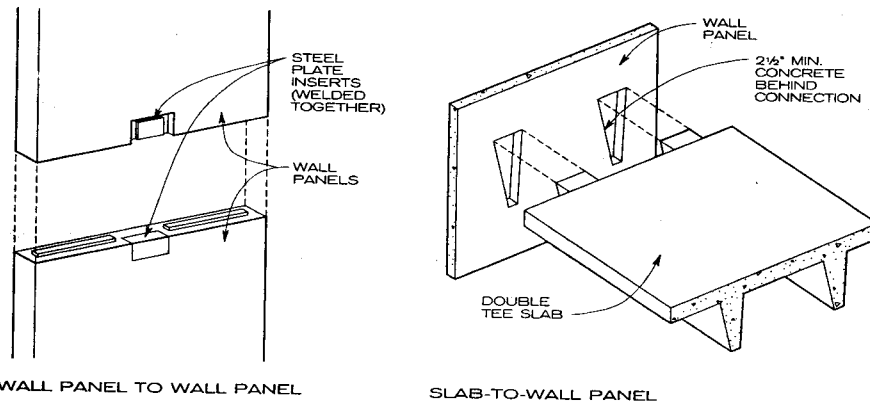

NOTE

Pocket connection may be at top of panel.

BEARING PANEL CONDITIONS

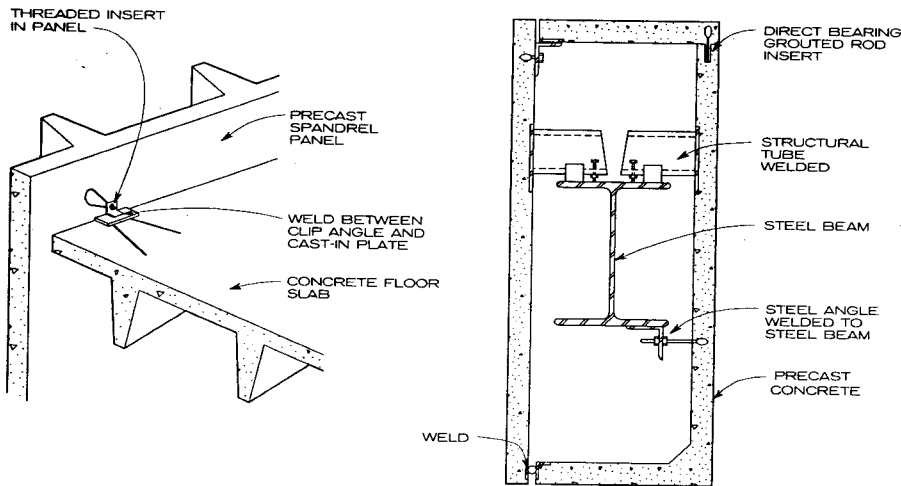

SPANDREL CONDITIONS

Sidney Freedman; Precast/Prestressed Concrete Institute; Chicago, Illinois

WALL PANELS

Carefully distinguish between the more specialized architectural wall panel and the structural wall panel that is a derivative of floor systems. Always work with manufacturers early in the design process. Careful attention must be given to manufacturing and joint tolerance during design. Thoroughly examine joint sealants for adhesion and expected joint movement.

FINISHES

Form liner molds provide a wide variety of smooth and textured finishes. Finishes after casting but prior to hardening include exposed aggregate, broom, trowel, screed, float, or stippled. After hardening, finishes include acid-etched, sandblasted, honed, polished, and hammered rib.

COLORS

Select a color range, as complete uniformity cannot be guaranteed. White cement offers the best color uniformity, gray cement is subject to color variations even when supplied from one source. Pigments require high-quality manufacturing and curing standards. Fine aggregate color requires control of the mixture gradation; coarse aggregate color provides the best durability and appearance.

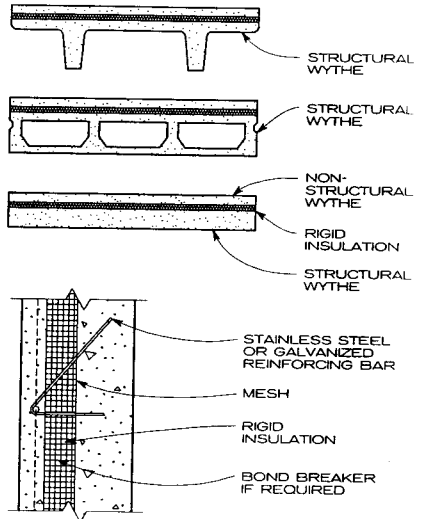

VERTICAL SECTION AT TIE

NOTE

Panel requires accurate location of ties and reinforcement and established concrete quality control.

SANDWICH WALL CONSTRUCTION

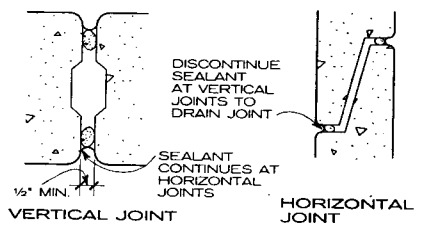

TWO-STAGE SEALANT JOINTS

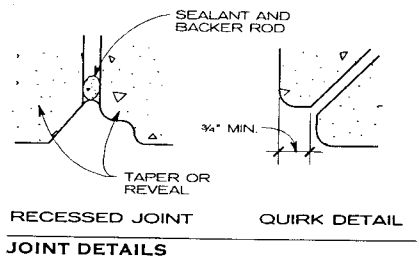

JOINT DETAILS

**GENERAL**

Architectural precast concrete is subject to the same erection and manufacturing tolerances as other building materials. When such tolerances are considered in the design stage, the task of determining and specifying them is simpler. By requiring realistic tolerances, architects strengthen and simplify their standards for acceptance. Unrealistic, close tolerances are costly, particularly for custom-produced elements.

Tolerances set the limits of size and shape for precast concrete units. Three groups of tolerances should be established in precast concrete design: product (manufacturing) tolerances, erection tolerances, and interfacing tolerances. Product and erection tolerances usually do not cause site problems. Tolerances are most problematic at the interface of precast concrete and other building materials.

Tolerances should be established for the following reasons:

**STRUCTURAL:** To ensure that structural design properly accounts for factors sensitive to variations in dimensional control. Examples include eccentric loading condition, bearing areas, hardware and hardware anchorage locations, and locations of reinforcing or prestressing steel.

**FEASIBILITY:** To ensure acceptable performance of joints and interfacing materials in the finished structure.

**VISUAL:** To ensure that the variations will be controllable and result in a structure that is visually acceptable.

**ECONOMIC:** To ensure ease and speed of production and erection by having agreed-upon dimensions for precast concrete products.

**LEGAL:** To avoid encroaching on property lines and to establish a standard against which the work can be compared in event of a dispute.

**CONTRACTUAL:** To establish a known acceptability range and responsibility for developing, achieving, and maintaining mutually agreed-upon tolerances.

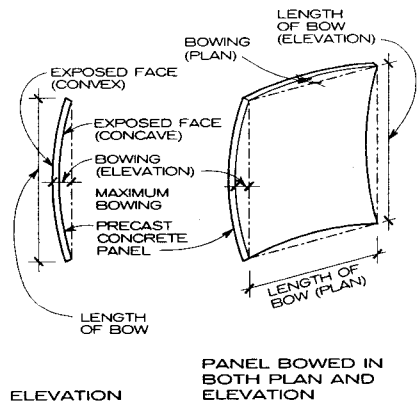
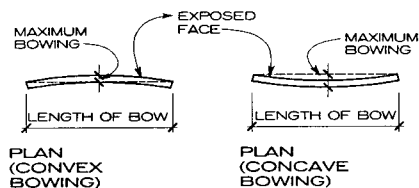

**BOWING DEFINITIONS FOR PANELS**

**GUIDELINES FOR PANEL THICKNESS<sup>1</sup>**

PANEL DIMENSIONS <sup>2</sup>	8 FT	10 FT	12 FT	16 FT	20 FT	24 FT	28 FT	32 FT
4 ft	3 in.	4 in.	4 in.	5 in.	5 in.	6 in.	6 in.	7 in.
6 ft	3 in.	4 in.	4 in.	5 in.	6 in.	6 in.	6 in.	7 in.
8 ft	4 in.	5 in.	5 in.	6 in.	6 in.	7 in.	7 in.	8 in.
10 ft	5 in.	5 in.	6 in.	6 in.	7 in.	7 in.	8 in.	8 in.

<sup>1</sup> This table should not be used for panel thickness selection.  
<sup>2</sup> This table shows a relationship between overall flat panel dimensions and thicknesses below which suggested

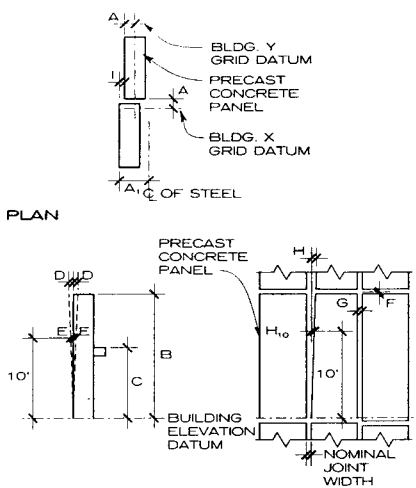

**ELEVATION**

- A = Plan location from building grid datum  $\pm 1/2$  in.<sup>1</sup>
  - A<sub>1</sub> = Plan location from centerline of steel  $\pm 1/2$  in.<sup>2</sup>
  - B = Top elevation from nominal top elevation: exposed individual panel  $\pm 1/4$  in.; nonexposed individual panel  $\pm 1/2$  in.; exposed relative to adjacent panel  $1/4$  in.; non-exposed relative to adjacent panel  $1/2$  in.
  - C = Support elevation from nominal elevation: maximum low  $1/2$  in.; maximum high  $1/4$  in.
  - D = Maximum plumb variation over height of structure or 100 ft, whichever is less 1 in.<sup>1</sup>
  - E = Plumb in any 10 ft of element height  $1/4$  in.
  - F = Maximum jog in alignment of matching edges  $1/4$  in.
  - G = Joint width (governs over joint taper)  $\pm 1/4$  in.
  - H = Joint taper max.  $3/8$  in.
  - H<sub>10</sub> = Joint taper over 10 ft length  $1/4$  in.
  - I = Max. jog in alignment of matching faces  $1/4$  in.
  - J = Differential bowing or camber as erected between adjacent members of the same design  $1/4$  in.
- <sup>1</sup> For precast buildings taller than 100 ft, tolerances A and D can increase at the rate of  $1/8$  in. per story to a maximum of 2 in.  
<sup>2</sup> For precast concrete erected on a steel frame building, this tolerance takes precedence over tolerance on dimension A.

**ERECTION TOLERANCES FOR WALL PANELS**

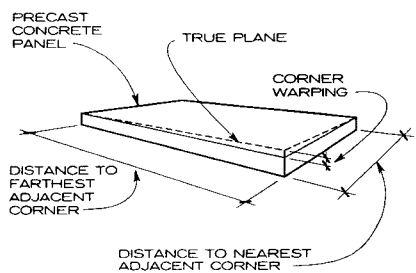

**WARPING DEFINITIONS FOR PANELS**

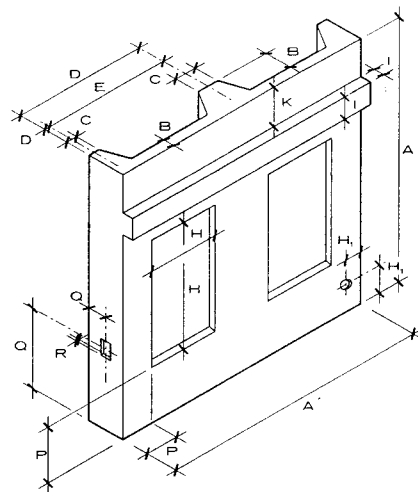

- A = Overall length and width (measured at neutral axis of ribbed members): 10 ft or under  $\pm 1/8$  in.; 10 to 20 ft  $\pm 1/8$  in.;  $\pm 1/16$  in.; 20 to 40 ft  $\pm 1/4$  in.; each additional 10 ft  $\pm 1/16$  in. per 10 ft.
  - B = Total thickness or flange thickness  $-1/8$  in.,  $+1/4$  in.
  - C = Rib thickness  $\pm 1/8$  in.
  - D = Rib to edge of flange  $\pm 1/8$  in.
  - E = Distance between ribs  $\pm 1/8$  in.
  - F = Angular variation of plane of side mold  $\pm 1/32$  in. per 3 in. of depth or  $\pm 1/16$  in., whichever is greater.
  - G = Variation from square or designated skew (difference in length of the two diagonal measurements)  $\pm 1/8$  in. per 6 ft of diagonal or  $\pm 1/2$  in., whichever is greater.\*
  - H = Length and width of blockouts and openings within one unit  $\pm 1/4$  in.
  - H<sub>1</sub> = Location and dimensions of blockouts hidden from view and used for HVAC and utility penetrations  $\pm 1/4$  in.
  - H<sub>2</sub> = Some types of window and equipment frames require more accurate types of openings. When this is the case, the minimum practical tolerance should be defined with input from the producer.
  - I = Dimensions of haunches  $\pm 1/4$  in.
  - J = Haunch bearing surface deviation from specified plane  $\pm 1/8$  in.
  - K = Difference in relative position of adjacent haunch bearing surfaces from specified relative position  $\pm 1/4$  in.
  - L = Bowing  $\pm L/360$  max. 1 in.
  - M = Differential bowing between adjacent panels of the same design  $1/2$  in.
  - N = Local smoothness  $1/4$  in. in 10 ft. (does not apply to visually concealed surfaces).
  - O = Warping of distance from nearest adjacent corner  $1/16$  in. per ft.
  - P = Location of window opening within panel  $\pm 1/4$  in.
  - Q = Position of plates  $\pm 1$  in.
  - R = Tipping and flushness of plates  $\pm 1/4$  in.
- \* Applies both to panel and to major openings in the panel.

Position tolerance for cast-in items measured from datum line location as shown on approved erection drawings: weld plates  $\pm 1$  in.; inserts  $\pm 1/2$  in.; handling devices  $\pm 3$  in.; reinforcing steel and welded wire fabric where position has structural implications or affects concrete cover  $\pm 1/4$  in.; otherwise  $\pm 1/2$  in.; tendons  $\pm 1/8$  in.; flashing reglets  $\pm 1/4$  in.; flashing reglets at edge of panel  $\pm 1/8$  in.; reglets for glazing gaskets  $\pm 1/16$  in.; groove width for glazing gaskets  $\pm 1/16$  in.; electrical outlets, hose bibs, etc.  $\pm 1/2$  in.; haunches  $\pm 1/4$  in.

**TOLERANCES FOR PANELS, SPANDRELS, AND COLUMN COVERS**

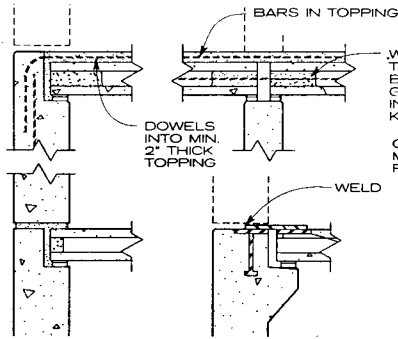

HOLLOW CORE SLAB DETAILS

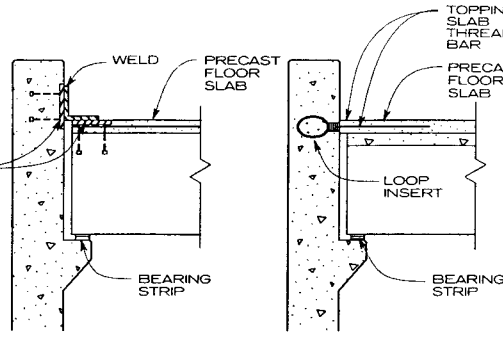

FLOOR-TO-BEARING WALL CONNECTIONS

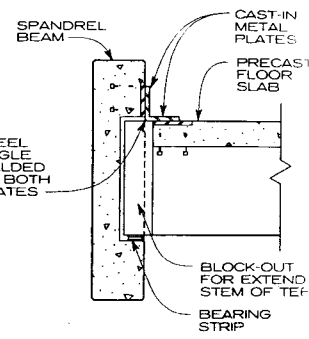

SPANDREL CONNECTION

FLOOR-TO-WALL CONNECTIONS

GENERAL

To fasten members to foundations, set them on shims, tighten nuts to level, then fill space with nonshrink grout.

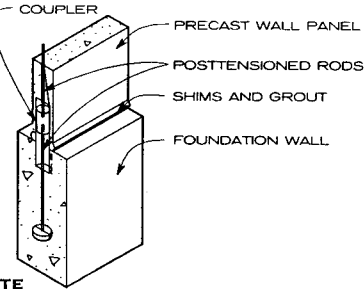

NOTE

Vertical posttensioning can be used to resist uplift forces; moment resistance is achieved.

POSTTENSIONED WALL-TO-FOUNDATION CONNECTION

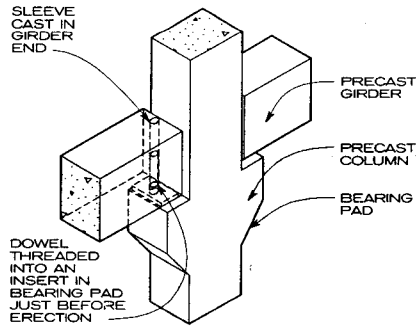

NOTE

The girder sits on the bearing pad, which provides uniform bearing and accommodates small movements due to shrinkage, creep, and temperature changes.

DOWELED BEAM-TO-COLUMN CONNECTION

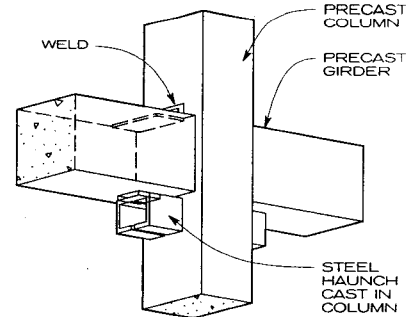

NOTE

Steel haunches are smaller than concrete bearing pads, which is important if headroom is critical.

HAUNCHED BEAM-TO-COLUMN CONNECTION

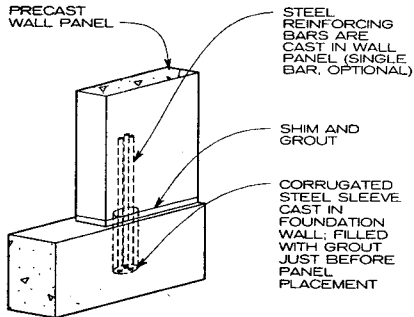

GRouted WALL-TO-FOUNDATION CONNECTION

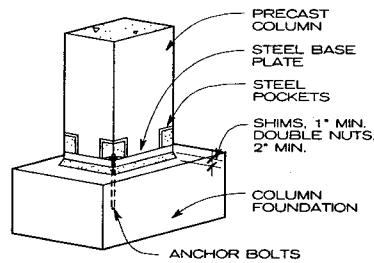

COLUMN-BASE CONNECTION

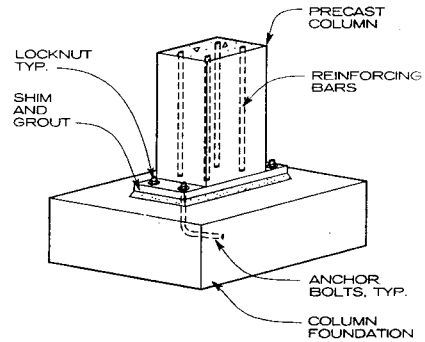

OVERSIZED BASE PLATE AT COLUMN-BASE CONNECTION

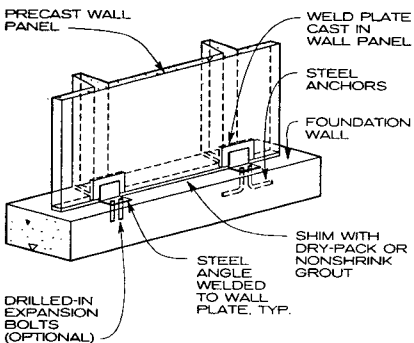

BOLTED WALL-TO-FOUNDATION CONNECTION

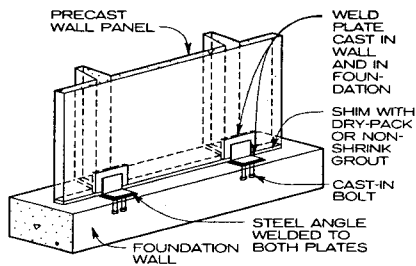

NOTE

Two connections per panel are typical.

WELDED WALL-TO-FOUNDATION CONNECTION

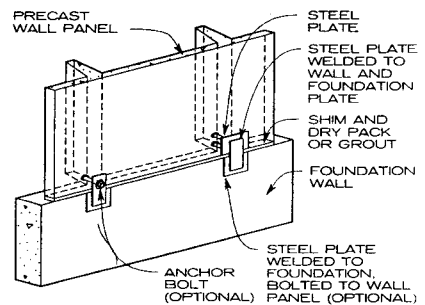

WELDED PLATE-TO-FOUNDATION CONNECTION

Sidney Freedman; Precast/Prestressed Concrete Institute; Chicago, Illinois

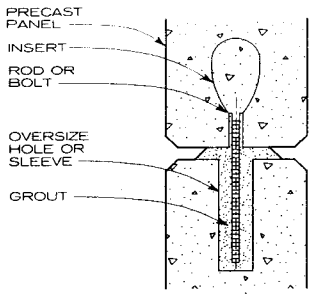

**NOTE**  
Shim stacks occur at two points per panel adjacent to connection.

**DIRECT BEARING CONNECTION**

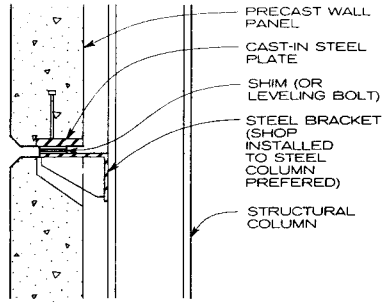

**DIRECT BEARING CONNECTION**

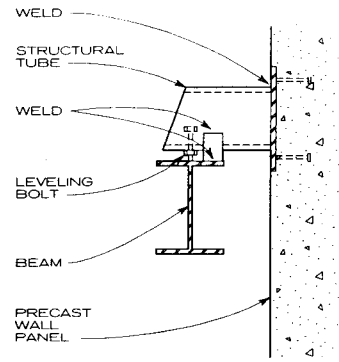

**ECCENTRIC BEARING CONNECTION**

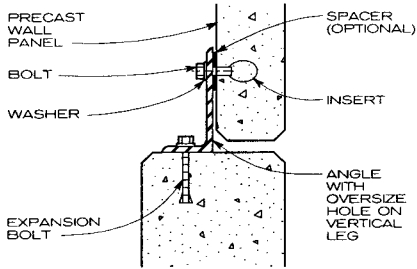

**NOTE**  
Accommodates large tolerance with expansion bolts.

**BOLTED TIE-BACK**

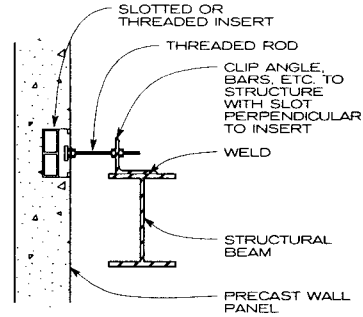

**BOLTED TIE-BACK CONNECTION**

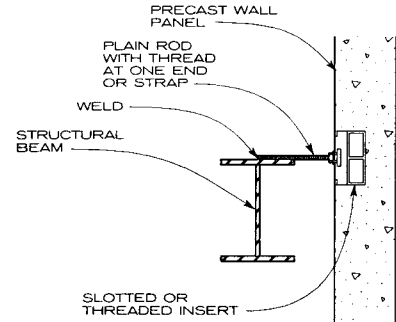

**WELDED TIE-BACK CONNECTION**

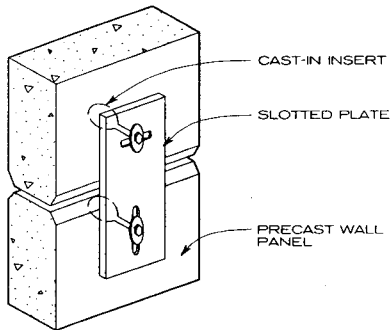

**BOLTED ALIGNMENT**

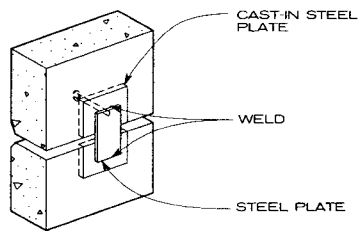

**NOTES**  
1. Good shear transfer.  
2. Rigid connection.  
3. Possible volume change restraint problems.

**WELDED ALIGNMENT**

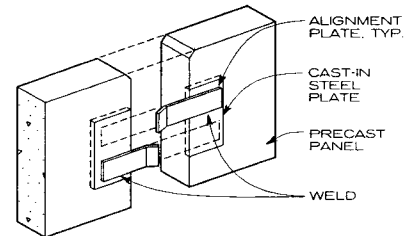

**NOTE**  
Alignment plate is welded to one plate only to allow for possible volume change of panels.

**WELDED ALIGNMENT**

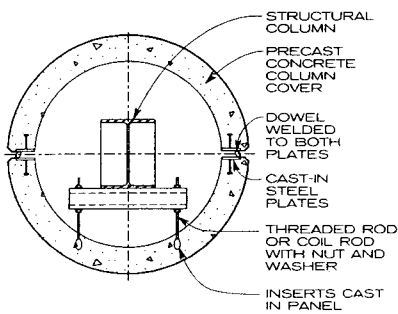

**COLUMN COVER CONNECTION**

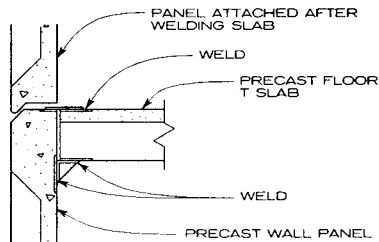

**NOTES**  
1. Avoid use of this detail at both ends of slab to prevent excessive restraint.  
2. Rotation of wall elements and effects on bracing wall connections and volume changes must be considered.

**SLAB-TO-WALL CONNECTION**

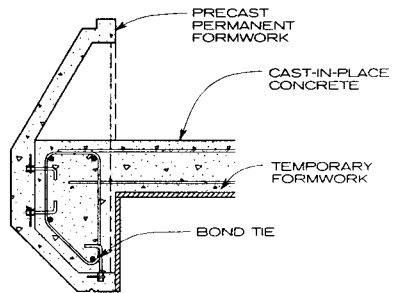

**NOTE**  
One-piece spandrels may require support and restrict placement of concrete.

**PRECAST PERMANENT FORMWORK**

**GENERAL**

Tilt-up concrete construction is a fast, economical method of enclosing a building with durable, load-bearing walls. The wall panel units are formed and cast horizontally at the job site, on either the building slab floor or on a temporary casting slab. Since the panels do not have to be transported, there are fewer restrictions on panel size. Wood formwork is typically used to define the edges, reveals, details, and openings in the panel. Once the concrete has reached sufficient strength, the panels are lifted, or tilted up, by crane and placed on isolated or continuous foundations (usually grade beams). The panels are braced against the floor slab or a brace foundation until they are tied to the roof and floor system and become an integral part of the completed structure. Although tilt-up concrete construction is mainly restricted to buildings of one story, walls up to four stories tall have been cast and lifted into position.

**DESIGN**

Panel thickness varies from 5 1/2" to 11 1/4" in. depending on height, loads, span, depth of reveals, surface finish, local codes, and construction practices. Full-height panel widths of 20 ft and weights of 30,000 to 50,000 lb are typical. Spans of 30 ft are common for spandrel panels, as are can-

tilers of 10 to 15 ft. Panels are designed structurally to resist lifting stresses, which frequently exceed in-place loads. Floor slab design must accommodate panel and crane loads.

**FINISH**

Most of the finishes used for factory precast concrete are possible in tilt-up construction. Panels can be cast either face down or face up, depending on desired finish and formwork methods. The face-down method, however, is usually easier to erect. Casting method, desired finish, and available aggregates affect concrete mix design. Control of the concrete mix design and placement of the concrete in the forms are more difficult than with factory-cast units. Discoloration occurs if cracks and joints in the casting are not sealed. Commonly used finishes are as follows:

1. Sandblasting (light, medium, or heavy exposure)
2. Fracture (similar to bushhammered)
3. Form liner (metal deck, plastic, fiberglass, EPS)
4. Paint (usually textured)
5. Brick or tile veneer
6. Aggregate (cast face down in sand bed)

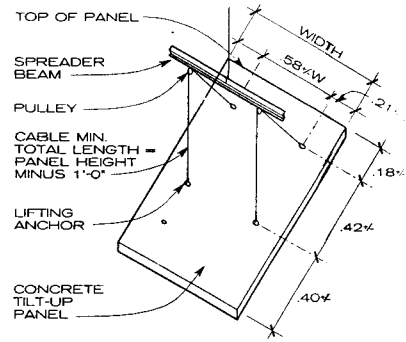

**NOTE**

The rigging and anchor configuration shown is the most common for tilt-up construction for plain panels without openings. Other configurations may be required depending on the size and shape of the panel; consult a tilt-up construction specialist.

**TILT-UP PROCEDURE**

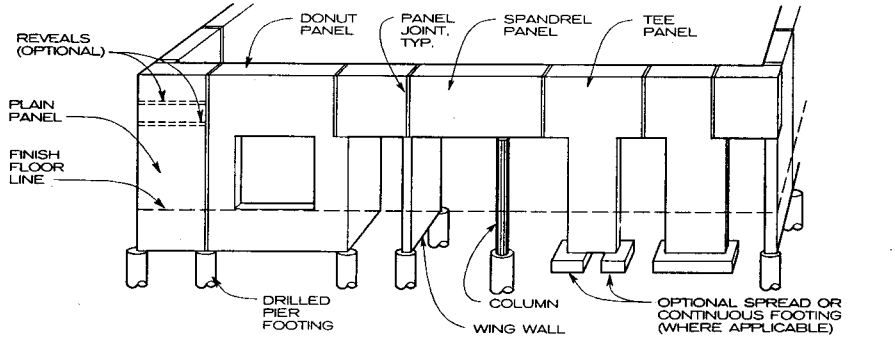
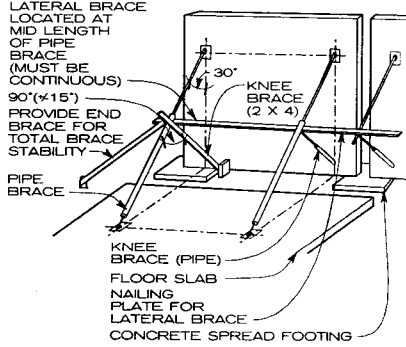

**PANEL TYPES**

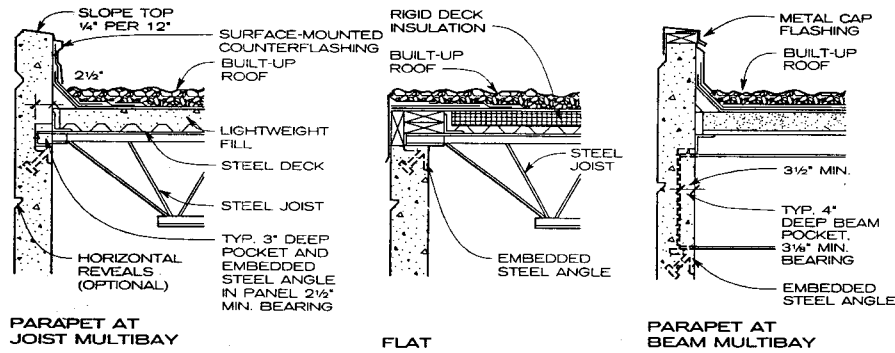

**TEMPORARY CONSTRUCTION BRACING**

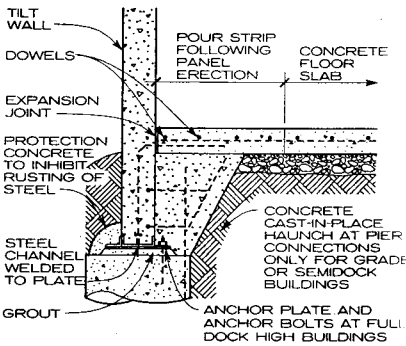

**LOAD-BEARING PANEL CONNECTIONS AT ROOF (SECTIONS)**

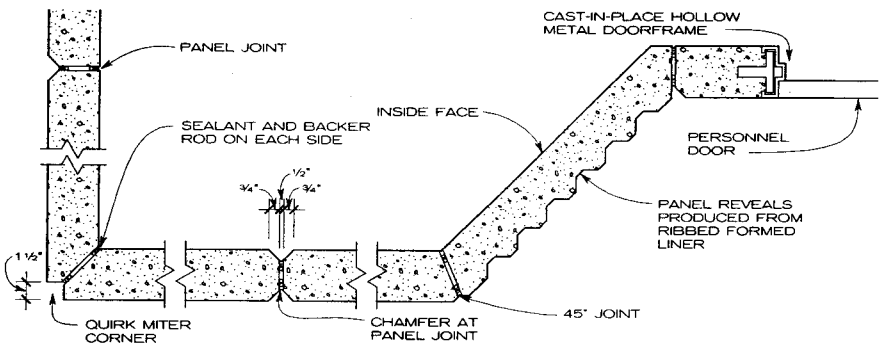

**PIER CONNECTION (SECTION)**

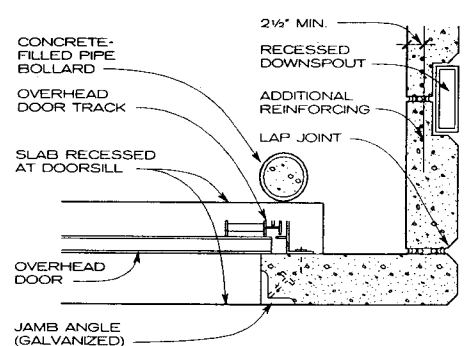

**PANEL DETAILS (PLAN)**

Haynes Whaley Associates, Structural Engineers; Houston, Texas  
Robert P. Foley, P.E.; Con/Steel Tilt-up Systems; Dayton, Ohio

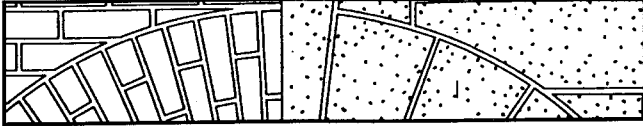

# MASONRY

Masonry Mortar 210

Masonry Accessories 212

Masonry Units 218

Glass Unit Masonry 244

Stone 247



**INTRODUCTION**

Mortar and grout are the cementitious bonding agents that integrate masonry units into masonry assemblies. Because concrete, masonry mortar, and grout contain the same principal ingredients, some designers assume what is good practice for one will also be good practice for another. In reality, the three materials differ in proportions, working consistencies, methods of placement, and structural performance.

Mortar and grout structurally bind masonry units together, whereas concrete is usually itself a structural material. One of the most important functions of concrete elements is to carry load, whereas the principal function of mortar and grout is to develop a complete, strong, and durable bond with masonry units. Concrete is poured into nonabsorbent forms with a minimum amount of water. Mortar and grout are placed, with much more water, between absorptive forms (masonry units). The water/cement ratio, as mixed, is very important in concrete work, but it is less important in working with mortar or grout for brick masonry. When mortar or grout is placed with masonry units, the water/cement ratio rapidly decreases because of the bricks' absorbency. It is important to distinguish between the requirements for concrete, masonry mortar, and grout.

**ASTM SPECIFICATIONS**

**ASTM C 270—MORTAR FOR UNIT MASONRY**

This standard specification covers four types of mortar in each of two methods: proportion specifications and property specifications. When specifying a particular mortar type, either the proportion or the property requirements should be given, but not both. When neither proportion nor property specifications are specified, the proportion specification is mandated. Table 1 shows the proportion requirements for types M, S, N, and O mortars.

Mortar conforming to the property specifications must be established by tests of laboratory prepared mortar, which should be mixed from the mortar materials to be used in the masonry structure. Table 2 provides the property requirements for types M, S, N, and O mortars.

Although ASTM C 270 uses the same letters to designate mortar type under both the proportion and property specifications, the properties of these mortar types are not equivalent. A mortar mixed to the type N proportion specification will have a laboratory prepared compressive strength significantly higher than that of a type N mortar required by the property specifications. Mortars may be made with either portland cement or masonry cement.

**ASTM C 476—GROUT FOR MASONRY**

This is the standard specification governing grout for reinforced and nonreinforced masonry assemblies. Two types of grout, fine and coarse, are specified by proportions of ingredients. Both types should be proportioned within the limits given in Table 5.

Grout consists of cementitious materials and aggregate thoroughly mixed with sufficient water to attain the desired consistency. Grout should be wet enough to pour without segregation of the constituents. Grout can be used to bond two wythes of masonry, to provide additional material to resist load, or to bond steel reinforcement to masonry so the two materials exert common action under load.

**MATERIALS**

**PORTLAND CEMENT**

Portland cement, a hydraulic cement, is the principal cementitious ingredient of mortar and grout. Three types of portland cement covered by ASTM C 150—Standard Specification for Portland Cement are recommended:

Type I: For general use when the special properties of Types II and III are not required

Type II: For use when moderate sulfate resistance or moderate heat of hydration is desired

Type III: For use when high early strength is desired

The allowable stresses for the structural design of brick masonry are based on the results of tests in which only portland cements were used. The use of blended hydraulic cements and natural cements is not recommended unless the strength of the masonry is first established by appropriate tests. For nonstructural masonry, such cements may be substituted for regular portland cement without testing.

**HYDRATED LIME**

Hydrated lime, a dry powder, is made by adding water to quicklime, thus converting the calcium oxide into calcium hydroxide. Hydrated lime can be used without extra preparation and thus is more convenient to use than quicklime.

Grace S. Lee; Rippeteau Architects, PC; Washington, D.C.  
 Brian E. Trimble; Brick Institute of America; Reston, Virginia  
 Stephen S. Szoke, P.E.; National Concrete Masonry Association; Herndon, Virginia

ASTM C 207—Hydrated Lime for Masonry Purposes is available in four types: S, SA, N, and NA. Because unhydrated oxides and plasticity are not controlled in types N or NA, only type S hydrated lime should be used for masonry mortar and grout.

**MASONRY CEMENT**

These proprietary mortar mixes are widely used in mortar because of their convenience and good workability. Masonry cements, however, should not be used in grout. The requirements for masonry cement are covered in ASTM C 91—Standard Specification for Masonry Cement. Masonry cements are prepackaged as types M, S, or N mortar mixes. Most building codes have lower allowable stresses when masonry cements are used.

**AGGREGATE**

Either natural or manufactured aggregate may be used. Gradation limits are given in ASTM C 144 and C 404 for aggregate used in mortar and grout. Only fine aggregate may be used in mortar; fine and coarse aggregate may be used in grout. Gradation can be easily altered by adding fine or coarse sands. Only clean sand is recommended for use in masonry mortar and grout.

**WATER**

Clean, potable water that is free of deleterious acids, alkalis, or organic materials is suitable for masonry mortar and grout.

**COLOR AND OTHER ADMIXTURES**

Many different types of admixtures can be added to mortar grouts. Admixtures are used in mortar to provide color, enhance workability, reduce water penetration, accelerate curing, and substitute for conventional materials. Admixtures are used in grout to increase fluidity, accelerate curing, and decrease shrinkage. Admixtures must be used with extreme caution so the performance of the masonry is not affected. Admixtures containing chlorides should never be used because they tend to corrode metal.

Air entrainment has the detrimental effect of reducing the bond between mortar and masonry units or reinforcement. The use of air-entraining portland cements (types IA, IIA, or IIIA) and air-entrained lime (types SA and NA) for masonry mortar and grout may not be appropriate. Two different air-entraining agents should not be used in the same mortar or grout. Air-entraining admixtures should not be used in structural masonry. Building codes mandate lower allowable flexural tension stresses if air-entrained cements or lime are used in mortar.

**TABLE 1: PROPORTION REQUIREMENTS FOR MASONRY MORTARS\***

MORTAR	TYPE	PROPORTIONS BY VOLUME (CEMENTITIOUS MATERIALS)					AGGREGATE RATIO (MEASURED IN DAMP, LOOSE CONDITIONS)
		PORTLAND CEMENT OR BLENDED CEMENT	MASONRY CEMENT			HYDRATED LIME OR LIME PUTTY	
			M	S	N		
Cement-lime	M	1	—	—	—	1/4	Not less than 2 1/4 and not more than 3 times the sum of the separate volumes of cementitious materials.
	S	1	—	—	—	over 1/4 to 1/2	
	N	1	—	—	—	over 1/2 to 1 1/4	
	O	1	—	—	—	over 1 1/4 to 2 1/2	
Masonry cement	M	1	—	—	1	—	
	S	—	1	—	—	—	
	S	1/2	—	—	1	—	
	N	—	—	1	—	—	
	O	—	—	—	1	—	

**NOTE**

\* Two air-entraining materials shall not be combined in mortar.

**TABLE 2: MORTAR PROPERTY SPECIFICATION REQUIREMENTS<sup>1</sup>**

MORTAR	TYPE	AVERAGE COMPRESSIVE STRENGTH AT 28 DAYS MIN. PSI (MPA)	WATER RETENTION MINIMUM %	AIR CONTENT MAXIMUM %	AGGREGATE RATIO (MEASURED IN DAMP, LOOSE CONDITIONS)
Cement-lime	M	2500 (17.2)	75	12	Not less than 2 1/4 and not more than 3 1/2 times the sum of the separate volumes of cementitious materials.
	S	1800 (12.4)	75	12	
	N	750 (5.2)	75	14 <sup>2</sup>	
	O	350 (2.4)	75	14 <sup>2</sup>	
Masonry cement	M	2500 (17.2)	75	See note 3	
	S	1800 (12.4)	75	See note 3	
	N	750 (5.2)	75	See note 3	
	O	350 (2.4)	75	See note 3	

**NOTES**

- Laboratory prepared mortar only.
- When structural reinforcement is incorporated in cement-lime mortar, the maximum air content is 12%.
- When structural reinforcement is incorporated in masonry cement mortar, the maximum air content is 18%.

**TABLE 3: GUIDE FOR THE SELECTION OF MASONRY MORTAR<sup>1</sup>**

LOCATION	BUILDING SEGMENT	MORTAR TYPE	
		RECOMMENDED	ALTERNATIVE
Exterior, above grade	Load bearing wall	N	S or M
	Non-load bearing wall	O <sup>2</sup>	N or S
	Parapet wall	N	S
Exterior, at or below grade	Foundation wall, retaining wall, manholes, sewers, pavements, walks, and patios	S <sup>3</sup>	M or N <sup>3</sup>
Interior	Load bearing wall	N	S or M
	Non-bearing partitions	O	N

**NOTES**

- This table does not include many specialized mortar uses, such as chimney reinforced masonry and acid-resistant mortar.
- Type O mortar is recommended for use where the masonry is unlikely to be frozen when saturated, or unlikely to be subjected to high winds or other significant lateral loads. Types N or S mortar should be used in other cases.
- Masonry exposed to weather in a nominally horizontal surface is extremely vulnerable to weathering. Mortar for such masonry should be selected with due caution.



**RECOMMENDED TYPES**

**MORTAR**

No single type of mortar is best suited for all purposes, but there are several rules for selecting mortar type. Never use a mortar that is stronger in compression than needed by the structural requirements. Always select the mortar weakest in compression that is consistent with the performance requirements of the project. However, this guideline should be coupled with good engineering judgment; for example, it would be uneconomical and unwise to change mortar types in various parts of a structure. If mortar is used with reinforcement in a collar joint or in a cell of a hollow unit, then the air content must be less than 12% for portland cement-lime mortars and 18% for masonry cements. The use of mortar is recommended only in unreinforced collar joints of 3/4 in. (19 mm) or less.

Following are the recommended uses for different types of mortar:

**Type N mortar:** A medium strength mortar suitable for general use in exposed masonry above grade and recommended specifically where high compressive or transverse masonry strengths are not required.

**Type S mortar:** A high strength mortar suitable for general use and specifically for circumstances where high transverse strength of masonry is desired; for reinforced masonry, where mortar bonds the facing and backing; and for areas subject to winds greater than 80 mph (130 kph).

**Type M mortar:** A high strength mortar suitable for general use and recommended specifically for masonry below grade or in contact with earth, such as foundations, retaining walls, or paving.

**Type O mortar:** A low strength mortar suitable for use in non-load bearing applications in walls of low axial compressive strength and where masonry is not subject to severe weathering.

**TABLE 5: GROUT PROPORTIONS BY VOLUME**

TYPE	PARTS BY VOLUME OF PORTLAND CEMENT OR BLENDED CEMENT	PARTS BY VOLUME OF HYDRATED LIME OR LIME PUTTY	AGGREGATE (MEASURED IN A DAMP, LOOSE CONDITION)	
			FINE	COARSE
Fine grout	1	0 - 1/10	2 1/4 - 3 times the sum of the volumes of cementitious materials	—
Coarse grout	1	0 - 1/10	2 1/4 - 3 times the sum of the volumes of cementitious materials	1 - 2 times the sum of the volumes of cementitious materials



Brick more than 75% solid  
Net area equals gross area  
Full mortar bedding

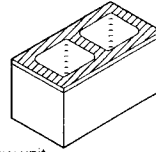

Hollow unit  
Full mortar bedding  
(requires alignment of crosswebs)

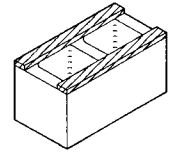

Hollow unit  
Face shell bedding

**NET CROSS-SECTIONAL AREA**

**GROUT**

Grout should be mixed thoroughly in a plastic mix suitable for placement without separation of the constituents. Add enough water to achieve a slump of 8 to 11 in. (200 to 275 mm). The compressive strength of the grout should match that of the brick masonry but must have a minimum compressive strength of 2000 psi (13.9 MPa).

**Fine grout:** Can be used for grouting interior vertical spaces between two wythes of masonry or aligned, unobstructed vertical spaces in hollow masonry units. See Table 4 for grout space requirements.

**Coarse grout:** May be used when the grout space exceeds 2 in. (50 mm) in width. If the minimum grout space dimension exceeds 6 in. (150 mm), a larger aggregate size may be specified.

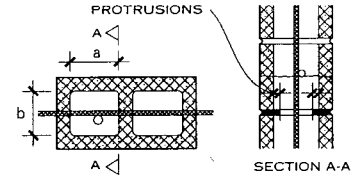

- a > Minimum grout space dimension
- b > Minimum grout space dimension plus horizontal bar diameter plus horizontal protrusions (see table)

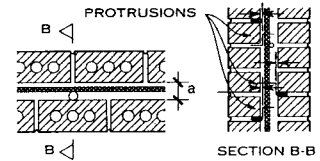

- a > Minimum grout space dimension plus horizontal bar diameter plus horizontal protrusions (see table)

**TABLE 4: GROUT SPACING REQUIREMENTS**

SPECIFIED GROUT TYPE	MAXIMUM GROUT FOUR HEIGHT (FT)	MINIMUM WIDTH OF GROUT SPACE (IN.)	MINIMUM GROUT SPACE DIMENSIONS FOR GROUTING CELLS OF HOLLOW UNITS (IN. X IN.)
Fine	1	3/4	1 1/2 x 2
	5	2	2 x 3
	12	2 1/2	2 1/2 x 3
	24	3	3 x 3
Coarse	1	1 1/2	1 1/2 x 3
	5	2	2 1/2 x 3
	12	2 1/2	3 x 3
	24	3	3 x 4

**NOTES**

- Grout space dimension is the clear dimension between any masonry protrusion and shall be increased by the diameters of the horizontal bars within the cross section of the grout space.
- Area of vertical reinforcement should not exceed 6% of the area of the grout space.

**GROUT SPACE REQUIREMENTS**

**TYPES OF JOINTS**

Mortar serves multiple functions:

- Joins and seals masonry, allowing for dimensional variations in masonry units.
- Affects overall appearance of wall color, texture, and patterns.
- Bonds reinforcing steel to masonry, creating composite assembly.

**MORTAR JOINT FINISH METHODS**

- Troweled: Excess mortar is struck off. The trowel is the only tool used for shaping and finishing.
- Tooled: A special tool is used to compress and shape mortar in the joint.

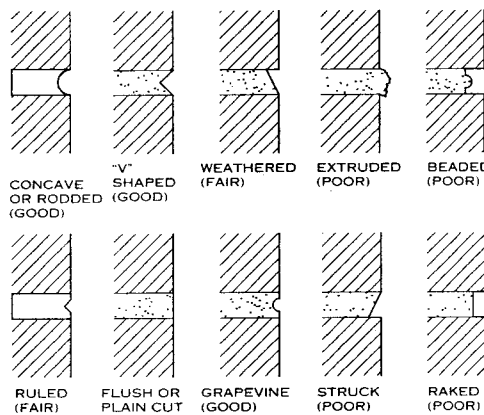

**TYPES OF JOINTS (WEATHERABILITY)**

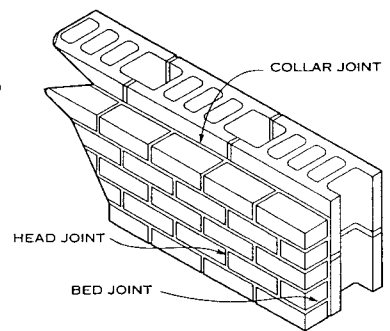

**TERMS APPLIED TO JOINTS**

**MORTAR JOINTS**

Grace S. Lee; Rippeteau Architects, PC; Washington, D.C.  
 Brian E. Trimble; Brick Institute of America; Reston, Virginia  
 Stephen S. Szoke, P.E.; National Concrete Masonry Association; Herndon, Virginia

**GENERAL**

Masonry construction has not always required the inclusion of metal elements. Historically, composite masonry construction consisted of multiple wythes of masonry bonded together by headers. However, contemporary masonry walls require ties between the inner and outer wythes, which are then anchored to the structural frame. Many people use the terms *wall tie* and *anchor* interchangeably, but in practice the term *tie* refers to combining a wythe of masonry to its backing system, while *anchor* refers to a component that secures structural elements to a structural support. A fastener is a device used to attach nonstructural elements to masonry. Anchors and ties with flexible components can accommodate differential movement between the structural frame and the masonry wall by allowing for in-plane movement.

**CORROSION PROTECTION**

The durability of any metal accessory is usually based on its ability to resist corrosion. Since masonry walls are often subject to moisture, metal items must be protected, either by galvanizing them or by use of corrosion resistant metals. The following ASTM standards apply to corrosion protection of carbon steel metal accessories based on their location and the size of the piece:

1. ASTM A 641—Mill galvanizing: joint reinforcement, interior
2. ASTM A 153—Hot-dip galvanized: joint reinforcement, wire ties, and wire anchors, exterior or moist interior
3. ASTM A 153—Hot-dip galvanized: sheet metal ties, exterior or moist interior
4. ASTM A 525—sheet metal ties, interior
5. ASTM A 123 or A 153—steel plates and bars

Corrosion protection is also provided by stainless steel anchors and ties conforming to ASTM A 167, Type 304.

**ANCHORS AND REINFORCEMENT**

Selection of anchors and reinforcement is determined by the relationship of the masonry element to the structural support. Reinforcing bars may be placed horizontally or vertically in masonry. The reinforcement may be placed in the cores or cells of masonry units or between wythes of masonry. The use of dovetail slots welded on steel or concrete columns requires coordination during the steel or concrete fabrication stage. The type of anchor specified, including its size, diameter, and spacing, should be called out on the contract documents.

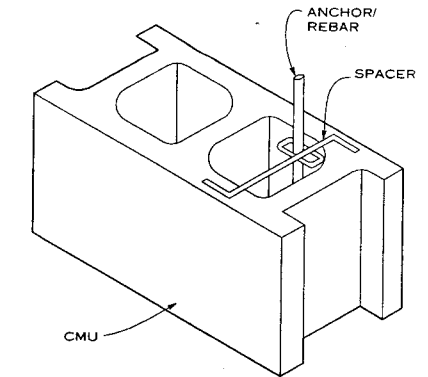
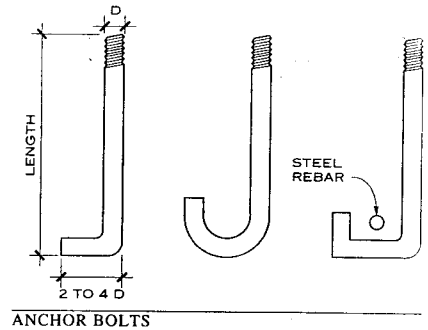
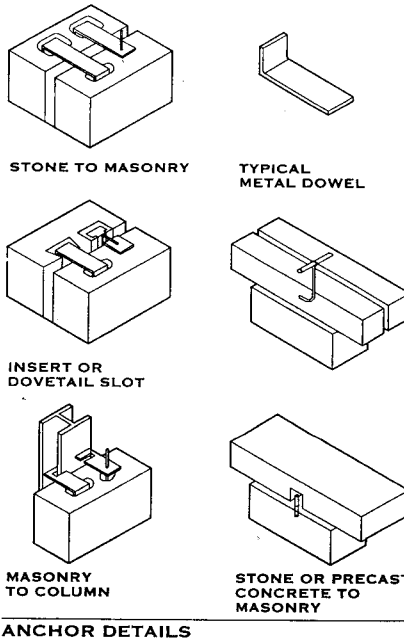

**ANCHOR BOLT/REINFORCING BAR SPACERS**

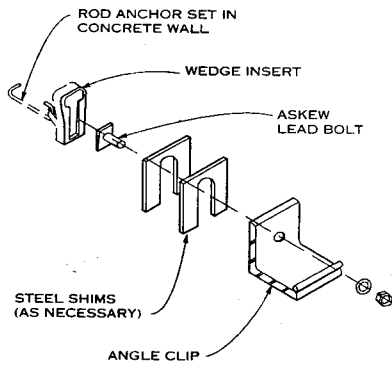
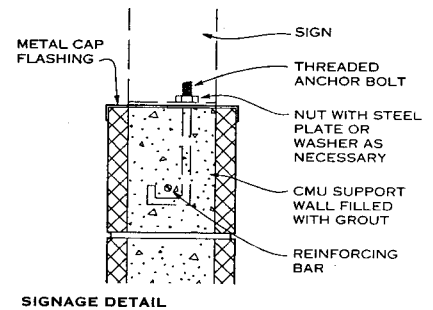

**ANGLE CLIP ANCHOR**

**TIE SPACING RECOMMENDATIONS\***

WALL TYPE	TIE AND GAUGE	MAXIMUM AREA PER TIE (SQ FT)	MAXIMUM VERTICAL SPACING (IN.)	MAXIMUM HORIZONTAL SPACING (IN.)
Multiwythe walls	W 1.7 (9 gauge)	2 1/3	24	36
	W 2.8 (7/16 in. dia.)	4 1/2	24	36
Cavity walls	W 1.7 (9 gauge)	2 1/3	24	36
	W 2.8 (7/16 in. dia.)	4 1/2	24	36
	Adjustable W 2.8 (7/16 in. dia.)	1.77	16	16
Veneer	Corrugated or wire tie	3 1/2	18	32

**NOTE**

\* Masonry laid in running bond. Consult applicable building code for special bond patterns such as stack bond.

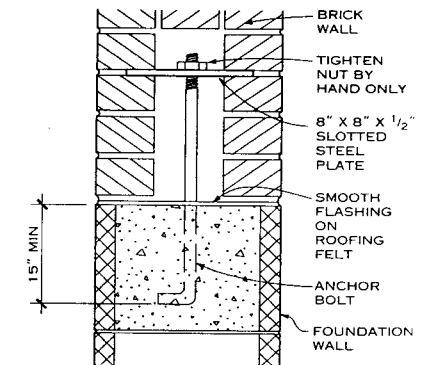
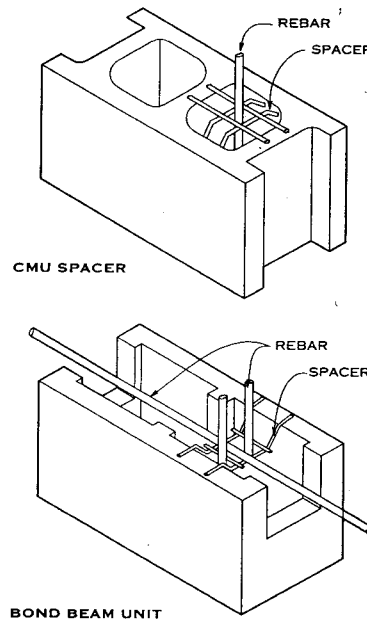

**MASONRY WALL TO FOUNDATION ANCHORAGE DETAIL**

**ANCHOR BOLT DETAILS**

Brian E. Trimble; Brick Institute of America; Reston, Virginia

**MASONRY TIES**

Wall ties perform one or more functions: they provide a connection, transfer lateral loads, permit in-plane movement to accommodate differential movements, and may act as horizontal structural reinforcement. As shown on this page, wall ties include unit ties, joint reinforcement, adjustable unit ties, and adjustable joint reinforcement. Wall tie spacing is listed in a table on the AGS page on Anchorage and Reinforcement. The ties should be staggered in alternate rows, and only one row of ties should be located in the same bed joint to allow proper embedment in the mortar.

In wall construction in which masonry wythes are built up together and the joints align, a single piece is laid over both wythes. Where one wythe of masonry is laid up before the other wythe or when joints do not align, adjustable ties may be necessary. Adjustable ties are advantageous for several reasons: (1) interior wythes can be constructed before the exterior wythe, allowing the structure to be enclosed faster; (2) the risk of damage to the ties when the exterior wythe is constructed is reduced; (3) adjustable ties can more readily accommodate construction tolerances; and (4) adjustable ties can accommodate larger differential movements. However, adjustable ties must be installed properly or the tie may be rendered useless. Location of the first piece is critical since the second piece must engage the first and be properly embedded in the exterior wythe. Large eccentricities may occur between the two pieces, which would result in less strength and stiffness than anticipated.

**RECOMMENDED MINIMUM TIE DIAMETERS AND GAUGES**

TIE SYSTEM	MINIMUM SPECIFIED DIMENSION*	
	DIAMETER (IN.)	GAUGE
Standard Ties		
Unit		
Rectangular and "Z"	3/16	-
Corrugated	-	22
Joint reinforcement		
Ladder and truss	-	9
Tab	-	9
Adjustable Ties		
Unit		
Rectangular and "Z"	3/16	-
Dovetail/channel slot	-	-
Wire	3/16	16
Corrugated	-	22
Connector slot	-	22
Slotted plate		
Wire	3/16	-
Slot plate	-	14
Backer plate	-	14
Joint reinforcement		
Standard section	-	9
Tabs	3/16	-

\*Thicker diameters and gauges are available.

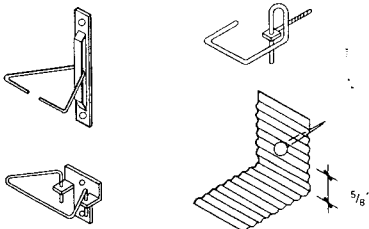

ADJUSTABLE UNIT TIES—STUD

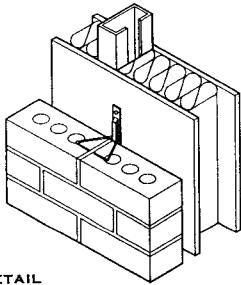

**TIE DETAIL**

**NOTE**

Differential movement must always be accounted for in stud-backed wall systems with adjustable ties.

**ADJUSTABLE UNIT TIE FOR STEEL STUD BACKUP**

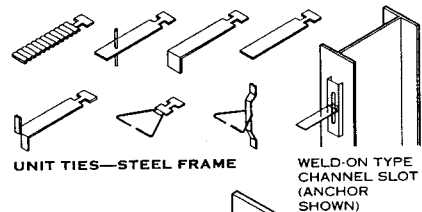

UNIT TIES—STEEL FRAME

WELD-ON TYPE CHANNEL SLOT (ANCHOR SHOWN)

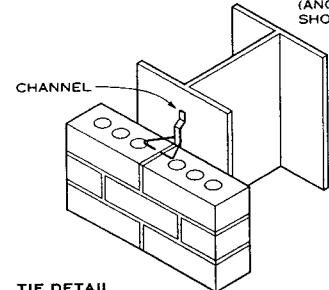

**TIE DETAIL**

**ADJUSTABLE UNIT TIE—STEEL FRAME BACKUP**

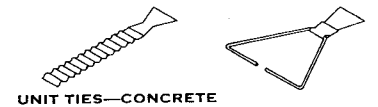

UNIT TIES—CONCRETE

DOVETAIL SLOT

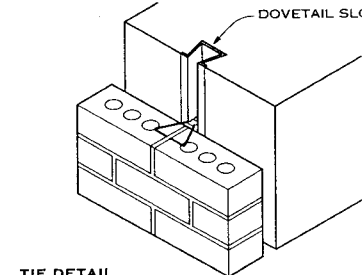

**TIE DETAIL**

**ADJUSTABLE UNIT TIE FOR CONCRETE FRAME BACKUP**

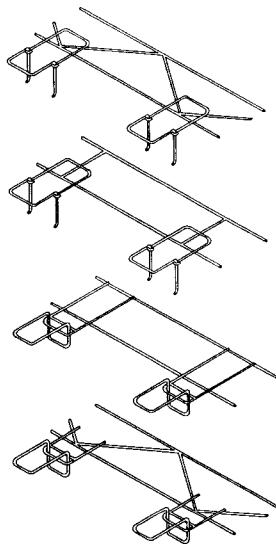

ADJUSTABLE JOINT REINFORCEMENT

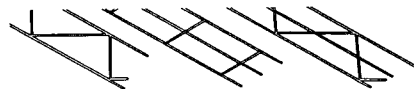

TRUSS TYPE LONGITUDINAL WIRE LADDER TYPE LONGITUDINAL TRUSS TYPE

**JOINT REINFORCEMENT FOR MASONRY BACKUP**



UNIT TIES—MASONRY

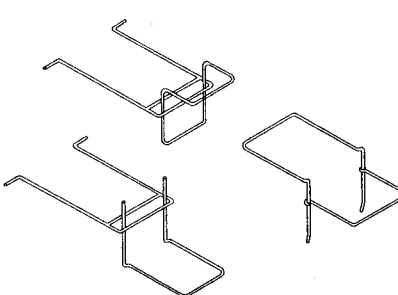

ADJUSTABLE UNIT TIES—MASONRY

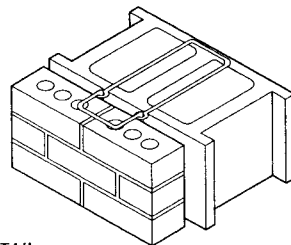

**TIE DETAIL**

**NOTES**

1. Z ties can be used only with solid masonry veneer units.
2. Tie must extend a minimum of 1 1/2 in. onto solid masonry units and be fully embedded in mortar on the outer face shell of hollow masonry units.

**UNIT TIE FOR MASONRY BACKUP**

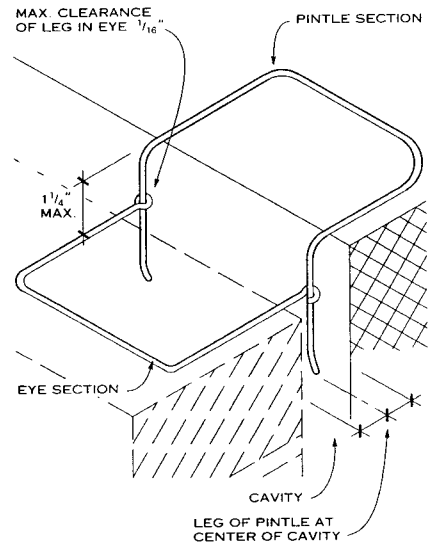

TYPICAL ADJUSTABLE UNIT TIE

Brian E. Trimble; Brick Institute of America; Reston, Virginia

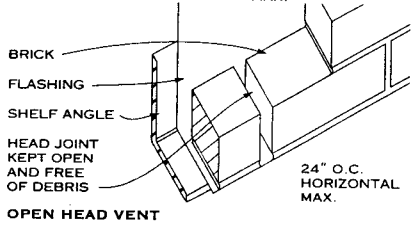
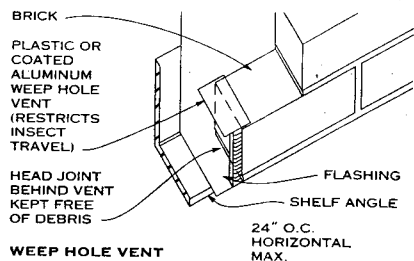

WEEP HOLE DETAILS

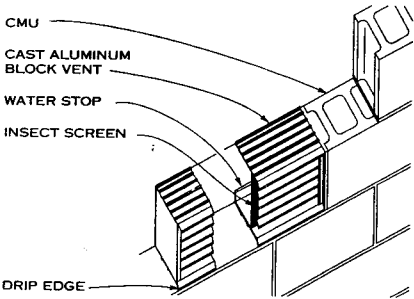

BRICK OR BLOCK VENT

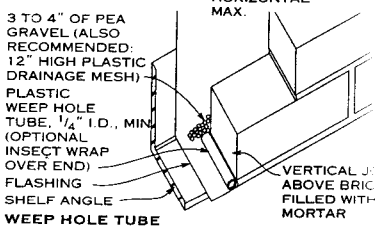
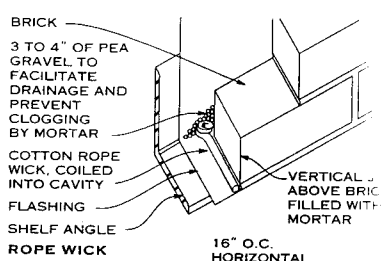

WEEP HOLE DETAILS

WEEP HOLES AND VENTS

With proper design and installation, weep holes and discharge water and moisture as vapor in wall cavities must always be used with flashing. When vents are located at the bottom of the wall, directly above flashing and in junction with small openings at the top of the cavity, void is vented, allowing moisture removal from the wall. The type of weep hole chosen is not critical as long as properly sized and spaced at the required locations. Weep holes are sometimes created by placing greased or oiled tubes or coils into the mortar and then extracting them when the mortar is ready to be tooled. For CMUs, under adverse weather conditions, it may be necessary to install weep holes at the base of the first course at all openings as well as at the head joints for wall cavity venting. Weep holes should never be located below grade and should be small enough to keep out rodents.

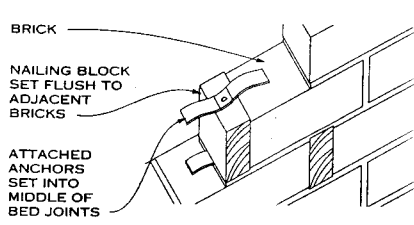

NAILING BLOCK

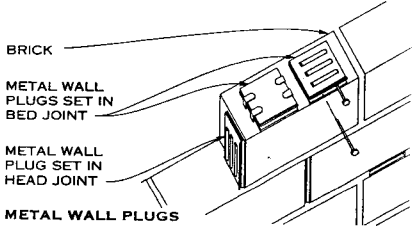

NAILING RECEIVERS (SET IN MASONRY)

NAILING BLOCKS AND WALL PLUGS

The procedure for attaching other materials, fixtures, and the like to brick masonry is relatively simple and can be executed either during or after construction. Postconstruction fasteners, such as lag bolts and shields, are commonly used because of their flexibility in placement. However, when the precise location of the fastener is determined, nailing blocks and metal wall plugs are an acceptable means of attachment to brick masonry. They are placed in mortar joints as the bricks are laid.

Wood nailing block should be of seasoned softwood to prevent shrinkage and be treated to inhibit deterioration. They should only be placed in the head joint. Metal wall plugs are made of galvanized metal and may contain wooden or fiber inserts. Such plugs may be placed in either the head or bed joints of masonry.

GALVANIC CORROSION (ELECTROLYSIS) POTENTIAL BETWEEN COMMON CONSTRUCTION MATERIALS

CONSTRUCTION MATERIALS	CONSTRUCTION MATERIALS					
	COPPER	ALUMINUM	STAINLESS STEEL	GALVANIZED STEEL	ZINC	LEAD
<b>FLASHING MATERIALS</b>						
Copper		●	●	●	●	●
Aluminum			○	○	○	○
Stainless steel				●	●	●
Galvanized steel					○	○
Zinc alloy						○
Lead						

- NOTES**
- Galvanic action will occur, hence direct contact should be avoided.
  - Galvanic action may occur under certain circumstances and/or over a period of time.
  - Galvanic action is insignificant; metals may come into direct contact under normal circumstances.
2. Galvanic corrosion is apt to occur when water runoff from one material comes in contact with a potentially reactive material.

ASTM STANDARD REINFORCING BARS FOR MASONRY

BAR SIZE DESIGNATION	WEIGHT (LB/FT)	NOMINAL DIMENSIONS	
		DIAMETER (IN.)	CROSS-SECTIONAL AREA (SQ IN.)
#3	0.376	0.375	0.11
#4	0.668	0.500	0.20
#5	1.043	0.625	0.31
#6	1.502	0.750	0.44
#7	2.044	0.875	0.60
#8	2.670	1.000	0.79
#9	3.400	1.128	1.00
#10	4.303	1.270	1.27
#11*	5.313	1.410	1.56

\* Bar sizes larger than #11 are not permitted in masonry work.

LASHING MATERIALS AND SELECTED GALVANIC CORROSION POTENTIALS

LASHING MATERIALS	SELECTED GALVANIC CORROSION POTENTIALS				
	BRONZE	MONEL	UNCURED MORTAR OR CEMENT	WOODS WITH ACID (REDWOOD AND RED CEDAR)	IRON/STEEL
BRONZE	●	●	○	○	●
MONEL	●	○	●	●	●
UNCURED MORTAR OR CEMENT	●	●	○	○	●
WOODS WITH ACID (REDWOOD AND RED CEDAR)	●	●	○	○	●
IRON/STEEL	●	●	○	○	○

NOMINAL AREA (SQ IN.)	PERIMETER (IN.)	
	DIAMETER (IN.)	CROSS-SECTIONAL AREA (SQ IN.)
0.11	0.375	0.11
0.20	0.500	0.20
0.31	0.625	0.31
0.44	0.750	0.44
0.60	0.875	0.60
0.79	1.000	0.79
1.00	1.128	1.00
1.27	1.270	1.27
1.56	1.410	1.56

Grace S. Lee and A. Harris Lokmanhakim, AIA; Rippeteau Architects, PC; Washington, D.C.  
 Brian E. Trimble; Brick Institute of America; Reston, Virginia  
 Stephen S. Szoke, P.E.; National Concrete Masonry Association; Herndon, Virginia

**INTRODUCTION**

The various materials and elements used to construct a building are in constant motion. All building materials change in volume in response to internal or external stimuli, such as temperature changes, moisture expansion, and elastic deformation due to loads or creep. Restraining such movements may cause stresses within the building elements, which in turn may result in cracks.

To avoid cracks, the building design should minimize volume change, prevent movement, or accommodate differential movement between materials and assemblies. A system of movement joints can prevent cracks and the problems they cause. Movement joints can be designed by estimating the magnitude of the several types of movements that may occur in masonry and other building materials.

**MOVEMENTS OF CONSTRUCTION MATERIALS**

The design and construction of most buildings do not allow precise prediction of movements of building elements. Volume changes depend on material properties and are highly variable. Age of material and temperature at installation also influence expected movement. When mean values of material properties are used in design, the actual movement may be underestimated or overestimated. Designers should use discretion when selecting the applicable values. The types of movement affecting various building materials are indicated in the table.

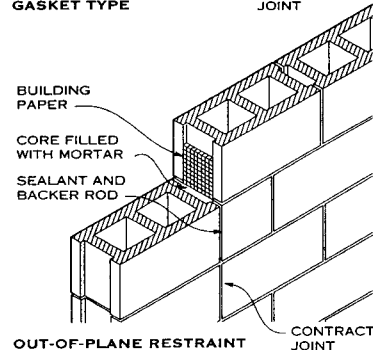
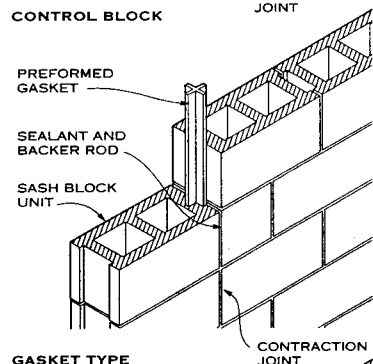
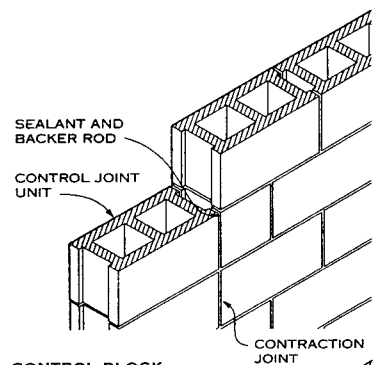

**CONTROL JOINTS**

Grace S. Lee; Rippeteau Architects, PC; Washington, D.C.  
Brian E. Trimble; Brick Institute of America; Reston, Virginia  
Stephen S. Szoke, P.E.; National Concrete Masonry Association; Herndon, Virginia

**MOVEMENT JOINTS**

There are various types of movement joints in buildings: expansion joints, control joints, building expansion joints, and construction joints. Each type of movement joint is designed to perform a specific task and should not be used interchangeably.

Expansion joints are used to separate brick masonry into segments to prevent cracking from changes in temperature, moisture expansion, elastic deformation due to loads, and shrinkage and creep in concrete framed buildings. Expansion joints may be horizontal or vertical. They are formed of elastomeric materials placed in a continuous, unobstructed opening through the brick wythe. This construction allows the joints to close if the size of the brickwork increases. Expansion joints must be located so the structural integrity of the brick masonry is not compromised. In some cases expansion joints are necessary in concrete masonry walls. Architects often designate these joints as control joints.

Control joints are used in concrete or concrete masonry to create a plane of weakness that, used in conjunction with reinforcement or joint reinforcement, controls the location of cracks caused by volume changes resulting from shrinkage and creep. A control joint, usually vertical and formed of inelastic materials, will open rather than close. Control joints must be located so the structural integrity of the concrete masonry wall is not affected.

A building expansion (isolation) joint is used to separate a building into discrete structural sections so that stresses developed in one section will not affect the integrity of the

**TYPES OF MOVEMENT OF BUILDING MATERIALS**

BUILDING MATERIAL	THERMAL	REVERSIBLE MOISTURE	IRREVERSIBLE MOISTURE	ELASTIC DEFORMATION	CREEP
Brick masonry	x	—	x	x	x
Concrete masonry	x	x	—	x	x
Concrete	x	x	—	x	x
Steel	x	—	—	x	—
Wood	x	x	—	x	x

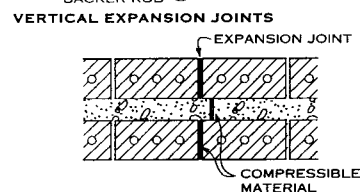
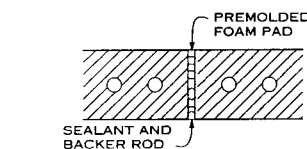
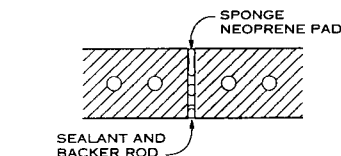

**GROUPED MULTIPLE WYTHE MASONRY**

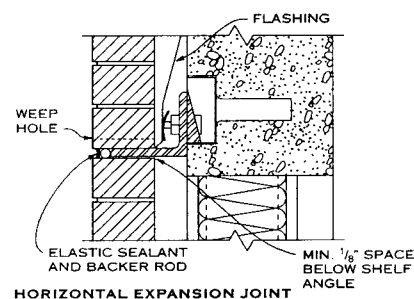

**EXPANSION JOINTS**

entire structure. The isolation joint is a through-the-building joint, including the roof assembly.

A construction (cold) joint is used primarily in concrete construction when construction work is interrupted. Construction joints are located where they will least impair the strength of the structure.

**SPACING OF EXPANSION AND CONTROL JOINTS**

No single recommendation on the positioning and spacing of expansion and control joints can be applicable to all structures. Each building should be analyzed to determine the extent of movement expected within that particular structure. Provisions should be made to accommodate these movements and their associated stresses with a series of expansion and control joints.

Generally, spacing of expansion joints is determined by considering the amount of expected wall movement and the size of compressibility of the expansion joint and expansion joint materials. Expansion joints are often sized to resemble a mortar joint, usually 3/8 in. (10 mm) to 1/2 in. (13 mm). The maximum size of the expansion joint may depend on the sealant capabilities. Extensibility of highly elastic expansion joint materials is typically in the range of 25 to 50%. Compressibility of backing materials can range up to 75%.

Expansion and control joints do not have to be aligned in cavity walls; however, they should be aligned in multiwythe walls.

**CONTROL JOINT SPACING FOR MOISTURE CONTROLLED, TYPE I CONCRETE MASONRY UNITS**

RECOMMENDED SPACING OF CONTROL JOINTS	VERTICAL SPACING OF JOINT REINFORCEMENT			
	NONE	24"	16"	8"
Expressed as ratio of panel length to height (L/H)	2	2 1/2	3	4
Panel length (L) not to exceed (regardless of height (H))	40'	45'	50'	60'

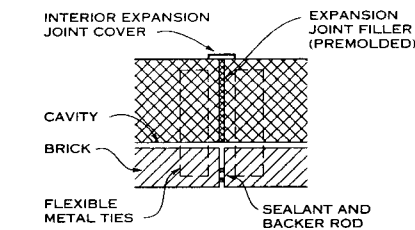

**EXPANSION JOINT AT MASONRY CAVITY WALL**

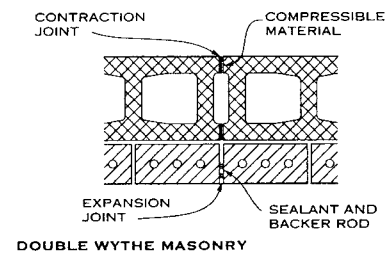

**EXPANSION AND CONTROL JOINTS**

**PURPOSE**

Flashing in masonry construction is necessary to collect moisture that enters the wall system and to channel it to the exterior through weep holes. Moisture enters masonry walls through condensation, penetration of wind-driven rains, failed sealant joints, interfaces with other components, or other components themselves, such as windows or roofs.

There are two types of flashing. Exposed flashings can be applied to all masonry construction, while use of embedded flashing is usually limited to drainage walls. Masonry is a durable, long-lasting construction material. Thus, the flashing materials selected should also be durable and have a long life, especially embedded flashing materials, which are difficult to replace.

**MATERIALS**

Flashing may be made of sheet metal (copper, lead, stainless steel, galvanized steel, or aluminum), plastic, or composite materials (usually paper-backed, coated, metallic sheet, or fibrous glass mesh). When selecting flashing materials, avoid those that would have cathodic reactions with mortar, other metals, or other construction materials. The thickness of the flashing material specified should take into account the span between embedment, bends, or connections. Copper may cause a patina, which may be desir-

able. Lead and galvanized metal may result in some white staining, but this may be minimal if coated materials are used. Choose aluminum as an embedded flashing only if it is properly coated, so it will not react with the mortar. Polyethylene should not be used as flashing unless it has been chemically stabilized so it will not deteriorate when exposed to sunlight (ultraviolet radiation). Asphalt-impregnated building paper (building felt) is not an acceptable flashing material. Adhered flashings must be held back from the face of the wall to avoid deterioration and staining caused by high temperatures.

**INSTALLATION**

Embedded flashing is typically used in drainage walls at the base, above all openings, at sills and shelf angles, and under copings. Continuous embedded flashing should be lapped at least 6 in. and sealed with an appropriate sealer. Discontinuous flashing should have the ends turned up at least 1 in. to form a dam. Dams prevent water collected on the flashing from draining off the ends of the flashing back into the wall system or into framing or mullions.

Embedded flashing should extend at least 8 in. vertically within the wall system; it should extend at least 1 1/2 in. into the interior wythe and through the exterior wythe at least 1/4 in. to form a drip. The drip minimizes possible staining. Sometimes, it may be necessary to avoid the drip, as with rough textured units and ribbed, scored, or fluted masonry units. The flashing must be carefully brought to the surface

of the recessed portion of the masonry. Plastic flashing is often exposed and cut off flush with the face of the masonry. If the flashing is recessed and does not reach the surface, water collected on it may be channeled by mortar under the flashing and back into the wall system.

Weep holes are required in the head joints of the course of masonry immediately above all embedded flashing. Weep holes may be open head joints, holes formed with nylon rope or oiled rods, plastic or metal tubes, fibrous rope, or cotton sash cord. Open head joints are often fitted with vents or screens to keep out insects or rodents. Formed weep holes should have a minimum diameter of 1/4 in.; tubes used for weep holes should have a minimum inside diameter of 1/4 in. Weep holes are preferred as open head joints occurring no more than 32 in. on center, although in brick masonry it is generally recommended that they be spaced no more than 24 in. on center. If cord or rope is used, the material should be at least 16 in. long. Weep holes other than open head joints should be spaced no more than 16 in. on center.

Drainage within the wall system is critical for proper performance. Placing two to six inches of gravel or drainage material immediately above embedded flashing will help ensure proper drainage within the wall and effective channeling of water to the weep holes. The drainage material or pea gravel will act as a drainage field within the wall system and help keep mortar droppings from clogging the weep holes.

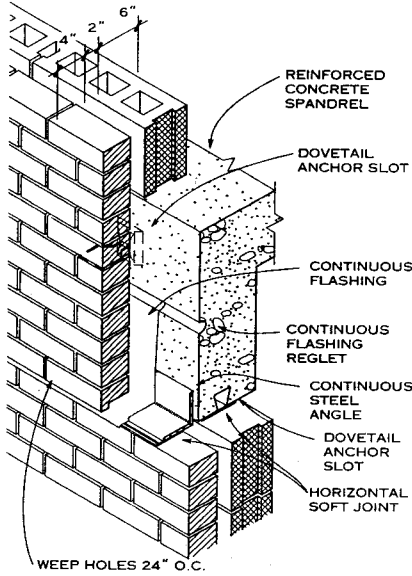

**CAVITY WALL FLASHING**

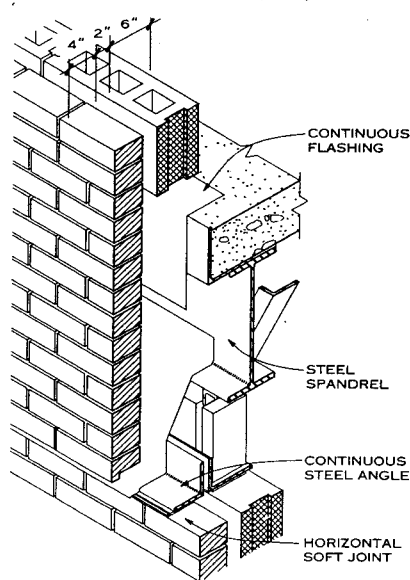

**CAVITY WALL FLASHING**

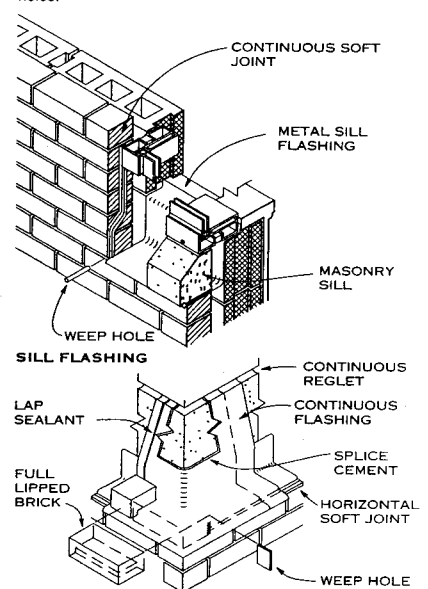

**OUTSIDE CORNER FLASHING**

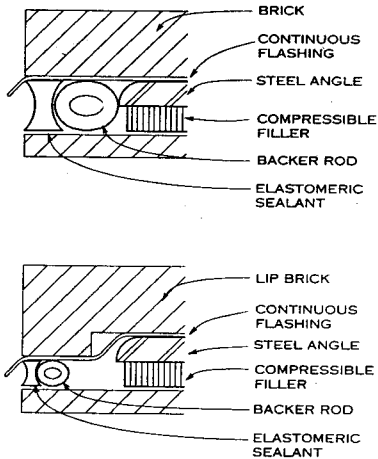

**HORIZONTAL SOFT JOINT**

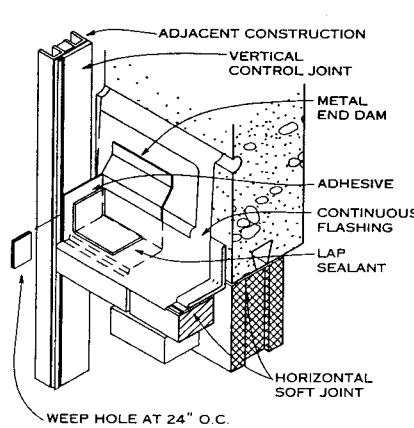

**END DAM**

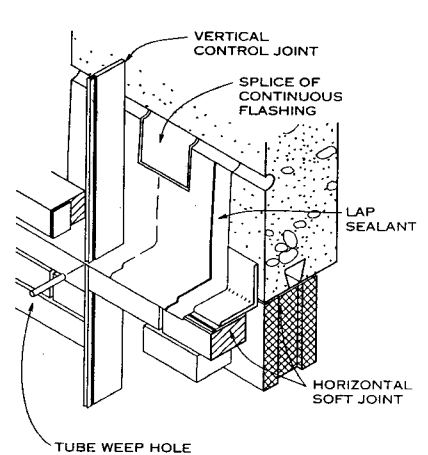

**HORIZONTAL SOFT JOINT AND VERTICAL CONTROL JOINT**

Theodore D. Sherman, AIA; Lev Zetlin Associates, Engineers and Designers; New York, New York  
 Brian E. Trimble; Brick Institute of America; Reston, Virginia

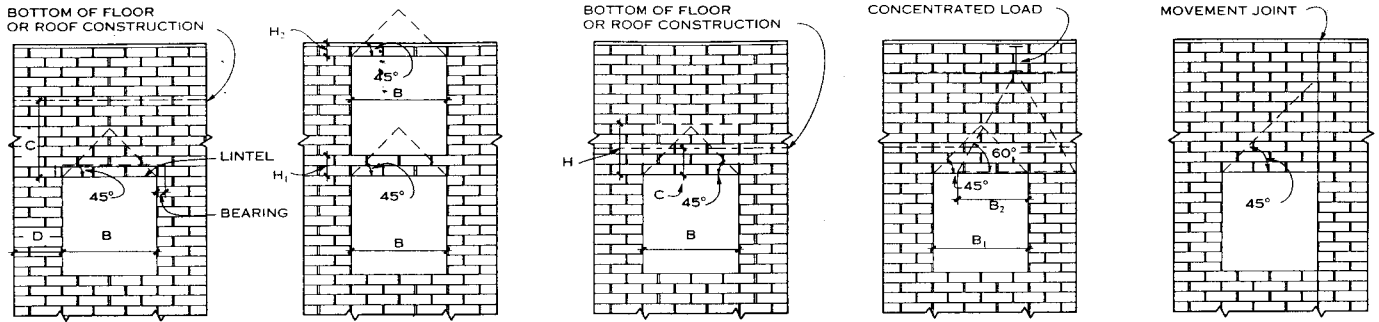

Simple lintel with arch action carries wall load only in triangle above opening:  $C \geq B$  and  $D \geq B$   
 Simple lintel without arch action carries less wall load than triangle above opening:  $H_1$  or  $H_2 < 0.6B$   
 Lintel with uniform floor load carries both wall and floor loads in rectangle above opening:  $C < B$   
 Lintel with concentrated load carries wall and portion of concentrated load distributed along length  $B_2$   
 Lintels at movement joints require special design considerations.

LINTEL LOADING CONDITIONS (CONSULT STRUCTURAL HANDBOOK FOR DESIGN FORMULAS)

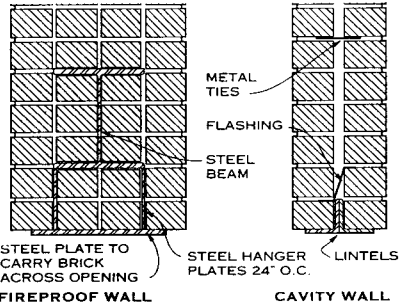

STEEL PLATE TO CARRY BRICK ACROSS OPENING  
 FIREPROOF WALL  
 STEEL HANGER PLATES 24" O.C.  
 CAVITY WALL  
 LINTELS

**NOTE**  
 Fireproof lintel for long spans. All steel members to be designed by structural engineer. Flashing details must be designed to suit job condition.

ALLOWABLE UNIFORM SUPERIMPOSED LOAD (IN LB) PER LINEAR FOOT FOR STEEL ANGLE LINTELS

HORIZONTAL LEG	ANGLE SIZE	WEIGHT PER FT (LB)	SPAN (FT) (CENTER TO CENTER OF REQUIRED BEARING)											
			3	4	5	6	7	8	9	10	11	12		
3 1/2	3 x 3 1/2 x 1/4	5.4	956	517	262	149	91	59						
		6.6	1166	637	323	184	113	73						
	3 1/2 x 3 1/2 x 1/4	5.8	1281	718	406	232	144	94	65					
		7.2	1589	891	507	290	179	118	80					
	4 x 3 1/2 x 1/4	6.2	1622	910	580	338	210	139	95	68				
		7.7	2110	1184	734	421	262	173	119	85	62			
	5 x 3 1/2 x 1/4	9.1	2434	1365	855	490	305	201	138	98	71			
		10.6	2760	1548	978	561	349	230	158	113	82	60		
	6 x 3 1/2 x 1/4	7.0	2600	1460	932	636	398	264	184	132	97	73		
		8.7	3087	1733	1106	765	486	323	224	161	119	89		
	6 x 3 1/2 x 1/4	12.0	4224	2371	1513	1047	655	435	302	217	160	120		
		7.9	3577	2009	1283	888	550	439	306	221	164	124		
6 x 3 1/2 x 1/4	9.8	4390	2465	1574	1090	798	538	375	271	201	151			
	11.7	5200	2922	1865	1291	945	636	443	320	237	179			

**NOTE**  
 Allowable loads to the left of the heavy line are governed by moment, and to the right by deflection.  $F_y = 36,000$  psi. Maximum deflection  $1/700$ . Consult structural engineer for long spans.

STEEL LINTEL DETAILS

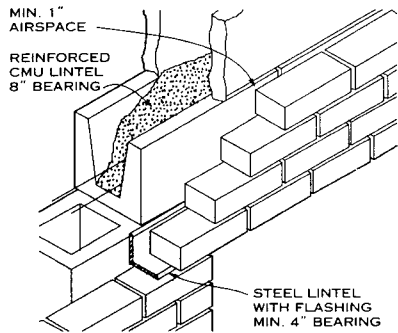

MASONRY LINTEL DETAIL

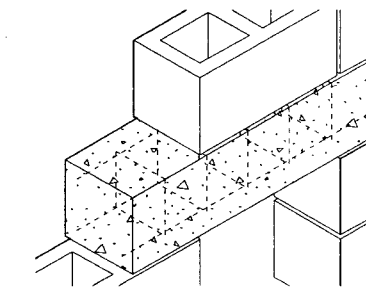

PRECAST CONCRETE LINTEL DETAIL

REQUIRED REINFORCING FOR SIMPLY SUPPORTED REINFORCED CONCRETE MASONRY LINTELS

TYPE OF LOAD	LINTEL SECTION NOMINAL SIZE (IN.)	REQUIRED REINFORCING CLEAR SPAN								
		3' - 4"	4' - 0"	4' - 8"	5' - 4"	6' - 0"	6' - 8"	7' - 4"	8' - 0"	
Wall loads	6 x 8	1 - #3	1 - #4	1 - #4	2 - #4	2 - #5				
	6 x 16					1 - #4	1 - #4	1 - #4	1 - #4	
Floor and roof loads	6 x 16	1 - #4	1 - #4	2 - #3	1 - #5	2 - #4	2 - #4	2 - #5	2 - #5	
	8 x 8	1 - #3	2 - #3	2 - #3	2 - #4	2 - #4	2 - #5	2 - #6	2 - #6	
Floor and roof loads	8 x 16								2 - #5	2 - #5
	8 x 8	2 - #4								
	8 x 16	2 - #3	2 - #3	2 - #3	2 - #4	2 - #4	2 - #4	2 - #5	2 - #5	

**NOTES**  
 1. Includes weight of lintel  
 2. Wall loads assumed to be 300 lb per linear ft  
 3. Floor and roof loads including wall loads assumed to be 1000 lb/linear ft  
 4. 8 in. lintels assumed to weigh 50 lb/ft  
 5. 16 in. lintels assumed to weigh 100 lb/ft

MAXIMUM DESIGN LOADS FOR PRECAST CONCRETE LINTELS (LB/LINEAR FT)

REINFORCEMENT	CLEAR SPAN											
	3' - 4"	4' - 0"	4' - 8"	5' - 4"	6' - 0"	6' - 8"	7' - 4"	8' - 0"	8' - 8"	9' - 4"	10' - 0"	10' - 8"
2 - #3	1585	1150	850	625	475	365	285	225	180	145	115	90
2 - #4	1855	1300	910	665	500	380	300	235	185	150	120	95
2 - #5	1825	1410	1005	725	535	410	315	250	195	155	125	100

**NOTE**  
 Lintel properties: width = 7 5/8 in., height = 7 5/8 in., weight = 60 lb/linear ft,  $f'_c = 2500$  psi

Grace S. Lee; Rippeteau Architects, PC; Washington, D.C.  
 Brian E. Trimble; Brick Institute of America; Reston, Virginia  
 Stephen S. Szoke, P.E.; National Concrete Masonry Association; Herndon, Virginia



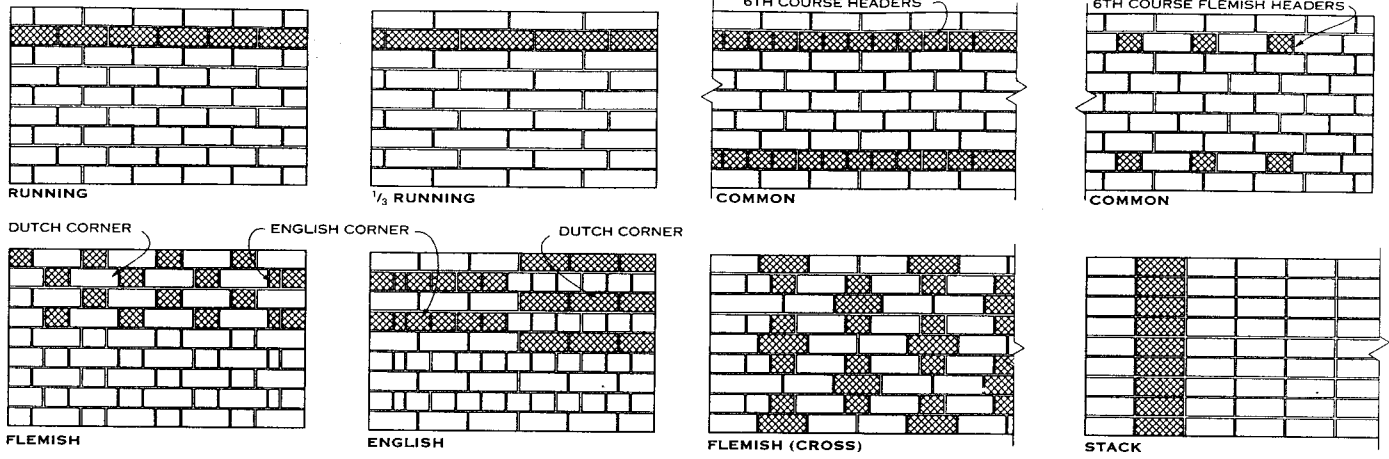

**BRICK BONDS**

When a circular masonry wall is to be laid up in running bond, the projections of the corners of units beyond the face of the units on the courses above and below may need to be limited for aesthetic reasons. Generally, projections of approximately 1/8 in. for nominal 8 in. long units and 1/4 in. for nominal 16 in. long units are acceptable. If the wall surface is to be stuccoed or otherwise covered, projections of 1/2 to 3/4 in. may not be objectionable. However, if it is desirable to obtain a smooth appearance for the curve or limit the shadows created by the projected corners, the projections should not exceed those indicated above. Projections of less than 1/8 in. are usually impractical because of construction tolerances.

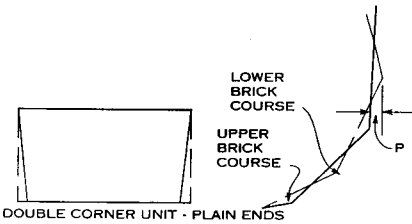

DOUBLE CORNER UNIT - PLAIN ENDS

**MINIMUM RADII OF MASONRY**

NOMINAL LENGTH	NOMINAL WIDTH (IN.)	3/8 IN. EXTERIOR MORTAR JOINT			1/2 IN. EXTERIOR MORTAR JOINT		
		RADIUS OF WALL	NUMBER OF UNITS IN 360°	PROJECTION OF UNIT (IN.)	RADIUS OF WALL	NUMBER OF UNITS IN 360°	PROJECTION OF UNIT (IN.)
8 in. (uncut)	4	9'-9"	92	1/16	6'-6"	61	3/32
	8	20'-4"	192	1/32	13'-7"	126	1/16
	12	31'-1"	293	1/32	20'-8"	195	1/32
16 in. (uncut)	4	19'-6"	92	1/8	13'-1"	61	7/32
	8	40'-9"	192	1/16	27'-5"	128	3/32
	12	62'-2"	293	1/16	41'-9"	195	1/16
8 in. (3/4 in., cuts interior face, both ends)	4	1'-6"	14	7/16	1'-4"	13	1/2
	8	8'-0"	26	7/32	2'-9"	26	1/4
	12	4'-6"	42	5/32	4'-3"	40	5/32
16 in. (3/4 in., cuts interior face, both ends)	4	2'-11"	14	7/8	2'-9"	13	15/16
	8	5'-11"	26	7/16	5'-7"	26	1/2
	12	8'-11"	42	5/16	8'-6"	40	5/16

**NOTE**

Interior mortar joints maintained at approximately 1/8 in.

**RADIAL WALLS AND BRICK PROJECTIONS**

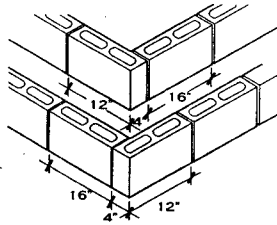

4 IN. WALL TO 4 IN. WALL

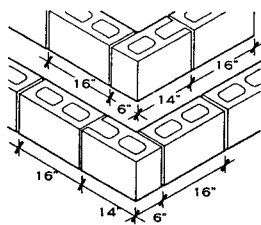

6 IN. WALL TO 6 IN. WALL

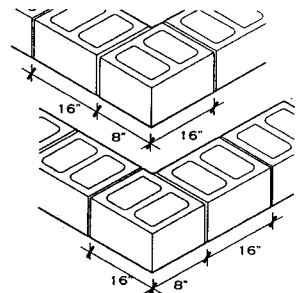

8 IN. WALL TO 8 IN. WALL

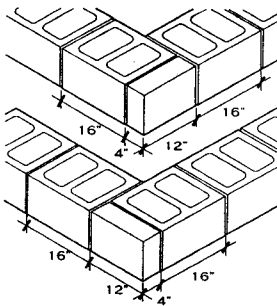

12 IN. WALL TO 12 IN. WALL

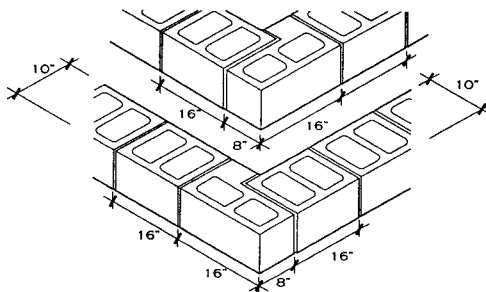

10 IN. WALL TO 10 IN. WALL

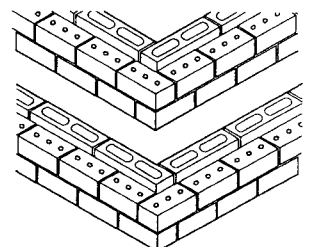

10 IN. CAVITY WALL

**CORNER LAYOUT SHOWING ALTERNATING COURSES**

A. Harris Lokmanhakim, AIA; Rippeteau Architects, PC; Washington, D.C.  
 Stephen S. Szoke, P.E.; National Concrete Masonry Association; Herndon, Virginia  
 Brian E. Trimble; Brick Institute of America; Reston, Virginia

**BRICK AND TILE CLASSIFICATION**

Brick and tile are classified according to the specific location where they are used. Standard specifications have been developed to produce uniform requirements for brick. The American Society for Testing and Materials (ASTM) publishes the most widely accepted standards on brick. Standard specifications include strength, durability, and aesthetic requirements.

**CLASSIFICATIONS**

TYPE OF BRICK UNIT	ASTM DESIGNATION
Building brick	C 62
Facing brick	C 216
Hollow brick	C 652
Paving brick	C 902
Ceramic glazed brick	C 126
Thin brick veneer units	C 1088
Sewer and manhole brick	C 32
Chemical resistant brick	C 279
Industrial floor brick	C 410
TYPE OF TILE UNIT	
Structural clay load bearing tile	C 34
Structural clay non-load bearing tile	C 56
Structural clay facing tile	C 212
Structural clay non-load bearing screen tile	C 530
Ceramic glazed tile	C 126

**GENERAL REQUIREMENTS**

Terms used in each standard for classification may include exposure, appearance, physical properties, efflorescence, dimensional tolerances, distortion, chipping, core, and frogs. Bricks can be classified by use, grade, type, and/or class in most specifications. All options should be specified, as each ASTM standard has minimum requirements for grade and type that apply automatically if an option is omitted. If the desired requirements are not specified, a delivery may contain bricks unsuitable for the intended use.

**EXPOSURE**

Specific grades of brick are required to accommodate the various climates found in the United States and the differ-

ent applications in which brick can be used. Bricks must meet a grade of SW, MW, or NW based on the weathering index and the exposure they will receive. The weathering index is the product of the average annual number of freezing cycle days and the average annual winter rainfall in inches (see map below). The exposure is related to whether the brick is used on a vertical or horizontal surface and whether the unit will be in contact with the earth (see table 3). A higher weathering index or a more severe exposure will require face brick to meet the SW requirements. The grade is typically based on physical properties of the brick. The grades for each specification are listed in table 2.

**TABLE 2: GRADE REQUIREMENTS FOR FACE EXPOSURES\***

EXPOSURE	WEATHERING INDEX	
	LESS THAN 50	50 AND GREATER
In vertical surfaces:		
In contact with earth	MW	SW
Not in contact with earth	MW	SW
In other than vertical surfaces:		
In contact with earth	SW	SW
Not in contact with earth	MW	SW

\*See map below.

**TABLE 3: EXPOSURE**

ASTM STANDARD	MORE SEVERE EXPOSURE	LESS SEVERE EXPOSURE
C 62 Grade	SW	MW NW
C 216 Grade	SW	MW
C 652 Grade	SW	MW
C 902 Grade	SX	MX NX
C 126 <sup>1</sup>	—	—
C 1088 Grade	—	Exterior Interior
C 32 sewer <sup>2</sup>	SS	SM
Grade manhole	MS	MM

**NOTES**

1. No requirements for durability.
2. Based on durability and abrasion.

**APPEARANCE**

Brick types are related to the appearance of the unit, and specifically to limits on dimensional tolerances, distortion tolerances, and chippage. The brick type can be selected depending on whether a high degree of precision is necessary, a wider range of color or size is permitted, or a characteristic architectural effect is desired. The types of brick for each specification are listed in table 4.

**TABLE 4: APPEARANCE**

ASTM STANDARD	TIGHTER TOLERANCES		LOOSER TOLERANCES	
C 62			None	
C 216 Type	FBX		FBS	FBA
C 652 Type	HBX	HBS	HBB	HBA
C 902 application	PX		PS	PA
C 126 Grade	S		SS	—
C 1088 Type	TBX		TBS	TBA
C 32 sewer manhole			None	None

**AESTHETICS AND SHAPES**

Brick is readily available in many sizes, colors, textures, and shapes, all adaptable for virtually any style or expression. Brick's small module can be related to the scale of the wall, and its sizes can be combined to create different appearances and patterns. Sizes available are shown in table 1.

When specifying the size of units, dimensions should be listed in the following order: width by thickness by length. The size of the brick influences cost because larger units require fewer bricks, normally resulting in less labor. Specially shaped bricks are available to add interest to a wall, including water table bricks, radials, caps, copings, corners, and others. Consult the manufacturer for specific sizes and availability.

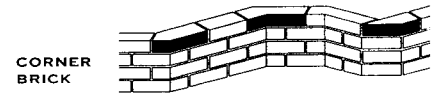

**CORNER BRICK**

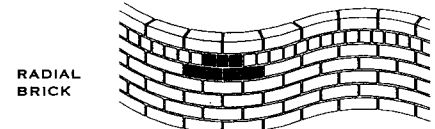

**RADIAL BRICK**

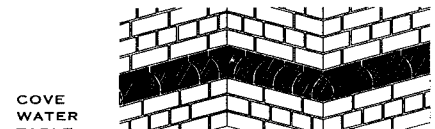

**COVE WATER TABLE**

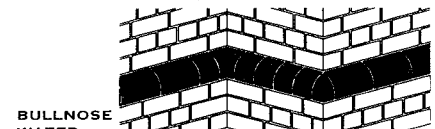

**BULLNOSE WATER TABLE**

**BRICK SHAPES**

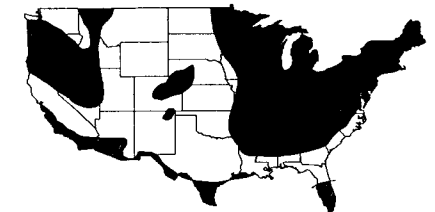

- NEGLIGIBLE WEATHERING
- MODERATE WEATHERING
- SEVERE WEATHERING

**U.S. WEATHERING INDEXES**

**TABLE 1: STANDARD NOMENCLATURE FOR BRICK SIZES**

UNIT DESIGNATION	MODULAR BRICK SIZES							
	NOMINAL DIMENSIONS (IN.)			JOINT THICKNESS <sup>1</sup> (IN.)	SPECIFIED DIMENSIONS <sup>2</sup> (IN.)			VERTICAL COURSING
	W	H	D		W	H	L	
Modular	4	2 <sup>2</sup> / <sub>3</sub>	8	<sup>3</sup> / <sub>8</sub> <sup>1</sup> / <sub>2</sub>	<sup>3</sup> / <sub>8</sub> <sup>3</sup> / <sub>2</sub>	2 <sup>1</sup> / <sub>4</sub> 2 <sup>1</sup> / <sub>4</sub>	<sup>7</sup> / <sub>8</sub> 7 <sup>1</sup> / <sub>2</sub>	3C = 8 in.
Engineer modular	4	3 <sup>1</sup> / <sub>5</sub>	8	<sup>3</sup> / <sub>8</sub> <sup>1</sup> / <sub>2</sub>	<sup>3</sup> / <sub>8</sub> <sup>3</sup> / <sub>2</sub>	2 <sup>3</sup> / <sub>4</sub> 2 <sup>13</sup> / <sub>16</sub>	<sup>7</sup> / <sub>8</sub> 7 <sup>1</sup> / <sub>2</sub>	5C = 16 in.
Closure modular	4	4	8	<sup>3</sup> / <sub>8</sub> <sup>1</sup> / <sub>2</sub>	<sup>3</sup> / <sub>8</sub> <sup>3</sup> / <sub>2</sub>	<sup>3</sup> / <sub>8</sub> 3 <sup>1</sup> / <sub>2</sub>	<sup>7</sup> / <sub>8</sub> 7 <sup>1</sup> / <sub>2</sub>	1C = 4 in.
Roman	4	2	12	<sup>3</sup> / <sub>8</sub> <sup>1</sup> / <sub>2</sub>	<sup>3</sup> / <sub>8</sub> <sup>3</sup> / <sub>2</sub>	1 <sup>5</sup> / <sub>8</sub> 1 <sup>1</sup> / <sub>2</sub>	11 <sup>5</sup> / <sub>8</sub> 11 <sup>1</sup> / <sub>2</sub>	2C = 4 in.
Norman	4	2 <sup>2</sup> / <sub>3</sub>	12	<sup>3</sup> / <sub>8</sub> <sup>1</sup> / <sub>2</sub>	<sup>3</sup> / <sub>8</sub> <sup>3</sup> / <sub>2</sub>	2 <sup>1</sup> / <sub>4</sub> 2 <sup>1</sup> / <sub>4</sub>	11 <sup>5</sup> / <sub>8</sub> 11 <sup>1</sup> / <sub>2</sub>	3C = 8 in.
Engineer norman	4	3 <sup>1</sup> / <sub>5</sub>	12	<sup>3</sup> / <sub>8</sub> <sup>1</sup> / <sub>2</sub>	<sup>3</sup> / <sub>8</sub> <sup>3</sup> / <sub>2</sub>	2 <sup>3</sup> / <sub>4</sub> 2 <sup>13</sup> / <sub>16</sub>	11 <sup>5</sup> / <sub>8</sub> 11 <sup>1</sup> / <sub>2</sub>	5C = 16 in.
Utility	4	4	12	<sup>3</sup> / <sub>8</sub> <sup>1</sup> / <sub>2</sub>	<sup>3</sup> / <sub>8</sub> <sup>3</sup> / <sub>2</sub>	<sup>3</sup> / <sub>8</sub> 3 <sup>1</sup> / <sub>2</sub>	11 <sup>5</sup> / <sub>8</sub> 11 <sup>1</sup> / <sub>2</sub>	1C = 4 in.
NONMODULAR BRICK SIZES								
Standard				<sup>3</sup> / <sub>8</sub> <sup>1</sup> / <sub>2</sub>	<sup>3</sup> / <sub>8</sub> <sup>3</sup> / <sub>2</sub>	2 <sup>1</sup> / <sub>4</sub>	8	3C = 8 in.
Engineer standard				<sup>3</sup> / <sub>8</sub> <sup>1</sup> / <sub>2</sub>	<sup>3</sup> / <sub>8</sub> <sup>3</sup> / <sub>2</sub>	2 <sup>3</sup> / <sub>4</sub> 2 <sup>13</sup> / <sub>16</sub>	8	5C = 16 in.
Closure standard				<sup>3</sup> / <sub>8</sub> <sup>1</sup> / <sub>2</sub>	<sup>3</sup> / <sub>8</sub> <sup>3</sup> / <sub>2</sub>	3 <sup>5</sup> / <sub>8</sub> 3 <sup>1</sup> / <sub>2</sub>	8	1C = 4 in.
King				<sup>3</sup> / <sub>8</sub>	3 2 <sup>3</sup> / <sub>4</sub>	2 <sup>3</sup> / <sub>4</sub> 2 <sup>5</sup> / <sub>8</sub>	9 <sup>5</sup> / <sub>8</sub> 9 <sup>5</sup> / <sub>8</sub>	5C = 16 in.
Queen				<sup>3</sup> / <sub>8</sub>	3 2 <sup>3</sup> / <sub>4</sub>	2 <sup>3</sup> / <sub>4</sub> 2 <sup>3</sup> / <sub>4</sub>	8 8	5C = 16 in.

**NOTES**

1. Common joint sizes used with length and width dimensions. Actual joint thicknesses vary between bed joints and head joints.
2. Specified dimensions may vary within this range among manufacturers.

Grace S. Lee; Rippeteau Architects, PC; Washington, D.C.  
 Stephen S. Szoke, P.E.; National Concrete Masonry Association; Herndon, Virginia  
 Brian E. Trimble; Brick Institute of America; Reston, Virginia

**GENERAL**

Concrete masonry units (CMU) conform to ASTM standard specifications. The most common concrete masonry units used in building construction are load bearing units and concrete brick. Non-load bearing units may be specified for partitions and are commonly used for fire protection of steel columns and fire-rated partitions.

Type I or moisture-controlled units are specified to obtain a uniform degree of volume change due to moisture loss in a particular climate. The specification of Type I units facilitates the location of control joints. Type II or non-moisture controlled units may be more economical but will typically require closer spacing of control joints.

In addition to type, concrete bricks are specified by grade. Grade N is intended for use as architectural veneer and facing units in exterior walls and for use when high strength and resistance to moisture penetration and severe frost action are desired. Grade S is intended for general masonry where moderate strength and resistance to frost action and moisture penetration are required.

Concrete masonry units are available in a variety of colors, sizes, textures, configurations, and weights to accommodate design, detailing, and construction. Colors are now provided with lightfast metallic oxide pigments conforming to ASTM C 979. The textures may be smooth, ground, split, ribbed, or otherwise prepared to maximize design versatility. Smooth finishes and more color options are available with prefaced, "integral glazed" concrete masonry units.

Concrete masonry units are specified as width by height by length. The nominal dimensions are usually 3/8 in. larger than the actual unit dimensions. The most common nominal widths of concrete masonry units are 4 in., 6 in., 8 in., 10 in., and 12 in. The nominal heights are mostly 8 in. and 4 in., except concrete bricks are typically 2 2/8 in. high. The nominal lengths are usually 16 or 18 in. Concrete brick length is usually 8 in. but is often 12 in. Lengths may be 18 or 24 in. in some regions. These longer lengths are usually more economical for placement.

**VOLUMETRIC CHARACTERISTICS OF TYPICAL HOLLOW CONCRETE MASONRY UNITS (7 1/2 X 15 1/2 IN.)**

WIDTH (IN.)	GROSS VOLUME, CU IN. (CU FT)	MINIMUM THICKNESS		2 CORE UNITS	
		SHELL (IN.)	WEB (IN.)	PERCENT SOLID VOLUME	EQUIVALENT SOLID THICKNESS (IN.)
3 5/8	432 (0.25)	0.75	0.75	64	2.32
		1.00	1.00	73	2.66
5 5/8	670 (0.388)	1.00	1.00	57	3.21
		1.12	1.00	61	3.43
		1.25	1.00	64	3.60
		1.37	1.12	68	3.82
7 5/8	908 (0.526)	1.25	1.00	53	4.04
		1.37	1.12	57	4.35
		1.50	1.12	59	4.50
9 5/8	1145 (0.664)	1.25	1.12	48	4.62
		1.37	1.12	51	4.91
		1.50	1.25	54	5.20
11 5/8	1385 (0.803)	1.25	1.12	44	5.12
		1.37	1.12	46	5.35
		1.50	1.25	49	5.70
		1.75	1.25	52	6.05

The weight of the units also varies. Depending on the aggregate used, concrete masonry units are typically made using concretes with densities ranging from 85 to 140 pcf. The lighter units tend to provide more fire resistance and have an improved noise reduction coefficient, and they often are more economical to place in the wall. Heavier units tend to provide increased compressive strength, better resistance to sound penetration, higher water penetration resistance, and greater thermal storage capabilities.

**ASTM STANDARD SPECIFICATIONS**

- C 55—Concrete Brick
- C 73—Calcium Silicate Face Brick (sand-lime brick)
- C 90—Load Bearing Concrete Masonry Units
- C 129—Non-load Bearing Concrete Masonry Units
- C 139—Concrete Masonry Units for the Construction of Catch Basins and Manholes
- C 744—Prefaced Concrete and Calcium Silicate Masonry Units
- C 936—Solid Concrete Interlocking Paving Units

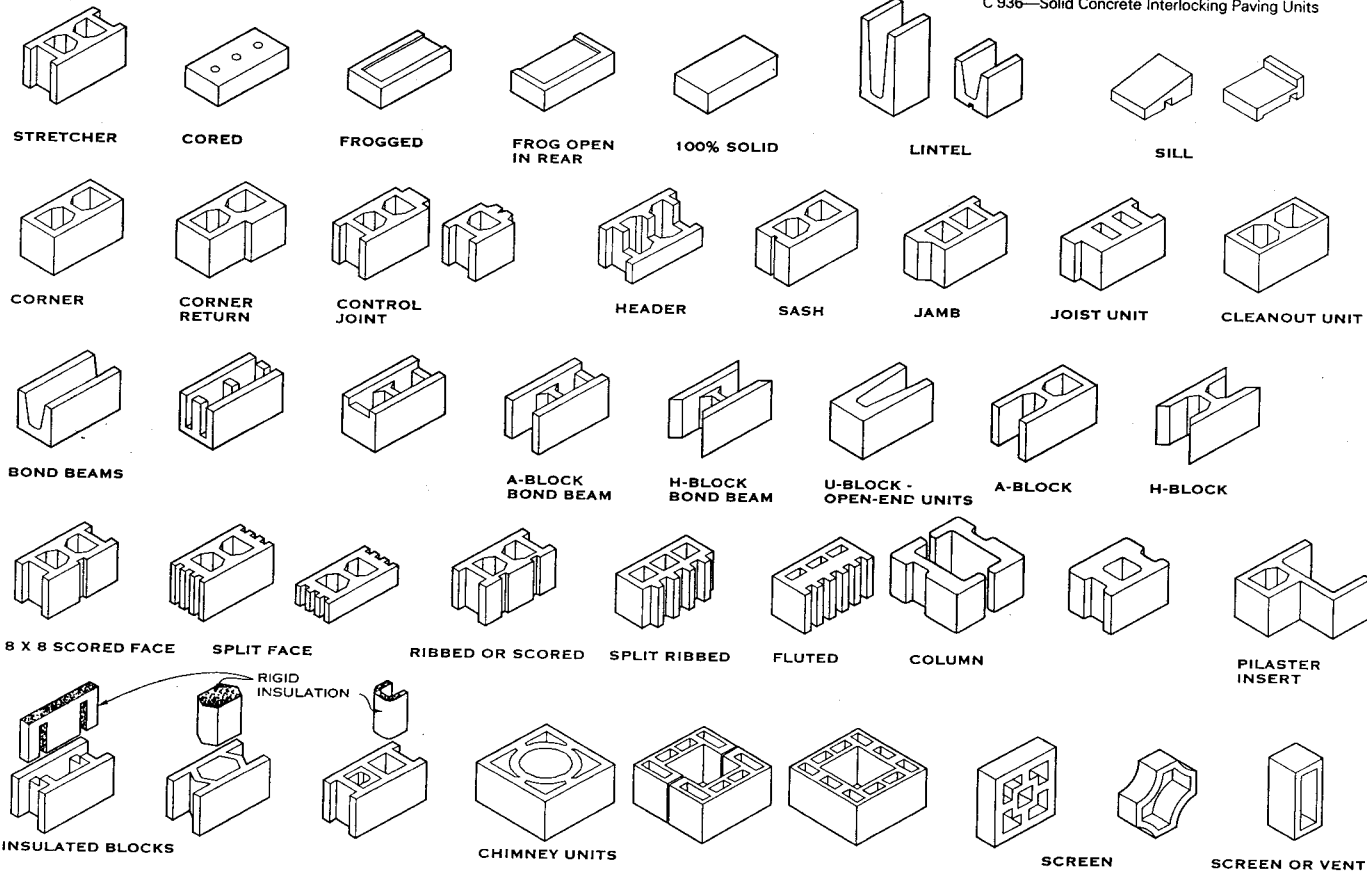

**TYPICAL CONCRETE MASONRY UNIT SHAPES**

Stephen S. Szoke, P.E.; National Concrete Masonry Association; Herndon, Virginia  
 Grace S. Lee; Rippeteau Architects, PC; Washington, D.C.

**GENERAL**

Masonry walls have long served as foundations for structures. Today, most masonry foundation walls consist of single wythe, hollow or solid masonry unit construction, depending on the required bearing capacity. The wall systems may be used as perimeter walls for slab-on-grade construction or to form crawl spaces or basements. The walls are reinforced as necessary to resist lateral loads. Generally, such reinforcement should be held as close to the interior face shell as possible, to provide the maximum tensile strength most economically.

Foundation systems, especially basement walls, need to do more than simply support the structure. They must protect against heat, insect infestation (particularly termites), fire, and penetration of water and soil gas.

Thermal protection may be provided with interior furring and batts or rigid board insulation, an exterior rigid board insulation and protection system, or with integral insulation strategies. The latter include foamed-in-place insulation, granular fill insulations, and premolded polystyrene inserts. Use of interior and exterior insulation rather than premolded inserts allows reinforcing steel to be installed more easily.

Optimal insect protection can be achieved using interior or integral insulation and a termite shield. Metal flashing materials often perform well as termite shields. For exterior insulation strategies in locations where termites are a concern, the termite shield must extend over the exterior insulation.

Waterproofing and dampproofing are specified by building codes, as discussed in chapter 7. Generally, waterproofing makes the foundation or basement wall resistant to air infil-

tration and thereby resistant to soil gases such as radon. Typical waterproofing consists of a minimum 3/8 in. coat of cement stucco parging and an appropriate liquid-applied membrane, but some liquid-applied membranes alone or combined with built-up membranes are acceptable. Surface-bonding mortar mixes are also effective for resisting water and soil-gas penetration. A good perimeter drainage system in contact with open air or connected to a sump pit should be used for effective drainage.

If radon is a major concern, the top course of the masonry and the course of masonry at or below the slab should be constructed of 100% solid units or hollow units fully filled with grout. French drains (drainage channels at the interfaces of foundation walls and floor slabs), which often are used to collect and drain condensation moisture in basements, should be avoided in areas where soil-gas entry is a concern.

Architectural masonry units may be used to improve the appearance of foundation walls, often in the above-grade portion of the walls. Masonry units with architectural finishes facing the interior can be used for economical construction of finished basement space.

Masonry easily accommodates any floor plan, and returns and corners increase the structural performance of the wall for lateral load resistance. Returns and corners that support porches, fireplaces, and the like may also serve as wine cellars. Returns for window wells permit an increase in daylighting, making below-grade areas more attractive as habitable space.

**THICKNESS OF FOUNDATION WALLS**

FOUNDATION WALL CONSTRUCTION	NOMINAL THICKNESS (IN.)	MAXIMUM DEPTH OF UNBALANCED FILL (FT)
Masonry of hollow units, ungrouted	8	5
	10	6
	12	7
Masonry of solid units	8	5
	10	7
	12	7
Masonry of hollow or solid units, fully grouted	8	7
	10	8
	12	8

**NOTE**

Drainage must be provided on surface and below grade to remove ground water from foundation wall. The backfill must be granular and soil conditions nonexpansive.

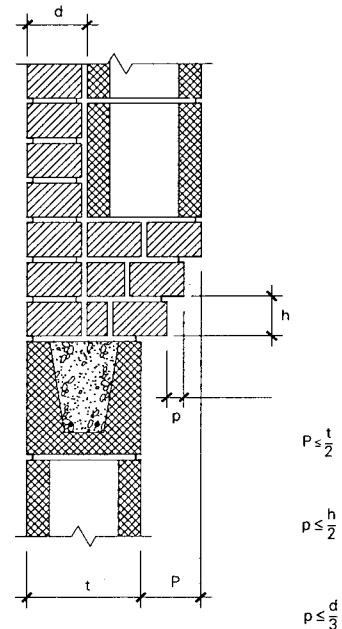
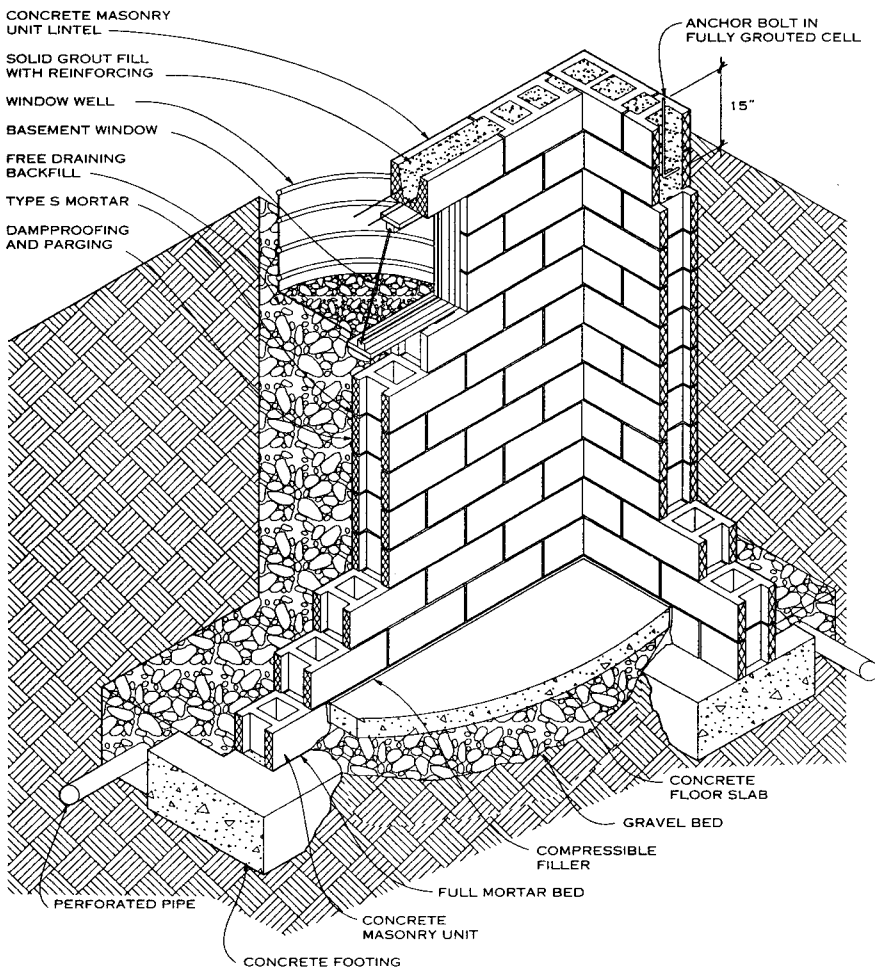

**Where:**

- P = allowable total horizontal projection of corbeling
- p = allowable projection of one unit
- t = nominal wall thickness (actual thickness plus the thickness of one mortar joint)
- h = nominal unit height (actual height plus the thickness of one mortar joint)
- d = nominal unit bed depth (actual bed depth plus the thickness of one mortar joint)

**NOTE**

Corbeling is used to increase wall thickness to suit bearing requirements above foundation. Corbeling may be equal on both sides of the wall.

**LIMITATIONS ON CORBELING**

**TYPICAL FOUNDATION WALL**

Grace S. Lee; Rippeteau Architects, PC; Washington, D.C.  
 Stephen S. Szoke, P.E.; National Concrete Masonry Association; Herndon, Virginia

**NOTE**  
 S = spacing of vertical reinforcing bars  
 B = bar size  
 H = height of backfill

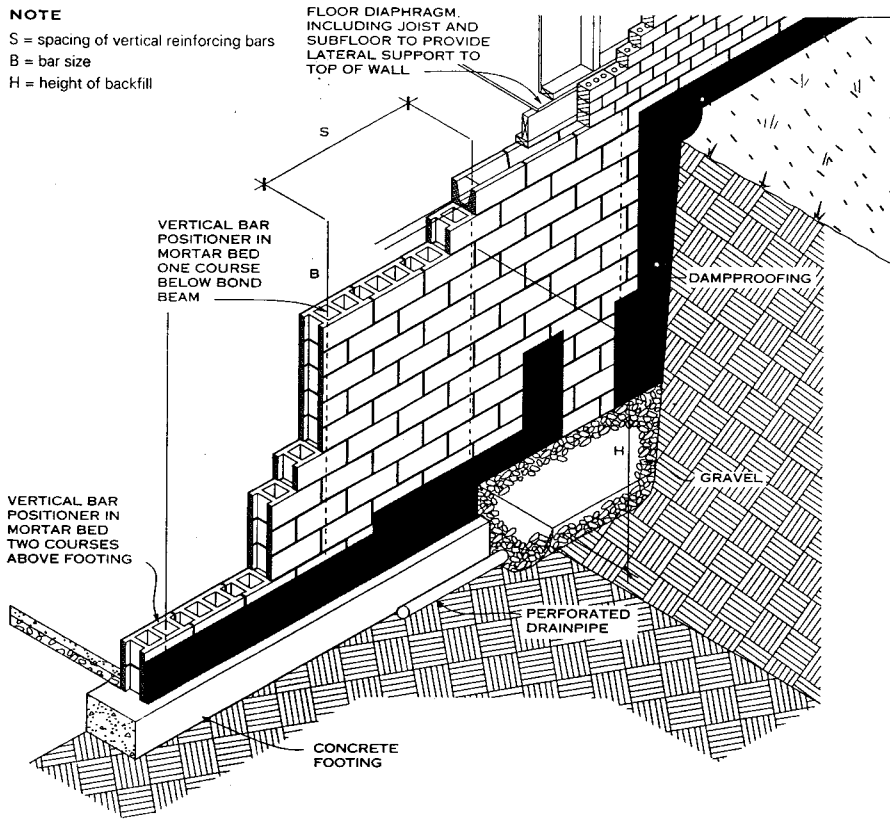

**FOUNDATION WALL REINFORCEMENT**

VERTICAL REINFORCEMENT					
BAR SIZE AND MAXIMUM BAR SPACING					
Bar size, B	HEIGHT OF BACKFILL, H				
	8'	7'	6'	5'	4'
Spacing, S	#6 48"	#6 56"	#5 64"	#5 72"	#4 72"

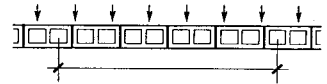

HORIZONTAL JOINT REINFORCEMENT					
MORTAR JOINT	HEIGHT OF BACKFILL, H				
	8'	7'	6'	5'	4'
13	—	—	—	—	—
12	—	—	—	—	—
11	8 ga.	9 ga.	9 ga.	9 ga.	9 ga.
10	—	—	—	—	—
9	8 ga.	9 ga.	9 ga.	9 ga.	—
8	—	—	—	—	9 ga.
7	8 ga.	9 ga.	9 ga.	9 ga.	—
6	—	—	—	—	—
5	8 ga.	9 ga.	9 ga.	9 ga.	—
4	—	9 ga.	9 ga.	9 ga.	9 ga.
3	8 ga.	9 ga.	9 ga.	9 ga.	9 ga.
2	—	—	—	—	—
1	—	—	—	—	—

**NOTES**

1. The empirical design method of the Building Code Requirements for Masonry Structures, ACI 530/ASCE 5, chapter 9, allows up to 5 ft of backfill on an 8 in. nonreinforced concrete masonry wall.
2. As an alternate, 9 gauge joint reinforcement placed in joints numbers 3, 4, 5, 7, 8, and 11 may be used.

**VERTICAL REINFORCEMENT SPACING**

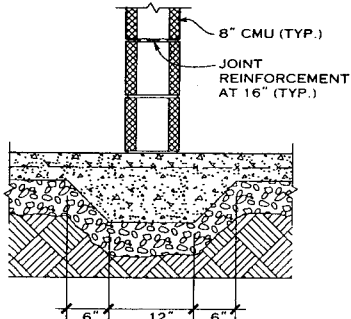
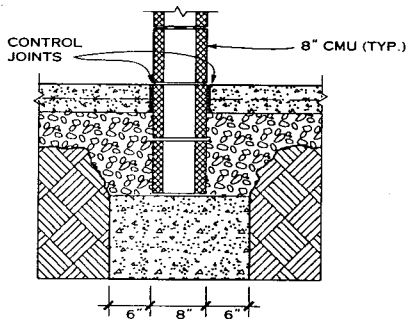
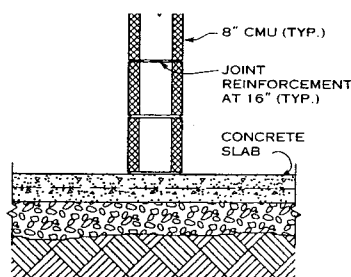
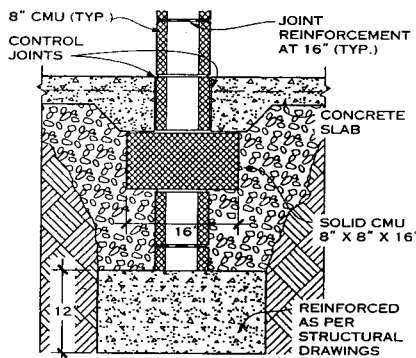

**WALL FOUNDATION FOR INTERIOR BEARING WALLS**

**WALL FOUNDATION FOR NON-BEARING OR BEARING INTERIOR WALLS**

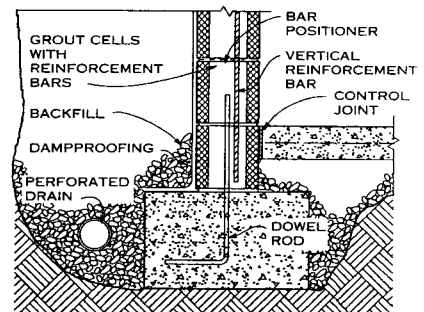

**DOWELED FOOTING DETAIL**

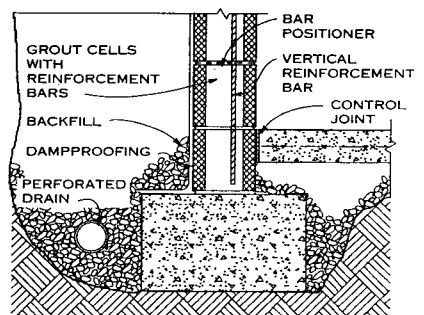

**REINFORCED FOUNDATION WALL DETAIL**

Grace S. Lee; Rippeteau Architects, PC; Washington, D.C.  
 Stephen S. Szoke, P.E.; National Concrete Masonry Association; Herndon, Virginia

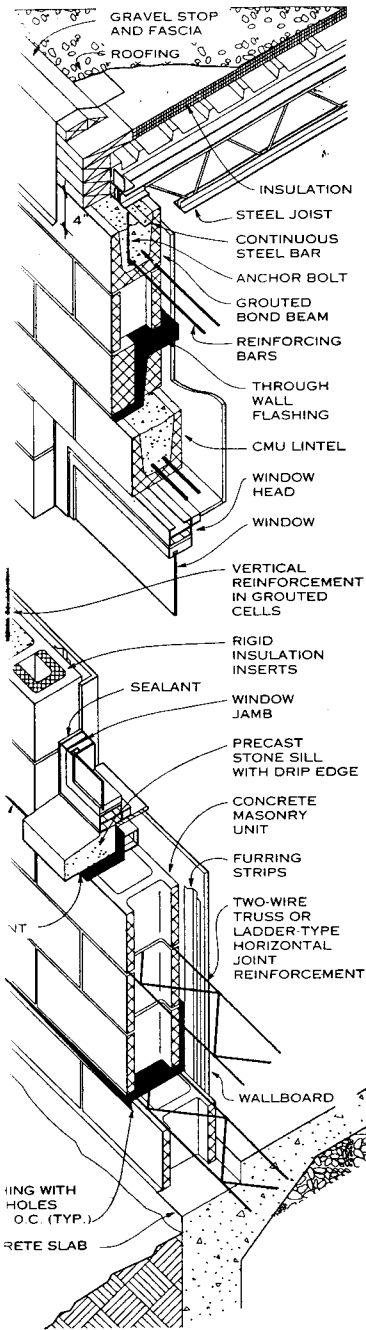

**SINGLE WYTHE MASONRY WALL WITH STEEL FRAME**

**SINGLE WYTHE MASONRY**

Single wythe masonry wall construction is common for both load bearing and non-load bearing interior and exterior walls. These systems are frequently used as interior partitions for fire protection.

Single wythe walls may be integrally insulated with precast fill insulation, foamed-in-place insulation, or site cast or factory installed molded polystyrene inserts. Single wythe walls may also be insulated on the interior or exterior. The insulation may be adhered or mechanically

Prepared by: S. Lee; Rippeteau Architects, PC; Washington, D.C.  
 Prepared by: S. Szoke, P.E.; National Concrete Masonry Association; Herndon, Virginia  
 Prepared by: J. Trimble; Brick Institute of America; Reston, Virginia

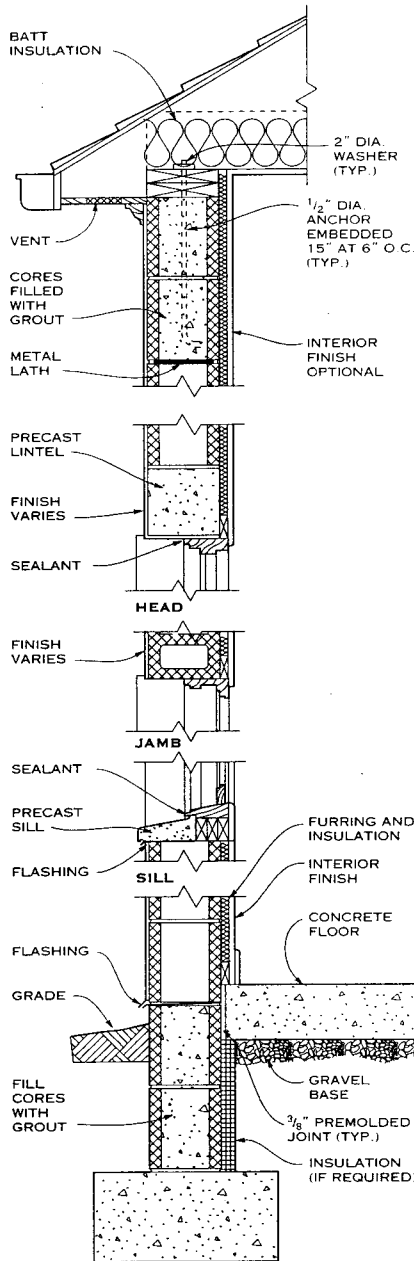

**SINGLE WYTHE MASONRY WALL WITH WOOD FRAME**

fastened directly to the masonry, or it may be installed in conjunction with conventional furring or studding systems. The benefits of thermal mass are generally optimized with integral and exterior insulation strategies.

When single wythe walls are used as exterior walls and a high degree of water penetration resistance is required, the use of integral water repellents; exterior coatings, sealers, or finishes; or both may be required for concrete masonry construction. Clay masonry does not require these treatments.

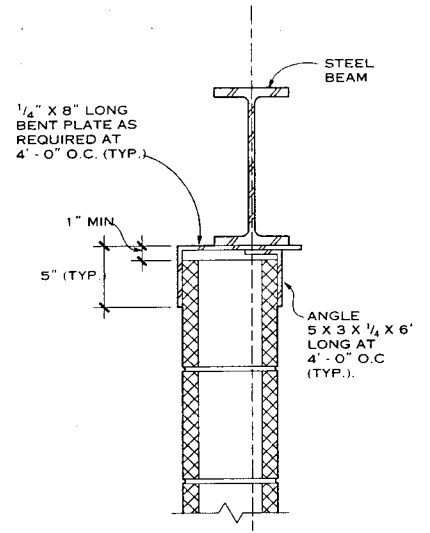

**HORIZONTAL SUPPORT FOR NON-LOAD BEARING WALLS — STEEL FRAME**

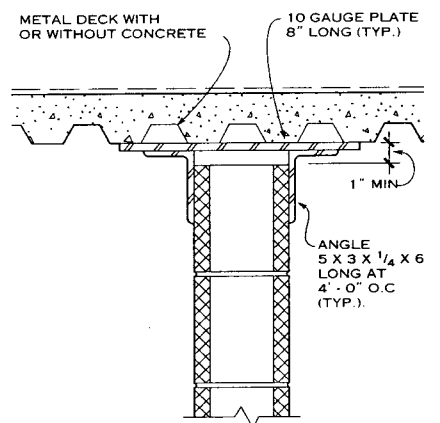

**HORIZONTAL SUPPORT FOR NON-LOAD BEARING WALLS — METAL DECK**

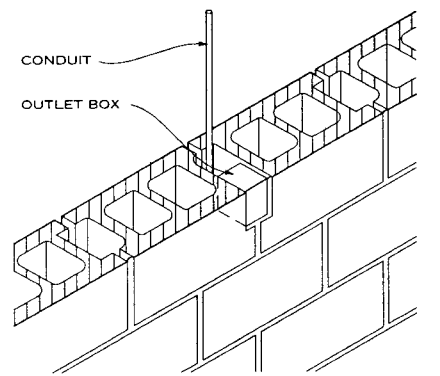

**ELECTRICAL OUTLET BOX IN CMU WALL**

**GENERAL**

Design of multistory bearing wall buildings is based on combined structural action of the floor and roof system with the masonry walls. Floors carry the vertical loads and, acting as diaphragms, also distribute lateral loads to the walls. In masonry bearing wall buildings, lateral forces from winds or earthquakes are usually resisted by shear walls parallel to the direction of the lateral force. By their shearing and flexural resistance, these walls transfer lateral forces to the foundation.

The action of roof and floor diaphragms affects the distribution of lateral forces to the shear walls. Diaphragms are classified into three groups: rigid, semirigid (or semiflexible), and flexible. In design, the rigid diaphragm is assumed to distribute horizontal forces to vertical shear walls in proportion to their relative rigidities (longer or thicker walls being more rigid than shorter or thinner walls). More complex design approaches may consider the diaphragms to be semirigid or flexible. The distribution of loads in these more complex designs is similar to continuous beam design and design based on tributary areas, respectively.

For the diaphragms to be effective, there must be adequate connections between the roof and floor systems and the masonry walls. In many instances, adequate connection is achieved with the walls supported on masonry bond beams. Horizontal members (roofs and floors) are often connected to the walls with reinforcing steel. Adequate connections may be reinforcing steel into bond beams or may be coordinated with the masonry wall reinforcement. Connections will vary with the requirement to resist loads.

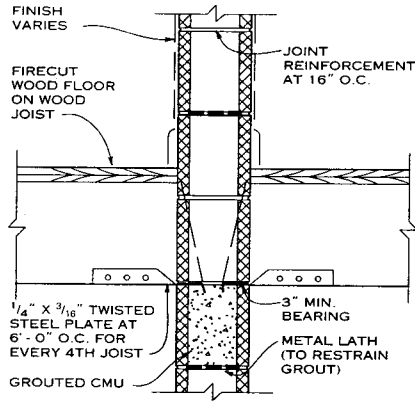

CMU WALL TO WOOD JOIST ANCHORAGE

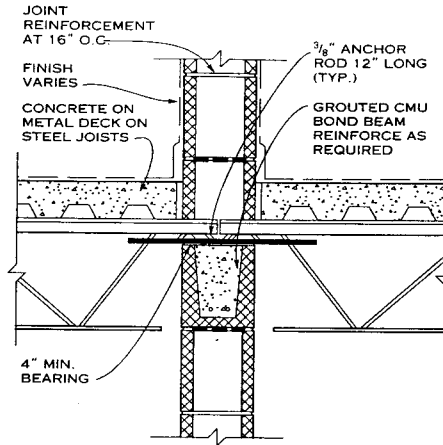

CMU WALL TO STEEL JOIST ANCHORAGE

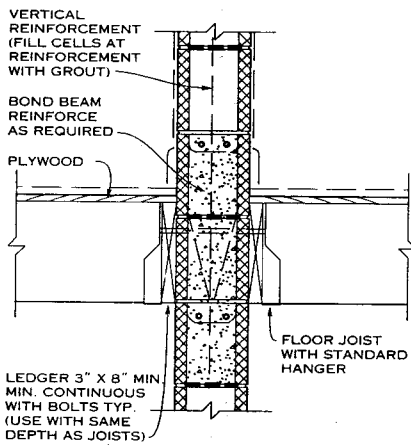

INTERIOR WALL TO JOIST ANCHORAGE

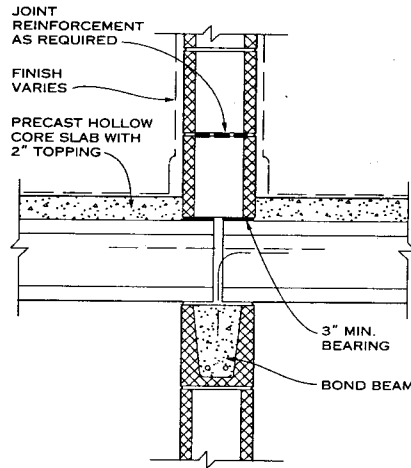

CMU WALL TO CONCRETE JOIST ANCHORAGE

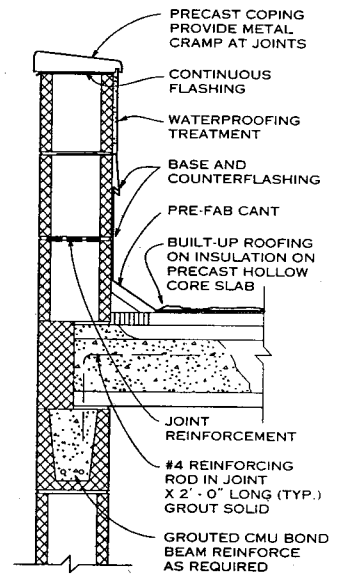

CMU PARAPET TO CONCRETE ROOF ANCHORAGE

**WALL ANCHORAGE DETAILS**

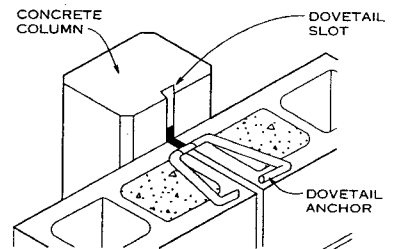
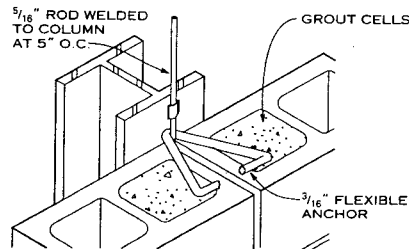
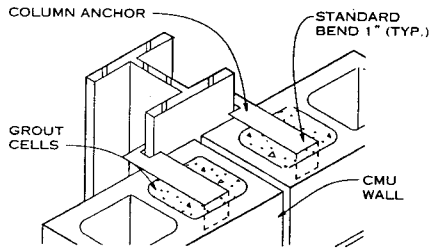

**WALL TO COLUMN ANCHORAGE DETAILS**

Grace S. Lee; Rippeteau Architects, PC; Washington, D.C.  
 Stephen S. Szoke, P.E.; National Concrete Masonry Association; Herndon, Virginia  
 Brian E. Trimble; Brick Institute of America; Reston, Virginia

**REINFORCEMENT**

In many applications, single wythe walls are reinforced. The term *partially reinforced* is erroneous. Reinforcement schedules are designed for a particular application, and all the required reinforcement is necessary.

Walls are often partially grouted, that is, only the cells or cavities of the wall containing reinforcement are grouted. When walls are partially grouted, special units or construction fabric are used for vertical containment of the grout. Horizontal containment is usually provided by mortaring the webs of the masonry units. When steel placement is frequent, it may become economical or necessary to fully grout the walls.

Structural components of a building using reinforced masonry combine the tensile strength of reinforcement with the compressive strength of the masonry to resist design loads. Walls, columns, pilasters, and beams are designed to resist dead, live, wind, seismic, and lateral earth pressures using reinforced masonry. The benefits of incorporating reinforcement are improved ductility, structural integrity, and resistance to flexural and shear stresses. Reinforced masonry walls are extensively used for warehouses, institutional buildings, retaining walls, shear walls, basement walls, and load bearing walls, particularly in multistory hotels and apartment buildings. Reinforced masonry provides economical construction, especially when a high degree of resistance to lateral loads is necessary.

Seismic performance categories A and B require no special provisions. In many instances, the wind loads will govern the minimum reinforcing levels in seismic performance category C and above.

For designs in seismic performance category C, vertical reinforcement of at least 0.20 in. in cross-sectional areas shall be provided continuously from support to support at each corner, at each side of each opening, and at the ends of walls. Horizontal reinforcement of not less than 0.20 in. shall be provided at the bottom and top of all openings and extend not less than 24 in. nor less than 40 bar diameters past the opening. Horizontal reinforcement should be installed continuously at structurally connected roof and floor levels, at the tops of walls, and at the bottom of the wall or at the top of the foundation; maximum spacing is 10 ft unless uniformly distributed joint reinforcement is provided.

For designs in seismic performance categories D and E, walls shall be reinforced both vertically and horizontally. Requirements in addition to those for seismic performance category C include that spacing shall not exceed 4 ft, except for designs using moment resisting space frames, where the spacing of principal reinforcement shall not exceed 2 ft. Also, the diameter of the reinforcement shall not be less than 3/8 in., except for joint reinforcement.

**STANDARD MATERIALS SELECTION FOR REINFORCED MASONRY**

MASONRY UNITS		MORTAR AND GROUT		REINFORCEMENT	
ASTM C 90	Load bearing Concrete Masonry Units	ASTM C 270	Mortar for Unit Masonry Construction	ASTM A 82	Steel Wire, Plain
ASTM C 216	Facing Brick (solid masonry units made from clay or shales)	ASTM C 476	Grout for Masonry	ASTM A 615	Deformed and Plain Billet-Steel Bars
ASTM C 652	Hollow Brick (hollow masonry units made from clay or shale)			ASTM A 616	Rail-Steel Deformed and Plain Bars
				ASTM A 706	Low-Alloy Steel Deformed Bars
				UBC 24-15	Joint Reinforcement for Masonry

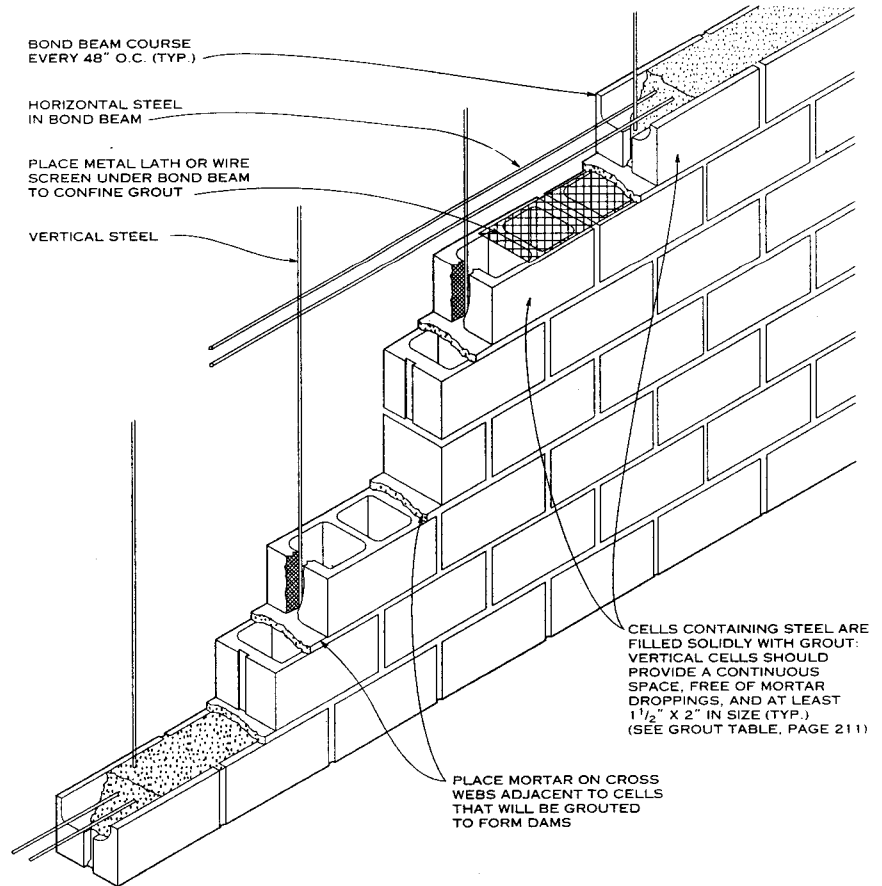

**METHODS OF REINFORCING**

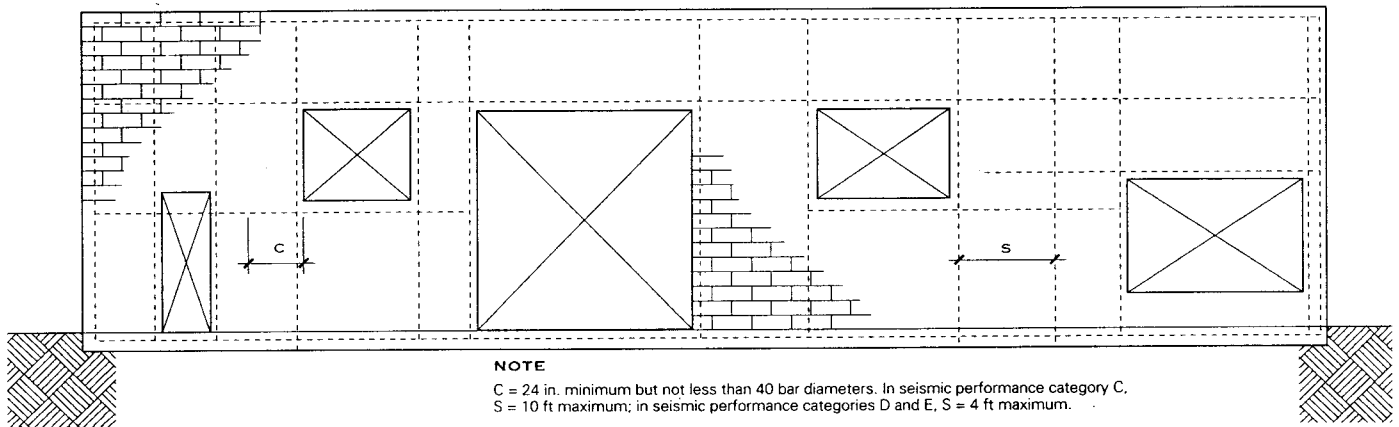

**NOTE**  
 C = 24 in. minimum but not less than 40 bar diameters. In seismic performance category C,  
 S = 10 ft maximum; in seismic performance categories D and E, S = 4 ft maximum.

**REINFORCED LOAD BEARING BRICK OR CMU WALLS**

Grace S. Lee; Rippeteau Architects, PC; Washington, D.C.  
 Stephen S. Szoke, P.E.; National Concrete Masonry Association; Herndon, Virginia  
 Brian E. Trimble; Brick Institute of America; Reston, Virginia



**MULTI-WYTHE MASONRY**

Multiwythe masonry construction is common for many applications, both load bearing and non-load bearing and for interior and exterior walls. These systems are frequently used as exterior walls or other applications when exposed architectural masonry units are required on one or both sides of the masonry. Such walls are constructed with full collar joints between wythes of masonry. The most common multiwythe wall is the composite wall, which consists of a clay brick wythe and a concrete masonry wythe with a 1/2 in. collar joint, and brick headers or anchors. The collar joint is often difficult to fill and may be filled by parging the backup or by grouting. Generally the method of filling the joint should not be specified. The mason should be permit-

ted to use the method that is most effective based on the talent available, the wall configuration, and the construction sequence. Often a single wythe of the wall might be reinforced. See the section on single wythe walls for a discussion of reinforced masonry. In multiwythe construction the collar joint may contain reinforcement. If this is so, the collar joint width must be increased to provide adequate coverage for the reinforcement. The diameter of the reinforcement should not exceed half the collar joint thickness. When fine grout is used there must be at least 1/4 in. between the reinforcement and the masonry. When coarse grout is used, the space must be at least 1/2 in.

Multiwythe walls may be constructed as partially grouted walls, using cavity wall or multiwythe wall construction. For

this type of wall, the grout is contained horizontally with building fabric and vertically with dams. The dams are typically masonry units placed within the cavity. In partially grouted hollow wall construction, flashing may be necessary at horizontal interruptions in the cavity.

Insulation for exterior walls may be integral in a wythe of masonry or may be on the exterior of the wall, but it is usually on the interior. The insulation may be adhered or mechanically fastened directly to the masonry, or the insulation system may be part of a conventional furring or studing system. The benefits of thermal mass are generally optimized with integral and exterior insulation strategies.

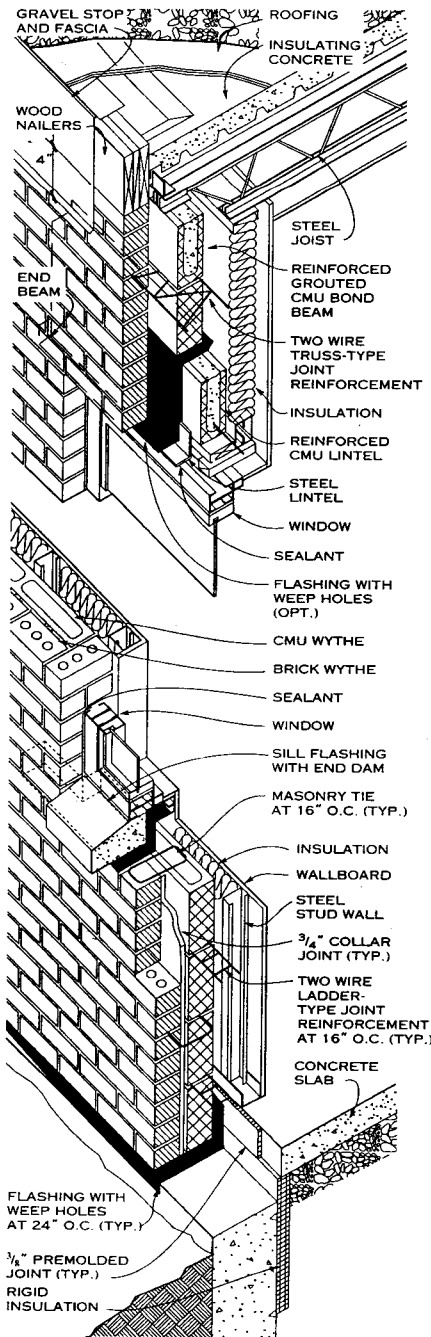

**MULTI-WYTHE MASONRY WALL**

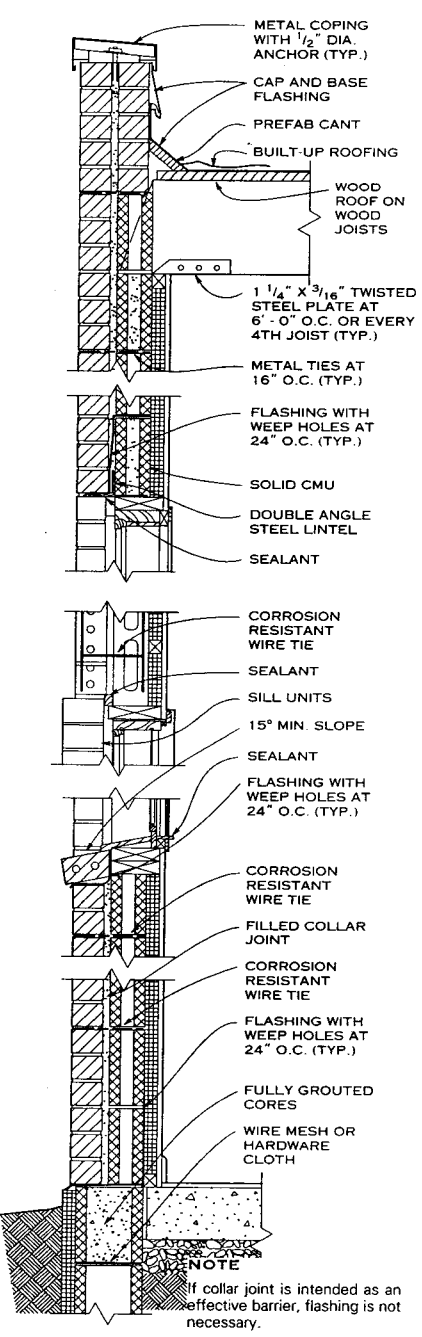

**ALTERNATE MULTI-WYTHE WALL SECTION**

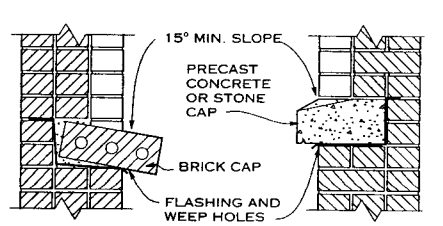

**RECESS AND SILL DETAILS IN BRICK WALLS**

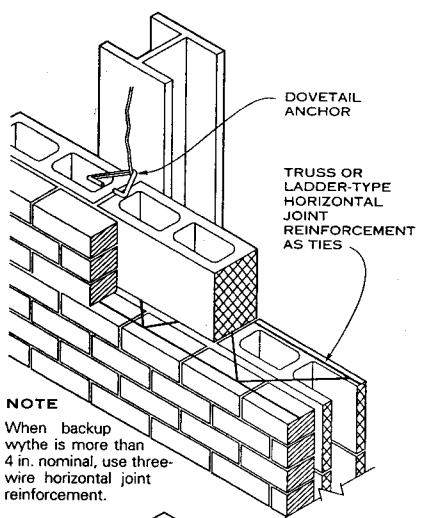

**NOTE**  
When backup wythe is more than 4 in. nominal, use three-wire horizontal joint reinforcement.

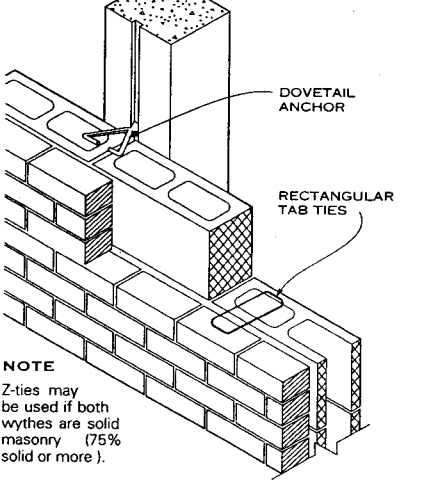

**NOTE**  
Z-ties may be used if both wythes are solid masonry (75% solid or more).

**STEEL AND CONCRETE COLUMN ANCHORAGE**

Grace S. Lee; Rippeteau Architects, PC; Washington, D.C.  
 Stephen S. Szoke, P.E.; National Concrete Masonry Association; Herndon, Virginia  
 Brian E. Trimble; Brick Institute of America; Reston, Virginia

**4 MASONRY UNITS**

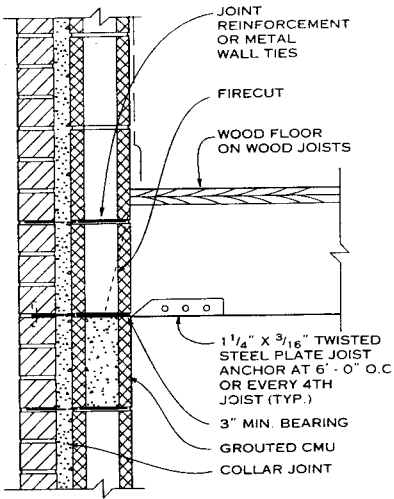

WALL TO WOOD JOIST ANCHORAGE

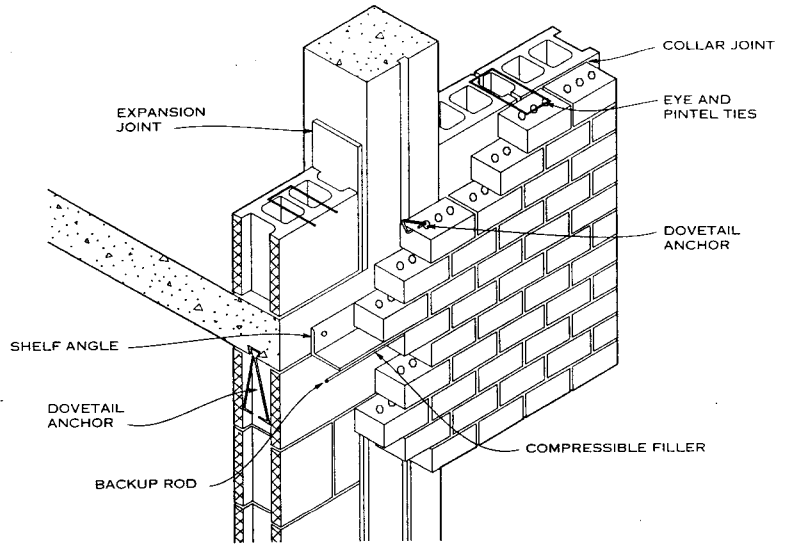

CONCRETE BEAM AND COLUMN ANCHORAGE DETAIL

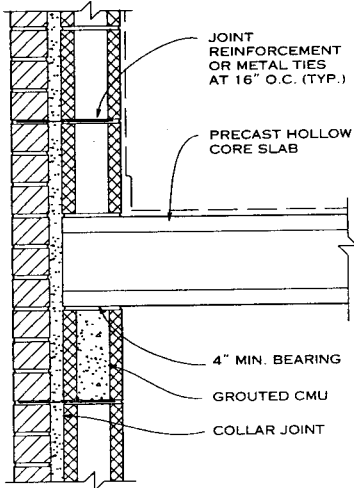

WALL TO CONCRETE JOIST ANCHORAGE

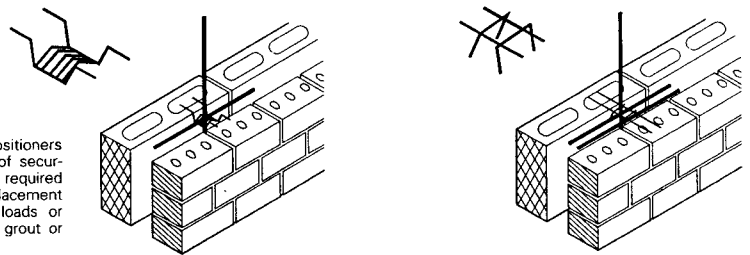

**NOTE**  
Placement of positioners or other means of securing anchorage is required to prevent displacement by construction loads or by placement of grout or mortar.

TYPICAL REBAR POSITIONERS

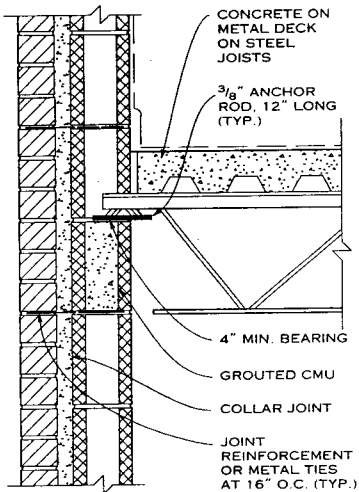

WALL TO STEEL JOIST ANCHORAGE

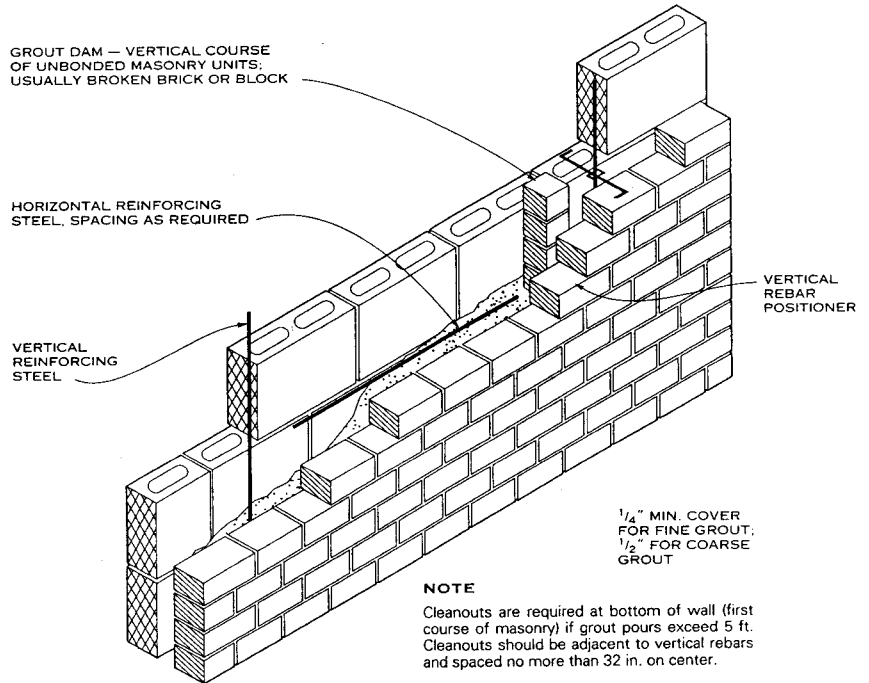

GRouted HOLLOW WALL

**NOTE**  
Cleanouts are required at bottom of wall (first course of masonry) if grout pours exceed 5 ft. Cleanouts should be adjacent to vertical rebars and spaced no more than 32 in. on center.

Grace S. Lee; Rippeteau Architects, PC; Washington, D.C.  
Stephen S. Szoke, P.E.; National Concrete Masonry Association; Herndon, Virginia  
Brian E. Trimble; Brick Institute of America; Reston, Virginia

**GENERAL**

Cavity walls consist of two wythes of masonry separated by at least a 2 in. airspace. The airspace may be increased to 4 1/2 in. with only minor increases in tie size and or spacing. If the cavity is to be more than 4 1/2 in., the wall system should be appropriately engineered. Either or both wythes of the wall system may be load bearing.

The cavity wall is a drainage-type wall that provides excellent resistance to water penetration. The mass and discontinuity of construction provided by the metal ties result in optimal sound penetration resistance. The calculated fire resistance of cavity walls usually exceeds 4 hours. Interior and exterior wythes may be considered as thermal mass for specific thermal requirements. Either or both wythes may be used to provide the desired architectural finishes, interior or exterior. For these reasons, the masonry cavity wall is generally preferred.

When the cavity wall is selected because of its thermal performance, generally only the interior wythe is load bearing. This construction permits the insulation layer to be continuous within the wall and pass the slabs, minimizing thermal bridges. The insulation may be granular fill or rigid board insulation. If rigid board insulation is selected, there must be a nominal 1 in. airspace between the back of the exterior wythe and the exterior surface of the insulation board. The insulation board may be held in place with the wall ties. Two-piece adjustable ties serve well for this application. Seams in the insulation should be made with tongue-and-groove joints, shiplapped, or sealed with tape. If the ties selected are not appropriate for holding the insulation against the backup wythe, then the rigid board insulation should be adhered or mechanically fastened to the backup. If granular fill is used, it is necessary to select weep hole systems that will permit drainage but keep the granular fill within the wall system. Typical cavity walls may contain 2 to 4 1/2 in. of granular fill insulation or 3 1/2 in. of rigid board insulation.

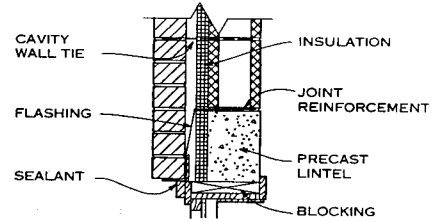
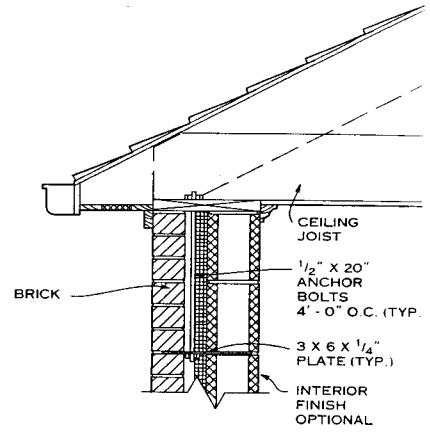
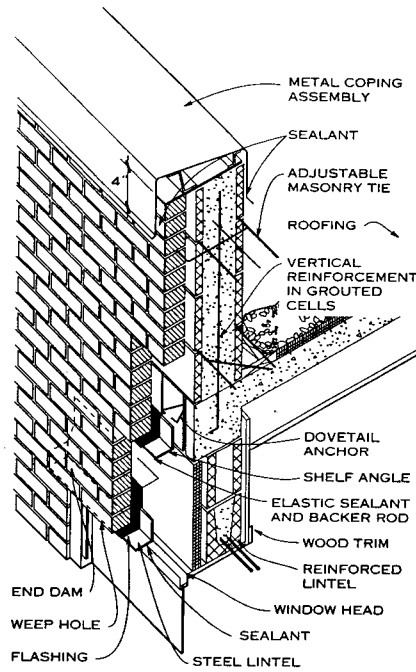

**HEAD**

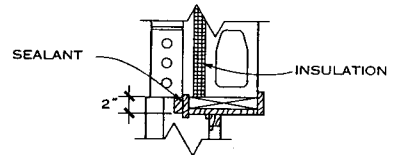

**JAMB**

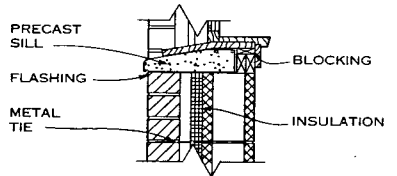

**SILL**

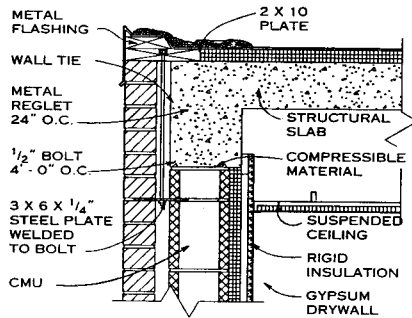
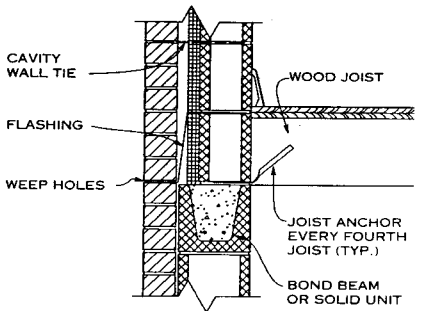

**ALTERNATE ROOF DETAIL**

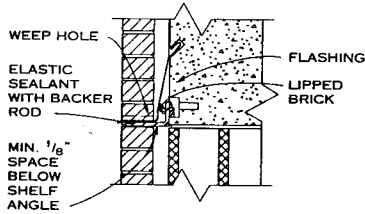

**ALTERNATE EXPANSION JOINT DETAIL**

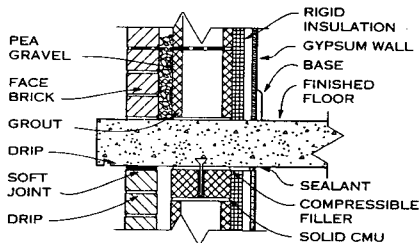

**EXPOSED SLAB DETAIL**

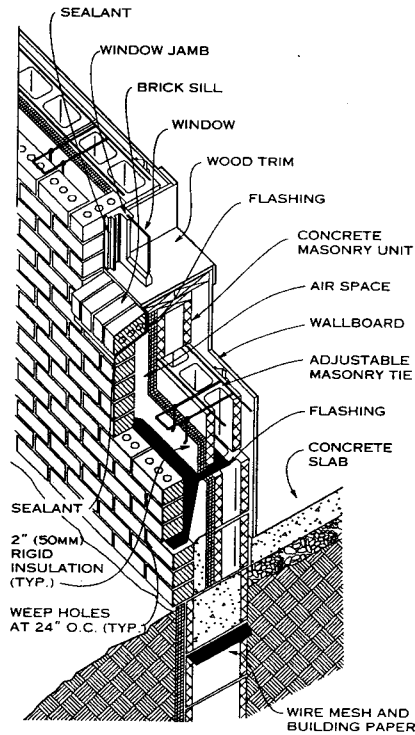

**BRICK AND CMU CAVITY WALL**

**ALTERNATE BRICK AND CMU CAVITY WALL SECTION**

Grace S. Lee and A. Harris Lokmanhakim, AIA; Rippeteau Architects, PC; Washington, D.C.  
 Stephen S. Szoke, P.E.; National Concrete Masonry Association; Herndon, Virginia  
 Brian E. Trimble; Brick Institute of America; Reston, Virginia

**4 MASONRY UNITS**

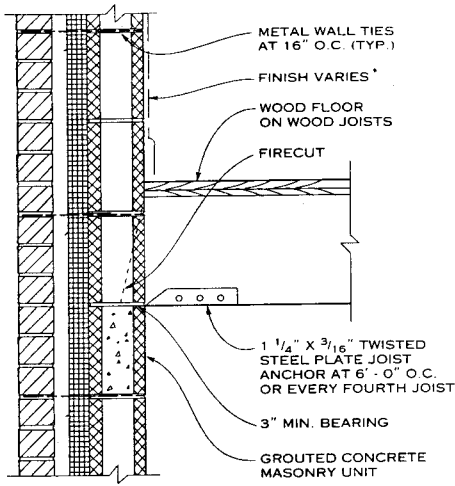

WOOD FLOOR

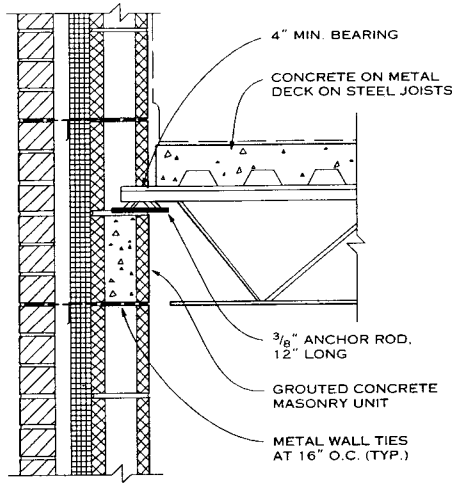

STEEL JOIST FLOOR

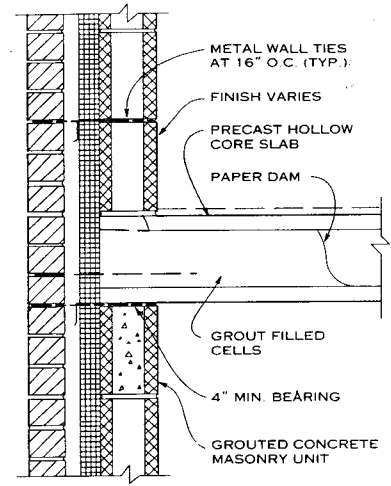

PRECAST HOLLOW CORE FLOOR

WALL TO FLOOR ANCHORAGE AT CAVITY WALLS

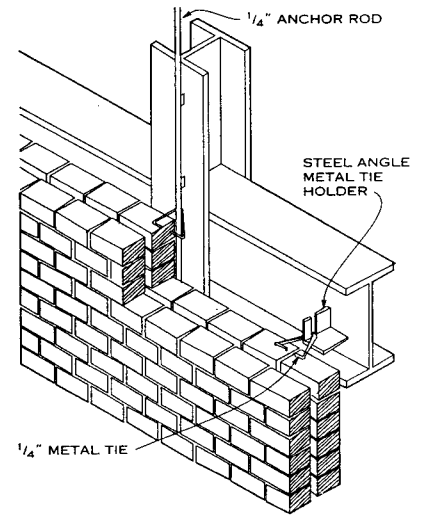
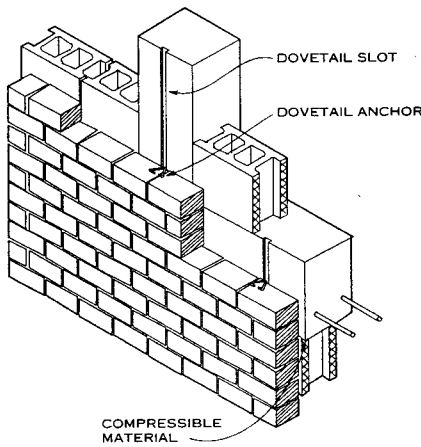
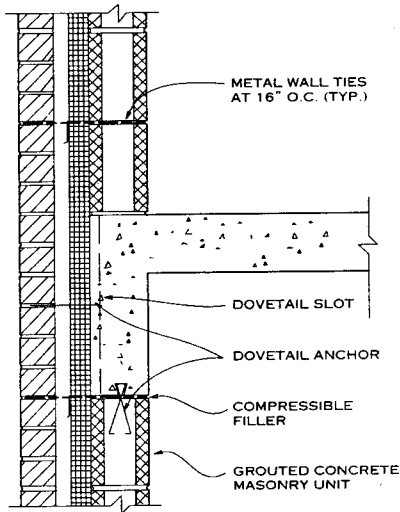

SPANDREL DETAIL

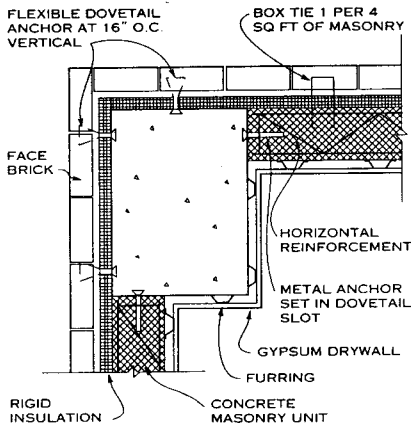

DOVETAIL ANCHORS AT CORNER

COLUMN AND BEAM ANCHORAGE DETAILS

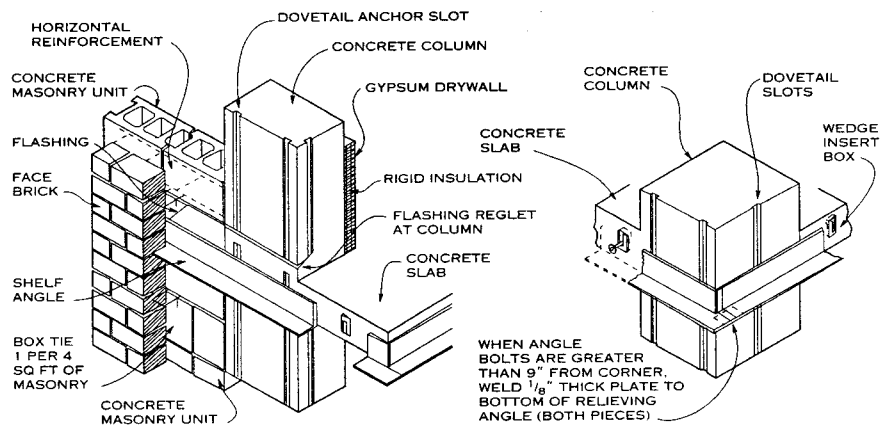

SHELF ANGLE AT CORNER COLUMN

Grace S. Lee, Rippeteau Architects, PC; Washington, D.C.  
 Stephen S. Szoke, P.E.; National Concrete Masonry Association; Herndon, Virginia  
 Brian E. Trimble; Brick Institute of America; Reston, Virginia

NOTES

1. Both wythes of solid masonry units (75% solid or more).
2. Both wythes nominal 4 in. or less. Wythes should be erected simultaneously for this tie strategy.

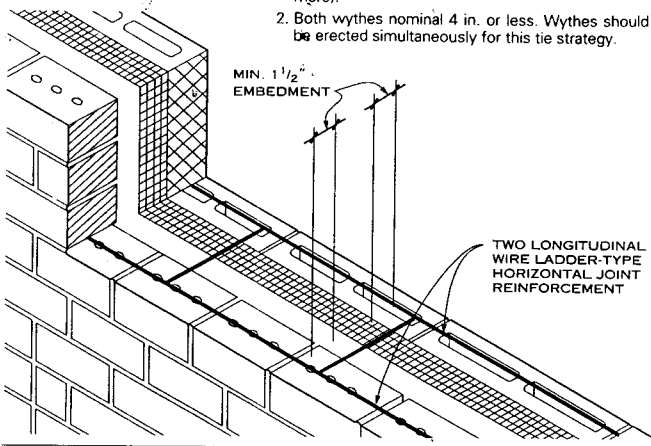

LADDER-TYPE HORIZONTAL JOINT REINFORCEMENT AS TIES FOR 4 IN. WYTHES OR LESS

NOTES

1. Horizontal joint reinforcement as ties at 8, 16, or 24 in. on center vertically (typical) as required.
2. Both wythes constructed simultaneously.

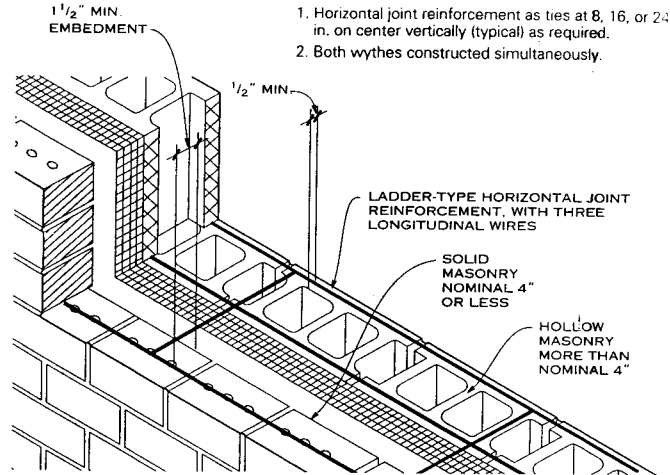

LADDER-TYPE HORIZONTAL JOINT REINFORCEMENT AS TIES FOR MORE THAN 4 IN. WYTHES

NOTES

1. Rectangular tab ties and horizontal joint reinforcement in alternating courses (typical).
2. Both wythes nominal 4 in. or less.
3. Both wythes constructed simultaneously.
4. Z-ties are acceptable if both wythes are constructed of solid masonry.

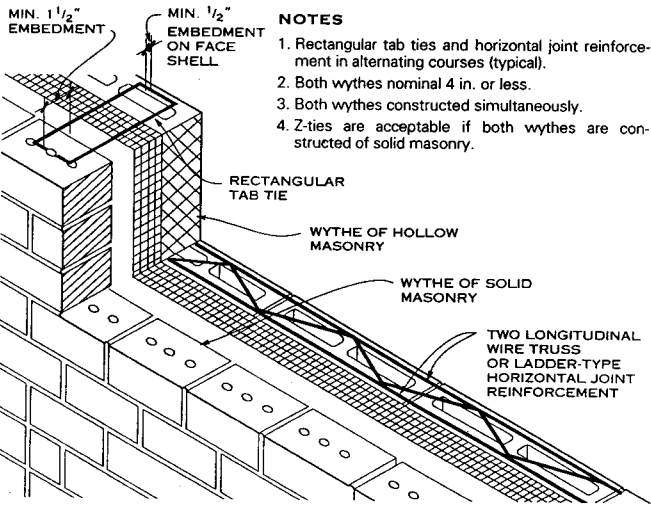

RECTANGULAR TAB TIES FOR 4 IN. WYTHES OR LESS

NOTES

1. Rectangular tab ties and horizontal joint reinforcement in alternating courses (typical).
2. Both wythes constructed simultaneously.

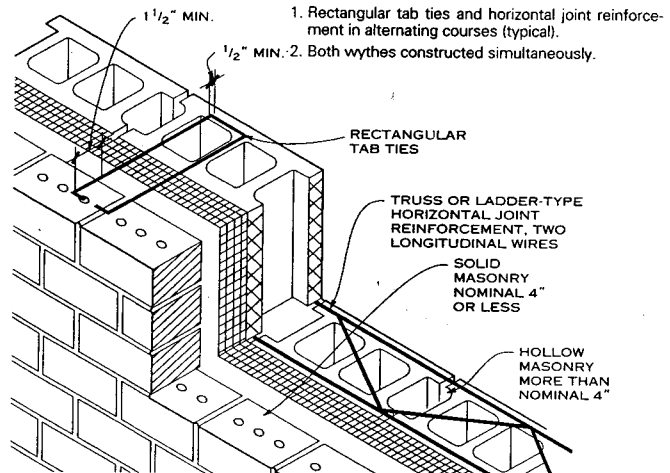

RECTANGULAR TAB TIES FOR MORE THAN 4 IN. WYTHES

NOTES

1. Maximum misalignment of courses is 1 1/4 in.
2. Both wythes nominal 4 in. or less.
3. Both wythes not constructed simultaneously.
4. Pintels hold rigid board insulation in place.

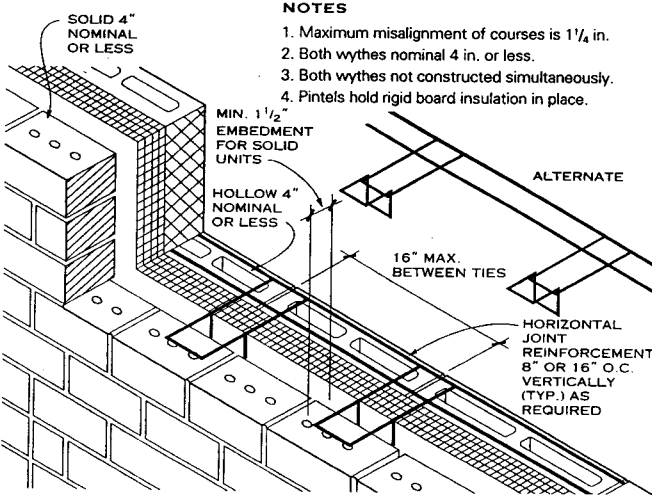

ADJUSTABLE TIES FOR 4 IN. WYTHES OR LESS

NOTES

1. Maximum misalignment of courses is 1 1/4 in.
2. Both wythes not constructed simultaneously.
3. Pintels hold rigid board insulation in place.

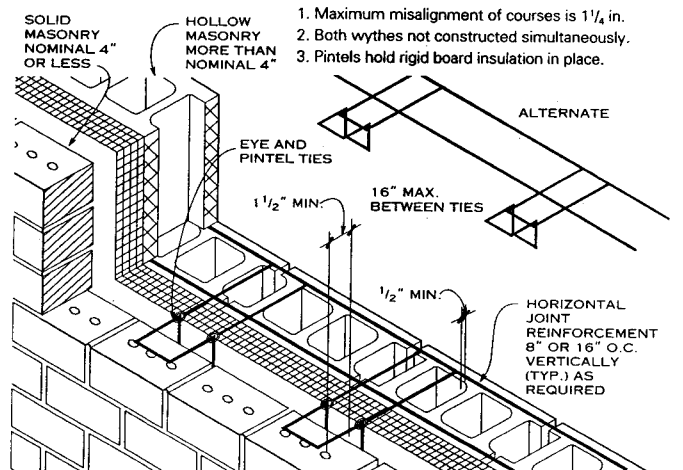

ADJUSTABLE TIES FOR MORE THAN 4 IN. WYTHES

Grace S. Lee; Rippeteau Architects, PC; Washington, D.C.  
 Stephen S. Szoke, P.E.; National Concrete Masonry Association; Herndon, Virginia  
 Brian E. Trimble; Brick Institute of America; Reston, Virginia

4 MASONRY UNITS

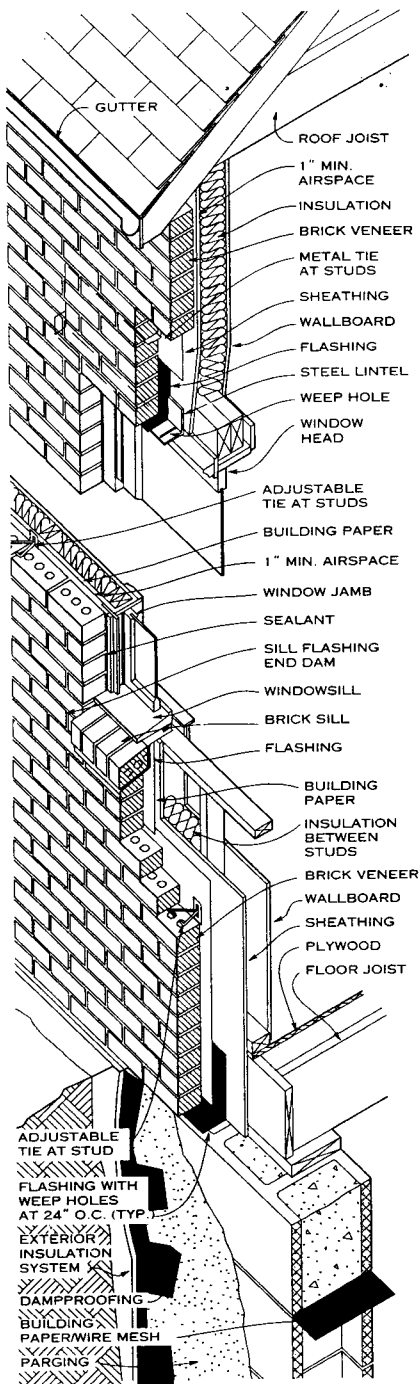

**BRICK VENEER ON WOOD STUD BACKUP**

**ANCHORED VENEERS**

Masonry veneers provide an aesthetic, durable, noncombustible, weather resistant finish for structural masonry or light framing construction. The inherent mass of the veneer provides increased thermal performance, sound penetration resistance, and fire resistance. Anchored veneers typically consist of nominal 3 or 4 in. wythes of masonry tied to a backing system. Veneers are not intended to support any loads other than their own weight. All lateral loads are intended to be transferred to the backing system. Empirical design permits the construction of masonry veneers with a nominal thickness of 4 in. to heights of three stories, 30 ft

Grace S. Lee; Rippeteau Architects, PC; Washington, D.C.  
 Brian E. Trimble; Brick Institute of America; Reston, Virginia

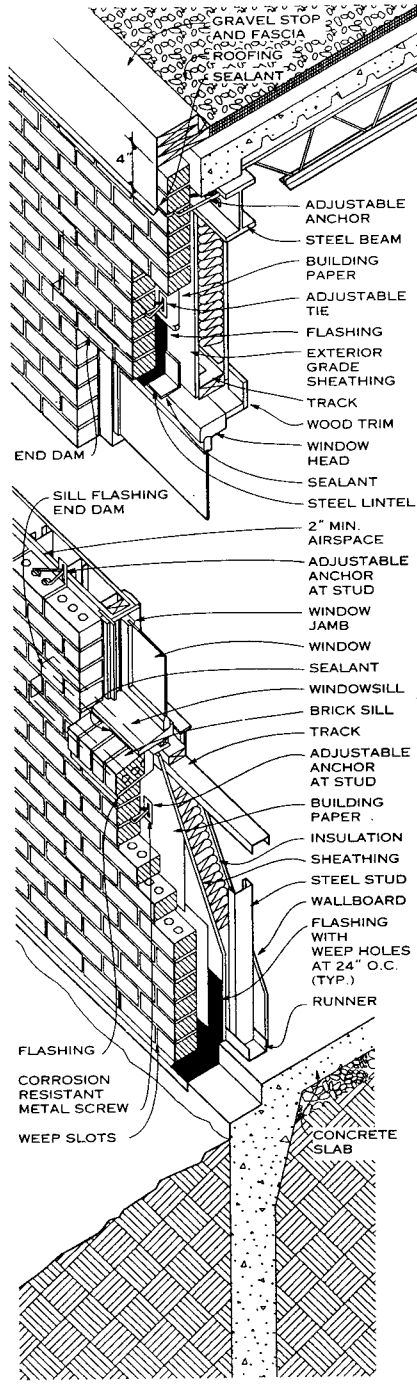

**BRICK VENEER ON STEEL STUD BACKUP**

at the plate and 38 ft at the gables. For veneers with a nominal thickness of 3 in., the height is limited to two stories, 20 ft at the plate and 28 ft at the gable. For building heights greater than two stories, the brick veneer must be supported by a shelf angle at every floor.

Veneers are drainage-type walls. Although a nominal 1 in. airspace is acceptable for drainage in most low-rise, residential applications, a minimum 2 in. airspace between the back of the masonry and the exterior surface of the backing or exterior sheathing is recommended for masonry veneers in mid-rise and high-rise construction.

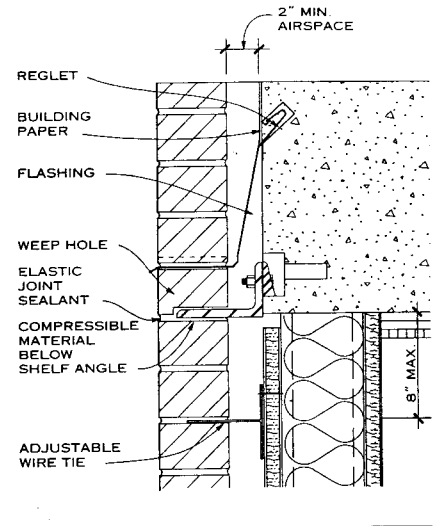

**SHELF ANGLE DETAIL**

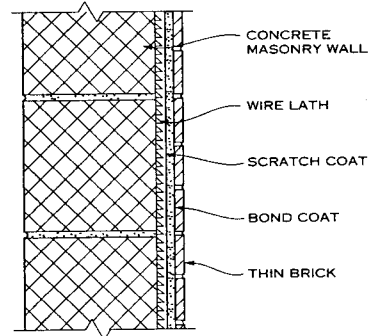

**THIN BRICK VENEER ON CMU**

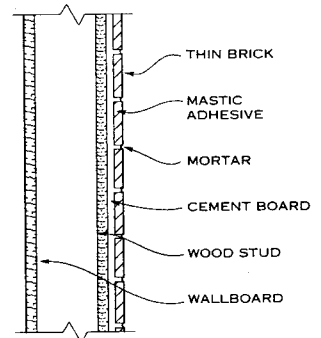

**THIN BRICK VENEER ON WOOD FRAME**

**ADHERED VENEERS**

Thin brick veneer, also referred to as adhered veneer, is an application of thin brick veneer units—between 1/2 to 1 3/4 in. thick—on a backing system. Adhered veneer relies on the bonding agent between the thin brick units and the backup substrate. This construction may be classified as either thin bed set or thick bed set. The thin brick can be adhered to a stud backing, attached to a concrete masonry backing, cast into a concrete panel, or laid into a preformed modular panel. Thin brick panels can be prefabricated or laid in place, depending on the size or intricacies of the project.

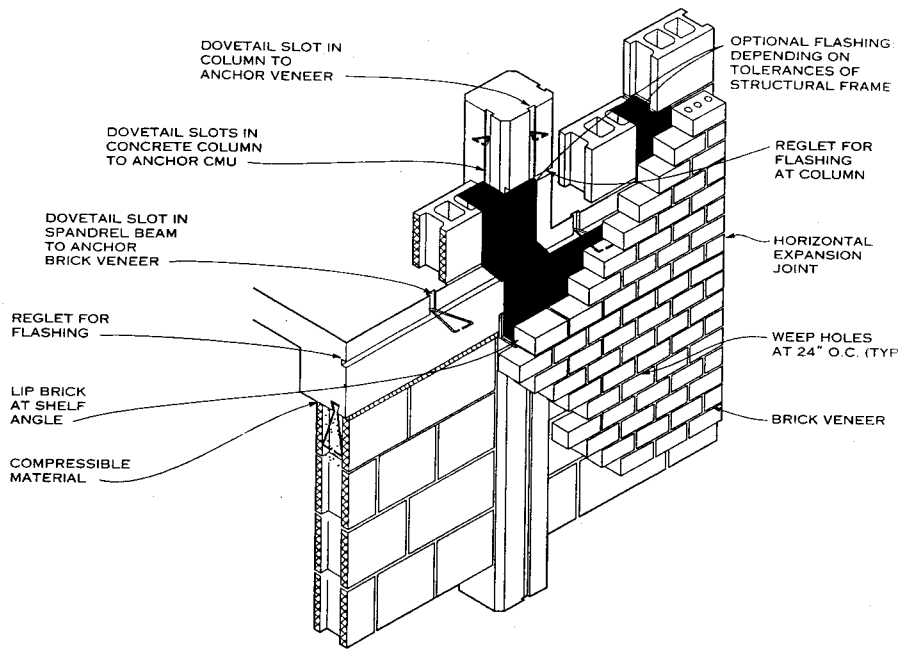
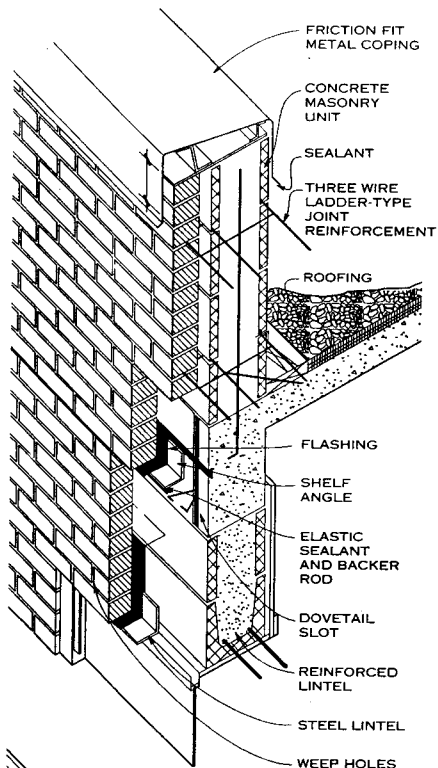

**WALL ANCHORAGE IN CONCRETE COLUMNS AND BEAMS**

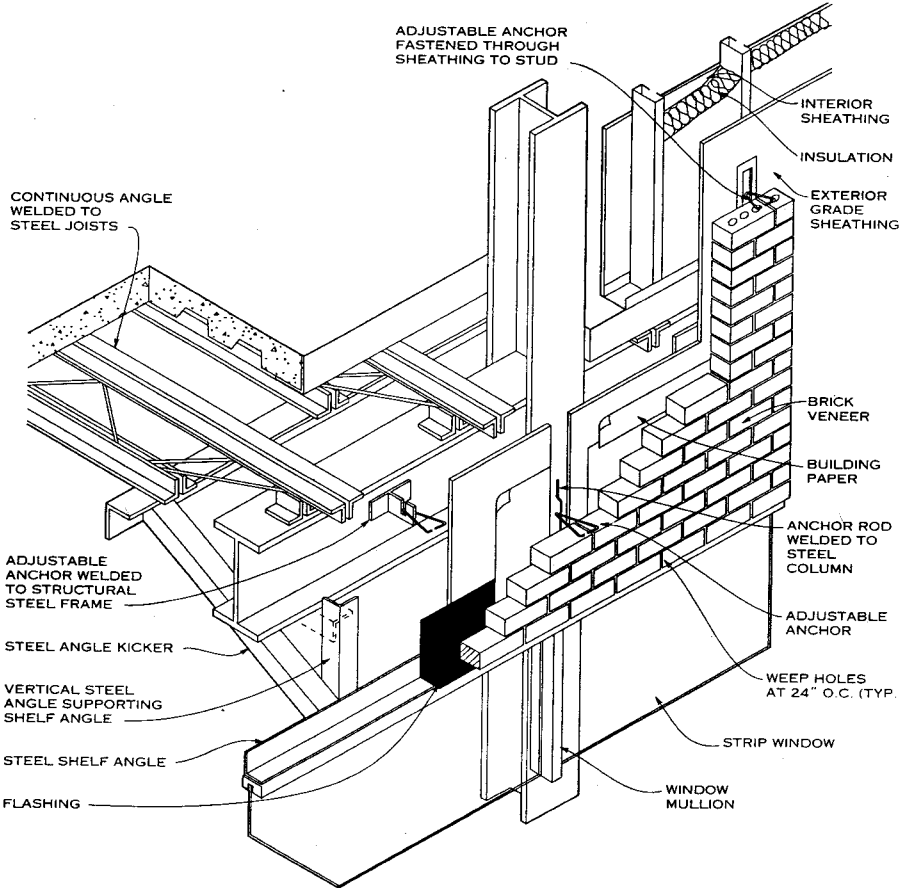
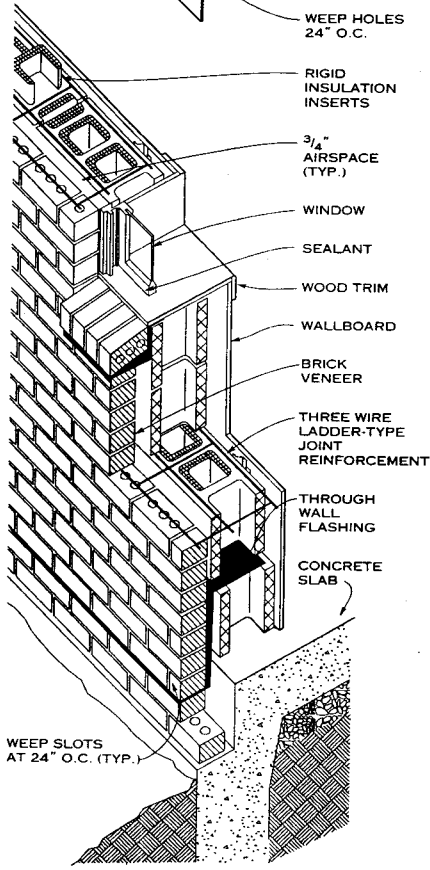

**BRICK VENEER ON CONCRETE MASONRY UNIT BACK-UP**

**WALL ANCHORAGE IN STEEL COLUMNS AND BEAMS**

Grace S. Lee; Rippeteau Architects, PC; Washington, D.C.  
 Brian E. Trimble; Brick Institute of America; Reston, Virginia

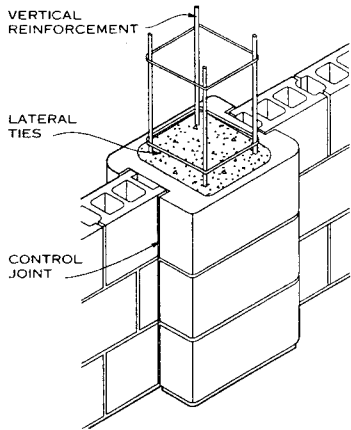

TYPICAL SPECIAL PILASTER UNIT FOR USE WITH CONTROL JOINTS

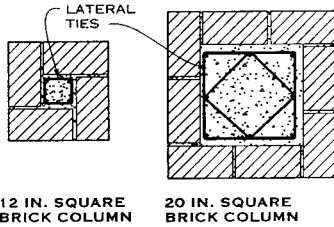

REINFORCED COLUMNS

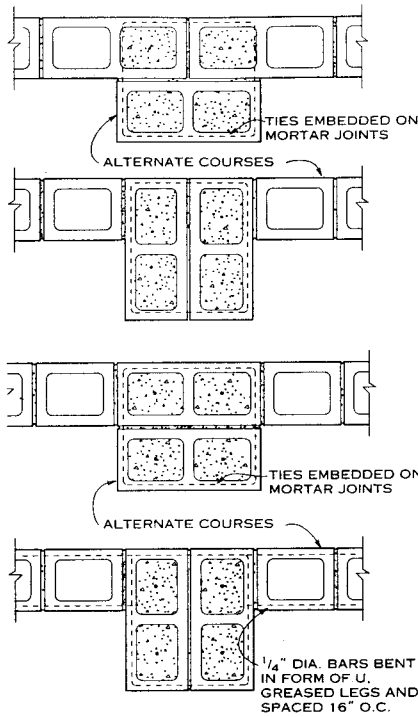

TYPICAL PILASTER LAYOUTS

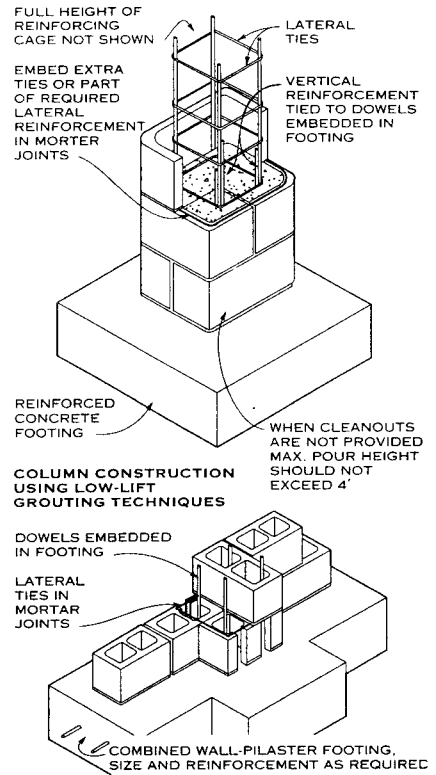

PILASTER CONSTRUCTION USING LOW-LIFT GROUTING TECHNIQUES

**NOTE**  
Cut block in first course before laying to form cleanout openings at base of cells to be filled. Remove all mortar droppings, set and inspect vertical reinforcement, and form over opening before filling with grout or concrete. When cleanouts are not provided maximum pour should not exceed 4 ft.

COLUMN AND PILASTER CONSTRUCTION

NUMBER AND SIZE OF REBARS REQUIRED

LINTEL TYPE	CLEAR SPAN (MAX.)	8" BRICK WALL (80 LB/SQ FT)	8" CMU WALL (50 LB/SQ FT)
Reinforced concrete (7 5/8" square section)	4'-0"	4 - #3	4 - #3
	6'-0"	4 - #4	4 - #3
	8'-0"	4 - #5	4 - #4
Concrete masonry unit (7 5/8" square section)	4'-0"	2 - #4	2 - #3
	6'-0"	2 - #5	2 - #4
	8'-0"	2 - #6	2 - #5

NOTES

- For precast concrete and reinforced concrete masonry unit lintels with no superimposed loads.
- fc' = 3000 psi concrete and grout; fy = 60,000 psi

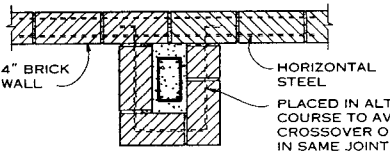

REINFORCED BRICK MASONRY COLUMN

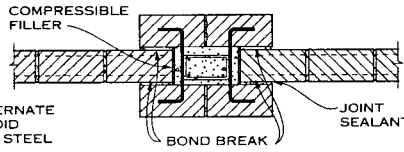

REINFORCED BRICK MASONRY PILASTER

BRICK CURTAIN WALL AND PANEL WALL REINFORCEMENT

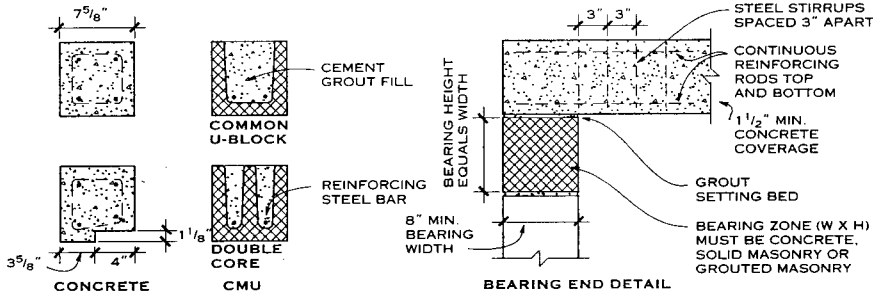

PRECAST CONCRETE AND CMU BEAMS OR LINTELS

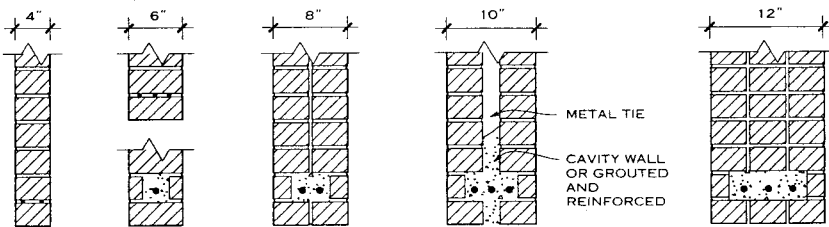

REINFORCED BRICK BEAMS OR LINTELS

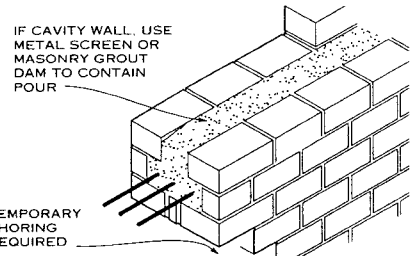

Grace S. Lee; Rippeteau Architects, PC; Washington, D.C.  
 Brian E. Trimble; Brick Institute of America; Reston, Virginia; S  
 Stephen S. Szoke, P.E.; National Concrete Masonry Association; Herndon, Virginia



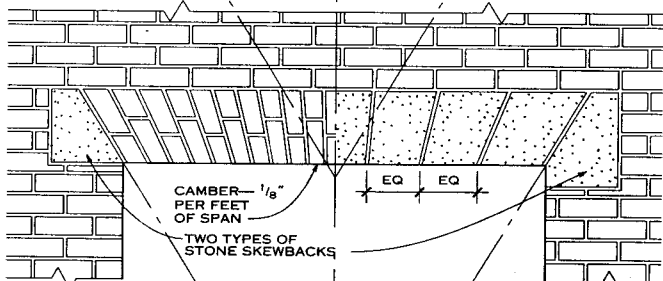
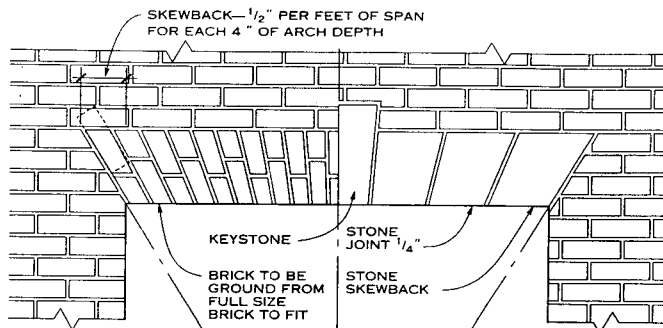

TYPES OF JACK ARCHES

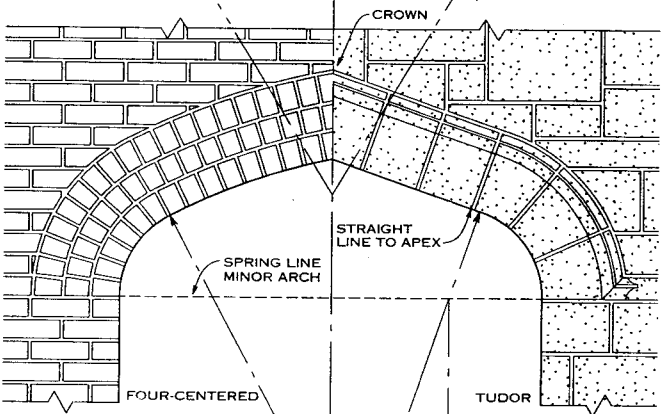

FOUR-CENTERED AND TUDOR

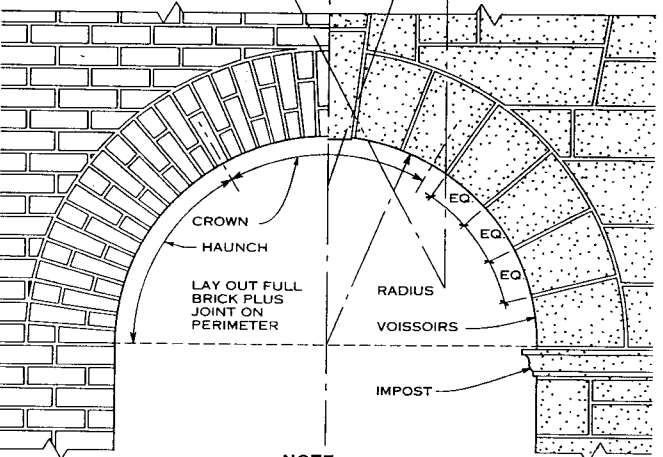

ROMAN OR SEMICIRCULAR

**NOTE**  
Walls, piers, or abutments adjacent to masonry must be of sufficient strength to resist horizontal thrusts.

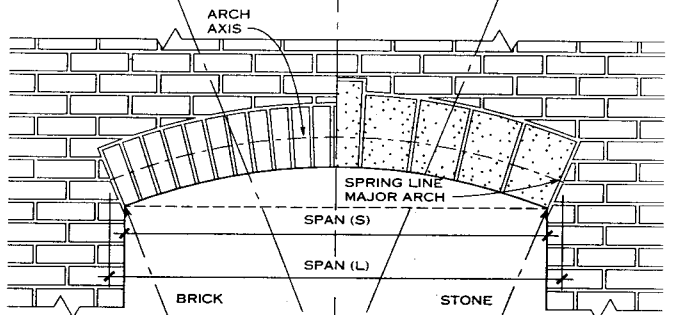
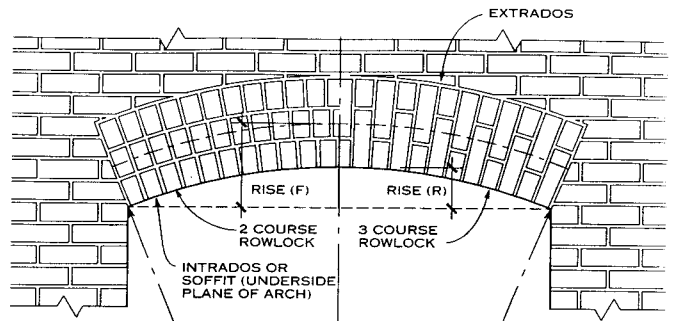

TYPES OF SEGMENTAL ARCHES

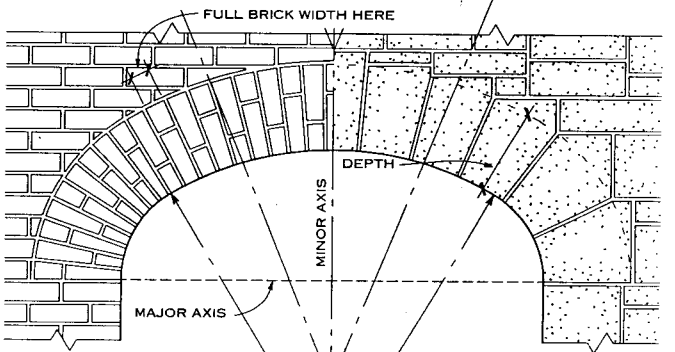

ELLIPTICAL

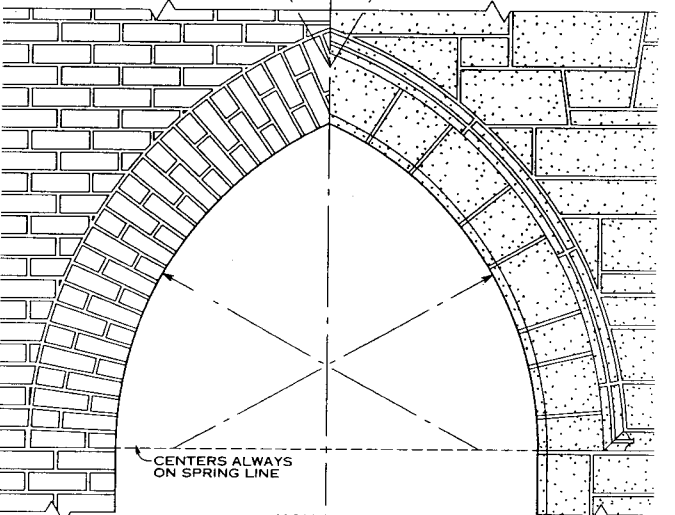

GOTHIC

**NOTE**  
Arch is called pointed when radii are equal to span and is called lancet when radii are greater than span.

Charles George Ramsey, AIA and Harold Reeve Sleeper, FAIA; New York, New York

4

MASONRY UNITS

**GENERAL**

The fireplace and chimney are usually large elements in residences, but their scale can be adapted to any architectural style. The purpose of the residential fireplace has changed over the years from heating to decoration. However, increasing public interest in renewable forms of energy has instigated a new demand for fireplaces for heating homes. Fireplace design and construction are governed by building and mechanical codes. The internal diagram of a working fireplace shows the several required parts and their vertical organization. Each part is illustrated on succeeding pages.

The main function of the fireplace and chimney is to sustain combustion and carry smoke away safely. Their design is

based on empirical data proven with years of safe performance. The charts on the following pages show the appropriate sizes of fireplace and chimney elements. One of the most important design decisions is the location of the fireplace. To prevent heat loss to the exterior, it is best to locate a fireplace at the center of the house. Again to improve performance, a fireplace should not be located opposite an outside door or near an open stairway leading to an upper floor, a forced air furnace, or a return air register. Combustion can be improved by providing a measured supply of outside air, independent of room air, to the fireplace. This is done by installing an air duct from the exterior of the house to the fireplace. The chimney must be properly sized to carry the combustion products away. Two factors primarily affect the chimney draft: size of the fireplace

opening and height of the chimney. The figure on the following page should be used to size the flue accurately based on these factors.

Several distinct types of fireplaces are currently used in residential applications. Single-face fireplace styles are the most popular and include the conventional fireplace, the Rumford fireplace, the Rosin fireplace, and air circulating fireplaces. Multiface fireplaces are also popular and include the see-through fireplace, the corner fireplace, and the free-standing fireplace. The masonry heater, or masonry stove, is a specialized type of fireplace and is the most efficient of all these types.

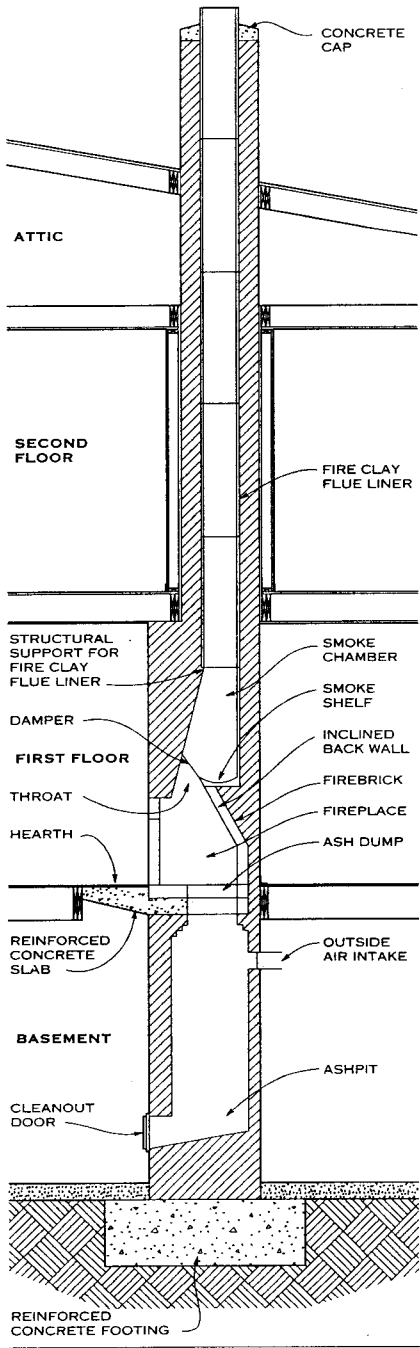

**SECTION**

Brian E. Trimble; Brick Institute of America; Reston, Virginia  
Grace S. Lee; Rippeteau Architects, PC; Washington, D.C.

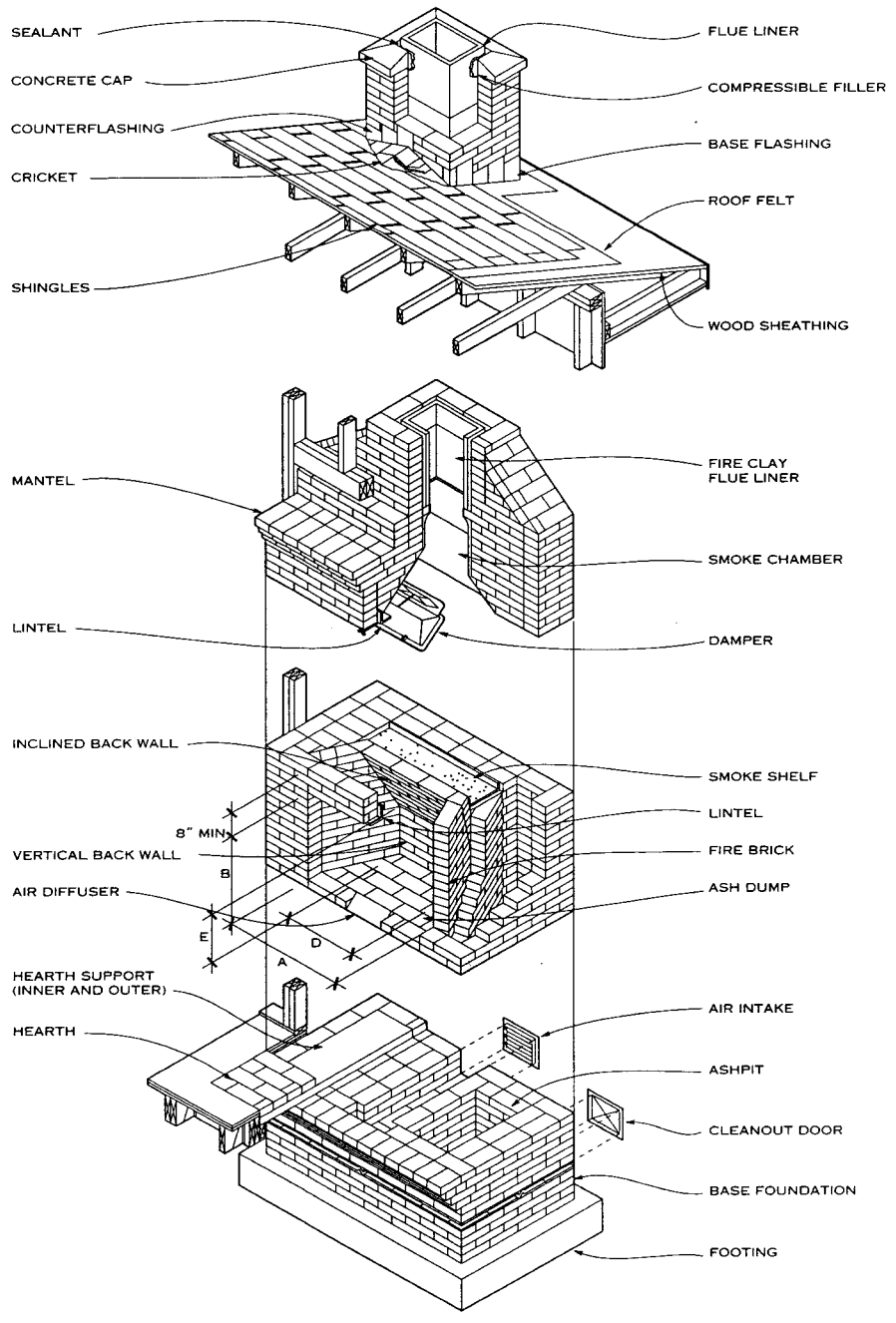

**ISOMETRIC**

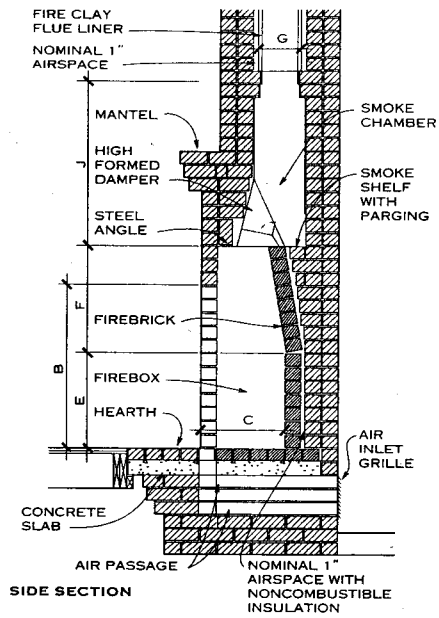

SIDE SECTION

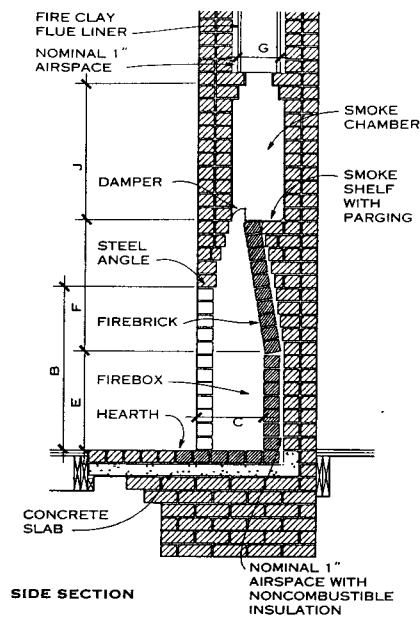

SIDE SECTION

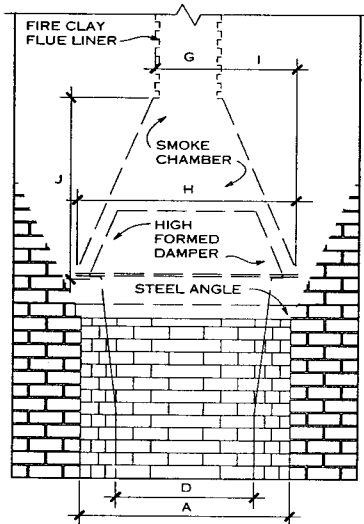

FRONT ELEVATION

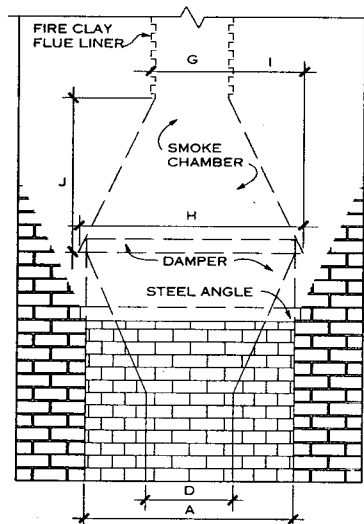

FRONT ELEVATION

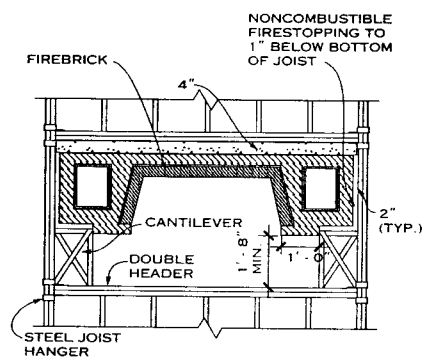

FLOOR FRAMING AT FIREPLACE

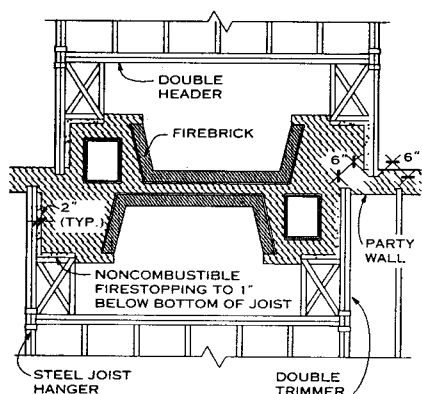

FIREPLACES BACK TO BACK IN PARTY WALL

CONVENTIONAL FIREPLACES

The design of single-face fireplaces has been well documented, resulting in the development of a reasonably accurate set of design dimensions for fireplace openings, dampers, and flue liners.

Single-face fireplaces can be efficient radiant heaters. The amount of heat radiated and reflected into the room is directly proportional to the masonry surface area exposed to the fire. The Rumford fireplace is a variation of the single-face fireplace with a shallow firebox, a high throat, and widely splayed sides, all features that contribute to optimal direct radiant heating.

In addition, the energy efficiency of new fireplaces can be improved by following these recommendations:

1. Locate the fireplace on the interior of the house.
2. Supply outside air for combustion and maintenance of positive room pressure.
3. Provide glass fireplace screens to prevent unwanted air infiltration when the fireplace is not in use.

CONVENTIONAL SINGLE-FACE FIREPLACE DIMENSIONS\* (IN.)

FINISHED FIREPLACE OPENING						ROUGH BRICKWORK			
A	B	C	D	E	F	H	I	J	
24	24	16	11	14	18	32	10	19	
26	24	16	13	14	18	34	11	21	
28	24	16	15	14	18	36	12	21	
30	29	16	17	14	23	38	13	24	
32	29	16	19	14	23	40	14	24	
36	29	16	23	14	23	44	16	27	
40	29	16	27	14	23	48	16	29	
42	32	16	29	16	24	50	17	32	
48	32	18	33	16	24	56	20	37	
54	37	20	37	16	29	68	26	45	
60	37	22	42	16	29	72	26	45	
60	40	22	42	18	30	72	26	45	
72	40	22	54	18	30	84	32	56	
84	40	24	64	18	30	96	36	61	
96	40	24	76	18	30	108	42	75	

NOTE

\* Determine flue liner dimensions, G. Dimensions are equal to the outside dimensions of the flue liner plus at least 1 in. (25 mm).

RUMFORD SINGLE-FACE FIREPLACE DIMENSIONS\* (IN.)

FINISHED FIREPLACE OPENING						ROUGH BRICKWORK			
A	B	C	D	E	F	H	I	J	
36	32	16	16	16	28	44	14	27	
40	32	16	16	16	28	48	16	29	
40	37	16	16	16	33	48	16	29	
40	40	20	20	20	32	48	16	29	
48	37	16	16	20	33	56	18	36	
48	40	20	20	20	32	56	18	36	
48	48	20	20	20	40	56	18	36	
54	40	20	20	20	32	66	23	45	
54	48	20	20	20	40	66	23	45	
54	54	20	20	20	46	66	21	42	
60	48	20	20	20	40	72	24	45	

NOTE

\* Determine flue liner dimensions, G. Dimensions are equal to the outside dimensions of the flue liner plus at least 1 in. (25 mm) for airspace surrounding flue liner.

Grace S. Lee; Rippeteau Architects, PC; Washington, D.C.

4 MASONRY UNITS

**GENERAL**

Masonry heaters make use of two basic principles to obtain high combustion and heating efficiencies—controlled air intake to the combustion chamber/firebox and a heat exchange system of baffled chambers through which hot combustion gases are circulated. Such heaters are efficient, clean burning devices.

Brick masonry heaters or masonry stoves used in North America are adapted from those used in northern and eastern Europe, which were employed for cooking as well as heating. Modern masonry heaters come in a wide variety of shapes and sizes. The size and layout of the house, the climate, and the needs of the homeowner are all considered in the design of a masonry heater. For optimum performance, however, it should be located near the center of the house. Masonry heaters may be custom built on site or assembled from prefabricated components. Modern masonry heaters may incorporate fire viewing, bake ovens, stoves, and warming benches.

Two safety concerns that apply to brick masonry heaters but are not listed in the major model building codes are the integrity of the enclosing walls of the heater and the temperature of the exterior surfaces of the walls:

To maximize the integrity of masonry heater walls, they should be constructed of two wythes of brick (ASTM C 216 or C 62 for facing brick) with a nominal 1-in. airspace between them. Fill the airspace with a compressible, non-combustible material such as insulation, and tie both wythes together with corrosion-resistant metal ties. Add horizontal joint reinforcement every sixth course (only at exterior wythe).

To safeguard against the effects of the high surface temperatures of the heater (between 100° and 190°F), a minimum 12-in. clearance should be observed between the heater and any combustibles and there should be a 20-in. extended hearth in front.

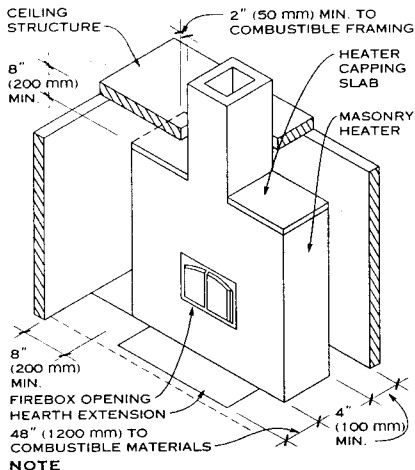

**NOTE**  
For clearances from specific types of firebox openings and other requirements, consult ASTM E 1602 and local codes. Most clearances may be reduced if an engineered protection system is provided.

**CLEARANCE TO COMBUSTIBLES FOR MASONRY HEATERS**

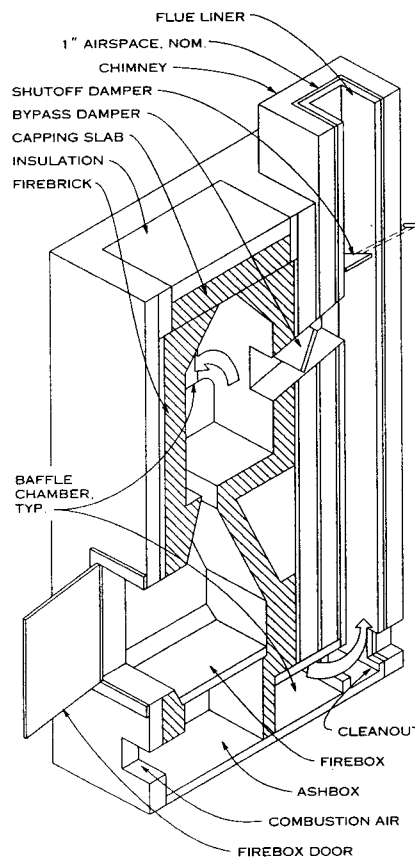

**NOTE**  
In Finnish or contraflow heaters, heated air is forced from the top of the smoke chamber down through the baffles on the sides of the heater, while room air rises by convection along the exterior surfaces of the masonry. This construction allows for even heating of the masonry and efficient radiant heating of the room. The baffles converge below the firebox and open out to the flue at the base of the chimney.

**FINNISH (FOUNTAIN-STYLE) HEATER**

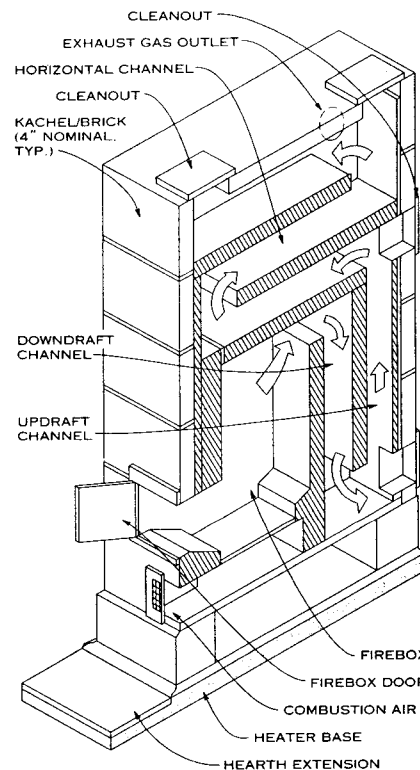

**GERMAN TILE/BRICK HEATER (GRUNDOFEN)**

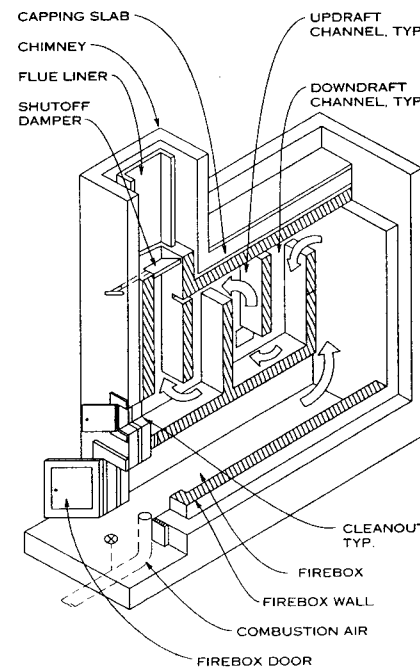

**NOTE**  
Russian heaters are typically deep with a small opening to the firebox, above which is a system of either vertically or horizontally aligned baffles in place of the smoke chamber. After circulating through the baffle system, exhaust gases pass directly into the flue.

**RUSSIAN (MULTIFLUE) HEATER**

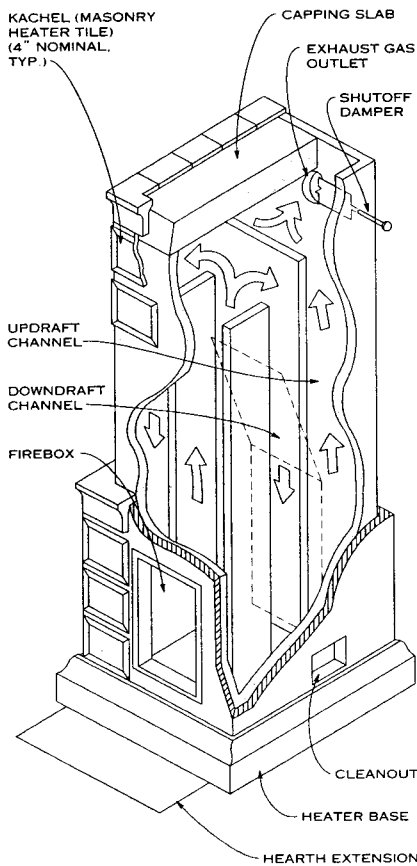

**SWEDISH TILE HEATER (KAKELUGN)**

Timothy B. McDonald; Washington, D.C.  
Brian E. Trimble, Engineer; Brick Industry Association; Reston, Virginia

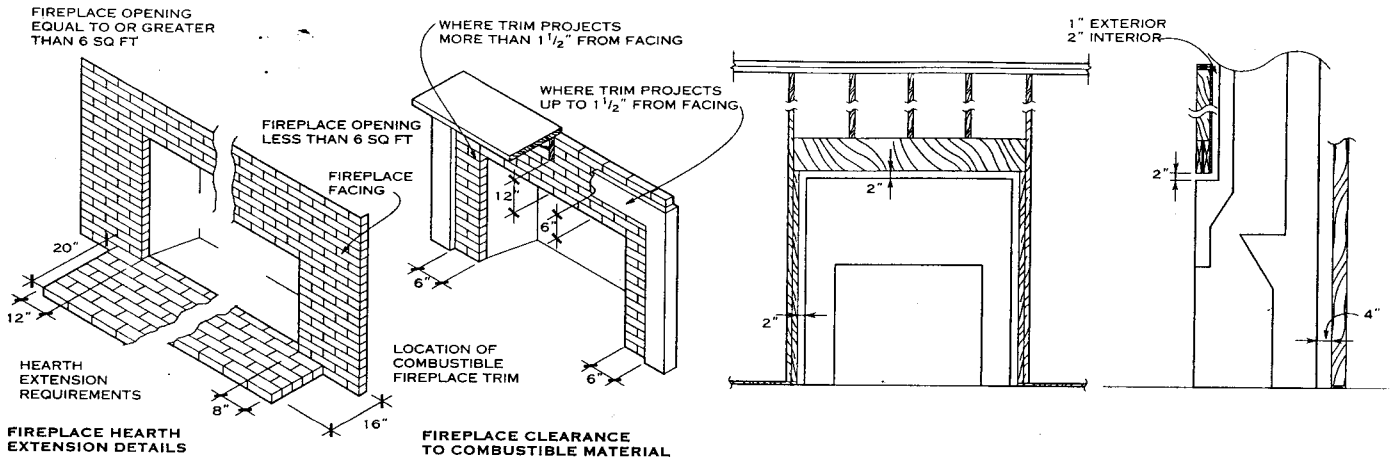

**FIREPLACE CLEARANCES**

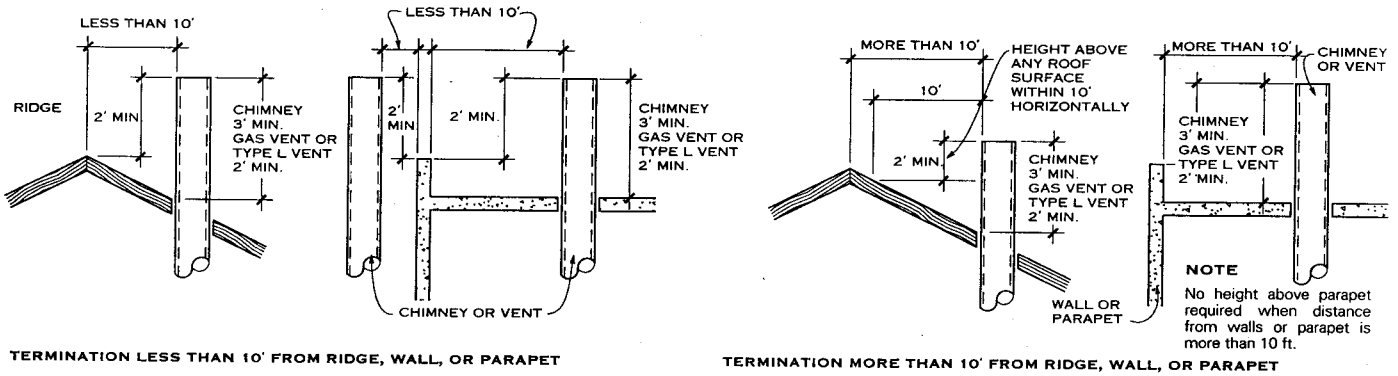

**CHIMNEY CLEARANCES**

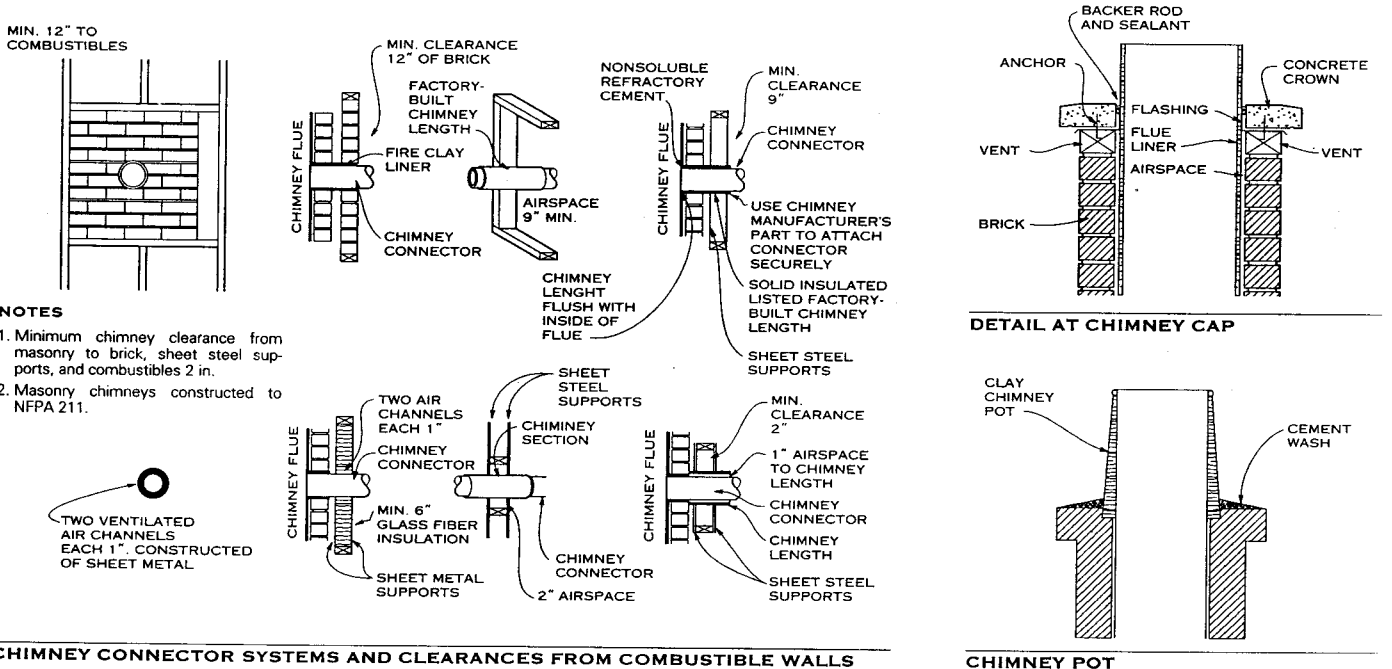

Grace S. Lee; Rippeteau Architects, PC; Washington, D.C.  
 Brian E. Trimble; Brick Institute of America; Reston, Virginia

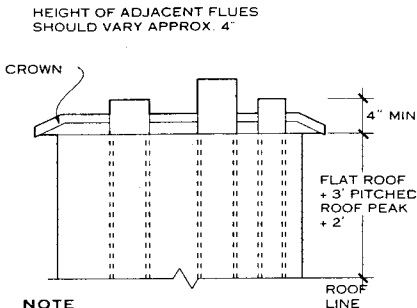

**NOTE**  
Each fireplace or stove requires its own separate flue.

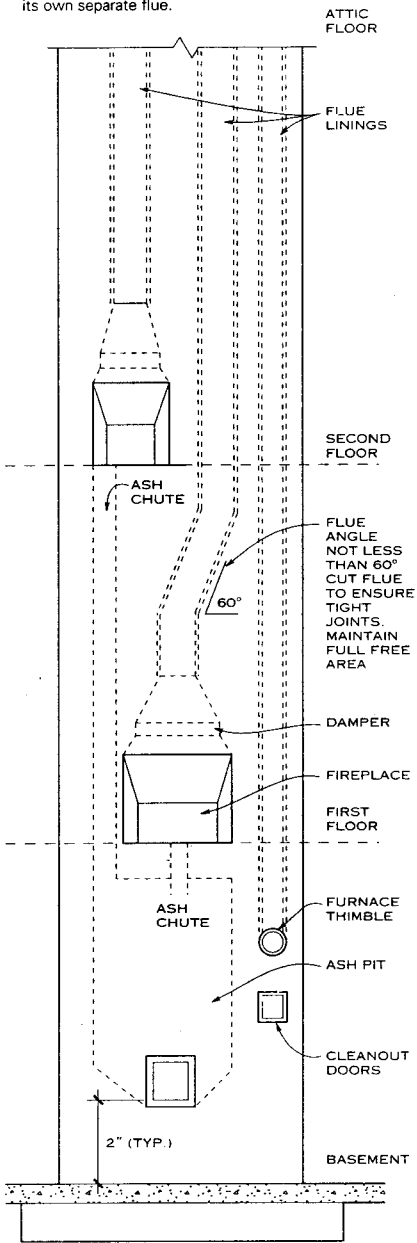

TYPICAL RESIDENTIAL CHIMNEY

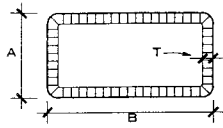

**RECTANGULAR FLUE LINING (STANDARD)**

AREA (SQ IN.)	A	B	T
51	8 1/2"	8 1/2"	3/4"
79	8 1/2"	13"	3/8"
108	8 1/2"	18"	1"
125	13"	13"	3/8"
168	13"	17 3/4"	1"
232	17 3/4"	17 3/4"	1 1/4"
279	20"	20"	1 3/8"
338	20"	24"	1 1/2"
420	24"	24"	1 5/8"

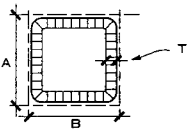

**RECTANGULAR FLUE LINING (MODULAR)**

AREA (SQ IN.)	A	B	T
57	7 1/2"	11 1/2"	3/4"
87	11 1/2"	11 1/2"	3/8"
120	11 1/2"	15 1/2"	1"
162	15 1/2"	15 1/2"	1 1/8"
208	15 1/2"	19 1/2"	1 1/4"
262	19 1/2"	19 1/2"	1 3/8"
320	19 1/2"	23 1/2"	1 1/2"
385	23 1/2"	23 1/2"	1 5/8"

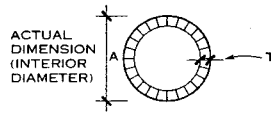

**ROUND FLUE LINING**

AREA (SQ IN.)	A	T	LENGTH
47	8"	3/4"	2'-0"
74.5	10"	7/8"	2'-0"
108	12"	1"	2'-0"
171	15"	1 1/8"	2'-0"
240	18"	1 1/4"	2'-0"
298	20"	1 3/8"	2'-0"
433	24"	1 5/8"	2'-0"

**CLAY FLUE LININGS**

**NOTES**

1. Availability of specific clay flue liners varies according to location. Generally, round flue liners used in construction with reinforcing bars are available in the western states, while rectangular flue liners are commonly found throughout the eastern states. Check with local manufacturers for available types and sizes.
2. Nominal flue size for round flues is interior diameter; nominal flue sizes for standard rectangular flues are the exterior dimensions and, for modular flue linings, the outside dimensions plus 1/2 in.

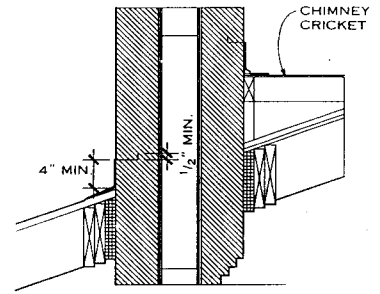

INSULATION OF WOOD FRAMING MEMBERS AT A CHIMNEY

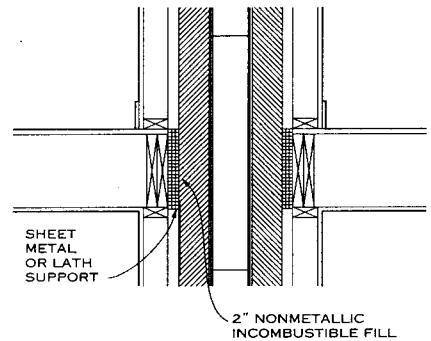

BRICK CHIMNEY CONCEALED BEHIND STUD WALL

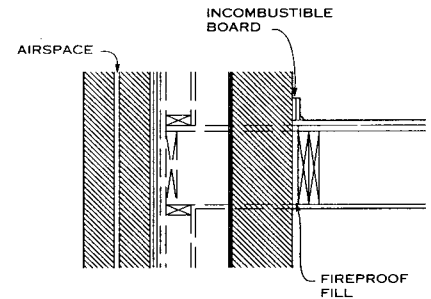

BRICK CHIMNEY EXPOSED

**CHIMNEY FRAMING AND INSULATION**

3. Areas shown are net minimum inside areas.
4. All flue liners are generally available in 2 ft lengths.
5. Fireplace flue sizes can be approximated using the following rules of thumb: One-tenth the area of fireplace opening recommended; one-eighth the area of opening recommended if chimney is higher than 20 ft and rectangular flues are used; one-twelfth the area is minimum required; verify with local codes.

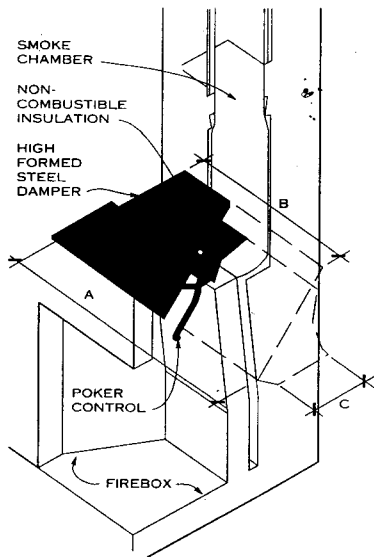

**HIGH FORMED DAMPER (IN.)**

A	B	C
32	15 1/4	9 1/4
36	19 1/4	9 1/4
40	23 1/4	9 1/4
44	27 1/4	9 1/4
48	31 1/4	9 1/4

HIGH FORMED DAMPERS provide correct ratio of throat-to-fireplace opening with an optional preformed smoke shelf, which can reduce material and labor requirements. They are useful for both single and multiple opening fireplaces.

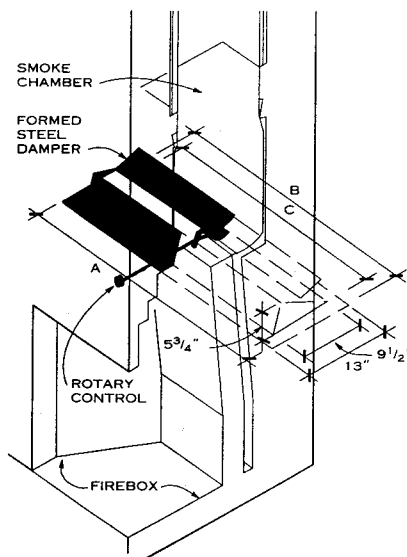

**FORMED DAMPER (IN.)**

WIDTH OF OPENING	DAMPER DIMENSIONS (IN.)		
	A	B	C
24 to 26	28 1/4	26 3/4	24
27 to 30	32 1/4	30 3/4	28
31 to 34	36 1/4	34 3/4	32
35 to 38	40 1/4	38 3/4	36
39 to 42	44 1/4	42 3/4	40
43 to 46	48 1/4	46 3/4	44
47 to 50	52 1/4	50 3/4	48

FORMED STEEL DAMPERS are designed to provide the correct ratio of throat-to-fireplace opening, producing maximum draft. These dampers are equipped with poker type control and are easily installed.

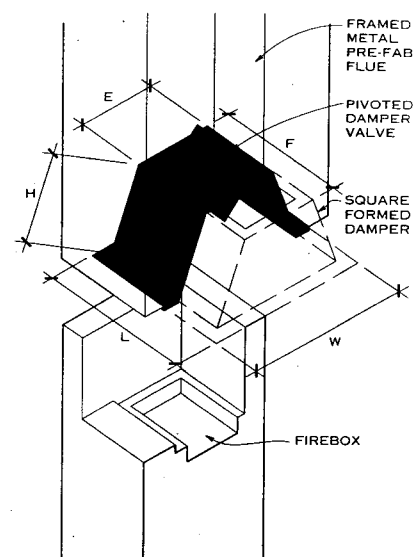

**SQUARE FORMED DAMPER (IN.)**

TOP OUTLET			OVERALL SIZE	
E	F	H	L	W
17	17	17	41	27
17	17	25	45	27
17	23	25	49	27

SQUARE FORMED DAMPERS have high sloping sides that promote even draw on all sides of multiple opening fireplaces. They are properly proportioned for a strong draft and smokefree operation.

**FORMED STEEL DAMPERS**

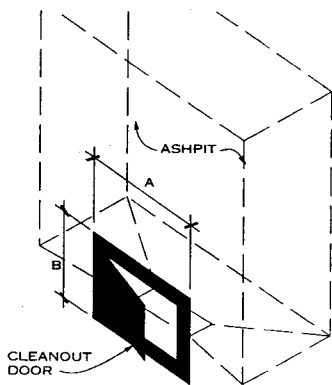

**DOOR DIMENSIONS (IN.)**

A	B
6	8
8	8, 10
10	10, 12
12	8, 10, 12, 16, 18

**CLEANOUT OR ASHPIT DOOR**

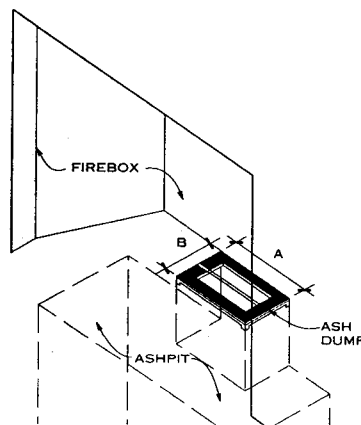

**DUMP DIMENSIONS (IN.)**

A	B
3 1/2	4 1/2
7	9
7	10

**NOTE**

Ash dumps and cleanout doors are available in heavy gauge steel or cast iron. See local manufacturers for available types and sizes.

**ASH DUMP**

**NOTES**

1. Locate bottom of damper minimum 6 to 8 in. from top of fireplace opening.
2. Mineral wool blanket allows for expansion of metal damper walls.
3. Dampers are available in heavy gauge steel or cast iron. Check with local suppliers for specific forms and sizes.
4. A cord of wood consists of 128 cu ft or a stack 4 ft high and 8 ft wide, with logs 4 ft long.
5. A face cord of wood consists of 64 cu ft or a stack 4 ft high and 8 ft wide, with logs 2 ft long.
6. Logs are cut to lengths of 1 ft 4 in., 2 ft 0 in., 2 ft 6 in., and 4 ft. Allow 3 in. minimum clearance between logs and each side of fireplace.

Timothy B. McDonald; Washington, D.C.

**GENERAL**

Multifaced fireplaces have more than one face of the firebox open to the room. There are three types of multifaced fireplaces: projected corner, with two adjacent sides open; double faced, with two opposite sides open; and three faced, with only one side built of masonry construction. Multifaced fireplaces usually are not as energy-efficient as conventional, single-faced fireplaces because there is less mass surrounding the fire to hold and radiate heat to the room. However, multifaced fireplaces usually are located on the interior of a space, not on an exterior wall, and their energy-efficiency can be augmented by the features discussed below.

The addition of energy-efficient features to fireplace design can increase both the combustion of the wood and the ability to heat the room or building. Energy-efficient features for conventional fireplaces include glass doors, damper controls, and outside air intake to the firebox. Designs that increase radiant heat also are energy-efficient. For example, the obliquely flared sides of Rumford-type fireplaces increase radiant heat. Air-circulating fireplaces increase the amount of radiant heat emanating from a fireplace through natural convection or by forced-air circulation.

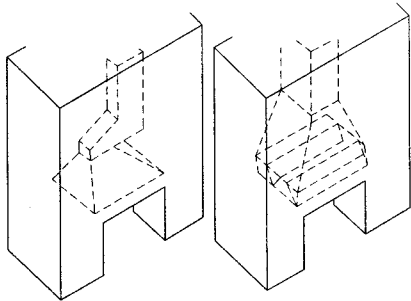

**SINGLE HIGH                      DOUBLE LOW**

**DAMPER ARRANGEMENT**

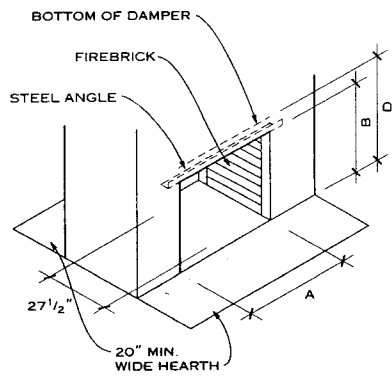

**TYPICAL DIMENSIONS (IN.)**

A	B	D
28	24	30
32	30	35
36	30	35
40	30	35
48	30	37

**NOTE**

The fireplace must be located and designed to allow proper updraft through both openings. Exterior doors should not be located opposite the fireplace on either side because they may cause cross-drafts through the fireplace.

**TWO-FACED FIREPLACE**

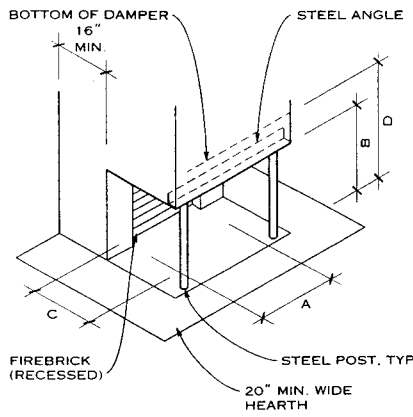

**TYPICAL DIMENSIONS (IN.)**

A	B	C	D
28	26½	20	32
32	26½	20	32
36	26½	20	32
40	30	20	35
48	30	20	35
54	30	20	37
60	30	20	37

**NOTE**

The sides of the fireplace are partially enclosed by recessing the brick into the wall behind the fireplace. This design helps eliminate smoke from cross-drafts.

**THREE-FACED, WIDE FRONT FIREPLACE**

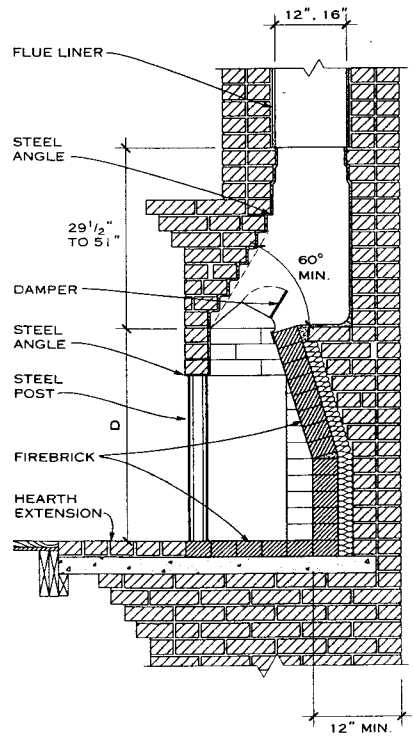

**NOTE**

This design is similar to the projected-corner fireplace.

**THREE-FACED, WIDE FRONT FIREPLACE—SECTION**

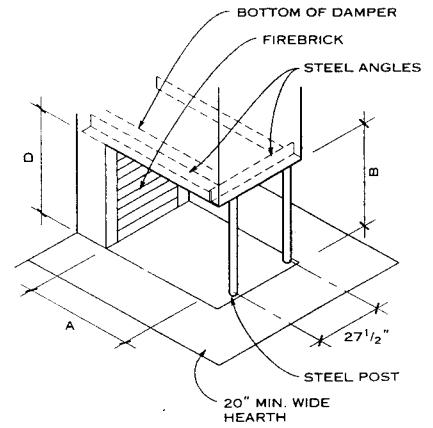

**TYPICAL DIMENSIONS (IN.)**

A	B	D
28	27½	32
32	27½	32
36	27½	32
40	27½	32
48	27½	32

**NOTE**

The narrowness and length of narrow-front fireplaces require that they be fitted with two square-end dampers. To allow for expansion, the dampers should be neither solidly embedded in mortar nor mechanically fastened to steel angles.

**THREE-FACED, NARROW FRONT FIREPLACE**

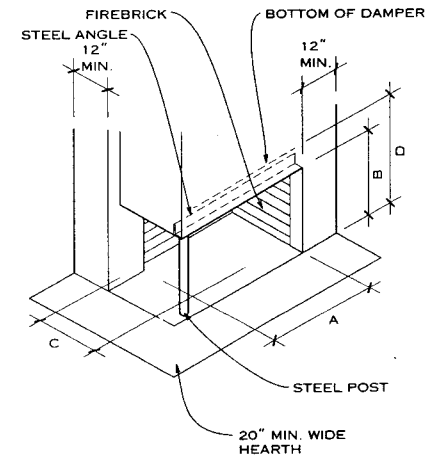

**TYPICAL DIMENSIONS (IN.)**

A	B	C	D
28	26½	16	34
32	26½	16	34
36	26½	16	34
40	30	16	34
48	30	20	38
54	30	20	37
60	30	20	37

**NOTE**

The significant difference between a projected-corner fireplace and a conventional single-faced fireplace is the shape of the damper. A projected-corner fireplace uses a square-end damper instead of a tapered-end damper. The open side should have a short wall to help stop the escape of combustible gases when cross-drafts occur.

**PROJECTED-CORNER FIREPLACE**



**GENERAL**

Structural clay facing tile is chosen as an attractive and durable wall system in many specialized applications, especially when maintenance and resistance to vandalism are considered. Applications include walls and partitions in correctional facilities, schools, public buildings, and food processing facilities. Structural clay tile can be glazed or unglazed, load bearing or non-load bearing, and behaves similarly to brick. Structural clay tile is manufactured in many sizes and shapes. Numbers and letters shown on the units in the figures indicate the standard shape classifications of structural clay facing tile used by manufacturers.

**WALL SECTIONS AND PROPERTIES**

WALL TYPE NUMBER	1	2	3	4	5	
Allowable load (lb/linear ft)	Types M and S mortar		9660	9660	12390	
	Type N mortar		8280	8280	10620	
Material quantity (per 100 sq ft)	Mortar (cu ft) 25% waste added	2.19	2.19	3.36	3.36 <sup>2</sup>	6.97
	Facing tile 2% waste added	230	230	230	230	230
	Brick 5% waste added					709
U values (BTU/sq ft hr °F)	Unplastered partition	0.40	0.40	0.35	0.34	
	Exterior wall					0.30
	With 2 in. insulation					0.08
Lateral support spacing required (ft)	Non-load bearing	12	12	18	18	24
	Load bearing			9	9	12
Wall weight	Unplastered	30	30	41	47	67
Sound resistance (dB)	Unplastered	45	45	47	48	54
Fire resistance (hr)	Regular coring	See note 1	See note 1	1	2	3
	Fire rated coring	1	1	2	3	4

**NOTES**

- 3/4 in. plaster on back of these units will produce 1 hour fire rating.
- If collar joint is filled, add 2.6 cu ft per 100 sq ft of wall.

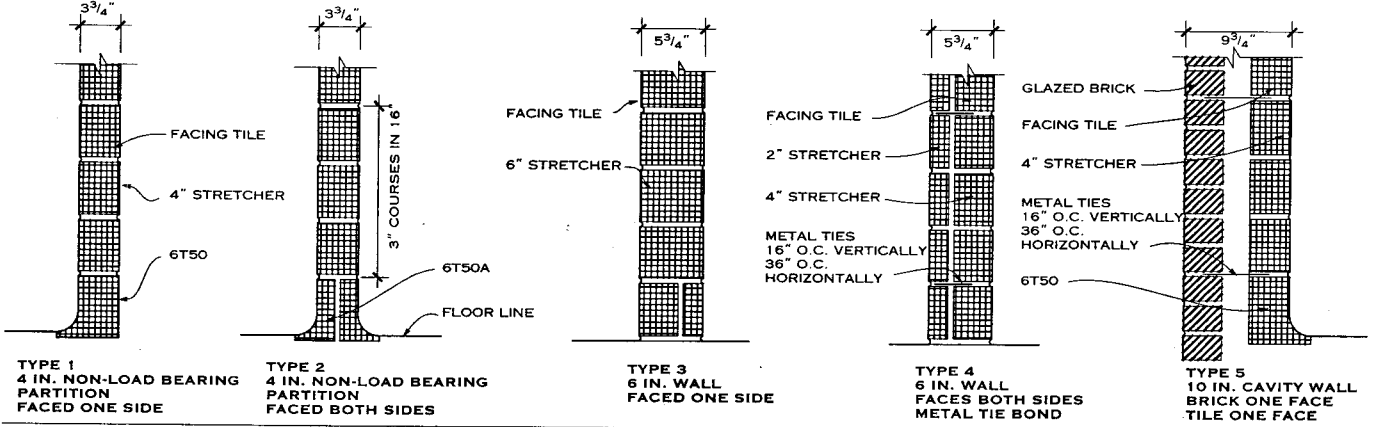

**SECTION**

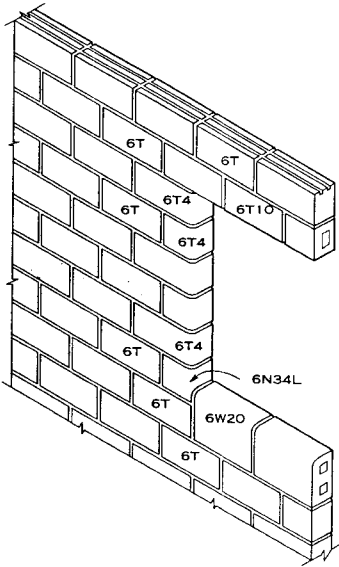

4 IN. SINGLE-FACED WALL WITH BULLNOSE SILL AND JAMB; SQUARE LINTEL RUNNING BOND

**SECTION**

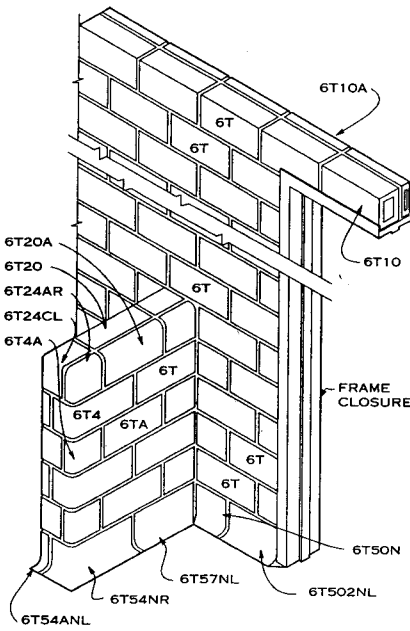

6 IN. DOUBLE-FACED WING WALL BONDED TO MAIN WALL WITH TYPICAL BUTT JOINTS

**SECTION**

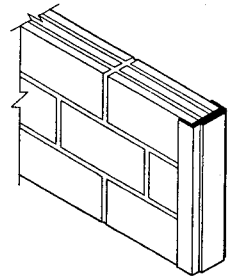

4 IN. WALL

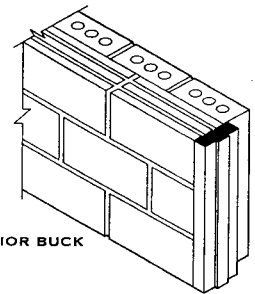

EXTERIOR BUCK

**FRAME FITTINGS**

Grace S. Lee; Rippeteau Architects, PC; Washington, D.C.  
Facing Tile Institute; Washington, D.C.



MASONRY UNITS

**TERRA-COTTA**

Terra-cotta is a high grade of weathered or aged clay, which, when mixed with sand or with pulverized fired clay, can be molded to a hardness and compactness not obtainable with other materials. Used extensively until the 1930s, terra-cotta has been largely replaced with ceramic veneer.

Terra-cotta was usually hollow cast in blocks, open to the back to reveal internal webbing.

Ceramic veneer is not hollow cast but is a veneer of glazed ceramic tile that is ribbed on the back. It is frequently attached to metal ties that are anchored to the building.

Other types of terra-cotta are:

1. Brownstone terra-cotta. A dark red or brown block, which is hollow cast. Used extensively in the mid- to late-19th century.
2. Fireproof construction terra-cotta. Inexpensive and lightweight, these rough-finished hollow building blocks span beams. The blocks are available but not used widely today.
3. Glazed architectural terra-cotta. Hollow units were hand cast in molds or carved in clay and heavily glazed. Sometimes called architectural ceramics, this terra-cotta type was used until the 1930s.

**NOTES**

Ceramic veneer can be anchored or adhered to masonry.

The ceramic veneer manufacturer should provide scale shop drawings as detailed from the architect's drawings. To be used for setting, the shop drawings should indicate all dimensions and sizes of joints, and all anchors, hangers, expansion, and control or pressure-relieving joints.

Nonferrous metal anchors should be embedded in the masonry and encased for protection from corrosion.

The minimum thickness of anchored-type ceramic veneer, exclusive of ribs, should be 1 in.

Ceramic veneer should be set true to line in setting mortar. Spaces between anchored ceramic veneer and backing walls should be filled with grout: spaces 3/4 in. or more in width with pea gravel and spaces 3/4 in. with mortar.

The minimum thickness of adhesion-type ceramic veneer, including ribs, should be 1/4 in. with ribbed or scored backs.

An evenly spread coat of neat portland cement and water should be applied to the wall and the entire back of the ceramic veneer panel about to be set. Then one half of the setting mortar coat should be immediately applied on the chosen wall area and the other on the ceramic veneer piece's entire back. Tap the piece into place on the wall to completely fill all voids, with the total thickness of the mortar averaging 3/4 in. There should be some excess mortar forced out at the joints and edge of the ceramic veneer.

**MOLD-PRESSED CERAMIC VENEER**

The minimum thickness of the exposed faces of mold-pressed ceramic veneer is 1 in. Backs of special shapes should be open and ribbed.

For placement, turn all units bottom-side up and fill solidly with grout filler for mold-pressed ceramic veneer. When the fill has set sufficiently to permit handling, set the units.

When applied to soffits, each piece of ceramic veneer, in addition to the usual centers and wooden wedges, shall be supported by bent and vertical wooden shores. A constant upward pressure is needed until the mortar coat has set.

Adhesion can be tested with a 1 x 1 x 4 in. vitrified test bar. First dissolve vinyl acetate in methyl iso-butyl ketone. Apply to the ceramic veneer surface and test bar. The adhesive is heated by means of an infrared lamp until bubbling ceases. Press the two surfaces together until cool. Then knock or pry off test bar.

**TERRA-COTTA VENEER PRECAST PANEL**

Terra-cotta precast panels have a keyback design, which allows each piece to easily become an integral part of the precast unit through a mechanical bond. No fasteners are needed.

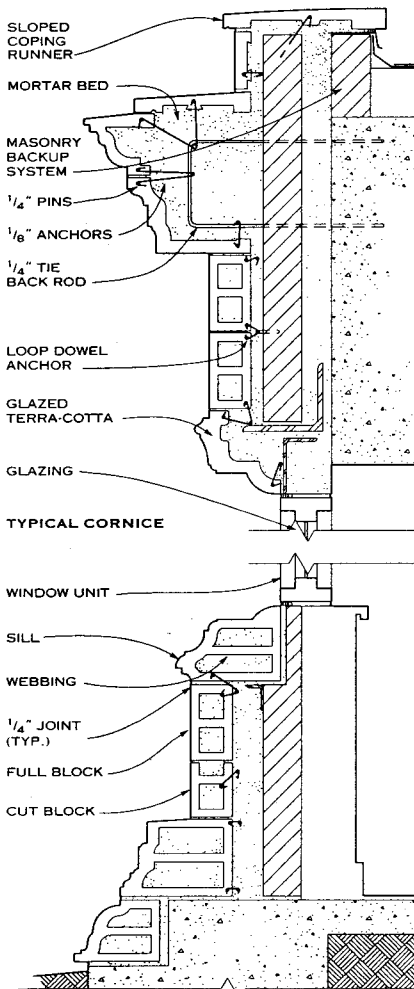

TYPICAL BASE  
NOTE  
Design of Best Products Corporation

**TERRA-COTTA WALL SECTION**

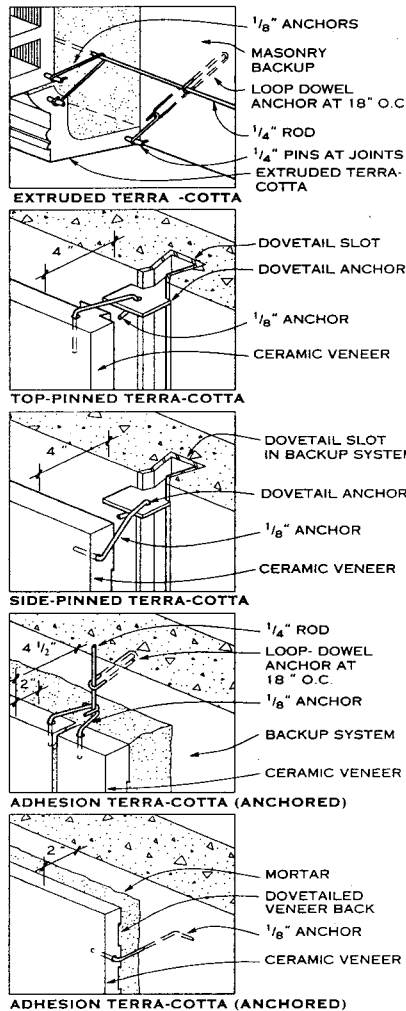

**ANCHORING SYSTEMS**

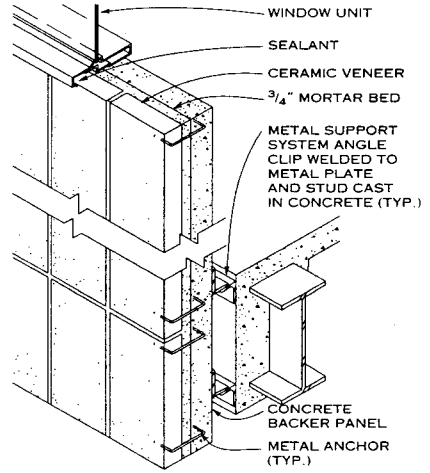

**TERRA-COTTA PRECAST PANEL**

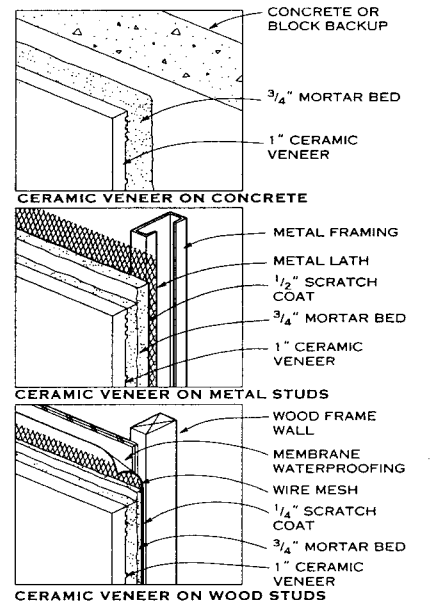

**GROUT-ADHERED CERAMIC VENEER**

Eric K. Beach; Rippeteau Architects, PC; Washington, D.C.

**GENERAL**

Glass block is a diverse building material whose many applications exhibit its multifaceted characteristics. The varying forms of glass block — type, thickness, size, shape, and patterns — along with the methods of installation can combine to create unique design solutions. Applications range from entire facades, windows, interior dividers, and partitions to skylights, floors, walkways, and stairways. In all applications, glass block units permit the control of light, both natural and artificial, for function or drama. Glass block also allows for control of thermal transmission, noise, dust, and drafts. With the use of thick-faced glass block or solid 3 in. bullet-resistant block, security can also be achieved.

**MORTAR**

An optimum mortar mix for installing glass block units is 1 part portland cement, 1/2 part lime, and 4 parts sand.

The table below gives the number of glass block that can be installed with a mortar batch consisting of:  
 1.0 cu ft (1 bag/94 lb) portland cement  
 0.5 cu ft (20 lb) lime  
 4.0 cu ft (320 lb) sand

**GLASS BLOCK/MORTAR BATCH**

SERIES	BLOCK SIZE <sup>1</sup>	BLOCK NUMBER <sup>2</sup>
Regular	4 x 8	350
	6 x 6	350
	8 x 8	260
	12 x 12	190
Thin	4 x 8	450
	6 x 6	450
	8 x 8	335

**NOTES**

1. Includes 15% waste
2. Based on a 1/4 in. exposed joint

**SOUND TRANSMISSION<sup>1</sup>**

STC <sup>2</sup>	SIZE	PATTERN	ASSEMBLY CONSTRUCTION
31	8" x 8" x 3"	All patterns	Silicone system
37 <sup>3</sup>	8" x 8" x 4"	All patterns	Mortar
40	8" x 8" x 4" with LX fibrous filter	All patterns	Mortar
50	8" x 8" x 4" thick faced block	Thick block	Mortar
53	8" x 8" x 3" solid units	Solid block	Mortar

**NOTES**

1. Tested in accordance with ASTM E90-90 "... Measurement of Airborne Sound Transmission Loss..."
2. STC rating value in accordance with ASTM E413-87 "Classification for Rating Sound Insulation."
3. Test method and STC rating value in accordance with ASTM E90-81 and ASTM E413-73 accordingly.

**THERMAL PERFORMANCE/LIGHT TRANSMISSION<sup>1,2</sup>**

BLOCK TYPE	HEAT TRANSMISSION <sup>2</sup> U-VALUE (BTU/HR FT <sup>2</sup> °F)	THERMAL RESISTANCE <sup>2</sup> R-VALUE (HR FT <sup>2</sup> °F/BTU)	THERMAL EXPANSION COEFFICIENT (1/°F)	VISIBLE LIGHT TRANSMISSION (%)	SHADING COEFFICIENT <sup>4</sup>
Regular series	0.51 (0.48 with "LX")	1.96 (2.08 with "LX")	47 x 10 <sup>7</sup>	75	0.65
Solar reflective	0.51	1.96	47 x 10 <sup>7</sup>	5 - 20	0.20 - 0.25
Thin series	0.57 (0.54 with "LX")	1.75 (1.85 with "LX")	47 x 10 <sup>7</sup>	75	0.65
Solid	0.87	1.15	47 x 10 <sup>7</sup>	80	
Flat sheet glass	1.04	0.96	47 x 10 <sup>7</sup>	90	1.00

**NOTES**

1. Values equal ± 5%.
2. Winter night values.
3. To calculate instantaneous heat gain through glass block panels, see ASHRAE Handbook of Fundamentals, 1985, section 22.41.B.
4. Based on 8 in. square units: ratio of heat gain through glass block panels vs. that through a single light of double strength sheet glass under specific conditions.

Grace S. Lee; Rippeteau Architects, PC; Washington, D.C.

**4 GLASS UNIT MASONRY**

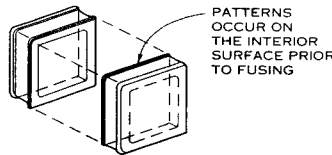

The basic glass block unit is made of two halves fused together with a partial vacuum inside. Faces may be clear, figured, or with integral relief forms.

Glass block is available in thicknesses ranging from a minimum of 3 in. for solid units to a maximum of 4 in. (nominal) for hollow units. Metric thicknesses range from 76 to 98 mm.

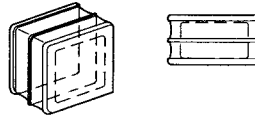

**SQUARE**

- 4 1/2 in. x 4 1/2 in.
- 6 in. x 6 in. (5 3/4 in. x 5 3/4 in. actual)
- 1/2 in. x 7 1/2 in.
- 8 in. x 8 in. (7 3/4 in. x 7 3/4 in. actual)
- 9 1/2 in. x 9 1/2 in.
- 12 in. x 12 in. (11 3/4 in. x 11 3/4 in. actual)

- 115 mm x 115 mm
- 190 mm x 190 mm
- 240 mm x 240 mm
- 300 mm x 300 mm

Metric sizes are available from foreign manufacturers through distributors in the United States.

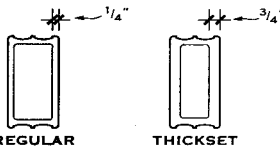

Some manufacturers provide thick blocks for critical applications where a thick-faced, heavier glass block is needed. These blocks have a superior sound transmission rating properties. Their faces are three times as thick as regular units.

**THICK BLOCK**

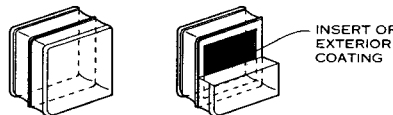

Solid glass block units (glass bricks) are impact resistant and allow through vision.

Solar control units have either inserts or exterior coatings to reduce heat gain. Coated units require periodic cleaning to remove alkali and metal ions that can harm the surface coating. Edge drips are required to prevent moisture run-down on the surface.

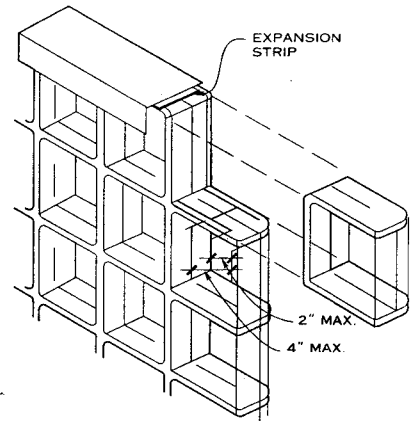

End block units have a rounded, finished surface on one edge. They may be used to end interior partitions or walls as well as space dividers when installed horizontally.

**END BLOCK**

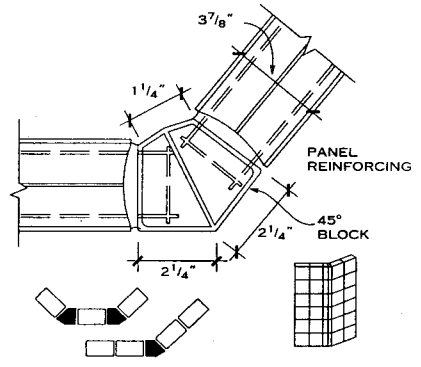

**45° BLOCK**

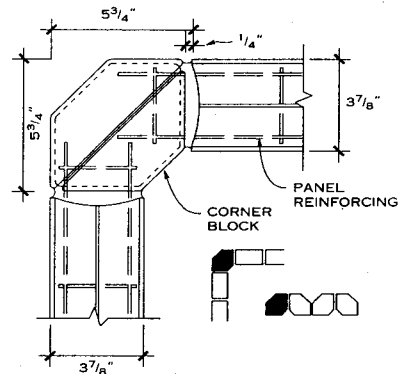

**CORNER BLOCK**

A few manufacturers have special shapes to execute corner designs. These units also may be placed together for varying patterns and forms.

**SPECIAL SHAPES (CORNERS)**

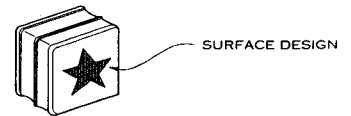

Surface decoration may be achieved with fused-on ceramic, etching, or sandblasting. Glass block units may be split or shipped in halves in order to apply some decoration to the inside. Blocks then must be resealed. Resealed blocks will not perform the same under various stresses as factory sealed units. Placement in walls or panels should be limited to areas receiving minimum loading.

**MAXIMUM PANEL DIMENSIONS**

PERIMETER SUPPORT METHOD	REGULAR SERIES			THIN SERIES		
	AREA (SQ FT)	HEIGHT (FT)	WIDTH (FT)	AREA (SQ FT)	HEIGHT (FT)	WIDTH (FT)
<b>EXTERIOR</b>						
Channel type restraint	144	20	25	85	10	25
Panel anchors	144	20	25	85	10	25
Channels or panel anchors with intermediate stiffener	250	20	25	150	20	25
<b>INTERIOR</b>						
Channel type restraint	250	20	25	150	20	25
Panel anchors	250	20	25	150	20	25

**NOTE**  
Maximum exterior panel sizes are based on a design wind load of 20 lb/sq ft with a 2.7 safety factor.

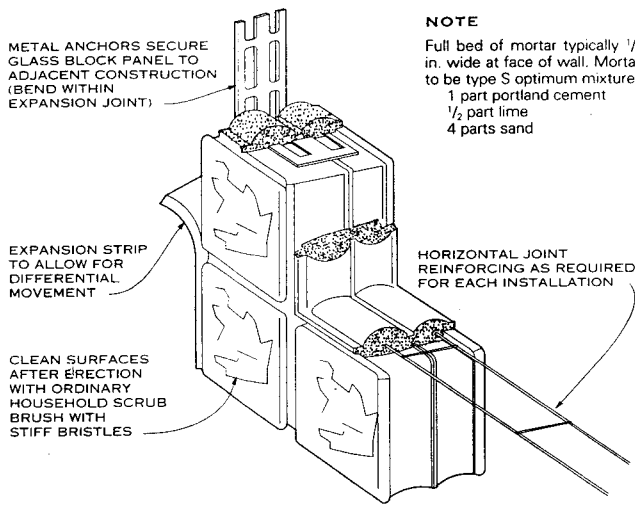

**NOTE**  
Full bed of mortar typically 1/2 in. wide at face of wall. Mortar to be type S optimum mixture:  
1 part portland cement  
1/2 part lime  
4 parts sand

**GLASS BLOCK PANEL COMPONENTS**

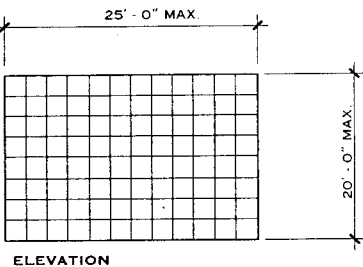

- NOTES**
1. Area of exterior unbraced panel should not exceed 144 sq ft.
  2. Area of interior unbraced panel should not exceed 250 sq ft.
  3. Panels are designed to be mortared at sill, with head and jambs providing for movement and settling. Deflection of lintel at head should be anticipated.
  4. Consult manufacturers for specific design limitations of glass block panels. Thickness of block used also determines maximum panel size.

**NUMBER OF BLOCKS FOR 100 SQ FT PANEL**

BLOCK SIZE (NOMINAL)	6"	8"	12"
Number of blocks	400	225	100

**GLASS BLOCK PANELS**

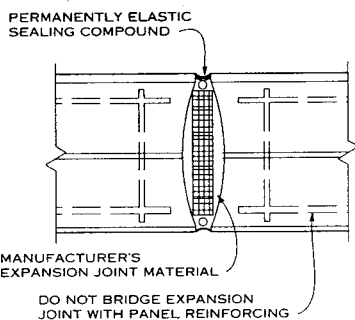

**NOTE**  
Expansion joints should be installed at every change of direction of a multicurved wall, at points of curved wall intersection with straight walls, and at center of curvature in excess of 90 degrees.

**GLASS BLOCK EXPANSION JOINT**

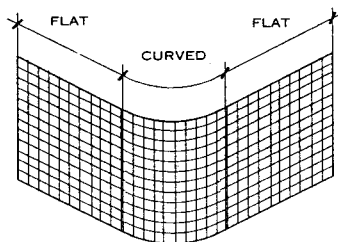
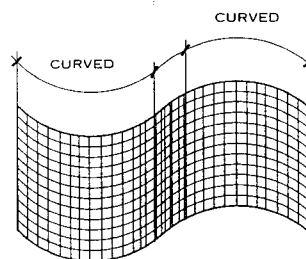
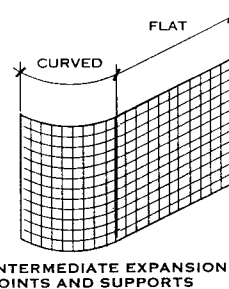
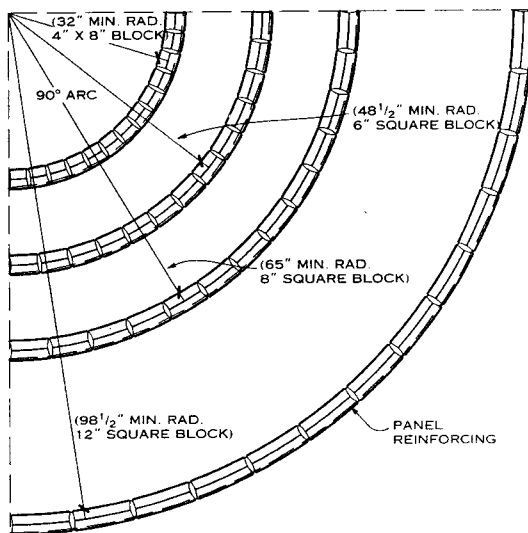

**INTERMEDIATE EXPANSION JOINTS AND SUPPORTS**

- NOTES**
1. It is suggested that curved areas be separated from flat areas by intermediate expansion joints and supports, as indicated in these drawings.
  2. When straight, ladder-type reinforcing is used on curved walls, the innermost parallel wire may be cut periodically and bent to accommodate the curvature of the wall.

**CURVED PANEL CONSTRUCTION**

**RADIUS MINIMUMS FOR CURVED PANEL CONSTRUCTION**

BLOCK SIZE	INSIDE RADIUS (IN.)	NUMBER OF BLOCKS IN 90° ARC	JOINT THICKNESS (IN.)	
			INSIDE	OUTSIDE
4" x 8"	32	13	1/8	5/8
6" x 6"	48 1/2	13	1/8	5/8
8" x 8"	65	13	1/8	5/8
12" x 12"	98 1/2	13	1/8	5/8

**TYPICAL SUPPORT DESIGN CRITERIA**

When specifying supports and shelf angles, the installed weight and deflection limitation of the glass block should be taken into account. Local building codes should be checked for any limits on panel sizes or installation details.

**INSTALLED WEIGHT OF GLASS BLOCK**

TYPE OF UNIT	INSTALLED WEIGHT (LB/SQ FT)
Regular	20
Thin	16
Thick	26
Solid	38

**DEFLECTION LIMITATIONS**

Maximum deflection of structural members supporting glass block panels shall not exceed:

$$\frac{L}{600}$$

Where L = distance between vertical supports

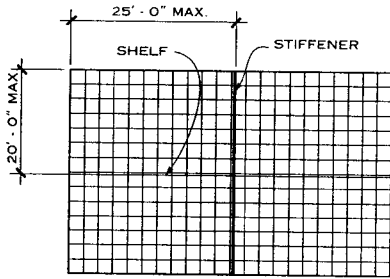

**ELEVATION**

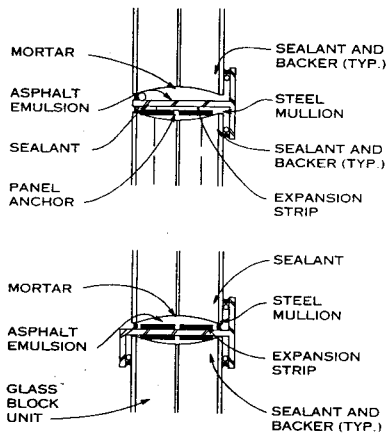

**SHELF ANGLES IN MULTIPLE VERTICAL PANELS**

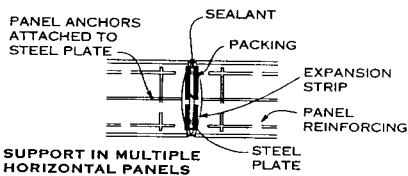

**SUPPORT IN MULTIPLE HORIZONTAL PANELS**

**NOTE**

Panels with an expansion joint stiffener incorporating a concealed vertical plate should be limited to 10 ft maximum height.

**SECTIONS AT SUPPORTS**

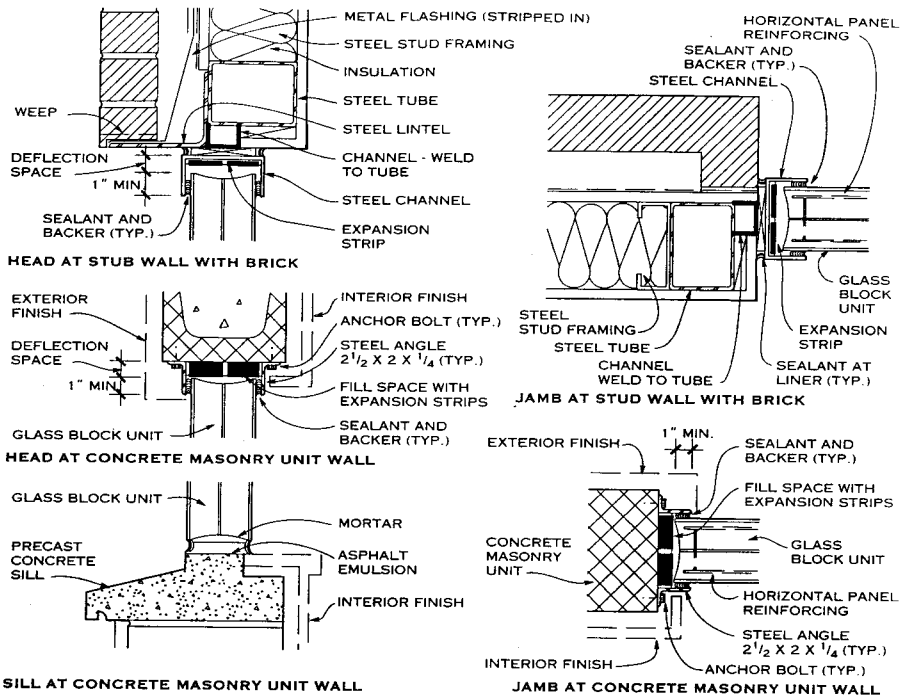

**EXTERIOR CONNECTION DETAILS**

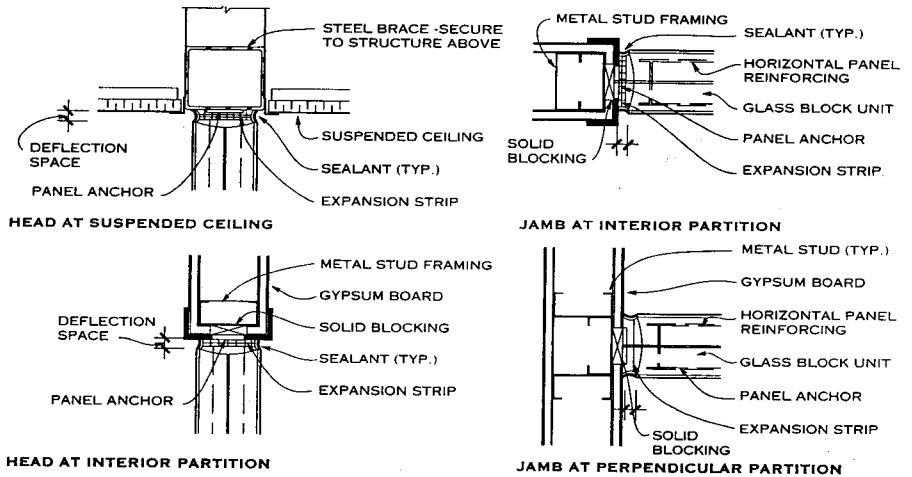

**INTERIOR CONNECTION DETAILS**

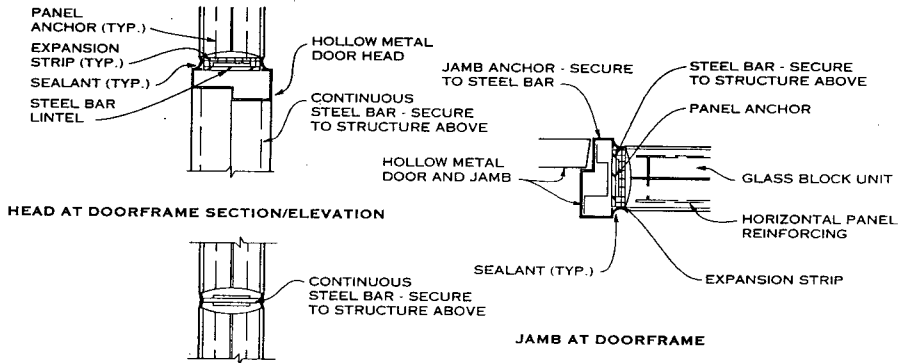

**DOORFRAME DETAILS**

Grace S. Lee; Rippeteau Architects, PC; Washington, D.C.

**GENERAL**

Natural stone is used in building as a facing, veneer, and decoration. The major factors affecting the suitability and use of stone fall under two broad, but overlapping categories: physical and structural properties and aesthetic qualities. The three factors of building stone that most influence their selection by architects for aesthetic reasons are pattern, texture, and color. Consideration also should be given to costs, availability, weathering characteristics, physical properties, and size and thickness limitations.

Stone patterns are highly varied, and they provide special features that make building stone a unique material. Texture is varied, ranging from coarse fragments to fine grains and crystalline structures. Texture also varies with the hardness of minerals composing the stone. To accurately compare stone colors, the rock color chart published by the Geological Society of America (Boulder, CO) is recommended. Samples also may be used to establish acceptable color ranges for a particular installation.

Pattern, texture, and color all are affected by how the stone is fabricated and finished. Granites tend to hold their color and pattern, while limestone color and pattern changes with exposure. Textures may range from rough and flamed finishes to honed or polished surfaces. The harder the stone, the better it takes and holds a polish.

The three rock classes are igneous, sedimentary, and metamorphic. Common construction stones are marketed under the names given in the table below, although specialty stones such as soapstone and serpentine also are available. Each stone has various commercial grades. Limestone grades are A, statuary; B, select; C, standard; D, rustic; E, variegated; and F, old Gothic. Marble is graded A, B, C, or D on the basis of working qualities, uniformity, and flaws and imperfections.

**PHYSICAL PROPERTIES OF STONE**

The physical characteristics of a particular stone must be suitable for its intended use. It is important to determine the physical properties of the actual stone being used rather than using values from a generic table, which can be very misleading. Considerations of the physical properties of the stone being selected include modulus of rupture, shear strength, coefficient of expansion, permanent irreversible growth and change in shape, creep deflection, compressive strength, modulus of elasticity, moisture resistance, and weatherability. Epoxy adhesives, often used with stone, are affected by cleanliness of surfaces to be bonded and ambient temperature. Curing time increases with cold temperatures and decreases with warmer temperatures.

**FABRICATION AND INSTALLATION**

With the introduction of new systems of fabrication and installation and recent developments in the design and detailing of stone cutting, support, and anchorage, costs are better controlled. Correct design of joints, selection of mortars, and use of sealants affect the quality and durability of installation. Adequate design and detailing of the anchorage of each piece of stone are required. The size and thickness of the stone should be established based on physical properties of the stone, its method of anchorage, and the loads it must resist. Appropriate safety factors should be developed based on the variability of the stone properties as well as other considerations such as imperfect workmanship, method of support and anchorage, and degree of exposure of the cladding installation. Relieving angles for stone support and anchorage may be necessary to preclude unacceptable loading of the stone. The stone should be protected from staining and breakage during shipment, delivery, and installation.

Since stone cladding design and detailing vary with type of stone and installation, the designer should consult stone suppliers, stone-setting specialty contractors, industry standards (such as ASTM), and other publications to help select and implement a stone cladding system. Resource information is available in publications such as the Indiana Limestone Institute's *Indiana Limestone Handbook* and the Marble Institute of America's *Dimensioned Stone*, (vol. 3).

**STONE CLASSIFIED ACCORDING TO QUALITIES AFFECTING USE**

CLASS	COLOR	TEXTURE	SPECIAL FEATURES	PARTING	HARDNESS	CHIEF USES
Sandstone	Very light buff to light chocolate brown or brick red; may tarnish to brown	Granular, showing sand grains, cemented together	Ripple marks; oblique color bands ("cross bedding")	Bedding planes; also fractures transverse to beds	Fairly hard if well cemented	General; walls; building; flagstone
Limestone	White, light gray to light buff	Fine to crystalline; may have fossils	May show fossils	Parallel to beds; also fractures across beds	Fairly soft; steel easily scratches	All building uses
Marble	Highly varied; snow white to black; also blue-gray and light to dark olive green; also pinkish	Finely granular to very coarsely crystalline showing flat-sided crystals	May show veins of different colors or angular rock pieces or fossils	Usually not along beds but may have irregular fractures	Slightly harder than limestone	May be used for building stone but usually in decorative panels
Granite (light igneous rock)	Almost white to pink-and-white or gray-and-white	Usually coarsely crystalline; crystals may be varicolored; may be fine grained	May be banded with pink, white, or gray streaks and veins	Not necessarily any regular parting but fractures irregularly	Harder than limestone and marble; keeps cut shape well	Building stone, but also in paneling if attractively colored
Dark igneous rock	Gray, dark olive green to black; Laurvikite is beautifully crystalline	Usually coarsely crystalline if quarried but may be fine grained	May be banded with lighter and darker gray bands and veins	Not necessarily any regular parting but may fracture irregularly	About like granite; retains cut shape well	Building stone, but also used in panels if nicely banded or crystalline
Lavas	Varies: pink, purple, black; if usable, rarely almost white	Fine grained; may have pores locally	Note rare porosity	Not necessarily any regular parting, as a rule, but some have parallel fractures	About as strong as granite; if light colored, usually softer	Good foundation and building stone; not decorative
Quartzite	Variable: white, buff, red, or brown	Dense, almost glassy ideally	Very resistant to weather and impact	Usually no special parting	Very hard if well cemented, as usually the case	Excellent for building but hard to "shape"
Slate	Grayish-green, brick red, or dark brown, usually gray; may be banded	Finely crystalline; flat crystals give slaty fracture	Some slate have color-fading with age	Splits along slate surface, often crossing color bands	Softer than granite or quartzite; scratches easily	Roofing; blackboards; paving
Gneiss	Usually gray with some pink, white, or light gray bands	Crystalline, like granite, often with glassy bands (veins)	Banding is decorative; some bands very weak, however	No special parting; tends to break along banding	About like granite	Used for buildings; also may be decorative if banded

**PHYSICAL PROPERTIES OF REPRESENTATIVE STONES**

PHYSICAL PROPERTY	IGNEOUS ROCK		SEDIMENTARY ROCK		METAMORPHIC ROCK	
	GRANITE	TRAPROCK	LIMESTONE	SANDSTONE	MARBLE	SLATE
Compressive — ultimate strength (psi)	15,000 – 30,000	20,000	4000 – 20,000	3000 – 20,000	10,000 – 23,000	10,000 – 15,000
Compressive — allowable working strength (psi)	800 – 1500		500 – 1000	400 – 700	500 – 900	1000
Shear — ultimate stress (psi)	1800 – 2700		1000 – 2000	1200 – 2500	900 – 1700	
Shear — allowable working stress (psi)	200		200	150	150	
Tension — allowable working stress (psi)	150		125	75	125	
Weight (psf)	156 – 170	180 – 185	147 – 170	135 – 155	165 – 178	170 – 180
Specific gravity	2.4 – 2.7	2.96	2.1 – 2.8	2.0 – 2.6	2.4 – 2.8	2.7 – 2.8
Absorption of water (percentage by weight)	0.13%		2.63%	4.16%	0.33%	0.23%
Modulus of elasticity (psi)	6 – 10,000,000	12,000,000	4 – 14,000,000	1 – 7,500,000	4 – 13,500,000	12,000,000
Coefficient of expansion (psf)	0.0000040		0.0000045	0.0000055	0.0000045	0.0000058

**NOTE**

Particular stones may vary greatly from average properties shown in table. A particular stone's physical properties, as

well as its allowable working values, always should be developed for each particular application.

The McGuire & Shook Corporation; Indianapolis, Indiana  
Christine Beall, RA, CCS; Austin, Texas

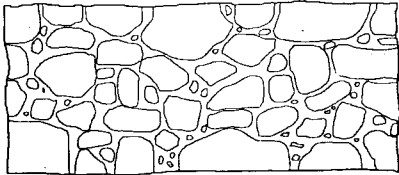

UNCOURSED FIELDSTONE PATTERN

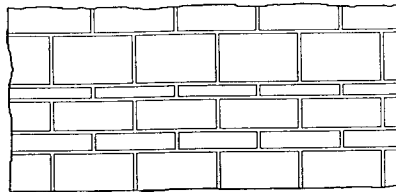

COURSED ASHLAR — RUNNING BOND

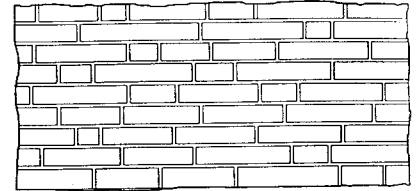

ONE-HEIGHT PATTERN (SINGLE RISE)

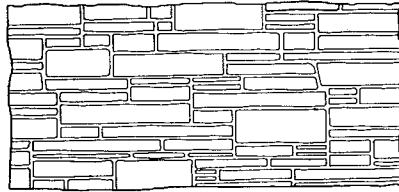

UNCOURSED LEDGE ROCK PATTERN

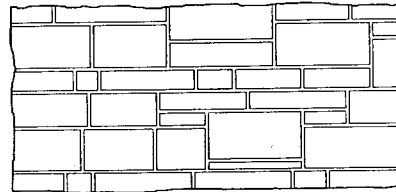

RANDOM COURSED ASHLAR

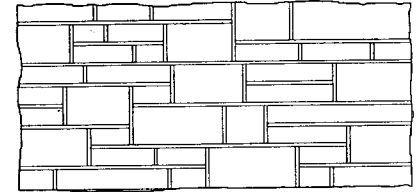

TWO-HEIGHT PATTERN (40% AT 2 1/4 IN.; 60% AT 5 IN.)

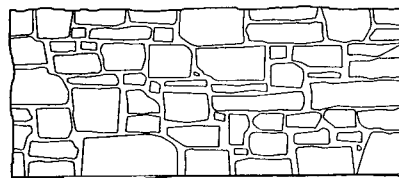

UNCOURSED ROUGHLY SQUARE PATTERN

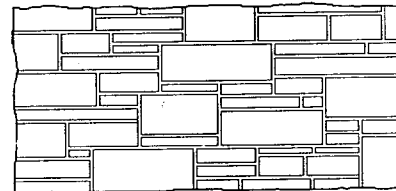

RANDOM BROKEN COURSED ASHLAR

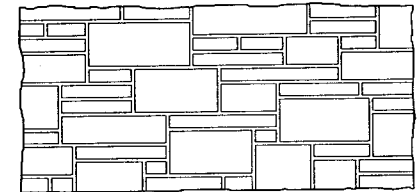

THREE-HEIGHT PATTERN (15% AT 2 1/4 IN.; 40% AT 5 IN.; 45% AT 7 1/2 IN.)

RUBBLE STONE MASONRY PATTERNS — ELEVATIONS

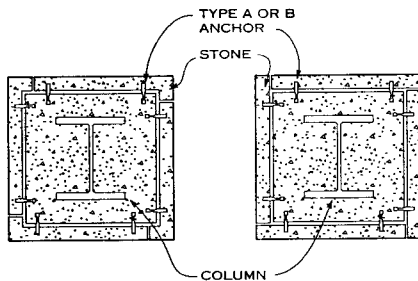

SQUARE COLUMNS

SPLIT STONE MASONRY PATTERNS — ELEVATIONS

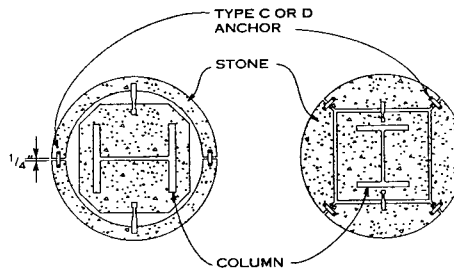

ROUND/QUADRANT COLUMNS

SPLIT STONE MASONRY HEIGHT PATTERNS — ELEVATIONS

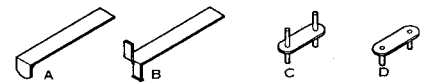

STONE TO STRUCTURE      STONE TO STONE

ANCHORS

NOTES

1. A course is a horizontal row of stone. Bond pattern is described by the horizontal arrangement of vertical joints. (See also Brickwork.) Structural bond refers to the physical tying together of load bearing and veneer portions of a composite wall. Structural bond can be accomplished with metal ties or with stone units set as headers into the backup.
2. Ashlar masonry is composed of squared-off building stone units of various sizes. Cut ashlar is dressed to specific design dimensions at the mill. Ashlar is often used in random lengths and heights, with jointing worked out on the job.
3. All ties and anchors must be made of noncorrosive material. Chromium-nickel stainless steel types 302 and 304 and eraydo alloy zinc are the most resistant to corrosion and staining. Use stainless steel type 316 in highly corrosive environments (polluted or near the sea). Copper, brass, and bronze will stain under some conditions. Local building codes often govern the types of metal that may be used for some stone anchors.
4. Nonstaining cement mortar should be used on porous and light colored stones. At all corners use extra ties and when possible, larger stones. Joints for rough work are usually 1/2 to 1 1/2 in. and 3/8 to 3/4 in. for ashlar. Prevent electrochemical reaction between different metals combined in the same assembly by properly isolating or coating them.

INSTALLATION DETAILS

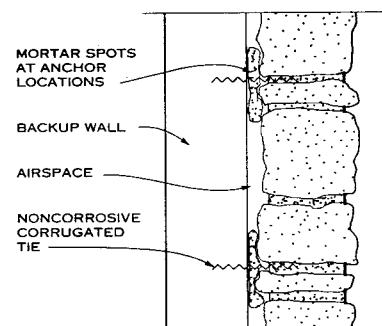

CAVITY VENEERED WALL

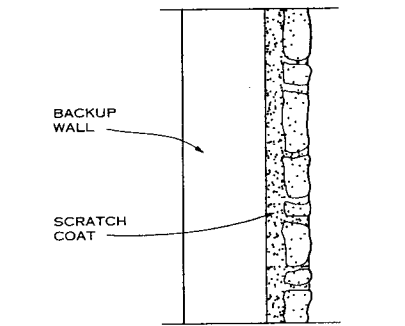

THIN VENEERED WALL (INTERIOR ONLY)

TYPICAL WALL SECTIONS

George M. Whiteside, III, AIA and James D. Lloyd; Kennett Square, Pennsylvania  
 Building Stone Institute; New York, New York  
 Alexander Keyes; Rippeteau Architects, PC; Washington, D.C.

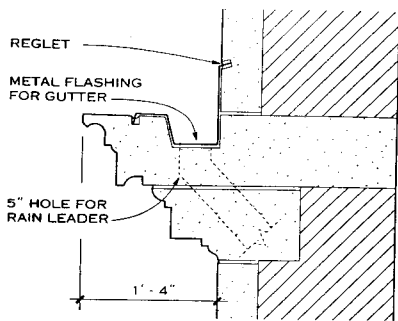

CORNICE WITH BUILT-IN GUTTER

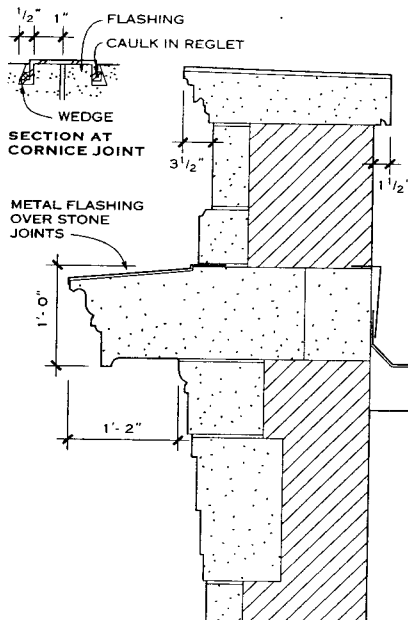

CORNICE WITH SEPARATE PARAPET

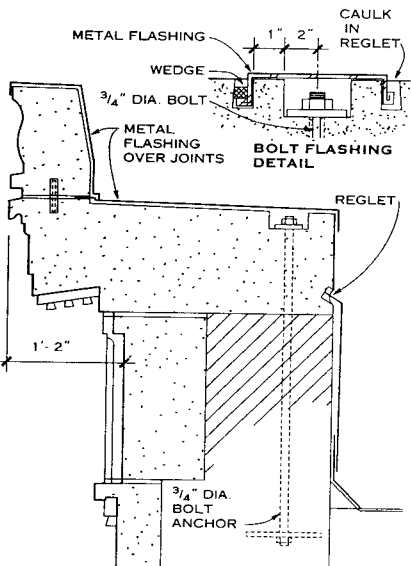

PARAPET AS CORNICE  
STONE PARAPET DETAILS

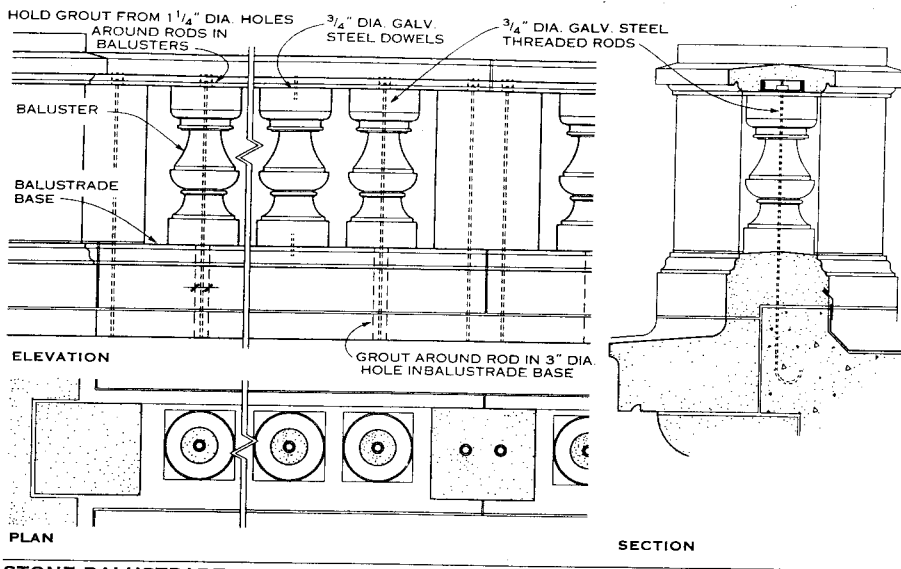

STONE BALUSTRADE

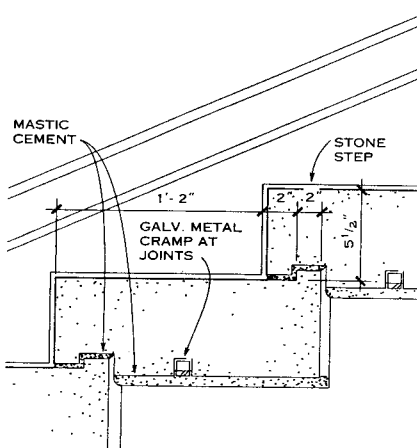

SECTION

STONE STEPS AND CURBS

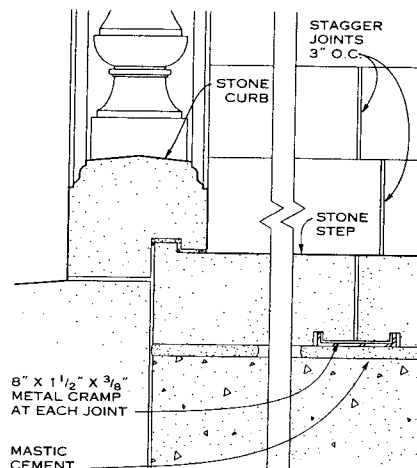

SECTION

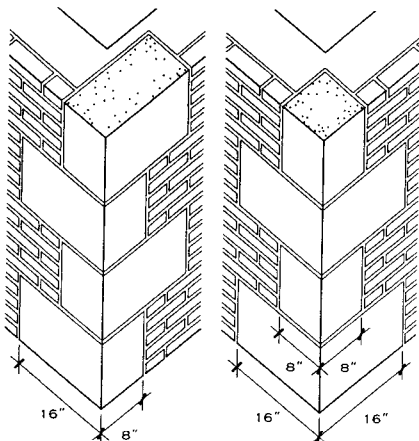

STAGGERED PATTERN  
ALTERNATING PATTERN  
STONE QUOIN IN BRICK WALL

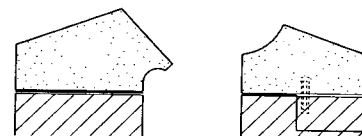

NOTE

Dowel between stone pieces allows flat interrupted flashing. Dowel set vertically is typical for stepped flashing (min. 2 dowels per stone).

GOthic-TYPE STONE COPINGS, INSIDE WASH

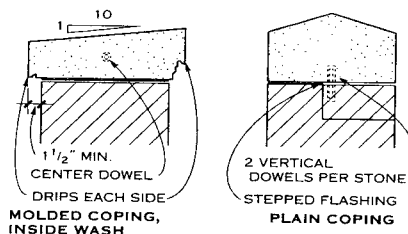

STONE COPINGS



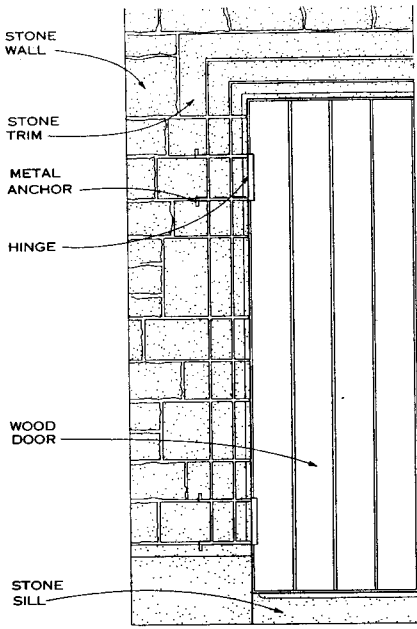

ELEVATION—WOOD DOOR IN STONE WALL

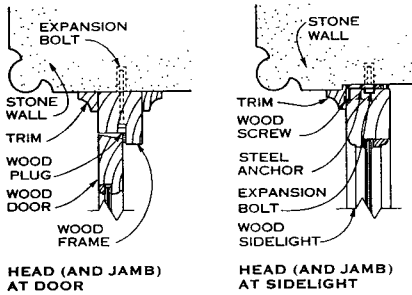

HEAD (AND JAMB) AT DOOR

HEAD (AND JAMB) AT SIDELIGHT

WOOD FRAME DETAILS

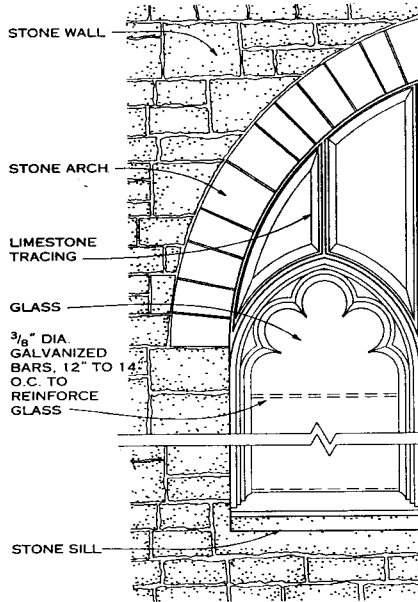

ELEVATION—WINDOW IN STONE WALL

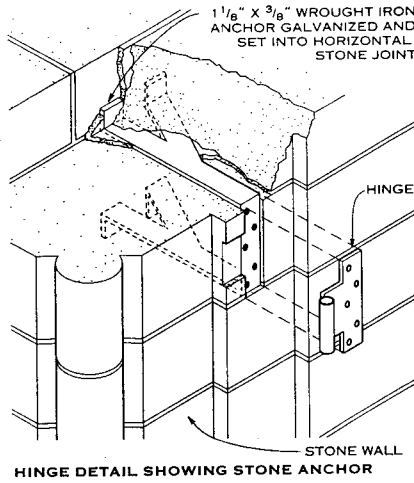

HINGE DETAIL SHOWING STONE ANCHOR

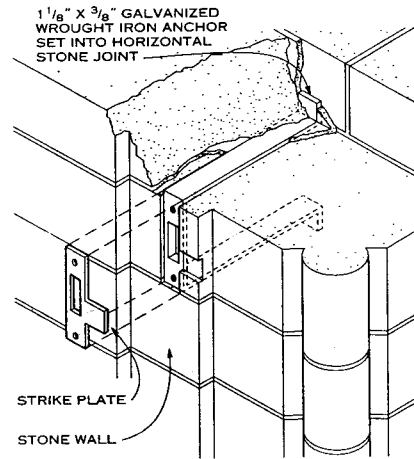

STRIKE DETAIL SHOWING STONE ANCHOR

CONCEALED ANCHOR DOOR DETAILS

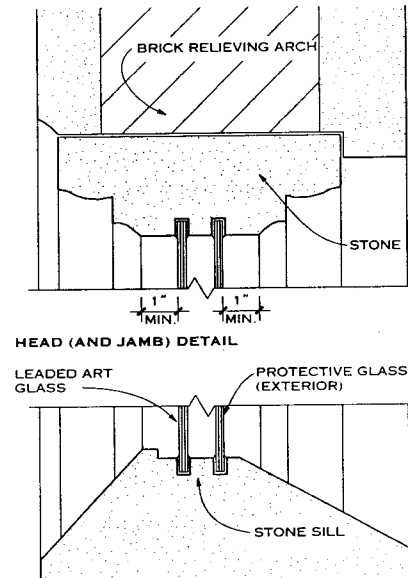

HEAD (AND JAMB) DETAIL

SILL DETAIL

SECTION A—WINDOW IN STONE WALL

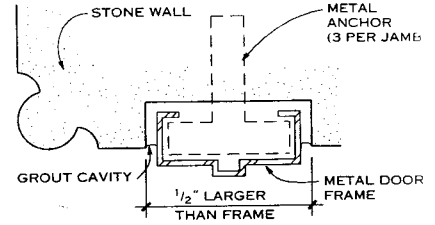

HOLLOW METAL FRAME

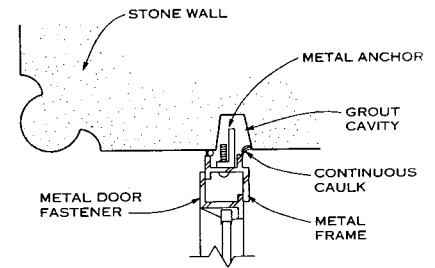

HEAD AND JAMB DETAILS AT STONE WALL

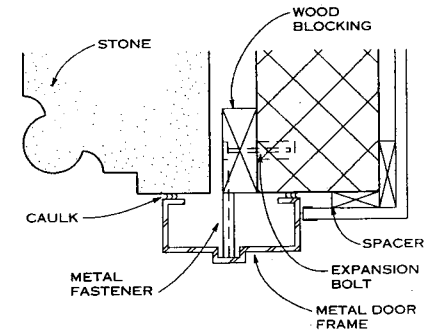

HEAD AND JAMB DETAILS AT CAVITY WALL

ALTERNATE METAL FRAME DETAILS

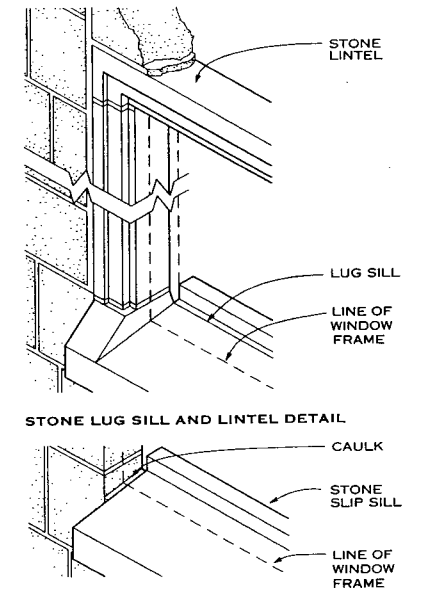

STONE LUG SILL AND LINTEL DETAIL

STONE SLIP SILL DETAIL

ALTERNATE STONE TRIM DETAILS

Richard J. Vitullo, AIA; Oak Leaf Studio; Crownsville, Maryland

**NOTES**

Use of the steel stud support system as shown requires an architect or engineer to develop adequate and realistic performance criteria, including thorough consideration of the long-term durability and corrosion resistance of light gauge members, mechanical fasteners, and other system components; provisions for adequate thermal movement; development of adequate system strength and stiffness; recognition of the structural interaction between the stone support system; and consideration of vapor retarders and flashing to control moisture migration. It also is important that adequate provisions be developed to ensure quality workmanship necessary to implement the system and to achieve the expected quality and durability.

The stone thickness depicted is a minimum of 1 1/2 in. Thicker stone materials can use the same type of support system; however, engineering analyses of the system will be necessary to ensure proper performance and compliance with recommended design practices.

Design criteria for stone anchorage must include consideration of the particular stone's average as well as lowest strength values for safety, particularly at anchorage points. The proposed stone should be tested for adequate design properties and values. Stone anchorage size and location depend on establishing the particular stone's strength values, natural faults, and other properties; the stone's thickness and supported area; the expected lateral as well as gravity loading; and the amount of thermal movement to be accommodated.

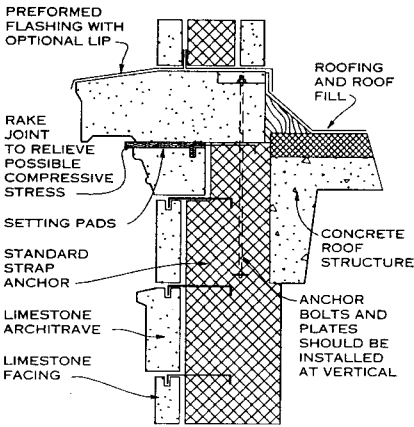

**WALL SECTION**

Shown here is the most common method of anchoring a cornice, which has a projection large enough to be balanced in the wall.

The bed joint immediately below the heavy cornice is open far enough back to remove any compressive stress that would have a tendency to break off stone below.

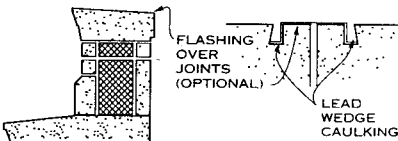

**SECTION**

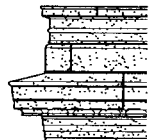

**NOTE**

Shown are five possible cornice designs. Indiana limestone can be fabricated easily and economically to almost any profile. See examples.

**ELEVATION**

**TRADITIONAL CORNICES**

The Specter Group; North Hills, New York

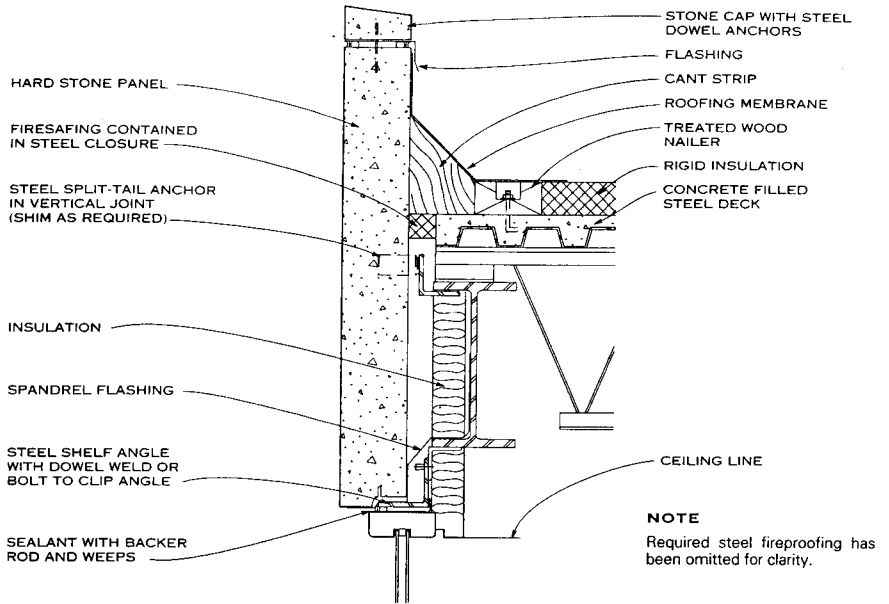

**NOTE**

Required steel fireproofing has been omitted for clarity.

**SECTION THROUGH ROOF PARAPET AT HARD STONE PANEL**

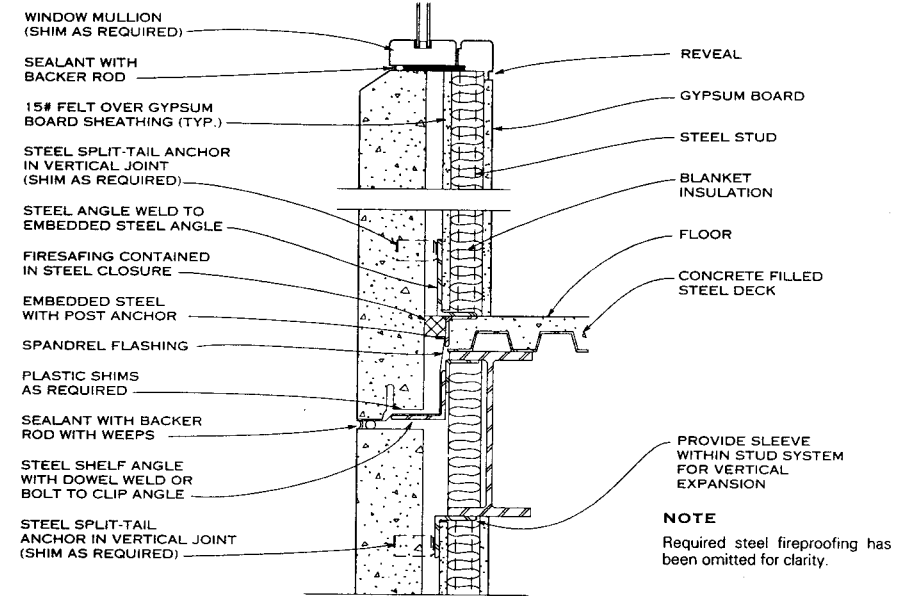

**NOTE**

Required steel fireproofing has been omitted for clarity.

**SECTION THROUGH HARD STONE PANEL AT WINDOW WALL**

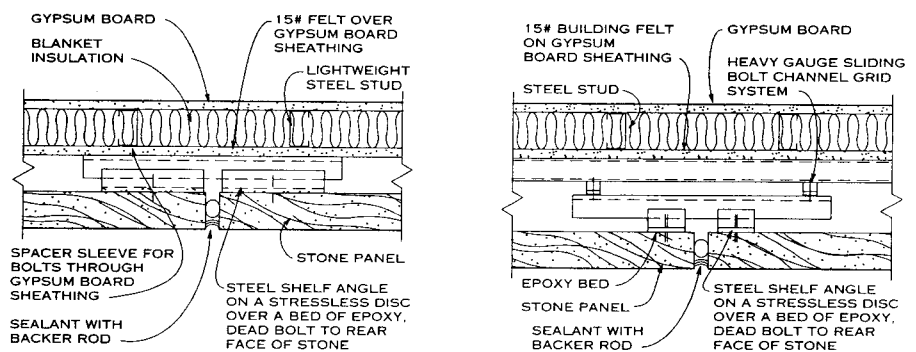

**SECTIONAL AT VERTICAL JOINT**

**SECTION AT VERTICAL JOINT**

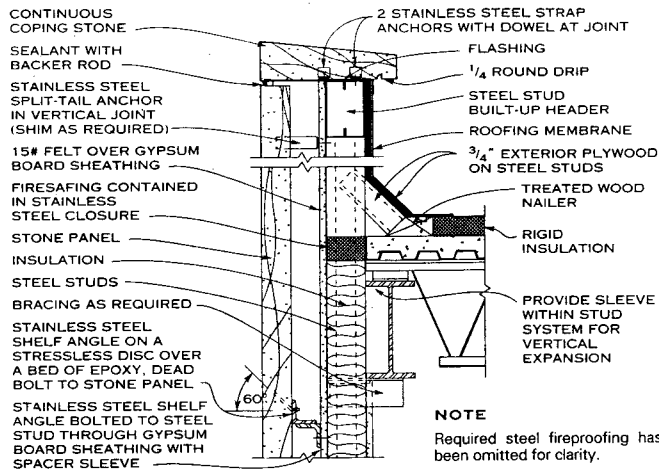

SECTION AT ROOF PARAPET AND WINDOWLESS WALL

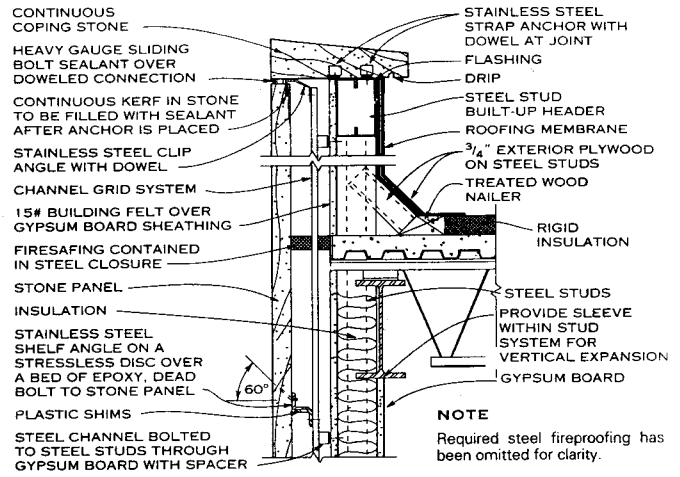

SECTION AT ROOF PARAPET AND WINDOWLESS WALL

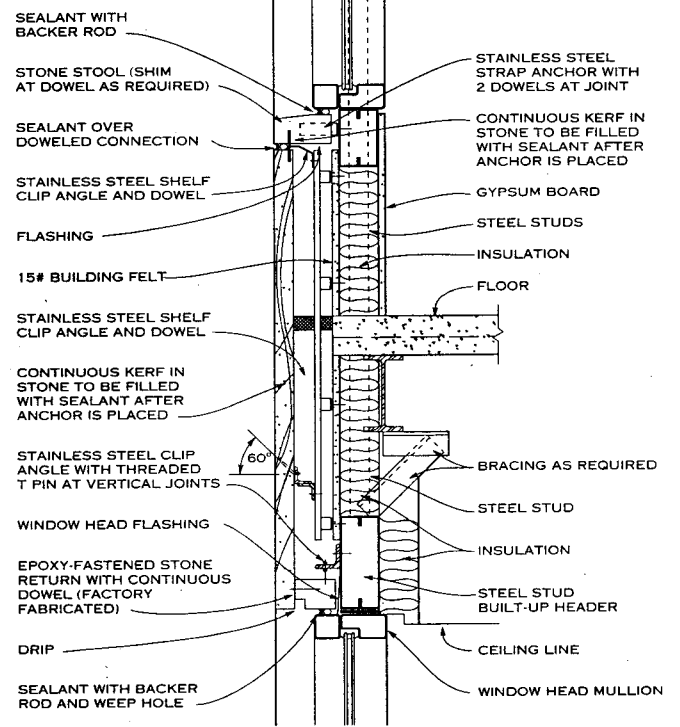
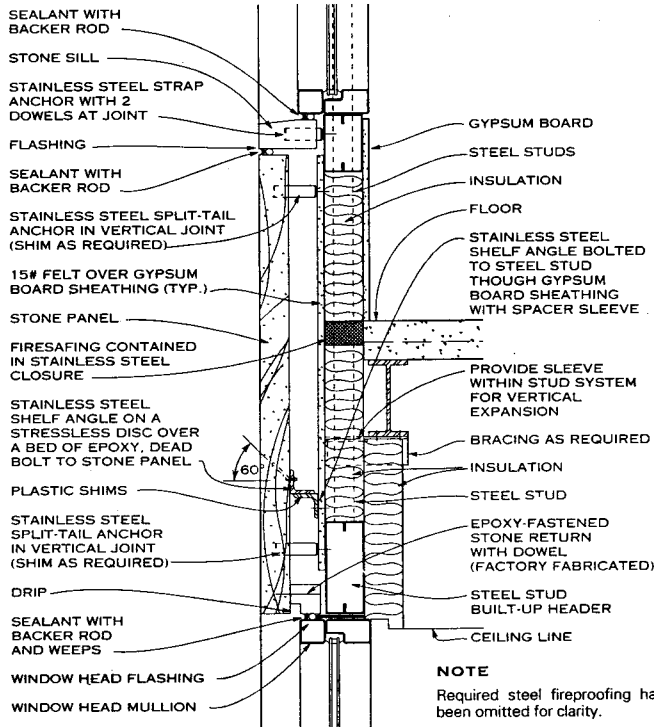

STONE SPANDREL AT WINDOW HEAD AND SILL

STONE SPANDREL AT WINDOW HEAD AND SILL

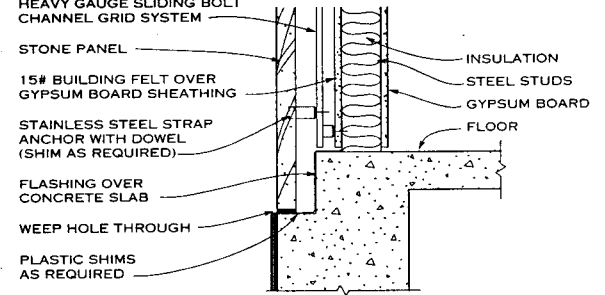
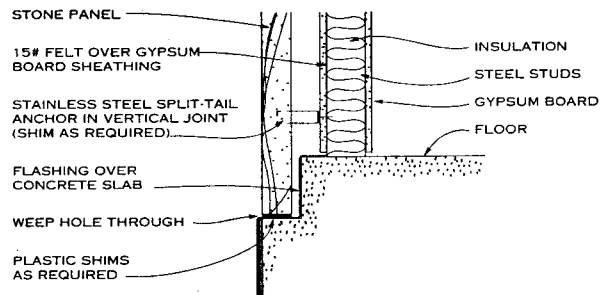

STONE SPANDREL AT GRADE

STONE SPANDREL AT GRADE

The Spector Group; North Hills, New York

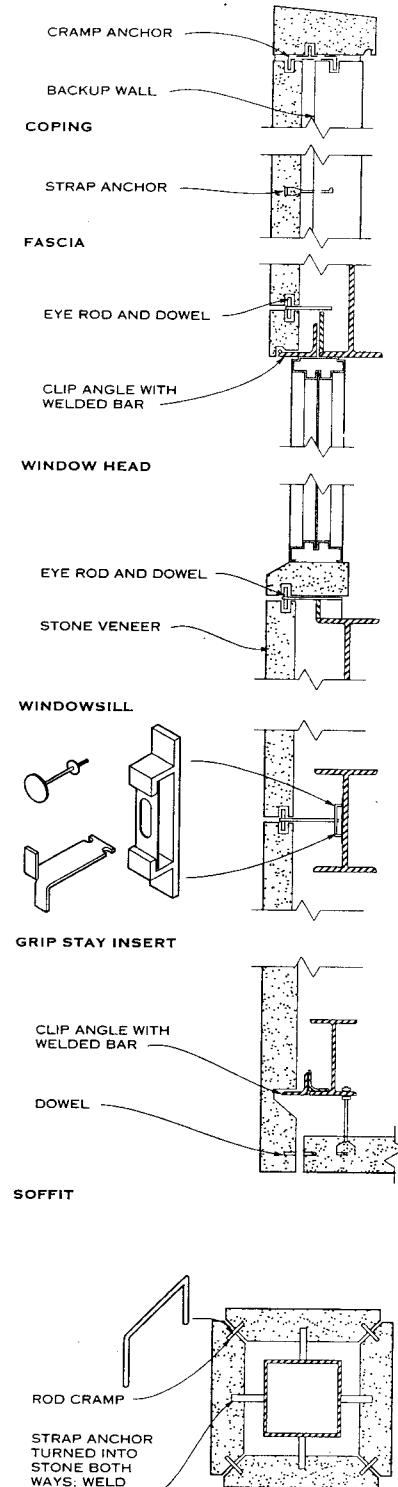
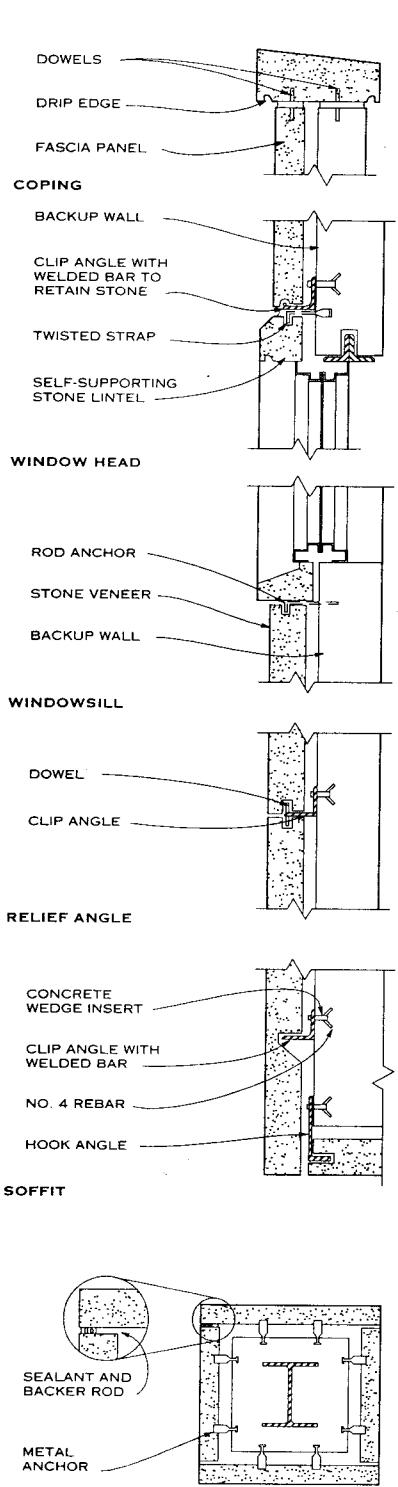

**NOTES**

1. Throughout this section, flashing, sealants, and other ancillary materials necessary for sound weatherproof construction sometimes have been omitted for clarity. See flashing and sealant details elsewhere.
2. Allow for tolerances by including correct shimming to prevent installation problems or performance failure.
3. All stone anchors embedded in or in contact with stone shall be stainless steel type 300 series.
4. Stone support or anchor systems should be designed by an architect or engineer experienced in stone cladding design and construction.

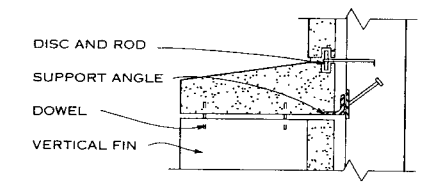

**SUN SCREEN**

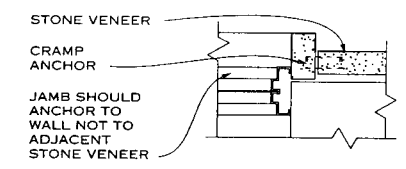

**WINDOW JAMB**

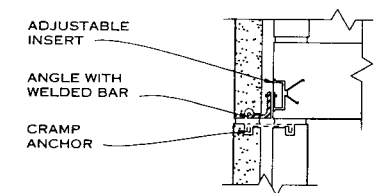

**RELIEF ANGLE**

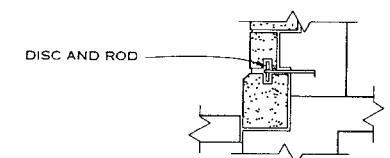

**BOND WALL AND BASE**

**STONE VENEER DETAILS: OPTIONS**

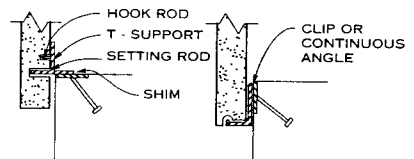

**HOOK ROD ANCHOR**

**ANGLE WITH WELDED BAR**

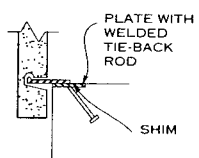

**PLATE WITH WELDED BAR**

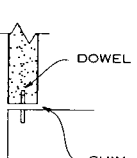

**DOWEL PIN CONNECTION**

**BASE DETAILS**

**STONE VENEER ON CONCRETE WITH MASONRY BACKUP**

**STONE VENEER ON STEEL FRAME**

George M. Whiteside, III, AIA, and James D. Lloyd; Kennett Square, Pennsylvania  
Building Stone Institute, New York, New York

Alexander Keyes; Rippeteau Architects, PC; Washington, D.C.

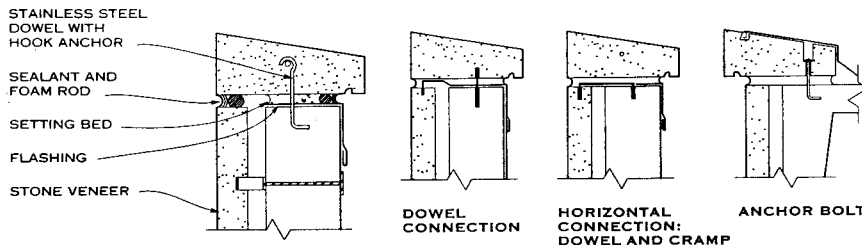

**ANCHORAGE DIMENSIONS**

Standard flat stock anchors are made of strap 1 and 1 1/2 in. wide by 1/8, 3/16, and 1/4 in. thick. Lengths vary up to 6, 8, 10, and 12 in. Dovetail anchors are usually 4 1/4 in. overall with 3 1/2 in. projection for face of concrete. Bends are 3/4, 1, and 1 1/4 in.

Round stock anchors are made from stock of any diameter: 1/4 and 3/8 in. are most common for rods; 1/8 in. (#11 ga.) through 3/16 in. (#6 ga.) for wire anchors; and 1/4 and 3/8 in. are most common for dowels. Dowel lengths are usually 2 to 6 in.

**NOTES**

1. Refer to page on 3 in. stone veneer for additional anchorage information.
2. Allow for tolerances by including correct shimming to prevent installation fitting problems or performance failure.
3. Stone anchorage systems should be designed by a professional engineer experienced in stone cladding design.
4. Sizes may differ widely from the standard sizes listed here.
5. Specify stainless steel.

**COPINGS**

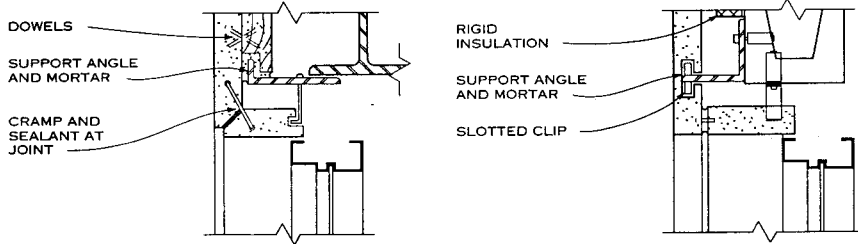

**HEAD (JAMB SIMILAR)**

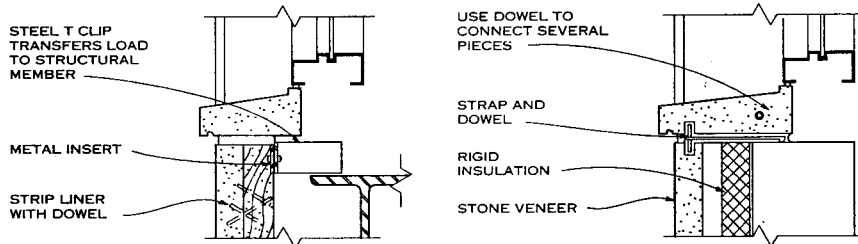

**SILL**

**SILL**

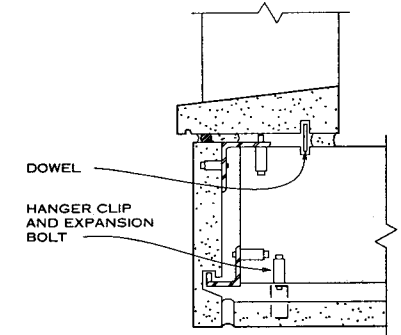

**SILL DETAIL**

**WINDOW DETAILS**

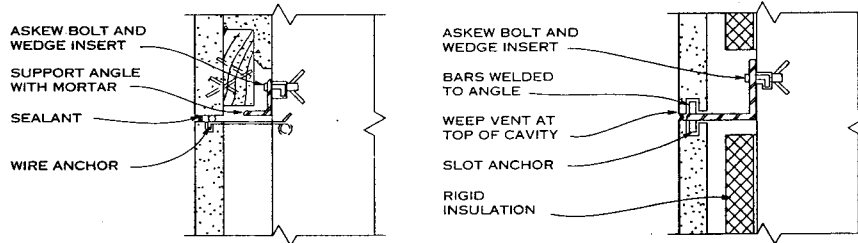

**RELIEF ANGLE WITH LINER**

**ANGLE SUPPORT WITH SHEAR RESISTANCE**

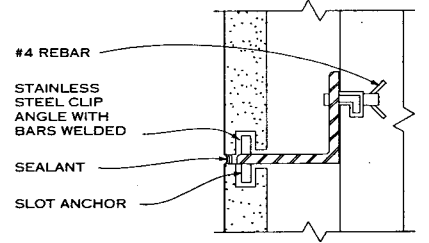

**EXPANSION JOINT DETAIL**

**RELIEF ANGLE SUPPORTS**

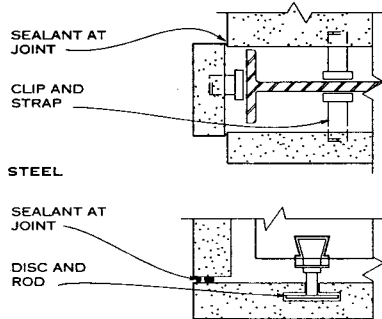

**CONCRETE**

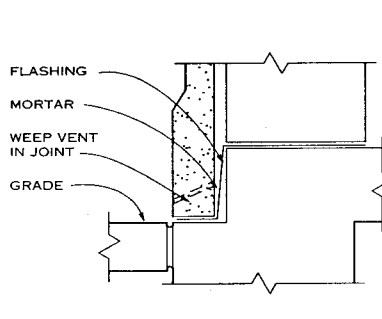

**BASE DETAILS**

**NOTE**

It is recommended that water repellent treatment be provided at the sidewalk.

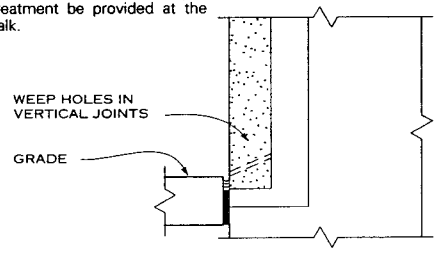

**CORNER DETAILS**

George M. Whiteside, III, AIA, and James D. Lloyd; Kennett Square, Pennsylvania  
 Building Stone Institute; New York, New York  
 Alexander Keyes; Rippeteau Architects, PC; Washington, D.C.

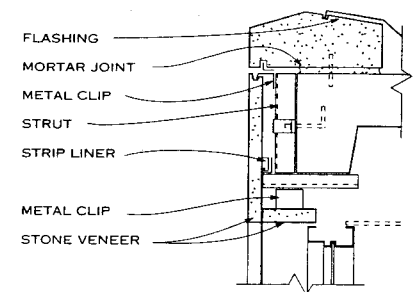

COPING, FASCIA, AND HEAD

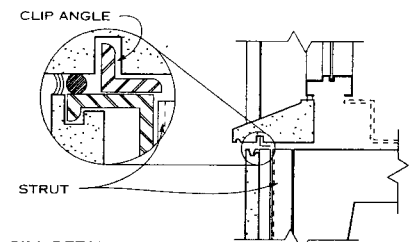

SILL DETAIL

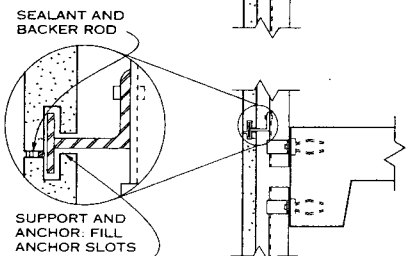
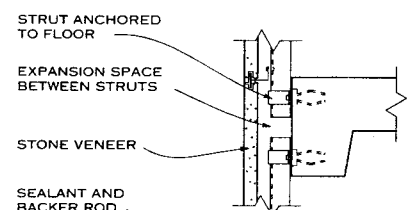

WALL SECTION

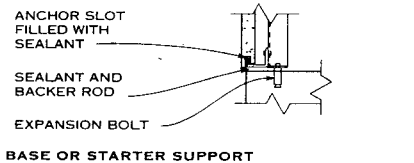

BASE OR STARTER SUPPORT

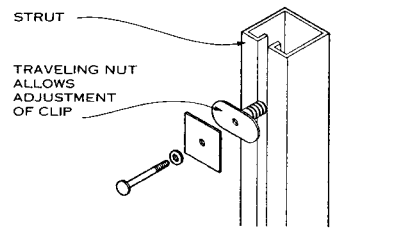

CLIP ANCHORING SYSTEM

**GRID STRUT SYSTEM - CONCRETE FRAME**

George M. Whiteside, III, AIA, and James D. Lloyd; Kennett Square, Pennsylvania  
Building Stone Institute; New York, New York  
Alexander Keyes; Rippeteau Architects, PC; Washington, D.C.

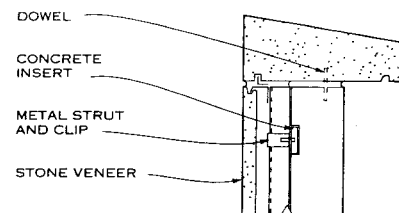

COPING

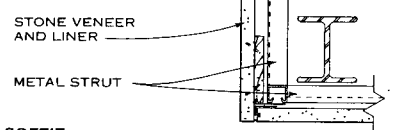

SOFFIT

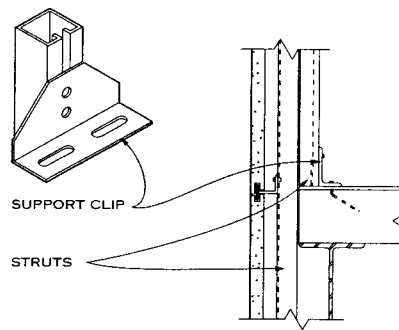

SHEAR WALL SUPPORT

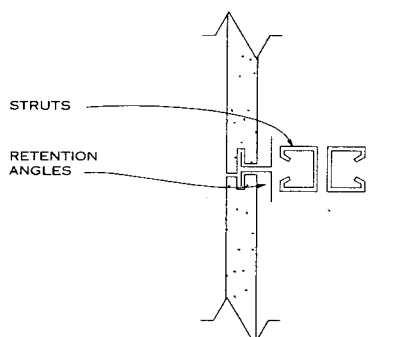

SHEAR WALL SIDE RETENTION (PLAN)

**GRID STRUT SYSTEM - METAL FRAME**

**GRID ANCHOR SPACING AND STRUT SIZE — MARBLE**

MAXIMUM SPACING	ANCHOR	STRUT SIZE
4'-0"	1 1/4" THICK	1 5/8" x 1 5/8"
7'-0"	1 1/4" THICK	1 5/8" x 2 1/8"
10'-0"	1 1/4" THICK	1 5/8" x 3 1/4"
15'-0"	1 1/4" THICK	1 5/8" x 4 7/8"

**NOTES**

1. "X" = dimension between strut and outside face of stone.
2. "X" = 1 1/8" for 7/8" marble.
3. "X" = 1 3/4" for 1 1/4" marble.

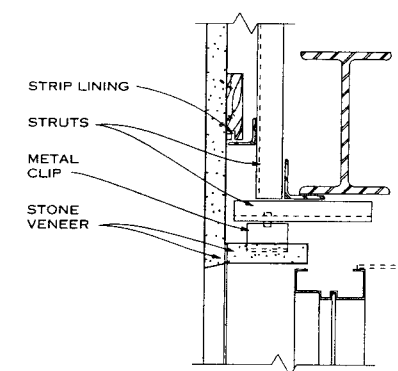

FASCIA AND WINDOW HEAD

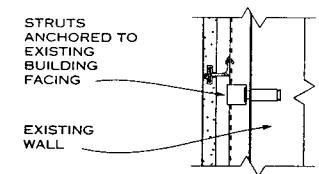

CONNECTION TO EXISTING FACING

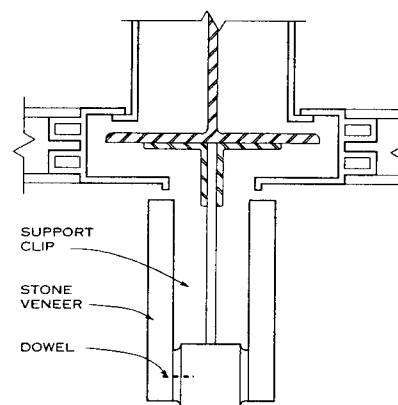

PLAN

**COLUMN RETURN**

**NOTES**

1. Engineering design of all supports for this type of construction is essential.
2. Grid strut spacing is subject to engineering design.

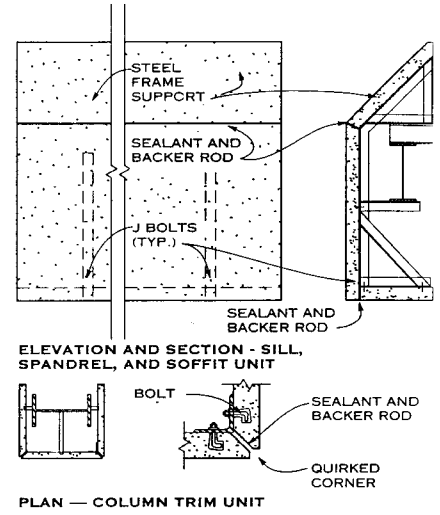
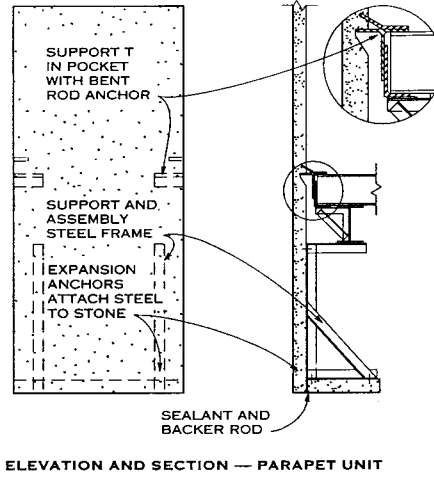
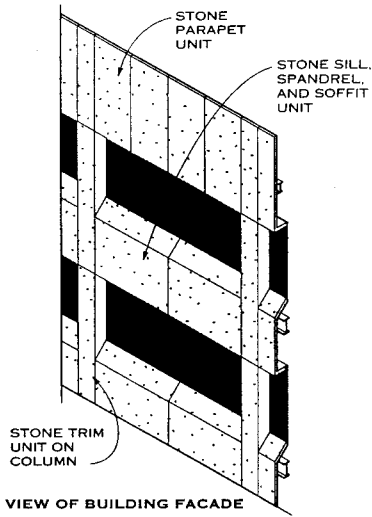

PREASSEMBLED STONE UNIT WITH EPOXY ON STEEL FRAME

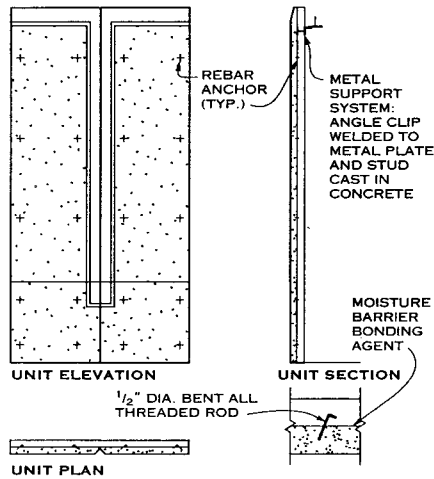
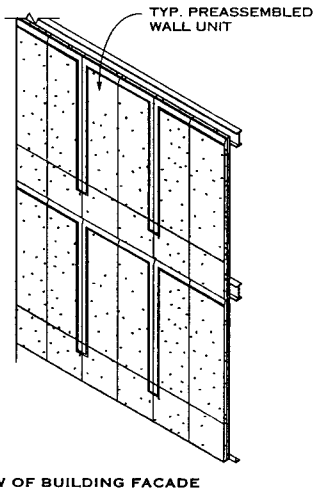

STONE UNIT PRECAST WITH CONCRETE BACKUP

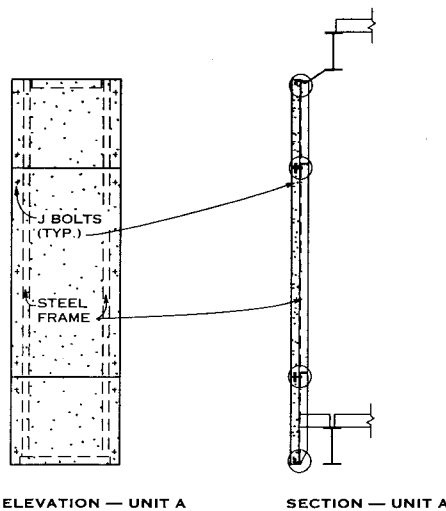
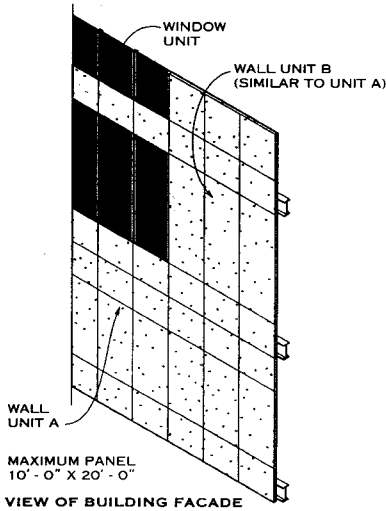

PREASSEMBLED PANELS

Preassembled stone panel technology offers savings in on-site labor and accurate component stone unit joining.

Shipping and erection stresses on the stone panels and stone anchorage system to the preassembled units should be evaluated.

Design of sealant joints between preassembled units should include at least the following: thermal movement, fabrication and erection tolerances, irreversible material growth or shrinkage, and sealant movement potential.

STONE ON STEEL FRAME WITH EPOXY JOINTS

Stone units are mounted in a steel frame plus expansion anchors and dowel pins (as recommended by manufacturer). Joints in stone are epoxied and held to approximately 1/8 in. when finished for delivery. All stones in the assembly are anchored as a unit to the structure. Preassembled unit installation reduces individual leveling, plumbing, and aligning, and on-site joint sealing is not as extensive as with individual stone panels.

COMPOSITE ASSEMBLIES OF STONE AND CONCRETE

Stone units are bonded to reinforced precast concrete panels with bent stainless steel anchors. A moisture barrier and a bonding agent are installed between the stone and concrete in conditions where concrete alkali slats may stain stone units.

STONE AND STEEL ASSEMBLIES WITH SEALANT JOINTS

Stone units are shimmed and anchored to a steel frame using standard stone connecting hardware. Joints may be sealed on site, along with joints between assemblies.

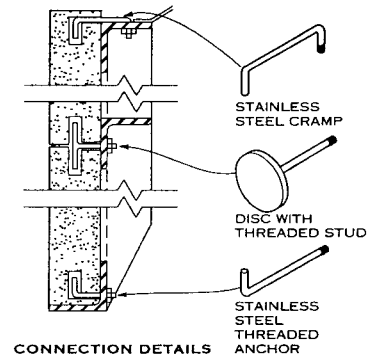

PREASSEMBLED STONE UNIT ON STEEL FRAME

George M. Whiteside, III, AIA, and James D. Lloyd; Kennett Square, Pennsylvania  
Building Stone Institute; New York, New York  
Alexander Keyes; Rippeteau Architects, PC; Washington, D.C.

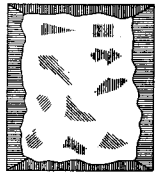

ROCK OR PITCH FACE



SAWED FINISH



SHOT SAWED (ROUGH)

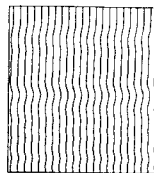

MACHINE FINISH (PLANER)

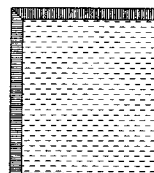

POINTED FINISH

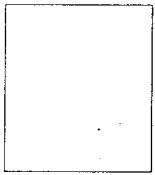

BUSH HAMMERED



PATENT BUSH HAMMER



DROVE OR BOASTED

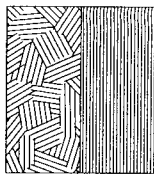

RANDOM+PARALLEL HAND TOOLED

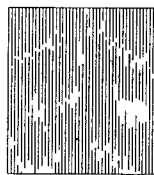

PEEN HAMMERED

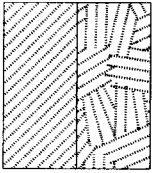

PARALLEL+RANDOM CRANDALLED

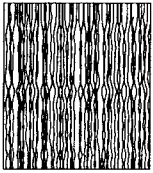

PLUCKER FINISH

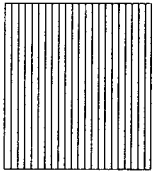

MACHINE TOOLED

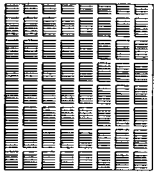

TOOTH CHISEL

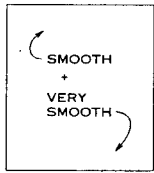

SMOOTH + VERY SMOOTH  
SMOOTH-RUBBED (WET FINISH) OR VERY SMOOTH (CARBORUNDUM, HONED, AND POLISHED)

NOTE

Consult stone fabricators about which finishes are appropriate for which type of stone.

TYPICAL STONE FINISHES

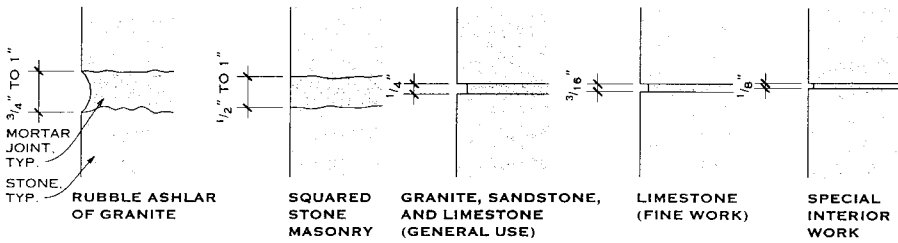

TYPICAL STONE JOINT SPACING

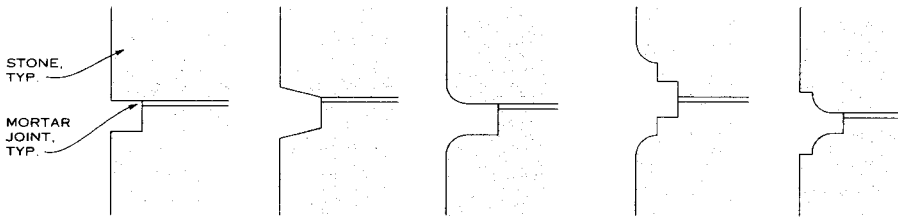

RUSTICATED JOINTS

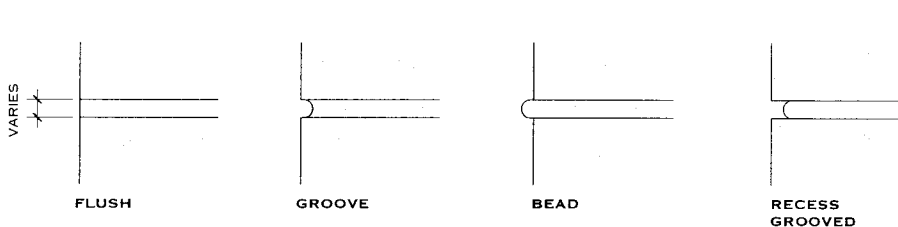

TYPICAL JOINT PROFILES

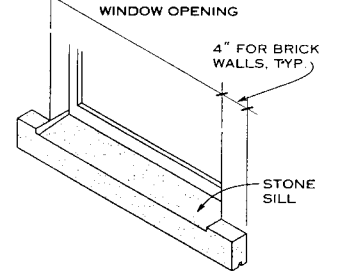
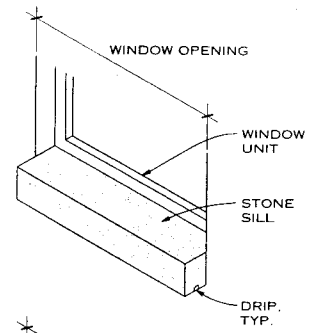

LUG SILL

STONE SILL TYPES

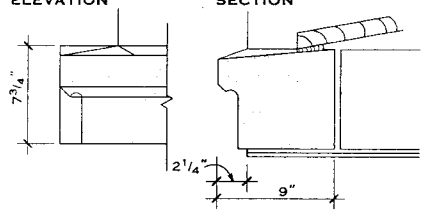
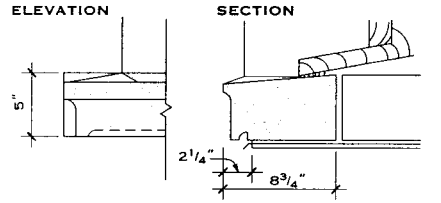
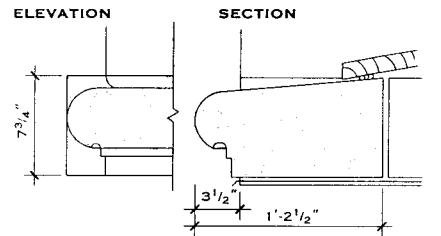
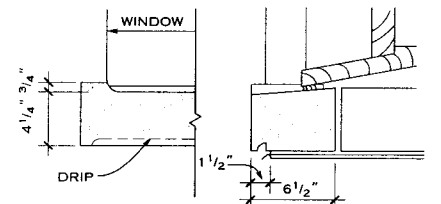

STONE LUG SILL PROFILES



**GENERAL**

A traditional structural stone wall typically consists of two independent faces (interior and exterior) of closely fitted stones with a code-prescribed percentage of bonding unit stones that extend the full thickness of the wall. Together, these two stone faces create a massively thick wall, rarely less than 24 in. thick. An interior finish backup stud or furred wall with a vapor barrier and insulation typically completes the wall system.

For structural stone walls, it is best to lay the stone in regular courses, 12 to 15 in. high per course. Limiting the height from the top of one level course to the top of the next level course ensures that the wall joints will be consistently bridged, thereby avoiding long continuous vertical joints both perpendicular to and parallel to the plane of the wall face. This will help prevent long cracks from developing, which can cause large sections of the wall to split and fall off. Control joints should be built into masonry construction in wall sections up to 30 ft long to account for expansion and contraction of the stone.

**NOTES**

1. A simple rule-of-thumb for masonry construction is to rely on gravity, not the bond of mortar, as the predominant "bonding agent" for stone.
2. Consult codes to determine the minimum percentage of bonding units per structural stone wall. Some codes require that 15% of the face area be composed of bonding units.

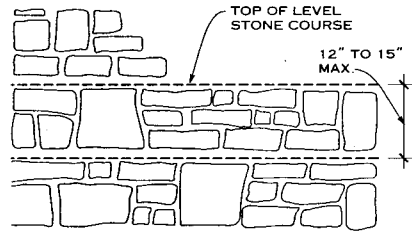

ELEVATION

**STONE WALL COURSES**

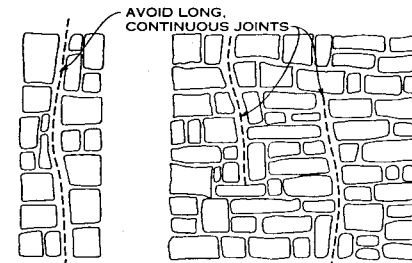

SECTION ELEVATION

**STONEMASONRY JOINTS—NOT RECOMMENDED**

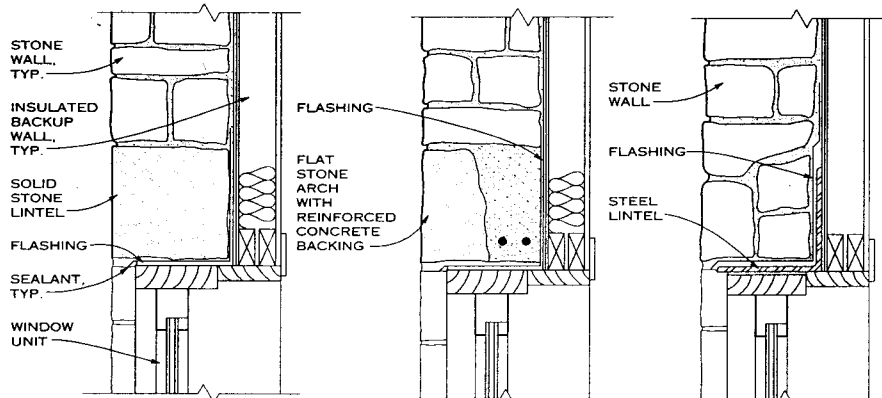

SOLID STONE LINTEL

STONE ARCH WITH REINFORCED CONCRETE BACKING

STEEL LINTEL

**STONE WALL LINTELS**

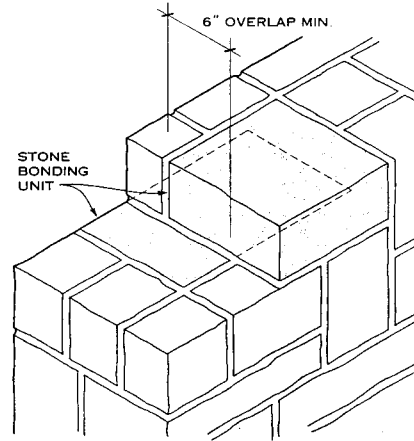

BONDING UNIT TYPE 2

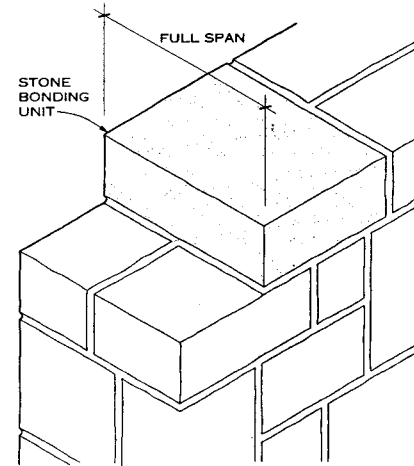

BONDING UNIT TYPE 1

**NOTE**  
Some building codes require full span bonding units and some permit a minimum 6 in. overlap between adjacent stones.

**STONE WALL BONDING UNITS**

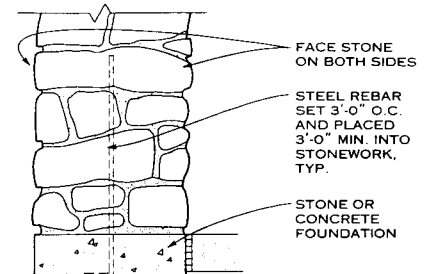

TRADITIONAL/SOLID

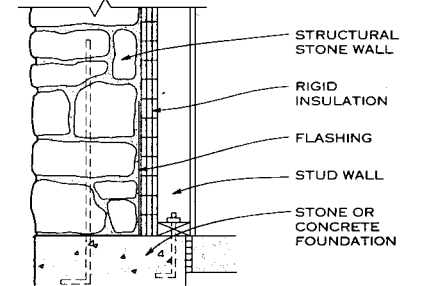

RIGID INSULATION BACKING

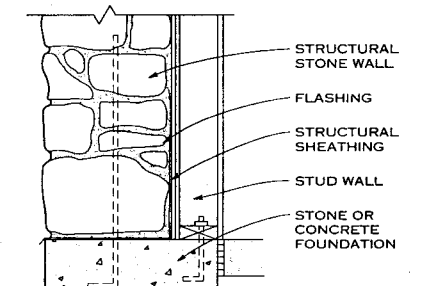

STRUCTURAL SHEATHING BACKING

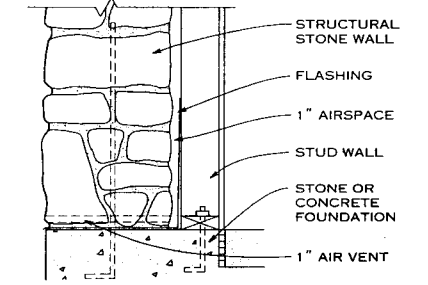

VENTED

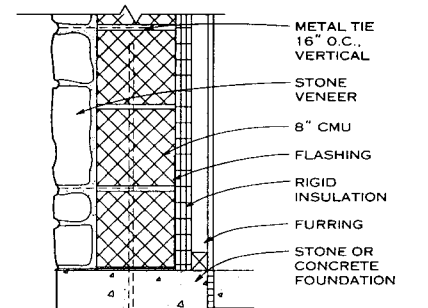

STONE VENEER WITH CMU BACKING

**TYPICAL WALL SECTIONS**

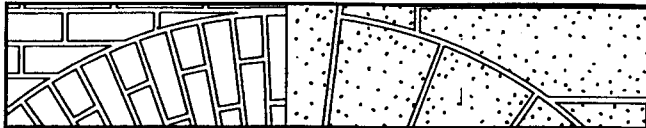

# METALS

Metal Materials 260

Metal Fastenings 264

Structural Metal Framing 266

Metal Joists 273

Metal Deck 275

Cold-Formed Metal Framing 277

Metal Fabrications 284

Ornamental Metal 291

Expansion Control 296

## PROPERTIES OF METALS

Basic metals and their alloys are classified in two broad categories, ferrous and nonferrous. Ferrous metals are mainly iron, and nonferrous metal alloys normally contain no iron.

### FERROUS METALS

Iron, steel, and their alloys are usually the most cost-effective metal choices for structural applications.

Iron that contains no trace of carbon is soft, ductile, and easily worked, but it rusts in a relatively short time and is susceptible to corrosion by most acids.

The characteristics of the many types of cast iron vary widely among six basic groups: gray, malleable, ductile, white, compacted graphite, and high alloy iron. All cast irons have high compressive strengths, but tensile and yield strengths vary widely depending on basic type. Cast iron is relatively corrosion-resistant but cannot be hammered or beaten into shapes.

Gray irons are rather brittle because they have a high carbon and silicon content. Castings of gray iron possess excellent damping (absorbing vibrations) and are produced in eight ASTM classes or grades with tensile-strength ratings from 20,000 to 60,000 psi. Applications include decorative shapes, such as fences and posts, gratings, and stair components, as well as utility uses such as manhole covers and fireplugs.

Malleable iron, which is more expensive than gray iron, has been used for decades in applications that require great toughness and high ductility. This low-carbon white iron is cast, reheated, and slowly cooled, or annealed, to improve its workability.

Ductile iron is made by adding magnesium to molten iron shortly before the metal is poured into molds. The magnesium alters the surface-tension mechanism of the molten iron and precipitates the carbon out as small spheres instead of flakes, which make the iron casting more ductile. Ductile iron is less brittle, stiffer, stronger, and more shock-resistant than gray iron. Ductile iron castings are more expensive than gray iron but usually less than malleable iron. Ductile iron is the fastest growing segment of the metal casting industry.

Ductile irons are produced in strength ratings from 55,000 to 130,000 psi. Ductile castings using a special austempering heat-treating process offer much higher tensile strengths, ranging from 125,000 to 230,000 psi. Called ADI castings, they rival or surpass certain alloy steel castings in tensile and yield strengths.

White iron castings, which are extremely hard and brittle, are used primarily in industrial machinery parts that experience high wear and require abrasion resistance.

The characteristics of compacted graphite iron fall between those of gray and ductile iron. The properties of this metal are so difficult to control during production that very few metal casters manufacture it.

High alloy irons are gray, ductile, or white irons with an alloy content of 3 to more than 30%. Their properties are significantly different from those of unalloyed irons.

Wrought iron or steel is relatively soft, corrosion- and fatigue-resistant, and machinable. It is easily worked, making it ideal for railings, grilles, fences, screens, and various types of ornamental work. It is commercially available in bars, rods, tubing, sheets, and plates.

Carbon steel is iron that contains low to medium amounts of carbon. A higher carbon content increases metal strength and hardness but reduces its ductility and weldability. The corrosion resistance of carbon steels is improved by galvanizing, which is a hot zinc dipping process, or applying an organic coating. Some architectural uses include structural shapes such as welded fabrications or castings, metal studs and joists, fasteners, wall grilles, and ceiling suspension grids.

High strength, low alloy (HSLA) steels have better corrosion resistance than carbon steels, and they are chosen when weight is a consideration and higher strength is specified. Low alloy steels are seldom used in exterior architectural applications that involve water runoff because adjacent materials could become stained with rust.

Typical elements used to modify steel include the following:

1. Aluminum for surface hardening.
2. Chromium for corrosion resistance.
3. Copper for atmospheric corrosion resistance.
4. Manganese in small amounts for additional hardening, in larger amounts for better wear resistance.
5. Molybdenum, combined with other metals such as chromium and nickel, to increase corrosion resistance and raise tensile strength without reducing ductility.
6. Nickel to increase tensile strength without reducing ductility; in high concentrations, nickel improves corrosion resistance.
7. Silicon to strengthen low alloy steels and improve oxidation resistance; larger amounts produce hard, brittle castings that are resistant to corrosive chemicals.
8. Sulfur for free machining, especially.
9. Titanium to prevent intergranular corrosion of stainless steels.
10. Tungsten, vanadium, and cobalt for hardness and corrosion resistance.

Stainless steels are at least 11.5% chromium. Nickel is added to boost atmospheric corrosion resistance; molybdenum is added when maximum corrosion resistance is needed, such as when iron will come into contact with sea water. Stainless steel is used in construction for flashing, coping, fasciae, wall panels, floor plates, gratings, handrails, hardware, fasteners, and anchors. Decorative shapes and statuary can be cast in stainless steel.

### NONFERROUS METALS

Nonferrous metals and their alloys can be categorized into seven major groups for architectural applications: those based on aluminum, copper (pure copper, brasses, and bronzes), lead, zinc, tin, nickel, and magnesium. Another approach is to divide nonferrous alloys into two groups: heavy metals (copper-, zinc-, lead-, and nickel-based) and light metals (aluminum- and magnesium-based).

#### ALUMINUM

The nonferrous metal workhorse for architectural applications is aluminum. It has good forming and casting characteristics and offers good corrosion resistance. When exposed to air, aluminum does not oxidize progressively because a hard, thin oxide coating forms on the surface and seals the metal from its environment.

Aluminum and its alloys, numbering in the hundreds, are widely available in common commercial forms. Aluminum alloy sheets can be formed, drawn, stamped, or spun. Many wrought or cast aluminum alloys can be welded, brazed, or soldered, and aluminum surfaces readily accept a wide variety of finishes, both mechanical and chemical.

Although it is light in weight, commercially pure aluminum has a tensile strength of about 13,000 psi. Most aluminum alloys lose strength at elevated temperatures. At subzero temperatures, on the other hand, aluminum is stronger than at room temperature but no less ductile. Cold-working the metal may nearly double its tensile strength. Aluminum can be further strengthened by alloying it with elements such as manganese, silicon, copper, magnesium, zinc, or lithium. The manganese-based aluminum alloy 3003 is used for roofing, sheet metal, siding, and electrical conduit.

#### BRASS, COPPER, AND BRONZE

Good thermal and electrical conductivity, corrosion resistance, and easy forming and joining all make copper and its alloys useful in construction. However, copper and many of its alloys have relatively low strength-to-weight ratios, and their strength is even further reduced at elevated temperatures. These metals are offered in rod, plate, strip, sheet, and tube shapes; forgings; castings; and electrical wire.

These metals can be grouped according to composition in several general categories: copper, high-copper alloys, and many types of brass and bronze. Monel metal is a copper-nickel alloy that offers excellent corrosion resistance; it is often used for corrosion-resistant fasteners.

Bronze originally was a copper-tin alloy, but today there are aluminum bronzes, silicon bronzes, and leaded phosphor bronzes, among others. Phosphor bronze is a copper-tin-phosphorus alloy; and leaded phosphor bronze is composed of copper, lead, tin, and phosphorus.

Brass is copper with zinc as its principal alloying element. It is important to know that some brass alloys may be called bronzes even though they have little or no tin in them. Some common nonbronze brass alloys are commercial bronze (90% copper, 10% zinc), naval brass (60% copper, 29% zinc, and .1% tin), Muntz metal (60% copper, 40% zinc), and manganese bronze (58% copper, 39% zinc, and 1% tin and iron). When a metal is identified as bronze, the alloy cannot contain zinc or nickel; if it does, it is probably brass. Architectural bronzes and bronzes are actually all bronzes; they are used for doors, windows, door and window frames, railings, trim and grilles, and finish hardware. Muntz metal, also called malleable brass, is a bronze alloy resembling extruded architectural bronze in color. It is available in sheet and strip and is used in flat surfaces in architectural compositions in connection with extruded architectural bronze.

Copper-based alloys characteristically form adherent films that are relatively impervious to corrosion and protect the base metal from further attack. Certain alloy systems darken rather rapidly from brown to black outdoors. Under most outdoor weather conditions, however, copper surfaces, such as roofs or statuary, develop a blue-green patina. Lacquer coatings can help retain the original alloy color.

#### LEAD

An extremely dense metal, lead is corrosion-resistant and easily worked. Alloys are added to it to improve properties such as hardness and strength. Typical applications of lead include waterproofing, sound and vibration isolation, and radiation shielding. It can be combined with tin alloy to plate iron or steel, which is commonly called "terneplate." Care should be taken how and where lead is used because lead vapors and lead dust are toxic if ingested.

#### ZINC

Although it is corrosion-resistant in water and air, zinc is brittle and low in strength. Its major use is in galvanizing (dipping hot iron or steel in molten zinc), although zinc is also used to create sand-cast or die-cast components. Major building industry uses are roofing, flashing, nails, plumbing hardware, structural parts, and decorative shapes.

#### TIN

Key properties of tin are its low melting point (450° F), relative softness, good formability, and readiness to form alloys. Principal uses for tin are as a constituent of solder, a coating for steel (tinplate, terneplate), and an alloy with other metals that can be cast, rolled, extruded, or atomized. Tin is most popular as an alloy for copper, antimony, lead, bismuth, silver, and zinc. Pewter alloys contain 1 to 8% antimony and 0.5 to 3% copper. Alloy metal in tin solders ranges from 40% lead to no lead and 3.5% silver.

#### NICKEL

Whitish in color, nickel is used for plating other metals or as a base for chromium plating. Nickel polishes well and does not tarnish. It is also widely applied as an additive in iron and steel alloys as well as other metal alloys. Nickel-iron castings are more ductile and more resistant to corrosion than conventional cast iron. Adding nickel makes steel more resistant to impact.

#### CHROMIUM

A hard, steel-gray metal, chromium is commonly used to plate other metals, including iron, steel, brass, and bronze. Plated cast shapes can be brightly polished and do not tarnish. Several steel alloys, such as stainless plate, contain as much as 18% chromium. Chromium does not rust, which makes chromium alloys excellent for exterior uses.

#### MAGNESIUM

Lightest of all metals used in construction, pure magnesium is not strong enough for general structural functions. (For comparison, if a block of steel weighs 1,000 lb, equal volumes of aluminum and magnesium weigh 230 lb and 186 lb respectively.) Combining other metals such as aluminum with magnesium results in lightweight alloy materials used in ladders, furniture, hospital equipment, and wheels for automobiles.

Robert C. Rodgers, P.E.; Richmond Heights, Ohio

# 5

## METAL MATERIALS

**METAL CORROSION**

Corrosion, which is caused by galvanic action, occurs between dissimilar metals or between metals and other material when sufficient moisture is present to carry an electrical current. The galvanic series shown in the table below is a useful indicator of corrosion susceptibility caused by galvanic action. The metals listed are arranged in order from the least noble (most reactive to corrosion) to the most noble (least reactive to corrosion). The farther apart two metals on the list are, the greater the deterioration of the less noble one will be if they come in contact under adverse conditions.

Metal deterioration also occurs when metals come in contact with chemically active materials, particularly when moisture is present. For example, aluminum corrodes when in direct contact with concrete or mortar, and steel corrodes when in contact with certain treated woods.

Pitting and concentration cell corrosion are other types of metal deterioration. Pitting takes place when particles or bubbles of gas are deposited on a metal surface. Oxygen deficiency under these deposits sets up anodic areas, which cause pitting. Concentration cell corrosion is similar to galvanic corrosion; the difference is in the electrolytes. Concentration cell corrosion can be produced by differences in ion concentration, oxygen concentration, or foreign matter adhering to the surface.

**SHAPING AND FABRICATION OF METALS**

Many different manufacturing processes are applied to metal to produce structural forms and shapes required in the construction and ornamentation of buildings.

Rolling hot or cold metal between pressurized rollers produces most of the readily available, standard construction material shapes. Baked enamel-coated aluminum is cold rolled to make siding and gutters.

In the extruding process, heated metal ingots or bars are pushed through a die orifice to produce a wide variety of simple and complex shapes. Sizes are limited only by the size or capacity of the die.

**THE GALVANIC SERIES**

Anode (least noble) +	Magnesium, magnesium alloys
	Zinc
	Aluminum 1100
	Cadmium
	Aluminum 2024-T4
	Steel or iron, cast iron
	Chromium iron (active)
	Ni-Resist
	Type 304, 316 stainless (active)
	Hastelloy "C"
	Lead, tin
Electric current flows from positive (+) to negative (-)	Nickel (Inconel) (active)
	Hastelloy "B"
	Brasses, copper, bronzes, copper-nickel alloys, monel
	Silver solder
	Nickel (Inconel) (passive)
	Chromium iron (passive)
	Type 304, 316 stainless (passive)
	Silver
	Titanium
Cathode (most noble) -	Graphite, gold, platinum

Casting is a process in which molten metal is poured into molds or forced into dies and allowed to solidify in the shape of the mold or die. The casting process is used with virtually all metals; however, surface quality and physical characteristics are greatly affected by the metal alloy and casting process selected. Almost all metals can be cast in sand molds. Only aluminum, zinc, and magnesium are ordinarily cast in metal dies in what is called either a die-casting or permanent-mold process. Round, hollow building products such as cast-iron pipe for plumbing and sewer applications are made by centrifugal casting machines.

In the drawing process, either hot or cold metal is pulled through dies that alter or reduce its cross-sectional shape to produce architectural product configurations. Common drawn products are sheets, tubes, pipes, rods, bars, and wires. Drawing can be used with all metals except iron.

Forging is hammering hot metal or pressing cold metal to a desired shape in dies of a harder metal. The process usually improves the strength and surface characteristics of the metal. Aluminum, copper, and steel can be forged.

Machining is used to finish areas of castings or forgings requiring highly precise fits or contours. Shapes can also be machined from heavy plate or solid blocks of metal.

Bending produces curved shapes in tubing, pipe, and extrusions.

Brake forming of metal plate or sheet metal is a process of successive pressings to achieve shapes with straight-line angles.

In the spinning process, ductile types of sheet metal (usually copper or aluminum) are shaped with tools while being spun on an axis.

Embossing and coining are stamped metal with textured or raised patterns.

Blanking is shearing, sawing, or cutting metal sheets with a punch press to achieve a desired configuration.

Perforating is punching or drilling holes through flat plate or sheet metal.

**WEIGHTS OF METALS FOR BUILDINGS**

MATERIAL	SPECIFIC GRAVITY	DENSITY	
		(LB/CU FT)	(LB/CU IN.)
Magnesium	1.76	110	0.064
Aluminum	2.77	173	0.100
Zinc	7.14	446	0.258
Cast iron	7.22	450	0.260
Wrought iron	7.70	480	0.278
Steel	7.85	490	0.283
Brass	8.47	529	0.306
Copper and bronze	8.92	556	0.322
Lead	11.35	708	0.410

**TYPES AND PROPERTIES OF BRASS**

NAME	ARCHITECTURAL-BRONZE	COMMERCIAL BRONZE	MUNTZ METAL
Composition (%)			
Copper (Cu)	56.5	90.0	60.0
Zinc (Zn)	41.25	10.0	40.0
Lead (Pb)	2.25		
Color	Bronze	Bronze	Light yellow
Cold workability	Very poor	Excellent	Fair
Machinability	Good	Poor	Good
Weldability	Poor	Gas, carbon arc, metal arc	Gas, carbon arc, metal arc, spot and seam welding for thin sheets
Hot workability (and soldering and polishing)	Very good	Very good	Very good
Other properties	Excellent forging and free-machining	Very ductile	High strength; low ductility

Piercing punches holes through metal without removing any of the metal.

Fusion welding is used to join metal pieces by melting filler metal (welding rod) and the adjacent edges briefly with a torch and then allowing the molten metal to solidify. Two common types of fusion welding are electric-arc and gas. Electric-arc or metallic-arc welding normally uses metal welding rods as electrodes in the welding tool.

Gas welding is also known as oxyacetylene welding because it uses a mixture of oxygen and acetylene to fuel the flames produced by the blowtorch. Oxyacetylene blowtorches are widely used in construction work to cut through metal structural beams and metal plates.

Soldering is a metal joining process that uses either hard or soft solder. The metal pieces being joined together do not melt as they do in the welding process because solders melt at much lower temperatures. Soft solders consist of tin with a high percentage of lead and melt at temperatures of 360° to 370°F. Hard solders are composed of tin and a low content of antimony or silver and melt at temperatures ranging from 430 to 460°F.

Brazing, which is sometimes called hard soldering, also joins two pieces of metal together by torch melting a filler rod material between them. The filler has a high content of copper and melts between 800 and 900°F.

**MELTING TEMPERATURES OF METALS**

BASE METAL	MELTING TEMPERATURES	
	DEGREES C	DEGREES F
Aluminum	660	1220
Antimony	631	1168
Cadmium	321	610
Chromium	1857	3375
Cobalt	1495	2723
Copper	1083	1981
Gold	1064	1947
Iron	1535	2795
Lead	328	622
Magnesium	649	1200
Manganese	1244	2271
Nickel	1453	2647
Silver	962	1764
Tin	232	450
Zinc	420	788
Zirconium	1852	3366

Robert C. Rodgers, P.E.; Richmond Heights, Ohio

**GENERAL**

The finishes commonly used on architectural metals fall into three categories:

**MECHANICAL FINISHES** are the result of physically changing the surface of the metal through mechanical means: the forming process itself or a subsequent procedure performed either before or after the metal is fabricated into an end-use product.

**CHEMICAL FINISHES** are achieved by means of chemicals, which may or may not have a physical effect on the surface of the metal.

**COATINGS** are applied as finishes, either to the metal stock or the fabricated product. These coatings either change the metal itself, through a process of chemical or electrochemical conversion, or they are simply applied to the metal surface.

Application environments, service requirements, and aesthetics together determine which metal finish or coating is best to specify. Finishes are usually selected for both appearance and function: Chromium plating on metal bathroom water faucets and handles or baked enamel on sheet metal lighting fixtures, for example, must be attractive as well as functionally protective.

For structural and exterior metal building products, such as steel framing products, metal siding, and outdoor lighting fixtures, function and operating environments are more important criteria. From a design standpoint, it is important to recognize how various finishes and coatings resist wear, corrosion, and erosion. To choose the right coating or finish, architects must know which material or process is best suited for a specific application.

**MECHANICAL FINISHES**

**AS-FABRICATED FINISHES** are the texture and surface appearance given to a metal by the fabrication process.

**BUFFED FINISHES** are produced by successive polishing and buffing operations using fine abrasives, lubricants, and soft fabric wheels. Polishing and buffing improve edge and surface finishes and render many types of cast parts more durable, efficient, and safe.

**PATTERNED FINISHES** are available in various textures and designs. They are produced by passing an as-fabricated sheet between two matched-design rollers, embossing patterns on both sides of the sheet, or between a smooth roll and a design roll, embossing or coining on one side of the sheet only.

**DIRECTIONAL TEXTURED FINISHES** are produced by making tiny parallel scratches on the metal surface using a belt or wheel and fine abrasive, or by hand rubbing with steel wool. Metal treated this way has a smooth, satiny sheen.

**PEENED FINISHES** are achieved by firing a stream of small steel shot at a metal surface at high velocity. The primary aim of shot peening is increasing the fatigue strength of the component; the decorative finish is a by-product. Other nondirectional textured finishes are produced by blasting metal, under controlled conditions, with silica sand, glass beads, and aluminum oxide.

**CHEMICAL FINISHES**

**CHEMICAL CLEANING** cleans the metal surface without affecting it in any other way. This finish is achieved with chlorinated and hydrocarbon solvents and inhibited chemical cleaners or solvents (for aluminum and copper) and pickling, chlorinated, and alkaline solutions (for iron and steel).

**ETCHED FINISHES** produce a matte, frosted surface with varying degrees of roughness by treating the metal with an acid (sulfuric and nitric acid) or alkali solution.

The **BRIGHT FINISH** process, not used widely, involves chemical or electrolytic brightening of a metal surface, typically aluminum.

**CONVERSION COATING** is typically categorized as a chemical finish, but since a layer or coating is produced by a chemical reaction, it could be considered a coating as well. Conversion coatings typically prepare the surface of a metal for painting or for receiving another type of finish but are also used to produce a patina or statuary finish. A component is treated with a dilute solution of phosphoric acid or sulfuric acid and other chemicals that convert the surface of the metal to an integral, mildly protective layer of insoluble crystalline phosphate or sulphate or the like. Such coatings can be applied by either spray or immersion and provide temporary resistance to a mildly corrosive environment. They can be specified for gray, ductile, and malleable iron castings as well as steel castings, forgings, or weldments, such as railings and outdoor furniture.

**COATINGS**

**ORGANIC COATINGS** on metal can provide protection only or serve both protective and decorative functions. The former category includes primers or undercoats, pigmented topcoats in hidden areas, and clear finishes. Organic coatings serving double duty include pigmented coatings in visible areas, clear finishes used for gloss, and transparent or translucent clear finishes with dyes added.

Organic coatings usually fall under the general categories of paints, varnishes, enamels, lacquers, plastisols, organosols, and powders. Literally hundreds of different organic coating formulations offer an almost unlimited range of properties. Many organic coatings are applied with brushes and rollers, but dipping and spraying of paints account for most industrial and commercial building projects. Dipping is useful for coating complex metal parts, but spraying is used for most architectural applications. Spraying is fast and inexpensive, and new computer-controlled guns can follow even complex curvatures. Conventional spraying, however, has two disadvantages. For one thing, there is no easy, inexpensive way to collect and re-use the coating material. And when solvent-based paints are used, there is the added problem of meeting environmental restrictions.

**ELECTRODEPOSITION**, an increasingly popular alternative to spraying, is similar to electroplating, except that organic resins are deposited instead of metal. Electrodeposition is based on the principles of electrophoresis—the movement of charged particles in a liquid under the influence of an applied voltage.

Electrodeposition offers several advantages: The coating builds up to a uniform thickness without runs or sags; very little paint is wasted; low levels of volatile organic compounds (VOCs) are emitted; and coatings can be deposited even into deeply recessed areas of a complex shape. Electrodeposition also has disadvantages. Coating thickness is limited, and because only one coat can be applied this way, subsequent coats must be sprayed.

**POWDER COATING** is perhaps the best known environmentally acceptable painting process. Powder coatings offer several advantages. Because the paints are solventless, they are safer and "greener." In addition, the paints cost less and last a long time.

Powdered paints are formulated in much the same way as solvent-based paints, with the same pigments, fillers, and extenders, but are dry at room temperatures. Heat-reactive or "heat-latent" hardeners, catalysts, or cross-linkers are used as curing agents.

Powder coatings are either thermoplastic or thermosetting. As the term implies, thermoplastic coatings, which include vinyl, polyethylene, and certain polyesters, are melted by heat during application. Before such coatings are applied, the surface must be primed to ensure good adhesion. Thermosetting paints undergo a chemical change; they cannot be remelted by heat. The thermosets do not require a primer. Coating powders include epoxies, polyurethanes, acrylics, and polyesters.

**COMPARATIVE APPLICABILITY OF VARIOUS FINISHES FOR ARCHITECTURAL APPLICATIONS**

TYPE OF FINISH OR TREATMENT	METAL			
	ALUMINUM	COPPER ALLOYS	STAINLESS STEEL	CARBON STEEL AND IRON
<b>MECHANICAL FINISHES</b>				
As fabricated	Common to all of the metals (produced by hot rolling, extruding, or casting)			
Bright rolled	Commonly used (produced by cold rolling)			Not used
Directional grit textured	Commonly used (produced by polishing, buffing, hand rubbing, brushing, or cold rolling)			Rarely used
Nondirectional matte textured	Commonly used (produced by sand or shot blasting)			Rarely used
Bright polished	Commonly used (produced by polishing and buffing)			Not used
Patterned	Available in light sheet gauges of all metals			
<b>CHEMICAL FINISHES</b>				
Nonetch cleaning	Commonly used on all of the metals			
Matte finish	Etched finishes widely used	Seldom used	Not used	Not used
Bright finish	Limited uses	Rarely used	Not used	Not used
Conversion coatings	Widely used as pretreatment for painting	Widely used to provide added color variation	Not used	Widely used as pretreatment for painting
<b>COATINGS</b>				
Organic	Widely used	Opaque types rarely used; transparent types common	Sometimes used	Most important type of finish
Anodic	Most important type of finish	Not used	Not used	Not used
Vitreous	Widely used	Limited use	Not used	Widely used
Metallic	Rarely used	Limited use	Limited use	Widely used
Laminated	Substantial uses	Limited use	Not used	Substantial uses

**NOTE**

For more information, see the "Metal Finishes Manual for Architectural and Metal Products," published by the Architectural Metal Products Division of the National Association of Architectural Metal Manufacturers.

Robert C. Rodgers, P.E.; Richmond Heights, Ohio



METAL MATERIALS

**GENERAL**

The two most common methods of applying powdered finishes to metal are spraying and dipping, the same as those used for solvent-based paint. Electrostatic spraying is used to apply powder films from 1 to 5 mil thick. A mixture of air and powder moves from a hopper to a spray gun. The mixture is charged electrostatically as it passes through the spray gun, causing it to stick to any grounded metal object. Powder that falls to the floor is recycled.

For coatings thicker than 5 mil, fluidized-bed dipping is used. The powder is placed in a special tank into which air is blown, turning the powder into a fluid-like mass. Parts are dipped in the "fluid" and baked to cure the finish.

**ANODIC COATINGS**

Anodic oxides are widely used to protect aluminum and many of its alloys from corrosion. When the metal is anodized in one of a variety of acids, a protective oxide is formed on the surface. Depending on the acid, the oxide may range from thin and nonporous to thick and porous. Three types of anodizing are used for aluminum: chromic, sulfuric, and hardcoat.

**CHROMIC ANODIZING** results in a relatively soft coating and is the least used of the three types, but it does offer several advantages. It has excellent corrosion resistance, so rinsing is not as important. It is suitable for complex cast parts and offers a coating of the most consistently uniform thickness and the most enduring fatigue strength.

**SULFURIC ANODIZING**, the most widely used method, produces a harder coating than chromic anodizing, but it can be scratched. It offers a pleasing appearance and can be dyed in several colors. Corrosion resistance is good.

**HARDCOAT ANODIZING** produces a relatively thick, extremely hard coating that can be dyed in a range of colors. Corrosion resistance is good. Hardcoats are porous, making them suitable as a base for paints and adhesives.

Since all anodic processes produce porous aluminum-oxide coatings, sealing is usually desirable. The coating is immersed in hot water, the oxide is hydrated, and the pores swell shut. Several manufacturers claim that their sealing agents do the same thing through catalytic action at lower temperatures. Chromic- and sulfuric-anodized coatings nearly always are sealed, but hardcoats are not.

**VITREOUS COATINGS** are composed of inorganic glossy materials (glass). Porcelain enamels are the most commonly used vitreous coating for architectural applications. Although one of the hardest and most durable finishes, they are brittle. Deformation of metal surfaces can cause cracking and splitting. Porcelain enamel coatings come in a wide range of colors and finishes and are typically applied to steel and aluminum (bathtubs, sinks, column covers). Embossed patterns and textures may be applied by altering the metal backing surface or the coating itself.

**HOT DIPPING** of ferrous metal objects consists of immersing clean parts into a molten bath of the desired coating metal. In general, molten aluminum, lead, zinc, and some alloys can be applied as hot-dip coatings to irons. Each offers specific advantages. Hot-dip coatings are particularly suitable for intricately shaped cast ferrous items such as metal roofing components and nails and other fasteners.

**METALLIC PLATING** is done by either electrodeposition or electroplating.

In electrodeposition, an electrical current is carried across an electrolyte and an organic resin substance deposited on an electrode (the metal object being painted). In electroplating, the "substance" is a metal, such as chromium, in an electrolyte. Water usually serves as the solvent in the electrolyte. Although chromium is commonly used for plating, many metals can be deposited on the substrate.

Similarly, a wide range of plating quality is available. For example, a thin coating of zinc will protect a metal compo-

nent from rust or corrosion for a short time. Chromium plating, on the other hand, protects longer and looks better.

Materials widely used to plate complex metal components include bronze, brass, chromium, cadmium, chromates, copper, lead, lead-tin, nickel, phosphates, silver, tin-nickel, and tin-zinc. Not all of these materials can be deposited on all metal substrates. For example, zinc electroplate can be used on steel but not on cast iron. Therefore, coating/substrate compatibility is a crucial consideration in matching coating performance to application requirements. Typical applications for plating include food servicing areas, plumbing fixtures, exterior metal, and architectural products.

**LAMINATED COATINGS**

Lamination involves bonding preformed plastic films to metals with adhesives. Laminated coatings provide finishes for products such as interior paneling, partitions, and exterior metalwork. Three types of plastic film are widely used: polyvinyl chloride (PVC), polyvinyl fluoride (PVF), and acrylic.

PVC films provide excellent stain and abrasion resistance. Available in five or six colors, these laminates may come with graining or embossing to simulate wood grain, leather, or fabric. Film thicknesses range from 0.004 in. to 0.041 in., but most common and most economical are those from 0.008 and 0.014 in.

PVF films are usually laminated in a thickness of 0.002 in. and have a smooth, medium gloss surface. Despite their thinness, they are very strong, tough, and weather resistant, making them particularly suited to exterior applications such as siding materials. Their color range is limited, but they resist staining and chemical damage well.

Acrylic films are low cost products that stand up well to weather and are widely used for exterior metalwork. They resist UV radiation and yellowing and retain their flexibility with aging. They are usually applied in a thickness of 0.003 in. and are reasonably priced.

**REPRESENTATIVE ARCHITECTURAL USES AND COMPARATIVE PROPERTIES OF COATINGS**

BINDER TYPE	TYPICAL USES <sup>1</sup>	COST	OUTDOOR LIFE (YEARS)	COLOR STABLE, EXTERIOR	GLOSS RETENTION, EXTERIOR	STAIN RESISTANCE	WEATHER RESISTANCE	ABRASION AND IMPACT RESISTANCE	FLEXIBILITY	WATER REDUCIBLE AVAILABLE	CLEAR AVAILABLE	WELDABLE AS PRIMER
Acrylics												
Solvent-reducible		M	10	yes	G	F	G	G	G	—	yes	yes <sup>2</sup>
Water-reducible: air dried	Residential siding and similar products; cabinets and implements; clear topcoats	M	5-10	yes	F	F	G	G	G	yes	yes	yes <sup>2</sup>
		M	15-20	yes	G-E	F	G-E	G	G	yes	yes	yes <sup>2</sup>
Alkyds	Exterior primers and enamels	L-M	5-9	no	G	F	F	F	F-G	yes	yes	yes <sup>2</sup>
Cellulose (acetate or butyrate)	Decorative high-gloss finishes	M	NA	yes	G	F	G	G	G	no	yes	no
Chlorinated rubber	Corrosion-resistant paints; swimming pool coatings; protection of dissimilar metals	M	10	yes	F	F	G	G	G	no	no	no
Chloro sulfonated polyethylene	Paints for piping, tanks, valves, etc.	VH	15	yes	NA	F	E	F-G	E	no	no	no
Epoxy	Moisture- and alkali-resistant coatings; nondescriptive interior uses requiring high chemical resistance	H-VH	15-20	no	P	G	G-E	E	G	no	no	yes <sup>2</sup>
Fluorocarbons	High-performance exterior coatings; industrial siding; curtain walls	VH	20+	yes	E	E	E	E	G	no	no	no
Phenol formaldehyde	Chemical- and moisture-resistant coatings	M	10	no	F	F	G-E	G-E	G	no	yes	yes <sup>2</sup>
Polyester	Cabinets and furniture; ceiling tile; piping	H	15	some versions	G-E	G-E	G-E	G	G-E	yes	yes	no
Polyvinyl chloride	Residential siding; plastisols; industrial siding; curtain walls	H	15	yes	G	F	G-E	G	G-E	yes	no	yes <sup>2</sup>
Silicates (inorganic)	Corrosion-inhibitive primers; solvent-resistant coatings	H	NA	NA	NA	NA	NA	G	G	no	no	yes
Silicone-modified polymers	High-performance exterior coatings; industrial siding; curtain walls	H-VH	15-20	yes	G-E	G	G-E	G-E	G	yes	no	no
Urethane (aliphatic-cured)	Heavy-duty coatings for stain chemical, abrasion, and corrosion resistance	VH	20+	some versions	E	G-E	G-E	G-E	E	yes	yes	yes <sup>2</sup>

L—low; M—moderate; H—high; VH—very high; NA—not applicable or not available; P—poor; F—fair; G—good; E—excellent

<sup>1</sup> All coatings may be shop applied; all may be field applied except solvent reducible acrylics, baked acrylic, cellulose, and fluorocarbons.

<sup>2</sup> For light nonstructural welding only.

Robert C. Rodgers, P.E.; Richmond Heights, Ohio

**STRUCTURAL WELDING**

Structural welds can be made with hundreds of different welding processes. The most common are forms of shielded metal arc and oxyfuel gas welding. These processes are designed for the specific welding conditions: type of metal, structural requirements, weld position, and joint specifications. Normally, however, the designer does not specify the process which is to be used to make a welded joint. The designer specifies the type and size of weld needed for the specific joint and leaves the details of how the joint is to be made up to the fabricator.

The two most important types of structural welds are fillet welds and groove welds. They are the most useful in structural applications. Back welds are used in conjunction with single groove welds to complete the weld penetration. Plug, slot, and flare welds are of secondary importance and are limited in application.

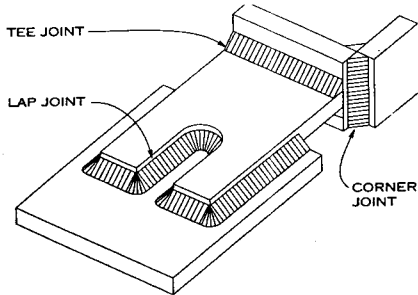

**FILLET WELD JOINTS**

With a triangular cross section, fillet welds join two surfaces approximately at right angles to each other in lap, tee, and corner joints. They are also used with groove welds as reinforcements in corner joints.

**FILLET WELDS**

Groove welds are welds made in a groove between adjacent ends, edges, or surfaces of two parts to be joined in a butt, tee, or corner joint.

The edge or ends of parts to be groove welded are usually prepared by flame cutting, arc air gouging, or edge planing to provide square, vee, bevel, U-, or J-shaped grooves that are straight and true to dimension. The preparation is done to ensure that the base metal is welded evenly completely through the joint. With thicker metal it is also done to open up the joint area for welding. Relatively thin material may be groove welded with square cut edges.

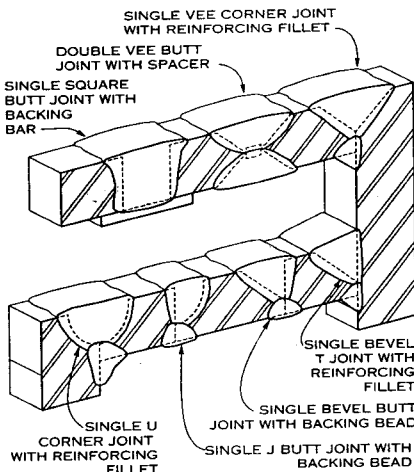

**EXAMPLES OF COMPLETE PENETRATION GROOVE WELDS**

The two types of groove welds are complete penetration and partial penetration. A complete penetration weld is one that achieves fusion of weld and base metal throughout the depth of the joint. It is made by welding from both sides of the joint, from one side to a backing bar, or back welding the first weld.

**GROOVE WELDS**

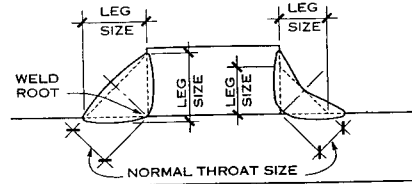

**FILLET WELD NOMENCLATURE**  
The model cross section of a fillet weld is a right triangle with equal legs. The leg size designates the effective size of the weld. The length of a fillet weld is the distance from end-to-end of the full size fillet, measured parallel to its root line. For curved fillet welds the effective length is equal to the throat length, measured along a line bisecting the throat area.

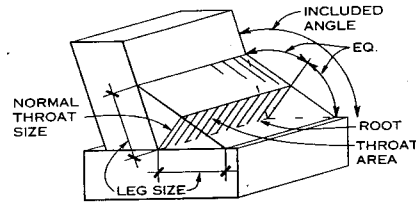

The cross section of a fillet weld may differ from the right triangle model in several ways. The included angle of the weld may vary from 60° to 135°, or unequal leg welds may be employed. When unequal leg welds are used, the use of the normal throat size as the effective size in weld strength calculations will, in most cases, be conservative. However, when the included angle of weld deposit is substantially greater than 90°, the effective throat size should be determined from the actual dimensions of the weld according to American Welding Society specifications.

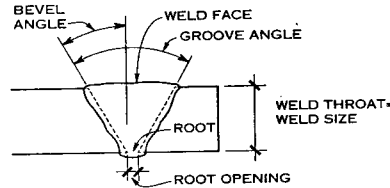

**FULL PENETRATION GROOVE WELD NOMENCLATURE**

Except where backing bars are employed, specifications require that the weld roots generally must be chipped or gouged to sound metal before making the second weld. For purposes of stress computation, the throat dimension of a full penetration groove weld is considered to be the full thickness of the thinner part joined, exclusive of weld reinforcement, such as backing bars.

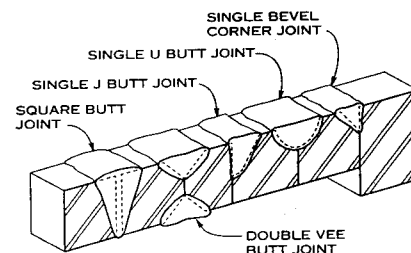

**EXAMPLES OF PARTIAL PENETRATION GROOVE WELDS**

Partial penetration groove welds are employed when stresses to be transferred do not require full penetration, or when welding must be done from one side of a joint only and it is not possible to use backing bars or to gouge weld roots for back welds. The application of partial penetration groove welds is governed by specifications and may limit the effective throat thickness or the thickness of the material on which they are to be used.

**JOINT PREQUALIFICATION**

Welded joints that conform to all American Welding Society code and specification provisions for design, material, and workmanship are prequalified joints. There are a variety of specific fillet and groove welded joints that meet most structural work requirements and are recommended for general use in buildings and bridges. Joints that are not prequalified under the AWS code are required to be qualified by tests as prescribed by the code.

For quick reference and more advanced consideration, the prequalified joints are shown in AWS "Structural Welding Code-Steel."

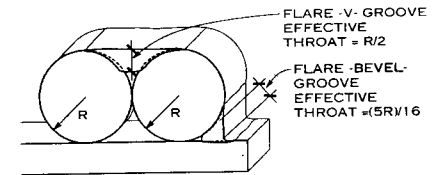

**FLARE WELD NOMENCLATURE**

Flare welds are special cases of groove welds in which the groove surface of one or both parts of a joint is convex. This convexity may be the result of edge preparation, but more often one or both components consists of a round rod or rounded shape. Complete penetration in a flare weld is usually difficult to achieve and the quality of the weld is difficult to control; therefore, design values should be applied conservatively and special considerations need to be taken in certain instances.

**FLARE WELDS**

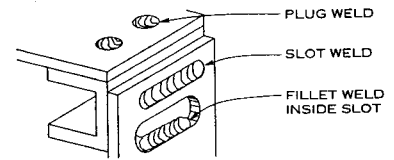

**PLUG AND SLOT WELDS**

Plug and slot welds are used in lap joints to transmit shear loads, prevent buckling of lapped parts, or join component parts of built-up members. Round holes or slots are punched or otherwise formed in one component of the joint before assembly. With parts in position, weld metal is deposited in the openings, which may be partially or completely filled, depending on the thickness of the punched material. AWS "Structural Welding Code-Steel" should be consulted for allowable proportion and spacing of holes and slots and the depth of welds.

It is necessary to distinguish between plug or slot welds and fillet welds placed around the inside of a hole or slot. Fillet welds in a slot are easier to make and inspect and are usually preferred over fillet welds in round holes or plug and slot welds.

**PLUG AND SLOT WELDS**

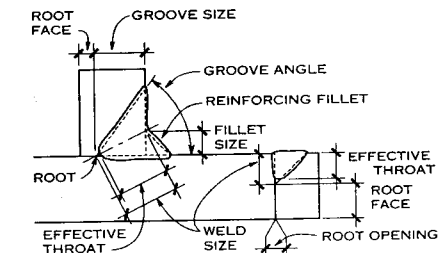

**PARTIAL PENETRATION GROOVE WELD NOMENCLATURE**

Edge preparation of base material for partial penetration groove welds is similar to that for full penetration groove welds, but it usually covers less than the full thickness. The effective throat thickness and, hence, the weld strength of partial penetration groove welds is normally limited to less than the full joint thickness.

The use of partial penetration welds is subject to AWS code and other specification provisions. These are more restrictive in bridge specifications than in building codes.

**BASIC WELDING SYMBOLS**

The three basic parts needed to form a welding symbol are: an arrow pointing to the joint, a reference line upon which the dimensional data are placed, and a weld device symbol indicating the weld type required. The tail of the welding symbol is only necessary to indicate additional data, such as specification, process, or detail references.

The arrow indicates the joint where the weld is to be made. The basic weld device symbol or device indicates the type of weld to be made, for example: fillet, U-groove, bevel, or plug. The position of the basic weld symbol or device indicates which side of the joint is to be welded. The bottom side of the reference line is designated as the arrow side, meaning any welding operation shown on this side of the reference line is to be performed on the same side of the joint as the arrow. When an operation is shown on the top side of the reference line it is to be performed on the joint side opposite the arrow.

The weld dimensions, size, length, pitch, etc., are placed on the reference line next to the weld device. These dimensions read from left to right regardless of which side the arrow is on.

**FILLET WELDS**

The dimensions needed for fillet welds are weld size and length and, for intermittent fillet welds, pitch. The weld size is equal to the weld leg size, assuming that the legs are equal. In the rare instance that the legs are not equal, the size is not given in the welding symbol but instead the weld legs are dimensioned in the drawing to avoid confusion. If there is a typical weld size for a particular drawing, the size may be noted in the notes and left off of the symbol. If the joint is to be welded on both sides, then both sides must be dimensioned, even if they are the same.

If the length of a fillet weld is omitted, it is understood to mean that the weld is to extend the full distance between abrupt changes in the part of the joint outlined specified by the weld symbol arrow. If the same size fillet is required for the full length of all sides of a particular joint, regardless of abrupt changes in its direction, the weld-all-around symbol can be used to simplify the drawing.

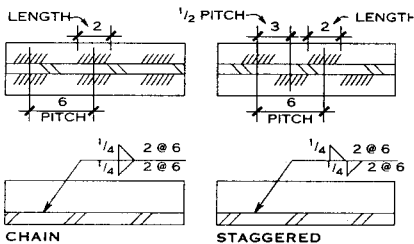

**INTERMITTENT FILLET WELDS**

Pitch is used with intermittent fillet welds to give the center to center dimensions between welded sections. When using pitch, length is the dimension of the individual weld sections.

**COMPLETE PENETRATION GROOVE WELDS**

When detailing complete penetration groove welds the dimensions usually include the weld size, root opening, the groove angle for vee, bevel, J, and U welds, and the groove radii for J and U welds. The length of groove welds is not given, because the welds are accepted to go from end to end of pieces welded. Any deviation from this requires additional detailing.

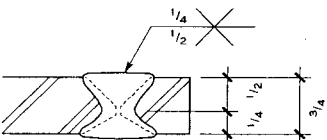

**UNSYMMETRICAL GROOVE WELD CALLOUT**

Normally the weld size of a complete joint penetration groove weld is understood to be the full thickness of the thinner metal connected, and its dimension need not be shown on the welding symbol. However, if the preparation of a double groove weld is not symmetrical, the size of each side of the weld must be shown.

The root opening is shown near the root of the groove device. The groove angle is to be shown within the groove

**BASIC WELD DEVICE SYMBOLS**

BACK WELD	FILLET WELD	PLUG OR SLOT	GROOVE SQUARE	OR BUTT JOINTS					
				V	BEVEL	U	J	FLARE V	FLARE BEVEL

**SUPPLEMENTARY WELD SYMBOLS**

BACKING	SPACER	WELD-ALL-AROUND	FIELD - WELD	FLUSH	CONVEX

NOTE: For additional basic and supplementary weld symbols, see the American Welding Society A2.4-79.

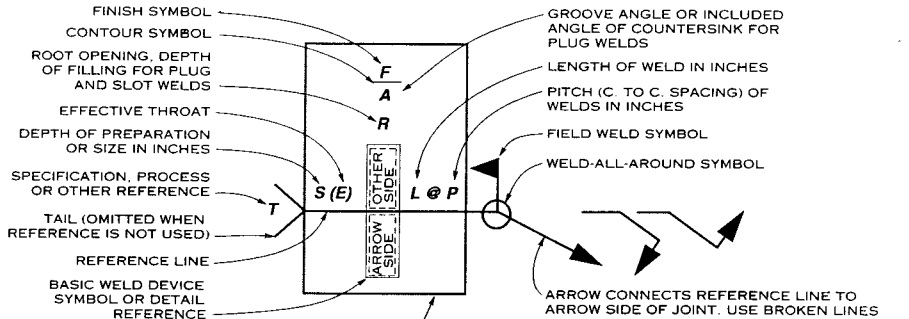

THESE PARTS OF WELD SYMBOL ALWAYS READ THE SAME DIRECTION REGARDLESS OF WHICH DIRECTION THE ARROW IS POINTING

**NOTES**

1. Size, weld symbol, length of weld, and spacing must read in that order from left to right along the reference line. Neither orientation of reference line nor location of the arrow alters this rule.
2. The perpendicular leg of  $\Delta$ ,  $\nabla$ ,  $\nabla$ ,  $\nabla$  weld symbols must be at left.
3. Arrow and other side welds are of the same size unless otherwise shown. Dimensions of fillet welds must be shown on both the arrow side and the other side symbol.
4. The point of the field weld symbol must point toward the tail
5. Symbols apply between abrupt changes in direction of welding unless governed by the "all-around" symbol or otherwise dimensioned.
6. These symbols do not explicitly provide for the case that frequently occurs in structural work, where duplicate material (such as stiffeners) occurs on the far side of a web or gusset plate. The fabricating industry has adopted the following convention: when the billing of the detail material discloses the existence of a member on the far side as well as on the near side, the welding shown for the near side shall be duplicated on the far side.

**STANDARD LOCATION OF ELEMENTS OF A WELDING SYMBOL**

faces of the device and above the root opening. The angle is understood to be the total, or included, angle of the groove.

There is no provision for dimensioning radii of U and J groove welds in the AWS welding symbol. This is usually covered by the fabricator's standard weld proportions, with reference to AWS prequalified joints. If not, it must be shown by note or sketch in the drawing.

**PARTIAL PENETRATION GROOVE WELDS**

Partial penetration groove welds require all of the same dimensions as complete penetration groove welds, plus two additional dimensions: effective throat and weld size. With partial penetration groove welds, the weld preparation usually is less than the thickness of the material being welded. Because of this the weld size must always be given. The effective throat must also be given because it

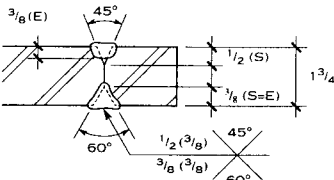

**PARTIAL PENETRATION GROOVE WELD CALLOUT**

can vary from the weld size due to welding process, welding position, or the groove angle used. Depending on these factors, the depth of weld deposit, or the effective throat, can be less than the depth of the groove, or weld size.

Partial penetration groove welds can be used as intermittent welds. Consideration must be given to the transition at the beginning and end of the weld. Therefore, contract design drawings should only specify the effective weld length and the required effective throat. The shop drawings should then show the groove depth and geometry that will provide for the required effective throat.

**PLUG AND SLOT WELDS**

The size for plug welds specifies the diameter of the punched hole. For slot welds the size includes the width and length of the slot. Plug and slot welds will be completely filled unless the depth of the filling is shown inside the weld symbol. Slot welds are noted by detail references in the tail that refer to dimensioned sketches of the slot for clarity. The arrow and other side indicates which side of the joint is to be punched. The flush weld symbol is used if the top of the weld is to be leveled off.

**CONTOUR SYMBOLS**

The flush and convex symbols are used to modify the shape of the weld face. The contour symbols are placed over the weld device. Almost all of the basic weld symbols can be combined with each other and with the spacer, backing bar, back weld, and contour symbols to create many different welds.



**SAFE TOTAL UNIFORMLY DISTRIBUTED LOAD (KIPS) FOR BEAMS  
LATERALLY SUPPORTED—ASTM A 572 GRADE 50 STEEL, ALLOWABLE STRESS DESIGN\***

SPAN LENGTH (FT)	DEPTH <sup>2</sup> (IN.)	W 6				W 8						W 10				W 12				W 14		M 14									
		9	12	16	10	13	15	18	21	24	28	31	12	15	17	19	22	26	30	33	14	16	19	22	26	30	35	40	22	26	18
6		20	27	37	28	36	43	56	67	77	89	91	40	51	59	69	85	102	119	113	55	63	78	93	112	128	150		106	129	77
8		15	20	28	21	27	32	42	50	57	67	76	30	38	45	52	64	77	89	96	41	47	59	70	92	106	125	141	80	97	58
10		12	16	22	17	22	26	33	40	46	53	60	24	30	36	41	51	61	71	77	33	38	47	56	73	85	100	114	64	78	46
12		10	13	19	14	18	22	28	33	38	45	50	20	25	30	34	43	51	59	64	27	31	39	47	61	71	84	95	53	65	39
14		8.7	11	16	12	16	19	24	29	33	38	43	17	22	25	30	36	44	51	55	23	27	33	40	52	61	72	82	46	55	33
16					11	14	16	21	25	29	33	38	15	19	22	26	32	38	45	48	20	24	29	35	46	53	63	71	40	49	29
18					9	12	14	19	22	26	30	34	13	17	20	23	28	34	40	43	18	21	26	31	41	47	56	63	35	43	26
20					9	11	13	17	20	23	27	30	12	15	18	21	26	31	36	39	16	19	23	28	37	42	50	57	32	39	23
22													11	14	16	19	23	28	32	35	15	17	21	25	33	39	46	52	29	35	21
24													10	13	15	17	21	26	30	32	14	16	20	23	31	35	42	48	27	32	19

\* For capacity of beams not shown see *AISC Manual of Steel Construction*, 2d ed. (load and resistance factor design) and 9th ed. (allowable stress design).  
<sup>2</sup> Depth = steel designation (in.); weight = lb/ft; kip = 1000 lb.

**NOTES**

1. Consult structural engineer to verify lateral support.
2. Multiply loads by 1.5 to obtain approximate capacities for load and resistance factor design method.

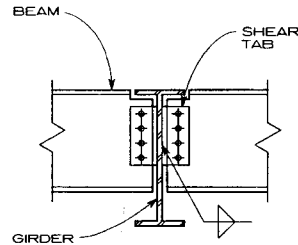
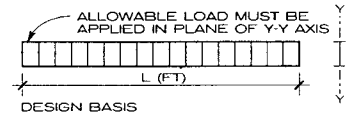

SHOP WELDED TAB FIELD HIGH STRENGTH BOLTED

SHEAR CONNECTION BEAM TO GIRDER

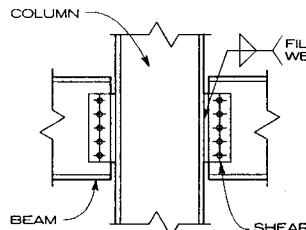

SHOP WELDED TAB FIELD HIGH STRENGTH BOLTED

NONMOMENT CONNECTION BEAM TO COLUMN FLANGE

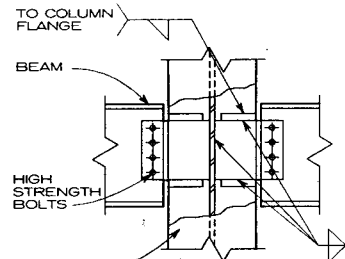

SHOP WELDED TAB TO COLUMN WEB AND PLATES FIELD H.S. BOLTED

NONMOMENT CONNECTION BEAM TO COLUMN WEB

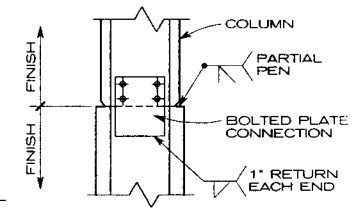

WEB-FIELD H.S. BOLTED FLANGE-PARTIAL PENETRATION

COLUMN SPLICE FLANGE AND WEB

**CONNECTIONS AND SPLICES**

**SAFE TOTAL CONCENTRIC LOAD (KIPS) FOR COLUMNS—ASTM A 572 GRADE 50 STEEL (W SHAPES) AND ASTM A 500 STEEL (TS-SHAPES AND PIPE, 46 KSI), ALLOWABLE STRESS DESIGN\***

DESIGNATION	**	6	7	8	9	10	11	12	13	14	15	16	17	18	19	20	22	24
W4	13	79	70	60	49	40	33	28	24	20	18	16						
W6	15	108	102	96	89	82	74	66	57	49	43	38	33	30	27	24	20	17
	20	145	137	129	121	112	102	92	81	70	61	54	47	42	38	34	28	24
W8	25	182	173	163	152	141	129	117	103	90	78	69	61	54	49	44	36	31
	24	178	170	161	152	142	132	121	109	97	85	74	66	59	53	48	39	33
	28	208	198	188	178	166	154	142	128	114	100	88	78	69	62	56	46	39
Pipe 3", 3.5" O.D.	31	241	234	226	217	208	199	189	179	168	156	145	132	119	107	97	80	67
	0.216	38	36	34	31	28	25	22	19	16	14	12	11	10	9			
	0.300	52	48	45	41	37	33	28	24	21	18	16	14	12	11			
Pipe 3.5", 4" O.D.	0.600	91	84	77	69	60	51	43	37	32	28	24	22					
	0.226	48	46	44	41	38	35	32	29	25	22	19	17	15	14	12	10	
Pipe 4", 4.5" O.D.	0.318	66	63	59	55	51	47	43	38	33	29	25	23	20	18	16		
	0.237	59	57	54	52	49	46	43	40	36	33	29	26	23	21	19	15	13
Pipe 5", 5.563" O.D.	0.337	81	78	75	71	67	63	59	54	49	44	39	35	31	28	25	21	17
	0.674	147	140	133	126	118	109	100	91	81	70	62	55	49	44	40	33	
	0.258	83	81	78	76	73	71	68	65	61	58	55	51	47	43	39	32	27
Pipe 6", 6.625" O.D.	0.375	118	114	111	107	103	99	95	91	86	81	76	70	65	59	54	44	37
	0.750	216	209	202	195	187	178	170	160	151	141	130	119	108	97	87	72	61
	0.280	110	108	106	103	101	98	95	92	89	86	82	79	75	71	67	59	51
TS 4 x 4	0.432	166	162	159	155	151	146	142	137	132	127	122	117	111	105	99	86	73
	0.864	306	299	292	284	275	266	257	247	237	227	216	205	193	181	168	142	119
TS 5 x 5	0.250	83	79	75	70	65	60	55	49	43	38	33	29	26	24	21	18	15
TS 6 x 6	0.250	111	108	104	100	96	92	87	82	77	72	66	60	54	49	44	36	31
TS 6 x 6	0.250	140	137	133	130	126	122	117	113	108	104	99	94	88	83	77	65	55
TS 5 x 3	0.250	76	70	64	58	51	43	36	31	28	23	20	18	16	15			
TS 6 x 4	0.250	107	103	98	92	87	81	75	68	61	54	48	42	38	34	30	25	21
TS 8 x 4	0.250	132	126	120	114	108	101	94	86	79	70	62	55	49	40	33		

\* For additional columns and actual dimensions of tubing, see *AISC Manual of Steel Construction*, 2d ed. (load and resistance factor design) and 9th ed. (allowable stress design).

\*\* Weight per ft for W columns. Wall thickness for tubing. kip = 1000 lb; K = effective length factor (verify with structural engineering consultant).

**NOTE**

Multiply loads by 1.5 to obtain approximate capacities for load and resistance factor design method.

**W SHAPES—  
DIMENSIONS FOR DETAILING**

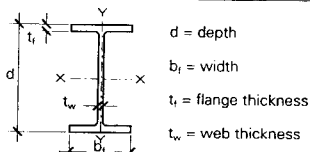

DESIG-NATION	DEPTH (IN.)	FLANGE		THICK-NESS (IN.)
		WIDTH (IN.)	THICK-NESS (IN.)	
W36 x 300	36 3/4	16 5/8	1 11/16	5/16
x 280	36 1/2	16 5/8	1 9/16	7/8
x 260	36 1/4	16 1/2	1 7/16	13/16
x 245	36 1/8	16 1/2	1 3/8	13/16
x 230	35 7/8	16 1/2	1 1/4	3/4
W36 x 210	36 3/4	12 1/8	1 3/8	13/16
x 194	36 1/2	12 1/8	1 1/4	3/4
x 182	36 3/8	12 1/8	1 3/16	3/4
x 170	36 1/8	12	1 1/8	11/16
x 160	36	12	1	5/8
x 150	35 7/8	12	15/16	5/8
x 135	35 1/2	12	13/16	5/8
W33 x 241	34 1/8	15 7/8	1 3/8	13/16
x 221	33 7/8	15 3/4	1 1/4	3/4
x 201	33 3/8	15 3/4	1 1/8	11/16
W33 x 152	33 1/2	11 5/8	1 1/16	5/8
x 141	33 1/4	11 1/2	1 5/16	5/8
x 130	33 3/8	11 1/2	7/8	9/16
x 118	32 1/8	11 1/2	3/4	9/16
W30 x 211	31	15 1/8	15/16	3/4
x 191	30 5/8	15	1 3/16	11/16
x 173	30 1/2	15	1 1/16	5/8
W30 x 132	30 1/4	10 1/2	1	5/8
x 124	30 1/8	10 1/2	15/16	9/16
x 116	30	10 1/2	7/8	9/16
x 108	29 7/8	10 1/2	3/4	9/16
x 99	29 5/8	10 1/2	11/16	1/2
W27 x 178	27 3/4	14 3/8	1 3/16	3/4
x 161	27 5/8	14	1 1/16	11/16
x 146	27 3/8	14	1	5/8
W27 x 114	27 1/4	10 5/8	15/16	9/16
x 102	27 1/8	10	13/16	1/2
x 94	26 7/8	10	3/4	1/2
x 84	26 3/4	10	5/8	7/16
W24 x 162	25	13	1 1/4	11/16
x 146	24 3/4	12 7/8	1 1/16	5/8
x 131	24 1/2	12 7/8	15/16	5/8
x 117	24 1/4	12 3/4	7/8	9/16
x 104	24	12 3/4	3/4	1/2
W24 x 94	24 1/4	9 1/8	7/8	1/2
x 84	24 1/8	9	3/4	1/2
x 76	23 7/8	9	11/15	7/16
x 68	23 3/4	9	9/16	7/16
W24 x 62	23 3/4	7	9/16	7/16
x 55	23 5/8	7	1/2	3/8
W21 x 147	22	12 1/2	1 1/8	3/4
x 132	21 7/8	12 1/2	1 1/16	5/8
x 122	21 5/8	12 3/8	15/16	5/8
x 111	21 1/2	12 3/8	7/8	9/16
x 101	21 3/8	12 1/4	13/16	1/2
W21 x 93	21 1/8	8 3/8	15/16	9/16
x 83	21 3/8	8 3/8	13/16	1/2
x 73	21 1/4	8 1/4	3/4	7/16
x 68	21 1/8	8 1/4	11/16	7/16
x 62	21	8 1/4	5/8	3/8
W21 x 57	21	6 1/2	5/8	3/8
x 50	20 7/8	6 1/2	9/16	3/8
x 44	20 5/8	6 1/2	7/16	3/8
W18 x 119	19	11 1/4	1 1/16	5/8
x 106	18 3/4	11 1/4	15/16	9/16

DESIG-NATION	DEPTH (IN.)	FLANGE		THICK-NESS (IN.)
		WIDTH (IN.)	THICK-NESS (IN.)	
x 97	18 5/8	11 1/8	7/8	9/16
x 86	18 3/8	11 1/8	3/4	1/2
x 76	18 1/4	11	13/16	7/16
W18 x 71	18 1/2	7 5/8	13/16	1/2
x 65	18 3/8	7 5/8	3/4	7/16
x 60	18 1/4	7 1/2	11/16	7/16
x 55	18 1/8	7 1/2	5/8	3/8
x 50	18	7 1/2	9/16	3/8
W18 x 46	18	6	5/8	3/8
x 40	17 7/8	6	1/2	5/16
x 35	17 3/4	6	7/16	5/16
W16 x 100	17	10 3/8	1	9/16
x 89	16 3/4	10 3/8	3/8	1/2
x 77	16 1/2	10 1/4	3/4	7/16
x 67	16 3/8	10 1/4	11/16	3/8
W16 x 57	16 3/8	7 1/8	11/16	7/16
x 50	16 1/4	7 1/8	5/8	3/8
x 45	16 1/8	7	9/16	3/8
x 40	16	7	1/2	9/16
x 36	15 7/8	7	7/16	5/16
W16 x 31	15 7/8	5 1/2	7/16	1/4
x 26	15 3/4	5 1/2	3/8	1/4
W14 x 730	22 3/8	17 7/8	4 15/16	3 1/16
x 665	21 5/8	17 5/8	4 1/2	2 13/16
x 605	20 7/8	17 3/8	4 3/16	2 5/8
x 550	20 1/4	17 1/4	3 13/16	2 3/8
x 500	19 5/8	17	3 1/2	2 3/16
x 455	19	16 7/8	3 3/16	2
W14 x 426	18 5/8	16 3/4	3 1/16	1 7/8
x 398	18 1/4	16 5/8	2 7/8	1 3/4
x 370	17 7/8	16 1/2	2 11/16	1 5/8
x 342	17 1/2	16 3/8	2 1/2	1 9/16
x 311	17 1/8	16 1/4	2 1/4	1 7/16
x 283	16 3/4	16 1/8	2 1/16	1 5/16
x 257	16 3/8	16	1 7/8	1 3/16
x 233	16	15 7/8	1 3/4	1 1/16
x 211	15 3/4	15 3/4	1 9/16	1
x 193	15 1/2	15 3/4	1 7/16	7/8
x 176	15 1/4	15 5/8	1 5/16	13/16
x 159	15	15 3/8	1 3/16	3/4
x 145	14 3/4	15 1/2	1 1/16	11/16
W14 x 132	14 5/8	14 3/4	1	5/8
x 120	14 1/2	14 5/8	15/16	9/16
x 109	14 3/8	14 5/8	7/8	1/2
x 99	14 1/8	14 5/8	3/4	1/2
x 90	14	14 1/2	11/16	7/16
W14 x 82	14 1/4	10 1/8	7/8	1/2
x 74	14 1/8	10 1/8	13/16	7/16
x 68	14	10	3/4	7/16
x 61	13 7/8	10	5/8	3/8
W14 x 53	13 3/8	8	11/16	3/8
x 48	13 3/4	8	5/8	5/16
x 43	13 5/8	8	1/2	5/16
W14 x 38	14 1/8	6 3/4	1/2	5/16
x 34	14	6 3/4	7/16	5/16
x 30	13 7/8	6 3/4	3/8	1/4
W14 x 26	13 7/8	5	7/16	1/4
x 22	13 3/4	5	5/16	1/4
W12 x 336	16 7/8	13 3/8	2 15/16	1 3/4
x 305	16 3/8	13 1/4	2 11/16	1 5/8
x 279	15 7/8	13 1/8	2 1/2	1 1/2
x 252	15 3/8	13	2 1/4	1 3/8
x 230	15	12 7/8	2 1/16	1 5/16
x 210	14 3/4	12 3/4	1 7/8	1 3/16
W12 x 190	14 3/8	12 5/8	1 3/4	1 1/16
x 170	14	12 5/8	1 9/16	15/16
x 152	13 3/4	12 1/2	1 3/8	7/8
x 136	13 3/8	12 3/8	1 1/4	13/16
x 120	13 1/8	12 3/8	1 1/8	11/16

DESIG-NATION	DEPTH (IN.)	FLANGE		THICK-NESS (IN.)
		WIDTH (IN.)	THICK-NESS (IN.)	
x 106	12 7/8	12 1/4	1	5/8
x 96	12 3/4	12 1/8	7/8	9/16
x 87	12 1/2	12 1/8	13/16	1/2
x 79	12 3/8	12 1/8	3/4	1/2
x 72	12 1/4	12	11/16	7/16
x 65	12 1/8	12	5/8	3/8
W12 x 58	12 1/4	10	5/8	3/8
x 53	12	10	9/16	3/8
W12 x 50	12 1/4	8 1/8	3/8	5/8
x 45	12	8	5/16	9/16
x 40	12	8	5/16	1/2
W12 x 35	12 1/2	6 1/2	5/16	1/2
x 30	12 3/8	6 1/2	1/4	7/16
x 26	12 1/4	6 1/2	1/4	3/8
W12 x 22	12 1/4	4	7/16	1/4
x 19	12 1/8	4	3/8	1/4
x 16	12	4	1/4	1/4
x 14	11 7/8	4	1/4	3/16
W10 x 112	11 3/8	10 3/8	1 1/4	3/4
x 100	11 1/8	10 3/8	1 1/8	11/16
x 88	10 7/8	10 1/4	1	5/8
x 77	10 5/8	10 1/4	7/8	1/2
x 68	10 3/8	10 1/8	3/4	1/2
x 60	10 1/4	10 1/8	11/16	7/16
x 54	10 1/8	10	5/8	3/8
x 49	10	10	9/16	5/16
W10 x 45	10 1/8	8	5/8	3/8
x 49	9 7/8	8	1/2	5/16
x 33	9 3/4	8	7/16	5/16
W10 x 30	10 1/2	5 3/4	1/2	5/16
x 26	10 3/8	5 3/4	7/16	1/4
x 22	10 1/8	5 3/4	3/8	1/4
W10 x 19	10 1/4	4	3/8	1/4
x 17	10 1/8	4	5/16	1/4
x 15	10	4	1/4	1/4
x 12	9 7/8	4	3/16	3/16
W8 x 67	9	8 1/4	15/16	3/16
x 58	8 3/4	8 1/4	13/16	1/2
x 48	8 1/2	8 1/8	11/16	3/8
x 40	8 1/4	8 1/8	9/16	3/8
x 35	8 1/8	8	1/2	5/16
x 31	8	8	7/16	5/16

**M SHAPES—  
DIMENSIONS FOR DETAILING**

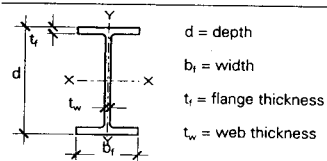

DESIG-NATION	DEPTH (IN.)	FLANGE		THICK-NESS (IN.)
		WIDTH (IN.)	THICK-NESS (IN.)	
M14 x 18	14	4	1/4	3/16
M12 x 11.8	12	3 1/8	1/4	3/16
x 10.8	12	3 1/8	1/4	3/16
x 10	12	3 1/4	3/16	3/16
M10 x 9	10	2 3/4	3/16	3/16
x 8	10	2 3/4	3/16	3/16
x 7.5	10	2 3/4	3/16	1/8
M8 x 6.5	8	2 1/4	3/16	1/8
M6 x 4.4	6	1 7/8	3/16	1/8
M5 x 18.9	5	5	7/16	5/16

**ANGLES — DIMENSIONS FOR DETAILING**

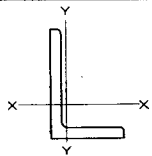

SIZE AND THICKNESS (IN.)	WEIGHT PER FT (LB)	SIZE AND THICKNESS (IN.)	WEIGHT PER FT (LB)
L8 x 8 x	1/8	L4 x 4 x	3/4
	1		5/8
	3/4		1/2
	3/16		7/16
	5/8		3/8
	9/16		1/4
L8 x 6 x	1	L4 x 3 1/2 x	1/2
	3/4		7/16
	3/8		3/8
	5/8		5/16
	9/16		1/4
	1/2		3/16
L8 x 4 x	1	L4 x 3 x	1/2
	3/4		7/16
	3/8		3/8
	5/8		5/16
	9/16		1/4
	1/2		3/16
L7 x 4 x	3/4	L3 1/2 x 3 1/2 x	1/2
	5/8		7/16
	1/2		3/8
	3/8		5/16
	1/4		1/4
	3/16		3/16
L6 x 6 x	1	L3 1/2 x 3 x	1/2
	3/4		7/16
	3/8		3/8
	5/8		5/16
	9/16		1/4
	1/2		3/16
L6 x 4 x	1	L3 1/2 x 2 1/2 x	1/2
	3/4		7/16
	3/8		3/8
	5/8		5/16
	9/16		1/4
	1/2		3/16
L6 x 3 1/2 x	1/2	L3 x 3 x	1/2
	3/8		7/16
	5/8		3/8
	9/16		5/16
	1/2		1/4
	3/8		3/16
L5 x 5 x	3/4	L3 x 2 1/2 x	1/2
	5/8		7/16
	1/2		3/8
	3/8		5/16
	1/4		1/4
	3/16		3/16
L5 x 3 1/2 x	3/4	L3 x 2 x	1/2
	5/8		7/16
	1/2		3/8
	3/8		5/16
	1/4		1/4
	3/16		3/16
L5 x 3 x	5/8	L2 1/2 x 2 1/2 x	1/2
	1/2		7/16
	3/8		3/8
	1/4		5/16
	3/16		1/4
	1/8		3/16
L5 x 3 x	5/8	L2 1/2 x 2 x	3/8
	1/2		7/16
	3/8		3/8
	1/4		5/16
	3/16		1/4
	1/8		3/16
L5 x 3 x	5/8	L2 x 2 x	3/8
	1/2		7/16
	3/8		3/8
	1/4		5/16
	3/16		1/4
	1/8		3/16

**MISCELLANEOUS CHANNELS— DIMENSIONS FOR DETAILING**

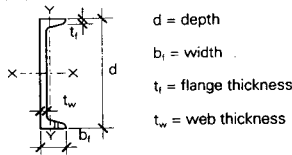

DESIG-NATION	DEPTH (IN.)	FLANGE		WEB THICKNESS (IN.)	
		WIDTH (IN.)	AVG. THICKNESS (IN.)		
MC 18 x 58	18	4 1/4	5/8	11/16	
	x 51.9	4 1/8	5/8	5/8	
	x 45.8	4	5/8	1/2	
	x 42.7	4	5/8	7/16	
MC 13 x 50	13	4 3/8	5/8	13/16	
	x 40	4 1/8	5/8	9/16	
	x 35	4 1/8	5/8	7/16	
	x 31.8	4	5/8	3/8	
MC 12 x 50	12	4 1/8	11/16	13/16	
	x 45	4	11/16	11/16	
	x 40	3 7/8	11/16	9/16	
	x 35	3 3/4	11/16	7/16	
MC 12 x 37	12	3 3/8	5/8	5/8	
	x 32.9	3 1/2	5/8	1/2	
	x 30.9	3 1/2	5/8	7/16	
	x 10.6	1 1/2	5/16	3/16	
MC 10 x 41.1	10	4 3/8	9/16	13/16	
	x 33.6	4 1/8	9/16	9/16	
	x 28.5	4	9/16	7/16	
	x 25	3 3/8	9/16	3/8	
MC 10 x 8.4	10	1 1/2	1/4	3/16	
	x 6.5	1 1/8	3/16	1/8	
	MC 9 x 25.4	9	3 1/2	7/16	9/16
	x 23.9	3 1/2	3/8	9/16	
MC 8 x 22.8	8	3 1/2	7/16	1/2	
	x 21.4	3 1/2	3/8	1/2	
MC 8 x 20	8	3	3/8	1/2	
	x 18.7	3	3/8	1/2	
MC 8 x 8.5	8	1 1/8	3/16	5/16	

**HP SHAPES— DIMENSIONS FOR DETAILING**

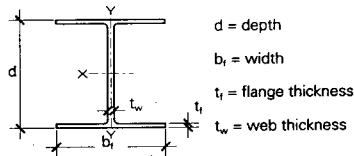

DESIG-NATION	DEPTH (IN.)	FLANGE		WEB THICKNESS (IN.)
		WIDTH (IN.)	AVG. THICKNESS (IN.)	
HP 14 x 117	14 1/4	14 7/8	13/16	13/16
	x 102	14 3/4	11/16	11/16
	x 89	13 7/8	14 3/4	5/8
HP 13 x 100	13 3/8	13 1/4	3/4	3/4
	x 87	13 3/8	11/16	11/16
	x 73	12 3/4	13	9/16
HP 12 x 84	12 1/2	12 1/8	7/16	7/16
	x 60	12 1/4	11/16	11/16
	x 74	12 1/8	12 1/4	5/8
HP 10 x 57	10	10 1/4	9/16	9/16
	x 63	12 1/8	7/16	7/16
	x 53	11 3/4	12	7/16
HP 10 x 57	10	10 1/4	9/16	9/16
	x 42	9 3/4	10 1/8	7/16

**S SHAPES— DIMENSIONS FOR DETAILING**

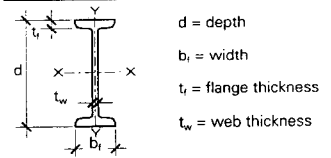

DESIG-NATION	DEPTH D (IN.)	FLANGE		WEB THICKNESS TW
		WIDTH BF (IN.)	AVG. THICKNESS TF (IN.)	
S24 x 121	24 1/2	8	1 1/16	13/16
	x 106	24 1/2	7 7/8	1 1/16
S24 x 100	24	7 1/4	7/8	3/4
	x 90	24	7 1/8	7/8
S20 x 96	20 1/4	7 1/4	15/16	13/16
	x 86	20 1/4	7	15/16
S20 x 75	20	6 3/8	13/16	5/8
	x 66	20	6 1/4	13/16
S18 x 70	18	6 1/4	11/16	11/16
	x 54.7	18	6	11/16
S15 x 50	15	5 5/8	5/8	9/16
	x 42.9	15	5 1/2	5/8
S12 x 50	12	5 1/2	11/16	11/16
	x 40.8	12	5 1/4	11/16
S12 x 35	12	5 1/8	9/16	7/16
	x 31.8	12	5	9/16
S10 x 35	10	5	1/2	5/8
	x 25.4	10	4 5/8	1/2
S8 x 23	8	4 1/8	7/16	7/16
	x 18.4	8	4	7/16

**AMERICAN STANDARD CHANNELS— DIMENSIONS FOR DETAILING**

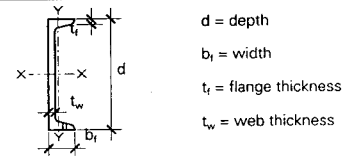

DESIG-NATION	DEPTH (IN.)	FLANGE		WEB THICKNESS (IN.)	
		WIDTH (IN.)	AVG. THICKNESS (IN.)		
C 15 x 50	15	3 3/4	5/8	11/16	
	x 40	15	3 1/2	5/8	1/2
	x 33.9	15	3 3/8	5/8	3/8
C 12 x 30	12	3	1/2	1/2	
	x 25	12	3	1/2	3/8
	x 20.7	12	3	1/2	5/16
C 10 x 30	10	3	7/16	11/16	
	x 25	10	2 7/8	7/16	1/2
	x 20	10	2 3/4	7/16	3/8
C 9 x 20	9	2 5/8	7/16	7/16	
	x 15	9	2 1/2	7/16	5/16
	x 13.4	9	2 3/8	7/16	1/4
C 8 x 18.75	8	2 1/2	3/8	1/2	
	x 13.75	8	2 3/8	3/8	5/16
	x 11.5	8	2 1/4	3/8	1/4
C 7 x 14.75	7	2 1/4	3/8	7/16	
	x 12.25	7	2 1/4	3/8	5/16
	x 9.8	7	2 1/8	3/8	3/16
C 6 x 13	6	2 1/8	5/16	7/16	
	x 10.5	6	2	5/16	5/16
	x 8.2	6	1 7/8	5/16	3/16
C 5 x 9	5	1 7/8	5/16	5/16	
	x 6.7	5	1 3/4	5/16	3/16

American Institute of Steel Construction; Chicago, Illinois

**STRUCTURAL TEES CUT FROM W SHAPES— DIMENSIONS FOR DETAILING**

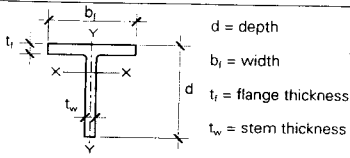

DESIGNATION	DEPTH OF TEE (IN.)	FLANGE		STEM THICKNESS (IN.)	
		WIDTH (IN.)	THICKNESS (IN.)		
WT 16.5 x 177	17 3/4	16 1/8	2 1/16	1 3/16	
x 159	17 9/16	16	1 7/8	1 1/16	
x 145.5	17 7/16	15 7/8	1 3/4	1	
x 131.5	17 1/4	15 3/4	1 9/16	7/8	
x 120.5	17 1/8	15 1/8	1 3/8	3/4	
x 110.5	17	15 1/4	1 1/4	3/4	
x 100.5	16 3/8	15 1/4	1 1/8	1 1/16	
WT 16.5 x 84.5	16 3/8	15 1/4	1 1/4	1 1/16	
x 76	16 3/4	11 5/8	1 1/16	5/8	
x 70.5	16 3/8	11 1/2	1 5/16	5/8	
x 65	16 1/2	11 1/2	7/8	9/16	
x 59	16 3/8	11 1/2	3/4	9/16	
WT 15	x 117.5	15 5/8	15	1 1/2	1 3/16
x 105.5	15 1/2	15 1/8	1 9/16	3/4	
x 95.5	15 3/8	15	1 3/8	1 1/16	
x 86.5	15 1/4	15	1 1/4	5/8	
WT 15	x 74	15 5/16	10 1/2	1 3/16	5/8
x 66	15 1/8	10 1/2	1	5/8	
x 62	15 1/8	10 1/2	1 5/16	9/16	
x 58	15	10 1/2	7/8	9/16	
x 54	14 7/8	10 1/2	3/4	9/16	
x 49.5	14 7/8	10 1/2	1 1/16	1/2	
WT 13.5 x 108.5	14 3/8	14 1/8	1 1/2	1 3/16	
x 97	14 1/16	14	1 5/16	3/4	
x 89	13 3/8	14 1/8	1 3/16	3/4	
x 80.5	13 3/4	14	1 1/16	1 1/16	
x 73	13 3/4	14	1	5/8	
WT 13.5 x 64.5	13 3/16	10	1 1/8	5/8	
x 57	13 3/8	10 1/8	1 5/16	9/16	
x 51	13 1/2	10	1 3/16	1/2	
x 47	13 1/2	10	3/4	1/2	
x 42	13 3/8	10	5/8	7/16	
WT 12	x 88	12 5/8	12 1/8	1 5/16	3/4
x 81	12 1/2	13	1 1/4	1 1/16	
x 73	12 3/8	12 1/8	1 1/16	5/8	
x 65.5	12 1/4	12 1/8	1 5/16	5/8	
x 58.5	12 1/8	12 3/4	7/8	9/16	
x 52	12	12 3/4	3/4	1/2	
WT 12	x 51.5	12 1/4	9	1	9/16
x 47	12 1/8	9 1/8	7/8	1/2	
x 42	12	9	3/4	1/2	
x 38	12	9	1 1/16	7/16	
x 34	11 7/8	9	9/16	7/16	
WT 12	x 31	11 7/8	7	9/16	7/16
x 27.5	11 3/4	7	1/2	3/8	
WT 10.5 x 83	11 1/4	12 3/8	1 3/8	3/4	
x 73.5	11	12 1/2	1 1/8	3/4	
x 66	10 7/8	12 1/2	1 1/16	5/8	
x 61	10 7/8	12 3/8	1 5/16	5/8	
x 55.5	10 3/4	12 3/8	7/8	9/16	
x 50.5	10 5/8	12 1/4	1 3/16	1/2	
WT 10.5 x 46.5	10 3/4	8 3/8	1 5/16	9/16	
x 41.5	10 3/4	8 3/8	1 3/16	1/2	
x 36.5	10 5/8	8 1/4	3/4	7/16	
x 34	10 5/8	8 1/4	1 1/16	7/16	
x 31	10 1/2	8 1/4	5/8	3/8	
WT 10.5 x 28.5	10 1/2	6 1/2	5/8	3/8	
x 25	10 3/8	6 1/2	9/16	3/8	
x 22	10 3/8	6 1/2	7/16	3/8	

DESIGNATION	DEPTH OF TEE (IN.)	FLANGE			STEM THICKNESS (IN.)
		WIDTH (IN.)	THICKNESS (IN.)	THICKNESS (IN.)	
WT 9	x 71.5	9 3/2	11 1/4	1 5/16	3/4
x 65	9 5/8	11 1/8	1 3/16	1 1/16	
x 59.5	9 1/2	11 1/4	1 1/16	5/8	
x 53	9 3/8	11 1/4	1 5/16	9/16	
x 48.5	9 1/4	11 1/8	7/8	9/16	
x 43	9 1/4	11 1/8	3/4	1/2	
x 38	9 1/8	11	1 1/16	7/16	
WT 9	x 35.5	9 1/4	7 5/8	1 3/16	1/2
x 32.5	9 1/8	7 5/8	3/4	7/16	
x 30	9 1/8	7 1/2	1 1/16	7/16	
x 27.5	9	7 1/2	5/8	3/8	
x 25	9	7 1/2	9/16	3/8	
WT 9	x 23	9	6	5/8	3/8
x 20	9	6	1/2	5/16	
x 17.5	8 7/8	6	7/16	5/16	
WT 8	x 50	8 1/2	10 3/8	1	9/16
x 44.5	8 7/8	10 3/8	7/8	1/2	
x 38.5	8 1/4	10 3/8	3/4	7/16	
x 33.5	8 1/8	10 1/4	1 1/16	3/8	
WT 8	x 28.5	8 1/4	7 1/8	1 1/16	7/16
x 25	8 1/8	7 1/8	5/8	3/8	
x 22.5	8 1/8	7	9/16	3/8	
x 20	8	7	1/2	5/16	
x 18	7 7/8	7	7/16	5/16	
WT 8	x 15.5	8	5 1/2	7/16	1/4
x 13	7 7/8	5 1/2	3/8	1/4	
WT 7	x 365	11 1/4	17 1/8	4 13/16	3 1/16
x 332.5	10 7/8	17 1/8	4 1/2	2 13/16	
x 302.5	10 1/2	17 3/8	4 3/16	2 5/8	
x 275	10 1/8	17 1/4	3 1/2	2 3/8	
x 250	9 3/4	17	3 1/2	2 3/16	
x 227.5	9 1/2	16 7/8	3 13/16	2	
x 213	9 3/8	16 3/4	3 1/16	1 7/8	
x 199	9 1/8	16 3/8	2 7/8	1 3/4	
x 185	9	16 1/2	2 1 1/16	1 5/8	
x 171	8 3/4	16 3/8	2 1/2	1 9/16	
x 155.5	8 1/2	16 1/4	2 1/4	1 7/16	
x 141.5	8 3/8	16 1/8	2 1/8	1 5/16	
x 128.5	8 1/4	16	1 7/8	1 13/16	
x 116.5	8	15 7/8	1 3/4	1 1/16	
x 105.5	7 7/8	15 5/4	1 9/16	1	
x 96.5	7 3/4	15 3/4	1 7/16	7/8	
x 88	7 5/8	15 5/8	1 5/16	13/16	
x 79.5	7 1/2	15 5/8	1 3/16	3/4	
x 72.5	7 3/8	15 1/2	1 1/16	1 1/16	
WT 7	x 66	7 3/8	14 3/4	1	5/8
x 60	7 1/4	14 5/8	1 5/16	9/16	
x 54.5	7 1/8	14 3/8	7/8	1/2	
x 49.5	7 1/8	14 3/8	3/4	1/2	
x 45	7	14 1/2	1 1/16	7/16	
WT 7	x 41	7 1/8	10 1/8	7/8	1/2
x 37	7 1/8	10 1/8	1 3/16	7/16	
x 34	7	10	3/4	7/16	
x 30.5	7	10	5/8	3/8	
WT 7	x 26.5	7	8	1 1/16	3/8
x 24	6 7/8	8	5/8	5/16	
x 21.5	6 7/8	8	1/2	5/16	
WT 7	x 19	7	6 3/4	1/2	5/16
x 17	7	6 3/4	7/16	5/16	
WT 7	x 13	7	5	7/16	1/4
x 11	6 3/8	5	5/16	1/4	
WT 6	x 168	8 3/8	13 3/8	2 15/16	3/4
x 152.5	8 1/8	13 1/4	2 1 1/16	1 5/8	
x 139.5	7 7/8	13 3/8	2 1/2	1 1/2	
x 126	7 1/2	13	2 1/4	1 3/8	
x 115	7 1/2	12 7/8	2 1/16	1 1/16	
x 105	7 3/8	12 3/4	1 7/8	1 3/16	
x 95	7 1/4	12 5/8	1 3/4	1 1/16	
x 85	7	12 5/8	1 9/16	1 5/16	

DESIGNATION	DEPTH OF TEE (IN.)	FLANGE			STEM THICKNESS (IN.)
		WIDTH (IN.)	THICKNESS (IN.)	THICKNESS (IN.)	
x 76	6 7/8	12 1/2	1 3/8	7/8	
x 68	6 3/4	12 7/8	1 1/4	1 3/16	
x 60	6 1/2	12 3/8	1 1/8	1 1/16	
x 53	6 1/2	12 1/4	1	5/8	
x 48	6 3/8	12 1/8	7/8	9/16	
x 43.5	6 1/4	12 1/8	1 3/16	1/2	
x 39.5	6 1/4	12 7/8	3/4	1/2	
x 36	6 1/8	12	1 1/16	7/16	
x 32.5	6	12	5/8	3/8	
WT 6	x 29	6 7/8	10	5/8	3/8
x 26.5	6	10	9/16	3/8	
WT 6	x 25	6 7/8	8 7/8	5/8	3/8
x 22.5	6	8	9/16	5/16	
x 20	6	8	1/2	5/16	
WT 6	x 17.5	6 1/4	6 1/2	1/2	5/16
x 15	6 1/8	6 1/2	7/16	1/4	
x 13	6 1/8	6 1/2	3/8	1/4	
WT 6	x 11	6 1/8	4	3/16	1/4
x 9.5	6 1/8	4	3/16	1/4	
x 8	6	4	1/4	1/4	
x 7	6	4	1/4	3/16	
WT 5	x 56	5 3/8	10 3/8	1 1/4	3/4
x 50	5 1/2	10 3/8	1 1/8	1 1/16	
x 44	5 3/8	10 1/4	1	5/8	
x 38.5	5 1/4	10 1/4	7/8	1/2	
x 34	5 1/4	10 1/8	3/8	1/2	
x 30	5 1/8	10 1/8	1 1/16	7/16	
x 27	5	10	5/8	3/8	
x 24.5	5	10	9/16	3/16	
WT 5	x 22.5	5	8	5/8	3/8
x 19.5	5	8	1/2	5/16	
x 16.5	4 7/8	8	7/16	5/16	
WT 5	x 15	5 1/4	5 3/4	1/2	5/16
x 13	5 1/8	5 3/4	7/16	1/4	
x 11	5 1/8	5 3/4	3/8	1/4	

**STRUCTURAL TEES CUT FROM S SHAPES— DIMENSIONS FOR DETAILING**

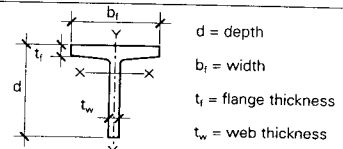

DESIGNATION	DEPTH OF TEE (IN.)	FLANGE			STEM THICKNESS (IN.)
		WIDTH (IN.)	THICKNESS (IN.)	THICKNESS (IN.)	
ST 10 x 48	10 1/8	7 1/4	1 5/16	1 3/16	
x 43	10 1/8	7	1 5/16	1 1/16	
ST 10 x 37.5	10	6 3/8	1 3/16	5/8	
x 33	10	6 1/4	1 3/16	1/2	
ST 9 x 35	9	6 1/4	1 1/16	1 1/16	
x 27.35	9	6	1 1/16	7/16	
ST 7.5 x 25	7 1/2	5 5/8	5/8	9/16	
x 21.4	7 1/2	5 1/2	5/8	7/16	
ST 6 x 25	6	5 1/2	1 1/16	1 1/16	
x 20.4	6	5 1/4	1 1/16	7/16	
ST 6 x 17.5	6	5 1/8	9/16	7/16	
x 15.9	6	5	9/16	3/8	
ST 5 x 17.5	5	5	1/2	5/8	
x 12.7	5	4 3/8	1/2	5/16	
ST 4 x 11.5	4	4 1/8	7/16	7/16	
x 9.2	4	4 1/8	7/16	1/4	
ST 3.5 x 10	3 1/2	3 7/8	3/8	7/16	
x 7.65	3 1/2	3 5/8	3/8	1/4	

**MOMENT-RESISTING FRAME**

A moment-resisting frame's lateral stability and resistance to wind and seismic forces depend on a fixed connection of beams and columns. A moment-resisting connection is achieved when the top and bottom flanges of each beam are welded to the flanges of the connecting columns with full-depth welds. By directly welding the beam web to the column flange, the beam's horizontal reaction to wind forces is transferred to the column. (A connection using web angles and high-strength bolts is also permitted.) The building's floors are designed to act as diaphragms that connect all of the columns and beams, enabling the building to react as a unit.

Moment-resisting frames are uneconomical in tall steel buildings because the larger lateral forces in such buildings can be handled more efficiently by compression and tension diagonal members, as found in braced frames. To save costs, often the upper stories of a braced frame building use moment-resisting beam-column connections to resist wind loads.

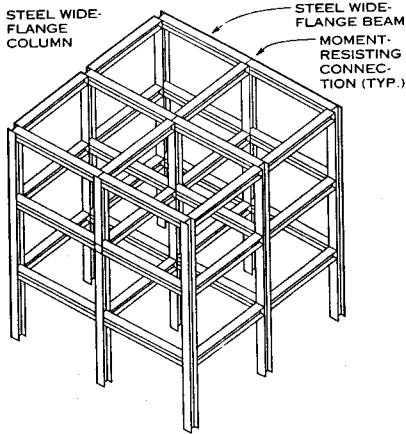

**MOMENT-RESISTING STEEL FRAME**

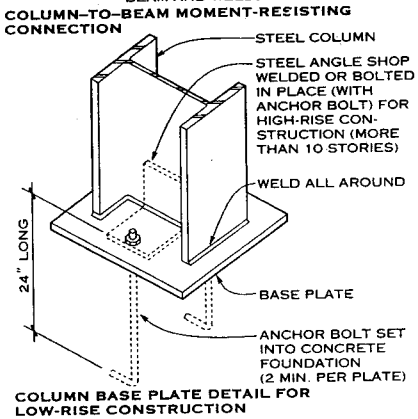
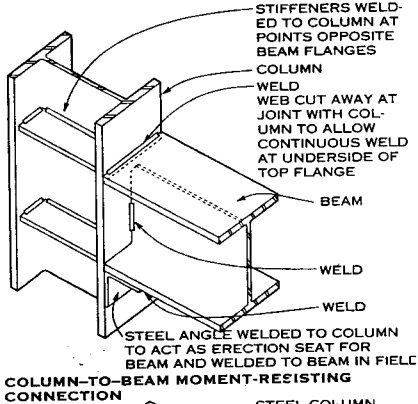

**MOMENT-RESISTING FRAME**

**RIGID FRAME**

Rigid frame construction combines columns and a beam or girder welded together to make a rigid connection. Such a frame can carry vertical loads and resist horizontal forces, either wind or seismic. Rigid frame buildings are usually single story and are available with provisions for cranes, balconies, and mezzanines. The roofs are generally sloped, which permits the use of combined roof decks and waterproofing systems; the slope varies but is usually at least 1 in 12.

Because they span fairly long distances relatively cheaply (widths range between 30 and 130 ft), rigid frame structures are used for recreational buildings; warehouses; light industrial buildings; and commercial buildings, such as supermarkets, automobile dealer showrooms, and garages. Bay sizes are usually 20 to 24 ft but may be extended to 30 ft. The roof profile is most often configured as a symmetrical gable, but such a profile is not a structural necessity. Roofs and side walls are usually covered with 26-gauge colored steel siding; insulation options vary. Some manufacturers offer precast concrete and masonry siding. Pre-engineered buildings most often use rigid frames for roof and wall supports.

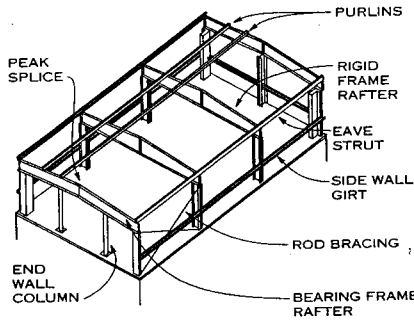

**RIGID FRAME**

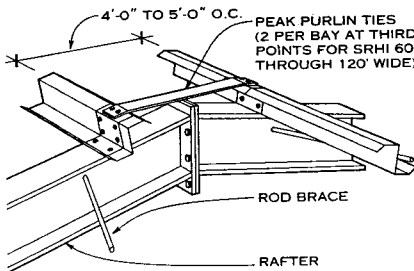

**RIDGE DETAIL**

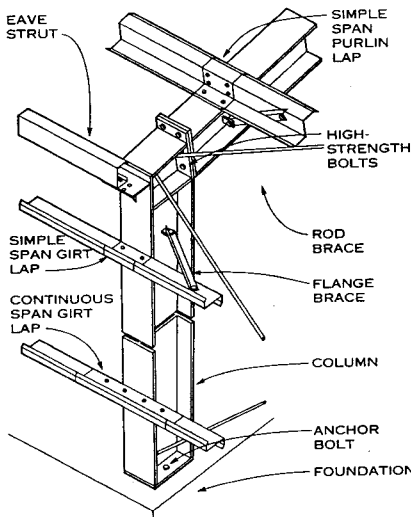

**RAFTER-TO-COLUMN DETAIL**

**RIGID FRAME**

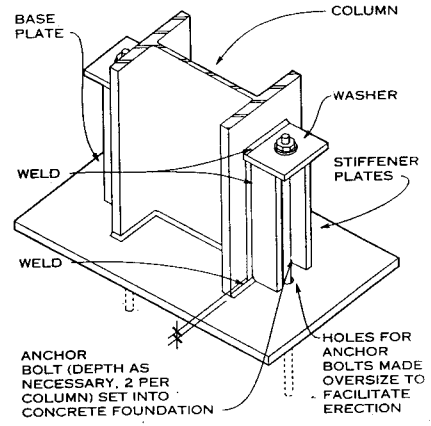

**TYPICAL SEISMIC FOUNDATION CONNECTION**

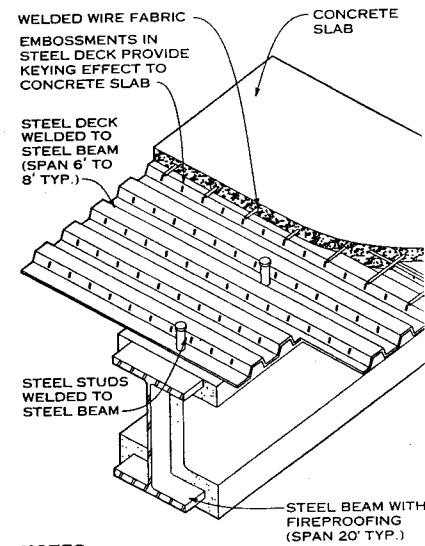

**NOTES**

1. For nonfire-rated ceiling situations
2. Typically used for heavy loads; noncomposite floor system for light loads

**COMPOSITE FLOOR AND BEAM SYSTEM**

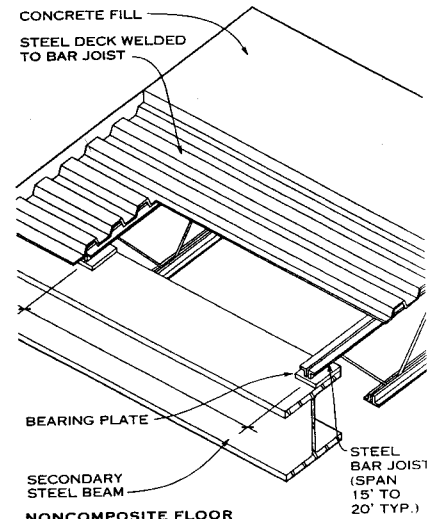

**TYPICAL FLOOR SYSTEMS**

Donald J. Neubauer, P.E.; Neubauer - Sohn, Consulting Engineers; Potomac, Maryland  
Richard J. Vitullo, AIA; Oak Leaf Studio; Crownsville, Maryland

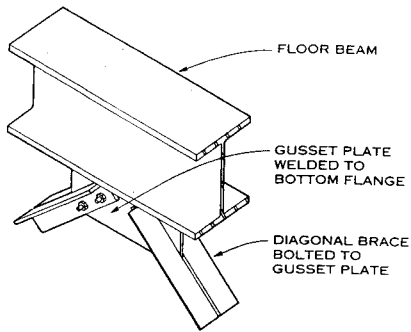

DIAGONAL BRACE CONNECTION AT FLOOR BEAM—INTERMEDIATE (MIDSPAN)

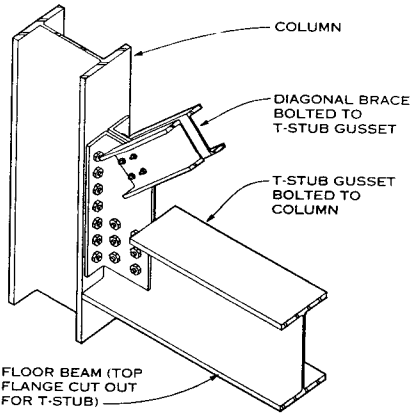

DIAGONAL BRACE CONNECTION AT FLOOR BEAM—END

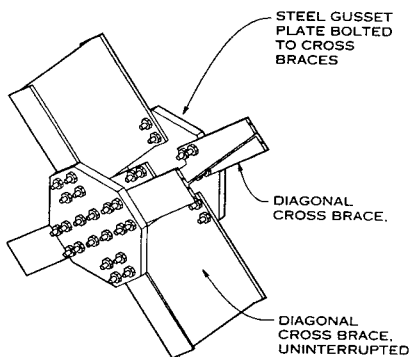

CROSS BRACING CONNECTION—INTERMEDIATE

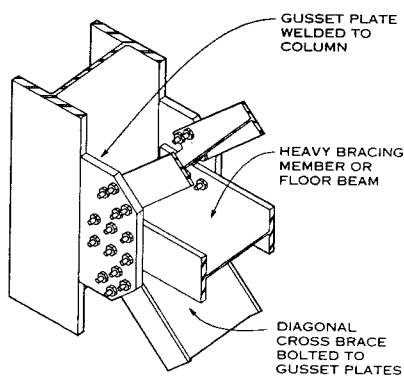

CROSS BRACING CONNECTION—END

VERTICAL BRACING DETAILS

FRAMED TUBE

In the framed tube system, structural steel members form the load bearing exterior perimeter wall; this wall is designed so the entire building becomes, in effect, a structural steel tube. The tubular strength is achieved in two ways: the exterior columns are spaced closely together, perhaps 6 ft on center, and connected to spandrel beams; the structure is stiffened by the floors to form a torsionally rigid tube. The spandrel beams are generally very deep, in units of feet as opposed to inches. The columns and spandrel beams are welded together to create a moment-resisting connection. Often this system is referred to as a pierced tube, the pierced areas being the window openings.

The framed tube system is most economical for very tall buildings. The World Trade Center Towers in New York and

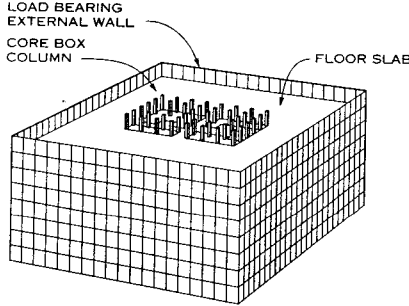

FRAMED TUBE

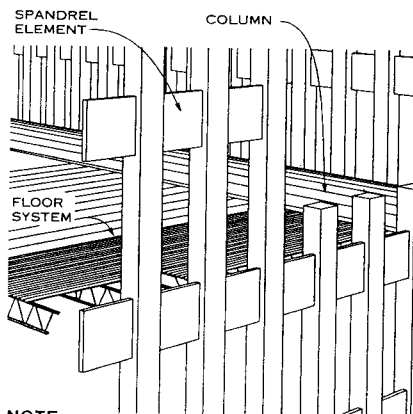

NOTE

External wall units typically staggered in one-story heights

PERIMETER WALL DETAIL

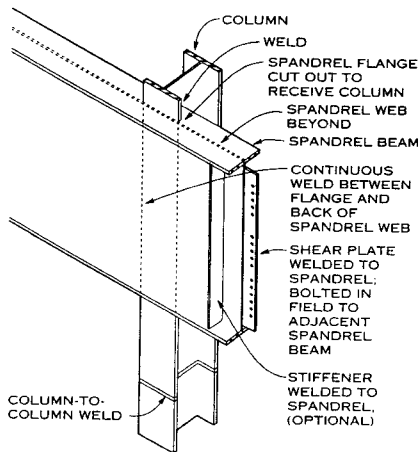

SPANDREL AND COLUMN DETAILS

FRAMED TUBE

the Sears Tower in Chicago are the most conspicuous examples. Systems like that at the Sears Tower, a combination of nine framed tubes in a 3 by 3 array, are sometimes called bundled tubes.

BRACED CORE

In the braced core system, walls around elevator shafts and stairwells are designed to act as vertical trusses that cantilever up from the foundation. The chords of each truss are building columns; the floor beams act as ties. Diagonals placed in a K pattern (occasionally in an X pattern) complete the truss. A system employing knee braces is used in seismic areas because of its greater ability to dissipate earthquake energy. Braced core systems can be used efficiently in single-story buildings as well as in buildings over 50 stories.

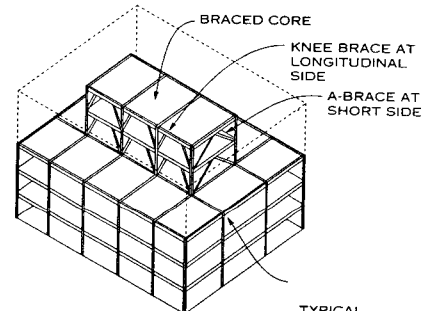

BRACED CORE

NOTE

Bracing design to be determined by structural engineer based on specific loading configurations

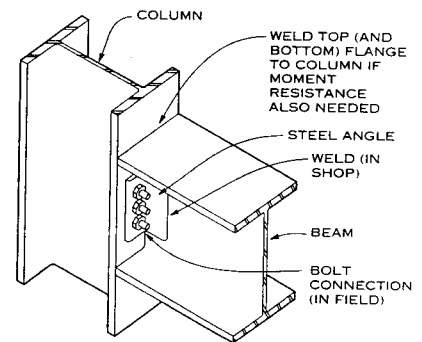

COLUMN-TO-BEAM SHEAR CONNECTION

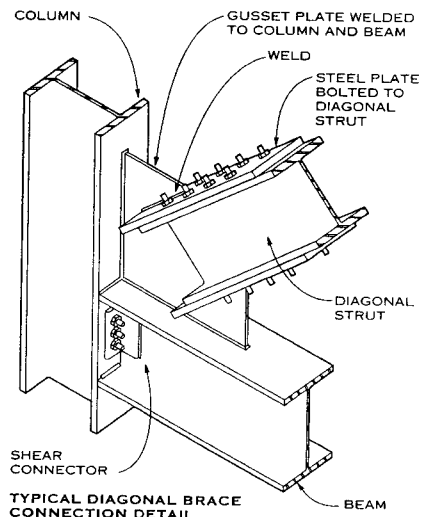

BRACED CORE

Donald J. Neubauer, P.E.; Neubauer - Sohn, Consulting Engineers; Potomac, Maryland  
Richard J. Vitullo, AIA; Oak Leaf Studio; Crownsville, Maryland

**GENERAL**

A space frame is a three-dimensional truss with linear members that form a series of triangulated polyhedrons. It can be seen as a plane of constant depth that can sustain fairly long spans and varied configurations of shape.

**NOTES**

1. The prime attributes of space frame structural systems are their light weight; inherent rigidity; their wide variety of form, size, and span; and compatible interaction with other building support systems, primarily HVAC.
2. Most systems are designed for specific applications, and a structural engineer with space frame experience should always be consulted. Manufacturers can provide the full range of capabilities—loading, spans, shapes, specific details—for their products. Standardized systems in 4- and 5-ft modules are available.
3. Metal space frames are classified as noncombustible construction and can usually be exposed when 20 ft above the floor. However, an automatic fire extinguishing system or a rated ceiling may be required. Consult applicable building and fire codes.
4. The finishes commonly available are paint, thermoset polyester, galvanizing, stainless steel, or metal plating.

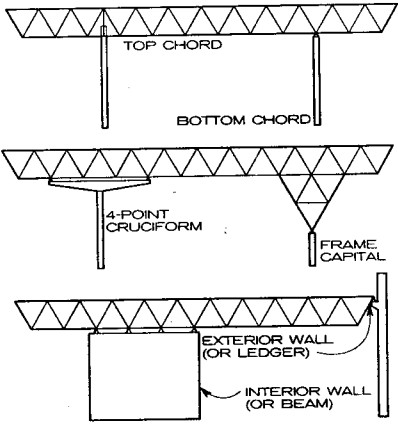

**SUPPORT TYPES**

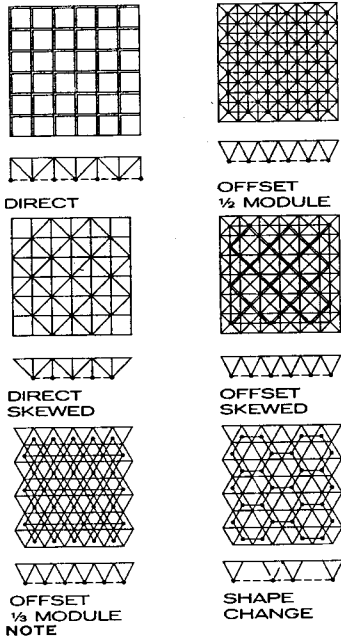

Many proprietary node systems are available for specific applications and budgets. Keep field connections to a minimum; welded connections often eliminate joint pieces.

**COMMON PATTERNS**

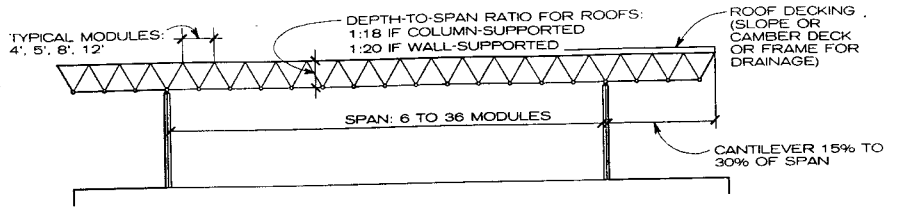

**NOTE**

Select a space frame module that is compatible with the building planning module in shape (e.g., a square module with orthogonal plan) and size (a multiple of the planning

module); is consistent with the limitations of the interfacing systems (e.g., the maximum span of the roof deck or mullion spacing of the glazing system); and satisfies the spatial and aesthetic effects in scale and form.

**MODULE SELECTION AND CHARACTERISTICS**



**NOTE**

Square tubes or angles within their span range are often the most economical.

**MEMBER SHAPES**

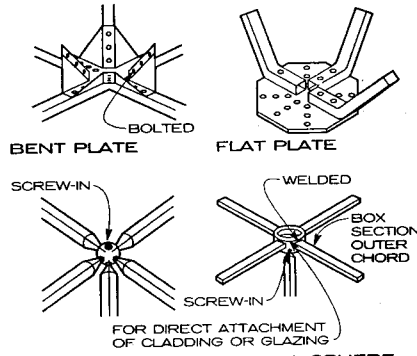

FOR DIRECT ATTACHMENT OF CLADDING OR GLAZING

Space frame supports are at panel joints only, not along members.

**NODE CONNECTIONS**

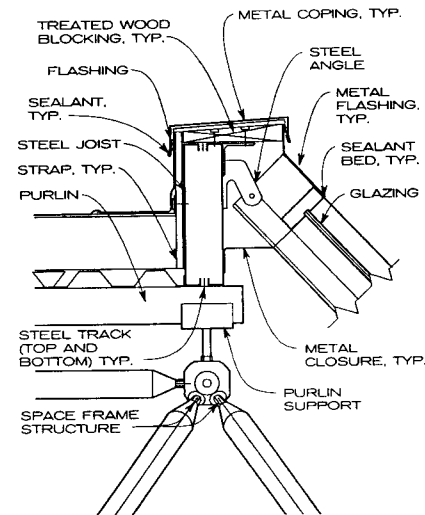

**SLOPED GLAZING**

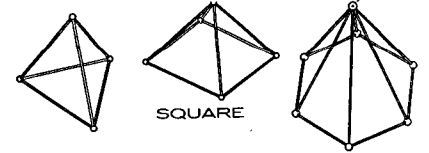

TETRAHEDRON

HEXAGONAL

**GRID SHAPES**

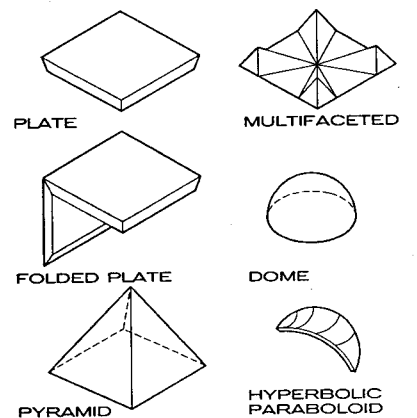

**SPACE FRAME FORM TYPES**

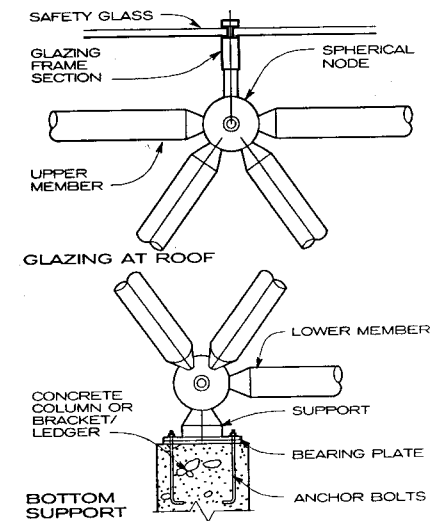

**ROOF AND FLOOR CONNECTIONS**

Severud Associates; New York, New York

**PRELIMINARY JOIST SELECTION**

The accompanying tables are not to be used for final joist design but are intended as an aid in selecting steel joists for preliminary design and planning. Determining the final design must be a separate and thorough process, involving a complete investigation of pertinent conditions; this page is not intended to support that effort. Consult a structural engineer.

An example of how to use the information presented here follows: Assume a particular clear span. By assuming a joist spacing and estimating the total load, a joist can immediately be selected from the table. Then proceed with preliminary design studies.

**NOTES**

1. Total safe load = live load + dead load. Dead load includes the weight of the joists. For dead loads and recommended live loads, see pages on weights of materials. Local codes will govern.
2. Span should not exceed a depth 24 times that of a nominal joist.
3. For more information, refer to the standard specifications and load tables adopted by the Steel Joist Institute.

**NOTE**

The following information applies to both open-web and long-span steel joists.

**JOIST DESIGNATION:**

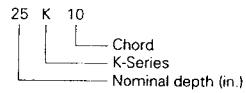

For greater economy, the K-series joist replaced the H-series joist in 1986.

**ROOF CONSTRUCTION:** Joists are usually covered with steel decking topped with either rigid insulation board or lightweight concrete fill and either a roof of built-up felt and gravel or single-ply roofing with ballast. Plywood, poured gypsum, or structural wood fiber deck systems can also be used with a built-up roof.

**CEILING:** Ceiling supports can be suspended from or mounted directly to the bottom chords of joists, although suspended systems are recommended because of dimensional variations in actual joist depths.

**FLOOR CONSTRUCTION:** Joists are usually covered by 2 1/2 to 3 in. of concrete on steel decking. Concrete thickness may be increased to accommodate electrical conduit or electrical/communications raceways. Precast concrete, gypsum planks, or plywood can also be used for the floor system.

**VIBRATION:** Objectionable vibrations can occur in open web joist and 2 1/2 in. concrete slab designs for open floor areas at spans between 20 and 40 ft, especially at 28 ft. When a floor area cannot have partitions, objectionable vibrations can be prevented or reduced by increasing slab thickness or modifying the joist span. Attention should also be given to support for framing beams, which can magnify a vibration problem when unsupported.

**OPENINGS IN FLOOR OR ROOF SYSTEMS:** Small openings between joists are framed with angles or channel supported on the adjoining two joists. Larger openings necessitating interruption of joists are framed with steel angle or channel headers spanning the two adjoining joists. The interrupted joists bear on the headers.

**ROOF DRAINAGE:** On level or near level roofs, especially those with parapet walls, roof drainage should be carefully considered. Roof insulation can be sloped, and joists can be sloped or obtained with top chords that slope in one or both directions. Overflow scuppers should be provided in parapet walls. If roof slope is less than 1/4 in. per ft, the roof system should be investigated to ensure stability under ponding conditions.

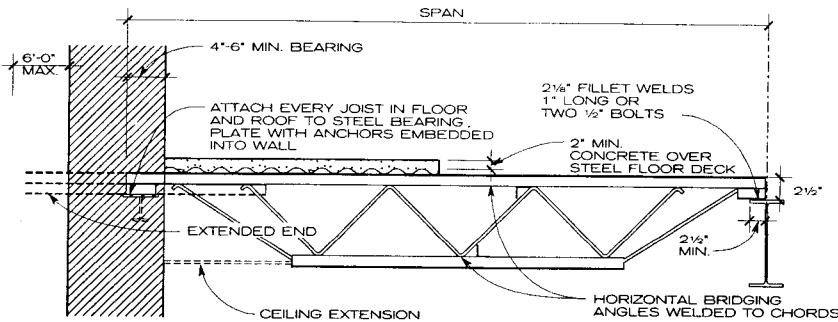

**SECTION THROUGH JOIST BEARING**

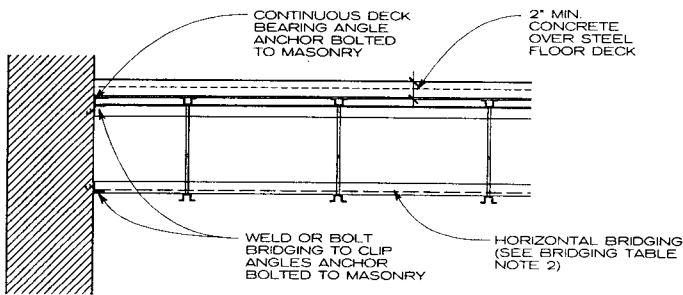

JOIST PROFILES

**SECTION THROUGH JOISTS**

**SELECTED LOAD TABLES: K SERIES—TOTAL SAFE UNIFORMLY DISTRIBUTED LOAD (LB/FT)**

JOIST DESIGNATION	SPAN (FT)												
	8	12	16	20	24	28	32	26	42 <sup>1</sup>	48 <sup>1</sup>	54 <sup>1</sup>	60 <sup>1</sup>	
K SERIES = 30,000													
8K1	550	444	246										
10K1		550	313	199									
12K3		550	476	302	208								
14K4			550	428	295	216							
16K5			550	550	384	281	214 <sup>2</sup>						
18K6				550	473	346	264	208 <sup>2</sup>					
20K7				550	550	430	328	259					
22K9					550	550	436	344	252 <sup>2</sup>				
24K9					550	550	478	377	276	211 <sup>2</sup>			
26K10						550	549	486	356	272			
28K10						550	549	487	384	294	232 <sup>2</sup>		
30K11							549	487	417	362	285 <sup>2</sup>	231 <sup>2</sup>	
30K12							549	487	417	365	324 <sup>2</sup>	262 <sup>2</sup>	

<sup>1</sup> All joists 40 ft or longer require a row of bolted bridging in place before hoisting lines are slackened.

<sup>2</sup> Where the designed joist span is equal to or greater than this span, the row of bridging nearest the midspan of the joist shall be installed as bolted diagonal bridging. Hoisting cables shall not be released until this bolted diagonal bridging is completely installed.

**NUMBER OF ROWS OF BRIDGING**

CHORD SIZE <sup>1</sup>	1 ROW <sup>2</sup>	2 ROWS <sup>2</sup>	3 ROWS <sup>2</sup>	4 ROWS <sup>2</sup>	5 ROWS <sup>2</sup>
#1	up to 16	16-24	24-28		
#2	up to 17	17-25	25-32		
#3	up to 18	18-28	28-28	38-40	
#4	up to 19	19-28	28-38	38-48	
#5	up to 19	19-29	29-39	39-50	50-52
#6	up to 19	19-29	29-39	39-51	51-56
#7	up to 20	20-33	33-45	45-58	58-60
#8	up to 20	20-33	33-45	45-58	58-60
#9	up to 20	20-33	33-46	46-59	59-60
#10	up to 20	20-37	37-51	51-60	
#11	up to 20	20-38	38-53	53-60	
#12	up to 20	20-39	39-53	53-60	

<sup>1</sup> Last digit(s) of joist designation shown in accompanying load table.

<sup>2</sup> Check maximum joist span for required midspan bolted diagonal bridging.

**NOTE**

Distances are clear span dimensions (ft).



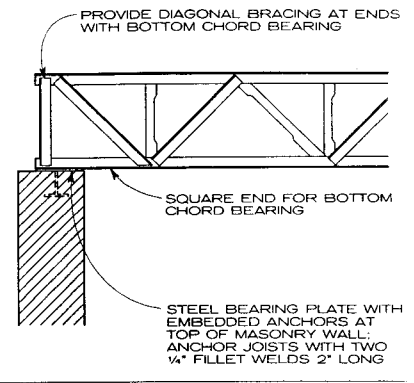
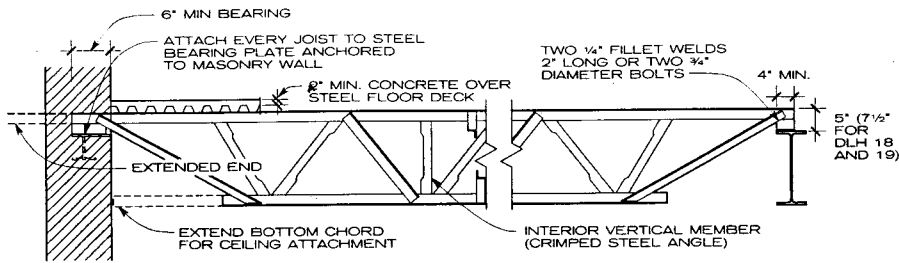

**NOTE**  
Web member type depends on span and load characteristics.

**SECTION THROUGH JOIST BEARING**

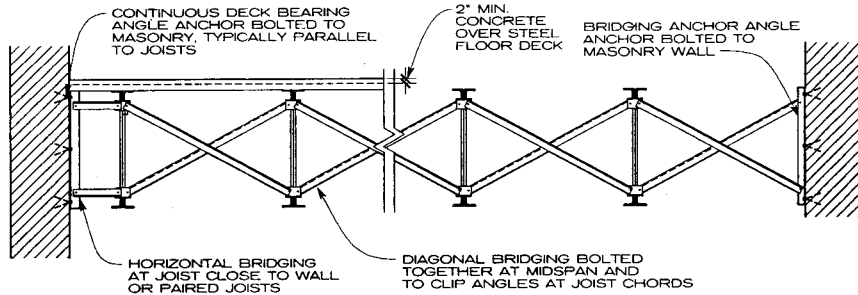

**BOTTOM CHORD BEARING AT SQUARE END**

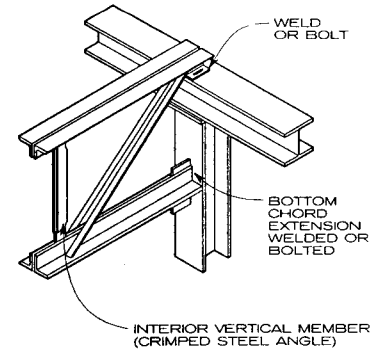

**SECTION THROUGH JOISTS**

**FIRE RESISTANCE RATING**

TIME (HR)	FLOOR/CEILING ASSEMBLIES	TIME (HR)	ROOF/CEILING ASSEMBLIES
1	2 1/2 in. reinforced concrete, listed 5/8 in. gypsum plaster on metal lath attached to bottom chord of joist	1	Built-up roofing on listed 1 in. wood with cement binder fiberboard over 1 1/2 in. metal deck with listed 3/4 in. gypsum plaster ceiling on metal lath attached to furring channels hung from joist
	2 in. reinforced concrete, listed 5/8 in. cement plaster over metal lath attached to bottom chord of joist		Built-up roofing on listed 1 in. wood fiberboard over 1 1/2 in. metal deck with listed 3/4 in. gypsum plaster ceiling on metal lath attached to furring channels supported from joist
2	2 1/2 in. reinforced concrete, listed 3/4 in. gypsum plaster on metal lath attached to bottom chord of joist	2	Built-up roofing on listed 1 7/8 in. wood with cement binder fiberboard over 1 1/2 in. gypsum plaster ceiling on metal lath attached to furring channels supported from joist
	2 1/2 in. reinforced concrete, listed 5/8 in. type X wallboard attached to furring channels tied to bottom chord of joist		Built-up roofing on listed 1 1/2 in. wood fiberboard over 1 1/2 in. metal deck with listed 7/8 in. gypsum plaster ceiling on metal lath attached to furring channels supported from joist
	2 1/2 in. reinforced concrete, listed 3/4 in. wood fiber gypsum plaster over metal lath on channels secured to joist		Built-up roofing on listed 1 in. expanded perlite board over 1 1/2 in. metal deck with listed 7/8 in. gypsum-vermiculite plaster on metal lath attached to runner channels supported from joist

**NOTE**  
These are abbreviated assembly descriptions. Table 7-C of the Uniform Building Code gives complete descriptions. Underwriters Laboratories and Factory Mutual provide additional system, material, and approval guidelines.

**BOTTOM CHORD EXTENSION DETAIL**

**PRELIMINARY JOIST SELECTION**

The accompanying tables should not be used for final joist design but are intended to speed selection of steel joists for preliminary design and planning.

Determining the final design must be a separate, thorough process, involving a complete investigation of pertinent conditions; this page is not to be used for that purpose. Consult a structural engineer.

An example of how to use the information presented here follows: Assume a particular clear span. By assuming a joist spacing and estimating the total load, a joist can immediately be selected from the table. Then proceed with preliminary design studies.

**NOTES**

- Total safe load = live load + dead load. Dead load includes the weight of the joist. For dead loads and recommended live loads, see pages on weights of materials. Local codes will govern.
- Span should not exceed 24 times the depth of a nominal joist for roofs, 20 times the depth of a nominal joist for floors.
- For more information, refer to standard specifications and load tables adopted by the Steel Joist Institute.

**SELECTED LOAD TABLES: LH AND DLH SERIES—TOTAL SAFE UNIFORMLY DISTRIBUTED LOAD (LB/FT)**

JOIST DESIGNATION	CLEAR SPAN (FT)												
	28	32	36	42	48	54	60	66	72	78	84	90	96
LH Series f <sub>t</sub> = 30,000 psi	18LH05	581	448	355									
	20LH06	723	560	444									
	24LH07			588	446	343							
	28LH09				639	499	401						
	32LH10						478	389					
	26LH11							451	378	322			
	40LH12								472	402	346		
	44LH13										423	369	
											444	390	346
		90	96	102	108	114	120	126	132	138	144		
DLH Series f <sub>t</sub> = 30,000 psi	52DLH13	433	381	338									
	56DLH14			411	368								
	60DLH15				442	398	361						
	64DLH16					466	421	382					
	68DLH17							460	420				
	72DLH18								505	463	426		

**NOTE**  
Number preceding letter is joist depth (32LH10 is 32 in. deep).

**LH AND DLH BRIDGING**

BRIDGING SPACING (FT)	
CHORD SIZE	MAXIMUM SPACING (FT)
02-04	11
05-06	12
07-08	13
09-10	14
11-14	16
15-17	21
18-19	26

**NOTE**  
Welded horizontal bridging is used for typical joist spans. Check joist bridging requirements when joist spans require midspan bolted diagonal bridging. For spans of more than 60 ft, all bridging should be bolted diagonal bridging.

Charles M. Ault; Setter, Leach & Lindstrom, Architects & Engineers; Minneapolis, Minnesota

**METAL DECKING**

Some of the many types of metal decking available are:

1. Roof deck
2. Floor deck (noncomposite)
3. Composite floor deck interacting with concrete
4. Permanent forms for self-supporting concrete slabs
5. Cellular deck (composite or noncomposite)
6. Acoustical roof deck
7. Acoustical cellular deck (composite or noncomposite)
8. Electric raceway cellular deck
9. Prevented roof deck (used with lightweight insulating concrete fill)

**INSTALLATION AND DESIGN**

All metal floor and roof decks must be secured to all supports, generally by means of puddle welds made through the deck to supporting steel. Steel sheet lighter than 22 gauge (0.0295 in. thick) should be secured by use of welding washers. Shear studs welded through the floor deck also serve to secure the deck to supporting steel.

Side laps between adjacent sheets of deck must be secured by button-punching standing seams, welding, or screws, in accordance with the manufacturer's recommendations.

Decks used as lateral diaphragms must be welded to steel supports around their entire perimeter to ensure development of diaphragm action. More stringent requirements may govern the size and/or spacing of attachments to supports and side lap fasteners or welds.

Roof deck selection must consider construction and maintenance loads, as well as the capacity to support uniformly distributed live loads. Consult Steel Deck Institute recommendations and Factory Mutual requirements.

Floor deck loadings are virtually unlimited in scope, ranging from light residential and institutional loads to heavy-duty industrial floors utilizing composite deck with slabs up to 24 in. thick. Designers can select the deck type, depth, and gauge most suitable for the application.

Roof-mounted mechanical equipment should not be placed directly on a metal roof deck. Equipment on built-up or pre-fabricated curbs should be supported directly on main and supplementary structural members and the deck must be supported along all free edges. Heavy items such as cooling towers that must be elevated should be supported by posts extending through pitch pockets directly onto structural members below the deck. Openings through the deck may be handled as discussed above.

**FIRE RESISTANCE RATINGS**

Fire resistance ratings for roof deck assemblies are published by Underwriters Laboratories and Factory Mutual. Ratings of 1 to 2 hr are achieved with spray-on insulation; a 1-hr rating with a suspended acoustical ceiling and a 2-hr rating with a metal lath-and-plaster ceiling.

Floor deck assembly fire resistive ratings are available both with and without spray-applied fireproofing and with regular weight or lightweight concrete fill. Ratings from 1 to 3 hr are possible using only concrete fill; consult Underwriters Laboratories Fire Resistance Index for assembly ratings.

Consult the manufacturer's literature and technical representatives for additional information. Consult the *Steel Deck Institute Design Manual for Floor Decks and Roof Decks* and the *Tentative Recommendations for the Design of Steel Deck Diaphragms* by the Steel Deck Institute.

**ADVANTAGES OF METAL ROOF DECKS**

1. A high strength-to-weight ratio reduces roof dead load.
2. Metal roof decks can be erected in most weather conditions.

3. A variety of depths and rib patterns is available.
4. Acoustical treatment is possible.
5. Metal roof decks can serve as the base for insulation and roofing.
6. Fire ratings can be obtained with standard assemblies.
7. Metal roof decks can provide a lateral diaphragm.
8. Metal roof decks can be erected quickly and economically.
9. Metal roof decks make it easy to create roof slopes for drainage.

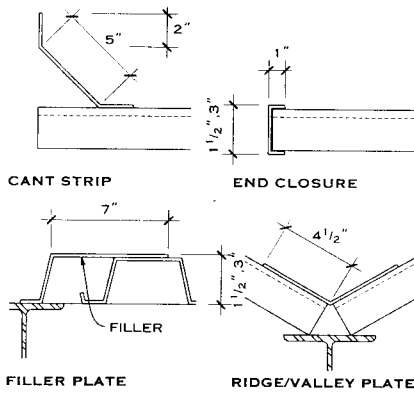

**ROOF DECK ACCESSORIES**

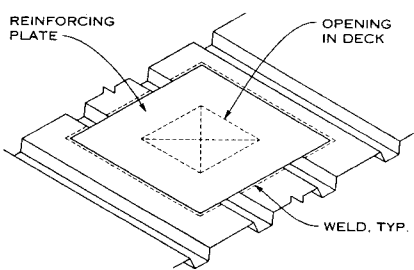

**NOTES**

1. Small openings (up to 6 x 6 in. or 6 in. in diameter) usually may be cut in a roof or floor deck without reinforcing the deck.
2. Openings up to 10 x 10 in. or 10 in. in diameter require reinforcing of the deck either by welding a reinforcing plate to the deck all around the openings or providing channel-shaped headers and/or supplementary reinforcing parallel to the deck span. Reinforcing plates should be 14-gauge sheets with a minimum projection of 6 in. beyond all sides of the opening, and they should be welded to each cell of the deck.
3. Larger openings should be framed with supplementary steel members so that all free edges of the deck are supported.

**OPENINGS IN DECK**

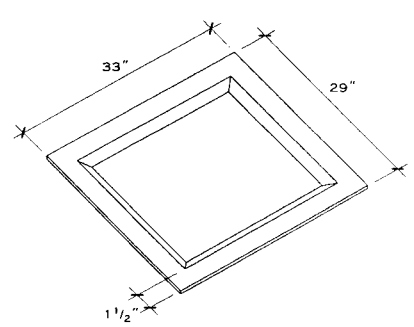

**NOTE**

Preformed recessed sump pans are available from deck manufacturers for use at roof drains.

**RECESSED SUMP PAN**

**ROOF DECK TYPES**

TYPE	PROFILE	REMARKS	SPAN (FT-IN.)	WIDTH (IN.)	MAX. LENGTH (FT-IN.)
Economy		Most economical deck for shorter spans; use with 1 in. or more insulation	2'-6" to 8'-0"	32" to 33"	42'-0"
Narrow rib (1 in. wide)		Use with 1/2 in. insulation; max. surface area on top for adhering insulation	4'-0" to 11'-0"	36"	42'-0"
Intermediate rib (1 3/4 in. wide)		Use with 1 in. insulation	4'-0" to 11'-0"	36"	42'-0"
Wide rib (2 1/2 in. wide)		Use with 1 in. insulation	5'-0" to 12'-0"	36"	42'-0"
Acoustical deck		Perforated type for sound absorption only	10'-0" to 20'-0"	24"	42'-0"
Cellular		For use as electrical raceway or as acoustical ceiling; bottom plate is perforated for sound absorption	9'-0" to 12'-0"	24"	40'-0"
Cellular			10'-0" to 13'-0"	24"	40'-0"
Cellular			20'-0" to 30'-0"	24"	30'-0"

Donald Neubauer, P.E.; Neubauer Consulting Engineers; Potomac, Maryland  
 Walter D. Shapiro, P.E.; Tor, Shapiro & Associates; New York, New York

**COMPOSITE FLOOR DECK WITH CONCRETE FILL**

TYPE	PROFILE	REMARKS	SPAN (FT-IN.)	WIDTH (IN.)	MAX. LENGTH (FT-IN.)
Shallow deck		Convex embossments bond with concrete fill; reverse deck for concave embossments	5'-0" to 12'-0"	36"	42'-0"
Intermediate deck		Convex embossments	6'-0" to 13'-0"	24" or 36"	42'-0"
Deep deck		Convex embossments	7'-0" to 14'-0"	24" or 36"	42'-0"

**NONCOMPOSITE FLOOR DECK WITH CONCRETE FILL**

TYPE	PROFILE	REMARKS	SPAN (FT-IN.)	WIDTH (IN.)	MAX. LENGTH (FT-IN.)
Shallow deck		Narrow rib	2'-0" to 5'-6"	30", 35", 36"	42'-0"
Intermediate deck		Narrow rib	3'-0" to 10'-0"	32", 33"	42'-0"
Intermediate deck		Narrow rib	4'-0" to 11'-0"	32"	42'-0"
Intermediate deck		Narrow rib	4'-0" to 11'-0"	30", 36"	42'-0"
Deep deck		Wide rib	5'-6" to 14'-0"	24", 36"	42'-0"

**COMPOSITE AND NONCOMPOSITE CELLULAR FLOOR DECK WITH CONCRETE FILL**

TYPE	PROFILE	SPAN (FT-IN.)	WIDTH (IN.)	CELL CROSS-SECTIONAL AREA
3 x 12 in. cellular deck (for steel frames requiring studs)		12'-0" to 15'-0"	24", 36"	17.7 sq in./cell (35 sq in./sheet)
3 x 8 in. cellular deck (not suitable for structural studs)		12'-0" to 15'-0"	24"	17.4 sq in./cell (52.2 sq in./sheet)
1.5 x 6 in. cellular deck (for thinner total slabs)		4'-0" to 8'-0"	24", 30", 36"	6 sq in./cell (24 sq in./sheet)

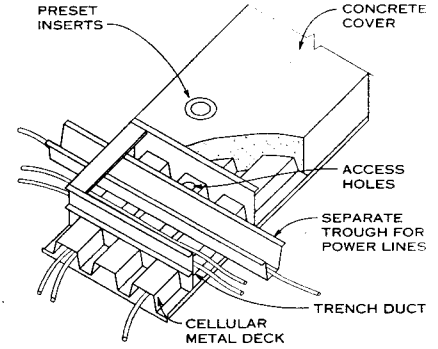

**NOTE**

Electric raceways may be built into floor slabs by using cellular deck or special units that are blended with plain deck. Two-way distribution is achieved by using trench ducts that sit astride the cellular units at right angles.

Using trench ducts with composite floor deck may reduce or eliminate entirely the effectiveness of composite action at the trench duct. This is also true for composite action between steel floor beams and concrete fill. Trench duct locations must be taken into account in deciding whether composite action is possible.

**ELECTRICAL TRENCH DUCT**

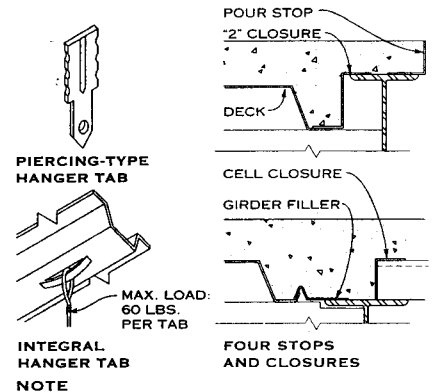

**NOTE**

A convenient, economical means of supporting lightweight acoustical ceilings is attaching a suspension system to hanger tabs at side laps, piercing tabs driven through the deck, or pre-punched tabs in the roof deck. Do not use this tab-and-metal deck arrangement to support plaster ceilings, piping, ductwork, electrical equipment, or other heavy loads. Such elements must be suspended directly from structural members or supplementary subframing.

**FLOOR DECK ACCESSORIES**

**METAL FLOOR DECKING**

Two items to keep in mind when designing with metal decking:

1. When lightweight concrete is used in the construction, use galvanized deck material.
2. In a fireproof assembly, metal components should be unprimed.

**ADVANTAGES OF METAL FLOOR DECKS**

1. Metal floor decks provide a working platform, eliminating temporary wood planking in high-rise use.
2. Composite decks provide positive reinforcement for concrete slabs.
3. Both noncomposite and composite decks serve as forms for concrete, eliminating the need for forming and stripping.
4. Consult the Underwriters Laboratories directory for specific fire rating requirements.
5. Acoustical treatment is possible.
6. Electric raceways may be built into the floor slab.
7. Metal floor decking provides economical floor assemblies.

Donald Neubauer, P.E.; Neubauer Consulting Engineers; Potomac, Maryland  
Walter D. Shapiro, P.E.; Tor, Shapiro & Associates; New York, New York

**ALLOWABLE SPANS FOR SINGLE-SPAN FLOOR JOISTS**

NOMINAL JOIST SIZE (WITH MIL THICKNESS)	10 PSF DEAD LOAD + 30 PSF LIVE LOAD			10 PSF DEAD LOAD + 40 PSF LIVE LOAD		
	SPACING O.C. (IN.)			SPACING O.C. (IN.)		
	12	16	24	12	16	24
2 x 6 x 33	11 ft 7 in.	10 ft 7 in.	9 ft 1 in.	10 ft 7 in.	9 ft 7 in.	8 ft 1 in.
2 x 6 x 43	12 ft 8 in.	11 ft 6 in.	10 ft 0 in.	11 ft 6 in.	10 ft 5 in.	9 ft 1 in.
2 x 6 x 54	13 ft 7 in.	12 ft 4 in.	10 ft 9 in.	12 ft 4 in.	11 ft 2 in.	9 ft 9 in.
2 x 6 x 68	14 ft 6 in.	13 ft 2 in.	11 ft 6 in.	13 ft 2 in.	12 ft 0 in.	10 ft 6 in.
2 x 6 x 97	16 ft 1 in.	14 ft 7 in.	12 ft 9 in.	14 ft 7 in.	13 ft 3 in.	11 ft 7 in.
2 x 8 x 33	15 ft 8 in.	13 ft 3 in.	8 ft 10 in.	14 ft 0 in.	10 ft 7 in.	7 ft 1 in.
2 x 8 x 43	17 ft 1 in.	15 ft 6 in.	13 ft 7 in.	15 ft 6 in.	14 ft 1 in.	12 ft 3 in.
2 x 8 x 54	18 ft 4 in.	16 ft 8 in.	14 ft 7 in.	16 ft 8 in.	15 ft 2 in.	13 ft 3 in.
2 x 8 x 68	19 ft 8 in.	17 ft 11 in.	15 ft 7 in.	17 ft 11 in.	16 ft 3 in.	14 ft 2 in.
2 x 8 x 97	21 ft 10 in.	19 ft 10 in.	17 ft 4 in.	19 ft 10 in.	18 ft 0 in.	15 ft 9 in.
2 x 10 x 43	20 ft 6 in.	18 ft 8 in.	15 ft 3 in.	18 ft 8 in.	16 ft 8 in.	13 ft 1 in.
2 x 10 x 54	22 ft 1 in.	20 ft 1 in.	17 ft 6 in.	20 ft 1 in.	18 ft 3 in.	15 ft 11 in.
2 x 10 x 68	23 ft 8 in.	21 ft 8 in.	18 ft 10 in.	21 ft 6 in.	19 ft 7 in.	17 ft 1 in.
2 x 10 x 97	26 ft 4 in.	23 ft 11 in.	20 ft 11 in.	23 ft 11 in.	21 ft 9 in.	19 ft 0 in.
2 x 12 x 43	23 ft 5 in.	20 ft 3 in.	14 ft 1 in.	20 ft 11 in.	16 ft 10 in.	11 ft 3 in.
2 x 12 x 54	25 ft 9 in.	23 ft 4 in.	19 ft 7 in.	23 ft 4 in.	21 ft 3 in.	17 ft 6 in.
2 x 12 x 68	27 ft 8 in.	25 ft 1 in.	21 ft 11 in.	25 ft 1 in.	22 ft 10 in.	19 ft 11 in.
2 x 12 x 97	30 ft 9 in.	27 ft 11 in.	24 ft 5 in.	27 ft 11 in.	25 ft 4 in.	22 ft 2 in.

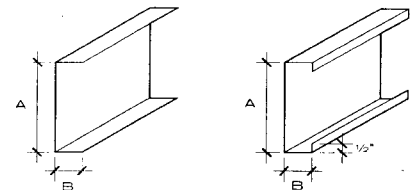
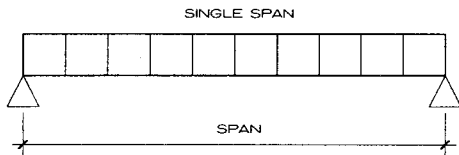

CHANNEL STUDS		C MEMBER	
A (IN.)	B (IN.)	A (IN.)	B (IN.)
2 1/2	1	3 1/2	1 5/8
3 1/4	1 3/8	5 1/2	
3 5/8		8	
4		10	
6		12	

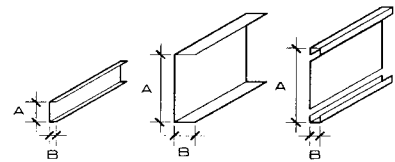

**ALLOWABLE SPANS FOR MULTIPLE-SPAN FLOOR JOISTS**

NOMINAL JOIST SIZE (WITH MIL THICKNESS)	10 PSF DEAD LOAD + 30 PSF LIVE LOAD			10 PSF DEAD LOAD + 40 PSF LIVE LOAD		
	SPACING O.C. (IN.)			SPACING O.C. (IN.)		
	12	16	24	12	16	24
2 x 6 x 33	12 ft 10 in.	10 ft 6 in.	7 ft 10 in.	11 ft 0 in.	9 ft 0 in.	6 ft 7 in.
2 x 6 x 43	15 ft 8 in.	13 ft 6 in.	11 ft 0 in.	14 ft 0 in.	12 ft 1 in.	9 ft 10 in.
2 x 6 x 54	17 ft 7 in.	15 ft 3 in.	12 ft 5 in.	15 ft 9 in.	13 ft 8 in.	11 ft 2 in.
2 x 6 x 68	19 ft 6 in.	17 ft 2 in.	14 ft 0 in.	17 ft 8 in.	15 ft 4 in.	12 ft 6 in.
2 x 6 x 97	21 ft 7 in.	19 ft 7 in.	16 ft 8 in.	19 ft 7 in.	17 ft 10 in.	14 ft 11 in.
2 x 8 x 33	12 ft 9 in.	10 ft 2 in.	7 ft 1 in.	10 ft 9 in.	8 ft 6 in.	5 ft 8 in.
2 x 8 x 43	19 ft 5 in.	16 ft 8 in.	12 ft 6 in.	17 ft 5 in.	14 ft 3 in.	10 ft 8 in.
2 x 8 x 54	23 ft 0 in.	19 ft 11 in.	16 ft 3 in.	20 ft 6 in.	17 ft 9 in.	14 ft 6 in.
2 x 8 x 68	25 ft 10 in.	22 ft 5 in.	18 ft 3 in.	23 ft 2 in.	20 ft 0 in.	16 ft 4 in.
2 x 8 x 97	29 ft 4 in.	26 ft 7 in.	21 ft 11 in.	26 ft 7 in.	24 ft 0 in.	19 ft 7 in.
2 x 10 x 43	20 ft 3 in.	16 ft 5 in.	12 ft 1 in.	17 ft 3 in.	13 ft 11 in.	10 ft 2 in.
2 x 10 x 54	25 ft 6 in.	22 ft 1 in.	18 ft 0 in.	22 ft 10 in.	19 ft 9 in.	15 ft 6 in.
2 x 10 x 68	30 ft 6 in.	26 ft 5 in.	21 ft 7 in.	27 ft 4 in.	23 ft 8 in.	19 ft 3 in.
2 x 10 x 97	35 ft 4 in.	31 ft 9 in.	25 ft 11 in.	32 ft 1 in.	28 ft 5 in.	23 ft 2 in.
2 x 12 x 43	19 ft 8 in.	15 ft 9 in.	11 ft 3 in.	16 ft 7 in.	13 ft 3 in.	9 ft 0 in.
2 x 12 x 54	27 ft 8 in.	23 ft 9 in.	17 ft 10 in.	24 ft 9 in.	20 ft 4 in.	15 ft 2 in.
2 x 12 x 68	32 ft 7 in.	28 ft 3 in.	23 ft 0 in.	29 ft 2 in.	25 ft 3 in.	20 ft 7 in.
2 x 12 x 97	41 ft 3 in.	36 ft 7 in.	29 ft 10 in.	37 ft 5 in.	32 ft 9 in.	26 ft 9 in.

FURRING CHANNEL		C JOIST CLOSURE		NESTABLE JOIST	
A (IN.)	B (IN.)	A (IN.)	B (IN.)	A (IN.)	B (IN.)
3/4	1/2	5 1/2	1 1/4	7 1/4	1 3/4 in.
1 1/2	1 1/32	6		7 1/2	
		7 1/4		8	
		8		9 1/4	
		9 1/4		9 1/2	
		10		11 1/2	
		12		13 1/2	
		Normally available in all joist sizes			

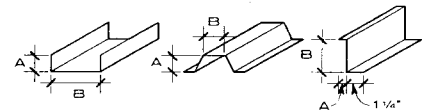

**NOTES**

- The tables above provide maximum joist spans, in feet and inches. For multiple spans, span is either to the right or left of the interior support.
- Interior bearing supports for multiple span joists should consist of structural (bearing) walls or beams.
- Bearing stiffeners should be installed at all support points and concentrated loads. End bearing stiffeners are not required for floor joists 54 mil or thicker, spanning 14 ft or less, for one-story houses (walls and roof only) in areas with maximum ground snow load of 30 psf or less.
- Joists supporting a roof and single wall only may cantilever up to a maximum of 24 in. measured from the centerline of the bearing point, provided that bearing stiffeners are installed at the end of the cantilever and the bearing point and no punchouts are allowed in the cantilevered section. Hole reinforcements may be used to cover up holes.
- Deflection criteria: L/480 for live loads; L/240 for total loads.

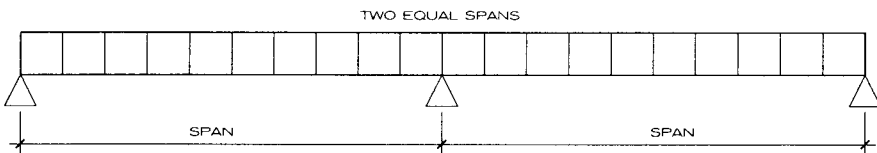

RUNNER CHANNEL		FURRING HAT CHANNEL		Z FURRING	
A (IN.)	B (IN.)	A (IN.)	B (IN.)	A (IN.)	B (IN.)
3/4	2 11/16	7/8	1 3/8	3/4	1
1	3 13/16	1 1/2	1 1/4		1 1/2
1 3/8	3 7/16				2
1 1/2	4 3/16				3
1 7/8	6 3/16				
1 3/4	8 3/16				
3 1/2					

**NOTE**

Members available in dimensions of 33 through 97 mil.

**LIGHT-GAUGE FRAMING MEMBERS**

**COLD-FORMED STEEL—MINIMUM MATERIAL THICKNESS**

Designation (mil)*	18	27	33	43	54	68	97
Minimum delivered uncoated thickness inches (mm)	0.018 (0.455)	0.027 (0.683)	0.033 (0.836)	0.043 (1.087)	0.054 (1.367)	0.068 (1.720)	0.097 (2.454)
Reference gauge number	25	22	20	18	16	14	12

\* 1 mil = 1/1000 in.

**CEILING JOISTS ALLOWABLE SPANS—SINGLE SPANS, WITHOUT ATTIC STORAGE**

NOMINAL JOIST SIZE	UNBRACED SPACING (IN.)			MID-SPAN BRACING SPACING (IN.)			THIRD-POINT BRACING SPACING (IN.)		
	12	16	24	12	16	24	12	16	24
2 x 4 x 33	9 ft 10 in.	9 ft 2 in.	8 ft 3 in.	11 ft 4 in.	10 ft 4 in.	9 ft 0 in.	11 ft 4 in.	10 ft 4 in.	9 ft 0 in.
2 x 4 x 43	10 ft 8 in.	9 ft 11 in.	8 ft 10 in.	12 ft 4 in.	11 ft 2 in.	9 ft 9 in.	12 ft 4 in.	11 ft 2 in.	9 ft 9 in.
2 x 4 x 54	11 ft 7 in.	10 ft 8 in.	9 ft 6 in.	13 ft 2 in.	12 ft 0 in.	10 ft 6 in.	13 ft 2 in.	12 ft 0 in.	10 ft 6 in.
2 x 4 x 68	12 ft 8 in.	11 ft 7 in.	10 ft 4 in.	14 ft 1 in.	12 ft 10 in.	11 ft 2 in.	14 ft 1 in.	12 ft 10 in.	11 ft 2 in.
2 x 4 x 97	14 ft 11 in.	13 ft 7 in.	12 ft 1 in.	15 ft 6 in.	14 ft 1 in.	12 ft 4 in.	15 ft 6 in.	14 ft 1 in.	12 ft 4 in.
2 x 6 x 33	11 ft 2 in.	10 ft 5 in.	9 ft 5 in.	15 ft 9 in.	14 ft 5 in.	10 ft 0 in.	16 ft 2 in.	14 ft 8 in.	10 ft 0 in.
2 x 6 x 43	12 ft 1 in.	11 ft 2 in.	10 ft 1 in.	16 ft 10 in.	15 ft 7 in.	13 ft 10 in.	17 ft 7 in.	15 ft 11 in.	13 ft 11 in.
2 x 6 x 54	13 ft 0 in.	12 ft 0 in.	10 ft 9 in.	17 ft 11 in.	16 ft 7 in.	14 ft 9 in.	18 ft 10 in.	17 ft 1 in.	14 ft 11 in.
2 x 6 x 68	14 ft 0 in.	12 ft 11 in.	11 ft 7 in.	19 ft 2 in.	17 ft 8 in.	15 ft 10 in.	20 ft 2 in.	18 ft 4 in.	16 ft 0 in.
2 x 6 x 97	16 ft 3 in.	14 ft 11 in.	13 ft 2 in.	21 ft 6 in.	19 ft 10 in.	17 ft 8 in.	22 ft 4 in.	20 ft 3 in.	17 ft 8 in.
2 x 8 x 33*	12 ft 7 in.	11 ft 8 in.	10 ft 6 in.	17 ft 8 in.	16 ft 5 in.	14 ft 9 in.	21 ft 5 in.	19 ft 5 in.	16 ft 7 in.
2 x 8 x 43	13 ft 6 in.	12 ft 6 in.	11 ft 3 in.	18 ft 10 in.	17 ft 6 in.	15 ft 10 in.	23 ft 0 in.	21 ft 2 in.	17 ft 9 in.
2 x 8 x 54	14 ft 4 in.	13 ft 4 in.	11 ft 11 in.	20 ft 0 in.	18 ft 7 in.	16 ft 9 in.	24 ft 4 in.	22 ft 7 in.	20 ft 0 in.
2 x 8 x 68	15 ft 5 in.	14 ft 3 in.	12 ft 9 in.	21 ft 3 in.	19 ft 8 in.	17 ft 8 in.	25 ft 9 in.	23 ft 11 in.	21 ft 4 in.
2 x 8 x 97	17 ft 8 in.	16 ft 2 in.	14 ft 5 in.	23 ft 8 in.	21 ft 10 in.	19 ft 6 in.	28 ft 4 in.	26 ft 3 in.	23 ft 6 in.
2 x 10 x 43*	14 ft 5 in.	13 ft 4 in.	12 ft 1 in.	20 ft 2 in.	18 ft 9 in.	16 ft 11 in.	24 ft 8 in.	22 ft 11 in.	20 ft 6 in.
2 x 10 x 54	15 ft 4 in.	14 ft 2 in.	12 ft 9 in.	21 ft 4 in.	19 ft 10 in.	17 ft 10 in.	26 ft 0 in.	24 ft 2 in.	21 ft 9 in.
2 x 10 x 68	16 ft 5 in.	15 ft 2 in.	13 ft 7 in.	22 ft 8 in.	21 ft 0 in.	18 ft 11 in.	27 ft 6 in.	25 ft 6 in.	23 ft 0 in.
2 x 10 x 97	18 ft 7 in.	17 ft 1 in.	15 ft 2 in.	25 ft 1 in.	23 ft 2 in.	20 ft 9 in.	30 ft 2 in.	27 ft 11 in.	25 ft 1 in.
2 x 12 x 43	15 ft 2 in.	14 ft 1 in.	12 ft 8 in.	21 ft 4 in.	19 ft 10 in.	17 ft 11 in.	26 ft 1 in.	24 ft 3 in.	21 ft 6 in.
2 x 12 x 54	16 ft 1 in.	15 ft 0 in.	13 ft 5 in.	22 ft 7 in.	20 ft 11 in.	18 ft 11 in.	27 ft 6 in.	25 ft 7 in.	23 ft 1 in.
2 x 12 x 68	17 ft 3 in.	15 ft 11 in.	14 ft 4 in.	23 ft 11 in.	22 ft 2 in.	19 ft 11 in.	29 ft 0 in.	27 ft 0 in.	24 ft 4 in.
2 x 12 x 97	19 ft 5 in.	17 ft 10 in.	15 ft 11 in.	26 ft 4 in.	24 ft 4 in.	21 ft 10 in.	31 ft 8 in.	29 ft 4 in.	26 ft 5 in.

\* Bearing stiffeners shall be installed at all support points and concentrated loads.

**CEILING JOISTS ALLOWABLE SPANS—SINGLE SPANS, WITH ATTIC STORAGE (20 PSF)**

NOMINAL JOIST SIZE	UNBRACED SPACING (IN.)			MID-SPAN BRACING SPACING (IN.)			THIRD-POINT BRACING SPACING (IN.)		
	12	16	24	12	16	24	12	16	24
2 x 4 x 33	8 ft 8 in.	8 ft 0 in.	6 ft 0 in.	9 ft 7 in.	8 ft 8 in.	6 ft 0 in.	9 ft 7 in.	8 ft 8 in.	6 ft 0 in.
2 x 4 x 43	9 ft 4 in.	8 ft 8 in.	7 ft 8 in.	10 ft 5 in.	9 ft 5 in.	8 ft 3 in.	10 ft 5 in.	9 ft 5 in.	8 ft 3 in.
2 x 4 x 54	10 ft 0 in.	9 ft 3 in.	8 ft 3 in.	11 ft 2 in.	10 ft 1 in.	8 ft 10 in.	11 ft 2 in.	10 ft 1 in.	8 ft 10 in.
2 x 4 x 68	10 ft 11 in.	10 ft 0 in.	8 ft 11 in.	10 ft 11 in.	10 ft 0 in.	8 ft 11 in.	11 ft 11 in.	10 ft 0 in.	8 ft 11 in.
2 x 4 x 97	12 ft 8 in.	11 ft 7 in.	10 ft 3 in.	13 ft 1 in.	11 ft 11 in.	10 ft 5 in.	13 ft 1 in.	11 ft 11 in.	10 ft 5 in.
2 x 6 x 33*	9 ft 10 in.	9 ft 0 in.	6 ft 0 in.	12 ft 0 in.	9 ft 0 in.	6 ft 0 in.	12 ft 0 in.	9 ft 0 in.	6 ft 0 in.
2 x 6 x 43	10 ft 7 in.	9 ft 10 in.	8 ft 10 in.	14 ft 7 in.	13 ft 4 in.	11 ft 6 in.	14 ft 10 in.	13 ft 5 in.	11 ft 8 in.
2 x 6 x 54	11 ft 3 in.	10 ft 5 in.	9 ft 5 in.	15 ft 7 in.	14 ft 4 in.	12 ft 6 in.	15 ft 11 in.	14 ft 5 in.	12 ft 7 in.
2 x 6 x 68	12 ft 2 in.	11 ft 3 in.	10 ft 0 in.	16 ft 8 in.	15 ft 4 in.	13 ft 5 in.	17 ft 0 in.	15 ft 5 in.	13 ft 6 in.
2 x 6 x 97	13 ft 11 in.	12 ft 9 in.	11 ft 4 in.	18 ft 7 in.	17 ft 1 in.	14 ft 11 in.	18 ft 10 in.	17 ft 1 in.	14 ft 11 in.
2 x 8 x 33	11 ft 0 in.	10 ft 3 in.	9 ft 3 in.	15 ft 6 in.	14 ft 4 in.	12 ft 5 in.	17 ft 10 in.	15 ft 11 in.	13 ft 4 in.
2 x 8 x 43	11 ft 10 in.	10 ft 11 in.	9 ft 10 in.	16 ft 7 in.	15 ft 5 in.	13 ft 8 in.	19 ft 9 in.	16 ft 0 in.	13 ft 8 in.
2 x 8 x 54	12 ft 7 in.	11 ft 8 in.	10 ft 6 in.	17 ft 6 in.	16 ft 3 in.	14 ft 7 in.	21 ft 2 in.	19 ft 3 in.	16 ft 8 in.
2 x 8 x 68	13 ft 5 in.	12 ft 5 in.	11 ft 2 in.	18 ft 7 in.	17 ft 3 in.	15 ft 6 in.	22 ft 6 in.	20 ft 7 in.	18 ft 0 in.
2 x 8 x 97	15 ft 2 in.	13 ft 11 in.	12 ft 5 in.	20 ft 6 in.	18 ft 11 in.	17 ft 0 in.	24 ft 8 in.	22 ft 9 in.	20 ft 1 in.
2 x 10 x 43*	12 ft 7 in.	11 ft 9 in.	10 ft 7 in.	17 ft 9 in.	16 ft 6 in.	14 ft 10 in.	21 ft 7 in.	19 ft 10 in.	17 ft 1 in.
2 x 10 x 54	13 ft 5 in.	12 ft 5 in.	11 ft 2 in.	18 ft 9 in.	17 ft 5 in.	15 ft 8 in.	22 ft 10 in.	21 ft 1 in.	16 ft 9 in.
2 x 10 x 68	14 ft 3 in.	13 ft 3 in.	11 ft 10 in.	19 ft 10 in.	18 ft 5 in.	16 ft 7 in.	24 ft 1 in.	22 ft 4 in.	19 ft 11 in.
2 x 10 x 97	16 ft 0 in.	14 ft 9 in.	13 ft 2 in.	21 ft 9 in.	20 ft 2 in.	18 ft 1 in.	26 ft 3 in.	24 ft 4 in.	21 ft 10 in.
2 x 12 x 43	13 ft 4 in.	12 ft 5 in.	11 ft 2 in.	18 ft 9 in.	17 ft 5 in.	15 ft 8 in.	22 ft 9 in.	20 ft 9 in.	18 ft 0 in.
2 x 12 x 54	14 ft 1 in.	13 ft 1 in.	11 ft 9 in.	19 ft 9 in.	18 ft 5 in.	16 ft 7 in.	24 ft 2 in.	22 ft 5 in.	20 ft 1 in.
2 x 12 x 68	15 ft 0 in.	13 ft 11 in.	12 ft 6 in.	20 ft 11 in.	19 ft 5 in.	17 ft 6 in.	25 ft 6 in.	23 ft 8 in.	21 ft 3 in.
2 x 12 x 97	16 ft 9 in.	15 ft 5 in.	13 ft 10 in.	22 ft 11 in.	21 ft 2 in.	19 ft 0 in.	27 ft 8 in.	25 ft 8 in.	23 ft 1 in.

\* Bearing stiffeners shall be installed at all support points and concentrated loads.

**NOTES**

1. The tables above provide the maximum ceiling joist span in feet and inches.
2. Deflection criteria: L/240 for total loads.
3. Ceiling dead load = 5 psf (0.24 kPa)
4. 1 in. = 25.4 mm, 1 ft = 304.8 mm, 1 psf = 48 Pa.

American Iron and Steel Institute; Washington, D.C.

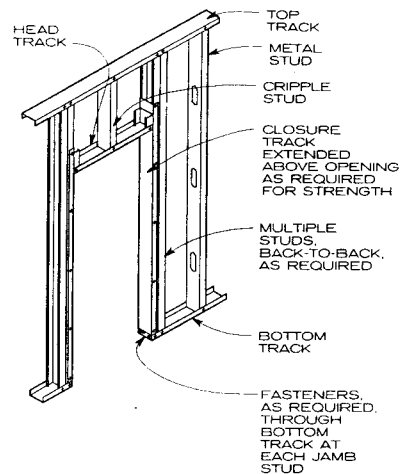
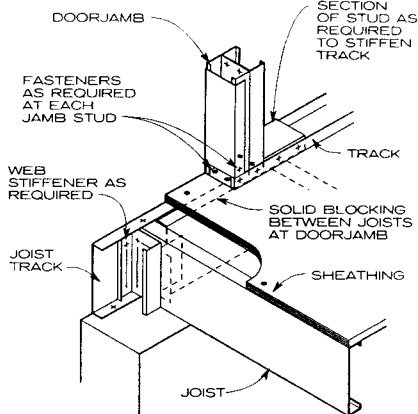
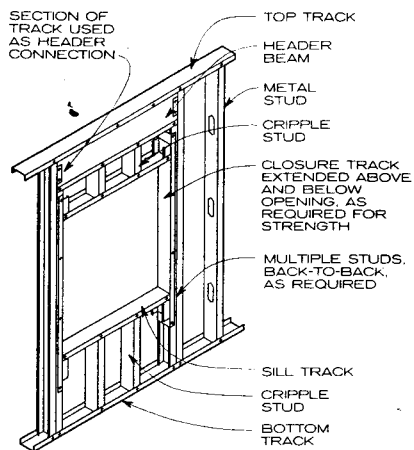

**WINDOW OPENING**

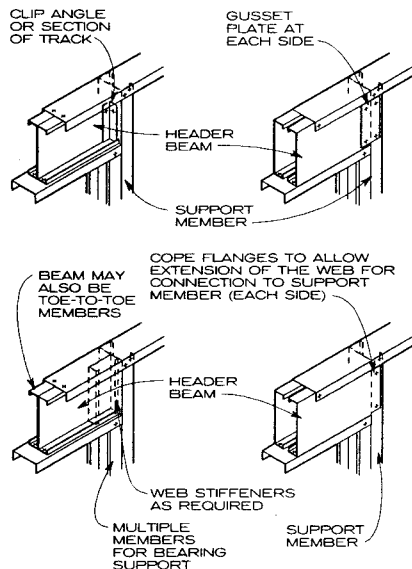

**DOORJAMB BASE AT FLOOR FRAMING**

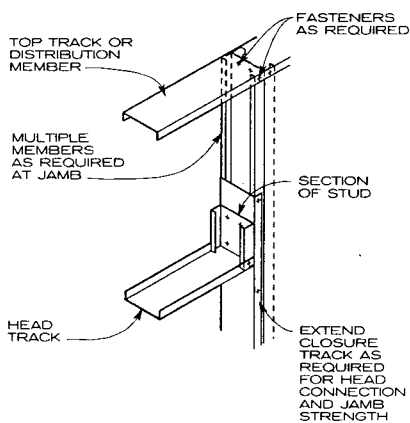

**DOOR OPENING**

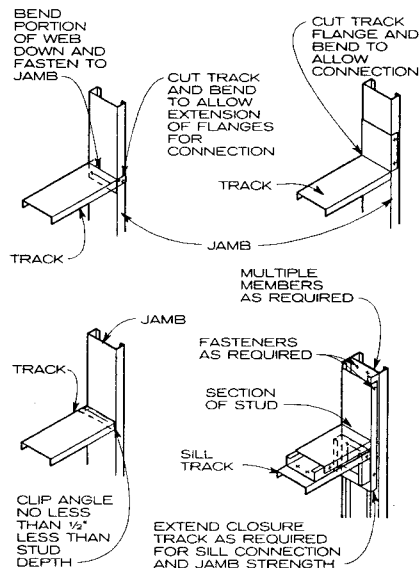

**NOTE**

Detail may be applicable to larger openings in interior partitions. For nonaxial loads.

**HEADER BEAMS FOR WIDE OPENINGS**

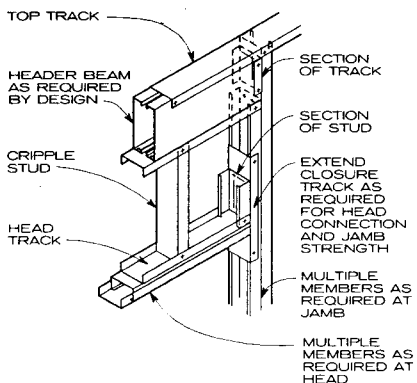

**NOTE**

For axial loads.

**OPENING GREATER THAN OR EQUAL TO 4 FEET (LOAD-BEARING WALL)**

**HEAD AT OPENING LESS THAN 4 FEET (LOAD-BEARING WALL)**

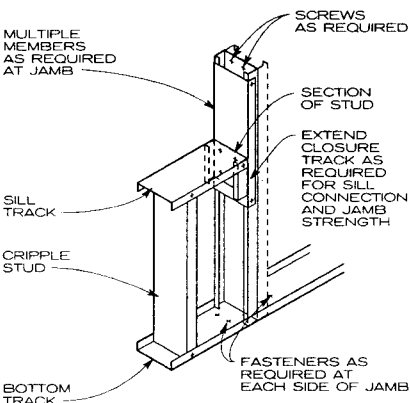

**JAMB AND SILL AT OPENING LESS THAN 4 FEET**

**SILL CONNECTIONS AT JAMB**

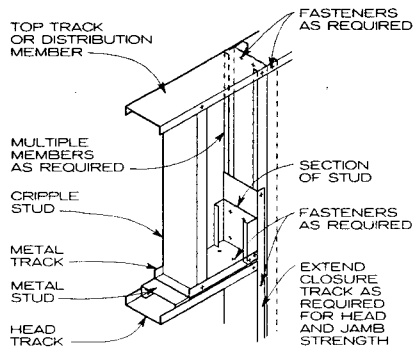

**NOTE**

For nonaxial loads.

**OPENINGS GREATER THAN OR EQUAL TO 4 FEET (LOAD-BEARING WALL)**

American Iron and Steel Institute; Washington, D.C.

**GENERAL**

Lightweight steel framing is cold-formed, which means the components are manufactured by brake-forming and punching galvanized coil and sheet stock. Steel framing members consist of two basic types of components that are C-shaped in section: one type has 1/4-in. flanges folded inward and the other has no flanges. Studs, joists, and rafters are made with flanges to stiffen them so they will more readily stand vertically. Components without flanges, called tracks, have unpunched solid webs. For added strength, tracks are sized slightly larger than the flanged members so the tracks will fit snugly inside them as sill or top plates or as part of posts or headers.

Steel framing is strong and versatile. The strength (and load-carrying capacity) of a member can be increased simply by increasing the thickness, or gauge, of the metal; the dimensions of the member, or the spacing, do not necessarily have to be increased. There is little limitation on the length of steel framing members; joists or studs may be fabricated in lengths up to 40 ft. If handled with care, steel framing is straight and consistent; also, it is not affected by moisture content.

Disadvantages of steel framing include lack of insulating qualities, difficulty in cutting compared to wood, and dangerously sharp edges. Consult the American Iron and Steel Institute (AISI) for further information.

**BRACING**

Buildings must be properly braced to resist racking under wind and seismic loads. Diagonal strap bracing is sloped to resist racking forces in tension and fastened by screws or welds to studs and plates. Properly spaced lateral steel bracing resists stud rotation and minor axis bending under wind, seismic, and axial loads; it is especially critical during construction, before sheathing or finishes are installed.

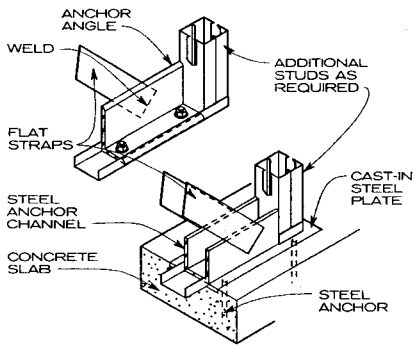

**NOTE**

The top detail is for one-to-two story buildings and the bottom detail for buildings greater than two stories. Steel channel, plate, and anchor size depend on applied uplift and horizontal shear forces.

**DIAGONAL STABILITY BRACING ANCHORAGE DETAILS**

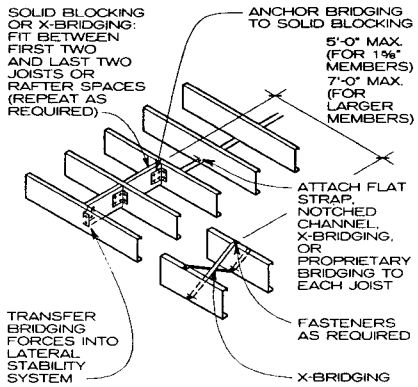

**NOTE**

If sheathing is not installed on members, bridging is required on both flanges.

**JOIST OR RAFTER BRIDGING**

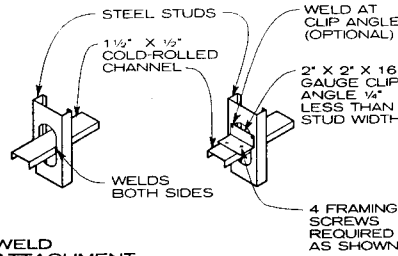

**WELD ATTACHMENT (FOR 3 3/8" OR SMALLER STUDS; 16-GAUGE OR HEAVIER)**

**SCREW ATTACHMENT (FOR 3 3/8" TO 8" STUDS)**

**NOTE**

Channels to be spaced as required by design.

**LATERAL BRACING ATTACHMENT**

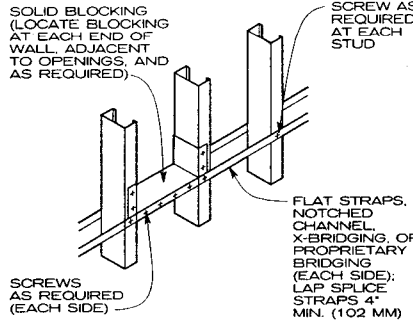

**NOTE**

Number of rows of bridging as required by design.

**WALL BRIDGING**

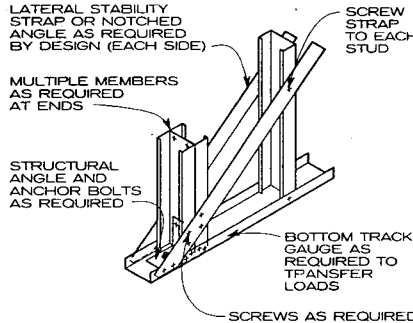

**NOTE**

Strap forces may require additional stiffening of the bottom track or structural angle.

**DIAGONAL STABILITY BRACING ANCHORAGE**

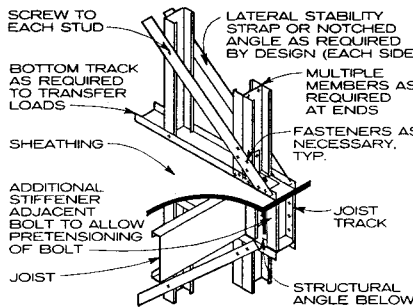

**NOTE**

Strap forces may require additional stiffening of top and bottom track or structural angle.

**DIAGONAL STABILITY BRACING AT INTERMEDIATE FLOOR**

**LIMITING HEIGHT TABLES FOR INTERIOR PARTITIONS AND CHASE WALL PARTITIONS**

STUD WIDTH	STUD SPACING	ALLOW. DEFL.	PARTITION ONE LAYER	PARTITION TWO LAYERS

**LIMITING HEIGHT 18 MIL STEEL STUD ASSEMBLIES**

1 1/8"	16"	1/120	10' 9" d	10' 9" d
		1/240	9' 6" d	10' 6" d
		1/240	8' 9" f	8' 9" f
2 1/2"	16"	1/120	14' 3" f	14' 3" f
		1/240	12' 6" d	13' 6" d
		1/240	11' 6" f	11' 6" f
3 5/8"	16"	1/120	18' 3" f	18' 3" f
		1/240	16' 0" d	17' 0" d
		1/240	15' 0" f	15' 0" f
4"	16"	1/120	14' 0" d	14' 9" d
		1/240	19' 6" f	19' 6" f
		1/240	17' 3" d	18' 3" d
	24"	1/120	16' 0" f	16' 0" f
		1/240	15' 0" d	15' 9" d
		1/240	15' 0" d	15' 9" d

**33 MIL STEEL STUD ASSEMBLIES**

2 1/2"	16"	1/120	17' 9" d	18' 6" d
		1/240	14' 0" d	14' 0" d
		1/240	15' 6" d	16' 3" f
3 5/8"	16"	1/120	12' 3" d	13' 0" d
		1/240	23' 0" d	24' 0" d
		1/240	18' 3" d	19' 0" d
4"	16"	1/120	20' 0" d	20' 9" f
		1/240	16' 0" d	16' 6" d
		1/240	24' 9" d	25' 9" d
	24"	1/120	19' 6" d	20' 3" d
		1/240	21' 6" d	22' 0" f
		1/240	17' 3" d	17' 9" d

**LIMITING HEIGHT 18 MIL CHASE WALL PARTITIONS**

1 1/8"	16"	1/120	15' 3" f	15' 3" f
		1/240	13' 3" d	14' 6" d
		1/240	12' 6" f	12' 6" f
2 1/2"	16"	1/120	11' 6" d	12' 6" f
		1/240	90' 3" f	20' 3" f
		1/240	17' 6" d	19' 0" d
24"	16"	1/120	16' 6" f	16' 6" f
		1/240	15' 6" d	16' 6" f
		1/240	25' 9" f	25' 9" f
3 5/8"	16"	1/120	22' 9" d	24' 3" d
		1/240	21' 0" d	21' 0" f
		1/240	19' 9" d	21' 0" f
2 1/2"*	16"	1/120	24' 3" d	25' 9" d
		1/240	19' 3" d	20' 6" d
		1/240	21' 3" d	22' 6" f
	24"	1/120	17' 0" d	18' 0" d
		1/240		
		1/240		

\* 33 mil chase wall partitions.

**NOTE**

Limiting height for 1/2 or 3/8 in. thick panels and 5 psf uniform load perpendicular to partition or furring. Use one-layer heights for unbalanced assemblies. Consult local code authority for limiting criteria (d—deflection, f—bending stress).

American Iron and Steel Institute; Washington, D.C.

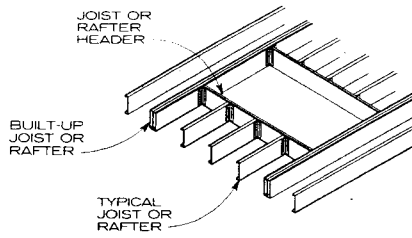

TYPICAL OPENING IN JOISTS/RAFTERS

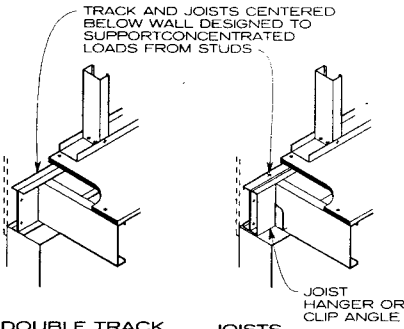

DOUBLE TRACK DETAIL

JOISTS PERPENDICULAR TO WALL

RIM JOIST DETAILS

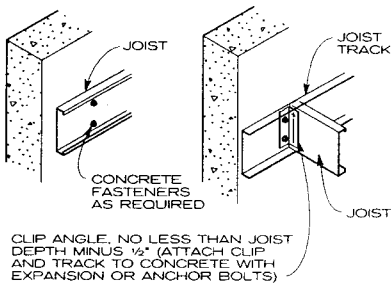

FLOOR JOISTS PARALLEL TO WALL

FLOOR JOIST SUPPORT AT WALL

NOTE

Provide solid blocking and bridging as required.

FLOOR JOISTS AT CONTINUOUS WALL

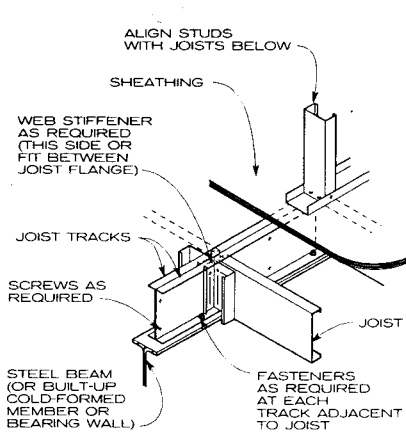

JOISTS SUPPORTED BY BEAM OR BEARING WALL

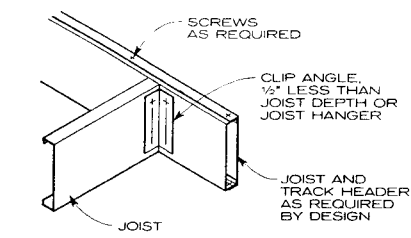

JOIST-TO-JOIST HEADER

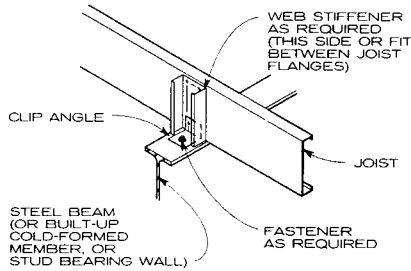

NOTES

1. Continuous bridging is required between each joist above a beam. Solid blocking in every other space may be used in lieu of bridging.
2. When a bearing wall is above, the studs must align with the joists below.
3. Web stiffeners are not required when continuous solid blocking is used.

JOISTS OVER BEAM OR BEARING WALL (CONTINUOUS SPAN)

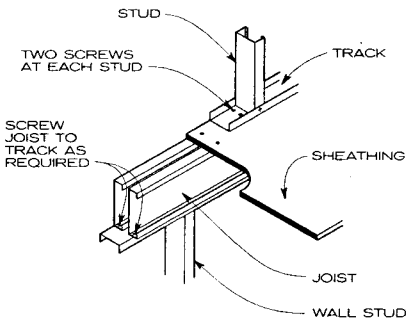

FLOOR JOISTS PARALLEL TO EXTERIOR WALL

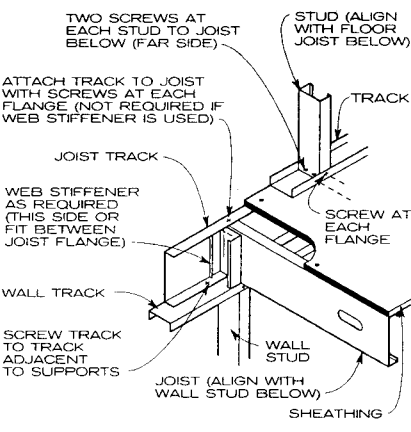

FLOOR FRAMING AT EXTERIOR WALL

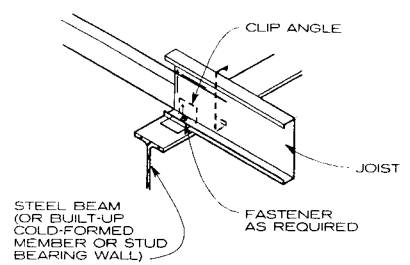

NOTES

1. Continuous bridging is required between each joist above a beam. Solid blocking in every other space may be used in lieu of bridging.
2. When a bearing wall is above, studs must align with joists below.

FLOOR JOISTS SUPPORTED BY BEAM OR BEARING WALL (OVERLAPPED)

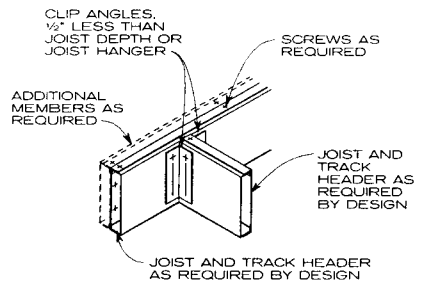

JOIST HEADER TO BUILT-UP JOISTS

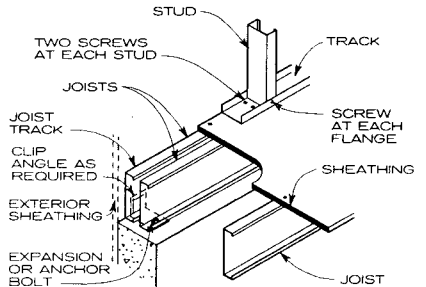

NOTE

Provide solid blocking and bridging as required.

FLOOR JOISTS PARALLEL TO FOUNDATION

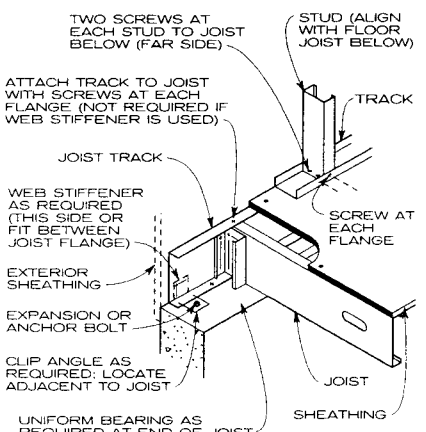

FLOOR JOISTS BEARING ON FOUNDATION



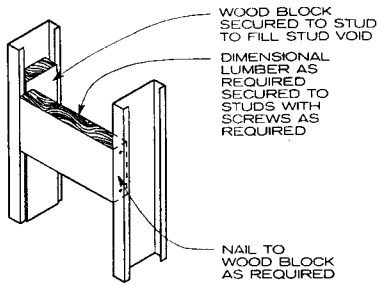

**HEAVY FIXTURE ATTACHMENT**

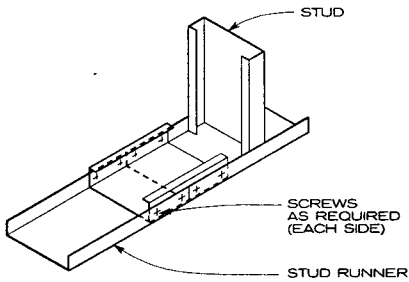

**TOP AND BOTTOM TRACK SPLICE**

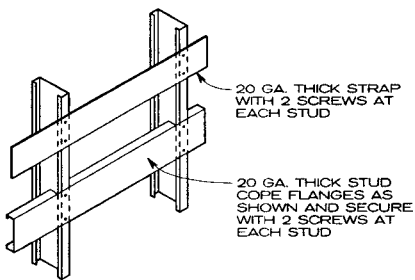

**NOTE**

Dimensional lumber may also be used for backing.

**BACKING FOR CABINETS**

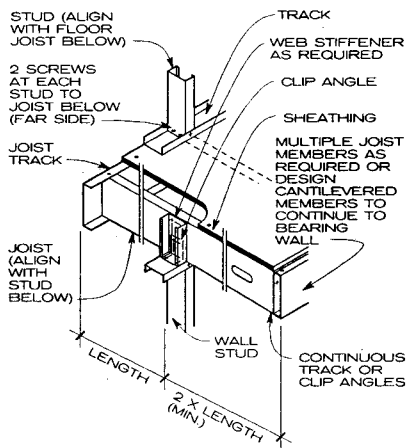

**NOTES**

1. Provide continuous bridging between each joist at the lower wall.
2. Solid blocking in every other space may be used in lieu of bridging.
3. Where axial load-bearing members do not align vertically, provide top track distribution members at wall below.

**FLOOR CANTILEVER**

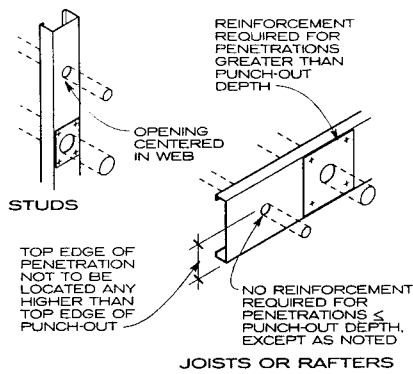

**NOTES**

1. Do not notch or cut flanges.
2. Capacity verification by design is required for any openings located at concentrated loads and bearing ends.
3. For unpunched members, consult the manufacturer.

**JOIST, STUD, OR RAFTER WEB PENETRATIONS**

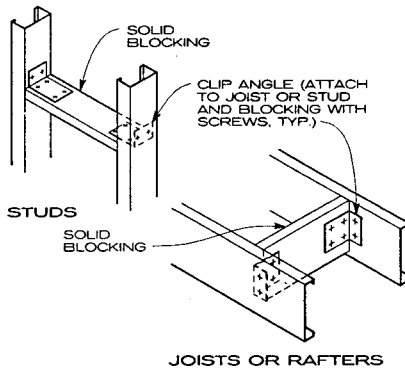

**NOTES**

1. Where blocking material thickness allows, notch and bend track 90 degrees for connection.
2. Where provisions are made for transfer of flange forces to solid blocking, blocking need not be in the full depth of the member.

**SOLID BLOCKING**

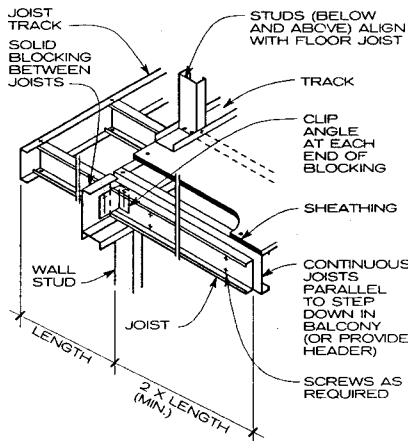

**NOTES**

1. Balconies require special detailing and protection against moisture and thermal bridging.
2. Where axial load-bearing members do not align vertically, provide top track distribution members at wall below.

**BALCONY WITH STEP DOWN**

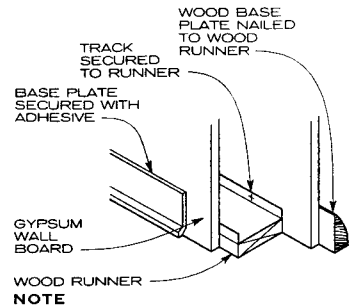

This detail is optional depending on contractor preference.

**AVAILABLE BASE PLATE**

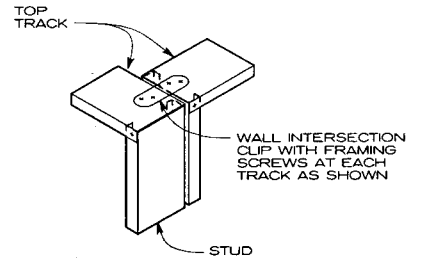

**TOP PLATE INTERSECTION**

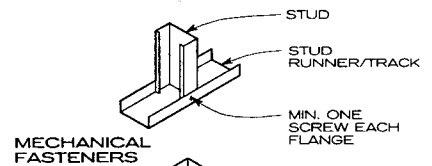

**MECHANICAL FASTENERS**

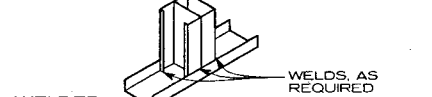

**WELDED CONNECTION NOTE**

Load-bearing studs must be seated tight to track web.

**STUD-TO-TRACK CONNECTION**

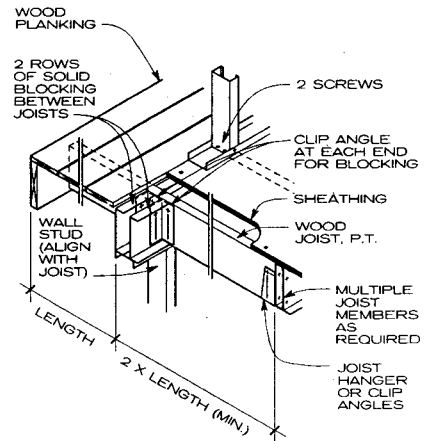

**NOTES**

1. Balconies require special detailing and protection against moisture and thermal bridging.
2. Where axial load-bearing members do not align vertically, provide top track distribution members at top of wall below.

**WOOD DECK BALCONY**

American Iron and Steel Institute; Washington, D.C.

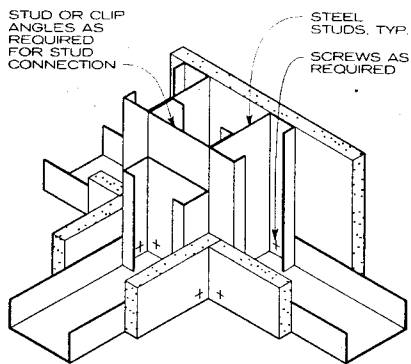

WALL INTERSECTION FRAMING

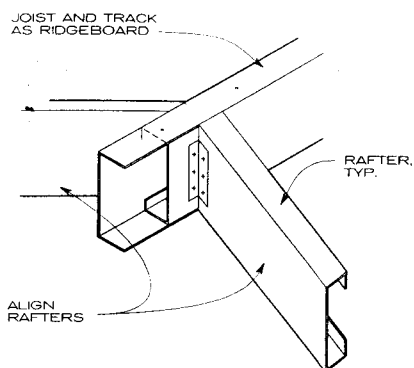

RIDGEBOARD

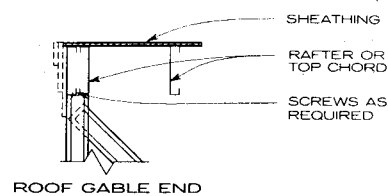

ROOF GABLE END

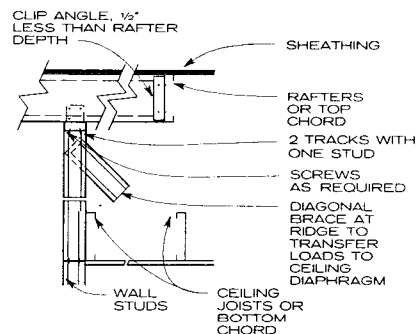

CANTILEVERED ROOF GABLE END

NOTE

Provide bridging at ceiling joists and roof rafters and continuous bridging between rafters at wall.

ROOF END DETAILS

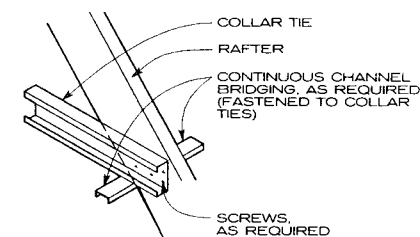

COLLAR TIE DETAIL

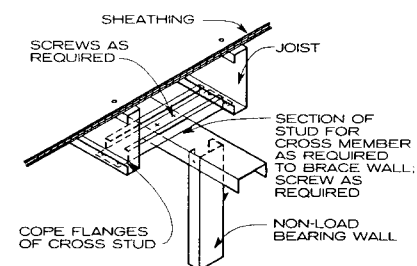

TOP OF NON-LOAD BEARING WALL PARALLEL TO JOISTS

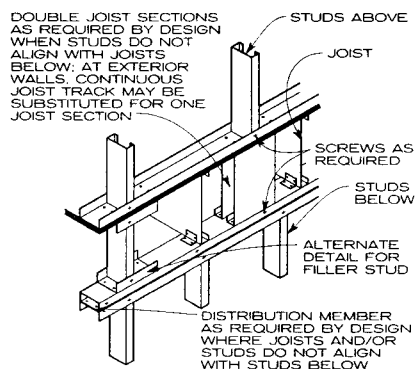

TOP TRACK DISTRIBUTION MEMBER

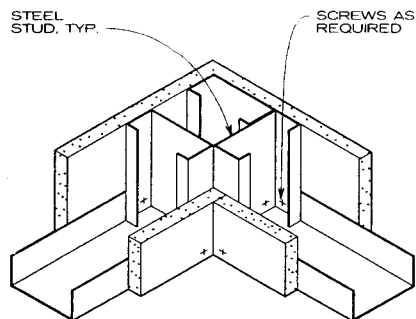

CORNER FRAMING

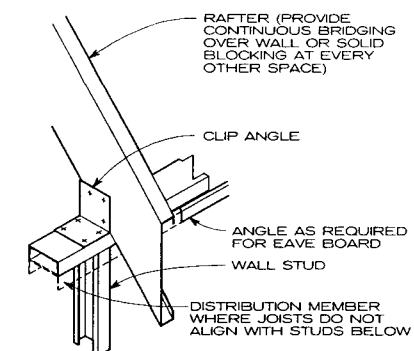

ROOF EAVE AT CATHEDRAL CEILING

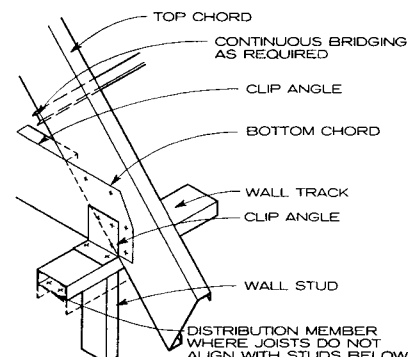

ROOF TRUSS EAVE DETAIL

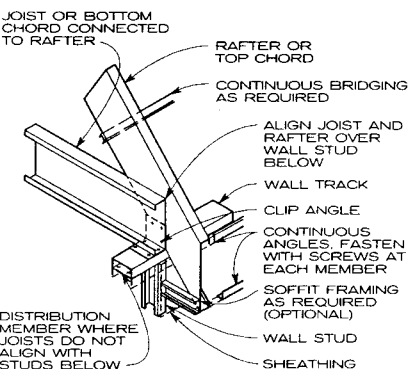

ROOF EAVE DETAIL

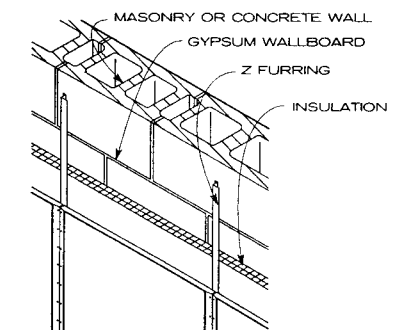

FURRING CHANNELS

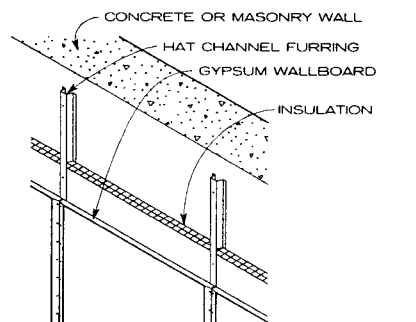

FURRING CHANNELS

**NOTE**

The following tables show sizes and shapes usually stocked or readily available. Manufacturers' data

**STEEL CHANNEL**

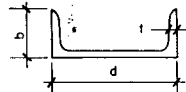

**STEEL CHANNELS—BAR SIZE (IN.)**

d x b x t	d x b x t	d x b x t
3/4 x 5/16 x 1/8	1 1/4 x 1/2 x 1/8	2 x 3/16 x 3/16
3/4 x 3/8 x 1/8	1 1/2 x 1/2 x 1/8	2 x 5/8 x 1/4
7/8 x 3/8 x 1/8	1 1/2 x 9/16 x 3/16	2 x 1 x 1/8
7/8 x 7/16 x 1/8	1 1/2 x 3/4 x 1/8	2 x 1 x 3/16
1 x 3/8 x 1/8	1 1/2 x 1 1/2 x 3/16	2 1/2 x 5/8 x 3/16
1 x 1/2 x 1/8	1 3/4 x 1/2 x 3/16	
1 1/8 x 9/16 x 3/16	2 x 1/2 x 1/8	

**NOTE:** For structural channel sizes (d = 3 in. and larger) see Dimensions of Channel Shapes in this chapter.

**STEEL TEES**

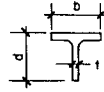

**STEEL TEES—BAR SIZE (IN.)**

b x d x t	b x d x t	b x d x t
3/4 x 3/4 x 1/8	1 1/2 x 1 1/2 x 3/16	2 x 2 x 5/16
1 x 1 x 1/8	1 1/2 x 1 1/2 x 1/4	2 1/4 x 2 1/4 x 1/4
1 x 1 x 3/16	1 3/4 x 1 3/4 x 3/16	2 1/2 x 2 1/4 x 1/4
1 1/4 x 1 1/4 x 1/8	1 3/4 x 1 3/4 x 1/4	2 1/2 x 2 1/2 x 5/16
1 1/4 x 1 1/4 x 3/16	2 x 1 1/2 x 1/4	2 1/2 x 2 1/2 x 3/8
1 1/4 x 1 1/4 x 1/4	2 x 2 x 1/4	

**STRUCTURAL**

3 x 2 1/2 x 5/16	3 x 3 x 3/8	4 x 4 x 1/2
3 x 3 x 5/16	4 x 3 x 3/8	5 x 3 1/8 x 1/2

**ALUMINUM ANGLE STRUCTURAL**



**ALUMINUM ANGLES—STRUCTURAL—EQUAL LEGS (IN.)**

SIZE x t	SIZE x t	SIZE x t
3/4 x 3/4 x 1/8, 1/16	2 x 2 x 3/16, 1/8	3 1/2 x 3 1/2 x 1/4
1 x 1 x 1/8, 1/16	2 x 2 x 1/4	3 1/2 x 3 1/2 x 3/8
1 x 1 x 3/16	2 x 2 x 5/16	3 1/2 x 3 1/2 x 1/2
1 x 1 x 1/4	2 x 2 x 3/8	4 x 4 x 1/4
1 1/4 x 1 1/4 x 1/8	2 1/2 x 2 1/2 x 1/8	4 x 4 x 5/16
1 1/4 x 1 1/4 x 3/16	2 1/2 x 2 1/2 x 3/16	4 x 4 x 3/8
1 1/4 x 1 1/4 x 1/4	2 1/2 x 2 1/2 x 1/4	4 x 4 x 1/2
1 1/2 x 1 1/2 x 1/8	2 1/2 x 2 1/2 x 5/16	4 x 4 x 3/4
1 1/2 x 1 1/2 x 3/16	2 1/2 x 2 1/2 x 3/8	5 x 5 x 3/8
1 1/2 x 1 1/2 x 1/4	3 x 3 x 3/16	5 x 5 x 1/2
1 3/4 x 1 3/4 x 1/8	3 x 3 x 1/4	6 x 6 x 3/8
1 3/4 x 1 3/4 x 3/16	3 x 3 x 5/16	6 x 6 x 1/2
1 3/4 x 1 3/4 x 1/4	3 x 3 x 3/8	8 x 8 x 1/2
2 x 2 x 1/8	3 x 3 x 1/2	

**UNEQUAL LEGS (IN.)**

1 1/2 x 1 1/4 x 1/8	2 1/2 x 2 x 5/16	4 x 3 x 1/2
1 1/2 x 1 1/4 x 3/16	2 1/2 x 2 x 3/8	5 x 3 x 3/8
1 1/2 x 1 1/4 x 1/4	3 x 2 x 3/16	5 x 3 x 1/2
1 3/4 x 1 1/4 x 1/8	3 x 2 x 1/4	5 x 3 1/2 x 5/16
1 3/4 x 1 1/4 x 3/16	3 x 2 x 3/8	5 x 3 1/2 x 3/8
1 3/4 x 1 1/4 x 1/4	3 x 2 1/2 x 1/4	5 x 3 1/2 x 1/2
2 x 1 1/2 x 1/8	3 x 2 1/2 x 3/8	6 x 3 1/2 x 5/16
2 x 1 1/2 x 3/16	3 1/2 x 2 1/2 x 1/4	6 x 3 1/2 x 1/2
2 x 1 1/2 x 1/4	3 1/2 x 2 1/2 x 3/8	6 x 4 x 3/8
2 1/2 x 1 1/2 x 1/4	3 1/2 x 3 x 1/4	6 x 4 x 1/2
2 1/2 x 2 x 3/16	4 x 3 x 1/4	6 x 4 x 5/8
2 1/2 x 2 x 1/4	4 x 3 x 3/8	8 x 6 x 3/4

should be checked for availability of sizes other than those in these tables. Where necessary, and where extra cost is warranted, other sections may be produced by welding, cutting, or other methods.

**STEEL ANGLES UNEQUAL LEGS**

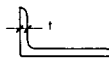

**STEEL ANGLES—UNEQUAL LEGS—BAR SIZE (IN.)**

SIZE x t	SIZE x t	SIZE x t
1 x 5/8 x 1/8	1 3/4 x 1 1/4 x 1/4	2 1/2 x 1 1/2 x 3/16
1 x 3/4 x 1/8	2 x 1 1/4 x 3/16	2 1/2 x 1 1/2 x 1/4
1 3/8 x 7/8 x 1/8	2 x 1 1/4 x 1/4, 3/16	2 1/2 x 1 1/2 x 5/16
1 3/8 x 7/8 x 3/16	2 x 1 1/2 x 1/8	2 1/2 x 2 x 3/16
1 1/2 x 1 1/4 x 3/16	2 x 1 1/2 x 3/16	2 1/2 x 2 x 1/4
1 3/4 x 1 1/4 x 1/8	2 x 1 1/2 x 1/4	2 1/2 x 2 x 5/16
1 3/4 x 1 1/4 x 3/16	2 1/4 x 1 1/2 x 3/16	2 1/2 x 2 x 3/8

**NOTE:** For structural angle sizes (3 x 2 x 3/16 in. and larger) see Dimensions of Angle Shapes in this chapter.

**STEEL ZEES**

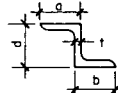

**STEEL ZEES—BAR SIZE (IN.)**

d x a x b x t	d x a x b x t
1 x 1 1/2 x 3/8 x 1/8	1 3/8 x 3/4 x 1 3/16 x 1/8
1 3/16 x 5/8 x 3/4 x 1/8	1 3/4 x 1 1/4 x 3/4 x 3/16

**STRUCTURAL**

3 x 2 1/16 x 2 1/16 x 1/4	4 1/8 x 3 3/16 x 3 3/16 x 3/8
3 x 2 1/16 x 2 1/16 x 3/8	5 x 3 1/4 x 3 1/4 x 5/16
3 x 2 1/16 x 2 1/16 x 1/2	5 x 3 3/4 x 3 3/4 x 1/2
4 x 3 1/16 x 3 1/16 x 1/4	5 1/16 x 3 5/16 x 3 5/16 x 3/8
4 1/16 x 3 3/8 x 3 3/8 x 5/16	6 x 3 1/2 x 3 1/2 x 3/8

**ALUMINUM ANGLE SQUARE CORNERS**



**ALUMINUM ANGLES—SQUARE CORNERS—EQUAL LEGS (IN.)**

SIZE x t	SIZE x t	SIZE x t
1/2 x 1/2 x 1/16	1 1/4 x 1 1/4 x 1/4	2 1/2 x 2 1/2 x 3/16, 1/4
1/2 x 1/2 x 1/8	1 1/2 x 1 1/2 x 1/8	3 x 3 x 1/8
5/8 x 5/8 x 1/8	1 1/2 x 1 1/2 x 3/16	3 x 3 x 3/16, 1/4
3/4 x 3/4 x 1/16, 1/8	1 1/2 x 1 1/2 x 1/4	3 x 3 x 5/16, 3/8, 1/2
1 x 1 x 1/8	1 3/4 x 1 3/4 x 3/16, 1/4	3 1/2 x 3 1/2 x 1/4
1 x 1 x 3/16	2 x 2 x 1/8	3 1/2 x 3 1/2 x 3/8
1 x 1 x 1/4	2 x 2 x 3/16, 1/8	3 1/2 x 3 1/2 x 1/2
1 1/8 x 1 1/8 x 3/16	2 x 2 x 1/4, 5/16, 3/8	4 x 4 x 1/4, 3/8, 1/2
1 1/4 x 1 1/4 x 1/8	2 1/2 x 2 1/2 x 1/8	6 x 6 x 3/8, 1/2

**UNEQUAL LEGS (IN.)**

3/4 x 3/8 x 3/32	2 x 3/4 x 1/8	3 1/2 x 2 x 1/8
1 x 1/2 x 1/8	2 x 1 x 1/8	3 1/2 x 2 1/2 x 3/8
1 x 3/4 x 1/8	2 x 1 x 3/16	3 1/2 x 3 x 1/8
1 1/4 x 1 1/2 x 1/8	2 x 1 1/2 x 1/8	4 x 2 x 1/8
1 1/2 x 1 1/2 x 1/8	2 1/2 x 1 x 1/8	4 x 3 x 1/8
1 1/2 x 3/4 x 1/8	2 1/2 x 1 1/2 x 1/8	5 x 3 x 1/8
1 1/2 x 1 x 1/8	2 1/2 x 2 x 1/8	5 x 4 x 1/8
1 3/4 x 1 x 1/8	3 x 1 x 1/8	5 1/4 x 2 1/4 x 1/8
1 3/4 x 1 1/2 x 1/8	3 x 2 x 1/8	
2 x 1 1/2 x 1/8	3 1/2 x 1 1/4 x 1/8	

**ALUMINUM ZEES SQUARE CORNERS**

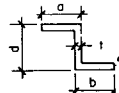

**ALUMINUM ZEES—SQUARE CORNERS (IN.)**

d x a x b x t	d x a x b x t
1/2 x 1/2 x 1 1/2 x 3/32	1 x 1 1/8 x 1 1/8 x 1/8
3/4 x 3/4 x 3/4 x 1/8	1 x 5/8 x 7/8 x 1/8
7/8 x 3/4 x 3/4 x 1/8	

**STEEL ANGLES EQUAL LEGS**



**STEEL ANGLES—EQUAL LEGS—BAR SIZE (IN.)**

SIZE x t	SIZE x t	SIZE x t
1/2 x 1/2 x 1/8	1 1/4 x 1 1/4 x 3/16	2 x 2 x 3/16
5/8 x 5/8 x 1/8	1 1/4 x 1 1/4 x 1/4	2 x 2 x 1/4
3/4 x 3/4 x 1/8	1 1/2 x 1 1/2 x 1/8	2 x 2 x 5/16
7/8 x 7/8 x 1/8	1 1/2 x 1 1/2 x 3/16	2 x 2 x 3/8
1 x 1 x 1/8	1 1/2 x 1 1/2 x 3/8	2 1/2 x 2 1/2 x 3/16
1 x 1 x 3/16	1 3/4 x 1 3/4 x 1/8	2 1/2 x 2 1/2 x 1/4
1 x 1 x 1/4	1 3/4 x 1 3/4 x 3/16	2 1/2 x 2 1/2 x 5/16
1 1/8 x 1 1/8 x 1/8	1 3/4 x 1 3/4 x 1/4	2 1/2 x 2 1/2 x 3/8
1 1/4 x 1 1/4 x 1/8	2 x 2 x 1/8	2 1/2 x 2 1/2 x 1/2

**NOTE:** For structural angle sizes (3 x 3 x 3/16 in. and larger) see Dimensions of Angle Shapes in this chapter.

**ALUMINUM CHANNEL SQUARE CORNERS**

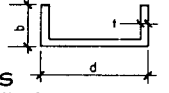

**ALUMINUM CHANNELS—SQUARE CORNERS (IN.)**

d x b x t	d x b x t	d x b x t
3/8 x 3/8 x 7/64	1 1/4 x 3/4 x 1/8	2 1/2 x 3/4 x 1/8
1/2 x 3/8 x 1/8	1 1/4 x 1 1/4 x 1/8	2 1/2 x 1 1/2 x 1/8
1/2 x 1/2 x 3/32	1 1/2 x 1 1/2 x 1/8	2 1/2 x 2 1/2 x 1/8
1/2 x 3/4 x 1/8	1 1/2 x 5/8 x 1/8	3 x 1 1/2 x 1/8
5/8 x 5/8 x 1/8	1 1/2 x 3/4 x 1/8	3 x 1 x 1/8
5/8 x 1 x 1/8	1 1/2 x 1 x 1/8	3 x 2 x 1/8
3/4 x 3/8 x 1/8	1 1/2 x 1 1/2 x 1/8	3 x 3 x 1/8
3/4 x 1/2 x 1/8	1 3/4 x 1/2 x 1/8	4 x 1 1/2 x 1/8
3/4 x 3/4 x 1/8	1 3/4 x 3/4 x 1/8	4 1/2 x 2 x 1/8
1 x 1/2 x 1/8	1 3/4 x 1 x 1/8	5 x 2 x 3/16
1 x 3/4 x 1/8	2 x 1/2 x 1/8	
1 x 1 x 1/8	2 x 1 x 1/8	
1 1/4 x 1/2 x 1/8	2 x 2 x 1/8	
1 1/4 x 5/8 x 1/8	2 1/4 x 7/8 x 1/8	

**NOTE:** For aluminum channels in American Standard sizes and Aluminum Association Standard sizes, see Dimensions of Channel Shapes in this chapter.

**ALUMINUM TEES SQUARE CORNERS**

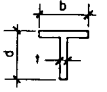

**ALUMINUM TEES—SQUARE CORNERS (IN.)**

b x d x t	b x d x t	b x d x t
3/4 x 3/4 x 1/8	1 1/8 x 1 1/2 x 3/8	2 x 3/4 x 1/8
3/4 x 1 1/4 x 1/8	1 1/8 x 1 1/8 x 1/8	2 x 2 x 3/16
1 x 3/4 x 1/8	1 1/4 x 7/8 x 1/8	
1 x 1 x 1/8	1 1/2 x 1 1/2 x 1/8	

**ALUMINUM TEES SQUARE CORNERS**

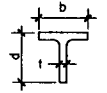

**STRUCTURAL (IN.)**

1 1/2 x 1 1/2 x 1/4	2 1/4 x 2 1/4 x 1/4	4 x 4 x 3/8
2 x 2 x 1/4	3 x 3 x 3/8	

**STAINLESS STEEL ANGLES**



**STAINLESS STEEL ANGLES (IN.)**

SIZE x t	SIZE x t	SIZE x t
3/4 x 3/4 x 1/8	1 1/2 x 1 1/2 x 3/16	2 1/2 x 2 1/2 x 1/4
1 x 1 x 1/8	1 1/2 x 1 1/2 x 1/4	3 x 3 x 1/4
1 x 1 x 3/16	2 x 2 x 1/8	3 x 3 x 5/16
1 1/4 x 1 1/4 x 1/8	2 x 2 x 3/16	3 x 3 x 3/8
1 1/4 x 1 1/4 x 3/16	2 x 2 x 1/4	
1 1/2 x 1 1/2 x 1/8	2 1/2 x 2 1/2 x 3/16	

**RECTANGULAR TUBING - STEEL**

SIZE (IN.)	T = WALL THICKNESS (BW GAUGE OR IN.)							
	16	14	11	11	11	11	11	11
1 x 1/2	16							
1 1/2 x 3/4	14	14	11					
1 1/2 x 1	16	14	11					
2 x 1	16	15	14	11				
2 x 1 1/4	14							
2 x 1 1/2	14	11						
2 1/2 x 1	14							
2 1/2 x 1 1/4	14							
2 1/2 x 1 1/2	14	11	1/8"	3/16"	1/4"			
3 x 1	14	11						
3 x 1 1/2	14	12	11	1/8"	3/16"	1/4"		
3 x 2	14	11	1/8"	7/16"	1/2"	3/16"	1/4"	5/16"
4 x 2	14	11	1/8"	7/16"	1/2"	3/16"	1/4"	5/16"
4 x 2 1/2	1/8"							
4 x 3	1/8"	7	3/16"	1/4"	5/16"			
5 x 2	7	3/16"	1/4"	5/16"				
5 x 2 1/2	1/8"	3/16"						
5 x 3	7	3/16"	1/4"	5/16"	3/8"	1/2"		
6 x 2	7	3/16"	1/4"	5/16"				
6 x 3	7	3/16"	1/4"	5/16"	3/8"	1/2"		
6 x 4	7	3/16"	1/4"	5/16"	3/8"	1/2"		
7 x 3	3/8"							
7 x 4	3/16"	1/4"	3/8"					
7 x 5	0.135"	7	3/16"	1/4"	3/8"	1/2"		
8 x 2	7	3/16"	1/4"	5/16"	3/8"			
8 x 3	3/16"	1/4"	3/8"	1/2"				
8 x 4	7	3/16"	1/4"	5/16"	3/8"	1/2"		
8 x 6	7	3/16"	1/4"	5/16"	3/8"	1/2"		
9 x 5	3/8"							
9 x 7	1/4"	5/16"						
10 x 2	3/16"	1/4"						
10 x 4	7	3/16"	1/4"	5/16"	3/8"	1/2"		
10 x 5	1/4"							
10 x 6	1/4"	5/16"	3/8"	1/2"				
10 x 8	1/4"	3/8"	1/2"					
12 x 2	3/16"							
12 x 4	7	1/4"	3/8"	1/2"				
12 x 6	1/4"	3/8"	1/2"					
12 x 8	1/4"	3/8"	1/2"					

**ALUMINUM**

1 x 1/2	0.125"							
1 x 2	0.125"							
1 1/2 x 2	0.125"							
1 1/2 x 2 1/2	0.125"							
1 1/2 x 3	0.125"							
1 3/4 x 2 1/4	0.125"							
1 3/4 x 3	0.125"							
1 3/4 x 3 1/2	0.125"							
1 3/4 x 4	0.125"							
1 3/4 x 4 1/2	0.125"							
1 3/4 x 5	0.125"							
2 x 3	0.125"							
2 x 4	0.125"							
2 x 5	0.125"							
2 x 6	0.125"							
2 x 8	0.125"							

**STAINLESS STEEL**

1 x 1/2	11							
1 x 2	11							
2 x 3	11	7						
2 x 4	11	7	1/4"					

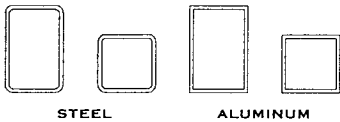

**RECTANGULAR AND SQUARE TUBING**

**RECTANGULAR ALUMINUM TUBING (IN.)**

SIZE x T	SIZE x T	SIZE x T
1 1/2 x 1 1/2 x 1/8	1 3/4 x 2 1/4 x 1/8	2 x 3 x 1/8
1 x 2 x 1/8	1 3/4 x 3 x 1/8	2 x 4 x 1/8
1 1/2 x 2 x 1/8	1 3/4 x 3 1/2 x 1/8	2 x 5 x 1/8
1 1/2 x 2 1/2 x 1/8	1 3/4 x 4 x 1/8	2 x 6 x 1/8
	1 3/4 x 4 1/2 x 1/8	3 x 5 x 1/8
	1 3/4 x 5 x 1/8	3 x 5 x 1/8

**SQUARE ALUMINUM TUBING (IN.)**

SIZE x T	SIZE x T	SIZE x T
1/2 x 1/2 x 1/16	1 1/4 x 1 1/4 x 1/8	2 x 2 x 1/8
3/4 x 3/4 x 1/16	1 1/2 x 1 1/2 x 1/8	2 1/2 x 2 1/2 x 1/8
3/4 x 3/4 x 1/8	1 1/2 x 1 1/2 x 3/64	3 x 3 x 1/8
1 1/2 x 3/4 x 1/8	1 1/2 x 1 1/2 x 1/8	4 x 4 x 1/8
1 x 1 x 1/16	1 3/4 x 1 3/4 x 1/8	
1 x 1 x 1/8		

**NOTE**

Rectangular and square tubing with sharp corners is usually used for miscellaneous architectural metalwork.

**ROUND TUBING - COPPER**

SIZE (IN.) NOMINAL INSIDE DIA.	OUTSIDE DIA. (BW GAUGE)	INSIDE DIAMETER (BW GAUGE)			
		TYPE K	TYPE L	TYPE M	TYPE DMV
1/2	0.375	0.305	0.315		
3/4	0.625	0.527	0.545	0.569	
1	0.875	0.745	0.785	0.811	
1 1/2	1.125	0.995	1.025	1.055	
2	1.625	1.481	1.505	1.527	1.541
4	2.125	1.959	1.985	2.009	2.041
	4.125	3.857	3.905	3.935	4.009

**NOTES**

Round tubing, usually manufactured for mechanical purposes, is used for architectural metalwork to supplement round pipe. Round tubing is measured by the outside diameter and the wall thickness by gauge, fractions, or decimals of an inch. Round tubing is used where a high grade finish is required and exact diameters are necessary.

Round tubing is available in steel, aluminum, copper, stainless steel, and other metals. Individual manufacturers' catalogs should be consulted for availability of materials and sizes.

**ROUND PIPE - STEEL**

SIZE (IN.) NOMINAL INSIDE DIA.	OUTSIDE DIA. (BW GAUGE)	INSIDE DIAMETER (BW GAUGE)		
		STD.	EXTRA STRONG	DOUBLE EXTRA STRONG
1/8	0.405	0.269	0.215	
1/4	0.540	0.364	0.302	
3/8	0.675	0.493	0.423	
1/2	0.840	0.622	0.546	
3/4	1.050	0.824	0.742	
1	1.315	1.049	0.957	
1 1/4	1.660	1.380	1.278	
1 1/2	1.900	1.610	1.500	
2	2.375	2.067	1.939	1.503
2 1/2	2.875	2.469	2.323	1.771
3	3.500	3.068	2.900	2.300
3 1/2	4.000	3.548	3.364	
4	4.500	4.026	3.826	3.152
5	5.563	5.047	4.813	4.063
6	6.625	6.065	5.761	4.897
8	8.625	7.981	7.625	6.875
10	10.750	10.020	9.750	
12	12.750	12.000	11.750	

**NOTE**

Round pipe is made primarily in three weights: standard, extra strong (or extra heavy), and double extra strong (or double extra heavy). Outside diameters of the three weights of pipe in each size are always the same; extra wall thickness is always on the inside and therefore reduces the inside diameter of the heavier pipe. All sizes are specified by what is known as the "nominal inside diameter."

Round pipe is also available in aluminum and stainless steel. Individual manufacturers' catalogs should be consulted for sizes.

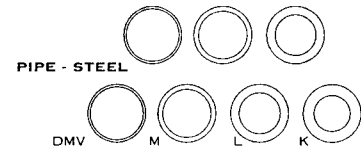

**ROUND TUBING AND PIPE**

**SQUARE TUBING - STEEL**

SIZE (IN.)	WALL THICKNESS (BW GAUGE OR IN.)											SIZE (IN.)	WALL THICKNESS (BW GAUGE OR IN.)			
	20	18	0.063	16												
1/2 x 1/2	20	18	0.063	16												
3/4 x 3/4	20	18	16													
1 x 1	20	18	0.063	16	14	11										
1 1/8 x 1 1/8	18	16														
1 1/4 x 1 1/4	18	0.063	16	15	14	13	12	11	0.135	3/16"						
1 1/2 x 1 1/2	18	0.063	16	15	14	13	12	11	0.145	3/16"	1/4"					
1 3/4 x 1 3/4	16	14	11													
2 x 2	18	0.063	16	15	14	13	12	11	1/8"	10	7	3/16"	1/4"			
2 1/4 x 2 1/4	16															
2 1/2 x 2 1/2	14	11	1/8"	10	7	3/16"	1/4"									
3 x 3	14	11	1/8"	7	3/16"	1/4"	5/16"	3/8"								
3 1/2 x 3 1/2	1/8"	7	3/16"	1/4"	5/16"											
4 x 4	11	1/8"	7	3/16"	1/4"	5/16"	3/8"	1/2"								
4 1/2 x 4 1/2	3/16"	1/4"														
5 x 5	1/8"	7	3/16"	1/4"	5/16"	3/8"	1/2"									
6 x 6	7	3/16"	1/4"	5/16"	3/8"	1/2"										
7 x 7	3/16"	1/4"	5/16"	3/8"	1/2"											
8 x 8	7	3/16"	1/4"	5/16"	3/8"	1/2"	5/8"									
10 x 10	1/4"	5/16"	3/8"	1/2"	5/8"											
12 x 12	1/4"	3/8"	1/2"													
14 x 14	1/2"															
16 x 16	1/2"															

**GENERAL**

Lally columns are prefabricated structural units that consist of a load-bearing steel column, filled with concrete. This creates a column with increased load-bearing capacity in a space no larger than a standard column. Fireproof lally columns have a thin steel shell and a layer of insulating material between the shell and the structural steel. Fire ratings range from two to four hours depending on the thickness of the insulating material. The protective steel shell allows fireproof lally columns to be left exposed in either interior or exterior applications.

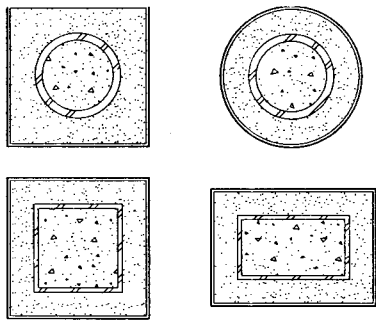

TYPICAL LALLY COLUMN SHAPES

**CONCRETE FILLED STEEL TUBING**

OUTER DIMENSION OF TUBING	WALL THICKNESS	WEIGHT PER FT	ALLOWABLE SAFE LOADS IN KIPS													U.L. RATED/FIRE-PROOFED COLUMN		
			EFFECTIVE LENGTH IN FEET KL WITH RESPECT TO RADIUS OF GYRATION													SQUARE SHELL SIZES (IN.)		
			6	8	10	12	14	16	18	20	22	24	2 HR.	3 HR.	4 HR.			
3 x 3	1/4	15	62	53	40										6 x 6	7 x 7	8 x 8	
3 1/2 x 3 1/2	1/4	20	77	68	55	42									6 x 6	7 x 7	8 x 8	
4 x 4	3/8	25	98	89	78	65	51	40							6 x 6	7 x 7	8 x 8	
	1/2	28	132	119	102	85	64											
5 x 5	1/4	36	137	128	118	107	94	80	64						7 x 7	8 x 8	9 x 9	
	3/8	40	185	172	158	141	124	103	82									
	1/2	44	229	212	194	173	150	124										
6 x 6	1/4	49	178	169	160	150	138	125	110	95	79							
	3/8	55	241	228	215	200	183	165	145	124	101							
	1/2	60	299	283	267	248	226	204	177	151								
7 x 7	1/4	65	221	213	204	194	183	171	158	143	128	111						
	3/8	72	297	285	273	259	243	227	208	189	168	146						
	1/2	78	369	354	337	320	301	279	255	230	204	176						
8 x 8	1/4	82	266	259	251	240	231	218	206	193	178	163						
	3/8	90	357	346	334	321	306	291	272	254	236	215						
	1/2	98	440	427	412	395	377	355	334	311	286	259						
10 x 10	1/4	122	364	357	349	340	330	320	308	296	282	267						
	3/8	132	482	471	460	448	435	419	404	388	369	350						
	1/2	142	592	579	566	550	533	515	495	474	453	428	12 x 12	13 x 13	14 x 14			

**NOTE**  
Load table based on  $F_y = 46$  ksi

**CONCRETE FILLED STEEL PIPE**

OUTER DIAMETER OF PIPE (IN.)	WALL THICKNESS	WEIGHT PER FT	ALLOWABLE SAFE LOADS IN KIPS													U.L.-RATED FIREPROOFED COLUMNS							
			EFFECTIVE LENGTH IN FEET KL WITH RESPECT TO RADIUS OF GYRATION													SQUARE SHELL SIZES (IN.)			ROUND SHELL SIZES (IN.)				
			6	8	10	12	14	16	18	20	22	24	26	2 HR.	3 HR.	4 HR.	2 HR.	3 HR.	4 HR.				
3	.216	15	45	40	32										6 x 6	7 x 7	8 x 8	6 5/8	6 5/8	8 5/8			
	.300	17	58	49	39																		
	.600	23	94	79	60																		
4	.226	20	58	53	45	36									6 x 6	7 x 7	9 x 9	6 5/8	8 5/8	8 5/8			
	.318	22	75	66	56	46																	
	.674	36	155	139	122	102	41	52															
4 1/2	.237	24	73	66	59	51	41								7 x 7	8 x 8	9 x 9	6 5/8	8 5/8	8 5/8			
	.337	27	93	86	76	65	52																
	.674	36	155	139	122	102	41	52															
5 1/2	.258	36	106	99	92	85	75	66	54							8 x 8	9 x 9	10 x 10	8 5/8	8 5/8	10 3/4		
	.375	39	139	130	120	110	98	84	69														
	.750	52	230	215	198	178	156	132															
6 5/8	.280	49	144	139	132	123	114	104	93	81	68							9 x 9	10 x 10	11 x 11	8 5/8	10 3/4	10 3/4
	.432	56	197	188	178	166	153	140	125	109	169												
	.864	73	327	312	293	272	249	225	198														
8 5/8	.322	81	232	225	218	210	201	190	179	167	154	141	127										
	.500	91	314	305	295	283	270	257	242	226	209	191	171	11 x 11	12 x 12	13 x 13	10 3/4	12 3/4	12 3/4				
	.875	111	475	460	444	425	404	383	359	334	307	278	248										
10 3/4	.365	123	342	336	328	320	311	300	289	277	264	251	237	13 x 13	14 x 14	15 x 15	14	14	16				
	.500	133	423	415	406	394	383	370	356	342	326	309	291										
	.750	169	534	526	517	507	496	484	470	457	442	426	409	15 x 15	16 x 16	17 x 17	16	16	18				

**NOTE**  
Load table based on  $F_y = 46$  ksi

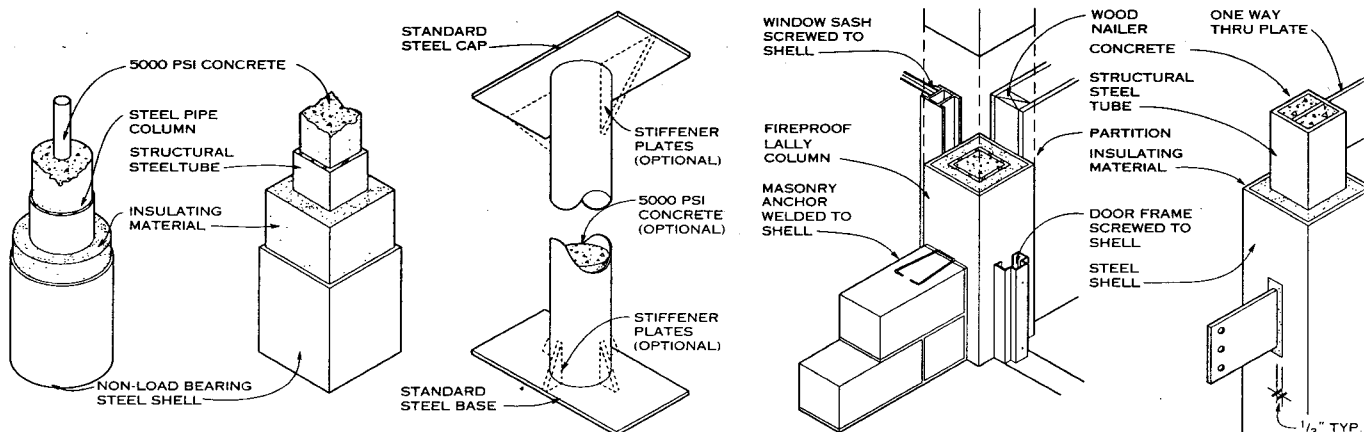

FIREPROOF COLUMNS      TYPICAL COLUMN BASE AND CAP      ATTACHMENTS TO STEEL SHELL      BEAM CONNECTIONS

**TYPICAL LALLY COLUMN ASSEMBLIES**

Eric Gastier; Alexandria, Virginia

**GUIDELINES**

1. Width of stair:
  - a. Dwelling stairs: minimum 36 in. treads.
  - b. Public exit stairs: minimum 44 in. treads.
  - c. Rescue assistance area (ADA): 48 in. between handrails.
2. Treads:
  - a. Dwellings: 9 in. minimum (nosing to nosing).
  - b. Other (ADA): 11 in. minimum (nosing to nosing).
  - c. Uniform width within one flight.
3. Risers:
  - a. Dwellings: 8 1/2 in. maximum.
  - b. Other (ADA): minimum 4 in., maximum 7 in.
  - c. Uniform height within one flight.
4. Nosing: maximum 1 1/2 in. with 60° under nosing; maximum 1/2 in. radius at edge.
5. Stair rails:
  - a. Height in dwellings: 36 in.
  - b. Height in exit stairs: 42 in.
  - c. Rails should be arranged so that a sphere 4 in. in diameter cannot be passed through.

- d. Rails should be arranged to discourage climbing.
  - e. Concentrated load nonconcurrently applied at the top rail shall be 200 lb per ft in vertical downward and horizontal direction. The test loads are applicable for railings with supports not more than 8 ft apart.
6. Handrails:
    - a. Dwellings: on one side only, required.
    - b. Other (ADA): required on both sides.
    - c. Height: 34 to 38 in.
    - d. Grip surface: 1 1/4 to 1 1/2 in.
    - e. Clearance at wall: 1 1/2 in.
    - f. Projecting or recessed.
    - g. Extension at top of run: 12 in.
    - h. Extension at bottom of run: 12 in. plus width of tread.
    - i. When a guardrail more than 38 in. high is used, a separate handrail should be installed (ASTM).
    - j. Nothing should interrupt the continuous sliding of hands.
  7. Regulators and standards: building codes, ADA, ASTM, ANSI, NFPA, and OSHA.

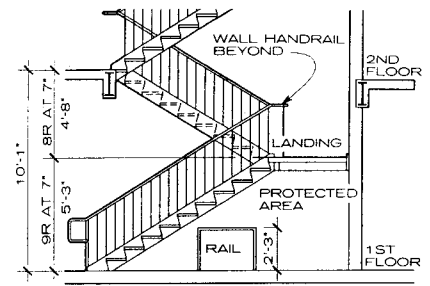

STAIR SECTION

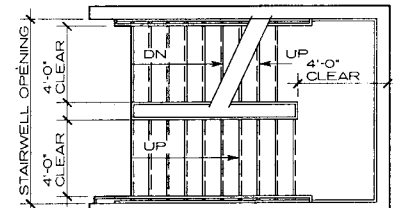

PLAN DIMENSIONS REQUIRED FOR RESCUE ASSISTANCE (ADA)

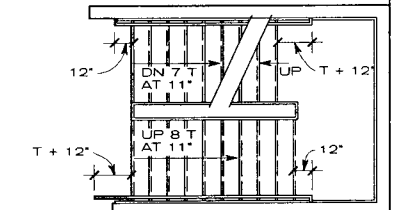

PLAN SHOWING HANDRAIL EXTENSIONS

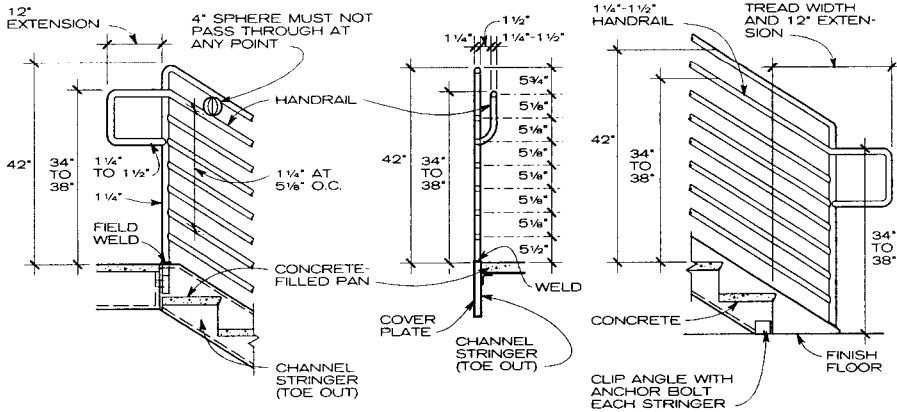

**STEEL STAIR RAILS**

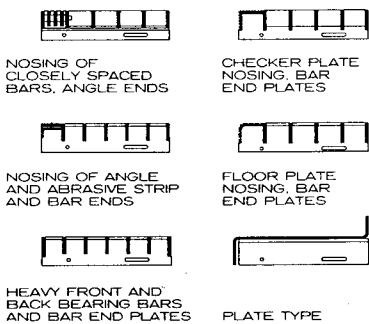

**TREADS**

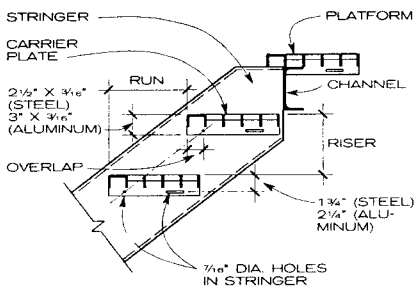

**NOTE**  
This stair is not suitable for persons with disabilities.

**INDUSTRIAL AND SERVICE STAIRS**

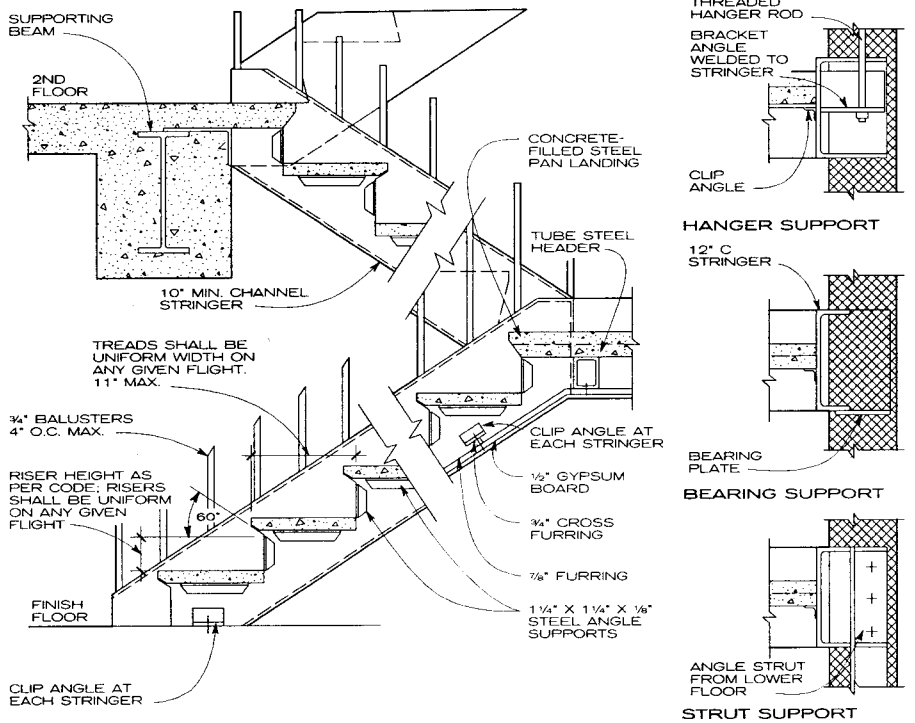

**PAN-TYPE STAIR CONSTRUCTION**

Charles A. Szoradi, AIA; Washington, D.C.

**GENERAL NOTES**

1. Materials for ladders and supports include galvanized steel and aluminum. Galvanized steel ladders are fastened to the wall with galvanized steel fasteners; aluminum ladders are fastened with stainless steel fasteners.
2. All fixed wall ladders must conform to OSHA/ANSI A14.3 standards. Also consult local codes for design requirements.

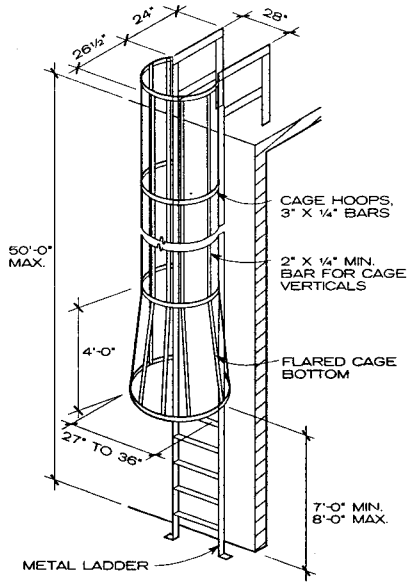

**NOTE**  
Cages should be used on ladders at hazardous locations or on short ladders at high locations.

**FIXED VERTICAL LADDER (50 FEET OR LESS)**

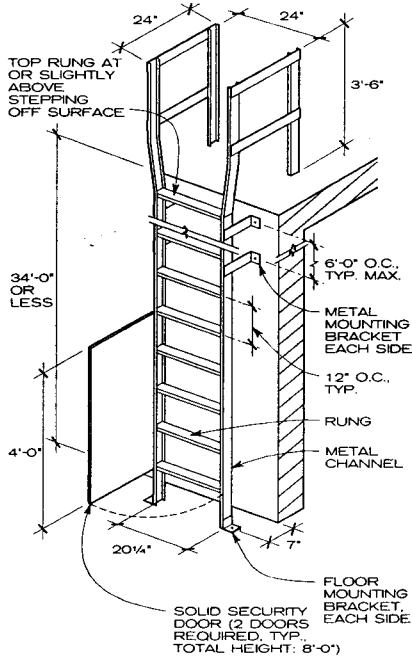

**FIXED VERTICAL LADDER (UP TO 24 FEET)**

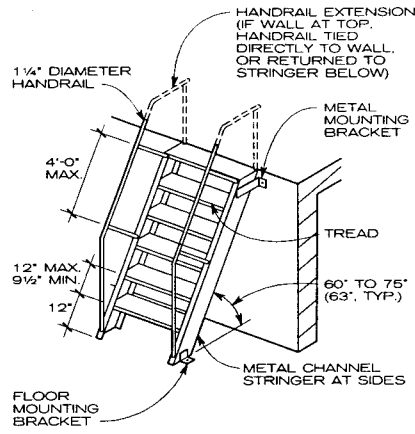

**NOTE**  
The maximum rise between treads depends on exact ladder height and angle.

**SHIP'S LADDER**

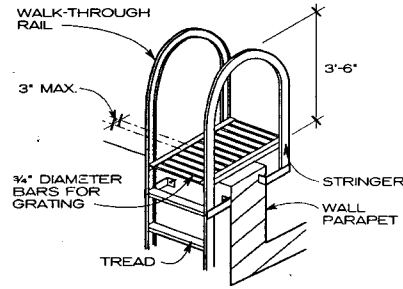

**ALTERNATE VERTICAL LADDER WALK THROUGH**

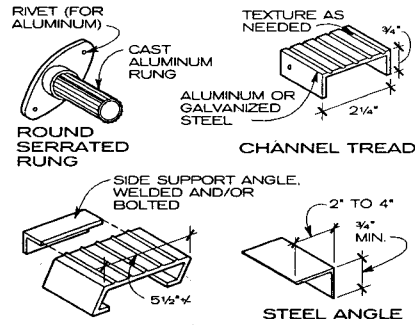

**SHIP'S LADDER TREADS AND RUNGS**

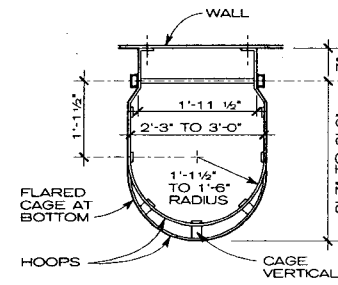

**SAFETY CAGE**

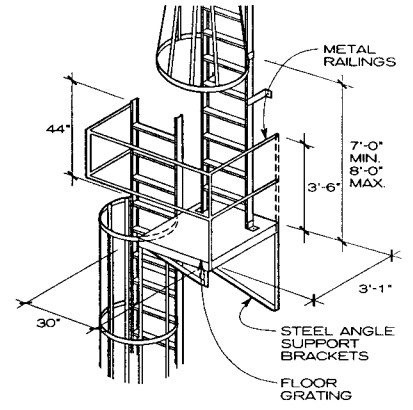

**NOTE**  
Cages and rest platforms are required for climbing heights of more than 50 ft.

**REST PLATFORM**

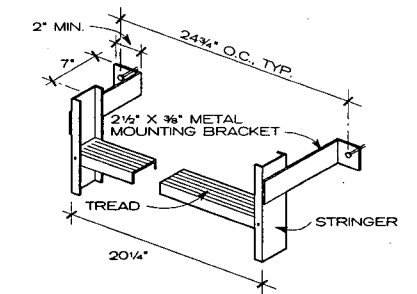
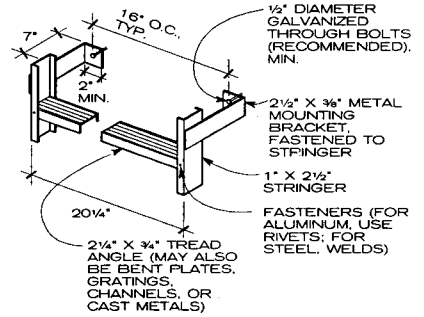

**SIDE RAIL MOUNTING BRACKET DETAILS**

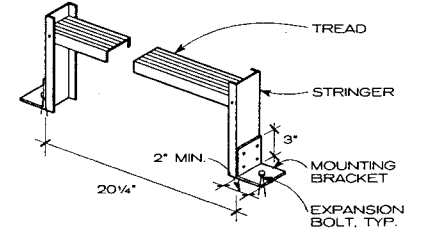

**FLOOR-MOUNTING BRACKET DETAIL**

Richard J. Vitullo, AIA; Oak Leaf Studio; Crownsville, Maryland

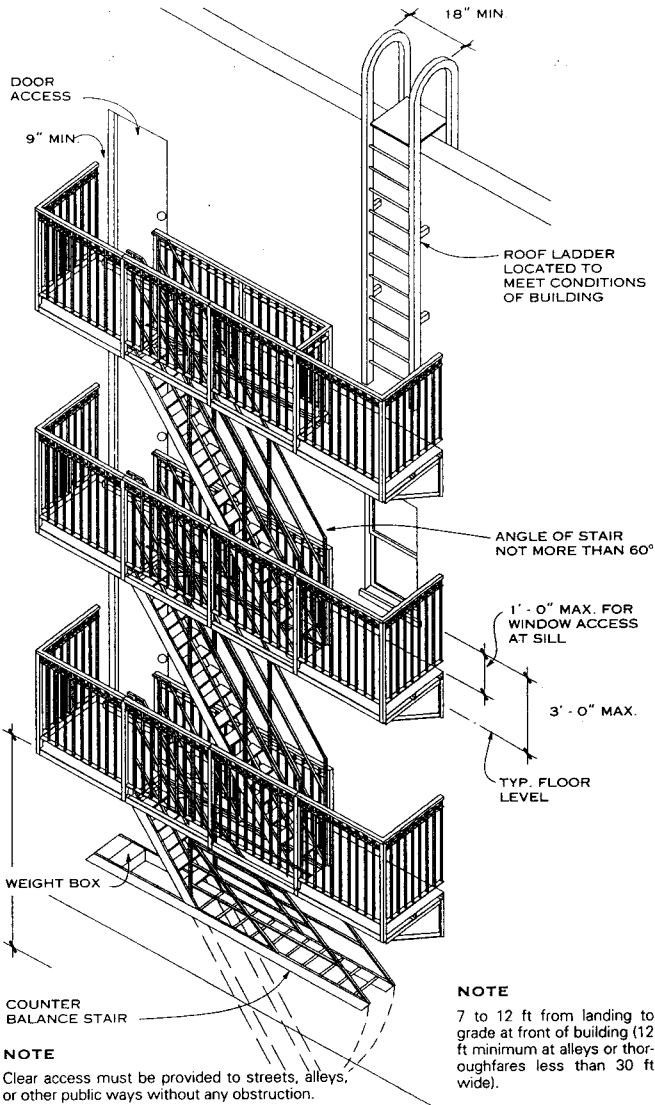

**FIRE ESCAPE**

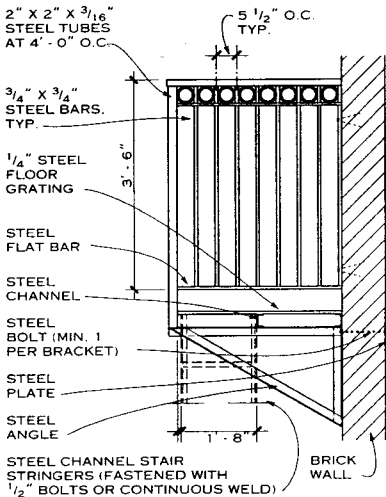

**ELEVATION - FIRE ESCAPE**

**NOTE**

7 to 12 ft from landing to grade at front of building (12 ft minimum at alleys or thoroughfares less than 30 ft wide).

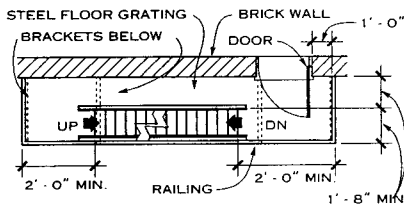

**PLAN - FIRE ESCAPE**

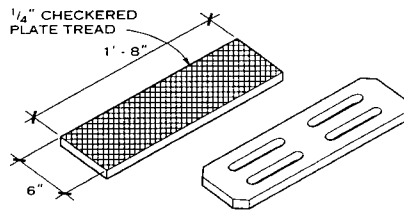

**TYPICAL STAIR TREADS**

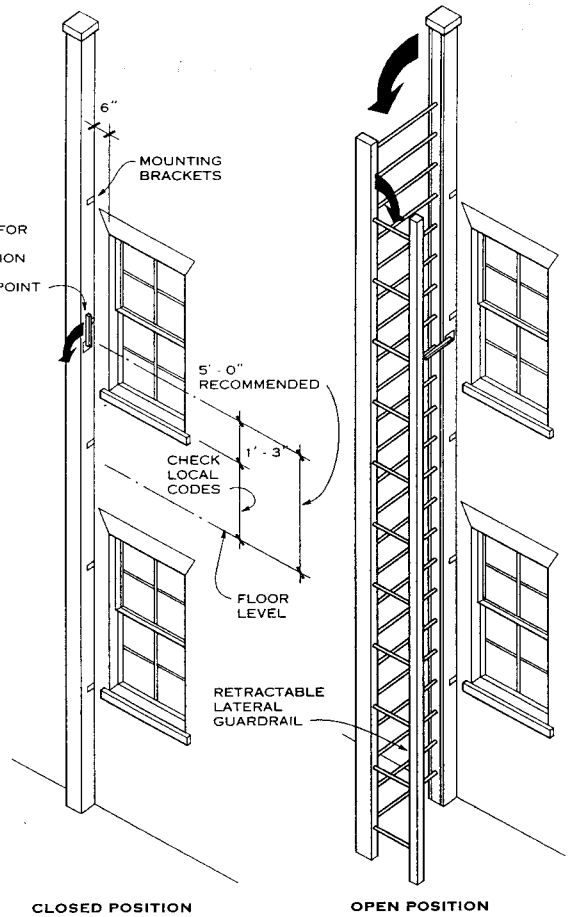

**RETRACTABLE ESCAPE LADDER**

**FIRE ESCAPE NOTES**

1. In general, exterior fire escapes are not permitted as any part of the required means of egress for new buildings, but may be continued as a component in the means of egress in existing buildings. New fire escapes for existing buildings are permitted only where exterior stairs cannot be utilized due to lot lines that limit stair size or due to sidewalks, alleys, or streets at grade level. Access by windows is generally not permitted.
2. For other specific requirements, refer to applicable national and local building codes.
3. For standards for fire escapes as well as for stairs and means of egress, consult ANSI 117.1, OSHA, and NFPA 1010 (Life Safety Code).
4. Since fire escapes are mounted outside of the building envelope, consideration must be given to exterior lighting provided on the building itself or general street lighting that would illuminate it.
5. Standard fire escapes are typically designed to support a live load of 100 lb/sq ft; stair treads shall be designed to support a concentrated live load of 250 lb at any point.

**ESCAPE LADDER NOTES**

1. Located adjacent to windows or balconies, the retractable aluminum escape ladder is used solely for emergency exit, rescue, or supplemental escape route. Also provides access to mechanical equipment or other secured spaces. Not to be used as any component in the means of egress.
2. Consult manufacturer for mounting details. Refer to national and local building codes for specific requirements concerning access opening types, sill heights, clearances, and maximum installation heights allowed. In some instances, a balcony may be used at any level to access the ladder.

Richard J. Vitullo, AIA; Oak Leaf Studio; Crownsville, Maryland  
Jomy Safety Ladder Company, Inc.; Boulder, Colorado



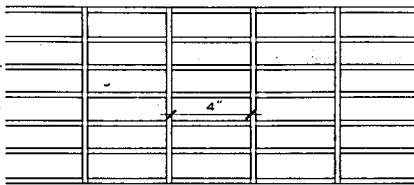

WITH SPACER BARS WELDED 4" O.C.  
NOTE

Constructed of flat bearing bars of steel or aluminum I-bars, with space bars at right angles. Space bars may be square, rectangular, or of another shape. Spacer bars are connected to bearing bars by pressing them into prepared slots or by

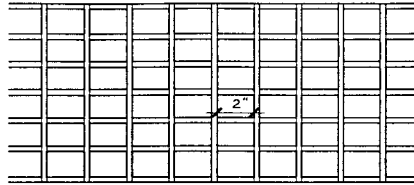

WITH SPACER BARS WELDED 2" O.C.

welding. They have open ends or ends banded with flat bars about the same size as welded bearing bars. Standard bar spacings are  $\frac{15}{16}$  and  $\frac{13}{16}$  in.

RECTANGULAR BAR GRATING (WELDED OR PRESSURE LOCKED)

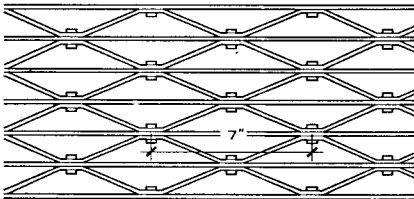

WITH SPACER BARS RIVETED APPROX. 7" O.C.  
USED FOR AVERAGE INSTALLATION

NOTE

Flat bearing bars are made of steel or aluminum, and continuous bent spacer or reticulate bars are riveted to the bearing bars. Usually they have open ends or ends that are banded with flat bars of the same size as bearing bars, welded across the ends. Normal spacing of bars:  $\frac{3}{4}$ ,  $1\frac{1}{8}$ , or

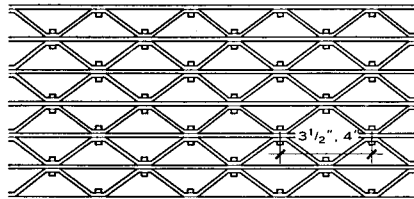

WITH SPACER BARS RIVETED 3 1/2" OR 4"  
USED FOR HEAVY TRAFFIC AND WHERE WHEELED EQUIPMENT IS USED

$2\frac{5}{16}$  in. Many bar gratings cannot be used in areas of public pedestrian traffic (openings are too big for crutches, canes, pogo sticks, women's shoes, etc.). Close mesh grating ( $\frac{1}{4}$  in.) is available in steel and aluminum for use in pedestrian traffic areas.

RETICULATED GRATING (RIVETED)

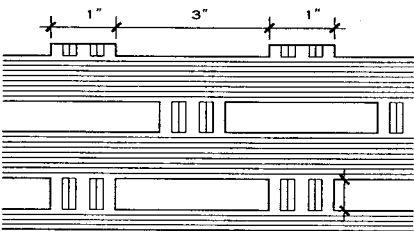

PLAN

NOTE

Grating is extruded from aluminum alloy in one piece with integral I-beam ribs and can have a natural finish or be anod-

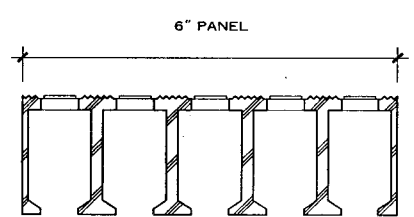

SECTION

ized. Top of surface may be solid or punched. Standard panel width is 6 in.

ALUMINUM PLANK GRATING

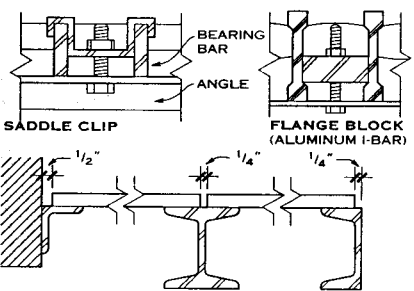

STANDARD ERECTION CLEARANCES

USUALLY ATTACHED BY WELDING, WHERE SUPPORT AND GRATE ARE CONSTRUCTED AS A UNIT

FIXED OR LOOSE GRATINGS—TYPICAL DETAILS

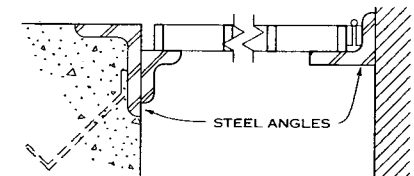

SIZES OF ANGLES SUPPORTING GRATING DEPEND ON DEPTH OF GRATING BARS

HINGED GRATINGS—TYPICAL DETAILS

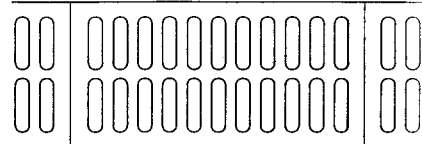
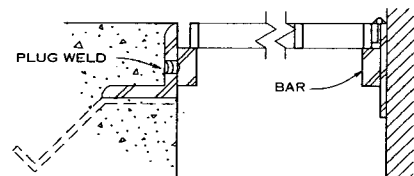
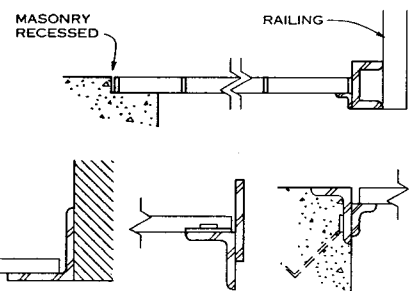

STANDARD DOUBLE-SLOT GRATING

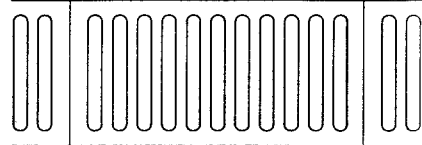

STANDARD SINGLE-SLOT GRATING

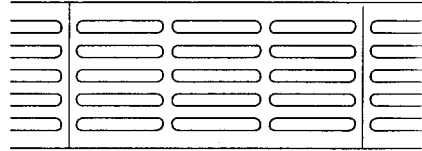

TRIPLE-SLOT GRATING  
SLOTS PARALLEL TO FRAME

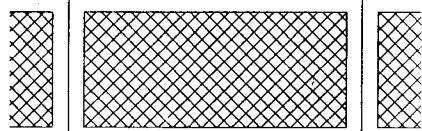

SOLID COVER

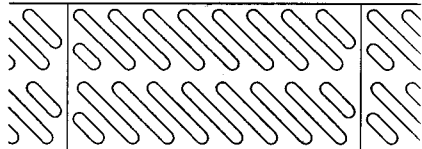

WHEELCHAIR/BICYCLE GRATING

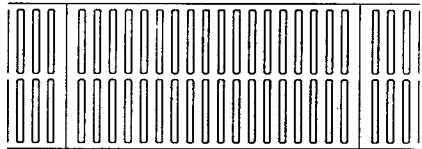

PEDESTRIAN GRATING

NOTE

Grates made of gray cast iron, ductile cast iron, or cast aluminum

STANDARD GRATE DESIGNS

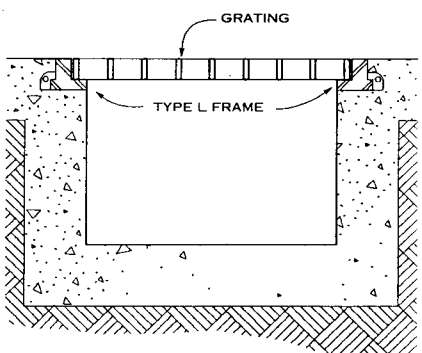

SECTION

TRENCH GRATINGS—FRAME DETAIL

Charles F. D. Egbert, AIA; Washington, D.C.  
Vicente Cordero, AIA; Arlington, Virginia

**GENERAL**

Wrought iron is a commercial form of iron with a relatively soft and malleable fibrous structure. The term literally means "fashioned" or "formed" iron and is widely associated with ironwork details. ASTM A 186 defines wrought iron as iron with a carbon content between 0.03 and 0.05%, a material prevalent up to the 19th century. Iron with such a low carbon content is scarce today, so most fabricators use steels containing combinations of iron with a higher percentage of carbon for ornamental details. Low carbon steel or mild steel is the most desirable of these.

**NOTES**

1. Steel and iron are the metals most frequently used for ornamental structures. Other popular metals are aluminum (favored for its light weight and rust resistance), polished bronze, brass, and copper. Blacksmiths primarily

produce custom work today; a smaller proportion of their work is restoration.

2. Working with iron is a craft not readily mastered by generalists; low bidders may not be qualified to deliver a high-quality product. Check references for similar types of jobs performed or jobs at similar costs. Consult the National Ornamental and Miscellaneous Metal Association (NOMMA) and the Artists-Blacksmiths Association of North America for more information on references and lists of blacksmith shops in the United States.

3. NOMMA publishes voluntary guidelines for joint finishes in ornamental work. They are Finish #1 (no evidence of a welded joint); Finish #2 (completely sanded joint, some undercutting and pinholes); Finish #3 (partially dressed weld with splatter removed); and Finish #4 (good quality, uniform undressed weld with minimal splatter).

**TYPICAL SIZES AND WEIGHTS (LB PER FT) FOR SOLID IRON AND CARBON STEEL BARS**

DIAMETER OR THICKNESS (IN.)	1/8	3/16	1/4	5/16	3/8	7/16	1/2	5/8	3/4	7/8	1	1 1/4	1 1/2	
<b>ROUNDS (DIAMETER IN.)</b>	.042	.094	.167	.261	.376	.511	.668	1.04	1.50	2.04	2.67	4.17	6.01	
Flat bars (width)	1/8 in.	0.053												
	3/16 in.	0.080	0.120											
	1/4 in.	0.106	0.160	0.213										
	5/16 in.	0.133	0.200	0.266	0.322									
	3/8 in.	0.159	0.239	0.399	0.398	0.478								
	7/16 in.	0.186	0.279	0.372	0.464	0.558	0.651							
	1/2 in.	0.212	0.319	0.425	0.531	0.637	0.744	0.850						
	5/8 in.	0.266	0.398	0.531	0.664	0.797	0.930	1.062	1.328					
	3/4 in.	0.319	0.478	0.637	0.797	0.956	1.116	1.275	1.594	1.912				
	7/8 in.	0.372	0.558	0.748	0.930	1.116	1.302	1.487	1.859	2.231	2.603			
	1 in.	0.425	0.637	0.850	1.062	1.275	1.487	1.700	2.125	2.550	2.975	3.400		
	1 1/4 in.	0.531	0.797	1.062	1.328	1.594	1.859	2.125	2.656	3.187	3.719	4.250	5.312	
	1 1/2 in.	0.638	0.956	1.275	1.594	1.913	2.231	2.550	3.188	3.825	4.463	5.100	6.375	7.650
	1 3/4 in.	0.744	1.116	1.488	1.859	2.231	2.603	2.975	3.719	4.463	5.206	5.950	7.438	8.925
	2 in.	0.850	1.275	1.700	2.125	2.550	2.975	3.400	4.250	5.100	5.950	6.800	8.500	10.200
	2 1/2 in.	1.063	1.594	2.125	2.656	3.188	3.719	4.250	5.313	6.375	7.438	8.500	10.625	12.750

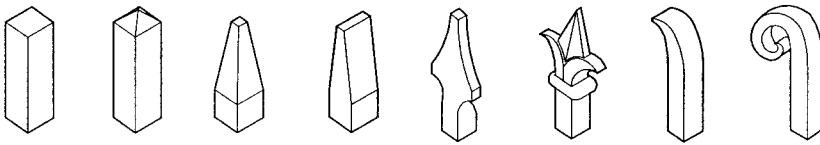

**BAR ENDS**

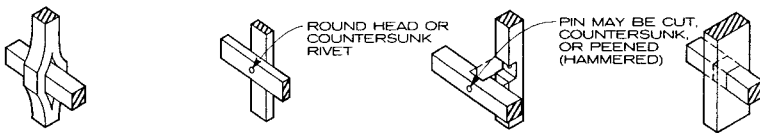

**INTERSECTING MEMBERS**

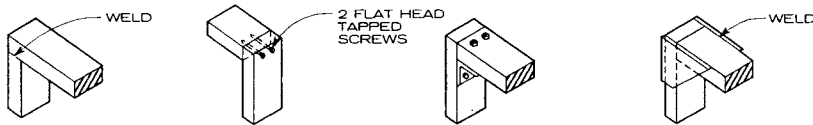

**CORNER CONDITIONS**

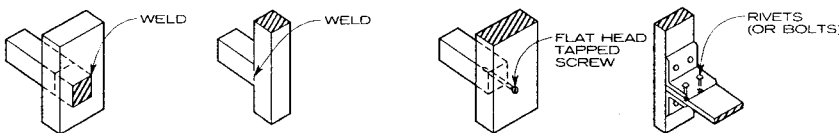

**EDGE CONDITIONS**

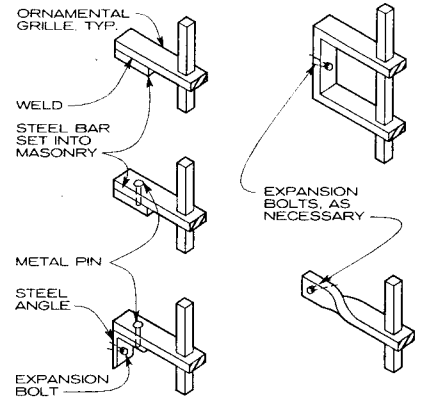

**METAL GRILLWORK INSTALLATION—DETAILS FOR MASONRY OPENINGS**

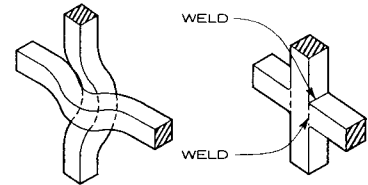

**CRIMPED AND WELDED MEMBERS**

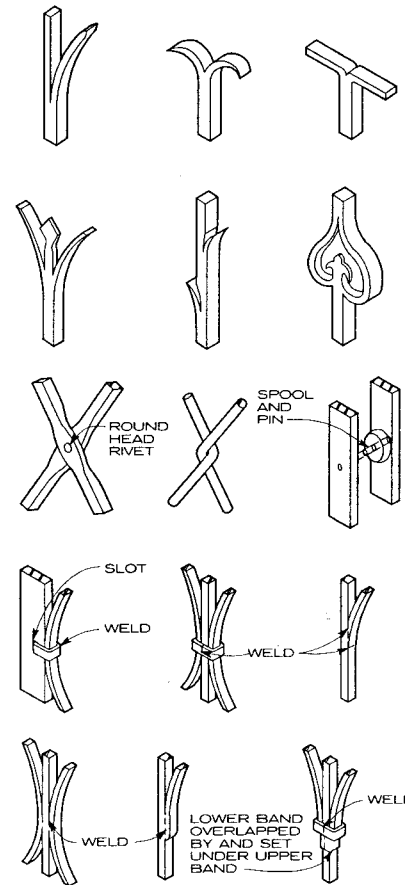

**MISCELLANEOUS CONNECTIONS**

Richard J. Vitullo, AIA; Oak Leaf Studio; Crownsville, Maryland

**GENERAL**

Perforated metals were initially created to fulfill industrial needs such as minimizing the weight of a particular component or controlling the passage of fluids or gasses. As an architectural component, perforated metals can be used as control devices or simply as decoration. They can serve as sound suppression acoustical devices in ceilings, walls, and grilles; when incorporated into light fixtures, grilles, or ceiling and wall components, they can filter light and obscure views. Since perforated metals retain a great deal of their strength and also ventilate well, they are often employed in furniture and other designs. Because they can bend and interrupt wavelengths of many types, perforated metals are used to contain microwave radiation and the EMI/RFI radiation emitted by electrical devices.

**NOTES**

1. Metal is typically perforated with hole-punching machines, which work best on sheets .008 in. to 3/4 in. thick. Specialized equipment is available for thicker metal.
2. The intended use of the perforated metal sheet determines the size, shape, and pattern of the holes punched. The strength and stiffness required vary according to use. Since perforated materials can be used in different applications involving a wide range of geometries, materials, and loading conditions, design data are given in very general form.
3. The enormous number of perforating patterns possible with round holes, squares, slots, and other special perforations make it impractical to list every pattern combination. The numbered perforations listed by the Industrial Perforators Association (IPA) are considered standard.
4. For design and tolerances of perforated metals, consult the IPA.
5. Round holes from .020 in. to more than 6 in. in diameter make up the majority of all perforated metal sheets produced. This is because round holes can be produced with greater efficiency and less expense and are generally stronger than other hole shapes.

6. Nonstandard end patterns may require special dies. Unperforated borders may cause distortions of the finished sheet. Roller leveling may be used to correct some of these distortions but may not always work. To calculate the (round) holes per square inch:

$$\% \text{ Open area} = \frac{78.54 \times D \times D}{L \times W}$$

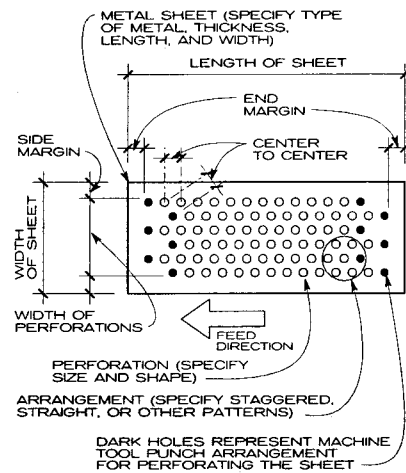

**NOTE**

Spacing can be specified as a center-to-center dimension, a percentage of open area, or holes per square inch.

**TYPICAL TERMS FOR SPECIFYING PERFORATED METAL**

**ROUND HOLES**

IPA NUMBERS	PERFORATIONS (IN.)	CENTERS (IN.)	HOLES PER SQ IN.	% OPEN AREA	LINE	S*/S, STRENGTH	
						WIDTH DIRECTION	LENGTH DIRECTION
100	.020		625	20	Staggered	.530	.465
101	.023		576	24	Straight		
102	.027		400	23	Straight		
103	.032		324	26	Straight		
104	.040		225	30	Straight		
105	.045		224	37	Straight		
106	1/16	1/8		23	Staggered	.500	.435
107	3/64	7/64		46	Staggered	.286	.225
108	1/64	1/8		36	Staggered	.375	.310
109	3/32	5/32		32	Staggered	.400	.334
110	3/32	3/16		23	Staggered	.500	.435
111	3/32	1/4		12	Staggered		
112	1/10	5/32		36	Staggered	.360	.296
113	1/8	3/16		40	Staggered	.333	.270
114	1/8	7/32		29	Staggered	.428	.363
115	1/8	1/4		23	Staggered	.500	.435
116	5/32	7/32		46	Staggered	.288	.225
117	5/32	1/4		36	Staggered	.375	.310
118	3/16	1/4		51	Staggered	.250	.192
119	3/16	5/16		33	Staggered	.400	.334
120	1/4	5/16		58	Staggered	.200	.147
121	1/4	3/8		40	Staggered	.333	.270
122	1/4	7/16		30	Staggered	.428	.363
123	1/4	1/2		23	Staggered	.500	.435
124	3/8	1/2		41	Staggered	.250	.192
125	3/8	9/16		50	Staggered	.333	.270
126	3/8	5/8		33	Staggered	.400	.334
127	7/16	5/8		45	Staggered	.300	.239
128	1/2	11/16		47	Staggered	.273	.214
129	9/16	3/4		51	Staggered	.250	.192
130	5/8	13/16		53	Staggered	.231	.175
131	3/4	1		51	Staggered	.250	.192

S\* = yield strength of perforated material  
 S = yield strength of unperforated material (strength for 60° standard staggered pattern)

Length direction = parallel to straight row of holes  
 Width direction = direction of stagger

**CHECKLIST OF PERFORATING COST INFLUENCES**

1. Material type: The least expensive material may not save money; a higher strength alloy may allow thickness to be reduced.
2. Material thickness: Thinner materials can be perforated easier and faster.
3. Hole shape and pattern: Round holes are the most economical; the 60x° staggered round hole pattern is the strongest, most versatile, and most common.
4. Hole size: Do not go below a 1-to-1 ratio of hole to size to sheet thickness; stay with a 2-to-1 ratio or larger if possible.
5. Bar size: Do not use bars with less than a 1-to-1 ratio with sheet thickness.
6. Center distance: This controls the feed rate and thus the conduction rate. If possible, choose a pattern with longer center distance.
7. Open areas: Extreme open area proportions tend to increase distortion; if possible, stay under 70 percent.
8. Margins: Keep side margins to a minimum to reduce distortion. Use standard unfinished end margins if possible.
9. Blank areas: Consider the die pattern when determining blank areas; consult the metal supplier.
10. Standardization: Specify standard hole patterns, material dimensions, and tolerances when possible. Before specifying a "special," ask the perforator what can be done with existing tooling.
11. Accept normal commercial burrs unless otherwise specified.

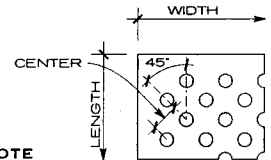

**NOTE**

This standard IPA option is stronger than straight row patterns but not as strong as a 60x° staggered arrangement. It is also not as versatile in providing compact hole spacing and high open areas as the 60x° arrangement.

**45° STAGGERED ROUND HOLE PATTERN**

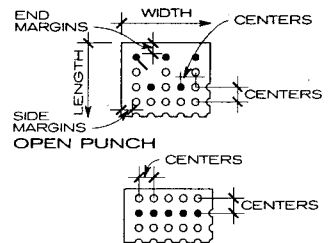

**CLOSED PUNCH NOTE**

A straight line pattern of holes is weaker than a staggered arrangement and can stretch the material more. Dark holes in the drawings above indicate the punch patterns.

**STRAIGHT LINE ROUND HOLE PATTERN**

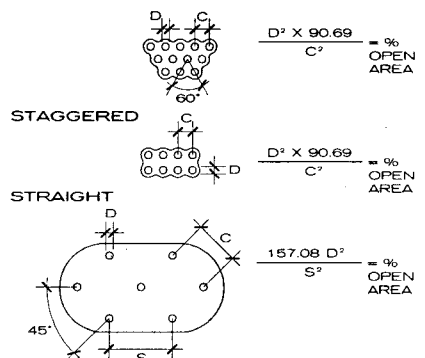

**45° STAGGERED PATTERN (SPECIAL) ROUND HOLE OPEN AREAS**

Industrial Perforators Association; Milwaukee, Wisconsin  
 McKey Perforating Company; New Berlin, Wisconsin

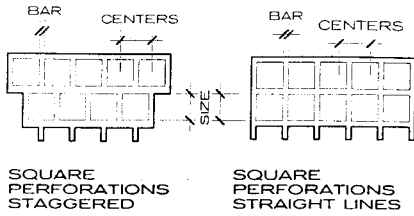

**SQUARES**

IPA NUMBER	PERFORATIONS (IN.)	CENTERS (IN.)	OPEN AREA	LINE
200	2/10	1/4	64%	Straight
201	1/4	3/8		
202	3/8	1/2	56%	Straight
203	1/2	11/16	53%	Straight
204	3/4	1	56%	Straight
205	1	1 1/4		Straight
206	1	1 3/8		Straight

**SQUARE HOLE OPEN AREAS**

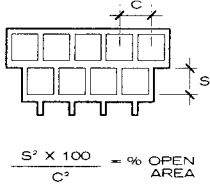

**NOTE**

Square holes, principally used for grilles and machine guards, offer optimal visibility and throughput. Typically punched in a straight line, in either straight or staggered patterns, square holes make for weaker perforated sheets than round hole patterns and are generally more expensive. Sharp corners make square hole tooling wear out faster than round hole tooling.

**SQUARE HOLES**

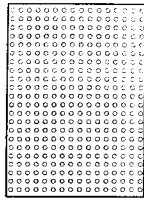

NO. 105, .045" DIA., 37% OPEN AREA

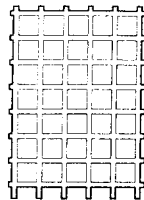

NO. 200 1/8" .64% OPEN AREA

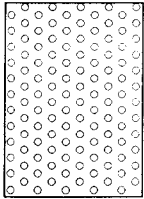

NO. 108, 5/64" DIA., 36% OPEN AREA

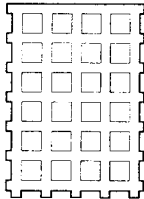

NO. 201, 1/4" OPENING

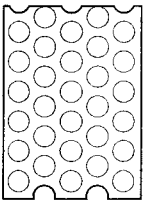

NO. 120, 1/4" DIA., 58% OPEN AREA

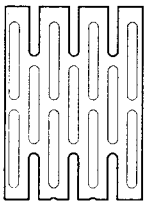

NO. 208, 1/8" X 1" OPENING, 43% OPEN AREA

**MISCELLANEOUS PERFORATION PATTERNS**

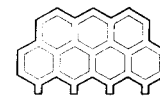

HEXAGONAL HOLES

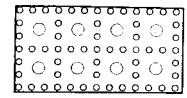

ROUND CANE

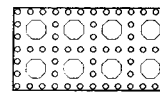

OCTAGONAL CANE

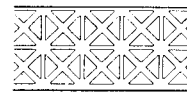

GRECIAN

**NOTE**

A broad assortment of nonstandard hole shapes and patterns is available; consult metal perforator. Also available are indented holes, collared holes, and louvered holes.

**MISCELLANEOUS NONSTANDARD PERFORATION PATTERNS**

**NOTE**

These three types of slots are IPA standard types. Non-standard square-end slots are also available. Consult manufacturers for other open area calculations for slots.

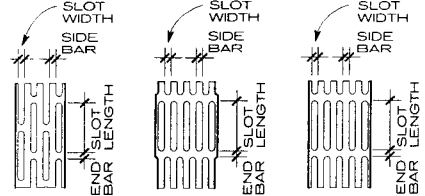

SLOTS SIDE STAGGER

SLOTS END STAGGER

SLOTS STRAIGHT LINES

**SLOTS**

IPA NUMBER	PERFORATIONS	OPEN AREA	LINE
207	1/8" x 3/4"	41%	Side staggered
208	1/8" x 1"	43%	Side staggered

**SLOTS**

**GAUGES AND WEIGHTS OF SHEET METALS\***

GAUGE	STEEL		GALVANIZED STEEL		LONG TERNE		STAINLESS-USS GAUGE			MONEL	
	USS GAUGE REV.		USS GAUGE		USS GAUGE		LB/SQ FT			USS GAUGE	
	DECIMAL THICKNESS	LB/SQ FT	DECIMAL THICKNESS	LB/SQ FT	DECIMAL THICKNESS	LB/SQ FT	DECIMAL THICKNESS	CHROME ALLOY	CHROME NICKEL	DECIMAL THICKNESS	LB/SQ FT
32	.0100		.0130	.563			.0100	.418	.427		
31	.0110		.0140	.594			.0109	.450	.459		
30	.0120	500	.0157	.656	.012	.518	.0125	.515	.525		
29	.0135	.563	.0172	.719	.014	.581	.0140	.579	.591		
28	.0149	.625	.0187	.781	.015	.643	.0156	.643	.656		
27	.0164	.688	.0202	.844	.017	.706	.0171	.708	.721		
26	.0179	.750	.0217	.906	.018	.768	.0187	.772	.787	.0187	.827
25	.0209	.875	.0247	1.031	.021	.893	.0218	.901	.918	.0218	.965
24	.0239	1.000	.0276	1.156	.024	1.018	.0250	1.030	1.050	.0250	1.148
23	.0269	1.125	.0306	1.281	.027	1.143	.0281	1.158	1.181	.0281	1.286
22	.0299	1.250	.0336	1.406	.030	1.268	.0312	1.287	1.312	.0312	1.424
21	.0329	1.375	.0366	1.531	.033	1.393	.0343	1.416	1.443	.0343	1.562
20	.0359	1.500	.0396	1.656	.036	1.518	.0375	1.545	1.575	.0375	1.700
19	.0418	1.750	.0456	1.906	.042	1.768	.0437	1.802	1.837	.0437	1.975
18	.0478	2.000	.0516	2.156	.048	2.018	.0500	2.060	2.100	.0500	2.297
17	.0538	2.250	.0575	2.406	.054	2.268	.0562	2.317	2.362	.0562	2.572
16	.0598	2.500	.0635	2.656	.060	2.518	.0625	2.575	2.625	.0625	2.848
15	.0673	2.812	.0710	2.969	.068	2.831	.0703	2.896	2.953	.0703	3.216
14	.0747	3.125	.0785	3.281	.075	3.143	.0781	3.218	3.281	.0781	3.583
13	.0897	3.750	.0934	3.906	.090	3.768	.0937	3.862	3.937	.0937	4.272
12	.1046	4.375	.1084	4.531	.105	4.393	.1093	4.506	4.593	.1093	5.007
11	.1196	5.000	.1233	5.156	.120	5.018	.1250	5.150	5.250	.1250	5.742
10	.1345	5.625	.1382	5.781	.135	5.643	.1406	5.793	5.906	.1406	6.431
9	.1494	6.250	.1532	6.406			.1562	6.437	6.562	.1562	7.166
8	.1644	6.875	.1681	7.031			.1718	7.081	7.218	.1718	7.855
7	.1793	7.500					.1875	7.590	7.752	.1875	8.590

\*Gauges and weights have been computed subject to standard commercial tolerances.

Industrial Perforators Association; Milwaukee, Wisconsin  
McKey Perforating Company; New Berlin, Wisconsin

GUIDE FOR SELECTING CARBON STEEL FOR PERFORATING APPLICATIONS

TYPE	DESCRIPTION	RECOMMENDED SIZE					CARBON CONTENT	TYPICAL MECHANICAL PROPERTIES				APPROXIMATE RELATIVE COST (10-GA. H.R. STEEL = 100)	
		SHEETS			COILS			TENSILE PSI	YIELD, PSI	% ELONG 2 IN.	HARD- NESS	SHEETS	COILS
		TH	W	L	TH	W							
<b>HOT-ROLLED STEELS</b>													
Commercial quality (SAE or ASI 1008; ASTM A 569)	A low-cost sheet steel with moderate drawing and forming qualities for use when finish is unimportant. For best perforating results specify pickled and oiled for removal of oxides.	7 to 16 ga.	up to 60 in.	up to 144 in.	7 to 16 ga.	up to 60 in.	0.10 max.	45,000 to 60,000	30,000 to 40,000	28 to 38	55 to 70	100 pickled and oiled-104	95 99
Drawing quality (SAE or AISI 1008; ASTM A 621)	This quality is intended for use when forming requirements are too severe for commercial quality. Pickling and oiling to remove oxides is recommended. In-stock availability is not as great as commercial quality.	7 to 16 ga.	up to 60 in.	up to 144 in.	7 to 16 ga.	up to 60 in.	0.10 max.	45,000 to 60,000	30,000 to 40,000	28 to 38	55 to 70	103	98
High-strength, low alloy (USS Cor-Ten or equivalent; ASTM A 375)	Good formability because of low carbon content in combination with relatively high Yield and Tensile properties permit these steels to be used in lighter gauges to reduce weight in applications in which strength is important. Readily available.	7 to 16 ga.	up to 60 in.	up to 144 in.	11 to 14 ga.	up to 60 in.	0.12 max.	70,000 min	50,000 min	22 min	80 to 90	132	126
Abrasion-resisting (C .35-.50; Mn 1.50-2.00; P .050 max.; S .055 max.; Si .15-.35)	High manganese content in combination with intermediate carbon greatly enhances resistance to abrasion; can improve part life 2 to 10 times. Moderate formability.	7 to 16 ga.	up to 60 in.	up to 144 in.	N.A.	N.A.	.35 to .50	100,000 to 120,000	55,000 to 70,000	10 to 20	210 to 225 (Bhn.)	118	N.A.
<b>COLD-ROLLED STEELS</b>													
Commercial quality (SAE or AISI 1008; ASTM A 366)	Cold rolled steels have improved surface finishes and tighter size tolerances than hot rolled steels. They are available in two classes: Class 1 is intended for exposed applications; Class 2 is for unexposed use. Three finishes can be specified: Matte is the standard finish. It is uniformly dull and suitable for painting. Commercial bright finish is a relatively bright, intermediate finish. Luster finish is smooth and bright and most suitable for plating. Because perforating alters surface appearance, surface preparation after perforating may be required before application of the final finish.	7 to 28 ga.	up to 60 in.	up to 18 ft	11 to 28 ga.	up to 60 in.	0.10 max.	40,000 to 50,000	25,000 to 35,000	30 to 40	45 to 60	119 (16 ga.)	113
Drawing quality (ASTM A 619)	Recommended for use when forming requirements are too severe for commercial quality. Can be supplied (Class 1) free of fluting or stretcher straining when intended for use in a reasonably short time. Available in mill quantities.	7 to 28 ga.	up to 60 in.	up to 18 ft	11 to 28 ga.	up to 60 in.	0.10 max.	40,000 to 50,000	20,000 to 30,000	38 to 40	40 to 50	125 (16 ga.)	120
Drawing quality special milled (ASTM A 620)	For use when the material must be free of surface disturbances without roller leveling immediately before use and essentially free from significant changes in mechanical properties over an extended period of time. Available in mill order quantities.	7 to 28 ga.	up to 60 in.	up to 18 ft	11 to 28 ga.	up to 60 in.	0.10 max.	40,000 to 50,000	20,000 to 30,000	38 to 40	40 to 50	127 (16 ga.)	122
<b>CORROSION-RESISTANT STEELS</b>													
Galvanized (ASTM 525)	A versatile, low-cost, corrosion-resistant steel with a zinc coating applied in a continuous hot-dip process. Available in commercial, drawing, and other qualities.	10 to 20 ga.	up to 60 in.	up to 18 ft	12 to 28 ga.	up to 60 in.	0.10 max.	45,000 to 55,000	35,000 to 45,000	25 to 35	50 to 65	147 (20 ga.)	145
Mill-bonderized galvanized	Galvanized sheet with a coating of mill-bonderized phosphate for immediate painting without flaking or peeling.	16 to 26 ga.	up to 60 in.	up to 18 ft	16 to 26 ga.	up to 60 in.	0.10 max.	45,000 to 55,000	35,000 to 45,000	25 to 35	50 to 65	149 (20 ga.)	N.A.
Galvanealed (coating designation A 60)	Heat-treated galvanized sheet, dull gray without spangles with a rough texture well suited to painting. Can withstand temperatures to 750° without flaking. Less ductile than regular galvanized coating.	14 to 26 ga.	up to 48 in.	up to 18 ft	14 to 26 ga.	up to 48 in.	0.10 max.	40,000 to 55,000	32,000 to 42,000	25 to 35	50 to 65	150 (20 ga.)	147
Electro-galvanized (ASTM A 591)	A thin zinc coating is applied to cold rolled steel by electroplating so as not to appreciatively affect the weight-thickness relationship. Smooth, without spangles, it is recommended as an undercoat for painted finishes. Available in commercial and drawing qualities.	14 to 26 ga.	up to 60 in.	up to 18 ft	14 to 26 ga.	up to 60 in.	0.10 max.	40,000 to 50,000	25,000 to 35,000	30 to 40	45 to 60	146 (20 ga.)	144
Aluminized, type 1 (ASTM 463)	Sheet steel coated on both sides with aluminum combines the properties of both metals. Type 1 is provided in two weights, regular and light, and is available in commercial and drawing qualities. If the heaviest Type 2 aluminized coating is desired, consult with a supplier or the steel manufacturer.	14 to 26 ga.	up to 60 in.	up to 18 ft	14 to 26 ga.	up to 60 in.	0.10 max.	50,000 to 60,000	35,000 to 45,000	18 to 28	60 to 70	162 (20 ga.)	157

Industrial Perforators Association; Milwaukee, Wisconsin



ORNAMENTAL METAL

**NOTES**

1. Follow all local code requirements for ramp design, rail diameter, and rail clearances; also see ASTM, ANSI, ADA, and OSHA requirements.
2. Verify allowable design stresses of rails, posts, and panels.
3. Verify the structural value of fasteners and anchorage to building structure for both vertical and lateral forces.
4. ASTM E-985 requirements:  
**GUARDRAILS** - Protect occupants at or near the outer edge of a ramp, landing, platform, balcony, or accessible roof. Railing systems usually are not provided where the vertical distance between adjacent levels is 24 in. or less. Railing members should be arranged to discourage climbing. Provide 4 in. high toeboards where tools or other objects could be dislodged. Concentrated load non-concurrently applied at the top rail shall be 200 lb/ft in the horizontal and vertical direction. The test loads are applicable for railings with supports not more than 8 ft apart.  
**HANDRAILS** - Corridors, ramps, and walkways having a slope of at least 1 in 20 shall have handrails. When a guardrail of more than 38 in. height is used, a separate handrail shall be installed. Nothing should interrupt the continuous sliding of hands. The ends of the handrail shall be returned to walls or arranged to avoid projecting rail ends.

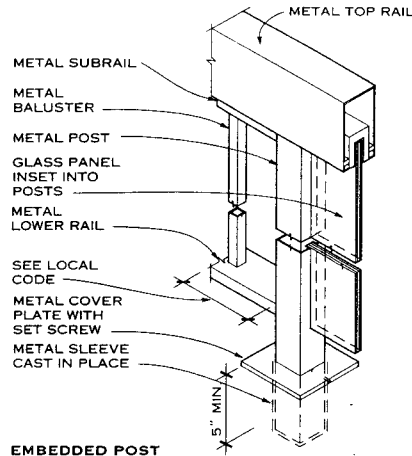

**EMBEDDED POST  
METAL POST AND RAIL**

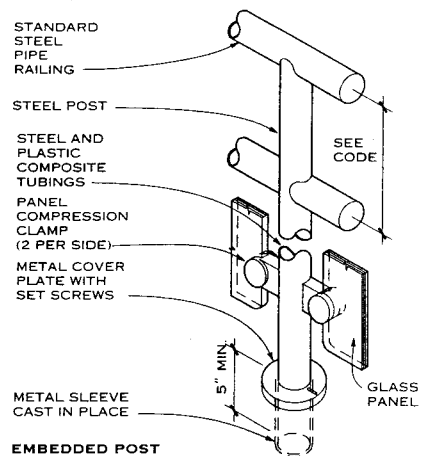

**EMBEDDED POST  
PIPE RAILING**

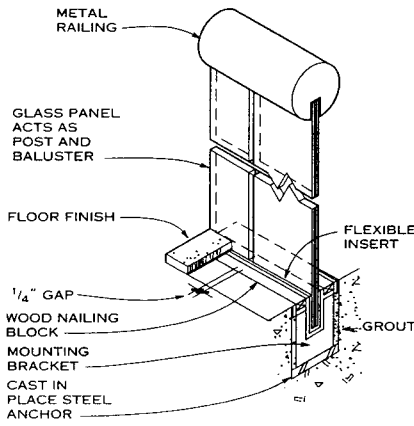

**FLUSH MOUNTED GLASS RAIL SYSTEM**

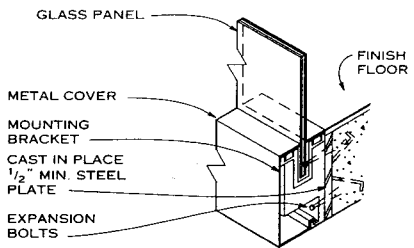

**SIDE MOUNTED GLASS PANEL**

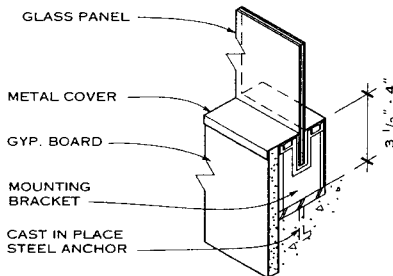

**SURFACE MOUNTED GLASS PANEL**

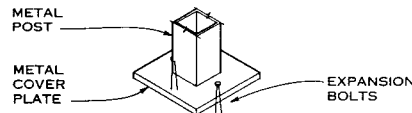

**SURFACE MOUNTED**

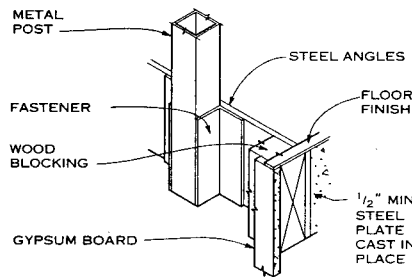

**SIDE MOUNTED**

**POST MOUNTING**

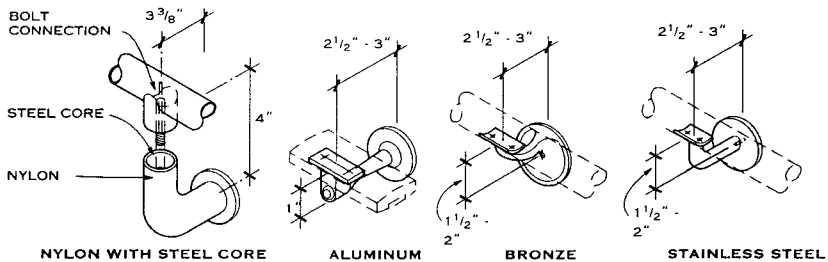

**WALL BRACKETS**

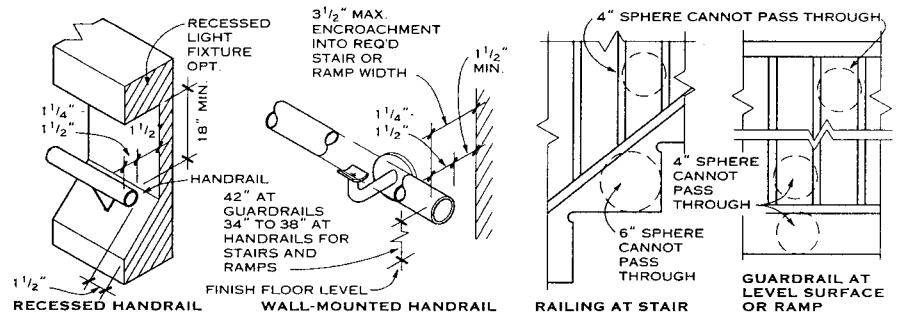

**ACCESSIBLE HANDRAILS/GUARDRAILS DIMENSIONS**

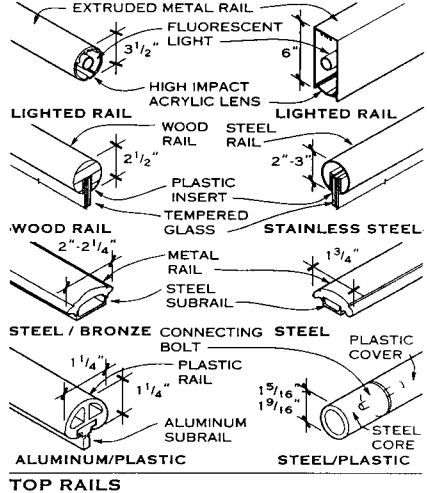

Richard J. Vitullo, AIA; Oak Leaf Studio; Crownsville, Maryland

NOTES

1. A large selection of prefabricated assemblies to cover interior expansion joints is available from various manufacturers to satisfy most joint and finish conditions.
2. Fire-rated barrier-type inserts are available and applicable to most assemblies.
3. Expansion joint covers that will respond to differential movement, both laterally and horizontally, should be provided at joints in structures located where seismic action (earth tremors and quakes) may be expected or where differential settlement is anticipated.

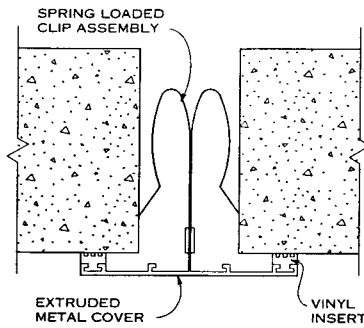

AT WALL OR CEILING

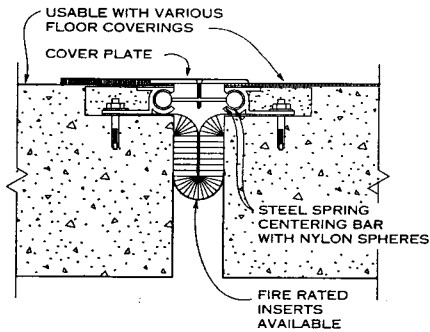

AT FLOOR

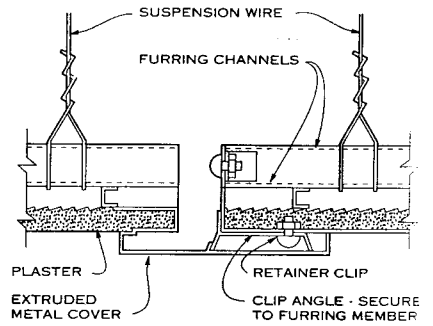

AT SUSPENDED CEILING

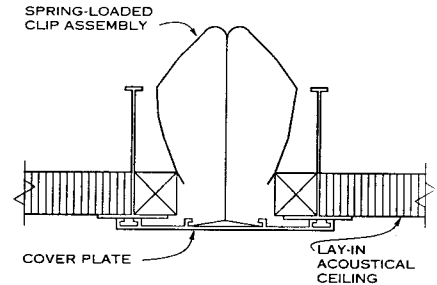

SUSPENDED ACOUSTICAL CEILING

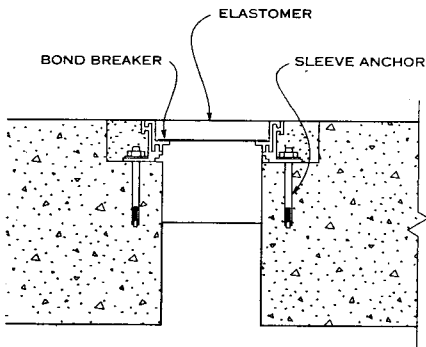

ELASTOMERIC JOINT COVER (REMOVABLE)

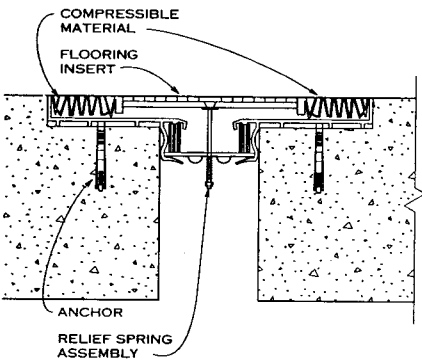

SEISMIC FLOOR JOINT COVER FOR JOINTS UP TO 24 IN.

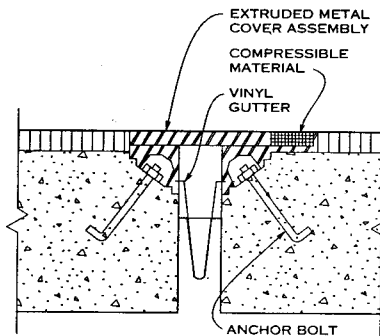

AT WALL

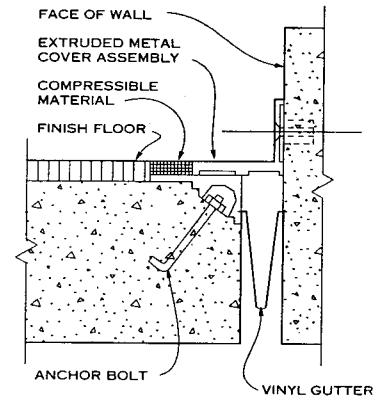

AT FLOOR AND WALL

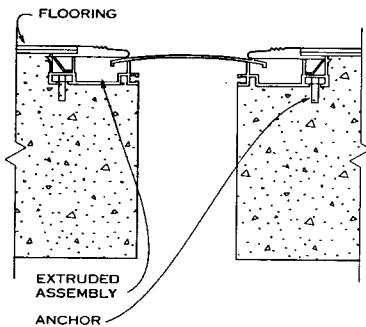

SEISMIC FLOOR JOINT COVER FOR JOINTS UP TO 8 IN.

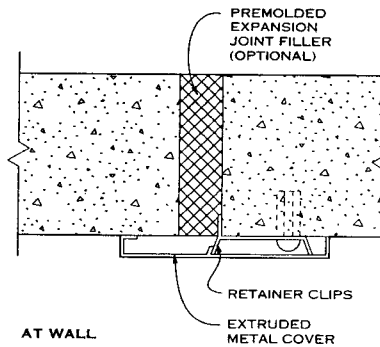

AT WALL

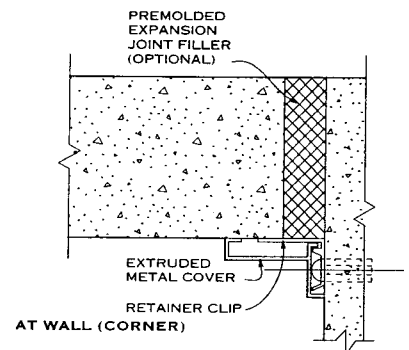

AT WALL (CORNER)

PREFABRICATED INTERIOR EXPANSION JOINT COVERS

Paul Bonsall and Robert D. Abernathy; J. N. Pease Associates; Charlotte, North Carolina

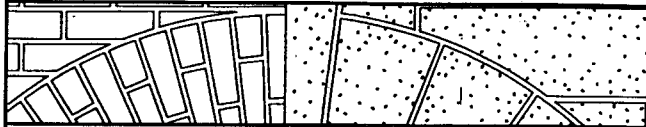

# WOOD AND PLASTICS

Introduction	298	Wood Decking	352
Design Load Tables	300	Sheathing	355
Wood Treatment	314	Wood Trusses	361
Wood and Plastic Fastenings	317	Glued-Laminated Construction	373
Rough Carpentry	323	Finish Carpentry	378
Structural Panels	339	Architectural Woodwork	380
Heavy Timber Construction	341		



**WOOD AS A CONSTRUCTION MATERIAL**

Approximately nine of every ten buildings constructed in the United States each year are framed with wood, including most single-family and multifamily residences and a large percentage of commercial, institutional, and public buildings. Wood is favored as both a structural material and a finish material for its economy, architectural flexibility, and visual qualities. Many contractors know how to build with it. Small work crews can handle most wood members without special lifting equipment; cutting and fastening can be accomplished on site with hand or portable power tools; and the skills needed for wood construction are easily learned. Yet wood is one of the most difficult materials for the designer to master, because it is virtually the only building material that is vegetable rather than mineral. With this vegetable origin comes a host of idiosyncrasies relating to directional properties, strength, stiffness, grain patterns, shrinkage, distortion, decay, insect damage, and fire resistance.

Today most wood comes from younger forests, with trees typically smaller than those harvested a few decades ago. Large solid timbers are increasingly hard to obtain, and the general quality of lumber is declining. As a result architects and builders must depend more and more on manufactured wood products such as laminated wood, laminated veneer lumber, parallel strand lumber, and manufactured wood I-joists and trusses. These products tend to be straighter, stronger, stiffer, less prone to distortion, and more economical of trees than conventional solid lumber, but they are not always suitable for display in a building.

**TYPES OF WOOD CONSTRUCTION**

Building codes categorize wood construction into two distinct types—heavy-timber and light wood-frame.

Heavy-timber construction, consisting of exposed columns, girders, beams, and decking large enough to be slow to catch fire and burn, is permitted for use in relatively large buildings across a broad spectrum of uses. Because of its large member dimensions and spans, heavy-timber construction is best suited to buildings with regular, repetitive bays. Heavy-timber buildings are engineered in accordance with the National Design Specification for Wood Construction, published by the American Wood Council.

Light wood-frame construction is made up of nominal 2 in. (38 mm) framing members spaced closely together and normally concealed by interior finish materials such as plaster, gypsum board, or wood paneling. Light wood-frame construction, with its small members and close member spacings, adapts readily to even the most intricate spaces and architectural forms. However, because such construction is less resistant to fire than heavy-timber construction, building codes severely limit the heights and areas of light wood-frame buildings. The maximum height generally permitted in residential light wood-frame buildings is three stories, although four stories are possible if an approved sprinkler system is installed. Most light wood-frame engineering can be done following values from tables in the CABO One and Two Family Dwelling Code, which has been widely adopted by states and municipalities.

**WOOD AS A STRUCTURAL MATERIAL**

On the basis of performance per unit weight, typical construction lumber is at least as strong and stiff as structural steel. Because of its microstructure of longitudinal cells, wood has different structural properties in its two principal directions. Parallel to the grain, wood is strong and stiff; perpendicular to the grain, it is weak and deformable. Fasteners that act in a direction parallel to the grain can transmit considerably more force than those that act perpendicular to the grain. The strength of wood varies with the duration of the load: For short-term loads such as those from snow, wind, and impact, allowable stress values are 15 to 100% higher than those allowed for normal-term loads. Under very long term loading, however, wood has a tendency to creep, and reduced stress values must be used.

**WOOD AS A FINISH MATERIAL**

Wood is used as a finish material in buildings of every kind. Limited quantities of wood finish may be used even in the most fire-resistant types of construction. With proper protection from water and sunlight, wood can serve as a durable exterior material for cladding, trim, and even roofing. For interior finishes, despite recent concerns regarding the depletion of rare or old-growth species, woods of many types remain commonly available in solid or veneer form, exhibiting great variety in hardness, grain figure, color, suitability for different finishes, and cost. Finish woods are readily available in many preformed shapes and are also easily shaped and cut in the field. Wood and wood products

Edward Allen, AIA; South Natick, Massachusetts  
Joseph Iano, Architect; Mercer Island, Washington  
Greg Heuer; Architectural Woodwork Institute; Reston, Virginia

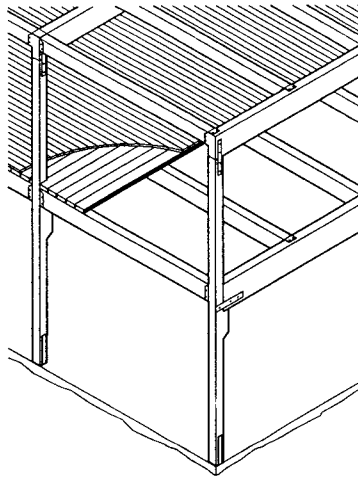

**HEAVY-TIMBER CONSTRUCTION**

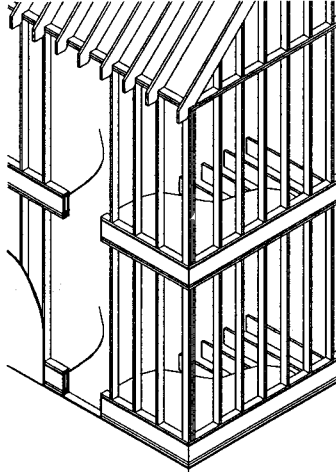

**LIGHT WOOD-FRAME CONSTRUCTION**

may be finished with transparent or opaque coatings or serve as a base for applied plastic laminates.

**SELECTION OF INTERIOR FINISH WOOD MATERIALS**

Following are the major factors that influence lumber selection for finish wood applications as specified by the Architectural Woodwork Institute:

**AESTHETIC CHARACTERISTICS:** Different species exhibit a variety of colors, grains (open or close grain), and figures (grain patterns) that are further distinguished by the sawing method (plain sawn, quarter sawn, rift sawn) and finishing characteristics (receptivity to finish processes, such as fillers, stains, etc.).

**AVAILABILITY:** The availability of particular species varies by season and popularity.

**SIZE LIMITATIONS:** Some species produce longer and/or wider members.

**STRENGTH, HARDNESS, AND DENSITY:** The ability of selected lumber to sustain stress; resist indentation, abuse, and wear; and carry its anticipated load contributes to its suitability for particular uses.

**DIMENSIONAL STABILITY:** Swelling and shrinking due to relative humidity and moisture content changes varies according to the species and product type.

**ADAPTABILITY FOR EXTERIOR USE:** Certain species are more durable when used in exterior applications. Heartwood of all species is more resistant to damage by the elements than sapwood. The following species are rot resistant and acceptable for exterior use: Eastern and Western red cedar; redwood; mahogany, and teak.

**FIRE RETARDANCE:** Natural fire retardant qualities and acceptability of treatment vary with species. Flame Spread Classification is the generally accepted measurement for fire rating of materials. Fire-retardant treatments and build-up of members can be used to improve the fire rating of wood materials.

**PRESERVATIVE TREATMENTS:** Certain species used for architectural woodwork can be treated with preservative compounds to extend their life when exposed to the elements.

**LUMBER PRODUCTION**

Commercially marketed lumber includes trees of dozens of species roughly divided into softwoods, which are the ever-green species, and hardwoods, those species that drop their leaves in the fall. Nearly all framing lumber comes from the comparatively plentiful softwoods. Hardwoods, with their greater range of colors and grain figures, are used primarily for interior finishes, flooring, cabinets, and furniture.

Seen under a low-power magnifier, wood is made up primarily of hollow tubular cells of cellulose that run parallel to the long axis of the tree trunk. When the tree is harvested, both the hollows and the walls of these tubes are full of watery sap. The tree is sawed into rough lumber while in this saturated or "green" condition. Finish lumber is seasoned (dried of much of its moisture), either by stacking it in the open air for a period of months or, more commonly, by heating it in a kiln for a period of days. During seasoning, moisture evaporates first from the hollows of the tubes, and then from the cellulose walls of the tubes, causing the lumber to shrink. By the time the lumber leaves the kiln, it is considerably smaller. Further shrinkage usually occurs after the lumber has been incorporated into a building, as the moisture content in the wood comes gradually to equilibrium with the moisture content of the surrounding air. Wood absorbs moisture during damp weather and gives it off during dry weather in a never-ending cycle of swelling and shrinking, a fact that must be taken into account when detailing wood components of building.

Most lumber is surfaced after seasoning to reduce it to its final dimensions and give it smooth faces. Edges are rounded to make the lumber easier and safer to handle.

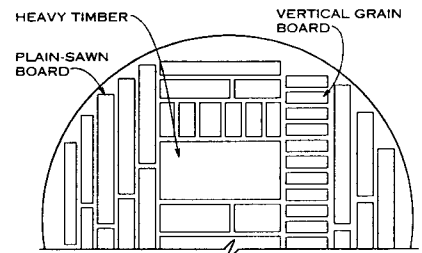

**TYPICAL SAWING OF A LARGE LOG**

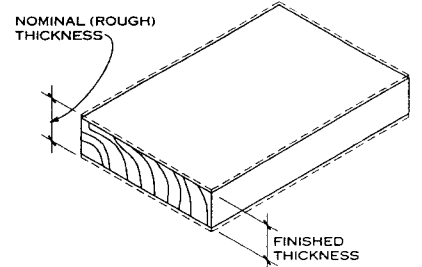

BEFORE MACHINING		AFTER MACHINING	
Nominal (rough) thickness		AWI finished thickness (in.)	
In.	Quarters	Hardwoods	Softwoods
1	4/4	3/4	3/4
1 1/4	5/4	1	1 1/16
1 1/2	6/4	1 1/4	1 3/8
2	8/4	1 3/4	1 1/2
2 1/2	10/4	2	2 1/4
3	12/4	2 1/2	2 1/2

**LUMBER THICKNESS**

**LUMBER GRADING**

Wood is a natural product and thus varies greatly in appearance and structural properties. Consequently, elaborate systems of grading have been established to indicate the quality of each piece of lumber. Within each species of wood there are two grading systems, one based on structural strength and stiffness, the other on appearance. Appearance is graded visually. Structural grading is based either on visual inspection, the sizes and positions of knots and other defects, or structural properties as measured by machines that flex each piece of lumber.

Strength and stiffness values for wood are tabulated elsewhere in this chapter of AGS. They vary considerably from one species and grade to another. When engineering a wood structure, it is necessary to know what species and grade will be specified. If in doubt, base structural calculations on the weakest species and grade locally available.

**JOINING WOOD**

Nailing is the most common method of joining light structural members. Nails are inexpensive to buy and install and may be driven by hand or with a pneumatic gun. When applied in proper size, number, and spacing, they form a strong, resilient joint. Sheet metal straps, anchors, and brackets can be nailed to connections where greater resistance to tension or shear is necessary. Detailed nailing requirements for light wood-frame construction are included in building codes. Heavy-timber construction typically relies on bolts and lag screws, together with fabricated metal connecting devices.

In finish wood construction, nearly headless finish nails are used for improved appearance. Screws, concealed or embedded fasteners, splines, and fitted and glued joints provide greater mechanical stiffness and optimal appearance. The Architectural Woodwork Institute has established standards for finish joinery based on appearance and cost.

**MOISTURE MOVEMENT IN WOOD**

The shrinkage of wood as it dries is not uniform. Wood shrinks very little along the length of the grain, somewhat in the radial direction of a cylindrical log, and more in the tangential direction of the log, as shown in the accompanying graph. One consequence of the difference between the radial and tangential shrinkage is that radial splits called checks form during seasoning, especially in lumber of large

dimension. In addition, pieces of lumber distort noticeably in accordance with their original positions in the tree trunk. For pieces of lumber that must stay flat, such as flooring, outdoor decking, baseboards, casings, and paneling, vertical-grain lumber, which is sawed so the annual growth rings are more or less perpendicular to the broad face of the board, is often specified. One particular sawing pattern that produces vertical-grain lumber is called quarter-sawing. For ordinary framing, seasoning distortions are of little consequence, so plain-sawn boards are used.

A number of accepted wood detailing practices have been developed in response to the great moisture movement that occurs in wood and the distortions that result from the differing rates of shrinkage along the three axes of the grain. In applying wood siding, it is necessary to use nailing patterns that do not restrain the cross-grain seasonal shrinking and swelling of the wood. Horizontal bevel siding is nailed so that each board is fastened by one row of nails only, creating a sliding joint at each overlapping edge to allow for movement. Tongue-and-groove siding boards are nailed at the tongue edge only, the other edge being restrained by the tongue of the adjacent board sliding freely in its groove. Vertical board-and-batten siding is nailed only at the centers of the boards and battens, allowing for free expansion and contraction of the wood.

Because wood shrinkage is so much greater in the tangential direction than in the radial, plain-sawn boards tend to cup noticeably in a direction opposite to the curvature of the annual rings. Plain-sawn decking and flooring should be laid with the "bark side" of each board facing down to reduce the raising of edges. On outdoor decks, this practice will also minimize puddling of water on the boards. Vertical-grain flooring and deck boards are preferable to plain-sawn boards, not only because they minimize cupping but because their tighter grain pattern wears better underfoot.

Broad interior finish pieces are frequently given a relieved back, a hidden groove or grooves that reduce the effective thickness of the piece and thus the tendency of the piece to cup. Many stock millwork patterns include relieved backs. Boards may be relieved on site by cutting multiple grooves with a table saw. Cupping can also be minimized by back priming, painting the back surface of each piece a day or more before installation. After the piece has been installed and the exposed side has been painted or varnished, the back priming causes the back side to absorb and give off moisture at about the same rate as the exposed side, minimizing distortions.

**DECAY AND INSECTS**

Wood provides food and habitat to various insects and decay-causing fungi. For the most part, decay and insect attack can be avoided by detailing a building in a way that keeps wood dry at all times. Wood components should be kept at least 6 in. (150 mm) away from the soil. Details that trap and hold moisture, such as connections in exterior decks and railings, should be avoided unless preservative-treated wood or decay-resistant species such as redwood, cedar, or cypress are used.

**FIRE**

Wood burns easily, giving off highly toxic combustion products, so it is important to design wooden buildings for fire safety. The first step is to follow the height and area restrictions of the building codes, along with code provisions for easy egress from wooden buildings. Smoke and heat alarms are essentials in wooden residential buildings. Heavy-timber buildings have a natural resistance to fire because their massive timbers are slow to ignite and burn in comparison to the smaller framing members in light wood-frame construction. Light wood-frame buildings have internal hollow passages that encourage the spread of fire; these must be closed off at each floor by wood blocking or the floor platform framing. Light wood-frame buildings are generally finished with interior surfaces of gypsum plaster or gypsum wallboard, which are highly resistant to fire.

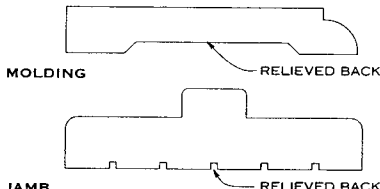

**JAMB NOTE**

By reducing the effective thickness of the woodwork, relieved backs reduce the tendency of the wood to cup.

**RELIEVED BACKS IN WOODWORK**

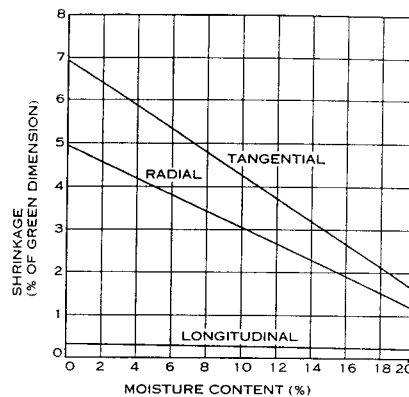

**MOISTURE SHRINKAGE OF A TYPICAL SOFTWOOD**

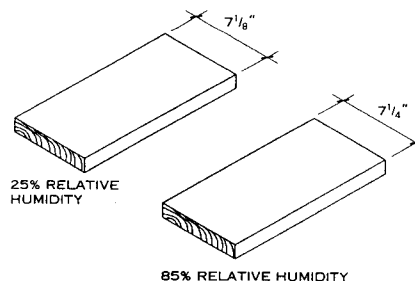

**EXPANSION DUE TO MOISTURE IN THE AIR**

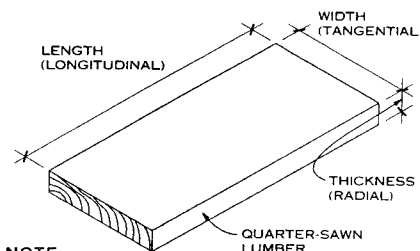

**NOTE**

Length: .1 to .2% shrinkage; thickness: 2 to 5% shrinkage; width: 5 to 10% shrinkage.

**SHRINKAGE DUE TO DRYING FOR QUARTER-SAWN LUMBER**



**SHRINKAGE DISTORTION OF PLAIN-SAWN DECKING**

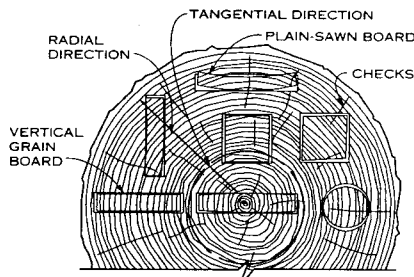

**SHRINKAGE DISTORTIONS BY POSITION IN LOG**

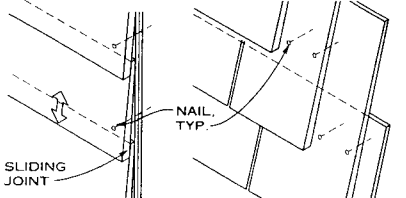

**HORIZONTAL SIDING WOOD SHAKE SIDING**

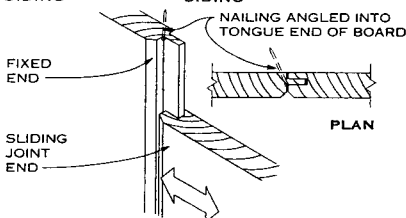

**VERTICAL WOOD SIDING**

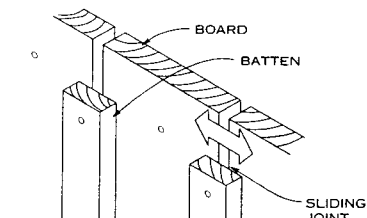

**BOARD AND BATTEN SIDING**

**SLIDING JOINTS IN WOOD SIDING**

Edward Allen, AIA; South Natick, Massachusetts  
Joseph Iano, Architect; Mercer Island, Washington

**DESIGN CRITERIA**

**STRENGTH:** Live load of 30 psf plus dead load of 10 psf determines the required fiber stress value.

**DEFLECTION:** For 30 psf live load. Limited to span in inches divided by 360.

**FLOOR JOISTS—30 LB LIVE LOAD**

ALL ROOMS USED FOR SLEEPING AREAS AND ATTIC FLOORS

JOIST (IN.)		MODULUS OF ELASTICITY, E, IN 1,000,000 PSI														
SIZE	SPACING	0.5	0.6	0.7	0.8	0.9	1.0	1.1	1.2	1.3	1.4	1.5	1.6	1.7	1.8	1.9
2 x 6	12	8-0	8-6	8-11	9-4	9-9	10-1	10-5	10-9	11-0	11-3	11-7	11-10	12-0	12-3	12-6
		510	570	640	700	750	810	860	910	960	1010	1060	1100	1150	1200	1240
	16	7-3	7-9	8-2	8-6	8-10	9-2	9-6	9-9	10-0	10-3	10-6	10-9	10-11	11-2	11-4
		560	630	700	770	830	890	950	1000	1060	1110	1160	1220	1270	1320	1360
	24	6-4	6-9	7-1	7-5	7-9	8-0	8-3	8-6	8-9	8-11	9-2	9-4	9-7	9-9	9-11
		640	720	800	880	950	1020	1080	1150	1210	1270	1330	1390	1450	1510	1560
2 x 8	12	10-7	11-3	11-10	12-4	12-10	13-4	13-9	14-2	14-6	14-11	15-3	15-7	15-10	16-2	16-6
		510	570	640	700	750	810	860	910	960	1010	1060	1100	1150	1200	1240
	16	9-7	10-2	10-9	11-13	11-8	12-1	12-6	12-10	13-2	13-6	13-10	14-2	14-5	14-8	15-0
		560	630	700	770	830	890	950	1000	1060	1110	1160	1220	1270	1320	1360
	24	8-5	8-11	9-4	9-10	10-2	10-7	10-11	11-3	11-6	11-10	12-1	12-4	12-7	12-10	13-1
		640	720	800	880	950	1020	1080	1150	1210	1270	1330	1390	1450	1510	1560
2 x 10	12	13-6	14-4	15-1	15-9	16-5	17-0	17-6	18-0	18-6	19-0	19-5	19-10	20-3	20-8	21-0
		510	570	640	700	750	810	860	910	960	1010	1060	1100	1150	1200	1240
	16	12-3	13-0	13-8	14-4	14-11	15-5	15-11	16-5	16-10	17-3	17-8	18-0	18-5	18-9	19-1
		560	630	700	770	830	890	950	1000	1060	1110	1160	1220	1270	1320	1360
	24	10-8	11-4	11-11	12-6	13-0	13-6	13-11	14-4	14-8	15-1	15-5	15-9	16-1	16-5	16-8
		640	720	800	880	950	1020	1080	1150	1210	1270	1330	1390	1450	1510	1560
2 x 12	12	16-5	17-5	18-4	19-2	19-11	20-8	21-4	21-11	22-6	23-1	23-7	24-2	24-8	25-1	25-7
		510	570	640	700	750	810	860	910	960	1010	1060	1100	1150	1200	1240
	16	14-11	15-10	16-8	17-5	18-1	18-9	19-4	19-11	20-6	21-0	21-6	21-11	22-5	22-10	23-3
		560	630	700	770	830	890	950	1000	1060	1110	1160	1220	1270	1320	1360
	24	13-0	13-10	14-7	15-2	15-10	16-5	16-11	17-5	17-11	18-4	18-9	19-2	19-7	19-11	20-3
		640	720	800	880	950	1020	1080	1150	1210	1270	1330	1390	1450	1510	1560

NOTE: The required extreme fiber stress in bending,  $F_b$ , in psi is shown below each span.

**DESIGN CRITERIA**

**STRENGTH:** Live load of 40 psf plus dead load of 10 psf determines the required fiber stress value.

**DEFLECTION:** For 40 psf live load. Limited to span in inches divided by 360.

**FLOOR JOISTS—40 LB LIVE LOAD**

ALL ROOMS EXCEPT THOSE USED FOR SLEEPING AREAS AND ATTIC FLOORS

JOIST (IN.)		MODULUS OF ELASTICITY, E, IN 1,000,000 PSI														
SIZE	SPACING	0.5	0.6	0.7	0.8	0.9	1.0	1.1	1.2	1.3	1.4	1.5	1.6	1.7	1.8	1.9
2 x 6	12	7-3	7-9	8-2	8-6	8-10	9-2	9-6	9-9	10-0	10-3	10-6	10-9	10-11	11-2	11-4
		520	590	660	720	780	830	890	940	990	1040	1090	1140	1190	1230	1280
	16	6-7	7-0	7-5	7-9	8-0	8-4	8-7	8-10	9-1	9-4	9-6	9-9	9-11	10-2	10-4
		580	650	720	790	860	920	980	1040	1090	1150	1200	1250	1310	1360	1410
	24	5-9	6-2	6-6	6-9	7-0	7-3	7-6	7-9	7-11	8-2	8-4	8-6	8-8	8-10	9-0
		660	750	830	900	980	1050	1120	1190	1250	1310	1380	1440	1500	1550	1610
2 x 8	12	9-7	10-2	10-9	11-3	11-8	12-1	12-6	12-10	13-2	13-6	13-10	14-2	14-5	14-8	15-0
		520	590	660	720	780	830	890	940	990	1040	1090	1140	1190	1230	1280
	16	8-9	9-3	9-9	10-2	10-7	11-0	11-4	11-8	12-0	12-3	12-7	12-10	13-1	13-4	13-7
		580	650	720	790	850	920	980	1040	1090	1150	1200	1250	1310	1360	1410
	24	7-7	8-1	8-6	8-11	9-3	9-7	9-11	10-2	10-6	10-9	11-0	11-3	11-5	11-8	11-11
		660	750	830	900	980	1050	1120	1190	1250	1310	1380	1440	1500	1550	1610
2 x 10	12	12-3	13-0	13-8	14-4	14-11	15-5	15-11	16-5	16-10	17-3	17-8	18-0	18-5	18-9	19-1
		520	590	660	720	780	830	890	940	990	1040	1090	1140	1190	1230	1280
	16	11-1	11-10	12-5	13-0	13-6	14-0	14-6	14-11	15-3	15-8	16-0	16-5	16-9	17-0	17-4
		580	650	720	790	850	920	980	1040	1090	1150	1200	1250	1310	1360	1410
	24	9-9	10-4	10-10	11-4	11-10	12-3	12-8	13-0	13-4	13-8	14-0	14-4	14-7	14-11	15-2
		660	750	830	900	980	1050	1120	1190	1250	1310	1380	1440	1500	1550	1610
2 x 12	12	14-11	15-10	16-8	17-5	18-1	18-9	19-4	19-11	20-6	21-0	21-6	21-11	22-5	22-10	23-3
		520	590	660	720	780	830	890	940	990	1040	1090	1140	1190	1230	1280
	16	13-6	14-4	15-2	15-10	16-5	17-0	17-7	18-1	18-7	19-1	19-6	19-11	20-4	20-9	21-1
		580	650	720	790	860	920	980	1040	1090	1150	1200	1250	1310	1360	1410
	24	11-10	12-7	13-3	13-10	14-4	14-11	15-4	15-10	16-3	16-8	17-0	17-5	17-9	18-1	18-5
		660	750	830	900	980	1050	1120	1190	1250	1310	1380	1440	1500	1550	1610

NOTE: The required extreme fiber stress in bending,  $F_b$ , in psi is shown below each span.

American Forest and Paper Association; Washington, D.C.

**GENERAL DESIGN INFORMATION**

For floor construction where live loading is heavier than customarily found in residential occupancies, tabular data are provided.

The tabulated spans are based on bending strength using the live load indicated in each table heading plus a dead load of 10 psf. In calculating the required modulus of elasticity for the tabulated span, the live load only was used, since this is in accordance with established practice for design of floor joists.

**SPAN**

While the effective span length for an isolated beam is customarily taken as the distance from face to face

of supports plus one-half the required length of bearing at each end, it is the practice in designing joists spaced not over 24 in. apart to consider the span as the clear distance between supports.

**NET SIZES OF LUMBER**

Joists are customarily specified in terms of nominal sizes, but calculations to determine the allowable span and required modulus of elasticity are based on actual sizes.

**DESIGN STRESSES**

Unit design values for design of wood joists are given in the National Design Specification for Wood Construc-

tion, available from the American Forest & Paper Association.

**ADJUSTMENT OF MODULUS OF ELASTICITY**

The modulus of elasticity values listed in the span tables for joists are those required for the tabulated spans if deflection under the live load is limited to  $\ell/360$ . Where other deflection limits are acceptable, the tabular E values may be adjusted by multiplying them by the following factors:

- For limit of  $\ell/300$ : 0.833
- For limit of  $\ell/240$ : 0.667
- For limit of  $\ell/180$ : 0.500

**FLOOR JOISTS—50 LB LIVE LOAD**

JOIST (IN.)		EXTREME FIBER STRESS IN BENDING, $F_b$ (PSI)									
SIZE, SPACING	900	1000	1100	1200	1300	1400	1500	1600	1800	2000	
2 x 6	12	8-8 1.063	9-2 1.246	9-7 1.437	10-0 1.637	10-5 1.846	10-10 2.063	11-3 2.289	11-7 2.521	12-3 3.007	12-11 3.522
	16	7-6 0.924	7-11 1.083	8-4 1.249	8-8 1.423	9-1 1.605	9-5 1.794	9-9 1.989	10-0 2.191	10-7 2.614	11-2 3.062
	24	6-1 0.744	6-5 0.871	6-9 1.005	7-1 1.144	7-4 1.291	7-7 1.443	7-11 1.600	8-2 1.762	8-7 2.103	9-1 2.463
2 x 8	12	11-5 1.063	12-1 1.246	12-7 1.437	13-3 1.631	13-9 1.846	14-3 2.063	14-9 2.289	15-3 2.521	16-2 3.007	17-1 3.522
	16	9-11 0.924	10-5 1.083	11-0 1.249	11-6 1.423	11-11 1.605	12-5 1.794	12-10 1.989	13-3 2.191	14-0 2.614	14-10 3.062
	24	8-1 0.744	8-6 0.871	8-11 1.005	9-4 1.144	9-8 1.291	10-1 1.443	10-5 1.600	10-9 1.762	11-5 2.103	12-0 2.463
2 x 10	12	14-7 1.063	15-5 1.246	16-2 1.437	16-10 1.637	17-6 1.846	18-2 2.063	18-10 2.289	19-5 2.521	20-7 3.007	21-9 3.522
	16	12-7 0.924	13-4 1.083	14-0 1.249	14-7 1.423	15-3 1.605	15-10 1.794	16-4 1.989	16-10 2.191	17-11 2.614	18-11 3.062
	24	10-3 0.744	10-10 0.871	11-4 1.005	11-10 1.144	12-4 1.291	12-10 1.443	13-3 1.600	13-9 1.762	14-7 2.103	15-4 2.463
2 x 12	12	17-9 1.063	18-9 1.246	19-7 1.437	20-6 1.637	21-4 1.846	22-2 2.063	22-11 2.289	23-8 2.521	25-1 3.007	26-6 3.522
	16	15-5 0.924	16-3 1.083	17-1 1.249	17-10 1.423	18-6 1.605	19-2 1.794	19-10 1.989	20-6 2.191	21-9 2.614	23-0 3.062
	24	12-6 0.744	13-2 0.871	13-10 1.005	14-5 1.144	15-0 1.291	15-7 1.443	16-2 1.600	16-7 1.762	17-8 2.103	18-10 2.463
2 x 14	12	20-11 1.063	22-1 1.246	23-2 1.437	24-2 1.637	25-2 1.846	26-1 2.063	27-0 2.289	27-11 2.521	29-7 3.007	31-2 3.522
	16	18-2 0.924	19-2 1.083	20-1 1.249	20-11 1.423	21-9 1.605	22-7 1.794	23-5 1.989	24-2 2.191	25-7 2.614	27-0 3.062
	24	14-9 0.744	15-6 0.871	16-3 1.005	17-0 1.144	17-8 1.291	18-4 1.443	19-0 1.600	19-7 1.762	20-10 2.103	22-0 2.463
3 x 6	12	11-2 1.373	11-10 1.608	12-5 1.855	12-11 2.113	13-6 2.383	14-0 2.663	14-6 2.953	14-11 3.254	15-10 3.882	16-9 4.547
	16	9-9 1.193	10-3 1.397	10-9 1.612	11-3 1.836	11-8 2.071	12-2 2.314	12-7 2.567	12-11 2.827	13-9 3.374	14-6 3.952
	24	7-11 0.960	8-4 1.124	8-9 1.297	9-2 1.478	9-6 1.666	9-10 1.862	10-2 2.065	10-6 2.275	11-2 2.714	11-9 3.179
3 x 8	12	14-9 1.373	15-7 1.608	16-4 1.855	17-1 2.113	17-9 2.383	18-5 2.663	19-1 2.953	19-9 3.254	20-11 3.882	22-1 4.547
	16	12-10 1.193	13-6 1.397	14-2 1.612	14-10 1.836	15-5 2.071	16-0 2.314	16-7 2.567	17-1 2.827	18-1 3.374	19-1 3.952
	24	10-5 0.960	11-0 1.124	11-6 1.297	12-0 1.478	12-6 1.666	13-0 1.862	13-5 2.065	13-10 2.275	14-8 2.714	15-6 3.179
3 x 10	12	18-10 1.373	19-10 1.608	20-10 1.855	21-9 2.113	22-7 2.383	23-6 2.663	24-4 2.953	25-1 3.254	26-7 3.882	28-1 4.547
	16	16-4 1.193	17-3 1.397	18-1 1.612	18-10 1.836	19-7 2.071	20-5 2.314	21-1 2.567	21-10 2.827	23-2 3.374	24-5 3.952
	24	13-3 0.960	14-0 1.124	14-8 1.297	15-4 1.478	16-0 1.666	16-7 1.862	17-2 2.065	17-8 2.275	18-9 2.714	19-10 3.179
3 x 12	12	22-11 1.373	24-2 1.608	25-4 1.855	26-5 2.113	27-6 2.383	28-7 2.663	29-7 2.953	30-7 3.254	32-5 3.882	34-2 4.547
	16	19-11 1.193	20-11 1.397	21-11 1.612	22-11 1.836	23-11 2.071	24-10 2.314	25-8 2.567	26-6 2.827	28-1 3.374	29-7 3.952
	24	16-2 0.960	17-0 1.124	17-10 1.297	18-8 1.478	19-5 1.666	20-2 1.862	20-10 2.065	21-6 2.275	22-10 2.714	24-1 3.179
3 x 14	12	27-0 1.373	28-5 1.608	29-10 1.855	31-2 2.113	32-5 2.383	33-8 2.663	34-10 2.953	36-0 3.254	38-2 3.882	40-3 4.547
	16	23-5 1.193	24-8 1.397	25-11 1.612	27-1 1.836	28-2 2.071	29-3 2.314	30-3 2.567	31-3 2.827	33-1 3.374	34-11 3.952
	24	19-0 0.960	20-0 1.124	21-0 1.297	22-0 1.478	22-11 1.666	23-9 1.862	24-7 2.065	25-5 2.275	26-11 2.714	28-4 3.179

NOTE: The required modulus of elasticity, E, in 1,000,000 psi is shown below each span, if deflection under the live load is limited to  $\ell/360$ .

American Forest and Paper Association; Washington, D.C.

**GENERAL DESIGN INFORMATION**

For floor construction where live loading is heavier than customarily found in residential occupancies, tabular data are provided.

The tabulated spans are based on bending strength using the live load indicated in each table heading plus a dead load of 10 psf. In calculating the required modulus of elasticity for the tabulated span, the live load only was used, since this is in accordance with established practice for design of floor joists.

**SPAN**

While the effective span length for an isolated beam is customarily taken as the distance from face to face

of supports plus one-half the required length of bearing at each end, it is the practice in designing joists spaced not over 24 in. apart to consider the span as the clear distance between supports.

**NET SIZES OF LUMBER**

Joists are customarily specified in terms of nominal sizes, but calculations to determine the allowable span and required modulus of elasticity are based on actual sizes.

**DESIGN STRESSES**

Unit design values for design of wood joists are given in the National Design Specification for Wood Construc-

tion, available from the American Forest & Paper Association.

**ADJUSTMENT OF MODULUS OF ELASTICITY**

The modulus of elasticity values listed in the span tables for joists are those required for the tabulated spans if deflection under the live load is limited to  $\ell/360$ . Where other deflection limits are acceptable, the tabular E values may be adjusted by multiplying them by the following factors:

For limit of  $\ell/300$ : 0.833

For limit of  $\ell/240$ : 0.667

For limit of  $\ell/180$ : 0.500

**FLOOR JOISTS—60 LB LIVE LOAD**

JOIST (IN.) SIZE, SPACING	EXTREME FIBER STRESS IN BENDING, $F_b$ (PSI)										
	900	1000	1100	1200	1300	1400	1500	1600	1800	2000	
2 x 6	12	8-1 1.012	8-6 1.186	8-11 1.368	9-3 1.558	9-8 1.757	10-0 1.964	10-5 2.179	10-9 2.400	11-5 2.863	12-0 3.353
	16	7-0 0.880	7-4 1.031	7-9 1.189	8-1 1.355	8-5 1.528	8-8 1.708	9-0 1.894	9-4 2.191	9-10 2.489	10-5 2.915
	24	5-8 0.708	6-0 0.829	6-4 0.957	6-7 1.089	6-10 1.229	7-1 1.374	7-4 1.523	7-7 1.677	8-0 2.002	8-5 2.345
2 x 8	12	10-7 1.012	11-2 1.186	11-9 1.368	12-3 1.558	12-9 1.757	13-3 1.964	13-8 2.179	14-1 2.400	15-0 2.863	15-10 3.353
	16	9-2 0.880	9-8 1.031	10-2 1.189	10-7 1.355	11-0 1.528	11-5 1.708	11-10 1.894	12-3 2.191	13-0 2.489	13-8 2.915
	24	7-6 0.708	7-11 0.829	8-3 0.957	8-7 1.089	9-0 1.229	9-4 1.374	9-7 1.523	9-11 1.677	10-7 2.002	11-2 2.345
2 x 10	12	13-6 1.012	14-3 1.186	14-11 1.368	15-7 1.558	16-3 1.757	16-10 1.964	17-5 2.179	18-0 2.400	19-1 2.863	20-2 3.353
	16	11-9 0.880	12-3 1.031	13-0 1.189	13-6 1.355	14-0 1.528	14-6 1.708	15-1 1.894	15-7 2.191	16-7 2.489	17-6 2.915
	24	9-6 0.708	10-0 0.829	10-6 0.957	11-0 1.089	11-6 1.229	11-11 1.374	12-4 1.523	12-9 1.677	13-6 2.002	14-3 2.345
2 x 12	12	16-6 1.012	17-4 1.186	18-2 1.368	19-0 1.558	19-9 1.757	20-6 1.964	21-3 2.179	21-11 2.400	23-3 2.863	24-6 3.353
	16	14-3 0.880	15-0 1.031	15-9 1.189	16-6 1.355	17-2 1.528	17-10 1.708	18-5 1.894	19-0 2.191	20-2 2.489	21-3 2.915
	24	11-7 0.708	12-3 0.829	12-10 0.957	13-5 1.089	13-11 1.229	14-5 1.374	14-11 1.523	15-5 1.677	16-5 2.002	17-5 2.345
2 x 14	12	19-5 1.012	20-5 1.186	21-5 1.368	22-4 1.558	23-3 1.757	24-2 1.964	25-0 2.179	25-10 2.400	27-5 2.863	28-11 3.353
	16	16-10 0.880	17-8 1.031	18-6 1.189	19-4 1.355	20-2 1.528	20-11 1.708	21-8 1.894	22-5 2.191	23-9 2.489	25-1 2.915
	24	13-8 0.708	14-5 0.829	15-1 0.957	15-9 1.089	16-5 1.229	17-0 1.374	17-7 1.523	18-2 1.677	19-3 2.002	20-4 2.345
3 x 6	12	10-4 1.307	10-11 1.531	11-6 1.766	12-0 2.012	12-6 2.269	13-0 2.535	13-5 2.811	13-10 3.098	14-8 3.696	15-6 4.329
	16	9-0 1.136	9-6 1.330	10-0 1.535	10-5 1.748	10-10 1.972	11-3 2.203	11-8 2.444	12-0 2.691	12-9 3.212	13-5 3.762
	24	7-4 0.914	7-9 1.070	8-1 1.235	8-5 1.406	8-9 1.586	9-1 1.773	9-5 1.966	9-9 2.166	10-4 2.584	10-11 3.026
3 x 8	12	13-8 1.307	14-5 1.531	15-2 1.766	15-10 2.012	16-6 2.269	17-1 2.535	17-8 2.811	18-3 3.098	19-4 3.696	20-5 4.329
	16	11-10 1.136	12-6 1.330	13-1 1.535	13-8 1.748	14-3 1.972	14-10 2.203	15-4 2.444	15-10 2.691	16-9 3.212	17-8 3.762
	24	9-7 0.914	10-1 1.070	10-7 1.235	11-1 1.406	11-7 1.586	12-0 1.773	12-5 1.966	12-10 2.166	13-7 2.584	14-4 3.026
3 x 10	12	17-5 1.307	18-5 1.531	19-4 1.766	20-2 2.012	21-0 2.269	21-9 2.535	22-7 2.811	23-4 3.098	24-9 3.696	26-1 4.329
	16	15-2 1.136	16-0 1.330	16-9 1.535	17-6 1.748	18-2 1.972	18-10 2.203	19-6 2.444	20-2 2.691	21-5 3.212	22-7 3.762
	24	12-4 0.914	13-0 1.070	13-7 1.235	14-2 1.406	14-9 1.586	15-4 1.773	15-10 1.966	16-4 2.166	17-5 2.584	18-4 3.026
3 x 12	12	21-3 1.307	22-4 1.531	23-5 1.766	24-6 2.012	25-6 2.269	26-6 2.535	27-5 2.811	28-4 3.098	30-0 3.696	31-7 4.329
	16	18-5 1.136	19-5 1.330	20-4 1.535	21-3 1.748	22-2 1.972	23-0 2.203	23-9 2.444	24-6 2.691	26-0 3.212	27-5 3.762
	24	15-0 0.914	15-9 1.070	16-6 1.235	17-3 1.406	18-0 1.586	18-8 1.773	19-4 1.966	20-0 2.166	21-2 2.584	22-4 3.036
3 x 14	12	25-0 1.307	26-4 1.531	27-7 1.766	28-10 2.012	30-1 2.269	31-3 2.535	32-4 2.811	33-4 3.098	35-4 3.696	37-4 4.329
	16	21-8 1.136	22-10 1.330	24-0 1.535	25-1 1.748	26-1 1.972	27-1 2.203	28-0 2.444	28-11 2.691	30-8 3.212	32-4 3.762
	24	17-7 0.914	18-7 1.070	19-6 1.235	20-4 1.406	21-2 1.586	22-0 1.773	22-9 1.966	23-6 2.166	24-11 2.584	26-3 3.026

NOTE: The required modulus of elasticity, E, in 1,000,000 psi is shown below each span, if deflection under the live load is limited to  $\ell/360$ .

American Forest and Paper Association; Washington, D.C.

**GENERAL DESIGN INFORMATION**

For floor construction where live loading is heavier than customarily found in residential occupancies, tabular data are provided.

The tabulated spans are based on bending strength using the live load indicated in each table heading plus a dead load of 10 psf. In calculating the required modulus of elasticity for the tabulated span, the live load only was used, since this is in accordance with established practice for design of floor joists.

**SPAN**

While the effective span length for an isolated beam is customarily taken as the distance from face to face

of supports plus one-half the required length of bearing at each end, it is the practice in designing joists spaced not over 24 in. apart to consider the span as the clear distance between supports.

**NET SIZES OF LUMBER**

Joists are customarily specified in terms of nominal sizes, but calculations to determine the allowable span and required modulus of elasticity are based on actual sizes.

**DESIGN STRESSES**

Unit design values for design of wood joists are given in the National Design Specification for Wood Construc-

tion, available from the American Forest & Paper Association.

**ADJUSTMENT OF MODULUS OF ELASTICITY**

The modulus of elasticity values listed in the span tables for joists are those required for the tabulated spans if deflection under the live load is limited to  $\ell/360$ . Where other deflection limits are acceptable, the tabular E values may be adjusted by multiplying them by the following factors:

- For limit of  $\ell/300$ : 0.833
- For limit of  $\ell/240$ : 0.667
- For limit of  $\ell/180$ : 0.500

**FLOOR JOISTS—70 LB LIVE LOAD**

JOIST (IN.)		EXTREME FIBER STRESS IN BENDING, $F_b$ (PSI)									
SIZE, SPACING		900	1000	1100	1200	1300	1400	1500	1600	1800	2000
2 x 10	12	12-8 0.963	13-4 1.133	14-0 1.306	14-7 1.488	15-2 1.678	15-9 1.875	16-4 2.081	16-10 2.292	17-11 2.733	18-10 3.201
	16	11-1 0.840	11-7 0.984	12-1 1.135	12-7 1.294	13-2 1.459	13-8 1.631	14-2 1.808	14-7 1.992	15-6 2.376	16-4 2.783
	24	8-11 0.676	9-5 0.792	9-10 0.914	10-3 1.040	10-8 1.174	11-1 1.312	11-6 1.454	11-11 1.602	12-7 1.912	13-3 2.239
2 x 12	12	15-5 0.963	16-3 1.133	17-0 1.306	17-9 1.488	18-6 1.678	19-2 1.875	19-10 2.081	20-6 2.292	21-9 2.733	22-11 3.201
	16	13-4 0.840	14-1 0.984	14-9 1.135	15-5 1.294	16-0 1.459	16-7 1.631	17-3 1.808	17-10 1.992	18-10 2.376	19-11 2.783
	24	10-10 0.676	11-5 0.792	12-0 0.914	12-6 1.040	13-0 1.174	13-6 1.312	14-0 1.454	14-5 1.602	15-4 1.912	16-4 2.239
2 x 14	12	18-2 0.963	19-1 1.133	20-0 1.306	20-11 1.488	21-9 1.678	22-7 1.875	23-5 2.081	24-2 2.292	25-7 2.733	27-0 3.201
	16	15-9 0.840	16-7 0.984	17-5 1.135	18-2 1.294	18-11 1.459	19-7 1.631	20-3 1.808	20-11 1.992	22-3 2.376	23-5 2.783
	24	12-9 0.676	13-6 0.792	14-2 0.914	14-9 1.040	15-4 1.174	15-11 1.312	16-6 1.454	17-0 1.602	18-1 1.912	19-1 2.239
3 x 8	12	12-10 1.248	13-6 1.462	14-2 1.686	14-9 1.921	15-4 2.166	15-11 2.421	16-6 2.684	17-1 2.958	18-1 3.529	19-1 4.133
	16	11-1 1.084	11-8 1.270	12-3 1.465	12-10 1.669	13-4 1.883	13-10 2.103	14-4 2.333	14-10 2.570	15-8 3.067	16-7 3.592
	24	9-0 0.873	9-6 1.022	10-0 1.179	10-5 1.344	10-10 1.514	11-3 1.693	11-8 1.877	12-0 2.068	12-9 2.467	13-5 2.900
3 x 10	12	16-4 1.248	17-3 1.462	18-1 1.686	18-10 1.921	19-7 2.166	20-4 2.421	21-1 2.684	21-9 2.958	23-1 3.529	24-4 4.133
	16	14-2 1.084	14-11 1.270	15-8 1.465	16-4 1.669	17-0 1.883	17-8 2.103	18-3 2.333	18-11 2.570	20-1 3.067	21-1 3.592
	24	11-6 0.873	12-2 1.022	12-9 1.179	13-3 1.344	13-10 1.514	14-4 1.693	14-10 1.877	15-4 2.068	16-3 2.467	17-2 2.900
3 x 12	12	19-11 1.248	20-11 1.462	21-11 1.686	22-11 1.921	23-10 2.166	24-9 2.421	25-8 2.684	26-6 2.958	28-1 3.529	29-7 4.133
	16	17-3 1.084	18-2 1.270	19-1 1.465	19-11 1.669	20-9 1.883	21-6 2.103	22-3 2.333	23-0 2.570	24-4 3.067	25-8 3.592
	24	14-0 0.873	14-9 1.022	15-6 1.179	16-2 1.344	16-10 1.514	17-6 1.693	18-1 1.877	18-7 2.068	19-9 2.467	20-10 2.900
3 x 14	12	23-4 1.248	24-7 1.462	25-10 1.686	27-0 1.921	28-1 2.166	29-2 2.421	30-2 2.684	31-2 2.958	33-1 3.529	34-11 4.133
	16	20-3 1.084	21-4 1.270	22-5 1.465	23-5 1.669	24-5 1.883	25-4 2.103	26-2 2.333	27-0 2.570	28-8 3.067	30-3 3.592
	24	16-6 0.873	17-4 1.022	18-7 1.179	19-0 1.344	19-9 1.514	20-6 1.693	21-3 1.877	22-0 2.068	23-4 2.467	24-7 2.900
4 x 8	12	15-2 1.490	16-0 1.745	16-10 2.015	17-7 2.295	18-3 2.588	18-11 2.891	19-7 3.207	20-3 3.533	21-6 4.217	22-7 4.939
	16	13-2 1.300	13-11 1.533	14-7 1.757	15-3 2.002	15-11 2.257	16-6 2.522	17-1 2.799	17-7 3.082	18-7 3.676	19-7 4.306
	24	10-9 1.054	11-4 1.234	11-11 1.425	12-5 1.625	12-11 1.831	13-5 2.046	13-11 2.268	14-4 2.500	15-2 2.922	16-0 3.492
4 x 10	12	19-5 1.490	20-5 1.745	21-5 2.015	22-5 2.295	22-4 2.588	24-2 2.891	25-0 3.207	25-10 3.533	27-5 4.217	28-9 4.939
	16	16-10 1.300	17-9 1.533	18-7 1.757	19-5 2.002	20-3 2.257	21-0 2.522	21-9 2.799	22-5 3.082	23-10 3.676	25-1 4.306
	24	13-8 1.054	14-5 1.234	15-2 1.425	15-10 1.625	16-6 1.831	17-1 2.046	17-8 2.268	18-3 2.500	19-3 2.922	20-5 3.492
4 x 12	12	23-7 1.490	24-10 1.745	26-1 2.015	27-3 2.295	28-4 2.588	29-5 2.891	30-5 3.207	31-5 3.533	33-4 4.217	35-2 4.939
	16	20-6 1.300	21-7 1.533	22-7 1.757	23-7 2.002	24-7 2.257	25-6 2.522	26-5 2.799	27-4 3.082	28-5 3.676	30-6 4.306
	24	16-8 1.054	17-7 1.234	18-5 1.425	19-3 1.625	20-1 1.831	20-10 2.046	21-6 2.268	22-2 2.500	23-6 2.922	24-10 3.492

NOTE: The required modulus of elasticity, E, in 1,000,000 psi is shown below each span, if deflection under the live load is limited to  $\ell/360$ .

American Forest and Paper Association; Washington, D.C.

**GENERAL DESIGN INFORMATION**

For floor construction where live loading is heavier than customarily found in residential occupancies, tabular data are provided.

The tabulated spans are based on bending strength using the live load indicated in each table heading plus a dead load of 10 psf. In calculating the required modulus of elasticity for the tabulated span, the live load only was used, since this is in accordance with established practice for design of floor joists.

**SPAN**

While the effective span length for an isolated beam is customarily taken as the distance from face to face

of supports plus one-half the required length of bearing at each end, it is the practice in designing joists spaced not over 24 in. apart to consider the span as the clear distance between supports.

**NET SIZES OF LUMBER**

Joists are customarily specified in terms of nominal sizes, but calculations to determine the allowable span and required modulus of elasticity are based on actual sizes.

**DESIGN STRESSES**

Unit design values for design of wood joists are given in the National Design Specification for Wood Construc-

tion, available from the American Forest & Paper Association.

**ADJUSTMENT OF MODULUS OF ELASTICITY**

The modulus of elasticity values listed in the span tables for joists are those required for the tabulated spans if deflection under the live load is limited to  $\ell/360$ . Where other deflection limits are acceptable, the tabular E values may be adjusted by multiplying them by the following factors:

- For limit of  $\ell/300$ : 0.833
- For limit of  $\ell/240$ : 0.667
- For limit of  $\ell/180$ : 0.500

**FLOOR JOISTS—80 LB LIVE LOAD**

JOIST (IN.)		EXTREME FIBER STRESS IN BENDING, $F_b$ (PSI)									
SIZE, SPACING		900	1000	1100	1200	1300	1400	1500	1600	1800	2000
2 x 10	12	11-11 0.926	12-7 1.084	13-2 1.250	13-9 1.423	14-4 1.604	14-11 1.795	15-5 1.988	15-11 2.191	16-10 2.617	17-9 3.062
	16	10-4 0.803	10-11 0.941	11-5 1.086	11-11 1.236	12-5 1.395	12-11 1.561	13-4 1.730	13-9 1.903	14-7 2.273	15-5 2.662
	24	8-5 0.646	8-10 0.758	9-3 0.873	9-8 0.995	10-1 1.124	10-6 1.254	10-10 1.390	11-2 1.533	11-10 1.829	12-6 2.143
2 x 12	12	14-6 0.926	15-4 1.084	16-1 1.250	16-9 1.423	17-5 1.604	18-1 1.795	18-9 1.988	19-4 2.191	20-6 2.617	21-7 3.062
	16	12-7 0.803	13-3 0.941	13-11 1.089	14-6 1.236	15-1 1.395	15-8 1.561	16-3 1.730	16-9 1.903	17-9 2.273	18-9 2.662
	24	10-3 0.646	10-9 0.758	11-3 0.873	11-9 0.995	12-3 1.124	12-9 1.254	13-2 1.390	13-7 1.533	14-5 1.829	15-5 2.143
2 x 14	12	17-1 0.926	18-0 1.084	18-10 1.250	19-8 1.423	20-6 1.604	21-4 1.795	22-1 1.988	22-9 2.191	24-2 2.617	25-5 3.062
	16	14-10 0.803	15-7 0.941	16-4 1.086	17-1 1.236	17-10 1.395	18-6 1.561	19-2 1.730	19-9 1.903	20-11 2.273	22-1 2.662
	24	12-0 0.646	12-8 0.758	13-4 0.873	13-11 0.995	14-5 1.124	15-0 1.254	15-6 1.390	16-0 1.533	17-0 1.829	18-0 2.143
3 x 8	12	12-0 1.195	12-8 1.399	13-4 1.614	13-11 1.838	14-6 2.073	15-1 2.317	15-7 2.569	16-1 2.831	17-1 3.377	18-0 3.956
	16	10-6 1.038	11-0 1.215	11-7 1.402	12-1 1.597	12-7 1.802	13-1 2.013	13-6 2.233	13-11 2.459	14-9 2.935	15-7 3.438
	24	8-6 0.835	9-0 0.978	9-5 1.128	9-10 1.286	10-3 1.449	10-7 1.620	11-0 1.797	11-4 1.979	12-0 2.361	12-8 2.766
3 x 10	12	15-5 1.195	16-3 1.399	17-0 1.614	17-9 1.838	18-6 2.073	19-2 2.317	19-10 2.569	20-6 2.831	21-8 3.377	22-11 3.956
	16	13-4 1.038	14-1 1.215	14-9 1.402	15-5 1.597	16-0 1.802	16-7 2.013	17-3 2.233	17-9 2.459	18-10 2.935	19-11 3.438
	24	10-10 0.835	11-5 0.978	12-0 1.128	12-6 1.286	13-0 1.446	13-6 1.620	14-0 1.797	14-5 1.979	15-4 2.361	16-2 2.766
3 x 12	12	18-9 1.195	19-9 1.399	20-8 1.614	21-7 1.838	22-6 2.073	23-4 2.317	24-2 2.569	25-0 2.831	26-5 3.377	27-11 3.956
	16	16-3 1.038	17-1 1.215	17-11 1.402	18-9 1.597	19-6 1.802	20-3 2.013	20-11 2.233	21-7 2.459	22-11 2.935	24-2 3.438
	24	13-2 0.835	13-11 0.978	14-7 1.128	15-3 1.286	15-10 1.449	16-5 1.620	17-0 1.797	17-7 1.979	18-7 2.361	19-7 2.766
3 x 14	12	22-1 1.195	23-3 1.399	24-4 1.614	25-5 1.838	26-6 2.073	27-6 2.317	28-6 2.569	29-5 2.831	31-2 3.377	32-10 3.956
	16	19-2 1.038	20-2 1.215	21-2 1.402	22-1 1.597	23-0 1.802	23-10 2.013	24-8 2.233	25-6 2.459	27-1 2.935	28-6 3.438
	24	15-6 0.835	16-4 0.978	17-2 1.128	17-11 1.286	18-8 1.449	19-5 1.620	20-1 1.797	20-9 1.979	22-0 2.361	23-2 2.766
4 x 8	12	14-4 1.426	15-1 1.670	15-10 1.928	16-6 2.196	17-2 2.475	17-10 2.766	18-5 3.068	19-0 3.379	20-3 4.034	21-4 4.725
	16	12-5 1.243	13-1 1.457	13-9 1.681	14-4 1.915	14-11 2.159	15-6 2.413	16-1 2.677	16-7 2.948	17-7 3.516	18-6 4.119
	24	10-2 1.009	10-8 1.180	11-2 1.363	11-8 1.554	12-2 1.752	12-6 1.957	13-1 2.170	13-6 2.391	14-4 2.795	15-1 3.340
4 x 10	12	18-3 1.426	19-3 1.670	20-2 1.928	21-1 2.196	21-11 2.475	22-9 2.766	23-7 3.068	24-4 3.379	25-10 4.034	27-3 4.725
	16	15-10 1.243	16-8 1.457	17-6 1.681	18-4 1.915	19-1 2.159	19-10 2.413	20-6 2.677	21-2 2.948	22-5 3.516	23-7 4.119
	24	12-11 1.009	13-7 1.180	14-3 1.363	14-11 1.554	15-6 1.752	16-1 1.957	16-8 2.170	17-2 2.391	18-2 2.795	19-3 3.340
4 x 12	12	22-3 1.426	23-5 1.670	24-6 1.928	25-7 2.196	26-8 2.475	27-8 2.766	28-8 3.068	29-7 3.379	31-5 4.034	33-2 4.725
	16	19-3 1.243	20-4 1.457	21-4 1.681	22-3 1.915	23-2 2.159	24-1 2.413	24-11 2.677	25-9 2.948	27-3 3.516	28-9 4.119
	24	15-9 1.009	16-7 1.180	17-4 1.363	18-1 1.554	18-10 1.752	19-7 1.957	20-3 2.170	20-11 2.391	22-2 2.795	23-5 3.340

NOTE: The required modulus of elasticity, E, in 1,000,000 psi is shown below each span, if deflection under the live load is limited to  $\ell/360$ .

American Forest and Paper Association, Washington, D.C.



DESIGN LOAD TABLES





FLOOR AND ROOF BEAMS—DESIGN TABLES 20 POUNDS PSF

REQUIRED VALUES FOR FIBER STRESS IN BENDING (f) AND MODULUS OF ELASTICITY (E) FOR THE SIZES SHOWN TO SUPPORT SAFELY A LIVE LOAD OF 20 POUNDS PER SQUARE FOOT WITH A DEFLECTION LIMITATION OF 1/300 l = SPAN IN INCHES.

Table with columns for Span of Beam, Nominal Size of Beam, and Minimum 'f' & 'E' in PSI for Beams Spaced 6'-0", 7'-0", and 8'-0".

American Forest and Paper Association, Washington, D.C.



DESIGN LOAD TABLES



FLOOR AND ROOF BEAMS—DESIGN TABLES 40 POUNDS PSF

REQUIRED VALUES FOR FIBER STRESS IN BENDING (f) AND MODULUS OF ELASTICITY (E) FOR THE SIZES SHOWN TO SUPPORT SAFELY A LIVE LOAD OF 40 POUNDS PER SQUARE FOOT WITHIN A DEFLECTION LIMITATION OF 1/300 L = SPAN IN INCHES.

SPAN OF BEAM	NOMINAL SIZE OF BEAM	MINIMUM "f" & "E" IN PSI FOR BEAMS SPACED:						SPAN OF BEAM	NOMINAL SIZE OF BEAM	MINIMUM "f" & "E" IN PSI FOR BEAMS SPACED:					
		6'-0"		7'-0"		8'-0"				6'-0"		7'-0"		8'-0"	
		f	E	f	E	f	E			f	E	f	E	f	E
10'	1-3 x 8	2055	1700000	2400	1984000	2740	2266000	17'	2-3 x 10	1825	2010000	2310	2345000	2430	2679000
	2-2 x 8	1710	1417000	1995	1654000	2280	1889000		2-4 x 10	1300	1436000	1520	1676000	1735	1914000
	1-4 x 8	1470	1211000	1715	1413000	1960	1614000		3-3 x 10	1215	1341000	1420	1565000	1620	1787000
	1-6 x 8	875	697000	1020	813000	1165	929000		1-8 x 10	1150	1236000	1340	1442000	1535	1647000
	2-2 x 10	1050	681000	1225	795000	1400	908000		3-2 x 12	1370	1241000	1600	1448000	1825	1654000
	1-3 x 10	1260	819000	1470	956000	1680	1092000		4-2 x 12	1025	931000	1195	1086000	1365	1241000
	1-4 x 10	900	585000	1050	683000	1200	780000		5-2 x 12	820	745000	955	869000	1095	993000
									2-3 x 12	1230	1119000	1435	1306000	1640	1492000
									3-3 x 12	820	737000	955	860000	1095	982000
11'	2-2 x 8	2070	1886000	2415	2201000	2760	2514000	2-4 x 12	880	799000	1025	932000	1175	1065000	
	1-4 x 8	1775	1616000	2070	1886000	2365	2154000	1-6 x 12	1070	951000	1250	1110000	1425	1268000	
	1-6 x 8	1055	929000	1230	1084000	1405	1238000	1-8 x 12	785	697000	915	813000	1045	929000	
	2-2 x 10	1275	906000	1490	1057000	1700	1208000								
	1-3 x 10	1525	1090000	1780	1272000	2030	1453000	2-4 x 10	1460	1705000	1705	1990000	1945	2273000	
	1-4 x 10	1090	779000	1270	909000	1455	1038000	3-3 x 10	1365	1591000	1595	1857000	1820	2121000	
	3-2 x 10	850	605000	990	706000	1135	806000	1-8 x 10	1300	1470000	1515	1715000	1730	1959000	
								3-2 x 12	1540	1475000	1800	1721000	2050	1966000	
								4-2 x 12	1150	1105000	1340	1289000	1530	1473000	
12'	1-6 x 8	1255	1206000	1465	1407000	1670	1607000	5-2 x 12	920	885000	1075	1033000	1225	1180000	
	3-2 x 8	1645	1631000	1920	1903000	2190	2174000	2-3 x 12	1380	1326000	1610	1547000	1840	1767000	
	2-2 x 10	1510	1180000	1760	1377000	2010	1573000	3-3 x 12	920	875000	1075	1021000	1225	1166000	
	1-3 x 10	1820	1415000	2125	1651000	2425	1886000	2-4 x 12	990	949000	1155	1107000	1320	1265000	
	1-4 x 10	1300	1010000	1515	1179000	1735	1346000	1-6 x 12	1200	1129000	1400	1317000	1600	1505000	
	3-2 x 10	1010	786000	1180	917000	1345	1048000	1-8 x 12	880	829000	1025	967000	1175	1105000	
	2-3 x 10	905	706000	1055	824000	1205	941000	3-4 x 12	660	632000	770	737000	880	842000	
	1-6 x 10	785	594000	915	693000	1045	792000								
	2-4 x 10	650	505000	760	589000	865	673000								
13'	1-6 x 8	1475	1535000	1720	1791000	1965	2046000	3-3 x 10	1520	1872000	1775	2184000	2025	2495000	
	2-3 x 8	1735	1866000	2025	2178000	2315	2487000	3-2 x 12	1710	1735000	1995	2025000	2280	2313000	
	2-4 x 8	1235	1335000	1440	1558000	1645	1779000	4-2 x 12	1280	1300000	1495	1517000	1705	1733000	
	3-2 x 10	1185	1000000	1380	1167000	1580	1333000	5-2 x 12	1025	1040000	1195	1214000	1365	1386000	
	2-2 x 10	1780	1500000	2075	1750000	2370	2000000	2-3 x 12	1540	1560000	1795	1820000	2050	2079000	
	1-3 x 10	2130	1799000	2485	2099000	2840	2398000	3-3 x 12	1025	1029000	1195	1201000	1365	1372000	
	2-3 x 10	1070	900000	1250	1050000	1425	1200000	2-4 x 12	1100	1115000	1280	1301000	1465	1486000	
	1-4 x 10	1525	1537000	1780	1794000	2035	2049000	1-6 x 12	1335	1326000	1560	1547000	1780	1767000	
	2-4 x 10	760	642000	890	749000	1015	856000	1-8 x 12	980	973000	1145	1135000	1305	1297000	
14'	2-4 x 8	1435	1666000	1675	1944000	1915	2221000	3-4 x 12	735	744000	860	868000	980	992000	
	2-3 x 10	1375	1246000	1605	1454000	1830	1661000	4-3 x 12	770	780000	900	910000	1025	1040000	
	1-4 x 10	1235	1121000	1440	1308000	1645	1494000	2-6 x 12	740	775000	865	904000	985	1033000	
	1-6 x 10	1770	1605000	2065	1873000	2360	2139000	1-10 x 12	860	896000	1005	1046000	1145	1194000	
	2-4 x 10	890	801000	1025	935000	1175	1068000	2-3 x 14	1230	1114000	1435	1300000	1640	1485000	
	3-3 x 10	825	749000	960	874000	1100	988000								
	1-6 x 10	1145	1571000	1335	1833000	1525	2094000	4-2 x 12	1570	1756000	1830	2049000	2095	2341000	
	1-8 x 10	780	691000	910	806000	1040	921000	5-2 x 12	1255	1405000	1465	1640000	1675	1873000	
	4-2 x 10	1030	936000	1200	1092000	1375	1248000	3-3 x 12	1255	1389000	1465	1621000	1675	1851000	
2-2 x 12	1395	1040000	1630	1214000	1860	1386000	2-4 x 12	1345	1505000	1570	1756000	1795	2006000		
15'	3-2 x 10	1575	1535000	1840	1791000	2100	2046000	1-8 x 12	1200	1315000	1400	1535000	1600	1753000	
	2-3 x 10	1420	1381000	1655	1612000	1890	1841000	3-4 x 12	895	1004000	1045	1172000	1195	1338000	
	2-4 x 10	1010	986000	1175	1151000	1345	1314000	4-3 x 12	935	1054000	1090	1230000	1245	1405000	
	1-6 x 10	1225	1160000	1430	1354000	1635	1546000	2-6 x 12	820	896000	955	1046000	1095	1194000	
	1-8 x 10	900	850000	1050	992000	1200	1133000	1-10 x 12	950	1039000	1110	1212000	1265	1385000	
	4-2 x 10	1180	1151000	1375	1343000	1575	1534000	2-3 x 14	1355	1290000	1580	1505000	1805	1719000	
	2-2 x 12	1600	1280000	1865	1494000	2130	1706000	1-6 x 14	1190	1109000	1390	1294000	1585	1478000	
	3-2 x 12	1065	854000	1240	997000	1420	1138000	2-4 x 14	930	871000	1085	1016000	1240	1161000	
	1-3 x 12	1920	1536000	2240	1792000	2560	2047000								
4-2 x 12	800	640000	935	747000	1065	853000									
2-3 x 12	960	767000	1120	895000	1280	1022000									
16'	3-2 x 10	1795	1861000	2095	2172000	2395	2481000	4-2 x 12	1720	2020000	2005	2357000	2295	2693000	
	2-3 x 10	1610	1676000	1880	1956000	2145	2234000	5-2 x 12	1375	1615000	1605	1885000	1830	2153000	
	2-4 x 10	1155	1199000	1350	1399000	1540	1598000	3-3 x 12	1375	1596000	1605	1862000	1830	2127000	
	3-3 x 10	1075	1117000	1255	1303000	1435	1489000	3-4 x 12	985	1154000	1150	1347000	1315	1538000	
	1-6 x 10	1395	1406000	1625	1641000	1860	1874000	4-3 x 12	1030	1211000	1200	1413000	1375	1614000	
	1-8 x 10	1020	1031000	1190	1203000	1360	1374000	2-6 x 12	900	1031000	1050	1203000	1200	1374000	
	4-2 x 10	1345	1396000	1570	1629000	1790	1861000	1-10 x 12	1035	1194000	1205	1393000	1380	1592000	
	2-2 x 12	1820	1551000	2120	1810000	2425	2067000	2-3 x 14	1485	1484000	1730	1732000	1980	1978000	
	3-2 x 12	1210	1035000	1410	1208000	1610	1380000	1-6 x 14	1305	1275000	1525	1488000	1740	1700000	
4-2 x 12	910	776000	1060	905000	1215	1034000	2-4 x 14	1025	1001000	1195	1168000	1365	1334000		
5-2 x 12	730	621000	850	725000	975	828000	3-3 x 14	995	981000	1160	1145000	1325	1308000		
2-3 x 12	1095	931000	1280	1086000	1460	1241000	3-4 x 14	680	667000	795	778000	905	889000		

American Forest and Paper Association; Washington, D.C.



**CEILING JOISTS—10 LB/SQ FT LIVE LOAD (GYPSUM WALLBOARD CEILING)**  
 No attic storage and roof slope not steeper than 3 IN 12.

**MAXIMUM ALLOWABLE LENGTHS L BETWEEN SUPPORTS**

JOIST SIZE (NOMINAL) (IN.)	JOIST SPACING (NOMINAL) (IN.)	SPAN L LIMITED BY DEFLECTION AND F <sub>b</sub> IS EXTREME FIBER STRESS			
		E =	1,000,000	1,200,000	1,400,000
2 x 4	12	L = 10-7 F <sub>b</sub> = 830	11-3 930	11-10 1030	12-5 1130
	16	L = 9-8 F <sub>b</sub> = 910	10-3 1030	10-9 1140	11-3 1240
	24	L = 8-5 F <sub>b</sub> = 1040	8-11 1170	9-5 1300	9-10 1420
2 x 6	12	L = 16-8 F <sub>b</sub> = 830	17-8 930	18-8 1030	19-6 1130
	16	L = 15-2 F <sub>b</sub> = 910	16-1 1030	16-11 1140	17-8 1240
	24	L = 13-3 F <sub>b</sub> = 1040	14-1 1170	14-9 1300	15-6 1420
2 x 8	12	L = 21-11 F <sub>b</sub> = 830	23-4 930	24-7 1030	25-8 1130
	16	L = 19-11 F <sub>b</sub> = 910	21-2 1030	22-4 1140	23-4 1240
	24	L = 17-5 F <sub>b</sub> = 1040	18-6 1170	19-6 1300	20-5 1420
2 x 10	12	L = 28-0 F <sub>b</sub> = 830	29-9 930	31-4 1030	32-9 1130
	16	L = 25-5 F <sub>b</sub> = 910	27-1 1030	28-6 1140	29-9 1240
	24	L = 22-3 F <sub>b</sub> = 1040	23-8 1170	24-10 1300	26-0 1420

NOTE: L in feet and inches; E and F<sub>b</sub> in pounds per square inch as shown above.

**DESIGN CRITERIA**

1. Maximum allowable deflection = 1/240 of span length.
2. Live load of 10 lb/sq ft plus dead load of 5 lb/sq ft determine required fiber stress value.

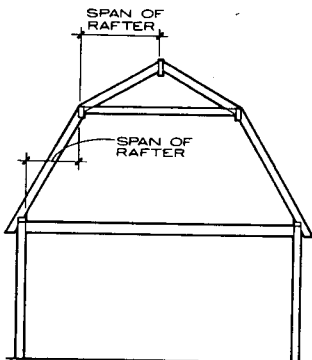

GAMBREL ROOF

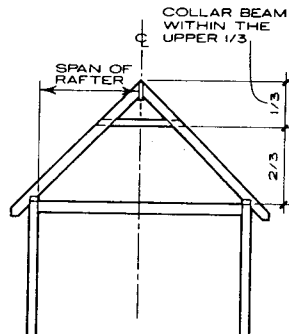

GABLE ROOF (SLOPE OVER 3 IN 12)

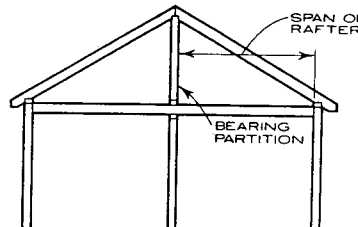

GABLE ROOF (SLOPE UNDER 3 IN 12)

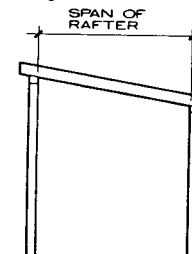

LEAN-TO OR SHED ROOF

**CEILING JOISTS—20 LB/SQ FT LIVE LOAD (GYPSUM WALLBOARD CEILING)**  
 Limited attic storage where development of future rooms is not possible.

**MAXIMUM ALLOWABLE LENGTHS L BETWEEN SUPPORTS**

JOIST SIZE (NOMINAL) (IN.)	JOIST SPACING (NOMINAL) (IN.)	SPAN L LIMITED BY DEFLECTION AND F <sub>b</sub> IS EXTREME FIBER STRESS				
		E =	1,000,000	1,200,000	1,400,000	1,600,000
2 x 4	12	L = 8-5 F <sub>b</sub> = 1040	8-11 1170	9-5 1300	9-10 1420	
	16	L = 7-8 F <sub>b</sub> = 1140	8-1 1290	8-7 1430	8-11 1570	
	24	L = 6-8 F <sub>b</sub> = 1310	7-1 1480	7-6 1640	7-10 1790	
2 x 6	12	L = 13-3 F <sub>b</sub> = 1040	14-1 1170	14-9 1300	15-6 1420	
	16	L = 12-0 F <sub>b</sub> = 1140	12-9 1290	13-5 1430	14-1 1570	
	24	L = 10-6 F <sub>b</sub> = 1310	11-2 1480	11-9 1640	12-3 1790	
2 x 8	12	L = 17-5 F <sub>b</sub> = 1040	18-6 1170	19-6 1300	20-5 1420	
	16	L = 15-10 F <sub>b</sub> = 1140	16-10 1290	17-9 1430	18-6 1570	
	24	L = 13-10 F <sub>b</sub> = 1310	14-8 1480	15-6 1640	16-2 1790	
2 x 10	12	L = 22-3 F <sub>b</sub> = 1040	23-8 1170	24-10 1300	26-0 1420	
	16	L = 20-2 F <sub>b</sub> = 1140	21-6 1290	22-7 1430	23-8 1570	
	24	L = 17-8 F <sub>b</sub> = 1310	18-9 1480	19-9 1640	20-8 1790	

NOTE: L in feet and inches; E and F<sub>b</sub> in pounds per square inch as shown above.

**DESIGN CRITERIA**

1. Maximum allowable deflection = 1/240 of span length.
2. Live load of 20 lb/sq ft plus dead load of 10 lb/sq ft determine required fiber stress value.

**NOTE**

For rafters, design values in F<sub>b</sub> may be greater than the design values for normal duration of load, by the following amounts:

- 15% for 2 months' duration, as for snow.
- 25% for 7 days' duration, as for construction loading.

**NOTE**

(Applicable to this page and the following pages on joist and rafter sizes.)

**SPANS LIMITED BY DEFLECTION:** The weight of plaster itself was ignored in the assumed loads for the deflection computations, because the initial deflection from the dead load occurs before plaster sets. The influence of live loads, rather than dead loads, when the ratio of live to dead loads is relatively high, is the principal factor to be considered. Also with joisted floors, flooring and bridging serve to distribute moving or concentrated loads to adjoining members. The omission of the plaster weight in load assumption applies to deflection computations only; the full dead and live load is considered when computing for strength.

E = modulus of elasticity  
 F<sub>b</sub> = extreme fiber stress in bending  
 L = span length between supports

**LIVE LOAD ASSUMPTIONS:** Uniformly distributed.

**PARTITIONS:** Spans shown are computed for the given live load plus the dead load and do not provide for additional loads such as partitions. Where concentrated loads are imposed the spans should be recomputed to provide for them.

**SECTION MODULUS**

LUMBER SIZES (NOMINAL)	S (IN. <sup>3</sup> )
2 x 3	1.56
2 x 4	3.06
2 x 6	7.56
2 x 8	13.14
2 x 10	21.39
2 x 12	31.64
3 x 6	12.60
3 x 8	21.90
3 x 10	35.65
3 x 12	52.73
3 x 14	73.15
4 x 4	7.15
4 x 6	17.65
4 x 8	30.66
4 x 10	49.91
4 x 12	73.83

**SECTION MODULUS**

$$S = \frac{bd^2}{6}$$

(IN.<sup>3</sup>)

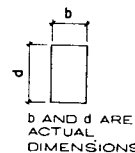

DESIGN CRITERIA

STRENGTH: 15 psf dead load plus 20 psf live load determines required fiber stress.

RAFTERS: Spans are measured along the horizontal projection, and loads are considered as applied on the horizontal projection.

DEFLECTION: For 20 psf live load. Limited to span in inches divided by 240.

FLAT OR SLOPED RAFTERS—20 LB LIVE LOAD  
FLAT ROOF OR CATHEDRAL CEILING WITH NO ATTIC SPACE—SUPPORTING GYPSUM WALLBOARD CEILING

RAFTER SIZE, SPACING (IN.)	EXTREME FIBER STRESS IN BENDING, $F_b$ (PSI)															
	500	600	700	800	900	1000	1100	1200	1300	1400	1500	1600	1700	1800	1900	
2 x 6	12	8-6 0.26	9-4 0.35	10-0 0.44	10-9 0.54	11-5 0.64	12-0 0.75	12-7 0.86	13-2 0.98	13-8 1.11	14-2 1.24	14-8 1.37	15-2 1.51	15-8 1.66	16-1 1.81	16-7 1.96
	16	7-4 0.23	8-1 0.30	8-8 0.38	9-4 0.46	9-10 0.55	10-5 0.65	10-11 0.75	11-5 0.85	11-10 0.96	12-4 1.07	12-9 1.19	13-2 1.31	13-7 1.44	13-11 1.56	14-4 1.70
	24	6-0 0.19	6-7 0.25	7-1 0.31	7-7 0.38	8-1 0.45	8-6 0.53	8-11 0.61	9-4 0.70	9-8 0.78	10-0 0.88	10-5 0.97	10-9 1.07	11-1 1.17	11-5 1.28	11-8 1.39
2 x 8	12	11-2 0.26	12-3 0.35	13-3 0.44	14-2 0.54	15-0 0.64	15-10 0.75	16-7 0.86	17-4 0.98	18-0 1.11	18-9 1.24	19-5 1.37	20-0 1.51	20-8 1.66	21-3 1.81	21-10 1.96
	16	9-8 0.23	10-7 0.30	11-6 0.38	12-3 0.46	13-0 0.55	13-8 0.65	14-4 0.75	15-0 0.85	15-7 0.96	16-3 1.07	16-9 1.19	17-4 1.31	17-10 1.44	18-5 1.56	18-11 1.70
	24	7-11 0.19	8-8 0.25	9-4 0.31	10-0 0.38	10-7 0.45	11-2 0.53	11-9 0.61	12-3 0.70	12-9 0.78	13-3 0.88	13-8 0.97	14-2 1.07	14-7 1.17	15-0 1.28	15-5 1.39
2 x 10	12	14-3 0.26	15-8 0.35	16-11 0.44	18-1 0.54	19-2 0.64	20-2 0.75	21-2 0.86	22-1 0.98	23-0 1.11	23-11 1.24	24-9 1.37	25-6 1.51	26-4 1.66	27-1 1.81	27-10 1.96
	16	12-4 0.23	13-6 0.30	14-8 0.38	15-8 0.46	16-7 0.55	17-6 0.65	18-4 0.75	19-2 0.85	19-11 0.96	20-8 1.07	21-5 1.19	22-1 1.31	22-10 1.44	23-5 1.56	24-1 1.70
	24	10-1 0.19	11-1 0.25	11-11 0.31	12-9 0.38	13-6 0.45	14-3 0.53	15-0 0.61	15-8 0.70	16-3 0.78	16-11 0.88	17-6 0.97	18-1 1.07	18-7 1.17	19-2 1.28	19-8 1.39
2 x 12	12	17-4 0.26	19-0 0.35	20-6 0.44	21-11 0.54	23-3 0.64	24-7 0.75	25-9 0.86	26-11 0.98	28-0 1.11	29-1 1.24	30-1 1.37	31-1 1.51	32-0 1.66	32-11 1.81	33-10 1.96
	16	15-0 0.23	16-6 0.30	17-9 0.38	19-0 0.46	20-2 0.55	21-3 0.65	22-4 0.75	23-3 0.85	24-3 0.96	25-2 1.07	26-0 1.19	26-11 1.31	27-9 1.44	28.6 1.56	29-4 1.70
	24	12-3 0.19	13-5 0.25	14-6 0.31	15-6 0.38	16-6 0.45	17-4 0.53	18-2 0.61	19-0 0.70	19-10 0.78	20-6 0.88	21-3 0.97	21-11 1.07	22-8 1.17	23-3 1.28	23-11 1.39

NOTE: The required modulus of elasticity, E, in 1,000,000 psi is shown below each span.

DESIGN CRITERIA

STRENGTH: 15 psf dead load plus 30 psf live load determines required fiber stress.

RAFTERS: Spans are measured along the horizontal projection, and loads are considered as applied on the horizontal projection.

DEFLECTION: For 30 psf live load. Limited to span in inches divided by 240.

FLAT OR SLOPED RAFTERS—30 LB LIVE LOAD  
FLAT ROOF OR CATHEDRAL CEILING WITH NO ATTIC SPACE—SUPPORTING GYPSUM WALLBOARD CEILING

RAFTER SIZE, SPACING (IN.)	EXTREME FIBER STRESS IN BENDING, $F_b$ (PSI)															
	500	600	700	800	900	1000	1100	1200	1300	1400	1500	1600	1700	1800	1900	
2 x 6	12	7-6 0.27	8-2 0.36	8-10 0.45	9-6 0.55	10-0 0.66	10-7 0.77	11-1 0.89	11-7 1.01	12-1 1.14	12-6 1.28	13-0 1.41	13-5 1.56	13-10 1.71	14-2 1.86	14-7 2.02
	16	6-6 0.24	7-1 0.31	7-8 0.39	8-2 0.48	8-8 0.57	9-2 0.67	9-7 0.77	10-0 0.88	10-5 0.99	10-10 1.10	11-3 1.22	11-7 1.35	11-11 1.48	12-4 1.61	12-8 1.75
	24	5-4 0.19	5-10 0.25	6-3 0.32	6-8 0.39	7-1 0.46	7-6 0.54	7-10 0.63	8-2 0.72	8-6 0.81	8-10 0.90	9-2 1.00	9-6 1.10	9-9 1.21	10-0 1.31	10-4 1.43
2 x 8	12	9-10 0.27	10-10 0.36	11-8 0.45	12-6 0.55	13-3 0.66	13-11 0.77	14-8 0.89	15-3 1.01	15-11 1.14	16-6 1.28	17-1 1.41	17-8 1.56	18-2 1.71	18-9 1.86	19-3 2.02
	16	8-7 0.24	9-4 0.31	10-1 0.39	10-10 0.48	11-6 0.57	12-1 0.67	12-8 0.77	13-3 0.88	13-9 0.99	14-4 1.10	14-10 1.22	15-3 1.35	15-9 1.48	16-3 1.61	16-8 1.75
	24	7-0 0.19	7-8 0.25	8-3 0.32	8-10 0.39	9-4 0.46	9-10 0.54	10-4 0.63	10-10 0.72	11-3 0.81	11-8 0.90	12-1 1.00	12-6 1.10	12-10 1.21	13-3 1.31	13-7 1.43
2 x 10	12	12-7 0.27	13-9 0.36	14-11 0.45	15-11 0.55	16-11 0.66	17-10 0.77	18-8 0.89	19-6 1.01	20-4 1.14	21-1 1.28	21-10 1.41	22-6 1.56	23-3 1.71	23-11 1.86	24-6 2.02
	16	10-11 0.24	11-11 0.31	12-11 0.39	13-9 0.48	14-8 0.57	15-5 0.67	16-2 0.77	16-11 0.88	17-7 0.99	18-3 1.10	18-11 1.22	19-6 1.35	20-1 1.48	20-8 1.61	21-3 1.75
	24	8-11 0.19	9-9 0.25	10-6 0.32	11-3 0.39	11-11 0.46	12-7 0.54	13-2 0.63	13-9 0.72	14-4 0.81	14-11 0.90	15-5 1.00	15-11 1.10	16-5 1.21	16-11 1.31	17-4 1.43
2 x 12	12	15-4 0.27	16-9 0.36	18-1 0.45	19-4 0.55	20-6 0.66	21-8 0.77	22-8 0.89	23-9 1.01	24-8 1.14	25-7 1.28	26-6 1.41	27-5 1.56	28-3 1.71	29-1 1.86	29-10 2.02
	16	13-3 0.24	14-6 0.31	15-8 0.39	16-9 0.48	17-9 0.57	18-9 0.67	19-8 0.77	20-6 0.88	21-5 0.99	22-2 1.10	23-0 1.22	23-9 1.35	24-5 1.48	25-2 1.61	25-10 1.75
	24	10-10 0.19	11-10 0.25	12-10 0.32	13-8 0.39	14-6 0.46	15-4 0.54	16-1 0.63	16-9 0.72	17-5 0.81	18-1 0.90	18-9 1.00	19-4 1.10	20-0 1.21	20-6 1.31	12-1 1.43

NOTE: The required modulus of elasticity, E, in 1,000,000 psi is shown below each span.

American Forest and Paper Association; Washington, D.C.



DESIGN CRITERIA

STRENGTH: 10 psf dead load plus 20 psf live load determines required fiber stress.

RAFTERS: Spans are measured along the horizontal projection, and loads are considered as applied on the horizontal projection.

DEFLECTION: For 20 psf live load. Limited to span in inches divided by 240.

FLAT OR LOW SLOPE RAFTERS—20 LB LIVE LOAD  
NO CEILING LOAD—SLOPE 3 IN 12 OR LESS

RAFTER SIZE, SPACING (IN.)		EXTREME FIBER STRESS IN BENDING, $F_b$ (PSI)														
		500	600	700	800	900	1000	1100	1200	1300	1400	1500	1600	1700	1800	1900
2 x 6	12	9-2 0.33	10-0 0.44	10-10 0.55	11-7 0.67	12-4 0.80	13-0 0.94	13-7 1.09	14-2 1.24	14-9 1.40	15-4 1.56	15-11 1.73	16-5 1.91	16-11 2.09	17-5 2.28	17-10 2.47
	16	7-11 0.29	8-8 0.38	9-5 0.48	10-0 0.58	10-8 0.70	11-3 0.82	11-9 0.94	12-4 1.07	12-10 1.21	13-3 1.35	13-9 1.50	14-2 1.65	14-8 1.81	15-1 1.97	15-6 2.14
	24	6-6 0.24	7-1 0.31	7-8 0.39	8-2 0.48	8-8 0.57	9-2 0.67	9-7 0.77	10-0 0.88	10-5 0.99	10-10 1.10	11-3 1.22	11-7 1.35	11-11 1.48	12-4 1.61	12-8 1.75
2 x 8	12	12-1 0.33	13-3 0.44	14-4 0.55	15-3 0.67	16-3 0.80	17-1 0.94	17-11 1.09	18-9 1.24	19-6 1.40	20-3 1.56	20-11 1.73	21-7 1.91	22-3 2.09	22-11 2.28	23-7 2.47
	16	10-6 0.29	11-6 0.38	12-5 0.48	13-3 0.58	14-0 0.70	14-10 0.82	15-6 0.94	16-3 1.07	16-10 1.21	17-6 1.35	18-2 1.50	18-9 1.65	19-4 1.81	19-10 1.97	20-5 2.14
	24	8-7 0.24	9-4 0.31	10-1 0.39	10-10 0.48	11-6 0.57	12-1 0.67	12-8 0.77	13-3 0.88	13-9 0.99	14-4 1.10	14-10 1.22	15-3 1.35	15-9 1.48	16-3 1.61	16-8 1.75
2 x 10	12	15-5 0.33	16-11 0.44	18-3 0.55	19-6 0.67	20-8 0.80	21-10 0.94	22-10 1.09	23-11 1.24	24-10 1.40	25-10 1.56	26-8 1.73	27-7 1.91	28-5 2.09	29-3 2.28	30-1 2.47
	16	13-4 0.29	14-8 0.38	15-10 0.48	16-11 0.58	17-11 0.70	18-11 0.82	19-10 0.94	20-8 1.07	21-6 1.21	22-4 1.35	23-2 1.50	23-11 1.65	24-7 1.81	25-4 1.97	26-0 2.14
	24	10-11 0.24	11-11 0.31	12-11 0.39	13-9 0.48	14-8 0.57	15-5 0.67	16-2 0.77	16-11 0.88	17-7 0.99	18-3 1.10	18-11 1.22	19-6 1.35	20-1 1.48	20-8 1.61	21-3 1.75
2 x 12	12	18-9 0.33	20-6 0.44	22-2 0.55	23-9 0.67	25-2 0.80	26-6 0.94	27-10 1.09	29-1 1.24	30-3 1.40	31-4 1.56	32-6 1.73	33-6 1.91	34-7 2.09	35-7 2.28	36-7 2.47
	16	16-3 0.29	17-9 0.38	19-3 0.48	20-6 0.58	21-9 0.70	23-0 0.82	24-1 0.94	25-2 1.07	26-2 1.21	27-2 1.35	28-2 1.50	29-1 1.65	29-11 1.81	30-10 1.97	31-8 2.14
	24	13-3 0.24	14-6 0.31	15-8 0.39	16-9 0.48	17-9 0.57	18-9 0.67	19-8 0.77	20-6 0.88	21-5 0.99	22-2 1.10	23-0 1.22	23-9 1.35	24-5 1.48	25-2 1.61	25-10 1.75

NOTE: The required modulus of elasticity, E, in 1,000,000 psi is shown below each span.

DESIGN CRITERIA

STRENGTH: 10 psf dead load plus 30 psf live load determines required fiber stress.

RAFTERS: Spans are measured along the horizontal projection, and loads are considered as applied on the horizontal projection.

DEFLECTION: For 30 psf live load. Limited to span in inches divided by 240.

FLAT OR LOW SLOPE RAFTERS—30 LB LIVE LOAD  
NO CEILING LOAD—SLOPE 3 IN 12 OR LESS

RAFTER SIZE, SPACING (IN.)		EXTREME FIBER STRESS IN BENDING, $F_b$ (PSI)														
		500	600	700	800	900	1000	1100	1200	1300	1400	1500	1600	1700	1800	1900
2 x 6	12	7-11 0.32	8-8 0.43	9-5 0.54	10-0 0.66	10-8 0.78	11-3 0.92	11-9 1.06	12-4 1.21	12-10 1.36	13-3 1.52	13-9 1.69	14-2 1.86	14-8 2.04	15-1 2.22	15-6 2.41
	16	6-11 0.28	7-6 0.37	8-2 0.47	8-8 0.57	9-3 0.68	9-9 0.80	10-2 0.92	10-8 1.05	11-1 1.18	11-6 1.32	11-11 1.46	12-4 1.61	12-8 1.76	13-1 1.92	13-5 2.08
	24	5-7 0.23	6-2 0.30	6-8 0.38	7-1 0.46	7-6 0.55	7-11 0.65	8-4 0.75	8-8 0.85	9-1 0.96	9-5 1.08	9-9 1.19	10-0 1.31	10-4 1.44	10-8 1.57	10-11 1.70
2 x 8	12	10-6 0.32	11-6 0.43	12-5 0.54	13-3 0.66	14-0 0.78	14-10 0.92	15-6 1.06	16-3 1.21	16-10 1.36	17-6 1.52	18-2 1.69	18-9 1.86	19-4 2.04	19-10 2.22	20-5 2.41
	16	9-1 0.28	9-11 0.37	10-9 0.47	11-6 0.57	12-2 0.68	12-10 0.80	13-5 0.92	14-0 1.05	14-7 1.18	15-2 1.32	15-8 1.46	16-3 1.61	16-9 1.76	17-2 1.92	17-8 2.08
	24	7-5 0.23	8-1 0.30	8-9 0.38	9-4 0.46	9-11 0.55	10-6 0.65	11-0 0.75	11-6 0.85	11-11 0.96	12-5 1.08	12-10 1.19	13-3 1.31	13-8 1.44	14-0 1.57	14-5 1.70
2 x 10	12	13-4 0.32	14-8 0.43	15-10 0.54	16-11 0.66	17-11 0.78	18-11 0.92	19-10 1.06	20-8 1.21	21-6 1.36	22-4 1.52	23-2 1.69	23-11 1.86	24-7 2.04	25-4 2.22	26-0 2.41
	16	11-7 0.28	12-8 0.37	13-8 0.47	14-8 0.57	15-6 0.68	16-4 0.80	17-2 0.92	17-11 1.05	18-8 1.18	19-4 1.32	20-0 1.46	20-8 1.61	21-4 1.76	21-11 1.92	22-6 2.08
	24	9-5 0.23	10-4 0.30	11-2 0.38	11-11 0.46	12-8 0.55	13-4 0.65	14-0 0.75	14-8 0.85	15-3 0.96	15-10 1.08	16-4 1.19	16-11 1.31	17-5 1.44	17-11 1.57	18-5 1.70
2 x 12	12	16-3 0.32	17-9 0.43	19-3 0.54	20-6 0.66	21-9 0.78	23-0 0.92	24-1 1.06	25-2 1.21	26-2 1.36	27-2 1.52	28-2 1.69	29-1 1.86	29-11 2.04	30-10 2.22	31-8 2.41
	16	14-1 0.28	15-5 0.37	16-8 0.47	17-9 0.57	18-10 0.68	19-11 0.80	20-10 0.92	21-9 1.05	22-8 1.18	23-6 1.32	24-4 1.46	25-2 1.61	25-11 1.76	26-8 1.92	27-5 2.08
	24	11-6 0.23	12-7 0.30	13-7 0.38	14-6 0.46	15-5 0.55	16-3 0.65	17-0 0.75	17-9 0.85	18-6 0.96	19-3 1.08	19-11 1.19	20-6 1.31	21-2 1.44	21-9 1.57	22-5 1.70

NOTE: The required modulus of elasticity, E, in 1,000,000 psi is shown below each span.

DESIGN CRITERIA

STRENGTH: 15 psf dead load plus 20 psf live load determines required fiber stress.

RAFTERS: Spans are measured along the horizontal projection, and loads are considered as applied on the horizontal projection.

DEFLECTION: For 20 psf live load. Limited to span in inches divided by 180.

MEDIUM OR HIGH SLOPE RAFTERS—20 LB LIVE LOAD  
HEAVY ROOF COVERING—NO CEILING LOAD—SLOPE OVER 3 IN 12

RAFTER SIZE, SPACING (IN.)	EXTREME FIBER STRESS IN BENDING, $F_b$ (PSI)															
	500	600	700	800	900	1000	1100	1200	1300	1400	1500	1600	1700	1800	1900	
2 x 4	12	5-5 0.20	5-11 0.26	6-5 0.33	6-10 0.40	7-3 0.48	7-8 0.56	8-0 0.65	8-4 0.74	8-8 0.83	9-0 0.93	9-4 1.03	9-8 1.14	9-11 1.24	10-3 1.36	10-6 1.47
	16	4-8 0.17	5-1 0.23	5-6 0.28	5-11 0.35	6-3 0.41	6-7 0.49	6-11 0.56	7-3 0.64	7-6 0.72	7-10 0.80	8-1 0.89	8-4 0.98	8-7 1.08	8-10 1.17	9-1 1.27
	24	3-10 0.14	4-2 0.18	4-6 0.23	4-10 0.28	5-1 0.34	5-5 0.40	5-8 0.46	5-11 0.52	6-2 0.59	6-5 0.66	6-7 0.73	6-10 0.80	7-0 0.88	7-3 0.96	7-5 1.04
2 x 6	12	8-6 0.20	9-4 0.26	10-0 0.33	10-9 0.40	11-5 0.48	12-0 0.56	12-7 0.65	13-2 0.74	13-8 0.83	14-2 0.93	14-8 1.03	15-2 1.14	15-8 1.24	16-1 1.36	16-7 1.47
	16	7-4 0.17	8-1 0.23	8-8 0.28	9-4 0.35	9-10 0.41	10-5 0.49	10-11 0.56	11-5 0.64	11-10 0.72	12-4 0.80	12-9 0.89	13-2 0.98	13-7 1.08	13-11 1.17	14-4 1.27
	24	6-0 0.14	6-7 0.18	7-1 0.23	7-7 0.28	8-1 0.34	8-6 0.40	8-11 0.46	9-4 0.52	9-8 0.59	10-0 0.66	10-5 0.73	10-9 0.80	11-1 0.88	11-5 0.96	11-8 1.04
2 x 8	12	11-12 0.20	12-3 0.26	13-3 0.33	14-2 0.40	15-0 0.48	15-10 0.56	16-7 0.65	17-4 0.74	18-0 0.83	18-9 0.93	19-5 1.03	20-0 1.14	20-8 1.24	21-3 1.36	21-10 1.47
	16	9-8 0.17	10-7 0.23	11-6 0.28	12-3 0.35	13-0 0.41	13-8 0.49	14-4 0.56	15-0 0.64	15-7 0.72	16-3 0.80	16-9 0.89	17-4 0.98	17-10 1.08	18-5 1.17	18-11 1.27
	24	7-11 0.14	8-8 0.18	9-4 0.23	10-0 0.28	10-7 0.34	11-2 0.40	11-9 0.46	12-3 0.52	12-9 0.59	13-3 0.66	13-8 0.73	14-2 0.80	14-7 0.88	15-0 0.96	15-5 1.04
2 x 10	12	14-3 0.20	15-8 0.26	16-11 0.33	18-1 0.40	19-2 0.48	20-2 0.56	21-2 0.65	22-1 0.74	23-0 0.83	23-11 0.93	24-9 1.03	25-6 1.14	26-4 1.24	27-1 1.36	27-10 1.47
	16	12-4 0.17	13-6 0.23	14-8 0.28	15-8 0.35	16-7 0.41	17-6 0.49	18-4 0.56	19-2 0.64	19-11 0.72	20-8 0.80	21-5 0.89	22-1 0.98	22-10 1.08	23-5 1.17	24-1 1.27
	24	10-1 0.14	11-1 0.18	11-11 0.23	12-9 0.28	13-6 0.34	14-3 0.40	15-0 0.46	15-8 0.52	16-3 0.59	16-11 0.66	17-6 0.73	18-1 0.80	18-7 0.88	19-2 0.96	19-8 1.04

NOTE: The required modulus of elasticity, E, in 1,000,000 psi is shown below each span.

DESIGN CRITERIA

STRENGTH: 15 psf dead load plus 30 psf live load determines required fiber stress.

RAFTERS: Spans are measured along the horizontal projection, and loads are considered as applied on the horizontal projection.

DEFLECTION: For 30 psf live load. Limited to span in inches divided by 180.

MEDIUM OR HIGH SLOPE RAFTERS—30 LB LIVE LOAD  
HEAVY ROOF COVERING—NO CEILING LOAD—SLOPE OVER 3 IN 12

RAFTER SIZE, SPACING (IN.)	EXTREME FIBER STRESS IN BENDING, $F_b$ (PSI)															
	500	600	700	800	900	1000	1100	1200	1300	1400	1500	1600	1700	1800	1900	
2 x 4	12	4-9 0.20	5-3 0.27	5-8 0.34	6-0 0.41	6-5 0.49	6-9 0.58	7-1 0.67	7-5 0.76	7-8 0.86	8-0 0.96	8-3 1.06	8-6 1.17	8-9 1.28	9-0 1.39	9-3 1.51
	16	4-1 0.18	4-6 0.23	4-11 0.29	5-3 0.36	5-6 0.43	5-10 0.50	6-1 0.58	6-5 0.66	6-8 0.74	6-11 0.83	7-2 0.92	7-5 1.01	7-7 1.11	7-10 1.21	8-0 1.31
	24	3-4 0.14	3-8 0.19	4-0 0.24	4-3 0.29	4-6 0.35	4-9 0.41	5-0 0.47	5-3 0.54	5-5 0.61	5-8 0.68	5-10 0.75	6-0 0.83	6-3 0.90	6-5 0.99	6-7 1.07
2 x 6	12	7-6 0.20	8-2 0.27	8-10 0.34	9-6 0.41	10-0 0.49	10-7 0.58	11-1 0.67	11-7 0.76	12-1 0.86	12-6 0.96	13-0 1.06	13-5 1.17	13-10 1.28	14-2 1.39	14-7 1.51
	16	6-6 0.18	7-1 0.23	7-8 0.29	8-2 0.36	8-8 0.43	9-2 0.50	9-7 0.58	10-0 0.66	10-5 0.74	10-10 0.83	11-3 0.92	11-7 1.01	11-11 1.11	12-4 1.21	12-8 1.31
	24	5-4 0.14	5-10 0.19	6-3 0.24	6-8 0.29	7-1 0.35	7-6 0.41	7-10 0.47	8-2 0.54	8-6 0.61	8-10 0.68	9-2 0.75	9-6 0.83	9-9 0.90	10-0 0.99	10-4 1.07
2 x 8	12	9-10 0.20	10-10 0.27	11-8 0.34	12-6 0.41	13-3 0.49	13-11 0.58	14-8 0.67	15-3 0.76	15-11 0.86	16-6 0.96	17-1 1.06	17-8 1.17	18-2 1.28	18-9 1.39	19-3 1.51
	16	8-7 0.18	9-4 0.23	10-1 0.29	10-10 0.36	11-6 0.43	12-1 0.50	12-8 0.58	13-3 0.66	13-9 0.74	14-4 0.83	14-10 0.92	15-3 1.01	15-9 1.11	16-3 1.21	16-8 1.31
	24	7-0 0.14	7-8 0.19	8-3 0.24	8-10 0.29	9-4 0.35	9-10 0.41	10-4 0.47	10-10 0.54	11-3 0.61	11-8 0.68	12-1 0.75	12-6 0.83	12-10 0.90	13-3 0.99	13-7 1.07
2 x 10	12	12-7 0.20	13-9 0.27	14-11 0.34	15-11 0.41	16-11 0.49	17-10 0.58	18-8 0.67	19-6 0.76	20-4 0.86	21-1 0.96	21-10 1.06	22-6 1.17	23-3 1.28	23-11 1.39	24-6 1.51
	16	10-11 0.18	11-11 0.23	12-11 0.29	13-9 0.36	14-8 0.43	15-5 0.50	16-2 0.58	16-11 0.66	17-7 0.74	18-3 0.83	18-11 0.92	19-6 1.01	20-1 1.11	20-8 1.21	21-3 1.31
	24	8-11 0.14	9-9 0.19	10-6 0.24	11-3 0.29	11-11 0.35	12-7 0.41	13-2 0.47	13-9 0.54	14-4 0.61	14-11 0.68	15-5 0.75	15-11 0.83	16-5 0.90	16-11 0.99	17-4 1.07

NOTE: The required modulus of elasticity, E, in 1,000,000 psi is shown below each span.

American Forest and Paper Association; Washington, D.C.



DESIGN CRITERIA

STRENGTH: 7 psf dead load plus 20 psf live load determines required fiber stress.

RAFTERS: Spans are measured along the horizontal projection, and loads are considered as applied on the horizontal projection.

DEFLECTION: For 20 psf live load. Limited to span in inches divided by 180.

MEDIUM OR HIGH SLOPE RAFTERS—20 LB LIVE LOAD  
LIGHT ROOF COVERING—NO CEILING LOAD—SLOPE OVER 3 IN 12

RAFTER SIZE, SPACING (IN.)	EXTREME FIBER STRESS IN BENDING, $F_b$ (PSI)															
	500	600	700	800	900	1000	1100	1200	1300	1400	1500	1600	1700	1800	1900	
2 x 4	12	6-2 0.29	6-9 0.38	7-3 0.49	7-9 0.59	8-3 0.71	8-8 0.83	9-1 0.96	9-6 1.06	9-11 1.23	10-3 1.37	10-8 1.52	11-0 1.68	11-4 1.84	11-8 2.00	12-0 2.17
	16	5-4 0.25	5-10 0.33	6-4 0.42	6-9 0.51	7-2 0.61	7-6 0.72	7-11 0.83	8-3 0.94	8-7 1.06	8-11 1.19	9-3 1.32	9-6 1.45	9-10 1.59	10-1 1.73	10-5 1.88
	24	4-4 0.21	4-9 0.27	5-2 0.34	5-6 0.42	5-10 0.50	6-2 0.59	6-5 0.68	6-9 0.77	7-0 0.87	7-3 0.97	7-6 1.08	7-9 1.19	8-0 1.30	8-3 1.41	8-6 1.53
2 x 6	12	9-8 0.29	10-7 0.38	11-5 0.49	12-3 0.59	13-0 0.71	13-8 0.83	14-4 0.96	15-0 1.09	15-7 1.23	16-2 1.37	16-9 1.52	17-3 1.68	17-10 1.84	18-4 2.00	18-10 2.17
	16	8-4 0.25	9-2 0.33	9-11 0.42	10-7 0.51	11-3 0.61	11-10 0.72	12-5 0.83	13-0 0.94	13-6 1.06	14-0 1.19	14-6 1.32	15-0 1.45	15-5 1.59	15-11 1.73	16-4 1.88
	24	6-10 0.21	7-6 0.27	8-1 0.34	8-8 0.42	9-2 0.50	9-8 0.59	10-2 0.68	10-7 0.77	11-0 0.87	11-5 0.97	11-10 1.08	12-3 1.19	12-7 1.30	13-0 1.41	13-4 1.53
2 x 8	12	12-9 0.29	13-11 0.38	15-1 0.49	16-1 0.59	17-1 0.71	18-0 0.83	18-11 0.96	19-9 1.09	20-6 1.23	21-4 1.37	22-1 1.52	22-9 1.68	23-6 1.84	24-2 2.00	24-10 2.17
	16	11-0 0.25	12-1 0.33	13-1 0.42	13-11 0.51	14-10 0.61	15-7 0.72	16-4 0.83	17-1 0.94	17-9 1.06	18-5 1.19	19-1 1.32	19-9 1.45	20-4 1.59	20-11 1.73	21-6 1.88
	24	9-0 0.21	9-10 0.27	10-8 0.34	11-5 0.42	12-1 0.50	12-9 0.59	13-4 0.68	13-11 0.77	14-6 0.87	15-1 0.97	15-7 1.08	16-1 1.19	16-7 1.30	17-1 1.41	17-7 1.53
2 x 10	12	16-3 0.29	17-10 0.38	19-3 0.49	20-7 0.59	21-10 0.71	23-0 0.83	24-1 0.96	25-2 1.09	26-2 1.23	27-2 1.37	28-2 1.52	29-1 1.68	30-0 1.84	30-10 2.00	31-8 2.17
	16	14-1 0.25	15-5 0.33	16-8 0.42	17-10 0.51	18-11 0.61	19-11 0.72	20-10 0.83	21-10 0.94	22-8 1.06	23-7 1.19	24-5 1.32	25-2 1.45	25-11 1.59	26-8 1.73	27-5 1.88
	24	11-6 0.21	12-7 0.27	13-7 0.34	14-6 0.42	15-5 0.50	16-3 0.59	17-1 0.68	17-10 0.77	18-6 0.87	19-3 0.97	19-11 1.08	20-7 1.19	21-2 1.30	21-10 1.41	22-5 1.53

NOTE: The required modulus of elasticity, E, in 1,000,000 psi is shown below each span.

DESIGN CRITERIA

STRENGTH: 7 psf dead load plus 30 psf live load determines required fiber stress.

RAFTERS: Spans are measured along the horizontal projection, and loads are considered as applied on the horizontal projection.

DEFLECTION: For 30 psf live load. Limited to span in inches divided by 180.

MEDIUM OR HIGH SLOPE RAFTERS—30 LB LIVE LOAD  
LIGHT ROOF COVERING—NO CEILING LOAD—SLOPE OVER 3 IN 12

RAFTER SIZE, SPACING (IN.)	EXTREME FIBER STRESS IN BENDING, $F_b$ (PSI)															
	500	600	700	800	900	1000	1100	1200	1300	1400	1500	1600	1700	1800	1900	
2 x 4	12	5-3 0.27	5-9 0.36	6-3 0.45	6-8 0.55	7-1 0.66	7-5 0.77	7-9 0.89	8-2 1.02	8-6 1.15	8-9 1.28	9-1 1.42	9-5 1.57	9-8 1.72	10-0 1.87	10-3 2.03
	16	4-7 0.24	5-0 0.31	5-5 0.39	5-9 0.48	6-1 0.57	6-5 0.67	6-9 0.77	7-1 0.88	7-4 0.99	7-7 1.11	7-11 1.23	8-2 1.36	8-5 1.49	8-8 1.62	8-10 1.76
	24	3-9 0.19	4-1 0.25	4-5 0.32	4-8 0.39	5-0 0.47	5-3 0.55	5-6 0.63	5-9 0.72	6-0 0.81	6-3 0.91	6-5 1.01	6-8 1.11	6-10 1.21	7-1 1.32	7-3 1.43
2 x 6	12	8-3 0.27	9-1 0.36	9-9 0.45	10-5 0.55	11-1 0.66	11-8 0.77	12-3 0.89	12-9 1.02	13-4 1.15	13-10 1.28	14-4 1.42	14-9 1.57	15-3 1.72	15-8 1.87	16-1 2.03
	16	7-2 0.24	7-10 0.31	8-5 0.39	9-1 0.48	9-7 0.57	10-1 0.67	10-7 0.77	11-1 0.88	11-6 0.99	12-0 1.11	12-5 1.23	12-9 1.36	13-2 1.49	13-7 1.62	13-11 1.76
	24	5-10 0.19	6-5 0.25	6-11 0.32	7-5 0.39	7-10 0.47	8-3 0.55	8-8 0.63	9-1 0.72	9-5 0.81	9-9 0.91	10-1 1.01	10-5 1.11	10-9 1.21	11-1 1.32	11-5 1.43
2 x 8	12	10-11 0.27	11-11 0.36	12-10 0.45	13-9 0.55	14-7 0.66	15-5 0.77	16-2 0.89	16-10 1.02	17-7 1.15	18-2 1.28	18-10 1.42	19-6 1.57	20-1 1.72	20-8 1.87	21-3 2.03
	16	9-5 0.24	10-4 0.31	11-2 0.39	11-11 0.48	12-8 0.57	13-4 0.67	14-0 0.77	14-7 0.88	15-2 0.99	15-9 1.11	16-4 1.23	16-10 1.36	17-4 1.49	17-11 1.62	18-4 1.76
	24	7-8 0.19	8-5 0.25	9-1 0.32	9-9 0.39	10-4 0.47	10-11 0.55	11-5 0.63	11-11 0.72	12-5 0.81	12-10 0.91	13-4 1.01	13-9 1.11	14-2 1.21	14-7 1.32	15-0 1.43
2 x 10	12	13-11 0.27	15-2 0.36	16-5 0.45	17-7 0.55	18-7 0.66	19-8 0.77	20-7 0.89	21-6 1.02	22-5 1.15	23-3 1.28	24-1 1.42	24-10 1.57	25-7 1.72	26-4 1.87	27-1 2.03
	16	12-0 0.26	13-2 0.34	14-3 0.43	15-2 0.53	16-2 0.63	17-0 0.74	17-10 0.85	18-7 0.97	19-5 1.09	20-1 1.22	20-10 1.35	21-6 1.49	22-2 1.63	22-10 1.78	23-5 1.93
	24	9-10 0.19	10-9 0.25	11-7 0.32	12-5 0.39	13-2 0.47	13-11 0.55	14-7 0.63	15-2 0.72	15-10 0.81	16-5 0.91	17-0 1.01	17-7 1.11	18-1 1.21	18-7 1.32	19-2 1.43

NOTE: The required modulus of elasticity, E, in 1,000,000 psi is shown below each span.



RELATIVE TREATABILITY OF SELECTED DOMESTIC SPECIES

HEARTWOOD LEAST DIFFICULT TO PENETRATE	HEARTWOOD MODERATELY DIFFICULT TO PENETRATE	HEARTWOOD DIFFICULT TO PENETRATE	HEARTWOOD VERY DIFFICULT TO PENETRATE
Bristlecone pine, pinyon pine, redwood	Bald cypress, California red fir, Douglas fir (coast), Eastern white pine, jack pine, loblolly pine, longleaf pine, ponderosa pine, red pine, shortleaf pine, sugar pine, Western hemlock	Eastern hemlock, Engelmann spruce, grand fir, lodgepole pine, noble fir, sitka spruce, Western larch, white fir, white spruce	Alpine fir, corkbark fir, Douglas fir (Rocky Mountain), Northern white cedar, tamarack, Western red cedar

RELATIVE HEARTWOOD DECAY RESISTANCE OF NATURALLY RESISTANT UNTREATED WOODS\*

RESISTANT OR VERY RESISTANT	MODERATELY RESISTANT	SLIGHTLY OR NONRESISTANT
Bald cypress (old growth), cedar, white oak, redwood	Bald cypress (new growth), Douglas fir, Western larch, Eastern white pine, Southern yellow pine (longleaf, slash), tamarack	Pines other than longleaf, slash, and Eastern white, spruces, true firs

\* Source: U.S. Forest Products Laboratory Wood Handbook

GENERAL

Wood may be destroyed by decay fungi; by insects like carpenter ants and termites; and by marine borers in saltwater exposures. Four conditions must exist before these organisms can destroy wood: (1) a free oxygen supply; (2) a moisture level in the wood above the fiber saturation point (20%); (3) a temperature in the range of 50 to 90°F; (4) the presence of a food source, in this case, the wood.

In most indoor environments, where moisture levels are generally low, wood will last for a very long time. In certain indoor environments, however, and in many exterior environments, wood cannot be kept dry or out of the proximity of moisture. Most building codes recognize this by requiring the use of pressure-treated wood or naturally resistant wood species where building components come into contact with concrete, masonry, or exposed soil. This requirement also covers floor joists and crawl space support members within 12 to 18 in. of exposed soil.

DECAY-RESISTANT WOOD

When specifying a wood that will resist decay, the choice is between naturally decay-resistant wood or wood treated with preservatives. The first requires use of the heartwood of naturally decay-resistant woods such as Western red cedar, bald cypress, redwood, and others that contain natural poisons called extractives, which are not palatable to decay-causing organisms. However, not all grades or species of these woods are suitable for some structural situations. Treating wood with preservatives is a process that impregnates wood with chemicals through a pressure-treatment process. Use of nonpressure treatments such as spraying, dipping, and brushing is mostly limited to field treatment of wood during construction or remedial treatment of existing wood in place.

PRESSURE-TREATED WOOD

There are two processes commonly used for pressure treating wood, the full cell and modified full cell processes. In both, the wood is placed in a large, cylindrical tank and the preservative forced under pressure into its cells.

In the modified full-cell process the preservative coats the walls of the wood cells and is absorbed when the process is finished the wood cell cavities are empty of preservatives. Most over-the-counter pressure-treated wood is treated with this process. In the full-cell process, a vacuum is introduced at the beginning to force the air out of the wood cell cavities, which then remain filled with preservative after treatment. The full-cell process is used in most creosote and pentachlorophenol treating for wood used in severe environments, including applications such as utility poles, railroad ties, saltwater piles, and timber bridges. Regardless of which process is used, the wood is generally dried to a 20% moisture content prior to treatment to promote maximum penetration of the preservative.

PENETRATION AND RETENTION OF PRESERVATIVES

Penetration and retention are the two measures that define the effectiveness of preservation methods. Penetration depends on the species of wood and the size of the lumber member being treated. Some species that resist preservative penetration, such as Douglas fir, are incised with small slits to make treatment more effective. Others, such as Southern yellow pine, are easily treated without incisions. While the sapwood of some species is readily penetrated, the heartwood of most resists penetration (although the

heartwood of all species naturally resists decay). While the penetration of preservatives is hard to determine without damaging the wood, retention of the preservative can be measured directly by weighing the wood, stated in terms of pounds (of the chemical retained) per cubic foot (pcf). Retention standards are set by the American Wood Preservers' Association and enforced through chemical analysis of treated wood by an independent third-party agency approved by the American Lumber Standard Committee (ALSC). A quality mark outlining pertinent information can be found on complying wood stock.

PRESERVATIVE TYPES

Three classes of preservatives are in use today: creosote, oil-borne (organic), and waterborne (inorganic).

CREOSOTE is a coal-tar product that is dissolved in a distilled solution or petroleum oil. It is an effective preservative in applications with extreme exposure to decay or insect attack (marine borers in saltwater environments, such as marine piles or bridge timbers). Wood treated with the full-cell process is more effective in these applications, but the creosote may bleed into the surroundings, causing contamination. Most utility poles, freshwater piles, and fenceposts are treated with the empty-cell process, which yields a clean, nonbleeding surface. Creosote-treated products cannot be painted, but epoxy shellac and coal-tar pitch are acceptable sealants. This type of preservative can last from thirty to sixty years. Clean air standards prohibit the use of creosote in many areas.

ORGANIC OIL-BORNE PRESERVATIVES are carried in organic solvents such as liquefied isobutane and are used to treat most softwoods and hardwoods. These preservatives include pentachlorophenol (penta), copper naphthenate, tributyl tin oxide (TBTO), and copper 8-quinolinolate.

Penta extends the service life of wood by twenty to forty years and is used to treat utility poles, fenceposts, and highway timbers. Tinted light to dark brown, penta-treated wood accepts adhesives and finishes reasonably well once the oil medium has evaporated. Polyurethane, shellac, varnish, and latex enamel are effective as sealants. Penta can migrate to the surface of wood, leach into the surrounding soil, and contaminate groundwater. Only slowly does it break down into biodegradable compounds.

Plywood and other wood treated with copper-8-quinolinolate can be used in applications where food is harvested, transported, or stored. The chemical is dissolved in liquid petroleum gas or light hydrocarbon solvents so the surface is clean and free of solvent odor. Consult with the treatment company regarding applicable FDA and USDA acceptances.

INORGANIC WATERBORNE PRESERVATIVES are the most popular and commonly available types used for treating wood. They include chromated copper arsenate (CCA), ammoniacal copper arsenate (ACA), and ammoniacal copper zinc arsenate (ACZA). These preservatives are related chemically and have a lot in common. Chromium holds the other components in the wood and prevents leaching; ammonia helps carry copper, zinc, and arsenic deeper into the wood; arsenic guards against attack by termites and fungi. Southern yellow pine is usually treated with CCA, and Douglas fir and other western woods with ACA and ACZA. The various formulations of CCA vary in the amount of chromium, copper, and arsenic they contain. The oxide form of CCA, type C, is widely preferred for most construction. During the treatment process, CCA is water soluble, but air drying for a few days renders it insoluble. This is

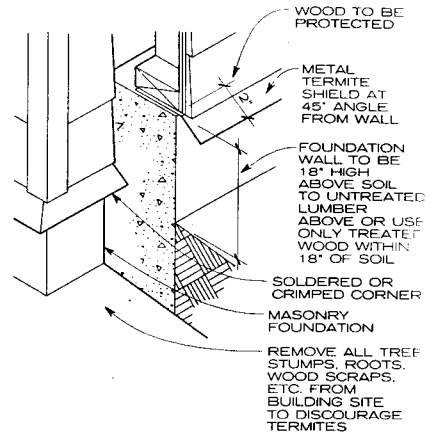

TERMITE PROTECTION DETAILS

because the chromium reacts chemically with the wood permanently bonding itself and the copper and arsenic to the cell walls, preventing leaching during its service life. CCA-treated wood can last up to forty years.

Another waterborne preservative is borax, which has promise due to its effectiveness against fungi and insects and its low-toxicity to people and animals. However, it leaches out when the wood gets wet.

FINISHING OF PRESERVATIVE-TREATED WOOD

Waterborne preservatives are recommended when clean, odorless, and paintable wood products are required. Wood treated with such preservatives may be used indoors if sawdust and construction debris are cleaned up. Painting wood treated with creosote or oil-borne pentachlorophenol is not recommended, as it is difficult to use, requiring extensive care and an aluminum-based paint. Paintable waterborne pentachlorophenol treatments are available. For certain interior applications in commercial, industrial, or farm buildings, creosote- or penta-treated wood may be used if exposed surfaces are sealed with two coats of urethane or epoxy paint or shellac. Guidelines for precautions in these cases are outlined in an EPA-approved consumer information sheet for each preservative treatment.

FASTENERS

CCA, ACA, and ACC are corrosive to uncoated metals. For aboveground construction, hot-dipped or hot-tumbled galvanized steel and stainless steel fasteners are recommended. Joist hangers and framing anchors should also be corrosion resistant. For below-grade construction, such as treated wood foundation systems, types 304 and 316 stainless steel Type H silicon bronze, ETP copper, and monel fasteners are required. Adhesives work well with CCA-treated wood. Phenolresorcinol, resorcinol, and melamine-formaldehyde structural adhesives are used in glulam beams made from treated wood members. On job sites, use adhesives recommended for use with treated wood.

PRECAUTIONS FOR USE AND HANDLING

The chemical formulations used for preservative treatment of wood are registered with the EPA, which has approved guidelines for the use of pressure-treated wood to ensure safe handling and avoid environmental or other health hazards. Some guidelines for use and handling follow:

1. Dispose of treated wood by ordinary trash collection or burial. Treated wood should never be burned in open fires or in stoves, fireplaces, or residential boilers.
2. Avoid frequent inhalation of sawdust from treated wood. Whenever possible, sawing and machining of treated wood should be done outdoors.
3. Avoid frequent or prolonged skin contact with penta- or creosote-treated wood.
4. After handling treated wood products, wash exposed areas thoroughly before eating or drinking.

Richard J. Vitullo, AIA; Oak Leaf Studio; Crownsville, Maryland  
American Plywood Association; Tacoma, Washington

SOUTHERN PINE PRESERVATIVE RETENTIONS AND APPLICABLE AWWA STANDARDS<sup>1</sup>

WOOD USES	APPLICATIONS	RETENTION ASSAY OF TREATED WOOD—LB/CU FT								
		WATERBORNE PRESERVATIVES <sup>2</sup>			AWWA STANDARDS	CREOSOTE AND OILBORNE PRESERVATIVES <sup>3</sup>				
		AMMONIACAL COPPER ARSENATE (ACA)	AMMONIACAL COPPER ZINC ARSENATE (ACZA)	CHROMATED COPPER ARSENATE (CCA)		CREOSOTE	CREOSOTE-PETROLEUM	CREOSOTE SOLUTIONS	PENTA-CHLORO-PHENOL (PENTA)	
LUMBER, TIMBERS, AND PLYWOOD	Aboveground	0.25	0.25	0.25	C2/C9	8 <sup>5</sup>	8 <sup>5</sup>	8 <sup>5</sup>	0.40	
	Soil and freshwater use	0.40	0.40	0.40	C2/C9	10 <sup>5</sup>	10 <sup>5</sup>	10 <sup>5</sup>	0.50	
	Permanent wood foundation (PWF)	0.60	0.60	0.60	C22	NR*	NR	NR	NR	
	Saltwater use	2.5	2.5	2.5	C2/C9	25	NR	25	NR	
PILES	Land or freshwater use and foundations	0.80	0.80	0.80	C3	12	12	12	0.60	
	Marine One prevalent marine organism	Teredo only	2.5 <sup>4</sup> and 1.5	2.5 <sup>4</sup> and 1.5	2.5 <sup>4</sup> and 1.5	C18	20	NR	20	NR
		Pholads only	NR	NR	NR	C18	20	NR	20	NR
		Limnoria tripunctata only	2.5 <sup>4</sup> and 1.5	2.5 <sup>4</sup> and 1.5	2.5 <sup>4</sup> and 1.5	C18	NR	NR	NR	NR
	Marine Sphaeroma terribans or combination of pholads and limnoria tripunctata (use a dual treatment)	First treatment	1.0	1.0	1.0	C18	—	—	—	—
		Second treatment	—	—	—	C18	20	—	20	—
POLES	Utility	Normal	0.60	0.60	0.60	C4	7.5	7.5	7.5	0.38
		Severe service conditions (high incidence of decay and termite attack)	0.60	0.60	0.60	C4	9.0	9.0	9.0	0.45
	Building construction	Round	0.60	0.60	0.60	C23	9.0 <sup>5</sup>	NR	NR	0.45
POSTS	Commercial-residential fence	Round, half-round, and quarter-round	0.40	0.40	0.40	C5	8 <sup>5</sup>	8 <sup>5</sup>	8 <sup>5</sup>	0.40
		Sawn four sides	0.40	0.40	0.40	C2	10 <sup>5</sup>	10 <sup>5</sup>	10 <sup>5</sup>	0.50
	Highway construction: Fence, guide, sign, and sight	Round, half-round, and quarter-round	0.40	0.40	0.40	C14	8	8	8	0.40
		Sawn four sides	0.40	0.40	0.40	C14	10	10	10	0.50
	Highway construction: Guardrail and spacer blocks	Round	0.50	0.50	0.50	C14	10	10	10	0.50
Sawn four sides	0.50	0.50	0.50	C14	12	12	12	0.60		

\* NR = not recommended

<sup>1</sup> American Wood Preservers' Association (AWPA) Standards detail plant operating procedures for pressure treatment of wood. These standards include minimum vacuum, pressure, and penetration requirements and maximum steaming parameters. AWWA also details minimum retention requirements, sampling zones for assay and maximum redrying temperature allowances for each preservative, commodity, and wood species. For a copy of the AWWA standards booklet, write to the American

Wood Preservers' Association, P.O. Box 286, Woodstock, MD 21163-0286. For other wood species, contact the relevant organization.

<sup>2</sup> ACA, ACZA, and CCA are the most commonly available waterborne preservatives. Ammoniacal copper quat (ACQ) is also approved by AWWA as a waterborne preservative for Southern pine, Western hemlock, Hem-fir, and Douglas fir as lumber, timbers, plywood, and fenceposts.

<sup>3</sup> Copper naphthenate is also approved by AWWA as an oilborne preservative for specific wood species and applications excluding saltwater use.

<sup>4</sup> Assay retentions are based on two assay zones—0 to 0.5 in. and 0 to 2.0 in.

<sup>5</sup> Not recommended where cleanliness and freedom from odor are necessary.

USE PRECAUTIONS FOR PRESSURE-TREATED WOOD<sup>1</sup>

APPLICATIONS	ORGANIC PRESERVATIVES		INORGANIC PRESERVATIVES
	CREOSOTE	PENTACHLOROPHENOL	ARSENICALS
1. Skin contact applications	Okay <sup>2</sup>	Okay <sup>2</sup>	Okay
2. Residential interiors	No	No	Okay
3. For interior components of industrial and farm buildings that are in ground contact and subject to decay or insect attack (also see #5 below)	Okay <sup>2</sup>	Okay <sup>2</sup>	Okay
4. Laminated beams for commercial or industrial buildings	No	Okay <sup>2</sup>	Okay
5. Interiors of farm buildings when animals can crib (bite) or lick the treated wood	No	No	Okay
6. Agricultural farrowing or brooding facilities	No	No	Okay
7. Applications in which preservatives may become a component of food or animal feed, such as structures or containers for storing silage or food	No	No	No
8. Cutting boards or countertops for preparing food	No	No	No
9. Decks, patios, and walkways if surface is visibly clean and free from residues	Okay	Okay	Okay
10. Portions of beehives that may come into contact with honey	No	No	No
11. Applications in which treated wood can come into direct or indirect contact with drinking water for public or animal consumption	No <sup>3</sup>	No <sup>3</sup>	No <sup>3</sup>

<sup>1</sup> Based on EPA-approved consumer information sheets

<sup>2</sup> Must be painted with two coats of recommended sealer

<sup>3</sup> Okay for incidental contact such as bridges or docks

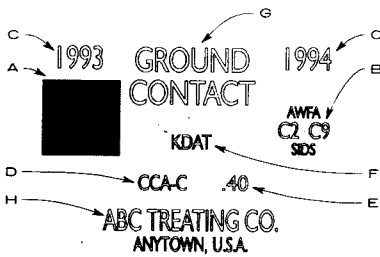

A: Trademark of inspection agency certified by the American Lumber Standard Committee (ALSC); contact the Southern Pine Council (SPC) or ALSC for a list of certified inspection agencies.

B: Applicable American Wood Preservers' Association (AWPA) standard

C: Year of treatment

D: Preservative used for treatment

E: Retention level

F: Dry or KDAT (kiln-dried after treatment), if applicable

G: Proper exposure conditions

H: Treating company and location

TYPICAL QUALITY MARK FOR TREATED LUMBER

Richard J. Vitullo, AIA; Oak Leaf Studio; Crownsville, Maryland  
Southern Pine Council; Kenner, Louisiana  
American Plywood Association; Tacoma, Washington

**GENERAL**

Building construction materials are tested for four criteria related to performance during a fire: fire resistance, flame spread, fuel contributed, and smoke developed. Fire resistance is the material's ability to resist burning while retaining its structural integrity. Flame spread measures the rate at which flames travel along the surface of a material. Fuel contributed is a measure of how much combustible matter a material furnishes to a fire. Smoke developed is a measure of the surface burning characteristics of a material.

How fire spreads through wood structures depends on the size and arrangement of wood members and the details that restrict or encourage air movement around them. Larger cross sections take longer to burn. As wood burns, it develops an outer layer of charcoal, which insulates the wood beneath and slows burning. This "char" layer proceeds through the burning wood at an average rate of 1 1/2 in. per hour. Various design strategies can be used to resist fire damage to a wood structure and its spread to adjacent areas, but the most important is to protect the wood members by means of coverings, coatings, or treatments.

**FIRE-RETARDANT TREATMENT**

Modern fire-retardant treatment (FRT) of wood consists of pressure treatment with aqueous solutions of various organic and inorganic chemicals, followed by kiln drying to reduce moisture content to 19% or less for lumber under 2 in. thick and 15% or less for plywood. All proprietary FRTs must conform to UL classifications. FRT wood is commonly used in plywood sheathing, roof trusses, rafters, floor joists, studs, staging, and shingles and shakes. Fire-retardant chemical combinations include zinc chloride, ammonium sulfates, borax or boric acid, and lesser amounts of sodium dichromate. Ammonium phosphates are no longer used because they cause rapid disintegration of wood.

Fire retardants work when fire-retardant chemicals react with the tars and gases normally produced by burning wood. The resultant carbon char acts as thermal insulation (greater than on untreated wood), slowing the rate of burning. Gases released from the FRT wood are diluted with carbon dioxide and water vapor, lessening the chance of flashback, in which wood gases are ignited by high temperatures and then explode.

**FRT STANDARDS AND CLASSIFICATIONS**

Interior fire retardants meet Class I ratings, which are required by code for vertical exit ways and special areas. Class II ratings are required for horizontal exit ways, but this rating is rarely reached with untreated wood. FRT lumber and plywood are recognized substitutes for noncombustible materials for insurance purposes. Many codes accept FRT wood products for a variety of applications.

Both the flame spread index and smoke-developed index give numerical scales for a material's fire classification. The flame spread index is the primary test for fire performance, according to ASTM E-84, which mandates a flame spread rating of 25 or less. In the Model Building Codes, flame spread ratings are classified as 0-25 (Class I or A), 26-75 (Class II or B), and 76-200 (Class III or C).

A smoke-developed index of 450 or less is permitted for FRT wood. The UL FR-S listing applies only to treated products with a UL-723 (ASTM E-84) flame and smoke classification not exceeding 25 in a 30-min. test. The classification applies to the species tested and does not pertain to the structures in which the materials are installed.

Fire retardants come in interior and exterior types. Interior fire retardants are used on wood trusses and studs; exterior retardants protect exterior lumber, siding, roof shakes and shingles, and scaffold planking. The latter type offers durable, nonleachable, long-term fire protection in outdoor or moist (relative humidity of 95% or greater) conditions.

Some codes count Class C or Class B FRT shingles and shakes as noncombustible materials. For wood exposed to the weather, specify exterior-type retardants that retain their protective properties under the standard rain test.

Interior Type A wood is appropriate for interior and weather-protected applications with less than 95% relative humidity. In rare instances, when relative humidity is less than 75%, Type B can be specified. Interior Type A is used when a wood with low hygroscopicity (the rate at which the chemical draws moisture from the air) is required.

**FRT INTERIOR WOODWORK**

Instead of solid lumber, it is often desirable to build members of treated cores clad with untreated veneers 1/32 in. thick or less. Most codes discount this narrow finishing in determining the flame spread index of the wood, permit-

UL CLASSIFICATION OR CONTROL NUMBER

TREATER'S NAME (REQUIRED)

PROPRIETARY BRAND NAME (ALL FRT IS PROPRIETARY)

AMERICAN WOOD PRESERVERS ASSOCIATION STANDARD FOR MOISTURE CONTENT (M.C.): C-20 FOR LUMBER IS 19% M.C. C-27 FOR PLYWOOD IS 15% M.C.

NATIONAL EVALUATION REPORT CLASSIFICATION NUMBER (NOT REQUIRED)

CLASSIFICATIONS ARE INTERIOR TYPE A, INTERIOR TYPE B (RARELY USED), OR EXTERIOR TYPE

\*KILN DRIED AFTER TREATMENT\* (SOMETIMES PRODUCT IS AIR DRIED)

**NOTE**

Wood shakes and shingles are further classified as class B or C. Rather than stamp each piece, each bundle is tagged with an identification mark.

**TYPICAL FIRE-RETARDANT TREATED WOOD IDENTIFICATION MARK**

Use of untreated wood in about 10% of the combined wall and ceiling surface area. Sizes and species currently being treated (flame spread index less than 25) include red oak and Western red cedar up to 4/4 and yellow poplar up to 8/4. Color and finishes are affected by FRTs.

**FINISHING AND FINISHES**

FRT lumber and plywood can be lightly sanded for cosmetic cleaning after treatment. Painting and staining are possible but not always successful, particularly transparent finishes. Test finishes for compatibility before application.

Treated lumber may be end cut, but ripping and extensive surfacing will normally void the UL label. To the extent possible, materials should be pre-cut before treatment, otherwise a wood treater should be consulted. Treated plywood can be cut in either direction without loss of fire protection.

Intumescent coatings are sometimes used to reduce flammability of wood surfaces in both opaque and transparent finishes. Under high heat, these coatings expand or foam, creating an insulating effect that reduces flame spread.

**FLAME SPREAD INDEX**

MATERIAL <sup>1</sup>		ASTM E-84 FLAME SPREAD	SOURCE <sup>2</sup>
Lumber	Birch, yellow	105-110	UL
	Cedar, Western red	70	HPM A
	Douglas fir	70-100	UL
	Maple (flooring)	104	CWC
	Oak, red or white	100	UL
	Pine, Ponderosa	105-230 <sup>3</sup>	UL
	Pine, Southern yellow	130-195	UL
	Poplar	170-185	UL
	Redwood	65	CRA
	Spruce, Northern	65	UL
Softwood plywood (Exterior glue)	Douglas fir, 1/2"	118	CWC
	Douglas fir, 5/8"	95	APA
	Southern pine, 1/4"	95-110	APA
Hardwood plywood	Lauan, 1/4"	150	HPM A
	Particleboard		
Particleboard	1/2", 47 lb/cu ft	156	NBS
	5/8", 44 lb/cu ft	153	NBS
Flakeboard	Red oak, 1/2", 42-47 lb/cu ft (four types)	71-189	FPL
Shakes	Western red cedar, 1/2"	69	HPM A
	Shingles	Western red cedar, 1/2"	49

<sup>1</sup> Unless indicated, thickness of material is 1 in. nominal.  
<sup>2</sup> Sources: APA—American Plywood Association; CRA—California Redwood Association; CWC—Canadian Wood Council; FPL—USDA Forest Products Laboratory; HPMA—Hardwood Plywood Manufacturers Association; NBS—National Bureau of Standards; UL—Underwriters Laboratories.  
<sup>3</sup> Average of 18 tests was 154 with three values over 200.  
<sup>4</sup> Hardwood Plywood Manufacturers Association test records

ALL BUILDING CODES REQUIRE A THIRD-PARTY INSPECTION AGENCY (USUALLY UL)

INDICATES FLAME SPREAD TEST ACCORDING TO ASTM E-84 (STANDARD DURATION OF TEST IS 10 MIN.)

REQUIRED TEST RESULTS IF NOT FR-S RATED

INDICATES THAT TEST RESULTS ARE 25 OR LESS FOR BOTH TESTS

DATE OF TREATMENT (SOME CODES REQUIRE THIS)

ABC WOOD PRESERVERS ANYTOWN, U.S.A.			UND. LAB. INC. Classified Treated Lumber		
Species	Flame Spread	Smoke Developed	15 25 30 min.		
Pond. Pine	10	20-50			
S/P/F		FR-S			
Hem. Fir		FR-S			
Doug. Fir		FR-S			
In Accordance With AWWA C-20 Interior Type A			JAN 94		
NER-3034KDAT					

Check local codes before specifying these coatings because they tend to be less durable, softer, and more hygroscopic than standard finishes.

**NOTES**

- These standards apply to FRT wood: ASTM E-84, ASTM D-2898, ASTM D-3201, ASTM E-108, AWWA C-20, AWWA C-27, and ULI Building Materials Directory (current edition). For more information, contact the American Wood Preservers' Association (AWPA), American Wood Preservers' Institute, USDA Forest Service, Southern Forest Products Association, Western Wood Preservers Institute, and American Forest and Paper Association.
- FRT wood has increased weight and decreased strength; consult a structural engineer and the wood treater for actual design values for structural applications.
- FRT wood fasteners must be hot-dipped, zinc-coated galvanized stainless steel, silicon bronze, or copper; other materials deteriorate upon contact with FRT chemicals.
- The smoke-developed index for the products listed in the flame spread index remained below 450, the limiting value used in most building codes.

**FLAME SPREAD INDEX OF FACTORY-FINISHED PRODUCTS**

MATERIAL			ASTM E-84 FLAME SPREAD <sup>4</sup>
Particleboard	1/32"	Factory finish printed	118-178
	1/2"	Paper overlay	175
	5/8"	Vinyl overlay	100
Medium-density fiberboard (MDF)	3/16"	Factory finish printed	167
	Hardboard	1/8"	Factory finish printed
		Paper overlay	155-166
Flakeboard	Aromatic cedar, 3/16"		156
Hardwood plywood	Aspen, 1/4"	Factory finished	196
	Birch, 5/32"	Factory finished	160-195
	Cherry, 1/4"	Factory finished	160
	Hickory, 1/4"	Factory finished	140
	Lauan, 1/4"	Factory finish printed	99-141
	Maple, 1/4"	Factory finished	155
	Oak, 1/4"	Factory finished	125-185
	Pine, 1/4"	Factory finished	120-140
	Walnut, 1/4"	Factory finished	138-160

Richard J. Vitullo, AIA; Oak Leaf Studio; Crownsville, Maryland

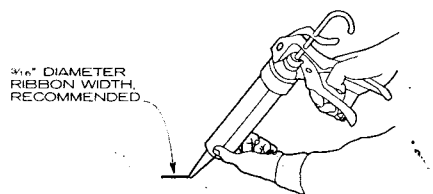

ADHESIVE GUN

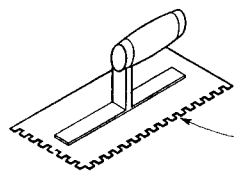

NOTCHED TROWEL (TO SPREAD ADHESIVE OVER LARGE AREAS)

ADHESIVE APPLICATIONS

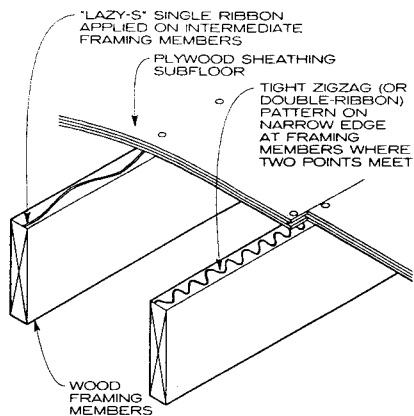

NOTE

Adhesive is applied to one surface only.

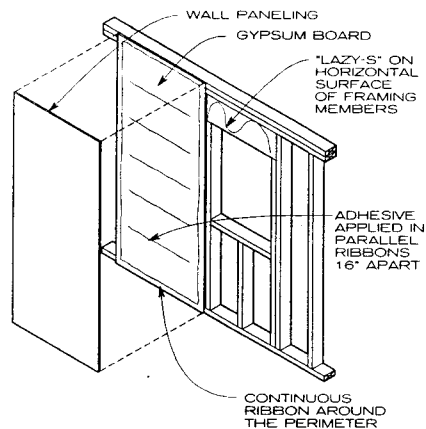

RECOMMENDED ADHESIVE BEAD PATTERNS

ADHESIVES SUMMARY

CLASS	FORM	PROPERTIES	TYPICAL USES
Urea resin	Dry powders or liquids; may be blended with melamine or other resins	High strength under both wet and dry conditions; moderately durable under damp conditions; moderate to low resistance to temperatures above 120°F; white or tan color	Hardwood plywood for interior use and furniture; interior particleboard; flush doors; furniture core stock
Phenol resin*	Dry powders or liquids	High strength under both wet and dry conditions; very resistant to moisture and damp conditions; dark red in color	Primary adhesive for exterior softwood plywood and flakeboard
Resorcinol resin and phenol-resorcinol resins	Liquid; hardener supplied separately	High strength under both wet and dry conditions; very resistant to moisture and damp conditions; dark red color	Primary adhesive for laminated timbers and assembly joints to withstand severe service conditions
Polyvinyl acetate resin emulsions	Liquid; ready to use	Generally high strength in dry conditions; low resistance to moisture and elevated temperatures; joints tend to yield under continued stress; white or yellow color	Furniture assembly, flush doors, bonding of plastic laminates, architectural woodworking
Cross-linkable polyvinyl acetate resin emulsions	Similar to polyvinyl acetate resin emulsions but includes a resin capable of forming linkage	Improved resistance to moisture and elevated temperatures; improved long-term performance in moist or wet environment; color varies	Interior and exterior doors, molding and architectural woodworking
Contact adhesives	Typically an elastomer base in organic solvents or water emulsion	Initial joint strength develops immediately upon pressing, increases slowly over a period of weeks; dry strength generally lower than those of conventional woodworking glues; water resistance and resistance to severe conditions variable; color varies	For some nonstructural bonds; high-pressure decorative laminates to substrates. Useful for low-strength metal and some plastic bonding.
Mastics (elastomeric construction adhesives)	Puttylike consistency, synthetic or natural elastomer base, usually in organic solvents	Gap filling; develops strength slowly over several weeks; water resistance and resistance for severe conditions vary; color varies	Lumber and plywood to joists and studs; gypsum board; styrene and urethane foams
Thermoplastic synthetic resins (hot melts)	Solid chunks, pellets, ribbons, rods, or films; solvent-free	Rapid bonding; gap filling; lower strength than conventional woodworking adhesives; minimal penetration; moisture resistant; white to tan color	Edge banding of panels; films and paper overlays
Epoxy resins	Chemical polymers, usually in two parts, both liquid; completely reactive, no solvents	Good adhesion to metals, glass, certain plastics, and wood products; permanence in wood joints not adequately established; gap-filling	Used in combination with other resins for bonding metals, plastics, and materials other than wood; fabrication of cold-molded wood panels
Protein glues (casein and hide)	Dry powders or reconstituted liquid	Bonds extremely well to wood; moisture resistant	Interior applications; laminating beam

\*Most types used in the U.S. are alkaline-catalyzed. The general statements refer to this type.

Data: Adapted from Table 100-G-12, *Architectural Woodwork Quality Standards* (6th ed., version 1.1, 1994)

GENERAL

Adhesives have been used for bonding wood for centuries, but until the 1930s they were limited to only a few naturally derived substances—those based on animal or vegetable proteins, gums, or resins. Stepped-up materials research efforts during World War II spurred the development of synthetic adhesives for bonding metals, concrete, glass, rubber, plastics, and wood.

Many of these synthetic adhesives are used to manufacture products such as plywood, oriented-strand board (OSB), and laminated timbers. They can also be used during construction to attach plywood subfloors to floor joists, adhere ceramic tiles to floors or walls, attach drywall, and the like. In addition to their structural use, adhesives also can be used to eliminate squeaks in floors and for some mechanical fastening.

Adhesives are composed of a base component, dispersion medium, and various additives that impart specific properties. The elastomeric base of a construction-type adhesive accounts for 30 to 50% of its weight. Depending on its

intended application, this base is made of natural rubber (isoprene) or synthetic rubbers such as neoprene, butyl, polyurethane, polysulfide, nitrile, styrene-butadiene, or butadiene acrylonitrile. Additives include tackifiers, flow and extrusion modifiers, curing agents, antioxidants, and fillers. Together, the base and the additives are dispersed (or dissolved) in a liquid, typically an organic solvent or water.

Currently, most adhesives use organic solvents, but water-based adhesives are gaining in popularity because they do not emit harmful vapors, are easy to clean up, and can be discarded as regular trash. During the specification process, disposal of the containers from organic solvents must be considered. Many jurisdictions are enacting clean air statutes in which organic solvents are targeted as air pollutants. In addition, organic solvents can have adverse effects on the workers who apply them as well as future building occupants. One drawback to most water-based adhesives is that they tend only to resist water, while the solvent-based adhesives are waterproof.

CONSTRUCTION ADHESIVES

Construction adhesives are defined as elastomer-based extrudable mastics, which means that the main adhesive component is elastic and will continue to maintain some of its flexibility indefinitely. Mastics are a type of adhesive with high viscosity, or resistance to flow. A construction adhesive is a substance capable of holding materials together by surface attachment.

Adhesives used for building have been formulated to tolerate many of the often adverse conditions that exist at most job sites, such as extreme temperatures and temperature fluctuations. They are excellent for filling gaps, and thus work on both smooth and rough surfaces. Because they form bond lines up to 1/4 in. thick, they can bridge gaps between ill-fitting pieces. The degree of adhesion depends on the surface conditions of the materials; ice, dirt, grease, or other contaminants will all have a negative effect.

Many of the characteristics of modern adhesives are described in the table. Note that most adhere to wood, but performance depends on careful consideration of physical and chemical compatibility of glue and wood, processing requirements, mechanical properties, and durability under design conditions.

Richard J. Vitullo, AIA; Oak Leaf Studio; Crownsville, Maryland

**GENERAL NOTES**

1. Nails are made of many materials for diverse uses. When selecting nails, follow the recommendation of the manufacturer of the material to be fastened, as well as building codes when applicable.
2. Select nails so as to avoid galvanic action between the nail and the nailed material.
3. Select nail head size according to the strength and area of the material to be held.
4. In wood framing the correct size and number of nails must be used at any given point to withstand stress. Procedures for calculating nailed connections can be found in National Design Specifications for Wood Construction (Washington: National Forest Products Association [American Forest and Paper Association]).
5. Base nail selection on the type(s) of wood or other materials to be assembled, joined, or connected.
6. Nails with serrated or helically threaded shanks have increased holding power. Such nails are difficult, if not impossible, to remove without destroying the surrounding material.
7. Where nails are exposed to moisture or weather, for example, in exterior stucco lath, use nonferrous (aluminum or zinc-coated) nails.
8. Choose nails for automatic nailing equipment specifically for the equipment used. See ANSI "Safety Requirements for Power Actuated Fastening Systems" and OSHA regulations.

**ROUGH CONSTRUCTION**

NAME	SHAPE	MATERIAL	FINISH
COMMON		Steel or aluminum	Smooth
ANNULAR		Steel, hardened steel, copper, brass, bronze, silicon bronze, nickel silver, aluminum, monel, or stainless steel	Bright, hardened
HELICAL			
COMMON CUT STRIKE		Steel or iron	Bright or zinc-coated
DOUBLE-HEADED		Steel	Bright or zinc-coated
		Aluminum	Bright
SQUARE		Steel	Smooth, bright, zinc-coated
ROUND WIRE			
ANNULAR		Aluminum	Bright or hard

**ROOFING**

NAME	SHAPE	MATERIAL	FINISH
SIDING & SHINGLE		Steel, copper, or aluminum	Smooth, bright, zinc- or cement-coated
ROOFING (BARBED)		Steel or aluminum	
ROOFING		Steel	Bright or zinc-coated
NONLEAKING ROOFING			
SHINGLE NAIL		Steel or cut iron	Plain or zinc-coated
CUT SLATING (NONFERROUS)		Copper, muntz metal, or zinc	
GUTTER SPIKE (ROUND)		Steel	Bright or zinc-coated
GUTTER SPIKE (ANNULAR)		Copper	Bright

**FINISH WORK**

NAME	SHAPE	MATERIAL	FINISH
WALLBOARD		Steel or aluminum	Smooth, bright, blued, or cement-coated
FINE NAIL		Steel	Bright
LATH			Blued or cement-coated
LATH		Steel or aluminum	Smooth, bright, blued, or cement-coated
CASING OR BRAD			Bright or cement-coated
FINISHING		Steel	Smooth

**MISCELLANEOUS**

NAME	SHAPE	MATERIAL	FINISH
CEMENT			Smooth, bright, or oil-quenched
CEMENT (FLUTED HELICAL)			Hardened
OFFSET (LATH)		Steel	
HOOKED (LATH)			Bright, blued, or zinc-coated
STAPLE			

**COMMON NAIL SIZES**

LENGTH	PENNY	GAUGE	DIA. OF HEAD (IN.)	NAILS/LB
1	2	15	1/64	847
1 1/4	3	14	13/64	543
1 1/2	4	12 1/2	1/4	296
1 3/4	5	12 1/2	1/4	254
2	6	11 1/2	11/64	167
2 1/4	7	11 1/2	11/64	150
2 1/2	8	10 1/4	9/32	101
2 3/4	9	10 1/4	9/32	92.1
3	10	9	5/16	66
3 1/4	12	9	5/16	66.1
3 1/2	16	8	11/32	47.4
4	20	6	13/32	29.7
4 1/2	30	5	7/16	22.7
5	40	4	15/32	17.3
5 1/2	50	3	1/2	13.5
6	60	2	11/32	10.7

Charles F. D. Egbert, AIA; Architect: Washington, D.C.

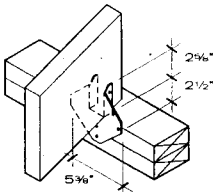

NOTE: For tying unnotched 2x rafters to top wall plates; for uplift and lateral load resistance.

**TWO-SIDED RAFTER TIE**

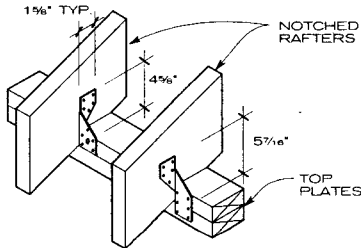

NOTE: Ties one or two top plates to notched rafters for tension cord connections.

**ONE-SIDED RAFTER TIES**

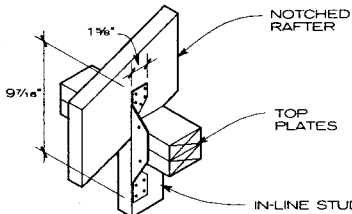

NOTE: Ties notched rafter to stud on same plane as rafter for tension load connection.

**RAFTER-TO-STUD TIE**

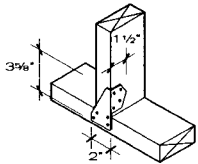

NOTE: Ties stud to bottom plate for tension load connection.

**STUD TIE**

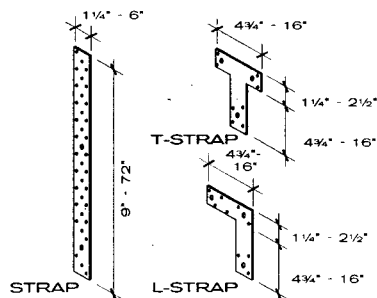

STRAP: For tying varied tension load connections, e.g., joists at ridge, wall-to-floor connections, etc.

T- AND L-STRAPS: For varied vertical to horizontal connections.

**TIES**

**NOTES**

1. For utmost rigidity, strength, and service, each type of fastener requires joint designs adapted to wood strength along and across the grain and to dimensional changes that may occur with variations in moisture content.
2. For forces such as wind uplift and lateral loads (wind and earthquake), the foundation, floor-to-floor, and roof connections are the main areas of concern, although, in varying degrees, all connections taken together will resist

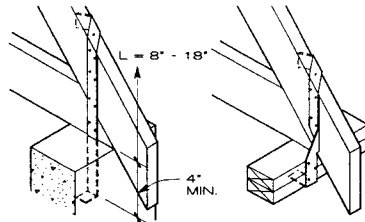

**TRUSS ANCHOR**  
NOTE: Provides tension for wood-to-wood or wood-to-masonry connections for wood trusses and joists.

**TRUSS ANCHORS**

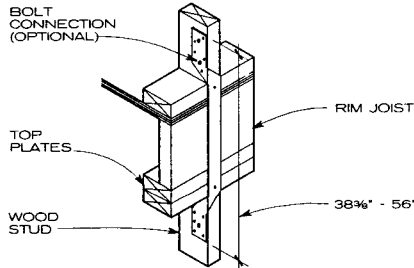

NOTE: Provides floor-to-floor tension connection; for nailed or bolted connections.

**FLOOR TIE ANCHOR**

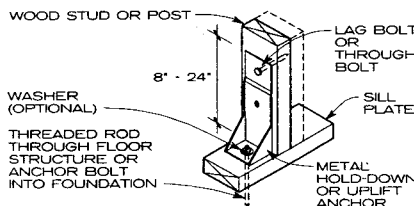

NOTE: Transfers tension loads between floors; ties studs/posts to foundation.

**METAL HOLD-DOWN/UPLIFT ANCHOR**

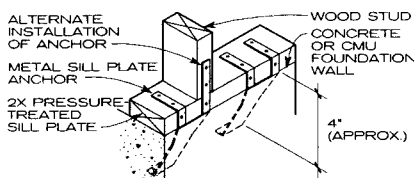

NOTE: Anchors sill plate to concrete or CMU foundation wall and/or studs.

**SILL PLATE ANCHORS/SIDE INSTALLATION**

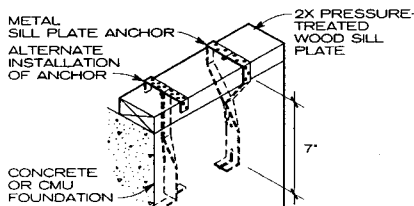

NOTE: Anchors sill plate to concrete or CMU foundation wall.

**SILL PLATE ANCHORS/CENTERLINE INSTALLATION**

**ANCHORS**

- these forces. In some joints, the fastener or connector is the only resistor to the applied load.
3. Most fasteners used to join wood framing or to attach metal connectors to framing are made of steel, with a hot-dipped galvanized coating the most typical finish used. Stainless steel, or finishes such as a corrosion-resistant primer or a copolymer coating, can also be used. In the presence of moisture, metals used for nails

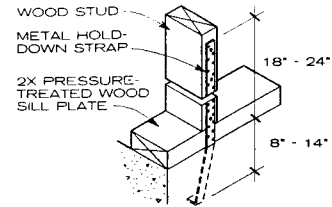

NOTE: Anchors sill plate and stud to concrete or CMU foundation wall.

**METAL HOLD-DOWN/UPLIFT STRAP**

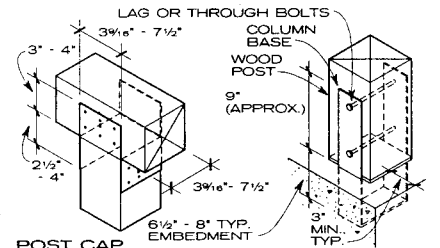

**POST CAP AND BASE**  
POST CAP/BASE: For varied post cap or base connections.  
**COLUMN BASE**  
COLUMN BASE: Attaches wood post to concrete embedment to resist high uplift loads.

**COLUMN CAPS AND BASES**

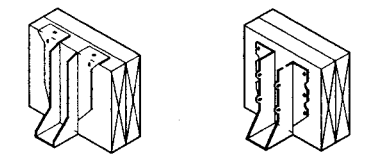

NOTE: Joist connector (in wide variety of sizes).

**JOIST HANGERS**

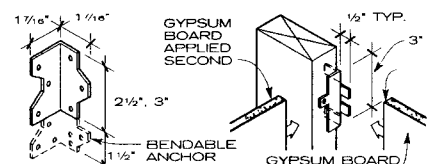

**FRAMING ANCHOR**  
FRAMING ANCHOR: For varied wood-to-wood two-way connections; optional bendable extensions allow three-way connections.

**BACK-UP CLIP**  
BACK-UP CLIP: To provide back-up support for gypsum board in lieu of wood framing; can save wood material.

NOTE: Anchors sill plate to concrete or CMU foundation wall.

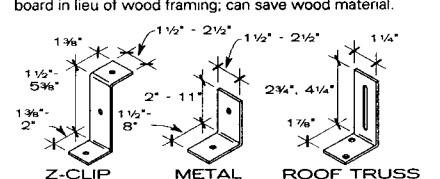

**Z-CLIP**: Secures 2x blocking between joists and/or trusses.

**METAL ANGLE**: Provides varied wood-to-wood or wood-to-concrete anchorage.

**ROOF TRUSS CLIP**: Provides alignment control between roof truss and nonbearing walls; slot permits load-induced truss movement.

**VARIOUS CLIPS AND ANCHORS**

and other fasteners may corrode when in contact with material treated with certain preservatives. Fasteners made of hot-dipped galvanized steel, copper, silicon bronze, and 304 and 316 stainless steel have performed well in wood treated with ammoniacal copper arsenate (ACA) and chromated copper arsenate (CCA), the most common preservatives for wood. Of course, provision should always be made to avoid galvanic action between dissimilar metals.

Richard J. Vitullo, AIA: Oak Leaf Studio; Crownsville, Maryland

MACHINE BOLT ANCHORS AND SHIELDS (IN.)

BOLT DIA.	THPS PER INCH	DECIMAL EQUIV. (IN.)	SINGLE EXPANDING ANCHOR (CAULKING)		SINGLE EXPANDING ANCHOR (NONCAULKING)		MULTIPLE EXPANDING ANCHOR (PLAIN STYLE)			MULTIPLE EXPANDING ANCHOR (THREADED STYLE)			DOUBLE ACTING SHIELD	
			A	L	A	L	A	L UNITS		A	L UNITS		A	L
								2	3		2	3		
6	32	.138	5/16	1/2										
8	32	.164	5/16	1/2										
10	24	.190	3/8	5/8										
12	24	.216	1/2	7/8										
1/4	20	.250	1/2	7/8	1/2	1 3/8	1 1/2"	1 1/8	1/2	1		1/2	1 1/4	
5/16	18	.312	5/8	1	5/8	1 5/8						5/8	1 1/2	
3/8	16	.375	3/4	1 1/4	5/8	1 5/8	3/4	1 1/2	3/4	1 1/2		3/4	1 3/4	
1/2	13	.500	7/8	1 1/2	7/8	2 1/2	1	1 3/4	2 3/8	1	1 3/4	2 1/4	7/8	2 1/4
5/8	11	.625	1 1/8	2	1	2 3/4	1 1/8	*	2 5/8	1 1/8	*	2 1/2	1	2 1/2
3/4	10	.750	1 1/4	2 1/4	1 1/4	2 7/8	1 3/8	*	3	1 3/8	*	3 1/8	1 1/4	3 1/2
7/8	9	.875					1 1/2	*	3 1/2	1 1/2	*	3 5/8	1 5/8	4"
1	8	1.00					1 5/8	*	3 7/8	1 5/8	*	3 3/4	1 3/4	4 1/4

\*Use of three units in these diameters is recommended.

NOTE

- Extension sleeve for deep setting.
- Expansion shields and anchors shown are representative of many types, some of which may be used in single or multiple units.
- Many are threaded for use with the head of the screw outside, some with the head inside and some types require setting tools to install.
- In light construction plastic expansion shields are used frequently.

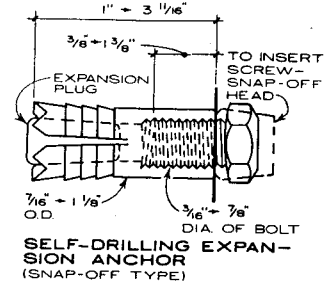

SELF-DRILLING EXPANSION ANCHOR (SNAP-OFF TYPE)

NOTE

- Refer to manufacturers for size variations within the limits shown, and for different types of bolts.
- The anchor is made of case hardened steel and drawn carburizing steel.

HOLLOW WALL ANCHORS

ANCHOR DIA. (IN.)	A		L	
	A	L	A	L
1/8	5/16	1-2 9/16		XS-L
3/16	7/16	2 1/4-3 1/2		
1/4	1/2	2 1/4-3 1/2		

SHIELDS FOR LAG BOLTS AND WOOD SCREWS (IN.)

LAG SCREW DIA. (IN.)	WOOD SCREW SIZES	DECIMAL EQUIV. (IN.)	LAG BOLT EXPANSION SHIELD		LEAD SHIELD FOR LAG BOLT OR WOOD SCREW		
			L		A	L	
			A	SHORT	LONG	A	L
6	.138				1/4	3/4-1 1/2	
8	.164				1/4	3/4-1 1/2	
10	.190				5/16	1-1 1/2	
12	.216				5/16	1-1 1/2	
1/4	14	.250	1/2	1	1 1/2	5/16	1-1 1/2
	16	.268				3/8	1 1/2
	18	.294				3/8	1 1/2
5/16	20	.320	1/2	1 1/4	1 3/4	7/16	1 3/4
3/8	24	.372	5/8	1 3/4	2 1/2	7/16	1 3/4
1/2		.500	3/4	2	3		
5/8		.625	7/8	2	3 1/2		
3/4		.750	1	2	3 1/2		

ONE PIECE ANCHORS (IN.)

ANCHOR SIZE AND DRILL SIZE	DECIMAL EQUIV. (IN.)	WEDGE ANCHOR		STUD ANCHOR		SLEEVE ANCHOR		HEAD STYLE
		L	MIN. HOLE DEPTH D	L	MIN. HOLE DEPTH D	L	MIN. HOLE DEPTH D	
1/4	.250	1 3/4-3 1/4	1 3/8	1 3/4-3 1/4	1 3/8	5/8-2 1/4	1/2-1 1/8	Acorn nut
5/16	.320					1 1/2-2 1/2	1 1/8	Hex nut
3/8	.375	2 1/4-5	1 3/4	2 1/4-6	1 5/8	1 7/8-3	1 1/2	"
1/2	.500	2 3/4-7	2 1/8	2 3/4-5 1/4	1 7/8	2 1/4-4	1 7/8	"
5/8	.625	3 1/2-8 1/2	2 5/8	3 3/8-7	2 3/8	2 1/4-6	2	"
3/4	.750	4 1/4-10	3 1/4	4 1/4-8 1/2	2 7/8	2 1/2-8	2 1/4-5 1/2	"
7/8	.875	6-10	3 3/4					
1	1.00	6-12	4 1/2					
1 1/4	1.25	9-12	5 1/2					

Sleeve anchors available in acorn nut, hex nut, flat head, round head, Phillips round head, and tie wire head styles.



MACHINE SCREW AND STOVE BOLT (INS.)

STOVE BOLT DIAM.	MACHINE SCREW DIAM.	ROUND HEAD	FLAT HEAD	FILLISTER HEAD	OVAL HEAD	OVEN HEAD
	2	1/8-7/8		1/8-7/8		
	3	1/8-7/8		1/8-7/8		
	4	1/8-1 1/2	40 N.C.	1/8-1 1/2		
	4	1/8-1 1/2	36 N.C.	1/8-1 1/2	1/8-3/4	
1/8	5	1/8-2		1/8-2	3/8-2	
	6	1/8-2		1/8-2	1/8-1	
5/32	8	3/16-3		3/16-3	3/16-2	
3/16	10	3/16-6		3/16-3	1/4-6	
	12	1/4-3		1/4-3		
1/4	1/4	3/16-6		3/16-3	3/8-6	
3/16	3/16	3/8-6		3/8-3	3/4-6	
3/8	3/8	1/2-5		1/2-3	3/4-5	
1/2	1/2	1-4				

Length intervals = 1/16 in. increments up to 1/2 in., 1/8 in. increments from 1/2 in. to 1 1/4 in., 1/4 in. increments from 1 1/2 in. to 3 in., 1/2 in. increments from 3 1/2 in. to 6 in.

NOTE: N.C. = Course thread

SCREW AND BOLT LENGTHS (INS.)

DIAMETER (INS.)	CAP SCREWS				BOLTS		
	BUTTON HEAD	FLAT HEAD	HEXAGON HEAD	FILLISTER HEAD	MACHINE BOLT	CARRIAGE BOLT	LAG BOLT
1/4	1/2-2 1/4		1/2-3 1/2	3/4-3	1/2-8	3/4-8	1-6
3/16	1/2-2 3/4		1/2-3 1/2	3/4-3 3/4	1/2-8	3/4-8	1-10
3/8	3/4-3		1/2-4	3/4-3 1/2	3/4-12	3/4-12	1-12
1/2	3/4-3		3/4-4	3/4-3 3/4	3/4-12	1-12	1-12
5/8	1-4		3/4-4 1/2	3/4-4	3/4-24	1-20	1-12
3/4	1-4		1-4 1/2	1-4	1-30	1-20	
7/8	1-4		1-5	1 1/4-4 1/2	1-30	1-20	1 1/2-16
1	1-4		1 1/4-5	1 1/2-4 1/2	1-30	1-20	1 1/2-16
			2-6	1 3/4-5	1 1/2-30		2-16
			2-6	2-5	1 1/2-30		2-16

Length intervals = 1/8 in. increments up to 1 in., 1/4 in. increments from 1 1/4 in. to 4 in., 1/2 in. increments from 4 1/2 in. to 6 in.

Length intervals = 1/4 in. increments up to 6 in., 1/2 in. increments from 6 1/2 in. to 12 in., 1 in. increments over 12 in.

Length intervals = 1/2 in. increments up to 8 in., 1 in. increments over 8 in.

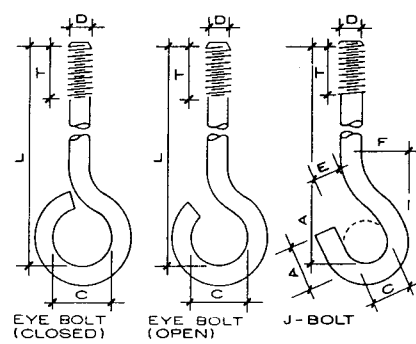
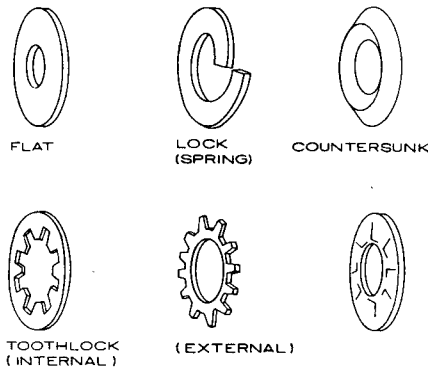
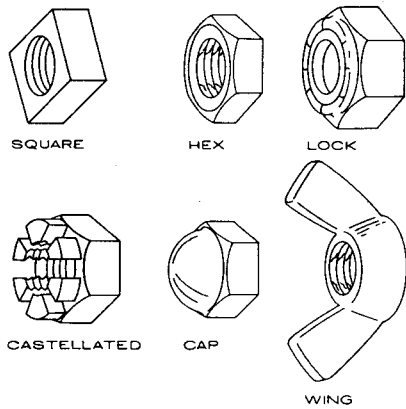
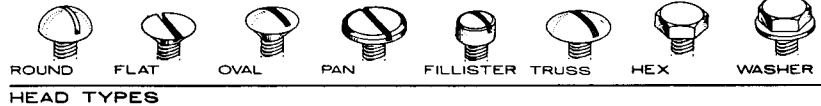

Self-locking nuts have a pin that acts as a ratchet, sliding down the thread as the bolt is tightened, to prevent loosening from shock and vibration.



The bolt's clamping force causes protrusions on the washer to flatten partially, closing the gap between the washer and the bolt head. Measurement of the gap indicates whether the bolt has been tightened adequately.

NUTS

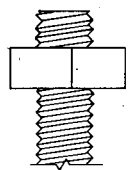

Fiberglass nuts and bolts are noncorrosive and nonconductive. Bolts are available in 3/8 in., 1/2 in., 5/8 in., 3/4 in., and 1 in. standard diameters.

FIBERGLASS NUTS AND BOLTS

Interference body bolts are driven into reamed or drilled holes to create a joint in full bearing.

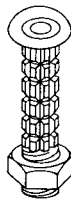

INTERFERENCE BODY BOLTS

HELICAL INSERTS

NOTES

1. Bent bolts are specialty items made to order.
2. D = bolt diameter; C = inside opening width; T = thread length; L = inside length of bolt; A = inside depth.

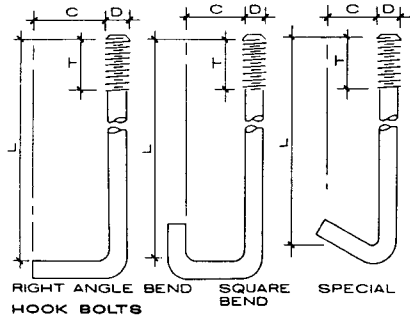
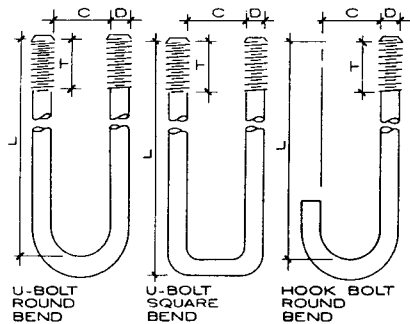

Timothy B. McDonald; Washington, D.C.



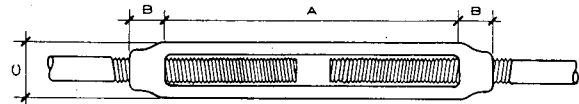

TURNBUCKLE WITH STUB ENDS

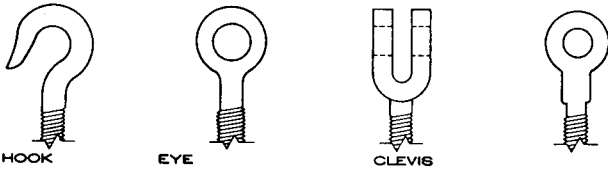

TURNBUCKLES (IN INCHES)

DIAMETER	1/4	5/16	3/8	1/2	5/8	3/4	7/8	1
DECL. EQUIV.	.250	.313	.375	.500	.625	.750	.875	1.00
A	4	4 1/2	6"	6"	6"	6"	6"	6"
B	7/16	1/2	9/16	3/4	29/32	1 1/16	1 7/32	1 3/8
C	3/4	7/8	3 1/32	1 7/32	1 1/2	1 23/32	1 7/8	2 1/32

DIAMETERS OVER 1" AVAILABLE, NOT ALWAYS STOCKED.

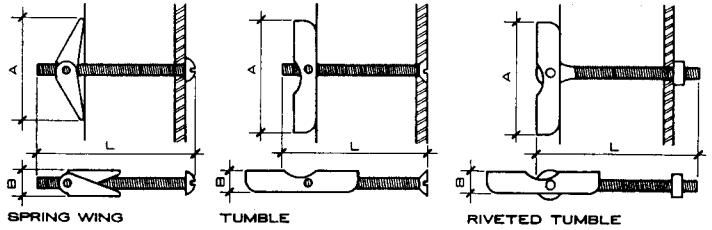

TOGGLE BOLTS (IN INCHES)

DIAMETER	1/8	5/32	3/16	1/4	5/16	3/8	1/2
DECIMAL EQUIV.	.138	.164	.190	.250	.313	.375	.500
SPRING WING	A	1.438	1.875	1.875	2.063	2.750	2.875
	B	.375	.500	.500	.688	.875	1.000
	L	2-4	2 1/2-4	2-6	2 1/2-6	3-6	3-6
TUMBLE	A	1.250	2.000	2.000	2.250	2.750	2.750
	B	.375	.500	.500	.688	.875	.875
	L	2-4	2 1/2-4	3-6	3-6	3-6	3-6
RIVETED TUMBLE	A	2.000	2.000	2.250	2.750	2.750	3.375
	B	.375	.375	.500	.625	.688	.875
	L	2 1/2-4	3-6	3-6	3-6	3-6	3-6

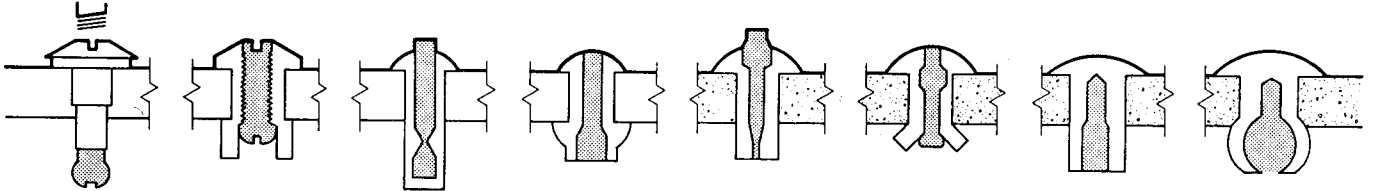

BLIND RIVETS FOR USE IN A JOINT THAT IS ACCESSIBLE FROM ONLY ONE SIDE

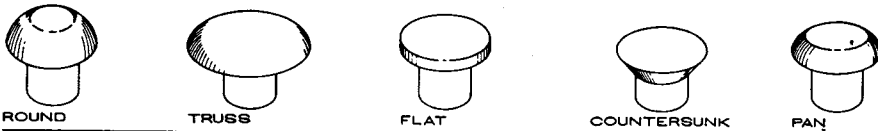

RIVETS  
STANDARD RIVETS AVAILABLE WITH SOLID, TUBULAR AND SPLIT SHANKS OF STEEL, BRASS, COPPER, ALUMINUM, MONEL METAL AND STAINLESS STEEL; IN DIAMETERS OF 1/8" TO 7/16" AND LENGTHS OF 3/16" TO 4 IN.



Self-drilling fasteners: used to attach metal to metal, wood, and concrete. Consult manufacturer for sizes and drilling capabilities.

SELF-DRILLING FASTENERS

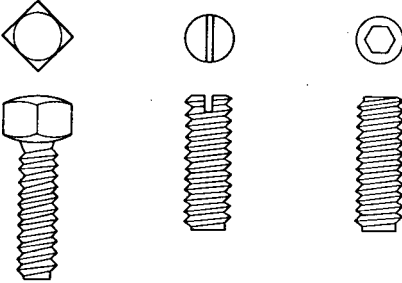

Set Screws: headless with socket or slotted top; made in sizes 4 in. to 1/2 in., and in lengths 1/2 in. to 5 in. Square head sizes 1/4 in. to 1 in., and lengths 1/2 in. to 5 in.

SET SCREWS



SHEET METAL GIMLET POINT  
Sheet metal gimlet point: hardened, self-tapping. Used in 28 gauge to 6 gauge sheet metal; aluminum, plastic, slate, etc. Usual head types.



SHEET METAL BLUNT POINT  
Sheet metal blunt point: hardened, self-tapping. Used in 28 to 18 gauge sheet metal. Made in sizes 4 to 14 in usual head types.



THREAD CUTTING- CUTTING SLOT  
Thread cutting, cutting slot: hardened. Used in metals up to 1/4 in. thick in sizes 4 in. to 5/16 in. in usual head types.

SHEET METAL & THREADING SCREWS

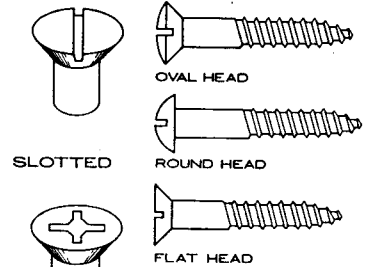

WOOD SCREWS (IN IN.)

PHILLIPS

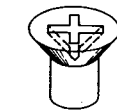

FREARSON



DRIVE TYPES

DIA.	DECI. EQUIV.	LENGTH
0	.060	1/4 - 3/8
1	.073	1/4 - 1/2
2	.086	1/4 - 3/4
3	.099	1/4 - 1
4	.112	1/4 - 1 1/2
5	.125	3/8 - 1 1/2
6	.138	3/8 - 2 1/2
7	.151	3/8 - 2 1/2
8	.164	3/8 - 3
9	.177	1/2 - 3
10	.190	1/2 - 3 1/2
11	.203	3/8 - 3 1/2
12	.216	5/8 - 4
14	.242	3/4 - 5
16	.268	1 - 5
18	.294	1 1/4 - 5
20	.320	1 1/2 - 5
24	.372	3 - 5

Timothy B. McDonald; Washington, D.C.

# 6 WOOD AND PLASTIC FASTENINGS

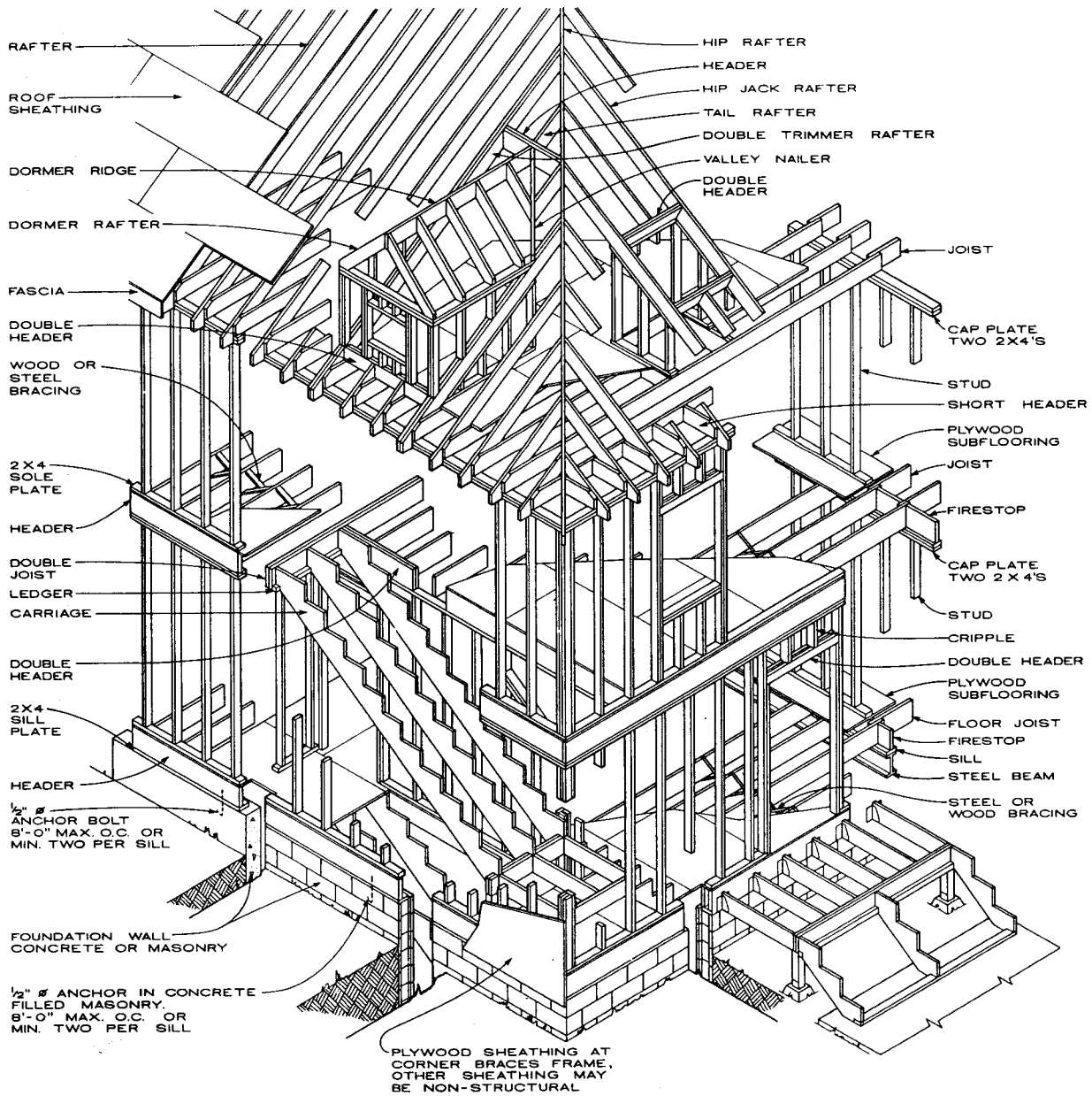

**PLATFORM FRAMING**

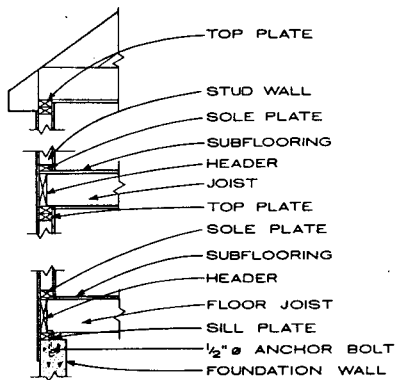

**NOTES**

**WESTERN OR PLATFORM FRAMING**

Before any of the superstructure is erected, the first floor subflooring is put down making a platform on which the walls and partitions can be assembled and tilted into place. The process is repeated for each story of the building. This framing system is used frequently.

**FIRESTOPPING**

All concealed spaces in framing, with the exception of areas around flues and chimneys, are to be fitted with 2 in. blocking arranged to prevent drafts between spaces.

**EXTERIOR WALL FRAMING**

One story buildings: 2 x 4's, 16 in. or 24 in. o.c.;  
2 x 6's, 24 in. o.c.  
Two and three stories: 2 x 4's, 16 in. o.c.;  
2 x 6's, 24 in. o.c.

**BRACING EXTERIOR WALLS**

Because floor framing and wall frames do not interlock, adequate sheathing must act as bracing and provide the necessary lateral resistance. Where required for additional stiffness or bracing, 1 x 4's may be let into outer face of studs at 45° angle secured at top, bottom, and to studs.

**BRIDGING FOR FLOOR JOISTS**

May be omitted when flooring is nailed adequately to joist; however, where nominal depth-to-thickness ratio of joists exceeds 6, bridging would be installed at 8 ft. 0 in. intervals. Building codes may allow omission of bridging under certain conditions.

Steel bridging is available. Some types do not require nails.

Timothy B. McDonald; Washington, D.C.

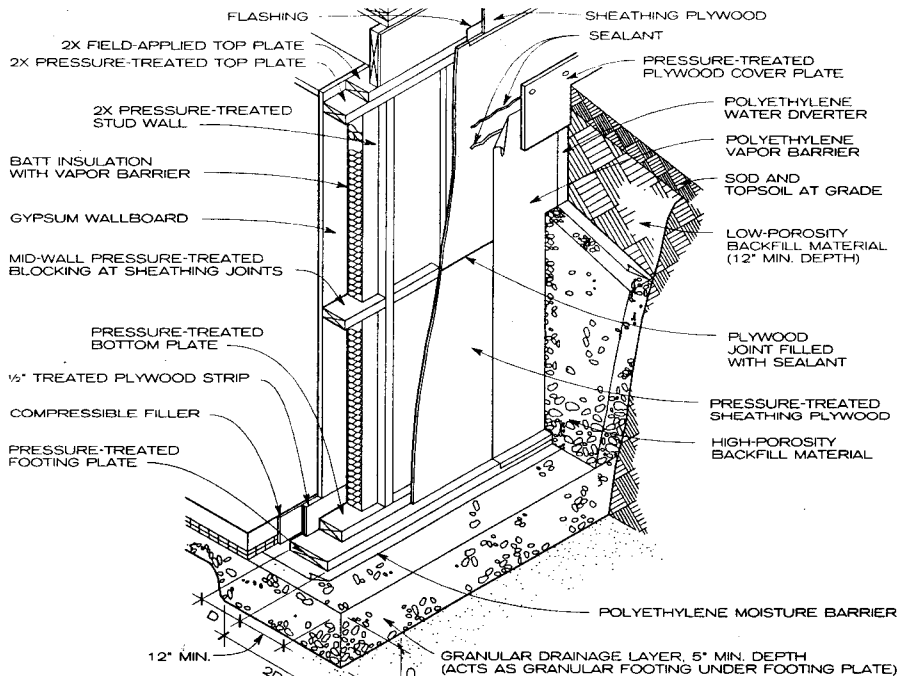

**NOTE**

1. Geotextile material may be used under and around drainage layers and backfill if soil conditions warrant.
2. Stud size and spacing vary with material grade and back-

fill depth. In general, 42 in. backfill requires 2 x 4 at 12 in. o.c., 64 in. requires 2 x 6 at 16 in. o.c., and 84 in. requires 2 x 6 at 12 in. o.c.

**TYPICAL BASEMENT WALL**

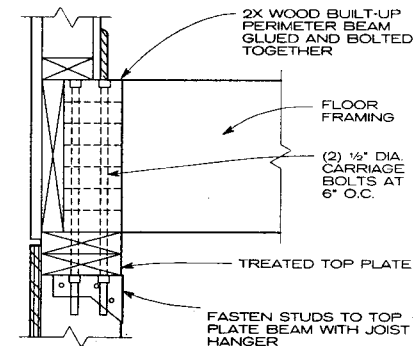

**BUILT-UP PERIMETER BEAM AT STAIRS**

**INTRODUCTION**

The construction of treated wood foundations is similar to the construction of standard wood light-frame walls except for two factors: (1) the wood used is pressure treated with wood preservatives, and (2) the extra loading and stress requirements caused by below-grade conditions must be accommodated in the design and detailing of the fasteners, connections, blocking, wall corners, and the like.

As with standard masonry or concrete foundation systems, treated wood foundations require a good drainage system in order to maintain dry basements and crawl spaces. However, the drainage system typically used with treated wood foundations is different from that used with masonry or concrete systems. The components of a drainage system suitable for use with a treated wood foundation are

1. A highly porous backfill material, which directs water down to a granular drainage layer.
2. A porous granular drainage layer under the entire foundation and floor system to collect and discharge water.
3. Positive discharge of water by means of a sump system designed for the soil type. This drainage system, developed for treated wood foundations, takes the place of the typical porous backfill over a perimeter drain tile.

Richard J. Vitullo, AIA; Oak Leaf Studio; Crownsville, Maryland  
American Forest & Paper Association; Washington, D.C.

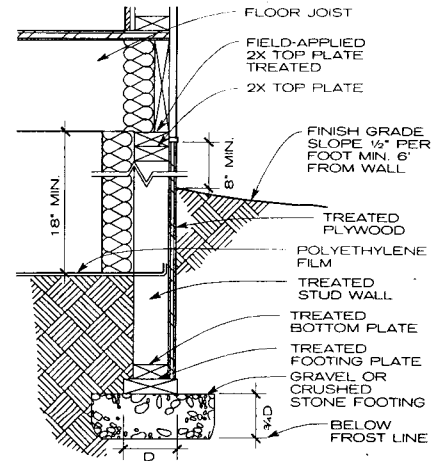

**CRAWL SPACE WALL**

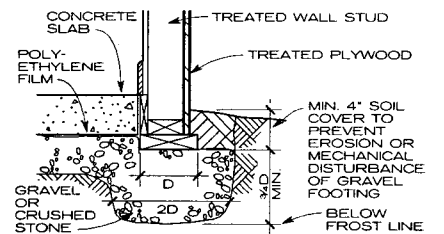

**MINIMUM SOIL COVER ON SHALLOW FOOTINGS**

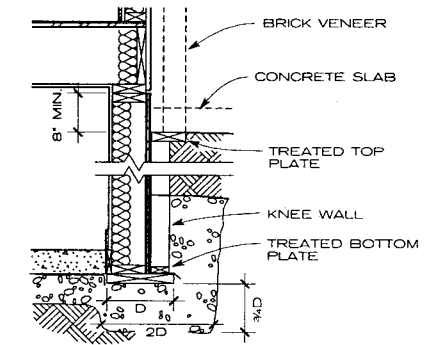

**BASEMENT WALL WITH EXTERIOR KNEE WALL**

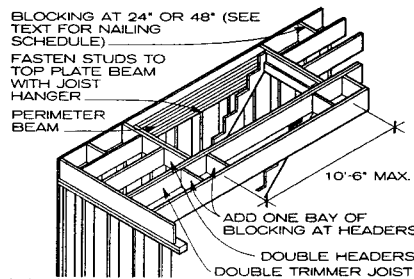

**NOTE**

For less than 48 in. backfill, use standard framing methods and fasten stairwell header to top plate with three 10d toenails.

**STAIR OPENING AT PERIMETER WALL**

**NOTES**

1. Characteristics of a treated wood foundation system:
  - a. All framing is standard 2x construction.
  - b. Can be erected in any weather and when site access for concrete or masonry is a problem.
  - c. Deep wall cavities allow use of high R-value insulation without loss of interior space.
  - d. Wiring and finishing are easily achieved.
2. Treated wood foundations are not appropriate for all sites. Selection of the proper foundation system for a project depends on site conditions, including soil types, drainage conditions, ground water, and other factors. Wet sites in low areas, especially areas with coarse-grained soil, should be avoided if a full basement is desired, although a crawl space-type foundation can be used in these cases. Consult a soils engineer to determine the viability of any foundation system.
3. Lumber and plywood used in treated wood foundations must be grade-stamped for foundation use and are typically pressure treated with chromated copper arsenate. Treated wood products used in foundation construction are required to contain more preservative than treated wood used in applications such as fencing and decking. Codes generally call for hot-dipped galvanized fasteners above grade and stainless steel fasteners below grade.

4. Avoid skin contact and prolonged or frequent inhalation of sawdust when handling or working with any pressure-treated wood product.
5. Consult applicable building codes and the American Forest & Paper Association's "Permanent Wood Foundation System—Design, Fabrication, Installation Manual" for requirements and design guidelines. In the early stages of a project, consult with the building code officials for the area or jurisdiction to assess their familiarity with and willingness to approve this type of system.
6. The vertical and horizontal edge-to-edge joints of all plywood panels used in these systems should be sealed with a suitable sealant. Consult the American Plywood Association Source List "Caulks and Adhesives for Permanent Wood Foundation System, Form H405" for a list of high-performance caulking compounds.
7. Correct materials and details of construction are very important for treated wood foundations. If the contractor to be used for the installation is unfamiliar with this foundation system, the design should include the use of pre-fabricated foundation panels. Most problems with treated wood foundations can be traced to improper installation by inexperienced workers.
8. Since this type of foundation system depends especially on the first floor deck to absorb and distribute any backfill loads, backfilling cannot occur until the first floor deck is complete.

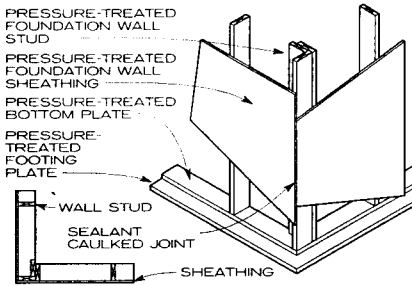

**NOTES**

1. At an outside corner, soil pressures tend to force the wall sections together, making reinforcement unnecessary.
2. Three studs should be used at the corner to support interior finishes.

**OUTSIDE CORNER DETAILS**

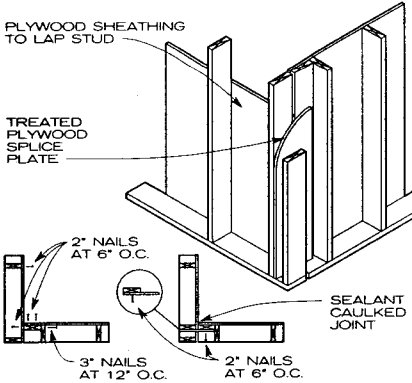

**DETAIL 1**

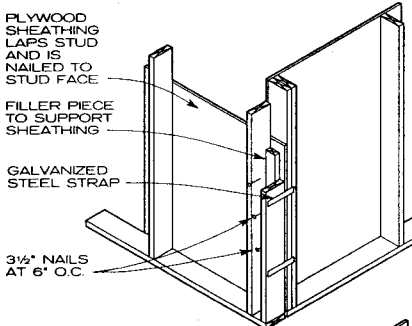

**DETAIL 2**

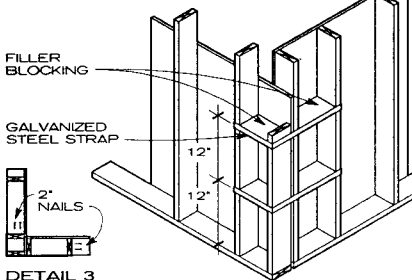

**DETAIL 3**

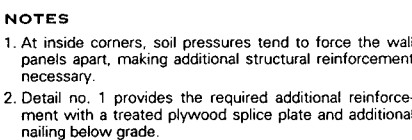

**INSIDE CORNER DETAILS**

Richard J. Vitullo, AIA; Oak Leaf Studio; Crownsville, Maryland  
American Forest & Paper Association; Washington, D.C.

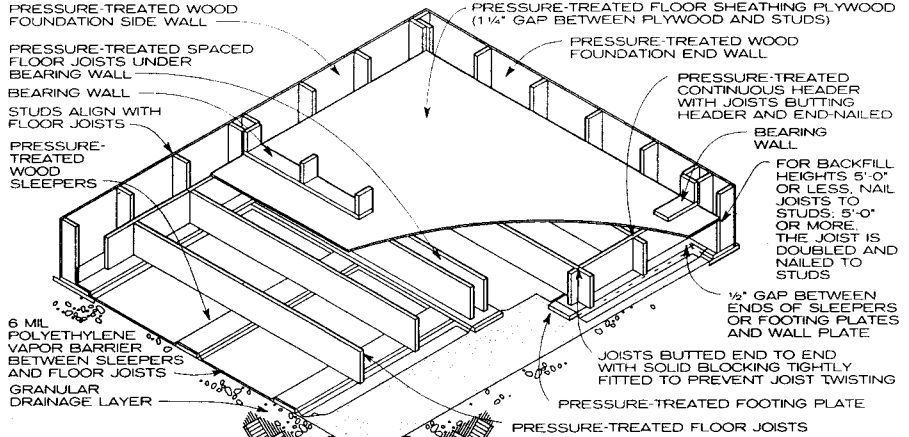

**NOTES**

1. Joists to be butted end to end over pressure-treated wood sleepers.
2. Floor stiffness will be increased by blocking between every joist above each sleeper.

**WOOD SLEEPER FLOOR SYSTEM**

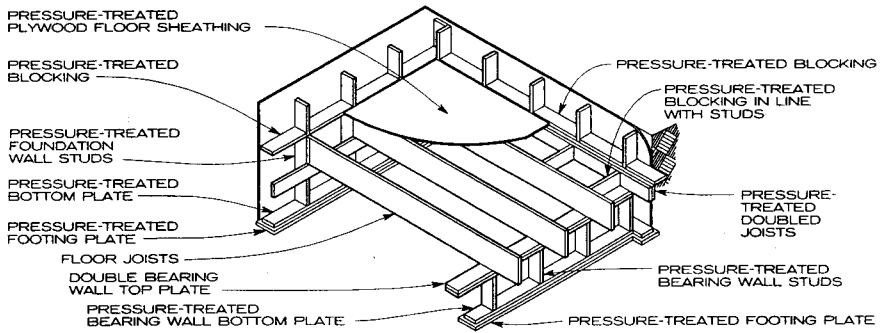

**SUSPENDED WOOD FLOOR**

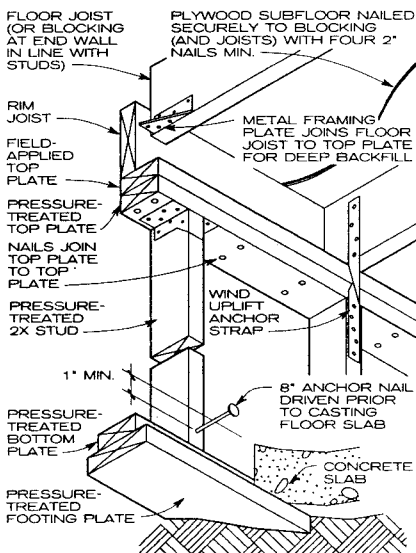

**NOTES**

1. Fasteners and connector plates transfer soil pressure thrust from wall sheathing and studs to floor system; type and amount of fasteners and connectors depend on height of backfill.
2. Wind uplift anchor straps and anchor nails spaced as required by code.

**WALL ANCHORAGE DETAIL**

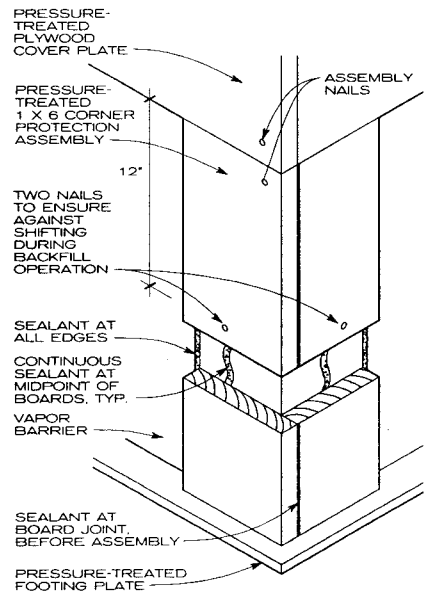

**OUTSIDE CORNER PROTECTION DETAIL**

**NOTE**

All wood members within 18 in. of the ground should be bottom treated.

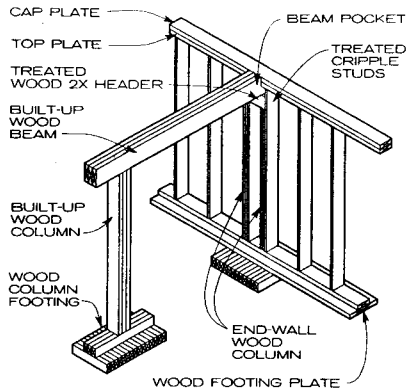

**MAIN BEAMS AND COLUMNS**

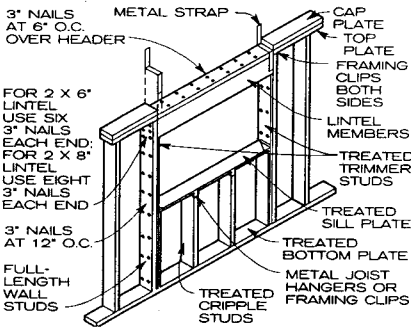

**NOTES**

1. For backfill heights up to 4 ft 6 in. and if width of opening is 4 ft 0 in. to 5 ft 6 in., use double sill plates and double full-length wall studs.
2. For backfill heights up to 4 ft 6 in. and if width of opening is 6 ft 0 in. to 9 ft 0 in., use triple sill plates and triple full-length wall studs.
3. For backfill heights of 48 in. or less, nailing and fastening can conform to the appropriate building code.
4. For backfill heights greater than 4 ft 6 in. or openings wider than 9 ft 0 in., contact engineer for design.

**WINDOW FRAMING DETAIL**

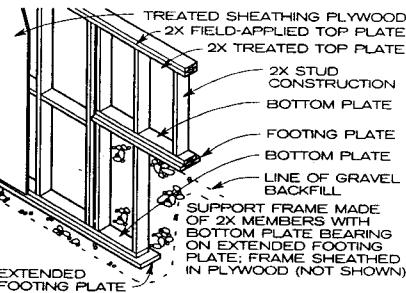

**STEPPED FOOTING DETAIL**

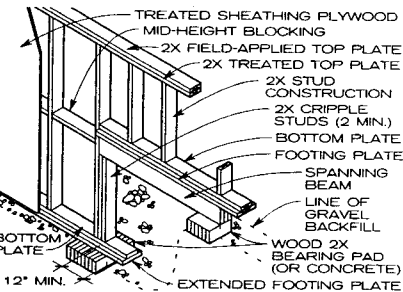

**SPANNING BEAM DETAIL**

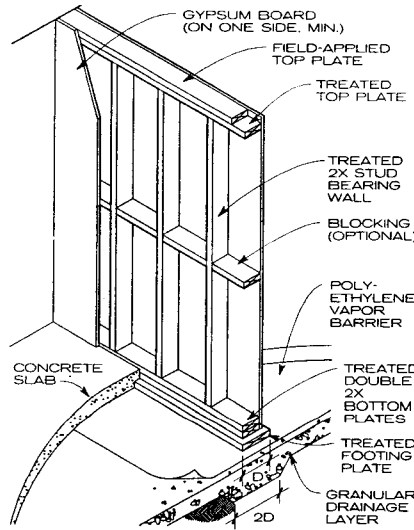

**BEARING WALL AT CONCRETE SLAB**

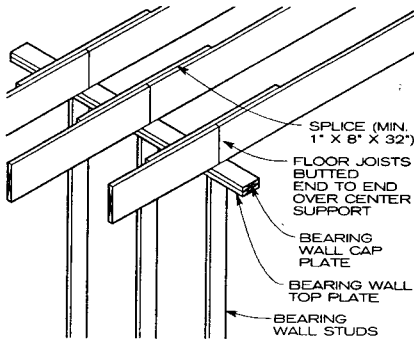

**INTERIOR BEARING WALL—FLOOR JOIST SUPPORT**

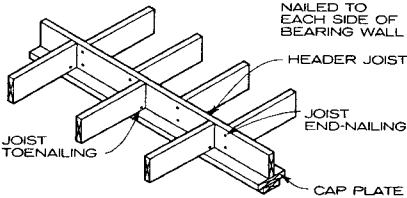
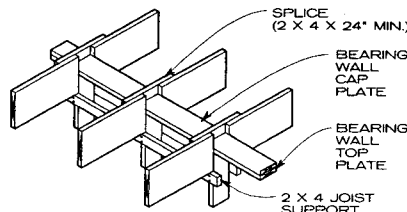
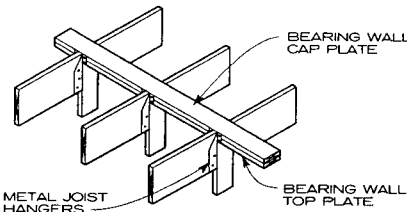

**INTERIOR BEARING WALL—FLOOR JOIST SUPPORT (ALTERNATIVES)**

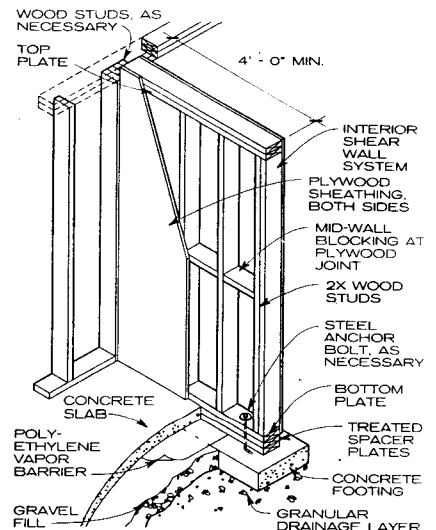

**NOTE**

Interior shear wall material does not need to be treated with wood preservatives.

**INTERIOR SHEAR WALL DETAIL**

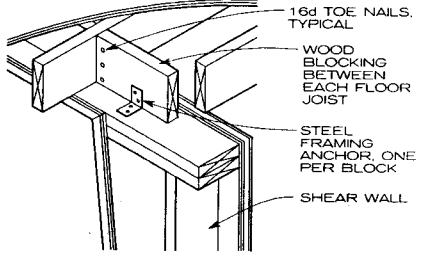
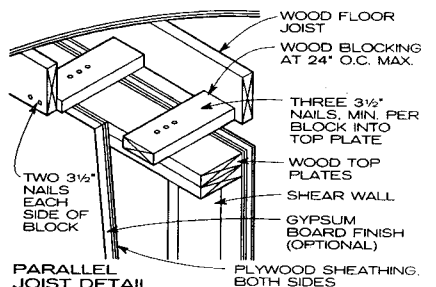

**PERPENDICULAR JOIST DETAIL**

**SHEAR WALL ANCHORAGE**

**SHEAR WALLS AS RACKING RESISTANCE**

Foundation walls may be subject to racking loads, which occur parallel to a wall and can cause shearing forces along the plane of the wall. Racking loads are caused by soil pressure and other lateral forces such as earthquake and wind. Walls, connections, and fasteners must be designed to resist these forces. Generally, soil pressure comes into play for backfill greater than 24 in. in height; check anticipated wind and earthquake forces to determine how best to accommodate them.

Check long shear walls or those with a length-to-width ratio greater than 2:1 for diaphragm deflection, particularly if the structure is built on a slope. The unequal heights of the backfill on a slope apply unequal loads to the end walls or walls parallel to the floor joist system. These walls, having received these loads by the diaphragm action of the floor system, then act as shear walls. Internal shear walls, accommodated within interior partitions, also may be needed.

The strength of a diaphragm or shear wall depends on careful nailing of the plywood to the structural members. Plywood joints should be staggered to increase stiffness.

Richard J. Vitullo, AIA; Oak Leaf Studio; Crownsville, Maryland  
American Forest & Paper Association; Washington, D.C.

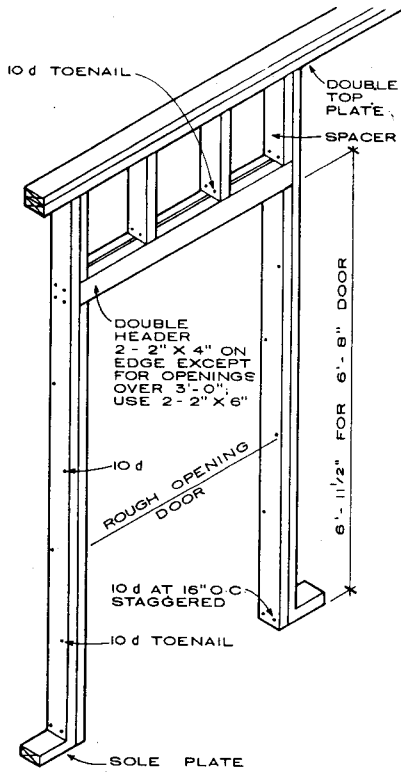

DOOR OPENING

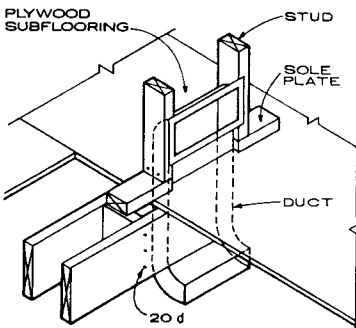

SMALL OPENING

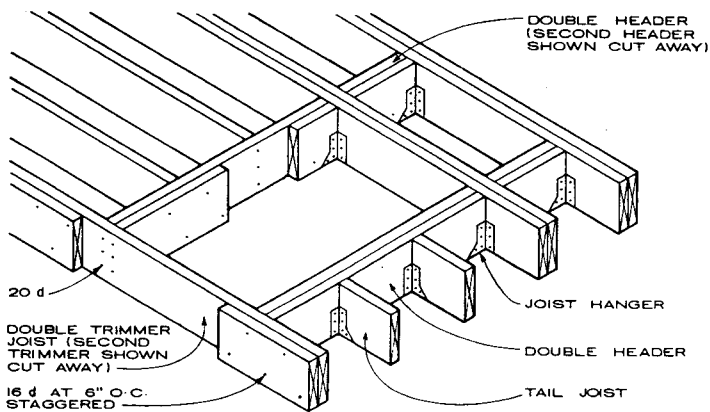

LARGE OPENING REMOVED FROM BEARING WALLS

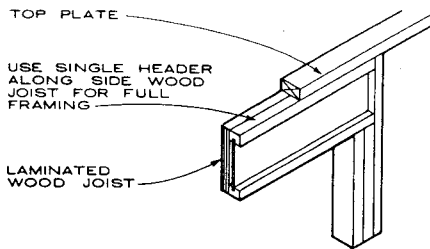

NOTE: DOUBLE TRIMMER REQUIRED FOR ADEQUATE BEARING ON OPENINGS LARGER THAN 9'-0".

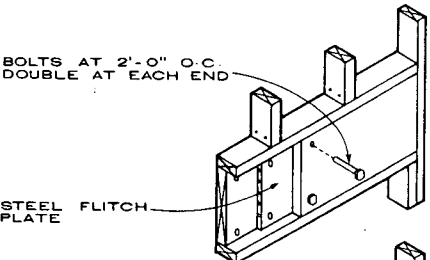
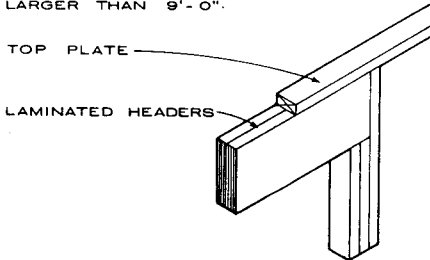

CHECK LOCAL CODE FOR USE OF STEEL CHANNEL

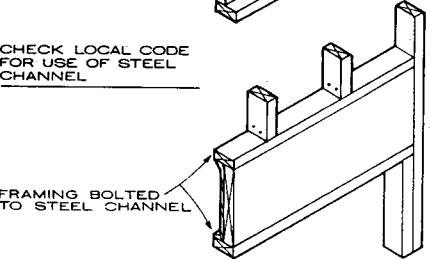

LINTELS FOR WIDE OPENINGS

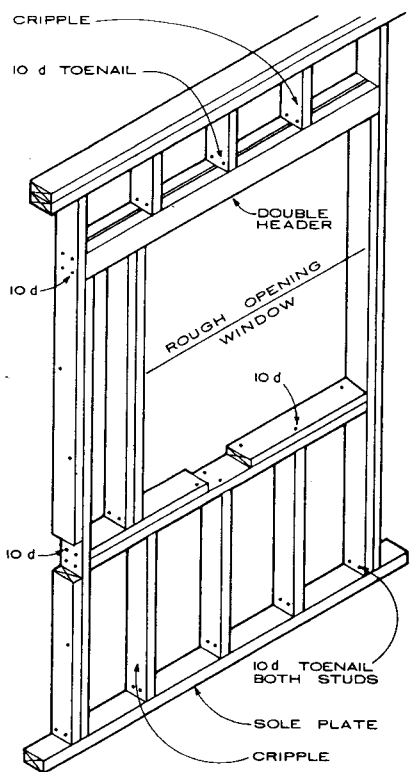

WINDOW OPENING

NOTES

1. Steel lintels are selected from steel beam design tables on the basis of floor, wall, and roof openings.
2. Wood lintels over openings in bearing walls may be engineered as beams.
3. Composite beams, such as glued laminated beams, also are appropriate in some applications. Plywood box beams are used for garage doors. Steel flitch plates can add strength without adding extra width to a composite beam.
4. Check with local codes and standards for fire resistance requirements.

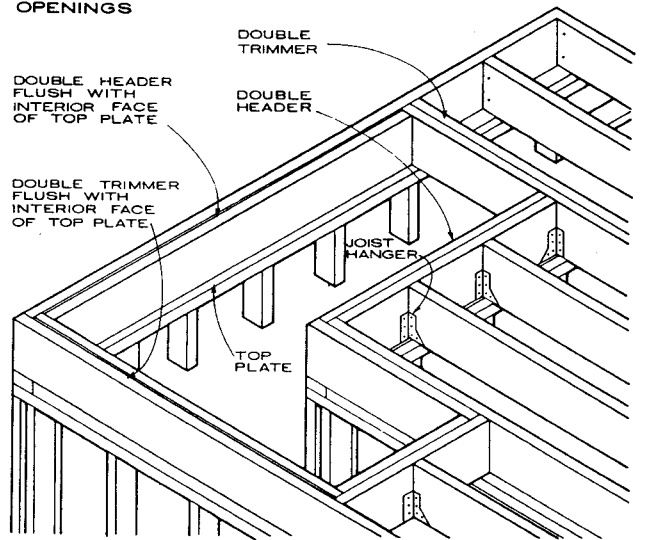

STAIR OPENING AT EXTERIOR WALL

Joseph A. Wilkes, FAIA; Wilkes and Faulkner; Washington, D.C.

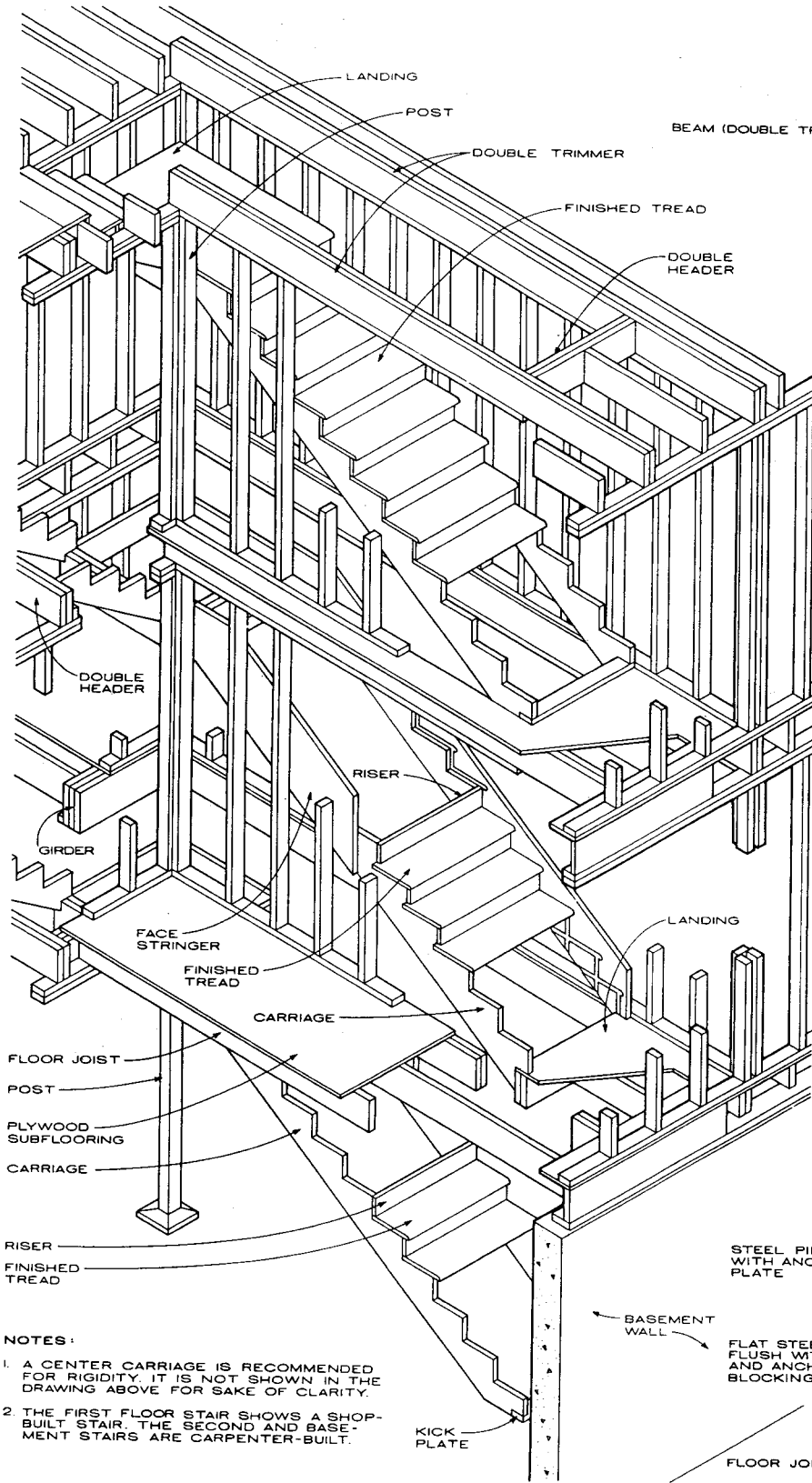

NOTES:

1. A CENTER CARRIAGE IS RECOMMENDED FOR RIGIDITY. IT IS NOT SHOWN IN THE DRAWING ABOVE FOR SAKE OF CLARITY.
2. THE FIRST FLOOR STAIR SHOWS A SHOP-BUILT STAIR. THE SECOND AND BASEMENT STAIRS ARE CARPENTER-BUILT.

STAIR FRAMING DETAIL

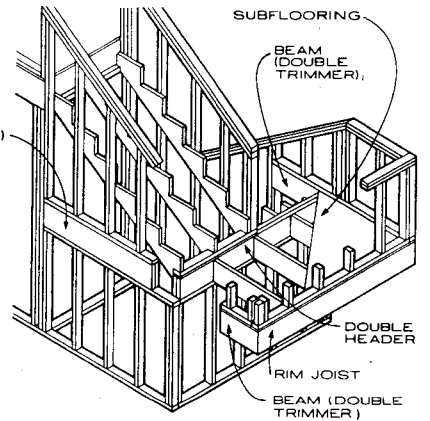

CANTILEVERED LANDING

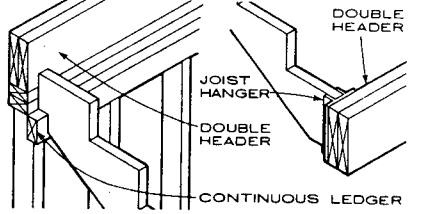
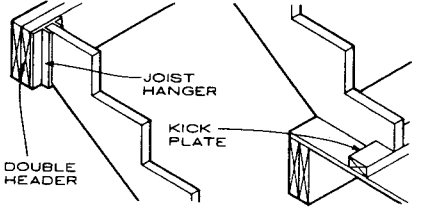
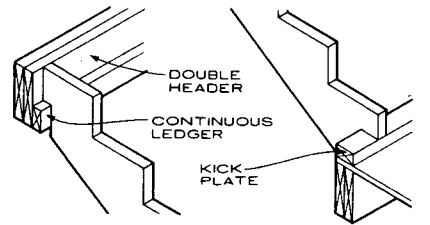

STAIR DETAILS

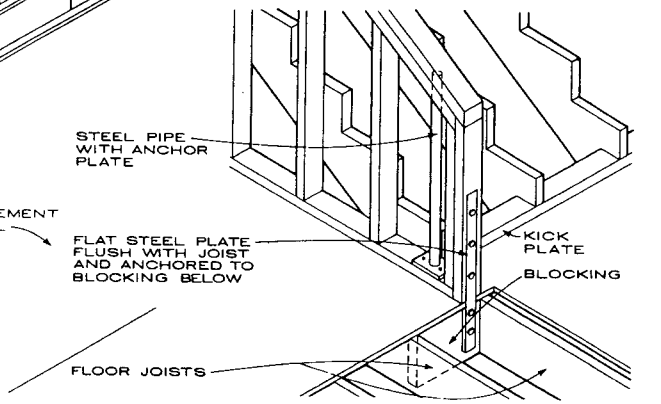

ANCHORS AT END OF SOLID RAIL

Timothy B. McDonald; Washington, D.C.

6 ROUGH CARPENTRY

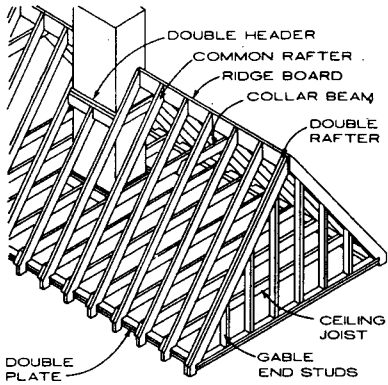

GABLE ROOF

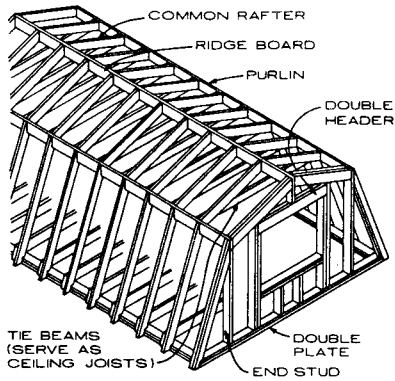

GAMBREL ROOF

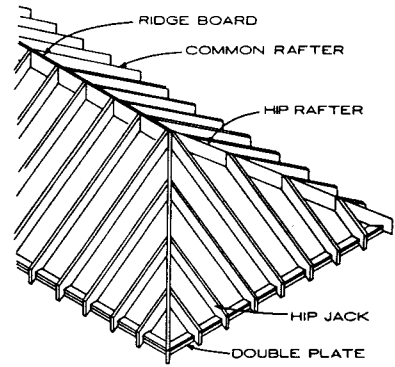

HIP ROOF

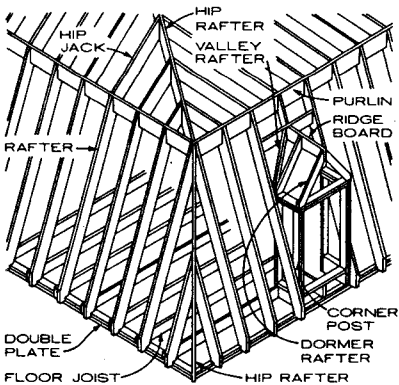

MANSARD ROOF

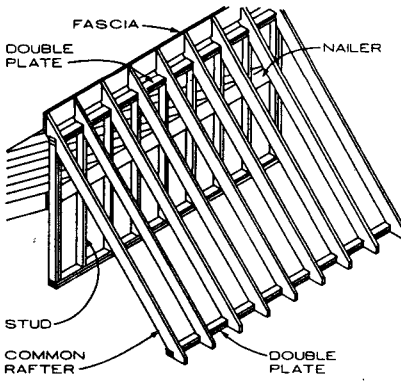

SHED ROOF

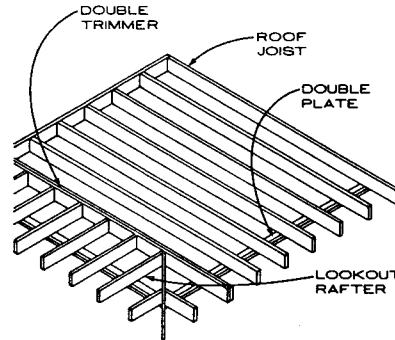

FLAT ROOF

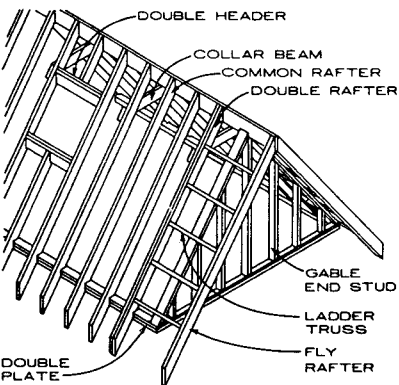

GABLE ROOF WITH OVERHANG

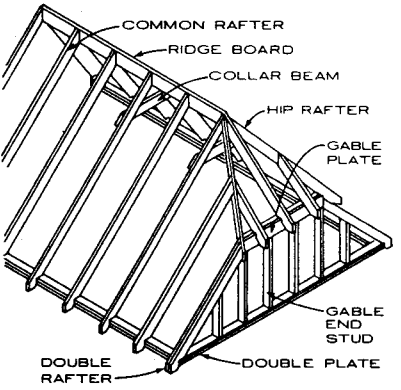

HIP GABLE ROOF

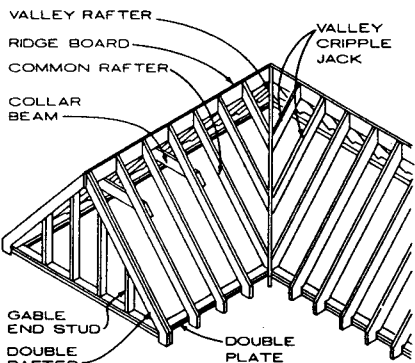

INTERSECTING ROOF

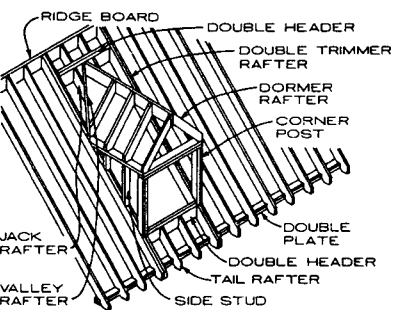

DORMER

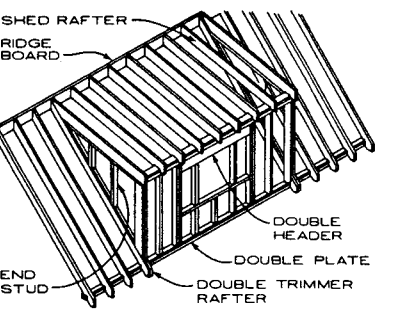

SMALL SHED DORMER

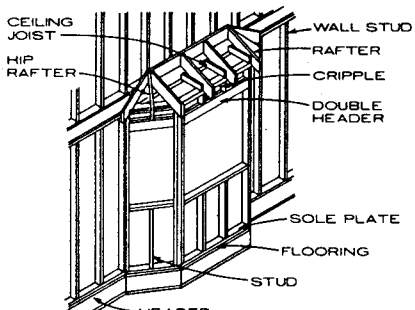

BAY WINDOW

Timothy B. McDonald; Washington, D.C.



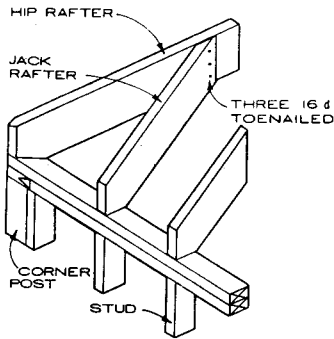

**JACK RAFTERS**  
NOTE: d = PENNY

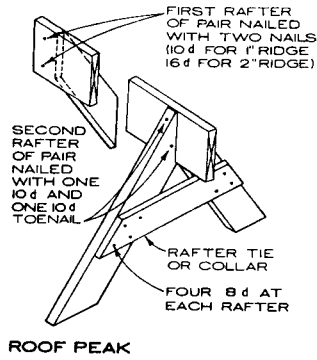

**ROOF PEAK**

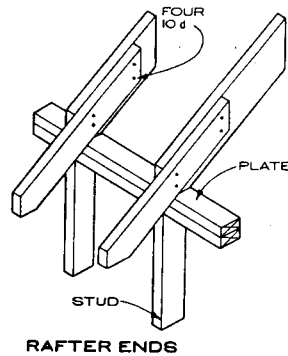

**RAFTER ENDS**

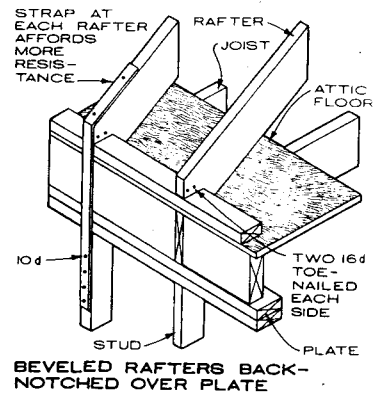

**BEVELED RAFTERS BACK-NOTCHED OVER PLATE**

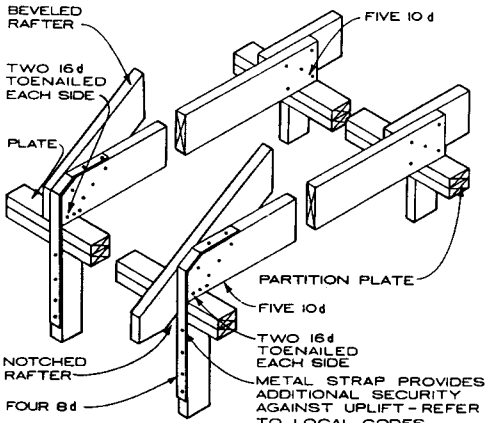

**RAFTERS AND CEILING JOISTS RESTING ON WALL PLATES**

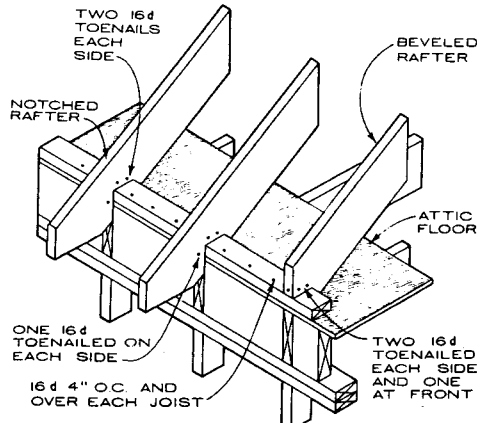

**NOTCHED OR BEVELED RAFTERS RESTING ON PLATE**

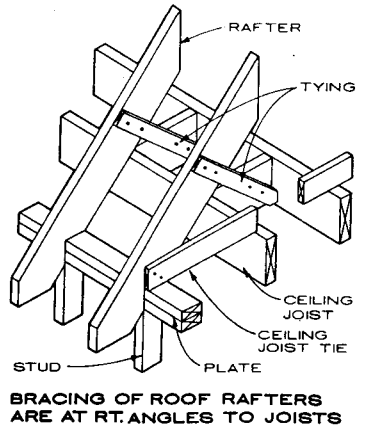

**BRACING OF ROOF RAFTERS ARE AT RT. ANGLES TO JOISTS**

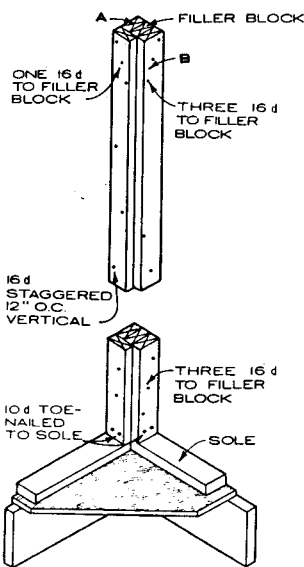

STUD A TO HAVE SAME NAILING TO FILLER BLOCK AS STUD B

**CORNER POST**

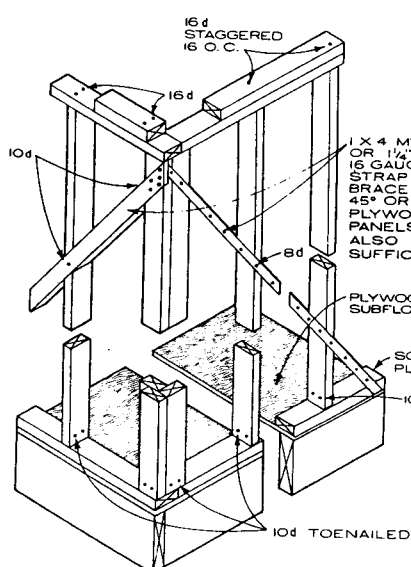

**TOP PLATE AND BRACING**

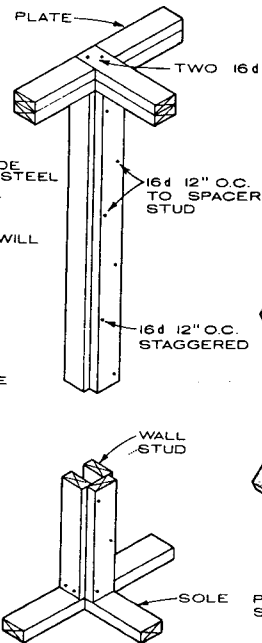

**PARTITION TO WALL CONNECTION**

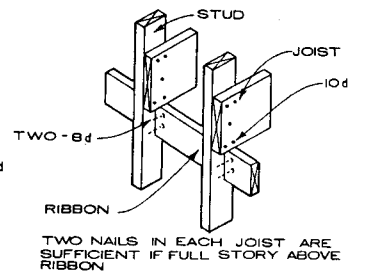

TWO NAILS IN EACH JOIST ARE SUFFICIENT IF FULL STORY ABOVE RIBBON

**JOISTS BEARING ON RIBBON**

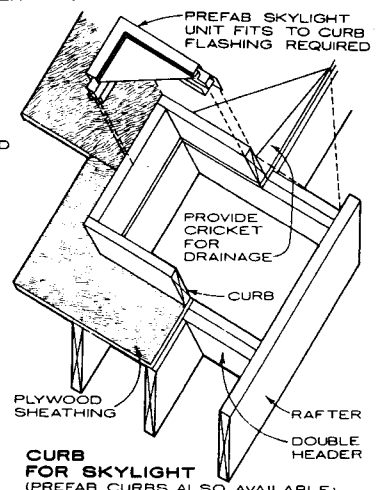

**CURB FOR SKYLIGHT (PREFAB CURBS ALSO AVAILABLE)**

Joseph A. Wilkes, FAIA; Wilkes and Faulkner; Washington, D.C.

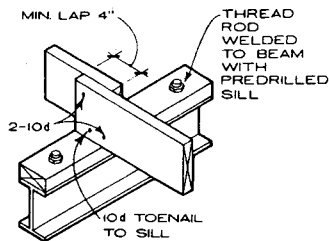

LAPPED OVER WOOD SILL

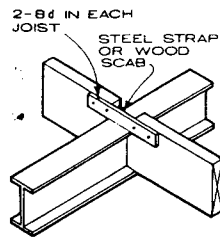

ON LOWER FLANGE

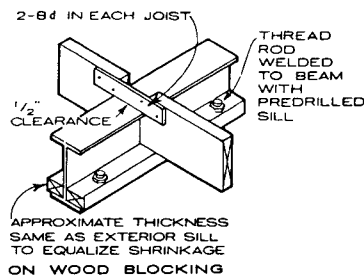

APPROXIMATE THICKNESS SAME AS EXTERIOR SILL TO EQUALIZE SHRINKAGE ON WOOD BLOCKING

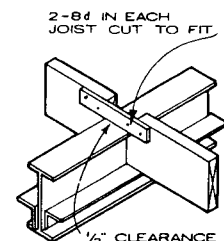

ON STEEL ANGLES

WOOD JOISTS SUPPORTED ON STEEL GIRDERS

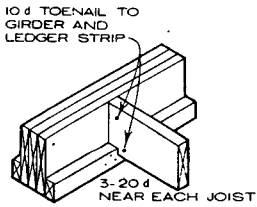

JOIST NOTCHED OVER LEDGER STRIP NOTCHING OVER BEARING NOT RECOMMENDED

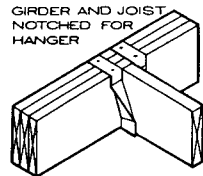

JOIST IN JOIST HANGER IRON ALSO CALLED STIRRUP OR BRIDLE IRON

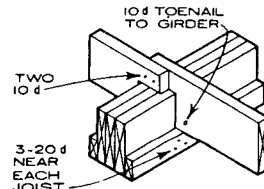

OVERLAPPING JOISTS NOTCHED OVER GIRDER BEARING ONLY ON LEDGER, NOT ON TOP OF GIRDER

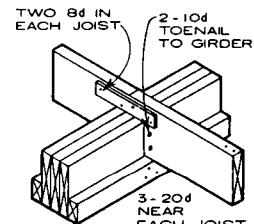

JOISTS NOTCHED OVER GIRDER BEARING ONLY ON LEDGER, NOT ON TOP OF GIRDER

WOOD JOISTS SUPPORTED ON WOOD GIRDERS

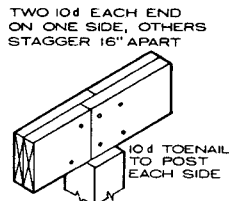

TWO PIECE GIRDER GIRDER JOINTS ONLY AT SUPPORTS STAGGER JOINTS

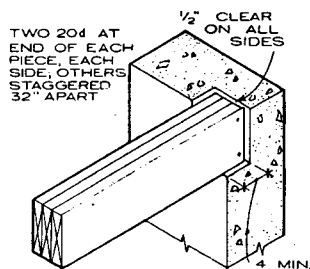

THREE PIECE GIRDER FOR FOUR PIECE GIRDER: ADD NAILS

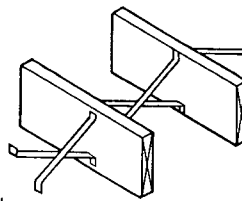

STEEL BRIDGING SOME HAVE BUILT-IN TEETH, NEEDS NO NAILS

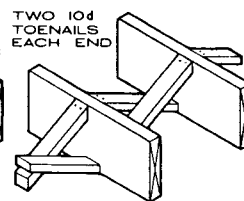

1" X 3" CROSS BRIDGING LOWER ENDS NOT NAILED UNTIL SUBFLOORING IS LAYED

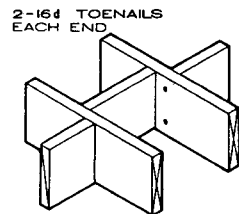

SOLID BRIDGING USED UNDER PARTITIONS FOR HEAVY LOADING STAGGER BOARDS FOR EASE OF NAILING

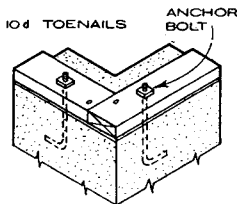

2 X 6 SILL

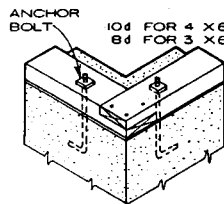

3 X 6, 4 X 6 SILL HALVED AT CORNERS

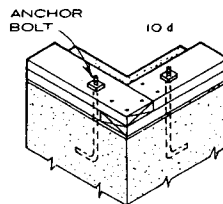

4 X 6 DOUBLE SILL NAILS STAGGERED ALONG SILL 24" ON CENTER

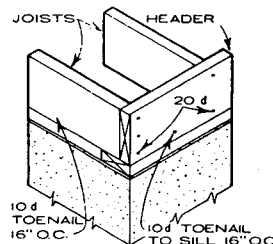

PLATFORM FRAMING TOENAIL TO SILL NOT REQUIRED IF DIAGONAL SHEATHING USED

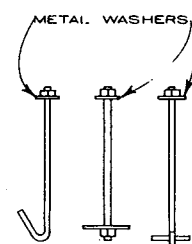

TYPES OF SILL ANCHOR BOLTS

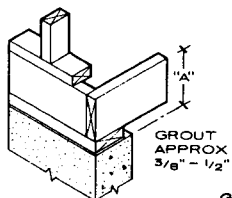

SHRINKAGE SELECT JOIST-GIRDER DETAIL THAT HAS APPROXIMATE SAME SHRINKAGE "A" AS THE SILL DETAIL USED

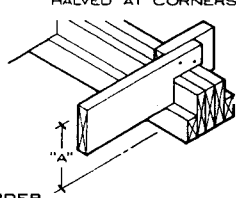

GIRDER

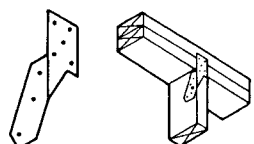

DU-AL-CLIP METAL FRAMING DEVICES

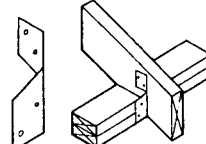

TY-DOWN ANCHOR

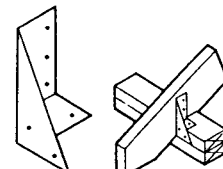

TRIP-L-GRIP 16-18 GAUGE ZINC COATED STEEL

Joseph A. Wilkes, FAIA; Wilkes and Faulkner; Washington, D.C.

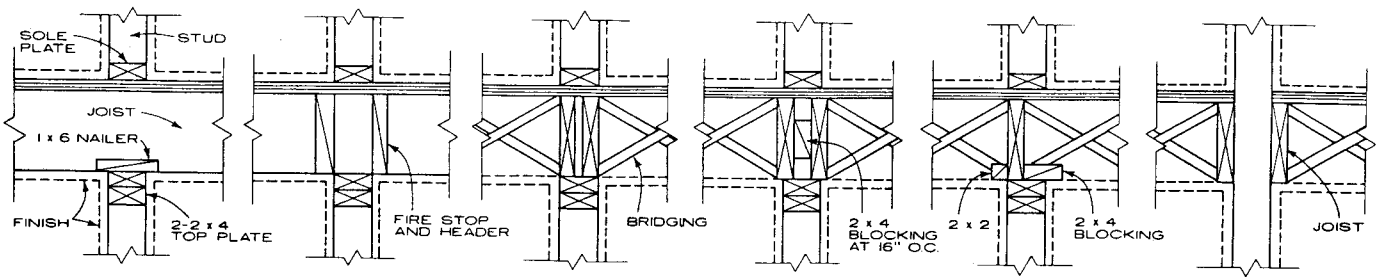

PARTITIONS PERPENDICULAR TO JOISTS      PARTITIONS PARALLEL TO JOISTS      BALLOON AND BRACED BEARING INTERIOR PARTITIONS

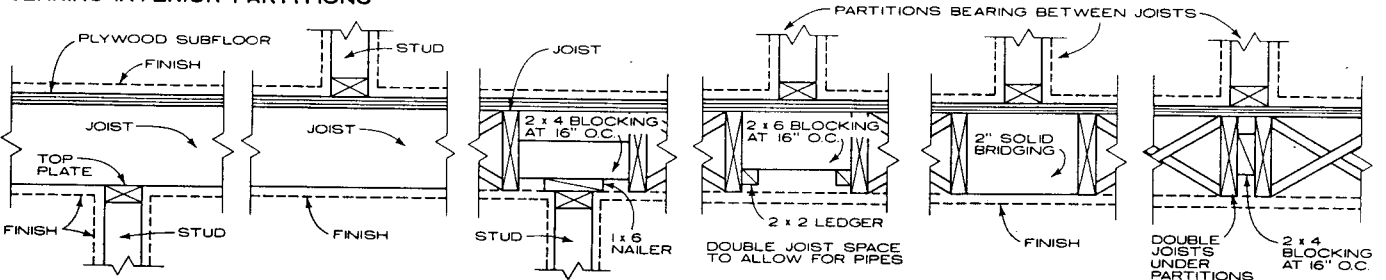

NO PARTITION ABOVE      NO PARTITION BELOW      NO PARTITION ABOVE      NO PARTITION BELOW  
PARTITIONS PERPENDICULAR TO JOISTS      PARTITIONS PARALLEL TO JOISTS

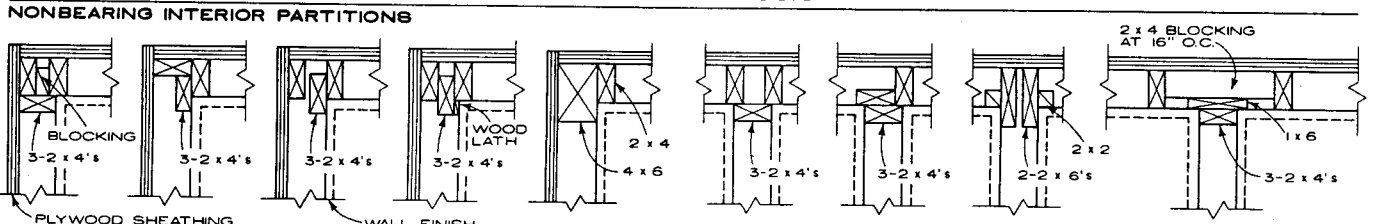

PLANS OF OUTSIDE CORNERS      PLANS OF INTERSECTING PARTITIONS

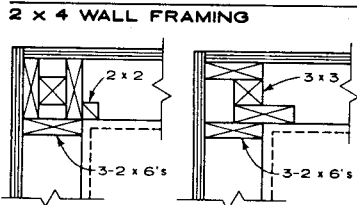

2 x 4 WALL FRAMING  
PLAN  
2 x 6 CORNER WALL FRAMING

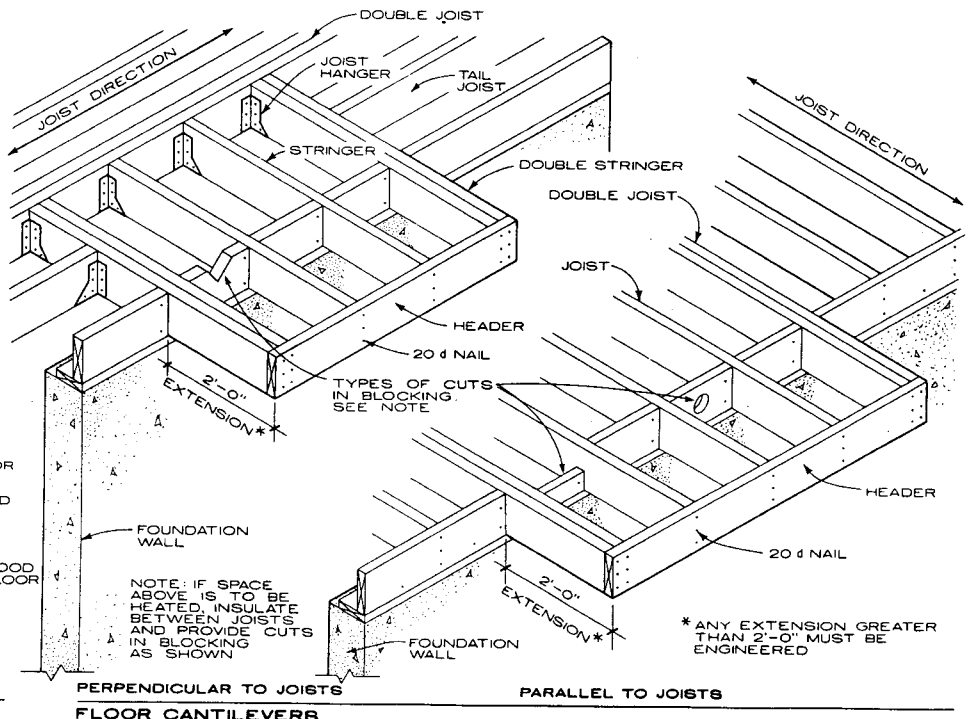
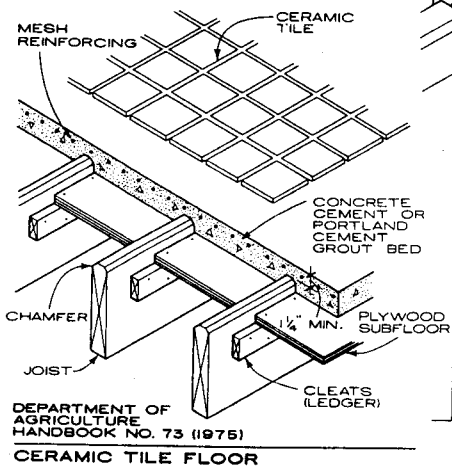

John Ray Hoke, Jr., FAIA; Washington D.C.

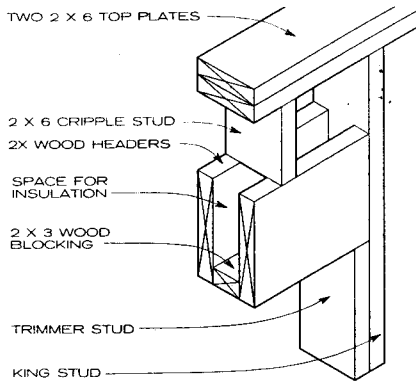

**2X6 BEARING WALL—HEADER DETAIL**

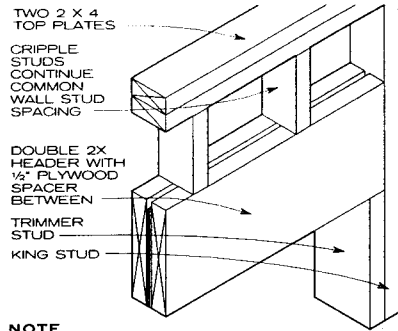
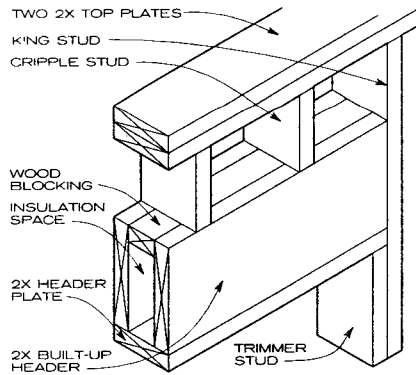

**2X4 BEARING WALL—HEADER DETAIL**

**2X4 BEARING WALL—HEADER DETAIL**

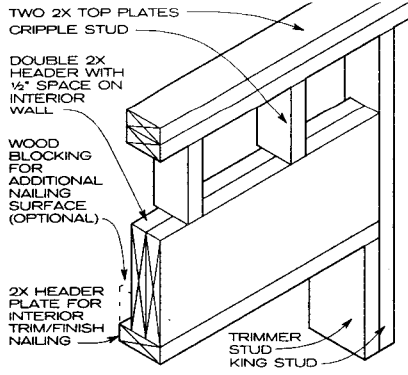

**2X BEARING WALL—HEADER DETAIL**

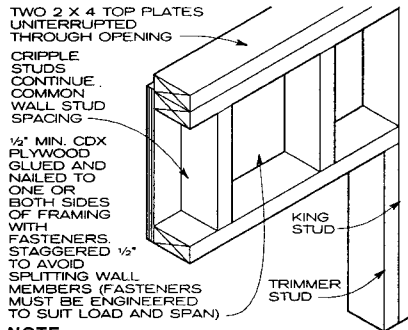

**NOTE**  
Interior plywood face must be smooth for finishing with gypsum board.

**2X4 BEARING WALL—OPEN BOX PLYWOOD—HEADER DETAIL**

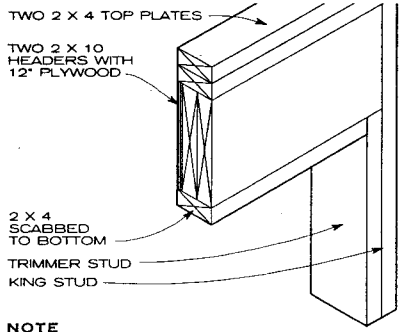

**NOTE**  
This detail eliminates cripple studs above opening.

**2X BEARING WALL—HEADER DETAIL**

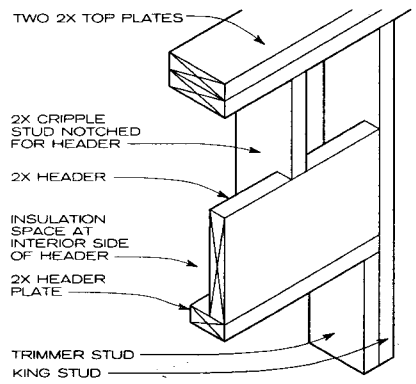

**2X BEARING WALL—HEADER DETAIL**

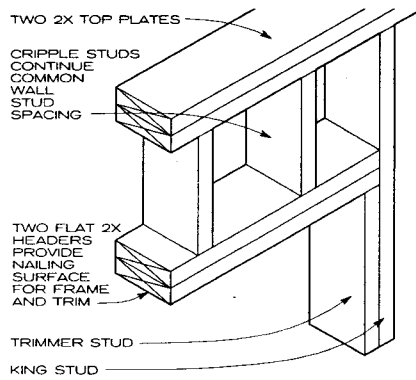

**2X PARTITION WALL—HEADER DETAIL**

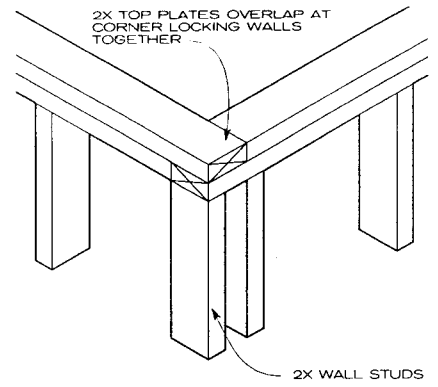

**TOP PLATE FRAMING DETAIL**

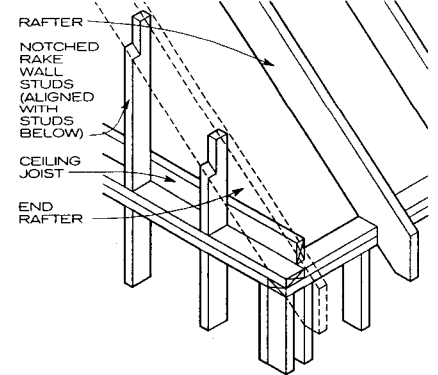

**RAKE WALL DETAIL—PLATFORM FRAMING**

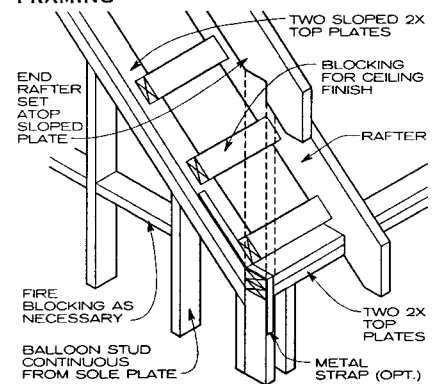

**RAKE WALL DETAIL—BALLOON FRAMING**

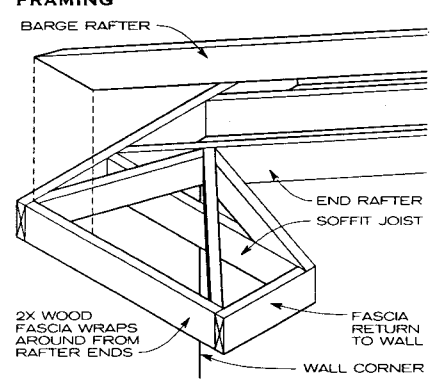

**GREEK RETURN**

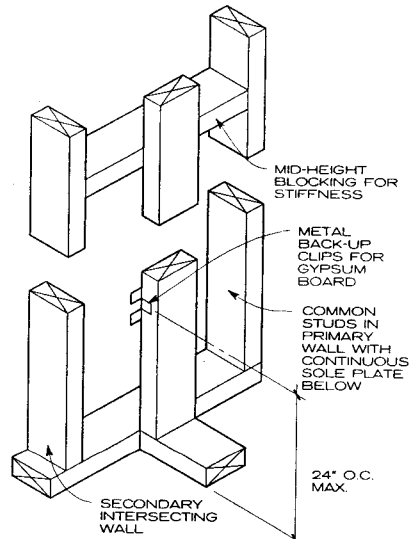

INTERSECTING WALLS WITH METAL GYPSUM BOARD CLIPS

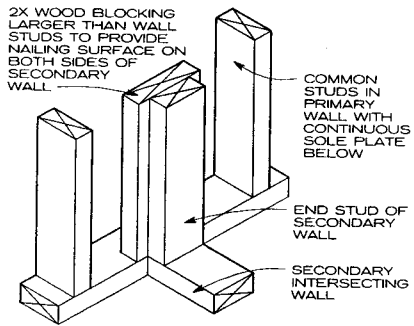

INTERSECTING WALLS WITH BLOCKING

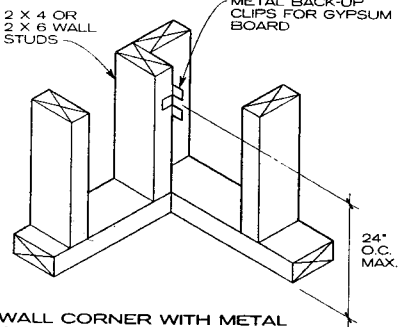

WALL CORNER WITH METAL GYPSUM BOARD CLIPS

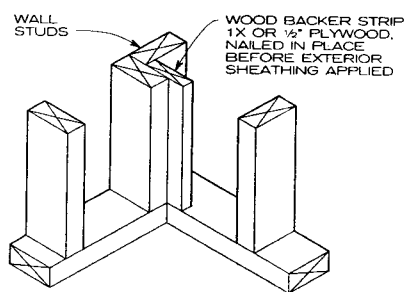

CORNER BLOCKING DETAIL  
INSULATED WALL DETAILS

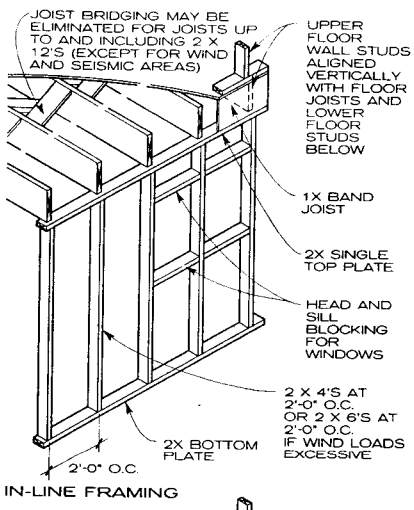

IN-LINE FRAMING

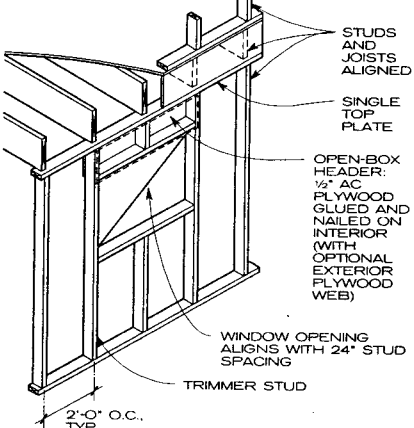

IN-LINE FRAMING WITH WIDE OPENING

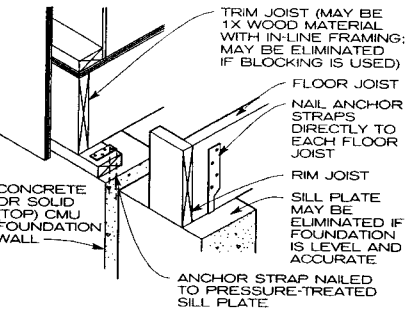

REDUCED SILL PLATE AND RIM JOIST DETAILS

**NOTES**

1. Some framing details rely on techniques that reduce the amount of lumber in wood construction. Among these are in-line framing details and corner details with metal framing clips for gypsum board. These types of details were developed to conserve wood resources, reduce material cost and job-site waste, and enhance energy efficiency by reducing thermal bridging across wall systems and increasing insulation cavities. When wood levels are to be reduced, a structural engineer should first be consulted.
2. Gypsum board installed at inside corners with metal clips or wood backers does not get fastened to either. The sheet resting against the backer or clips is installed first so the second sheet (which is nailed to the stud) will lock the first sheet in place. The "floating joint" that results is recommended to reduce cracks in the corner.

REDUCED WOOD FRAMING DETAILS

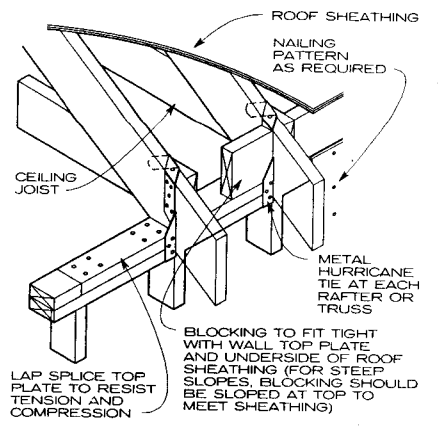
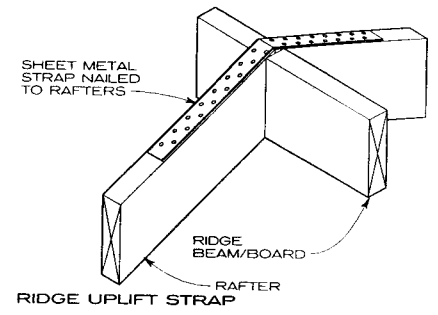

ROOF DIAPHRAGM PERIMETER

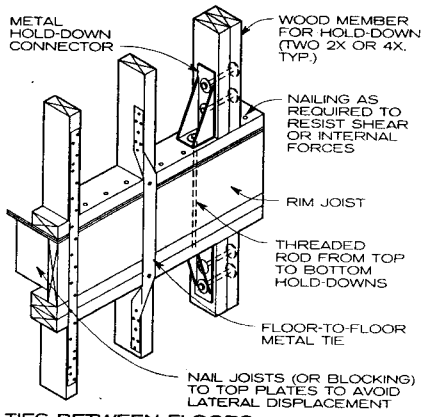

TIES BETWEEN FLOORS

**NOTE**

It is essential to provide a continuous path of resistance from roof to foundation in order to dissipate both lateral and uplift forces. Connections along this load path will guarantee uninterrupted resistance. Seismic and wind forces are transferred from the roof diaphragm to shear walls and through the walls into the ground at the foundation. Shear walls resist horizontal forces in the roof and floor diaphragms and so must be connected to them. It is important to apply wall sheathing to the full wall height, nailing it to the top plate, blocking, or rim joist and also to the mud sill or bottom plate. Shear wall height/width ratios are an important consideration; consult a structural engineer for their design. The details illustrated show several connection paths; for each specific design, a structural engineer familiar with seismic and wind resistant construction should be consulted. Many of the requirements for high wind situations apply to seismic loading as well, except in shear wall design.

Ties between floors: Wood members (studs) must be sized for the load-carrying capacity at the critical net section.

**WIND AND SEISMIC CONNECTOR FRAMING**

Richard J. Vitullo, AIA; Oak Leaf Studio; Crownsville, Maryland

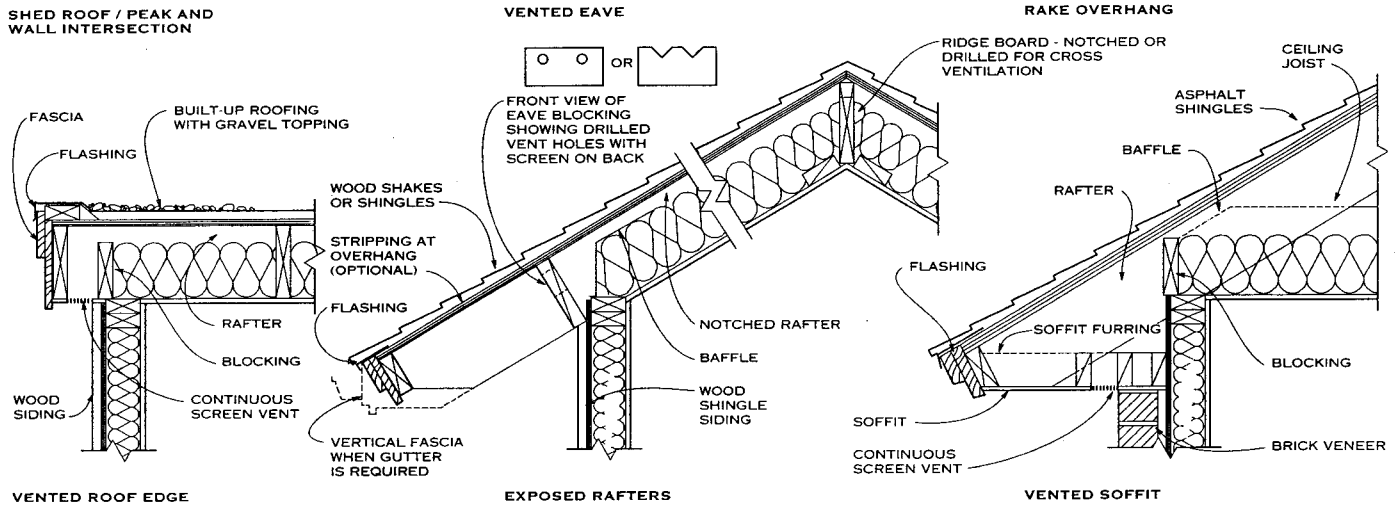
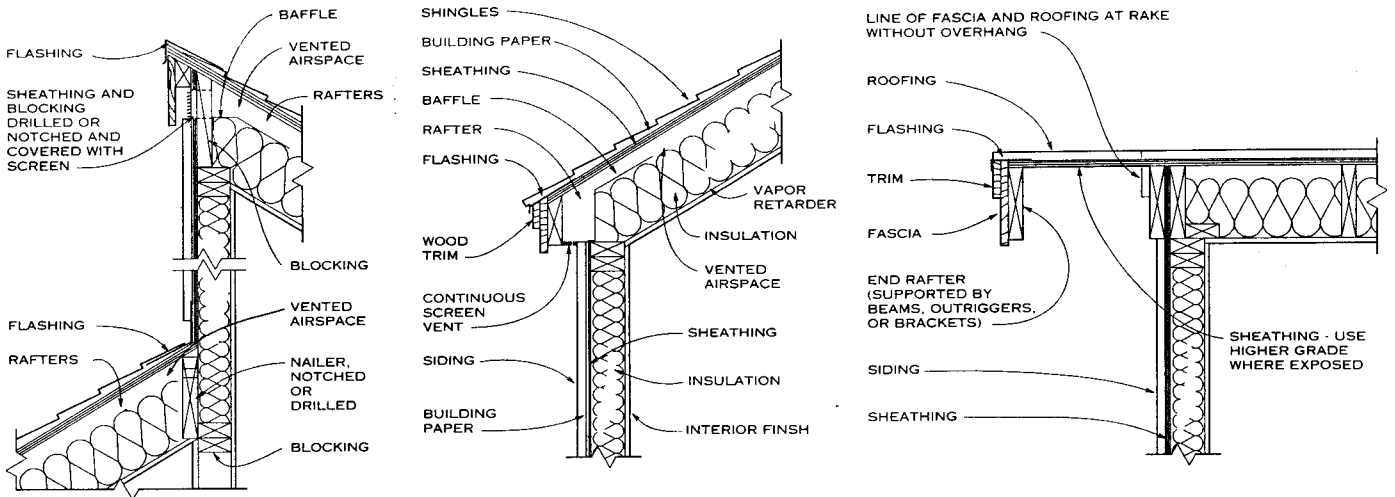

EAVE AND OVERHANG SECTIONS

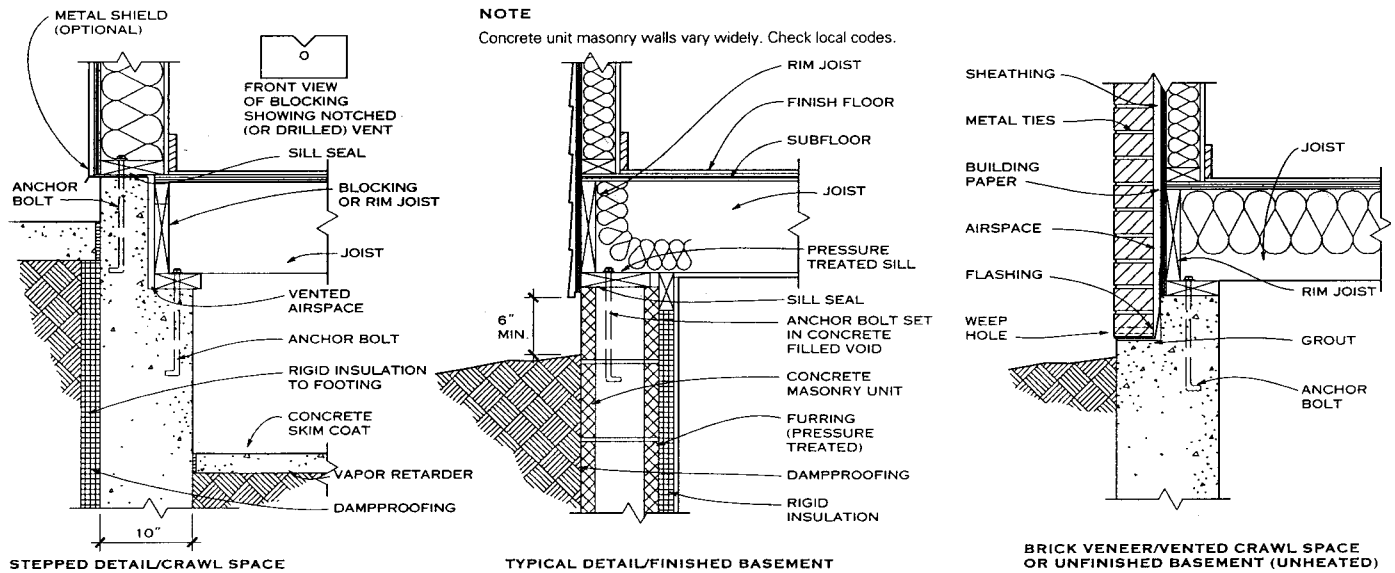

FOUNDATION WALL SECTIONS

Ted Cameron, AIA; The Bumgardner Architects; Seattle, Washington

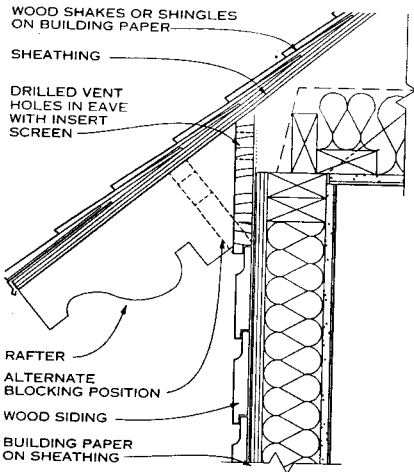

EXPOSED RAFTER END

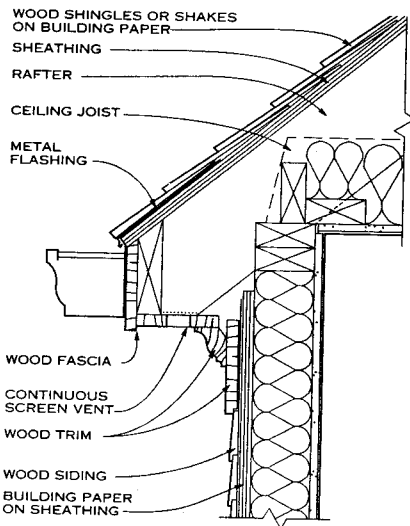

EAVE AT WOOD SIDING

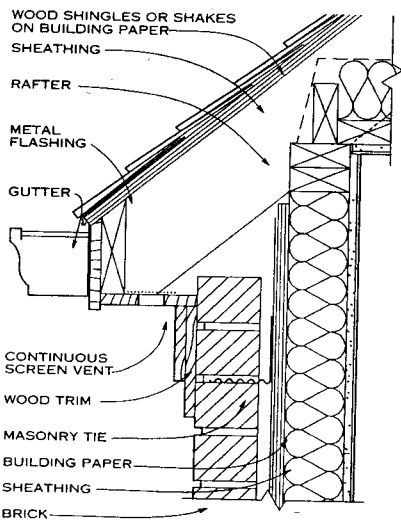

EAVE AT BRICK VENEER

**NOTE**  
An eave is the lower edge of a sloping roof that projects past the face of the wall below. An overhang is a more general term for any projection out from a wall, sloping or flat. Both protect the wall below from precipitation by either throwing

the water away from the wall (and foundation) or directing it into gutters and downspouts. Both also provide protection and shading for openings below.

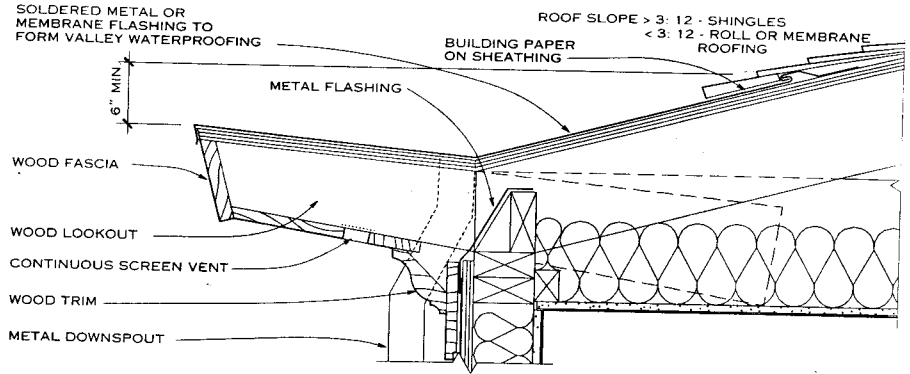

REVERSE SLOPE OVERHANG

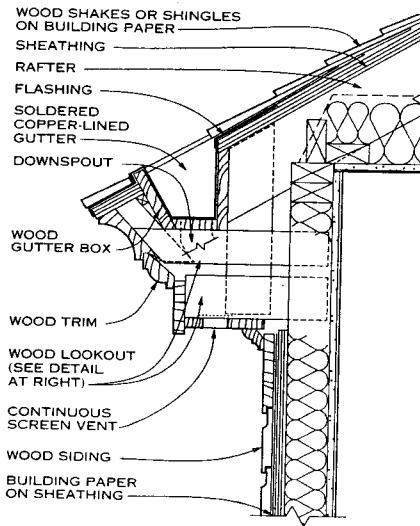

EAVE WITH BUILT-IN GUTTER

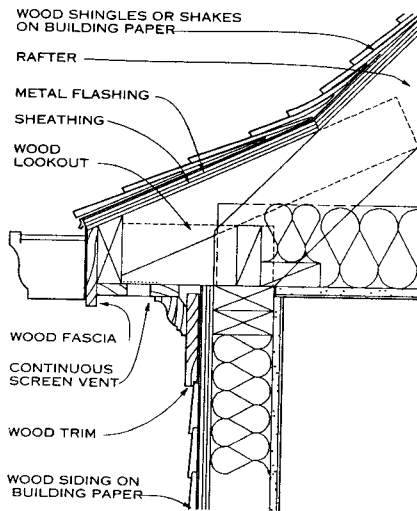

PROJECTED EAVE WITH SHALLOW SLOPE

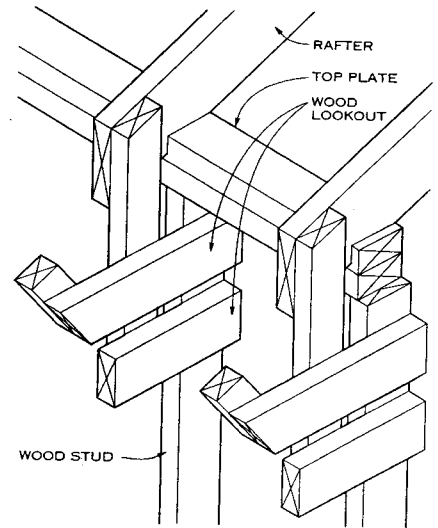

CORNICE SUPPORT DETAIL

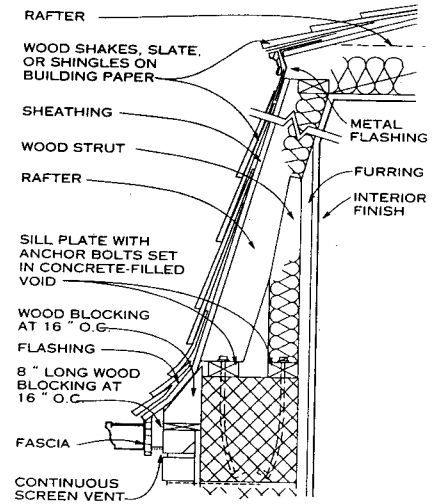

MANSARD ROOF

Richard J. Vitullo, AIA; Oak Leaf Studio; Crownsville, Maryland

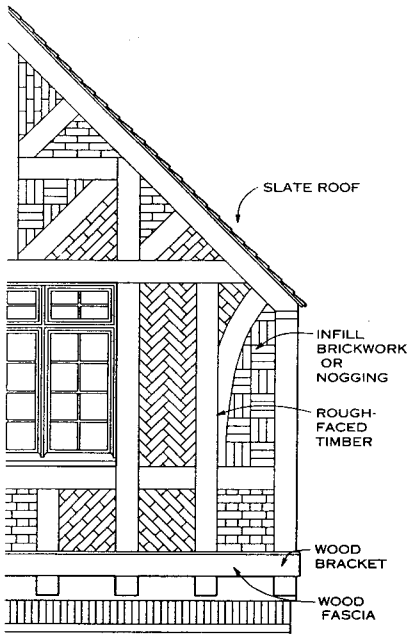

**GENERAL**

In the 16th and 17th centuries half timber structures were built with strong timber foundations, supports, and studs. The spaces between the framework were filled in with either stone, brick, plaster, or boarding laid horizontally. Today the primary structure is wood stud or masonry backup, and the half timber construction is attached as veneer. Half timber is an inherently leaky type of wall construction in which the timbers are subject to premature decay.

**NOTE**

Shown are some of many brick infill panel design types.

**ELEVATION - BRICK AND TIMBER**

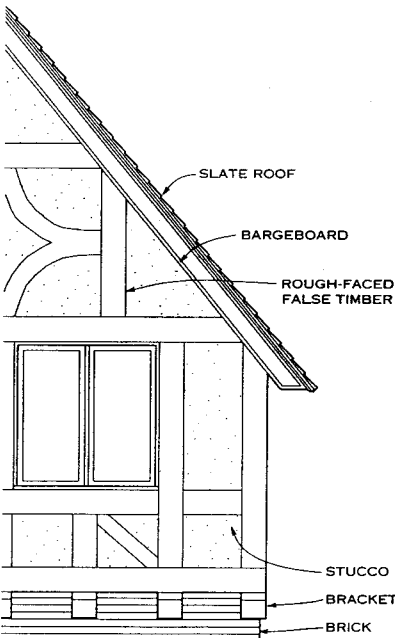

**NOTE**

To preserve historical character of half-timber construction a ridge vent is recommended for attic venting.

**ELEVATION - STUCCO AND TIMBER**

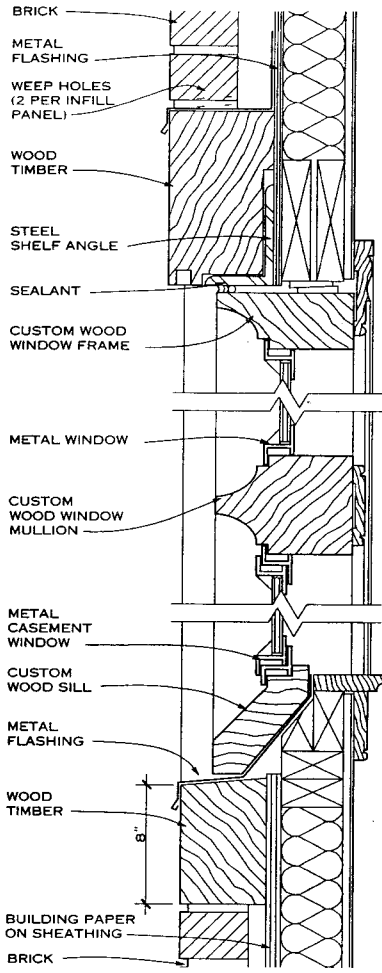

**WINDOWSILL DETAIL**

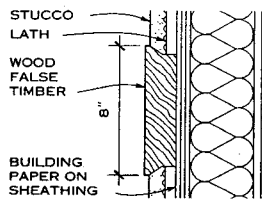

**FALSE TIMBER DETAIL**

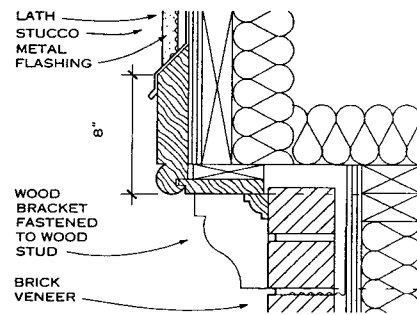

**OVERHANG DETAIL**

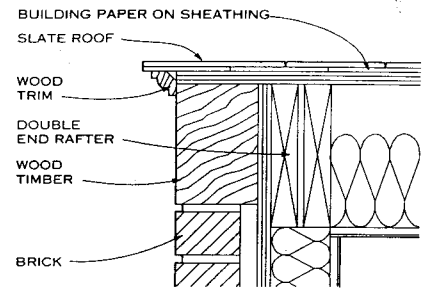

**GABLE EDGE DETAIL**

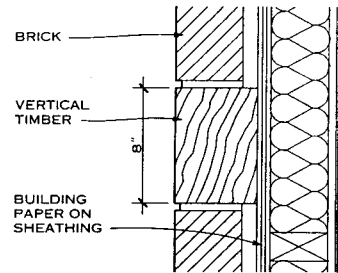

**TIMBER DETAIL**

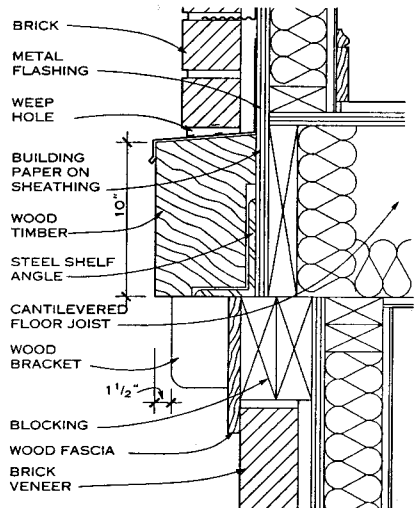

**TIMBER SHELF DETAIL**

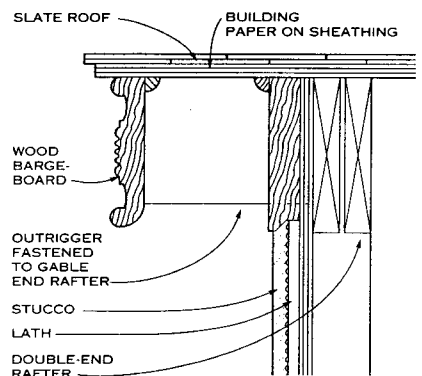

**BARGEBOARD DETAIL**

Richard J. Vitullo, AIA; Oak Leaf Studio; Crownsville, Maryland



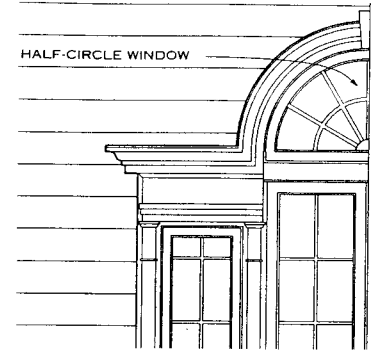
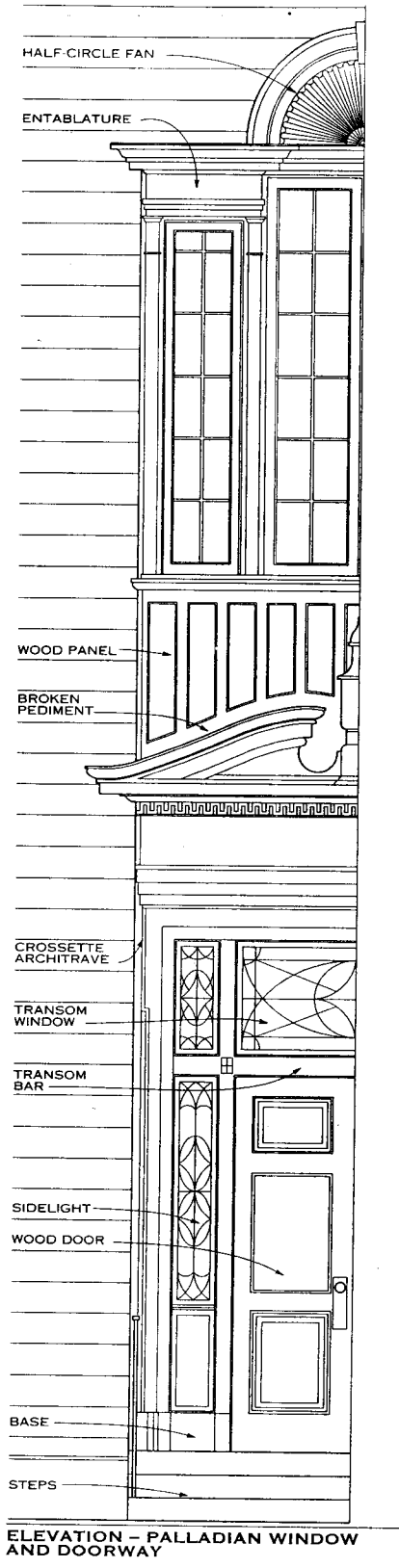

ALTERNATE ELEVATION - HALF-CIRCLE WINDOW

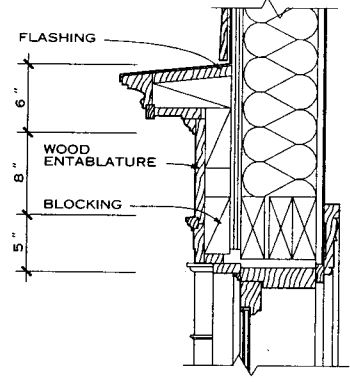

ENTABLATURE SECTION

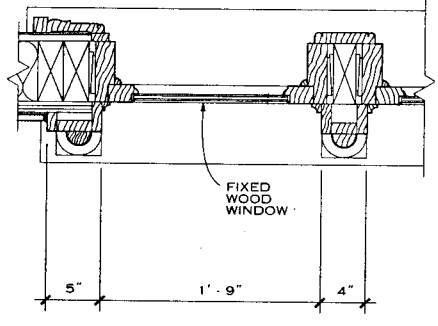

WINDOW PLAN

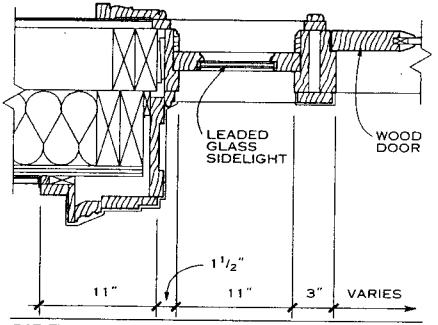

SIDELIGHT AND ENTRANCE DOOR PLAN

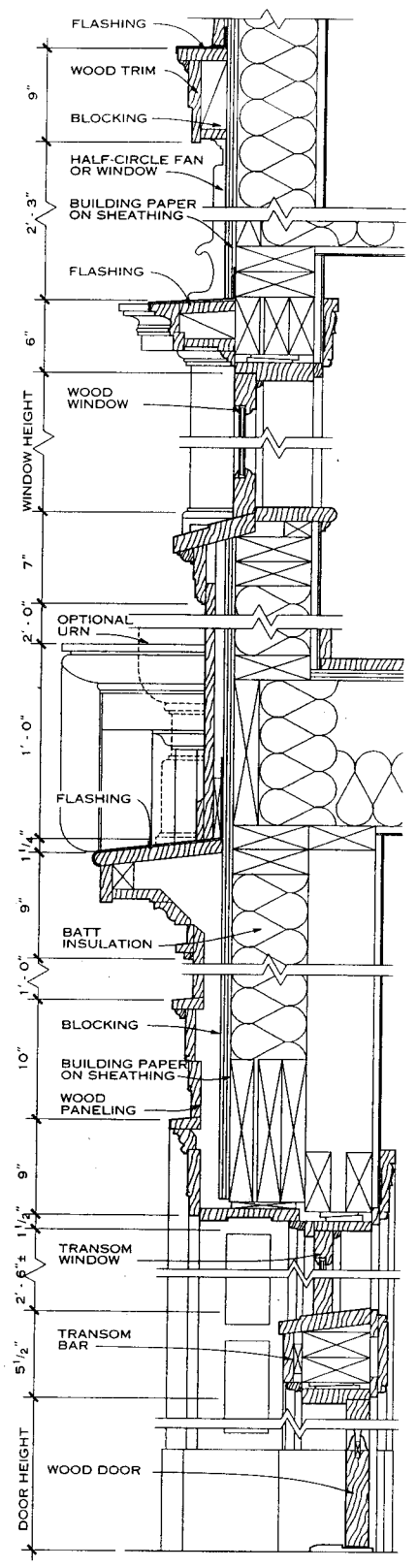

VERTICAL SECTION

Richard J. Vitullo, AIA; Oak Leaf Studio; Crownsville, Maryland

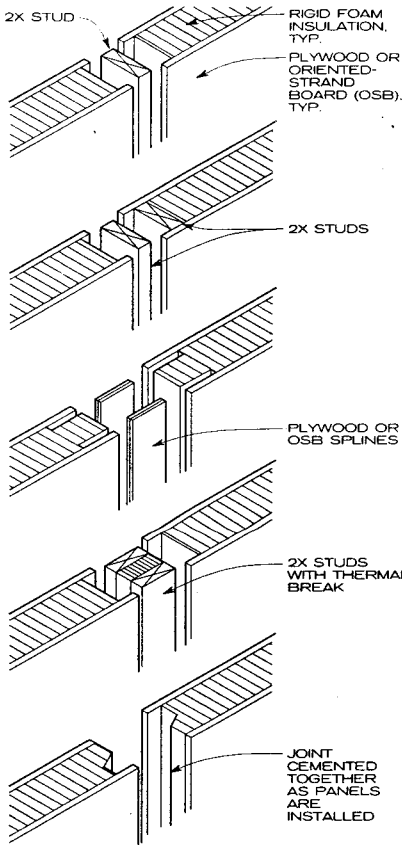

**NOTE**  
Studs and splines are screwed (and usually glued) to panels from both sides. Consult manufacturer's specifications. Joints are typically sealed with expanding foam.

**TYPICAL INTERMEDIATE PANEL SPLINE DETAILS**

**GENERAL**

Structural building panels are factory-assembled composite panels ready for installation as a complete structural and/or insulating wall section. The material of each component of the panel system is very important when selecting a panel manufacturer. Components include the skin, foam core, adhesive, and optional exterior or interior finish. The application for which the panel is intended determines the materials used. Consult manufacturers for specifications.

Sizes vary from 4 by 8 ft panels weighing about 100 lb to 8 by 28 ft panels that must be installed using a crane.

**PANEL TYPES**

There are two main types of structural building panels—stress-skin panels and foam core panels:

**STRESS-SKIN PANELS** are manufactured by gluing and nailing plywood skins to both sides of a wood frame, resulting in a unit that performs like an I-beam. Stress-skin panels are not necessarily insulated.

**STRUCTURAL FOAM CORE PANELS** fall into two groups: sandwich panels and unfaced panels. Sandwich panels are rigid-foam panels faced with two structural-grade skins, usually made of oriented-strand board (OSB) or plywood. Depending on the application and the manufacturer, these foam core panels may or may not include framing members within the core. Unfaced structural foam core panels look like panels of stick-framing with rigid foam between the members instead of fiberglass batt insulation. Interior and exterior finishes are applied to these panels in the field.

The skins of structural building panels (like I-beam flanges) resist tension and compression, while the wood frame or core (like an I-beam web) resists shear and prevents buckling of the skins.

Richard J. Vitullo, AIA; Oak Leaf Studio; Crownsville, Maryland

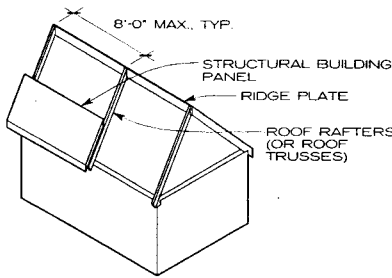

**ROOF FRAMING WITH RAFTERS AND TRUSSES**

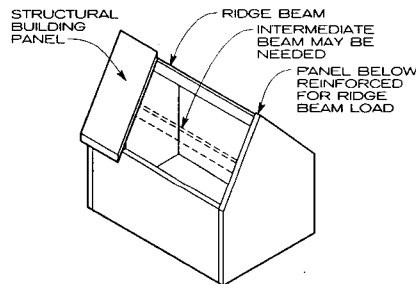

**ROOF FRAMING WITH RIDGE BEAM**

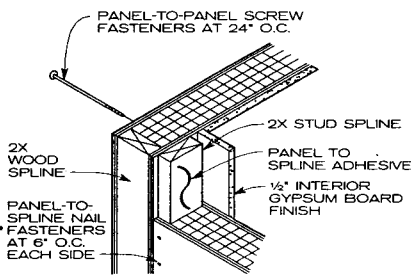

**TYPICAL CORNER DETAIL**

All structural foam core panels are insulated with a core of expanded polystyrene (EPS), extruded polystyrene, or urethane foam, from 3 1/2 to 11 1/4 in. thick. Urethane panels are either glue-laminated like polystyrene or foamed in place (either in the factory or in the field). Urethane has an R-value of 6 or 7 per inch versus R-5 for extruded polystyrene and R-4 for EPS foam. Urethane is about twice as strong in compression as polystyrene and has a perm rating of less than one, which technically qualifies it as a vapor barrier. EPS has a perm rating of from 1 to 3 and may require a vapor barrier. EPS, however, is inert, nontoxic (if ingested), and resilient; it doesn't feed microorganisms and is generally cheaper than urethane. Consult manufacturers on CFC and formaldehyde content in the foam core and skin material as it varies among manufacturers. Regarding flammability of both foam core types, consult with the manufacturer about the individual product.

**APPLICATIONS**

In above-grade applications, the most common materials for exterior facings are plywood OSB or finish materials like T-111 plywood, tongue-and-groove pine, and other wood siding material. For below-grade situations, pressure-treated plywood skins and splines are used. Generally, structural building panels should not be used for plumbing walls, as the spaces needed for plumbing runs would compromise the insulation and structural integrity of the panel.

For roof applications it is best to use a vented structural foam panel, either integral or field-installed. Many asphalt-shingle manufacturers will not warrant their product when it is installed on unvented panels because of overheating, which accelerates deterioration.

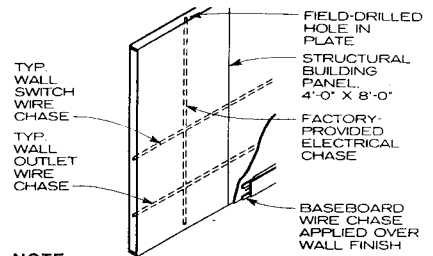

**NOTE**  
Consult local codes for all electrical installations.

**TYPICAL WIRE CHASE LOCATIONS IN PANELS**

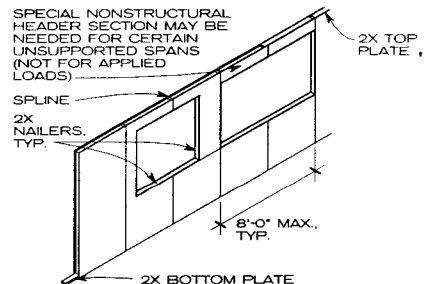

**TYPICAL WINDOW DETAILS**

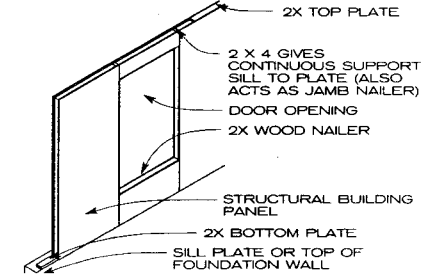

**TYPICAL REINFORCED DOOR OPENING DETAIL**

**CHARACTERISTICS**

Using structural building panels generally enhances the speed of construction because the panels replace three different steps in standard construction: framing, sheathing, and insulation. Panel systems offer superior energy performance compared to a stick-frame house of similar cost and standard of construction. This is largely because the rigid insulation has higher R-values, there are fewer seams to seal, and conductive heat is not lost through air infiltration around the framing. Structural building panels also offer good resistance to lateral loads.

Panels can be susceptible to infestation by insects such as carpenter ants and termites, which eat through wood and tunnel through the foam core material, reducing insulation value and even compromising structural integrity. Use of termite shields, foam cores treated with insect repellent, and other strategies should be considered.

**NOTES**

1. Since structural building panels are a relatively new building system, code officials should be consulted early and often to prevent any misunderstandings or delays in the code approval process. Also, check with manufacturers to determine whether their product has received compliance approval with BOCA, ICBO, SBCCI, or HUD.
2. The seams are the part of a structural building panel system most prone to infiltration and weakness and most likely to show the results of expansion and contraction. Tight spline connections with sealant at all edges—top, bottom, and sides—can greatly increase thermal efficiency.

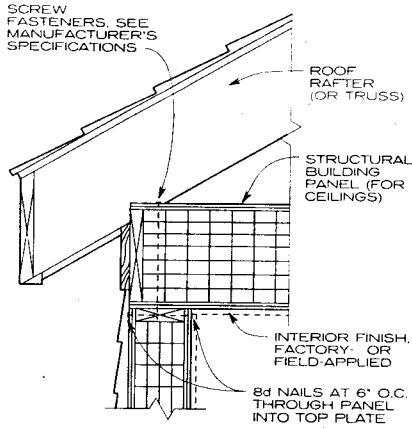

**ROOF EAVE DETAIL WITH PANEL CEILING**

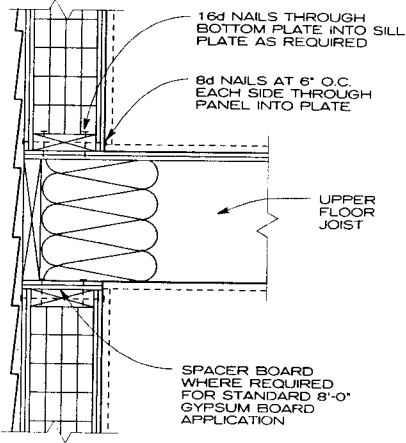

**ROOF EAVE DETAIL WITH SLOPED CEILING**

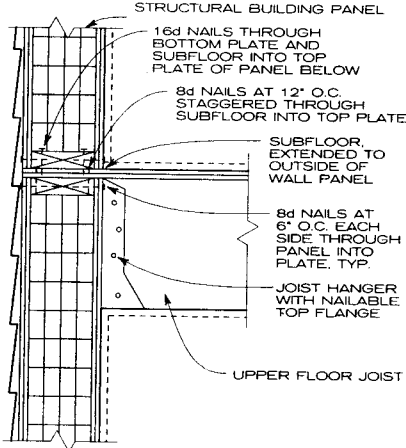

**PANEL AT RIDGE CONNECTION**

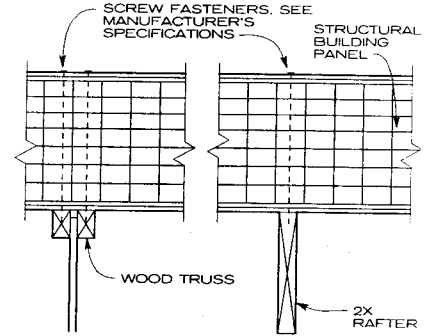

**CONTINUOUS PANEL DETAIL AT ROOF**

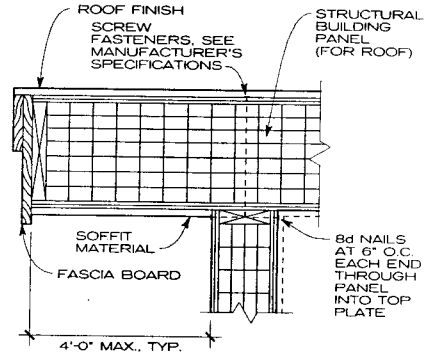

**PANEL AT UPPER FLOOR CONNECTION WITH FLOOR JOIST BETWEEN**

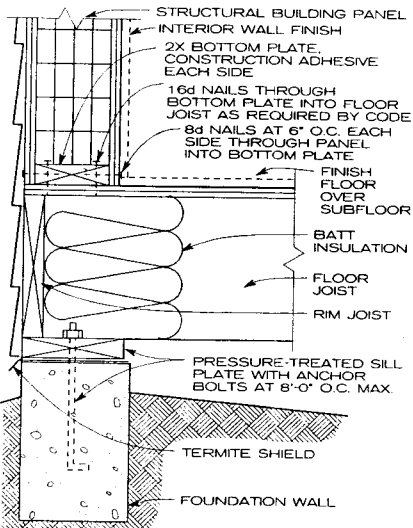

**PANEL AT UPPER FLOOR CONNECTION WITH FLOOR JOIST ADJACENT**

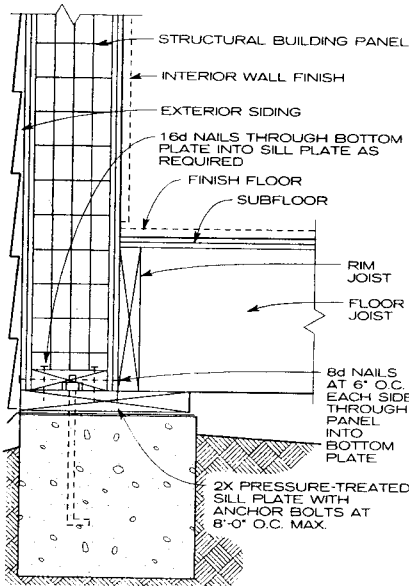

**GABLE END OVERHANG AT ROOF PANEL DETAIL**

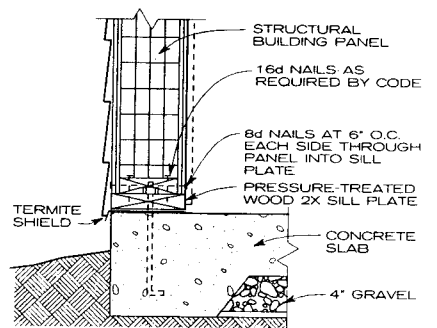

**NOTE**

Check perm rating of foam core insulation to determine whether additional vapor barrier is required. Consult local codes.

**PANEL AT SILL WITH FLOOR JOIST BELOW CONNECTION**

**PANEL AT SILL CONNECTION WITH FLOOR JOIST ADJACENT**



**PANEL AT SILL ON SLAB-ON-GRADE**

Richard J. Vitullo, AIA; Oak Leaf Studio; Crownsville, Maryland

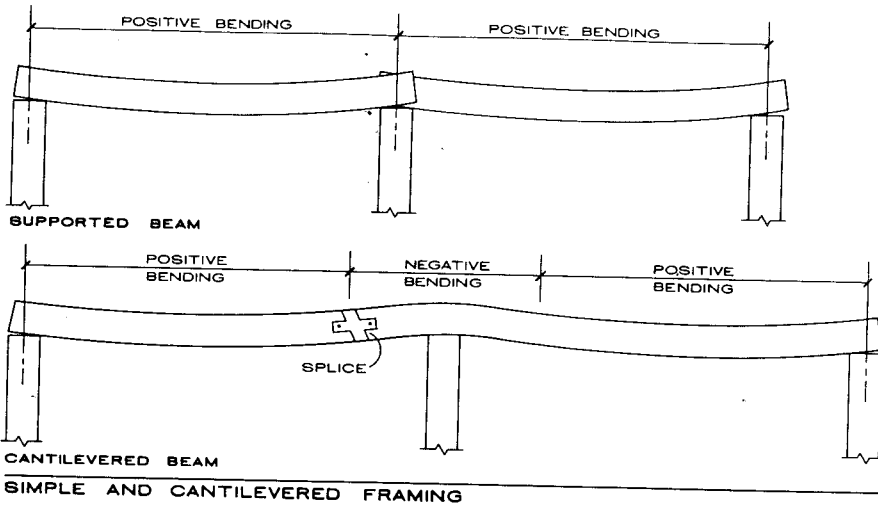

**SIMPLE FRAMING**: This illustration shows the "positive" or downward bending that occurs in conventional framing with simple spans.

**CANTILEVERED FRAMING**: This illustration shows the combination of "positive" (downward) and "negative" (upward) bending that occurs with beams spliced at quarterpoint producing supported beam and cantilevered beam. The two types of bending counterbalance each other, which produces more uniform stresses each other, and uses material more efficiently. In-line joists simplify plywood subflooring.

**MOMENT SPLICE**: Compression stress is taken in bearing on the wood through a steel compression plate. Tension is taken across the splice by means of steel straps and shear plates. Side plates and straps are used to hold sides and tops of members in position. Shear is taken by shear plates in end grain. Bolts and shear plates are used as design and construction considerations require.

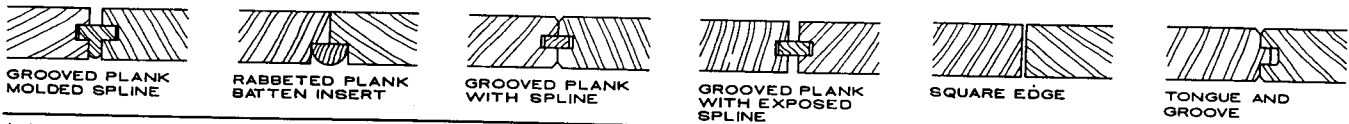

**JOINT TYPES IN EXPOSED PLANK CEILINGS**

**DESIGN TABLE FOR NOMINAL 2 IN. PLANK**

REQUIRED VALUES FOR FIBER STRESS IN BENDING (f) AND MODULUS OF ELASTICITY (E) TO SUPPORT SAFELY A LIVE LOAD OF 20, 30, OR 40 LB/SQ FT WITHIN A DEFLECTION LIMITATION OF 1/240, 1/300, OR 1/360.

SPAN (FT)	LIVE LOAD (PSF)	DEFLECTION LIMITATION	TYPE A		TYPE B		TYPE C		TYPE D		TYPE E	
			SINGLE SPAN		DOUBLE SPAN		THREE SPAN		COMBINATION SINGLE AND DOUBLE SPAN		RANDOM LAYUP	
			f (PSI)	E (PSI)	f (PSI)	E (PSI)	f (PSI)	E (PSI)	f (PSI)	E (PSI)	f (PSI)	E (PSI)
6	20	1/240	360	576,000	360	239,000	288	305,000	360	408,000	360	442,000
		1/300	360	720,000	360	299,000	288	381,000	360	509,000	360	553,000
		1/360	360	864,000	360	359,000	288	457,000	360	611,000	360	664,000
	30	1/240	480	864,000	480	359,000	384	457,000	480	611,000	480	664,000
		1/300	480	1,080,000	480	448,000	384	571,000	480	764,000	480	829,000
		1/360	480	1,296,000	480	538,000	384	685,000	480	917,000	480	995,000
40	1/240	600	1,152,000	600	478,000	480	609,000	600	815,000	600	885,000	
	1/300	600	1,440,000	600	598,000	480	762,000	600	1,019,000	600	1,106,000	
	1/360	600	1,728,000	600	717,000	480	914,000	600	1,223,000	600	1,327,000	
7	20	1/240	490	915,000	490	380,000	392	484,000	490	647,000	490	702,000
		1/300	490	1,143,000	490	475,000	392	605,000	490	809,000	490	878,000
		1/360	490	1,372,000	490	570,000	392	726,000	490	971,000	490	1,054,000
	30	1/240	653	1,372,000	653	570,000	522	726,000	653	971,000	653	1,054,000
		1/300	653	1,715,000	653	712,000	522	907,000	653	1,213,000	653	1,317,000
		1/360	653	2,058,000	653	854,000	522	1,088,000	653	1,456,000	653	1,581,000
40	1/240	817	1,829,000	817	759,000	653	968,000	817	1,294,000	817	1,405,000	
	1/300	817	1,187,000	817	949,000	653	1,209,000	817	1,618,000	817	1,756,000	
	1/360	817	2,744,000	817	1,139,000	653	1,451,000	817	1,941,000	817	2,107,000	
8	20	1/240	640	1,365,000	640	567,000	512	722,000	640	966,000	640	1,049,000
		1/300	640	1,707,000	640	708,000	512	903,000	640	1,208,000	640	1,311,000
		1/360	640	2,048,000	640	850,000	512	1,083,000	640	1,449,000	640	1,573,000
	30	1/240	853	2,048,000	853	850,000	682	1,083,000	853	1,449,000	853	1,573,000
		1/300	853	2,560,000	853	1,063,000	682	1,345,000	853	1,811,000	853	1,966,000
		1/360	853	3,072,000	853	1,275,000	682	1,625,000	853	2,174,000	853	2,359,000
40	1/240	1,067	2,731,000	1,067	1,134,000	853	1,144,000	1,067	1,932,000	1,067	2,097,000	
	1/300	1,067	3,413,000	1,067	1,417,000	853	1,805,000	1,067	2,145,000	1,067	2,621,000	
	1/360	1,067	4,096,000	1,067	1,700,000	853	2,166,000	1,067	2,898,000	1,067	3,146,000	

Timothy B. McDonald; Washington, D.C.

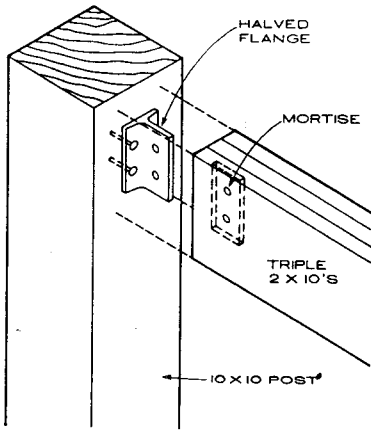

BEAM AND COLUMN CONNECTION

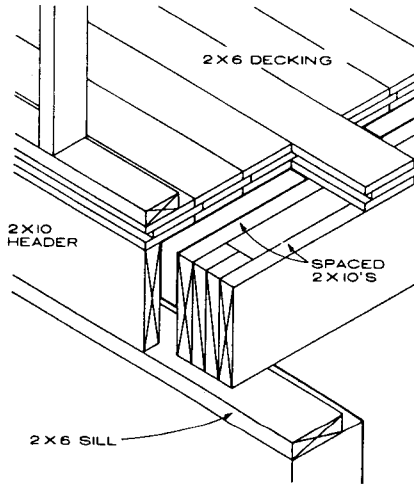

SPACED BEAM AT FOUNDATION

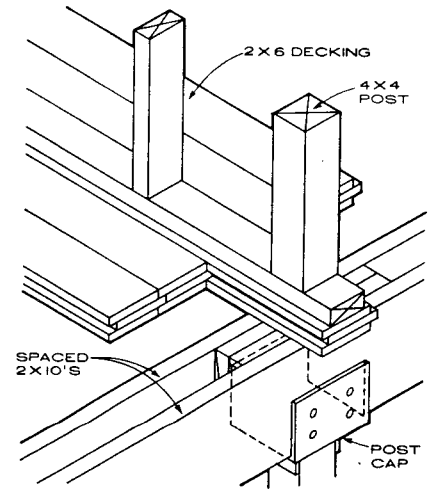

SPACED BEAM BEARING ON INTERIOR COLUMN

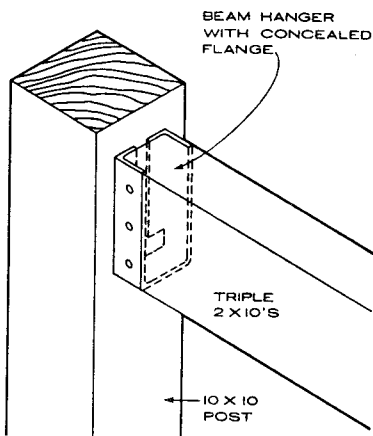

BEAM HANGER CONNECTION

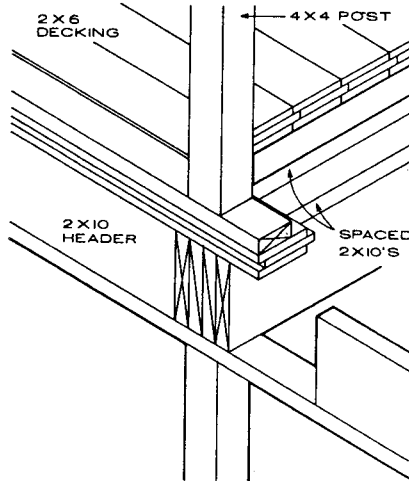

SPACED BEAM BEARING AT EXTERIOR WALL

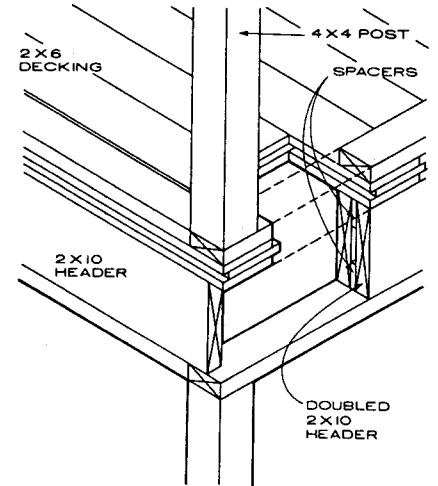

CORNER CONNECTION

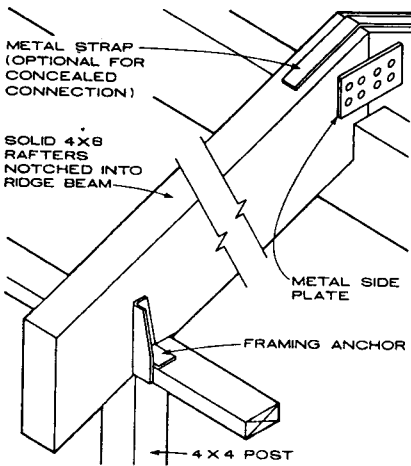

ROOF BEAM AT COLUMN AND RIDGE

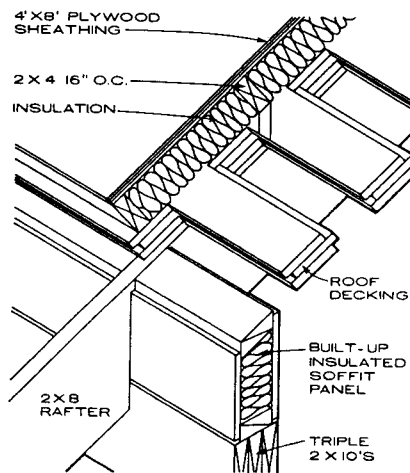

RAFTER AND PLATE DETAIL

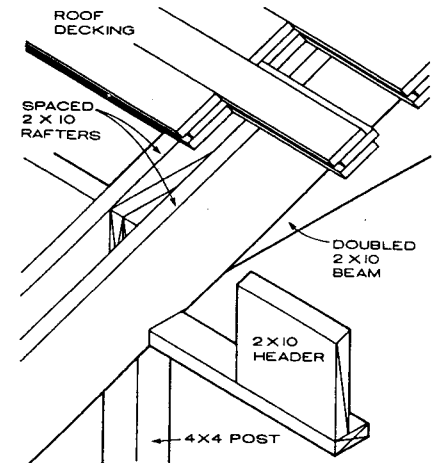

SPACED ROOF BEAM AT EXTERIOR COLUMN

Timothy B. McDonald; Washington, D.C.

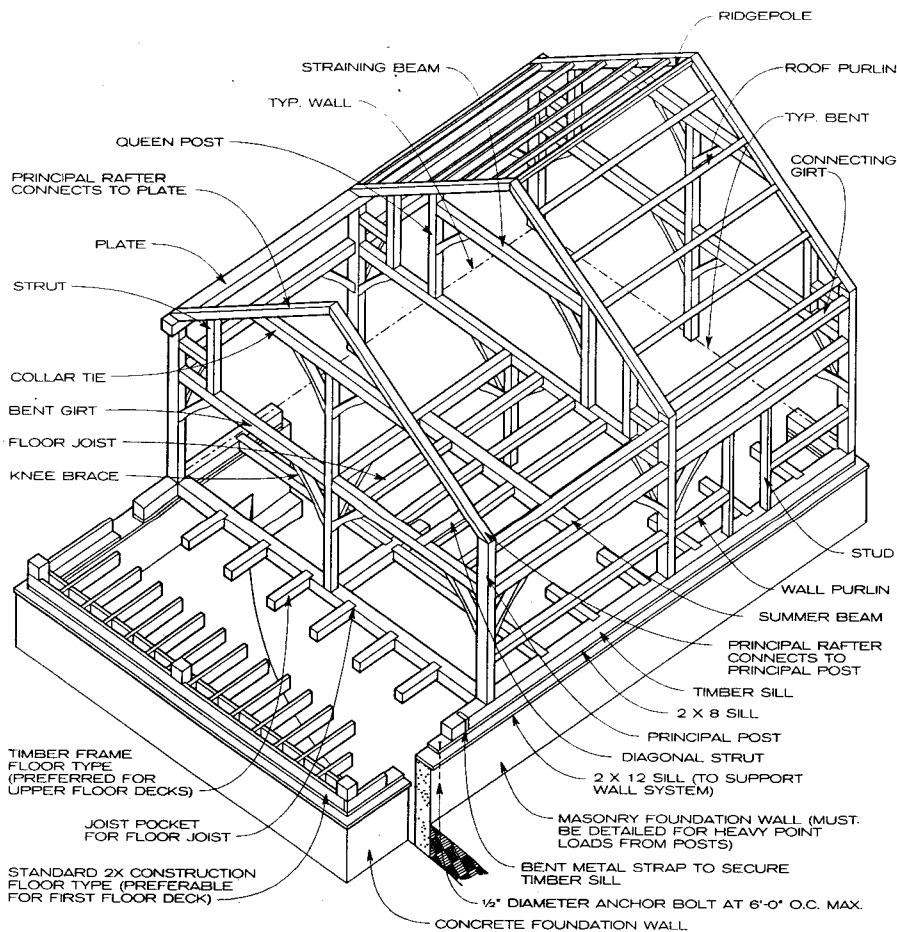

TYPICAL TIMBER FRAME (SHOWING TWO ROOF AND FLOOR TYPES)

**GENERAL**

Timber frame buildings are characterized by large, exposed timber structural members. The distinction between timber framing and other types of heavy timber construction is somewhat subjective, but in a true timber frame, the posts, beams, and braces are connected to one another with elegant, largely all-wood joints based on very old traditions. Sound timber frame construction requires high standards of design, engineering, and workmanship. It can be compared to the craftsmanship of cabinetmaking, rather than to conventional wood frame construction.

One of the reasons timber frame construction faded from popularity around 1900, after centuries of dominance, was the cost of its labor-intensive building methods. During the past twenty years, techniques have been developed that offset this drawback: the frame can be prefabricated in shops with heavy tools, and structural, insulated wall panels can be used to build the walls. Connection details in true timber frame construction are still rooted in the ancient wood-pegged, mortise-and-tenon joint. More modern wood connectors of steel can be used, depending on budget and aesthetics, but many would say the resulting structure would not be a true timber frame.

Typically, posts in timber-framed buildings are spaced in a grid, 8 to 16 ft apart. These relatively large posts support beams, girts, connectors, plates, and principal rafters. In turn, those members support rafters, purlins, summer beams, and joists, which are spaced at 2 to 6 ft centers. The relatively large timbers make timber frame construction inherently fire resistant, qualifying as Class IV construction under most building codes.

The walls and roof in a timber frame, freed of the task of supporting great loads, can be made of materials that need to function only as a rain screen and curtain walls. These materials are attached to the outside of the larger, struc-

tural members, enclosing the space while exposing the timbers to the interior and protecting the frame from deterioration.

Nonstructural foam-core panels with an exterior layer of wood sheathing, a foam core, and an interior drywall finish layer are extremely energy efficient and cost-effective for use in wall and roof construction in a timber frame. Sometimes it is preferable to use structural foam-core panels, with oriented-strand board (OSB) or plywood sheathing on both sides, as they better resist warping and lateral forces and provide a better nailing surface for attaching interior trim, cabinets, artwork, etc. These structural panels are typically installed outside a layer of gypsum board that is back-screwed to the inner OSB skin.

**ANATOMY OF A TIMBER FRAME BUILDING**

In the design process, the general layout of timbers is determined first, based on the rough program and layout of spaces. Once the wood species has been selected, each timber is sized individually. Next, the connection details, or joinery, and the embellishments and finishes are designed.

A typical timber frame can be divided into four major systems: walls, floors, roof, and bents. Walls, in the terminology of timber framing, are planar compositions of timbers parallel to the ridge. Bents run perpendicular to the walls and are often the primary preassembled sections of the building. Usually, bents include the principal structural posts of the frame and the major supporting rafters. The space between two bents is called a bay and is generally between 10 and 16 ft wide. If the roof structure is not included in the bent system, a large timber plate is set at the top of the bent or wall for the roof framing to rest on.

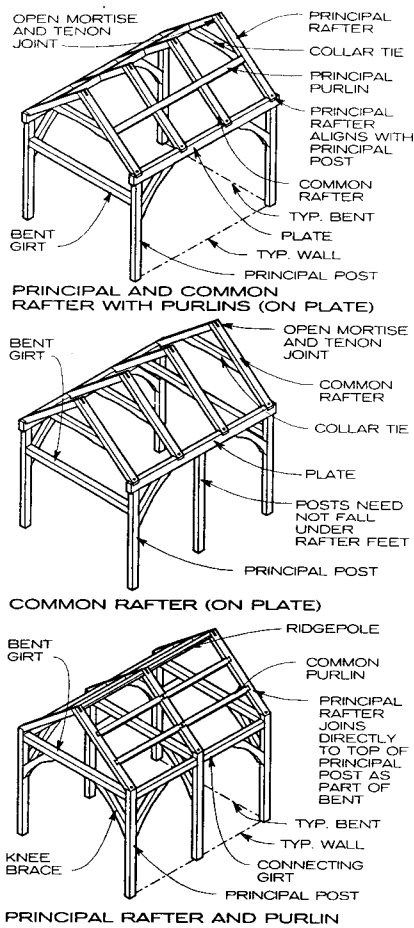

TIMBER FRAME ROOF TYPES

**ROOF SYSTEMS**

More than any other factor, the arrangement of timbers in the roof determines whether the walls or the bents will be the principal structural unit. Frames are often defined by the type of roof they support, since the roof is usually the most difficult aspect of the frame to design, detail, and erect. The choice of roof system most appropriate to a particular building depends on the shape and pitch of the roof, the loading, wood species, available timber length, floor plan, and personal aesthetic preferences.

**NOTES**

1. Wood shrinks considerably across the grain but very little along the grain, and all dimensions based on sections through plates and sills must account for this shrinkage. Bents that connect principal rafters directly to the posts and are not interrupted by plates will have negligible differential movement between roof and wall joints.
2. Timber systems that rely on full-length plates, sills, ridgepoles, or tie beams tend to require timbers of considerable length, which are scarce. Therefore, these long lengths must be assembled from shorter members tied together with scarf joints. Since most sawmills cannot obtain timbers longer than 30 ft, it is important to consult with a structural engineer and local sawmill to determine the most practical dimensions for the timbers before the design is completed.
3. Depending on budget or aesthetic priorities, hybrid systems can be devised, such as timber frame walls with conventional roof framing or conventional stud walls with a timber frame roof. Consult a structural engineer about the design, detailing, and integration of these systems.

Richard J. Vitullo, AIA; Oak Leaf Studio; Crownsville, Maryland  
Tedd Benson and Ben Brungraber, Ph.D., PE; Benson Woodworking Co., Inc.; Alstead, New Hampshire

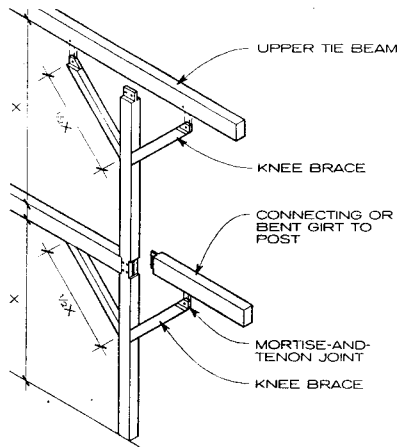

**NOTE**

For basic structural rigidity within a timber frame, the knee brace is a critical component. It is typically used between the upper ends of vertical posts and horizontal beams, but may also be used at the base of a post or to brace an inclined member, such as a rafter. Rigidity in a frame can be achieved by using a few well-placed long braces or several shorter braces. Braces typically should not be shorter than half the length of the beam-to-beam span of the post.

**KNEE BRACE**

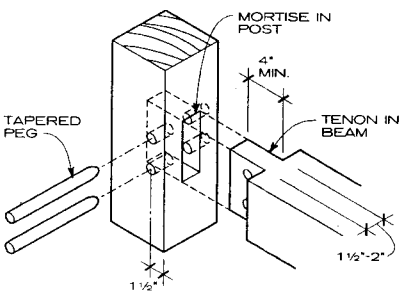

**NOTE**

The basic mortise-and-tenon joint can be very effective in resisting both tension and compression forces. To increase tensile strength, increase the depth and thickness of the tenon and use additional pegs if the width and length of the tenon allow.

**BASIC MORTISE-AND-TENON JOINT**

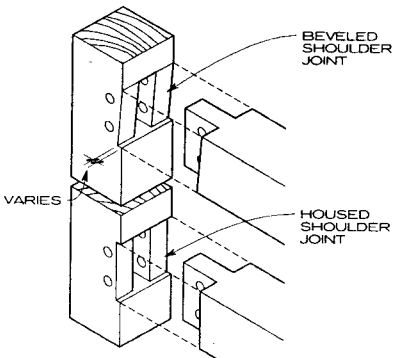

**NOTE**

A beveled shoulder or housed joint is used to connect all load-bearing beams, such as bent and connecting girts and summer beams, to posts. Angled variations can be used when principal rafters join to posts or for diagonal braces. The depth of the shoulder depends on loading, torsion, other joinery in the area, and wood species.

**SHOULDERED MORTISE-AND-TENON JOINTS**

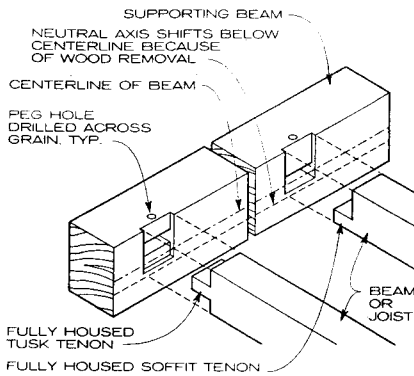

**TUSK AND SOFFIT TENON JOINTS**

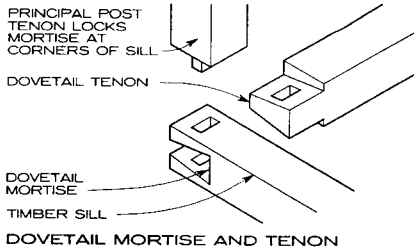

**DOVETAIL MORTISE AND TENON**

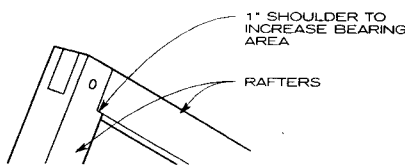

**RAFTER JOINT**

**OPEN MORTISE-AND-TENON JOINTS**

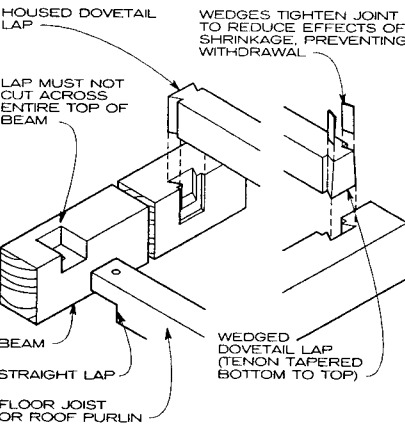

**LAP JOINTS**

**WOOD JOINERY**

Most timber framing joints are variations on the mortise and tenon, in which a tongue on one timber is received by a slot in the other and locked with rounded pegs driven through holes drilled through both parts of the joint. The simplest version of this joint is used in compression situations or for situations with minimal loading. Knee braces and collar ties generally use an angled variation.

Spline joints are similar to a mortise and tenon, except that a third member, called a spline or "free tenon" (usually hardwood), is introduced to connect between mortised timbers and to serve as the tie. Spline joints are an effective way to achieve minimum end and edge distances without being dependent on the size and capacity of the receiving post or beam.

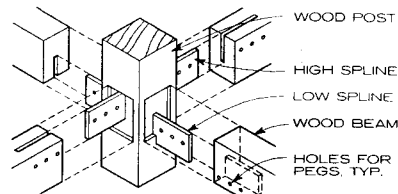

**FOUR-WAY SPLINE JOINT**

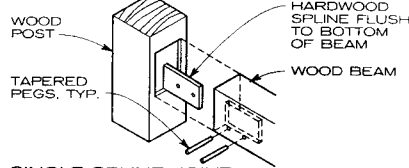

**SINGLE SPLINE JOINT**

**NOTE**

Using through-splines made of hardwood leaves all the pegs loaded parallel to the grain, with plenty of available end-grain distance, and avoids loaded edges in the posts. Spline edges often are left prominent to achieve a decorative effect.

**SPLINE JOINTS**

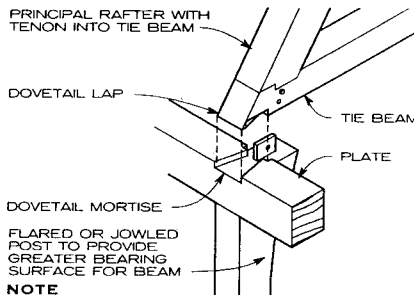

**NOTE**

A tying joint is a combination of joints used to connect several members. The intersection of a principal post, a plate, a tie beam, and a rafter is known as a tying joint.

**TYING JOINT**

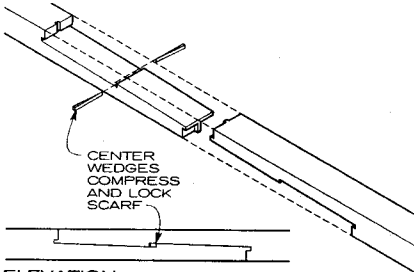

**ELEVATION**

**NOTE**

Scarf joints are lap joints used to splice two or more shorter timbers into one long timber. Although there are many variations, scarf joints are used primarily for plates and sills that demand long continuous timber.

**SCARF JOINT**

Lap joints, such as simple overlaps or dovetails, constitute the other broad category of joints used in timber frames. Scarfs, used to splice timbers along their length, are variations of the lap joint.

Joints are chosen on the basis of the tasks they are to fulfill, including locking the frame together, bearing weight, and transferring forces and building loads from one timber to another.

Compound joinery, such as where two timber valley rafters meet at a purlin, is one of the difficult aspects of timber framing. The complex geometry and the precision required demand master-level craftsmanship.

Richard J. Vitullo, AIA; Oak Leaf Studio; Crownsville, Maryland  
Tedd Benson and Ben Brungaber, Ph.D., PE; Benson Woodworking Co., Inc.; Alstead, New Hampshire

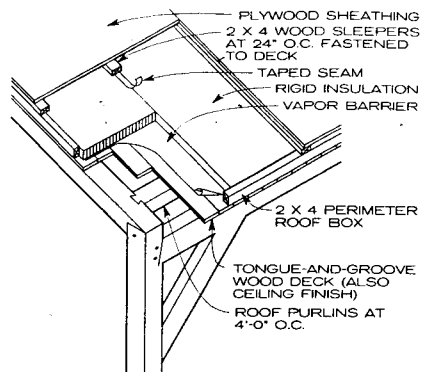

**WOOD SLEEPERS AND TONGUE-AND-GROOVE CEILING ON ROOF PURLINS**

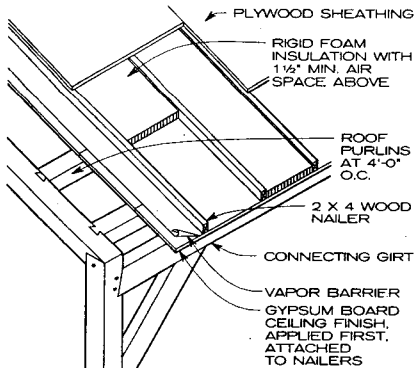

**WOOD NAILERS ON ROOF PURLINS**

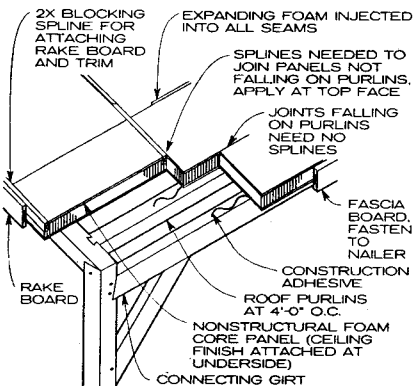

**NONSTRUCTURAL FOAM CORE PANELS ON ROOF PURLINS**

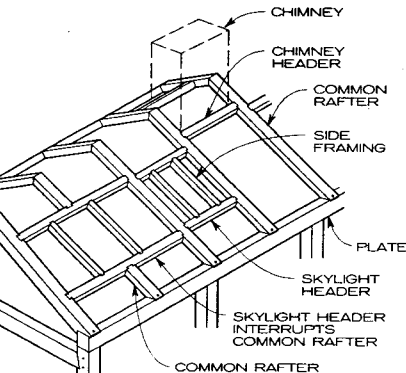

**ROOF FRAMING HEADERS**

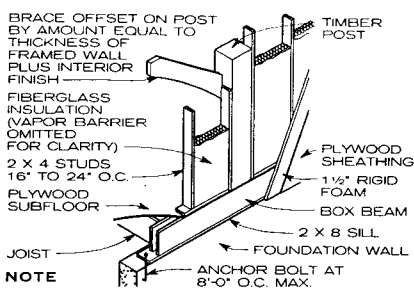

**NOTE**  
This system reduces the exposure of the timber frame by partially concealing the frame in the wall system. It allows air infiltration due to shrinkage and movement and requires an exterior rigid foam insulation layer to minimize the potential for air movement and condensation.

**INFILL WOOD STUD SYSTEM**

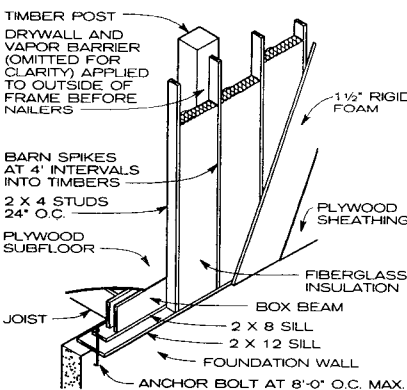

**EXTERIOR WOOD STUD SYSTEM**

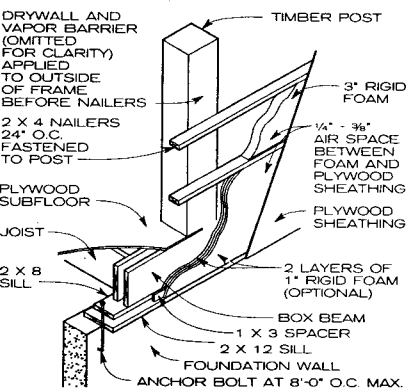

**HORIZONTAL NAILER WALL SYSTEM**

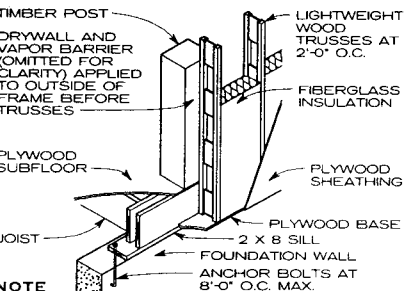

**NOTE**  
This system allows a great deal of insulation to be packed into the nonstructural wall cavity between trusses. The foundation wall may be offset to the outside of the truss system (with pilasters added on the inside to support timber posts) to avoid the appearance of excess overhang.

**EXTERIOR LIGHTWEIGHT WOOD TRUSS SYSTEM**

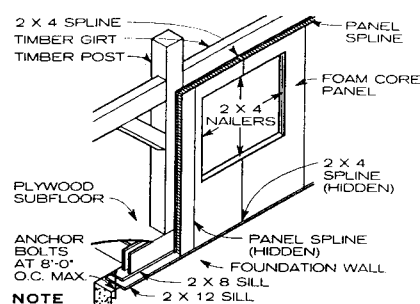

**NOTE**  
Structural foam core panels (with wood sheathing on both sides of the foam core) may be needed at areas that may have excess stress or loading with interior finish attached to the frame before the panels are attached.

**FOAM CORE PANEL WALL SYSTEM**

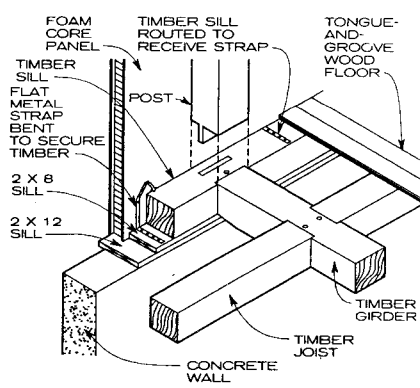

**TIMBER SILL AND JOIST SYSTEM**

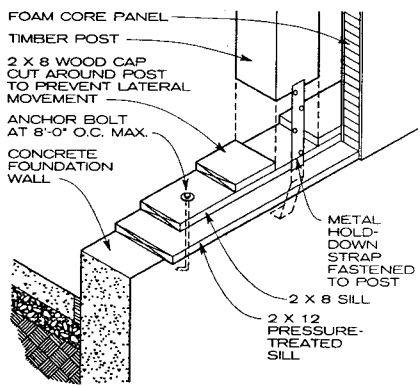

**STANDARD 2X LUMBER SILL**

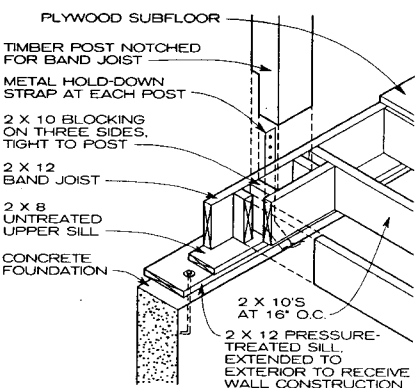

**STICK FRAME SILL AND FLOOR DECK**

Richard J. Vitullo, AIA; Oak Leaf Studio; Crownsville, Maryland  
Tedd Benson and Ben Brungraber, Ph.D., PE; Benson Woodworking Co., Inc.; Alstead, New Hampshire



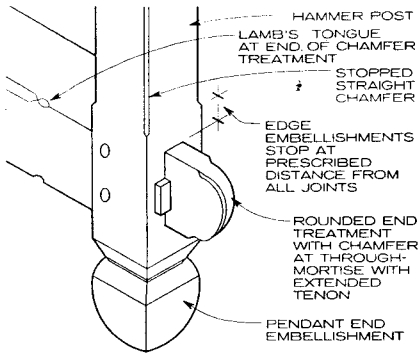

**END AND EDGE EMBELLISHMENTS**

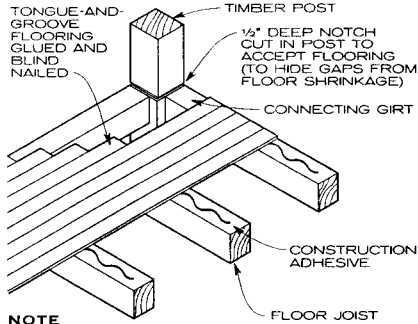

**NOTE**

Maintain  $\frac{3}{8}$  in. gap between flooring edge and wall for expansion and contraction.

**STANDARD TONGUE-AND-GROOVE FLOOR**

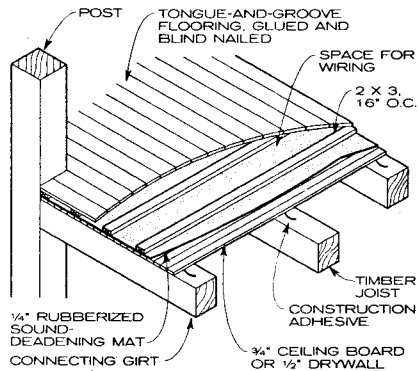

**SOUND-RESISTANT FLOOR DETAIL**

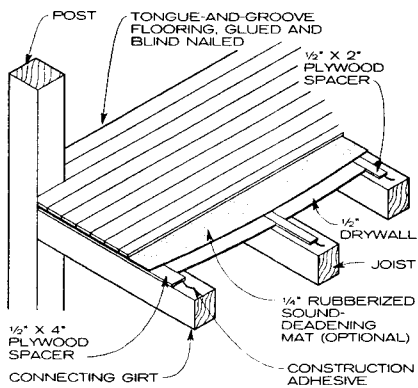

**GYPSUM BOARD CEILING WITH SPACERS**

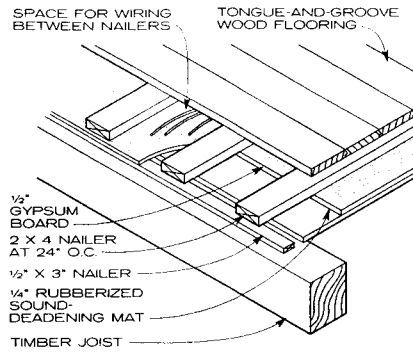

**UNDER FLOOR SERVICE CHASE**

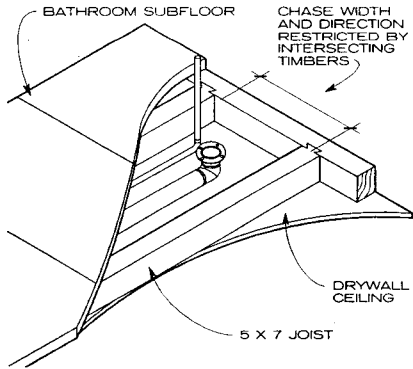

**UNDER FLOOR SERVICE CHASE BETWEEN TIMBER JOISTS**

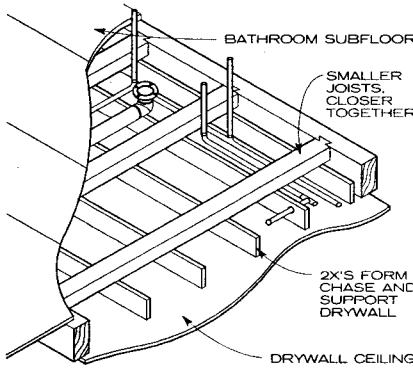

**UNDER FLOOR SERVICE CHASE WITH DROPPED CEILING DETAIL**

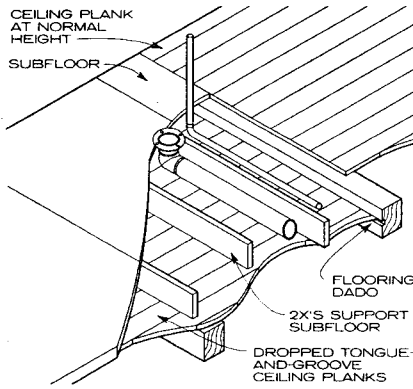

**UNDER FLOOR SERVICE CHASE WITH DROPPED FLOOR DETAIL**

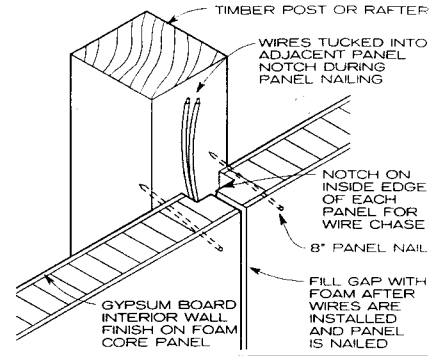

**TIMBER POST OR RAFTER AT FOAM CORE PANEL WIRE CHASE DETAIL**

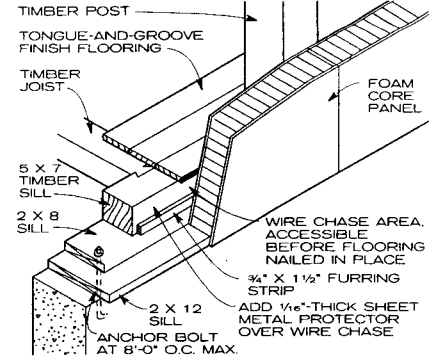

**TIMBER-SILL WIRE CHASE DETAIL**

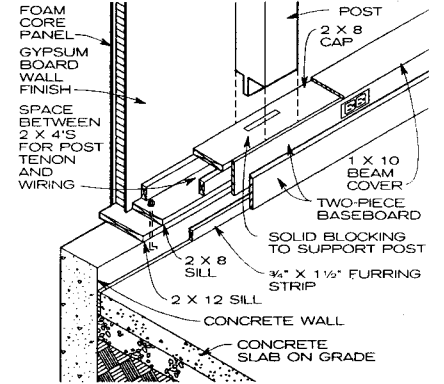

**BOX BEAM SILL WIRE CHASE DETAIL**

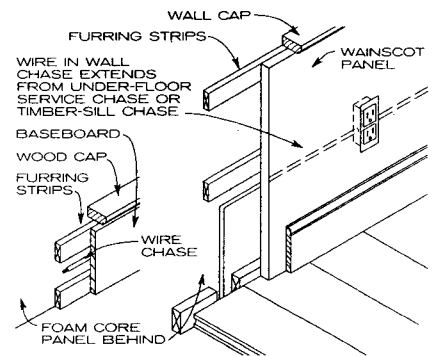

**BASEBOARD WAINSCOT CHASE**

**SURFACE-MOUNTED WIRE CHASES AT FOAM CORE PANEL**

Richard J. Vitullo, AIA; Oak Leaf Studio; Crownsville, Maryland  
 Tedd Benson and Ben Brungaber, Ph.D., PE; Benson Woodworking Co., Inc.; Alstead, New Hampshire

NOTES

1. Pole embedment depth depends on soil, slope and seismic zone.
2. Cross-bracing between poles may be required to resist lateral loads if shallow embedment. Treat all exposed surfaces with approved pressure treatment.
3. Pole notching for major beams can help align beams and walls that otherwise would be out of plumb due to pole warp. Notching improves bearing of major beams but weakens poles.
4. Roofs, walls and floors should be insulated to suit local climatic conditions. Wall and soffit insulation should meet continuously at the joint. Penetration of insulation should be minimal.
5. Various siding types can be used.
6. Dapping is a U.S. carpentry term for cutting wood to receive timber connectors.

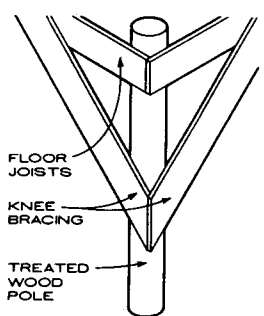
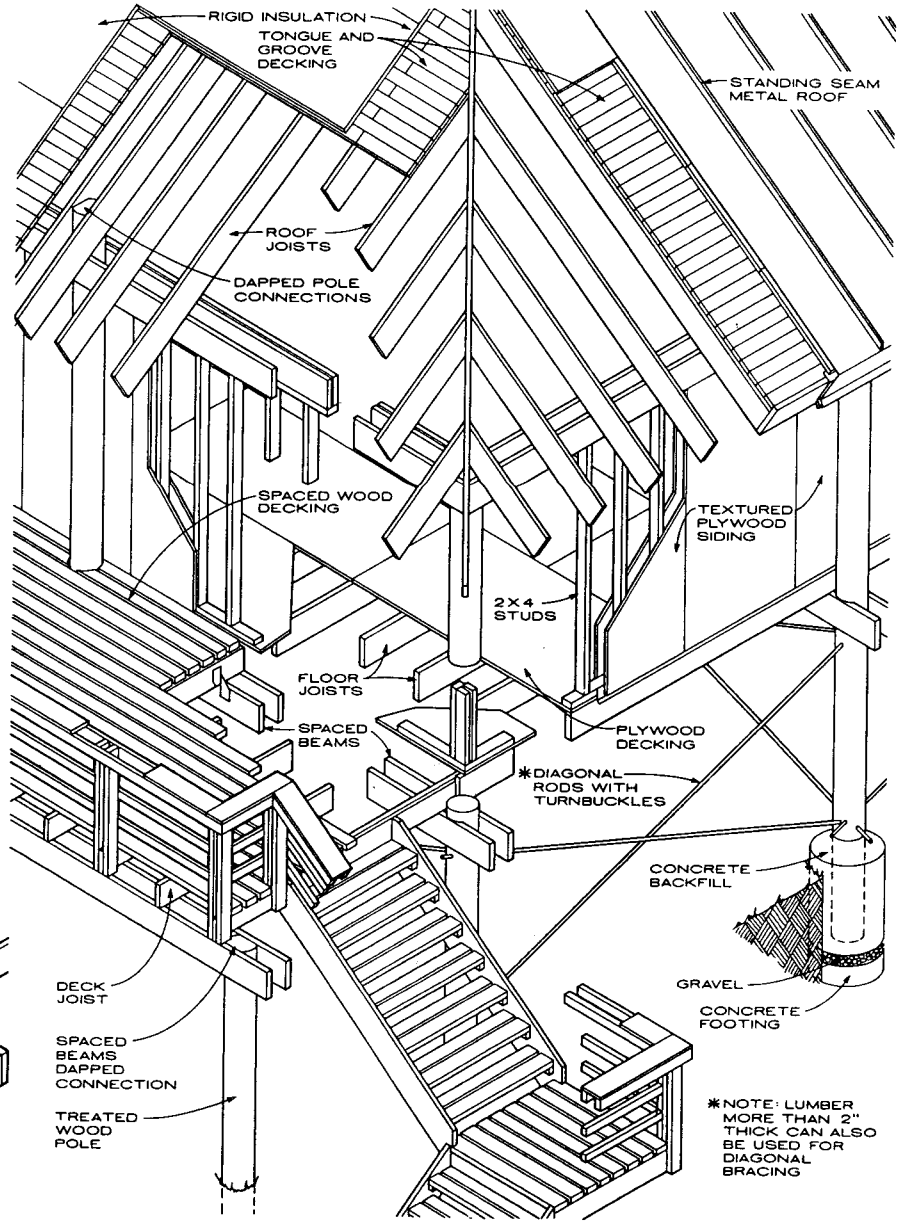

KNEE BRACING

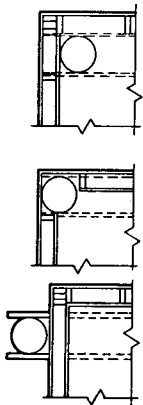

EXTERIOR WALL FRAMING OPTIONS

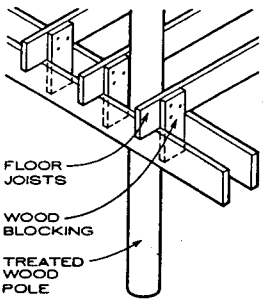

JOIST ANCHORS

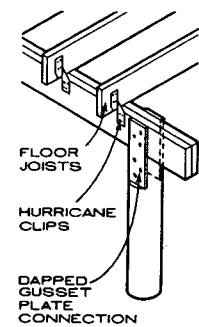

JOIST ANCHORS

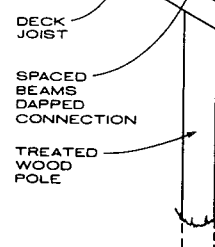

ISOMETRIC OF POLE HOUSE

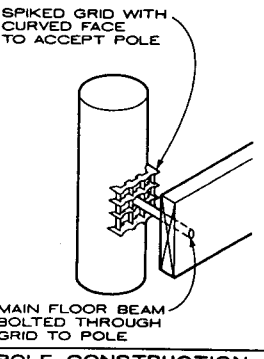

POLE CONSTRUCTION

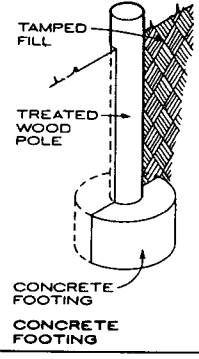

CONCRETE FOOTING

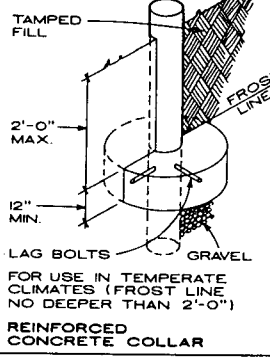

REINFORCED CONCRETE COLLAR

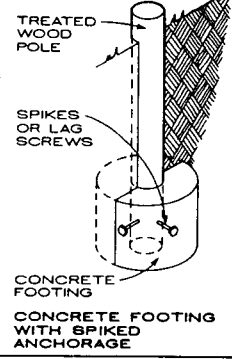

CONCRETE FOOTING WITH SPIKED ANCHORAGE

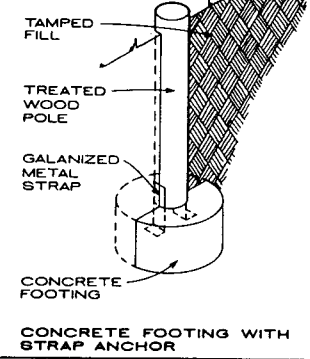

CONCRETE FOOTING WITH STRAP ANCHOR

Timothy B. McDonald; Washington, D.C.

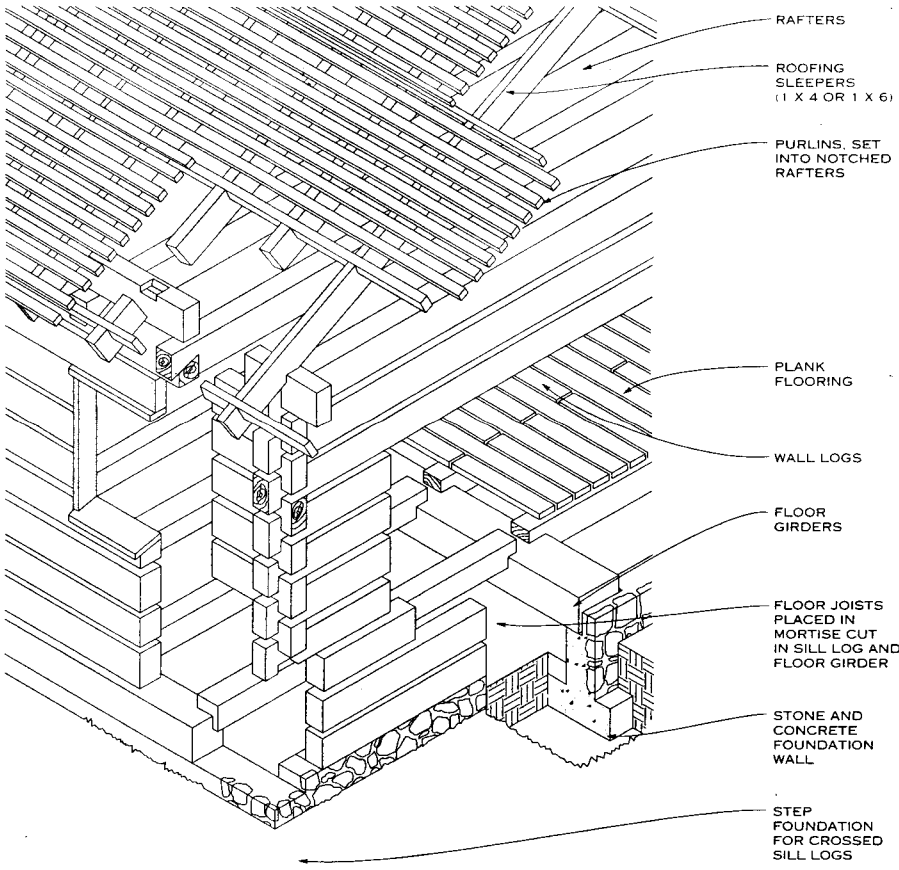

**GENERAL**

Residential log buildings have become a significant part of the home construction industry. The log house industry comprises two main segments: manufactured, or milled, houses built from kits and custom-built log houses. Houses built from kits use logs that have been machined or milled to a uniform shape in a variety of profiles. Although kit-built houses can be put together quickly and with few construction skills, the finished product tends to look artificial. Custom-built log houses are produced from hand-peeled, hand-hewn logs in their natural profile. These houses more closely resemble a traditional log structure. Kits for hand-hewn houses are also available, but their reconstruction on site is often complicated because of longer log lengths and the heavier weight of the logs. A hydraulic crane is usually required. Many building officials require a structural engineer's approval to accompany the plans, whether the log house company generates these plans or an architect hired by the owner.

**NOTES**

1. Hewing logs square removes most of the sapwood, which reduces the weight of the log and its susceptibility to insect damage and rot. The flat surfaces of square logs are also easy to work with.
2. Damage from rot (fungal decay) can be prevented or controlled in several ways: remove sapwood, which is high in cellulose and lignum on which fungi feed; reduce the log's moisture content to 20% or less by air or kiln drying; or provide proper air circulation under floors and around foundations. Generous roof overhangs and properly maintained gutters help keep water off the sides of the building.
3. Insect damage from termites, beetles, and carpenter ants can be prevented by properly seasoning the wood (kiln or air drying) and by providing continuous vapor barriers under ground floors. Also, good air circulation can help prevent infestations.
4. Exposed interior logs must be coordinated carefully with placement of plumbing, electrical wiring, and mechanical equipment.
5. Good drainage around the building is important, since log buildings are susceptible to rot.
6. Manufacturers of prefabricated log structures offer milled log details to reduce air leakage and improve weatherability of the wall. Such details include tongue-and-groove joints, dovetailing use of steep splines, and butyl gaskets.
7. Spaces between individual logs (chink area) are filled with chinking, which can vary from less than an inch to three or more inches in width.

**LOG FRAMING**

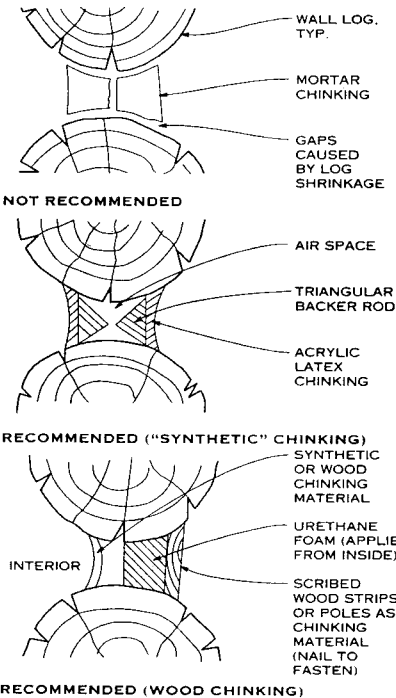

**CHINKING DETAILS**

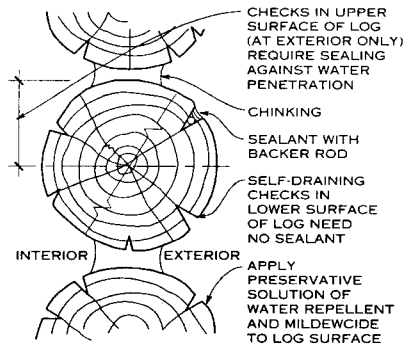

**WOOD PRESERVATION—DETAIL**

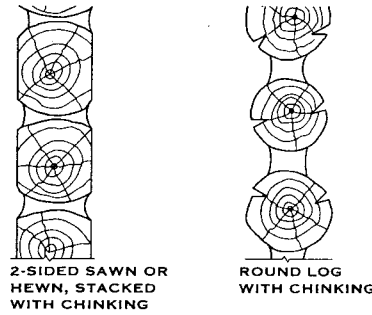

**TYPICAL LOG WALL PROFILES**

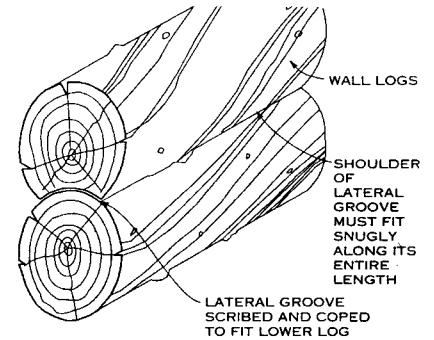

**SCRIBED OR CHINKLESS LOG JOINERY**

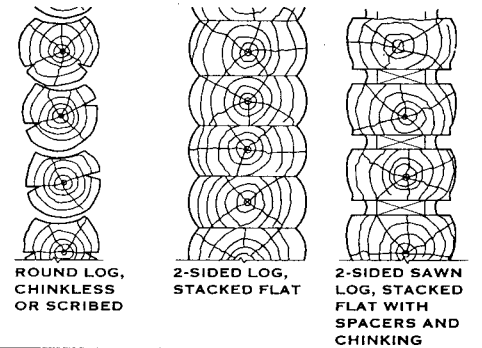

Arthur Thiede; Log Homes Connect; Hailey, Idaho

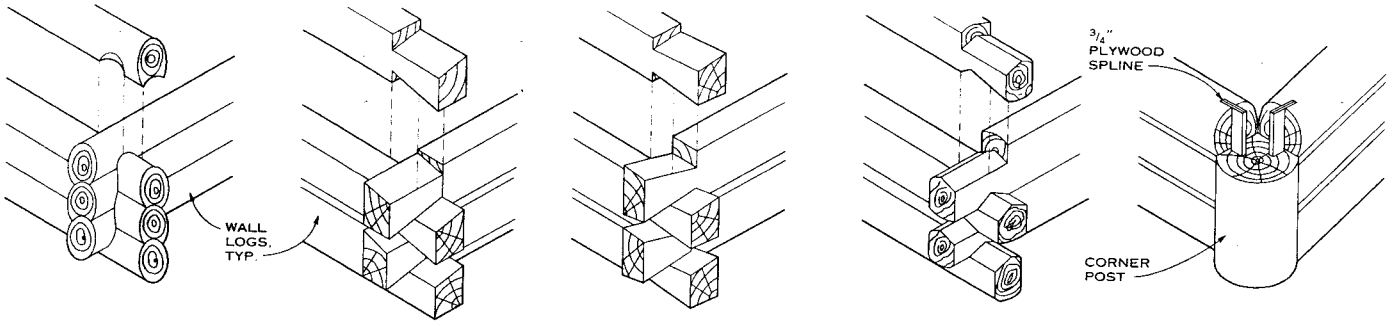

SADDLE NOTCHES      FULL DOVETAIL      HALF DOVETAIL      V-NOTCHES      POSTED CORNER

TYPICAL CORNERS

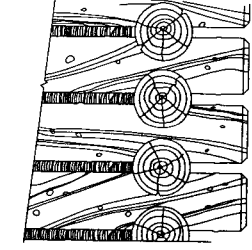

PLUMB LOG ENDS

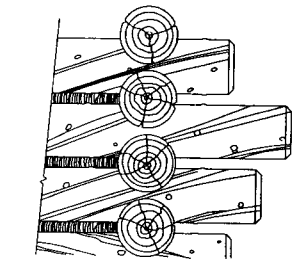

STAGGERED LOG ENDS

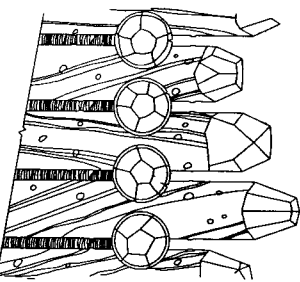

BEAVER CUT LOG ENDS

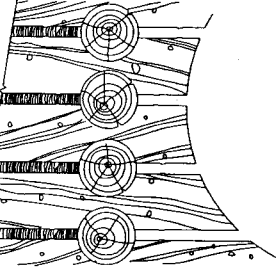

ARCHED LOG ENDS  
LOG END PROFILES

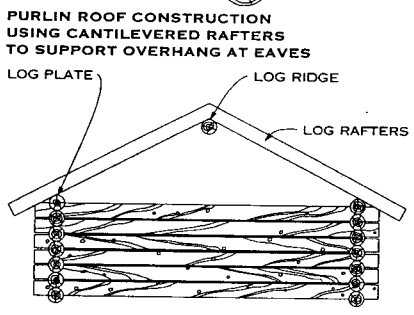
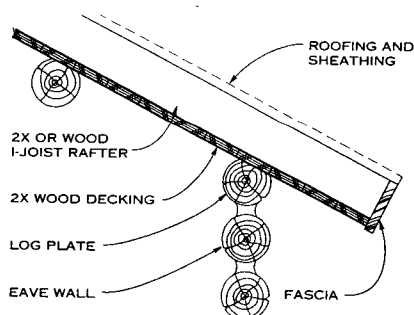

SECTION—LOG RAFTER CONSTRUCTION

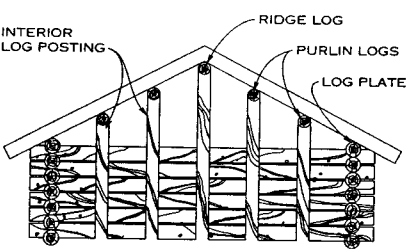

SECTION—LOG PURLIN ROOF CONSTRUCTION

ROOF STRUCTURE—DETAILS

ROOFS

The roof system on a log house should be carefully thought-out. Since many log houses are built in areas of high snow loading, log roof systems are more complex than those in conventionally framed structures. Although log roof members are desirable from an aesthetic standpoint, engineered values for logs are difficult to obtain because the logs are not graded. It is therefore necessary to build a structural roof of engineered materials over the log roof, resulting in, essentially, two structural roofs. The engineered roof can be buried in the insulation or cold roof space, but doing this adds considerably to the cost of the structure. Log or timber framed trusses can be used to support purlins (and produce a dramatic visual effect), but this is also an expensive alternative.

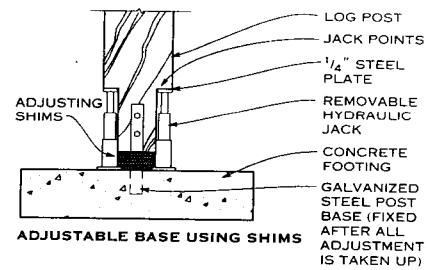

ADJUSTABLE BASE USING SHIMS

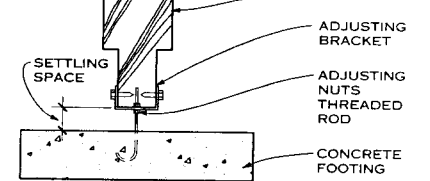

ADJUSTABLE POST BASE IN CRAWL SPACE APPLICATION  
MITIGATION OF SETTLING—DETAILS

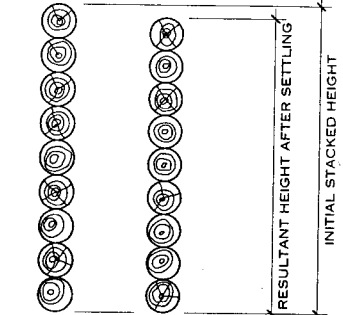

NOTE  
Shrinkage varies according to the moisture content of the logs and the humidity level at the building site.

WALL SETTLING IN LOG CONSTRUCTION

SETTLING DETAILS

Log movement and settling caused by shrinkage can be a significant problem in log construction. The problem can be mitigated through careful detailing.

Shrinkage problems are more prevalent in custom-built houses, which use full round logs, than in manufactured or milled log structures because the latter use kiln-dried logs. Although custom log companies keep shrinkage to a minimum by using dead standing trees, the moisture content usually is still higher than in kiln-dried logs.

Arthur Thiede: Log Homes Connect; Hailey, Idaho

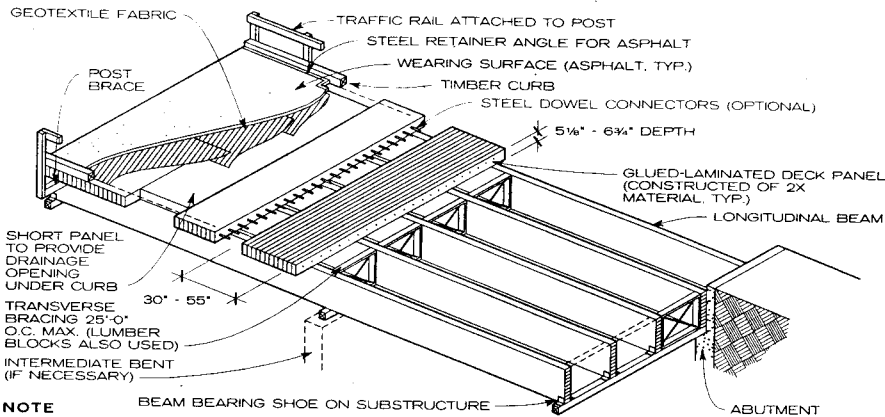

**NOTE**

Clear spans for glued-laminated longitudinal beams are from 20 to 100 ft. For sawn lumber beams, clear spans can

be made up to 25 ft. Wood species used are generally Douglas fir-larch or Southern pine.

**TYPICAL LONGITUDINAL BEAM BRIDGE**

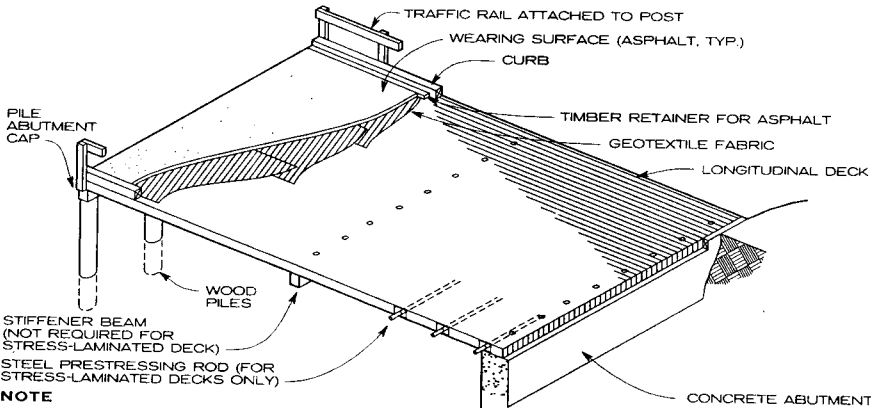

**NOTE**

Clear spans for glued-laminated decks are approximately 35 ft.

**TYPICAL LONGITUDINAL DECK SUPERSTRUCTURE**

**INTRODUCTION**

Although wood was probably the first material used to construct a bridge, in the 20th century concrete and steel have become the major bridge construction materials. Wood is still widely used for short- and medium-span bridges. The strength, light weight, and energy absorption properties of timber make it a desirable material for bridge construction. Timber can carry short-term overloads without adverse effects. Large wood members are fire resistive, impervious to continuous freezing and thawing, and resist the harmful effects of de-icing agents.

In modern applications, the life of timber bridges is extended to forty years or longer through the use of preservative-treated wood, which requires little or no maintenance. The specifications and standards for the preservative treatment of wood maintained by the American Wood Preservers Association (AWPA) are the most widely used and comprehensive documents covering treatment procedures for sawn lumber, glued-laminated timber (glulam), piling, and poles used for timber bridges.

**STRUCTURAL CHARACTERISTICS**

All timber bridges consist of two basic components—the superstructure and the substructure. The superstructure is the framework of the bridge span and includes the deck, floor system, main supporting members, railings, and other incidental components. The five basic types of superstructure are beam, deck (slab), truss, arch, and suspension. The substructure is the portion of the bridge that transmits loads from the superstructure to the supporting rock or soil. Timber substructures include abutments and bents. Abutments support the two bridge ends, while bents provide intermediate support for multiple-span crossings.

**TIMBER SUPERSTRUCTURES**

**LONGITUDINAL BEAM** (in bridge design, the longitude is measured in the direction of traffic flow): The simplest and

most common timber bridge superstructure, the longitudinal beam type consists of a deck system supported by a series of timber beams between two or more supports. Beams are constructed from logs, sawn lumber, glued-laminated timber (glulam), or laminated veneer lumber (LVL).

**LONGITUDINAL DECK:** Longitudinal deck or slab superstructures are constructed of glulam, nail-laminated sawn lumber, or stress-laminated lumber decks placed longitudinally between supports, with the wide dimension of the lamination vertical. In this type of superstructure, the deck is designed to resist all applied loads and deflection without additional supporting members or beams. Nonetheless, transverse distributor beams are usually attached to the underside of the deck to help distribute the load. Maximum clear spans are approximately 35 ft.

**TRUSS:** Trusses are structural frames consisting of straight members connected to form a series of triangles. Trusses can span distances of up to 250 ft. In bridge applications, a typical truss superstructure consists of two main trusses, a floor system, and bracing. This type is classified as a deck truss (in which the deck is at or above the level of the top chord) or a through truss (in which the deck is near the bottom chord). When the height of a through truss is insufficient for overhead bracing, it is called a half-through or pony truss. Timber trusses are constructed in many geometric configurations, but two of the most popular are the bowstring truss and parallel chord truss.

**ARCH:** Arches used in clear span timber bridge construction have glued-laminated timbers for the main members. This type of superstructure, called a glulam deck arch, probably best shows the versatility of glulam in bridge construction. The glulam arches are manufactured in segmental, circular, or parabolic shapes. Two basic arch types are used: the two-hinge arch (for short spans of 80 ft or less) and the three-hinge arch (for long spans of between 80 and 200 ft). The roadway for deck arch bridges is supported by glulam

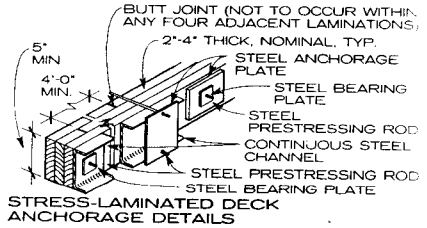
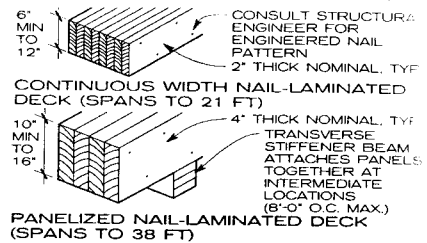

**LONGITUDINAL DECK DETAILS**

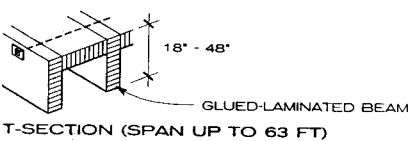
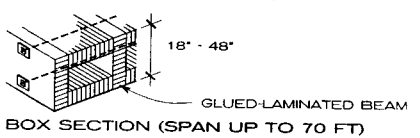
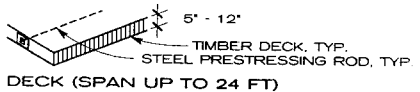

**NOTE**

T-section may be preferable over box section for long spans because of ease of inspection and maintenance.

**TYPICAL STRESS-LAMINATED TIMBER SUPERSTRUCTURES**

post bents connected to the arches with steel gusset plates. Use of this design is most practical when considerable height is required and when foundations can be constructed to resist horizontal end reactions. It is particularly suitable for deep crossings because long clear spans result in substantial substructure cost savings.

**SUSPENSION:** Timber suspension bridges consist of a timber deck structure suspended from flexible steel cables or chains supported by timber towers. This superstructure type is capable of spanning clear distances of more than 500 ft and is normally used only when span requirements make other bridge types impractical or when it is not feasible to use intermediate bents.

**TIMBER SUBSTRUCTURES**

**ABUTMENTS:** Abutments support the bridge ends and contain roadway embankment material. The simplest timber abutment is a sawn lumber or glulam spread footing placed directly on the surface of the embankment if foundation materials permit. Another type is the post abutment, in which the superstructure is supported on sawn lumber or glulam posts connected to a spread footing. Pile abutments may be used if soils cannot hold footings.

**BENTS:** Bents are intermediate supports between abutments used for multiple-span bridges. They are made from timber piles or sawn lumber frames, depending on height requirements and soil conditions.

**GENERAL DESIGN CRITERIA**

For design criteria and specifications for timber bridges, refer to the current edition of the American Association of State Highway and Transportation Officials (AASHTO) Standard Specifications for Highway Bridges and "Timber Bridges: Design, Construction, Inspection, and Maintenance," U.S. Department of Agriculture, August 1992.

Richard J. Vitullo, AIA; Oak Leaf Studio; Crownsville, Maryland  
Michael A. Ritter, PE, Structural Engineer; Forest Products Lab, USDA; Madison, Wisconsin

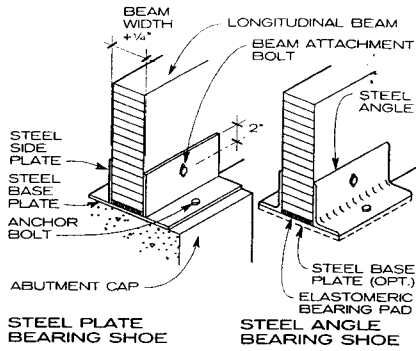

TYPICAL BEARING SHOE DETAILS

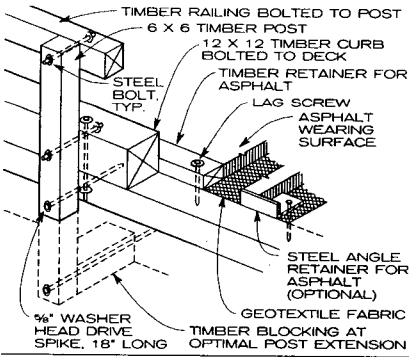

BRIDGE EDGE CONDITION

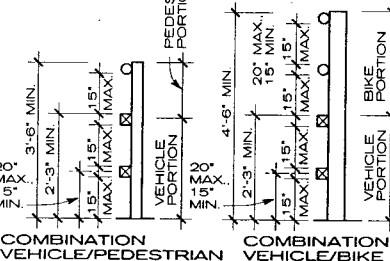
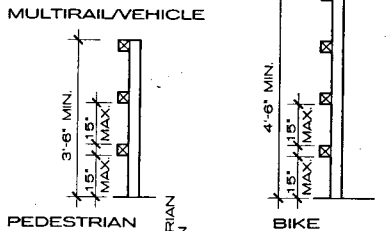
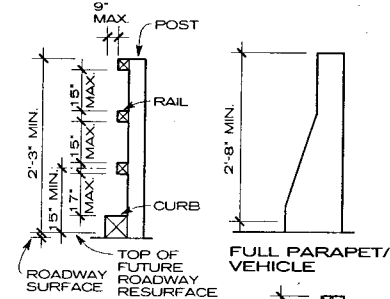

TYPICAL RAIL SYSTEMS

Richard J. Vitullo, AIA; Oak Leaf Studio; Crownsville, Maryland  
 Michael A. Ritter, PE, Structural Engineer; Forest Products Lab, USDA; Madison, Wisconsin

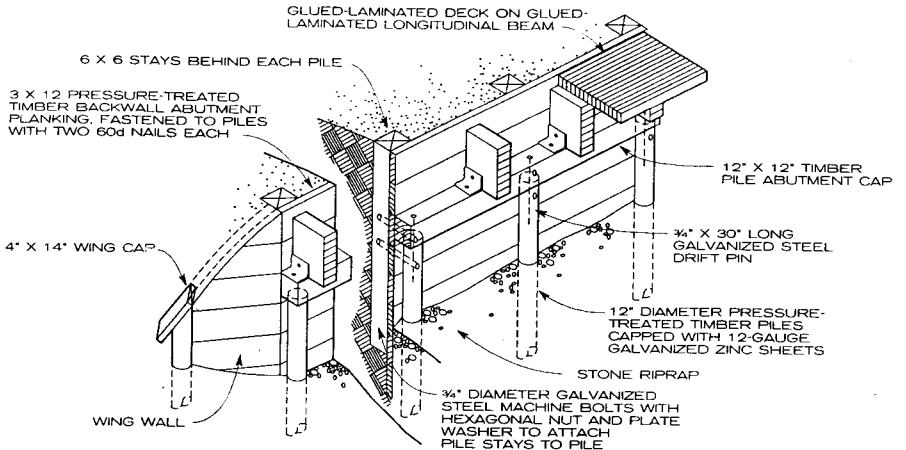

TYPICAL PILE ABUTMENT DETAIL

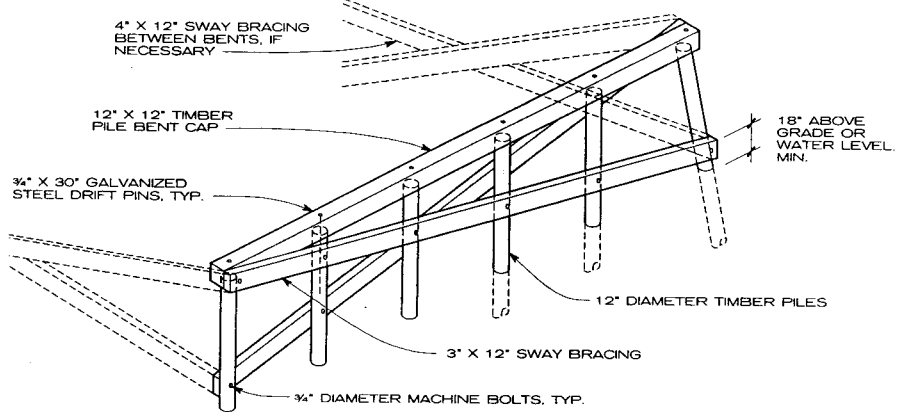

TYPICAL PILE BENT DETAIL

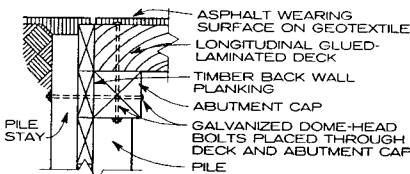

STEEL BOLT AT TIMBER CAP ATTACHMENT

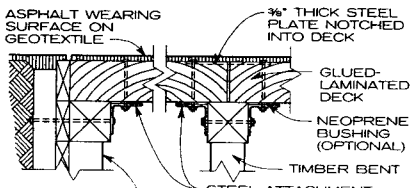

STEEL ANGLE AT TIMBER CAP ATTACHMENT

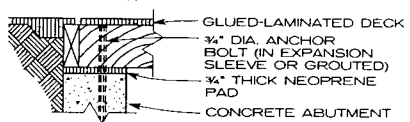

STEEL BOLT AT CONCRETE ABUTMENT ATTACHMENT

TYPICAL LONGITUDINAL DECK ATTACHMENT DETAILS

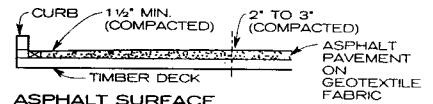

ASPHALT SURFACE

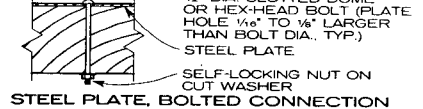

STEEL PLATE, BOLTED CONNECTION

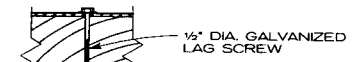

STEEL PLATE, LAG SCREW ATTACHMENT

TYPICAL WEARING SURFACES

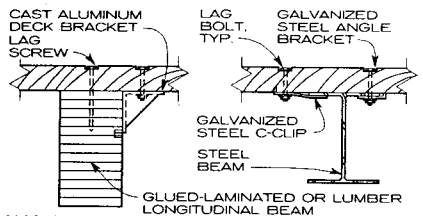

NOTE

Deck brackets include small teeth that firmly grip the deck and beam.

TYPICAL GLUED-LAMINATED DECK ATTACHMENT DETAILS

LAMINATED DECK—ALLOWABLE UNIFORMLY DISTRIBUTED TOTAL ROOF LOADS (LB/SQ FT; LIVE AND DEAD LOADS)

SIZES	SPAN	DOUGLAS FIR/LARCH E = 1,800,000 psi F <sub>b</sub> = 2,585 psi F <sub>v</sub> = 165 psi				PONDEROSA PINE E = 1,150,000 psi F <sub>b</sub> = 1,485 psi F <sub>v</sub> = 150 psi				PONDEROSA PINE FACE E = 1,200,000 psi F <sub>b</sub> = 1,720 psi F <sub>v</sub> = 130 psi				INLAND RED CEDAR FACE E = 1,250,000 psi F <sub>b</sub> = 1,485 psi F <sub>v</sub> = 130 psi			
		SIMPLE SPAN		RANDOM LENGTH CONTINUOUS		SIMPLE SPAN		RANDOM LENGTH CONTINUOUS		SIMPLE SPAN		RANDOM LENGTH CONTINUOUS		SIMPLE SPAN		RANDOM LENGTH CONTINUOUS	
		(ft)	L/180 (psf)	L/240 (psf)	L/180 (psf)	L/240 (psf)	L/180 (psf)	L/240 (psf)	L/180 (psf)	L/240 (psf)	L/180 (psf)	L/240 (psf)	L/180 (psf)	L/240 (psf)	L/180 (psf)	L/240 (psf)	L/180 (psf)
2 x 6 or 2 x 8 nominal 	5	127	95	215	161	81	61	137	103	84	63	143	108	88	66	137f	112
	6	73	55	124	93	47	35	79	60	49	36	83	62	51	38	86	65
	7	46	35	78	59	29	22	50	38	31	23	52	39	32	24	54	41
	8	31	23	52	39	20	15	33	25	21	15	35	26	22	16	36	27
	9	22	17	37	28	14	11	24	17	14	12	25	18	15	12	26	19
3 x 6 or 3 x 8 nominal 	6	254	191	375f	323	162	122	216f	206	169	128	250f	215	176	133	216f	216f
	7	160	120	271	203	102	76	158f	130	107	80	180	135	111	83	158f	141
	8	107	80	181	136	68	52	116	86	71	54	121	90	74	56	121f	94
	9	75	56	127	95	48	36	81	61	50	37	84	63	52	39	88	66
	10	55	41	93	70	35	26	60	45	36	27	62	47	38	28	65	49
	11	41	31	69	52	26	20	44	33	27	21	46	35	28	22	48	36
	12	32	24	54	41	20	16	34	26	21	16	36	27	22	17	37	28
	13	25	19	42	32	16	12	27	20	16	12	28	21	17	13	29	22
4 x 6 or 4 x 8 nominal 	9	171	128	289f	218	109	82	185	139	114	85	193	145	119	89	199f	151
	10	125	94	212f	159	80	60	135	101	84	62	141	106	87	65	147	110
	11	94	71	159	119	60	45	101	76	62	47	106	80	65	49	110	83
	12	72	54	122	92	46	34	78	59	48	36	82	61	50	37	85	64
	13	57	43	97	73	37	28	62	47	38	29	64	49	40	30	67	51
	14	46	35	78	59	29	22	50	38	31	23	52	39	32	24	54	41
	15	37	28	63	47	24	17	40	30	25	18	42	32	26	19	44	33
	16	31	23	52	39	20	15	33	25	21	15	35	26	22	16	36	27
	17	25	19	42	32	16	12	27	20	16	12	28	21	17	13	29	22
5 x 6 or 5 x 8 nominal 	9	352	264	416f	416f	224	168	321f	285	234	176	372f	298	244	183	321f	310
	10	256	192	378f	366	164	122	260f	208	171	128	289	217	178	133	260f	226
	11	193	146	312f	245	123	93	209	166	129	97	218	163	134	101	215f	270
	12	148	111	251	188	95	71	160	120	99	74	167	125	103	77	174	130
	13	117	88	198	149	75	56	126	95	78	59	132	99	81	61	137	103
	14	93	70	157	118	60	45	100	75	62	47	105	79	65	49	109	82
	15	76	57	129	97	49	37	83	62	51	38	86	64	53	40	90	67
16	63	47	107	80	40	30	68	52	42	32	71	53	44	33	74	56	

NOTE

Load figures marked with an f are controlled by bending. Loads controlled by bending or shear are based on a 2-month duration of load factor of 1.15. For normal duration of loading or floor loads, values must be divided by 1.15. Loads in table are limited by deflection; F<sub>b</sub> = extreme fiber stress in bending; F<sub>v</sub> = horizontal shear, E = modulus of elasticity in millions of psi.

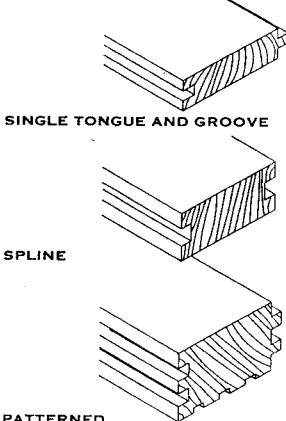

MACHINE-SHAPED DECKING TYPES

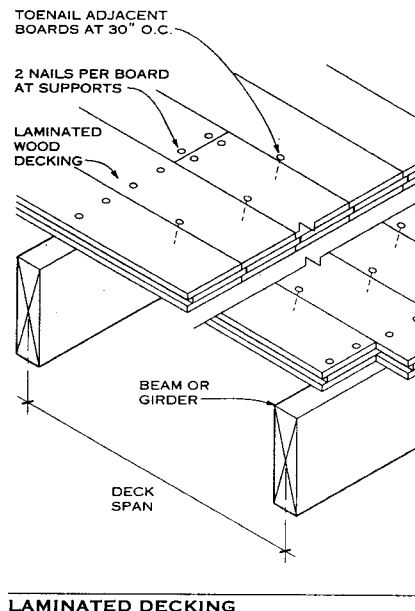

LAMINATED DECKING

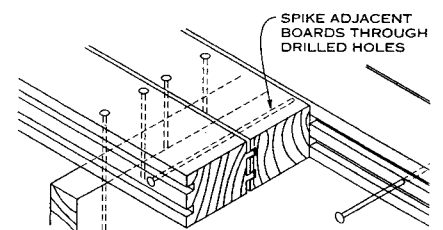

SOLID DECKING

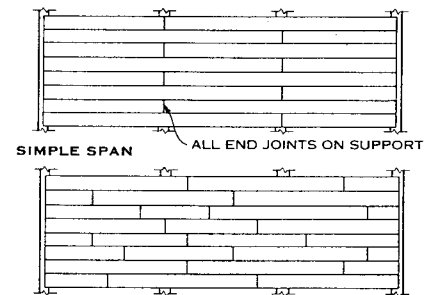

WOOD DECKING JOINT PATTERNS

David S. Collins, FAIA; American Forest & Paper Association; Cincinnati, Ohio

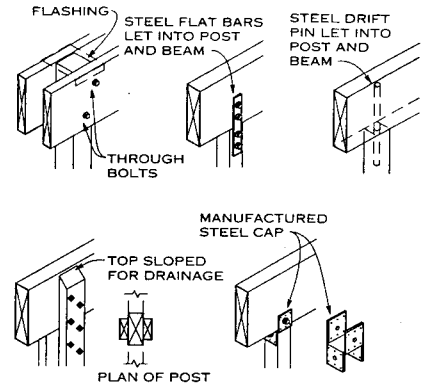
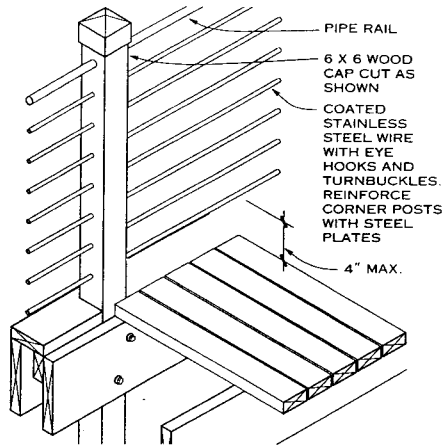
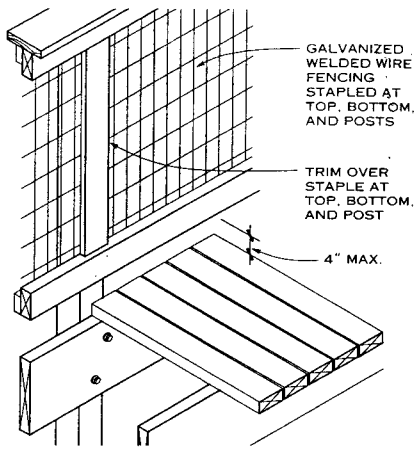

POST AND BEAM CONNECTIONS

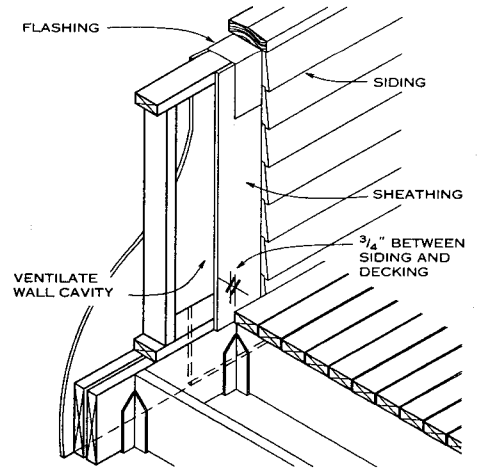
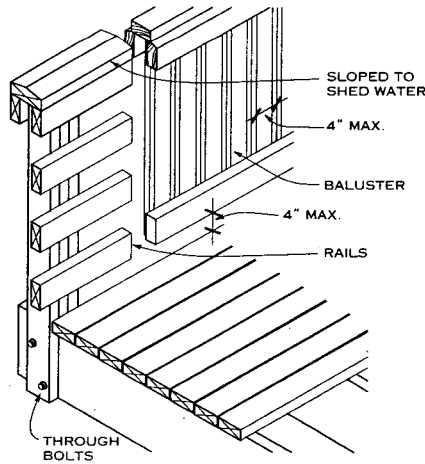
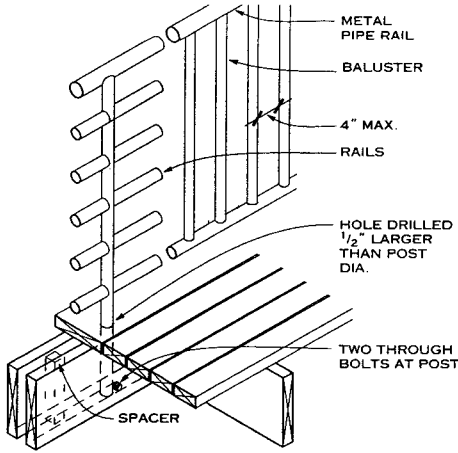

RAILINGS

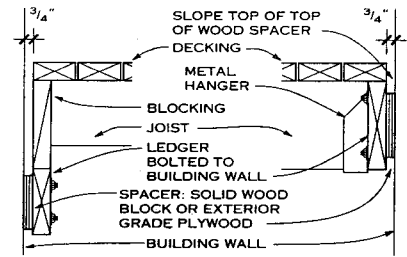

CONNECTIONS AT BUILDING WALL

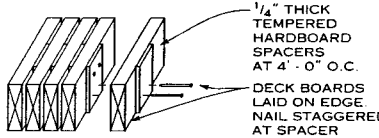
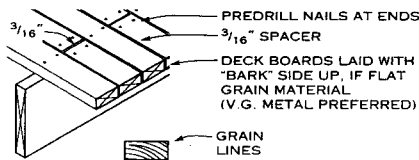

NOTE  
1/4" spacing not recommended for walking surfaces where high heels are anticipated.

DECKING APPLICATIONS

The Bumgardner Architects; Seattle, Washington

RELATIVE COMPARISON OF VARIOUS QUALITIES OF WOOD USED IN DECK CONSTRUCTION

	DOUGLAS FIR LARCH <sup>4</sup>	SOUTHERN PINE <sup>4</sup>	HEMLOCK FIR <sup>1,4</sup>	SOFT PINE <sup>2,4</sup>	WESTERN RED CEDAR	REDWOOD	SPRUCE	CYPRESS
Hardness	Fair	Fair	Poor	Poor	Poor	Fair	Poor	Fair
Warp resistance	Fair	Fair	Fair	Good	Good	Good	Fair	Fair
Ease of working	Poor	Fair	Fair	Good	Good	Fair	Fair	Fair
Paint holding	Poor	Poor	Poor	Good	Good	Good	Fair	Good
Stain acceptance <sup>3</sup>	Fair	Fair	Fair	Fair	Good	Good	Fair	Fair
Nail holding	Good	Good	Poor	Poor	Poor	Fair	Fair	Fair
Heartwood decay resistance	Fair	Fair	Poor	Poor	Good	Good	Poor	Good
Proportion of heartwood	Good	Poor	Poor	Fair	Good	Good	Poor	Good
Bending strength	Good	Good	Fair	Poor	Poor	Fair	Fair	Fair
Stiffness	Good	Good	Good	Poor	Poor	Fair	Fair	Fair
Strength as a post	Good	Good	Fair	Poor	Fair	Good	Fair	Fair
Freedom from pitch	Fair	Poor	Good	Fair	Good	Good	Good	Good

NOTES

1. Includes West Coast and eastern hemlocks.
2. Includes western and northeastern pines.
3. Categories refer to semitransparent oil base stain.
4. Use pressure preservative treated material only. All materials below deck surfaces should be pressure treated.



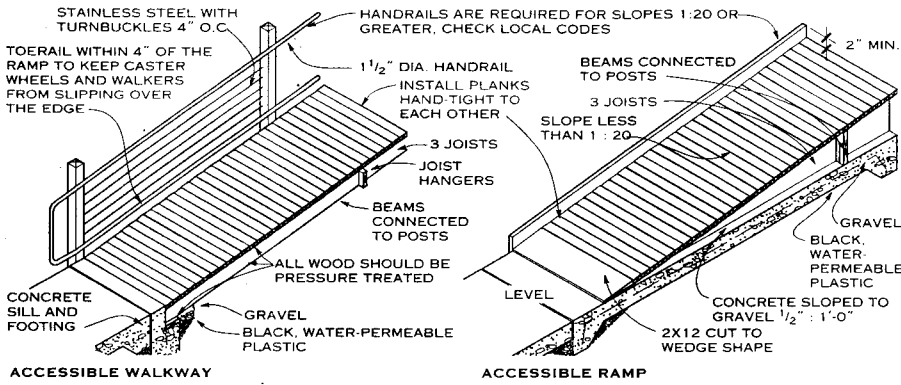

**ACCESSIBLE WALKWAY**  
**WALKWAYS AND RAMPS**

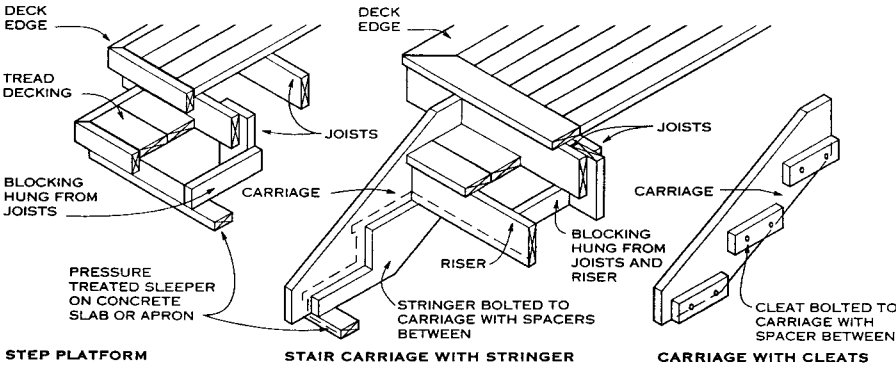

**STEP PLATFORM**  
**STAIRS AND STAIRS**

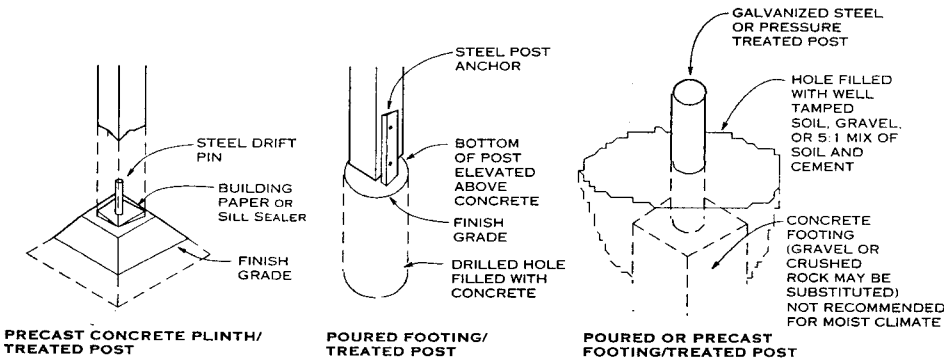

**PRECAST CONCRETE PLINTH/TREATED POST**  
**POURED FOOTING/TREATED POST**  
**POURED OR PRECAST FOOTING/TREATED POST**  
**POSTS AND FOOTINGS**

**FASTENERS**

1. Use hot-dipped galvanized fasteners to avoid corrosion and staining.
2. To reduce board splitting by nailing: blunt nail points; pre-drill (3/4 of nail diameter); stagger nailing; place nails no closer to edge than one-half of board thickness.
3. Avoid end grain nailing and toenailing if possible.
4. Use flat washers under heads of lag screws and bolts, and under nuts.
5. Hot-dipped galvanized casing nails or stainless steel deck screws are best decking fasteners.
6. Plated ring shank or spiral groove shank nails are suitable for arid climates.

**MOISTURE PROTECTION**

1. All wood members should be protected from weather by pressure treatment or field application of preservatives, stains, or paints.
2. All wood in direct contact with soil and concrete must be pressure treated.
3. Bottoms of posts on piers should be 6 in. above grade.
4. Sterilize or cover soil with membrane to keep plant growth away from wood members so as to minimize moisture exchange.
5. Treat all ends, cuts, holes, etc. with preservative before placement.
6. Decking and flat trim boards, 2 x 6 and wider, should be kerfed on the underside with 3/4 in. deep saw cuts at 1 in. o.c. to prevent cupping.
7. Avoid horizontal exposure of end grain or provide adequate protection by flashing or sealing. Avoid or minimize joint situations where moisture may be trapped by using spacers and/or flashing, caulking, sealant, or plastic roofing cement.

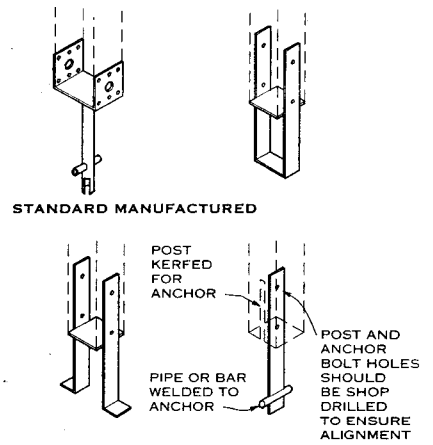

**STANDARD MANUFACTURED**  
**SHOP FABRICATED**  
**LOW DECK EDGES**

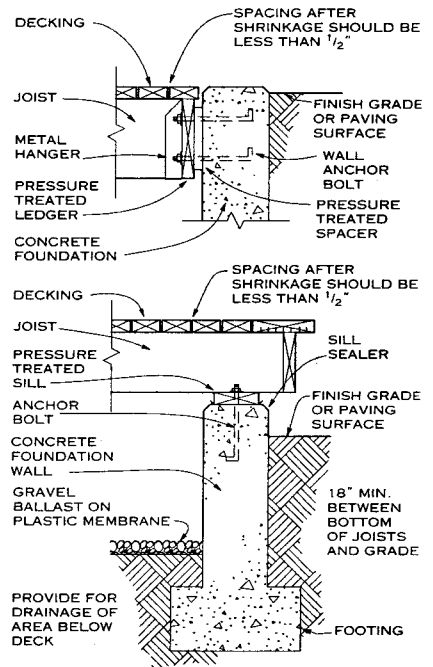

**LOW DECK EDGES**

**CONSTRUCTION**

1. **WOOD SELECTION:** Usual requirements are good decay resistance, nonsplintering, fair stiffness, strength, hardness, and warp resistance. Selection varies according to local climate and structure.
2. **BRACING:** On large decks, or decks where post heights exceed 5 ft, lateral stability should be achieved with horizontal bracing (metal or wood diagonal ties on top or bottom of joists, or diagonal application of decking) in combination with vertical bracing (rigid bolted or gusseted connections at tops of posts, knee bracing, or cross bracing between posts), and/or connection to a braced building wall. Lateral stability should be checked by a structural engineer.

The Bumgardner Architects; Seattle, Washington  
Mark J. Mazz, AIA; CEA, Inc.; Hyattsville, Maryland

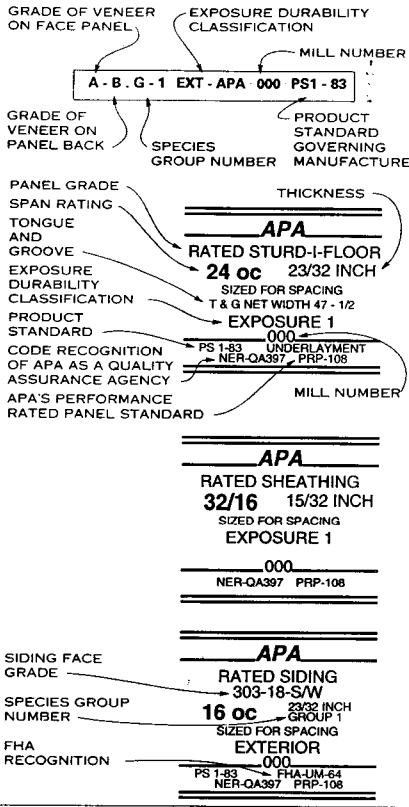

**APA TRADEMARKS**

**GRADE DESIGNATIONS**

Structural panel grades are generally identified in terms of the veneer grade used on the face and back of the panel (e.g., A-B, B-C, etc.) or rated by a name suggesting the panel's intended end use (e.g., APA-rated Sheathing, APA-rated Sturd-I-Floor, etc.).

**VENEER GRADES**

Veneer grades define veneer appearance in terms of natural unprepared growth characteristics and the number and size of repairs allowable during manufacture. The highest quality veneer grades are N and A. The minimum grade of veneer permitted in Exterior plywood is C-grade. D-grade veneer is used only for backs and inner plies of panels intended for interior use or applications protected from exposure to permanent or severe moisture.

- N—Smooth surface "natural finish" veneer. Select, all heartwood or all sapwood. Free of open defects. Allows not more than 6 repairs, wood only, per 4 x 8 panel, made parallel to grain and well matched for grain and color.
- A—Smooth, paintable. Not more than 18 neatly made repairs, boat, sled, or router type, parallel to grain permitted. May be used for natural finish in less demanding applications. Synthetic repairs permitted.
- B—Solid surface. Shims, circular repair plugs, and tight knots to 1 in. across grain permitted. Some minor splits and synthetic repairs permitted.
- C—PLUGGED—Improved C-grade veneer with splits limited to 1/2 in. width, knotholes and borer holes limited to 1/4 x 1/2 in. Admits some broken grain. Synthetic repairs permitted.
- C—Tight knots to 1 1/2 in. Knotholes to 1 in. across grain and some to 1 1/2 in. if total width of knots and knotholes is within specified limits. Synthetic or wood repairs. Discoloration and sanding defects that do not impair strength permitted. Limited splits allowed. Stitching permitted.
- D—Knots and knotholes to 2 1/2 in. width across grain and 1/2 in. larger within specified limits. Limited splits allowed. Stitching permitted. Limited to interior and Exposure 1 panels.

**SPAN RATINGS**

APA-rated Sheathing, APA-rated Sturd-I-Floor, and APA-rated Siding carry numbers in their trademarks called span ratings. These denote the maximum recommended center-to-center spacing in inches of supports for the panels in construction applications. Except for APA-rated Siding panels, the span rating in the trademark applies when the long panel dimension is across supports, unless the strength axis is otherwise identified. The span rating in the trademark of rated Siding panels applies when installed vertically.

The span rating in APA-rated Sheathing trademarks appears as two numbers separated by a slash, such as 32/16, 48/14, etc. (An exception is APA-rated Sheathing intended for use on walls only. The trademarks for these contain a single number similar to the span rating for APA-rated Siding.) The left-hand number denotes the maximum recommended spacing of supports when the panel is used for roof sheathing with the long dimension or strength axis of the panel across three or more supports. The right-hand number indicates the maximum recommended spacing of supports when the panel is used for subflooring with the long dimension or strength axis of the panel across three or more supports. A panel marked 32/16, for example, may be used for roof decking over supports 32 in. o.c. or for subflooring over supports 16 in. o.c.

The span ratings in the trademarks on APA-rated Sturd-I-Floor and Siding panels appear as a single number. APA-rated Sturd-I-Floor panels are designed specifically for single-floor (combined subfloor underlayment) applications under carpet and pad and are manufactured with span ratings of 16, 20, 24, 32, and 48 in. The span ratings for APA-rated Sturd-I-Floor panels, like those for APA-rated Sheathing, are based on application of the panel with the long dimension or strength axis across three or more supports.

APA-rated Siding is available with span ratings of 16 and 24 in. Span-rated panels and lap siding may be applied direct to studs or over nonstructural wall sheathing (Sturd-I-Wall construction), or over nailable panel or lumber sheathing (double wall construction). Panels and lap siding with a span rating of 16 in. may be applied direct to studs spaced 16 in. o.c. Panels and lap siding bearing a span rating of 24 in. may be applied direct to studs 24 in. o.c. All rated siding panels may be applied horizontally direct to studs 16 or 24 in. o.c., provided horizontal joints are blocked. When used over nailable structural sheathing, the span rating of rated siding panels refers to the maximum recommended spacing of vertical rows of nails rather than to stud spacing.

**GROUP NUMBER**

Plywood can be manufactured from more than 70 species of wood. These species are divided, on the basis of bending strength and stiffness, into five groups under U.S. Product Standard PS 1-83. Strongest species are in Group 1, the next strongest in Group 2, and so on. The group number that appears in the trademark on some APA trademarked panels—primarily sanded grades—is based on the species of face and back veneers. Where face and back veneers are not from the same species group, the higher group number is used, except for sanded and decorative panels 3/8 in. thick or less. These are identified by face species because they are chosen primarily for appearance and used in applications where structural integrity is not critical. Sanded panels greater than 3/8 in. are identified by face species if C or D grade backs are at least 3/8 in. and are no more than one species group number larger. Some species are used widely in plywood manufacture, others rarely. Check local availability before specifying if a particular species is desired.

**CLASSIFICATION**

GROUP 1	GROUP 2		GROUP 3	GROUP 4	GROUP 5
Apitong	Cedar,	Hemlock,	Alder, Red	Aspen,	Basswood
Beech, American	Port	Western	Birch, Paper	Bigtooth	Poplar,
Birch,	Oxford	Maple, Black	Cedar, Alaska	Quaking	Balsam
Sweet	Cypress	Mengkulang	Fir, Subalpine	Catwo	
Yellow	Douglas	Meranti,	Hemlock,	Cedar,	
Douglas Fir No. 1 <sup>a</sup>	Fir No. 2 <sup>a</sup>	Red <sup>b</sup>	Eastern	Incense	
Kapur	Fir,	Mersawa	Maple,	Western Red	
Keruing	Balsam	Pine,	Bigleaf	Cottonwood,	
Larch, Western	California	Pond	Pine,	Eastern	
Maple, Sugar	Red	Red	Jack	Black	
Pine,	Grand	Virginia	Lodgepole	(Western	
Caribbean	Noble	Western	Ponderosa	Poplar)	
Ocote	Pacific Silver	White	Spruce	Pine,	
Pine, Southern	White	Spruce,	Redwood	Eastern	
Loblolly	Lauan,	Black	Spruce,	White	
Longleaf	Almon	Red	Engelmann	Sugar	
Shortleaf	Bagtikan	Sitka	White		
Slash	Mayapis	Sweetgum			
Tanoak	Red	Tamarack			
	Tangile	Yellow-Poplar			
	White				

**NOTES**

- a. Douglas Fir from trees grown in the states of Washington, Oregon, California, Idaho, Montana, and Wyoming and the Canadian provinces of Alberta and British Columbia shall be classed as Douglas Fir No. 1. Douglas Fir from trees grown in the states of Nevada, Utah, Colorado, Arizona, and New Mexico shall be classed as Douglas Fir No. 2.
- b. Red Meranti shall be limited to species having a specific gravity of 0.41 or more based on green volume and oven dry weight.

Bloodgood, Sharp, Buster Architects and Planners; Des Moines, Iowa  
American Plywood Association; Tacoma, Washington

**APA-RATED SIDING PANELS**

For exterior siding, fencing, etc. Can be manufactured as conventional veneered plywood, as a composite, or as an overlaid oriented strand board siding. Both panel and lap siding available. Special surface treatment such as V-groove, shallow channel groove, deep groove (such as APA Texture 1-11), kerfed groove, brushed, rough-sawn, and texture-embossed (MDO). Span Rating (stud spacing for siding qualified for APA Sturd-I-Wall applications) and face grade classification (for veneer-faced siding) indicated in trademark Exposure Durability Classification: Exterior. Common thicknesses: 1/32, 3/8, 1/2, 5/8, 15/32, 1/2, 19/32, 5/8.

**303-PLYWOOD SIDING FACE GRADES**

CLASS	GRADE <sup>1</sup>	WOOD PATCHES	SYNTHETIC PATCHES
Special Series 303	303-OC <sup>2,3</sup>	Not permitted	Not permitted
	303-OL <sup>4</sup>	Not applicable for overlays	
	303-NR <sup>5</sup>	Not permitted	Not permitted
303-6	303-SR <sup>6</sup>	Not permitted	Permitted as natural defect shape only
	303-6-W	Limit 6	Not permitted
303-18	303-6-S	Not permitted	Limit 6
	303-6-S/W	Limit 6 - any combination	
	303-18-W	Limit 18	Not permitted
303-30	303-18-S	Not permitted	Limit 18
	303-18-S/W	Limit 18 - any combination	
	303-30-W	Limit 30	Not permitted
303-30-S	303-30-S	Not permitted	Limit 30
	303-30-S/W	Limit 30 - any combination	

**NOTES**

1. Limitations on grade characteristics are based on 4 x 8 ft panel size. Limits on other sizes vary in proportion. All panels except 303-NR allow restricted minor repairs such as shims. These and such other face appearance characteristics as knots, knotholes, splits, etc., are limited by both size and number in accordance with panel grades. 303 OC being most restrictive and 303-30 being least. Multiple repairs are permitted only on 303-18 and 303-30 panels. Patch size is restricted on all panel grades. For additional information, including finishing recommendations, see APA Product Guide: 303 Plywood Siding, E300.
2. Check local availability.
3. "Clear"
4. "Overlaid" (e.g., Medium Density Overlay siding)
5. "Natural Rustic"
6. "Synthetic Rustic"

**APA TEXTURE 1-11**

Special 303-Siding panel with grooves 1/4 in. deep, 3/8 in. wide, spaced 4 or 8 in. o.c. Other spacings may be available on special order. Edges shiplapped. Available unsanded, textured, and other surfaces. Exposure Classification: Exterior. Thicknesses: 19/32 and 5/8 only.

**APA SANDED AND TOUCH-SANDED PANELS<sup>(3,4,6)</sup>**

**APA A-A**

Use where appearance of both sides is important for interior applications such as built-ins, cabinets, furniture, partitions; and exterior applications such as fences, signs, boats, shipping containers, tanks, ducts, etc. Smooth surfaces suitable for painting. Exposure Durability Classifications: Interior, Exposure 1, Exterior. Common thicknesses: 1/4, 3/8, 1/2, 5/8, 3/4, 6/8.

**APA A-B**

For use where appearance of one side is less important but where two solid surfaces are necessary Exposure Durability Classifications: Interior, Exposure 1, Exterior. Common thicknesses: 1/4, 3/8, 1/2, 5/8, 3/4, 6/8.

**APA A-C**

For use where appearance of only one side is important in exterior applications, e.g., soffits, fences, structural uses, boxcar and truck linings, farm buildings, tanks, trays, commercial refrigerators, etc. Exposure Durability Classification: Exterior. Common thicknesses: 1/4, 3/8, 1/2, 5/8, 3/4, 6/8.

**APA A-D**

For use where appearance of only one side is important in interior applications, e.g., paneling, built-ins, shelving, partitions, etc. Exposure Durability Classifications: Interior, Exposure 1. Common thicknesses: 1/4, 3/8, 1/2, 5/8, 3/4, 6/8.

**APA B-B**

Utility panels with two solid sides. Exposure Durability Classifications: Interior, Exposure 1, Exterior. Common thicknesses: 1/4, 3/8, 1/2, 5/8, 3/4, 6/8.

**APA B-C**

Utility panel for farm service and work buildings, boxcar and truck linings, containers, tanks, agricultural equipment, as a base for exterior coatings and other exterior uses. Exposure Durability Classification: Exterior. Common thicknesses: 1/4, 3/8, 1/2, 5/8, 3/4, 6/8.

**APA B-D**

Utility panel for backing, sides of built-ins, industry shelving, slip sheets, separator boards, bins, and other interior or protected applications. Exposure Durability Classifications: Interior, Exposure 1. Common thicknesses: 1/4, 3/8, 1/2, 5/8, 3/4, 6/8.

**APA UNDERLAYMENT**

For application over structural subfloor. Provides smooth surface for application of carpet and pad and has high concentrated and impact load resistance. Touch-sanded. Exposure Durability Classifications: Interior, Exposure 1. Common thicknesses: 3/8, 1/2, 19/32, 5/8, 23/32, 3/4, 11/32.

**APA C-C PLUGGED**

For use as underlayment over structural subfloor, refrigerated or controlled atmosphere storage rooms, pallet bins, tanks, truck floors, linings and other exterior applications. Touch-sanded. Exposure Durability Classification: Exterior. Common thicknesses: 3/8, 1/2, 19/32, 5/8, 23/32, 3/4, 11/32.

**APA C-D PLUGGED**

For open soffits, built-ins, cable reels, walkways, separator boards, and other interior or protected applications. Not a substitute for underlayment or APA-rated Sturd-I-Floor as it lacks puncture resistance. Exposure Durability Classifications: Interior, Exposure 1. Common thicknesses: 3/8, 1/2, 19/32, 5/8, 23/32, 3/4.

**APA SPECIALTY PANELS**

**APA DECORATIVE**

Rough-sawn, brushed, grooved, or other faces. For paneling, interior accent walls, built-ins, counter facing, exhibit displays. Can also be made by some manufacturers in Exterior for siding, gable ends, fences, etc. Use recommendations for exterior panels vary with the particular product; check with manufacturer. Exposure Durability Classifications: Interior, Exposure 1. Exterior. Common thicknesses: 5/16, 3/8, 1/2, 5/8.

**APA HIGH-DENSITY OVERLAY (HDO)**

Has a hard semi-opaque resin-fiber overlay both sides. Abrasion-resistant. For concrete forms, cabinets, countertops, signs, tanks. Also available with skid-resistant screen-grid surface. Exposure Durability Classification: Exterior. Common thicknesses: 3/8, 1/2, 5/8, 3/4.

**APA MEDIUM-DENSITY OVERLAY (MDO)**

Smooth, opaque, resin-fiber overlay one or both sides. Ideal base for paint, indoors and outdoors. Available as a 303 Siding. Exposure Durability Classification: Exterior. Common thicknesses: 11/32, 3/8, 1/2, 5/8, 3/4, 15/32, 19/32, 23/32.

**APA MARINE**

Ideal for boat hulls. Made only with Douglas fir or western larch. Special solid-jointed core construction. Subject to special limitations on core gaps and face repairs. Also available with HDO or MDO faces. Exposure Durability Classification: Exterior. Common thicknesses: 1/4, 3/8, 1/2, 5/8, 3/4.

**APA B-B PLYFORM CLASS I AND II**

Concrete form grades with high reuse factor. Sanded both sides and mill-oiled unless otherwise specified. Special restrictions on species. Class I panels are stiffest, strongest, and most commonly available. Also available in HDO for very smooth concrete finish, in Structural I (all plies limited to Group 1 species), and with special overlays. Exposure Durability Classification: Exterior. Common thicknesses: 19/32, 5/8, 23/32, 3/4.

**APA PLYRON**

Hardboard face on both sides. Faces tempered, untempered, smooth, or screened. For countertops, shelving, cabinet doors, flooring, etc. Exposure Durability Classifications: Interior, Exposure 1, Exterior. Common thicknesses: 1/2, 5/8, 3/4.

**APA PERFORMANCE-RATED PANELS<sup>(1,2)</sup>**

**APA-RATED SHEATHING**

Specially designed for subflooring and wall and roof sheathing. Also good for broad range of other construction and industrial applications. Can be manufactured as a conventional veneered plywood, as a composite, or as a non-veneered panel. For special engineered applications, veneered panels conforming to PS1 may be required. Exposure Durability Classifications: Exterior, Exposure 1, Exposure 2. Common thicknesses: 5/16, 3/8, 7/16, 1/2, 5/8, 3/4, 15/32, 19/32, 23/32.

**APA STRUCTURAL I AND II RATED SHEATHING**

Unsanded all-veneer PS1 plywood grades for use where strength is of maximum importance; for box beams, gusset plates, stressed-skin panels, containers, pallet bins. Structural I is more commonly available. Exposure Durability Classifications: Exterior, Exposure 1. Common thicknesses: 5/16, 3/8, 1/2, 15/32, 19/32, 5/8, 23/32.

**APA-RATED STURD-I-FLOOR**

Specially designed as combination subfloor-underlayment. Provides smooth surface for application of carpet and pad and possesses high concentrated and load impact resistance. Can be manufactured as a nonveneered panel. Available square-edged or tongue-and-grooved. Exposure Durability Classifications: Exterior, Exposure 1, Exposure 2. Common thicknesses: 19/32, 5/8, 23/32, 3/4.

**APA-RATED STURD-I-FLOOR 48 OC (2-4-1)**

For combination subfloor-underlayment on 32- and 48-inch spans and for heavy timber roof construction. Manufactured only as conventional veneered plywood. Available square-edged or tongue-and-grooved. Exposure Durability Classifications: Exposure 1. Thickness: 1 1/8.

**NOTES FOR SANDED AND PERFORMANCE-RATED PANELS**

1. Specify performance-rated panels by thickness and span rating. Span ratings are based on panel strength and stiffness. Since these properties are a function of panel composition and configuration as well as thickness, the same span rating may appear on panels of different thickness. Conversely, panels of the same thickness may be marked with different span ratings.
2. All plies in Structural I panels are limited to Group 1 species. Structural II panels are seldom available.
3. Exterior sanded panels, C-C Plugged, C-D Plugged, and Underlayment grades can also be manufactured in Structural I (all plies limited to Group 1 species).
4. Some manufacturers also produce panels with premium N-grade veneer on one or both faces. Available only by special order.
5. Can also be manufactured in Structural I (all plies limited to Group 1 species).
6. Also available in 11/32, 15/32, 19/32, 23/32 in. thicknesses.

Bloodgood, Sharp, Buster Architects and Planners; Des Moines, Iowa  
American Plywood Association; Tacoma, Washington

**EXTERIOR TYPE PANELS**

APPEARANCE <sup>2</sup>		VENEER			THICKNESS (IN.)						
GRADE <sup>1</sup>	COMMON USES	F	M	B	1/4	5/16	3/8	1/2	5/8	3/4	
A-A EXT	Use where both sides are visible	A	C	A	*	*	*	*	*	*	
A-B EXT	Use where view of one side is less important	A	C	B	*	*	*	*	*	*	
A-C EXT	Use where only one side is visible	A	C	C	*	*	*	*	*	*	
B-B EXT	Utility panel with two solid faces; for interior or protected applications	B	C	B	*	*	*	*	*	*	
B-C EXT	Utility panel; also used as base for exterior coatings on walls and roofs	B	C	C	*	*	*	*	*	*	
HDO EXT	High-density overlay plywood has a hard, semio-paque resin fiber overlay on both faces. Abrasion resistant. Use for concrete forms, cabinets; suitable for permanent exterior exposure without further finishing	A B	C	A B	*	*	*	*	*	*	
MDO EXT	Medium-density overlay with smooth resin fiber overlay on one or two faces. Recommended for siding and other outdoor applications. Ideal base for paint	B	C	B C	*	*	*	*	*	*	
PANEL SIDING EXT <sup>4</sup>	Special surface treatment such as V-groove, channel groove, striated, brushed, rough sawn		C	C	*	*	*	*	*	*	
T1-11 EXT <sup>4</sup>	Special 303 panel having grooves 1/4 in. deep, 3/8 in. wide, spaced 4 or 8 in. o.c.; other spacing optional. Edges shiplapped. Available unsanded, textured, and medium-density overlay	A B C	C	C	*	*	*	*	*	*	
PLYRON EXT	Hardboard faces both side; tempered, smooth, or screened	HB	C	HB	*	*	*	*	*	*	
UNDERLAYMENT C-C PLUGGED EXT	For application over structural subfloor. Provides smooth surface for application of carpet and pad. Touch-sanded.	C	C	C	*	*	*	*	*	*	
C-C PLUGGED EXT	Commonly used for severe moisture conditions, including refrigerated and controlled-atmosphere rooms.	C- Plugged	C	C	*	*	*	*	*	*	
B-B PLYFORM CLASS I and CLASS II EXT <sup>3</sup>	Concrete form grades with high reuse factor. Sanded both sides and mill-oiled unless otherwise specified. Special restrictions on species. Also available in HDO for very smooth concrete finish.	B	C	B	*	*	*	*	*	*	
PERFORMANCE RATED <sup>2</sup>		VENEER			THICKNESS						
GRADE	COMMON USES	F	M	B	1/4	5/16	3/8	1/2	5/8	3/4	
SHEATHING EXT	Exterior sheathing panel for subflooring and wall and roof sheathing, siding on service and farm buildings. Manufactured as conventional veneered plywood.	C	C	C	*	*	*	*	*	*	
STRUCTURAL 1 SHEATHING EXT	For engineered applications in construction and industry where full exterior type panels are required. Unsanded.	C	C	C	*	*	*	*	*	*	
STURDI-FLOOR EXT	For combination subfloor underlayment under carpet and pad where severe moisture conditions exist (e.g., balcony decks). Touch-sanded and tongue and groove.	C	C	C	*	*	*	*	*	*	

**INTERIOR TYPE PANELS**

APPEARANCE <sup>2</sup>		VENEER			THICKNESS (IN.)						
GRADE <sup>1,8</sup>	COMMON USES	F	M	B	1/4	5/16	3/8	1/2	5/8	3/4	
A-A INT	For applications where both sides are visible. Smooth face; suitable for painting	A	D	A	*	*	*	*	*	*	
A-B INT	Use where view of one side is less important but two solid surfaces are needed	A	D	B	*	*	*	*	*	*	
A-D INT	Use where only one side is visible	A	D	D	*	*	*	*	*	*	
B-B INT	Utility panel with two solid sides	B	D	B	*	*	*	*	*	*	
B-D INT	Utility panel with one solid side	B	D	D	*	*	*	*	*	*	
DECORATIVE PANELS-INT	Rough sawn, brushed, grooved, or striated faces for walls and built-ins	A B C	D	D	*	*	*	*	*	*	
PLYRON-INT	Hardboard face on both sides; tempered smooth or screened for counters and doors	HB	C	HB D	*	*	*	*	*	*	
UNDERLAYMENT-INT	For application over structural subfloor. Provides smooth surface for application of carpet and pad. Touch-sanded. Also available with exterior glue	C	C	D	*	*	*	*	*	*	
C-D PLUGGED INT	For built-ins, wall and ceiling tile backing, cable reels, walkways, separator boards. Not a substitute for UNDERLAYMENT or STURDI-FLOOR as it lacks their indentation resistance. Touch-sanded. Also made with exterior glue	C	D	D	*	*	*	*	*	*	
PERFORMANCE RATED <sup>2,5</sup>		VENEER <sup>3</sup>			THICKNESS						
GRADE	COMMON USES	F	M	B	1/4	5/16	3/8	1/2	5/8	3/4	
SHEATHING EXP 1	Commonly available with exterior glue for sheathing and subflooring. Specify Exposure 1 treated wood foundations	C	D	D	*	*	*	*	*	*	
STRUCTURAL 1 SHEATHING EXP 1	Unsanded structural grades where plywood strength properties are of maximum importance. Made only with exterior glue for beams, gusset plates, and stressed-skin panels	C <sup>6</sup>	D <sup>6</sup>	D <sup>6</sup>	*	*	*	*	*	*	
FLOOR EXP 1 and 2	For combination subfloor and underlayment under carpet and pad. Specify Exposure 1 where moisture is present. Available in tongue and groove	C	C	D	*	*	*	*	*	*	
FLOOR 48 in. o.c. EXP 1	Combination subfloor underlayment on 32 and 48 in. spans and for heavy timber roofs. Touch-sanded or fully sanded	C	C	D	*	*	*	*	*	1/8	

**NOTES—EXTERIOR AND INTERIOR PANELS**

- <sup>1</sup> Available in Group 1, 2, 3, 4, or 5 unless otherwise noted.
- <sup>2</sup> Standard 4 x 8 panel sizes; other sizes available.
- <sup>3</sup> Also available in Structural I.
- <sup>4</sup> Maximum recommended support spacing for roofs and floors is indicated in sheathing and single layer floor trademarks. Wall span ratings are included in rated siding panels.
- <sup>5</sup> Exposure 2 allowed but not typically produced.
- <sup>6</sup> Special improved grade for structural panels.
- <sup>7</sup> Special construction to resist indentation from concentrated loads.
- <sup>8</sup> Interior type panels with exterior glue are identified as Exposure I.
- <sup>9</sup> Also available as nonveneer or composite panels.

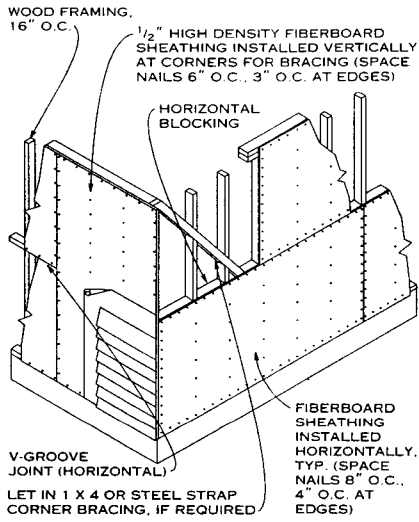

**FIBERBOARD SHEATHING**

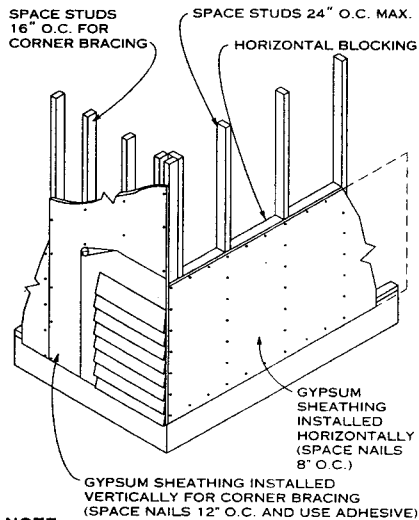

**NOTE**  
Nail siding through gypsum board to studs; refer to manufacturer's recommendations for specific installation instructions.

**GYPHUM BOARD SHEATHING**

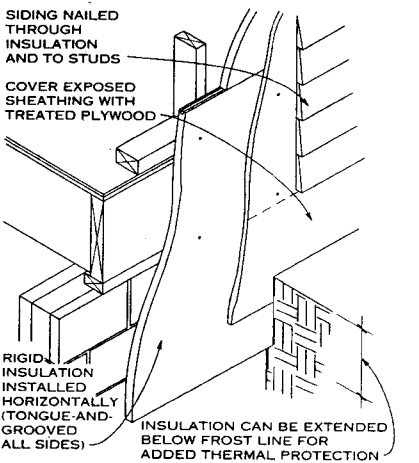

**RIGID INSULATION SHEATHING**

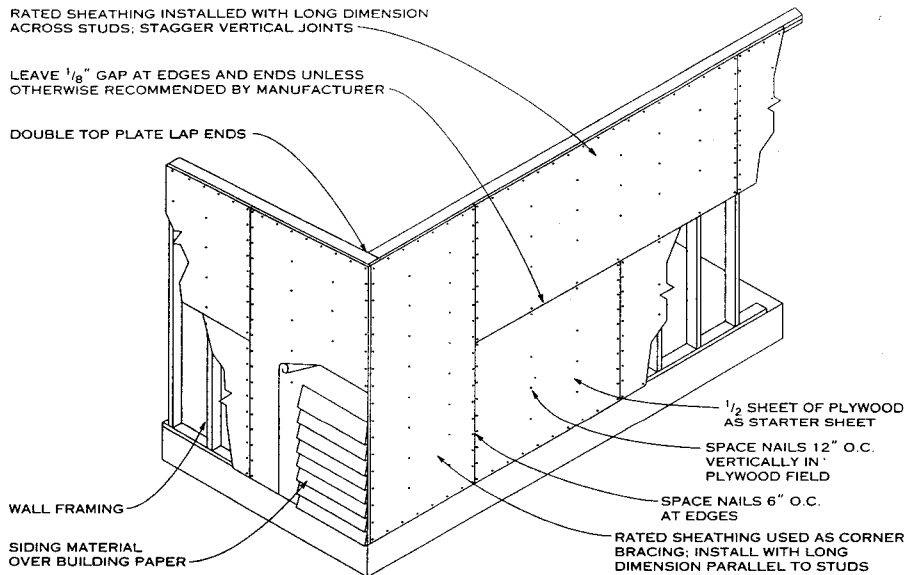

**STRUCTURAL WALL SHEATHING**

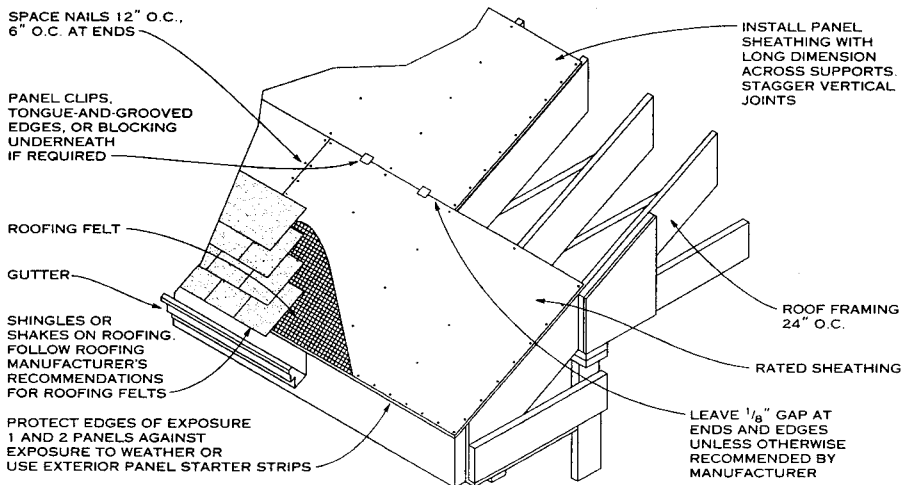

**NOTE**  
Cover roof sheathing as soon as possible with roofing felt for extra protection from moisture before roofing is applied.

**STRUCTURAL ROOF SHEATHING**

**SHEATHING MATERIALS**

CHARACTERISTICS	STRUCTURAL SHEATHING	GYPHUM	FIBERBOARD	PLASTIC
Available base	Yes	No	Only high-density	No
Vapor barrier	No	No	If asphalt-treated	Yes
Insulation R value (1/2 in. thickness)	1.2	0.7	2.6	Varies with manufacturer
Corner bracing provided	yes	Yes (see manufacturer's recommendations)	Only high-density	No
Panel sizes (ft, except plastic in in.)	4 x 8, 4 x 9, 4 x 10	2 x 8, 4 x 8, 4 x 10, 4 x 12, 4 x 14	4 x 8, 4 x 9, 4 x 10, 4 x 12	16 x 96, 24 x 48, 224 x 96, 48 x 96, 48 x 108
Panel thickness (in.)	5/16, 3/8, 7/16, 1/2, 19/32, 5/8, 23/32, 3/4, 7/8, 1, 1 1/8	1/4, 3/8, 1/2, 5/8	1/2, 25/32	1/2 to 6 (for roof)
Other remarks	Plywood grades commonly used for roof and wall sheathing have span ratings of 12/0, 16/0, 20/0, 24/0, 24/16, 32/16, 40/20, and 48/24; exposure durability classifications are Exposure 1 and Exterior. For unsupported edges, refer to manufacturer's recommendations.	Fire-rated panels are available in 1/2 and 5/8 in. thicknesses.	Also called insulation board. Can be treated or impregnated with asphalt. Available in regular and high-density panels.	Considered an effective vapor barrier, so walls must be well vented. Some products emit toxic fumes when burned; refer to manufacturer's specifications.

David S. Collins, FAIA; American Forest & Paper Association; Cincinnati, Ohio

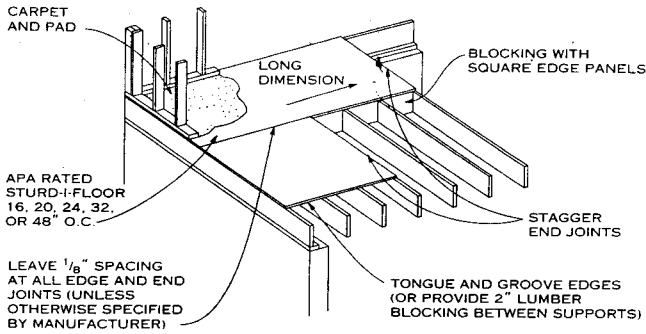

**APA RATED STURD-I-FLOOR**

SPAN RATING (MAXIMUM JOIST SPACING, IN.)	PANEL THICKNESS (IN.)	NAIL SIZE AND TYPE	FASTENING			
			GLUE/ NAILED	NAILED ONLY	GLUE/ NAILED	NAILED ONLY
			SPACING (IN.)			
			PANEL EDGE	INTERMEDIATE		
16	<sup>19</sup> / <sub>32</sub> , <sup>5</sup> / <sub>8</sub> , <sup>21</sup> / <sub>32</sub>	6d ring or screw shank <sup>3</sup>	12	6	12	12
20	<sup>19</sup> / <sub>32</sub> , <sup>5</sup> / <sub>8</sub> , <sup>23</sup> / <sub>32</sub> , <sup>3</sup> / <sub>4</sub>	6d ring or screw shank <sup>3</sup>	12	6	12	12
24	<sup>11</sup> / <sub>16</sub> , <sup>23</sup> / <sub>32</sub> , <sup>3</sup> / <sub>4</sub>	6d ring or screw shank <sup>3</sup>	12	6	12	12
	<sup>7</sup> / <sub>8</sub> , 1	8d ring or screw shank <sup>3</sup>	12	3	12	12
48	1 <sup>1</sup> / <sub>8</sub>	8d ring or screw shank <sup>4</sup>	6	6		

- NOTES**
- For conditions not listed, see APA literature.
  - Use only APA Specification AFG-01 adhesives, properly applied. Use only solvent based glues on nonveneered panels with sealed surfaces and edges.
  - 8d common nails may be substituted if ring or screw-shank nails are not available.
  - 10d common nails may be substituted with 1<sup>1</sup>/<sub>8</sub> in. panels if supports are well seasoned.
  - Space nails 6 in. for 48 in. spans and 12 in. for 32 in. spans.

**UNDERLAYMENT NAILING SCHEDULE**

Use 3d ring shank nails for underlayment up to 1/2 in. thickness, 4d for 19/32 in. and thicker. Use 16 gauge staples, except that 18 gauge may be used with 1/4 in. thick underlayment. Crown width should be 3/8 in. for 16 gauge staples, 2/16 in. for 18 gauge. Length should be sufficient to penetrate subflooring at least 3/8 in. or extend completely through. Space fasteners at 3 in. along panel edges and 6 in. each way in the panel interior, except for 1 1/2 in. or thicker underlayment applied with ring shank nails. In this case, use 6 in. spacing along edges and 8 in. spacing each way in the panel interior. Unless subfloor and joists are of thoroughly seasoned material and have remained dry during construction, countersink nail heads below surface of the underlayment just prior to laying finish floors to avoid nail popping. Space joints 1/32 in. If thin resilient flooring is to be applied, fill and thoroughly sand joints.

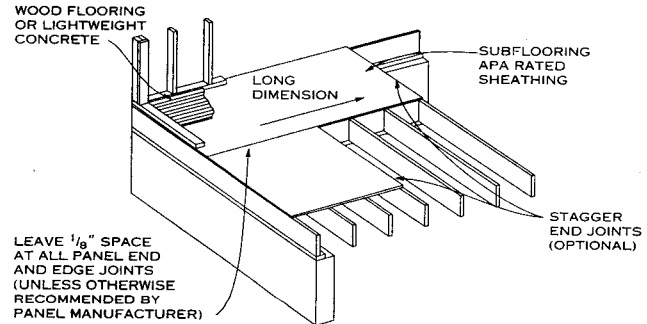

**APA PANEL SUBFLOORING<sup>1</sup>**

PANEL SPAN RATING (OR GROUP NUMBER)	PANEL THICKNESS (IN.)	MAXIMUM SPACING <sup>2,3,5</sup> (IN.)
24/16	<sup>7</sup> / <sub>16</sub> , 1/2	16
32/16	<sup>15</sup> / <sub>32</sub> , 1/2, <sup>5</sup> / <sub>8</sub> , <sup>23</sup> / <sub>32</sub>	16 <sup>4</sup>
40/20	<sup>19</sup> / <sub>32</sub> , <sup>5</sup> / <sub>8</sub> , <sup>23</sup> / <sub>32</sub> , <sup>3</sup> / <sub>4</sub>	20 <sup>4</sup>
48/24	<sup>23</sup> / <sub>32</sub> , <sup>3</sup> / <sub>4</sub> , 1 <sup>1</sup> / <sub>8</sub>	24
1 <sup>1</sup> / <sub>8</sub> in., Groups 1 and 2	1 <sup>1</sup> / <sub>8</sub>	48

- NOTES**
- Applies to APA rated sheathing grades only.
  - The spans assume plywood continuous over two or more spans with long dimension across supports.
  - In some nonresidential buildings, special conditions may require construction in excess of minimums given.
  - May be 24 in. if 3/4 in. wood strip flooring is installed at right angles to joists.
  - Spans are limited to the values shown because of the possible effect of concentrated loads.

**SUBFLOORING NAILING SCHEDULE**

For 7/16 in. panel, use 6d common nails at 6 in. o.c. at panel edges, 12 in. o.c. at intermediate supports. For 19/32 to 1/8 in. panels, use 8d common nails at 6 in. o.c. at panel edges, 12 in. o.c. at intermediate supports. For 1 1/8 and 1 1/4 in. panels up to 48 in. span, use 10d common nails 6 in. o.c. at panel edges and 6 in. o.c. at intermediate supports.

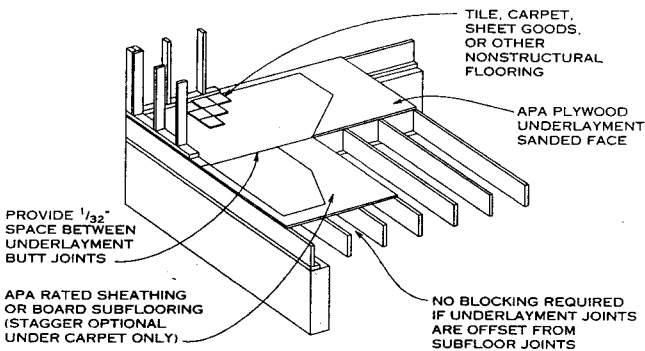

**PLYWOOD UNDERLAYMENT<sup>1</sup>**

PLYWOOD GRADES AND SPECIES GROUP	APPLICATION	MIN. PLYWOOD THICKNESS (IN.)
Groups 1, 2, 3, 4, and 5 UNDERLAYMENT INT-APA (with interior or exterior glue), or UNDERLAYMENT EXT-APA (C-C plugged) EXT	Over smooth subfloor	1/4
	Over lumber subfloor or other uneven surfaces	1 1/32
Same grades as above, but Group 1 only	Over lumber floor up to 4 in. wide. Face grain must be perpendicular to boards	1/4

- NOTES**
- For tile, carpeting, sheet goods, or other nonstructural flooring (consult Tile Council of America for recommendations regarding ceramic tile).
  - Where floors may be subject to unusual moisture conditions, use panels with exterior glue (Exposure 1) or UNDERLAYMENT C-C Plugged EXT-APA. C-D Plugged is not an adequate substitute for underlayment grade, since it does not ensure equivalent dent resistance.
  - Recommended grades have a solid surface backed with a special inner ply construction that resists punch-through and dents from concentrated loads.

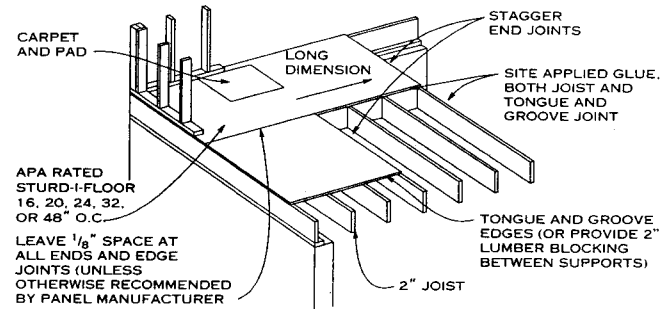

**GLUED FLOOR SYSTEM**

- For complete information on glued floors, including joist span tables (based on building code criteria and lumber sizes), application sequence, and a list of recommended adhesives, contact the American Plywood Association.
- Place APA STURD-I-FLOOR T&G across the joists with end joints staggered. Leave 1/8 in. space at all end and edge joints.
- Although tongue and groove is used more often, square edge may be used if 2 x 4 blocking is placed under panel edge joints between joists.
- Based on live load of 40 psf, total load of 50 psf, deflection limited to 1/360 at 40 psf.
- Glue to joists and at tongue and groove joints. If square edge panels are used, block panel edges and glue between panels and between panels and blocking.

**GLUED FLOOR NAILING SCHEDULE**

Panels should be secured with power driven fasteners or nailed per APA STURD-I-FLOOR table, above.

Bloodgood, Sharp, Buster Architects and Planners; Des Moines, Iowa  
American Plywood Association; Tacoma, Washington

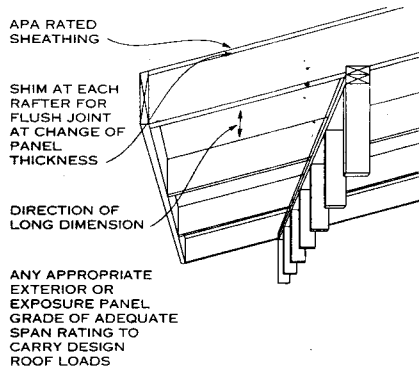

OPEN SOFFIT

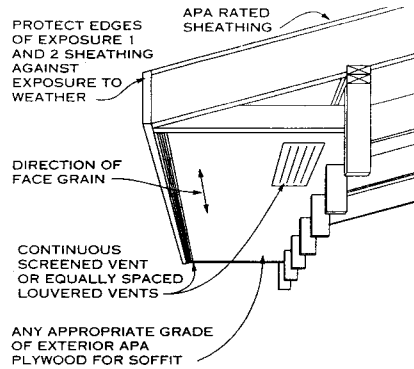

CLOSED SOFFIT

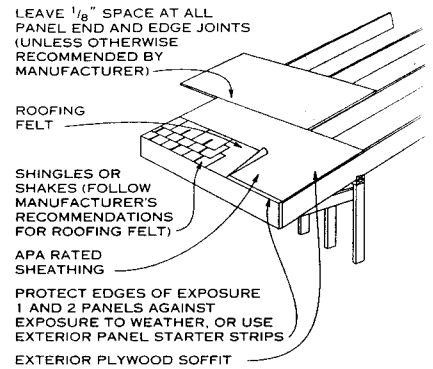

GABLE ROOF

EXTERIOR OPEN SOFFITS/ COMBINED CEILING DECKING

PANEL DESCRIPTIONS, MINIMUM RECOMMENDATIONS	GROUP	MAXIMUM SPAN (IN.)
1 1/32" APA 303 siding	1, 2, 3, 4	16
1 1/32" APA sanded and MDO	1, 2, 3, 4	16
1 1/32" APA 303 siding	1	24
1 1/32" APA sanded and MDO	1, 2, 3	24
1 1/32" APA 303 siding	1, 2, 3, 4	24
1 1/32" APA sanded and MDO	1, 2, 3, 4	24
1 1/32" APA 303 siding	1	32 <sup>2</sup>
1 1/32" APA sanded and MDO	1	32 <sup>2</sup>
2 3/32" APA 303 siding	1, 2, 3, 4	32 <sup>2</sup>
2 3/32" APA sanded and MDO	1, 2, 3, 4	32 <sup>2</sup>
1 1/8" APA textured	1, 2, 3, 4	48 <sup>2</sup>

NOTES

- Plywood is assumed to be continuous across two or more spans with face grain across supports.
- For spans of 32 or 48 in. in open soffit construction, provide adequate blocking, tongue and groove edges, or other support such as panel clips. Minimum loads are at least 30 psf live load, plus 10 psf dead load.

EXTERIOR CLOSED PLYWOOD SOFFITS

NOMINAL PLYWOOD THICKNESS	GROUP	MAXIMUM SPAN (IN.) ALL EDGES SUPPORTED
1 1/32" APA 303 Siding or APA sanded	All species groups	24
1 1/32" APA 303 Siding or APA sanded		32
1 1/32" APA 303 Siding or APA sanded		48

NOTE

Plywood is assumed to be continuous across two or more spans with face grain across supports.

NAILING SCHEDULE

For closed soffits, use nonstaining box or casing nails, 6d for 1 1/32 in. and 1 1/32 in. panels and 8d for 1 1/32 in. panels. Space nails 6 in. at panel edges and 12 in. along intermediate supports for spans less than 48 in.; 6 in. at all supports for 48 in. spans.

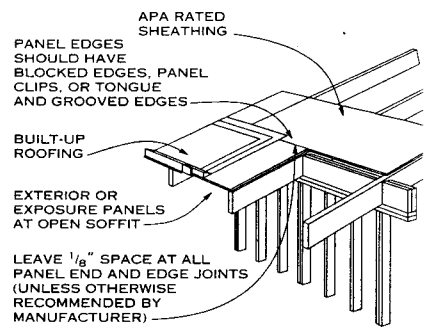

FLAT LOW-PITCHED ROOF

APA PANEL ROOF SHEATHING

PANEL SPAN RATING	PANEL THICKNESS (IN.)	MAXIMUM SPAN (IN.)		NAIL SIZE AND TYPE	NAIL SPACING (IN.)		
		WITH EDGE SUPPORT	WITHOUT EDGE SUPPORT		PANEL EDGES	INTERMEDIATE	
12/0	5/16	12	12	6d common	6	12	
16/0	5/16, 3/8	16	16				
20/0	5/16, 3/8	20	20				
24/0	3/8, 7/16, 1 1/32, 1/2	24	20				
24/16	7/16, 1 1/32, 1/2	24	24				
32/16	1 1/32, 1/2	32	28				
32/16	1 1/32, 5/8	32	28				
40/20	1 1/32, 5/8, 2 3/32, 3/4, 7/8	40	32				
40/24	2 3/32, 3/4, 7/8	48	36				
(see above)	5/16	(see above)		8d common	STAPLING SPACES (IN.)		
	3/8				LEG LENGTH	PANEL EDGES	INTERMEDIATE
	7/16, 1 1/32, 1/2				1 1/4"	4	8
				1 3/8"			
				1 1/2"			

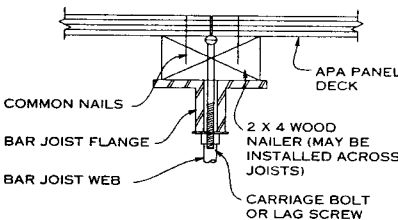
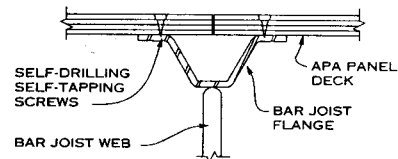

CONNECTIONS TO OPEN WEB STEEL JOIST

NAILING SCHEDULE

Use 6d common smooth, ring shank, or spiral thread nails for plywood 1/2 in. thick or thinner and 8d for plywood to 1 in. thick. Use 8d ring shank or spiral thread or 10d common smooth for 2-4-1 and 1 1/8 in. panels. Space nails 6 in. at panel edges and 12 in. at intermediate supports, except for 48 in. or longer spans where nails should be spaced 6 in. at all supports.

NOTES

- Applicable to APA rated panel sheathing.
- All panels will support at least 30 psf live load plus 10 psf dead load at maximum span. Uniform load deflection limit is 1/180 span under live load plus dead load, or 1/240 under live load only.
- Special conditions may require construction in excess of the given minimums.
- Panel is assumed to be continuous across two or more spans with long dimension across supports.

Bloodgood, Sharp, Buster Architects and Planners; Des Moines, Iowa  
American Plywood Association; Tacoma, Washington

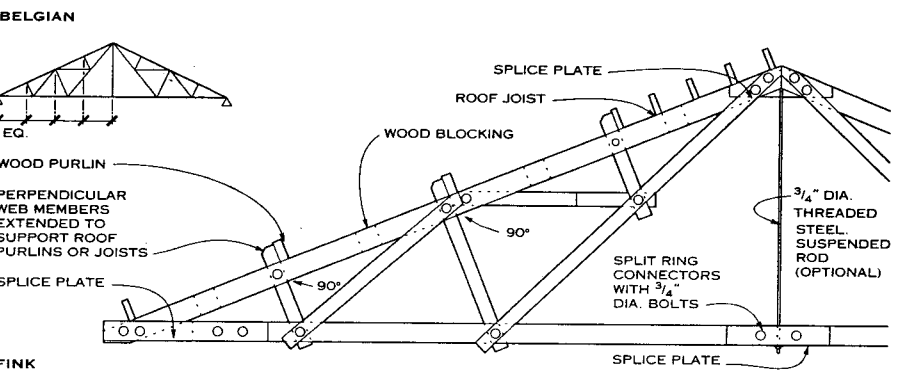
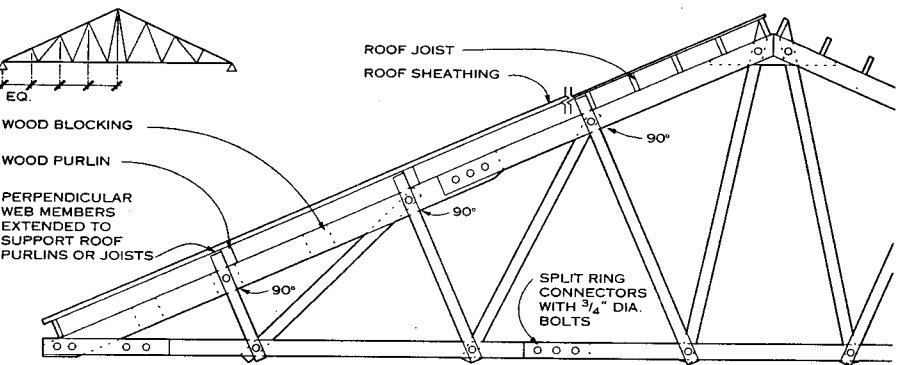
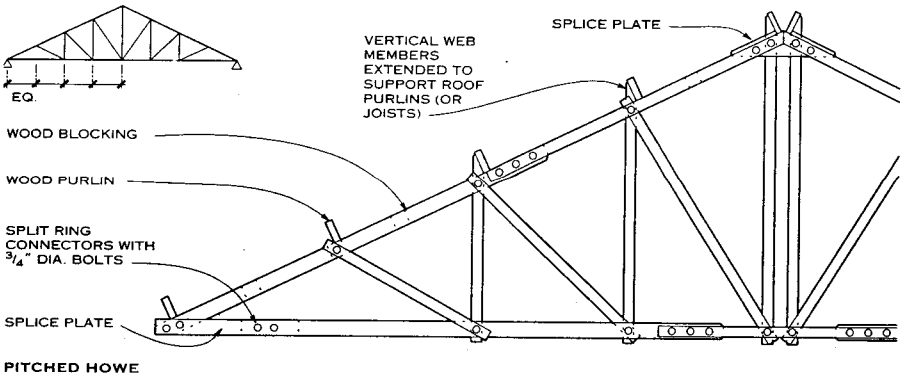
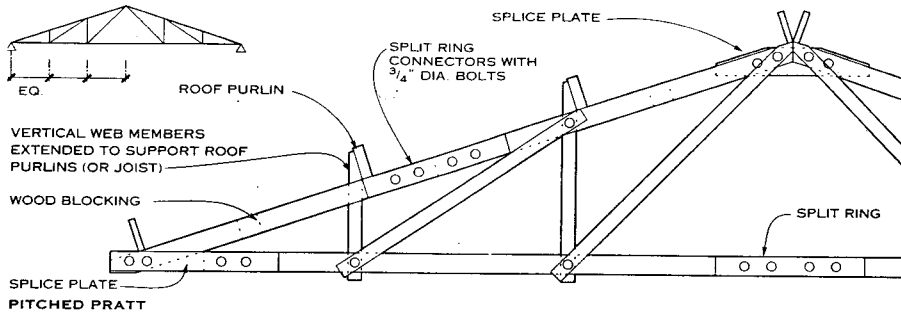

Pitched trusses are very economical for spans up to 70 ft (with an average spacing of 15 ft), since the member sizes are small, the joint details relatively simple, and the trusses easily fabricated.

All pitched trusses require either knee braces to columns or some other provision for lateral restraint against wind or other forces.

A typical span (l) / depth (d) ratio for the Pratt, Howe, or Belgian truss is 4 to 6, which gives a relatively normal slope of 4:12 to 6:12. Fink trusses are preferred where the slope is steep (over 7:12). Scissors trusses and other types of raised lower chord pitched roof trusses are used for special conditions where clearance or appearance requires an arched bottom chord. Consult with structural engineer to check deflection.

**PITCHED TRUSSES**

TECO Products; Collier, West Virginia  
Richard J. Vitullo, AIA; Oak Leaf Studio; Crownsville, Maryland

**GENERAL**

The first wood trusses were developed for bridge design, with the kingpost truss the earliest form. It uses a primary engineering principle: a triangle will hold its shape under a load until its side members or its joints are crushed.

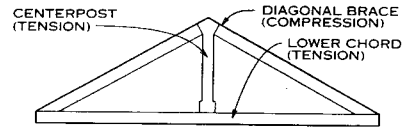

**QUEENPOST**

Next came the queenpost truss, in which the peak of the kingpost was replaced by a horizontal crosspiece to allow a longer base.

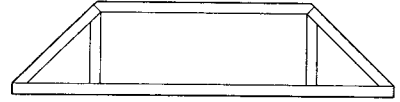

**NOTES**

Further amplifications permitted greater flexibility to overcome different spanning challenges and to integrate various combinations of inclined wood braces, wood arches, steel tension rods, etc.

**NOTES**

1. A built-in camber of approximately 1 in. per 40 ft span will be introduced in the top and bottom chords during fabrication.
2. When lumber is not adequately seasoned, the trusses should be inspected periodically and adjusted, if necessary, until moisture equilibrium is reached.
3. These truss designs are meant only as a guide. To develop specific designs, including bracing and anchorage, consult a structural engineer.

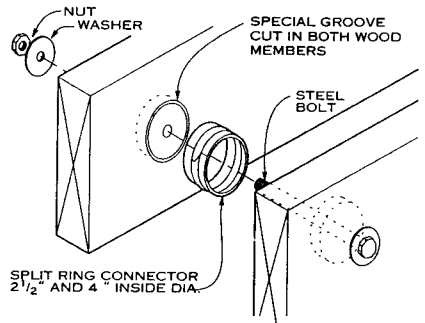

**SPLIT RING CONNECTOR**

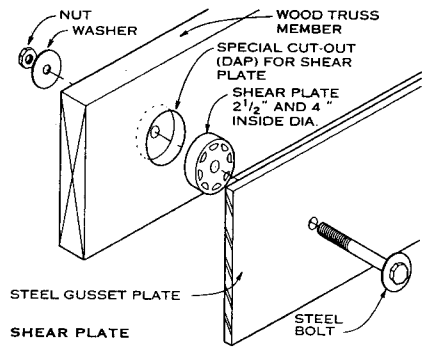

Shear plate connectors are commonly used to connect wood truss members to steel gusset plates but may be used to connect wood to wood.

**CONNECTORS**



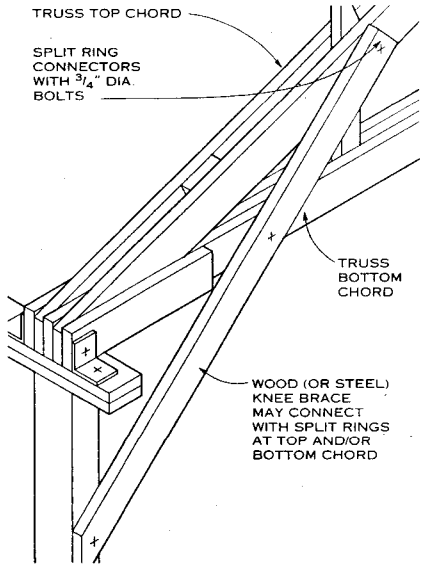

**NOTE**  
Knee braces are useful where building supports depend on truss for stability.

**DETAIL—KNEE BRACE**

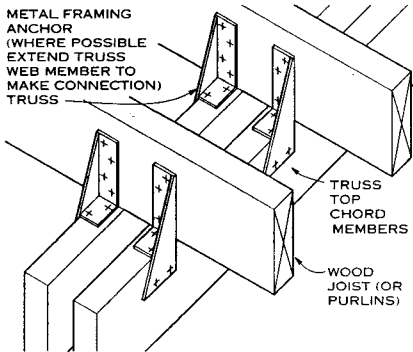

**NOTE**  
Top chord lateral bracing is achieved by fastening roof sheathing to joists or purlins, which are securely fastened to the truss.

**DETAIL—BRACE OF JOIST AND PURLIN TO TRUSS**

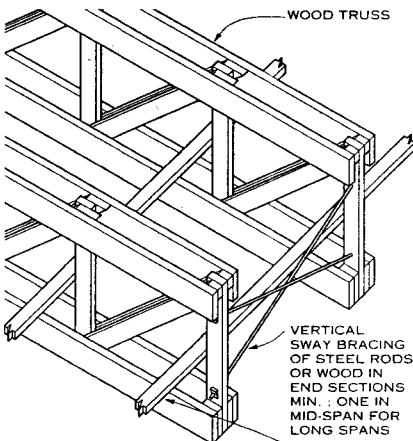

**DETAIL—LATERAL AND VERTICAL SWAY BRACING**

TECO Products: Collier, West Virginia  
Richard J. Vitullo, AIA; Oak Leaf Studio; Crownsville, Maryland

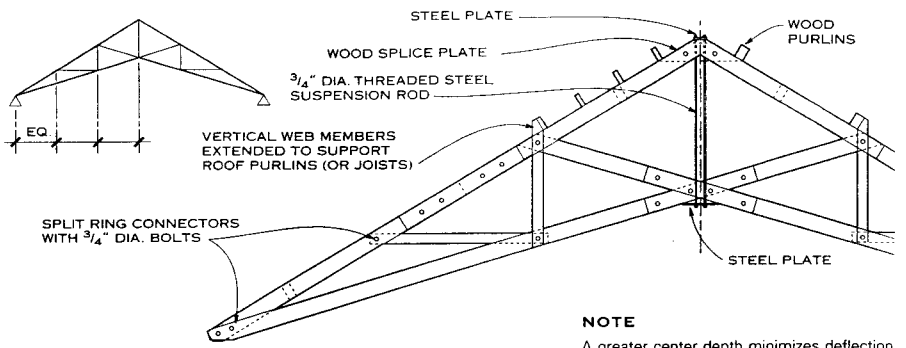

**NOTE**  
A greater center depth minimizes deflection and thrust on walls.

**SCISSORS  
PITCHED TRUSSES**

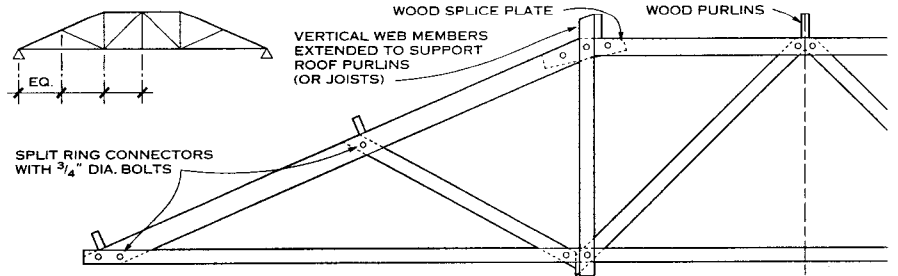

**SEGMENTAL BOWSTRING**

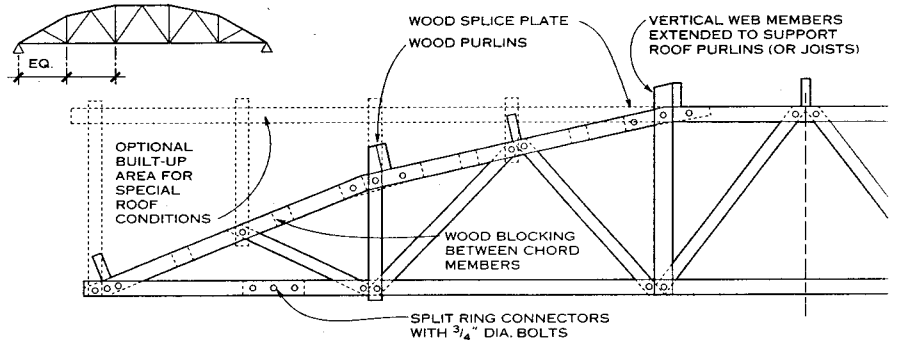

**SEGMENTAL BOWSTRING**

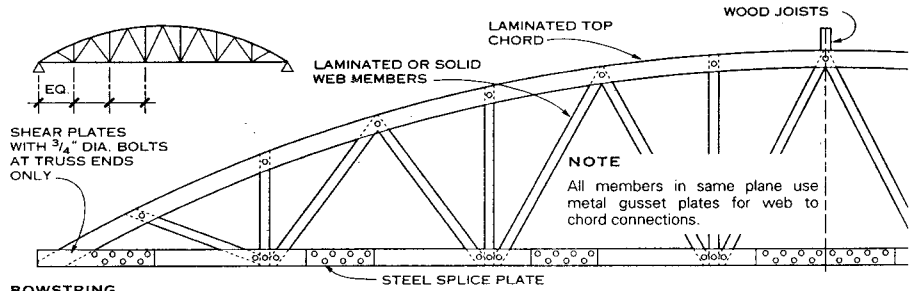

**NOTE**  
All members in same plane use metal gusset plates for web to chord connections.

**BOWSTRING**

Bowstring trusses are theoretically the most efficient and economical of all wood truss types for larger spans, particularly over 80 ft, although spans up to 250 ft are obtainable. Connections are simple and designed to give minimum stresses to the web members. A typical span (l)/depth (d) ratio for bowstring trusses is 6 to 8.

Connections and knee brace requirements are similar to that of pitched trusses, since lateral load forces have a similar effect on them. The bottom chord members may also be glue laminated to eliminate splices.

**BOWSTRING TRUSSES**

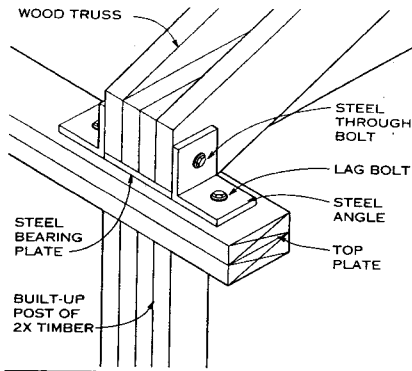

DETAIL—STEEL ANGLE BRACE TO WOOD PLATE

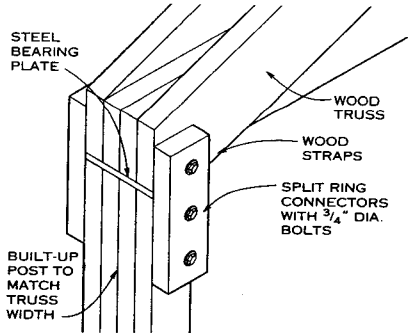

DETAIL—WOOD STRAP AT WOOD COLUMN

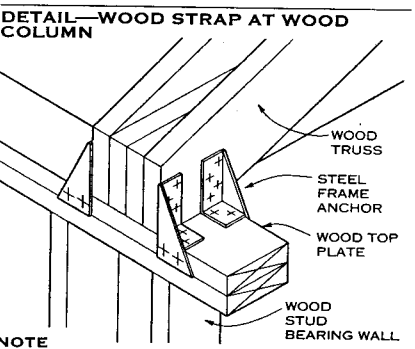

DETAIL—STEEL FRAMING ANCHOR

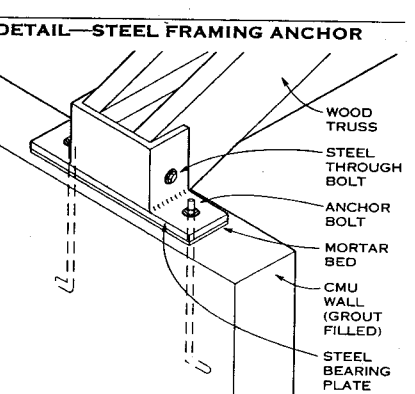

DETAIL—BEARING ON MASONRY WALL

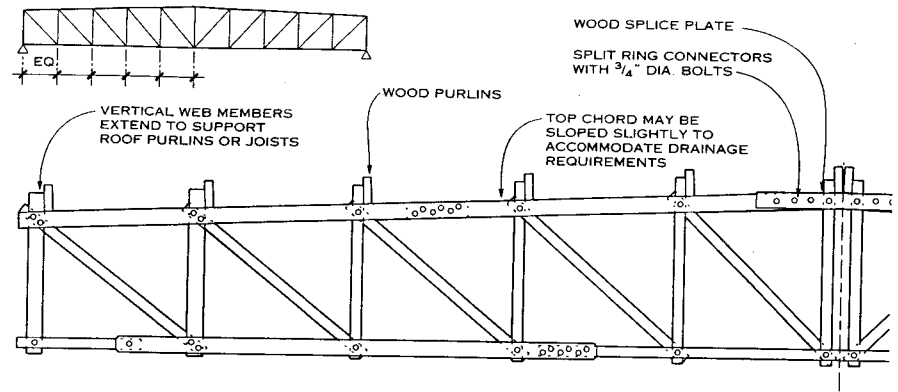

FLAT PRATT

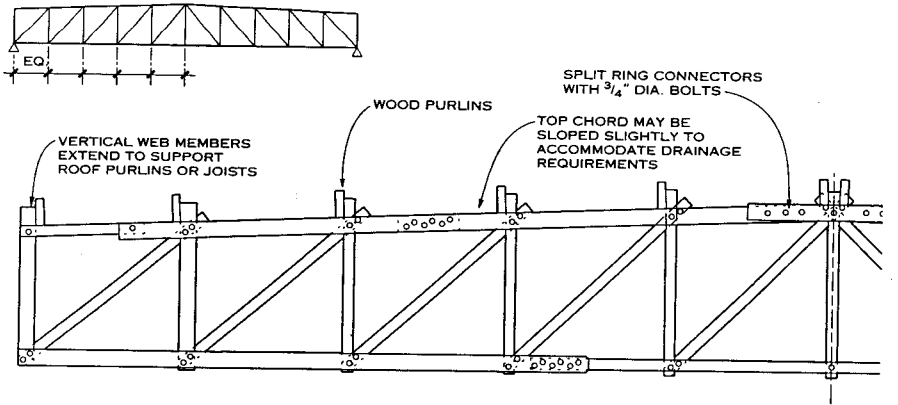

FLAT HOWE

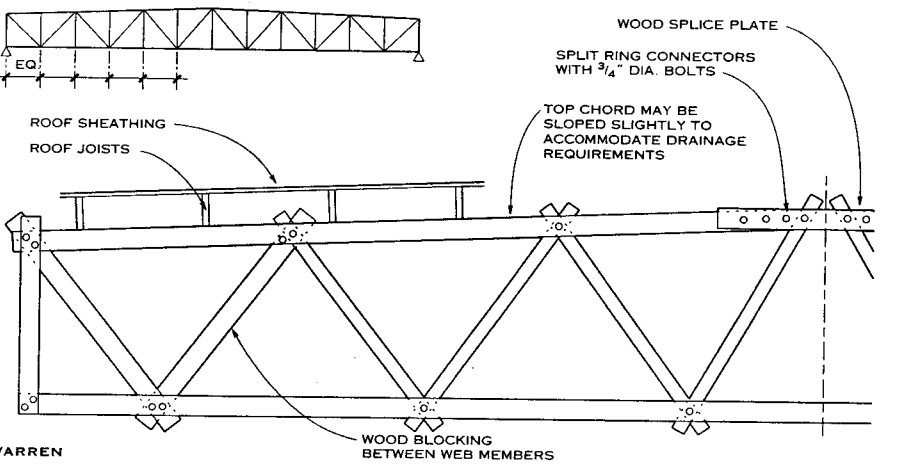

WARREN

Flat trusses are generally less economical than pitched or bowstring trusses, since connections are usually more complicated and higher side walls are required. But because of their geometry, flat trusses allow the smallest roof area versus pitched or bowstring trusses for the same span. As in pitched trusses, the maximum span for flat trusses is about 70 ft.

A typical span (l)/depth (d) ratio for all types of flat trusses is generally 8 to 10.

Combinations of flat truss types are sometimes useful. For instance, a truss may be built having one-half Pratt and one-half Howe design. Warren trusses may have ends of either Pratt or Howe designs incorporated, depending on the type of support. In general, Warren trusses are used for shorter spans.

Flat trusses do not require knee braces since the upper and lower chords take the place of a lateral brace.

FLAT TRUSSES

TECO Products; Collier, West Virginia  
Richard J. Vitullo, AIA; Oak Leaf Studio; Crownsville, Maryland

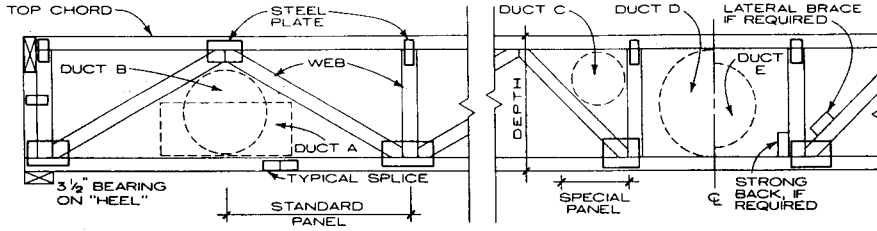

RESIDENTIAL TYPE TRUSSED FLOOR JOIST STEEL PLATE CONNECTED

**DUCT SIZES**

Ease of running electrical and mechanical services through framing is a major advantage of trussed joists. Most manufacturers provide a large rectangular open panel at midspan; this void will generally accommodate a trunk line.

Sizes given here are approximations. Because web size and angles vary with different brands, the designer is cautioned to verify individual sizes carefully. Note that shape E is the duct that will fit in a flat truss with double chords top and bottom.

**DEPTH OF TRUSS AND SIZE OF DUCTWORK**

DEPTH	12"	16"	20"	24"
SHAPE				
A	4 x 9	6 x 12	7 x 13	8 x 14
B	7"	10"	12"	14"
C	5"	7"	8"	9"
D	9"	13"	17"	21"
E	6"	10"	14"	18"

**WOOD TRUSSED RAFTERS SPANS FOR PRELIMINARY DESIGN**

DEPTH	RESIDENTIAL LIVE LOADS									
	FLOORS 55 PSF (A)		ROOFS 40 PSF (B)		55 PSF (C)		(DOUBLE CHORDS) 55 PSF (C)			
	TRUSSED RAFTERS SPACING (C TO C)									
12"	23-6	21-0	17-1	24-0	21-4	21-11	18-2			
13"	24-11	22-0	17-11							
14"	26-4	22-11	18-8	27-5	23-3	24-5	19-10			
15"	27-7	23-10	19-5							
16"	28-7	24-9	20-1	30-3	25-0	26-4	21-4	31-10	27-10	
18"	30-6	26-4	21-5	32-11	26-9	28-1	22-9	35-1	30-7	
20"	32-4	27-11	22-8	34-8	28-0	29-7	23-11	38-1	33-1	
22"	34-0	26-9	23-11							
24"	35-8	30-10	25-0	38-3	30-11	32-7	26-4	43-10	36-7	
28"				41-6	33-6	35-5	28-7	49-2	39-11	
32"				44-3	35-7	37-8	30-4	52-9	42-9	
36"				47-0	37-10	40-1	32-3	56-3	45-7	
48"								60-0	53-3	
DEPTH	COMMERCIAL LIVE LOADS									
	FLOORS 80 PSF (D)			100 PSF (E)			120 PSF (F)			
	TRUSSED RAFTERS SPACING (C TO C)									
12"	19-0	17-3	15-1	17-3	15-8	13-7	16-0	14-7	12-4	
14"	21-4	19-4	16-6	19-4	17-7	14-9	18-0	16-4	13-6	
16"	23-6	21-5	17-10	21-5	19-5	15-11	19-10	17-11	14-6	
18"	25-8	23-4	19-0	23-4	21-0	17-0	21-8	19-2	15-6	
20"	27-8	24-10	20-2	25-2	22-3	18-0	23-4	20-3	16-5	
24"	31-6	27-5	22-2	28-5	24-6	19-10	25-11	22-4	18-1	
16"*	27-7	25-1	21-11	25-1	22-9	19-11	23-2	21-2	18-5	
24"*	38-0	34-6	30-1	34-6	31-4	27-4	32-0	29-1	25-1	
32"*	47-1	42-9	36-1	42-9	38-10	32-3	39-8	36-1	29-5	
Top chord live load		40 psf	20 psf	35 psf	60 psf	80 psf	100 psf			
Top chord dead load		10 psf	10 psf	10 psf	10 psf	10 psf	10 psf			
Bottom chord dead load		5 psf	10 psf	10 psf	10 psf	10 psf	10 psf			
Total load		(A) 55 psf	(B) 40 psf	(C) 55 psf	(D) 80 psf	(E) 100 psf	(F) 120 psf			

**NOTES**

- Spans are clear, inside to inside, for bottom chord bearing. Values shown would vary very slightly for a truss with top chord loading.
- Spans should not exceed 24 x depth of truss.
- Designed deflection limit under total load is  $\ell/240$  for roofs,  $\ell/360$  for residential floors, and  $\ell/480$  for commercial floors.
- Roof spans include a +15% short term stress.
- Asterisk (\*) indicates that truss has double chords, top and bottom.
- Spans shown are for only one type of lumber; in this case—#2 Southern pine, with an  $f_b$  value of 1550. Charts are available for other grades and species. Lumber and grades may be mixed in the same truss, but chord size must be identical. Repetitive member bending stress is used in this chart.

Michael Bengis, AIA; Hopatcong, New Jersey

6 WOOD TRUSSES

**GENERAL**

Monoplaner trusses are usually made up from 2 x 4 or 2 x 6 lumber. Spacing, normally 24 in. o.c., varies for special uses, especially in agriculture. Camber is designed for dead load only. Bottom chord furring generally is not required for drywall ceiling. Joints in plywood floor or roof should be staggered. Many trusses are approved by model codes, such as BOCA, ICBO, FHA, and SBC.

$$\text{CAMBER (USUAL)} = \frac{L(\text{FT})}{60}$$

**BRACING**

Adequate bracing of trusses is vital. Sufficient support at right angles to plane of truss must be provided to hold each truss member in its designated position. Consider bracing during design, fabrication, and erection. In addition, provide permanent bracing/anchorage as an integral part of the building. Strongbacks are often used.

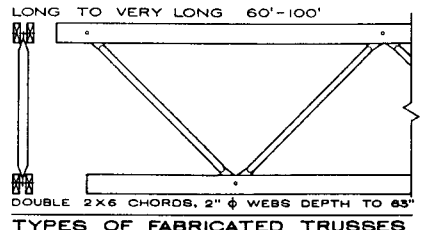
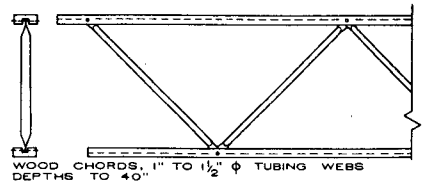
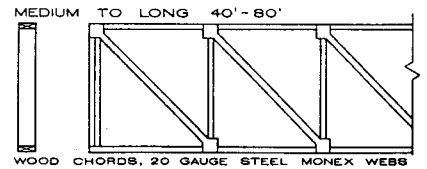
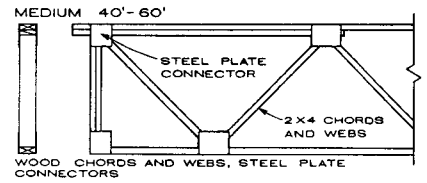
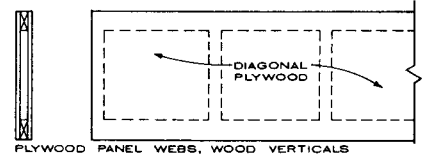
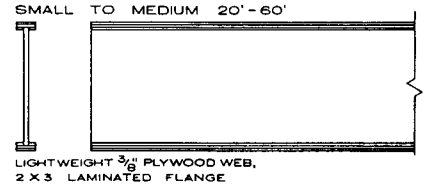

TYPES OF FABRICATED TRUSSES

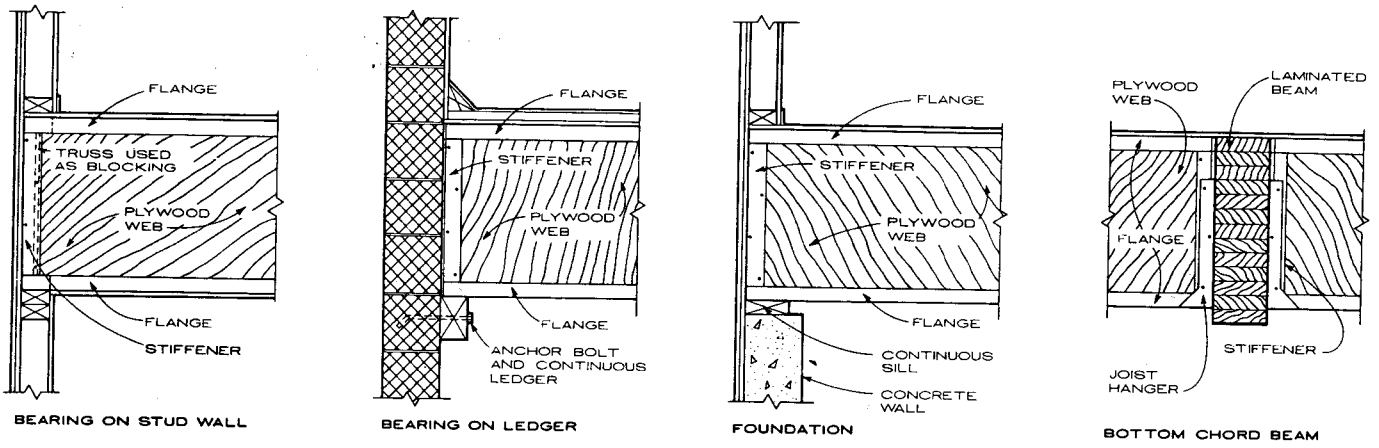

PLYWOOD WEB TRUSS (WOOD CHORDS AND FLANGES)

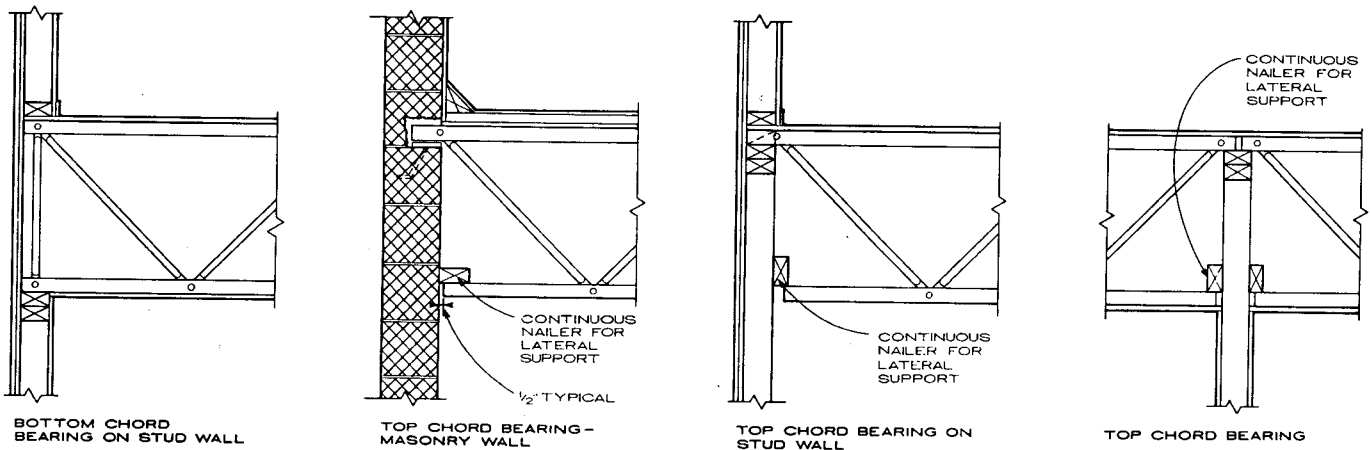

OPEN WEB TRUSS (STEEL WEB WOOD CHORD)

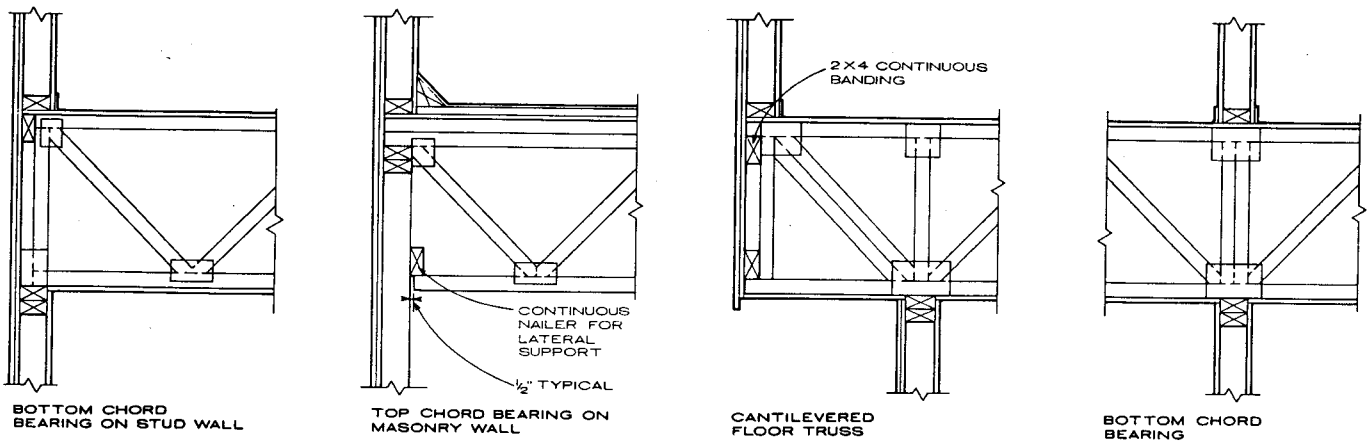

OPEN WEB TRUSS (WOOD CHORDS AND WEB, METAL PLATE CONNECTORS)

Timothy B. McDonald; Washington, D.C.

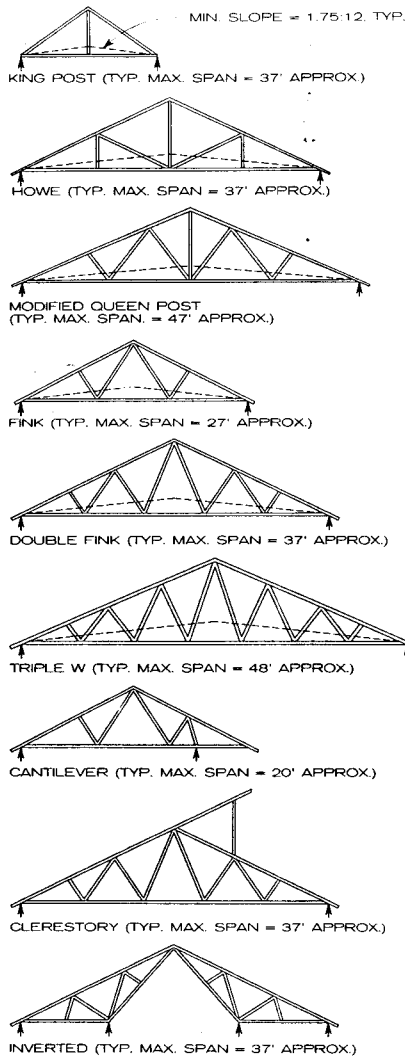

**NOTES**

1. The average spacing for light trusses (trussed rafters) is 2 ft o.c. but varies up to 4 ft. The average combined dead and live loads is 45 lb per sq ft. Spans are usually between 20 and 32 ft but can be as much as 50 ft.
2. Early in the design process, consult an engineer or truss supplier for pre-engineered truss designs to establish the most economical and efficient truss proportions. The supplier may provide final truss engineering design.
3. Permanent and temporary erection bracing must be installed as specified to prevent failure of properly designed trusses.
4. Some locales require an engineer's stamp when prefab trusses are used. Check local codes.
5. Member forces in a truss rise rapidly as the lower chord is raised above the horizontal.

**PITCHED CHORD TRUSSES**

PLATE TOOTH PUNCHED THROUGH PLATE HAS PARTICULAR LENGTH, SHAPE, AND TWIST; ALL AFFECT WITHDRAWAL STRENGTH (TOOTH LATERAL RESISTANCE)

GAUGE NET AREA OF STRUCTURAL STEEL LEFT IN PLATE AFTER PUNCHED TEETH ARE FORMED; RESIDUAL STRENGTH OF THIS UNPUNCHED STEEL IS USED TO TRANSFER FORCES IN TRUSS JOINT

PLATE CONNECTOR PRESSED BY PNEUMATIC, HYDRAULIC, OR ROLLER PRESS INTO BOTH SIDES OF TRUSS

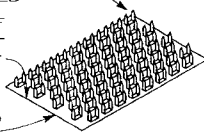

**TYPICAL METAL PLATE CONNECTOR**

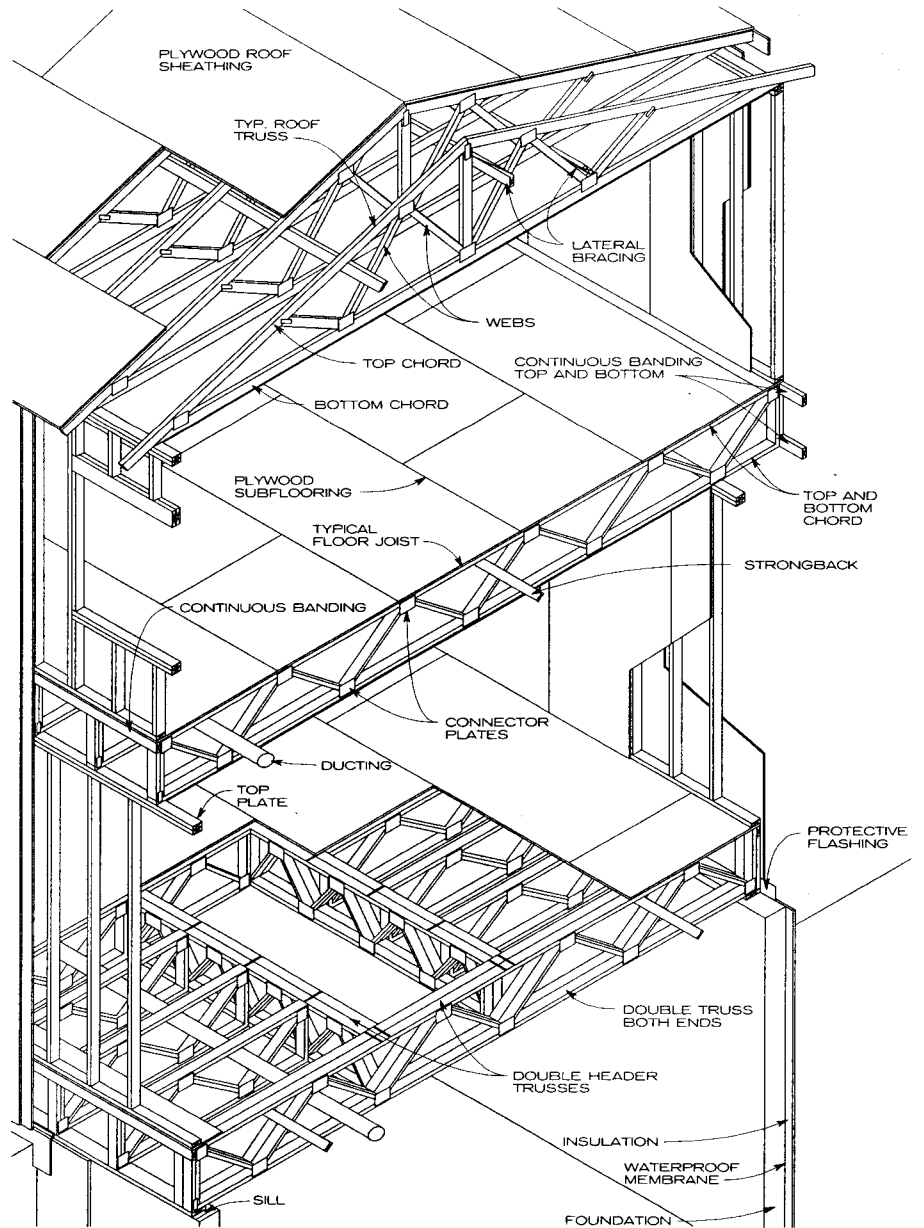

**TRUSS FRAMING**

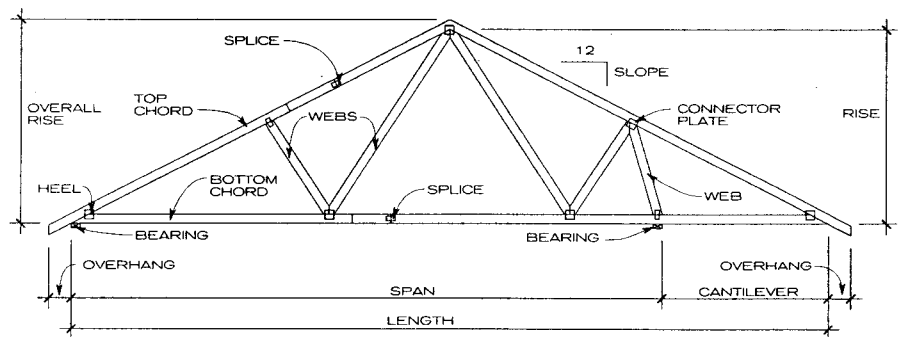

**TYPICAL PITCHED CHORD ROOF TRUSS**

Richard J. Vitullo, AIA; Oak Leaf Studio; Crownsville, Maryland

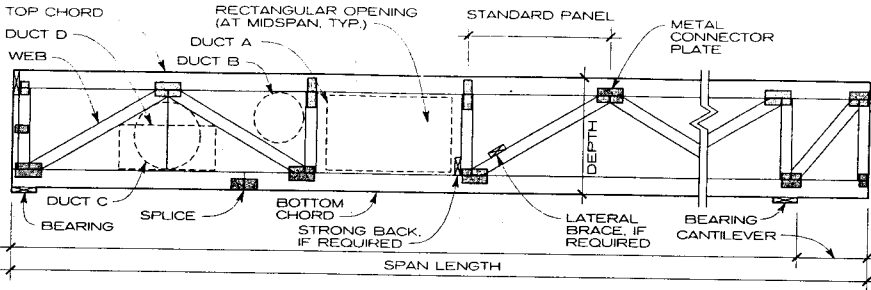

TYPICAL PARALLEL CHORD FLOOR AND ROOF TRUSS

DEPTH OF TRUSS AND SIZE OF DUCTWORK (IN.)

DEPTH	A	B	C	D		
10	6 1/2 x 22	5 1/2	5	3 x 25	4 x 15	5 x 9
12	8 1/2 x 22	6 1/2	7	5 x 20	6 x 14	7 x 7
14	10 1/2 x 22	7 1/2	9	6 x 23	7 x 16	8 x 11
16	12 1/2 x 22	9	11	7 x 22	8 x 18	9 x 14
18	14 1/2 x 22	10	12	8 x 24	9 x 20	10 x 16
20	16 1/2 x 22	11	14 1/2	8 x 28	9 x 24	10 x 21
22	18 1/2 x 22	12	16	8 x 30	10 x 25	12 x 19

NOTE: The relative ease of running electrical and mechanical components through framing is a major advantage of a truss roof system. Sizes given here are approximate; verify individual sizes carefully. Duct sizes are based on maximum panel sizes allowable by prior arrangement.

PARALLEL CHORD TRUSS—SPANS FOR PRELIMINARY DESIGN

DEPTH (IN.)	TRUSSED RAFTERS SPACING (C TO C)(IN.)—RESIDENTIAL LOADS								
	FLOORS				ROOFS				
	A. 55 PSF			B. 40 PSF		C. 55 PSF		C. 55 PSF*	
12	12	16	24	16	24	16	24	16	24
12	23-6	21-0	17-1	24-0	21-4	21-11	18-2		
13	24-11	22-0	17-11						
14	26-4	22-11	18-8	27-5	23-3	24-5	19-10		
15	27-7	23-10	19-5						
16	28-7	24-9	20-1	30-3	25-0	26-4	21-4	31-10	27-10
18	30-6	26-4	21-5	32-11	26-9	28-1	22-9	35-1	30-7
20	32-4	27-11	22-8	34-8	28-0	29-7	23-11	38-1	33-1
22	34-0	28-9	23-11						
24	35-8	30-10	25-0	38-3	30-11	32-7	26-4	43-10	36-7
28				41-6	33-6	35-5	28-7	49-2	39-11
32				44-3	35-7	37-8	30-4	52-9	42-9
36				47-0	37-10	40-1	32-3	56-3	45-7
48								60-0	53-3

DEPTH (IN.)	TRUSSED RAFTERS SPACING (C TO C)(IN.)—COMMERCIAL FLOOR LOADS								
	D. 80 PSF			E. 100 PSF			F. 120 PSF		
	12	16	24	12	16	24	12	16	24
12	19-0	17-3	15-1	17-3	15-8	13-7	16-0	14-7	12-4
14	21-4	19-4	16-6	19-4	17-7	14-9	18-0	16-4	13-6
16	23-6	21-5	17-10	21-5	19-5	15-11	19-10	17-11	14-6
18	25-8	23-4	19-0	23-4	21-0	17-0	21-8	19-2	15-6
20	27-8	24-10	20-2	25-2	22-3	18-0	23-4	20-3	16-5
24	31-6	27-5	22-2	28-5	24-6	19-10	25-11	22-4	18-1
16*	27-7	25-1	21-11	25-1	22-9	19-11	23-2	21-2	18-5
24*	38-0	34-6	30-1	34-6	31-4	27-4	32-0	29-1	25-1
32*	47-1	42-9	36-1	42-9	38-10	32-3	39-8	36-1	29-5

LOAD	A (PSF)	B (PSF)	C (PSF)	D (PSF)	E (PSF)	F (PSF)
Top chord live load	40	20	35	60	80	100
Top chord dead load	10	10	10	10	10	10
Bottom chord dead load	5	10	10	10	10	10
TOTAL LOAD	55	40	55	80	100	120

\* indicates a double-chorded truss, top and bottom.

NOTES

- Spans are clear, inside to inside, for bottom chord bearing. Values shown would vary only slightly for a truss with top chord loading.
- Designed deflection limit under total load is  $l/240$  for roofs,  $l/360$  for residential floors, and  $l/480$  for commercial floors.

- Spans should not exceed 24 in. x depth of truss.
- Roof spans include a +15% short-term stress.
- Spans shown are for only one type of lumber; in this case—#2 Southern pine, with an  $f_b$  value of 1550. Charts are available for other grades and species. Lumber and grades may be mixed in the same truss, but chord size must be identical. Repetitive member bending stress is used in this chart.

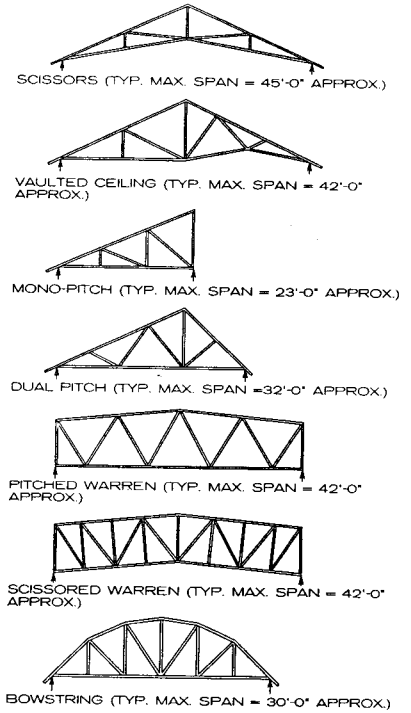

PITCHED TRUSSES

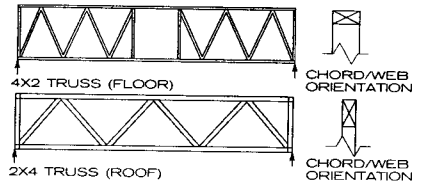

PARALLEL TRUSSES

GENERAL

Metal plate-connected wood trusses have been used in building construction since 1953, when the metal connector plate was invented. These proprietary metal plates are available in a range of styles and tooth orientations. The metal plates are punched with bars that grab onto the wood truss, thus reducing the hand nailing required to fabricate a structure. Plate size for a given truss is based on a combination of the tooth withdrawal strength of the plate, the tensile and shear strength of the steel, and the net sectional area of the lumber.

This system is primarily used for roofs with either pitched or parallel chord trusses. It is occasionally employed for floors with parallel chord trusses. Individual trusses are cut from 2 x 4 in. or 2 x 6 in. lumber and can be spaced 24 in. or 48 in. o.c. For typical residential construction, 24 in. o.c. is used. Exceptionally long spans are possible with metal plate-connected trusses, allowing the large, unencumbered interior spaces often required in commercial, agricultural, and other nonresidential building types.

Camber is designed for dead load only:  
Camber (in.) = Length (ft)/60

BRACING

Providing adequate bracing for trusses is essential, both during installation and in the overall roof design. Truss members must be held in place with supports that meet them at right angles. Truss chords and web members are placed in a vertical, plumb position and maintain that position, resisting applied design loads, throughout the life of the structure. Permanent bracing and anchorage are expected to be an integral part of construction, and strong-backs are often used for this purpose.

Movement by crane can damage trusses. Crane spreader bars are used to avoid this "out-of-plane" buckling. Special stiffening may be applied to trusses during erection.

Richard J. Vitullo, AIA; Oak Leaf Studio; Crownsville, Maryland

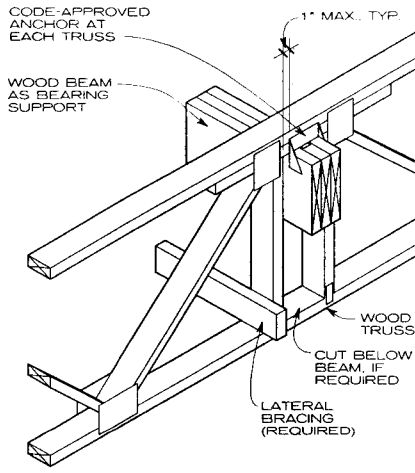

**TOP CHORD SUPPORT DETAIL AT WOOD BEAM**

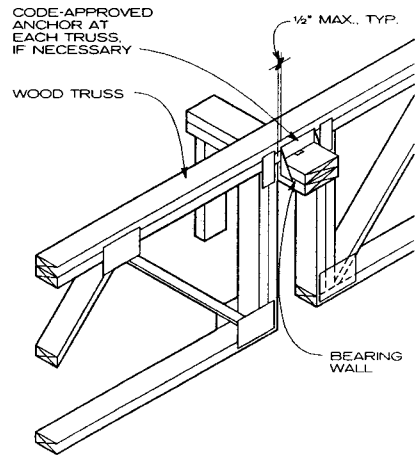

**TOP CHORD SUPPORT DETAIL AT INTERIOR BEARING WALL**

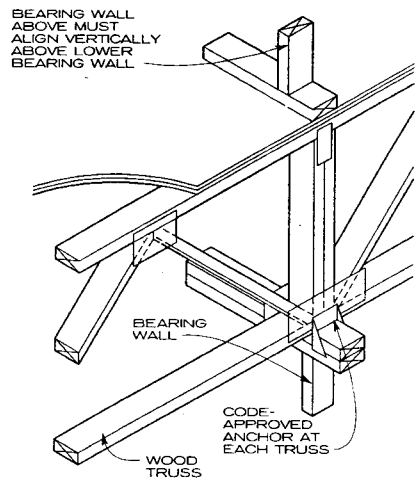

**BOTTOM CHORD SUPPORT AT BEARING WALL**

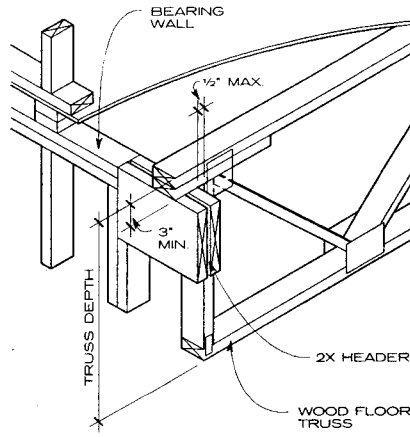

**TOP CHORD SUPPORT DETAIL AT EXTERIOR BEARING WALL**

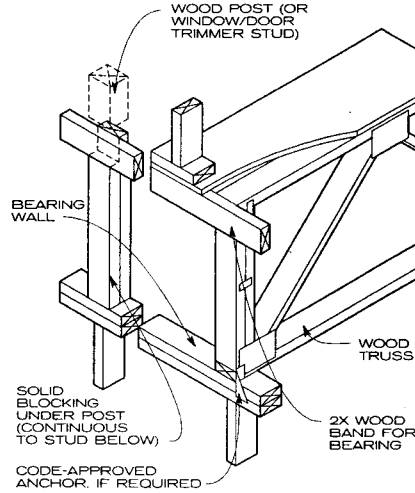

**EXTERIOR WALL BEARING DETAIL**

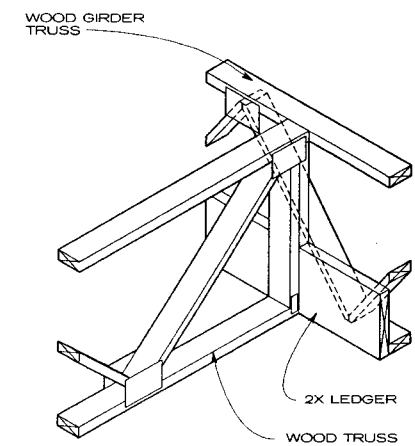

**LEDGER DETAIL**

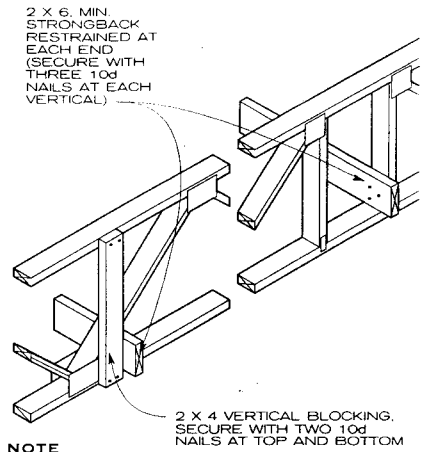

**NOTE**  
Locate strongbacks at maximum 10 ft o.c. at free-span trusses.

**STRONGBACK DETAILS**

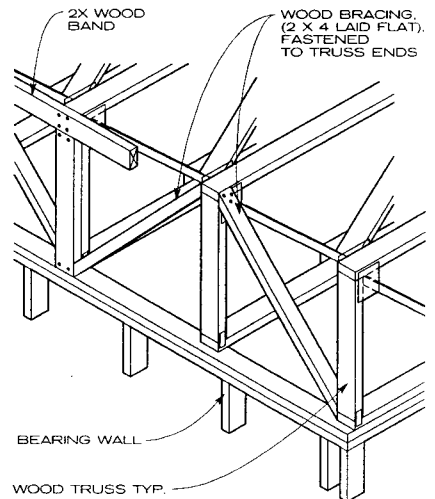

**DIAGONAL BRACING AT BEARING END**

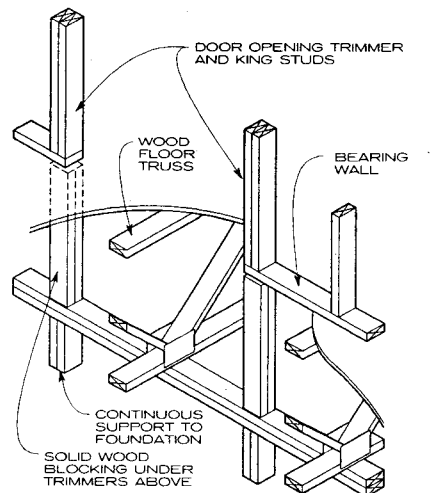

**BLOCKING DETAIL AT INTERIOR BEARING WALL**

Richard J. Vitullo, AIA; Oak Leaf Studio; Crownsville, Maryland

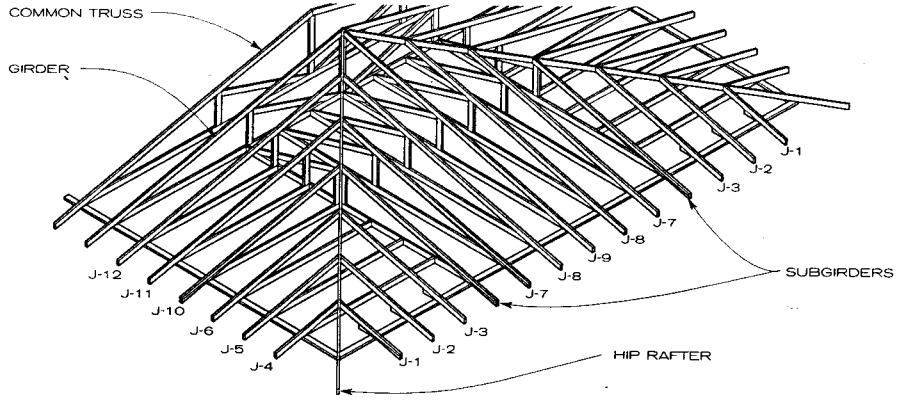
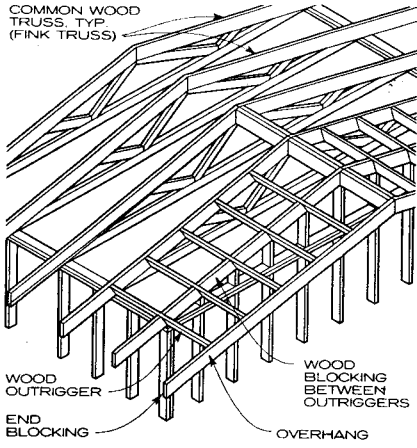

**GABLE ROOF OVERHANG DETAIL**

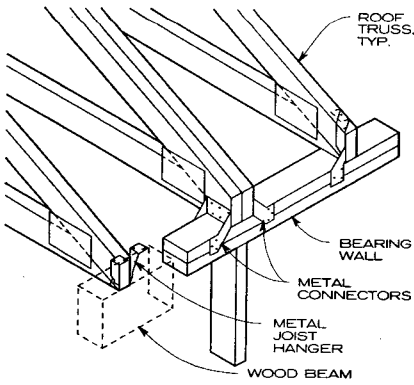

**END-BEARING ROOF TRUSS WITH METAL CONNECTORS**

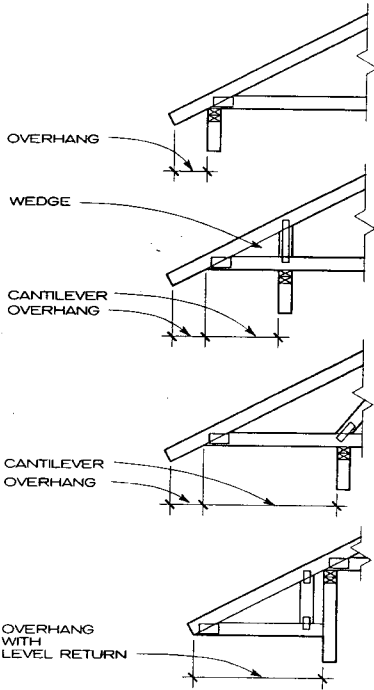

**OVERHANG DETAILS**

**JACK TRUSS SYSTEM**

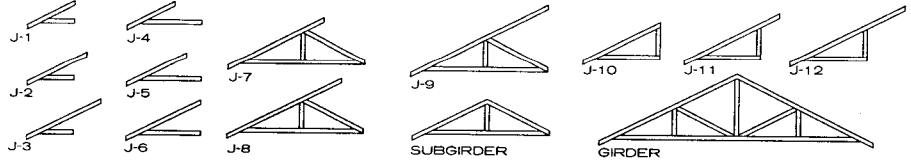

**JACK TRUSS COMPONENTS**

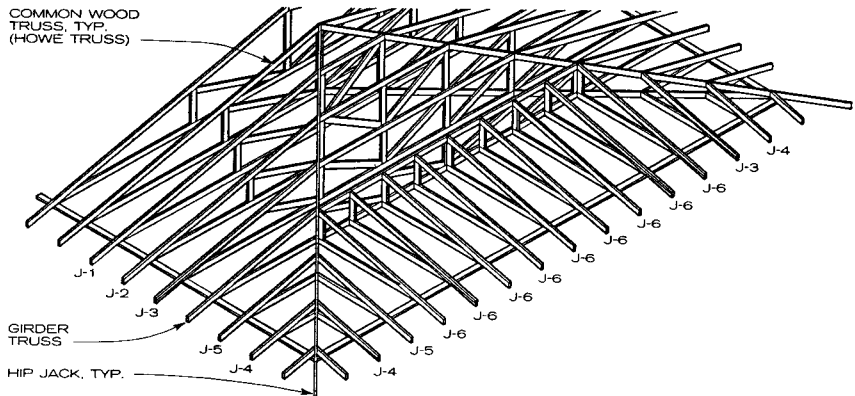

**STEP-DOWN TRUSS SYSTEM**

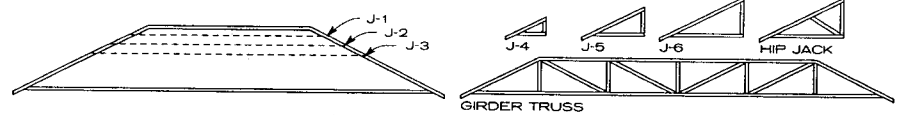

**STEP-DOWN COMPONENTS**

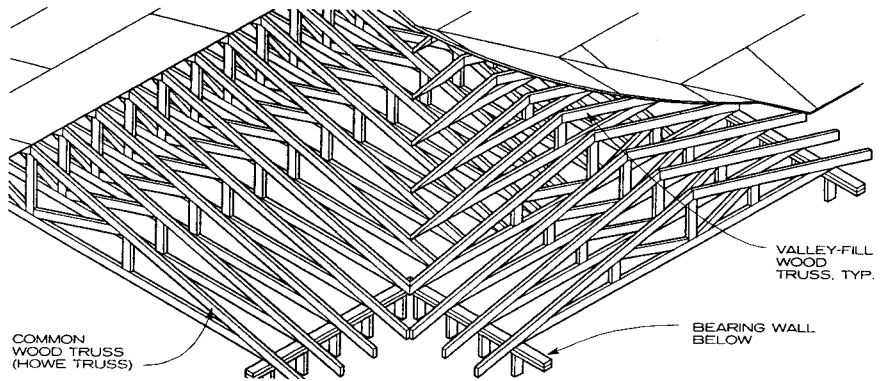

**ROOF INTERSECTION WITH VALLEY FILL**

Richard J. Vitullo, AIA; Oak Leaf Studio; Crownsville, Maryland



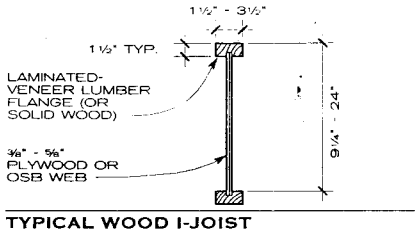

TYPICAL WOOD I-JOIST

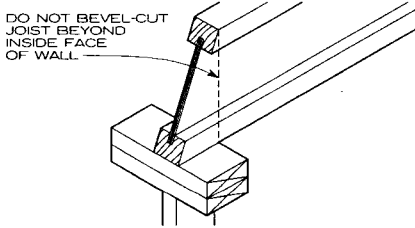

TYPICAL BEVEL-CUT JOIST

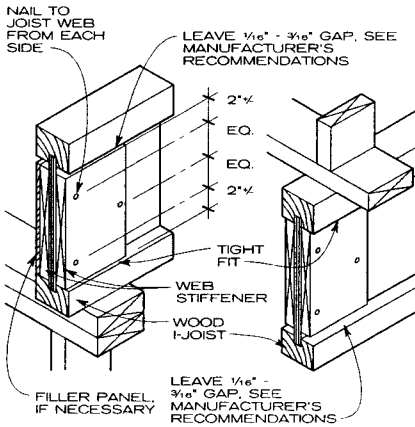

BEARING WALL BELOW BEARING WALL ABOVE  
WEB STIFFENER DETAILS

**GENERAL**

A wood I-joist is made of a web with top and bottom flanges. It is similar in shape and profile to the steel I-beam, but while the steel component is forged from a single ingot, the wood member is a composition. Plywood or oriented strand board (OSB) is used for the web of the wood I-joist, and either solid lumber or laminated-veneer lumber for the flanges. Many manufacturers produce wood I-joists under different trade names, and each differs in its dimensions, as well as span and deflection, loading, and performance characteristics. Consult manufacturers for details and performance criteria.

Compared to solid lumber, wood I-joists have both relative advantages and disadvantages:

**ADVANTAGES**

1. Easier to handle and lighter weight, with about 50% less wood material per joist than an equivalent solid wood member.
2. Makes efficient use of a natural resource—the I-joist can be made from second and third growth timber stands, with no need for old growth trees.
3. Available in lengths up to 60 ft, priced per linear foot.
4. Greatest strength when loaded parallel to plane of web.
5. A high degree of uniformity, with no crowns, checks, or loose knots.
6. Plumbing and HVAC can easily be run through web structure (based on the manufacturer's guidelines).
7. Starts with dry materials, so there is much less shrinkage than with solid lumber.
8. Wood I-joists can generally be set at wider on-center spacing, thus reducing installation time.

Richard J. Vitullo, AIA; Oak Leaf Studio; Crownsville, Maryland

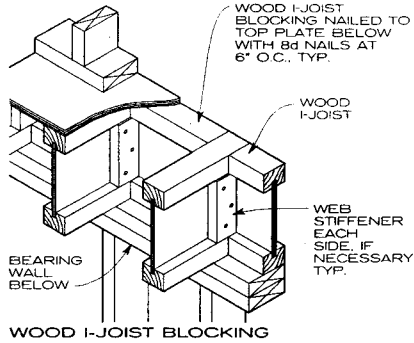

WOOD I-JOIST BLOCKING

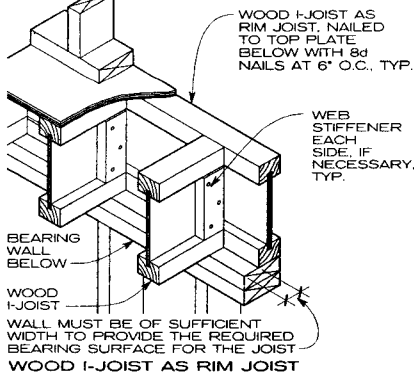

WOOD I-JOIST AS RIM JOIST

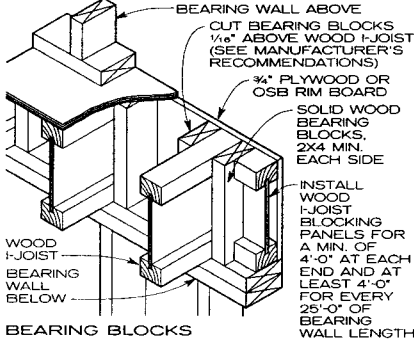

BEARING BLOCKS

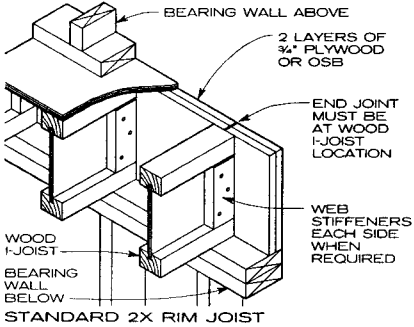

STANDARD 2X RIM JOIST

**NOTE**  
Check building code for appropriate detail in areas of high lateral load.

**STUD BEARING WALL DETAILS**

**DISADVANTAGES**

1. Material costs are generally more (per linear foot) than for solid lumber (for standard residential floor joist dimensions and spans).
2. Contractors are less familiar with wood I-joists and can create problems by cutting holes into webs and weakening the member.

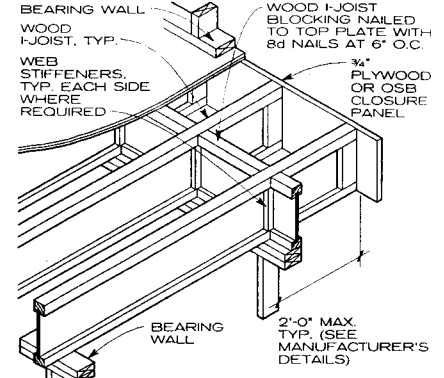

**NOTE**  
Joist must be designed to carry the load-bearing wall.  
LOAD-BEARING CANTILEVER DETAIL

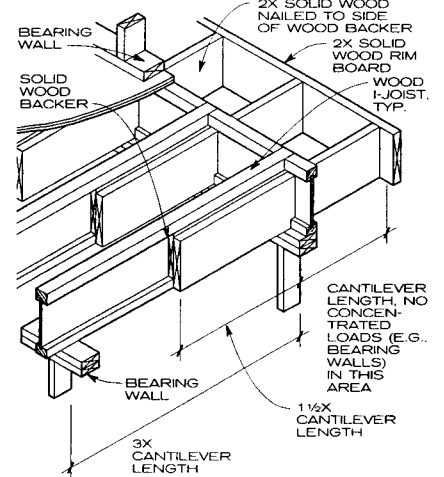

NON-LOAD-BEARING DROPPED CANTILEVER DETAIL

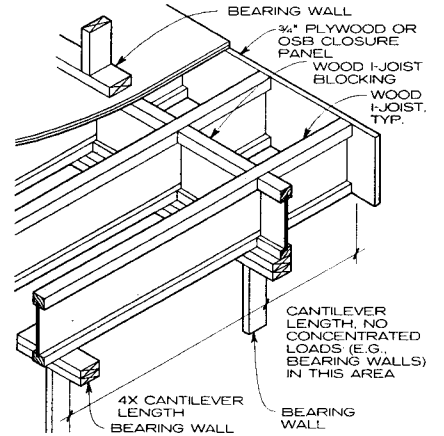

NON-LOAD-BEARING CANTILEVER DETAIL

**CANTILEVER DETAILS**

3. Less lateral stiffness than solid lumber.
4. Can be shifted by winds during construction due to light weight.
5. Some adhesives used in laminated-veneer components may pose indoor air-quality problems.

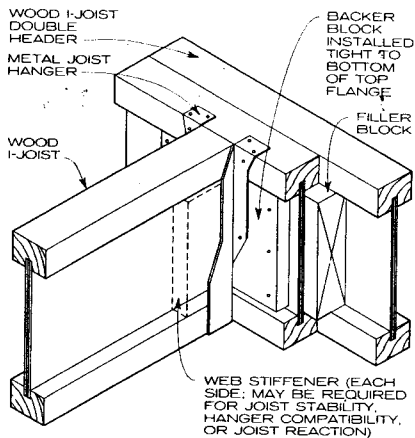

**NOTE**  
Connection between joists must provide adequate load transfer between members.

**WOOD I-JOIST CONNECTION TO WOOD I-JOIST HEADER**

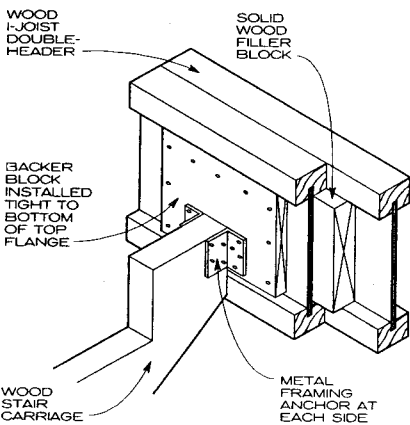

**NOTE**  
Connection between joists must provide adequate load transfer between members.

**STAIR CARRIAGE CONNECTION DETAIL**

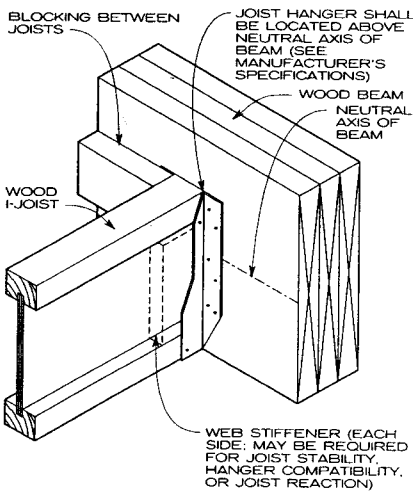

**JOIST HANGER DETAIL**

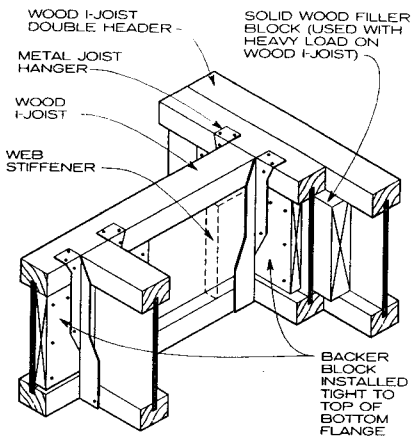

**NOTE**  
Connection between joists must provide adequate load transfer between members.

**WOOD I-JOIST CONNECTION TO WOOD I-JOIST HEADER (HEAVY LOAD)**

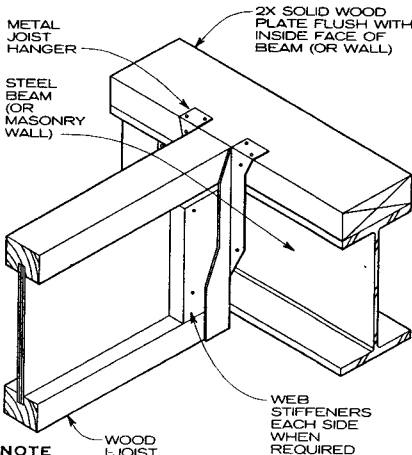

**NOTE**  
Thicker wood plate over beam may be required; check hanger manufacturer's top flange nailing requirements.

**WOOD I-JOIST SUPPORTED AT TOP OF BEAM (OR WALL)**

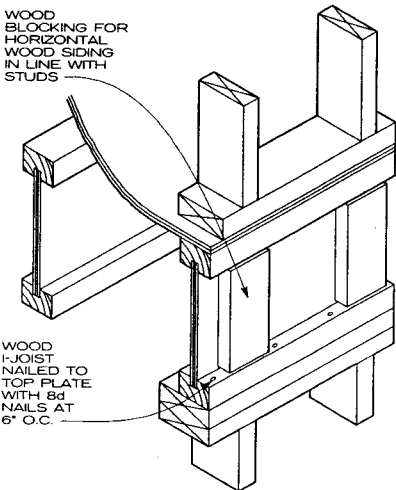

**TYPICAL WOOD BLOCKING AT EXTERIOR WALL**

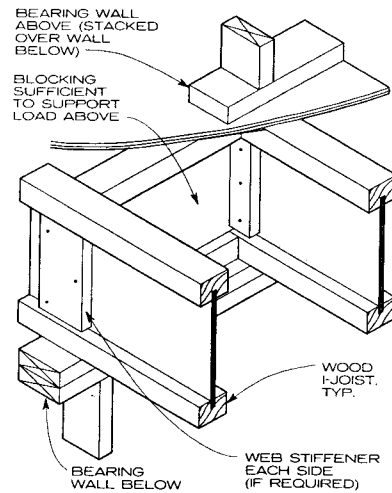

**BEARING WALL ABOVE AND BELOW**

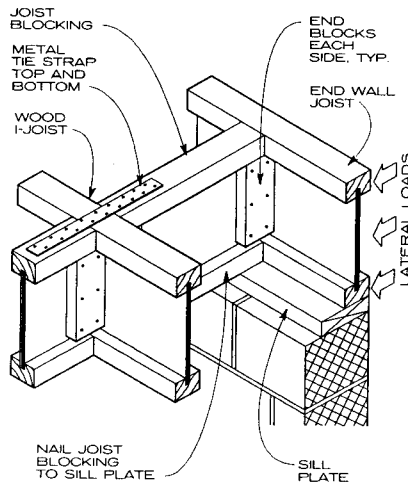

**LATERAL LOAD BLOCKING AT END WALL**

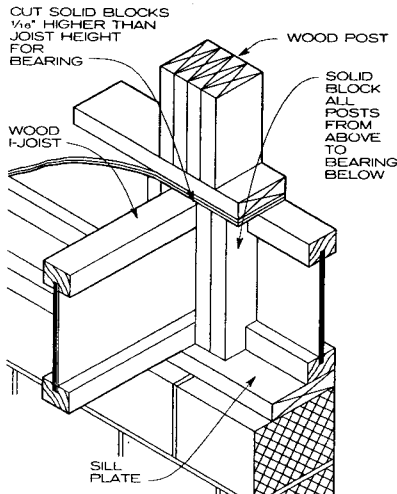

**COLUMN LOAD TRANSFER**

Richard J. Vitullo, AIA; Oak Leaf Studio; Crownsville, Maryland

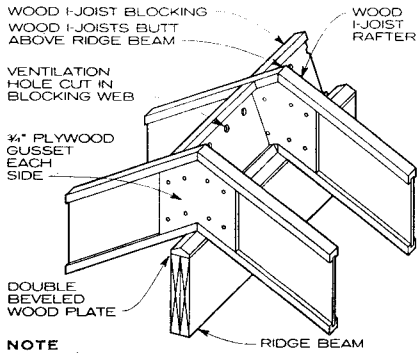

**NOTE**  
Uplift connections may be required.

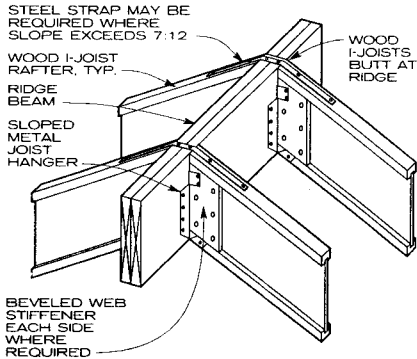

**WOOD I-JOIST RAFTER AT RIDGE BEAM DETAIL**

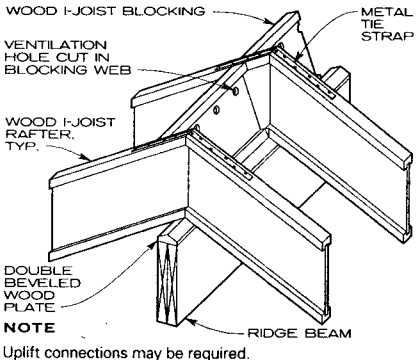

**WOOD I-JOIST RAFTER AT RIDGE BEAM DETAIL**

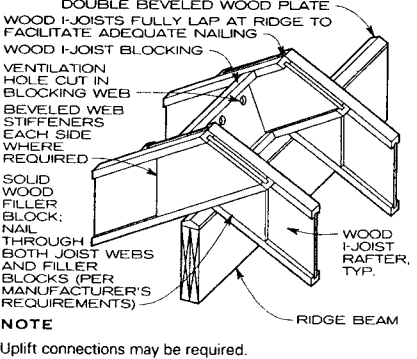

**LAPPED WOOD I-JOIST RAFTER AT RIDGE BEAM**

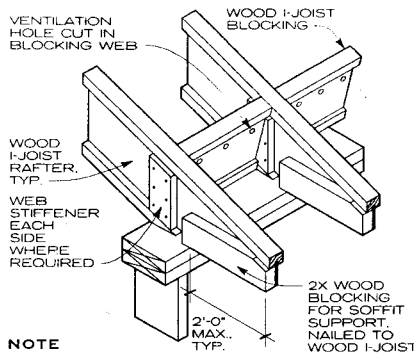

**NOTE**  
Uplift connections may be required.

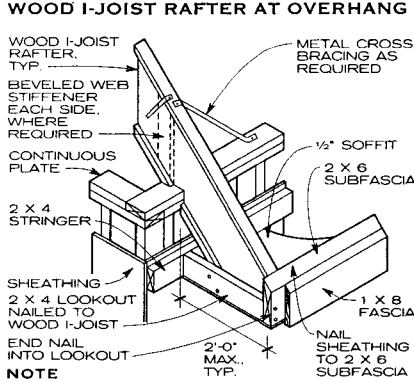

**WOOD I-JOIST RAFTER AT OVERHANG**

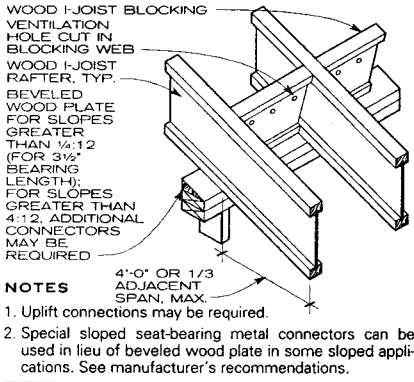

**WOOD I-JOIST RAFTER AT OVERHANG**

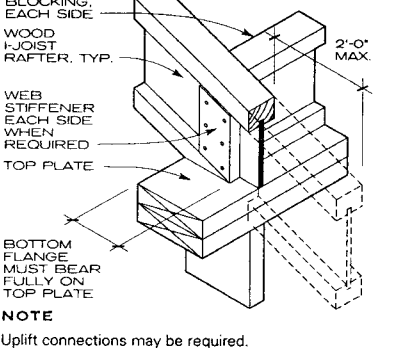

**TYPICAL BIRD'S MOUTH I-JOIST CUT DETAIL**

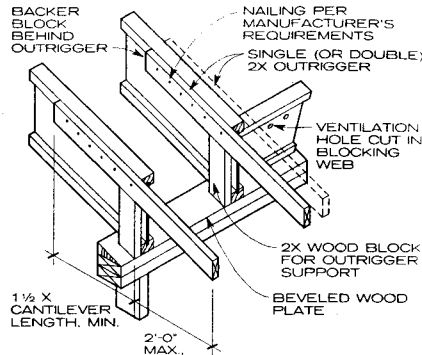

**NOTE**  
Uplift connections may be required.

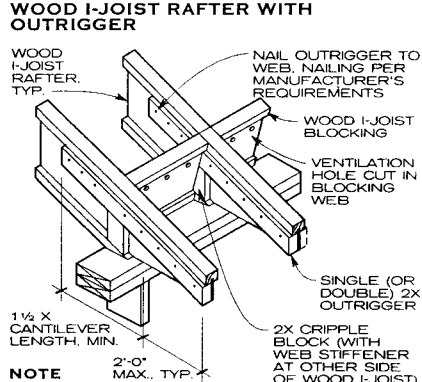

**WOOD I-JOIST RAFTER AT OUTRIGGER**

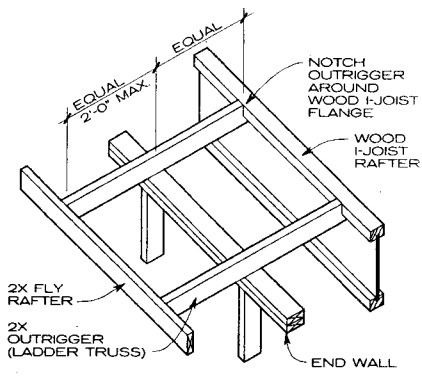

**FLY RAFTER DETAIL**

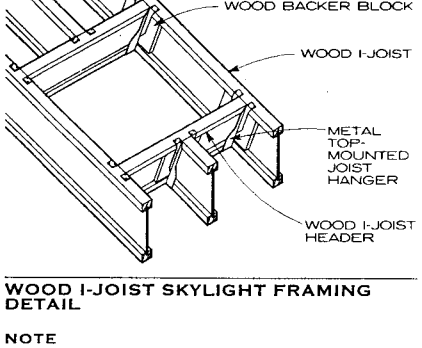

**NOTE**  
Check code and manufacturer's requirements for all ventilation hole sizes cut in blocking web.

Richard J. Vitullo, AIA; Oak Leaf Studio; Crownsville, Maryland

**STRUCTURAL GLUED LAMINATED TIMBER**

The term "structural glued laminated timber" refers to an engineered, stress-rated product made of wood laminations bonded with adhesives, with the grain approximately parallel lengthwise. Laminated pieces can be end-joined to form any length, or glued edge-to-edge to make wider pieces, or of bent pieces curved during gluing.

**STANDARD DEPTHS**

Dimensional lumber surfaced to 1 1/2 in. (38 mm) is used to laminate straight members and members that have a curvature within the bending radius limitations for the species. Boards surfaced to 3/4 in. (19 mm) are recommended for laminating curved members when bending radius is too short to permit the use of dimension lumber, provided that the bending radius limitations for the species are observed. Other lamination thicknesses may be used to meet special requirements.

**STANDARD WIDTHS**

Nominal width	3	4	6	8	10	12	14	16
in.	2 1/8	3 1/8	5 1/8	6 3/4	8 3/4	10 3/4	12 1/4	14 1/4
Net finished width	57	79	130	171	222	273	311	362
mm								

\* 3, 5, 8 1/2, and 10 1/2 in. for southern pine

**CAMBER**

Camber is curvature (circular or parabolic) made into structural glued laminated beams opposite the anticipated deflection movement. The recommended minimum camber is one and one-half times dead load deflection. After initial dead load deflection and additional plastic deformation (creep) has taken place, this usually will produce a near level floor or roof beam under dead load conditions. Additional camber or slope may insure adequate drainage of roof beams. On long-span roof beams and floor beams of multistory buildings, additional camber may be needed to counter the optical illusion of the beam sagging.

**FIRE SAFETY**

The self-insulating qualities of heavy timber cause a slow burning. Good structural details, elimination of concealed spaces, and use of vertical fire stops contribute to its fire performance. Heavy timber retains its strength under fire longer than unprotected metals.

Building codes generally classify glued laminated timber as heavy timber construction if certain minimum dimensional requirements are met. Codes also allow for calculation of one-hour fire ratings for exposed glued laminated timbers. See Council of American Building Officials National Evaluation Service Committee Report No. NER-250.

It is not recommended that fire-retardant treatments be applied to glued laminated timber as they do not substantially increase the fire resistance of heavy timber construction. In considering fire-retardant treatments, the reduction of strength related to type and penetration of treatment, the compatibility of treatment and adhesive, the use of special gluing procedures, the difficulty of application, and the effect on wood color and fabrication procedures must be investigated.

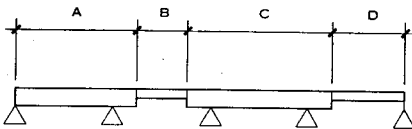

A-SINGLE CANTILEVER  
B-SUSPENDED  
C-DOUBLE CANTILEVER  
D-SINGLE END SUSPENDED

**CANTILEVERED AND CONTINUOUS SPAN**

Cantilever beam systems may be composed of any of the various types and combinations of beams shown above. Cantilever systems generally permit longer spans or larger loads per size member than do simple span systems.

For economy, the negative bending moment at the support of a cantilevered beam should be equal in magnitude to the positive moment.

Roger W. Kipp, AIA; Thomas Hodne Architects, Inc.; Minneapolis, Minnesota

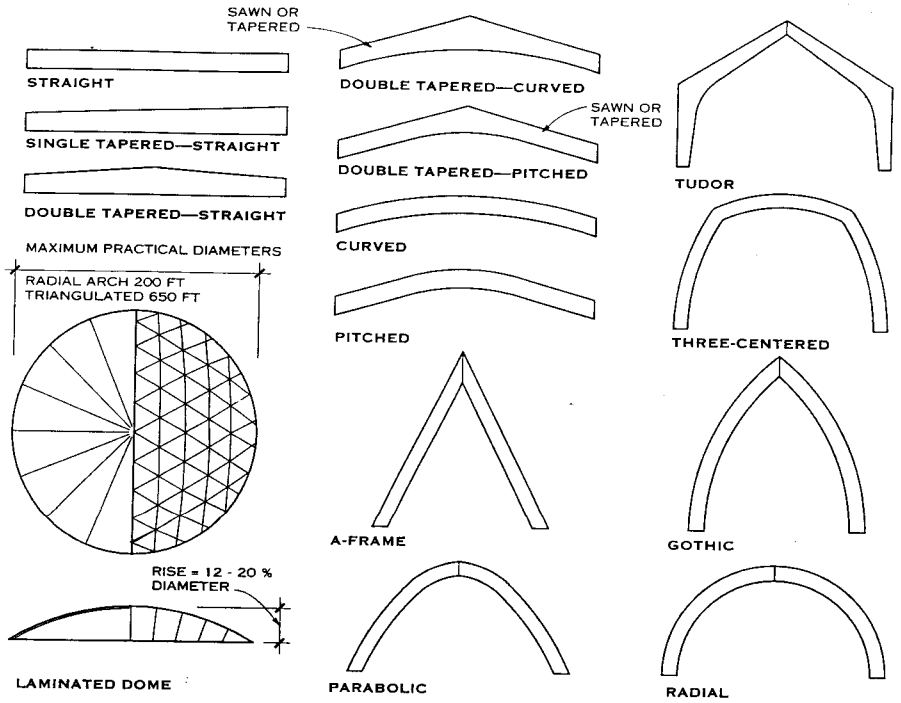

**STRUCTURAL GLUED LAMINATED TIMBER SHAPES**

**NOTES ON SHAPES**

1. Beam names describe top and bottom surfaces of the beam. Sloped or pitched surfaces should be used on the tension side of the beam.
2. The three hinged arches and frames shown above produce horizontal reactions requiring horizontal ties or modified foundations.
3. The triangulated and the radial arch are the two basic types of structural glued laminated wood dome systems available. Both systems require a tension ring at the dome spring line to convert axial thrusts to vertical loads.

Consideration must be given to the perimeter bond beam design since wind forces will produce loads in this member. The length of main members of the radial arch system, which must span a distance greater than half the dome diameter, limit the maximum practical dome diameter. The far smaller members of the triangulated dome result in the greater diameters. The triangulated system can be designed for five or more segments with an equal number of peripheral supports at each segment.

4. More complicated shapes may be fabricated. Contact the American Institute of Timber Construction (AITC) and the American Plywood Association (APA).

**CONNECTION DESIGN**

The design of connections for glued laminated timbers is similar to the design of connections for sawn lumber. Since glued laminated timbers often are much larger than sawn lumber and the loads transferred also are larger, the effect of increased size should be taken into account in the design of connections. In addition to being designed for strength to transfer loads, connections also should be designed to avoid splitting of the member and to accommodate swelling and shrinking of the wood.

**BEAM END CONNECTIONS**

Beam end connections should be designed to carry both induced horizontal and vertical loads. Bolts or fastenings at the end of the beam should be located toward the bottom of the beam so that the effect of shrinkage between the bottom of the beam and the fastening is minimized. Bolts or connectors located near or above the beam's neutral axis should not be used on large glued laminated beams or girders since the concentration of the tension perpendicular to grain due to restraint of shrinkage, and shear stresses acting at fasteners located in these beam areas tend to cause splitting of the member.

**SUSPENDED LOADS**

In cases where it is not possible for the suspending system to be carried on top of the beam, it is good practice to place the fastener above the neutral axis, particularly when other than light loading is involved or when a number of loads are to be suspended from the member. For heavy loads, a saddle detail placing loads directly on top of the beam is recommended.

Very light loads may be suspended near the bottom of a glued laminated timber. The distance above the beam bottom must exceed the specified edge distance of the fastener used.

**PURLIN TO BEAM CONNECTIONS**

The preferred purlin to beam connection method is to transfer the end reaction by bearing perpendicular to grain in a saddle type connection extending over the beam top.

When the end reaction of the beam or purlin is relatively small, the hanger can be fastened to the face of the girder. The bolts or connectors in the main carrying beam or girder should be placed above the neutral axis of the member, and in the supported member should be placed near the bottom to avoid potential splitting.

**SPLICE CONNECTIONS**

At beam splice connections occurring over columns, it is important to allow for movement in the upper portions of the beam due to end rotation. Slotted connections will help to reduce the problem by allowing for some beam movement.

**CONCEALED AND PARTIALLY CONCEALED PURLIN HANGERS**

Partially concealed purlin hangers are used for normal loads. Concealed hangers are appropriate for relatively light loads, as well as connections where the support plate at the base is notched into the beam, should be designed as notched beam reactions.

It is recommended that the support for the purlin be close to the bottom of the member to utilize the maximum effective area for shear. End fastenings should not include rows of bolts or other fasteners perpendicular to the grain. Glued laminated timbers, although relatively dry at the time of manufacture, may shrink when the members reach equilibrium moisture content in place. This may cause tension perpendicular to the grain and result in splitting.

ALLOWABLE UNIT STRESS RANGES FOR STRUCTURAL GLUED LAMINATED TIMBER<sup>2</sup>—NORMAL DURATION OF LOADING

SPECIES	EXTREME FIBER IN BENDING <sup>3</sup>	TENSION PARALLEL TO GRAIN	COMPRESSION PARALLEL TO GRAIN	HORIZONTAL SHEAR	COMPRESSION PERPENDICULAR TO GRAIN	MODULUS OF ELASTICITY
DRY CONDITIONS OF USE—MOISTURE CONTENT IN SERVICE LESS THAN 16%						
Douglas fir - larch	1600 TO 2400	700 TO 1300	875 TO 1750	80-165	560 TO 650	1.5 TO 1.9
Hemlock fir	1600 TO 2400	825 TO 1150	825 TO 1550	155	375 TO 500	1.4 TO 1.8
Southern pine	1600 TO 2600	650 TO 1250	950 TO 1750	90-200	560 TO 650	1.3 TO 1.9
California redwood	1600	900	1400	125	315	1.1
WET CONDITIONS OF USE FACTORS—MOISTURE CONTENT IN SERVICE 16% OR MORE (REQUIRES WET-USE ADHESIVES)						
	0.8	0.8	0.73	0.875	0.53	0.833

NOTES

- Multiply dry-condition-of-use stress ranges by the above factors for corresponding wet-conditions-of-use value.
- Values given are for members loaded perpendicular to wide faces of laminations. For ranges of allowable stresses for members loaded primarily as axial members or loaded parallel to the wide face of laminations, see current American Institute of Timber Construction Publication AITC 117—Design (Table 2).
- Values shown are for the tension zones of the member.

LAMINATED FLOOR, ROOF BEAM, AND PURLIN DESIGN CHART  
TYPICAL SINGLE-SPAN, SIMPLY SUPPORTED, GLUED LAMINATED BEAMS (MEMBER SIZES IN IN.)

SPAN (FT)	SPACING (FT)	TOTAL LOAD CARRYING CAPACITY (PSI)—ROOF					FLOOR BEAMS 50 PSF
		30 PSF	35 PSF	40 PSF	45 PSF	50 PSF	
12	6	3 1/8 x 7 1/2	3 1/8 x 7 1/2	3 1/8 x 7 1/2	3 1/8 x 7 1/2	3 1/8 x 7 1/2	3 1/8 x 9
	8	3 1/8 x 7 1/2	3 1/8 x 7 1/2	3 1/8 x 7 1/2	3 1/8 x 9	3 1/8 x 9	3 1/8 x 10 1/2
	10	3 1/8 x 7 1/2	3 1/8 x 9	3 1/8 x 9	3 1/8 x 9	3 1/8 x 10 1/2	3 1/8 x 10 1/2
16	8	3 1/8 x 9	3 1/8 x 10 1/2	3 1/8 x 10 1/2	3 1/8 x 10 1/2	3 1/8 x 12	3 1/8 x 13 1/2
	12	3 1/8 x 10 1/2	3 1/8 x 12	3 1/8 x 12	3 1/8 x 12	3 1/8 x 13 1/2	3 1/8 x 15
	14	3 1/8 x 12	3 1/8 x 12	3 1/8 x 13 1/2	3 1/8 x 13 1/2	3 1/8 x 15	3 1/8 x 15
20	8	3 1/8 x 12	3 1/8 x 12	3 1/8 x 13 1/2	3 1/8 x 13 1/2	3 1/8 x 13 1/2	3 1/8 x 16 1/2
	12	3 1/8 x 13 1/2	3 1/8 x 13 1/2	3 1/8 x 15	3 1/8 x 15	3 1/8 x 15	5 1/8 x 15
	16	3 1/8 x 15	3 1/8 x 16 1/2	3 1/8 x 16 1/2	3 1/8 x 18	5 1/8 x 15	5 1/8 x 16 1/2
24	8	3 1/8 x 13 1/2	3 1/8 x 15	3 1/8 x 15	3 1/8 x 16 1/2	3 1/8 x 16 1/2	5 1/8 x 16 1/2
	12	3 1/8 x 16 1/2	3 1/8 x 16 1/2	3 1/8 x 18	5 1/8 x 15	5 1/8 x 16 1/2	5 1/8 x 18
	16	3 1/8 x 18	5 1/8 x 16 1/2	5 1/8 x 16 1/2	5 1/8 x 18	5 1/8 x 18	5 1/8 x 21
28	6	3 1/8 x 16 1/2	3 1/8 x 16 1/2	3 1/8 x 18	3 1/8 x 18	5 1/8 x 16 1/2	5 1/8 x 19 1/2
	8	3 1/8 x 18	5 1/8 x 16 1/2	5 1/8 x 18	5 1/8 x 18	5 1/8 x 18	5 1/8 x 21
	10	5 1/8 x 18	5 1/8 x 18	5 1/8 x 19 1/2	5 1/8 x 21	5 1/8 x 19 1/2	5 1/8 x 24
32	8	3 1/8 x 18	5 1/8 x 18	5 1/8 x 18	5 1/8 x 22 1/2	5 1/8 x 21	5 1/8 x 25 1/2
	12	5 1/8 x 18	5 1/8 x 16 1/2	5 1/8 x 19 1/2	5 1/8 x 21	5 1/8 x 21	5 1/8 x 25 1/2
	16	5 1/8 x 19 1/2	5 1/8 x 21	5 1/8 x 22 1/2	5 1/8 x 24	5 1/8 x 25 1/2	5 1/8 x 27
40	12	5 1/8 x 22 1/2	5 1/8 x 24	5 1/8 x 24	5 1/8 x 25 1/2	5 1/8 x 27	6 3/4 x 28 1/2
	16	5 1/8 x 24	5 1/8 x 27	5 1/8 x 28 1/2	5 1/8 x 30	6 3/4 x 28 1/2	6 3/4 x 31 1/2
	20	5 1/8 x 27	5 1/8 x 30	6 3/4 x 28 1/2	6 3/4 x 30	6 3/4 x 31 1/2	6 3/4 x 33
48	12	5 1/8 x 27	5 1/8 x 28 1/2	5 1/8 x 30	6 3/4 x 28 1/2	6 3/4 x 28 1/2	6 3/4 x 33
	16	5 1/8 x 30	6 3/4 x 28 1/2	6 3/4 x 30	6 3/4 x 31 1/2	6 3/4 x 33 1/2	6 3/4 x 36
	20	6 3/4 x 28 1/2	6 3/4 x 31 1/2	6 3/4 x 34 1/2	8 3/4 x 36	8 3/4 x 33	8 3/4 x 36
	24	6 3/4 x 31 1/2	6 3/4 x 34 1/2	8 3/4 x 33	8 3/4 x 34 1/2	8 3/4 x 37 1/2	8 3/4 x 39

NOTES

- Total load carrying weight capacity includes beam weight. Floor beams are designed for uniform loads of 40 psf live load and 10 psf dead load.
- Allowable stresses:  $F_b = 2,400$  psi (modified volume factor),  $F_v = 165$  psi,  $E = 1,800,000$  psi.
- Deflection limits: roof =  $1/180$ , floor =  $1/360$ .
- Values are for preliminary design purposes only. For complete information see the American Institute of Timber Construction *Timber Construction Manual*.
- AITC tables extend to members up to 40 feet in span. American Plywood Association (APA) tables extend up to 48 feet in span. The design of members of far greater span is possible using good engineering practice.

APPEARANCE GRADES

Structural glued laminated timber is produced in three appearance grades that do not modify design stresses, fabrication controls, grades of lumber used, or other provisions of the applicable standards. A textured (rough sawn) surface may be called for instead of the surfacing described. In all grades, laminations will possess the natural growth characteristics of the lumber grade.

INDUSTRIAL APPEARANCE GRADE

Void filling on lamination edges is not required. The wide face of laminations exposed to view will be free of loose knots and open knotholes. Edge joints on the wide face will not be filled. Members will be surfaced on two sides only, an occasional miss being permitted.

ARCHITECTURAL APPEARANCE GRADE

On exposed surfaces, knotholes and other voids wider than 3/4 in. (19 mm) will be dressed with clear wood inserts or a wood-tone colored filler. Inserts will be selected for similarity of the grain and color to the adjacent wood. The wide face of laminations exposed to view will be free of loose knots and open knotholes; all voids greater than 1/16 in. (2 mm) wide in edge joints on this face will be filled. Exposed faces must be surface smooth. Misses are not permitted. The corners on the wide face of laminations exposed to view will be eased. The current practice for eased edges is for a radius between 1/8 in. (3 mm) and 1/2 in. (13 mm).

PREMIUM APPEARANCE GRADE

Similar to architectural grade except that all knotholes and other voids on exposed surfaces will be replaced with wood inserts or a wood-tone colored filler. Remaining knots will be limited in size to 20% of the net face width of the lamination, with no more than two maximum size knots occurring in a 6 ft (1.8 m) length.

FINISHES

Glued laminated timber finishes include sealers, stains, and paints.

End sealers retard moisture transmission and minimize checking and normally are applied to the ends of all members.

Two types of sealers protect against soiling, control grain raising, minimize checking, and serve as a moisture retardant. Penetrating sealers provide limited protection and are used when the final finish requires staining or a natural finish. Primer and sealer coats provide maximum protection by sealing the surface of the wood but should not be specified for a natural or stained final finish. Wood color is modified by any sealer application; therefore, wood sealers followed by staining will look different from stained, untreated wood.

Roger W. Kipp, AIA; Thomas Hodne Architects, Inc.; Minneapolis, Minnesota



GLUED-LAMINATED CONSTRUCTION

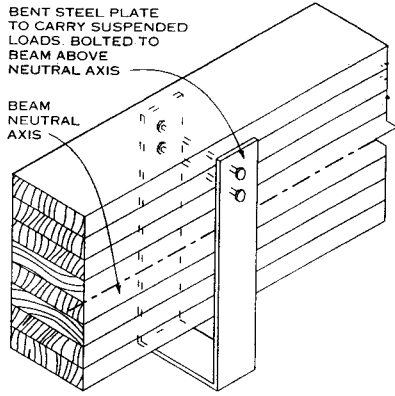

**NOTE**  
Very light loads may be placed near bottom of beam; however, the heavier the load the higher on the beam the suspension points should be located.

**SUSPENDED LOAD—BENT PLATE ATTACHED TO SIDE**

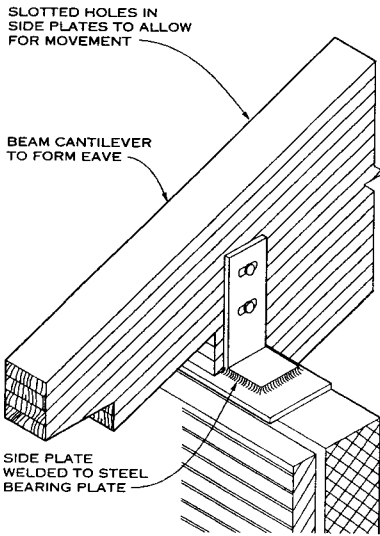

**RAFTER TO BEARING WALL**

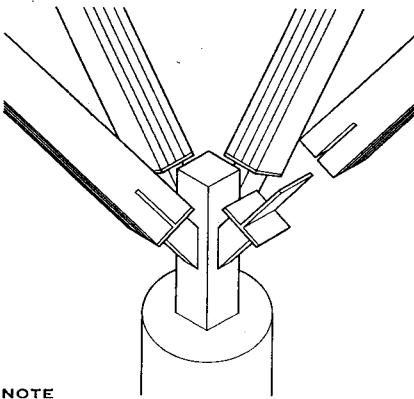

**NOTE**  
The detail above is just one of a large variety of special connections and connection assemblies possible using structural glued laminated timber. It is critical that connections be designed carefully in accordance with good engineering practice.

**SPECIAL CONNECTION**

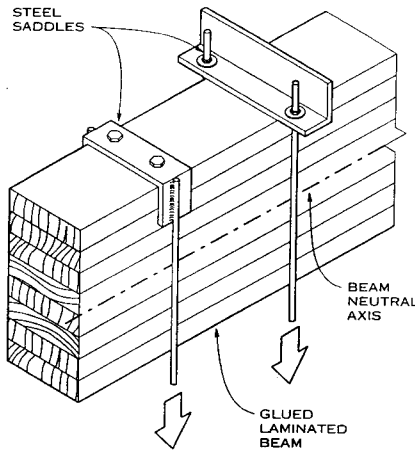

**NOTE**  
This detail is recommended for use with heavy loads.

**SUSPENDED LOAD—SADDLE**

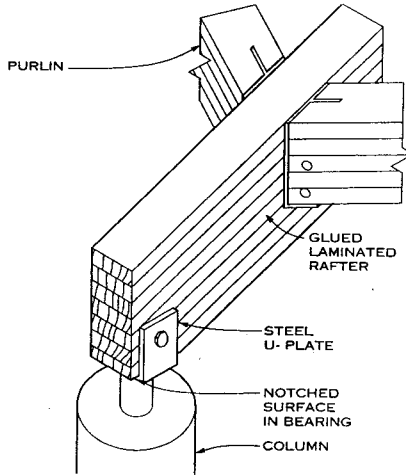

**NOTE**  
An abrupt notch in the end of a wood member reduces the effective shear strength of the member and may permit a more rapid migration of moisture in the lower portion of the member causing potential splitting. The shear strength of the end of the member is reduced and the exposed end grain may also result in splitting because of drying. At inclined beams, the taper cut should be loaded in bearing.

**NOTCHED BEARING CONDITION**

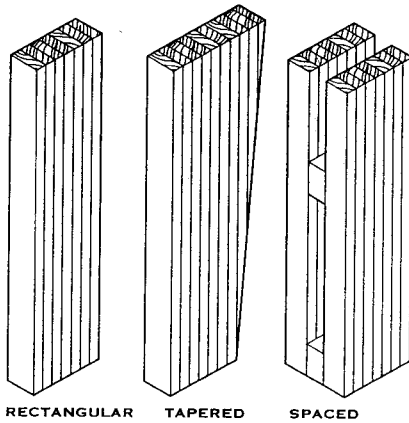

**GLUED LAMINATED COLUMNS**

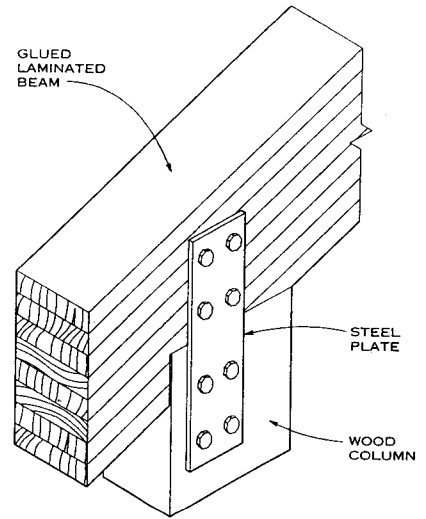

**RAFTER TO COLUMN CONDITION**

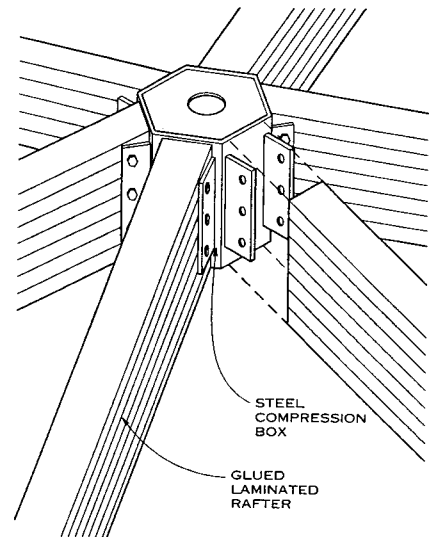

**STEEL COMPRESSION BOX**

**CONNECTION DESIGN**

The design of connections for glued laminated timber and sawn timber is similar. Glued laminated timbers and their loads, however, often are much larger than sawn lumber, so the effect of increased size should be taken into account in the design.

Used to add strength to transfer loads, connections should be designed to avoid splitting and to accommodate swelling and shrinking.

**GLUED LAMINATED COLUMNS**

Structural glued laminated timber columns offer higher allowable stresses, controlled appearance, and the ability to fabricate variable sections. For simple rectangular columns, the slenderness ratio (the ratio of the unsupported length between points of lateral support to the least column dimension) may not exceed 50. The least dimension for tapered columns is the sum of the smaller dimension and one-third the difference between the smaller and greater dimensions. Spaced columns consist of two or more members with longitudinal axes parallel, separated at the ends and at the midpoint by blocking, and joined at the ends by shear fastenings. The members act together to carry the total column load; because of the end fixity developed, a greater slenderness ratio than allowed for solid columns is permitted.

Roger W. Kipp, AIA; Thomas Hodne Architects, Inc.; Minneapolis, Minnesota

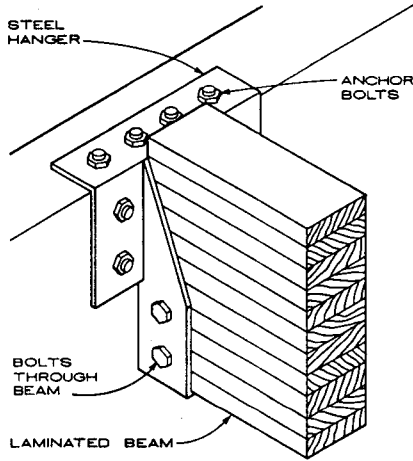

BEAM HANGER

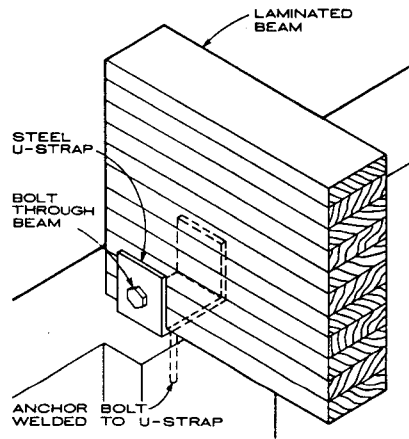

BEAM ANCHOR

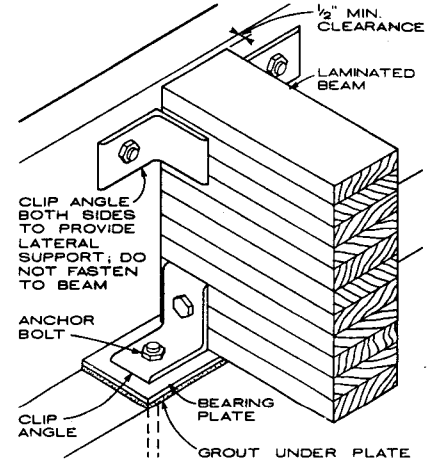

BEAM ANCHOR

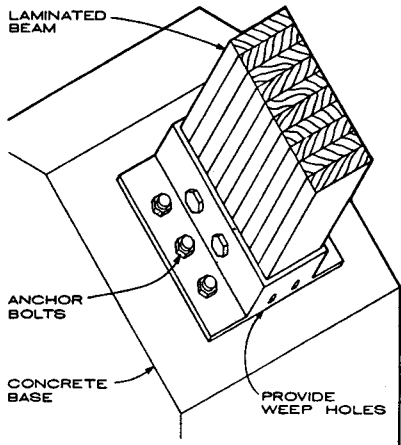

FIXED ARCH ANCHORAGE

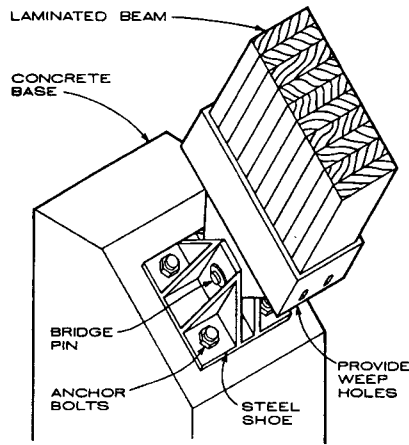

TRUE HINGE ANCHORAGE FOR ARCHES

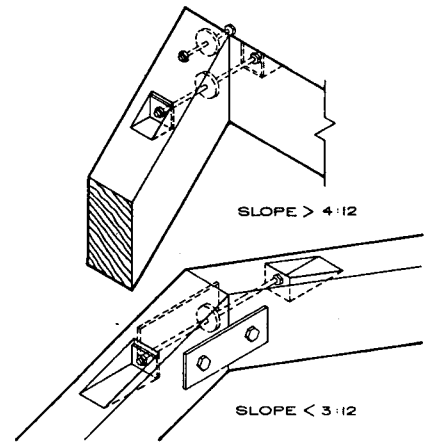

ARCH PEAK CONNECTION

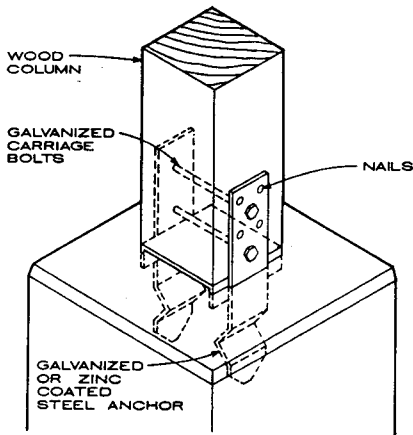

WET POST ANCHORAGE TO CONCRETE BASE

This detail is recommended for heavy duty use where moisture protection is desired. Anchor is set and leveled in wet concrete after screeding.

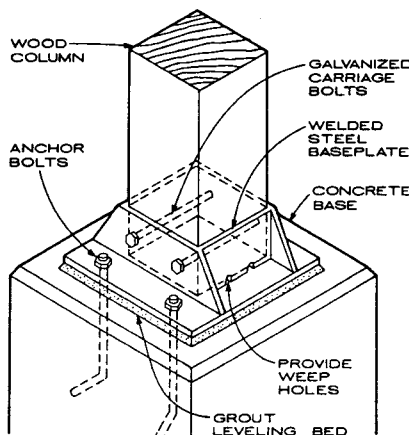

WOOD COLUMN ANCHORED WITH STEEL BASEPLATE

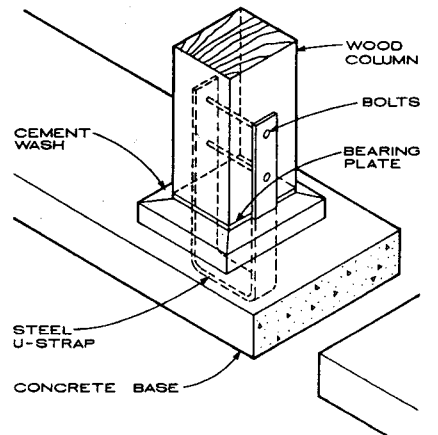

U-STRAP COLUMN ANCHORAGE TO CONCRETE BASE

This detail is recommended for industrial buildings and warehouses to resist both horizontal forces and uplift. Moisture barrier is recommended. It may be used with shear plates.

Timothy B. McDonald; Washington, D.C.

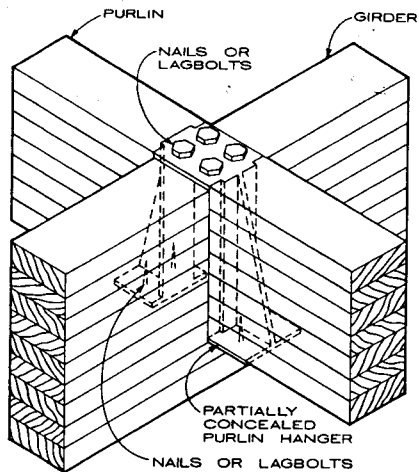

BEAM TO PURLIN CONNECTION

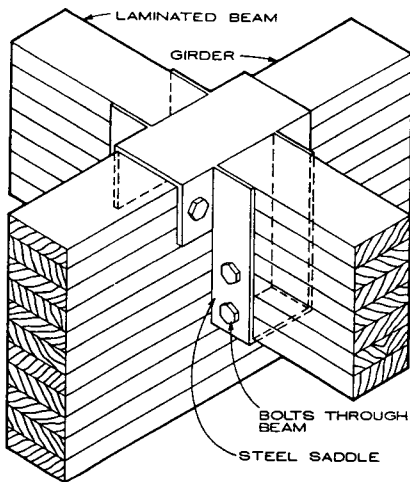

BEAM TO GIRDER CONNECTION

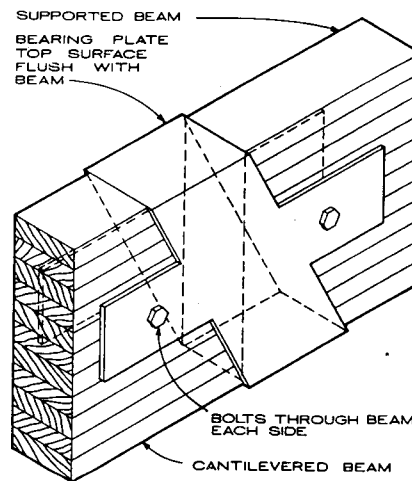

BEAM SPLICING

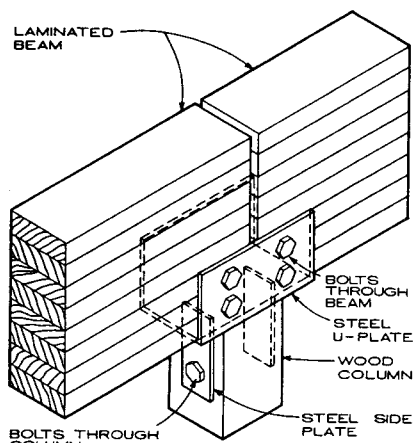

BEAM TO COLUMN CONNECTION

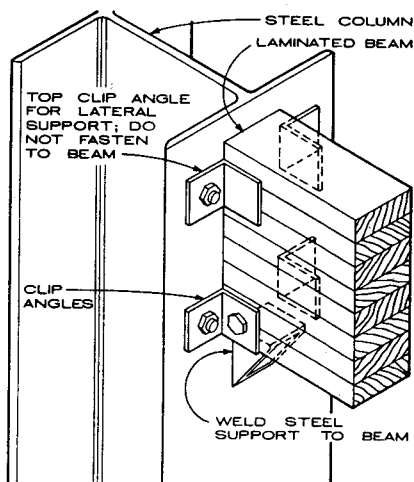

BEAM TO COLUMN CONNECTION

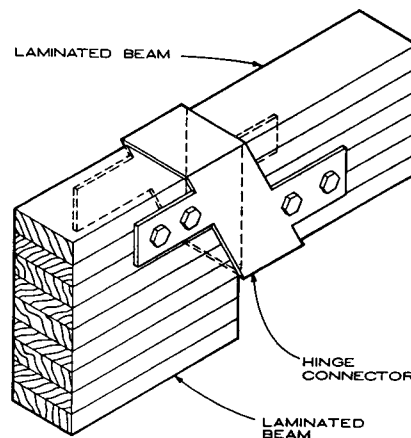

BEAM SPLICING

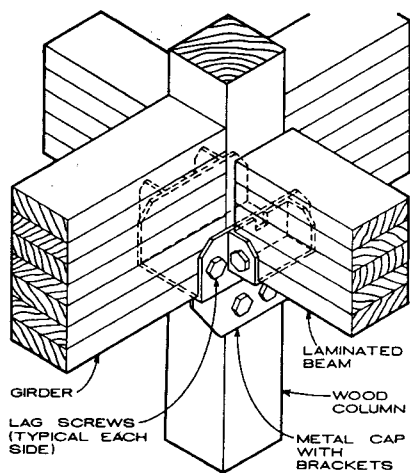

METAL COLUMN CAP WITH BEAM SEATS

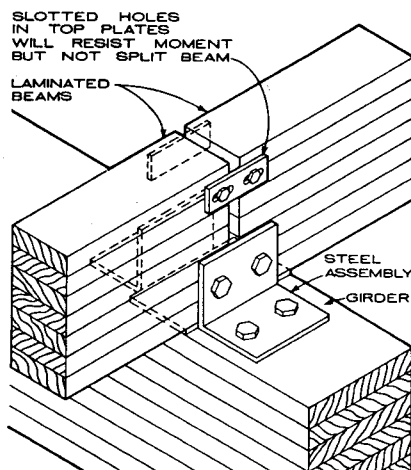

BEAM CONNECTION

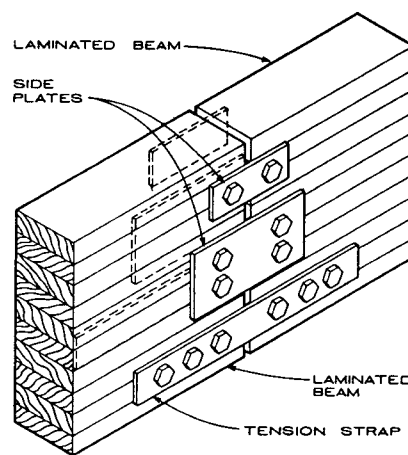

MOMENT SPLICING

Timothy B. McDonald; Washington, D.C.



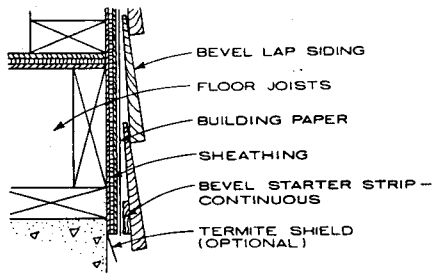

STARTER STRIP

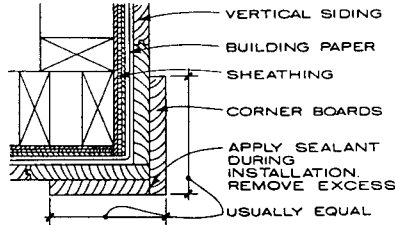

CORNER BOARD JOINT A

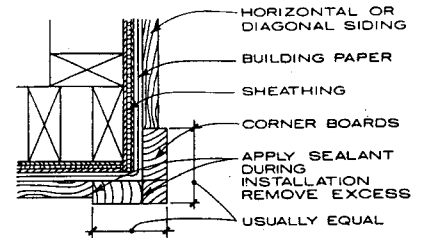

CORNER BOARD JOINT B

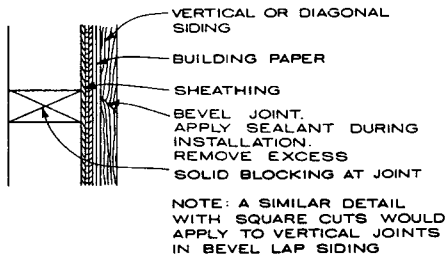

BEVEL BUTT JOINT

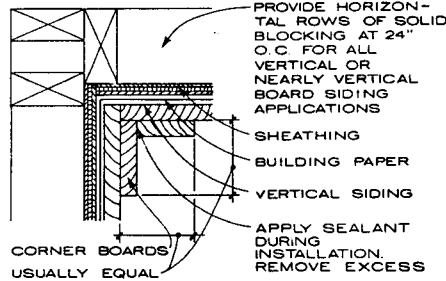

CORNER BOARD JOINT C

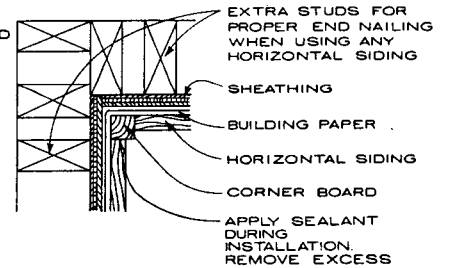

CORNER BOARD JOINT D

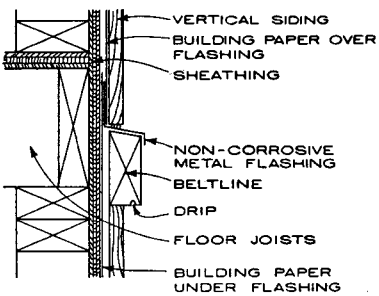

BELTLINE JOINT A

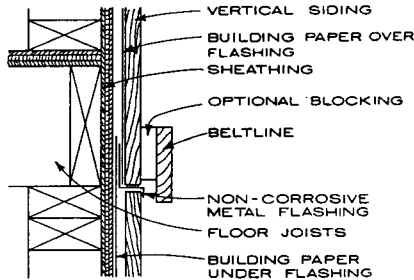

BELTLINE JOINT B

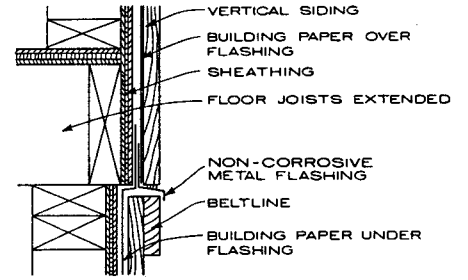

BELTLINE JOINT C

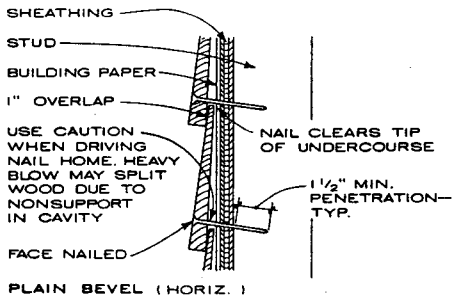

PLAIN BEVEL (HORIZ.)

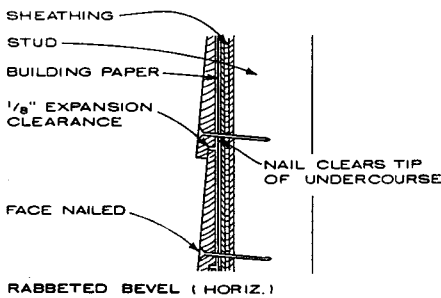

RABBETED BEVEL (HORIZ.)

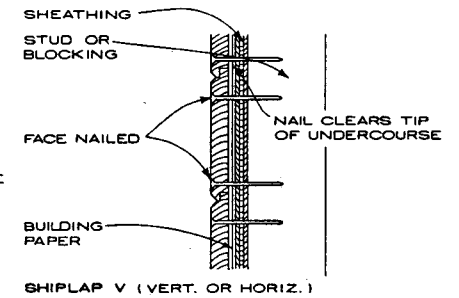

SHIPLAP V (VERT. OR HORIZ.)

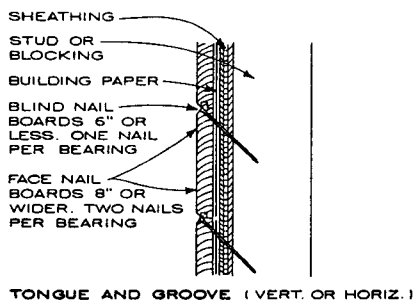

TONGUE AND GROOVE (VERT. OR HORIZ.)

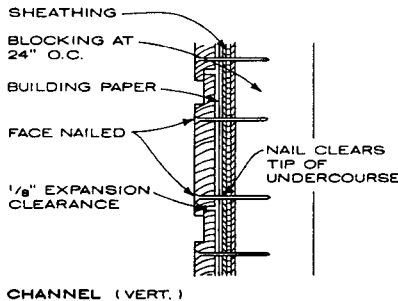

CHANNEL (VERT.)

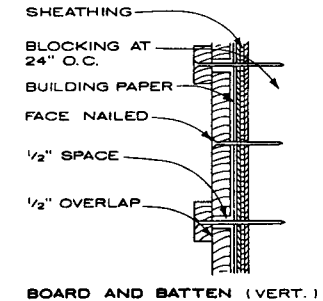

BOARD AND BATTEN (VERT.)

Gerald D. Graham; CTA Architects Engineers; Billings, Montana

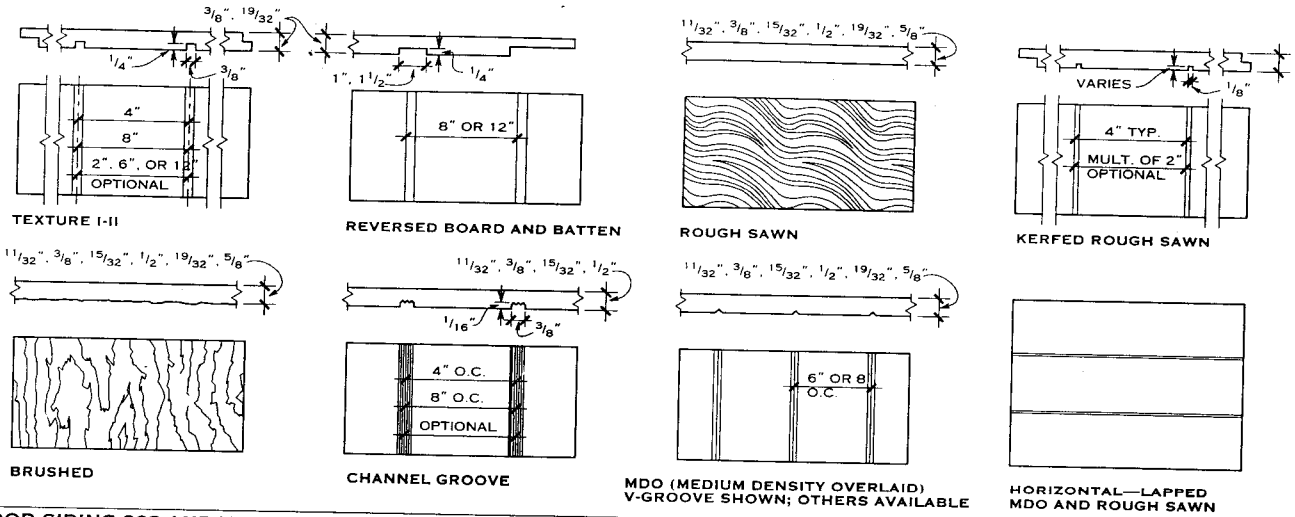

**PLYWOOD SIDING 303 AND T1-11 (303 SPECIAL)**

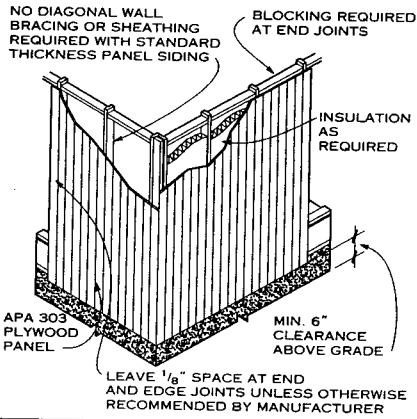

Medium density overlay (MDO) plywood lap siding: standard thickness is 3/8 in. in lengths to 16 ft on order; standard widths are 12 or 16 in.

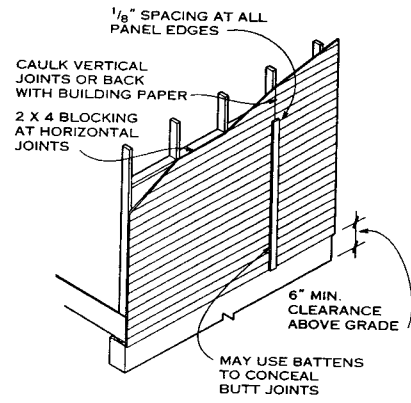
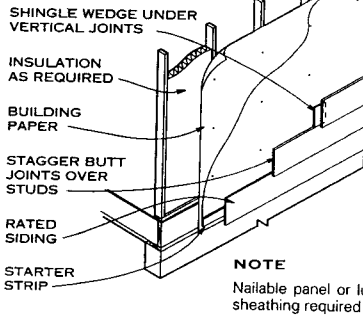

**PANEL SIDING VERTICAL APPLICATION**

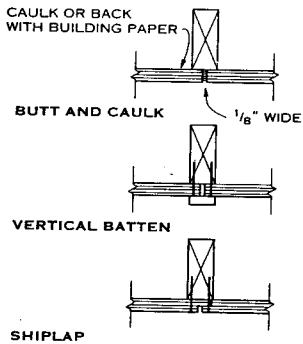

**VERTICAL JOINTS**

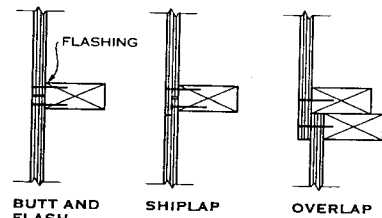

**HORIZONTAL JOINTS**

**LAP SIDING APPLICATION**

**APA STURD-I-WALL CONSTRUCTION RECOMMENDATIONS (SIDING DIRECT TO STUDS AND OVER NONSTRUCTURAL SHEATHING)**

PANEL SIDING DESCRIPTION (ALL SPECIES GROUPS)	NOMINAL THICKNESS OR SPAN RATING (IN.)	MAX. STUD SPACING (IN.)		NAIL SIZE (USE NONSTAINING BOX, SIDING, OR CASING NAILS) <sup>1,2</sup>	NAIL SPACING (IN.)	
		FACE GRAIN VERTICAL	FACE GRAIN HORIZONTAL		PANEL EDGES	INTERMEDIATE
APA MDO EXT	1 1/32" and 3/8"	16	24	6d for panels 1/2" thick or less 8d for thicker panels	6"	12
	1/2" and thicker	24	24			
APA rated siding EXT	16 o.c.	16	24			
APA rated siding EXT	24 o.c. <sup>3</sup>	24	24			

**NOTES**

- If siding is applied over sheathing thicker than 1/2 in., use next regular nail size. Use nonstaining box nails for siding installed over foam insulation sheathing.
- Hot-dipped or hot-tumbled galvanized steel nails are recommended for most siding applications. For best performance, stainless steel nails or aluminum nails should be considered. APA tests also show that electrically or mechanically galvanized steel nails appear satisfactory when plating meets or exceeds thickness requirements of ASTM A641 Class 2 coatings and is further protected by yellow chromate coating.
- Only panels 1 1/32 in. and thicker that have certain groove depths and spacing qualify for 24 in. o.c. Span Rating.
- For braced wall sections with 1 1/32 in. or 3/4 in. siding applied horizontally over studs 24 in. o.c., space nails 3 in. o.c. along panel edges.

**MINIMUM BENDING RADII FOR PLYWOOD PANELS**

	PANEL THICKNESS (IN.)				
	1/4	3/8	1/2	5/8	3/4
Across grain (ft)	2	3	6	8	12
Parallel to grain (ft)	5	8	12	16	20

**NOTE**

The types of plywood recommended for exterior siding are APA grade trademarked medium density overlay (MDO), Type 303 siding or Texture 1-11 (T1-11 special 303 siding). T1-11 plywood siding is manufactured with 3/8 in. wide parallel grooves and shiplapped edges. MDO is recommended for paint finishes and is available in a variety of surfaces. 303 plywood panels are also available in a wide variety of surfaces. The most common APA plywood siding panel dimensions are 4 x 8 ft but the panels are also available in 9 and 10 ft lengths, lap siding to 16 ft.

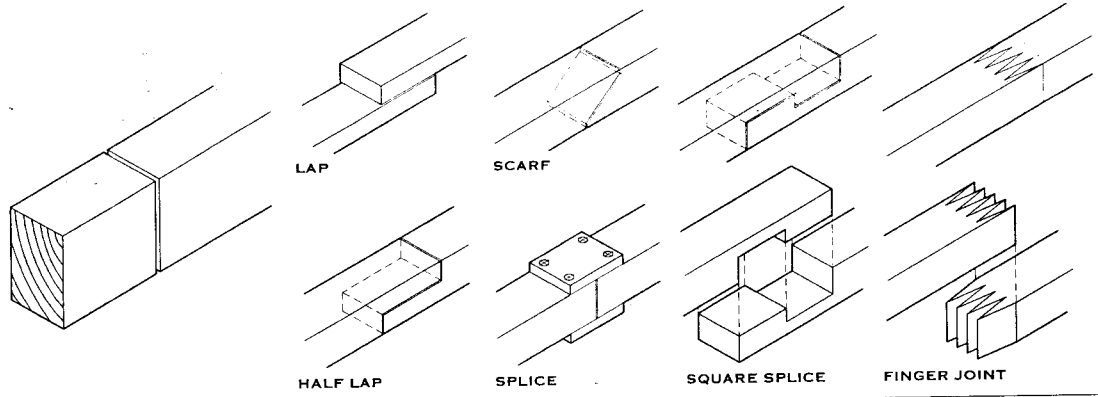

END JOINTS—TO INCREASE LENGTH

ALTERNATE DIRECTION OF END GRAINS FOR STABILITY AND FLATNESS

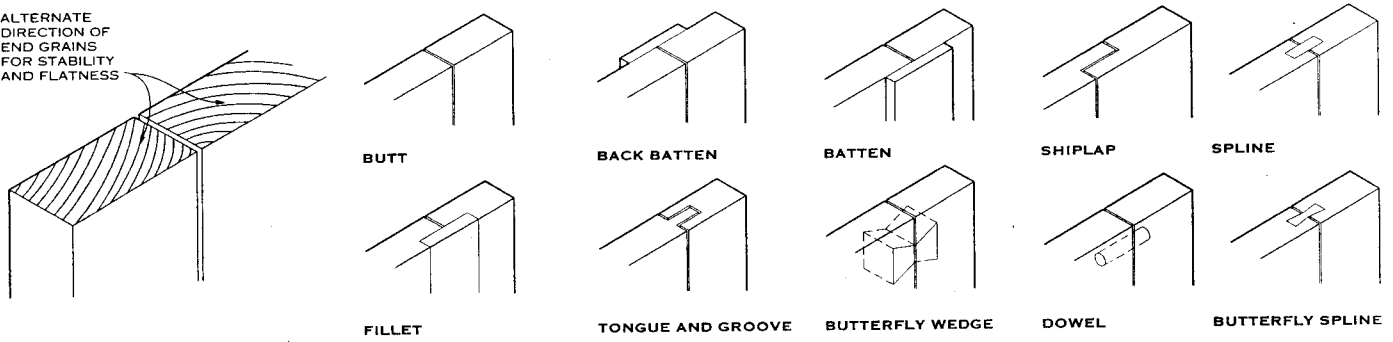

EDGE JOINTS—TO INCREASE WIDTH

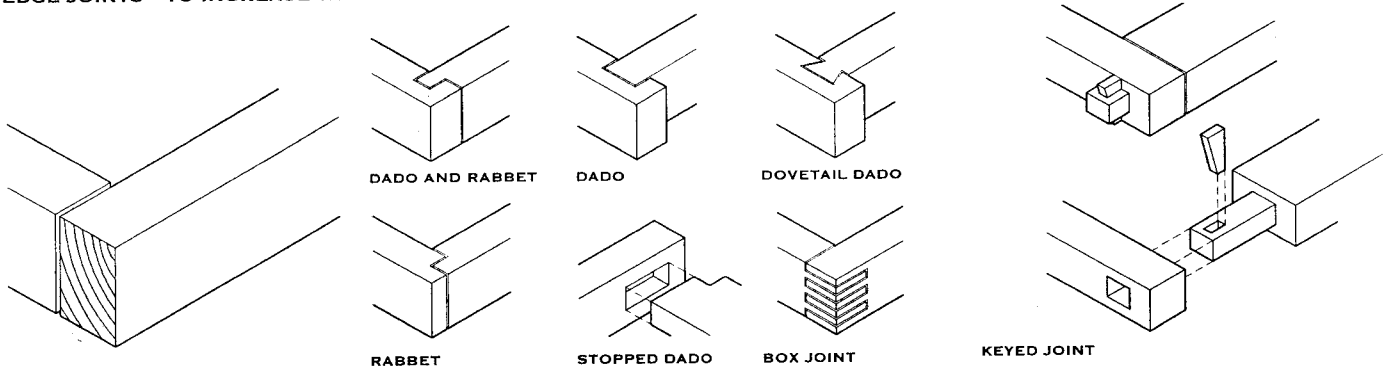

RIGHT ANGLE JOINTS

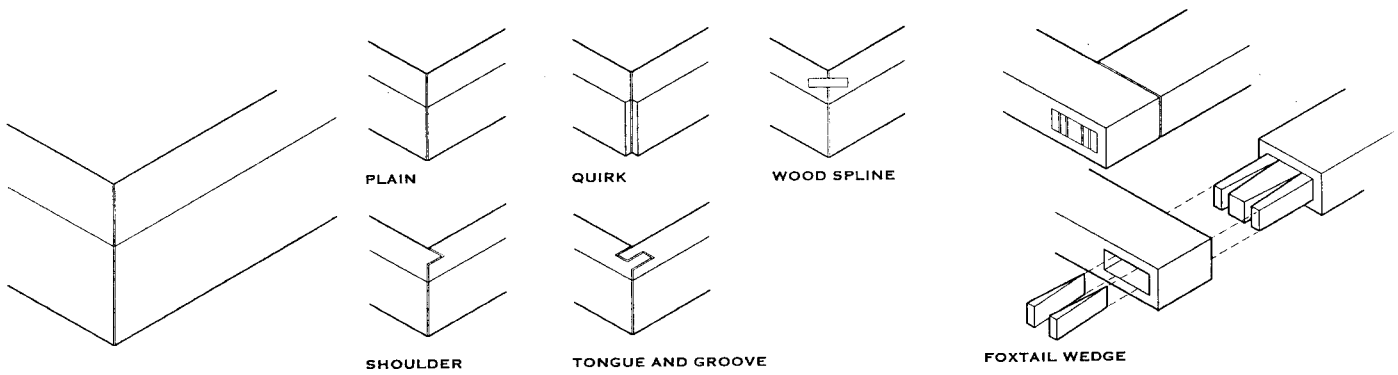

MITER JOINTS

WEDGED JOINTS

Richard J. Vitullo, AIA; Vitullo Architecture Studio; Washington, D.C.

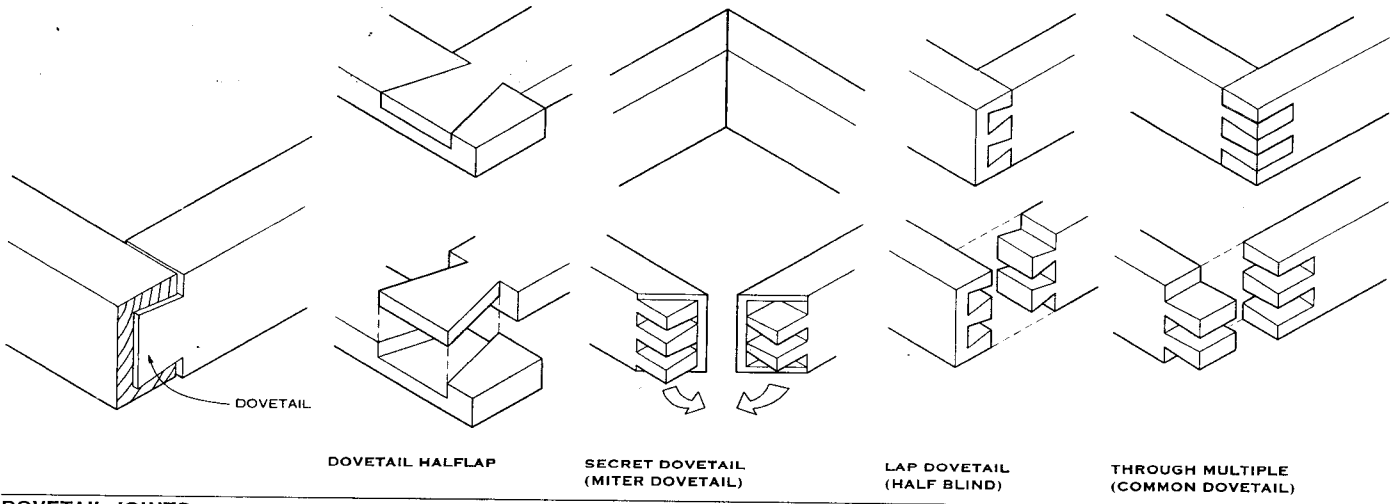

DOVETAIL JOINTS

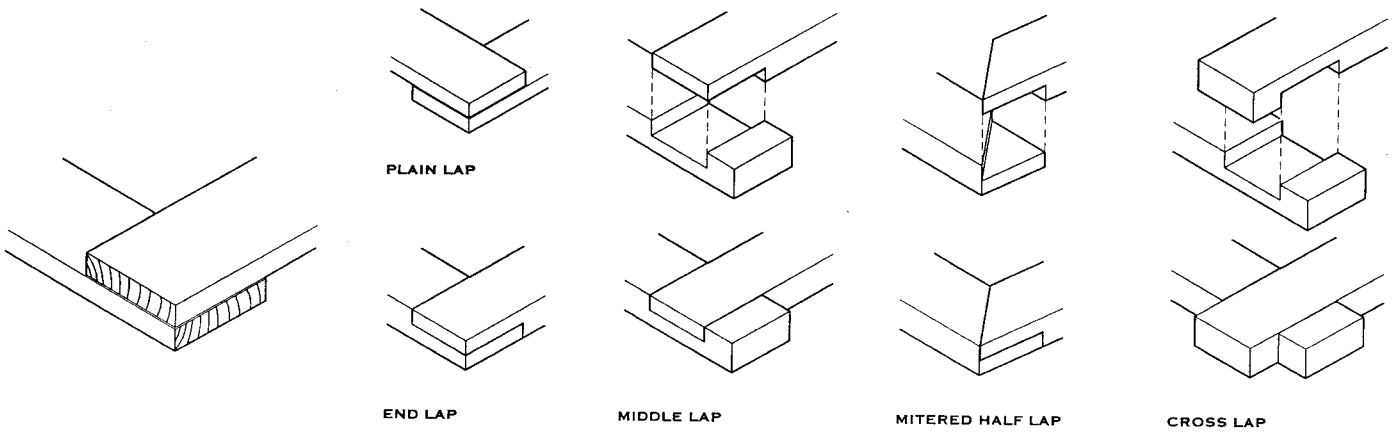

LAP JOINTS

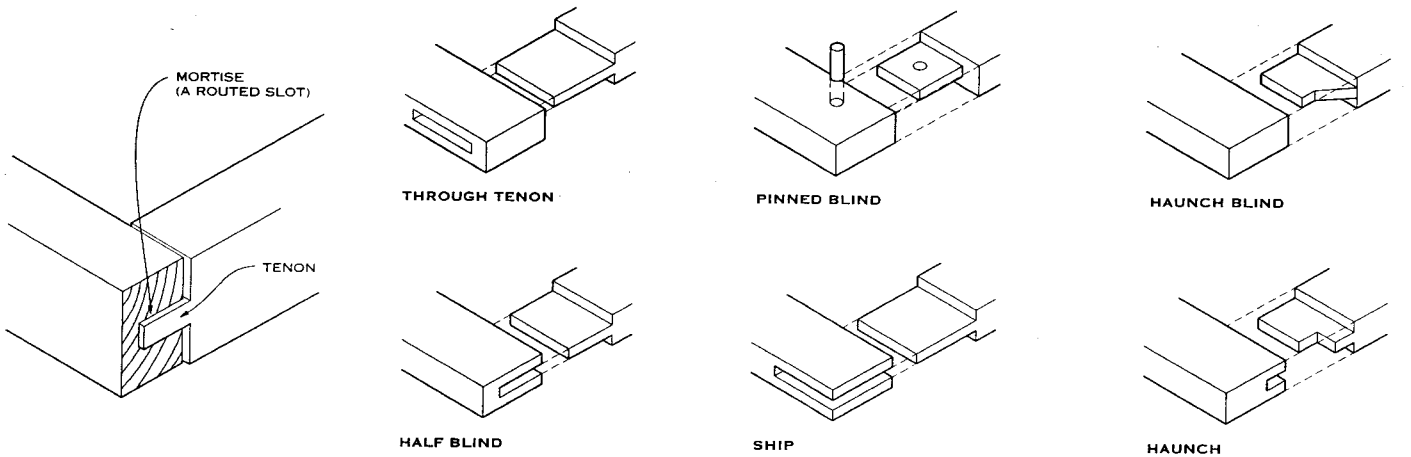

MORTISE AND TENON JOINTS

Richard J. Vitullo, AIA; Vitullo Architecture Studio; Washington, D.C.

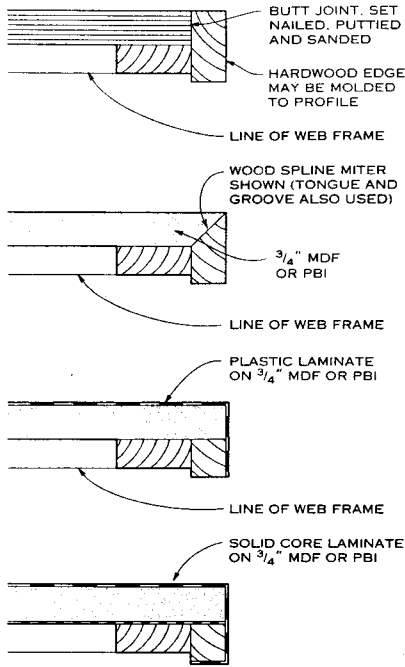

EDGE DETAILS

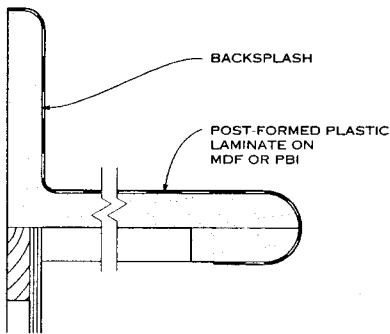

POST-FORMED LAMINATE COUNTERTOP

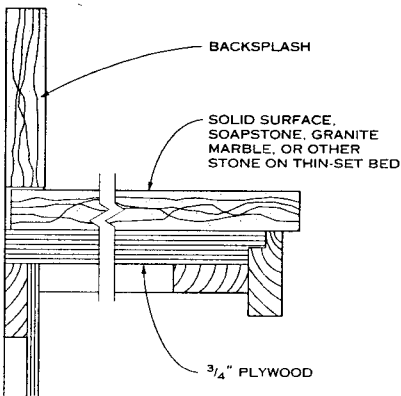

STONE COUNTERTOP

COUNTER AND BACKSPLASH DETAILS

GENERAL

The Architectural Woodwork Institute's Quality Standards classify custom-manufactured cabinets in three categories: premium, custom, and economy. The materials, joinery, and finish quality are delineated in the specifications for cabinet shops to follow. Premium is the highest grade, with close tolerances reserved for only the finest cabinets. Custom-grade cabinets, the most common, are made from very good materials with durable joinery. Economy-grade cabinets are used for utilitarian and inexpensive residential cabinets.

The AWI Quality Standards classify cabinet parts as exposed, semiexposed, and concealed, and specify a minimum grade for each. The finish to be used is specified as paint grade or stain grade or whether plastic laminate or other material will be used.

To prevent movement caused by wood shrinkage, use only kiln-dried solid lumber or panel product for base supports.

ABBREVIATIONS

The following abbreviations are used on the three AGS pages on cabinet details: MDF—medium-density fiberboard; PBI—industrial particleboard.

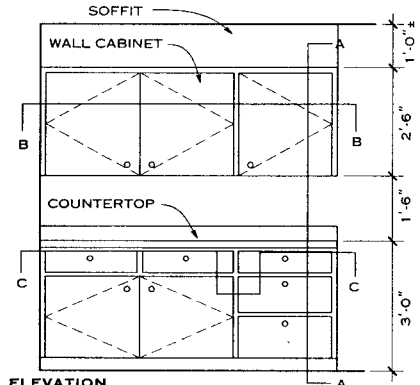

ELEVATION NOTE

Flush overlay construction offers a clean, contemporary design because only the doors and drawer fronts are visible in elevation. The grain between doors and drawer fronts can be matched by cutting all pieces from the same panel. This cabinet style lends itself well to the use of plastic laminate for exposed surfaces. Conventional and concealed hinges are available for a variety of door thicknesses. Door and drawer joinery and materials may vary from the selection shown in the details.

FLUSH OVERLAY CONSTRUCTION

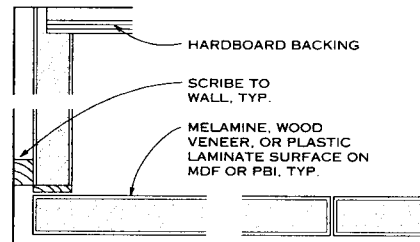

WALL CABINET—SECTION B-B

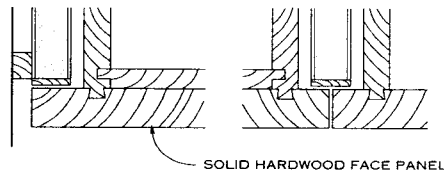

BASE CABINET—SECTION C-C

FLUSH OVERLAY CONSTRUCTION—HORIZONTAL SECTIONS

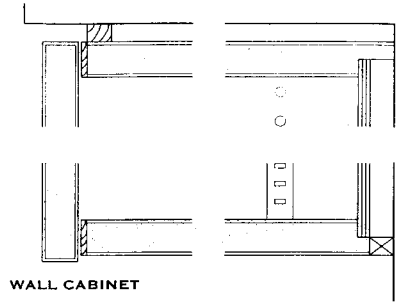

WALL CABINET

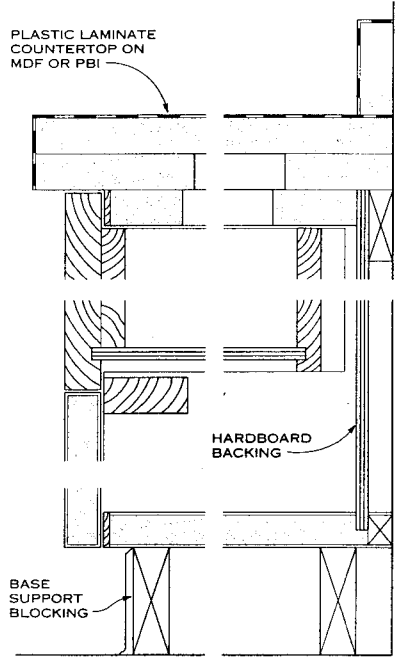

BASE CABINET

FLUSH OVERLAY CONSTRUCTION—VERTICAL SECTION A-A

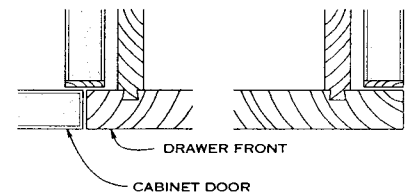
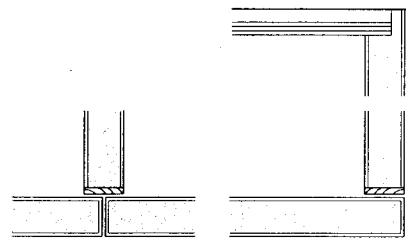

Greg Heuer; Architectural Woodwork Institute; Reston, Virginia

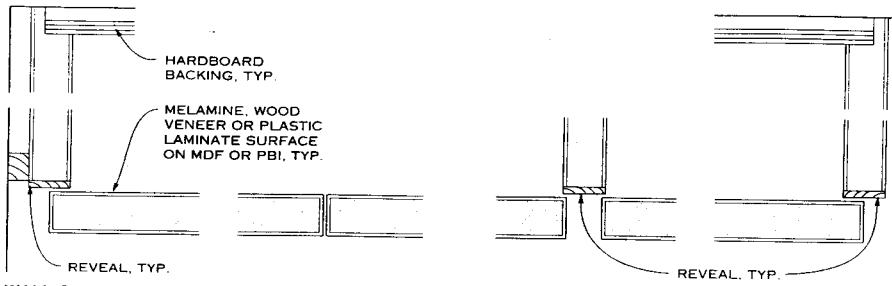

WALL CABINET SECTION B-B

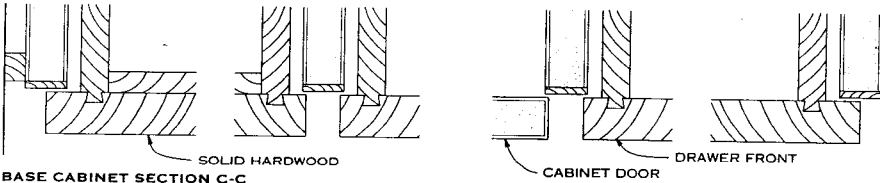

BASE CABINET SECTION C-C

REVEAL OVERLAY CONSTRUCTION—HORIZONTAL SECTIONS

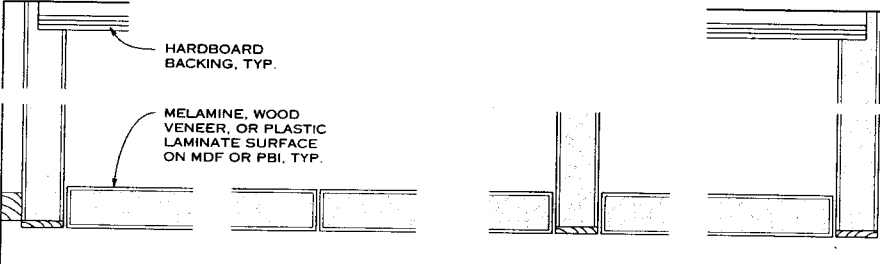

WALL CABINET SECTION A-A

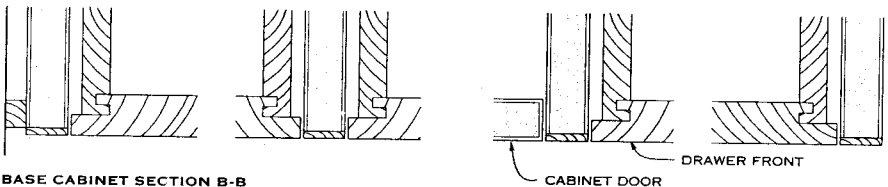

BASE CABINET SECTION B-B

FLUSH INSET CONSTRUCTION (WITHOUT FACE FRAME)—HORIZONTAL SECTIONS

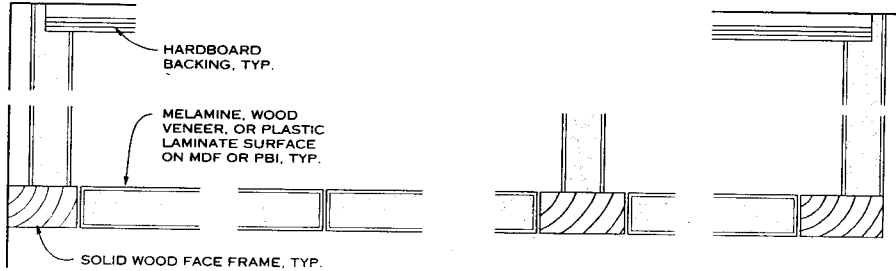

WALL CABINET SECTION B-B

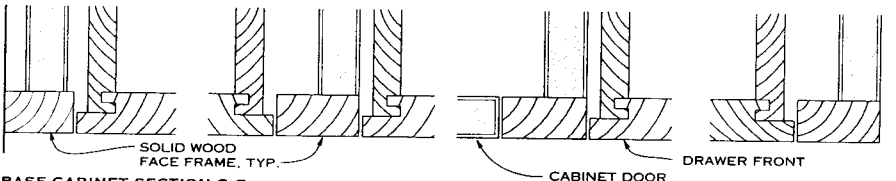

BASE CABINET SECTION C-C

FLUSH INSET CONSTRUCTION (WITH FACE FRAME)—HORIZONTAL SECTIONS

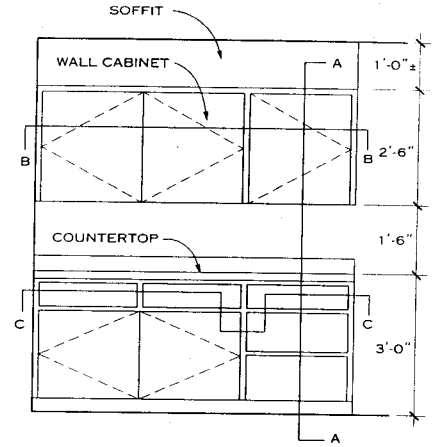

TYPICAL CABINET ELEVATION

REVEAL OVERLAY CONSTRUCTION

In this style of cabinet construction, the separation between doors and drawer fronts is accented by the reveal. The style is suited equally to either wood or plastic laminate construction. The details shown at left show a reveal at all vertical and horizontal joints, but the designer may vary this arrangement.

A reveal greater than 1/2 inch would require the addition of a face frame, which would change the hinge requirements. With or without a face frame, this style allows the use of conventional or concealed hinges. Door/drawer joinery and materials may vary from selections shown in the drawings.

FLUSH INSET CONSTRUCTION WITHOUT FACE FRAME

In this style of construction, all door and drawer faces are flush with the face of the cabinet. This style allows the use of door and drawer fronts with different thicknesses.

Conventional as well as concealed hinges are available for a variety of door thicknesses. The material chosen for the case and doors and drawers influences the choice of hinges. Avoid conventional butt hinges when hinge screws would be attached to the edge-grain of panel products.

Flush inset construction without any face frame is generally an expensive style because increased care is necessary to fit and align the doors and drawers. The design features of this case-work style are the same as for conventional flush construction with face frame except that here the face frame has been eliminated.

This style does not lend itself to the economical use of plastic laminate covering finishes. Door/drawer joinery and materials may vary from selections shown in details.

FLUSH INSET CONSTRUCTION WITH FACE FRAME

In this style of construction, all door and drawer faces are flush with the face of the cabinet. This style allows the use of different thicknesses for door and drawer fronts.

Conventional as well as concealed hinges are available for a variety of door thicknesses. The hinges chosen depend on the case and door/drawer material chosen. Avoid conventional butt hinges when hinge screws would be attached to the edge-grain of panel products.

Flush inset construction with face frame is generally the most expensive of the four cabinet door styles because, in addition to the cost of providing the face frame, there is the cost of the increased care needed to fit and align the doors and drawers.

This style does not lend itself well to the economical use of plastic laminate surfaces. Door/drawer joinery and materials may vary from the selections shown.

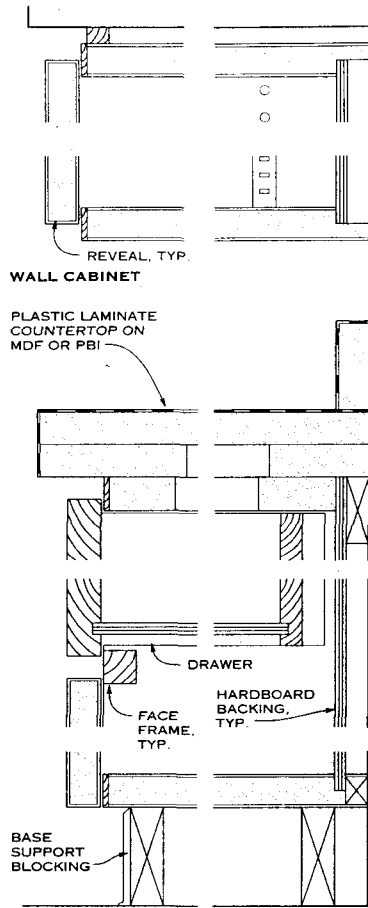

REVEAL OVERLAY CONSTRUCTION  
VERTICAL SECTION A-A

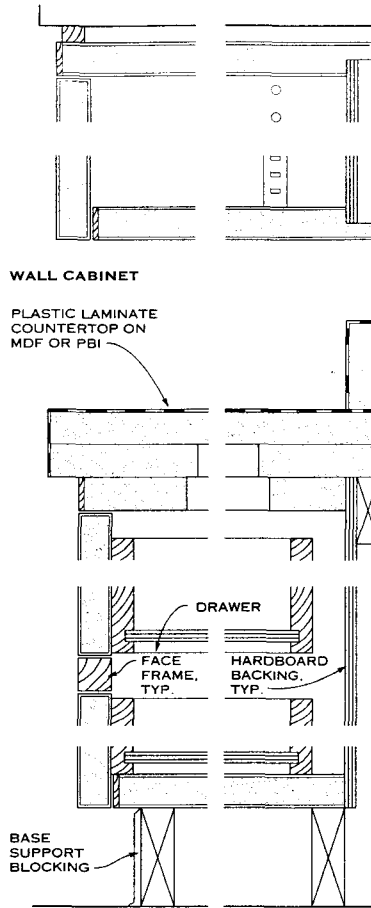

FLUSH INSET CONSTRUCTION  
(WITHOUT FACE FRAME)  
VERTICAL SECTION A-A

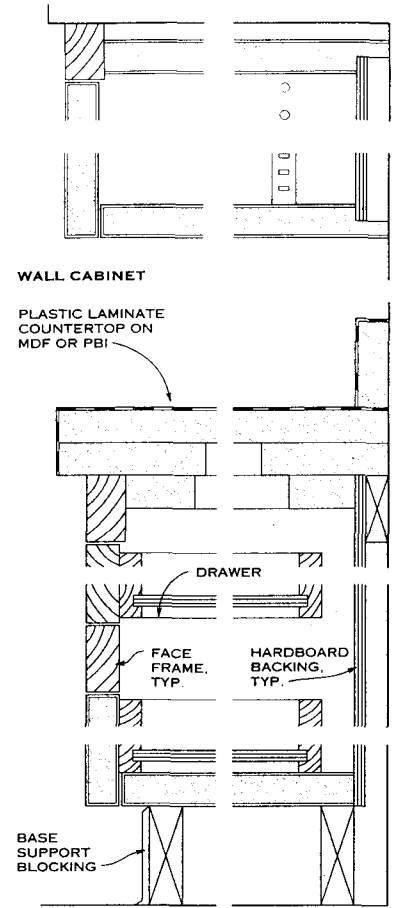

FLUSH INSET CONSTRUCTION (WITH  
FACE FRAME) VERTICAL SECTION A-A

**HARDWARE HINGES**

	BUTT	PIVOT	WRAPAROUND	EUROPEAN STYLE
<b>HINGE TYPE</b>				
<b>Applications</b>	Conventional flush with face frame	Reveal overlay, flush overlay	Conventional reveal overlay	Conventional flush without face frame, reveal overlay, flush overlay
<b>Strength</b>	High	Moderate	Very high	High moderate
<b>Concealed when closed</b>	No	Semi	No	Yes
<b>Requires mortising</b>	Yes	Usually	Occasionally	Yes
<b>Cost of hinge</b>	Low	Low	Moderate	High moderate
<b>Ease of installation</b>	Moderate	Moderate	Easy	Very easy
<b>Adjusted easily after installation</b>	No	No	No	Yes
<b>Remarks</b>	Door requires hardwood edge	Door requires hardwood edge	Exposed knuckle and hinge body	Specify degree of opening; no catch required on self-closing styles

**MINIMUM NOMINAL THICKNESS AND MATERIAL FOR CABINET COMPONENTS**

COMPONENTS	MATERIALS	MIN. NOMINAL THICKNESS
Body members (ends, divisions, bottoms, tops)	Panel product	3/4 in.
Face frames, rails	Lumber or panel product	3/4 in.
Shelves <sup>1</sup>	Lumber	3/4 in. for spans up to 36 in. 1 1/16 in. for spans up to 48 in.
	Veneer core plywood	3/4 in. for spans up to 36 in. 1 in. for spans up to 48 in.
	Medium density particleboard or fiberboard	3/4 in. for spans up to 32 in. 1 in. for spans up to 42 in.
Backs	Panel product	1/4 in.
Mounting or hanger strips	Lumber or panel product	1/2 in.
Drawer sides, backs, subfronts	Lumber or panel product	1/2 in.
Drawer bottoms	Panel product	1/4 in.
Drawer fronts	Lumber or panel product	3/4 in.
Stile and rail cabinet doors and drawers <sup>2</sup>	Lumber	3/4 in.
Frames for glass doors <sup>3</sup>	Lumber	3/4 in.
Frameless glass doors	Frameless glass	1/4 in.
Flush cabinet doors and drawer fronts <sup>4</sup>	Medium density particleboard or fiberboard	3/4 in. up to 30 in. width by 80 in. height

<sup>1</sup> Consult a woodworking professional for shelf specifications to carry anticipated loads.  
<sup>2</sup> Give special consideration to building very wide and/or very tall doors of this thickness; consult manufacturer for guidelines.  
<sup>3</sup> Thickness of glass for doors should meet local code.  
<sup>4</sup> Use like materials and thicknesses for face of cabinet doors and drawer fronts. Veneer core doors cannot be guaranteed against warping, telegraphing, or delamination.

Greg Heuer; Architectural Woodwork Institute; Reston, Virginia  
 Architectural Woodwork Institute, *Architectural Woodwork Quality Standards*, 7th ed. (version 1), 1997.

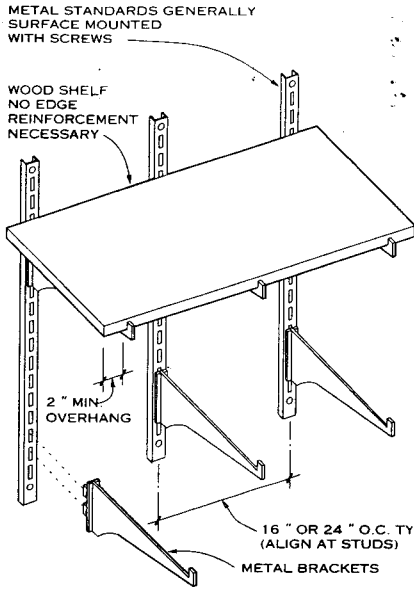

**STANDARDS AND BRACKETS SYSTEM**

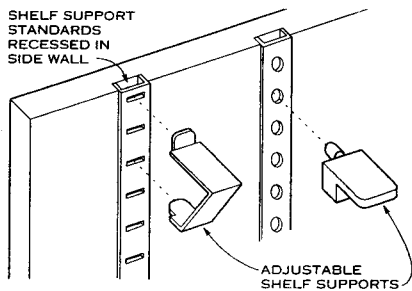

**STANDARDS AND CLIP SYSTEM**

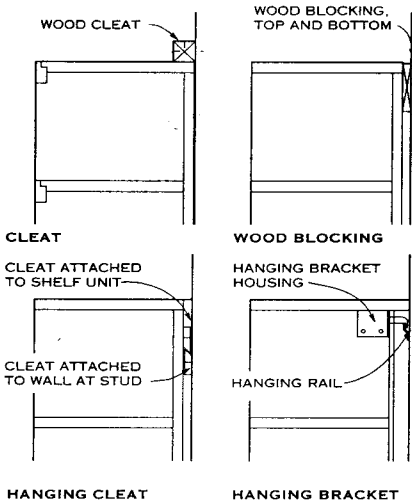

**NOTE**  
All details except hanging bracket and rail must also be floor supported.

**BOOKSHELF WALL ATTACHMENT**

Richard J. Vitullo, AIA; Oak Leaf Studio; Crownsville, Maryland  
Helmut Guenschel, Inc.; Baltimore, Maryland

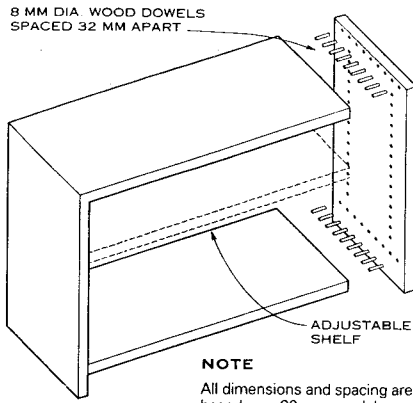

**NOTE**  
All dimensions and spacing are based on a 32 mm module

**BOX FRAME DIAGRAM**  
8 MM DIA. HOLES FOR BOX FRAME CONSTRUCTION

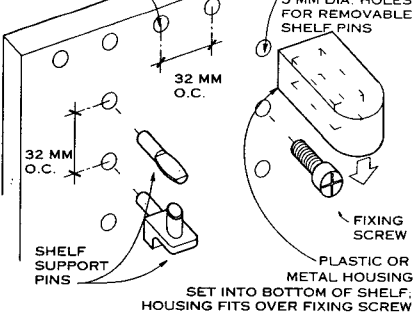

**32 MM BOX FRAME SYSTEM**

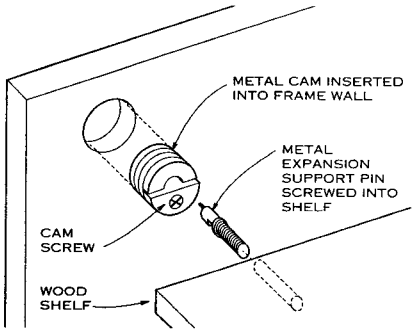

**NOTE**  
This system can be hand mounted or machine inserted. A half turn of the cam screw tightens connection and prevents disassembly.

**SEMI-FIXED FRAME/SHELF DETAIL**

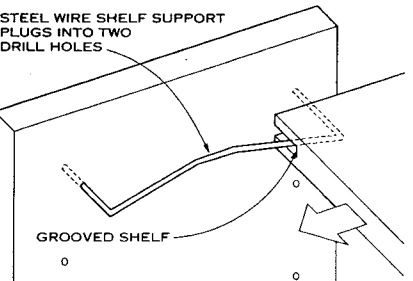

**NOTE**  
This system can be used for horizontal shelf attachment or vertical divider support.

**REMOVABLE GROOVED SHELF DETAIL**

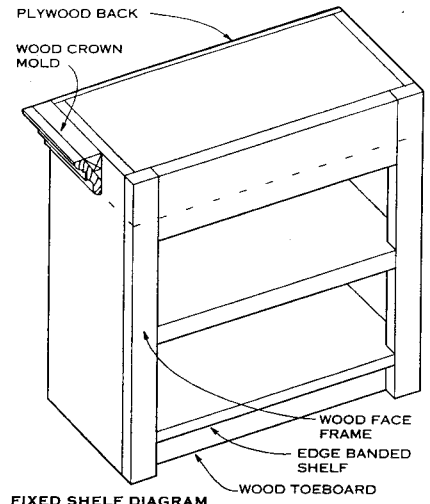

**FIXED SHELF DIAGRAM**

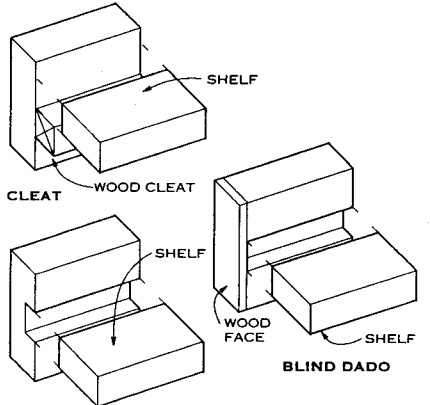

**THROUGH DADO SUPPORT DETAILS AT SIDE**

**FIXED SHELF SYSTEM**

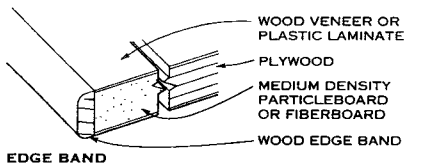

**EDGE BAND**

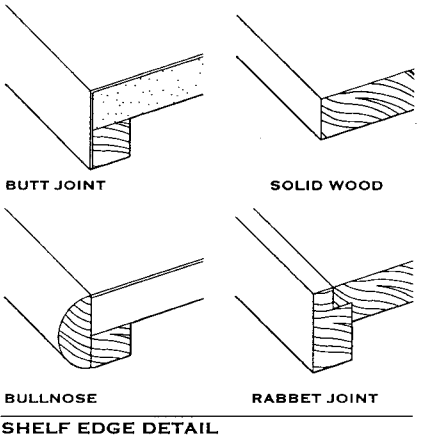



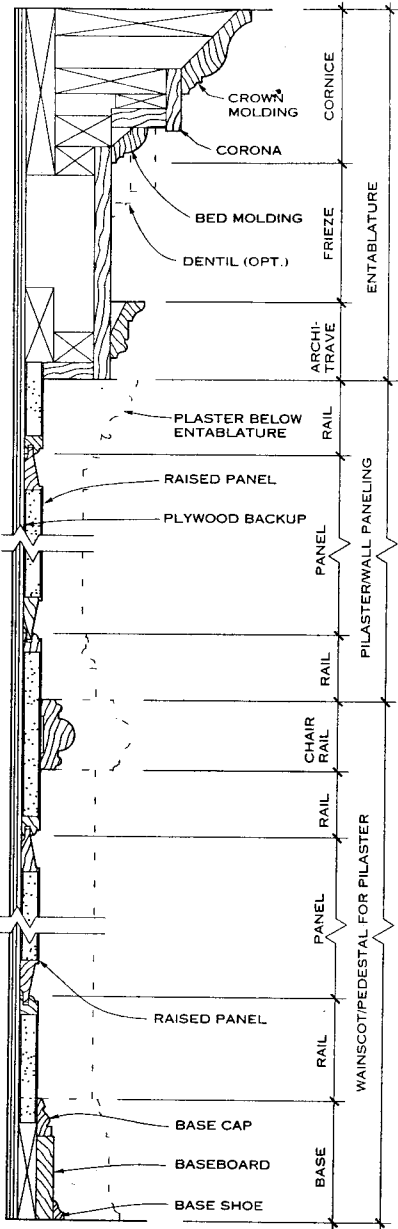

**NOTES**

1. Because of its stability, plywood is preferable to solid lumber or other materials as backup.
2. To join stile to rail, mortise and tenon or dowelled joints are used. Stile to stile joints at outside corners are spline joints or lock miters; inside corners are butt jointed.

**SECTION - FULL HEIGHT WALL PANEL**

**INTERIOR WALL PANEL DETAILS**

Architectural interior paneling consists of a series of thin sheets of wood (panels) framed together by means of stouter strips of wood, vertical (stiles) and horizontal (rails), to form either a door, screen, or lining for internal walls. Paneling was first used as a wall covering in England in the 13th century. Up to the 16th century, the framing was almost as massive as half-timber construction. Then it was progressively lightened until by the middle of that century when the thickness of the framing was reduced to an inch. Today, inch thick or less panels are made from veneers over plywood or composition boards, which can be treated for fire protection. The stiles and rails are made from solid wood or veneered boards. Rim and lip moldings and other trims are almost exclusively made from solid wood.

Richard J. Vitullo, AIA; Oak Leaf Studio; Crownsville, Maryland  
Architectural Woodwork Institute; Arlington, Virginia

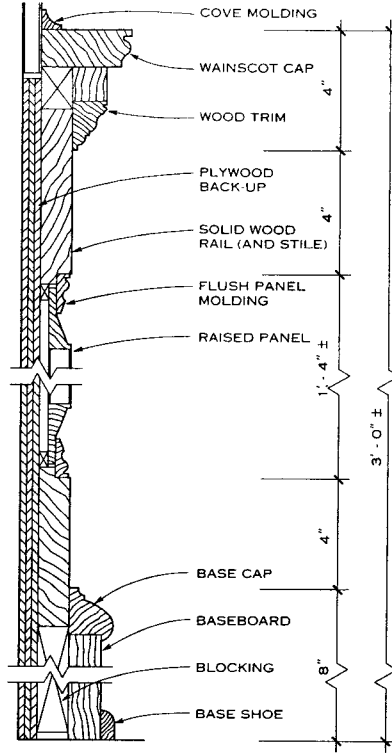

**SECTION - WAINSCOT WITH RAISED PANEL AND FLUSH MOLDING**

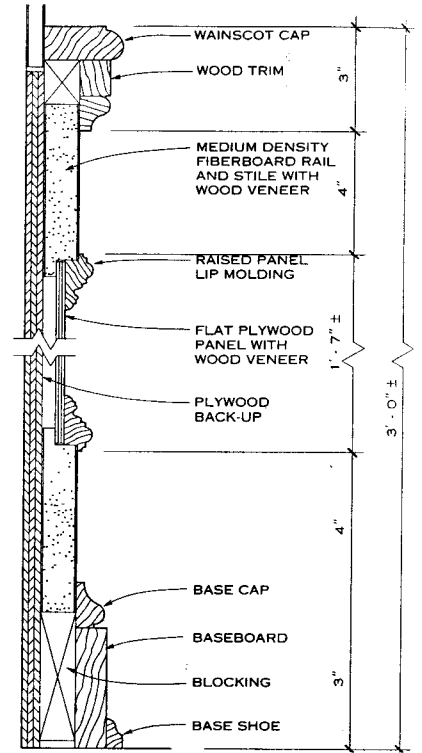

**SECTION - WAINSCOT WITH FLUSH PANEL AND RAISED MOLDING**

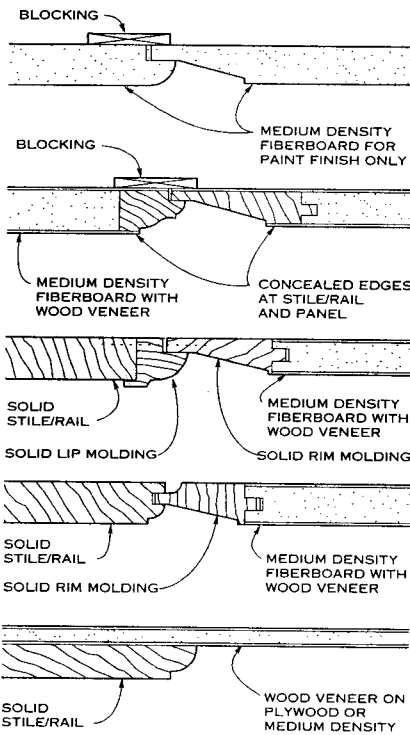

**STILE/RAIL TO PANEL JOINERY TYPES**

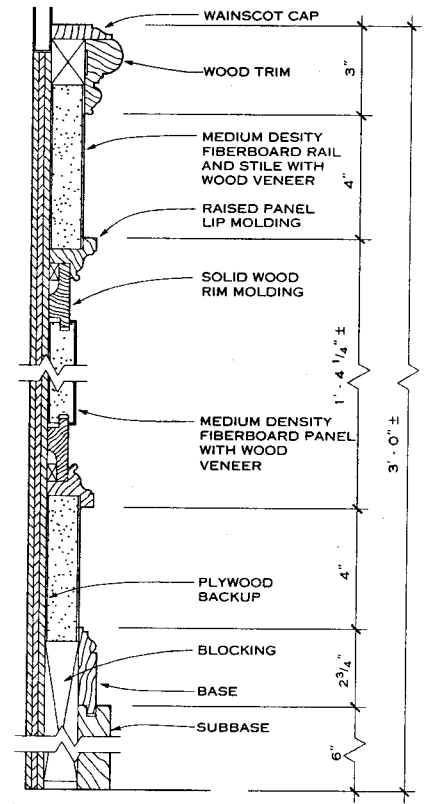

**SECTION - WAINSCOT WITH RAISED PANEL AND RAISED MOLDING**

**GUIDELINES**

Construction details on this page are for shop-built stairs using Premium Grade Standards of the Architectural Woodwork Institute. Wood stairs used in private, residential applications usually are not governed by the ADA; however, wood stairs in commercial facilities and places of public accommodation must conform to ADA accessibility guidelines (ADAAG). Details on these two pages depict both alternatives.

1. Check current local building codes and regulations for requirements that may differ from the general recommendations provided here.
2. Interior stair width: 36 in. minimum.
3. Minimum headroom is 6 ft 8 in. as measured vertically from a diagonal line connecting tread nosings to the underside of the finished ceiling or stair landing directly above the stair run. Recommended headroom is 7 ft.
4. Only handrails and stair stringers may project into the

- required width of a stair.  
 Handrail projection: 3/2 in. maximum.  
 Stringer projection: 1 1/2 in. maximum.
- For a stair to comply with ADAAG, no projections are allowed into the minimum required stair width.
5. The width of a landing or platform should be at least as wide as the stair.
  6. The maximum vertical rise of a stair between landings is 12 ft.
  7. Riser height: 4 in. min. and 7 in. max.  
 Tread width: 11 in. min., measured from riser to riser.  
 Variation in adjacent treads or risers should not exceed 3/16 in. The maximum difference allowed the tread width or riser height within a flight of stairs is 3/8 in. ADAAG requires uniform treads and risers.  
 Nosings project 1 1/2 in. max. Check codes and ADAAG for other restrictions.

8. Height of handrail above stair nosings: 30 to 34 in.; 34 to 38 in. per ADAAG. Guardrail height at landings: 36 or 42 in.; check local code.
9. Design handrails that can be gripped easily and fit the hand. Recommended diameter is 1 1/4 to 1 1/2 in. for round handrails and a similar size for an elliptical or rounded square edge section. Handrails should be structurally designed so that both downward (vertical) and lateral (horizontal) thrust loads are considered.
10. Extensions of handrail at top and bottom of stair may affect total length of required run. Verify extensions required by local codes or ADAAG when designing a stair.
11. Refer to related stair topics in chapters 1, 3, 4, 5, and 9.

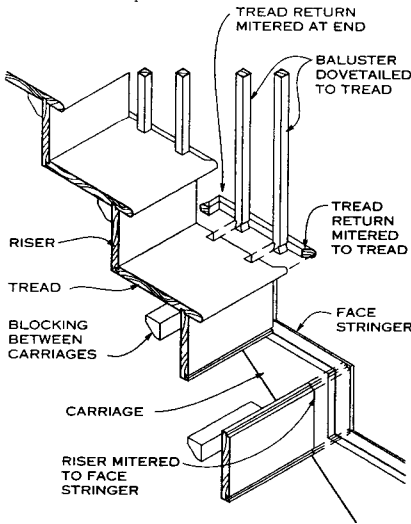

**BALUSTERS AND TRIM AT FACE STRINGER**

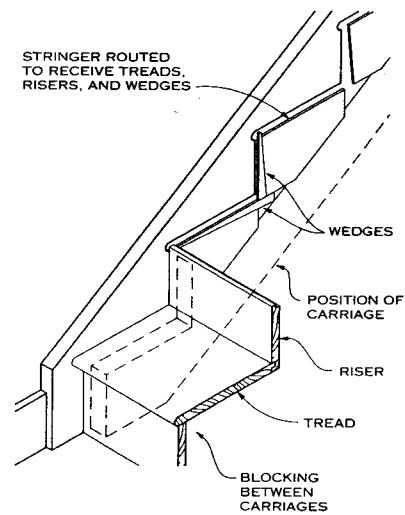

**TREADS AND RISERS AT HOUSED STRINGER**

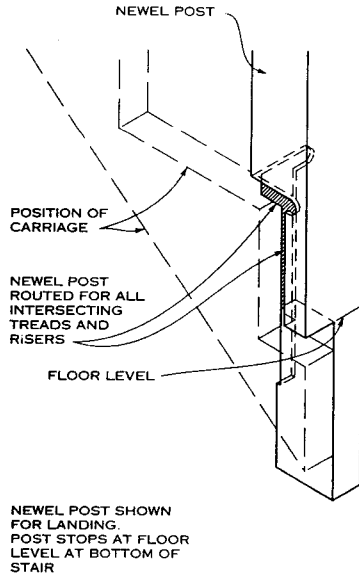

**NEWEL POST**

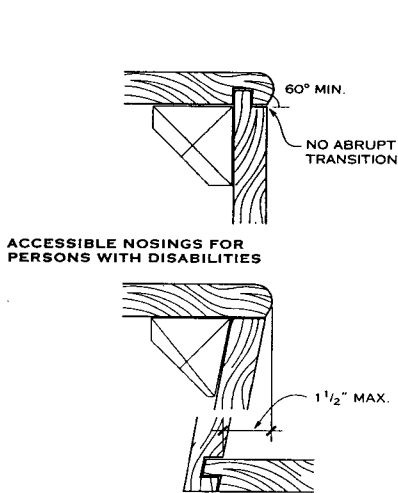

**ACCESSIBLE NOSINGS**

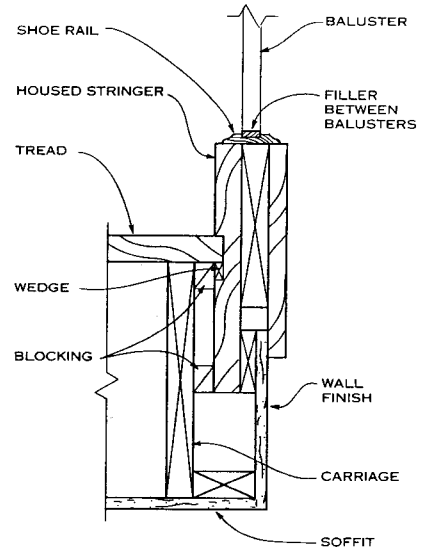

**SECTION A**

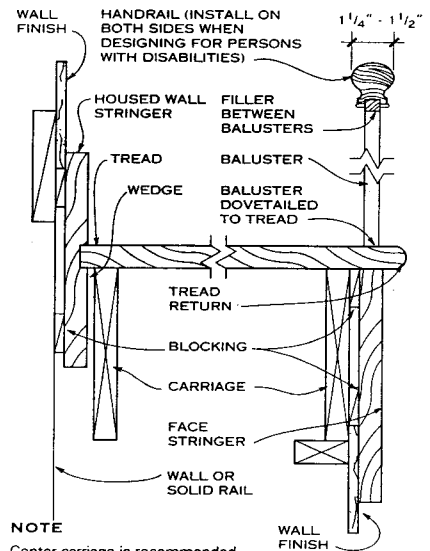

**SECTION B**

The Bumgardner Architects; Seattle, Washington  
 Janet B. Rankin, AIA; Rippeteau Architects; Washington, D.C.

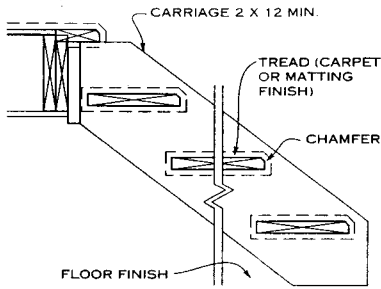

**NOTE**  
Open riser stairs do not comply with Americans with Disabilities Act Accessibility Guidelines.

**OPEN RISER STAIR**

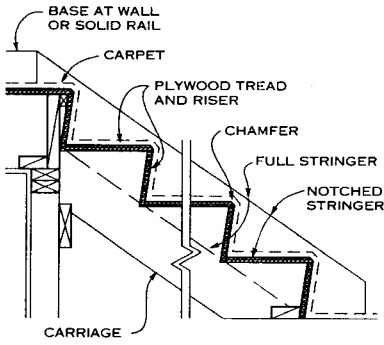

**CLOSED RISER STAIR/CARPET FINISH**

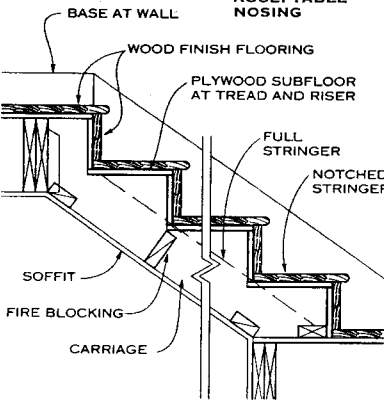
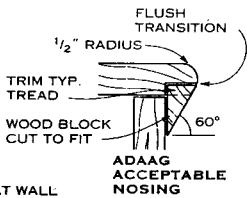

**CLOSED RISER STAIR/WOOD FINISH**

The Bumgardner Architects; Seattle, Washington  
Janet B. Rankin, AIA; Rippeteau Architects; Washington, D.C.

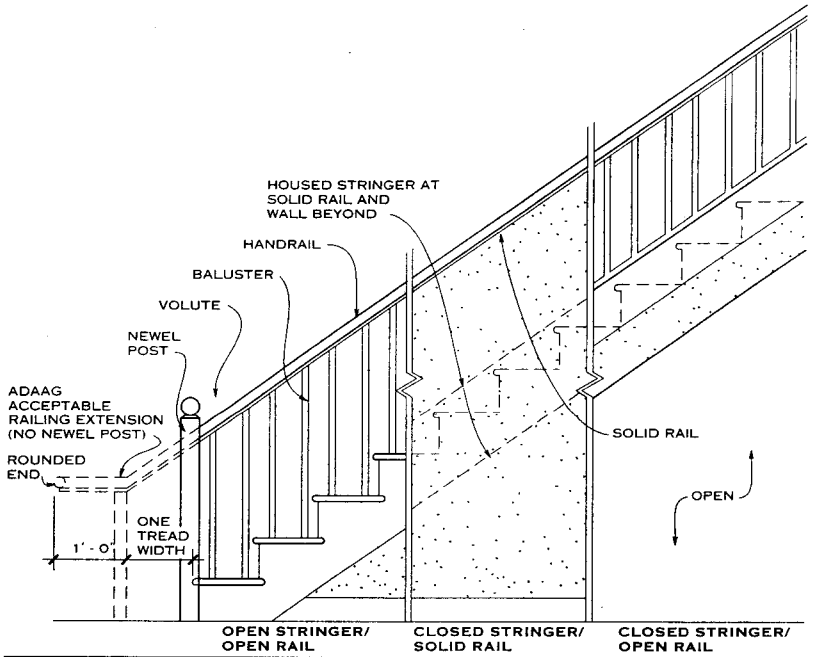

**ELEVATION OF FACE STRINGER**

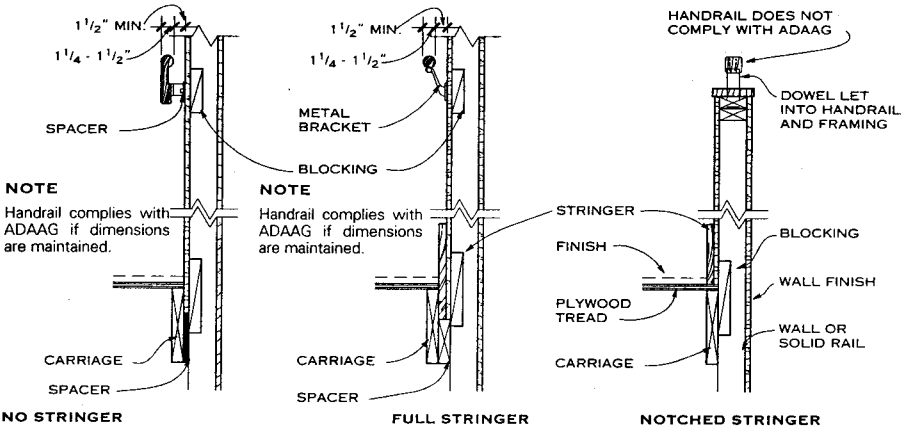

**CLOSED RISER STAIRS AT WALLS AND SOLID RAILING WALLS**

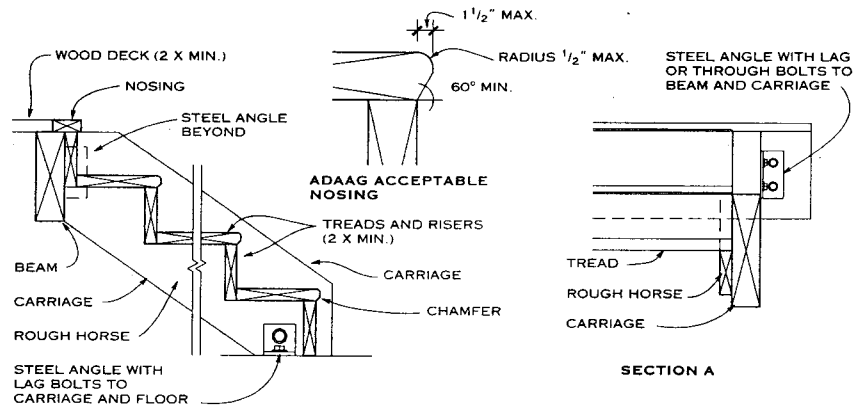

**HEAVY TIMBER STAIR**

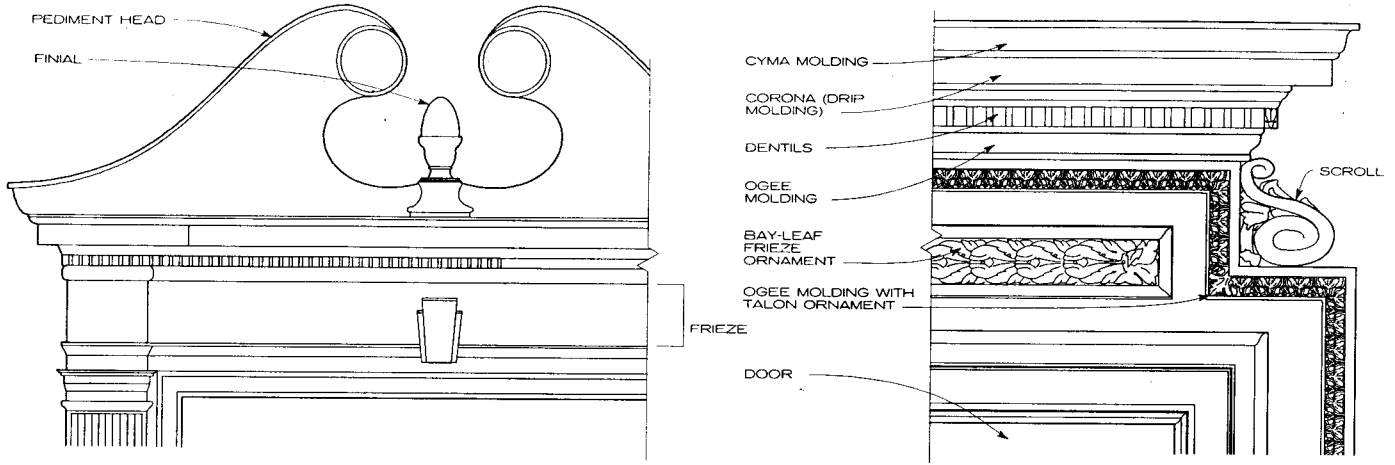

OVERDOOR DETAILS

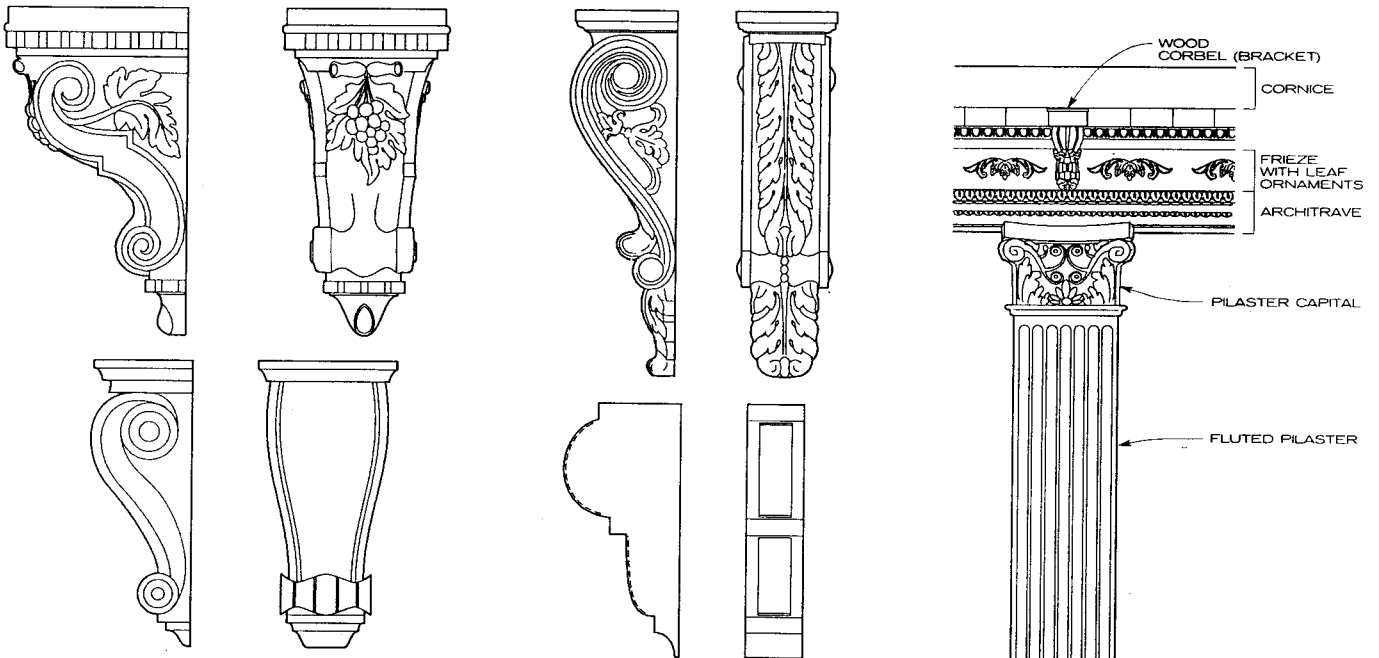

WOOD CORBELS

GENERAL

Woodwork is considered an ornament when it has a special or unique design that does not fall within the standard categories of architectural woodwork as defined by the Architectural Woodwork Institute.

Some typical uses for ornamental wood include pediment heads, mantels, ornamental grilles, fluted pilasters, cupolas, finials, medallions, corbels, balusters, posts, and columns. Within the classification of ornamental wood are combinations of flat or molded solid lumber, or cored lumber components with wood veneer faces with, or without, the addition of moldings. All joinings between ornamental members should be designed for functional as well as decorative purposes.

Wood ornamentation is an art that can take shape in an almost infinite number of forms and designs, limited only by the mechanical production constraints of woodworking shops. "Wood" ornaments can also be produced in larger quantities (in molds) with the synthetic material polyurethane. Once cured, the polyurethane can be painted and substituted for the wood ornaments.

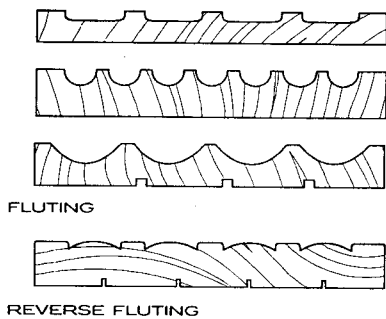

FLUTING

REVERSE FLUTING

FLUTING SECTIONS

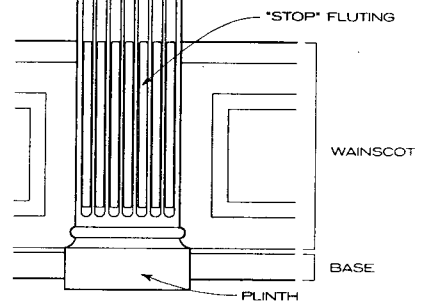

ORNAMENTAL WOOD PILASTER

Richard J. Vitullo, AIA; Oak Leaf Studio; Crownsville, Maryland

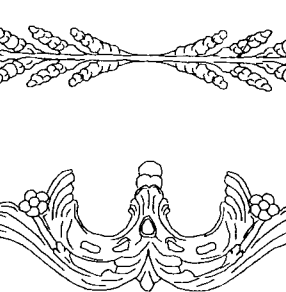
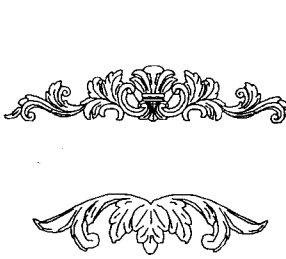
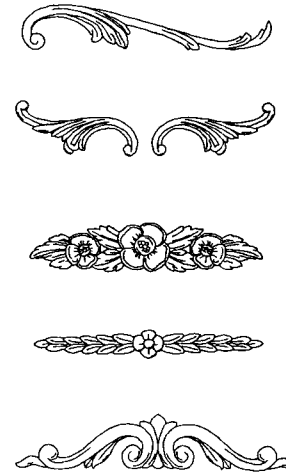
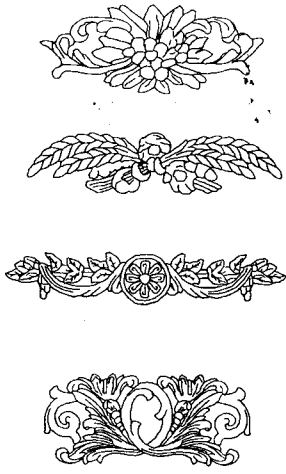

FRIEZE ORNAMENTS

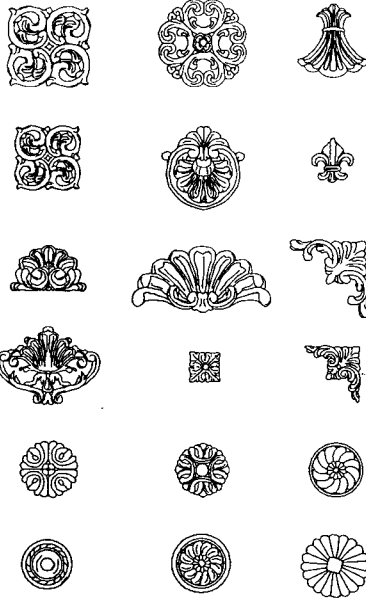

MISCELLANEOUS ORNAMENTS

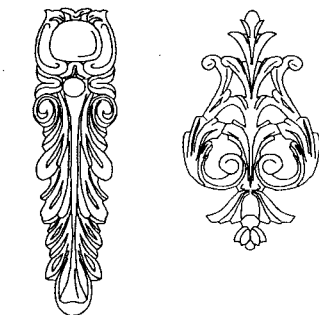
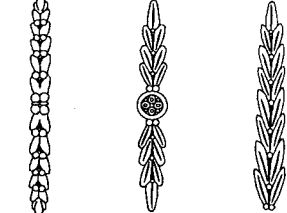
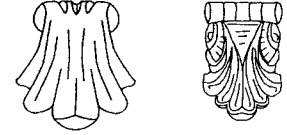
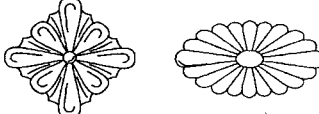

MISCELLANEOUS ORNAMENTS

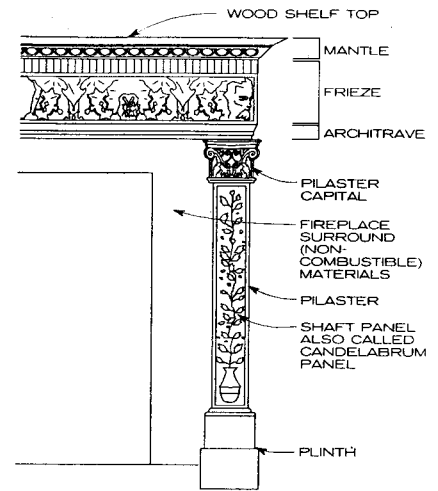

FIREPLACE MANTEL

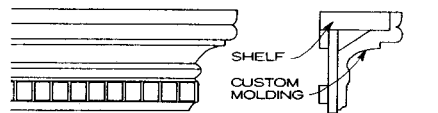
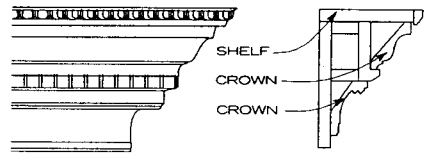
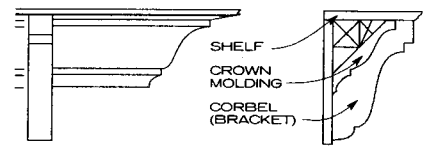

MANTELS

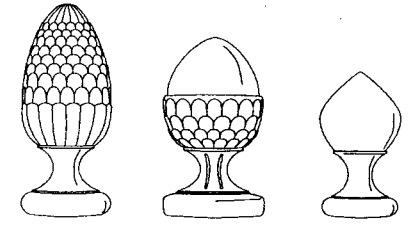

PINEAPPLE

ACORN

ACORN

FINIALS

Richard J. Vitullo, AIA; Oak Leaf Studio; Crownsville, Maryland

**GENERAL**

Interior trim is a generally decorative treatment applied after wall, floor, and ceiling finishes have been installed. It can be made of flat or molded wood from single pieces of wood or built-up pieces that give a more complex and decorative appearance. Interior trim conceals joints between different materials and blocks air infiltration through walls, which typically is greatest at material joints. Interior trim also frames wall and ceiling openings (door and window/skylight trim), defines planar edges (crown and base molding), and acts as a visual divider between dissimilar materials (chair rail).

The Architectural Woodwork Institute differentiates wood trim according to its length. Standing wood trim is trim that can be accommodated easily with single lengths of wood (depending on species), such as crown moldings, fascias, soffits, chair rails, baseboards, and shoe moldings. Running trim is usually made up of finger-jointed wood to achieve the lengths customarily needed for this type of trim.

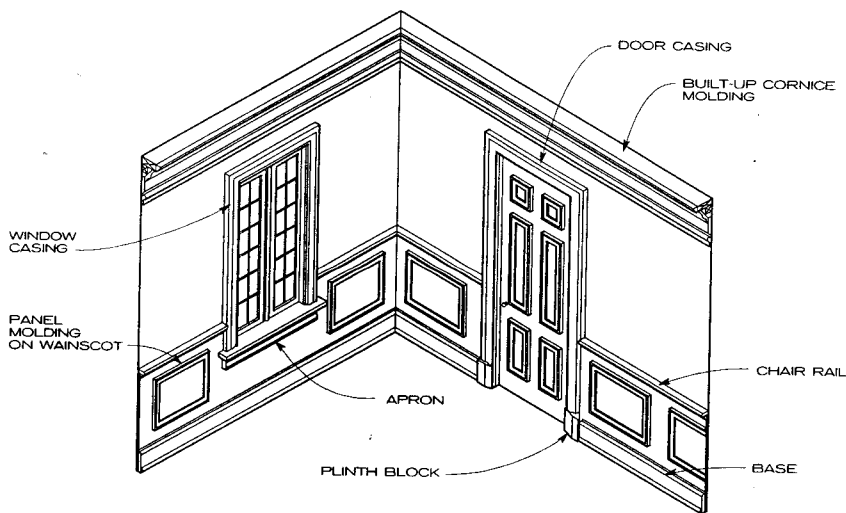

**NOTES**

1. Blocking that receives moldings should be set plumb, level, true, and straight, with no distortion, and should be provided for full surface contact. Attach blocking to substrates with nails, screws, or bolts.
2. Woodwork should be stored in a dry, ventilated space. If this is not possible, seal the ends of all pieces as soon as possible. Moldings should be at optimum moisture content at the time of installation and should be allowed to acclimate to project conditions before installation.
3. Joints in adjacent and related members should be staggered. Cope at inside corners and miter at outside corners to produce tight-fitting joints with full surface contact throughout the length of the joint; use scarf joints (face mitered) for end-to-end joints in trim.
4. Blind nail where possible, and use finishing nails in exposed areas. Predrill as required to eliminate splitting; set exposed nail heads for filling.
5. Most flat trim like baseboards and casing has a ploughed or relieved back, which gives wide trim a degree of flexibility, allowing it to fit snugly against a wall surface.
6. The molding profiles illustrated are a small sampling of those available from most millwork shops. Custom profiles should be shown on drawings full size. Dimensions given are for typical stock molding profiles.

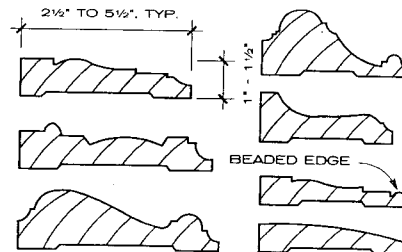

**NOTE**

Casings are used to finish the joint between the window or door head and side jambs and wall finish. Often a casing used at windows is also used as apron material, with the wide side toward the stool.

**CASINGS**

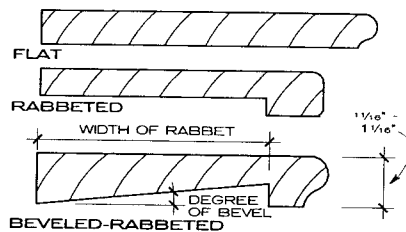

**NOTE**

Stools are used as interior caps on windowsills and receive casing from above and apron below. They are specified by width of rabbet and degree of bevel.

**STOOLS**

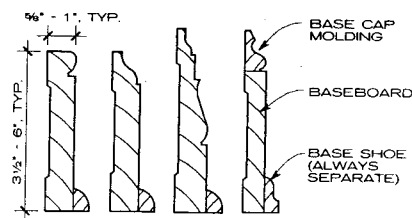

**NOTE**

Baseboards and base moldings are used at the juncture of wall and floor exclusively. Baseboard may be one piece (with integral base cap) or flat with optional base cap. Separate caps and shoes are flexible and facilitate a close fit to uneven wall and floor surfaces.

**BASEBOARD AND BASE MOLDINGS**

**TYPICAL WOOD TRIM AND MOLDINGS**

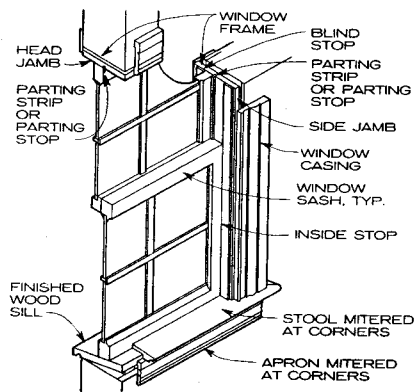

**TYPICAL WINDOW TRIM**

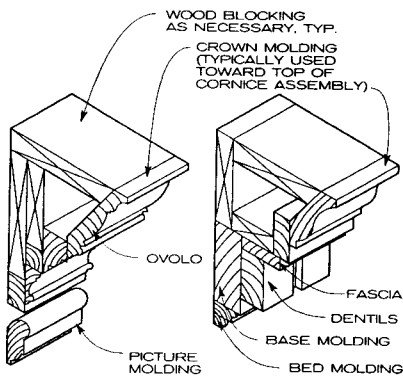

**TYPICAL CORNICE TRIM**

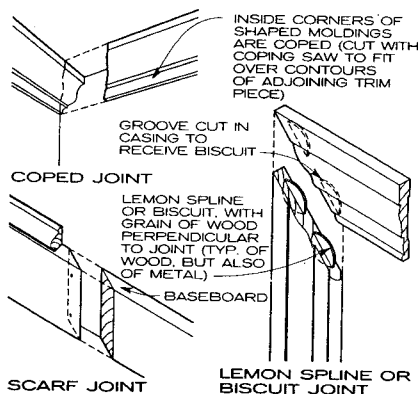

**MOLDING CONNECTION DETAILS**

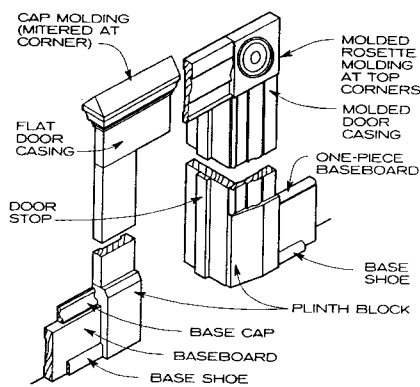

**TYPICAL DOOR AND BASE TRIM**

Richard J. Vitullo, AIA; Oak Leaf Studio; Crownsville, Maryland

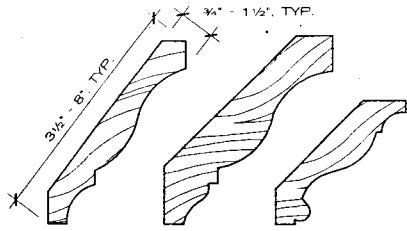

**NOTE**

Crown moldings are applied alone at the joint between wall and ceiling or together with other moldings in a built-up cornice, typically toward the top of the cornice assembly, measured edge to edge.

**CROWN MOLDINGS**

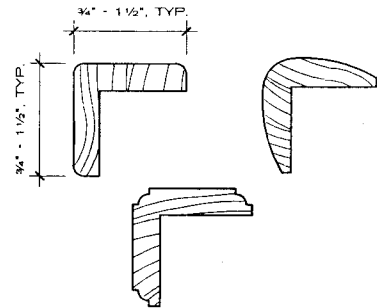

**NOTE**

This molding is used on outside corners.

**CORNERS**

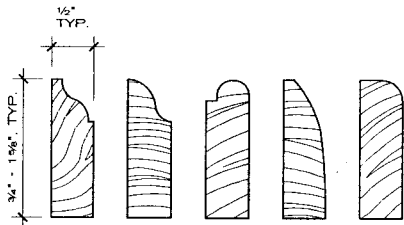

**NOTE**

Stops are used at jambs to guide windows and stop doors.

**STOPS**

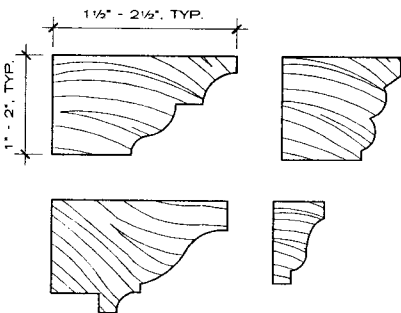

**NOTE**

Cap or rake moldings are used at head of door and window trim and at top of wainscots.

**CAP OR RAKE MOLDINGS**

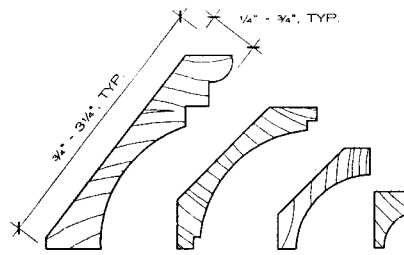

**NOTE**

Cove moldings are used at inside corners, such as wall-to-wall or ceiling-to-wall.

**COVE MOLDINGS**

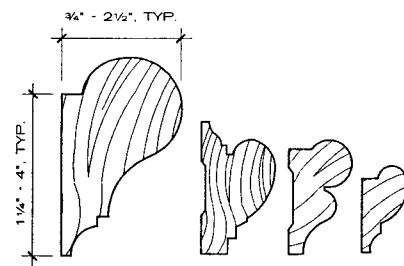

**NOTE**

Often integrated with cornices, picture moldings are used as continuous projecting supports for picture hooks. Custom-made hooks are available to fit these profiles.

**PICTURE MOLDINGS**

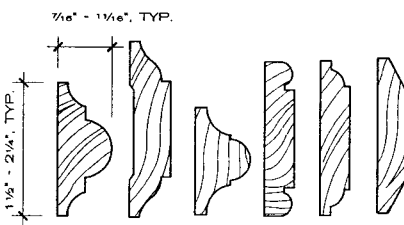

**NOTE**

These moldings are used in panels to conceal joints, over window jamb edges in a multiple-opening window, and as astragals at middle joints of double-leaf doors.

**PANEL STRIPS, BATTENS, AND ASTRAGALS**

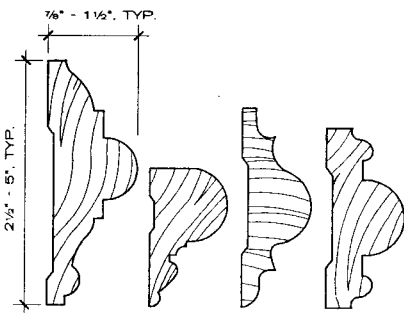

**NOTE**

Chair rails were originally meant to protect the wall surface from chair backs; applied typically 1/2 up from the floor, either alone or atop wainscot paneling.

**CHAIR RAILS**

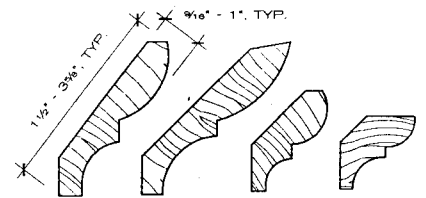

**NOTE**

Bed moldings are used at the bottom of built-up cornices and at other vertical-to-horizontal junctures.

**BED MOLDINGS**

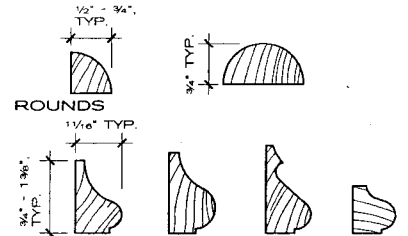

**BASE CAPS**

**NOTES**

1. Half-rounds are used to conceal vertical and horizontal joints. Quarter-rounds are used at inside corners and as base shoe.
2. Base caps are applied at the top of the baseboard, flush against the wall.

**BASE CAPS AND ROUNDS**

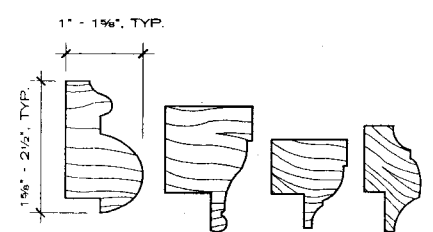

**NOTE**

Backbands are applied as trim at the outer edge of door jamb and head, among other uses.

**BACKBANDS**

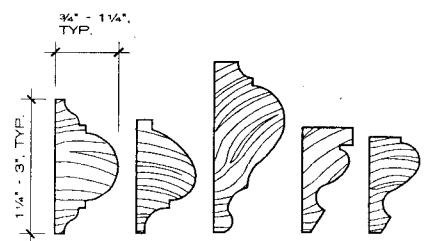

**NOTE**

Panel moldings are typically used as door and wainscot trim, mitered together and arranged in rectangles.

**PANEL MOLDINGS**

Richard J. Vitullo, AIA; Oak Leaf Studio; Crownsville, Maryland

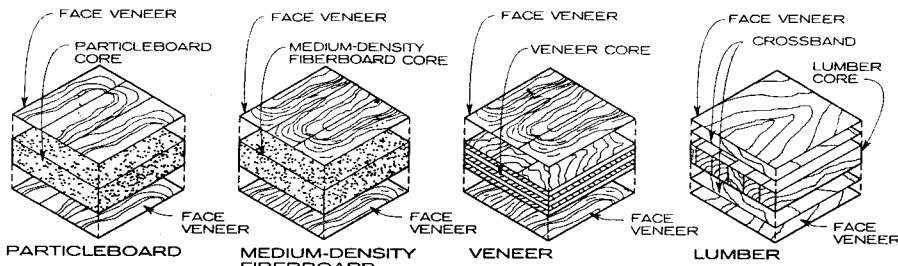

**HARDWOOD PLYWOOD CORE TYPES**

**GENERAL**

Architectural wood panels are made from wood material that is cut or formed into sheet products that are referred to as the "panel core." These sheets are used alone (with or without a finish) or laminated together with other veneer products to make plywood. A great variety of panels are manufactured using different core materials and adhesives or binders and various forming techniques and surface treatments. The characteristics of the panels vary with these differences in material and construction.

**PANEL CORE TYPES**

Panel cores, which serve as the substrate for laminates and veneers on the outer surface, are classified by ingredients and methods of manufacture. The following types of panel cores are suitable for architectural use:

**INDUSTRIAL GRADE PARTICLEBOARD CORE**

This core type is made by using heat and pressure to bond together synthetic resin or binder and wood particles of various sizes. Employed in a wide variety of architectural woodwork applications, industrial grade particleboard is especially well suited as a substrate for high-quality veneers and decorative laminates. When used as panels without any surface layers, the product is called particleboard. When used with wood veneer on the surface, the panels are referred to as particle-core plywood. Particleboard core classified by density or weight per cubic ft falls into three categories:

1. Low density—less than 40 lb per cubic ft (640 kg per cubic meter)
2. Medium density—40 to 50 lb per cubic ft (640 to 800 kg per cubic meter)
3. High density—more than 50 lb per cubic ft (800 kg per cubic meter)

**MOISTURE-RESISTANT PARTICLEBOARD CORE**

Some medium-density industrial particleboard is bonded with phenolic resins, which makes it more resistant to swelling when exposed to moisture. Phenolic resins, unlike urea resins, do not emit significant quantities of formaldehyde. The most common grades are type 2-M-2 (M-2 exterior glue) and 2-M-3 (M-3 exterior glue).

**CHARACTERISTICS OF CORE MATERIAL PERFORMANCE**

PANEL TYPE	FLATNESS	VISUAL EDGE QUALITY	SURFACE UNIFORMITY	DIMENSIONAL STABILITY	SCREW HOLDING	BENDING STRENGTH	AVAILABILITY
Industrial particleboard core (medium-density)	Excellent	Good	Excellent	Fair	Fair	Good	Ready
Medium-density fiberboard core (MDF)	Excellent	Excellent	Excellent	Fair	Good	Good	Ready
Veneer core—all hardwood	Fair	Good	Good	Excellent	Excellent	Excellent	Ready
Veneer core—all softwood	Fair	Good	Fair	Excellent	Excellent	Excellent	Ready
Lumber core—hardwood or softwood	Good	Good	Good	Good	Excellent	Excellent	Limited
Standard hardboard core	Excellent	Excellent	Excellent	Fair	Good	Good	Ready
Tempered hardboard core	Excellent	Good	Good	Good	Good	Good	Limited
Moisture-resistant particleboard core	Excellent	Good	Good	Fair	Fair	Good	Limited
Moisture-resistant MDF core	Excellent	Excellent	Good	Fair	Good	Good	Limited
Fire-resistant particleboard core	Excellent	Fair	Good	Fair	Fair	Good	Limited

**NOTE**

Characteristics of core material performance are influenced by the grade and thickness of the core and specific gravity of the core species. Visual edge quality is rated before treatment with edge bands or fillers and, for lumber core, assumes the use of "clear edge" grade. Surface uniformity

**FIRE-RETARDANT PARTICLEBOARD CORE**

Medium-density industrial particleboard may be treated during manufacture to carry a UL Class 1 fire rating stamp (flame spread 20, smoke developed 25). This material can be used as substrate for paneling requiring a Class 1 rating.

**MEDIUM-DENSITY FIBERBOARD (MDF) CORE**

MDF is made from wood particles reduced to fibers in a moderate-pressure steam vessel, combined with resin, and bonded together under heat and pressure. The surface is flat, smooth, uniform, dense, and free of knots or grain pattern. MDF is useful as a substrate for paint, thin overlay materials, veneers, and decorative laminates. The homogeneous edge allows machining and paint finishes. MDF is one of the most stable mat-formed panel products and is widely used as an architectural panel.

**MOISTURE-RESISTANT MDF CORE**

Some MDF is bonded with an exterior resin to produce a highly water-resistant product.

**VENEER CORE (PLYWOOD)**

This panel product is made up of alternating layers of thin veneer and is commonly known as plywood. Adhesive is placed between the layers, and the panels are pressed until the adhesive is set; heat is often used to speed the cure. The two outside layers, often selected for species, grain, and appearance, are called the face veneers.

**HARDBOARD CORE**

Hardboard is made of interfelted fibers consolidated under heat and pressure to a density of 31 lb per cubic ft or more. Available with either one side (S1S) or two sides (S2S) smooth, hardboard is often used for casework backs, drawer bottoms, and divider panels. Architectural woodworkers typically use two types of hardboard core: standard (untempered) and tempered, which is standard hardboard that has been subjected to a curing treatment to increase its stiffness, hardness, and weight.

is directly related to the performance of fine veneers placed over the surface. Dimensional stability is usually related to exposure to wide variations in relative humidity. Screw holding and bending strength are influenced by proper design and engineering.

**PLYWOOD TYPES**

The term "plywood" means a panel product made of three or more layers (plies) of wood or wood products (veneers or overlays and/or core materials) that have been laminated into a single sheet (panel). Plywood falls into two groups according to materials and manufacturing:

**HARDWOOD PLYWOOD** panels are made from hardwood or decorative softwood veneers over a core material such as medium-density particleboard, medium-density fiberboard, or low-density lumber.

**SOFTWOOD PLYWOOD** panels are made with softwood face veneers and are seldom incorporated into finished architectural woodworking projects because of the instability of the core material and core voids.

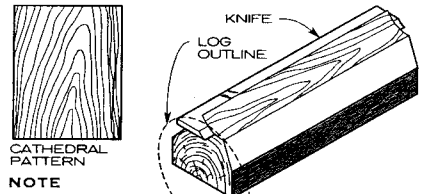

**NOTE**  
This is the slicing method most often used to produce veneers for high-quality architectural woodworking. Slicing is done parallel to a line through the center of the log. A combination of cathedral and straight-grain patterns results, with a natural progression of pattern from leaf to leaf.

**PLAIN-SLICED (FLAT-SLICED) VENEER**

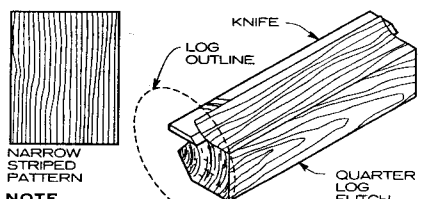

**NOTE**  
Quarter slicing, roughly parallel to a radius line through the log segment, simulates the quarter-sawing process used with solid lumber. In many species the individual leaves are narrow as a result. A series of stripes is produced, varying in density and thickness among species. "Flake" is a characteristic of this slicing method in red and white oak.

**QUARTER-SLICED VENEER**

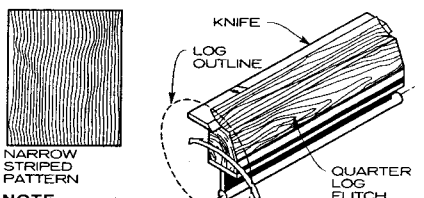

**NOTE**  
Rift veneers are produced most often in red and white oak, rarely in other species. Note that rift veneers and rift-sawn solid lumber are produced so differently that a "match" between them is highly unlikely. In both cases the cutting is done slightly off the radius lines, minimizing the "flake" associated with quarter slicing.

**RIFT-SLICED (RIFT-CUT) VENEER**

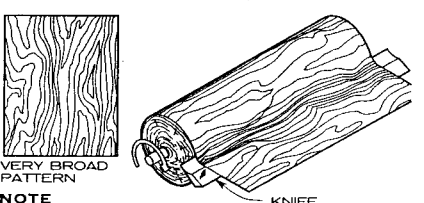

**NOTE**  
To create rotary-cut veneers, the log is center mounted on a lathe and "peeled" along the path of the growth rings, like unwinding a roll of paper. This provides a bold, random appearance. Rotary-cut veneers vary in width, and matching at veneer joints is extremely difficult. Almost all softwood veneers are cut this way. Rotary-cut veneers are the least useful in fine architectural woodwork.

**ROTARY-CUT VENEER**

Richard J. Vitullo, AIA; Oak Leaf Studio; Crownsville, Maryland  
Architectural Woodwork Institute; Centreville, Virginia



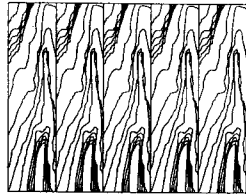

SLIP MATCH

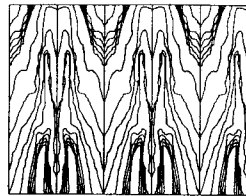

BOOK MATCH

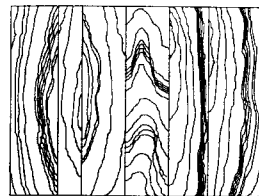

RANDOM MATCH

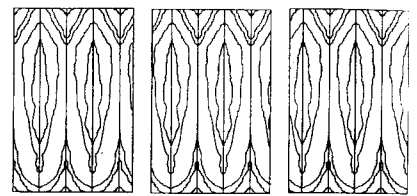

RUNNING MATCH

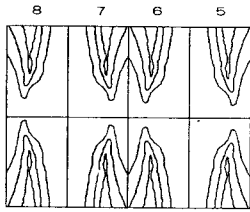

PANEL END MATCH

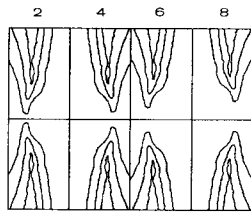

ARCHITECTURAL END MATCH

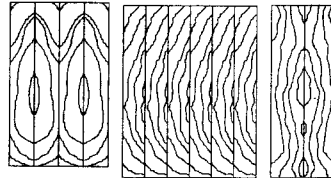

BALANCE AND CENTER MATCH

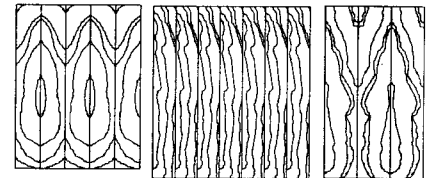

BALANCE MATCH

VENEER MATCH TYPES

GENERAL CHARACTERISTICS OF WOOD VENEER SPECIES

SPECIES		WIDTH TO (IN.)	LENGTH (FT)	FLITCH SIZE	COST <sup>1</sup>	AVAILABILITY
Mahogany	Plain sliced Honduras mahogany	18	12	Large	Moderate	Good
	Quartered Honduras mahogany	12	12	Large	High	Moderate
	Plain sliced African mahogany	18	12	Large	Moderate	Moderate
	Quartered African mahogany	12	12	Large	High	Good
Ash	Plain sliced American white ash	12	10	Medium	Moderate	Good
	Quartered American white ash	8	12	Small	High	Good
	Quartered or plain sliced European ash	6, 10	10	Medium	High	Limited
Anegre	Quartered or plain sliced anegre	6, 12	12	Large	High	Good
Avodire	Quartered avodire	10	10	Large	High	Limited
Cherry	Plain sliced American cherry	12	11	Medium	Moderate	Good
	Quartered American cherry	4	10	Very small	High	Moderate
Birch	Rotary cut birch (natural)	48	10	Large	Low	Good
	Rotary cut birch (select red or white)	36	10	Medium	Moderate	Moderate
	Plain sliced birch (natural)	10	10	Small	Moderate	Limited
	Plain sliced birch (select red or white)	5	10	Small	High	Limited
Butternut	Plain sliced butternut	12	10	Medium	High	Limited
Makore	Quartered or plain sliced makore	6, 12	12	Large	High	Good
Maple	Pl. sl. (half round) American maple	12	10	Medium	Moderate	Good <sup>2</sup>
	Rotary bird's-eye maple	20	10	Medium	Very high	Good
Oak	Plain sliced English brown oak	12	10	Medium	Very high	Limited
	Quartered English brown oak	10	10	Medium	Very high	Limited
	Plain sliced American red oak	16	12	Large	Moderate	Good
	Quartered American red oak	8	10	Small	Moderate	Good
	Rift sliced American red oak	10	10	Medium	Moderate	Good
	Comb grain rift American red oak	8	10	Small	Very high	Limited
	Plain sliced American white oak	16	12	Medium	Moderate	Good
	Quartered American white oak	8	10	Small	Moderate	Good
	Rift sliced American white oak	8	10	Medium	High	Good
Comb grain rift American white oak	8	10	Small	Very high	Limited	
Hickory or Pecan	Plain sliced American hickory or pecan	12	10	Small	Moderate	Good
Sapele	Quartered or plain sliced sapele	6, 12	12	Large	High	Good
Sycamore	Plain sliced English sycamore	10	10	Medium	Very high	Limited
	Quartered English sycamore	6	10	Medium	Very high	Limited
Teak	Plain sliced teak	16	12	Large	Very high	Limited <sup>3</sup>
	Quartered teak	12	12	Medium	Very high	Limited <sup>3</sup>
Walnut	Plain sliced American walnut	12	12	Medium	Moderate	Good
	Quarter sliced American walnut	6	10	Very small	High	Rare

<sup>1</sup>Cost reflects raw veneer costs weighted for waste or yield characteristics and degree of labor difficulty.

<sup>2</sup>Seasonal factors may affect availability.

<sup>3</sup>Availability of blond teak is very rare.

NOTE

When quartered or plain sliced are listed on the same line, the width dimensions are listed with quartered first and plain sliced second.

MATCHING BETWEEN ADJACENT VENEER LEAVES

It is possible to achieve certain visual effects by the manner in which the leaves are arranged. Rotary cut veneers are difficult to match, therefore most matching is done with sliced veneers. Matching of adjacent veneer leaves must be specified. Consult your AWI woodworker for choices.

BOOK MATCHING

Book matching is the most commonly used match in the industry. In it, every other piece of veneer is reversed so adjacent pieces (leaves) are "opened" like the pages of a book. Because the "tight" and "loose" faces alternate in adjacent leaves, they reflect light and accept stain differently. The veneer joints match, creating a symmetrical pattern that yields maximum continuity of grain.

SLIP MATCHING

Adjoining leaves are placed (slipped out) in sequence without being turned, thus all the same face sides are exposed. The grain figure repeats but joints do not show grain pattern. All faces have some light refraction.

END MATCHING

End matching is often used to extend the apparent length of available veneers for high wall panels and long conference tables. End matching occurs in two types:

**ARCHITECTURAL END MATCH:** Leaves are individually book or slip matched, alternating end-to-end and side-to-side. Architectural end matching yields the best continuous grain patterns for length as well as width.

**PANEL END MATCH:** Leaves are book or slip matched on panel subassemblies, with sequenced subassemblies end matched, resulting in some modest cost savings on projects where applicable. For most species, panel end matching yields a pleasing, blended appearance and grain continuity.

RANDOM MATCHING

Veneer leaves are placed next to each other in a random order and orientation, producing a casual board-by-board effect in many species. Conscious effort is made to mismatch the grain at joints.

RUNNING MATCHING

Each panel face is assembled from as many veneer leaves as necessary. This often results in an asymmetrical appearance, with some veneer leaves of unequal width.

BALANCE MATCHING

Each panel face is assembled from an odd or even number of veneer leaves of uniform width before edge trimming.

BALANCE AND CENTER MATCHING

Each panel face is assembled from an even number of veneer leaves of uniform width before edge trimming. Thus, there is a veneer joint in the center of the panel, producing horizontal symmetry.

Richard J. Vitullo, AIA; Oak Leaf Studio; Crownsville, Maryland  
Architectural Woodwork Institute, Centreville, Virginia

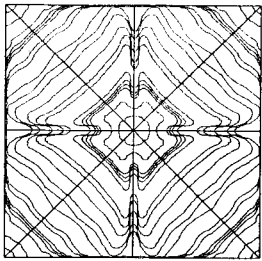

8-PIECE SUNBURST

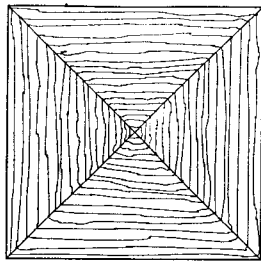

BOX MATCH

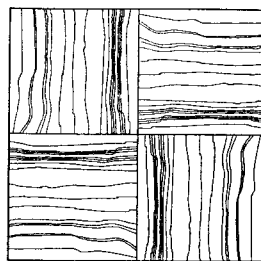

PARQUET MATCH

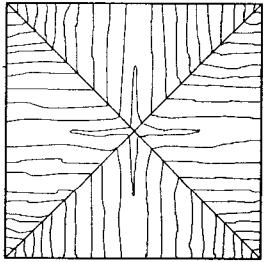

REVERSE OR END GRAIN BOX

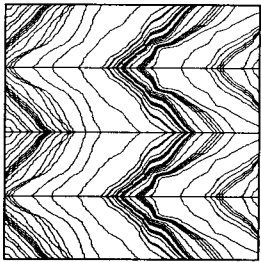

HERRINGBONE

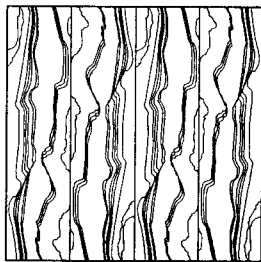

SWING MATCH

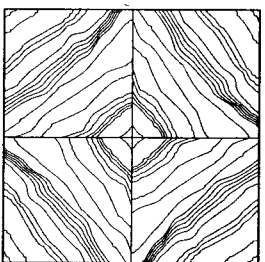

DIAMOND

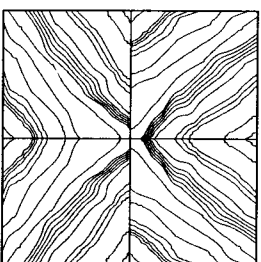

REVERSE DIAMOND

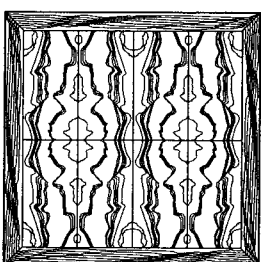

SKETCH FACE

**NOTE**

During specification, use both names and illustrations to define the desired effect, as names vary by region for these matching techniques.

**SPECIAL WOOD VENEER MATCHING OPTIONS**

**COMMON FACE VENEER PATTERNS OF SELECTED COMMERCIAL SPECIES**

PRIMARY COMMERCIAL HARDWOOD SPECIES	FACE VENEER PATTERNS <sup>1</sup>			
	PLAIN SLICED (FLAT CUT)	QUARTER CUT	RIFT CUT AND COMB GRAIN	ROTARY CUT
Ash	Yes	Yes	—	Yes
Birch	Yes	—	—	Yes
Cherry	Yes	Yes	—	Yes
Hickory	Yes	—	—	Yes
Lauan	—	Yes	—	Yes
Mahogany (African)	Yes	Yes	—	Yes
Mahogany (Honduras)	Yes	Yes	—	Yes
Maple	Yes	Yes	—	Yes
Meranti	—	Yes	—	Yes
Oak (red)	Yes	Yes	Yes	Yes
Oak (white)	Yes	Yes	Yes	Yes
Pecan	Yes	—	—	Yes
Walnut (black)	Yes	Yes	—	Yes
Yellow poplar	Yes	—	—	Yes
Typical methods of cutting <sup>2</sup>	Plain slicing or half-round on rotary lathe	Quarter slicing	Offset quarter on rotary lathe	Rotary lathe

<sup>1</sup> The headings above refer to the face veneer pattern, not to the method of cutting. Face veneer patterns other than those listed are obtainable by special order.

<sup>2</sup> The method of cutting for a given face veneer pattern shall be at mill option unless otherwise specified by the

buyer in an explicit manner to avoid the possibility of misunderstanding. For example, plain-sliced veneer cut on a vertical slicer or plain-sliced veneer cut on a half-round rotary lathe could be specified.

**FACING MATERIAL TYPES**

Wood product substrates are classified in two main facing material categories: decorative laminates/overlays and wood veneers.

**DECORATIVE LAMINATES/OVERLAYS**

This finish surface category can be broken down into the following broad groups:

**HIGH-PRESSURE DECORATIVE LAMINATES** are formed under heat and pressure from resin-impregnated kraft paper substrates with decorative plastic face materials and a clear protective top sheet. This assembly, commonly called plastic laminate, offers resistance to wear and many stains and chemicals. Common uses include casework exteriors, countertops, and wall paneling.

**THERMALLY FUSED DECORATIVE PANELS** are flat pressed from a thermoset polyester or melamine resin-impregnated web, and most have been prelaminated to industrial particleboard or medium-density fiberboard substrates when they arrive at the woodwork fabricator. Performance is similar to that of high-pressure decorative laminates. Common uses include casework interiors, furniture, shelving, display materials, and decorative paneling.

**MEDIUM-DENSITY OVERLAYS** are made from pressed resin-impregnated paper overlays and are highly resistant to moisture. They are available applied to cores suitable for both interior and exterior uses. The seamless panel face and uniform density offer a sound base for opaque finishes and paint.

**VINYL FILMS, FOILS, AND LOW BASIS WEIGHT PAPERS** are decorative facing materials that, although they have limited use in custom architectural woodwork, are suitable for some installations.

**WOOD VENEERS**

Wood veneers are produced in a variety of industry standard thicknesses. The slicing process is controlled by a number of variables, but the thickness of the veneer has little bearing on the quality of the end product.

There are two types of veneers, hardwood and softwood. Hardwood veneers are available in many domestic and imported wood species and are normally plain sliced, but certain species can be rift sliced, quarter sliced, or rotary cut. Softwood veneers are usually sliced from Douglas fir, but pine and other softwoods are available. Most softwood veneer is rotary cut, but plain-sliced and rift-sliced (vertical grain) softwoods can be obtained with a special order.

Most veneers are taken from large trees, but some are sliced from fast-growing trees, dyed, and reglued in molds to create "grain" patterns. The color of these reconstituted veneers is established during manufacture because the high percentage of glue line resists later staining.

The manner in which a log segment is cut with relation to the annual rings of the tree determines the appearance of the veneer. Individual pieces of veneer, referred to as "leaves," are kept in the order in which they were sliced for reference during installation. The group of leaves from one slicing is called a "fitch" and is identified by a number and the gross square feet it contains. The faces of the leaves with relation to their position in the log are identified as the "tight face" (toward the outside of the log) and the "loose face" (toward the inside or heart of the log).

**NOTES**

- To achieve balanced construction, panel products should be absolutely symmetrical from the center line. Materials used on either side should contract and expand or exhibit moisture permeability at the same rate as the veneer.
- In panel construction, the thinner the facing material, the less force it can generate to cause warping. The thicker the substrate, the more it can resist a warping movement or force.
- Wood veneer standards: For hardwood plywood, the face veneer characteristics of the Hardwood Plywood and Veneer Association (HPVA) have generally been adapted for use. These face grades apply to custom architectural woodwork.
- Flame spread factors: The fire rating of the core material determines the rating of the assembled panel. Fire-retardant veneered panels must have a fire-retardant core. Particleboard core is available with a Class I (Class A) rating, but MDF is not currently available with a fire rating. Existing building codes, except where locally amended, provide that facing materials 1/32 in. or thinner are not considered in determining the flame spread rating of the panel. For more information, refer to the Architectural Woodwork Institute guide "Fire Code Summary."

Richard J. Vitullo, AIA; Oak Leaf Studio; Crownsville, Maryland  
 Architectural Woodwork Institute; Centreville, Virginia  
 Chart reprinted with permission from the Hardwood Plywood and Veneer Association

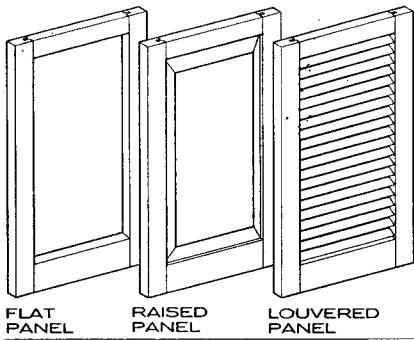

SHUTTER TYPES

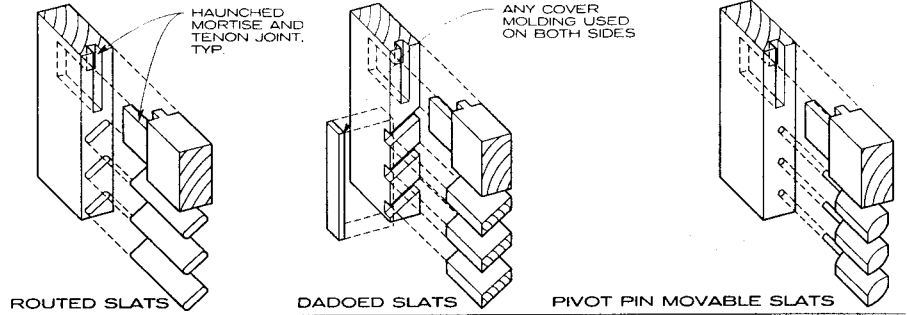

LOUVER TYPES

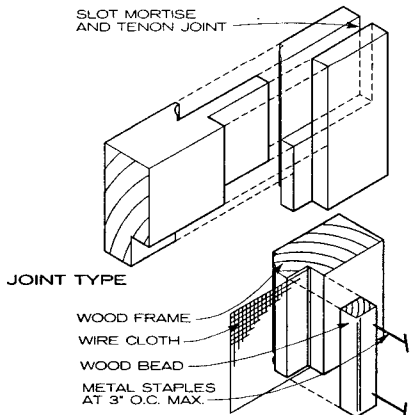

WIRE CLOTH INSTALLATION DETAIL  
CUSTOM WORKMANSHIP GRADE  
SCREEN DETAILS

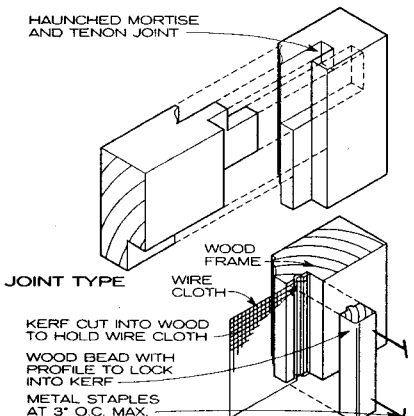

WIRE CLOTH INSTALLATION DETAIL  
PREMIUM WORKMANSHIP GRADE  
SCREEN DETAILS

- NOTES**
- For additional information, refer to Architectural Woodwork Quality Standards, 6th edition (version 1.1), 1994, Architectural Woodwork Institute (AWI).
  - Lumber grades indicated in the charts on this page are according to AWI quality standards:  
Grade I: Pieces are selected for uniform grain and color on exposed faces and edges.  
Grade II: Pieces are selected for uniform grain on exposed faces and edges.  
Grade III: No matching for grain or color is required.
  - AWI recognizes three levels of workmanship for wood screens, blinds, and shutters:  
**CUSTOM GRADE:** Most conventional architectural woodwork falls within this grade. High-quality workman-

**SCREEN MATERIALS**

WORKMANSHIP LEVEL	CUSTOM		PREMIUM		ECONOMY	
APPLIED FINISH	TRANSPARENT FINISH	OPAQUE FINISH	TRANSPARENT FINISH	OPAQUE FINISH	TRANSPARENT FINISH	OPAQUE FINISH
AWI lumber grade	II	II	I	II	II	II
Screen frame parts, any of the listed species unless otherwise specified	Ponderosa pine, sugar pine, Idaho white pine, northern white pine, mahogany, Douglas fir	Unless otherwise specified, same as transparent	Teak, South American mahogany, African mahogany	Unless otherwise specified, same as transparent	Any pine, fir, hemlock, larch	Unless otherwise specified, same as transparent
Wire cloth, any of the listed materials unless otherwise specified	Aluminum wire, bronze wire (18 x 14 mesh)		Bronze wire (18 x 14 mesh)		Nylon or fiberglass mesh	

**BLIND AND SHUTTER MATERIALS**

MATERIALS		CUSTOM WORKMANSHIP		PREMIUM WORKMANSHIP		ECONOMY WORKMANSHIP	
		TRANSPARENT FINISH	OPAQUE FINISH	TRANSPARENT FINISH	OPAQUE FINISH	TRANSPARENT FINISH	OPAQUE FINISH
AWI grade lumber	Stiles, rails, slats and mullions	II plus compatibility of color between veneer and lumber	II	I plus compatibility of grain and color between veneer and lumber	II	II with no selection for grain or color	II
	Applied moldings						
	Flat panels	II permitted for panels less than 14 in. across the grain		not permitted		II permitted for panels in any dimension	
	Raised panels	II used to rim panel product centers and permitted for panels less than 14 in. across the grain		I used to rim panel product centers	II used to rim panel product centers	II permitted for panels in any dimension	
Panel products	Veneered stiles, rails, and mullions	particleboard or fiberboard (veneer only by direct specification)	particleboard or fiberboard recommended (veneer permitted)	particleboard or fiberboard (veneer only by direct specification)		not applicable	
	Flat and raised panel core	particleboard or fiberboard (veneer only by direct specification)	particleboard or fiberboard recommended (veneer permitted)	particleboard or fiberboard (veneer only by direct specification)		particleboard or fiberboard recommended (veneer permitted)	particleboard, fiberboard, or veneer
	Face: veneer grade for transparent finish and material for opaque finish	"A" face plus compatibility of color between veneer and lumber	"B" veneer, plain fiberboard, or medium-density overlay	"AA" face plus compatibility of grain and color between veneer and lumber	"A" veneer, plain fiberboard, or medium-density overlay	"B" face veneer	"B" veneer, plain fiberboard, or medium-density overlay
Minimum panel products thickness	Veneered stiles and rails	3/4" (19 mm)		3/4" (19 mm)		1/2" (13 mm)	
	Flat panels	1/2" (13 mm)		1/2" (13 mm)		1/4" (6 mm)	
	Raised panels	3/4" (19 mm)		3/4" (19 mm)		1/2" (13 mm)	

ship, materials, and installation are required for work with this designation.  
**PREMIUM GRADE:** This specification requires careful oversight to guarantee the highest quality workmanship, materials, installation, and execution of design intent. It is typically reserved for special projects or project features.  
**ECONOMY GRADE:** This grade indicates the minimum expectations for quality, materials, and installation within the scope of AWI standards.

- All exterior screens and shutters must be treated with a wood preservative in accordance with AWI Quality Standards, Section 100.
- Pivot pins for use in damp or coastal areas must be manufactured of nylon, stainless steel, or brass.
- Exterior grade panel products are recommended for blinds and shutters because once installed they are typically kept open, with one face constantly exposed to the sun and other weathering (and drying) conditions, while the other face is likely to retain moisture.

Richard J. Vitullo, AIA; Oak Leaf Studio; Crownsville, Maryland

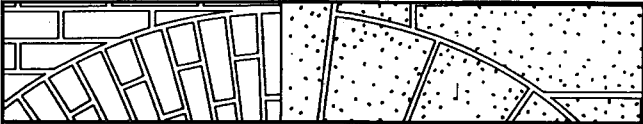

# THERMAL AND MOISTURE PROTECTION

Waterproofing and  
Dampproofing 398

Thermal Protection 402

Exterior Insulation and Finish  
Systems 404

Vapor Retarders 405

Shingles, Roof Tiles, and Roof  
Coverings 406

Roofing and Siding Panels 413

Membrane Roofing 415

Flashing and Sheet Metal 429

Sheet Metal Roofing 434

Flashing 438

Roof Specialties and  
Accessories 450

Gutters and Downspouts 459

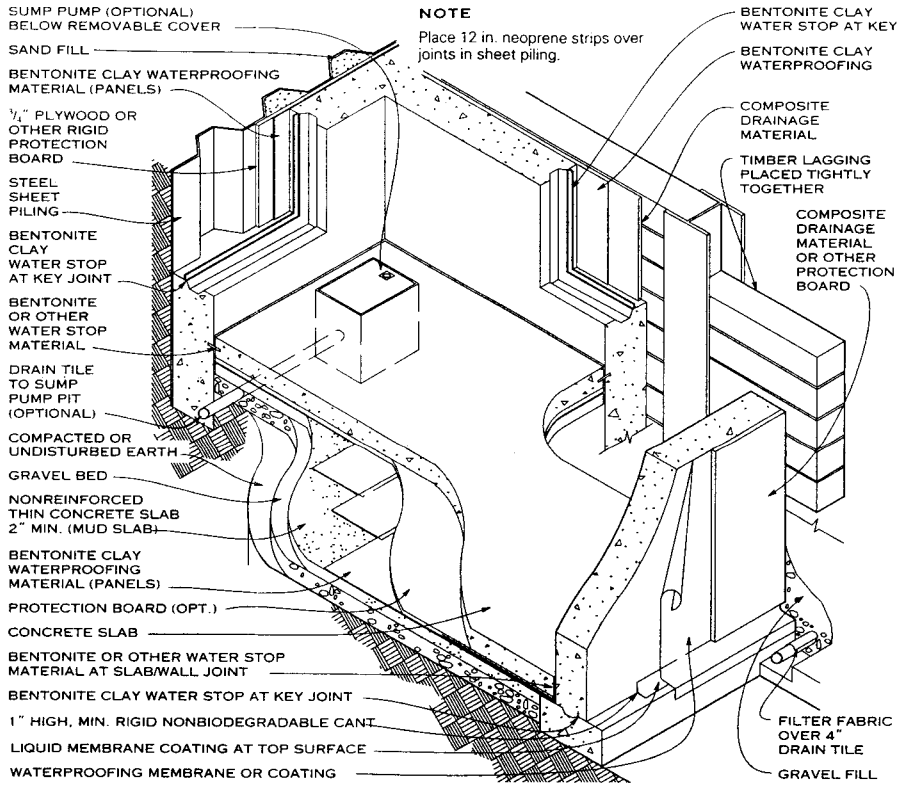

- NOTES**
1. Consult a soils engineer to determine soil types and groundwater levels and their effect on drainage and waterproofing methods. Consult a waterproofing specialist to determine a specific design approach for problem soils and conditions.
  2. Most waterproofing materials require a stable, rigid, and level substrate. Generally, a mud slab (subslab that is nonreinforced and nonstructural) is used when the waterproofing material is placed below the structural slab and/or when a solid working surface is needed on unstable soils. When waterproofing materials are placed on top of the structural slab, a protective cover, such as another concrete slab, is required.
  3. Bentonite clay waterproofing is usually manufactured in the form of corrugated cardboard panels with bentonite clay material filling the corrugation voids. When moistened, the clay swells and takes on a gel-like consistency, forming an impermeable barrier when confined. Bentonite panels may be placed over a substrate of compacted earth, sand, and pea gravel (or mud slab, for reinforced slabs greater than 6 in. thick). Since the panels swell when hydrated, pressure is exerted on adjacent construction. For slabs less than 6 in. thick, which may be adversely affected by bentonite swelling, special panels, made to accommodate the swelling, are required. A 6-mil polyethylene vapor barrier between the mud slab and gravel base will provide additional protection against water penetration. Consult with a structural engineer and the manufacturer to assure proper use and structural adequacy.
  4. Protect membrane waterproofing or coatings during construction and backfilling. Protection materials include the following (select according to soil, climate, and cost requirements):
    - a. Composite drainage material: Recommended when water is frequently present in soils surrounding foundations. Usually made up of a rigid open-weave material, approximately 3/4 in. thick, covered on both sides by a geotextile filter fabric preventing small stones or other materials from clogging the drainage route of water inside. Typically terminated at drain tiles at the bottom of the foundation. Higher in cost than other protection board materials.
    - b. Rigid insulation boards: Used above frostline or if ground temperatures are low. Usually made of expanded polystyrene. Minimum thickness is 1/4 in. (when used as protection board only), up to 1 1/2 in. thick (or greater, if desired) which gives an R-8 insulating value.
    - c. Protection board: Used only to protect waterproofing; does not drain or insulate. Usually made of 1/8 in. asphalt-impregnated fiberboard or, as mentioned above, 1/4 in. extruded polystyrene. Least expensive.
  5. Footing drains are recommended when groundwater level may rise above top of floor slab or when the foundation is subject to hydrostatic pressure after heavy rain. Composite drainage material conveys water to the drain tile, thus reducing hydrostatic pressure.
  6. Special negative-side coating on interior face of foundation wall is only recommended when exterior is not accessible.
  7. Bentonite clay water stop should be placed on top of footing, at vertical concrete keyed joints, and along inside edge of outermost vertical rebars before pouring the concrete wall.
  8. Grout, packed around pipes penetrating the foundation, should have a mixture of iron oxide. Iron oxide chemically alters the grout to be more water-resistant.

**WATERPROOFING APPLICATIONS AT CONCRETE FOUNDATION CONDITIONS**

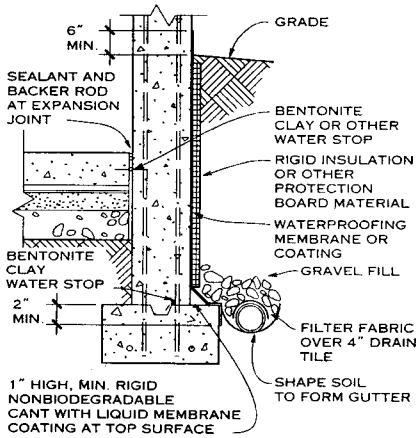

**CONCRETE FOOTING**

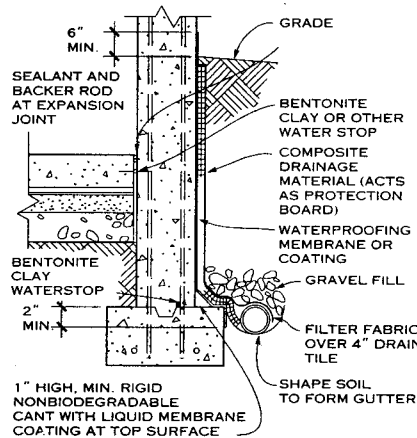

**CONCRETE FOOTING IN WET SOILS**

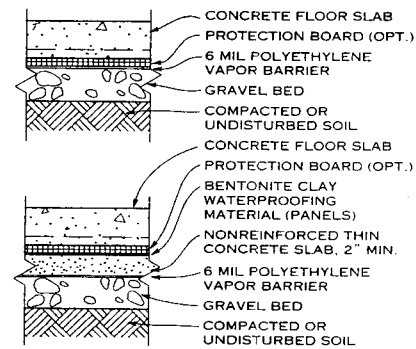

**WATERPROOFING UNDER SLAB**

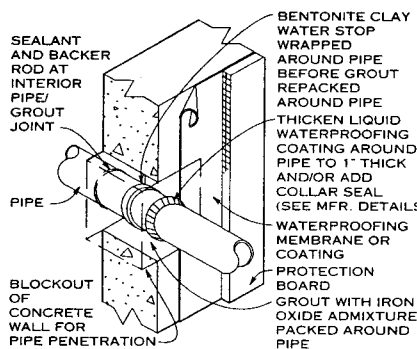

**PIPE PENETRATION AT WALL**

Krommenhoek/McKeown & Associates; San Diego, California  
Richard J. Vitullo, AIA; Oak leaf Studio; Crownsville, Maryland; in consultation with James B. Thompson Co.; San Marino, California

**7 WATERPROOFING AND DAMPPROOFING**

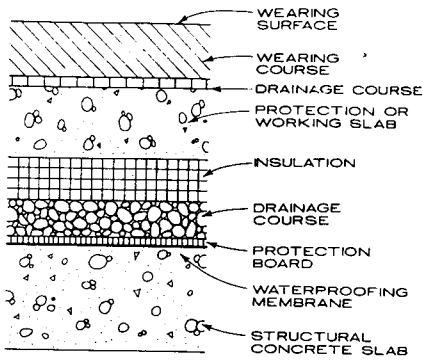

**BASIC COMPONENTS OF WATERPROOFING SYSTEMS**

**GENERAL**

The basic components, subsystems, and features for a building deck waterproofing system are the structural building deck or substrate to be waterproofed, waterproofing membrane, protection of membrane, drainage, insulation, and wearing course. See following pages for generic membrane applications.

**SUBSTRATE**

The substrate referred to is reinforced cast-in-place structural concrete. Precast concrete slabs pose more technical problems than cast-in-place concrete and the probability of lasting watertightness is greatly diminished and difficult to achieve because of the multitude of joints which have the capability of movement and must be treated accordingly.

The concrete used for the substrate should have a minimum density of 1762 kg/m<sup>3</sup> (110 lb/ft<sup>3</sup>) and have a maximum moisture content of 8% when cured.

**SLOPE FOR DRAINAGE**

A monolithic concrete substrate slope of a minimum 11 mm/m (1/8 in./ft) should be maintained. Slope is best achieved with a monolithic structural slab and not with a separate concrete fill layer.

**MEMBRANE**

Detection of leakage can be a significant problem when the membrane is not bonded to the structural slab or when additional layers of materials separate it from the structural slab. Therefore, only membranes that can be bonded to the substrate should be used.

The membrane should be applied under dry, frost-free conditions on the surface as well as throughout the depth of the concrete slab.

When the membrane is turned up on a wall, it is preferable to terminate it above the wearing surface to eliminate the possibility of ponded surface water penetrating the wall above the membrane and running down behind it into the building.

Penetrations should be avoided wherever possible. For protection at such critical locations, pipe sleeves should be cast into the structural slab against which the membrane can be terminated by flashing onto the pipe sleeve.

Treatment at reinforced and nonreinforced joints depends on the membrane used. See following pages.

Two concepts can be considered in the detailing of expansion joints at the membrane level: the positive seal concept directly at the membrane level and the watershed concept with the seal at a higher level than the membrane. Where additional safeguards are desired, a drainage gutter under the joint could be considered. Flexible upward support of the membrane is required in each case to provide watershed-type drainage. Expansion joint details should be considered and used in accordance with their movement capability.

The positive seal concept entails a greater risk than the watershed concept, since it relies fully on positive seal joinery of materials at the membrane level, where the membrane is most vulnerable to water penetration. Since the precision required is not always attainable, this concept is best avoided.

The watershed concept, although requiring a greater height and more costly concrete forming, is superior in safeguarding against leakage, having the advantage of providing a monolithic concrete water dam at the membrane level. However, if a head of water rises to the height of the materials joinery, this concept becomes almost as vulnerable as the positive seal concept. Therefore, drainage is recommended at the membrane level.

**PROTECTION BOARD**

The membrane should be protected from damage throughout construction. Protection board should be applied after the membrane is installed. The proper timing of application after placement of the membrane is important and varies with the type of membrane used. Follow the manufacturer's printed instructions.

**DRAINAGE SYSTEM**

Drainage should be considered as a total system from the wearing surface down to the membrane, including use of multilevel drains.

Drainage at the wearing surface is generally accomplished in one of two ways: (1) by an open joint and pedestal system permitting the rainwater to penetrate rapidly down to the membrane level and subsurface drainage system; and (2) by a closed-joint system designed to remove most of the rainwater rapidly by slope

to surface drains and to allow a minor portion to infiltrate to the membrane.

A drainage course of washed, round gravel or prefabricated drainage composite should be provided above the protection board, over the membrane. This permits water to filter to the drain and provides a place where it can collect and freeze without damaging the wearing course.

**INSULATION**

When required, insulation should be located above the membrane, but not in direct contact with it.

**PROTECTION OR WORKING SLAB**

A concrete slab could be placed soon after the membrane, protection board, drainage course, and insulation, if required, have been installed. It would serve as protection for the permanent waterproofing materials and insulation below, provide a working platform for construction traffic and storage of materials (within weight limits), and provide a substantial substrate for the placement of the finish wearing course materials.

**WEARING COURSE**

The major requirements for the wearing course are a stable support of sufficient strength, resistance against lateral thrust, adequate drainage to avoid ponding of water, and proper treatment of joints. Under a thick-set mortar bed supporting masonry units, a prefabricated drainage composite helps resist freeze-thaw damage to the wearing course by expediting water flow down to the subsurface drainage system.

Joints in which movement is anticipated should be treated as expansion joints. Various compression seals are available that can be inserted into a formed joint under compression. Most of these, however, are not flush at the top surface and could fill up with sand or dirt.

Wet sealants are the materials most commonly used in moving joints at the wearing surface level. Dimension A is the design width dimension or the dimension at which the joint will be formed. The criterion normally used for determining this dimension with sealants capable of ± 25% movement is to multiply the maximum expected movement in one direction by 4. Generally, this is expected to be about three-fourths of the total anticipated joint movement, but if there is any doubt, multiply the total anticipated joint movement by 4. It is better to have the joint too wide than too narrow. Dimension B (sealant depth) is related to dimension A and is best established by the sealant manufacturer. Generally, B is equal to A for widths up to 13 mm (1/2 in.), 15 mm (9/16 in.) for a 16 mm (5/8 in.) width, and 16 mm (5/8 in.) for 19 mm (3/4 in.) and greater widths. This allows some tolerance for self-leveling sealants.

Reference: ASTM C 898 and C 981. Highlights of text and figures are reprinted with permission from Committee C-24 of the American Society for Testing Materials.

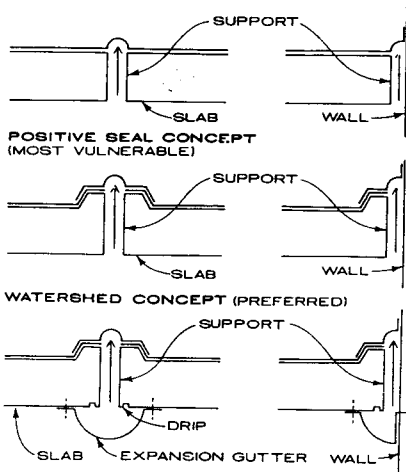

**EXPANSION JOINT CONCEPTS AT MEMBRANE LEVEL**

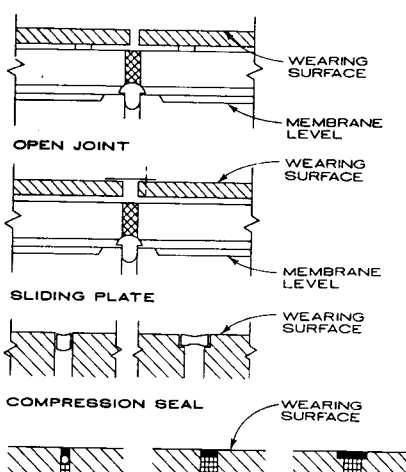

**"WET" SEALANTS EXPANSION JOINT CONCEPTS AT WEARING SURFACE LEVEL**

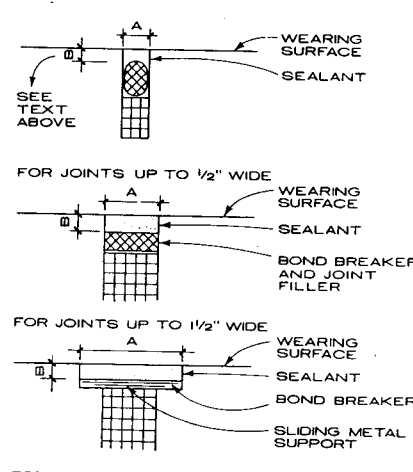

**SEE OTHER PAGES FOR JOINT DESIGN DIMENSIONS WET SEALANT DETAILS AT WEARING SURFACE**

Charles J. Parise, FAIA, FASTM; Smith, Hinchman & Grylls Associates, Inc.; Detroit, Michigan

**SUBSTRATE**

The building deck or substrate referred to is reinforced cast-in-place structural concrete.

The structural slab should have a finish of sufficiently rough texture to provide a mechanical bond for the membrane, but not so rough to preclude achieving continuity of the membrane across the surface.

The concrete should be cured a minimum of 7 days and aged a minimum of 28 days, including curing time, before application of the bituminous membrane. Curing is accomplished chemically with moisture and should not be construed as drying. Liquid or chemical curing compounds should not be used unless approved by the manufacturer of the built-up bituminous membrane as the material may interfere with the bond of the membrane to the structural slab.

**MEMBRANE**

A built-up bituminous waterproofing membrane consists of components joined together and bonded to its substrate at the site. The major membrane components include primers, bitumens, reinforcements, and flashing materials.

Surfaces to receive waterproofing must be clean, dry, reasonably smooth, and free of dust, dirt, voids, cracks, laitance, or sharp projections before application of materials.

Concrete surfaces should be uniformly primed to enhance the bond between the membrane and the substrate, so as to inhibit lateral movement of water.

The number of plies of membrane reinforcement required is dependent upon the head of water and strength required by the design function of the wearing surface. Plaza deck membranes should be composed of not less than three plies. The composition of the membrane is normally of a "shingle" or "ply-on-ply" (phased) construction.

For application temperatures, follow the recommendations of the manufacturers of the membrane materials.

Over reinforced structural slab joints, one ply of 6-in.-wide membrane reinforcement should be applied before application of the bituminous membrane.

Nonreinforced joints should receive a bead of compatible sealant in a recessed joint before application of the membrane.

At expansion joints, gaskets and flexible preformed sheets are required inasmuch as bituminous membranes have little or no movement capability. Since such materials must be joined to the bituminous membrane, the watershed concept should be used.

Reinforce all intersections with walls and corners with two layers of woven fabric embedded in hot bitumen.

Flashing membranes should extend above the wearing surface and the highest possible water level and not less than 150 mm (6 in.) onto the deck membrane.

The flashing should extend over the wall dampproofing or membrane waterproofing not less than 100 mm (4 in.).

Drains must be provided with a wide metal flange or base and set slightly below the drainage level. Metal flashing for the drain, if required, and the clamping ring should be set on the membrane in bituminous plastic cement. The metal flashing should be stripped in with a minimum of two plies of membrane reinforcement and three applications of bituminous plastic cement.

Penetrations through the membrane such as conduits and pipes should be avoided whenever possible. Penetrations must be flashed to a height above the anticipated water table that may extend above the wearing surface.

The built-up bituminous membrane should be protected from damage. Protection board should be placed on the waterproofing membrane when the final mopping is being placed. It will then be adhered to the membrane.

Reference: ASTM C 981. Highlights of text and figures are reprinted with permission from ASTM Committee C-24 of the American Society for Testing and Materials.

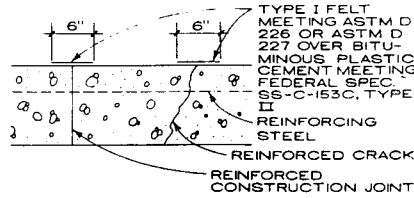

**TREATMENT AT REINFORCED JOINTS**

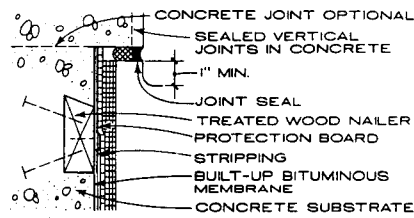

**TERMINAL CONDITION ABOVE FINISH GRADE ON CONCRETE WALL**

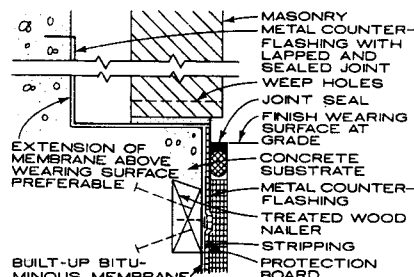

**TERMINAL CONDITION WITH MASONRY ABOVE FINISH WEARING SURFACE AT GRADE**

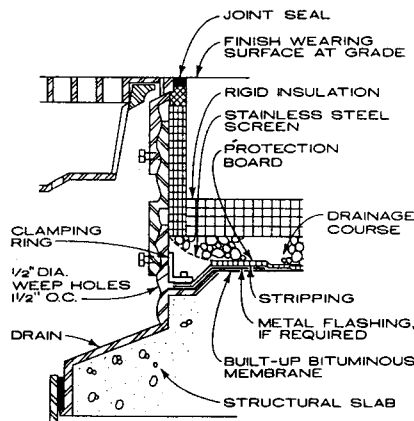

**TERMINATION AT DRAIN**

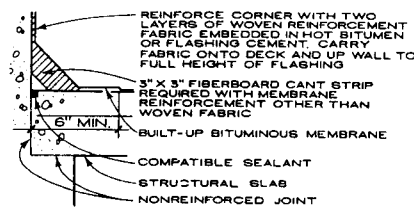

**TREATMENT AT NONREINFORCED JOINTS**

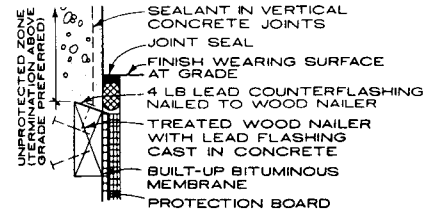

**TERMINAL CONDITIONS ON CONCRETE WALL BELOW FINISH WEARING SURFACE AT GRADE**

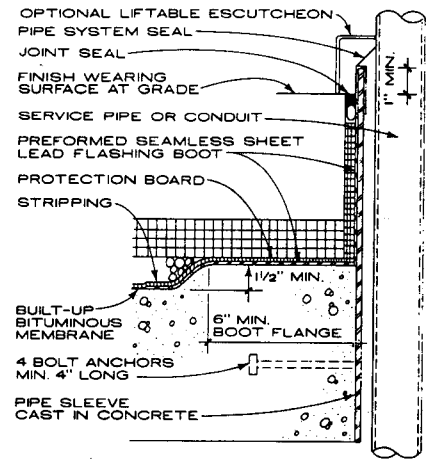

**TERMINATION AT PIPE PENETRATIONS**

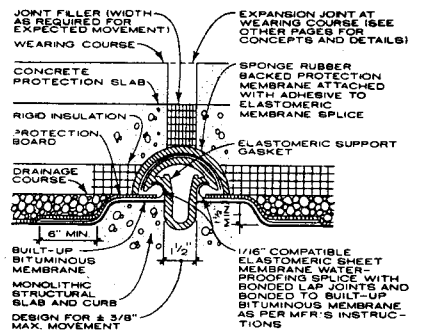

**WATERSHED CONCEPT EXPANSION JOINT**

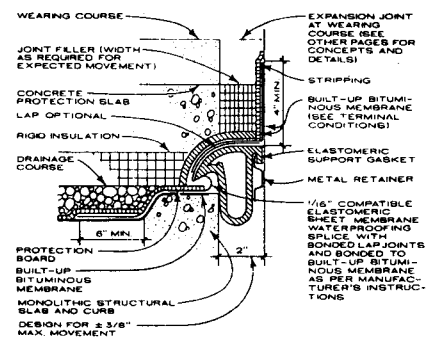

**WATERSHED CONCEPT EXPANSION JOINT**

Charles J. Parise, FAIA, FASTM; Smith, Hinchman & Grylls Associates, Inc.; Detroit, Michigan

**SUBSTRATE**

The building deck or substrate referred to is reinforced cast-in-place structural concrete.

Polymeric, latex, or other organic chemical-based admixtures or modifiers can coat the concrete particles and reduce the ability of the membrane to bond to the substrate. Admixtures should not be used in the concrete unless determined that they are acceptable for use with the membrane.

The underside of the concrete deck should not have an impermeable barrier. A metal liner or coating that forms a vapor barrier on the underside traps moisture in the concrete and destroys or prevents the adhesive bond of the membrane to the upper surface of the concrete.

The surface should be of sufficiently rough texture to provide a mechanical bond for the membrane, but not so rough as to preclude achieving continuity of the membrane of the specified thickness across the surface.

The concrete should be cured a minimum of 7 days and aged a minimum of 28 days, including curing time, before application of the liquid-applied membrane. Curing is accomplished chemically with moisture and should not be construed as drying. Liquid or chemical curing compounds should not be used unless approved by the manufacturer of the liquid-applied membrane as the material may interfere with the bond of the membrane to the structural slab.

**MEMBRANE**

The membrane should be applied under dry, frost-free conditions on the surface as well as throughout the depth of the concrete slab. Use manufacturer's requirements for the particular membrane.

**TERMINATION ON WALLS**

A liquid-applied membrane, because of its inherent adhesive properties, may be terminated flush on the wall without the use of a reglet. However, the use of a reglet in a concrete wall has the advantage of providing greater depth protection at the terminal.

**TERMINATION AT DRAINS**

Drains should be designed with a wide flange or base as an integral part. The drain base should be set flush with the structural slab. Vehicular supporting drains generally require additional weep holes drilled into them (see detail).

**TREATMENT AT REINFORCED JOINTS**

One recommended treatment of reinforced concrete joints in the structural slab is to apply a double layer of membrane over the crack. This type of detail is quite limited and implicitly relies on the membrane's crack-bridging ability. An alternative approach is to prevent the membrane from adhering to the substrate for a finite width centered on the joint or crack by means of a properly designed compatible bond-breaker tape.

**TREATMENT AT NONREINFORCED JOINTS**

Since the joints are not held together with reinforcing steel, some movement, however slight, should be anticipated and provided for, since the liquid-applied membrane has limited ability to take movement.

**TREATMENT AT EXPANSION JOINTS**

Gaskets and flexible preformed sheets lend themselves better to absorbing large amounts of movement. Since such materials, when used at an expansion joint, must be joined to the liquid-applied membrane, the watershed concept should be used.

**PROTECTION BOARD**

The liquid-applied membrane should be protected from damage prior to and during the remainder of deck construction. The proper timing of the application of the board is important and the manufacturer's printed instructions should be followed.

Reference: ASTM C 898. Highlights of text and figures are reprinted with permission from ASTM Committee C-24 of the American Society for Testing and Materials.

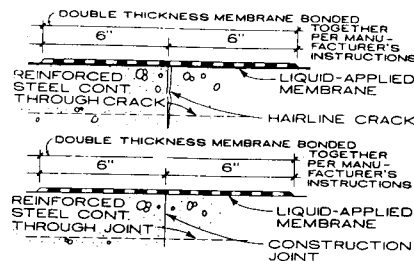

**TREATMENT OF REINFORCED CRACKS AND JOINTS IN CONCRETE SLAB**

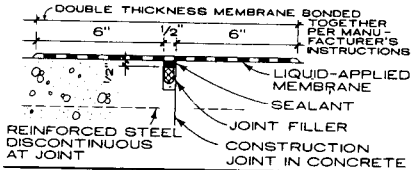

**TREATMENT OF NONREINFORCED BUTTED JOINT IN CONCRETE SLAB**

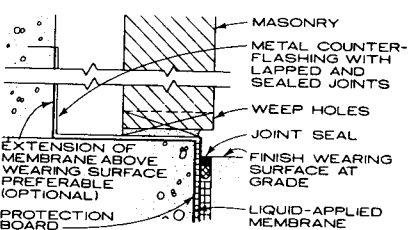

**TERMINAL CONDITION WITH MASONRY ABOVE FINISH WEARING SURFACE AT GRADE**

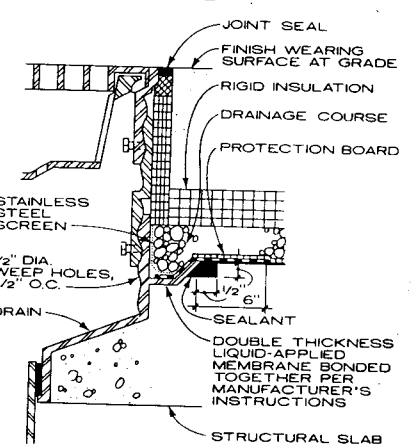

**TERMINATION AT DRAIN**

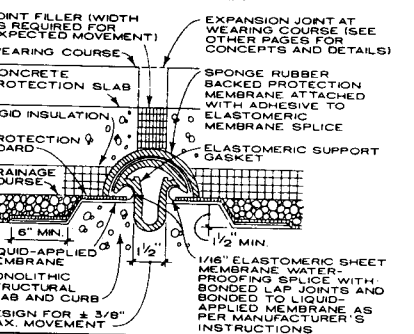

**WATERSHED CONCEPT EXPANSION JOINT**

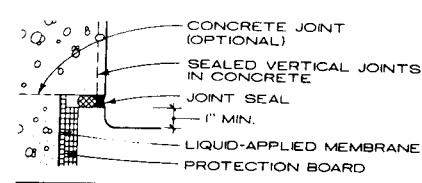

**TERMINAL CONDITION ABOVE FINISH GRADE ON CONCRETE WALL**

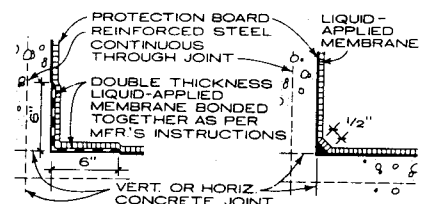

**TURNUP DETAILS AT REINFORCED JOINT**

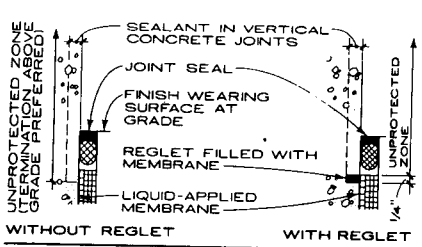

**TERMINAL CONDITIONS ON CONCRETE WALL BELOW FINISH WEARING SURFACE AT GRADE**

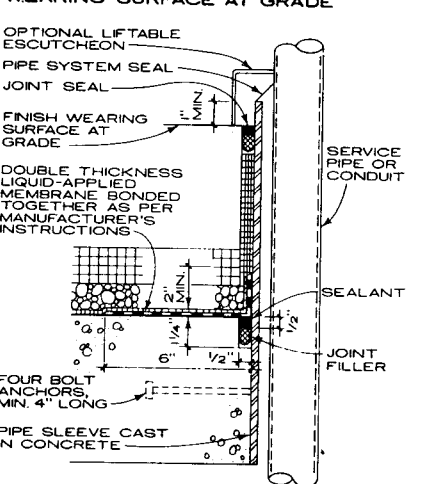

**TERMINATION AT PIPE PENETRATIONS**

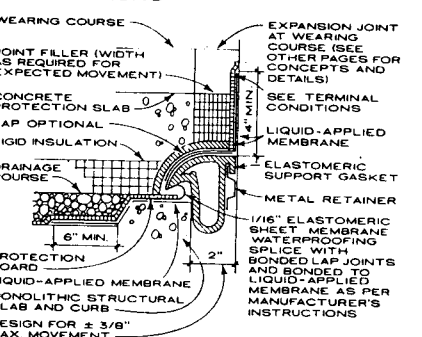

**WATERSHED CONCEPT EXPANSION JOINT**

Charles J. Parise, FAIA, FASTM; Smith, Hinchman & Grylls Associates, Inc.; Detroit, Michigan



**INSULATION DEFINED**

The word insulate comes from the Latin "insula," meaning island, i.e., an isolated and/or separated place or condition. An insulating material is one that isolates sources of electricity, heat, or sound energy. Building insulation should effectively isolate heat, sound or both.

Nature seeks consonance. This explains why heat (energy) moves toward cold (lack of energy). A balance and harmony is being sought. The primary concept of insulators is to resist the natural tendency of energy to flow from the source and affect the surroundings. By this definition, any material that effectively blocks, absorbs, slows down, or reflects heat and sound is a building insulator.

**VAPOR AND MOISTURE**

In conjunction with thermal insulators is the necessary concern for vapor retarders and barriers. Although heat energy moves in a variety of ways such as direct radiation, convection, and conduction, one primary vehicle for heat transfer is air. Air expands when it is heated and gains the capacity to hold more water vapor. When warm and moist air is cooled, it condenses and loses the capacity to hold the same amount of vapor. The water vapor condenses, dew-point is reached, and the water vapor becomes liquid in the same manner that moisture occurs on the warm side (outer surface) of a cold glass of iced tea on a hot and humid day. Since an insulator is normally placed on the warm side of the building, closest to the interior to resist the flow of heat to cold, it follows that this is also where the greatest potential for moisture and moisture damage may occur inside the building section.

It is virtually impossible to construct a perfect vapor barrier. The word "barrier" is used in common building terminology. Construction vapor barriers are actually very effective vapor retarders made of such materials as polyethylene and various facings on insulation that do not totally stop moisture vapor transmission. When a retarder reduces the transmission of moisture to one perm or less, it may be referred to as a vapor barrier.

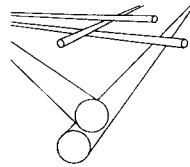

**GLASS FIBERS**

The fibers of glass fiber insulation have firm and cylindrical cross sections that only touch at tangent points. Therefore, there is little heat transmitted by conduction. In addition, glass fibers trap a large amount of air, which increases insulation potential.

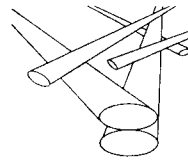

**CELLULOSE FIBERS**

The fibers of cellulose and other blown or hand packed insulators are softer fibers that have wider contact points. This permits more heat transfer through conduction than glass fibers. These fibers also trap a large quantity of air that increases insulation value.

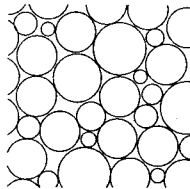

**GRANULAR**

Vermiculite and perlite insulation are composed of small, rock-like, rounded granules that have small contact points that limit heat conduction. Spaces between the granules contain insulating air.

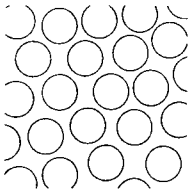

**CELLULAR**

Extruded, molded, and foamed plastic insulations are cellular or honeycombed. Walls of the cells conduct heat around the cells. Cells contain a large volume of air that greatly increases insulation value.

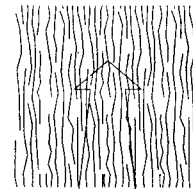

**HEAT FLOW PARALLEL**

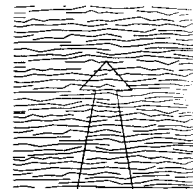

**HEAT FLOW PERPENDICULAR**

If fibrous insulation is used, the direction of the fibers in relation to the direction of the heat flow will affect the rate of heat movement. Under equal conditions, fibers perpendicular to heat flow transmit heat slower than fibers parallel to heat flow.

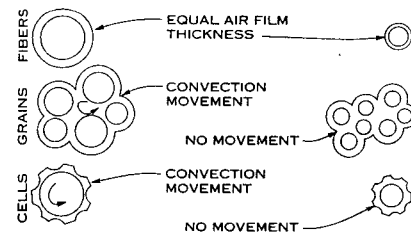

If there are many small fibers of insulation material within a given space, they provide more surface area than larger fibers in the same area. Since thickness of air films surrounding any fiber is essentially the same under still air conditions, smaller fibers provide more surface and more air. Larger fibers may leave larger gaps and paths that allow air to flow by means of convection. Granular and cellular insulation also possess air films. If the cell or space between granules is too large, convection currents can occur that will transmit heat across the space.

**MATERIAL PROPERTIES OF COMMON BUILDING INSULATION**

BUILDING INSULATION	DENSITY (LB/CU FT)	RESISTANCE (R) (HR/SQ FT OF BTU PER 1 IN. THICKNESS)	WATER VAPOR PERMEABILITY (PERM IN.)	WATER ABSORPTION (% BY WEIGHT)	SURFACE BURNING CHARACTERISTICS		TOXICITY	EFFECTS OF AGING	DEGRADATION DUE TO				CORROSIVENESS
					FLAME SPREAD	SMOKE DEVELOPED			DIMENSIONAL STABILITY	TEMPERATURE	MOISTURE	FUNGAL OR BACTERIAL GROWTH	
Glass fiber batts and blankets rigid boards	1.5-4.0 4.0-9.0	3.14 3.8-4.8	100 100	2% 10%	15-25 0-25	0-50 0-50	Some fumes if burned	None	OK below 450°F	None	None	None	None
Rock or slag wool	1.5-2.5	2.9-3.7	100	2%	0-25	0-20	None	None	600°F	Transient	None	None	None
Cellulose (loose blown)	2.0-3.0	2.8-3.7	100	15%	0-50	0-45	CO if burned	Settles 0-20%	Possible with long exposure	Possible with long exposure	Maybe	Possible with long exposure	Steel, aluminum, and copper
Molded polystyrene (rigid boards)	0.9-1.8	3.6-4.4	1.2-5.0	2-3%	25	10-400	CO if burned	None	If above 165°F	None	None	UV degrades	None
Extruded polystyrene (rigid boards)	1.6-3.0	4.0-6.0	0.3-0.9	1-4%	25	10-400	CO if burned	None	If above 165°F	None	None	UV degrades	None
Polyurethane (rigid boards)	1.7-4.0	5.8-6.2 <sup>2</sup>	2-3	Negligible	25-75	155-200	CO if burned	0-12% change	If above 250°F	?	None	None	None
Polyisocyanurate (rigid boards)	1.7-4.0	5.8-7.8 <sup>2</sup>	2.5-3.0	Negligible	25	55-200	CO if burned	0-12% change	If above 250°F	?	None	None	None
Perlite (loose fill)	5-8	2.63	100	Low	0	0	None	Settles 0-10%	If above 1200°F	None	None	None	None
Vermiculite (loose fill)	4-10	2.4-3.0	100	None	0	0	None	Settles 0-10%	If above 1000°F	None	None	None	None
Phenolic (foamed-in-place or rigid boards)	2.5-4.0	4.4-8.2	1.0 for rigid	1-2% for rigid	20-50	0-35	None	None	If above 250°F	None	None	UV degrades	None

**NOTES**

1. By volume
2. Aged unfaced or spay applied

David F. Hill; Burt Hill Kosar Rittelmann Associates; Butler, Pennsylvania  
Donald Bosserman, AIA; Saunders, Cheng & Appleton; Alexandria, Virginia

**7 THERMAL PROTECTION**

**THERMAL INSULATION**

Thermal insulation controls heat flow under temperatures ranging from absolute zero to 3000°F. This broad range can be subdivided into four general temperature regimes that classify applications for various types of insulation:

1. **LOW TEMPERATURES:** Insulation for vessels containing cryogenic materials, such as liquefied natural gas.
2. **AMBIENT TEMPERATURES:** Insulation for building structures.
3. **MEDIUM TEMPERATURES:** Insulation for tanks, pipes, and equipment in industrial process heat applications.
4. **HIGH TEMPERATURES:** Refractory or other specialized insulation materials used in foundry work, nuclear power facilities, the aerospace industry, and so on.

Architects and builders are generally concerned with the design and material performance of building insulations that operate within ambient temperature limits. As temperatures range much above or below ambient conditions, design and performance requirements change and must be matched with insulation materials that withstand the stress introduced by extreme temperatures, large temperature differentials, and thermal cycling.

**BUILDING INSULATION—THERMAL FUNCTIONS**

The two major functions of building insulations are to (1) control temperatures of inside surfaces that affect the comfort of occupants and aid or deter condensation and (2) conserve energy by reducing heat transmission through building sections that determine the energy requirements for both heating and cooling. Economics in fuel consumption can be calculated with reasonable accuracy and balanced against initial costs of insulation and the costs for heating and cooling with equipment (see figure).

**ADDITIONAL FUNCTIONS**

Thermal insulations may also perform several other functions:

1. Add structural strength to a wall, ceiling, or floor section.
2. Provide support for a surface finish.
3. Impede water vapor transmission.
4. Prevent or reduce damage to equipment and structure from exposure to fire and freezing conditions.
5. Reduce noise and vibration.

**BASIC MATERIALS**

Thermal insulation is made from the following basic materials:

1. **MINERAL FIBROUS:** Material such as glass, rock, slag, or asbestos that is melted and spun into thin fibers.
2. **MINERAL CELLULAR:** Material such as foamed glass, calcium silicate, perlite, vermiculite, foamed concrete, or ceramic.
3. **ORGANIC FIBROUS:** Material such as wood, cane, cotton, hair, cellulose, or synthetic fibers.
4. **ORGANIC CELLULAR:** Material such as cork, foamed rubber, polystyrene, or polyurethane.
5. **METALLIC:** Aluminum or other foils, or metallized organic reflective membranes that must face air, gas filled, or evacuated spaces.

**PHYSICAL STRUCTURE AND FORM**

Thermal insulation is available in the following physical forms:

1. **LOOSE FILL:** Dry granules, nodules, or fibers poured or blown into place.
2. **FLEXIBLE OR SEMIRIGID:** Blankets and batts of wool-like material.
3. **RIGID:** Boards and blocks.
4. **MEMBRANE:** Reflective insulation.
5. **SPRAY APPLIED:** Mineral fiber or insulating concrete.
6. **POURED-IN-PLACE:** Insulating concrete.
7. **FOAMED-IN-PLACE:** Polyurethane, urea formaldehyde.

**MECHANISMS OF HEAT TRANSFER**

Heat flows through materials and space by conduction, convection, and radiation. Convection and conduction are functions of the roughness of surfaces, air movement, and the temperature difference between the air and surface. Mass insulations, by their low densities, are designed to suppress conduction and convection across their sections by the entrapment of air molecules within their structure. Convective air currents are stilled by the surrounding matrix of fibers or cells, and the chances of heat transfer by the collision of air molecules is reduced. Radiant heat transfer between objects operates independently of air currents and is controlled by the character of the surfaces (emissivity) and the temperature difference between warm objects emitting radiation and cooler objects absorbing radiation.

The resistance of these modes of heat transfer may be retarded by the elements of a building wall section.

1. **OUTSIDE SURFACE FILMS:** The outside surface traps a thin film of air, which resists heat flow. This film varies with wind velocity and surface roughness.
2. **MATERIAL LAYERS:** Each layer of material contributes to the resistance of heat flow, usually according to its density. A layer of suitable insulation is normally many times more effective in resisting heat transfer than the combination of all other materials in the section.
3. **AIRSPACE:** Each measurable airspace also adds to the overall resistance. Foil faced surfaces of low emissivities that form the boundaries of the airspace can further reduce the rate of radiant transfer across the space.
4. **INSIDE SURFACE FILM:** The inside surface of the building section also traps a thin film of air. The air film thus formed is usually thicker because of much lower air velocities.

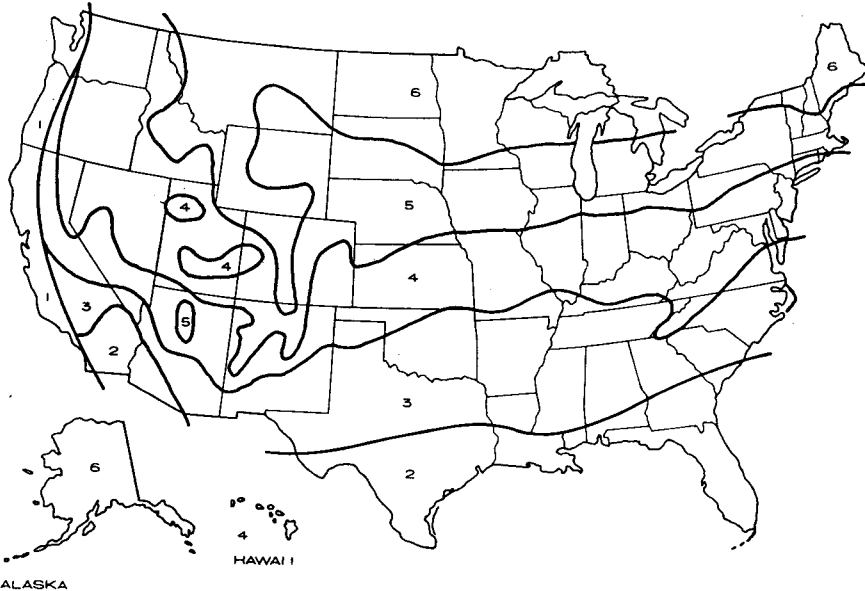
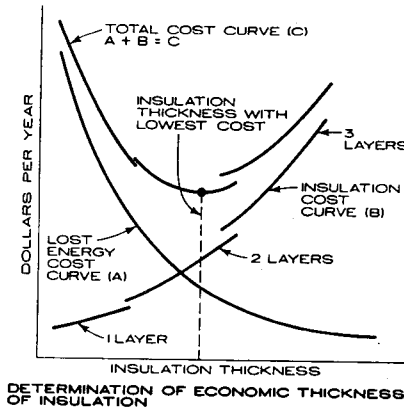

NOTE: RECOMMENDED INSULATION ZONES FOR HEATING AND COOLING

**RECOMMENDED MINIMUM THERMAL RESISTANCES (R) OF INSULATION**

ZONE	CEILING	WALL	FLOOR
1	19	11	11
2	26	13	11
3	26	19	13
4	30	19	19
5	33	19	22
6	38	19	22

NOTE: The minimum insulation R values recommended for various parts of the United States as delineated on the map of insulation zones.

**INSULATION ZONES**

David F. Hill; Burt Hill Kosar Rittelmann Associates; Butler, Pennsylvania  
 Donald Bosserman, AIA; Saunders, Cheng & Appleton; Alexandria, Virginia

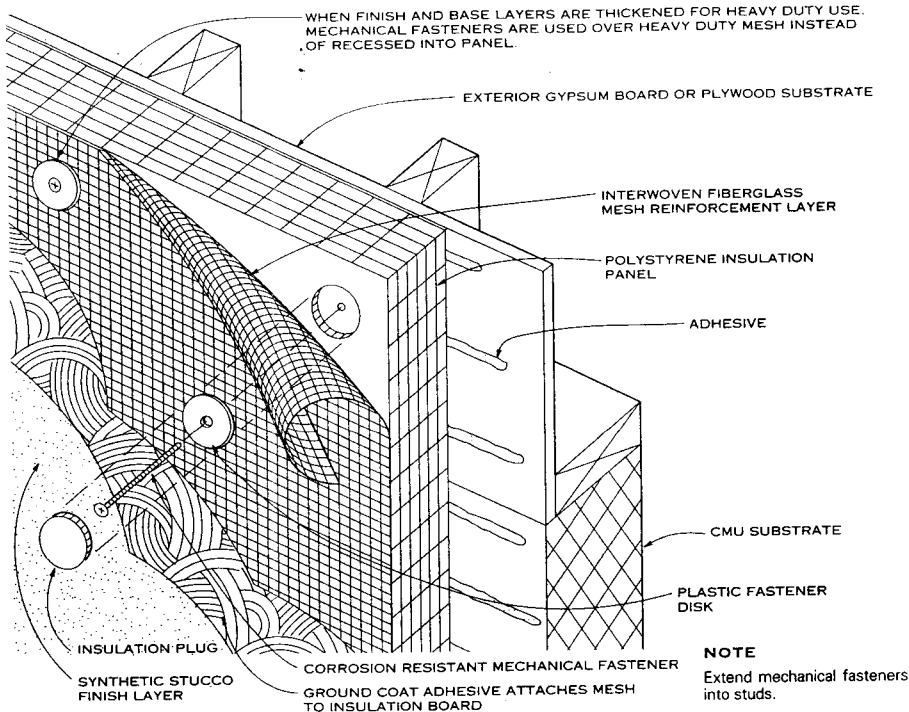

**GENERAL**

Exterior insulation and finish systems provide an uninterrupted layer of rigid insulation that is attached by adhesives or mechanical fasteners directly onto the building substrate. A continuous fiberglass mesh layer is then applied and attached by adhesives or mechanical fasteners. A finish coat covers and seals the entire system.

**NOTES**

1. Insulation panels are made in varying thicknesses from 1 to 4 in., depending on the wall U-factor requirements. They come in varying sizes, generally 2 x 2 ft, 2 x 4 ft, or 2 x 8 ft, depending on manufacturer or system used. Expanded polystyrene (1 to 2 lb/cu ft) is generally used above grade; extruded polystyrene (2 to 3 lb/cu ft) is generally used below grade or in high traffic areas.
2. For areas likely to receive abuse by high impact or high traffic, a heavy duty fiberglass mesh reinforcement layer is used in addition to, or in place of, the standard mesh. Also, zinc casing beads are frequently used at finish layer edges.
3. When mechanical fasteners are used they should be installed flush with or, preferably, recessed into the insulation panel to prevent "bubbles" on the surface. When recessed, some manufacturers provide an insulation plug over the fastener to leave a continuous layer of insulation at the surface before the finish is applied.
4. For walls with damaged or brittle substrates, a mechanically fastened track system is used by some manufacturers to fasten the insulation panels to the substrate.
5. The synthetic-stucco finish layer is generally weather resistant, crack resistant, and vapor permeable and is troweled, rolled, or sprayed onto the surface over the ground coat adhesive. It is generally made from acrylic polymers with an aggregate or silica sand, quartz chips, or marble chips to give it the desired texture. Color is achieved by either tinting the finish coat with pigment or painting the surface.

**EXTERIOR INSULATION AND FINISH SYSTEM**

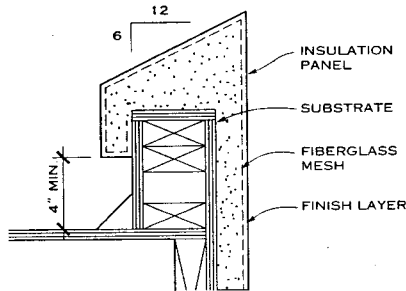

PARAPET DETAIL

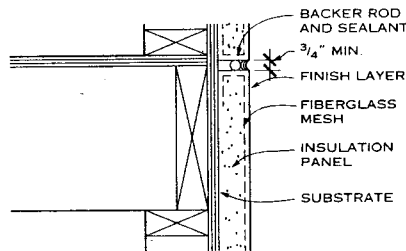

EXPANSION JOINT DETAIL AT FLOOR LEVEL

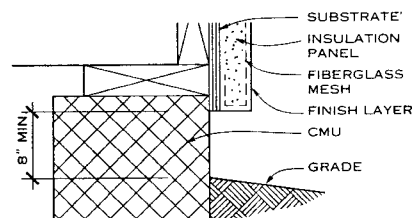

DETAIL AT GRADE  
**WOOD FRAME DETAILS**

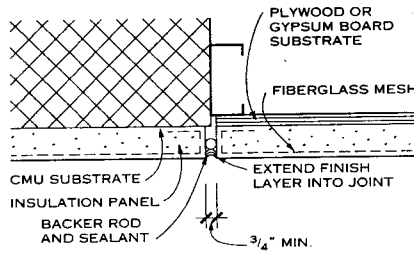

EXPANSION JOINT AT DISSIMILAR SUBSTRATES

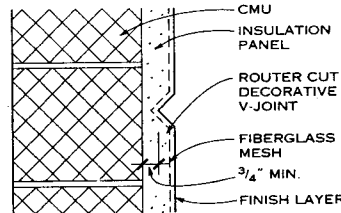

DECORATIVE JOINT

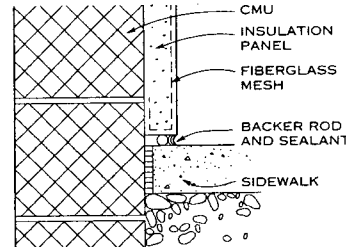

DETAIL AT SIDEWALK  
**MASONRY DETAILS**

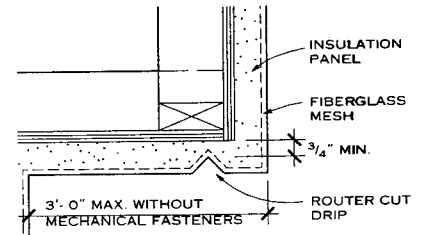

SOFFIT DETAIL

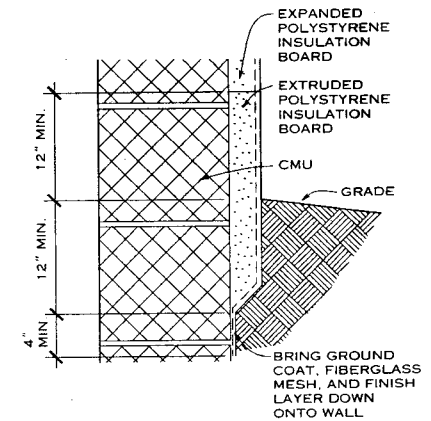

DETAIL BELOW GRADE  
**MISCELLANEOUS DETAILS**

Richard J. Vitullo, AIA; Oak Leaf Studio; Crownsville, Maryland

**WATER VAPOR MIGRATION**

Water is present as vapor in indoor and outdoor air and as absorbed moisture in many building materials. Within the range of temperatures encountered in buildings, water may exist in the liquid, vapor, or solid states. Moisture related problems may arise from changes in moisture content, from the presence of excessive moisture, or from the effects of changes of state, such as freezing within walls or deterioration of materials due to rotting or corrosion.

In the design and construction of the thermal envelope of buildings (the enclosure of desired temperatures and humidities), the behavior of moisture must be considered, particularly the change of state from vapor to liquid (condensation). Problems arise when moisture comes into contact with a relatively cold surface (temperature below the dew point), such as a window, or within outdoor walls or under-roof ceilings. Excessive condensation within indoor walls that enclose cold spaces must be considered.

While moisture moves in still air by vapor pressure differences, it is important to recognize that moisture in air is moved by the air. Consequently, the causes of air motion must be considered, especially the infiltration and exfiltration at undesirable leakage rates at windows, doors, and other penetrations through the thermal envelope of the building.

Moisture problems in residences generally occur in seasons when the outdoor temperature and vapor pressure are low and there are many indoor vapor sources. These may include cooking, laundering, bathing, breathing, and perspiration for the occupants, as well as automatic washers and dryers, dishwashers, and humidifiers. All of these sources combine to cause vapor pressure indoors to be much higher than outdoors, so that the vapor tends to migrate outward through the building envelope. Vapor cannot permeate glazed windows or metal doors, but most other building materials are permeable to some extent. Walls are particularly susceptible to this phenomenon, and such migration must be prevented or at least minimized by the use of low permeance membranes, called *vapor retarders* (formerly, *vapor barriers*). They are now called *retarders*, not *barriers*, because they do not stop moisture flow completely. A vapor retarder is a material that has a flow rating of one perm or less. (1 perm = 1 grain/hr ft · in. Hg vapor pressure difference; there is no metric perm.)

Vapor retarders should be installed as close as possible to the side of the wall through which moisture enters. Establish the side of moisture entrance in walls of controlled rooms within buildings. However, the beneficial effects of good vapor retarders are lost without adequate air barriers.

Moisture in building materials usually increases their thermal conductance significantly and unpredictably. Porous materials that become saturated with moisture lose most of their insulating capability and may not regain it when they dry out. Dust, which usually settles in airspaces, may become permanently affixed to originally reflective surfaces. Moisture migration by evaporation, vapor flow, and condensation can transport significant quantities of latent heat, particularly through fibrous insulating materials.

Positive steps should be taken to prevent migration of moisture in the form of vapor and accumulation in the form of water or ice within building components. Vapor retarders, correctly located near the source of the moisture, are an effective means of preventing such migration. Venting of moisture laden air from bathrooms, laundry rooms, and kitchens will reduce indoor vapor pressure, as will the introduction of outdoor air with low moisture content.

**BUILDING SECTION ANALYSIS FOR POTENTIAL CONDENSATION**

Any building section may be analyzed with simple calculations to determine where condensation might occur and what might be done in selecting materials or their method of assembly to eliminate that possibility. The section may or may not contain a vapor retarder, or it may contain an inadequate one; the building section may include cold-side materials of comparatively high resistance to the passage of vapor (which is highly undesirable). With few exceptions, the vapor resistance at or near the warm surface should be five times that of any components. The table gives permeance and permeability of building and vapor retarder materials. These values can be used in analyzing building sections by the following simple method:

- List the materials, without surface films or airspaces, in the order of their appearance in the building section, beginning with the inside surface material and working to the outside.
- Against each material list the permeance (or permeability) value from the table or a more accurate value if available from tests or manufacturers' data. Where a range is

given, select an average value or use judgment in assigning a value based on the character and potential installation method of the material proposed for use.

- Start at the top of the list and note any material that has less permeance than the materials above it on the list. At that point the possibility exists that vapor leaking through the first material may condense on the second, provided the dew point (condensation point) is reached and the movement is considerable. In that case, provide ventilation through the cold-side material or modify the design to eliminate or change the material to one of greater permeance.

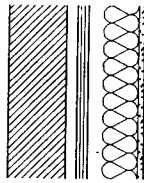

**ESTIMATED PERMEANCE**

MATERIAL	PERM IN. <sup>2</sup>
<b>THERMAL INSULATIONS</b>	
Cellular glass	0.05
Mineral wool, unprotected	29.0
Expanded polystyrene (R-11 blown)	0.4 - 1.65
Expanded polystyrene - extruded	1.25
Expanded polystyrene - bead	2.0 - 5.85
<b>PLASTIC AND METAL FOILS AND FILMS<sup>2</sup></b>	
Aluminum foil (1 mil)	0.0
Polyethylene (4 mil)	0.08
Polyethylene (6 mil)	0.06
Polyethylene (8 mil)	0.04
Polyester (1 mil)	0.7
Polyvinylchloride, unplasticized (2 mil)	0.68
Polyvinylchloride, plasticized (4 mil)	0.8 - 1.4
<b>BUILDING PAPERS, FELTS, ROOFING PAPERS<sup>3</sup></b>	
Duplex sheet, asphalt laminated, aluminum foil one side (43) <sup>4</sup>	0.176
Saturated and coated roll roofing (326) <sup>4</sup>	0.24
Kraft paper and asphalt laminated, reinforced 30-120-30 (34) <sup>4</sup>	1.8
Asphalt-saturated, coated vapor barrier paper (43) <sup>4</sup>	0.6
Asphalt-saturated, not coated sheathing paper (22) <sup>4</sup>	20.2
15-lb asphalt felt (70) <sup>4</sup>	5.6
15-lb tar felt (70) <sup>4</sup>	18.2
Single kraft, double infused (16) <sup>4</sup>	42
<b>LIQUID APPLIED COATING MATERIALS</b>	
Paint - two coats	
Aluminum varnish on wood	0.3 - 0.5
Enamels on smooth plaster	0.5 - 1.5
Primers and sealers on interior insulation board	0.9 - 2.1
Miscellaneous primers plus one coat flat oil paint on plastic	1.6 - 3.0
Flat paint on interior insulation board	4
Water emulsion on interior insulation board	30 - 85
Paint - three coats	
Exterior paint, white lead and oil on wood siding	0.3 - 1.0
Exterior paint, white lead-zinc oxide and oil on wood	0.9
Styrene-butadiene latex coating, 2 oz/sq ft	11
Polyvinyl acetate latex coating, 4 oz/sq ft	5.5
Asphalt cutback mastic	
1/16 in. dry	0.14
3/16 in. dry	0.0
Hot melt asphalt	
2 oz/sq ft	0.5
3.5 oz/sq ft	0.1

**EXAMPLE**

In this example the vapor retarder transmits 1 grain of moisture per square foot per hour for each unit of vapor pressure difference, or one perm, and nothing else transmits less. However, since the cold brick veneer is nearly as low in permeance, it is advisable to make certain that the vapor retarder is expertly installed, with all openings at pipes and with outlet boxes or joints carefully fitted or sealed. Alternatively, the brick veneer may have open mortar joints near the top and bottom to serve both as weep holes and as vapor release openings. They will also ventilate the wall and help reduce heat gain in summer.

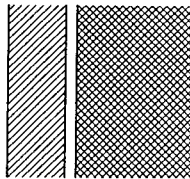

**ESTIMATED PERMEANCE**

MATERIAL	PERM IN. <sup>2</sup>
<b>ESTIMATED PERMEANCE</b>	
GWB (2/8")	50.0
Vapor retarder	0.6 (lowest)
Insulation	29.0
Wood sheathing	2.9
4" brick veneer	1.1 (next)

**EXAMPLE**

Vapor (under pressure) would easily pass through the interior finish, be slowed by the concrete masonry unit, and be nearly stopped by the cold brick veneer. Unless this design is radically improved, the masonry will become saturated and may cause serious water stains or apparent "leaks" in cold weather. In addition, alternating freezing and thawing of condensation within the masonry wall can physically damage the construction.

**PERMEANCE AND PERMEABILITY OF MATERIALS TO WATER VAPOR**

MATERIAL	PERM IN. <sup>2</sup>
<b>MATERIALS USED IN CONSTRUCTION</b>	
Concrete (1:2:4 mix)	3.25
Brick-masonry (4 in. thick)	0.8 - 1.1
Concrete masonry (8 in. cored, limestone aggregate)	2.4
Plaster on metal lath (3/4 in.)	15
Plaster on plain gypsum lath (with studs)	20
Gypsum wallboard (5/8 in. plain)	50
Structural insulating board (sheathing quality)	20 - 50 <sup>5</sup>
Structural insulating board (interior, uncoated, 1/2 in.)	50 - 90
Hardboard (1/8 in. standard)	11
Hardboard (1/8 in. tempered)	5
Built-up roofing (hot mopped)	0.0
Wood, fir sheathing, 3/4 in.	2.9
Plywood (Douglas fir, exterior glue, 1/4 in.)	0.7
Plywood (Douglas fir, interior glue, 1/4 in.)	1.9
Acrylic, glass fiber reinforced sheet, 56 mil	0.12
Polyester, glass fiber reinforced sheet, 48 mil	0.05

**NOTES**

1. The vapor transmission rates listed will permit comparisons of materials, but selection of vapor retarder materials should be based on rates obtained from the manufacturer or from laboratory tests. The range of values shown indicates variations among mean values for materials that are similar but of different density. Values are intended for design guidance only.
2. Usually installed as vapor retarders. If used as exterior finish and elsewhere near cold side, special considerations are required.
3. Low permeance sheets used as vapor retarders. High permeance used elsewhere in construction.
4. Bases (weight in lb/500 sq ft).
5. Permeability (perm in.)

Based on data from ASHRAE Handbook of Fundamentals, 1984 I-P section, chapter 22.

David F. Hill; Burt Hill Kosar Rittelmann Associates; Butler, Pennsylvania  
 Marc A. Giaccardo; College of Architecture, Texas Tech University; Lubbock, Texas

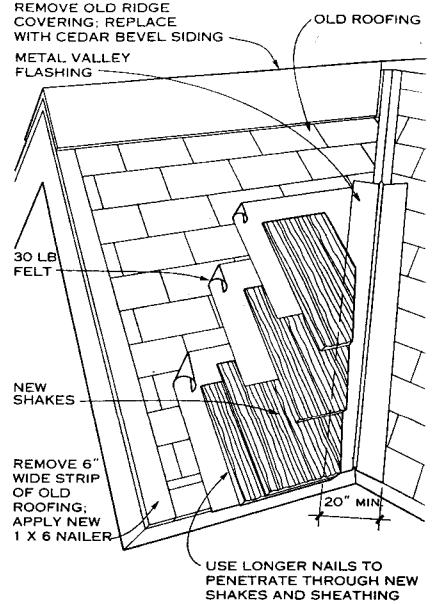
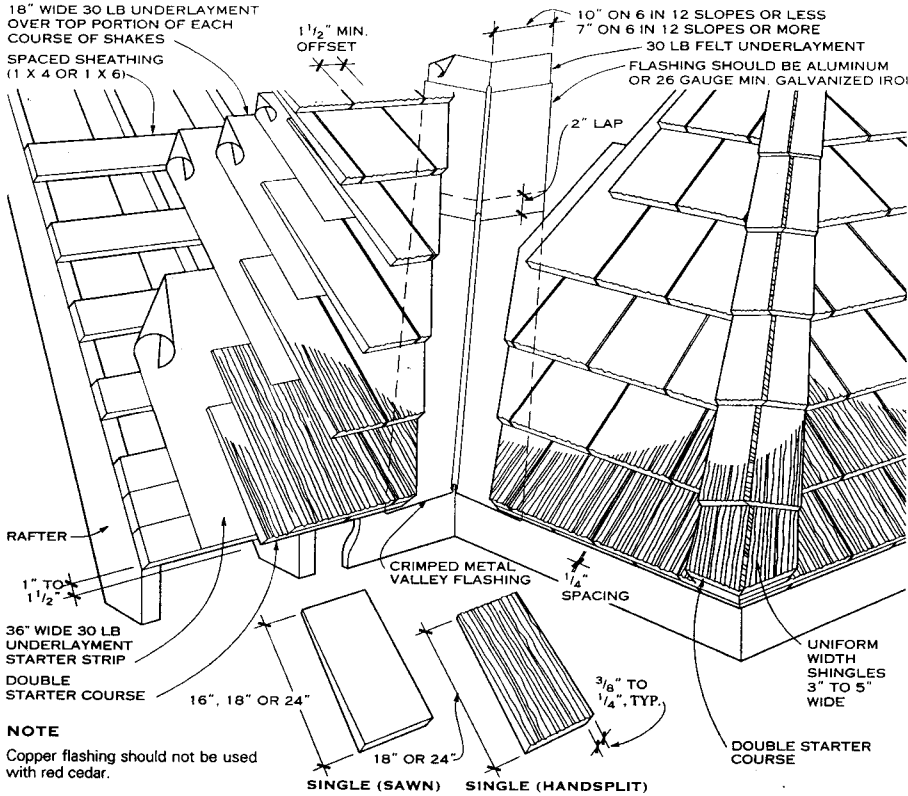

**NOTES**

Shakes can also be applied over any existing wall or roof. Brick or other masonry requires vertical frameboards and horizontal nailing strips.

Over stucco, horizontal nailing strips are attached directly to wall. Nails should penetrate sheathing or studs. Over wood, apply shakes directly just as if on new sheathing.

**WOOD SHAKES APPLIED TO EXISTING ROOF**

**GENERAL NOTES**

1. Wood shingles and shakes are cut from wood species that are naturally resistant to water, sunlight, rot, and hail: i.e., red cedar, redwood, and tidewater red cypress. They are typically installed in the natural state, although stains, primers, and paint may be applied.
2. Nails must be hot dipped in zinc or aluminum. Nail heads should be driven flush with the surface of the shingle or shake but never into the wood.
3. Underlayment and sheathing should be designed to augment the protection provided by the shingles or shakes, depending on roof pitch and climate. A low-pitched roof subject to wind driven snow should have solid sheathing and an additional underlayment.

**RED CEDAR HANDSPLIT SHAKES**

**RED CEDAR HANDSPLIT SHAKES**

GRADE	LENGTH AND THICKNESS	DESCRIPTION
No. 1 handsplit and resawn	15" starter-finish 18 x 1/2" medium 18 x 3/4" heavy 24 x 3/8" medium 24 x 1/2" medium 24 x 3/4" heavy	These shakes have split faces and sawn backs. Cedar logs are first cut into desired lengths. Blanks or boards of proper thickness are split and then run diagonally through a bandsaw to produce two tapered shakes from each blank.
No. 1 tapersplit	24 x 1/2"	Produced largely by hand, using a sharp bladed steel froe and a wooden mallet. The natural shinglelike taper is achieved by reversing the block, end-for-end, with each split.
No. 1 straight	18 x 3/8" side wall 18 x 3/8" 24 x 3/8"	Produced in the same manner as tapersplit shakes except that by splitting from the same end of the block, the shakes acquire the same thickness throughout.

**RED CEDAR SHINGLES**

	NO. 1 BLUE LABEL			NO. 2 RED LABEL			NO. 3 BLACK LABEL		
	MAXIMUM EXPOSURE RECOMMENDED FOR ROOFS (IN.)								
ROOF PITCH	16	18	24	16	18	24	16	18	24
3 in 12 to 4 in 12	3 3/4	4 1/4	5 3/4	3 1/2	4	5 1/2	3	3 1/2	5
4 in 12 and steeper	5	5 1/2	7 1/2	4	4 1/2	6 1/2	3 1/2	4	5 1/2

**UNDERLAYMENT AND SHEATHING**

ROOFING TYPE	SHEATHING	UNDERLAYMENT	NORMAL SLOPE		LOW SLOPE	
Wood shakes and shingles	Solid or spaced	No. 30 asphalt saturated felt interlayment	4 in 12 and up	Underlayment starter course; interlayment over entire roof	3 in 12 to 4 in 12	Single layer underlayment over entire roof; interlayment over entire roof

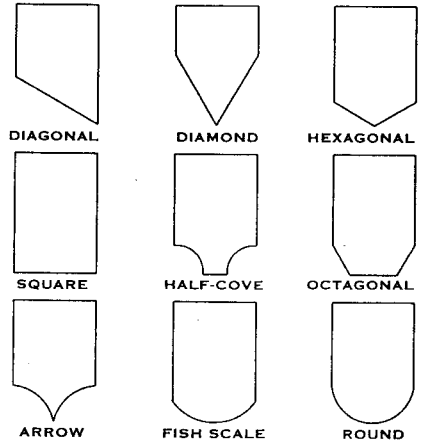

**NOTE**

Fancy butt shingles are 5 in. wide and 7 1/2 in. long, custom produced to individual orders.

**FANCY BUTT RED CEDAR SHINGLE SHAPES**

Richard J. Vitullo, AIA; Oak Leaf Studio; Crownsville, Maryland

**7 SHINGLES, ROOF TILES, AND ROOF COVERING**

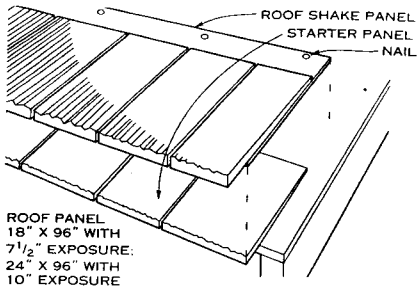

ROOF PANEL SYSTEM

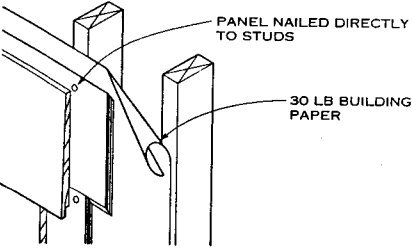

SIDEWALL PANEL APPLIED TO STUDS

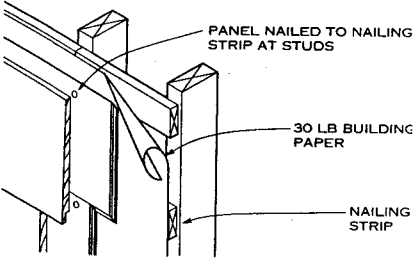

SIDEWALL PANEL APPLIED TO NAILING STRIPS

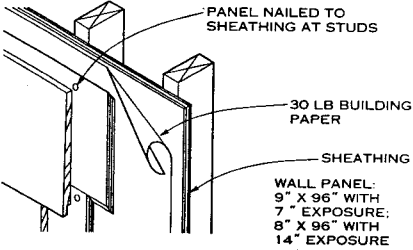

SIDEWALL PANEL APPLIED TO SHEATHING

NOTES

- With the panel system, shakes and shingles plus sheathing go up in one operation: 8 ft roof panels have 16 hand-split shakes bonded to 6 x 1/2 in. plywood strip, which forms a solid deck when the panels are nailed. A 4 to 12 or steeper roof pitch is recommended.
- After application of starter panels, attach panels directly to rafters. Although designed to center on 16 in. or 24 in. spacing, they may meet between rafters. Use two 6d nails at each rafter.
- 8 ft sidewall panels are of two-ply construction:
  - Surface layer of individual #1 grade shingles or shakes.
  - Backup of exterior grade plywood shakes or shingles is bonded under pressure with exterior type adhesives to plywood backup.
- Lap building paper behind panels 3 in. vertically and horizontally. Stagger joints between panels.
- Application types are determined by local building codes.
- Matching factory-made corners for sidewall or roof panels are available.

PANEL SYSTEMS

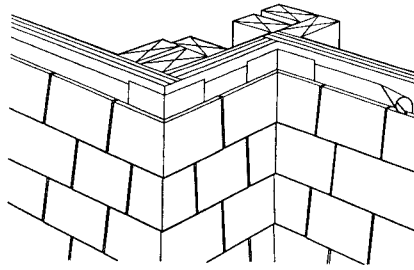

MITERED OUTSIDE AND INSIDE CORNERS (RECOMMENDED)

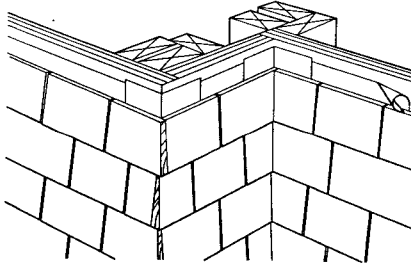

WOVEN OUTSIDE AND INSIDE CORNERS (MORE ECONOMICAL)

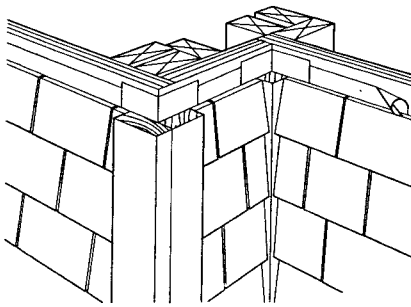

CORNER BOARDS AT OUTSIDE AND INSIDE CORNERS

WOOD SHINGLES AND SHAKES FOR SIDING

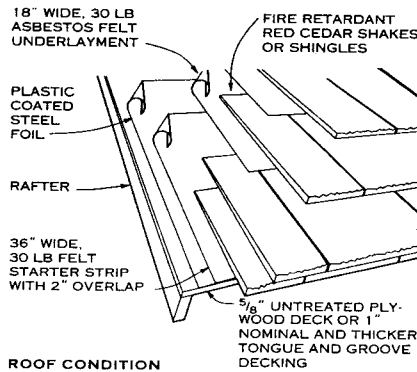

ROOF CONDITION

NOTE

In treating shakes, fire-retardant chemicals are pressure impregnated into the wood cells, and chemicals are then fixed in the wood to prevent leaching. Treatment does not alter appearance. Fire-retardant red cedar shakes are classified as Class C by UL. Class B classification by UL can be met with the addition of the deck constructed of 5/8 in. plywood with exterior glue or 1 in. nominal tongue and groove boards, overlaid with a layer of approved asbestos felt lapped 2 in. on all joints and an 18 in. wide strip of approved asbestos felt between each shake and not exposed to the weather. Decorative stains may be applied.

FIRE RATED CONSTRUCTION

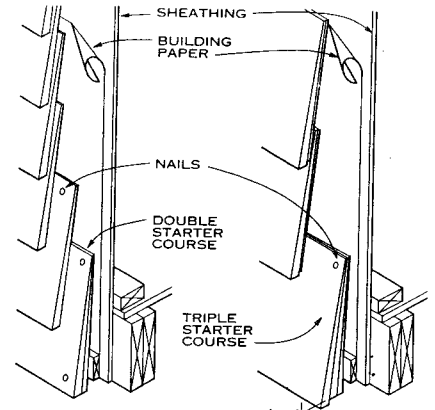

SINGLE COURSING APPLICATION

DOUBLE COURSING APPLICATION

EXPOSURE FOR SHINGLES AND SHAKES USED FOR SIDING (IN.)

LENGTH OF SHINGLES	EXPOSURE OF SHINGLES	
	SGL. COURSE	DBL. COURSE
16	6 to 7 1/2	8 to 12
18	6 to 8 1/2	9 to 14
24	8 to 11 1/2	12 to 20

NAILING: THICKNESS AND NAILS

16" long	5 butts = 2"	3d
18" long	5 butts = 2 1/4"	3d
24" long	4 butts = 2"	4d
25" to 27"	1 butt = 1/2"	5 or 6d
25" to 27"	1 butt = 5/8" to 1 1/4"	7 or 8d

SHEATHING NOTES

- Sheathing may be strip type, solid 1 x 6 in., and diagonal type, in plywood, fiberboard, or gypsum board. Horizontal wood nailing strips (1 x 2 in.) should be used over fiberboard and gypsum sheathing. Space strips equal to shingle exposure.
- Many finishes can be used on red cedar shakes and shingles: solid color or semitransparent ("weathering") stains, exterior latex paint with primer, wood preservative, and bleaches.

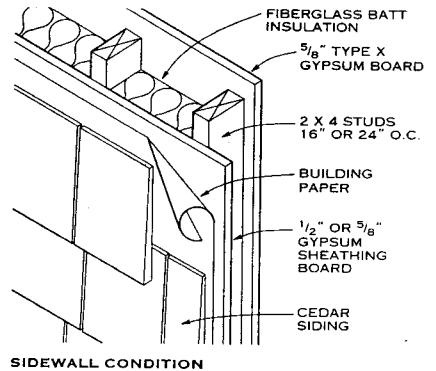

SIDEWALL CONDITION

Richard J. Vitullo, AIA; Oak Leaf Studio; Crownsville, Maryland

**SCHEDULE OF UNDERLAYMENT**

SLOPE	TYPE OF UNDERLAYMENT
Normal slope: 4 in 12 and up	Single layer of 15 lb asphalt saturated felt over entire roof
Low slope: 3 in 12 to 4 in 12	Two layers of 15 lb asphalt saturated felt over entire roof

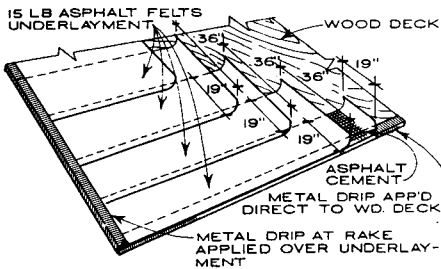

Use only enough nails to hold underlayment in place until shingles are laid.

**APPLICATION OF UNDERLAYMENT ON LOW SLOPE ROOFS**

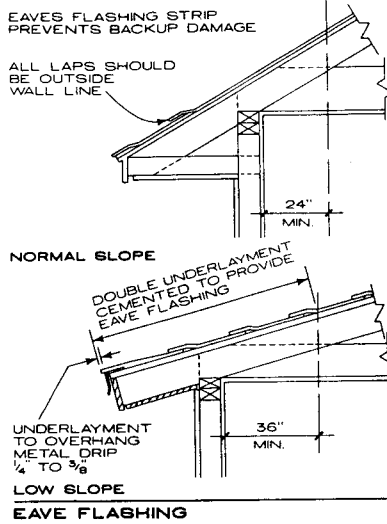

**EAVE FLASHING**

Eave flashing is required wherever the January daily average temperature is 30°F or less or where there is a possibility of ice forming along the eaves.

**NORMAL SLOPE—4 IN./FT OR OVER**

A course of 90 lb mineral surfaced roll roofing or a course of 50 lb smooth roll roofing is installed to overhang the underlay and metal edge from 1/4 to 3/8 in. Extend up the roof far enough to cover a point at least 24 in. inside the interior wall line of the building. When the overhang requires flashing wider than 36 in., the horizontal lap joint is cemented and located on the roof deck extending beyond the exterior line of the building.

**LOW SLOPE—3 TO 4 IN./FT**

Cover the deck with two layers of 15# asphalt saturated felt. Begin with a 19 in. starter course laid along the eaves, followed by a 36 in. wide sheet laid even with the eaves and completely overlapping the starter course. The starter course is covered with asphalt cement. Thereafter, 36 in. sheets are laid in asphalt cement, each to overlap the preceding course 19 in., exposing 17 in. of the underlying sheet.

The plies are placed in asphalt cement to a point at least 36 in. inside the interior wall line of the building.

**SCHEDULE OF SHINGLE TYPES (1)**

DESCRIPTION	DESIGN	MATERIAL	U.L. RATING	WEIGHT	SIZE
Three-tab square butt		Fiberglass Organic felts	A C (4)	205-225 lb/sq 235-300 lb/sq	36" x 12"
Two-tab square butt		Fiberglass Organic felts	A C (4)	260-325 lb/sq 300 lb/sq	36" x 12"
Laminated overlay (2)		Fiberglass Organic felts	A C (3)	300 lb/sq 330-380 lb/sq	36" x 14"
Random edge cut		Fiberglass Organic felts	A C (3)	225-260 lb/sq 250 lb/sq	36" x 12"

NOTE: Exposure 5", edge lap 2".

**NOTES**

1. Exposure 5 in., edge lap 2 in., for all designs.
2. More than one thickness for varying surface texture.
3. Many rated as wind resistant.
4. All rated as wind resistant.

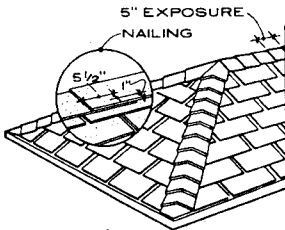

**HIP AND RIDGE**

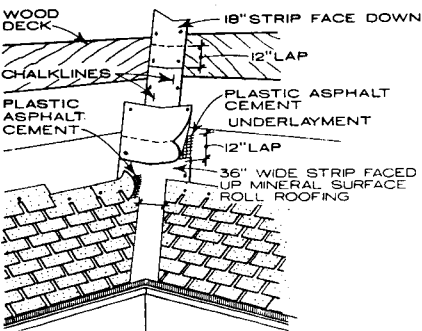

**OPEN VALLEY**  
•Valley width should be 6" wide at ridge and spread wider at the rate of 1/8"/foot downward to eave. Establish valley width using chalkline from ridge to eave.

**APPLICATION DIAGRAMS**

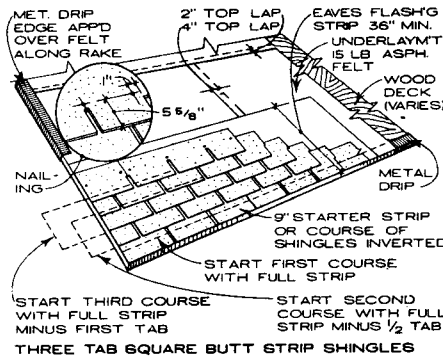

**THREE TAB SQUARE BUTT STRIP SHINGLES**

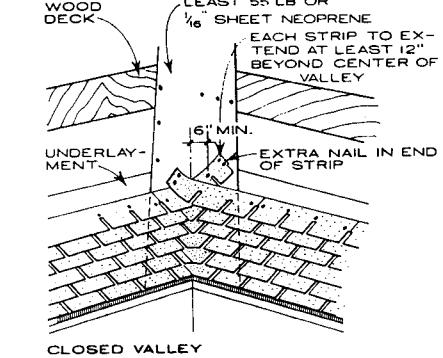

**CLOSED VALLEY**

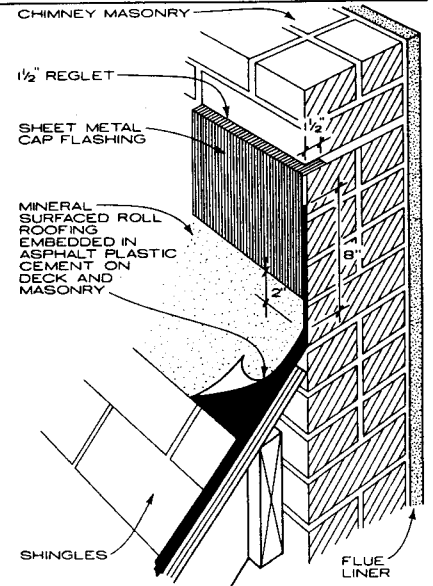

**METHOD OF SECURING CAP FLASHING TO CHIMNEY MASONRY**

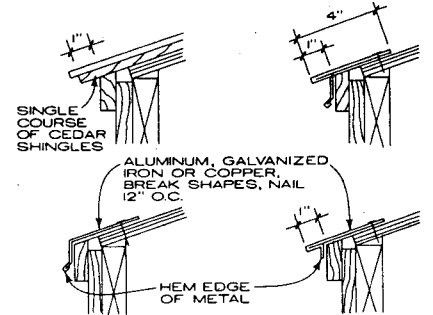

**DRIP EDGE DETAILS**

NAIL TYPES	NAILING OF SHINGLES RECOMMENDATION	
	DECK TYPE	NAIL LENGTH
	1" Wood sheathing	1 1/4"
	3/8" Plywood	7/8"
	1/2" Plywood	1"
	Reroofing over asphalt shingles	1 1/4"

Robert E. Fehlberg, FAIA; CTA Architects Engineers; Billings, Montana

**7 SHINGLES, ROOF TILES, AND ROOF COVERING**

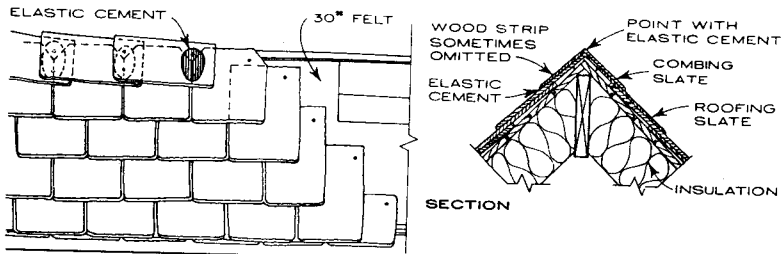

SADDLE RIDGE

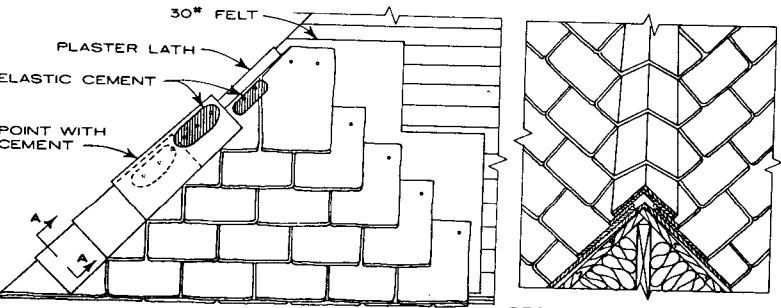

SADDLE HIP

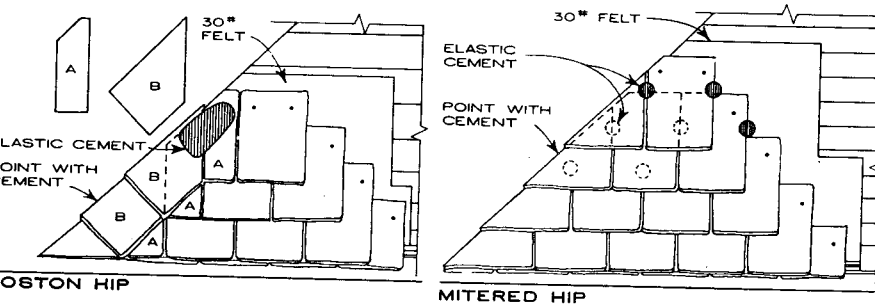

BOSTON HIP

MITERED HIP

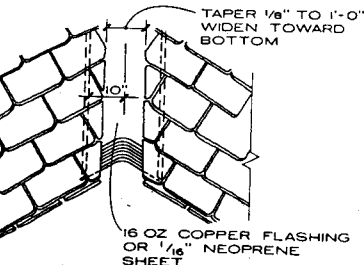

OPEN VALLEY

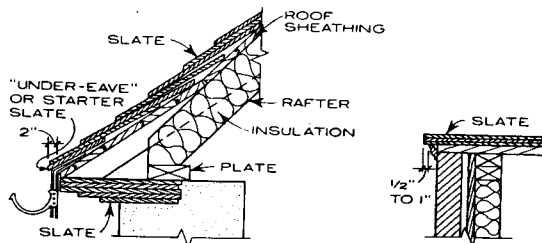

EAVE

GABLE RAKE

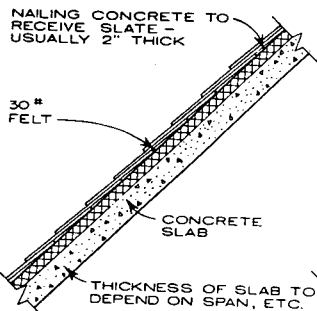

NAILING CONCRETE ON CONCRETE SLAB

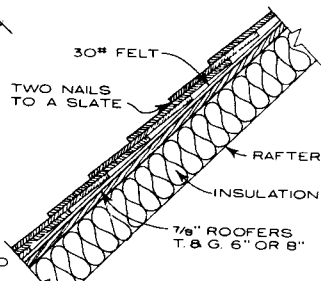

WOOD RAFTER TO RECEIVE SLATE

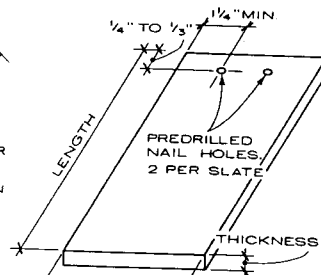

ROOFING SLATE

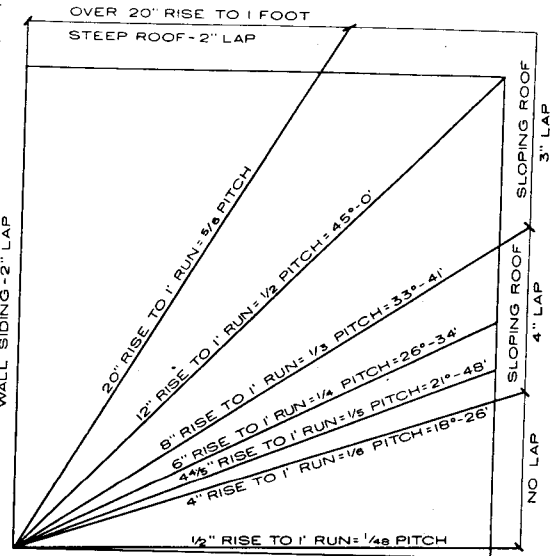

DIAGRAM OF PROPER LAP FOR RISE/RUN

**GENERAL NOTES**

- COMMERCIAL STANDARD:** The quarry run of 3/16 in. thickness; includes tolerable variations above and below 3/16 in.
- TEXTURAL:** A rough textured slate roof with uneven butts; the slates vary in thickness and size, which is generally not true of slate more than 3/8 in. thick.
- GRADUATED:** A textural roof of large slates; more variation in thickness, size, and color.
- A SQUARE OF ROOFING SLATE:** A number of slates of any size sufficient to cover 100 ft<sup>2</sup> with a 3 in. lap. Weight per square: 3/16 in. - 800 lb; 1/4 in. - 900 lb; 3/8 in. - 1100 lb; 1/2 in. - 1700 lb; 3/4 in. - 2600 lb.
- STANDARD NOMENCLATURE FOR SLATE COLOR:** Black, blue black, mottled gray, purple, green, mottled purple and green, purple variegated, red; to be preceded by the word "Unfading" or "Weathering." Other colors and combinations are available.
- PROPER JOINTING FOR PITCHED ROOFS:** Requires a 3 in. minimum vertical overlap. Overlap varies with pitch; see graph above.
- FELT:** With Commercial Standard Slate use 30# saturated felt. With graduated roofs use 30# for 1/4 in. slate and 45#, 50#, or 65# prepared roll roofing for heavier slate.
- NAIL FASTENING:** Use large head, slaters' hard copper wire nails, cut copper, cut brass, or cut yellow metal slating nails. Each slate punched with two nail holes. Use nails that are 1 in. longer than thickness of slate. Cover all exposed heads with elastic cement. In dry climates hot dip galvanized nails may be used.

**STANDARD SLATE DIMENSIONS\***

LENGTH (IN.)	WIDTH (IN.)
10 <sup>†</sup>	6, 7, 8, 9, 10
12 <sup>†</sup>	6, 7, 8, 9, 10, 12
14 <sup>†</sup>	7, 8, 9, 10, 11, 12
16	8, 9, 10, 11, 12, 14
18	9, 10, 11, 12, 13, 14
20	9, 10, 11, 12, 13, 14
22	10, 11, 12, 13, 14
24	11, 12, 13, 14, 16

\*The slates are split in these thicknesses: 3/16, 1/4, 3/8, 1/2, 3/4, 1, 1 1/4, and 1 1/2 in. 1 1/2 in. and larger slates are not often used in these sizes. Random widths are usually used.

Domenic F. Valente, AIA, Architect & Planner; Medford, Massachusetts



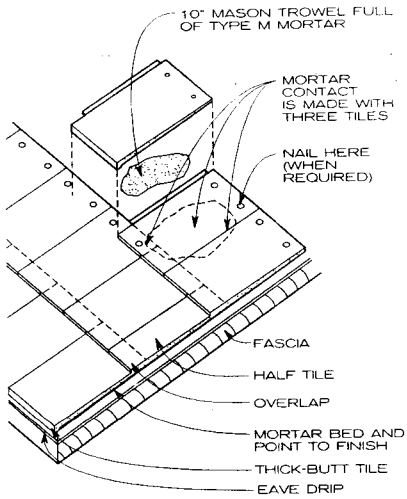

**FLAT TILE NOTE**

Mortar contact is made with 3 tiles.

**MORTAR AND TILE PLACEMENT**

**GENERAL**

Concrete tile is manufactured by extruding a mixture of portland cement, sand, and water on individual molds under high pressure. The finish surface of the tile is covered with a cementitious material that has been colored with synthetic oxides. The tiles are cured to required strengths in chambers where humidity and temperature are controlled. Moisture absorption by concrete tiles can lead to structural roof problems, and particular care should be given to specifying the correct concrete tile for a given environment.

For both categories of concrete tile—roll or flat—it is important to adhere to minimum slope requirements as follows:

1. Roll tile and flat tile can be installed on roof decks with slopes of 4 in. per ft or more when at least one layer of 30-lb felt underlayment is applied horizontally and tiles are nailed or wired with a minimum 3 in. headlap. Use of spaced sheathing is not recommended.
2. Any concrete tile can be used on solid-sheathed roof decks with slopes less than 4 in. per ft as long as two or more layers of No. 30 or No. 40 asphalt-saturated (non-perforated) felt are set in hot asphalt or mastic to serve as the underlayment. A single layer of modified bitumen-coated roofing systems roll-good sheet with laps either torched or heat welded is acceptable. Vertical lath stringers with horizontal battens are installed over the underlayment, creating a supporting surface for the tile, which must be installed with at least 4 in. headlap. Do not use spaced sheathing.
3. Regardless of slope, in localities where the January mean temperature is less than 30°F, stricter minimum requirements apply. Refer to the National Roofing Contractors Association manual.

**FLAT TILE**

When using flat roof tiles, a metal eave-riser with weep holes should be installed at the eave line. During installation, adjust tile spacing to provide uniform exposure, with a minimum 3 in. headlap.

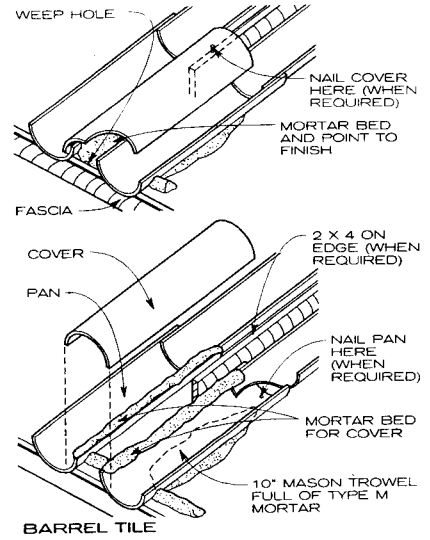
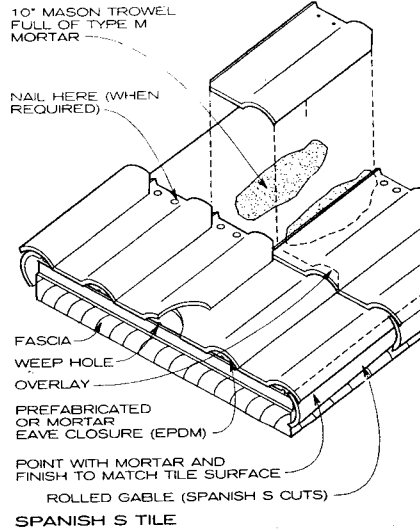

**ROLL TILE**

When using roll, or mission, tile, apply the first course above a metal bird-stop with weep holes. Fit the underside of the tile with specially formed eave closure strips, fastened inside the tile cover. The heads of all remaining tiles should be aligned with the horizontal guide lines. Adjust roll tile spacing to provide uniform exposure, with at least a 3 in. headlap. Jamming interlocking tiles together (side to side) will restrict movement and result in broken corners.

**ROOF SLOPE**

For roof slopes 5 in. in 12 and less, solid sheathing may be used with or without battens. Nailing is not required with battens, but every tile should be nailed if battens are not used. In either case, perimeter nailing is required for 3 ft or three courses, whichever is greater, from all eaves, rakes, ridges, hips, or valleys. (Do not nail into valley metal.)

For roof slopes between 5 and 7 in. in 12, nail every other tile over solid sheathing with battens and every tile if battens are not used. For slopes between 7 and 12 in. in 12, every other tile should be nailed over solid sheathing with battens. Perimeter nailing is required in all these situations.

For slopes 12 in. in 12 and greater, nail every tile over solid sheathing with battens; perimeter nailing is necessary.

**TILES SET IN MORTAR**

The practice of installing cement tiles with mortar over a built-up subroof evolved in high-wind and high-moisture areas of the southeastern United States. In this system, the built-up subroof provides the moisture barrier, and the tiles protect the subroof from solar ultraviolet rays, high winds, and external damage. This concrete tile system can also be used on low-slope roofs, but the minimum is 2 in. in 12. On slopes between 5 in. in 12 and 7 in. in 12, additional mechanical fastening is required for the first three courses of tile in areas subject to high winds. For roofs with steeper slopes, tile should be mechanically fastened.

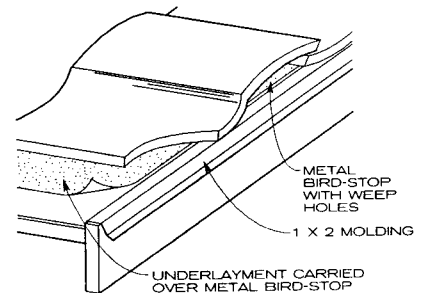

**TYPICAL ROLL TILES**

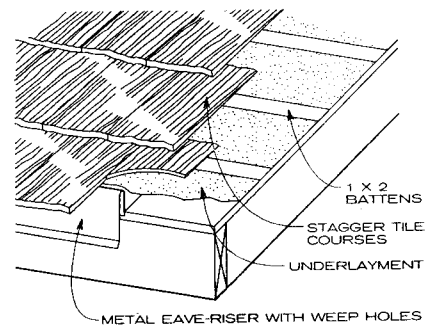

**NOTE**

This detail is for pitches 4:12 and greater.

**FIELD INSTALLATION OF FLAT TILES**

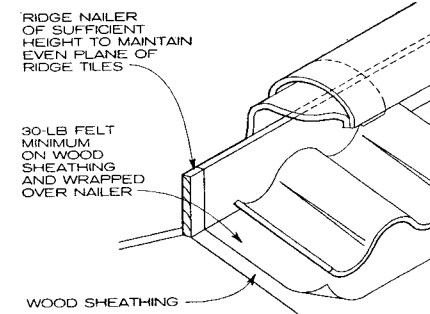

**HIP AND RIDGE DETAIL**

**ATTACHMENT PROCEDURES FOR CONCRETE ROOF TILES**

ROOF SLOPE	FIELD TILE NAILING		NAILING FOR PERIMETER TILE AND TILE ON CANTILEVERED AREAS <sup>1</sup>
	SOLID SHEATHING WITH BATTENS	SOLID SHEATHING WITHOUT BATTENS <sup>1</sup>	
3:12 to and including 5:12	Not required	Every tile	Every tile
Above 5:12 to less than 12:12	Every other tile	Every tile to 7:12	Every tile
12:12 and over	Every tile	N/A	Every tile

**NOTES**

1. For slopes exceeding 7:12, battens are required.
2. Perimeter nailing areas include three tile courses but not less than 36 inches from either side of hips or ridges and

from edges of eaves and gable rakes. In special wind areas designated by the building official, additional fastenings may be required.

National Roofing Contractors Association; Rosemont, Illinois  
Grace S. Lee; Rippeteau Architects, PC; Washington, D.C.

**7 SHINGLES, ROOF TILES, AND ROOF COVERING**

**COMPOSITE ROOFING TILES**

Fiber cement, cement wood, galvanized steel with acrylic coating, and ceramic slate roofing tiles are popular alternatives to clay or concrete roofing tiles. These composite tiles have been designed to be lighter, stronger, and easier to install than traditional, "natural" tiles. Their strength and combination of materials make them more fire retardant and wind resistant than conventional tiles.

**FIBER CEMENT**

Fiber cement tiles combine organic fiber with cement, silica, water, and other additives. The resulting product is a roof slate that is lightweight, strong, versatile, and easy to install. The tiles can be made in a variety of distinctive shapes, colors, and textures that mimic natural materials such as slate and patterned wood shingles. Fiber cement tiles resist deterioration and moisture penetration and are immune to pests and fungal growth. They are well-suited for coastal regions and other areas with high humidity.

Fiber cement tiles should be applied to nailable decks only. For plywood decks with rafters spaced 20 in. or less, the plywood should be at least 1/2 in. thick. If rafters are spaced greater than 20 in., 5/8 in. plywood is recommended. To fasten, use standard 1 1/2 in. galvanized 11-gauge flat-head roofing nails with a 3/8 in. head. Flashing should be of a noncorrosive metal not lighter than 28 gauge.

**CERAMIC SLATE**

Ceramic slate tiles combine the look of natural slate with the fired-in strength and durability of ceramic tile. Such tiles have the thickness, texture, and appearance of older slate but at a fraction of the weight and cost. They are impervious to freeze-thaw cycles, fire, moisture, and efflorescence.

**CEMENT WOOD TILES**

Cement wood tiles are lightweight tiles that can be used for reroofing as well as for new construction. They have excellent impact resistance and are easily sawn and nailed. As a richly textured, composite product, cement wood tiles create an aesthetic similar to that of heavy cedar shakes yet provide the fire protection associated with cementitious products. Cement wood tiles, with their composite of portland cement and wood fiber, are long lasting. The portland cement is noncombustible and allows for Class A fire ratings, and the wood fibers provide excellent tensile strength and a light weight when compared to standard concrete tiles.

**METAL ROOFING TILES**

The advantage of metal roofing tiles over traditional clay or concrete tiles is that they are lightweight. They are easier to handle, quicker to install, and, because they require fewer building components, are less costly. Minimum recommended roof pitch for use of metal roofing tiles is a slope of 3 in 12. Roofs with shallower slopes require sealant in all side laps.

Metal roofing tiles usually come in sheets and have a base material of roll-formed 24- to 26-gauge prepainted galvanized or galvalume steel. A layer of crushed and graded stone granules is bonded to the steel panels with an acrylic resin formula and then a clear acrylic overglaze is applied. Slow oven curing completes the process, and the underside of the tile is protected with a final coat of polyester paint. Panels can be installed quickly and are secured to either wood or steel battens, creating a strong, weather-proof construction. The panels can be installed directly over existing roofs, unlike clay or concrete tiles, and are thus ideally suited for retrofitting roofs.

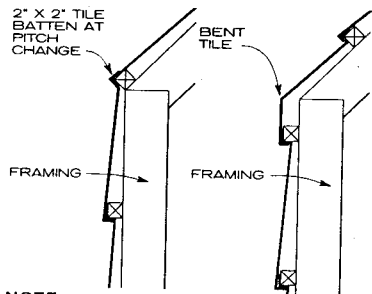

**NOTE**  
When an equal number of full courses cannot be accommodated at the pitch change, a full panel can be bent to suit. When the roofline changes dramatically, install a batten at the pitch change.

**METAL ROOFING AT PITCH CHANGE**

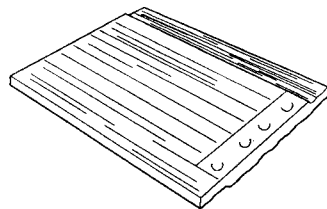

**BOTTOM RIBBED SIDE OF FIELD SHAKE**

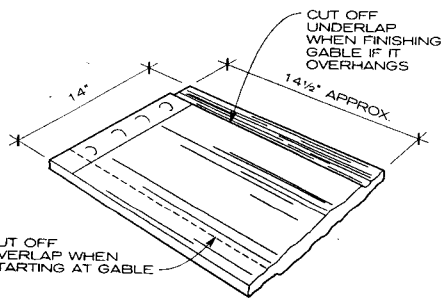

**TOP SIDE OF FIELD SHAKE  
CEMENT WOOD TILES**

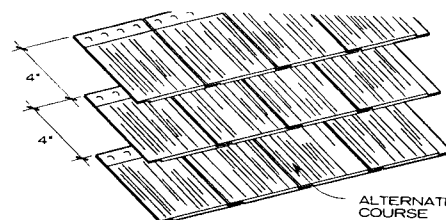

**CEMENT WOOD TILE LAYOUT**

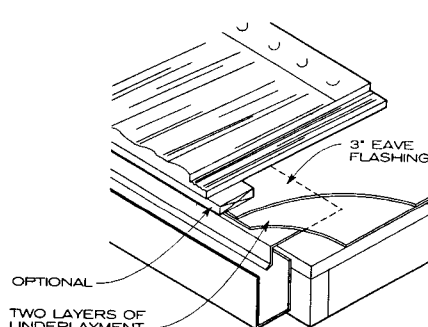

**OPTIONAL  
TWO LAYERS OF  
UNDERLAYMENT  
EAVE DETAIL**

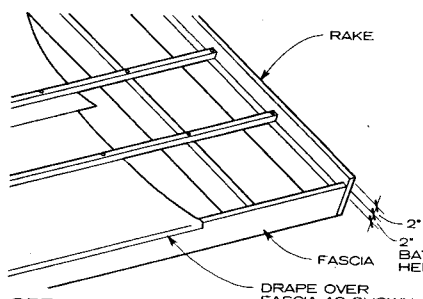

**OPEN RAFTER  
NOTE**

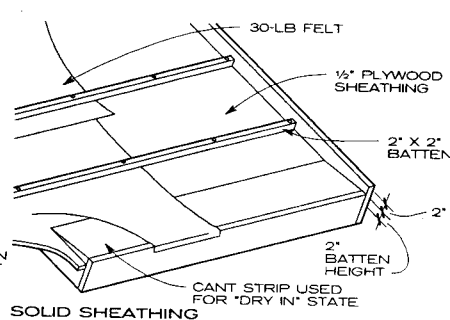

**SOLID SHEATHING**

Metal roofing panels can be applied directly over solid plywood sheathing or over open rafters if a self-supporting underlayment is used.

**METAL ROOFING TILE UNDERLAYMENT**

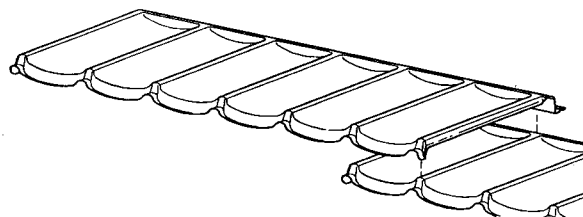

**VERTICAL LAP  
METAL ROOFING TILES**

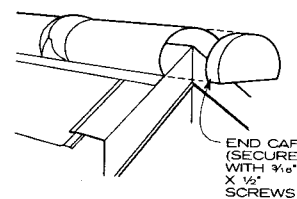

**RIDGE AT GABLE**

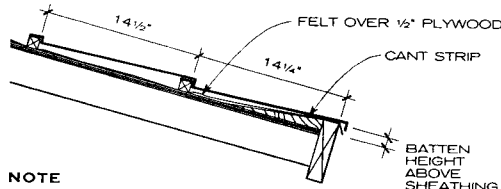

**NOTE**  
The fascia must be positioned above the roof deck sheathing or rafters by the height of the batten. The fascia becomes the first panel batten.

**SOLID SHEATHING AT EAVE**

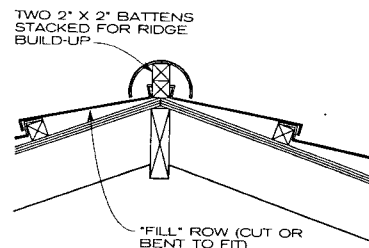

**SOLID SHEATHING RIDGE DETAIL**

**METAL ROOFING DETAILS AT EAVE AND RIDGE**

Grace S. Lee; Rippeteau Architects, PC; Washington, D.C.

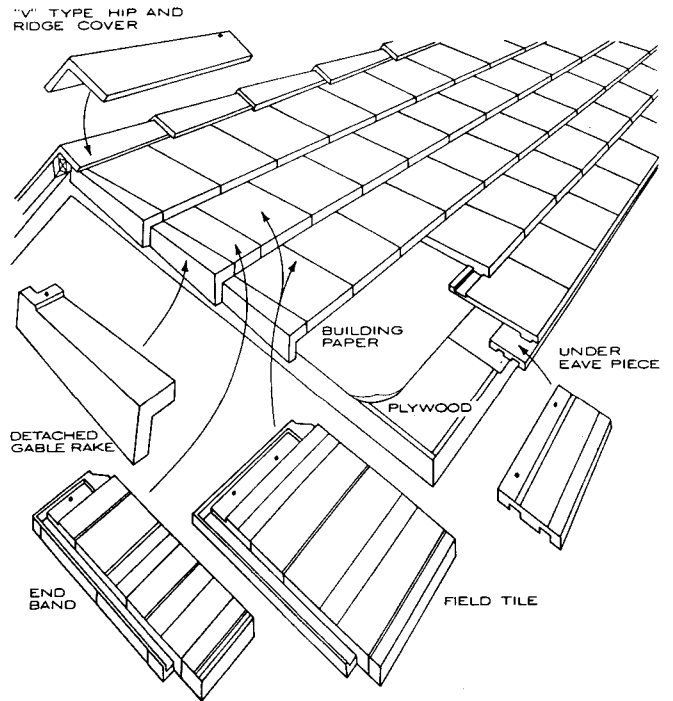
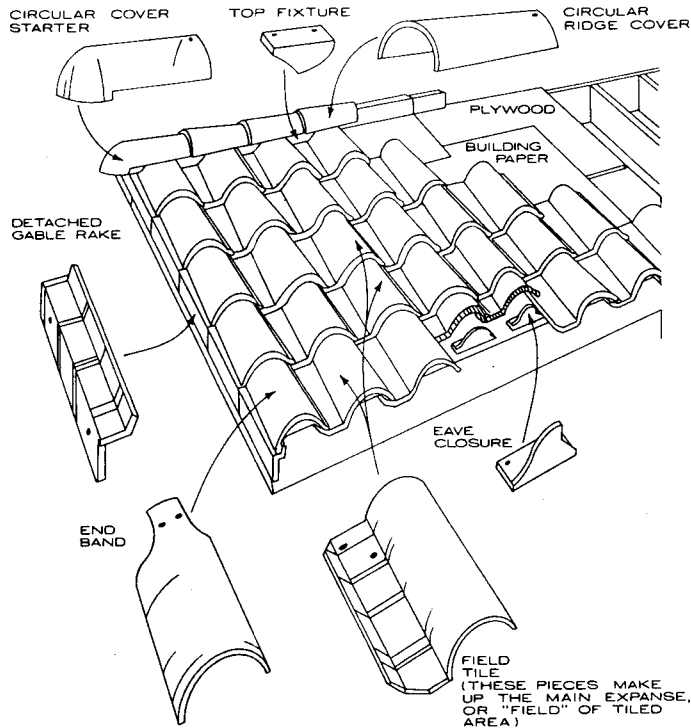

**SPANISH TILE**

TYP. FIELD TILE IS 13 1/2" LONG AND 9 3/4" WIDE. WHEN INSTALLED, EXPOSED LENGTH AVERAGES 10 1/4". WIDTH 8 1/4". ONE SQUARE OF TILES WEIGHS ABOUT 900 LBS. ROOF SLOPE SHOULD BE NOT LESS THAN 4" IN 12"

**FLAT INTERLOCKING**

FIELD TILES ARE 14" LONG AND 9" WIDE. INSTALLED, EXPOSED LENGTH = 11" WIDTH = 8 1/4". ONE SQUARE WEIGHS ABOUT 800 LBS. ROOF SLOPE: 4" IN 12" MIN. ANCHOR TILES WITH NONCORROSIVE NAILS.

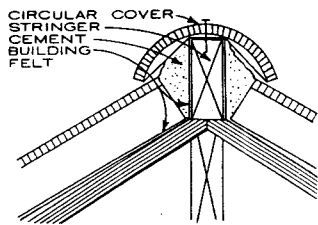

HIP SECTION

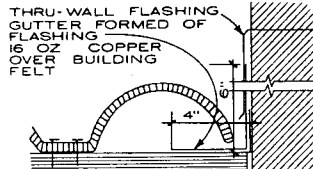

FLASHING UNDER TILE WHERE ROOF SLOPES PAST WALL

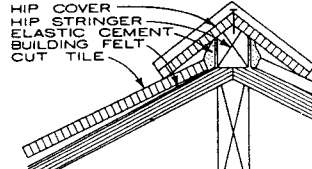

THE HIP ANGLE IS FLATTER THAN THE ANGLE OF THE "V" TYPE COVER HIP SECTION

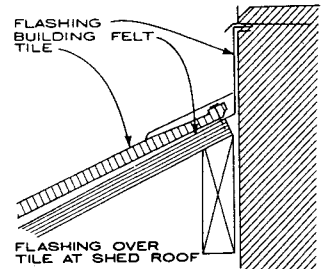

FLASHING OVER TILE AT SHED ROOF

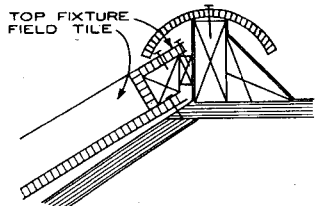

FLAT ROOF MEETS SLOPE TILES

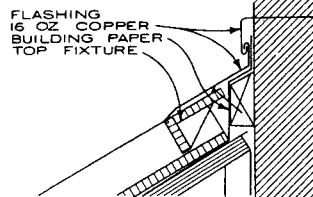

FLASHING OVER TILE AT SHED ROOF

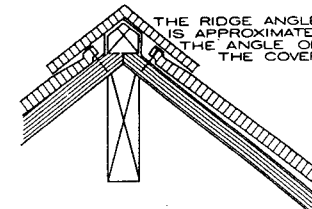

RIDGE SECTION

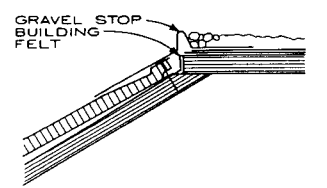

FLASHING OVER TILE AT FLAT ROOF

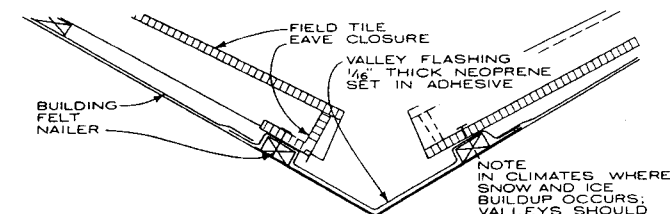

VALLEY SECTION / CONCRETE ROOF

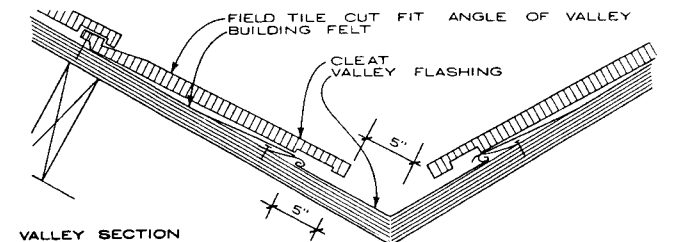

VALLEY SECTION

Darrel Downing Rippeteau, Architect; Washington, D.C.

**7 SHINGLES, ROOF TILES, AND ROOF COVERING**

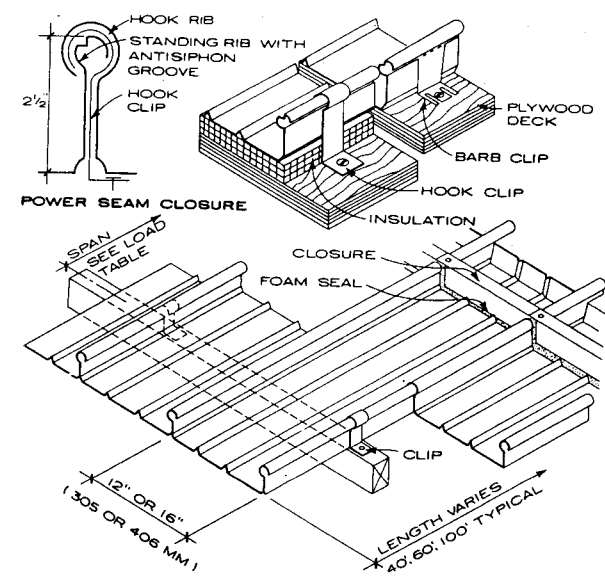
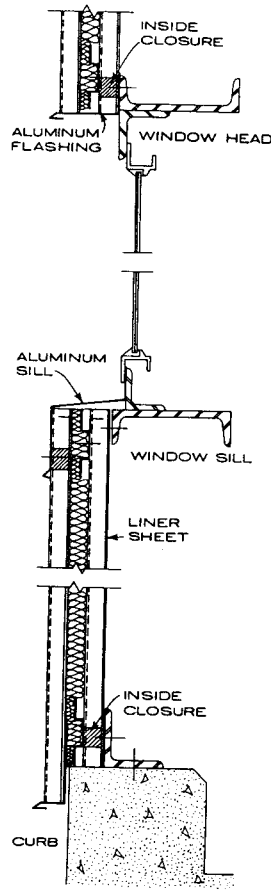
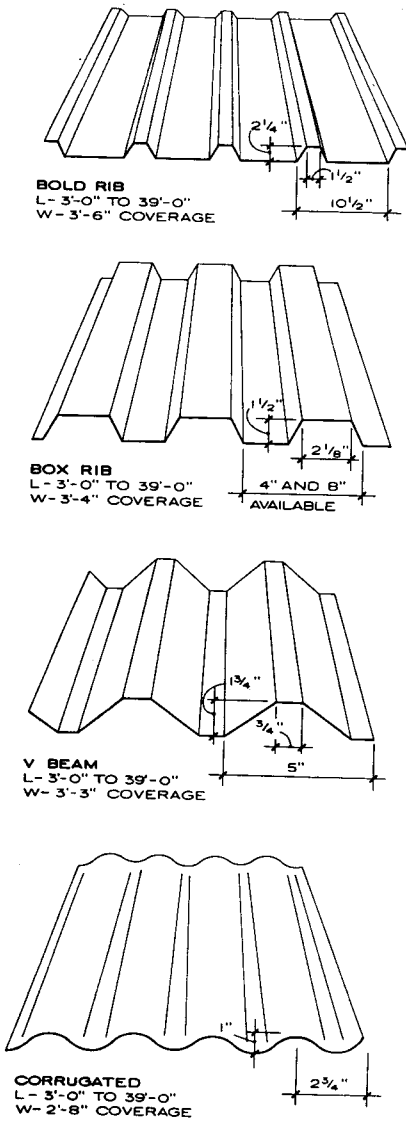

**STANDING SEAM ALUMINUM ROOFING**

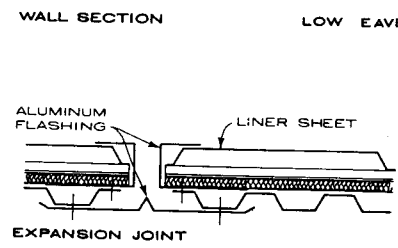
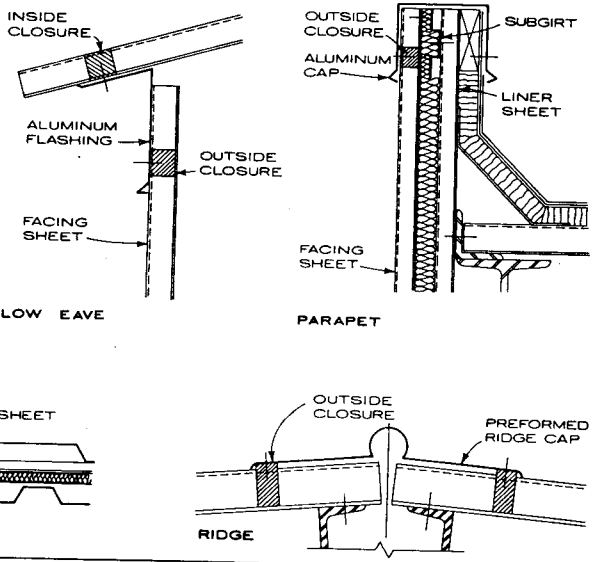

**FORMED ALUMINUM ROOFING AND SIDING**

- NOTES**
1. Endlaps for roofing and siding shall be at least 6 in. and fastened at every rib. Two fasteners may be required when designing for a negative (uplift) loading condition.
  2. Minimum sidelaps shall be equal to one rib or corrugation and laid away from prevailing wind. Fasteners shall be spaced a maximum of 12 in. on center for all types of roofing and siding.
  3. For roofing, fasteners shall pierce only the high corrugation. For siding, fasteners shall pierce either the high or low corrugation. Consult manufacturer for proper sheet metal fasteners and accessories.
  4. Minimum slopes for sheet roofing are as follows:
    - a. 1 in. depth corrugated—3 in 12.
    - b. 1 1/2 in. depth ribbed—2 in 12.
    - c. 1 3/4 in. v-corrugated—2 in 12.
  5. See page on Metal Walls for insulation details and fire rated wall assemblies.

**MAXIMUM SPAN TABLE FOR FORMED ALUMINUM ROOFING AND SIDING (IN.)**

DESIGN LOAD (PSF)	BOLD RIB		4" BOX RIB		V BEAM		CORRUGATED		STANDING SEAM	
	0.032 IN. THICK	0.040 IN. THICK	0.032 IN. THICK	0.040 IN. THICK	0.032 IN. THICK	0.040 IN. THICK	0.032 IN. THICK	0.040 IN. THICK	0.032 IN. THICK	0.040 IN. THICK
20	95	123	100	120	131	151	90	98	103	124
30	77	100	82	98	107	124	73	80	86	104
40	67	87	71	85	92	107	64	69	77	92
50	60	76	63	76	83	96	57	62	70	83

NOTE: Values are based on uniform positive (downward) and walking loads on single span only.

John A. Schulte; Hellmuth, Obata & Kassabaum, Inc.; St. Louis, Missouri

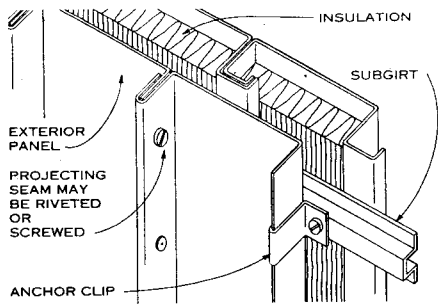

TYPICAL INSULATED FIELD-ASSEMBLED SYSTEMS

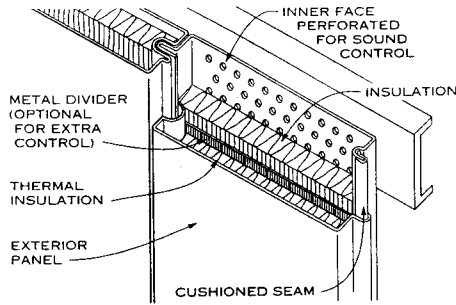

ACOUSTICAL

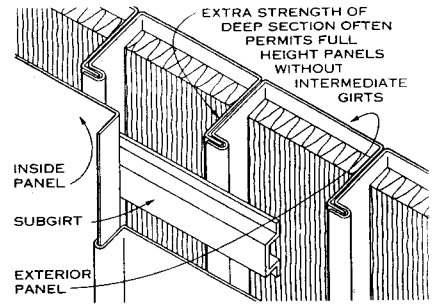

EXTRA RIGID

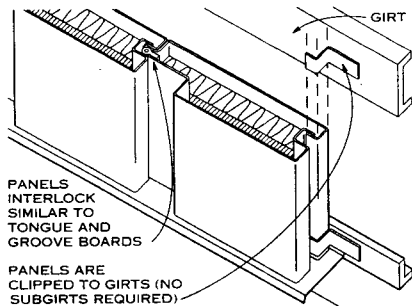

TYPICAL INSULATED FACTORY-ASSEMBLED SYSTEMS

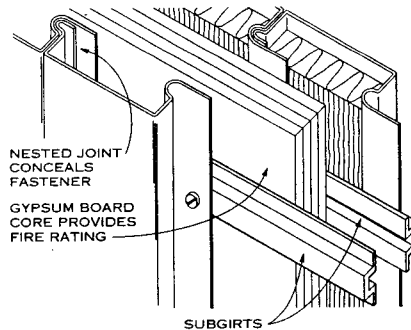

FIRE-RATED

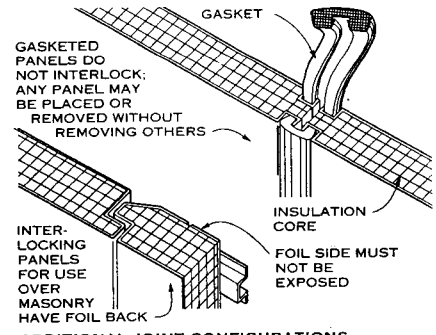

ADDITIONAL JOINT CONFIGURATIONS

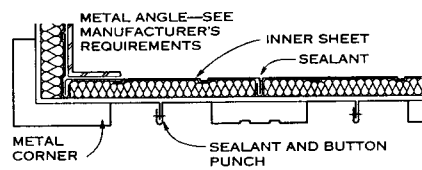

OUTSIDE CORNER

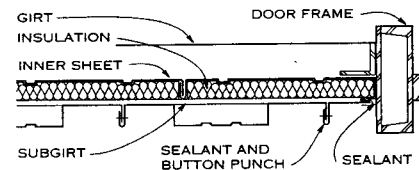

JAMB AT DOOR

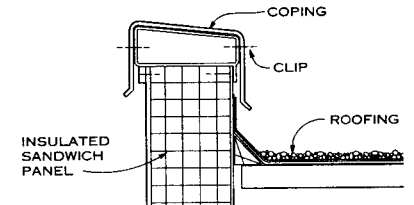

COPING

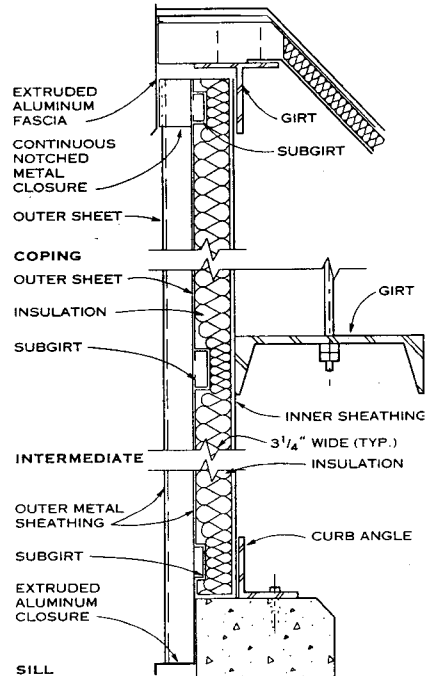

FIELD-ASSEMBLED INSULATED METAL WALLS

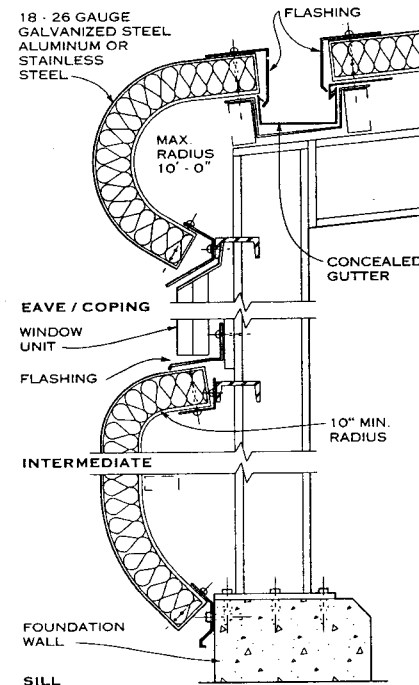

FACTORY-FORMED, FIELD-ASSEMBLED INSULATED METAL

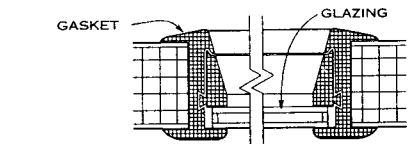

GASKETED WINDOW PREDESIGNED DETAILS

NOTES

Shown here are basic panel designs with an assortment of connection details. A vast array of folded, ribbed, and grooved sheet configurations is available.

Typical applied finishes available for outer sheets are acrylics, vinyls, alkyds, fluoropolymers, porcelain enamel, and, on aluminum only, various anodized finishes. Length of sheets available is 40 ft. Span and wind load must be considered in the selection of panel components and spacing of girts.

Panels can span from 9 ft 6 in. to 26 ft or more if placed in multispan arrangements. Face panel configuration and wind load value vary.

Consult manufacturers for thermal and acoustical ratings.

Eric K. Beach; Rippeteau Architects, PC; Washington, D.C.

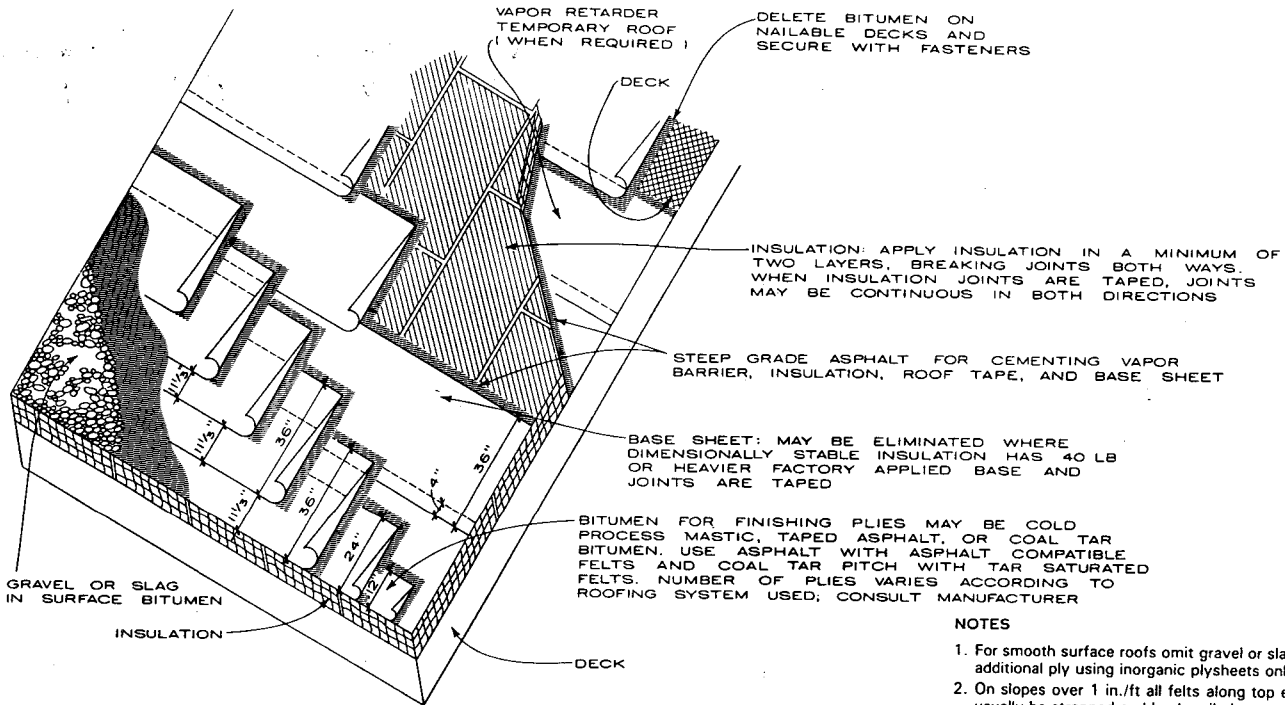

**NOTES**

1. For smooth surface roofs omit gravel or slag and add additional ply using inorganic plysheets only.
2. On slopes over 1 in./ft all felts along top edge must usually be strapped and back-nailed.
3. When vapor retarder is used, edges of felt should be turned up to a height of 2 in. above cant strip at vertical surfaces. Felts should overlap all roof edges a minimum of 6 in. before application of roofing. 6 in. of felt must be re-turned over the insulation and mopped solidly.

20 YEAR TYPE BUILT-UP ROOF OVER INSULATION

**NOTES**

1. Over nonnailable deck or insulation omit rosin paper and cement with asphalt. Nailing strips must be provided.
2. Minimum slope for organic felt: 1/2 in./ft.
3. Minimum slope for fiberglass felt: 0 in./ft.
4. Consult manufacturer for spacing of nails for particular roofing system.

**SCHEDULE OF FELT OVERLAP (INCHES)**

Organic base sheet	4
Fiberglass or base sheet	2
2-ply felts/plysheets	19
3-ply felts/plysheets	24 <sup>2/3</sup>
4-ply felts/plysheets	27 <sup>1/2</sup>
Fiberglass mineral	3 if selvage granulated
Surface cap sheet	2 if selvage granulated

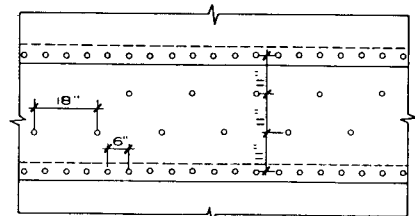
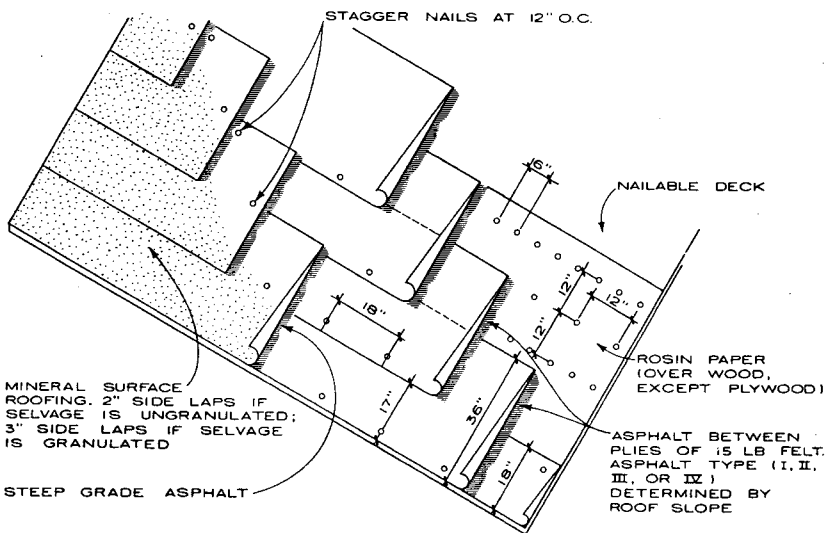

PATTERN FOR NAILING BASE SHEET OR VAPOR RETARDER OVER NAILABLE DECK

MINERAL SURFACE BUILT-UP ROOF

Kent Wong; Hewlett, Jamison, Atkinson & Luey; Portland, Oregon;  
 Developed by Angelo J. Forlidas, AIA; Charlotte, North Carolina; from data furnished by Robert M. Stafford, P.E., Consulting Engineer; Charlotte, North Carolina

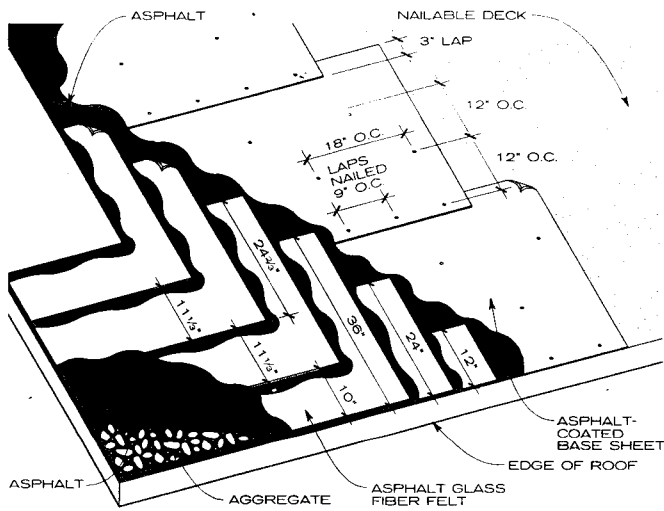

**THREE-PLY OVER NAILABLE DECK**

- NOTES**
1. If applied over sheathing panels, add rosin-sized sheathing paper between the deck and base sheet.
  2. In lieu of asphalt, coal tar is an acceptable product.

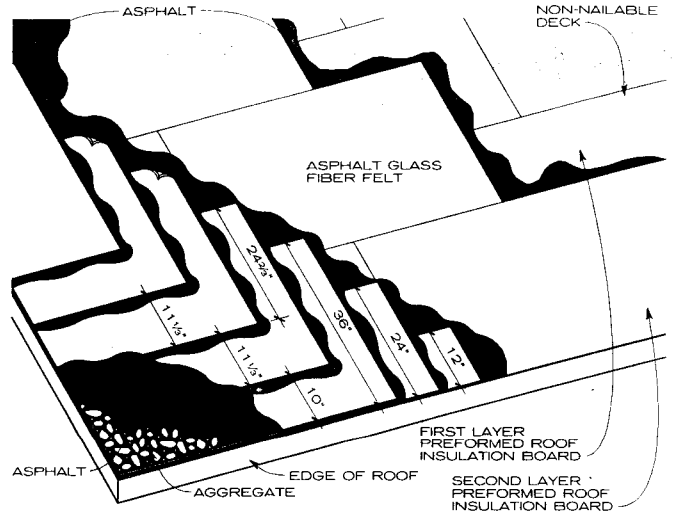

**THREE-PLY OVER NON-NAILABLE DECK**

- NOTES**
1. For a more conservative system, specify four plies rather than three.
  2. In lieu of asphalt, coal tar is an acceptable product.

**AGGREGATE SURFACE BUILT-UP ROOFING**

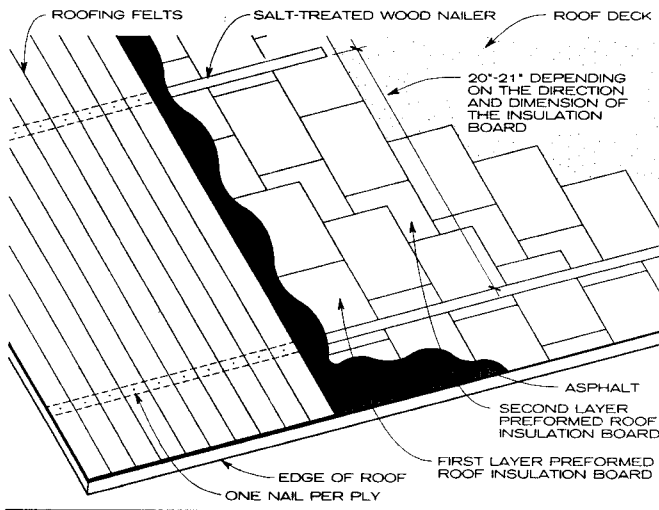

**WOOD NAILER BACKNAILING SYSTEM**

**GENERAL**

A built-up roofing (BUR) system is composed of a base sheet attached to the roof substrate, two or more reinforcing felt ply sheets, and a surfaced cap sheet. Asphalt and coal tar are the bitumens used for built-up roofing. As the heated mopping bitumen fuses with the saturating bitumen in the roofing felts, the layers are welded together. Surfacing include aggregate, minerals, protective or reflective coatings, and smooth surface.

Four types of asphalt and two types of coal tar are presently used as bitumens in built-up roofing systems. The grade of asphalt used for BUR systems should be appropriate for the slope of the roof. Backnailing of felts is recommended for built-up roofing whenever the roof slope exceeds 1/2 in. per ft. Aggregate-surfaced built-up roofing should not be used on slopes exceeding 3 in. per ft.

Reinforcing felts for BUR may be saturated, coated, or impregnated with bitumen and are manufactured from both organic and inorganic materials. Organic felts are manufactured from the fiber of paper, wood, or rags. Saturated felts are saturated with asphalt or coal tar bitumen. Impregnated roofing felts are generally lighter in weight and termed impregnated because their surface is not completely covered (coated) with asphalt. Saturated and coated roofing felts are generally factory coated on both sides and sur-

faced on one or both sides with fine mineral sand or other release agents to prevent adhesion inside the roll prior to application.

Prepared roofing materials are saturated and coated felts with talc, mica, sand, or ceramic granules incorporated into the weather surface of the felts, both to provide weather protection and for decorative purposes. Reinforced flashing membrane consists of a glass-fiber base felt that is laminated with cotton or glass-fiber fabric and coated with asphalt. Rosin-sized sheathing paper is a rosin-coated building paper generally used in built-up roofing to separate felts from wood plank roof decks.

**TEMPERATURE**

Proper application temperatures are vital to the creation of a quality roof membrane system. Temperatures that are too high can lead to incomplete coverage, voids, and a lack of waterproofing qualities. Temperatures that are too low can lead to poor adhesion, high expansion properties, and low tensile strength.

Bitumens can be heated at high temperatures for short periods of time without damage and must be heated at

high temperatures in order to achieve complete fusion and strong bonding of the plies. There is an optimum viscosity range and an optimum temperature range at the point of application that allow complete fusion, optimum wetting and mopping properties, and the desirable interply bitumen weight. The equiviscous temperature (EVT) is defined as the temperature at which the viscosity of roofing asphalt is 125 centistokes, plus or minus 25°F, at the mop bucket or felt layer immediately prior to application to the substrate. A centistoke is a unit that measures the kinematic viscosity.

Centistokes = [Dynamic Viscosity/Density] x Centipoise

The recommended EVT range for roofing asphalt, Types I, II, III, and IV, is the temperature at which a viscosity of 75 centipoise is attained, plus or minus 25°F. The recommended EVT range for coal tar products, types I and III, is the temperature at which a viscosity of 25 centipoise is attained, plus or minus 25°F. One consequence of a change in EVT from 125 centistokes to 75 centipoise, plus or minus 25°F, is the potential need to increase the temperature at which bitumen is heated in the kettle or tanker. Excessive and prolonged heating of asphalt and coal tar products may have a deleterious effect on the quality of the product.

**COAL TAR TYPES**

ASTM D-450 TYPE NO.	KIND OF COAL TAR	SOFTENING POINT (°F)	
		MIN.	MAX.
I	Coal-tar pitch	126	140
II	Waterproofing pitch	106	126
III	Coal-tar bitumen	133	147

**ASPHALT TYPES**

TYPE	KIND OF ASPHALT	SOFTENING POINT (°F)		MAX. TEMP. (°F)
		MIN.	MAX.	
I	Dead level asphalt	151	135	475
II	Flat asphalt	176	158	500
III	Steep asphalt	205	185	525
IV	Special steep asphalt	225	210	525

National Roofing Contractors Association; Rosemont, Illinois  
Valerie Eickelberger; Rippeteau Architects, PC; Washington, D.C.

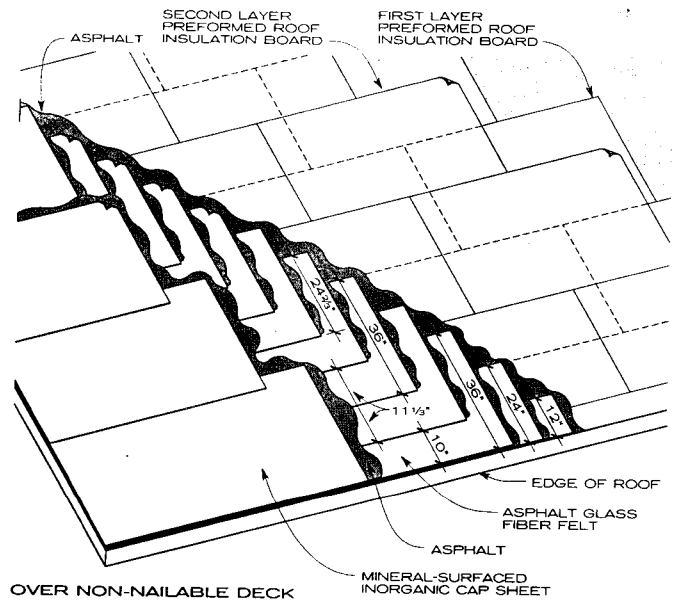
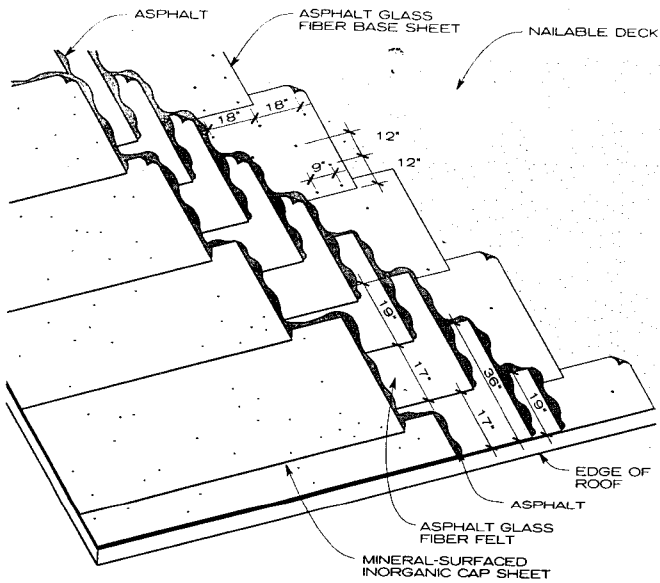

**OVER NAILABLE DECK NOTE**

If applied over nailable deck sheathing panels, add a rosin-sized sheathing paper between the deck and base sheet.

**MINERAL-SURFACED CAP SHEET BUILT-UP ROOFING**

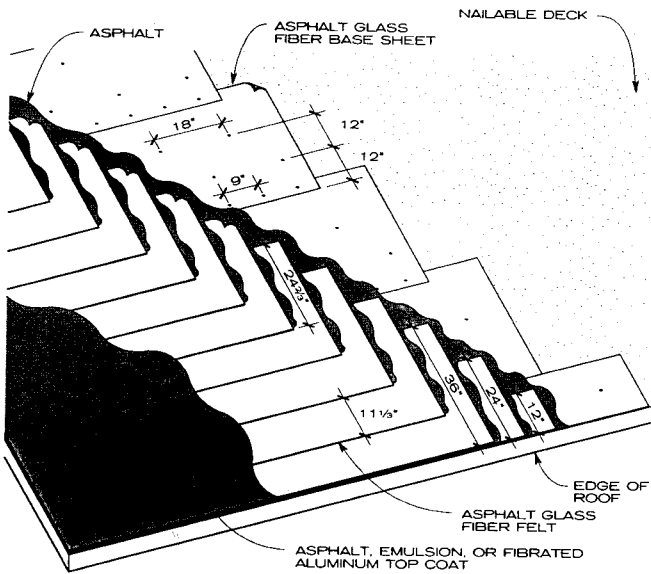

**THREE-PLY OVER NAILABLE DECK NOTE**

If applied over sheathing panels, add a rosin-sized sheathing paper between the deck and base sheet.

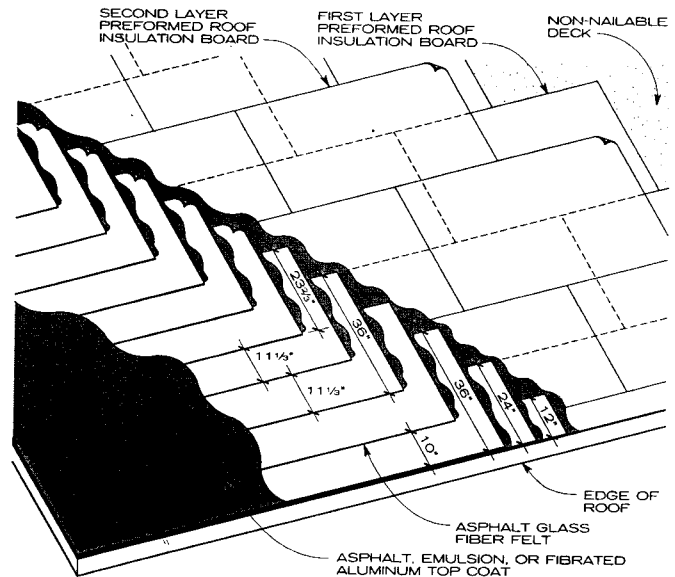

**THREE-PLY OVER NON-NAILABLE DECK**

**NOTE**

For a more conservative system, specify four plies rather than three.

**SMOOTH SURFACE BUILT-UP ROOFING**

**BUILT-UP ROOF SURFACING**

Surfacing protects the bitumen and felts of a built-up roof from direct sunlight and weather exposure, and may provide other properties such as fire resistance or reflectivity. Surfacing types include aggregate, smooth surfacing, and mineral cap sheet.

**AGGREGATE SURFACING**

The aggregate in roofing serves as an opaque covering that improves the appearance and fire resistance of the roof and helps resist premature aging and damage from weather, temperature fluctuations, and ultraviolet rays. Aggregate also increases the wind uplift resistance of the roof mem-

brane and permits much heavier pourings of bitumen than would otherwise be possible.

**SMOOTH SURFACING**

Built-up roof membranes may be left smooth, surfaced with a top coating of hot asphalt. Smooth surfacing should not be confused with a built-up membrane left unsurfaced (exposed felts). Smooth surfaced built-up roofing should be specified only in those circumstances where aggregate-surfaced built-up roofing is impractical, such as when the roof surface exceeds 3 in. per ft, where the proximity of an air-intake or exhaust equipment may cause loose aggregate, or where appropriate aggregate is not available.

**MINERAL SURFACED (CAP SHEET)**

Some areas of the country, particularly the far western and southern states, use mineral-surfaced cap sheets as the final surfacing for built-up roofing membranes. These specifications are similar to aggregate and smooth-surfaced specifications except that a final layer of prepared roofing material is installed on top of the multiply built-up roof assembly. This specification is not popular in colder climates, primarily because it requires phased construction of the final layer of roofing material.

National Roofing Contractors Association; Rosemont, Illinois  
Valerie Eickelberger; Rippeteau Architects, PC; Washington, D.C.



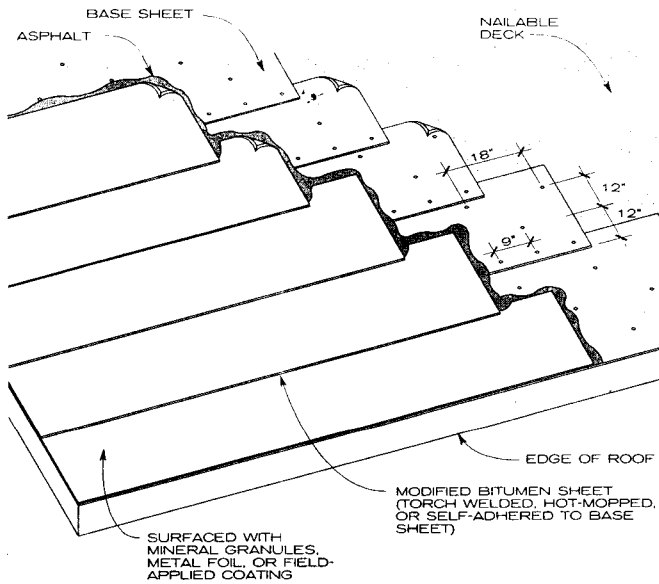

TWO-PLY OVER NAILABLE DECK

**NOTE**

If applied over-sheathing panels when the cap sheet is hot-mopped, add a rosin-sized sheathing paper between the deck and base sheet.

**TWO-PLY MODIFIED BITUMEN MEMBRANE**

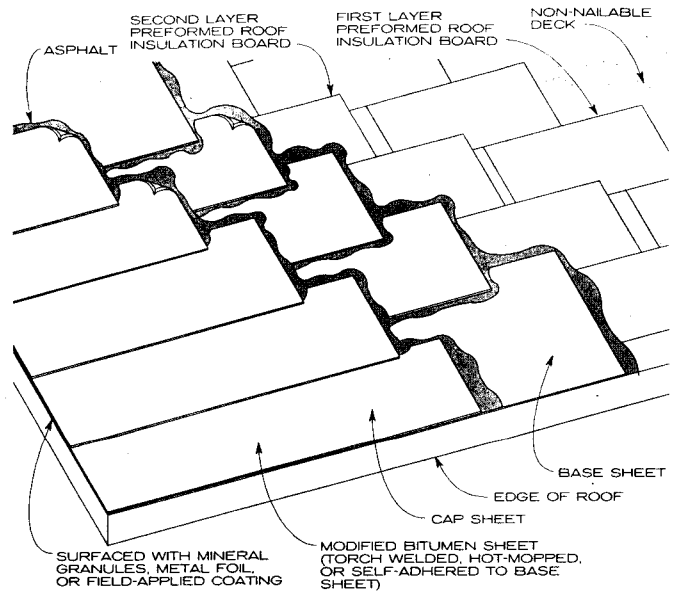

TWO-PLY OVER NON-NAILABLE DECK

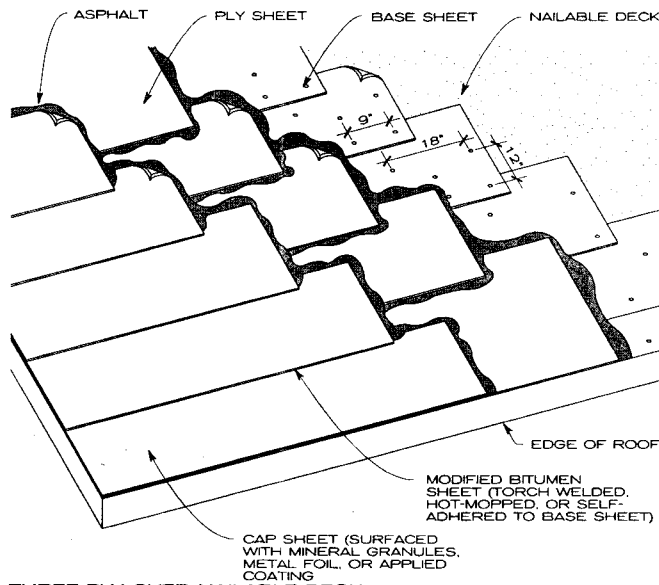

THREE-PLY OVER NAILABLE DECK

**NOTE**

If applied over-sheathing panels when the cap sheet is hot-mopped, add a rosin-sized sheathing paper between the deck and base sheet.

**THREE-PLY MODIFIED BITUMEN MEMBRANE**

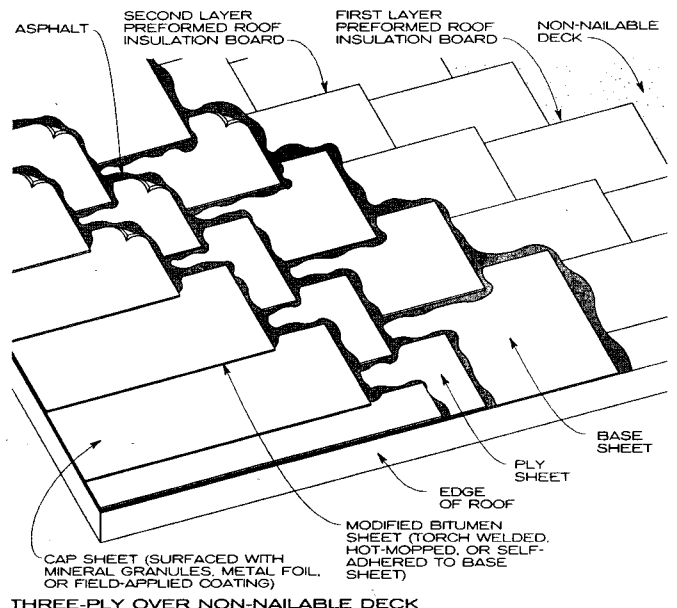

THREE-PLY OVER NON-NAILABLE DECK

**MODIFIED BITUMEN MEMBRANES**

Polymer-modified bitumen membranes couple bitumen and polymers with various reinforcements to form a membrane system with improved properties. Modifiers include atactic polypropylene, styrene-butadiene-styrene, and styrene-butadiene-rubber. The modifying compounds impart improved flexibility, cohesive strength, toughness, and resistance to flow at high temperatures. The seams are sealed by torch welding or with hot asphalt. Thickness ranges from 40 to 160 mils.

For some systems a base sheet is fastened to the deck as an underlayment. In the hot-mopped system, the membrane is constructed similar to a built-up roof with hot asphalt mopped between the plies. Self-adhered sheets have a factory-applied asphalt-adhesive coating on the underside. The protective sheet is peeled away to stick the membrane to the roof deck. Torch-applied membrane systems have a factory-applied coating of modified asphalt on the underside of the sheet, which is melted with a propane torch to make the sheet adhere.

Reinforcing materials for polymer modified bitumen membranes include plastic film, polyester mat, glass fiber, felt or fabric, and metal foils, embedded within or laminated onto the modified bitumen sheet. Membranes may be surfaced with liquid coatings, metallic laminates, or ceramic or mineral granules to enhance resistance to weathering, ultraviolet rays, or fire or to improve appearance. Terminations at roof edges, parapets, and other flashings may be torch-applied, hot-mopped, or self-adhered. Laps are formed as the sheet is being applied.

National Roofing Contractors Association; Rosemont, Illinois  
Valerie Eickelberger; Rippeteau Architects, PC; Washington, D.C.

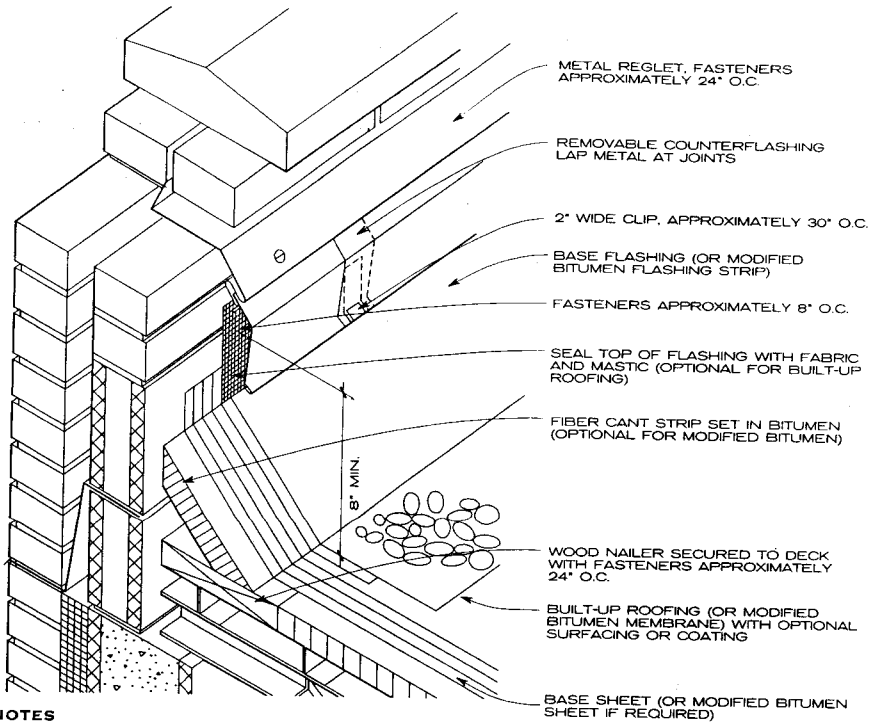

- NOTES**
1. This detail should be used only when the deck is supported by the wall.
  2. The joints in the two pieces of flashing should not be soldered. Breaks in soldered joints could channel water behind the flashing. Clips at the bottom of the flashing are not necessary on flashings of 6 in. or less.

**BASE FLASHING FOR WALL-SUPPORTED DECK**

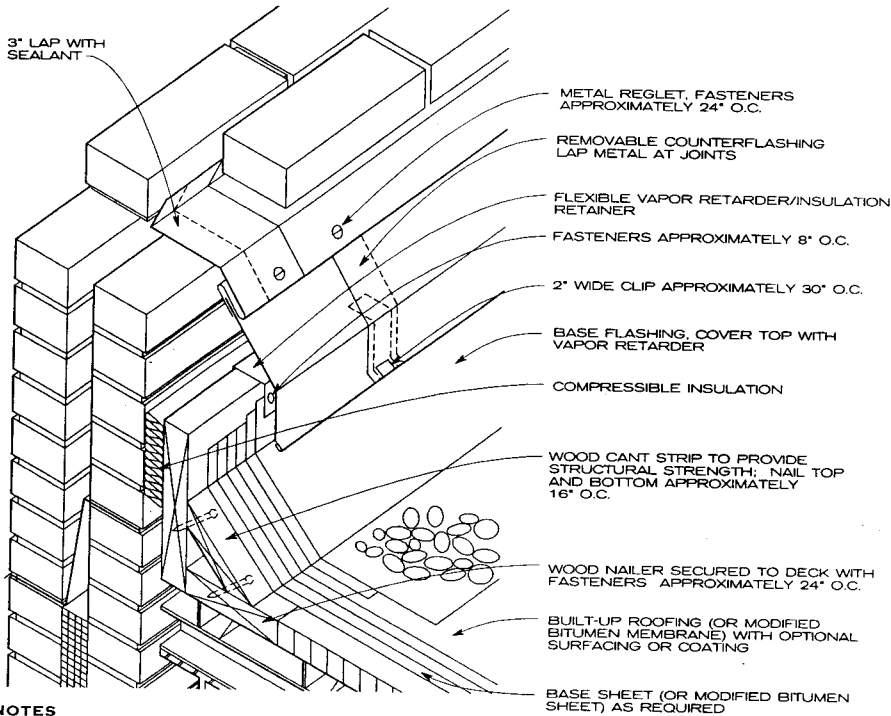

- NOTES**
1. This detail allows wall and deck to move independently.
  2. This detail should be used where there is any possibility that differential movement will occur between the deck and a vertical surface, such as at a penthouse wall. The vertical wood member should be fastened to the deck only. This is one satisfactory method of joining the two-piece flashing system. Other methods may be used.

**BASE FLASHING FOR NON-WALL-SUPPORTED DECK**

National Roofing Contractors Association; Rosemont, Illinois  
 Valerie Eickelberger; Rippeteau Architects, PC; Washington, D.C.

**GENERAL**

In general, the details for installation of bitumen roofing, whether built-up roofing or modified bitumen roofing, are similar in many respects. Details for both types of roofing are included where applicable. The details show typical conditions that occur at bitumen roofs, such as roof edge conditions, piping penetrations, and equipment supports.

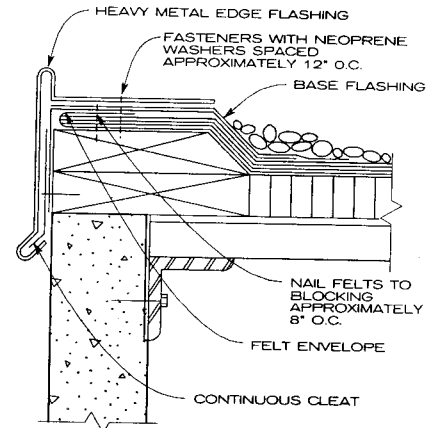

**HEAVY METAL ROOF EDGE**

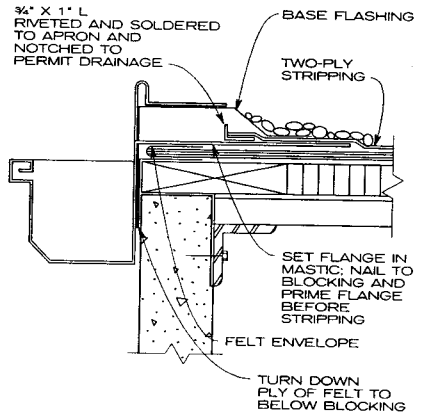

**SCUPPER THROUGH ROOF EDGE**

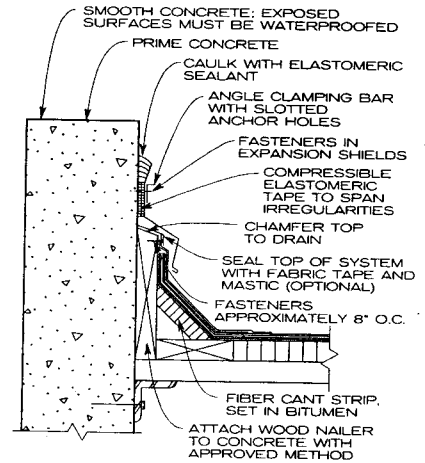

**COUNTERFLASHING CONCRETE PARAPET**

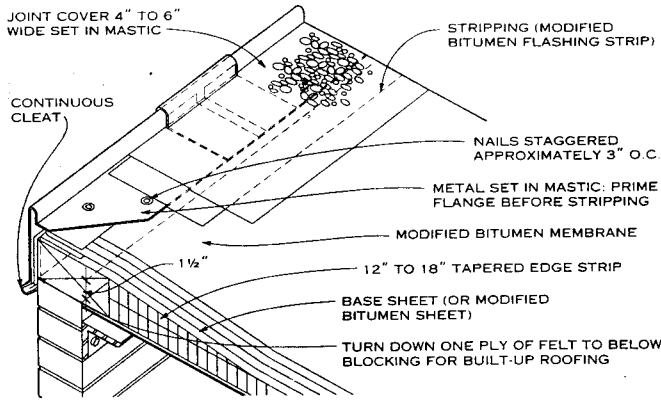

**NOTES**

1. Envelope shown is for coal tar pitch and low-slope asphalt.
2. Attach nailer to masonry wall.
3. This detail should be used only where the deck is supported by the outside wall.
4. This detail should be used with light-gauge metals, such as 16 oz. copper, 24-gauge galvanized metal, or 0.040 in. aluminum. A tapered edge strip is used to raise the gravel stop. Frequent nailing is necessary to control thermal movement.
5. Wood blocking may be slotted for venting where required.

**GRAVEL STOP**

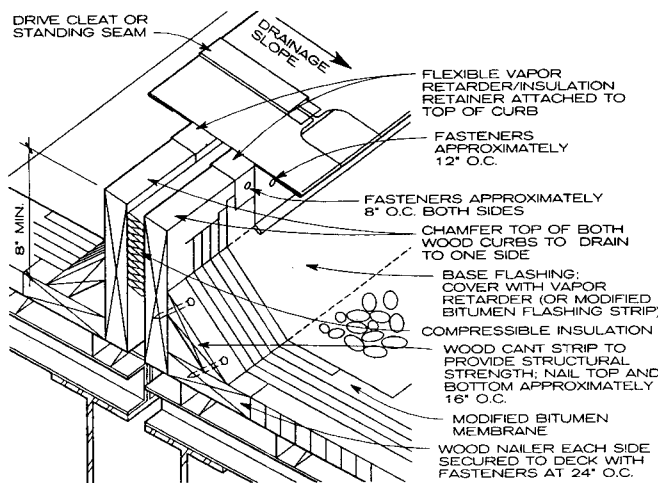

**EXPANSION JOINT**

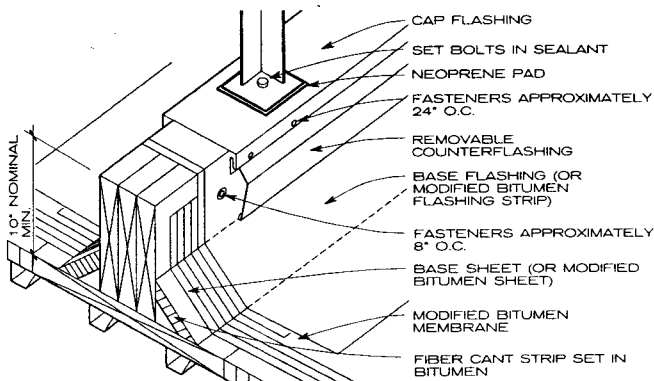

**NOTE**

This detail allows for roof maintenance around the equipment support. Continuous support is preferred in lightweight roof systems because equipment weight can be spread over two or more supporting members. Clearance must be provided for removal and replacement of roofing and flashing between parallel supports.

**EQUIPMENT SUPPORT ON LIGHT ROOF DECK**

National Roofing Contractors Association; Rosemont, Illinois  
Valerie Eickelberger; Rippeteau Architects, PC; Washington, D.C.

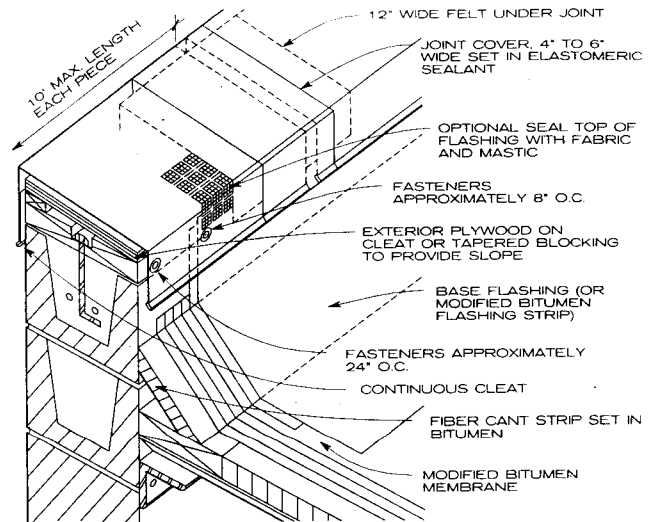

**NOTE**

This detail should be used only when the deck is supported by the wall. An expansion joint detail should be used for a deck not supported by a wall.

**LIGHT METAL PARAPET CAP**

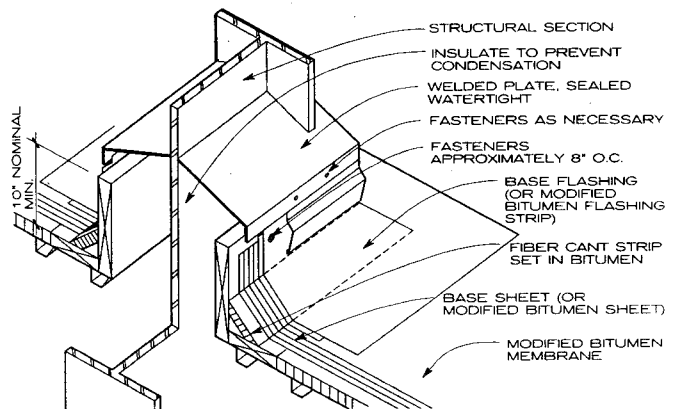

**NOTE**

This detail illustrates one method of eliminating pitch pockets. The curbed system allows for movement in the structural member without disturbing the roof system.

**STRUCTURAL MEMBER THROUGH ROOF**

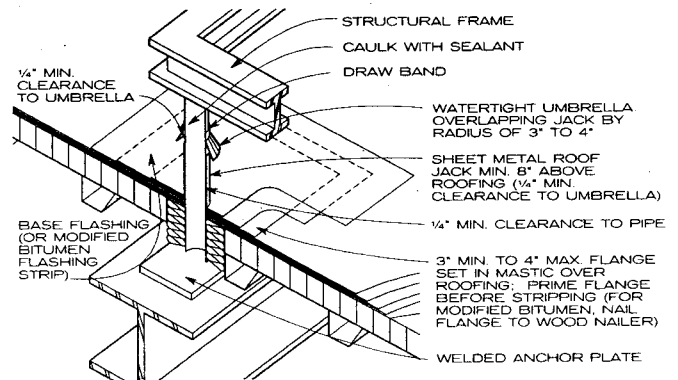

**NOTE**

This detail depicts site-fabricated construction. Many manufacturers now offer prefabricated flashing pieces or permit the use of materials for flashing purposes other than those shown here. Proprietary designs vary widely; consult individual manufacturers about use.

**INSULATED DECK STEEL FRAME SUPPORT**

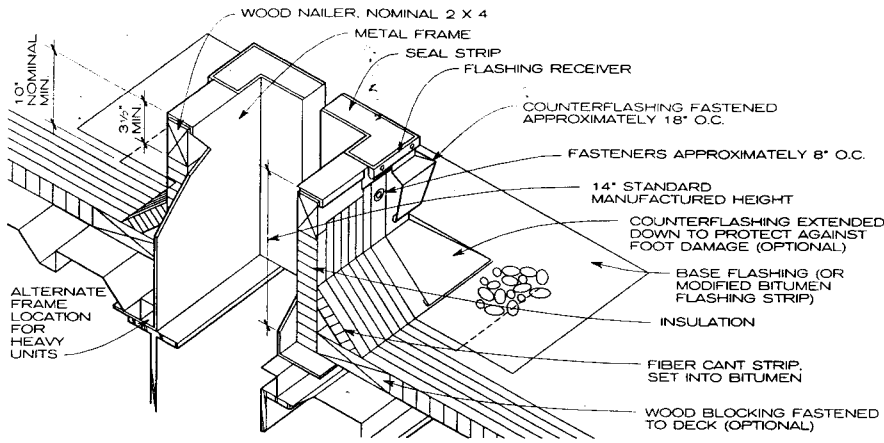

**EQUIPMENT CURB**

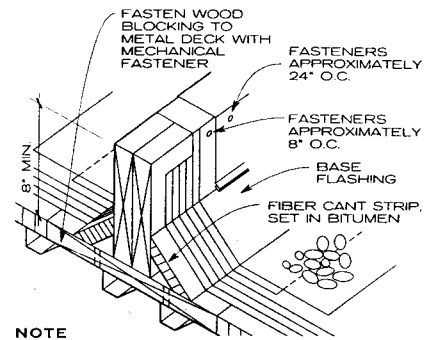

**NOTE**

An area divider is designed simply as a raised double wood member attached to a properly flashed wood base plate that is anchored to the roof deck. Area dividers should be located between the roof's expansion joints at 150 to 200 ft intervals, depending upon climatic conditions and area practices. They should never restrict the flow of water.

**AREA DIVIDER**

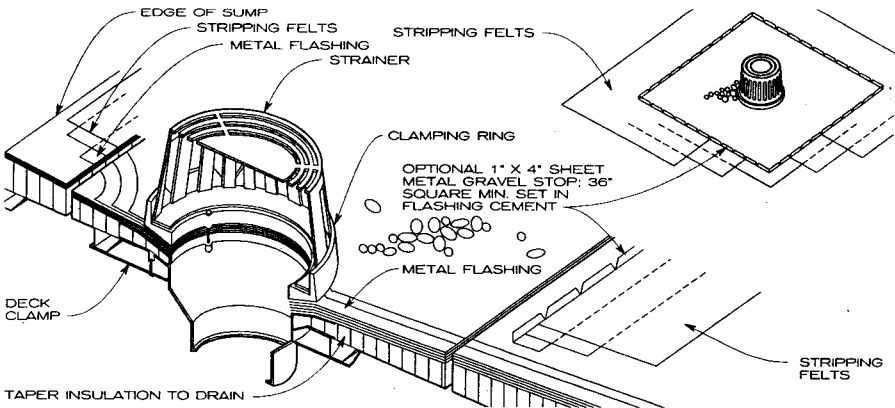

**NOTES**

1. Minimum 30 in. square, 2 1/2 to 4 lb lead or 16 oz soft copper flashing set on finished roof felts set in mastic. Prime top surface before stripping.
2. Membrane plies, metal flashing, and flash-in plies extend under the clamping ring.
3. Stripping felts extend 4 in. and 6 in. beyond edge of flashing sheet, but not beyond edge of sump.
4. The use of metal deck sump pans is not recommended.

**ROOF DRAIN**

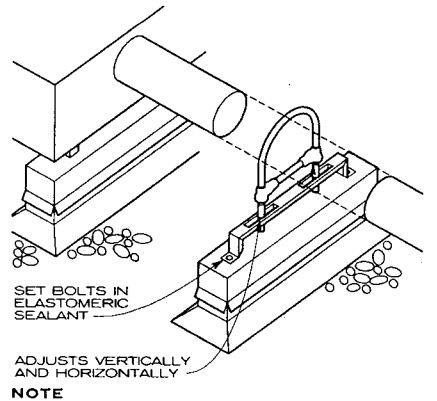

**NOTE**

This detail allows for expansion and contraction of pipes without roof damage.

**PIPE ROLLER SUPPORT**

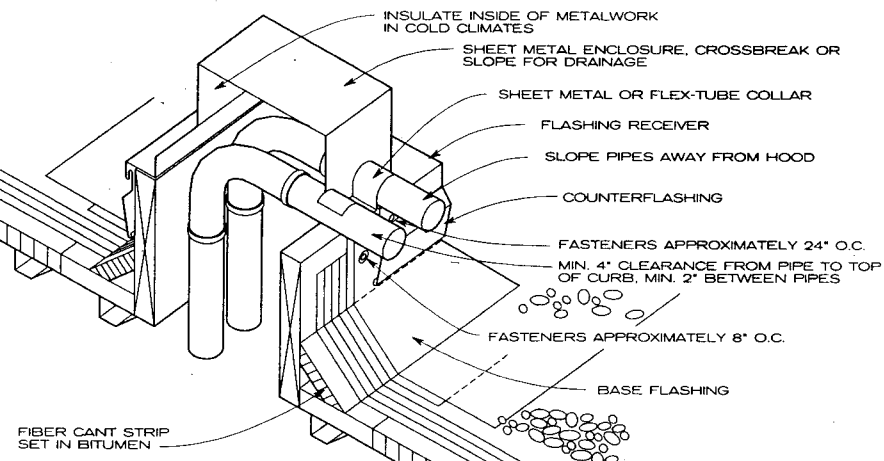

**NOTE**

This detail illustrates another method of eliminating pitch pockets and a satisfactory method of grouping piping that must come up above the roof surface.

**MULTIPLE PIPE PENETRATION**

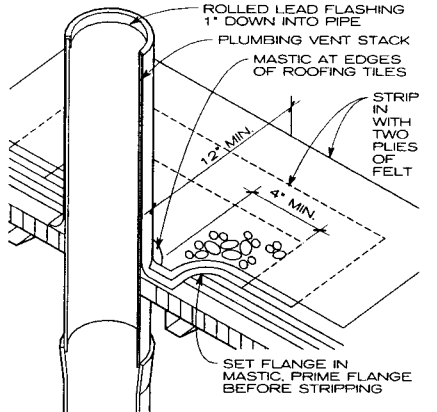

**SITE-FABRICATED DETAIL**

PREFABRICATED PIPING BOOT (CONSULT MANUFACTURER FOR SPECIFICATIONS)

**PREFABRICATED DETAIL NOTES**

1. Sheet lead minimum of 2 1/2 lb per sq ft.
2. Minimum clearance of 12 in. from cant strips and other curbs or pipes.

**SINGLE PIPE PENETRATION**

National Roofing Contractors Association; Rosemont, Illinois  
Valerie Eickelberger; Rippeteau Architects, PC; Washington, D.C.

**EPDM SINGLE-PLY ROOFING**

Ethylene propylene diene monomer (EPDM) membranes are 30 to 60 mil thick, single-sheet roofing materials. They are available either nonreinforced or reinforced with fabric. Seams in the membrane are spliced and cemented. EPDM membranes are highly resistant to degradation from certain chemicals, ozone, and ultraviolet radiation and have excellent resilience, tensile strength, abrasion resistance, hardness, and weathering properties.

EPDM membranes may be laid loose, mechanically fastened, or fully adhered to either nailable or non-nailable decks. For loose-laid systems, ballast provides resistance

against wind uplift forces. Some membranes require field application of surfacings or coatings to provide weather resistance, aesthetics, or other properties. Specifications for formulation and installation of EPDM membranes vary with the individual manufacturer.

Separation layers of asphalt-saturated organic felt or board-type roof insulation permit the membrane to move relative to the deck without abrasion. Membrane terminations at roof edges, parapets, and other flashings employ material identical to the roof membrane material shaped to conform to the substrate and area being flashed. Standards for EPDM membranes are maintained by ASTM and the Rubber Manufacturers Association.

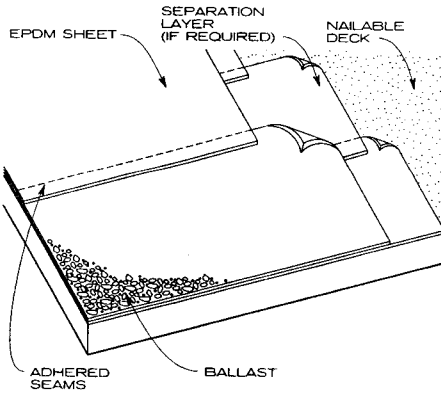

**OVER NAILABLE DECK  
LOOSE-LAID EPDM ROOFING**

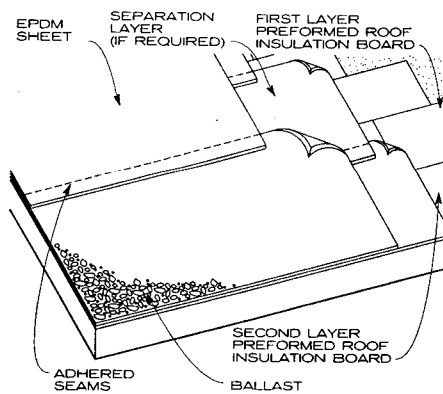

**OVER NON-NAILABLE DECK**

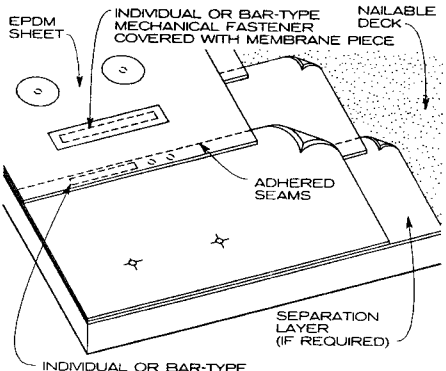

**OVER NAILABLE DECK  
MECHANICALLY FASTENED EPDM ROOFING**

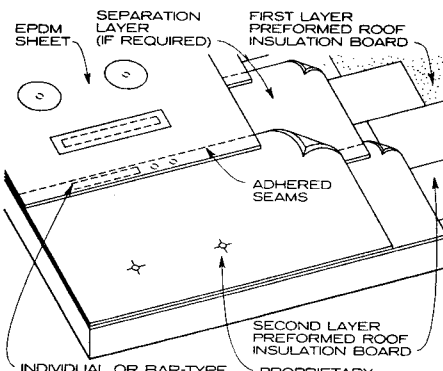

**OVER NON-NAILABLE DECK**

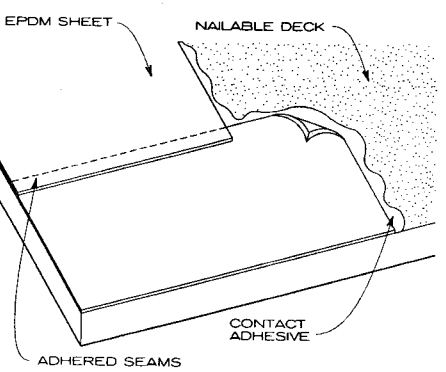

**OVER NAILABLE DECK  
FULLY ADHERED EPDM ROOFING**

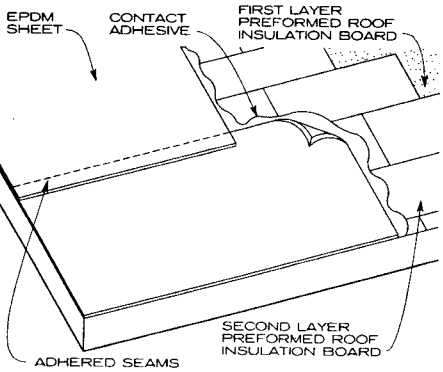

**OVER NON-NAILABLE DECK**

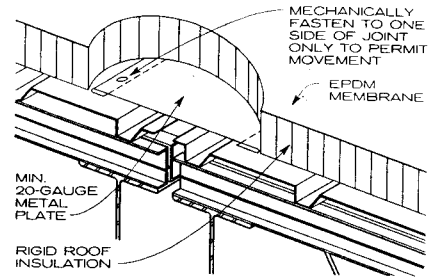

**LOOSE-LAID EXPANSION JOINT**

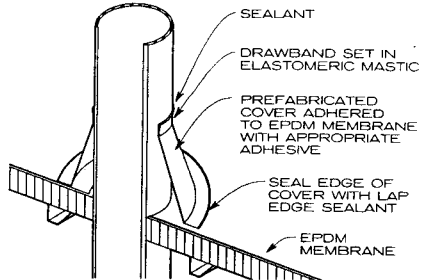

**PREFABRICATED PIPE FLASHING**

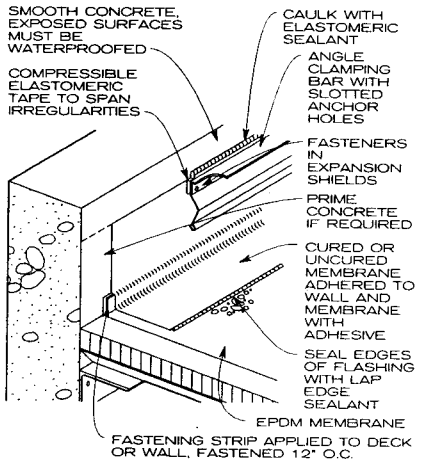

**PARAPET COUNTERFLASHING**

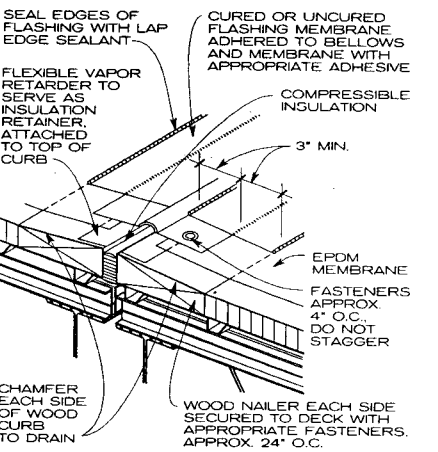

**EXPANSION JOINT**

National Roofing Contractors Association; Rosemont, Illinois  
Valerie Eickelberger; Rippeteau Architects, PC; Washington, D.C.

**SINGLE-PLY PVC ROOFING**

Polyvinyl chloride (PVC) membranes may be unreinforced or reinforced with glass fibers or polyester fabric 45 to 60 mils thick. Seams are formed by heat or chemical welding, and may require additional caulking. PVC membranes are resistant to bacterial growth, industrial chemical atmospheres, root penetration, and extreme weather conditions. PVC membranes have excellent fire resistance and seaming capabilities.

ASTM Standard D-4434 classes PVC materials into several types and classes depending upon the construction of the sheet material:

- TYPE I: Unreinforced sheet
- TYPE II, CLASS I: Unreinforced sheet containing fibers
- TYPE II, CLASS II: Unreinforced sheet containing fabrics
- TYPE III: Reinforced sheet containing fibers or fabrics

PVC membranes may be laid loose, mechanically fastened, or fully adhered to either nailable or non-nailable decks. For loose-laid systems, ballast provides resistance against wind uplift forces. Some PVC membranes have a factory-applied coating to provide weather resistance, aesthetics, or other properties to the membrane. Some membranes may require field application of surfacings or coatings to provide these properties.

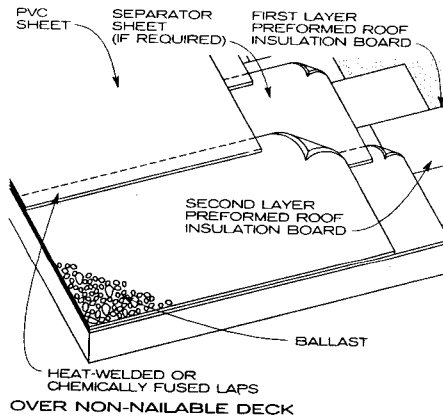
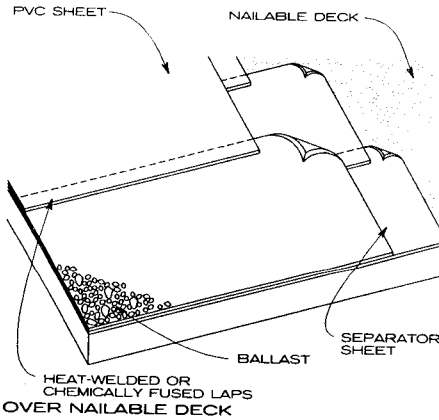

**LOOSE-LAID PVC ROOFING**

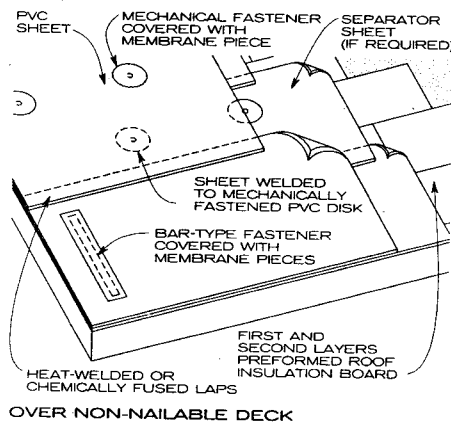
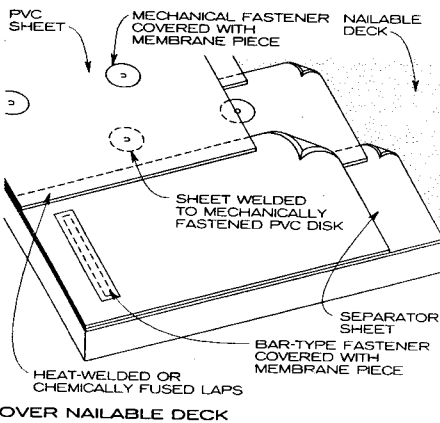

**MECHANICALLY FASTENED PVC ROOFING**

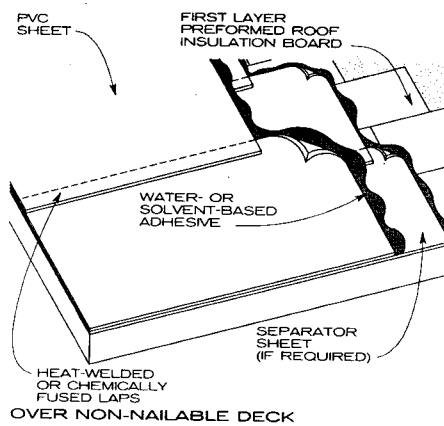
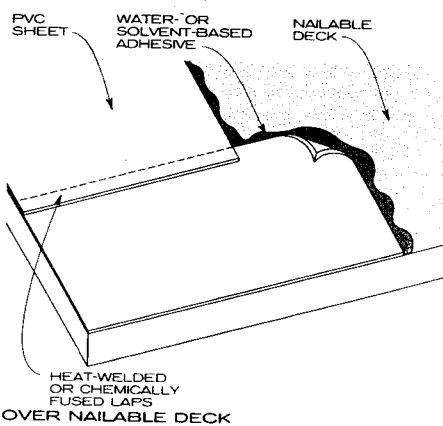

**FULLY ADHERED PVC ROOFING**

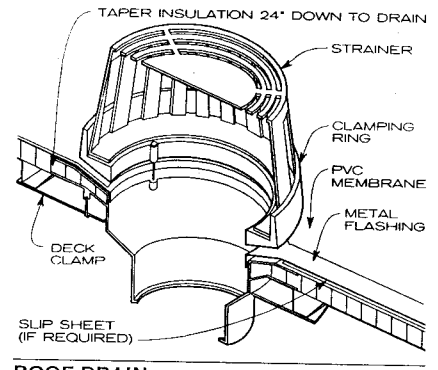

**ROOF DRAIN**

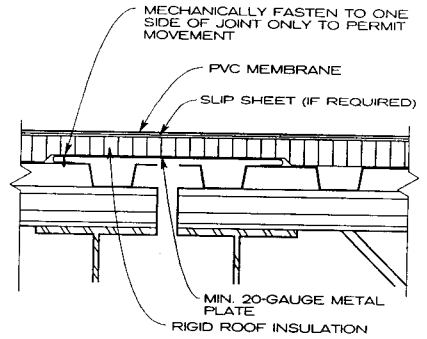

**LOOSE-LAID EXPANSION JOINT**

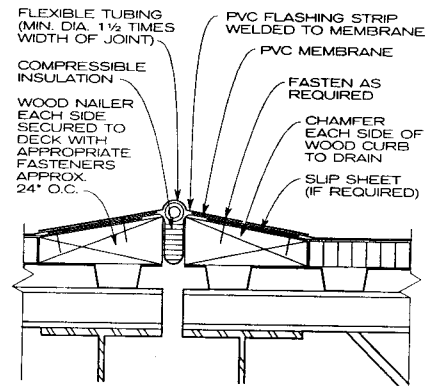

**EXPANSION JOINT**

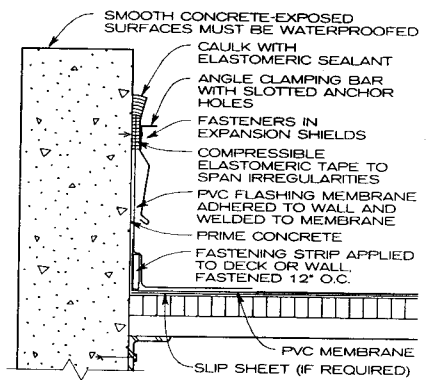

**PARAPET COUNTERFLASHING**

National Roofing Contractors Association; Rosemont, Illinois  
Valerie Eickelberger; Rippeteau Architects, PC; Washington, D.C.

**NOTE**

Polyvinyl chloride (PVC) is a semirigid material that requires the addition of plasticizers to fabricate a flexible roofing membrane. PVC exhibits excellent weldability for making lap joints or attaching to PVC clad metal flashing.

**TYPES OF MEMBRANE**

- Unreinforced sheet
- Sheet reinforced with fiberglass or polyester

**METHOD OF MANUFACTURE**

- Calendering
- Spread coating
- Extruding

**GENERAL**

Single ply roofing systems are also referred to as flexible sheet roofing systems. Consult manufacturers for specific requirements regarding materials selection and installation requirements. Compatibility of materials comprising total roofing system is essential.

**MATERIAL PROPERTIES**

- Thickness: Typically 48 and 60 mil; 45 mil minimum
- Color: Typically gray; other colors available

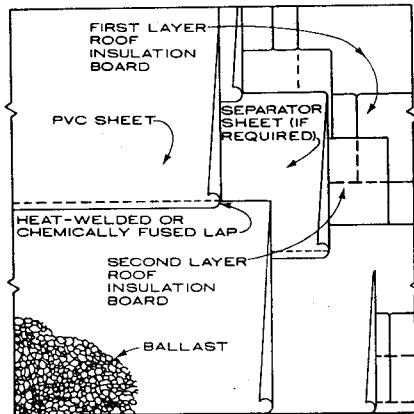

Membrane sheets are laid loose over roof insulation (also laid loose) and secured at the perimeter and around penetrations only. The membrane is then covered with a ballast of river-washed stones (typically 10 lb/sq ft) or appropriate pavers.

This system works efficiently with insulation approved by the membrane manufacturer and on roofs with a slope not exceeding 2 in 12.

**LOOSE-LAID BALLASTED SHEETS**

Membrane sheets are laid loose over a sloped roof deck and with the insulation on top of it. When the roof deck is dead level, tapered roof insulation is either loose laid or mechanically attached under the membrane to achieve positive slope to drainage. In either instance, a layer of insulation is placed over the membrane and held in place by one of two methods: Either a loose fabric is laid over the insulation, with a minimum of 10 lb/sq ft of ballast laid over the fabric, or insulation with an integrally bonded concrete facing is used in place of the fabric and loose ballast. Membrane manufacturers should be consulted for their approved insulation list. In this roofing system, the membrane is protected from year-round temperature extremes, direct exposure to weather, and damage from other sources. The heat gain or loss is just the same as if the insulation were installed under the membrane. Since the waterproofing membrane is placed on the warm side of the insulation, it functions as a vapor retarder. For high humidity conditions with a dead level roof deck utilizing tapered insulation, a separate vapor barrier should be placed directly beneath the tapered insulation to prevent condensation.

**PROTECTED MEMBRANE SHEET**

CTA Architects Engineers; Billings, Montana

**7 MEMBRANE ROOFING**

Contaminants to avoid: Bitumen, oils, animal fats, and coal tar pitch. See manufacturer's chemical resistance list.

Minimum standards: ASTM has developed standard test methods to evaluate the materials properties of PVC roof membranes. These test results form a useful basis for comparing various PVC membranes. ASTM's standard specification establishes minimum performance criteria for tensile strength, elongation, tear resistance, heat aging, weathering, and water absorption.

**INSTALLATION**

General guidelines: It is recommended that all roofing materials be installed on roofs with positive slope to drainage. Check with manufacturers regarding their specific requirements.

Lap joining methods: Hot air or solvent weld

Flashing methods: Membrane or PVC coated metal

Types of preformed accessories available: Inside and outside corners; pipe stacks

Weather restrictions during installation: 0°-120°F temperature range. Substrates and welding/bonding surfaces must be dry.

Method of repair: Clean surface; hot air or solvent weld of PVC patch

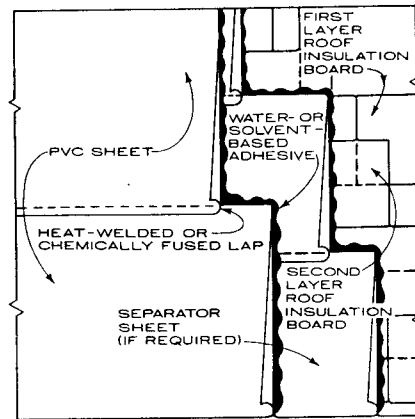

For system with no slope limitations which secures membrane to substrate with bonding adhesive and by mechanically fastening the membrane to perimeter and penetrations. System is appropriate for contoured roofs and roofs that cannot withstand weight of ballasted system.

Membrane can be directly applied to deck surface of concrete, wood surfaces, or be applied to compatible insulation that is mechanically fastened to the deck.

**FULLY ADHERED SHEETS**

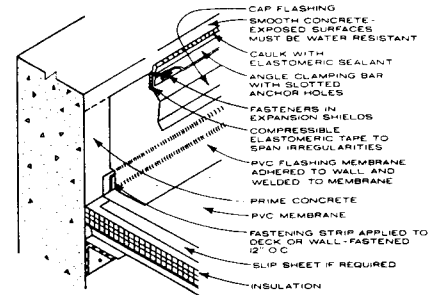
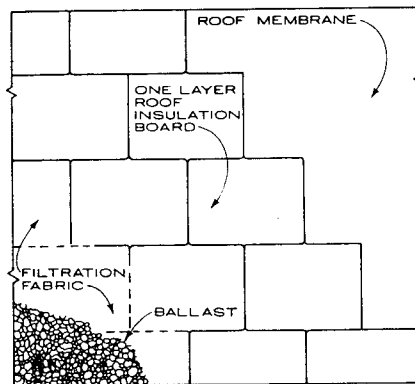

**TYPICAL PARAPET FLASHING**

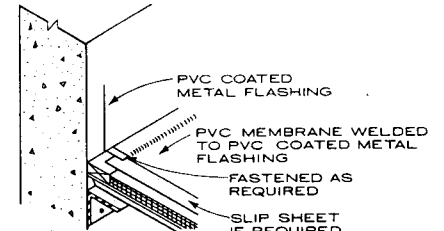

**ALTERNATE PARAPET FLASHING**

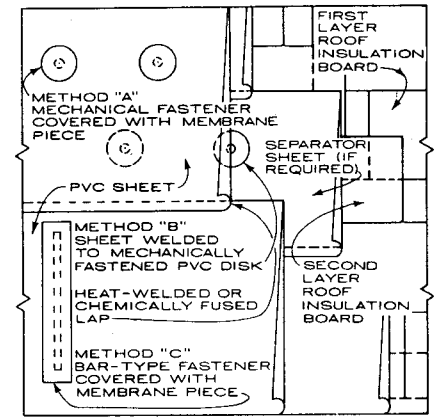

A mechanically anchored roof system is appropriate for roofs that cannot carry the additional load of ballasted roof systems. Systems are available with fasteners that penetrate the membrane or that require no membrane penetration.

The membrane is anchored to the roof using metal bars or individual clips, and it may be installed over concrete, wood, metal, or compatible insulation.

**MECHANICALLY ATTACHED SHEETS**

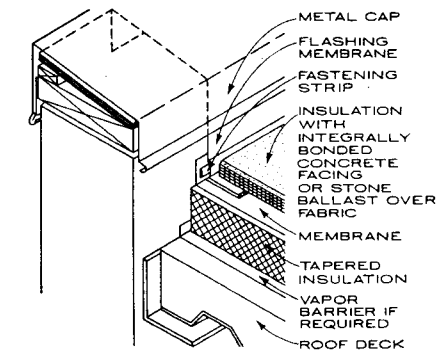

**DEAD LEVEL ROOF**

**GENERAL**

Liquid-applied roofing systems are systems primarily applied as liquids at ambient temperatures. Most of them have some sort of reinforcing fabric that is applied along with the liquid component. Liquid-applied roofing applied over existing roofs is not generally accepted as a "membrane" but as a coating.

Acrylic latex and urethane are the two main types of liquid-applied roofing. Acrylic latex refers to a family of products that use water-based polymers and cure by water evaporation. Liquid-applied urethane roof coatings are chemically cured to form an elastomeric membrane. Because these coatings are applied as liquids, installation is relatively simple, even for roofs with irregular geometries or multiple penetrations. For systems using a reinforcing fabric, a coating is applied to an acceptable surface. While the coating is still wet, a layer of polyester or fiberglass is laid into it followed by an additional layer of coating. Subsequent layers may be added as desired or necessary.

Liquid-applied roofing systems are appropriate for new construction but are most commonly used as enhancements or for repairs to existing roofs, including modified bitumen roofs and built-up roofs.

Advantages of liquid-applied roofing are that it conforms very well to irregular surfaces, is easily applied, and comes in various colors. However, it does cause marginal ponded water performance and is best used in sloped roof situations.

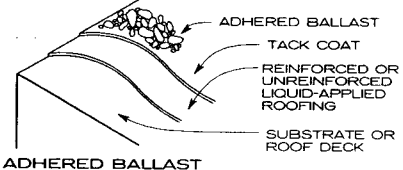
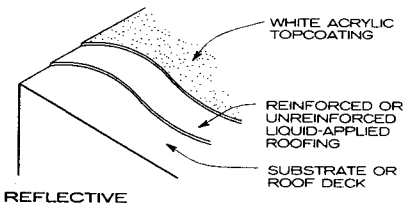

**NOTE**  
Liquid-applied roofing systems may also be used under rigid insulation and ballast for further protection. Refer to "Protected Membrane Roofing" for further details.

**LIQUID-APPLIED ROOFING SYSTEMS**

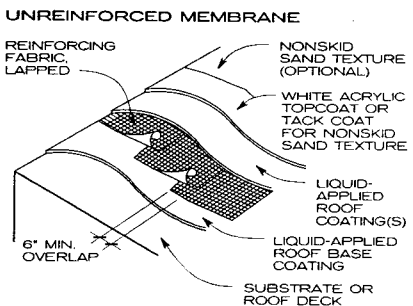
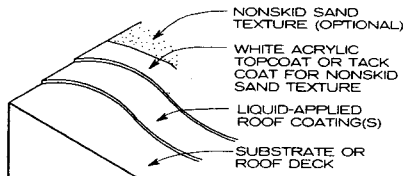

**LIQUID-APPLIED MEMBRANE TYPES**

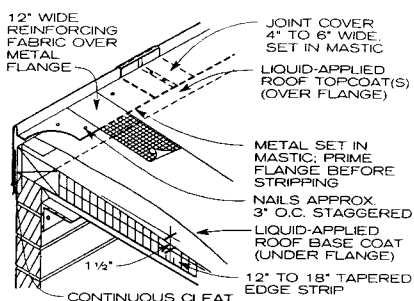

- NOTES**
1. Attach nailer to masonry wall. Refer to Factory Mutual data sheet # 1-49.
  2. This detail should be used only when the deck is supported by the outside wall.
  3. This detail should be used with light-gauge metals such as a 16-oz copper, 24-gauge galvanized metal, or 0.04-in. aluminum. A tapered edge strip is used to raise the gravel stop. Frequent nailing is necessary to control thermal movement.

**GRAVEL STOP**

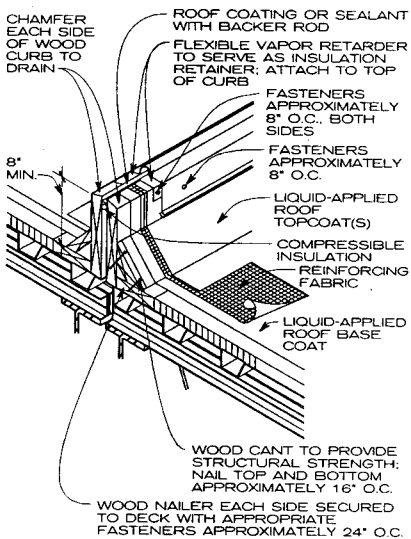

**EXPANSION JOINT**

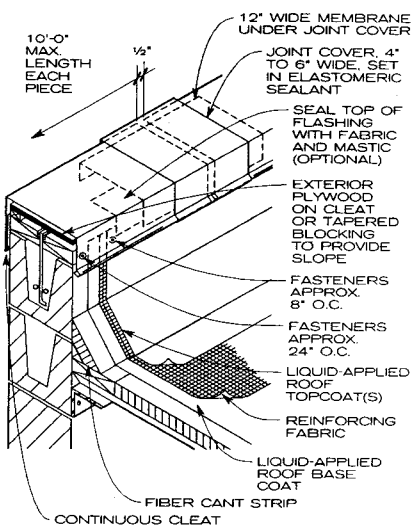

**LIGHT METAL PARAPET CAP**

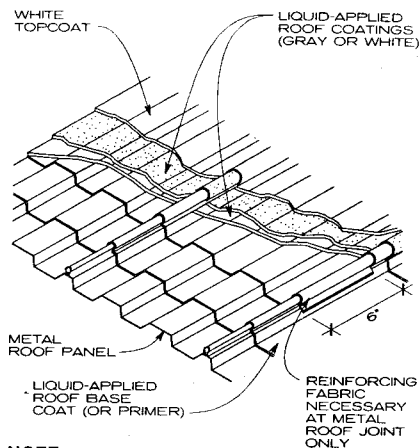

**NOTE**  
Roof slope minimum is 1/4 in. in 12 or 2%; no maximum.

**RETROFIT LIQUID-APPLIED ROOFING OVER EXISTING METAL ROOF**

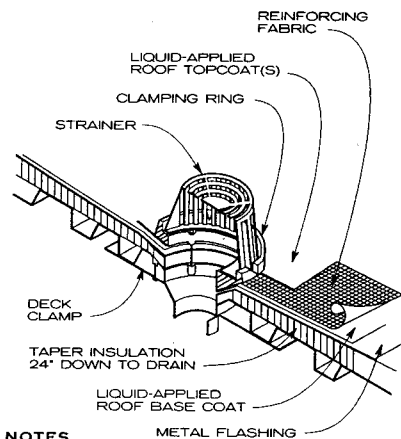

- NOTES**
1. Use minimum 30-in. sq. 2 1/2 lb to 4 lb lead flashing. Set in mastic. Prime top surface before stripping.
  2. Liquid-applied roof coatings, reinforcing fabric, and metal flashing (optional) extend under clamping ring.

**ROOF DRAIN**

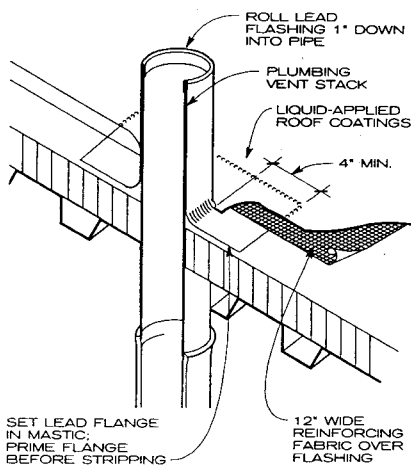

**NOTE**  
Sheet lead minimum of 2 1/2 lb per sq ft.

**SINGLE PIPE PENETRATION**

Richard J. Vitullo, AIA; Oak Leaf Studio; Crownsville, Maryland  
Rich Boon; The Roofing Industry Educational Institute; Englewood, Colorado



NOTES

There are three generic installation methods for EPDM roofing:

1. Fully Adhered: Membrane roofing is rolled onto the substrate and allowed to relax. Underside is then fully coated with bonding adhesive. After both surfaces are tacky, the membrane is pressed onto the substrate with a push broom. Adjoining sheets must overlap at least 3 in., with laps spliced and cemented. Membrane is mechanically secured at perimeter and penetration edges. Flashing protects all edges, openings, and penetrations.
2. Loose Laid: Roofing in this application is laid loose over the substrate, either deck or rigid insulation, and ballasted in place. It is positioned without stretching, allowed to attain its natural shape, and adjacent sheets spliced with adjoining sheets overlapping at least 3 in. Sheets are cemented and rolled together to seal seams. The membrane is mechanically secured at perimeter and penetration edges, and flashing is installed. For ballast, a sufficient amount of river-washed gravel is laid over the membrane to provide 10 lb/sq ft of weight. As an alternate, a pre-cast roof paver system is applied to hold the roofing membrane.
3. Mechanically Fastened: Membrane roof is directly attached to the roof deck with mechanical fasteners. The substrate is anchored to the roof deck, and the fasteners either go through both membrane and insulation or only go through the insulation and deck, with the membrane held down by retainer and cap over the base. Sealant protects against moisture.

Many EPDM membranes are field surfaced to improve resistance to weathering and fire, or to enhance appearance.

GENERAL NOTES

EPDM elastomeric roofing is synthesized from ethylene, propylene, and a small amount of diene monomer. Manufactured sheets range in thickness from 30 to 60 mils.

Advantages: EPDM roofing exhibits a high degree of resistance to ozone, ultraviolet, extreme temperature and other elements, and degradation from abrasion. It is resilient, strong, elastic, and less prone to cracking and tearing when compared to other forms of membrane roofing.

Disadvantages: Application methods, specific formulas and configurations for adhesives, fasteners, and coatings are unique with each system manufactured. Materials, design, and appropriate use vary widely. Close supervision and regular inspection by manufacturer are a requirement. Labor cost and time allotted for installation may vary.

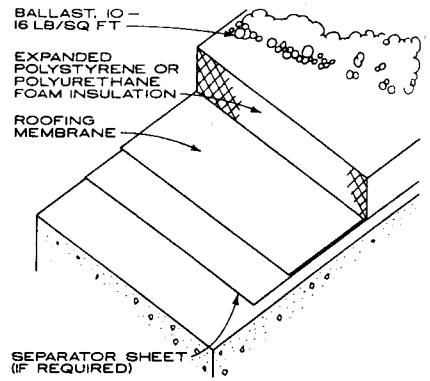

INSULATED ROOF MEMBRANE APPLICATION

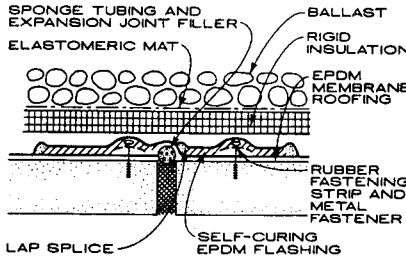

EXPANSION JOINT: INSULATED ROOF MEMBRANE BALLASTED

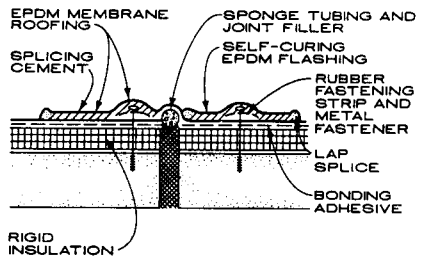

EXPANSION JOINT: FULLY ADHERED ROOF MEMBRANE

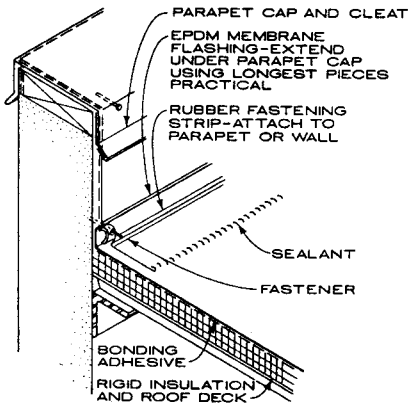

FULLY ADHERED ROOF AT PARAPET OR WALL

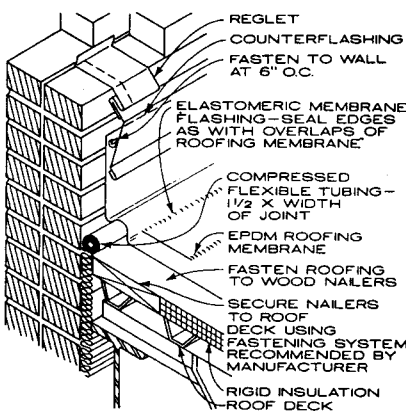

ROOF EDGE AT NONSUPPORTING WALL

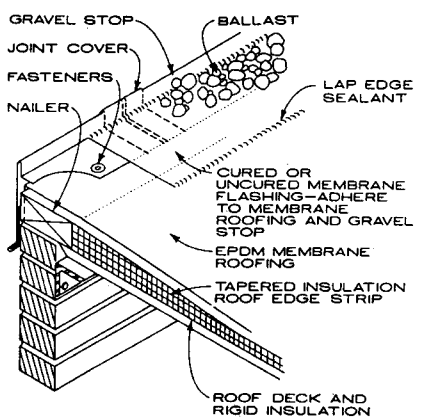

LIGHT METAL ROOF EDGE

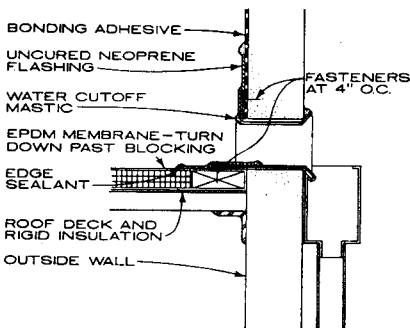

FULLY ADHERED ROOF SCUPPER

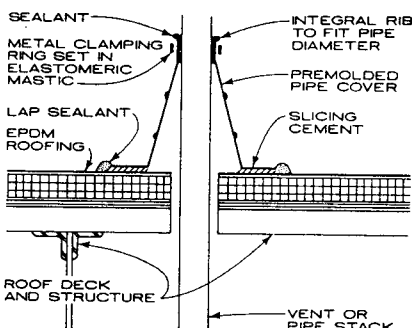

PREMOLDED VENT PIPE FLASHING

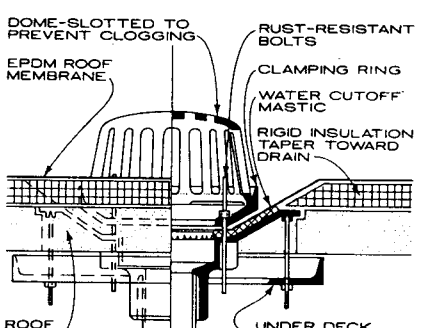

ROOF DRAIN

Catherine A. Broad, Washington, D.C.

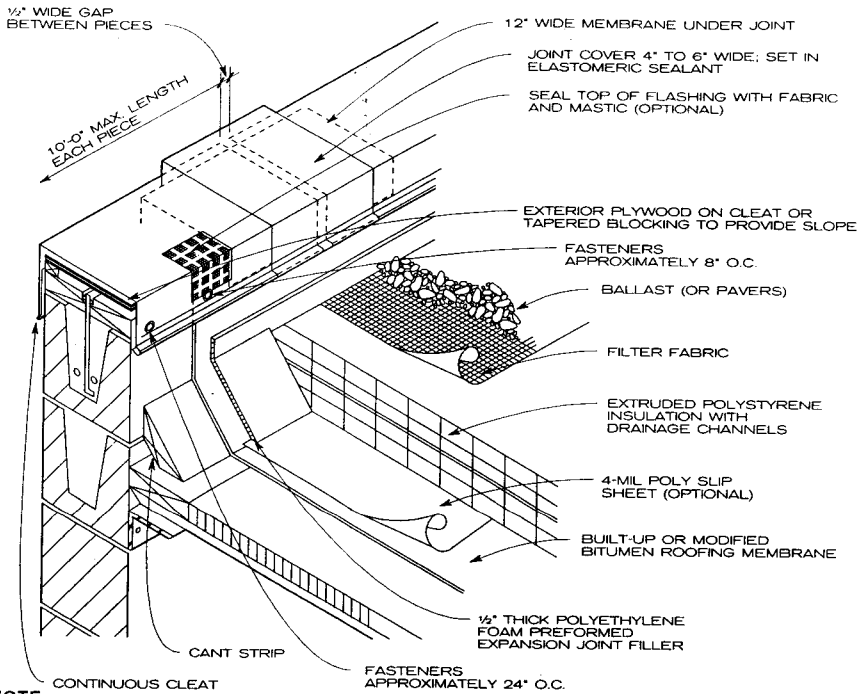

**NOTE**

Membrane may be built-up, modified bitumen, or single-ply. If thermoplastic membrane is specified, provide slip sheet between insulation and membrane.

**LIGHT METAL PARAPET CAP AT BUILT-UP OR MODIFIED BITUMEN ROOF**

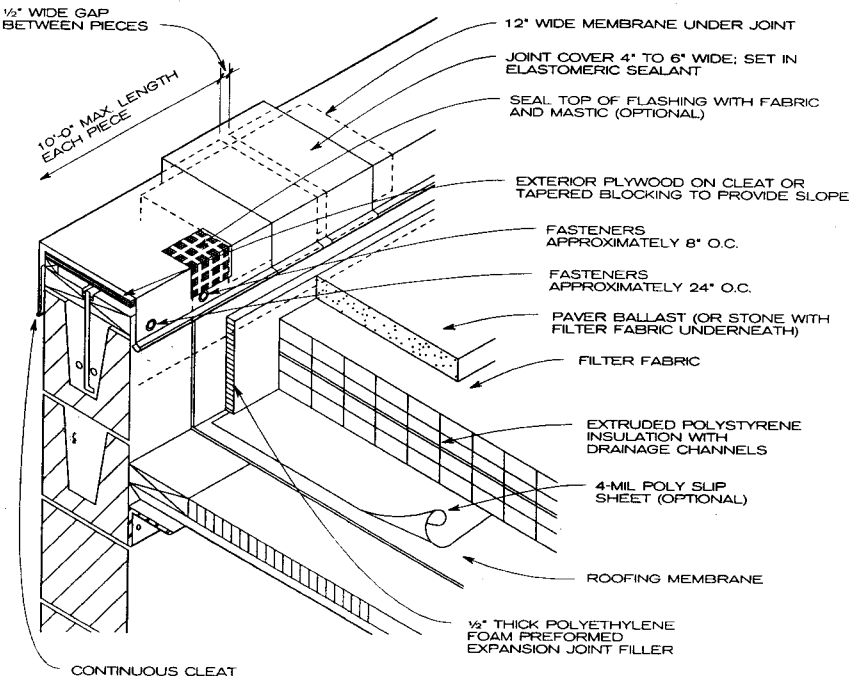

**NOTES**

1. Membrane must be single-ply. If thermoplastic membrane is specified, provide slip sheet between insulation and membrane.
2. Set pavers on pedestals or specify that the top layer of insulation boards have ribs on the top side to facilitate drying.

**LIGHT METAL PARAPET AT SINGLE-PLY ROOF**

Richard J. Vitullo, AIA; Oak Leaf Studio; Crownsville, Maryland  
 Rich Boon; The Roofing Industry Educational Institute; Englewood, Colorado

**GENERAL**

In a typical roofing system, the waterproof membrane system (built-up, modified bitumen, or single-ply) is applied on top of the insulation, which lies on top of the substrate and/or structural deck. The membrane in this situation is exposed to temperature extremes and wear and tear from people walking or working on the roof. In a protected membrane roof (sometimes called the inverted or insulated roof membrane assembly, or IRMA), a layer of extruded polystyrene insulation board protects the membrane. Extruded polystyrene is the only material generally approved for this application because it does not absorb moisture. This roofing system is best used in extreme climates, where it is important to protect the membrane from the elements, or where the rooftop will receive heavy use (e.g., plaza or parking deck applications).

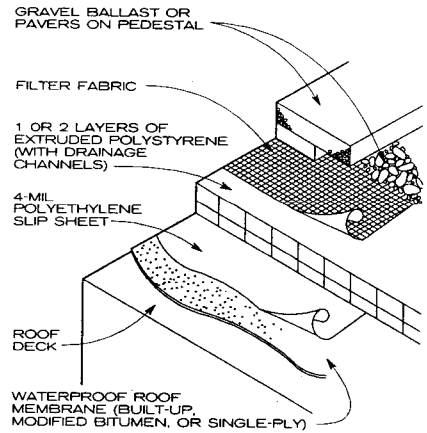

**NOTES**

1. Ballast weight is a minimum of 10 lb per square foot.
2. Refer to ANSI/SPRI/RMA RP-4 for wind design guidance.
3. In lieu of aggregate or concrete ballast, proprietary insulation boards with concrete topping are available. These boards weigh between 4.5 lb per square foot and 10 lb per square foot, depending on the product selected.

**TYPICAL PROTECTED MEMBRANE ROOF SYSTEM**

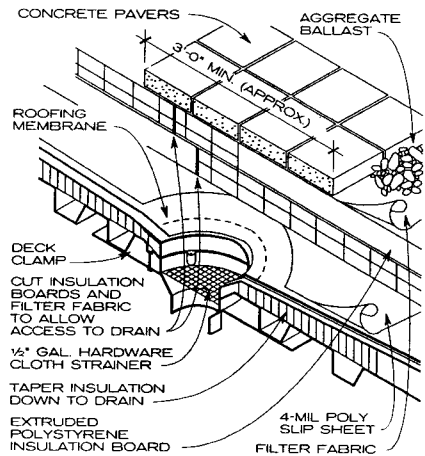

**NOTES**

1. Standard weight concrete pavers should be used to mark drain locations and to facilitate access to drains.
2. To facilitate placement of insulation boards, etc., the clamping ring and strainer are to be removed from metal drains. A 1/2 in. hardware cloth strainer should be laid at the bottom of the drain bowl.
3. For a thermoplastic membrane, use a 4-mil polyethylene slip sheet between the membrane and the insulation boards. Cut a hole in the sheet at the drain, approximately 2 in. larger than the diameter of the drain bowl.

**ROOF DRAIN**

**GENERAL**

Polyurethane foam roofing is spray-applied, seamless, and fully adhered. The foam is made by mixing isocyanate and resin components at a 1:1 ratio. Spray polyurethane foam is a closed-cell foam that provides good insulation and water resistance. These systems are used with a protective coating or stone ballast covering system, which protects the foam roofing from ultraviolet rays and mechanical damage.

These systems can be applied in varying thicknesses to eliminate ponding, to improve drainage, and to meet specified R-values (approximately R-6.25 per inch). Some advantages of spray foam systems are that they can be used over highly irregular surfaces, unusual geometries, or existing sloped metal systems. They are also inherently lightweight and offer good wind uplift resistance.

**NOTES**

1. Before spray polyurethane foam is applied, all surfaces must be clean, free of contaminants, securely fastened to the substrate, and completely dry. Moisture-sensitive indicators may be needed to detect any moisture within the existing roof assembly. Vapor retarders may be necessary; consult with the manufacturer to coordinate a specific roofing condition with foam application.
2. Most polyurethane foam manufacturers produce three seasonal grades: winter (fast), regular, and summer (slow).
3. If wind speed affects foam quality, use wind screens or discontinue spraying. The surface texture of sprayed foam can vary due to wind, equipment adjustment, spray technique, and characteristics of the system used. Foam that will be elastomeric coated should have a smooth texture resembling orange peel. For an aggregate covering, the texture should be no rougher than popcorn.

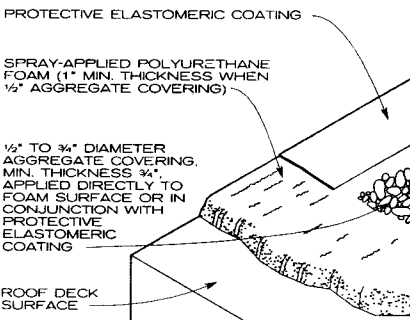

**NOTES**

1. Protection systems fall into two general classifications, protective elastomeric coatings and aggregate. There are seven generic types of elastomeric protective coatings: acrylic, silicone, urethane, butyl, hypalon, neoprene, and modified asphalt. The physical properties of these coatings may vary, and the coating manufacturer should be consulted for recommendations on specific needs.
2. Granules may be applied to the wet uncured protective topcoat to enhance the resistance of the coating systems to UV or mechanical damage.

**SPRAY-APPLIED POLYURETHANE FOAM ROOFING SYSTEM**

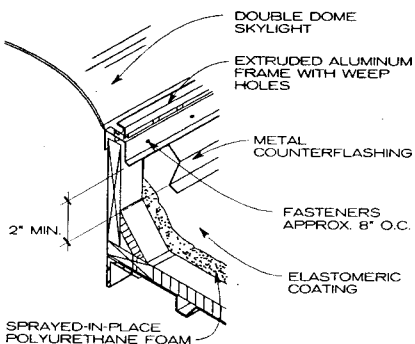

**NOTE**

On skylights, do not cover weep holes with polyurethane foam or coating.

**SKYLIGHT, SCUTTLE, OR VENT CURB**

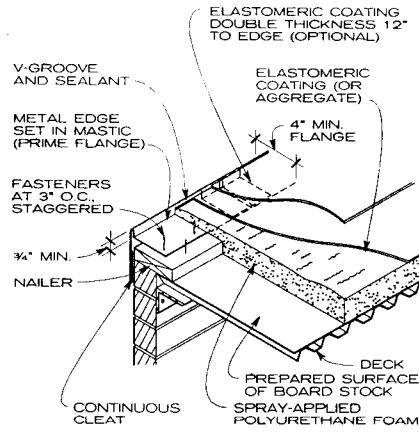

**METAL ROOF EDGE**

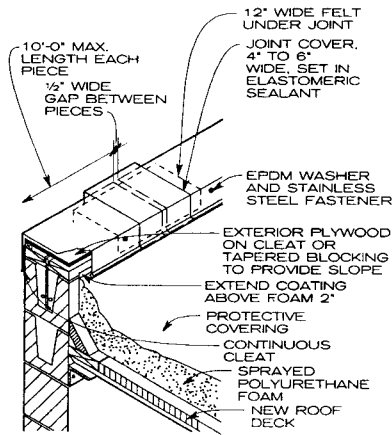

**NOTE**

This detail should be used only when the deck is supported by the wall. An expansion joint detail should be used for non-wall-supported decks.

**LIGHT METAL PARAPET CAP**

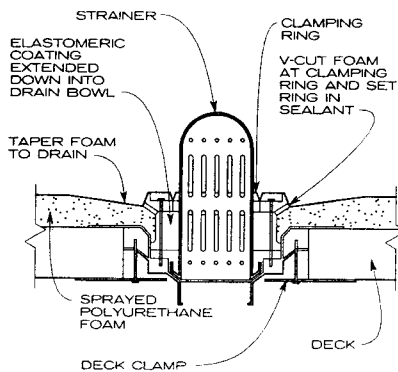

**NOTES**

1. Remove clamping ring prior to foam application. Place protective covering over drain bowl opening to prevent overspray from filling bowl.
2. Taper foam toward drain bowl to provide positive drainage.
3. The use of metal deck sump pans is not recommended.

**ROOF DRAIN**

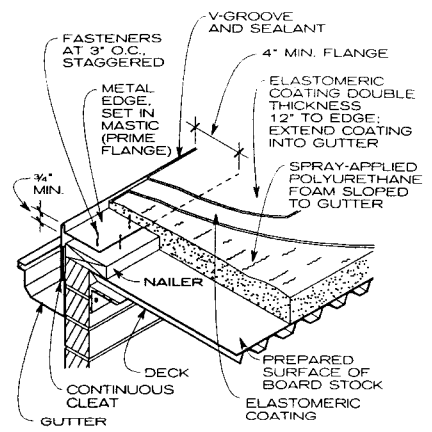

**ROOF EDGE AT GUTTER**

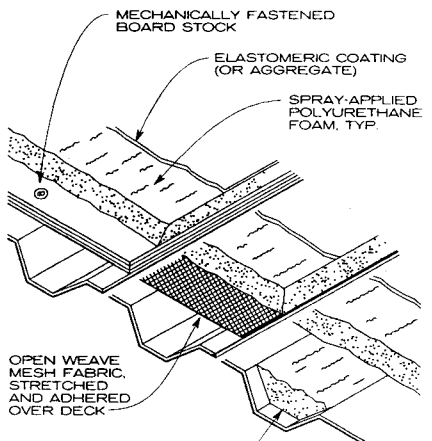

**METAL DECK DETAILS**

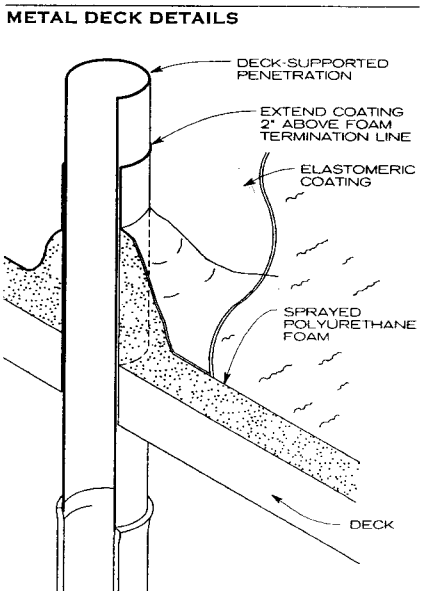

**SINGLE PIPE PENETRATION**

Richard J. Vitullo, AIA; Oak Leaf Studio; Crownsville, Maryland  
Rich Boon; The Roofing Industry Educational Institute; Englewood, Colorado

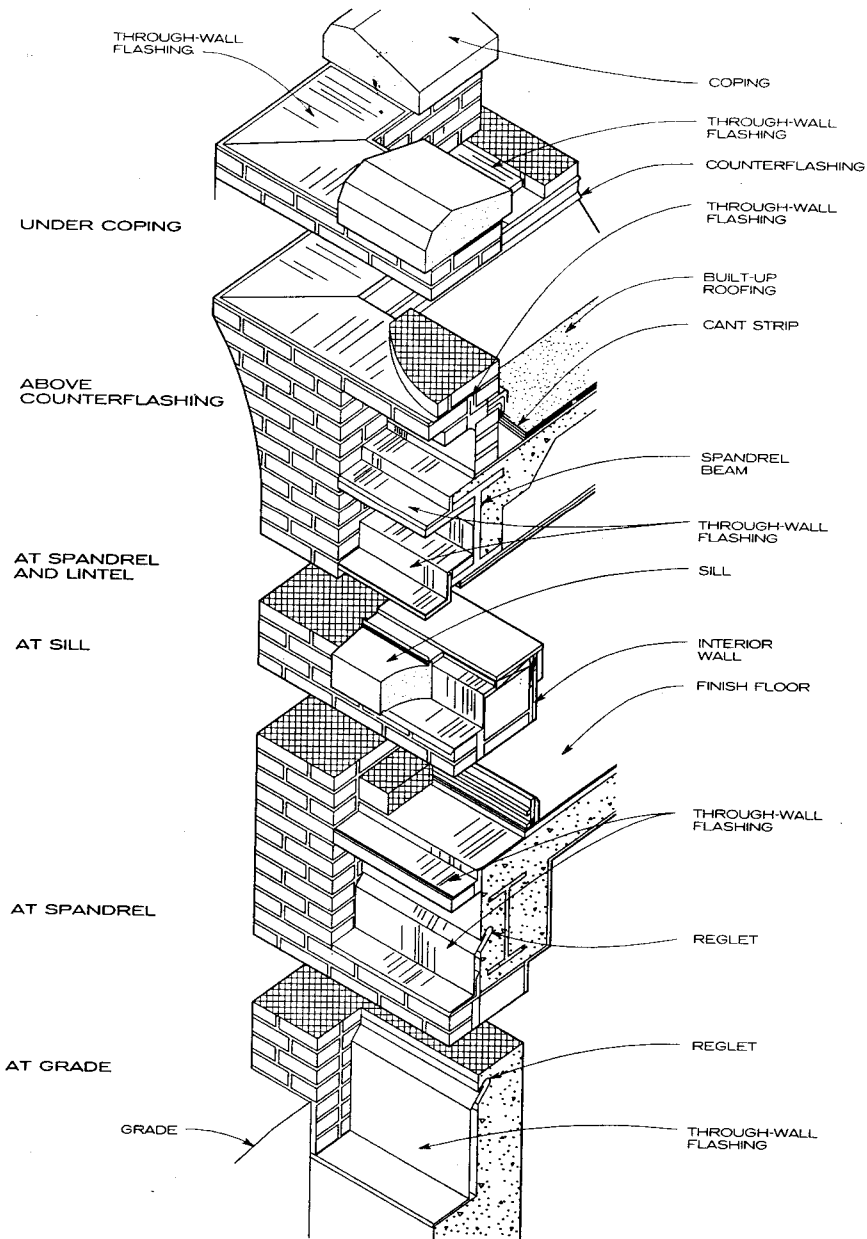

**THROUGH-WALL FLASHING INSTALLATION**

**GENERAL**

Modern building materials are often waterproof, but they are not permanently impervious to wind-driven moisture. Gradual shrinkage of some materials and the natural movement of buildings can eventually cause leaks. When moisture enters walls it tends to form pockets of water, which eventually drain into the interior of the building, sometimes by gravity, other times by capillary action. This water will damage interiors, deface exteriors, disintegrate mortar and masonry, and rust steel spandrels, lintels, etc.

Flashings should be used wherever there is any possibility of water entering a structure. Through-wall flashing is the most successful method of permanently preventing leaks, except in areas exposed to earthquakes, where through-wall flashing is not recommended. Through-wall flashing is

made of many different materials, including metals, plastics, and combinations of metals with paper, fabric, or rubber. Materials that are in contact must be compatible without deterioration.

Joints in flashings must be durable and waterproof and should usually lap 4 in. When the flashing is metal, joints should be soldered. Flashing should be extended to within 1/2 in. of the exterior face. End- and edge-formed dams should be used where necessary to control drainage direction. Metal flashing that extends below grade is installed in reglets after the surface waterproofing has been applied below-grade.

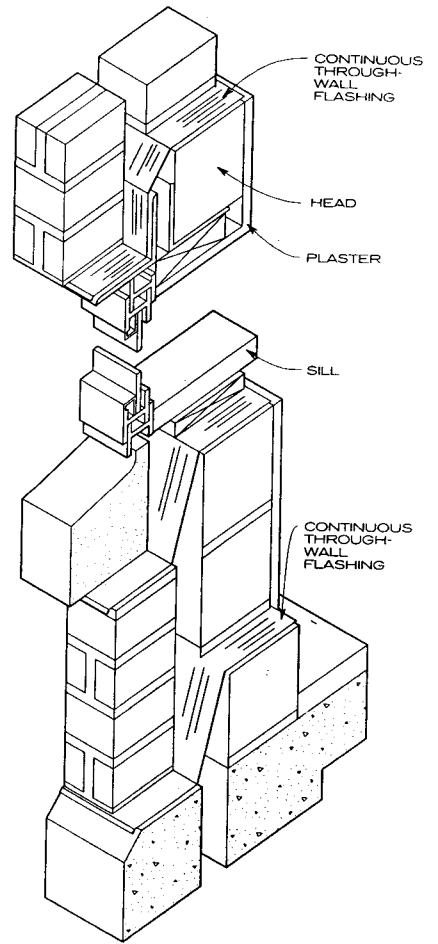

**THROUGH-WALL FLASHING AT CAVITY WALL**

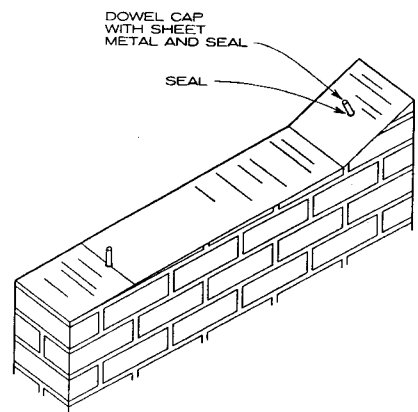

**THROUGH-WALL FLASHING UNDER COPING**

SMACNA, Inc., from the SMACNA Architectural Sheet Metal Manual, 5th ed., with permission Valerie Eickelberger; Rippeteau Architects, PC; Washington, D.C.

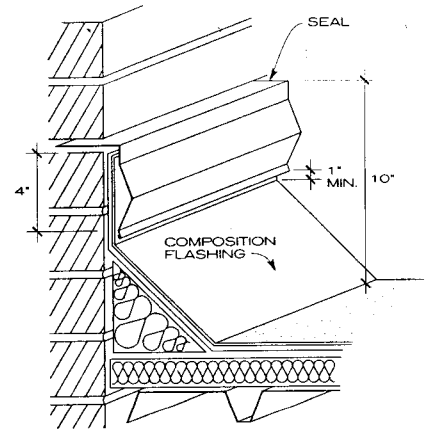
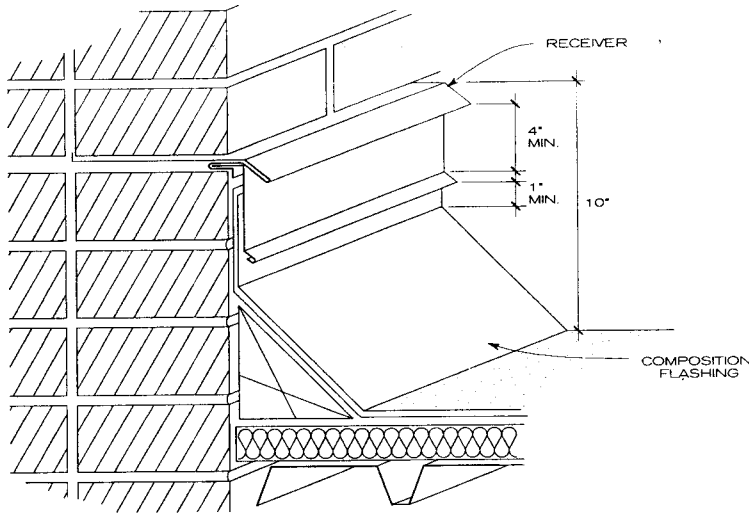

COUNTERFLASHING WITH RECEIVER

COUNTERFLASHING INSTALLATION

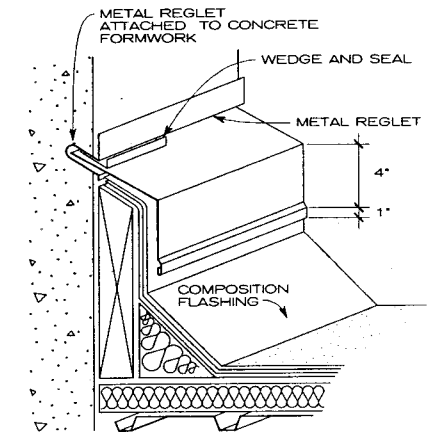
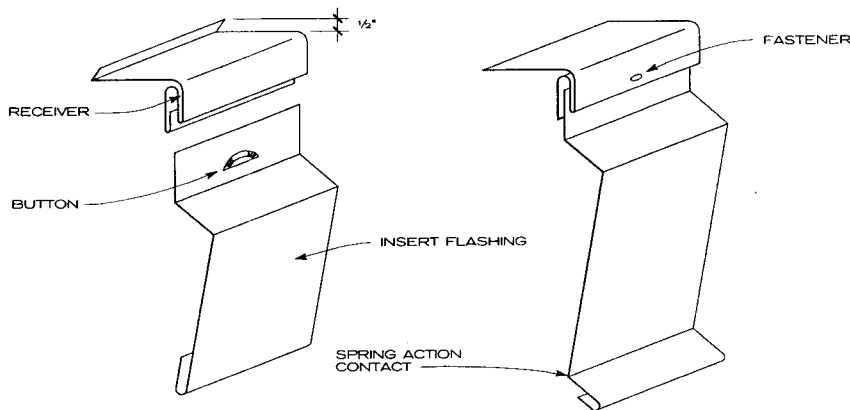

COUNTERFLASHING WITHOUT RECEIVER

TWO-PIECE COUNTERFLASHING

GENERAL

Careful consideration must be given to flashing systems where a roof and wall meet. The base flashing system must keep water from entering the building and must allow for building movement. Counterflashing turns water away from a wall onto the roof or base flashing. The base flashing is usually inserted into a reglet, which must be capable of supporting the flashing. In high wind areas, clips can be specified for the lower edge of the counterflashing. Counterflashing that is removable is cost effective for the work installation sequence and for repair of roofing systems.

All membrane roofing should have removable counterflashing. Metal counterflashing should be used in conjunction with composition base flashing. Metal base flashings are used with shingle or metal roofs, but are not recommended for use with membrane roofing systems. A metal base

flashing may be used over a composition flashing as a protective cover in locations where the base flashing may be abused by traffic. It is recommended that base flashings be applied over a cant and be extended up the wall a minimum of 10 in. above the roofline.

Receivers for counterflashing should be elevated 10 in. above the finished roof. Install metal counterflashing to cover a minimum of 4 in. of the base flashing. After the counterflashing is installed, the receiver is bent 45 degrees to provide a drip edge. The lower edge of metal counterflashing should be a minimum of 1 in. above a cant. The counterflashing is notched and lapped at inside corners and joints, and seamed at outside corners. The flashing receiver is notched and lapped 4 in. at corners and joints.

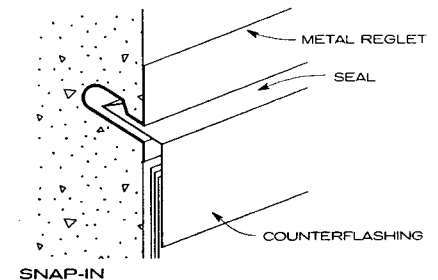

SNAP-IN

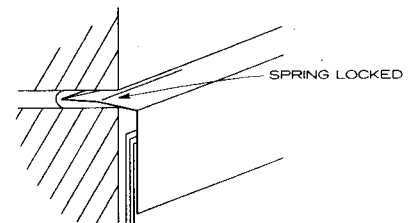

SPRING LOCKED  
INSERT FLASHING DETAIL

SMACNA, Inc., from the SMACNA Architectural Sheet Metal Manual, 5th ed., with permission Valerie Eickelberger, Rippeteau Architects, PC, Washington, D.C.

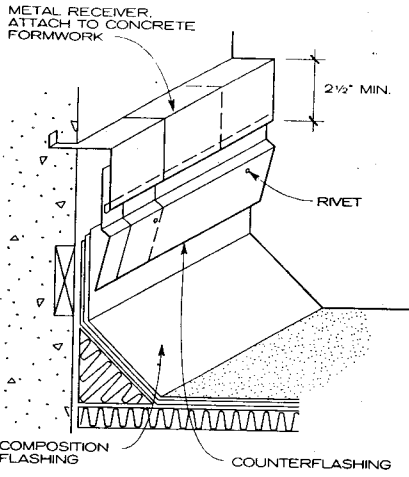

COUNTERFLASHING FOR CONCRETE

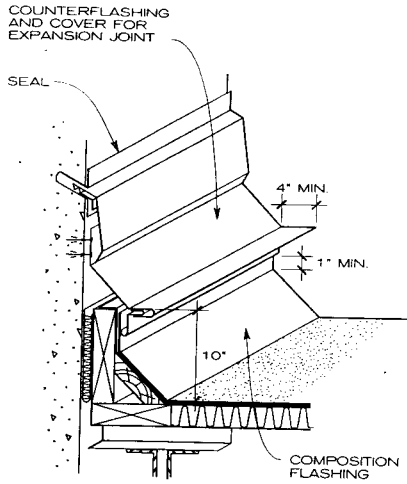

COUNTERFLASHING EXPANSION JOINT

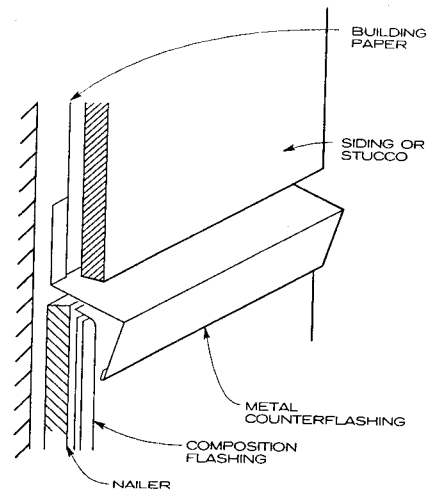

COUNTERFLASHING FOR NONMASONRY WALL

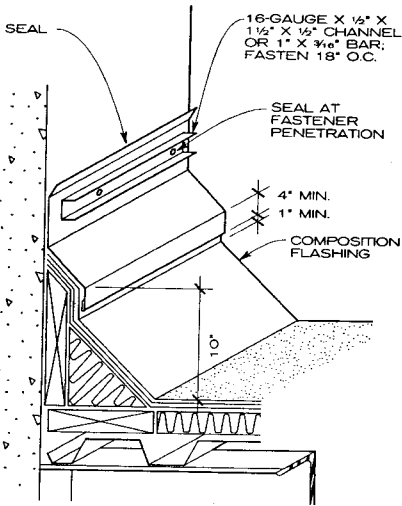

COUNTERFLASHING AT EXISTING WALL

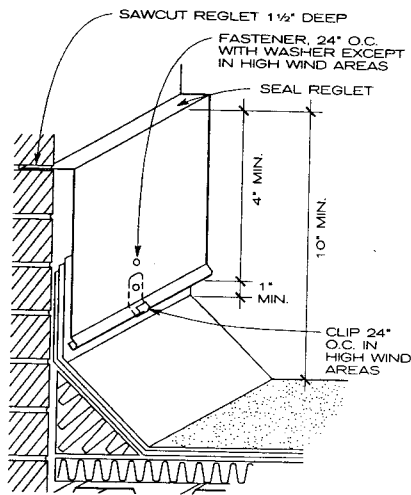

COUNTERFLASHING WITHOUT RECEIVER

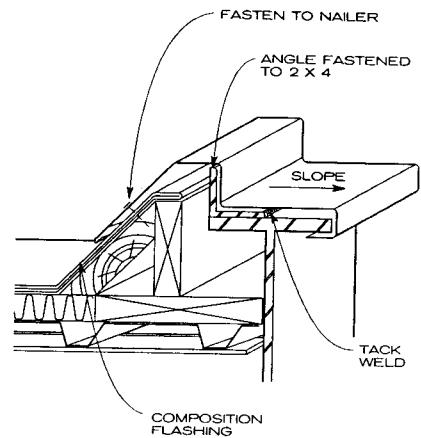

COUNTERFLASHING OVER STRUCTURAL STEEL

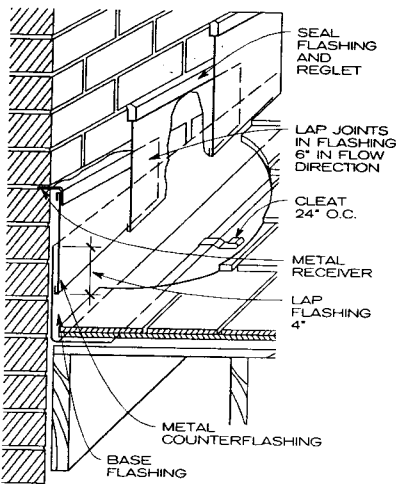

COUNTERFLASHING AT SLOPED ROOF

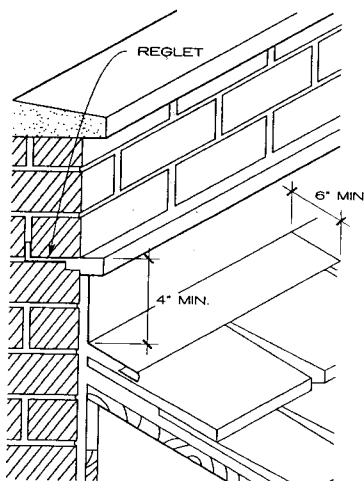

COUNTERFLASHING AT SLOPED ROOF

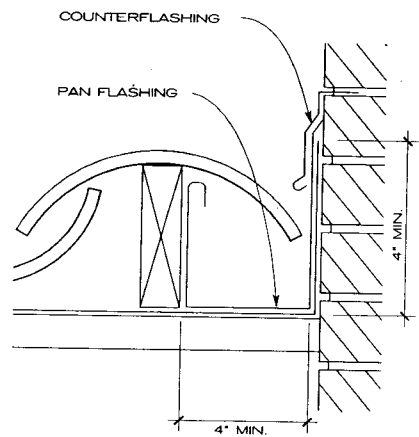

COUNTERFLASHING AT TILE ROOF

SMACNA, Inc., from the SMACNA Architectural Sheet Metal Manual, 5th ed., with permission Valerie Eickelberger; Rippeteau Architects, PC; Washington, D.C.

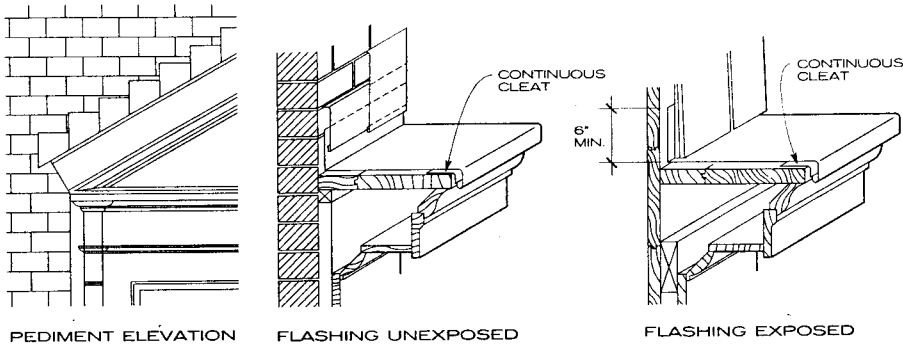

WOOD PEDIMENT LEDGE FLASHING

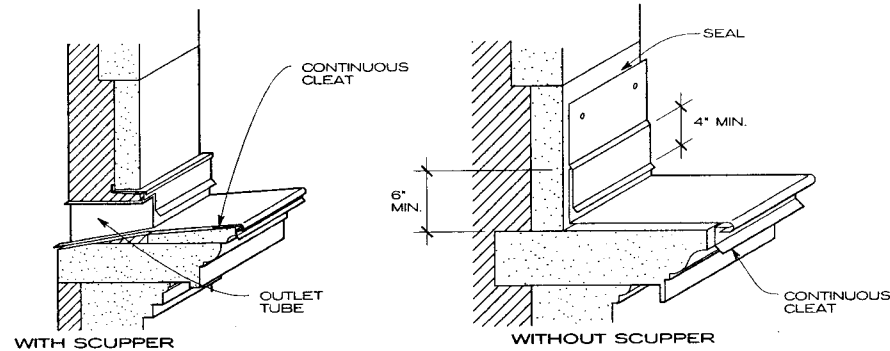

STONE LEDGE FLASHING

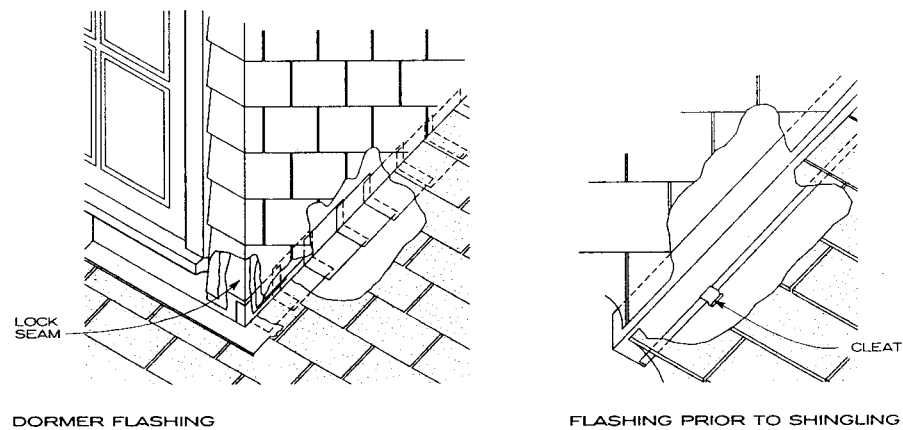

DORMER FLASHING

DORMER FLASHING

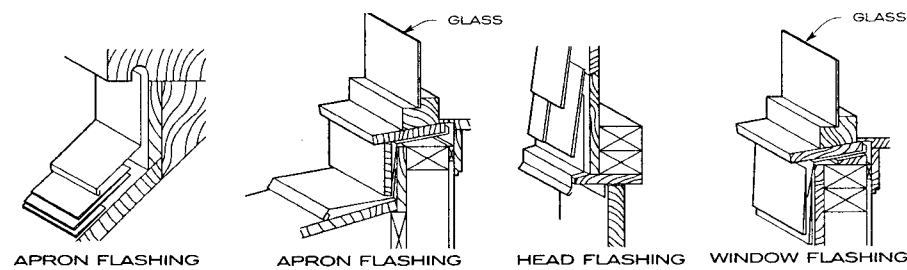

APRON FLASHING

APRON FLASHING

HEAD FLASHING

WINDOW FLASHING

DORMER FLASHING DETAILS

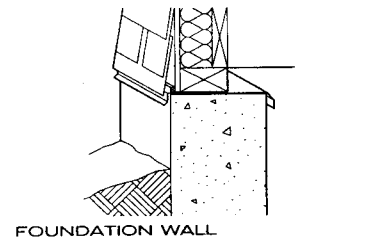

FOUNDATION WALL

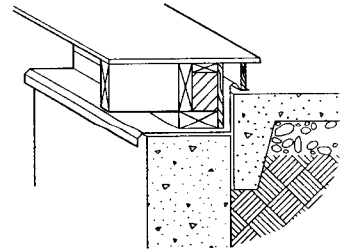

FOUNDATION WALL WITH PORCH FLOOR

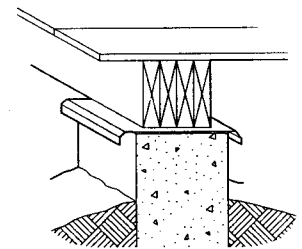

INTERNAL SUPPORT WALL

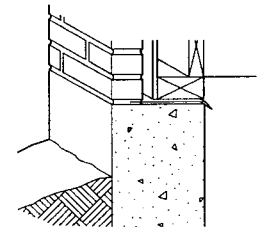

BRICK VENEER WALL

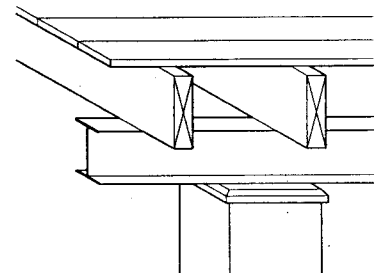

INTERNAL FLOOR SUPPORT

**NOTES**

1. Termite shields may be fabricated of copper or galvanized steel. Aluminum may be used except where masonry is above the termite shield.
2. Joints should be lapped  $\frac{3}{4}$  in. and soldered or flat locked. Corners should be notched, filled, and soldered.

**TERMITE SHIELDS**

SMACNA, Inc., from the SMACNA Architectural Sheet Metal Manual, 5th ed., with permission Valerie Eickelberger; Rippeteau Architects, PC; Washington, D.C.

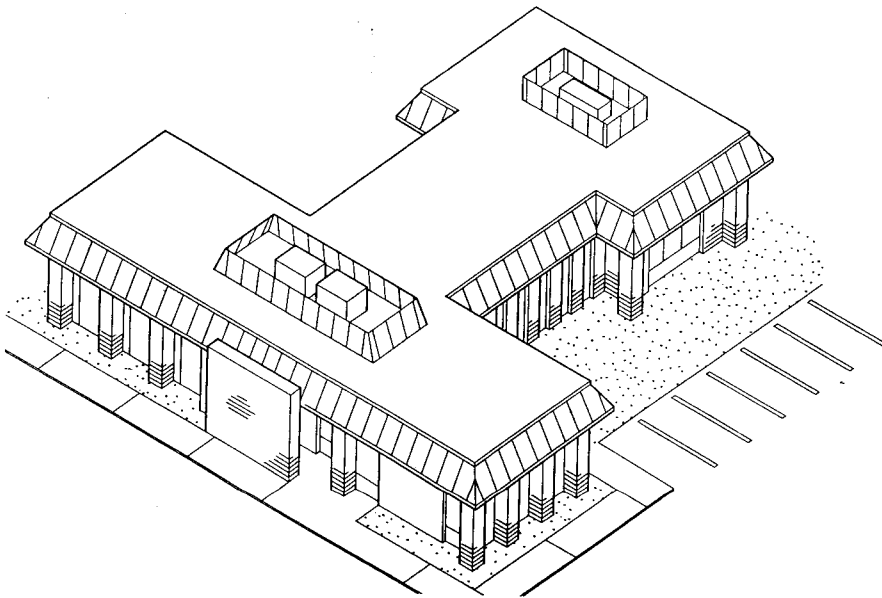

TYPICAL MANSARD ROOF

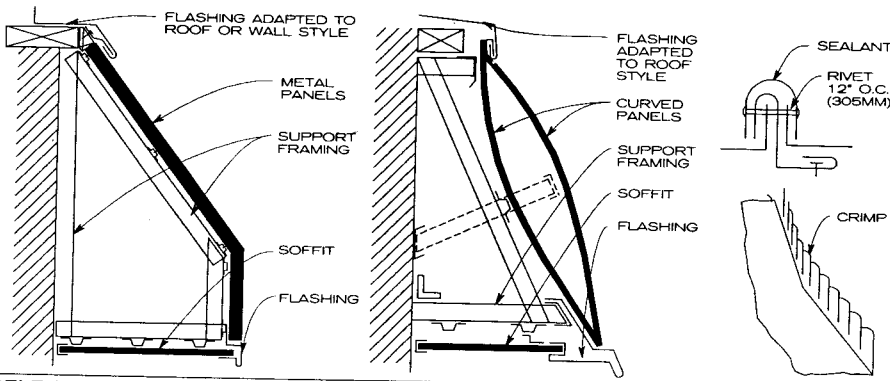

SELF-SUPPORTING ROOF

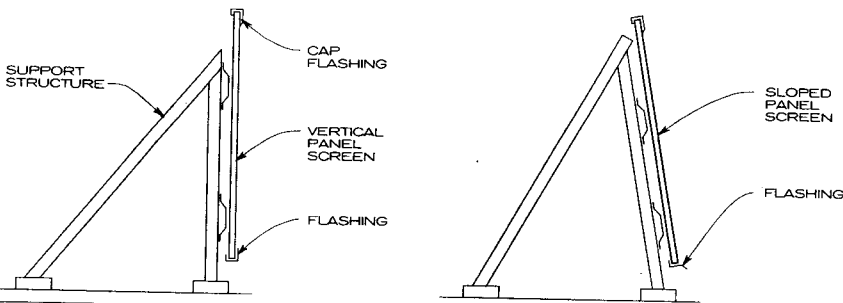

CONTINUOUSLY SUPPORTED ROOF

**METAL MANSARD ROOFS**

Metal mansard roofs are typically used on one-story commercial structures. Often they conceal rooftop equipment, using batten screens or louvered enclosures. Metal mansard roofs are also used for flat or curved ornamental roofs or canopies for the front of buildings.

Aluminum, copper, stainless steel, galvanized steel, or pre-finished metals may be used for metal mansard roofs. The metal can be prefabricated for several styles of field connection using various seam configurations. Prefinished metals used in curved applications typically have a 15-ft

radius limit. Concave or convex panels normally have a 24-in. minimum radius for standing seams and a 72-in. minimum radius for batten seams. Soft metals are used when the metal must be stretched.

Metal mansard roofs may be continuously supported or self-supporting. Continuously supported roofs have a continuous sheathing substrate. Self-supporting roofs have structural framing with vertical and horizontal members located where needed for metal panel attachment. Mansard roofs require cap and sill flashing.

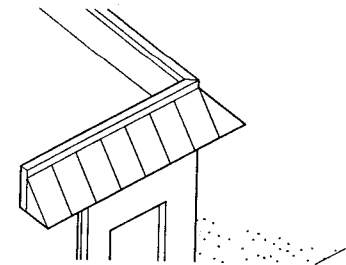
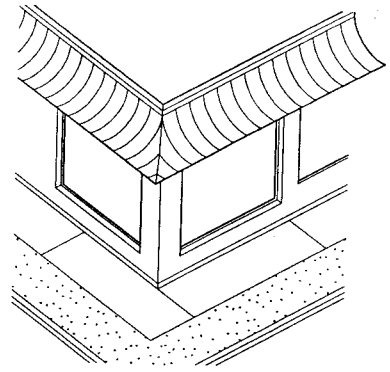

ORNAMENTAL ROOF CANOPY

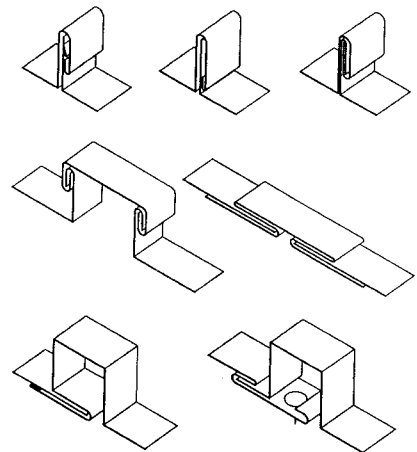

SEAM PROFILES

SMACNA, Inc., from the SMACNA Architectural Sheet Metal Manual, 5th ed., with permission Valerie Eickelberger; Rippeteau Architects, PC; Washington, D.C.



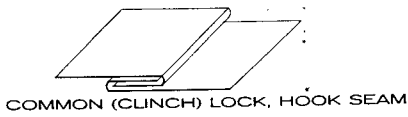

COMMON (CLINCH) LOCK, HOOK SEAM

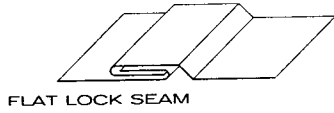

FLAT LOCK SEAM

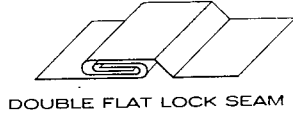

DOUBLE FLAT LOCK SEAM

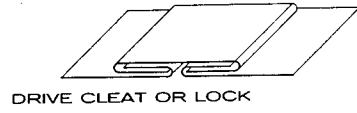

DRIVE CLEAT OR LOCK

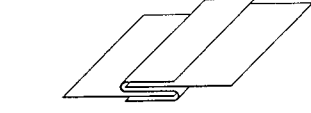

S CLEAT OR LOCK

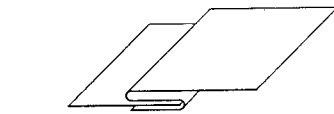

S POCKET

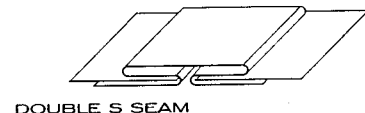

DOUBLE S SEAM

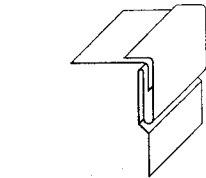

PITTSBURGH LOCK

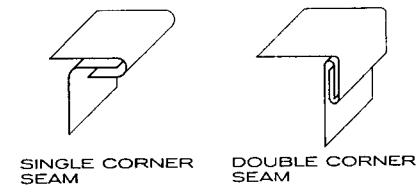

SINGLE CORNER SEAM

DOUBLE CORNER SEAM

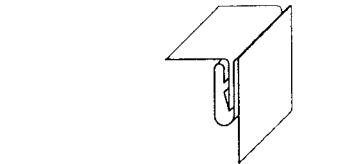

BUTTON LOCK CORNER SEAM

LOCK SEAM

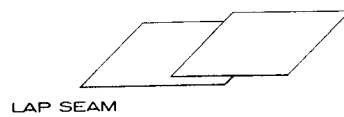

LAP SEAM

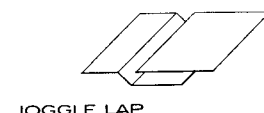

JOGGLE LAP

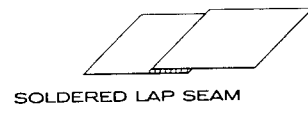

SOLDERED LAP SEAM

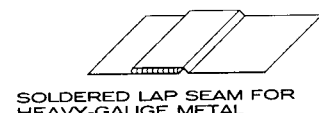

SOLDERED LAP SEAM FOR HEAVY-GAUGE METAL

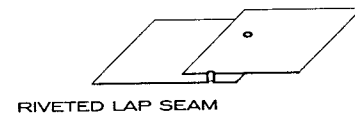

RIVETED LAP SEAM

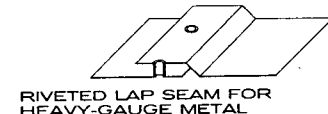

RIVETED LAP SEAM FOR HEAVY-GAUGE METAL

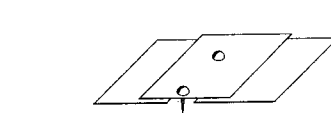

COVERED PLATE SEAM

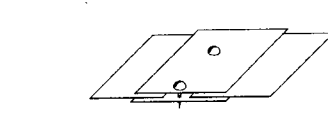

COVERED PLATE WITH BACKUP PLATE

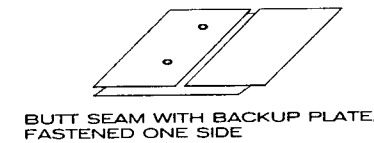

BUTT SEAM WITH BACKUP PLATE, FASTENED ONE SIDE

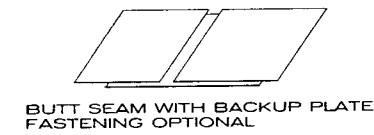

BUTT SEAM WITH BACKUP PLATE, FASTENING OPTIONAL



WELDED JOINT

FLAT SEAM

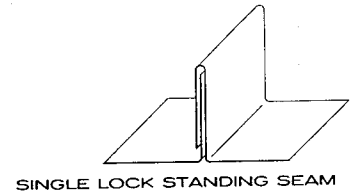

SINGLE LOCK STANDING SEAM

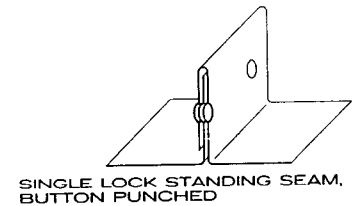

SINGLE LOCK STANDING SEAM, BUTTON PUNCHED

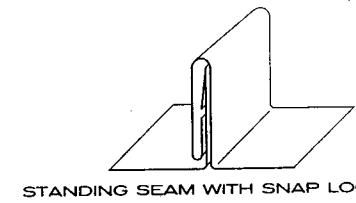

STANDING SEAM WITH SNAP LOCK

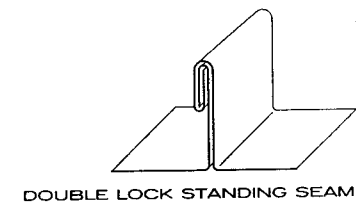

DOUBLE LOCK STANDING SEAM

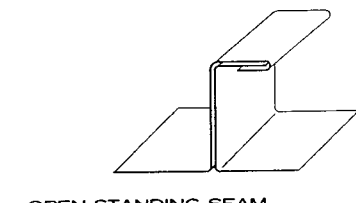

OPEN STANDING SEAM

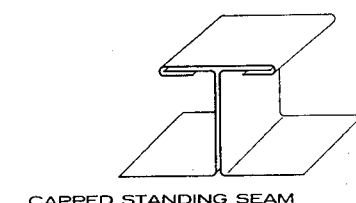

CAPPED STANDING SEAM

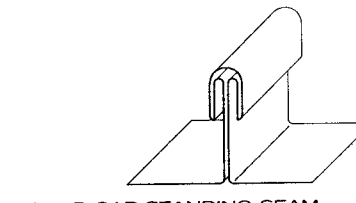

SNAP CAP STANDING SEAM

STANDING SEAM

SMACNA, Inc., from the SMACNA Architectural Sheet Metal Manual, 5th ed., with permission Valerie Eickelberger; Rippeteau Architects, PC, Washington, D.C.

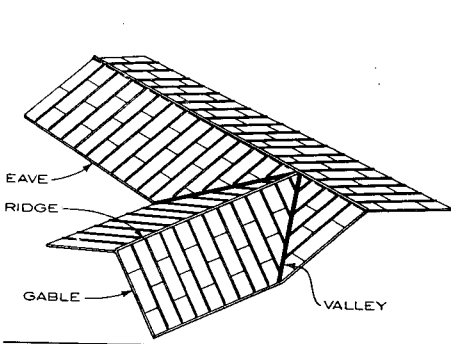

STANDING SEAM METAL ROOF

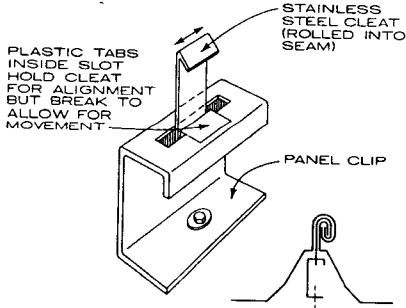

NOTES

To allow for expansion and contraction movement in roof panels, some manufacturers set movable cleats into a stationary panel clip system. The cleat is held in position in the center of a slot in the panel clip by two temporary plastic tabs. This allows for correct alignment of the cleat with the roof panel. Once the cleat has been rolled into the panel seam, it will move with the roof panel by forcing the plastic tabs to break under movement pressure.

MOVABLE CLEAT

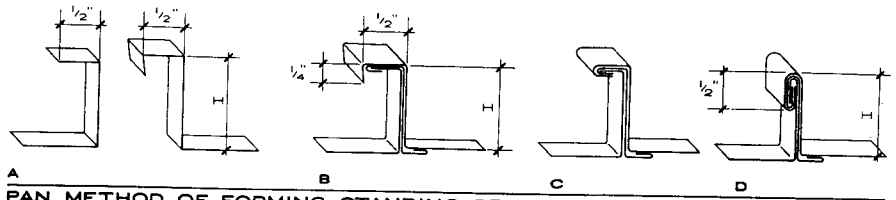

PAN METHOD OF FORMING STANDING SEAM

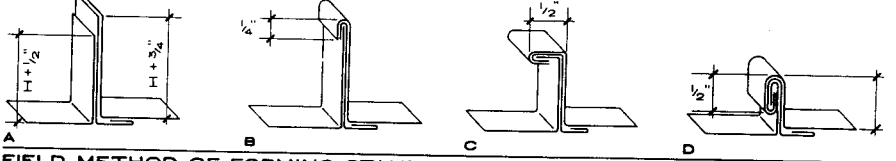

FIELD METHOD OF FORMING STANDING SEAM

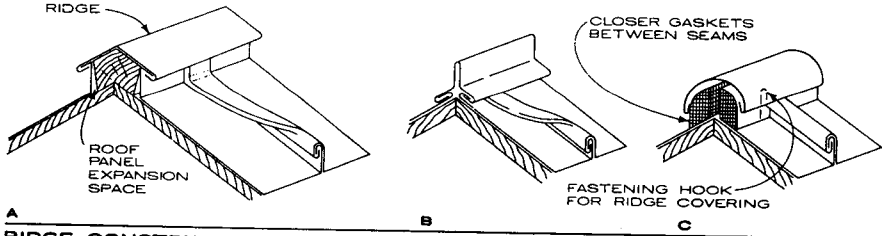

RIDGE CONSTRUCTION

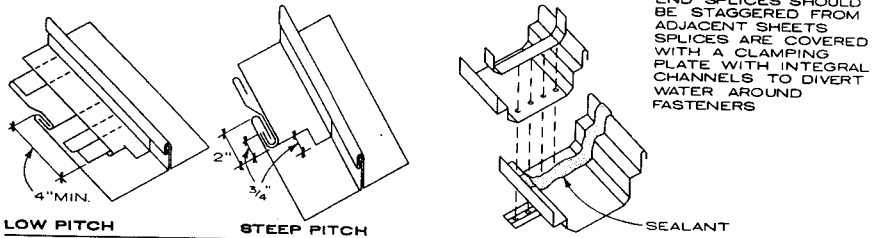

LOW PITCH STEEP PITCH  
TRANSVERSE SEAM AND PANEL SPLICE

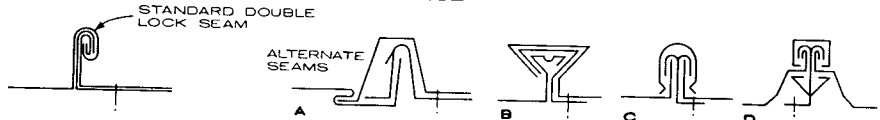

Standing seam roofing may be installed on slopes as gentle as 1/4 in./ft. Because of the architectural appearance of the roof system, it is more commonly used on steeper roof slopes, allowing the panels to be seen as part of the overall design.

The spacing of seams may vary within reasonable limits to suit the architectural style of a given building. Preformed sheets (as used with preengineered metal buildings) have seam locations set by locations of prepunched holes in the structural framing members.

The two methods of forming a standing seam are the pan method and the roll method. In the pan method, the

top, bottom, and sides of the individual sheets are preformed to allow locking together at each edge. Seams at the top and bottom of each sheet are called transverse seams. In the roll method, a series of long sheets are joined together at their ends with double flat lock seams. These field-formed seams can be executed either manually or with a seaming machine (a wheeled electronic device which runs along the sheet joint forming the seam).

In either method, cleats (spaced as recommended by the manufacturer) are formed into the standing seam. Seam terminations are usually soldered.

STANDING SEAM METHODS AND SHAPES

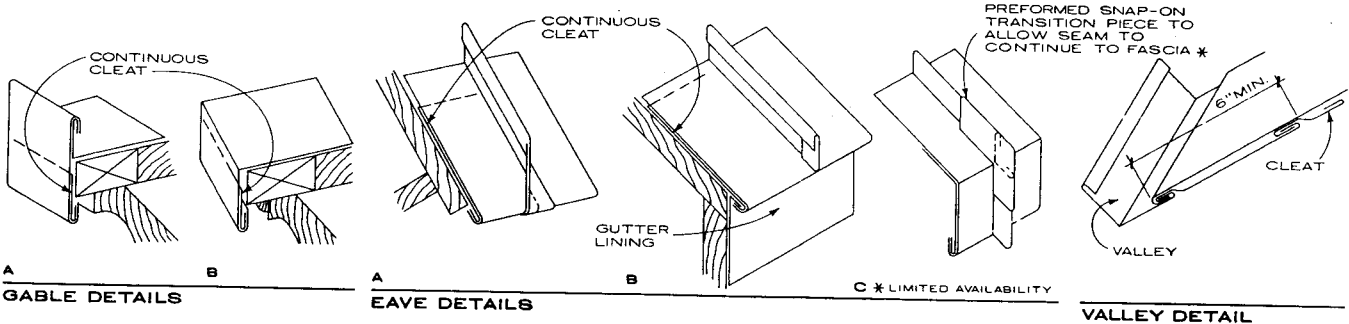

GABLE DETAILS

EAVE DETAILS

VALLEY DETAIL

Raso-Greaves, An Architecture Corporation; Waco, Texas  
 Straub Associates/Architects; Troy, Michigan  
 Emory E. Hinkel, Jr.; A. G. Odell, Jr. and Associates; Charlotte, North Carolina

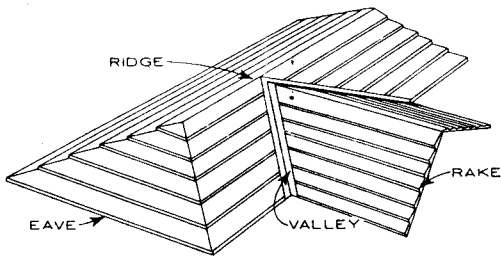

BERMUDA TYPE METAL ROOF

RECOMMENDED GAUGES OR WEIGHTS FOR PAN WIDTHS

WIDTH OF SHEET (IN.)	WIDTH OF PAN "D" (IN.)	COPPER (OZ)	GALVANIZED STEEL (GAUGE)	STAINLESS STEEL (GAUGE)	PAINTED TERNE 40 LB COATING
20	16 1/2	16	26	28	0.015 IN.
22	18 1/2	16	26	28	0.015 IN.
24	20 1/2	16	26	26	0.015 IN.
26	22 1/2	20	24	26	0.0178 IN.
28	24 1/2	20	24	26	0.0178 IN.

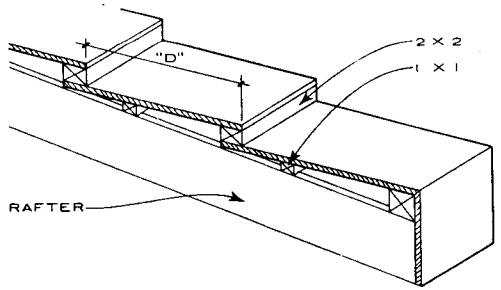

DETAIL 1-WOOD FRAMING

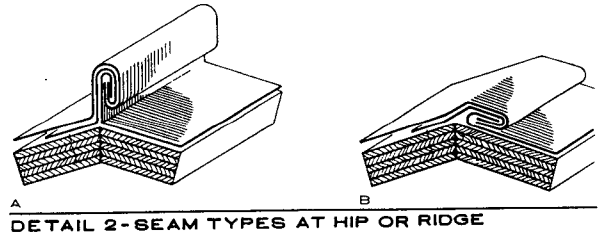

DETAIL 2-SEAM TYPES AT HIP OR RIDGE

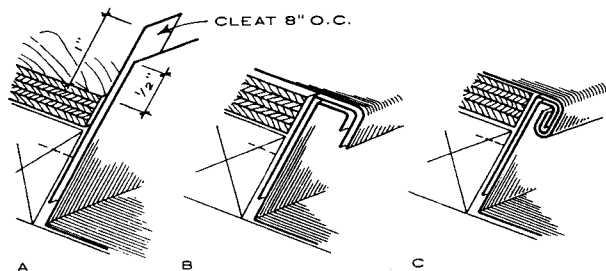

DETAIL 3-CONSTRUCTION AT BATTEN

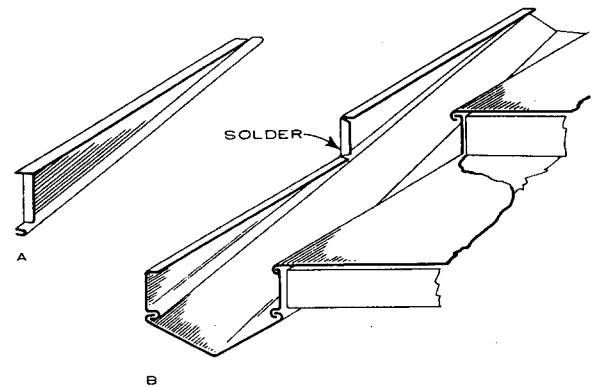

DETAIL 4-CONSTRUCTION AT CLOSURE AND VALLEY

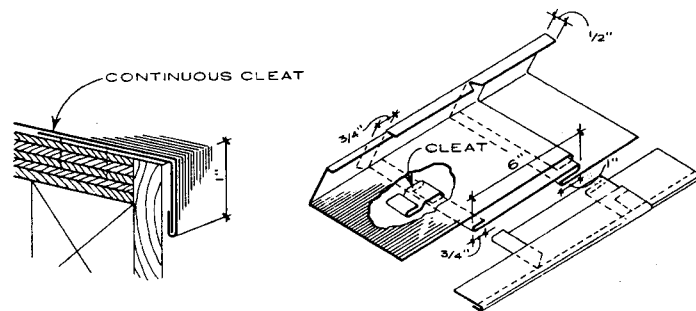

DETAIL 5-EAVE

DETAIL 6-EXPANSION JOINT

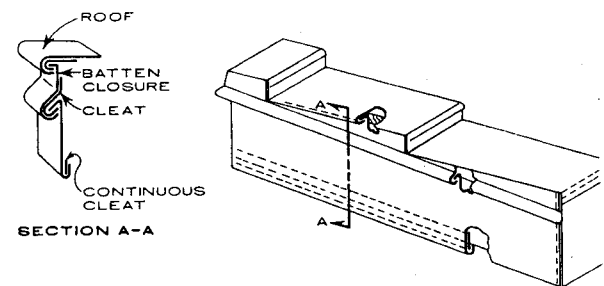

DETAIL 7-CONSTRUCTION AT RAKE

NOTES

1. The Bermuda roof may be used for roofs having a slope greater than 2 1/2 in./ft. Wood framing must be provided as shown in detail 1. Dimension "D" and gauge of metal will depend on the size of sheet used. See chart. Consult general notes on metal roofs for recommended surface preparation.
2. Bermuda roof is applied beginning at the eave. The first pan is hooked over a continuous cleat as shown in detail 5. The upper portion of the first and each succeeding pan is attached as shown in detail 3. Cleats spaced on 8 in. centers are nailed to batten

as in A of detail 3. Joint is developed as shown in B of detail 3 and malleted against batten as shown in C of detail 3. All cross seams are single locked and soldered except at expansion joints. Cross seams should be staggered. Expansion joints should be used at least every 25 ft and formed as shown in detail 6. Roofing is joined at hip or ridge by use of a standing seam as shown in A of detail 2. Seam may be malleted down as shown in B of detail 2.

3. Detail 4 shows the method of forming valleys. Valley sections are lapped 8 in. in direction of flow.

Individual closures for sides of valley are formed as shown in A of detail 4 and must be soldered as indicated in B of detail 4. A method of terminating the roof at rake is shown in detail 7. The face plate (optional) is held in place by continuous cleats at both top and bottom. The batten closure is formed as a cleat to hold edge of roof pan as shown in section A-A of detail 7.

See also Metal Roofs for general notes.

Straub Associates/Architects; Troy, Michigan  
Emory E. Hinkel, Jr.; A. G. Odell, Jr. and Associates; Charlotte, North Carolina

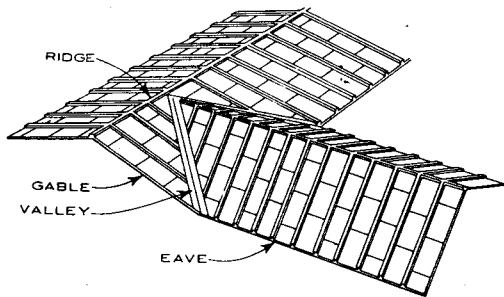

BATTEN SEAM METAL ROOF

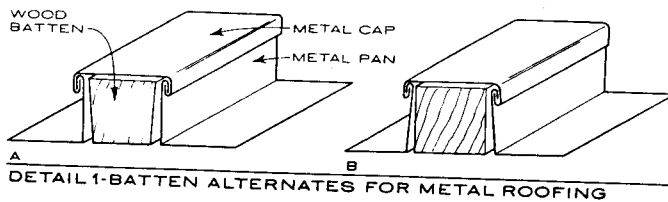

DETAIL 1-BATTEN ALTERNATES FOR METAL ROOFING

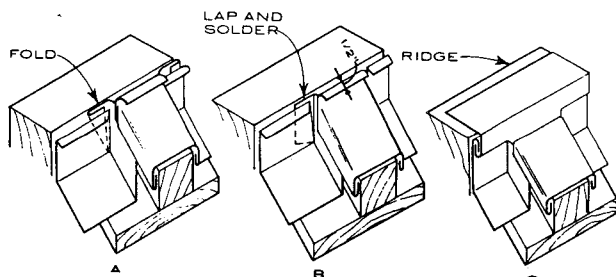

DETAIL 2-RIDGE CONSTRUCTION

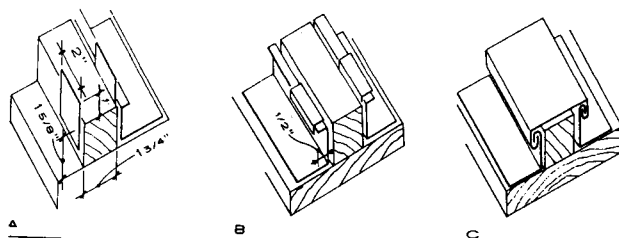

DETAIL 3-BATTEN JOINT CONSTRUCTION

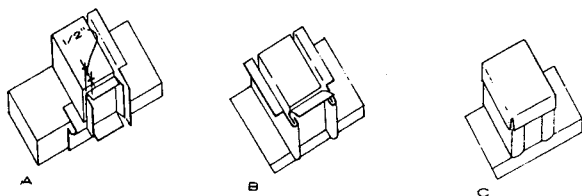

DETAIL 4-BATTEN CAP CONSTRUCTION

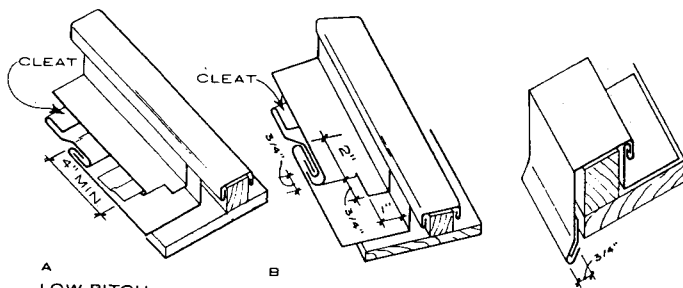

DETAIL 5-TRANSVERSE SEAM

DETAIL 6-GABLE

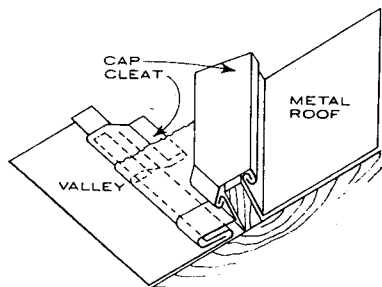

DETAIL 7-VALLEY

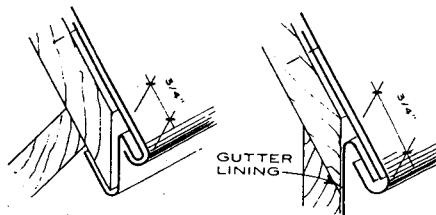

DETAIL 8-EAVES

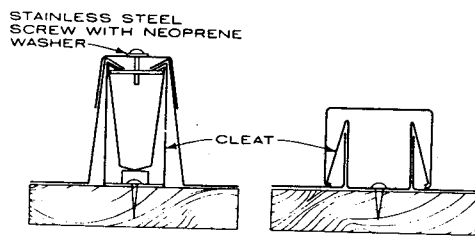

DETAIL 9-PREFABRICATED BATTENS

NOTES

1. Batten seam roofing may be applied on slopes of 3 in./ft or greater. If the surface to receive the roofing is other than wood, the battens should be bolted into place. All batten fasteners must be countersunk into battens. See general notes on Metal Roofs for recommended surface preparation.
2. The spacing of the wood battens may vary within reasonable limits to suit the architectural style and scale of the building, but the recommended maximum distance is 20 in. between battens. Care should be taken to space the battens in such a manner that waste of metal is held to a minimum. Battens may be shaped as shown in A or B of detail 1.

A is preferred, since it automatically makes allowance for expansion. When battens shown in B are used, care must be taken to provide for expansion by bending the metal where it meets the batten at greater than 90°.

3. Sheets are formed into pans with each side turned up 2 1/8 in. A 1/2 in. flange is turned toward the center of the pan as shown in B of detail 3. At lower end of the pan, the sheet is notched and a hook edge is formed as in A or B of detail 5. For low pitched roofs the upper end of the sheet is formed as in A of detail 5. On steeper roofs the upper end is formed as shown in B of detail 5. Pans

are installed, starting at the eave, and held in place with cleats spaced not over 12 in. on center as shown in A of detail 3. Each pan is hooked to the one below it and cleated into place. After pans are in place, a cap is installed over the batten as shown in B and C of detail 3.

4. A number of manufacturers have developed metal roofing systems using several prefabricated devices. A and B of detail 9 show two common prefabricated battens in use.
5. See also Standing Seam Metal Roofing for details on combination batten and standing or flat seam roofing. See also Metal Roofs for general notes.

Straub Associates/Architects; Troy, Michigan  
Emory E. Hinkel, Jr.; A. G. Odell, Jr. and Associates; Charlotte, North Carolina

MINIMUM THICKNESS (GAUGES OR WEIGHT) FOR COMMON FLASHING CONDITIONS

CONDITIONS	COPING WIDTH													NOTE	
	BASE COURSE	WALL OPENINGS HEAD AND SILL	THROUGH WALL AND SPANDREL	CAP AND BASE FLASHING	VERTICAL AND HORIZONTAL SURFACES	ROOF EDGE RIDGES AND HIPS	CRICKETS VALLEY OR GUTTER	CHIMNEY PAN	LEDGE FLASHING	ROOF PENETRATIONS	UP TO 12"	ABOVE 12"	EDGE STRIPS		CLEATS
MATERIALS	10 oz	10 oz	10 oz	16 oz	16 oz	16 oz	16 oz	16 oz	16 oz	16 oz	16 oz	20 oz	20 oz	16 oz	
Copper	0.019"	0.019"	0.019"	0.019"	0.019"	0.019"	0.019"	0.019"	0.019"	0.040"	0.032"	0.040"	0.024"		Note 6
Aluminum	30 GA	30 GA	30 GA	26 GA	30 GA	26 GA	26 GA	30 GA	26 GA	26 GA	26 GA	24 GA	24 GA		Note 5
Stainless steel	26 GA	26 GA	26 GA	26 GA	26 GA	24 GA	24 GA	26 GA	24 GA	24 GA	24 GA	22 GA	26 GA	22 GA	Note 2
Galvanized steel	0.027"	0.027"	0.027"	0.027"	0.027"	0.027"	0.027"	0.027"	0.027"	0.027"	0.027"	0.032"	0.040"	0.027"	Note 4
Zinc alloy	3#	2 1/2 #	2 1/2 #	2 1/2 #	3#	3#	3#	3#	3#	3#	3#	3#	3#	3#	Note 3
Lead	40#	40#	40#	20#	40#	20#	40#	20#	40#	40#			20#	40#	Note 8
Painted terne	See Note 7														Note 7
elastomeric sheet; fabric-coated metal	See Note 7														Note 7

GENERAL NOTES

- All sizes and weights of material given in chart are minimum. Actual conditions may require greater strength.
- All galvanized steel must be painted.
- With lead flashing use 16 oz copper cleats. If any part is exposed, use 3# lead cleats.
- Coat zinc with asphaltum paint when in contact with redwood or cedar. High acid content (in these woods only) develops stains.
- Type 302 stainless steel is an all purpose flashing type.
- Use only aluminum manufactured for the purpose of flashing.
- See manufacturer's literature for use and types of flashing.
- In general, cleats will be of the same material as flashing, but heavier weight or thicker gauge.
- In selecting metal flashing, precaution must be taken not to place flashing in direct contact with dissimilar metals that cause electrolysis.
- Spaces marked  $\otimes$  in the table are uses not recommended for that material.

GALVANIC CORROSION (ELECTROLYSIS) POTENTIAL BETWEEN COMMON FLASHING MATERIALS AND SELECTED CONSTRUCTION MATERIALS

CONSTRUCTION MATERIALS	COPPER	ALUMINUM	STAINLESS STEEL	GALVANIZED STEEL	ZINC	LEAD	BRASS	BRONZE	MONEL	UNCURED MORTAR OR CEMENT	WOODS WITH ACID (REDWOOD AND RED CEDAR)	IRON/STEEL
FLASHING MATERIALS												
Copper		●	●	○	●	○	○	○	○	○	○	○
Aluminum			○	○	○	○	○	○	○	○	○	○
Stainless steel				○	○	○	○	○	○	○	○	○
Galvanized steel					○	○	○	○	○	○	○	○
Zinc alloy						○	○	○	○	○	○	○
Lead							○	○	○	○	○	○

- Galvanic action will occur, hence direct contact should be avoided.
- Galvanic action may occur under certain circumstances and/or over a period of time.
- Galvanic action is insignificant, metals may come into direct contact under normal circumstances.

GENERAL NOTE: Galvanic corrosion is apt to occur when water runoff from one material comes in contact with a potentially reactive material.

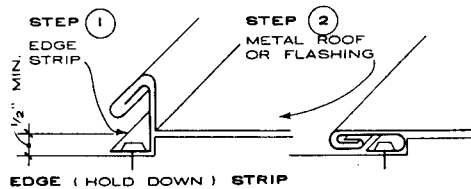

SINGLE LOCK BEAM NOTES

- Field fold end of each adjoining sheet in opposite direction.
- Hook folded edges together and dress down joint with a mallet.

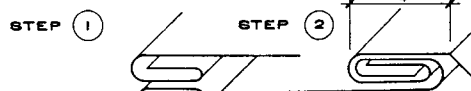

NOTES

- Double fold end of each adjoining sheet in opposite direction with bar folder.
- Slide edges together and dress down joint with a mallet.

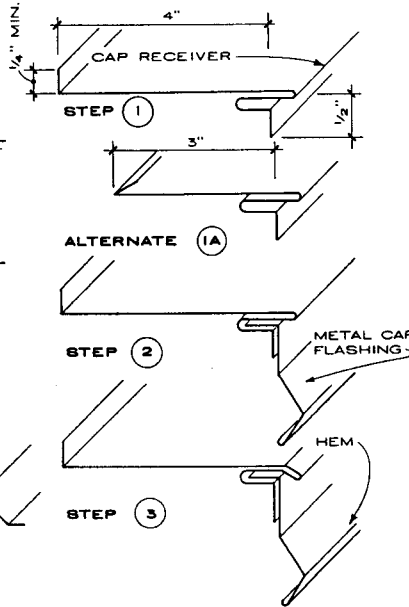

DEVELOPMENT OF CAP FLASHING

NOTE: Hem in cap flashing recommended for stiffness; but may be omitted if heavier gauge material used.

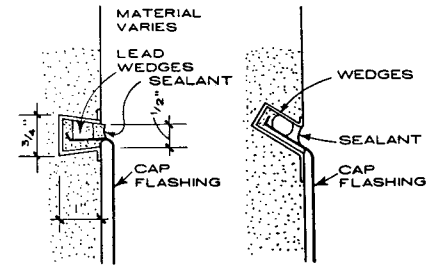

METAL REGLETS CAST IN PLACE

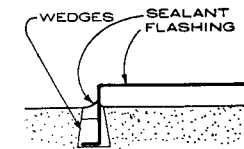

TYPICAL REGLETS

NOTE

Various types of metal reglets are available for cast in place and masonry work; see manufacturer's literature. Where material permits, reglets may be sawn. Flashing is secured in reglets with lead wedges at max. 12" o.c., fill reglet with nonhardening water-resistant compound.

Michael Scott Rudden; The Stephens Associates P.C.—Architects; Albany, New York

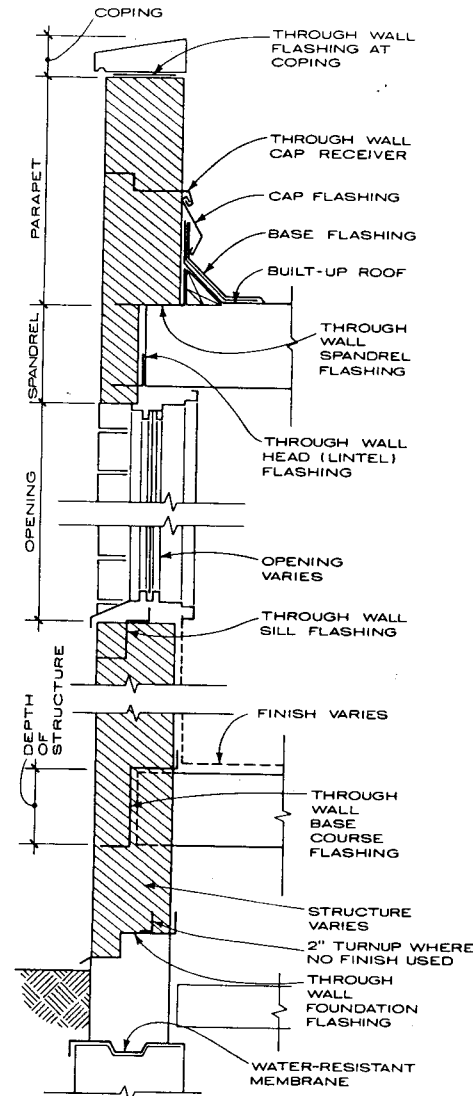

TYPICAL THROUGH WALL FLASHING AT WALL SECTION

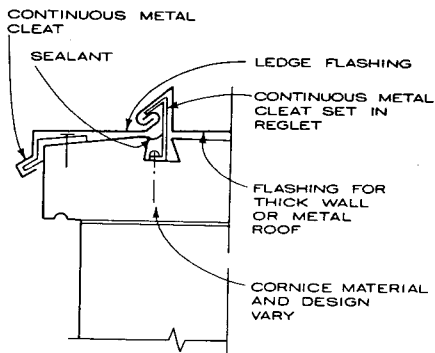

CORNICE FLASHING WITH METAL ROOF

SNAP-IN FLASHING WITH WIND PREVENTION CLIP

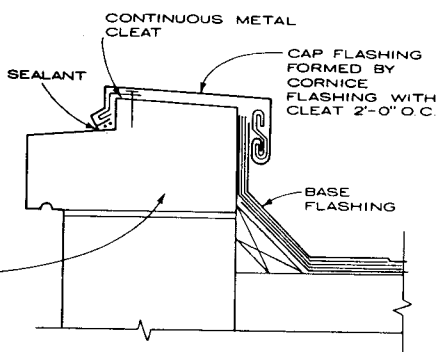

CORNICE FLASHING WITH CAP FLASHING

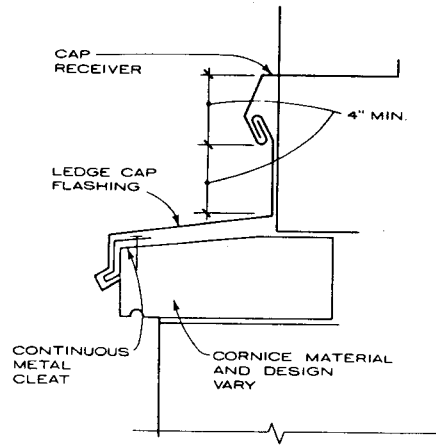

CORNICE LEDGE CAP FLASHING AND RECEIVER

CORNICE FLASHING

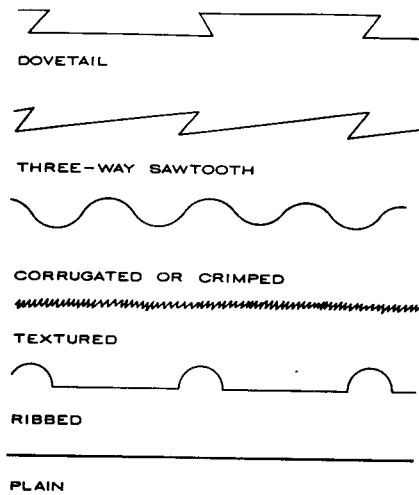

TYPICAL PROFILES OF THROUGH WALL FLASHING (PROPORTIONS EXAGGERATED)

DEFINITIONS

BASE FLASHINGS are essentially a continuation of the built-up roofing membrane at the upturned edges, applied in an operation separate from the application of the roof membrane itself.

CAP FLASHINGS (COUNTERFLASHINGS) are normally made of sheet metal and shield the exposed top of the base flashing. Some nonmetallic cap flashings are made of felts, and are made water-resistant with flashing cement.

CONCEALED FLASHINGS are invisible from the exterior or interior of the building. Metal sheet or foil, fabric, plastic, or various combinations of these materials may be used, depending on climate and structural requirements.

EXPOSED FLASHINGS are exposed to view and affect the aesthetics of the building. Metals are almost entirely used. Attention must be paid to the corrosive potential between dissimilar metals.

NOTES

1. Select flashing that is flexible for flashing supports and can withstand expected thermal, wind, and structural movement. Provide expansion joints in place of flashing as required by conditions.
2. Consult manufacturer's literature for choice of flashing materials and details.
3. Avoid sharp bends in bituminous base flashings. Use cant strips with 45° maximum bend.
4. Provision for differential movement between roof deck and wall is recommended.
5. Ribbed or embossed through wall flashing is not recommended for earthquake areas.
6. Base flashing should extend 8 to 12 in. above highest anticipated waterline. Metal counterflashings should lap base flashing at least 4 in. minimum. Lap all vertical joints.
7. At cavity walls with more than 3/4" space between wythes, use flashing of type that provides mechanical bond.

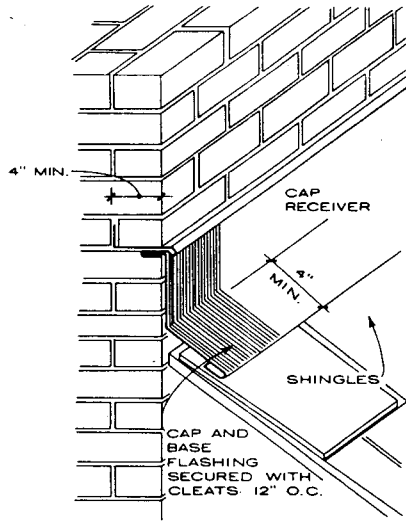

APRON FLASHING WHERE ROOF SLOPES FROM WALL

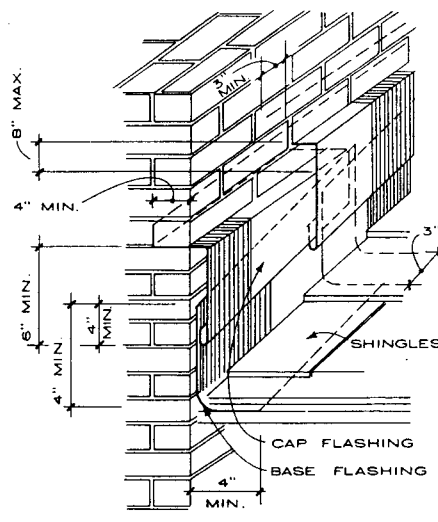

SEPARATE PIECES OF BASE FLASHING

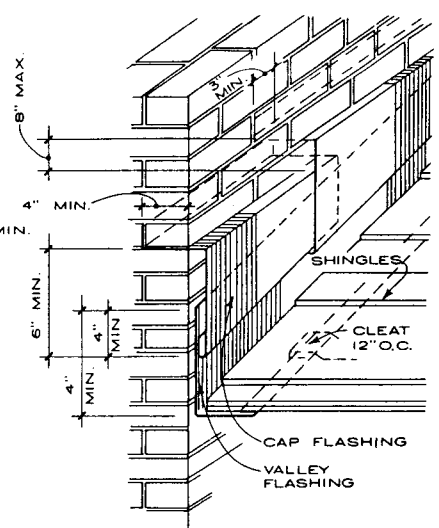

RUNNER BASE FLASHING

PITCHED ROOF WITH WALL FLASHING

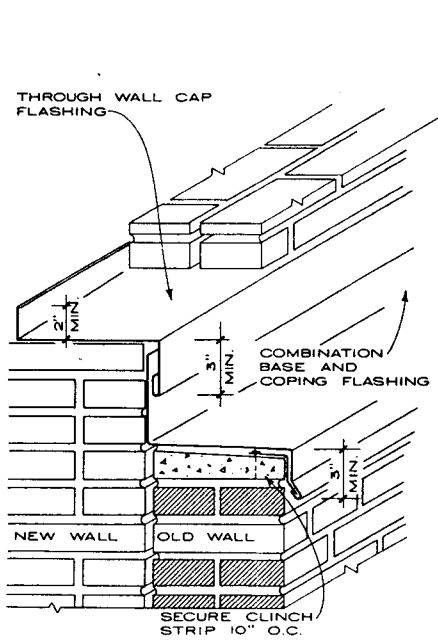

NEW WALL HIGHER THAN OLD WALL

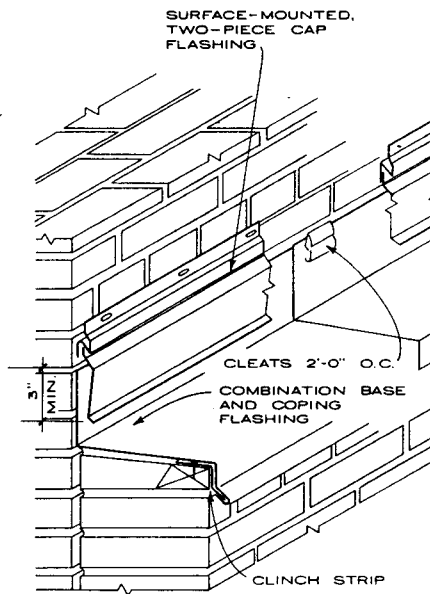

NEW WALL LOWER THAN OLD WALL

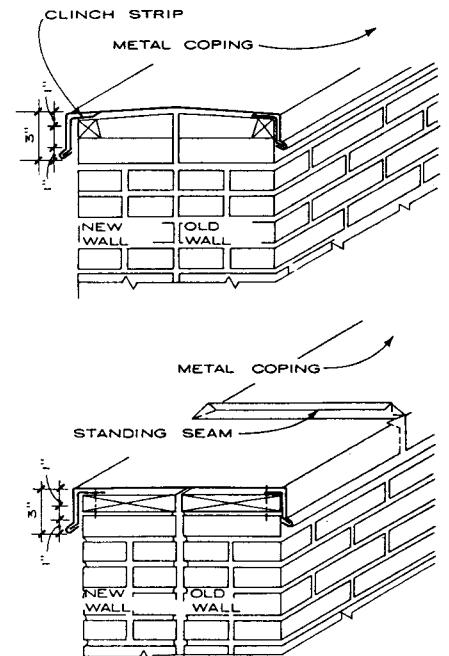

COPING FLASHING

NEW WALL TO OLD WALL FLASHING

NOTE  
Through wall flashing not recommended in earthquake areas.

Michael Scott Rudden; The Stephens Associates P.C.—Architects; Albany, New York

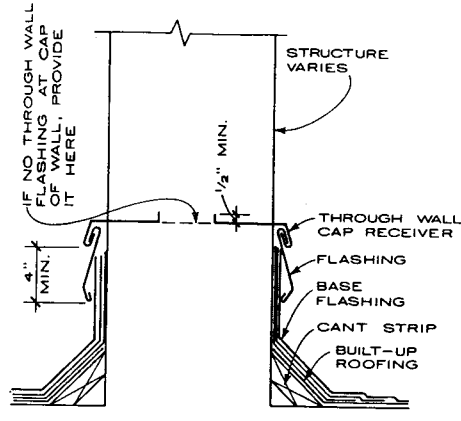

FIRE WALL

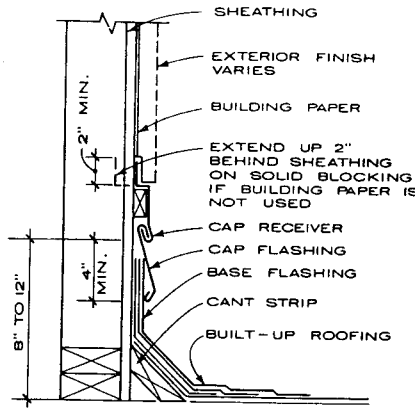

FRAME WALL

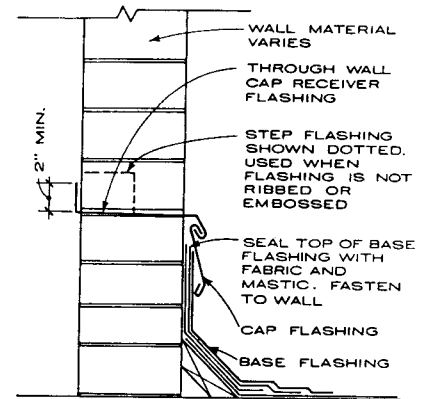

MASONRY WALL

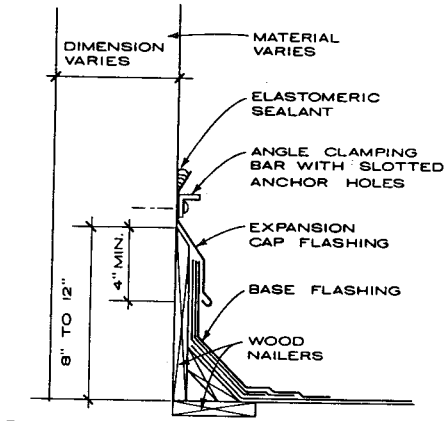

CAST IN PLACE CONC. WALL

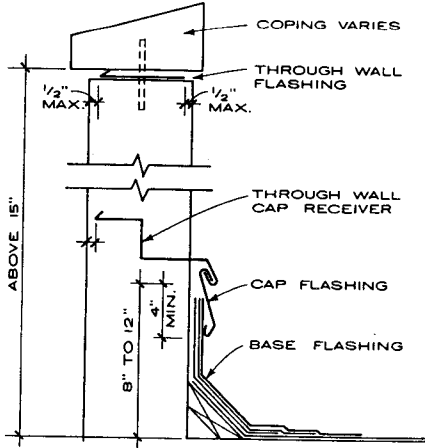

HIGH PARAPET FLASHING

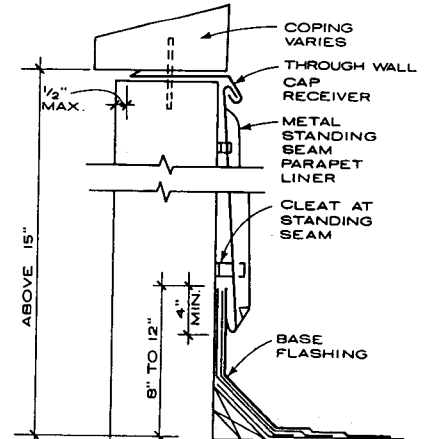

HIGH PARAPET WITH LINING

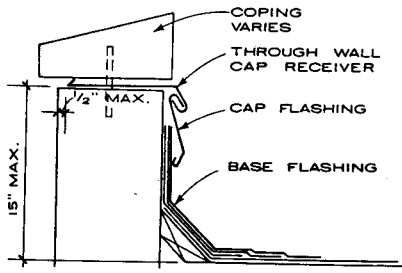

LOW PARAPET FLASHING

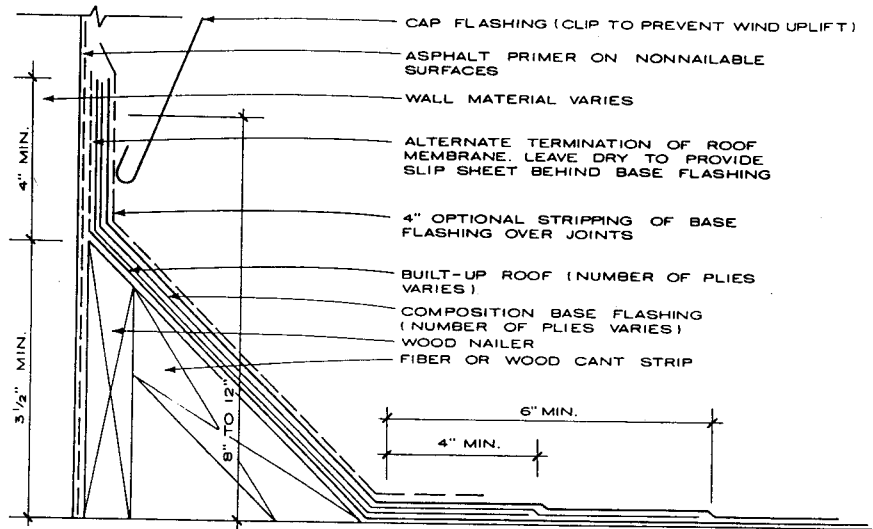

TYPICAL BASE FLASHING

**GENERAL NOTES**

1. Select flashing that is flexible for molding to flashing supports and that can withstand expected thermal, wind, and structural movement. Provide expansion joints in place of flashing as required by conditions.
2. Consult manufacturer's literature for choice of flashing materials and details.
3. Avoid sharp bends in bituminous base flashings. Use cant strips with 45° maximum bend.
4. Provision for differential movement between roof deck and wall is recommended.
5. A ribbed or embossed pattern should be used for all through wall flashing. Through wall flashing is not recommended for earthquake areas.
6. Base flashing should extend 8 to 12 in. above highest anticipated waterline. Metal counterflashing should lap base flashing by at least 4 in. Lap all vertical joints.

Michael Scott Rudden; The Stephens Associates P.C.—Architects; Albany, New York



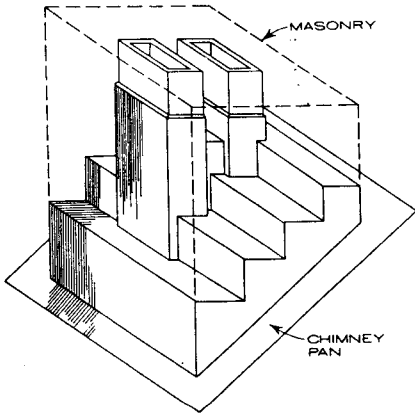

**STEPPED-PAN THROUGH WALL FLASHING**

RECOMMENDED FOR CHIMNEYS BUILT OF STONE, RUBBLE, ASHLAR, AND ANY POROUS MATERIAL.

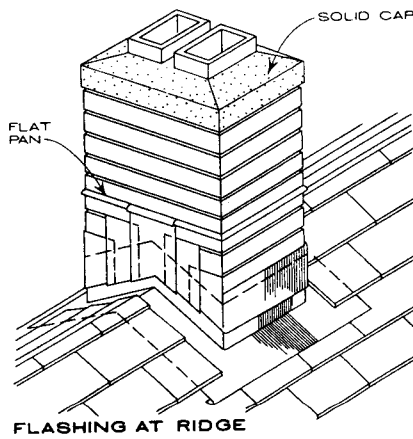

**FLASHING AT RIDGE**

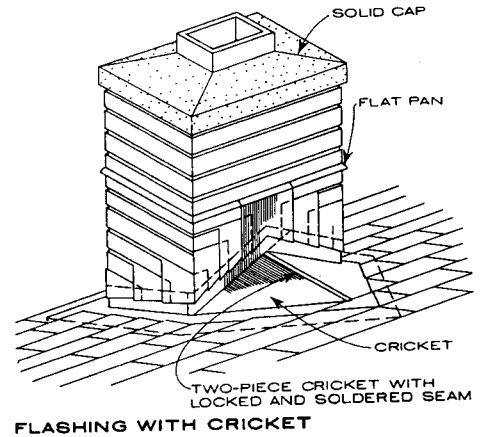

**FLASHING WITH CRICKET**

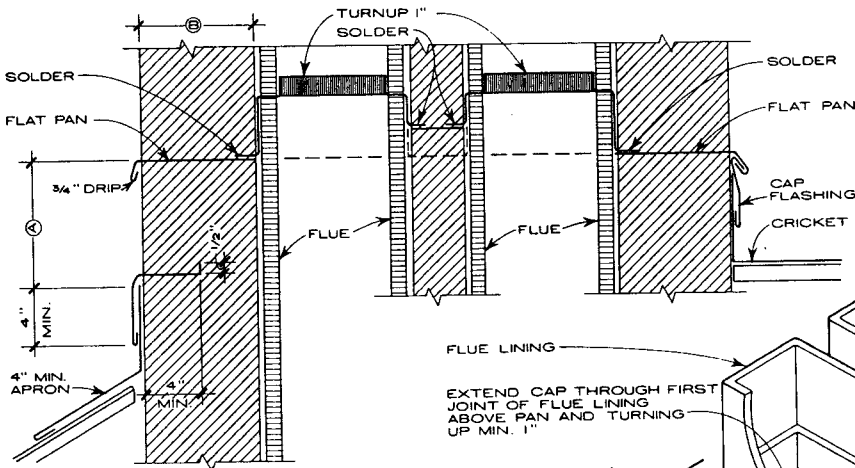

**SECTION A-A**

**NOTE**  
WHEN (A) DIMENSION EXCEEDS (B) DIMENSION OR (C) GREATER THAN 12" USE STEPPED-PAN THROUGH WALL FLASHING.

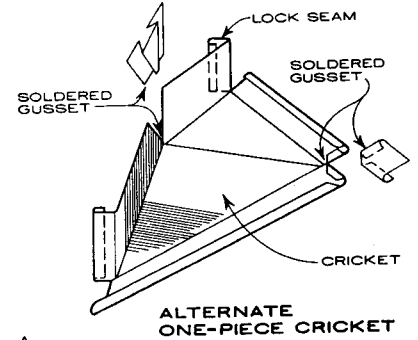

**ALTERNATE ONE-PIECE CRICKET**

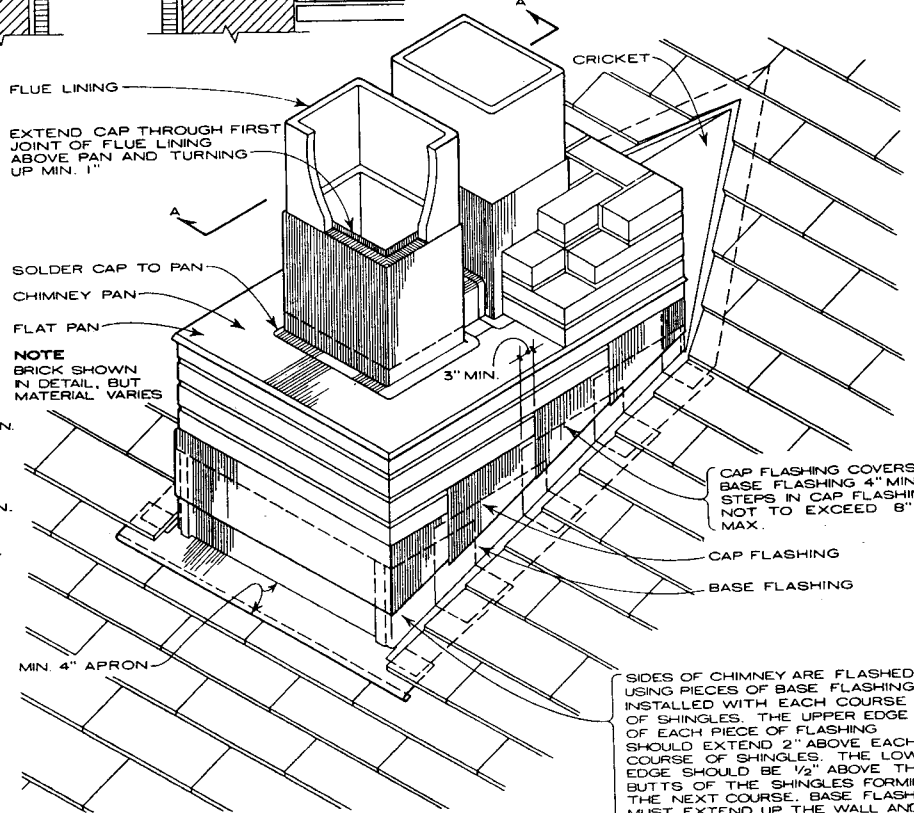

**FLAT PAN THROUGH WALL FLASHING**

SIDES OF CHIMNEY ARE FLASHED USING PIECES OF BASE FLASHING INSTALLED WITH EACH COURSE OF SHINGLES. THE UPPER EDGE OF EACH PIECE OF FLASHING SHOULD EXTEND 2" ABOVE EACH COURSE OF SHINGLES. THE LOWER EDGE SHOULD BE 1/2" ABOVE THE BUTTS OF THE SHINGLES FORMING THE NEXT COURSE. BASE FLASHING MUST EXTEND UP THE WALL AND ONTO THE ROOF MIN. OF 4".

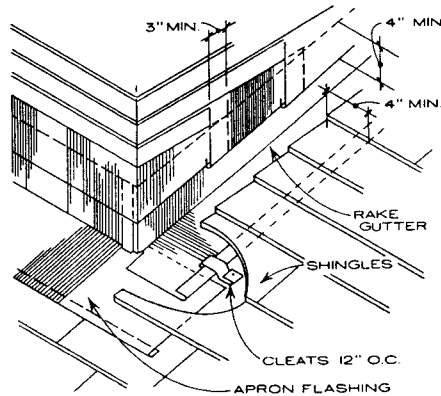

**ALTERNATE ONE-PIECE BASE FLASHING**

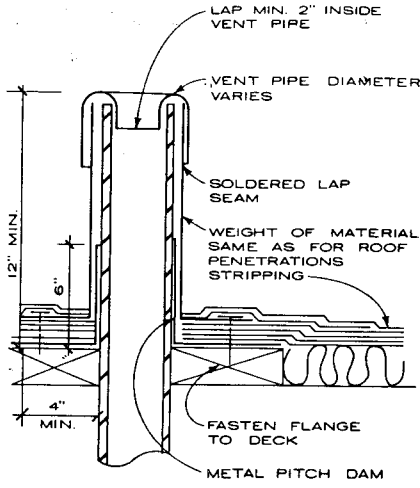

VENT PIPE

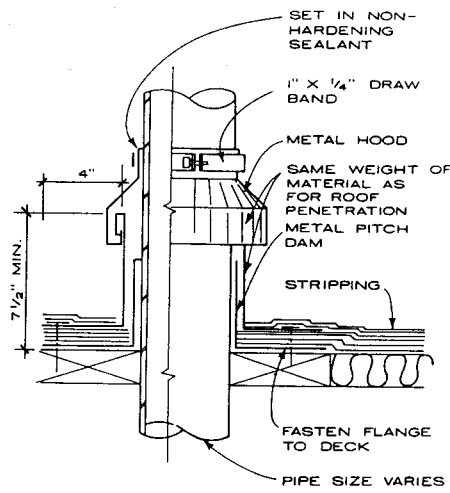

FLAGPOLES AND TALL PIPES

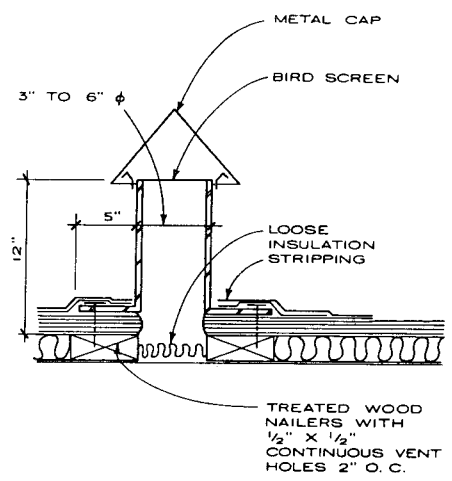

ROOF RELIEF VENT

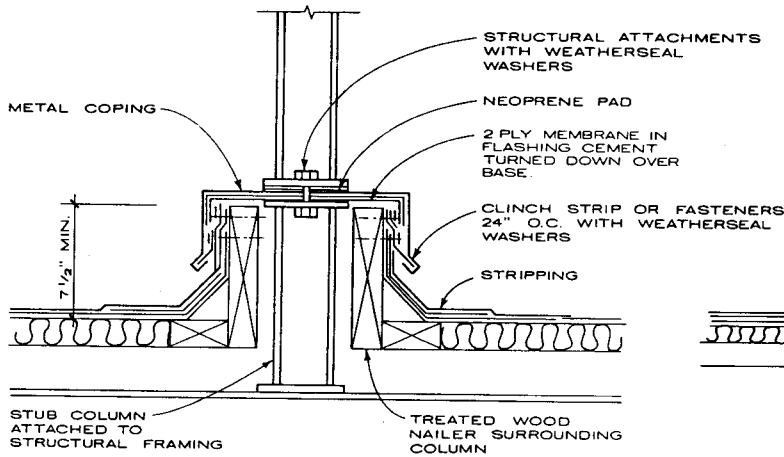

FUTURE COLUMNS, SIGN SUPPORTS, AND STEEL ANGLES

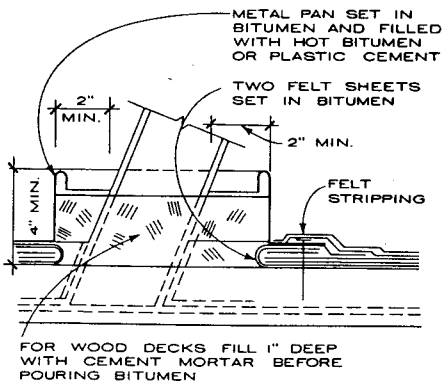
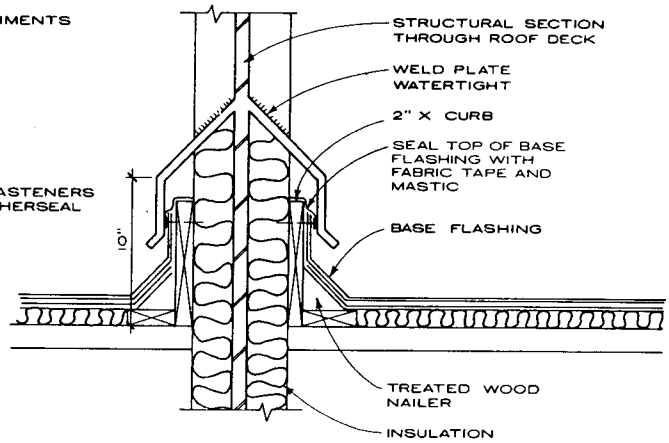

**NOTE**  
Whenever possible avoid the use of pitch pockets in favor of curbs with base and cap flashing around the penetrating member.

PITCH POCKET

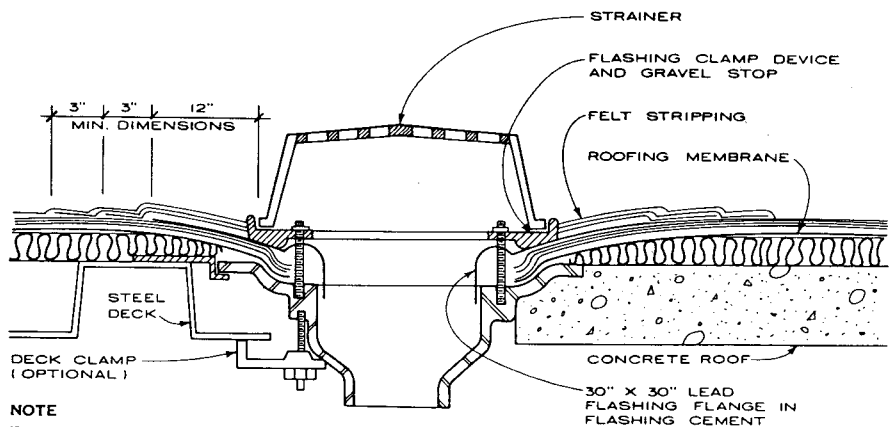

**NOTE**  
To obtain proper drainage, roof drains should be located at points of the lowest expected deflection in roof deck.

ROOF DRAIN

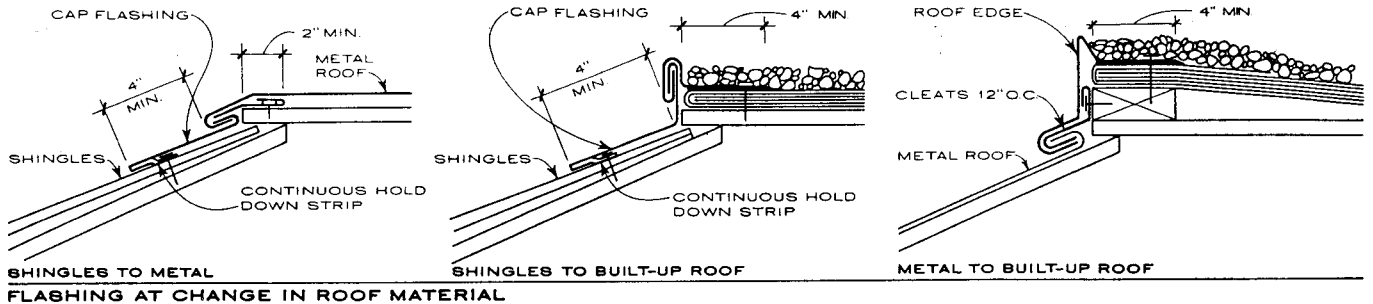

FLASHING AT CHANGE IN ROOF MATERIAL

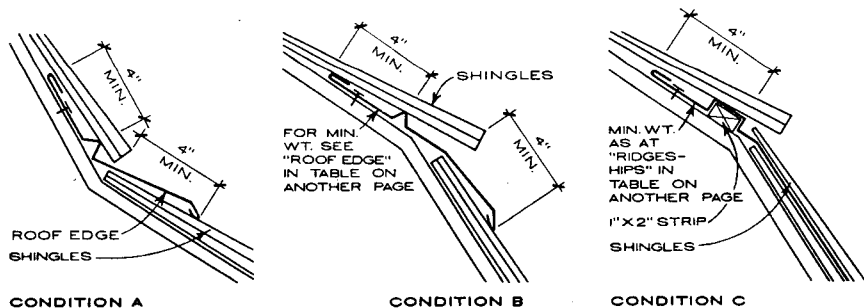

CONDITION A  
NOTE: Shingle material varies. Flashing nailed to sheathing 8" o.c.  
FLASHING OF BREAK IN SLOPE OF SHINGLE ROOFS

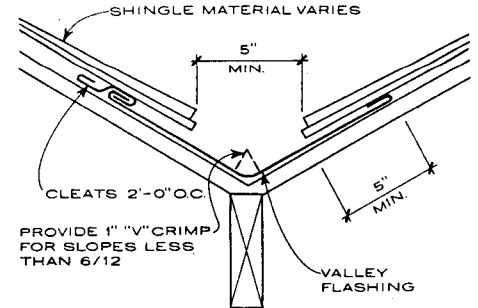

EQUAL SLOPES

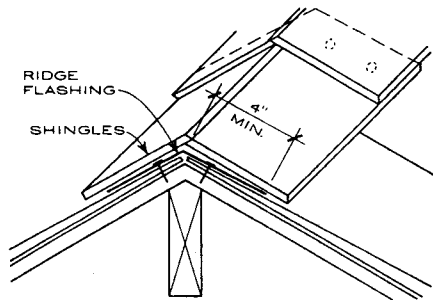

CONCEALED RIDGE FLASHING  
NOTE  
Ridge flashing formed in 10' lengths and lapped 4". Flashing is nailed to sheathing after shingles are installed, then flashing is covered with ridge shingles.

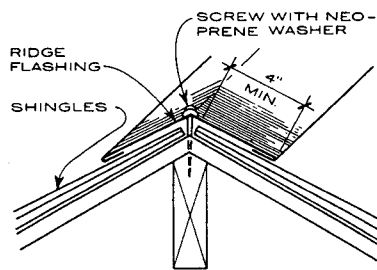

EXPOSED RIDGE FLASHING  
NOTE  
Ridge flashing formed in 10' lengths and lapped 4".

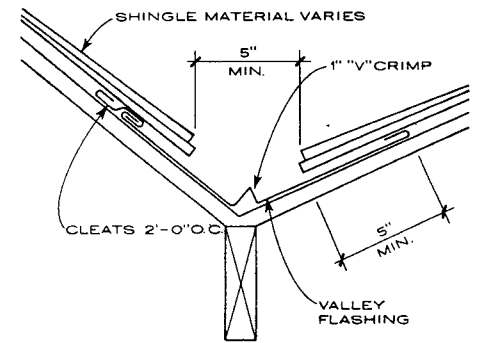

UNEQUAL SLOPES  
OPEN VALLEY FLASHING

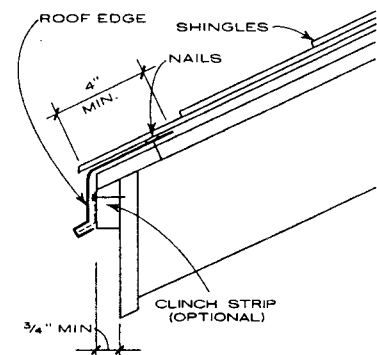

ROOF EDGE FLASHING

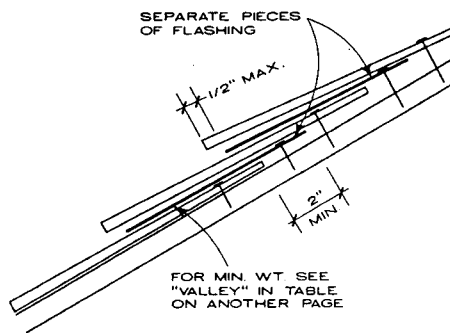

SECTION A-A  
CONCEALED VALLEY FLASHING

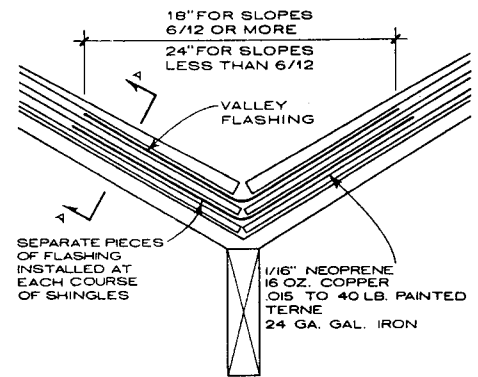

CROSS SECTION

Michael Scott Rudden; The Stephens Associates P.C.—Architects; Albany, New York

7 FLASHING

**GENERAL**

A water table is a ledge or slight projection of masonry, wood or other construction on the outside of a foundation wall, or just above. It protects the foundation from rain by throwing the water away from the wall. In the architectural hierarchy of a building form, the water table forms the transitional line between the base and middle sections. A water table is referred to as an offset when the base plane projects out from the upper plane.

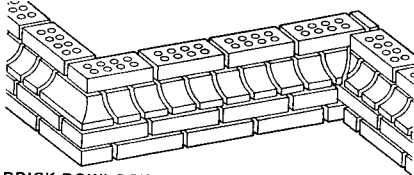

**BRICK ROWLOCK WATER TABLE**

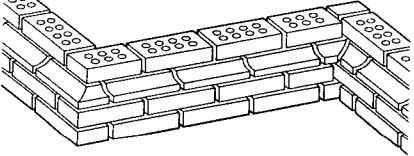

**BRICK STRETCHER WATER TABLE**

**BRICK VENEER**

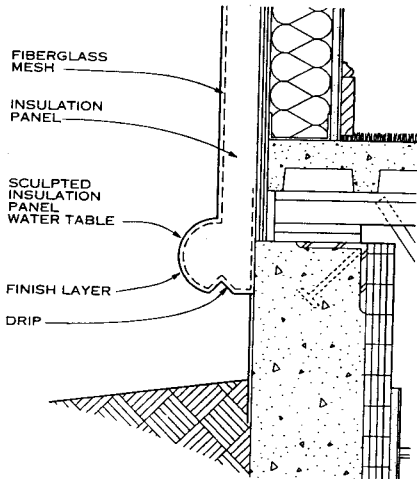

**EXTERIOR INSULATION AND FINISH SYSTEM**

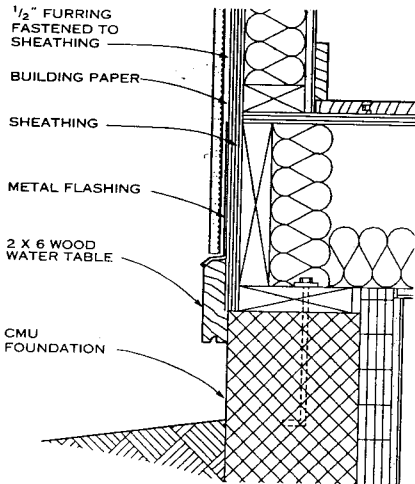

**STUCCO**

**TROWELED EXTERIOR VENEER**

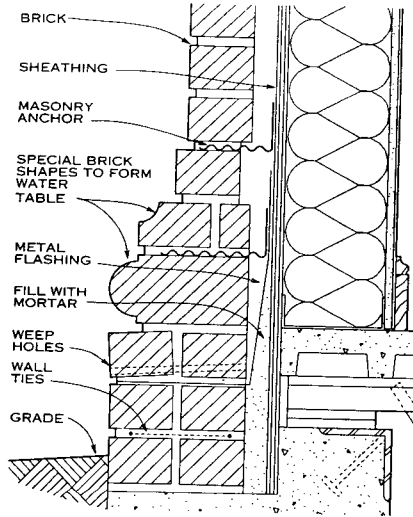

**BRICK WATER TABLE**

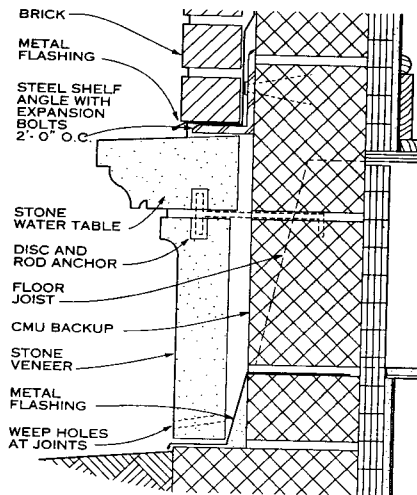

**BRICK VENEER WITH STONE WATER TABLE**

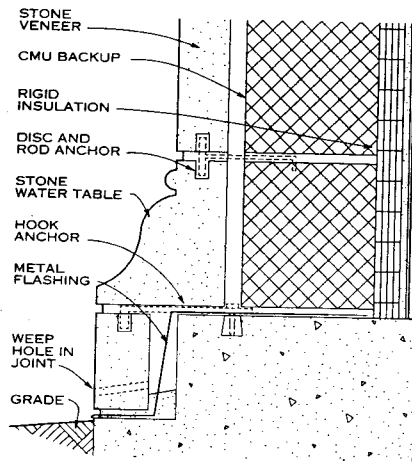

**STONE VENEER WITH STONE WATER TABLE**

**MASONRY VENEER**

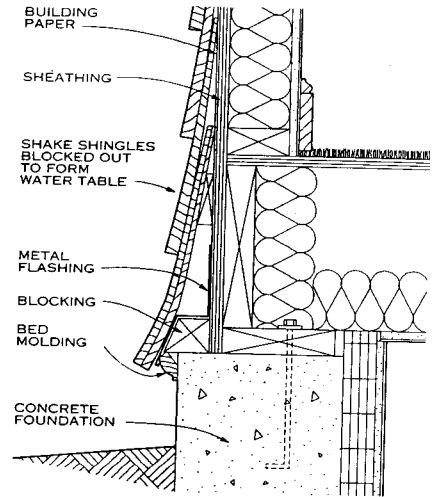

**BLOCKED-OUT SHAKE SHINGLES WITH PROTRUDED FOUNDATION**

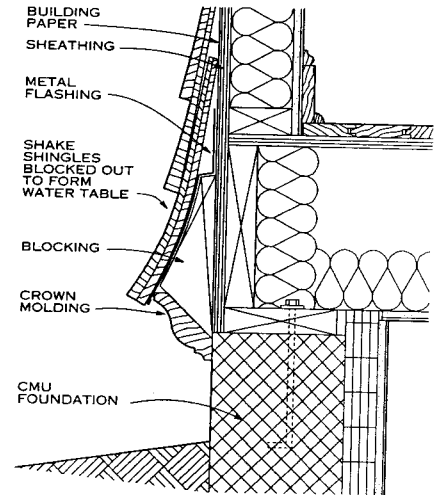

**BLOCKED-OUT SHAKE SHINGLES**

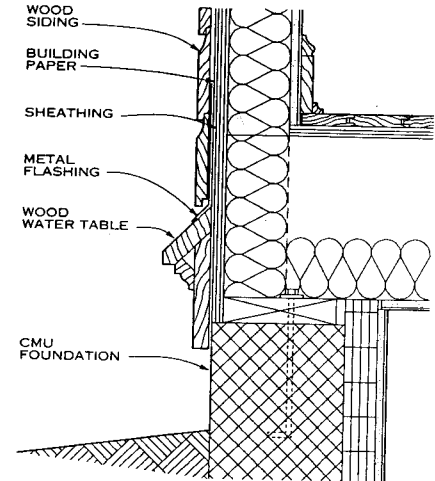

**STRAIGHT SIDING FLUSH WITH FOUNDATION**

**WOOD SIDING**

Richard J. Vitullo, AIA; Oak Leaf Studio; Crownsville, Maryland

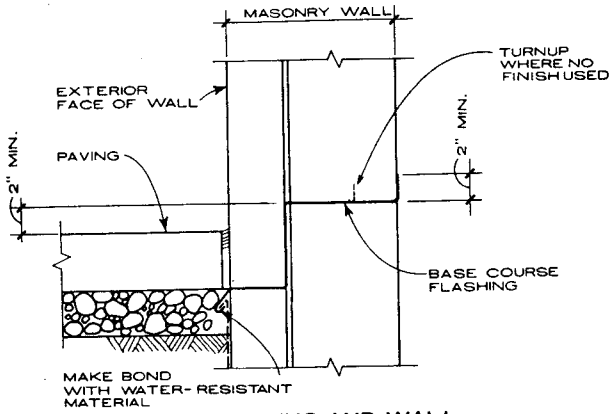

BASE COURSE AT PAVING AND WALL

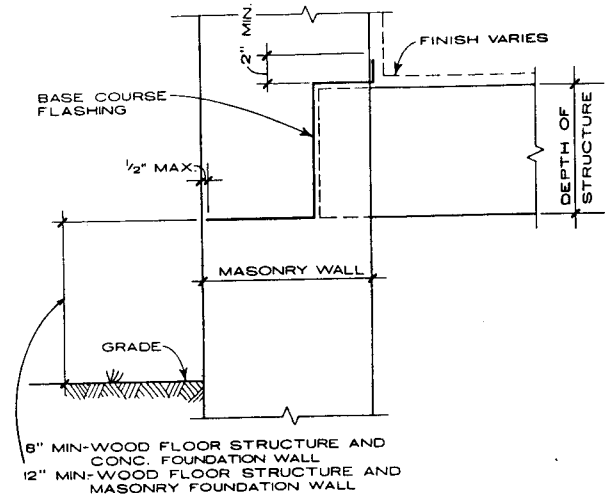

BASE COURSE AT FLOOR CONSTRUCTION

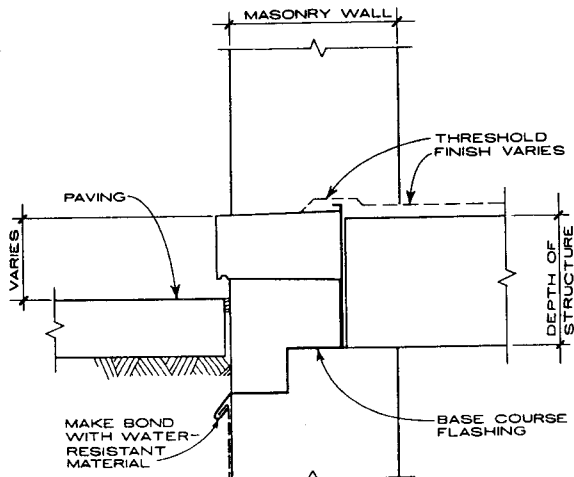

BASE COURSE AT SILL OF MASONRY CONSTRUCTION

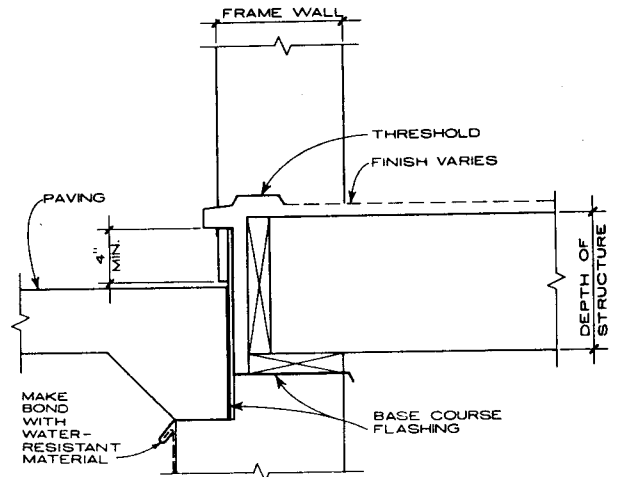

BASE COURSE AT SILL OF FRAME CONSTRUCTION

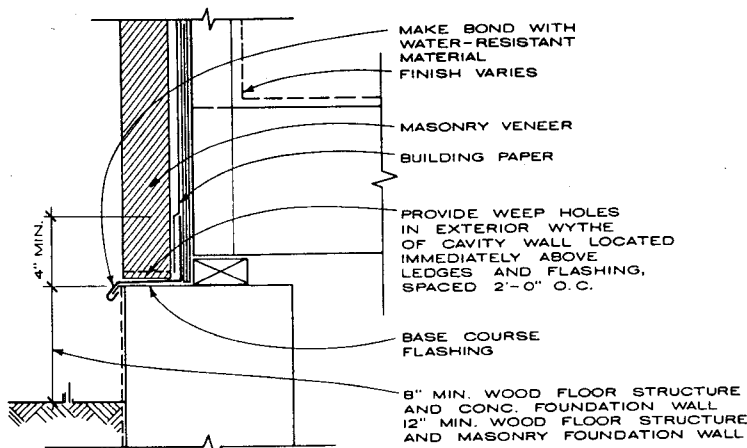

BASE COURSE AT MASONRY VENEER

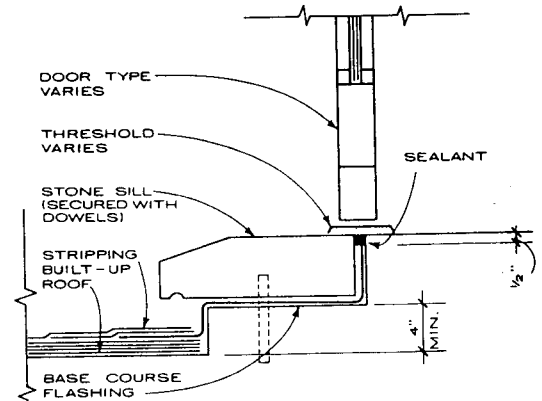

BASE COURSE AT SILL TO BUILT-UP ROOF

Michael Scott Rudden; The Stephens Associates P.C.—Architects; Albany, New York

7 FLASHING

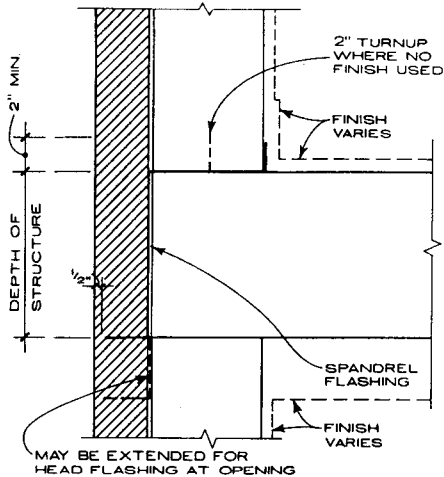

CONDITION NO. 1

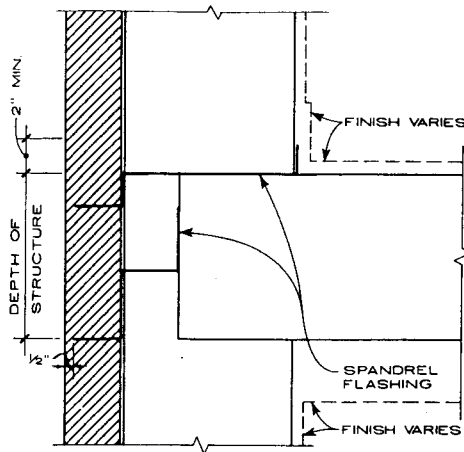

CONDITION NO. 2

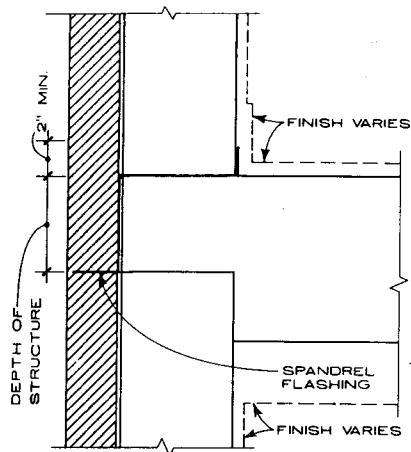

CONDITION NO. 3

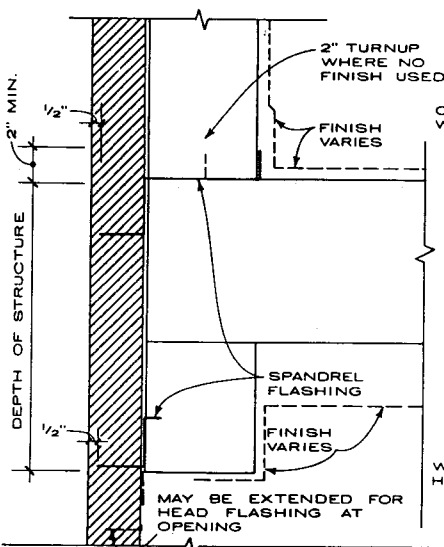

CONDITION NO. 4

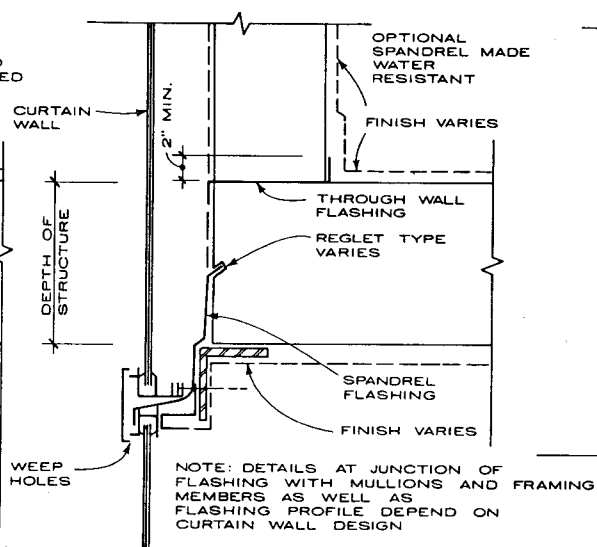

CONDITION NO. 5

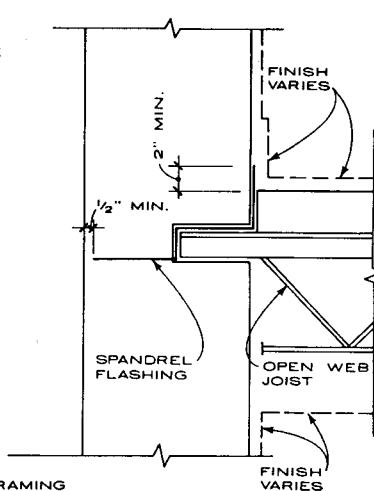

CONDITION NO. 6

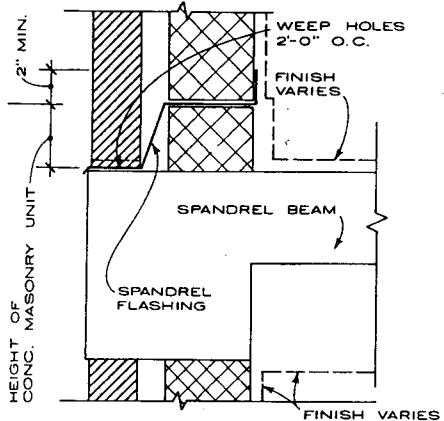

CONDITION NO. 7

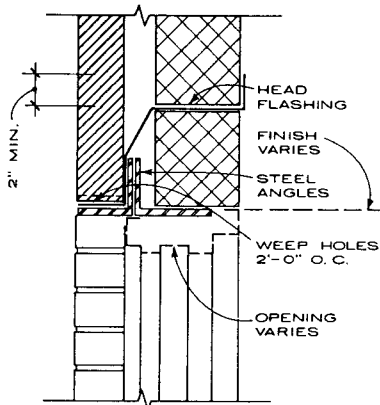

HEAD FLASHING

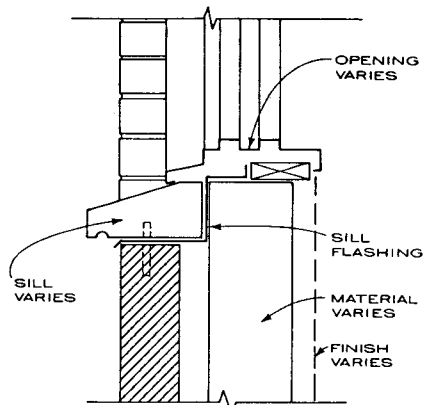

SILL FLASHING

Michael Scott Rudden; The Stephens Associates P.C.—Architects; Albany, New York

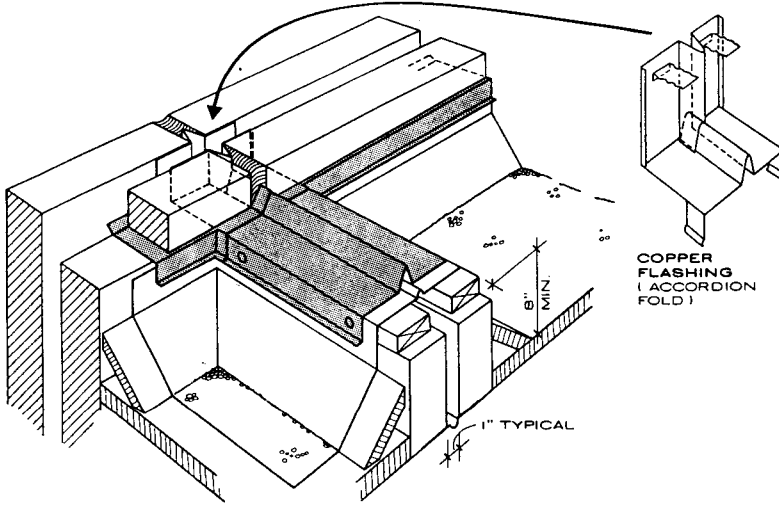

EXPANSION JOINT AT INTERSECTION OF WALL AND PARAPET

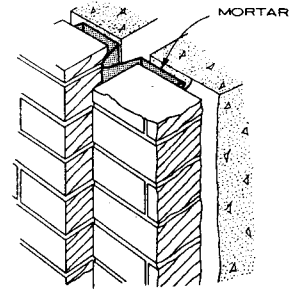

WATERSTOPS SHOULD RUN CONTINUOUS FROM FOOTING TO TOP OF BUILDING. LAP JOINT 4" IN DIRECTION OF FLOW

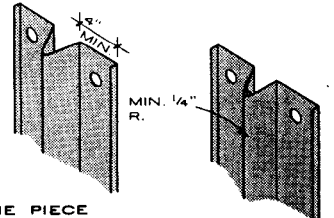

ONE PIECE

TWO PIECE

VERTICAL EXPANSION JOINT AT WALL

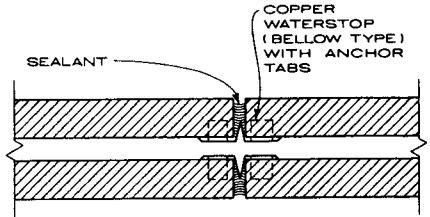

PLAN SECTION AT PARAPET WALL

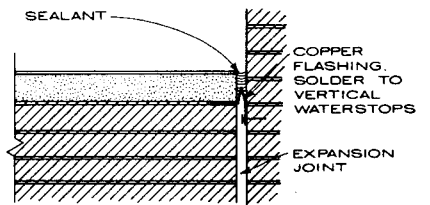

VERTICAL SECTION AT PARAPET COPING

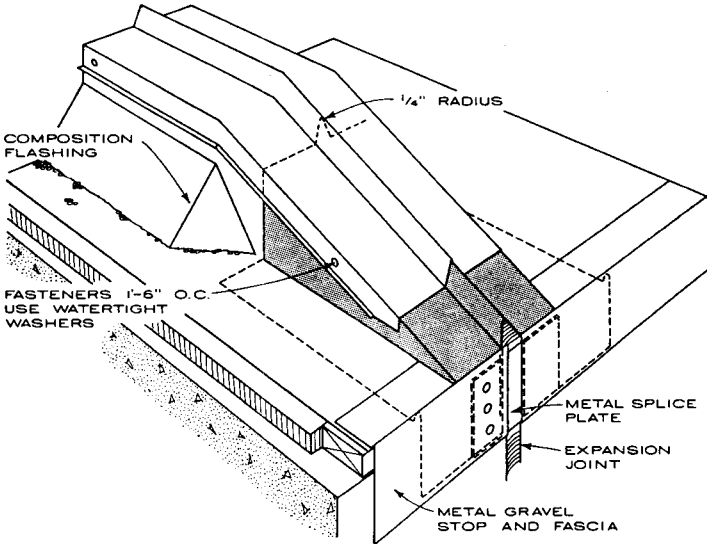

EXPANSION JOINT TRANSITION AT EAVE

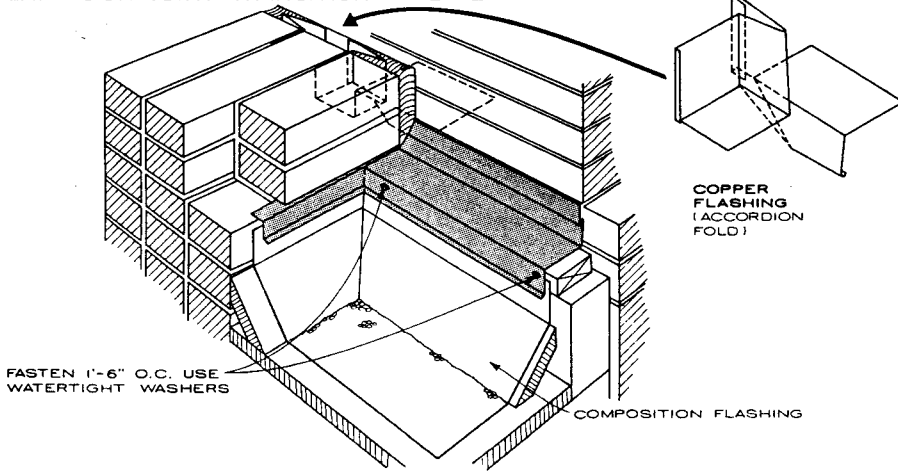

EXPANSION JOINT AT INTERSECTION OF WALL AND PARAPET

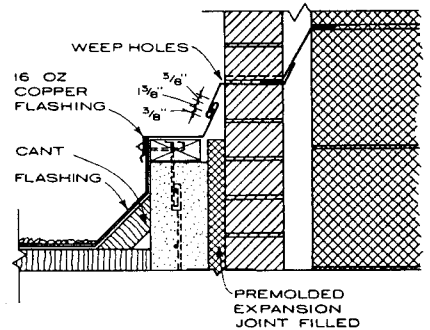

EXPANSION JOINT AT ROOF AND WALL

CTA Architects Engineers; Billings, Montana

7 FLASHING

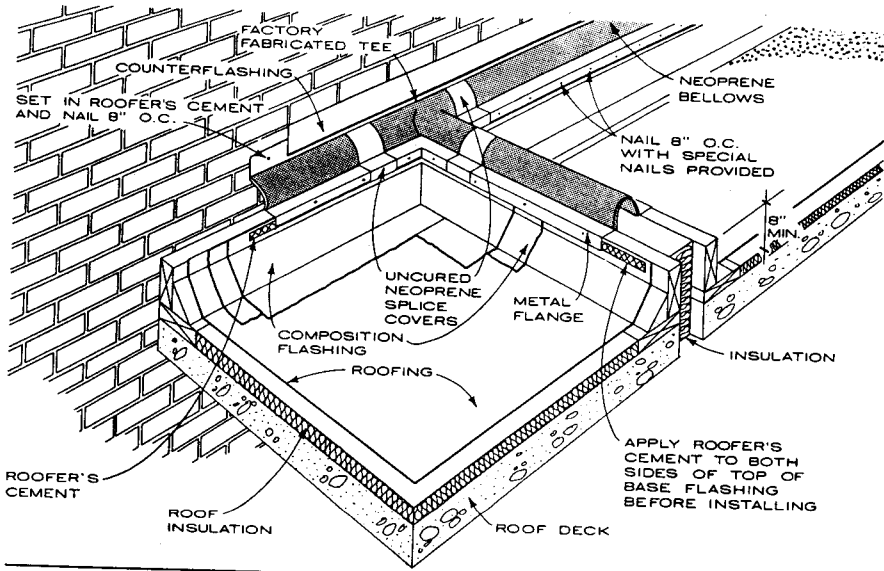

CURB FLANGE EXPANSION JOINT COVER AT WALL

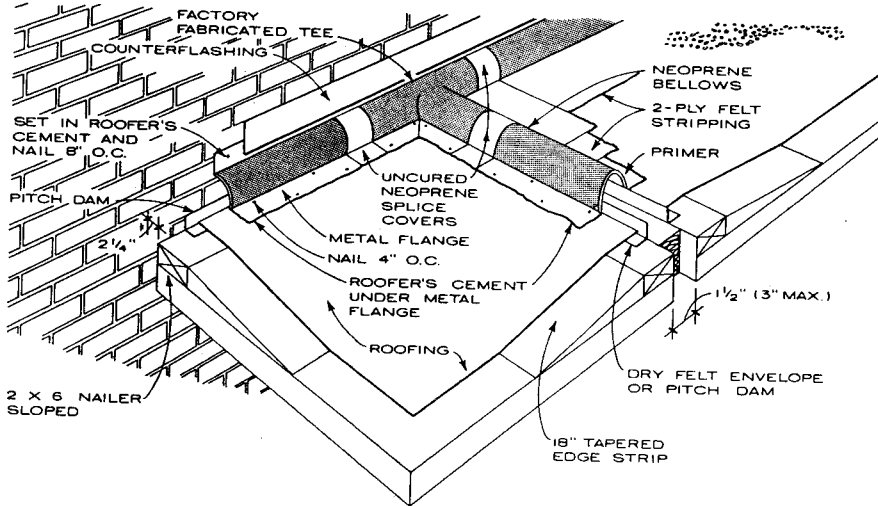

STRAIGHT FLANGE EXPANSION JOINT COVER AT WALL

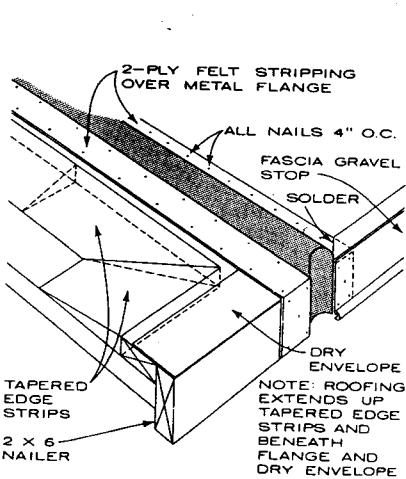

STRAIGHT FLANGE AT GRAVEL STOP

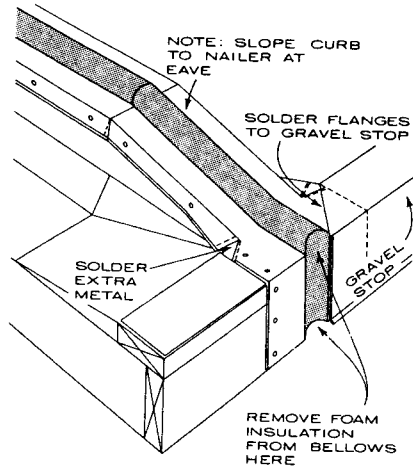

CURB FLANGE AT GRAVEL STOP

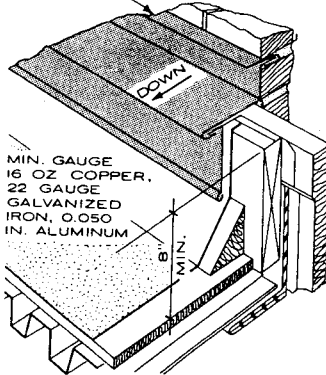
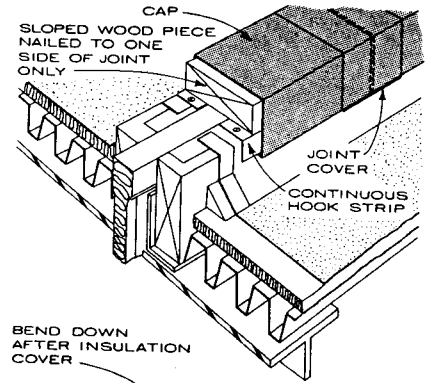
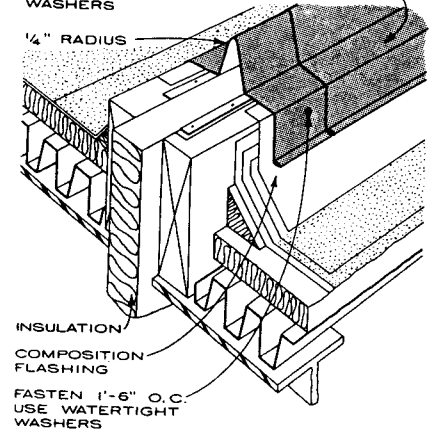
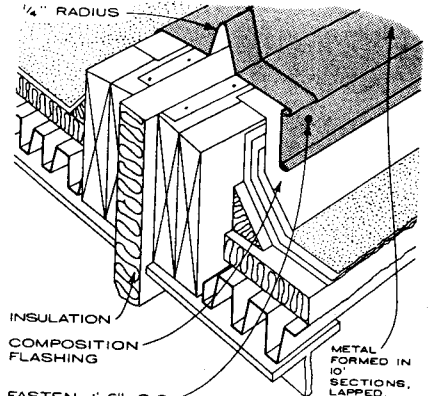

BUILDING EXPANSION JOINTS



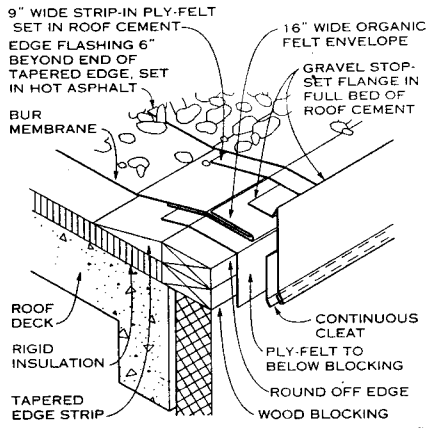

EDGE FLASHING

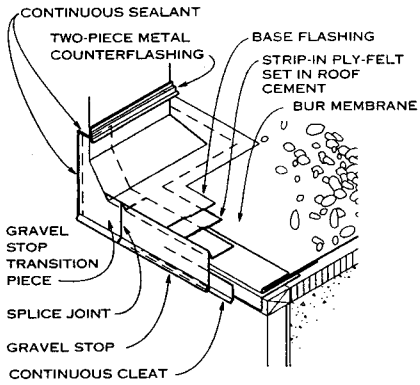

GRAVEL STOP TRANSITION

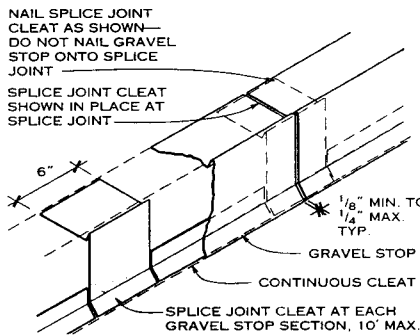

GRAVEL STOP SPLICE JOINT

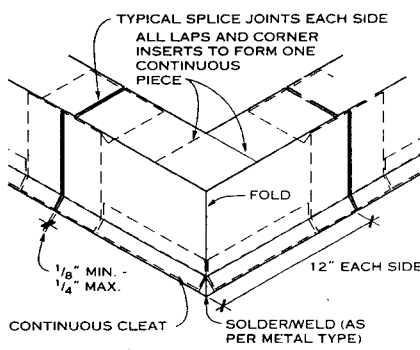

GRAVEL STOP OUTSIDE CORNER FABRICATION

RECOMMENDED MINIMUM GAUGES FOR GRAVEL STOP—FASCIA

D (MAX) (IN.)	GALVANIZED STEEL (GAUGE)	COPPER (OZ.)	ALUMINUM (IN.)	ZINC ALLOY (IN.)	STAINLESS STEEL (GAUGE)
4	24	16	0.025	0.020	26
5	24	16	0.032	0.027	26
6	22	20	0.040	0.027	24
7	22	20	0.040	-	22
8	20	20	0.050	-	20

RECOMMENDED MINIMUM GAUGES FOR COPING

WIDTH OF COPING TOP (IN.)	GALVANIZED STEEL (GAUGE)	STAINLESS STEEL (GAUGE)	ALUMINUM (IN.)	COPPER (OZ.)
Through 12	24	26	0.232	16
13 to 18	22	24	0.040	20

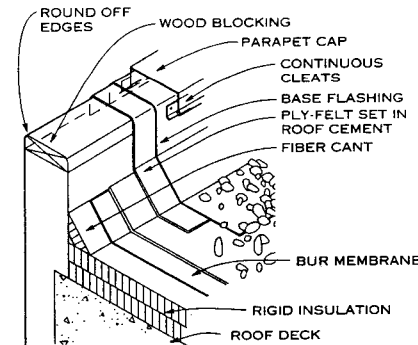

PARAPET EDGE DETAIL

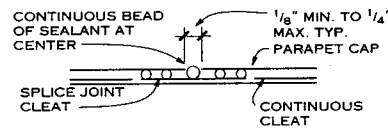

SECTION THROUGH SPLICE JOINT

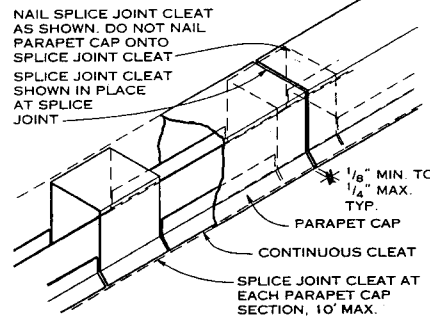

PARAPET CAP SPLICE JOINT

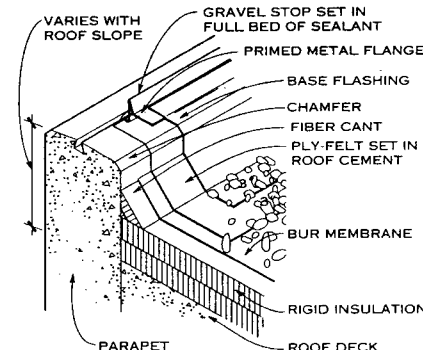

EDGE DETAIL

SELECTION OF FLASHING METAL

Each commonly used flashing metal has distinctive characteristics, uses, and limitations. Thickness of materials is a function of material size, aesthetic consideration (prevention of oil-canning), and wind uplift due to metal movement during violent storms.

GALVANIZED STEEL

Galvanized steel flashings should be a minimum of 24 gauge with a G-90 galvanized coating. Of commonly used flashing metals, galvanized steel probably is the most common and least expensive. Although galvanized flashing metal may be left exposed, generally it is painted to further protect the steel from corrosion. Before it is painted, galvanized metal must be prepared. Plain galvanized material chemically etched in the field is preferred for surfaces to be painted. Factory etching, in which the metal is dipped in an acid bath, etches it on all sides. As a result, exposed edges often rust. Field etching is preferred because only the surfaces to be painted are etched. After etching, the surface should be primed and finish painted, preferably with two coats.

Galvanized steel is easy to solder, low in cost, and easy to work. All flashing metal transitions and terminations should be soldered fully for permanent installation; however, this should not be done at metal flashing joints where movement caused by thermal expansion is expected or at building expansion joints.

STAINLESS STEEL

Stainless steel retains many of the advantages of other steel products and yet is generally corrosion resistant. In addition to resisting corrosion, stainless steel can be field soldered so as to accommodate difficult transition and termination conditions. If the mill finish appearance is not acceptable, the stainless steel may be field painted after installation by using a primer followed by finish painting.

COPPER

Copper is also among the lifetime materials that are considered maintenance free. It can be soldered and molds very easily, which makes it adaptable to complicated transitions and changes of plane. Since copper can be soldered in the field, it should be terminated with fully soldered conditions. The designer should be aware, however, that the runoff from the metal can stain adjoining building materials. Copper is generally found to be a softer material than other flashing metals. Copper has a moderate coefficient of expansion in that it is higher than steel and yet less than aluminum.

ALUMINUM

Aluminum is among the permanent materials because it corrodes at a slow rate. Aluminum will, however, oxidize and pit over time, depending on the exposure. Since aluminum can only be connected by welding, field conditions are more difficult to accommodate. Although corner conditions can very often be prefabricated, unusual or difficult changes of plane may be difficult to properly accommodate in aluminum. Aluminum also has a high coefficient of expansion and contraction compared with other flashing metals and field welding is difficult. Due to the limitations of in-field fabrications, aluminum is best used on roofs of simple configurations and few transitions.

Joseph J. Williams, AIA; A/R/C Associates Inc.; Orlando, Florida

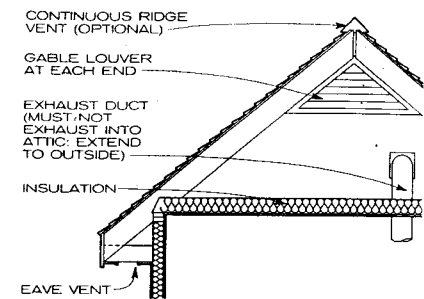

GABLE ROOF WITH UNOCCUPIED ATTIC

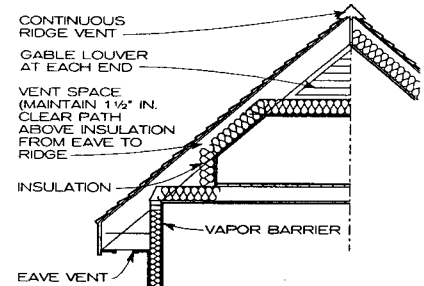

GABLE WITH OCCUPIED SPACE UNDER ROOF

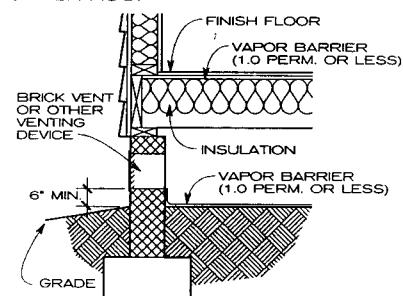

CRAWL SPACE

VENT APPLICATIONS

GENERAL

Attics and crawl spaces must be ventilated to remove moisture and water vapor that has entered the spaces from surrounding air or soil or that has been created by human activity. Generally, crawl spaces (and basements) require a greater amount of ventilation than an equivalent area of attic. The quantity of water vapor depends on the building type (e.g., residence, school, etc.), activity (e.g., bathroom, kitchen, etc.), air temperature, and relative humidity. If the temperature of the ventilated space falls below the dew point temperature, condensation will occur which will deteriorate insulation, framing, etc. This can be avoided by proper detailing to limit moisture infiltration and increase ventilation to remove it if it does enter the space.

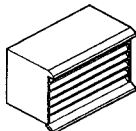

BRICK VENT

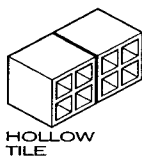

HOLLOW TILE

NOTE

Insect screen must be added to back of tile.

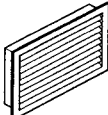

LOUVER

NOTE

Most vents for crawl spaces are set into unit masonry (and are sized accordingly) or concrete. Consult manufacturers. Metal louvers and vents have integral insect screens.

CRAWL SPACE VENTILATION MATERIALS

VENTILATION REQUIREMENTS TO PREVENT CONDENSATION

SPACE	DESCRIPTION	TOTAL NET AREA OF VENTILATION (A)	REMARKS
Joist/rafter (finish ceiling attached to underside of joists)	Flat	$a = A/250$ . Uniformly distributed vents at eaves.	Vent each joist space at both ends. Maintain 1 1/2 in. minimum clear path above insulation for ventilation.
	Sloped	$a = A/150$ . Uniformly distributed vents at eaves with a continuous ridge vent.	
Attic (unheated)	Gable	$a = A/150$ . At least two louvers on opposite sides near ridge or one continuous ridge vent. Uniformly distributed vents at eaves.	Any combination of gable/hip louvers and/or ridge vents may be used to achieve required ventilation.  Vent area may be reduced by inclusion of wind-driven or mechanical ventilators. Consult mechanical engineer.
	Hip		
Crawl space/basement		$a = 2L/100 + A/300$ Where L = crawl space/basement perimeter (linear feet)	Provide at least one opening per side, as high as possible in wall.

NOTES

1. A = area of space to be ventilated, in square feet.
2. The openings in insect screening should not exceed 1/4 in. (6 mm). The effective net area of ventilation is

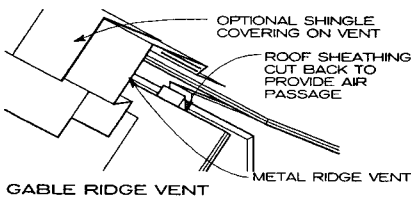

GABLE RIDGE VENT

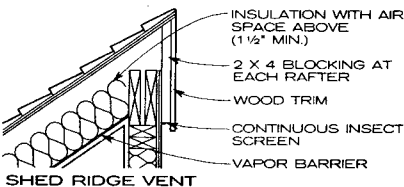

SHED RIDGE VENT

RIDGE VENTS

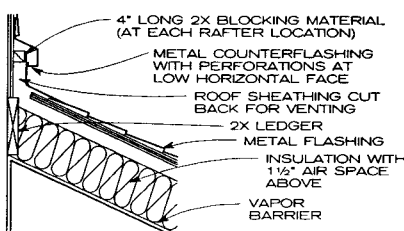

VENT FOR SHED ROOF AT WALL

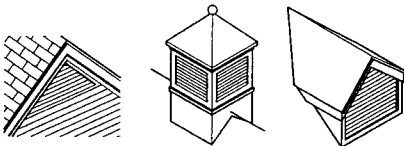

ROOF LOUVER TYPES

reduced by screening; consult manufacturers of screening materials for percentage of "free air" flow reduced by the amount of solid material in screening.

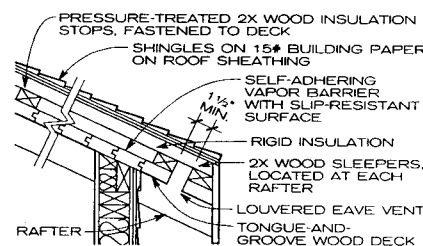

NOTES

1. Provide ridge vent to complete cavity ventilation detail.
2. Fasteners should be carefully selected and located to secure insulation, stops, sleepers, sheathing, etc. to structural tongue-and-groove deck.

INSULATED TONGUE-AND-GROOVE ROOF VENTILATION DETAIL

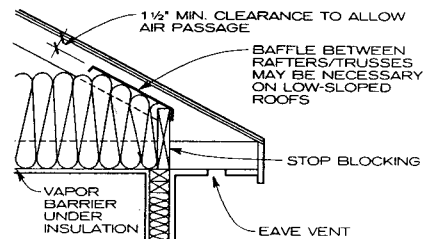

INSULATION BLOCKING AND BAFFLE

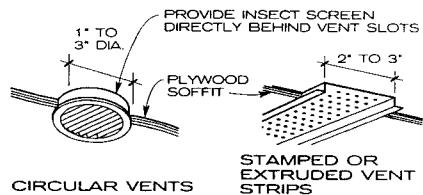

EAVE VENTILATION TYPES

Richard J. Vitullo, AIA; Oak Leaf Studio; Crownsville, Maryland  
Erik K. Beach; RippetEAU Architects, PC; Washington, D.C.

**GENERAL**

Structural metal panels are used in roofing applications when removal of the existing roof membrane is too costly or undesirable. Metal panel roofs are durable, have good wind and fire resistance ratings, and require little maintenance. The panels are manufactured either from steel or aluminum and are mechanically seamed on the job site. Sealants in tape or gel form are used as a gasket between metal connections. The sealant, applied in the female corrugation to make the roof more weathertight, allows the panels to expand and contract independently of the insulation and structural systems.

Two-part clips concealed inside the standing seams accommodate thermal expansion and eliminate the need for fasteners in the flat parts of the panel. The top part of the clip holds the metal panel, while the base of the clip is fastened to the structural member. A slot between the two parts of the clips allows independent movement. The concealed clip also provides the attachment necessary for wind uplift ratings.

Structural metal roofs can be used with slopes as low as 1/4 in. per ft but may also be used in a steep slope configuration. The panels are available in a wide variety of colors and typically have corrosion-resistant coatings.

Before adding the weight of structural metal roof panels to a building, it is important to verify the load-bearing capacity of the existing roof structure.

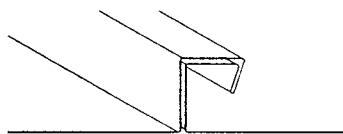
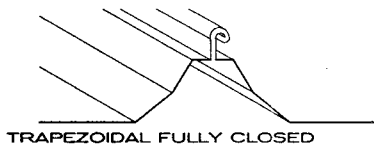
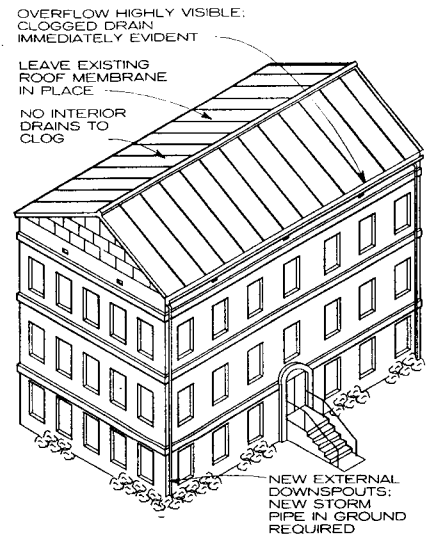
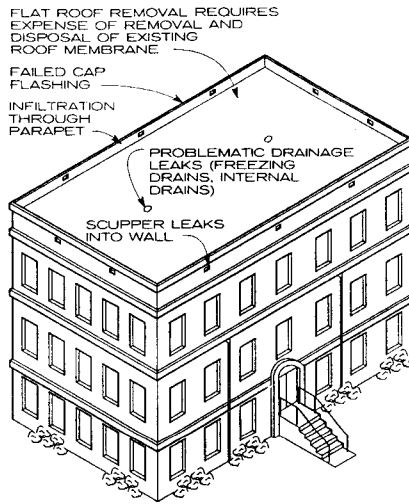

**SEAM TYPES FOR METAL ROOFING PANELS**

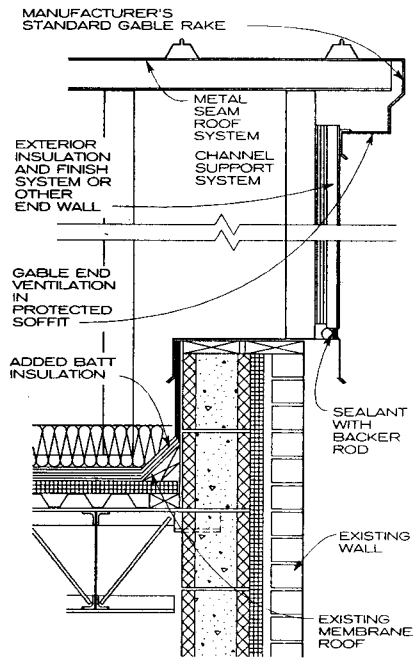

**GABLE END WALL**

**EXISTING PROBLEMATIC FLAT ROOF**

REPLACEMENT METAL ROOFING

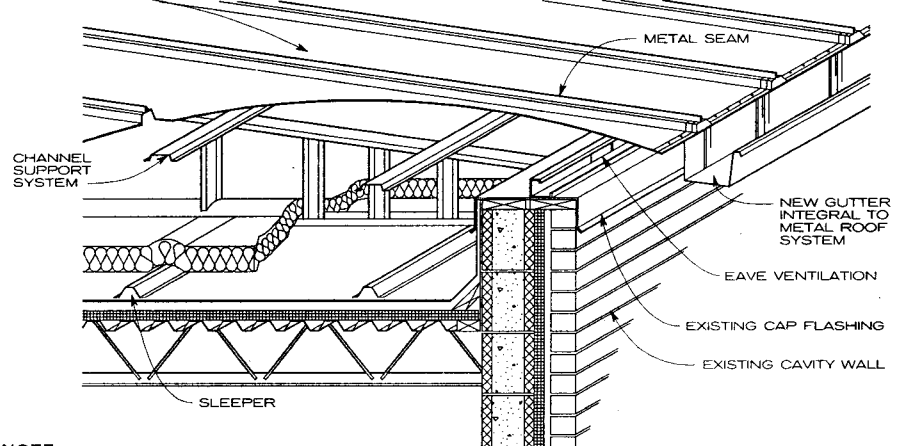

**NOTE**

Design sleeper to distribute roof load adequately over the roof surface. Consider compressibility of insulation and condition of membrane. Provide bearing plates and hold-down clips as necessary.

**BUILDING SECTION THROUGH ROOF SYSTEM**

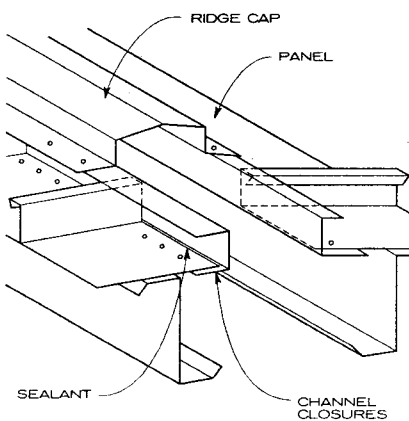

**RIDGE CAP FOR METAL ROOFING PANELS**

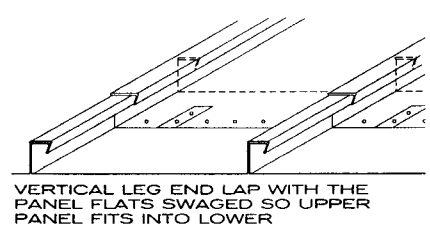
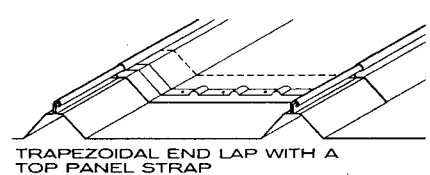

**END LAPS FOR METAL ROOFING PANELS**

Valerie Eickelberger; Rippeteau Architects, PC; Washington, D.C.  
Paul Nimitz; PDN Associates; Blue Springs, Montana

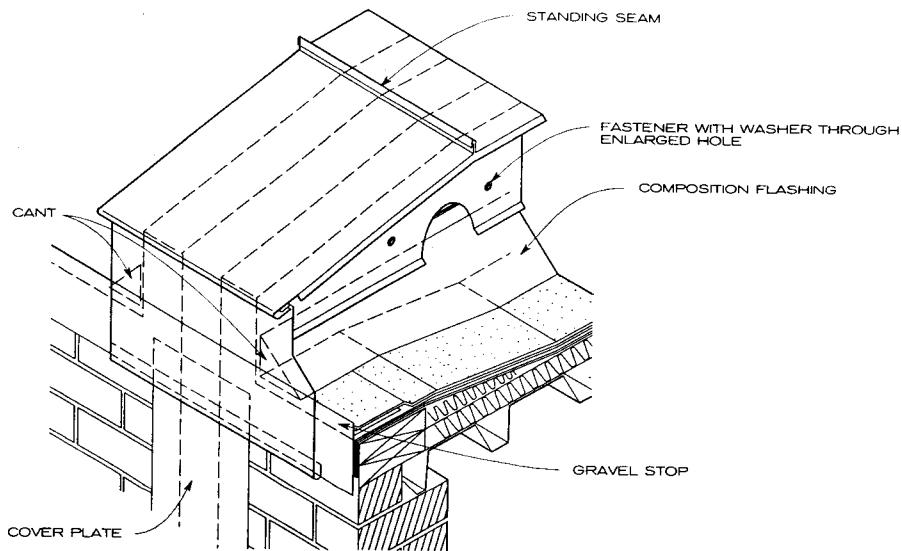

EXPANSION JOINT AT GRAVEL STOP

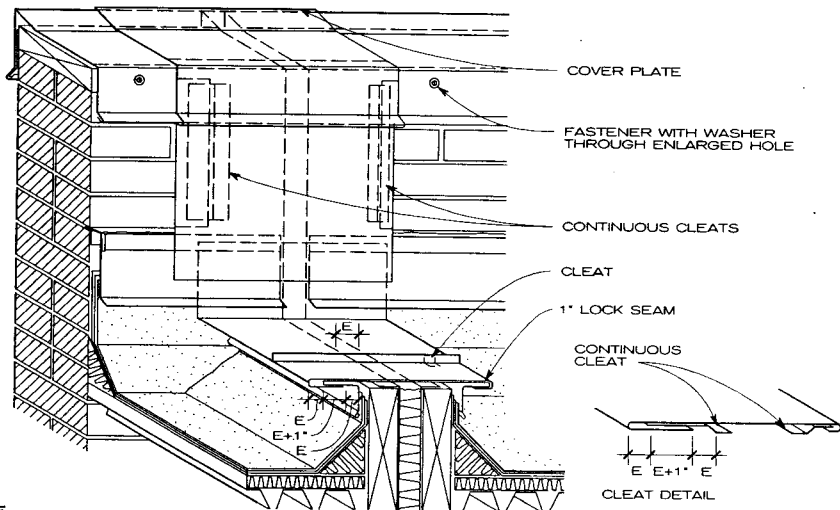

**NOTE**  
E = Maximum allowance for expansion.

EXPANSION JOINT AT PARAPET

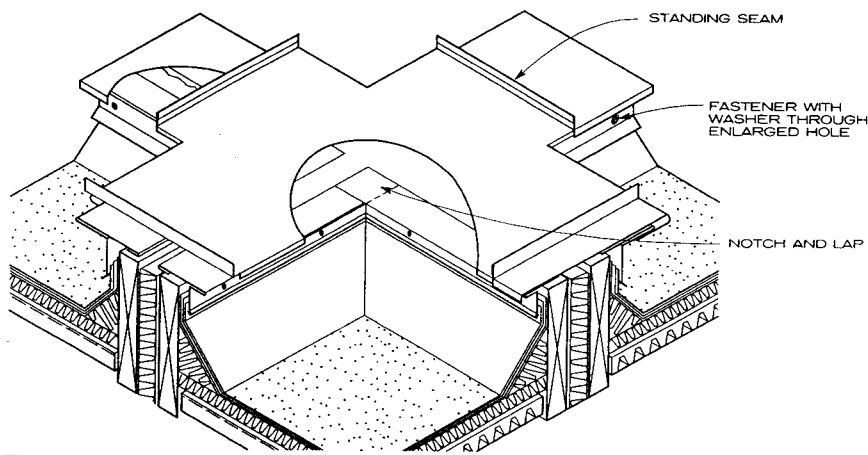

EXPANSION JOINT INTERSECTION

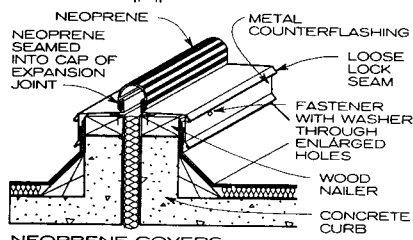
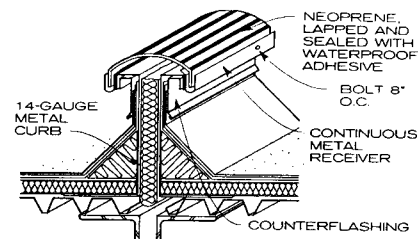

NEOPRENE COVERS

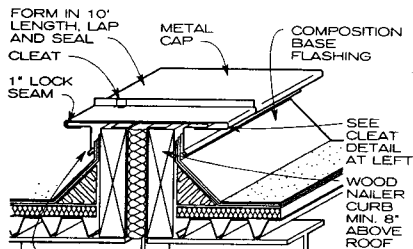

FLANGE FOR EXPANSION JOINT: ATTACH FASTENERS WITH WASHERS THROUGH SLOTTED HOLE 24\"/>

METAL COVER

**NOTES**

1. The minimum recommended gauge for the expansion joint shown is 24-gauge stainless steel, 16 oz copper, 22-gauge galvanized steel, or 0.050 in. aluminum.
2. Expansion joints allow independent movement of the roof structure.

**ROOF EXPANSION JOINT**

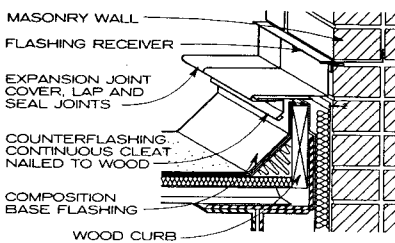
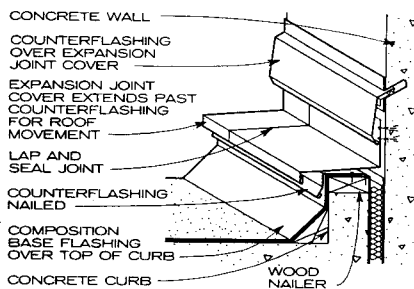

**NOTES**

1. The minimum recommended gauge for the expansion joint shown is 24-gauge stainless steel, 16 oz copper, 22-gauge galvanized steel, or 0.050 in. aluminum.
2. Expansion joints allow independent movement of the roof structure.

**ROOF-TO-WALL EXPANSION JOINT**

SMACNA, Inc., from the SMACNA Architectural Sheet Metal Manual, 5th ed., with permission Valerie Eickelberger; Rippeteau Architects, PC; Washington, D.C.

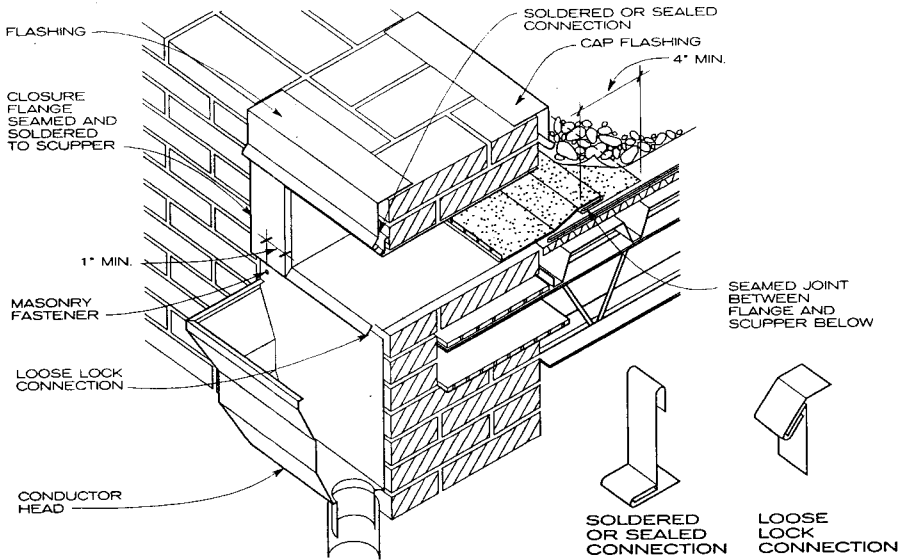

SCUPPER DETAIL AT PARAPET WALL (CONDUCTOR HEAD SIDE)

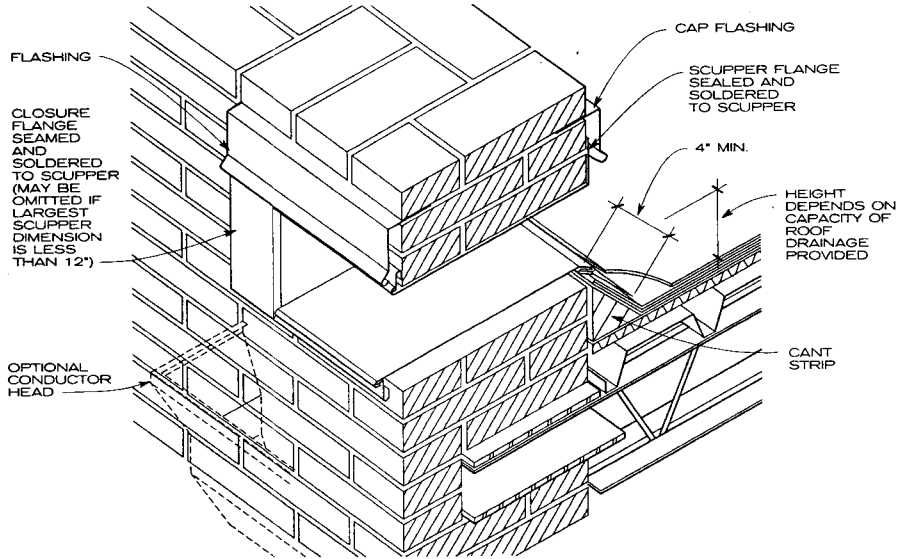

**NOTES**

1. Use overflow scuppers when roof is completely surrounded by parapets and drainage depends on scuppers or internal damage.
2. Precast concrete panels with scuppers do not need closure flanges on face; all penetrations should be seated.

**OVERFLOW SCUPPER DETAIL AT PARAPET WALL**

**SCUPPER CAPACITY IN GPM\***

HEAD (H) (IN.)	LENGTH (L) OF WEIR (IN.)									
	4	6	8	10	12	18	24	30	36	48
1	11.0	17.4	23.40	29.3	35.4	53.4	71.5	89.5	107.5	143.2
2	30.5	47.5	64.4	81.4	98.3	149.1	200.0	251.1	302.0	403.4
3	52.9	84.1	115.2	146.3	177.5	270.9	364.3	457.7	551.1	737.9
4	76.7	124.6	172.6	220.5	269.0	412.3	556.1	700.0	843.7	1133.3
6	123.3	211.4	299.4	387.5	475.5	739.7	1003.9	1268.1	1532.3	2060.7

\*Based on the Francis formula:  $Q = 3.33 (L - 0.2H) H^{1.5}$ , in which  
 Q = Flow rate, cubic ft per second  
 L = Length of scupper opening, ft (should be 4 to 8 times H)  
 H = Head on scupper, ft (measured 6 ft back from opening)  
 1 GPM = 448.8 CFS

SMACNA, Inc., from the SMACNA Architectural Sheet Metal Manual, 5th ed., with permission Grace S. Lee; Rippeteau Architects, PC; Washington, D.C.

**7 ROOF SPECIALTIES AND ACCESSORIES**

**GENERAL**

The size and number of scuppers should be carefully determined to control ponding on roofs. Rectangular shapes convey more water (per inch of water depth on the roof) than round shapes. The performance of rectangular shapes approximates that of a broad-crested weir. Standard equations for channel flow are based on test models larger than typical roof scuppers. While downspout sizes normally are based on draining a given area of roof, that flow rate may not pass through a scupper that has been sized to have a cross-sectional area equal to the downspout area.

**SCUPPER SIZING PROCEDURES**

1. Determine the head (H) in inches of water (typically 1 in. minimum by code) at a point 6 ft back from the scupper opening.
2. Determine the roof drainage area in sq ft (SF).
3. Using rainfall intensity in inches per hour (IPH) from a rainfall data table, determine discharge capacity in gallons per minute (GPM).  $GPM = SF \text{ of room area} \times IPH \times 0.0104$ . The constant is 7.48 gallons per cubic foot divided by 12 inches per foot divided by 60 minutes per hour.  
 $GPM = (0.0104) IPH \times SF$
4. Using H and the GPM, find the aggregate scupper length (L) in the scupper capacity table (below).
5. Select enough individual scuppers to satisfy the total GPM requirement and locate them proportionately.

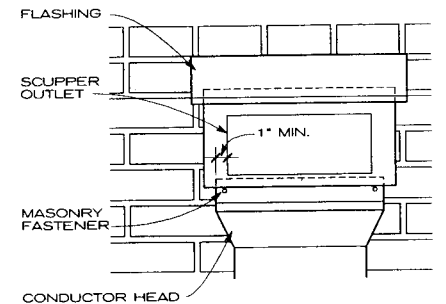

**NOTE**

Scupper assemblies from top to bottom (flashing to scupper outlet to conductor head) should be overlapped to ensure that water will be directed away from the wall.

**SCUPPER ASSEMBLY ELEVATION**

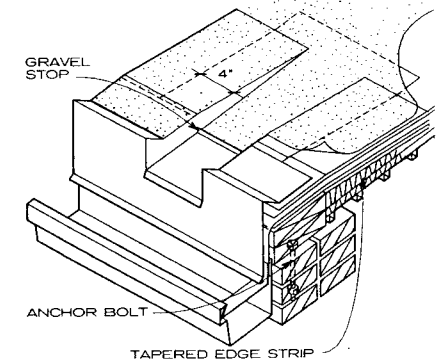

**NOTE**

Scuppers that empty into a gutter may be integrated with a roof edge. The scuppers are soldered into a formed gravel stop-fascia system. The suggested maximum scupper interval is 10 ft. The front rim of the gutter must be 1 in. below the back edge, and it should be below the nailers used to elevate the roof edge. The drip edge on the fascia should lap the back edge of the gutter a minimum of 1 in. The gutter must be free to move behind the fascia.

**COMBINATION SCUPPER AND GUTTER**

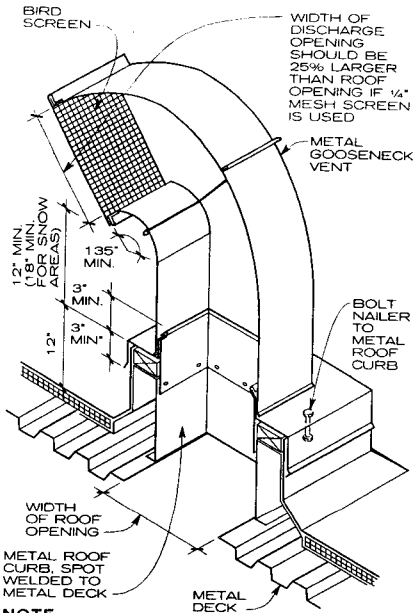

**NOTE**  
This ventilator may be used for either intake or exhaust with gravity flow.

**GOOSENECK GRAVITY VENTILATOR**

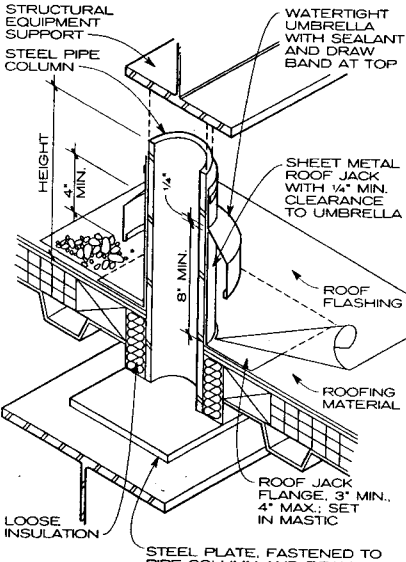

- NOTES**
1. This detail can be adapted for other uses, such as sign supports.
  2. Many roofing manufacturers offer prefabricated flashing pieces or permit the use of materials other than those shown here for flashing. Specifications on these proprietary designs vary; consult the manufacturers.
  3. For access to areas underneath equipment, vary pipe column height as shown in the accompanying chart.

**COLUMN EQUIPMENT SUPPORT**

**PIPE COLUMN HEIGHT**

EQUIPMENT WIDTH (IN.)	COLUMN HEIGHT (IN.)
Up to 24	14
25 to 36	18
37 to 48	24
49 to 60	30
61 and wider	48

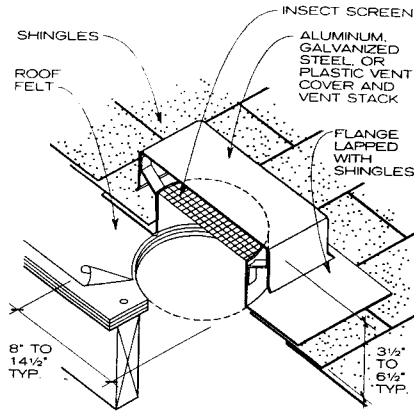

**ROOF VENT IN SLOPED ROOF**

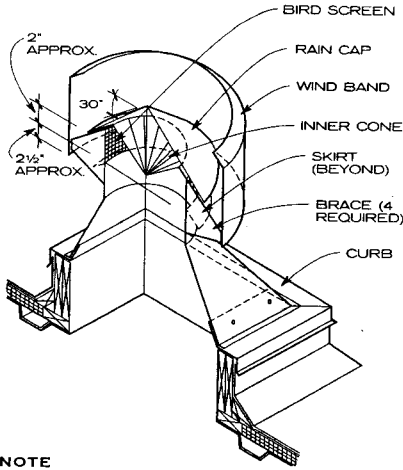

**NOTE**  
All sloped partial or full conical shapes should be based on the same angle (generally 30°).

**STATIONARY GRAVITY ROOF VENTILATOR**

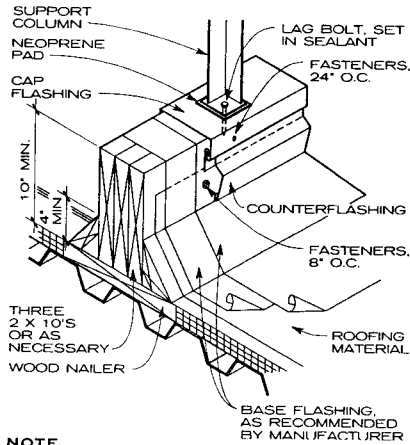

**NOTE**  
This detail allows for roof maintenance around the equipment or sign. The continuous support, in contrast to the point load of a pipe column support, is preferred for lightweight roof systems. Clearance must be provided for removal and replacement of roofing and flashing between parallel supports.

**CONTINUOUS EQUIPMENT SUPPORT CURB**

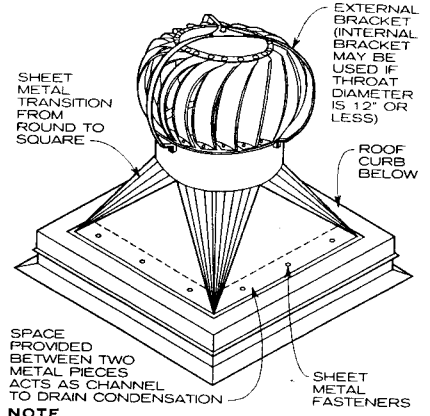

This ventilator may be used on a sloped roof.

**ROTATING VENTILATOR**

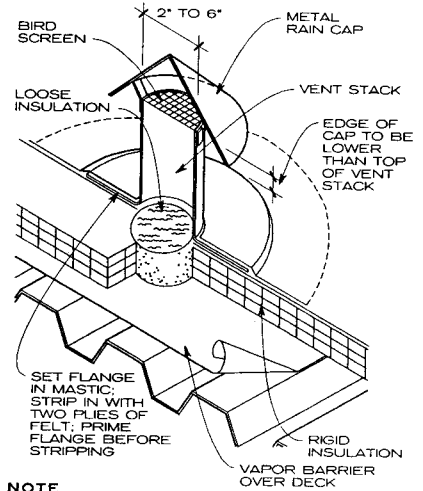

**NOTE**  
This detail allows moisture due to leaks, faulty vapor barriers, or construction work to escape from the roof system.

**ROOF RELIEF VENT**

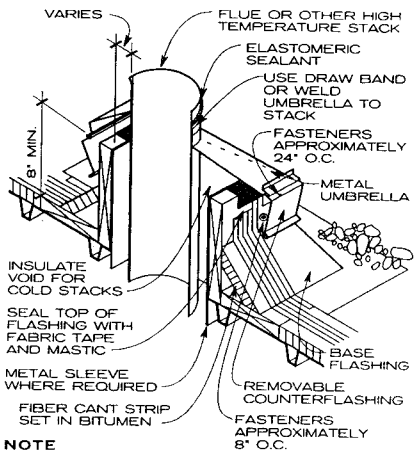

**NOTE**  
This detail allows the opening to be completed before the stack is placed. The metal sleeve and the clearance necessary will depend on the temperature of the material handled by the stack.

**FLUE STACK ROOF PENETRATION**

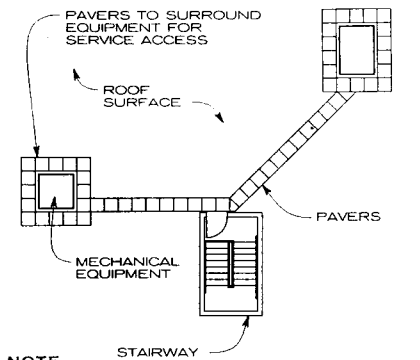

**NOTE**  
 Roof pavers provide a stable walking service on any flat roof surface and protect the roof membrane from wear and tear. Service walkways should follow the most direct route to equipment to avoid shortcuts by maintenance personnel. Consult mechanical engineer about access needed to mechanical equipment.

**SERVICE WALKWAYS ON ROOFS**

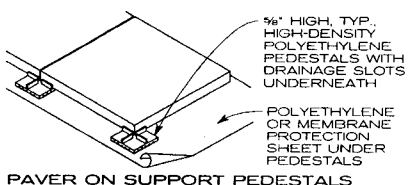
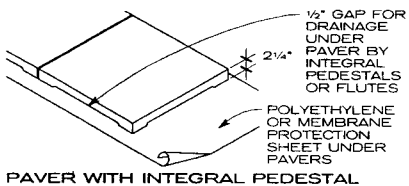
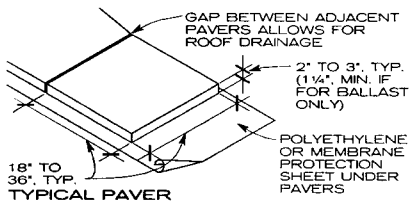

**NOTE**  
 Ballast pavers are typically made from precast concrete with a non-skid texture on the surface.

**BALLAST PAVERS**

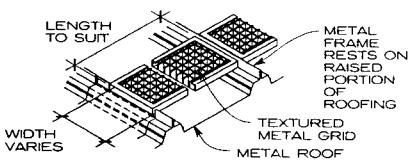
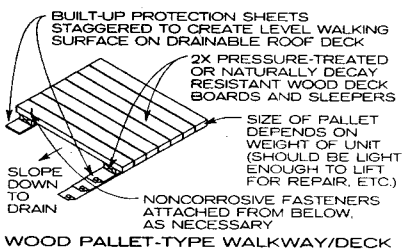

**MISCELLANEOUS ROOF WALKING SURFACES**

Richard J. Vitullo, AIA; Oak Leaf Studio; Crownsville, Maryland

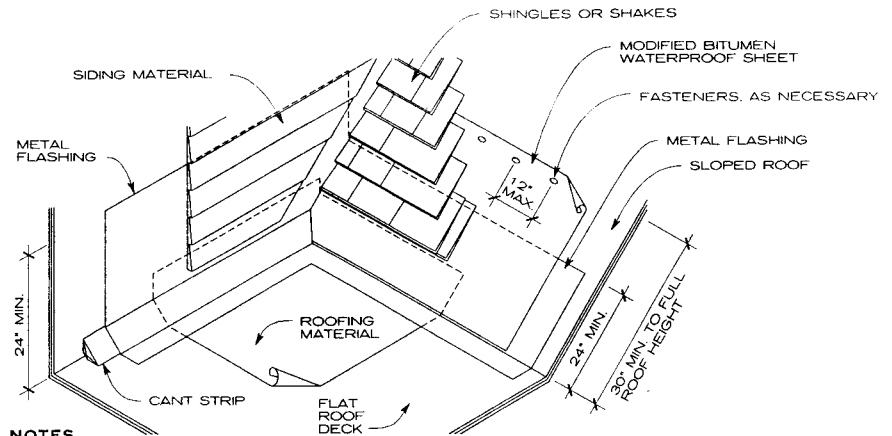

**NOTES**  
 1. Modified bitumen sheet specified to provide self-sealing around fastener.  
 2. Height of flashing and waterproof sheet depends on local snow probabilities and codes and on the roof slope.

**WATERPROOFING AT ROOF TRANSITIONS**

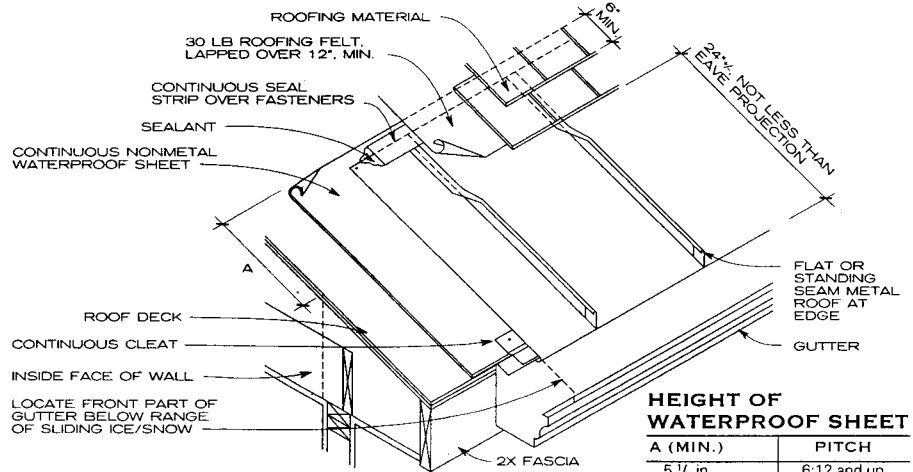

**HEIGHT OF WATERPROOF SHEET**

A (MIN.)	PITCH
5 1/2 in.	6:12 and up
14 1/2 in.	5:12
23 1/2 in.	4:12
to ridge	3:12

**NOTE**  
 Provide gutters where required to protect building; if not required, avoid gutters where icing is common.

**ICE DAM DETAILING AT EAVE WITH GUTTER**

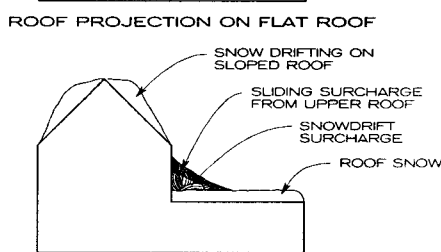
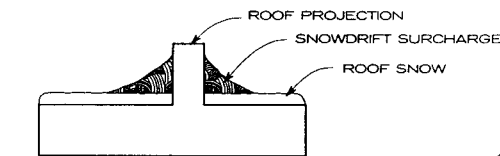

**NOTES**  
 1. Consult codes for projected local snow heights.

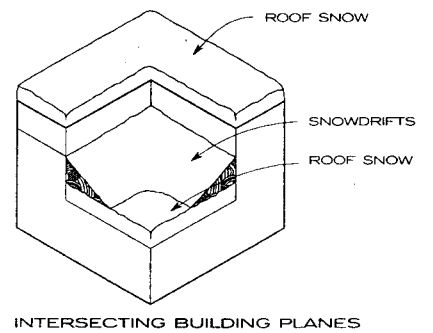

2. Snow accumulation on roofs is generally unequal due to wind action. The resulting unequal load distribution might be aggravated by unequal melting of accumulated snow.

**SNOW TENDENCIES ON BUILDING SURFACES**

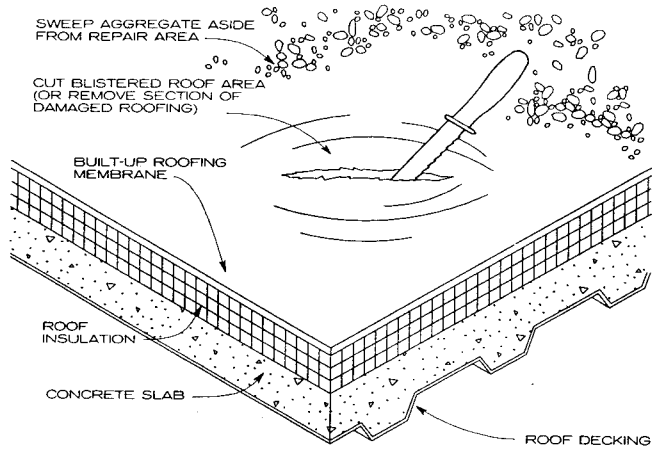

PREPARATION

MEMBRANE ROOF REPAIR

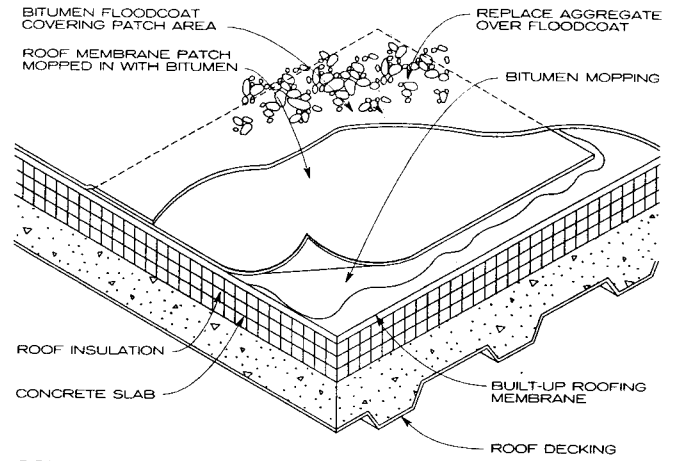

COMPLETION

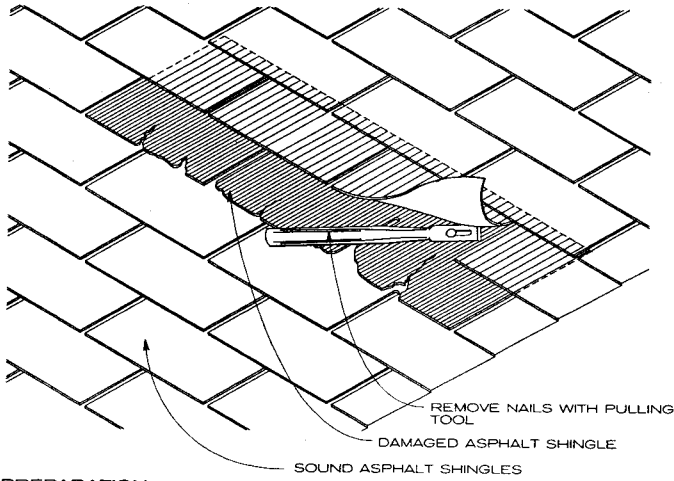

PREPARATION

ASPHALT SHINGLE REPAIR

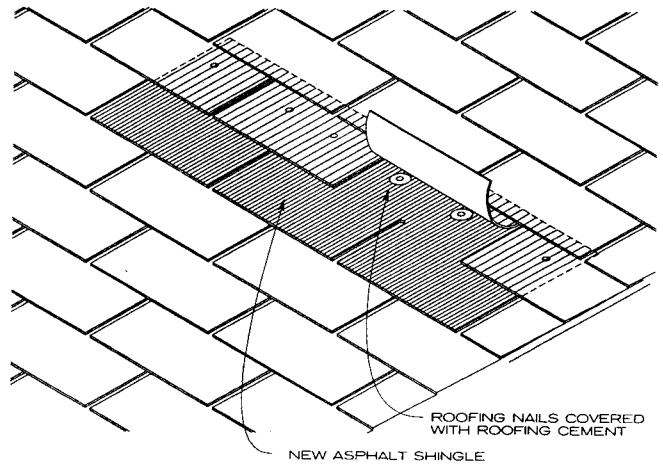

COMPLETION

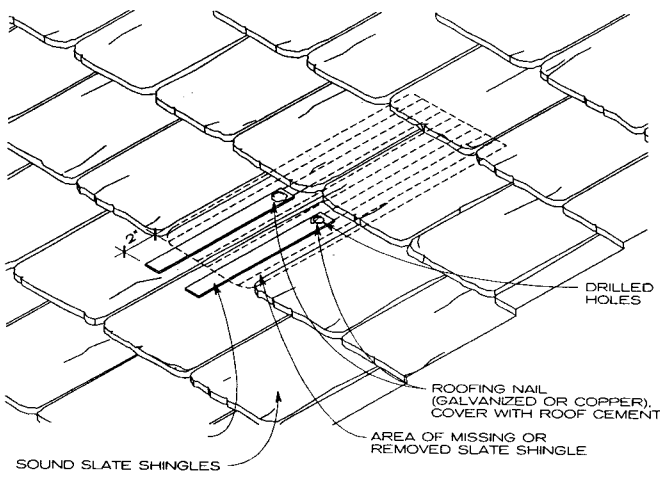

PREPARATION

SLATE SHINGLE REPAIR

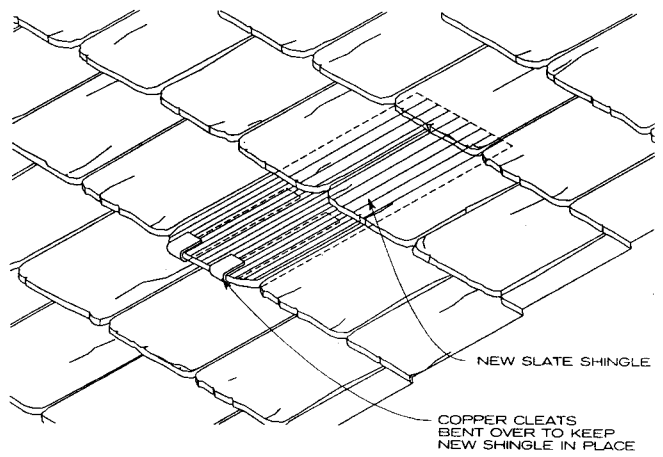

COMPLETION

Valerie Eickelberger, Rippeteau Architects, PC, Washington, D.C.



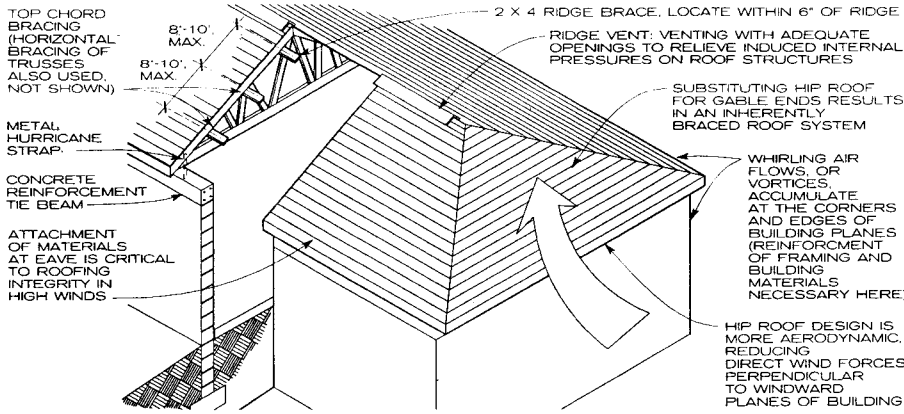

**RECOMMENDED WOOD FRAME ROOF DESIGN**

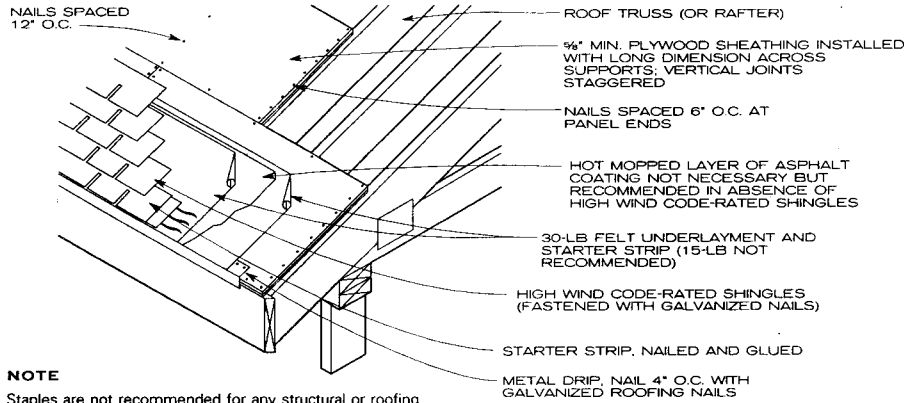

**NOTE**

Staples are not recommended for any structural or roofing fastenings.

**HIGH WIND RESISTANCE DETAIL—COMPOSITION AND ASPHALT SHINGLES**

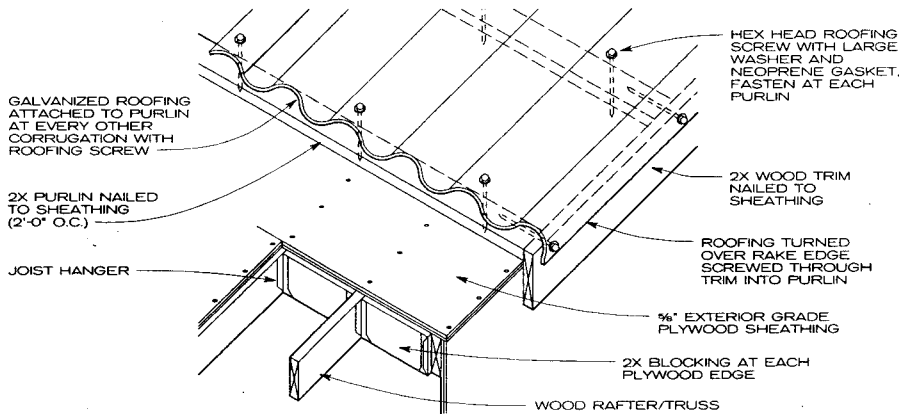

**HIGH WIND RESISTANCE DETAIL—GALVANIZED METAL ROOFING**

**GENERAL**

Roofing materials are particularly susceptible to damage from wind uplift and debris borne by high winds. Contributing to this problem is the use of inferior roofing materials and fasteners, substandard workmanship practices, and poor design choices for areas known for frequent or potentially severe high winds. Use of design practices that resist wind uplift and lateral forces can protect the total building system from damage due to high winds and/or hurricanes. Anchoring framing members to the foundation system, tying together all framing, and bracing members, particularly roof trusses, are practices that strengthen and brace the entire building. Only when that has been accomplished are good roofing design and details relevant.

**ROOFING FAILURES IN HIGH WIND**

Some of the main reasons for roofing material failure caused by high winds are described here:

1. Roof sheathing—Inadequate reinforcement at the edges causes sheathing to separate from the roof truss or rafter. Wafer board, composite board, oriented strand board, or structural particleboard used as sheathing does not provide sufficient wind resistance.
2. Composition shingle and felt underlayment—Use of shingles, attachment adhesives, and/or fasteners not rated

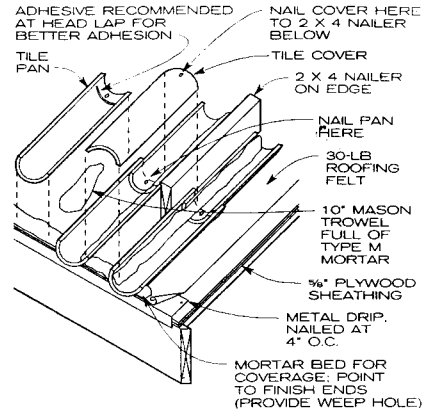

**HIGH WIND RESISTANCE DETAIL—BARREL TILE ROOFING**

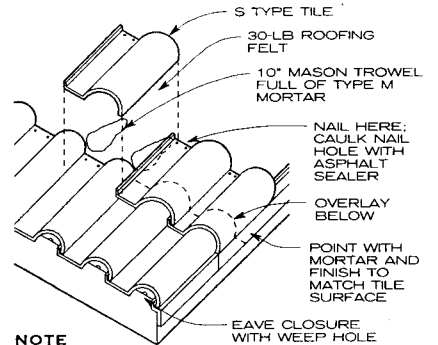

**NOTE**

After tile roofs are laid up completely, traffic should not be allowed on roof and no work that creates vibration in framing or roof sheathing should be allowed for 72 hours, minimum (24 hours is needed to ensure proper set).

**HIGH WIND RESISTANCE DETAIL—S TYPE TILE ROOFING**

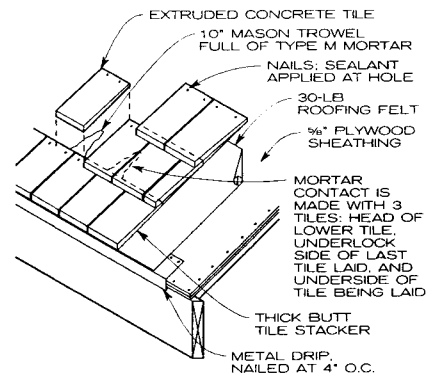

**HIGH WIND RESISTANCE DETAIL—EXTRUDED CONCRETE**

for high winds or fasteners used in insufficient numbers, locations, and/or orientation can lead to wind damage.

3. Extruded concrete or clay tile—Poor nailing and/or mortar connections and underlayment failure due to lack of bonding between the underlayment and mortar or mortar and tile can cause failure of the roof. As well, clay tile may shatter when hit with flying debris.
4. Sheet metal—Inadequately adhered and fastened eave flashing, drips, and metal gravel stops can cause failure.

Richard J. Vitullo, AIA; Oak Leaf Studio; Crownsville, Maryland

**7 ROOF SPECIALTIES AND ACCESSORIES**

**GUTTER DESIGN**

Design for gutters and downspouts for buildings depends on the following factors:

1. Design area of the roof (total roof area x pitch factor).
2. Rainfall intensity for the geographic area.
3. Length of gutter and roof area per downspout.

For rectangular gutters, use the rectangular gutter sizing graph on this page to determine size. Choose the depth/width ratio based on the proportions of the gutter desired, stock availability, or other relevant factors. The ratio of depth to width must be known before the actual design width can be determined. For semicircular gutters, first size the downspout from the downspout tables, then size the gutter one inch larger in diameter. For irregularly shaped gutters, determine an equivalent rectangular size and use the rectangular gutter sizing method.

**NOTES**

1. Most gutters are run level for appearance. However, a slope of 1/16 in. per foot is desirable as a minimum for drainage.
2. For residential work, allow 100 sq ft of design roof area per one sq in. of downspout.
3. The terms "leader" and "conductor" have the same meaning as downspout.

**DOWNSPOUT CAPACITY**

Intensity in in./hr lasting 5 min.	2	3	4	5	6	7	8	9	10	11
Sq ft roof/sq in. of downspout	600	400	300	240	200	175	150	130	120	110

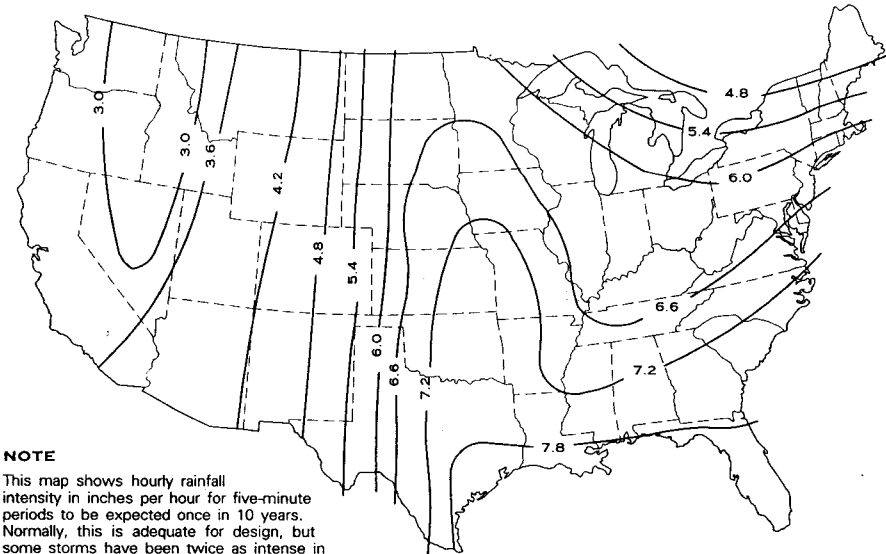
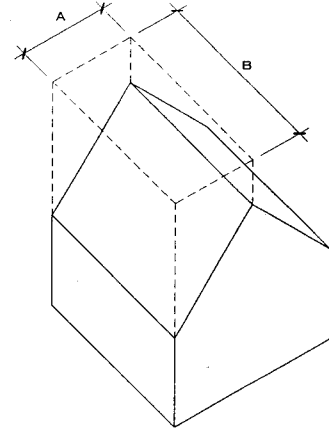

**NOTE**  
This map shows hourly rainfall intensity in inches per hour for five-minute periods to be expected once in 10 years. Normally, this is adequate for design, but some storms have been twice as intense in some areas. See local records.

**RAINFALL INTENSITY MAP**

**WIDTH OF RECTANGULAR GUTTERS FOR GIVEN ROOF AREAS AND RAINFALL INTENSITIES**

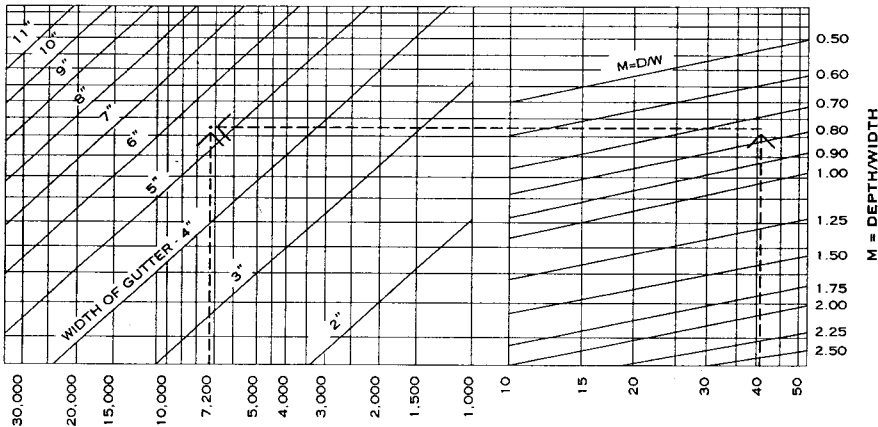

IA = RAINFALL INTENSITY X AREA

L = LENGTH OF GUTTER IN FEET

**SAMPLE GUTTER SIZING PROBLEM**

A New York City building with a footprint of 120 ft x 30 ft needs a gutter system. The building has a flat roof with a raised roof edge on three sides; a gutter is to be located on one of the 120-ft sides. So each gutter section will be no more than 50 ft, three downspouts will be used with two gutter expansion joints. The area to be drained by each 40-

ft section gutter is 1200 sq ft. The rainfall intensity according to the map is 6 in., and the ratio of gutter depth to width is 0.75. On the chart above, find the vertical line representing L = 40. Proceed vertically along this line to its intersection with the oblique line representing M = 0.75. Move horizontally to the left to intersect the vertical line repre-

PITCH	FACTOR
Level to 3 in./ft	1.00
4 in./ft to 5 in./ft	1.05
6 in./ft to 8 in./ft	1.10
9 in./ft to 11 in./ft	1.20
12 in./ft	1.30

**NOTE**  
A roof that is level up to a 3 in. per foot slope is considered a "flat" roof and has a pitch factor of 1.0. When a roof is sloped greater than 3 in. per foot, neither a "plan area" nor an "actual area" should be used to size drainage since the pitch affects the area in two ways, by increasing the actual area and by affecting the speed of the runoff. Instead, multiply the plan area (A x B) by the factor shown in the chart above to obtain the design area.

**DESIGN AREAS FOR PITCHED ROOFS**

**DOWNSPOUT SIZES**

TYPE	AREA (SQ IN.)	NOMINAL SIZE (IN.)	ACTUAL SIZE (IN.)
Plain round	7.07	3	3
	12.57	4	4
	19.63	5	5
	28.27	6	6
Corrugated round	5.94	3	3
	11.04	4	4
	17.72	5	5
Corrugated rectangular	25.97	6	6
	3.80	2	1 1/4 x 2 1/4
	7.73	3	2 1/8 x 3 1/4
	11.70	4	2 1/4 x 4 1/2
Plain rectangular	18.75	5	3 1/2 x 5
	3.94	2	1 1/4 x 2 1/4
	6.00	3	2 x 3
	12.00	4	3 x 4
	20.00	5	3 1/2 x 4 1/4
	24.00	6	4 x 6

senting IA = 7200. The point of intersection occurs between the oblique line representing gutter widths of 5 and 6 in. With a required gutter width of 6 in. and a depth-to-width (M) ratio of 0.75, calculate the depth of the gutter by multiplying the width (6 in.) by M (0.75) to calculate the gutter depth at 4 1/2 in.

Lawrence W. Cobb; Columbia, South Carolina

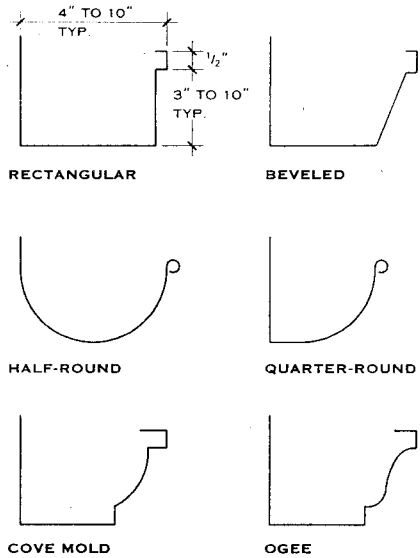

**TYPICAL GUTTER SHAPES AND SIZES**

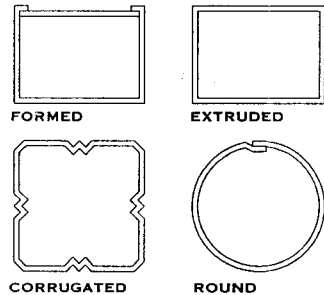

**NOTES**

1. Formed and extruded downspout sizes are 3 x 4 to 6 x 6; round sizes are 3, 4, or 5 in. in diameter. (Extruded downspouts are for heavy traffic.)
2. Generally, space downspouts a minimum of 20 ft and a maximum of 50 ft apart.
3. A downspout of 7 sq. in. minimum should be used, except for canopies or small porches.
4. Corrugated shapes resist breakage due to freezing better than straight profiles.
5. Elbows are available in 45-, 60-, 75-, and 90-degree angles.

**TYPICAL DOWNSPOUT SHAPES AND SIZES**

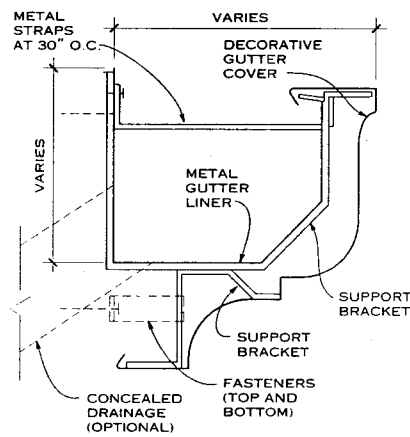

**CONCEALED GUTTER**

Jones/Richards and Associates; Ogden, Utah  
Lawrence W. Cobb; Columbia, South Carolina

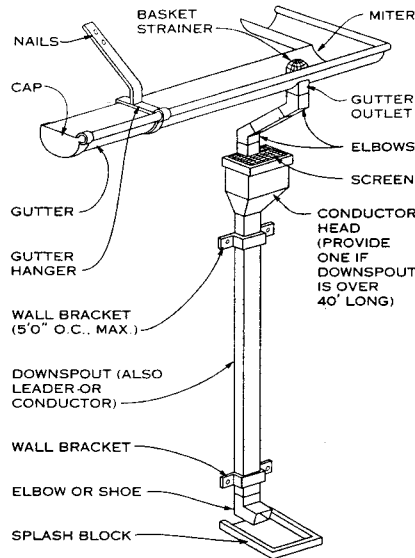

**PARTS OF A GUTTER/DOWNSPOUT SYSTEM**

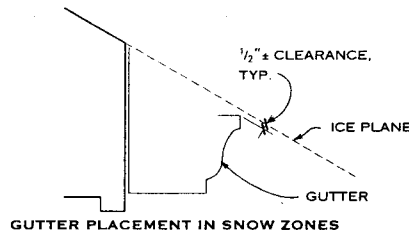

**GUTTER PLACEMENT IN SNOW ZONES**

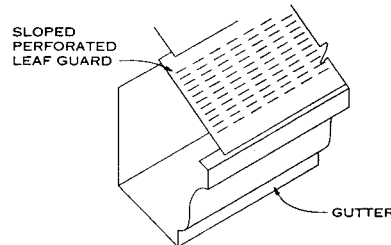

**LEAF GUARD**

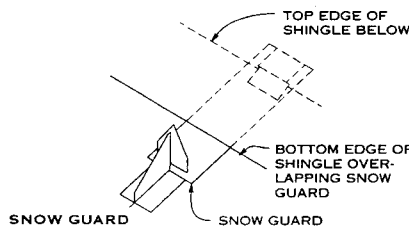

**SNOW GUARD**

**NOTES**

1. Gutters should be placed below the slope line so snow and ice can slide clear. A steeper pitch requires less clearance.
2. Snow guards are installed on roofs to protect gutters from snow slides and snow overloading. They hold the snow in place evenly over the entire roof, allowing it to melt gradually into the gutter system. They also help prevent snow from collecting over the eaves, where it may thaw and refreeze, potentially causing damage.
3. Snow guard placement depends on the roof slope, local snow conditions, the insulation at the roof below, and the length of the rafters. Snow guards typically are staggered on the roof, with the first row starting 2 ft from the eave.

**GUTTER PROTECTION**

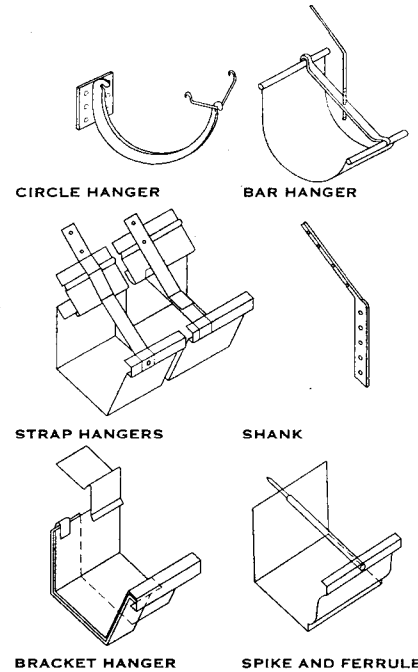

**GUTTER BRACKET OR STRAP SIZES (IN.)**

GIRTH	GALVANIZED STEEL	COPPER	ALUMINUM	STAINLESS
Up to 15	1/8 x 1	1/8 x 1	3/16 x 1	1/8 x 1
15 to 20	3/16 x 1	1/4 x 1	1/4 x 1	1/8 x 1 1/2
20 to 24	1/4 x 1 1/2	1/4 x 1 1/2	1/4 x 2	1/8 x 2

**NOTES**

1. Gutter hangers are normally spaced 3 ft on center. Reduce spacing to 1 ft 6 in. o.c. where snow and ice are prevalent.
2. Spike and ferrule hangers are not recommended if girth is greater than 15 in.
3. Hangers are available in many sizes, shapes, and materials and are matched to the design of the gutter used. Consult manufacturers' design manuals.

**GUTTER HANGERS**

**NOTES**

1. Continuous gutters may be formed at the installation site with cold forming equipment, thus eliminating joints in long runs of gutter.
2. Gutters and downspouts are available in aluminum, galvanized steel, copper, and stainless steel. Consult manufacturers for custom materials.
3. Girth is the width of the sheet metal from which a gutter is fabricated.
4. Although all joining methods are applicable to most gutter shapes, lap joints are more commonly used. Seal all joints with mastic or by soldering. Lock, slip, or lap joints do not provide for expansion.
5. Expansion joints should be used on all straight runs over 40 ft. In a 10-ft section of gutter that will undergo a 100-degree temperature change, linear expansion will follow these coefficients of expansion (CE) and movements:  
Aluminum: CE—.00128; movement—.15 in.  
Copper: CE—.00093; movement—.11 in.  
Galvanized steel: CE—.0065; movement—.08 in.
6. Always keep the front of the gutter 1/2 in. lower than the back.
7. Use a minimum width of 4 in. except for canopies and small porches. The minimum ratio of depth to width should be 3 to 4.
8. Many custom shapes for gutters and downspouts are available; consult manufacturers' design manuals. See the Sheet Metal and Air Conditioning Contractors National Association (SMACNA) *Architectural Sheet Metal Manual* for gutter sizing and details.

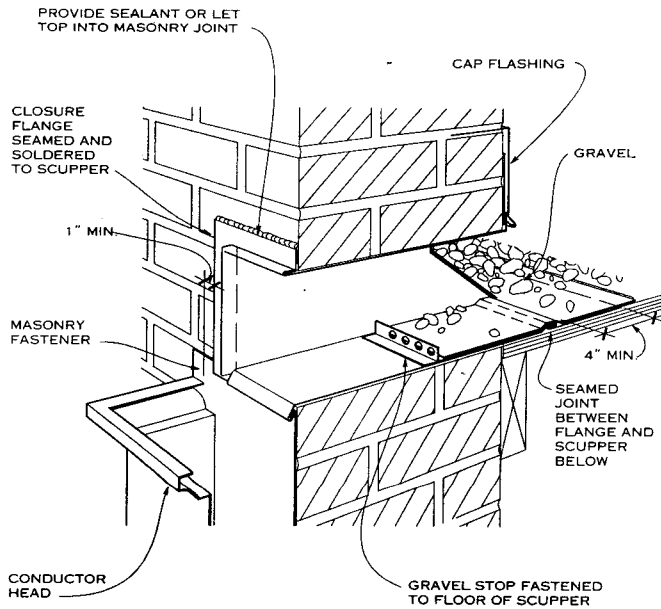

SCUPPER DETAIL AT PARAPET WALL (CONDUCTOR HEAD SIDE)

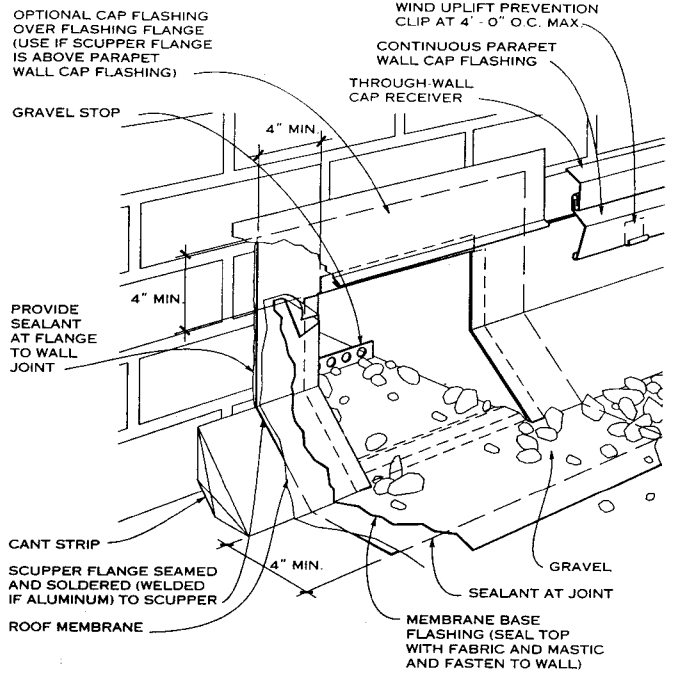

SCUPPER DETAIL AT PARAPET WALL (ROOF SIDE)

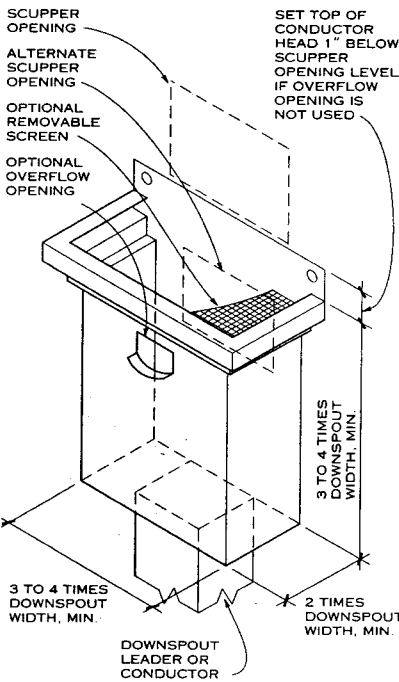

TYPICAL CONDUCTOR HEAD

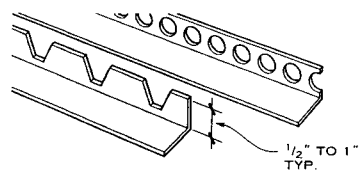

TYPICAL GRAVEL STOPS

NOTES

1. Overflow openings are recommended in heavy icing areas and for drains that may become plugged with leaves or other debris. Check local codes for elevation of overflow opening.
2. Conductor heads and downspouts should be fabricated of the same material. Recommended minimum for construction of conductor heads is 24 gauge galvanized steel, 0.032 in. aluminum, 16 oz. copper, or 26 gauge stainless steel.
3. Edges of conductor head must be suitably stiff, based on dimensional characteristics.

CONDUCTOR HEAD TOP TILTED DOWN FOR MAXIMUM OVERFLOW CAPACITY (CHECK LOCAL CODES FOR HEIGHT)

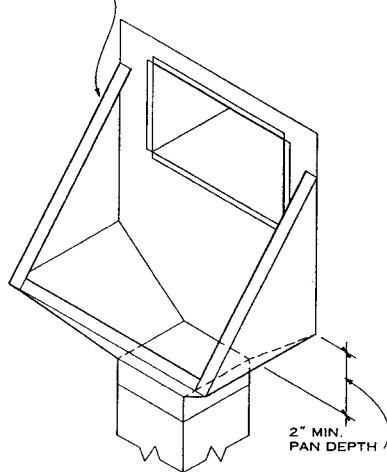

CONDUCTOR HEAD-MAXIMUM OVERFLOW

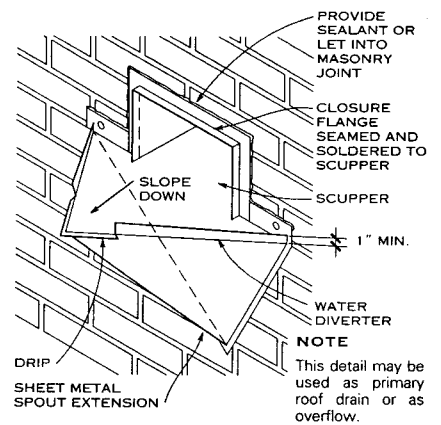

RAINSPOUT DETAIL

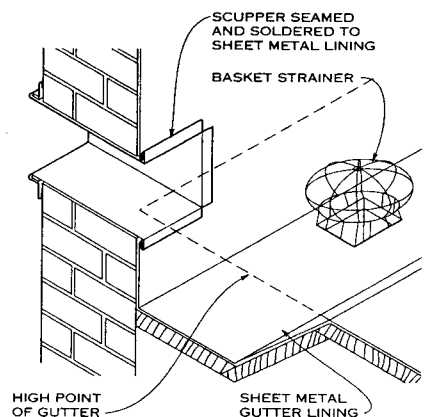

OVERFLOW SCUPPER AT BUILT-IN GUTTER

Richard J. Vitullo, AIA; Oak Leaf Studio; Crownsville, Maryland

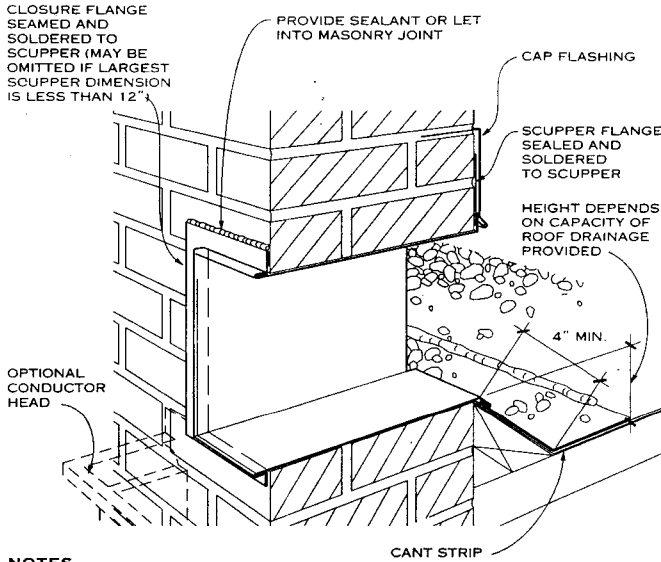

- NOTES**
1. Use overflow scuppers when roof is completely surrounded by parapets and drainage depends on scuppers or internal drainage.
  2. Precast concrete panels with scuppers do not need closure flanges on face; all penetrations should be sealed.

**OVERFLOW SCUPPER DETAIL AT PARAPET WALL**

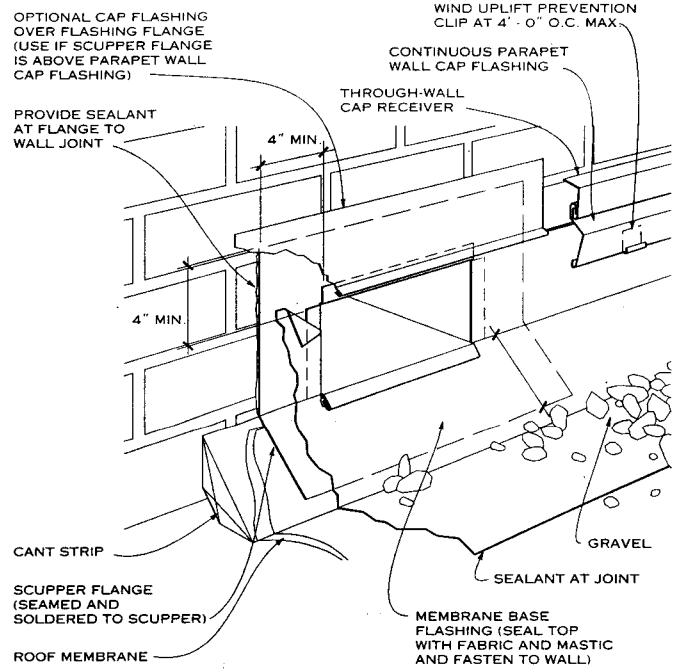

**OVERFLOW SCUPPER DETAIL AT PARAPET WALL (ROOF SIDE)**

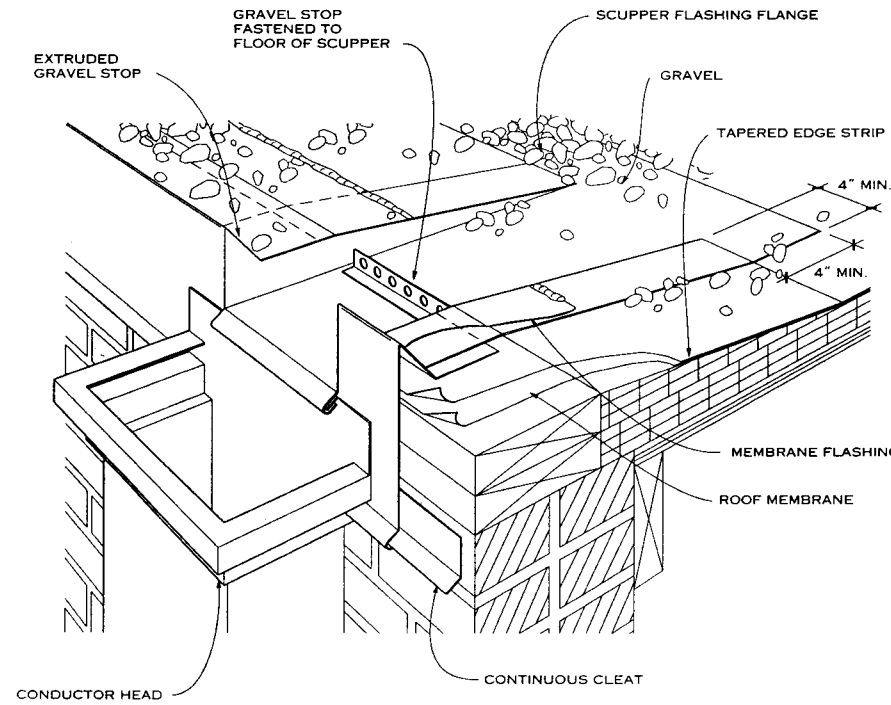

**SCUPPER DETAIL AT GRAVEL STOP (CONDUCTOR HEAD SIDE)**

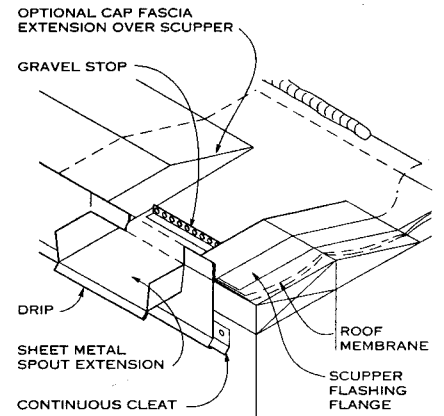

**RAINSPOUT DETAIL**

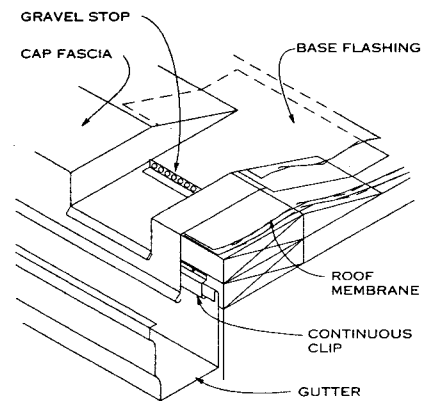

**SCUPPER DETAIL AT RAISED CURB**

Richard J. Vitullo, AIA; Oak Leaf Studio; Crownsville, Maryland

# 7 GUTTERS AND DOWNSPOUTS

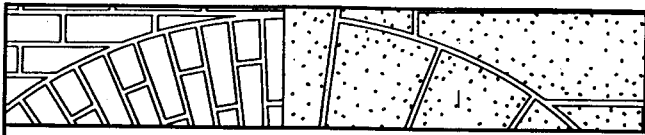

# DOORS AND WINDOWS

Fire Rating and Security	464	Entrances and Storefronts	482
Door and Window Openings	467	Windows	486
Metal Doors and Frames	469	Skylights	498
Wood and Plastic Doors	473	Hardware	503
Specialty Doors	478	Glazing	512

**GENERAL**

Fire-rated assemblies for door and window openings, used to protect against the spread of fire and smoke, consist of a fire-rated door or window with frame, hardware, and accessories, including gasketing. Each component is crucial to the overall performance of the assembly as a fire barrier. Choices to be made regarding the enclosure of openings in fire-rated walls include the following:

1. Fire-rated wall requirements
2. Size of opening
3. Means of egress
  - a. Required size per occupancy
  - b. Quantity and location
  - c. Direction of egress flow and operation of enclosure
  - d. Hardware requirements
  - e. Window egress requirements
4. Materials and finishes
5. Security
6. Visibility and glazing

**FIRE PROTECTION CRITERIA**

NFPA 80, Standard for Fire Doors and Fire Windows, is a consensus standard that establishes minimum criteria for installing and maintaining assemblies and devices used to protect openings in walls, ceilings, and floors from the spread of fire and smoke. The degree of fire protection (in hours) required for a given opening is referenced in the model building codes (BOCA, SBCCI, and UBC) and the Life Safety Code (NFPA 101). Fire doors are classified by hourly references determined by testing done in accordance with NFPA 252, Standard Method of Fire Tests of Door Assemblies (also known as UL 10B). Further information is available in chapter 6, section 6 of the NFPA's Fire Protection Handbook.

**TYPES OF OPENINGS**

**4-HR AND 3-HR OPENINGS** (formerly class A): located in fire walls or in walls that divide a single building into fire areas.

**1 1/2-HR AND 1-HR OPENINGS** (formerly class D and B, respectively): located in multistory vertical communication enclosures and in 2-hr rated partitions providing horizontal fire separations.

**3/4-HR AND 20-MIN. OPENINGS** (formerly class C, E): located in walls or partitions between rooms and corridors with a fire-resistance rating of one hour or less.

The hourly protection rating for openings depends on the use of the barrier, as in exit enclosures, vertical openings in buildings, building separation walls, corridor walls, smoke barriers, and hazardous locations. In most codes, class designations have been replaced by hour classifications.

**TYPES OF FRAMES**

Fire-rated doorframes can be assembled at the factory or in the field. Frames must be adequately anchored at the jams and floor according to the manufacturer's specifications. Codes require doors to be installed in accordance with NFPA 80, Section 2-5, Frames, indicates only labeled frames are to be used.

**LIGHT-GAUGE METAL FRAME:** head and jamb members with or without transom panel made from aluminum (45-min. maximum rating) or light-gauge steel (1 1/2-hr maximum rating); installed over finished wall.

**PRESSED STEEL (HOLLOW METAL):** head and jamb members with or without solid or glazed transoms or sidelights made from 18-gauge or heavier steel (3-hr. maximum rating); required for most metal doors.

**DEFINITIONS**

The following definitions are typically used in relation to fire-rated openings:

**AUTOMATIC:** providing a function without the necessity of human intervention.

**FIRE BARRIER:** a continuous membrane, either vertical or horizontal (for example, a wall, floor, or ceiling assembly), that is designed and constructed with a specified fire-resistance rating to limit the spread of fire and restrict the movement of smoke.

**FIRE RESISTANCE:** the property of materials or their assemblies that prevents or retards the passage of excessive heat, hot gas, or flames under conditions of use.

**FIRE-RESISTANCE RATING:** the time, in minutes or hours, that materials or assemblies have withstood fire exposure in accordance with the test procedure of NFPA 252.

**LABELED:** equipment or materials marked with the label, symbol, or other identifying mark of an organization concerned with product evaluation and acceptable to the local jurisdiction. This organization must periodically inspect production of labeled equipment, and the manufacturer, by labeling the product, indicates compliance in a specified manner with appropriate standards or performance.

**NONCOMBUSTIBLE:** a material that, in the form in which it is used and under the conditions anticipated, will not aid combustion or add appreciable heat to an ambient fire.

**SELF-CLOSING:** as applied to a fire door or other protective opening, self-closing means the door is normally closed and is equipped with an approved device that will ensure closure after the door has been opened.

**SMOKE BARRIER:** a continuous membrane, either vertical or horizontal, such as a wall, floor, or ceiling assembly, that is designed and constructed to restrict the movement of smoke. A smoke barrier may or may not have a fire-resistance rating.

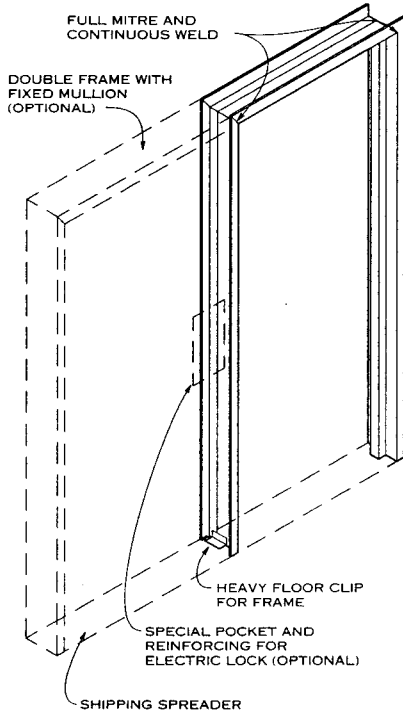

**SECURITY FRAME REINFORCING FOR FIRE-RATED OPENINGS**

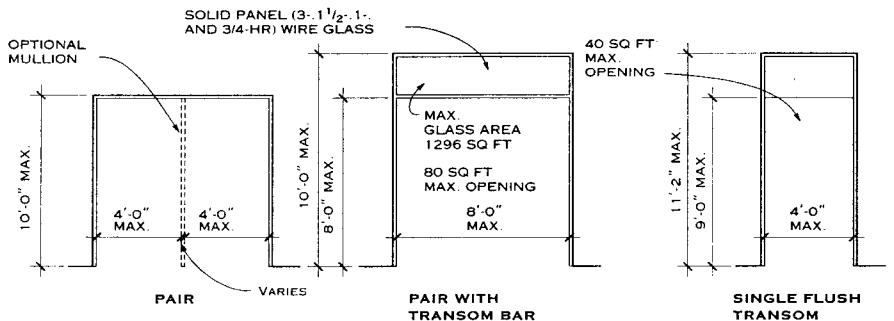

**FIRE-RATED STEEL FRAME ELEVATIONS**

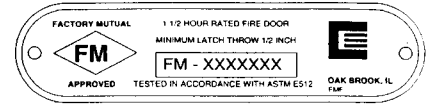

**DOOR LABEL**

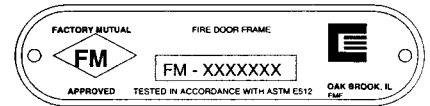

**FRAME LABEL**

**NOTE**

Various agencies test and rate fire door and window units and assemblies. Manufacturers locate metal labels in accessible but concealed locations (the hinge edge of doors, for example); these labels must remain in place, unpainted, uncovered, and unaltered.

**TESTING LABELS**

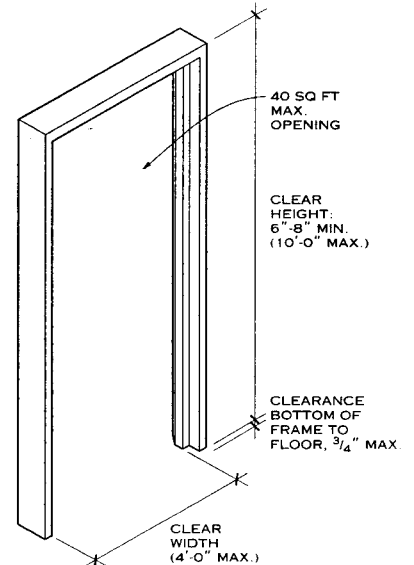

**NOTE**

The minimum width of each door opening must be sufficient for the occupant load it serves. Verify the following general guidelines for door width with local codes:

1. Dwelling units that are not required to be accessible or adaptable: 29 3/4 in.
2. Hospital and other medical facilities: 36 in.
3. Standard openings: 32 in.

**DOOR OPENINGS FOR MEANS OF EGRESS**

National Fire Protection Association; Quincy, Massachusetts  
Daniel F. C. Hayes, AIA; Washington, D.C.

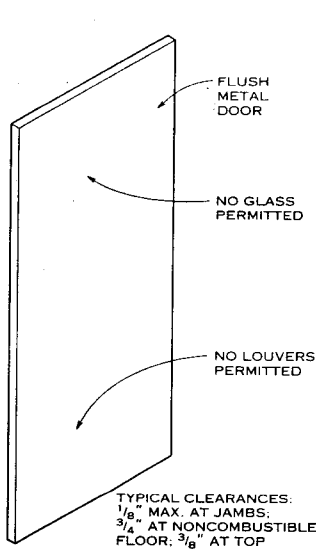

4-HOUR/3-HOUR CLASSIFICATION

NOTES

1. All hinges or pivots must be steel. Two hinges are required on doors up to 5 ft in height; an additional hinge is required for each additional 2 ft 6 in. of door height or fraction thereof. The same requirement holds for pivots.

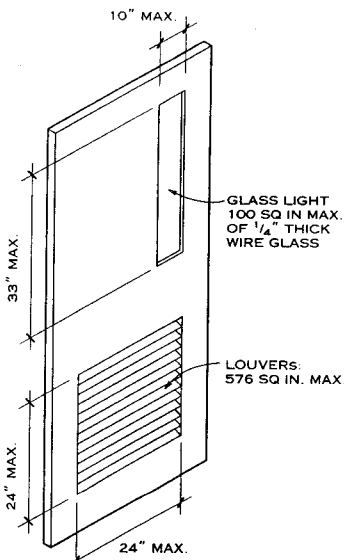

1 1/2-HOUR/1-HOUR CLASSIFICATION

2. While wired glass 1/4 in. thick is the most common material used for glass lights, other materials have been listed and approved for installation. Refer to the UL fire protection directory.

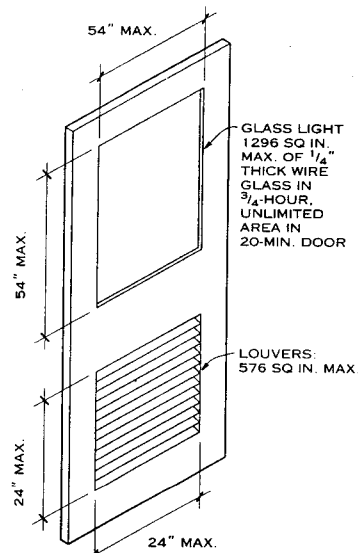

3/4-HOUR/20-MIN. CLASSIFICATION

3. Consult all authorities with jurisdiction before installation of glass lights and louvers.  
4. Fusible-link/automatic closing louvers are permitted in fire-rated doors with restrictions; they are not permitted in smoke-barrier doors.

FIRE-RATED DOOR CLASSIFICATIONS

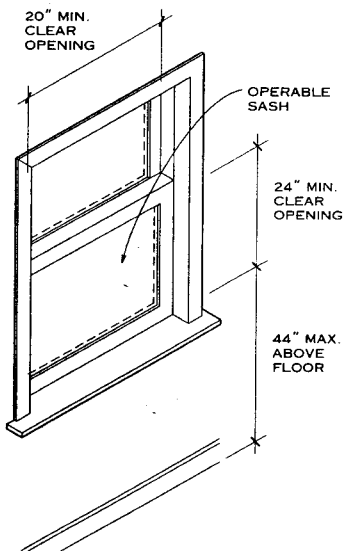

NOTE

When required for egress, such as in sleeping areas in residences, windows must meet the following criteria:

1. Clear opening per sash must be a minimum of 5.7 sq ft.
2. Bars, grilles, or screens must be releasable from inside without use of tools or key.
3. Windows opening onto fire escapes have additional requirements; refer to codes.
4. Check with manufacturers for integral release hardware options for awning, casement, pivot, or other windows.
5. Double-hung window units with fully removable sash that do not require special tools, force, or knowledge to operate may offer greater flexibility in unit selection to meet size requirements for egress openings; verify with manufacturers and code officials.

WINDOW EGRESS REQUIREMENTS

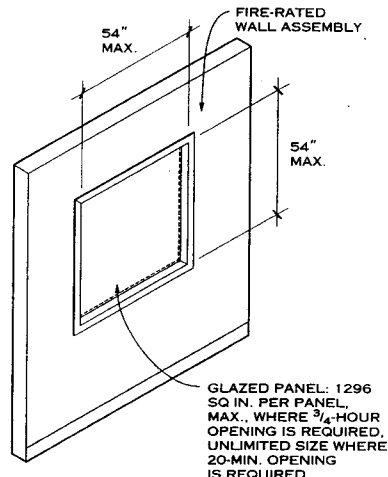

NOTE

Glazed panel assemblies in fire-rated walls must conform to the size limitations indicated below and to wire glass and other approved material requirements. Multiple panels are permitted, but the aggregate area of all panels and openings must not exceed 25% of the wall surface. Refer to specific codes for details.

GLAZED PANEL REQUIREMENTS

MAXIMUM DOOR SIZES (HOLLOW METAL, ALL CLASSES\*)

Single door	4 x 10 ft with labeled single-point or 3-point latching device
	4 x 8 ft with fire exit hardware
Pair of doors	8 x 10 ft active leaf with labeled single-point or 3-point latching device
	8 x 10 ft inactive leaf with labeled 2-point latching device or top and bottom bolts
	8 x 8 ft with fire exit hardware

\*Wood door size requirements are similar.

CONSTRUCTION OF SWINGING FIRE DOORS

Outlined here are different types of swinging fire doors and notes about the hardware used with them.

TYPES OF DOORS

1. Composite fire doors: wood, steel, or plastic sheets bonded to and supported by a solid core material.
2. Hollow metal fire doors: flush or panel design with a steel face of not less than 20-gauge steel.
3. Metal-clad fire-doors: flush or panel design consisting of metal-covered wood cores or stiles and rails and insulated panels that are covered with steel of 24-gauge or lighter.
4. Sheet metal fire doors: 22-gauge or lighter steel of corrugated, flush sheet, or panel design.
5. Tin-clad fire doors: wood core with a terne plate or galvanized steel facing (30- or 24-gauge).
6. Wood core doors: wood, hardboard, or plastic face sheets bonded to a wood block or wood particleboard core material with untreated wood edges.

DOOR OPERATION

1. Doors that swing in the direction of egress are preferred for fire-rated doors.
2. Horizontal sliding and revolving doors are permitted with restrictions.

HARDWARE

1. Door hardware is provided by the builder independent of the assembly or furnished by the manufacturer with the door assembly. In either case, the manufacturer prepares the door and frame to receive hardware to ensure the integrity of the fire-rated assembly.
2. Fire doors are hung on steel ball-bearing hinges and must be self-closing. Labeled automatic latches and door closers can be self-operated or controlled by fail-safe devices that activate in a fire.
3. Pairs of doors require coordinators with astragals to ensure that both doors close.
4. Heads and jambs should be sealed with gaskets when smoke control is required.
5. Panic hardware may be required when space occupancy is greater than 100 people.



**GUIDE SPECIFICATIONS FROM THE HOLLOW METAL MANUFACTURERS ASSOCIATION (HMMA)**

	HMMA 860	HMMA 861	HMMA 862	HMMA 863
<b>DOORS</b>				
Face sheets interior	20 ga.	18 ga.	14 ga.	14 or 12 ga.
Face sheets exterior	18 ga.	16 ga.	14 ga.	14 or 12 ga.
Minimum thickness	1 3/4"	1 3/4"	1 3/4"	2"
Stiffeners	22 ga.	22 ga.	18 ga.	18 ga.
Vertical edges	Continuous weld or interlocking seam welded at top and bottom of door	Continuous weld	Continuous weld	Reinforced by 10 ga. continuous steel channel, continuous weld
Top and bottom edges	Closed with 16 ga. continuous recessed steel channel	Closed with 16 ga. continuous recessed steel channel, spot welded to face sheets	Closed with 12 ga. continuous recessed steel channel, spot welded to face sheets	Reinforced with continuous steel channel, 10 ga. spot welded to face sheets 4" on center
Glass molding and stops	Fixed moldings welded to door on security side; loose stops, 20 ga.	Fixed moldings welded to door on security side; loose stops, 20 ga.	Fixed moldings welded to door on security side; all stops, 16 ga.	Fixed moldings, 12 ga. spot welded to face sheets 5" o.c.; removable glass stops, 14 ga. pressed steel channel
<b>FRAMES</b>				
Interior openings	16 ga. (18 ga. for wood doors, 20 ga. for hollow core wood doors)	16 ga.; 14 ga. for openings over 4' - 0" in width	12 ga.	12 ga.
Exterior openings	16 ga.	14 ga.	12 ga.	12 ga.
Construction	Welded or knocked-down with integral stop and trim	Welded units with integral stop and trim	Welded units with integral stop and trim	Welded units with integral stop and trim
Floor anchors	16 ga. welded inside jambs	14 ga. welded inside jambs	14 ga. welded inside jambs	Same ga. as frame, welded inside jambs with at least 4 spot welds per anchor
Jamb anchors	In masonry walls 16 ga. steel or 0.156" diameter steel wire. For stud partitions, 18 ga. steel anchors welded inside jambs	In masonry walls 16 ga. steel or 0.156" diameter steel wire. For stud partitions, 18 ga. steel anchors welded inside jambs	In masonry walls 14 ga. steel or 0.156" diameter steel wire. For stud partitions, 16 ga. steel anchors welded inside jambs	Same ga. as frame
Loose glazing stops	20 ga. cold-rolled steel	20 ga. cold-rolled steel	16 ga. cold-rolled steel	10 ga. cold-rolled steel

**NOTES**

- HMMA 860: For use in building projects where traffic is relatively light and hard usage is not anticipated.
- HMMA 861: For use in commercial and industrial applications where rigorous use is anticipated, such as schools, hospitals, industrial buildings, office buildings, hotels, nursing homes, airports, and convention centers.
- HMMA 862: For use in applications where security is paramount due to high susceptibility to vandalism, break-in, and theft, such as entrances and back doors of businesses, storerooms, warehouses, strip stores, apartments, and condominiums. HMMA 862 incorporates testing procedures and performance requirements promulgated by NILECJ for Class IV doors (ASTM F476-84) including jamb/wall stiffness test, jamb/wall stiffness performance, door impact test, door and glazing panel impact resistance performance.
- HMMA 863: For applications in jails, prisons, detention centers, and secured areas in hospitals or courthouses. HMMA 863 requires five tests: static load test, rack test, impact load test, removable glazing stop test, and bullet resistance test.
- Reprinted with permission from the Hollow Metal Manufacturers Association, division of NAAMM.

**PERFORMANCE REQUIREMENTS FOR SLIDING GLASS DOOR UNIT SECURITY**

PARAMETER	REQUIREMENTS	
	CLASS I UNIT	CLASS II UNIT
Disassembly	No entry	No entry
Latch operator loiding resistance	10 lbf (45 N)	10 lbf (45 N)
Latch loiding resistance	300 lbf (1335 N) plus weight of panel	600 lbf (2670 N) plus weight of panel
Locking device stability	Horizontal - 50 lbf (222 N) Vertical - 50 lbf (222 N) plus weight of panel (10 cycles)	Horizontal - 50 lbf (222 N) Vertical - 50 lbf (222 N) plus weight of panel (10 cycles)
Door panel removal resistance	Horizontal - 100 lbf (445 N) Vertical - 300 lbf (1335 N) plus weight of panel	Horizontal - 100 lbf (445 N) Vertical - 600 lbf (2670 N) plus weight of panel
Locking device strength	300 lbf (1335 N)	600 lbf (2670 N)
Fixed panel fastening strength	300 lbf (1335 N)	600 lbf (2670 N)
Meeting stile fastening strength	150 lbf (667 N)	Horizontal - 100 lbf (445 N) 300 lbf (1335 N)
Glazing impact strength	None	37 ft-lbf (50 Joules)

**NOTES**

- Table from the National Institute of Justice (NIJ) Standard 0318.00, Physical Security of Sliding Glass Door Units.
- Class I sliding door units provide a minimum level of physical security. Class II sliding door units provide a moderate level of physical security.
- Loiding is a method of manipulating a locking device from the exterior of a sliding glass door unit by means of a thin, flat object or a thin stiff wire that is inserted between the locking stile and the strike so as to force the locking device toward the unlocked position.

McCain McMurray, Architect; Washington, D.C.



**SLIDING DOOR UNITS**

Sliding glass doors are a particular concern in securing a building. The locking devices should include vertical rod, or lever bolts, at top and bottom; the frame should be solid or reinforced at the locking points; the stile must also be reinforced at the locking points. The operating panels should be designed so that they cannot be lifted out of their tracks when in the locked position. Glazing and other components should be installed from the inside so that entry cannot be gained by disassembly.

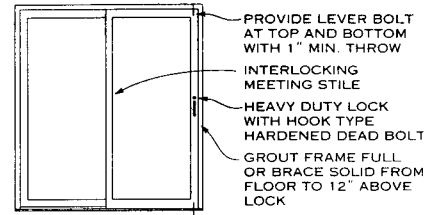

**SLIDING GLASS DOOR**

**WINDOW SECURITY DESIGN CRITERIA**

The following items should be considered when designing and selecting windows:

- If accessible (residential: 12 ft vertical, 6 ft horizontal; commercial: 18 ft vertical, 10 ft horizontal) and hidden from public view, a higher grade is required.
- If windows are protected by a detection device (such as shutters, security screens, or bars), the window grade could be irrelevant. If security screens, bars, or shutters are used, requirements for fire exiting must be met.
- The existence of windbreaks near a building may provide cover for intruders.
- The use of shades and window coverings may deter intruders, depending on the ease of removal of these devices or the noise from breakage. The use of lockable shutters or roll-down blinds is very effective.
- Window units should at least comply with ASTM F588-85 Standard Test Methods for Resistance of Window Assemblies to Forced Entry for a minimum grade performance and with NIJ-STD-0316, Physical Security of Window Units, for higher grade performance.

**FRAME DESIGN ELEMENTS**

- A rigid frame and sash is important to resist prying and should be removable from the inside only.
- The quality of the hardware and its placement and anchorage are critical to security. Exposed removable hinges should not be used.
- Special attention must be given to the use of weather stripping, since this can permit insertion of wires to unlock windows.

**GLAZING DESIGN ELEMENTS**

- Multiple glazing systems provide a greater hazard to entry/exit through broken-out windows.
- Reflective glazing impedes outside daytime surveillance.

**MATERIALS AND METHODS FOR WINDOWS**

- Class IV. Very heavy fixed frames with laminated glass over 1/4 in. thick security screen, bars, or shutters with special locking device.
- Class III. Heavy duty sash with laminated glass over 1/4 in. thick or polycarbonate glazing 1/4 in. thick. Lock should include at least two heavy duty dead locking bolts.
- Class II. Heavy duty sash with laminated glass or polycarbonate glazing; if wood, sash must be reinforced or heavy; double locks required.
- Class I. Regular glazing in commercial sash with double locks; can be wood frame.

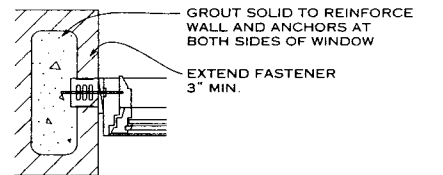

**WINDOW JAMB DETAIL**

**DEFINITIONS**

**BUCK:** a subframe of wood or metal set in a wall or partition to support the finish frame of a door or window; also called door buck or rough buck.

**CASING:** the finished, often decorative framework around a door or window opening, especially that which is parallel to the surrounding surface and at right angles to the jamb; also called trim.

**SUBCASING:** finish frame components that support and guide the door or sash.

**HEAD:** horizontal members at top of door or window.

**JAMB:** vertical members at sides of door or window.

**STOP:** integral or applied member that prevents a door or window from swinging past its closed position, or members that guide horizontal or vertical sliding movement.

**SILL:** horizontal members at bottom of door or window.

**THRESHOLD:** applied wood, stone, or metal plate, usually weatherproof.

**SADDLE:** part of a threshold, usually bridging dissimilar flooring materials.

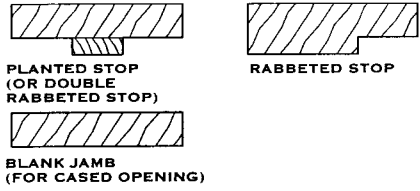

**FRAME AND STOP TYPES**

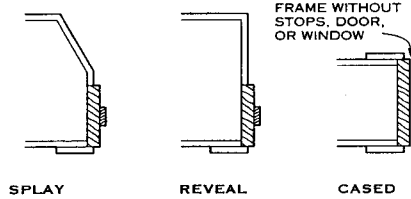

**OPENING TYPES**

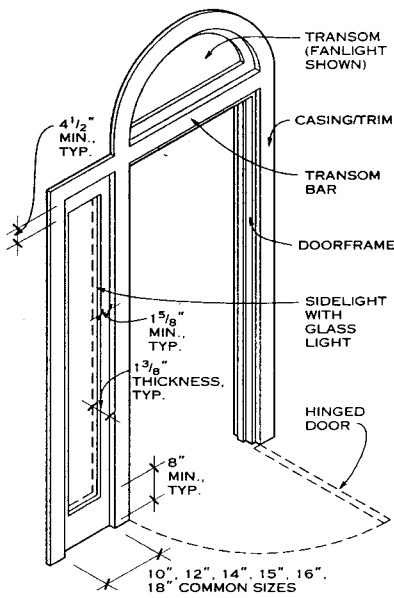

**DOOR ACCESSORIES**

Daniel F. C. Hayes, AIA; Washington, D.C.

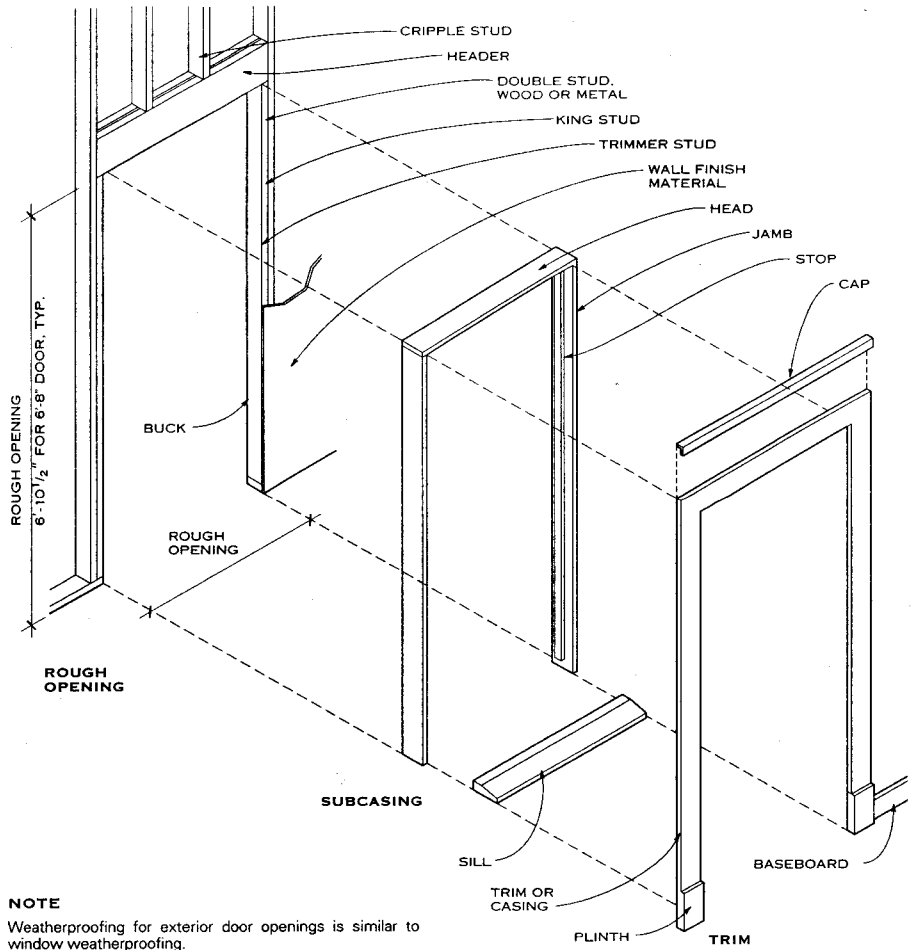

**NOTE**

Weatherproofing for exterior door openings is similar to window weatherproofing.

**DOOR OPENING COMPONENTS**

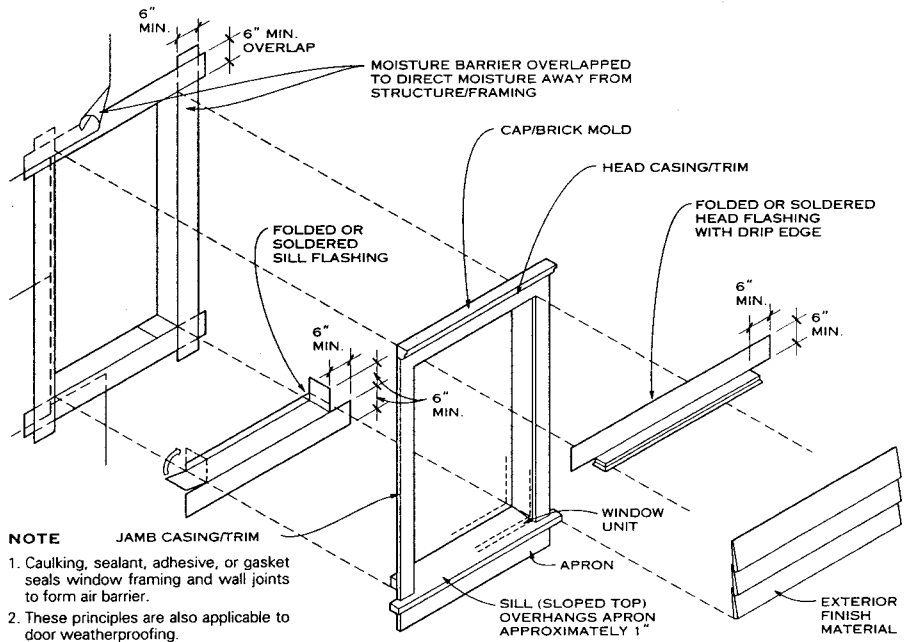

**NOTE**

1. Caulking, sealant, adhesive, or gasket seals window framing and wall joints to form air barrier.
2. These principles are also applicable to door weatherproofing.

**WINDOW WEATHERPROOFING PRINCIPLES**

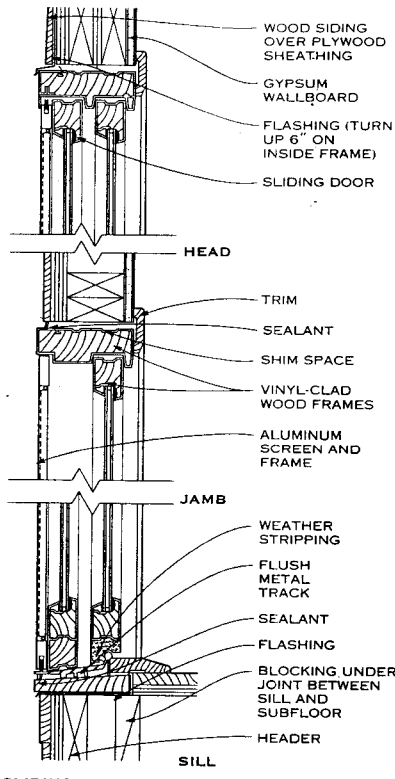

SLIDING DOOR IN WOOD FRAME

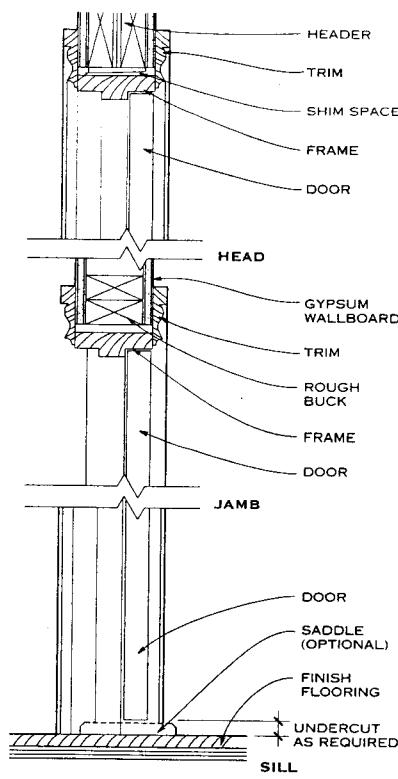

INTERIOR SWING DOOR IN WOOD FRAME

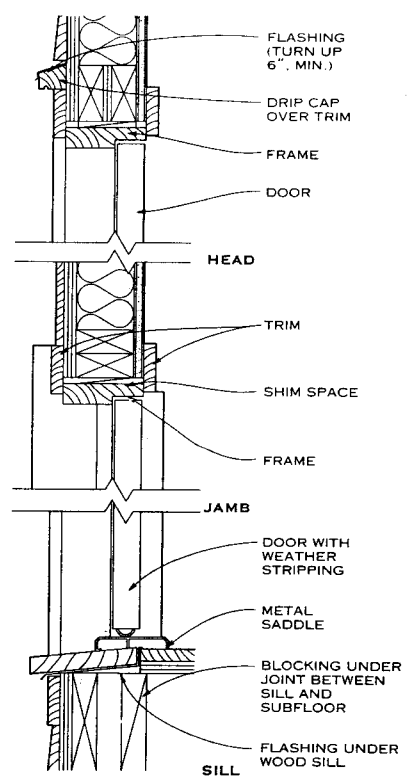

EXTERIOR SWING DOOR IN WOOD FRAME

DOORFRAME DETAILS IN WOOD WALL CONSTRUCTION

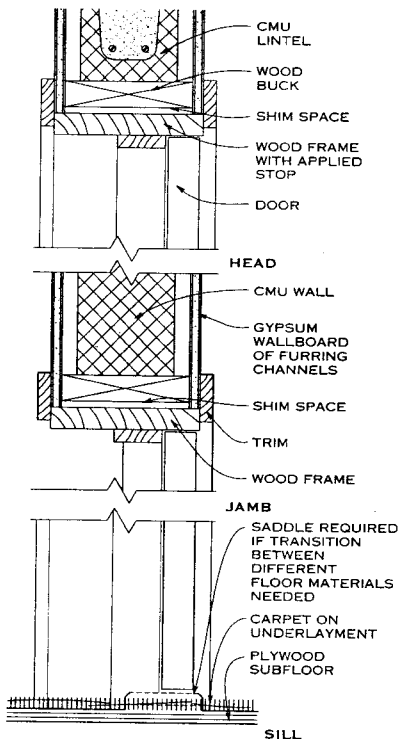

INTERIOR SWING DOOR IN MASONRY WALL

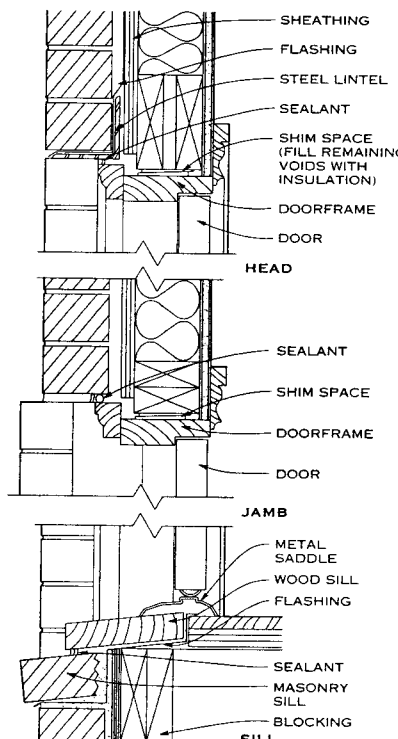

SWING DOOR IN MASONRY VENEER

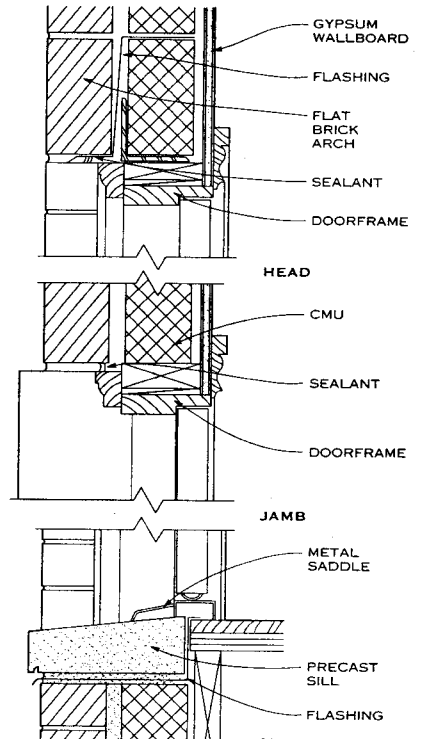

SWING DOOR IN SOLID MASONRY

DOORFRAME DETAILS IN MASONRY WALL CONSTRUCTION

Daniel F. C. Hayes, AIA; Washington, D.C.  
Richard J. Vitullo, AIA; Oak Leaf Studio; Crownsville, Maryland

**MATERIALS**

Hollow metal doorframes are available in various steel gauges according to where and how they will be used. Local codes and governing authorities establish minimum gauges, which should always be consulted. Some manufacturers make custom moldings for a specific design, as long as a sufficient quantity is required.

For security, the exterior moldings on exterior doors should be welded into the frame and exposed fasteners should be tamperproof.

**TYPES OF FRAMES**

Doorframes can be factory or field assembled. All frames must be adequately anchored at the jambs and floor according to the manufacturer's specifications.

**LIGHT-GAUGE METAL FRAME:** head and jamb members, with or without a transom panel, of aluminum (45 min. maximum rating) or light-gauge steel (1.5 hr maximum rating). Frame is installed over finished wall.

**PRESSED STEEL (HOLLOW METAL):** head and jamb members, with or without solid or glazed transoms or sidelights, of 18-gauge or heavier steel (3 hr maximum rating). This frame is required for most metal doors.

**FINISHES**

Hollow metal frames should receive at least one shop coat of rust-inhibitive primer before delivery to the job site. In very corrosive atmospheres, such as saltwater beach locations, is it advisable to have doors and frames hot dipped galvanized for additional protection.

Frames with factory-applied paint finishes in various colors are available from several manufacturers.

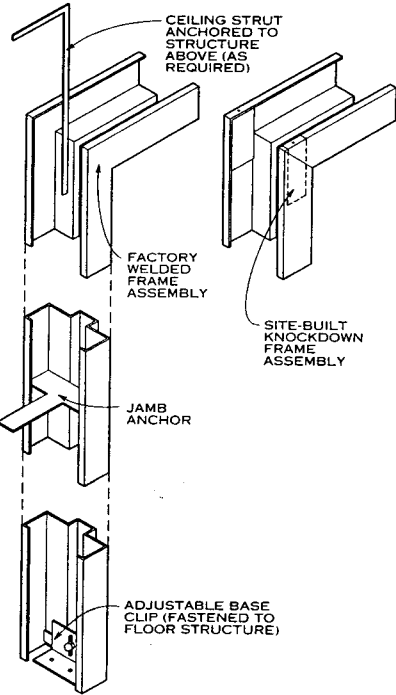

**HOLLOW METAL FRAME COMPONENTS**

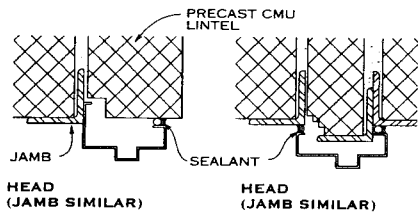

**WEATHERPROOF INSTALLATIONS**

James W. G. Watson, AIA; Ronald A. Spahn and Associates; Cleveland Heights, Ohio  
Daniel F. C. Hayes, AIA; Washington, D.C.

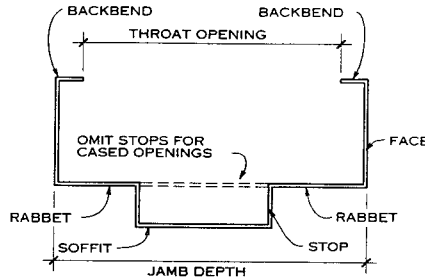
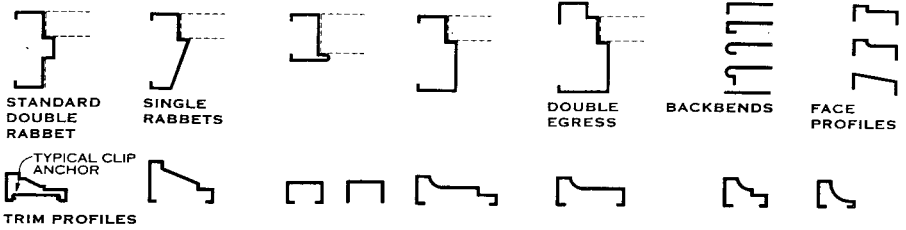

**STANDARD DOUBLE RABBET NOTE**

Maximum gauge is 10; consult manufacturers for lighter gauges.

**VARIOUS STANDARD PROFILES**

	JAMB DEPTH (IN.)									
	2 <sup>3</sup> / <sub>4</sub>	3	3 <sup>3</sup> / <sub>4</sub>	4 <sup>3</sup> / <sub>4</sub>	5 <sup>1</sup> / <sub>2</sub>	5 <sup>3</sup> / <sub>4</sub>	6 <sup>3</sup> / <sub>4</sub>	7 <sup>3</sup> / <sub>4</sub>	8 <sup>3</sup> / <sub>4</sub>	
Rabbet*	Single rabbet only		1 <sup>5</sup> / <sub>16</sub> in. standard for 1 <sup>3</sup> / <sub>4</sub> in. door							
Soffit*										
Rabbet*	1 <sup>9</sup> / <sub>16</sub> in. standard for 1 <sup>3</sup> / <sub>8</sub> in. door									
Backbend	1/2	7/16	1/2	1/2	3/4	1/2	1/2	1/2	1/2	
Throat	1 <sup>3</sup> / <sub>4</sub>	2 <sup>1</sup> / <sub>8</sub>	2	3 <sup>3</sup> / <sub>4</sub>	4	4 <sup>3</sup> / <sub>4</sub>	5 <sup>3</sup> / <sub>4</sub>	6 <sup>3</sup> / <sub>4</sub>	7 <sup>3</sup> / <sub>4</sub>	

\* Omit stops for cased opening frames.

**NOTES**

1. Many other profiles are available; consult manufacturers' lists for dimensions and options.
2. Depths vary in 1/8 in. increments to 12<sup>3</sup>/<sub>4</sub> in. maximum.
3. Standard stops are 5/8 in. (1/2 in. minimum); standard faces are 2 in. (1 in. minimum).

**HOLLOW METAL FRAME PROFILES AND COMPONENTS**

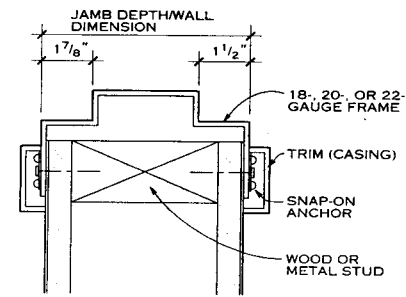

**LIGHT-GAUGE FRAME**

**FRAME GAUGES**

GRADE	DUTY	MINIMUM GAUGE
I	Standard	18
II	Heavy	16
III	Extra heavy	16

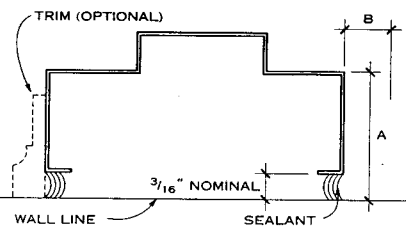

**BUTT FRAME/FLUSH FRAME**

**NOTES**

1. Use anchors appropriate for the type of wall construction; a minimum of three per jamb is required.
2. Grout frame with mortar or plaster as used in wall.
3. Caulk frame at wall.
4. Dimension A is minimum 3 in. in area of pull or knob hardware.
5. Trim may be used to cover joint at wall line.
6. Check dimension B on hinge side for door swing greater than 90°.

**FRAME CONDITION AT WALL**

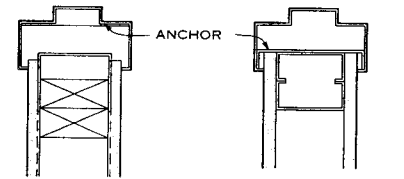

**WOOD STUDS WITH PLASTER**

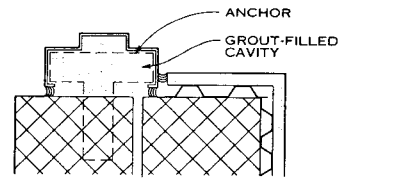

**MASONRY WITH GYPSUM BOARD BUTTED TO FRAME**

**METAL FRAME INSTALLATIONS**

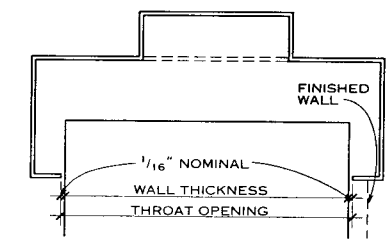

**WRAPAROUND FRAME**

**NOTES**

1. Basic wall dimension is less than throat opening dimension.
2. Use anchors appropriate for the type of wall construction; a minimum of three per jamb is required.
3. Fill frame with mortar or plaster as used in the wall.
4. Grout frame at masonry wall.
5. Backbend may vary as selected.

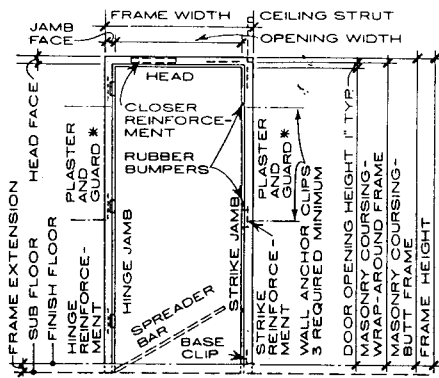

\*REQUIRED EXCEPT IN DRYWALL CONSTRUCTION

STANDARD STEEL FRAME

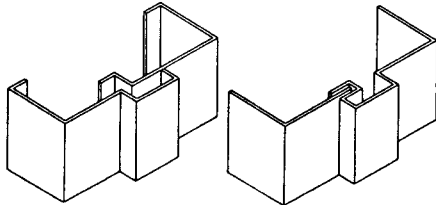

ADJUSTABLE FRAME TWO-PIECE FRAME

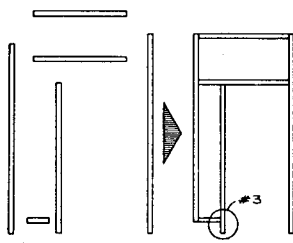

STICK SYSTEM

THIS SYSTEM USES CERTAIN STD PROFILES IN ANY VARIETY OF LINEAR ARRANGEMENTS; FABRICATES EASILY AND QUICKLY. JOINTERY VARIES BETWEEN MANUFACTURERS

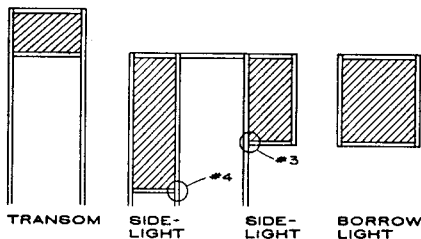

TRANSOM SIDE-LIGHT SIDE-LIGHT BORROW LIGHT

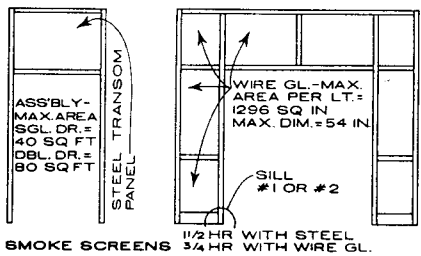

SMOKE SCREENS 1/2 HR WITH STEEL 3/4 HR WITH WIRE GL.

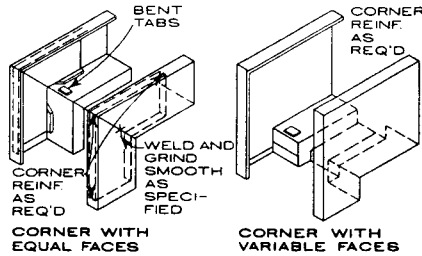

METHOD AND TYPE OF CONSTRUCTION VARIES BETWEEN MANUFACTURERS. MECH. FASTENING TO BE SPECIFIED TO ASSURE TIGHT CORNER

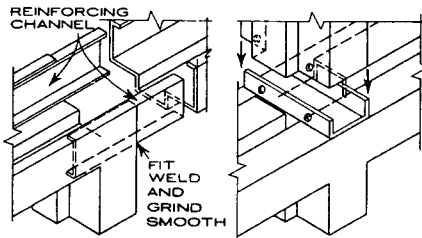
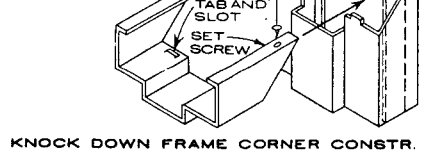

HORIZ. FIELD JOINT VERT. FIELD JOINT

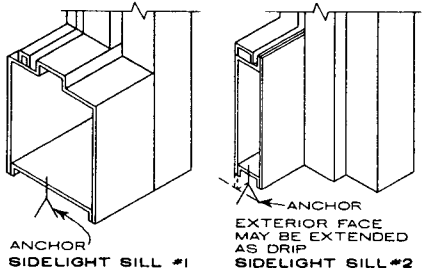

ANCHOR SIDELIGHT SILL #1 ANCHOR SIDELIGHT SILL #2

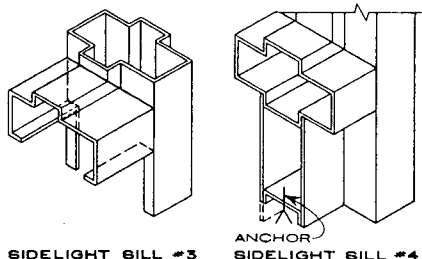

SIDELIGHT SILL #3 ANCHOR SIDELIGHT SILL #4

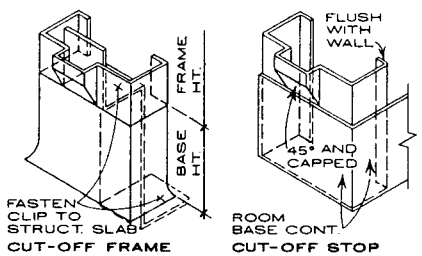

CUT-OFF FRAME CUT-OFF STOP HOSPITAL STOP

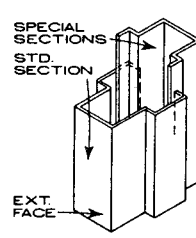
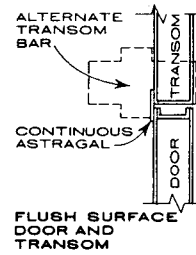
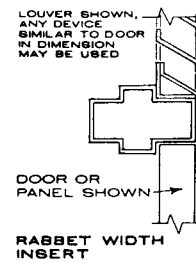

FLUSH SURFACE DOOR AND TRANSOM WELDED OR DRIVEN MULLION

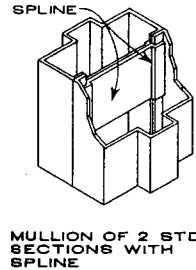

MULLION OF 2 STD. SECTIONS WITH SPLINE

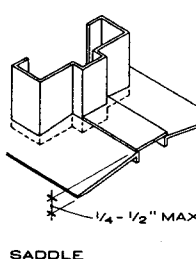

SADDLE REMOVABLE MULLION (SILL)

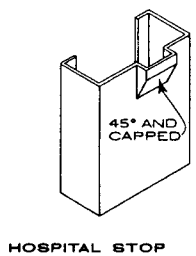

HOSPITAL STOP

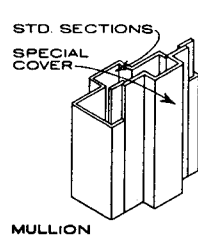
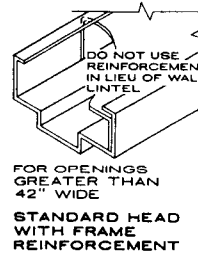
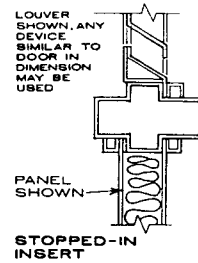

STD. SECTIONS SPECIAL COVER

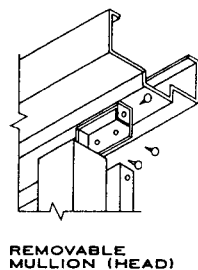

REMOVABLE MULLION (HEAD)

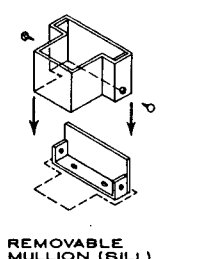

REMOVABLE MULLION (SILL)

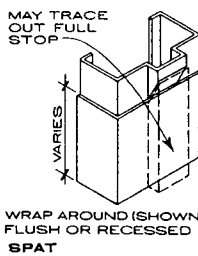

WRAP AROUND (SHOWN) FLUSH OR RECESSED SPAT

James W. G. Watson, AIA; Ronald A. Spahn and Associates; Cleveland Heights, Ohio



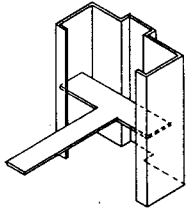

LOOSE "T" ANCHOR

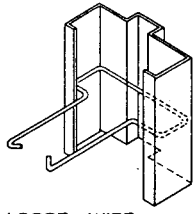

LOOSE WIRE ANCHOR

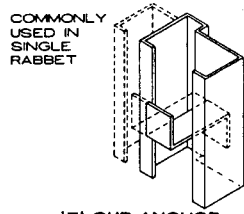

COMMONLY USED IN SINGLE RABBET

'Z' CUP ANCHOR LABEL AVAIL.

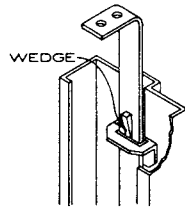

CEILING STRUT

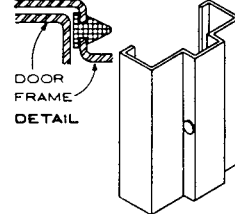

RUBBER SILENCERS

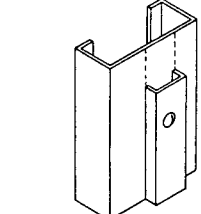

REMOVABLE STOP

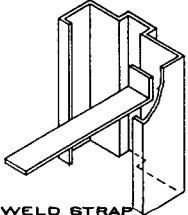

WELD STRAP ANCHOR

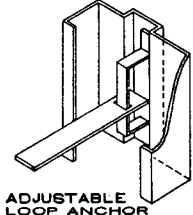

ADJUSTABLE LOOP ANCHOR LABEL AVAILABLE

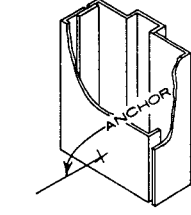

ROUGH BUCK #1

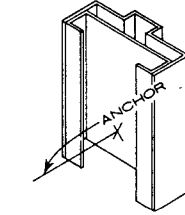

ROUGH BUCK #2

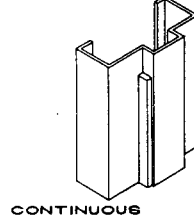

CONTINUOUS RESILIENT GASKET

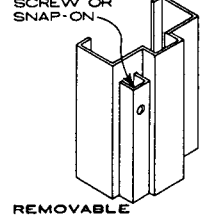

SCREW OR SNAP-ON

REMOVABLE GLAZING BEAD

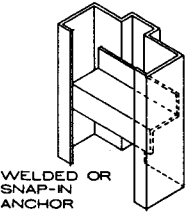

WELDED OR SNAP-IN ANCHOR STEEL CHANNEL ANCHOR

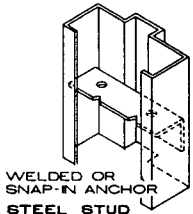

WELDED OR SNAP-IN ANCHOR STEEL STUD ANCHOR

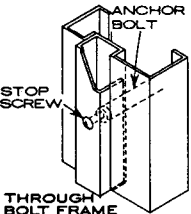

THROUGH BOLT FRAME ANCHOR LABEL AVAIL.

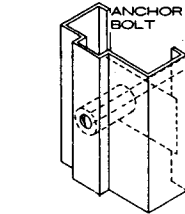

THROUGH BOLT FRAME ANCHOR

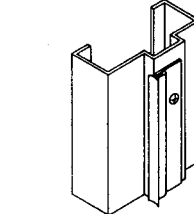

APPLIED GASKET

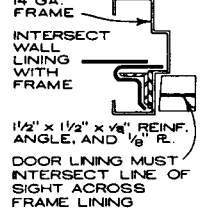

14 GA. FRAME INTERSECT WALL LINING WITH FRAME

1/2" x 1/2" x 1/8" REINF. ANGLE, AND 1/8" R. DOOR LINING MUST INTERSECT LINE OF SIGHT ACROSS FRAME LINING LEAD LINED FRAME

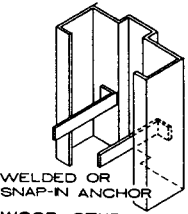

WELDED OR SNAP-IN ANCHOR WOOD STUD ANCHOR

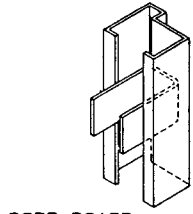

CORE BOARD ANCHOR

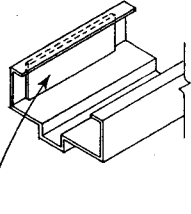

CLOSER REINF.

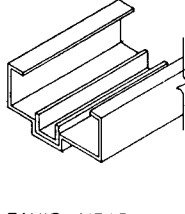

PANIC HEADER REINFORCING

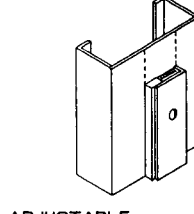

ADJUSTABLE SOUND STOP

NOTE Use STC\* rated door w/ automatic door bottom & frame w/adjustable stops; filled & installed in compatible wall construction. \*S.T.C. = Sound Transmission Class.

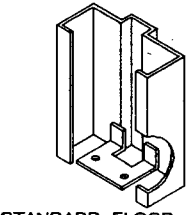

STANDARD FLOOR KNEE

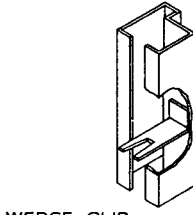

WEDGE CLIP ANCHOR

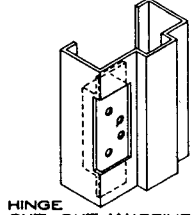

HINGE CUT-OUT W/REINF AND PLASTER GUARD

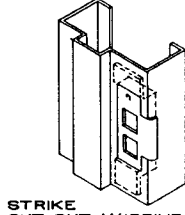

STRIKE CUT-OUT W/REINF AND PLASTER GUARD

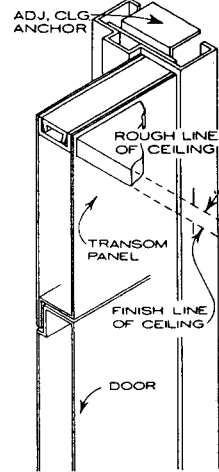

ADJ. CLG ANCHOR

ROUGH LINE OF CEILING

TRANSOM PANEL

FINISH LINE OF CEILING

DOOR

HEADLESS DOOR FRAME LABEL AVAIL.

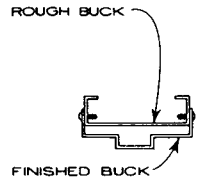

ROUGH BUCK

FINISHED BUCK

ROUGH BUCK #3 LABEL AVAIL.

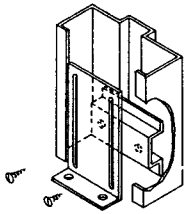

ADJUSTABLE FLOOR KNEE

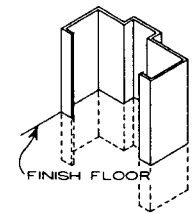

EXTENDED FRAME W/BASE ANCHOR

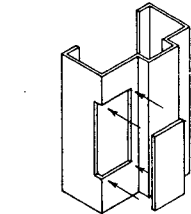

HINGE CUT-OUT W/ BLANK COVER

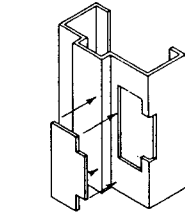

STRIKE CUT OUT W/ BLANK COVER

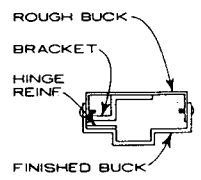

ROUGH BUCK

BRACKET

HINGE REINF.

FINISHED BUCK

ROUGH BUCK #4 LABEL AVAIL.

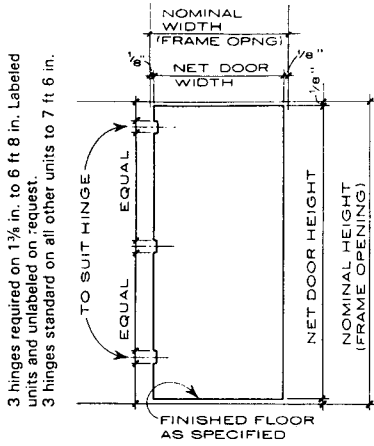

STANDARD DOOR AND DOOR CLEARANCE

Tubular stiles and rails compose structural elements.

A flush or recessed panel is held in place by stiles and rails.

A recessed panel door, generally considered an industrial type door, may be used for decorative purposes.

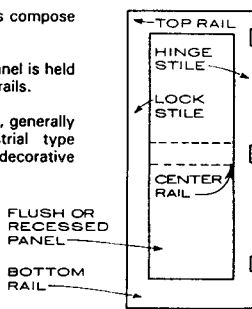

STILE AND RAIL CONSTRUCTION

Relatively wide center panel connected to hinge and lock stile by interlocking and/or welding—forming two exposed vertical seams on door face.

Inverted channel closes top and bottom.

Exterior door is furnished with cap.

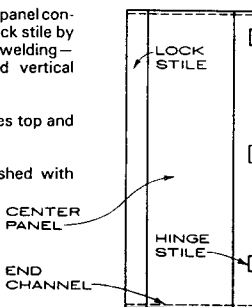

STILE AND PANEL CONSTRUCTION

Pan type or enclosed grid construction. No seams visible on face.

Exposed seams may be on vertical edges where two pans join.

Top and/or bottom of door may be flush or recessed.

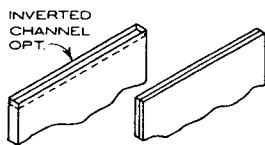

SEAMLESS FLUSH CONSTRUCTION FULL FLUSH CONSTRUCTION

DOOR TYPES

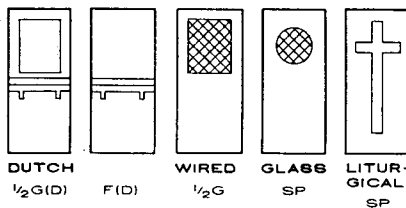
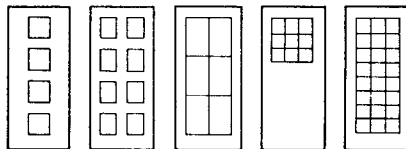
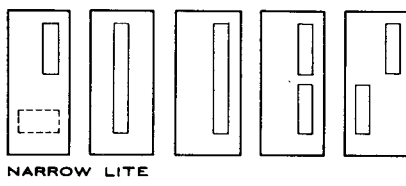
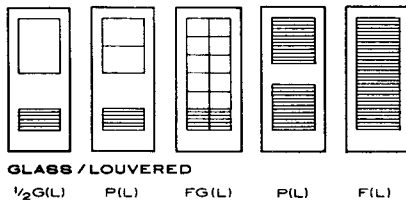
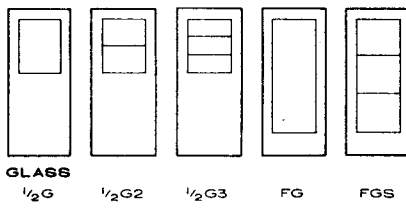
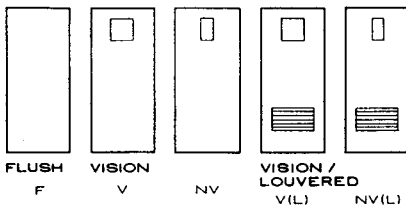

NOTES

Door types may be imposed on any door construction.

Defined areas are filled with glass, screening, louvers, or recessed or flush panels unless otherwise noted.

Stiles and rails or muntins make divisions.

FINISHES

Standard: primed and/or galvanized  
 Paint: baked enamel  
 Applied: vinyl clad  
 Textured, embossed: stainless steel, aluminum  
 Polished: stainless steel

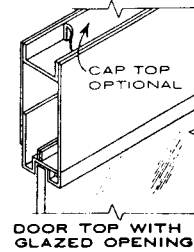

DOOR TOP WITH GLAZED OPENING

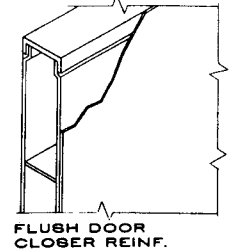

FLUSH DOOR CLOSER REINF.

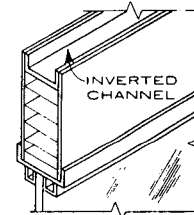

STILE AND PANEL DOOR TOP WITH GLAZED OPENING

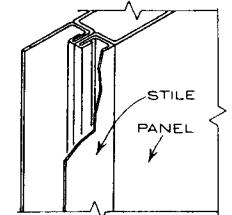

STILE AND PANEL JOINT

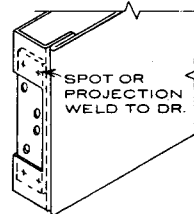

HINGE REINFORCEMENT

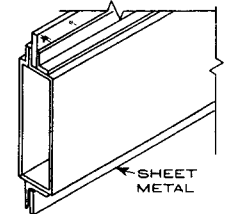

STILE AND RAIL DOOR

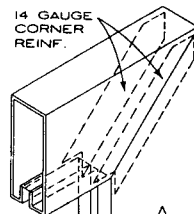

STILE AND RAIL CORNER

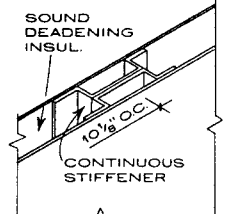

FLUSH CONSTR.

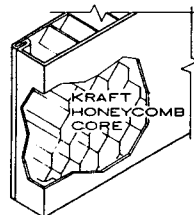

FLUSH DOOR CORE

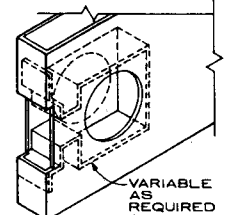

LOCK REINFORCEMENT

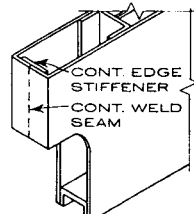

FLUSH DOOR BOTTOM AND EDGE CONST.

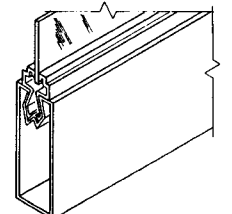

STILE AND RAIL DOOR BOTTOM CONST.

James W. G. Watson, AIA; Ronald A. Spahn and Associates; Cleveland Heights, Ohio

**HOLLOW METAL DOORS**

Hollow metal doors are available in steel gauges ranging from 20 to 12; which gauge to use depends on where and how a door will be used. Consult local codes and governing authorities for minimum gauges that may have been established. Some manufacturers will custom make doors to a specific design if an order is large enough.

For security, exterior moldings on exterior doors should be welded into the door and all exposed fasteners should be tamperproof.

**FINISHES**

Hollow metal doors should receive at least one shop coat of rust-inhibitive primer before delivery to the job site. In very corrosive atmospheres, such as saltwater beach locations, the doors and frames should be hot-dipped galvanized for additional protection.

Doors can be purchased from the manufacturer with factory-applied paint finishes in various colors.

**FLUSH WOOD DOORS**

**CORE MATERIAL**

**SOLID CORE:** wood block, single specie, maximum 2 1/2 in. width, surfaced two sides, no spaces or defects impairing strength or visible through hardwood veneer facing.

**HOLLOW CORE:** wood, wood derivative, or class A insulation board.

**SPECIAL CORES**

**SOUND-INSULATING CORE:** thicknesses of 1 3/4 and 2 1/4 in.; sound transmission class rating of 36 for 1 3/4 in. and 42 for 2 1/4 in. barrier faces separated by a void or damping compound to keep faces from vibrating in unison. Special stops, gaskets, and threshold devices may be required.

**LEAD-LINED CORE:** 1/32 in. to 1/2 in. continuous lead sheeting from edge to edge inside door construction; may be reinforced with lead bolts or glued. (See UL requirements.)

**GROUNDED CORE:** wire mesh at center of core, grounded with copper wire through hinges to frame.

**WOOD FACE TYPES**

Standard thickness face veneers range from 1/16 in. to 1/32 in.; they are bonded to hardwood with a crossband (1/10 in. to 1/16 in.) and are the most economical and widely used veneer type. Face veneers inhibit checking in the finish but are difficult to refinish or repair. They can be used on all cores.

Bonded to a crossband, 1/8 in. sawn veneers are easily refinished and repaired.

Staved-block and stile-and-rail solid cores take 1/4 in. sawn veneers. These are the same as 1/8 in. sawn veneers but do not have a crossband on stile-and-rail solid cores with horizontal blocks. Faces can be cut with decorative grooves.

**LIGHT AND LOUVER OPENINGS**

Custom made to specifications, this type of door has wood beads and slats that match the face veneer. Space between the opening in the door and the edge of the door can be no less than 5 in.

In hollow-core doors, the cutout area can be at most half the height of the door. Doors with openings greater than 40% are not guaranteed. Weatherproofing of exterior doors is required to prevent moisture from leaking into the core.

**FACTORY FINISHING**

Partial finishing is available, with sealing coats in place but the final finish applied on the job. Complete factory finishing requires the door to be prefit and premachined.

**SPECIAL FACING**

For opaque finishes only, high or medium-low density overlay faces of phenolic resins and cellulose fibers can be fused to the inner faces of a hardwood door to serve as a base for the final finish.

Laminated plastic (1/16 in. thick, minimum) can be bonded to a wood back of two or more plies (1/16 in., minimum).

Hardboard, 1/8 in. thick and smooth on one or both sides, can be used as a facing.

**GENERAL NOTES: WOOD DOORS**

1. Kiln-dried wood: moisture content at 6-12%.
2. Type I doors: fully waterproof bond, exterior and interior.
3. Type II doors: water-resistant bond, interior only.

Daniel F. C. Hayes, AIA; Washington, D.C.

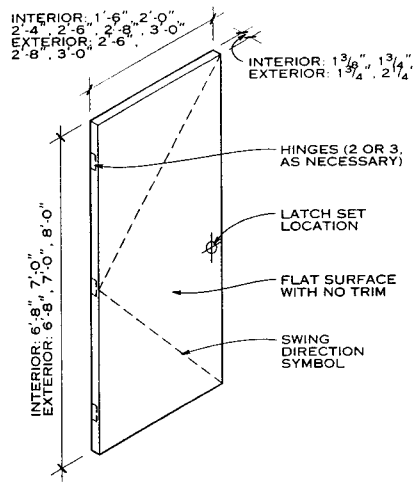

**TYPICAL FLUSH DOOR SIZES AND CHARACTERISTICS**

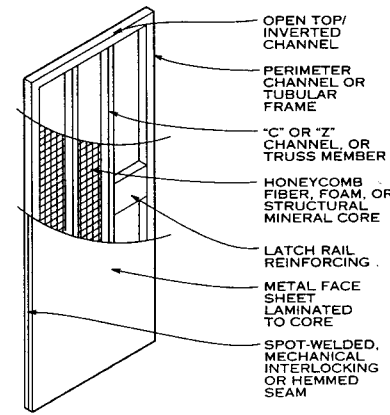

**HOLLOW METAL DOOR WITH STIFFENED CORE**

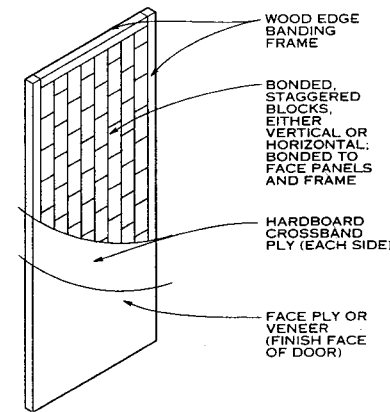

**NOTE**

For bonded blocks, stave core is the most economical and widely used. Other materials include particleboard (heavier, more soundproof, economical) and mineral composition (lighter, difficult cutouts and detailing, lower screw strength).

**WOOD SOLID CORE DOOR**

4. Tolerances: height, width, thickness, squareness, and warp per NWWDA standards; vary with solid vs. builtup construction.
5. Prefit: doors at 3/16 in. less than width and 1/8 in. less in height than nominal size, ±1/32 in. tolerance, with vertical edges eased.

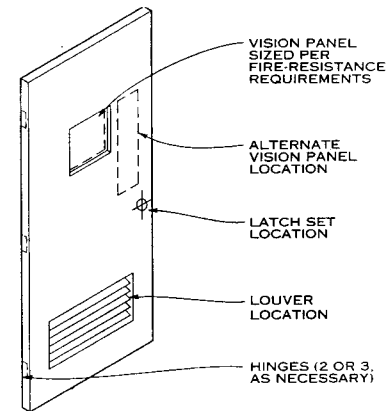

**NOTE**

Louvers are sized per mechanical requirements. Fire-resistance regulations require closable louvers or preclude installation in smoke-barrier doors and certain fire-rated doors.

**VISION OR LOUVERED DOOR**

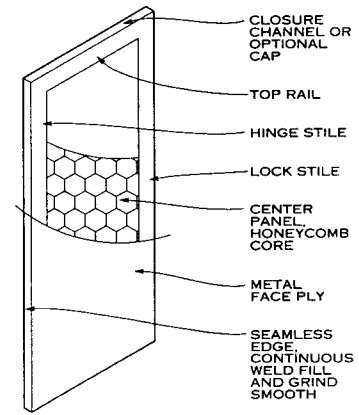

**HOLLOW METAL DOOR WITH STILE AND RAIL**

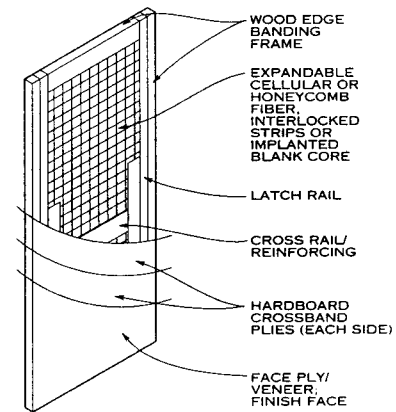

**NOTE**

Acoustical materials may be used to cut sound transmission.

**WOOD HOLLOW CORE DOOR**

6. Premachining: doors mortised for locks and cut out for hinges when so specified.
7. Premium: for transparent finish; good/custom: for paint or transparent finish; sound: for paint, with two coats completely covering defects.





**GENERAL**

Panel doors consist of a framework of vertical (stile) and horizontal (rail) members that hold solid wood or plywood panels, glass lights, or louvers in place.

**CONSTRUCTION**

Doors are made of solid or builtup stiles, rails, and vertical members (muntins), doweled as in NWWDA standards. Stock material includes ponderosa pine or other Western pine, fir, hemlock, or spruce and hardwood veneers. Hardboard, metal, and plastic facings are available in patterns simulating panel doors.

**GRADES**

Premium (select) grade is used for natural, clear, or stained finishes. Exposed wood is free of defects that affect appearance.

Standard grade is used for opaque finishes. Defects, discoloration, mixed species, and finger joints are permitted if undetectable after finishing.

**GLAZING**

All glazing in doors must be safety glazing. Insulated glazing is available.

**BUILTUP MEMBERS**

The core and edge and end strip material is similar to the material used in flush doors. Face veneer is typically hardwood at 1/8 in. minimum thickness.

**STICKING, GLASS STOPS, AND MUNTINS**

Typical profiles used are cove, bead, or ovolo.

**PANELS**

Flat panels are typically 3-ply hardwood or softwood. Raised panels are constructed of solid hardwood or softwood built up of two or more plies. Doors 1 ft 6 in. wide or less are one panel wide.

**ADA ACCESSIBILITY GUIDELINES**

For opening width compliance, use doors 3 ft 0 in. wide. Door projections, such as Dutch door shelves, may be no more than 4 in. if more than 27 in. above finished floor. Thresholds and saddles must be no higher than 1/2 in. with beveled edges. Kickplates are recommended outdoors along accessible routes.

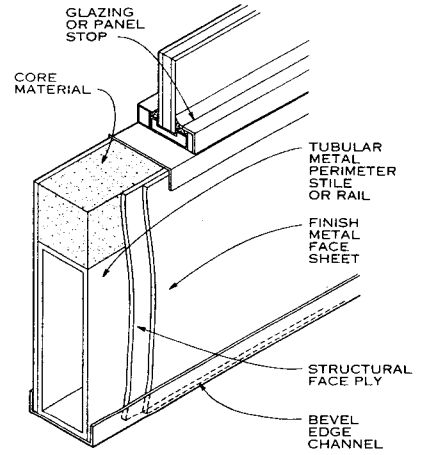

**HOLLOW METAL DOOR STILE AND RAIL DETAIL**

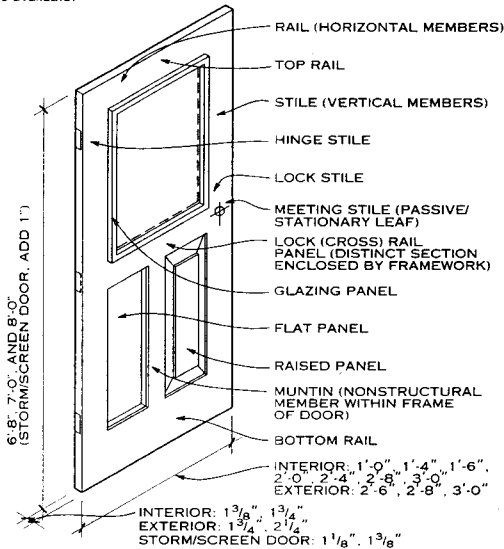

**TYPICAL SIZES AND CHARACTERISTICS**

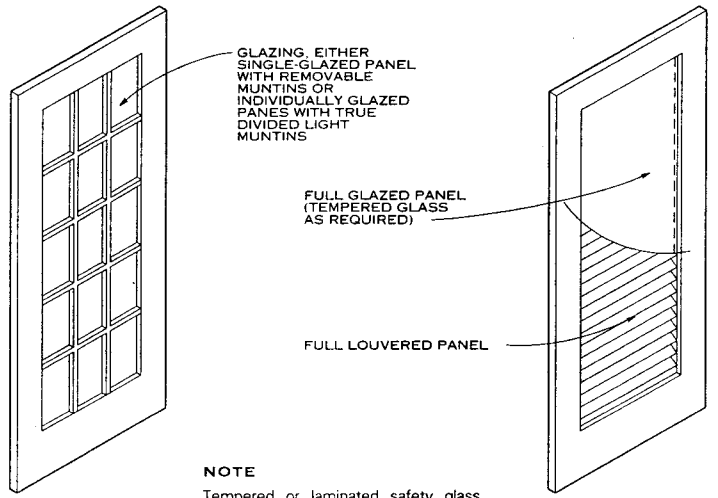

**NOTE**  
Tempered or laminated safety glass should be used in glazed panels.

**FRENCH DOOR**

**GLAZED/LOUVERED DOOR**

**STILE AND RAIL DOOR TYPES**

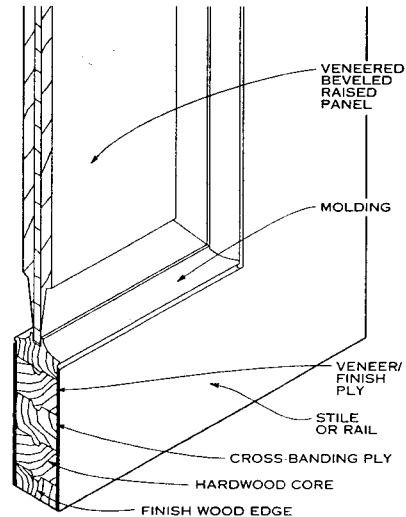

**TYPICAL BEVELED RAISED PANEL DOOR**

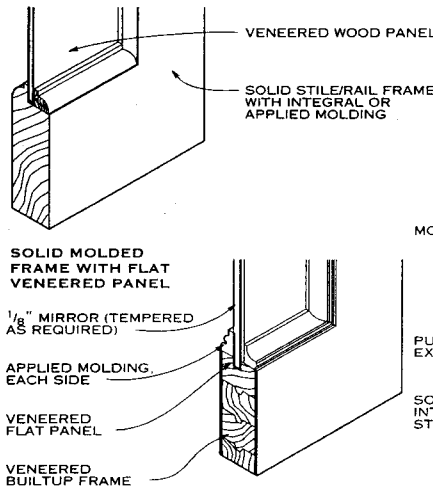

**STILE AND RAIL DOOR DETAILS**

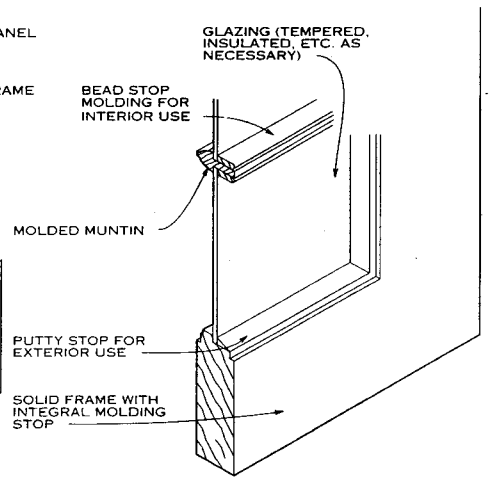

**GLAZED DOOR**

Jeffrey R. Vandevoort, Talbott Wilson Associates, Inc.; Houston Texas  
Daniel F. C. Hayes, AIA; Washington, D.C.



**GENERAL**

Consider the following when designing a door: aesthetics (the design and look of the door), operation (how the door moves), fire-resistance ratings/egress requirements, accessibility for people with disabilities, size and weight, location, materials/method of construction, glazing requirements, special requirements (sound transmission, containment of harmful material such as x-rays or projectiles), security issues, energy conservation, electrostatic grounding, hardware, and weatherproofing.

Refer to local, state, and federal codes and trade association and manufacturers' specifications and recommendations for additional information and requirements.

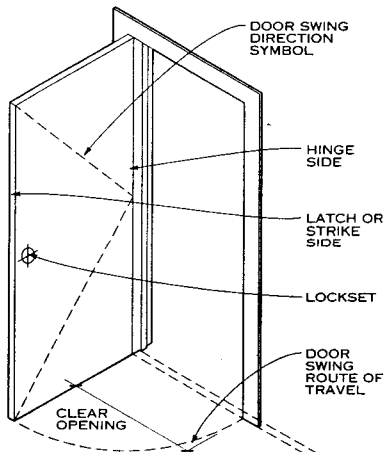

**NOTE**  
Doors that swing, the most common type of door operation, rotate around an axis determined by hinges or pivots.

**DOOR AND OPENING CHARACTERISTICS**

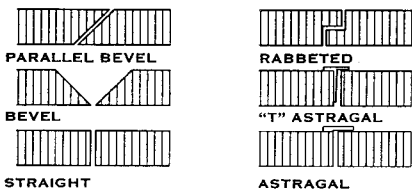

**MEETING EDGE TYPES FOR DOUBLE DOOR LEAVES**

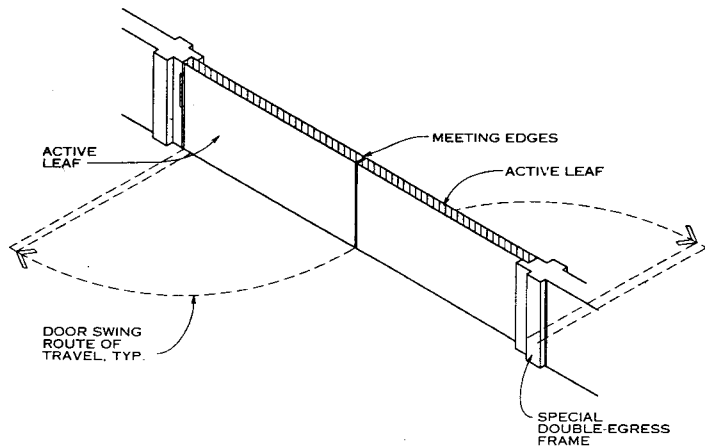

**DOUBLE-EGRESS DOORS**

**NOTE**  
Double-egress doors have a pair of swinging leaves that operate in opposite directions, permitting equal access to two or more means of passage.

**DOUBLE DOOR LEAF TYPES**

Richard J. Vitullo, AIA; Oak Leaf Studio; Crownsville, Maryland  
Daniel F. C. Hayes, AIA; Washington, D.C.

**DEFINITIONS**

**ACTIVE LEAF:** the primary operating leaf of a door pair.

**AIR CURTAIN:** a mechanically produced downward stream of air across a door opening intended to prevent transmission of heat and weather.

**AUTOMATIC DOOR:** a door fully or partially operated with an external mechanism (door opener) triggered by sensor or switch/button, as opposed to manual operation; refer to accessibility and fire code requirements.

**HAND:** denotes direction of door movement.

**LEAF:** a door panel.

**LEFT-HINGED DOOR:** a door with hinges mounted on the left stile of the active panel.

**PASSIVE/INACTIVE DOOR:** a door that operates independently of and secondarily to the active leaf of a door pair; normally held closed with floor and head bolts; the strike plate of this door receives the latch of the active leaf.

**PREHUNG DOOR:** door and frame combination fabricated and assembled by the manufacturer and shipped to the site.

**RIGHT-HINGED DOOR:** a door with hinges mounted on the right stile of the active panel.

**STATIONARY (FIXED) DOOR:** a nonoperational leaf.

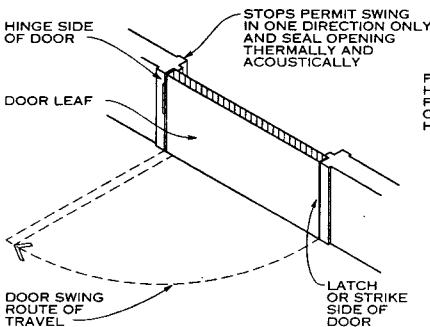

**SINGLE-ACTING DOOR**

**NOTE**  
The single-acting door, the most common door type, has a leaf that operates in a swinging or sliding motion in only one direction.

**SINGLE DOOR LEAF TYPES**

**SPACE REQUIREMENTS (VARIOUS DOOR WIDTHS—IN.)**

	34	36	38	40	42	44
X	21 1/4	23 1/4	25 1/4	23 1/4	25 1/4	27 1/4
Y		12 3/4			16 1/4	
Z		7 1/8			8 7/8	

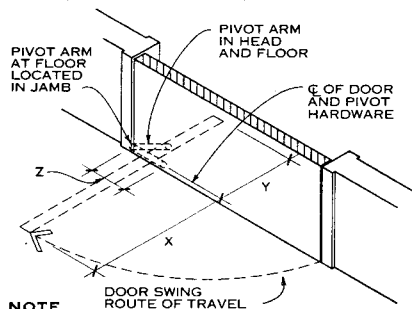

**NOTE**  
A balanced door is a single-action swinging door mounted on offset pivots. The leaf operates independently of the jamb, and the elliptical trajectory of the leaf requires less clear floor space than a conventional swinging door.

**BALANCED DOOR**

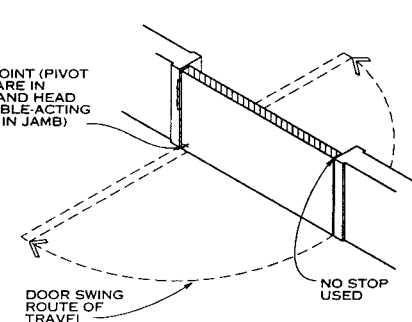

**DOUBLE-ACTING DOOR**

Double-acting doors have a leaf that operates in two directions. There is usually no stop present to restrict the motion of the door, but when the door can be stopped, it can be released mechanically to permit access in an emergency.

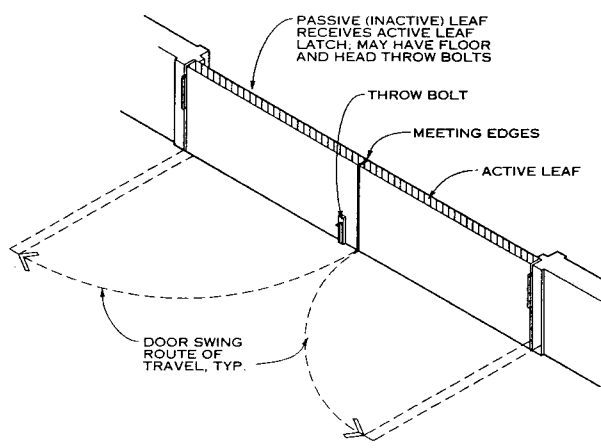

**DOUBLE OR PAIRED DOORS**

Double or paired doors have two leaves (of equal or unequal size) that operate either together or independently.

They create a doorway with variable widths suitable for differing occupancy/egress requirements.



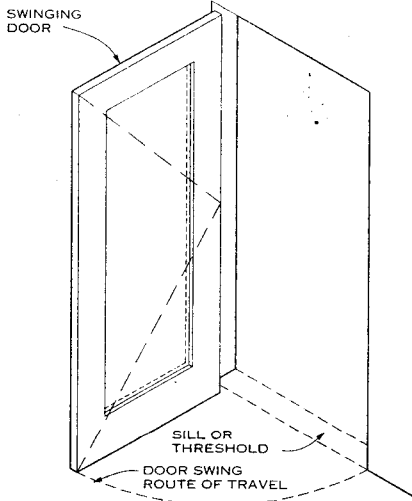

**NOTE**

Swinging doors rotate on hinges or pivots, require adequate floor space to accommodate outswing, and are used for egress openings. See codes for requirements.

**SWINGING DOORS**

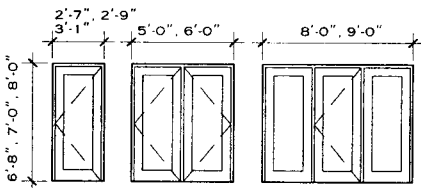

**SWINGING DOOR SIZES**

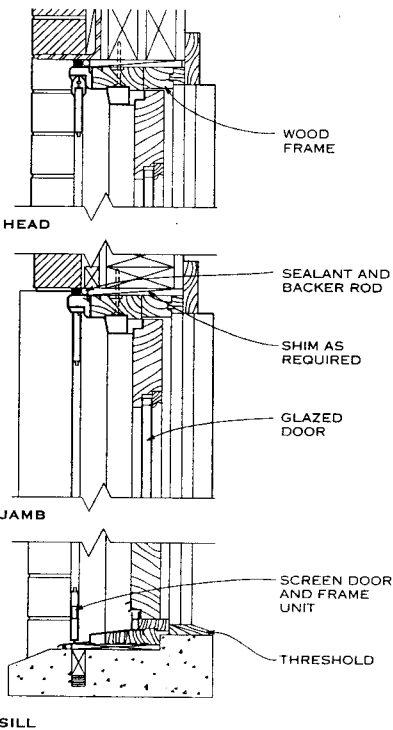

**DETAIL—EXTERIOR SWINGING DOOR**

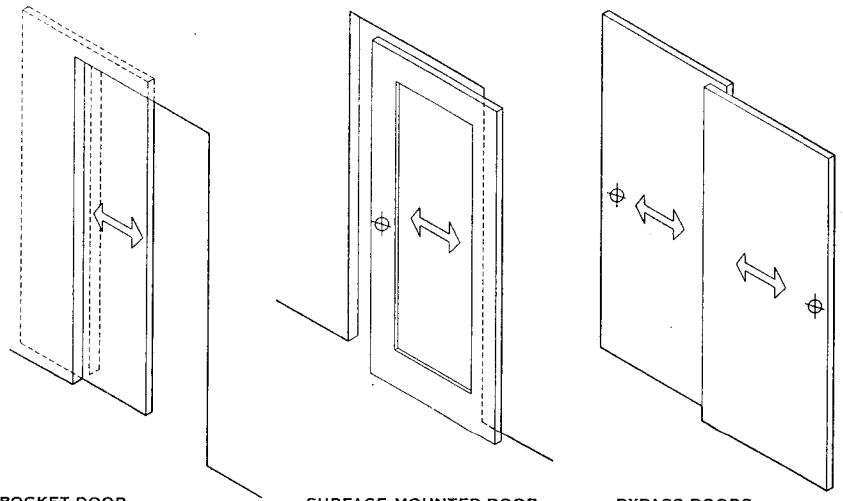

**NOTE**

Wood, metal, or glass doors that slide horizontally or vertically on tracks create totally clear openings without the

**SLIDING DOORS**

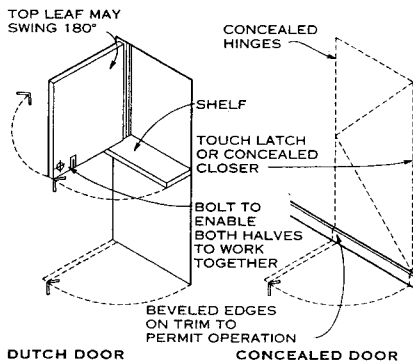

**SPECIAL SWINGING DOORS**

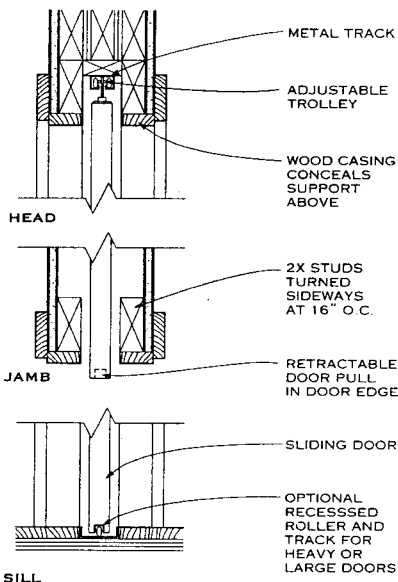

**DETAIL—SLIDING POCKET**

floor space requirements of swinging doors. See codes for egress requirements.

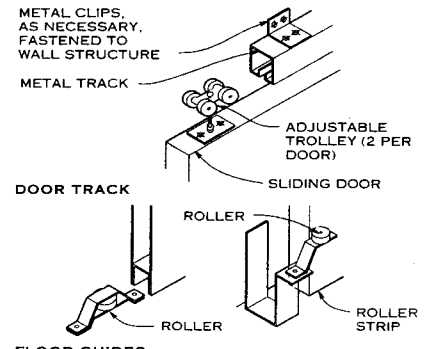

**HARDWARE FOR BYPASS DOORS**

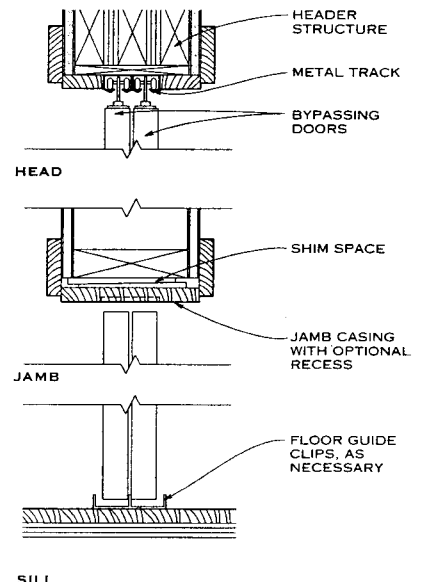

**DETAIL—BYPASS DOOR**

Daniel F. C. Hayes, AIA; Washington, D.C.

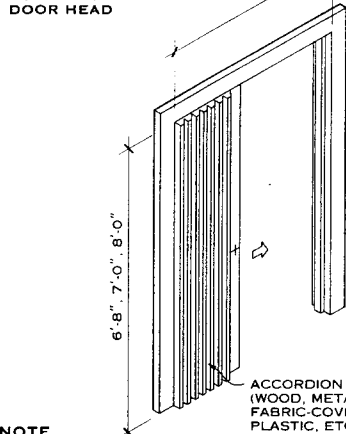
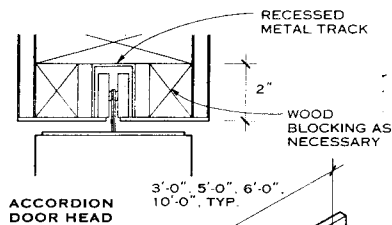

**NOTE**

Accordion doors are multipaneled units of relatively narrow wood or fabric that are hinged together. Track-guided hangers/trolleys and optional jamb-side pivots allow the entire assembly to fold together like an accordion. The stacking distance of the panels when open may encroach upon the clear opening dimension or be concealed in a recessed pocket. Sizes vary from traditional doorways to room dividers. Accordion doors require less floor space than swing doors. Refer to codes for egress requirements.

**TYPICAL ACCORDION DOOR**

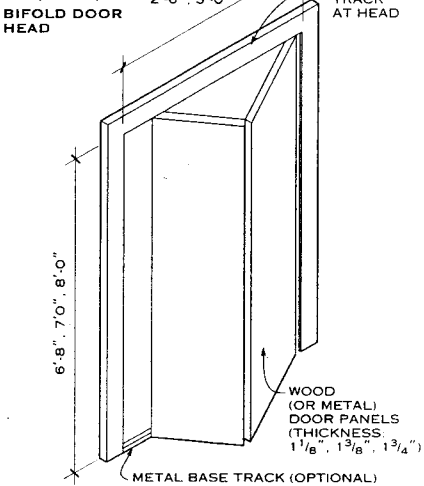
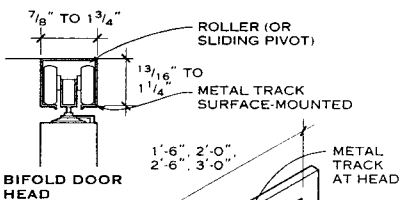

**NOTE**

Bifold doors are wood or metal door pairs hinged together with pivots at the jamb. Track-guided hangers/trolleys allow the doors to fold against each other when they open. Bifold doors require less floor space than swing doors, but the thickness of the door panels reduces the clear opening.

**TYPICAL BIFOLD DOOR**

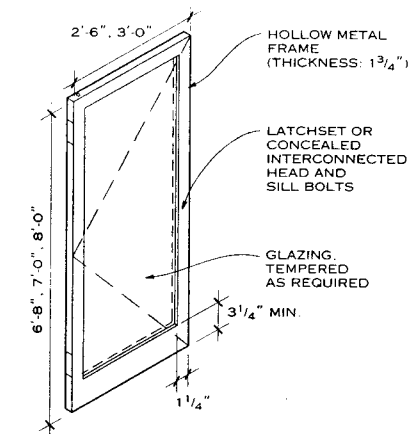

**TYPICAL FRAMED DOOR**

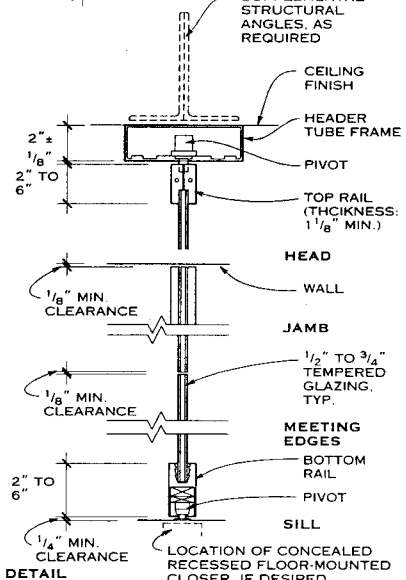
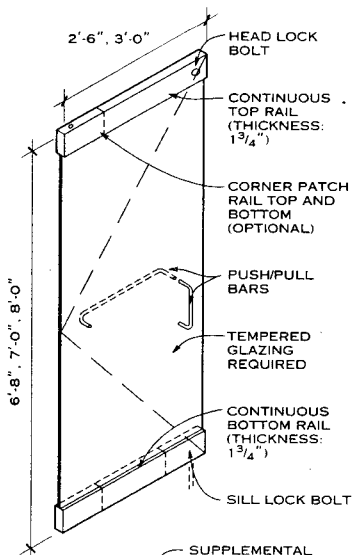

**TYPICAL ALL-GLASS DOOR**

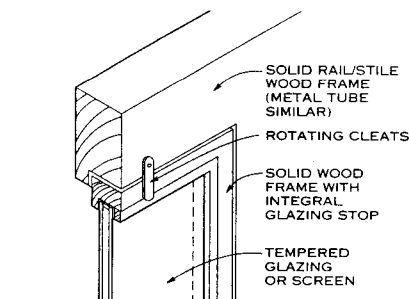
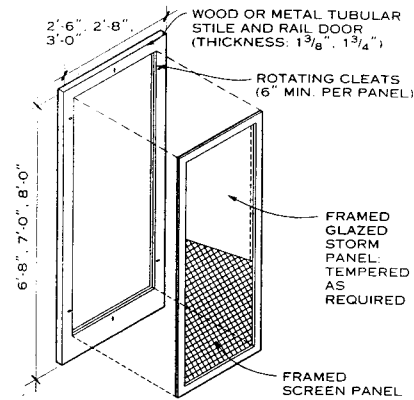

**DETAIL**

**DOOR WITH REMOVABLE STORM/SCREEN PANEL**

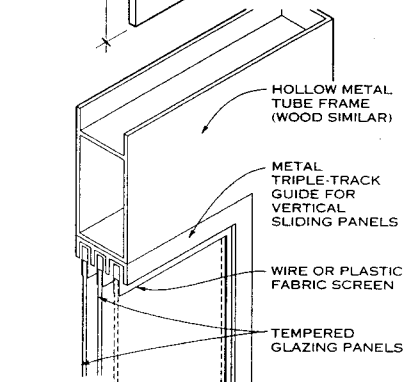
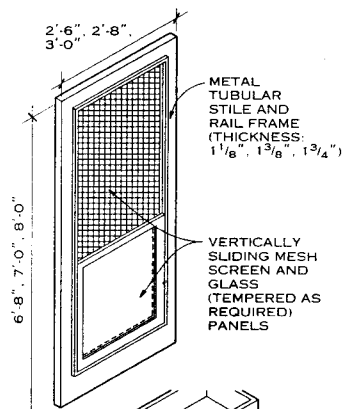

**DETAIL**

**COMBINATION STORM/SCREEN DOOR**

Daniel F. C. Hayes, AIA; Washington, D.C.

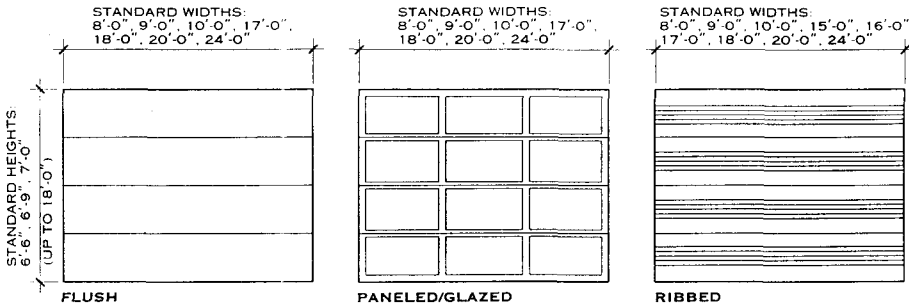

- NOTES**
- Standard commercial doors are designed to wind loads of 20 lb/sq ft.
  - Glazing may be safety glass, plexiglass, or wired glass.
  - Motor operators may be turned on and off by remote electrical switch, radio signal, photoelectrical control, or key lock switch for security.

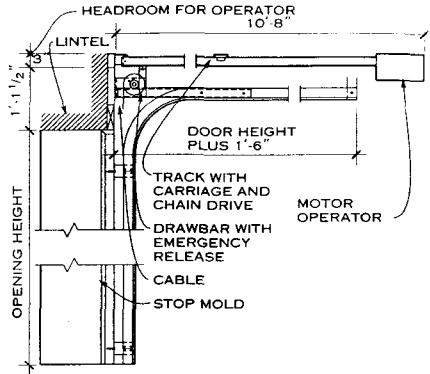

**UPWARD-ACTING SECTIONAL DOORS**

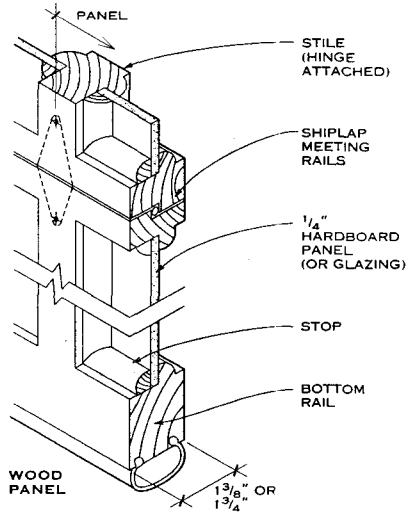

**NOTE**

Typical maximum width for wood panel sectional doors is 24 ft (6 panels); typical maximum height is 18 ft (9 sections).

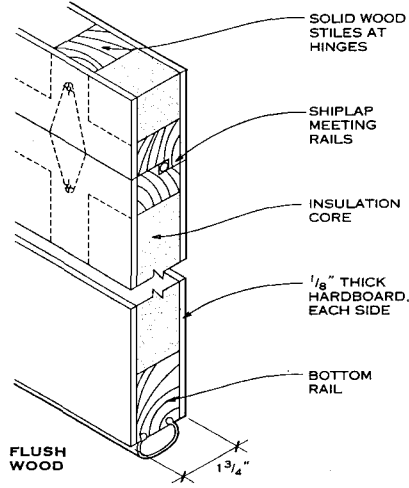

**NOTE**

Typical maximum width for flush wood sectional doors is 24 ft (6 panels); typical maximum height is 18 ft (9 sections).

**INSTALLATION DETAILS**

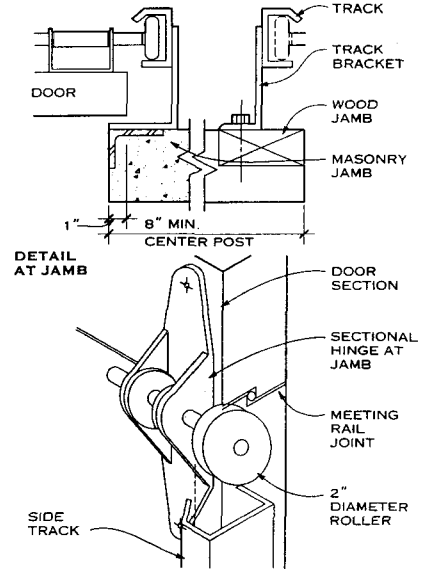

**HINGE AND ROLLER AT JAMB**

**SECTIONAL DOOR DETAILS**

**WOOD SECTIONAL DOORS**

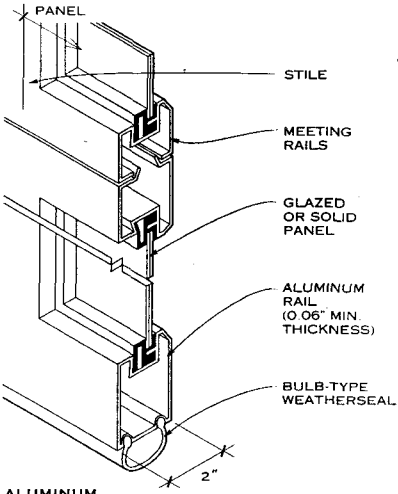

**NOTE**

Typical maximum width for aluminum sectional doors is 18 ft (5 panels); typical maximum height is 14 ft (7 sections).

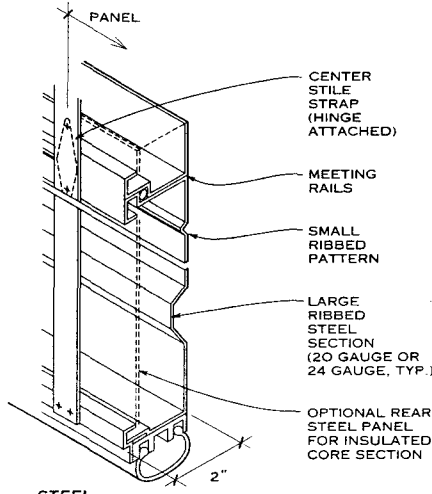

**NOTE**

Typical maximum width for steel sectional doors is 24 ft (7 panels); typical maximum height is 18 ft (9 sections).

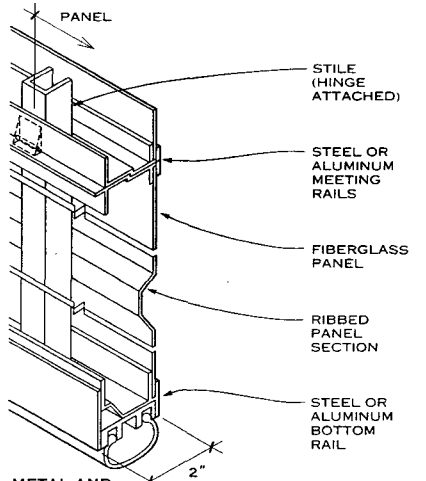

**NOTE**

Typical maximum width for metal and fiberglass sectional doors is 20 ft (6 panels); typical maximum height is 16 ft (8 sections).

**METAL SECTIONAL DOORS**

Daniel F. C. Hayes, AIA; Washington, D.C.

OPERATION OF ROLLING DOOR OR SHUTTER IS MANUAL (PUSH-UP) OR MECHANICAL, DRIVEN BY CHAIN, CRANK, OR MOTOR

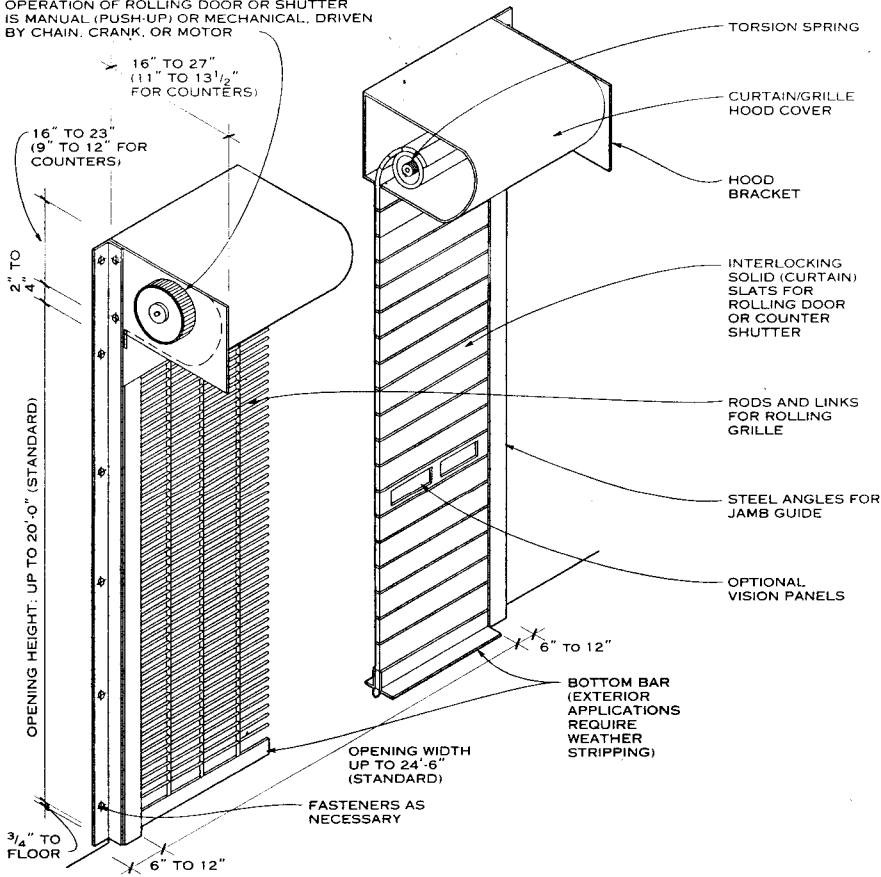

- NOTES**
1. Motor operators vary from 1/2 HP to 2 HP and may be wall-mounted alongside a curtain hood bracket or bracket-mounted alongside or behind a curtain hood, depending on building conditions. Consult manufacturers for all requirements and clearances.
  2. Rolling fire doors and counter shutters are typically rated up to UL Class A (3-hr rated). Automatic door closure and

hood smoke and flame baffle activation are initiated when fusible link melts or when electromechanical devices are activated by heat detector, smoke detector, or building alarm system.

3. Rolling door jamb guides for fire-rated doors are required to have 3/4 in. clearance below bottom of guide to allow for heat expansion in case of fire.
4. Standard curtain doors are designed to withstand a wind load of 20 lb/sq ft.

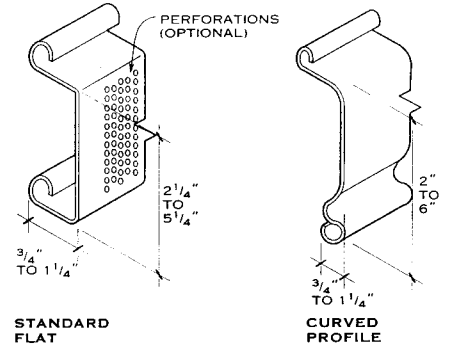

STANDARD FLAT

CURVED PROFILE

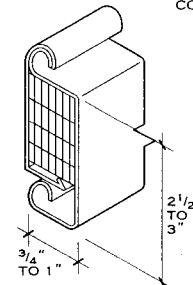

INSULATED NOTES

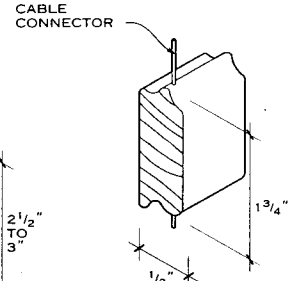

WOOD (COUNTER SHUTTER ONLY)

- NOTES**
1. Solid (curtain) slats are made of roll-formed steel (22 to 16 gauge), either prime-painted galvanized or stainless steel or anodized aluminum.
  2. Standard flat (nonperforated) and curved slats may be used in fire-rated applications. Other standard or custom slat designs are available; consult manufacturers.
  3. Acrylic vision slats may be inserted within standard slats for light transmission and visibility.
  4. Counter shutters are available in standard heights up to 7 ft and widths up to 11 ft.
  5. Manual, crank, and motor operators are available for counter shutters.

**CURTAIN DOOR AND COUNTER SHUTTER SLAT TYPES**

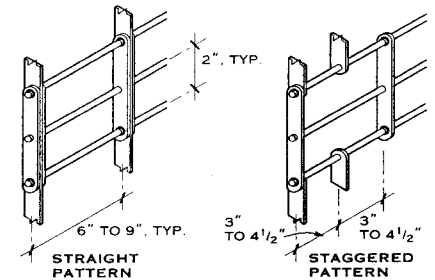

**NOTE**

Grilles are made either from steel or aluminum rods and links. Custom materials are available from manufacturers.

**ROLLING GRILLE DOOR TYPES**

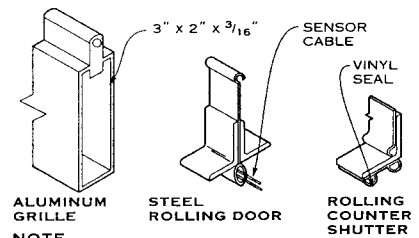

**NOTE**

Electric and pneumatic sensor edge types stop or reverse motor-operated doors if they hit something while closing.

**BOTTOM BAR TYPES**

**TYPICAL ROLLING DOOR, COUNTER SHUTTER, AND GRILLE**

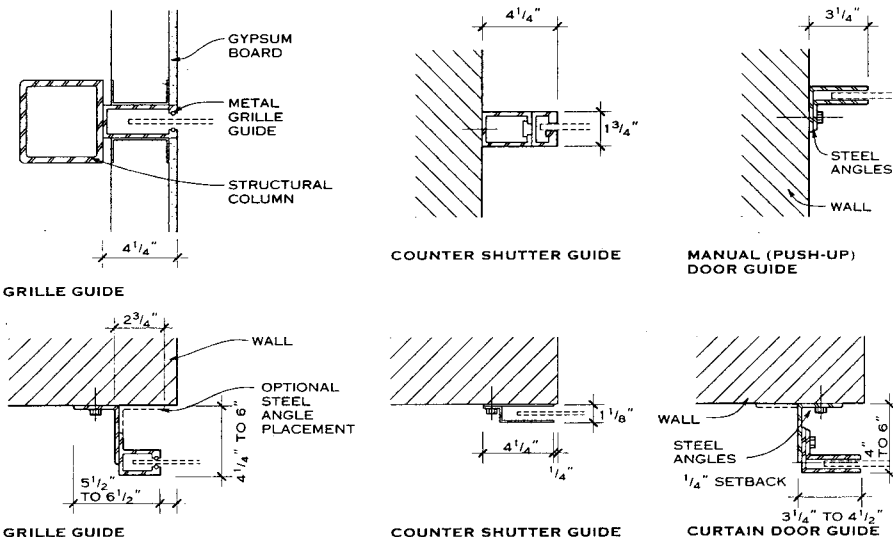

**GUIDE RAIL JAMB DETAILS**

Richard J. Vitullo, AIA, Oak Leaf Studio; Crownsville, Maryland

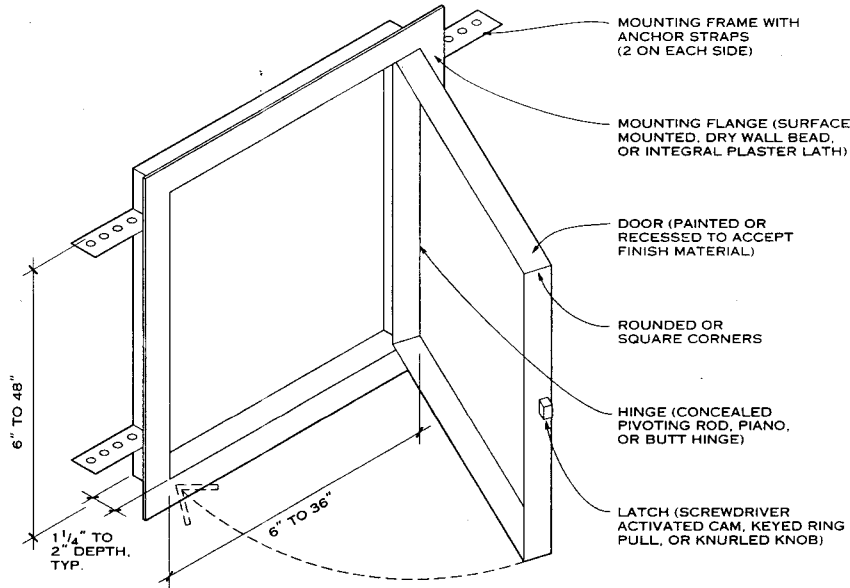

**WALL OR CEILING ACCESS DOOR CHARACTERISTICS**

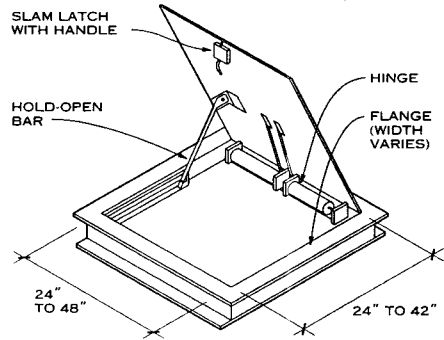

**NOTE**  
Floor hatches usually open to 90° and may be single or double leaf.

**DOOR IN FLOOR**

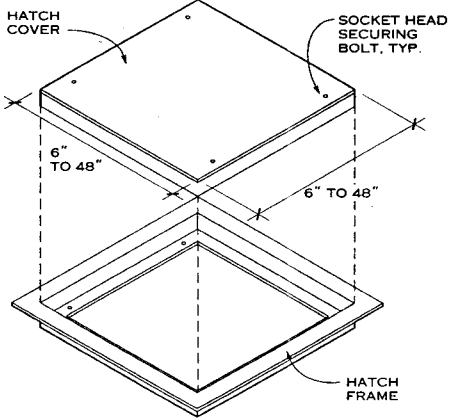

**NOTES**  
1. Hatch cover may be topped with stone, tile, wood, carpet, and the like over a 1/2 in. (minimum) layer of

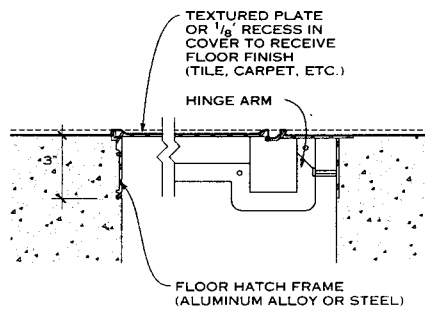

**DETAIL**

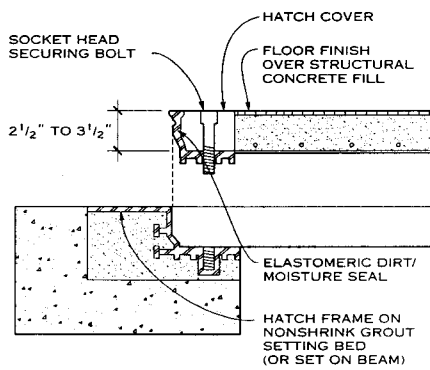

**DETAIL**

concrete, providing a flat, vibration-free surface.  
2. Frame and hatch are fabricated from aluminum or steel.

**FLOOR ACCESS HATCH**

Daniel F. C. Hayes, AIA; Washington, D.C.

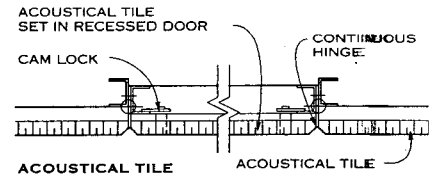
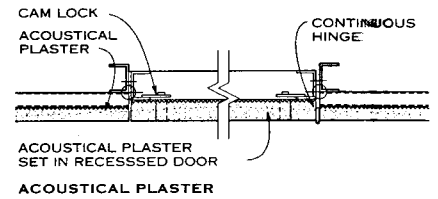
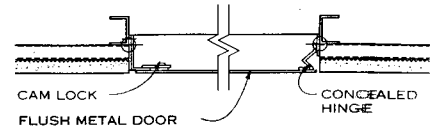

**NOTES**

1. Spring-operated, swing-down, and swing-up panels frequently are used for access.
2. Acoustical tile may be fire-rated and recessed in the door.
3. Doors and frames may be galvanized or stainless steel.
4. Other finish ceiling panels are detailed similar to acoustical tiles.

**CEILING ACCESS PANELS**

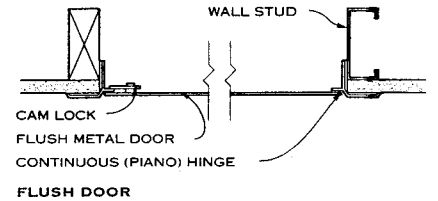

**FLUSH DOOR**

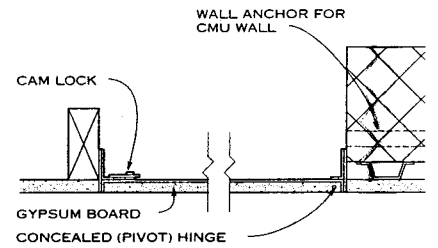

**RECESSED DOOR FOR GYPSUM BOARD**

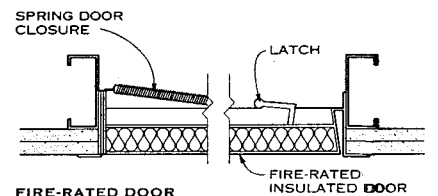

**FIRE-RATED DOOR**

**NOTES**

1. Doors may be hinged, set in with clips, or fastened with screws. Hinges may be butt or pivot, separate or continuous, surface or concealed.
2. The fire rating of access panels should be similar to the rating of the wall in which they occur. Access panels larger than 144 sq in. require automatic closers.
3. The minimum size for attic and crawl-space often is specified by building code.

**WALL ACCESS DOORS**

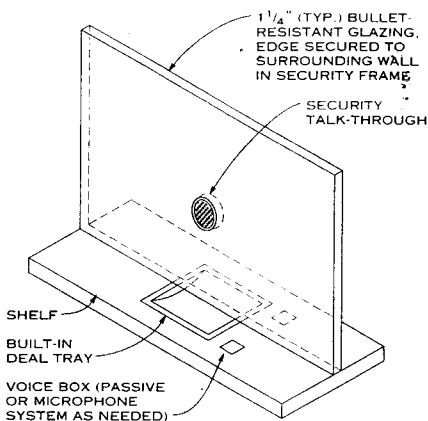

ONE-PIECE GLAZING WITH DEAL TRAY

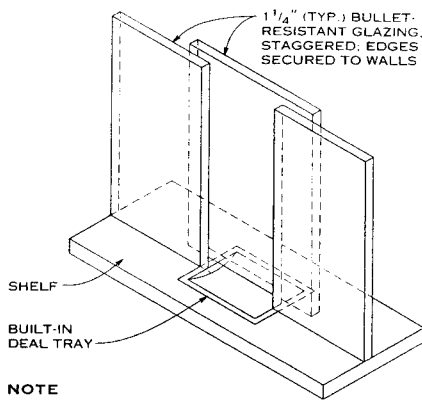

NOTE  
Staggered panels allow sound to pass through them without the use of a microphone system.  
THREE-PIECE GLAZING WITH DEAL TRAY

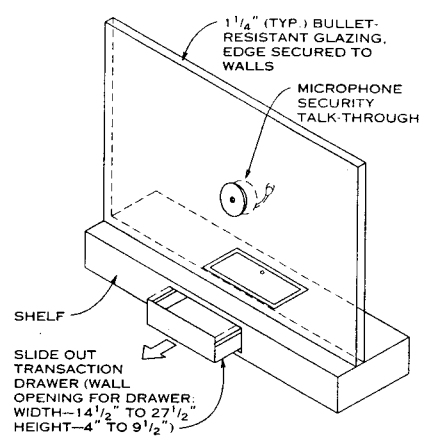

ONE-PIECE GLAZING WITH TRANSACTION DRAWER

**SECURITY TELLER WINDOWS**  
**GENERAL**

Security doors and windows are designed to provide physical and psychological protection for the occupants of the protected space and to notify security personnel of unauthorized entry. Such doors and windows are constructed of hardened materials and hardware and usually include one of the following methods to control passage: card, eye, palm, or thumbprint readers; electronic or other type of locks; and microphone enhanced voice talk-through devices. The level of security required by the owner determines the design and details of these doors and windows.

**NOTES**

1. Ballistic/forced entry modular units from manufacturers can be combined to form a wall or room.
2. Fire-rated, opaque security doors are available.
3. Ballistic-resistant glazing is manufactured in various thicknesses to attain the required level of resistance (for example, to resist a 9mm, high-powered rifle).
4. To maximize resistance to forced entry, security doors must swing outward (toward the attack side).
5. Custom doors can be fabricated when designed within manufacturers' parameters.
6. Walls must be constructed to meet the same level of resistance as the windows and doors installed in them.

7. Doors and windows must be anchored in strict accordance with the manufacturer's directions to attain standard of resistance.
8. Ballistic/forced entry windows used in exterior building openings are similar to the teller windows detailed on this page.

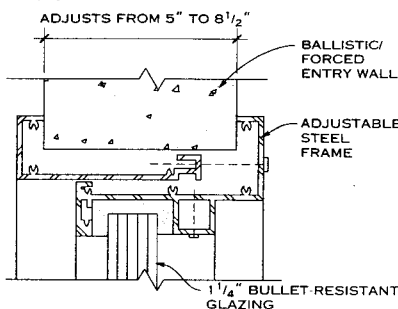

ADJUSTABLE WINDOW FRAME—DETAIL

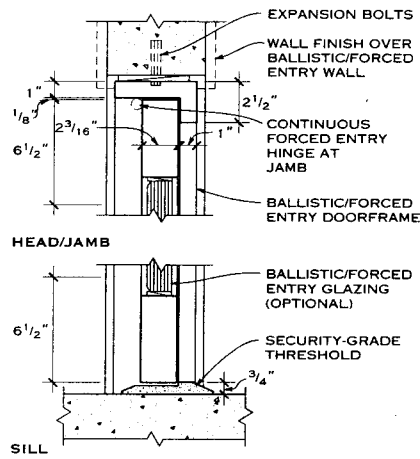

BALLISTIC/FORCED ENTRY DOOR—DETAILS

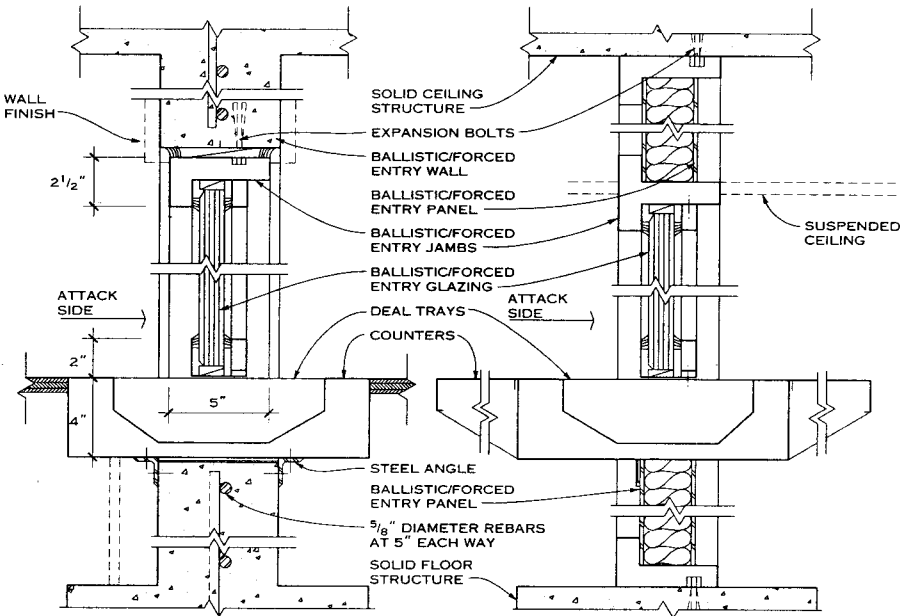

SECTION AT CUSTOM WALL CONSTRUCTION

SECTION AT MODULAR WALL UNIT

**BALLISTIC/FORCED ENTRY TELLER WINDOWS**

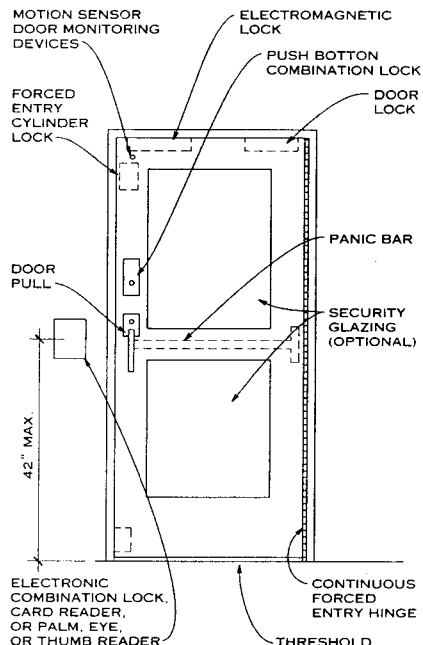

TYPICAL SECURITY DOOR HARDWARE AND ACCESSORIES

Edwin Daly, AIA; Joseph Handwerger Architects; Washington, D.C.  
William G. Miner, AIA; Washington, D.C.  
Daniel F. C. Hayes, AIA; Washington, D.C.





**BACKGROUND**

A successful storefront or retail entrance attracts the casual passerby. In order to attract, a shopfront must:

1. Catch the eye
2. Identify the shop
3. Display the merchandise in the most appealing way
4. Entice the passerby to enter

**SHOP CHARACTER**

The character of a retail entrance is influenced by the following factors:

1. Neighborhood or retail development character
2. Types of products sold
3. Accessibility—on foot or by car
4. Glazed area in relation to product
5. Fascia—visibility of shop name
6. Lettering—size, color, style, use of logos
7. Illumination—intensity, color, or use of daylight
8. Color—select predominant, coordinate with interior
9. Finishes—cost, design guidelines, and durability

**ENVIRONMENTAL FACTORS**

The external features of a shop are influenced by the following factors:

1. Solar—shade southern exposures
2. Wind—provide protection with deep lobbies
3. Corrosive—provide protective finishes
4. Street traffic—lobbies or air locks to keep out fumes

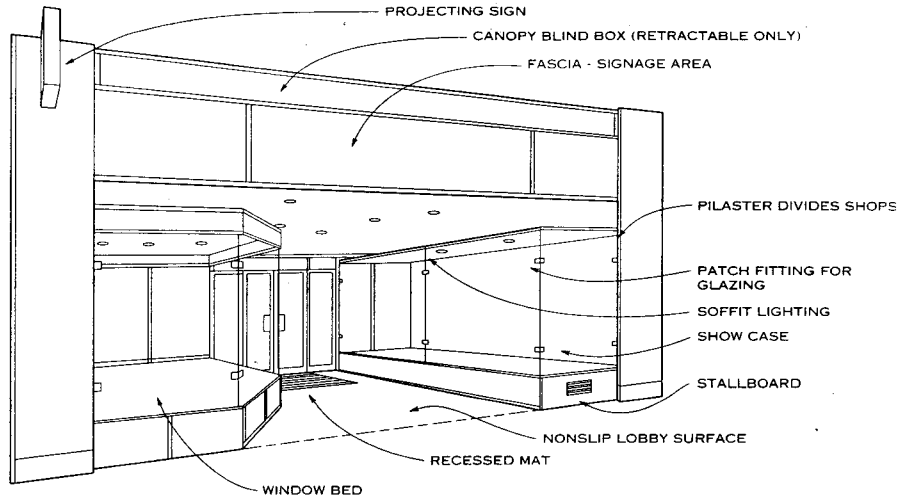

**STOREFRONT INTERIOR AND EXTERIOR—COMMON ELEMENTS**

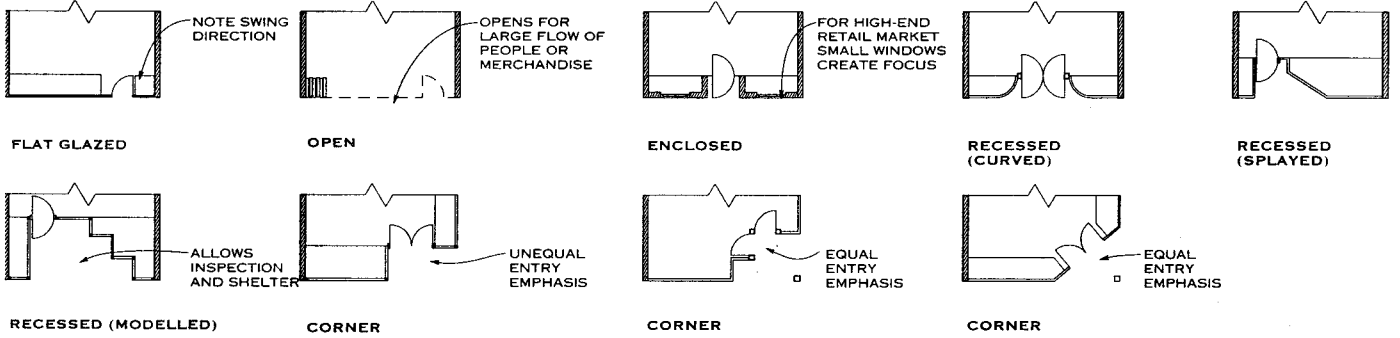

**STOREFRONT TYPES**

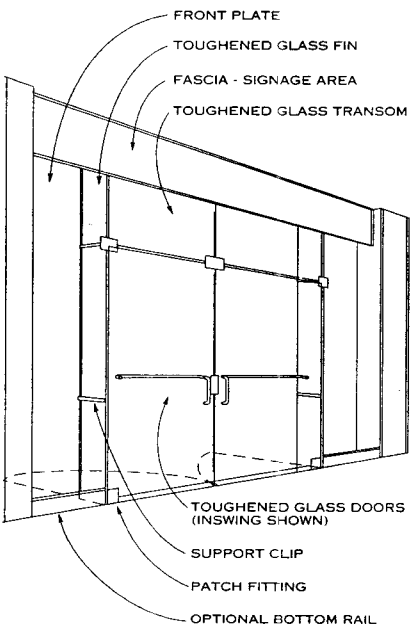

**ALL-GLASS STOREFRONT**

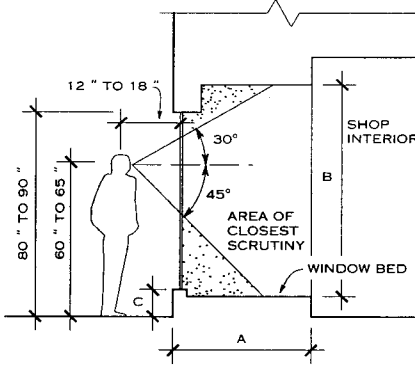

REFER TO TABLE BELOW

**WINDOW DIMENSIONS**

**TYPICAL WINDOW DIMENSIONS**

VIEW POINT	TYPE OF SHOP	A WINDOW DEPTH	B WINDOW HEIGHT	C SILL HEIGHT
Very close	Jewelry, eyeglass, picture, and books	18" to 36"	up to 36"	30" to 36"
Close	Toys, shoes, electronic, optical, CD's, and gifts	30" to 60"	up to 80"	18" to 30"
Medium	Clothing, china, glass sporting goods, and appliances	40" to 96"	up to 96"	12" to 18"
Distant	Furniture, floor covering, and automobiles	80" to 120"	Ceiling height	0" to 6"

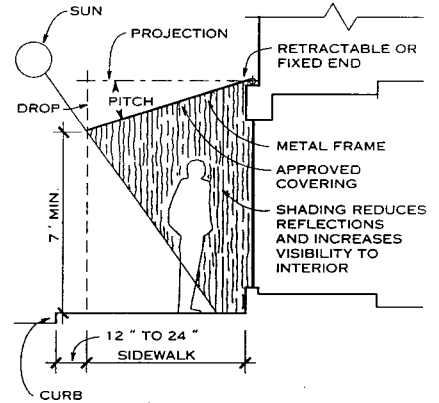

CHECK LOCAL CODES TO VERIFY REQUIREMENTS

**CANOPY DIMENSIONS/SOLAR**

Eric K. Beach; Rippeteau Architects, PC; Washington, D.C.



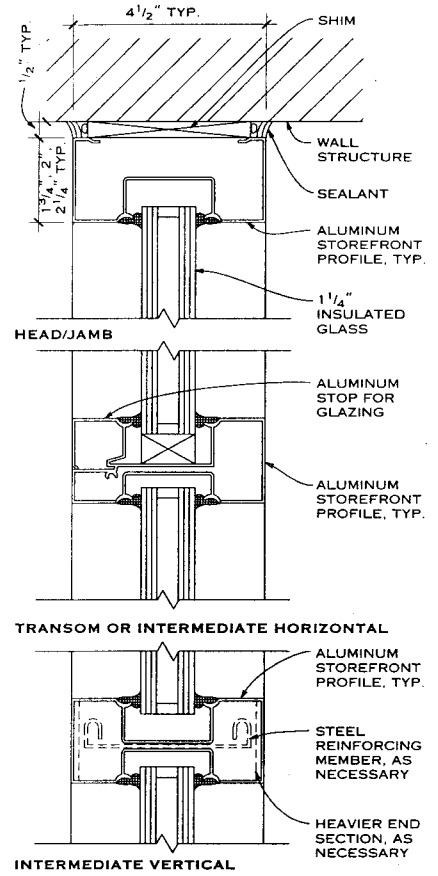
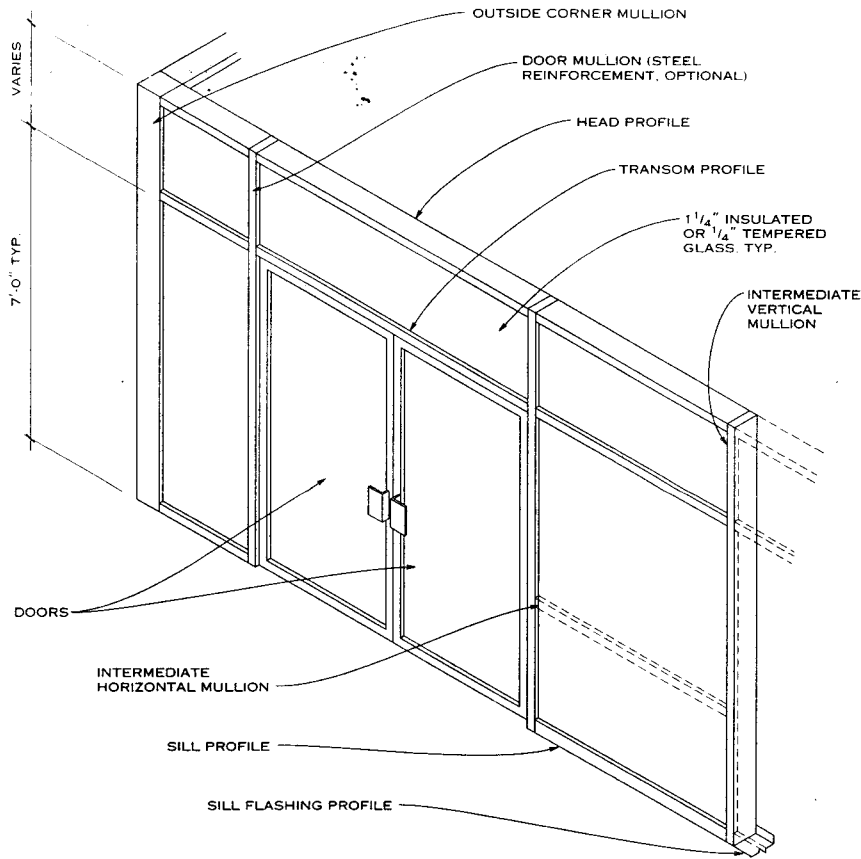

**TYPICAL STOREFRONT**

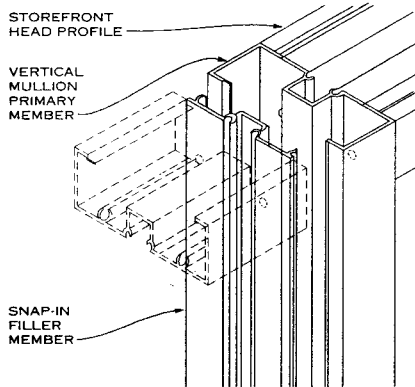

**NOTE**  
 The head, intermediate horizontal profile, and sill members are screwed to vertical members at predrilled locations.

**SNAP-TOGETHER/SCREW SPLINE STOREFRONT ASSEMBLY**

**GENERAL**

Glass and metal frame storefront systems typically are designed to allow good views into and out of ground level commercial spaces. Metal members and glass sections are assembled on site to form both wall and entrance systems, which typically are attached to the floor structure below and ceiling structure above.

**NOTES**

1. Storefront systems are available in a variety of attachment/assembly types, depending on the structural or aesthetic design and on the manufacturer. Glass and metal materials come in various shapes, colors, profiles, and structural capabilities.

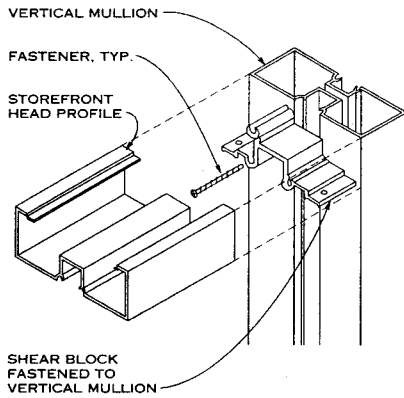

**SHEAR BLOCK STOREFRONT ASSEMBLY**

2. Consult applicable codes for safety requirements, glass size, thickness, and tempering. ADAAG requires accessible hardware, thresholds, and, in some cases, automatic door openers.
3. Consult manufacturers' data on structural adequacy for required loads and for frame and transom bar reinforcement. Calculations for deflection and wind-load stresses must be considered in the design of storefront systems. Reinforcing for required loads can be provided by steel reinforcing inserts or by use of a heavier metal mullion profile. Consult a structural engineer for analysis and design.
4. The height of entrance doors is typically 7 ft 0 in. Typical door widths are 3 ft 0 in., 3 ft 6 in., pair of 2 ft 6 in., pair of 3 ft 0 in.

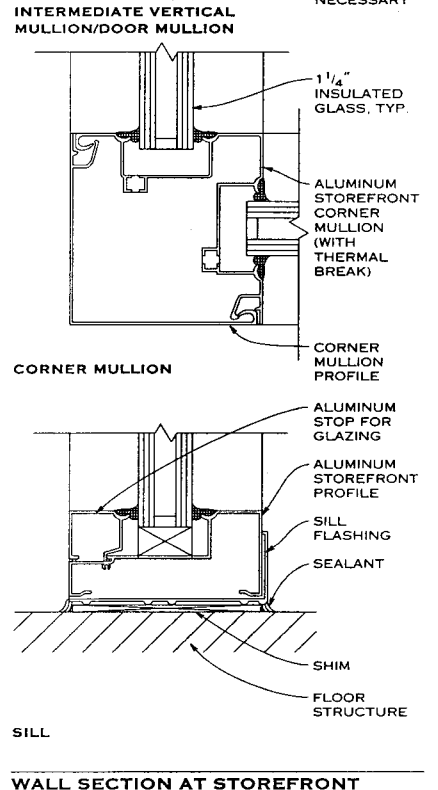

Daniel F. C. Hayes, AIA; Washington, D.C.

**TYPES AND APPLICATIONS**

1. Darkroom revolving doors act as a light barrier.
2. Automated revolving doors for large size doors, for persons with disabilities accessibility, etc.
3. Motorized oval doors for small groups, wheelchairs, or grocery carts.
4. Security revolving doors that are noncollapsible until a magnetic shear lock is automatically released in an emergency.
5. Sliding night door of solid metal construction to close off open quadrant at exterior opening.
6. Manually operated.

**DESIGN CONSIDERATIONS**

1. Mount entirely on one slab.
2. Do not attach to adjacent walls.
3. Floor must be level.

**NOTES**

1. Circular glass enclosure walls may be annealed 1/4 in. glass. However, this varies with different government bodies. Some jurisdictions require laminated glass. Tempered glass is not available for this use. Refer to the Consumer Products Safety Commission's standards for glazing.
2. Practical capacity equals 25 to 35 people per minute.
3. Doors fabricated from stainless steel, aluminum, or bronze sections are available. Stainless steel is the most durable; lead times vary with construction techniques. Stainless steel is available in a number of satin and polished finishes. Aluminum is the most common and economical. It is available in anodized or painted finishes. Bronze is most difficult to maintain; satin, polished, or statuary finishes must have a protective lacquer coating. Doors are available with only top and bottom stiles to be used with all-glass storefront doors. Wall enclosures may be all metal, all glass, partial glass, or housed-in construction.
4. Optional heating and cooling source should be placed immediately adjacent to the enclosure.
5. For general planning, use 6 ft 6 in. diameter. For hotels, department stores, airports, or other large traffic areas, use 7 ft or greater diameter.
6. Codes may allow 50% of legal exiting requirements by means of revolving doors. Some do not credit any and require hinged doors adjacent. Verify with local authorities.

**REVOLVING DOOR ENCLOSURE DIMENSIONS**

DIAMETER	OPENING		WALL LENGTH		RECOMMENDED MAXIMUM HEIGHT
	4 WING	3 WING	4 WING	3 WING	
6'-0"	4'-1"		4'-7 3/8"		10'-0"
6'-2"	4'-2 1/2"		4'-9 1/8"		9'-10"
6'-4"	4'-3 7/8"		4'-10 1/2"		9'-8"
*6'-6"	*4'-5 1/4"	3'-1/4"	*4'-11 7/8"	6'-1/4"	9'-6"
6'-8"	4'-6 5/8"	3'-1 1/4"	5'-1 1/4"	6'-2 1/32"	9'-4"
6'-10"	4'-8 1/8"	3'-2 1/4"	5'-1 1/4"	6'-3 3/4"	9'-2"
*7'-0"	4'-9 1/2"	*3'-3 1/4"	5'-4 1/8"	*6'-5 1/2"	9'-0"
7'-6"	5'-1 3/4"	3'-6 1/4"	5'-8 3/4"	6'-10 11/16"	8'-6"
8'-0"	5'-6"	3'-9 1/4"	6'-5/8"	7'-3 7/8"	8'-0"
9'-0"		4'-3/4"		8'-2 1/8"	8'-0"
10'-0"		4'-9 1/4"		9'-9/16"	8'-0"
14'-0"	9'-8 1/8"	6'-9 1/4"	10'-3 1/4"	12'-6 1/8"	8'-0"
16'-0"	11'-1 1/8"	7'-9 1/4"	11'-8 1/4"	14'-2 1/8"	8'-0"

\* Standard sizes

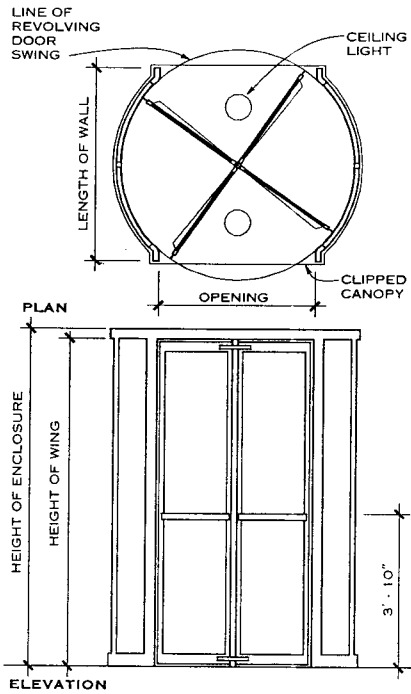
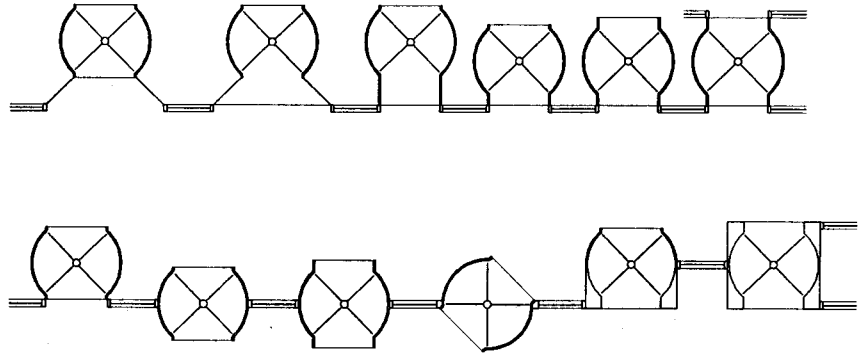

**LAYOUT TYPES**

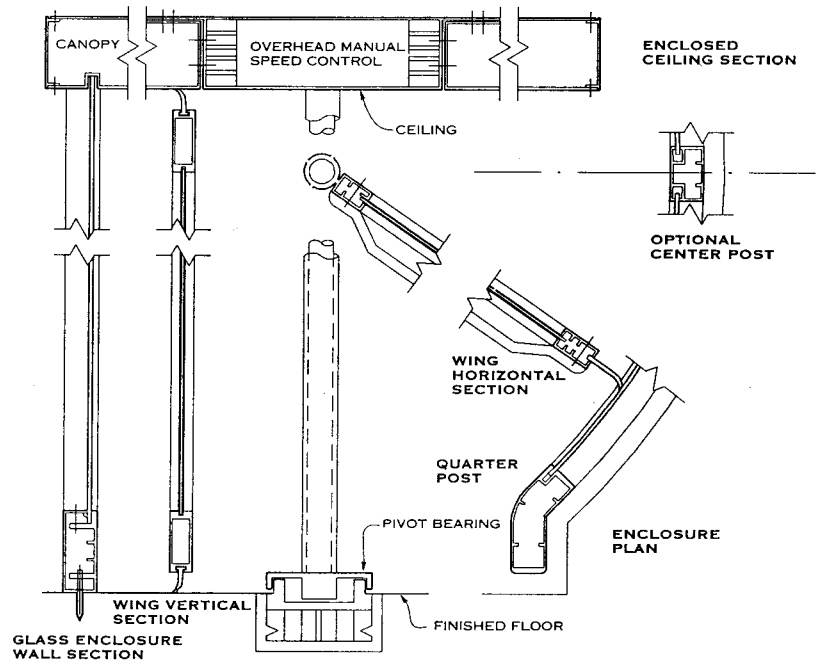

Jane Hansen, AIA; DeStefano + Partners, Chicago, Illinois

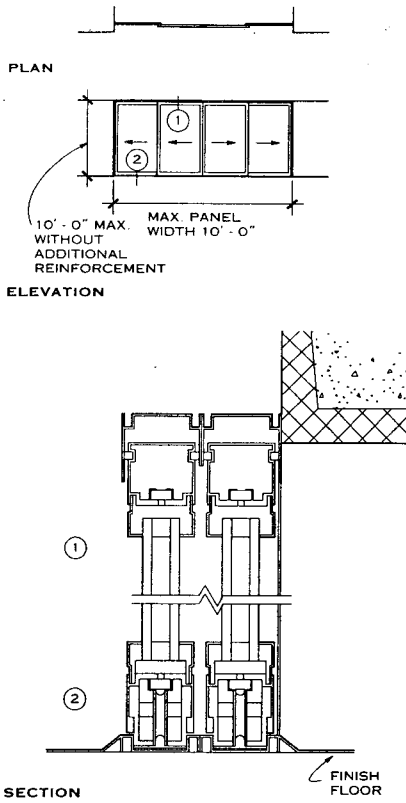

**BYPASS DOOR DETAILS**

**NOTES**

1. Sliding glass door wood finishes are available in clear pine with natural varnish, primed, or painted finishes.
2. Cladding for wood doors is available in vinyl or aluminum with electrostatic paint or in anodized aluminum.
3. Aluminum frames are available anodized or with electrostatic paint finishes.
3. Check with manufacturer's literature for material, cladding, and color options.

**GLAZING OPTIONS**

Standard glazing	Low emissivity insulating glass
	Low emissivity solar insulating glass
Safety glazing	Tempered glass <sup>1</sup>
	Wire glass <sup>1</sup>
	Laminated glass <sup>1</sup>
Nontransparent glass	Obscure glass <sup>1</sup>
	Composite veneer porcelain faced panels
	Glass fiber reinforced plastic
Sound control glazing	Spandrel panel
	Insulated glass

**NOTES**

1. This glazing can have the same low emissivity coating found on the standard glazings.
2. Most glazing options available with insulating glass with low emissivity films, some also with argon gas.
3. To reduce breakage and avoid injury it is recommended that tempered or safety glass be used.
4. Glazing options vary; check manufacturer's literature for specifics.

Joseph A. Wilkes, FAIA; Annapolis, Maryland

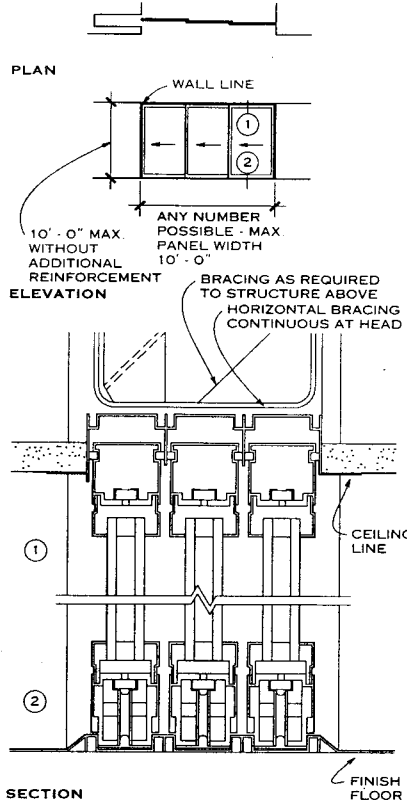

**POCKET DOOR DETAILS**

**PERFORMANCE DATA FOR GLAZING OPTIONS**

	ENERGY EFFICIENCY			HEAT GAIN (BTU) <sup>1</sup>	INSIDE GLASS SURFACE TEMPERATURES <sup>2</sup>	SHADING COEFFICIENTS <sup>3</sup>
	U - VALUE	R - VALUE	CENTER OF GLASS U - VALUE			
Single pane aluminum frame without thermal breaks	1.31	0.76	1.11	216	17°F	1.00
Ordinary double-pane	0.48	2.10	0.55	190	43°F	0.91
Low emissivity insulating glass	0.30	3.30	0.27	150	56°F	0.73
Low emissivity solar insulating glass	0.30	3.30	0.27	76	56°F	0.36

**NOTES**

1. Relative heat gain Btu/sq ft/hr: When ASHRAE solar heat gain factor is 200 Btu/hr - sq ft and the outdoor air temperature is 14° warmer than the indoor temperature.
2. Inside glass surface temperatures assume the following: outside temperature, 0°F; inside room temperature, 70°F; outside wind velocity, 15 mph; no air movement inside; and uniform heating conditions.
3. The shading coefficients listed above may vary a few percentage points.
4. R and U values based on Lawrence Berkeley method.

**ULTRAVIOLET REDUCTION RATES**

Double-pane clear	34%
Low emissivity insulating glass	66%
Low emissivity solar insulating glass	84%

**NOTE**

Low emissivity insulating glass and low emissivity solar windows help reduce ultraviolet rays.

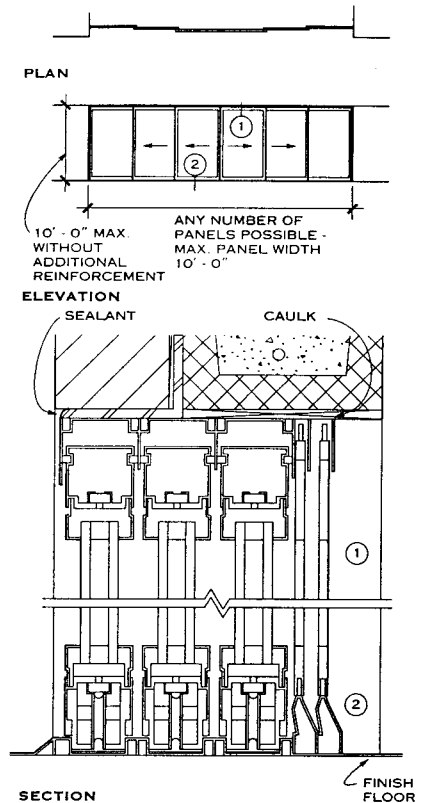

**MULTIPLE SLIDING DOOR DETAILS**

**RELATIVE HEAT GAIN**

	HEAT GAIN
Clear	214
Single-pane 3/32 or 1/8 in.	208
Single-pane 3/16 in.	186
Double-pane insulating	152
Double-pane high-performance insulating	
Tinted grey/bronze	165
Single-pane grey 3/16 in.	168
Single-pane bronze 3/16 in.	78
Double-pane high-performance sun insulating	
Medium performance reflective	
Single-pane bronze	106

**NOTE**

Relative heat gain BTU/sq ft/hr: When ASHRAE solar heat gain factor is 200 BTU/hr - sq ft and the outdoor air temperature is 14° warmer than the indoor temperature.



## DEFINITIONS

**ABSORPTANCE:** the ratio of radiant energy absorbed by a glazing system to the total incident radiant energy in it.

**AIR LEAKAGE RATING:** a measure of the rate of infiltration around a window or skylight in the presence of a specific air pressure difference. It is expressed in units of cubic feet per minute per square foot of window area (cfm/sq ft) or cubic feet per minute per foot of window perimeter length (cfm/ft). The lower the air leakage rating of a window, the more airtight it is.

**COMPOSITE FRAME:** a frame made of two or more materials—for example, a frame that is wood on the interior and fiberglass on the exterior.

**DOUBLE GLAZING:** in general, two thicknesses of glass separated by an air space within an opening intended to improve insulation against heat transfer and/or sound transmission. In factory-made double-glazed units, the air between the glass sheets is thoroughly dried and the space is sealed airtight, eliminating possible condensation and providing superior insulating properties.

**EMITTANCE:** the ratio of the radiant energy emitted by a surface to that emitted by a blackbody at the same temperature and under the same conditions.

**GAS FILL:** a gas other than air, usually argon or krypton, placed between window or skylight panes to suppress conduction and convection and thus reduce the U-factor.

**LIGHT-TO-SOLAR-GAIN RATIO (LSG):** a measure of the ability of glazing to provide light without excessive solar heat gain. It is the ratio between the visible transmittance of a glazing material and its solar heat gain coefficient.

**LOW-CONDUCTANCE SPACERS:** an assembly of materials designed to reduce heat transfer at the edge of an insulating window. Spacers are placed between the panes of glass in a double- or triple-glazed window.

**LOW-EMITTANCE (LOW-E) COATING:** microscopically thin, virtually invisible metal or metallic oxide layers deposited on a window or skylight glazing surface primarily intended to reduce the U-factor by suppressing radiative heat flow. A typical type of low-E coating is transparent to the solar spectrum (visible light and short-wave infrared radiation) but reflects long-wave infrared radiation.

**REFLECTANCE:** the ratio of reflected radiant energy to incident radiant energy.

**R-VALUE:** a measure of the resistance of a glazing material or fenestration assembly to heat flow. It is the inverse of the U-factor ( $R = 1/U$ ) and is expressed in units of hr x sq ft x °F/Btu. A high-R-value window has a greater resistance to heat flow and a higher insulating value than one with a low R-value.

**SHADING COEFFICIENT (SC):** a measure of the ability of a window or skylight to transmit solar heat relative to that ability for 1/8-in., clear, double-strength, single glass. This measure is being phased out in favor of the solar heat gain coefficient. The SC is approximately equal to the SHGC multiplied by 1.15 and is expressed as a number without units between 0 and 1. The lower a window's solar heat gain coefficient or shading coefficient, the less solar heat it transmits and the greater shading ability it has.

**SOLAR HEAT GAIN COEFFICIENT (SHGC):** the fraction of incident solar radiation admitted through a window or skylight, including both directly transmitted radiation and that absorbed and subsequently released inward. The SHGC has replaced the shading coefficient as the standard indicator of a window's shading ability. It is expressed as a number between 0 and 1. The lower a window's solar heat gain coefficient, the less solar heat it transmits and the greater its shading ability. The SHGC can be expressed in terms of the glass alone or can refer to the entire window assembly.

**SPECTRALLY SELECTIVE GLAZING:** a coated or tinted glazing with optical properties that are transparent to some wavelengths of energy and reflective to others. Typical spectrally selective coatings are transparent to visible light and reflect short-wave and long-wave infrared radiation. Usually the term spectrally selective is applied to glazings that reduce heat gain while providing substantial daylight.

**SUPERWINDOW:** a window with a very low U-factor, typically less than 0.15, achieved through the use of multiple glazings, low-E coatings, and gas fills.

**TRANSMITTANCE:** the percentage of radiation that can pass through glazing. It can be defined for different types of light or energy, e.g., visible light transmittance, solar transmittance, or total solar energy transmittance.

**U-FACTOR (U-VALUE):** a measure of the rate of nonsolar heat loss or gain through a material or assembly. It is expressed in units of Btu/hr x sq ft x °F (W/sq m x °C). Values are normally given for NFRC/ASHRAE winter conditions of 0°F (18°C) outdoor temperature, 70°F (21°C) indoor temperature, 15 mph wind, and no solar load. The U-factor may be expressed for the glass alone or the entire window, which includes the effect of the frame and the spacer materials. The lower the U-factor, the greater a window's resistance to heat flow and the better its insulating value.

**VISIBLE TRANSMITTANCE (VT):** the percentage or fraction of the visible spectrum (380 to 720 nanometers) weighted by the sensitivity of the eye that is transmitted through the glazing.

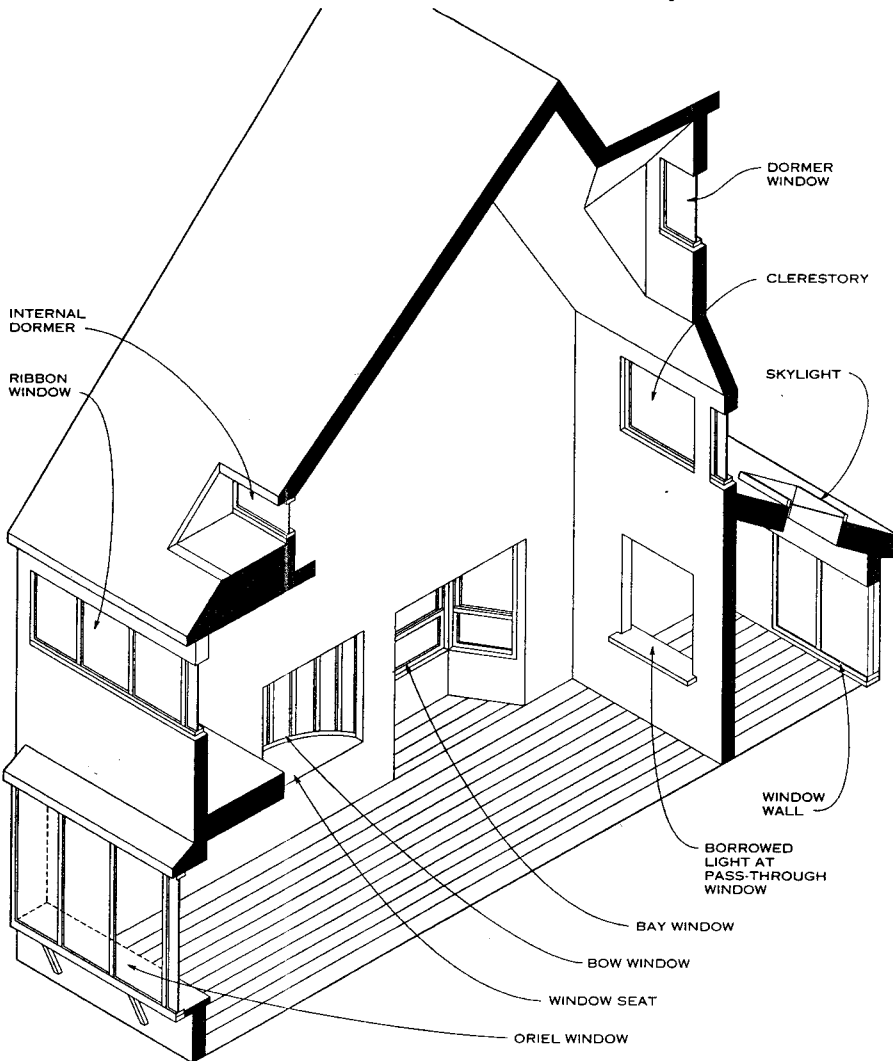

## NOTES

1. BORROWED LIGHT: an interior wall opening or window that allows light to be transferred into another space.
2. CLERESTORY: the portion of a wall above an adjacent roof level; a fixed or operable window located in this part of a wall.

3. INTERNAL DORMER: a vertical window set below the line of a sloped roof.
4. ORIEL WINDOW: a bay window supported by brackets, corbeling, or cantilevers.
5. WINDOW WALL: a continuous series of fixed or operable sash, separated by mullions, that form an entire non-load-bearing wall surface.

## WINDOW CONFIGURATIONS

John Carmody, University of Minnesota; Minneapolis, Minnesota  
Stephen Selkowitz, Lawrence Berkeley National Laboratory; Berkeley, California



WINDOWS

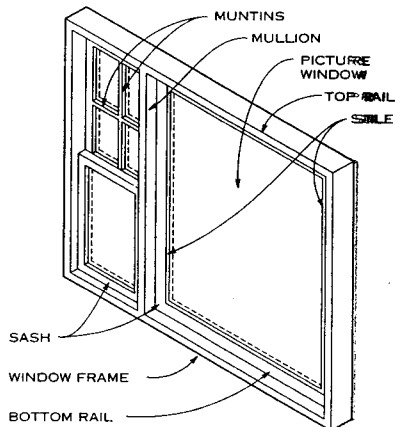

## NOTES

1. MULLION: a slender vertical member separating lights, sashes, windows, or doors.
2. MUNTIN: nonstructural members separating panes within a sash; also called a glazing bar or sash bar.
3. SASH: the basic unit of a window, consisting of frame, glazing, and gasketing; may be stationary or operable.

## PARTS OF A WINDOW

**WINDOW SELECTION**

Architects choose fenestration products based on many unique priorities and circumstances. Nonetheless, a number of common considerations apply to most situations. Factors affecting window choice are

**APPEARANCE:** size and shape, operating type and style, frame materials, glass color and clarity.

**FUNCTION:** visible light transmittance (provision of daylight), glare control, reduction in fading from ultraviolet radiation, thermal comfort, resistance to condensation, ventilation, sound control, maintenance, and durability.

**ENERGY PERFORMANCE:** U-value; solar heat gain coefficient (SHGC), which is replacing the shading coefficient; air leakage; annual heating and cooling season performance; and peak load impacts.

**COST:** initial cost of window units and installation, maintenance and replacement costs, effect on heating and cooling plant costs, and cost of annual heating and cooling energy.

Many designers and homeowners find it difficult to assess the impacts of choosing a more energy-efficient window. Although some basic thermal and optical properties (U-factor, solar heat gain coefficient, and air leakage rate) can be identified if a window is properly labeled (see AGS page that discusses NFRC labels), this information does not tell how these properties influence annual energy use for heating and cooling. This must be determined by using an annual energy rating system or by computer simulation.

**MANUFACTURED WINDOW UNITS**

The manufactured window units discussed here have a self-contained frame and glazing assembly that can be installed in a wall or roof opening. Used in almost all residential and some nonresidential buildings, manufactured window units are fabricated with a variety of glazing, frame, and operating types.

Technical innovations in glazing and frame design have improved window performance considerably in recent years, and determining window performance regarding heat loss, heat gain, and daylight can be complex. Key window performance characteristics are the U-value, which indicates the rate of heat loss and gain; the solar heat gain coefficient (SHGC), which indicates the rate of heat gain; the air leakage rate; and visible transmittance, which indicates the amount of daylight that passes through the window. The SHGC is gradually replacing the shading coefficient (SC) as an index for measuring heat gain through windows.

When selecting windows, it is important to remember that these characteristics are sometimes given for the glazing alone and sometimes for the whole window unit. To reduce confusion, the National Fenestration Rating Council (NFRC) certifies and labels the performance of manufactured window and skylight units based on whole window values.

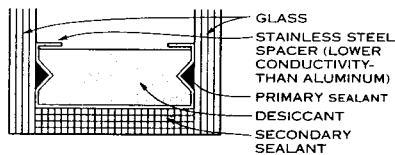

**WARM EDGE SPACER**

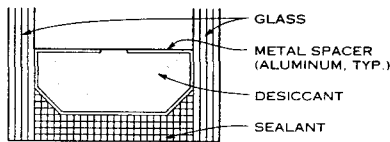

**CONVENTIONAL SPACER**

**NOTE**

The layers of glazing in an insulating unit must be held apart with spacers. Conventional metal spacers reduce the thermal performance of the glazing unit, but new "warm edge" spacers reduce heat loss and condensation with the use of new designs and materials. The spacer must accommodate stress induced by thermal expansion and pressure differences, provide a moisture barrier that prevents fog in the unit, prevent loss of any low-conductance gas from the air space, and create an insulating barrier that reduces the formation of interior condensation at the edge.

**INSULATED GLASS EDGE SPACER**

John Carmody, University of Minnesota; Minneapolis, Minnesota  
Stephen Selkowitz, Lawrence Berkeley National Laboratories; Berkeley, California

**TECHNOLOGICAL IMPROVEMENTS**

A series of innovations has resulted in more energy gain and loss control in the window assembly or glass itself. Some technological innovations currently appearing in fenestration products are outlined here:

1. Glazing unit structure: Multiple layers of glass or plastic film improve thermal resistance and reduce heat loss attributed to convection between window layers. Additional layers provide more surfaces for low-E or solar control coatings.
2. Low-emittance coatings: Low-E coatings are highly transparent and virtually invisible but have a high rate of reflectance (low emittance) with long-wavelength infrared radiation. This reduces long-wavelength heat transfer between glazing layers by a factor of 5 to 10, which reduces total heat transfer between the layers. Low-E coatings may be applied directly to glass surfaces or to plastic film, which is then suspended in the air cavity between the interior and exterior glazing layers.
3. Low-conductance gas fills: When a low-E coating is used, heat transfer across a gap is dominated by conduction and natural convection. While air is a relatively good insulator, other gases (such as argon, krypton, and carbon dioxide) have lower thermal conductivities. Using one of these nontoxic gases in an insulating glass unit can reduce heat transfer between glazing layers.
4. Solar control glazings and coatings: To reduce cooling loads, specify new types of tinted glass and new coatings that reduce the effect of the sun's heat without sacrificing views. Spectrally selective glazings and coatings absorb and reflect the infrared portion of sunlight while transmitting visible daylight, thus reducing solar heat gain coefficients and resultant cooling loads. Solar control coatings can also have low-emittance characteristics.
5. Warm edge spacers: Heat transfer through metal spacers used to separate glazing layers can increase heat loss and cause condensation to form at the edge of the window. "Warm edge" spacers use new materials and better design to reduce this effect.
6. Thermally improved sash and frame: Traditional sash and frame designs contribute to heat loss and can represent a large fraction of the total loss when high-performance glass is used. New materials and improved designs can reduce this loss.
7. Improved weatherstripping: Weatherstripping today is made of more durable materials that will provide improved reduction in air leakage over a longer time period than did materials in the past.

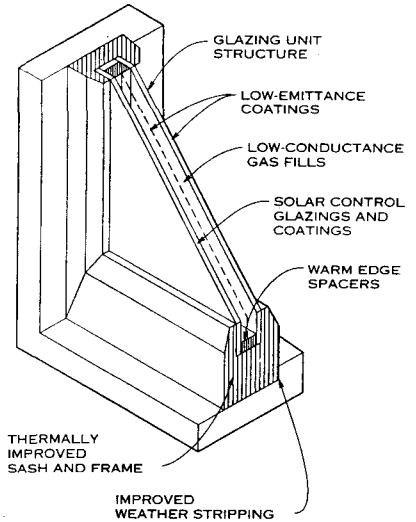

**MANUFACTURED WINDOW COMPONENTS**

NFRC 200-95. "Procedure for Determining Fenestration Product Solar Heat Gain Coefficients at Normal Incidence."

NFRC 300-94. "Procedures for Determining Solar Optical Properties of Simple Fenestration Products."

NFRC 301-93. "Standard Test Method for Emittance of Specular Surfaces Using Spectrometric Measurements."

NFRC 400-95. "Procedure for Determining Fenestration Product Air Leakage."

NFRC 900-95. "Procedure for Determining the Annual Heating and Cooling Energy Ratings of Fenestration Products Used in Residential Dwellings."

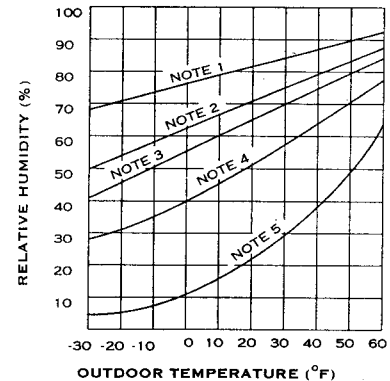

**NOTES**

1. Triple-glazed windows with two low-E coatings and argon gas fill.
2. Double-glazed windows with a low-E coating and argon gas fill.
3. Double-glazed windows with a low-E coating.
4. Double-glazed windows.
5. Single-glazed windows.

**CONDITIONS THAT LEAD TO CONDENSATION ON WINDOWS**

**CONDENSATION POTENTIAL**

The chart above shows the potential for condensation on glazing (at the center of glass) at various outdoor temperature and indoor relative humidity conditions. Condensation can occur at any point on or above the curves. (Note: All air spaces are 1/2 in.; all coatings are E = 0.10.)

**EXAMPLE:** At 20°F (-7°C) outside, condensation will form on the inner surface of double glazing when the indoor relative humidity is 52 percent or higher. It will form at an indoor relative humidity of 70 percent or higher if a double-pane window with a low-E coating and argon fill is used.

**STANDARDS**

**AMERICAN ARCHITECTURAL MANUFACTURERS ASSOCIATION (AAMA)**

AAMA 910-93. "Voluntary Life Cycle Specifications and Test Methods for Architectural Grade Windows and Sliding Glass Doors."

AAMA 1503.1-1988. "Voluntary Test Method for Thermal Transmittance and Condensation Resistance of Windows, Doors, and Glazed Wall Sections."

AAMA TIR-A10-1992. "Wind Loads on Components and Cladding for Buildings Less Than 90 Feet Tall."

AAMA CW #2-1979. "The Rain Screen Principle and Pressure-Equalized Wall Design."

AAMA CW #11-1985. "Design Wind Loads for Buildings and Boundary Layer Wind Tunnel Testing."

AAMA/NWWDA. "Voluntary Specifications for Aluminum, Vinyl (PVC), and Wood Windows and Glass Doors—1996."

ANSI/AAMA 101-93. "Voluntary Specifications for Aluminum and Poly (Vinyl Chloride) (PVC) Prime Windows and Glass Doors."

ANSI/AAMA 1002.10-93. "Voluntary Specifications for Insulating Storm Products for Windows and Sliding Glass Doors."

**NATIONAL FENESTRATION RATING COUNCIL (NFRC)**

NFRC 100-91. "Procedure for Determining Fenestration Product Thermal Properties (Currently Limited to U-values)."

\_\_\_\_\_. "Attachment A: Interim Standard Test Method for Measuring the Steady-State Thermal Transmittance of Fenestration Systems Using Hot Box Methods."

\_\_\_\_\_. "Section B: Procedure for Determining Door System Product Thermal Properties (Currently Limited to U-values)."

**GENERAL**

The National Fenestration Rating Council (NFRC) has developed a fenestration energy rating system based on whole product performance. The system accurately accounts for the energy-related effects of all of a product's component parts and prevents misleading comparisons of information about a single component with whole product properties. At this time, NFRC labels on window units give ratings for U-value, solar heat gain coefficient, and visible light transmittance. Soon labels will include air infiltration rates and an annual fenestration heating and cooling rating. The initial development of the NFRC rating system has focused on window units manufactured mainly for residential applications. In the future, the NFRC will adapt the rating system to commercial glazing and curtain wall systems.

Manufacturers of modern fenestration products want to take credit for the technological advances and increasing complexity of their products but these are not easily visually verified. Thus, in 1989, the NFRC was established to develop a fair, accurate, and credible rating system for these products. State energy codes began to incorporate NFRC procedures in 1992, and the National Energy Policy Act provided for the development of a national rating system. The U.S. Department of Energy has certified the NFRC procedures as the national rating system, and they are now referenced in and being incorporated into the Model Energy Code and ASHRAE Standards 90.1 and 90.2.

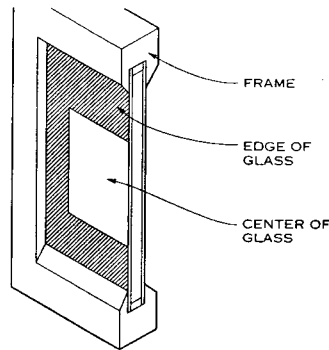

**NOTE**  
The total window U-factor takes into account the glass (edge of glass and center of glass) and the frame in a vertical position. Changing the mounting angle can affect the U-factor of a window.

**ZONES FOR DETERMINING HEAT LOSS IN WINDOW ASSEMBLY**

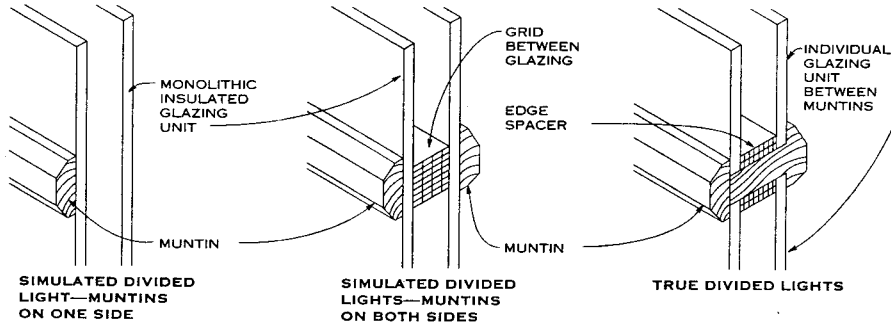

**NOTE**  
The energy performance of a window unit with muntins on both sides can be comparable to that of a unit with no muntins if the grid set between the lights is at least 1/8 in. away from both panes of glass.

**DIVIDED LIGHT TYPES**

**CHARACTERISTICS OF SELECTED WINDOW TYPES**

CHARACTERISTIC	EXAMPLE 1	EXAMPLE 2	EXAMPLE 3	EXAMPLE 4	EXAMPLE 5	EXAMPLE 6	EXAMPLE 7	EXAMPLE 8
General glazing description	Single-glazed clear	Double-glazed clear	Double-glazed bronze	Double-glazed clear	Double-glazed low-E	Double-glazed spectrally selective	Triple-glazed clear	Triple-glazed low-E superwindow
Layers of glazing and spaces (outside to inside)	1/8 in. clear	1/8 in. clear 1/2 in. air 1/8 in. clear	1/8 in. bronze 1/2 in. air 1/8 in. clear	1/8 in. clear 1/2 in. air 1/8 in. clear	1/8 in. clear 1/2 in. argon low-E (0.20) on 1/8 in. clear	1/8 in. low-E (0.04) 1/2 in. argon 1/8 in. clear	1/8 in. clear 1/2 in. air 1/8 in. clear	low-E (0.08) on 1/8 in. clear 1/2 in. krypton 1/8 in. clear 1/2 in. krypton low-E (0.08) on 1/8 in. clear
Center of glass								
U-factor	1.11	0.49	0.49	0.49	0.30	0.24	0.31	0.11
Solar heat gain coefficient	0.86	0.76	0.62	0.76	0.74	0.41	0.69	0.49
Shading coefficient	1.00	0.89	0.72	0.89	0.86	0.47	0.81	0.57
Visible transmittance	0.90	0.81	0.61	0.81	0.74	0.72	0.75	0.68
Frame								
Type	Aluminum, no thermal break	Aluminum, thermal break	Aluminum, thermal break	Wood or vinyl	Wood or vinyl	Wood or vinyl	Wood or vinyl	Insulated vinyl
U-factor	1.90	1.00	1.00	0.40	0.30	0.30	0.30	0.20
Spacer	—	Aluminum	Aluminum	Aluminum	Stainless	Stainless	Stainless	Insulated
Total window								
U-factor	1.30	0.64	0.64	0.49	0.33	0.29	0.34	0.15
Solar heat gain coefficient	0.79	0.65	0.55	0.58	0.55	0.31	0.52	0.37
Visible transmittance	0.69	0.62	0.47	0.57	0.52	0.51	0.53	0.48
Air leakage								
Cubic ft/min per lin. ft of crack	0.65	0.37	0.37	0.37	0.10	0.10	0.10	0.05
Cubic ft/min per sq ft of unit	0.98	0.56	0.56	0.56	0.15	0.15	0.15	0.08

Units for all U-factors are Btu/hr-sq ft-F. All values for total window are based on a 2 x 4 foot casement window. (Source: Carmody, Selkowitz, and Hescong, *Residential Windows—New Technologies and Energy Performance*, 1996.)

John Carmody, University of Minnesota; Minneapolis, Minnesota  
Stephen Selkowitz, Lawrence Berkeley National Laboratories; Berkeley, California



**AAA WINDOW COMPANY**

MANUFACTURER STIPULATES THAT THESE RATINGS WERE DETERMINED IN ACCORDANCE WITH APPLICABLE NFRC PROCEDURES

ENERGY RATING FACTORS	RATINGS RESIDENTIAL		PRODUCT DESCRIPTION
	U-factor	Solar heat gain coefficient	
U-factor	0.40	0.38	Model 1000 Casement Low-E = 0.2 0.5" gap Argon-filled
Solar heat gain coefficient	0.65	0.66	
Visible light transmittance	0.71	0.71	
Air leakage	0.20	0.20	

NFRC ratings are determined for a fixed set of environmental conditions and specific product sizes and may not be appropriate for directly determining seasonal energy performance.

**NOTES**

- Ratings of the basic thermal and optical properties of all fenestration products (windows, doors, skylights) must include the effects of the glass, the sash, and the frame and be in accordance with the appropriate National Fenestration Rating Council (NFRC) standard. Products must be labeled with ratings for these properties, and the manufacturer must certify they are in accordance with the NFRC Product Certification Program.
- The NFRC standards for the basic thermal and optical properties of fenestration products are as follows: NFRC 100 for the U-factor, NFRC 200 for the solar heat gain coefficient (SHGC), NFRC 300 for visible light transmittance, and NFRC 400 for air leakage.

**NFRC WINDOW PRODUCT IDENTIFICATION MARK**

**PROPERTIES OF GLAZING MATERIALS USED IN MANUFACTURED WINDOW UNITS**

Three things happen to solar radiation as it passes through a glazing material: some is transmitted, some is reflected, and the rest is absorbed. These three components determine many of the other energy-performance properties of a glazing material. Manipulating the proportion of transmittance, reflectance, and absorptance for different wavelengths of solar radiation has been the source of much recent innovation in window energy performance. The four basic properties of glazing that affect radiant energy transfer are transmittance, reflectance, absorptance, and emittance.

Before the recent innovations in the technology of glass, the primary property of glass was its ability to transmit visible light, and its quality was judged by how clear it was. However, as attention focused on improving the total energy performance of glass, it became clear that transparency to visible light is only part of the picture.

Visible light is a small portion of the electromagnetic spectrum. Beyond the blues and purples lie ultraviolet radiation and other higher energy short wavelengths, from X rays to

gamma rays. Beyond red light are the near-infrared, given off by very hot objects, the far-infrared, given off by warm room-temperature objects, and the longer microwaves and radio waves.

Glazing types vary in their transparency to different parts of the spectrum. On the simplest level, a glass that appears to be tinted green as you look through it toward the outside will transmit more sunlight from the green portion of the visible spectrum and reflect/absorb more of the other colors. Similarly, bronze-tinted glass will absorb the blues and greens and transmit the warmer colors. Neutral gray tints absorb most colors equally.

This same principle applies outside the visible spectrum. Most glass is partially transparent to at least some ultraviolet radiation, while plastics are commonly more opaque to ultraviolet. Glass is opaque to far-infrared radiation but generally transparent to near-infrared.

With the recent advances in glazing technology, manufacturers can control how glazing materials behave in different areas of the spectrum. The basic properties of the substrate material (glass or plastic) can be altered, and coatings can be added to the surfaces of the substrates. For example, a window optimized for daylighting and for reducing

solar heat gain should transmit adequate light in the visible portion of the spectrum but exclude unnecessary heat gain from the near-infrared part of the solar spectrum. On the other hand, a window optimized for collecting solar heat gain in winter should transmit the maximum amount of visible light as well as heat from the near-infrared wavelengths in the solar spectrum, while blocking the lower energy radiant heat in the far-infrared range (an important heat-loss component). These are the strategies of spectrally selective and low-emittance coatings, respectively.

**PERFORMANCE OF COMMON GLAZING TYPES**

The figures on this page illustrate the solar heat gain and visible light transmittance for common glazing types used in manufactured windows. The figures are for the center of the glass only; the characteristics of the frame must be included to obtain performance information on the whole window unit. The darker arrows indicate the total transmitted and total rejected solar energy. The lighter arrows indicate the amount of transmitted and reflected daylight. Daylight that is neither transmitted nor reflected is absorbed. Not all low-E coatings are the same; use NFRC rated and labeled values.

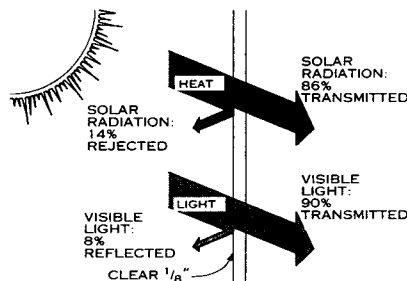

**NOTE**  
U-value=1.11; SHGC=0.86; SC=1.00; VT=0.90  
**SINGLE GLAZING—CLEAR GLASS**

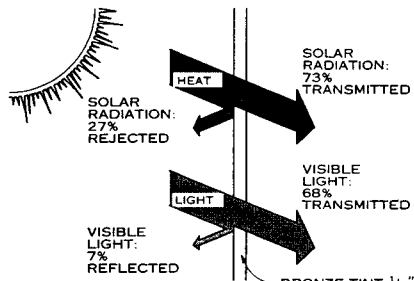

**NOTE**  
U-value=1.11; SHGC=0.73; SC=0.85; VT=0.68  
**SINGLE GLAZING—BRONZE TINT**

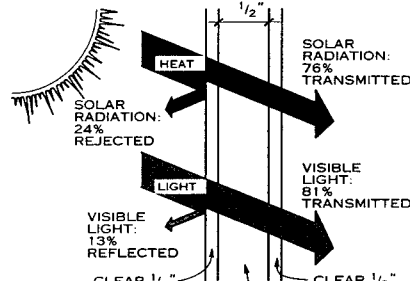

**NOTE**  
U-value=0.49; SHGC=0.76; SC=0.88; VT=0.81  
**DOUBLE GLAZING—CLEAR GLASS**

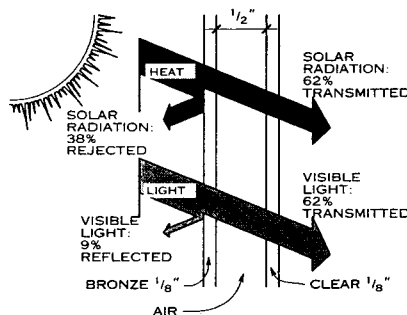

**NOTE**  
U-value=0.49; SHGC=0.62; SC=0.72; VT=0.62  
**DOUBLE GLAZING—BRONZE TINT**

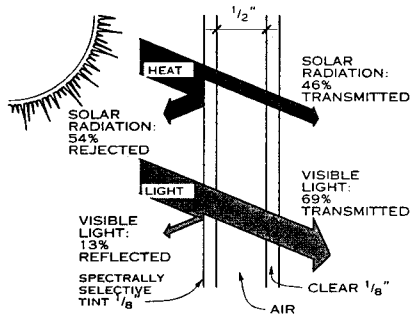

**NOTE**  
U-value=0.49; SHGC=0.46; SC=0.54; VT=0.69  
**DOUBLE GLAZING—SPECTRALLY SELECTIVE TINT**

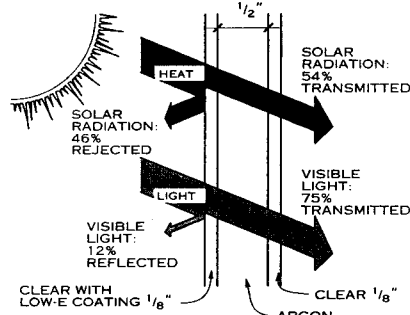

**NOTE**  
U-value=0.26; SHGC=0.54; SC=0.62; VT=0.75  
**DOUBLE GLAZING—LOW-E COATING**

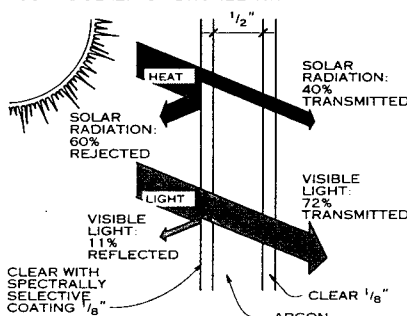

**NOTE**  
U-value=0.24; SHGC=0.40; SC=0.47; VT=0.72  
**DOUBLE GLAZING—SPECTRALLY SELECTIVE COATING**

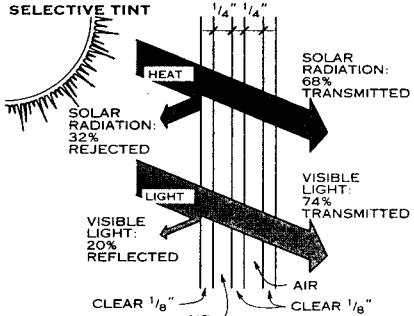

**NOTE**  
U-value=0.39; SHGC=0.68; SC=0.79; VT=0.74  
**TRIPLE GLAZING—CLEAR GLASS**

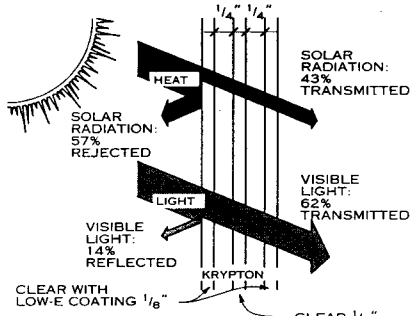

**NOTE**  
U-value=0.14; SHGC=0.43; SC=0.50; VT=0.62  
**TRIPLE GLAZING—CLEAR AND TWO LOW-E COATINGS**

**PERFORMANCE OF 1/8-INCH THICK GLASS IN A MANUFACTURED WINDOW ASSEMBLY**

John Carmody, University of Minnesota; Minneapolis, Minnesota  
Stephen Selkowitz, Lawrence Berkeley National Laboratory; Berkeley, California



**PERFORMANCE OF GLAZING**

The figures on this page illustrate the solar heat gain and visible light transmittance for common glazing types used in windows and curtain walls in commercial buildings. The figures are for the center of the glass only; the characteristics of the frame must be included to obtain performance information on the whole window assembly. The darker arrows indicate the total admitted and total rejected solar energy. The lighter arrows indicate the amount of transmitted and reflected daylight. Daylight that is neither transmitted nor reflected is absorbed.

**ABBREVIATIONS**

SHGC: solar heat gain coefficient; SC: shading coefficient; VT: visible transmittance

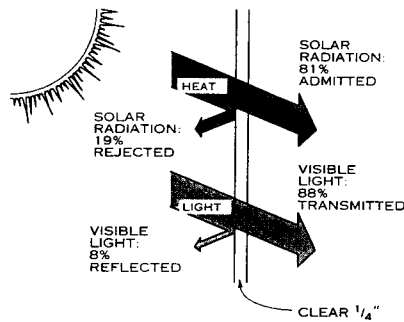

**NOTE**  
U-value=1.09; SHGC=0.81; sc=0.94; VT=0.88

**SINGLE GLAZING—CLEAR GLASS**

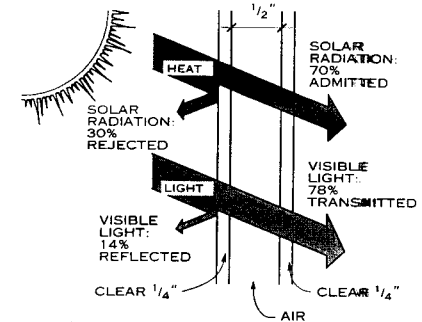

**NOTE**  
U-value=0.45; SHGC=0.70; SC=0.81; VT=0.78

**DOUBLE GLAZING—CLEAR GLASS**

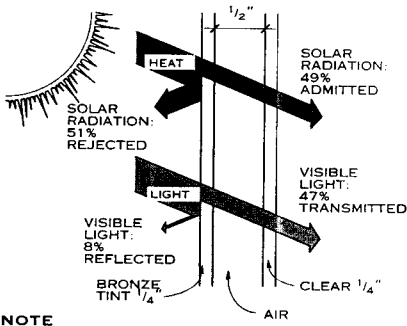

**NOTE**  
U-value=0.48; SHGC=0.49; SC=0.57; VT=0.47

**DOUBLE GLAZING—BRONZE TINT**

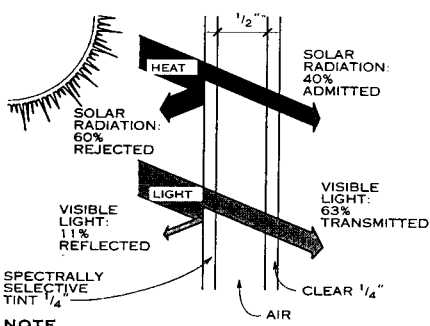

**NOTE**  
U-value=0.48; SHGC=0.40; SC=0.46; VT=0.63

**DOUBLE GLAZING—SPECTRALLY SELECTIVE TINT**

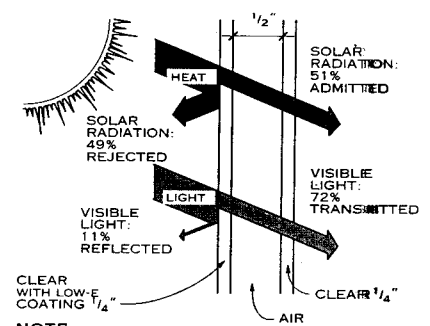

**NOTE**  
U-value=0.31; SHGC=0.51; SC=0.59; VT=0.72

**DOUBLE GLAZING—CLEAR GLASS WITH LOW-E COATING**

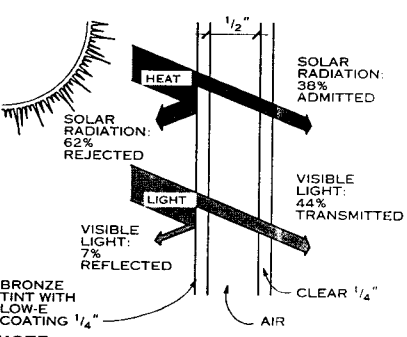

**NOTE**  
U-value=0.31; SHGC=0.38; SC=0.44; VT=0.44

**DOUBLE GLAZING—BRONZE TINT WITH LOW-E COATING**

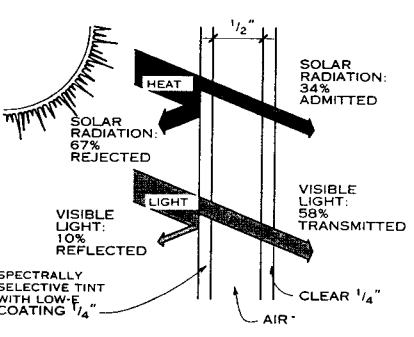

**NOTE**  
U-value=0.31; SHGC=0.34; SC=0.39; VT=0.58

**DOUBLE GLAZING—SPECTRALLY SELECTIVE TINT AND LOW-E COATING**

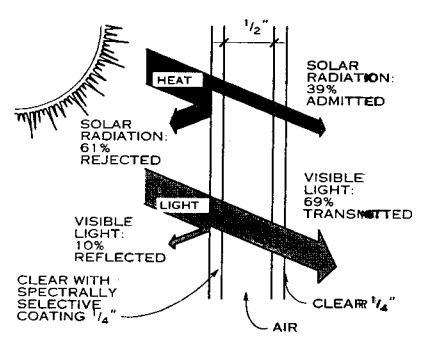

**NOTE**  
U-value=0.29; SHGC=0.39; SC=0.46; VT=0.69

**DOUBLE GLAZING—CLEAR GLASS WITH SPECTRALLY SELECTIVE COATING**

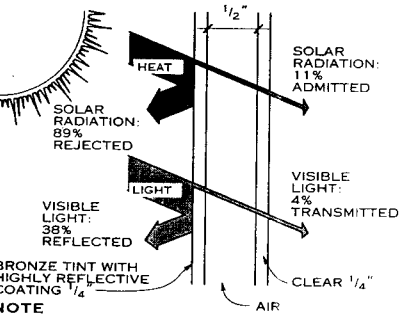

**NOTE**  
U-value=0.48; SHGC=0.11; SC=0.13; VT=0.04

**DOUBLE GLAZING—BRONZE TINT WITH HIGHLY REFLECTIVE COATING**

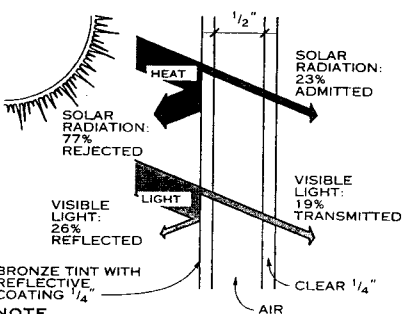

**NOTE**  
U-value=0.48; SHGC=0.23; SC=0.27; VT=0.19

**DOUBLE GLAZING—BRONZE TINT WITH REFLECTIVE COATING**

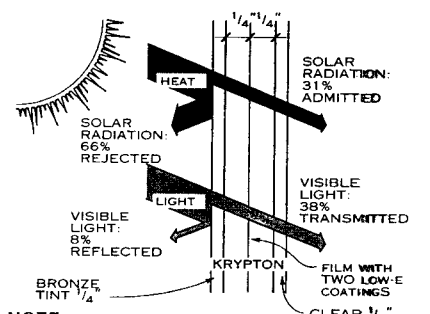

**NOTE**  
U-value=0.14; SHGC=0.31; SC=0.36; VT=0.38

**TRIPLE GLAZING—BRONZE TINT AND TWO LOW-E COATINGS ON FILM + CLEAR**

**PERFORMANCE OF 1/4-IN. THICK GLASS IN WINDOWS AND CURTAIN WALLS FOR COMMERCIAL BUILDINGS**

John Carmody, University of Minnesota; Minneapolis, Minnesota  
Stephen Selkowitz, Lawrence Berkeley National Laboratory; Berkeley, California

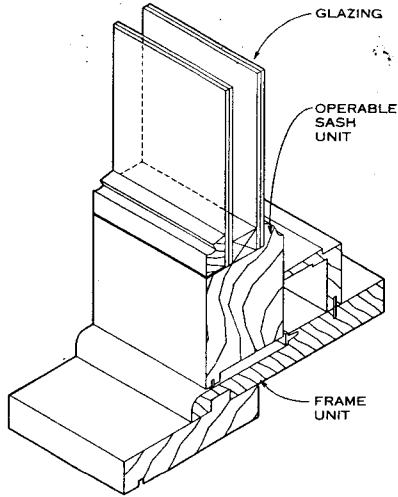

WOOD

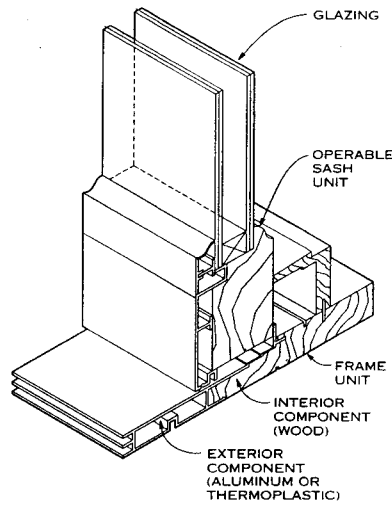

HYBRID

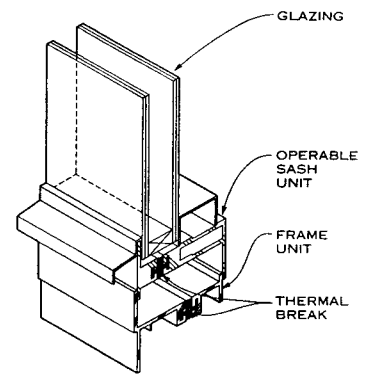

ALUMINUM

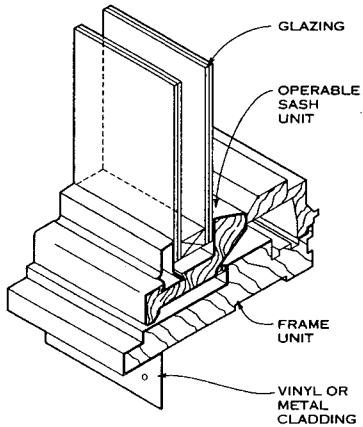

WOOD WITH CLADDING

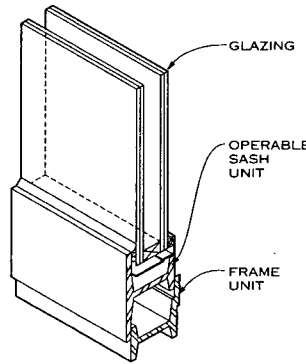

STEEL

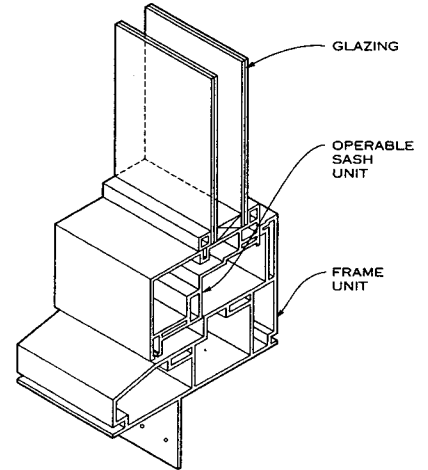

VINYL OR FIBERGLASS

WINDOW FRAME DETAILS

WINDOW FRAME TYPES

FRAME TYPE	CHARACTERISTICS	MAINTENANCE	FINISHES	HEAT TRANSFERENCE	SUSTAINABILITY	NOTES
Wood	Solid members; ease of milling into complex shapes; attractive and traditional appearance U-factor: 0.3-0.5	Rot prevention: refinish in 5 to 10-year cycle or permanent finish	Oil or latex paint, stains, oils, or varnishes; preservatives; polyurethane resin coatings; prefinished or site finished	Low	Renewable resource; requires high-quality solid stock	Traditional and typical material; variety of species available; easy repair
Wood with cladding	Metal- or plastic-clad wood U-factor for vinyl clad: 0.3-0.5; for metal clad: 0.4-0.6	Minimal	See metal and plastic frames	Low with vinyl cladding, slightly higher with metal	Use of less desirable wood materials; salvageable cladding	Wood for stability/strength, cladding for maintenance
Hybrids	Wood interior, metal or plastic exterior U-factor for vinyl/wood: 0.3-0.5; for metal/wood: 0.4-0.6	See wood, metal, and plastic categories	See other categories	Low with vinyl/wood hybrid, slightly higher with metal/wood hybrid	Use of lower quantities of any one material	Good interior look with good exterior performance and low maintenance
Steel	Thin bar/ angle steel profiles; cast, extruded, forged U-factor: similar to that of aluminum	Rust prevention: refinish in 5 to 10-year cycle or permanent finish	Galvanizing, zinc-phosphate coatings; primed, painted; factory finishes: baked enamel, fluoropolymer, polyurethane coatings	High, unless thermal break is installed	Non-renewable, salvageable	High strength/smallest frame profiles of all types; stainless steel available but expensive
Aluminum	Box profiles; extrusions; lightweight U-factor: 1.0 (with thermal break), 1.9-2.2 (without thermal break)	Minimal	Natural; factory-applied: baked enamel, epoxy, anodized, electrostatic (powder), fluoropolymer coatings	High unless thermal break is installed	Non-renewable, salvageable	High strength, no maintenance
Vinyl (PVC)	High impact resistance; box profiles; multi-chambered extrusions U-factor for hollow: 0.3-0.5; for insulated: 0.2-0.4	Minimal	Integral when fabricated (limited colors)	Low	Non-renewable, petroleum-based	UV/sun protection from discoloration may be required; salt air and acid resistant
Fiberglass	Box profiles, polymer-based thermoplastic; dimensionally stable U-factor for hollow: 0.3-0.5; for insulated: 0.2-0.4	Minimal	Integral when fabricated	Low	Spun glass in resin binders	More expensive but more structurally stable than vinyl

John Carmody, University of Minnesota; Minneapolis, Minnesota  
 Stephen Selkowitz, Lawrence Berkeley National Laboratory; Berkeley, California

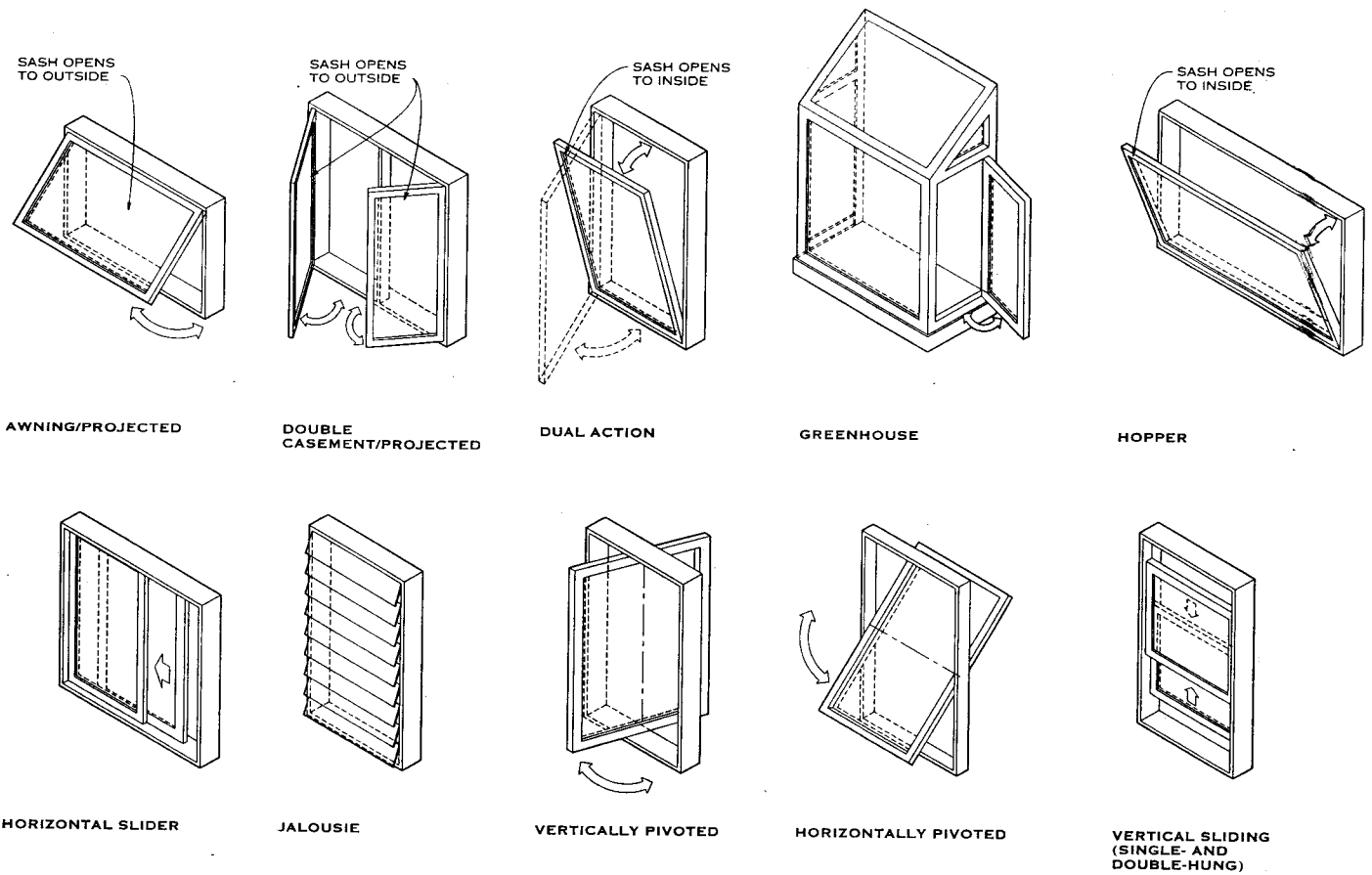

WINDOW OPERATION TYPES

CHARACTERISTICS OF WINDOW OPERATION TYPES

OPERATION TYPE	DIRECTION	SCREEN LOCATION	MAXIMUM OPENING (%)	WEATHER PROTECTION (WHEN OPEN)	EGRESS (CLEAR OPENING SIZE GOVERNS)	CLEANABILITY (EXTERIOR FROM INTERIOR)	NOTES
Awning/projected	Swings outward from hinge or pivot at top	Interior	100	Limited	Not possible without special hardware	Difficult	Not for use adjacent to walkways
Casement/projected	Swings outward or inward from a hinge or pivot on the side	Interior or exterior	100	Poor (wind-buffeting)	Good	Single units are difficult, paired windows easier	When outswinging, not suitable for use adjacent to walkways
Dual action	Swings inward from hinge or pivot on bottom (hopper for ventilation, casement for cleaning)	Exterior	10 usually (100 when casement)	Good	Good	Easy	
Greenhouse (may be combined with other operation types)	May swing outward but may not be operable	Depends on window operation type	Depends on window operation type	Good	Poor	Difficult	Unit projects from building; primarily residential use
Hopper/projected	Swings inward with hinge or pivot at bottom	Exterior	100	Good with side vents	Not without special hardware	Easy	
Horizontal sliding	Slides sideways with a guide at top and bottom	Exterior	50, for equal-sized sash	Poor	Good	Difficult (easy with tilt-in feature)	Horizontal or square units operate more easily than tall units
Jalousie	Swings outward from pivots on the side	Interior	100	Limited (interior storm windows available)	Poor	Tedious	Translucent/opaque panes provide additional sun-screening; high air leakage
Pivoted/reversible (horizontally and vertically pivoted)	Swings around vertical or horizontal axis	Rare, but special-shaped screens	100	Poor (wind-buffeting)	Poor (size of clear opening restrictions)	Easy	
Vertical sliding (single- and double-hung)	Slides up and down along guide on the side	Exterior	50, for equal-sized sash	Poor (but good with hospital sills)	Good	Difficult (easy with tilt-in feature)	

John Carmody, University of Minnesota; Minneapolis, Minnesota  
 Stephen Selkowitz, Lawrence Berkeley National Laboratory; Berkeley, California  
 Daniel F. C. Hayes, AIA; Washington, D.C.

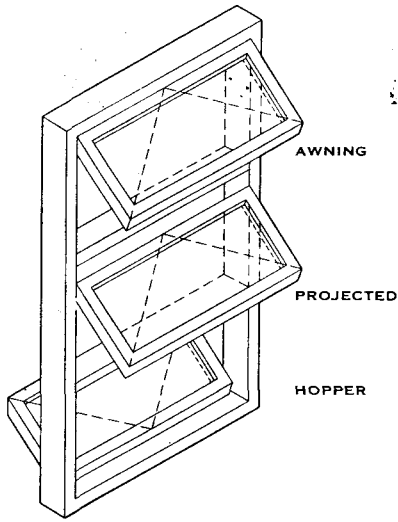

**OUTWARD- AND INWARD-SWINGING WINDOW TYPES**

**DEFINITIONS**

**AWNING WINDOW:** a unit (or series of mechanically inter-connected units) that swings outward from top-mounted pivots or hinges.

**HOPPER WINDOW:** a unit (or series of mechanically inter-connected units) that usually swing inward from bottom-mounted pivots or hinges; they may have side-mounted triangular draft barriers.

**PROJECTED WINDOW:** a window, which operates similarly to awning or hopper windows, in which the hinge or pivot side of the sash frame slides along a track toward the latch side as the window is opened.

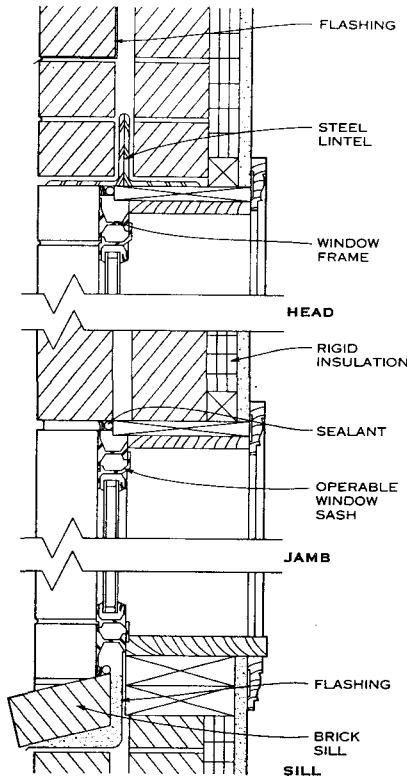

**STEEL PROJECTED WINDOW IN MASONRY CONSTRUCTION**

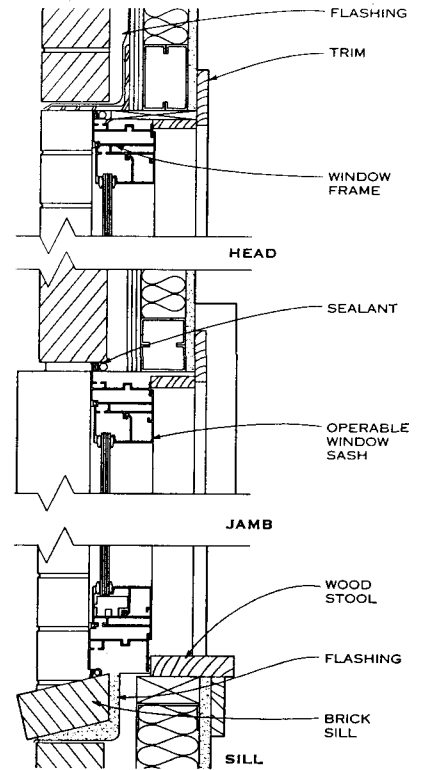

**ALUMINUM HOPPER WINDOW IN BRICK VENEER CONSTRUCTION**

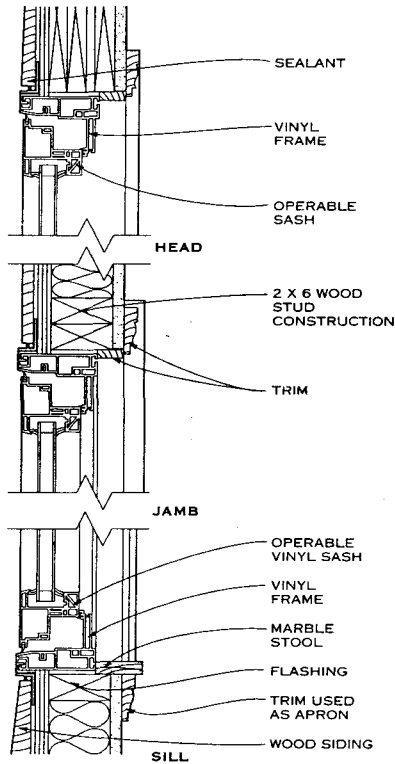

**VINYL WINDOW IN WOOD STUD CONSTRUCTION**

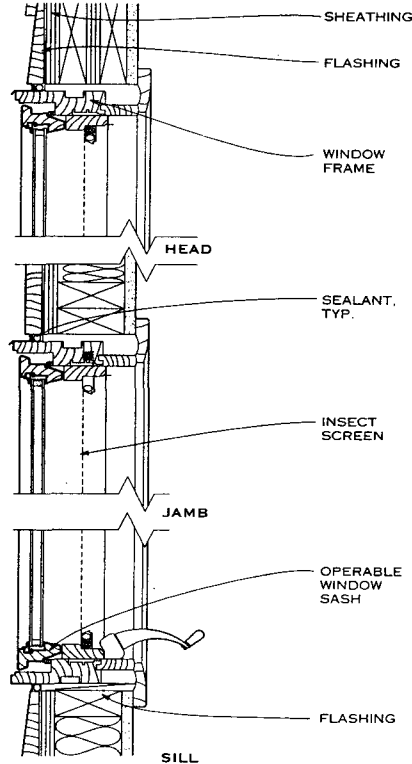

**METAL-CLAD WOOD WINDOW IN WOOD CONSTRUCTION**

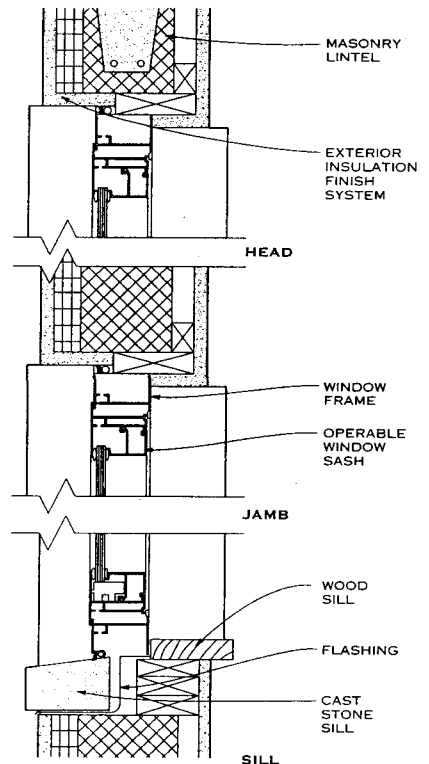

**ALUMINUM WINDOW IN EXTERIOR INSULATION FINISH SYSTEM ON MASONRY**

**AWNING WINDOW INSTALLATION DETAILS**

Daniel F. C. Hayes, AIA, Washington, D.C.

**DEFINITIONS**

**CASEMENT WINDOW:** a window unit or pair that operates like a door, either on hinges or pivots attached to the jamb or by sliding along tracks at the head and sill.

**CREMO(R)INE BOLT:** an exposed or concealed fastening mechanism composed of sill and head bolts and strikes connected by rods to a centrally mounted turn-knob device.

**FRENCH WINDOW:** a pair of tall casements that may serve as a door onto a balcony, porch, or terrace.

**LEVER OPERATOR:** a gearless mechanism in which a rod sliding through a clasp positions and secures the sash.

**OPERATING HARDWARE:** hardware used to work a window, including stays, lever operators, roto-operators, and cremo(r)ine bolts.

**PIVOT WINDOW:** a unit with sash that rotate either vertically or horizontally around center-mounted pivots.

**ROTO-OPERATOR:** a geared crank-and-worm drive mechanism that positions and secures the sash.

**STAY:** a bar that holds the sash open in various positions.

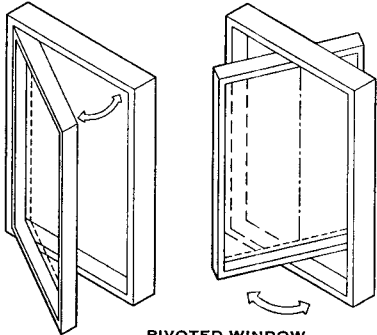

**CASEMENT**      **PIVOTED WINDOW (VERTICAL PIVOT SHOWN)**  
**CASEMENT AND PIVOT WINDOWS**

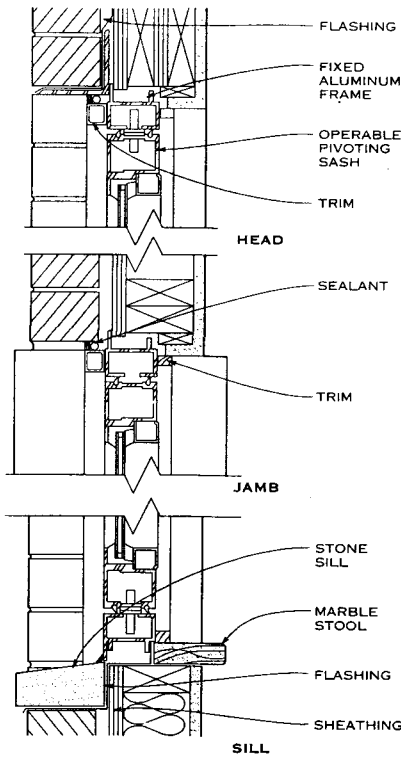

**VERTICALLY PIVOTED ALUMINUM WINDOW IN BRICK VENEER CONSTRUCTION**

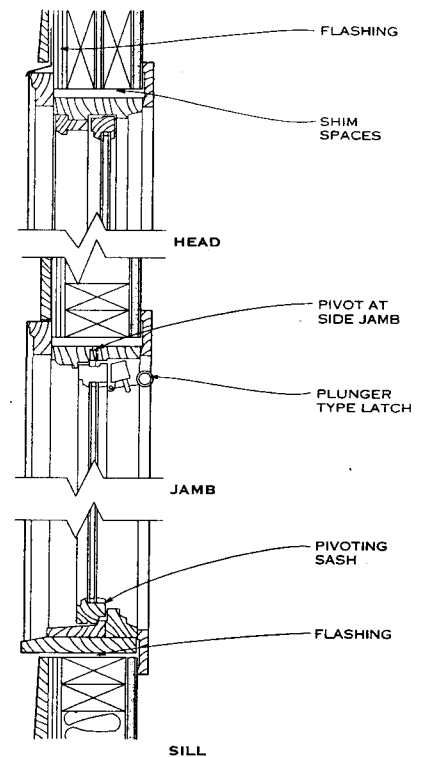

**HORIZONTALLY PIVOTED WOOD WINDOW IN WOOD CONSTRUCTION**

**PIVOT WINDOW INSTALLATION DETAILS**

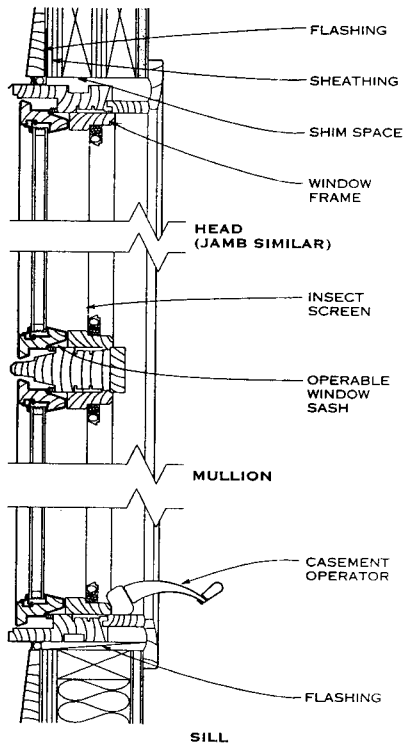

**VINYL-CLAD WOOD IN WOOD CONSTRUCTION**

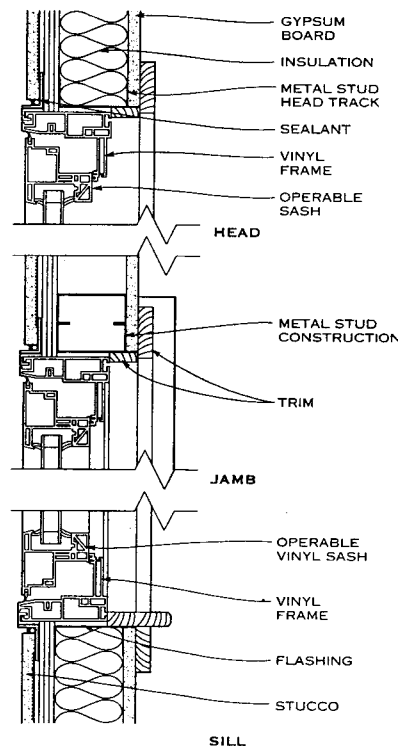

**VINYL WINDOW IN STUCCO AND METAL STUD CONSTRUCTION**

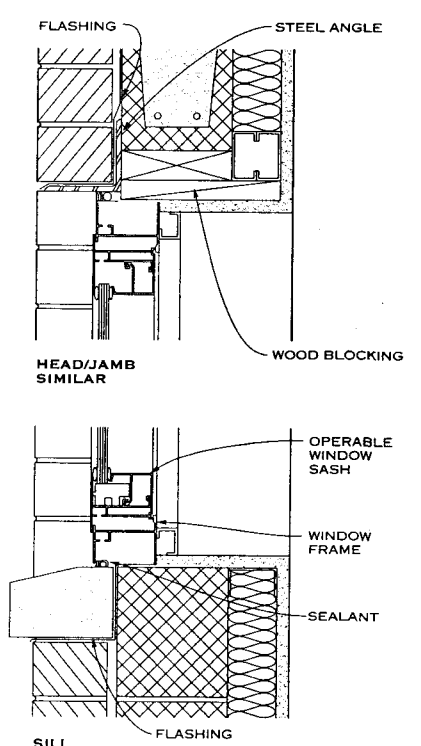

**ALUMINUM WINDOW IN MULTIPLYTHE MASONRY CONSTRUCTION**

**CASEMENT WINDOW INSTALLATION DETAILS**

Daniel F. C. Hayes, AIA; Washington, D.C.

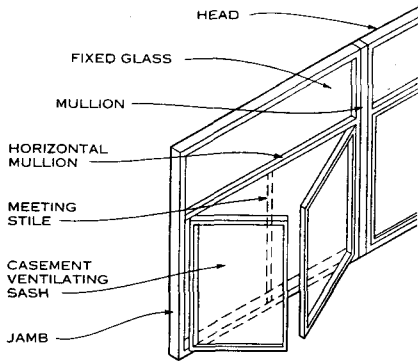

TYPICAL CASEMENT WINDOW

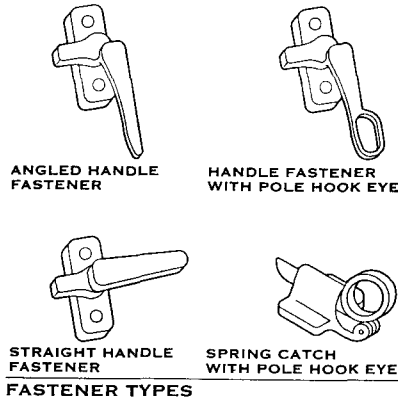

FASTENER TYPES

NOTES

1. Window sizes and dimensioning methods are not uniform for all manufacturers. Some manufacturers have no stock sizes, producing only custom work. Check with local suppliers for details.
2. In general, heavier grades of windows offer greater configuration flexibility. Larger operating sash can be produced with heavier members, allowing fixed lights shown for taller steel sash to be avoided, if desired.
3. Insect screens are necessarily installed on the interior and must be taken into account when selecting hardware.
4. The raindrip indicated on the horizontal mullion may be required at ventilating heads if sash are placed flush with the exterior face of the wall.
5. Drawings or specifications must contain the following information: window size and location; installation details for sills, stools, flashing, sealing, and anchors; sash material and finish; glazing material; glazing method (tape, putty, or bead, inside or outside); weatherstripping, insect screen material, and hardware.

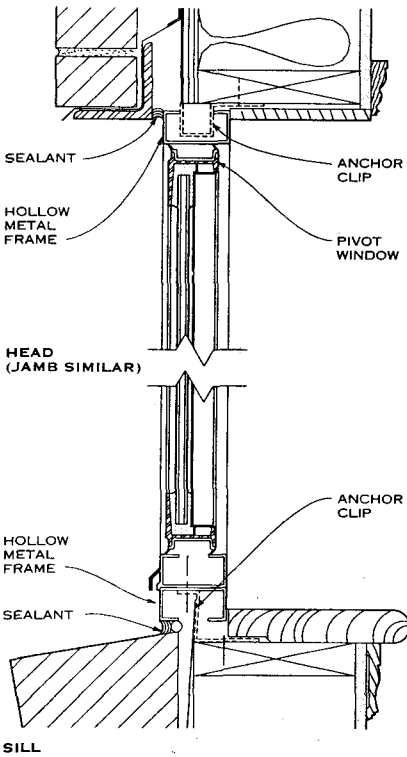

REVERSIBLE PIVOT FRAMING SECTION

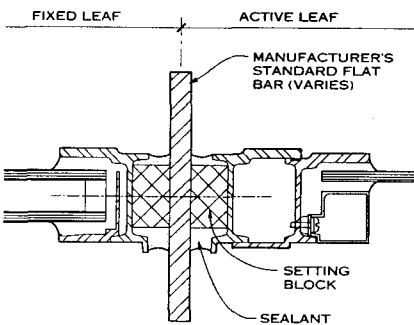

NOTE  
Alternate glazing types are shown for each leaf.

JAMB REINFORCING: STEEL BAR TYPE

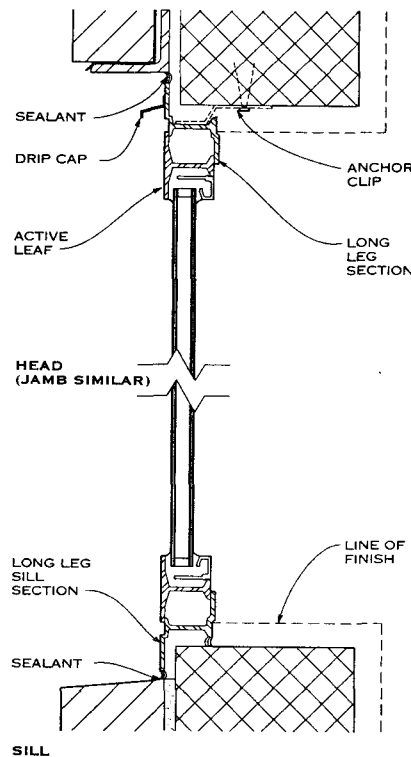

LONG LEG FRAMING SECTION

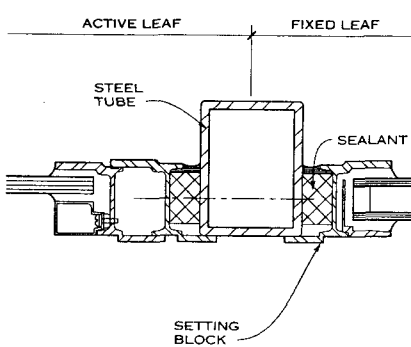

JAMB REINFORCING: STEEL TUBE TYPE

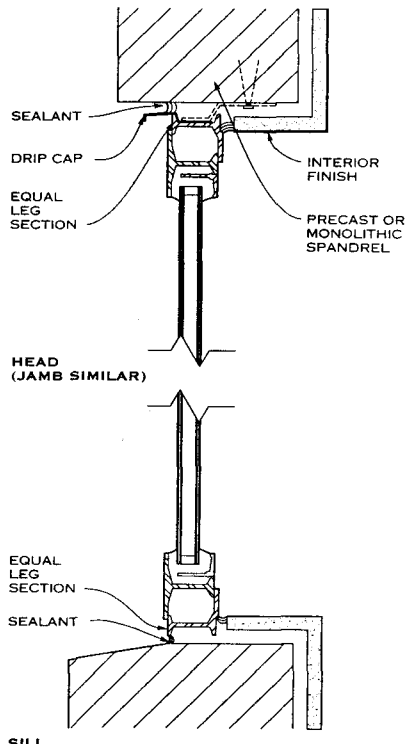

EQUAL LEG FRAMING SECTION

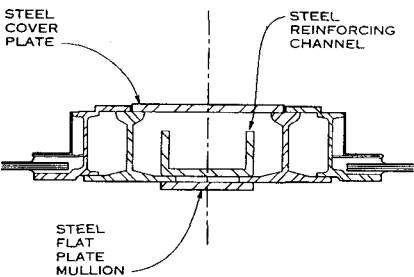

TYPICAL MULLION BETWEEN UNITS IN A MULTIPLE RUN

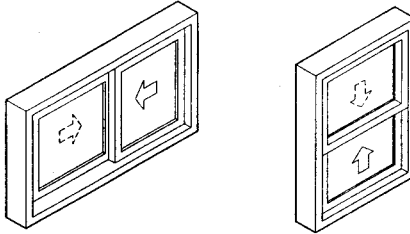

HORIZONTAL SLIDING WINDOW

VERTICAL SLIDING WINDOW (SINGLE- AND DOUBLE-HUNG)

SLIDING WINDOW TYPES

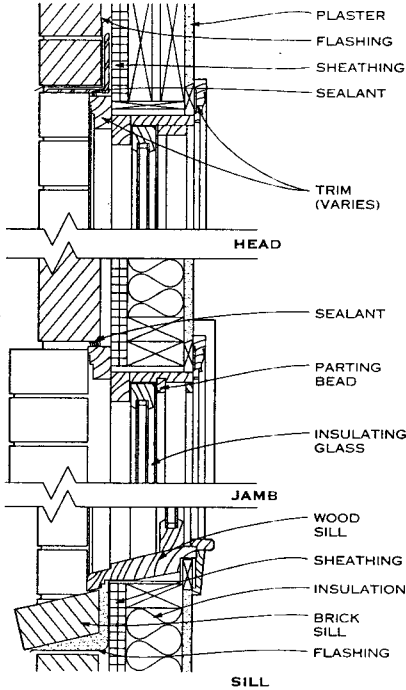

WOOD WINDOW IN BRICK VENEER CONSTRUCTION

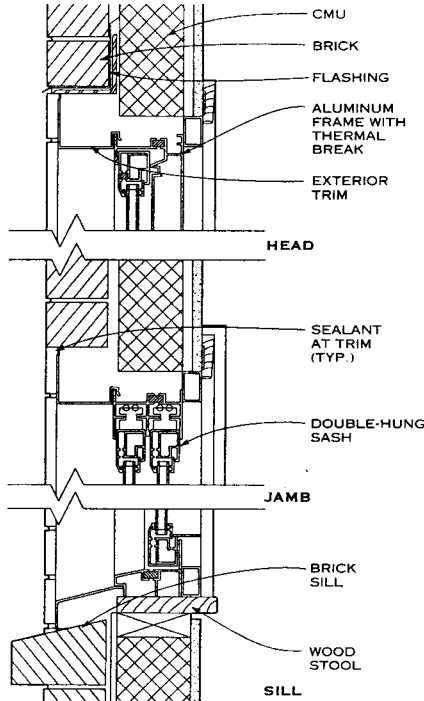

ALUMINUM WINDOW IN MASONRY CONSTRUCTION

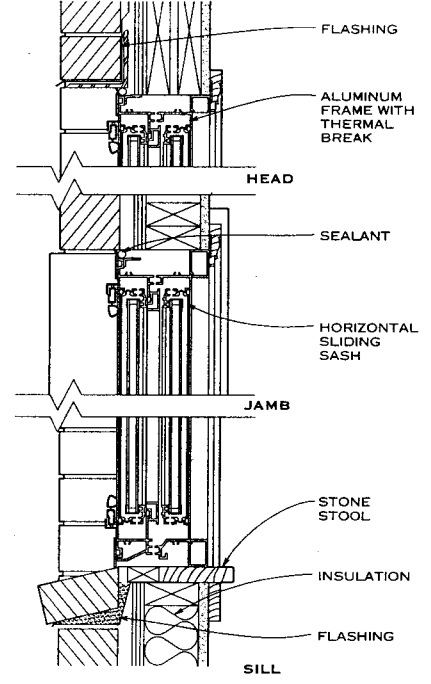

ALUMINUM WINDOW IN BRICK VENEER CONSTRUCTION

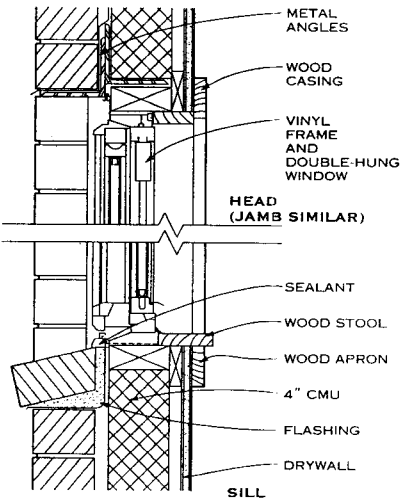

VINYL WINDOW IN MASONRY CONSTRUCTION

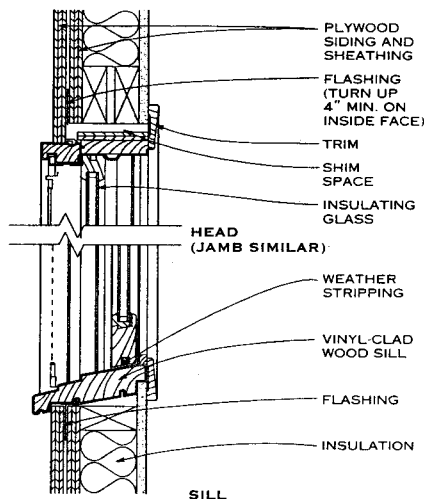

DOUBLE-HUNG VINYL-CLAD WINDOW IN WOOD FRAME CONSTRUCTION

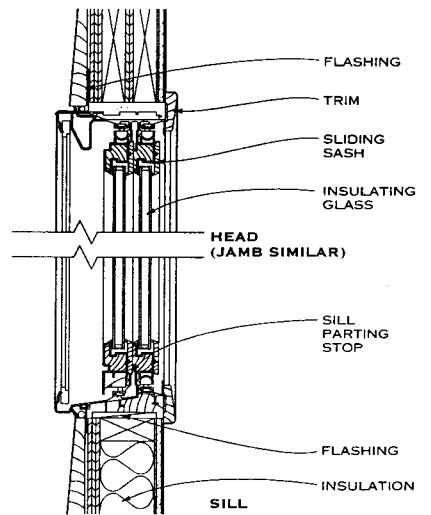

DOUBLE-HUNG VINYL-CLAD WINDOW IN WOOD FRAME CONSTRUCTION

VERTICAL SLIDING (DOUBLE-HUNG) WINDOWS

HORIZONTAL SLIDING WINDOWS

DEFINITIONS

DOUBLE-HUNG WINDOW: multiple operating sash in one unit (also comes as triple-hung).

HOSPITAL SILL: a raised stool that allows the meeting rails to be separated for ventilation while the head and sill rails remain sealed to weather penetration.

HORIZONTAL SLIDING WINDOW: a unit having at least two sash, one or more of which slides along horizontal tracks at the top and bottom of the frame.

POCKET COVER: a part of the jamb casing that can be removed to reach the weights or balances for maintenance.

SASH CORD: a rope or chain that connects the sash weight to the sash.

SASH RIBBON: a metal strip that connects the sash with either weights or spring balances.

SASH WEIGHT: a cast-iron or lead cylindrical counterweight.

SINGLE-HUNG WINDOW: a pair of sash, only one of which operates (by vertically sliding).

SPRING BALANCE: a spring-loaded mechanism used in place of a counterweight.

VERTICAL SLIDING WINDOW: a unit with sash that slide vertically in jamb-mounted tracks. Weights, springs, or friction-resistant jambs counterbalancing gravity or mechanical catches embedded in the jamb hold the sash open. The single, double, or triple-operating sash of these windows may stack against each other or, when full ventilation is required, be recessed in pockets above or below the window.

Daniel F. C. Hayes, AIA; Washington, D.C.

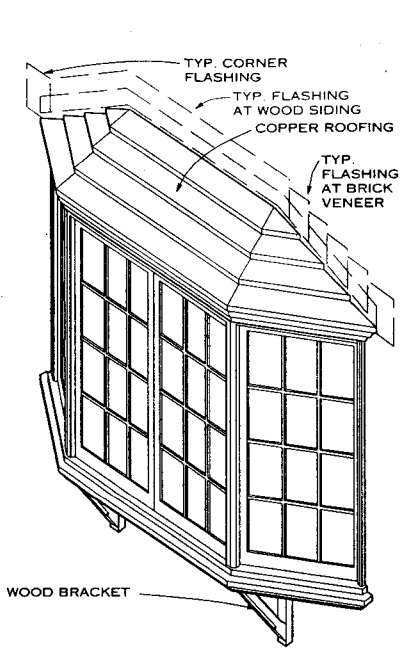

**GENERAL**

An oriel window is a window projecting from the wall face of the upper story of a building and supported on brackets, corbelling, or cantilevered. Oriels were often used in late Gothic and Tudor residential architecture.

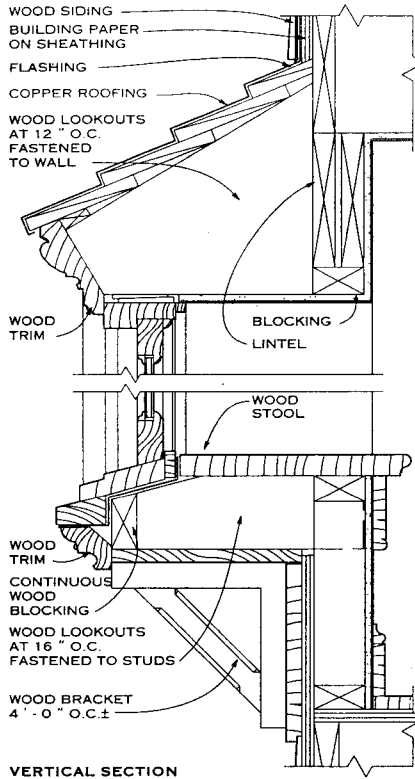

**VERTICAL SECTION**

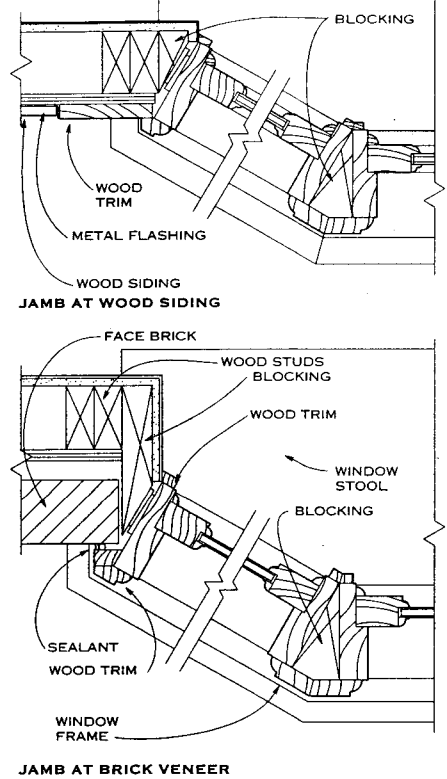

**ORIEL WINDOW**

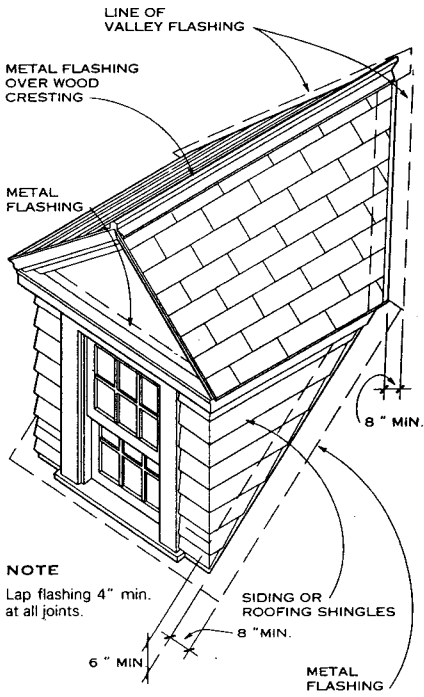

**GENERAL**

A dormer is a vertical window projecting from the sloping roof of a building and having vertical sides or cheeks and a gabled or shed roof.

**DORMER WINDOW**

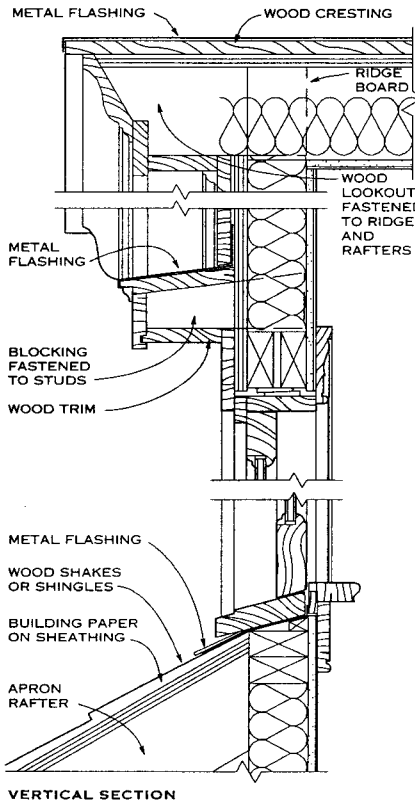

**VERTICAL SECTION**

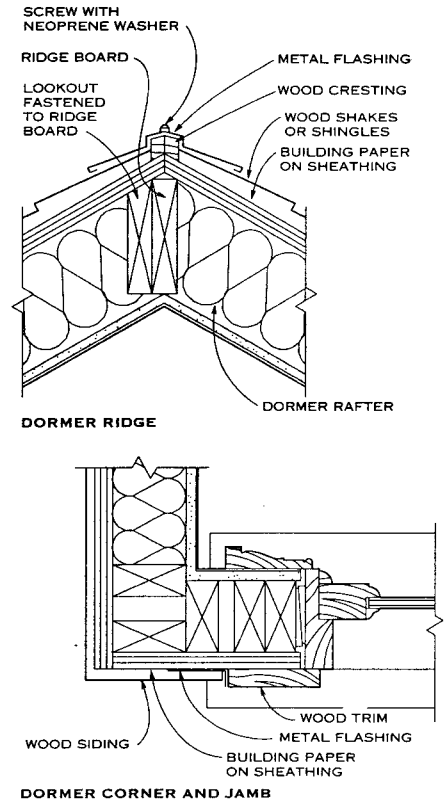

**DORMER CORNER AND JAMB**

Richard J. Vitullo, AIA; Oak Leaf Studio; Crownsville, Maryland



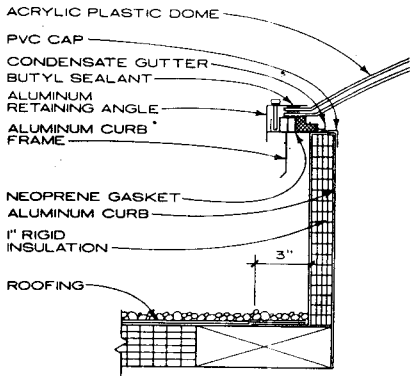

**INSULATED CURB**

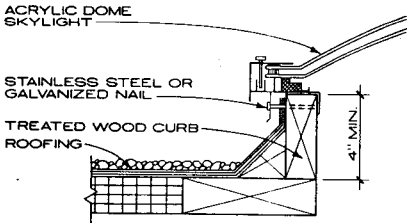

**WOOD CURB**

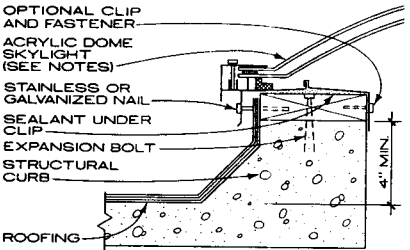

**CONCRETE CURB**

**DETAIL A: CURB TYPES**

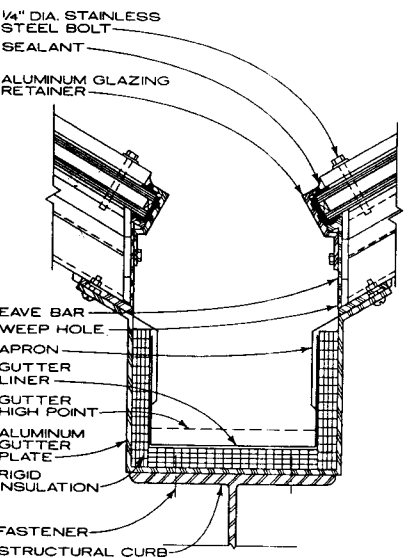

NOTE  
STRUCTURAL GUTTER SYSTEM AVAILABLE FOR MULTIPLE AND GRID NETWORK SYSTEMS OF RIDGE AND PYRAMID TYPE ENCLOSURES

**DETAIL B: GUTTER**

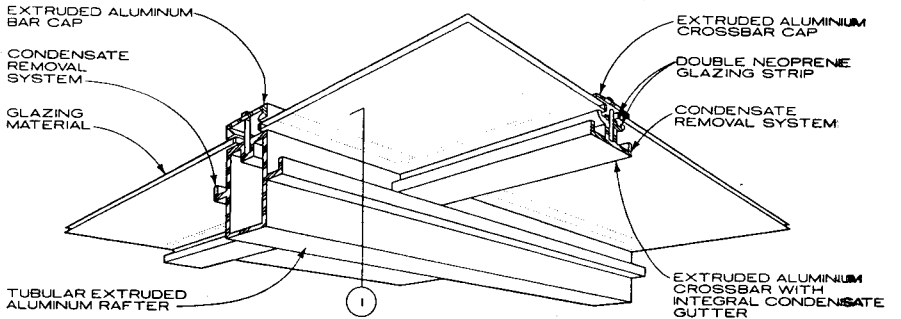

**DETAIL C: TYPICAL TUBULAR ALUMINUM FRAMING**

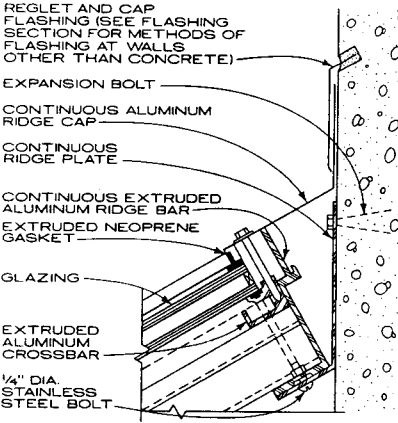

**DETAIL D: RIDGE AT SHED**

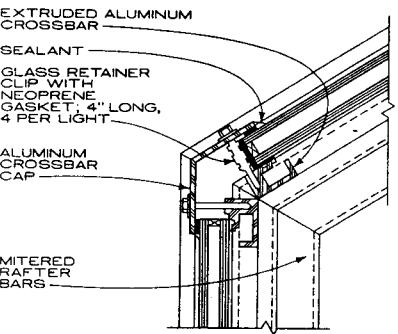

**DETAIL E: KNEE EDGE**

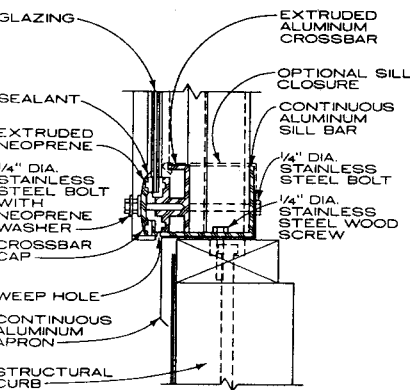

**DETAIL F: VERTICAL SILL**

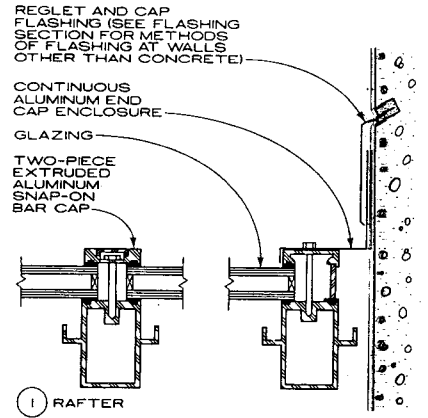

**DETAIL G: RAFTER AND END WALL**

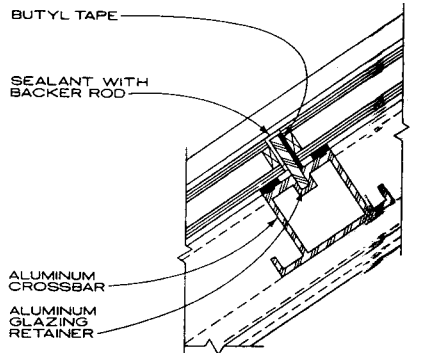

**DETAIL H: BUTT GLAZING**

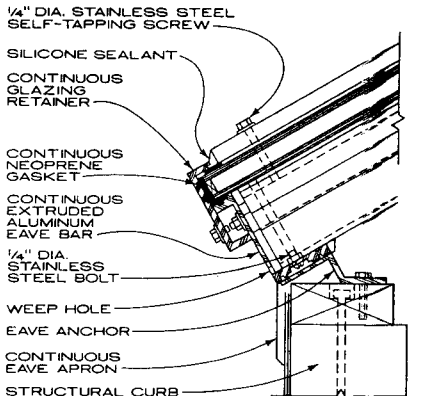

**DETAIL J: EAVE OR SILL**

CTA Architects Engineers; Billings, Montana  
Wheeler & Guay Architects P.C.; Alexandria, Virginia

**GENERAL**

Roof openings such as skylights, scuttles, and vents must be detailed with care, considering they will be exposed to the same external factors as the roof assembly itself. These factors include wind pressure—both positive and negative—which acts on the framing and/or glazing; rainwater penetration; live loads from snow and ice; dynamic loads from impact; daily cycles of thermal expansion and contraction; drainage of water and melting snow; and abuse from maintenance personnel. In addition, measures must be specified to keep people from falling through these openings.

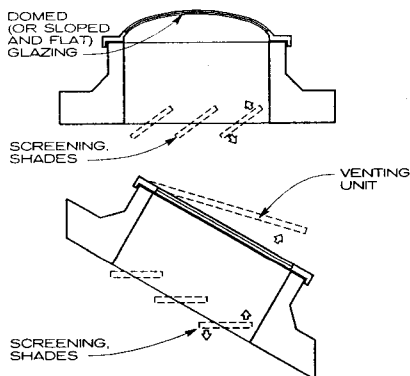

**NOTE**

In determining the desired form and size of the skylight unit/assembly, consideration should be given to

1. Environmental conditions, including orientation and winter and summer solar penetration angles at the site
2. Prevailing wind direction and patterns
3. Precipitation quantity and patterns
4. Adjacent topography and landscaping (shade trees, etc.)
5. Coordination with HVAC system
6. Use of shading, screening, or light reflecting/bouncing devices
7. Views desired relative to view obstructions, streetlights, etc.

**SKYLIGHTS**

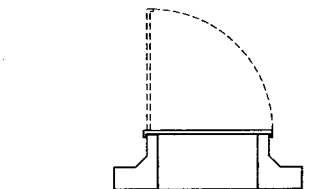

SINGLE LEAF

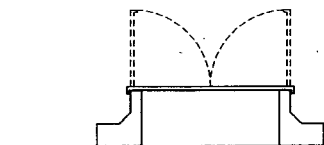

DOUBLE LEAF

**SCUTTLES**

**SCUTTLES**

Scuttles, often referred to as roof hatches, provide roof access for maintenance personnel using ladders, a built-in ship's ladder, or stairs; an emergency escape route in the event of a fire; and access for moving large equipment into or out of the building, possibly eliminating the need for extra-large doors in rooms and corridors below.

Scuttles come as preassembled units, often with integral curbs, and are usually made with spring-assisted openings. When glazing is introduced, scuttles can function as skylights as well. For use as smoke/fire vents, scuttles must have automatic opening capability.

If scuttles are to serve as a required means of egress, consult building codes for number, size, and location required; type of access permitted (ship's ladder, stair, etc.); and type of operation permitted (manual force required to open unit or powered opening).

**SKYLIGHTS**

Skylights provide daylight to interior spaces and can reduce dependence on electrical lighting. In passive solar designs, skylights are used to admit direct solar radiation, enhancing space heating, and, when vented properly, to induce convective airflow, reducing cooling loads through natural ventilation.

Skylights are available as preassembled units, which are shipped to the site ready to be installed, or as framed assemblies of stock components, which arrive prefabricated for site assembly. Both fixed and hinged skylights are manufactured. The hinged variety can be opened manually or by remote control devices for venting. Frames are typically mounted on a built-up prefabricated or site-built curb, with integral counterflashing; they can be assembled with or without insulation.

Self-flashing skylight units are available with or without curbs. Those without curbs are intended only for pitched roof assemblies and are not recommended for roof assemblies with finished spaces below.

Framed skylight assemblies are custom designed by manufacturers to meet the necessary wind, roof, and dead loads of the assembly itself. When a skylight is pitched beyond a certain angle, it must be designed to resist environmental factors as does a curtain wall assembly. Roof drainage for rain- and storm water can limit skylight dimensions. Condensate gutters are needed in the body of the skylight assembly and around its perimeter.

**FRAMING, GLAZING, AND GASKETS**

The heart of a well-designed skylight unit or skylight framed assembly is the detailing of frames, glazing, and sealant systems. Thickness, size, and geometric profile of all glass and acrylic glazing materials should be carefully selected for compliance with building codes and manufacturers' recommendations. The following glazing materials are considered resistant to impact and breakage and are generally approved by codes (listed in descending order of cost):

1. Formed acrylic with mar-resistant finish
2. Formed acrylic
3. Polycarbonates
4. Flat acrylic
5. Laminated glass
6. Tempered glass
7. Clear polished wire glass
8. Textured obscure wire glass

Framed skylights require somewhat greater mullion widths when glazed with acrylics in order to accommodate the expansion and contraction characteristics of plastics. When glazed with glass, framed skylight mullions are spaced according to the standard glass widths: laminated glass (48 in., maximum), wire glass (60 in., maximum), and tempered glass (72 in., maximum). High-performance insulating glass is generally used in preassembled units (and sometimes framed assemblies) and provides important energy savings.

For economy, tinted acrylics should be limited to 1/4 in. thickness. A combination fiberglass sheet and aluminum frame system with high insulating value and good light diffusion can be a cost-effective alternative. Domed acrylic glazing is almost self-cleaning, as the sloped shapes facilitate rain washing of the surface.

Frame systems must be engineered to carry the total resultant forces of the loads imposed on the skylight in accordance with all building codes. Framing, glazing, and gaskets also must be able to resist exposure to airborne pollutants. Frames with thermal breaks incorporated have better energy performance.

Finishes for aluminum frame components are available as mill finish, clear anodized, duranodic bronze or black, acrylic enamel, and fluorocarbon.

Gaskets are especially subject to degradation from solar ultraviolet rays. Excessive expansion and contraction of acrylic glazing can cause "rolling" of the gasket between metal framing. Small valleys created at the bottom of the sloped glazing and the horizontal glazing cap will hold water, which increases the chance of gasket breakdown and subsequent water infiltration.

**SECURITY AND SAFETY**

Frames or screens to protect glazing from impact, fire brands, or forced entry can be designed into the skylight system. To avoid forced entry, a framed skylight should include deterrents to disassembling the framing, removing the snap-on cover, and melting the glazing (acrylics can easily be burned with a torch). Metal security screens may be required.

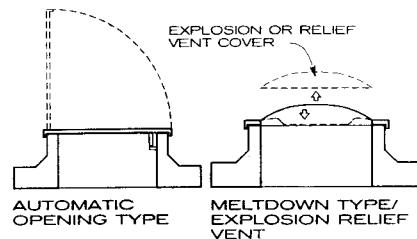

**FIRE AND SMOKE VENTS**

**FIRE AND SMOKE VENTING**

In certain building types and occupancies, such as those with large expanses of unobstructed space, fire and smoke vents that open automatically with a fire-induced temperature increase are required. Roof vents are often required over stairs, elevator hoistways, high-hazard occupancy areas (to offer explosion relief), and in areas behind the proscenium in theaters. The vents permit smoke, heat, and volatile gases to escape, lower the temperature at floor level, and reduce water damage by limiting active sprinkler heads to those in the immediate area of the fire.

There are two basic types of fire and smoke vents, both commonly available with integral curbs and flashing:

1. Meltdown: plastic glazing that softens and drops out of the frame when exposed to high temperatures (unit must be replaced once exposed to fire).
2. Automatic opening: solid or glazed cover with springs held by a fusible link that melts when the temperature rises, releasing the springs and opening the vent.

Enough vents must be distributed over the entire roof area to ensure early venting of a fire, regardless of its location. The size and spacing of the vents must be determined for each building according to its size and use and the degree of hazard involved. When UL- or FM-listed vents are required, choice of size is generally limited to stock sizes. Venting is based on moving a specific number of cubic feet of air per minute through the vents. Consult building codes for required capacity, size, and spacing.

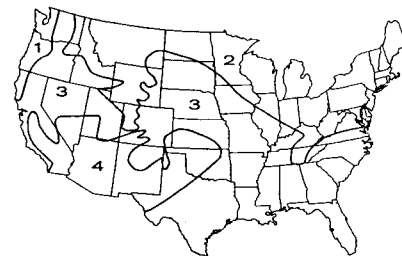

**PERCENTAGE OF ROOF AREA REQUIRED FOR SKYLIGHTING**

LIGHT ZONE	LIGHT DESIGN LEVELS (FC)		
	30	60	120
1	3.3	5.2	13.3
2	2.8	4.3	10.8
3	1.8	3.2	6.9
4	1.5	2.8	4.0

Typical roof vent area requirements are 0.67% roof area for low heat release occupancies, 1% roof area for moderate heat release occupancies, and 2% roof area for high heat release occupancies.

Generally, several small units satisfy the total venting area requirement better than a few larger ones (NFPA #204). Roof scuttles are available that may also serve as fire and smoke vents. Consider the spacing of vents relative to interior spaces and their uses, proximity to exits, and, if glazed, their role in daylighting.

Explosion relief vents are a type of fire and smoke vent that opens automatically when interior pressure rises above a predetermined level. Plastic glazed units deform under higher than normal air pressure and are released from their frame.

Richard J. Vitullo, AIA; Oak Leaf Studio; Crownsville, Maryland



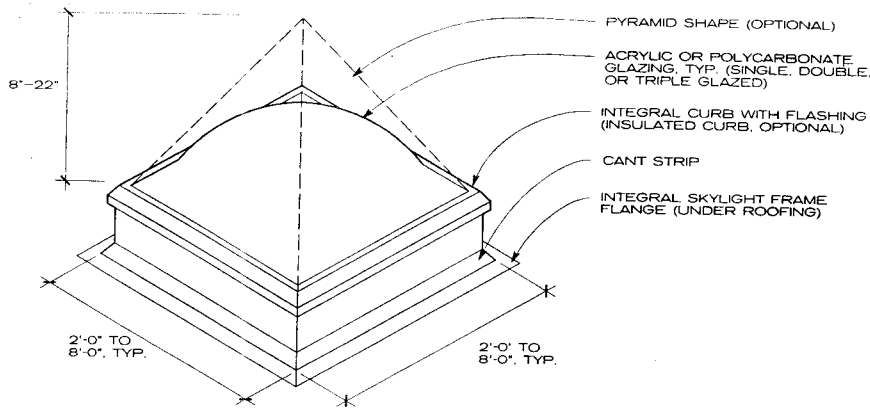

**NOTE**

Glazing may be clear, tinted transparent, or white translucent.

**DOMe UNIT SKYLIGHT—FLAT ROOF**

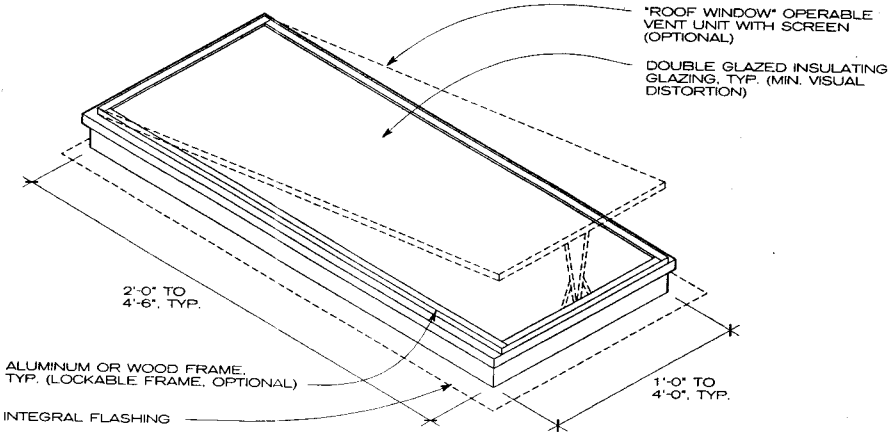

**NOTE**

1. Clear and tinted transparent glass, typical; tempered, laminated, and wire glass available.
2. Manual and powered vent operation, venetian blinds, shades, and exterior awnings available. Consult manufacturer.

**FLAT PANEL UNIT SKYLIGHT—SLOPED ROOF**

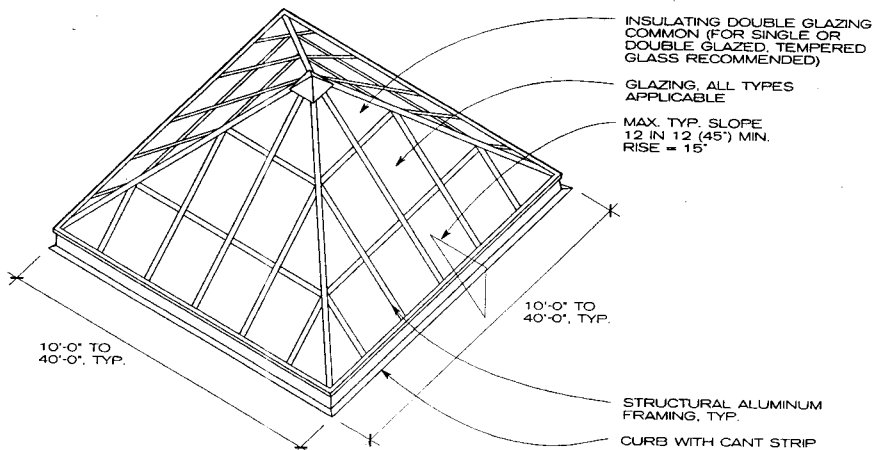

**PYRAMID FRAMED SKYLIGHT ASSEMBLY**

Richard J. Vitullo, AIA; Oak Leaf Studio; Crownsville, Maryland



SKYLIGHTS

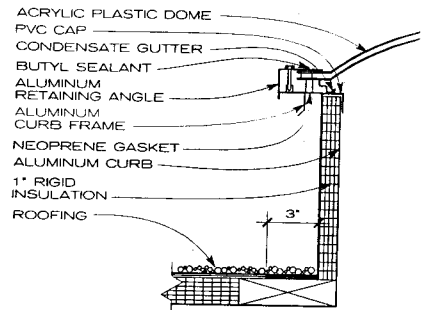

**INSULATED CURB**

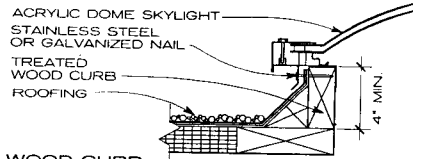

**WOOD CURB**

**UNIT SKYLIGHT SECTION**

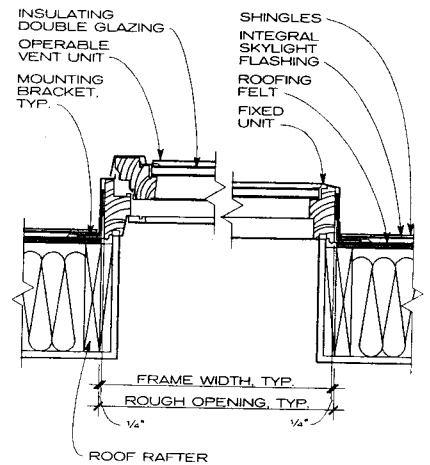

**FLAT PANEL UNIT SKYLIGHT SECTION**

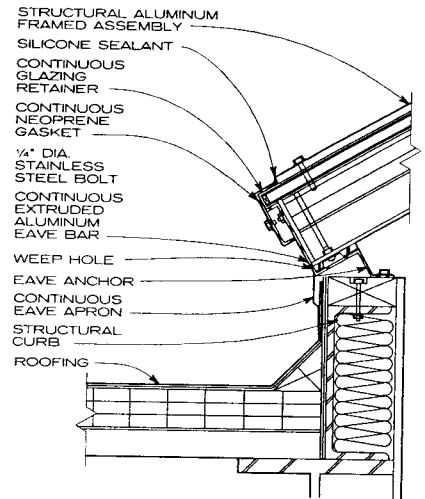

**CURB DETAIL AT SLOPED FRAMED ASSEMBLY**

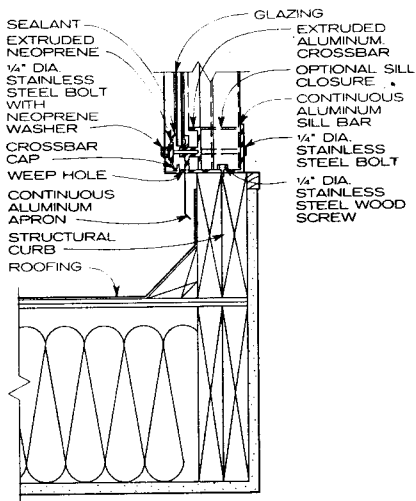

**VERTICAL FRAME CURB DETAIL (WOOD FRAME)**

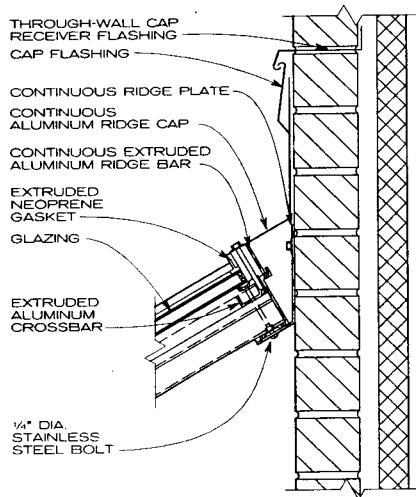

**SINGLE-PITCH BACK WALL DETAIL AT TOP (MASONRY WALL)**

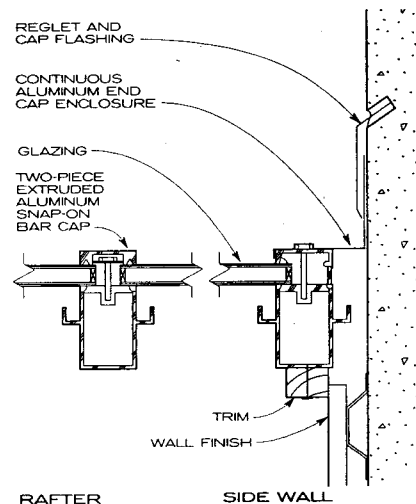

**SINGLE-PITCH RAFTER AND SIDE WALL DETAIL (CONCRETE WALL)**

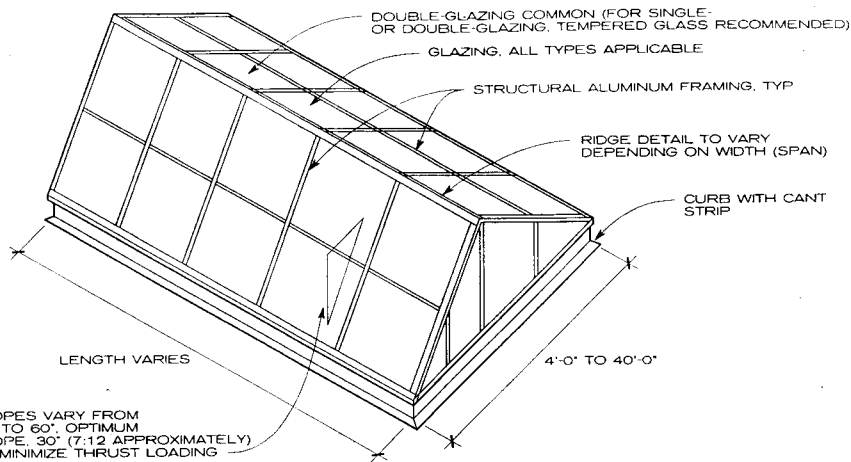

SLOPES VARY FROM 10° TO 60°. OPTIMUM SLOPE, 30° (7:12 APPROXIMATELY) TO MINIMIZE THRUST LOADING

**NOTE**

Options for a pitched skylight include (1) integration of skylight with roof structure at ridge, slope of skylight to match

slope of roof, no end glazing; (2) hip end glazing; and (3) vaulted framing; minimum rise is 22%.

**DOUBLE-PITCH FRAMED SKYLIGHT ASSEMBLY**

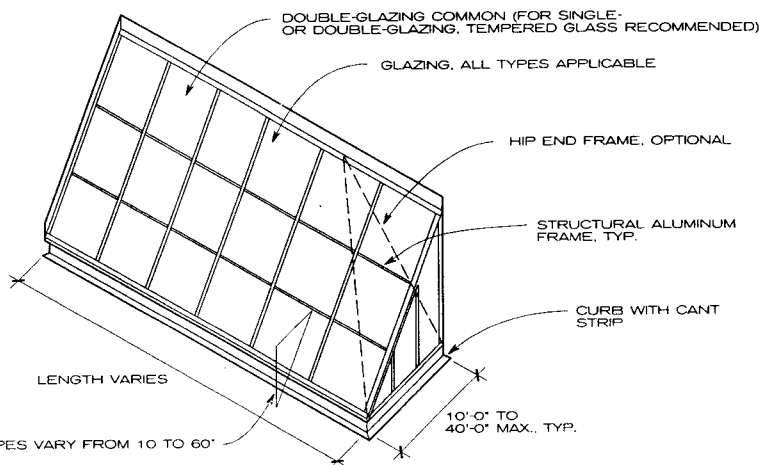

SLOPES VARY FROM 10 TO 60°

**NOTE**

Sloped aluminum frame may be segmented or curved.

**SINGLE-PITCH FRAMED SKYLIGHT ASSEMBLY**

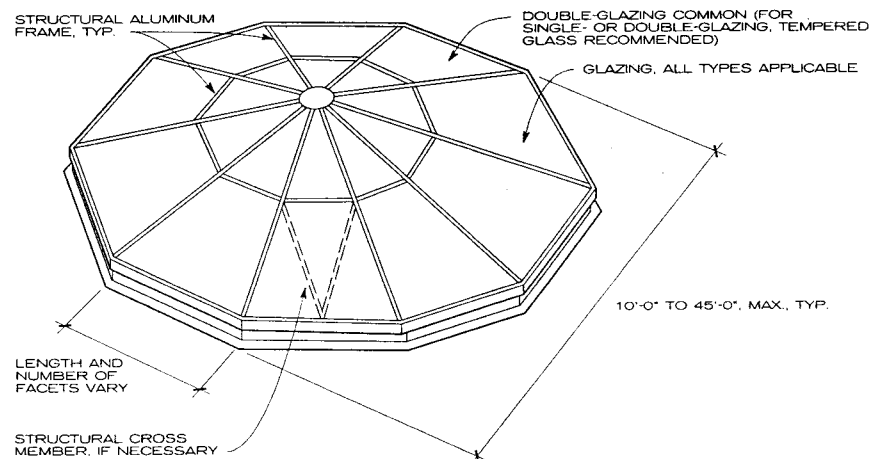

**POLYGONAL FRAMED SKYLIGHT ASSEMBLY**

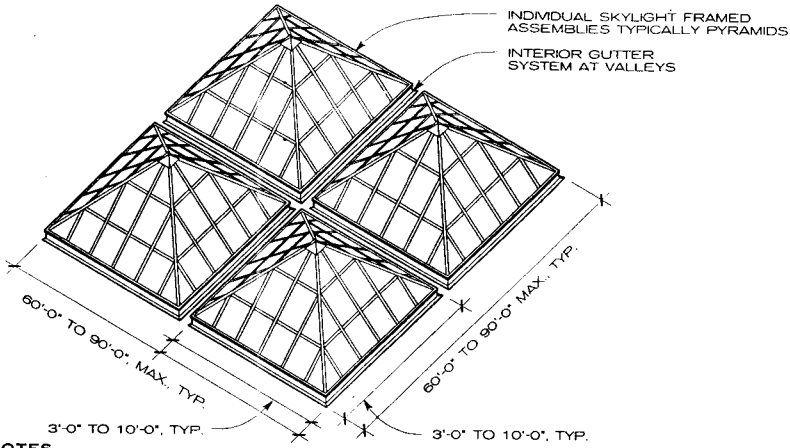

**NOTES**

1. Individual skylights for unit skylights may be pyramids or domes for flat roofs or flat panels for sloped roofs.
2. The number of multiples of individual skylights depends

only on the structural frame system below, although the larger the grid assembly, the more water runoff must be accommodated.

**MULTIPLE-GRID SKYLIGHTS—UNIT AND FRAMED ASSEMBLIES**

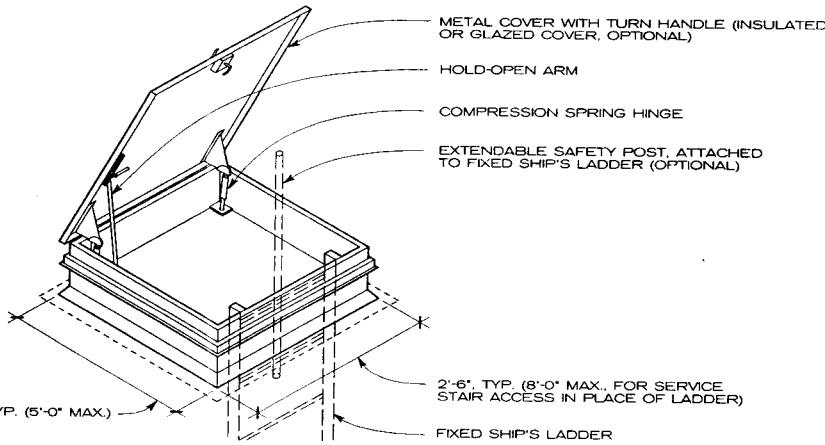

**NOTE**

Double leaf scuttles are typically specified for larger openings.

**ROOF SCUTTLE**

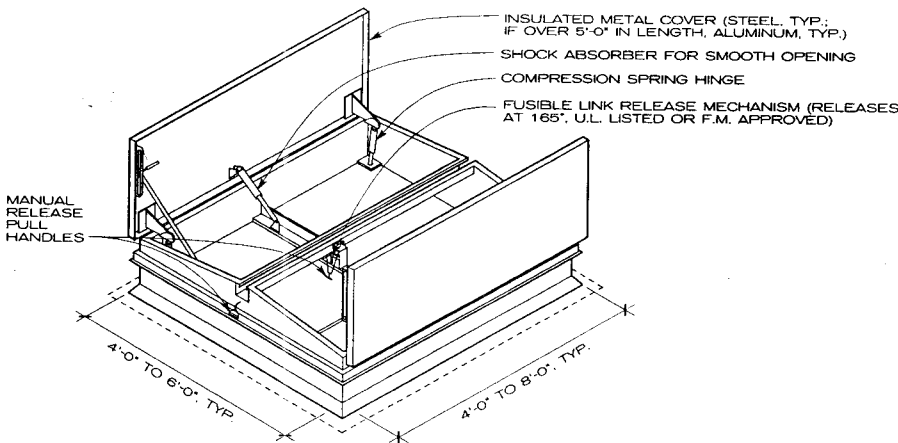

**NOTE**

Vents are manufactured both with and without labels. Consult codes for vent requirements. Fire and smoke vents can be adapted for use as explosion vent.

**FIRE AND SMOKE VENT**

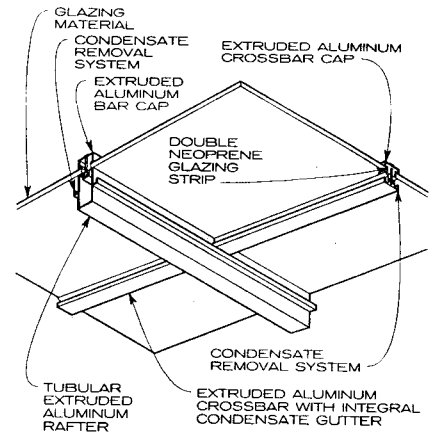

**TYPICAL TUBULAR ALUMINUM FRAME DETAIL**

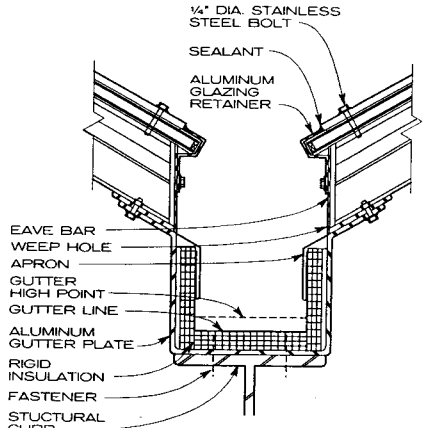

**NOTE**

Structural gutter system available for multiple and grid network systems of ridge- and pyramid-type enclosures.

**MULTIPLE GRID GUTTER SECTION DETAIL**

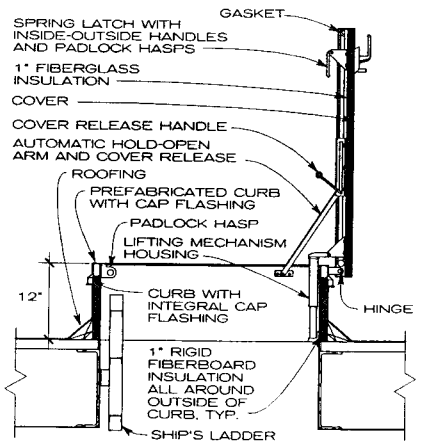

**NOTE**

Fire and smoke vent section is similar in construction, hardware, and integration with roof assembly. Consult manufacturer for all additional hardware.

**SCUTTLE SECTION DETAIL**

Richard J. Vitullo, AIA; Oak Leaf Studio; Crownsville, Maryland

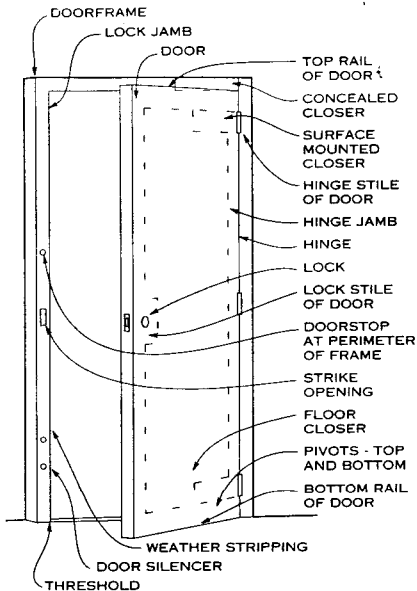

**PARTS OF A DOOR**

**GLOSSARY**

- Coordinator:** A device used on a pair of doors to ensure that the inactive leaf is permitted to close before the active leaf.
- Cylinder (of a lock):** The cylindrical shaped assembly containing the tumbler mechanism and the keyway, which can be actuated only by the correct keys.
- Cylinder lock:** A lock in which the locking mechanism is controlled by a cylinder.
- Deadbolt (of a lock):** A lock bolt having no spring action or bevel, and which is operated by a key or turnpiece.
- Door bolt:** A manually operated rod or bar attached to a door providing means of locking.
- Doorstop:** A device to stop the swing or movement of a door at a certain point.
- Electric strike:** An electrical device that permits releasing of the door from a remote control.
- Exit device:** A door locking device that grants instant exit when someone presses a crossbar to release the locking bolt or latch.
- Flush bolt:** A door bolt set flush with the face or edge of the door.
- Hand (of a lock, etc.):** A term used to indicate the direction of swing or movement, and locking security side of a door.
- Lock set:** A lock, complete with trim, such as handles, escutcheons, or knobs.
- Mortise:** A cavity made to receive a lock or other hardware; also the act of making such a cavity.
- Mortise lock (or latch):** A lock designed to be installed in a mortise rather than applied to the door's surface.
- Rabbet:** The abutting edges of a pair of doors or windows, shaped to provide a tight fit.
- Reversible lock:** A lock that, by reversing the latch bolt, may be used by any hand. On certain types of locks, other parts must also be changed.
- Rose:** A trim plate attached to the door under the handle; sometimes acts as a handle bearing.
- Shank (of a handle):** The projecting stem of handle into which the spindle is fastened.
- Spindle (of a handle):** The bar or tube connected with the knob or lever handle that passes through the hub of the lock or otherwise engages the mechanism to transmit the handle action to the bolt(s).
- Stop (of a lock):** The button, or other small device, that serves to lock the latch bolt against the outside handle or thumb piece or unlock it if locked. Another type holds the bolt retracted.
- Strike:** A metal plate or box that is pierced or recessed to receive the bolt or latch when projected; sometimes called "keeper."
- Three-point lock:** A device sometimes required on 3-hour fire doors to lock the active leaf of a pair of doors at three points.

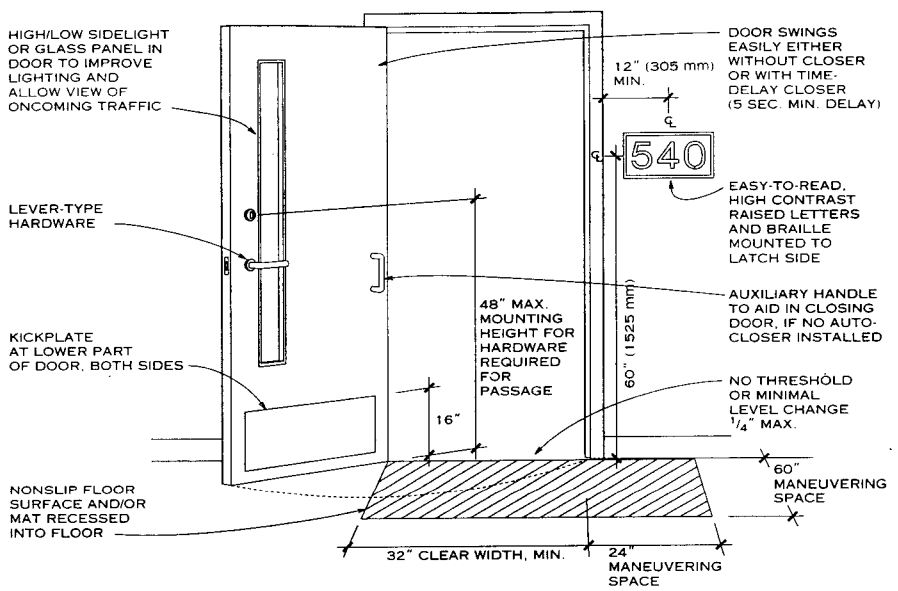

**IDEAL ACCESSIBLE DOOR**

**NOTES**

- See also Hollow Metal Frames and Doors.
- Face the outside of the door to determine its hand. The outside of the door is the "key side," or that side which would be secured should a lock be used. This would usually be the exterior of an entrance door or the corridor side of an office door.

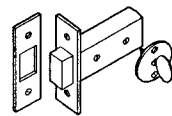
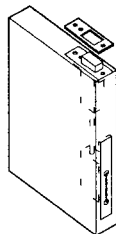

**NOTE**  
A miniature deadlock, with bolt projected or retracted by a turn of the small knob.

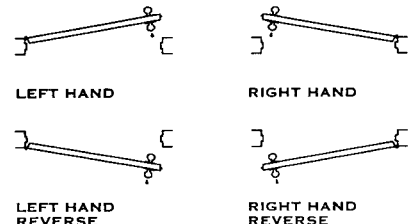

**NOTE**  
In the architectural hardware industry, the position of the hinges on a door — right or left as viewed from outside the entryway — determines the hand.

**BOLT MECHANISMS**

**DOOR FINISHES**

NEAREST U.S. EQUIVALENT	BHMA CODE	FINISH DESCRIPTION	BASE MATERIAL
USP	600	Primed for painting	Steel
US1B	601	Bright japanned	Steel
US2C	602	Cadmium plated	Steel
US2G	603	Zinc plated	Steel
US3	605	Bright brass, clear coated	Brass*
US4	606	Satin brass, clear coated	Brass*
US9	611	Bright bronze, clear coated	Bronze*
US10	612	Satin bronze, clear coated	Bronze*
US10B	613	Oxidized satin bronze, oil rubbed	Bronze*
US14	618	Bright nickel plated, clear coated	Brass, Bronze*
US15	619	Satin nickel plated, clear coated	Brass, Bronze*
US19	622	Flat black coated	Brass, Bronze*
US20A	624	Dark oxidized, statuary bronze, clear coated	Brass, Bronze*
US26	625	Bright chromium plated	Brass, Bronze*
US26D	626	Satin chromium plated	Brass, Bronze*
US27	627	Satin aluminum, clear coated	Aluminum
US28	628	Satin aluminum, clear anodized	Aluminum
US32	629	Bright stainless steel	Stainless steel 300 series
US32D	630	Satin stainless steel	Stainless steel 300 series
-	684	Black chrome, bright	Brass, Bronze*
-	685	Black chrome, satin	Brass, Bronze*

**NOTE**

\* Also applicable to other base metals under a different Builders' Hardware Manufacturers Association code number.

Richard J. Vitullo, AIA; Oak Leaf Studio; Crownsville, Maryland

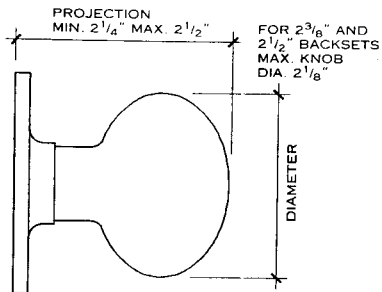

**DOORKNOB**

**NOTE**  
Doorknobs are not allowed on accessible doors.



PROJECTION  
MAX. 2 1/2"

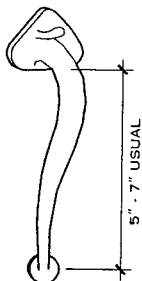

**ENTRANCE HANDLE**

**NOTE**

Complete lockset for entrance door handle includes mortise lock, handle outside, and knob and rose inside.

**PROJECTION**

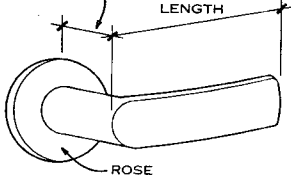

**LEVER HANDLE**

PROJECTION: 1 3/4 to 2 1/2 in.  
LENGTH: 2 to 4 in.  
ROSE: Maximum diameter 1 1/2 to 3 in.  
STILE: Larger stile takes larger rose

**NOTE**

Local codes may require a return or special clearance on lever handle (e.g., fire codes may require return to prevent fire hose from catching behind lever handle). Also, push-type mechanisms and U-shaped handles are acceptable designs. Consult ANSI and ADAAG and manufacturers' catalogs for other approved designs. Maximum height for accessible hardware is 48 in. above finished floor.

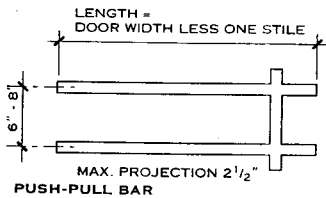

**PUSH-PULL BAR**

**NOTE**

Double push-pull bars may be used on the pull side of single-acting doors or on either side of double-acting doors.

**KNOB, HANDLES, PLATE, AND BAR**

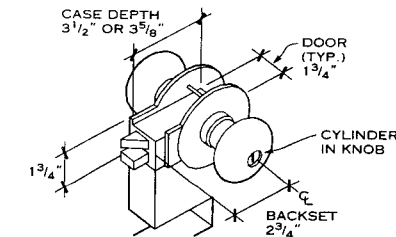
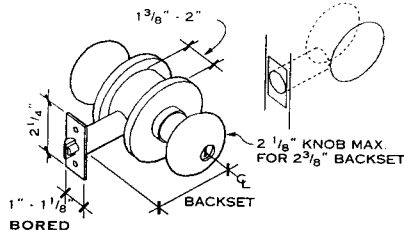

**PREASSEMBLED**

**NOTE**

Installation requires notch cut in lock side of door to suit case size. Complete factory assembly eliminates much adjustment on the job.

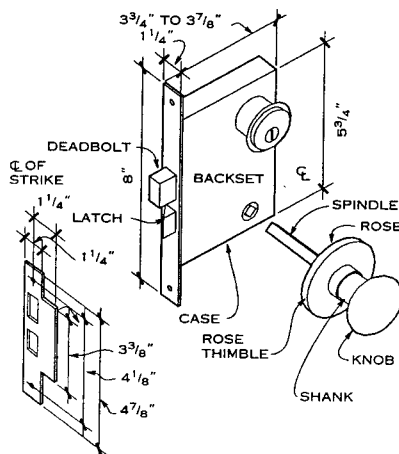

**MORTISE**

**NOTES**

1. Installation requires mortise opening in door.
2. See American Standards Association Lock Strikes A-115V-1959 for metal doorframes. To determine lip length, measure from centerline of strike to edge of jamb and add 1/4 in. Outside strike dimensions standard for all lock types shown.

**GENERAL NOTES**

Based on use characteristics, there are four main types of latches and locks: passage, privacy, entry, and classroom. (In all cases, latch bolt can be operated by handle from either side.)

1. **PASSAGE:** Latches can be operated by handle from either side at all times.
2. **PRIVACY:** Outside handle is locked by push-button inside (or if deadbolt latch, by a turn) and unlocked by emergency key outside.
3. **ENTRY:** Outside handle is made inoperative by mechanical means, other than a key, on inside; latch bolt is operated by key in outside handle or by manual means at inside handle.
4. **CLASSROOM:** Outside handle is locked from outside by key; when outside handle is locked, latch bolt may be retracted by key from outside or by rotating inside handle.

**LOCK TYPES**

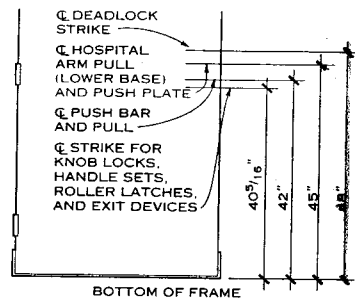

**DOOR HARDWARE LOCATIONS**

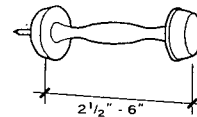

**STOPS**

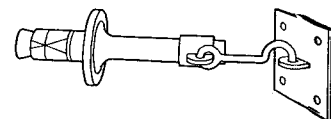
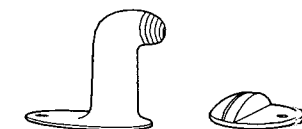
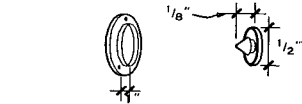

**COMBINATION**

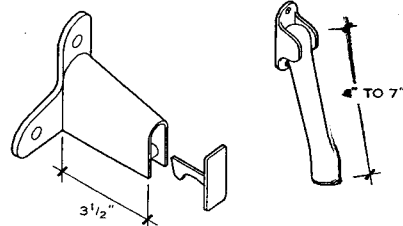
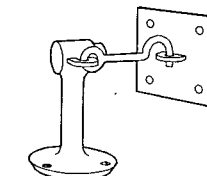

**HOLDERS**

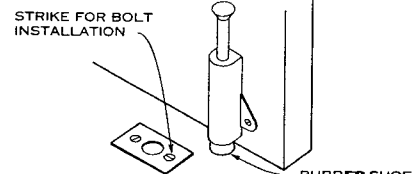

**PLUNGER-TYPE HOLDER OR BOLT**  
**STOPS AND HOLDERS**

Richard J. Vitullo, AIA; Oak Leaf Studio; Crownsville, Maryland



**HARDWARE**

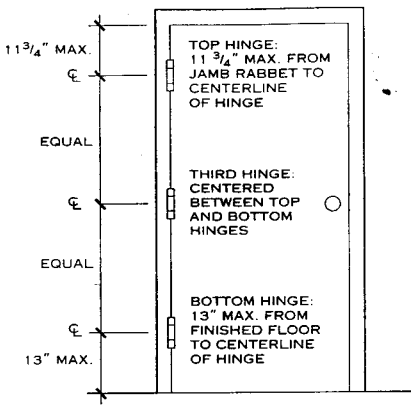

**NOTES**

1. Use three hinges for doors as high as 7 ft 6 in. Add one hinge for each additional 30 in. in height.
2. In specifying hinges, the following design criteria are important: door material, weight, and dimensions; hinge weight (standard or heavy), material, finish, and special features (e.g., swing clear, spring hinge, etc.); "clearance," that is, distance between door and frame when door is opened 180°; frequency of use; conditions of use (e.g., exterior, corrosive atmosphere, potential for abuse or vandalism, etc.); type of pin tips; and type of screws.

**HINGE LOCATION AND SPECIFICATION**

**HINGE WIDTH**

THICKNESS OF DOOR (IN.)	CLEARANCE REQUIRED* (IN.)	OPEN WIDTH OF HINGES (IN.)
1 3/8	1 1/4 1 3/4	3 1/2 4
1 3/4	1 1 1/2 2 3	4 4 1/2 5 6
2	1 1 1/2 2 1/2	4 1/2 5 6
2 1/4	1 2	5 6
2 1/2	3/4 1 3/4	5 6
3	3/4 2 3/4 4 3/4	6 8 10

**NOTE**

\* Clearance is computed for door flush with doorframe.

**HINGE TYPE**

TYPE OF BUILDING AND DOOR	DAILY FREQUENCY	HINGE TYPE
<b>HIGH FREQUENCY</b> Large department store entrance	5000	Heavy weight
Large office building entrance	4000	
School entrance	1250	
School toilet room	1250	
Store or bank entrance	500	
Office building toilet door	400	
<b>AVERAGE FREQUENCY</b> School corridor door	80	Standard weight anti-friction bearing (except on heavy doors)
Office building corridor door	75	
Store toilet door	60	
Dwelling entrance	40	
<b>LOW FREQUENCY</b> Dwelling toilet door	25	Plain bearing hinges may be used on light doors
Dwelling corridor door	10	
Dwelling closet door	6	

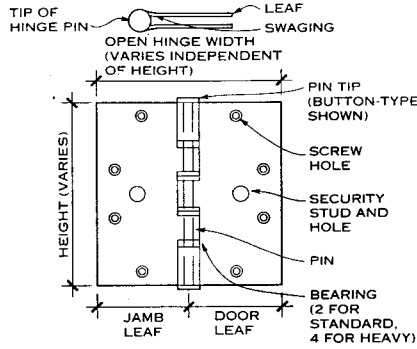

**NOTES**

1. Swaging is a slight offset of the hinge at the barrel, which permits the leaves to come closer together and improves the operation and appearance of the door.
2. A leaf is one of the two attaching plates that, when fastened together by the hinge pin, form a complete hinge.
3. Bearings (ball, oil-impregnated, or antifriction) offer the best ease of operation and durability.
4. Nonrising pins are a feature of quality hinges. Also available: nonremovable pins (NRP), with set screws; spun pins (FSP), without tips; and floating pins (FTP), with tips driven in both ends.
5. Tolerances: Close tolerances, especially in the pins, prevent excessive wear and are characteristic of high-quality, heavy-duty hinges.
6. A security stud, with matching hole in opposite leaf, is attached to a hinge to prevent door removal even if the pin is removed.
7. Hinges are available in brass, bronze, stainless steel, and carbon steel.

**ELEMENTS OF A HINGE**

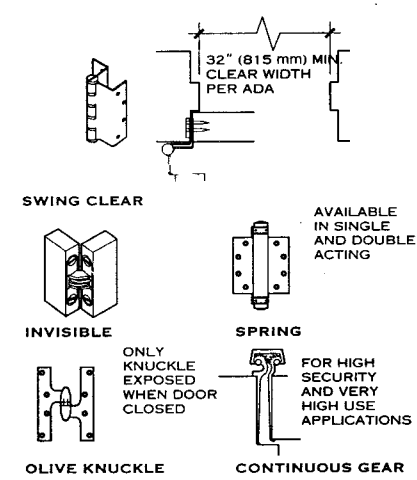

**SPECIALTY HINGES**

**HINGE HEIGHT**

THICKNESS (IN.)	WIDTH OF DOORS (IN.)	HEIGHT OF HINGES (IN.)
Doors 3/4 to 1 cabinet	Any	2 1/2
1 1/8 screen or combination	To 36	3
1 3/8	To 36 Over 36	3 1/2 4
1 3/4	To 41 Over 41	4 1/2 4 1/2 heavy
1 3/4 to 2 1/4	Any	5 heavy
<b>Transoms</b>		
1 1/4 and 1 3/8		3
1 3/4		3 1/2
2, 2 1/4, and 2 1/2		4

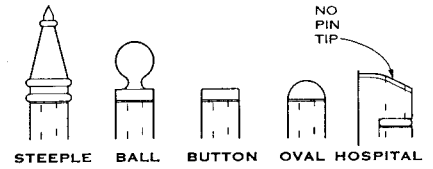

**TYPES OF HINGE PIN**

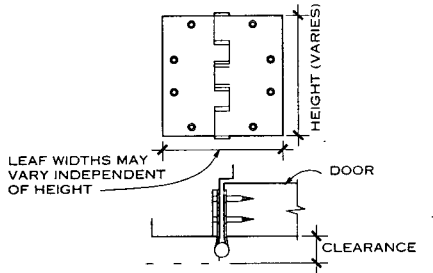

**FULL MORTISE**

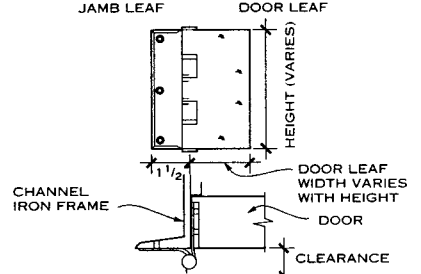

**HALF-MORTISE**

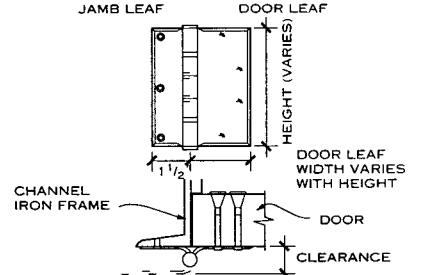

**FULL SURFACE**

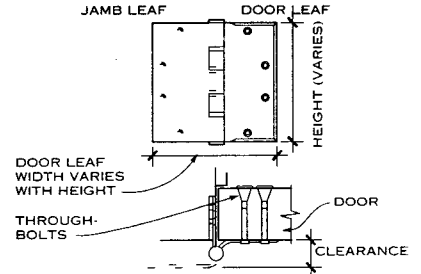

**HALF-SURFACE**

**TYPES OF HINGES**



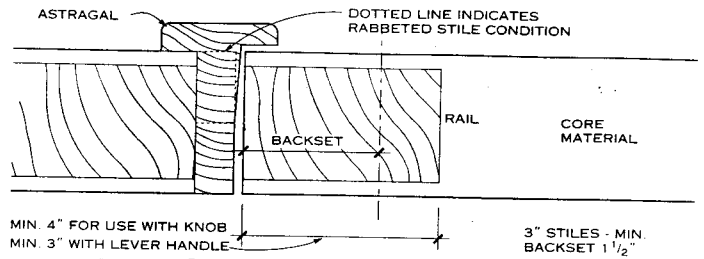
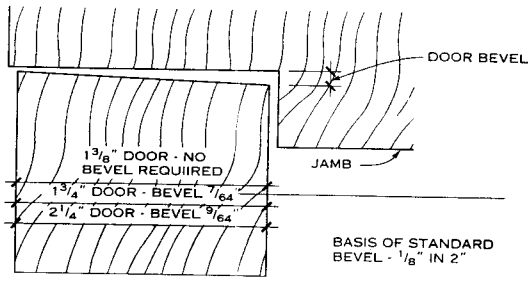

**DOOR BEVELS**

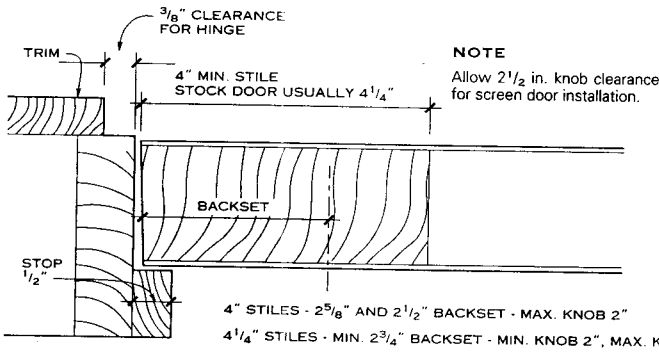

MIN. 4" FOR USE WITH KNOB  
MIN. 3" WITH LEVER HANDLE

4" STILES - 2 5/8" AND 2 1/2" BACKSET - MAX. KNOB DIA. 2"  
4 1/4" STILES (4 3/4" FOR RABBETED STILES) - 2 3/4" BACKSET, MAX. KNOB DIA. 2 1/2"

3" STILES - MIN. BACKSET 1 1/2"

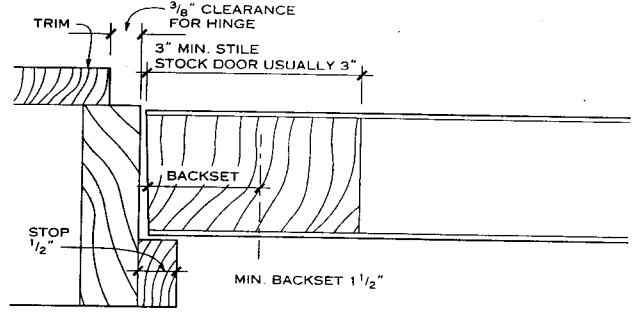

**DOOR WITH LEVER HANDLE OR KNOB USING CYLINDER LOCK**

**DOUBLE DOORS WITH FLAT ASTRAGAL (ALSO APPLIES TO DOOR WITH RABBETED MEETING STILES)**

**DOOR STILES**

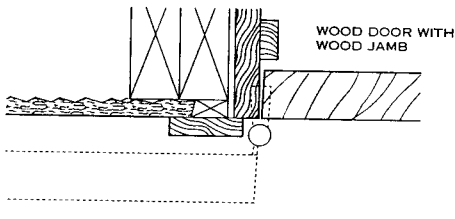

**FULL MORTISE NONTEMPLATE**

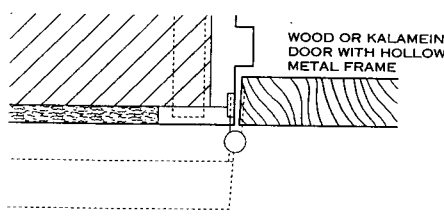

**FULL MORTISE TEMPLATE**

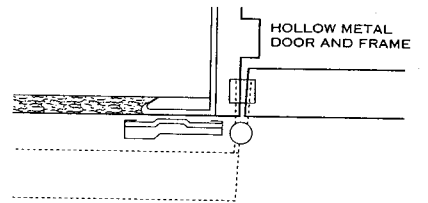

**FULL MORTISE TEMPLATE**

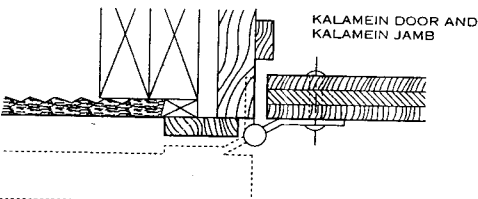

**HALF-SURFACE TEMPLATE**

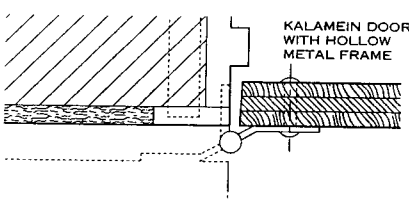

**HALF-SURFACE TEMPLATE**

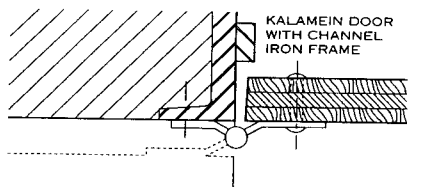

**FULL SURFACE TEMPLATE**

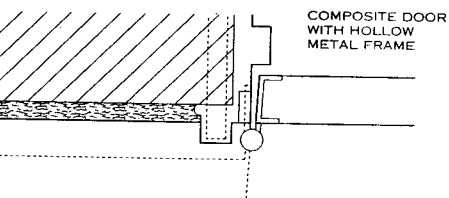

**FULL MORTISE TEMPLATE**

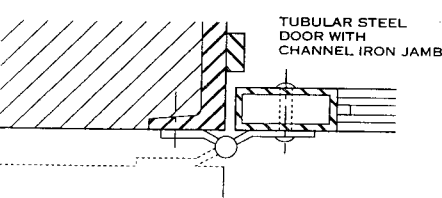

**FULL SURFACE TEMPLATE**

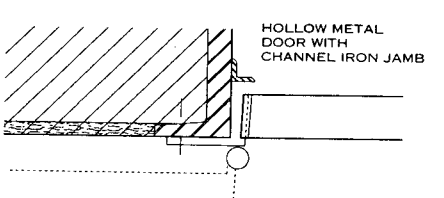

**HALF MORTISE TEMPLATE**

**MORTISE TEMPLATES**

Richard J. Vitullo, AIA; Oak Leaf Studio; Crownsville, Maryland

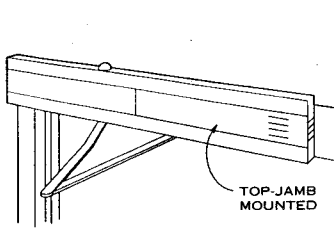

CLOSER, HOLDER, AND DETECTOR — STOP SIDE

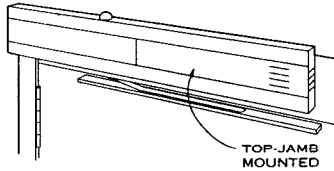

CLOSER, HOLDER, AND DETECTOR — HINGE SIDE

**NOTES**

1. A combination fire and smoke detector, door holder, and closer is available. Ionization, photoelectric, or heat-sensing devices detect smoke or any combustion products and hold open or close the door.
2. Smoke and fire doors are most commonly held open by electromagnetic or pneumatic devices and are released and closed manually or by means of smoke- or fire-detection devices. Most jurisdictions do not allow the old-fashioned fusible-link door closer in areas of human occupation, except for overhead doors. Consult local codes.
3. Some hold-open devices incorporate an electric switch that allows building maintenance staff to turn off the hold-open feature; however, such a switch should never shut off the detector.
4. A combination device (closer/holder/detector) most often is connected to the fire alarm system but may also be used merely to release and close the fire- or smoke-barrier doors without such a connection.
5. Smoke-sensing devices detect both visible and invisible airborne particles. Various operating principles include ionization, photoelectric, resistance, sampling, and cloud-chamber detection.
6. Ionization detection closers contain a small quantity of radioactive material within the sensing chamber. The resulting ionized air permits an electric current flow between electrodes. When smoke particles reduce the flow of ionized air between electrodes to a certain level, the detection circuit responds. Closing mechanisms usually consist of a detector, electromechanical holding device, and a door closer.
7. Ionization detectors sense ordinary products of combustion from sources such as kitchens, motors, power tools, and automobile exhausts.
8. Photoelectric-detection closers consist of a light source and a photoelectric cell. They activate when smoke becomes dense enough to change the reflectance of light reaching the photoelectric device. Photoelectric detectors may be spot or beam type. Closing mechanisms consist of a detector, electromechanical holding device, and a door closer.
9. Other types of smoke detectors include electrical bridging, sampling, and cloud chambers. Each has operating characteristics similar to ionization and photoelectric detectors.
10. Requirements for closers and detectors vary by code and governing jurisdiction. Refer to local building codes, the life-safety code of the National Fire Protection Association (NFPA), and other applicable regulations.

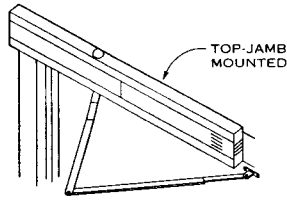

CLOSER AND HOLDER ONLY — STOP SIDE

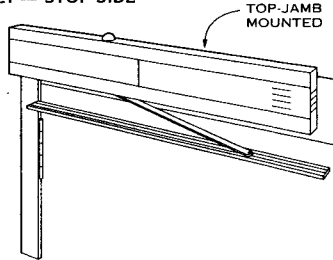

CLOSER AND HOLDER ONLY — HINGE SIDE

**NOTES**

1. A combination closer and holder (only) will hold door in open position when incorporated with an independent detector or when wired into any type of fire detecting system.
2. All these units have unlimited hold-open from 0° to approximately 170°, or limited hold-open from 85 to 170° for cross-corridor doors.

**COMBINATION CLOSER/HOLDER/ DETECTOR — SURFACE MOUNTED**

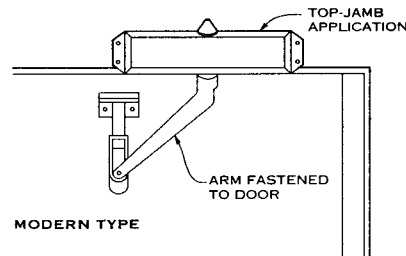

MODERN TYPE

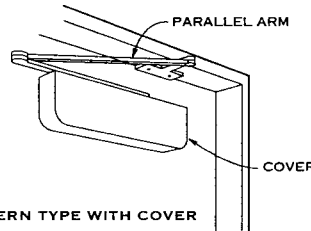

MODERN TYPE WITH COVER

**NOTES**

1. Door closers may be surface mounted or concealed in the door, frame, or floor. There are three ways to mount surface closers: hinge side, parallel arm, and top jamb. A wide variety of brackets, including corner and soffit types, is available to meet varying door and frame conditions.
2. Surface-mounted and concealed-in-door closers are used exclusively for single-acting doors; floor closers and frame-concealed closers may be used for either single- or double-acting doors.

**CLOSER ONLY — SURFACE MOUNTED**

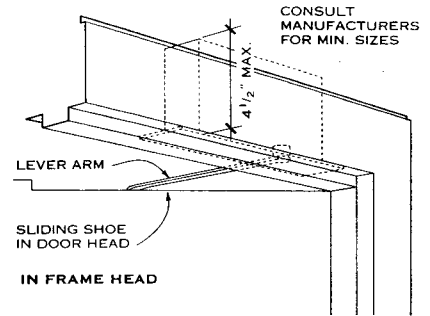

IN FRAME HEAD

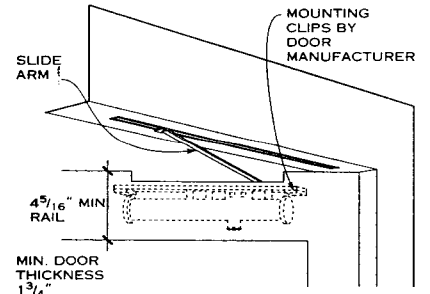

IN DOOR HEAD

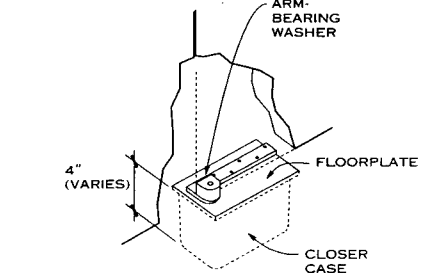

IN FLOOR

**CLOSER ONLY — CONCEALED**

**NOTES**

1. A door closer, when properly installed and adjusted, should control the door throughout the opening and closing swings. It combines three basic components: (a) a power source to close a door; (b) a checking source to control the rate at which the door closes; and (c) a connecting component (arm that transmits the closing force from the door to the frame).  
In all modern closers, the power source is a spring and the checking source is a hydraulic mechanism. The spring and checking mechanism is connected to a common shaft, and arms attached to this shaft act as linkage to communicate movement between the door and mechanism. In addition to serving as linkage, the arms, through leverage, can amplify the power of the spring, providing maximum power at the latch point.
2. Additional features for safety and convenience also are available in many types of closers. These include back check, delayed action, adjustable spring power, and a variety of hold-open functions: regular, fusible link, and hospital.
3. A full range of closer sizes is available to suit various door dimensions, locations, and job conditions. The manufacturer's recommendations should be considered carefully.
4. Closers with delayed-action features give a person more time to maneuver through doorways. They are particularly useful on frequently used interior doors such as entrances to toilet rooms. ADAAG requires a closing speed of at least 3 seconds; ANSI requires 5 seconds.

**COMBINATION CLOSER/HOLDER/ DETECTOR — SURFACE MOUNTED**

Richard J. Vitullo, AIA; Oak Leaf Studio; Crownsville, Maryland

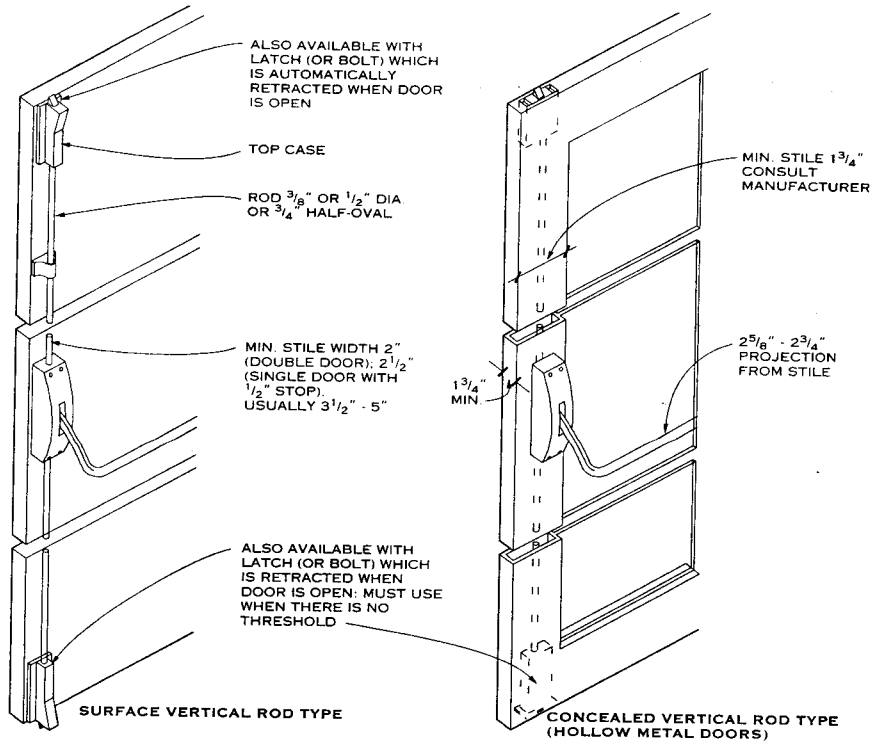
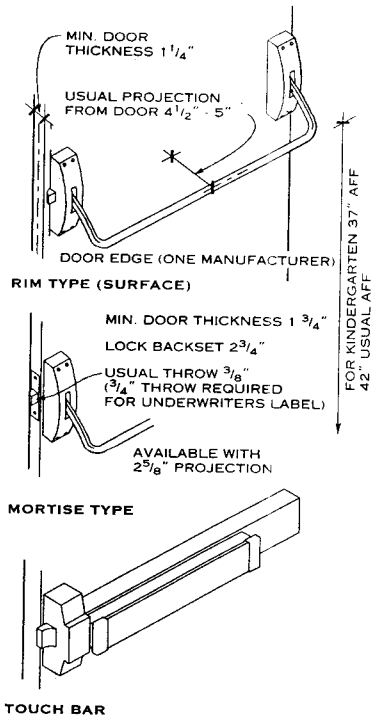

**EXIT DEVICES**

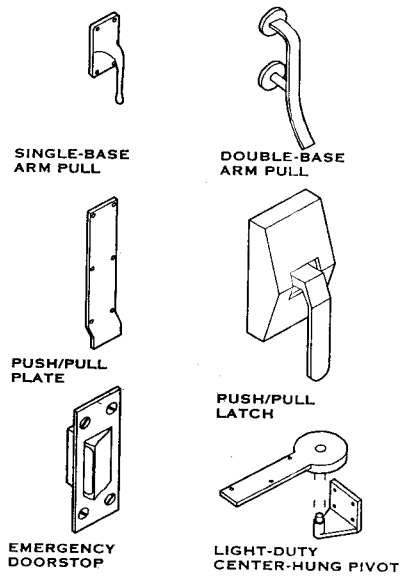

**NOTES**

1. To permit reverse opening of a door in an emergency, a foldable or collapsible stop, in conjunction with a center-hung pivot, is needed. Such devices typically are used on private or semiprivate toilet doors.
2. If a slowly opening, low-powered automatic door mechanism is used, it shall comply with ANSI 156.19-1984. Such doors shall not open to backcheck faster than 3 seconds and shall require no more than 15 lbf to stop door movement. If a power-assisted door is used, its door opening force shall comply with ANSI 4.13.11 and its closing force shall comply with ANSI A156.19-1984.

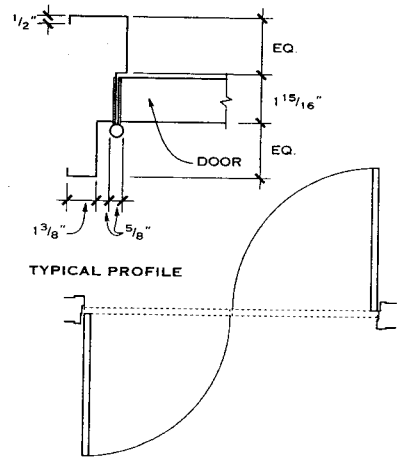
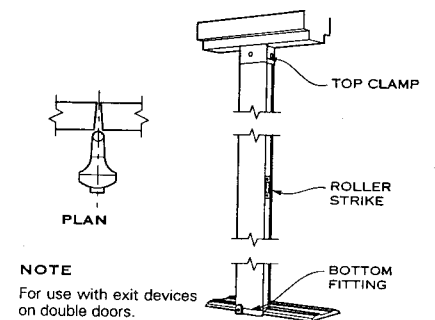
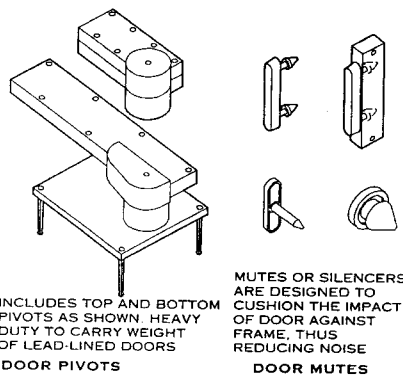
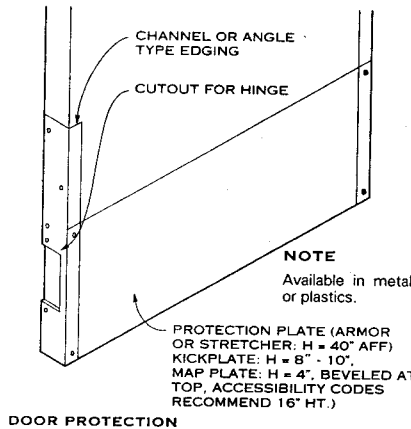

**HEALTH-RELATED INSTITUTIONAL HARDWARE**

Richard J. Vitullo, AIA; Oak Leaf Studio; Crownsville, Maryland

**DOUBLE-EGRESS DOORS**

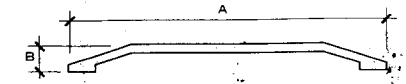

PLAIN, UNFLUTED (IN.)

BRASS		ALUMINUM		BRONZE	
A	B	A	B	A	B
3	1/4	4 5/64	3/32	4	1/2
2 1/4	3/16	2 1/4	3/16	4 5/64	1/2
4, 5, and 6	1/2	2 1/2, 3	1/4	5, 6	6
		2 1/4	3/16	4	7/16

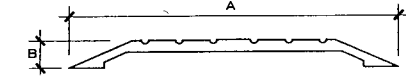

FLUTED (IN.)

BRASS		ALUM.		BRONZE		STEEL	
A	B	A	B	A	B	A	B
3, 3 1/2, 4, 5, and 6	1/2	3, 4, 5, 6, 6 1/2, 7, 7 1/2	1/2	3	5/16	3, 4	1/2
				4, 4 1/2, 5, 6, and 7	1/2	5 1/2	3/16

NOTE

Threshold profiles vary among manufacturers. Consult manufacturer's catalog for additional sizes. Standard length is 18 to 20 ft, or thresholds may be cut to size.

ONE-PIECE THRESHOLDS

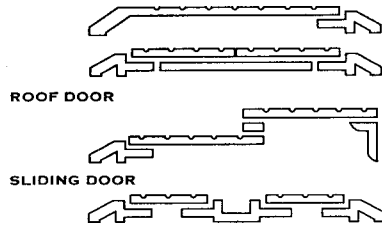

NOTE

By combining components, saddles may be made to any width; joints will not show as fluting pattern is identical.

TYPICAL ASSEMBLED THRESHOLDS

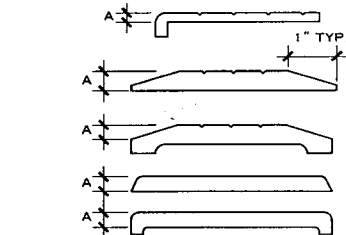

RECOMMENDED PRACTICE

A	IRON	BRONZE	ALUMINUM
1/4"		To 6" wide	To 10" wide
5/16"	To 6" wide	To 10" wide	To 18" wide
3/8"	To 12" wide	To 18" wide	To 24" wide
7/16"	To 24" wide	To 24" wide	To 36" wide
1/2"	To 30" wide	To 30" wide	To 42" wide

NOTE

Length to 9 ft 6 in. When width exceeds 32 in., length should not exceed 7 ft 6 in. Standard widths are 4, 5, and 6 in. Raised threshold shall be beveled with a slope no greater than 1:20.

CAST METAL ABRASIVE-SURFACE THRESHOLD

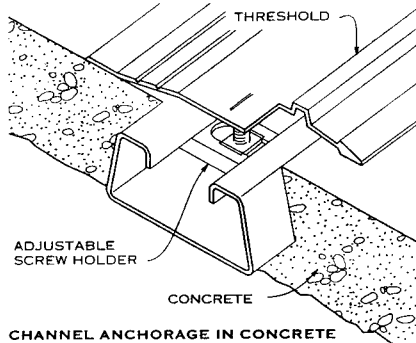

CHANNEL ANCHORAGE IN CONCRETE

NOTES

- For channel-type threshold anchors, exact location is required at time concrete floor is poured.
- For installation on wood floors, use wood screws; for masonry floors, use no less than a #10 machine screw and double-cinch anchors for best results. In descending order of holding power, the following may be satisfactory, depending on frequency of use: machine screws with lead anchors, wood screws with lead expansion shields, wood screws with plastic anchors.

THRESHOLD ANCHORAGE

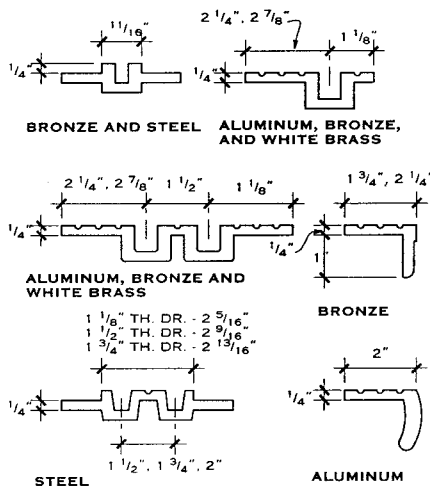

COMPONENTS FOR SLIDING DOOR

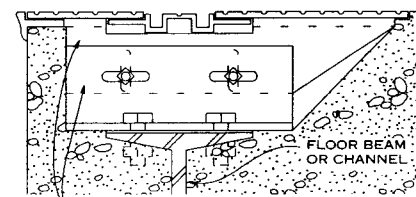

2 ANGLES, EACH WITH SLOTTED HOLES. FASTENED IN SHAPE OF A Z. FASTEN LEGS TO SADDLE AND FLOOR BEAM. LEVEL THE SADDLE. TIGHTEN BOLTS. AND FILL WITH CONCRETE

SILL DETAIL

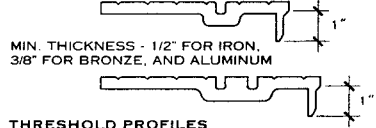

THRESHOLD PROFILES

ELEVATOR THRESHOLDS

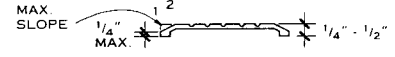

TYPICAL ACCESSIBLE THRESHOLD

RAMP TYPE (ONE PIECE)

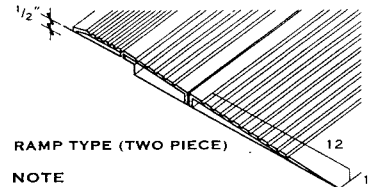

RAMP TYPE (TWO PIECE)

NOTE

Level changes at thresholds up to 1/4 in. (6 mm) may be vertical, without edge treatment. Level changes between 1/4 and 1/2 in. shall be beveled with a slope no greater than 1:2. Abrasive finish recommended for threshold surface. Consult manufacturer for other threshold profiles and textures. ADAAG limits new thresholds to 1/2 in. maximum height except at exterior sliding doors (3/4 in. maximum

ACCESSIBLE THRESHOLD

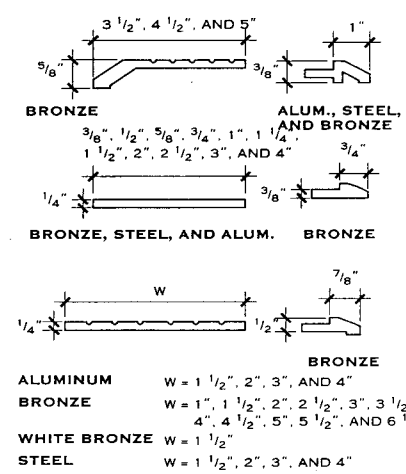

COMPONENTS FOR REGULAR OPENING

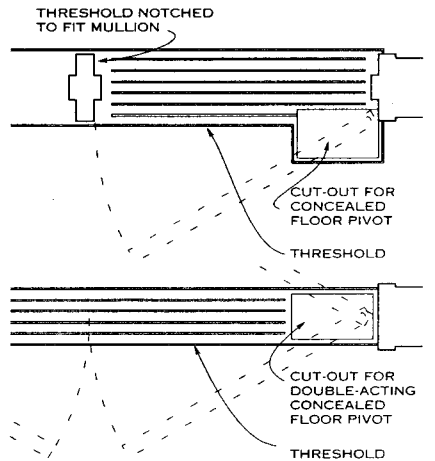

FLOOR HINGE CUTOUTS

Richard J. Vitullo, AIA; Oak Leaf Studio; Crownsville, Maryland

**GENERAL**

Installation of a suitable type and quality of noncorrosive weather stripping around exterior door and window openings can have a significant effect on energy savings in virtually any building. Weather stripping seals joints between a sash or door and its frame, blocking air infiltration. Weather stripping may also be used at interior openings to create smoke, light, or sound seals between spaces.

Materials used for weather stripping include felt, neoprene, pile/brush, kerf-in foam, sponge neoprene, silicone, butyl, and vinyl. Weather stripping should be continuous around the entire perimeter of a door or window, including a weather strip-type threshold at doors. High-quality closers used on exterior doors can ensure that no door is left open. In extreme climates, consider using double weather stripping, combining a neoprene gasket with pile-type sweeps.

Avoid creating conditions that interfere with the operation of other hardware. In particular, consider potential difficulties that may arise for handicapped users. Also, weather stripping must be coordinated with door and frame types. Benefits gained through the use of quality weather stripping can be virtually wasted if an uninsulated hollow metal door is used.

To meet accessibility standards, changes in level greater than 1/4 in. (13 mm) must be ramped at a 1:2 (rise:run) slope. Any vertical change in level (perpendicular to floor) shall not exceed 1/4 in. (6.5 mm) in height.

Since most windows are manufactured with frames, sash, and weather stripping preassembled as a unit, weather stripping details are not shown. However, if custom windows are specified, any appropriate door weather stripping material and configuration may be used.

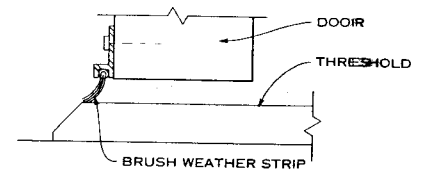

**NOTE**

Brush weather stripping is ideally suited for applications requiring low closing force. Nylon brush blocks smoke and air infiltration and can be used on overhead doors, sliding doors, and automatic doors.

**BRUSH WEATHER STRIPPING**

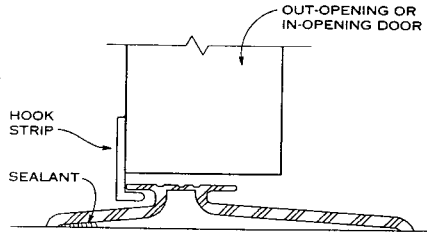
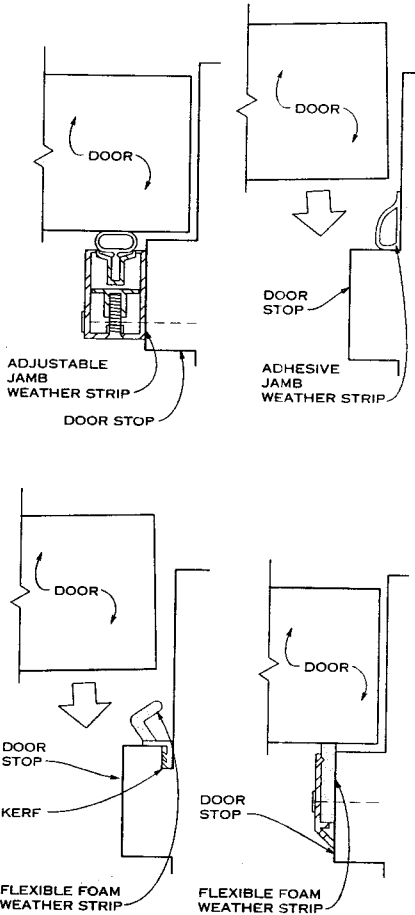

**INTERLOCKING**

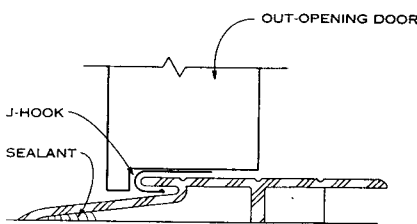

**INTERLOCKING AT LEVEL CHANGE**

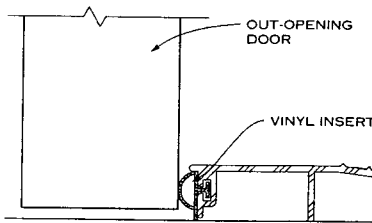

**VINYL INSERT**

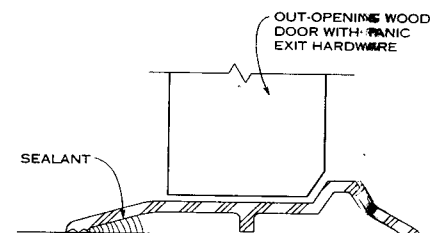

**LATCH TRACK**

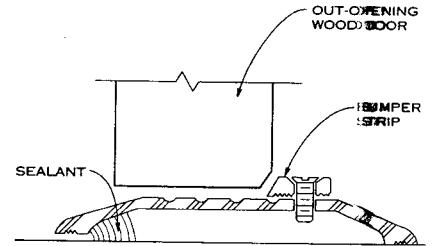

**FLAT SADDLE**

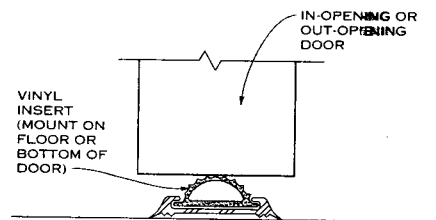

**VINYL INSERT**

**JAMBS**

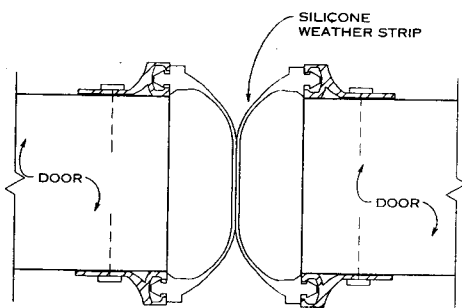

**THRESHOLDS**

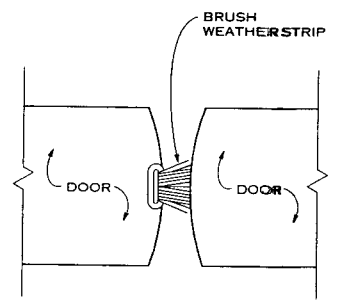
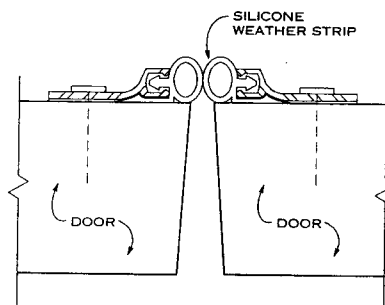

**ASTRAGALS**

Daniel F. C. Hayes, AIA; Washington, D.C.

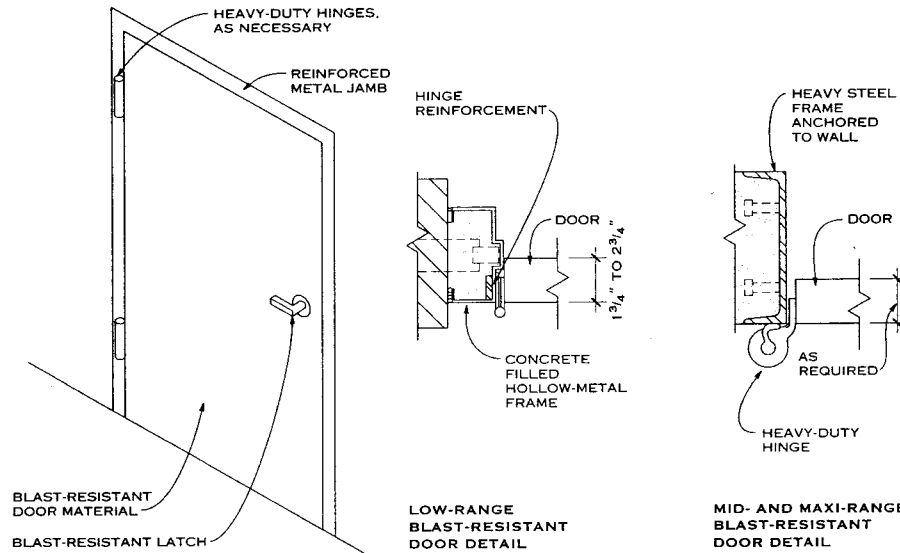
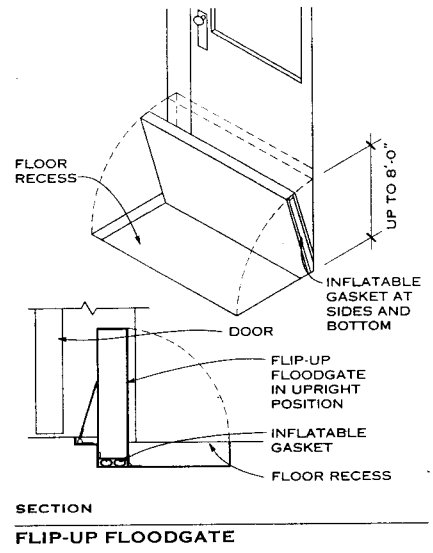
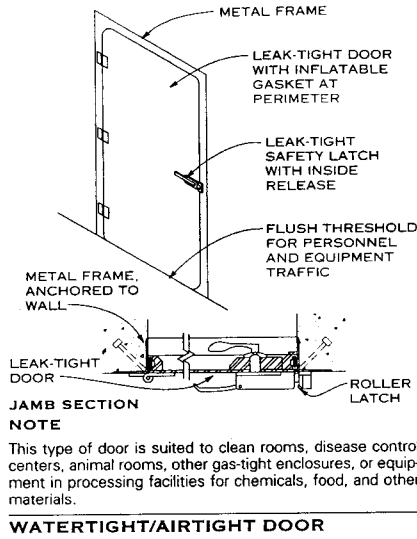
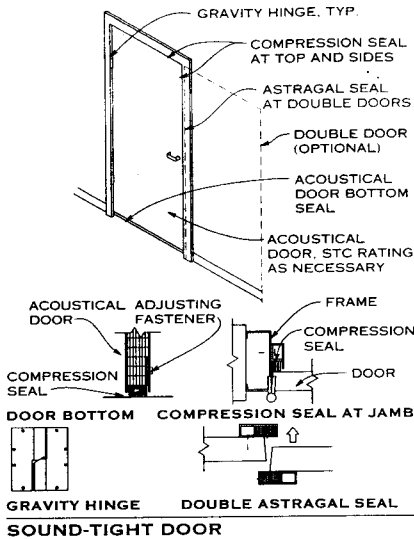

- NOTES**
- Blast-resistant doors can be designed to offer sound-retarding, watertight, airtight, and radiation-shielded features. Exit bar, key locking, and electronic security systems may be required with these types of doors. Blast-resistant doors are also available as manual or power-operated vertical lift or horizontal sliding doors.
  - When establishing blast door criteria, it is important to consider the following factors:
    - Opening size and whether swing, slide, or vertical lift
    - Direction of door opening in relation to direction of blast force
    - Type of potential blast or hazard, whether chemical, nuclear, steam, pressure (tornado, etc.), or other
    - Amount of potential blast force and angle of incidence or direction of potential blast, if known (assume zero degrees, which gives maximum protection)
    - Whether doors must be operable after blast and whether they will be subjected to repeated blasts (plastic and elastic design properties)
    - Rebound percentage as percentage of reflected pressure (suction phase of blast)
    - Equivalent static design pressure
    - Door operation type (power or manual) and type of hardware required
    - Wall construction, frame, threshold conditions desired
    - UL requirements and other hazards to be controlled, such as fire, smoke, gas fumes, missiles, or noise
    - Primary use, to protect life or equipment or both

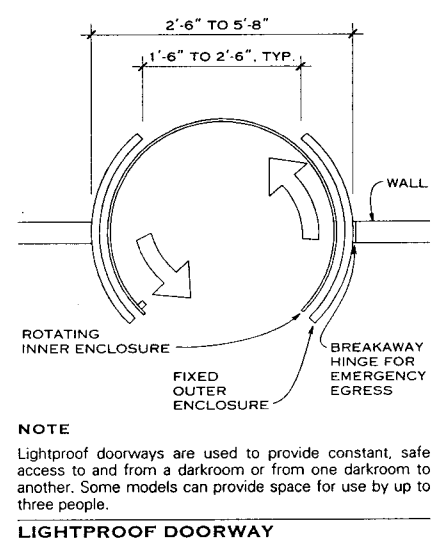
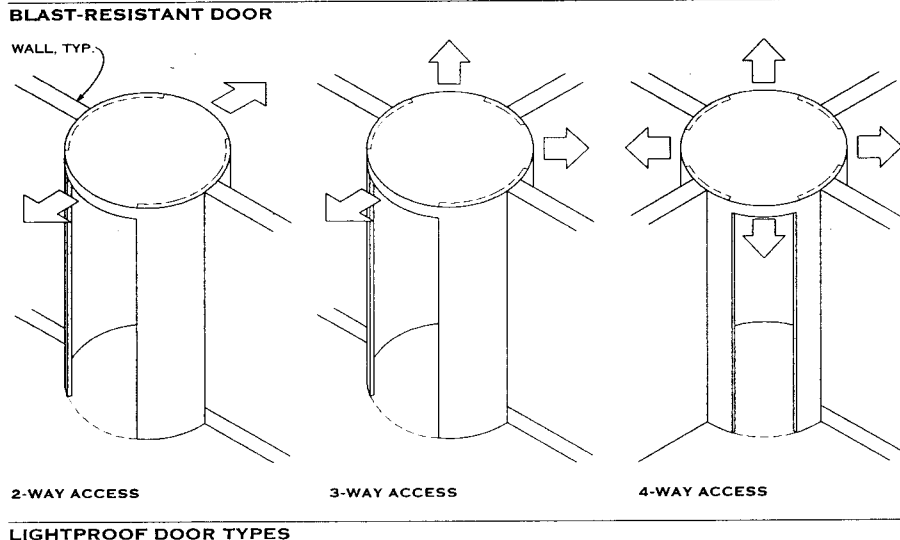

Daniel F. C. Hayes, AIA; Washington, D.C.

## DEFINITION OF GLASS

Glass is a hard, brittle amorphous substance made by melting silica (sometimes combined with oxides of boron or phosphorus) with certain basic oxides (notably sodium, potassium, calcium, magnesium, and lead) to produce annealed flat glass by a controlled cooling process. Most glasses soften at 932 to 2012°F (500 to 1100°C). The brittleness of glass is such that minute surface scratches in manufacturing greatly reduce its strength.

## INDUSTRY QUALITY STANDARDS

ASTM Standard C1036: Specification for Flat Glass.

ASTM Standard C1048: Specification for Heat-treated Flat Glass—Kind HS, Kind FT Coated and Uncoated Glass.

UL Standard 752: Bullet-resistant Material.

UL Standard 972: Burglary-resistant Glazing Material.

AAMA Standard No. 12: Structural Properties of Glass, Aluminum Curtain Wall Series.

ASTM Standard E1300: Practice for Determining the Minimum Thickness of Annealed Glass Required to Resist a Specified Load.

CPSC Standard 16CFR 1201: Standard on Architectural Glazing Materials.

ANSI Z97.1: establishes standards for testing safety glazing material.

ASTM C1172: Specification for Laminated Architectural Flat Glass.

### NOTE

Consult glass manufacturers for current information because processes, qualities, finishes, colors, sizes, thickness, and limitations are revised continually. The following information represents one or more manufacturers' guidelines.

## BASIC TYPES OF CLEAR GLASS

### SHEET GLASS

Sheet glass is manufactured by a horizontal flat or vertical draw process, then annealed slowly to produce a natural flat fired, high gloss surface. It generally is used in residential and industrial applications. Because it is not mechanically polished, inherent surface waves are noticeable in sizes larger than 4 sq ft. For minimum distortion, larger sizes are installed with the wave running horizontally. The width is listed first when specifying.

Sheet glass for architectural applications is either single strength (0.101 in. thick) or double strength (0.134 in. thick). Very little glass is produced in the United States by this process; almost all sheet glass is produced by the float process.

### FLOAT GLASS

Generally accepted as the successor to polished plate glass, float glass has become the quality standard of the glass industry. It is manufactured by floating molten glass on a surface of molten tin, then annealing it slowly to produce a transparent flat glass, thus eliminating grinding and polishing.

This process produces a glass with very uniform thickness and flatness, making it suitable for applications requiring excellent optical properties, such as architectural windows, mirrors, and specialty applications. It is available in thicknesses ranging from 1/8 to 3/4 in. Float glass is made to the specification requirements of ASTM C1036, and its minimum thickness to resist wind load is established using ASTM E1300.

### PLATE GLASS

Transparent flat glass is ground and polished after rolling to make plate glass. Cylindrical and conical shapes can be bent to a desired curvature (within limits). Only glass for specialty applications is produced by this method; it is not produced for widespread use in architectural applications.

## VARIATIONS OF BASIC GLASS TYPES

### PATTERNED GLASS

Patterned glass is known also as rolled or figured glass. It is made by passing molten glass through rollers that are etched to produce the design. Designs include flutes, ribs,

grids, and other regular and random patterns, which provide translucency and a degree of obscurity. Usually only one side of the glass is imprinted with a pattern. Patterned glass is available in thicknesses of 1/8, 3/16, and 1/2 in.

### WIRE GLASS

Wire glass is available as clear polished glass or in various patterns such as square welded mesh, diamond welded mesh, and linear parallel wires. Some distortion, wire discoloration, and misalignment are inherent. Some 1/4 in. wired glass products are recognized as certified safety glazing materials for use in hazardous locations (for example, fire-rated windows, doors, and skylights). For applicable fire and safety codes that govern their use, refer to ANSI Z97.1.

### CATHEDRAL GLASS

Cathedral glass is known also as art glass, stained glass, or opalescent glass. It is produced in many colors, textures, and patterns. Cathedral glass is usually 1/8 in. thick and is used primarily in decorating leaded glass windows. Specialty firms usually contract this type of glass.

### OBSCURE GLASS

Obscure glass is used to obscure a view or create a design. The entire surface on one or both sides of the glass can be sandblasted, acid etched, or both. When a glass surface is altered by any of these methods, the glass is weakened and may be difficult to clean.

## STRENGTHENED GLASS

Glass can be strengthened by either a controlled heating and cooling process or by immersion in a chemical bath. Both processes have glass thickness, size, and use restrictions that should be verified.

### HEAT-TREATED GLASS

Heat-strengthened (Kind HS) and tempered (Kind FT) glass are produced by reheating annealed float glass close to its softening point and then rapidly quenching (cooling) it with high velocity blasts of air. Both types have greatly increased mechanical strength and resistance to thermal stresses. Before it is heat-treated, the glass must be fabricated to its exact size and shape (including any holes), because neither type of glass can be altered after heat treatment.

Most manufacturers heat-treat the glass using a horizontal process that can introduce warpage, kinks, and bowing into the finished product, which may create aesthetic or technical concerns. A vertical process may still be available that produces long marks or depressions into the glass surface near the suspended edge. The heat treatment quenching pattern on the surface of the glass can become visible as a pattern of light and dark areas at certain oblique viewing angles and with polarized light. This effect can be more pronounced with thicker glass and may be an aesthetic consideration. Refer to ASTM C1048 for allowable tolerances and other properties.

Heat-strengthened glass is generally two to three times stronger than annealed glass. It cannot be cut, drilled, or altered after fabrication. Unlike tempered glass, it breaks into large, sharp shards similar to broken annealed glass. Heat-strengthened glass is not acceptable for safety glazing applications.

### TEMPERED GLASS

Tempered glass is generally four to five times stronger than annealed glass. It breaks into innumerable small, cube-shaped fragments. It cannot be cut, drilled, or altered after fabrication; the precise size required and any special features (such as notches, holes, edge treatments, etc.) must be specified when ordering.

Tempered glass can be used as a safety glazing material provided it complies with the ANSI and CPSC references listed on the following "Glass Products" page under the "Laminated Glass" heading. Tempered glass can be used in insulating and laminated assemblies and in wired, patterned, and coated processes. All float and sheet glass 1/8 in. or thicker may be tempered.

### CHEMICALLY TREATED GLASS

Chemically treated glass is produced by submerging annealed float glass in a bath of molten potassium salts. The larger potassium ions in the bath exchange places with the smaller sodium ions in the glass surface, creating a surface compression layer that strengthens the glass. Chemically treated glass breaks into large, sharp shards similar to broken annealed glass. It does not have the visual distortion that can be caused by a heat-treated strengthening process. At present, chemical strengthening is primarily limited to the glass lights of laminated security glass.

## HEAT-ABSORBING OR TINTED GLASS

This type of float glass was developed to help control solar heat and glare in large areas of glass. It is available in blue, bronze, gray, or green and in thicknesses ranging from 1/8 to 1/2 in. The glass absorbs a portion of the sun's energy because of its admixture contents and thickness (see graphic); it then dissipates the heat to both the exterior and interior. The exterior glass surface rejects some heat, depending on the sun's position. Heat-absorbing glass has a higher temperature when exposed to the sun than does clear glass; thus the central area expands more than the cooler shaded edges, causing edge tensile stress buildup. When designing heat-absorbing or tinted glass windows, consider the following:

1. To minimize shading problems and tensile stress buildup at the edges, provide conditions in which glass edges warm as rapidly as the exposed glass (for example, framing systems with low heat capacity and minimal glass grip or stops). Structural rubber gaskets can be used.
2. The thicker the glass, the greater the solar energy absorption.
3. Indoor shading devices such as blinds and draperies reflect energy back through the glass, thus increasing the temperature of the glass. Spaces between indoor shading devices and the glass, including ceiling pockets, should be vented adequately. Heating elements always should be located on the interior side of shading devices, directing warm air away from the glass.
4. The glass can be heat-treated to increase its strength and resistance to edge tensile stress buildup.

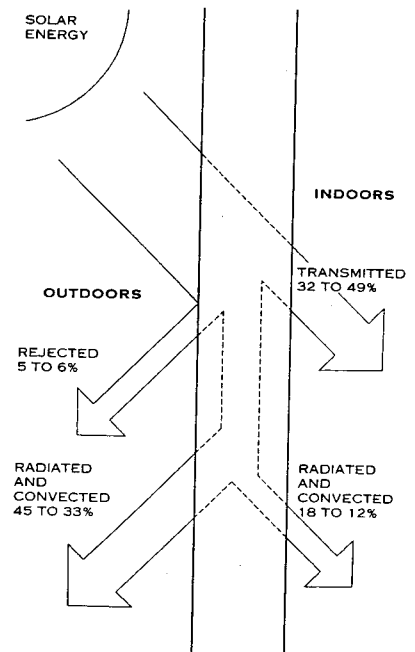

SOLAR PERFORMANCE OF HEAT-ABSORBING OR TINTED GLASS

## SPANDREL GLASS

Spandrel glass is available tinted or with reflective, ceramic frit (patterned and solid colors), direct-to-glass polyvinylidene fluoride (Kynar 500 resin) coatings. It can be heat-treated or laminated and is available as insulating glass units. Insulation and vapor retarders can be added to spandrel glass; consult with spandrel glass manufacturers for guidelines.

## SOUND CONTROL GLASS

Laminated, insulating, laminated insulating, and double laminated insulating glass products commonly are used for sound control. STC ratings from 31 to 51 are available depending on glass thicknesses, air space size, polyvinyl butyral film thickness, and the number of laminated units used in insulating products.

Thomas F. O'Connor, AIA, FASTM; Smith, Hinchman & Grylls; Detroit, Michigan



GLAZING

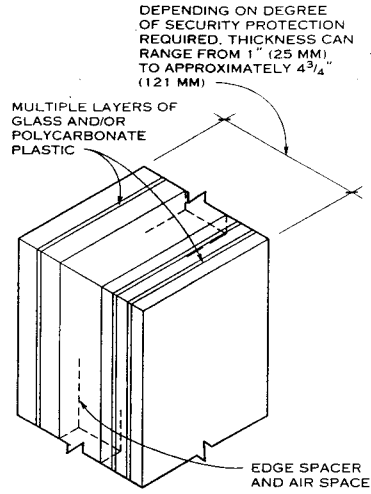

**TYPICAL INSULATING OR SPACED CONSTRUCTION SECURITY GLASS PROFILE**

DEPENDENT ON DEGREE OF SECURITY PROTECTION REQUIRED, THICKNESS CAN RANGE FROM 3/8" (10 MM) TO APPROXIMATELY 2 1/2" (64 MM)

BONDING LAYER, POLYVINYL BUTYRAL (PVB) FOR GLASS LAYERS AND POLYURETHANE FOR POLYCARBONATE PLASTIC LAYERS

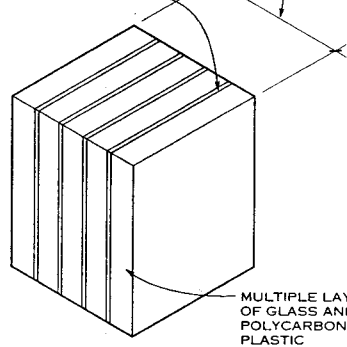

**TYPICAL MULTILAYER SECURITY GLASS PROFILE**

**SECURITY GLASS**

Security glass is composed of multiple layers of glass and/or polycarbonate plastic laminated together (under heat and pressure) with a polyvinyl butyral (for glass) or polyurethane plastic (for polycarbonate) film. It is available in multilayer laminated glass, insulating, laminated insulating, and double laminated insulating or spaced configurations, generally in thicknesses from 3/8 in. (10 mm) to 2 1/2 in. (64 mm) as a laminated product and up to about 4 3/4 in. (121 mm) for insulating and spaced construction products. Bullet-resistant glass should be tested to UL 752 and burglar-resistant to UL 972. Consult manufacturers for blast-resistant glass. Security glass products, depending on type, are subject to size limitations, and some are not recommended for exterior applications; consult with the manufacturer for glazing requirements and restrictions on use.

**COATED GLASS**

A reflective or low emissivity coating can be applied to the surface of monolithic glass. Generally, only pyrolytically applied "hard" coatings, which have scratch resistance, are used on exposed glass surfaces. During glass manufacture, pyrolytic coatings are sprayed onto the glass before it cools, which integrates them with the glass surface. Magnetically sputtered or "soft" coatings can also be applied to the glass surface but must be protected from the elements as part of an insulating or laminated glass product. The range of coating types, aesthetic appearances, and thermal performance available for pyrolytic coatings is generally less than that available for sputtered coatings.

**ULTRACLEAR GLASS**

The high clarity and high visible light transmittance that characterize ultraclear glass comes from the special soda lime mixture it is made from, which minimizes the iron content that normally gives a slight greenish color to clear flat glass. Ultraclear glass is generally available in thicknesses from 1/8 in. to 3/4 in. (3 mm to 19 mm). It can be heat strengthened, tempered, sand blasted, etched, or assembled into laminated glass. Ultraclear glass is used for commercial display cases, museum cases, display windows, frit-coated spandrel glass, aquariums, mirrors, shelving, security glass, and other uses in which clarity and better color transmittance are required.

**LAMINATED GLASS**

A tough, clear plastic polyvinyl butyral (PVB) sheet (interlayered), ranging in thickness from 0.015 to 0.090 in. (0.381 to 2.3 mm), is sandwiched, under heat and pressure, between lights of sheet, plate, float, wired, heat-absorbing, tinted, reflective, low emissivity, or heat-treated glass or combinations of each. When laminated glass breaks, the particles tend to adhere to the plastic film. Laminated glass is manufactured to the specification requirements of ASTM C1172. Laminated safety glass should be manufactured to comply with ANSI Z97.1 and CPSC 16CFR 1201.

DEPENDENT ON PVB AND GLASS LIGHT THICKNESS, LAMINATED GLASS CAN VARY FROM 1/4" (6 MM) TO 3/4" (19 MM) IN THICKNESS

POLYVINYL BUTYRAL (PVB) THICKNESS RANGES FROM 0.03" (0.8 MM) TO 0.09" (2.3 MM)

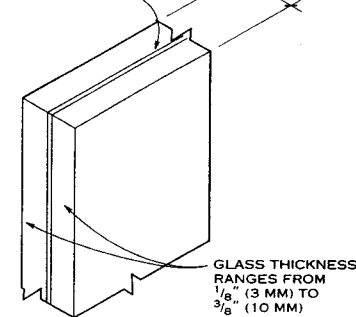

**LAMINATED GLASS PROFILE**

**BENT GLASS**

Clear, tinted, ceramic frit-coated spandrel, pyrolytically coated, patterned, laminated, and wire glass are among glass types that can be bent in thicknesses to about 1 in. (25 mm) and to a minimum radius of about 4 in. (102 mm). Sharp angle bends to 90°, edgework, pattern cutting, and tempering (meeting safety glazing standards) and heat-strengthening are also available. Bent glass can be fabricated into insulating glass units. Bent glass tolerances must be compatible with the glazing system. Size, configuration, and product availability vary by fabricator.

**PHOTOVOLTAIC GLASS**

There are two types of photovoltaic (PV) glass: crystalline silicon sandwiched between two lights of glass and thin-film amorphous silicon applied to an interior facing glass surface. When these arrangements are exposed to sunlight, they generate either DC or AC power, which is transferred by concealed wiring to the building's power system.

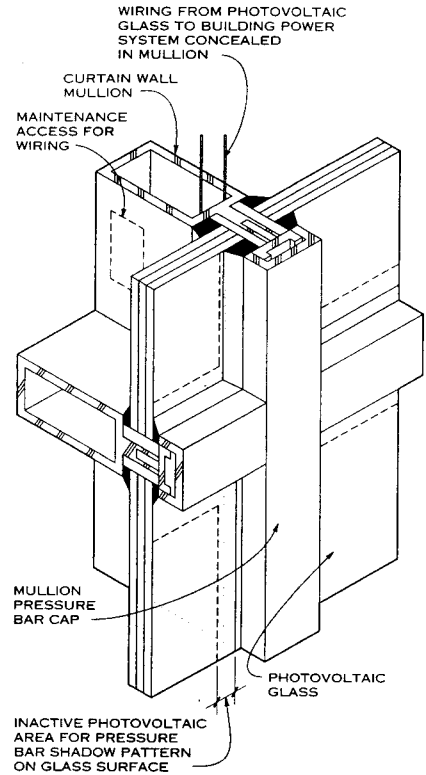

**PHOTOVOLTAIC GLASS (IN A PRESSURE BAR FRAMING SYSTEM)**

Pressure bar or structural silicone flush glazed curtain walls and skylights, awnings, sunshades, light shelves, and roof panels are some of the systems that can incorporate PV glass. For curtain walls and skylights, the pressure bar type allows easy concealment of the wiring. Shadow patterns from the cap on the PV glass surface must be considered in system design. Flush glazed systems have no shadow patterns, but wiring concealment is more difficult and the PV module on the glass must be kept from reacting with the structural silicone sealant. Both types of PV glass are used for opaque curtain wall spandrel panels and can be used for curtain wall or skylight vision glass if the quality of daylighting and visibility is acceptable. Consult PV glass and metal framing system manufacturers to determine availability, suitability, and cost for a particular application.

**DECORATIVE SILK-SCREENED (OR FRIT) GLASS**

Annealed clear or tinted glass is washed and ceramic frit paint (in standard or custom color) silk-screened on its surface in a standard or custom pattern or design (such as dots, holes, lines, or a logo) and then dried in an oven. The frit-coated glass is then subjected to very high temperatures in a tempering furnace to fire the ceramic frit permanently to the glass surface. As a result, silk-screened glass will be either heat strengthened or tempered after firing. Reflective and low emissivity coatings can also be applied to the glass surface. Silk-screened glass can be used monolithically or for insulating or laminated glass products.

**AVERAGE PERFORMANCE VALUES OF 1/4 IN. (6 MM) UNCOATED GLASS**

GLASS TYPE	% TRANSMITTANCE			% REFLECTANCE AVERAGE DAYLIGHT	SHADING COEFFICIENT
	AVERAGE DAYLIGHT	TOTAL SOLAR	ULTRAVIOLET		
Ultraclear	91	89	85	8	1.04
Clear	89-88	78-76	71-62	9-8	0.95-0.94
Clear laminated	86-84	67-64	<1	8-7	0.86-0.83
Green	77-75	42-47	42-30	8-7	0.70-0.67
Blue-green	75-71	49-35	32-28	7	0.72-0.60
Blue	55	47	41	6	0.70
Bronze	55-51	51-48	23-31	6	0.74-0.71
Gray	46-43	49-42	25-32	5-6	0.72-0.66

Thomas F. O'Connor, AIA, FASTM; Smith, Hinchman & Grylls; Detroit, Michigan





**LEADED STAINED GLASS**

Decorative stained glass is characterized by pieces of glass joined together with cames (H-shaped strips) of various widths. Varying the widths adds to the window's decorative effect. Joints are soldered on both sides of the panel. To prevent leakage, a mastic waterproofing material is inserted between the glass and came flange.

Another method of joining the pieces of glass is banding the edges of the glass with a copper foil tape burnished to the glass and then soldered with a continuous bead of solder on both sides.

Bracing bars are fastened to the sash at frequent intervals to strengthen and support the leaded glass. Round bars tied to the leaded glass with twisted copper wires are the most flexible and resilient, allowing for great amounts of thermal movement. Where this system is not suitable, galvanized steel flat bars can be soldered to the surface of the leaded glass.

When the glass requires detail painting, shading, or texturing, it must be done with special mineral pigments and fired at temperatures of 1000 to 1200°F or higher to ensure absolute permanency.

**INSTALLATION**

It is recommended that decorative glass be installed into specially designed metal frames provided with glazing beads and sealed with a modern flexible glazing material. However, with proper maintenance, high-quality wood frames with suitable division bars are acceptable.

A stained glass studio should be consulted for the location of division bars, mullions, and muntins to best complement the artistic design. Decorative glass weighs approximately 4 lb/sq ft.

**OUTSIDE PROTECTION GLASS**

Properly made decorative glass does not necessarily need additional glazing to make it waterproof, but it is valuable for insulating purposes and to afford some protection from external damage. Frames should be designed with a 3/4 in. ventilated space between glass and should be arranged for the protection glass to be installed from the exterior and the decorative glass from the interior. Clear glass or textured glass 3/16 to 1/4 in. thick is most successful.

Depending on geographic location and economics, insulating glass should be considered as the protective outside glazing.

Acrylic and polycarbonate are two types of plastic protection material that can be employed when protection from vandalism is needed. Outside protection glass should be installed by the stained glass studio whenever possible to ensure an integrated system.

**GLAZING SEALANTS**

Exterior decorative glass must be pressed into a deep back bed of mastic compound or glazing tape. When outside protection glass is used, a watertight seal is not required, and foam tape compressed between the glazing bead and glass may suffice.

**SIZE LIMITATIONS**

Decorative glass panels should not exceed 12 sq ft, making it necessary to divide larger openings with metal division bars: tee bars for single glazed windows, and special channel bars for windows with outside protection glass.

**GLASS COLORS**

Machine-made and blown glass from the United States, England, France, and Germany are available in most solid colors; also mixed colors and textures. Uniformity of color will vary from glass of different batches. Special colors are derived by "sumping," or kiln firing.

**WORKERS' PROTECTION**

Work in decorative glass studios involves handling and storage of many toxic substances and waste such as lead, fluxes, patinas, cleaners, and solvents. The Occupational Safety and Health Administration has established guidelines for use by studios, including blood testing, cleaning, air purification, respirators, work clothing, and toxic waste handling.

Randall S. Lindstrom, AIA; Ware Associates, Inc.; Chicago, Illinois  
Joseph A. Wilkes, FAIA; Annapolis, Maryland  
Bobbie Burnett Studio; Annapolis, Maryland

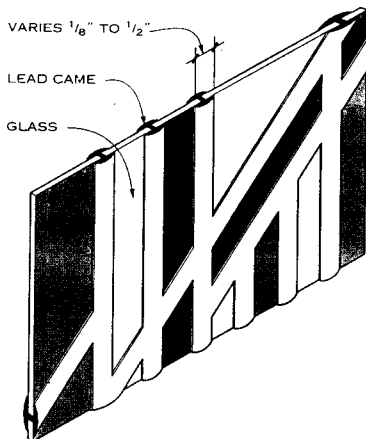

**DECORATIVE GLASS PANELS**

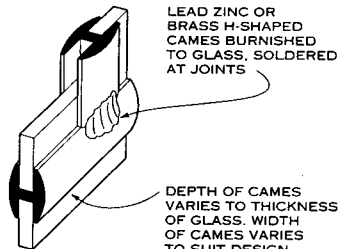

**H-SHAPED CAME METHOD**

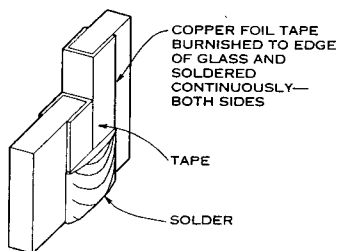

**COPPER FOIL METHOD**

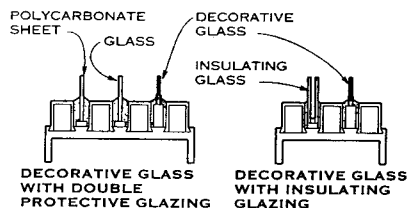

**ALUMINUM FRAMES FOR DECORATIVE GLASS**

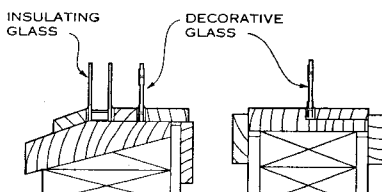

**WOOD FRAMES FOR DECORATIVE GLASS**

**FACETED STAINED GLASS**

A 20th century development in the art of stained glass introduced the use of glass dalles 8 x 12 x 1 in., cast in hundreds of different colors that can be cut to any shape and used, in combination with opaque matrix of epoxy resin or reinforced concrete 3/8 to 1 in. in thickness, to create translucent windows and walls of great beauty.

**SIZE LIMITATIONS**

No single panel of faceted glass should exceed 16 sq ft. The length to width ratio of each panel should not exceed 4:1. Large openings must have horizontal supports to support the weight of stacked panels. When panels are to be stacked vertically, a minimum matrix thickness of 3/8 in. is recommended. Joints between panels should be sealed with flexible caulking, as described below.

**INSTALLATION**

Faceted glass can be installed in frames of masonry, metal, or wood. Frames must be detailed to support the weight of the glass and matrix (approximately 10 to 13 lb/sq ft) and the thicker edge of epoxy panels. A stained glass studio should be consulted for the location of division bars and mullions to coordinate with the design.

**OUTSIDE PROTECTION GLASS**

Because of its high resistance to breakage, waterproof construction, and excellent insulating qualities, faceted glass does not usually need outer glazing. If protection is required, 3/4 to 1 in. ventilated space between the outer surface of the faceted glass and the inside surface of the protection glass is recommended. Divisions in the protection glass should be designed by the artist to complement the design.

**GLAZING SEALANTS**

Faceted glass panels should be set into a non-hardening caulking such as butyl, acrylic, silicone, or polysulfide, used both as a bedding and finish bead. For spaces in excess of 1/4 in. between faceted glass and frame, fillers such as ethafoam are recommended under the caulking bead. A clearance of 3/16 in. should be allowed between the frame and panel edge for proper expansion and contraction. Neoprene spacers are used to ensure proper clearance.

Further information is available from the Stained Glass Association of America.

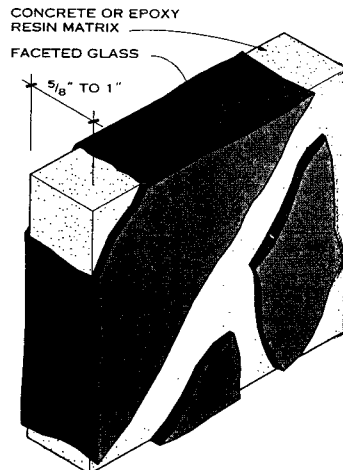

**FACETED STAINED GLASS**

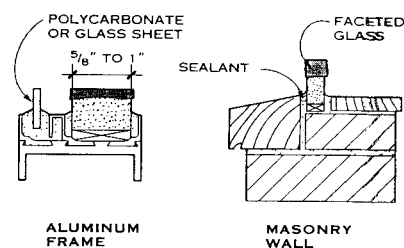

**FACETED GLASS WITH PROTECTIVE GLAZING**

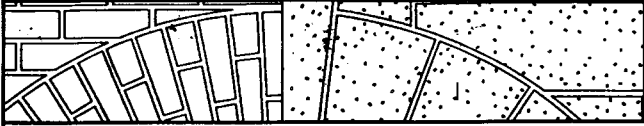

# FINISHES

Plaster and Gypsum Board 516

Tile 531

Stone Floor and Wall  
Coverings 534

Terrazzo 538

Special Ceiling Surfaces 539

Special Flooring 541

Unit Masonry Flooring 542

Wood Flooring 543

Resilient Flooring 546

Carpet 547

Wall Coverings 549

Special Wall Surfaces 551

Acoustical Treatment 552

Paints and Coatings 556

Special Coatings 561

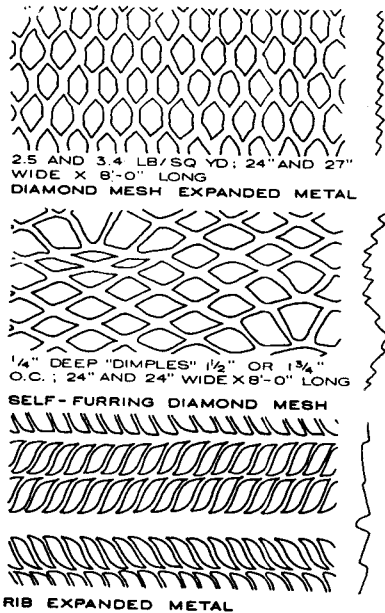

LATHING SYSTEMS

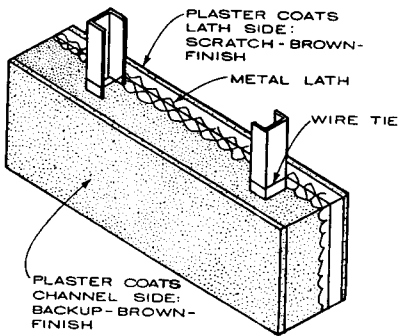

SOLID PARTITION SYSTEMS

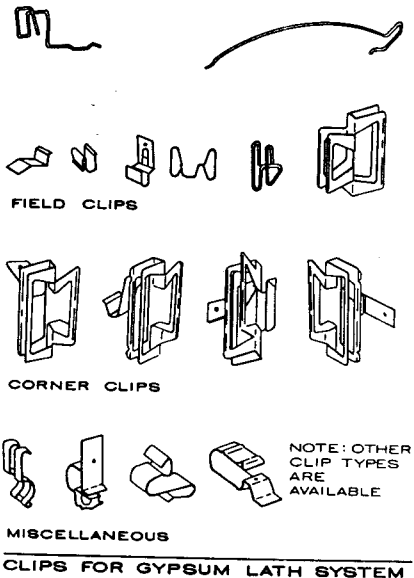

NOTES

Self-furring paperbacked reinforcing is available in diamond mesh, welded wire, and hexagonal woven wire. Paperbacks are available to conform to Federal Specifications UU-B-790, Type 1, Grade A, Style 2 for highly water-vapor resistant paper.

Metal lath is also manufactured in large diamond mesh 27 x 96 in., 2.5 or 3.4 lb/sq yd, painted steel or galvanized; 1/8 in. flat rib 27 x 96 in., 2.75 or 3.4 lb/sq yd painted or galvanized; 3/8 in. rib expanded 27 x 96 in., 3.4 lb/sq yd painted or galvanized and 3/4 in. rib expanded 24 x 96 in., 5.4 lb/sq yd painted.

Other types of lath are available from some manufacturers.

GYPSUM LATH

Gypsum lath is composed of an air entrained gypsum core sandwiched between two sheets of fibrous absorbent paper and used as a basecoat for gypsum plaster.

1. PLAIN GYPSUM LATH: 3/8 and 1/2 in. thick, 48 in. long, and 16 in. wide (16 1/8 in. in the Western U.S.).
2. PERFORATED GYPSUM LATH: Plain gypsum lath with 3/4 in. diameter holes punched 4 in. o.c. in both directions to provide mechanical key to plaster.
3. INSULATING GYPSUM LATH: Plain gypsum lath with aluminum foil laminated to the backside as insulator or vapor barrier.
4. LONG LENGTH GYPSUM LATH: 16 and 24 in. wide, in lengths up to 12 ft, available insulated or plain with square or vee-jointed Tongue and Groove edges or interlocking as ship-lap edge.

SOLID PLASTER PARTITION CONSTRUCTION

PARTITION CONSTRUCTION	THICKNESS	MAXIMUM HEIGHT
3/4" cold-rolled channels Diamond mesh lath and plaster	2"	12'-0"
3/4" cold-rolled channels Diamond mesh lath and plaster	2 1/2"	16'-0"
1 1/2" cold-rolled channels Diamond mesh lath and plaster	3"	20'-0"
1 1/2" cold-rolled channels Diamond mesh lath and plaster	3 1/2"	22'-0"

NOTE: Maximum partition length is unrestricted if less than 10 ft tall. Twice the height if over 10 ft tall; one and one half the height if over 14 ft tall and equal to the height if over 20 ft tall.

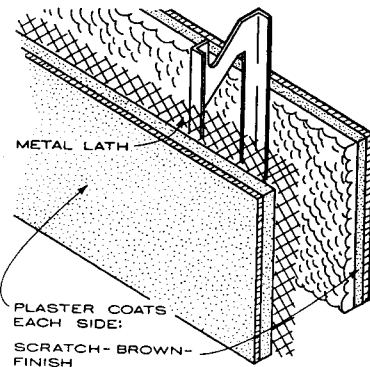

NOTES

Prefabricated metal studs are used as the supporting elements of lath and plaster hollow partitions. They are available in 1 5/8, 2, 2 1/2, 3 1/4, 4, and 6 in. widths. Lengths are available in various increments up to 24 ft. Prefabricated studs are usually of the nonload bearing type, but load bearing metal studs also are manufactured. Designs vary with the manufacturer, and most manufacturers produce a line of related accessories, such as clips, runners, stud shoes, and similar articles.

HOLLOW PARTITION SYSTEMS

DEFINITIONS

- AGGREGATE:** Inert material used as filler with a cementitious material and water to produce plaster or concrete. Usually implies sand, perlite, or vermiculite.
- BASECOAT:** Any plaster coat applied before the finish coat.
- BEAD:** Light gauge metal strip with one or more expanded or short perforated flanges and variously shaped noses; used at the perimeter of plastered surfaces.
- BROWN COAT:** In three-coat plaster, the brown coat is the second coat; in two-coat plaster, the base coat.
- CALCINED GYPSUM:** Gypsum that has been partially dehydrated by heating.
- CLIP:** A device made of wire or sheet metal for attaching various types of lath to the substructure and lath sheets to one another.
- FIBERED PLASTER:** Gypsum plaster containing fibers of hair, glass, nylon, or sisal.
- FINISH COAT:** The final coat of plaster, which provides the decorative surface.
- FURRING:** Grillage for the attachment of gypsum or metal lath.
- GAUGING:** Cementitious material, usually calcined gypsum or portland cement combined with lime putty to control set.
- GROUND:** A formed metal shape or wood strip that acts as a combined edge and gauge for various thicknesses of plaster to be applied to a plaster base.
- GYPSUM:** Hydrous calcium sulphate, a natural mineral in crystalline form.
- GYPSUM LATH:** A base for plaster; a sheet having a gypsum core, faced with paper.
- GYPSUM READY MIX PLASTER:** Ground gypsum that has been calcined and then mixed with various additives to control its setting and working qualities; used, with the addition of aggregate and water, for basecoat plaster.
- HYDRATED LIME:** Quicklime mixed with water, on the job, to form a lime putty.
- LIME:** Obtained by burning various types of limestone, consisting of oxides or hydroxides of calcium and magnesium.
- LIME PLASTER:** Basecoat plaster of hydrated lime and an aggregate.
- NEAT PLASTER:** Basecoat plaster, fibered or unfibered, used for job mixing with aggregates.
- PERLITE:** Siliceous volcanic glass containing silica and alumina expanded by heat for use as a lightweight plaster aggregate.
- PLASTER:** Cementitious material or combination of cementitious materials and aggregate that, when mixed with water, forms a plastic mass that sets and hardens when applied to a surface.
- PORTLAND CEMENT:** Manufactured combination of limestone and an argillaceous substance.
- SCRATCH COAT:** In three-coat plastering, the first coat, which is then scratched to provide a bond for second or brown coat.
- SCREED:** A device secured to a surface which serves as a guide for subsequent applications of plaster. Thicknesses and widths vary with the thicknesses desired for each operation.
- STUCCO PORTLAND CEMENT:** Plaster used in exterior application.
- VERMICULITE:** Micaceous mineral of silica, magnesium, and alumina oxides made up in a series of parallel plates or laminae and expanded by heat for use as a lightweight plaster aggregate.

NOTES

Keene's cement plaster is a specialty finish coat of gypsum plaster primarily used where a smooth, dense, white finish is desired. Thickness, proportions of mixes of various plastering materials, and finishes vary. Systems and methods of application vary widely depending on local traditions and innovations promoted by the industry.

The Marmon Mok Partnership; San Antonio, Texas

9 PLASTER AND GYPSUM BOARD

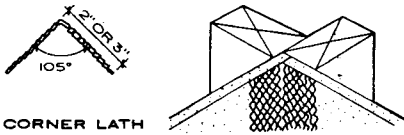

CORNER LATH

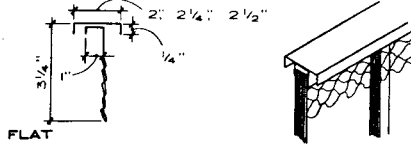

FLAT

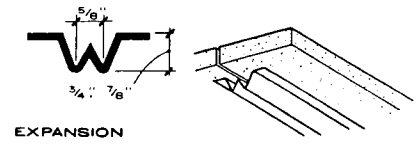

EXPANSION

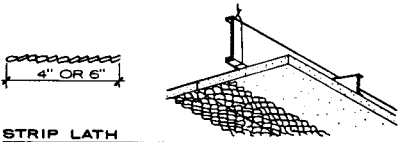

STRIP LATH  
JOINT REINFORCEMENT

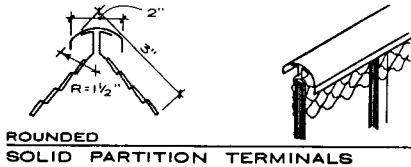

ROUNDED  
SOLID PARTITION TERMINALS

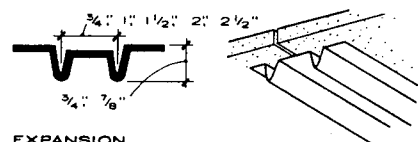

EXPANSION

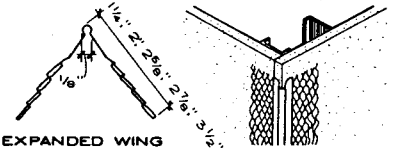

EXPANDED WING

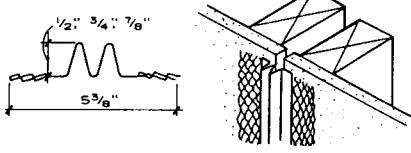

CONTROL JOINTS

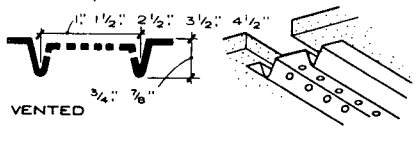

VENTED

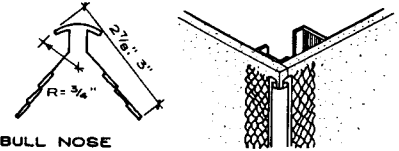

BULL NOSE

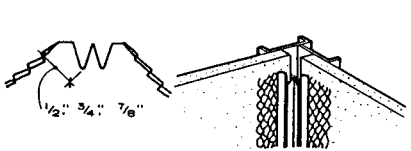

CONTROL JOINTS

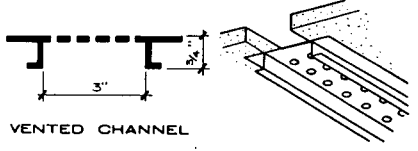

VENTED CHANNEL

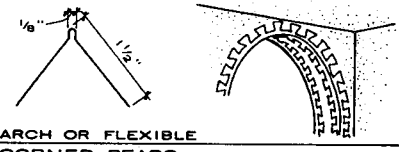

ARCH OR FLEXIBLE  
CORNER BEADS

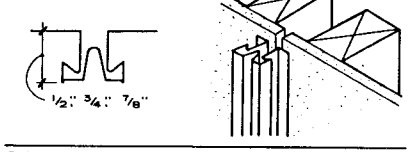

CONTROL JOINTS

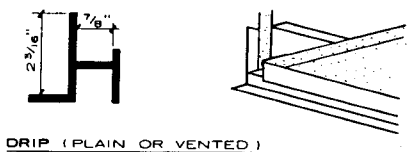

DRIP (PLAIN OR VENTED)  
SCREEDS

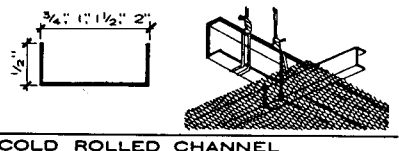

COLD ROLLED CHANNEL

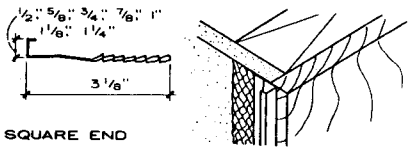

SQUARE END

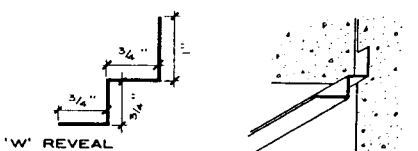

'W' REVEAL

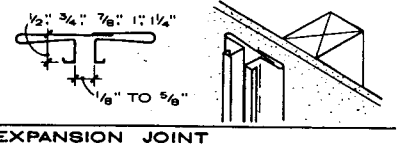

EXPANSION JOINT

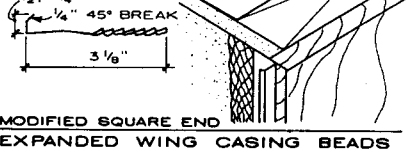

MODIFIED SQUARE END  
EXPANDED WING CASING BEADS

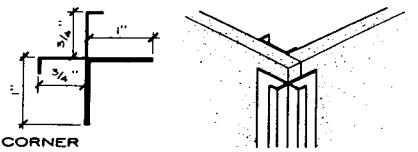

CORNER

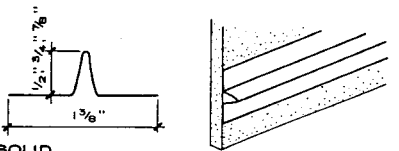

SOLID

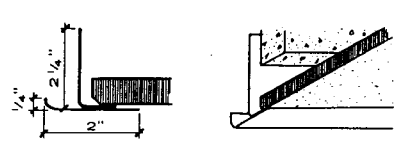

ACOUSTICAL TILE TERMINAL



'F' REVEAL

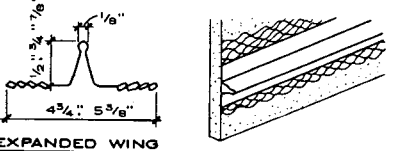

EXPANDED WING  
BASE SCREEDS

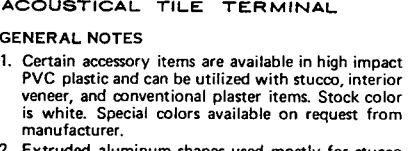

FASCIA CORNER  
MOLDING

GENERAL NOTES

1. Certain accessory items are available in high impact PVC plastic and can be utilized with stucco, interior veneer, and conventional plaster items. Stock color is white. Special colors available on request from manufacturer.
2. Extruded aluminum shapes used mostly for stucco are available in a variety of anodized finishes.

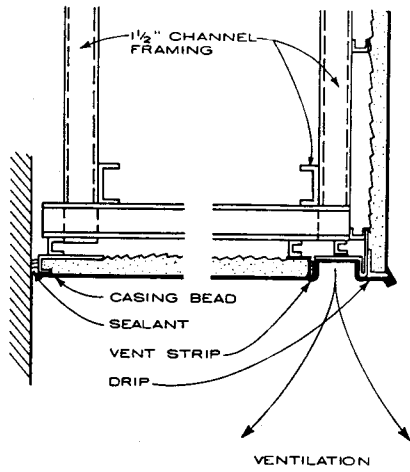

SOFFIT DETAIL

NOTE

Framing details for exterior cement plaster (stucco) are similar to details shown. Wind loads must be considered in designing framing systems for exterior stucco work. Galvanized mesh is available for exterior applications and use in humid areas. Ventilation strips should be used for ventilating all dead airspaces. Where plenum or attic spaces are closed off by ceiling installation, ventilation shall be provided with a minimum of 1/2 sq. in./sq. ft. of horizontal surface.

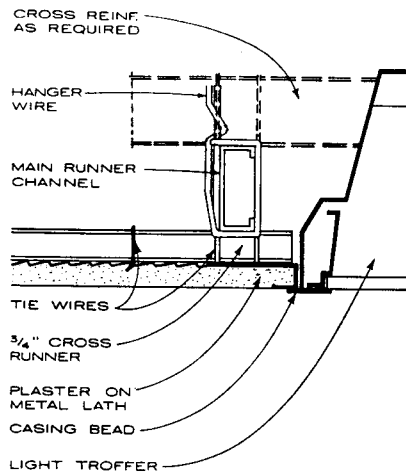

SUSPENDED PLASTER CEILING AT RECESSED LIGHT FIXTURE

NOTE

Penetrations of the lath and plaster ceiling—at borrowed light openings, vents, grilles, access panels, and light troffers, for example—require additional reinforcement to distribute concentrated stresses if a control joint is not used. Where a plaster surface is flush with metal, as at metal access panels, grilles, or light troffers, the plaster should be grooved between the two materials.

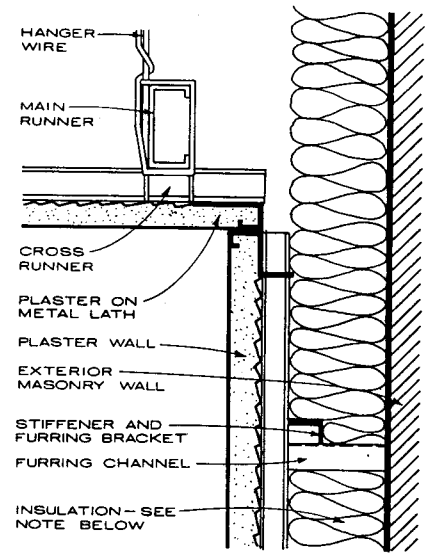

SUSPENDED PLASTER CEILING AT FURROWED MASONRY WALL

NOTE

When interior walls are furrowed from an exterior masonry wall and insulated, the ceiling should stop short of the furrowed space. This allows wall insulation to continue above the ceiling line to ceiling or roof insulation, thus forming a complete insulation envelope. In a suspension system that abuts masonry wall, provide 1 in. clearance between ends of main runners or furring channels and wall face.

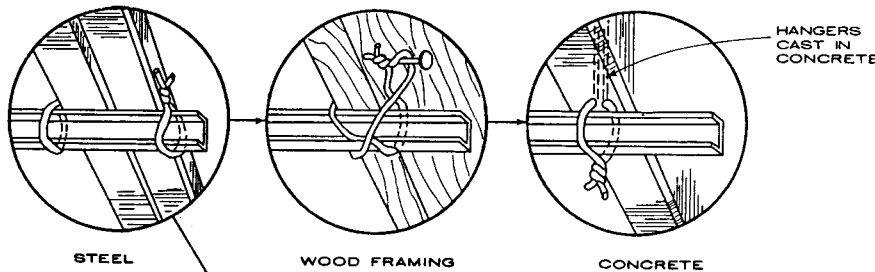

STEEL

WOOD FRAMING

CONCRETE

HANGERS CAST IN CONCRETE

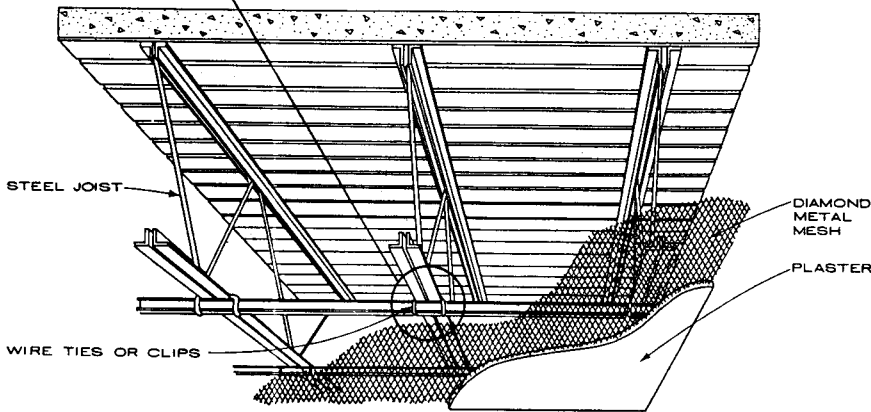

STEEL JOIST

DIAMOND METAL MESH

PLASTER

WIRE TIES OR CLIPS

NOTE  
RIB METAL LATH MAY BE USED IN LIEU OF DIAMOND MESH LATH AND FURRING CHANNELS IF LATH SPANS DO NOT EXCEED ALLOWABLE MAXIMUM. SEE TABLE 1

FURRED METAL LATH ON STEEL JOIST

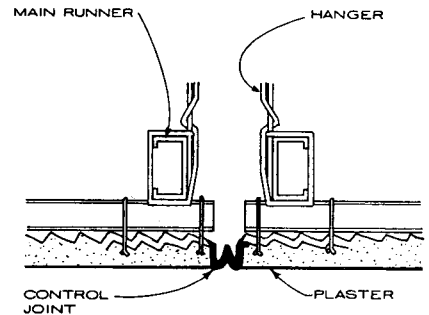

CONTROL JOINT DETAIL

NOTE

Control joints shall be spaced no further than 30 ft on center in each direction for large plastered ceiling areas. Area shall not exceed 900 sq ft without provision for expansion control. Exterior plaster soffits should have control joints spaced no further than 25 ft on center. For portland cement plaster (stucco) areas, interior or exterior, control joints should be placed at 10 ft on center and areas should not exceed 100 sq ft without provisions for expansion/contraction control. Control joints are spaced closer for cement plaster because of its inherent shrinkage during curing.

NOTE

Details shown are for furrowed (contact) ceilings that are attached directly to the structural members. The architect or ceiling designer should give consideration to the deflection and movement of the structure, since movement and deflection of more than 1/320 of the span will cause cracking of plaster ceilings. If spacing of structural members exceeds the maximum span of furring members shown in the span charts, the addition of suspended main runners between structural members will be required. Flat rib lath may be attached directly to wood framing members, but is subjected to stresses created by the inherent properties of wood members.

James E. Phillips, AIA; Enwright Associates, Inc.; Greenville, South Carolina



PLASTER AND GYPSUM BOARD

**DIRECTIONS FOR USING TABLES**

1. Select lath and plaster system.
2. Determine spacing of cross furring channels from Table 1—Lath Span.
3. Determine spacing of main runners from Table 2—Maximum Spacing between Runners.
4. Determine hanger support spacing for main runner from Table 3—Maximum Spacing between Hangers.
5. Calculate area of ceiling supported per hanger.
6. Select hanger type from Table 4—Hanger Selection.
7. Select tie wire size from Table 5—Tie Wire Selection.

**TABLE 1. LATH SPAN**

	LATH TYPE	WEIGHT/SQ. FT.	SPAN (IN.)
Gypsum lath	3/8" plain	1.5#	16
	1/2" plain	2.0#	16
	1/2" veneer	1.8#	16
	5/8" veneer	2.25#	16
	3/8" perforated	1.4#	16
Metal lath	Diamond mesh	0.27#	12
	Diamond mesh	0.38#	16
	1/8" flat rib	0.31#	12
	3/8" flat rib	0.38#	24

**TABLE 2. MAXIMUM SPACING BETWEEN RUNNERS**

CROSS FURRING TYPE	CROSS FURRING SPACING			
	12"	16"	19"	24"
1/4" diam. pencil rod	2'-0"	-	-	-
3/8" diam. pencil rod	2'-6"	-	2'-0"	-
3/4" CRC, HRC (0.3 lb/ft)	-	4'-6"	3'-6"	3'-0"
1" HRC (0.41 lb/ft)	5'-0"	-	4'-6"	4'-0"

CRC = Cold rolled channel  
HRC = Hot rolled channel

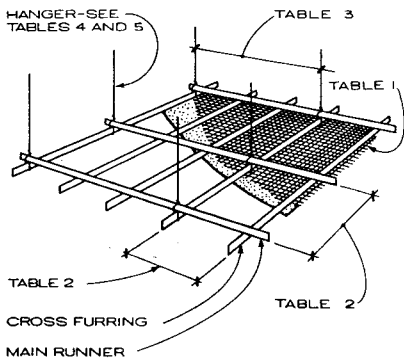

**FURRED AND SUSPENSION SYSTEM COMPONENT SELECTION DETAIL**

- SUSPENSION SYSTEM TIE WIRES AS REQUIRED
- MAIN RUNNER CHANNEL
- 3/4" CROSS FURRING CHANNEL

**NOTE**  
Dimensional requirements for support spacing, runner spacing, hanger spacing, hanger type selection, and tie wire selection are given in tables on this page.

**TABLE 3. MAXIMUM SPACING BETWEEN HANGERS**

MAIN RUNNER TYPE	MAIN RUNNER SPACING				
	3'-0"	3'-6"	4'-0"	4'-6"	5'-0"
3/4" CRC (0.3 lb/ft)	2'-0"	-	-	-	-
1 1/2" CRC (0.3 lb/ft)	3'-0"*	-	-	-	-
1 1/2" CRC (0.875 lb/ft)	4'-0"	3'-6"	3'-0"	-	-
1 1/2" HRC (1.12 lb/ft)	-	-	-	4'-0"	-
2" CRC (0.59 lb/ft)	-	-	5'-0"	-	-
2" HRC (1.26 lb/ft)	-	-	-	-	5'-0"
1/2" x 1/2" x 3/16" ST1	-	5'-0"	-	-	-

\*For concrete construction only—a 10-gauge wire may be inserted in the joint before concrete is poured.

**TABLE 4. HANGER SELECTION**

MAX. CEILING AREA	MIN. HANGER SIZE
12 sq. ft.	9-gauge galvanized wire
16 sq. ft.	8-gauge galvanized wire
18 sq. ft.	3/16" mild steel rod*
25 sq. ft.	1/4" mild steel rod*
25 sq. ft.	3/16" x 1" steel flat*

\*Rods galvanized or painted with rust inhibitive paint and galvanized straps are recommended under severe moisture conditions.

**TABLE 5. TIE WIRE SELECTION**

	SUPPORT	MAX. CEILING AREA	MIN. HANGER SIZE
Cross furring		8 sq. ft.	14-gauge wire
		8 sq. ft.	16-gauge wire (two loops)
Main runners	Single hangers between beams	8 sq. ft.	12-gauge wire
		12 sq. ft.	10-gauge wire
	Double wire loops at supports	16 sq. ft.	8-gauge wire
		8 sq. ft.	14-gauge wire
		12 sq. ft.	12-gauge wire
		16 sq. ft.	11-gauge wire

**ERECTION OF METAL LATH SUSPENSIONS**

Metal lath suspensions commonly are made below all types of construction for fire rated plaster ceilings. The lath is supported by framing channels and furring channels suspended with wire hangers from the floor or roof structure above. Framing channels normally are spaced up to 4 ft. o.c. perpendicular to joists and should be erected to conform with the contour of the finished ceiling. Framing channels normally are furred with 3/4 in. channels placed at right angles to the framing. Spacing varies by lath types and weights. The lath should be lapped at both sides and ends and secured to the 3/4 in. channels with wire ties every 6 in. Where plaster on metal lath ceilings abuts masonry walls, partitions, or arch soffits, galvanized casing beads should be installed at the periphery.

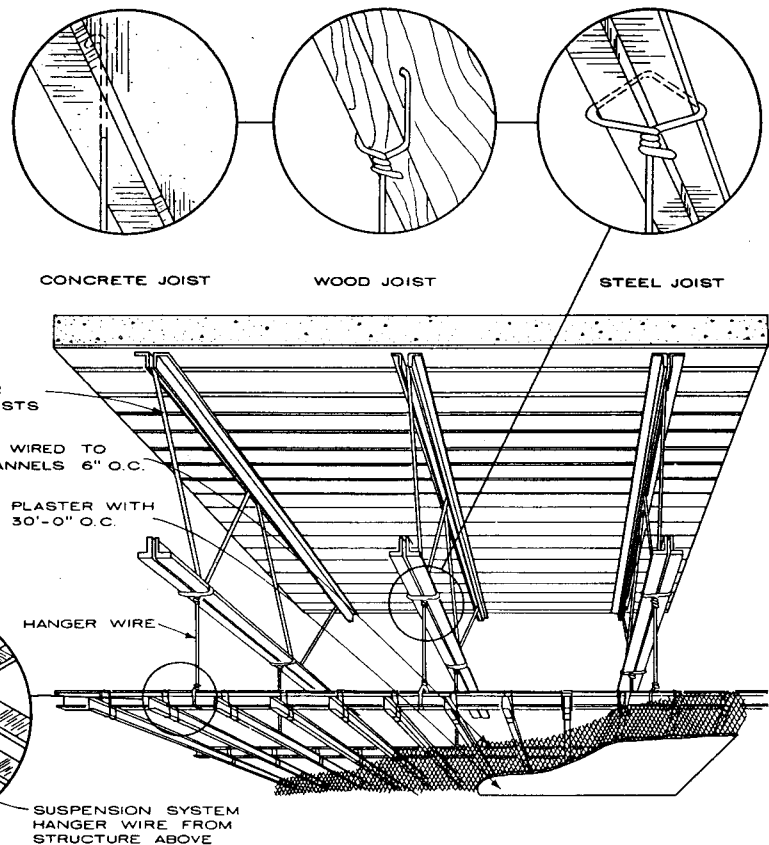

**METAL LATH SUSPENDED FROM STEEL JOISTS**

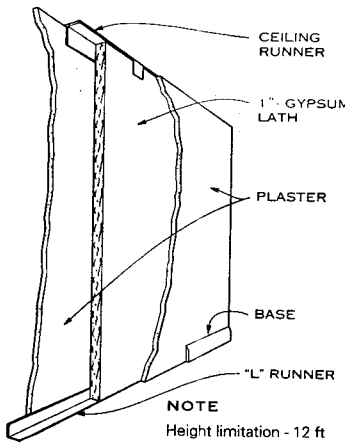

SECTION THROUGH TYPICAL WALL



PLAN

**2 IN. SOLID GYPSUM LATH**

**CHANNEL STUD SPACING**

TYPE OF LATH	WEIGHT LB/ SQ YD	SPACING OF SUPPORTS
Diamond mesh	2.5	16
Flat rib	3.4	16
	2.75	16
	3.4	24*

\*Spacing for solid partitions not to exceed 16' - 0" in height.

**CHANNEL STUD SIZE**

PARTITION HEIGHT	PARTITION THICKNESS	CHANNEL
12'	2"	
14'	2 1/4"	3/4 in. 300 lb per 1000 ft
16'	2 1/2"	
18'	2 3/4"	1 1/2 in. 475 lb per 1000 ft

**METAL STUD WITH METAL LATH STUD SPACING AND HEIGHT LIMITATION\***

STUD WIDTH	THICKNESS	MAXIMUM HEIGHT		
		16" O.C.	19" O.C.	24" O.C.
2 1/2"	4"	15'	14'	9'
3 1/4"	4 3/4"	21'	18'	13'
4"	5 1/2"	22'	20'	16'
6"	7 1/2"	26'	24'	20'

\*For length not exceeding 1 1/2 times height; for lengths exceeding this, reduce 20%.

**METAL STUDS WITH 3/8 IN. GYPSUM LATH HEIGHT LIMITATIONS\***

STUD SIZE	LIMIT HEIGHT	I <sub>MIN.</sub>	S <sub>MIN.</sub>
1 5/8"	10' - 6"	0.038	0.044
2 1/2"	13' - 0"	0.103	0.076
3 5/8"	16' - 3"	0.243	0.125
4"	17' - 3"	0.307	0.143
6"	15' - 0"	0.810	0.255

\*25 gauge studs (ASTM C-645) spaced at 16 in. o.c..

**FRAME AND FASTENER SPACING WITH ROCK LATH PLASTER BASE**

FRAMING TYPE	BASE THICKNESS		FASTENER	FRAME SPACING (MAX.)		FASTENER SPACING (MAX.)	
	IN.	MM		IN.	MM	IN.	MM
Unimast	3/8"	9.5	1 in. drywall screws	16	406	12	305
Steel stud	1/2"	12.7		24	610	6	152

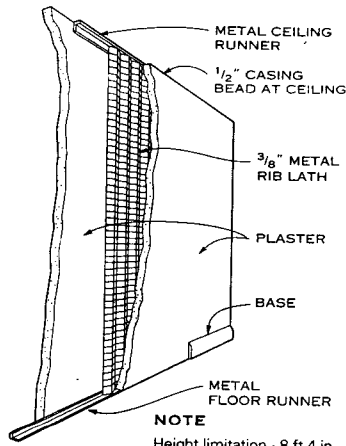

SECTION THROUGH TYPICAL WALL



PLAN

**2 IN. SOLID METAL LATH AND PLASTER**

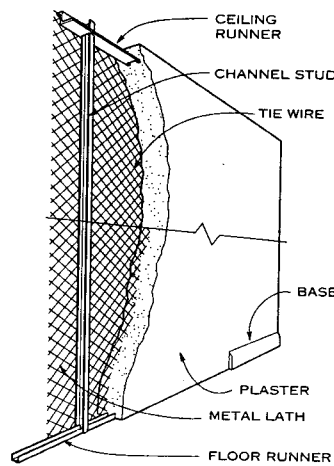

SECTION THROUGH TYPICAL WALL



PLAN

**METAL LATH - CHANNEL STUD - PLASTER - 1 HOUR FIRE RATED**

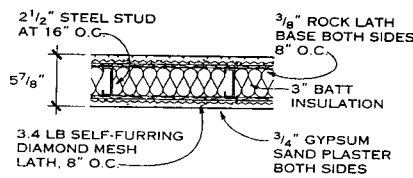

**GYPSUM AND PLASTER LATH - 2 HOUR FIRE RATED PARTITION**

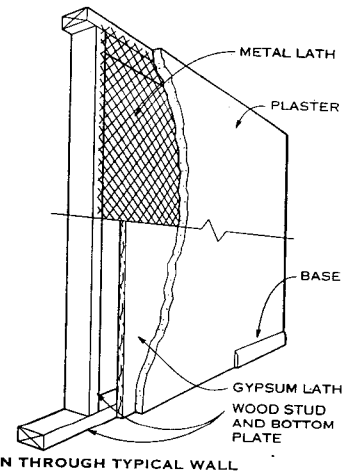

SECTION THROUGH TYPICAL WALL

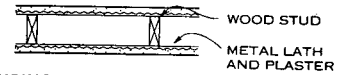

PLAN-USING METAL LATH



PLAN-USING GYPSUM LATH

**WOOD STUD AND LATH**

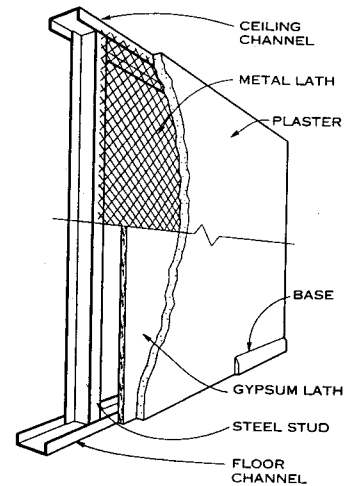

SECTION THROUGH TYPICAL WALL

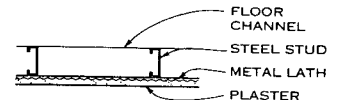

PLAN



PLAN

**PREFABRICATED METAL STUD**

United States Gypsum Company, Chicago, Illinois  
Walter H. Sobel, FAIA & Associates, Chicago, Illinois



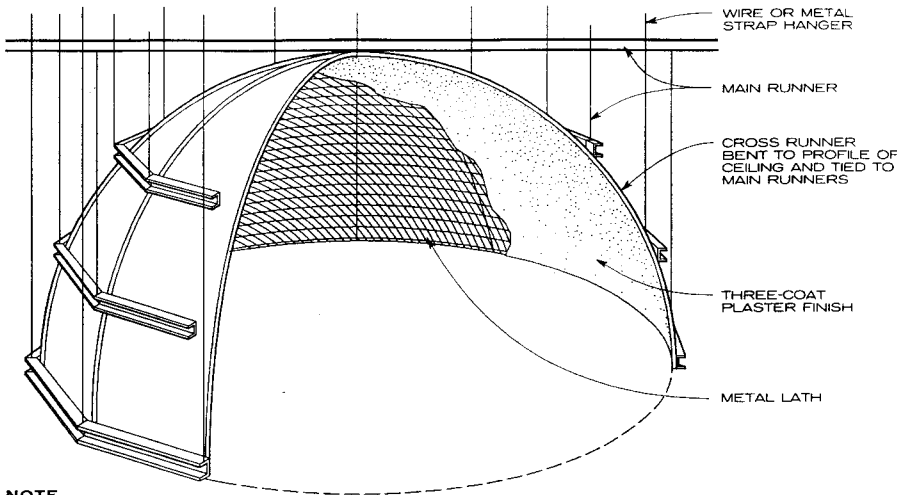

**NOTE**  
The time required for field installation of furring and lath and the weight of a three-coat plaster finish are factors to consider when designing this system.

**PLASTER DOME BUILT IN PLACE (VAULTS CONSTRUCTED SIMILARLY)**

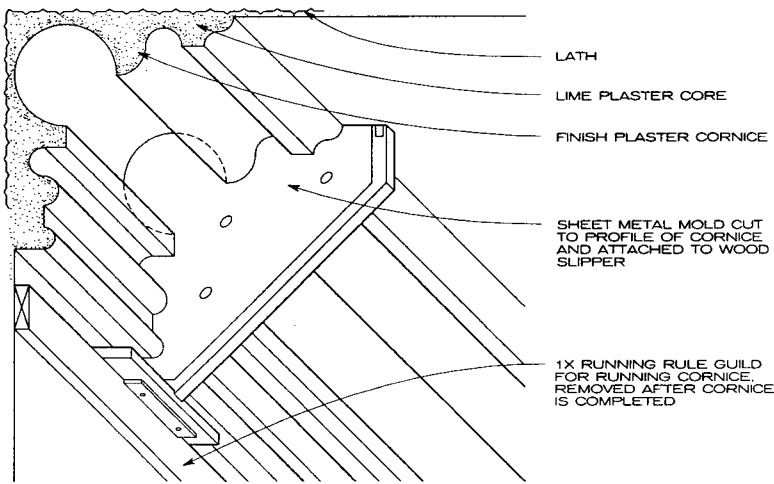

**RUN-IN-PLACE CORNICE**

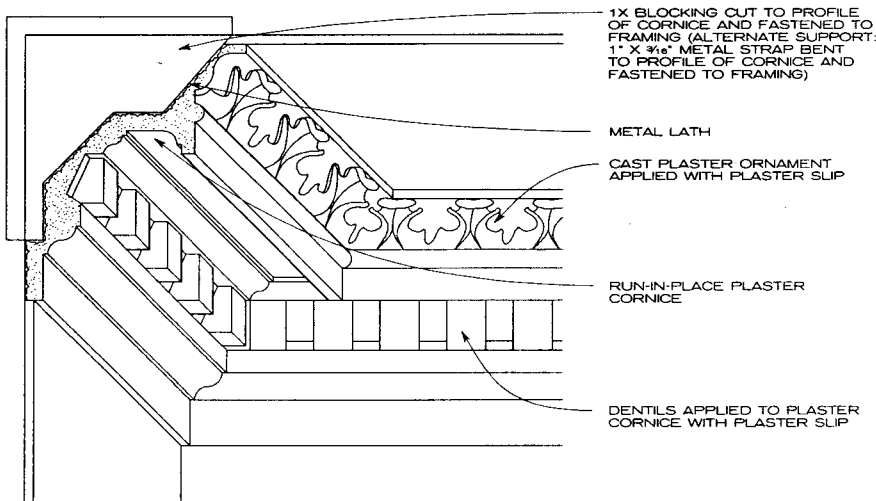

**BRACKETED CORNICE RUN IN PLACE WITH STUCK-ON ORNAMENT**

**TYPES OF ORNAMENTAL PLASTER**

**RUN-IN-PLACE:** This type of ornament is moulded or applied in its final position while in its plastic state using a three-coat plaster system. This method requires installation of the furring, lath, base plaster coats, and finish plaster ornament and surfaces on site, a time-consuming process that results in relatively heavy assemblies. It is typically used to repair or replace sections of damaged existing and historic plaster ornament.

**CAST PLASTER ORNAMENT:** This type of ornament, which can be made in panels, is run, cast, or fabricated in a shop and installed after hardening. Joints between sections of ornament are finished in the field. Typically gypsum plaster reinforced with glass fibers, cast plaster is fabricated by laying or spraying the material into a mold. Castings are reinforced with jute rope, burlap, wood lath, or metal framing, depending on the casting size and installation methods. Controlled shop fabrication processes, reduced on-site time, and the ability to fabricate thinner, lighter sections often make this method less costly than run-in-place.

**NOTES**

**MODELS:** Models are the "positive" form of the cast ornament and can be fabricated from clay, plaster, or wood as necessary to achieve the desired appearance. When existing ornament is being matched, it can serve as the model.

**MOLDS:** Typically made of urethane or silicone rubber, molds from which ornament is cast are "negative" forms produced from models. Molds for run-plaster ornament are sheet metal templates cut to the profile of the molding and attached to a wood backing called a "slipper."

**ATTACHMENT:** Small cast ornament is typically applied using a plaster "slip" made of plaster and water as an adhesive. Large sections of cast plaster ornament are attached with screws or hung with metal hangers.

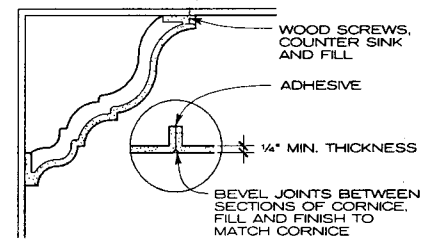

**GLASS FIBER-REINFORCED GYPSUM CORNICE**

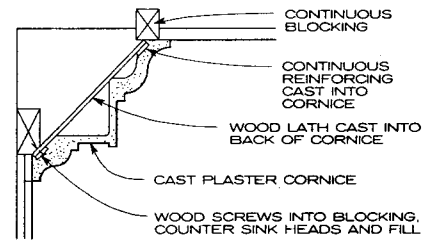

**CAST PLASTER ORNAMENT ATTACHED WITH SCREWS**

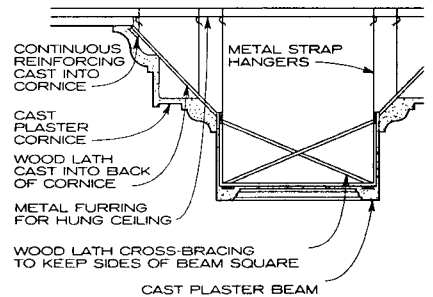

**CAST PLASTER CORNICE AND BEAM SCREWED AND HUNG**

Reed A. Black; Oehrlein & Associates; Washington, D.C.



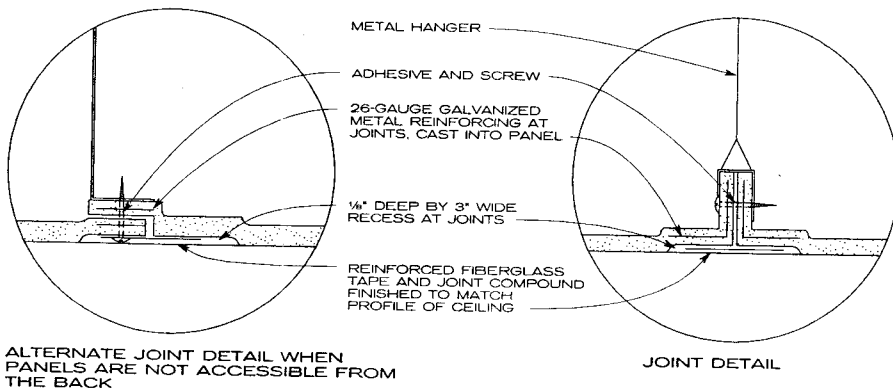
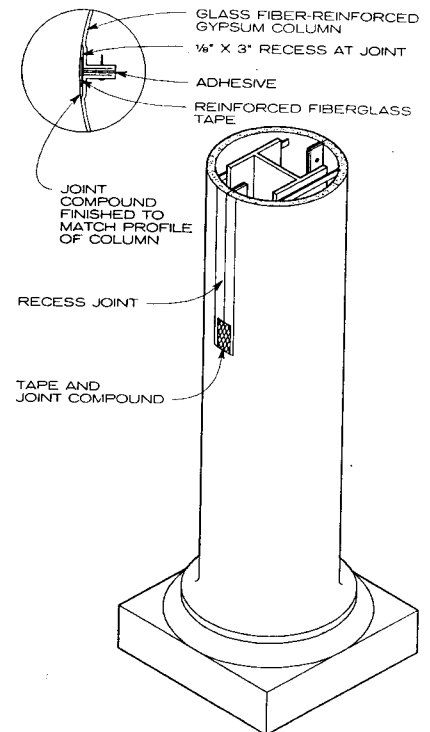
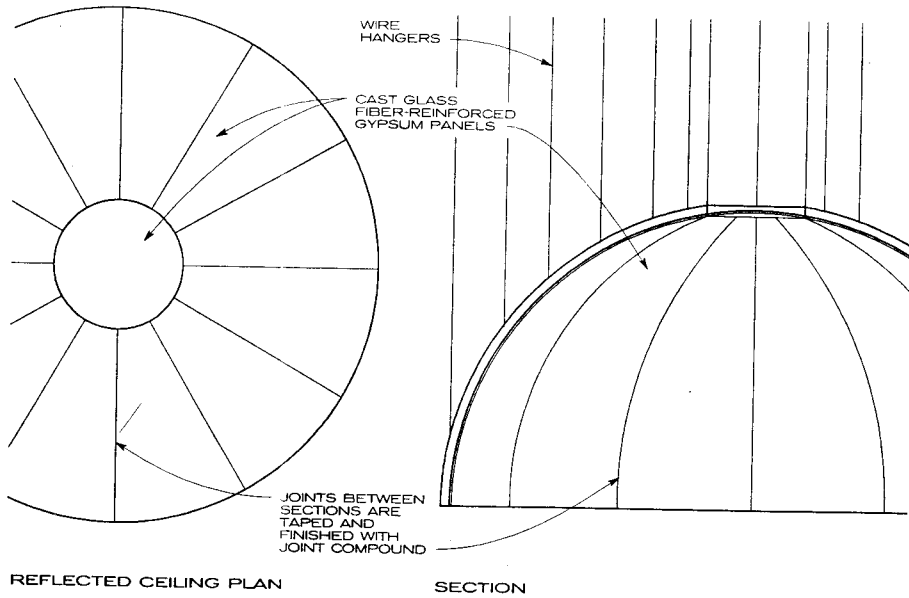

**TWO-PIECE GLASS FIBER-REINFORCED GYPSUM COLUMN**

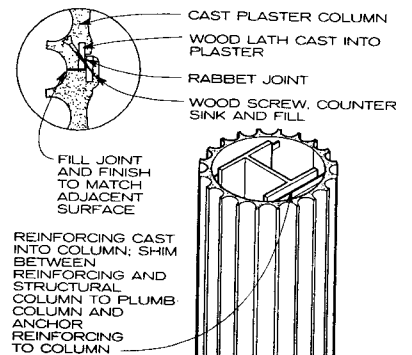

**NOTE**  
Columns may be fabricated in one piece without joints and seams when they do not have to fit around the building structure.

**TWO-PIECE CAST PLASTER COLUMN**

**NOTE**  
Cast fabrications are typically lighter and require less on-site construction time than built-in-place plaster systems. Large cast sections may require structural reinforcing and special cradles for fabrication, shipping, and erection.

**CAST GLASS FIBER-REINFORCED GYPSUM DOME (VAULTS ARE SIMILAR)**

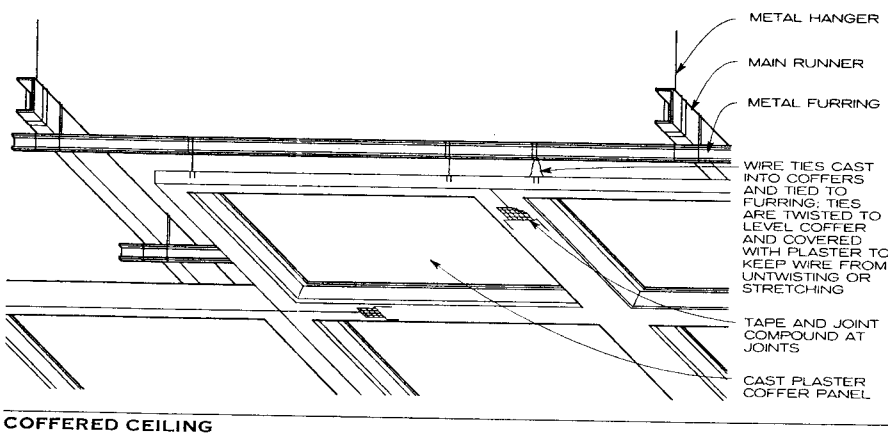

Reed A. Black; Oehrlein & Associates; Washington, D.C.

TYPES OF GYPSUM PANEL PRODUCTS

DESCRIPTION	THICKNESS (IN.)	WIDTH/EDGE (FT)	STOCK LENGTH (FT)
Regular gypsum wallboard used as a base layer for improving sound control; repair and remodeling with double layer application	1/4	4, square or tapered	8-10
Regular gypsum wallboard used in a double wall system over wood framing; repair and remodeling	3/8	4, square or tapered	8-14
Regular gypsum wallboard for use in single layer construction	1/2, 5/8	4, square or tapered	8-16
Rounded taper edge system offers maximum joint strength and minimizes joint deformity problems	3/8 1/2, 5/8	4, rounded taper	8-16
Type X gypsum wallboard with core containing special additives to give increased fire resistance ratings. Consult manufacturer for approved assemblies	1/2, 5/8	4, tapered, rounded taper, or rounded	8-16
Aluminum foil backed board effective as a vapor barrier for exterior walls and ceilings and as a thermal insulator when foil faces 3/4" minimum air space. Not for use as a tile base or in air conditioned buildings in hot, humid climates (Southern Atlantic and Gulf Coasts)	3/8 1/2, 5/8	4, square or tapered	8-16
Water resistant board for use as a base for ceramic and other nonabsorbant wall tiles in bath and shower areas. Type X core is available	1/2, 5/8	4, tapered	8, 10, 12
Prefinished vinyl surface gypsum board in standard and special colors. Type X core is available	1/2, 5/8	2, 2 1/2, 4, square and beveled	8, 9, 10
Prefinished board available in many colors and textures. See manufacturers' literature	5/16	4, square	8
Coreboard for use to enclose vent shafts and laminated gypsum partitions	1	2, tongue and groove or square	8-12
Shaft wall liner core board type X with gypsum core used to enclose elevator shafts and other vertical chases	1, 2	2, square or beveled	6-16
Sound underlayment gypsum wallboard attached to plywood subfloor acts as a base for any durable floor covering. When used with resiliently attached gypsum panel ceiling, the assembly meets HUD requirements for sound control in multifamily dwellings	3/4	4, square	6-8
Exterior ceiling/soffit panel for use on surfaces with indirect exposure to the weather. Type X core is available	1/2, 5/8	4, rounded taper	8, 12
Sheathing used as underlayment on exterior walls with type X or regular core	1/2	2, tongue and groove	8
	1/2, 5/8	4, square	8, 9, 10

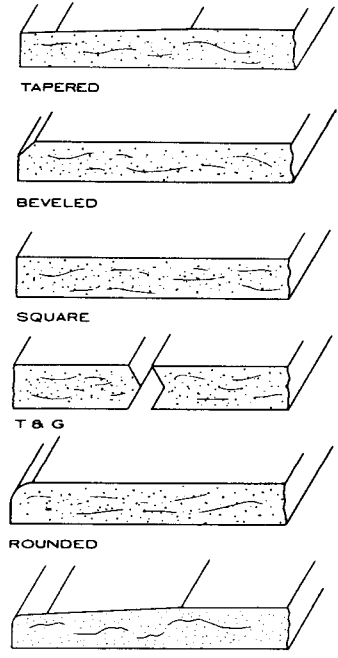

ROUNDED TAPER TYPES OF EDGES

MAX. BENDING FOR DRYWALL

THICKNESS	BENDING RADII	
	LENGTHWISE	WIDTH
1/4"	5'-0"	15'-0"
3/8"	7'-6"	25'-0"
1/2"	20'-0"	-

Shorter radii may be obtained by moistening face and back so that water will soak well into core of board.

MAXIMUM ALLOWABLE PARTITION HEIGHT (5 PSF LOADING, L240 DEFLECTION, 25 GA STUDS)

STUD SPACING (IN.) (FACING ON EACH SIDE)	STUD DEPTH (IN.)				
	1 3/8"	2 1/2"	3 3/8"	4"	6"
16 (1/2 one-ply)	9'-6"	12'-6"	16'-0"	17'-3"	20'-0"
24 (1/2 one-ply)	8'-3"	10'-9"	13'-6"	14'-3"	15'-0"
24 (1/2 two-ply)	8'-9"	11'-3"	13'-6"	14'-3"	15'-0"

\* 1 3/8" stud with single layer of gypsum wallboard recommended for chase walls and closets only.

NOTE: A large range of adhesives, sealants, joint treatments, and texture products are available from the manufacturers of most gypsum board products. Consult available literature for current recommendations and products.

3/8" TYPE S-12 PAN HEAD (FOR STEEL TO STEEL FRAMING)

1" TYPE S BUGLE HEAD (FOR STEEL FRAMING)

1 5/8" TYPE S TRIM HEAD (FOR WOOD TRIM)

1/2" TYPE G BUGLE HEAD (FOR WOOD OR STEEL FRAME)

TYPES OF DRYWALL SCREWS

METAL EDGE TRIM

MET. FURRING CHAN

MET. RESILIENT CHAN.

CONTROL JOINT

METAL THIN-COAT BEAD

VINYL TRIM

PREFINISHED DIVIDER

PREFINISHED CORNER

Z-FURRING CHANNEL

COLD ROLLED CHANNEL

METAL RUNNER

Ferdinand R. Scheeler, AIA; Skidmore, Owings & Merrill; Chicago, Illinois  
James Lloyd; Kennett Square, Pennsylvania

FIRE RATING	STC	WALL THICKNESS	CONSTRUCTION DESCRIPTION	WALL SECTIONS
1 HOUR	30 TO 34	4 7/8"	One layer 1/2 in. type X veneer base nailed to each side of 2 x 4 in. wood studs 16 in. o.c. with 5d coated nails 8 in. o.c. Minimum 3/32 in. gypsum veneer plaster. Joints staggered vertically 16 in. and horizontal joints each side at 12 in.	
		4 7/8"	One layer 5/8 in. type X gypsum wallboard or veneer base nailed to each side of 2 x 4 in. wood studs 16 in. o.c. with 6d coated nails 7 in. o.c. Stagger joints 24 in. on each side.	
	35 TO 39	5 1/8"	Two layers 3/8 in. regular gypsum wallboard or veneer base nailed to each side of 2 x 4 in. wood studs 16 in. o.c. First layer attached with 4d coated nails, second layer applied with laminating compound and nailed with 5d coated nails 8 in. o.c. Stagger joints 16 in. o.c. each side.	
	45 TO 49	5 3/8"	Base layer 3/8 in. regular gypsum wallboard or veneer base nailed to each side of 2 x 4 in. wood studs 16 in. o.c. Face layer 1/2 in. (same as base layer). Use 5d coated nails 24 in. o.c. for base layer and 8d coated nails 12 in. o.c. to edge and 24 in. o.c. to intermediate studs. Stagger joints 16 in. o.c. each layer and side.	
		5 7/8"	Base layer 1/2 in. wood fiberboard to each side of 2 x 4 in. wood studs 16 in. o.c. with 5d coated nails 24 in. o.c. on vertical joints and 16 in. o.c. to top and bottom plates. Face layer 5/8 in. type X gypsum wallboard or veneer base applied to each side with laminating compound and nailed with 8d coated nails 24 in. o.c. on vertical joints and 16 in. o.c. to top and bottom plates. Stagger joints 24 in. o.c. each layer and side.	
		5 7/8"	Both sides resilient channels 24 in. o.c. attached with GWB 54 drywall nails to each side of 2 x 4 in. wood studs 16 in. o.c. One layer 5/8 in. type X gypsum wallboard or veneer base attached with 1 in. type S drywall screws 12 in. o.c. to each side and vertical joints back-blocked. GWB filler strips along floor and ceiling both sides. Stagger joints 24 in. o.c. each side.	
	50 TO 54	5 3/8"	Base layer 1/4 in. proprietary gypsum wallboard applied to each side of 2 x 4 in. wood studs 16 in. o.c. with 4d coated nails 12 in. o.c. Face layer 5/8 in. type X gypsum wallboard or veneer base applied with laminating compound and nailed with 6d coated nails 16 in. o.c. to each side. 1 1/2 in. mineral fiber insulation in cavity. Stagger joints 24 in. o.c. each side.	
		5 3/8"	One side resilient channel 24 in. o.c. with 1 1/4 in. type S drywall screws to 2 x 4 in. wood studs 16 in. o.c. Both sides 5/8 in. gypsum wallboard or veneer base attached to resilient channel with 1 in. type S drywall screws 12 in. o.c. and GWB to stud with 1 1/4 in. type W drywall screws. 1 1/2 in. mineral fiber insulation in cavity. Stagger joints 48 in. o.c. each side.	
	60 TO 64	6 7/8"	One side resilient channels 24 in. o.c. attached with 1 in. type S drywall screws to 2 x 4 in. wood studs 16 in. o.c. Two layers of 5/8 in. type X gypsum wallboard or veneer base. First layer attached with 1 in. type S drywall screws, second layer applied with laminating compound. Other side one layer each of 5/8 in. and 1/2 in. gypsum wallboard or veneer base plus top 3/8 in. gypsum wallboard applied with laminating compound. Use 5d coated nails 32 in. o.c. for base, 8d for 1/2 in. center layer. 2 in. glass fiber insulation in cavity. Stagger all joints 16 in. o.c.	
	2 HOUR	40 TO 44	6 1/8"	Two layers 5/8 in. type X gypsum wallboard or veneer base applied to each side of 2 x 4 in. wood studs 24 in. o.c. Use 6d coated nails 24 in. o.c. for base layer and 8d coated nails 8 in. o.c. for face layer. Stagger joints 24 in. o.c. each layer and side.
50 TO 54		8"	Two layers 5/8 in. type X gypsum wallboard or veneer base applied to each side of 2 x 4 in. wood studs 16 in. o.c. staggered 8 in. o.c. on 2 x 6 in. wood plates. Use 6d coated nails 24 in. o.c. for base layer and 8d coated nails 8 in. o.c. for face layer. Stagger vertical joints 16 in. o.c. each layer and side.	
55 TO 59		10 3/4"	Two layers 5/8 in. type X gypsum wallboard or veneer base applied to each side of double row of 2 x 4 in. wood studs 16 in. o.c. on separate plates 1 in. apart. Use 6d coated nails 24 in. o.c. for base layer and 8d coated nails 8 in. o.c. for face layer. 3 1/2 in. glass fiber insulation in cavity. Stagger joints 16 in. o.c. each layer and side. GWB fire stop continuous in space between plates.	

FIRE RATING	STC	WALL THICKNESS	CONSTRUCTION DESCRIPTION	WALL SECTIONS
1 HOUR	35 TO 39	2 7/8"	One layer 5/8 in. type X gypsum wallboard or veneer base applied to each side of 1 1/8 in. metal studs 24 in. o.c. with 1 in. type S drywall screws 8 in. o.c. to edges and 12 in. o.c. to intermediate studs. Stagger joints 24 in. o.c. each side.	
	40 TO 44	3 3/8"	Base layer 3/8 in. regular gypsum wallboard or veneer base applied to each side of 1 1/8 in. metal studs 24 in. o.c. with 1 in. type S drywall screws 27 in. o.c. to edges and 54 in. o.c. to intermediate studs. Face layer 1/2 in. attached on each side to studs with 1 1/8 in. type S drywall screws 12 in. o.c. to perimeter and 24 in. o.c. to intermediate studs. Stagger joints 24 in. o.c. each layer and side.	
		4 7/8"	One layer 5/8 in. type X gypsum wallboard or veneer base applied to each side of 3/8 in. metal studs 24 in. o.c. with 1 in. type S drywall screws 8 in. o.c. to vertical edges and 12 in. o.c. to intermediate studs. Stagger joints 24 in. o.c. each side.	
	45 TO 49	3 1/8"	Two layers 1/2 in. regular gypsum wallboard or veneer base applied to each side of 1 1/8 in. metal studs 24 in. o.c. Use 1 in. type S drywall screws 12 in. o.c. for base layer and 1 1/8 in. type S drywall screws 12 in. o.c. for face layer. Stagger joints 24 in. o.c. each layer and side.	
		3 1/8"	Base layer 1/4 in. gypsum wallboard applied to each side of 1 1/8 in. metal studs 24 in. o.c. with 1 in. type S drywall screws 24 in. o.c. to edges and 36 in. o.c. to intermediate studs. Face layer 1/2 in. type X gypsum wallboard or veneer base applied to each side of studs with 1 1/8 in. type S drywall screws 12 in. o.c. Stagger joints 24 in. o.c. each layer and side.	
		5 1/2"	One layer 5/8 in. type X gypsum wallboard or veneer base applied to each side of 3/8 in. metal studs 24 in. o.c. with 1 in. type S drywall screws 8 in. o.c. to edge and vertical joints and 12 in. o.c. to intermediate stud. Face layer 5/8 in. (same as other layer) applied on one side to stud with laminating compound and attached with 1 1/8 in. type S drywall screws 8 in. o.c. to edges and sides and 12 in. o.c. to intermediate studs. 3 1/2 in. glass fiber insulation in cavity. Stagger joints 24 in. o.c. each layer and side.	
	50 TO 54	4"	Base layer 1/4 in. regular gypsum wallboard applied to each side of 2 1/2 in. metal studs 24 in. o.c. with 1 in. type S drywall screws 12 in. o.c. Face layer 1/2 in. type X gypsum wallboard or veneer base applied to each side of studs with laminating compound and with 1 1/8 in. type S drywall screws in top and bottom runners 8 in. o.c. 2 in. glass fiber insulation in cavity. Stagger joints 24 in. o.c. each layer and side.	
		4"	Two layers 1/2 in. type X gypsum wallboard or veneer base applied to one side of 2 1/2 in. metal studs 24 in. o.c. Base layer 1 in. and face layer 1 1/8 in. type S drywall screws 8 in. o.c. to edge and adhesive beads to intermediate studs. Opposite side layer 1/2 in. type X gypsum wallboard or veneer base applied with 1 in. type S drywall screws 8 in. o.c. to vertical edges and 12 in. o.c. to intermediate studs. 3 in. glass fiber insulation in cavity. Stagger joints 24 in. o.c. each layer and face.	
	55 TO 59	4 1/4"	Base layer 1/4 in. gypsum wallboard applied to each side of 2 1/2 in. metal studs 24 in. o.c. with 7/8 in. type S drywall screws 12 in. o.c. Face layer 5/8 in. type X gypsum wallboard or veneer base applied on each side of studs with 1 1/8 in. type S drywall screws 12 in. o.c. 1 1/2 in. glass fiber insulation in cavity. Stagger joints 24 in. o.c. each layer and side.	
	2 HOUR	40 TO 44	5"	Two layers 5/8 in. type X gypsum wallboard or veneer base applied to each side of 2 1/2 in. metal studs 16 in. o.c. braced laterally. Use 1 in. for base layer and 1 1/8 in. for facelayer type S-12 drywall screws 12 in. o.c. Stagger joints 16 in. o.c. each layer and side.
50 TO 54		3 5/8"	Base layer 1/2 in. type X gypsum wallboard or veneer base applied to each side of 1 1/8 in. metal studs 24 in. o.c. Use 1 in. type S drywall screws 12 in. o.c. for base layer and 1 1/8 in. type S drywall screws 12 in. o.c. for face layer. 1 1/2 in. glass fiber insulation in cavity. Stagger joints 24 in. o.c. each layer and side.	
55 TO 59		6 1/4"	Two layers 5/8 in. type X gypsum wallboard or veneer base applied to each side of 3/8 in. metal studs 24 in. o.c. Use 1 in. type S drywall screws 32 in. o.c. for base layer and 1 1/8 in. type S drywall screws 12 in. o.c. to edge and 24 in. o.c. to intermediate studs. One side third layer 1/4 or 3/8 in. gypsum wallboard or veneer base applied with laminating compound. Stagger joints 24 in. o.c. each layer and side.	

FIRE RATING	STC	WALL THICKNESS	CONSTRUCTION DESCRIPTION	WALL SECTIONS
1 HOUR	35 TO 39	3 1/8"	1 in. x 24 in. proprietary type X gypsum panels inserted between 2 1/2 in. floor and ceiling J runners with 2 1/2 in. proprietary vented C-H studs between panels. One layer 3/8 in. proprietary type X gypsum wallboard or veneer base applied parallel to studs on side opposite proprietary gypsum panels with 1 in. type S drywall screws spaced 12 in. o.c. in studs and runners. STC estimate based on 1 in. mineral fiber in cavity. (NLB)	
	40 TO 44	2 7/8"	3/4 in. x 24 in. proprietary type X gypsum panels inserted between 2 1/4 in. floor and ceiling track and fitted to proprietary 2 1/4 in. slotted metal I studs with tab-flange. Face layer 3/8 in. type X gypsum board applied at right angles to studs, with 1 in. type S drywall screws spaced 12 in. o.c. Sound tested with 1 in. glass fiber friction fit in stud space. (NLB)	
2 HOURS	30 TO 34	2 1/4"	One layer 3/8 in. type X gypsum wallboard or veneer base applied vertically to each side of 1 in. gypsum board panels (solid or laminated) with laminating compound combed over entire contact surface. Panel supported by metal runners at top and bottom and horizontal bracing angles of No. 22 gauge galvanized steel 3/4 in. x 1 1/4 in. spaced 5 ft. 0 in. o.c. or less on shaft side. (NLB)  *Limiting height shown is based on interior partition exposure conditions. Shaft wall exposure conditions may require reduction of limiting height.	
	35 TO 39	4 1/8"	Four layers 3/8 in. type X gypsum wallboard or veneer base applied at right angles to one side of 1 1/2 in. metal studs 24 in. o.c. Base layer attached to studs with 1 in. type S drywall screws 12 in. o.c. Second layer attached to studs with 1 1/2 in. type S drywall screws using only two screws per board. Third layer attached with 2 1/2 in. type S drywall screws similar to second layer. Steel strips 1 1/2 in. wide vertically applied over third layer at stud lines and attached 12 in. o.c. to studs with 2 1/2 in. type S drywall screws. Third layer also attached to top and bottom track with 2 1/2 in. type S drywall screws placed midway between studs. Face layer attached to steel strips with 1 in. type S drywall screws 8 in. o.c. at each stud. Stagger joints of each layer. (NLB)	
	40 TO 44	3 1/2"	1 in. x 24 in. proprietary type X gypsum panels inserted between 2 1/2 in. floor and ceiling J track with T section of 2 1/2 in. proprietary C-T metal studs between proprietary gypsum panels. Two layers of 1/2 in. type X gypsum wallboard applied to face of C-T studs. Base layer applied at right angles to studs with 1 in. type S drywall screws 24 in. o.c. and face layer applied at right angles to studs with 1 1/2 in. type S drywall screws 8 in. o.c. Stagger joints 24 in. o.c. each layer. (NLB)	
	45 TO 49	3 1/2"	1 in. x 24 in. proprietary type X gypsum panels inserted between 2 1/2 in. floor and ceiling track with tab-flange section of 2 1/2 in. metal I studs between proprietary gypsum panels. One layer of 1/2 in. proprietary type X gypsum wallboard or veneer base applied at right angles to each side of metal I studs with 1 in. type S drywall screws 12 in. o.c. Sound tested using 1 1/2 in. glass fiber friction fit in stud space. (NLB)	
	50 TO 54	4"	1 in. x 24 in. proprietary type X gypsum panels inserted between 2 1/2 in. floor and ceiling track with tab-flange section of 2 1/2 in. metal I studs between proprietary gypsum panels. One layer of 1/2 in. proprietary type X gypsum wallboard or veneer base applied at right angles to flanges of I studs adjacent to proprietary gypsum panels with 1 in. type S drywall screws 12 in. o.c. Resilient channels spaced 24 in. o.c. horizontally, screw attached to opposite flanges of I studs with 3/8 in. type S screws, one per channel-stud intersection. 1/2 in. proprietary type X gypsum wallboard or veneer base applied parallel to resilient furring channels with 1 in. type S drywall screws 12 in. o.c. Sound tested using 1 in. glass fiber friction fit in stud space. (NLB)	
3 HOURS	40 TO 44	4 1/8"	2 in. x 24 in. laminated gypsum board panels installed vertically between floor and ceiling 20 gauge J runners with 25 gauge steel H members between panels. Panels attached at midpoint to 2 1/2 in. leg of J runners with 2 1/2 in. type S-12 drywall screws. H studs formed from 20 or 25 gauge 2 in. x 1 in. channels placed back to back and spot welded 24 in. o.c. Base layer 3/8 in. gypsum wallboard or veneer base applied parallel to one side of panels, with 1 in. type S drywall screws 12 in. o.c. to H studs. Rigid furring channels horizontally attached 24 in. o.c. to H studs with 1 in. type S drywall screws. Face layer 3/8 in. gypsum wallboard or veneer base attached at right angles to furring channels with 1 in. type S drywall screws 12 in. o.c. Stagger joints 24 in. o.c. each layer and side. (NLB)	
	45 TO 49	5 1/4"	3/4 in. x 24 in. proprietary type X gypsum panels inserted between 2 1/4 in. floor and ceiling tracks and fitted to 2 1/4 in. slotted metal I studs with tab-flange. First layer 3/8 in. type X gypsum board applied at right angles to studs with 1 in. type S drywall screws 24 in. o.c. Second layer 3/8 in. type X gypsum board applied parallel to studs with 1 1/2 in. type S drywall screws 42 in. o.c. starting 12 in. from bottom. Third layer 3/8 in. type X gypsum board applied parallel to studs with 2 1/4 in. type S drywall screws 24 in. o.c. Resilient channels applied 24 in. o.c. at right angles to studs with 2 1/4 in. type S drywall screws. Fourth layer 3/8 in. type X gypsum board applied at right angles to resilient channels with 1 in. type S drywall screws 12 in. o.c. Sound tested with 1 in. glass fiber friction fit in stud space. (NLB)	



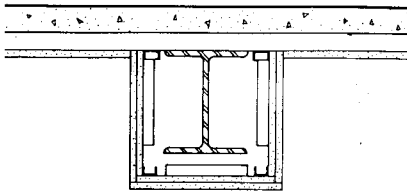

2 HOUR FIRE RATING

Two layers of 5/8 in. type X gypsum wallboard or veneer base around beam. Base layer attached with 1 1/4 in. type S drywall screws 16 in. o.c., face layer attached with 1 1/4 in. type S drywall screws 8 in. o.c. to horizontally installed U-shaped steel channels (25 gauge steel 1 1/16 in. wide and 1 in. legs) located not less than 1/2 in. from beam flanges. Upper channels secured to steel deck units with 1/2 in. type S pan head screws spaced 12 in. o.c. U-shaped brackets formed of steel channels spaced 24 in. o.c. suspended from the upper channels with 1/2 in. type S pan head screws and supported steel channels installed at lower corners of brackets. Outside corners of gypsum board protected by 0.020-in.-thick steel corner beads crimped or nailed. (2 hour restrained or unrestrained beam)

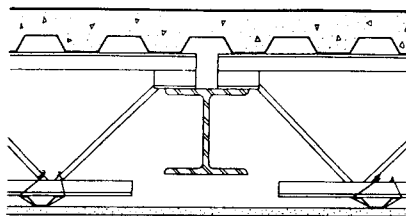

3 HOUR FIRE RATING

One layer 1/2 in. type X gypsum wallboard or veneer base applied at right angles to rigid furring channels with 1 in. type S drywall screws 12 in. o.c. Wallboard end joints located midway between continuous channels and attached to additional pieces of channel 54 in. long with screws at 12 in. o.c. Furring channels 24 in. o.c. attached with 18 gauge wire ties 48 in. o.c. to open web steel joists 24 in. o.c. supporting 3/8 in. rib metal lath or 1/8 in. deep, 28 gauge corrugated steel and 2 1/2 in. concrete slab measured from top of flute. Furring channels may be attached to 1 1/2 in. cold-rolled carrying channels 48 in. o.c. suspended from joists by 8 gauge wire hangers not over 48 in. o.c. (3 hour unrestrained beam)

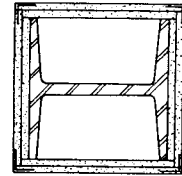

1 HOUR FIRE RATING

Base layer 1/2 in. gypsum wallboard or veneer base tied to column with 18 gauge wire 15 in. o.c. Face layer 1/2 in. gypsum wallboard or veneer base applied with laminating compound over entire contact surface.

BEAMS, GIRDERS AND TRUSSES

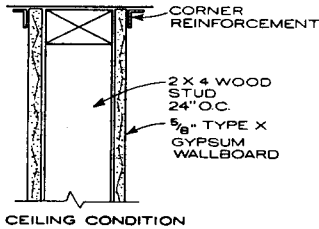

CEILING CONDITION

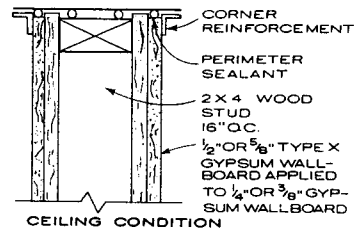

FLOOR CONDITION

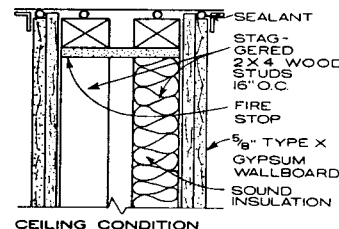

CEILING CONDITION

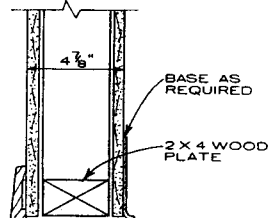

FLOOR CONDITION  
FIRE RATING 1HR STC 35 TO 39

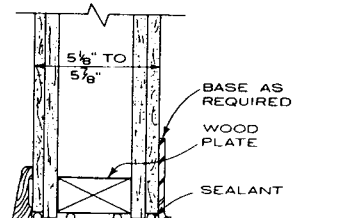

FLOOR CONDITION  
FIRE RATING 1HR STC 45 TO 49

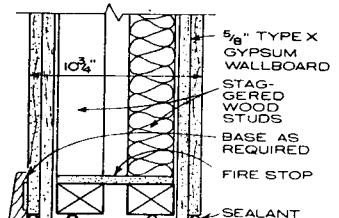

FLOOR CONDITION  
FIRE RATING 2HR STC 55 TO 59

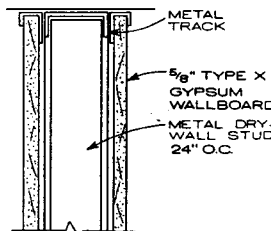

CEILING CONDITION

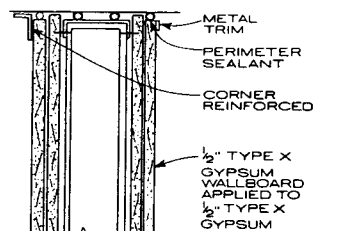

CEILING CONDITION

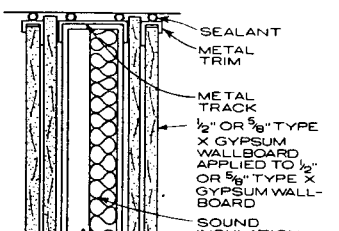

CEILING CONDITION

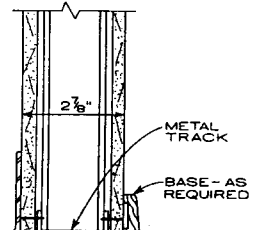

FLOOR CONDITION  
FIRE RATING 1HR STC 35 TO 39

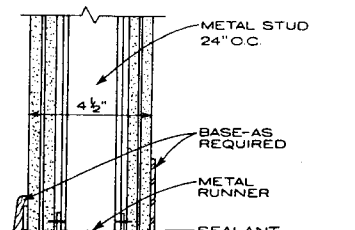

FLOOR CONDITION  
FIRE RATING 2HR STC 45 TO 49

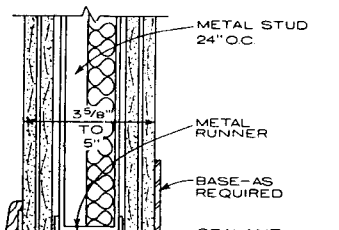

FLOOR CONDITION  
FIRE RATING 2HR STC 50 TO 54

GYPHUM WOOD AND METAL FRAMED TYPE PARTITIONS

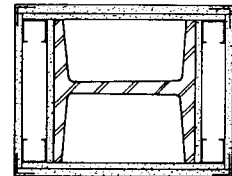

2 HOUR FIRE RATING

Base layer 1/2 in. type X gypsum wallboard or veneer base against flanges and across web openings fastened to 1 1/8 in. metal studs with 1 in. type S drywall screws 24 in. o.c. at corners. Face layers 1/2 in. type X gypsum wallboard or veneer base screw-attached to studs with 1 in. type S drywall screws 12 in. o.c. to provide a cavity between boards on the flange. Face layers across the web opening laid flat across the base layer and screw attached with 1 1/8 in. type S drywall screws 12 in. o.c. Metal corner beads nailed to outer layer with 4d nails 1 1/8 in. long, 0.067 in. shank, 1/16 in. heads, 12 in. o.c.

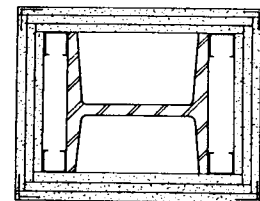

3 HOUR FIRE RATING

Three layers of 5/8 in. type X gypsum wallboard or veneer base screw attached to 1 1/8 in. metal studs located at each corner of column. Base layer attached with 1 in. type S drywall screws 24 in. o.c. Second layer with 1 1/8 in. type S drywall screws 12 in. o.c. and 18 gauge wire tied 24 in. o.c. Face layer attached with 2 1/4 in. type S drywall screws 12 in. o.c. and 1 1/4 in. corner bead at each corner nailed with 6d coated nails, 1 1/4 in. long, 0.0915 in. shank, 1/4 in. heads, 12 in. o.c.

COLUMNS  
FIRE-RESISTIVE  
CONSTRUCTION

Ferdinand R. Scheeler, AIA; Skidmore, Owings & Merrill; Chicago, Illinois  
James Lloyd; Kennett Square, Pennsylvania

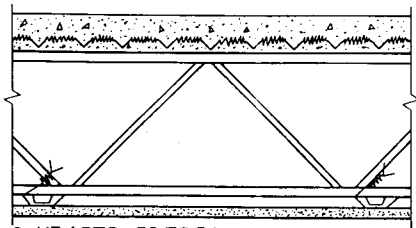

2 HR / STC 50 TO 54

1/2 in. type X gypsum wallboard or veneer base applied to drywall furring channels. Furring channels 24 in. o.c. attached with 18 gauge wire ties 48 in. o.c. to open web steel joists 24 in. o.c. supporting 3/8 in. rib metal lath or 9/16 in. deep, 28 gauge corrugated steel and 2 1/2 in. concrete slab measured from top of flute. Double channel at wallboard end joints.

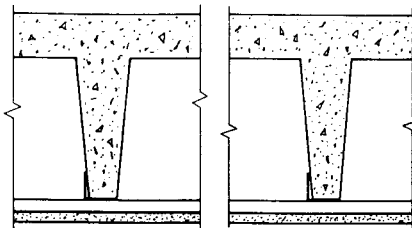

2 HR / STC 45 TO 49

5/8 in. type X gypsum wallboard or veneer base screw attached to drywall furring channels. Furring channels 24 in. o.c. suspended from 2 1/2 in. precast reinforced concrete joists 35 in. o.c. with 21 gauge galvanized steel hanger straps fastened to sides of joists. Joist leg depth, 10 in. Double channel at wallboard end joints.

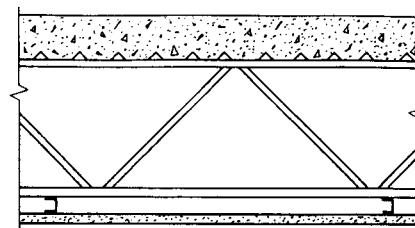

3 HR / STC 45 TO 49

5/8 in. proprietary type X gypsum wallboard or veneer base screw attached to furring channels 24 in. o.c. (double channels at end joints). Furring channel wire tied to open web steel joist 24 in. o.c. supporting 3 in. concrete slab over 3/8 in. rib metal lath. 5/8 x 2 3/4 in. type X gypsum wallboard strips over butt joints.

**FLOOR/CEILING ASSEMBLIES, NONCOMBUSTIBLE**

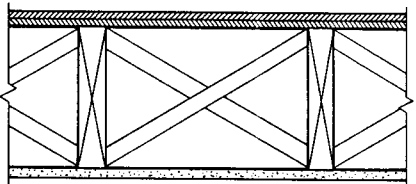

1 HR / STC 35 TO 39

5/8 in. type X gypsum wallboard or veneer base applied to wood joists 16 in. o.c. Joists supporting 1 in. nominal wood sub and finish floor, or 5/8 in. plywood finished floor with long edges T & G and 1/2 in. interior plywood with exterior glue subfloor perpendicular to joists with joints staggered.

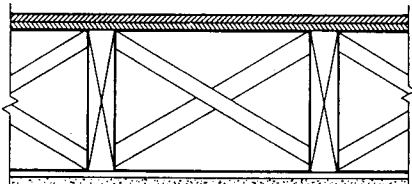

1 HR / STC 40 TO 44

1/2 in. type X gypsum wallboard or veneer base applied to drywall resilient furring channels 24 in. o.c. and nailed to wood joists 16 in. o.c. Wood joists supporting 1 in. nominal T & G wood sub and finish floor, or 5/8 in. plywood finished floor with long edges T & G and 1/2 in. interior plywood with exterior glue subfloor perpendicular to joists with joints staggered.

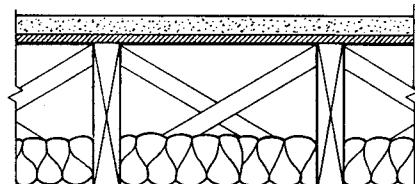

1 HR / STC 60 TO 64

1/2 in. type X gypsum wallboard or veneer base applied to resilient furring channels. Resilient channels applied 24 in. o.c. to wood joists 16 in. o.c. Wood joists support 1/2 in. plywood subfloor and 1 1/2 in. cellular or lightweight concrete over felt. 3 1/2 in. glass fiber batts in joist spaces. Sound tested with carpet and pad over 5/8 in. plywood subfloor.

**FLOOR/CEILING ASSEMBLIES, WOOD FRAMED**

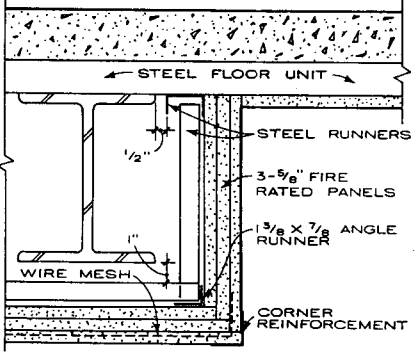

**BEAM PROTECTION**  
3 HR. RESTRAINED    2 HR. UNRESTRAINED

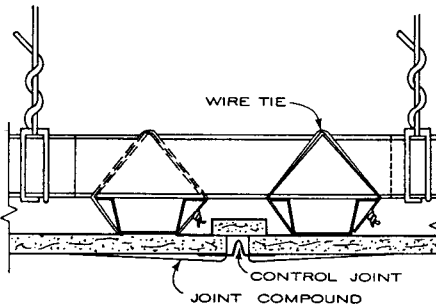

**CONTROL JOINT**

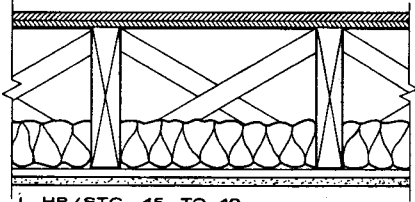

1 HR / STC 45 TO 49  
ELECTRIC RADIANT HEAT PANEL

5/8 in. proprietary type X gypsum board electrical radiant heating panels attached to resilient furring channels spaced 24 in. o.c. installed to 2 x 10 in. wood joists 16 in. o.c. 3/12 in. glass fiber insulation friction fit in joist space. Wood floor of nominal 1 in. T & G or 1/2 in. plywood subfloor and nominal 1 in. T & G or 5/8 in. plywood finish floor.

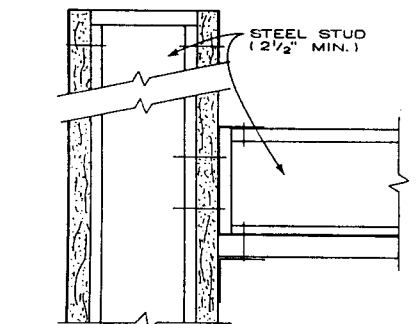

**PARTITION ATTACHMENT**  
(SCREW ATTACHED)

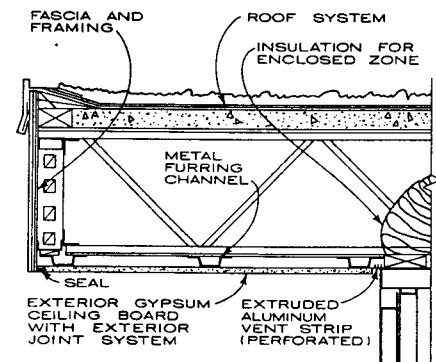

**EXTERIOR SOFFIT**

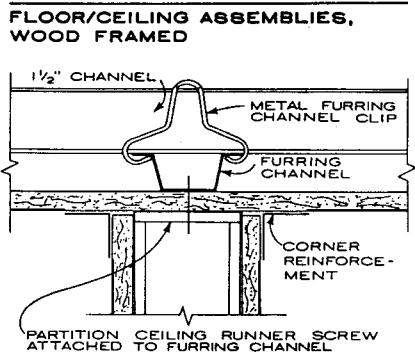

**CONTINUOUS CEILING**

James Lloyd; Kennett Square, Pennsylvania



NEW WALL ASSEMBLIES

FIRE RATING	STC	WALL THICKNESS (IN.)	CONSTRUCTION DESCRIPTION	WALL SECTIONS
1 Hour	40	Varies	<b>EXTERIOR WALL FURRING:</b> One layer 5/8 in. aluminum foil-backed gypsum wallboard applied to 3/4 x 1 1/2 in. Z furring channel 24 in. o.c., vertically applied with method appropriate to exterior wall. Use 1 in. type S drywall screws 8 in. o.c. to edges and 12 in. o.c. to intermediate Z channel flange. Insulate cavity with 24 x 1 1/2 in. rigid foam.	
1 Hour	40	8 1/8	<b>SECURITY WALL (15 minute):</b> One base layer of 13-gauge steel expanded metal mesh with nominal 1 x 2 1/2 in. grid-spacing under one layer of 3/4 in. plywood applied to one side of 6 in. metal studs 8 in. o.c. with 1 1/2 in. screws. One face layer of 5/8 in. type X gypsum wallboard applied to each side with 1 in. type S drywall screws 12 in. o.c. Stagger joints 16 in. o.c. each layer and side.	
1 Hour	52	10 3/4	<b>CAVITY WALL:</b> One layer 5/8 in. type X gypsum wallboard applied to outside face of two rows of 1 5/8 in. metal studs (air space 9 1/2 in. between inside wallboard faces) 24 in. o.c. with 1 in. type S drywall screws 8 in. o.c. to edges and 12 in. o.c. to intermediate studs. Crossbrace at third points vertically with 5/8 in. wallboard gussets 9 1/2 x 12 in. Use 3 1/2 in. fiberglass insulation in cavity.	
1 Hour	47	3 1/2	<b>PREFINISHED GYPSUM WALL PANELS:</b> One layer, 1/2 in. type X prefinished vinyl surface gypsum wall panels (prebowed) applied vertically at joints to each side of 2 1/2 in. metal studs 24 in. o.c. with 1 in. type S drywall screws 30 in. o.c. Attach to intermediate studs with 3/8 in. bead of adhesive. Attach at top and bottom with 1 3/8 inch matching finish nails 12 in. o.c. Attach aluminum batten retainer to panels at studs with 1 in. type S drywall screws 12 in. o.c. Install matching finish batten over retainers and 2 in. glass fiber insulation in cavity. Stagger joints 24 in. o.c. each side.	
1 Hour	45	5	<b>PREFINISHED GYPSUM WALL PANELS:</b> Base layer 1/4 in. regular gypsum wallboard nailed to 2 x 4 wood studs 16 in. o.c. with 1 3/8 in. 4d coated nails, 12 in. o.c., fire stopped at mid-height. Face layer 1/2 in. type X prefinished vinyl surface gypsum wall panels (prebowed) applied vertically to each side with laminating compound and 5/8 in. drywall screws, 12 in. o.c., at top and bottom. Stagger joints 24 in. o.c. each layer and side. Cover exposed fasteners with suitable molding.	
2 Hour	50	5 3/4	<b>WATER-RESISTANT WALL (ONE SIDE):</b> One layer 5/8 in. water-resistant gypsum wallboard applied to wet side of 3 3/8 in. 20-gauge metal studs 16 in. o.c. with 1 in. type S drywall screws 12 in. o.c. Opposite side, two layers 5/8 in. gypsum wallboard installed vertically. Use 3 in. fiber insulation in cavity. Stagger joints 24 in. o.c. each layer and side.	
2 Hour	45	8 1/4	<b>BULLET-RESISTANT WALL (ONE SIDE):</b> Base layer of 1/4 in. steel plate bolted to each side of steel tube framed wall with 4 x 1/4 in. steel tube at top, bottom, and 4 ft o.c., horizontally. Two layers each side 5/8 in. type X gypsum wallboard on 7/8 in. furring channels 24 in. o.c. applied with 1 in. type S drywall screws. Stagger joints 24 in. o.c. each layer and side.	

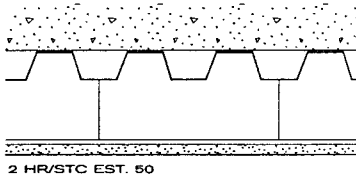

**NOTE**  
One layer 5/8 in. type X gypsum wallboard applied with 1 in. type S drywall screws perpendicular to the cross tees of a drywall suspension system suspended from a steel deck. Concrete floors 2 1/2 in. thick.

**DRYWALL SUSPENSION SYSTEM**

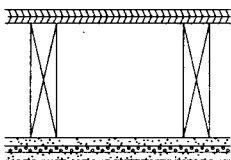

**NOTE**  
Base layer 5/8 in. type X gypsum wallboard applied at right angles to 2 x 10 wood joists with 1 in. type S drywall screws 16 in. o.c. Resilient furring channels spaced 24 in. o.c. and nailed through baseboard into and at right angles to joists. Face layer of 5/8 in. same type wallboard screwed to furring channel with same type screws. Tongue-and-groove sub- and finish floor.

**DOUBLE LAYER RESILIENT (WOOD FRAME)**

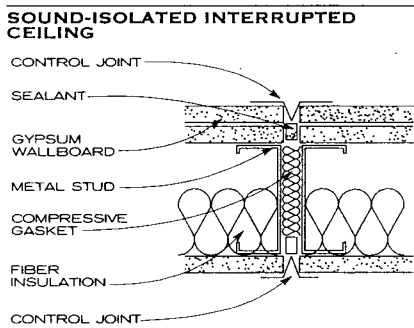
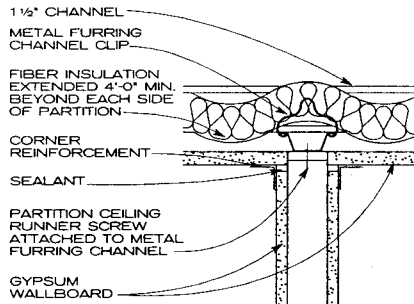

**WALL CONTROL JOINT**

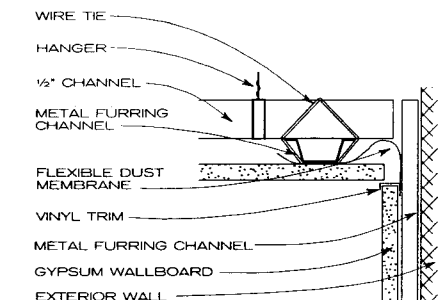

**EXTERIOR WALL INTERSECTION**

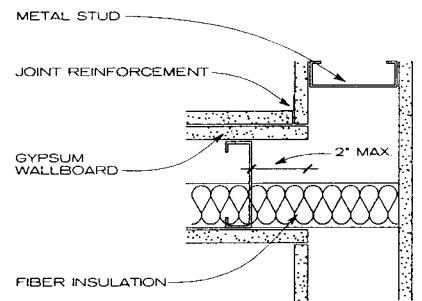

**SOUND-ISOLATED PARTITION INTERSECTION**

Thomas R. Krizmanic, AIA; Studios Architecture; Washington, D.C.  
United States Gypsum Company; Chicago, Illinois



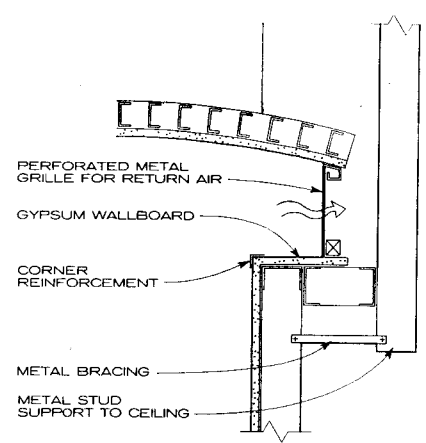
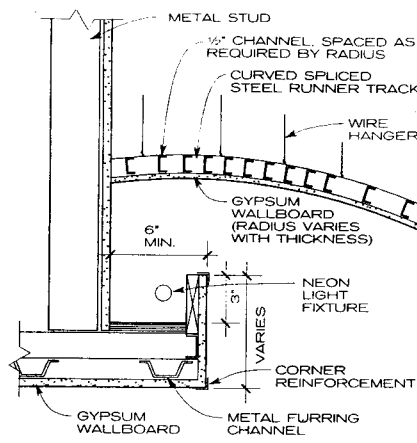
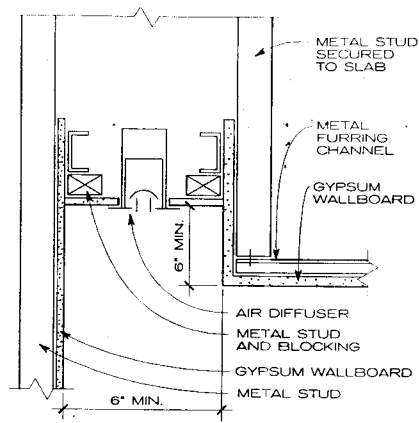

CEILING COVES

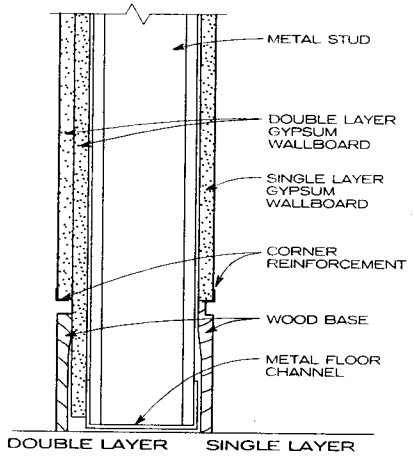

WALL AT WOOD BASE

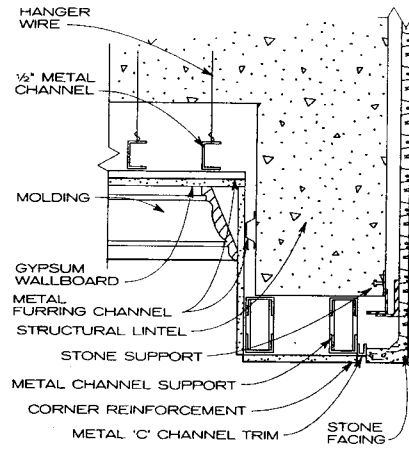

CEILING SOFFIT AT LINTEL

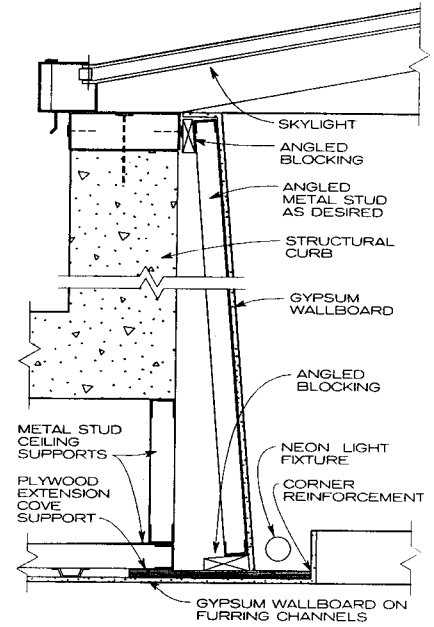

SKYLIGHT

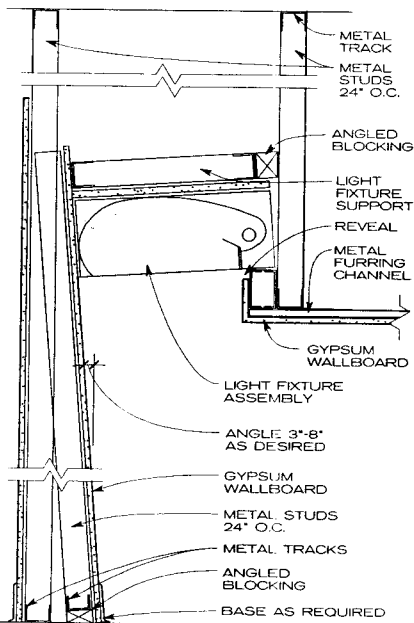

CANTED WALL WITH LIGHT COVE

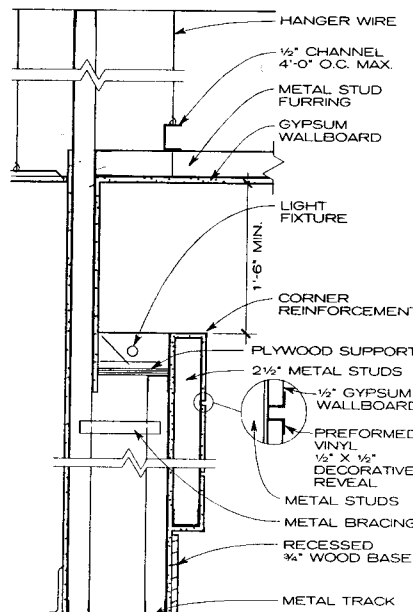

FEATURE WALL WITH LIGHT COVE

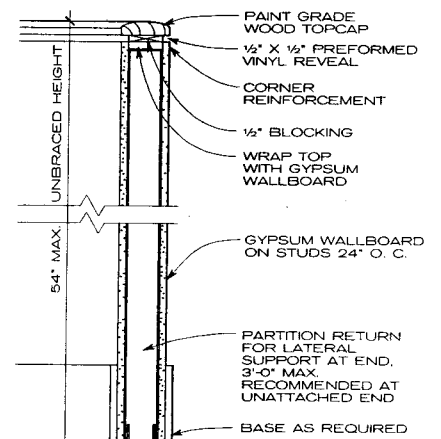

PARTIAL HEIGHT PARTITION

Thomas R. Krizmanic, AIA; Studios Architecture; Washington, D.C.



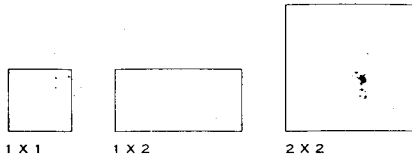

**FLAT TILE**

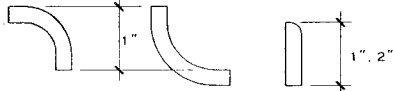

1 X 1  
2 X 1

1 X 1  
2 X 1

1 X 1, 1 X 2,  
2 X 2, 2 X 1

**BEAD**      **COVE**      **SURFACE BULLNOSE**

**TRIM UNITS**  
**NOTE**

Nominal thickness typically is 1/4 in.

**CERAMIC MOSAIC TILE**

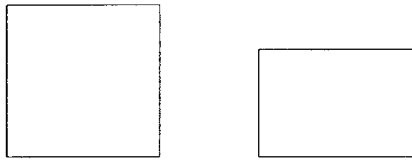

4 1/4 X 4 1/4  
6 X 6

6 X 4 1/4

**FLAT TILE**

**NOTE**

Nominal thickness typically is 5/16 in.

**GLAZED WALL TILE**

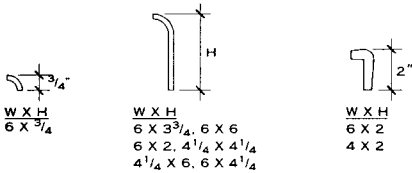

W X H  
6 X 3 3/4

W X H  
6 X 3 3/4, 6 X 6  
6 X 2, 4 1/4 X 4 1/4  
4 1/4 X 6, 6 X 4 1/4

W X H  
6 X 2  
4 X 2

**BEAD**      **BULLNOSE**      **COUNTER TRIM**

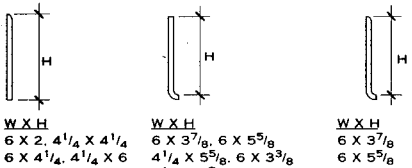

W X H  
6 X 2, 4 1/4 X 4 1/4  
6 X 4 1/4, 4 1/4 X 6

W X H  
6 X 3 7/8, 6 X 5 5/8  
4 1/4 X 5 5/8, 6 X 3 3/8  
4 1/4 X 3 7/8

W X H  
6 X 3 7/8  
6 X 5 5/8

**SURFACE BULLNOSE**      **COVE BASE**      **UNIVERSAL BASE**

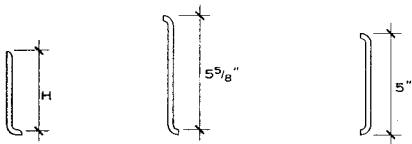

W X H  
6 X 3 7/8  
6 X 5 5/8

W X H  
6 X 5 5/8

W X H  
6 X 5

**BASE**      **BASE**      **CURB**

**WALL TILE TRIM UNITS**

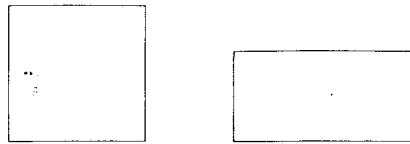

W X H X T  
6 X 6 X 3/8  
8 X 8 X 3/8  
3 X 3 X 1/2  
4 X 4 X 1/2  
6 X 6 X 1/2  
8 X 8 X 1/2  
6 X 6 X 3/4

W X H X T  
8 X 4 X 3/8  
6 X 3 X 1/2  
8 X 4 X 3/2  
8 X 4 X 3/4 (UNGLAZED ONLY)

**QUARRY TILE**

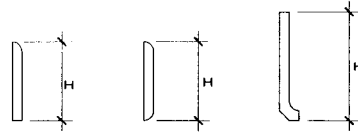

W X H X T  
4 X 4 X 1/2  
6 X 4 X 1/2  
6 X 6 X 1/2

W X H X T  
6 X 4 X 1/2  
6 X 6 X 1/2

W X H X T  
6 X 2 X 1/2  
6 X 5 X 1/2  
6 X 5 X 3/4  
6 X 2 X 3/4

**BULLNOSE**      **DOUBLE BULLNOSE**      **COVE**

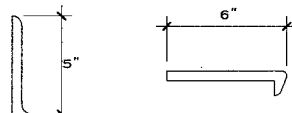

W X H X T  
6 X 5 X 1/2  
6 X 5 X 3/4

W X H X T  
6 X 6 X 3/4

**QUARRY TILE TRIM UNITS**

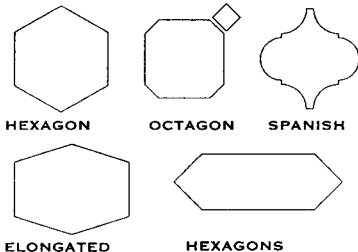

**HEXAGON**      **OCTAGON**      **SPANISH**

**ELONGATED**      **HEXAGONS**

**NOTE**

Special shapes and dimensions are available in all tile types. Consult manufacturers for details.

**SPECIAL TILE SHAPES**

**GENERAL**

Tile used for architectural floor and wall applications are manufactured compositions of natural clay or mixtures of clay and other ceramic materials (e.g., shale and porcelain). Relatively thin in relation to their facial area, they can be textured, sculptured, embossed, patterned, or engraved on the surface and are available either glazed or unglazed.

Generally, tile dimensions are nominal. Check with manufacturers for specific dimensions.

**DEFINITIONS**

**CERAMIC MOSAIC TILE** is formed either by the dust-pressed or the plastic method. Usually 1/4 to 3/8 in. thick with a facial area of less than 6 sq in., it may be made of either porcelain or natural clay and may be plain or have an abrasive mixture throughout.

**CONDUCTIVE TILE** has specific properties of electrical conductivity but retains other normal physical properties of tile.

**DECORATIVE THIN WALL TILE** is a glazed tile with a thin body that is usually nonvitreous. It is suitable for interior decorative residential use when breaking strength is not a requirement.

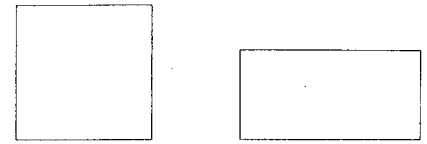

W X H X T  
3 X 3 X 1/4  
4 X 4 X 3/8  
8 X 8 X 3/8  
12 X 12 X 3/8  
4 X 4 X 1/2  
6 X 6 X 1/2  
8 X 8 X 1/2 (UNGLAZED ONLY)

W X H X T  
8 X 4 X 3/8  
8 X 4 X 1/2

**PAVER TILE**

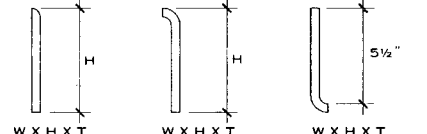

W X H X T  
8 X 8 X 3/8  
4 X 8 X 1/2  
6 X 6 X 1/2  
8 X 4 X 1/2  
4 1/2 X 4 1/4 X 3/8

W X H X T  
6 X 6 X 1/2 X 3/8

W X H X T  
6 X 5 1/2 X 1/2

**BULLNOSE**      **COVE**

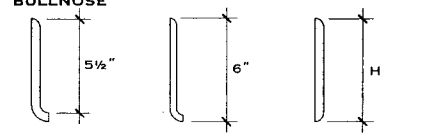

W X H X T  
6 X 5 1/2 X 1/2

W X H X T  
8 X 6 X 3/8

W X H X T  
6 X 6 X 1/2  
8 X 4 X 1/2  
**DOUBLE BULLNOSE**

**WINDOWSILL OR STEP NOSING**

**WINDOWSILL OR STEP NOSING**

**PAVER TILE TRIM UNITS**

**GLAZED TILE** has an impervious facial finish of ceramic materials that is fused to the body of the tile. The body may be nonvitreous, semivitreous, vitreous, or impervious.

**IMPERVIOUS TILE** has a water absorption rate of 0.5% or less.

**MOUNTED TILE** is assembled into units or sheets to facilitate handling and installation. Tile may be face-mounted, back-mounted, or edge-mounted. Material applied to the face of the tile usually is easily removed, but material bonded to the back is integrated into the tile installation.

**NATURAL CLAY TILE** is a ceramic mosaic or paver tile with a distinctive, slightly textured appearance. It is made by the dust-pressed or plastic method from clays that have a dense body.

**NONVITREOUS TILE** has a water absorption rate of more than 7%.

**PAVER TILE** is glazed or unglazed porcelain or natural clay tile formed by the dust-pressed method with a facial area of 6 sq in. (39 sq cm) or more.

**PORCELAIN TILE** is a ceramic mosaic or paver tile generally made by the dust-pressed method. It is dense, impervious, fine-grained, and smooth with a sharply formed face.

**QUARRY TILE** is glazed or unglazed tile made by the extrusion process from natural clay or shale. It usually has a facial area of 6 sq in. (39 sq cm) or more.

**SEMI-VITREOUS TILE** has a water absorption rate between 3 and 7%.

**UNGLAZED TILE** is a hard, dense tile of uniform composition that derives color and texture from the materials used to make it.

**VITREOUS TILE** has a water absorption rate between 0.5 and 3%.

**WALL TILE** is a glazed tile with a body suitable for interior use. Usually nonvitreous, it is not required or expected to withstand excessive impact or freezing and thawing conditions.

**TYPES OF MORTAR**

**PORTLAND CEMENT MORTAR**

A mixture of portland cement and sand (for floors) or lime (for walls) used for thick-bed installation.

**DRY-SET MORTAR**

A mixture of portland cement with sand and additives, imparting water retention that eliminates the need to soak tiles.

**LATEX PORTLAND CEMENT MORTAR**

A mixture similar to dry-set but with latex (an emulsion of polymer particles in water) added to replace all or part of the water in the mortar. It provides better adhesion, density, and impact strength than dry-set mortar, and it is more flexible and resistant to frost damage.

**MODIFIED EPOXY EMULSION MORTAR**

As with epoxy mortars, this mixture contains a resin and hardener along with portland cement and sand. Although it is not as chemically resistant as epoxy mortar, it binds well. Compared with straight portland cement, it allows little or no shrinkage.

**METHODS OF INSTALLATION**

In a thick-bed process tiles may be applied over a portland cement mortar bed  $\frac{3}{4}$  to 2 in. thick. The thick-bed allows for accurate slopes or planes in the finished tile work and is not affected by prolonged contact with water. If the backing surface is damaged, cracked, or unstable, use a membrane between the surface and the mortar bed.

In a thin-set process, tiles are set or bonded to the surface with a thin coat of material varying from  $\frac{1}{32}$  in. to  $\frac{1}{8}$  in. thickness. Bonding materials include dry-set mortar, latex portland cement mortar, organic adhesive, epoxy mortar or adhesive, and modified epoxy emulsion mortar. Thin-set application requires a continuous, stable, and undamaged surface.

**THIN-SET MORTAR WITHOUT PORTLAND CEMENT**

**EPOXY MORTAR**

A two-part mixture (resin and hardener with silica filler) used where chemical resistance is important. It has high bond strength and high resistance to impact. This mortar and furan mortar are the only two that can be recommended for use over steel plates.

**EPOXY ADHESIVE**

Mixture similar to epoxy mortar in bonding capability, but not as chemical or solvent resistant.

**ORGANIC ADHESIVE**

A one-part mastic mixture that requires no mixing. It remains somewhat flexible (as compared with portland cement mortar), and has good bond strength but should not be used for exterior or wet applications.

**FURAN MORTAR**

A two-part mixture (furan resin and hardener) excellent for chemical resistant uses and its high temperatures (350°F) tolerance.

**GROUT**

Grout is used to fill joints between tiles and is selected with a compatible mortar. Types include:

**PORTLAND CEMENT BASED GROUTS**

Include commercial portland cement grout, sand-portland cement grout, dry-set grout, and latex portland cement grout.

**EPOXY GROUT**

A two- or three-part mixture (epoxy resin hardener with silica sand filler) highly resistant to chemicals. It has great bond strength. This grout and furan grout are made for different chemical and solvent resistance.

**FURAN RESIN GROUT**

A two-part furan mixture (similar to furan mortar) that resists high temperatures and solvents.

**SILICONE RUBBER GROUT**

An elastomeric mixture of silicone rubber. It has high bond strength, is resistant to water and staining, and remains flexible under freezing conditions.

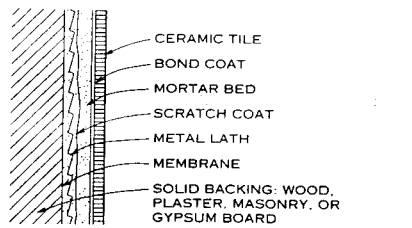

Use over solid backing, over wood or metal studs. Preferred method for showers and tub enclosures. Ideal for remodeling.

**CEMENT MORTAR**

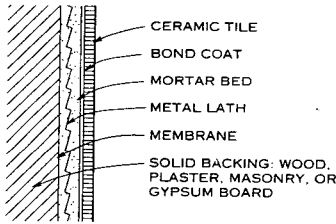

Use for remodeling or on surfaces that present bonding problems. Preferred method of applying tile over gypsum plaster or gypsum board in showers and tub enclosures.

**ONE-COAT METHOD**

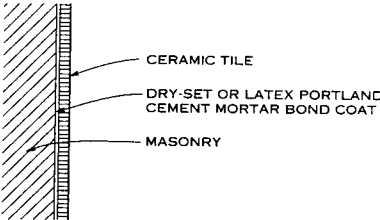

Use over gypsum board, plaster, or other smooth, dimensionally stable surfaces. Use cementitious backer units in wet areas.

**DRY-SET MORTAR**

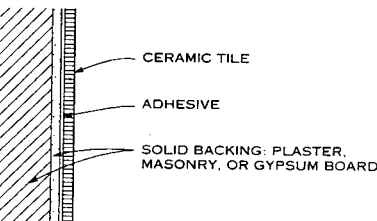

Use over gypsum board, plaster, or other smooth, dimensionally stable surfaces. Use water-resistant gypsum board in wet areas.

**ORGANIC ADHESIVE**

**WALL DETAILS**

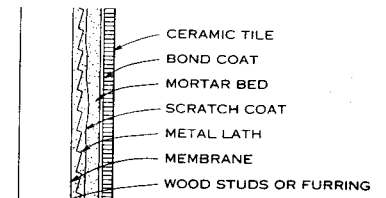
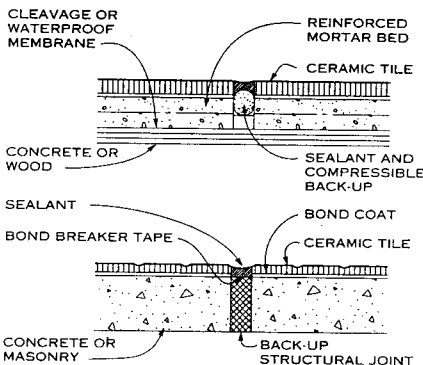

Use over dry, well-braced studs or furring. Preferred method of installation in showers and tub enclosures.

**CEMENT MORTAR**

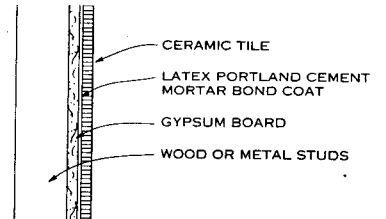

Use in dry interior areas in schools, institutions, and commercial buildings. Do not use in areas where temperatures exceed 125°F.

**LATEX - PORTLAND CEMENT MORTAR**

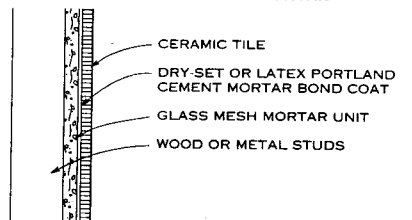

Use in wet areas over well-braced wood or metal studs. Stud spacing not to exceed 16 in. o.c., and metal studs must be 20 gauge or heavier.

**DRY-SET MORTAR (CEMENTITIOUS BACKER)**

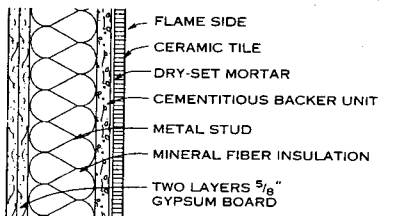

Use where a fire resistance rating of 2 hours is required with tile face exposed to flame. Stud spacing not to exceed 16 in. o.c. and mortar dry-set minimum thickness  $\frac{3}{32}$  in.

**DRY-SET MORTAR (FIRE-RATED WALL)**

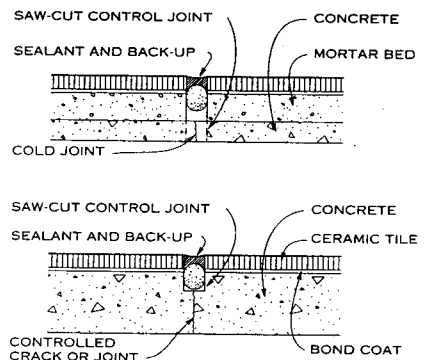

**VERTICAL AND HORIZONTAL EXPANSION JOINTS**

Tile Council of America, Inc.; Princeton, New Jersey  
Jess McIlvain, AIA, CCS, CSI; Jess McIlvain and Associates; Bethesda, Maryland

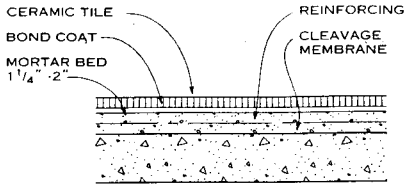

Use over structural floors subject to bending and deflection. Reinforcing mesh mandatory; mortar bed 1 1/4 to 2 in. thick and uniform.

**CEMENT MORTAR**

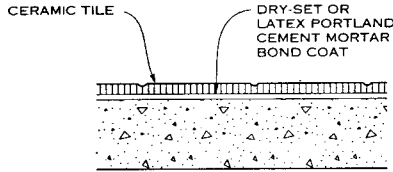

Use on level, clean slab-on-grade construction where no bending stresses occur and expansion joints are installed. Scarify existing concrete floors before installing tile.

**DRY-SET OR LATEX PORTLAND CEMENT MORTAR**

**FLOORING DETAILS—CEMENT**

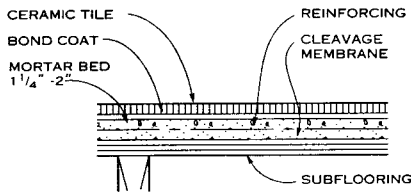

Use over wood floors that are structurally sound and where deflection, including live and dead loads, does not exceed 1/360 of span.

**CEMENT MORTAR**

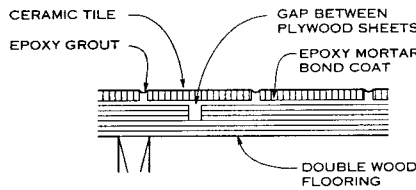

Use in residential, light commercial, and light institutional construction. Recommended where resistance to water, chemicals, or staining is needed.

**EPOXY MORTAR AND GROUT**

**FLOORING DETAILS—WOOD**

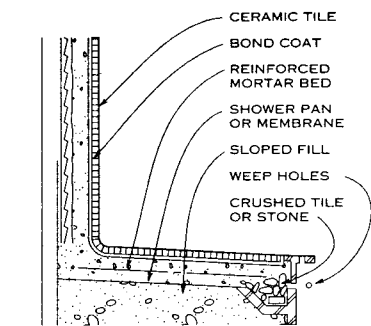

**TILE SHOWER RECEPTOR**

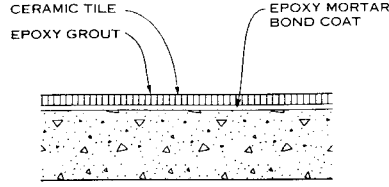

Use where moderate chemical exposure and severe cleaning methods are used, such as in commercial kitchens, dairies, breweries, and food plants.

**EPOXY MORTAR AND GROUT**

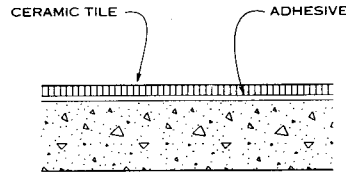

Use over concrete floors in residential construction only. Will not withstand high impact or wheel loads. Not recommended in areas where temperatures exceed 140°F.

**ORGANIC OR EPOXY ADHESIVE**

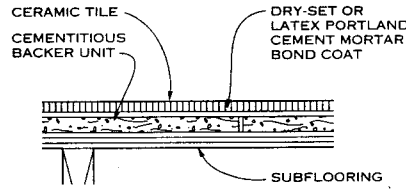

Use in light commercial and residential construction, deflection not to exceed 1/360, including live and dead loads. Waterproof membrane is required in wet areas.

**DRY-SET MORTAR**

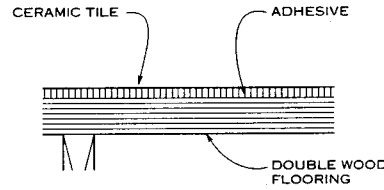

Use over wood or concrete floors in residential construction only. Not recommended for use in wet areas.

**ORGANIC ADHESIVE**

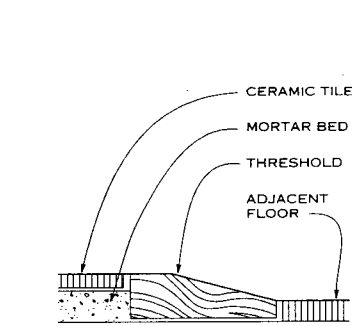

**THRESHOLDS AND SADDLES**

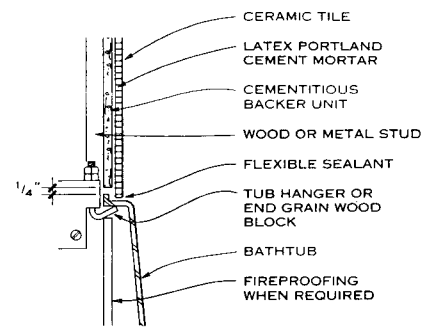

**CERAMIC TILE TUB ENCLOSURE**

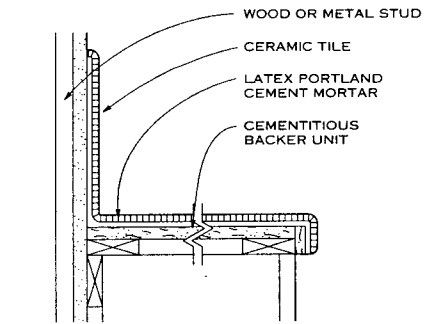

**THIN-SET COUNTERTOP**

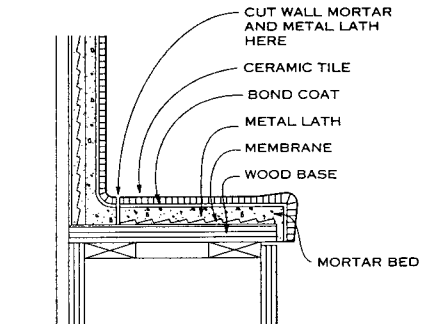

**CEMENT MORTAR COUNTERTOP**

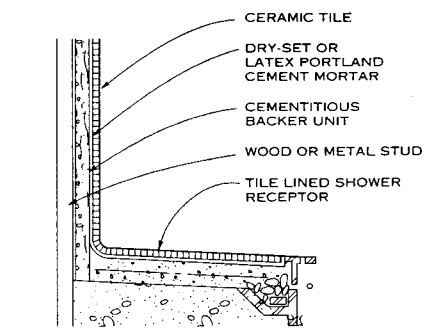

**CERAMIC TILE SHOWER RECEPTOR AND WALL**

Tile Council of America, Inc.; Princeton, New Jersey  
 Jess McIlvain, AIA, CCS, CSI; Jess McIlvain and Associates; Bethesda, Maryland

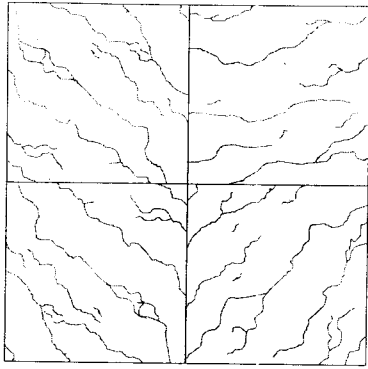

BLEND PATTERN

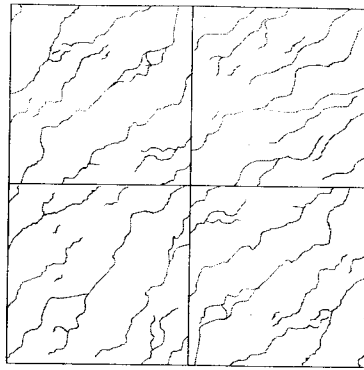

SIDE-SLIP OR END PATTERN

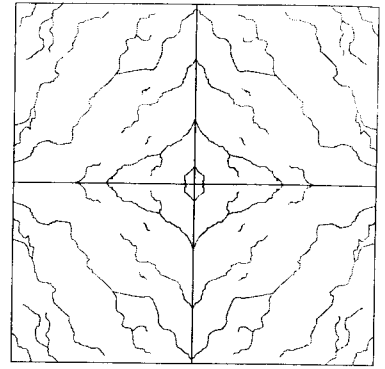

END-MATCH, BOOK-MATCH, OR QUARTER-MATCH PATTERNS

MARBLE WALL FACING PATTERN

MARBLE WALL FACING PATTERNS

Stone with distinctive texture and markings, such as certain marbles, lends itself to specific pattern arrangements. The markings vary depending on whether the marble veneer is cut with or across its setting bed.

**BLEND PATTERN:** Panels of the same variety of stone, but not necessarily from the same block, are arranged at random.

**SIDE-SLIP OR END-SLIP PATTERN:** Panels from the same block are placed side by side or end to end in sequence to give a repetitive pattern and blended color in the horizontal or vertical.

**END-MATCH OR BOOK-MATCH PATTERNS:** In an end-match pattern, the adjacent faces of panels A and B are finished and panel B is inverted above panel A. In a book-match pattern, panel B is placed next to panel A.

VENEER CUTTING

Quarry blocks are reduced to slabs by a gang saw. The gang saw consists of a series of parallel steel blades in a frame that moves forward and backward. The most productive and precise gang saws use diamond-tipped blades with individual hydraulic blade tensioners; others are fed a cutting abrasive in a stream of water.

Marble blocks can be sawn either parallel or perpendicular to the bedding plane. The perpendicular cut is referred to as an across-the-bed or vein cut. The parallel cut is a with-the-bed or Fleuri cut. Other marbles produce a pleasing surface only when sawn in one direction and are generally available only in that variety.

VENEER PATTERNS

Only certain marbles lend themselves to specific pattern arrangements, such as a side-slip or end-slip pattern, which require a constant natural marking trend throughout the marble block. Formal patterns require selectivity, which usually increases the installed cost of the marble veneer. Usually, material sawn for a vein cut can be matched; Fleuri cuts can only be blended.

NOTE

Although the above arrangements of matched panels indicate an almost perfect match of veining lines, such perfection is impossible because a portion of the marble block is lost during the sawing process and because the vein shifts. Ideally, jointing should be planned for groupings of four panels of equal size.

TYPICAL FINISHES AND COMMON SIZES OF STONE WALL PANELS FOR INTERIOR USE

STONE	GRADE	FINISH	MIN. THICKNESS (IN.)	MAX. FACE DIMENSION (IN.)	NOTES
Granite	Building (exterior) Veneer Masonry	Polished Honed	3/4 - 1 1/4 *	5 x 5	<ul style="list-style-type: none"> <li>This very hard and durable surface is not likely to stain.</li> <li>Many colors and grains are available.</li> </ul>
Marble	Group A (exterior) Group B Group C Group D	Polished Honed	1/2 - 3/8 *	4 x 7	<ul style="list-style-type: none"> <li>The most colorful and interesting marbles are in groups B, C, and D; however, some filling of natural voids may be required.</li> <li>Many colors and patterns are available.</li> </ul>
Limestone	Select Standard Rustic Variegated	Smooth Tooled Polished	7/8 - 3	4 x 9	<ul style="list-style-type: none"> <li>Soft and easy to shape, limestone shows wear and may discolor over time.</li> <li>Colors range in the buffs and grays.</li> </ul>
Slate	Ribbon Clear	Natural cleft Sand rubbed Honed	1 - 1 1/2	2 - 6 x 5	<ul style="list-style-type: none"> <li>Ribbon stock is distinguished by its ornamental, integral bands, which are usually darker than the rest of the stone.</li> <li>Colors range in the pastel hues.</li> </ul>

\* 1/4 - 1/2 in. tiles (usually a face dimension of 12 in. x 12 in.) available. Tiles can be directly applied to a wall with adhesive or thin-set mortar similar to flooring applications. Tiles are not recommended for walls over 8 ft high.

NOTES

1. Sizes and thicknesses shown are only indicative of some of the common sizes and thicknesses used. Intended use and size generally dictate minimum thickness.

2. Joint width between panels should be specified. Traditionally, it has been 1/16 in. minimum.

Mark Forma; Leo A. Daly Company; Washington, D.C.



STONE FLOOR AND WALL COVERINGS

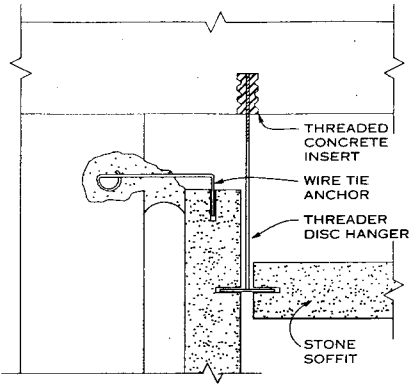

SOFFIT DETAIL AT WALL

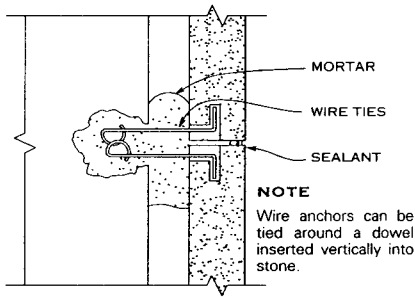

VERTICAL JOINT DETAIL — PLAN

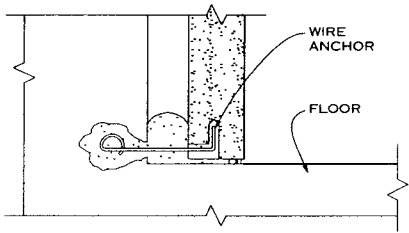

BASE DETAIL

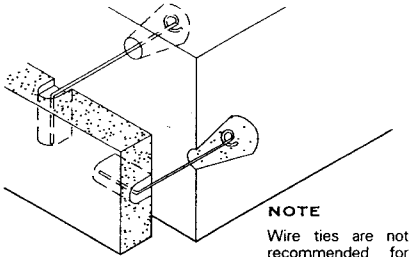

SIMPLE WIRE ANCHOR CONNECTION

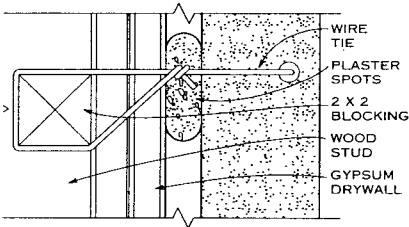

STONE PANEL ON WOOD STUDS

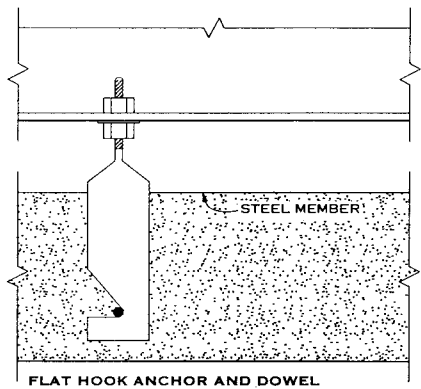
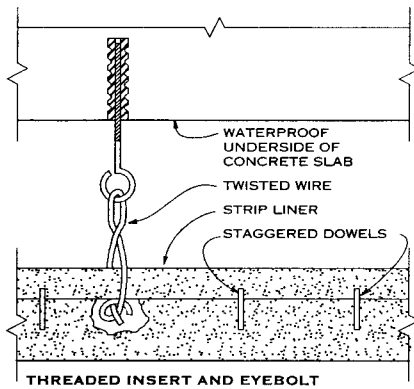
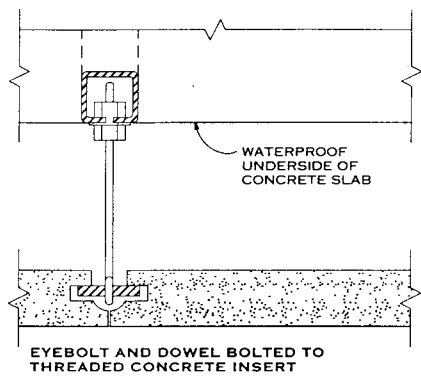
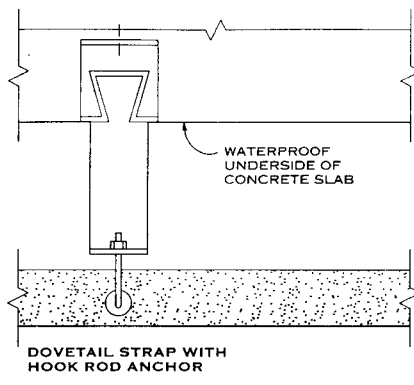

TYPICAL SYSTEMS FOR HANGING INTERIOR VENEER STONE

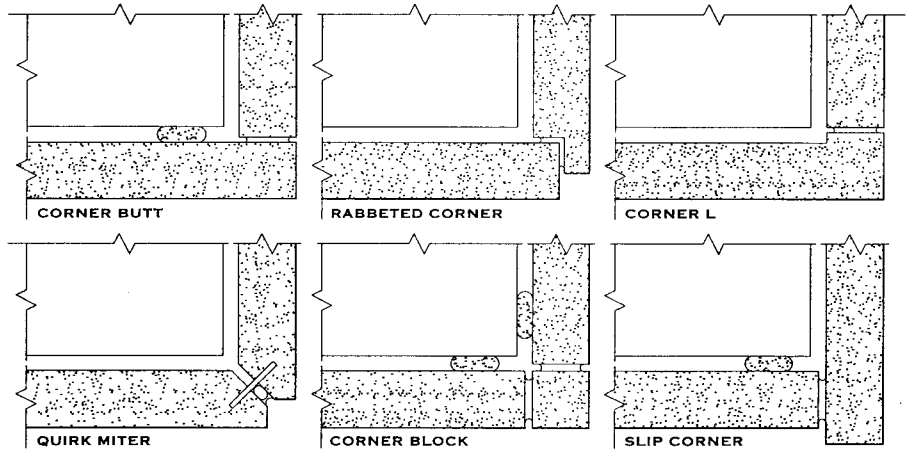

TYPICAL CORNER DETAILS

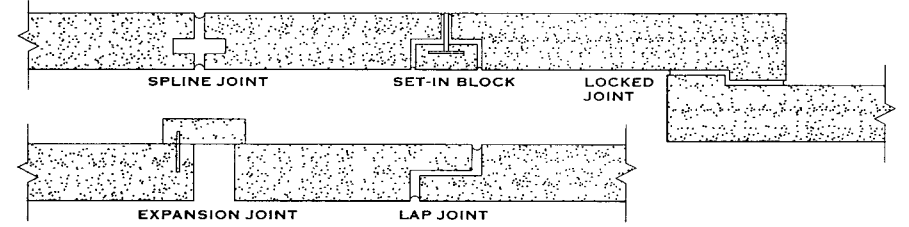

TYPICAL HORIZONTAL JOINTS

Building Stone Institute; New York, New York  
George M. Whiteside, III, AIA, and James D. Lloyd; Kennett Square, Pennsylvania  
Alexander Keyes; Darrel Downing Rippeteau, Architect; Washington, D.C.

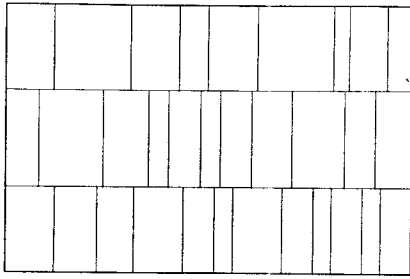

COURSED

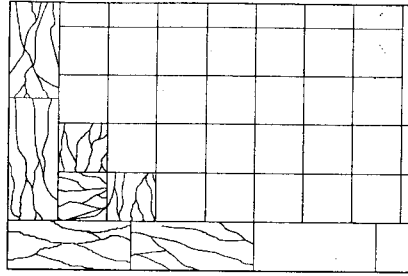

SQUARES

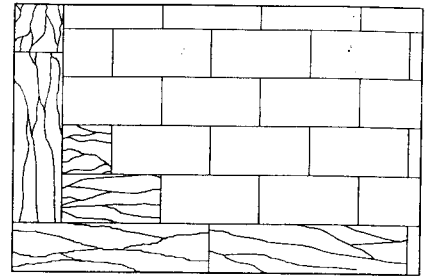

COURSED

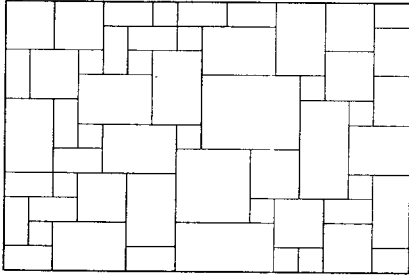

RANDOM RECTANGULAR

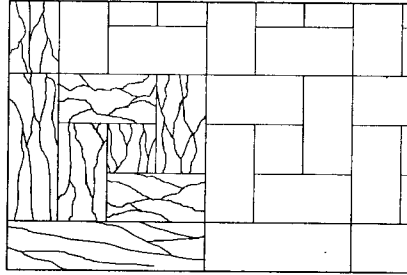

GEOMETRIC

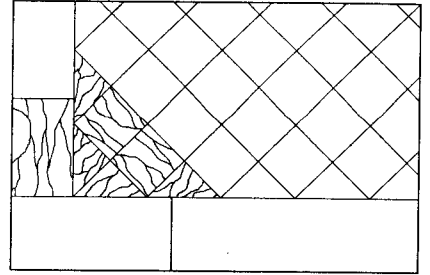

DIAMOND

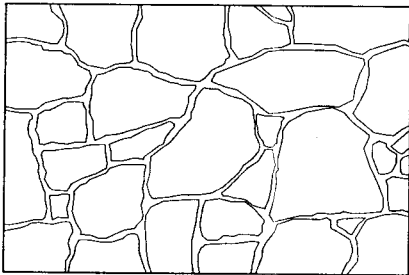

RANDOM IRREGULAR

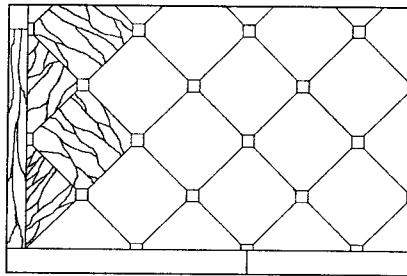

OCTAGON-SQUARE

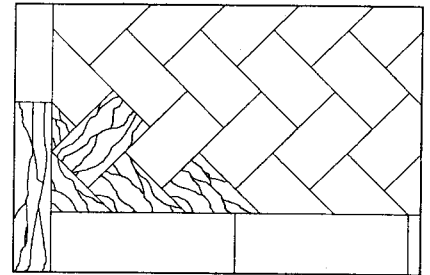

HERRINGBONE

**FLAGSTONE AND SLATE PATTERNS**

**FINISHES**

**POLISHED:** A glossy surface that brings out the full color of the stone. Generally, polished finishes can only be used on hard, dense material such as granite or marble.

**HONED:** A satin smooth surface with little or no gloss.

**THERMAL:** A planar surface with flame finish applied by mechanically controlled means to ensure uniformity. Surface coarseness varies depending on the grain structure of the stone. Generally, thermal finishes are used on granite.

**RUBBED:** A planar surface with occasional slight scratches.

**MARBLE AND GRANITE PATTERNS**

**TYPICAL FINISHES AND COMMON SIZES OF STONE TILES AND PAVERS**

STONE	FINISH	THICKNESS (IN.)(MIN.)	FACE DIMENSION (IN.)(MAX.)	HA
Granite	polished	$\frac{3}{8}$ - $\frac{1}{2}$ (tiles)	12 x 12 (tiles)	N/A
	honed thermal	$1\frac{1}{4}$ - 4 (pavers)	15 x 30 (pavers)	
Marble	polished	$\frac{1}{4}$ - $\frac{1}{2}$ (tiles)	12 x 12 (tiles)	10
	honed	$1\frac{1}{4}$ (pavers)	24 x 24 (pavers)	
Limestone	smooth	$1\frac{3}{4}$ - 2 $\frac{1}{2}$ (pavers)	24 x 36 (pavers)	10
Slate	natural cleft sand-rubbed	$\frac{1}{4}$ - 1	12 x 12 to 24 x 54	8
Flagstone	natural cleft semirubbed	$\frac{1}{2}$ - 4	12 x 12 to 24 x 36	8

**NOTES**

1. *Ha*, the abrasive hardness value, is the reciprocal of the volume of the material abraded multiplied by ten. A minimum value of 10 is recommended for flooring. Stones with a difference of 5 or more in *Ha* value should not be used together because they will wear differently.
2. Joint width should always be specified;  $\frac{1}{16}$  to  $\frac{1}{8}$  in. is considered standard.
3. Only attempt to set stone flooring over a wood subfloor after the subfloor has been reinforced to ensure against deflection.

4. Lippage is a condition that occurs when tiles are installed with a thin-bed method over an uneven surface. Tiles may "lip," one edge higher than their neighbors, giving the finished surface a ragged appearance. In some conditions, a certain amount of lippage is unavoidable. As a general rule, the recommended maximum variation of the finished surface should be no more than  $\frac{3}{16}$  in. cumulative over a 10 ft. 0 in. lineal measurement, with no more than  $\frac{1}{32}$  in. variation between individual tiles.

Mark Forma; Leo A. Daly Company; Washington, D.C.



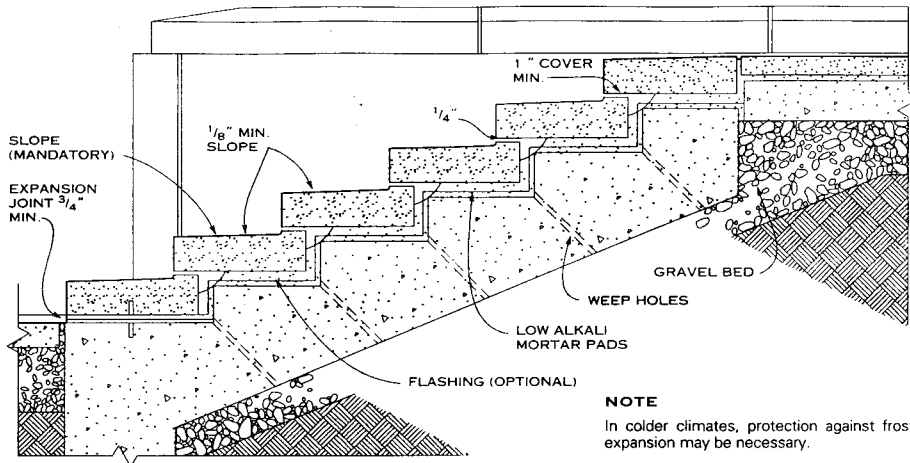

**NOTE**  
In colder climates, protection against frost expansion may be necessary.

**EXTERIOR STAIR SECTION**

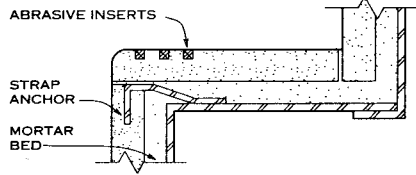

**METAL PAN WITH STONE SAFETY TREAD**

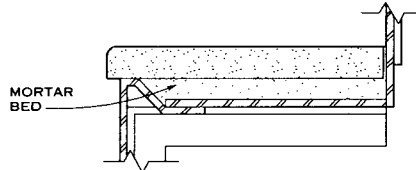

**STEEL SUBTREAD AND RISER WITH STONE TREAD**

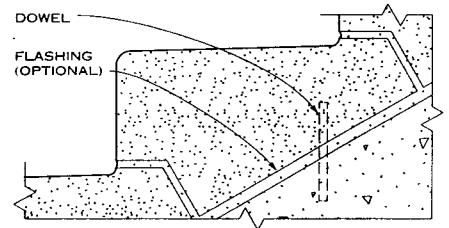
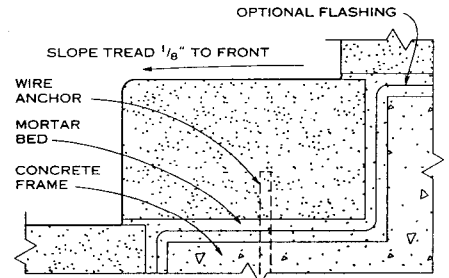
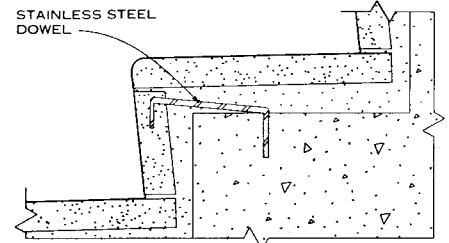
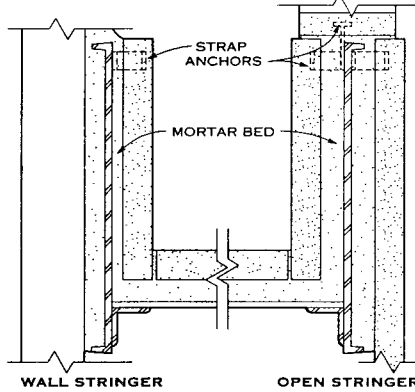

**STONE STAIRS WITH CONCRETE FRAME**

**DESIGN FACTORS FOR STONE STAIRS**

Stone used for steps should have an abrasive resistance of 10 (measured on a scale from a minimum of 6 to a maximum of 17). When different varieties of stone are used, their abrasive hardness should be similar to prevent uneven wear.

Dowels and anchoring devices should be noncorrosive. If a safety tread is used on stairs, a light bush hammered soft finish or nonslip finish is recommended.

To prevent future staining, dampproof the face of all concrete or concrete block, specify low alkali mortar, and provide adequate drainage (slopes and weep holes).

**STONE STAIRS WITH STEEL FRAME**

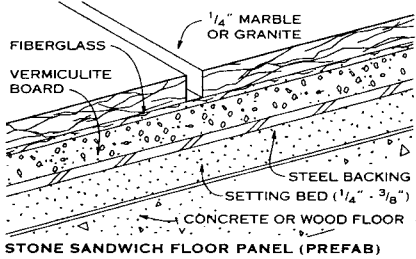
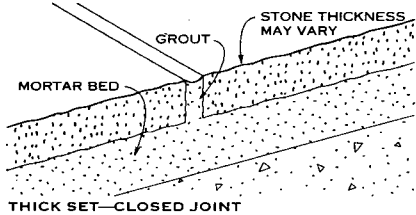
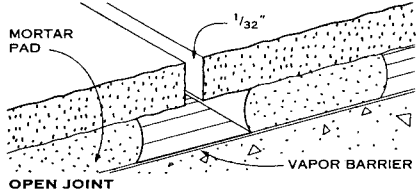

**STONE FLOORING**

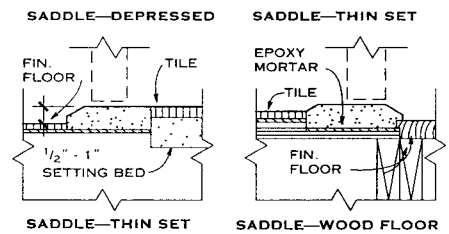
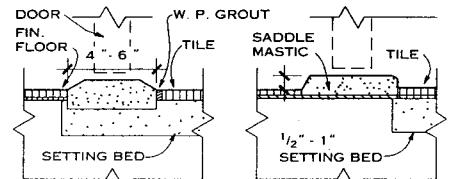
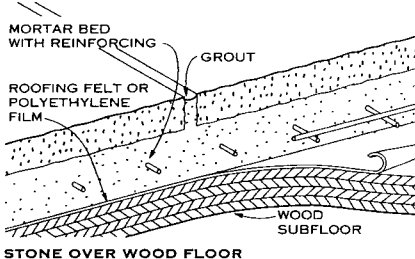
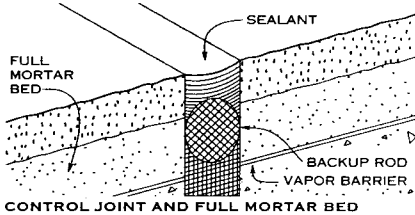
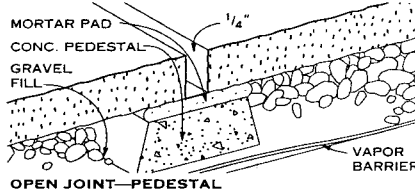

**STONE THRESHOLDS**

Eric K. Beach; Rippeteau Architects, PC; Washington, D.C.  
Building Stone Institute; New York, New York; George M. Whiteside, III, AIA, and James D. Lloyd; Kennett Square, Pennsylvania



Terrazzo is a material composed of stone chips and cement matrix and is usually polished. There are four generally accepted types, classified by appearance:

1. **STANDARD TERRAZZO:** The most common type; relatively small chip sizes (#1 and #2 size chips).
2. **VENETIAN TERRAZZO:** Larger chips (size #3 through #8), with smaller chips filling the spaces between.
3. **PALLADIANA:** Random fractured slabs of marble up to approximately 15 in. greatest dimension, 3/8 to 1 in. thick, with smaller chips filling spaces between.
4. **RUSTIC TERRAZZO:** Uniformly textured terrazzo in which matrix is depressed to expose chips, not ground or only slightly ground.

**MATRIX DATA**

Two basic types exist: portland cement and chemical binders. Color pigments are added to create special effects. Limeproof mineral pigments or synthetic mineral pigments compatible with portland cement are required. Both white and grey portland cement is used depending on final color.

**CHEMICAL BINDERS**

All five types of chemical binders provide excellent chemical and abrasion resistance, except for latex, which is rated good.

1. **EPOXY MATRIX:** Two component resinous matrix.
2. **POLYESTER MATRIX:** Two component resinous matrix.
3. **POLYACRYLATE MATRIX:** Composite resinous matrix.
4. **LATEX MATRIX:** Synthetic latex matrix.
5. **CONDUCTIVE MATRIX:** Special formulated matrix to conduct electricity with regulated resistance, use in surgical areas and where explosive gases are a hazard.

**PRECAST TERRAZZO**

Several units are routinely available and almost any shape can be produced. Examples include: straight, coved, and splayed bases; window sills; stair treads and risers; shower receptors; floor tiles; and wall facings.

**STONE CHIPS**

Stone used in terrazzo includes all calcareous serpentine and other rocks capable of taking a good polish. Marble and onyx are the preferred materials. Quartz, granite, quartzite, and silica pebbles are used for rustic terrazzo and textured mosaics not requiring polishing.

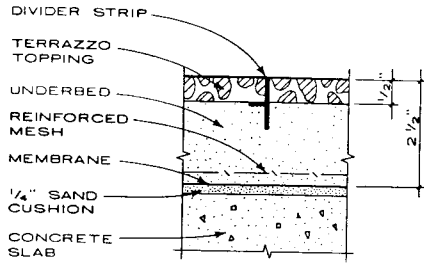

**SAND CUSHION TERRAZZO**

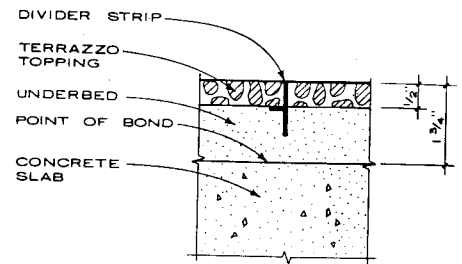

**BONDED TERRAZZO**

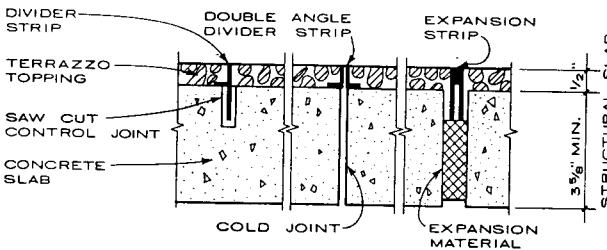

**MONOLITHIC TERRAZZO**

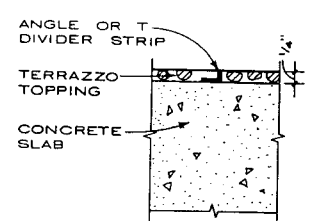

**THIN-SET TERRAZZO**

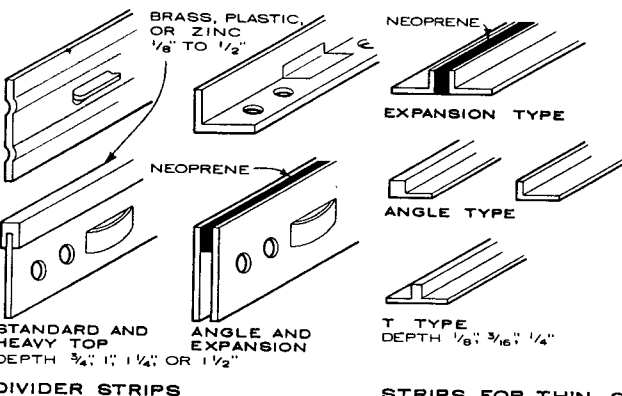

**DIVIDER STRIPS**

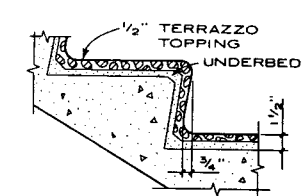

**STAIR TREAD AND RISER**

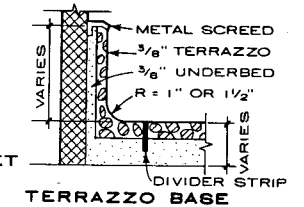

**TERRAZZO BASE**

**TERRAZZO SYSTEMS**

TERRAZZO SYSTEM	MINIMUM ALLOWANCE FOR FINISH	MINIMUM WEIGHT/SQ FT	CONTROL JOINT STRIP LOCATION	SUGGESTED PANEL SIZE AND DIVIDER STRIP LOCATION	COMMENTS
Sand cushion terrazzo	2 1/2"	27 lb	At all control joints in structure	9 to 36 sq ft	Avoid narrow proportions (length no more than twice the width) and acute angles
Bonded underbed or strip terrazzo	1 3/4"	18 lb	At all control joints in structure	16 to 36 sq ft	Avoid narrow proportions as in sand cushion
Monolithic terrazzo	1/2"	7 lb	At all control joints in structure and at column centers or over grade beams where spans are great	At column centers in sawn or recessed slots maximum 24 x 24 ft	T or L strips usually provide decorative feature only
Thin-set terrazzo (chemical binders)	1/4"	3 lb	At all control joints	Only where structural crack can be anticipated	
Modified thin-set terrazzo	3/8"	4 1/2 lb	At all control joints	Only where structural crack can be anticipated	
Terrazzo over permanent metal forms	Varies, 3" minimum	Varies	Directly over beam	Directly over joist centers and at 3 to 5 ft on center in the opposite direction	
Structural terrazzo	Varies, 4" minimum	Varies	At all control joints at columns and at perimeter of floor	Deep strip (1 1/2 in. min.) at all column centers and over grade beams	Use divider strip at any location where structural crack can be anticipated

**NOTES**

1. Venetian and Palladiana require greater depth due to larger chip size; 2 3/4 in. minimum allowance for finish 28 lb/sq ft.
2. Divider and control joint strips are made of white alloy of zinc, brass, aluminum, or plastic. Aluminum is not satisfactory for portland cement matrix terrazzo; use brass and plastic in chemical binder matrix only with approval of binder manufacturer.
3. In exterior terrazzo, brass will tarnish and white alloy of zinc will deteriorate.

John C. Lunsford, AIA; Varney Sexton Sydnor Architects; Phoenix, Arizona

**LINEAR METAL CEILINGS**

**PANS**

Dimensions: Typical widths range from 4 to 8 inches (100 to 200 mm).

Materials: Roll-formed sheet steel is for interior applications only; roll-formed aluminum can be used for interior or exterior applications.

Surface: Surfaces can be smooth, perforated or unperforated, or textured.

Finish: Baked polyester enamels, metallic coatings, and brushed or polished aluminum with a clear coating are available.

**CARRIERS**

Material: Roll-formed sheet steel is for interior use only, while roll-formed aluminum is suitable for interior or exterior applications.

Finish: The finish is flat black baked polyester enamel.

**ACCESSORIES**

Possible accessories include integral light fixtures and air diffusers, trim channels, splices, and end caps.

**OPTIONS**

Fire-rated and acoustically rated systems are available.

**EXTERIOR APPLICATIONS OF LINEAR METAL CEILINGS**

Wind loads must be factored in when exterior applications of linear metal ceilings and soffits are planned. Wind loads are determined by geographic conditions and a building's height above the ground. Linear metal systems must be engineered to withstand uplift pressure. Rigid bracing is used instead of suspension wires to support these systems.

**LINEAR BAFFLE CEILINGS**

Steel or aluminum baffles hung from a suspended ceiling framework mask exposed plenum areas. Baffles are available in a variety of profiles and depths ranging from 4 to 12 inches (100 to 300 mm).

TRIM CHANNEL (OPTIONAL)

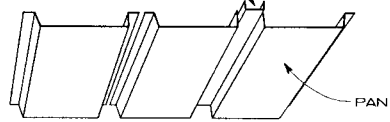

LINEAR METAL CEILING—OPEN REVEAL

TRIM CHANNEL (OPTIONAL)

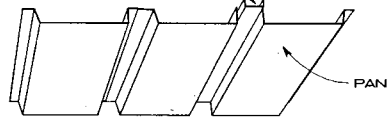

LINEAR METAL CEILING—CLOSED REVEAL

**TYPICAL PAN CONFIGURATIONS**

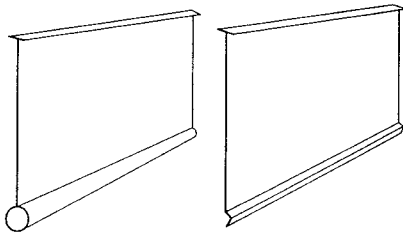

ROUNDED

DIAGONAL

**TYPICAL BAFFLE PROFILES**

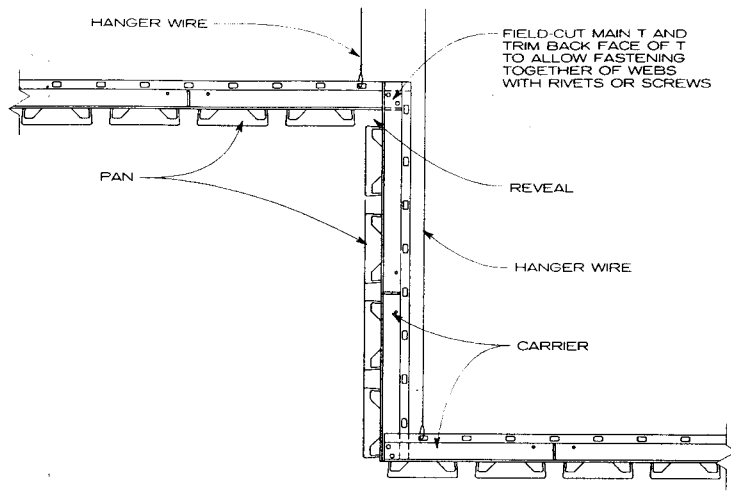

**LINEAR METAL CEILING SYSTEM**

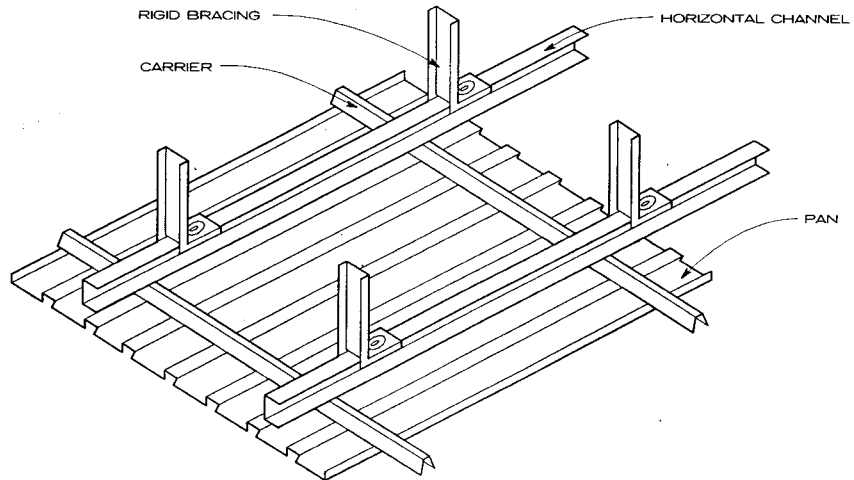

**EXTERIOR LINEAR METAL CEILING SYSTEM**

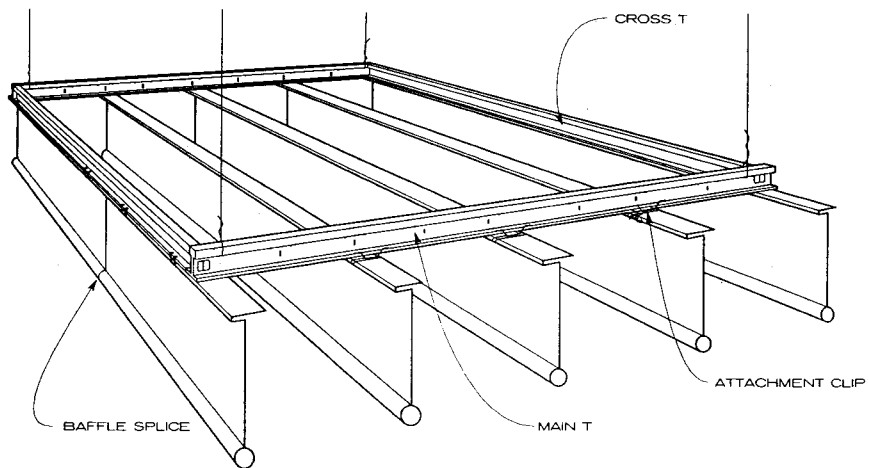

**LINEAR BAFFLE CEILING SYSTEM**

Keith McCormack, CCS, CSI; RTKL Associates; Baltimore, Maryland  
USG Interiors, Inc., Chicago, Illinois

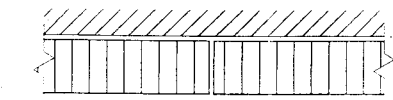

SQUARE-CUT TILE, ADHESIVE APPLIED

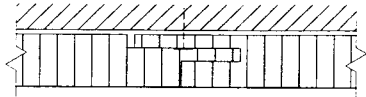

TONGUE AND GROOVE TILE, STAPLE ATTACHED

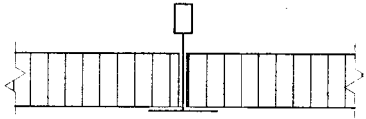

SQUARE-CUT TILE, EXPOSED T SYSTEM

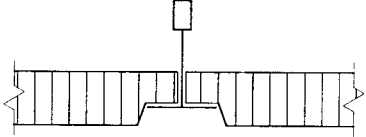

SQUARE-CUT REVEAL TILE, EXPOSED T SYSTEM

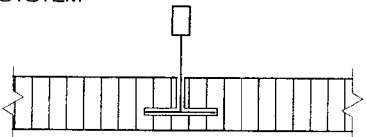

KERFED EDGE TILE, CONCEALED T SYSTEM

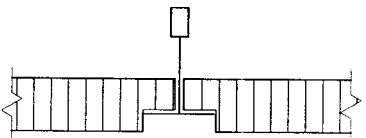

TAPERED REVEAL TILE, EXPOSED T SYSTEM

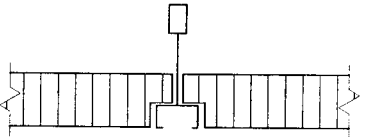

SQUARE-CUT REVEAL TILE, REVEAL T SYSTEM

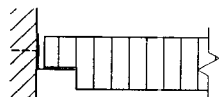

FIELD-CUT TILE EDGE, STANDARD WALL MOLDING



FIELD-CUT REVEAL TILE, STANDARD WALL MOLDING

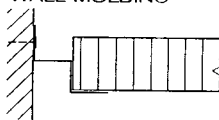

FIELD-CUT TILE EDGE, REVEAL WALL MOLDING

EDGE CONDITIONS AND SUPPORT SYSTEMS

TYPES OF ACOUSTICAL CEILING UNITS

ACOUSTICAL TILE

These prefabricated, sound-absorbing ceiling units are installed in a concealed suspension system or directly attached to the substrate with adhesive or staples. Typical size is 12 by 12 inches (305 by 305 mm).

ACOUSTICAL PANEL

These prefabricated, sound-absorbing ceiling units are installed in a suspension system. Typical sizes are 24 by 24 inches (610 by 610 mm) and 24 by 48 inches (610 by 1210 mm).

CONSTRUCTION OF ACOUSTICAL CEILING UNITS

CAST (MOLDED)

These ceiling units are composed of mineral fibers, fillers, binders, and water mixed together to form a slurry. The slurry is cast on trays and heat cured. The pattern and sound-absorbing qualities are created by the treatment of

the material face in the wet stage. After drying, acoustical units are painted; if color is added to the slurry, the unit will be colored throughout.

NODULAR

Nodular tiles are composed of mineral fibers, perlite, fillers, binders, and water mixed together to form a dry slurry. The slurry is formed into sheets, dried, and cut. The surface is inherently porous and is subsequently textured by mechanical fissinging and embossing; ceiling units are then painted.

WET-FELTED

Wet-felted tiles are composed of mineral fibers, fillers, binders, and water mixed together to form a slurry. The slurry is poured onto felts, drained, compacted, dried, and cut. Textures are created by mechanical perforation, fissinging, and stippling. Surface finishes include paint, fabric, polyester film, and vinyl-coated aluminum.

GLASS FIBER WITH FACING

This type of tile consists of nonwoven fiberglass insulation with a fabric or vinyl film surface finish.

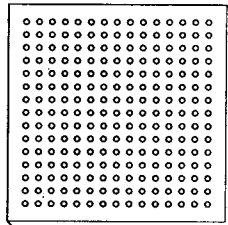

PERFORATED, REGULARLY SPACED HOLES

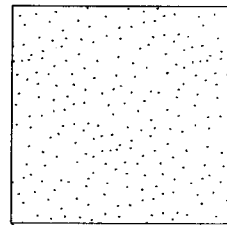

PERFORATED, RANDOMLY SPACED HOLES

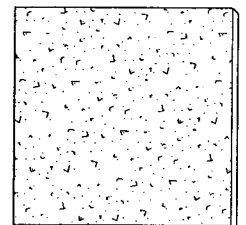

FISSURED

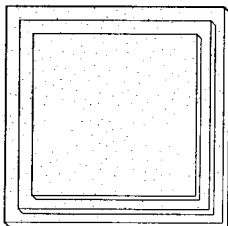

REVEAL EDGE, STIPPLE FINISH

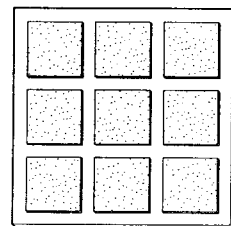

ROUTED PATTERN, PERFORATED FINISH

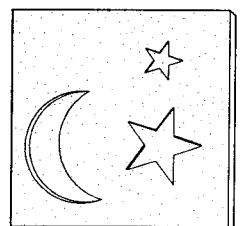

EMBOSSD DESIGN, STIPPLE FINISH

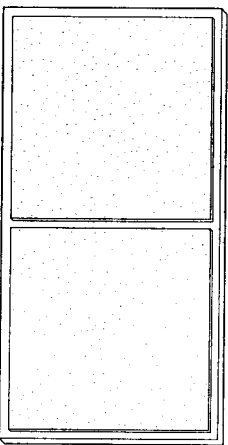

TWO-SQUARE, STIPPLE FINISH

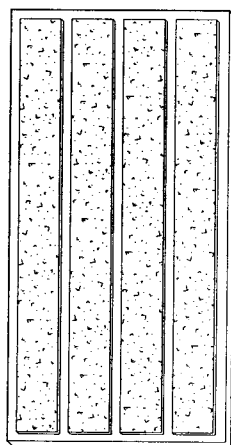

ROUTED LINEAR, FISSURED FINISH

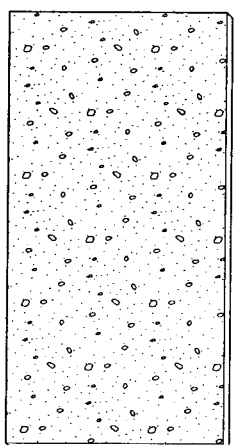

PEBBLE FINISH

ACOUSTICAL CEILING UNIT TEXTURES AND DESIGNS

Keith McCormack, CCS, CSI, RTKL Associates; Baltimore, Maryland

**SPECIAL FLOORING**

Special flooring manufacture is a constantly changing industry with myriad products and companies. Choose products to meet the requirements of a specific application after consultation with manufacturers. Select a well-established, reputable manufacturer with a tested and proven product. Have the product installed by experienced, factory-trained personnel.

**RESINOUS FLOORING**

**EPOXY RESIN FLOORING:** This abrasion- and impact-resistant, broadcast and/or trowel-applied, two-component epoxy resin floor is made of graded aggregates and mineral oxide pigments. Typical thicknesses are 1/8 and 1/4 in. Epoxy resin flooring can be applied to a variety of substrates and usually cures overnight, depending on the humidity. It is chemical resistant, fire retardant, and odor free and may be made slip resistant with a satin finish.

**ACRYLIC RESIN FLOORING:** This two- or three-component system is based on methyl methacrylate acrylic (MMA) resins; it has a low VOC. Four types are available in varying thicknesses: primer/sealers (8-10 mils), coatings (1/16 in.), toppings (1/16 - 3/16 in.), and overlays (3/16 - 3/8 in.). The system comprises graded aggregates, mineral oxide pigments, and pigmented topcoats. Typically, a 1/8 in. thick floor is sufficient for light loads and pedestrian traffic and a 1/4 in. thick floor is required for normal to heavy loads. Heavy-duty loads require a floor 1/2 in. thick or thicker. Uses include animal housing/runs, industrial, institutional, coolers/freezers, cafeterias, food preparation, and multipurpose recreational facilities.

**LATEX RESIN FLOORING:** This trowel-applied, jointless floor offers low absorption and good chemical resistance. Chemical-resistant types are available to handle a variety of anticipated chemical spills. A waterproof membrane may be used to make the floor entirely waterproof, and it may be turned up at the base to form an integral covered base. Uses include showers, laboratories, animal research housing, pharmaceutical plants, and TV studios.

**MAGNESIUM OXYCHLORIDE FLOORING**

This is a fireproof, trowel-applied, seamless, hard surface floor that is slip resistant in both wet and dry locations. Durable and simple to install, it is used primarily in commercial kitchens and manufacturing locations such as welding shops. Its use is not recommended when standing water or mineral corrosives will be present. The standard color is red, although some earth tones may be available.

**EPOXY MARBLE CHIP FLOORING AND SEAMLESS QUARTZ FLOORING**

This seamless decorative flooring consists of ceramic-coated quartz or colored quartz aggregates in clear epoxy. It may be broadcast or trowel-applied in thicknesses of 1/16, 1/8, or 1/4 in. Available in a wide range of aggregate colors, it may be slip resistant and is typically installed over concrete substrate. It is used in laboratories, locker rooms, and light manufacturing and institutional locations.

**ELASTOMERIC LIQUID FLOORING**

Conductive elastomeric liquid flooring—a multiple- or single-part system applied over concrete, metal, or wood substrates—consists of elastomeric resins, nonsparking aggregates, and a carbon or metallic conductive agent. Typically applied in thicknesses of 1/4 or 1/2 in., it may be applied to a wide variety of substrates and in a series of coats to achieve a smooth finish. Durable, easy to install, jointless (no divider strips), and waterproof are characteristics of this type of floor.

Elastomeric liquid flooring is designed to provide static control and spark resistance that can prevent electrostatic damage to electronic products as well as the conductivity required to prevent fire or explosions in high-hazard environments. The slab and conductive surface must be grounded and the floor well maintained in order for the floor to keep the required conductivity and static dissipative properties. Typical installations requiring these qualities include clean rooms and electronic manufacturing and assembly facilities. Typical installations requiring the conductive capabilities of elastomeric liquid flooring include arsenals, ammunition plants, chemical processing facilities, and hazardous explosive areas. End user static control and spark resistance must be clearly specified to ensure appropriate levels of resistance. People working in these environments must wear conductive footwear.

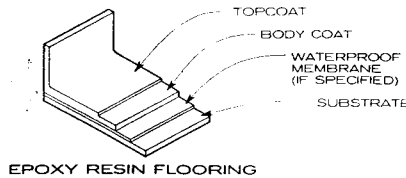

**EPOXY RESIN FLOORING**

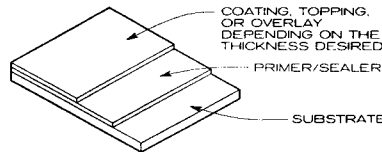

**ACRYLIC RESIN FLOORING**

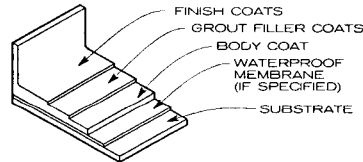

**LATEX RESIN FLOORING**

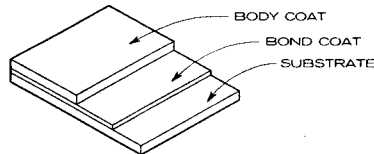

**MAGNESIUM OXYCHLORIDE FLOORING**

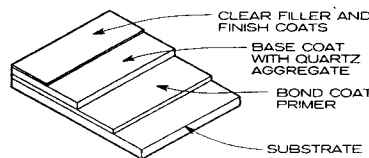

**EPOXY MARBLE CHIP/ SEAMLESS QUARTZ FLOORING**

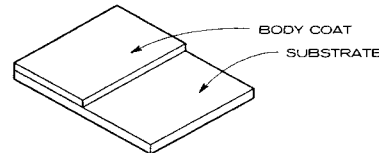

**ELASTOMERIC LIQUID FLOORING**

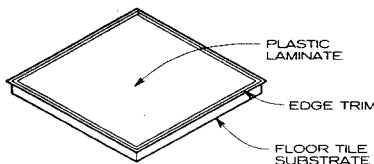

**PLASTIC LAMINATE FLOORING**

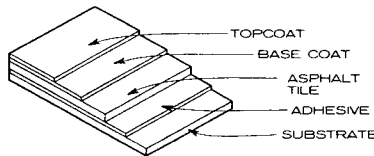

**ASPHALT TILE FLOORING**  
**FLOOR COATINGS**

**PLASTIC LAMINATE FLOORING**

Plastic laminate flooring generates and retains low static levels. It has a low sheen, matte finish. Durable, flexible, and easily maintained, it is used exclusively as the top finish surface for access flooring. Applied to access floor substrates of steel, aluminum, wood, or particleboard with moisture-resistant adhesives, this type of flooring consists of a formulated, washable, surface sheet over a melamine-impregnated printed pattern sheet with core layers of phenolic-impregnated kraft paper. Typical tile size is 24 x 24 in., with standard thicknesses of 1/16, 5/64, and 1/8 in., depending on load. Three quality grades are available. Floors must meet or exceed ANSI, NEMA, and NFPA codes and criteria.

**ASPHALT PLANK FLOORING**

A smooth, heavy-duty, comfortable, long-lasting, low maintenance tile floor, asphalt plank flooring is used in post offices, warehouses, and industrial locations. Tiles are set in adhesive troweled over a concrete substrate. An acrylic protective base coat is applied in two to three layers after the tiles have been set. A topcoat of two to three layers is applied to give the floor a high gloss for easier maintenance. Standard tile size is 1/2 x 12 x 24 in. Other available thicknesses are 1/4 - 3 in. Standard available colors are black and red.

**MASTIC FILLS**

Products described in other categories may also be considered in this one. Examples include self-adhering floor or deck coatings, traffic toppings, and underlayers that also fill cracks or uneven surfaces. Taken literally, this heading can include "mud set" mortar for tile over uneven substrates.

**FLOOR TREATMENT**

**METALLIC-TYPE STATIC-DISSEMINATING AND SPARK-RESISTANT FINISH**

This product is designed to provide static-control properties and spark-resistance capabilities that can prevent electrostatic damage to electronic products, as well as the conductivity required to prevent fire or explosions in high-hazard environments. Maintenance of the floor is critical in order to keep the required conductivity and static-dissipative properties. Typical installations requiring static-dissipative products include clean rooms and electronic manufacturing and assembly facilities. Typical installations requiring conductive products include arsenals, ammunition plants, and chemical processing and other explosive hazardous areas. End user static control and spark resistance must be clearly specified to ensure appropriate levels of resistance. People working in these environments must wear conductive footwear.

Dry-shake metallic floor hardener is blended with plasticizing agents and conductive binders. This blend is applied to the surface of plastic concrete and becomes an integral part of the floor surface. It can be applied with a mechanical spreader, by hand, or with a shovel. Concrete admixture, air content, and floor finish requirements are strictly defined by metallic floor hardener manufacturers in terms of compatibility and amount, etc.

**SLIP-RESISTANT FLOOR TREATMENT**

These cementitious or noncementitious coatings are specifically designed to provide a nonskid finish for interior or exterior floors. Silica or synthetic aggregates provide the nonskid capability. The treatment is formulated for use on concrete or masonry surfaces and may be brushed or rolled on or trowel- or fluid-applied.

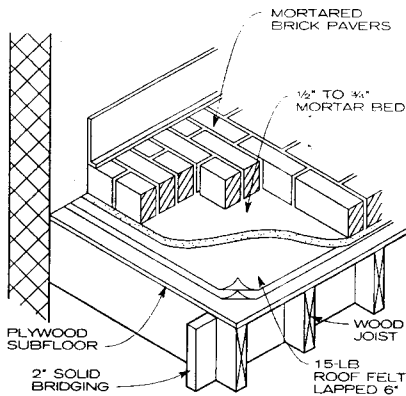

**MORTARED BRICK PAVERS ON WOOD FRAMING**

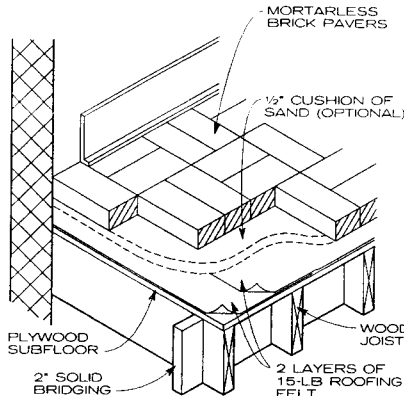

**MORTARLESS BRICK PAVERS ON WOOD FRAMING**

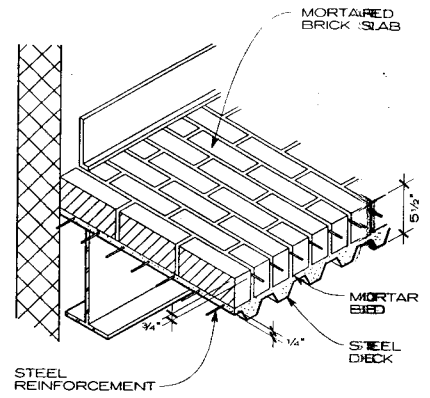

**MORTARED BRICK SLAB**

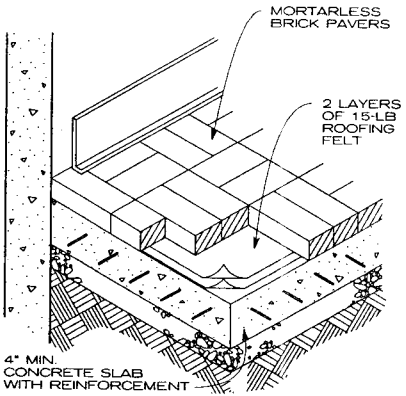

**MORTARLESS BRICK PAVERS ON CONCRETE SLAB**

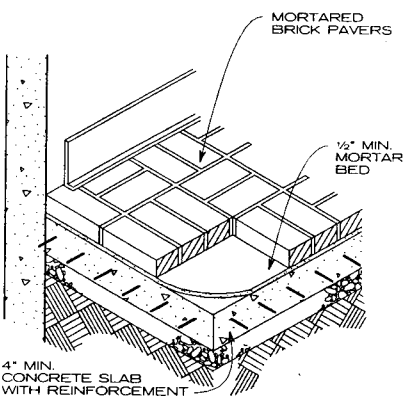

**MORTARED BRICK PAVER ON CONCRETE SLAB**

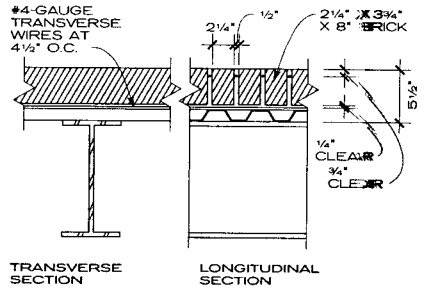

**TRANSVERSE SECTION LONGITUDINAL SECTION**

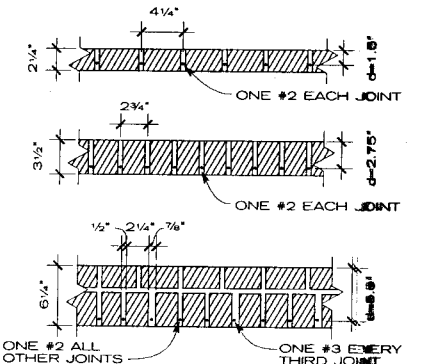

**REINFORCED BRICK MASONRY**

**REINFORCED BRICK MASONRY SLABS**

LIVE LOAD (PSF)	MAXIMUM CLEAR SPAN		
	$t = 2 \frac{1}{4}$ IN. 1 #2 EACH JOINT	$t = 3 \frac{1}{2}$ IN. 1 #2 EACH JOINT	$t = 6 \frac{1}{4}$ IN. 1 #3 EVERY 3RD JOINT 1 #2 OTHER JOINTS
30	6'-10"	10'-5"	14'-5"
40	6'-3"	9'-9"	13'-8"
50	5'-10"	9'-2"	13'-1"
100	4'-6"	7'-3"	10'-11"
250	1'-10"	5'-0"	7'-10"

**NOTES**

1. Design parameters for the table above: The compressive strength average of the brick is 8000 psi. The mortar is type M (1:1/4:3), portland cement:lime:sand. Reinforcement steel is ASTM A 82-66,  $f_y = 20,000$  psi. A simple span loading condition was assumed.

$$M = \frac{wl^2}{8}$$

2. All mortar joints are 1/2 in. thick for the slabs shown, except as noted.

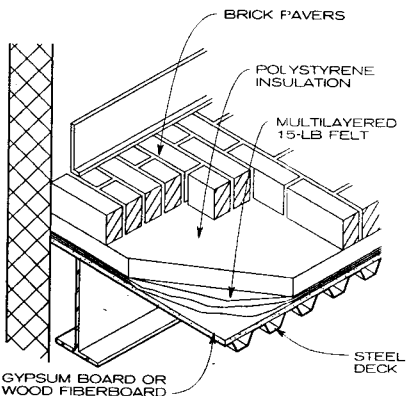

**BRICK PAVERS ON STEEL DECK**

**TYPICAL BRICK AND CONCRETE PAVER TYPE AND NOMINAL SIZE**

Brick pavers: 4 x 4 in., 4 x 8 in., 4 x 12 in.; 1/2 to 2 1/2 in. thick. Concrete pavers: 12 x 12 in., 12 x 24 in., 18 x 18 in., 18 x 24 in., 2 3/8 to 3 in. thick.

**NOTES**

1. Brick paving assemblies are classified by type of paving surface and type of base supporting the surface. Interior brick paving may be adapted to suspended diaphragm bases, reinforced brick structural slabs with mortar joints, and conventional concrete slabs on grade.
2. In residential wood joist design, the additional weight of brick pavers must be considered to ensure selection of a suitable grade and joist size. For mortared paving, deflection and diaphragm action must be considered in order to maintain the integrity of the mortar joints.

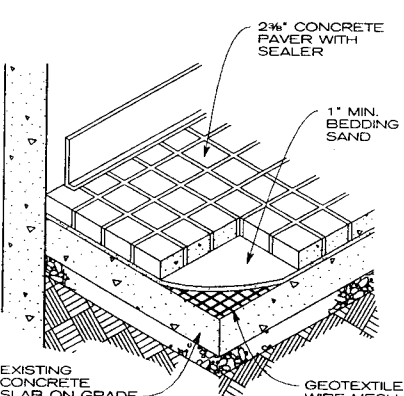

**CONCRETE PAVERS ON CONCRETE SLAB**

3. Reinforcement of brick masonry paving can eliminate the need for a separate reinforced concrete slab or other rigid base. Reinforced brick paving can be used to span an open space and is a practical system for relatively short spans. For continuous span application, an assembly combining both reinforced brick masonry and steel decking can be used.
4. Maintenance: Brick floors are abrasion resistant and hard-wearing. Coatings and waxes are desirable on interior brick floors, where they enhance appearance and make surfaces easier to clean. Prewaxing brick pavers on the exposed face facilitates cleaning, and applying a sealer locks in loose sand particles and provides an impervious finish.

Mark Forma; Leo A. Daly Company; Washington, D.C.

TYPICAL GRADES AND SIZES OF BOARDS BY SPECIES OR REGIONAL GROUP

GROUP	INDUSTRY ORGANIZATION	GRADE	THICKNESS (IN.)	WIDTH (IN.)	NOTES
Oak, ash, black cherry, and walnut Also beech, birch, hard maple, pecan, and hickory	National Oak Flooring Manufacturers Association Memphis, Tennessee Tel: (901) 526-5016 www.nofma.org	Oak, ash, black cherry, and walnut Clear Select Common (Nos. 1 and 2) Beech, birch, and hard maple First (including red and white) Second Third (See note for other species)	Strip 3/4 1/2 Maple, beech, birch only 3/4, 25/32, 33/32 Plank 3/4	Face 1 1/2, 2, 2 1/4, 3 1/4 1 1/2, 2 1 1/2, 2, 2 1/4, 3 1/4 3, 4, 5, 6, 7, 8	Factory-finished oak flooring is available in Prime, Standard, and Tavern grades 3/4 in. thick with a face width of 1 1/2 or 2 1/4 in.  NOFMA grades hickory/pecan first grade, first grade red, first grade white, second grade, second grade red, and third grade.
Hard maple (acer saccharum—not soft maple) Also beech and birch	Maple Flooring Manufacturers Association Northbrook, Illinois Tel: (847) 480-9138 www.maplefloor.org	First Second & Better Third	25/32, 33/32	Face 1 1/2 2 1/4 3 1/4	The Maple Flooring Manufacturers Association states that beech and birch have physical properties that make them fully suitable as substitutes for hard maple. See manufacturer for available width and thickness combinations.
Southern pine	Southern Pine Inspection Bureau Pensacola, Florida Tel: (850) 434-2611 www.spib.org	B & B C C & Better D No. 2	3/8, 1/2, 5/8, 1, 1 1/4, 1 1/2	Nominal 2 3 4 5 6 Face 1 1/8 2 1/8 3 1/8 4 1/8 5 1/8	Grain may be specified as edge (rift), near-rift, or flat. If not specified, manufacturer will ship flat or mixed grain boards. Check with manufacturer for available width and thickness combinations.
Western woods (Douglas fir, hemlock, Englemann spruce, Idaho white pine, incense cedar, lodgepole pine, Ponderosa pine, sugar pine, Western larch, Western red cedar)	Western Wood Products Association Portland, Oregon Tel: (503) 224-3930 www.wwpa.org	All but Idaho white pine B & Better Select C Select D Select Idaho white pine Supreme Choice Quality	2 in. and thinner	Nominal 3 4 6	Flooring is machined tongue and groove and may be furnished in any grade. Grain may be specified as vertical (VG), flat (FG), or mixed (MG). Basic size for flooring is 1 in. x 4 in. x 12 ft; standard lengths are 4 ft and above.  The moisture content of these grades is 15% MC with 85% of the pieces less than 12% MC.

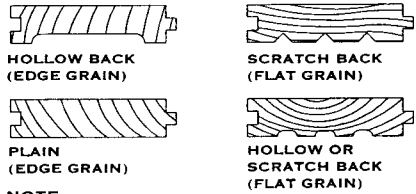

**NOTE**  
The underside of flooring boards may be patterned and often contains more defects than are allowed in the top face. Grain is often mixed in any given run of boards. Edge grain is also called vertical grain.

**BOARD CHARACTERISTICS**

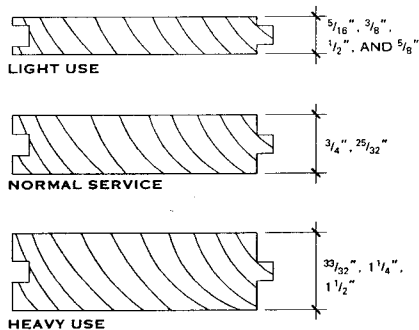

**NOTE**  
Most flooring is available in a variety of thicknesses to suit different wear requirements.

**VARIOUS THICKNESSES**

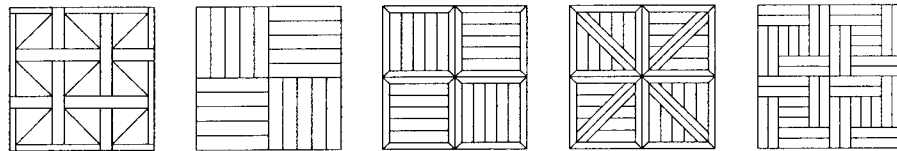

**NOTE**  
Many patterns are available; consult manufacturers' design manuals.

**PARQUET FLOOR PATTERNS**

**NOTES**

1. Flooring can be manufactured from practically every commercially available species of wood. For marketing purposes in the United States, wood flooring is roughly grouped according to species and region. Various grading systems are used with various species, and often specifications differ for boards of different sizes in a given species. For instance, recommended nail size and spacing vary among the several board sizes typically available in oak.
2. Use information given here for preliminary decision-making only. Precise specifications must be obtained from a supplier or from the appropriate industry organization (see table above).
3. Several considerations regarding selection and installation of wood flooring are applicable throughout the industry; these are illustrated on this page.
4. The table above shows typical grades and sizes of boards by species or regional group. Grade classifications vary, but in each case it can be assumed that the first grade listed is the highest quality and that the quality decreases with each succeeding grade. The best grade typically minimizes or excludes features such as knots, streaks,

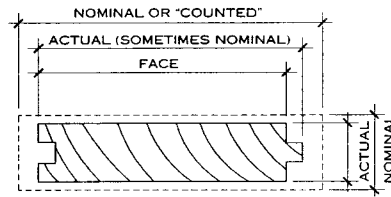

**NOTE**  
Cross-sectional dimensioning systems vary among species, patterns, and manufacturers. Trade organizations provide percentage multipliers for computing coverage.

**CROSS-SECTIONAL DIMENSIONS**

spots, checks, and torn grain and will contain the highest percentage of longer boards. Grade standards have been reduced in recent years for practically all commercially produced flooring, hence a thorough review of exact grade specifications is in order when selecting wood flooring.

5. End matching gives a complete tongue-and-grooved joint all around each board. Board length is reduced as required to obtain the matched ends.

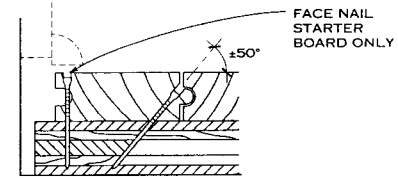
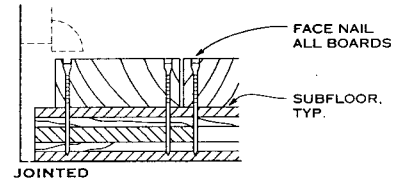

- NOTES**
1. Jointed flooring must be face nailed, usually with fully barbed flooring brads.
  2. Tongue-and-grooved boards are blind nailed with spiral floor screws, cement-coated nails, cut nails, or machine-driven fasteners; follow the manufacturer's recommendations.

**FASTENING**

**PARQUET FLOORING**

THICKNESS (IN.)	FACE DIMENSIONS (IN.)
Individual strips	
5/16	2 x 12 typical strips can be cut, mitered, etc. to obtain pieces required for special patterns
Square panels	
5/16 (most common), 7/16, 1 1/16, 3/4	6 x 6, ±6 1/2, x ±6 1/2, 12 x 12, 19 x 19; other sizes available from certain manufacturers

Rippeteau Architects, P.C.; Washington, D.C.

**GENERAL**

Wood flooring is visually attractive and provides an excellent wearing surface; however, wood requires particular care in handling and installation. Minimize moisture damage to wood floors by avoiding proximity to wet areas. In addition, installation of wood floors should occur after all "wet" jobs have been completed and after the heating plant and all permanent lighting have been installed to ensure constant temperature and humidity.

Expansion and contraction is a fact of life for most wood flooring. Perimeter base details that allow for movement and ventilation are included in the details on this page. Wood structures require adequate ventilation in basements and crawl spaces. Under a slab on or below grade, moisture control can be further enhanced by use of a vapor barrier; this provision should be carefully considered for each installation.

Wearing properties of wood flooring vary from species to species and should be considered along with appearance when specifying wood floors. In addition, grain pattern affects the durability of a given species. For instance, industrial wood blocks are typically placed with the end grain exposed because it presents the toughest wearing surface. The thickness of the wood above the tongues in tongue-and-groove flooring may be increased for extra service.

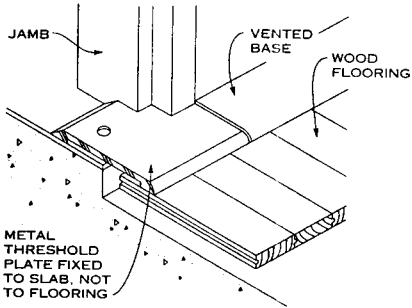

**EXPANSION PLATE AT DOORWAY/ JOINT WITH DISSIMILAR CONSTRUCTION**

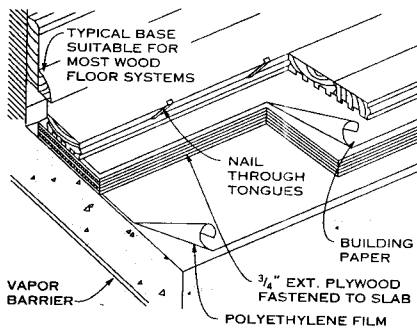

**STRIPS OVER PLYWOOD UNDERLAYMENT**

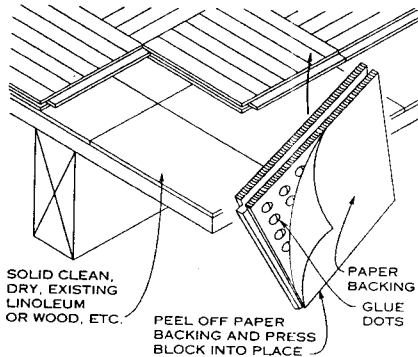

**PRESSURE-SENSITIVE "DO-IT-YOURSELF" PANELS (PREFINISHED)**

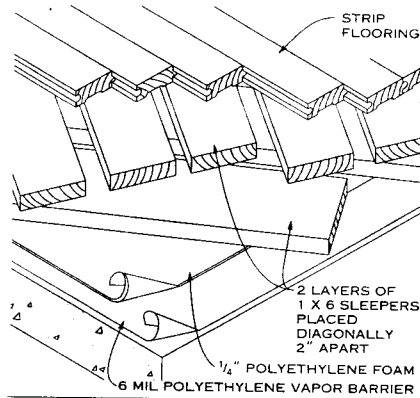

**STRIPS OVER VENTILATED SLEEPERS**

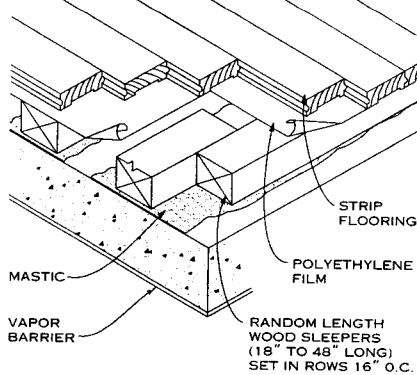

**STRIPS OVER STAGGERED 2X4 SLEEPERS**

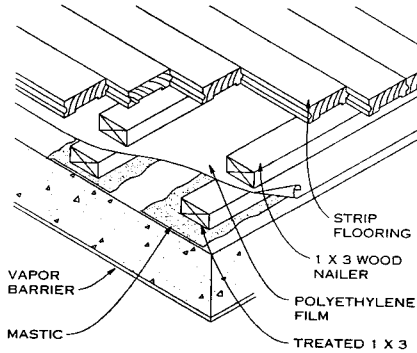

**DOUBLE COURSE OF SLEEPER STRIPS**

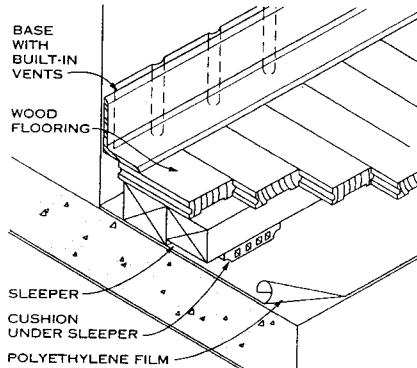

**STRIPS OVER CUSHIONED SLEEPERS**

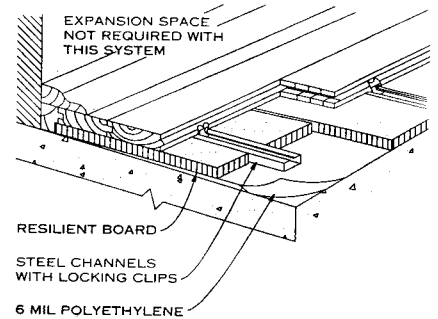

**NOTE**

Provide a vapor barrier under a slab on grade.

**METAL CHANNEL RUNNERS WITH CLIPS**

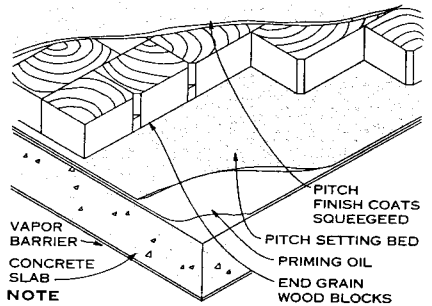

**NOTE**

Typical blocks are 3 x 6 in. up to 4 x 8 in. with depths of 2 to 4 in. Urethane finish coats are available for nonindustrial uses.

**INDUSTRIAL WOOD BLOCK**

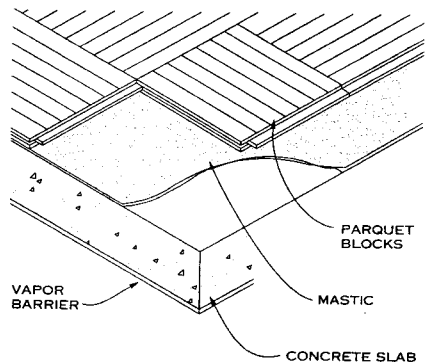

**PARQUET BLOCKS SET IN MASTIC**

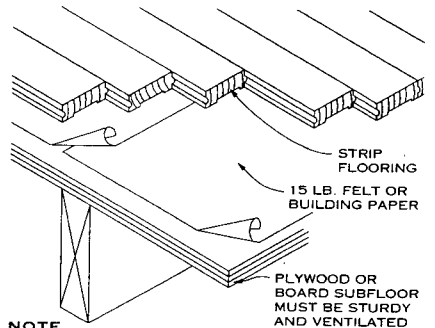

**NOTE**

For parquet flooring, the subfloor must be 3/4 in. tongue-and-groove plywood, minimum, with mastic over it.

**STRIPS OVER SUBFLOOR ON WOOD JOISTS**

Annica S. Emilsson; Rippeteau Architects. P.C.; Washington, D.C.

**GENERAL**

The wood flooring types shown on this page are those most commonly used for sports facilities. The specifics of each floor system differ from manufacturer to manufacturer. Some flooring systems are proprietary and protected by patents. Manufacturers can custom configure flooring systems for special uses.

The type of wood sports flooring chosen for a particular situation depends on the following criteria:

1. Cost
2. The performance of the floor
3. Sport(s) to be played on the floor
4. Other uses to which floor will be put
5. Durability
6. The environment in which the floor will be used

**GRADES OF WOOD SPORTS FLOORING**

Maple is the wood most commonly used for sports flooring in the United States. Maple sports flooring is available in three grades, which designate only the appearance of the floor and not its performance or durability.

**FIRST GRADE:** nearly free of defects; least color variation, with very little dark hardwood; used in premier sports venues where appearance is of primary concern.

**SECOND AND BETTER:** may have tight, sound knots and other slight imperfections and some color variation; floor has a generally light appearance.

**THIRD GRADE:** all defects and color variations permitted; floor is mostly dark heartwood; used when cost is a consideration.

**MAPLE FLOOR SYSTEM CHARACTERISTICS**

SYSTEM	COST	PERFORMANCE	DURABILITY	STABILITY
Proprietary	High	High	High	High
Sprung	High	High	Medium	High
Sleeper	Medium	Medium	Medium	High
Cushioned	Low	Medium	High	Medium
Channel	Low	Low	High	High
Mastic	Low	Low	High	Medium

**FINISHES AND GAME LINES**

Wood sports floors are sanded, sealed, and finished with at least two coats of sealer and two coats of finish.

Game lines are painted between the last coat of sealer and the first coat of finish. Game line paint must be compatible with sealer and finish.

**REFERENCE**

Maple Flooring Manufacturers Association  
60 Revere Drive, Suite 500  
Northbrook, IL 60062

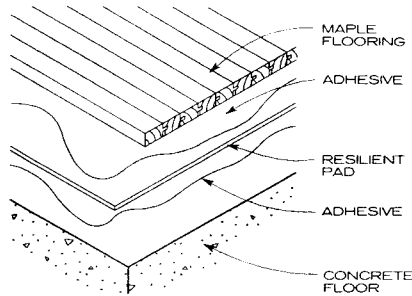

**NOTES**

1. Lowest cost
2. Easy to install
3. Suitable for multipurpose applications
4. Use where floor performance is not critical

**MASTIC APPLIED SYSTEM**

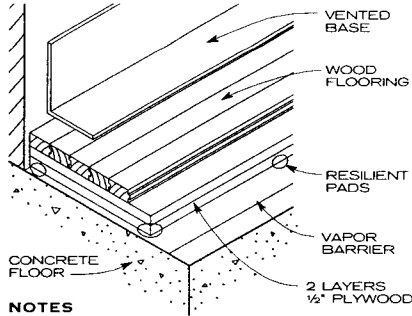

**NOTES**

1. Good performance characteristics
2. Relatively low cost
3. Susceptible to moisture damage

**CUSHIONED SYSTEM**

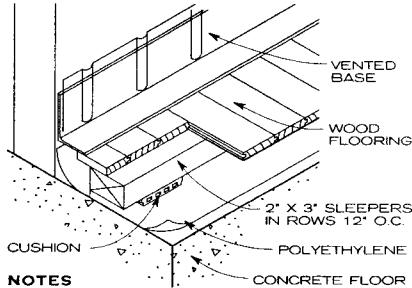

**NOTES**

1. Good performance
2. Can have dead spots
3. Susceptible to moisture damage
4. More difficult installation

**SLEEPER SYSTEM**

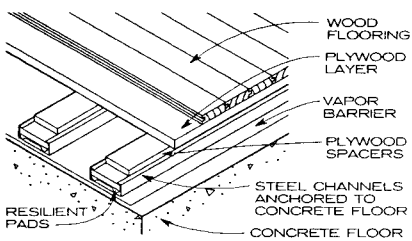

**NOTES**

1. Superior performance
2. Dimensionally stable
3. Suitable for multipurpose applications
4. A higher cost system

**PROPRIETARY FLOATING SYSTEM—ROBBINS BIO-CHANNEL®**

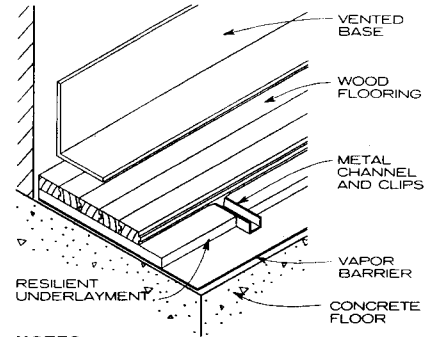

**NOTES**

1. Dimensionally stable in all environments
2. Good multipurpose floor
3. Limited performance characteristics

**CHANNEL AND CLIP SYSTEM**

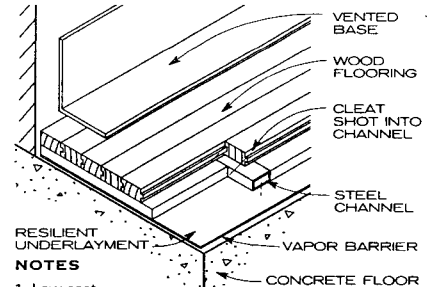

**NOTES**

1. Low cost
2. Fast installation
3. Dimensionally stable in all environments
4. Good multipurpose floor
5. Limited performance characteristics

**NAIL-IN-CHANNEL SYSTEM**

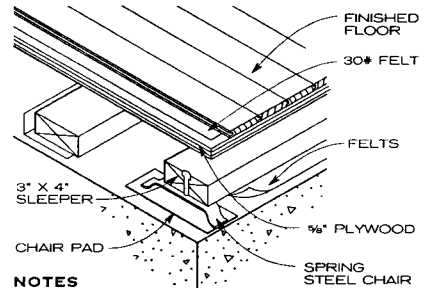

**NOTES**

1. Superior performance
2. High cost
3. Susceptible to moisture damage
4. More difficult installation

**SPRUNG SYSTEM**

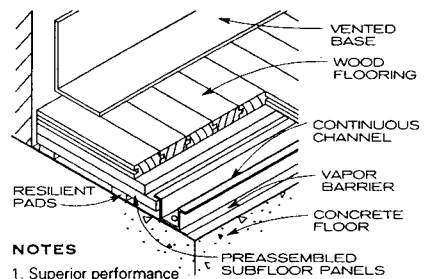

**NOTES**

1. Superior performance
2. Dimensionally stable
3. Suitable for multipurpose applications
4. A higher cost system

**PROPRIETARY SYSTEM—CONNOR/AGA REZILL CHANNEL®**

Jim Swords; HOK Sports Facilities Group; Kansas City, Missouri  
Connor/AGA Sports Flooring Corporation; Amasa, Michigan  
Robbins Sports Surfaces; Cincinnati, Ohio



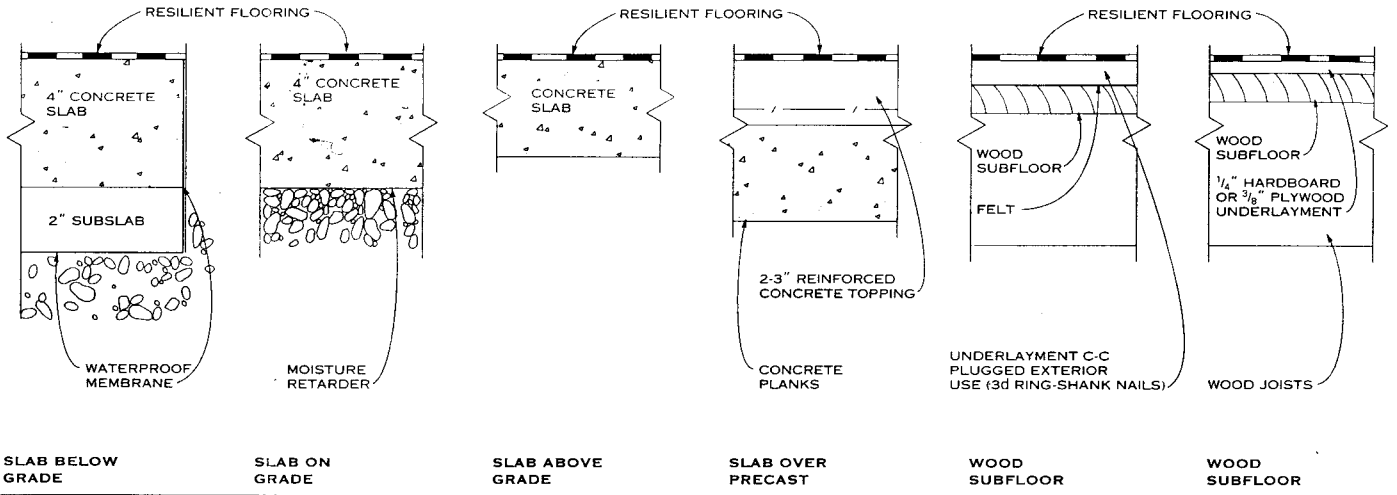

**RESILIENT FLOORING DETAILS**

**PREPARING THE BASE**

The primary issue concerning resilient flooring is preparation of an adequate base. Resilient flooring has no structural properties and will gradually conform to the topographies of the underlying surface. Bumps will "telegraph" through new flooring. Cracks in the substrate will result in cracks in the resilient flooring.

Rising damp will defeat resilient flooring. Properly cured slabs above grade are excellent substrates for resilient flooring. Slabs on grade and below grade must be proofed against groundwater. Tips for preparation of various base types follow:

**NEW CONCRETE FLOORS:** Allow a 30-day curing period. Apply sealer to the slab.

**OLD CONCRETE FLOORS:** Verify damp control. Remove all existing surface coatings. Wirebrush and sweep dusty, porous surfaces, and apply primer.

**LIFT SLABS:** Remove curing compounds before resilient flooring is installed.

**PREPARING OLD WOOD FLOORS**

TYPE OF SUBFLOOR		COVER WITH
Single wood floor	Tongue and groove not more than 3 in.	Hardboard or plywood, 1/4 in. or heavier
	Not tongue and groove	Plywood 1/2 in. or heavier
Double wood floor	Strips 3 in. or more	Hardboard or plywood 1 in. or heavier
	Strips less than 3 in., tongue and groove	Renail or replace loose boards, remove surface irregularities

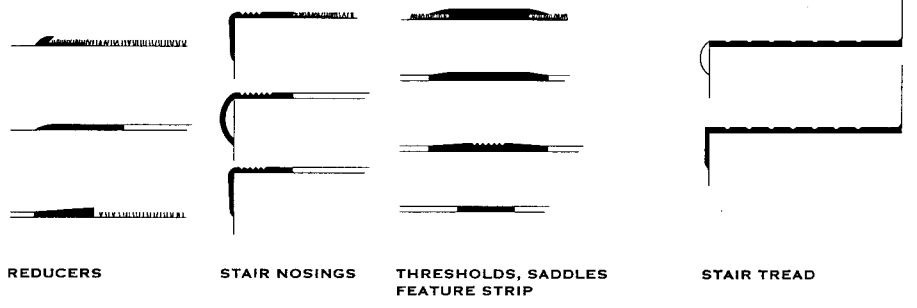
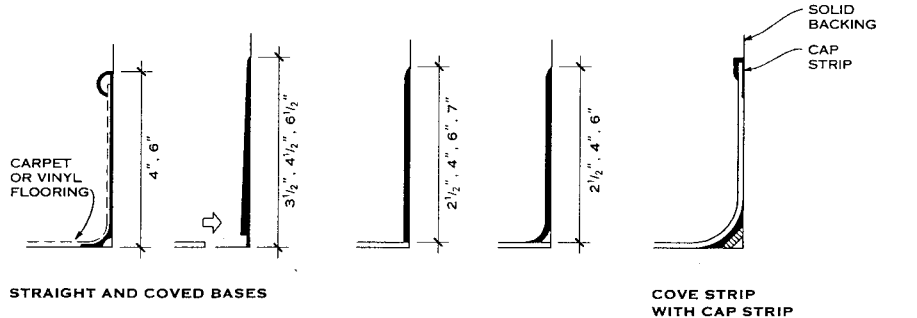

**TYPICAL ACCESSORIES FOR RESILIENT FLOORING AND CARPETING**

**RESILIENT FLOORING CHARACTERISTICS<sup>1</sup>**

TYPE	BASIC COMPONENTS	SUBFLOOR APPLICATION <sup>2</sup>		RECOMMENDED LOAD LIMIT (PSI)	DURABILITY	RESISTANCE TO HEEL DAMAGE	EASE OF MAINTENANCE	GREASE RESISTANCE	SURFACE ALKALI RESISTANCE	RESISTANCE TO STAINING	CIGARETTE BURN RESISTANCE	RESILIENCE	QUIETNESS
Homogeneous vinyl sheet	Vinyl resins and fillers		O S	125-750	1	1	2-4	2	1	2-4	3-4	3	3
Solid vinyl tile	Vinyl resins and fillers		O S	50-150	1-3	1	1-3	1-2	1	1-4	3	3	3
Vinyl composition tile	Vinyl resins and fillers	B	O S	75	3	3	4	2	2	3	2	5	5
Rubber sheet without backing	Rubber compound, homogeneous or layered		O S	50-75	1-3	1	3	5	3	3	1-2	2	2
Cork tile	Cork particles and resins		S	50-75	5	5	5	5	4	5	3	1	1
Rubber tile	Rubber compound, homogeneous or layered		O S	50-75	1-3	1	3	5	3	3	1-3	2	2
Linoleum sheet and tile	Linseed oil, resins, cork dust, wood flour, filler on a backing, cork, wood flour, and oleoresins		S	75-250	3	4	3	2	5	3	1-3	3-4	2-3

<sup>1</sup> Numerals indicate subjective ratings (relative rank of each floor to others listed above); "1" is the highest rating

<sup>2</sup> B—below grade; O—on grade; S—suspended

Credit: Bruce A. Kenan, AIA; Pederson, Hueber, Hares & Glavin; Syracuse, New York

Broome, Oringdulph, O'Toole, Rudolf & Associates; Portland, Oregon  
 Alan S. Glassman, Assoc. AIA, CSI; Armstrong World Industries, Inc.; Lancaster, Pennsylvania  
 Annica S. Emilsson; Rippeteau Architects, P.C.; Washington, D.C.

**BACKGROUND**

The word "carpet" comes from the Latin *carpere*, "to-card wool." Carpet production in the U.S. has grown from 100 million square yards in 1910 to over 1 billion square yards in the 1990s. Three events account for the increase.

1. 1930s: man-made fibers developed
2. 1950s: tufting replaced weaving
3. 1960s: tufting machine combined with piece dyeable bulked continuous filament (BCF) nylon. This gave the industry the ability to produce carpet styles with long color lines of up to 50 or more colors without large inventory costs.

**CARPET FIBERS**

Until the 1930s, nature accounted for 100% of face fiber production for floor coverings. The uncertain supply of desirable wools from about 20 countries, as well as variation in fiber length and increasing costs of scouring and processing, encouraged development of man-made fibers. Man-made fibers are easy to clean, mildew resistant, moth-proof, and nonallergenic.

**WOOL**

Of 1992 U.S. carpet production, 1% was wool. Its qualities have been copied but never quite duplicated. The natural tendency of animal fibers to stretch and return to their original length makes wool carpet resilient, with excellent recovery from crushing. Problems of supply make it the most expensive fiber and the only one requiring antimoth treatment.

**COTTON**

Negligible current usage. Tufted carpet was an offshoot of the "tufted" bedspread cottage industry in the South and had single-color, loop, or cut-pile fibers made of cotton.

**NYLON**

Of 1992 carpet production, 80% was nylon, a petrochemical engineered for carpet use, with easy dyeing characteristics. Successfully introduced into carpet in continuous filament, it was later cut and processed in staple lengths (like wool) to give more natural qualities to the finished product. Recent developments combine topical treatments with modified extrusions to give antisoil properties to the fibers. Adequate maintenance provisions should accompany specifications for these products, since soil will cause fiber damage unless removed by vacuuming and cleaning.

**ACRYLIC**

Negligible current usage. This hydrocarbon synthetic is considered to be the most wool-like of all man-made fibers.

**POLYPROPYLENE (OLEFIN)**

Of 1992 production, 12% and growing. This man-made hydrocarbon normally lacks resilience and the ability to be post-dyed. Its simplified extrusion capabilities plus the ability to be solution-dyed prior to extrusion, encouraged many carpet makers to install polypropylene fiber-making facilities.

**POLYESTER**

Of 1992 production, 7%. A high tensile strength synthetic made by the esterification of ethyl glycol, it has easy care and water-repellent qualities.

**CARPET CONSTRUCTION**

Woven carpet represents 2% of the total carpet production in the U.S. today. Whether hand-knotted, loomed, or mechanically produced, there are many similarities in production methods. The side-to-side progression in hand-knotted production is accelerated in a loom as the shuttle propels the weft (or wool) yarn back and forth over the 12 or 15 ft width of the finished carpet. This is missing in tufted and later methods. Common to all, however, is a progression of the leading edge of this 12-15 ft finished width in the direction of manufacture. This sets up the direction of lay of the finished face fibers, always in the opposite direction. The exception is in hand-knotted carpet, where the direction of lay of the face fibers falls to one side or the other, depending on the style of knot; the direction of lay changes during cleaning to follow the direction of brushing.

In tufted or woven broadloom, it is imperative that the direction of lay run in the same direction within a continuous installation. Otherwise, adjacent pieces, although perfectly seamed, will appear mismatched in color and texture.

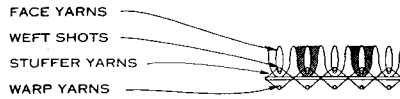

**VELVET CONSTRUCTION**

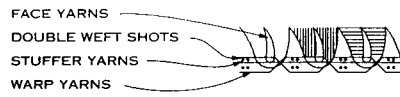

**AXMINSTER CONSTRUCTION**

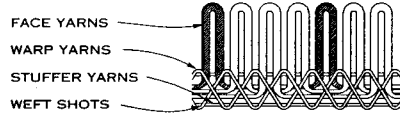

**WILTON CONSTRUCTION**

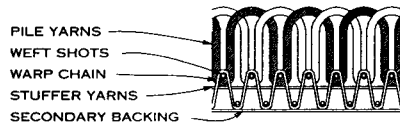

**KNITTED CONSTRUCTION**

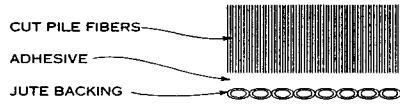

**FLOCKED CONSTRUCTION**

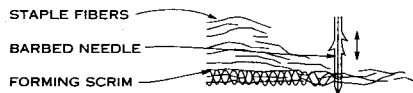

**NEEDLEPUNCHED CONSTRUCTION**

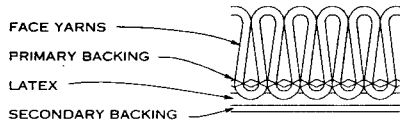

**TUFTED CONSTRUCTION**

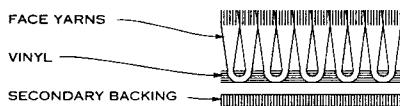

**FUSION BONDED CONSTRUCTION**

**CONSTRUCTION MODES**

**VELVET:** Simplest of all carpet weaves. Although the simplicity of the loom does not permit patterned designs, beautiful yarn color combinations can produce tweed effects. Pile forms as the warp yarns loop over removable "wires" inserted consecutively across the loom (weft-wise). Alternate height wires create high-low loop texture, while wires with a raised knife blade at the trailing end are used to create cut-pile upon retraction.

**AXMINSTER:** Has a smooth cut-pile surface, with almost all of the yarn appearing on the surface. Colors and patterns are limited only by the number of tufts in the carpet. Identifying feature is the heavy ribbed backing that only allows the carpet to be rolled lengthwise.

**WILTON:** Basic velvet loom, improved in the early 1800s by a Jacquard mechanism that feeds yarn through as many as six separate punched hole patterns to vary the texture or colored design. Uses only one color at a time on the surface; the other yarns remain buried; thus the reputation that Wiltons have a hidden quality because of the extra "hand" or feel this gives the finished carpet.

**KNITTED:** Resembles weaving in that knitted carpet is a warp-knitted fabric composed of warp chains, weft-forming yarns, and face yarns and is knitted in single operation. Warp chain stitches run longitudinally and parallel to each other. The backing yarns are laid weft-wise into the warp stitches and pass over three or four rows of warp stitches overlapping in the back of the carpet for strength and stiffness. As in tufted carpet, latex is applied to the back for stability and tuft lock. An additional backing may also be attached. Knitted carpets usually are solid colors or tweeds, with level loop textures.

**FLOCKED:** Made by propelling short strands of pile fiber (usually nylon) electrostatically against an adhesive-coated, prefabricated backing sheet (usually jute). As many as 18,000 pile fibers per inch become vertically embedded in the adhesive before a secondary backing is laminated to the fabric and the adhesive is cured. The pile fibers can be dyed prior to flocking or the finished surface can be printed after fabrication.

**NEEDLEPUNCHED:** First made of polypropylene fibers in solid colors for outdoor use (patios and swimming pools), they are now made for indoor and automotive use as well, using wool, nylon, acrylic, and/or olefin fibers in variegated colors and designs. They are made by impinging loose layers of random, staple carpet fibers into a solid sheet of polypropylene, from both sides, by means of thousands of barbed needles until the entire mass is compressed to a solid, bonded fiber mass of indoor/outdoor carpet.

**TUFTED:** This technique developed from an early method for making tufted bedspreads. Spacing of as many as 2000 needles on a huge sewing machine (12-15 ft wide) determines the carpet gauge. Face yarn is stitched through the primary backing, where it is bonded to a secondary backing with latex before curing in a drying oven. To conserve energy, some mills substitute hot-melt adhesive for latex, though this results in a loss of ability to pass flammability tests. "Single needle" tufting machines have a small stitching head that moves from side to side during carpet construction. They are used mainly for special orders for odd-shaped spaces to eliminate installation waste.

**FUSION BONDED:** This process produces dense cut-pile or level-loop carpet in solid or moresque colors. For cut-pile, the face yarn, fed simultaneously from the total width of the supply roll, or "beam," is folded back and forth between two vertically emerging primary backings as they are coated with a viscous vinyl paste that hardens, binding the folded face yarns alternately to the vertical backing sheet on each side. Final operation is a mid-line cutting that separates the vertical "sandwich" into two identical cut-pile finished rolls. To make loop-pile fusion-bonded carpet, one primary backing and the cutting operation are omitted. Fusion bonding is especially suited to making carpet tiles.

**ORIENTAL RUGS:** Defined by Oriental Rug Retailers of America as "a rug of either wool or silk, knotted entirely by hand by native craftsmen in some parts of Asia, from the shores of the Persian Gulf, north to the Caspian Sea, and eastward through Iran, the Soviet Union, Afghanistan, Pakistan, India, China, and Japan." An Oriental rug is classed an antique if it is more than 75 years old, semi-antique if less than 75 years old, and new if made in the past 15 years.

Dhurrie and Kilim rugs are flat woven rugs; they usually cost less than hand-knotted Orientals. They can be either machine- or hand-made and have primitive as well as modern designs. Other types of rugs are ryas from Scandinavia, Native American woven rugs, and Greek flatotakis. Braided and rag rugs are also available. Many carpet and rug makers offer custom designs (some computer aided) in a variety of fibers and modes of construction.

Neil Spencer, AIA; North Canton, Ohio

**USES FOR CARPET**

Carpet may be used in locations other than the floor. Tapestries, traditionally hung on walls, were useful as well as beautiful: they prevented through-wall drafts and were acoustically beneficial. In modern use, edges of full room carpeting may be upturned and used as a wall base. Used with wood trim and glued, carpet may be used in a wainscot, wall, or ceiling panel application. Flame-resistance of carpet should be checked before specifying.

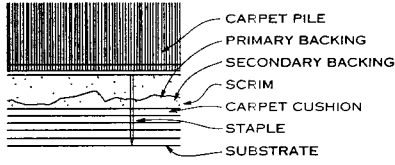

**STRETCH-IN TACKLESS**

Over separate cushion. Best condition for maximum carpet wear and most effective cleaning.

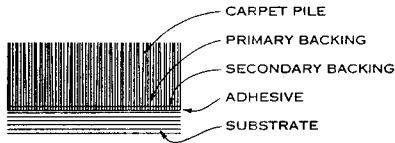

**DIRECT GLUE DOWN**

For large surface areas that make power-stretching and tackless installations prohibitive. Adhesive must be tailored to match carpet backing and substrate, as recommended by carpet manufacturer.

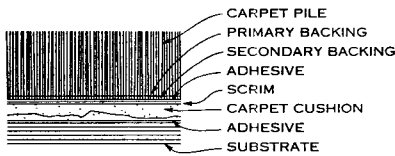

**DOUBLE GLUE DOWN**

Developed to counter early fiber failure, occurring in direct glue-down carpets in heavy traffic areas, due to lower than normal resilience level of man-made fibers. Provides ease of large area coverage plus benefits of separate pad.

**CARPET CUSHION OR UNDERLAYMENT**

Four major categories of carpet cushion are

1. Felt padding
2. Sponge rubber
3. Urethane foam
4. Foam rubber

Four reasons for considering separate carpet cushion in wall-to-wall installations are

1. Adds as much as 50% to the life of the carpet.
2. Absorbs as much as 90% of the traffic noise.
3. Can reduce installation costs by eliminating need for repairs to imperfect substrate.
4. Improves thermal environment by insulation, which varies depending on material.

**ACCESSIBILITY FOR PERSONS WITH DISABILITIES**

Carpet should be securely attached, have a firm underlayment (if provided), and have a level loop, textured loop, level cut pile, or level cut/uncut pile texture. The maximum pile thickness should be 1/2 in. (13 mm). Exposed edges should be fastened to floor surfaces and have trim along the entire length of the exposed edge. Carpet edge trim should not exceed 1/2 in. in height; if more than 1/4 in., the trim should be beveled 1:20.

Neil Spencer, AIA; North Canton, Ohio

**TRAFFIC CLASSIFICATION**

CARPETED AREAS	TRAFFIC RATING
<b>Educational</b>	
Schools and colleges	
Administration	Medium
Classroom	Heavy
Dormitory	Heavy
Corridor	Heavy
Libraries	Medium
Museums and art galleries	
Display room	Heavy
Lobby	Heavy
<b>Medical</b>	
Health care	
Executive	Light/medium
Patient's room	Heavy
Lounge	Heavy
Nurse's station	Heavy
Corridor	Heavy
Lobby	Heavy
<b>Commercial</b>	
Retail establishments	
Aisles	Heavy
Sales counters	Heavy
Small boutiques, etc.	Heavy
Office buildings	
Executive	Medium
Clerical	Heavy
Corridor	Heavy
Cafeteria	Heavy
Supermarkets	Heavy
Food services	Heavy
<b>Recreational</b>	
Recreation areas	Heavy
Clubhouse	Heavy
Locker room	Heavy
Convention centers	
Auditorium	Heavy
Corridor and lobby	Heavy
<b>Religious</b>	
Churches/temples	
Worship	Light/medium
Meeting rooms	Heavy
Lobby	Heavy

**NOTE**

If rolling traffic is a factor, carpet may be of maximum density for minimum resistance to rollers. Select only level loop or dense low cut pile for safety.

**FIBER CHARACTERISTICS**

FEATURES	NYLON	POLYPROPYLENE	POLYESTER	ACRYLIC	WOOL
Durability	EX	EX	VG	G	VG
Soil Resistance	G	F	F	F	G to EX
Resilience	G to EX	P	G	F	EX
Abrasion resistance	EX	EX	EX	G	G
Cleanability	VG	VG	VG	VG	VG

EX - Excellent, VG - Very good, G - Good, F - Fair, and P - Poor.

**MAINTENANCE PROGRAMMING**

The following maintenance-related factors should be considered in the selection of carpet:

**COLOR:** Carpets in the mid-value range show less soil than very dark or very light colors. Consider the typical regional soil color. Specify patterned or multicolored carpets for heavy traffic areas in hotels, hospitals, theaters, and restaurants.

**TRAFFIC:** The heavier the traffic, the heavier the density of carpet construction.

**TOPICAL TREATMENT:** The soil-hiding qualities of advanced generation fibers do not reduce the need for regular maintenance. Regular cleaning is important to remove hidden dirt that may contribute to early fiber failure.

**PLACEMENT:** The location of carpeted areas within a building affects the maintenance expense. Walk-off carpet areas can help reduce tracked-in soil near entrances.

**DEFINITIONS**

**CARPET TILES:** Square 18 to 36 in. modules, dense cut-pile or loop, heavy backed. Can be made to cover flat, regular wiring, low-voltage lighting systems ("safe-lites"), or under-floor utilities.

**CARPET WEAR:** As defined by fiber manufacturers, refers to percentage of face fiber lost over the life of a guarantee.

**COMMERCIAL:** Includes all contract, institutional, transportation; any use where carpet is specified by other than the end user.

**RESIDENTIAL:** Includes all carpet specified and purchased for residential use by the owner.

**LIFE CYCLE COSTING:** Permits comparison of diverse flooring methods by totaling initial cost, installation, and detailed predictable maintenance expenses over the expected life of the carpet.

**TRAFFIC:** Expressed in terms of floor traffic (person) per unit of time or as light, medium, or heavy, to define need for matching carpet construction, which normally increases in density as traffic increases. See table at left.

**PILE HEIGHT:** Height of loop or tuft from the surface of the backing to the top of the pile, measured in fractions, or decimals, of an inch.

**PILE WEIGHT (face weight):** Total weight of pile yarns in the carpet (measured in oz/sq yd excluding backing).

**PILE DENSITY:** D = 36 times the finished pile weight, in oz/yd, divided by the average pile height.

$$\text{WEIGHT DENSITY (WD)} = \frac{(\text{Face weight})^2 \times 36}{\text{Pile height}}$$

**PITCH (in woven carpet):** The number of yarn ends in a 27 in. finished width of carpet.

**GAUGE:** In tufted carpet, the number of needles per inch across the width of the finished carpet.

**STITCHES:** Number of rows of yarn ends per inch, finished carpet. Tufts per sq in.: Calculation made by multiplying pitch x wires for woven carpet, or gauge x stitches per inch for tufted.

**DERNIER:** Weight in grams of 9000 meters (9750 yd) of a single extruded filament of nylon. Based on the standard weight of 450 meters of silk weighing 5 centigrams.

**FILAMENT:** Continuous strand of extruded synthetic fiber, combined into a "singles" yarn by simply twisting, without the need for spinning.

**PLY:** Refers to the number of strands of "singles" yarn twisted together (for color or texture) to create a two-ply or three-ply yarn system.

**POINT:** A single tuft of carpet tile.

**BCF:** Bulked continuous filament.

**CUT-PILE PATTERN:** Plush or saxony type carpet with woven, tufted, or printed design or pattern.

**LEVEL LOOP:** Carpet made from uncut tufts in looped form and having all tufts the same pile height.

**CUT-PILE VELVET:** Solid color, tweed, or heather blend yarns that give smooth velvety or velour texture.

**CUT AND LOOP:** Carpet with areas of both cut pile and loop pile, most often with the cut pile being higher than the loop.

**FREEZE:** Cut pile carpet made from highly twisted yarns that are heat-set to give a curled random configuration to the pile yarns.

**PRIMARY BACKING:** The matrix used in making tufted carpet, consisting of woven or nonwoven fabric, usually jute or polypropylene, into which pile yarn tufts are stitched.

**SECONDARY BACKING:** The woven or nonwoven material adhered to the underside of a carpet during construction to provide additional tuft bind for tufted carpet and dimensional stability and body. Usually jute, or polypropylene, latex foam, or vinyl.

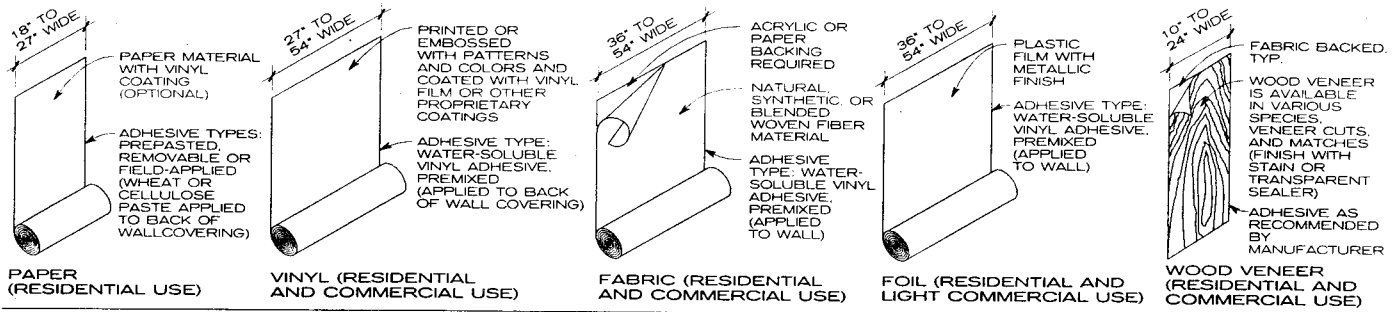

**WALL-COVERING MATERIALS**

**NOTES**

- In some installations, fabric-wrapped panel systems have advantages over standard adhesive-applied wall coverings. There is generally less damage to the original wall surface, less surface preparation is needed, and an acoustical or tackable wall panel (which improves the STR or NRC rating of a wall) can be added to a room and concealed behind the fabric wrapping. In addition, the fabric or backing panel can be easily changed.
- For wrapped panels, fabric or other wall covering should cure to room temperature and humidity conditions before installation.
- Instruct installer to cut and hang three test panels for architect's inspection and approval before cutting other material from the roll.
- The following terms apply to wall coverings:
  - Bolt: typically three continuous rolls of wall covering
  - Double cutting: trimming method that overlaps edges and forms a butt joint with a single cut
  - Single roll: from 30 to 36 sq ft wall covering
  - Double roll: from 60 to 72 sq ft wall covering
  - Railroading: installing wall covering in horizontal direction
  - Underlayment: any paper, fabric, or other liner material used to prepare a wall for installation of a wall covering
- Avoid exposed wall-covering edges. Specify continuous metal or plastic edge trim where required; wrap covering into any reveals that occur.

**FIBER CHARACTERISTICS FOR FABRIC WALL COVERINGS (RATING SCALE OF 1-5)**

FIBER/FABRIC	TYPE	DESCRIPTION/SOURCE	GENERAL PROPERTIES							
			DIMENSIONAL STABILITY	RESILIENCY AND ELASTICITY	STRENGTH	ELECTRICAL CONDUCTIVITY	HEAT CONDUCTIVITY	ABSORBENCY	MOISTURE REGAIN	SPECIFIC GRAVITY
Cotton	Natural	Soft, fibrous matter from seed pod of cotton plant	5	2	3	5	5	5	7 to 11%	1.54
Linen	Natural	Strong, lustrous yarn or fabric from the flax plant	5	1	4	5	1	5	8 to 12%	1.52
Wool	Natural	Protein fiber of hair taken from sheep	1	5	1	2	2	5	15%	1.32
Silk	Natural	Single filament protein fiber extruded from silkworm	5	4	4	2	2	4	11%	1.25
Acetate	Man-made	Modified cellulosic fibers	2	1	1	3	3	2	6%	1.32
Viscose rayon	Man-made	Regenerated cellulosic fiber made from wood or other pulp	3	1	1	4	4	5	11 to 14%	1.50 to 1.53
Olefin	Man-made	Synthetic polymers including polypropylene (or polyethylene)	4 <sup>a</sup>	5	5	1	1	1 <sup>a</sup>	0	0.92
Acrylic	Man-made	Synthetic polymer	5 <sup>b</sup>	4	3	1	1	1	1.0 to 2.5%	1.14 to 1.19
Nylon	Man-made	Petroleum-based synthetic polyamide fiber (some natural sources exist)	5 <sup>c</sup>	5	5	2	1	1	4.0 to 4.5%	1.14
Polyester	Man-made	Petroleum-based synthetic polymer	5 <sup>d</sup>	5	5	1	1	1 <sup>e</sup>	0.2 to 0.8%	1.38

**NOTES**

- The ratings for these charts use the following numerical system of 1 to 5, "1" meaning the property or resistance level is least applicable and "5" meaning the property or resistance level is most applicable. Also the following notes apply to the charts:
  - Hydrogen peroxide below 90°F will harm fiber.
  - Petroleum products safe; acetone harmful to fiber.
  - Will degrade if wet.
  - Carpet beetles will attack fabric.
  - Hydrogen peroxide is not harmful to fiber.
  - Fabric may shrink at high temperatures.
  - Long exposure will degrade fabric.
  - May shrink at high temperatures if not heat set.
  - Fabric will wick moisture.
  - Fabric is resistant if behind glass.
  - Will harm at high temperatures and concentrations.
- These charts are a general guide to the most significant performance-related properties of common untreated or natural fibers. There are many other properties associated with fibers and, particularly, fabrics, which can have many fiber-blend permutations. Consult the fabric manufacturer for those properties (and ASTM results) relevant to the individual installation.
- Care must be taken in cleaning any fabric used in an architectural installation. Consult fabric manufacturer for recommended cleaning procedures.
- The following are definitions of various terms used in the charts:
 

Strength—evaluated in terms of breaking, tearing, or bursting strength.

Electrical conductivity—the ability of a fiber or fabric to carry or transfer electrical charges. Low conductivity fabrics build up static electrical charge.

**RESISTANCE LEVELS OF FIBER/FABRIC (RATING SCALE OF 1-5)**

FIBER/FABRIC	RESISTANCE LEVEL OF FIBER/FABRIC TO				
	INSECTS AND MICROORGANISMS	OXIDIZING AGENTS (CHLORINE BLEACHES)	ORGANIC DRY CLEANING SOLVENTS (NAPHTHA, ETC.)	SUNLIGHT	AGE
Cotton	5 <sup>c</sup>	1	5	2	5
Linen	5 <sup>c</sup>	1	5	1	4
Wool	1	1	5	2	5
Silk	5 <sup>d</sup>	2 <sup>a</sup>	5	1	2
Acetate	4	5 <sup>a</sup>	5 <sup>b</sup>	2	4
Viscose rayon	not applicable	2	5	2	5
Olefin	5	not applicable	1	2	5
Acrylic	5	5 <sup>a</sup>	5	5	5
Nylon	5	not applicable	1	4 <sup>a</sup>	5
Polyester	5	5	5	4 <sup>b</sup>	5

- Heat conductivity—the ability of a fiber or fabric to carry or transfer heat.
- Specific gravity—related to the weight of a fiber, expressed as the density of the fiber in relation to the density of an equal volume of water at 40°C.
- Consult standards developed by the Association for Contract Textiles, the American Society for Testing and Materials, and the American Association of Textile Chemists and Colorists to establish performance guidelines for commercially installed textiles:
 

VERTICAL APPLICATION—Direct glue wall coverings

    - Flammability: ASTM E84 rated (see local code for building occupancy ratings).
    - Colorfastness to light: AATCC 16A or E/class 4 minimum at 40 hours.

- Colorfastness to wet and dry crocking: AATCC 8 class 3 minimum.
- VERTICAL APPLICATION—Panel or upholstered applications
- Flammability: ASTM E84 rated (see manufacturer and local code for specific applications).
  - Breaking/tensile strength: ASTM D3597, 50 pounds minimum/warp and weft directions.
  - Yarn/seam slippage: ASTM D3597, 25 pounds minimum/warp and weft directions.
  - Colorfastness to light: AATCC 16A or E/class 4 minimum at 40 hours.
  - Colorfastness to wet and dry crocking: AATCC 8/class 3 minimum.

Richard J. Vitullo, AIA; Oak Leaf Studio; Crownsville, Maryland  
 Kristie Strasen; Strasen Frost Associates; New York, New York

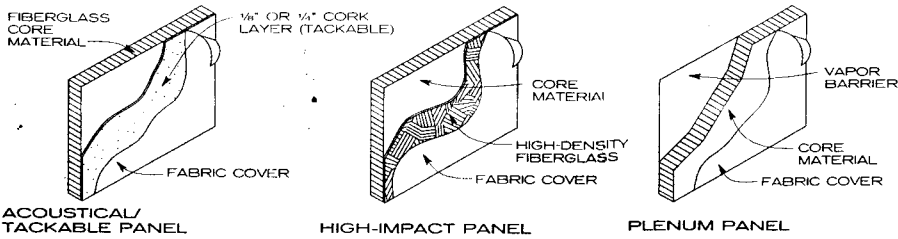

**NOTES**

1. In these types of fabric panels the fabric is permanently bonded to the substrate and/or core material. Panels can be manufactured to any size or shape with any corner or edge details; aluminum edge frames can be added for extra stiffness.
2. Panels are fastened to wall surfaces with magnets, foam tape, hook and loop, liquid adhesive, mechanical metal strip, or clip, with optional base support brackets.

**PREFABRICATED FABRIC-WRAPPED PANELS**

**WALL COVERING INSTALLATION**

When selecting a wall covering, it is necessary to consider the installation location, traffic patterns, light sources (both natural and man-made), and acoustical requirements. Consider the following when preparing a wall:

1. Wall covering weights vary from 7 to 12 oz per square yard (Type I); 13 oz per square yard (Type II); and 22 or more oz per square yard (Type III). The limited thickness and opacity of Type I and II materials may make wall surface imperfections and colors visible.
2. Before fabrics or other pervious wall coverings are installed, they are usually backed with a paper layer or liquid-applied acrylic coating to prevent seam slippage and adhesive bleed-through, as well as to increase stability and provide a neutral background for light-colored wall coverings. Backings allow the wall covering to be applied with conventional paper-hanging techniques.
3. Wall surfaces should be clean, smooth, dry, and structurally intact. Low spots should be filled and sanded, loose paint and other coverings removed, glossy surfaces sanded to roughen them slightly, and all dust removed.
4. The proper wall primer should be used on wall surfaces, particularly new gypsum wallboard. Not all water-based adhesives can be used over latex paint primer. Consult manufacturers for compatibility of adhesives and primer materials.
5. There are three basic adhesive types: wheat-based (the traditional paste, no longer popular), clay-based (traditionally used for heavy-duty applications), and vinyl (formulated for improperly prepared or problem wall surfaces).
6. When specifying adhesives, ask manufacturers and installers for recommendations to prevent buckling, sagging, delamination, and environmental considerations such as off-gassing.

**ESTIMATING WALL COVERING MATERIALS**

Wall coverings can be estimated by two methods:

**Square Foot Method (no pattern repeat):**

1. Measure the length of all walls and calculate the total.
2. Multiply the total combined length of the walls by the greatest wall height rounded up to the nearest foot to determine the total wall area.
3. Add 15% to the total area to account for waste.
4. Find the total area of all doors and windows wider than the width of a strip of wall covering.
5. Subtract total door and window area from total wall area. This will be the approximate square foot amount of wall covering required.
6. Divide the approximate square foot amount of wall covering by the number of square feet in each roll or bolt (refer to manufacturer's literature) to determine the number required for each job.

**Panel Method (patterns and materials with highly visible seams):**

1. Determine the trimmed width of material (54 in. wide becomes 52 in. wide).
2. On a scaled floor plan, place vertical seams in locations not less than 6 in. from inside and outside corners.
3. Adjust seam locations as necessary for desired seam arrangement, then count the panels. Count partial-width panels as whole widths.
4. Determine the panel height by measuring the floor-to-ceiling height and adding one pattern repeat for vertical patterns.
5. Multiply the number of panels by the adjusted panel height to determine the total material length required.
6. For wall coverings sold by linear yard, divide total length by three to determine the number of yards needed to complete the work. For wall coverings sold by the square foot, convert the total length of material into square feet and divide by the number of square feet in each roll or bolt (check with manufacturer).

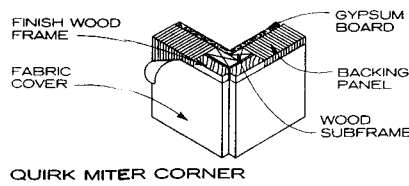

**QUIRK MITER CORNER**

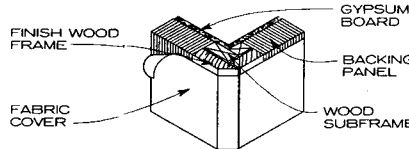

**45° BEVELED CORNER**

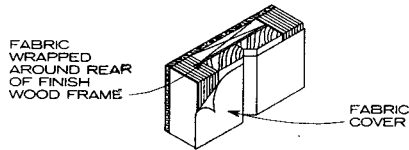

**45° BEVELED BUTT JOINT**

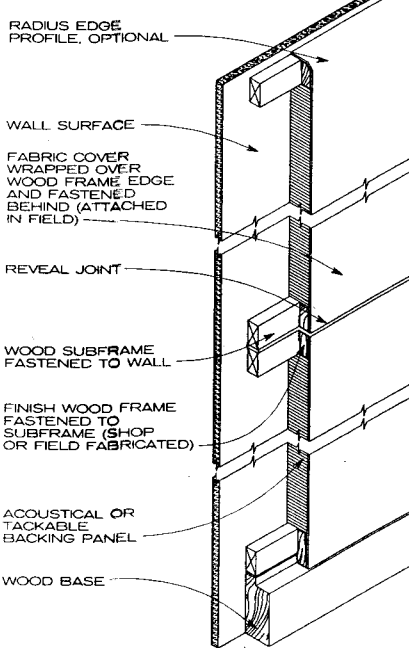

**FABRIC-WRAPPED PANELS—WOOD FRAME SYSTEM**

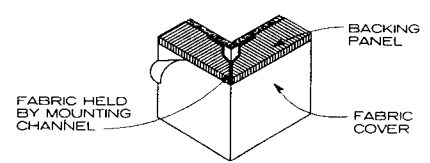

**OUTSIDE CORNER**

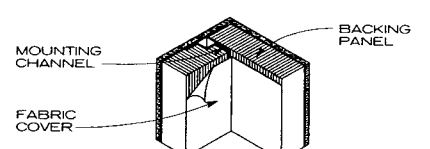

**INSIDE CORNER**

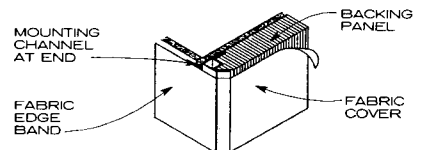

**45° BEVELED CORNER**

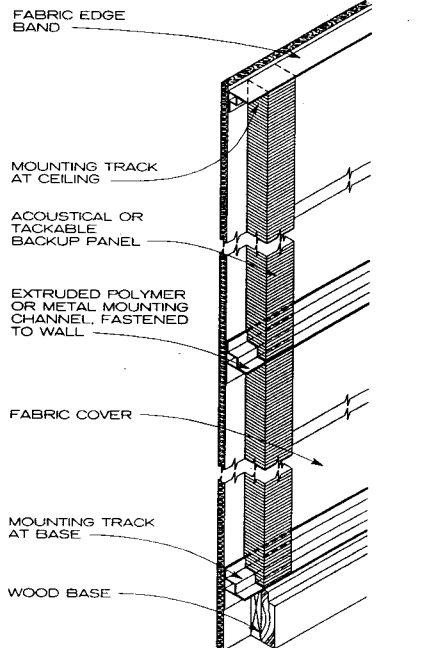

**FABRIC-WRAPPED PANELS—TRACK SYSTEM**

Richard J. Vitullo, AIA; Oak Leaf Studio; Crownsville, Maryland  
 Kristie Strasen; Strasen Frost Associates; New York, New York

**SURFACE CHARACTERISTICS**

CHARACTERISTIC	ADVANTAGES
High performance/durability	Resistant to abuse Abrasion resistant Weather resistant.
Nonporous surface	Germ inhibition
Low maintenance	Ease of cleaning
Installation	Lightweight panels Common installation procedures
Versatility	New construction Renovation Demountable Projection/marker surface
Chemical resistance	Resistant to chemical attack*
Fire resistance	Class A fire rating*
Color/texture/pattern availability	Standard/custom color, graphics textures

\* Refer to specific manufacturer's literature.

**PANEL CONSTRUCTION GUIDE**

PANEL COMPONENT	MATERIALS	ADVANTAGES
Face	Ceramic on steel Anodized aluminum Painted aluminum Stainless steel Painted steel Fiberglass-reinforced	Variety of finishes Matching adjacent metals Polished finish
Stabilizer panel	Tempered hardboard Asbestos-free board Mineral fiberboard Plywood* Gypsum board* Fire-rated fiberboard Polystyrene foam*	Lower cost, lighter weight Additional fire protection
Back	Ceramic on steel Galvanized sheet steel Aluminum sheet Exposed stabilizer panel	Attractive finished back May be finished in field
Anchors	Screws Concealed trim Exposed trim Plastic/metal rivets* Stainless steel nails*	

\* Applicable to fiberglass panels only.

**PANEL SIZE LIMITATIONS**

PANEL	CERAMIC/STEEL (IN.)	FIBERGLASS (IN.)
Maximum width	60*	48*
Maximum length	144*	144*

\* Custom size, color, and thickness available. Consult manufacturer.

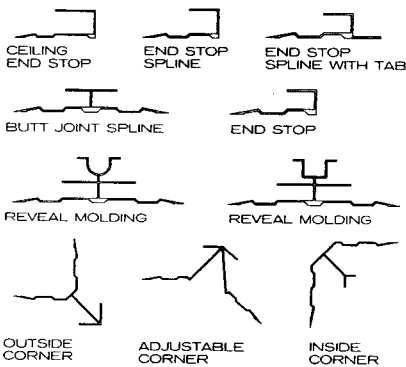

**CERAMIC STEEL TRIM COMPONENTS**

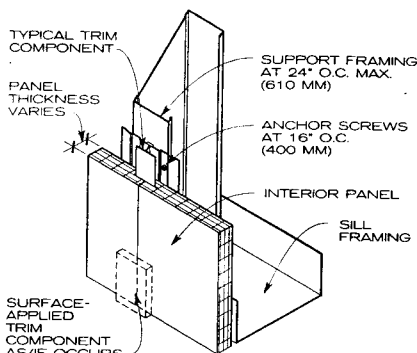

**TYPICAL VERTICAL BUTT JOINT**

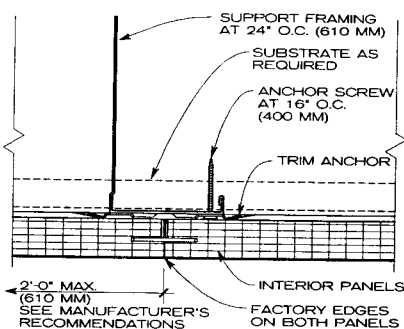

**VERTICAL BUTT JOINT WITH CONCEALED TRIM**

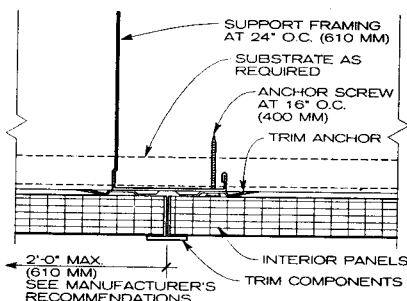

**VERTICAL BUTT JOINT WITH EXPOSED TRIM**

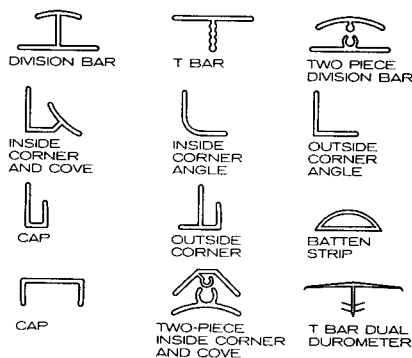

**FIBERGLASS/VINYL TRIM COMPONENTS**

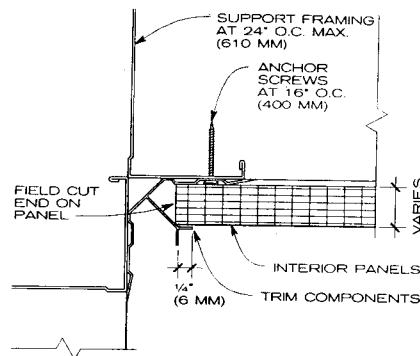

**INSIDE CORNER**

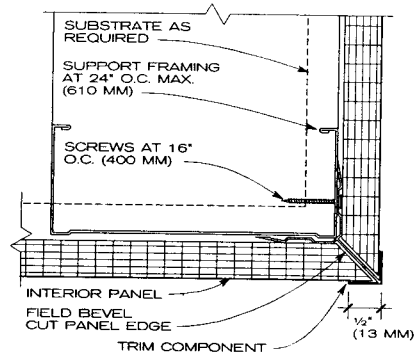

**OUTSIDE CORNER DETAIL**

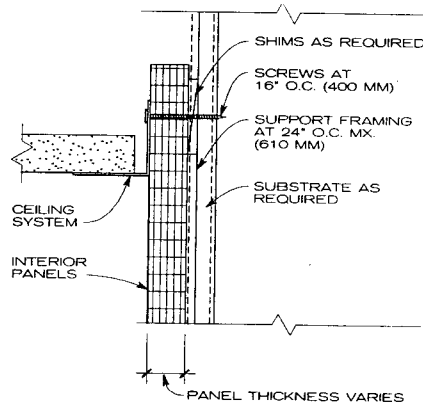

**DETAIL AT CEILING**

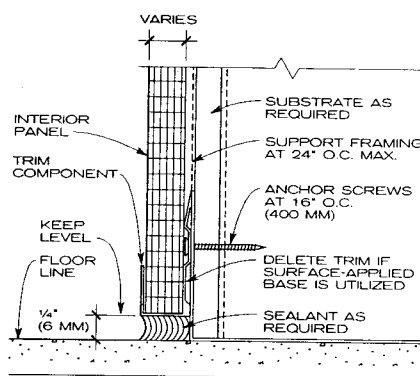

**PANEL AT SILL**

Kevin R. McDonald, AIA: HNTB Corporation; Alexandria, Virginia  
Alliance America; Norcross, Georgia

ACOUSTICAL CEILING SYSTEMS

CEILING TYPE	COMPONENTS											MATERIALS				FINISHES				ACOUSTIC TILE SIZES (IN.)						NOTES
	Main, Cross T	Access T's	Z channel	H channel	T spline	Flat spline	Spacer	Modular T	Metal pan T	Special	Bent steel	Bent steel alum. cap	Bent aluminum	Extruded aluminum	Galvanized	Painted	Anodized	Embossed pattern	Fire rating available	12 x 12	12 x 24	24 x 24	24 x 48	24 x 60	20 x 60	
Gypsum wallboard																										
Suspended	•																									
Exposed grid	•																									
Semiconcealed grid	•																									
Concealed H & T																										
Concealed T & G																										
Concealed Z																										
Concealed access	•	•																								
Modular	•																									
Metal pan																										50 or 60" sq main grid 12" sq pattern
Linear metal																										4" o.c. typical
Perforated metal	•																									1 way grid 4' - 8' o.c.
Luminous ceiling																										1" to 4" sq grid

ACOUSTICAL CEILING MATERIALS

MATERIALS	SIZES (IN.)								THICKNESS (IN.)				EDGES			NRC RANGE				USES											
	12 x 12	12 x 24	24 x 24	24 x 48	24 x 60	30 x 60	60 x 60	48 x 48	Custom sizes	1/2	5/8	3/4	1	1-1/2	3	Square	Regular	T & G	Keirfed and rabbeted	45-.60	.60-.70	.70-.80	.80-.90	.90-.95	High humidity	Exterior soffit	High abuse/impact	Scrubable	Fire rating available		
Mineral fiber:																															
Painted	•	•	•	•	•	•	•	•	•	•	•	•	•	•	•	•	•	•	•	•	•	•	•	•	•	•	•	•	•	•	•
Plastic face																															
Aluminum face	•	•	•	•	•	•	•	•	•	•	•	•	•	•	•	•	•	•	•	•	•	•	•	•	•	•	•	•	•	•	•
Ceramic face																															
Mineral face	•	•	•	•	•	•	•	•	•	•	•	•	•	•	•	•	•	•	•	•	•	•	•	•	•	•	•	•	•	•	•
Glass fiber:																															
Painted		•	•	•	•	•	•	•	•	•	•	•	•	•	•	•	•	•	•	•	•	•	•	•	•	•	•	•	•	•	•
Film face		•	•	•	•	•	•	•	•	•	•	•	•	•	•	•	•	•	•	•	•	•	•	•	•	•	•	•	•	•	•
Glass cloth face		•	•	•	•	•	•	•	•	•	•	•	•	•	•	•	•	•	•	•	•	•	•	•	•	•	•	•	•	•	•
Molded																															
Gypsum		•	•	•	•	•	•	•	•	•	•	•	•	•	•	•	•	•	•	•	•	•	•	•	•	•	•	•	•	•	•
Mylar face	•	•	•	•	•	•	•	•	•	•	•	•	•	•	•	•	•	•	•	•	•	•	•	•	•	•	•	•	•	•	•
Tectum		•	•	•	•	•	•	•	•	•	•	•	•	•	•	•	•	•	•	•	•	•	•	•	•	•	•	•	•	•	•

SPECIAL ACOUSTICAL SYSTEMS

SOUND ISOLATION

When it is necessary to isolate a high noise area from a building or a "quiet room" from a high surrounding noise level, floors, walls, and ceilings should be built free of rigid contact with the building structure to reduce sound and vibration transmission.

CUSTOM WALLS

Auditoriums, concert halls, and other special acoustically conditioned space may require both absorptive and reflective surfaces and, in some cases, surfaces that can be adjusted for varying absorption coefficients to "tune" the space.

SPECIAL PATTERNS AND PROFILES

Screen printed, scored, and face-cut acoustical panels with a variety of edge treatments are available in narrow profile, tegular ceilings. Compatible grid systems, some offering features to facilitate partition and equipment attachment, install in similar fashion to conventional T-bar components.

LOOSE BATTS

USE: Reduce sound transmission through or over partitions; installed over suspended acoustical tile. Also used between gypsum wall partitions.

MATERIALS: Expanded fiberglass or mineral fiber.

STC: Based on total designed system; can range from 40 to 60.

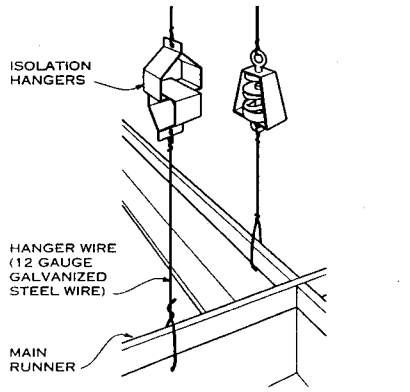

ISOLATION HANGER

CEILING ISOLATION HANGER

Isolates ceilings from noise traveling through the building structure. Hangers are also available for isolating ceiling systems to shield spaces from mechanical equipment and aircraft noise.

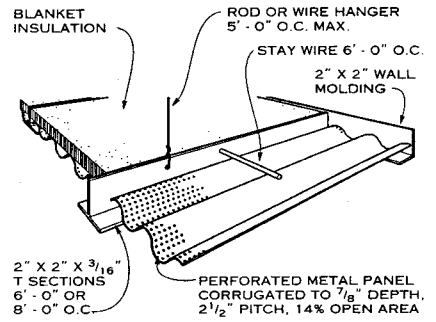

PERFORATED METAL CEILING

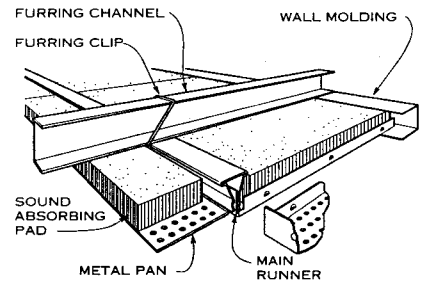

METAL PAN CEILING

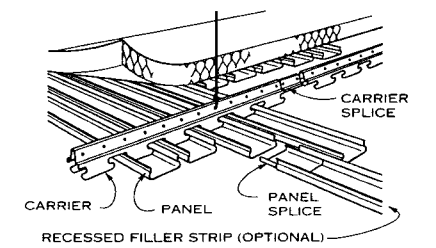

LINEAR METAL CEILING

METAL CEILINGS

USE: Sound absorption depends on batt insulation. MATERIALS: Bent steel, aluminum, or stainless steel. NRC: 0.70 to 0.90. FINISH: Painted, anodized, or stainless steel.

Setter, Leach & Lindstrom, Inc.; Minneapolis, Minnesota

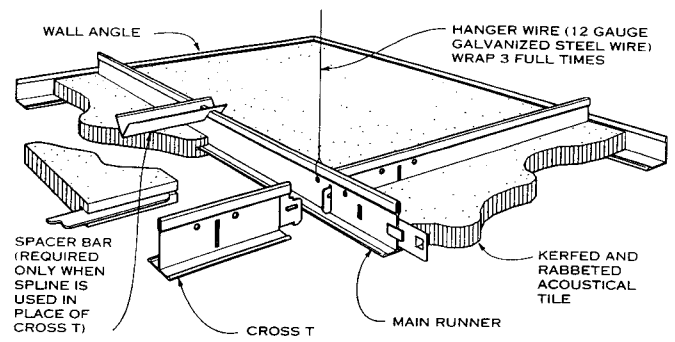
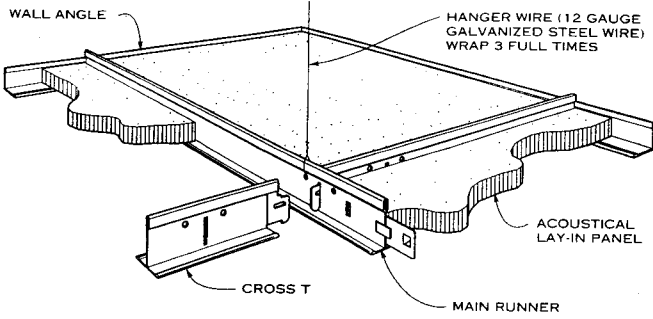

**EXPOSED GRID**

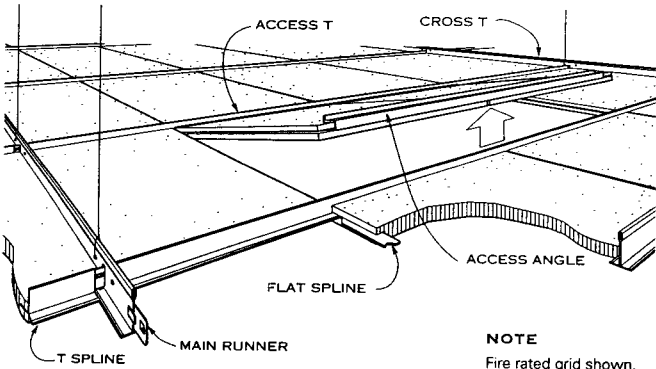

**CONCEALED GRID**

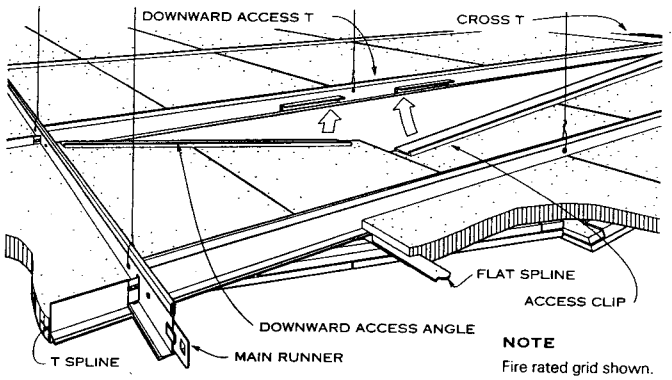

**CONCEALED GRID - UPWARD ACCESS (SIDE PIVOT SHOWN; END PIVOT AVAILABLE)**

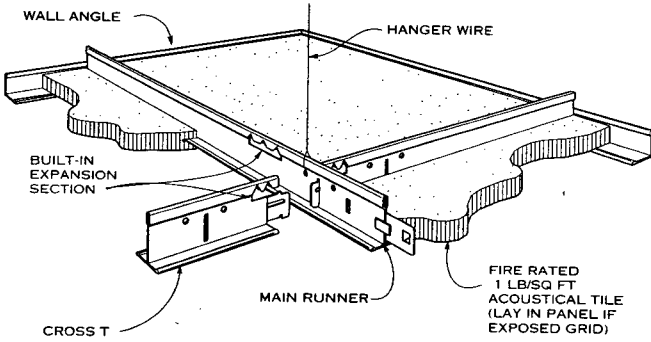

**CONCEALED GRID—DOWNWARD ACCESS (END PIVOT SHOWN; SIDE PIVOT AVAILABLE)**

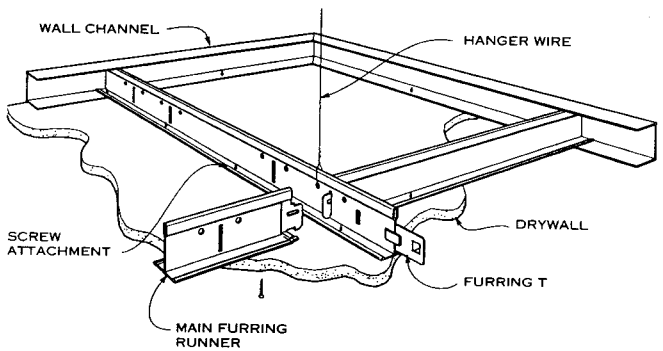

**FIRE RATED GRID (CONCEALED GRID SHOWN)**

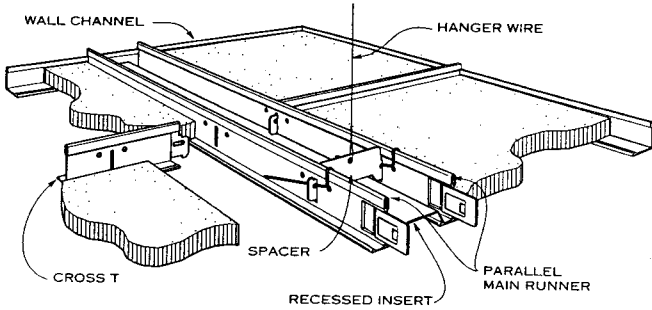

**DRYWALL FURRING SYSTEM**

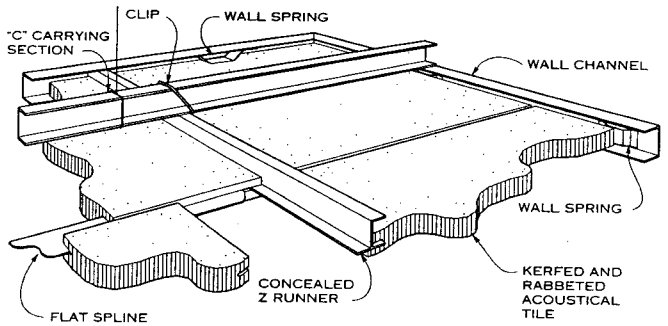

**LINEAR SYSTEM**

**CONCEALED Z SYSTEM**

Setter, Leach & Lindstrom, Inc.; Minneapolis, Minnesota  
Blythe + Nazdin Architects, Ltd.; Bethesda, Maryland



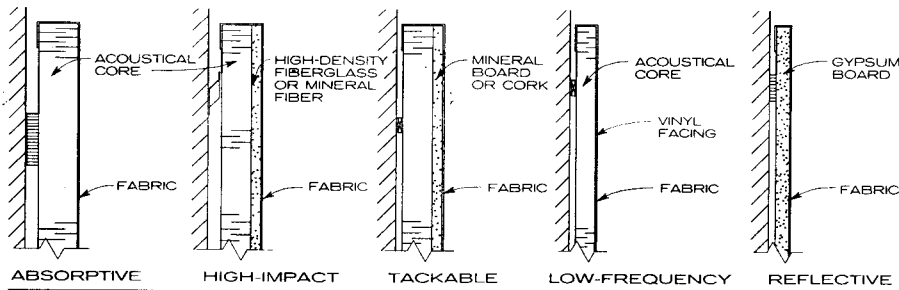

PANEL TYPES

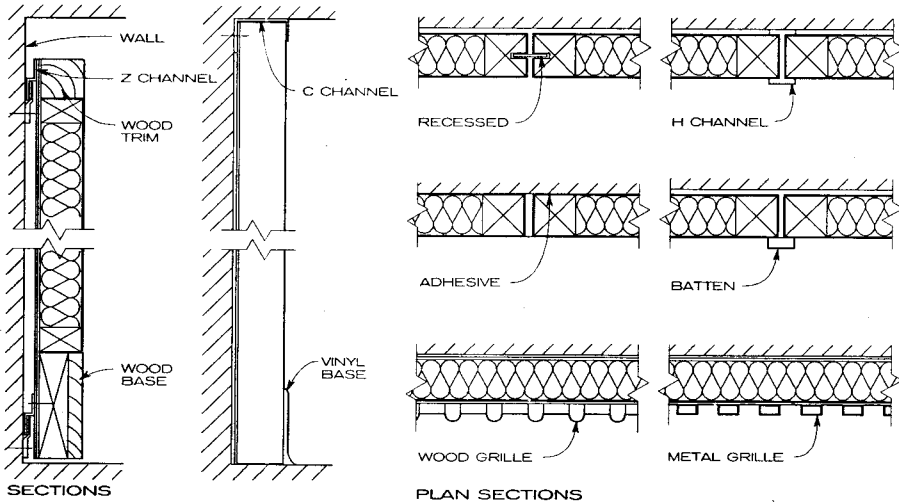

WALL TREATMENT

**ACOUSTICAL MASONRY UNITS**

1. USE: sound absorption and diffusion.
2. MATERIALS: concrete masonry units 4, 6, 8, or 12 in. thick, with fiberglass or metal baffle in the slotted area for sound absorption; quadratic residue sequence shaped surface for sound diffusion.
3. NRC: 0.45 to 0.85.

**NOTE**

Acoustical masonry units are available with glazed, split rib, and ground face masonry finishes. The units offer better sound absorption at low frequencies than at middle to high frequencies and can be used as load-bearing structural walls. Painting slightly reduces the NRC rating of these units.

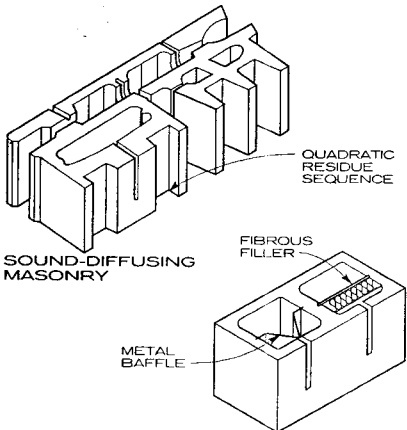

SOUND-ABSORBING MASONRY

ACOUSTICAL MASONRY UNITS

**DIFFUSIVE WALL TREATMENT**

1. USE: sound diffusion/scattering.
2. MATERIALS: factory-assembled wood, fiberglass, or fiberglass-reinforced gypsum panels with integrally shaped surfaces.
3. NRC: typically less than 0.30.
4. THICKNESS: up to 18 in. depending on panel shape.

**NOTE**

Wall panels may be used individually or grouped to form a monolithic wall system. Panels function best if they are installed 4 ft. above the floor surface (ear height) and extend to a minimum of 8 ft. above the floor surface. Maximum panel size varies with the manufacturer up to 4 x 8 ft.

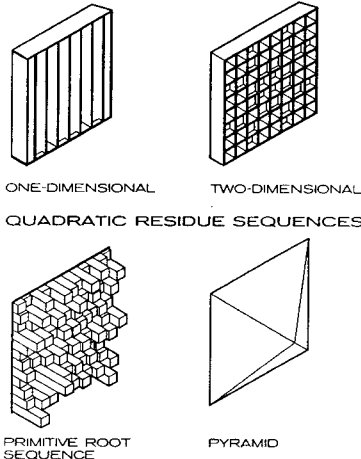

DIFFUSIVE WALL TREATMENT

**ABSORPTIVE WALL TREATMENT**

1. USE: sound absorption.
2. MATERIALS: factory- or field-assembled fabric wrapped glass fiber or mineral wood panels.
3. NRC: 0.55 to 1.0.
4. THICKNESS: one, two, or four inches.
5. PANEL TYPES: absorptive, high-impact, tackable, and special acoustical characteristics.
6. EDGE PROFILES: square, bevel, radius, and chamfer.
7. EDGE REINFORCEMENT: chemical treatment, metal, plastic, and wood.
8. INSTALLATION HARDWARE: mechanical clips, impaling pins, magnetic fasteners, hook and loop tape, and adhesives (the last two require installation of a metal angle at panel bottom to carry the weight of the panel).

**NOTE**

Wall panels may be used individually or grouped to form a monolithic wall system. The NRC coefficient varies with the thickness of the material, the acoustical transparency of the fabric, and the installation mounting. Panels are more effective at absorbing mid- and high-frequency sound. Vinyl facing over an acoustical core increases low-frequency absorption and decreases mid- and high-frequency absorption. Panels are not recommended for installation in high abuse areas unless perforated metal or high-density scrim facing protects the acoustical core. Maximum panel size varies with the manufacturer up to 4 x 12 feet.

**SPRAY-ON ACOUSTICAL MATERIAL**

1. USE: sound absorption.
2. MATERIALS: aerated concrete, mineral, or cellulose fibers spray-applied to metal lath or directly to hard surfaces such as concrete, steel, masonry, or gypsum wall-board.
3. NRC: 0.35 to 1.0.

**NOTE**

This material is available in thicknesses of 1/2 to 1 1/2 in. with abuse-resistant surfaces and fire protection ratings. Applying spray-on acoustical material to lath increases low-frequency sound absorption and makes it possible to accommodate irregular shapes. The NRC rating of this material depends on how it is mounted and the thickness of the material.

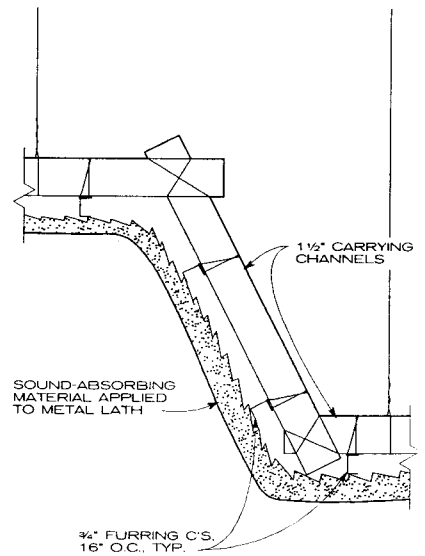

SPRAY-ON ACOUSTICAL MATERIAL

Michael G. Lawrence, AIA; M Lawrence Architects; Washington, D.C.  
Neil Thompson Shade; Acoustical Design Collaborative, Ltd.; Falls Church, Virginia

**GENERAL**

Sound travels in waves through matter. Sound transmission can be reduced by interfering with the travel and reflection of sound waves. The details on this page show methods of dampening sound waves by reducing reflection, increasing absorption, and/or providing a mass barrier.

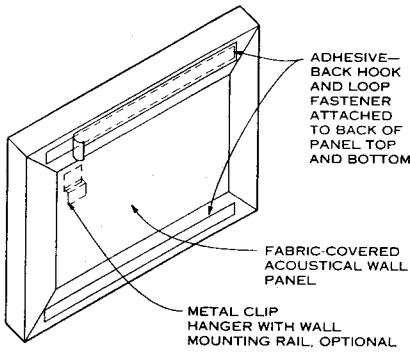

**WALL PANEL MOUNTING DETAIL**

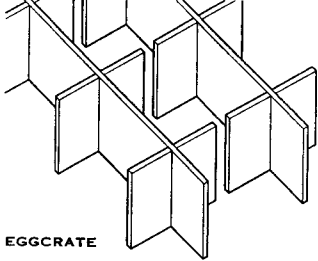

**EGGCRATE**

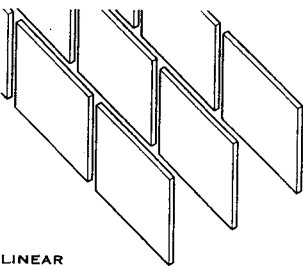

**LINEAR**

**SUSPENDED ACOUSTICAL BAFFLES**

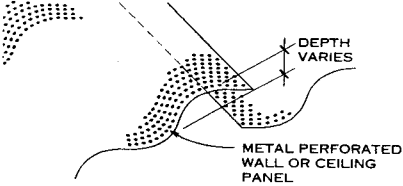

**CORRUGATED PANEL**

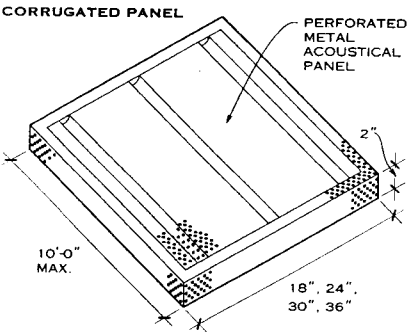

**BOX-SHAPED PANEL**

**PERFORATED METAL ACOUSTICAL PANELS**

Rippeteau Architects, P.C.; Washington, D.C.  
 Setter, Leach & Lindstrom, Inc.; Minneapolis, Minnesota  
 Blythe + Nazdin Architects, Ltd.; Bethesda, Maryland

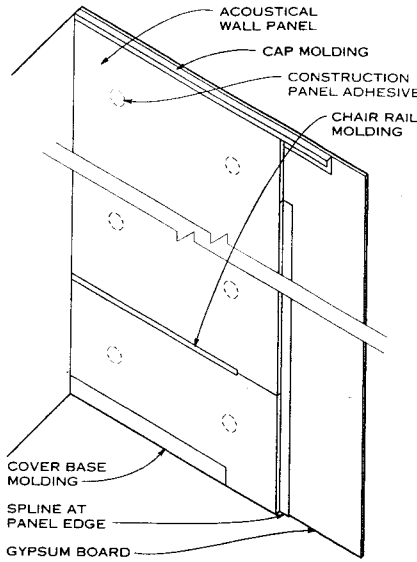

**TYPICAL ACOUSTICAL WALL PANEL APPLICATION**

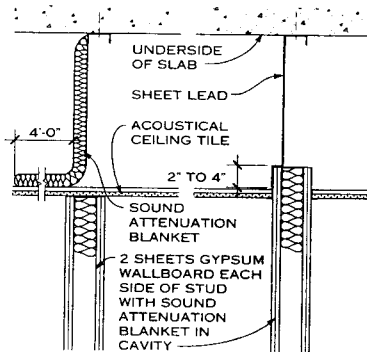
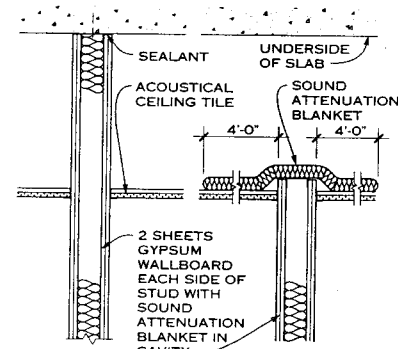

**PLENUM BARRIERS**

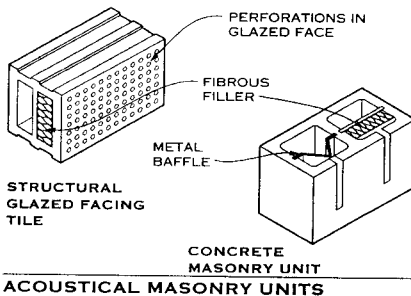

**STRUCTURAL GLAZED FACING TILE**

**CONCRETE MASONRY UNIT**

**ACOUSTICAL MASONRY UNITS**

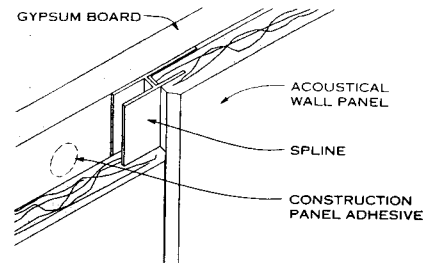

**CONCEALED VERTICAL JOINT**

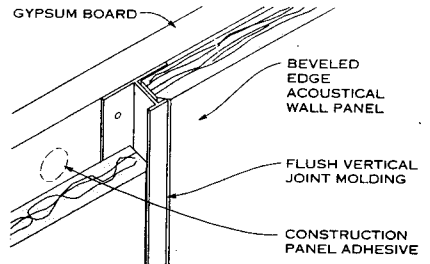

**FLUSH VERTICAL JOINT**

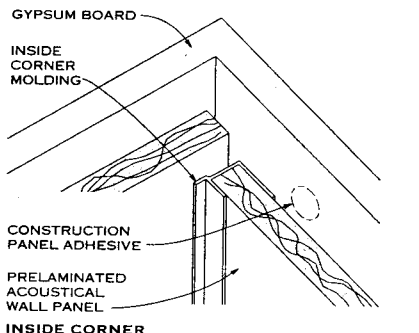

**INSIDE CORNER**

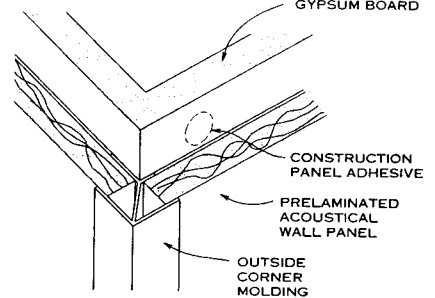

**OUTSIDE CORNER**

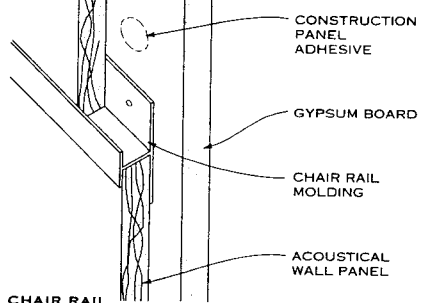

**FOAM AND FIBERGLASS PANEL ATTACHMENT DETAILS**

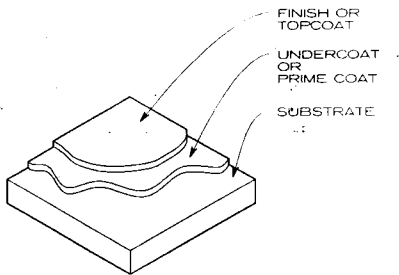

**COMPOSITION OF COATINGS**

**GENERAL**

Coatings are thin surface facings applied in liquid form which solidify to protect building components from harmful exposure. Appropriate coating selection depends upon performance, appearance, cost, and rate of deterioration of the substrate should the coating fail. Coatings are made up of the prepared substrate, prime coats or undercoats, and finish or topcoats, all of which should be compatible for adhesion and resistance to deterioration.

**DESIGN CONSIDERATIONS**

Environmental and ambient conditions affect coating performance. Resistance to sun, moisture, pollution, chemicals, extremes of temperature, soiling, and abrasion will determine a set of coatings, from which a selection is made based on remaining criteria. Design considerations should also include:

1. Flow, or ease of application.
2. Leveling or smoothing after application.
3. Drying time, of which two factors are important: (a) set-to-touch or surface drying, when surface resists contaminants, and (b) through-dry, when all layers are dry and ready to recoat.
4. Permeability: moisture migration through coating.
5. Wetting: penetration of coating to a lower level. Lower wetting ability requires greater surface preparation.
6. Film thickness: amount of protection provided by coating.
7. Adhesion between layers.
8. Flexibility: accommodation to changes in moisture and temperature.
9. Abrasion, impact, and stain resistance and ease of cleaning.

**TYPES**

Coatings are classified by appearance—clear, semitransparent, or opaque, and are water-based or organic solvent-based. Coatings are composed of a vehicle—alone when clear, or with pigments when semitransparent or opaque. The vehicle is in turn composed of binder and solvent. The binder is the nonvolatile part of the vehicle which forms the film of the coating and which bonds pigments when they are used. Additives for special properties, such as driers, stabilizers, plasticizers, and thinners, are included in the binder. The solvent is the volatile part of the vehicle which dissolves the binder to adjust viscosity, and which evaporates as the coating changes from liquid to solid state. Pigment adds opacity and/or color to the vehicle.

Clear coatings only slightly obscure the surface of the substrate. They are used when it is important to preserve appearance, such as the grain of wood or the color of an exposed concrete aggregate. Clear coatings are composed of a vehicle only, solvent and binder, with no pigment added. Sealers, waterproofing, and varnishes are typical examples of clear coatings.

Semitransparent coatings partially obscure the substrate surface. They can modify the appearance of the substrate by changing the color of wood without hiding its grain. Semitransparent coatings are composed of solvent, binder, and limited pigment. Stains are exemplary of this group.

Opaque coatings completely obscure the surface of the substrate. The color and/or texture of the substrate are changed; the original appearance unimportant or undesirable. Opaque coatings are made up of pigment, solvent, and binder. Paints are opaque coatings.

Coating properties are determined by the binder, which forms the surface film and bonds to the substrate. A combination of binders will alter the properties displayed by a coating, as will additives that modify the formation of the

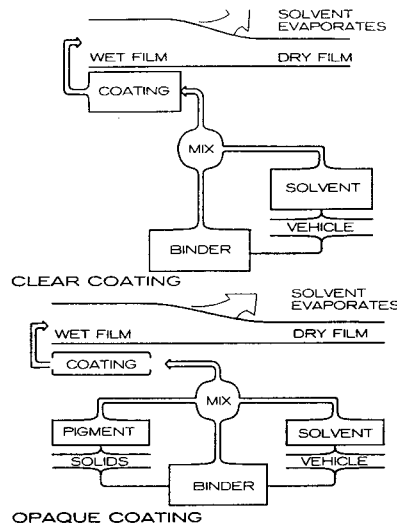

**TYPES OF COATINGS**

coating. Binders composed of small molecules (e.g., drying oils) penetrate rough surfaces and adhere well but dry slowly and are not chemically resistant. Binders composed of large molecules, built-up or polymerized of smaller molecules, yield strong, chemically resistant films but are susceptible to dissolution in the same solvent when formulated for solvent evaporation only. Large molecules may be formed by reaction between small molecules as in linseed oil; they may be made before application and dissolved in solvent to lower viscosity; or they may be formed by a combination of these two methods.

Pigments hide the substrate by adding opacity and color, but may also increase durability and protective characteristics by screening UV radiation, controlling transmission of moisture and gases, and inhibiting degradation or corrosion of the substrate. Colored pigments absorb some light rays while reflecting others, and white pigments absorb little light, so their hiding efficacy depends on the ability to scatter and reflect incident light. Scattering and reflecting ability in turn depends upon the size, distribution, and refractive index of the pigment particles. Pigment also determines the gloss of the coating finish through its relative proportion to binder and solvent in the vehicle.

Environmental exposure concurrent with or following application of the coating may affect the coating or the substrate. Some types of exposure to consider are atmospheric contamination, such as sulfurous or marine air which may discolor coatings and accelerate chalking and deterioration; mildew in humid environments; and sudden drops or rises in temperature at the time of application, which may flatten or blister a freshly applied coating.

**EXTERNAL FACTORS**

A number of external factors affect the stability of a coating.

**SOLAR RADIATION/UV RADIATION** can fade colored pigments, cause chemical reaction in some binders or solvents, and degrade the substrate if the coating is not UV opaque. It may be necessary for the coating to reflect, scatter, or absorb visible light to avoid this problem.

**TEMPERATURE:** Solar radiation raises the temperature of the coating, causing expansion and accelerating solvent evaporation. Exposure to heat through convection of hot air or other gases, or by conduction through the substrate (as through accidental exposure to fire) may also affect coating performance. Freezing temperatures hinder proper curing of some vehicles.

**RAIN:** A heated coating can undergo thermal shock when exposed to rain. Rainwater can also be absorbed and cause swelling of the coating or leach pigments from the coating. Rain may also penetrate through cracks or checks and freeze, causing damage to the coating and the substrate.

**WATER VAPOR:** Vapor may be required to properly cure some coatings. Under some conditions water vapor should be allowed to permeate the coating to prevent condensation, while at other times permeation must be prevented to protect the substrate.

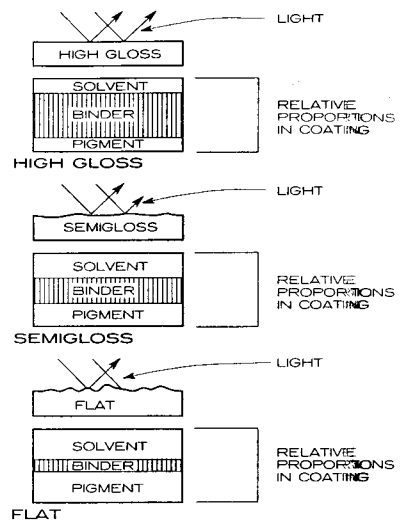

**EFFECT OF PIGMENT CONTENT ON GLOSS OF COATING**

**CHEMICAL FUMES:** Generated by chemical processes or by burning fossil fuels, chemical fumes can leave deposits on the coating, by reacting directly with it or by entering solution with rainwater or condensation.

**DUST, DIRT:** Dust penetrates porous coatings, collects airborne pollutants, and can stain and degrade the coating in reaction with rainwater. Marring of the coating may also be intentional, as with graffiti.

**ABRASION, IMPACT:** Coatings can be abraded by high-velocity flow of gaseous or liquid substances, by traffic, vandalism, or airborne dust. Impact may be through natural causes such as hailstones, may be accidental, or may be intentional, as with vandalism.

**SURFACE WATER:** External fresh or sea water can rise and fall, exposing normally submerged portions of the surface to solar radiation and oxygen and subjecting the coating and substrate to differential thermal expansion between the exposed and submerged portions of the surface.

**CHEMICAL SOLUTIONS:** Coatings may be submerged in chemical solutions such as sea water, sewage, oils, lubricants, or solvents and some of these may react with specific constituent parts of the coating, degrading or dissolving it.

**SELECTION CONSIDERATIONS**

Coating selection should be based on external environmental factors (see above), type and degree of exposure to these factors, including an estimate of speed of substrate deterioration should the coating fail. Conditions over the coating may vary over time, across a surface, or within the substrate, and contingencies should be planned. The possibility of an alkaline substrate such as concrete becoming moist through penetration or condensation should be considered before a non-alkaline-resistant coating is applied. Differential wear on walking or other surfaces should be considered, as well as applications of higher performance coatings.

The in-place cost of a coating accounts for surface preparation and application as well as the coating itself. Failure may result in permanent damage to the substrate, or may require complete removal and preparation for a new coating. The properties of the principal binder should determine the selection of a coating, with modifications and additions to the formulation made for specific job requirements.

**SAFETY AND HEALTH CONSIDERATIONS**

Hazards associated with coating application and surface preparation include toxic fumes from strong solvents; toxic dust from sandblasting, grinding, or fire; and toxicity of coating solvents when absorbed through skin or inhaled. In addition, use of photochemically reactive solvents may be limited or restricted by air-pollution controlling ordinances.

James W. Laffey; Washington, D.C.



PAINTS AND COATINGS: PROPERTIES

TYPE	PRINCIPAL BINDER	BASE/CURE	TYPICAL USES	COMPARATIVE COST RANGE	IN-SERVICE LIFE RANGE IN YEARS	GLOSS RETENTION	STAIN RESISTANCE	WEATHER RESISTANCE	ABRASION IMPACT RESISTANCE	FLEXIBILITY
Clear	Acrylic, methyl methacrylate copolymer	solvent; water	Waterproofing and surface sealer against dirt retention, graffiti; for vertical surfaces of concrete, masonry, stucco; may be pigmented.	moderate to high	5 to 10	excellent to good	fair	excellent to good	good	good
	Alkyd, spar varnish	solvent	For interior and protected exterior wood surfaces. Also as vehicle for aluminum pigmented coatings.	moderate	up to 1 exterior	fair to good	poor	poor	fair	good
	Phenolic, spar varnish	solvent	Exterior wood surfaces subject to moisture. May be used in marine environments. Also vehicle for aluminum pigment.	moderate to high	up to 2 exterior	fair to good	fair	good	good	good
	Silicone	solvent	Waterproofing and surface sealer against dirt retention for vertical surfaces of concrete, masonry, stucco.	moderate	5 to 7	flat	fair	good	penetrating coating	
	Urethane, one-part	moist cure <sup>1</sup>	Surfaces subject to chemical attack; abrasion, graffiti, heavy or concentrated traffic, such as gymnasium floors.	moderate to high	up to 15	excellent to good	good to excellent	good to excellent	good to excellent	excellent
Stain	Acrylic	solvent; water	Pigmented translucent or semi-opaque exterior surface sealers; solvent based for masonry, concrete; water based for wood.	moderate to low	3 to 5	flat finish	not a factor	good to fair	penetrating coatings—resistance same as for substrate	
	Alkyd	solvent; water	Pigmented exterior or interior surface sealer for wood surfaces such as shingles, does not impart sheen to surface.	moderate	3 to 5	flat finish		fair		
	Oil	solvent	Pigmented exterior or interior surface sealer for wood such as shingles, trim, opaque or semitransparent.	moderate	3 to 5	fair		fair		
Opaque	Acrylic	water	For exterior/interior vertical surfaces of wood, masonry, plaster, gypsum board, metals. Good color retention. Permeable to vapor.	moderate to low	5 to 8	good to fair	fair	good	good to fair	good to excellent
	Acrylic, epoxy modified, two-part	water	High performance coating for interior vertical surfaces subject to graffiti, stains, heavy scrubbing. May be used in food preparation areas.	high	10 to 15	good	good	good to excellent	good to excellent	good to excellent
	Alkyd	solvent; water	For exterior/interior vertical and horizontal surfaces, such as wood, metals, masonry. Poor permeability to vapor.	moderate	5 to 8	good to excellent	fair	fair to good	fair to good	fair to good
	Chlorinated rubber	solvent	Swimming pool coatings. Corrosion protection; isolating dissimilar metals.	high to very high	up to 10	fair	fair	good	fair to good	good
	Chlorosulfonated polyethylene	solvent	Protective coating for tanks, piping, valves, elastomeric roofing membranes.	very high	up to 15	not applicable	fair	excellent	fair to good	excellent
	Epoxy, two-part; epoxy ester, one part	solvent cure; solvent	Moisture/alkali resistant. Two-part for nondecorative interior uses highly resistant to chemicals. Esters in wide choice of colors.	high to very high	15 to 20; up to 10	poor to good	excellent for two-part	good to excellent	excellent	good to excellent
	Phenolic	solvent	Chemical- and moisture-resistant coatings. May be used over alkaline surfaces.	moderate to high	up to 10	fair	fair	good to excellent	good to excellent	good
	Polychloroprene	solvent <sup>2</sup>	Marketed as "Neoprene"; resistant to chemicals, moisture, ultraviolet radiation. Also used as roofing membrane; generally covered with Hypalon.	very high	up to 25	not applicable	good	excellent	excellent	good
	Polyester	solvent	Limited application in field; over cementitious surfaces, metal, plywood for exterior exposures.	high	up to 15	good to excellent	good to excellent	good to excellent	good	good to excellent
	Silicone	solvent	Surfaces with temperatures up to 1200°F. Often with aluminum pigments. Corrosion and solvent resistant.	very high	varies	not applicable, special purpose coating			good	good
	Silicone; modified acrylic, alkyd, epoxy	solvent	High-performance exterior coatings. Industrial siding, curtain walls, when shop-applied baked-on.	high to very high	15 to 20	good to excellent	good	good to excellent	good to excellent	good
	Styrene, butadiene	water	Interior coating for gypsum board, plaster, masonry. Limited exterior use over cementitious substrate, as filler over rough porous surfaces.	moderate to low	4 to 6	poor to fair	fair	poor	fair	good
	Urethane, one or two part	moist or chemical cure <sup>3</sup>	Heavy-duty wall and floor coatings. Resistance to stains, chemicals, graffiti, scrubbing, solvents, impact, abrasion.	high to very high	15 to 20	excellent	good to excellent	good to excellent	good to excellent	excellent
	Vinyl, polyvinyl chloride-acetate	solvent	Residential metal siding and trim, gutters, leaders, baseboard heating covers, when shop-applied, baked-on.	high	up to 15	good	fair	good	good	good to excellent
	Vinyl, polyvinylidene chloride	water	Metal and concrete surfaces in contact with dry and wet food, potable water, wastewater, jet and diesel fuels.	high	up to 10	good	fair	good	good	good
	Vinyl, polyvinyl acetate	water	Exterior and interior vertical surfaces, such as masonry, concrete, wood, plaster, gypsum board, metals. Permeable to vapor.	moderate to low	5 to 8	good to fair	fair	good	good to fair	good
	Bituminous, coal tar pitch, asphalt; emulsions, cut-backs	solvent	Waterproofing of metals, concrete, masonry, portland cement plaster, piping when below grade or immersed.	low	10 to 15 protected	not a factor		good	poor	fair
Cement	water	Leveling coat over porous masonry or concrete not subject to abrasion or scrubbing. Cement and oil used as primers for metal surfaces.	low	varies	flat finish	poor	poor for color	good	poor	

<sup>1</sup> Solvent-based, oil-modified urethane is also available; for use on interior/exterior vertical and horizontal wood surfaces. Cost is moderate.

<sup>2</sup> May be obtained as water-reducible coating; use as field-applied coating very limited; generally used as tank linings.

<sup>3</sup> Solvent base, oil-modified urethane is also available; for use on vertical and horizontal surfaces. Cost is moderate, but durability is lower than for other types.

NOTES

- Solvent-based acrylic is impermeable to water vapor, high gloss.
- Water-based acrylic is semigloss, water vapor permeable.
- Phenolic varnish has a dark tint; will darken with age; may be topcoated with clear alkyd.
- Clear varnishes are not recommended for exterior wood because of limited durability.
- Urethane may be formulated to yield hard, glossy surface so that graffiti can be removed with strong solvents.
- Fillers may be required when using clear coatings over hardwood, such as oak; abraded wood may limit choice; consult manufacturer's literature.
- Stains may be used as surface sealers to change color of wood and then be topcoated with clear coatings.
- Stains over exterior wood surfaces generally will provide better protection than clear coatings, but usually will not last as long as opaque coatings.
- Alkyd may be modified with silicone for better color retention.
- Epoxy-esters have intermediate properties between two-part epoxies and alkyds and phenolics.
- Bitumen-epoxy formulations are available for use as heavy-duty waterproofing of underground piping, structural members.
- Phenolic may chalk upon exterior exposure; high degree of resistance to acids, alkalis, and solvents; some formulations available for surface temperatures of up to 300-350°F.
- Polyesters available glass fiber reinforced; also used widely for baked-on factory applied finishes for formed metal wall panels.
- Silicone for high temperature applications generally with aluminum pigment.
- Polyvinyl chloride film is used for factory-applied finishes for formed metal wall panels.
- Cement paint will absorb rainwater and will darken until water evaporates; requires moist curing after application; if not properly cured will tend to dust and rub off.
- For high performance coatings under severe conditions, life expectancy may be less.

James W. Laffey; Washington, D.C.

**GENERAL**

Paints and coatings are in liquid form before and during application, after which they cure to form a non-self-supporting film. They cannot exist without a solid, generally rigid substrate to receive and support them. Since a coating bonds itself firmly and continuously to the substrate, the exposure, condition, and properties of the substrate, as well as its surface characteristics and defects, directly affect the coating during and after application.

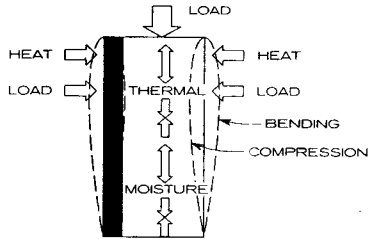

**NOTES**

Movement in the substrate, which may crack the coating, may result from

1. Thermal expansion/contraction due to exposure to solar radiation; sources of heat outside the substrate, such as heat-generating equipment adjacent to it; and heat-generating processes contained by the substrate.
2. Differential thermal movement between the substrate and the coating it supports, caused by variations in exposure. For example, rain may suddenly cool a coating over a hot substrate or solar radiation may heat a coating over a cold substrate.
3. Shrinking/swelling due to changes in the internal moisture content of the substrate. Under extreme conditions, variations may be as much as 5% or more across the grain in wood.
4. Deflection under load, vertical or horizontal, which induces tensile and compressive stresses in the substrate that may affect the coating.
5. Restrained end conditions of the substrate, which may cause bending stresses. Vibration in the substrate will result in cyclical stress reversals.

**SUBSTRATE MOVEMENT**

DENSE: GLASSY SMOOTH	DENSE OR POROUS	METALS GLAZED SURFACES CONCRETE; PLASTIC FORMS
POROUS: SMOOTH	POROUS	PLASTER WOOD GYPSUM BOARD
POROUS: ROUGH	POROUS	MASONRY CONCRETE

**SURFACE SUBSTRATE TYPICAL MATERIAL**

**NOTES**

Absorption at the surface of the substrate and that of the substrate itself may vary and affect the choice of coating or its performance characteristics:

1. Glassy dense surfaces, even applied over a porous substrate, will prevent absorption of a coating. Such surfaces may require roughening by sandblasting or acid etching to ensure proper adhesion of most coatings.
2. Porous substrates may have varying degrees of absorption within a continuous surface (for example, different rates of absorption in bands of spring and summer growth of wood). Different rates of absorption will result in different degrees of adhesion and may cause a coating to crack along junction lines between such bands.
3. The rough surface of a porous substrate may cause varying degrees of absorption in an application, even though the absorption of the substrate does not vary significantly. For instance, when the roughness of a surface prevents the application of a film of uniform thickness over it, different rates of absorption may result. This will cause changes in the gloss of the coating, overpigmentation in areas of excessive absorption of the vehicle, and varying degrees of adhesion.

**SUBSTRATE ABSORPTION**

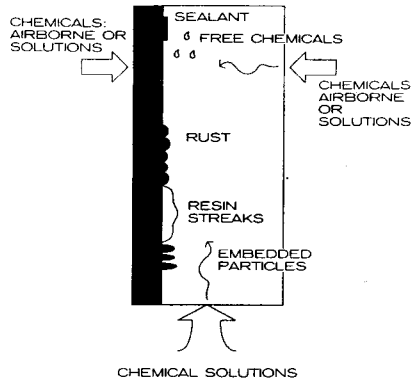

**NOTES**

Chemicals may be contained within the substrate or absorbed by it:

1. Soluble alkaline salts in concrete or mortar may be dissolved and crystallize on the surface.
2. Resin streaks in wood may react with the coating and bleed through, or old coatings may react chemically with new ones.
3. Rust deposits may stain some coatings and may impair adhesion.
4. Sealants used in joints may stain the substrate and/or coating.
5. Fasteners may corrode; loose particles of metal may lodge themselves in the substrate and corrode after the coating is applied.
6. Admixtures, form oils, curing agents, and antifreeze solutions used when concrete is cast may prevent proper adhesion of coatings or may react with them.
7. If cleaning solutions used during surface preparation are not completely removed before the coating is applied, they may react with the coating or impair its absorption and/or adhesion.

**CHEMICALS IN SUBSTRATE**

UNEVEN	POROUS	KNOTS GREASE, OIL SPILLS
IMPAIRED	POROUS OR DENSE	SATURATED SUBSTRATE WET SURFACE GLASSY
PREVENTED	DENSE	MILL SCALE HEAVY COAT OF RUST

**NOTES**

Uneven or impaired adhesion results in coating failure. Adhesion of the coating to the surface of a substrate is affected by

1. Surface defects such as knots, resin streaks in the wood, or surface contaminants such as oil, grease, or salt deposits over any type of substrate. Such defects impair bonding of the coating to the substrate, creating weak spots where vapor may condense. When the vapor expands, it breaks or lifts the film.
2. Moist or wet surfaces. These may impair adhesion of certain coatings. In particular, moisture collection at the bonding surface of coatings may result in blistering or lifting of the film.
3. Use over glassy surfaces. Incomplete adhesion to glassy surfaces may result in flaking and peeling of the film.
4. Deposits of mill scale, heavy coats of rust, and salts. These prevent adhesion.
5. Surface defects and contaminants that have not been corrected or removed before a coating is applied.

**ADHESION TO SUBSTRATE**

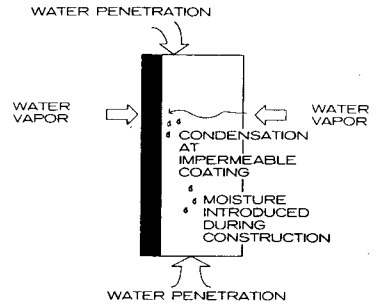

**NOTES**

Moisture may penetrate a porous substrate as

1. Water vapor migrating from high vapor pressure areas, such as warm, humid interior spaces, to low vapor pressure areas, such as cold, dry outdoors. If the dew point occurs within the substrate, vapor will condense, especially if the coating is of low permeability and blocks its free passage to the outdoors.
2. Water vapor penetrating a permeable coating to condense on a cold impermeable substrate such as metal.
3. Rain penetrating into the substrate through faulty joints, damaged or faulty flashings, or cracks in the coating.
4. Water absorbed when the substrate was exposed to rain or ground moisture while improperly stored before or during construction.
5. Water that was a constituent part of the substrate during construction and has not yet evaporated. Generally a slow process, this condition often occurs in concrete, mortar, or gypsum plaster since more water is generally used than is required by the hydration process.
6. Moisture in the substrate when the coating is applied, which may prevent proper adhesion.
7. Moisture penetrating the substrate after application of a coating, which may destroy the bond between substrate and coating.

**MOISTURE IN SUBSTRATE**

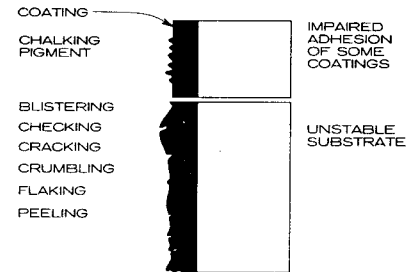

**CONDITION SUBSTRATE EFFECT**

**NOTES**

When new coatings are applied over previously coated substrate, the surface stability of the old coating may affect the performance of the new coating. All coatings deteriorate over a period of time, and deterioration of a coating may result in

1. Chalking, which leaves behind loose pigment. Chalking occurs when the vehicle is broken down by weathering, particularly solar radiation. Suitable coatings may be applied to surfaces that are chalking with little or no surface preparation, although loose chalk should always be removed as a minimal measure.
  2. Checking and cracking. Breaks can develop in coatings as they lose flexibility with age. These occur when stresses imposed on the coating by thermal or moisture movements in the substrate exceed the strength of the coating.
  3. Crumbling, flaking, and peeling. Generally caused when moisture and airborne pollutants penetrate the coating, crumbling, flaking, and peeling may follow checking and cracking.
- Coatings that have deteriorated until extensive checking is evident generally should not be used as a receiving surface for new coatings. Cracked, crumbling, flaking, or peeling surfaces should never be used, and the old coating must be completely removed from the substrate before application of a new coating.

**COATINGS AS SUBSTRATE**

EXTERIOR

SUBSTRATE	COATING SYSTEM TOPCOAT; TYPE AND BASE	PRINCIPAL BINDER	COATING GLOSS	COLOR RETENTION	SUB-STRATE SURFACE CONDITION	NOTES TO DESIGNER OR SPECIFIER			
Wood Dry, Vertical	SIDING, vertical/horizontal • recommended moisture content not over 12% • protected from moisture or limited occasional exposure to water  Typical components: • veneered plywood siding • MDO plywood siding • hardboard siding • redwood siding • cedar siding, shingles, and shakes	clear; solvent	topcoat	phenolic, tung oil	gloss semigloss	poor	dry only	<ol style="list-style-type: none"> <li>Clear coatings are not recommended for plywood.</li> <li>Light color stains have shorter durability than heavily pigmented ones.</li> <li>PVA is used on yellow pine and red cedar.</li> <li>Acrylic is resistant to ultraviolet rays, thus doesn't become brittle or yellowed.</li> <li>No coating for wet wood has been recommended; wood should be dry before any coating is applied.</li> <li>Opaque stains hide surface imperfections and will last longer but will also hide the wood grain.</li> <li>Wood requires primer to equalize absorption; hardboards require filler to smooth out grain.</li> <li>Always use oil-based primer under any coating on cedar and redwood.</li> <li>Backprime and edge seal wood in locations subject to occasional moisture penetration or to water vapor migration and/or condensation. Unless properly sealed, only permeable coatings such as acrylic should be used; even then, they may peel.</li> <li>Clear phenolic coatings may be protected with alkyd-type clear coatings for better color retention.</li> <li>All knots and pitch streaks should be sealed with shellac and all nails set and nail holes filled.</li> <li>Even galvanized, ferrous metal nails may corrode and stain water-based coatings because such coatings allow water vapor to penetrate to the nails, increasing the possibility of rusting.</li> <li>Alkyds may react with chemicals in previous coatings.</li> <li>Clear finishes for trim and doors may be pigmented to stain the wood, or a staining primer may be used.</li> <li>Extensive surface preparation, when required, applies to both previously coated and uncoated surfaces but principally to previously coated ones.</li> </ol>	
			primer	self-priming, topcoat, or shellac					dry only
		stain; water, or solvent	topcoat	alkyd, oil base, self-priming (solvent)	flat	fair			dry only
		opaque; solvent	topcoat	alkyd	gloss semigloss	good			dry only
			primer	alkyd, oil base					dry only
		opaque; water	topcoat	acrylic	semigloss flat	excellent			may be damp
	primer		alkyd, oil base acrylic, emulsion				dry only		
	TRIM • recommended moisture content not over 12% • occasional exposure to moisture or water  Typical components: • shutters • doors • accent areas of limited size • railings	clear; solvent	topcoat	urethane, one part oil modified	gloss semigloss	fair			dry only
			primer	self-priming					dry only
		stain; solvent	topcoat	none recommended					
		opaque; water or solvent	topcoat	alkyd, oil base (solvent)	gloss semigloss	good			dry only
			primer	alkyd, oil base					dry only
Wood Floors Dry		clear; solvent	topcoat	none recommended				<ol style="list-style-type: none"> <li>Clear coatings for exterior floors are not recommended because ultraviolet radiation may degrade not only the coating but the substrate as well. Once the substrate fails, it has to be completely refinished before it can receive another coating; clear coatings may last one to two years and may require yearly maintenance.</li> <li>Pigmented coatings only are recommended for wood exposed to sunlight; pigments used should block penetration of ultraviolet radiation to the substrate.</li> <li>Water-based coatings generally are porous and not sufficiently abrasion resistant for use on surfaces subject to abrasion.</li> <li>Urethane has excellent resistance to abrasion, alkali, acids, solvents, strong detergents, and fuels. Clear urethane is not recommended for exterior exposure due to possible degradation of the substrate by ultraviolet radiation.</li> </ol>	
	primer		not applicable						
	clear; solvent	topcoat	urethane, one part moist cure	gloss semigloss	fair		dry only		
		primer	self-priming; follow for hardwood recommended				dry only		
	clear; solvent	topcoat	urethane, one part, moisture cure	gloss, semigloss	fair		dry only		
		primer	self-priming				dry only		
Concrete, Masonry, and Stucco Dry, Vertical	clear; solvent	topcoat	silicone (min. 5% solution)	flat	N/A		<ol style="list-style-type: none"> <li>Solvent-based coatings are not recommended for use over exterior concrete or masonry surfaces as such coatings form an impermeable film, preventing the escape of any moisture that may still be present in or may later penetrate the substrate. Condensation at the interface of coating and substrate may also contain soluble alkaline salts; either one or both may cause blistering or peeling. Solvent-based coatings should only be used when the substrate is completely dry and there is no possibility of substantial moisture penetration.</li> <li>Water-based coatings generally allow water vapor to escape to the outside and do not present the same problem as solvent-based coatings.</li> <li>Silicone should be considered more as a water repellent than a coating film.</li> <li>Heavy-bodied, water-based coatings are available as fillers for rough surface masonry units.</li> </ol>		
		topcoat	acrylic, methyl methacrylate	semigloss	good			may be damp	
	opaque; solvent	topcoat	alkyd	gloss semigloss flat	good			dry only	
		primer	styrene-butadiene						
	opaque; water	topcoat	acrylic	semigloss flat	excellent				
		primer	self-priming						

Table continues on following page

EXTERIOR (CONTINUED)

SUBSTRATE		COATING SYSTEM		PRINCIPAL BINDER	COATING GLOSS	COLOR RETENTION	SUBSTRATE SURFACE CONDITION	NOTES TO DESIGNER OR SPECIFIER	
		TOPCOAT: TYPE AND BASE							
Concrete floors, Dry	<ul style="list-style-type: none"> <li>aged over 90 days</li> <li>light to moderate traffic</li> <li>surface intact, dusty</li> </ul>	clear; solvent	topcoat	epoxy ester	gloss	fair	dry only	<ol style="list-style-type: none"> <li>Sealers-hardeners are preferably applied to fresh concrete.</li> <li>Epoxy is a high-performance, high-cost coating suitable for floors exposed to heavy wear, chemical spills, and moisture. It may be used to resurface worn floors after proper patching.</li> <li>No coating will perform well over a poor quality substrate.</li> <li>The compatibility of coating with bond breakers, curing agents, and hardeners that may have been used over the substrate should be checked.</li> </ol>	
			primer	self-priming			dry only		
	<ul style="list-style-type: none"> <li>aged over 90 days</li> <li>light to moderate traffic</li> <li>surface worn, dusty</li> </ul>	opaque; solvent	topcoat	urethane, one-part moisture cure	gloss semigloss	fair	dry only		
			primer	self-priming, substrate to be patched			dry only		
Concrete, Wet	<ul style="list-style-type: none"> <li>aged under 30 days or when subject to water penetration or condensation</li> <li>surfaces cleaned to remove efflorescence</li> </ul> <p>Typical components:</p> <ul style="list-style-type: none"> <li>concrete walls</li> <li>concrete floors</li> </ul>	clear, or opaque; solvent	topcoat	hardening sealing compounds				<ol style="list-style-type: none"> <li>Epoxy may be used over damp surfaces; it is a high-performance, high-cost coating.</li> <li>Application of coatings should be delayed as long as possible to allow the substrate to dry out.</li> <li>Coatings considered should be water vapor permeable.</li> <li>Bleeding of alkaline salts to the surface may result in brown spots over permeable coatings. If impermeable coatings are used over permeable primer, such coatings are likely to blister and peel.</li> </ol>	
			primer						
		opaque; water	topcoat	none recommended					
			primer	not applicable					

INTERIOR

SUBSTRATE		COATING SYSTEM		PRINCIPAL BINDER	COATING GLOSS	COLOR RETENTION	SUBSTRATE SURFACE CONDITION	NOTES TO DESIGNER OR SPECIFIER
		TOPCOAT: TYPE AND BASE						
Gypsum Board Walls, Ceilings	<ul style="list-style-type: none"> <li>Subject to</li> <li>light scrubbing</li> <li>mild detergents</li> </ul>	opaque; water or solvent	topcoat	alkyd (solvent)	gloss semigloss flat	good	must be dry	<ol style="list-style-type: none"> <li>Epoxy-modified acrylic is suitable for severe exposure in food preparation areas; it is available USDA-approved when required.</li> <li>Solvent-base coatings should not be used directly over gypsum board as they tend to raise the nap of the paper facing.</li> <li>Joints in gypsum board should be taped and spackled; absorption over spackled areas may differ from that of paper facing.</li> <li>When fire resistance is required, intumescent coatings, either solvent or water based, may be selected.</li> </ol>
			primer	vinyl, polyvinyl acetate; water				
	<ul style="list-style-type: none"> <li>periodic scrubbing</li> <li>occasional splatter of grease; food stains</li> </ul>	opaque; water	topcoat	acrylic	semigloss flat	excellent	may be damp	
			primer	self-priming				
Wood Dry, Vertical, Horizontal	Doors, wood veneered Trim Paneling	clear; solvent	topcoat	alkyd; may be over stain	flat	good	dry only	<ol style="list-style-type: none"> <li>Single-component urethane may be applied over stain.</li> <li>Abraded or rough surfaces may restrict use of some coatings; consult manufacturers' literature.</li> <li>Fillers are recommended for open grain wood, such as oak, to smooth out the surface; stain may be added to filler when required.</li> <li>Edges of doors should be sealed to prevent absorption of moisture.</li> <li>Particleboard is generally finished with opaque coatings; for clear use filler and stain; absorption may be uneven.</li> <li>Hardboard is generally finished with opaque coatings only; primers are required.</li> <li>Alkyd for wood veneer and trim may be self-priming.</li> </ol>
	Doors, hardboard veneer Doors, wood veneer Trim	opaque; water or solvent	topcoat	alkyd (solvent)	gloss semigloss	good	dry only	
			primer	alkyd (solvent)			dry only	
	Floors, light to moderate use	clear; solvent	topcoat	alkyd, self-priming	gloss semigloss	good	dry only	
	Floors, heavy use	clear; solvent	topcoat	urethane, one part moisture cure	gloss semigloss	good	dry only	
Floors, moderate to high use	opaque; solvent	topcoat	alkyd, self-priming	gloss	good	dry only		
Concrete, Masonry, Portland Cement Plaster	Dry, not exposed to moisture penetration such as ground moisture  Typical components: • concrete and concrete masonry walls and partitions	opaque; water	topcoat	vinyl, polyvinyl acetate	semigloss flat	good	may be damp	<ol style="list-style-type: none"> <li>Cement-water paints may be used in damp areas such as on basement walls; colors generally are limited to light tints; moisture is required during curing period, usually 24 to 48 hours.</li> <li>Use of coatings is not recommended over alkaline substrate; coating of fresh concrete, masonry, or plaster should be delayed for as long as possible.</li> <li>Heavy-bodied primers/fillers are recommended for rough, porous surfaces.</li> </ol>
			primer	self-priming or styrene-butadiene				
		opaque; solvent	topcoat	alkyd	semigloss flat	good	dry only	
			primer	styrene-butadiene				
Concrete floors	Dry, not exposed to ground moisture penetration Light to moderate use	opaque; solvent	topcoat	urethane, one part moisture cure	gloss semigloss	good	dry only	<ol style="list-style-type: none"> <li>Dusting surfaces should be sealed first.</li> </ol>
			primer	self-priming				
Gypsum plaster	Dry, fully cured, no signs of efflorescence, protected from moisture penetration	opaque; water or solvent	topcoat	acrylic (water)	semigloss flat	excellent	may be damp	<ol style="list-style-type: none"> <li>Substrate may be alkaline; therefore, primers/coatings should be alkali resistant.</li> <li>Coating of plaster should be delayed for as long as possible to allow it to dry out.</li> </ol>
			primer	self-priming				

McCain McMurray, Washington, D.C.

## DEFINITION

Special coatings are adhesive materials that have been developed for specific purposes such as resisting severe or corrosive environments or other forms of abuse. Special skills and techniques are usually required to mix, handle, and apply these materials.

A "special coating system" includes applied materials used in prime, intermediate, and finish coats. Factors that influence the choice of a system include

1. Substrates
2. Environmental conditions and surroundings
3. Cost

Prime and finish coats should be specified from the same manufacturer to eliminate many compatibility problems.

Proper substrate preparation, priming, and spread rate thickness are important for successful application of special coatings. Application is made by spray, brush, roller, or trowel.

## SURFACE PREPARATION

The major reason coatings fail is poor surface preparation, which impairs adhesion. No coating is better than the surface over which it is applied. Surfaces must be prepared by a method suited to how they will be used and the exposure they will receive, in accordance with manufacturers' recommendations and the Steel Structures Painting Council (SSPC).

### METAL SURFACES

Before a coating is applied, metal surfaces must be thoroughly cleaned, eliminating all visible deposits of surface dirt, grease, oil, and other deposits. Loose mill scale, rust, paint, and other detrimental foreign matter must also be removed. Grind rough welds and sharp edges, and remove weld spatter.

The SSPC recommends a variety of methods for preparing steel surfaces before application of a coating:

- SSPC-SP-1 Solvent Cleaning
- SSPC-SP-2 Hand Tool Cleaning
- SSPC-SP-3 Power Tool Cleaning
- SSPC-SP-5 White Metal Blast Cleaning
- SSPC-SP-6 Commercial Blast Cleaning
- SSPC-SP-7 Brush-off Blast Cleaning
- SSPC-SP-8 Pickling
- SSPC-SP-10 Near White Blast Cleaning

## CONCRETE AND MASONRY SURFACES

Coatings adhere best to clean and slightly rough substrates. Grease, dirt, oils, efflorescence, laitance, and other surface deposits must be removed before additional surface preparation begins. Cleaning may be achieved by methods such as mechanical abrasion, abrasive blast, high pressure water wash, or acid etching. If cleaning solutions are applied, they must be completely removed before the coating is applied. Surfaces must be dry. If the surface is very smooth, it must be abraded or roughened slightly.

## TYPES OF SPECIAL COATINGS

### CEMENTITIOUS COATINGS

Polymer-modified, inorganic coatings can be ideal on concrete and masonry substrates. These coatings are primarily used on vertical surfaces above or below grade, on the exterior or interior, and on new construction or restoration and renovation work for aesthetics, permeability, and moisture resistance. They are also useful for walls subject to positive or negative hydrostatic pressure.

### ABRASION-RESISTANT COATINGS

Epoxy or elastomeric seamless coating may be used over substrates of brick, stucco, concrete, block, drywall, and plywood in both interior and exterior applications. These coatings may be weatherproof and resist chemicals. Abrasion resistance may be inherent or achieved through an additional topcoat.

### ELASTOMERIC COATINGS

Acrylic polymer coatings may be used over exterior concrete, masonry, and stucco surfaces. These thick, dirt-resistant, membrane-like coatings are flexible in a range of temperatures, displaying an ability to follow expansion and contraction of surfaces without rupturing or wrinkling. They are very high-build materials that bridge small cracks and protect against deterioration from moisture penetration of the substrate. Like other special coatings, these typically should not be used to bridge building expansion joints. Acrylic polymer coatings are available in smooth and textured finishes.

### HIGH-BUILD GLAZED COATINGS

Acrylic resin, elastomeric, or epoxy coatings may be suitable for use over exterior or interior concrete, block, masonry, plaster, stucco, wood, and metal surfaces in vertical or horizontal applications. Applied in multiple coats or thick single coats, these coatings usually provide resistance to chemicals and abrasion. These high-performance coatings provide good adhesion and hardness, producing a tile-like gloss finish. Some systems may be reinforced with fiberglass mesh between base and seal coats to increase maximum impact resistance.

### FIRE-RESISTANT PAINTS

Fire-resistant paints are able to withstand fire and protect the substrate for short periods of time, usually less than one hour. They will not support combustion and do not deteriorate readily under fire conditions. They will reduce or prevent the spread of flame over a combustible surface. In some cases they may be used as one component of a fire-rated assembly. The products of such an assembly are non-combustible, and the coating, which prevents oxygen from reaching the substrate, contains chemicals that inhibit the release of volatile gases necessary for combustion.

To be eligible for listing as a fire-retardant paint, a coating must either reduce the flame spread of the surface to which it is applied by at least 30% or have a flame spread rating of 70 or less as tested under current ASTM E-84 guidelines. Manufacturers may recommend a three- to five-year schedule for reapplying the coating in order to maintain its fire-resistant capability. Fire-resistant paints can be used to coat wood, drywall, plaster, and metal.

### INTUMESCENT PAINTS

Intumescent paint is a type of fire-resistant paint that behaves differently than typical such products in a fire condition. When subjected to flame or intense heat, intumescent paints liquefy, allowing escaping gases to form an insulating layer of char, which forms a protective layer around the substrate. Fire-resistant designs have been tested by independent laboratories to establish application requirements and the extent of protection available. Incompatible paints used as a topcoat with intumescent paints may prevent the chemical reactions necessary to form the intumescent char, thereby reducing or negating the fire-resistant property.

### GRAFFITI-RESISTANT COATINGS

Graffiti-resistant coatings permit the easy removal of graffiti without damage to the substrate. The system comprises a multicoat base system that increases the hardness of the substrate and a sacrificial, multicoat topcoat system. Cleaners can be nontoxic and do not require sandblasting, solvents, or toxic materials. Additional topcoats can be added after cleaning, if desired, to reinforce the sacrificial protection layer.

## COATING SYSTEMS FOR STEEL

Selection of steel coating systems for tanks and piping are primarily governed by substrate and service conditions. Industry specific standards also affect specifications. Water treatment, food processing, energy production, and chemical processing industries have different requirements and standards that should be verified prior to specification. Water tanks in most U.S. jurisdictions must meet very stringent National Sanitation Foundation (NSF) requirements for potable water storage.

### EXTERIOR COATING SYSTEM FOR STEEL STORAGE TANKS

Choice of coating for steel storage tank exteriors depends on tank condition and location, the weather during application, and the service conditions. A number of two-part epoxy systems and urethane systems have been formulated to address these concerns. Coatings may possess rust-inhibitive qualities, the ability to cure at low-temperatures, and excellent weathering ability and may offer galvanic protection. Dry-fall ability may be desirable in some instances and is available from alkyd products. Compatible products can be used as metal fillers and to accelerate curing rates. Local regulations regarding the content of volatile organic compounds (VOCs) will influence product selection and application techniques.

### INTERIOR COATING SYSTEM FOR STEEL STORAGE TANKS

Choice of coatings for steel storage tank interiors is affected by tank condition and location and service conditions. A number of two-part epoxy systems and phenolic systems have been formulated to address these concerns. These products are designed to provide sustained immersion service in food processing, petrochemical, and water treatment industries for use in freshwater, saltwater, and severe chemical environments. National Sanitation Foundation (NSF) approvals may be necessary in certain applications.

### COATING SYSTEM FOR STEEL PIPING

Coatings for steel piping are subject to many of the same conditions as coatings for steel tanks. Coatings for piping used for chemical service must be selected to match the level of chemical exposure expected. Mild exposures may permit the use of an acrylic coating, while aggressive chemical and moisture exposure may require the use of chlorinated rubber coatings. Severe chemical exposures typically require a two-part epoxy system.

The American Society of Mechanical Engineers and ANSI publish standardized color codes for pipe identification. For example, red means fire protection equipment; yellow, dangerous materials; blue, protective materials; green, safe materials; yellow with a black legend or stripe, radioactive materials.



CHEMICAL-RESISTANT COATINGS

EXPOSURE	TYPE OF COATING	APPLI-CATIONS	ALCOHOLS	ALIPHATIC HYDROCARBONS	ALKALI SOLUTIONS	AROMATIC HYDROCARBONS	FRESHWATER	KATONES	MINERAL ACIDS	MINERAL OILS	ORGANIC ACIDS	OXIDIZING AGENTS	SALT SOLUTIONS	VEGETABLE OILS	WASTEWATER	WEATHERING
Rural, urban light industrial	Alkyd primer and alkyd topcoat	Warehouses, manufacturing plants, schools, storage tank exteriors	O	O	N	N	O	N	N	C	N	N	N	N	N	G
Mild chemical	High-build epoxy, polyamide-cured, and urethane topcoat	Wood yards, plywood plants, sawmills	C	C	C	O	C	N	O	C	O	O	C	C	C	E
Fresh and salt water immersion; moderate chemical exposure	Coal tar epoxy, polyamide-cured	Pilings, waste treatment pits, pulp and paper mills, marine structures and barges, cogeneration	C	C	C	C	I	N	O	C	O	O	I	C	I	F
Fresh and potable water immersion	High-build epoxy, amine-cured	Water storage, tank interiors, locks, and water control gates	C	C	C	C	I	O	O	C	O	O	I	I	I	F
Severe chemical	High-build epoxy, polyamide-cured, and urethane topcoat	Pulp and paper mills, coal-handling, chemical pits, sour crude refineries, fertilizer plants	C	C	C	O	C	O	O	C	O	O	C	C	C	E
Severe chemical—acid resistance	High-build epoxy, amine-cured	Pulp and paper mills, dockside exposures, fertilizer pits, acid loading docks, dye plants	C	C	C	C	I	O	O	C	C	C	I	I	I	F
Severe chemical—alkali and solvent resistance	Organic zinc-rich epoxy primer and high-build epoxy, polyamide-cured, topcoat	Pulp and paper mills, coal-handling facilities, dockside exposures	C	C	C	C	I	O	O	C	O	O	C	C	I	F
Severe chemical—alkali resistance	Organic zinc-rich epoxy primer and high-build epoxy, polyamide-cured, and urethane topcoat	Capital structures where color and gloss retention are needed	C	C	C	O	C	O	O	C	O	O	C	C	C	E
Severe chemical—solvent and alkali resistance	Inorganic zinc-rich primer and high-build epoxy polyamide-cured topcoat	New construction, pulp and paper mills, power pits, coal liquefaction, cogeneration	C	C	C	C	I	O	O	C	O	O	C	C	I	F
Severe chemical	Zinc-rich primer and urethane topcoat	Where gloss retention and color are important	C	C	C	O	C	C	O	O	C	O	O	C	C	E
High temperature (up to 1200°F)	Heat-resistant silicone aluminum	Stacks, incinerators, super-heated steam lines, boiler casings and drums	O	O	N	N	N	N	N	C	N	N	N	N	N	E
Immersion, severe exposures	Coal tar epoxy polyamide-cured	Waste treatment pits, pulp and paper mills, cogeneration, power pits, sour crude exposures	C	C	C	O	I	N	O	C	O	O	I	C	I	F

I—immersion C—frequent contact O—occasional contact N—not recommended F—fair G—good E—excellent

CHEMICAL-RESISTANT COATINGS

Chemical-resistant coatings are selected according to substrate type and actual chemical exposure. Formulations of this product type vary widely from manufacturer to manufacturer and are subject to changes caused by technological advances and environmental legislation. Dry-film thick-

nesses, cure rates, and application methods also vary among product types and manufacturers. End user program requirements and consultation with manufacturers is recommended before specifying these products. In-place or laboratory testing may be advisable in critical conditions.

Isabel Ramirez and Ted Hallinan; Sverdrup Facilities Inc.; Arlington, Virginia  
Southern Coatings, Inc.; Sumter, South Carolina



SPECIAL COATINGS

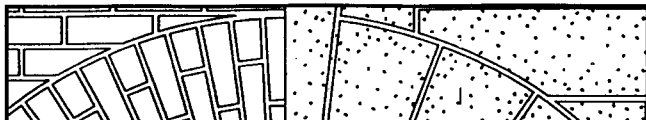

# SPECIALTIES

Compartments and  
Cubicles 564

Service Walls 565

Wall and Corner Guards 567

Fireplaces and Stoves 570

Flagpoles 573

Identifying Devices 574

Lockers 576

Fire Protection Specialties 577

Protective Covers 579

Postal Specialties 583

Partitions 584

**GUIDELINES**

1. Residential cabinets: enameled steel, stainless steel, aluminum, wood, plastic, etc.
2. Commercial cabinets: stainless steel and enameled steel
3. Accessories: chrome, stainless steel, brass, aluminum, plastic, and vitreous china
4. Cabinet and accessory types: recessed, semi-recessed, or surface mounted.
5. Light fixtures can be part of cabinets.
6. ADA requires reach height not to exceed 48 in. for forward reach or 54 in. for side reach.

**NOTE**

All dispensers and disposals can be recessed, semi-recessed, or surface mounted.

600 C-FOLD OR 800 MULTIFOLD 15 GALLON WASTE

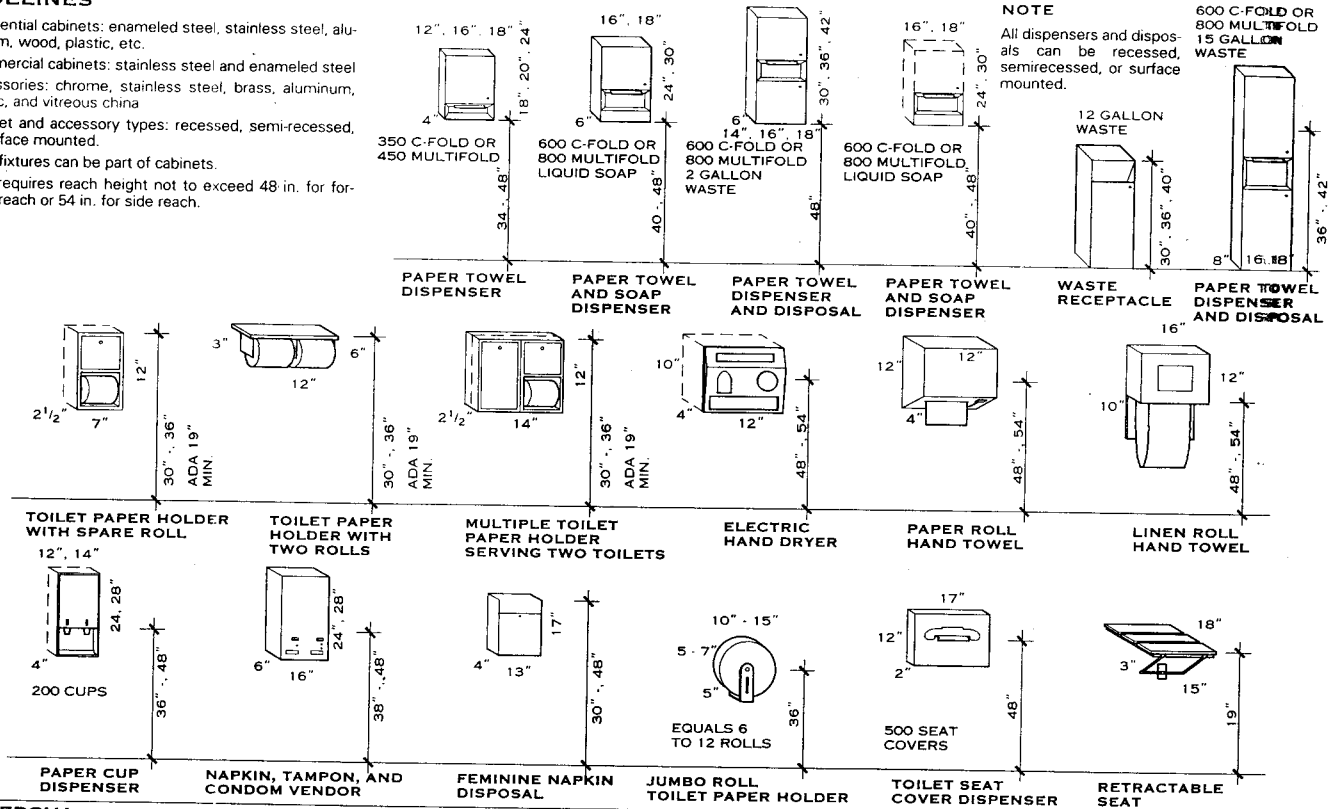

**COMMERCIAL**

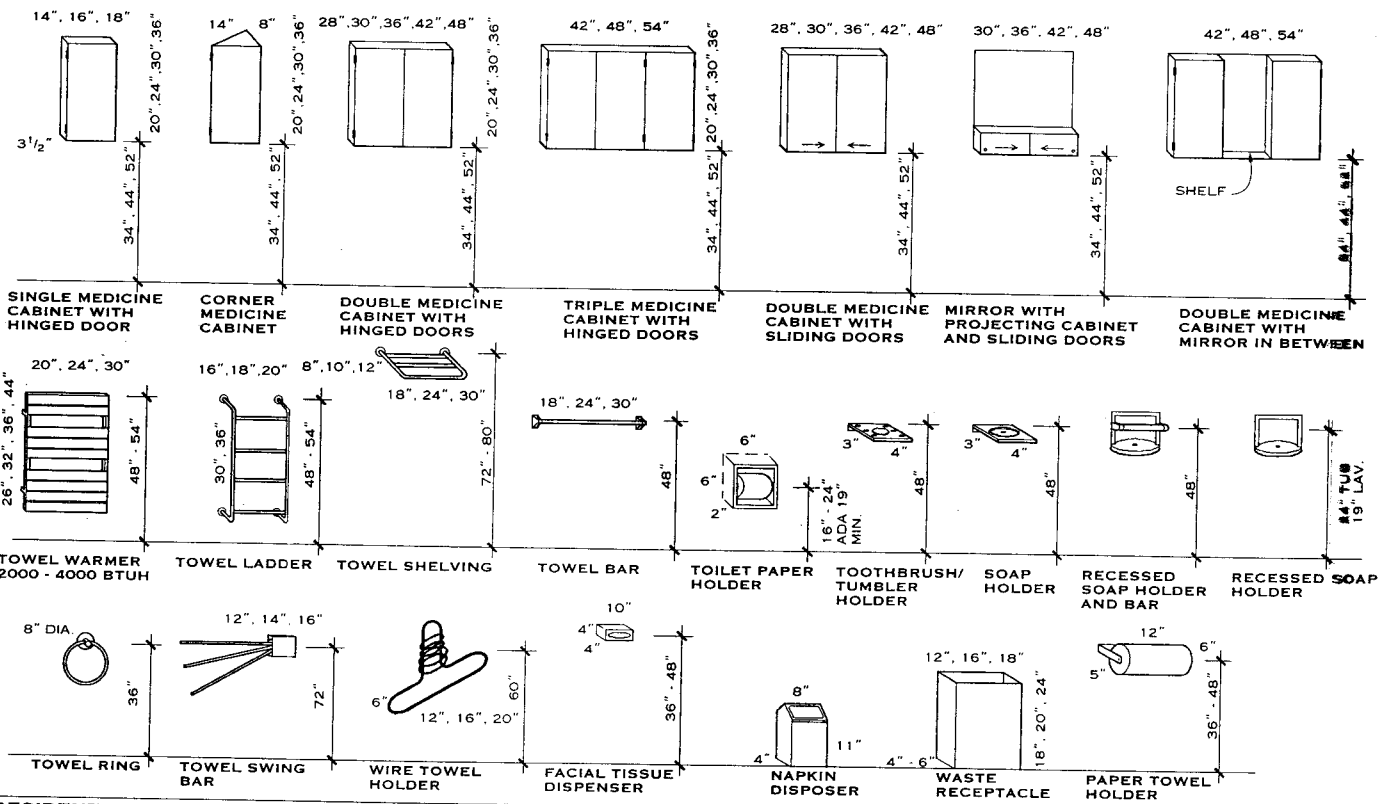

**RESIDENTIAL AND HOTEL**

Charles A. Szoradi, AIA; Washington, D.C.

10 COMPARTMENTS AND CUBICLES

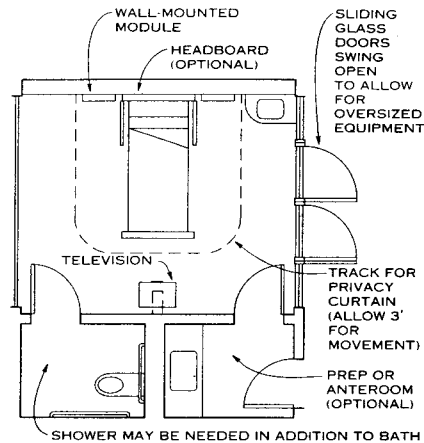
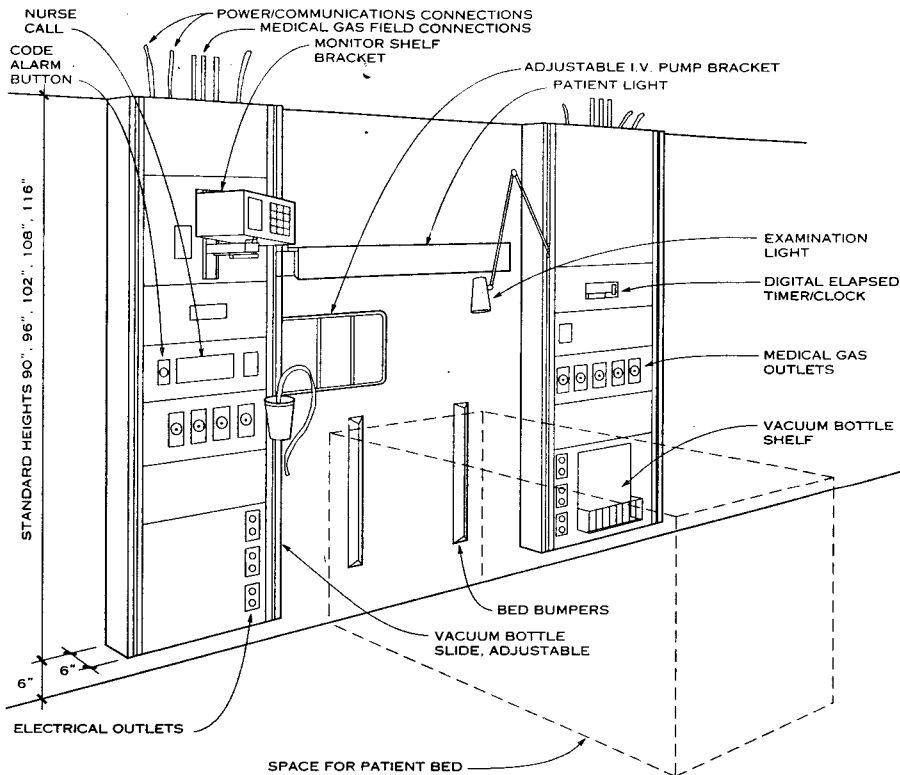

**NOTE**  
 Creating an efficient and unhampered space is important in the design of intensive care units. Several manufacturers offer modular units to help organize the distribution of services to the patient. These services include medical gases such as oxygen and nitrous oxide, air and vacuum service, communications, and power. Wall-mounted systems organize services in vertical or horizontal raceways or modules and are designed for beds that position the patient's head against a wall. Modules can be custom designed to serve the particular needs of each ICU and are flexible and adaptable to meet the needs of individual patients. These modules can be designed to serve one or two patient beds.

**TYPICAL LAYOUT/PLAN**

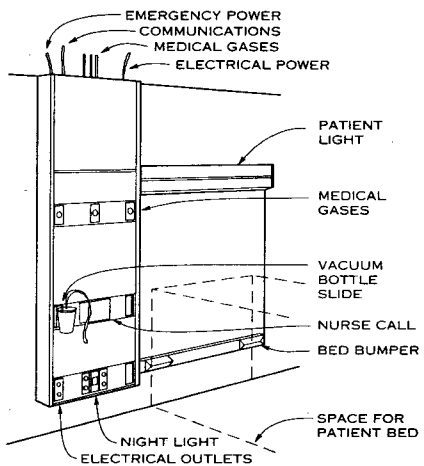

**SINGLE VERTICAL WALL-MOUNTED MODULE**

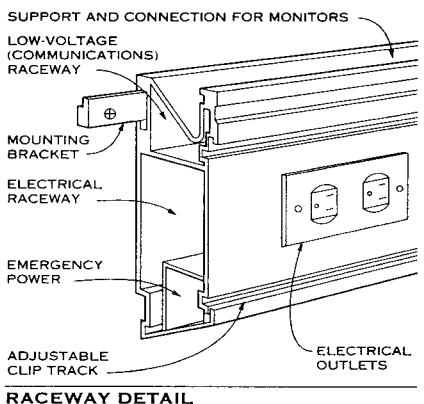

**RACEWAY DETAIL**

**VERTICAL WALL-MOUNTED MODULES**

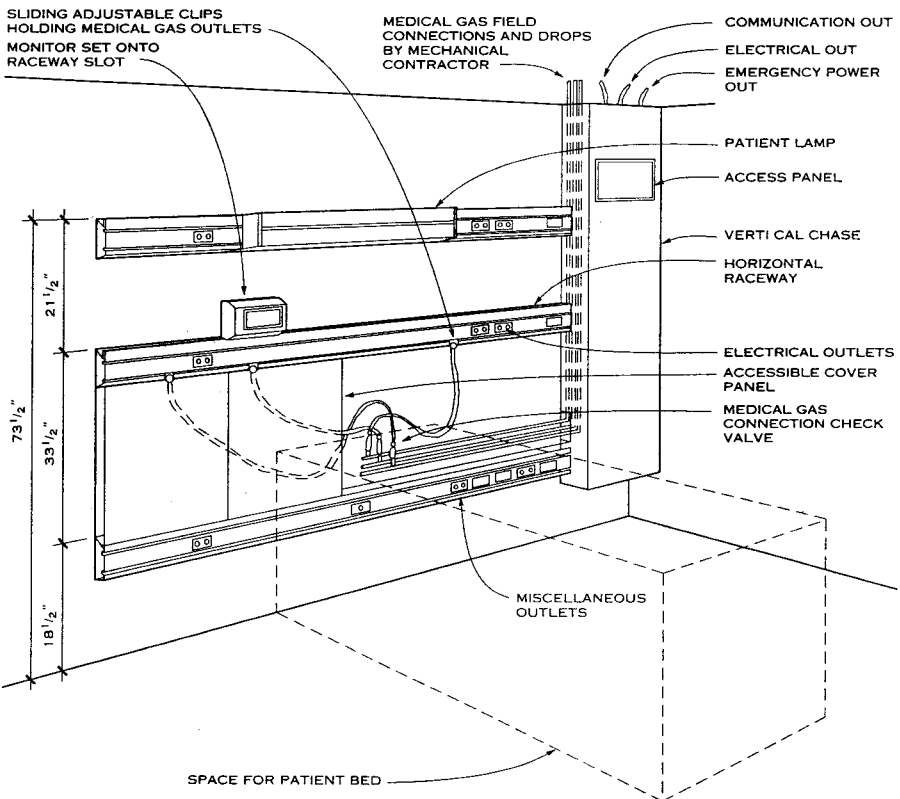

**VERTICAL CHASE WITH HORIZONTAL RACEWAY**

Richard J. Vitullo, AIA; Oak Leaf Studio; Crownsville, Maryland  
 Andrew Summers; University Park, Maryland

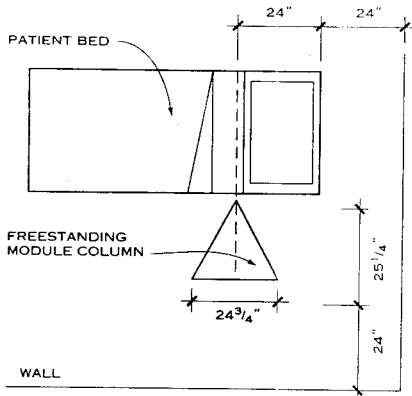

**NOTE**  
 Freestanding intensive care unit modules help organize and distribute patient services by accommodating situations in which the patient's bed is not against a wall, thereby allowing hospital staff access to the patient from all sides, particularly near the head. This system also reduces the clutter, inconvenience, and danger of disconnection created by long cords and hoses stretching from a wall-based system to a remote bed. In the rectangular and triangular models, the module is installed permanently, with all wiring and pipes accessed through the top of the unit. The pivoting module column pivots on fixed points in the floor and ceiling, rotating around a zone centered on the patient's chest.

Some of the services provided at the modules are electricity, nurse call, physiological monitor, telephone, emergency power, and medical gas piping (typically, oxygen, air, and vacuum). Each module can accommodate the design and component flexibility required by individual health care facilities.

**TYPICAL LAYOUT/PLAN**

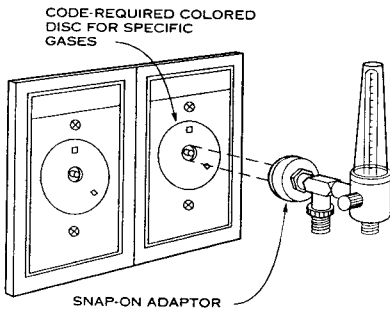

**STANDARD GAS OUTLET**

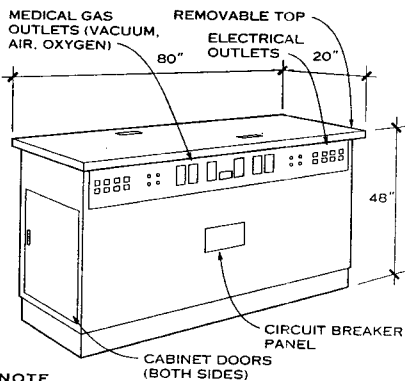

**NOTE**  
 Rear of module identical to front surface

**NEONATAL MODULE**

Richard J. Vitullo, AIA; Oak Leaf Studio; Crownsville, Maryland  
 Andrew Summers; University Park, Maryland

10 SERVICE WALLS

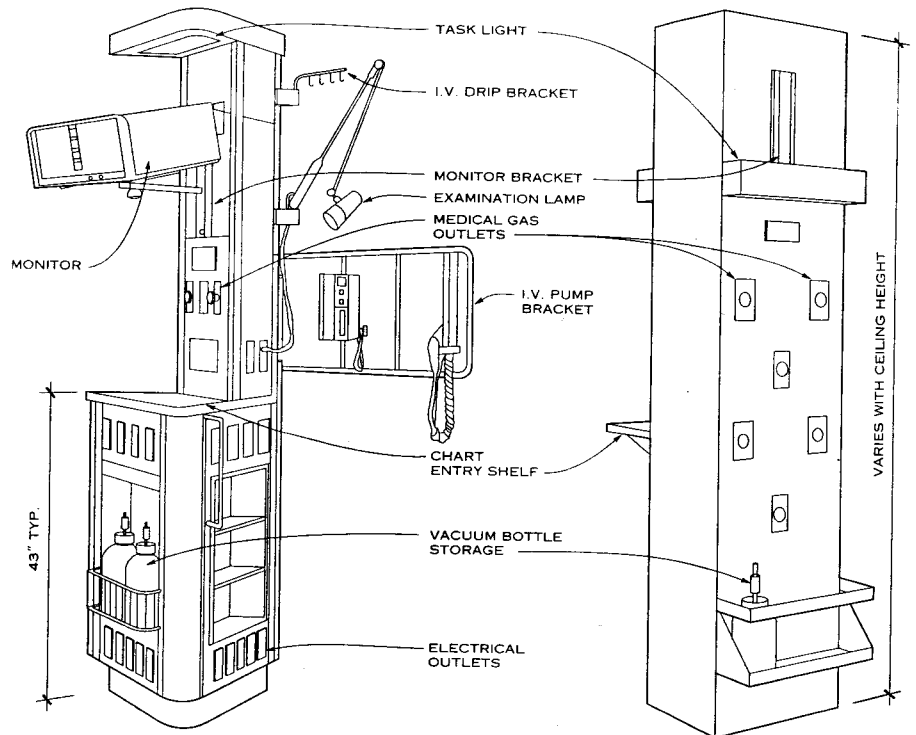

**TRIANGULAR MODULE COLUMN**

**RECTANGULAR MODULE COLUMN**

**FREESTANDING MODULE**

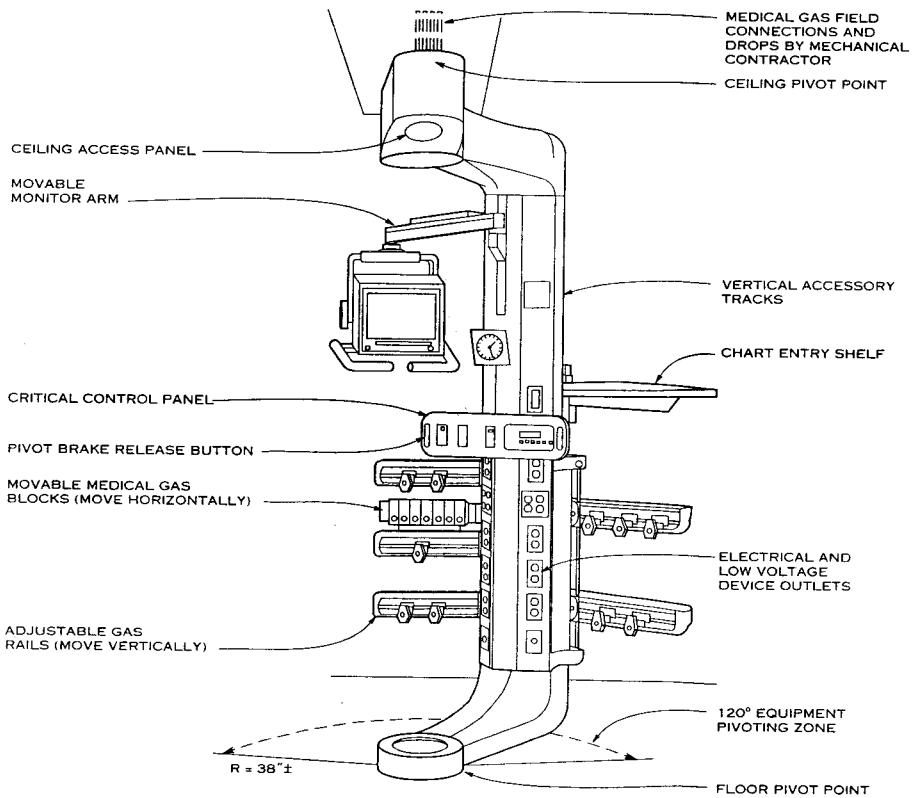

**PIVOTING MODULE COLUMN**

**GENERAL NOTES**

1. Wall guards, panels, and trim are typically attached to a finished wall surface with adhesive or screws. Panels are typically made of high-density fiberglass and covered with vinyl acrylic cladding, but they may also have fabric coverings in low impact areas.
2. Most wall and corner guard manufacturers supply inside and outside connector trim pieces, as well as end caps. Consult manufacturers.
3. For all wall and corner guard installations, it is important to provide backup blocking behind areas where fasteners are attached, particularly for handrail-type guards.

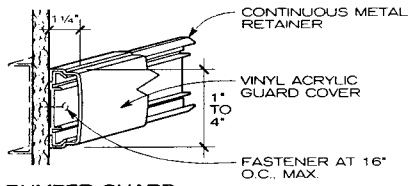

**BUMPER GUARD**

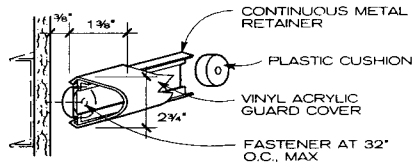

**BUMPER GUARD**

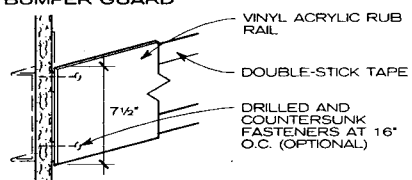

**RUB RAIL GUARD**

**BUMPER GUARDS**

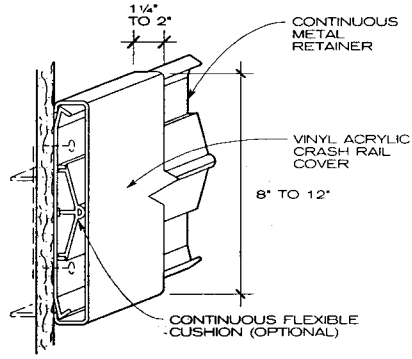

**SURFACE-MOUNTED**

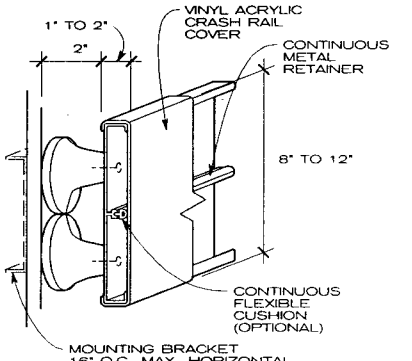

**WALL-HUNG**

**CRASH RAILS**

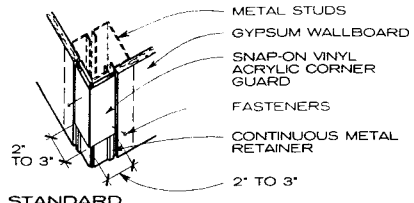

**STANDARD**

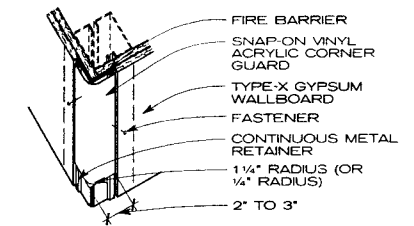

**FIRE-RATED**

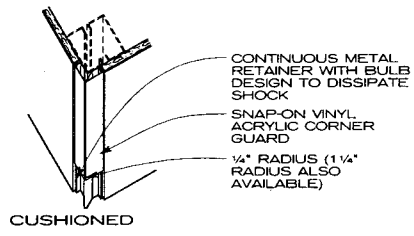

**CUSHIONED**

**NOTE**  
Depending on the design of the retainer, corner guards can be mounted to almost any wall angle intersection up to 135 degrees.

**FLUSH-MOUNTED CORNER GUARDS**

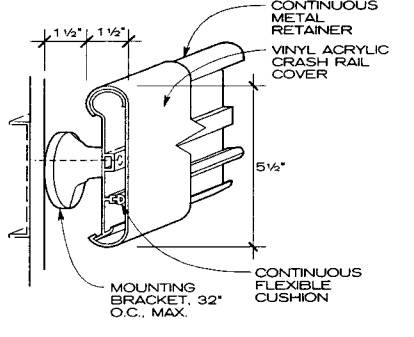

**HANDRAIL WITH BUMPER CUSHION**

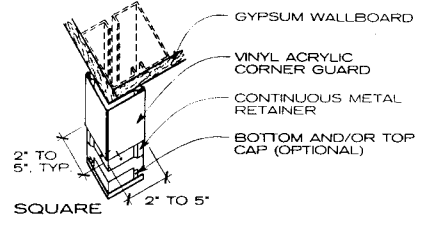
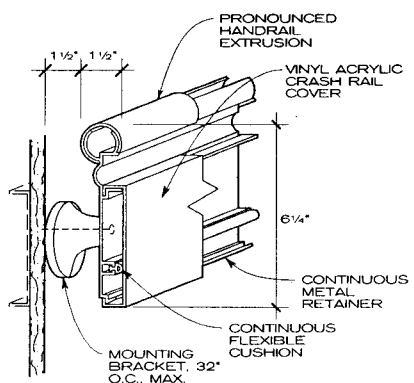

**SQUARE**

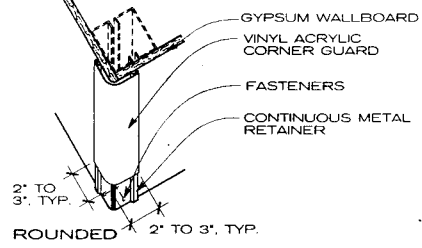

**ROUNDED**

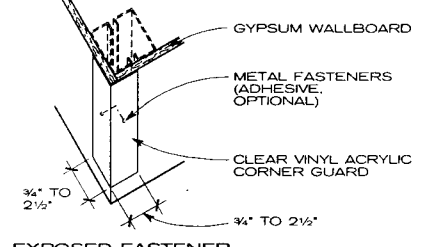

**EXPOSED FASTENER**

**SURFACE-MOUNTED CORNER GUARDS**

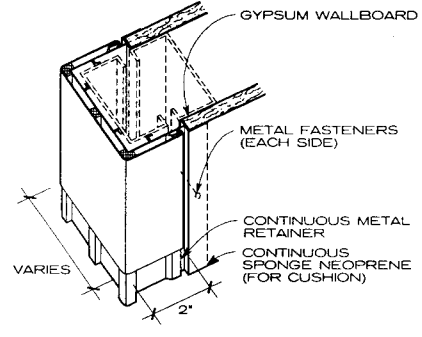

**WALL-END GUARD**

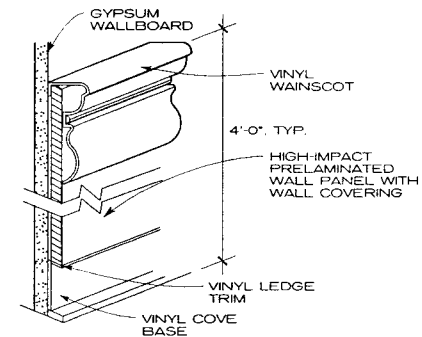

**WAINGSOT PANEL WALL GUARD**

Richard J. Vitullo, AIA; Oak Leaf Studio; Crownsville, Maryland

**GENERAL NOTES**

- Column and beam covers are designed to conceal and protect structural and mechanical components, although they also have aesthetic value. They are installed according to the manufacturers' designs, which may differ from one company to the next. Some are designed with one section of the cover permanently fixed in place and the other section removable. In other designs, more than one section of the cover is removable. Column and beam covers can be used in interior and exterior locations.
- The most common materials used for the cover superstructure are base metals of extruded aluminum (.063 to .25 in. thick), stainless steel (18 to 11 gauge), and galvanized steel (18-gauge base with finish cover). Factory-applied mechanical finishes include anodized (for aluminum); satin or mirror finish (on brass, aluminum, or stainless steel); Kynar coating (on galvanized steel); and embossed patterns on any base metal. Other factory-applied finishes include baked enamel, powder coat, and primer (for field painting). Clear lacquer coatings are sometimes applied in the field to preserve mirror or other finishes. For high-traffic and highly vulnerable areas where protection from graffiti is also a concern (e.g., mass transit facilities), use of factory-applied ceramic/porcelain veneer on steel is recommended.

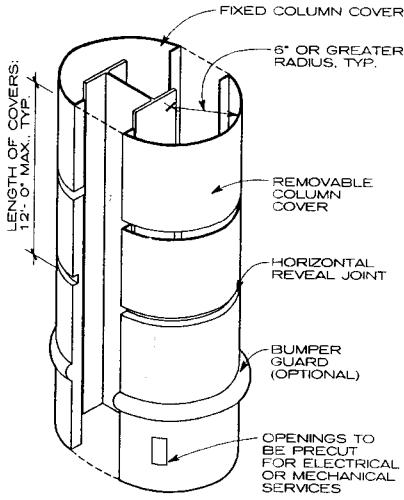

**TYPICAL FREESTANDING COLUMN COVER**

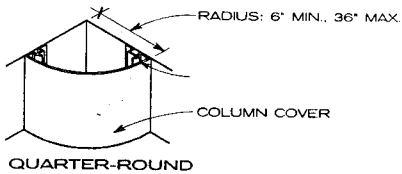

**QUARTER-ROUND**

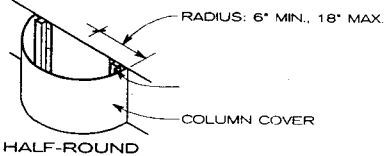

**HALF-ROUND**

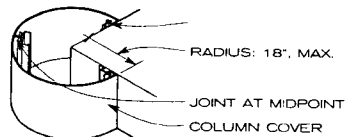

**THREE-QUARTER ROUND**

**TYPICAL COLUMN COVERS**

Richard J. Vitullo, AIA; Oak Leaf Studio; Crownsville, Maryland

**10 WALL AND CORNER GUARDS**

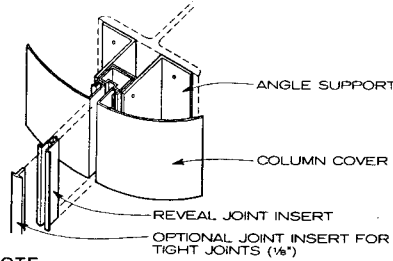

**NOTE**  
This detail is used to protect joint edges at ceramic-coated steel seams.

**COLUMN COVER WITH INSERTS**

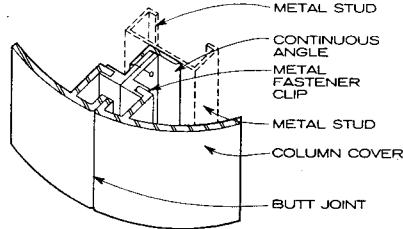

**BUTT JOINT COLUMN COVER WITH FASTENER CLIP**

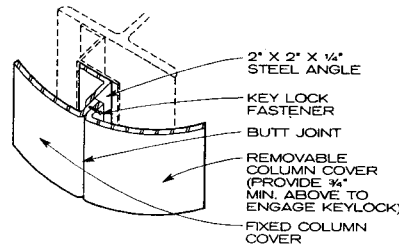

**BUTT JOINT COLUMN COVER WITH KEY LOCK**

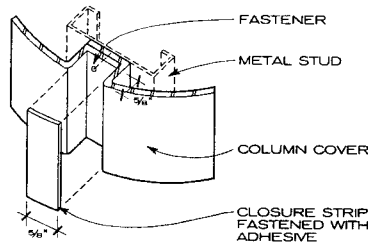

**COLUMN JOINT WITH CLOSURE STRIP**

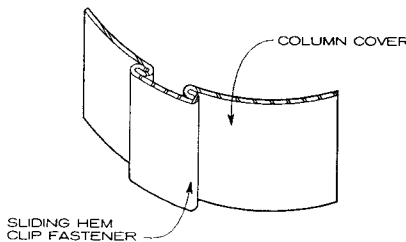

**SLIDING HEM CLIP**

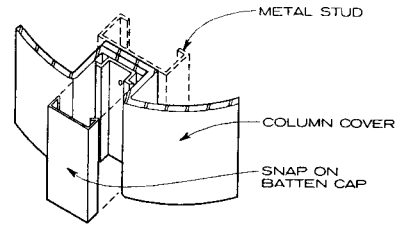

**NOTE**  
Batten caps are available in a wide variety of sizes, colors, and materials. Consult manufacturers.

**COLUMN COVER JOINT WITH BATTEN CAP**

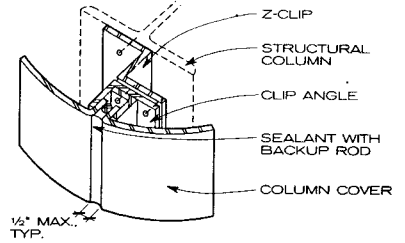

**COLUMN COVER WITH SEALANT JOINT**

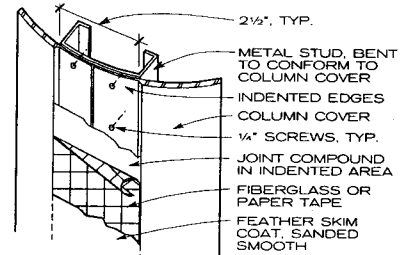

**COLUMN COVER WITH STANDARD JOINT COMPOUND DETAIL**

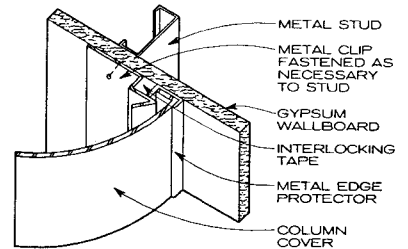

**PARTIAL COLUMN COVER—WALL MOUNT DETAIL**

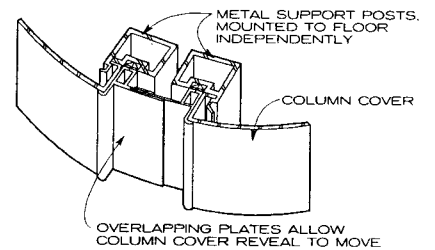

**COLUMN COVER AT EXPANSION JOINT**

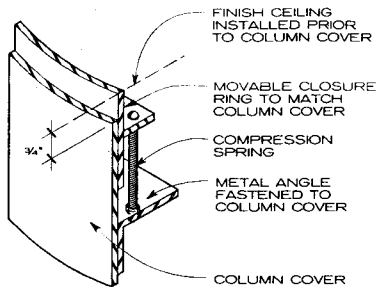

**NOTE**  
This type of column cover can be installed flush with a finished ceiling.

**SPRING-ACTIVATED COLUMN COVER CLOSURE**

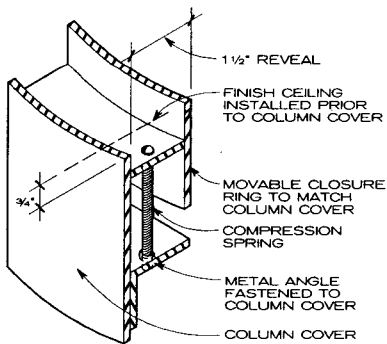

**SPRING-ACTIVATED COLUMN COVER CLOSURE WITH REVEAL**

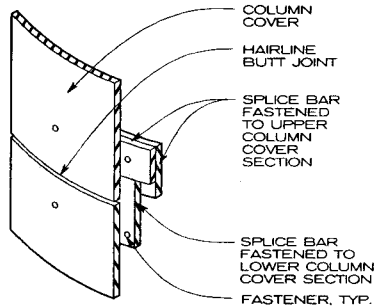

**HORIZONTAL SPLICE WITH BUTT JOINT**

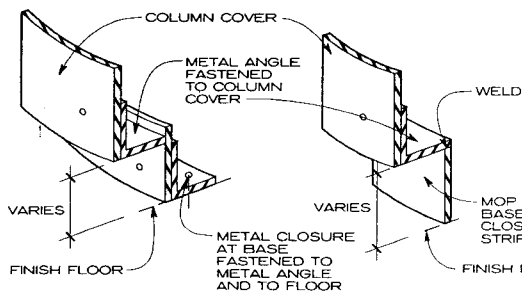

**NOTE**  
Column cover base assemblies are not fastened to floors but only to vertical supports (metal studs, etc.).

**COLUMN COVER BASE DETAILS**

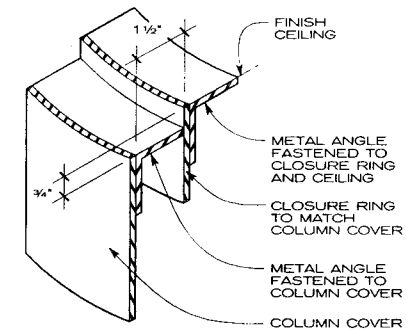

**CEILING-FASTENED CLOSURE RING WITH REVEAL**

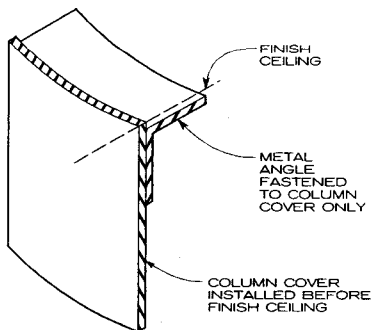

**CEILING DETAIL WITH FLUSH COLUMN COVER**

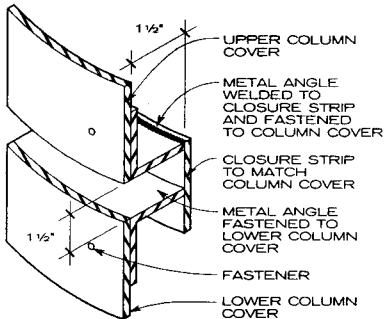

**HORIZONTAL REVEAL JOINT**

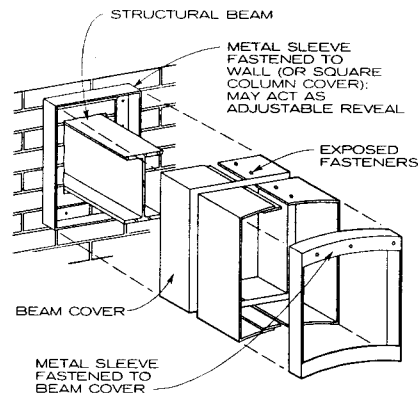

**NOTE**  
Dimensions and joint configurations vary according to design requirements or preference. Consult manufacturers.

**BEAM COVER AT WALL**

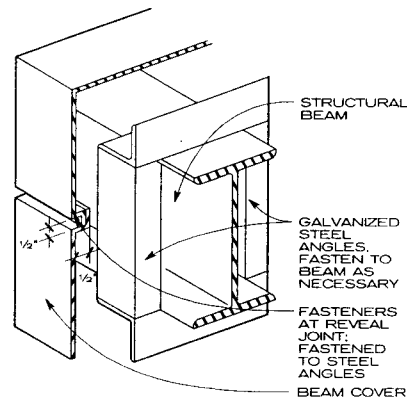

**BEAM COVER FASTENING DETAIL**

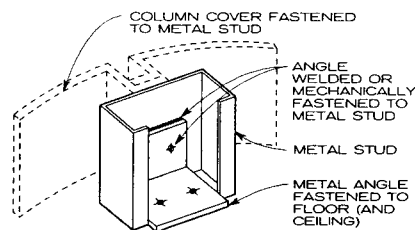

**DETAIL AT METAL STUD**

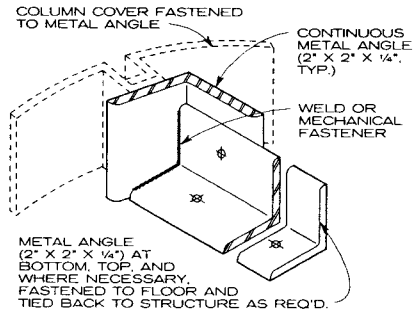

**DETAIL AT METAL ANGLE**

**COLUMN COVER SUBFRAME ATTACHMENTS**

Richard J. Vitullo, AIA: Oak Leaf Studio; Crownsville, Maryland



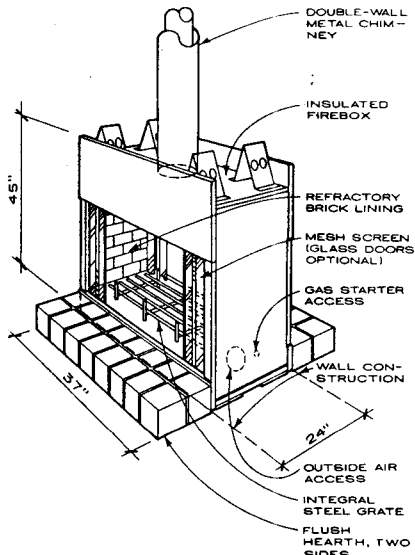

DOUBLE-ACCESS FIREPLACE

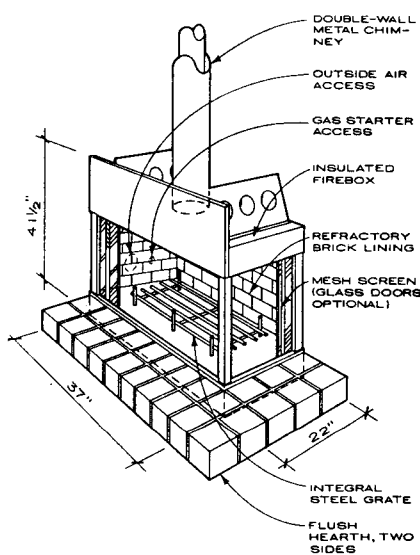

CORNER FIREPLACE

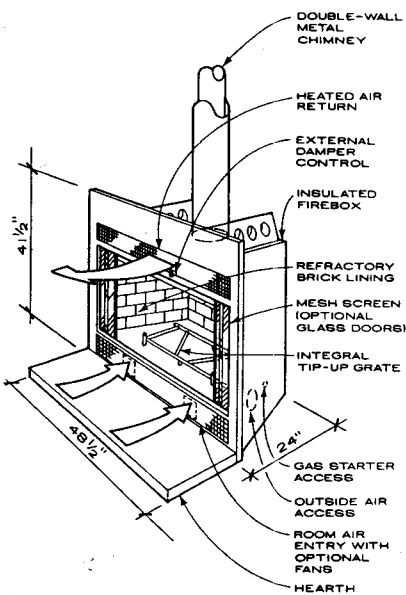

HEAT-CIRCULATING FIREPLACE

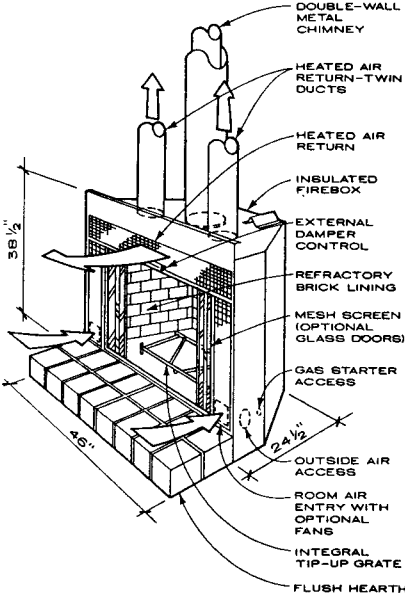

DUCTED HEAT-CIRCULATING FIREPLACE

- GENERAL NOTES**
1. Verify local/state codes for maximum and minimum chimney height clearances above roof deck.
  2. Chimney pipe requires a 2-in. clearance to combustible surfaces. In a multichase installation, chimney pipes should be 20 in. apart, center to center. Chase top must be constructed of noncombustible material.
  3. See manufacturer's specifications for chimney joint band and stabilizer locations.
  4. Fire-stop spacer must be used whenever a ceiling, floor, or sidewall is penetrated.
  5. No special floor support is usually necessary for prefabricated fireplaces; however, local/state codes should be checked to determine exact requirements.
  6. Facing material must not obstruct louvered or screened area at sides, top, or bottom of fireplace opening; however, noncombustible finishing material may be used over the black metal on fireplace fronts. See manufacturer's specifications.
  7. Inadequate ventilation can occur from air conditioning, heating, or other mechanical systems that generate negative air pressures in the fireplace room. Plan for proper ventilation to ensure smoke-free operation.
  8. There is no minimum or maximum horizontal distance for outside air access line.
  9. A noncombustible hearth extension must extend at least 8 in. on either side of firebox openings and 16-20 in. in front of firebox.
  10. Distances from combustible walls perpendicular to the front of the fireplace—including mantles—vary. Consult manufacturer's specifications.
  11. Outlet grilles must be at least 10 in. below ceiling for ducted heat-circulating fireplace.
  12. Room furnishings such as drapes, curtains, and chairs must be at least 4 ft 0 in. from firebox opening.

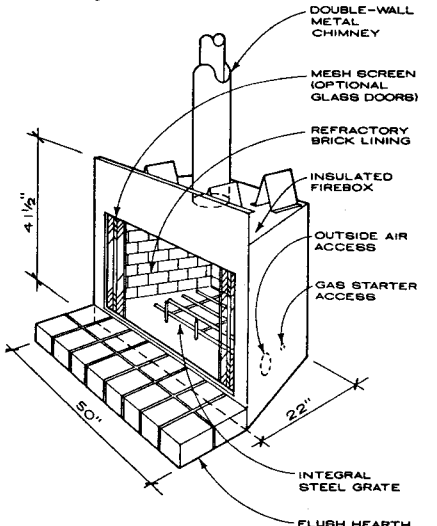

TRADITIONAL FIREPLACE

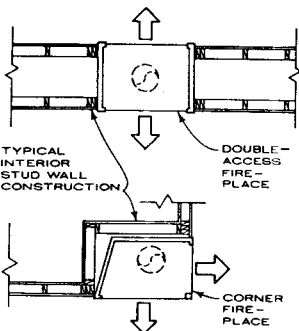

INTERIOR WALL CONDITION CHASE CONSTRUCTED ON ROOF

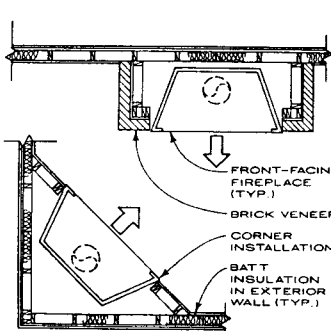

EXTERIOR WALL CONDITION CHASE CONSTRUCTED ON ROOF

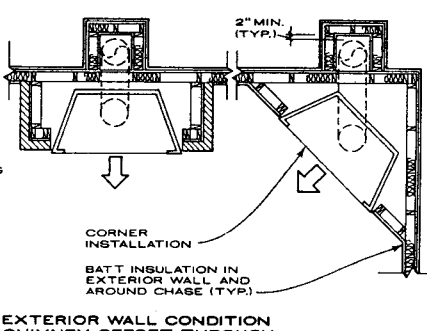

EXTERIOR WALL CONDITION CHIMNEY OFFSET THROUGH EXTERIOR WALL AND ENCLOSED IN CHASE

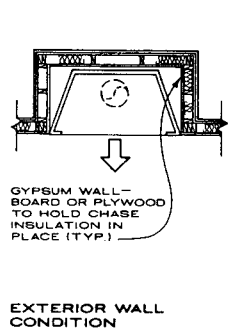

EXTERIOR WALL CONDITION FIREPLACE AND CHIMNEY ENCLOSED IN CHASE

**INSTALLATION CONDITIONS FOR PREFABRICATED FIREPLACES**

Richard J. Vitullo, AIA; Oak Leaf Studio; Crownsville, Maryland

**GENERAL NOTES**

- 1. APPLIANCE CLASSIFICATIONS:** Metal solid-fuel heaters efficiently heat areas ranging in size from a single room to an entire house. They are classified according to the fuel that powers them: woodstoves (cordwood) or pellet stoves (densified biomass). Woodstoves manufactured today burn both softwood and hardwood species of cordwood, which have variable moisture and Btu content but are readily accessible and manually prepared for use.
- 2. BURNING TECHNOLOGIES:** Current EPA regulations for solid-fuel appliances have resulted in woodstoves significantly more efficient than those produced before. The key to efficiency is igniting and burning the smoke and gases released during combustion, particularly during extended and reduced heat burns. Burning smoke and gases reduces fuel consumption, polluting emissions, and the frequency of chimney maintenance. Woodstoves must meet EPA standards for efficiency and cleanliness of burning. EPA standards differ for catalytic and noncatalytic technology, and within the latter category, for wood-burning and pellet-burning stoves.
- 3. APPLIANCE CONFIGURATIONS:** Both woodstoves and pellet stoves can be freestanding, a fireplace insert, or built in. Freestanding appliances are often chosen in new construction or for renovation when no chimney exists. Fireplace inserts are often used to retrofit an open fireplace to increase efficiency and heat output. Built-in heaters are chosen to achieve the look and performance of the fireplace insert without the expense of building a masonry fireplace and chimney. Instead, the built-in uses a high temperature metal chimney, usually concealed in a chase. Noncombustible materials such as brick, stone, or ceramic tile are applied around the appliance face to give the look of a traditional fireplace.
- 4. HEAT DISTRIBUTION, APPLIANCE PLACEMENT, AND SIZING:** The design of an appliance determines how it distributes heat. If the outside walls of the firebox are directly exposed to living space, the appliance is primarily a radiant heater. The heat created when waves of infrared energy from a stove strike solid objects is very comfortable in large open areas but may not be able to reach remote areas of a house.

Convection heaters feature double-wall construction. Radiant energy is converted to currents of warm air in the space between the firebox and the surrounding

metal cabinet. Natural convection currents of warm air moving through the house, cooling, and returning to the heater distribute heat gradually or with the assistance of an electric blower.

With the advent of clean glass technology, purely convection heaters completely surrounded by cabinets became rare. Much more common is a third type of heater, which combines the heat distribution qualities of the first two. A combination radiant/convection heater employs a cabinet around part of the heater for convection, but radiant energy is emitted from exposed parts of the firebox wall and the ceramic glass of the loading door. The combination offers even distribution of heat, delivering the radiant energy that heats immediate rooms comfortably and the convection currents that gradually deliver heat to more distant areas. Glass cleaning air wash technology and high-efficiency burning give the user a clear view of the fire and make the stove easier to operate.

Although a central location and open spaces provide optimum heat distribution, both radiant and combination stoves distribute heat satisfactorily if they are placed in a room of adequate size. Placement is often determined by how the living space is used and by the location of the chimney.

The performance of EPA-certified appliances on low burns allows some tolerance for oversizing an appliance for a heating area. However, appliances much too large for the area to be heated makes operation in mild weather difficult. Also important are heating expectations: A stove intended for occasional, recreational, or emergency use can be sized differently from one intended as a primary heat source. Manufacturers' recommendations for heating area capacity may not take into account local climate or the specifics of heat loss; consult a certified dealer.

- 5. AESTHETICS:** The material used to construct a stove has little effect on heating performance. Cast iron offers decorative features such as arches, curves, and relief work unattainable with steel. Steel stoves may come in styles varied through a choice of legs or pedestals, arched door frames, and brass or gold-plated accents. Stoves with soapstone panels are another option. Air wash technology, which keeps the glass clean, is perhaps the most popular design feature in all stoves.

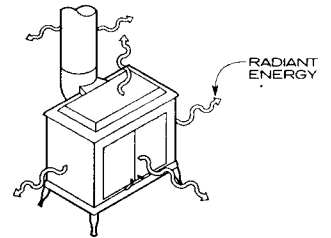

RADIANT

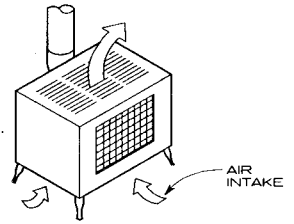

CONVECTION

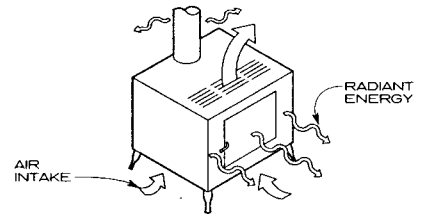

COMBINATION RADIANT/CONVECTION

**HEAT DELIVERY SYSTEMS**

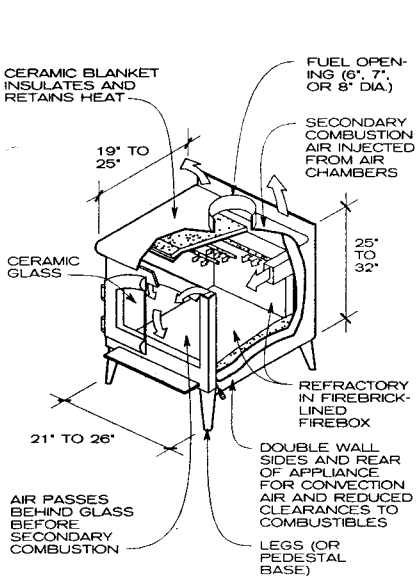

**NOTE**

Noncatalytic systems create the conditions necessary to burn combustible gases without the use of catalysts. The technology has a number of characteristics: Firebox insulation keeps temperatures high. Devices that reflect heat back into the firebox create the gas turbulence needed for complete combustion and give the gases a long route hot enough for them to burn before being cooled. Heated secondary air supplies ensure that enough oxygen is present. This secondary air is usually fed to the fire above the fuel bed through ducts with small holes.

**NONCATALYTIC STOVE SYSTEM**

**NOTE**

Pellets are a consistently low-moisture fuel made from dried ground wood waste or other biomass waste compressed into small cylinders about 6 mm (1/4 in.) in diameter and 25 mm (1 in.) long. The pressure and heat used for their production binds the pellets together without the need for additives. Pellets usually burn cleanly because they are fed to the combustion chamber at a controlled rate and are matched with the right amount of combustion air. Pellet-burning stoves generally can operate at lower emission levels than natural firewood appliances. Some pellet stoves also burn corn.

**TYPICAL DENSIFIED PELLET APPLIANCE**

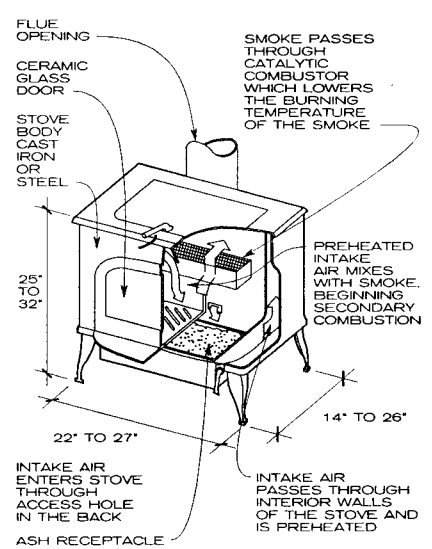

**NOTE**

A catalyst is a substance that effects a reaction without being consumed in the process. The catalyst in a catalytic combustion appliance is a coated ceramic honeycomb through which exhaust gas is routed. The catalytic coating, usually palladium and/or platinum, lowers the ignition temperature of the gases from 1000° to 500° F as they pass through, causing them to ignite. This arrangement allows catalytic appliances to operate at low firing rates and still burn cleanly. Because the catalyst restricts gas flow through the appliance, these units always include a bypass damper into the flue. The damper is opened when the appliance is loaded; when a hot fire has been established, it is closed, forcing the gases through the combustor for an extended clean burn.

**CATALYTIC SOLID-FUEL APPLIANCE**

Walter Moberg Design, Inc.; Portland, Oregon  
Hearth Education Foundation; Austin, Texas

**CHIMNEYS AND DRAFT**

The woodstove chimney and pellet stove vent are essential components of the solid-fuel heating system. For woodstoves, factory-built metal chimneys offer precise sizing (optimum draft is obtained by matching the cross-sectional area of the flue outlet), safety (heat-tested to 2100 °F, according to UL 103), and low maintenance (insulation reduces condensation). Masonry chimneys often need to be downsized with a UL 1777-listed stainless steel, poured or factory-built liner that extends from the appliance to the top of the chimney. Liners improve startup and draft, improve safety, and reduce and simplify maintenance.

Follow code or manufacturers' requirements for chimney clearance and height. For safety, follow the 2 ft/10 ft/3 ft rule: The chimney must terminate at least 2 ft higher than anything within 10 ft and extend at least 3 ft above the roof penetration. High-efficiency stoves may need added height to ensure adequate draft; a minimum height of 14 ft from appliance to chimney top is generally recommended.

Pellet appliances often use lower temperature double-wall pellet venting. Mechanical venting for some appliances can be totally horizontal if clearances to adjacent structures and openings are met, but additional vertical venting is recommended in case of unexpected shutdown. Mechanical draft pellet venting that penetrates the roof can terminate as little as 1 ft above the penetration; natural draft venting must be at least 2 ft higher than anything within 10 ft.

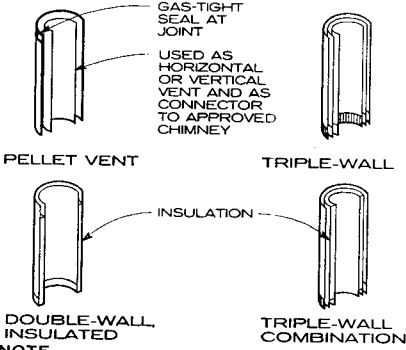

**NOTE**  
Chimneys keep flue gases as warm as possible, keep nearby combustibles at safe temperatures, and exhaust harmful smoke and gases to the outdoors.

**CHIMNEY TYPES FOR WOODSTOVES AND PELLET STOVES**

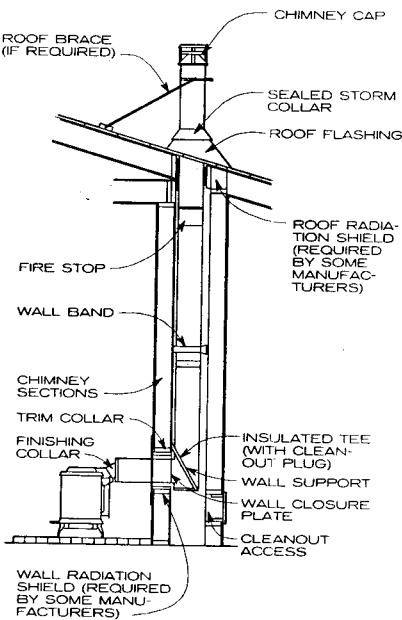

**THROUGH-THE-WALL INSTALLATION—FACTORY-BUILT CHIMNEY**

Walter Moberg Design, Inc., Portland, Oregon  
Hearth Education Foundation, Austin, Texas

**INSTALLATION**

Underwriters Laboratories tests and lists most woodstoves tested for close clearances to unprotected combustibles. Brick or sheet metal protectors are not usually necessary, and their use in any case cannot reduce required clearance to less than 12 in. Use of double wall connector pipe from the appliance to the chimney may be recommended to reduce clearances for woodstoves, but such pipe must be listed for use with both the appliance and the chimney to which it will be connected.

Pellet appliances are listed by UL (but to a different standard) for very close clearances. They are usually vented with listed pellet venting from the appliance to the outside.

Unlisted appliances should be installed according to the provisions of NFPA 211.

Acceptable floor protection materials and minimum size for these stoves are specified by the manufacturers; if not, follow NFPA 211 or local code requirements.

**REFERENCES**

HEARTH Education Foundation, *HEARTH Woodstove Specialist Training Manual*, Austin, Tex., 1993.

—, *HEARTH Pellet Appliance Specialist Training Manual*, Austin, Tex., 1995.

National Fire Protection Association, *NFPA 211: Chimneys, Fireplaces, Vent, and Solid-Fuel Burning Appliances*, Quincy, Mass., 1992.

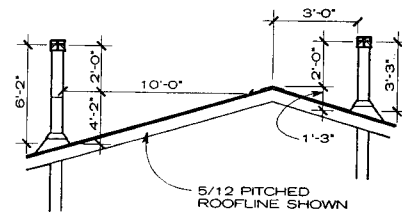

**NOTE**  
Chimney height must meet minimum draft requirements, generally 14 ft from stove to the chimney cap.

**CALCULATING CHIMNEY HEIGHTS WITH PITCHED ROOFS**

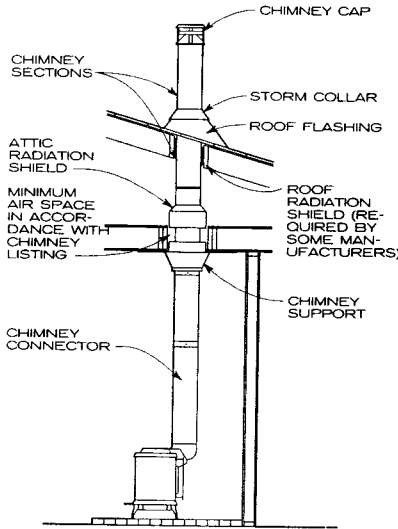

**NOTE**  
Chimney must meet manufacturers' recommendations for minimum height.

**STANDARD CEILING INSTALLATION—FACTORY-BUILT CHIMNEY**

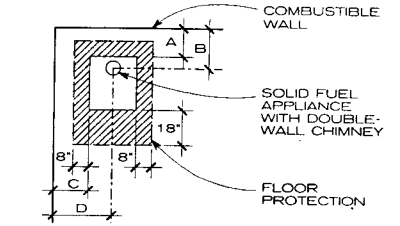
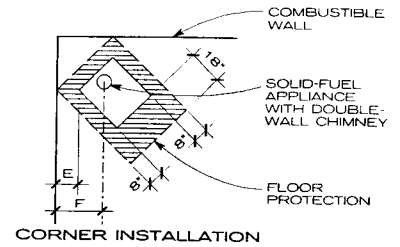

**PARALLEL INSTALLATION**

**NOTE**  
All clearances shown are subject to change based on manufacturers' specifications, local codes, and any clearance reduction systems used.

**MINIMUM CLEARANCES TO COMBUSTIBLES (IN.)**

SINGLE WALL CONNECTOR (RESIDENTIAL)					
A	B	C	D	E	F
15	21	18	30	11	25

DOUBLE WALL CONNECTOR (LISTED MOBILE HOME OR RESIDENCE, CLOSE CLEARANCE)					
A	B	C	D	E	F
8	14	16	28	7	21

**NOTE**  
Floor protection is required as follows: Minimum extension beyond loading door, 18 in.; beyond other sides, 8 in.

**TYPICAL LISTED SOLID-FUEL APPLIANCE CLEARANCES**

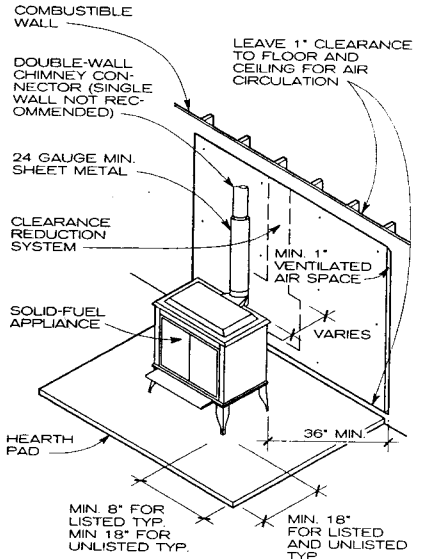

**NOTES**

- For stoves with legs 2 to 6 in., hearth pad should be 4-in. hollow masonry with 24-gauge (min.) sheet metal cover.
- With legs taller than 6 in., hearth pad should be 2-in. solid masonry with 24-gauge (min.) sheet metal cover.
- Stoves with legs shorter than 2 in. must be installed on a noncombustible floor even if there is a hearth pad.

**SOLID-FUEL APPLIANCE WALL CLEARANCE REDUCTION SYSTEM**

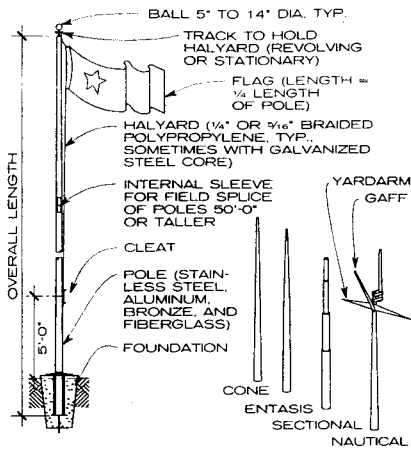

**NOTE**  
Flagpoles must withstand wind loads while the flag is flying. The combination wind load on pole and flag should be considered. Refer to wind load tests by the National Association of Architectural Metal Manufacturers (NAAMM).

**FLAGPOLE DESIGN**

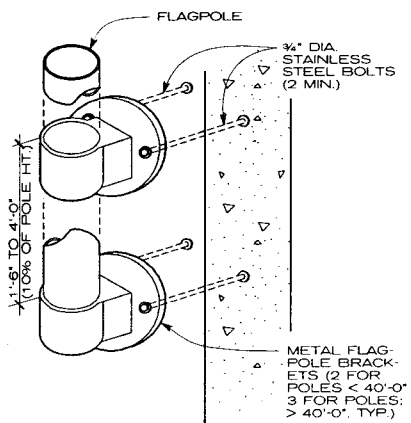

**NOTE**  
Brackets are made of cast aluminum, bronze, and stainless steel; designs vary.

**VERTICAL WALL-MOUNTED FLAGPOLE**

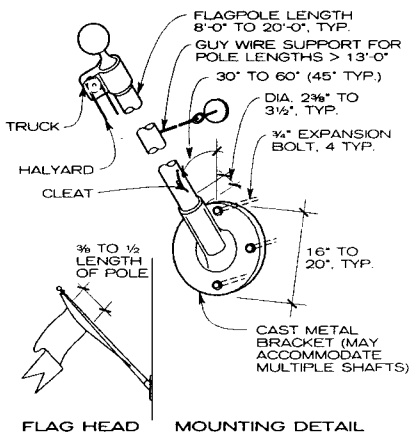

**OUTRIGGER WALL-MOUNTED FLAGPOLE**

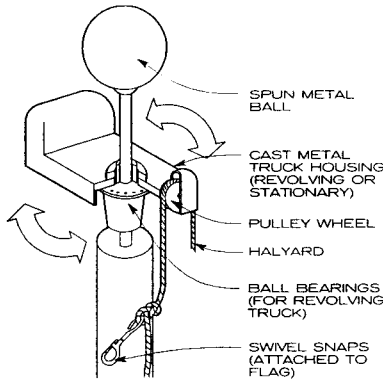

**NOTE**  
A revolving truck allows free movement of the flag while flying; a second truck is typically used as backup only, not simultaneously with the first truck.

**DOUBLE TRUCK DETAIL**

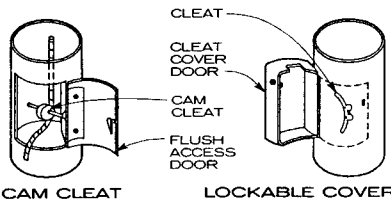

**VANDALPROOF CLEAT DETAILS**

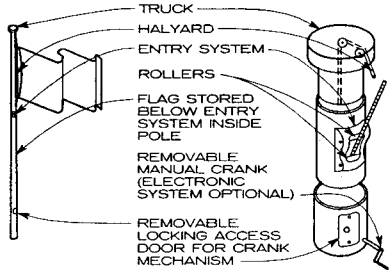

**SELF-STORING FLAGPOLE ENTRY SYSTEM DETAIL**

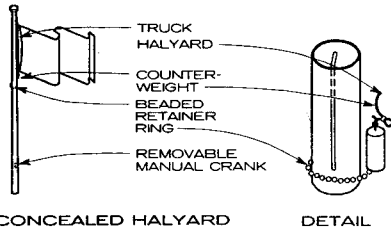

**VANDALPROOF FLAGPOLE DESIGN**

**SUGGESTED FLAG SIZES**

FOR GROUND-SET POLES		FOR VERTICAL WALL-SET POLES		FOR ROOF-SET POLES		FOR OUTRIGGER POLES	
EXPOSED POLE HEIGHT (FT)	FLAG SIZE (FT)	EXPOSED POLE HEIGHT (FT)	FLAG SIZE (FT)	EXPOSED POLE HEIGHT (FT)	FLAG SIZE (FT)	POLE LENGTH (FT)	FLAG SIZE (FT)
15	3 x 5	12 to 15	4 x 6	15	4 x 6	8	3 x 5
20 or 25	4 x 6	16 or 30	5 x 8	20 to 30	5 x 8	10 to 12	4 x 6
30 or 35	5 x 8	35 or 40	6 x 10	35 or 40	6 x 10	15 to 16	5 x 8
40 or 45	6 x 10	above top of wall		45 to 50	8 x 12	18 to 23	6 x 10
50, 55, or 60	8 x 12			60 to 65	10 x 15		
65 or 70	10 x 15			70 to 75	10 x 15		
80 or 90	10 x 15						
100	12 x 18						

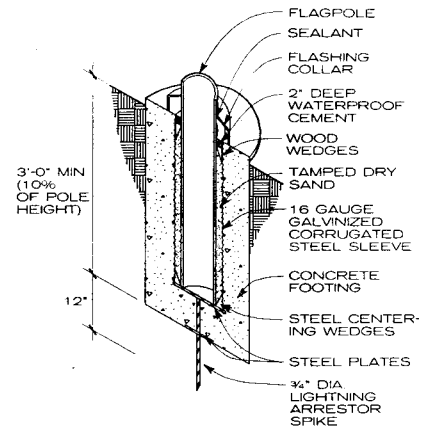

**FOUNDATION DETAIL**

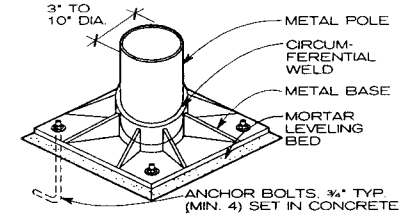

**NOTE**  
Electrical wiring may be threaded through the pole.

**SHOE BASE DETAIL**

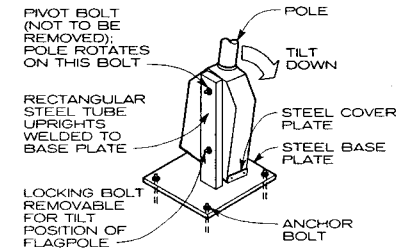

**COUNTERBALANCED TILTING POLE**

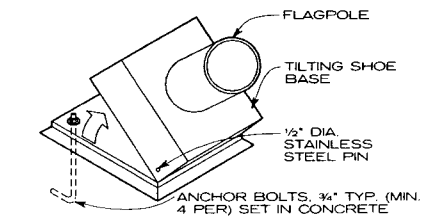

**HINGED TILTING POLE**

Richard J. Vitullo, AIA; Oak Leaf Studio; Crownsville, Maryland

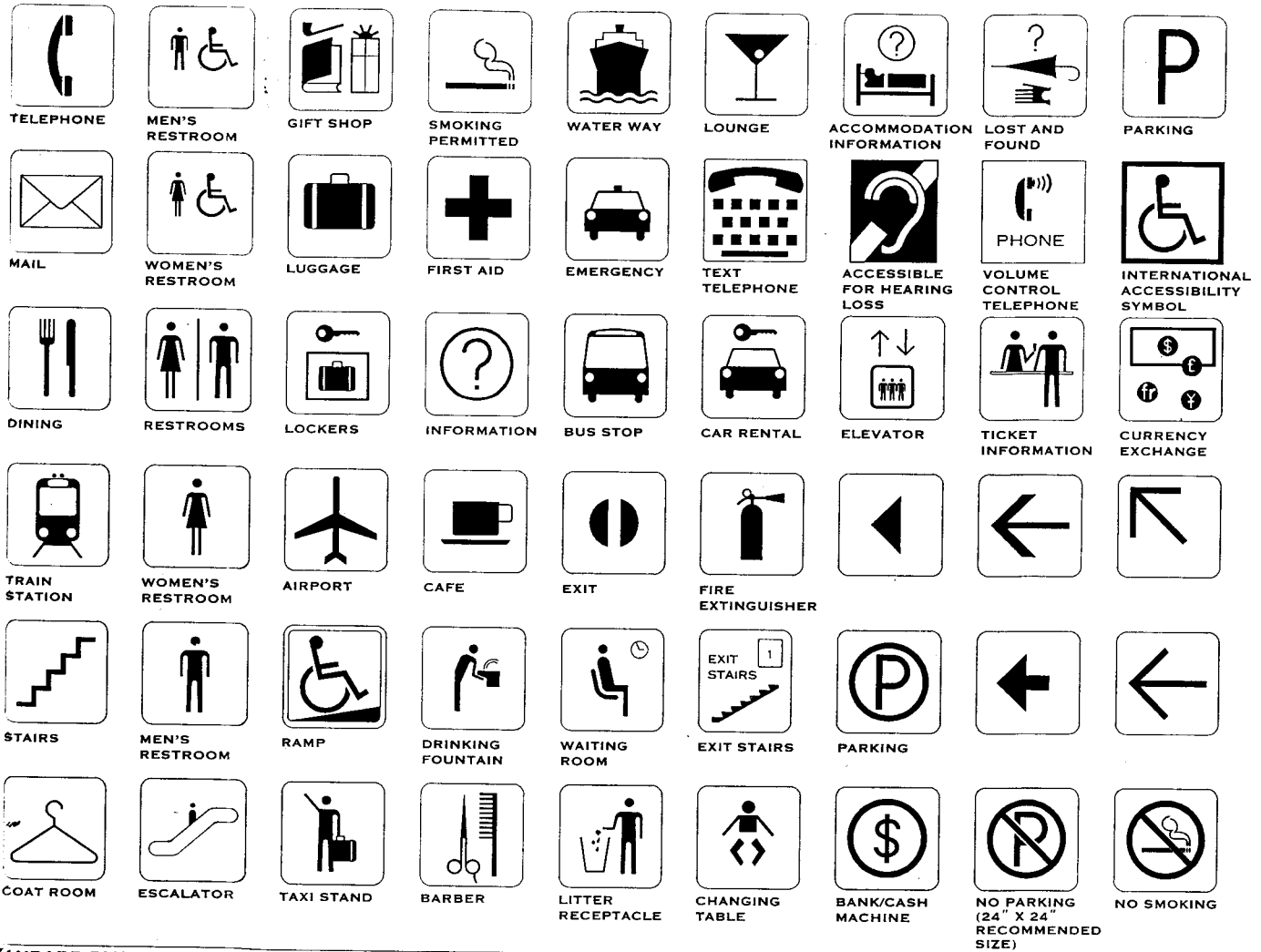

STANDARD PICTOGRAMS



HAZARD PICTOGRAMS

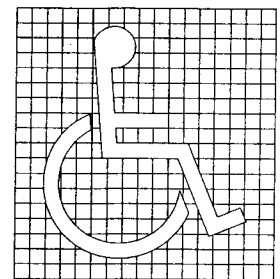

Proportions of the international symbol of accessibility  
SYMBOL OF ACCESSIBILITY

EMERGENCY/EGRESS/PROHIBITORY SIGNS

Mar Knapp Crawfis Association, Inc.; Mansfield, Ohio  
10 IDENTIFYING DEVICES

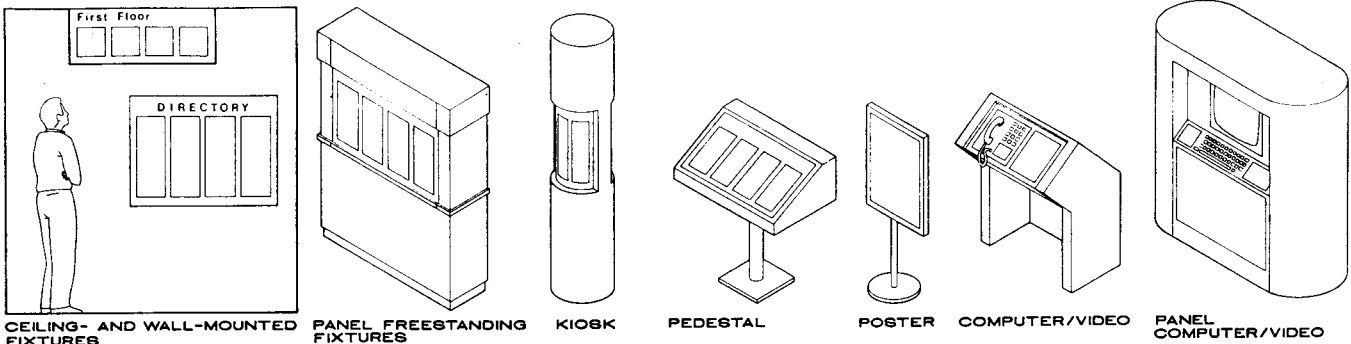

DIRECTORIES/ORIENTATION MAPS/INFORMATION SYSTEMS

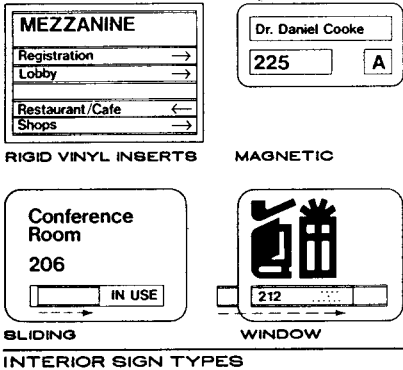

INTERIOR SIGN TYPES

ACCESSIBLE SIGNAGE FOR PERSONS WITH DISABILITIES

1. Accessible signs should identify permanent rooms and spaces, including room numbers, emergency exits, and toilet facilities. If room numbers are not used, signs such as "Cafeteria" must be accessible.
  - a. Letters and numerals: raised 1/32 in. minimum, uppercase, sans serif, 3/8 to 2 in. in height, and accompanied by grade 2 Braille.
  - b. Pictogram borders should be at least 6 in. high.
  - c. Surfaces should have a nonglare finish; level of sheen must be "eggshell" or less.
  - d. Provide contrast between the characters and background.
  - e. Mounting: 60 in. above finished floor to centerline of sign, preferably on the latch side of door or the closest wall space. Do not mount within the swinging path of a door or where a person cannot approach within 3 in. of the sign.
2. Directional and informational signs for permanent functional spaces (such as signs to auditoriums or elevators) should be accessible.
  - a. Character proportions should comply with ADAAG 4.30.2.
  - b. Characters should be at least 3 in. high; increase character height as viewing distance increases.
3. Identify such accessible features as assistive listening devices, parking, and text telephones. When not all such features are accessible, identify the accessible ones (e.g., toilet rooms and parking) and provide directional signage from inaccessible ones. Use pictograms at least 6 in. high accompanied by a verbal description.

GENERAL NOTES

EXTERIOR SIGNS

1. Identify entrance and exit of site and building, accessibility information, parking lot location, and facility identification.
2. Signs should be 6 ft 0 in. min. from face of curb, 7 ft 0 in. from grade to bottom of sign, and 100-200 ft from intersections.
3. Building signage materials: fabricated aluminum, illuminated plastic face, back lighted, cast aluminum, applied letter, die raised, engraved, and hot stamped.
4. Plaque and sign materials: cast bronze, cast aluminum, plastic/acrylic, stone (cornerstone), masonry, and wood.
5. For accessibility signage, designate building entrance access, identify parking areas, and direction to facilities. See ADAAG and state regulations for specific requirements.

DIRECTORIES AND MAPS

1. Locate these in main entrances and/or lobbies with appropriate information for persons with disabilities.
2. Place directory information adjacent to "You are here" information.
3. Directories should be placed in stair/elevator lobbies of each floor.
4. Mounting choices: surface mounted, semirecessed, full recessed (flush), cantilevered, chain suspended, rigidly suspended, mechanically fastened, or track mounted.

INTERIOR SIGNS

1. Lightweight freestanding signs should not be used in high-traffic areas. Use when specific location/information maneuverability is required.
2. Electronic, computer, and videotex technologies can provide an innovative and highly flexible directory/sign display system for mapping and/or routing, information (facility and local), advertisement and messages, and management tie-in capabilities.
3. Where changeability and flexibility is a design priority, a modular system is recommended. Rigid vinyl, aluminum, and acrylic inserts as well as magnetic systems may be used.
4. For maximum ease of reading interior signs, any given line in a sign should not exceed 30 characters in width, including upper and lower case letters and spaces between words.
5. Choose the height and "weight" of letter styles and symbols for readability. Consider background materials and contrast when choosing a color scheme.
6. Permanent mounting:
  - a. Vinyl tape/adhesive backing, usually factory applied.
  - b. Silastic adhesive, usually supplied with vinyl tape strips to hold sign in place until adhesive cures.
  - c. Mechanically fastened; specify hole locations.
7. Semipermanent: vinyl tape square can be used on inserts.
8. Changeable: dual-lock mating fasteners, magnets, magnetic tape, or tracks may be used.

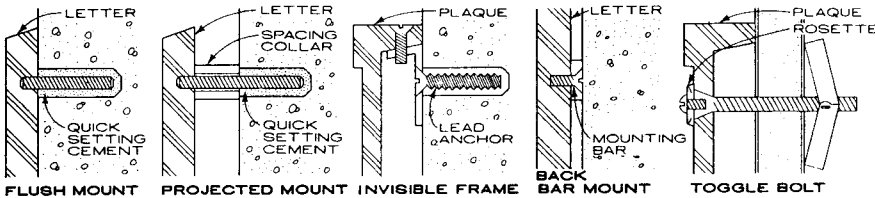

MOUNTING METHODS/MATERIALS

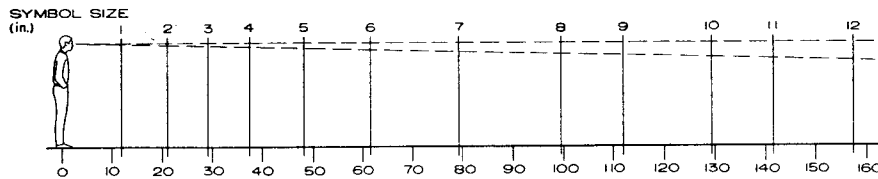

SYMBOL READABILITY

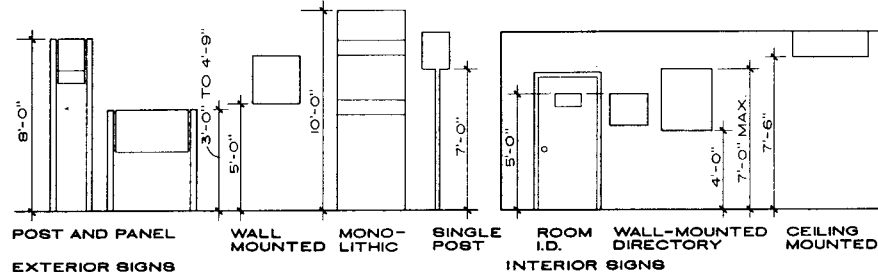

EXTERIOR SIGNS MOUNTING HEIGHTS

Marr Knapp Crawfis Associates, Inc., Mansfield, Ohio  
Richard J. Vitullo, AIA, Oak Leaf Studio; Crownsville, Maryland

GENERAL NOTES

- Construction of locker frame and door typically is of 16 gauge steel for sides and back. Top and bottom are typically 20 to 24 gauge steel. Finishes vary. Number plates, a shelf, and coat hooks on back and side walls are generally included. Other construction such as plastic laminate and wood is also used for club facilities.
- Door types may be solid, perforated (all or part), or louvered (all or part), and ordered in a variety of steel mesh patterns or in special finishes. Doors and locks may be provided with noise-deadening de-

- Locking mechanisms include built-in adjustable combination lock, built-in flat or grooved key, and latching locker handle (for padlock use). All locking mechanisms are available for surface or recessed applications.
- Optional locker equipment includes sloping top for nonrecessed locations with corner miters available, 6 in. legs for open base installation, interior partitions (some models), multiple shelves, coat rods (for models over 18 in. deep), closed base and closed-end base for legs, and attachable bench elements.

- Ventilation within locker spaces should provide 15 cu ft/min. air movement for locker.
- Handicapped user access may suggest use of some multiple tier lockers; shelf and coat hooks on single tier lockers are out of reach of most handicapped.
- Bench arrangements may be attached to locker front or may be freestanding and require a raised installation. Finishes of lockers may be varied as conditions dictate such as stainless steel bottoms or sides when used in areas where long-term chemical contamination may affect finishes.

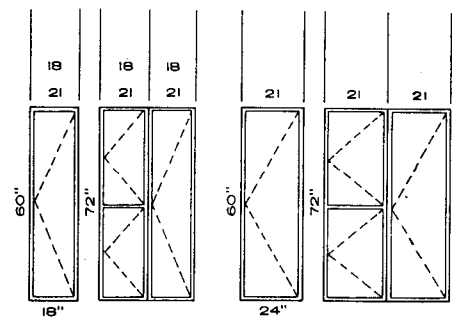
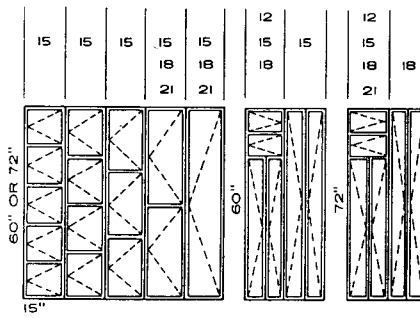
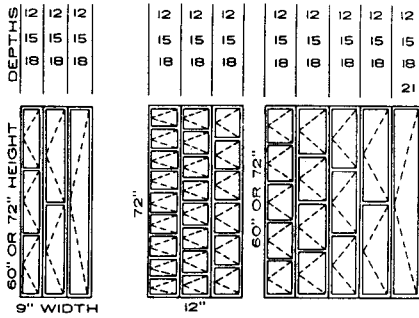

ELEVATIONS

LOCKERS

Checking lockers for heavy duty use are available in enameled steel or stainless steel. Locks are provided with built-in multiple coin selector, which is owner adjustable for coins, tokens, or "free" operation. They may be installed on legs or recessed and may be made movable. Overall height is 6 ft 0 in. on most models, 5 ft 0 in. on some.

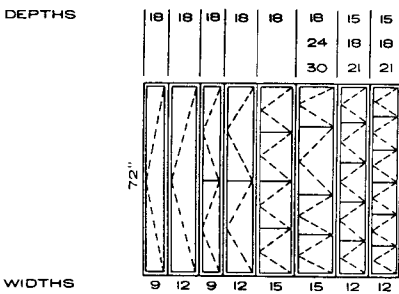

ELEVATION

CHECKING LOCKERS

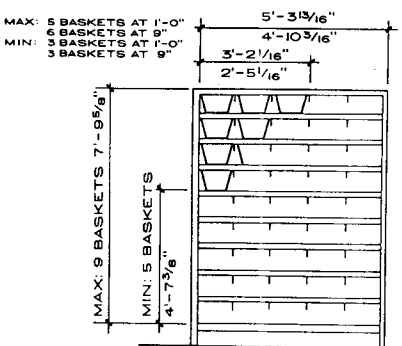

ELEVATION

BASKET RACKS

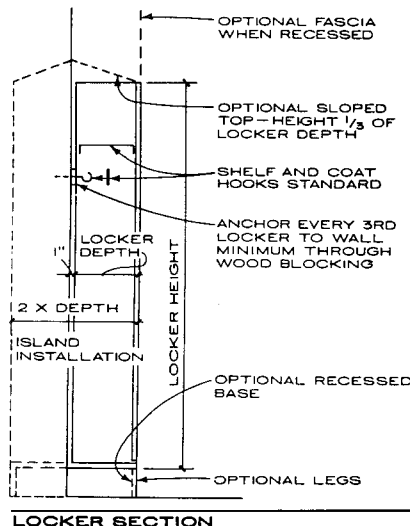

LOCKER SECTION

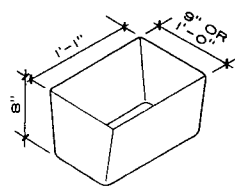

LOCKER BASKET

Basket racks may be arranged in single tier or back to back. Single tier depth is 1 ft 1 1/4 in. Optional pilfer guards may be installed on sides, top, and bottom, preventing access into adjacent baskets, and should be considered at the back as well. Basket materials include wire mesh (all surfaces), perforated steel ends and mesh sides and bottom, and louvered ends with perforated steel sides and bottom.

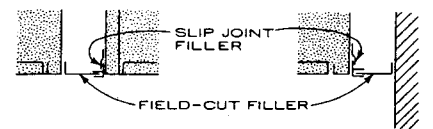

FILLER PIECE

FLUSH WALL JOINT

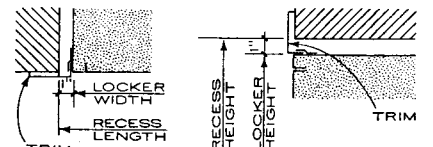

JAMB

HEAD AT FASCIA

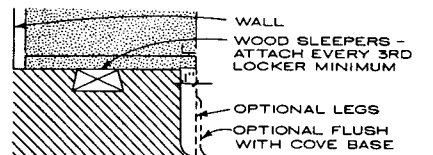

RECESSED/FLUSH BASE AT WALL

2 WOOD SLEEPERS REQUIRED FOR ISLAND INSTALLATION  
 ATTACH EVERY 3RD LOCKER FOR DOUBLE  
 ATTACH EVERY 2ND LOCKER FOR SINGLE

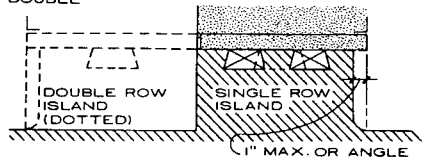

RECESSED/FLUSH BASE AT ISLAND  
 INSTALLATION DETAILS

Frederick C. Krenson, AIA; Rosser Fabrap International; Atlanta, Georgia

10 LOCKERS

**GENERAL**

Portable fire extinguishers can serve as a first line of defense against fires of limited size, even property equipped with automatic sprinklers or other fixed protection equipment. The following are criteria for selecting fire extinguishers:

1. Type and severity (size, intensity, and speed of travel) of potential fire hazard.
2. Environmental conditions of potential fire hazard (ambient temperature conditions, presence of fumes, etc.).
3. Effectiveness of extinguisher on potential fire hazard.
4. Ease of use.
5. Suitability for its environment.
6. Any anticipated adverse chemical reactions between the extinguishing agent and the burning materials.
7. Any health and operational safety concerns (exposure of operators during fire control efforts).
8. Training and physical capabilities of available personnel to operate extinguisher.
9. Upkeep and maintenance requirements.

**NOTES**

1. To comply with the Americans with Disabilities Act of 1990, fire extinguishers that protrude more than 4 in. into walks, halls, corridors, passageways, or aisles must be recessed into the wall.
2. The authority with jurisdiction over the location dictates

the number, type, and placement of fire extinguishers and fire extinguisher cabinets.

3. All extinguishers without wheels must be installed on hangers or brackets, mounted in cabinets, or set on shelves. Extinguishers weighing up to 40 lb should be no more than 5 ft above the floor. The top of extinguishers with a gross weight greater than 40 lb should be no more than 3 ft 6 in. above the floor.
4. Halon-type extinguishers are no longer manufactured as a result of an international environmental agreement.
5. These standards and classifications are taken from the National Fire Protection Association Publication 10, *Portable Fire Extinguishers*, 1994 ed. Always check local code requirements before specifying fire extinguishers.







**CLASSIFICATION OF OCCUPANCIES BY HAZARD TYPE**

1. **LIGHT (LOW) HAZARD:** Light hazard occupancies have few Class A combustible materials, including furnishings, decorations, and contents. This may include offices, classrooms, churches, or hotels.
2. **ORDINARY (MODERATE) HAZARD:** Ordinary hazard occupancies have more Class A combustibles and Class B flammables in light hazard occupancies. They include certain dining areas, mercantile shops, and research operations.
3. **EXTRA (HIGH) HAZARD:** Places with more Class A combustibles and Class B flammables than ordinary hazard occupancies present are extra hazard occupancies. Likely locations include woodworking, vehicle repair, and paint shops and cooking areas.

**DISTRIBUTION OF FIRE EXTINGUISHERS**

The minimum number of fire extinguishers needed to protect a property from Class A fires is determined by the accompanying tables; frequently, additional extinguishers are installed. Fire extinguishers rated for Class B fires are placed a maximum travel distance of 50 ft from the hazard (smaller rated extinguishers are placed no more than 30 ft from the hazard). Fire extinguishers rated for Class C fires shall be required in locations with energized electrical equipment that would require a nonconducting extinguishing medium. For Class D fires, extinguishers are located not more than 75 ft from the Class D hazard.

**FIRE CLASSIFICATIONS FOR SELECTING FIRE EXTINGUISHERS**

LETTER SYMBOL AND COLOR	PICTURE SYMBOL	DESCRIPTION
Green 		Class A: Fires involving ordinary combustible materials (such as wood, cloth, paper, rubber, and many plastics) that require the heat-absorbing (cooling) effects of water or water solutions, or the coating effects of certain dry chemicals that retard combustion.
Red 		Class B: Fires involving flammable or combustible liquids, flammable gases, greases and similar materials that are best extinguished by excluding air (oxygen), inhibiting the release of combustible vapors, or interrupting the combustion chain reaction.
Blue 		Class C: Fires involving energized electrical equipment where safety to the operator requires the use of electrically nonconductive extinguishing agents.
Yellow 		Class D: Fires involving combustible metals (such as magnesium, titanium, zirconium, sodium, lithium, and potassium).

**FIRE EXTINGUISHER SIZE AND PLACEMENT FOR CLASS A HAZARDS**

	LIGHT HAZARD OCCUPANCY	ORDINARY HAZARD OCCUPANCY	EXTRA HAZARD OCCUPANCY
Min. rated single extinguisher	2-A <sup>1</sup>	2-A <sup>1</sup>	4-A <sup>2</sup>
Max. floor area per unit of A	3,000 sq ft	1,500 sq ft	1,000 sq ft
Max. floor area for extinguisher	11,250 sq ft	11,250 sq ft	11,250 sq ft
Max. travel distance to extinguisher	75 ft	75 ft	75 ft

<sup>1</sup> Up to two water-type extinguishers with 1-A rating can be used to fulfill the requirements of one 2-A rated extinguisher for light hazard occupancies.

<sup>2</sup> Two 2 1/2 gallon (9.45 L) water-type extinguishers can be used to fulfill the requirements of one 4-A rated extinguisher.

**MULTIPURPOSE DRY CHEMICAL (CLASS A, B, AND C FIRES)**

Capacity (lb)	2 1/2	5	6	10	20
Height (in.)	14	14 1/2	16	20	24
Diameter (in.)	3	4 1/4	5	5	7
Class	1A:10B:C	2A:10B:C;3A:40B:C	3A:40B:C	4A:60B:C	20A:120B:C
Effective range	10 to 20 ft				
Discharge time	5 lb, 10 sec; 10 lb, 11 sec; 20 lb, 15 sec; 30 lb, 15 sec				
Recharge	After use				
Pressure source	Compressed gas				
Temperature effect	Will operate at - 65°F				
Electrical conductivity	Will not conduct				

NOTE: Fluidized and siliconized monoammonium phosphate powder is dispersed, smothers and breaks chain reaction of fire.

**CARBON DIOXIDE (CLASS B AND C FIRES ONLY)**

Capacity (lb)	5	10	15	20
Height (in.)	17 3/4	24	30	30
Diameter (in.)	5 1/4	7	7	8
Class	5B:C	10B:C	10B:C	10B:C
Effective range	3 to 8 ft			
Discharge time	2 1/2 lb, 12 sec; 5 lb, 22 sec; 10 lb, 23 sec; 15 lb, 26 sec; 20 lb, 25 sec			
Recharge	After use			
Pressure source	Compressed gas			
Temperature effect	Will operate at - 40°F			
Electrical conductivity	Will not conduct			

NOTE: Pressurized liquid carbon dioxide is released, changed into a gas, and appears as a cloud of white "snow," smothering fire.

**REGULAR DRY CHEMICAL (CLASS B AND C FIRES)**

Capacity (lb)	2 1/2	5	1/2	6	10	20
Height (in.)	14 1/8 to 14 5/8	14 5/8 to 15 1/4	14 5/8 to 15 1/4	15 1/2 to 16 1/4	20 to 20 1/2	23 1/4 to 24
Diameter (in.)	3	4 1/4	4 1/4	5	5 to 6	7
Class	10B:C	10B:C	40B:C	40B:C	60B:C	120B:C
Effective range	10 to 20 ft					
Discharge time	5 lb, 10 sec; 10 lb, 11 sec; 20 lb, 15 sec; 30 lb, 34 sec					
Recharge	After use					
Pressure source	Compressed gas					
Temperature effect	Will operate at - 40°F					
Electrical conductivity	Will not conduct					

NOTE: A siliconized sodium bicarbonate base (the traditional dry chemical design) extinguishes fire. A base of potassium bicarbonate is also available.

**PRESSURIZED WATER**

Capacity (gal)	2 1/2
Height (in.)	24 1/2
Diameter (in.)	7
Weight (lb)	28
Class	2A
Effective Range	30 ft
Discharge time	50 seconds
Recharge	Weigh cylinder and check annually; in all cases, follow instructions on label
Pressure source	Compressed air
Temperature effect	Will freeze
Electrical conductivity	Will conduct

**NOTE**

Water quenches fire and cools area.

**SODIUM CHLORIDE**

Capacity (lb)	30
Height (in.)	27 3/4
Diameter (in.)	7
Class	FM
Effective range	4 to 6 ft
Discharge time	28 seconds
Recharge	After use
Pressure source	Compressed gas
Temperature effect	-40 to +120
Electrical conductivity	Will not conduct

**NOTES**

1. Sodium chloride dry powder is dispersed over a burning combustible metal or alloy; heat from fire causes dry powder to cake and form exterior crust that excludes air and dissipates heat.
2. For lithium and lithium alloy Class D fires, a copper-based extinguishing agent is used.



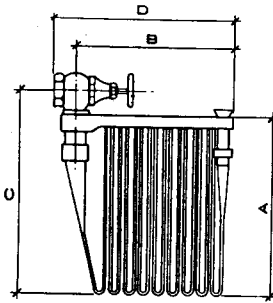

SWING RACK SEMIAUTOMATIC  
1 1/2" LINED HOSE

HOSE CAPACITY	25	50	75	100
A	10"	20"	24"	27"
B	15"	16"	19"	20"
C	14"	23"	27"	32"
D	17"	18"	20"	22"
WIDTH	4"	4"	4"	4"

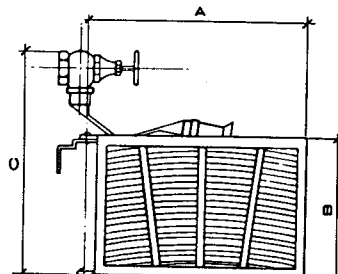

HUMP BACK SWING RACK  
1 1/2" AND 2 1/2" LINED HOSE

HOSE CAPACITY	50	100	150	200
A	30"	30"	34"	40"
B	17"	21"	28"	39"
C	30"	33"	40"	50"
WIDTH 1 1/2" HOSE	4"	4"	4"	4"
WIDTH 2 1/2" HOSE	6"	6"	6"	6"

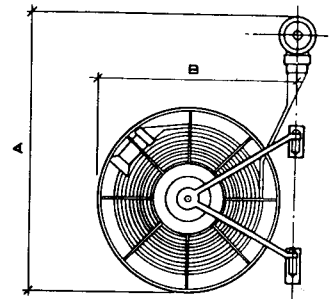

SWING REEL  
1 1/2" AND 2 1/2" LINED HOSE

HOSE CAPACITY	50	100	150
A	38"	38"	36"
B	21"	27"	31"
WIDTH 1 1/2" HOSE	4"	4"	4"
WIDTH 2 1/2" HOSE	6"	6"	6"

**FIRE HOSE RACK AND REELS**

**NOTE**

Recommended hose size for use with building standpipes should not exceed 1 1/2 in. in diameter and 100 ft in length. A larger hose used by amateurs is likely to tangle, cause excessive water damage, and create injuries.

A connection for 2 1/2 in. hose should be available to each station for the use of firemen. Many codes require 2 1/2 in. outlets at all standpipes.

By using a reducing coupling 1 1/2 in. hose can be attached. When a 2 1/2 in. stream is required the coupling may be removed. Industrial installations use 2 1/2 in. hoses and train personnel in the use of the heavier equipment. Valves may be located 5 ft 6 in. above floor (check local code).

Lined synthetic fiber plastic hose is recommended for use on standpipe installations. Cotton rubber lined

hose is standard for fire department and heavy equipment hose.

Tables show rack and reels for 1 1/2 and 2 1/2 in. lined hose only. Consult manufacturer's literature for rack and reel dimensions when other types and sizes of hose are used.

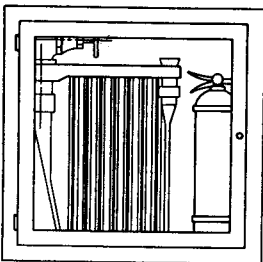

75' 1 1/2" LINED HOSE, RACK, AND ANGLE VALVE; 2 1/2 GAL EXTINGUISHER  
2'-9" x 2'-9" x 8 1/2" TO 2'-11" x 2'-11" x 9"

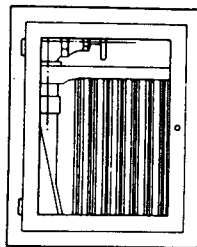

75' 1 1/2" LINED HOSE, RACK, AND ANGLE VALVE  
1'-9" x 2'-5" x 8" TO 1'-4" x 2'-7" x 8 1/2"

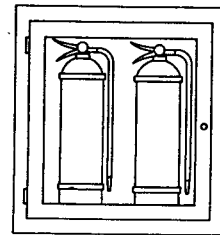

TWO 2 1/2 GAL EXTINGUISHERS  
1'-11" x 2'-9" x 7" TO 2'-2" x 2'-11" x 8"

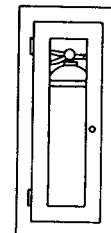

ONE 2 1/2 GAL EXTINGUISHER  
1'-0" x 2'-6" x 8" TO 1'-4" x 2'-7" x 8 1/2"  
NOTE: RESIDENTIAL EXTINGUISHER CABINET 1'-5" x 7" x 2"

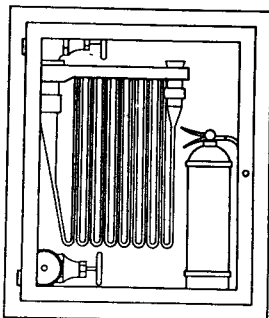

75' 1 1/2" LINED HOSE AND RACK; 1 1/2" AND 2 1/2" ANGLE VALVE; 2 1/2 GAL EXTINGUISHER  
2'-9" x 3'-4" x 8 1/2" TO 2'-10" x 3'-7" x 9"

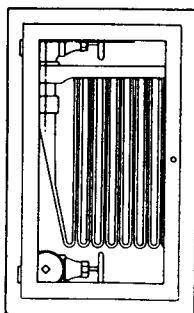

75' 1 1/2" LINED HOSE AND RACK; 1 1/2" AND 2 1/2" ANGLE VALVE  
1'-11" x 3'-3" x 8 1/2" TO 2'-4" x 3'-4" x 9"

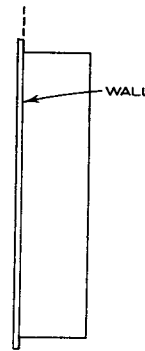

RECESSED

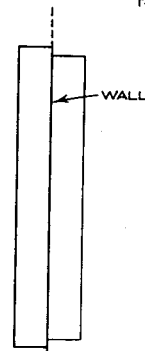

SEMIRECESSED

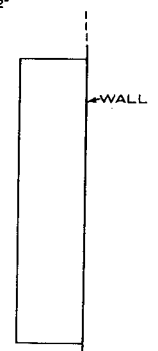

SURFACE MOUNTED

**FIRE HOSE AND EXTINGUISHER CABINETS**

**NOTE**

Cabinets are #18 gauge steel with glass doors as shown or with doors of metal, wood, mirror, and so on.

Consult manufacturer's literature for cabinets with special features such as revolving door, twin doors, pivoting door with attached extinguisher, and curved door.

Cabinets are obtainable for 25, 50, 75, and 100 ft hose racks. Rough dimensions are shown.

William G. Miner, AIA, Architect; Washington, D.C.

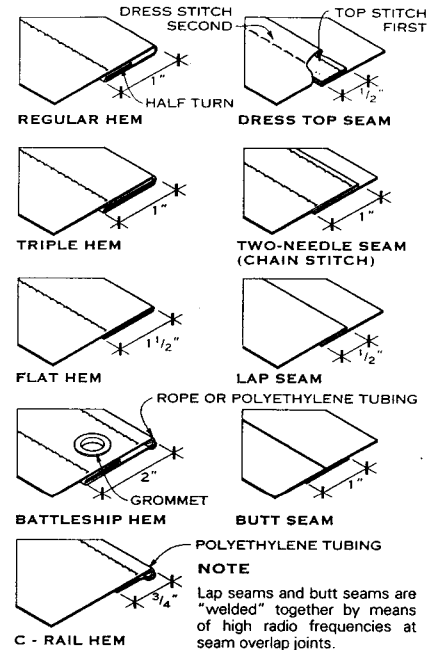
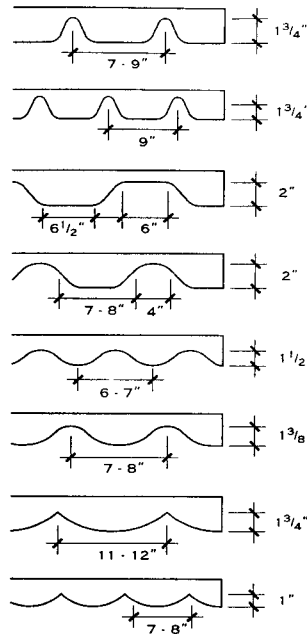
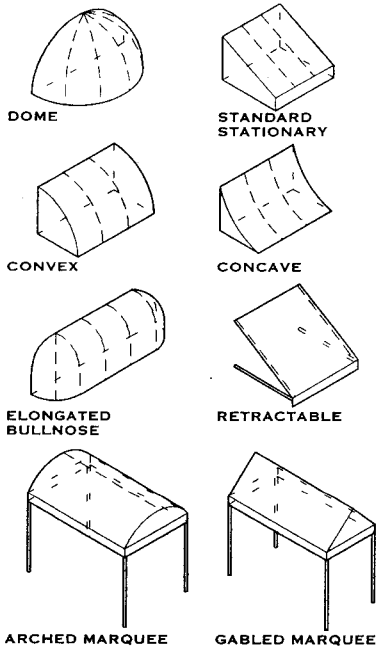

CANOPY AND AWNING SHAPES

VALANCE EDGE TYPES

FABRIC-TO-FABRIC SEAM AND HEM DETAILS

AWNING FABRIC CHARACTERISTICS

GENERAL CLASSIFICATION	PAINTED ARMY DUCK	VINYL COATED COTTON	VINYL LAMINATED POLYESTER	SOLUTION DYED ACRYLIC	VINYL COATED POLYESTER	ACRYLIC COATED POLYESTER	VINYL COATED POLY COTTON BLEND	SOLUTION DYED MODACRYLIC
Description	Acrylic painted cotton duck fabric	Vinyl coated on cotton duck fabric	Tri-layer fabric; top and bottom layers are vinyl, middle layer is a woven polyester	Woven fabric, made of 100% acrylic solution dyed fibers with a fluorocarbon finish	Vinyl coated on each side of polyester base fabric	Acrylic coated on each side of a polyester base fabric	Vinyl coated on each side of a 50% polyester base	Woven fabric made of 100% solution dyed modacrylic fiber with fluorocarbon finish
Typical weight	11 oz. per sq yd	15 oz. per sq yd	10 - 16 oz. per sq yd	9.25 oz. per sq yd	11 - 17 oz. per sq yd	9.5 - 12.5 oz. per sq yd	13 oz. per sq yd	9.25 oz. per sq yd
Properties	Resistant to ultraviolet light, mildew, and water	Resistant to ultraviolet light, mildew, and water	Resistant to ultraviolet light, mildew, and water	Resistant to ultraviolet light, color degradation, water, and mildew	Resistant to ultraviolet light, mildew, and water. Cleanable	Resistant to ultraviolet light and mildew; water repellent	Resistant to ultraviolet light and mildew; water repellent	Resistant to ultraviolet light and color degradation; water repellent and resistant
Colors	Stripes or solids, primary colors, pastels, and some earth tones	Stripes or solids; all colors are available	Stripes or solids; primary colors and pastels	Wide variety: stripes and solids, primary colors, and earth tones	Solids; same color on both sides or solid on frost back	Predominantly solids with some stripes. Same color both sides	Solid colors; same color both sides	Solid colors and tweeds. Same color, both sides
Underside	Pearl gray, green, or pearl gray with floral print.	Solid pearl gray	Linen-like pattern, solid coordinating color to match topside or same color as top	Same as top surface	Same as top surface	Same as top surface	Same as top surface	Same as top surface
Surface	Matte finish, with linen-like visible texture.	Smooth, non-glare surface with little or no texture	Smooth or matte, with slight woven or linen-like texture	Woven texture.	Smooth, somewhat glossy top surface.	Surface is textured with cloth appearance.	Surface is textured.	Woven texture surface
Transparency level	Opaque	Opaque	Translucent, depending on color. Certain styles are formulated for backlighting and are highly translucent	Translucent, depending on color	Translucent, depending on color	Translucent, depending on color	Opaque	Translucent, depending on color
Abrasion resistance	Very good	Very good	Good. Base fabric is very strong	Good	Good	Very good	Very good	Good
Dimensional stability (stretch)	Very good	Very good	Very good	Good. Some shrinkage in cold weather, some stretch in hot weather	Stable	Very good	Very good	Good
Mildew resistance	Good. Not recommended for areas of high humidity	Good. Not recommended for areas of high humidity	Very good. Recommended for sustained high humidity.	Very good	Very good	Very good	Very good	Very good
Durability*	5 - 8 years	5 - 8 years	5 - 8 years	5 - 10 years	5 - 8 years	5 - 8 years	5 - 8 years	5 - 10 years
Flame resistance (FR)	Some colors are available with flame retardant treatment	Some colors are available with flame retardant treatment	All colors are flame resistant	Non-flame resistant	All colors are flame resistant	All colors are flame resistant	All colors are flame resistant	All patterns are flame resistant
Width	31 inches	31 inches	31 and 62 inches	46 and 60 inches	37 and 62 inches	31 and 62 inches	60 and 61 inches	46 inches

\*Depends on climate and proper care of fabric

Industrial Fabrics Association International; St. Paul, Minnesota  
Richard J. Vitullo, AIA; Oak Leaf Studio; Crownsville, Maryland

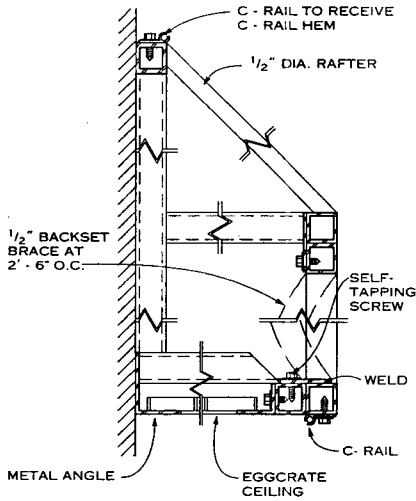
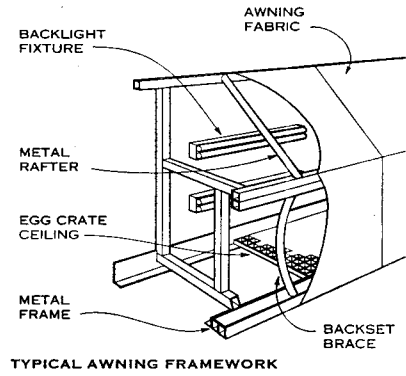

SECTION THROUGH AWNING FRAME

**FRAMEWORK DETAILS**

**FRAME CHARACTERISTICS**

GENERIC CLASSIFICATION	COMMON STANDARDS	YIELD STRENGTH (PSI)	MODULUS OF ELASTICITY (PSI)	REMARKS
Steel pipe	ASTM A53E ASTM A53S	35,000	29 x 10 <sup>6</sup>	Obtainable in black iron or galvanized. Nominal sizes are larger than equivalent nominal sizes for most tubing. Relatively thick walls. Available only in round shape.
Mild steel tubing	AISI 1018 AISI 1020 ASTMA513 Type 1 ASTM A135	32,000 35,000 - 44,000 32,000 30,000 - 35,000	29 x 10 <sup>6</sup>	Generally hot-rolled materials, which preserve ductility. Easily worked and welded. Must be painted or otherwise coated to provide corrosion protection. Can be obtained galvanized in certain sizes.
Aluminum tubing	6061 - T6 6063 - T6 6063 - T5	37,000 31,000 21,000	10 x 10 <sup>6</sup>	Note lower value for modulus of elasticity; this will produce larger deflections. Welded joints will cause materials to lose their heat treatment and result in locally reduced strength. Designer must take this into account. Good corrosion resistance. Lightweight. Available round, square, and rectangular.
Electrical metallic tubing	UL797		29 x 10 <sup>6</sup>	Difficult to specifically determine the steel properties since UL797 only requires that it be mild, ductile steel. Available only in round shape.
High-strength coated tubing (cold-formed)	ASTM A500 Gr. B.	46,000 - 52,000	29 x 10 <sup>6</sup>	Strong, relatively lightweight, thin-wall tubing with corrosion protection. Designer should take adequate account of the thin-wall characteristics, less ductile properties, and higher strength of the product as compared to mild steel tubing. Available in round or square shapes.
Stainless steel tubing	AISI Type 304	30,000 - 50,000	28 x 10 <sup>6</sup>	Excellent strength, corrosion resistance, and weldability.

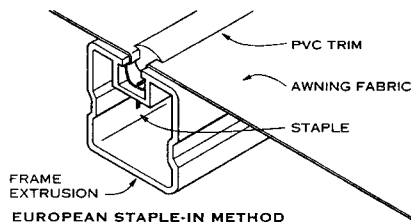
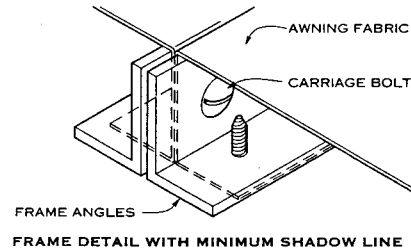
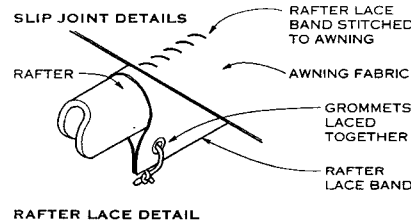
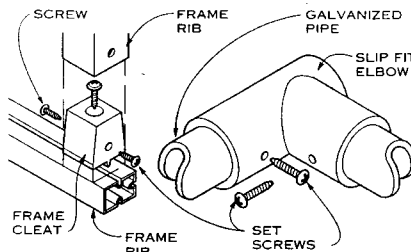

FRAMEWORK DETAILS

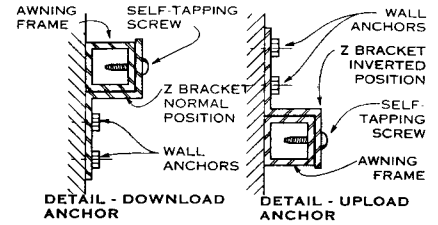

**NOTE**

Consideration should be given to alternating download (snow, wind, and material weight) and upload (wind) anchors on each awning frame. Provide blocking behind anchors as necessary.

**FIXED WALL ANCHORS**

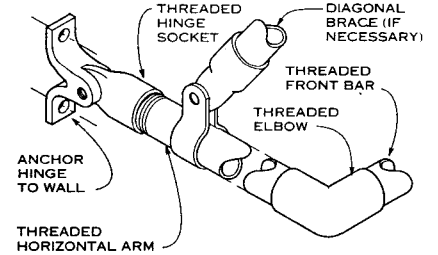

**THREADED FRAME DIAMETERS**

FRONT BAR SPAN LENGTHS	PIPE DIAMETERS
2'-0" to 4'-0"	3/8" (or 1/2" Solid)
4'-1" to 6'-0"	1/2"
6'-1" to 9'-6"	3/4"
9'-7" to 11'-6"	1"

**RETRACTABLE AWNING—HINGE DETAIL**

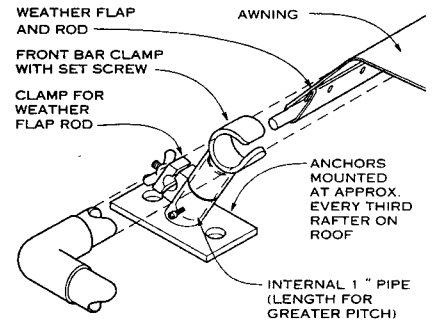

**FIXED AWNING—ROOF MOUNT DETAIL**

**NOTES**

1. Awnings and canopies are custom manufactured and engineered to provide sun and rain protection for windows, entrances, and walkways. They can be illuminated with backlighting or graphically embellished and used as signage as well.
2. Code requirements as well as design needs may determine the shape, size, graphics, materials, and lighting chosen. After lighting is installed, the underside of the awning or canopy is finished with a "ceiling," normally a prismatic glass, eggcrating, or an open weave vinyl coated polyester or other translucent fabric in order to hide the hardware and maximize light reflection.
3. Climatic conditions, wind and snow load requirements, and local design customs will affect the construction details of the awning or canopy framework systems.
4. A variety of methods are used to apply graphics to the awning, such as silk screening, hand painting, air brush, cut-out lettering, heat color transfer, pressure-sensitive graphics, and eradicating.
5. Slip fittings with set screws or direct tube-to-tube welding are the most common frame construction practices. Welded joints are more rigid, but shipping, assembly, and disassembly are easier and quicker with slip fitting joints.

Industrial Fabrics Association International; St. Paul, Minnesota  
Richard J. Vitullo, AIA; Oak Leaf Studio; Crownsville, Maryland

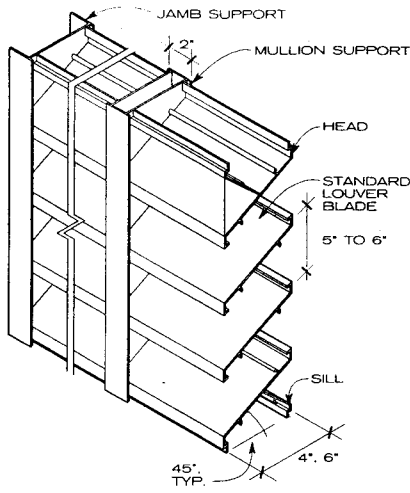

**NOTE**  
Generally, this is the most economical louver type.

**EXPOSED MULLION LOUVER**

**GENERAL NOTES**

1. Metal architectural louvers allow airflow through a wall for ventilation, especially of machine exhaust. They protect the interior space from vandalism, weather, insects, or birds and can be used to obscure unsightly views. Louvers can be fabricated in standard rectangles or custom shapes such as circles, triangles, and ellipses. Radiused corners and other details are available from some manufacturers. Penthouses frequently incorporate louvered walls to screen equipment and provide airflow.
2. Standard louver materials are 16-, 18-, or 20-gauge galvanized or cold-rolled steel and 8-, 12-, or 14-gauge extruded aluminum alloy. Other metals can be used for special applications. Translucent fiberglass is a standard blade material when daylighting is desirable. Fasteners are either aluminum or stainless steel. The dimensions shown are the most common; other sizes are available.

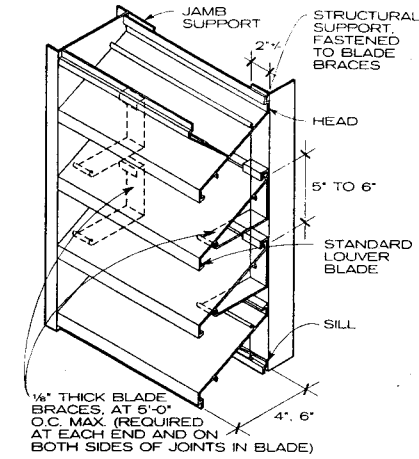

**NOTE**  
This louver type offers a visual line uninterrupted by exposed vertical supports.

**CONTINUOUS HORIZONTAL LOUVER**

3. Factory finishing is recommended for maximum control of color and durability. The finish for steel louvers is baked enamel, which comes in a variety of colors. Aluminum finishes include mill, clear lacquer, baked enamel, and anodic. Fluorocarbon polymeric finish coatings (kynar), which can be applied to steel or aluminum, resist chalking, ultraviolet deterioration, salts, chemicals, and pollutants.
4. Mechanically assembled extruded aluminum louvers are the most common type of louver assembly on the market. Mechanical fasteners are better than welding in extruded aluminum alloy construction because annealing occurs near the weld, weakening the material along both sides. Also, repairs are easier if mechanical fasteners are used.

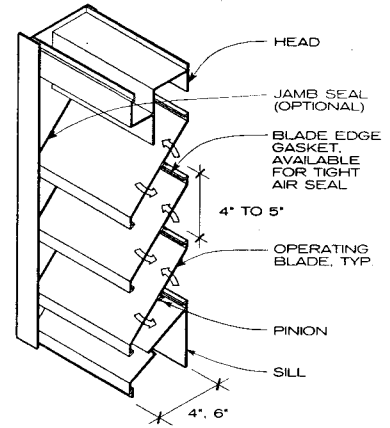

**NOTE**  
Adjustable operating louvers are available with manual, electric, or pneumatic actuators. Free area 38 to 58%.

**ADJUSTABLE OPERATING LOUVER**

5. With sheet metal, welding an assembly of louvers is easier and less expensive than using clip angles and screws to fasten the blades to the framework.
6. Free area is the net area of free airflow through a louver, generally measured in square feet or as a percentage of the area in the louver type selected. Manufacturers' free area ratings should include the effects of bird or insect screens, which reduce free area.
7. For all louvers servicing mechanical equipment, consult a mechanical engineer for design and specification of the louvers. Louvers are rated for air performance and water penetration and certified through the Air Movement and Control Association. The Building Services Resources and Information Association also rates the performance of metal louvers.

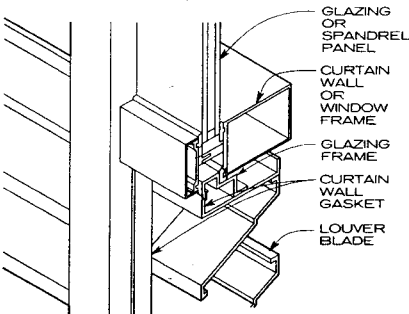

**LOUVER INSTALLATION IN CURTAIN WALL**

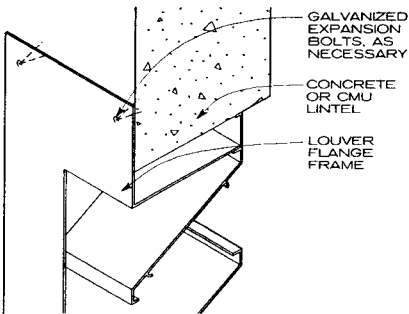

**FLANGE MOUNT DETAIL**

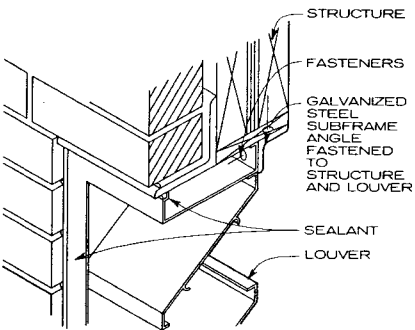
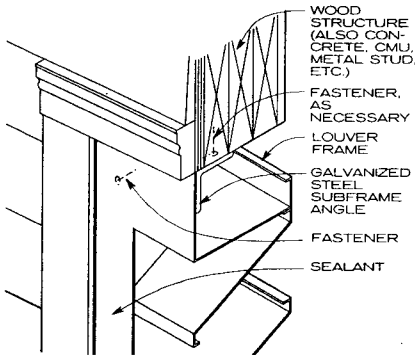

**ANGLE SUBFRAME DETAILS**

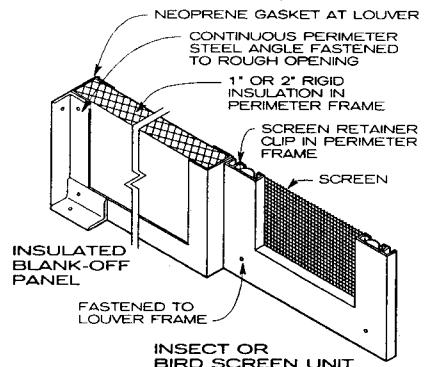

**INSECT OR BIRD SCREEN UNIT**

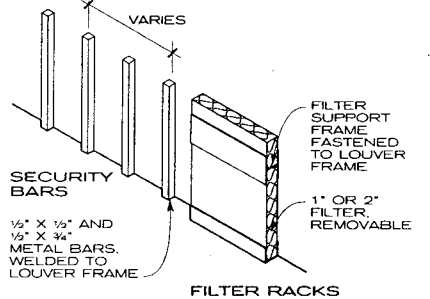

**MISCELLANEOUS LOUVER ACCESSORIES**

Richard J. Vitullo, AIA; Oak Leaf Studio; Crownsville, Maryland

**GENERAL**

Louver blades come in many shapes, sizes, and performance types that vary with the manufacturer; the blades illustrated here represent the basic types. Some blades are fixed only; others can be opened and shut. The center-to-center dimensions given are approximate; generally, standard blades (not specialty blades such as acoustic, air-foil, etc.) are designed with minimal overlap so they can obstruct views but maximize the free area.

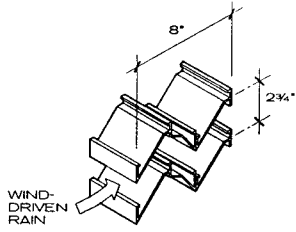

**NOTE**

Louvers utilizing this blade design completely obscure views and are tamperproof and storm-resistant. This blade prevents nearly 100% of wind-driven rain from entering (generally tested with winds up to 30 mph for one hour).

**HORIZONTAL STORM-RESISTANT BLADE**

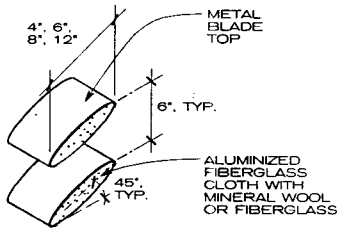

**NOTE**

Acoustically insulated air-foil blades block sound from inside or out and accommodate high air velocities. Free area is 29%; blades may be fixed or operable.

**FIXED AIR-FOIL ACOUSTICAL BLADE**

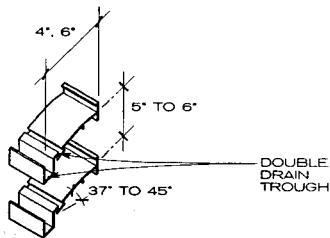

**NOTE**

This blade type provides high water resistance and a free area of about 50%. Typically employed in louvers with jamb and mullion drains, it is not designed to protect against wind-driven rain.

**DOUBLE DRAINABLE LOUVER BLADE**

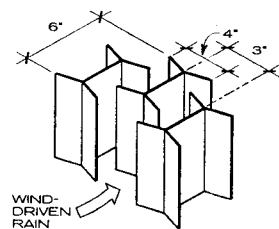

**NOTE**

Louvers utilizing this blade design completely obscure views and are tamperproof and completely stormproof.

**VERTICAL STORM-RESISTANT BLADE**

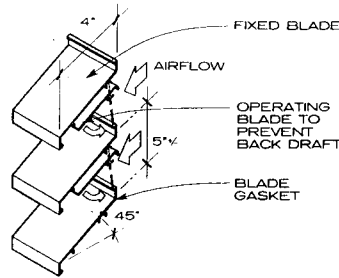

**AUTOMATIC EXHAUST DAMPER/LOUVER**

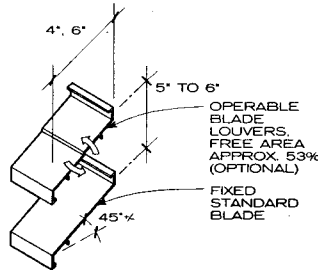

**NOTE**

Standard blades are suitable for most applications where water infiltration is not a concern. Free area is approximately 48%. Single operating panels should not exceed 48 in. wide x 96 in. high. This blade can be either fixed or operable.

**STANDARD BLADE**

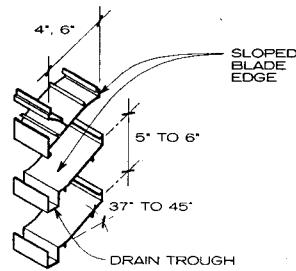

**NOTE**

Designed to provide high free area (55%) and low water penetration, this blade is not recommended for use with hidden mullions; louvers that employ these blades contain integral drains in their mullions that direct water away from the inside of the louver. All drain troughs must be kept free of debris. Not designed to hinder wind-driven rain.

**HIGH-PERFORMANCE DRAINABLE BLADE**

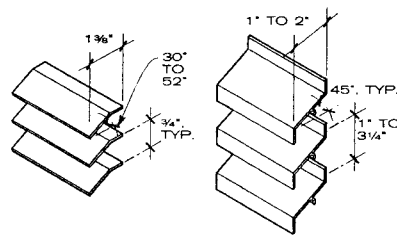

**NOTE**

These shallow louver blades can allow a very high free area (from 32 to 73%). They are often used when standard-depth louvers are not practical.

**SHALLOW AIR CONDITIONING BLADE**

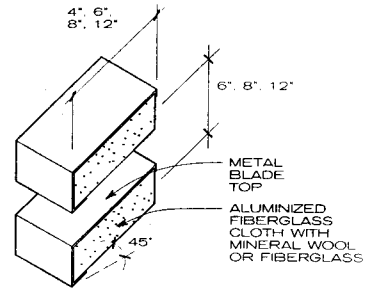

**NOTE**

Acoustically insulated blades block sound from inside or out and prevent weather infiltration. Free areas range from 21 to 29%. Blades may be fixed or operable.

**FIXED ACOUSTICAL LOUVER**

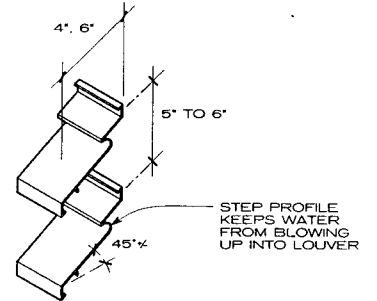

**NOTE**

Step blades help prevent water infiltration. Free area is approximately 48%.

**STEP BLADE PROFILE**

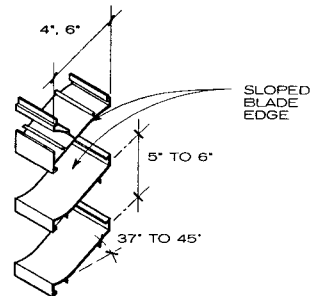

**NOTE**

Designed to provide a high free area (55%), this blade accommodates high air velocities and protects against wind-blown precipitation.

**HIGH-PERFORMANCE STANDARD BLADE**

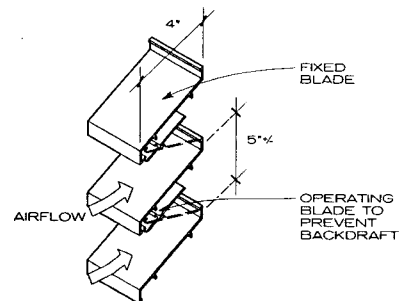

**AUTOMATIC INTAKE DAMPER/LOUVER**

Richard J. Vitullo, AIA; Oak Leaf Studio; Crownsville, Maryland

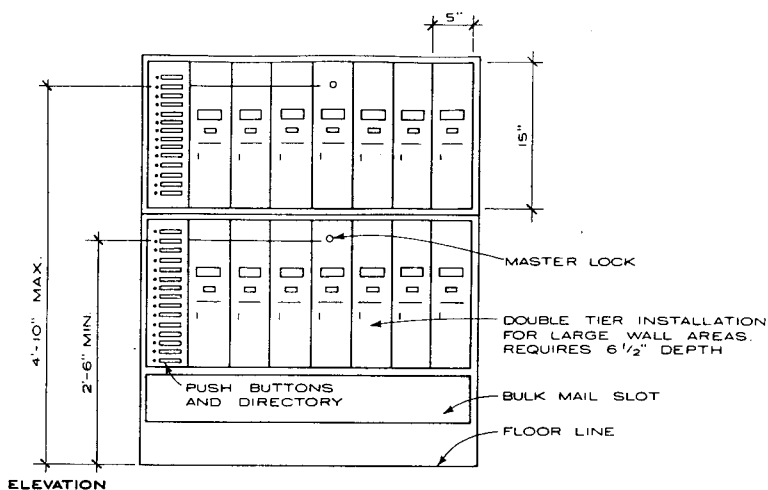

**VERTICAL COMPARTMENT TYPE**  
FRONT LOADING

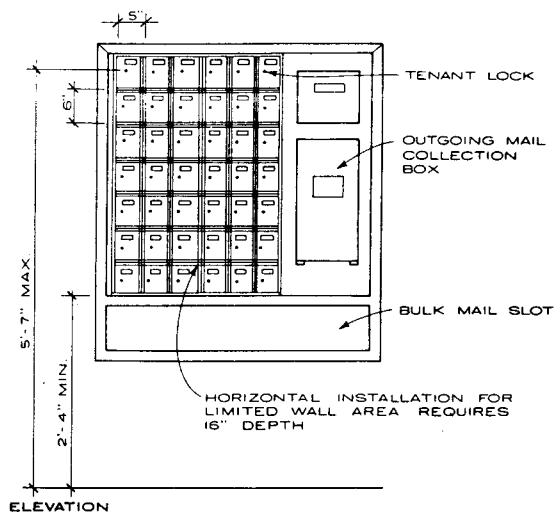

**HORIZONTAL COMPARTMENT TYPE**  
FRONT OR REAR LOADING

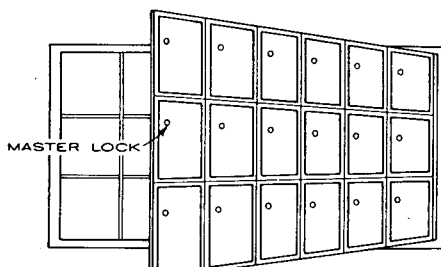
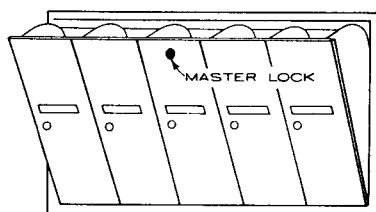

**VERTICAL (3 TO 7 BOXES PER LOCK)**    **HORIZONTAL (MAX. 35 BOXES PER LOCK)**  
**FRONT LOADING COMPARTMENTS WITH MASTER LOCK**

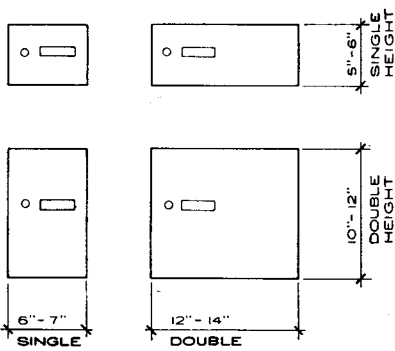

**COMPARTMENT SIZES**

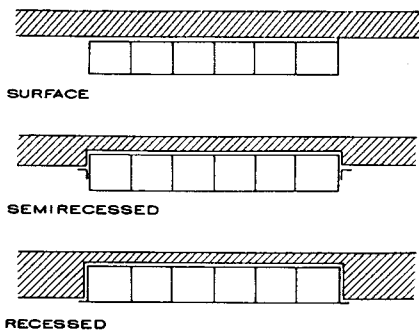

**MOUNTING TYPES**  
FRONT LOADED COMPARTMENTS

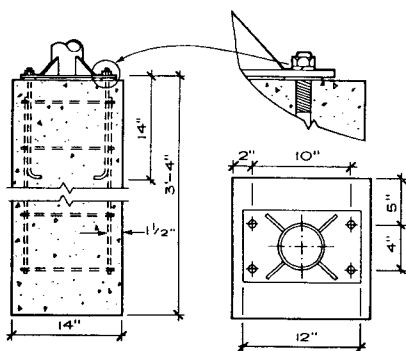

**FOUNDATION DETAILS OF**  
**PEDESTAL MOUNTED TYPE**

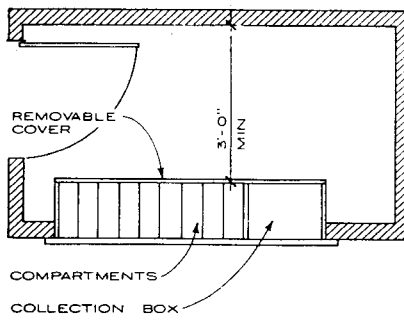

**MAILROOM PLAN**  
REAR LOADED COMPARTMENTS

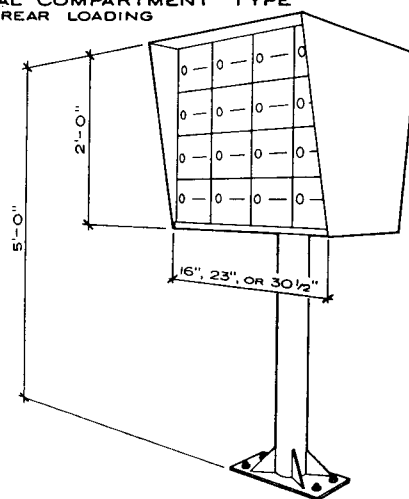

**PEDESTAL MOUNTED TYPE**

**GENERAL NOTES**

1. Postal Service approved mail receptacles are required for apartment houses containing three or more apartments with a common building entrance and street number.
2. Individual compartments should be large enough to receive long letter mail 4 1/2 in. wide and bulky magazines 14 1/2 in. long and 3 1/2 in. in diameter.
3. An outdoor installation should preferably be at least 15 ft from a street or public sidewalk, protected from driving rain, and visible from at least one apartment window.
4. All installations must be adequately lighted to afford better protection to the mail and enable carriers to read addresses on mail and names on boxes.
5. A directory, in alphabetical order, is required for installations with more than 15 compartments.
6. Each compartment group is supplied with mounting hardware for master lock.
7. One mailbox door is required for the Postal Service master lock and cannot be used for mail distribution.
8. Call buttons with telephone can be integrated into frame with mailboxes.
9. Depending on occupancy, a certain number of compartments shall be assigned to persons using wheelchairs. Key slots shall be no more than 48 in. from floor. Consult ADAAG and local codes for other requirements.
10. Use of collection boxes is subject to approval by local offices of the United States Postal Service.

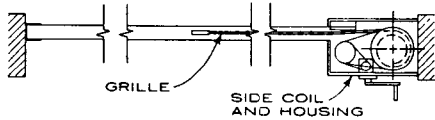
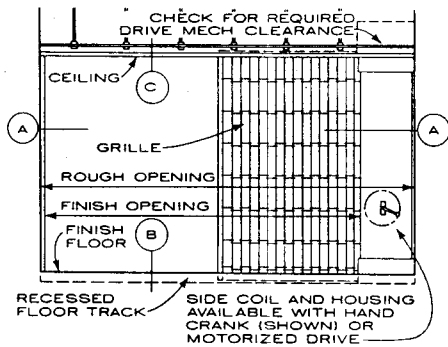

SECTION A-A

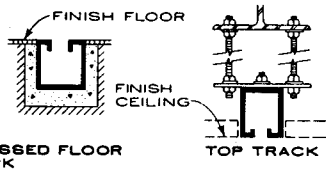

RECESSED FLOOR TRACK

SECTION B

SECTION C

RETRACTABLE GRILLE PARTITIONS

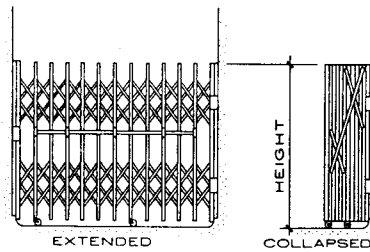

SINGLE FOLDING GATE, WITH FOLDING BRACE BAR, GATE HINGED WITH CASTERS AT FLOOR

BOSTWICK TYPE

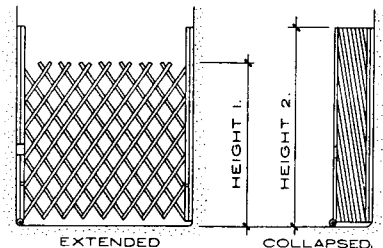

SINGLE FOLDING GATE, HINGED WITH CASTER AT FLOOR

LAZY TONG TYPE

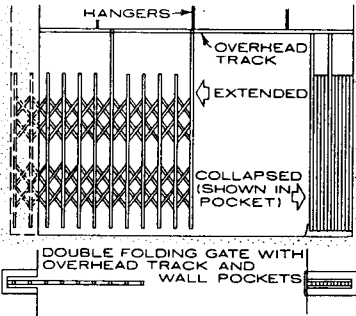

DOUBLE FOLDING GATE WITH OVERHEAD TRACK AND WALL POCKETS

DEEP POCKET TYPE

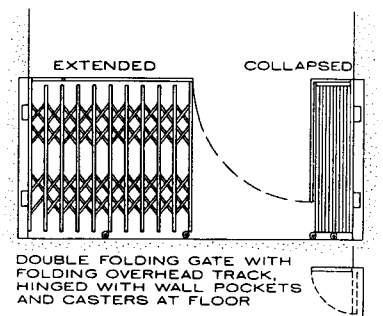

DOUBLE FOLDING GATE WITH FOLDING OVERHEAD TRACK, HINGED WITH WALL POCKETS AND CASTERS AT FLOOR

SHALLOW POCKET TYPE

FOLDING GATES

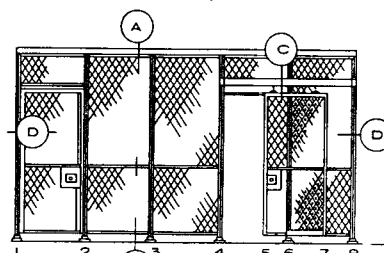

LOW TYPE UP TO 10'-0"

HIGH TYPE OVER 10'-0"

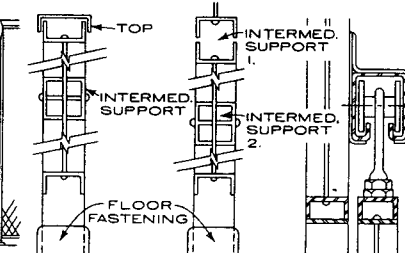

SECTION A-A

SECTION B-B

SECTION C

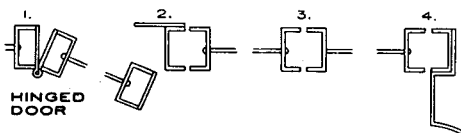

HINGED DOOR

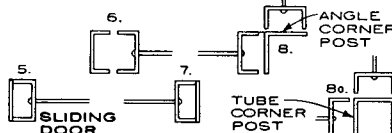

SLIDING DOOR

SECTION D-D

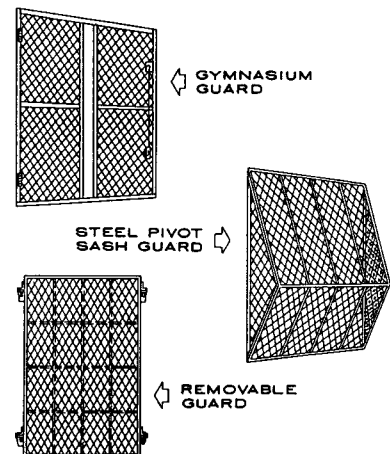

WINDOW GUARDS

RECOMMENDED USES FOR WIRE MESH PARTITIONS

MESH	PATTERN	WIRE SIZE	FRAMES	USES
1 1/4"	◇ □	11	1" C	Animal cages
1 1/2"	◇ □	10	1" C	Elevator shafts
1 3/4"	◇ □	9	1 1/4" C	Fire escapes
2"	◇ □	8	1 1/2" C	Cashier cages
2"	◇ □	6	1 1/4" "C"	Runways
			Channel 3/4" C	Stair enclosures Locker rooms Departmental divisions Stock rooms Tool rooms

OTHER USES FOR WOVEN WIRE MESH

MESH	PATTERN	WIRE SIZE	FRAMES	USES
3/4"	◇ □	12	5/16" O 3/4" C 1" L	Air intake screens Bird screens
1"	◇ □	12	3/8" O 1" C 1" L	Basement window guards Shelves and trays Skylight guards
1 1/2"	◇ □		3/8" O 1" C	Door and window guards
2 1/4"	◇ □	7	7/16" O	Wire roof signs
2 1/2"	◇ □	6	1 1/2" C	Fencing gratings

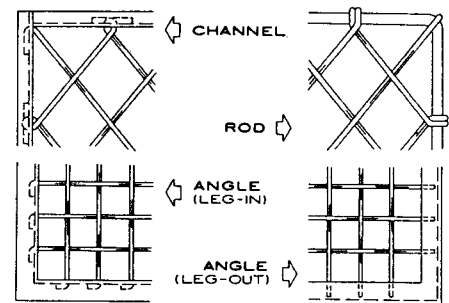

TYPES OF FRAMES AND WOVEN WIRE MESH

WIRE MESH PARTITIONS

HMC Group; Ontario, California

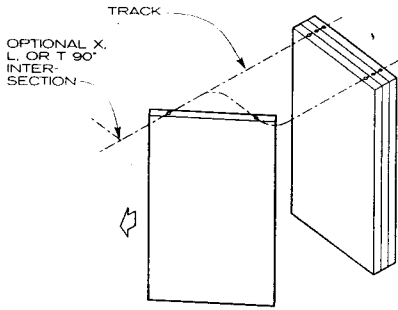

**INDIVIDUAL PANELS**  
**NOTE**

This manually operated system is for panels more than 16 ft tall (40 ft max. typically), which are supported by two carriers on each panel.

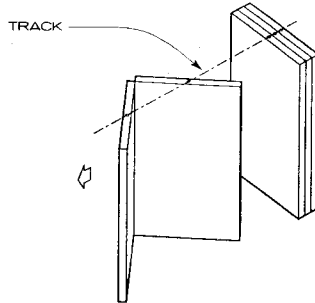

**HINGED PAIRS**  
**NOTE**

This manually operated system is for panels up to 18 ft in height and typically is used for straight runs only. Each panel has one carrier.

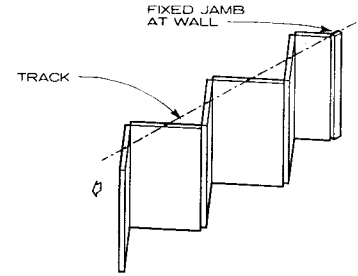

**CONTINUOUSLY HINGED**

**NOTE**

Panels are hinged together to form a continuous panel train. This type is manually operated for systems with a total wall weight under 3700 lb and operated with an electric motor for weights exceeding 3700 lb. This type of panel is typically suitable for straight run applications only.

**PANEL OPERATION TYPES**

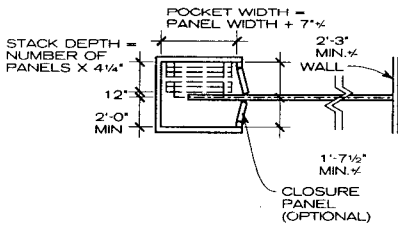

**PARALLEL STACK**

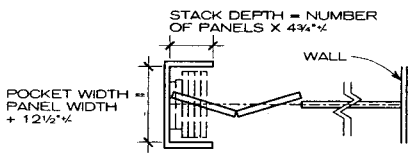

**CENTER STACK**

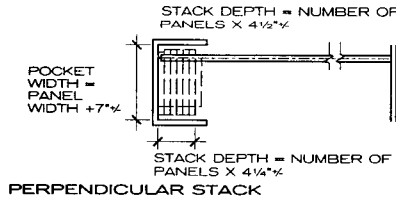

**PERPENDICULAR STACK**

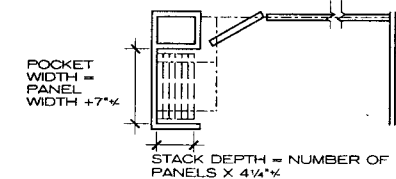

**REMOTE STACK**

**NOTE**

Dimensions given are for planning purposes only; consult manufacturer for specifics. Panels with automatic bottom seals require a wider stack storage area; dimensions given are for fixed, adjustable, or operable bottom seals.

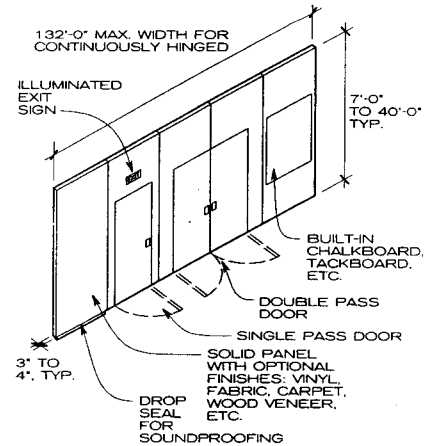

**NOTE**

Panel wall width for individual and paired panels is unlimited. Sound transmission coefficient ratings for typical panels are available up to 55.

**STORAGE ARRANGEMENTS FOR PANEL STACKS**

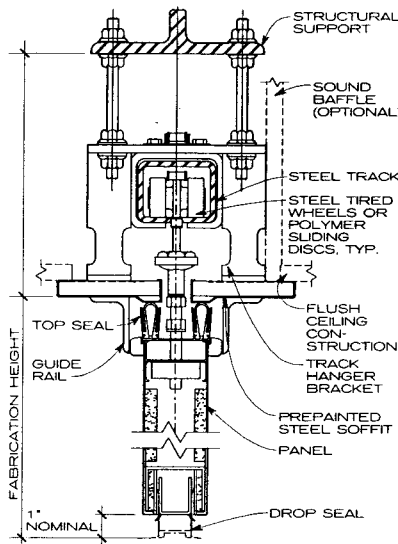

**TOP-HUNG FOLDING PARTITION**  
**DETAIL**

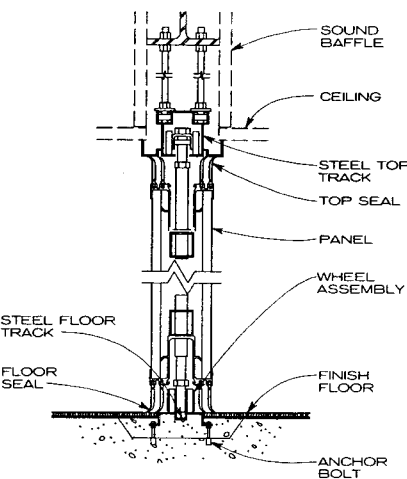

**NOTE**

The bottom carrier handles about 90% of the panel's weight.

**FLOOR-SUPPORTED FOLDING**  
**PARTITION DETAIL**

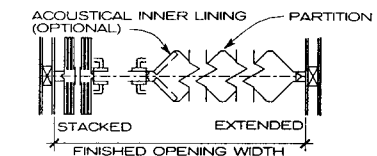
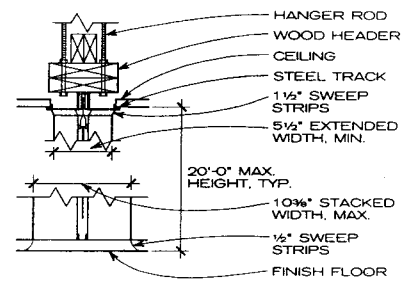

**PLAN**

**NOTE**

Acoustical inner liners can be added to these partitions. Typical partitions are either built of laminated panels or individual vinyl-clad steel panels with extruded vinyl hinges.

**ACCORDION PARTITIONS**

Richard J. Vitullo, AIA; Oak Leaf Studio; Crownsville, Maryland



**GENERAL**

Movable wall systems of non-load bearing interior partitions offer flexibility for office environments in which functions and layouts may change quickly or repeatedly. Generally, they are manufactured either as one-piece self-contained panels or as two-piece systems in which structure and cladding are independent of each other. In either case, floor and ceiling tracks are installed on finished (carpeted, etc.) floors and fastened to suspended ceiling grids. Height adjustment and leveling are accomplished with components included in a typical panel assembly. Panels may be attached to each other or independently fixed into floor and ceiling channels, offering more flexibility. Typically, movable wall systems delineate space, provide visual and sound privacy, channel power and telecommunications cable, and support storage and work surface components. Various manufacturers offer different features for electric and telecommunications cable raceways and access, opening treatments, connection details, panel/cladding and finish materials, sound transmission coefficient ratings, fire ratings, and demountability/mobility options. Consult manufacturers for specific features.

**ONE-PIECE PANELS**

One-piece panels are composite panels typically made from sheet steel or aluminum with a core of insulation and structural ribs for stiffness. Panels are typically 2 3/8 to 3 in. thick, although other thicknesses are available.

**TWO-PIECE PANELS**

These panels are manufactured as separate structural and cladding systems. The structure is made from steel members that are factory-assembled into panel-sized components and then installed. Panel cladding material varies and may include regular and high-impact vinyl-clad gypsum, insulation-filled sound control panels, or sandwich panels (steel sheets with a honeycomb infill), among others. Panel cladding is typically 1/2 to 3/4 in. thick.

**GENERAL NOTES**

1. Suspended ceilings are usually ineffective as a sound barrier. Consequently, when a series of soundproofed offices are planned under such a ceiling, the chances of sound travel over partitions should be considered. Baffles installed tightly above each run of the slab will eliminate cracks through which sound can easily pass.
2. The perimeter of the partition installation—ceiling, floor, and sides—should be gasketed with a factory-applied sealant. All door frames should be fitted with a factory-applied rubber liner at the head and jambs that compresses when the door is closed.
3. For extra sound control, all doors should have a continuous drop seal and threshold and glazing in doors and partitions should have double lights that are hermetically sealed.

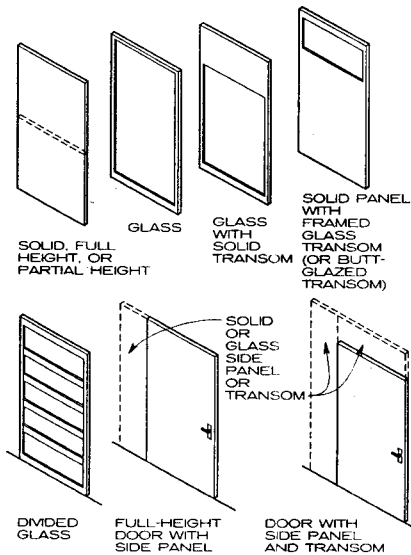

**NOTE**

Wall panel sizes range from 6 to 60 in. wide, up to a single panel height of 1 ft.

**PANEL TYPES**

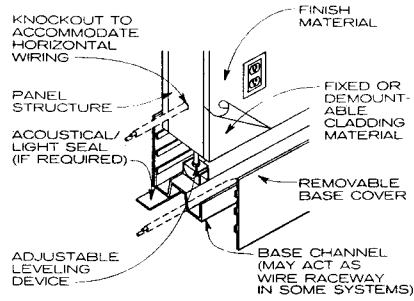

**NOTE**

Various locking devices fasten panels to the floor. Consult manufacturers.

**BASE DETAIL**

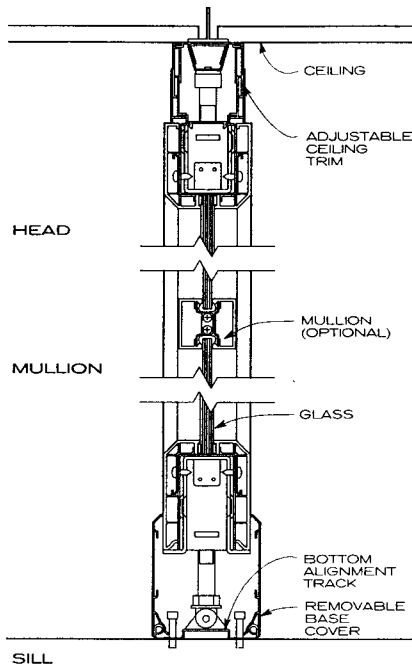

**GLAZED WALL SECTION DETAIL**

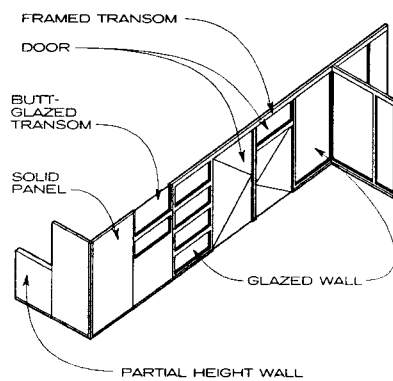

**WALL CONFIGURATION SHOWING PANEL TYPES**

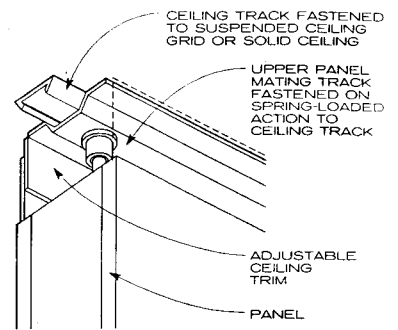

**CEILING DETAIL**

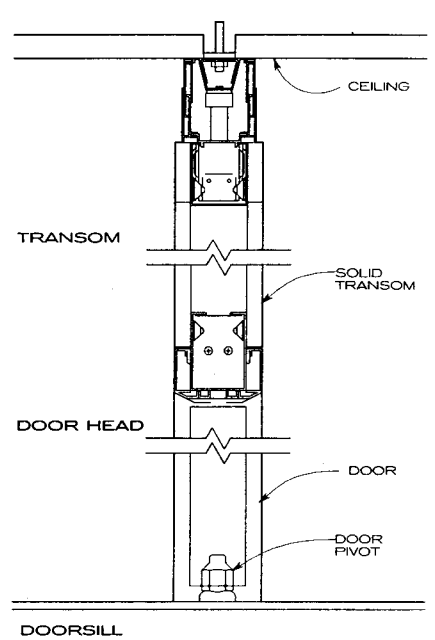

**DOOR SECTION DETAIL**

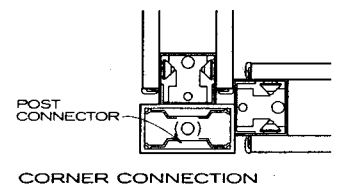

**CORNER CONNECTION**

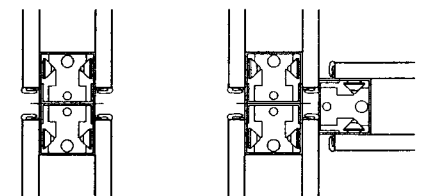

**IN-LINE CONNECTION 3-WAY CONNECTION  
PANEL CONNECTION DETAILS**

Richard J. Vitullo, AIA; Oak Leaf Studio; Crownsville, Maryland

# EQUIPMENT

Security and Vault Equipment	588	Loading-Dock Equipment	598
Teller and Service Equipment	589	Solid Waste Handling Equipment	599
Instrumental Equipment	591	Food Service Equipment	600
Commercial Laundry and Dry Cleaning Equipment	593	Residential Equipment	609
Vending Equipment	594	Darkroom Equipment	612
Audiovisual Equipment	595		

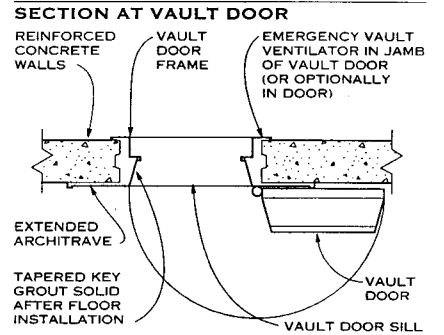
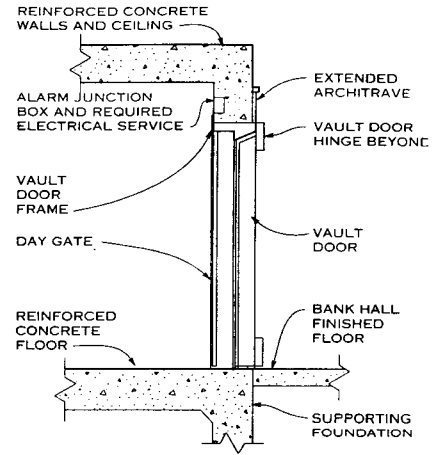
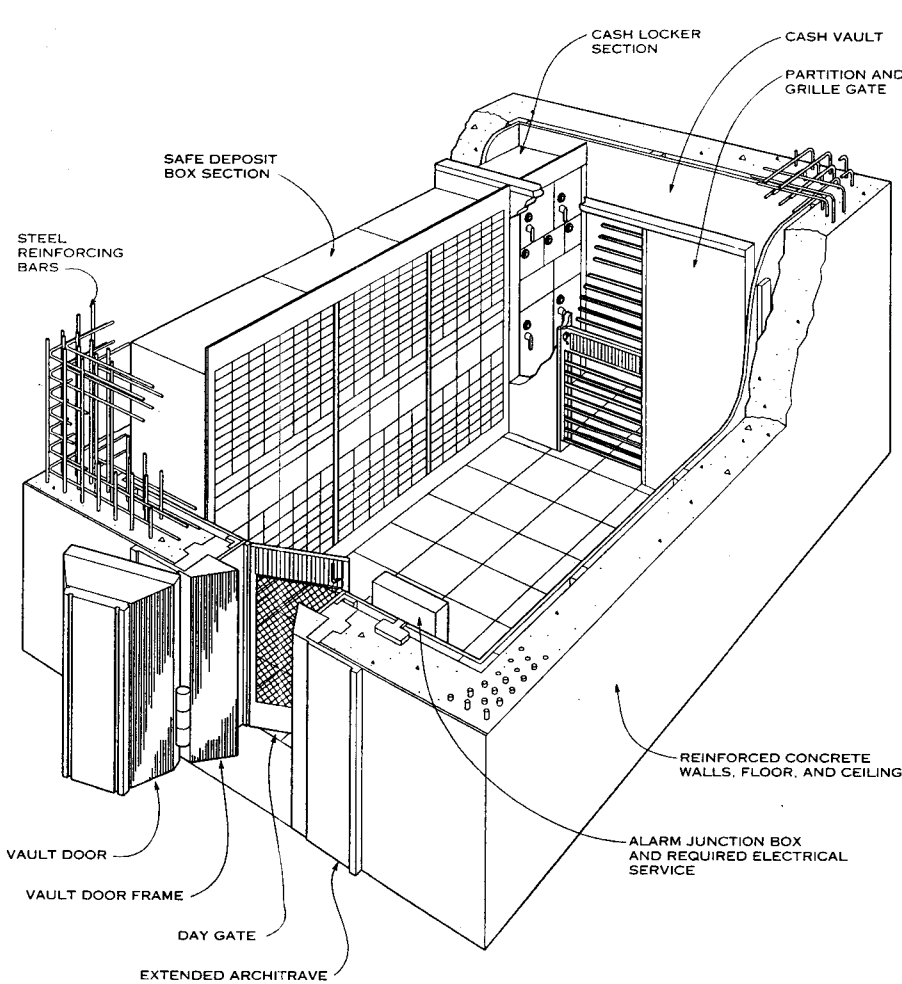

PLAN OF VAULT DOOR

**UNDERWRITERS LABORATORIES (UL) PERFORMANCE SPECIFICATIONS FOR VAULTS**

Class 1 1/2 hr attack resistance time	Not shown — available for application only in existing buildings where structural support (floor load) is critical (does not comply with Bank Protection Act).
Class 2 1 hr attack resistance time	A. 18 in. reinforced concrete B. 8 in. average thickness UL listed modular panel
Class 3 2 hr attack resistance time	A. 27 in. reinforced concrete B. 13 in. average thickness UL listed modular panel.

**INSURANCE SERVICES OFFICE NOTES**

- The size, configuration, and specific requirements of all equipment and alarm systems that might be included in a bank vault will vary with different manufacturers and design considerations.
- Class 2 is the minimum vault panel rating that will meet the requirements of regulation P of the Bank Protection Act.
- Concrete used in vault construction should develop an ultimate compression strength of at least 3000 lb/sq. in.
- With fire-resistive materials to meet local building codes, steel lining is not considered acceptable as burglary-resistant material equivalencies for UL vault construction and does not meet the Bank Protection Act requirements. Special approval is required.
- Class 1 UL listed vault is positioned as equal or superior to the 5R vault classification.
- Class 2 UL listed vault is positioned as superior to the 9R vault classification.
- Class 3 UL listed vault is positioned as superior to the 10R vault classification.
- The above UL listed vaults are superior to traditional ISO and Bank Protection Act construction.
- The Class 2 UL listed vault is recommended throughout the industry as minimum protection for safe deposit vault operations. A 2-hour, Class 3, is preferable.

**GENERAL**

Federally insured banks and savings institutions are regulated under the Bank Protection Act of 1968 as revised in 1973, which only recognizes vaults with walls, floor, and ceiling of reinforced concrete at least 12 in. thick. Revisions to the BPA in 1991 should be consulted when planning a new vault. The following comparative classification charts are used to rate security vaults.

**MINIMUM NUMBER OF GRIDS FOR DEFORMED BARS**

12 in. concrete thickness	3 grids
18 in. concrete thickness	4 grids
27 in. concrete thickness or over	5 grids

**MINIMUM NUMBER OF GRIDS FOR #6 EXPANDED STEEL**

12 in. concrete thickness	2 grids
18 in. concrete thickness	3 grids
27 in. concrete thickness or over	4 grids

**REINFORCING**

No. 5 (5/8 in. diameter) deformed steel reinforcing bars located on 4 in. centers in horizontal and vertical rows to form a grid, or expanded steel bank vault mesh weighing 6 lb/sq ft per grid and having a diamond pattern of 3 x 8 in.

Grids are to be located not less than 4 in. apart and shall be staggered in each direction. The number of grids required depends on the thickness of the wall, floor, and ceiling (and specific insurance requirements).

**INSURANCE SERVICES OFFICE (ISO)**

STEEL DOORS	WALL SPECIFICATIONS EFFECTIVE OCTOBER 30, 1974	ISO CLASSIFICATION
3 1/2 in.	A. 1/2 in. steel lining <sup>(4)</sup> B. 12 in. reinforced concrete	5R
3 1/2 in.	A. 1 in. steel lining <sup>(4)</sup> B. 1/2 in. steel lining and 12 in. reinforced concrete C. 18 in. reinforced concrete	6R
7 in.	A. 1 in. steel lining <sup>(4)</sup> B. 1/2 in. steel lining and 12 in. reinforced concrete C. 18 in. reinforced concrete	9R
7 in.	A. 1 1/2 in. steel lining <sup>(4)</sup> B. 1/2 in. steel lining and 12 in. reinforced concrete B. 1/2 in. steel lining and 18 in. reinforced concrete C. 27 in. reinforced concrete or 18 in. listed reinforced concrete	10R

Krommenhoek/McKeown and Associates; San Diego, California

**BANK EQUIPMENT REQUIREMENTS**

1. **STANDARDS:** Comply with the latest edition of "Comptroller's Manual for National Banks"; see the section on "Minimum Security Devices and Procedures." Higher standards may be specified in the construction documents. The following requirements are based on the Comptroller's Manual.
2. **SURVEILLANCE SYSTEM (general)** devices should be:
  - a. Capable of enlarging images of persons to produce a 1 in. vertical head size.
  - b. Reasonably silent in operation.
  - c. Taking at least one picture every 2 seconds and operating not less than 3 min.
3. **SURVEILLANCE SYSTEM (other than walk-up or drive-in at teller's station or windows):**
  - a. Placed to reproduce identifiable images of persons either leaving the banking office or in a position to transact business at each station or window.
  - b. Capable of actuation by initiating devices located at each teller's station or window.
4. **SURVEILLANCE SYSTEM (walk-up or drive-in at teller's station or windows):**
  - a. Placed to reproduce identifiable images of persons either leaving the banking office or in a position to transact business at each station or window, and capable of actuation by initiating devices located at each teller's station or window.
  - b. Capable of actuation by initiating devices located at each teller's station or window. Such devices may be omitted when the teller is effectively protected by a bullet-resistant barrier. However, if the teller is vulnerable to larceny or robbery, access to actuate a surveillance system should be available.
5. **ROBBERY ALARM SYSTEM:**
  - a. Provide for banking offices at which the police ordinarily can arrive within 5 minutes after an alarm is actuated; all other banking offices should be provided with appropriate devices for promptly notifying the police that a robbery has occurred or is in progress.
  - b. Signals the police, through an intermediary, indicating that a crime against the banking office has occurred or is in progress.
  - c. Capable of actuation by initiating devices located at each teller's station or window, except those protected by bullet-resistant barrier.

- d. Safeguarded against accidental transmission.
  - e. Equipped with a visual and audible signal capable of indicating improper functioning of or tampering with the system.
  - f. Equipped with an independent source of power sufficient to assure continuously reliable operation of the system for at least 24 hr.
6. **BURGLARY ALARM SYSTEM:**
- a. Provide for each banking office.
  - b. Capable of detecting promptly an attack on the outer door, walls, floor, or ceiling of each vault and each safe not stored in a vault.
  - c. Signals the police, through an intermediary, indicating that a crime against the banking office has occurred or is in progress. Where police cannot arrive within 5 minutes, a loud bell audible inside and 500 ft outside should be provided.
  - d. Safeguarded against accidental transmission.
  - e. Equipped with a visual and audible signal capable of indicating improper functioning of or tampering with the system.
  - f. Equipped with an independent source of power (such as a battery) sufficient to assure continuously reliable operation of the system for at least 80 hr in the event of failure of the usual source of power.
7. **WALK-UP AND DRIVE-IN TELLER'S STATIONS OR WINDOWS:**
- a. Tellers should be effectively protected by bullet-resistant barriers from robbery or larceny. Such barriers should be of glass at least 1 3/8 in. in thickness, or of material of at least equivalent bullet-resistance. Pass-through devices should not afford a person outside a direct line of fire.
8. **VAULTS, SAFES, AND SAFE DEPOSIT BOXES:** Requirements are described in detail in the manual. See also the Bank Vault page in this chapter.
9. **NIGHT DEPOSITORIES:**
- a. Should consist of a receptacle chest having cast or welded steel walls, top, and bottom, at least 1 in. thick; a steel door at least 1 1/2 in. thick, with a combination lock; and a chute, made of steel that is at least 1 in. thick, securely bolted or welded to the receptacle and to a depository entrance of strength similar to the chute. Each depository entrance should be equipped with a burglar alarm and be designed to protect against the "fishing" of a deposit from the deposit receptacle, and "trapping" of a deposit for extraction.

10. **AUTOMATED TELLER MACHINES (ATMs):**

- a. Should weigh at least 750 lb empty or be securely anchored to the premises. Cash dispensing machines should contain, among other features, a storage chest of cast or welded steel walls, top, and bottom, at least 1 in. thick, with a tensile strength of at least 50,000 psi. Any doors should be constructed of steel at least equivalent in strength to the storage chest and equipped with a combination lock and a relocking device that will effectively lock the door if the combination lock is punched. The housing covering the mechanism for removing the cash from the storage chest should be designed as to provide burglary resistance at least equivalent to the storage chest and should also be designed to protect against the "fishing" of cash from the storage chest. The cash dispensing control and delivering mechanism should be protected by steel, at least 1/2 in. in thickness, securely attached to the storage chest. A cash dispensing machine that also receives deposits should have a receptacle chest having the same burglary resistant characteristics as that of cash dispensing storage chest and should be designed to protect against the fishing and trapping of deposits. Necessary ventilation for the automated machines should be designed so as to avoid significantly reducing the burglary resistance of the machines. The cash dispensing machine should also be designed so as to be protected against actuation by unauthorized persons, should be protected by a burglar alarm, and be located in a well-lighted area.

**ATM ACCESSIBILITY**

ADA Accessibility Guidelines (ADAAG) Section 4.34 regulate automatic teller machines (ATMs) and require that they be accessible as per 4.1.3, that their controls comply with 4.27 (height of forward reach 48 in., height of side reach 54 in.), that they have clear floor space in compliance with 4.24 (30 x 48 in.), and that they be usable by persons with impaired vision. Each ATM must comply, except where two or more are provided at a location; then only one must comply. Drive-up-only ATMs are not required to comply with clear floor space and reach requirements of 4.27 and 4.34.

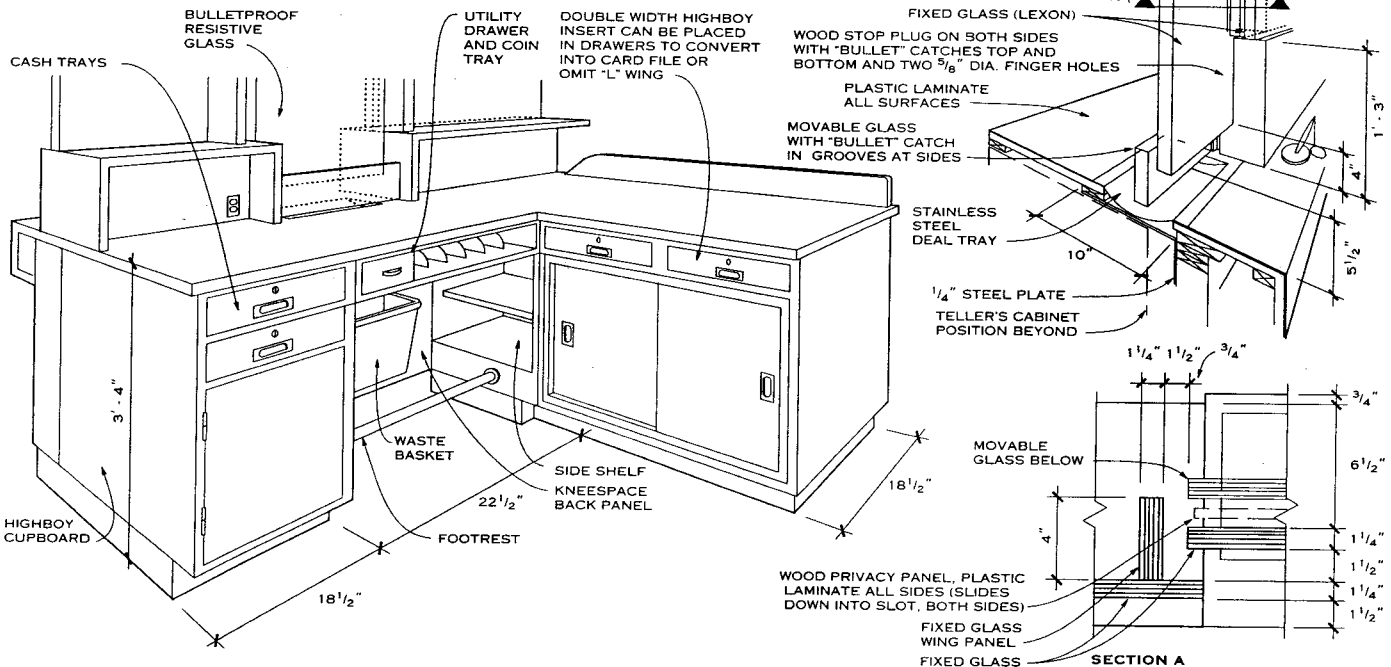

**TELLER STATION**

Charles Szoradi, AIA; Washington, DC

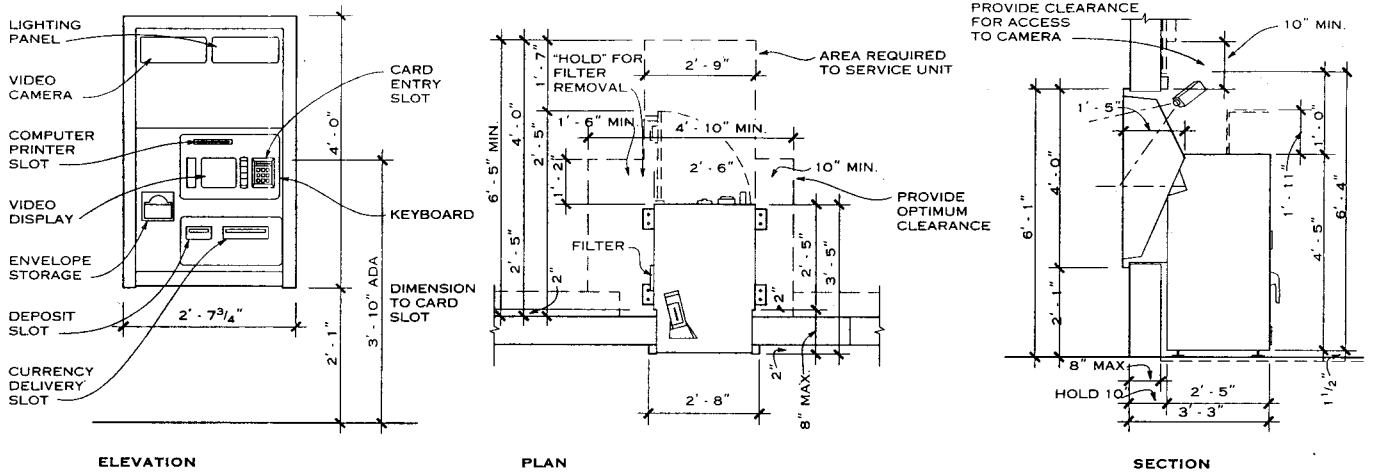

**AUTOMATED TELLER MACHINES (ATM)**

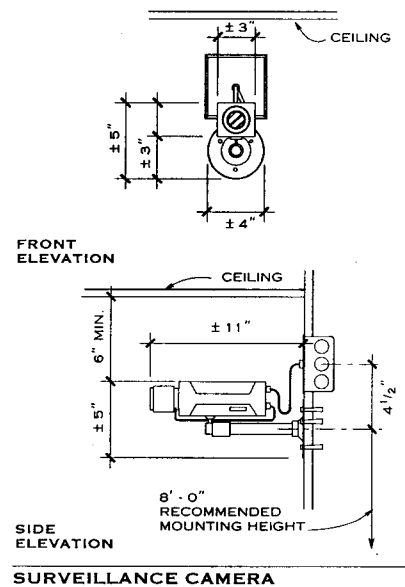
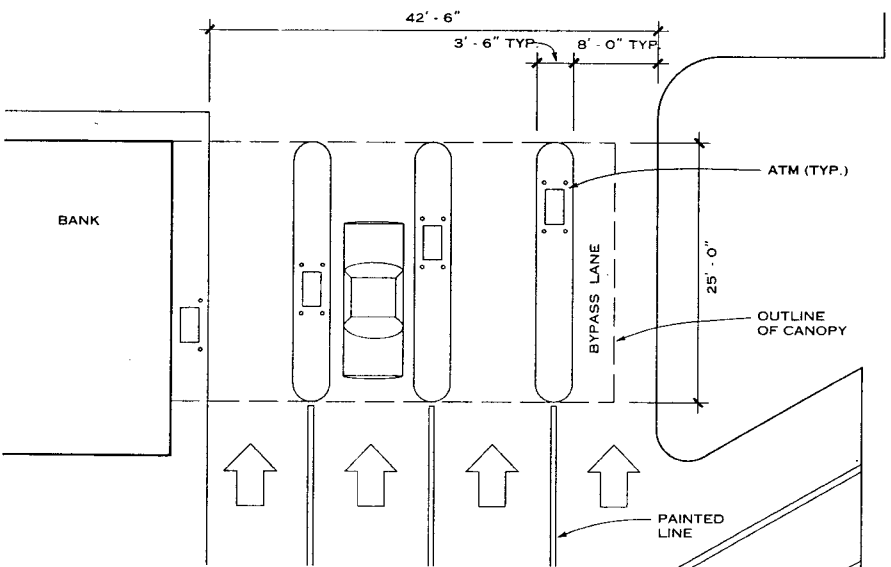
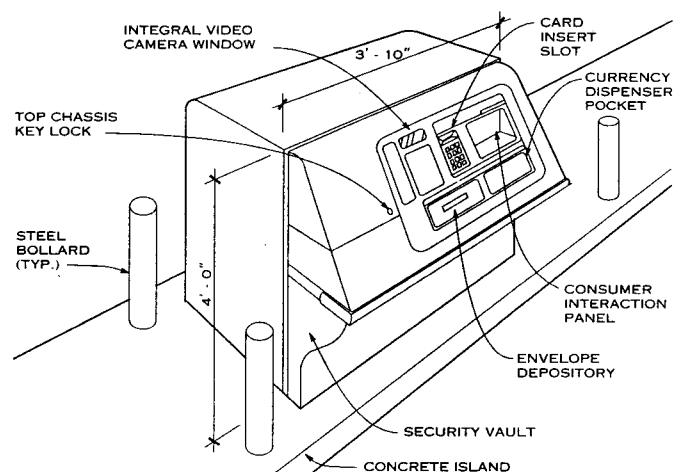
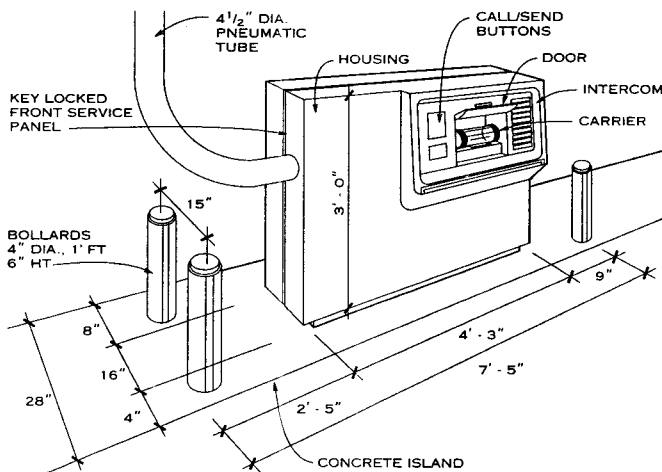

Charles Szoradi, AIA; Washington, D.C.  
 Equipment information was furnished by Diebold, Inc.; Canton, Ohio

**11 TELLER AND SERVICE EQUIPMENT**

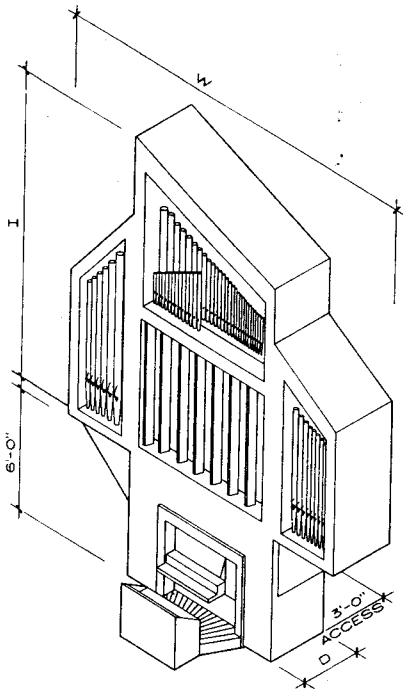

**MECHANICAL ACTIONED ORGAN (TRACKER)**

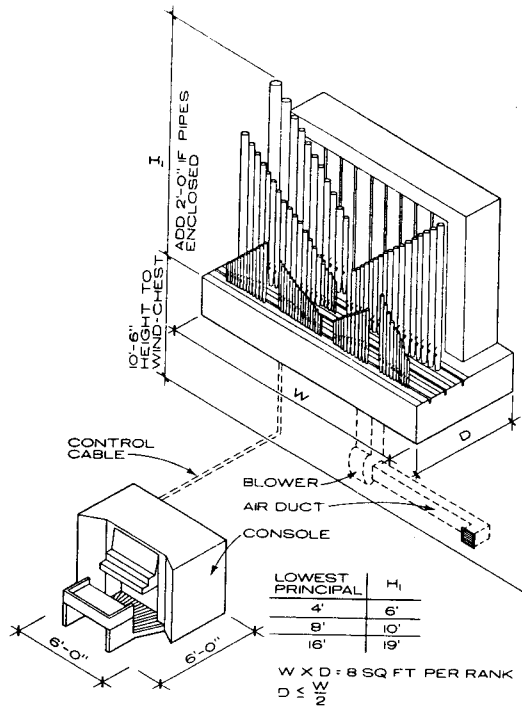

**ELECTROMECHANICAL OR ELECTROPNEUMATIC ORGAN**

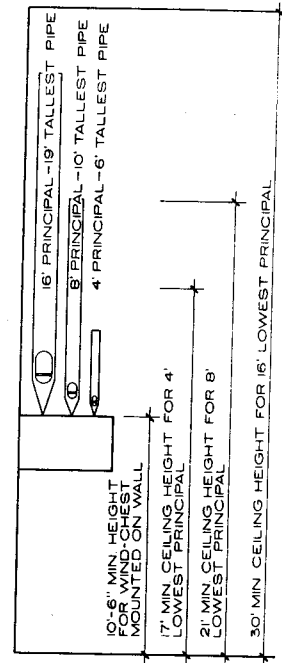

**PIPE ORGANS**

Organ builders recommend that the pipes and casework be located within the space they are to serve, not in an organ chamber. Organ and console, located in proximity to one another, should be placed so that sound can travel freely and directly to the listeners. No furnishings, people, or other barriers should be located in front of the organ pipes. Drafts and sudden temperature changes to the pipes may necessitate more frequent tuning.

While blowers may be built in to the organ casework, quieter operation can be achieved placing the blower in a remote space. However, air for the blower should be drawn from the room in which the organ is located to avoid tuning changes. Sound isolation, power requirements, serviceability, and need for a large duct chase to the organ must be considered when designing the blower room.

The number of stops or ranks required for an organ installation is related to musical flexibility rather than the loudness of an organ. The number of manuals will also vary depending on need for flexibility in the musical program. The table below outlines general guidelines to select the number of ranks for an organ installation.

**ELECTROMECHANICAL AND ELECTROPNEUMATIC ORGANS**

In these types of instruments, air that passes from the wind-chests into the pipes is controlled by either electromechanical or electropneumatic means. The required size of the organ pipe space will vary depending on the organ builder, but 8 sq ft per rank may be used as a general rule of thumb. If height is available, divisions may be stacked, reducing the floor area required by approximately 25%. All pipes must be accessible for tuning.

Weight of the organ will also vary. A general average is 450 lb per rank. If the organ is enclosed in a case, 50 lb per rank should be added. A stacked arrangement of pipe divisions will increase the floor loading proportionately.

**MECHANICAL ACTIONED ORGANS**

Commonly known as tracker organs, these instruments introduce air into the pipes through a valve mechanically attached to the keys on the console. The size of tracker organs is measured in terms of stops rather than ranks. Tracker organs are self-contained in wooden cases that house pipes, wind-chests, manuals, and mechanical

components. Such wooden cases may be designed to complement the architecture of the surrounding space. Compared to electromechanical and electropneumatic organs, a tracker organ will usually require more height for pipe cases but consequently less floor area. Often used in chapels because of their compactness, tracker organs are not limited to use in small worship spaces. In larger installations the console may be separated from the pipe chests by a limited distance, but must nonetheless be fixed, due to the mechanical connections between manuals and pipes.

Blowers for this type of instrument are built into the organ casework. Electrical power for the blower must be provided.

Mechanical actioned organs have an average weight of 400-500 lb per stop. A 3 ft 0 in. minimum access space behind the instrument is required for servicing and tuning.

Additional information is available through the Associated Pipe Organ Builders of America.

**GENERAL SIZE REQUIREMENTS BASED UPON VARIOUS SEATING CAPACITIES**

NO. OF SEATS	NO. OF STOPS	NO. OF RANKS	NO. OF DIVISIONS (1)	LOWEST PRINCIPAL (2)
150	4-9	6-12	2-3	4'
200	9-13	12-16	3	8'
250	12-18	16-23	3	8'
300	15-25	18-34	3	8'
400	20-30	26-44	3	16'
500	25-35	34-50	3-4	16'
750	30-45	44-64	4	16'
1000	35-50	50-78	4	16'

**MINIMUM DIMENSIONS FOR A TRACKER ORGAN CASE BASED UPON VARIOUS NUMBERS OF STOPS**

NO. OF SEATS	NO. OF STOPS	NO. OF RANKS	NO. OF DIVISIONS	LOWEST PRINCIPAL	W WIDTH	D DEPTH	H HEIGHT
150	4-9	6-12	2-3	4	10'	28"	10'
200	9-13	12-16	3	8	12'	28"	12'
250	12-18	16-23	3	8	15'	36"	14'
300	15-25	18-34	3	8	18'	42"	17'
400	20-30	26-44	3	16	20'	48"	23'
500	25-35	34-50	3-4	16	22'	52"	25'
750	30-45	44-64	4	16	22'	56"	25'
1000	35-50	50-78	4	16	22'	60"	25'

**NOTE**

Dimensions given are the maximum length, height, and width found if several models and styles exist.

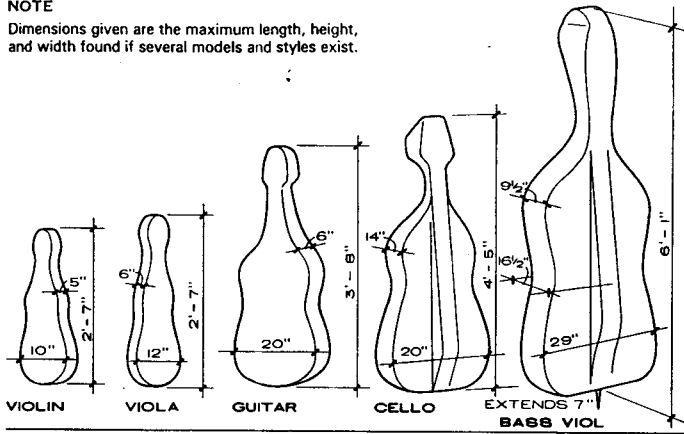

**STRINGS**

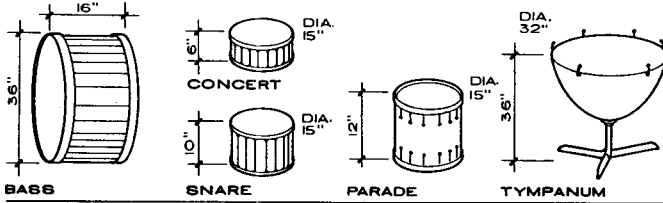

**BASS DRUMS**

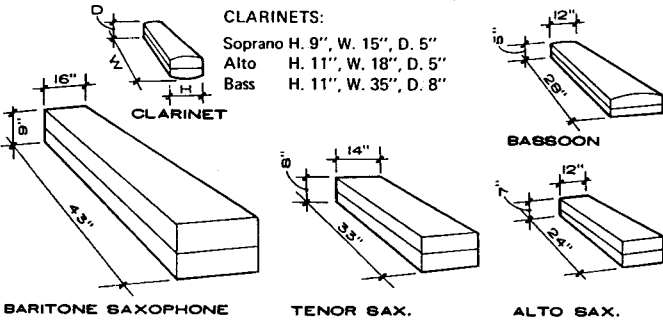

**CLARINETS:**

Soprano H. 9", W. 15", D. 5"  
 Alto H. 11", W. 18", D. 5"  
 Bass H. 11", W. 35", D. 8"

**REEDS**

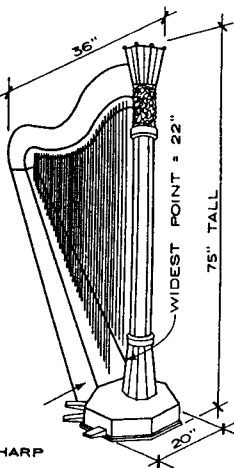

**HARP**

**NOTE**  
 Harps are made in various sizes. A typical larger model is shown. The widest dimension is at the "soundboard" and equals 22 in. A harp case is 25 in. wide x 84 in. deep. Total weight, including harp and case, is approximately 200 lb.

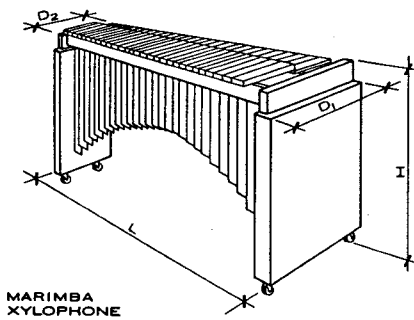

**MARIMBA XYLOPHONE**

	L	H	D <sub>1</sub>	D <sub>2</sub>	WEIGHT
Marimba	87	36	33	16	175 lb
Xylophone	54	34	32	13	70 lb

**NOTE:** All dimensions are in inches. Many sizes are manufactured. The sizes given above are typical larger size that are available.

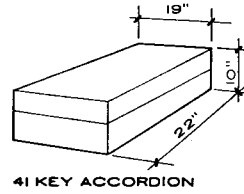

**41 KEY ACCORDION**

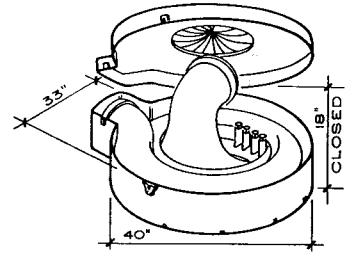

**ONE PIECE SOUSAPHONE**

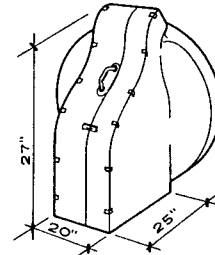

**TWO PIECE TUBA**

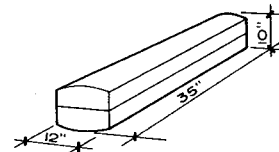
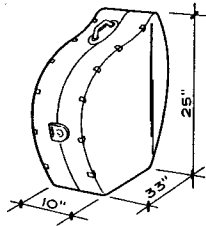

**TENOR TROMBONE**

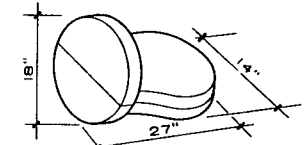

**FRENCH HORN MELLOPHONE 22"x13"x16"  
 EUPHONIUM 36"x14"x18"**

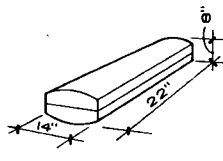

**TRUMPET**

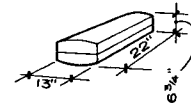

**CORNET**

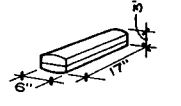

**FLUTE PICCOLO 10"x3"x2"**

**BRASS**

MUSIC RACK, WHEN OPEN INCREASES "H" 8" TO 10"

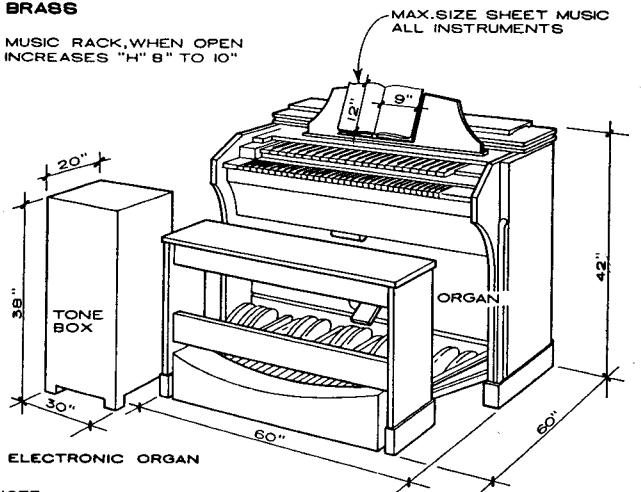

**ELECTRONIC ORGAN**

**NOTE**

Electronic organs are manufactured in many different types, styles, and models. Much smaller units than that shown are available as well as models weighing several tons. In general, allow space 72 in. wide x 72 in. long x 72 in. high. Also required is a clearance of approximately 50 in. to rear of unit for servicing. Consult organ manufacturers for exact details and models available.

Pipe organs are designed to fit the building in which they are to be used. After factory assembly and testing, they are disassembled and shipped. Pipes may vary from less than 1 in. to more than 30 ft in length. A single organ may have thousands of pipes. Basic components are the pipes, wind chest, blower, valve mechanism, and keyboards.

Leland D. Blackledge, AIA; South St. Paul, Minnesota  
 John A. Lesire, AIA; Arlington, Virginia

**11 INSTRUMENTAL EQUIPMENT**

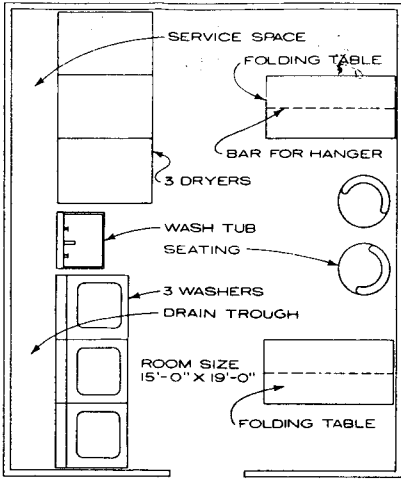

20 UNIT APARTMENT BUILDING

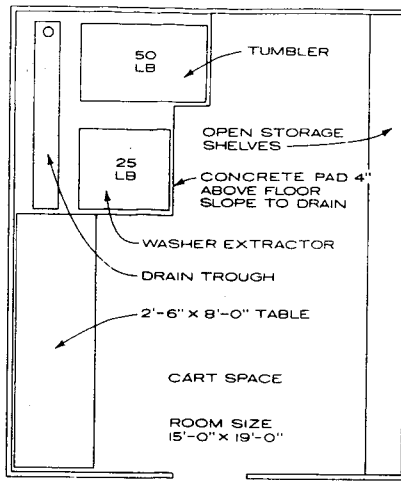

20-30 UNIT MOTEL

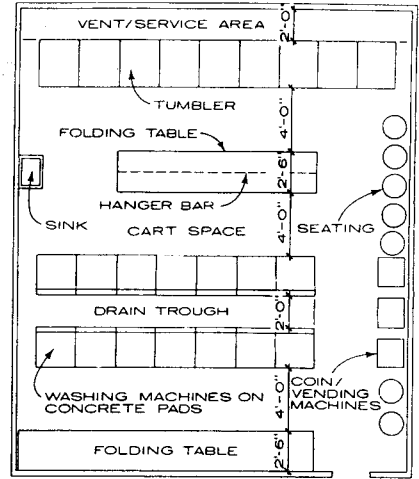

COIN-OPERATED LAUNDRY

TYPICAL PLANS FOR LAUNDRY ROOMS

DRYER SIZES

CAPACITY (LB)	WIDTH	DEPTH
30	31"	44"
50	38"	44"
75	38"	49"
100	46"	62"
200	72"	54"

NOTES

1. Drain trench underneath or behind washers is for washing machine overflow and is sized to contain one complete dump from all machines.
2. Variables that determine size of on-premise laundry machines for hotels include number of rooms and hotel occupancy (at 10 lb of laundry per room).
3. Variables that determine the mix of single, double, and triple load washing machines and size of tumblers in laundrettes include the neighborhood and clientele expected.
4. Heavy-duty machines have fewer parts prone to breakage than coin-operated residential machines.
5. Tumbler capacity is twice washer capacity for permanent press fabrics.
6. Venting, electrical, and gas lines should run overhead and drop down to machines.
7. Washing machines in apartment buildings are generally coin-operated residential sizes.
8. Stackable dryers can provide a maximum utilization of space.
9. Commercial laundries must be accessible to persons with disabilities. Front-loading machines with accessible coin boxes are required.

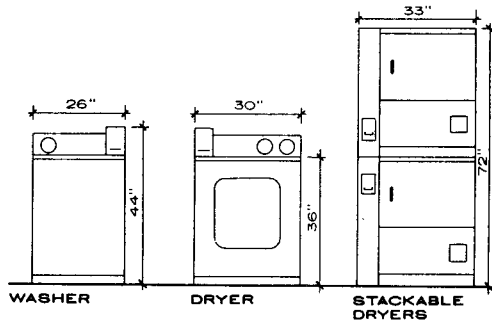

COIN-OPERATED LAUNDRY

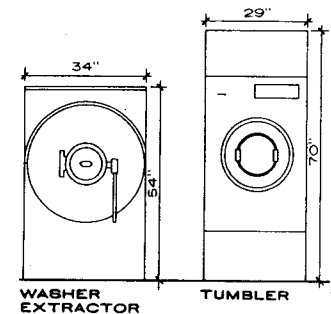

ON-SITE LAUNDRY

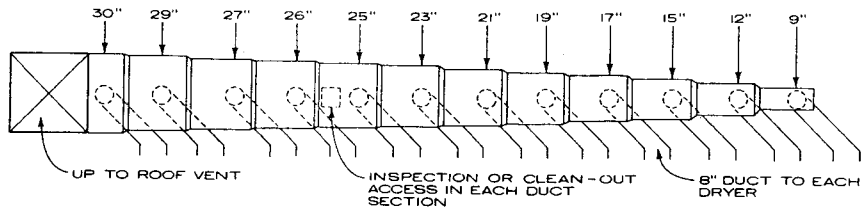

EXHAUST DUCT

WASHER/EXTRACTOR SIZES

CAPACITY (LB)	WIDTH	DEPTH
20	28"	30"
20-30	30"	32"
30-40	34"	36"
40-50	36"	44"
50-60	46"	40"

Above 60 lb, sizes may vary with manufacturer. Minimum clearances: 18 in. sides, 24 in. behind, and 48 in. front.

TUMBLER SIZES

CAPACITY (LB)	WIDTH	DEPTH
30	32"	45"
50	39"	47"
65	39"	53"
100	47"	64"

Minimum clearances: 24 in. behind, none sides, 48 in. front.

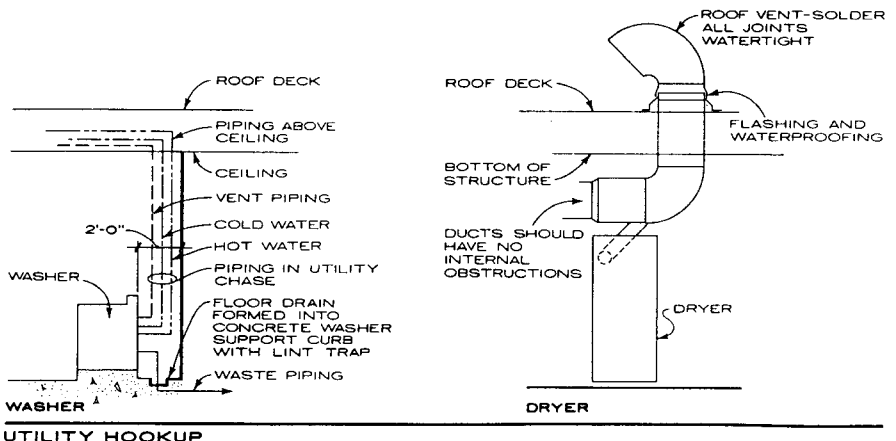

UTILITY HOOKUP

Duane Fisher; Richard Newlon Associates; Washington, D.C.



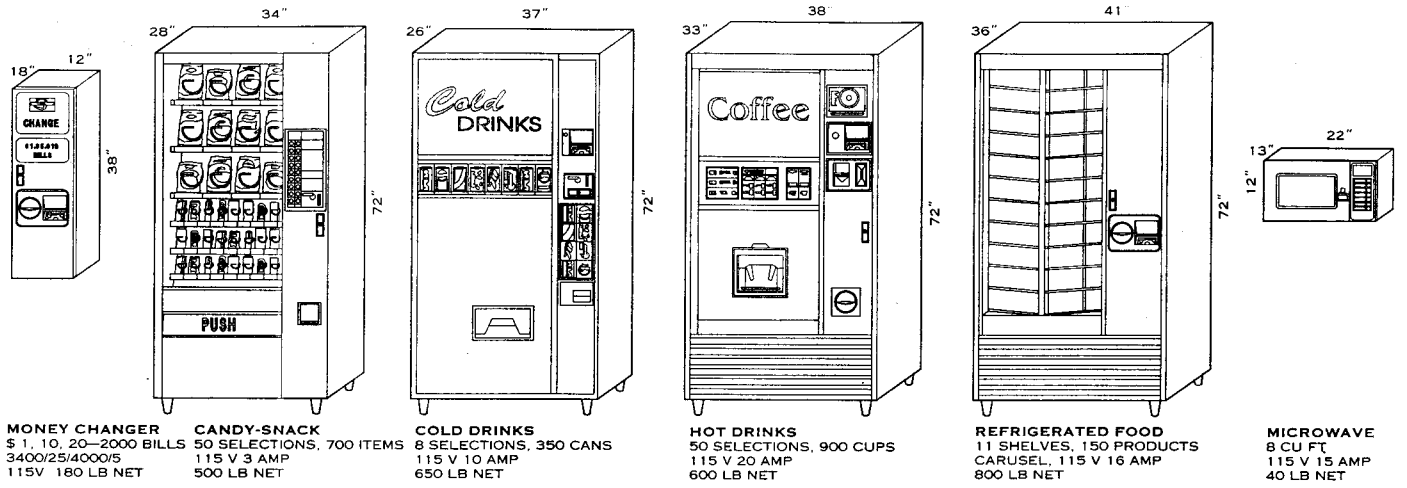

EXAMPLES OF MOST COMMONLY USED VENDING MACHINE TYPES

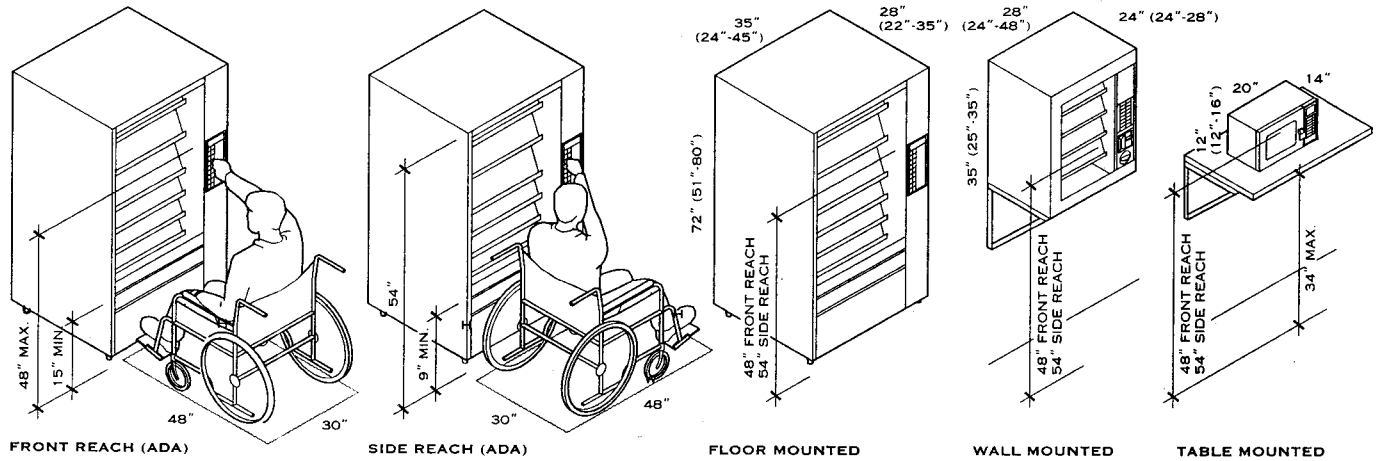

NOTE: Equipment dimensions are the most commonly used. Minimum and maximum dimensions are indicated in parenthesis

EQUIPMENT AND CLEARANCE DIMENSIONS

GUIDELINES

1. Front clearance of 5 ft preferred for machines.
2. Double door or larger than 3 ft wide door is preferred for vending machine area.
3. Americans with Disabilities Act (ADA) accessibility guidelines regarding reach heights, floor spaces, and clearance requirements must be followed.
4. Service access of machines is generally from the front. Some cigarette machines require access from the top.
5. Hot water is not required. Some beverage units require cold water supply with shut-off valve. Overflow waste collects into internal tray.
6. Refrigerated vending machines and microwave ovens require a rear wall clearance of up to 8 in. to permit cooling.
7. Electric service is 115 volt. Separate circuit for each machine is preferred. Amperages vary widely from 2 to 20 amp.
8. Merchandising flexibility is important.
9. Electronic controls allow multipricing.

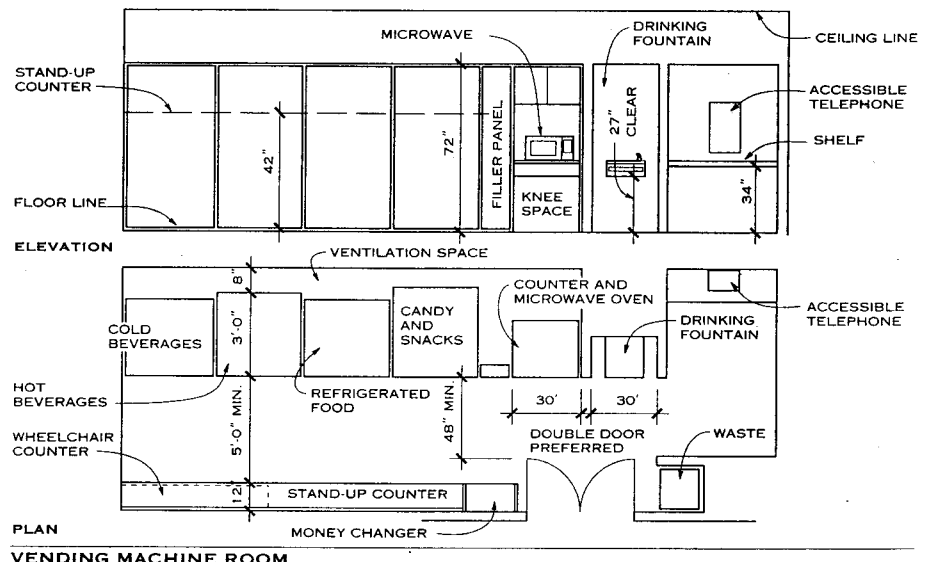

VENDING MACHINE ROOM

Charles A. Szoradi, AIA; Washington, D.C.

11 VENDING EQUIPMENT

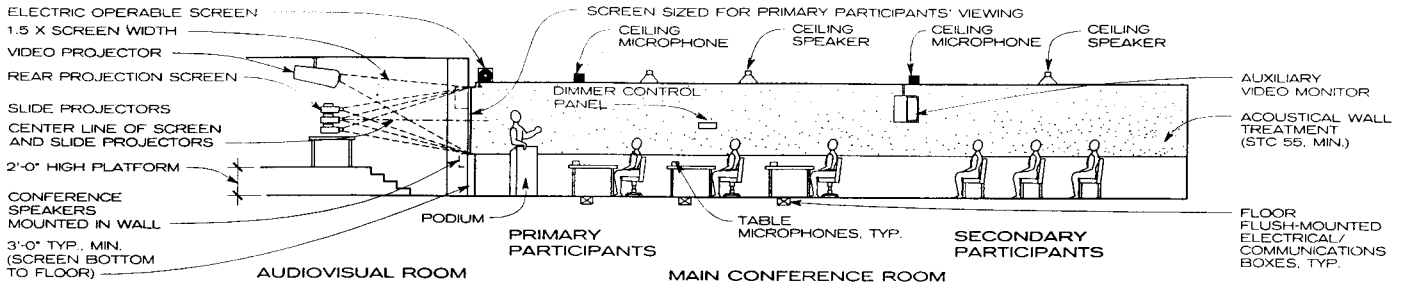

SECTION—MULTIMEDIA CONFERENCE ROOM

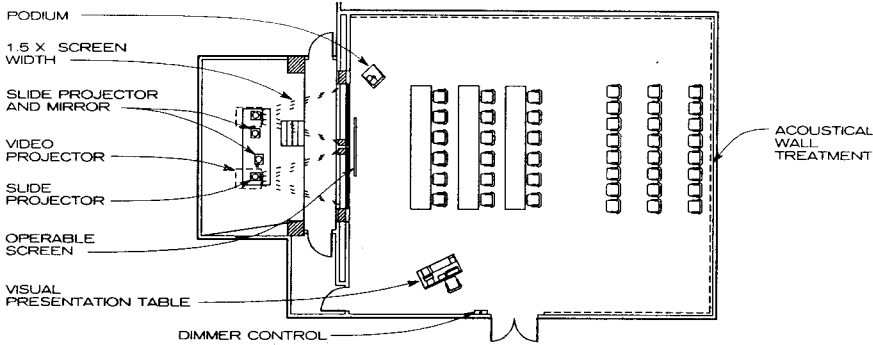

PLAN—MULTIMEDIA CONFERENCE ROOM

**GENERAL**

Teleconferencing is voice or data communication between remote locations and the origination site. Videoconferencing is teleconferencing with visual images added to voice and data communications. Generally, a videoconference space includes two video screens (with speaker for each), one screen for a video image from a remote location and another for supplementary images, such as those from a visual presenter, computer, or videocassette recorder.

**SCREENS**

Rear projection screens or large-screen monitors may be used for videoconferencing. When using a rear projection screen, it is possible to use brighter lights in the conference room during viewing than with a regular video monitor. (The forward projection screen may be perforated for sound. Forward projection systems do not need specially dedicated rooms but are usually mounted in a recess in the ceiling. They are not recommended for videoconference rooms since the high light levels required for video cameras tend to wash out forward projection screens.)

**PROJECTORS**

Slide, video, and overhead projectors are used in multimedia conference rooms. Video projectors are manufactured in three-lens CRT systems and single-lens LCD "light valve" systems. Three-lens projectors are best for screens up to 10 ft wide, a typical size for conference rooms, and are relatively inexpensive. If an audiovisual room is small, mirrors can be used to increase the image size for rear projection. For extra large conference rooms, with screens typically 15 to 25 ft wide, one-lens projectors can be placed any distance from the screen. This setup offers a bright, sharp image but presently is very expensive compared to the three-lens systems.

**SPEAKERS AND MICROPHONES**

Speaker placement is very important in a videoconference space. Speaker size usually depends on the size and shape of the space to be served.

There are three main types of speakers: Playback speakers, matched with prerecorded audio and video discs and tapes, are the largest speakers and offer the highest quality sound. Teleconference speakers, located below and near the center of the video screen, bring the audio feed from the remote videoconference space. Voice reinforcement speakers amplify voices from microphones in the same space. Microphones are placed at strategic locations in the videoconference space, including on tables, for primary participant involvement; on a stand, for secondary participant involvement; as a wireless or clip-on feature, for moderator/coordinator; and on the ceiling ("choir" microphones) to pick up specific sounds desired (to minimize feedback, these must be kept as far from the speakers as possible).

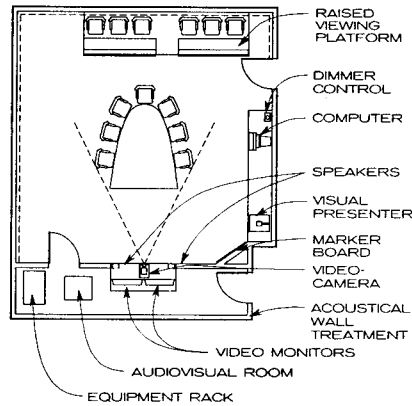

**NOTE**

A rear projection video camera and projection screen may be used with this arrangement; the room size depends on the screen size and video camera distance preferred.

**VIDEOCONFERENCE ROOM**

**AUXILIARY VIDEO MONITORS**

Space used by secondary videoconference participants may need auxiliary monitors to display supplementary video images such as charts or graphics that need close scrutiny. The main videoconference screen usually does not require this backup video screen.

**MISCELLANEOUS EQUIPMENT**

Some videoconference spaces are equipped with remote control systems, which control all electronic functions, including light and sound, from a central control panel. Some spaces are also equipped with special light fixtures that are tilted away from the screen area, shining more light on participants and less on the screen area.

Other equipment typically includes a videocassette player, an amplifier for speakers, an automatic microphone mixer, compact disc player, audiocassette player, matrix switcher, and coder/decoder equipment to convert analog signals to digital signals for fiber-optic transmission.

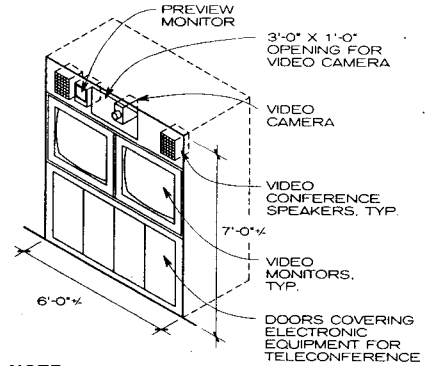

**NOTE**

This wall unit may be assembled on a portable console for mobility.

**TYPICAL VIDEO MONITOR VIDEOCONFERENCE WALL**

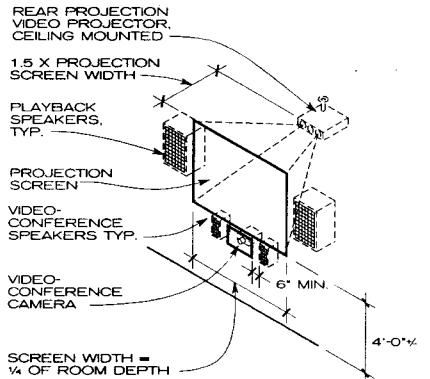

**NOTE**

Ratio of screen height to width: video 3:4; HDTV, 9:16.

**TYPICAL REAR PROJECTION VIDEOCONFERENCE WALL**

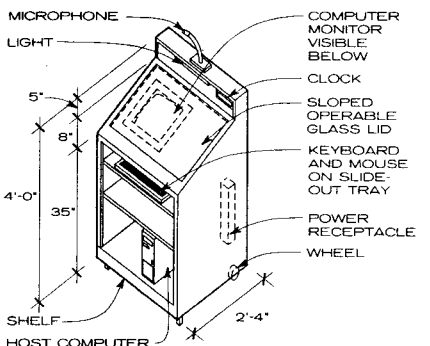

VIDEOCONFERENCE PODIUM

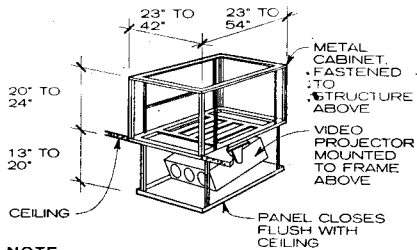

**NOTE**  
This system is typically operated by remote control and may be linked with motorized projection screen operation. Some models are equipped with a trapdoor-type closer.

**RETRACTABLE RECESSED VIDEO PROJECTOR MOUNT**

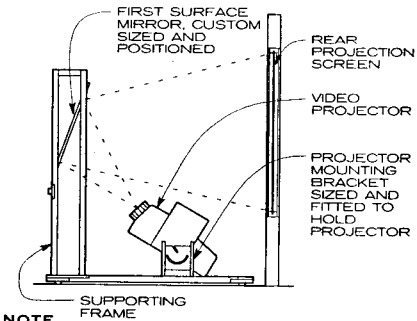

**NOTE**  
This system requires half the space of a direct-projected rear projection system. Rear projection offers the best image quality of all projectors.

**REAR PROJECTION VIDEO SCREEN FOR SMALL PROJECTION ROOM**

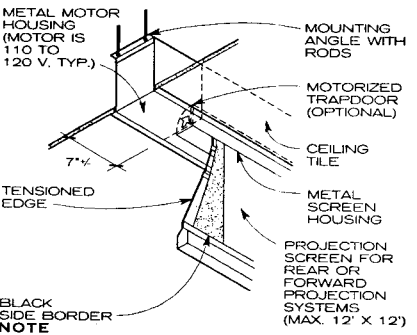

Ceiling tile may be installed under the metal housing and cut around a trapdoor with a tile piece attached. The tensioned screen edge keeps it taut, good for three-lens video and data projection, which require perfect convergence.

**MOTORIZED RECESSED PROJECTION SCREEN**

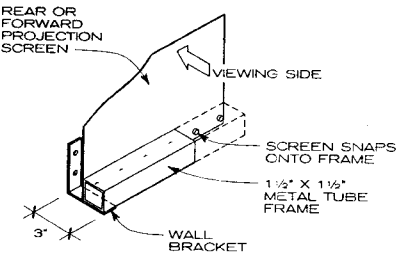

**NOTE**  
This mounting is for forward screens up to 20 ft wide and rear screens up to 12 ft wide.

**METAL FRAME SURFACE-MOUNTED PROJECTION SCREEN**

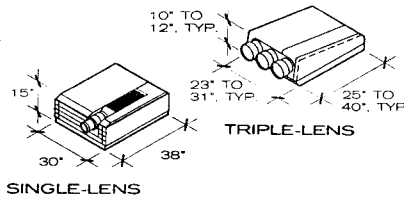

**NOTE**  
Single-lens video projectors do not require a predetermined distance or screen size for placement; they may be placed at any distance and focused like a slide projector. These projectors produce bright, high-resolution images.

**VIDEO PROJECTORS**

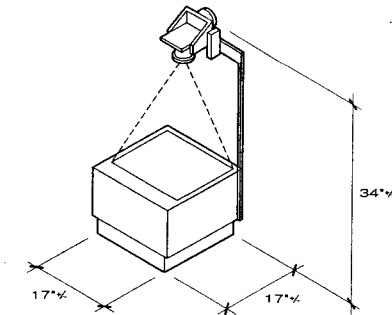

**OVERHEAD PROJECTOR**

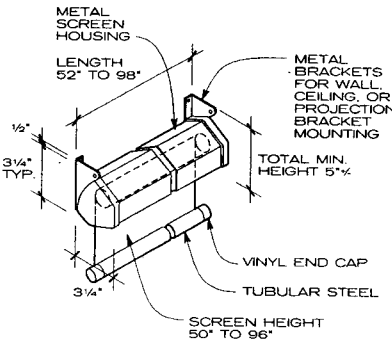

**NOTE**  
This forward projection screen is typically made of silver lenticular fiberglass that is matte white, glass-beaded, and flame and mildew resistant.

**SPRING ROLLER-OPERATED PROJECTION SCREEN**

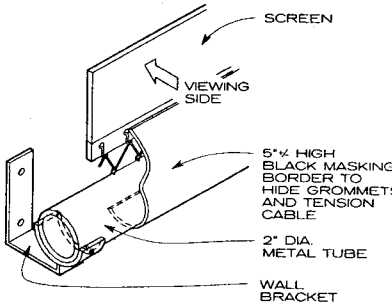

**NOTE**  
This mount is for rear projection screens up to 20 ft wide and forward projection screens up to 30 ft wide.

**METAL FRAME/TENSION CABLE PROJECTION SCREEN MOUNT**

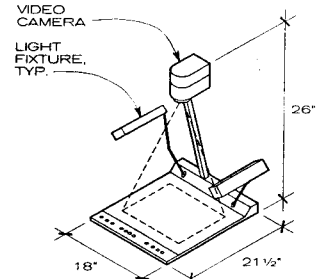

**NOTE**  
The image may be viewed in the room or a remote location.

**VISUAL PRESENTER**

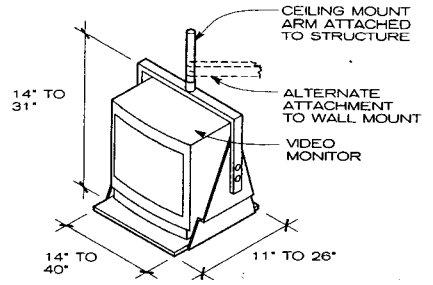

**VIDEO MONITOR MOUNTING**

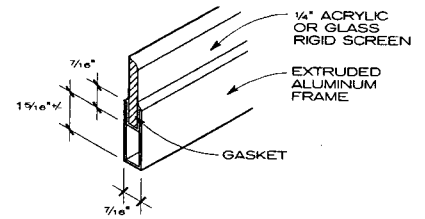

**NOTE**  
This framing detail is for screens approximately 6 ft high by 8 ft wide, maximum.

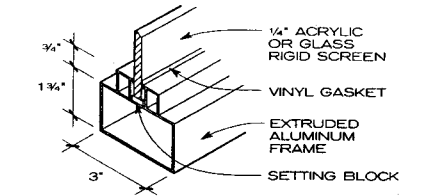

**NOTE**  
This framing detail is for heavy-duty use, for screens up to 10 ft high by 25 ft wide.

**REAR PROJECTION SCREEN FRAMING**

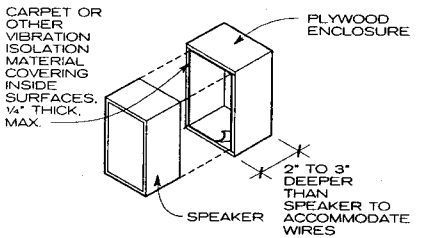

**SPEAKER INSTALLATION DETAIL**

Polysonics; Washington, D.C.

**GENERAL**

A typical computer workstation in the office is equipped with a central processing unit (CPU), monitor, keyboard, and mouse. Various peripheral devices to help store, process, and retrieve data (printers, plotters, scanners, tape backup units, etc.) can be attached.

**LOCAL AREA NETWORK (LAN)**

LANs have changed the layout of computer equipment in the office. In years past, each workstation had its own printer, modem, scanner, etc. With the introduction of networks, these peripheral devices are now shared among a group of users. For example, one printer/modem/scanner can easily service as many as 20 users.

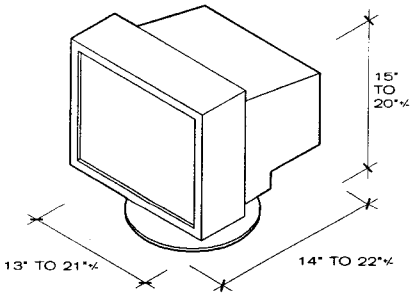

**NOTE**

Monitors display information to be processed. Available in one of three general types—monochrome, gray-scale, or color—they vary in diagonal screen dimensions from 13 to 21 in. (some are available between 9 and 13 in.).

**MONITOR**

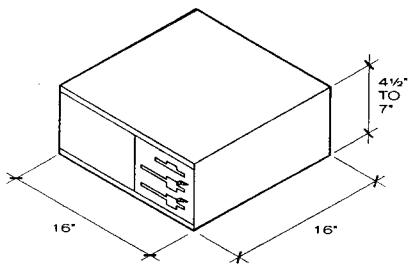

**DESK TOP**

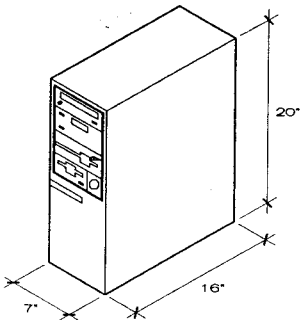

**TOWER TYPE**

**NOTE**

The central processing unit (CPU) is where computer data are stored, processed, and retrieved. CPUs are rated by processing speed (megahertz, MHz), hard-disk capacity (megabytes, MB, or gigabytes, GB), and random access memory (RAM).

**CENTRAL PROCESSING UNIT (CPU)**

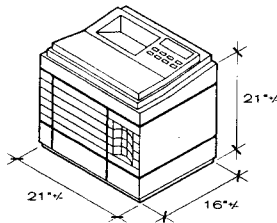

**NOTE**

Laser printers are typically used in larger business settings where speed, performance, and print quality are important. Most laser printers are rated at 4 to 8 pages per minute (ppm); some may be rated as high as 20 ppm.

**LASER PRINTER**

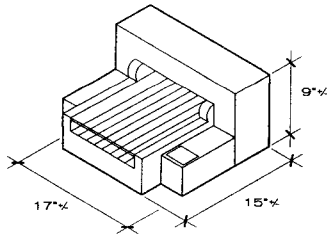

**NOTE**

Inkjet printers are generally more economical than laser printers. They are typically rated at 2 to 4 pages per minute (some may be as high as 8 ppm) and used in smaller business settings or home offices. The print quality is generally not as crisp as that from a laser printer.

**INKJET PRINTER**

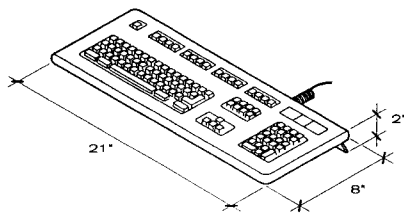

**NOTE**

The keyboard is a primary computer input device.

**KEYBOARD**

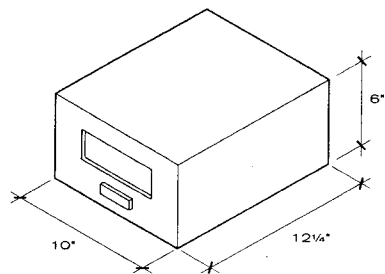

**NOTE**

A tape backup unit is an external storage device, typically used to copy and save data in case a hard disk crashes.

**TAPE BACKUP UNIT**

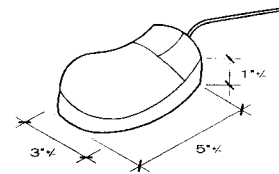

**NOTE**

A mouse is a pointing device used to move a cursor around a screen. It is helpful in operating a computer with a graphical user interface.

**MOUSE**

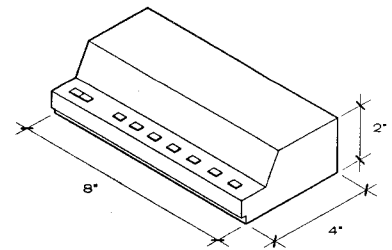

**NOTE**

A modem is used to transmit data from one computer to another computer or other device, such as a fax machine, via telephone lines.

**MODEM**

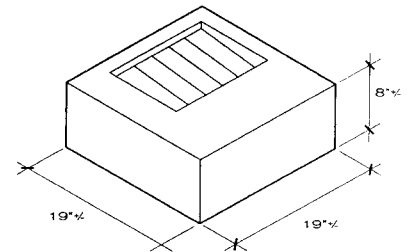

**NOTE**

Scanners allow a computer to read pictures or words from printed pages. This material is then stored in data files in the computer.

**SCANNER**

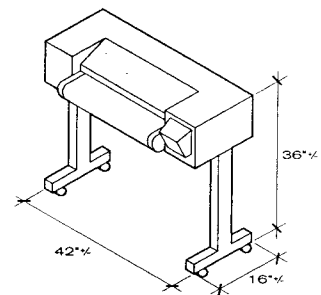

**NOTE**

A plotter is a device that draws with a plotting pen. It is typically used to plot or print graphics from CAD-type programs.

**PLOTTER**

Elin Landenburger; Alexandria, Virginia

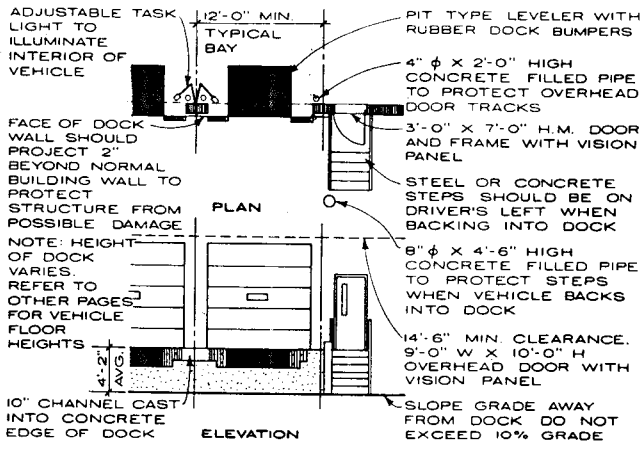

TYPICAL LOADING DOCK BAY

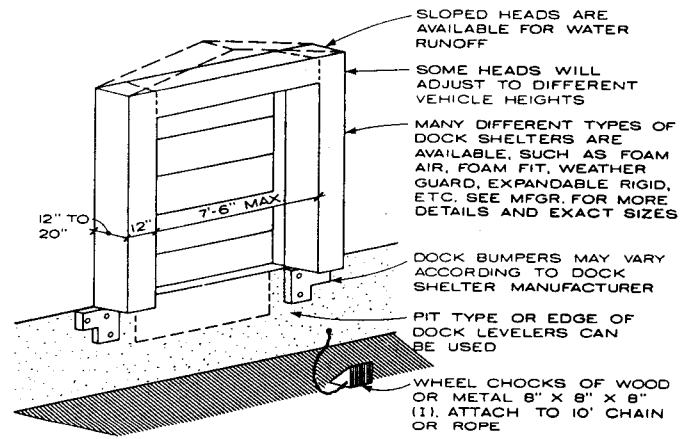

CUSHIONED DOCK SHELTER

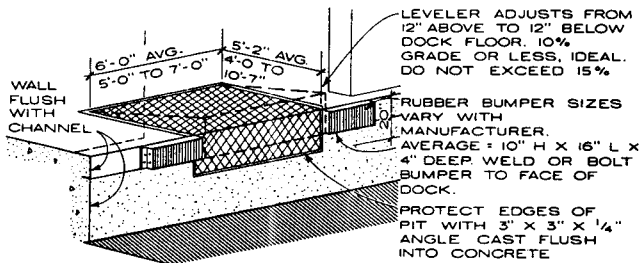

Automatic or manual operation for high volume docks where incoming vehicle heights vary widely; must be installed in a preformed concrete pit. Exact dimensions provided by manufacturer.

PIT TYPE DOCK LEVELER

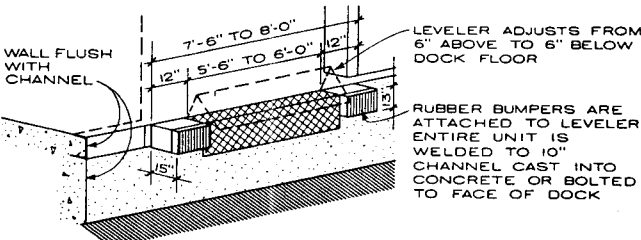

Manual operation for high or medium volume docks where pit type levelers are impractical or leased facilities are being used.

EDGE OF DOCK LEVELER

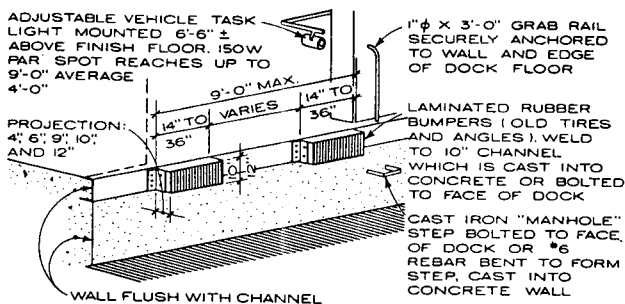

Used for low volume docks where incoming vehicle heights do not vary. Use portable type leveler such as a throw plate.

LOADING DOCK WITHOUT LEVELER

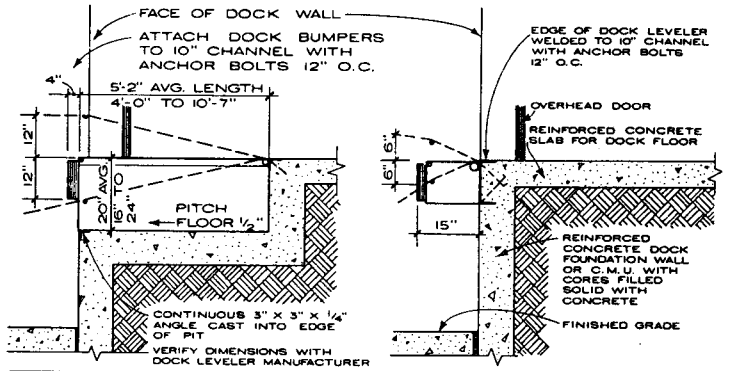

SILL FOR PIT LEVELER

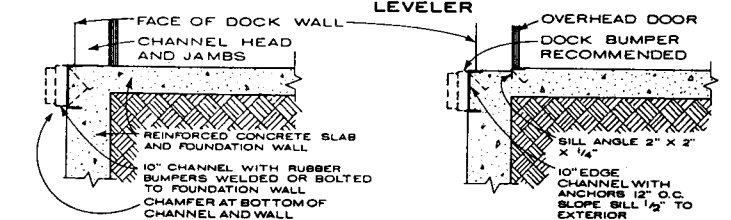

DOCK SILL WITHOUT LEVELERS

PERCENTAGE OF GRADE FOR EACH 2 IN. RISE FROM TRUCK BED TO DOCK FLOOR

RISE (IN.)	OVERALL LENGTH OF DOCK LEVELER (NOT INCLUDING 16 IN. LONG LIP)						MATERIAL HANDLER
	3'-6"	4'-0"	5'-0"	6'-0"	8'-0"	10'-0"	
2	6.1	5.1	3.9	3.3	2.4	1.9	Low lift Pallet Truck 10% max.
4	12.1	10.2	7.8	6.7	4.8	3.7	
6	18.2	15.4	11.8	10.0	7.2	5.6	Fork lift
8	24.2	20.4	15.7	13.3	9.6	7.4	
10	30.3	25.5	19.6	16.7	11.9	9.3	15% max. Marginal to unusable
12	36.4	30.5	23.5	20.0	14.3	11.1	
14	42.4	35.6	27.4	23.3	16.7	13.0	
16	48.5	40.7	31.4	26.7	19.1	14.8	
18	54.5	45.7	35.3	30.0	21.5	16.7	

MOLDED HARD RUBBER DOCK BUMPERS

Robert H. Lorenz, AIA; Preston Trucking Company, Inc.; Preston, Maryland

WASTE COMPACTORS AND CONTAINERS

UNIT TYPE	SIZE	CAPACITY OF CONTAINER
Average household compactor	12" W, 24" D, 33 1/2"-34 1/2" H	1.3 cu ft
Small industrial	See units A, B, and C	4 cu ft per bag
Industrial	See unit D	2 cu yd per container
Schools, offices, restaurants	26" W, 53" H, 31" D	6 cu ft
Apartment house stationary compactor with roll away containers	Units vary	2 to 8 cu yd
Industrial waste containers	95" W, 36" H, 62" D to 95" W, 102" H, 92" D	3 to 15 cu yd
Heavy duty industrial waste containers	8' ± W, 8'-10" H, 23'-2" L	Up to 43 cu yd
Combination shredder/compactor	45" W, 29" D, 78" H See unit "E"	5.25 cu ft per bag

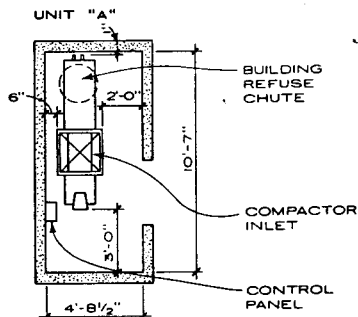

ROOM PLAN

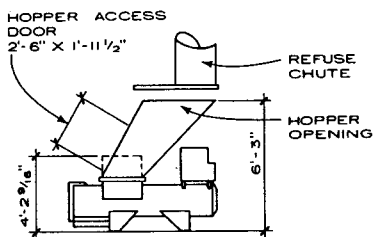

UNIT "A" COMPACTOR UNIT WITHOUT CONTAINERS

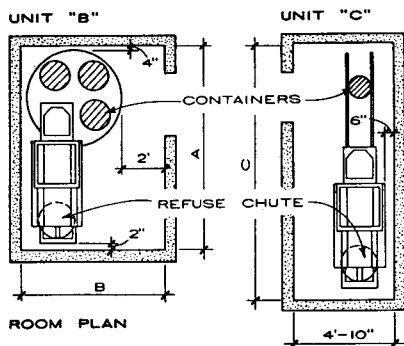

ROOM PLAN

ROOM PLAN

NO. OF CONTAINERS	A	B	C
3			11'-10"
4	9'-8"	7'-0"	13'-5"
5			17'-1"
6	10'-6"	8'-0"	
8	11'-6"	9'-1"	
10	12'-6"	10'-9"	

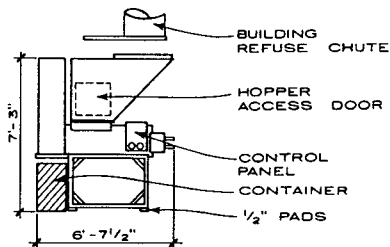

UNIT "B" & "C" COMPACTOR WITH STORAGE CONTAINERS

APARTMENT SELECTION GUIDE

The daily refuse output of 15 to 30 apartments is approximately 1/2 cu yd (13 1/2 cu ft) weighing about 75 lb. At standard compaction ratios of 4 or 5 to 1, a compactor will reduce the refuse to an approximate volume of 3 cu ft.

If the apartments are large, averaging two or three bedrooms, use the figure of 15 apartments per bag. If apartments average one or two bedrooms, use 20 to 25 apartments per compacted bag, and if the units are small efficiency apartments or one-bedroom apartments occupied by young working people or the elderly, use the figure of 30 apartments per compacted bag per day.

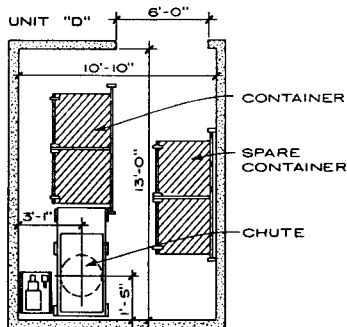

ROOM PLAN

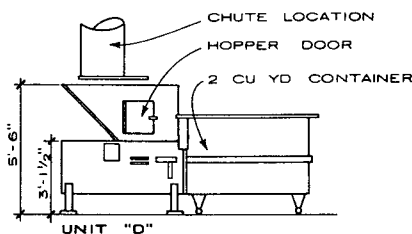

UNIT "D" INDUSTRIAL COMPACTOR

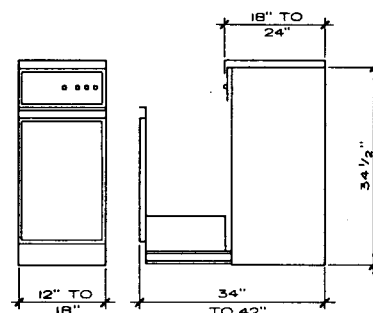

AVERAGE HOUSEHOLD COMPACTOR

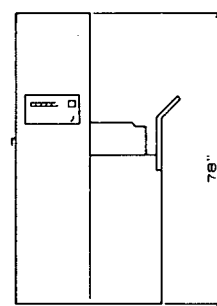
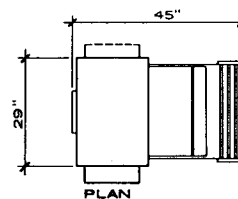

UNIT "E" COMBINATION SHREDDER COMPACTOR

Walter H. Sobel, FAIA, & Associates; Chicago, Illinois

**BOTTLE AND CASE DIMENSIONS**

SIZE	BOTTLE DIMENSIONS (IN.)			WEIGHT
	BORDEAUX	BURGUNDY	CHAMPAGNE	
375 ml	Diameter	2.4	2.6	2.8
	Length	9.5	9.5	10.5
	Incremental height	2.1	2.3	2.5
750 ml	Diameter	3.0	3.2	3.5
	Length	12.0	11.8	12.5
	Incremental height	2.6	2.8	3.0
1.5 L	Diameter	3.8	4.2	4.4
	Length	14.0	14.0	14.8
	Incremental height	3.3	3.6	3.8

**NOTES**

1. Bordeaux bottles represent the majority of wine from Italy, and from parts of France and the United States.
2. Burgundy bottles are from some parts of France and the United States.
3. Champagne bottle sizes are universal.
4. Incremental height of bottles is used where bottles are stacked staggered.

**PREMANUFACTURED CELLARS**

BOTTLE CAPACITY	HEIGHT (IN.)	WIDTH (IN.)	DEPTH (IN.)
50	34	24	24
465	74	52	27
765	80	73	49
1950	80	73	108

**GENERAL NOTES**

1. The ideal temperature range is 55-58°F. Temperature consistency is very important. Avoid diurnal swings in temperature, but a yearly variation of 5-10° is acceptable.
2. Relative humidity should stay in the 60-80% range. Lower humidity promotes evaporation loss through bottle corks; higher humidity allows mold, which breaks down the cellulose in labels and storage structures.

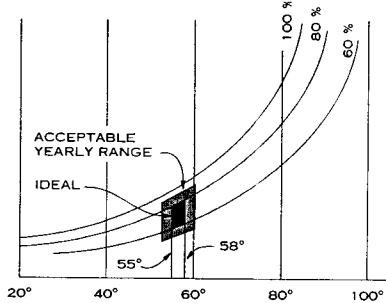

**PSYCHROMETRIC CHART**

3. Larger cellars should accommodate a range of storage options from individual bottles to full cases.
4. Air conditioning equipment may be single unit or split systems. Use systems designed for wine storage. Standard commercial refrigeration is too cold and lowers humidity. Standard room units are not designed to operate at low enough temperatures and coils tend to ice up.
5. In humid areas, provide a vapor barrier installed on the warm side of walls and ceilings.

**SAMPLE ESTIMATION OF AREA REQUIREMENTS**

To find the area required for a cellar to hold 2000 bottles of wine:

1. 2000 bottles (divided by) 12 = 166.66 cases  
Total weight = 5800 lbs.
2. One case occupies approximately one square foot of wall area.
3. Assume cases are raised off the floor one foot, and bottles are stacked five feet high. Therefore, 33.33 linear feet of wall area is required (166.66 (divided by) 5).
4. Assuming a minimum 3 ft aisle between storage bins along walls yields a cellar 5 ft wide by 16 ft long.

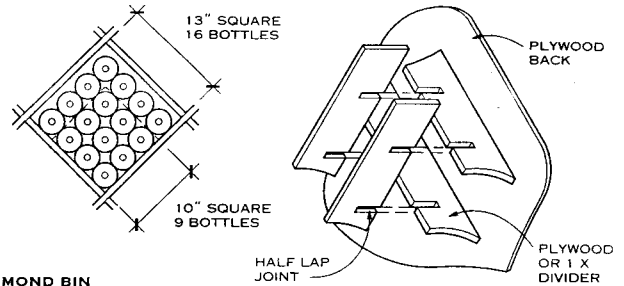

**DIAMOND BIN**

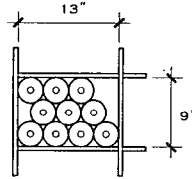

**RECTANGULAR BIN**

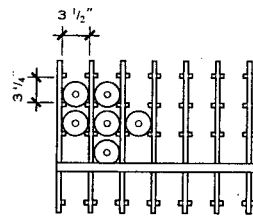
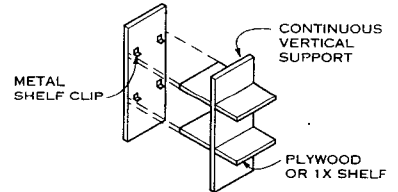

**INDIVIDUAL BOTTLE RACK**

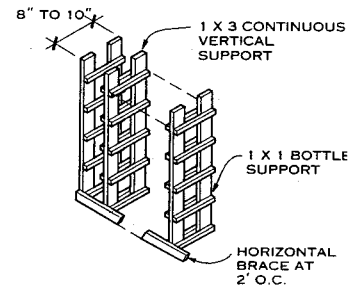

**BOTTLE STORAGE CONFIGURATIONS**

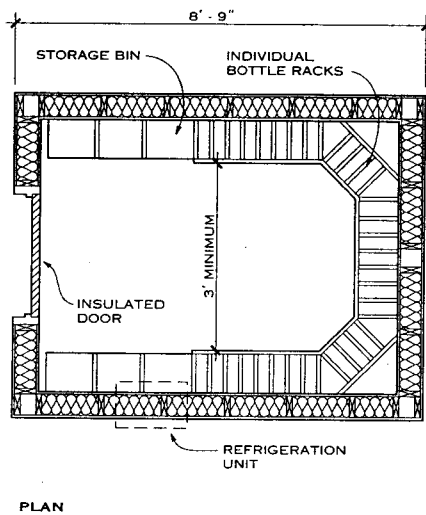

**PLAN**

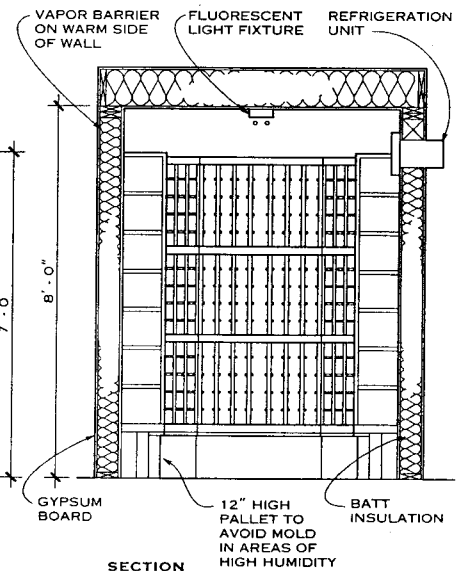

**SECTION**

**WOOD FRAME CELLAR FOR 875 BOTTLES**

J.T. Devine, AIA, and Robert E. Anderson, AIA; Robert E. Anderson Architect, AIA; Santa Rosa, California

**GENERAL NOTES**

1. Food service equipment must meet the sanitation and safety construction standards of the National Sanitation Foundation, an independent nonprofit organization dealing with public health issues. Other organizations involved in standards for food service equipment are Underwriters Laboratories (UL) and the American Society of Mechanical Engineers.
2. Food service equipment is either fabricated from a custom design or selected from a catalog. There are many variations in equipment specifications for such elements as power supply, door swings, finish, metal type, metal gauge, capacity, and accessories. These food service equipment pages show typical layouts and equipment for a mid-sized hotel kitchen that must produce a la carte meals, room service meals, banquets, etc. Equipment size and type will vary according to variables such as dining room size, menu type, and building type.
3. Prefabricated and custom-built walk-in refrigerators and freezers are specified differently. Consult a food service consultant for sizing, since these units can be specified to an infinite variety of sizes and shapes.
4. Food service equipment is primarily gas-powered, unless fumes are a concern, in which case electricity is used. If possible, steam is the preferred energy source because of its economy and efficiency.
5. Confer with a qualified food service consultant to determine the precise equipment and layout for the space to be served.

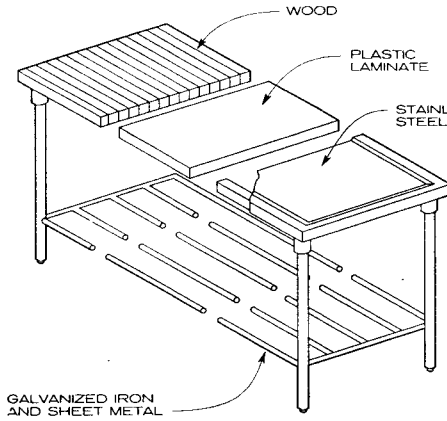

**NOTES**

1. Wood is used only for dining room or bakery production tables. Hard rock maple and pecan cutting tops are usually specified. Not to be used for nonbakery food production; cracks in wood surface can harbor bacteria.
2. Plastic laminate should not be used where cutting, chopping, or carving will occur. It will not warp or crack; it is an inexpensive substitute for stainless steel for nonfood production or decorative countertops, where codes allow.
3. Stainless steel is the most commonly used material for all areas in a commercial kitchen. Although relatively expensive, it is extremely durable. Cold-rolled steel stock is formed under pressure; welded connections are used only within equipment (bolted connections are used to connect pieces of equipment).
4. Galvanized iron and sheet metal are used as underbracing for equipment and as an inexpensive substitute for stainless steel for legs, tables, and interior shelves.
5. Other materials, including glass, ceramic tile, copper, and brass, may be used for food service equipment, but all surfaces that come into contact with food or the food handler should be smooth and nonporous and resist chipping or wear under frequent use. Surfaces must also resist the corrosive effects of salt, food acids, and oils.

**MATERIALS USED IN FOOD SERVICE EQUIPMENT**

**GAUGE AND USE OF GALVANIZED STEEL**

GAUGE	RECOMMENDED USE
12	Support channels and bracing
14	Undershelves and partitions
16	Undershelves and side panels
18	Utensil drawers, hoods, body panels, interior partitions

**GAUGE AND USE OF STAINLESS STEEL**

GAUGE	TYPICAL USE
8 and 10	Support elements for heavy equipment or at stress points
12	Heavily used tabletops, pot sinks, or other surfaces that will receive a great amount of wear
14	Tabletops, sinks, shelves, and brackets that will be used frequently or that will hold heavy objects
16	Small equipment tops and sides that will carry light objects; shelves under equipment and heavily used side panels
18	Side panels that are not exposed to much wear, equipment doors, hoods, and partitions
20	Covers for supported or insulated panels, such as refrigerators or insulated doors

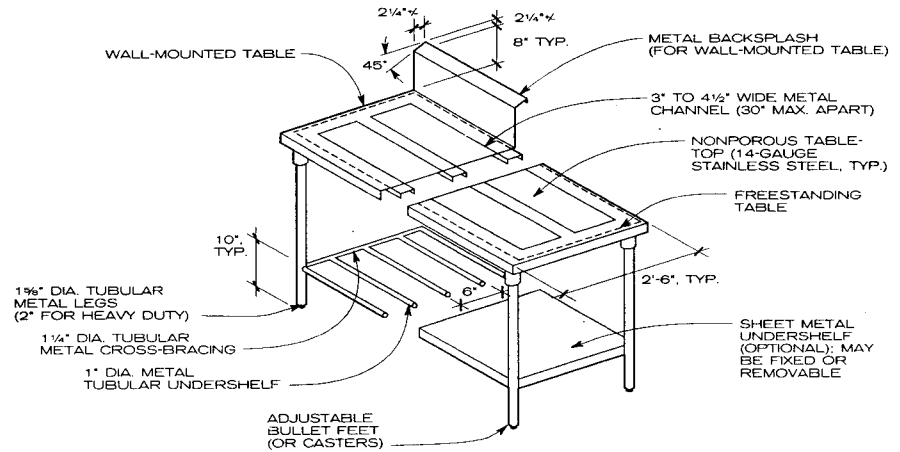

**NOTE**

Tubular metal pieces should be welded, coved together, and sanded smooth. A layer of cork-based sound-deadening material may be applied to the underside of tabletops

and finished with aluminum lacquer. Consult health codes for types of lacquer permitted.

**FABRICATED WORKTABLE**

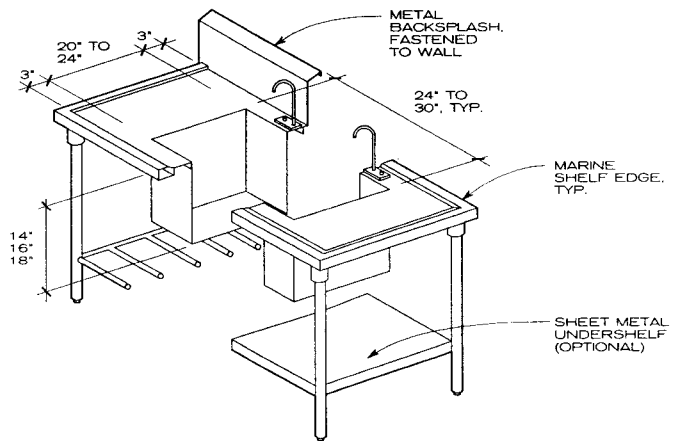

**FABRICATED WORKTABLE WITH SINK**

John Birchfield; Birchfield Foodsystems, Inc.; Annapolis, Maryland



**GENERAL**

Exhaust hoods remove air, water vapor, grease, and food odors from the kitchen area and air and water vapor from dish washing areas. Ovens and steam-jacketed kettles only require hoods that remove air, heat, and water vapor, but if large amounts of grease from a broiler, char-broiler, fryer, or grill are present, the hood system must extract this pollutant before the air is drawn outside by fans. This is done with grease "cartridges," or with stainless steel extractors, both of which violently blow the exhausted air around. This flings the grease particles to the sides of the baffles; then they are collected in a trough for easy removal, or run out a drain. The extractors can usually be washed in a standard kitchen dishwasher. Consultation with code officials and food service consultants is of utmost importance when designing exhaust hoods.

**NOTES**

1. CFM requirements for exhaust hoods are determined by the length of the hood and the equipment types underneath. Typical requirements range from 150 to 450 CFM per linear foot of hood.
2. Some codes may require a higher exhaust rate. To make up this air differential and to prevent more air from being drawn from surrounding areas, introduce air through a supply duct. The supplied air should make up 50 to 85% of the total exhaust.

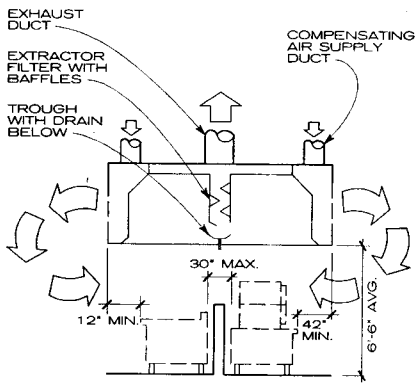

HEAVY COOKING EQUIPMENT SIDE (250 CFM/LINEAR FT) | LIGHT COOKING EQUIPMENT SIDE (150 CFM/LINEAR FT)

**NOTE**

Single exhaust hoods are available for single cooking lines. Dimensions and capacities of exhaust hoods vary with particular kitchen cooking requirements.

**TYPICAL EXHAUST HOOD REQUIREMENTS**

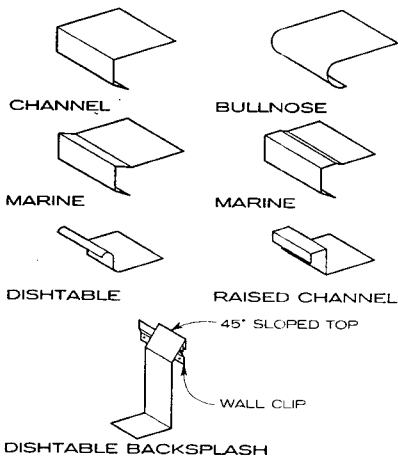

**NOTE**

Channel edges and bullnose edges are used only when water will not be spilled on the table surface.

**TABLE EDGE PROFILES**

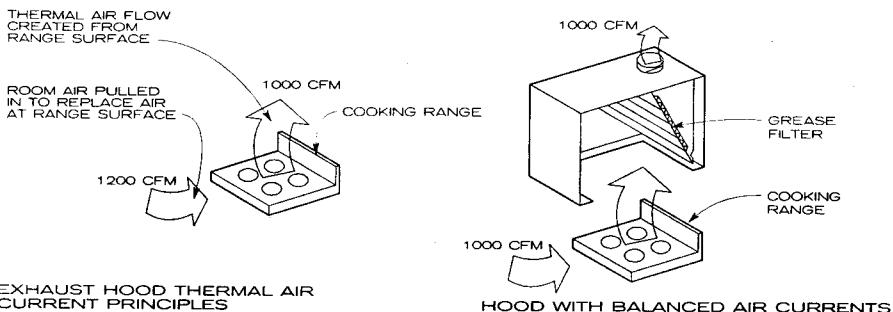

EXHAUST HOOD THERMAL AIR CURRENT PRINCIPLES

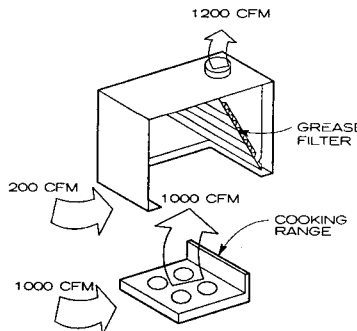

HOOD WITH 20% SAFETY FACTOR NOTE

Room air drawn in at the front of the hood at the rate of 200 cubic ft per minute (CFM) will create an extra 20% safety

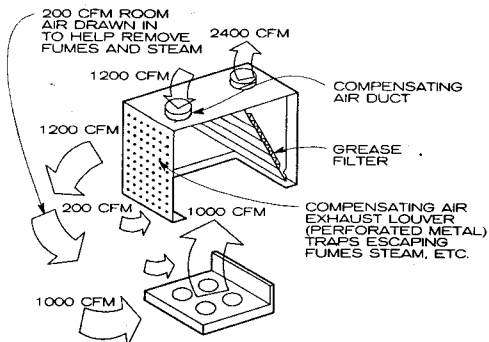

HOOD WITH 50% COMPENSATING AIR

margin at the hood to handle thermal surges, crosscurrents, etc.

**EXHAUST HOOD CHARACTERISTICS**

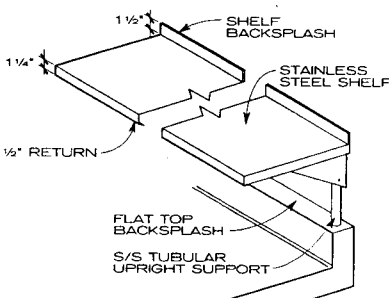

**ELEVATED TABLE-MOUNTED SHELF**

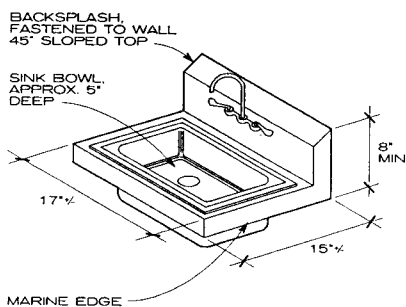

**NOTE**

Hand sinks are typically required by code near every major work area in the kitchen. Some are equipped with an electronic eye or foot levers to encourage workers to wash their hands.

**WALL-MOUNTED HAND SINK**

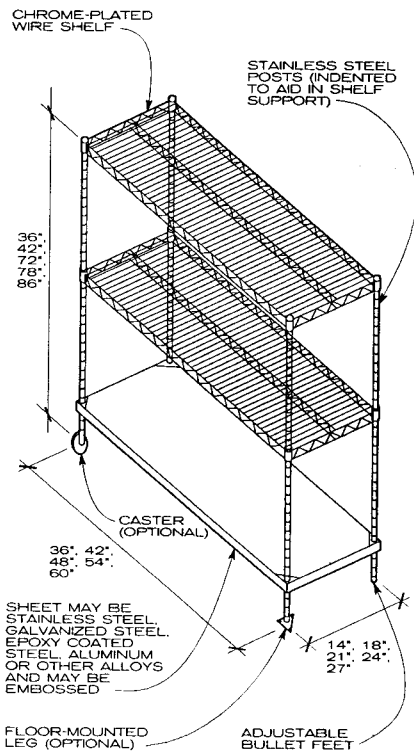

**FLOOR-MOUNTED LEG (OPTIONAL)**

**ADJUSTABLE BULLET FEET**

**NOTE**

This shelf may be used in dry storage rooms and walk-in refrigerators and freezers. Shelving may be mounted to the wall for stability and can be attached to other modular units.

**MODULAR WIRE SHELVING UNIT**

John Birchfield; Birchfield Foodsystems, Inc.; Annapolis, Maryland

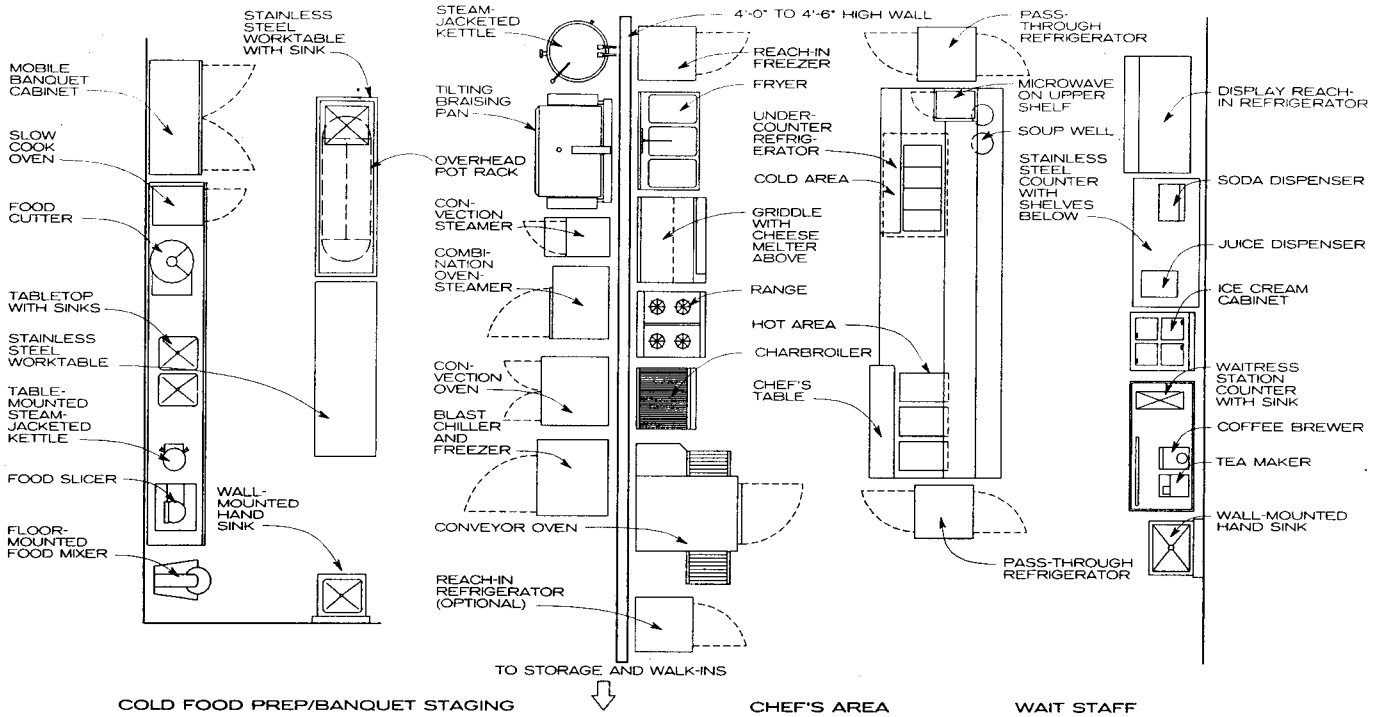

TYPICAL KITCHEN PLAN

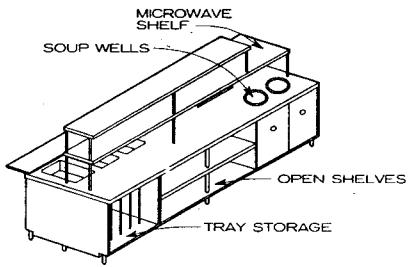
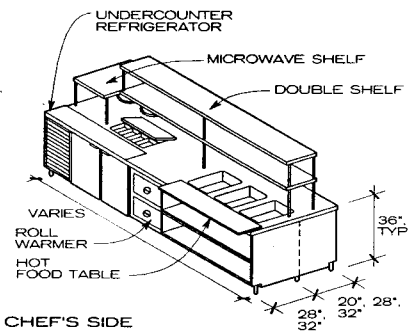

WAIT STAFF PICK-UP SIDE

NOTE

The chef's table is the heart of the kitchen operation; it is here the hot and cold food is arranged on plates for pick-up by the wait staff. Since both kitchen and wait staffs need access, the table is usually placed in an island configuration. Usually custom-built to meet the chef's requirements.

CHEF'S TABLE

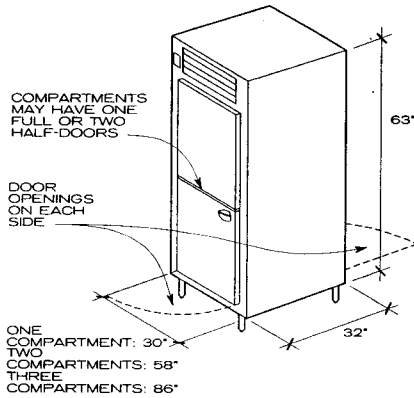

NOTE

This unit is typically placed either at end of the chef's table or in the wall separating the service area from the kitchen.

PASS-THROUGH REFRIGERATOR

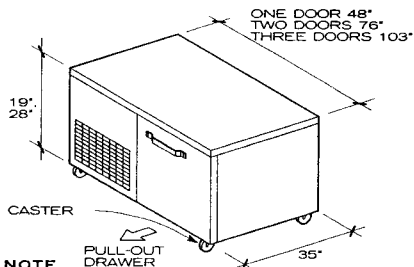

NOTE

This unit has a motor capacity from 1/4 to 1 HP and a maximum load of 500 to 1000 lb.

UNDERCOUNTER REFRIGERATOR FREEZER

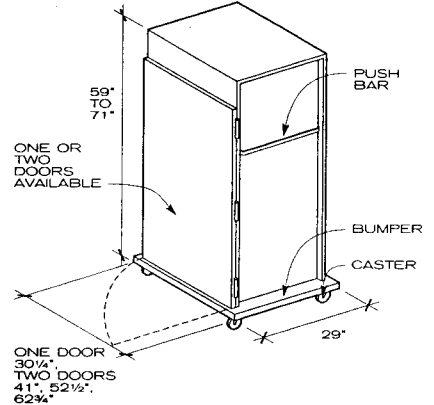

NOTE

This cabinet is used to keep preplated meals hot.

MOBILE BANQUET CABINET

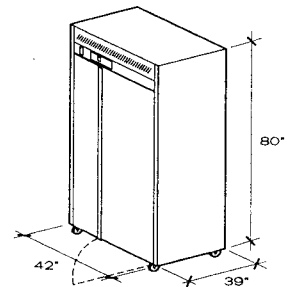

NOTE

This unit provides cook/chill and cook/freeze options.

BLAST CHILLER AND FREEZER

John Birchfield; Birchfield Foodsystems Inc., Annapolis, Maryland

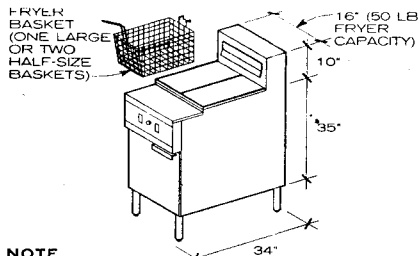

**NOTE**

Fryers cook food by immersing it in hot fat and are powered by either gas or electricity. Fryers can be either freestanding, table mounted, modular (electric only), or drop-in (electric only). Typical capacities range from 15 to 75 lb of shortening or fat. Two modular units with a filter dump station between them is a common fryer configuration.

**FRYER**

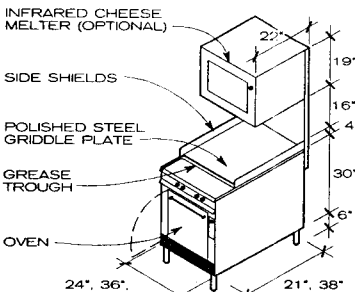

**NOTE**

Griddles, also called grills, have a flat, heated surface that cooks food quickly. They can be freestanding units, part of a range, table models, or part of a modular unit and are either gas- or electric-powered.

**GRIDDLE WITH CHEESE MELTER**

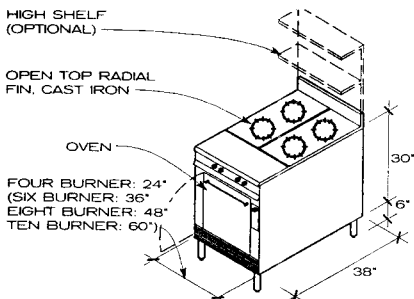

**NOTE**

The range is often the most heavily used piece of equipment in a food service facility. The open-top gas range is preferred by cooks, especially for sauteing, because the flame is visible and easily adjusted. Electric models are available.

**RANGE**

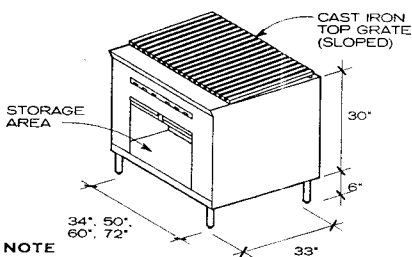

**NOTE**

A charbroiler cooks food rapidly, one side at a time, usually with radiant heat produced by gas or electricity. There are many types: freestanding top burner broilers, charbroilers, salamanders (small above-the-range broilers for last minute browning), conveyor broilers, and rotisseries.

**CHARBROILER**

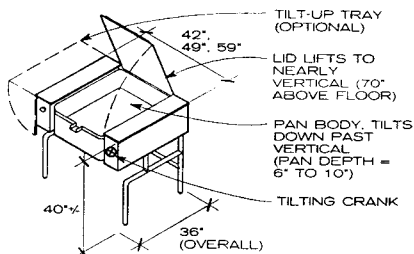

**NOTE**

Also called a tilting skillet or tilting frying pan, this braising pan can be used for grilling, steaming, braising, sauteing, or stewing. It holds a large volume of food, typically 20 to 40 gallons. The pan body tilts down so that liquids can be poured off, and also to aid in cleaning.

**TILTING BRAISING PAN**

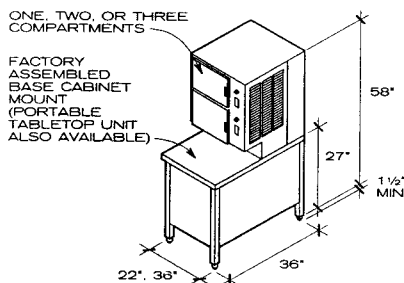

**NOTE**

Low- (5 lb per sq in.) and no-pressure steamers are used to prepare vegetables, seafood, eggs, rice, and pasta and work very efficiently. They are powered by gas, electricity, direct steam, or a steam coil.

**CONVECTION STEAMER**

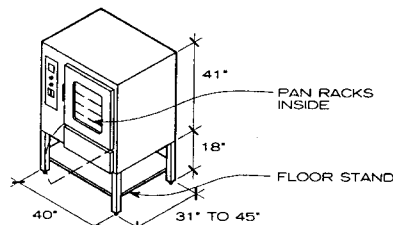

**NOTE**

Also called a "combi," it combines a convection oven with a steamer in one piece of equipment. It is popular because of its versatility.

**COMBINATION OVEN-STEAMER**

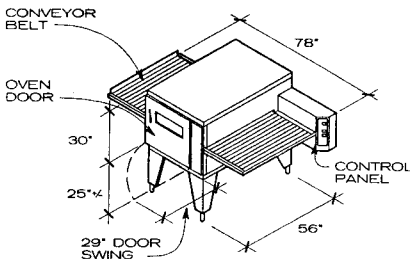

**NOTE**

A conveyor oven moves food through a heated cavity at a predetermined speed, ensuring even cooking time and allowing high-volume production. Heating is by convection or radiant heat, on one or both sides of the belt. Pizzas, cookies, hamburgers, and seafood all travel this route.

**CONVEYOR OVEN**

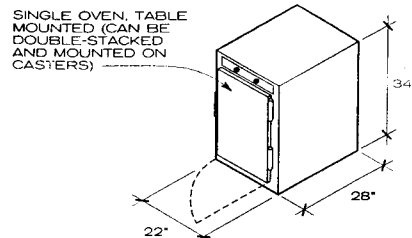

**NOTE**

Primarily used to roast meats, this oven can also be used to warm hot foods and proof bread or dough. Designed to cook at 200 to 240°F, these ovens reduce shrinkage of roast meats up to 40% and save energy.

**SLOW-COOK OVEN**

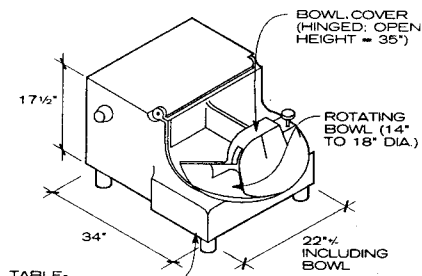

**NOTE**

Used for chopping meats and vegetables, this machine is similar in function to a food processor. It is also called a "buffalo chopper." Another larger type is a vertical cutter mixer (VCM), with a capacity of 30 to 45 quarts.

**FOOD CUTTER**

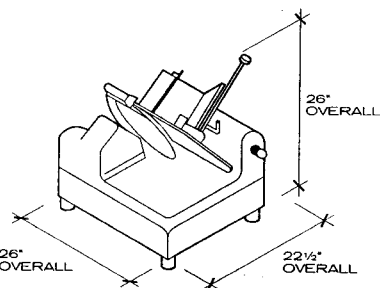

**NOTE**

Motor capacity varies from 1/5 to 1/2 HP.

**FOOD SLICER**

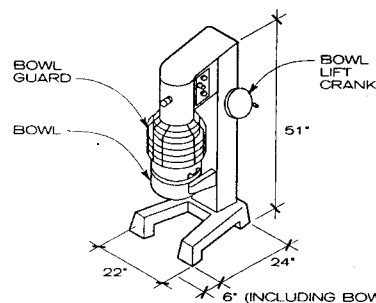

**NOTE**

This is used to mix/process large quantities of food, especially if a variety of attachments is required.

**FOOD MIXER**

John Birchfield; Birchfield Foodsystems Inc.; Annapolis, Maryland

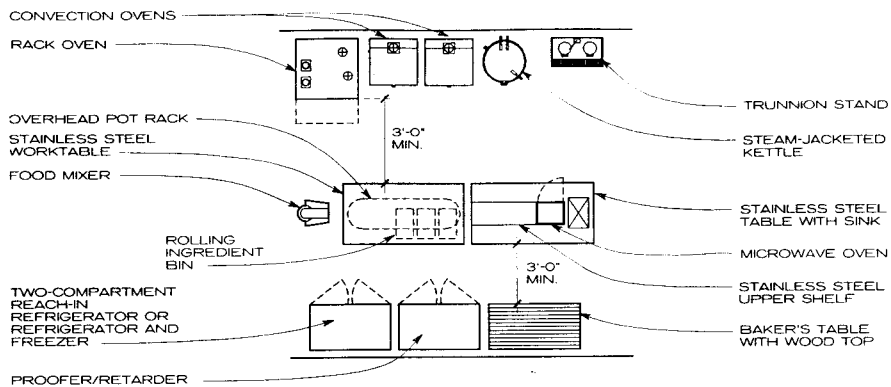

**TYPICAL BAKERY AREA PLAN**

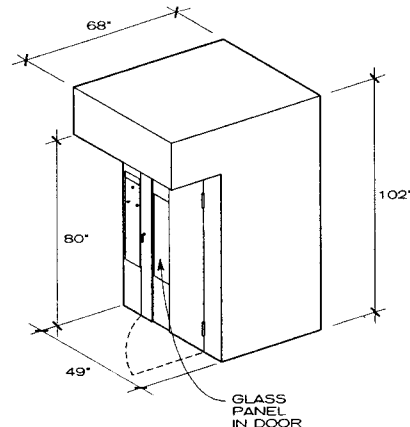
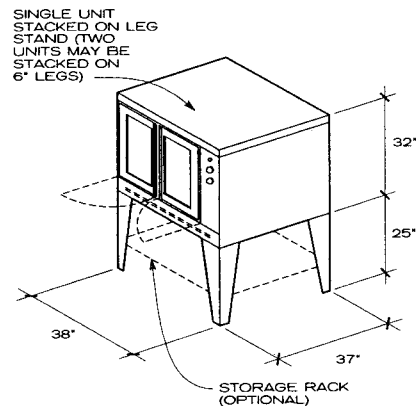

**NOTE**  
 Convection ovens need less energy and less space than other commercial kitchen ovens. A fan circulates heat evenly throughout the oven chamber, and the interior shelves can be stacked very close together.

**NOTE**  
 The rack is loaded, usually with baked goods, and wheeled into the oven. The rack rotates on a carousel or a ceiling hung bracket, baking food with a steady, even heat. Rack ovens are powered by gas, electricity, or oil.

**CONVECTION OVEN**

**RACK OVEN**

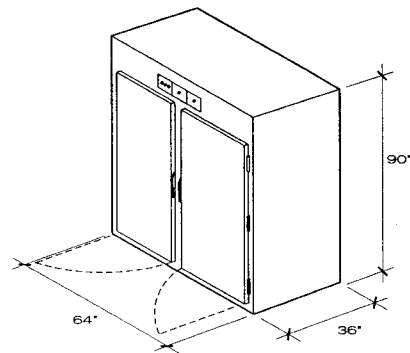
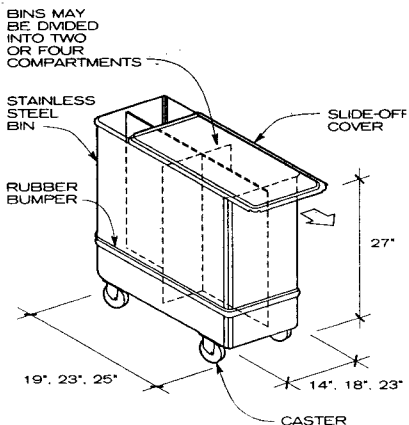

**NOTE**  
 Used for storage of baked goods and ingredients like flour, sugar, and rice. Bin can be stored under open-based tables.

**NOTE**  
 This unit proofs bakery items (emits the moist, low heat that dough needs to rise), then, after a specified amount of time, issues cold air to halt the rising.

**ROLLING INGREDIENT BIN**

**RETARDER/PROOFER**

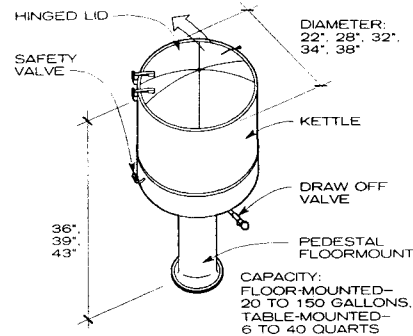

**NOTE**  
 A steam-jacketed kettle is used for soups, stews, sauces, boiled meats, etc. The kettle is double-walled; heat comes from an inner jacket that contains the steam. The kettle can be mounted either on a pedestal, on legs, on a yoke (trunnion) for tilting, on the wall, or on a tabletop.

**STEAM-JACKETED KETTLE**

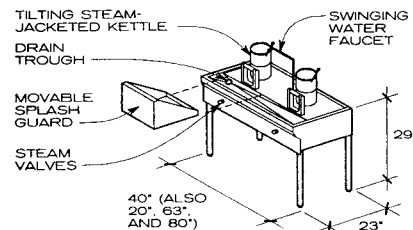

**NOTE**  
 This stand can hold up to four steam-jacketed kettles on pinions, or trunnions, which enable tilting and pouring.

**TRUNNION STAND**

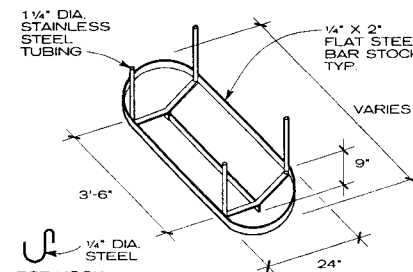

**NOTE**  
 Dimensions shown are for medium-use kitchens; review unusual conditions, such as use of extra large pots or need for wider support spans, with a structural engineer.

**OVERHEAD POT RACK**

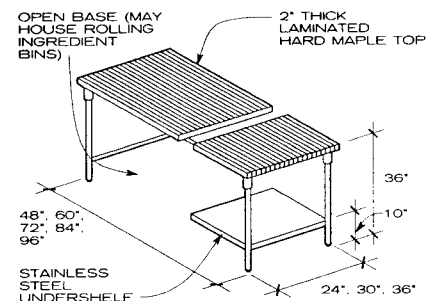

**NOTE**  
 Baker's tables are used exclusively for making baked goods. Any other use that could bring bacteria-laden foods into contact with the wood surface is prohibited.

**BAKER'S TABLE**

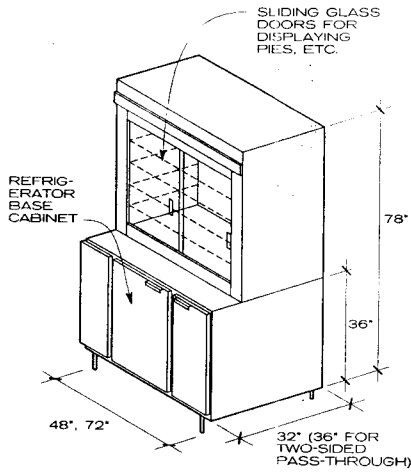

**DISPLAY REACH-IN REFRIGERATOR**

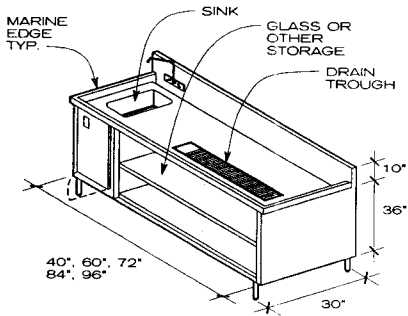

**NOTE**  
Multipurpose table unit used to store cups and glasses and to prepare soft drinks, coffee, tea, and other beverages.

**WAITRESS STATION COUNTER**

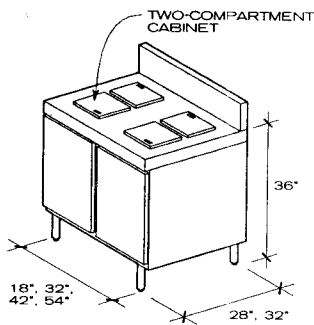

**ICE CREAM CABINET**

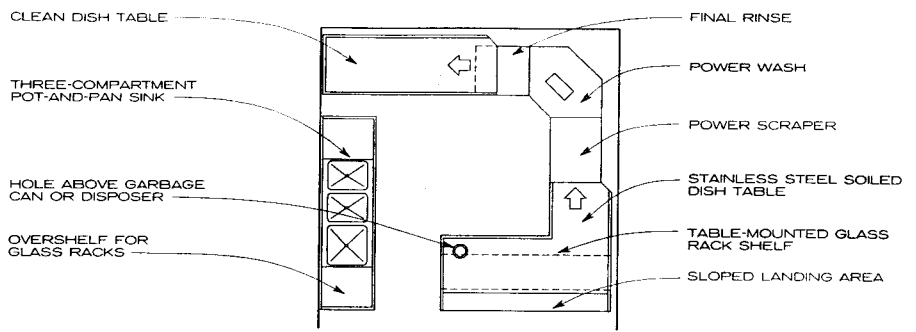

**TYPICAL DISHWASHING AREA PLAN**

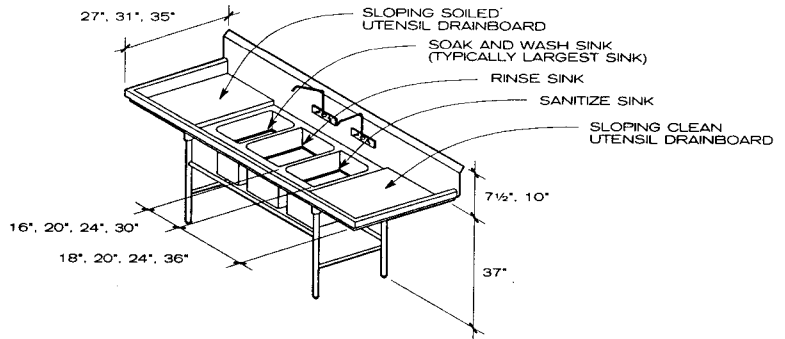

**NOTE**  
The sink illustrated is a fairly common type, but depth of sinks, number of sinks, and size of drainboards can vary.

**POT AND PAN SINK**

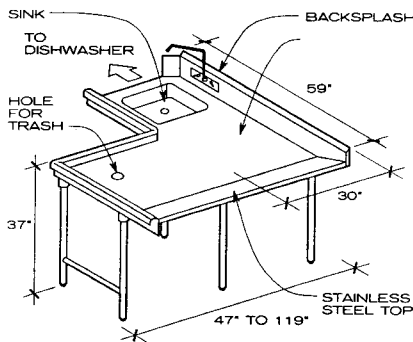

**SOILED DISH TABLE**

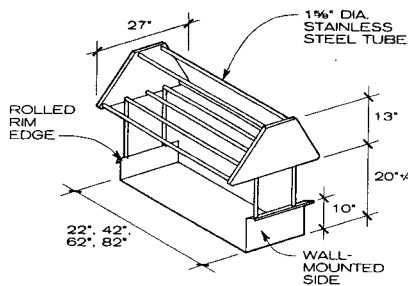

**NOTE**  
Typically this is mounted on the soiled dish table.

**TABLE-MOUNTED GLASS RACK SHELF**

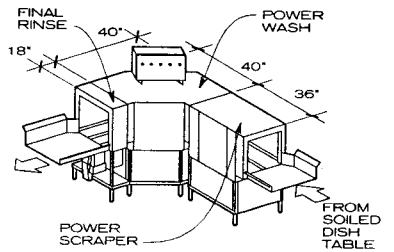

**NOTE**  
A spray of hot water and detergent washes the dishes, followed by a rinse of 180°F water or chemicals to sanitize them. Sometimes an exhaust hood is used; the design of machines varies greatly.

**DISHWASHING MACHINE**

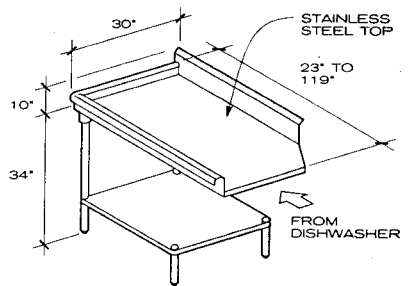

**CLEAN DISH TABLE**

John Birchfield; Birchfield Foodsystems Inc.; Annapolis, Maryland

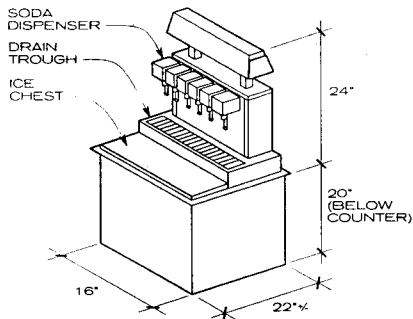

**NOTE**  
This drops into a cutout in the wait staff counter.

**DROP-IN SODA DISPENSER**

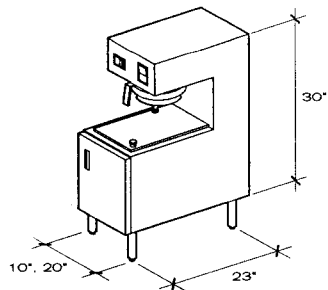

**NOTE**  
Typically tea makers sit on top of the wait staff counter.

**TEA MAKER**

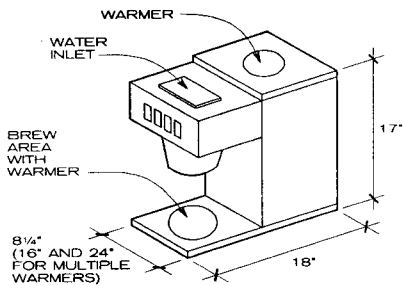

**NOTE**  
Coffee brewers sit on top of the wait staff counter.

**COFFEE BREWER**

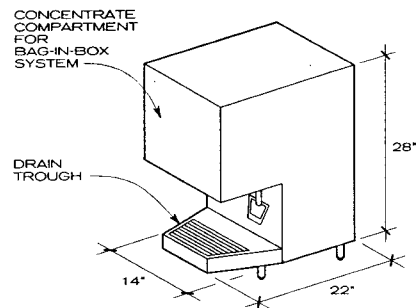

**NOTE**  
Juice dispensers sit on top of the wait staff counter.

**JUICE DISPENSER**

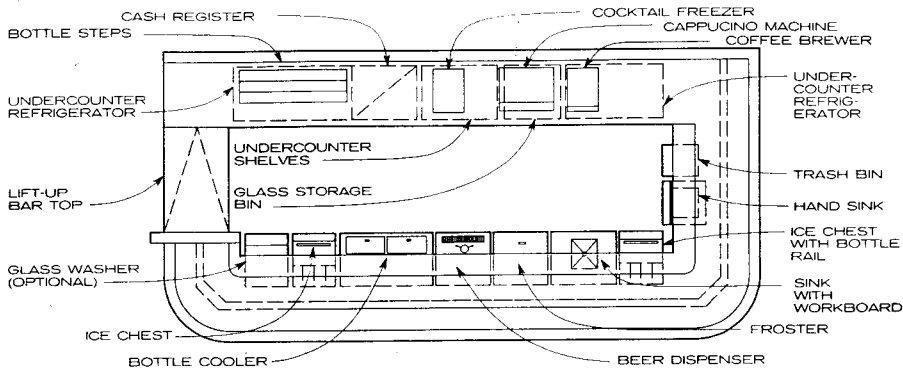

**TYPICAL BAR EQUIPMENT LAYOUT**

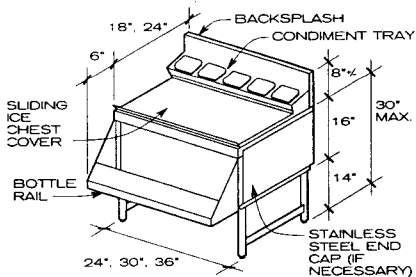

**NOTE**  
These units vary according to use, with different cover opening styles (hinged or sliding), condiment tray configurations, and placement of ice dividers in chest.

**ICE CHEST**

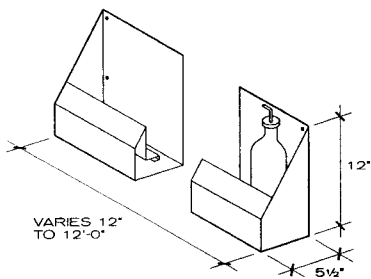

**NOTE**  
Bottle rails are attached to the front of sinks, ice chests, or other bar equipment. Lockable models are available.

**BOTTLE RAIL**

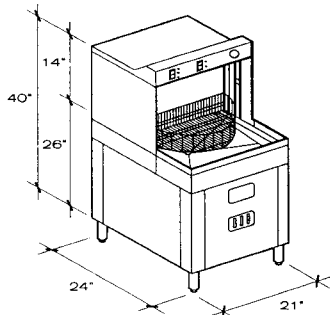

**NOTE**  
A sink with drainboard may be substituted for this.

**GLASS WASHER**

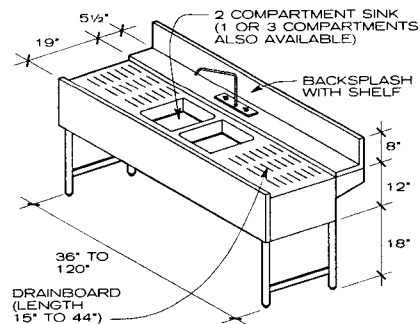

**NOTE**  
A mechanical glass washer may be substituted for this.

**SINK WITH WORKBOARD**

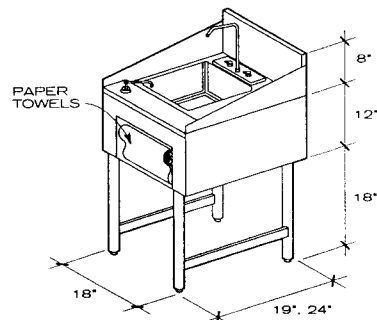

**BAR HAND SINK**

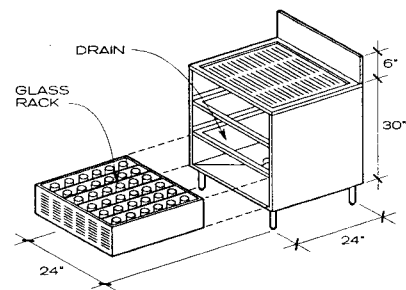

**GLASS STORAGE BIN**

Richard J. Vitullo, AIA; Oak Leaf Studio; Crownsville, Maryland

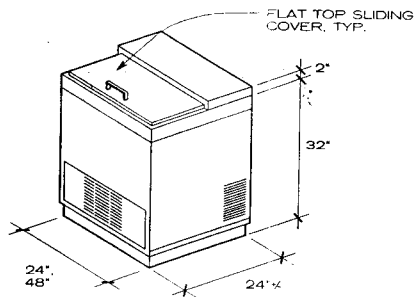

**NOTE**  
Frosters chill mugs, glasses, and plates to minus 10°F on interior shelves. Usually they are placed under the front bar.

**FROSTER**

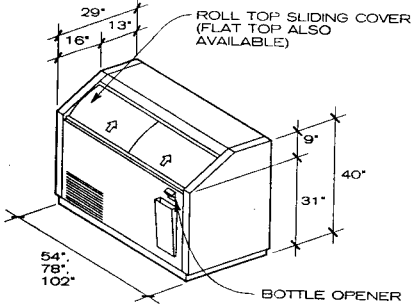

**NOTE**  
These are used to cool beverages to between 34° and 40°F.

**BOTTLE COOLER**

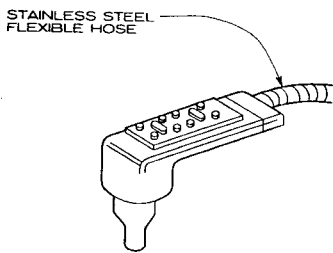

**NOTE**  
This dispenses water, soda, wine, and other drinks.

**MECHANICAL POSTMIX BAR DISPENSER**

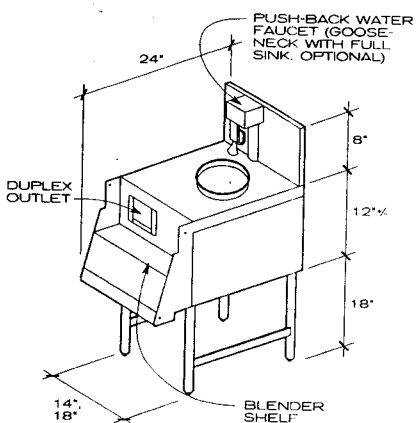

**BLENDER STATION**

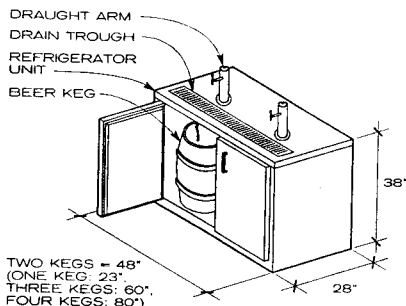

TWO KEGS = 48"  
(ONE KEG: 23",  
THREE KEGS: 60",  
FOUR KEGS: 80")

**NOTE**  
The dispenser shown is a direct draw system. Kegs may be up to 300 ft away from the bar (usually in a walk-in cooler).

**BEER DISPENSER**

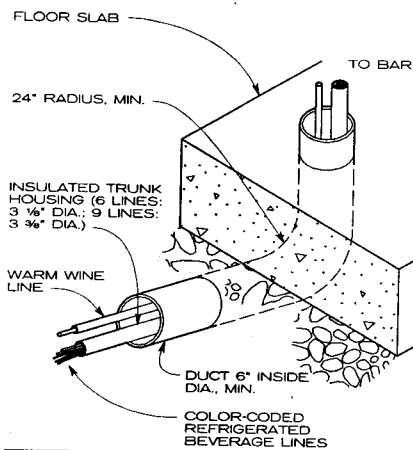

**REMOTE BEVERAGE DISPENSER DETAIL**

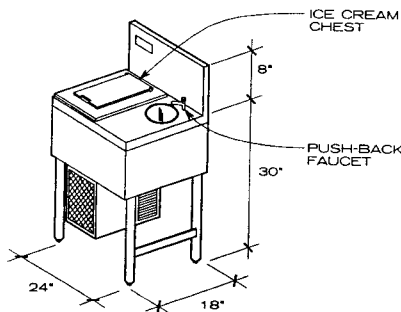

**ICE CREAM CABINET**

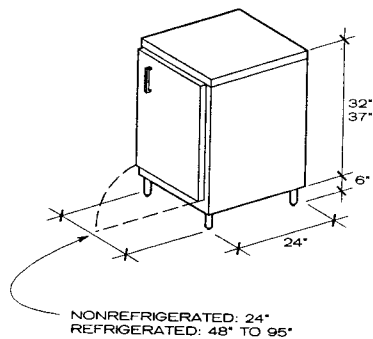

NONREFRIGERATED: 24"  
REFRIGERATED: 48" TO 95"

**BACK-BAR DRY STORAGE CABINET**

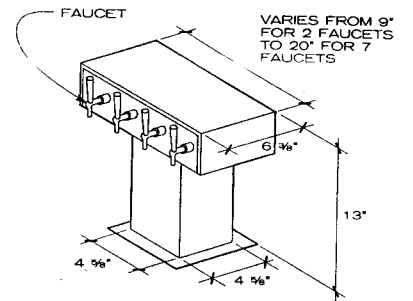

**TEE TOWER**

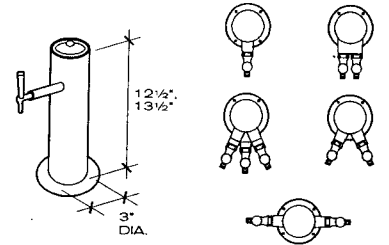

**DRAUGHT ARM BEER DISPENSING FAUCETS**

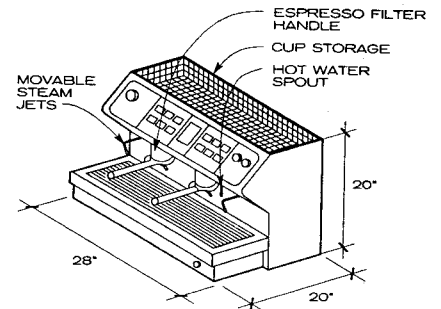

**CAPPUCCINO/ESPRESSO MACHINE**

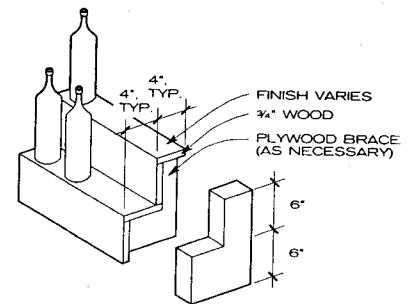

**NOTE**  
These are also called bottle steps.

**LIQUOR DISPLAY SHELVES**

Richard J. Vitullo, AIA; Oak Leaf Studio; Crownsville, Maryland

**GENERAL NOTES**

1. See kitchen and laundry layout pages for locations of washers, dryers, and dishwashers and their respective wall chases for pipes and vents.
2. Check manufacturers' catalogs for "open-door" dimensions if door clearances may be a problem.
3. All dimensions given are actual ones, but certain variations in body design may affect the actual depth of particular models. Check all units for exact voltage. Some units available with gas.

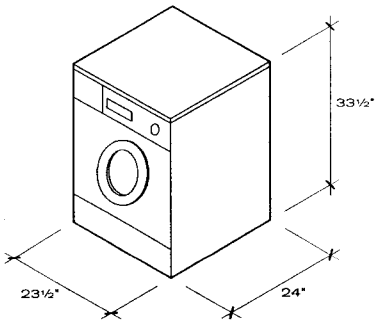

**NOTE**  
Front-loading washers may be equipped with an integral top if not mounted under a counter.

**BUILT-IN (UNDERCOUNTER) FRONT-LOADING WASHER**

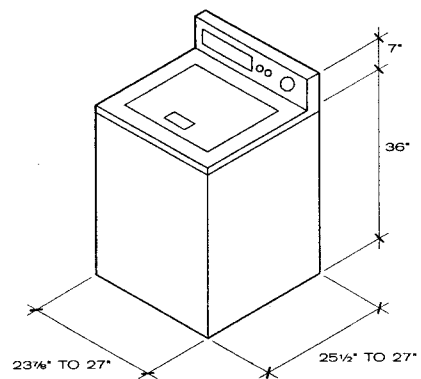

**FREESTANDING TOP-LOADING WASHER**

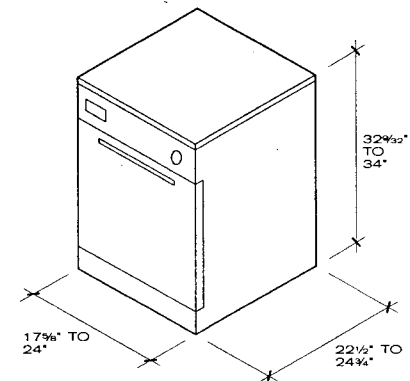

**NOTE**  
Do not place dishwasher farther than 10 ft from sink, typically, for proper drainage.

**BUILT-IN DISHWASHER**

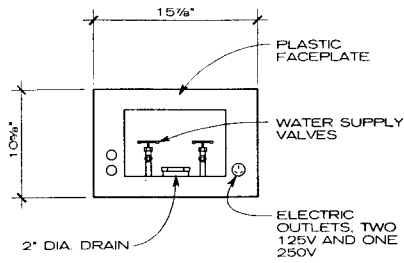

**ELEVATION**

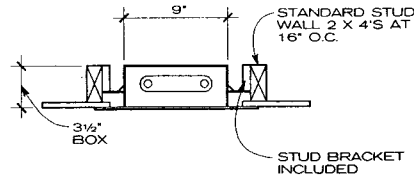

**SECTION**

**UTILITY CONNECTION BOX (RECESSED)**

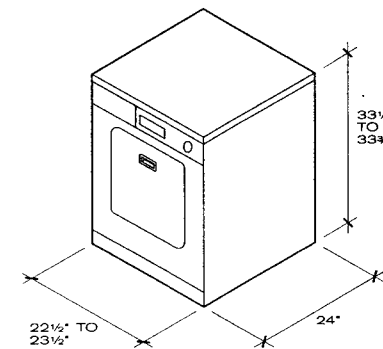

**NOTE**  
Front-loading dryers may be equipped with an integral top if not mounted under a counter.

**BUILT-IN (UNDERCOUNTER) FRONT-LOADING DRYER**

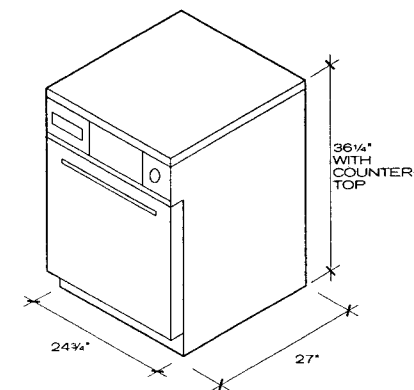

**NOTE**  
Some portable models may be converted to built-in.

**PORTABLE DISHWASHER**

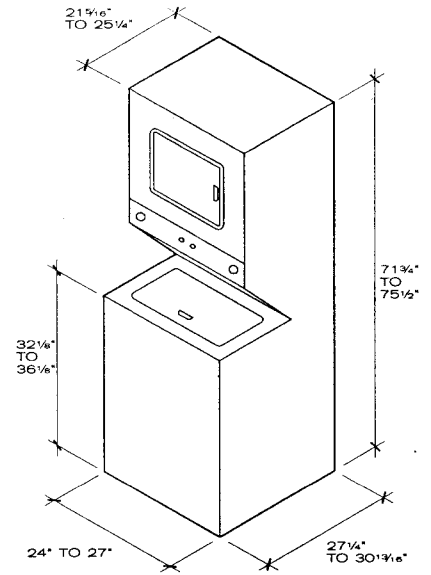

**STACKED WASHER-DRYER COMBINATION**

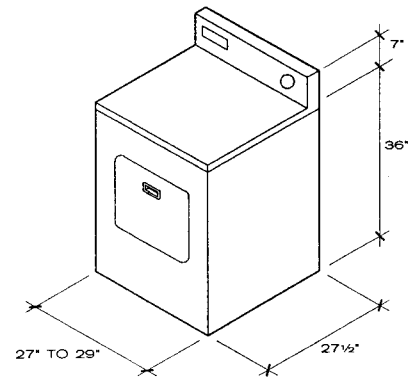

**FREESTANDING FRONT-LOADING DRYER**

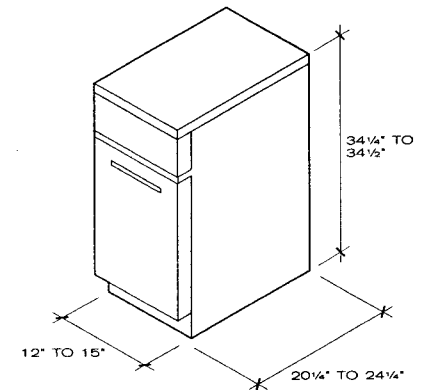

**TRASH COMPACTOR**

Richard J. Vitullo, AIA; Oak Leaf Studio; Crownsville, Maryland



**GENERAL NOTES**

1. Electric and gas ranges are available. Smooth surface electric cooktops have radiant and halogen heating elements or an induction coil below a glass-ceramic top. Radiant heating elements (below surface or surface units, plug-in, coil, or solid plate) provide heat directly from resistance elements. Halogen-type elements usually combine radiant elements with a halogen light source, which allows the element to heat up faster than

a radiant element alone. Other range options include griddles and charbroilers. Induction elements consist of a high frequency induction coil beneath a glass-ceramic surface. Metal cooking utensils are heated by magnetic friction without directly heating the cooktop surface. Induction elements are considered energy-efficient.

2. Ovens are available in gas or electric, either as conventional, combination radiant/convection, or microwave

models. Convection ovens have a dedicated third element (in addition to the top and bottom elements) surrounding the convection fan at the rear of the oven, which circulates heated air evenly throughout the oven, eliminating any unevenness in temperature.

3. All dimensions shown should be used as general guidelines only; consult manufacturers for specific dimensions.

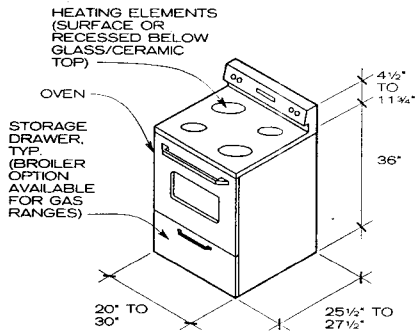

**NOTE**

Freestanding range/ovens may have front-mounted controls; if so, the backsplash area may be eliminated.

**FREESTANDING RANGE/OVEN**

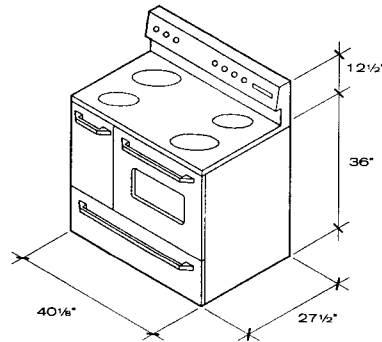

**FREESTANDING RANGE WITH LARGE AND SMALL OVENS**

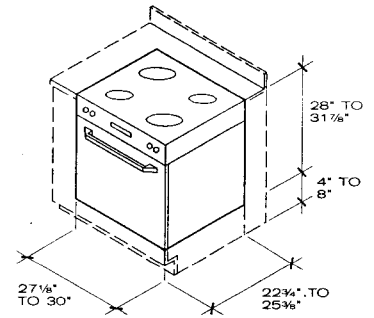

**NOTE**

Drop-in ranges typically hang from and are supported by the countertop and do not rest on the cabinet or floor below.

**DROP-IN RANGE OVEN**

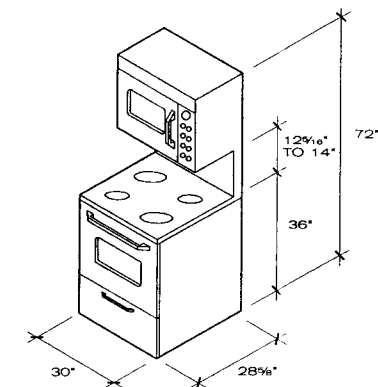

**NOTE**

Conventional or microwave ovens may be installed above a counter-height range/stove.

**FREESTANDING RANGE WITH UPPER AND LOWER OVENS**

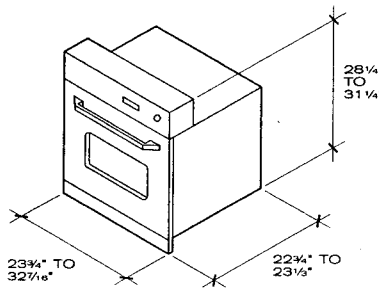

**NOTE**

Single wall ovens may be installed in a wall cabinet (at eye level) or under the counter in a base cabinet.

**BUILT-IN SINGLE WALL OVEN**

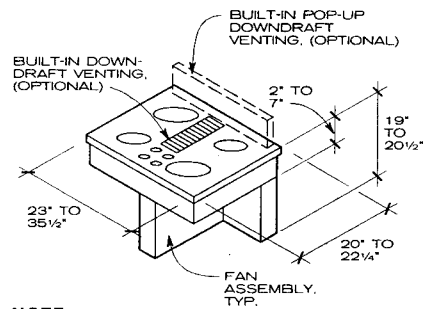

**NOTE**

Radiant and halogen cooktops typically require a 5 in. min. free area between the countertop and any combustible material below (typically shelving). Downdraft fan assemblies are located directly under a vent (rear pop-up vents offer the best free space under a counter). Available two-element cooktops are approximately 12 in. wide.

**DROP-IN RANGE COOKTOP**

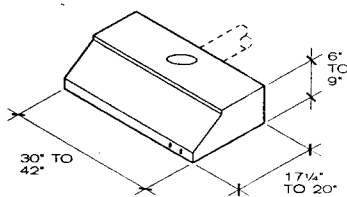

**NOTE**

Range hoods vent through filters back into the room (self-venting) or through ducts and filters to the outdoors. Accessories such as fans, filters, and lights vary greatly in design configuration. Some ranges and cooktops are equipped with downdraft venting, which may eliminate the need for an overhead range hood. Fans typically vent from 50 to 350 cu ft/min (CFM) of air for standard residential cooktop use. For commercial ranges, consult a design professional for CFM requirements.

**RANGE HOOD**

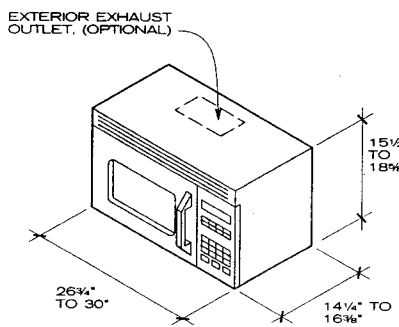

**NOTE**

Venting may be directed to the outside or recirculated.

**BUILT-IN MICROWAVE OVEN**

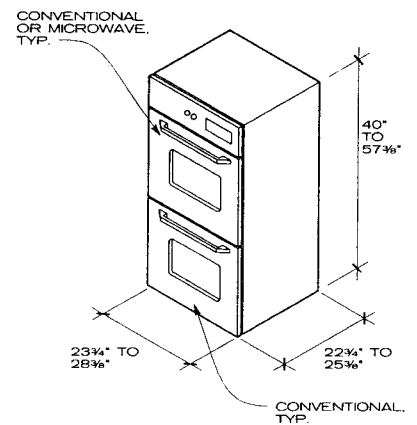

**BUILT-IN DOUBLE WALL OVEN**

Richard J. Vitullo, AIA; Oak Leaf Studio; Crownsville, Maryland

**GENERAL NOTES**

1. Ultra energy-efficient refrigerators/freezers are available in AC models for conventional utility power and DC models for alternative (remote) energy applications. Some models use 60 to 90% less energy than standard energy-efficient models. Many standard refrigerator and freezer manufacturers have CFC-free models, which means no CFCs were used in the insulation or in the coolant system. Consult manufacturers.
2. See manufacturers' catalogs for actual dimensions of specific units, which may include the number of burners, refrigerator size, sink size, finish materials, and options such as garbage disposal, range hood, microwave oven, ice maker, dishwasher, or freezer.

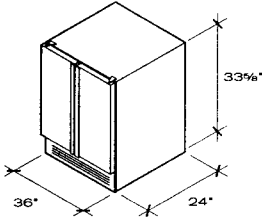

**SIDE-BY-SIDE (WITH FREEZER)**

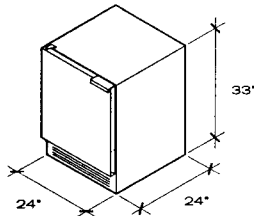

**SINGLE DOOR**

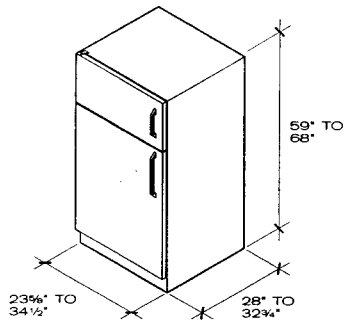

**REFRIGERATOR WITH TOP FREEZER**

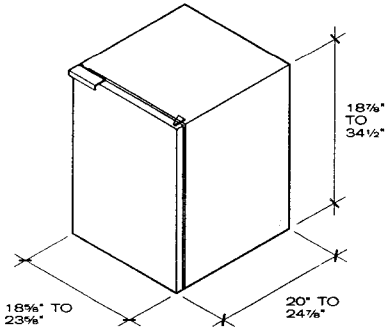

**SMALL CAPACITY FREESTANDING REFRIGERATOR**

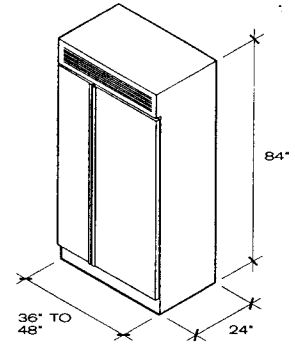

**BUILT-IN SIDE-BY-SIDE REFRIGERATOR/FREEZER**

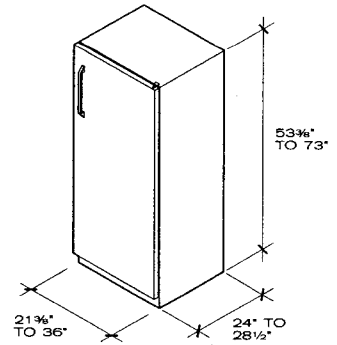

**UPRIGHT FREEZER**

**UNDERCOUNTER REFRIGERATORS**

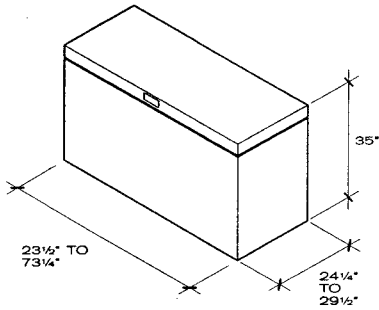

**CHEST FREEZER**

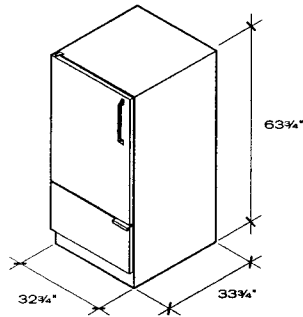

**REFRIGERATOR WITH BOTTOM FREEZER**

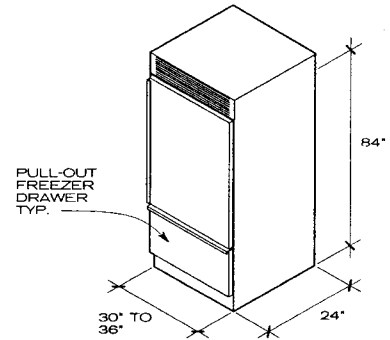

**BUILT-IN REFRIGERATOR WITH BOTTOM FREEZER**

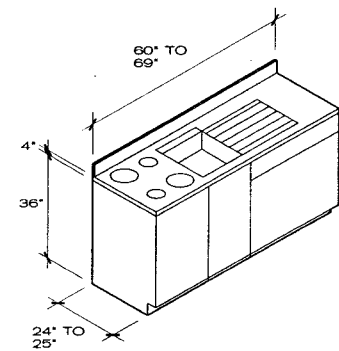

**UNIT KITCHENS**

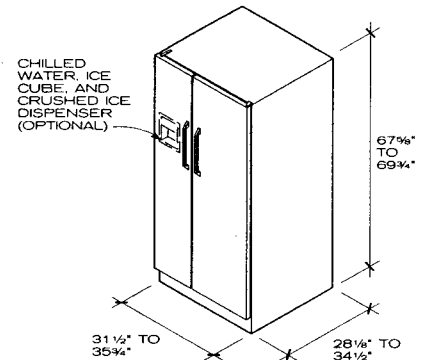
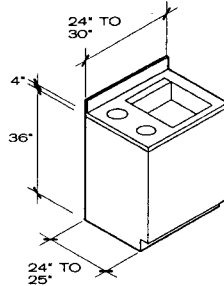
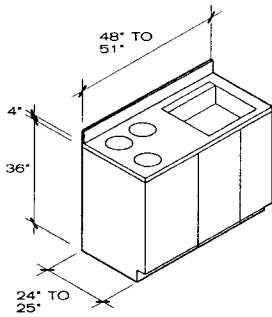

**SIDE-BY-SIDE REFRIGERATOR**

Richard J. Vitullo, AIA; Oak Leaf Studio; Crownsville, Maryland

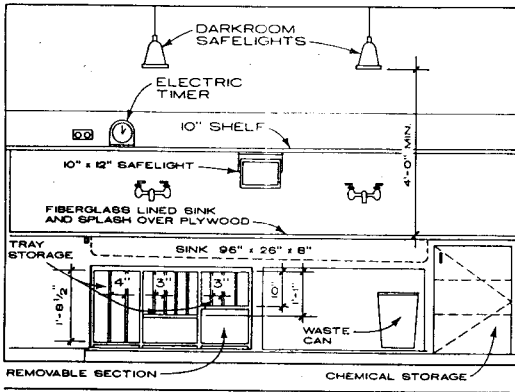

ELEVATION WET BENCH

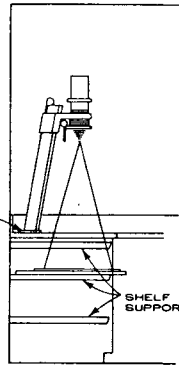

SECTION AT ENLARGER

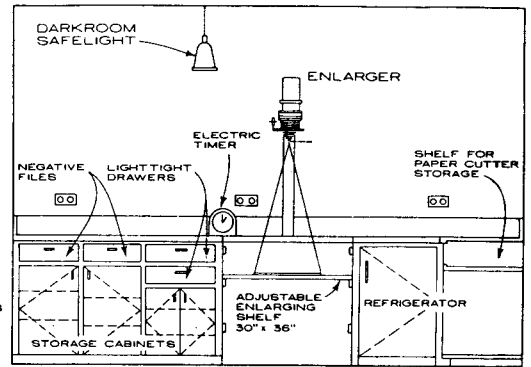

ELEVATION DRY BENCH

NOTES

1. Use filters on the air supply to prevent the introduction of dust into the darkroom.
2. Do not use fluorescent lighting, since the afterglow on the tubes may fog light sensitive material.
3. A darkroom is not required to be painted black. The area around the enlarger can be painted flat black. Ceiling can be white. Safelights can be mounted so that they shine up, creating indirect safe illumination.

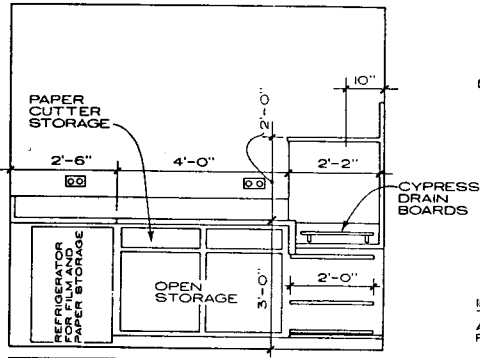

END ELEVATION

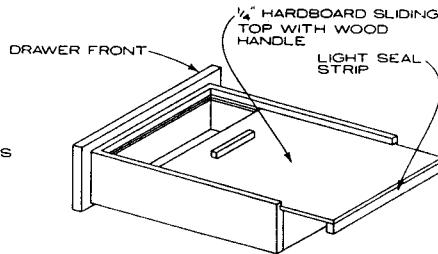

INSTALL STOP INSIDE CABINET SO THAT SLIDING DRAWER TOP WILL AUTOMATICALLY BE PUSHED FORWARD WHEN DRAWER IS CLOSED

LIGHTTIGHT DRAWER

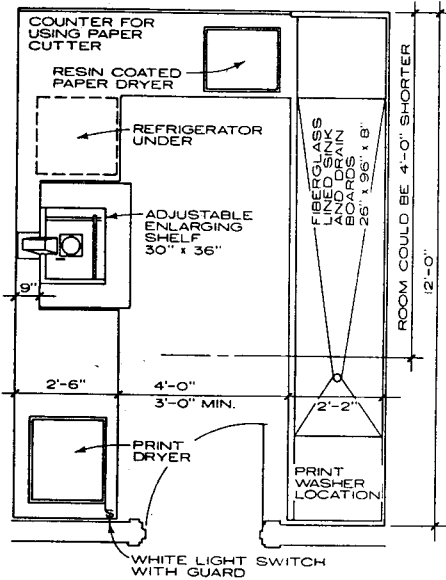

DARKROOM FLOOR PLAN

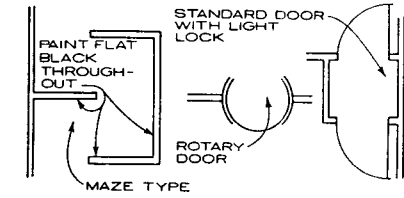

DARKROOM ENTRANCES

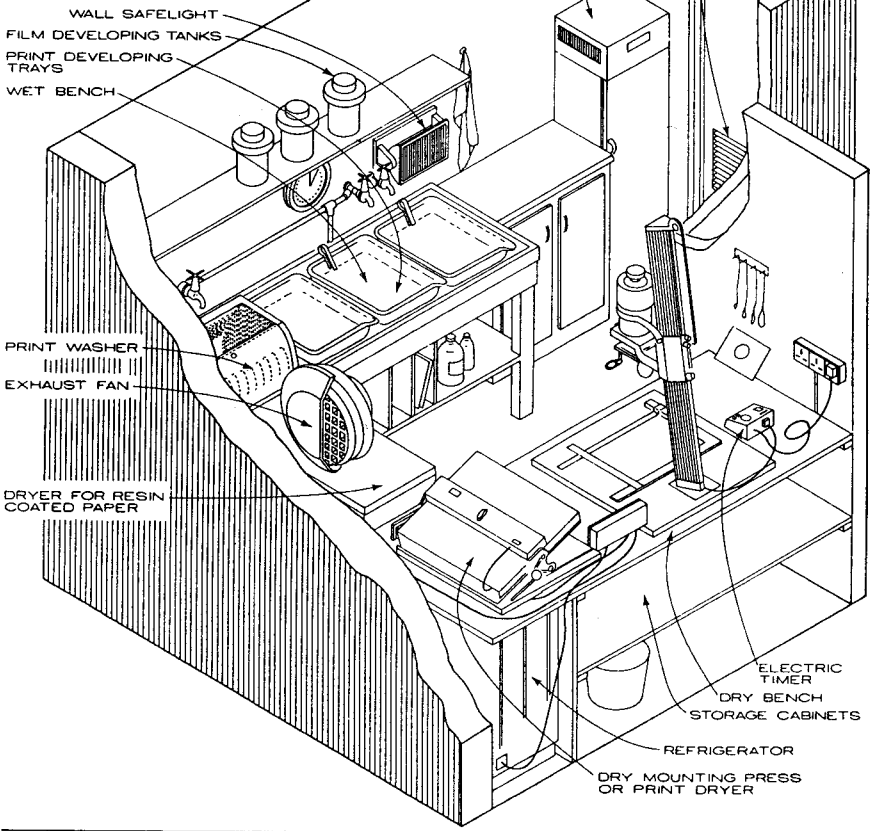

DARKROOM WITH TYPICAL EQUIPMENT

Robert E. Fehlberg, FAIA; CTA Architects Engineers; Billings, Montana

11 DARKROOM EQUIPMENT

# FURNISHINGS

Lamps 614

General Use Furniture 615

School and Library  
Furniture 619

Residential Furniture 624

Classic and Contemporary  
Furniture 627

Ecclesiastical Furniture 635

Office Furniture 637

Interior Plants and Planters 641

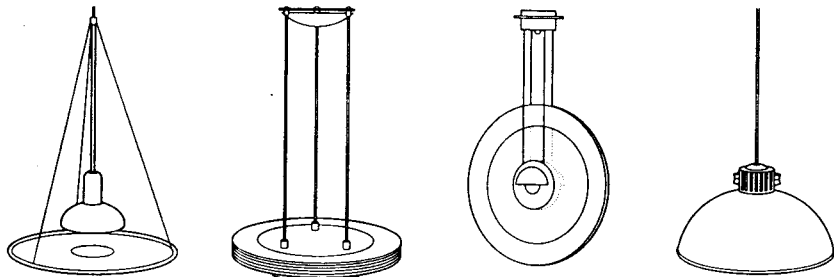

DIA. 23 1/2" H 29" WATTS 100 W <b>FRIBBI ATELIER INTERNATIONAL</b>	DIA. 23 1/2" H 12"-92" WATTS 3/50 W <b>AURORA ATELIER INTERNATIONAL</b>	DIA. 18" H 42" WATTS 2/12 V, 50 W <b>LUNA PENDANT BOYD LIGHTING</b>	DIA. 20" H 14" WATTS 100 W <b>CAFE II KOCH &amp; LOWY</b>
---	--	--	--

**CEILING FIXTURES**

**GENERAL NOTES**  
Lamps consist of three components:  
1. Light source.  
2. Reflector or diffuser.  
3. Support structure.

Various combinations of these components create an unlimited variety of lamps for accent lighting, task lighting, ambient lighting, and general lighting. Each type of bulb creates different qualities and quantities of light; consult manufacturer for specific attributes. Light can be reflected in specific directions for accent, task, or ambient lighting or diffused for general lighting.

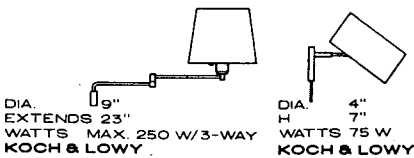

DIA. 9" EXTENDS 23" WATTS MAX. 250 W/3-WAY <b>KOCH &amp; LOWY</b>	DIA. 4" H 7" WATTS 75 W <b>KOCH &amp; LOWY</b>
--	---

**WALL LAMPS**

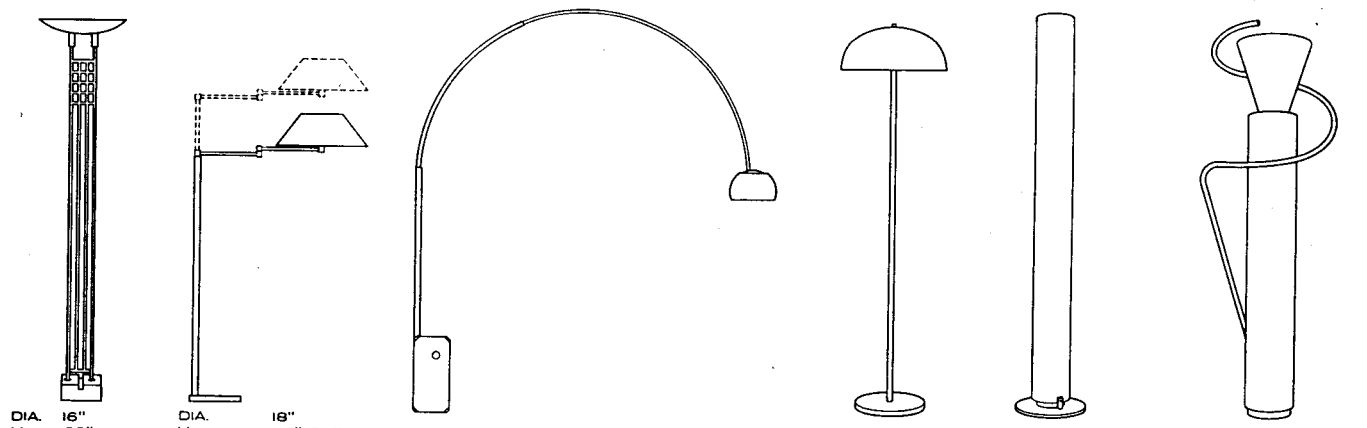

DIA. 16" H 69" BULB Q300T3 <b>GEORGE KOVACS KOCH &amp; LOWY</b>	DIA. 18" H 46"-58" EXTENDS 25" WATTS MAX. 250 W/ 3-WAY <b>ARCO ATELIER INTERNATIONAL</b>	W 78 1/2" H 95" WATTS 100 W <b>DUOMO KOCH &amp; LOWY</b>	DIA. 17" H 58" WATTS 3/75 W <b>STYLOS ATELIER</b>	DIA. TUBE 7" H 78" WATTS 1/150 W, 1/100 W <b>LUMINATOR ILLUMINATIONS</b>
--	---	---	--	--

**FLOOR LAMPS**

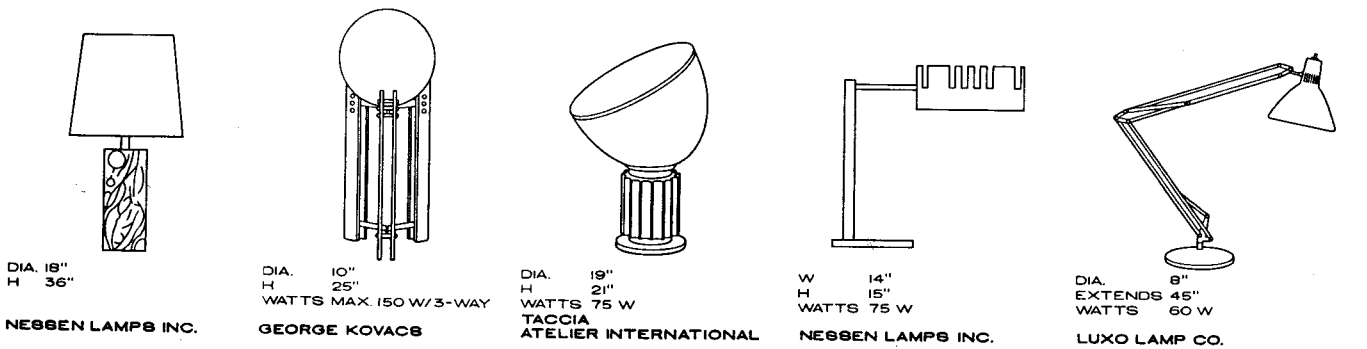

DIA. 18" H 36" <b>NESSEN LAMPS INC.</b>	DIA. 10" H 25" WATTS MAX. 150 W/3-WAY <b>GEORGE KOVACS</b>	DIA. 19" H 21" WATTS 75 W <b>TACCIA ATELIER INTERNATIONAL</b>	W 14" H 15" WATTS 75 W <b>NESSEN LAMPS INC.</b>	DIA. 8" EXTENDS 45" WATTS 60 W <b>LUXO LAMP CO.</b>
---	---	--	--	--

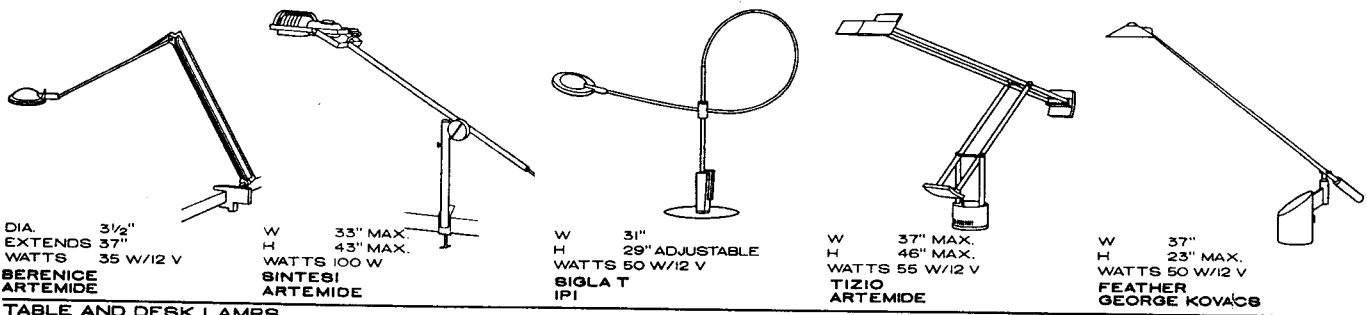

DIA. 3 1/2" EXTENDS 37" WATTS 35 W/12 V <b>BERENICE ARTEMIDE</b>	W 33" MAX. H 43" MAX. WATTS 100 W <b>SINTESI ARTEMIDE</b>	W 31" H 29" ADJUSTABLE WATTS 50 W/12 V <b>SIGLA T IPI</b>	W 37" MAX. H 46" MAX. WATTS 55 W/12 V <b>TIZIO ARTEMIDE</b>	W 37" H 23" MAX. WATTS 50 W/12 V <b>FEATHER GEORGE KOVACS</b>
---	--	--	--	--

**TABLE AND DESK LAMPS**

Robert Staples; Staples & Charles Ltd.; Washington, D.C.

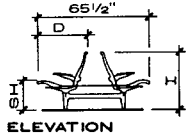
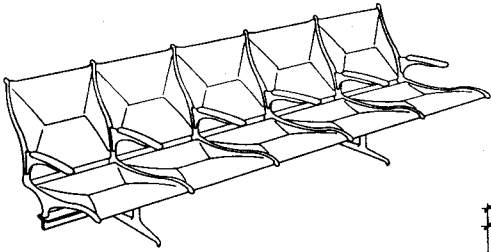

1 SEATING UNIT AVAILABLE  
2 TABLES AVAILABLE  
STANDARD UNIT W 23 1/4"  
D 28"  
H 34"  
SH 17 1/2"

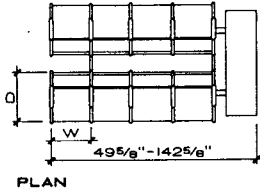

SINGLE ROW OR BACK-TO-BACK UNITS  
EAMES TANDEM SLING SEATING  
HERMAN MILLER, INC.

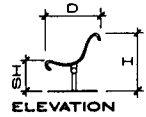
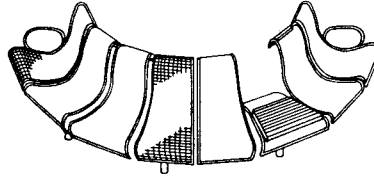

11 UNITS AVAILABLE  
2 TYPES SHOWN (22")  
STANDARD UNIT W 29"  
D 30"  
H 31"  
SH 17"

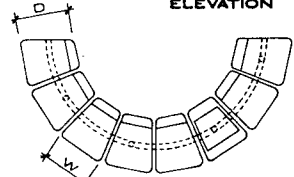

FLOOR OR WALL MOUNTED  
PLEXUS COLLECTION  
THE PUBLIC SPACE FURNITURE CO. PLAN

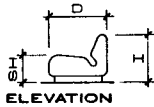
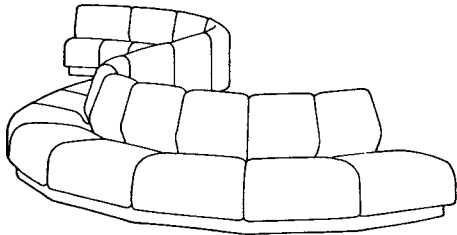

5 UNITS AVAILABLE  
3 TYPES SHOWN  
STANDARD UNIT W 28"  
D 31"  
H 27"  
SH 15 1/4"

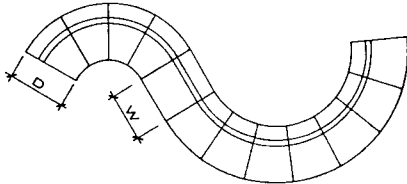

CHADWICK MODULAR  
SEATING  
HERMAN MILLER, INC. PLAN

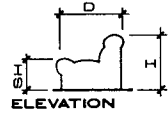
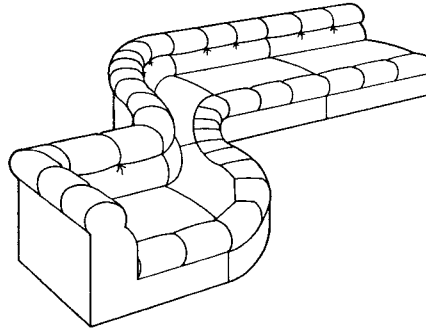

11 UNITS AVAILABLE  
4 TYPES SHOWN  
STANDARD UNIT W 32"  
D 37"  
H 30"  
SH 17"

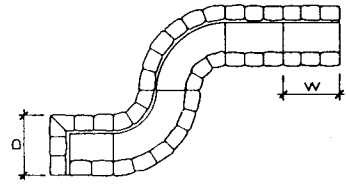

MONACO LOUNGE SEATING  
CUMBERLAND/I.M. ROSEN  
AND CO., INC. PLAN

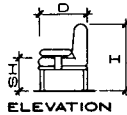
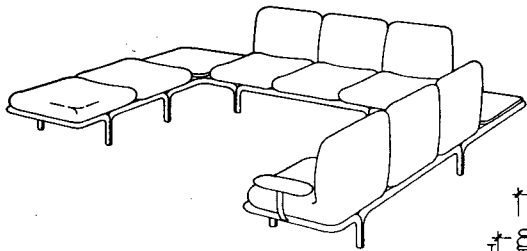

3 UNITS AVAILABLE  
3 TYPES SHOWN  
STANDARD UNIT W 27"  
D 27"  
H 29"  
SH 18"

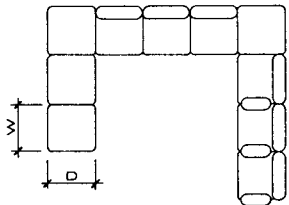

SERIES 10 PUBLIC SEATING  
METROPOLITAN FURNITURE CORP. PLAN

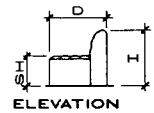
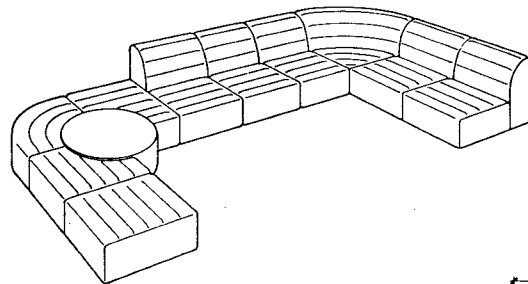

16 UNITS AVAILABLE  
6 TYPES SHOWN  
STANDARD UNIT W 26"  
D 3 1/2"  
H 31"  
SH 17"

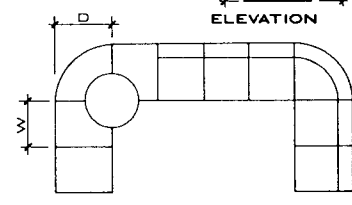

CONTOURS SERIES  
LOUNGE SEATING  
DAVIS PLAN

Robert Staples; Staples & Charles Ltd.; Washington, D.C.  
Richard J. Vitullo, AIA; Oak Leaf Studio; Crownsville, Maryland

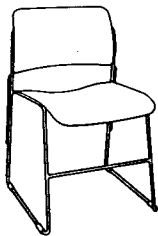

W 19 3/4"  
D 21 1/4"  
H 30"  
SH 17 3/4"

**40/4 CHAIR, 1964**  
DESIGNER: DAVID ROWLAND  
GF FURNITURE SYSTEMS

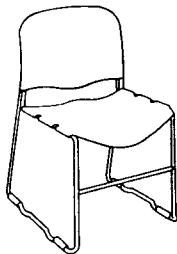

W 21"  
D 22"  
H 30"  
SH 17 1/4"

**MULTI-CHAIR  
STACKS 40 ON A DOLLY**  
SHAW-WALKER

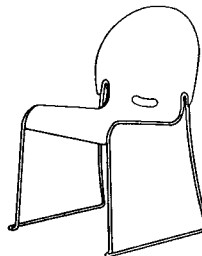

W 20 1/2"  
D 24"  
H 31 1/2"  
SH 18"

**STACKING CHAIR  
STACKS 20 ON A DOLLY**  
NIENKAMPER

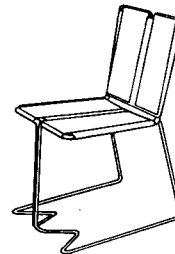

W 20"  
D 22"  
H 33 3/4"  
SH 18"

**BIBI VADER CHAIR**  
ACCIAIO, INC.

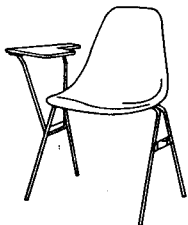

W 23 1/8"  
D 25 1/2"  
H 31 3/4"  
SH 18"

**STACKING CHAIR WITH ARM**  
DESIGNER: CHARLES EAMES  
HERMAN MILLER, INC.

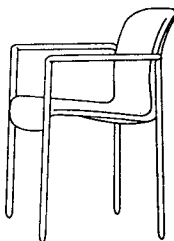

W 18 1/2"  
D 17"  
H 30"  
SH 17 1/2"

**PROPER CHAIR**  
HERMAN MILLER, INC.

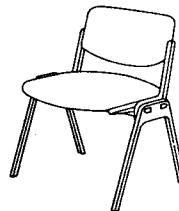

W 23"  
D 22"  
H 30 1/2"  
SH 18 1/2"

**APTA "SMART" CHAIR**  
DESIGNER: GIANCARLO PIRETTI  
CASTELLI/KRUEGER

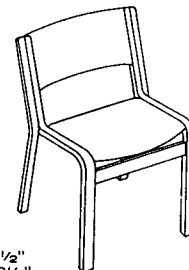

W 21 1/2"  
D 22 1/2"  
H 30 1/2"  
SH 18"

**STACKING CHAIR**  
DESIGNERS: THYGBEN/  
BORENSEN  
RUDD INTERNATIONAL



W 18"  
D 20 1/2"  
H 29 1/2"  
SH 17 1/2"

**TABLET ARMCHAIR**  
TABLET, 23" X 10"  
BAMSONITE FURNITURE CO.

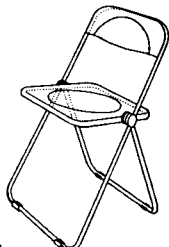

W 18 1/2"  
D 19 1/2"  
H 29 1/2"  
SH 17 1/2"

**PLIA FOLDING CHAIR**  
DESIGNER: GIANCARLO PIRETTI  
CASTELLI/KRUEGER

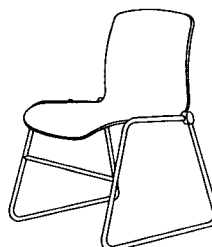

W 22"  
D 21"  
H 32"  
SH 18"

**STACKING CHAIR**  
KINETICS

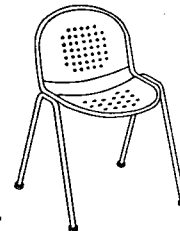

W 22"  
D 24"  
H 30"  
SH 17"

**RONDO CHAIR**  
PERFORATED STEEL  
FIXTURES FURNITURE

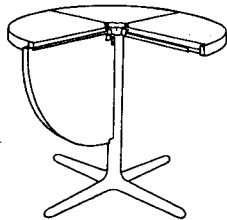

DIA. 37 1/2"  
H 28 1/2"

**PLANO FOLDING TABLE**  
DESIGNER: GIANCARLO PIRETTI  
CASTELLI/KRUEGER

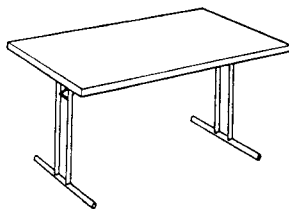

W 24" 30"  
D 60" 72"  
H 29"

**ENCORE FOLDING TABLE**  
FIXTURES FURNITURE

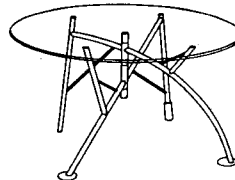

DIA. 48", 54", 60"  
H 28 1/4"

**DOLE MELIPONE FOLDING TABLE**  
DESIGNER: PHILIPPE STARCK  
ICF, INC.

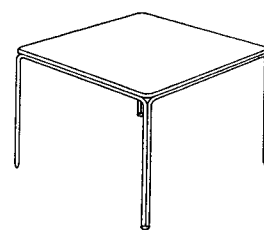

W 24", 30", 34 1/2", 42"  
D 24", 30", 34 1/2", 42"  
H 29"

**SQUARE STACKING TABLE**  
FIXTURES FURNITURE

Robert Staples; Staples & Charles Ltd.; Washington, D.C.  
Richard J. Vitullo, AIA; Oak Leaf Studio; Crownsville, Maryland

**TYPICAL END OR SIDE TABLE DIMENSIONS (IN.)**

DESCRIPTION	DEPTH		WIDTH		HEIGHT	
	MIN.	MAX.	MIN.	MAX.	MIN.	MAX.
RECTANGULAR	19	28	21	48	17	28
SQUARE	15	32	15	32	17	28
ROUND	16	30	16	30	18	22½

**TYPICAL LOW TABLE DIMENSIONS (IN.)**

DESCRIPTION	DEPTH		WIDTH		HEIGHT	
	MIN.	MAX.	MIN.	MAX.	MIN.	MAX.
RECTANGULAR	15½	24	21	86	12	18
SQUARE	36	42	32	42	15	17
ROUND	30	42	20	42	15	16½

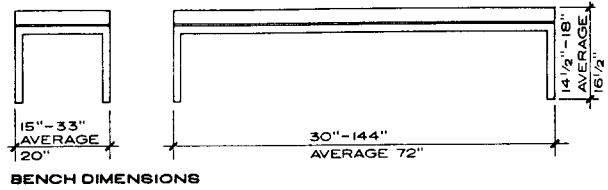

**BENCH DIMENSIONS**

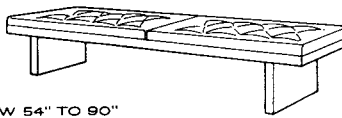

W 54" TO 90"  
D 20"  
H 18"  
**BENCH**  
LEHIGH FURNITURE CORP.



W 48¾"  
D 21¾"  
H 17¼"  
**BENCH**  
ALL-STEEL, INC.

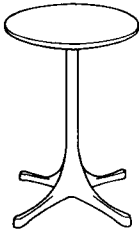

DIA 17"  
H 22"

**OCCASIONAL TABLE**  
DESIGNER: GEORGE NELSON  
HERMAN MILLER, INC.



DIA 13"  
H 15"

**WOODEN SPOOL TABLE**  
DESIGNER: RAY EAMES  
HERMAN MILLER, INC.

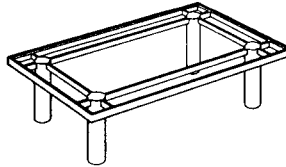

W 45", 60"  
D 45", 60"  
H 16"

**INTERSECT LOW TABLE**  
BRUETON

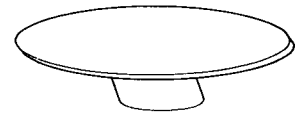

W 63"  
D 50"  
H 12"

**MERCER TABLE**  
DESIGNER: LUCIA MERCER  
KNOLL INTERNATIONAL

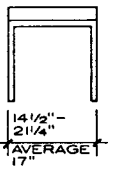
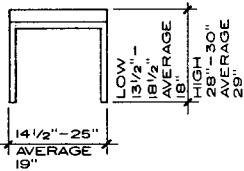

**STOOL DIMENSIONS**

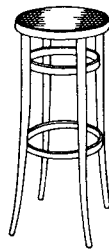

DIA 17"  
H 30"

**WOOD STOOL**  
THONET: DIVISION OF  
SHELBY WILLIAMS INDUSTRIES,  
INC.

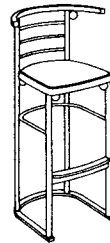

W 22½"  
D 18"  
H 41½"  
SH 30"

**FLEDERMAUS BAR CHAIR**  
THONET: DIVISION OF  
SHELBY WILLIAMS INDUSTRIES,  
INC.

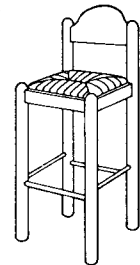

W 16½"  
D 19"  
H 43"  
SH 30"

**PADOVA BAR STOOL**  
HANK  
LOEWENSTEIN, INC.

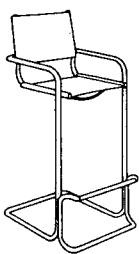

W 18¼"  
D 22¼"  
H 39½"  
SH 27"

**BADEN BAR STOOL**  
LOWENSTEIN/OGGO

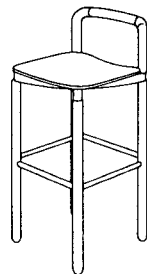

W 18"  
D 18"  
H 38"  
SH 30"

**RUBBER BAR STOOL**  
DESIGNER: BRIAN KANE  
METROPOLITAN FURNITURE  
CORP.

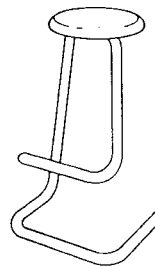

W 16"  
D 16"  
H 28"

**STOOL**  
KINETICS

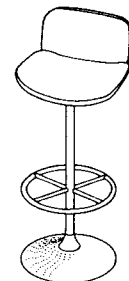

W 19"  
D 18"  
H 36"  
SH 29"

**CARIBE BAR STOOL**  
DESIGNER: ILMARI TAPIOVAARA  
ICF, INC.

Robert Staples; Staples & Charles Ltd.; Washington, D.C.  
Richard J. Vitullo, AIA; Oak Leaf Studio; Crownsville, Maryland



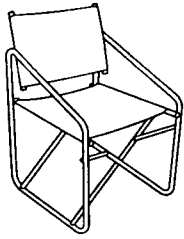

W 22 1/2"  
D 22 1/2"  
H 34 1/2"  
SH 17 1/2"

**NOMAD DINING CHAIR**  
BROWN JORDAN

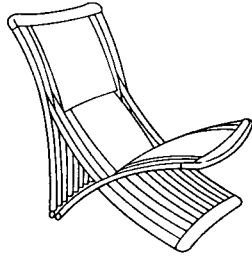

W 24"  
D 35"  
H 34"  
SH 11"

**STEAMER LOUNGE CHAIR**  
AMBIANT  
KNOLL INTERNATIONAL



W 17 1/2"  
D 16"  
H 29 1/2"  
SH 16"

**STACKING RIO CHAIR**  
EMU/USA



DIA. 8'-0", H 9'-0"  
UMBRELLA  
DIA. 42", H 28"

**TABLE**  
TRADEWINDS

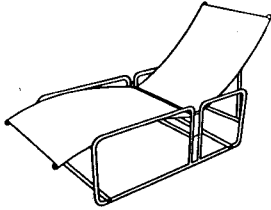

W 25"  
D 64"  
H 32"  
SH 17"

**ADJUSTABLE CHAISE**  
BROWN JORDAN

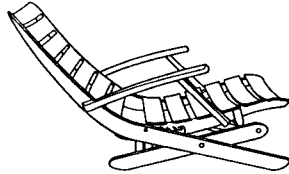

W 25"  
D 29"  
H 34"  
SH 15"

**ADJUSTABLE ARMCHAIR**  
GROSFILLEX

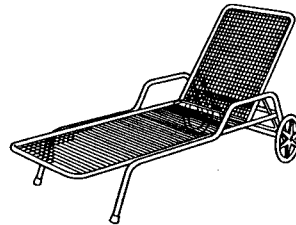

W 24 1/2"  
D 75 1/2"  
H 37 1/2"  
SH 10 1/2"

**POOL BED LOUNGE**  
EMU/USA

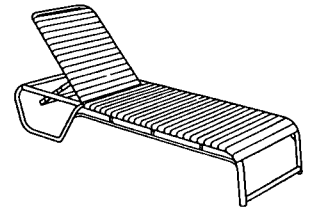

W 28"  
D 82"  
H 39"  
SH 12"

**STACKABLE SUN LOUNGE**  
TRADEWINDS

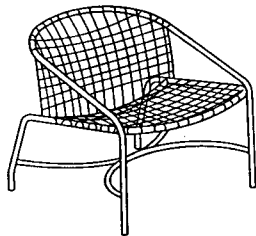

W 26"  
D 27 1/2"  
H 25 1/2"  
SH 13 1/2"

**KANTAN LOUNGE CHAIR**  
BROWN JORDAN

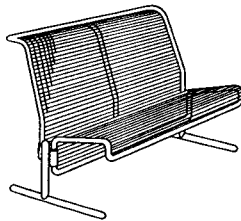

W 48 1/4"  
D 31 1/2"  
H 29 3/4"  
SH 17 3/4"

**TWO-SEAT PARK BENCH**  
KROIN INC.

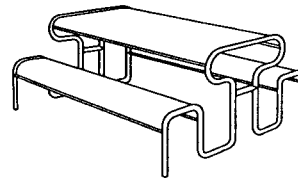

W 72"  
D 62"  
H 30"  
SH 17"

**METAL PICNIC TABLE**  
FORMS AND SURFACES

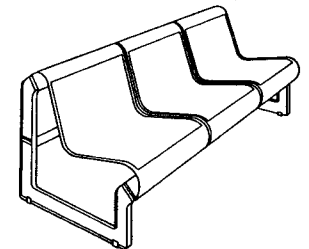

W 70"  
D 31 1/2"  
H 28"  
SH 16"

**LAGOS SEATING**  
ARTIFORT/KRUEGER

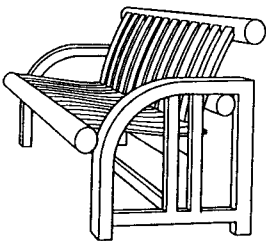

W 55"  
D 29"  
H 33"  
SH 17"

**GARDEN BENCH**  
SUMMIT FURNITURE INC.

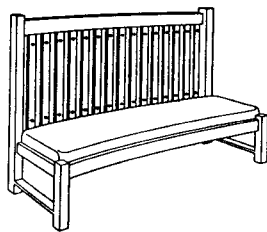

W 60"  
D 23 1/2"  
H 43 1/2"  
SH 15 1/2"

**LIVERPOOL BENCH**  
INTERNA DESIGNS, LTD.

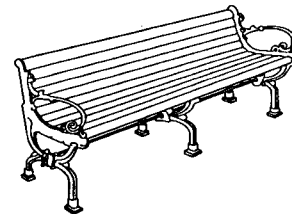

W 72"  
D 23"  
H 29"  
SH 17"

**CHARLESTON BENCH**  
WOODCRAFTERS OF FLORIDA, INC.

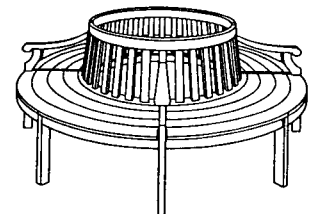

INSIDE DIA. 38"  
OUTSIDE DIA. 76"  
H 36"  
SH 17"

**MONHEGAN TREE BENCH**  
WEATHEREND/IMAGINEERING, INC.

Robert Staples; Staples & Charles Ltd.; Washington, D.C.  
Richard J. Vitullo, AIA; Oak Leaf Studio; Crownsville, Maryland

12 GENERAL USE FURNITURE

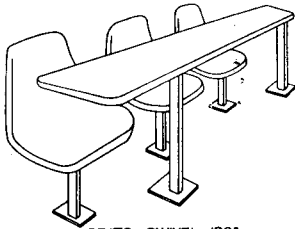

SEAT SWIVEL 180°  
 BEAT W 20" D 21" H 31"  
 TABLE W 27" D 18" H 29"  
 LAYOUT R 48" S 27"

**SEMINAR SEATING  
 KRUEGER**

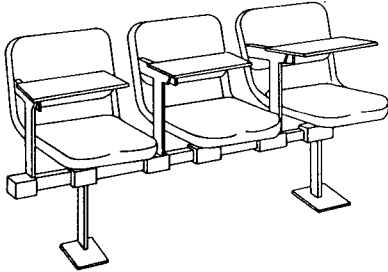

UNIT W 22" D 37" H 31"  
 BEAT W 36"-39" D 22" S 22"

**SEQUENCE SEATING  
 KRUEGER**

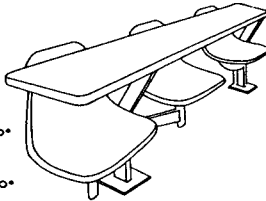

SWING ARM:  
 SEAT SWIVELS 90°

FIXED ARM:  
 SEAT SWIVELS 120°

UNIT W 27" D 26" WITH SWING ARM  
 D 34" WITH FIXED ARM H 31"  
 LAYOUT R 41" WITH SWING ARM  
 R 46" WITH FIXED ARM S 27"

**UNIVERSITY SEATING  
 KRUEGER**

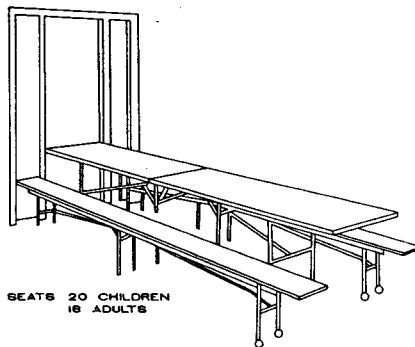

SEATS 20 CHILDREN  
 16 ADULTS

OPEN W 168" D 60" H 26-30"  
 CLOSED W 88" D 60" H 80"  
 D 6" (SURFACE MOUNT)  
 1" (RECESSED)

**FOLDING TABLE AND BENCHES  
 NELSON-ADAMS**

**NOTES**

1. All spacing dimensions are centerline dimensions.
2. Typical seat height is 17 in.
3. Unit dimensions are to farthest extremity.
4. Auditorium seating with tablet arms is used often. See index.
5. Left-handed tablet arms generally are available for fixed arm seating.
6. Ganged seating may be adapted for mounting on level floors, sloped floors and 6 in. to 14 in. risers for tiered seating.

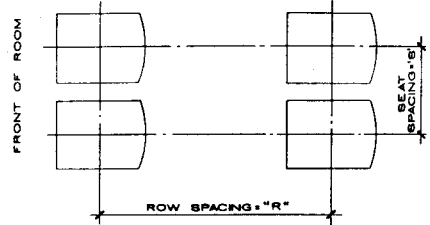

KEY TO LAYOUT DIMENSIONS

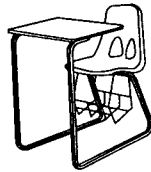

UNIT W 24" D 35" H 30"  
 LAYOUT R 37" S 39"

**COMBINATION STUDY  
 TOP DESK  
 SMITH SYSTEM**



UNIT W 18" D 50" H 30"  
 LAYOUT R 32" S 34"

**TABLET ARM CHAIR  
 SMITH SYSTEM**

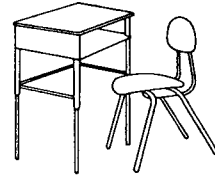

BEAT HEIGHT 9 1/2"-17 1/2"

DESK W 24" D 18" H 21"-29"  
 CHAIR W 18" D 20" H 24"-30"  
 LAYOUT R 46" S 24"

**OPEN FRONT DESK  
 AND CHAIR  
 SMITH SYSTEM**

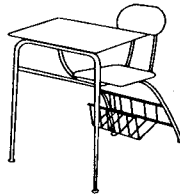

UNIT W 24" D 30" H 30"  
 LAYOUT R 32" S 39"

**COMBINATION STUDY  
 TOP DESK  
 SMITH SYSTEM  
 "SCHOOL FURNITURE"**

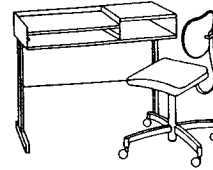

DESK W 34" D 18" H 29"  
 CHAIR W 23" D 23" H 32"  
 LAYOUT R 45" S 34"

**TYPING DESK  
 SMITH SYSTEM  
 CHAIR  
 HON**

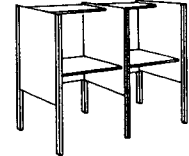

UNIT W 31" D 30" H 48"  
 BEAT W 31" D 30" H 48"  
 AVAILABLE WITH 26" HIGH DESK TOP FOR USE WITH COMPUTERS

**STUDY CARRELL  
 FLEETWOOD  
 FURNITURE CO.**

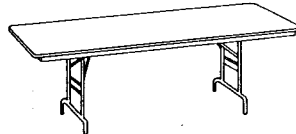

OPEN W 60"-96" D 18"-36" H 24"-36"  
 CLOSED L 60"-96" W 18"-36" D 4"

**FOLDING TABLE  
 KRUEGER**

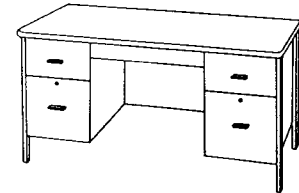

W 60" D 30" H 29"

**DOUBLE PEDESTAL DESK  
 SMITH SYSTEM**

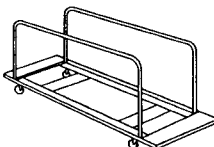

EMPTY W 78" D 27" H 28"  
 CAPACITY: UP TO 9 TABLES DEPENDING ON WIDTH

**FOLDING TABLE CADDY  
 KRUEGER**

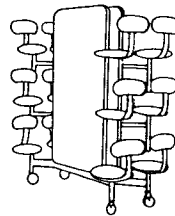

CLOSED W 60" D 30" H 81"-83"

**FOLDING TABLE AND CHAIRS  
 BICO INCORPORATED**

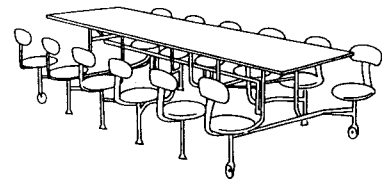

OPEN W 120" D 60" H 26"-29"

BACKRESTS OPTIONAL

Jeffrey R. Vandevort; Talbott Wilson Associates, Inc.; Houston, Texas  
 ISD Incorporated; Chicago, New York, Boston, Houston

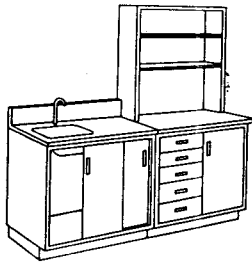

W 48"  
D 22"  
H 34"

WORK CENTER  
FLEETWOOD FURNITURE CO.

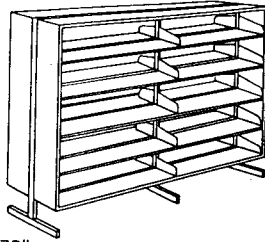

W 72"  
D 24"  
H 66"

LIBRARY SHELVING  
SMITH SYSTEM



W 24"  
D 18"  
H 42"

AUDIO-VISUAL/UTILITY TABLE  
LUXOR

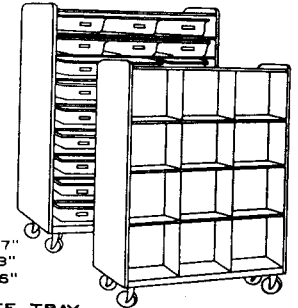

W 47"  
D 28"  
H 66"

TOTE TRAY  
AND CUBICLE CABINET  
FLEETWOOD FURNITURE CO.

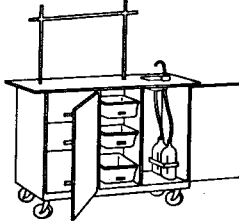

W 60"  
D 23"  
H 37"

SCIENCE CABINET  
FLEETWOOD FURNITURE CO.

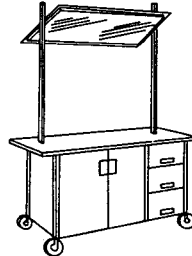

W 60"  
D 23"  
H 44"

DEMONSTRATION TABLE  
FLEETWOOD FURNITURE CO.

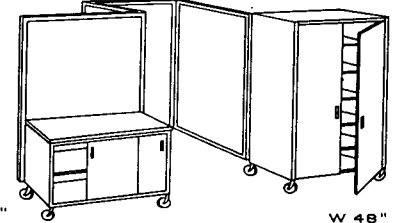

W 48"  
D 22"  
H 34"

OPEN PLAN UNIT  
FLEETWOOD FURNITURE CO.

W 48"  
D 22"  
H 60"

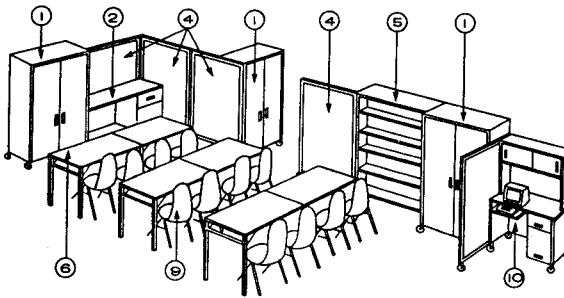

OPEN PLAN UNITS  
FLEETWOOD FURNITURE CO.

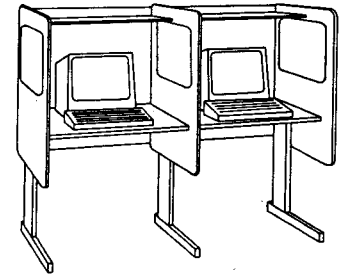

W 31" /  
SEAT  
D 28"  
H 48"

COMPUTER CARREL  
FLEETWOOD FURNITURE CO.

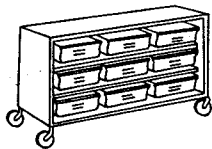

W 48"  
D 22"  
H 30"

TOTE TRAY CABINET  
FLEETWOOD FURNITURE CO.  
OPEN PLAN UNITS

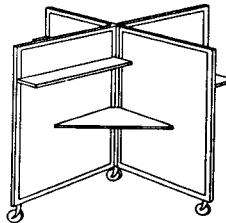

W 68"  
D 68"  
H 60"

FOUR PANEL CAROUSEL  
FLEETWOOD FURNITURE CO.

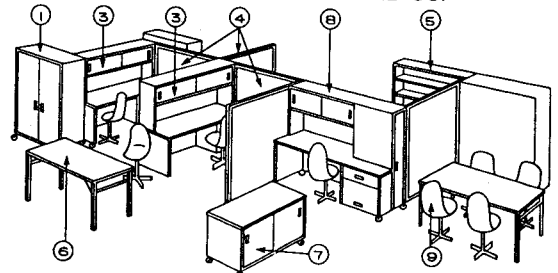

OPEN PLAN UNITS  
FLEETWOOD FURNITURE CO.

KEY	DESCRIPTION	MANUFACTURER	W (IN.)	D (IN.)	H (IN.)	SHELVES	DRAWER
1	cabinet	Fleetwood Furniture Co.	48	24	72	8	0
2	desk	Fleetwood Furniture Co.	48	28	29	0	2
3	desk	Fleetwood Furniture Co.	48	28	60	1	2
4	partition	Fleetwood Furniture Co.	48		60		
4	partition	Fleetwood Furniture Co.	48		72		
5	bookcase	Fleetwood Furniture Co.	48	22	60	10	
6	table	Krueger	48	24	29		
7	cabinet	Fleetwood Furniture Co.	48	22	34	1	0
8	desk/closet	Fleetwood Furniture Co.	48	28	60	1	2
9	chair	Krueger	21	20	32		
10	comp. desk	Fleetwood Furniture Co.	48	28	60	1	2

NOTES

1. Open classroom layouts are based on modular partition dimensions: 48 in. wide x 60 in. or 72 in. high.
2. Partitions are available with hinges to connect with standard height cabinets, or with casters for freestanding use.
3. Surfaces for partitions are vinyl, porcelain enameled steel, chalkboard, or tackboard.
4. Carrels may be ordered with 31 in. high desktops for use with wheelchairs.
5. Typical seat height is 17 in.
6. Unit dimensions are to farthest extremity.

Jeffrey R. Vandevort; Talbott Wilson Associates, Inc.; Houston, Texas  
ISD Incorporated; Chicago, New York, Boston, Houston

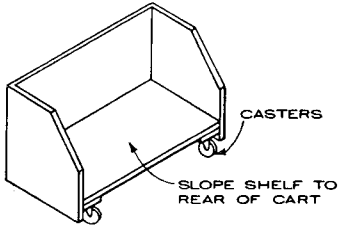

24" W X 12" TO 18" D X 15" TO 18" H  
BLOCK CART

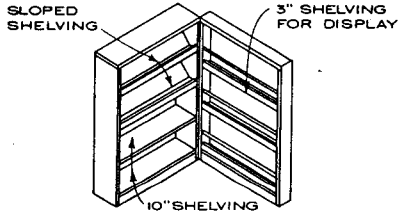

36" W X 52" H  
FOLDING BOOKCASE

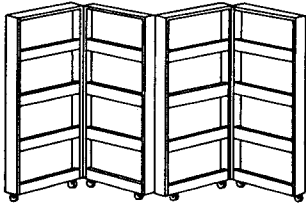

24" W X 3" D X 48" H SECTIONS  
FOLDING BOOKSCREEN

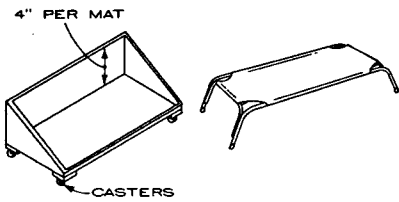

26" W X 14" D  
REST MAT CART STACKABLE REST COT

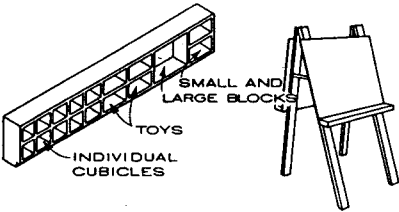

12" TO 18" D X 24" H  
BUILT-IN STORAGE CUBICLES

FLOOR EASEL

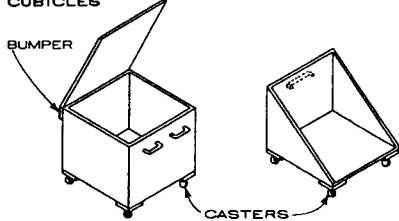

24" SQUARE CARTS TO CARRY 50-100LB  
UNDERCOUNTER CLAY CART



60" L X 41" W X 42" H  
EXERCISE LADDER



20" L X 22" W X 19" H  
SEAT  
PLAY HORSE

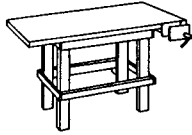

44" L X 20" W X 26" H  
WORKBENCH

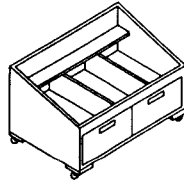

30" W X 24" D  
X 18" X 24" H  
CARPENTRY TOOL  
CART

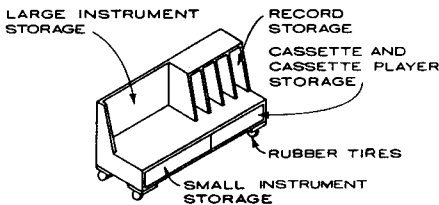

54" W X 18" D X 28" H  
MUSIC CART

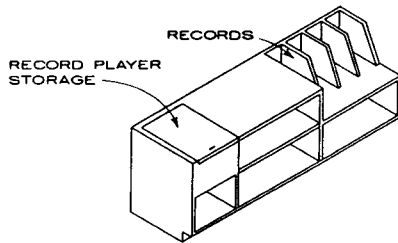

20" D X 24" H  
RECORD PLAYER AND STORAGE UNIT

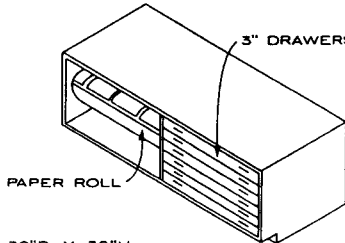

30" D X 36" H  
PAPER STORAGE UNIT

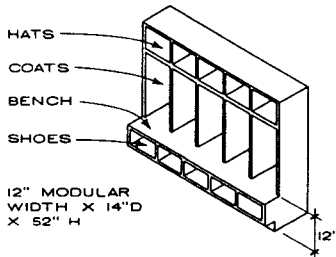

12" MODULAR  
WIDTH X 14" D  
X 52" H  
LOCKER UNIT

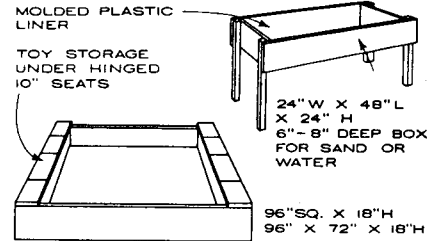

SANDBOXES

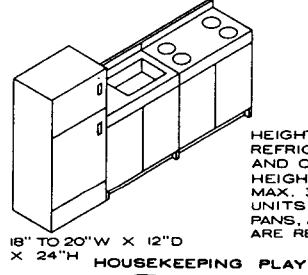

18" TO 20" W X 12" D  
X 24" H  
HOUSEKEEPING PLAY

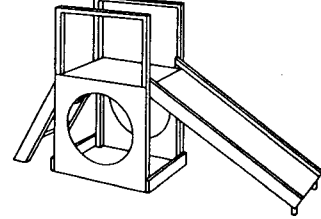

62" L X 24" W X 36" H  
INDOOR SLIDE

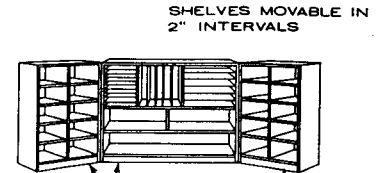

46" W (CLOSED) X 14" D X 34" H  
FOLDING STORAGE UNIT

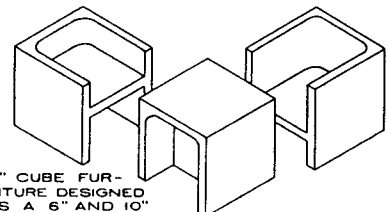

15" CUBE FURNITURE DESIGNED AS A 6" AND 10" SEAT AND 15" TABLE  
PRESCHOOL AND KINDERGARTEN SEATING

GENERAL CHAIR AND TABLE REQUIREMENTS

AGE OF CHILD	CHAIR SEAT HEIGHT				TABLE HEIGHT
	8"	10"	12"	14"	
2 years	80%	20%			-
3 years	40%	50%	10%		18"
4 years		25%	75%		20"
5 years			75%	25%	22"

Kent Wong; Hewlett, Jamison, Atkinson & Luey; Portland, Oregon

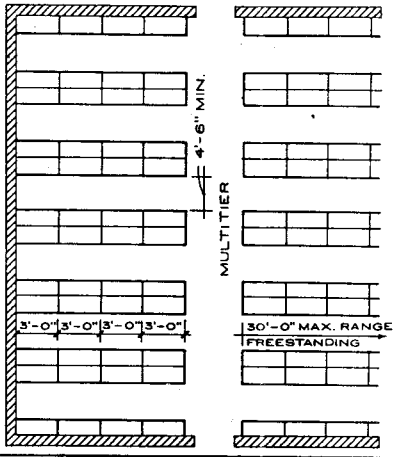

PLAN-WOOD OR STEEL

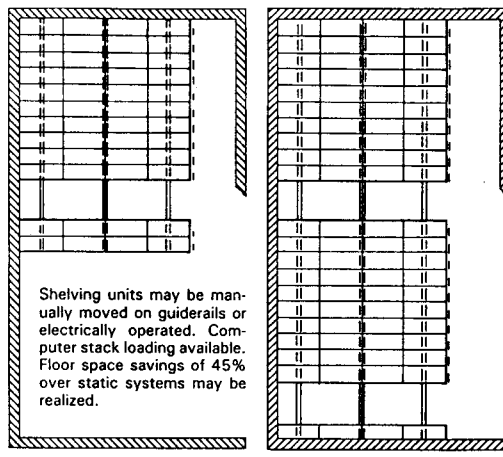

PLAN-TRACK OR STACK SHELVING

**SHELF CAPACITY AND DEPTH**

TYPE OF BOOK	VOLUMES PER LINEAR FT	SHELF DEPTH (IN.)
Children's	10-12	8
Fiction and economics	7	8
History and General Literature	7	8
Reference	7	10
Technical and Scientific	6	8
Medical	5	10
Law and public documents	4-5	8
Bound periodicals	5	10-12
U.S. Patent spec.	2	8

**BOOK CAPACITY PER GROSS FLOOR AREA**

Many variables must be considered: size and kind of books, book lifts, carrels, number and width of aisles, ultimate capacity, and so on. Variances run from 13 1/2 to 19 books/sq ft. For a rule of thumb allow 16 books/sq ft of gross area. The average dead load of books is 25 lb/cu ft.

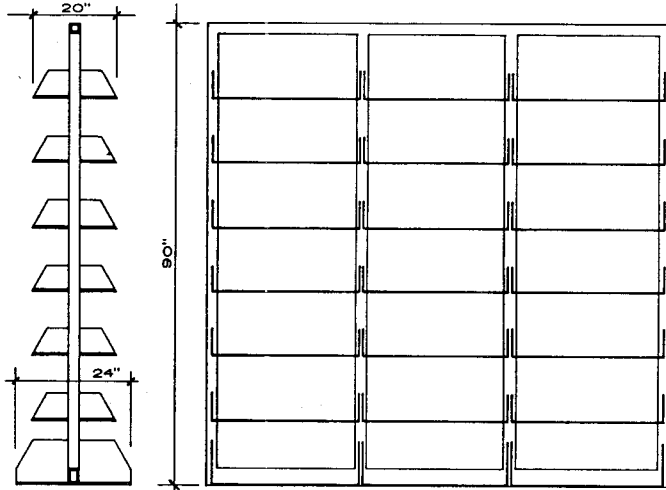

ADJUSTABLE SHELF UNIT, STEEL

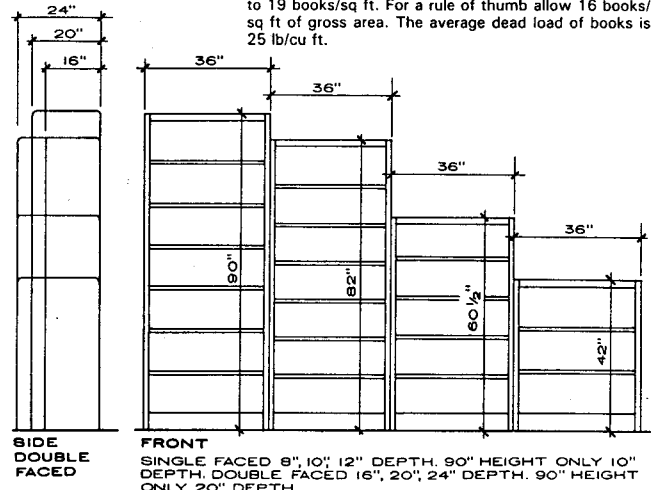

ADJUSTABLE SHELF UNIT, WOOD

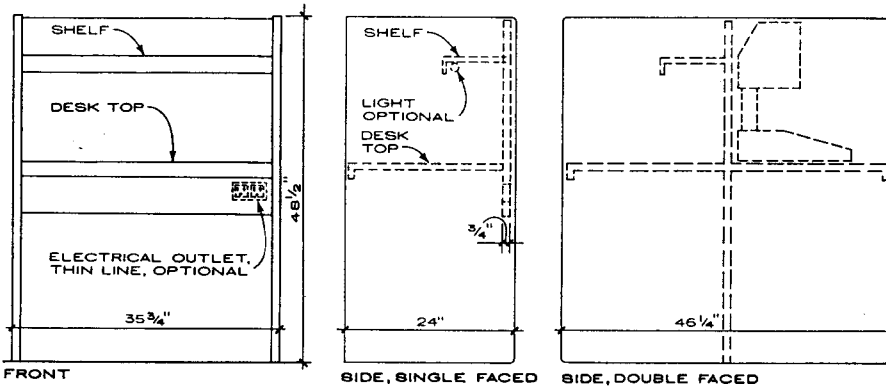

FRONT

SIDE, SINGLE FACED

SIDE, DOUBLE FACED

**CARRELS**

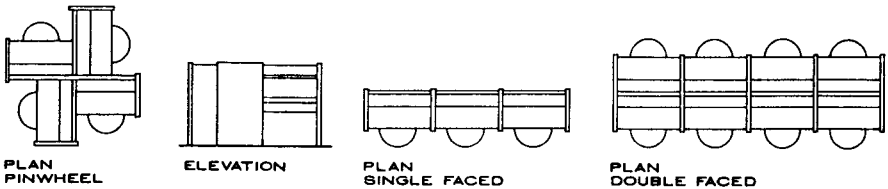

PLAN PINWHEEL

ELEVATION

PLAN SINGLE FACED

PLAN DOUBLE FACED

**CARREL ARRANGEMENTS**

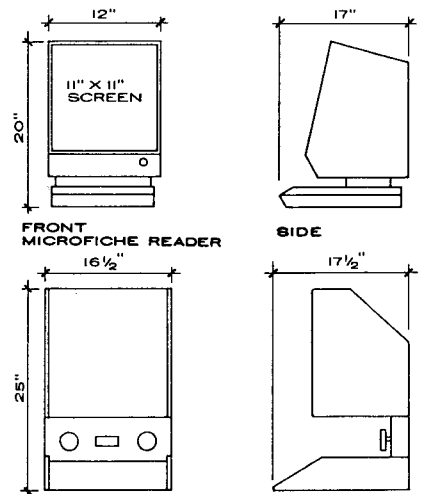

FRONT MICROFICHE READER

SIDE

FRONT MICROREADER FOR FICHE OR FILM

SIDE

NOTE

Generally microfilm and microfiche readers and video display terminals (VDT) are positioned on tables.

**LIBRARY EQUIPMENT**

Walter Hart Associates, AIA; White Plains, New York

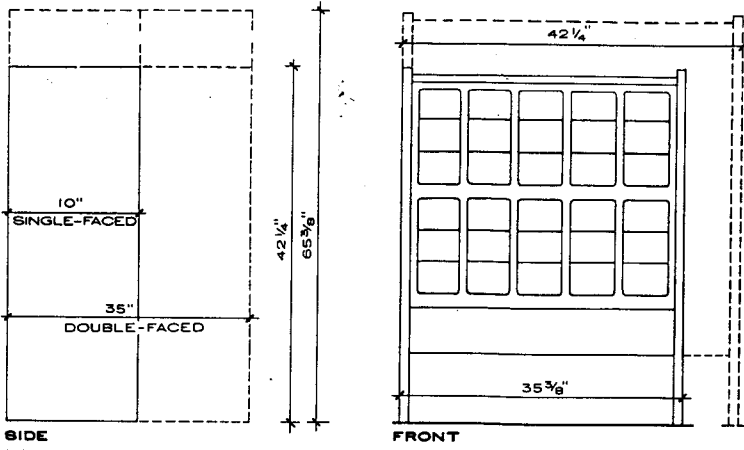

**SIDE**  
**NOTES**

Card catalog cases are available in units:  
Single-faced 15-60 trays, 42 1/4" H; double-faced 30-120 trays, 42 1/4" H; high, single, or double faced with pullout shelves, 72-144 trays, 65 3/8" H. Effective tray card filing depth 14 3/4", tray capacity 1250-1300 standard cards of 3" x 5".

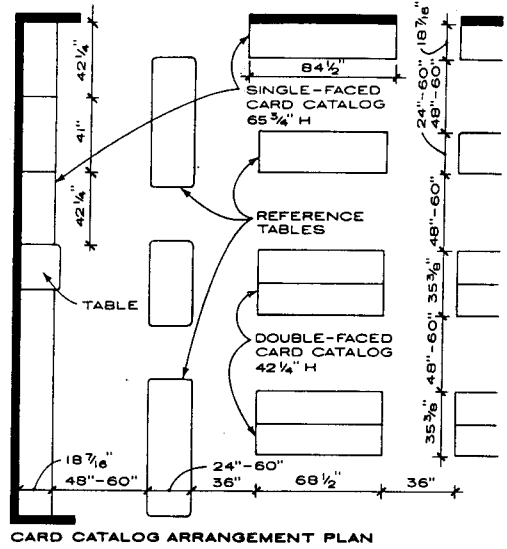

**CARD CATALOG ARRANGEMENT PLAN**

**CARD CATALOG CASES**

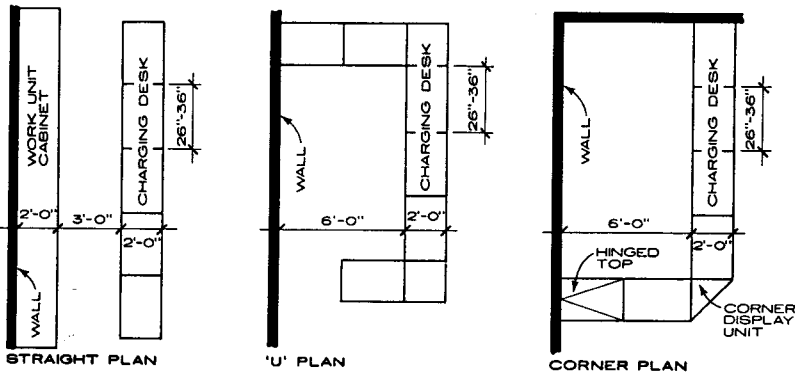

**STRAIGHT PLAN**

**'U' PLAN**

**CORNER PLAN**

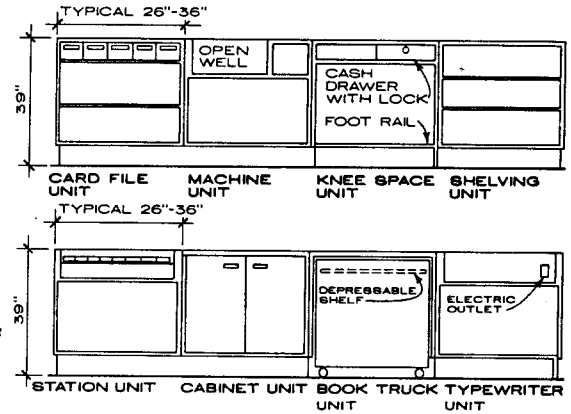

**CHARGING DESKS**

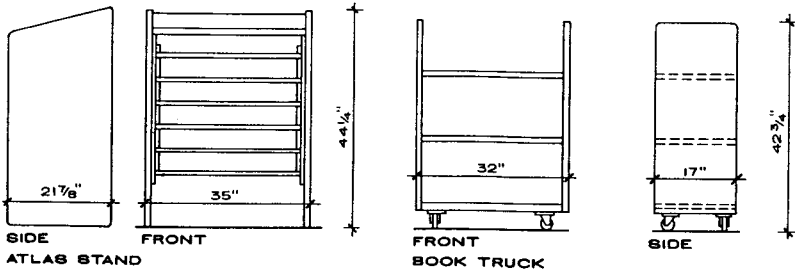

**SIDE**  
**FRONT**  
**ATLAS STAND**

**FRONT**  
**SIDE**  
**BOOK TRUCK**

**MISCELLANEOUS LIBRARY EQUIPMENT**

- Magazine display rack: wall, counter, revolving island, mobile
- Vertical newspaper rack
- Paperback rack or island drum
- Record storage: stands, shelving, rollout browser bins
- Record display unit
- Video cassette cabinets and display racks
- Audio cassette cabinets and display racks
- Audio/visual carrel
- Periodical index table
- Consultation benches
- Display units: wall and freestanding
- Security installation at checkout/charge desk
- High-density mobile shelving

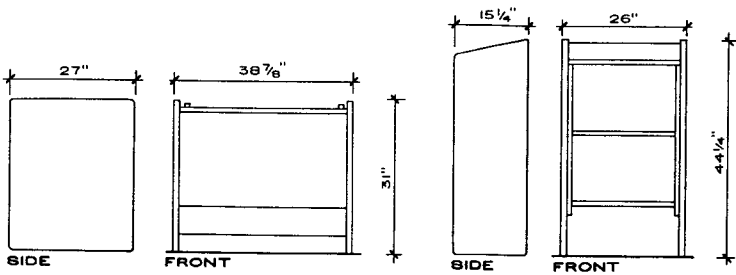

**SIDE**  
**FRONT**  
**NEWSPAPER STAND**

**SIDE**  
**FRONT**

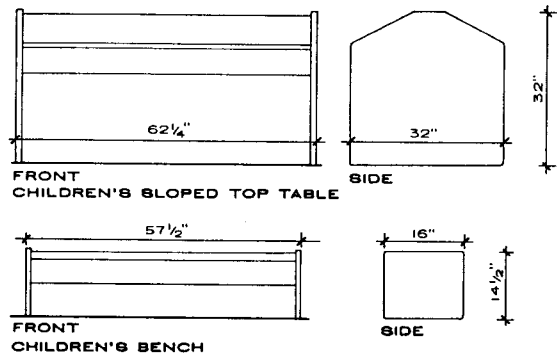

**FRONT**  
**SIDE**  
**CHILDREN'S SLOPED TOP TABLE**

**FRONT**  
**SIDE**  
**CHILDREN'S BENCH**

Walter Hart Associates, AIA; White Plains, New York

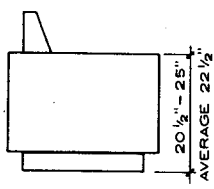

CHAIR

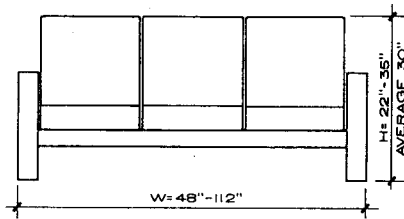
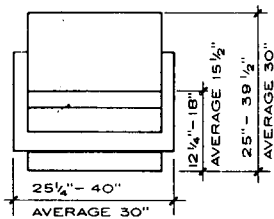

SOFA

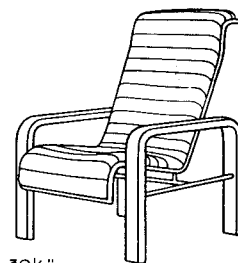

W 30 1/2"  
D 36"  
H 39 1/2"  
SH 17"

HIGH-BACK CHAIR  
MUELLER

TYPICAL LOUNGE SEATING DIMENSIONS

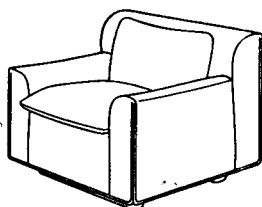

W 36"  
D 33"  
H 28"

HELI LOUNGE CHAIR  
DESIGNER: OTTO ZAPH  
KNOLL INTERNATIONAL

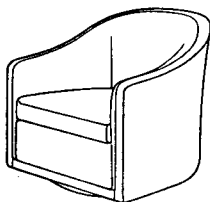

W 32"  
D 31"  
H 29"  
SH 16"

SWIVEL LOUNGE CHAIR  
DESIGNER: BEN BALDWIN  
JACK LENOR LARSEN

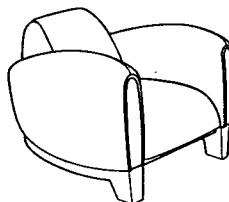

W 35 1/2"  
D 39 1/2"  
H 26 1/2"  
SH 17"

BUGATTI LOUNGE CHAIR  
DESIGNER: FRANZ ROMERO  
STENDIG INTERNATIONAL, INC.

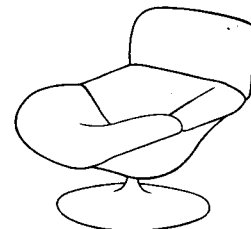

W 36"  
D 36"  
H 32"  
SH 15"

LOUNGE CHAIR  
DESIGNER: GEOFFREY HARCOURT  
ARTIFORT / KRUEGER

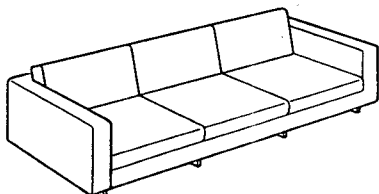

W 85 1/2"  
D 36"  
H 24 3/4"  
SH 17"

THREE-PLACE SETTEE  
GF

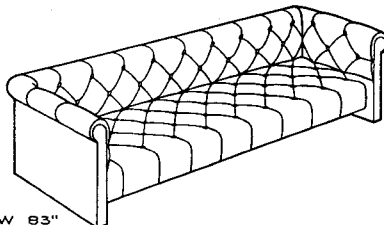

W 83"  
D 32"  
H 26"  
SH 15"

CLUB SOFA  
ZOGRAPHOS DESIGNS, LTD.

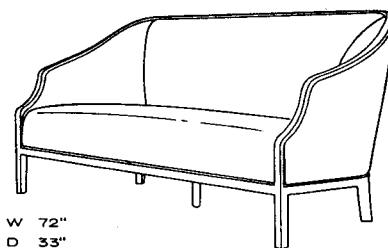

W 72"  
D 33"  
H 32"  
SH 17"

BANKERS SOFA  
DESIGNER: WARD BENNETT  
BRICKEL ASSOCIATES, INC.

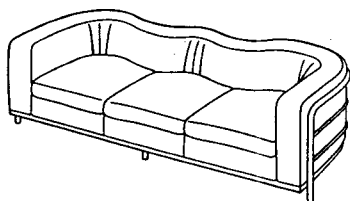

W 76 3/4"  
D 30 3/4"  
H 28 1/2"  
SH 17 3/4"

ONDA 3-BEAT SOFA  
DESIGNERS: DE PAS, D'URBINO, LOMAZZI  
ICF, INC.

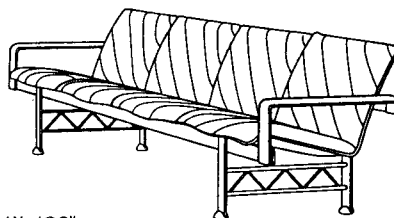

W 106"  
D 30"  
H 28 1/2"  
SH 17"

SPAN 4-BEAT SOFA  
DESIGNER: BURKHARD VOGTHERR  
BRAYTON INTERNATIONAL COLLECTION

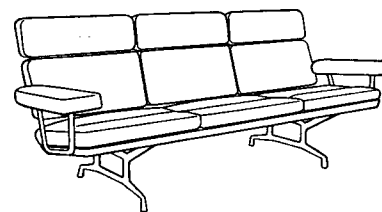

W 80"  
D 21"  
H 33"  
SH 16 1/2"

3-BEAT SOFA  
DESIGNER: CHARLES EAMES  
HERMAN MILLER, INC.

Robert Staples; Staples & Charles Ltd.; Washington, D.C.  
Richard J. Vitullo, AIA; Oak Leaf Studio; Crownsville, Maryland

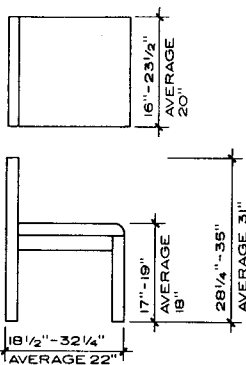

**SIDE CHAIR DIMENSIONS**

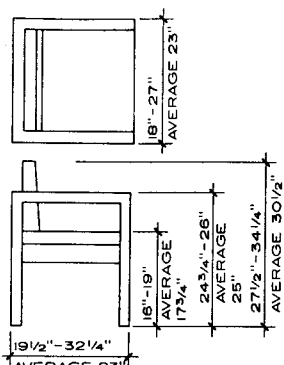

**ARMCHAIR DIMENSIONS**

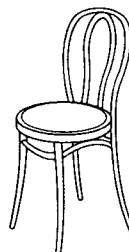

W 16"  
D 20"  
H 35"

**VIENNA CHAIR**  
DESIGNER: MICHAEL THONET  
THONET INDUSTRIES, INC.

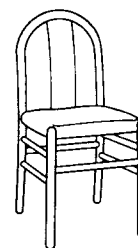

W 17 1/4"  
D 18 3/4"  
H 34 1/2"  
SH 18 1/2"

**THALIA SIDE CHAIR**  
DESIGNER: ANNIG BARIAN  
STENDIG INTERNATIONAL, INC.

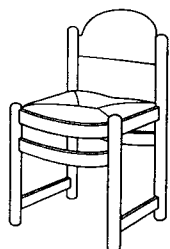

W 19 3/4"  
D 20"  
H 32"  
SH 18"

**PADOVA II SIDE CHAIR**  
LOWENSTEIN/OGGO

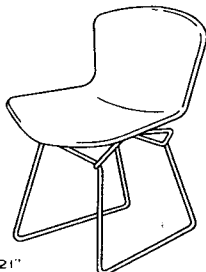

W 21"  
D 22 1/2"  
H 30"  
SH 18"

**SIDE CHAIR**  
DESIGNER: HARRY BERTOIA  
KNOLL INTERNATIONAL

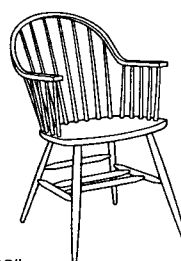

W 20"  
D 19"  
H 34"  
SH 17 1/2"

**WINDSOR ARMCHAIR**  
LOWENSTEIN/OGGO

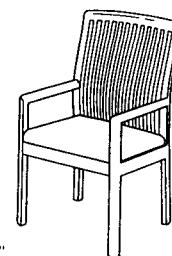

W 23"  
D 23 1/4"  
H 37"  
SH 18"

**CARRINGTON GUEST CHAIR**  
KIMBALL OFFICE FURNITURE CO.

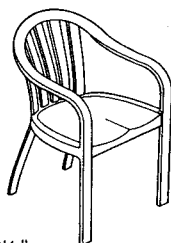

W 22 1/4"  
D 23 1/2"  
H 32"  
SH 17 3/4"

**COURTHOUSE CHAIR**  
GUNLOCKE

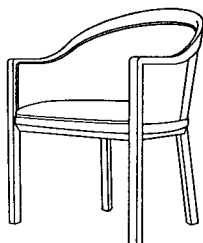

W 24"  
D 24 1/4"  
H 32 1/4"  
SH 18"

**WOOD FRAME ARMCHAIR**  
DESIGNER: WARD BENNETT  
BRICKEL ASSOCIATES

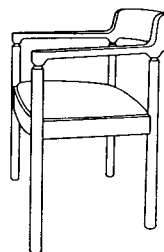

W 23"  
D 22 1/2"  
H 29"  
SH 17 1/2"

**ARMCHAIR**  
ZOGRAFOS DESIGNS LTD.

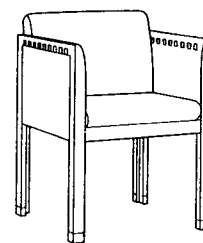

W 22 1/2"  
D 22 1/2"  
H 31"  
SH 19"

**ARMCHAIR**  
DESIGNER: BRIAN KANE  
METROPOLITAN FURNITURE  
CORP.

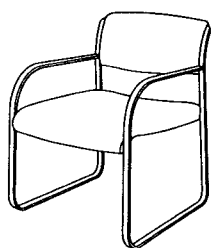

W 22 3/4"  
D 23 1/2"  
H 31"  
SH 18 1/4"

**SNODGRASS OPEN BACK  
ARMCHAIR**  
STEELCAGE

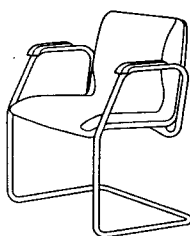

W 23 1/2"  
D 22"  
H 31"  
SH 17 1/2"

**VARIX ARMCHAIR**  
SAMSONITE FURNITURE CO.

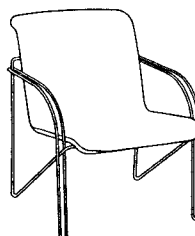

W 25"  
D 31"  
H 29"  
SH 16 1/2"

**VOLKSGCHAIR LOUNGE CHAIR**  
RUDD INTERNATIONAL CORP.

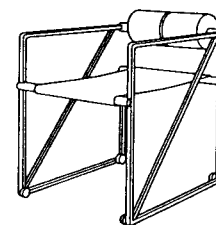

W 20 1/2"  
D 22 3/4"  
H 28 1/4"  
SH 18 1/2"

**SECONDA ARMCHAIR**  
DESIGNER: MARIO BOTTA  
ICF, INC.

Robert Staples; Staples & Charles Ltd.; Washington, D.C.  
Richard J. Vitullo, AIA; Oak Leaf Studio; Crownsville, Maryland



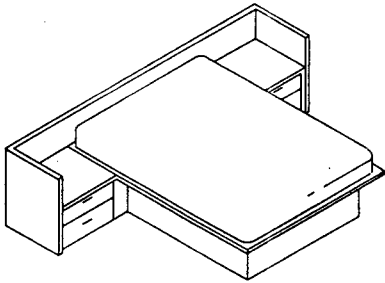

PLATFORM BED

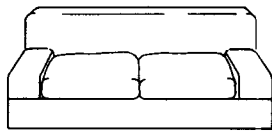

SOFA  
W 82 3/4"  
D 35 1/2"  
H 28 3/4"

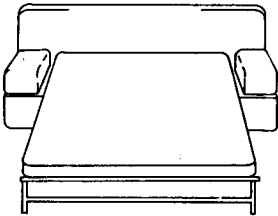

BED  
55" X 75"  
ICF

SOFA BED (PULL OUT)

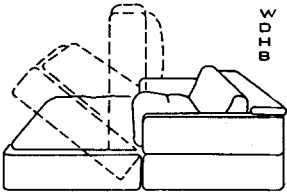

W 71 1/2"  
D 43 1/2"  
H 29 1/2"  
B & B AMERICA

SOFA BED (ROTATING)

MATTRESS  
24" X 58"  
49" X 58"  
74" X 58"

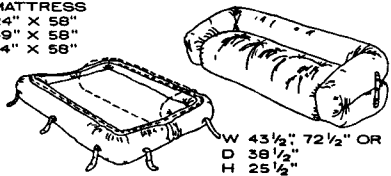

W 43 1/2", 72 1/2" OR 94 1/2"  
D 38 1/2"  
H 25 1/2"  
ICF

SOFA BED (FOLDING)  
BEDS

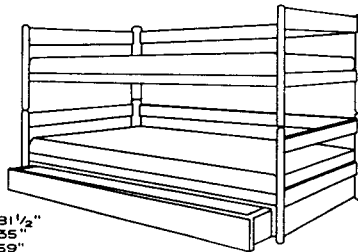

W 81 1/2"  
D 35"  
H 59"

ATELIER INTERNATIONAL, LTD.  
BUNK AND TRUNDLE

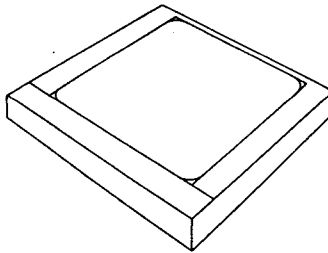

WATER BED COMPONENTS

- A. Mattress pad
- B. Water mattress
- C. Safety liner for mattress
- D. Heater
- E. Base
- F. Headboard
- G. Side frame

WATER BED

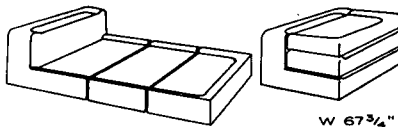

W 87 3/4"  
D 78"  
ICF

SECTIONAL DOUBLE BED

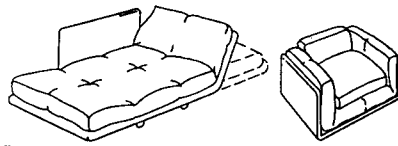

BBB BONACINA  
FOLDING ARMCHAIR BED

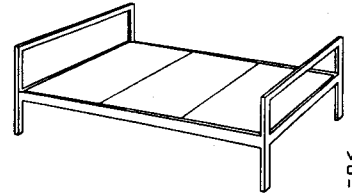

W 69"  
D 80 3/4"  
ICF

BED FRAME

STANDARD MATTRESS SIZES

- Bunk: 30" x 75", 33" x 75"
- Dormitory and hospital: 36" x 75" & 80"
- Twin: 39" x 75", 80" & 84"
- Double: 54" x 75"
- Queen: 60" x 80" & 84"
- King: 76" x 80" & 84"
- Revolving: 24"D x 41"W
- Foldout: 15"D x 41"W
- Water bed: Size varies; Weight of water 62.4 PCF

- Mattress
- Innerspring: 5 1/2"-6 1/2" D
- Foam: 4"-7 1/2" D
- Box spring: 5 1/2"-9" D (varies with mattress—height to equal average)

PILLOW SIZES

- Standard: 26"L x 20"W
- Queen: 30"L x 20"W
- King: 36"L x 20"W

W 25 1/2"  
L 51"  
H 31 1/2"



THE CHILDREN'S WORKBENCH  
JUNIOR CRIB

STANDARD JUVENILE MATTRESS SIZES (IN.)

TYPE	LENGTH	WIDTH
Bassinet	36	18
Bassinet	38 3/4	22 1/4
Junior crib	46	23
Junior crib	50 3/4	25 1/4
6-year crib	51	27
6-year crib	56 3/4	31 1/4
Youth bed	66	33
Youth bed	76	36

FOLDING CHAIR BED

W 72"  
D 20"  
H 29"  
INTREX

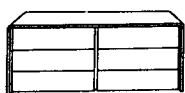

LOW DRESSERS

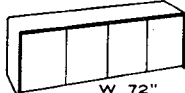

W 72"  
D 20"  
H 24"  
INTREX

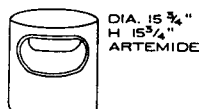

NIGHT TABLES

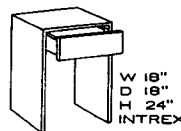

DIA. 15 3/4"  
H 15 3/4"  
ARTEMIDE

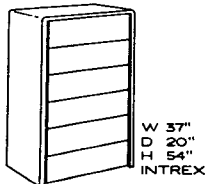

W 37"  
D 20"  
H 54"  
INTREX

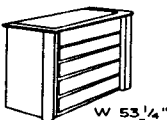

W 53 1/4"  
D 21 3/4"  
H 29"  
GINOVA

HIGH DRESSER DRESSER  
BEDROOM FURNITURE

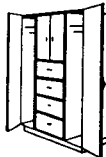

3 DOORS

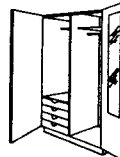

2 DOORS

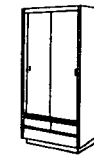

SLIDING DOORS

WARDROBE UNITS

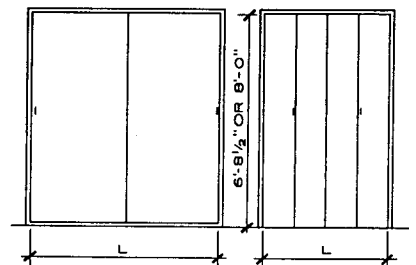

2 PANELS  
L 48", 60", 72",  
84", 96"

2 PANELS  
L 24", 30",  
36"

3 PANELS  
L 72", 108", 120",  
132", 144"

4 PANELS  
L 48", 60",  
72"

SLIDING BIFOLD  
MIRRORED CLOSET DOORS

Associated Space Design, Inc.; Atlanta, Georgia

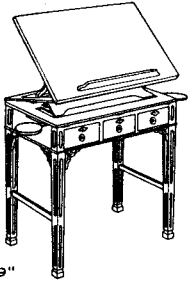

W 29"  
D 19"  
H 29½"

ARCHITECT'S TABLE  
CHIPPENDALE STYLE 1765  
BAKER

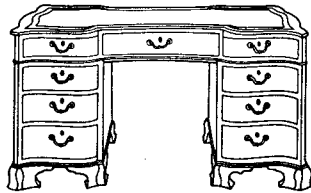

W 58"  
D 28¾"  
H 29"

DOUBLE PEDESTAL DESK  
CHIPPENDALE STYLE 1760  
BAKER

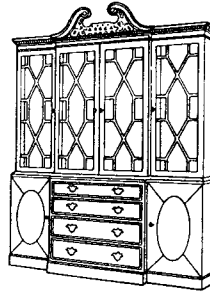

W 75¾"  
D 14½"  
H 94½"

BREAKFRONT  
CHIPPENDALE STYLE  
BAKER

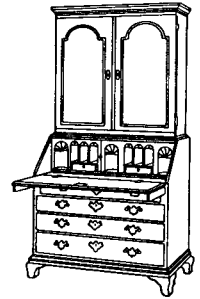

W 40"  
D 24½"  
H 82½"

DESK BOOKCASE  
HISTORIC NEWPORT STYLE  
KITTINGER

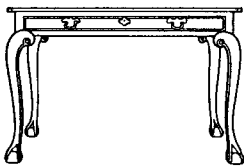

W 46"  
D 24"  
H 29"

CENTER TABLE  
GEORGE I STYLE 1720  
BAKER

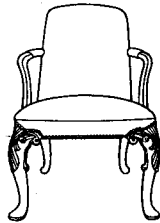

W 25"  
D 24"  
H 39"  
SH 19"

SHEPHERD'S CROOK ARMCHAIR  
GEORGE I STYLE 1718  
BAKER

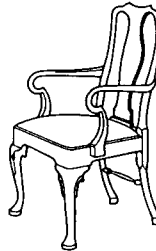

W 24"  
D 22¾"  
H 40½"  
SH 19"

OPEN ARMCHAIR  
QUEEN ANNE STYLE  
KITTINGER

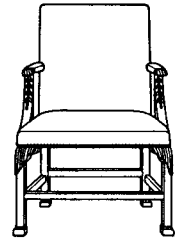

W 26"  
D 25¾"  
H 39¾"  
SH 19"

WENTWORTH ARMCHAIR  
GEORGE II STYLE 1750  
BAKER

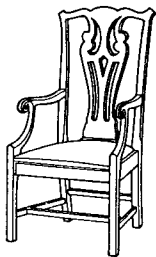

W 23¾"  
D 22½"  
H 45½"  
SH 19"

OPEN ARMCHAIR  
CHIPPENDALE STYLE  
KITTINGER



W 26"  
D 23½"  
H 38¾"  
SH 19¼"

OPEN ARMCHAIR  
CHIPPENDALE STYLE 1750  
BAKER

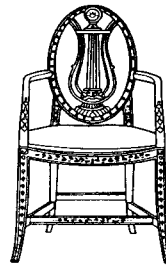

W 22"  
D 20⅞"  
H 34¼"  
SH 19"

OVAL AND LYRE BACK  
ARMCHAIR  
SHERATON STYLE 1780  
BAKER

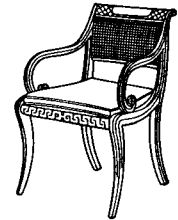

W 21⅞"  
D 22⅞"  
H 33"  
SH 19"

ARMCHAIR  
REGENCY STYLE  
KITTINGER

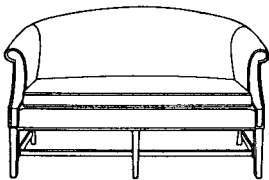

W 60"  
D 30"  
H 34½"  
SH 19"

LOVE SEAT  
SHERIDAN/HEPPLEWHITE  
STYLE  
KITTINGER

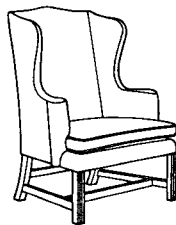

W 31"  
D 26"  
H 45½"  
SH 19"

WING CHAIR  
CHIPPENDALE STYLE  
KITTINGER

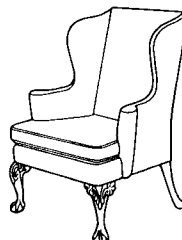

W 33"  
D 31½"  
H 44"  
SH 19"

WING CHAIR  
CHIPPENDALE STYLE  
KITTINGER

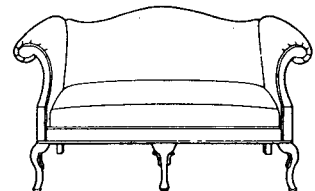

W 66"  
D 32"  
H 34" SH 19"

SETTEE  
CHIPPENDALE STYLE  
HICKORY BUSINESS  
FURNITURE

Robert Staples; Staples & Charles Ltd.; Washington, D.C.  
Eric J. Gastier; Darrel Downing Rippeteau Architects, PC; Washington, D.C.

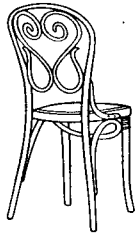

W 18"  
D 21"  
H 34½"  
SH 18"  
**CAFÉ DAUM CHAIR CIRCA 1849**  
DESIGNER: MICHAEL THONET  
THONET

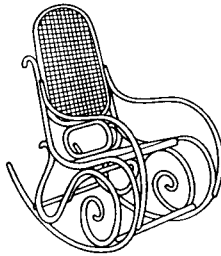

W 21"  
D 40"  
H 43"  
SH 17"  
**BENTWOOD ROCKER 1860**  
DESIGNER: MICHAEL THONET  
THONET



DIA. 23½"  
H 76"  
**BENTWOOD COSTUMER**  
DESIGNER: MICHAEL THONET  
THONET

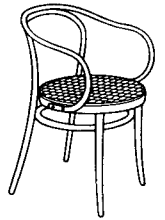

W 21½"  
D 22¼"  
H 31"  
SH 18½"  
**CORBUSIER CHAIR 1870**  
DESIGNER: MICHAEL THONET  
THONET

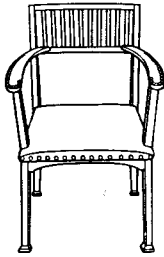

W 27"  
D 23"  
H 33"  
SH 18"  
**ARMCHAIR CIRCA 1898**  
DESIGNER: OTTO WAGNER  
THONET

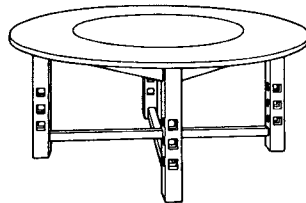

DIA. 75"  
H 29"  
**GSA TABLE 1900**  
DESIGNER:  
CHARLES R. MACKINTOSH  
ATELIER INTERNATIONAL

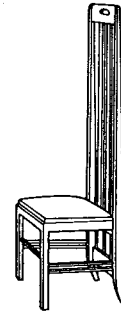

W 18½"  
D 17½"  
H 59¼"  
SH 17½"  
**INGRAM HIGH CHAIR 1900**  
DESIGNER:  
CHARLES R. MACKINTOSH  
ATELIER INTERNATIONAL

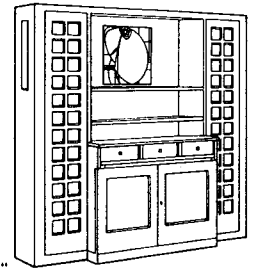

W 67"  
D 20"  
H 63"  
**SIDEBARD, 2 1918**  
DESIGNER:  
CHARLES R. MACKINTOSH  
ATELIER INTERNATIONAL

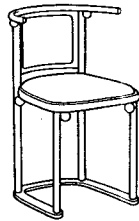

W 19½"  
D 18"  
H 30½"  
**FLEDERMAUS CHAIR 1905**  
DESIGNER: JOSEF HOFFMANN  
ICF, INC.

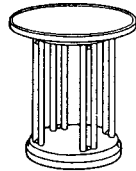

DIA. 25¾"  
H 25¾"  
**FLEDERMAUS TABLE 1905**  
DESIGNER: JOSEF HOFFMANN  
ICF, INC.

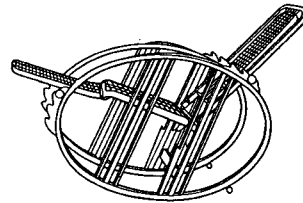

W 28¾"  
D 50½"  
H 45½"  
SH 18"  
**ROCKING CHAIR 1905**  
DESIGNER: JOSEF HOFFMANN  
ICF, INC.

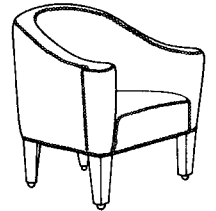

W 31"  
D 28½"  
H 30¾"  
SH 16½"  
**VILLA GALLIA ARMCHAIR 1913**  
DESIGNER: JOSEF HOFFMANN  
ICF, INC.

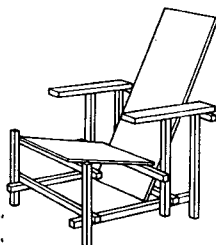

W 25¾"  
D 32¾"  
H 34½"  
SH 13"  
**RED AND BLUE LOUNGE CHAIR 1917**  
DESIGNER: GERRIT RIETVELD  
ATELIER INTERNATIONAL

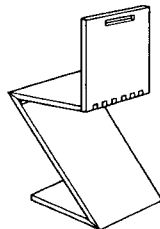

W 14½"  
D 17"  
H 29"  
SH 17"  
**ZIG ZAG CHAIR 1934**  
DESIGNER: GERRIT RIETVELD  
ATELIER INTERNATIONAL

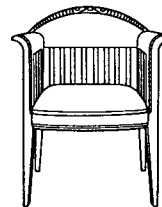

W 26¾"  
D 21¼"  
H 33"  
SH 17¾"  
**WHITE CHAIR CIRCA 1910**  
DESIGNER: ELIEL SAARINEN  
ICF, INC.

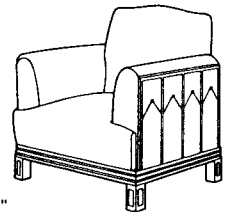

W 33¾"  
D 30½"  
H 35½"  
SH 17¾"  
**SAARINEN HOUSE LOUNGE CHAIR 1929/30**  
DESIGNER: ELIEL SAARINEN  
ARKITEKTURA

Robert Staples; Staples & Charles Ltd.; Washington, D.C.  
Eric J. Gastier; Darrel Downing Rippeteau Architects, PC; Washington, D.C.

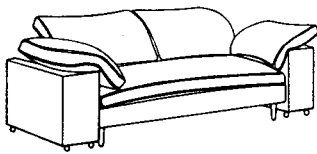

W 94 1/2"  
D 36 1/2"  
H 34 1/2"  
SH 17"

**LOTA SOFA 1924**  
DESIGNER: EILEEN GRAY  
PALAZZETTI

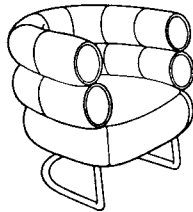

W 35 1/2"  
D 32 1/2"  
H 29"  
SH 16"

**POLTRONA ARMCHAIR 1927**  
DESIGNER: EILEEN GRAY  
PALAZZETTI

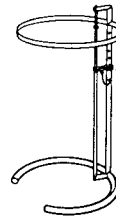

DIA. 20"  
H 21" - 36"

**ADJUSTABLE HEIGHT TABLE 1927**  
DESIGNER: EILEEN GRAY  
STENDIG INC.

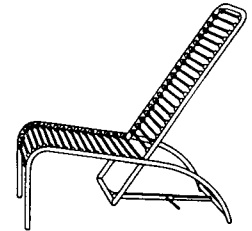

W 21 3/4"  
D 33 3/4"  
H 35 3/4"  
SH 13 1/4"

**LOUNGE CHAIR CIRCA 1920**  
DESIGNER: RENÉ HERBST  
JG FURNITURE SYSTEMS

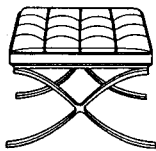

W 23"  
D 22"  
H 14 1/2"

**BARCELONA STOOL 1929**  
DESIGNER: MIES VAN DER ROHE  
KNOLL INTERNATIONAL

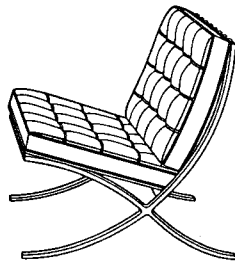

W 30"  
D 30"  
H 30"  
SH 17"

**BARCELONA CHAIR 1929**  
DESIGNER: MIES VAN DER ROHE  
KNOLL INTERNATIONAL

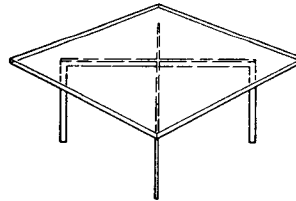

W 40"  
D 40"  
H 17"

**BARCELONA TABLE 1929**  
DESIGNER: MIES VAN DER ROHE  
KNOLL INTERNATIONAL

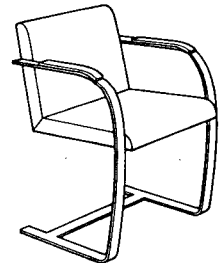

W 18"  
D 23"  
H 31 1/2"  
SH 17"

**BRNO ARMCHAIR 1929**  
DESIGNER: MIES VAN DER ROHE  
PALAZZETTI

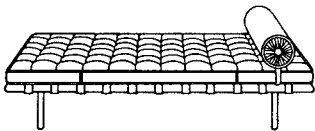

W 78"  
D 39"  
H 15 1/2"

**MIES COUCH**  
DESIGNER: MIES VAN DER ROHE  
KNOLL INTERNATIONAL

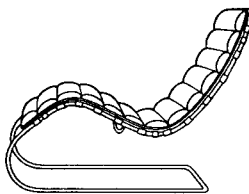

W 23 5/8"  
D 47 1/4"  
H 37 1/2"

**CHAISE LOUNGE 1931**  
DESIGNER: MIES VAN DER ROHE  
KNOLL INTERNATIONAL

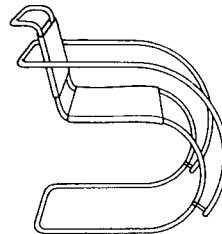

W 21 3/4"  
D 32 1/4"  
H 32 1/4"  
SH 17 1/4"

**MR. CHAIR 1927**  
DESIGNER: MIES VAN DER ROHE  
STENDIG INC.

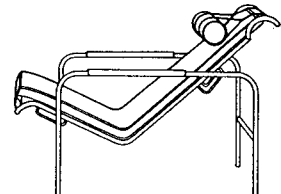

W 21 1/2"  
D 43"  
H 30"

**GENNI LOUNGE CHAIR 1935**  
DESIGNER: GABRIELE MUCCHI  
ICF INC.

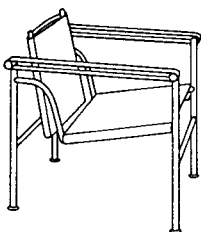

W 23 5/8"  
D 25 5/8"  
H 25 1/4"  
SH 15 3/4"

**LC 1 SLING CHAIR 1928**  
DESIGNER: LE CORBUSIER  
ATELIER INTERNATIONAL

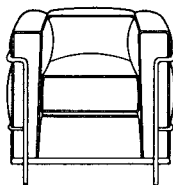

W 30"  
D 27 1/2"  
H 26 1/2"  
SH 17"

**LC 2 ARM CHAIR 1929**  
DESIGNER: LE CORBUSIER  
ATELIER INTERNATIONAL

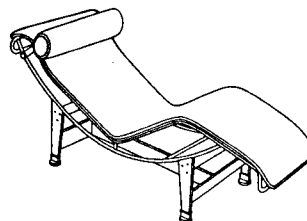

W 22"  
D 63"

**LC 4 CHAISE LOUNGE 1928**  
DESIGNER: LE CORBUSIER  
ATELIER INTERNATIONAL

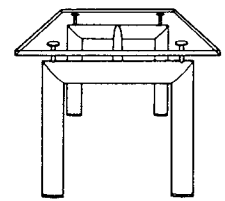

W 90"  
D 35 1/2"  
H 27" - 29"

**LC 6 TABLE 1925 - 28**  
DESIGNER: LE CORBUSIER  
ATELIER INTERNATIONAL

Robert Staples; Staples & Charles Ltd.; Washington, D.C.  
Eric J. Gastier; Darrel Downing Rippeteau Architects, PC; Washington, D.C.



W 22<sup>5</sup>/<sub>8</sub>"  
D 21<sup>5</sup>/<sub>8</sub>"  
H 31<sup>3</sup>/<sub>4</sub>"  
SH 16<sup>1</sup>/<sub>4</sub>"

**CESCA ARM CHAIR 1928**  
DESIGNER: MARCEL BREUER  
KNOLL INTERNATIONAL

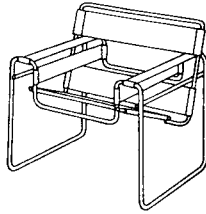

W 30<sup>3</sup>/<sub>4</sub>"  
D 27"  
H 28<sup>1</sup>/<sub>2</sub>"  
SH 17"

**WASSILY CHAIR 1925**  
DESIGNER: MARCEL BREUER  
KNOLL INTERNATIONAL

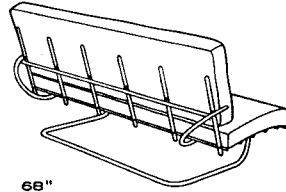

W 68"  
D 32"  
H 34"  
SH 16<sup>3</sup>/<sub>4</sub>"

**SOFA 1931**  
DESIGNER: MARCEL BREUER  
GLOBAL FURNITURE

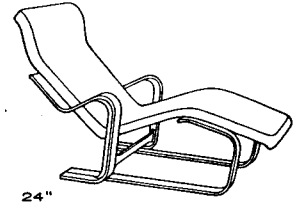

W 24"  
D 51"  
H 33"

**LONG CHAIR 1935/36**  
DESIGNER: MARCEL BREUER  
PALAZZETTI

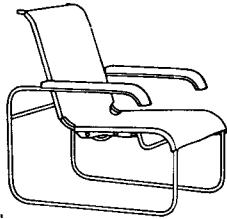

W 25<sup>1</sup>/<sub>2</sub>"  
D 31<sup>1</sup>/<sub>2</sub>"  
H 32<sup>1</sup>/<sub>2</sub>"  
SH 14<sup>1</sup>/<sub>2</sub>"

**BREUER LOUNGE CHAIR 1928**  
DESIGNER: MARCEL BREUER  
ICF, INC.

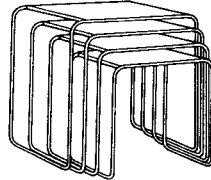

W 26"  
D 20"  
H 24"

**NESTING TABLES 1925**  
DESIGNER: MARCEL BREUER  
THONET

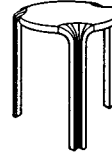

DIA. 15"  
H 17<sup>3</sup>/<sub>4</sub>"

**FAN-LEGGED TABLE 1954**  
DESIGNER: ALVAR AALTO  
ICF, INC.

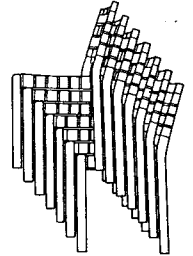

W 19"  
D 19<sup>1</sup>/<sub>4</sub>"  
H 31<sup>1</sup>/<sub>2</sub>"  
SH 17<sup>3</sup>/<sub>4</sub>"

**STACK CHAIR 1930**  
DESIGNER: ALVAR AALTO  
ICF, INC.

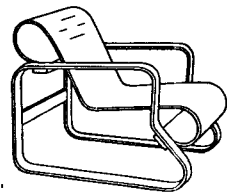

W 23<sup>1</sup>/<sub>2</sub>"  
D 31<sup>1</sup>/<sub>2</sub>"  
H 25"  
SH 13"

**"PAIMIO" CHAIR 1930-33**  
DESIGNER: ALVAR AALTO  
PALAZZETTI

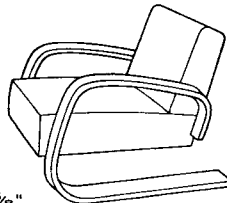

W 21<sup>5</sup>/<sub>8</sub>"  
D 30<sup>1</sup>/<sub>4</sub>"  
H 25<sup>5</sup>/<sub>8</sub>"  
SH 14<sup>1</sup>/<sub>2</sub>"

**LOUNGE CHAIR 1935**  
DESIGNER: ALVAR AALTO  
ICF, INC.

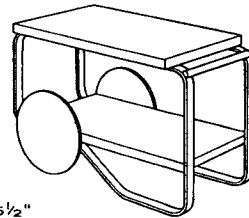

W 35<sup>1</sup>/<sub>2</sub>"  
D 19<sup>3</sup>/<sub>4</sub>"  
H 22<sup>1</sup>/<sub>4</sub>"

**TEA TROLLEY 1936/37**  
DESIGNER: ALVAR AALTO  
ICF, INC.

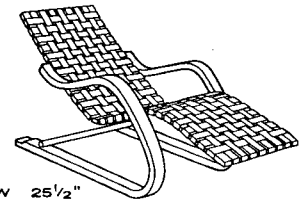

W 25<sup>1</sup>/<sub>2</sub>"  
D 63<sup>1</sup>/<sub>2</sub>"  
H 26"  
SH 10"

**CHAISE LOUNGE 1936**  
DESIGNER: ALVAR AALTO  
ICF, INC.

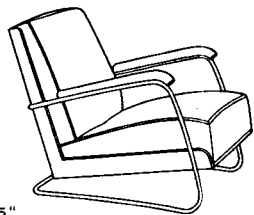

W 25"  
D 33<sup>1</sup>/<sub>4</sub>"  
H 31<sup>1</sup>/<sub>4</sub>"  
SH 17<sup>1</sup>/<sub>4</sub>"

**LOUNGE CHAIR 1932-34**  
DESIGNER: PAULI BLOMSTED  
ARKITEKTURA

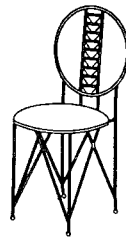

W 16"  
D 18"  
H 35"  
SH 18"

**MIDWAY CHAIR 1914**  
DESIGNER:  
FRANK LLOYD WRIGHT  
ATELIER INTERNATIONAL

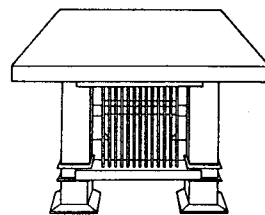

W 101"  
D 42"  
H 29"

**ALLEN TABLE 1917**  
DESIGNER:  
FRANK LLOYD WRIGHT  
ATELIER INTERNATIONAL

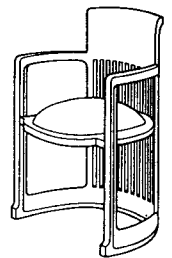

W 21<sup>1</sup>/<sub>2</sub>"  
D 22"  
H 32"  
SH 19<sup>1</sup>/<sub>2</sub>"

**BARREL CHAIR 1937**  
DESIGNER:  
FRANK LLOYD WRIGHT  
ATELIER INTERNATIONAL

Robert Staples; Staples & Charles Ltd., Washington, D.C.  
Eric J. Gastier; Darrel Downing Rippeteau Architects, PC; Washington, D.C.



W 25½"  
D 20"  
H 16"

**OTTOMAN 1948**  
DESIGNER: EERO SAARINEN  
KNOLL INTERNATIONAL

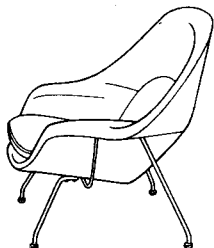

W 40"  
D 34"  
H 35½"  
SH 16"

**WOMB CHAIR 1948**  
DESIGNER: EERO SAARINEN  
KNOLL INTERNATIONAL



W 26"  
D 23½"  
H 32"  
SH 18½"

**ARMCHAIR 1956**  
DESIGNER: EERO SAARINEN  
KNOLL INTERNATIONAL

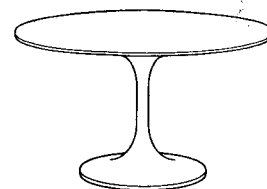

W 78"  
D 48"  
H 28½"

**OVAL TABLE 1956**  
DESIGNER: EERO SAARINEN  
KNOLL INTERNATIONAL

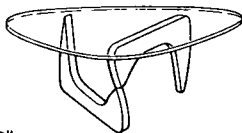

W 50"  
D 36"  
H 15¾"

**NOGUCHI TABLE 1950**  
DESIGNER: ISAMU NOGUCHI  
HERMAN MILLER, INC.

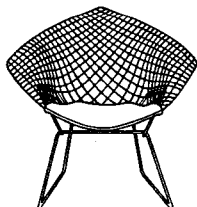

W 33¾"  
D 28"  
H 30½"  
SH 17"

**DIAMOND CHAIR 1952**  
DESIGNER: HARRY BERTOIA  
KNOLL INTERNATIONAL

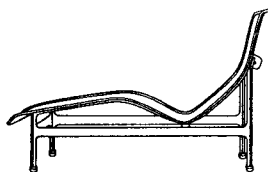

W 24½"  
D 58"  
H 33¾"  
SH 13"

**CONTOUR CHAISE LOUNGE**  
DESIGNER: RICHARD SCHULTZ  
ICF, INC.

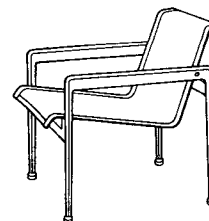

W 26"  
D 28¼"  
H 26½"  
SH 14"

**LOUNGE CHAIR 1966**  
DESIGNER: RICHARD SCHULTZ  
KNOLL INTERNATIONAL

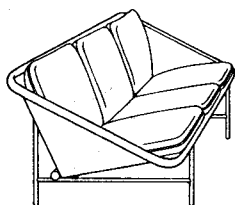

W 87"  
D 32¼"  
H 29¾"

**SLING SOFA 1964**  
DESIGNER: GEORGE NELSON  
HERMAN MILLER, INC.



W 21½"  
D 19½"  
H 29⅜"  
SH 18"

**MOLDED PLYWOOD CHAIR 1946**  
DESIGNER: CHARLES EAMES  
HERMAN MILLER, INC.

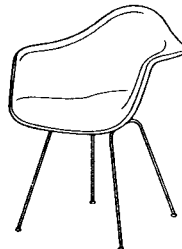

W 25"  
D 25½"  
H 31"  
SH 17⅝"

**MOLDED FIBERGLASS CHAIR 1949**  
DESIGNER: CHARLES EAMES  
HERMAN MILLER, INC.

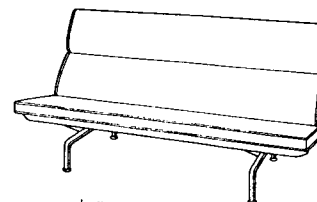

W 72½"  
D 30"  
H 35"  
SH 16"

**COMPACT SOFA 1952**  
DESIGNER: CHARLES EAMES  
HERMAN MILLER, INC.



W 32½"  
D 32¾"  
H 33½"  
SH 15"

**LOUNGE CHAIR 1956**  
DESIGNER: CHARLES EAMES  
HERMAN MILLER, INC.



W 26"  
D 21"  
H 15"

**OTTOMAN 1956**  
DESIGNER: CHARLES EAMES  
HERMAN MILLER, INC.



W 28½"  
D 24¾"  
H 33¾"  
SH 17½"

**ALUMINUM GROUP LOUNGE 1958**  
DESIGNER: CHARLES EAMES  
HERMAN MILLER, INC.

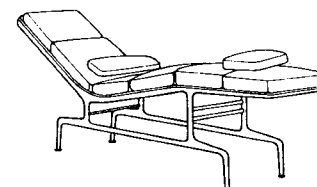

W 75"  
D 17½"  
H 28¾"  
SH 20½"

**CHAISE LOUNGE 1968**  
DESIGNER: CHARLES EAMES  
HERMAN MILLER, INC.

Robert Staples; Staples & Charles Ltd.; Washington, D.C.  
Eric J. Gastier; Darrel Downing Rippeteau Architects, PC; Washington, D.C.

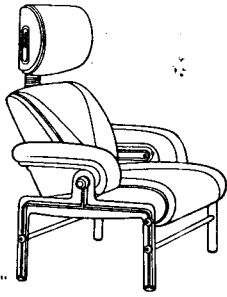

W 32<sup>3</sup>/<sub>8</sub>"  
D 34"  
H 43<sup>1</sup>/<sub>2</sub>"  
SH 16<sup>3</sup>/<sub>4</sub>"

**JEFFERSON CHAIR 1986**  
DESIGNER: NIELS DIFFRIENT  
SUNARHAUSERMAN

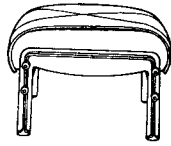

W 25"  
D 24"  
H 17<sup>1</sup>/<sub>2</sub>"

**OTTOMAN 1986**  
DESIGNER: NIELS DIFFRIENT  
SUNARHAUSERMAN

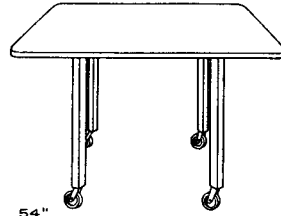

W 54"  
D 54"  
H 27<sup>1</sup>/<sub>2</sub>"

**SQUARE TABLE**  
DESIGNER: JOSEPH PAUL D'URSO  
KNOLL INTERNATIONAL

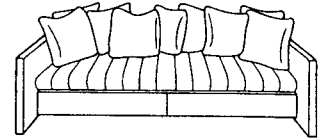

W 96"  
D 48"  
H 24"  
SH 15<sup>1</sup>/<sub>2</sub>"

**LARGE SOFA**  
DESIGNER: JOSEPH PAUL D'URSO  
KNOLL INTERNATIONAL

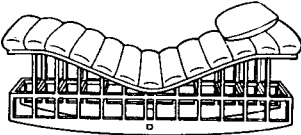

W 72"  
D 27<sup>1</sup>/<sub>2</sub>"  
H 25<sup>1</sup>/<sub>8</sub>"

**CHAISE LOUNGE 1982**  
DESIGNER: RICHARD MEIER  
KNOLL INTERNATIONAL

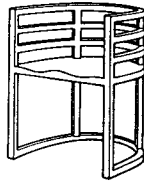

W 21"  
D 20"  
H 27<sup>1</sup>/<sub>2</sub>"  
SH 17<sup>1</sup>/<sub>2</sub>"

**CHAIR 1982**  
DESIGNER: RICHARD MEIER  
KNOLL INTERNATIONAL

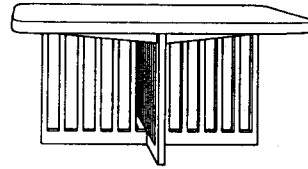

W 60"  
D 60"  
H 27<sup>1</sup>/<sub>2</sub>"

**TABLE 1992**  
DESIGNER: RICHARD MEIER  
KNOLL INTERNATIONAL

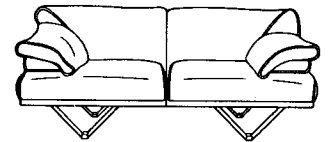

W 72"  
D 36"  
H 32"

**CORNELIUS SOFA 1986**  
DESIGNER: CARLO SANTI  
AXIOM DESIGNS

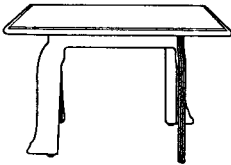

W 48"  
D 48"  
H 28<sup>1</sup>/<sub>2</sub>"

**CABRIOLE LEG TABLE 1984**  
DESIGNER: ROBERT VENTURI  
KNOLL INTERNATIONAL

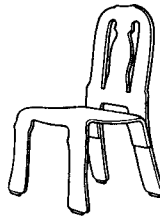

W 26<sup>1</sup>/<sub>2</sub>"  
D 23<sup>1</sup>/<sub>2</sub>"  
H 38<sup>1</sup>/<sub>2</sub>"  
SH 17<sup>1</sup>/<sub>2</sub>"

**QUEEN ANNE CHAIR 1984**  
DESIGNER: ROBERT VENTURI  
KNOLL INTERNATIONAL

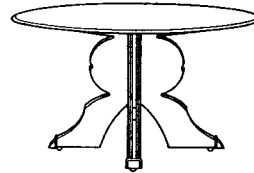

DIA. 60"  
H 28<sup>1</sup>/<sub>2</sub>"

**URN TABLE 1984**  
DESIGNER: ROBERT VENTURI  
KNOLL INTERNATIONAL

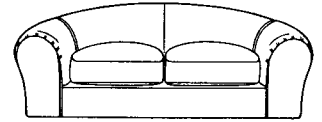

W 67"  
D 43<sup>1</sup>/<sub>2</sub>"  
H 33<sup>3</sup>/<sub>4</sub>"  
SH 20"

**SOFA 1984**  
DESIGNER: ROBERT VENTURI  
KNOLL INTERNATIONAL

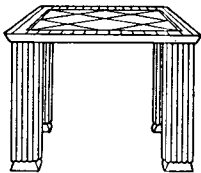

W 40<sup>1</sup>/<sub>2</sub>"  
D 40<sup>1</sup>/<sub>2</sub>"  
H 29"

**TABLE 1982**  
DESIGNER: MICHAEL GRAVES  
SUNARHAUSERMAN

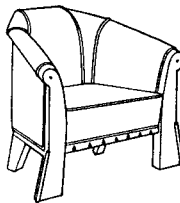

W 32"  
D 29"  
H 29"

**LOUNGE CHAIR 1982**  
DESIGNER: MICHAEL GRAVES  
SUNARHAUSERMAN

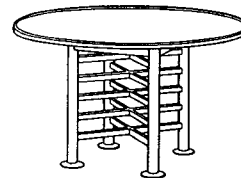

DIA. 48"  
H 29<sup>1</sup>/<sub>4</sub>"

**TABLE 1986**  
DESIGNER: MICHAEL MCCOY  
ARKITEKTURA

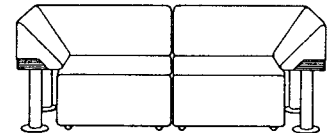

W 74"  
D 32"  
H 26<sup>1</sup>/<sub>2</sub>"  
SH 13<sup>1</sup>/<sub>2</sub>"

**QUADRIO SOFA**  
DESIGNER: MICHAEL MCCOY  
KRUEGER INTERNATIONAL DIV.

Robert Staples; Staples & Charles Ltd.; Washington, D.C.  
Eric J. Gastier; Darrel Downing Rippeteau Architects, PC; Washington, D.C.

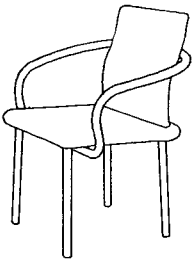

W 26"  
D 23 1/2"  
H 32 1/2"  
SH 16 3/4"

**MANDARIN ARMCHAIR 1986**  
DESIGNER : SOTTASS ASSOCIATES  
KNOLL STUDIO

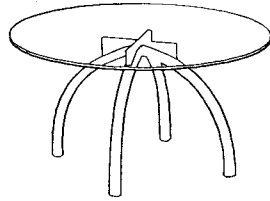

DIA. 53 1/4"  
H 28 1/3"

**SPYDER TABLE 1987**  
DESIGNER : SOTTASS ASSOCIATES  
KNOLL STUDIO

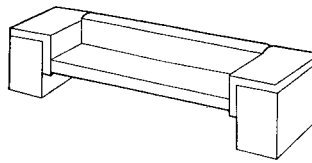

W 70"  
D 35 1/2"  
H 21 3/4"  
SH 15 3/4"

**BRIGADIER LOWBACK SEATEE 1977**  
DESIGNER : CINI BOERI  
KNOLL STUDIO

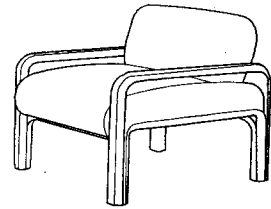

W 31 1/2"  
D 33 3/4"  
H 30 1/4"  
SH 17"

**LOUNGE CHAIR 1975**  
DESIGNER : GAE AULENTI  
KNOLL STUDIO

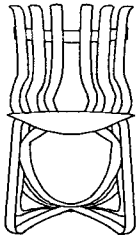

W 28 1/2"  
D 24 7/8"  
H 33 5/8"  
SH 18 1/8"

**CROSS CHECK ARMCHAIR 1992**  
DESIGNER : FRANK GEHRY  
KNOLL STUDIO

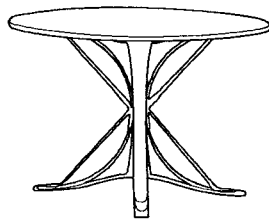

DIA. 40"  
H 28 3/4"

**FACE OFF CAFE TABLE 1992**  
DESIGNER : FRANK GEHRY  
KNOLL STUDIO

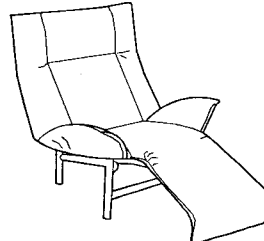

W 37.8"  
D 33.5"  
H 29.5" - 43.3"

**VERANDA ARMCHAIR 1983**  
DESIGNER : VICO MAGISTRETTI  
ATELIER INTERNATIONAL

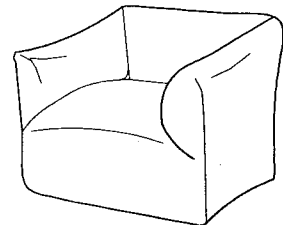

W 41.4"  
D 31.5"  
H 29.5"  
SH 16.2"

**685 ARMCHAIR 1973**  
DESIGNER : MARIO BELLINI  
ATELIER INTERNATIONAL

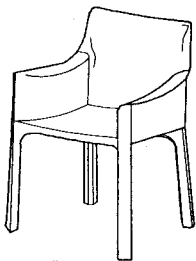

W 23.6"  
D 20.5"  
H 32.3"  
SH 17"

**CAB ARMCHAIR 1977, 1979**  
DESIGNER : MARIO BELLINI  
ATELIER INTERNATIONAL

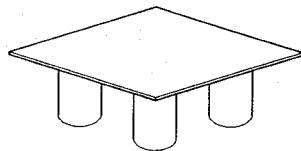

W 49.6"  
D 49.6"  
H 14.1"

**SERENISSIMO 36, LOW TABLE 1985**  
DESIGNER : LELLA AND MASSIMO  
VIGNELLI AND DAVID LAW  
ATELIER INTERNATIONAL

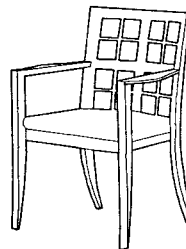

W 23.2"  
D 22"  
H 34.3"  
SH 18.5"

**FINESTRA ARMCHAIR 1989**  
DESIGNER : MICHAEL GRAVES  
ATELIER INTERNATIONAL

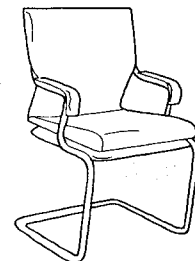

W 22.8"  
D 22.8"  
H 34.2"  
SH 17.3"

**ARCHIZOOM ARMCHAIR 1979**  
DESIGNER : ARCHIZOOM ASSOCIATES  
ATELIER INTERNATIONAL

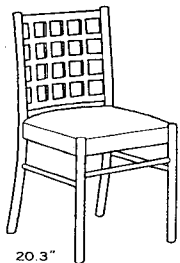

W 20.3"  
D 20"  
H 34"  
SH 19"

**DUO CHAIR 1988**  
DESIGNER : WERTHER TOFFOLONI  
ATELIER INTERNATIONAL

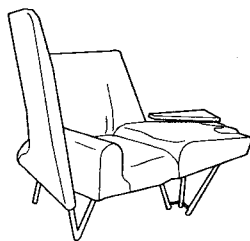

W 57.1"  
D 41.7"  
H 45.6"  
SH 17.7"

**TORSO CHAISE LOUNGE 1982**  
DESIGNER : PAOLO DEGANELLO  
ATELIER INTERNATIONAL

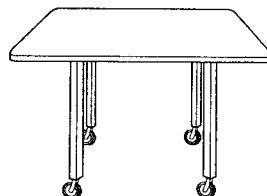

W 54"  
D 54"  
H 27 1/2"

**HIGH ROLLING TABLE 1980**  
DESIGNER : JOSEPH PAUL D'URSO  
KNOLL STUDIO

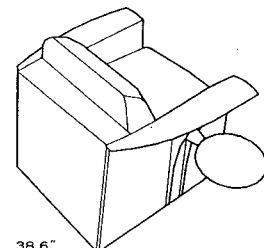

W 38.6"  
D 34.5"  
H 28.8"  
SH 18.2"

**LOUNGE CHAIR 1990**  
DESIGNER : DOUGLAS BALL  
ATELIER INTERNATIONAL

McCain McMurray, Architect; Washington, D.C.



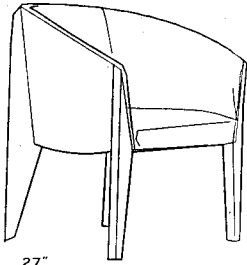

W 27"  
D 25 1/2"  
H 30"  
SH 18"  
**ARM SESSEL CHAIR 1987**  
DESIGNER: MARK MACK  
BERNHARDT

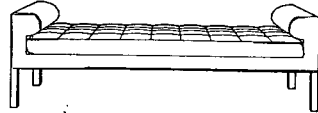

W 66"  
D 24"  
H 20 3/4"  
SH 15 1/2"  
**MUSEUM BENCH 1982**  
DESIGNER: CHARLES MCMURRAY  
CHARLES MCMURRAY DESIGNS

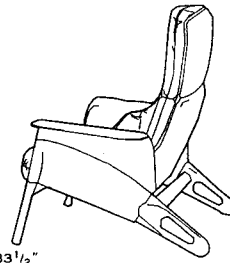

W 33 1/2"  
D 34"  
H 40"  
SH 17"  
**HOLLINGTON LOUNGE CHAIR**  
DESIGNER: GEOFF HOLLINGTON  
HERMAN MILLER

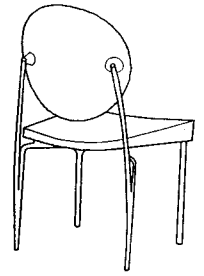

W 19"  
D 20"  
H 34 3/4"  
SH 18"  
**VIK-TER STACKING CHAIR 1991**  
DESIGNER: DAKOTA JACKSON  
DAKOTA JACKSON, INC.

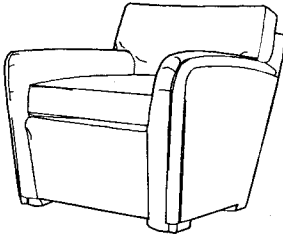

W 32"  
D 31"  
H 28"  
SH 16"  
**BABY DOLL LOUNGE CHAIR 1989**  
DESIGNER: BENTLEY LA ROSA SALASKY  
BRICKEL ASSOCIATES, INC.

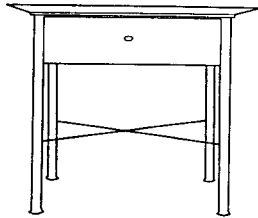

W 23 1/4"  
D 23 1/4"  
H 20 1/4"  
**END TABLE 1988**  
DESIGNER: BENTLEY LA ROSA SALASKY  
BRICKEL ASSOCIATES, INC.

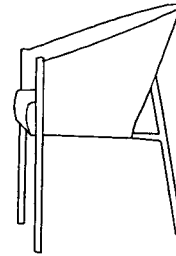

W 18 1/2"  
D 21 1/2"  
H 31"  
SH 18 1/2"  
**COSTES CHAIR 1984**  
DESIGNER: PHILIPPE STARCK  
DRIADE

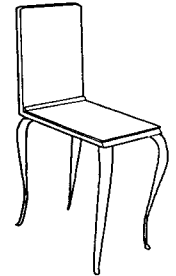

W 13"  
D 21"  
H 19" - 33"  
SH 18 1/2"  
**LOLA MUNDO 1986**  
DESIGNER: PHILIPPE STARCK  
DRIADE

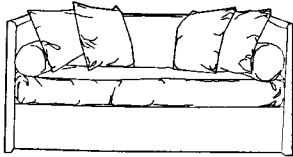

W 72"  
D 35"  
H 32 1/2"  
SH 19"  
**SHELTER SOFA 1985**  
DESIGNER: JOHN SALADINO  
SALADINO FURNITURE, INC.



W 72"  
D 36"  
H 29"  
**CITIES TABLE**  
DESIGNER: AL GLASS  
BDI

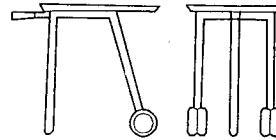

W 24 1/2"  
D 15 3/4"  
H 21 7/8"  
**BAISITY SERVOMUTO 1989**  
DESIGNER: ANTONIO CITTERIO  
B & B ITALIA

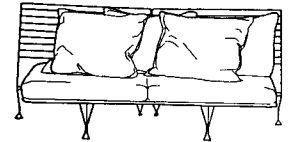

W 85"  
D 29 1/2"  
H 36 5/8"  
SH 16 1/2"  
**IKMISOU SOFA 1988**  
DESIGNER: PASCAL MOURGE  
VECTA

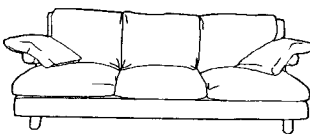

W 86"  
D 41"  
H 33 1/2"  
SH 15 1/2"  
**BAISITY SOFA 1989**  
DESIGNER: ANTONIO CITTERIO  
B & B ITALIA

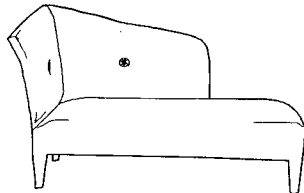

W 70"  
D 38"  
H 38"  
SH 17"  
**SPIRIT CHAISE**  
DESIGNER: JOHN HUTTON  
DONGHIA FURNITURE

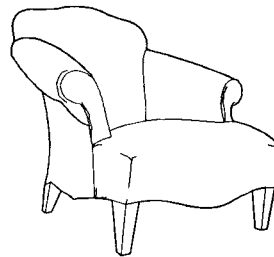

W 36"  
D 36"  
H 36"  
SH 18"  
**LUCIANO CLUB CHAIR**  
DESIGNER: JOHN HUTTON  
DONGHIA FURNITURE

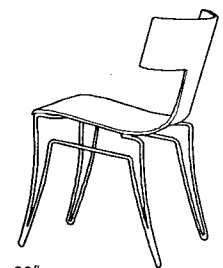

W 20"  
D 20"  
H 31 1/2"  
SH 17 1/2"  
**ANZIANO CHAIR**  
DESIGNER: JOHN HUTTON  
DONGHIA FURNITURE

McCain McMurray, Architect, Washington, D.C.

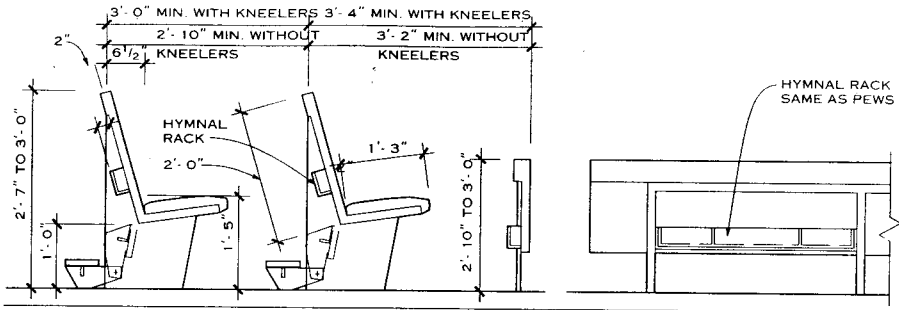

PEWS AND FRONTAL

**INTRODUCTION**

Ecclesiastical furnishings are as much a part of the ambience, symbolism, and meaning of a worship environment as the structure and architecture itself. Virtually all ecclesiastical furnishings are available from manufacturers in pre-designed, prefabricated form. For pews and chairs, in particular, such stock or semicustom items can be quite satisfactory and economical. When special scale, material, or symbolism is desired, custom-designed and custom-built furnishings may be more appropriate, as is often true for chancel/sanctuary furnishings such as the pulpit, communion table, font, and clergy chairs. Illustrations on this and the following page give information about the general size and character of such furnishings. The theological and liturgical attitudes of each church should guide the design and execution of ecclesiastical furnishings.

**PEWS**

Most pew manufacturers offer a diverse selection of styles, materials, and finishes, and many will custom build special designs prepared by architects. Pew ends contribute most to style and are available in numerous designs, from closed to semiopen to fully open. Kneelers are optional, some are available with hydraulic pistons to govern speed (and noise) when they are lowered and raised. Other options include book, card, pencil, and communion cup holders.

When planning pew locations, leave spaces at the ends of some pews for wheelchair users. Distribute these open areas around the sanctuary, leaving room at some locations for two to three wheelchair users to sit together.

**STACKING CHAIRS**

A variety of stacking or modular chairs are available and well suited for use in small churches, chapels, and choir areas, where flexibility of arrangement or complete removal is desired. Like pews, these chairs may be upholstered in differing degrees and equipped with kneelers, book holders, and other features. Most manufacturers offer an interlocking device that enables users to join rows of chairs together for temporarily fixed arrangements. In some jurisdictions, interlocking is a code requirement. Stacking capability allows efficient storage of chairs. When worship spaces are large enough to require a sloped floor for proper sight and sound lines, chairs are generally not advisable. (Stacking chairs are illustrated on the following page.)

**PULPIT**

The pulpit (Protestant) has historically been a fixed chancel/sanctuary furnishing. However, increasing demand for multiple uses of worship space often requires that all furnishings be movable. Among the most important features of a pulpit is an adjustable top, to accommodate the different heights of speakers. A drop-down step may also be desirable. A pulpit should include a concealed reading lamp

**PEW SPACING**

BACK-TO-BACK BETWEEN PEWS			PEW LENGTH*		
NO. OF SPACES	2'-10" SPACING	3'-0" SPACING	NO. OF PERSONS	1'-8" PER PERSON	1'-10" PER PERSON
5	14'-2"	15'-0"	3	5'-0"	5'-6"
10	28'-4"	30'-0"	5	8'-4"	9'-2"
20	56'-8"	60'-0"	7	11'-8"	12'-10"
30	85'-0"	90'-0"	9	15'-0"	16'-6"
			11	18'-4"	20'-0"
			12	20'-0"	

\*Minimum space allowed per person is 1 ft 6 in. Based on NFPA 101 Life Safety Code (1985), the maximum number of seats allowed in a row with aisles at both ends of the row is 14; maximum length allowed for a row is 21 ft 0 in.

(especially where A/V darkening is employed), A/V controls, and a built-in clock. Although lavalier or wireless microphones are used extensively, provide a concealed microphone cable raceway and pad the pulpit top to minimize the noise of rustling notes, which sensitive microphones may amplify.

**AMBO/READING DESK**

The ambo (Roman Catholic), or movable reading desk, is for reading or preaching. It requires an adjustable top to allow for the heights of various users. As shown, the top may be removable to accommodate readers in wheelchairs. A shelf pulled out from behind allows a book to be brought over the lap of a wheelchair-bound person. Size and scale of the desk will vary, depending on the size of the room.

**LECTERN/SONG LEADER DESK**

Lectors or song leaders use this very flexible, open, and mostly transparent stand. Its top is sloped, with a book stop much like the ambo but of smaller scale.

**COMMUNION RAIL**

Communion rails should provide for comfortable kneeling and perhaps for the disposition of individual communion cups. In worship spaces also used for concerts or drama, communion rails may need to be easily removable.

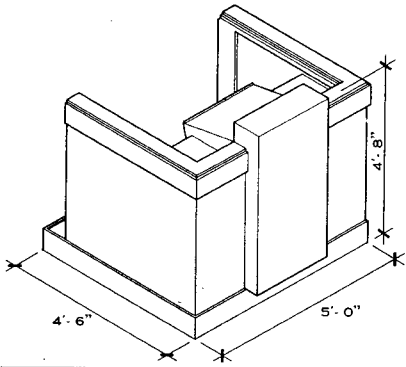

PULPIT (FIXED)

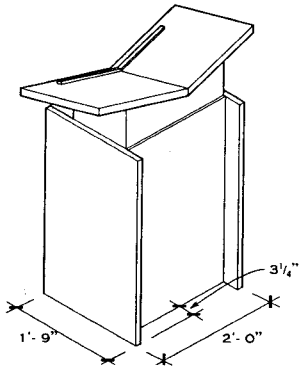

PULPIT (MOVABLE)

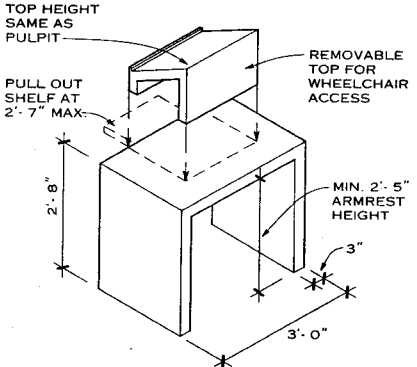

AMBO/READING DESK

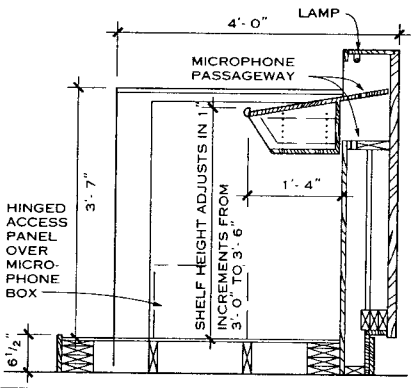

PULPIT (FIXED) SECTION

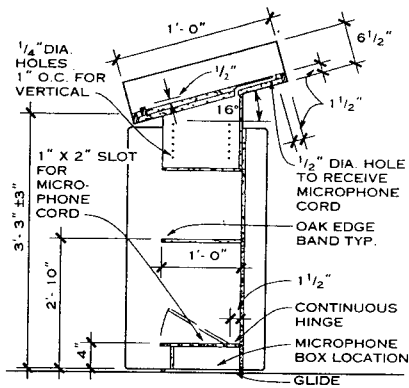

PULPIT (MOVABLE) SECTION

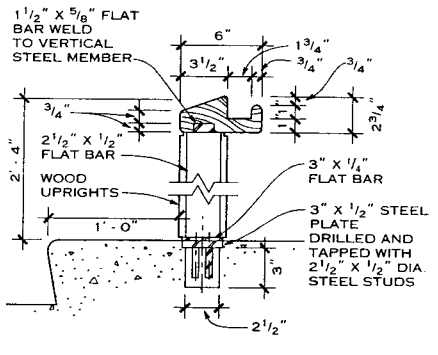

COMMUNION RAIL SECTION

Ware Associates, Inc.; Rockford, Illinois/Chicago/Los Angeles

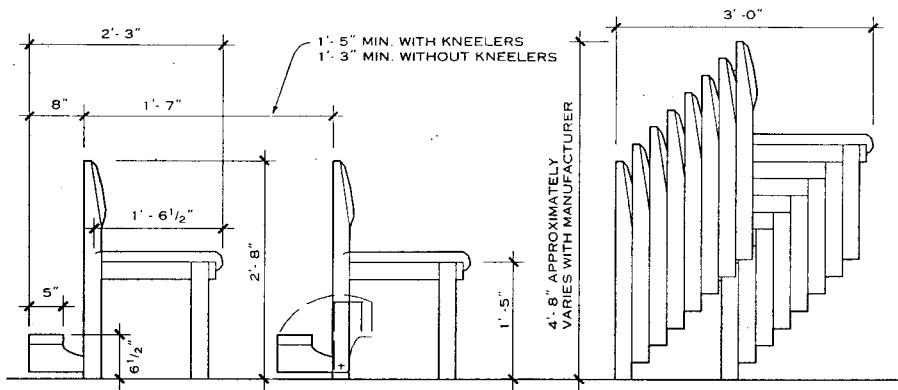

STACKING CHAPEL/CHOIR CHAIRS

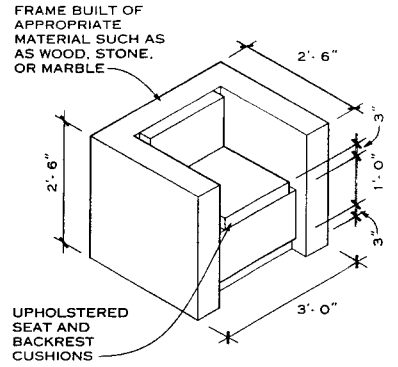

CLERGY/PRESIDER CHAIR

ALTAR/COMMUNION TABLE

In most churches, the altar or communion table is the primary focus and therefore the most visually prominent furnishing. Style and symbolism of the altar/table are deeply rooted in the liturgy of individual churches, and their design usually requires the participation and theological direction of both clergy and laity. Appropriateness of scale and material is particularly important and widely variable. The altar/table is among the furnishings most suited for artist collaboration in design and execution.

BAPTISMAL FONT

A font for baptizing infants and/or adults may be placed in various locations, including at the chancel/sanctuary or at the entrance to the church in the narthex. In some cases, the font may be alternately moved between these locations. Space for family and friends to gather around the font

is usually required. In many churches, the font must be in a position that permits the entire assembly to view the baptism.

BAPTISTRY

Churches practicing baptism by submersion require an altogether different style of baptistry, involving a pool or tank that allows full entry by laity and clergy. Prefabricated baptistry tanks are available and custom installations possible. For churches practicing infant baptism by submersion, allow for a pool 36 x 36 x 10 in. deep. For adult immersion, provide a 4 x 4 ft recessed area in the floor with a drain adjacent to the baptistry for water poured over the candidate. Baptistry water is to be heated and continuously circulated by a pump. Significant evaporation may take place and a means for automatic or regular refilling should be accom-

modated. Some areas may require water treatment. Some traditions may require, draining the pool back into the earth. When immersion or submersion is required, locate changing rooms and toilet facilities close to the baptistry.

TABERNACLE

The tabernacle generally associated with Roman Catholic, Orthodox, and Episcopalian (ambry, rather than tabernacle) churches is a very significant element in the worship environment, acting as the place of repose for the consecrated Host-the Body of Christ. It often has a highly artistic and custom furnishing. Pay careful attention to the liturgical attitudes of the individual church, and for Roman Catholic churches review the document *Environment and Art in Catholic Worship* to guide the design and placement of the tabernacle.

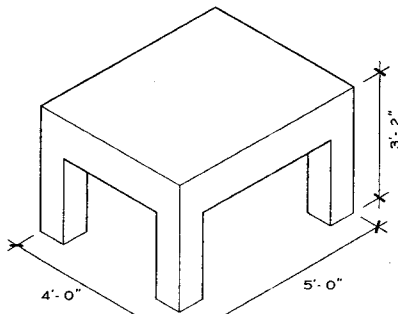

NOTE: May have a solid front

ALTAR

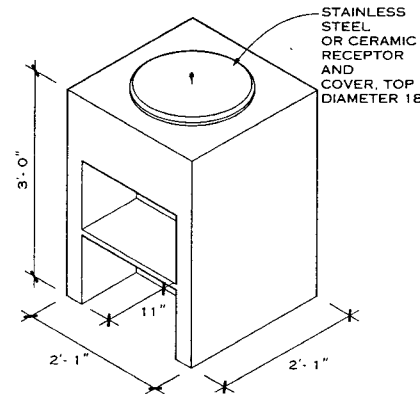

BAPTISMAL FONT

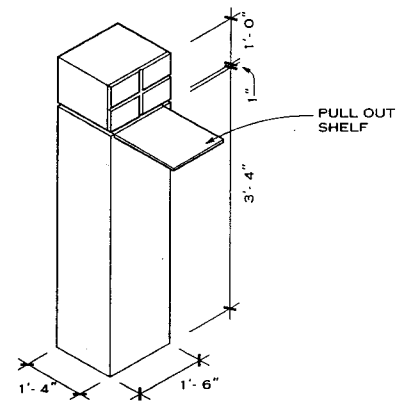

TABERNACLE

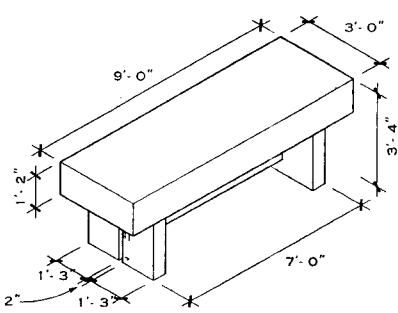

COMMUNION TABLE

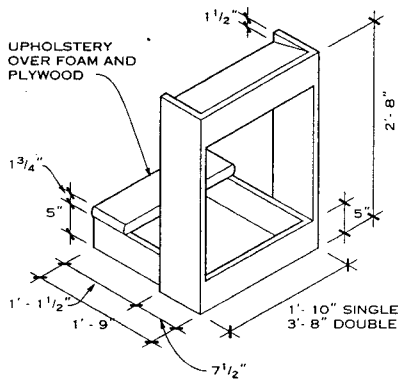

INDIVIDUAL KNEELER

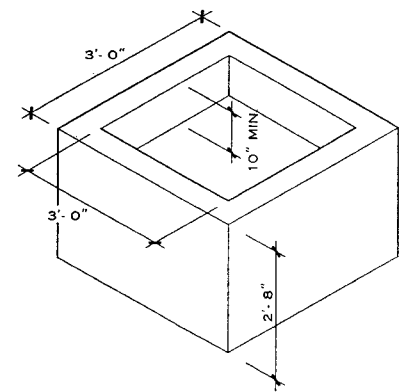

BAPTISTRY

Ware Associates, Inc.; Rockford, Illinois/Chicago/Los Angeles

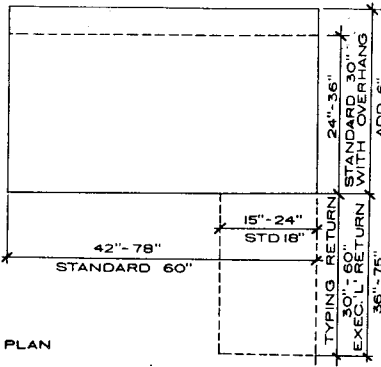

PLAN

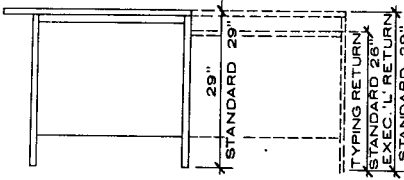

ELEVATION  
DESK: SINGLE OR DOUBLE PEDESTAL

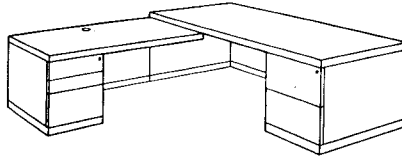

DESK RETURN  
W 86" D 30" H 29"  
W 42" D 24" H 27"  
SECRETARIAL DESK  
CORRYHIEBERT CORP.

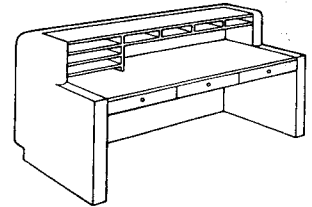

W 70"  
D 28"  
H 41"  
RECEPTION DESK  
THE PACE COLLECTION, INC.

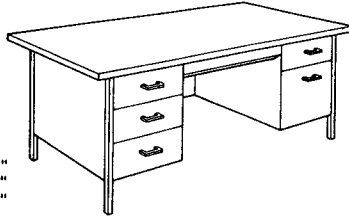

W 70"  
D 36"  
H 29"  
DOUBLE PEDESTAL DESK,  
SIDE OVERHANG 4200 SERIES  
STEELCASE, INC.

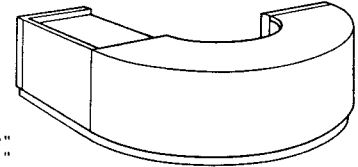

W 42"  
D 24"  
H 29"  
CURVED SEGMENTED DESK  
JG FURNITURE SYSTEMS, INC.

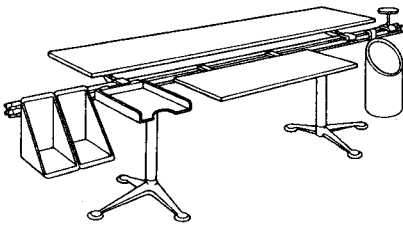

BURDICK GROUP  
HERMAN MILLER, INC.

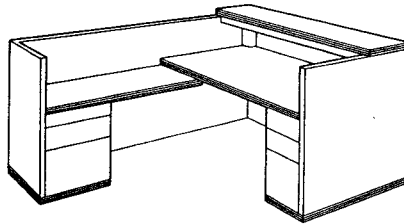

DESK, VARIA CASEGOODS  
MUELLER

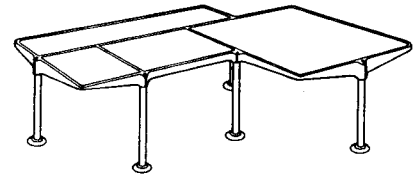

W 117"  
D 66 3/4"  
H 29"

MENHIR DESK  
KRUEGER INTERNATIONAL DIVISION

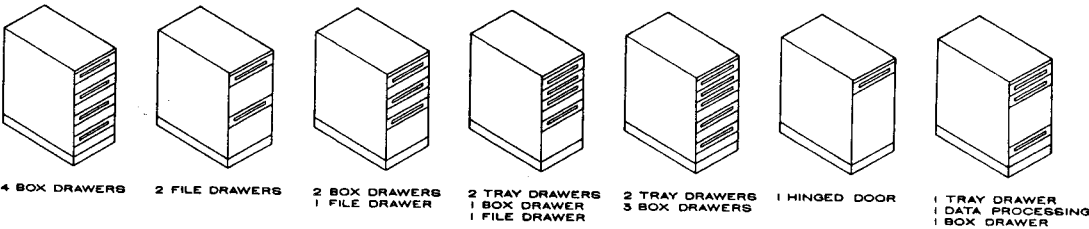

4 BOX DRAWERS 2 FILE DRAWERS 2 BOX DRAWERS 1 FILE DRAWER  
2 TRAY DRAWERS 1 BOX DRAWER 1 FILE DRAWER  
2 TRAY DRAWERS 3 BOX DRAWERS 1 HINGED DOOR  
1 TRAY DRAWER 1 DATA PROCESSING 1 BOX DRAWER  
NOTE: ALL PEDESTALS - W 15", D 24", H 29"  
4600/8600 CREDENZA PEDESTALS  
ALL-STEEL, INC.

TYPICAL CREDENZA DIMENSIONS

	WIDTH (IN.)	DEPTH (IN.)	HEIGHT (IN.)
One component	15-30	17 1/4-24	25 1/2-29 1/4
Two component	30-41 1/2		
Three component	45-60 1/2	17 1/4-24	25 1/2-29 1/4
Four component	60-79 1/4	17 1/4-24	25 1/2-29 1/4
Five component	75-98 1/2	17 1/4-24	25 1/2-29 1/4

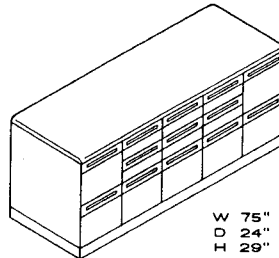

W 75"  
D 24"  
H 29"  
4600/8600 SERIES CREDENZA  
ALL-STEEL, INC.

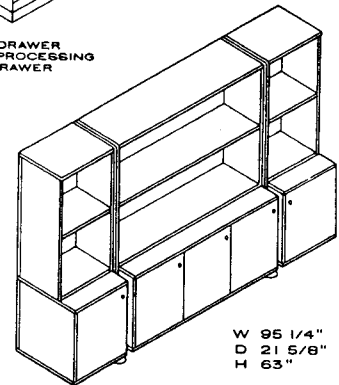

W 95 1/4"  
D 21 5/8"  
H 63"  
MENHIR CABINET  
KRUEGER INTERNATIONAL DIV.

Robert Staples; Staples & Charles Ltd.; Washington, D.C.  
Richard J. Vitullo, AIA; Oak Leaf Studio; Crownsville, Maryland

**RECTANGULAR**

WIDTH	LENGTH	APPROXIMATE SEATING
5'-0"	20'-0"	20-22
4'-6"	18'-0"	18-20
4'-6"	16'-0"	16-18
4'-6"	14'-0"	14-16
4'-0"	12'-0"	12-14
4'-0"	11'-0"	10-12
4'-0"	10'-0"	10-12
4'-0"	9'-0"	8-10
4'-0"	8'-0"	8-10
3'-6"	9'-0"	8-10
3'-6"	8'-0"	8-10
3'-6"	7'-6"	6-8
3'-6"	7'-0"	6-8
3'-0"	7'-0"	6-8
3'-0"	6'-6"	6-8
2'-6"	5'-6"	4-6
2'-6"	5'-0"	4-6

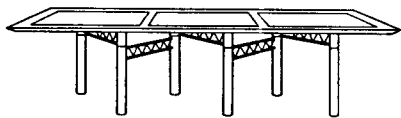

RECTANGLE 48" X 84", 96"  
(EXPANDABLE 48" X 48")  
MODULAR UNITS TO 280"  
H 29"  
**ZIPP TABLE**  
DESIGNER: RODNEY KINSMAN  
DAVIS FURNITURE INDUSTRIES, INC.

**SQUARE**

WIDTH	LENGTH	APPROXIMATE SEATING
5'-0"	5'-0"	8-12
4'-6"	4'-6"	4-8
4'-0"	4'-0"	4-8
3'-6"	3'-6"	4
3'-0"	3'-0"	4

**ROUND**

DIAMETER	CIRCUM-FERENCE	APPROXIMATE SEATING
8'-0"	25'-1"	10-12
7'-0"	21'-8"	8-10
6'-0"	18'-9"	7-8
5'-0"	15'-7"	6-7
4'-6"	14'-1"	5-6
4'-0"	12'-6"	5-6
3'-6"	11'-0"	4-5

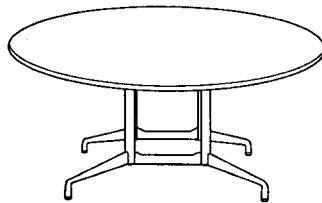

DIA 42"-72"  
W 42"-54"  
D 72"-144"  
H 28 1/2"  
**SEGMENTED BASE TABLE**  
DESIGNER: CHARLES EAMES  
HERMAN MILLER, INC.

**BOAT SHAPED**

WIDTH		LENGTH	APPROXIMATE SEATING
CENTER	END		
6'-0"	4'-0"	20'-0"	20-24
5'-6"	4'-0"	18'-0"	18-20
5'-6"	4'-0"	16'-0"	16-18
5'-0"	3'-6"	14'-0"	14-16
4'-6"	3'-6"	12'-0"	12-14
4'-0"	3'-2"	11'-0"	10-12
4'-0"	3'-2"	10'-0"	10-12
3'-6"	3'-0"	9'-0"	8-10
3'-6"	3'-0"	8'-0"	8-10
3'-0"	2'-10"	7'-0"	6-8
3'-0"	2'-10"	6'-0"	6-8

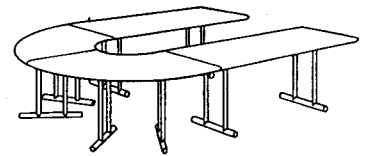

QUARTER CIRCLE: 168" O.D., 48" W  
RECTANGULAR: 96" W, 48" D  
H 29 1/4"

**OMEGA MODULAR TABLES**  
STENDIG INTERNATIONAL

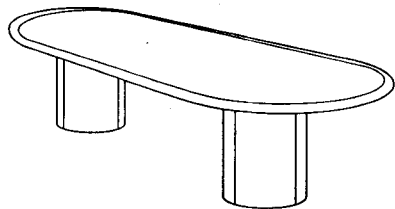

RECTANGULAR OR RADIUS END: 42" X 72" TO 60" X 240"  
ROUND OR SQUARE 42"-72"

**CYLINDER BASE TABLES**  
MUELLER

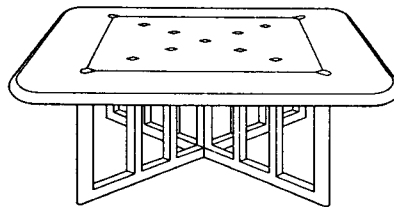

DIA. 36 1/2"-74", SQUARE 31 1/2"-71"  
RECTANGULAR 44" X 68", 92", 116"  
H 18" OR 28 1/4"

**DE MENIL TABLES**  
DESIGNER: GWATHMEY SIEGEL  
ICF, INC.

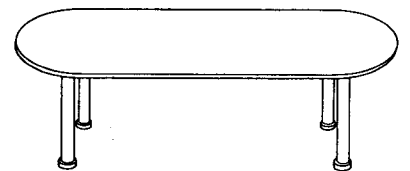

RECTANGULAR OR RADIUS END: 42" X 72" TO 48" X 192"  
ROUND OR SQUARE 42", 48", 54"

**THE DONNELLY CONFERENCE TABLE**  
DESIGNER: PHILIP DONNELLY  
JG FURNITURE SYSTEMS, INC.

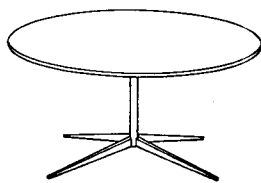

W 78"  
D 48"  
H 28"

**KNOLL TABLE DESK**  
DESIGNER: FLORENCE KNOLL  
KNOLL INTERNATIONAL

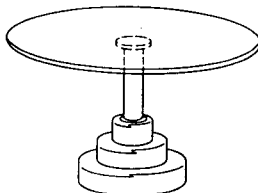

DIA. 24"-57"  
SQUARE 39"-57"  
RECTANGLE 16" X 51", 59", 71"

**MENHIR TABLE CONNECTION**  
DESIGNERS: L. AKERBIS,  
G. STOPPINO  
ATELIER INTERNATIONAL

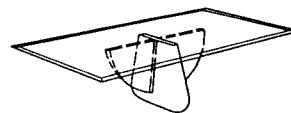

W 42", 48"  
D 84", 96"  
H 29"

**PINNACLE TABLE**  
DESIGNER: J. WADE BEAM  
BRUETON

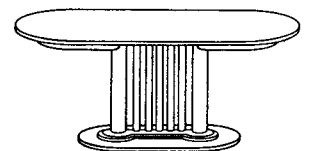

W 55"-75"  
D 39 1/2"  
H 28 1/2"

**WASHINGTON OVAL EXTENSION TABLE**  
DESIGNER: OTTO BLÜMEL  
STENDIG INTERNATIONAL, INC.

Robert Staples; Staples & Charles Ltd.; Washington, D.C.

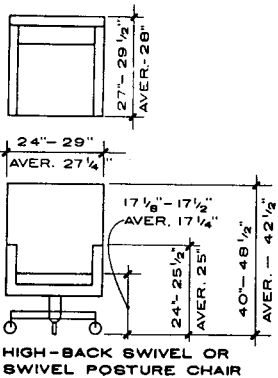

HIGH-BACK SWIVEL OR SWIVEL POSTURE CHAIR

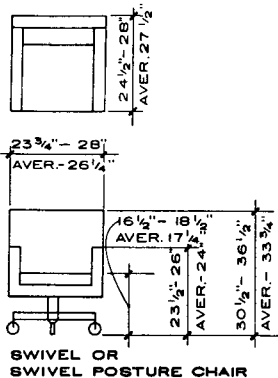

SWIVEL OR SWIVEL POSTURE CHAIR

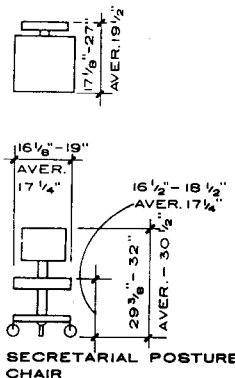

SECRETARIAL POSTURE CHAIR

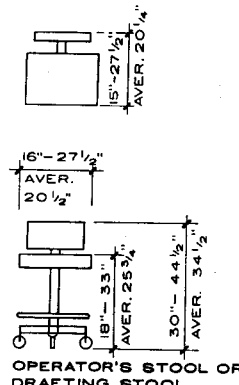

OPERATOR'S STOOL OR DRAFTING STOOL



W 22 1/2"  
D 23 3/4"  
H 40"-42"  
SH 18 1/2"-20 1/2"

HIGH-BACK ALUMINUM GROUP  
DESIGNER: CHARLES EAMES  
HERMAN MILLER, INC.



W 26 1/2"  
D 23 1/4"  
H 36 1/2"-42"  
SH 17"-20"

ERGON EXECUTIVE WITH ARMS  
DESIGNER: BILL STUMPF  
HERMAN MILLER, INC.

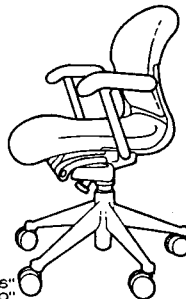

W 25 1/2"  
D 22 1/2"  
H 32"-36"  
SH 16"-20"

EQUA LOW-BACK WORK CHAIR  
DESIGNERS:  
BILL STUMPF/DON CHADWICK  
HERMAN MILLER, INC.

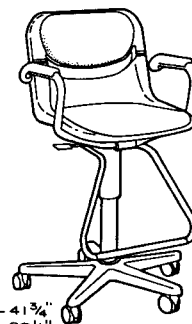

W 19"  
D 18 1/2"  
H 38 1/2"-41 3/4"  
SH 25 1/4"-28 1/2"

DORSAL OPERATIONAL STOOL  
DESIGNERS:  
E. AMBASZ/G. FIRETTI  
KRUEGER, INC.



W 25 3/4"  
D 24 1/4"  
H 40"-43 1/2"  
SH 18"-21 1/2"

CONCENTRIX MANAGER CHAIR  
STEELCASE, INC.



W 24 3/4"  
D 26 1/2"  
H 32 1/4"-35"  
SH 17 3/4"-20 1/2"

SAPPER ADVANCED LOW-BACK  
DESIGNER: RICHARD SAPPER  
KNOLL INTERNATIONAL



W 24"  
D 24 1/4"  
H 31 1/4"-34"  
SH 20"-22 1/2"

MORRISON/HANNAH CHAIR  
DESIGNERS:  
A.I. MORRISON/B.R. HANNAH  
KNOLL INTERNATIONAL

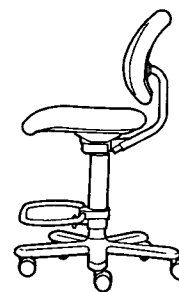

W 25 1/2"  
D 21"  
H 38"-48 1/2"  
SH 21 1/2"-32"

ADVANCED HIGH TASK CHAIR  
DESIGNER: NIELS DIFFRENT  
KNOLL INTERNATIONAL



W 27 1/4"  
D 27 1/2"  
H 43"  
SH 18 3/4"-21 1/2"

BRETON HIGH-BACK CHAIR  
STOW AND DAVIS



W 25 1/2"  
D 25 1/2"  
H 37"-41"  
SH 16 1/2"-20 1/2"

KELLY PNEUMATIC CHAIR  
DESIGNER: WILLIAM RAFTERY  
VECTA CONTRACT



W 23"  
D 20"  
H 31"-39"  
SH 17"-22"

SERIES 370 OPERATOR  
ARMCHAIR  
ELITE / BILRITE



W 19"  
D 19"  
H 39 1/4"-50"  
SH 23 1/2"-34"

SPRINGBOK TASK STOOL  
DESIGNER: JOHN BEHRINGER  
JG FURNITURE SYSTEMS, INC.

Robert Staples; Staples & Charles Ltd.; Washington, D.C.  
Richard J. Vitullo, AIA; Oak Leaf Studio; Crownsville, Maryland

OVERFILE STORAGE

TYPE	W	H	D	WEIGHT*
Over 2-drawer letter	30	26	29	170
Over 2-drawer legal	36		29	308
Over 3-drawer letter	43	37	29	377
Over 3-drawer legal	54		29	445

VERTICAL FILES

TYPE	W	H	D	WEIGHT*
5-drawer letter	15	60	29	405
5-drawer legal	18	60	29	430
4-drawer letter	15	50	29	324
4-drawer legal	18	50	29	344
3-drawer letter	15	41	29	258
3-drawer legal	18	41	29	162
2-drawer letter	15	30	29	162
2-drawer legal	18	30	29	172

INSIDE DRAWER DIMENSIONS

TYPE	W	H	D
Letter	12 <sup>1</sup> / <sub>4</sub>	10 <sup>1</sup> / <sub>2</sub>	26 <sup>3</sup> / <sub>4</sub>
Legal	15 <sup>1</sup> / <sub>4</sub>	10 <sup>1</sup> / <sub>2</sub>	26 <sup>3</sup> / <sub>4</sub>

\*Weights = fully loaded file.

VERTICAL FILE CABINETS

LATERAL FILES

TYPE	W	H	D	WEIGHT*
5-drawer	30, 36, 42	64	18	610-843
4-drawer	30-36-42	52	18	524-720
3-drawer	30, 36, 42	40	18	401-553
2-drawer	30, 36, 42	32	18	285-391

\*Weights = fully loaded file.

LATERAL FILE CABINETS

SPECIAL FILES

TYPE	W	H	D
A. Custom stack system	36	52	18
B. Check file	15	52	27
C. Special/double check	22	52	27
D. Card record file	22	52	27
6 drawer (3 x 5, 4 x 6 cards)	22	52	27
5 drawer (3 x 5, 4 x 6, 5 x 8)	22	52	27
E. Pedestal file	15	28	24
Library card file (see index)			

Note: Exact sizes vary with manufacturer.

SPECIAL FILING CABINETS

FIRE INSULATED FILES

TYPE	W	H	D	WEIGHT*
4-drawer letter	17	52	30	600
4-drawer legal	20	52	30	660
3-drawer letter	17	51	30	465
3-drawer legal	20	41	30	515
2-drawer letter	17	28	30	330
2-drawer legal	20	28	30	370
3-drawer lateral	39	56	24	1220
2-drawer lateral	39	39	24	875

\*Weight = fully loaded.

FIRE INSULATED FILE CABINETS

PLANNING

- Users' filing needs should be tabulated in inches and in turn converted into number of cabinets. Consult manufacturer for inches available in specific cabinets.
- For open space planning, the following square footage allowances should be used for files and use clearance:

TYPES	SPACE ALLOWANCE (FT <sup>2</sup> )
Vertical and 36 in. lateral files	10
Lateral file for computer printout	15

NOTE: All dimensions shown are approximate. Consult manufacturer for actual dimensions.

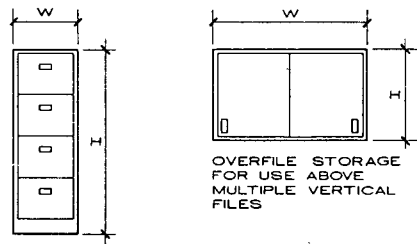

FILE CLEARANCES

	VERTICAL FILES	LATERAL FILES
A	106-120	82-94
B	29	18
C	48-62	46-58
D	18-26	16-22
E	30-36	30-36

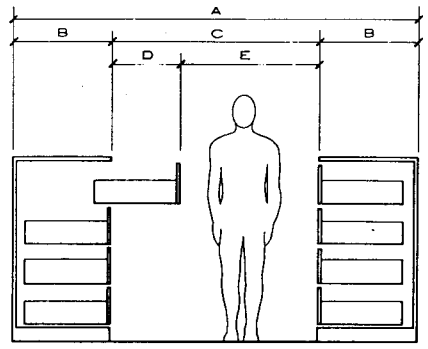

DIMENSIONS FOR PLANNING

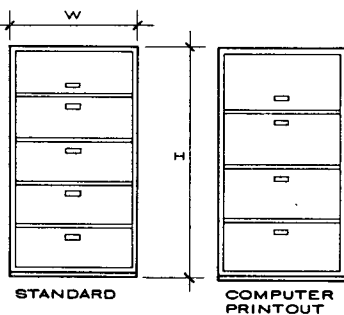

NOTES

- Basic types accommodate multiple configurations of drawers, doors, and shelves.
- 6 in. drawer accommodates cards and vouchers not exceeding 5 in. in one direction.
- 12 in. drawer accommodates letter and legal files.
- 15 in. drawer accommodates computer printouts.
- Files are available to five-drawer height. Files more than five drawers high are not recommended.
- Typical overfile storage is 26 or 37 in. high.

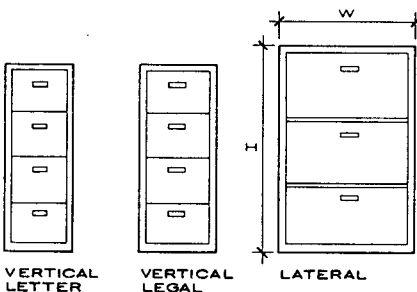
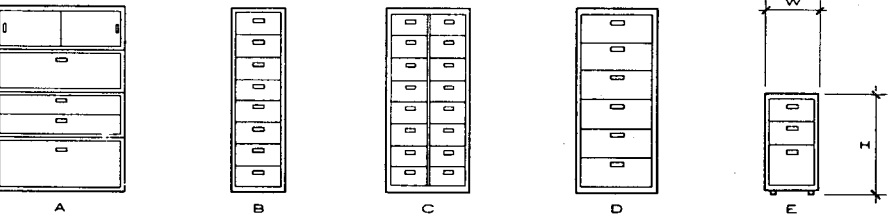

These units are designed to resist forced entry and are fabricated from heavy gauge steel plate. They are available only in legal size vertical format and are essentially the same size as fire insulated cabinets. They are available with or without fire protection.

SECURITY FILES

TYPE	WEIGHT*
5-drawer	1350
5-drawer fire insulated	1650
4-drawer	1050
4-drawer fire insulated	1400
2-drawer	650
2-drawer fire insulated	825

\*Weight = fully loaded

SECURITY FILE CABINETS

Blythe + Nazdin Architects, Ltd.; Bethesda, Maryland  
Associated Space Design, Inc.; Atlanta, Georgia

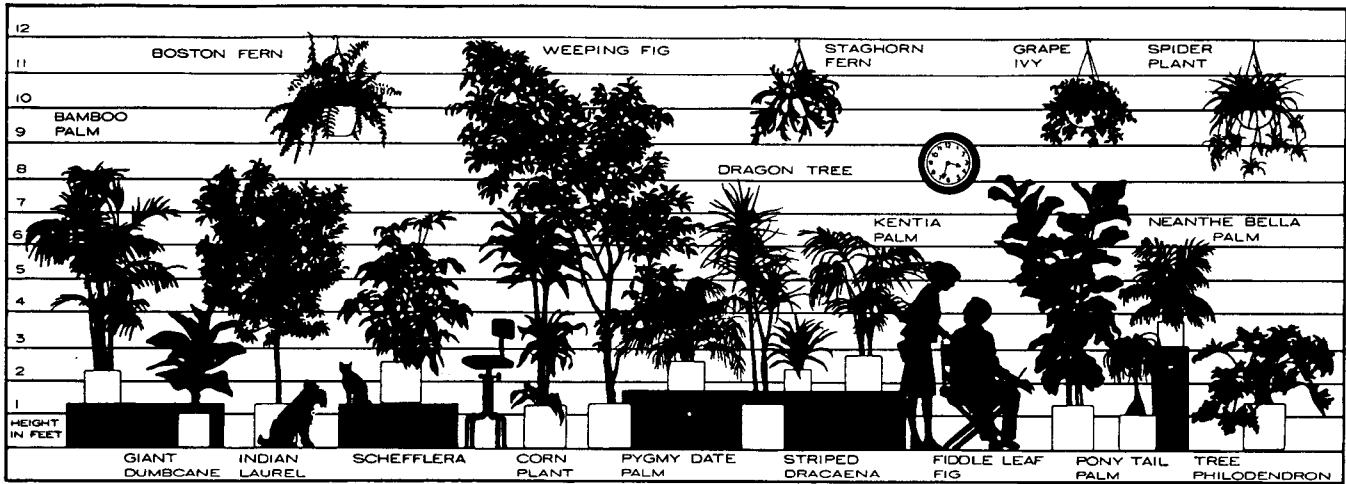

FORM, TEXTURE, AND SIZES OF SOME TYPICALLY USED INTERIOR PLANTS

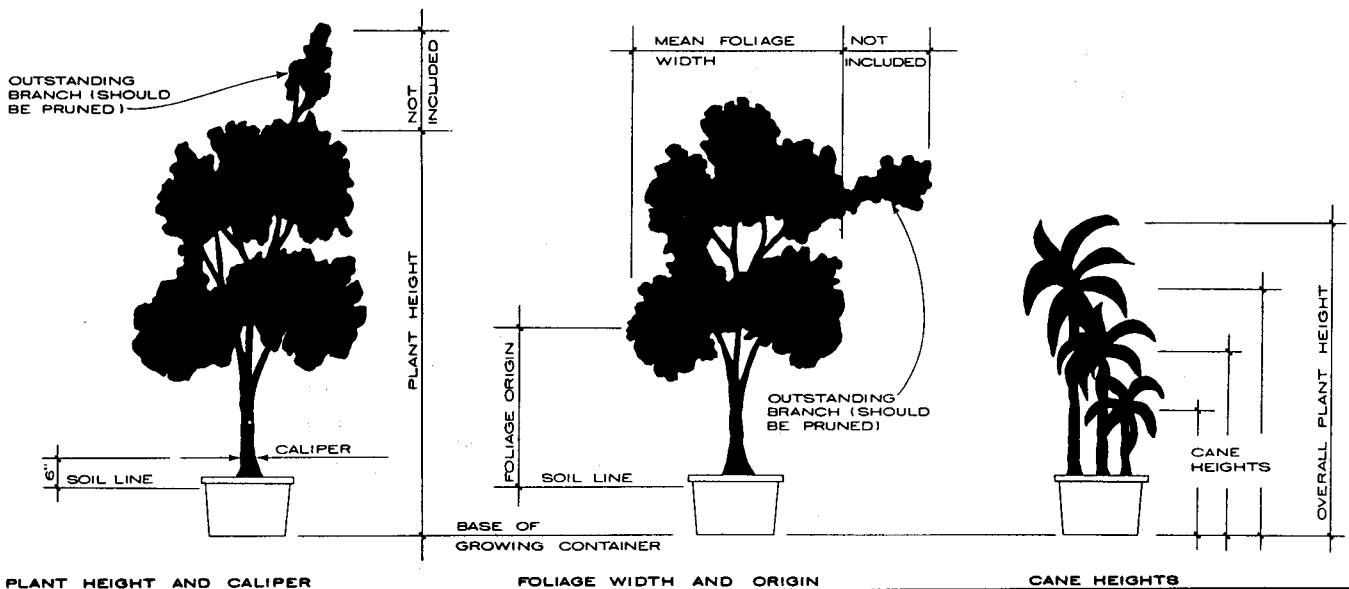

PLANT HEIGHT AND CALIPER  
INTERIOR PLANT SPECIFICATIONS

**NOTE**  
Plant height should be measured as overall height from the base of the growing container to mean foliage top. Isolated outstanding branches should not be included in height. (Since most plants are installed in movable planters, this overall height measurement should be utilized.)

FOLIAGE WIDTH AND ORIGIN

**NOTE**  
Foliage width should be measured across the nominal mean width dimension. Isolated outstanding branches should not be included in foliage width. Origin or start of foliage should be measured from the soil line.

CANE HEIGHTS

**NOTE**  
Many plant varieties are grown from rooted canes, with the plant being made up of one or more canes. The number of canes must be specified, if plant form is to be identified. Cane heights should always be measured from the base of the growing container.

**OTHER PLANT SPECIFICATION FACTORS**

1. Accurately describe plant form (e.g., multistem vs. standard tree form, clump form) and foliage spread desired. Indicate "clear trunk" measurements on trees, if desired. These measurements are from soil line to foliage origin point. Specify caliper, if significant.
2. Indicate lighting intensities designed or calculated for interior space where plants will be installed.
3. Indicate how plants will be used (i.e., in at-grade

4. Specify both botanical and common plant names.
5. Indicate any special shipping instructions or limitations.
6. Specify in-plant height column, whether plant height is measured as overall height or above-the-

- soil line height. Recommended height measurements:
- Interior plants: overall plant height (i.e., from bottom of growing container to mean foliage top).  
Exterior plants: above-the-soil line height.
7. Indicate whether plants are to be container grown or balled and burlapped (B & B) material.
  8. Indicate location of all convenient water supply sources on all interior landscaping layouts.

Richard L. Gaines; Plantscape House; Apopka, Florida



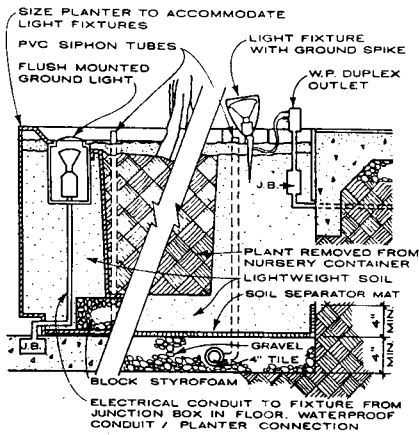

**MOVABLE PLANTER/AT-GRADE PLANTER UPLIGHTING / PLANTING DETAILS**  
**UPLIGHTING AND ELECTRICAL NEEDS**

1. May be of some benefit to plants, but inefficient for plant photosynthesis because of plant physiological structure. Chlorophyll is usually in upper part of leaf.
2. Uplighting should never be utilized as sole lighting source for plants.
3. Waterproof duplex outlets above soil line with a waterproof junction box below soil line are usually adequate for "atmosphere" uplighting and water fountain pumps.

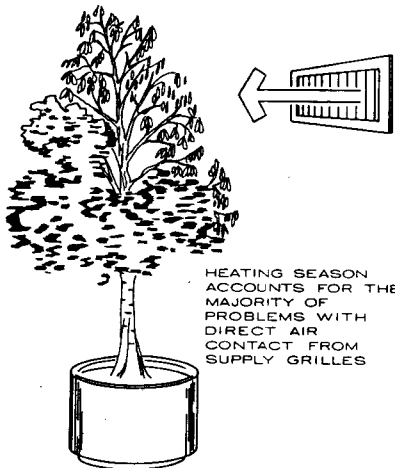

**FOLIAGE BURN FROM DIRECT HEAT CONTACT**

**HVAC EFFECT ON PLANTS**

1. Air conditioning (cooled air) generally is not detrimental to plants, even if it is "directed" at plants. The ventilation here is what counts! Good ventilation is a must with plants; otherwise oxygen and temperatures build up. Heat supply, on the other hand, when "directed" at plants, can truly be disastrous. Plan for supplies directed away from plants, but maintain adequate ventilation.
2. Extended heat or power failures of sufficient duration can damage plant health. The lower limit of temperature as a steady state is 65°F for plant survival. Brief drops to 55°F (less than 1 hr) are the lower limit before damage. Temperatures up to 85°F for only 2 days a week can usually be tolerated.
3. The relative humidity should not be allowed to fall below 30%, as plants prefer a relative humidity of 50-60%.

Richard L. Gaines; Plantscape House; Apopka, Florida

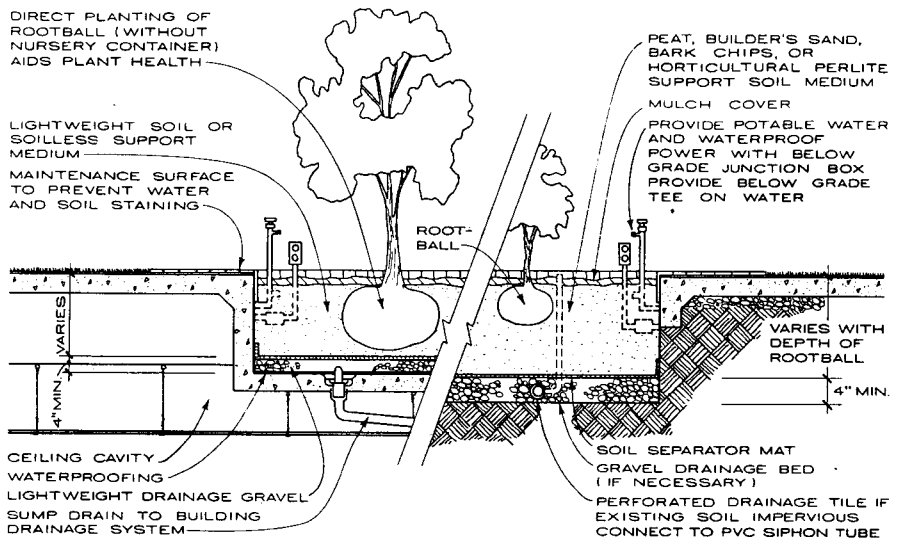

**ABOVE-GRADE PLANTER AT-GRADE PLANTER FLOOR PLANTER DETAILS**

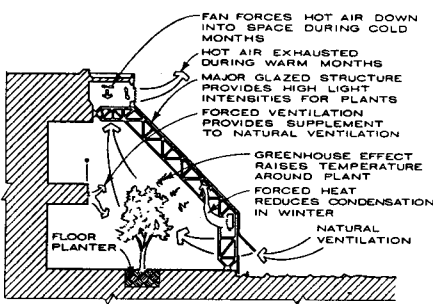

**GREENHOUSE EFFECT RAISES NEED FOR ADEQUATE VENTILATION**

**TEMPERATURE REQUIREMENTS**

1. Most plants prefer human comfort range: 70-75°F daytime temperatures and 60-65°F nighttime temperatures.
2. An absolute minimum temperature of 50°F must be observed. Plant damage will result below this figure. Rapid temperature fluctuations of 30-40°F can also be detrimental to plants.
3. "Q-10" phenomenon of respiration; for every 10°C rise in temperature, plants' respiration rate and food consumption doubles.
4. Both photosynthesis and respiration decline and stop with time, as temperatures go beyond 80°F. Beware of the greenhouse effect!

**WATER SUPPLY REQUIREMENTS**

1. Movable and railing planters are often watered by watering can. Provide convenient access to hot and cold potable water by hose bibbs and/or service sinks (preferably in janitor's closet) during normal working hours, with long (min. 24 in.) faucet-to-sink or floor distances. Provide for maximum of 200 ft travel on all floors.
2. At-grade floor planters are usually watered by hose and extension wand. Provide hose bibbs above soil line (for maximum travel of 50 ft) with capped "tee" stub-outs beneath soil line. If soil temperature is apt to get abnormally low in winter, provide hot and cold water by mixer-faucet type hose bibbs.
3. High concentrations of fluoride and chlorine in water supply can cause damage to plants. Provide water with low concentrations of these elements and with a pH value of 5.0-6.0. Higher or lower pH levels can result in higher plant maintenance costs.

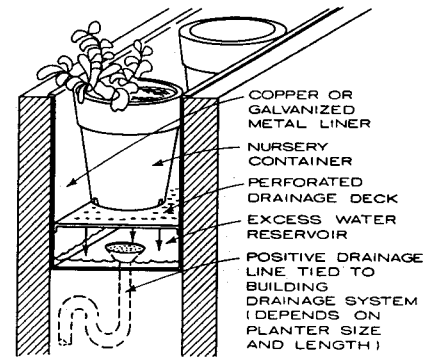

**RAILING PLANTER DETAIL**

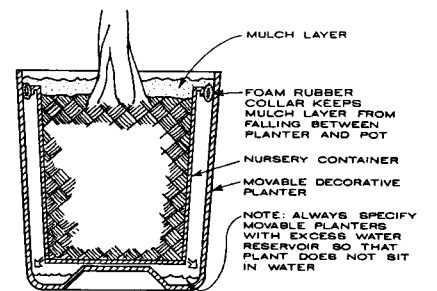

**MOVABLE DECORATIVE PLANTER DETAIL**

**STORAGE REQUIREMENTS**

Provide a secured storage space of approximately 30 sq ft for watering equipment and other maintenance materials. It may be desirable to combine water supply and janitor needs in the same storage area.

**AIR POLLUTION EFFECTS ON PLANTS**

Problems result from inadequate ventilation. Excessive chlorine gas from swimming pool areas can be a damaging problem, as well as excessive fumes from toxic cleaning substances for floor finishes, etc. Ventilation a must here!



# SPECIAL CONSTRUCTION

Air-Supported Structures 644

Special Purpose Rooms 645

Sound, Vibration, and Seismic  
Control 653

Radiation Protection 654

Pre-Engineered Structures 656

Building Automation and  
Control 660

Detection and Alarm 662

Fire Suppression 663

**GENERAL**

Air-supported structures are lightweight, totally free span structures that maintain stability in space and resist loads with a pressure differential between the interior and exterior. This method of support leaves the interior free of support devices that could interfere with the efficient use of space. The roof and side walls can be a single structural element in pure tension, a fabric envelope. The only compression members are the slightly pressurized air inside and the rigid base of the membrane.

**STRUCTURAL MEMBRANE**

The structural membrane is usually a nylon, fiberglass, or polyester fabric coated with polyvinyl chloride. Such skins have a life span from 7 to 10 years and offer fire retardation that passes NFPA 701. A urethane topcoat will reduce dirt adhesion and improve service life. Fluorocarbon top finishes further enhance characteristics and can double service life. Teflon-coated fiberglass membranes have a life expectancy of more than 25 years. This material is not combustible, passing ASTM E84, with a flame spread rating of 10, smoke developed < 50, and fuel contributed, 10. An acoustical liner (NRC = 0.65) is also available.

**NOTES**

1. Most air-supported structures are primarily designed to resist wind loads. Mechanical blowers must maintain 3 to 5 psf pressure inside the structure at all times. Architectural elements of the building must be detailed to avoid loss of air pressure.
2. Consult building codes to determine requirements for all air-supported structures.

**GROUND-MOUNTED AIR STRUCTURES**

The shape of ground-mounted air structures permits the structure to meet the ground vertically, allowing gravity loads to resist the membrane tension. The semicircular cross-section of the membrane structure has a curvature radius large enough to allow the fabric alone to carry wind forces that may affect the building. If lightweight fabrics are used, catenary cables or webbing may be required as well. Webbing is typically sewn into the fabric seams, forming a one-way system; cables are incorporated into pockets in a one-way system or formed into a cable net harness that is placed over the fabric in a two-way system.

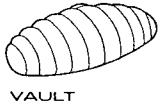
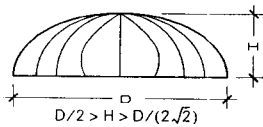

SPAN LIMITATIONS	VAULT	DOMES
Without cables	D = 120 ft	D = 150 ft
With cables	D = 400 ft	D = 600 ft

**BASIC CONFIGURATION OF GROUND-MOUNTED AIR STRUCTURES**

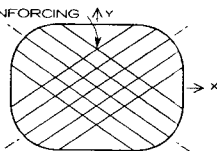
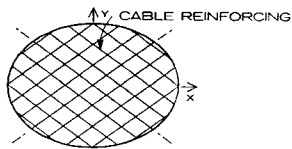

**LONG-SPAN DOME STRUCTURE TYPES**

Paul Gossen, Geiger Engineers, P.C.; Suffern, New York

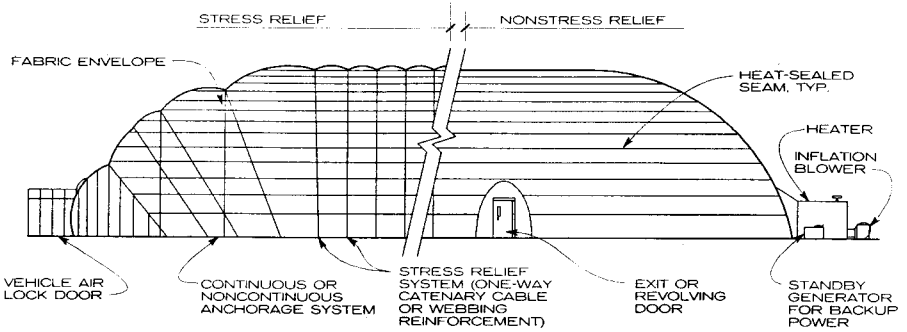

**NOTE**

For temporary structures, anchorage system may be water tanks, sandbags, earth screw anchors, etc., depending on conditions.

**TYPICAL GROUND-MOUNTED AIR-SUPPORTED STRUCTURE**

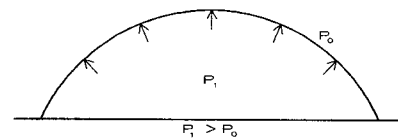

**SINGLE MEMBRANE**

This is the most common type of air-supported structure. The internal pressure ( $P_1$ ) is kept approximately 0.03 psi above the external atmospheric pressure ( $P_0$ ). It is this pressure difference that keeps the dome inflated.

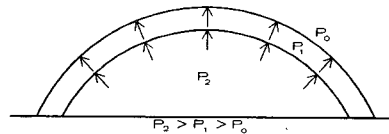

**DOUBLE MEMBRANE**

The air space between the two membranes is used for insulation and security. If the outer skin is punctured, the inner skin will remain standing. Both single and double membrane air-supported structures require the constant use of blowers to keep them inflated.

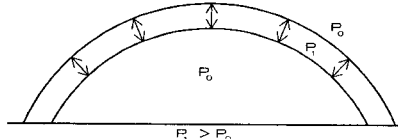

**DUAL MEMBRANE**

The internal and external pressures are the same in a dual membrane structure. Only the area between the skins is pressurized. This inflated area can be sealed, eliminating the need for constant use of blowers, although blowers are recommended to make up losses from leakage.

**AIR-INFLATED STRUCTURES**



**NOTE**

The membrane must be patterned to carry loads without wrinkling. Structural behavior is nonlinear with large displacements. The roof shape must be established so that under maximum loads the horizontal components of the cable forces result in minimum bending moment in the compression ring. Consult an air-supported structures specialist to integrate structural and architectural requirements.

**LONG-SPAN DOME STRUCTURE**

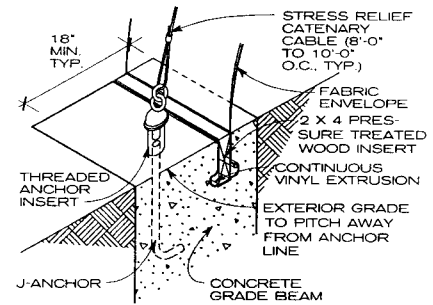

**WEDGE INSERT**

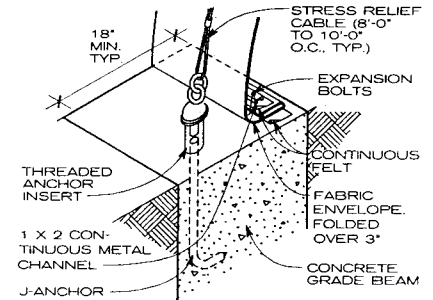

**SURFACE-MOUNTED FABRIC ENVELOPE**

**NOTE**

Beam design is based on actual uplift of air structure at the design inflation pressure and wind load.

**CONTINUOUS ANCHORAGE DETAILS**

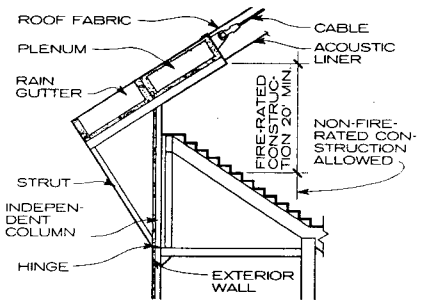

**NOTE**

The perimeter compression ring must be independent of the support structure to prevent radial restraint.

**LONG-SPAN STRUCTURE SUPPORT DETAIL**

**GENERAL NOTES**

- Doors—standard sizes:  
2 ft 6 in., 3 ft 0 in., 3 ft 6 in., 4 ft 0 in., 5 ft 0 in. wide x 6 ft 6 in. high; 4 ft 0 in. or 5 ft 0 in. wide by 6 ft 6 in. or 7 ft 0 in. high.  
Sliding, double action, and display doors are available. ADA requires a 32-in. clear opening. Doors are manually or electrically operated.
- Prefabricated insulated panels (nominal size)—standard sizes:  
Thickness: 4 in.  
Width: 11.5 in., 23 in., 46 in.  
Height: 7 ft 6 in., 8 ft 6 in., 10 ft 6 in., 11 ft 6 in.  
Finish material: aluminum, galvanized steel, or stainless steel.
- Walk-in unit sizes:  
Width: 3 ft 11 in., 5 ft 10 in., 7 ft 9 in., 9 ft 8 in., 11 ft 7 in.  
Length: 5 ft 10 in., 7 ft 9 in., 11 ft 7 in., 13 ft 6 in., 15 ft 5 in., 17 ft 4 in., 19 ft 3 in.  
Height: 7 ft 6 in., 8 ft 6 in., 9 ft 6 in., 10 ft 6 in., 11 ft 6 in.  
Available accessories: stationary or mobile shelf units and adjustable cantilevered shelves, windows, interior partitions, meat rails, floor racks, ramps, and walk-ins.
- Check local codes for drainage requirements.

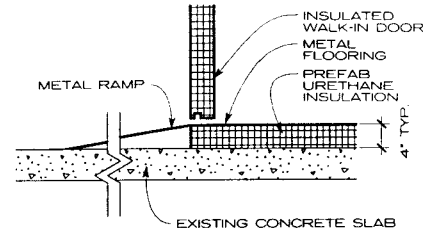
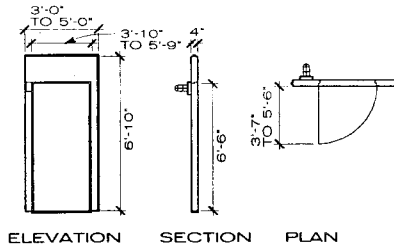

WALK-IN FLOOR OVER BUILDING FLOOR WITH EXTERIOR METAL RAMP

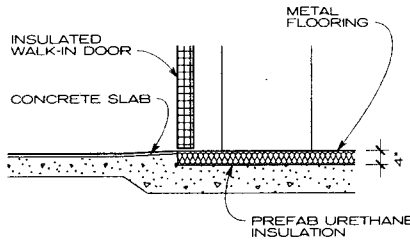

WALK-IN WITH FLUSH METAL FLOOR

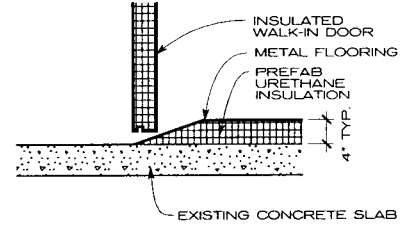

WALK-IN FLOOR OVER BUILDING FLOOR WITH INTERIOR METAL RAMP

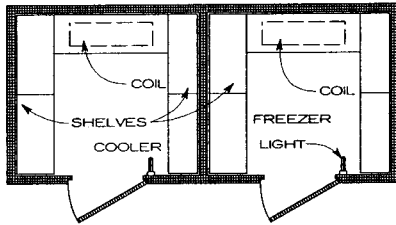

SIDE-BY-SIDE PLAN

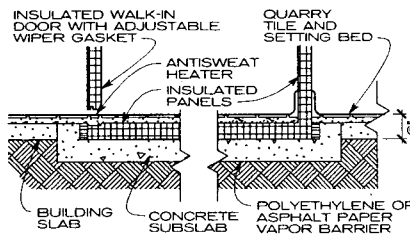

WALK-IN WITH FLUSH TILE

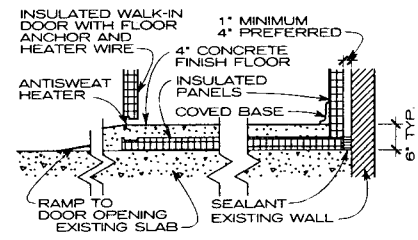

WALK-IN WITH BUILDING FINISH FLOOR AND EXTERIOR RAMP

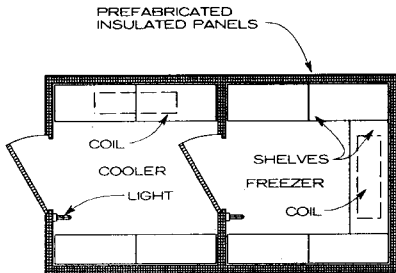

WALK-THROUGH PLAN

**NOTE**

Phase service is required for lights and anticondensate heaters on door panels. Connections are made to the junction box at the light, which is always inside the walk-in directly opposite the top hinge.

**NOTE**

Metal flooring is typically made of galvanized steel, stainless steel, or aluminum grating

**WALK-IN FLOOR DETAILS IN NEW CONSTRUCTION**

**WALK-IN DETAILS ON EXISTING SLAB**

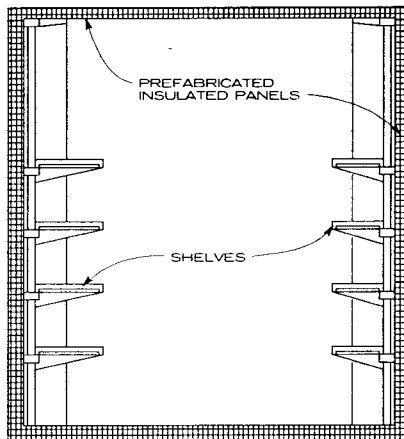

SECTION

TYPICAL WALK-IN UNITS

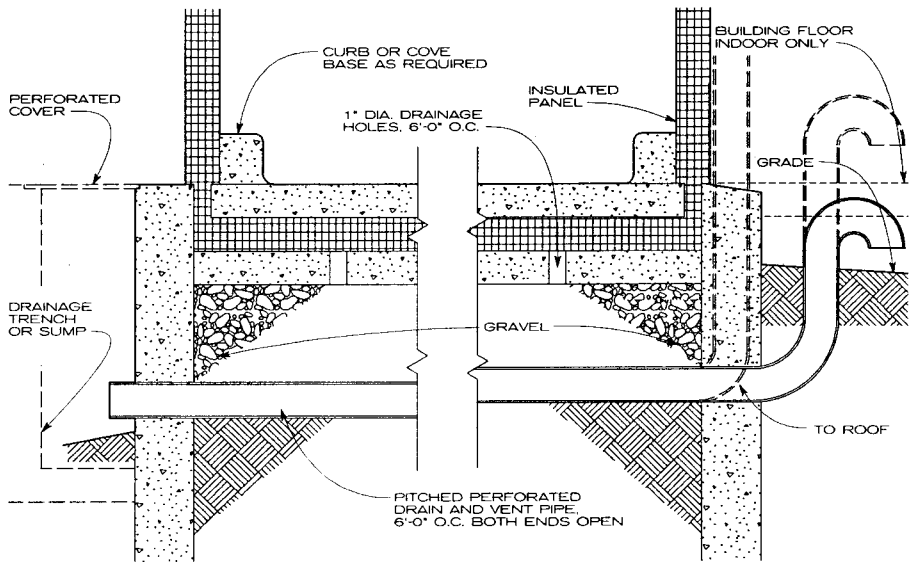

DRAIN AND VENT DETAIL

**CLEANROOM DESIGN**

A cleanroom is an environment in which specific particle control must be maintained for manufacturing and aseptic functions. Precise control of temperature, humidity, pressure, noise, and vibration are often part of cleanroom design criteria. Cleanrooms range in size from mini-environment enclosures to thousands of square feet, as is required for microelectronics fabrication (fab).

Cleanrooms are classified by standards that reference particle presence by quantity and size. Federal Standard 209E English classification references the number of 0.5 micrometer ( $\mu\text{m}$  or micron) particles per cubic foot. (A micrometer is  $10^{-6}$  meter.) The International Organization for Standardization (ISO) is developing a series of integrated standards for cleanrooms. ISO standards reference the number of 0.1 micron particles per cubic meter.

Cleanroom applications expand with the advance of technology. Cleanroom contamination can originate from workers and materials and includes human skin cells, spittle, hair (100 microns), tobacco smoke, cosmetics, bacteria (0.2 to 0.12 microns), viruses, dust, pollen, solvents, and moisture.

High-efficiency particulate air (HEPA) filters are very efficient (nominally 99.99 percent) in removing particles down to 0.3 micron in supply air. Ultra-low penetration air (ULPA) filters are very efficient (nominally 99.9995 percent) down to 0.12 micron particles. Supply air is distributed downward through modular ceiling filters (nominally 2 ft by 4 ft) gel-sealed into tracks.

Cleanroom air velocity can range from 10 ft per minute (FPM) in Class 10,000 (M6.5) up to 100 FPM in Class 1 (M1.5) with up to 600 air changes per hour. The percentage of room filter coverage affects contamination control. Filter coverage is based on the cubic ft per minute (CFM) of air required for the cleanroom classification and the CFM of air delivered per filter.

Class 1 cleanrooms utilize 100 percent ULPA coverage with air supplied vertically downward with minimal turbulence through a perforated raised-access floor. This airflow pattern is generally known as vertical laminar flow (VLF). VLF resists depositing contaminants on surfaces and captures particles in the cleanroom. The free area of floor panels and adjustment dampers below the panels balance the cleanroom airflow.

In higher cleanroom classes, air may be supplied with controlled turbulence for diffused coverage and returned through low wall return grilles. Pharmaceutical and food applications require aseptic detailing, with smooth, impervious, and cleanable surfaces. The walls and floor join with a radiused cove and require return air extraction by low wall return grilles.

Pressurization is a delicate balance between process exhaust and makeup air replenishment. Manufacturing cleanrooms are usually maintained at positive pressure with respect to adjacent areas to resist particle infiltration from the other areas. Cleanrooms with biohazards, however, are precisely controlled to a negative pressure. As the biohazard increases, the pressure must be maintained at a greater negative pressure.

The Centers for Disease Control and Prevention (CDC) and the National Institutes of Health (NIH) establish practices for biohazard containment including protocol, safety clothing and equipment (primary barrier), and the facility (secondary barrier). CDC/NIH have determined the biosafety levels (BSLs) for materials, which range from BSL-1 (low) to BSL-4 (high). Safety equipment includes class I, II, and III biological safety cabinets (BSC), which are small cleanroom-type workstations. A class III BSC is completely closed to the room environment. BSL-3 or BSL-4 cannot recirculate any room air, and exhaust air must be treated.

Portable cleanrooms and component modularity allow workspace reconfiguration for changing processes and equipment. Cleanroom design is supported by operational protocol, including having workers wear specified apparel and enter through gowning rooms and air showers. All materials entering or exiting cleanrooms must move through pass-through openings with interlocked doors. Operational protocols must be in place from the beginning of construction through testing and certification of the cleanroom as well as during use.

Cleanrooms constructed for microelectronics mitigate conductivity and static control interference with special materials and coatings. To minimize airborne molecular contamination, cleanroom construction materials are evaluated and selected for low outgassing characteristics. Vibration control is essential to cleanroom manufacturing processes involving photolithography, optics, and lasers.

**GENERAL COMPARISON OF CLEANROOM STANDARDS**

HISTORIC ENGLISH CLASS	FEDERAL STANDARD 209E	ISO 14644-1 CLASS	LIMIT OF NUMBER OF PARTICLES PER M <sup>3</sup> OF AIR BY SIZE						
			0.1 $\mu\text{m}$	0.2 $\mu\text{m}$	0.3 $\mu\text{m}$	0.5 $\mu\text{m}$	1.0 $\mu\text{m}$	5.0 $\mu\text{m}$	
		1	10	2					
		2	100	24	10	4			
1	M 1.5	3	1000	237	102	35	8		
10	M 2.5	4	10,000	2,370	1,020	353	83		
100	M 3.5	5	100,000	23,700	10,200	3,530	832	29	
1000	M 4.5	6	1,000,000	237,000	102,000	35,300	8,320	293	
10,000	M 5.5	7				353,000	83,200	2,930	
100,000	M 6.5	8				3,530,000	832,000	29,300	
		9				35,300,000	8,320,000	293,000	

**NOTE**

Only particle number limits for 0.5 micron particle size cor-

relate directly with Federal Standard 209E. Limits for different particle sizes vary somewhat between standards.

**CLEANROOM CLASSIFICATION BY INDUSTRY OR APPLICATION**

INDUSTRY OR APPLICATION	CONTAMINATION FOCUS	HISTORIC ENGLISH CLASSIFICATION, FEDERAL STANDARD 209E, ISO 14644-1						
		1	10	100	1000	10,000	100,000	
		M 1.5	M 2.5	M 3.5	M 4.5	M 5.5	M 6.5	
		3	4	5	6	7	8	
Microprocessor/semiconductor	Particles/molecules							
Electronics, assembly, controls	Particles							
Aerospace, instrumentation	Particles/molecules							
Fine optics or machine parts	Particles							
Biotechnology and cultures	Particles/microbes							
Medical testing (aseptic)	Particles/microbes							
General medical and operating rooms	Particles/microbes							
General pharmaceutical	Particles/microbes							
Food (beverage filling)	Microbes							
Food (dairy process)	Microbes							
Food (general and meat)	Particles/microbes							

**KEY**

□ Seldom used    ▨ Frequently used    ■ Commonly used

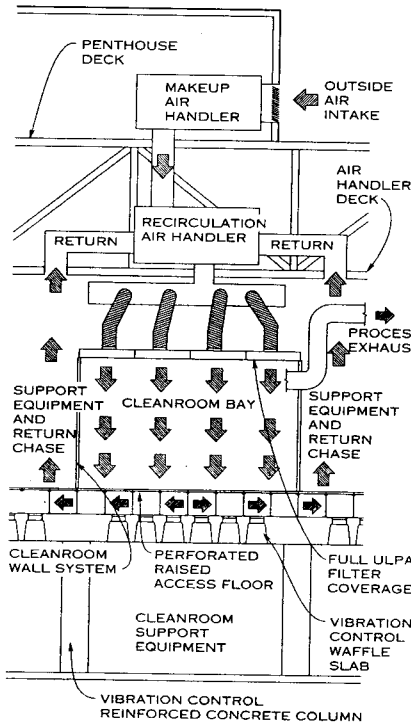

**SECTION THROUGH MICROELECTRONICS CLEANROOM (CLASS 1/M1.5) WITH CLEANROOM BAY AND RETURN CHASE**

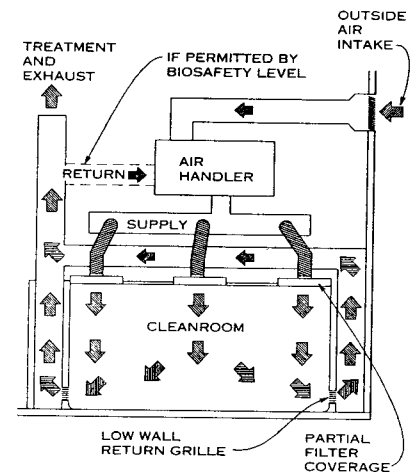

**SECTION THROUGH BIOTECHNOLOGY CLEANROOM (CLASS 1000/M4.5)**

IDC Architects, Inc.; Portland, Oregon

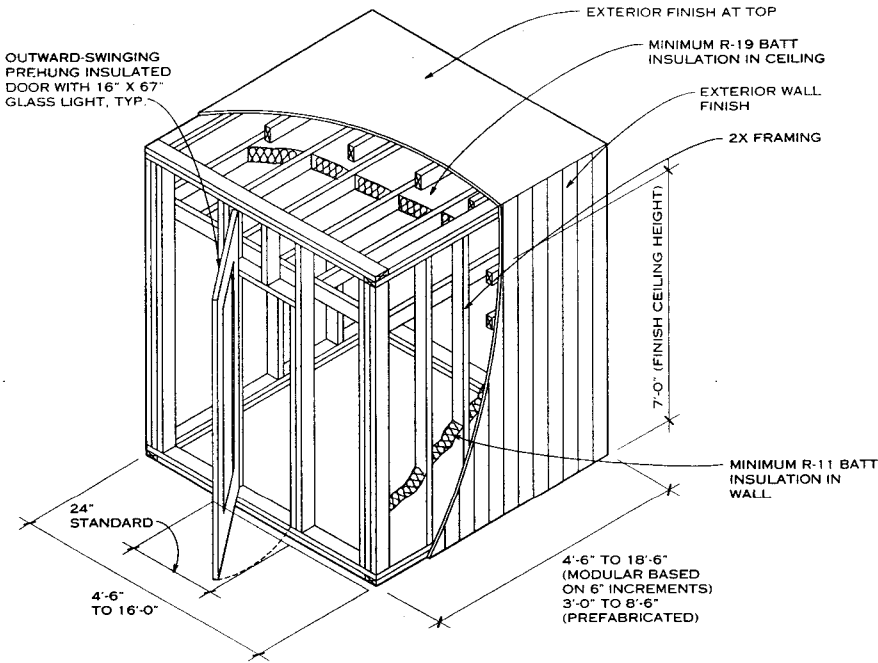

**NOTES**

1. If the sauna framing does not extend to the ceiling of the room outside the sauna, an exterior finish that encloses the top of the sauna is recommended.
2. A 1-in. gap is recommended between the bottom of the door and the threshold for ventilation.
3. Wood-framed baseplates should be made of pressure-treated wood; all other framing may be standard wood framing. Metal framing is not recommended because of its high heat-conductance property.

**SAUNA CONSTRUCTION**

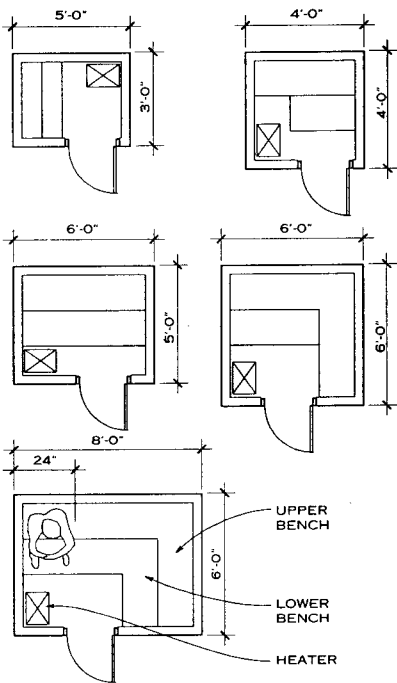

**NOTE**  
Design benches for a width of 24 in. per person (sitting) and a length of 72 in. per person (reclining).

**TYPICAL SAUNA PLAN CONFIGURATIONS**

Richard J. Vitullo, AIA; Oak Leaf Studio Architects; Crownsville, Maryland

**SAUNAS**

A sauna is a dry heat bath taken in a well-insulated room lined with untreated, kiln-dried softwood and heated by igneous rocks. The purpose of the sauna is to induce perspiration, which cleanses the pores in the skin by removing impurities and lactic acid built up from physical exertion.

Because of the dryness of the air in a sauna (25% humidity, average), the body can accept the higher temperatures a sauna produces (180°F, average). It is usually better to lie down than to sit up in a sauna, for the temperature rises about 18°F for every foot above the floor level. If a bather is lying down, the heat is equally dispensed over the entire body. Saunas should be located near a shower for the cool-down portion of the sauna.

Saunas may be prefabricated (precut pieces assembled on the site), modular (factory-built complete panels joined on the site), or custom built.

**NOTES**

1. The larger the sauna, the more heat is required; hence, the ceiling should be kept as low as possible within the limits imposed by the benches, which generally require 7 ft clear height.
2. A 24 in. wide, 6 ft 8 in. high, nonlockable door that opens outward is standard in a sauna. This door size maximizes bench space, minimizes heat loss, and provides safe entrance. A 36 in. wide door could make a design compatible with ADA guidelines, but wheelchair access is discouraged to protect the metal and plastic components of a wheelchair from excessive heat. Instead, an attendant can assist wheelchair-bound sauna users (liability and safety issues should be considered).
3. Because of the weight of the door, a pair of 4-in. brass butt hinges with ball bearings is recommended. A heavy ball or roller catch keeps the door closed. Door handles are made of wood.
4. Indirect lighting is recommended in a sauna. The best position for the light is above and slightly behind the bather's normal field of view; the switch is always outside the room.
5. Softwoods like western red cedar and redwood are used in the finish wall surfaces and bench construction of a sauna. Softwoods absorb humidity, keeping the atmosphere dry, and do not absorb heat as readily as hardwoods, keeping the surface comfortable to the touch. Wood should be kiln-dried to a 6 to 11% moisture content.
6. In private saunas, a water bucket and dipper for creating a burst of steam are common accessories. However, these are often not provided in public saunas to prevent misuse by unknowledgeable bathers, as premature or excessive water application can damage heater parts.

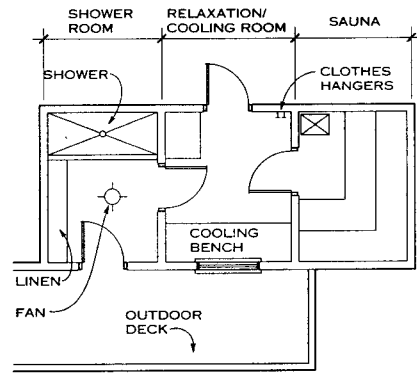

**NOTE**  
A sauna suite offers a complete heating and cooling cycle with indoor and outdoor cooling areas.

**SAUNA SUITE PLAN**

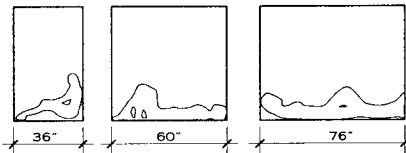

**BENCH DIMENSIONS**

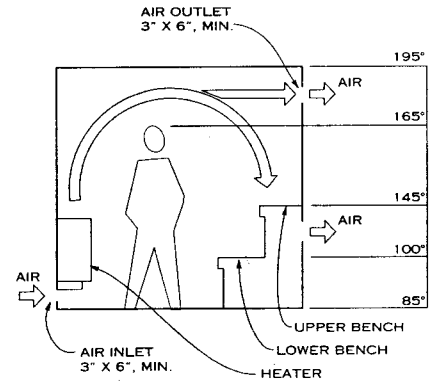

**NOTE**  
Air must be able to flow freely into and out of a sauna and should be changed 4 to 6 times per hour. Fresh air is provided through updraft action by combining an air inlet in the sauna wall directly below the heater with an air outlet located at least 6 in. from the ceiling and 24 in. higher than the inlet. A vent space below the door may also be used.

**AIR VENT AND TEMPERATURE DIAGRAM**

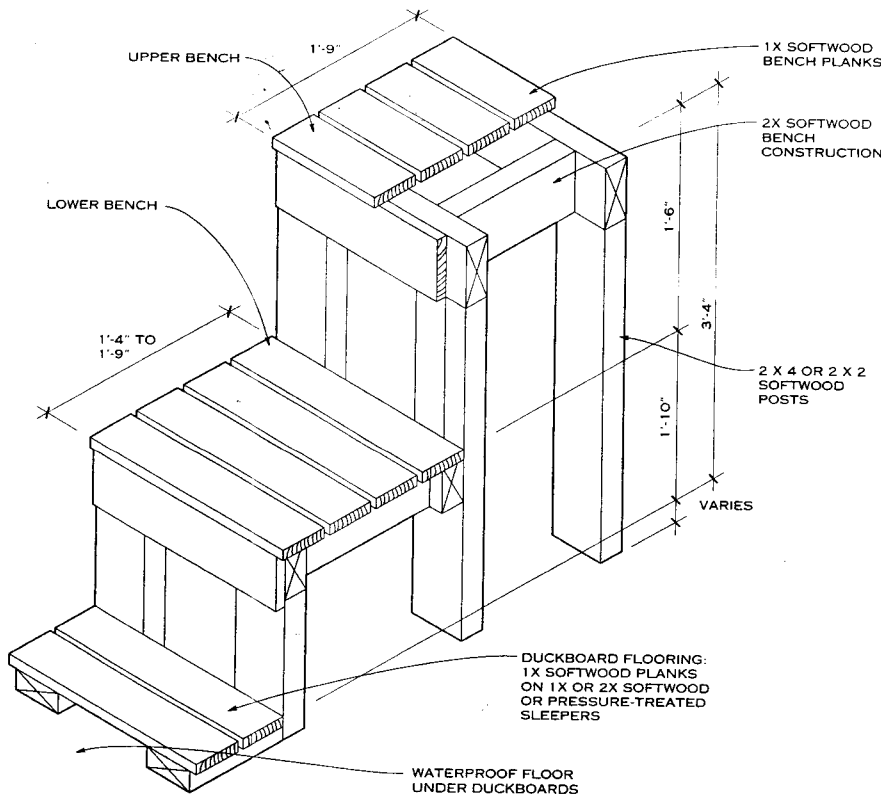

**NOTE**

Floors must be waterproof; cement, tile, and vinyl are appropriate materials. Provide a drain for commercial construction.

Two levels are recommended in a sauna because the top level provides access to higher heat ranges.

**SAUNA BENCH AND FLOORING CONSTRUCTION**

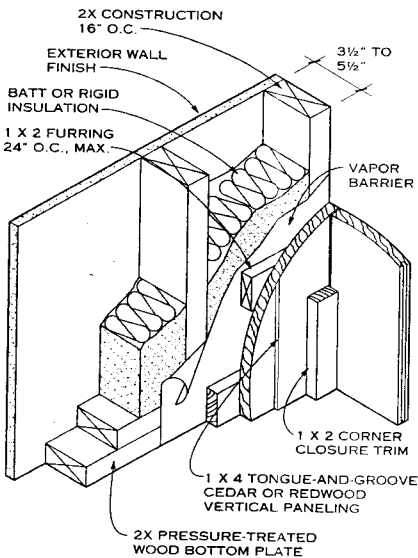

**CUSTOM**

**NOTES**

1. The tongue-and-groove boards used for interior finishes should be at least 5/8 in. thick but no wider than six times their thickness; they are made from softwoods like western red cedar or redwood. Blind nailing with galvanized, aluminum, or stainless steel nails is recommended.

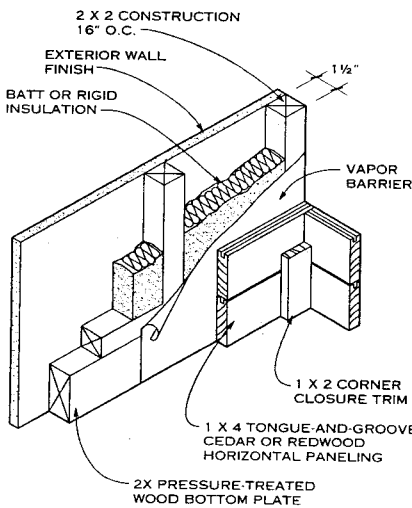

**PREFABRICATED**

2. Vapor barriers under paneling (whether attached to the insulation or separate) must be vaporproof and heat-resistant and act as a heat reflectant. Foil-backed, mineral-based insulation, R-11 minimum, is recommended.

**SAUNA WALL CONSTRUCTION—DETAILS**

Richard J. Vitullo, AIA; Oak Leaf Studio Architects; Crownsville, Maryland

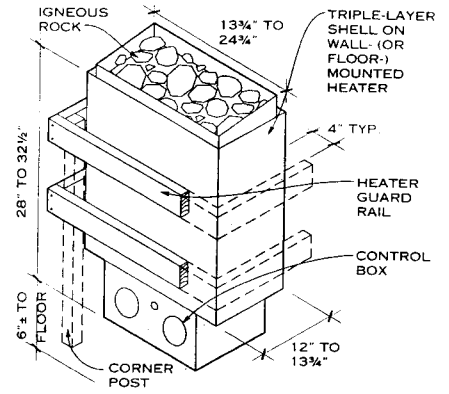

**NOTE**

The control box may be installed either on the heater (below it, usually) or apart from it but within 6 ft of the heat-sensing device inside the sauna. Controls include a thermostat, heat indicator light, light switch, and timer. The output capacity of the heater depends on the volume of the sauna room, but it generally ranges from 1700 to 15,000 watts. Stones completely cover the electric elements to filter the harsh heat and electromagnetic field.

**SAUNA HEATER**

**STEAM ROOMS**

Steam bathing has effects similar to the sauna but in a very different climate. Unlike the dry heat of a sauna, a steam bath (or Roman bath) is taken in a warm, moist atmosphere with temperatures up to 125°F and humidity near 100%. As with the sauna, the critical factor in steam bathing is the bather's interaction between heat and cold.

**NOTES**

1. Avoid use of exposed, untreated materials that are subject to decay or corrosion.
2. Steam room ceilings should be sloped a minimum of 2 in./ft to prevent condensation from collecting and dripping. Sloping from the middle to the edges reduces the height necessary to accomplish this. The ceiling should be no more than 8 ft high.
3. Use of vents inside the steam room is not recommended, but if they are installed, they must be positive closing with a vaportight seal and waterproof ducts.
4. Flooring should be skid-resistant, with a floor drain for condensation runoff and cleaning.
5. The steam generator must be compatible with the construction materials and the volume of the steam room. Residential steam generators can handle 50 to 500 cu ft, while larger models can service up to 1500 cu ft. Controls for the generator may be located inside or outside the room. The dimensions of the generator range from 13 to 17 in. high, 12 to 16 in. deep, and 7 to 8 in. wide.

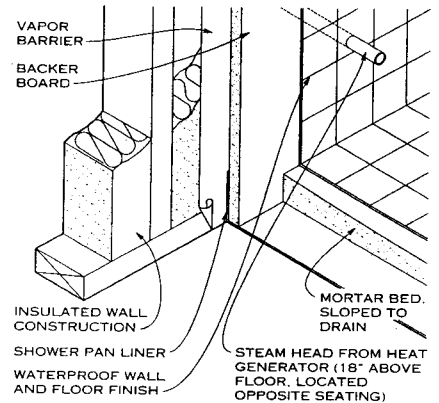

**NOTE**

1. Walls, ceiling, floor, and benches must be completely covered with a waterproof finish such as tile, marble, or acrylic. Exposed gypsum board or plaster is not recommended.
2. All joints must be filled with waterproof sealant.

**STEAM ROOM WALL CONSTRUCTION**

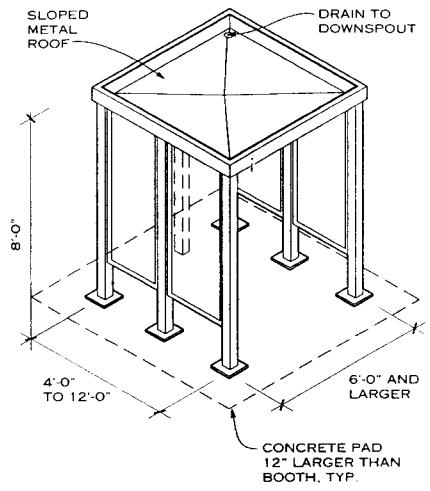
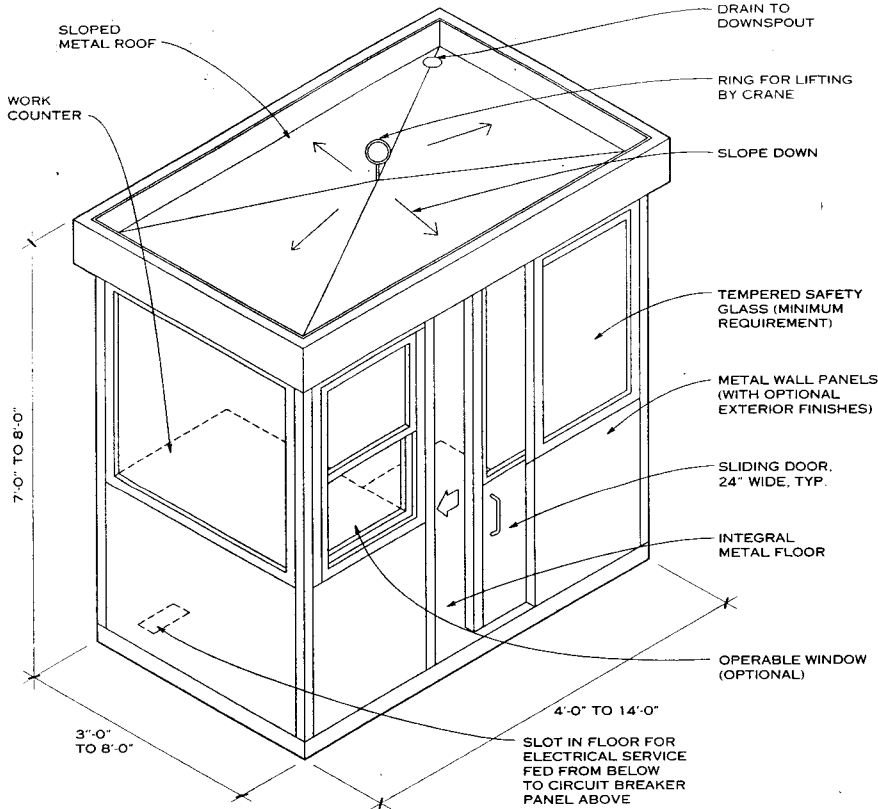

**PREFABRICATED BOOTH**

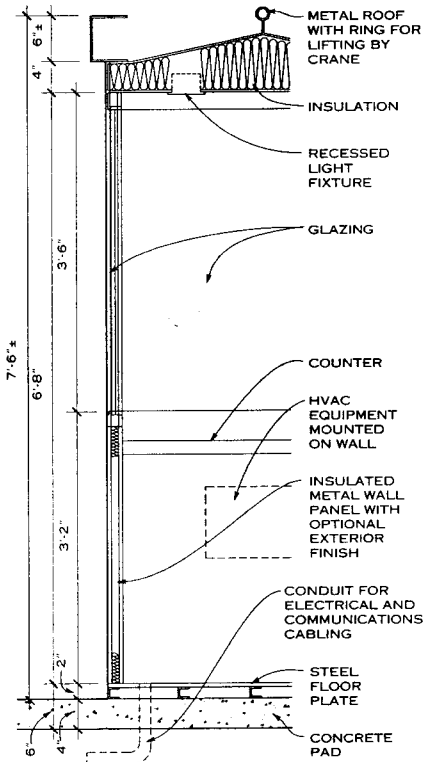

**NOTES ON BOOTHS**

1. Prefabricated booths are manufactured in a wide variety of designs, shapes, finishes, and sizes. Consult manufacturers for available design options.
2. Exterior finish materials that can be applied to wall panels include brick, cast stone, enameled steel panels, stainless steel, and aluminum.
3. Suitable glazing materials include tempered safety glass, unbreakable polycarbonate and impact-resistant acrylic sheets, and insulated and treated glazing.
4. Manufacturers usually offer bullet-resistant construction as an option for windows, walls, and floors up to Class VII protection. Hardening of HVAC, lighting, and other systems is also available.
5. Consult engineers and manufacturers for wind load design depending on site conditions. Appropriate stiffening and anchorage details may be necessary.
6. Lavatory or storage facilities may be built into booths, usually those 8 x 10 ft or larger.

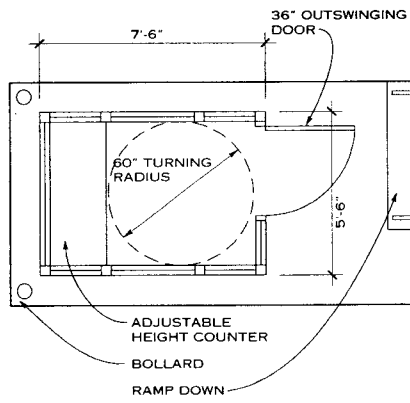

**ADA-COMPLIANT BOOTH**

**PREFABRICATED SHELTER**

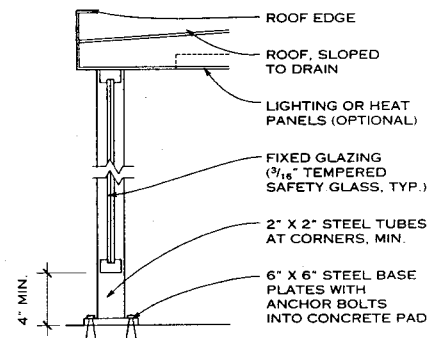

**SHELTER SECTION**

**NOTES ON SHELTERS**

1. Use a switch-operated wall fan to make a smoking shelter. Consult manufacturers for available fan capacities.
2. Benches are typically specified for shelter interiors. Consult manufacturers for sizes and attachment details.

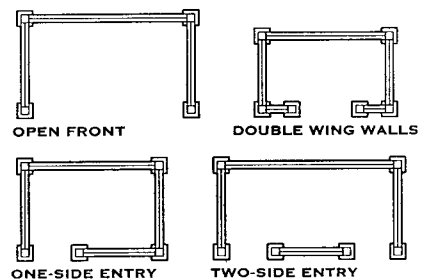

**SHELTER PLAN TYPES**

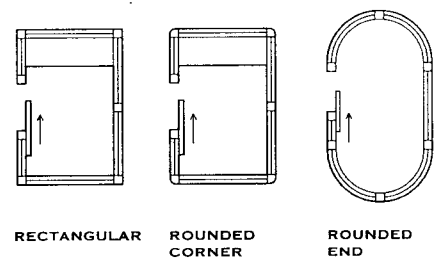

**BOOTH PLAN TYPES**

Richard J. Vitullo, AIA; Oak Leaf Studio Architects; Crownsville, Maryland



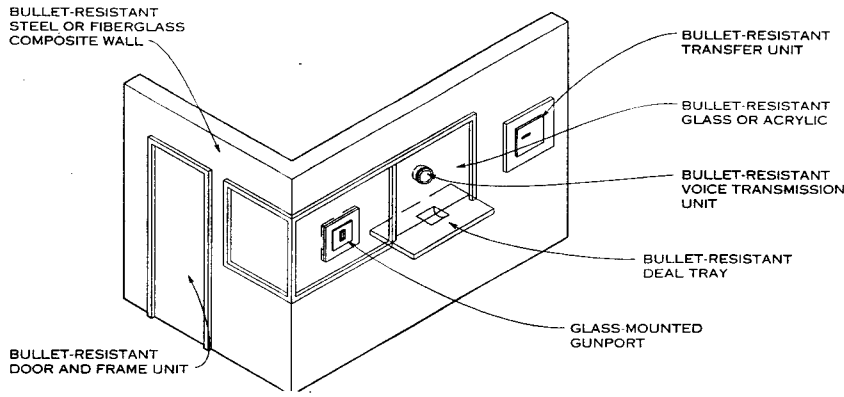

**BULLET-RESISTANT WALL DETAILS**

**GENERAL NOTES**

1. No construction can be bulletproof, but bullet-resistant construction is possible. Protected areas should be designed to withstand a level of attack based on the threat at that location, in particular the type of arms expected.
2. Each component in a bullet-resistant system must be bullet resistant; there can be no weak links and no gaps.
3. Consult a specialist in bullet-resistant construction.
4. A truly effective protection plan combines a bullet-resistant system with appropriate detection, alarm, communication, escape, and retaliation capabilities.
5. The complete bullet-resistant environment makes it possible for personnel to escape, retaliate against attack, summon help, and defend themselves against the threat of gunfire, flame, and chemical or mechanical attack.

**BULLET-RESISTANT DOOR ASSEMBLY NOTES**

1. The entire unit should be certified as bullet resistant by an independent testing laboratory.
2. Bullet-resistant doors are heavier than regular doors, so the doorframe and hinges must be properly reinforced and/or of heavy weight.
3. The doorframe must be constructed of bullet-resistant material equivalent to that of the door itself. A proper fit between the door and the frame is required to prevent gaps that could permit ballistic penetration. Ideally, the door and frame should be supplied by the manufacturer as a single unit.
4. Use of appropriate hardware is important. The lockset should be mortised with  $\frac{5}{8}$  in. minimum throw on the latch bolt and thoroughly armored to prevent the door from unlatching after assault.
5. The door should be equipped with a heavy-duty closer to ensure it closes completely.

**BULLET-RESISTANT WINDOW ASSEMBLY NOTES**

1. The entire unit should be certified as bullet resistant by an independent testing laboratory.
2. All elements in a bullet-resistant window assembly must be bullet resistant, including voice communication systems and trays.

3. The window framework must be bullet resistant as well as substantial enough to retain the glazing material under the impact of a projectile.
4. The window should be designed so the bullet-resistant framework and the bullet-resistant glass become an integral unit.

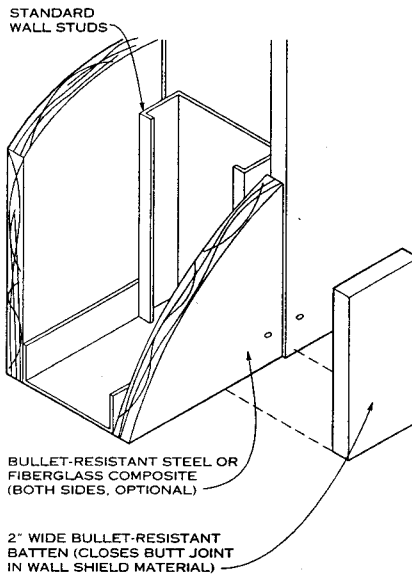

**BULLET-RESISTANT COMPOSITE WALL PANEL**

**TYPICAL BULLET-RESISTANT MATERIALS**

MATERIAL	FUNCTIONS AND CHARACTERISTICS	THICKNESS	WEIGHT	REMARKS
Steel	Cost-effective shielding against direct assault Thin Can be fabricated for retrofit Easy installation	$\frac{1}{8}$ -1 in.	6-24 psf	
Glass	Cost-effective vision-panel shield Scratch resistant, chemical resistant Substantial assault can defeat glass	$1\frac{3}{16}$ -2 in.	15-31 psf	One-way security glass is available $\frac{5}{8}$ - $1\frac{1}{8}$ in. thick, weight 7.1-18.2 psf
Plastics (acrylic)	Lighter weight and more impact resistant than glass Spall resistant Relatively high cost Substantial assault can defeat plastic	$1\frac{1}{4}$ in.	7.8 psf	Glass-clad polycarbonate is available $1-1\frac{11}{16}$ in. thick, weight 9.6-17.6 psf
Composites	Can be opaque or transparent Lighter weight alternative for direct assault shielding Composite vision panels can be made stronger than glass Workable, suitable for custom installation Relatively high cost	$\frac{1}{4}$ - $1\frac{1}{8}$ in.	2.5-11.5 psf	Available in 4 x 8 ft sheets

Jessica Powell; Rippeteau Architects, P.C.; Washington, D.C.

13 SPECIAL PURPOSE ROOMS

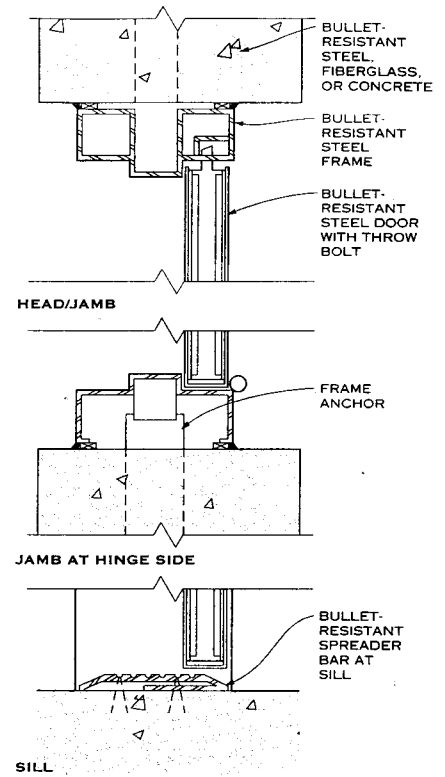

**BULLET-RESISTANT DOOR IN CONCRETE WALL**

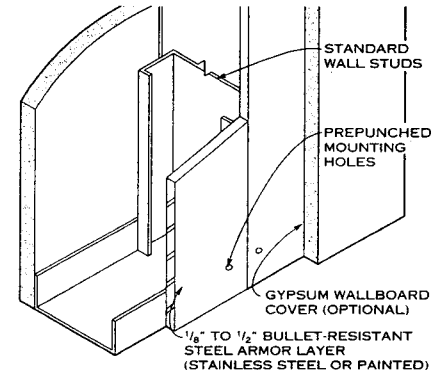

**BULLET-RESISTANT STEEL WALL PANEL**

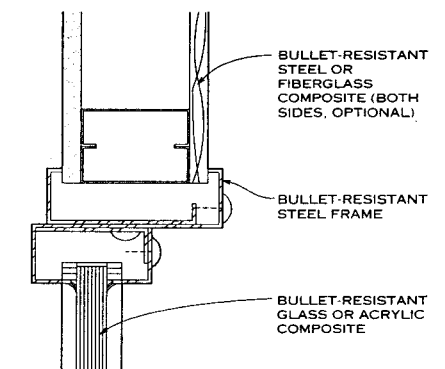

**BULLET-RESISTANT WINDOW HEAD/JAMB**

**GENERAL**

Radio frequency (RF) shielding consists of a barrier or shield of electrically conductive materials designed to protect sensitive electronic equipment from the disruptive effects of conducted or radiated electromagnetic interference (EMI).

RF shielding of rooms, large areas, or buildings (called architectural shielding) is designed to contain EMI within a given space (e.g., to protect cardiac pacemakers from EMI generated by magnetic imaging resonance [MRI] equipment) or to protect electronic devices from distortion by outside EMI (e.g., to protect computer data or medical ultrasound images from distortion by radio, television, or cellular phone signals).

Shielding from electromagnetic energy is achieved by metalizing walls, floors, and ceilings in a room or area. Metallizing isolates a space from energy transmitted through the air (radiated) or through a wire (conducted). Typically, RF shielding is created with knockdown galvanized steel modular rooms or architectural shielding achieved with copper paint or sheeting. Proper shielding requires RF treatment of all mechanical and electrical penetrations into an area, which is achieved by using RF-shielded doors and components for plumbing, HVAC systems, and electrical conductors for power, data, and telephone lines.

Rooms or areas may be RF tested to determine the level of shielding achieved, called shielding effectiveness. Shielding effectiveness typically ranges from 40 dB for commercial

WALL SURFACE (FINISH)  
APPLIED OVER SHIELDING  
(WALLPAPER, FABRIC,  
PAINT, OR GYPSUM  
WALLBOARD)

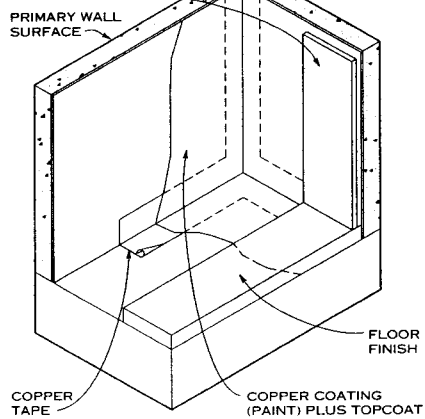

**NOTE**  
When applying wall and floor finishes over shielding, use nonintrusive methods such as adhesive.

**COPPER COATING DETAIL FOR WALLS, FLOORS, AND CEILINGS**

**SUMMARY OF SHIELDING SYSTEMS**

WELDED STEEL ENCLOSURE	MODULAR PAN ROOM	COPPER SHEET SYSTEM	COPPER COATING SYSTEM
<b>CONSTRUCTION</b>			
Shielding steel min. 28 gauge on structural frame or attached to existing walls	Min. 24-gauge galvanized steel pans	Copper sheets (3-12 oz)	Component system (water-based copper paint, fire-rated doors, vents, laminated windows, power and data filters, copper tape)
<b>JOINING METHODS</b>			
Welded or brazed	Bolted through RF gasketing	Soldered, taped, or stapled	Copper paint on wallboard, wood, and concrete; copper-taped joints
<b>TYPICAL ATTENUATION</b>			
1. Magnetic (H-field) 80 dB @ 14 kHz 110 dB @ 200 kHz	60 dB @ 14 kHz 110 dB @ 200 kHz	90 dB @ 200 MHz	—
2. Electric (E-field) 120 dB @ (20 kHz to 50 MHz)	120 dB (200 kHz to 50 MHz)	100 dB (10-50 MHz)	Minimum + 50 dB (10-50 MHz)
3. Plane wave + 110 dB (50 MHz to 10 GHz)	+ 100 dB (50 MHz to 10 GHz)	100 dB (50 MHz to 10 GHz)	Minimum + 50 dB (10 MHz to 1 GHz)
4. Microwave 100 dB (1-94 GHz)	—	—	—
<b>FEATURES</b>			
Highest attenuation	High attenuation, lightweight, easy to assemble	Nonferrous materials, quick installation	Easy for building trades to install; economical reflective shielding for new and existing construction
<b>INSTALLATION COST</b>			
Highest	Moderate	Low	Lowest
<b>APPLICATIONS</b>			
60-Hz magnetic field shielding, for electrical closets, power substations, UPS systems. Highest possible security projects, research and QC, testing facilities, and MRI rooms	High security areas, government and commercial communication and data processing centers	MRI and EEG rooms, government secure installations, conference rooms or rooms that require architectural finishing	Data processing centers, hospital audiological/neuropsychiatric rooms, radio, TV recording studios, manufacturing facilities for electronic equipment

John Soltis; Tecknit Shielding Systems; Passaic, New Jersey

requirements (99% reduction in radiation) to more than 100 dB (99.999% reduction) for military, government, and hospital MRI enclosures. Shielding effectiveness is always stated in dB of reduction over a frequency range expressed in hertz.

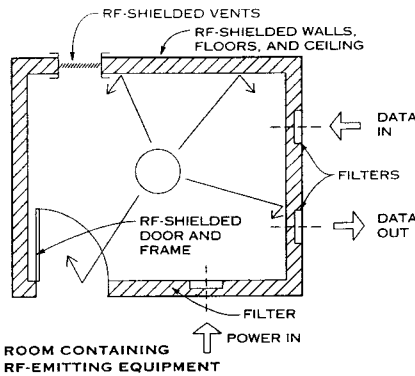

**ROOM CONTAINING RF-EMITTING EQUIPMENT**

**RF-SHIELDED SPACES**

The range of frequency that must be shielded varies from 60 Hz for AC power through the kHz (kilohertz) and MHz (megahertz) range for radio, TV, and cellular phones to the GHz (gigahertz) range for microwave energy such as radar.

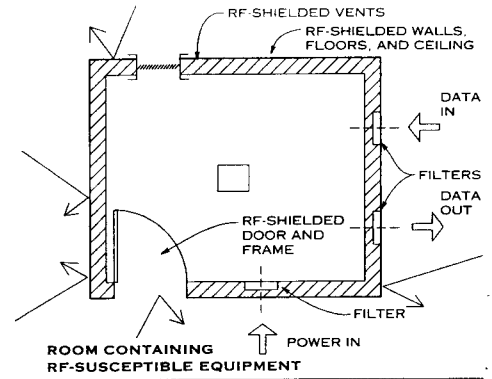

**ROOM CONTAINING RF-SUSCEPTIBLE EQUIPMENT**

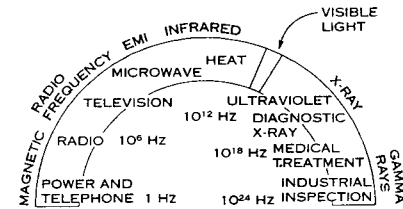

**NOTE**

Design for shielding against interference from electromagnetic radiation is based on the electromagnetic frequency spectrum. Since all radiated energy occurs in wave form, interference can be identified by its frequency, which is expressed in hertz. The diagram above shows where each type of radiated energy occurs in the electromagnetic spectrum. The lowest frequencies are in the range represented by electrical power and AM radio, the highest in the range represented by gamma rays (used in medical linear accelerators).

Each frequency range in the spectrum may require its own shielding design. In many modern projects, the designer and builder must contend with more than one frequency band at a time. A modern hospital, for instance, may require as many as five different shielding solutions, such as magnetic shielding for a 60 Hz power substation, magnetic and EMI shielding for MRI equipment, RF/EMI shielding for sensitive medical equipment, X-ray shielding for diagnostic X-ray equipment, and gamma ray shielding for a linear accelerator.

**ELECTROMAGNETIC SPECTRUM**

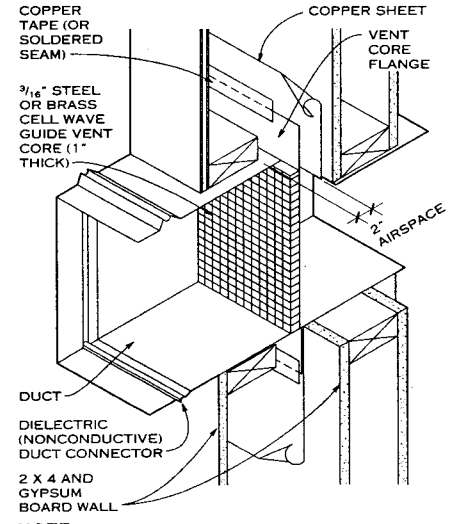

**NOTE**  
Solder seam of vent flange or use copper tape to attach it to copper sheet on all four sides.

**RF-SHIELDED DUCT DETAIL**

**GENERAL**

Radio frequency is abbreviated RF throughout this page.

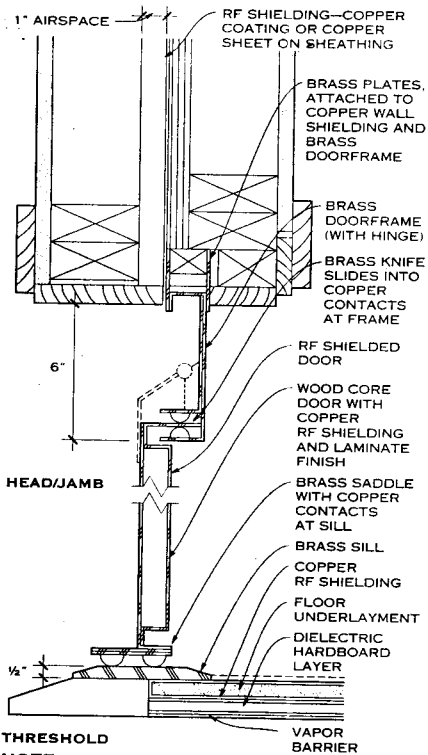

**THRESHOLD NOTE**

This detail is for construction other than modular panel room systems.

**RF-SHIELDED INTERIOR DOOR DETAILS**

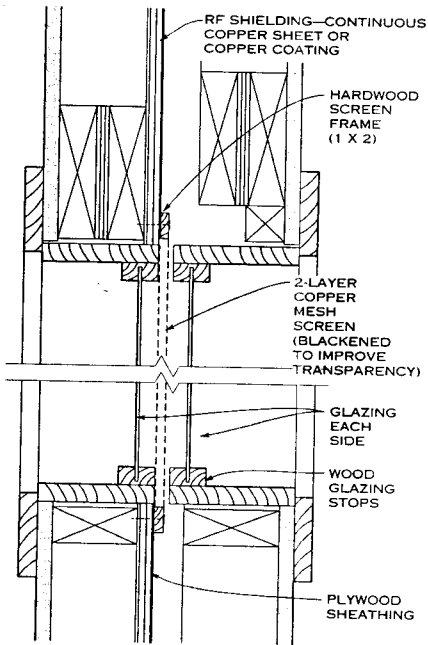

**NOTE**

Solder or use copper tape to fasten the wall shield to the mesh screen on all four sides.

**RF-SHIELDED WINDOW DETAIL (INTERIOR)**

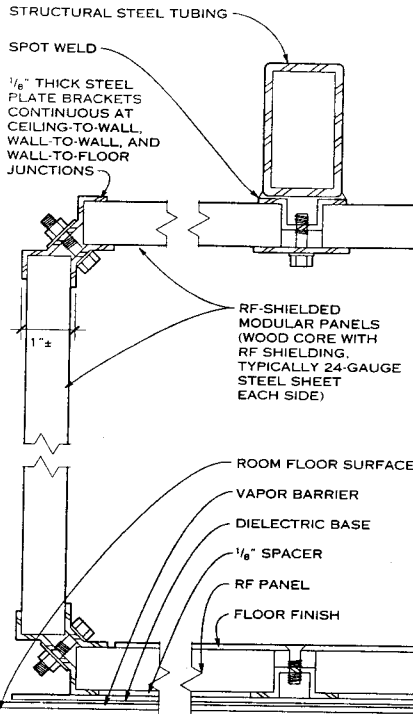

**MODULAR ROOM SECTION**

**NOTE**

A dielectric (nonconductive) base electrically isolates an RF-shielded structure from a parent room. Standard panels are

**RF-SHIELDED MODULAR PANEL ROOM SYSTEM DETAILS**

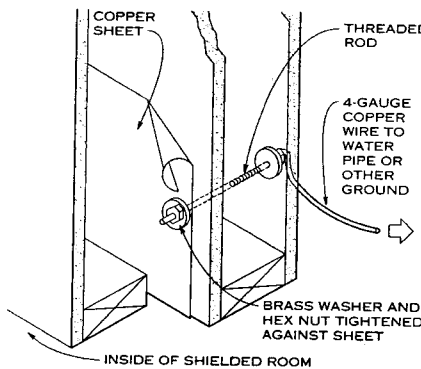

**WALL SHIELD GROUNDING DETAIL**

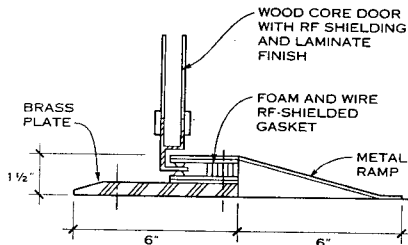

**RF-SHIELDED DOOR AT STANDARD RF-SHIELDED CONSTRUCTION**

**FLUSH POCKET THRESHOLD DETAILS**

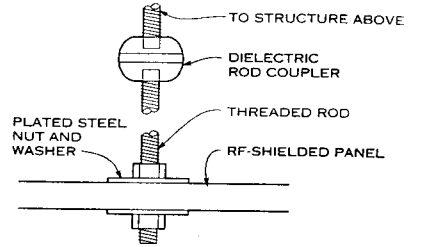

**ALTERNATE CEILING SUPPORT DETAIL (FOR ROOMS WIDER THAN 12' - 0\"/>**

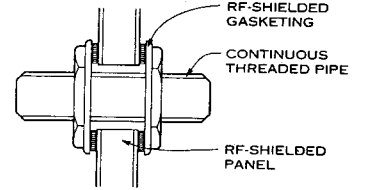

**GALVANIZED PIPE PENETRATION**

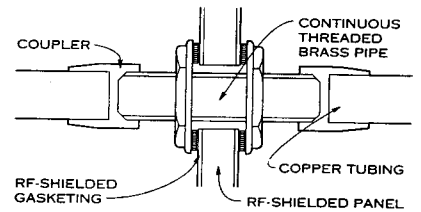

**COPPER PIPE PENETRATION**

4 x 8 ft and 4 x 10 ft; panels may be custom-cut in field.

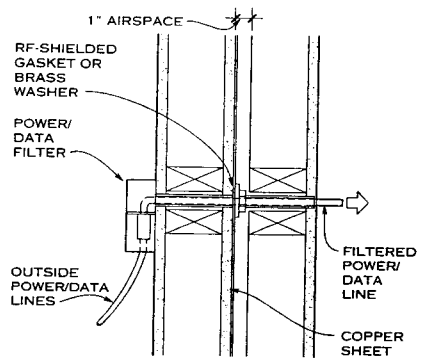

**POWER AND DATA FILTER DETAIL**

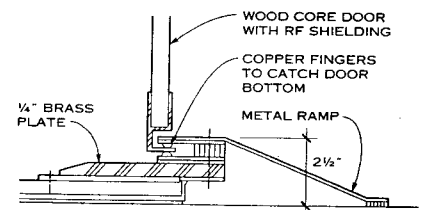

**RF-SHIELDED DOOR AT MODULAR RF-SHIELDED PANEL SYSTEM**

John Soltis; Tecknit Shielding Systems; Passaic, New Jersey

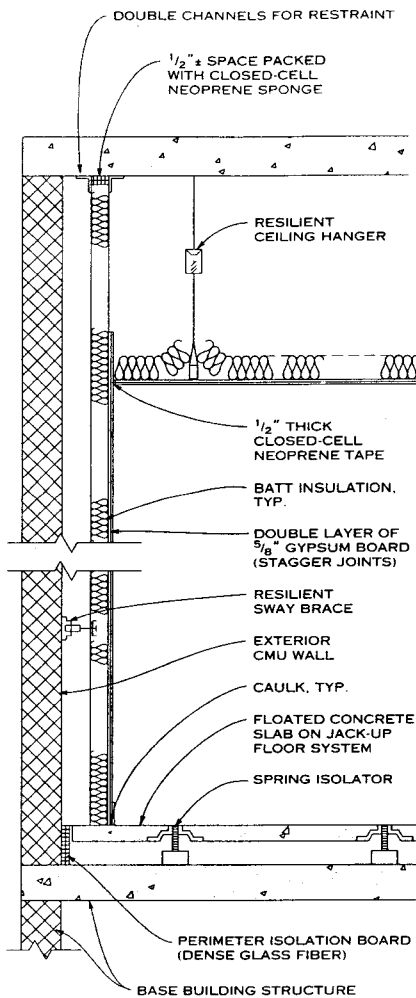

EXTERIOR WALL—SECTION

**ISOLATED ROOMS**

Isolated rooms incorporate special constructions to reduce intrusive noise and vibration from outside a room or to contain the sound and impact energy generated within a room. Typical applications include music practice rooms, sound studios, testing chambers, mechanical equipment rooms near sensitive areas, spaces exposed to nearby aircraft flyovers, and offices under gymnasiums. Construction of isolated rooms can be very expensive. It is therefore wise to isolate high-noise sources from acoustically critical uses early in the space planning and layout design phase.

The correct design of an isolated room is a "box-within-a-box." The inner box, which is the four walls, ceiling, and floor of the isolated room, should be an airtight enclosure constructed of dense, impervious materials; this box must be isolated by resilient supports from the surrounding structure. The base structure that supports the isolated room must be as rigid and massive as possible.

The most effective floor construction is a "floated" concrete pad, which is separated from the base building structure by steel springs, neoprene, or glass fiber isolation mounts. This slab can support inner walls. Any necessary structural bracing to the base building structure should be with a resilient, nonrigid connection. The ceiling of the box can be suspended from resilient hangers, or it can be supported from the walls of the inner box.

An isolation mat provides uniform deflection of the floating concrete floor under a wide range of design loads. It consists of 2-in.-thick, high-density, precompressed molded fiberglass isolation pads, separated by low-density acoustical fiberglass.

Cerami + Associates; New York, New York

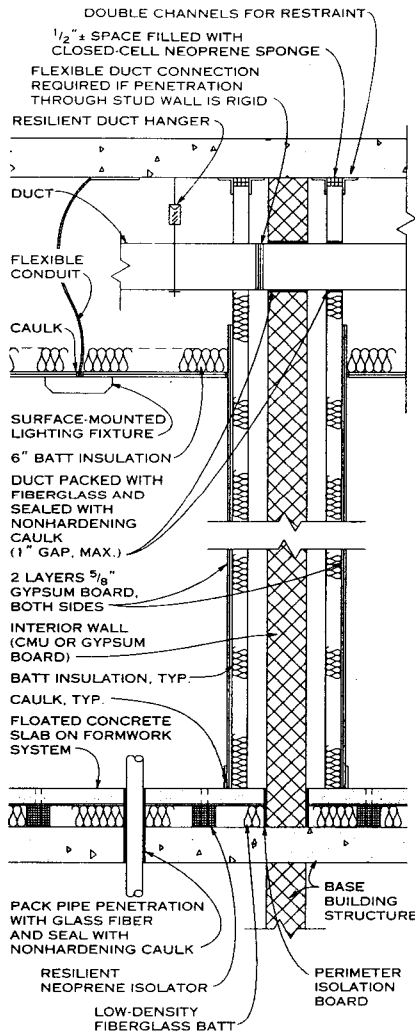

INTERIOR WALL—SECTION

Avoid all flanking paths between an isolated room and the base building structure. To ensure that wall penetrations and connections to outside services are as well isolated as the room itself, provide flexible connections in ducts and conduit between the inner and outer box and resilient supports for all piping. Weather stripped or sound-rated doors and double-glazed, acoustical windows should be part of the continuous, air-tight enclosure that defines the inner box.

**NOISE REDUCTION**

The degree of noise reduction that can be attained by an isolated room depends on the type of construction, its resiliency, the elimination of flanking paths, and the amount of dead airspace surrounding the inner box. A well-built isolated room can achieve field performance ratings of STC 60 to 70 for airborne sound and ratings of IIC 80 to 90 for impact noise. However, even minor flanking paths and acoustical short circuits through non-airtight joints can easily decrease these results by 10 points or more. The sound isolation between spaces will be only as great as the weakest sound path.

The advice and assistance of a qualified acoustical consultant should be sought in both the planning and design of isolated rooms and their related special constructions.

**PREFABRICATED UNITS**

In addition to field-erected isolated rooms as described above, several manufacturers make prefabricated units. These rooms are sold as self-contained music practice

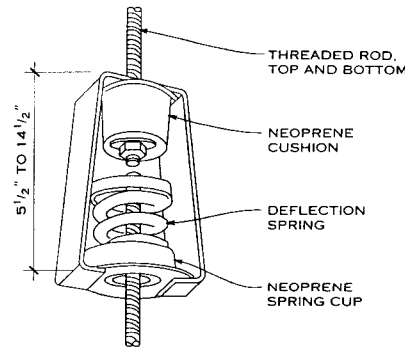

**NOTE**  
Resilient hangers typically are used to isolate duct vibration.  
**RESILIENT HANGER**

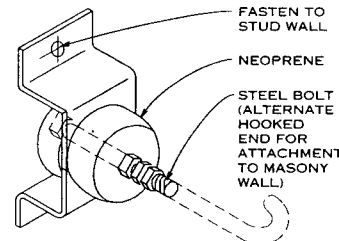

**NOTE**  
Sway braces prevent buckling or overturning of tall or extremely long walls.  
**SWAY BRACE**

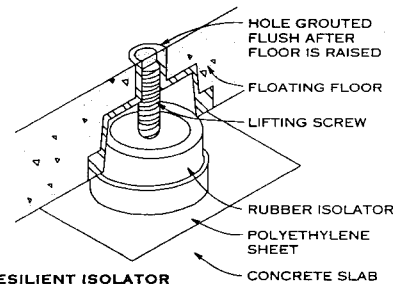

**RESILIENT ISOLATOR**

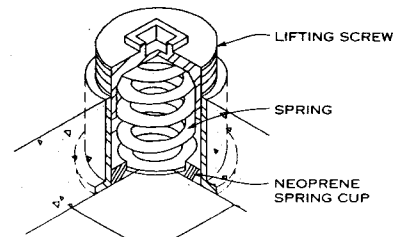

**SPRING ISOLATOR**  
**ISOLATOR DETAILS**

rooms, audiometric booths, and control booths for manufacturing plants. Although the detailing of these structures is proprietary, one will find the same design approach as outlined here: an airtight box separated from the building structure. The degree of noise reduction that these prefabricated rooms can attain depends on the parameters used for field-erected rooms.

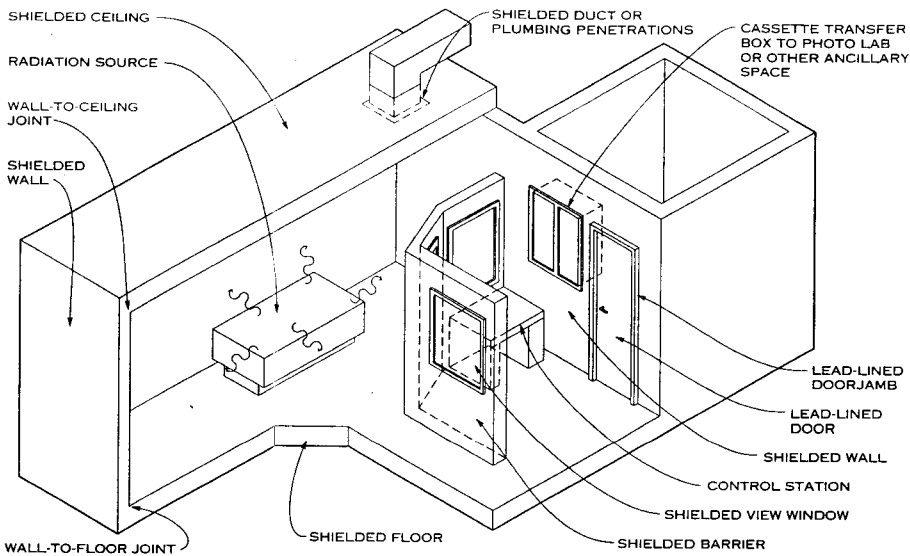

**TYPICAL SHIELDED ROOM DESIGN REQUIREMENTS**

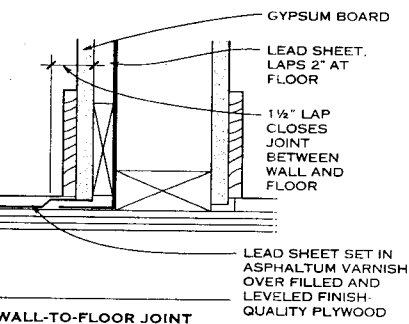
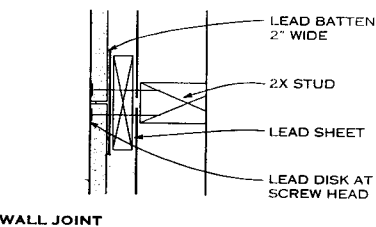
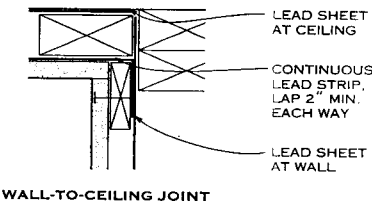
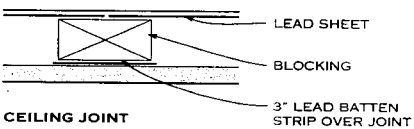

**LEAD SHEET IN WOOD CONSTRUCTION**

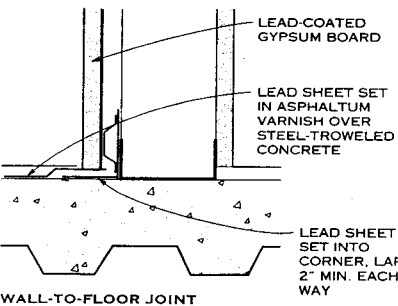
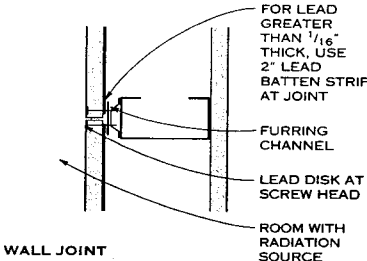
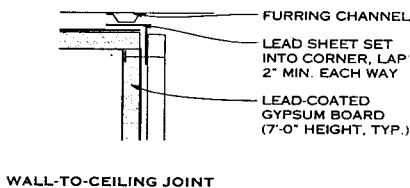
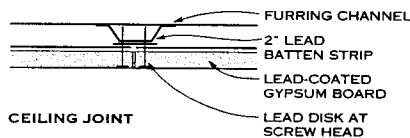

**STEEL STUD AND LEAD-COATED GYPSUM BOARD**

**GENERAL**

There are three ways to protect humans from harmful exposure to radiation: Keep people a sufficient distance from the radiation source, limit their time of exposure, and contain the radiation source with a protective shield.

Factors to consider in designing a protective shield are the type, characteristics, and amount of radiation; the type of construction; and the properties of the shielding system. It is important to think of an enclosure for a radiation source as a sealed module. Each component in the system must be lined with lead, and all of the connections must overlap to prevent leaks. Joint details are the most important design element once the shielding system has been selected.

Retain a radiation consultant to analyze project requirements and prescribe the necessary shielding system. The thickness of lead needed is based on the amount of radiation at the site and should be determined by an expert.

**NOTES ON LEAD SHIELDING**

1. Lead sheets are available in sizes from 1/64 to 1 in. thick.
2. Specify lead requirements in increments of 0.5 mm, with a minimum thickness of 1 mm (1/24 in.).
3. Adequate physical support is required for sheet lead installations.
4. For health and environmental considerations, lead sheet, plate, and brick are designed to be installed behind other materials.
5. Door and window frames must be lined with lead equal to the wall shielding level. Lead glass or lead acrylic glazing must be chosen to match wall and frame shielding levels.
6. Hinges and hardware for lead-lined doors must be designed to carry the weight of the lead.

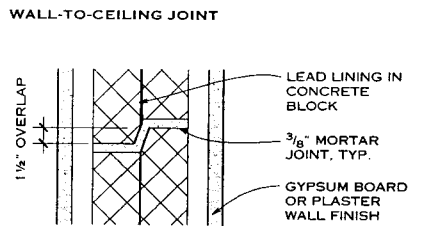
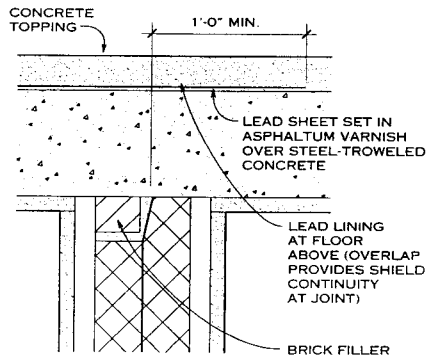

**TYPICAL BLOCK JOINT**

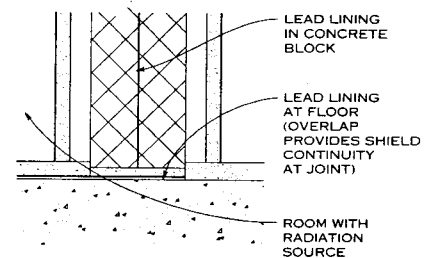

**LEAD-LINED BLOCK IN CONCRETE FRAME**

Jessica Powell; Rippeteau Architects, PC; Washington, D.C.

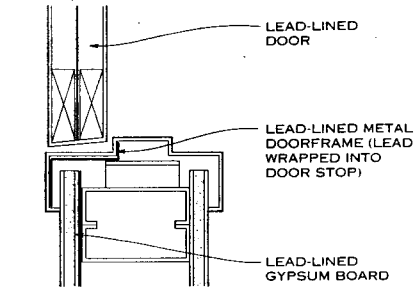

HEAD/JAMB

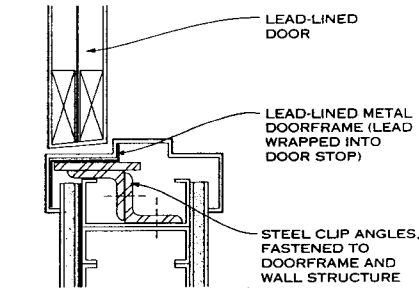

REINFORCED JAMB

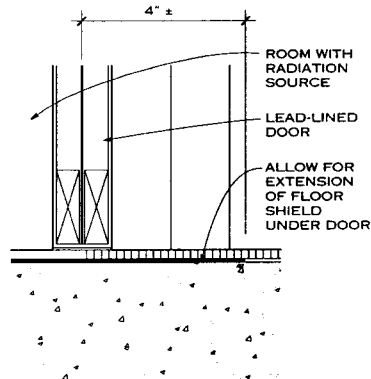

THRESHOLD DETAIL

LEAD-LINED DOOR DETAILS

NOTES

1. Lead-lined doors consist of a continuous sheet of lead sandwiched between two wood core panels; they generally measure 1 3/4 in. plus the thickness of the lead, which is specified by the architect or radiation physicist. Typically, the lead sheet is a minimum 1 3/4 in. thick and is covered with a flush-type wood veneer or plastic laminate. For lead thicknesses greater than 3/16 in., consult the manufacturer for door thicknesses. Use pivot or continuous hinges specifically designed to carry the weight of lead-lined doors. Depending on the thickness of the lead and the weight of the door, it may be necessary to reinforce the doorframe. Steel door frames are lined with lead of the same thickness as walls and doors. Lead-lined doors are available with leaded louvers or view windows.
2. For lead-lined wallboard and plywood, an unpierced lead sheet is laminated to a sheet of fire-rated wallboard or plywood. Lead thickness is specified by an architect or radiation physicist. Lead joint strips and screw plugs cover any construction gaps or penetrations.
3. Lead-lined shielding barriers are modular, custom-designed units with clear glazing material on top and a lead-lined opaque panel below. Glazing may be either lead acrylic or lead glass. Check local regulations to ensure that movable radiation shielding is permitted.
4. View windows are formed from telescoping steel frames (for walls 4 1/2 to 7 in. thick) with lead. These windows may include voice transmission passages and an adjustable glass stop. The stop permits installation of one to eight pieces of lead glass as required for radiation protection. Minimum thickness for the glass is 1/4 in., which is equivalent to 2 mm of lead. Windows can be laminated with float glass for increased protection.

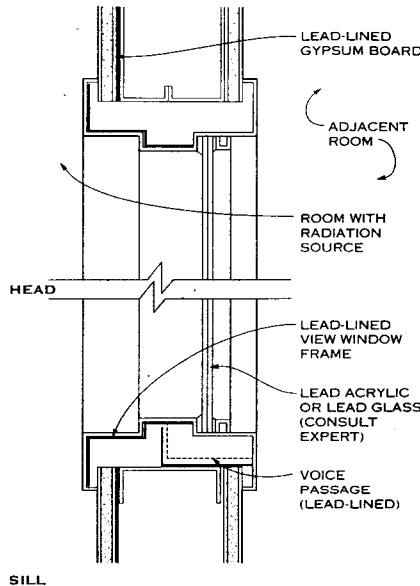

FIXED LEAD-LINED HOLLOW METAL VIEW WINDOW

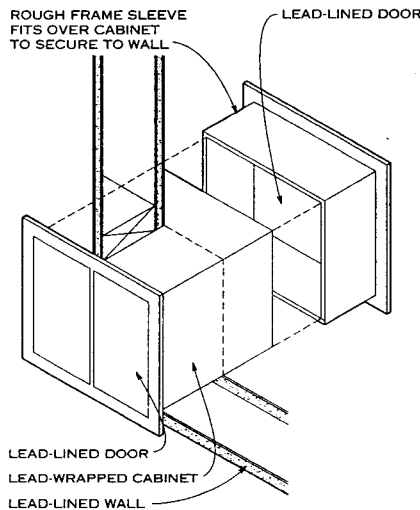

LEAD-LINED PASS-THROUGH CABINET

5. An X-ray cassette transfer box installed between diagnostic and film processing rooms facilitates quick transfer of developed and undeveloped X-rays. These boxes are constructed of steel panels lined with a specified lead thickness.

MEDICAL X-RAY PRODUCT APPLICATION GUIDELINES

APPLICATION	X-RAY COMPONENTS	SHIELDED DOORS	CONTROL WINDOWS
Linear accelerator (LINAC) room	Borated lead walls, lead brick	Borated polyethylene and lead	Telescopic widths 4 7/8 to 7 in. (typical), larger widths available
X-ray rooms, dental x-ray	Stationary or mobile control screens, lead-lined wallboard and plywood	Lead-lined in various lead thicknesses and door sizes	
CAT scan room, PET scan, cardiac catheterization	Lead-lined wallboard and plywood, lead brick (PET scan)	Lead-lined hollow metal and lead-lined solid-core wood doors	
Implant radiology	Interlocking lead brick, lead-lined plywood	Lead-lined doors and frames	

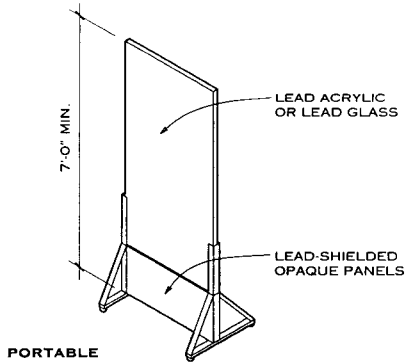
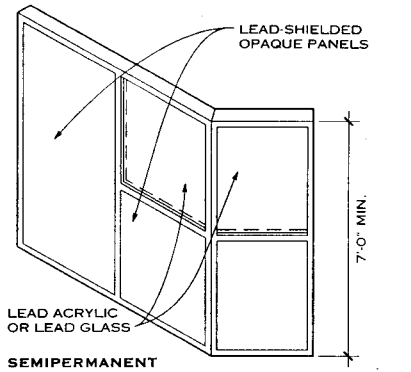

RADIATION SHIELDING BARRIERS

ALTERNATE METHOD IS TO INSTALL SHEET LEAD BEHIND BOX AT INSIDE OF OPPOSITE WALL SURFACE

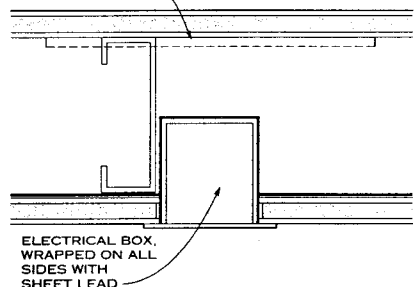

ELECTRICAL, PLUMBING, AND HVAC PENETRATION SHIELDING

6. Leaded X-ray glass is used for all windows in X-ray protection rooms. Typical material uses lead-barium glass with more than 60% heavy metal oxide, including at least 55% lead oxide. Typical glass sizes range from 8 x 10 in. to 48 x 96 in. Glass thickness is 8 mm (lead equivalent 1.8-2.0 mm) to protect against 100 kV X-rays, 11 mm (lead equivalent 2.5-2.7 mm) to protect against 150 kV X-rays, and 14 mm (lead equivalent 3.0-3.2 mm) to protect against 200 kV X-rays.

Jessica Powell; Rippeteau Architects, P.C.; Washington, D.C.  
John Soltis; Tecknit Shielding Systems; Passaic, New Jersey

**GENERAL**

Architectural fabric structures have undergone rapid development since the early 1970s and now can be considered a mature building technology. Due to improvements in materials, structural analysis, and environmental control, these structures can often be considered permanent buildings. This technology, with unique properties that make it useful for certain applications, offers an important alternative to conventional construction.

Fabric structures of a nonpneumatic kind fall into two categories. One type has a fabric membrane with a rigid frame support, usually of metal, and the other is a self-supporting fabric membrane kept in tension with a supporting structure of steel or concrete. The rigid frame structures typically form pyramidal or long, continuous geometric shapes like sheds or barrel vaults. The self-supporting structures rely on opposing curves to distribute the necessary tension and typically form saddle, conical, or hyperboloid (anticlastic) shapes.

The structure that creates and maintains tension on the fabric can consist of cables and masts, a compression ring, trussed gridwork, or tied edges. These mechanisms create pretension in the fabric sufficient to keep it taut at all times. Any compressive loads imposed on the fabric will be balanced or at most reduced by the prestress created by the structure.

**MATERIALS**

The intended life span of the structure is an important factor in design decisions, fabrication details, and the cost of architectural fabric structures. The life span is most affected by the fabric material or membrane selected. Fabric is a directional material and does not have the same strength or elongation in all directions under a load. Materials with little creep are preferable for tensioned structures, as original prestress can be lost if the fabric stretches or deforms. Details allowing for retensioning must be incorporated if materials with moderate to high creep are used. Generally, the materials used in a membrane are composites consisting of a woven substrate protected with an applied coating.

The membrane is the principal structural component of a self-supporting or tensioned fabric structure. Two materials are generally used for membranes—polyvinyl chloride (PVC)-coated materials and fluorocarbon (Teflon)-coated glass fiber fabric. PVC-coated polyester is a composite material composed of vinyl coating over both faces of a woven polyester fabric. The material is inexpensive, strong, translucent, and easy to fabricate but has a limited life span and is only fire resistant; for these reasons it is only used in temporary or

semipermanent structures. Fluorocarbon-coated glass fiber fabric is classified as a noncombustible material. Besides its advantages in fire safety, this fabric is extremely long-lasting, self-cleaning, and translucent and is the accepted material for most permanent installations. Development continues in fabric technology, and new products such as silicon-coated glass fiber may offer an improvement in the range of material characteristics.

**DESIGN**

In recent years, the structural design of fabric structures has improved due to the increased use of the computer in the engineering process. The first step in the design process aided by computer modeling is the definition of an acceptable surface geometry, such as the hyperboloid. A membrane mesh or network is then developed representing the surface as a grid of lines. This graphic model is "pre-stressed," and the reactions are analyzed in an iterative, or repetition-based, process. Live loads such as wind, rain, or snow are applied to the model and the stresses calculated in order to select the fabric and design the supporting structure or foundation.

The design, fabrication, and construction of fabric structures require close coordination among the architect, engineer, fabricator, and installer throughout the process to ensure the strict quality control this technology requires. However, since most of the work is completed in the factory, minimizing on-site construction time, it is not unreasonable to maintain tight specifications.

**APPLICATIONS**

Applications for fabric structures include the semipermanent and temporary fabric-and-frame structures applied to agricultural, greenhouse, and storage uses. Improved materials have allowed use of these structures for waste treatment facilities, tennis courts, and pool facilities. More elaborate configurations, curved in plan and section, serve as outdoor concert halls, enclosed sports facilities, and atrium spaces for larger structures such as office buildings, medical facilities, shopping malls, and airports. Fabric structures are not a substitute for conventional construction, but their unique qualities enable them to perform certain building tasks very efficiently. In general, special performance requirements, such as the need for long spans or for natural lighting, encourage the use of this building system.

**ENVIRONMENTAL CONSIDERATIONS**

Under certain circumstances, a tensioned fabric structure can reduce energy consumption in a building. The natural light from the translucent surface reduces artificial lighting

requirements, the reflectivity of the skin reduces heat gain, and the radiation of waste heat from the warm fabric surface to a cool sky results in an energy-efficient building in warm climates. In cold climates, a second skin or liner is normally used, often with glass fiber insulation in the cavity to further reduce heat loss. These structures can be as energy-efficient as conventional buildings in many applications.

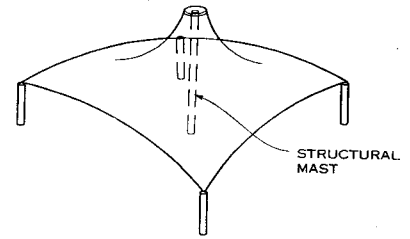

CONICAL-TYPE SURFACE GEOMETRY

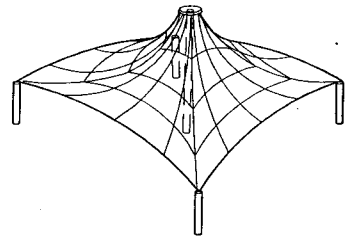

MEMBRANE MESH OVERLAY  
STRUCTURAL DESIGN PROCESS

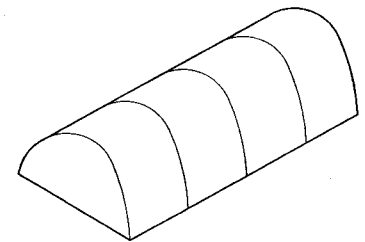

RIGID FRAME BARREL

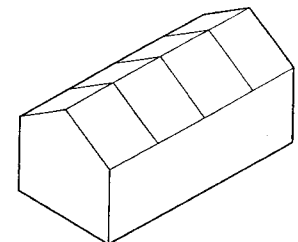

RIGID FRAME GABLE

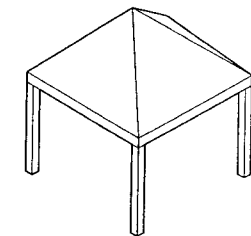

RIGID FRAME PYRAMID

**RIGID FRAME MEMBRANE STRUCTURES**

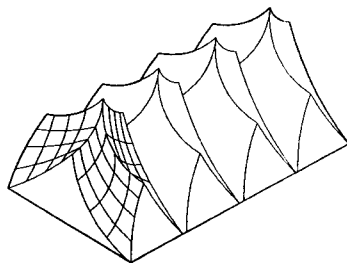

FOLDED PLATE TENSILE

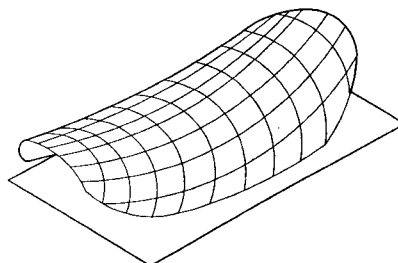

HYPERBOLIC PARABOLOID

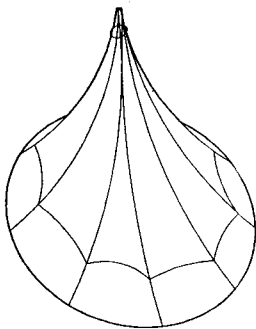

CONE-SHAPED TENSILE

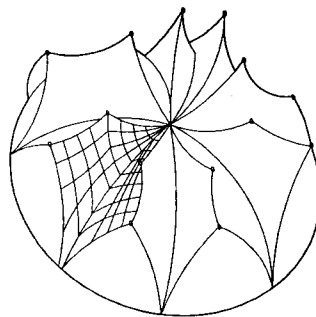

RADIAL FOLDED PLATE

**SELF-SUPPORTING MEMBRANE STRUCTURES**

Industrial Fabrics Association; Roseville, Minnesota  
Adapted with permission from *Architectural Fabric Structures: The Use of Tension Fabric Structures by Federal Agencies* (Washington: National Academy Press, 1985).  
Kathleen O'Meara; OM Architecture; Baltimore, Maryland

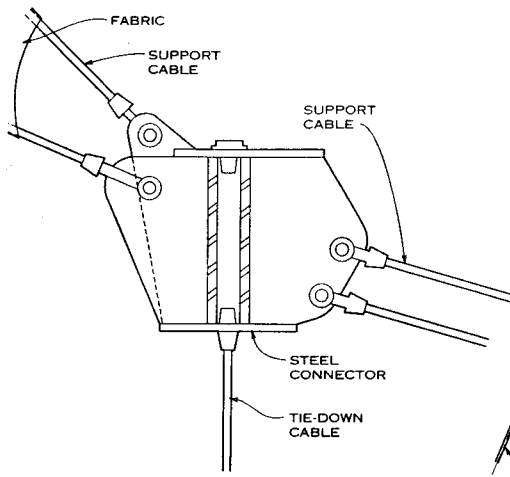

TIE-DOWN SECTION

FABRIC STRUCTURE ANCHORAGE DETAILS

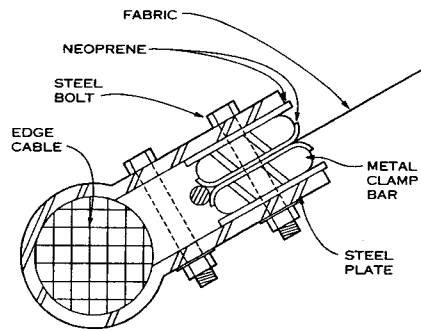

EDGE OR CATENARY CABLE ATTACHMENT DETAIL

RELATIVE FABRIC CHARACTERISTICS

FABRIC TYPE	STRENGTH	DIMENSIONAL STABILITY	FIRE RATING	DURABILITY	RESISTANCE TO SOILING	SOLAR TRANSMISSION	COST	TYPICAL USES	LIFE SPAN	REMARKS
PVC-coated polyester	5	3	3	3	3	2	4	Temporary to semipermanent	3-15 years	Large selection of products; top coatings are required for durability, can enhance appearance, and provide improved UV and fire resistance
PVC polyester scrim laminate	2	2	2	1	1	2	5	Temporary	1 year	Limited applications in architecture
PVC-coated fiberglass	4	4	4	3	3	2	3	Temporary to permanent	5-15 years	Limited availability; can be produced to order
PVC-coated Kevlar	5	3	3	3	2	2	2	Semipermanent	5-10 years	Kevlar has strength and durability but is UV sensitive; seams generally hand-sewn
PTFE-coated fiberglass	4	5	5	5	5	4	1	Permanent	25 years or more	Most durable material, now with a 25-year record of use
Silicon-coated fiberglass	3	5	5	4	2	5	2	Semipermanent to permanent	20 years	Seam strength has been a weakness
PTFE fiberglass laminate	3	5	5	5	4	5	1	Semipermanent to permanent	20 years	Relatively new material

Source: Geiger Engineers, Suffern, New York

NOTES

1. Relative comparisons are based on a scale from 0-5, with 0 a poor rating and 5 a very good one. The ratings are intended to provide a general relative comparison of the materials listed.

2. For the cost rating, the least expensive material has the highest rating.  
 3. All materials listed are composites. Generally, the material strength is provided by a scrim or woven textile that has been sealed and protected with a coating or film.

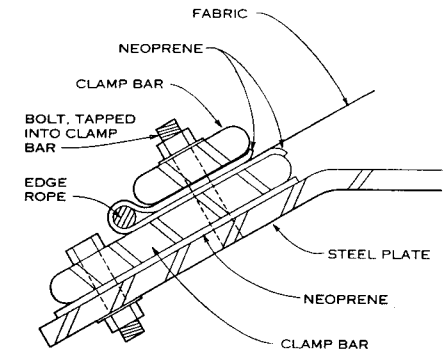

FABRIC EDGE CLAMP ATTACHMENT DETAIL

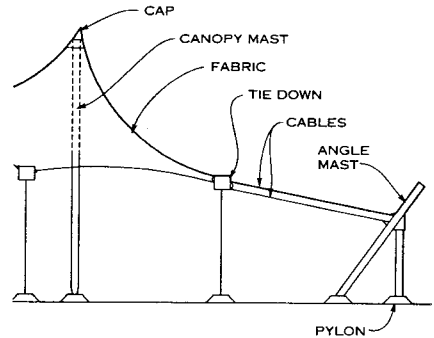

TYPICAL CONE-SHAPED TENSILE FABRIC STRUCTURE

GENERAL

The two primary ways of attaching fabric to anchorages are with edge catenary cables or clamps. Catenaries allow free-form design. When a tighter connection between fabric and building structure is required (e.g., on roofs, skylights, and air structures), a clamp system is used, in which the fabric is sandwiched between clamping bars or plates, which are bolted to the structure. Some membrane structures use both kinds of attachment. Air structures sometimes have sleeves and cables plus a fabric closure panel that extends beyond the cable.

Tensile structures usually are custom designed, and anchoring and connection details are customized also. However, basics, such as clamping systems, have become more standardized. Some frame and connection materials have been adapted from other industries, such as space frames and marine rigging. To determine the appropriate design aesthetic for a project, consider the following aspects:

1. Tensile structures are flexible, and the details must be designed to move under loads.
2. Tensile structures weigh a fraction of the amount of other buildings, and many of the materials are translucent.
3. Lateral forces play a much greater role in tensile structures than in conventional structures.

4. Make sure the physical resolution of each element's force vector (the angle of direction and magnitude) is accurate.
5. Details, material specifications, and reaction forces affecting interfacing structures should be developed with a consulting engineer or a design/build firm with the ability to design such structures.

David Campbell; Geiger Engineers; Suffern, New York



**BUILDING TYPES AND WIDTHS**

BUILDING TYPE (ROOF SLOPE)	TOTAL WIDTH (FT) ■ MOST COMMON ■ LIMITED AVAILABILITY																REMARKS			
	0	20	40	60	80	100	120	140	160	180	200	220	240	260	280	300		320	340	360
Small building or self-framing (1:12/1:48)		■	■																	
Tapered beam/straight columns (1:12/1:24)			■	■	■															
Rigid frame one-way slope (1:12/1:48)			■	■	■															With interior columns, width increases by: 1 col./100 ft; 2 col./120 ft; 3 col./160 ft; 4 col./200 ft
Rigid frame high profile (4:12)			■	■	■	■	■													
Rigid frame low profile (1:12/1:24)			■	■	■	■	■	■												
Beam and column with interior column (1:12)					■	■	■	■	■	■										
Beam and column with 2 interior columns (1:12)						■	■	■	■	■	■	■								
Beam and column with 3 interior columns (1:12)							■	■	■	■	■	■	■	■						
Rigid frame wing extensions (1:12/1:24/1:48)		■	■																	
Truss frame straight columns (1:12/3:24/5:24/1:48)			■	■	■															With interior columns width increases by: 1 col./120 ft; 2 col./180 ft; 3 col./200 ft

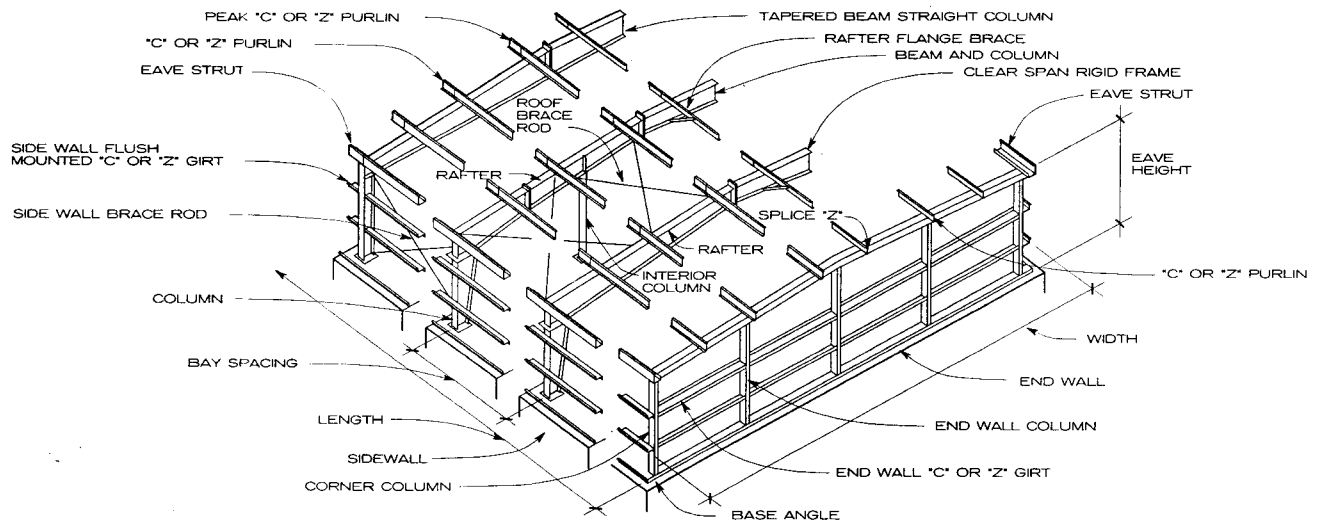

**FRAMING SYSTEMS COMPONENTS**

**DEFINITIONS**

Pre-engineered metal buildings are available in standard framing sizes and types from various manufacturers. The following definitions are those used by the metal building industry:

**BAY** refers to the dimension along a wall between the centerlines of wall columns and the dimension from the outside of an end wall corner column to the centerline of the first adjacent wall column. Spacings range from 18 to 30 ft, with 20 to 25 ft most common.

**WIDTH** is measured from the surface of the outside wall girts. Inside clearance varies.

**EAVE HEIGHT** is measured from the bottom of a wall column to the top of an eave strut. Nominal 2-ft increments vary from 10 to 30 ft.

**LOADS**, other than those provided by the manufacturer, should be specified during the structural design phase.

Future additional loads also should be considered. Roof live loads are those loads, including snow load, exerted on a roof except dead, wind, and lateral loads. Commonly available in 12, 20, or 40 psf. Dead load is the weight of all permanent roof framing and covering materials only and varies with the manufacturer.

**LATERAL LOADS** are dead loads other than the metal building framing, such as sprinklers, mechanical and electrical systems, and ceilings. They are commonly available in 15, 20, or 25 psf.

**WIND LOAD** is loading caused by the wind blowing from any horizontal direction. Site and atmospheric conditions needing special consideration should be specified.

**SEISMIC LOAD** is required for earthquake zones and must be specified for individual designs.

**AUXILIARY LOADS** are dynamic live loads other than basic design loads, such as cranes, materials handling systems, and impact loads.

**DIAGONAL BRACING** normally is required in the plane of the columns and beams in one or more bays to prevent racking and to resist lateral loading perpendicular to the span of the frames.

**GIRTS** are horizontal structural members that transmit lateral loads (pressure and suction) from the exterior walls to the columns. Sag rods may be needed to support the girts about the weak axis and to achieve design economy.

**ANCHOR BOLTS** are necessary to resist reactions at column bases. Foundations must be designed for reactions transmitted by the column bases and anchor bolts.

**NOTE**

The user should verify that individual manufacturer's standard practice and any special design considerations meet or exceed established engineering principles, local practice, and applicable building codes.

Robert P. Burns, AIA; Burns and Burns, Architects; Iowa City, Iowa

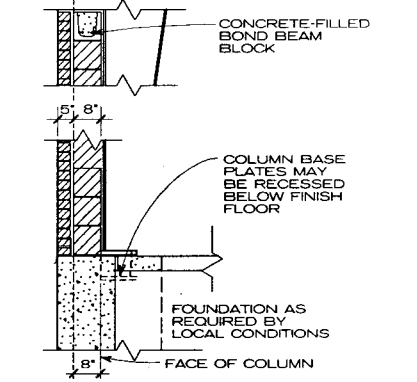
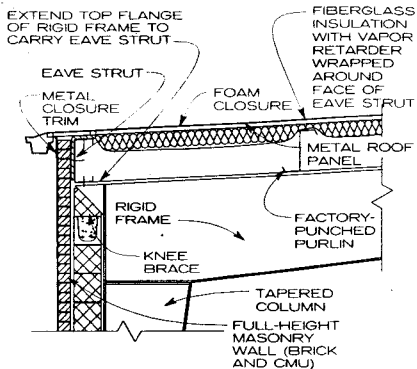

**MASONRY AND BRICK VENEER WALL SECTION**

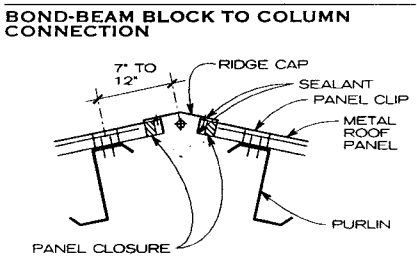
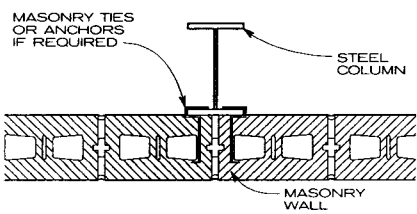

**RIDGE DETAIL**

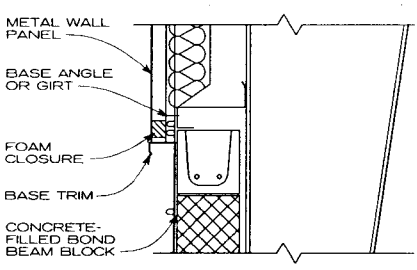

**MASONRY WALL AND METAL PANEL CONNECTION**

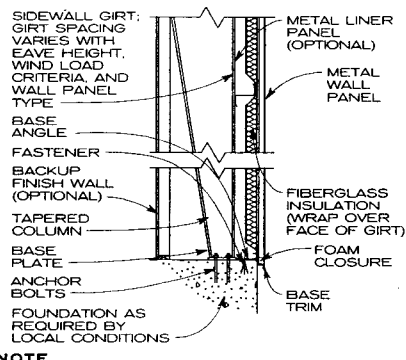
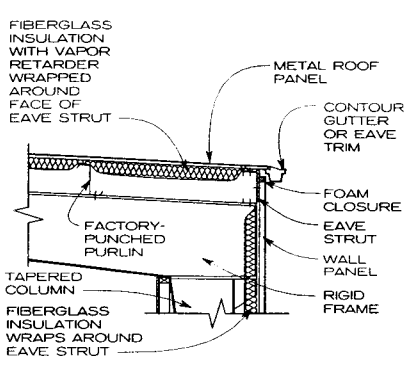

**NOTE**  
A sidewall girt may be inset between columns, attached by clip angles to the steel frame.

**METAL WALL PANEL SECTION**

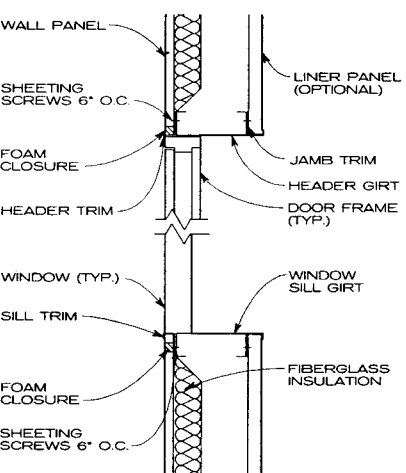

**DOOR/WINDOW HEAD AND SILL DETAIL**

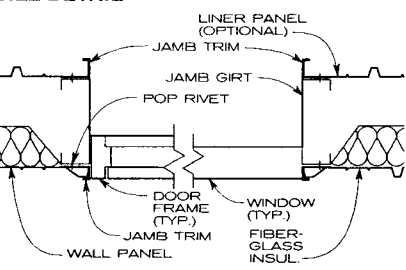

**DOOR/WINDOW JAMB DETAIL**

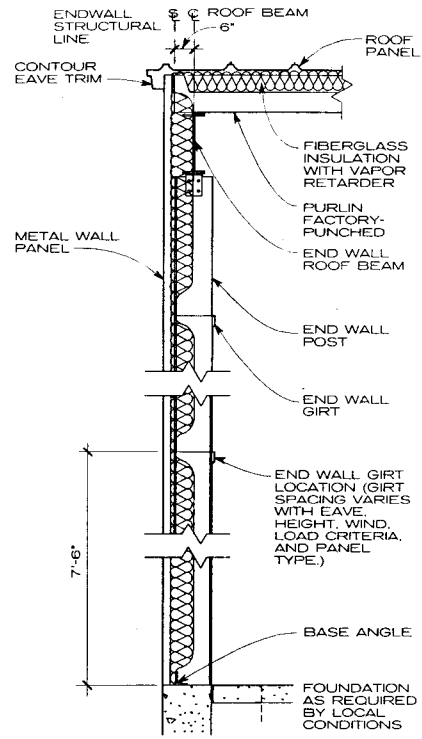

**NOTE**  
Column face is approximately 1 in. inside the structural line.

**END WALL CONDITION SECTION**

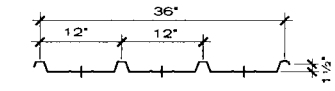

**EXPOSED FASTENERS**

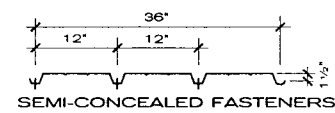

**SEMI-CONCEALED FASTENERS**

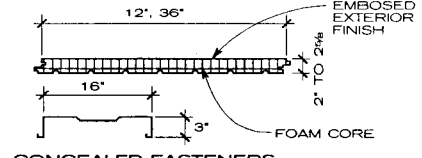

**CONCEALED FASTENERS**

**NOTE**  
Wall panels are installed vertically, in lengths, typically up to 40 ft. Finishes include painted metal with smooth or textured finish.

**WALL PANEL TYPES**

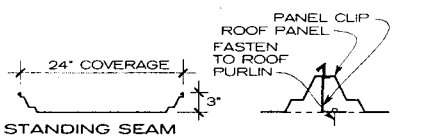

**STANDING SEAM**

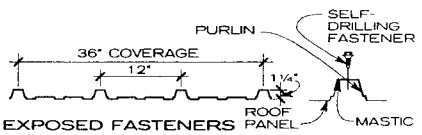

**EXPOSED FASTENERS**

**ROOF PANEL TYPES**

Robert P. Burns, AIA; Burns & Burns, Architects; Iowa City, Iowa

**OCCUPANCY SENSORS**

There are several types of occupancy sensors for turning lights on and off. They include ultrasonic, infrared, visible light, and audible sound sensors. The first two methods are by far the most prevalent. The infrared is a line-of-sight sensor, but will have some dead spots primarily at long distances from the sensor. The ultrasonic sensor has no dead spots, but is more sensitive to incidental air motion and may respond inappropriately. Either technique can be used in most applications; however, there are applications where the ultrasonic or the infrared occupancy sensor has a slight advantage.

Most occupancy sensor designs have controls that allow selection of a turnoff time and a means to set the sensor's sensitivity to motion. The placement of the sensor is important since it must cover the desired active area. Sensors are generally designed for placement in the ceiling, where there is a clear view of the area to be scanned. Recently simpler occupancy sensors have been designed to be wired directly into the wall switch. Care must be exercised since it is possible there may be many dead spots because the height of the sensor is about four feet off the floor and some active areas could be blocked by furniture.

Sensors are available that can scan an area from 200 sq ft up to about 4000 sq ft. The amount of energy they will save depends upon the amount of power they are controlling and the time of occupancy. Controlling small areas maximizes the time not in the space but controls little power; in controlling large areas, the occupancy time is increased while the controlled power is increased. It is important to have some knowledge of the occupancy time to determine the cost effectiveness of implementing this strategy. The best applications are spaces with limited occupancy such as lavatories, reproduction rooms, filing spaces, and storage spaces. They are also best used in spaces that are separated so that the on-off operation of the lamp does not disturb occupants in other spaces.

**PHOTOCELL PLACEMENT**

A key element in a successful daylight control system where there are visual tasks is the placement and calibration of the sensing photocell. The ideal position for the placement of the sensing photocell to maintain constant illuminance is on the task being performed. This poses two problems: interference with the task and communication with the lighting control system. Some systems have photocells that sense the illuminance outdoors. This approach is very difficult to calibrate because there is no information about the illuminance on the task. Most systems place the sensing photocell on the ceiling and view the task and the surrounding area. Thus, the information from the photocell can be easily interfaced with the lighting control to properly change the electric light levels. The photocell must also be shielded in such a manner as to block any direct daylight from the window. However, to maintain the specified illuminance on the task, the sensing system must be calibrated at night (no daylighting) and during the day with daylighting available. The reason for this is that the ratio of the electric light and daylight illuminance falling on the task is not the illuminance measured by the sensing photocell. The nighttime calibration (no daylight) is simple and the photocell output sets the light control to provide the specified illuminance. The second calibration is taken during the day, where the daylight on the task is not sufficient and requires an electric lighting contribution in order to provide the specified light level. The photocell output to the control is adjusted so that the electric lights provide sufficient light, supplementing the daylight to maintain the specified task illuminance.

The mechanics of the second calibration could be accomplished electronically with the proper computer software or with a two-cell photocell that independently senses either the electric lights or area surrounding the task. These techniques have been demonstrated and have been shown properly to maintain the specified illuminance on the task.

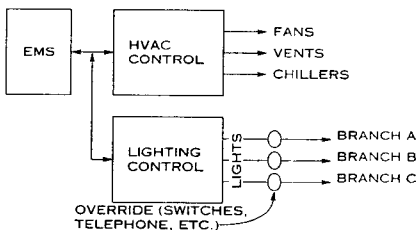

**COMPUTERIZED EMS FOR HVAC AND LIGHTING**

Rudolph R. Verderber; Lawrence Berkeley Laboratory; Berkeley, California

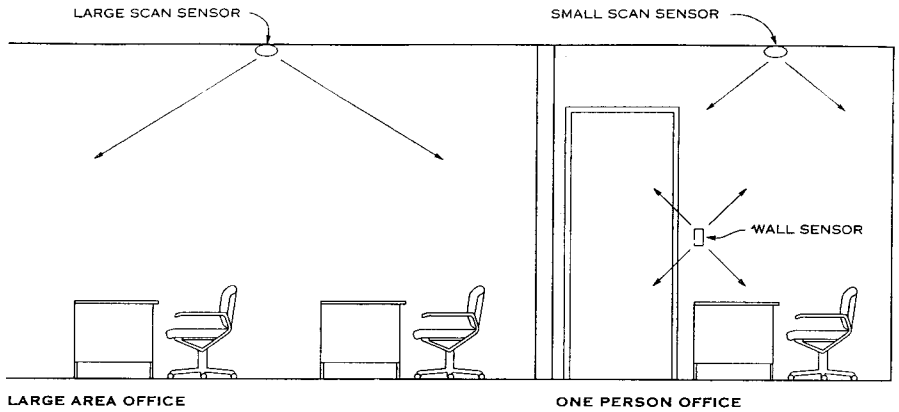

**OCCUPANCY SENSORS**

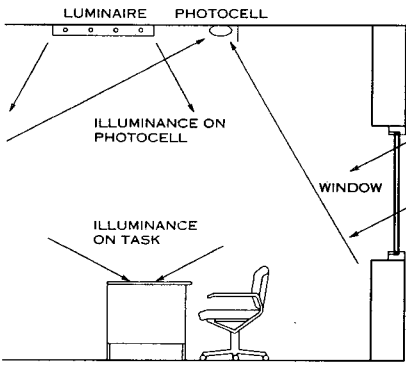

**PHOTOCELL PLACEMENT**

There are many applications (stores, shopping malls, atria, etc.) where there are no critical visual tasks. In these applications, the location of the photocell has many more options. In such applications the sensing photocell can be placed to view the outside as well as the interior space. The more important aspect is the ease of communication with the electrical lighting controls.

**COMPUTERIZED ENERGY MANAGEMENT AND CONTROL SYSTEMS**

Today virtually all new buildings incorporate an energy management system (EMS) that controls the HVAC system. Lighting control systems are being designed that will communicate with the EMS and can receive its commands. The simplest, least expensive technique is the use of relays to turn lights on and off at prescribed times based upon the normal working periods. Some states (e.g., California) require automatic lighting control that will at least turn off the lighting for all new construction. For buildings that have an EMS, retrofitting with lighting relay systems is a low cost, effective energy conservation strategy. The relay system can be installed in the electric closet to control branch circuits.

This scheduling technique can be more effective if the occupants must turn on their lights when they arrive at their workspace and the control automatically turns them off at the prescribed times, e.g., at lunch periods and in the evenings. This latter technique is particularly effective if the workforce has scattered starting times. In factories or disciplined offices where all staff is required to start at a particular time, turning on the lights automatically is suitable.

Buildings with automatic control of the lighting must have a suitable override system to accommodate occupants who must work during off hours. The override methods include telephone codes or conveniently located override switches.

The lighting scheduling strategy can also include reducing the light levels during the periods when the space is being maintained or cleaned. Most cleaning crews do not require the full light levels used by the occupants during the normal work periods.

**MULTILEVEL SWITCHING**

The effectiveness of the simplest low cost method of switching fluorescent lighting systems (relays) can be enhanced by proper wiring of the ballasts in the fixture. By wiring the ballasts to different control points, one can obtain three or four levels of illuminance. For example, in a four-lamp fixture with split wiring, one can obtain full, 1/2, and 0 light levels. Three-lamp fixtures or six-lamp fixtures can obtain full, 2/3, 1/3, and 0 light levels. This flexibility allows these systems to provide lower light levels over some spaces (aisles, storerooms, washrooms, etc.) that do not require full light levels. It enhances the savings for the scheduling strategy as it can reduce the light levels during cleaning periods since the cleaning operation usually does not require full light levels. Other lighting control strategies (lumen depreciation and daylighting) can also be considered. Although the latter two strategies are more energy efficient with continuous dimming controls, they are still cost effective, since the lighting control equipment cost will be less than the dimming control system. The multilevel systems can also address the state lighting codes that require fluorescent lamps to be operated at full and 1/2 illuminance levels.

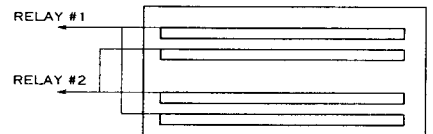

**FOUR-LAMP FIXTURE WITH TWO 2-LAMP BALLASTS**

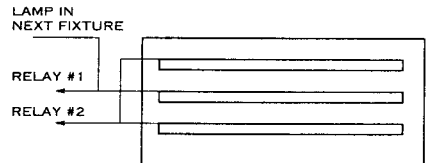

**THREE-LAMP FIXTURE WITH ONE 2-LAMP BALLAST AND ONE SHARED 2-LAMP BALLAST**

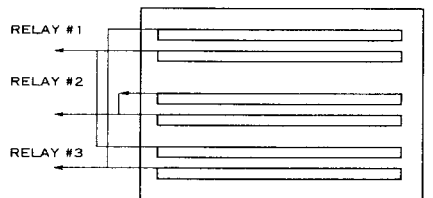

**SIX-LAMP FIXTURE WITH THREE 2-LAMP BALLASTS**

**MULTILEVEL SWITCHING**

**CONTINUOUS DIMMING LIGHTING CONTROLS**

Fluorescent lamps can be continuously dimmed with either standard magnetic ballasts or the new electronic ballasts. Lamps operated with magnetic ballasts are dimmed by conditioning the input power, i.e., the input voltage to the ballast is chopped, reducing the duty cycle. This technique requires switching devices that must control large power levels and is usually cost-effective when switching a large number of lamps. When fluorescent lamps are dimmed much below 50% of full light output, the filament voltage must be maintained at 3 to 4 volts in order to preserve the lamp life. When the duty cycle is reduced, the filament voltage is also reduced, which will accelerate lamp failure at the very low dimming levels, below 50% of full light output. Thus, techniques that condition input power have a practical dimming range. The fact that this technique is only cost-effective when controlling many lamps limits applications to control strategies that demand independent control of small areas, such as tuning and most daylighting strategies.

Electronic dimming ballasts dim fluorescent lamps by limiting the lamp current by a low voltage signal to the ballast's output circuit. The electronic ballasts have feedback circuits that permit the filament voltage to maintain the proper voltage at the very low dimming levels, down to 10% of full light output. Thus, the specified life of fluorescent lamps is still maintained when operated in the dimming mode at very low light levels. The low voltage method of communication allows the control of either large or small areas independent of the electrical power distribution, i.e., the branch circuits. The system efficacy is slightly reduced at the lower light levels since full filament voltage must be maintained; however, the energy use is always reduced. Dimming fluorescent lamps with electronic ballasts permits the effective application of all the lighting control strategies. Since the lamps can be safely dimmed over a wider range, the percentage of energy savings for each lighting control strategy will be maximized. There are additional savings because the electronic lamp-ballast system is more efficacious than the magnetic lamp-ballast systems.

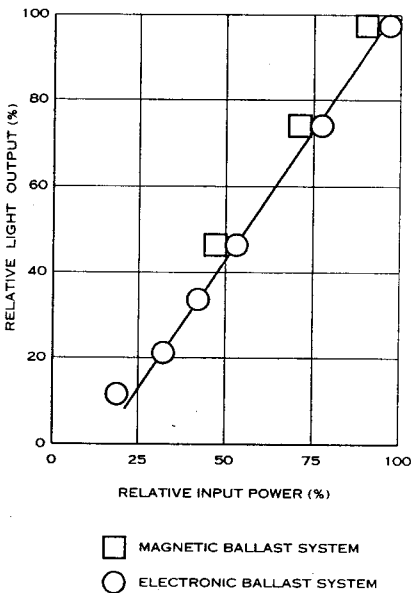

LAMP IN OPEN AIR

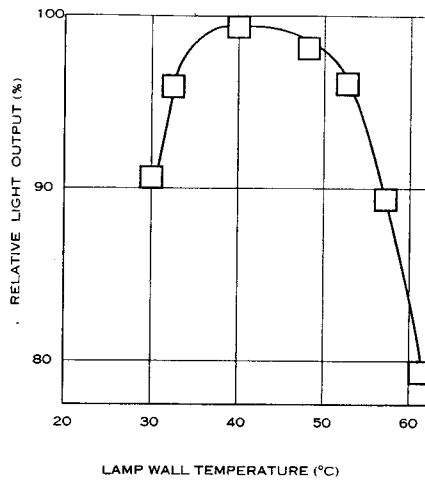

LAMP IN FIXTURE

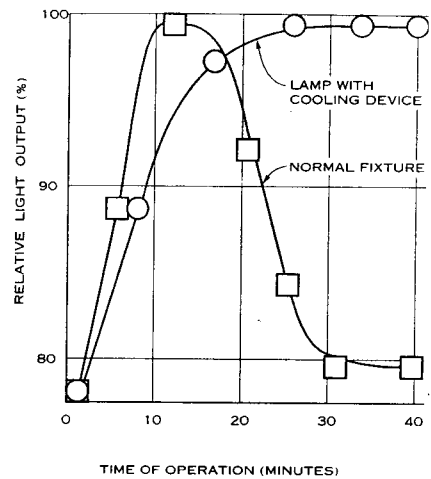

**LAMP LIGHT OUTPUT VS. TEMPERATURE IN CONTROLLED AND UNCONTROLLED FIXTURES**

**ENERGY SAVINGS WITH LIGHTING CONTROLS**

Lighting controls are used to provide the proper illumination in accordance with the activity in a space. In addition to improving the quality of the illuminance, considerable energy reduction can be achieved. The amount of energy reduction depends upon the number of control strategies that can be conducted, which depends upon the sophistication of the lighting control equipment. The control strategies include scheduling, tuning, lumen depreciation, and daylighting. Lighting controls also permit load shedding, which is effective in reducing utility demand charges.

Controlling lights with relays limits one to scheduling, turning lights on in the morning and off at night. For some special applications, such as malls and airports, where there is abundant daylighting, relay controls can be effectively employed. Some controls permit the dimming of magnetic ballasts by conditioning the input power. With this method, controlling large banks of luminaires is best considered. Dimming techniques that control large areas limit the strategies to scheduling, lumen depreciation, and simple daylighting applications, that is, where large areas of the space have similar daylighting patterns. The newly introduced dimming electronic ballast systems can perform all of the lighting control strategies. These systems can dim fluorescent lamps over a greater range without any loss in lamp life. It is also economically feasible to dim small areas as well as large areas, i.e., a small number of luminaires. This is because the low voltage control wiring can control lamps independently of the electrical distribution. This allows independent control of daylighted spaces where visual tasks are essential and the daylight distribution is not uniform. These spaces are generally found in offices where there is a great variety of important visual tasks performed during the day.

There have been several lighting control demonstrations that have measured the energy savings for each control strategy. The savings for each technique depends upon the architecture, the operation of space, the type of lamp-ballast system, and the lighting control equipment.

**THERMAL CONTROL OF FLUORESCENT LAMPS**

The light output from fluorescent lamps is very sensitive to lamp wall temperature and is 10 to 20% below maximum lumen output in most fixtures. There are fixtures available and new techniques being developed that can cool the lamp wall temperature to optimize both the lumen output and the efficiency. There are air handling fixtures in which the return air from the room flows over the lamps, cooling them to near the desired 40°C temperature. New techniques are being developed to employ slots for convective cooling and thermal bridges to obtain reduced lamp wall temperatures.

Of particular interest are many compact fluorescent lamp fixtures in which the internal fixture temperature is sufficiently high that, in addition to the reduction in lumen output and efficiency, there can be premature lamp and/or ballast failures.

By the use of the cooling techniques, full light output can be attained, not only increasing efficiency (reducing operating costs) but also reducing initial and maintenance costs since fewer fixtures (lamps and ballasts) will be required to provide the prescribed light levels.

**VENETIAN BLIND CONTROL FOR DAYLIGHTING**

Daylighting is most visually effective for a diffuse sky. This condition is generally for the north facing windows. Direct sunlight provides the highest luminance levels, but is usually too high and uncomfortable due to excessive glare. In fact, the discomfort glare may invoke an occupant to perceive the need for higher electric light levels. To effectively take advantage of daylight in the east, west, and south facing spaces, window treatments are needed. Venetian blinds are available that can block or divert the direct sunlight to reduce its glare. Venetian blinds are available that are either manual or automatic. The automatic systems are controlled by responding to a photocell that senses the direction of the sunlight.

The area controlled by either automatic or manual venetian blinds should be coordinated with the electric light control in the same area. This usually requires independent daylight control of relatively small areas. For example, if one designs a system where one photocell controls a large area, occupants may operate the manual blinds in their spaces differently, which will cause the photocell to sense the daylighting from only one area. This could result in one area meeting the specified light levels while other areas are seriously under-illuminated. This illustrates why the daylighting strategy is best applied with lighting control systems that control relatively small areas. There are unique architectural designs that have excellent symmetry with respect to the sun direction that have good results with control systems for relatively large areas. This requires integration of the internal space (usually open floor plans) with the proper positioning of the building with the north, east, south, and west directions.

**PRACTICAL CONTINUOUS DIMMING RANGES**

**RANGES OF ENERGY SAVINGS WITH LIGHTING CONTROLS**

	SCHEDULING	TUNING	LUMEN DEPRECIATION	DAYLIGHTING <sup>1</sup>
Relays	10 to 30%	NA	NA	15 to 25%
Magnetic ballasts <sup>2</sup>	30 to 40%	NA	6 to 10%	20 to 27%
Electronic ballasts <sup>2</sup>	17 to 50%	25%	8 to 12%	25 to 50%

**NOTES**

1. Energy savings in the daylight area only.
2. Continuous dimming systems.

Rudolph R. Verderber; Lawrence Berkeley Laboratory; Berkeley, California

**GENERAL**

The simplest fire alarm system is a self-contained, UL approved residential smoke detector. It senses products of combustion, sounds an alarm, and signals when the battery needs replacement. Most municipalities require the use of smoke detectors in houses, apartments, and motel/hotel rooms. Check local codes for requirements.

More complex systems are needed in buildings where public safety is an issue, such as schools, hospitals, office buildings, and other commercial establishments or institutions. Although there are still applications for small hard-wired and relay-operated alarm signaling systems, the trend is to use microprocessor-based digital multiplex systems that not only signal the presence of a fire but also initiate other measures, including conditioning fans and dampers, for smoke control, closing fire doors and shutters, releasing locked doors, capturing elevators, and transmitting voice messages. Voice communication is required in high-rise buildings of specific group occupancies as defined by the BOCA code. It is also recommended for large low-rise buildings to enhance life safety.

Fire alarm systems can either function alone or be integrated with security and building management functions. Processors and their peripheral equipment are generally located in a manned central command center accessible to firemen. Depending on the degree of reliability desired, redundancy can be provided in wiring and processors, along with battery backup.

Alarm system control cabinets can be 36 in. wide x 8 in. deep. They must have battery backup, be UL approved, conform to NFPA no. 72, and may also require local approval. In small systems where only one cabinet may be required, all the functions required at the command center can be incorporated in the same cabinet and located in the main entrance lobby. In larger systems, remote cabinets are generally located in wiring closets throughout the building and can be programmed to function independently of the central processor, should it fail.

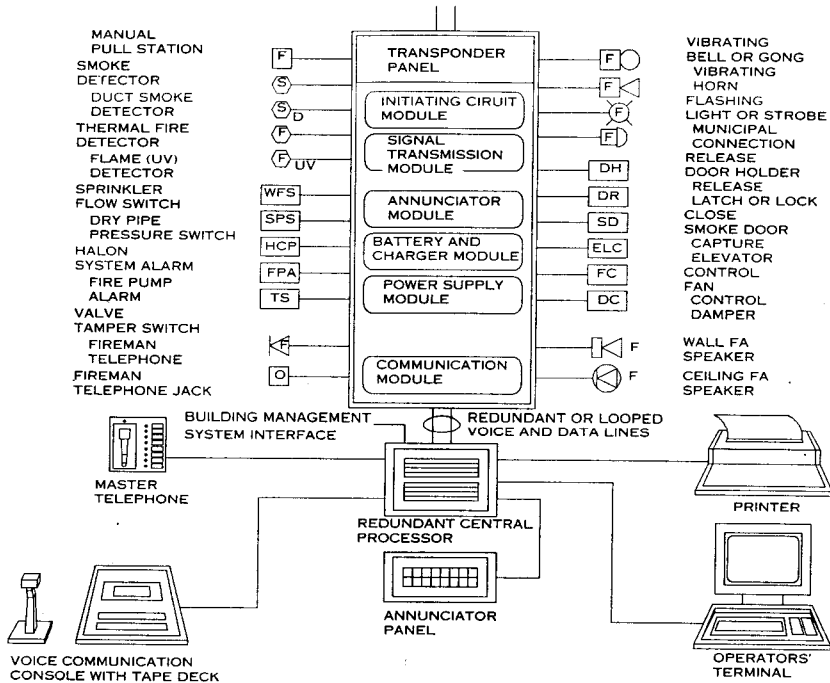

**ELECTRONIC FIRE ALARM/COMMUNICATION SYSTEM FUNCTION DIAGRAM**

**SIGNALING SYSTEM TYPES**

- NONCODED: Evacuation signal sounds continuously.
- MASTER CODED: Signal repeats four rounds.
- SELECTIVE CODED: Same as "master coded" except individual and assigned number code of up to three groups per round.
- PRESIGNAL: Same as "selective coded" except signals sound only at selected areas to prompt investigation. If hazard is determined, evacuation signal is initiated by key.
- VOICE: Direct (by microphone) or automatic prerecorded messages are transmitted over speakers, following an "alert" signal.

**AUDIBLE ALARMS**

Audible alarms must have an intensity and frequency that attract the attention of those with partial hearing loss. Such alarms should produce a sound that exceeds the prevailing sound level in the space by at least 15 dbA or exceeds maximum sound level with a duration of 60 seconds by 5 dbA, whichever is louder. Sound levels should not exceed 120 dbA.

**VISUAL ALARMS**

Visual alarm signals should be integrated into the building alarm system. Alarm stations should give both audible and visual signals. Visual alarm signals should have the following characteristics:

1. Lamp: xenon strobe type or equivalent.
2. Lamp color: clear or nominal white (i.e., unfiltered or clear filtered white light).
3. Maximum pulse duration: 0.2 sec with a maximum duty cycle of 40%. The pulse duration is defined as the time interval between initial and final points of 10% of maximum signal.
4. Intensity: 75 candela minimum.
5. Flash rate: 1 Hz min., 3 Hz max.
6. Place the alarm 80 in. above the highest floor level within the space or 6 in. below the ceiling, whichever is lower.
7. In any space required to have a visual alarm, generally all areas must be within 50 ft of the signal (measured horizontally). In large spaces, such as auditoriums, exceeding 100 ft across, with no obstructions over 6 ft high, devices may be placed around the perimeter, spaced a maximum of 100 ft apart, in lieu of suspending devices from the ceiling.

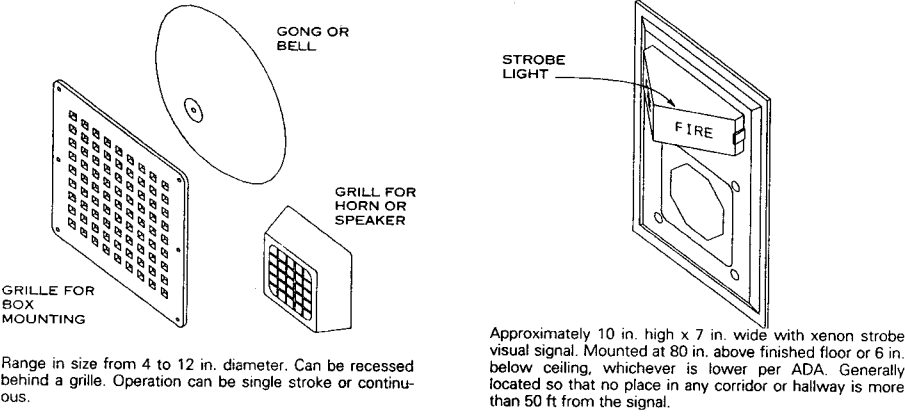

**BELL AND COVER**

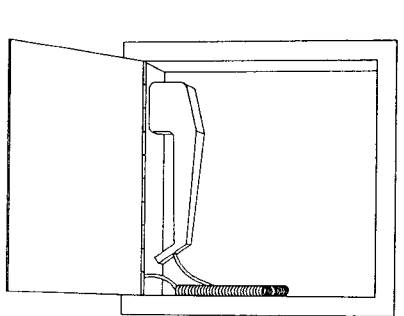

Approximately 12 in. high x 10 in. wide x 3 in. deep, surface or flush. Provided in lieu of jack plates for a total system. Door can be glass or plastic pane.

**FIREMAN TELEPHONE CABINET**

**HORN/SPEAKER/VISUAL SIGNAL**

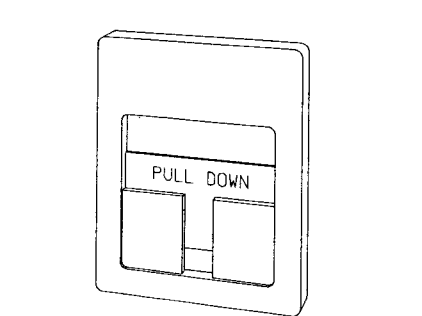

Approximately 7 in. high x 5 in. wide surface or semi-recessed mounted. Mounted 54 in. above finished floor to lever per ADA. Can be provided with break glass rod feature. Operation can be coded or noncoded.

Richard F. Humenn; PE; Joseph R. Loring & Associates, Consulting Engineers; New York, New York  
JRS Architect; Mineola, New York

**GENERAL**

The purpose of a fire suppression system is to extinguish or mitigate the effects of a fire. Selection of the extinguishing medium most appropriate for a project is based on availability, compatibility, cost, and code requirements.

**CODES AND STANDARDS**

Most model, state, and local codes have a separate fire protection section that mandates certain types of fire suppression systems based on occupancy types, potential fire hazards, height, and area of the structure. Insurance companies, such as Factory Mutual, American Risk Insurers, and American Risk Management, have developed design standards to be followed by the clients they insure. In addition, the National Fire Protection Association (NFPA) has developed consensus standards for various suppression systems that are referenced and required to be followed by most codes.

It is important that an adequate code search be made before the design phase of any project to ensure that the proper codes are complied with.

**BASIC DEFINITIONS**

Although the exact nature of fire and the combustion process is still not completely understood, it is known that three things are necessary for a fire to be maintained: fuel, oxygen, and a temperature high enough to start ignition or maintain combustion. All fire extinguishing methods remove one or all of these elements, causing the fire to be extinguished.

Fires are classified as class A, B, C, or D:

**CLASS A** fires occur in solid, combustible materials such as wood and paper.

**CLASS B** fires occur in combustible liquids such as oil and gasoline.

**CLASS C** fires are electrical in nature, such as a short circuit that causes a spark capable of igniting other substances.

**CLASS D** fires occur in metals with their own fuel supply.

Building occupancy and other, specific areas within a building are classified as light, ordinary, or extra hazard, according to the potential for fire. Light hazard occurs in office buildings, schools, and public buildings. Ordinary hazard is similar to warehouses and stores with large amounts of combustible material. Extra hazard occurs where there is considerable potential for easily started, large fires. These classifications are more fully explained in the applicable NFPA standards.

The term "automatic" is often used when referring to fire suppression systems. In this context, automatic means operation of the system without human intervention when fire conditions occur.

**SYSTEM TYPES**

Three general types of systems are used for suppression of fires: water-based, chemical-based (either liquid or powder), and gas-based.

**WATER-BASED SYSTEMS** use either water mixed with chemicals that add fire-extinguishing characteristics or undiluted water to cool the fire below ignition temperature or deprive it of oxygen.

**CHEMICAL-BASED SYSTEMS** interfere with the combustion process and deprive the fire of oxygen.

**GAS-BASED SYSTEMS** interfere with the combustion process and deprive the fire of oxygen.

**WATER-BASED SYSTEMS**

The medium most often used to extinguish fires is water. It is readily available, inexpensive, and easy to apply. The most important factor in the use of water-based systems is adequate water pressure. When pressure from the building water supply is inadequate to supply fire standpipe and sprinkler systems, a special fire pump, manufactured and installed specifically for fire suppression systems, is used to increase water pressure. The fire pump is installed in strict conformance with NFPA-20.

Fire standpipe, foam, and sprinkler systems are described on the second AGS page on Fire Suppression Systems.

**GAS-BASED SYSTEMS**

Some gas-based systems use inert gases, and others use chemical gases.

**INERT GASES**

These systems are used when chemicals that may react to water are present or when water will cause unacceptable damage. The gases (generally carbon dioxide or nitrogen) are discharged either directly onto a fire or used to reduce the oxygen level in a room or area to a point below that required to sustain combustion. (Note, however, that this low level also will not sustain life.)

The gas is stored compressed in high pressure cylinders or tanks and is connected to a piping system with open heads. A quick opening valve at the storage location detects heat, fire, or smoke at the hazard being protected, then opens to allow gas to enter the piping system and discharge out all the heads.

**OTHER GASES (HALON ALTERNATIVES)**

Chemical gases interfere with the combustion process, and chemical gas systems are often used to protect computer and electronic equipment and areas. The systems operate in the same way as inert gas systems, but a lower concentration of gas is usually required. Halon is no longer permitted because of environmental concerns. Many halon alternatives are available, but their use must be approved by authorities having jurisdiction.

Because of the force exerted by the discharging gas, hung ceilings should be reinforced in areas where heads are located and the heads mounted so they can resist the force of discharge.

**CHEMICAL SYSTEMS**

Both wet and dry chemical systems require extensive cleanup after a fire has been extinguished.

**DRY CHEMICALS**

This system is used to protect areas for which water is not a suitable extinguishing medium, such as chemical storage areas and cooking areas with exhaust ductwork that vents grease. A powdered chemical is stored in high-pressure cylinders or tanks connected to a piping system with open heads. Upon detecting heat, fire, or smoke at the hazard being protected, a quick opening valve at the storage location opens, allowing the powder to enter the piping system and discharge from all of the heads simultaneously.

**WET CHEMICALS**

The recent shift from animal fats to vegetable fats for cooking required a different medium for fighting fires in kitchens. This medium is a wet chemical, which operates in the same manner as the dry chemical system.

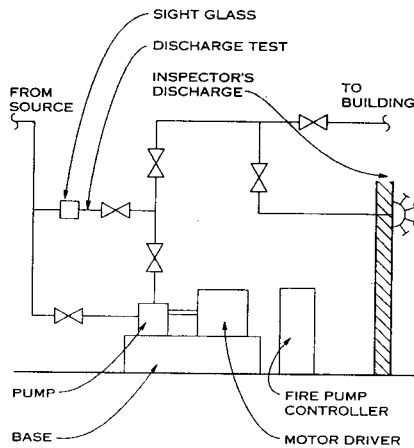

**TYPICAL FIRE PUMP SCHEMATIC**

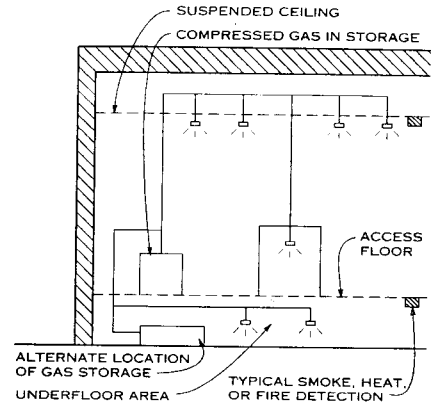

**TYPICAL GAS SYSTEM**

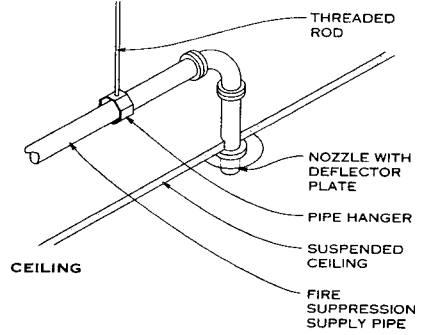

**RAISED FLOOR SYSTEM**

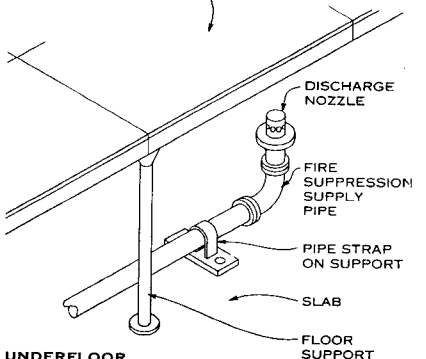

**TYPICAL GAS DISCHARGE NOZZLES**

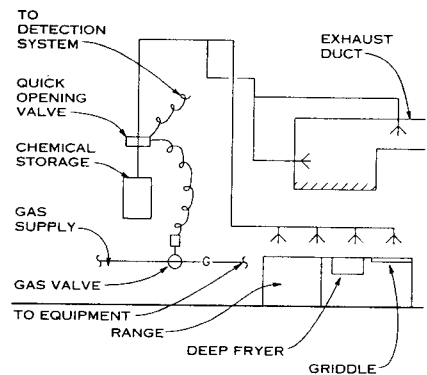

**DRY OR WET CHEMICAL SYSTEM FOR KITCHENS**

Michael Frankel, CIPE; Utility Systems Consultants; Somerset, New Jersey

**WATER-BASED SYSTEMS**

Three types of water-based fire suppression systems are detailed on this page: fire standpipe, foam, and sprinkler. Other system types are discussed on the other AGS fire suppression page.

**FIRE STANDPIPE (FSP)**

A fire standpipe system is a network of water-filled pipes, hose valves, and fire hose that allows the direct application of water onto a fire. The most common system configuration has hose valves only, which are connected to system piping to allow fire department personnel to connect their hose to the system. Mains are installed in high fire-rated areas such as stairwells. Hose valves are located so that all parts of the building can be reached with a 100-ft length of hose and a 20-ft water stream from the hose nozzle.

It is accepted practice to supply sprinkler heads from FSP mains in various areas throughout a building. Each connection point is provided with a flow alarm. A test connection is installed at each point to permit authorities to visually verify that the water discharged from one sprinkler head is actually flowing and will initiate an alarm. This test connection is combined with a drain line to permit the entire branch to be drained for maintenance and repair.

**FOAM**

A foam system consists of a water supply, chemical additive injector, piping, and heads placed to discharge foam. The system uses an additive injected into the water supply to produce a soapsuds-like discharge. This system is used to extinguish fires in flammable liquids that are lighter than water. The foam floats on top of the liquid and deprives the fire of oxygen.

**SPRINKLER SYSTEMS**

A sprinkler system uses water distributed through a network of valves, piping, and nozzles whose primary purpose is to set off an alarm and mitigate the effects of a fire, not necessarily to extinguish it. When a fire condition is present, the heat of the fire melts the element of a closed sprinkler head, allowing water to discharge automatically onto the fire.

The sprinkler piping system is sized using one of two methods, schedule or hydraulic. The schedule method uses pipe sizes based on a minimum available water pressure and the number of heads connected to the piping that appears in NFPA-13. The hydraulic method uses a remote area (that farthest from the water supply source) based on occupancy type, flow of water over the remote area, flow of water at each design point, and pressure available in the system.

**MAJOR SYSTEM COMPONENTS**

The major operating components of a sprinkler system are the operating valve assembly, piping, and nozzles (referred to as heads for some systems).

The operating valve assembly admits water to or sends an alarm upon the flow of water in the system. There are many types of operating valves, and the type of system installed determines the type of valve used.

Heads or nozzles distribute water in a special, predetermined pattern based on the requirements of the system. They are available in a wide variety of configurations, including upright, pendant, or sidewall, and can be closed or open. They have different temperature ratings to open the head, various orifice diameters for the discharge of water, standard or quick response, and standard or extended coverage. They can be installed in a hung ceiling as concealed, flush, or exposed fixtures.

**SPRINKLER SYSTEM TYPES**

**WET PIPE:** This automatic system uses piping filled with water under pressure and closed heads. The operating valve assembly, called an "alarm check valve," initiates an alarm when water flows and prevents the reverse flow of water into the building service if the system is supplied with water from a fire department connection. When a fire condition exists, the heat melts (fuses) a temperature-sensitive element in the head, causing the head to open and water to flow.

**DRY PIPE:** This automatic system uses piping filled with air under pressure and closed heads. The operating valve assembly is called a "dry pipe valve." An air compressor is required to make up air lost through leakage. Both water and compressed air are supplied only to the dry pipe valve. When a head fuses due to a fire condition, it lowers the air pressure, opens the valve, and permits water to enter the piping; the water then flows only from the open heads.

**PREACTION:** This automatic system uses closed heads and piping filled with air under atmospheric pressure. Water is supplied to the operating valve assembly, called a "preaction valve." An ancillary smoke or fire detection system initiates a signal upon detection of heat, fire, or smoke. The signal causes the preaction valve to enter the piping system. Water will not flow out of the heads unless they fuse due to a fire condition.

**DELUGE:** Used to protect high hazard areas and specific equipment, this automatic system uses piping filled with air under atmospheric pressure and open heads. Water is supplied to the operating valve assembly, called a "deluge valve." An ancillary smoke or fire detection system is required to initiate a signal upon detection of heat, fire, or smoke at the hazard being protected. This signal will open the deluge valve, admitting water throughout the piping system and allowing water to discharge out of all the heads connected to the piping network.

**ANTIFREEZE:** A wet pipe automatic system is filled with an antifreeze solution instead of water to protect areas subject to freezing but too small for a dry pipe system. Operations are similar to those of the standard wet pipe system.

**WATER MIST:** This automatic system uses high pressure water flowing through nozzles designed to discharge very small droplets of water directly onto a fire. A water pump is required to produce the high system pressure. Water is supplied to the pump, which is activated by ancillary heat, fire, or smoke detectors adjacent to the hazard protected.

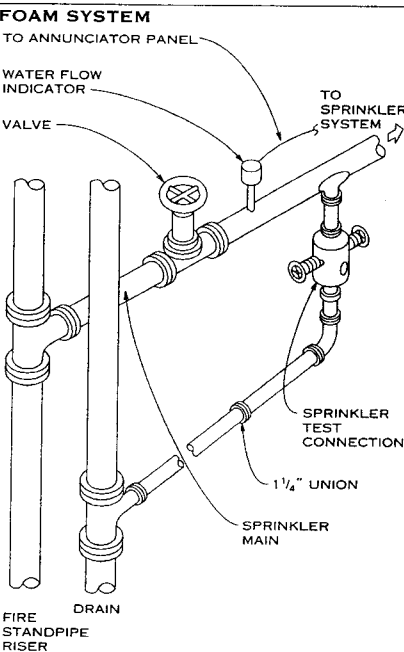
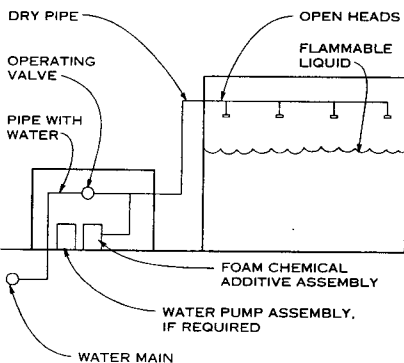

**TYPICAL SPRINKLER CONNECTION**

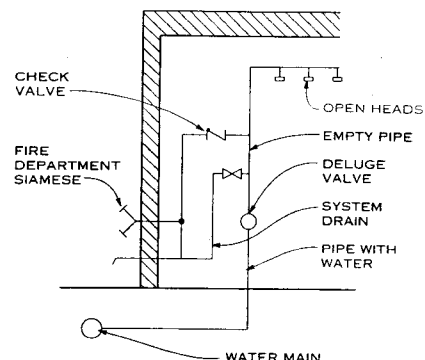

**DELUGE SYSTEM**

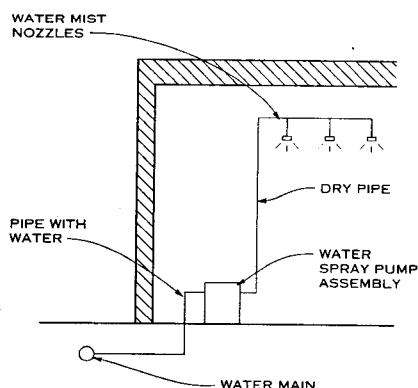

**WATER MIST SYSTEM**

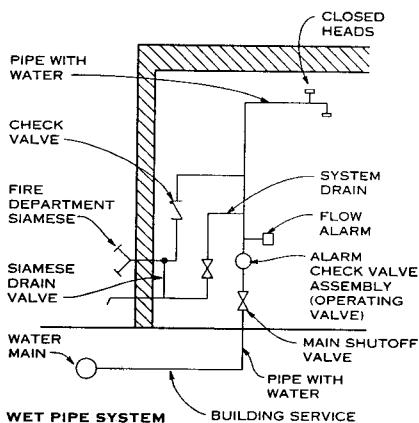

**WET PIPE SYSTEM**

**SPRINKLER SYSTEM TYPES**

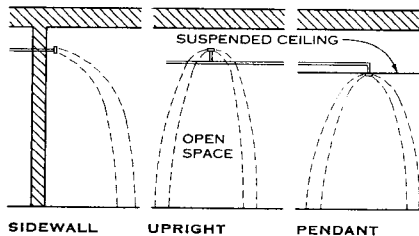

**NOTE**  
Coverage varies with mounting height and water pressure.  
**TYPICAL SPRINKLER HEAD PATTERNS**

Michael Frankel, CIFE; Utility Systems Consultants; Somerset, New Jersey

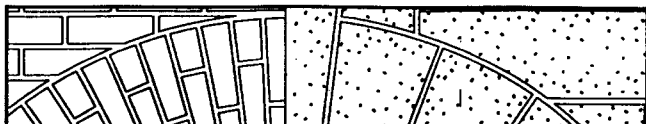

# CONVEYING SYSTEMS

Elevators 666

Escalators and Moving Walks 672

Material Handling 673



**GENERAL**

An elevator system is a major building component and as such must be carefully considered throughout the design process. Decisions about the number, size, speed, and type of elevators for an installation are based on a number of factors, including the handling capacity and quality of service desired. Proper selection also depends on the type of tenancy, number of occupants, and building design (number of floors, floor heights, building circulation, and other factors). In addition, passenger elevators on accessible routes should comply with the requirements of the Americans with Disabilities Act Accessibility Guidelines (ADAAG).

Consult representatives of the elevator industry or elevator engineers during the decision-making process to ensure selection of the most suitable elevator system for an application. Because elevator installation is highly regulated, it is advisable to consult local code officials.

Elevators should be located where they can provide efficient, easily reached service. As well, the operational systems (hoistway pit and machine room) and passenger spaces (lobby and elevator car) must be accommodated.

**ELEVATOR SYSTEMS**

An elevator system includes a hoistway, machine room, elevator car, and waiting lobbies.

**HOISTWAY**

The hoistway is a vertical shaft for the travel of one or more elevators. It includes a pit and usually terminates at the underside of the machine room in a traction system and at the underside of the roof over the hoistway in a hydraulic system. Access to the elevator car and hoistway is normally through hoistway doors at each floor serviced by the elevator system. Hoistway design is determined by the characteristics of the elevator system selected and by applicable code requirements for fire separation, ventilation, soundproofing, and nonstructural elements.

**MACHINE ROOM FOR TRACTION ELEVATOR**

The machine room for a traction elevator is usually located directly above the hoistway but could also be situated below, to the side, or to the rear of it. The machine room contains elevator hoisting machinery and electronic control equipment. Adequate ventilation, soundproofing, and structural support for the elevator must be supplied. Also, the machine room must have a self-closing, self-locking access door. Local codes may forbid placement of electrical or mechanical equipment not associated with the elevator in the machine room.

**MACHINE ROOM FOR HYDRAULIC ELEVATOR**

Normally located near the base of the hoistway, a machine room for hydraulic elevators contains a hydraulic pump unit

and electronic controls. Provisions should be made for adequate ventilation and soundproofing, and the room must have a self-closing, self-locking access door. Local codes may forbid placement of electrical or mechanical equipment not associated with the elevator in the machine room.

**ELEVATOR CAR**

Guided by vertical rails on each side, the elevator car conveys passengers or freight between floors. It is constructed within a supporting platform and frame. Design of the car focuses on ceiling, wall, floor, and door finishes and accompanying lighting, ventilation, and elevator signal equipment.

The car and frame of a hydraulic elevator system are supported by a piston or cylinder.

The car and frame of a traction elevator system are supported by the hoist machine. The elevator and its counterweight are connected with steel ropes.

**LOBBIES**

Elevator waiting areas are designed to allow free circulation of passengers, rapid access to elevator cars, and clearly visible elevator signals. All elevator lobbies must be enclosed with the exception of that at the entry level of the main building.

**ELEVATOR TYPES**

**HYDRAULIC ELEVATORS** use an oil hydraulic driving machine to raise and lower the elevator car and its load. Lower speeds and the piston length restrict the use of this system to heights of approximately 55 ft. Although it generally requires the least initial installation expense, this elevator type requires more power to operate.

**TRACTION ELEVATORS** are power elevators in which the energy is applied by means of an electric driving machine. Medium to high speeds and virtually limitless rise allow this elevator type to serve high-rise, medium-rise, and low-rise buildings.

**GEARED TRACTION ELEVATOR SYSTEMS** are designed to operate within the range of 100 to 450 ft/min, restricting their use to medium-rise buildings.

**GEARLESS TRACTION ELEVATOR SYSTEMS** are available in preengineered units with speeds of 500 to 1200 ft/min. They offer the advantages of a long life and a smooth ride.

**SERVICE ELEVATORS** in industrial, residential, and commercial buildings are often standard passenger elevator packages modified for service use.

**FREIGHT ELEVATORS** are usually classed as general freight loading, motor vehicle loading, industrial truck, or concentrated loading elevators. General freight loading elevators may be electric drum type or traction or hydraulic elevators.

**PRIVATE RESIDENTIAL ELEVATORS** may be installed only in a private residence or to serve a single unit in a building with multiple dwelling units. By code, elevators in private residences are limited in size, capacity, rise, and speed.

**BUILDING CHARACTERISTICS**

Physical building characteristics (such as building height and hoistway location) are considered with population characteristics to determine the size, speed, type, and location of elevator systems. Characteristics that particularly affect the elevator systems are

1. Height: Determine the distance of elevator travel from lowest terminal to top terminal, the number of floors, and the floor height.
2. Building use: Identify the location of heavily used building entrance areas, such as those leading to cafeterias, restaurants, auditoriums, and service areas. Typically, plan a building so that no prospective passengers must walk more than 200 ft to reach an elevator.

The elevator selection process must begin with a thorough analysis of how people will occupy the building. Four issues are pertinent:

1. Total population and density: Determine this figure for each floor.
2. Peak loading: Identify the periods when elevators will carry the highest traffic loads.
3. Waiting time: This is the length of time a passenger is expected to wait for the next elevator to arrive.
4. Demand for quality: Smooth operation may be as important as fancy finishes.

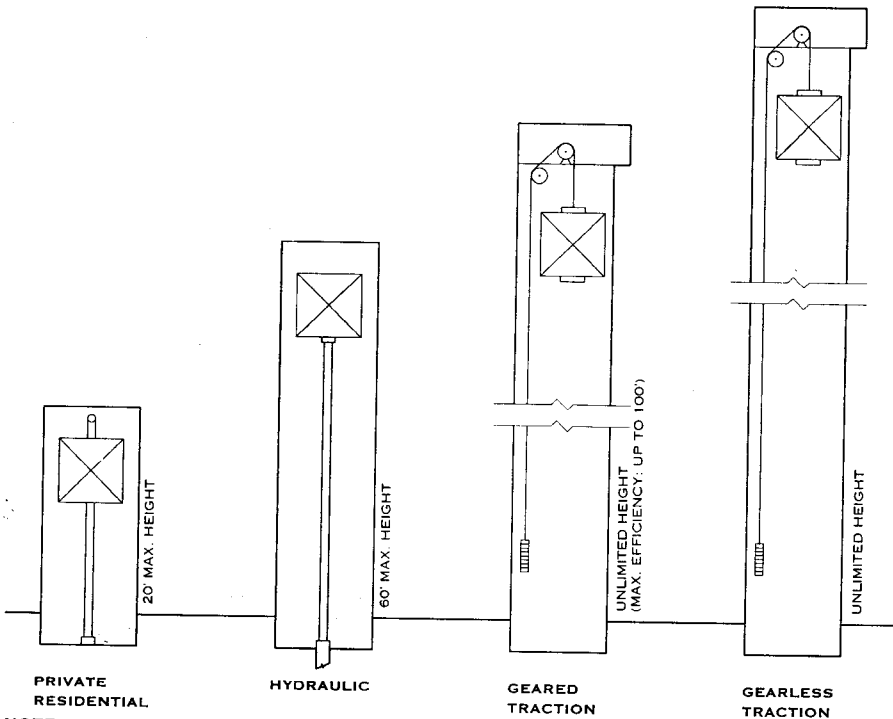

**NOTE**

These dimensions are general guidelines for selecting an elevator using height as a criterion.

**ELEVATOR TYPES**

**ELEVATOR TYPES BY USE**

NEED/USE	ELEVATOR TYPE			
	PRIVATE RESIDENTIAL	HYDRAULIC	GEARED TRACTION	GEARLESS TRACTION
Private houses	X			
Low-rise, low speed		X		
Medium-rise, moderate speed			X	
High-rise, high speed				X
Low initial cost		X		
No penthouse, lightweight construction		X		
Freight, low-rise		X	X	
Freight, high-rise			X	

Rippeteau Rollins Architecture + Design; Washington, D.C.

**GENERAL**

Guidelines for selecting an elevator for a private residence can be simplified to a few parameters. By code, residential elevators are limited in size, capacity, rise, and speed and can be installed only in a private residence or in a multiple dwelling as a means of access to a single residence. Preengineered systems generally offer only a few options for speed, capacity, aesthetic design, and electronic controls.

**BUILDING POPULATION** analysis involves identifying the needs of prospective users. Relevant information includes the type of expected occupancy (mixed or single occupancy and whether the elevator must accommodate an unassisted wheelchair user), the number of passengers expected to occupy the elevator in one trip, and elevator service in a given time period.

**BUILDING CHARACTERISTICS** affect elevator selection by establishing the building height (distance of elevator travel) and hoistway location. In private residences, the elevator may occupy a tier of closets, an exterior shaft, a room corner, or a stairwell.

**ELEVATOR SYSTEMS FOR PRIVATE RESIDENTIAL USE**

Two types of elevator systems are commonly used in private residences:

**WINDING-DRUM MACHINE**

This type of traction elevator employs a grooved drum around which the hoisting cable wraps as it operates. This elevator type does not require a counterweight or a machine room above the hoistway, making it more practical for small places than a standard traction system.

**HYDRAULIC ELEVATOR**

Hydraulic elevators in private residential use employ either a standard hole-less arrangement or a roped hydraulic machine. Both types eliminate major construction and drilling, making the system economical and an excellent selection for retrofit applications.

**NOTES**

1. **DIMENSIONS:** Dimensions may vary among manufacturers and according to the elevator system. Elevators carrying greater loads or operating at higher speeds require more clearance overhead and in pit areas. Elevator cars with higher interior clearances also require more overhead clearance in the hoistway.

The dimensions given here are appropriate for most applications. For exact dimensions required in specific circumstances, consult manufacturers.

2. **ELEVATOR CARS:** Typical car sizes, A x B, are 36 x 36 in., 42 x 42 in., and 36 x 48 in. The maximum platform size allowed by the National Elevator Code for residential elevators, ANSI A17.1, is 12 sq ft; however, this platform size does not meet the National Handicapped Access Code, ANSI A117.1, for use by an unassisted wheelchair-bound person.

3. **LOAD CAPACITY:** The load capacity of drum-type machines is 500 lb; speed is 30 ft/min. The load capacity of traction and hydraulic machines is 750 lb; speed is 36 ft/min.

4. **POWER SUPPLY:** Elevators operate on a 220/230 volt, single-phase power supply. A disconnect switch must be provided within sight of the machine. A 110V, single-phase power supply is required to light the machine area of the hoistway.

5. **HOISTWAY ENCLOSURES:** Enclosures are recommended for all hoistways. The fire rating of these enclosures and the access doors must be consistent with the fire rating of the building. See local codes.

6. **GUIDE RAILS:** Manufacturers usually provide guide rails in 5-ft sections, although some manufacturers offer rails that can span the distance from floor structure to floor structure. If a third guide rail is required, it is supplied in 3 ft 4 in. sections.

If an existing structure cannot support guide rails, manufacturers can provide a self-supporting elevator tower that transmits the load to its base. This tower requires increased horizontal clearance in the hoistway.

Elevator cars can be provided with openings on two sides; when this option is employed, guide rails must be located accordingly. Consult manufacturers.

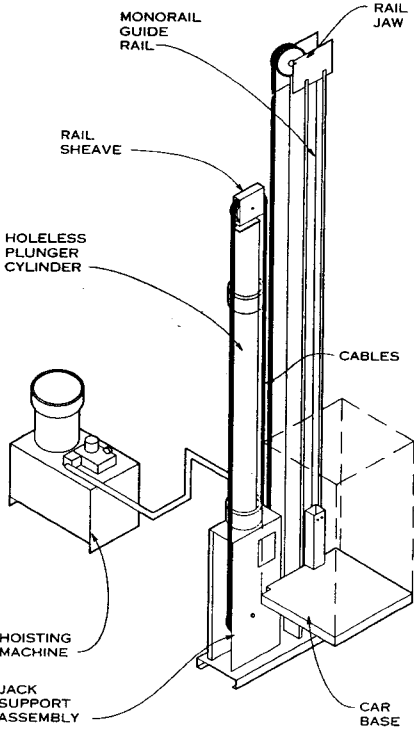

**WINDING-DRUM**

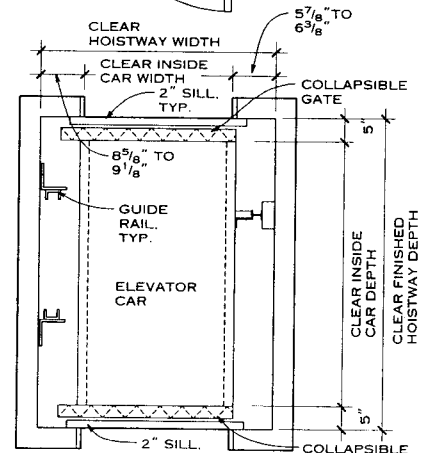
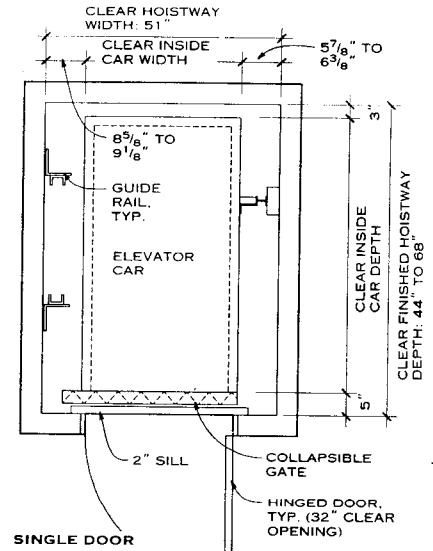

**TWO DOORS—OPPOSITE SIDES**

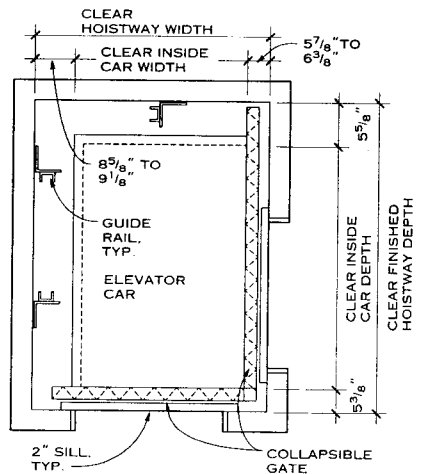

**NOTE**

Standard car size is 36 in. wide x 48 in. deep x 80 in. high. Other car depths available are 36 in. and 60 in.

**RESIDENTIAL ELEVATOR PLANS**

**ROPED HYDRAULIC ELEVATOR TYPES**

Rippeteau Rollins Architecture + Design; Washington, D.C.

**GENERAL**

Medium- and high-rise buildings require geared traction and gearless traction elevator systems. The main difference between the two systems lies in travel speed. General design considerations involving hoistway machine room, and elevator planning are similar.

Both geared and gearless drive units are governed by electronic controls, which coordinate car leveling, passenger calls, collective operation of elevators, door operation, car acceleration and deceleration, and safety applications. A broad range of control systems is available to meet individual building requirements.

Structural requirements call for the total weight of the elevator system to be supported by the machine beams and transmitted to the building (or hoistway) structure. Consult with elevator consultants and structural engineers.

**NOTES**

1. Pit depths, overhead clearances, and penthouse sizes should be in accordance with ASME requirements. Local codes may vary from these requirements.
2. All overhead dimensions for passenger elevators are based on standard 8-ft-high cabs.
3. Layout dimensions of the passenger elevator are based on center-opening entrances. Other types are available.
4. The machine room for traction elevators is usually located directly above the hoistway. Space must be provided for the elevator drive, electronic control equipment, and governor; provide sufficient clearance for equipment installation, repair, and removal. Adequate lighting and ventilation (temperature maintained between 65 and 100°F or 18 and 38°C are required by codes, and sound insulation should be provided. Machine room sizes may vary depending on number of cars, type of control, etc. Check with elevator consultant for requirements.
5. Check local codes for required fire enclosures.

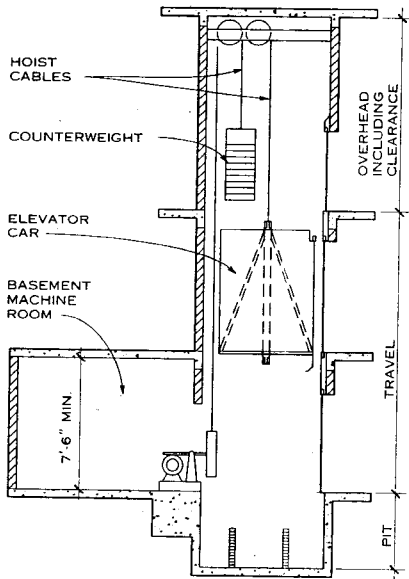

**NOTE**

This is a very specialized application, and consultation with experts is advised. Traction elevators with basement machine rooms are used in new and existing buildings where overhead clearance is limited.

**TRACTION ELEVATOR WITH BASEMENT MACHINE ROOM**

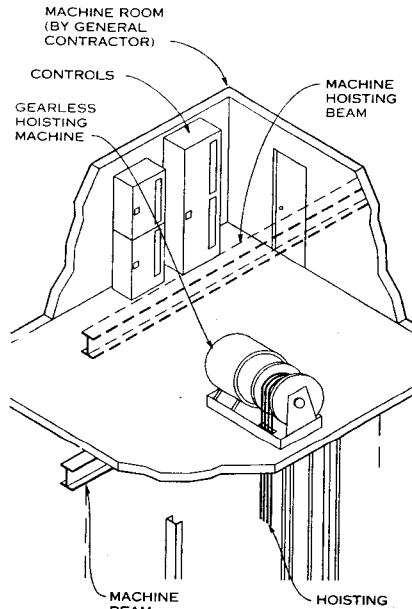

**GEARLESS ELEVATOR MACHINE ROOM**

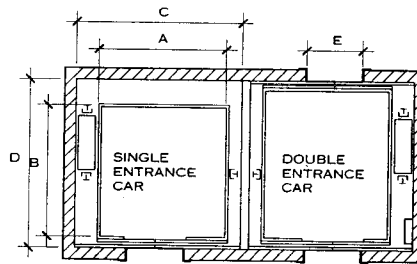

**NOTE**

Side-mounted counterweights allow an optional rear entrance door.

**SIDE-MOUNTED COUNTERWEIGHT**

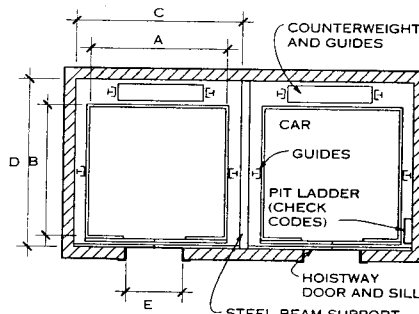

**REAR-MOUNTED COUNTERWEIGHT ELEVATOR HOISTWAY TYPES**

**TRACTION ELEVATOR DIMENSIONS (FT-IN)**

RATED LOAD (LB)	A	B	C	D	E
2000	5-8	4-3	7-4	6-11	3-0
2500	6-8	4-3	8-4	6-11	3-6
3000	6-8	4-7	8-4	7-5	3-6
3500	6-8	5-3	8-4	8-1	3-6
4500	5-8	7-10	8-2	10-5	4-0

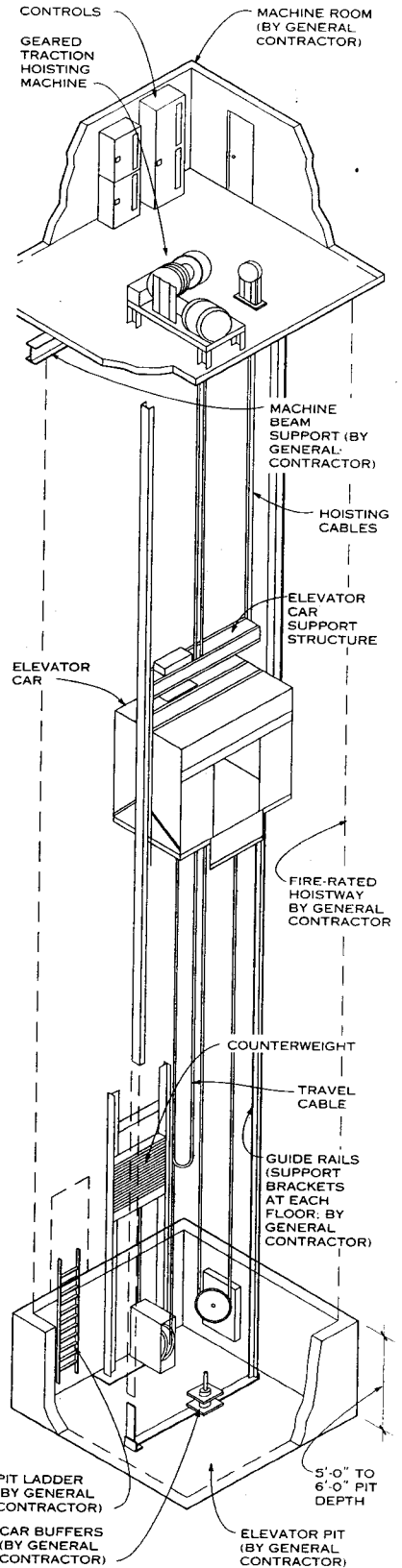

**TRACTION ELEVATOR (GEARED)**

Rippeteau Rollins Architecture + Design; Washington, D.C.

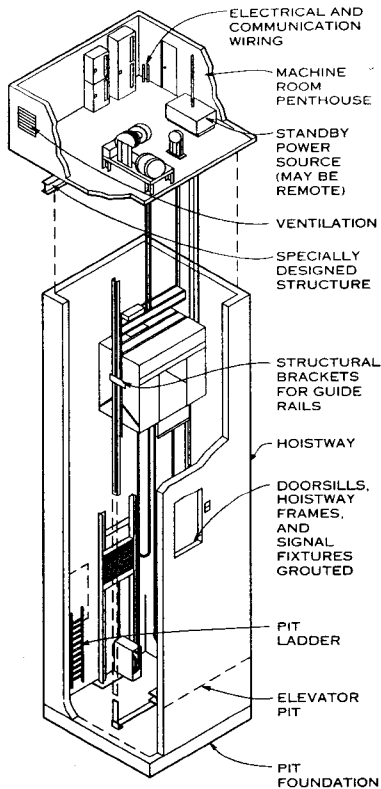

**ELEVATOR PLANNING DETAILS**

**BUILDING PREPARATION FOR ELEVATOR INSTALLATION**

The following base building preparatory work is required in order to install elevator equipment properly:

1. An enclosed elevator equipment room with electrical outlets, adequate lighting, and heating and ventilation sufficient to maintain the room at a temperature between 50°F (minimum) and 100°F (maximum).
2. Adequate supports and foundations to carry the loads of all equipment, including supports for guide rail brackets.
3. Complete connections from the electric power mains to each controller, including necessary circuit breakers and fused main line disconnect switches.
4. Electric power of the same characteristics as the permanent supply for construction, testing, and adjusting.
5. Trenching and backfilling for any underground piping or conduit.
6. Divider beams for rail bracket support as required.
7. Cutting of walls, floor, etc. and removal of any obstructions; setting of anchors and sleeves.
8. Grouting of doorsills, hoistway frames, and signal fixtures after installation of elevator equipment.
9. All painting, except as otherwise specified.
10. Temporary enclosures, barricades, or other protection from open hoistways and elevator work areas while the elevator is being installed.
11. Temporary elevator service prior to completion.
12. Heat and smoke sensors as required by NFPA.
13. All telephone wiring to machine room control panel, and installation of telephone instruments.
14. A standby power source when elevator operation from an alternate power supply is required.
15. Adequate storage facilities for elevator equipment before and during installation.
16. A means to disconnect the elevator's main line power supply automatically to protect the machine room equipment from water damage.
17. A plumb and legal hoistway; a pit of proper depth with a pit ladder for each elevator; drains, lights, access doors, waterproofing, and hoistway ventilation, as required.

Rippeteau Rollins Architecture + Design; Washington, D.C.

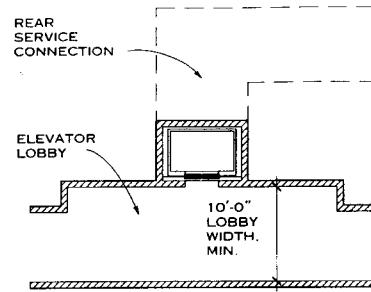

**SINGLE CAR**

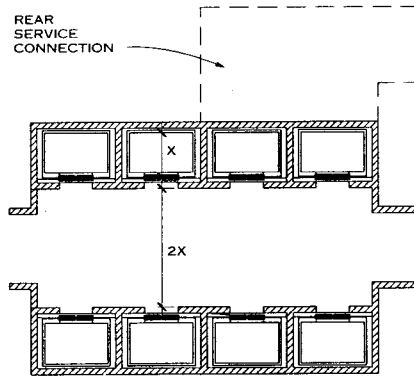

**FOUR-EIGHT CAR ARRANGEMENT**

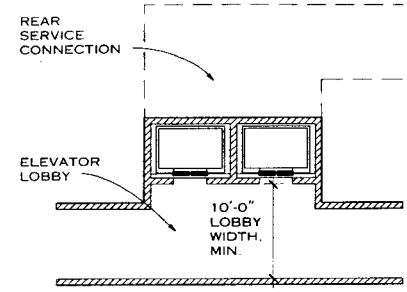

**PAIRED CARS**

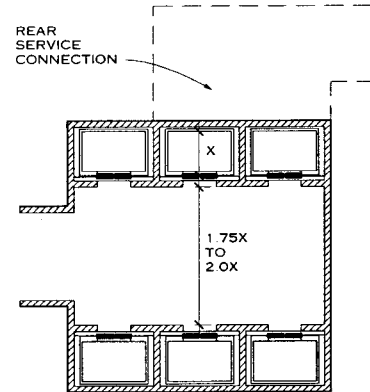

**THREE-SIX CAR ARRANGEMENT**

**NOTES**

1. Elevators should be centrally located, near the main entrance, and easily accessible on all floors. Groups of elevators should be arranged to minimize walking distance between cars. Lobby space must be sufficient to accommodate group movement. Elevators may not open into a corridor.
2. The largest practical grouping of elevators in a building is eight cars. One row of more than four cars is generally unacceptable. With groupings of four or six cars, waiting

lobbies may be closed at one end, forming an alcove, or open at both ends.

3. In buildings with several elevator groupings, one group may serve lower floors, while others serve as express elevators to upper floors.
4. When four or more elevators serve all or the same part of a building, they must be located in no fewer than two hoistways, but no more than four elevators can be located in any one hoistway.
5. Consider the option of rear access for trash removal.

**ELEVATOR LOBBY PLANNING**

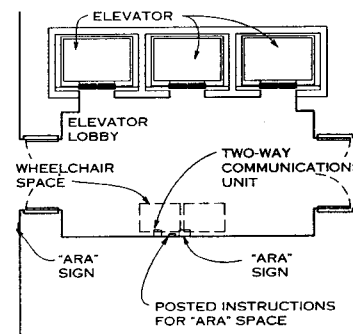

**NOTE**

An Area of Rescue Assistance is defined in the Americans with Disabilities Act Accessibility Guidelines as "an area, which has direct access to an exit, where people who are unable to use stairs may remain temporarily in safety to await further instructions or assistance during emergency evacuation."

The elevator lobby and shaft must be pressurized for smokeproof enclosure as required by the local building official. The pressurization system must be activated by smoke detectors in locations approved by the local building official. The system's equipment and ducts must be of 2-hour fire-resistant construction.

**ELEVATOR LOBBY DESIGNED AS AREA OF RESCUE ASSISTANCE (ARA)**

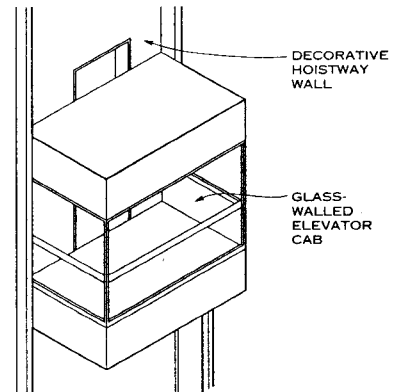

**NOTE**

Observation and glassback elevators travel outside of a hoistway or in a hoistway open on one side. Machinery is concealed or designed to be inconspicuous. Elevators may be engineered for hydraulic, geared, or gearless use. Cabs can be custom designed with more than 75% of wall area as glass. Only the rear panel is glass in glassback cabs. Safety barriers must be provided at floor penetrations and the ground floor, completely surrounding that part of the elevator not enclosed by the hoistway. This is a very specialized application; consultation is advised.

**GLASS-WALLED ELEVATOR CARS**

**GENERAL**

Hydraulic elevator systems are used primarily in low-rise installations, where moderate car speed (up to 150 ft per minute) is required. A car is connected to the top of a long piston that moves up and down in a cylinder. The car moves up when hydraulic fluid is pumped into the cylinder from a reservoir, raising the piston. The car is lowered when the hydraulic fluid returns to the reservoir. The up and down motions of the elevator car are controlled by the hydraulic valve.

The main space planning elements of a hydraulic elevator system are the machine room, usually located at the base, and the hoistway, which serves as a fire-protected, ventilated passageway for the elevator car. Adequate structure must be provided at the base of the hoistway to bear the load of the elevator car and its supporting piston or cylinder.

**NOTES**

1. The elevator pit should be reinforced to sustain the vertical forces generated by the system configuration. Consult manufacturer's representatives. All pit depths and overhead clearances should be in accordance with ASME requirements. Local codes may vary from these requirements.
2. Car and hoistway dimensions of preengineered units are for reference purposes only. A variety of units is available. Consult manufacturers for dimensions of specific systems.
3. Hoistway walls usually serve primarily as fireproof enclosures. Check local codes for required fire ratings.
4. Guide rails extend from the floor of the pit to the underside of the overhead (top of hoistway). Consult the elevator manufacturer for the special requirements of excessive floor heights.
5. Rail brackets typically are at each floor level. A bracket is required at the top of the hoistway, and an intermediate bracket may be required for certain floor-to-floor heights. Consult manufacturer.
6. Some hydraulic applications may require jack hole block-outs in the floor of the pit.

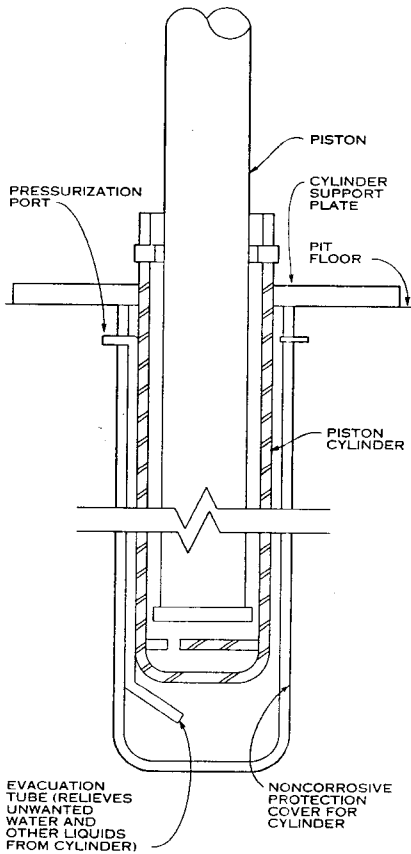

**PISTON AND CYLINDER DETAIL**

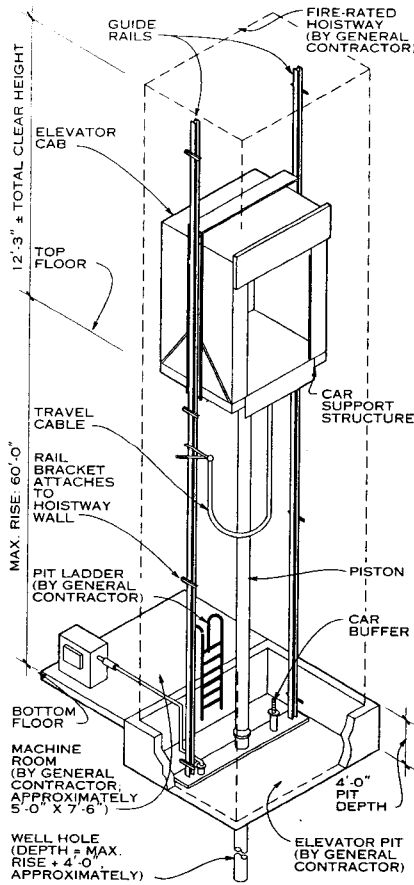

**HOLED HYDRAULIC ELEVATOR**

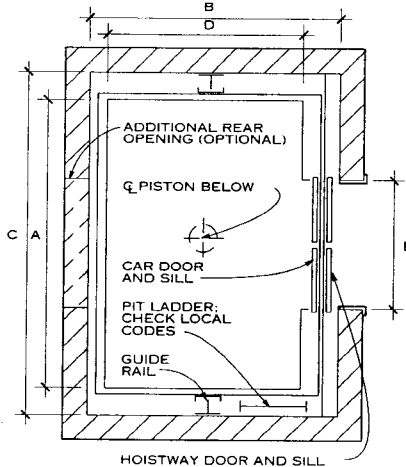

**HYDRAULIC ELEVATOR DIMENSIONS (FT-IN.)**

RATED LOAD (LB)	A	B	C	D	E
2000	5-8	4-3	7-4	5-11	3-0
2500	6-8	4-3	8-4	5-11	3-6
3000	6-8	4-7	8-4	6-3	3-6
3500	6-8	5-3	8-4	6-11	3-6
4500	5-8	7-10	7-5	10-0	4-0

**NOTE**

"A" and "B" dimensions are "clear inside." Rated speeds are 75 to 200 ft/min.

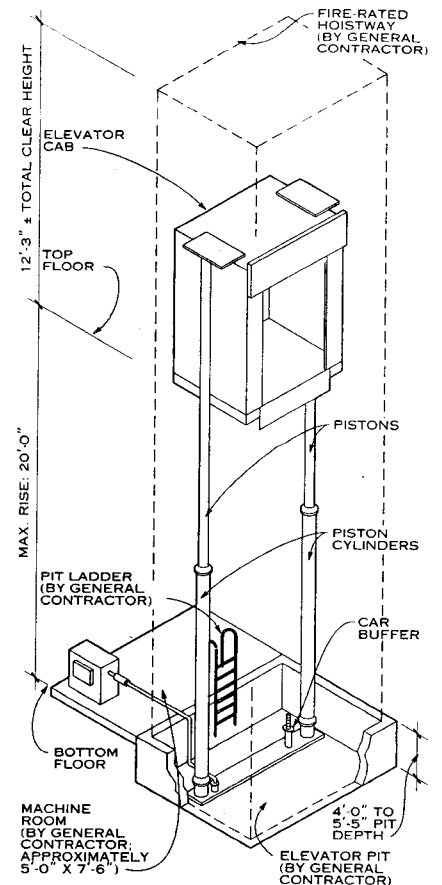

**HOLELESS HYDRAULIC ELEVATOR**

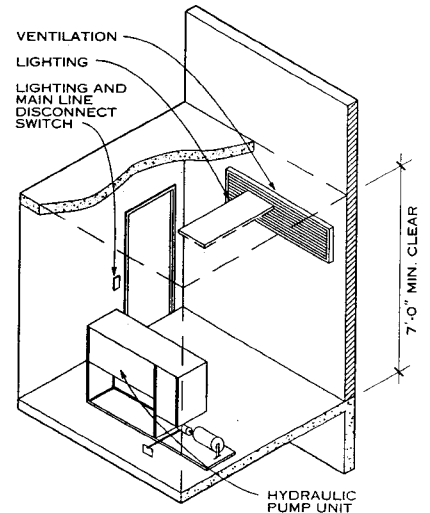

**NOTES**

1. A machine room, meeting code requirements and ventilated for temperatures between 65° and 100°F (18° and 38°C), must be provided for all elevators. It is usually located next to the hoistway at or near the bottom terminal landing. Room size may vary depending on the number of cars, capacity, and speed.
2. Machinery consists of a pump and motor drive unit, hydraulic fluid storage tank, and electronic control panel. Adequate ventilation, lighting, and entrance access (usually 3 ft 6 in x 7 ft) should be provided.

**MACHINE ROOM**

Rippeteau Rollins Architecture + Design; Washington, D.C.

**GENERAL**

General freight elevators with capacities of 2000 to 8000 lb satisfy a variety of material-handling requirements. Industrial truck freight elevators require special design considerations to handle truckloads of 10,000 to 20,000 lb or more.

General freight or industrial truck elevators may have either hydraulic or traction drive systems similar to those of other elevator systems. However, the units are usually custom-designed with vertical bipart doors and special structural support to accommodate heavy loads and eccentric loading conditions. Freight elevators usually have simple control systems and operate at slower speeds than other elevators. Their capacity must be sized for the largest expected load.

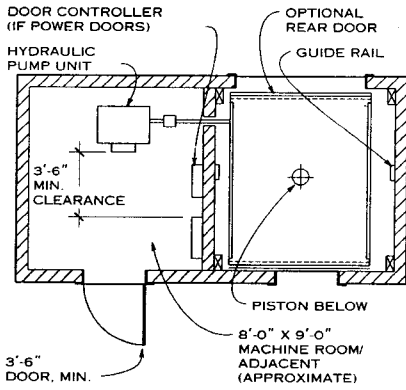

**HYDRAULIC FREIGHT ELEVATOR**

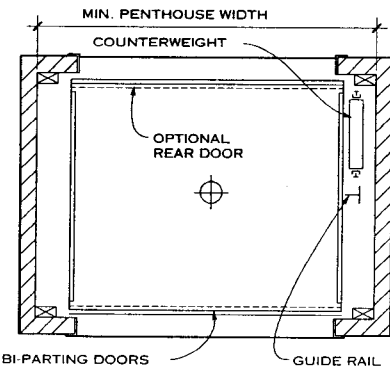

**TRACTION FREIGHT ELEVATOR**

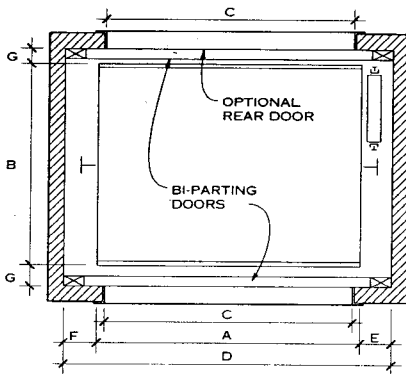

**NOTE**

G = 5 in. (127 mm) for regular counterbalanced hoistway doors and 6 3/4 in. (172 mm) for pass-type counterbalanced hoistway doors. Pass-type doors are required when floor heights are less than 11 ft (3350 mm) for 7-ft (2134 mm) openings and less than 12 ft 6 in. (3810 mm) for 8-ft (2458 mm) openings.

**KEY PLAN**

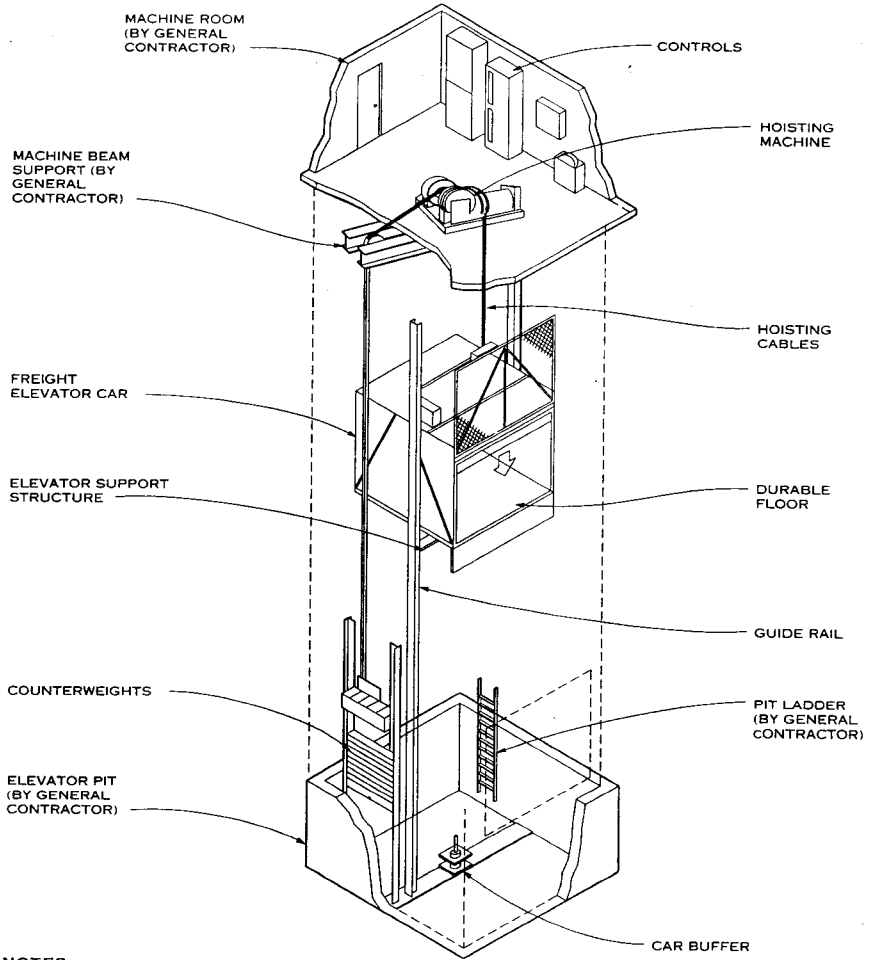

**NOTES**

1. Hoistway walls: Local building codes govern design characteristics; consult with appropriate agencies to determine requirements such as fire rating.
2. Traction elevators: The hoisting machine may be mounted directly overhead or at the side of the hoistway at any level, including the lowest landing. Special structural design considerations are necessary based on forces created by the use of traction equipment.
3. Guide rail bracket support: Freight elevators create horizontal forces greater than those created by passenger elevators. Vertical steel is installed within the hoistway to provide bracket support at elevations with bracket locations.
4. Truckable sills: At the edge of the building floor (leading into the elevator hoistway), a structural steel angle must be in place to avoid deterioration of the building floor through continued use of hand trucks, battery-operated pallet lifts, forklifts, etc.
5. Flooring: A variety of materials may be used for flooring in a freight elevator, including checkered steel plate, non-skid materials, galvanized steel, or high-density wood.

**FREIGHT ELEVATOR**

**TRACTION FREIGHT ELEVATORS**

CAPACITY IN LB (KG)	LIGHT- AND MEDIUM-DUTY			HEAVY-DUTY POWER TRUCK LOADING		
	DIMENSIONS IN FT-IN. (MM)					
	A	B	C	D	E	F
2500 (1134)	5-4 (1626)	7-0 (2134)	5-0 (1524)	7-10 (3150)	1-7 (483)	0-11 (279)
4000 (1814)	6-4 (1930)	8-0 (2438)	6-0 (1829)	8-10 (2692)	1-7 (483)	0-11 (279)
8000 (3629)	8-4 (2540)	10-0 (3048)	8-0 (2438)	10-10 (3302)	1-7 (483)	0-11 (279)
12,000 (6443)	10-4 (3150)	14-0 (4267)	10-0 (3048)	13-6 (4115)	1-7 (483)	0-11 (279)
20,000 (9072)	12-4 (3759)	20-4 (6196)	12-0 (3658)	16-6 (5029)	1-7 (483)	0-11 (279)

**HYDRAULIC FREIGHT ELEVATORS**

CAPACITY IN LB (KG)	LIGHT- AND MEDIUM-DUTY			HEAVY-DUTY POWER TRUCK LOADING	
	DIMENSIONS IN FT-IN. (MM)				
	A	B	C	D (MANUAL DOORS)	E (POWER DOORS)
2000 (967)	5-0 (1524)	6-0 (1829)	4-8 (1422)	6-4 (1930)	6-10 (2083)
4000 (1814)	6-6 (1981)	8-0 (2438)	6-2 (1880)	7-10 (2388)	8-4 (2540)
8000 (3629)	8-6 (2591)	12-0 (3658)	8-2 (2490)	10-6 (3200)	10-6 (3200)
12,000 (5443)	10-6 (3200)	14-0 (4267)	10-2 (3098)	12-6 (3810)	12-6 (3810)
20,000 (9072)	12-6 (3810)	20-0 (6096)	12-2 (3708)	14-6 (4420)	14-6 (4420)

Rippeteau Rollins Architecture + Design; Washington, D.C.

**GENERAL**

Escalators are a very efficient form of vertical transportation for very heavy traffic where the number of floors served is limited, normally a maximum of five to six floors. Escalators are not usually accepted as a required exit.

Dimensions shown are general and will vary somewhat with the manufacturer. Consult manufacturers for structural support, electrical supply, and specific dimensional requirements.

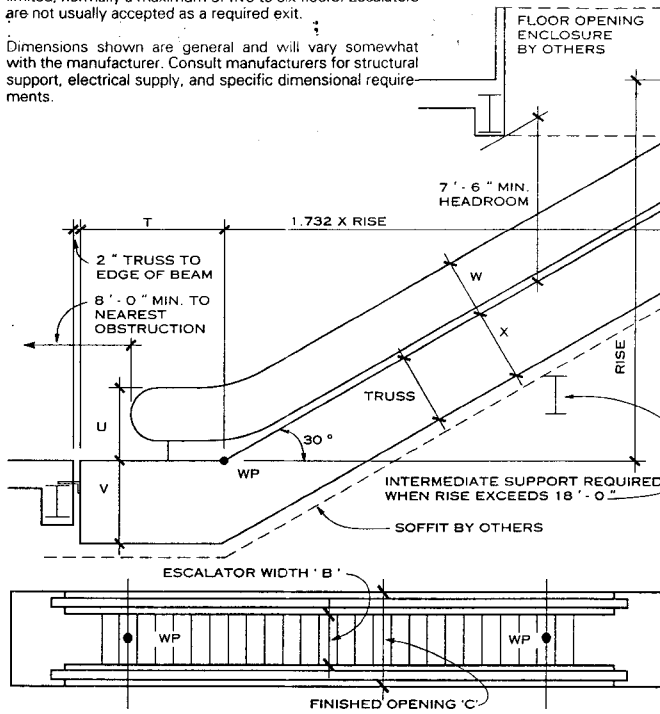

**ESCALATORS**

SYM-BOL	DESCRIPTION	MANUFACTURER'S DIMENSIONS								
		MONTGOMERY			OTIS			SCHINDLER		
A	Nominal width	32"	40"	48"	32"	40"	48"	32"	40"	48"
B	Width of step	24"	32"	40"	24"	32"	40"	24"	32"	40"
C	Overall deck width	4'-4"	5'-0"	5'-8"	3'-11 1/2"	4'-7 1/2"	5'-3 1/2"	3'-11 1/2"	4'-7 1/8"	5'-3"
T	WP to end of lower truss	7'-6 1/2"			5'-9 7/8"			7'-0 1/2"		
U	Top of handrail	2'-11 1/2"			3'-2 9/16"			2'-11 1/2"		
V	Depth of lower pit	3'-10"			3'-6"			3'-8"		
W	Top of handrail	2'-7 1/8"			2'-8 1/8"			2'-7"		
X	Depth of truss	3'-2"			3'-1 1/8"			2'-11 3/8"		
Y	Depth of upper pit	4'-1 13/16"			3'-3 1/2"			3'-3 3/4"		
Z	WP to end upper truss	7'-10 1/2"			8'-5"			8'-3"		

**ESCALATOR PROFILE**

Moving passenger conveyors are particularly useful in transportation terminals, sports arenas, and exposition centers where large numbers of people must move long distances horizontally. The conveyors may be arranged in any combination of horizontal runs and inclines with a practical maximum of 12°.

It is generally not economical to provide moving sidewalks for distances less than 100 ft; for distances greater than 300 ft they invoke passenger frustration by their slow operating speed. Narrower units (26 in.) accommodate one adult; 40 in. widths allow for both walking and standing passengers.

**MOVING PASSENGER CONVEYORS**

SYM-BOL	DESCRIPTION	MANUFACTURER'S DIMENSIONS							
		MONTGOMERY			OTIS			SCHINDLER	
A	Nominal width	32"	37"	40"	40"	48"	32"	48"	
B	Width of walk	24"	32"	40"	32"	40"	26"	40"	
C	Overall deck width	4'-4"	5'-0"	5'-8"	4'-7 9/16"	5'-3 9/16"	4'-4 1/2"	5'-8 1/2"	
W	Top of handrail	2'-11 7/16"			3'-2 5/8"			2'-11 7/16"	
X	Depth of truss	3'-10"			3'-5 3/8"			3'-6 1/2"	
Y	Length of pit	18'-10"			18'-0"			18'-10"	
Z	Maximum depth of truss	13"			17 3/4"			3'-4 7/16"	

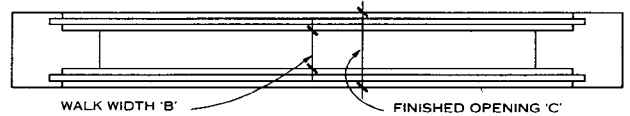
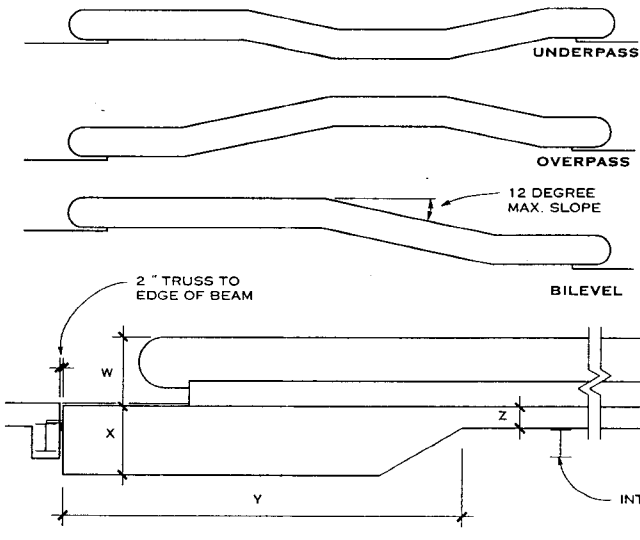

**PASSENGER CONVEYOR PROFILE**

Alan H. Rider, AIA; Daniel, Mann, Johnson, & Mendenhall; Washington, D.C.

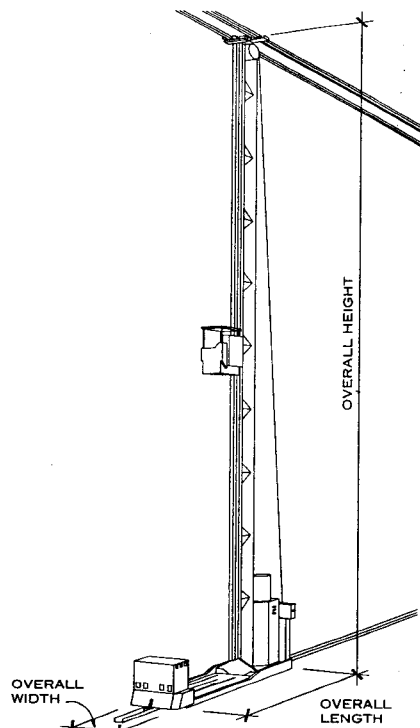

Used for high density storage and retrieval systems. Allows high lift capacity while operating in a narrow aisle. Can be used in numerous aisles unlike dedicated stacker cranes.

**HYBRID VEHICLE**

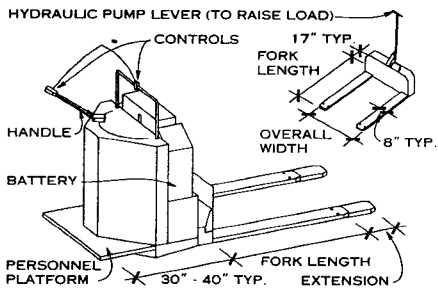

Used to transport unitized loads when stacking of loads is not necessary. Ideal for dock work and production areas.

**HAND PALLET TRUCK**

**FORKLIFTS - DIMENSION AND CAPACITIES**

	REACH TRUCK	COUNTERBALANCE TRUCK	ORDER PICKER TRUCK	TURRET TRUCK	HYBRID TRUCK	ELECTRIC PALLET TRUCK	HAND JACK
Load capacity (lb)	2000 to 7000	2000 to 15,000	1500 to 3000	3000 to 4000	3900	1500 to 6000	2000 to 6500
Maximum lift height	33' - 3"	22' - 0"	30' - 0"	to 40' - 0"	65' - 6"	6" to 7"	4" to 7 3/4"
Right angle stacking aisle requirement	6' - 0" to 10' - 0"	10' - 4" to 14' - 2"		5' - 7" to 6' - 1"	4' - 6" to 5' - 4"	Truck length plus 3' - 0"	Truck length plus 3' - 0"
Truck weight without load (lb)	4,000 to 8,000	5,400 to 22,000	5,700 to 9,500	7,000 to 15,000		1,000 to 2,000	250 to 300
Overall truck width	3' - 1" to 5' - 4"	2' - 11" to 4' - 10"	3' - 10" to 5' - 10"	4' - 10" to 7' - 1"	4' - 0 5/8"	2' - 7" to 3' - 2"	1' - 6" to 2' - 6"
Overall truck height	6' - 0" to 11' - 8"	5' - 8" to 7' - 6"	7' - 1" to 12' - 4"	7' - 6" to 22' - 6"	70' - 8"	4' - 0" to 5' - 0"	4' - 0"
Overall truck length with-out load	5' - 2" to 6' - 0"	5' - 6" to 9' - 7"	7' - 4" to 10' - 6"	11' - 3" to 12' - 2"	16' - 9"	5' - 7" to 9' - 7"	3' - 9" to 7' - 5"
Fork length	2' - 6" to 4' - 0"	2' - 6" to 4' - 0"	3' - 0" to 8' - 0"	2' - 6" to 4' - 0"	43"	2' - 6" to 7' - 0"	2' - 0" to 6' - 0"
Ramp slope	15 to 23%	10 to 37%	3 to 16%			Up to 10%	Manually operated

**NOTE**

Data and figures given here represent the ranges of general specification available on forklift trucks. Aisle width is controlled by type of forklift and pallet size used in a warehouse. Specific data and applications should be obtained

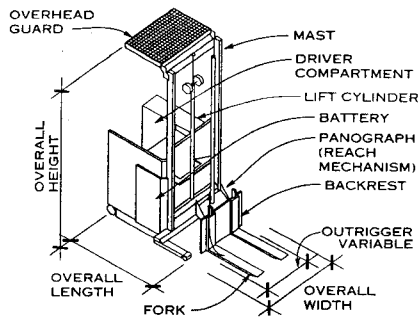

Narrow aisle operations without limiting pallet sizes and rack openings.

**REACH TRUCK**

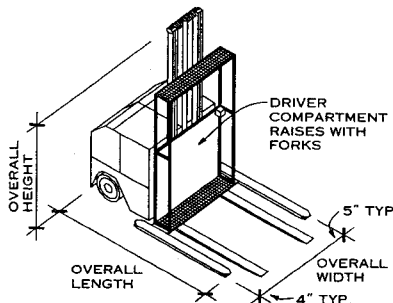

Allows access to multiple level pick slots; an efficient technique with a large item base that has limited space for selection line.

**ORDER PICKER TRUCK**

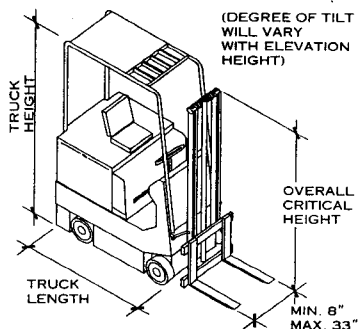

Ideal for moving large volumes of material where maneuvering area is not limited.

**COUNTERBALANCE TRUCK**

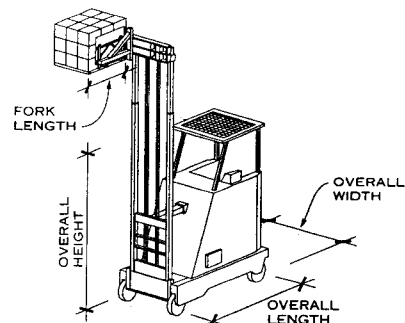

Allows narrow aisle operations. Forks can rotate 180° which allows access to both sides of the aisle without turning the truck around.

**TURRET TRUCK**

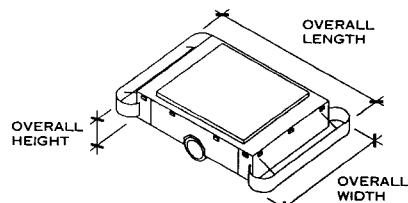

**AUTOMATIC GUIDED VEHICLES (AGV)**

**NOTE**

These vehicles are used throughout industry for transporting product from point to point with repeatable accuracy. They are totally automatic and require little or no human interface. The AGV follows a guidepath on the floor or can be radio controlled. The relatively low cost of changing or adding a guidepath makes the AGV a flexible system.

AGV's are controlled by a computer and are powered by industrial batteries.

**AGV - DIMENSIONS AND CAPABILITIES**

Load capacity	Up to 93,000 lbs
Lift height	Up to 15' - 7"
Turning radius	2' - 0" to 18' - 0"
Weight with battery	2000 to 22,000 lbs
Overall length	6' - 1" to 34' - 4"
Overall width	3' - 6" to 9' - 4"
Overall height	12 1/2" to 7' - 6"
Fork length	Up to 5' - 0"
Travel speeds	Up to 200 FPM

**NOTE**

Data and figures given are general specifications. AGV's are designed for specific tasks with dimensions and capabilities varying from application to application. Please consult the AGV manufacturer or material handling engineer for specific data.

St. Onge, Ruff & Associates; York, Pennsylvania  
Richard J. Vitullo, AIA; Oakleaf Studio; Crownsville, Maryland

from material handling engineers. The trucks presented are electrically powered (excluding the hand jack) using industrial batteries as a source of energy. Industrial batteries typically must be charged after each 8-hr shift. Two batteries

per truck are typical to allow back-to-back shift operation. The charging operation should take place in an area segregated from the warehouse or production area and must be designed to meet the various OSHA requirements.



**GENERAL**

Material-conveying systems are designed to carry either bulk material or unit items. Bulk materials include agricultural and food products, chemicals, solid fuels, pastes, and powders. Unit materials include luggage, envelopes, cases, parts, part bins, pallets, bags, and cans.

Conveyors are usually designed as complete systems by engineers who specialize in such systems. The choice and design of a conveying system should include consideration of material properties, containment, damage, capacity, speed, loading and unloading, control, reliability, safety, and maintainability.

Access to conveyors must be provided for equipment maintenance, clearing of load jams, and loading and unloading. Because mechanical conveyors have inherent safety hazards, guards and emergency stop controls are required to reduce the chance of injuries. Most conveyors are used in a controlled access environment such as a security area or industrial plant. Equipment accessed or used by the public must be specifically designed for safety.

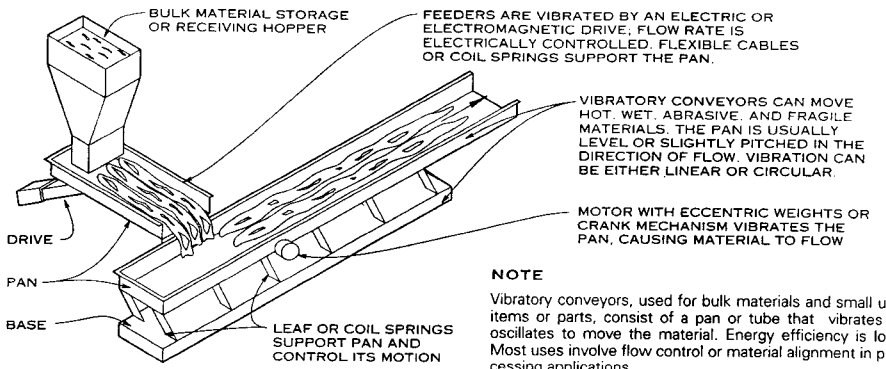

**NOTE**

Vibratory conveyors, used for bulk materials and small unit items or parts, consist of a pan or tube that vibrates or oscillates to move the material. Energy efficiency is low. Most uses involve flow control or material alignment in processing applications.

**VIBRATORY CONVEYORS**

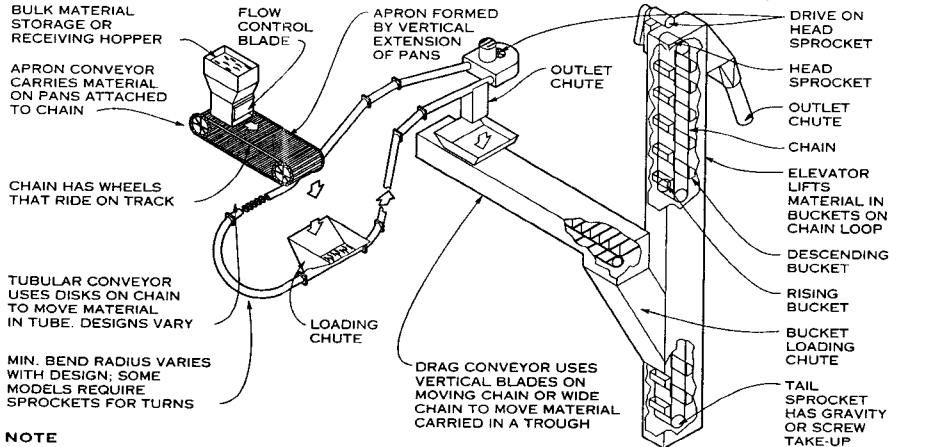

**NOTE**

Segmental conveyors are used for both bulk and unit materials. Although slow and not energy-efficient, they have durable carrying surfaces and can handle heavy loads and materials that are hot, abrasive, or fragile. They allow pre-

cise control and positioning of material and can be configured in complex and multiple curves. They are expensive and used for specialty applications.

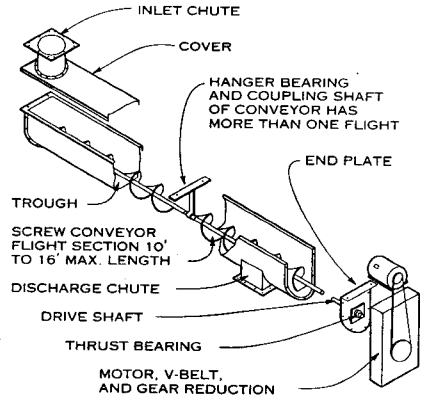

**NOTE**

Screw conveyors are only used for bulk materials. They can convey hot, wet, or dusty materials but become plugged by sticky or stringy material; they are not suitable for fragile materials. They can have multiple inlets and discharges and are often used for mixing and flow control.

**SCREW CONVEYORS**

**SEGMENTAL CONVEYORS**

SKIRTBOARDS KEEP MATERIAL ON BELT, USUALLY METAL WITH RUBBER SEALING STRIPS SPACED  $\frac{2}{3}$  OF THE BELT WIDTH; CONTINUOUS ON FLAT BELTS, AT LOADING POINT ON TROUGHED BELTS

ADJUSTABLE FLOW REGULATING BLADE

BELT FEEDER, USUALLY FLAT WITH CONTINUOUS SKIRTBOARDS, CONTROLS FLOW OF MATERIAL TO CONVEYING SYSTEM

RECEIVING HOPPER

CARRY IDLER

RETURN IDLER

SLOPED LOADING CHUTE

BELT WIDTH FOR BULK MATERIALS VARIES FROM 18" TO MORE THAN 6'-0"

2'-6" MIN.

PROVIDE SERVICE ACCESS AT TAIL PULLEY, DRIVE AREA, AND ALONG ONE SIDE

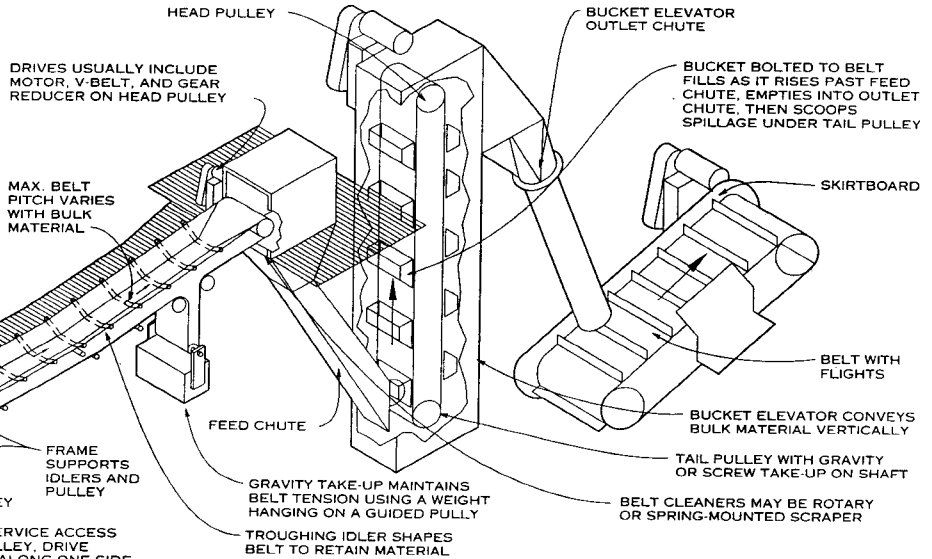

**NOTE**

Belt conveyors, used for both bulk and unit materials, are often chosen for superior speed, capacity, length, energy efficiency, and economy. They vary in width from one inch

to more than 8 feet and in length from less than a foot to more than a mile. At steeper angles, belts must have skirtboards to retain material and roughened surfaces or flights

to keep it from sliding. Belts typically are made of rubber-covered fabric; belt slippage and alignment can be a problem.

**BELT CONVEYORS**

Alpha Engineers, Inc.; Pocatello, Idaho

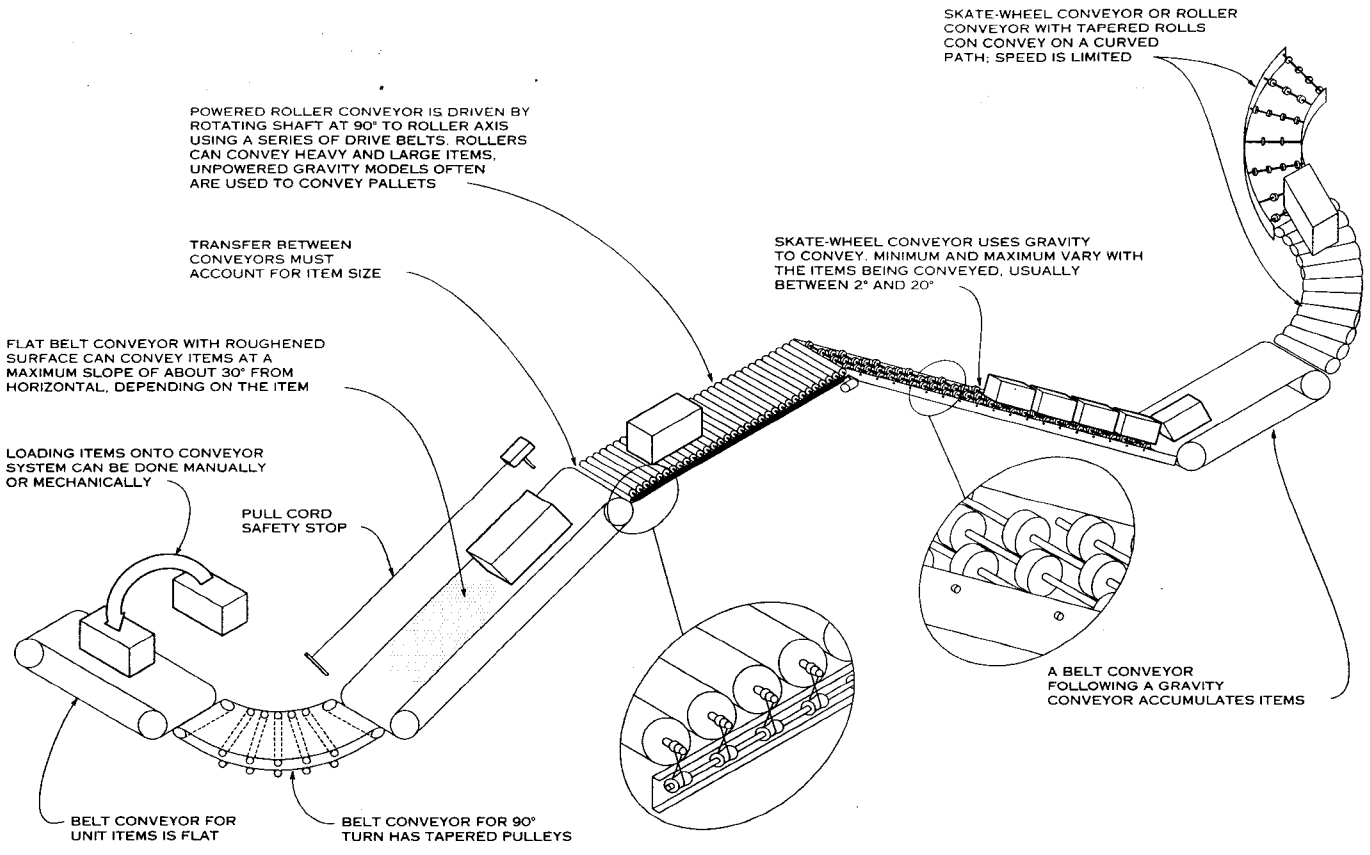

**NOTE**  
Unit conveyors use rollers or wheels on stationary shafts to carry items that must have a flat bottom surface. Rollers

may be gravity or power driven. Gravity units are economical and often portable. Items move independently on rollers, allowing materials to be paused or accumulated.

Systems often use sensors and automated diverters to sort and direct items to different destinations.

**UNIT CONVEYORS**

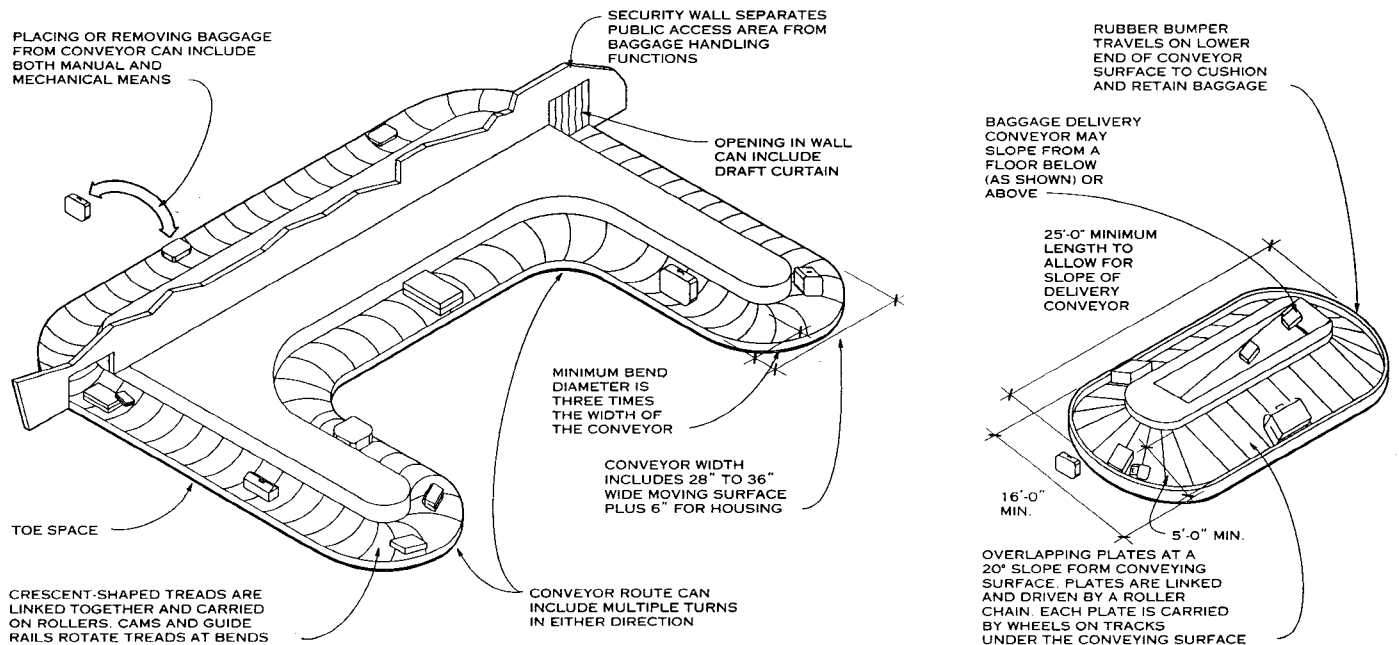

**CRESENT BAGGAGE CONVEYOR**

**BAGGAGE CLAIM CONVEYOR**

Alpha Engineers, Inc.; Pocatello, Idaho

**GENERAL**

Waste and linen chutes should extend full diameter through the roof and be capped with a metal safety vent or glass explosion cap. Sprinklers or flushing spray are recommended at alternate floors. Bottom-hinged hopper doors are commonly used for waste and loose linen. Square side-hinged doors are used for bagged linen. "B" label doors are recommended. To prevent clogging, door size is restricted in proportion to chute diameter. Type "H" hopper discharge doors are installed when discharge is built into wall and the receptacle is a cart or bin. Type "A" direct-open discharge doors (not shown) are commonly used when discharge is into a compactor.

**AVERAGE WASTE PRODUCTION/DAY**

BUILDING	AMOUNT
Apartment	5 lb/apartment + 1 lb/bedroom
Dormitory	3 lb/person
Hospital	8 lb/bed
Nursing home	6 lb/person
Hotel, motel	3 lb/room
School	10 lb/room + 1/4 lb/pupil

**AVERAGE LINEN PRODUCTION/DAY**

BUILDING	AMOUNT
Hospital	15 lb/bed
Hotel, motel	12 lb/bed

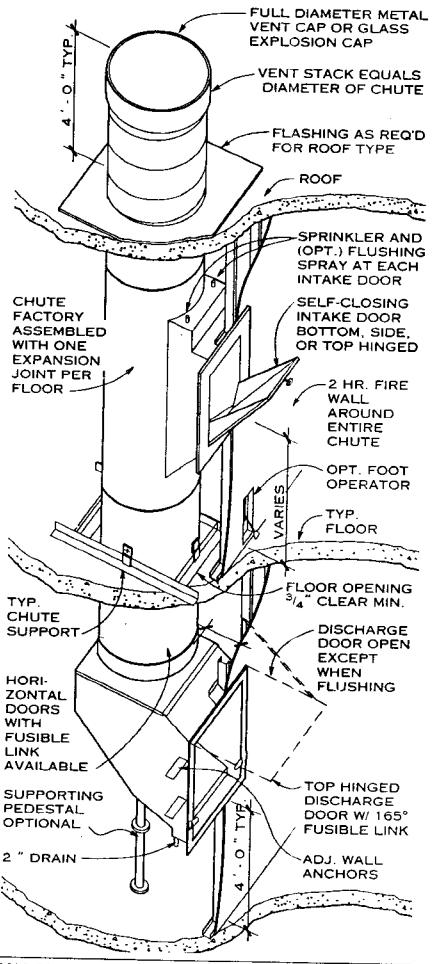

**WASTE OR LINEN CHUTE**

**NOTES**

1. Fire stops may be required at underside of every slab; check local codes.
2. Chute material: #18 - #16 U.S. gauge aluminized steel or stainless steel.

**NOTES**

1. Chutes should be used only for first class mail. The chute dimensions should be 2 x 8 in. and extend in a vertical line from beginning point to a receiving box or mailroom. A chute must be accessible its entire length. Chutes in pairs have a divider and dual receiving boxes.
2. Receiving boxes must be placed near the building's main entrance or near the loading area for U.S. Postal Service (USPS) mail collection. Using the shortest line, receiving boxes may not be placed more than 100 ft from the entrance used by the collection person. Locations require local postmaster approval. Receiving boxes must be placed on the same floor the collection person uses to enter the building. Doors must operate freely. Door openings must be at least 12 x 20 in. and not more than 18 x 30 in.
3. Auxiliary boxes should be located near receiving box if receiving box is too small to accommodate the volume of first class mail.
4. A bundle drop must accept a bundle at least 6 1/2 in. wide by 11 1/2 in. long and 4 in. high. To prevent removal of mail, the deposit opening must be fully protected by inside baffle plates. Inlet doors must be inscribed "Letters" and "Letter Mail Tied in Bundles." The bottom of the opening must be at least 61 in. above floor level.

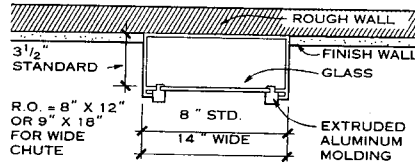

**MAIL CHUTE PLAN**

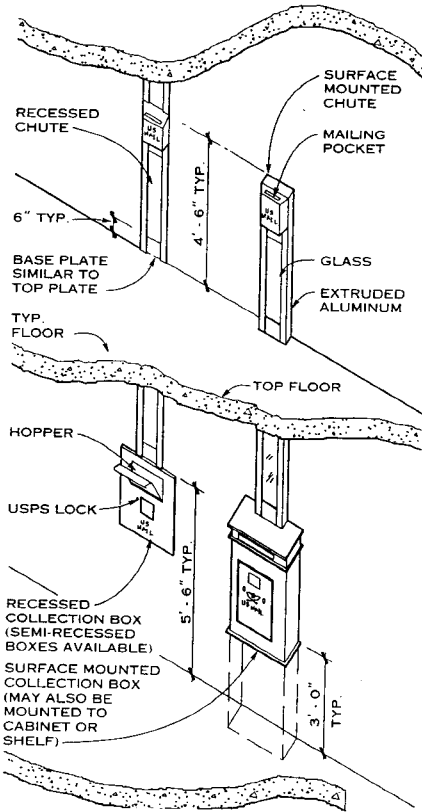

**MAIL CHUTE AND COLLECTION BOXES**

**NOTES**

1. All installations must comply with USPS requirements and are subject to inspection.
2. Floor penetrations may need fire stopping methods.
3. USPS provides listing of approved manufacturers.

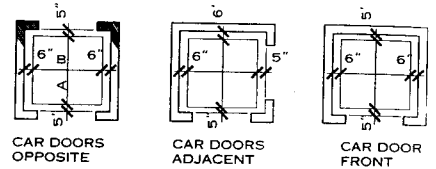

**PLANS OF TYPICAL DUMBWAITER**

**ELEVATOR CAPACITY**

CAR SIZE			CAPACITY (LB)
W	D	H	
18"	18"	24"	25-75
20"	20"	30"	100
28"	24"	36"	150-250
32"	30"	42"	300-350
36"	36"	48"	400-500

Capacity is determined by the maximum weight of the contents to be transported and the size of the dumbwaiter car. Maximum capacity is 500 lb. Normal speed is 50 ft per minute. The car platform may not exceed 9 sq ft. Car heights cannot exceed 4 ft. Machines may be located above, below, or adjacent to the hatchway. Drum type machines have a maximum rise of 35 to 40 ft; traction type machines have unlimited range of travel.

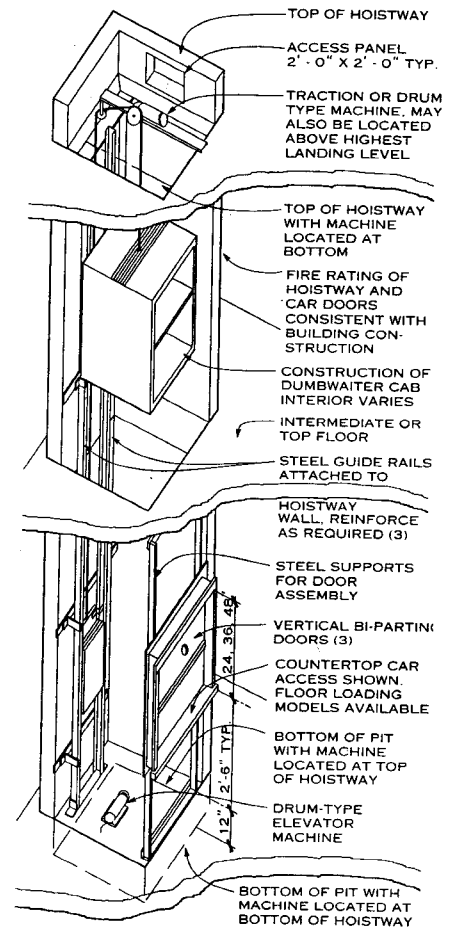

**DUMBWAITERS**

**NOTE**

Consult manufacturer's literature for specific dimensions and load capacity.

Eric K. Beach; Rippeteau Architects, PC; Washington, D.C.  
 Wilkinson Company, Inc., Cutler Manufacturing Corporation, Atlas Elevator Company, and Sidgwick Lifts, Inc.

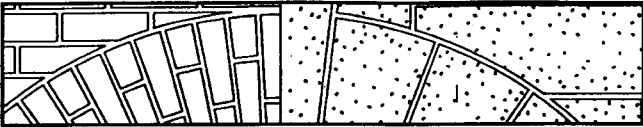

# MECHANICAL

Mechanical Insulation 678

Building Services Piping 679

Plumbing 690

Special Systems 704

Heat Generation Equipment 705

Refrigeration and Heat Transfer 710

HVAC Systems 716

Air Distribution 726

**GENERAL**

The primary purpose of insulation is to retard the flow of heat and water vapor from pipes, ducts, and equipment. An insulation system consists of the insulation itself; a jacket to cover it; and, if needed, an additional jacket to provide specific characteristics such as weather protection or the ability to be repeatedly cleaned. Code limitations for flame spread and amount of smoke developed established for components in fireproof and noncombustible buildings apply to these insulation system elements.

**COMMON INSULATION TYPES**

The insulation materials described here are identified by generic names rather than manufacturers' trade names.

**FIBERGLASS INSULATION (ASTM C 547)** is fibrous glass made plain or with a heat-resistant binder to help the fiberglass hold its shape. Material with a density of 3 to 5 lb/cu ft typically has an R value of 3.8 to 4.5.

Felted glass fiber without any binder is available in rolls. With a thermosetting resin binder, it is available in varying degrees of stiffness. The form most commonly used for pipe is molded and shaped into semicircular sections. A cover is needed to protect this type of insulation from physical damage, permit it to be firmly attached to the pipe, and prevent penetration of water vapor. Fiberglass insulation, recommended for temperatures from 35° to 800°F, is available in thicknesses from 1/2 to 5 in. for 1/2-in. to 33-in. pipe.

**CELLULAR GLASS INSULATION (ASTM C 552)** is pure glass with closed-cell air spaces. It offers a flame spread of 5, smoke developed rate of 0, and 0 perm rating; typical R value is 2.6. Form-fitting covers are used for standard components. The type of jacket used for abrasion resistance depends on the severity of service. Recommended applications include temperatures ranging from -450° to +450°F (adhesive type varies with the temperature). Cellular glass insulation, impervious to common acids and corrosive environments and hard enough to cut with a saw, is used when an extremely strong, impermeable material is required.

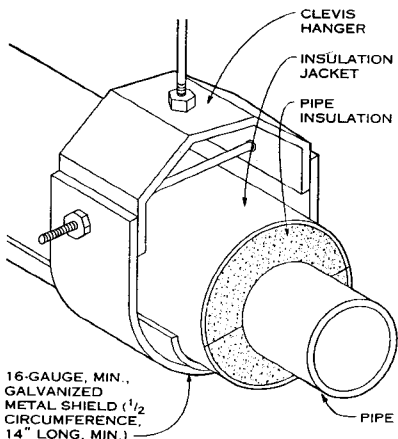

**METAL SHIELD SUPPORT**

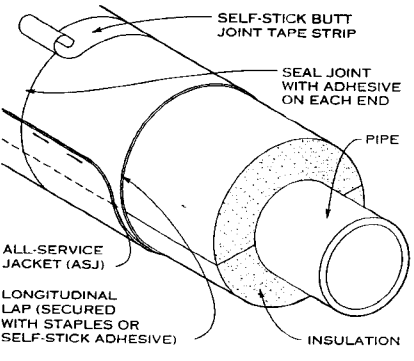

**PIPE INSULATION WITH NONMETALLIC JACKET**

**ELASTOMERIC PLASTIC INSULATION (ASTM C 534)** is an expanded foam, closed-cell material made from nitrile rubber and polyvinyl chloride resin. Typical R value is 3.6, and the perm rating is only 0.17. This material does not require a jacket except for appearance. The flame rating of 50 is valid for all thicknesses. For material 3/8 in. thick and less, a smoked-developed rating of 50 has been established; with 1-in. thickness, the rating is close to 150. Because of the high rating, building codes do not allow use of this type of insulation in all types of construction.

Commonly called "rubber," elastomeric plastic insulation is available in 1/2 and 3/4 in. thicknesses for pipe sizes up to 5 in. in diameter (iron pipe size). Recommended applications for pipe include temperatures from 35° to 220°F, except for sheets, which can be used only up to 180°F because of the adhesive used to apply them to a tank. This flexible insulation is used in pipe spaces and boiler and mechanical equipment rooms, where code requirements may be relaxed and the ease of application could make it the most cost-effective material.

**FOAMED PLASTIC INSULATION** is a continuously molded, closed-cell rigid product made from foaming plastic resin. Plastic materials typically used are polyurethane (C 591), polystyrene (C 578), and polyethylene. A factory-applied jacket is usually provided. Typical R value is 6.7. The fire rating varies by manufacturer because of the wide variety in composition of materials in this category of insulation. Although the materials are combustible, they can be made self-extinguishing. Foamed plastic is recommended for low temperatures, including cryogenic applications, and for moderate temperatures, generally up to 220°F.

**CALCIUM SILICATE (ASTM C 533)** insulation is a rigid material compounded from silica, asbestos-free reinforcing fibers, and lime. At 500°F, it has an R value of 2.0. A field-applied jacket is required.

**MINERAL FIBER (ASTM C 553)** insulation is a rigid material composed of rock and slag made into fibers and bound together with a heat-resistant inorganic binder; typical R value is 4.9. This material is good for high temperature work.

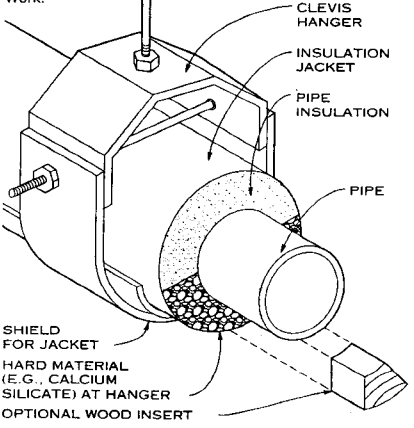

**HARD MATERIAL SUPPORT**

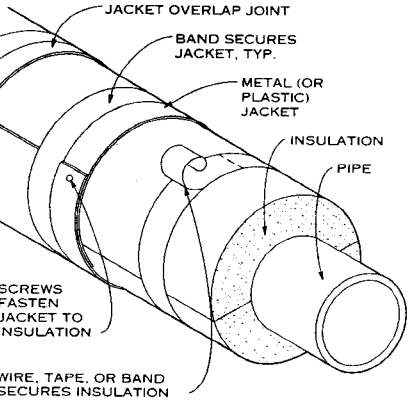

**PIPE INSULATION WITH METALLIC JACKET**

**JACKETS**

A jacket is any material (excluding cement and paint) that can be directly applied to insulation on a pipe, duct, or vessel in order to cover or protect the insulation. The type of jacket chosen depends on the application. Jackets come in various forms and types, which can be divided into three general categories: rigid (plastic, aluminum, or stainless steel), membrane (glass cloth, coated papers, treated papers, and foil- or cloth-laminated papers), and mastic. The most common jacket for fiberglass insulation is an all-service jacket or ASJ, which comprises laminated kraft paper, fiberglass cloth (skrim), and either aluminum foil or metalized film as a vapor barrier. This jacket type is sometimes called an FSK (foil, scrim, and kraft) jacket.

**INSTALLATION**

Proper installation of insulation on a pipe or duct is critical to the longevity of an insulation system. Typical installations of insulation on the outside of a duct, elastomeric insulation around a pipe, insulation with a nonmetallic jacket, and insulation with a metallic jacket are illustrated on this page.

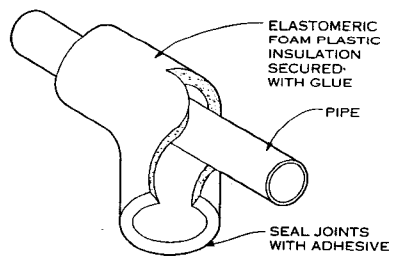

**ELASTOMERIC PLASTIC INSULATION**

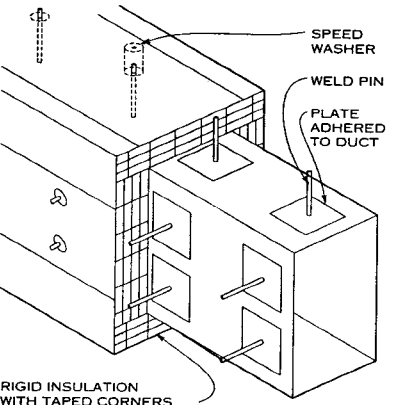

**DUCT INSULATION INSTALLED ON OUTSIDE**

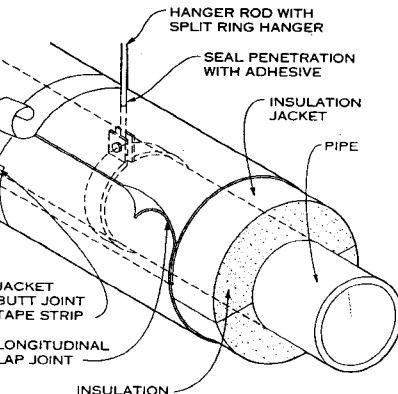

**PIPE INSULATION WITH SPLIT-RING HANGER**

American Society of Plumbing Engineers: Westlake, California  
Michael Frankel, CIPE, Utility Systems Consultants; Somerset, New Jersey

**GENERAL**

A building service is that portion of the supply piping on private property that extends below frost depth from the public utility main into the building. It includes the connection to the main, valves, pressure-reducing devices, backflow prevention devices, meters, and other requirements specific to the individual utility company.

**BUILDING WATER SUPPLY SERVICE**

The water supply service for commercial buildings is often divided into two separate services at the public main—potable water and fire protection water—because of different requirements. However, a single, combined service is sometimes used.

**BACKFLOW PREVENTION**

It is extremely important for a utility company to protect the public water supply from contamination flowing from any building to which it is supplying water. The device used to accomplish this is the backflow preventer (BFP), which prevents contaminated water from flowing backward into the potable water supply.

There are four types of BFP, and the degree of hazard in a particular situation determines which type is selected and installed:

**AIR GAP:** This BFP provides a physical separation between the supply of potable water and the storage tank or piping distribution network. This is a passive method and is considered the only absolutely safe concept.

**REDUCED PRESSURE ZONE:** This type of BFP is a mechanical device used when a high hazard is present. Liquids attempting to flow in reverse discharge out of the BFP instead. When installed in a building water supply, the RPZ backflow preventer should be located as close to the public water main as is practical.

**DOUBLE CHECK VALVE:** This is a mechanical device often used on fire protection water supplies and for smaller size piping that supplies equipment that has a back pressure and is not considered a high hazard.

**VACUUM BREAKER:** This mechanical device is used when there is no back pressure, such as for a submerged water supply to a water closet. It uses a flexible diaphragm that allows water to flow through in only one direction; it closes on itself, stopping flow in the reverse direction.

**NONRESIDENTIAL POTABLE WATER SERVICE**

After connecting a plumbing system to the public water main, it is necessary to provide a method of shutting off the water supply to the building without entering it. A curb valve installed close to the property line is used to serve this function. A second shutoff valve is provided inside the building at the service entrance.

For facilities labeled high hazard, a reduced pressure zone BFP should be installed as close to the public main as is reasonable to protect the public water supply from contamination. Because of the potentially large discharge of water, an aboveground, heated enclosure is recommended. For less hazardous locations, a double check valve assembly may be permitted. No water is discharged from a double check valve.

Water meters are necessary to measure the amount of water used in a facility. The arrangement of the water meter assembly is specific to each utility. The meter could be located in an outside pit or exposed inside the building. The meter used should be selected for accuracy. A compound meter, consisting of separate sections for low and high flows, is often used for applications such as multiple dwellings and dormitories.

A strainer may be required before the meter if solids are present in the water supply. A second backflow preventer may be required on individual water branches supplying specific equipment inside a building.

**WALL HYDRANT**

A wall hydrant is a water supply fixture on the exterior of a building used to attach hoses that maintenance personnel use for cleaning purposes, such as washing walkways. If freezing conditions are even a remote possibility, a non-freeze type hydrant should be installed. To prevent backflow, wall hydrants should be provided with an integral vacuum breaker.

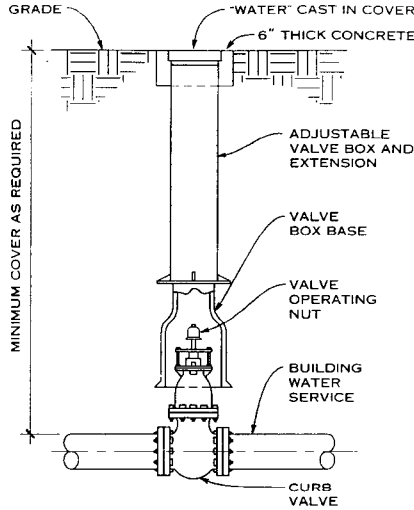

**TYPICAL CURB VALVE AND BOX**

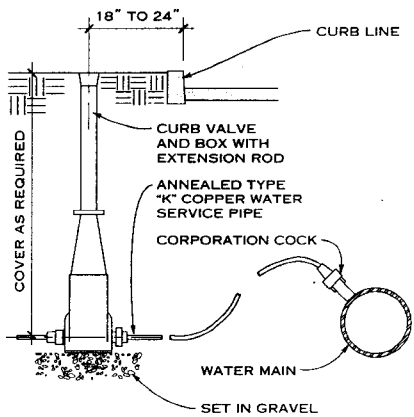

**TYPICAL RESIDENTIAL WATER SERVICE**

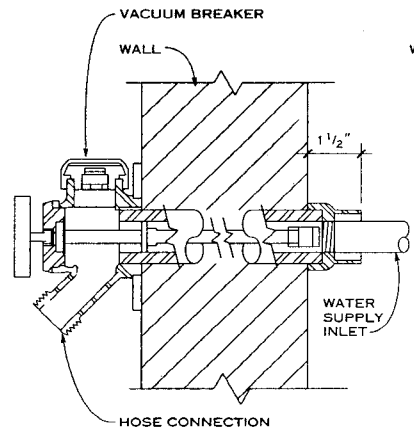

**EXPOSED TYPE  
NONFREEZE WALL HYDRANT**

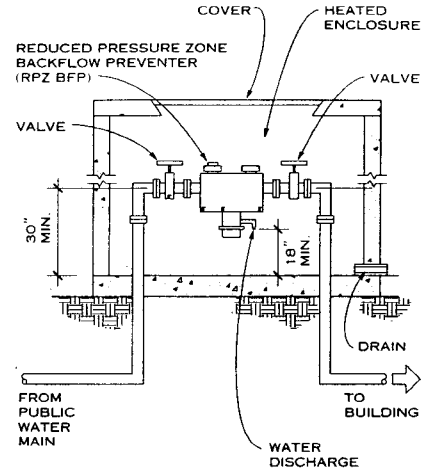

**REDUCED PRESSURE ZONE BACKFLOW PREVENTER (ABOVE GRADE)**

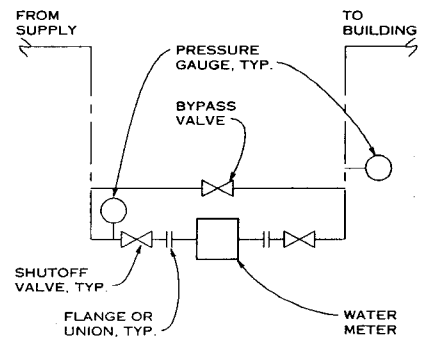

**TYPICAL RESIDENTIAL WATER METER ASSEMBLY**

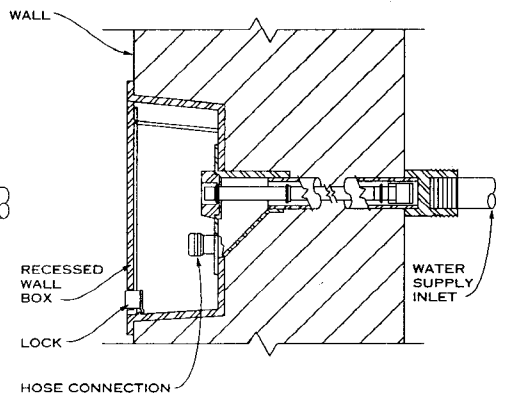

**CONCEALED TYPE**

Michael Frankel, CIPE; Utility Systems Consultants; Somerset, New Jersey

**FIRE PROTECTION WATER SUPPLY**

The purpose of the fire protection water supply is to provide a reliable source of water with the lowest reasonable pressure loss at the maximum flow rate for the most demanding fire-fighting requirements. The system is supplied with water from the site, either from an underground public water main or an elevated or on-grade storage tank of adequate size. The system design and components should strictly conform to various code requirements, including those written by insurance carriers that insure the building.

For larger sites, it is common practice to have a dedicated fire protection water main that can be divided into sections. This division is accomplished with valves that are placed to allow water to reach various portions of the site from two directions. Fire hydrants placed about 250 feet apart in easily accessible places allow fire department pumps to connect directly to a site main. When possible, the hydrants should be located adjacent to significant hazards and a minimum of 50 feet from building walls.

It is good engineering practice to have two separate building water services. However, if only one public main is available, the domestic water and fire protection water services should be divided outside the building so they enter it separately.

Each connection to the public or site water main should have a means of shutting off the water supply to the building that does not require entry. This can be accomplished by installing a valve on the building service branch. A second shutoff valve must be provided inside the building at the service entrance for the use of building occupants.

The fire department must be able to determine quickly whether the valves that control mains and building water supplies on a site are open or closed. A valve mounted on a post extending above grade (a post indicator valve or PIV) is used for this purpose.

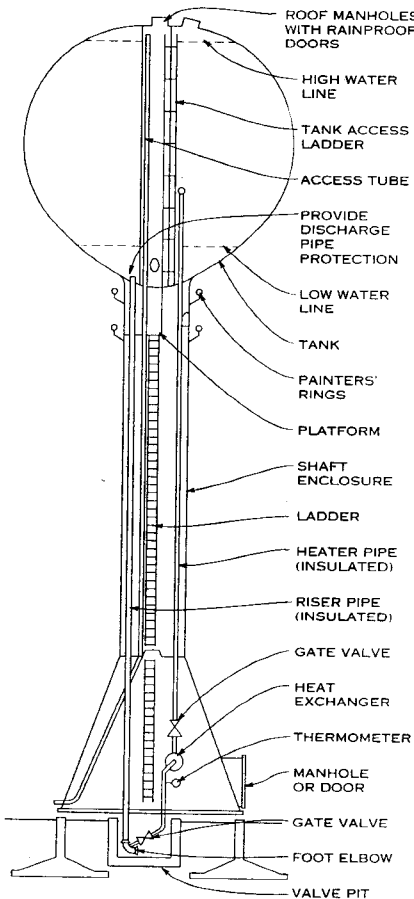

**TYPICAL ELEVATED WATER TANK**

To protect the public potable water main against contamination, a double check valve assembly is commonly provided on the building fire protection service. A reduced pressure zone (RPZ) backflow preventer may be required if there is a source of contaminated water, such as a lake or stream, that a fire department could use as a supply of water in emergency conditions.

Because the water in a fire protection system remains stagnant for long periods, freezing is a major concern. The underground building service water supply line must be buried below the frost line. The depth of frost penetration varies with the climate at the project site; this dimension can be obtained from the National Fire Protection Association. Observation of the minimum depth of bury is important, even in areas not normally subject to frost but where freezing temperatures are occasionally experienced.

**GAS SERVICE**

Fuel gas building service connects to a public main installed by a franchised public utility obligated to provide gas to every customer requesting it. As part of this service, the utility company usually supplies and installs the service line from the utility main to the property free of charge, in addition to providing a regulator/meter assembly in or adjacent to the building.

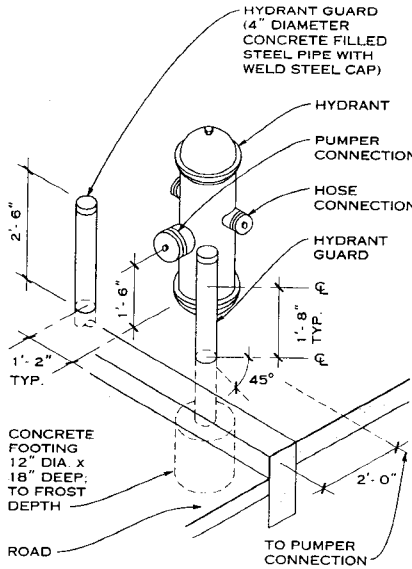

**TYPICAL FIRE HYDRANT**

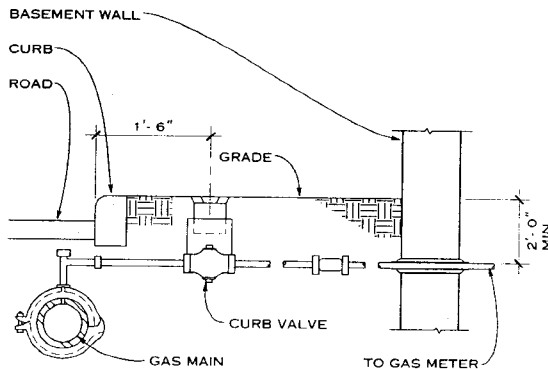

**NOTE**  
For additional meters, the minimum center-to-center dimension is 1 ft 6 in.

**TYPICAL RESIDENTIAL BUILDING GAS SERVICE**

It is important to advise the utility company in writing of the proposal to use gas at a site. This letter should list all the equipment to be connected, the gas requirements of that equipment, and the gas pressure required. Include the location or address of the project and the proposed start date of construction.

The meter assembly usually consists of a main pressure reducer (regulator) to reduce the higher pressure in the utility company mains to the lower pressure used by equipment in the building. The meter is selected by the utility company; exact dimensions are provided upon receipt of the gas letter. The meter assembly for private residences and apartments in multiple dwellings is relatively small. A main meter could be located either indoors or outdoors, although outdoors is preferred to avoid problems from gas accumulation caused by leakage. Individual gas meters, such as those used for private residences and multiple dwellings, are almost always located indoors.

If different gas pressures are required in a single facility, it is more cost-efficient to provide the higher pressure needed for the largest equipment and then to install a pressure regulator at the equipment that requires a lower pressure.

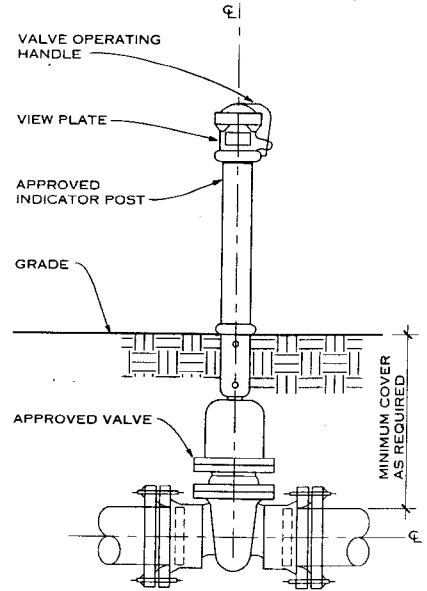

**TYPICAL POST INDICATOR VALVE**

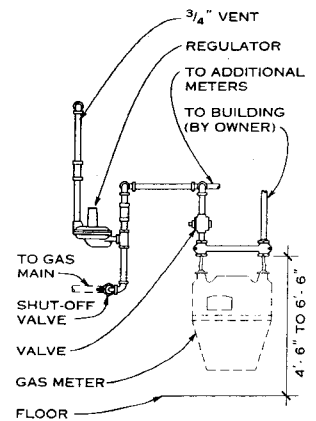

Michael Frankel, CIPE; Utility Systems Consultants; Somerset, New Jersey

**CAST-IRON PIPE**

Cast-iron (CI) pipe and fittings are manufactured in two weight classes: standard and extra heavy. Each class is available either with hub and spigot ends (ASTM A-74) or hubless (CISPI 301 pipe and CISPI 310 fittings).

High-silicon (acid-resistant ASTM A-861) hub-and-spigot cast-iron pipe and fittings are manufactured for laboratory drainage service. Hub-and-spigot pipes are joined with caulked or compression gasket joints and hubless pipe with compression couplings.

Cast-iron pipe is used for nonpressure, sanitary and storm water gravity drainage service above and below grade. The most commonly used pipe above grade is hubless, service-weight cast-iron; below grade it is service-weight, hub-and-spigot pipe with compression gaskets. High-silicon pipe uses caulked joints aboveground and sealing sleeves below grade. Some codes require extra heavy class pipe below grade.

**STEEL PIPE**

Carbon steel (CS) pipe is available in a variety of alloys, the most common being ASTM A-53 for general service and ASTM A-106 for high pressure, high temperature service. Stainless steel (SS) pipe encompasses a variety of alloys and is widely used in the chemical, pharmaceutical, and food processing industries; the most commonly used materials are type 304 and 316.

Steel pipe is manufactured either seamless (extruded) or welded. Wall thickness, known as "schedule," ranges from schedule 5 (thinnest) to schedule 160 (thickest). Steel pipe can be joined by welding or with flanges or threaded joints.

**COPPER TUBE**

Available as either hard (annealed) or drawn (soft) temper, seamless copper (CU) tube can be joined by soldering, brazing, flared joints, and flanges. It is manufactured for specific applications in the following types:

ASTM B-88. Types K, L, and M (thickest to thinnest wall) are used primarily for potable water service and noncritical laboratory gases. Type L hard temper is often used above-ground and type K soft temper underground.

ASTM B-819. Similar to B-88, this tubing is cleaned for laboratory and health care facilities and available only in types K and L hard temper. It is joined mostly by brazing.

ASTM B-75. Termed capillary tubing, this is available only in small diameters and soft temper and is generally used to

connect instruments in laboratory service. It is joined with flare joints and by soldering.

ASTM B-280. Type ACR is available only in small diameters and soft temper and is generally used for air conditioning and refrigeration service. It can be joined with flared fittings or by soldering.

ASTM B-306. Known as DWV for drainage, waste, and vent, this tubing is used for drainage service and is joined by soldering. It has the thinnest wall of any copper product.

ASTM B-837. Type G is primarily used for fuel gas service. It is joined by using soldering and flare fittings.

**BRASS PIPE**

Brass pipes (BR) are made of an alloy of copper and zinc that conforms to ASTM B-43. The proportion of copper varies from 85% (in red brass) to 67% (in yellow brass). Brass pipe is joined by threading, soldering, brazing, or using flanged fittings.

Larger brass pipes are used for potable water and sometimes for branch drainage lines. Fittings and castings made from an alloy different than the pipe may not be suitable for potable water service.

**GLASS PIPE**

Glass pipe (GL) is made from a low expansion borosilicate glass with a low alkali content. It is used for laboratory gravity waste service and is available in sizes up to 6 inches in diameter. Glass pipe must conform to ASTM C-599.

**PLASTIC PIPE**

Plastic (PL) has become the material of choice for piping systems used to convey a variety of liquids, including chemical drainage, pharmaceuticals, sewage, water, liquid fuel, and fuel gases. To convey potable water, plastic pipe must be listed by NSF International.

Plastic materials used for pipe are either thermoplastic or thermosetting. Thermoplastics, the most commonly used pipe materials, soften when heat is applied and rearden when cool so the pipe can be extruded or molded into shapes. Thermosetting plastics must be cured by heating or with a curing chemical to achieve permanent shapes; once shaped, they cannot be reformed.

Subclassifications of plastic pipe are based on the pipe material; the two most common are polyolefins and fluoroplastics.

Following is an explanation of the terms used in various consensus standards for plastic pipe:

1. SDR means standard dimensional ratio. The SDR is found by dividing the average outside diameter of a pipe by the wall thickness. This designation has yielded a series of preferred industry standard numbers that are constant for all sizes of pipe.
2. DR means dimensional ratio and is often incorrectly used interchangeably with SDR. The DR is found in the same way as the SDR and means the same thing but is used when a product does not have the preferred SDR number established by prevailing standards.
3. OD Controlled is the designation used when the outside diameter of a pipe is the controlling factor in its selection.
4. ID Controlled is the designation used when the inside diameter of a pipe is the controlling factor in its selection.
5. PR is a designation used when the pressure rating is the controlling factor in the selection of a pipe.
6. Schedule is a designation used to match the standard dimensions for metallic pipe sizes. The pressure rating of the pipe varies with pipe size. Some standards use iron pipe size (IPS) in lieu of schedule to keep a wall thickness consistent with iron pipe.
7. Plastic pipe can be joined with heat fusion (either butt or socket fusion), flanged joints, solvent cement, or threaded pipe of schedule 80 wall thickness or greater. Consult manufacturers for specific recommendations.

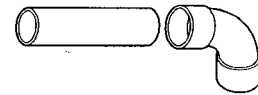

**SOLDERED OR BRAZED (COPPER AND BRASS)**

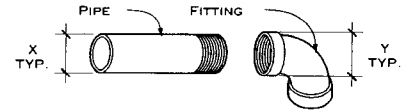

**THREADED (FERROUS AND BRASS)**

**PIPE CONNECTION TYPES**

**PROPERTIES OF PIPE**

NOMINAL PIPE SIZE	O.D. PIPE (DIMENSION X)					O.D. FITTINGS (DIMENSION Y)								WEIGHT OF PIPE (LB/LINEAR FT)				
	STANDARD WEIGHT CAST-IRON	TYPE L AND DWV COPPER	GLASS	SCHEDULE 40 STEEL, BRASS, PLASTIC	CAULKED ELASTOMERIC GASKET	THREADED	FLANGED (150 LB)	BRAZED SOLDERED	COMPRESSION COUPLING	SPLIT COUPLING (GROVED)	FLARED	SOCKET	STANDARD WEIGHT CAST-IRON	SCHEDULE 40 STEEL	TYPE L COPPER	BRASS	PLASTIC	GLASS
1/4		0.37		0.54				0.43			0.61	0.84		0.42	0.12	0.45	0.05	
5/16		0.43						0.49			0.68				0.15			
3/8		0.50						0.56			0.76			0.57	0.19	0.62	0.12	
1/2		0.62		0.84		1.30	3.90	0.70			1.00	1.30		0.85	0.28	0.93	0.18	
3/4		0.87		1.00		1.50	4.00	1.00			1.20	1.50		1.10	0.45	1.30	0.22	
1		1.13		1.30		1.80	4.30	1.40		4.20	1.70	1.80		1.70	0.65	1.80	0.34	
1 1/4		1.34		1.70		2.30	4.60	1.50		4.50	2.10	2.40		2.30	0.88	2.60	0.46	
1 1/2	1.90	1.62	1.90	1.90	3.00	2.50	5.00	1.80	2.80	4.80	2.50	2.70	2.50	2.70	1.10	3.10	0.54	0.87
2	2.40	2.10	2.40	2.40	4.00	3.00	6.00	2.30	3.30	5.50	3.30	3.20	4.00	3.70		4.10	0.74	1.10
2 1/2		2.60		2.80		3.50	7.00	2.80		6.10		3.90		5.80		6.00	1.20	
3	3.50	3.10	3.40	3.50	5.30	4.30	7.50	3.40	4.30	6.80		4.60	6.20	7.60		8.60	1.50	2.00
4	4.50	4.10	4.60	4.50	6.30	5.40	9.00	4.30	5.30	8.30		5.80	8.40	10.90		12.70	2.00	3.40
5	5.50	5.10		5.50	7.30	6.60	10.00	5.40	6.30	9.80		7.00	10.10	14.80		15.80	2.80	
6	6.50	6.10	6.70	6.60	8.30	8.00	11.00	6.30	7.30	10.80		8.00	12.40	19.10		19.00	3.50	6.30
8	8.80	8.10		8.60	11.00	10.60	13.50	8.50	9.30	13.50		9.40	20.00	25.50			5.10	
10	10.80			10.70	13.30	13.10	16.00		11.30	16.80		11.50	30.00	35.70			6.10	
12	12.80			12.70	15.30	15.50	19.00			18.50		13.50	36.00	44.50			8.20	
14				14.70						19.80				46.00			8.70	
15	15.90				18.80								52.00					

1. All dimensions are in inches.  
 2. O.D.—outside dimension, I.D.—inside dimension; refer to illustration of pipe connection types for X and Y dimensions.

American Society of Plumbing Engineers; Westlake, California  
 Michael Frankel, CIPE, Utility Systems Consultants; Somerset, New Jersey



**PIPE FITTINGS**

Fittings are used to connect pipes to one another, to change the direction of flow of fluids within a pipe, and to change the size of a pipe run. Often one fitting is used to provide all these features. An alternative to changing direction with fittings is to bend the pipe itself, but this method is rarely used except for soft temper copper tubing.

Drainage pipe requires special long radius Y-type fittings to achieve the best flow characteristics. These fittings are called sanitary or drainage-type fittings. In addition to the common fittings illustrated, manufacturers make many specialty combination drainage fittings, primarily for multiple-dwelling construction.

In general, fittings are made of the same material as the pipe to which they are attached, with the following exceptions: Fittings for copper tubing are either of a cast copper alloy that conforms to ANSI B16.18 or wrought copper that conforms to ANSI 16.22.4. Threaded fittings for steel pipe are generally cast-iron pressure fittings that conform to ANSI B-16.4 or malleable iron-banded fittings that conform to ANSI B-16.3.

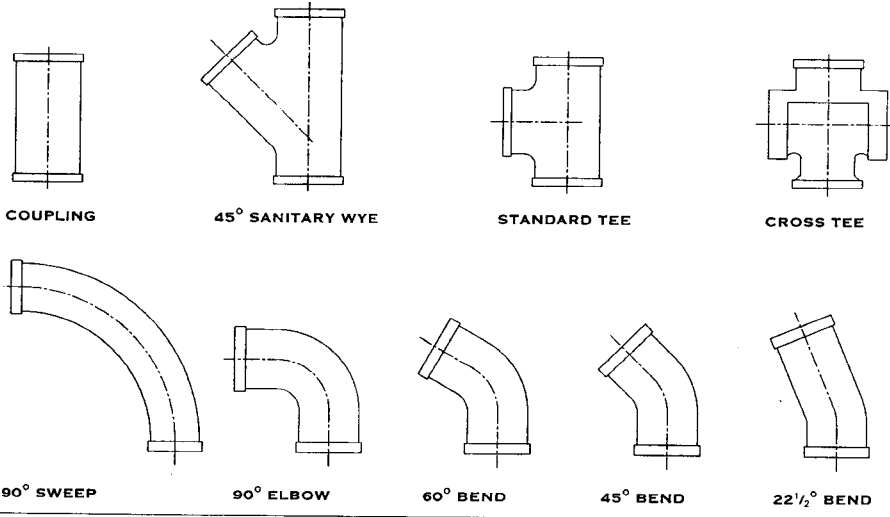

**FIXTURES AND TRAPS**

Plumbing codes establish a minimum acceptable standard for the design, materials, and installation of plumbing systems. Some aspects of these systems may be subject to other regulations as well. For example, health department requirements and utility company rules regulate the public supply of water and gas and the disposal of storm water and sanitary drainage effluent. The information that appears here is general and not meant for design purposes.

A PLUMBING FIXTURE is any approved receptacle specifically designed and manufactured to receive human (sanitary) or other waterborne effluent (waste) that discharges directly into the sanitary drainage system.

A FIXTURE UNIT is a dimensionless, arbitrary, and comparative value assigned to a plumbing fixture to represent the probable flow of water into the fixture or the effluent it discharges into the drainage system as compared to the function of other fixtures. The effluent discharged is different from the water input so they are separated into drainage fixture units (DFU) and water fixture units (WFU).

A FIXTURE TRAP is a U-shaped section of pipe deep enough to prevent the passage of sewer gas into a fixture. Traps must be self-cleaning, provide a liquid seal of at least 2 in. (larger when required), conform to local code requirements regarding minimum size, have an accessible cleanout, and be able to drain a fixture rapidly. All traps must be vented, unless waived by local codes. All fixtures directly connected to the sanitary drainage system must be trapped and vented.

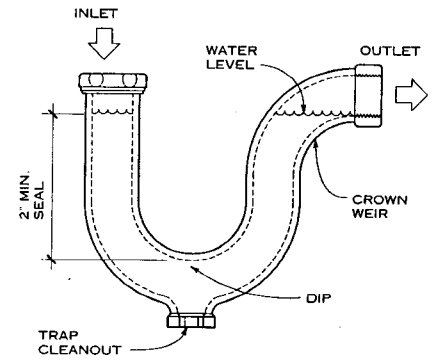

**PIPE FITTINGS**

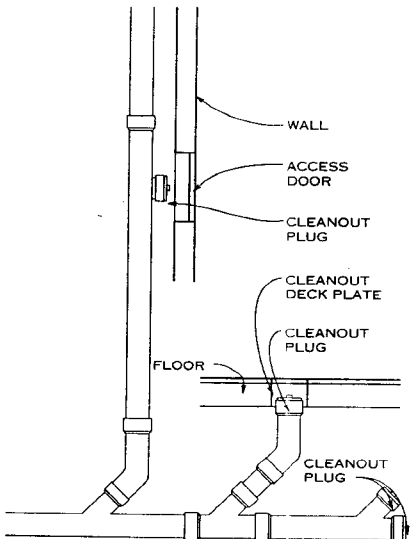

**WALL CLEANOUT** **FLOOR CLEANOUT** **IN-LINE CLEANOUT**

**NOTE**  
Cleanouts are typically used for ferrous or plastic drainage pipe only.

**TYPICAL CLEANOUT INSTALLATION**

**TYPICAL PLUMBING FIXTURE/PIPE SIZE SCHEDULE**

PLUMBING FIXTURE	DRAINAGE			WATER			
	DFU <sup>1</sup>	SIZE (IN.)		WFU <sup>2</sup>	SIZE (IN.)		FLOW (GPM)
		TRAP	VENT		COLD	HOT	
Automatic clothes washer	3	2	1 1/2	2	1/2	1/2	5
Bathroom group (WC, LAV, SH/BT) FV	8			8			
Bathroom group (WC, LAV, SH/BT) tank	6			6			
Bathtub (BT), with or without SH	2	1 1/2	1 1/2	2	1/2	1/2	5
Dishwasher, domestic	2	1 1/2	1 1/2	1	1/2	1/2	3
Drinking fountain (DF, EWC)	1/2	1 1/4	1 1/4	1/2	1/2		1 1/2
Floor drain (FD)	5	3	1 1/4				
Kitchen sink and tray, single 1.5 trap (KS)	2	1 1/2	1 1/2	2	1/2	1/2	3
Kitchen sink and tray, multiple 1.5 traps	3	1 1/2	1 1/2	2	1/2	1/2	3
Lavatory, private (LAV)	1	1 1/4	1 1/4	1	3/8	3/8	2
Lavatory, public (LAV)	2	1 1/4	1 1/4	2	3/8	3/8	2
Laundry tray, 1 or 2 compartments	2	1 1/2	1 1/2	2	1/2	1/2	5
Shower (SH) per head or stall	2	2	1 1/2	2	1/2	1/2	3
Service sink (SS)	3	3	1 1/2	3	3/4	3/4	4
Sink, pot and scullery (SK)	2	1 1/2	2	2	1/2	1/2	4 1/2
Sink, wash fountain, per faucet	2	1 1/2	1 1/2	2	1/2	1/2	2 1/2
Urinal (UR)	4	2	1 1/2	5	3/4		10-20
Water closet private flush valve (WC)	6	3	1 1/2	10	1		15-40
Water closet private tank type	4	3	1 1/2	5	1/2		3-5
Water closet private pressure tank	4	3	1 1/2	4	1/2		3-5
Water closet public flush valve	6	3	1 1/2	10	1		15-40
Water closet public tank type	4	3	1 1/2	5	1/2		3-5
Water closet public pressure tank	4	3	1 1/2	4	1/2		3-5
Wall hydrant, hose bibb						3/4	3

<sup>1</sup> DFU—drainage fixture units  
<sup>2</sup> WFU—water fixture units

American Society of Plumbing Engineers, Westlake, California  
Michael Frankel, CIPE, Utility Systems Consultants, Somerset, New Jersey

**GENERAL**

A joint is required to connect pipe to itself, a fitting, or a piece of equipment. The joint type selected for a particular application depends on the pipe material and wall thickness, pipe contents, system pressure, system temperature, disassembly requirements, and the applicable plumbing code.

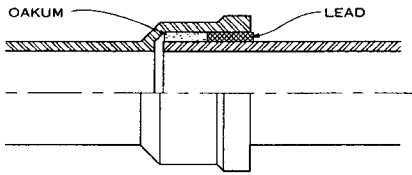

**NOTE**  
Caulked joints are only used to connect metal hub-and-spigot end pipes. Suitable for above- or belowground installation, this labor-intensive, rigid, nonpressure joint has largely been replaced with no-hub compression couplings aboveground and compression gaskets belowground.

**CAULKED JOINT**

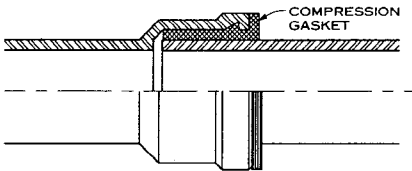

**NOTE**  
Compression gasket joints, used only with hub-and-plain end pipes, are flexible pressure joints suitable for gravity drainage and pressurized liquid systems compatible with the pipe and gasket.

**COMPRESSION GASKET JOINT**

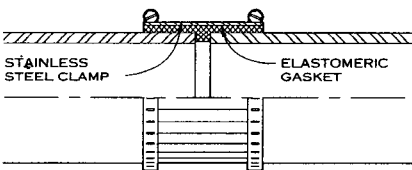

**NOTE**  
Compression coupling joints are rigid nonpressure joints used to join plain end drainage pipes. They are suitable for gravity drainage systems.

**COMPRESSION COUPLING**

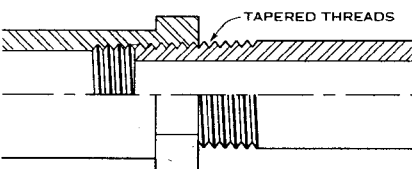

**NOTE**  
Threaded joints can be used for any pipe with walls thick enough to have threads cut. This rigid pressure joint is generally limited to 4-in. pipe as it is difficult to turn larger pipe. Threaded ends come tapered (for plumbing and utility pipe per ANSI B-2.1) and standard (for process pipe systems).

**THREADED JOINT**

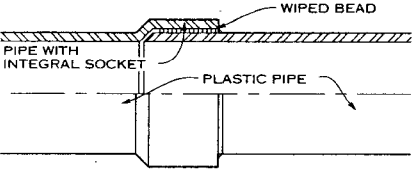

**NOTE**  
Solvent cement joints are rigid pressure joints used only with plastic pipe. Each plastic requires a specific solvent/cement combination recommended by the manufacturer. A joint created with solvent cement looks like a soldered joint, but the cement is used to soften and dissolve the plastic, after which it hardens into a homogeneous joint.

**SOLVENT CEMENT JOINT**

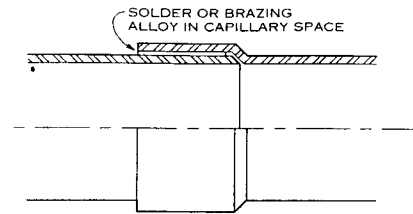

**NOTE**  
Soldered and brazed joints, used to join copper and copper alloy pipe and fittings, are rigid pressure-type joints. The distinction between soldering and brazing is the temperature required to melt the filler metal that enters the joint by capillary action. Solder requires a temperature of 950°F or less, while brazing uses a higher temperature.

Flux is required for solder and some types of brazing filler metal but is prohibited for use with gases installed in health care facilities. Filler metal for soldering consists of 50% tin and 50% lead. No lead is permitted for potable water systems, where an alloy of 95% tin and 5% antimony or a proprietary solder is used.

Soldered joints are used for relatively low pressure applications. Brazing filler metal is of two types: those containing 30-60% silver constitute the BAG class, while those with copper and phosphorus are known as BCuP type. Brazing produces joints stronger than the pipe itself. When used in health care facilities, no flux is permitted.

**SOLDERED AND BRAZED JOINT**

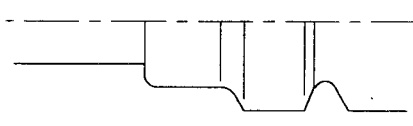
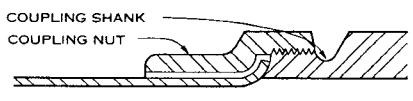

**NOTE**  
Flared joints are rigid pressure joints used for relatively low pressure applications on small diameter pipes made of soft copper or other metals. They are commonly used with capillary piping in laboratories and small diameter underground water piping. Proprietary types of flared fittings are available for high-pressure applications.

**FLARED JOINT**

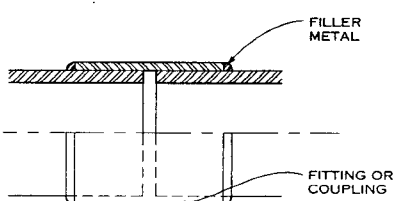
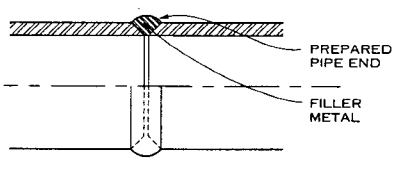

**SOCKET WELD**  
**NOTE**  
Welded joints are rigid pressure joints formed as butt-fused joints or socket welds. Butt-fused joints are created by melting prepared end metal pipes or square end plastic pipes then butting them together and fusing them, which forms a homogeneous joint upon hardening. Metal pipe ends are externally heated and melted with an electric arc or flame and filler metal added to form the joint. For plastic pipe, the ends are melted separately and brought together to form the joint with the use of a special machine. For a socket weld, a plain pipe end is placed inside a socket and the end of the socket fitting is welded to the exterior of the pipe to form a rigid joint.

**WELDED JOINTS**

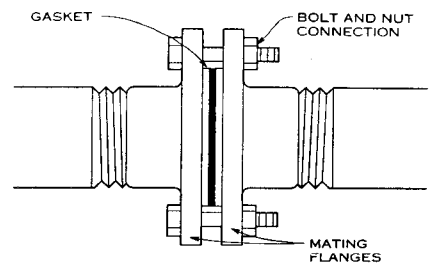

**NOTE**  
Flanged joints are rigid pressure-type joints that use bolts to connect the mating pipe ends, with or without an additional gasket between the ends. Flanges can be installed on the pipe end by welding, threading, or brazing.

**FLANGED JOINT**

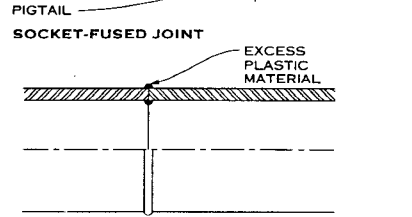
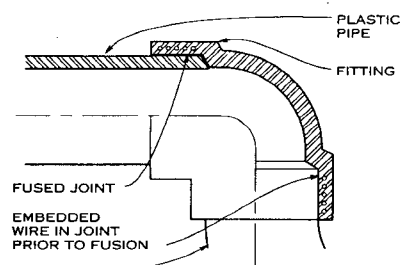

**SOCKET-FUSED JOINT**  
**NOTE**  
Heat-fused joints, used only for thermoplastic pipe, are rigid pressure joints. A special socket fitting has resistance heating wire embedded near the outer edge facing the pipe to be joined, complete with pigtailed extended outside the fitting. An external electrical power source is connected to the wire pigtailed to generate the heat to melt both the inside of the socket and the outside of the pipe in the area where the wire is embedded. When the material is cool, a rigid joint has been formed and the pigtailed are cut off.

**HEAT-FUSED JOINTS**

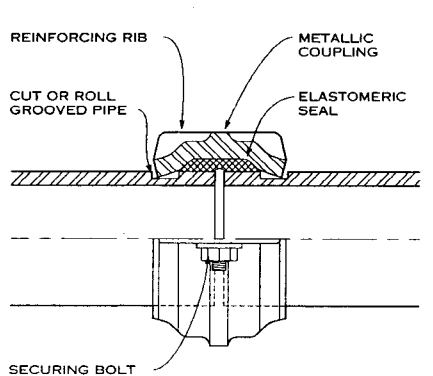

**NOTE**  
Split coupling (grooved) joints require two types of pipe end preparation, roll grooving (shoulder) and cut grooving. The latter method is stronger, but roll grooves must be used when the pipe is too thin for a groove. Couplings must conform to AWWA C606. These rigid pressure-type joints are well-suited for both pressure and nonpressure lines.

**SPLIT COUPLING JOINT**

**ROOF AND FLOOR DRAINS**

A floor drain removes liquids from interior, normally occupied areas of a building and discharges them into either the sanitary or an industrial waste drainage system. A commonly cited standard for floor drains is ANSI A-112.21.

A roof drain removes rainwater from roofs and other areas exposed to the weather (such as balconies or canopies) and discharges the effluent into the storm water drainage system. Specialized drain types are available for installation in specific exposed or interior locations; consult drain manufacturers for details.

Major components of drains are outlined below:

The **GRATE** or **DOME** is the component that allows liquid into a drain body while excluding larger solids. Grates are available in a wide variety of shapes, slot configurations, materials, and load-bearing capability from light to extra heavy. The high dome on the roof drain allows storm water to enter the drain if some debris accumulates at the bottom. A generally accepted practice has the open area of a grate twice that of the discharge pipe. Generally, an adjustable grate allows the grate top to be adjusted to the finished floor level.

A **SEDIMENT TRAP** or **BUCKET** is installed inside a floor drain to trap solids not eliminated by the grate. When space is not available for a sediment bucket, another method is to install a secondary grate.

A **FLANGE** is the part of the drain body that anchors the drain into a slab.

A **FLASHING RING** is provided to secure any flashing directly to the drain body to prevent leakage around the drain. Often, roof drains are provided with an integral gravel stop to keep gravel from built-up roofing from entering the drain.

An **UNDER-DECK CLAMP** is used to secure the drain body to a slab through an opening prior to the installation of any roof, slab finish, or piping.

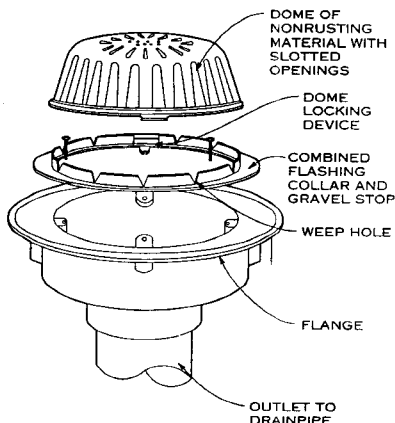

**ROOF DRAIN**

**INTERIOR STORM WATER DRAINAGE PIPE SIZING**

The size of storm water lines is based on the area (in sq ft) of the roof to be drained, the pitch of the pipe, and the rate of rainfall in inches per hour (obtained from the authority having jurisdiction).

To design a drainage system for a project, begin by locating the roof drains and designing the piping network. Next, establish the rainfall rate, and calculate the area contributing rain to each roof drain, including the side wall area (half of the area, in sq ft, of any two adjacent vertical walls).

At each design point add all of the area (in sq ft) for all drains together. In the table sizing horizontal drains, look under the pitch established for the piping in a project and find the figure that equals or exceeds the drainage area calculated. Find the applicable pipe size in the column labeled "diameter of drain."

For vertical drain lines, use the table for sizing vertical lines. Use the table for gutters and leaders to find the pipe size for gutters and leaders draining small areas of roof.

American Society of Plumbing Engineers; Westlake, California  
Michael Frankel, CIPE, Utility Systems Consultants; Somerset, New Jersey

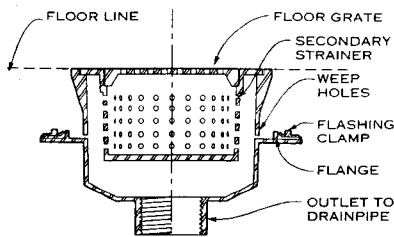

**FLOOR DRAIN (BOTTOM OUTLET)**

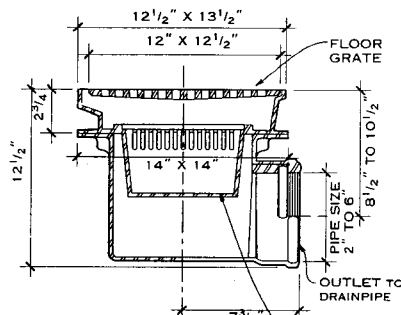

**FLOOR DRAIN (SIDE OUTLET)**

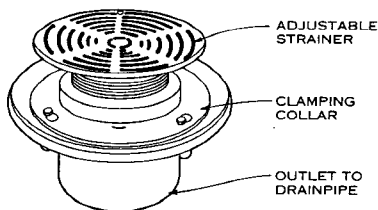

**SHOWER DRAIN ISOMETRIC**

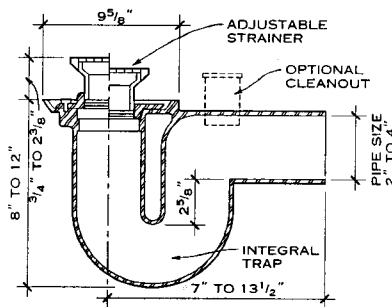

**SHOWER DRAIN SECTION**

**FLOOR AND SHOWER DRAINS**

**SIZE OF VERTICAL CONDUCTORS AND LEADERS<sup>1</sup>**

DIAMETER OF LEADER OR CONDUCTOR (IN.) <sup>2</sup>	MAXIMUM PROJECTED ROOF AREA	
	SQ FT	GPM
2	544	23
2 1/2	987	41
3	1,610	67
4	3,460	144
5	6,280	261
6	10,200	424
8	22,000	913

<sup>1</sup> Based on a maximum rate of rainfall of 4 in./hr and on the hydraulic capacities of vertical circular pipes flowing between a third and a half full at terminal velocity, computed by the method of NBS Mono. 31. Where maximum rates are not 4 in./hr, adjust the figures for drainage area by multiplying by 4 and dividing by the local rate in in./hr.

<sup>2</sup> The area of rectangular leaders should be equivalent to that of the circular leader or conductor required, while the ratio of width to depth of rectangular leaders should not exceed 3 to 1.

**SIZE OF ROOF GUTTERS<sup>1</sup>**

DIAMETER OF GUTTER (IN.) <sup>2</sup>	MAXIMUM PROJECTED ROOF AREA FOR GUTTERS OF VARIOUS SLOPES (SQ FT)			
	1/16 IN.	1/8 IN.	1/4 IN.	1/2 IN. AND VERTICAL
3	170	240	340	480
4	360	510	720	1,020
5	625	880	1,250	1,770
6	960	1,360	1,950	2,770
7	1,380	1,920	2,760	3,900
8	1,990	2,800	3,980	5,600
10	3,600	5,100	7,200	10,000

<sup>1</sup> Sizes shown are based on a 4 in./hr rainfall.

<sup>2</sup> Gutters other than semicircular ones must have an equivalent cross-sectional area.

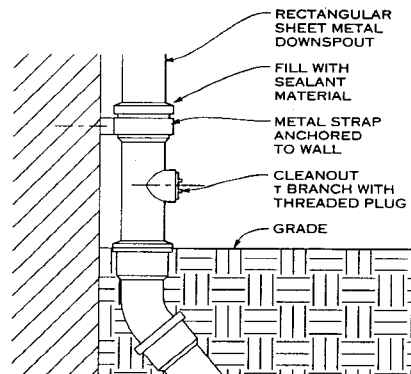

**LEADER BOOT DETAIL**

**SIZE OF HORIZONTAL STORM DRAINS, SINGLE RAINFALL RATE\***

DIAMETER OF DRAIN (IN.)	MAXIMUM PROJECTED ROOF AREA FOR GUTTERS OF VARIOUS SLOPES (SQ FT)					
	1/8-IN. SLOPE		1/4-IN. SLOPE		1/2-IN. SLOPE	
	SQ FT	GPM	SQ FT	GPM	SQ FT	GPM
3	822	34	1,160	48	1,644	68
4	1,880	78	2,650	110	3,760	156
5	3,340	139	4,720	196	6,680	278
6	5,350	222	7,550	314	10,700	445
8	11,500	478	16,300	677	23,000	956
10	20,700	860	29,200	1,214	41,400	1,721
12	33,300	1,384	47,000	1,953	66,600	2,768
15	59,500	2,473	84,000	3,491	119,000	4,946

\*The figures in this chart are based on a maximum rate of rainfall of 4 in./hr. Where maximum rates are more or less than 4 in./hr, adjust the figures for drainage by multiplying by 4 and dividing by the local rate in inches per hour.

**DRAINAGE AND WASTE PIPE SIZING**

The sizing of drainage and waste lines from fixtures is based on total DFUs, the pitch of the drainage pipe, and the classification of the line as a branch, stack, or building drain.

The fixture schedule shows the minimum size line permitted from a fixture. At each design point, add all DFUs together. Enter the chart based on line classification and the pitch of the pipe, and find a figure equal to or greater than the DFUs calculated. Read horizontally to find the pipe size.

The minimum pitch for branches 3 in. and smaller is 1/4 in./ft. For lines 4 in. and larger, it is 1/8 in./ft. A branch interval is the rough equivalent of one floor level. The minimum pitch for building drains (main lines inside the building) and building sewers (main lines outside the building that connect with the public sewer) is 1/16 in./ft.

**BUILDING DRAINS AND SEWERS<sup>1</sup>**

**MAXIMUM NUMBER OF FIXTURE UNITS THAT MAY BE CONNECTED TO ANY PORTION OF BUILDING DRAIN OR BUILDING SEWER<sup>2</sup>**

DIAMETER OF PIPE (IN.)	SLOPE PER FOOT			
	1/16 IN.	1/8 IN.	1/4 IN.	1/2 IN.
2			21	26
1 1/2			24	31
3			42 <sup>2</sup>	50 <sup>2</sup>
4		180	216	250
5		390	480	575
6		700	840	1000
8	1400	1600	1920	2300
10	2500	2900	3500	4200
12	2900	4600	5600	6700
15	7000	8300	10000	12000

<sup>1</sup> On-site sewers that serve more than one building may be sized according to current standards and specifications of the administrative authority for public sewers.

<sup>2</sup> Consult local building codes for exact requirements.

<sup>3</sup> No more than 2 water closets or 2 bathroom groups (except in single-family dwellings, no more than 3 water closets or 3 bathroom groups) may be installed.

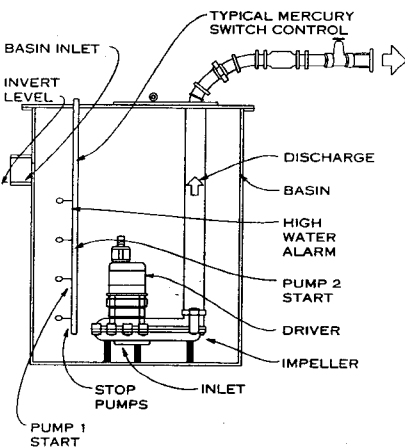

**EJECTOR PUMP FOR SUBMERSIBLE PUMP SYSTEM**

**PUMP SYSTEMS**

Ejector pumps are intended to transport sanitary waste with large suspended solids. Sump pumps transport turbid, non-sanitary effluent with small suspended solids. They use different impellers. Minimum recommended pump running time is one minute for optimum reliability.

To find the basin depth, use the following approximate dimensions as a guide, assuming duplex pumps and starting from the invert of the inlet pipe.

1. From the invert of the inlet pipe, allow 6 in. to the high water alarm.
2. From the high water alarm, allow 6 in. to pump 2 start in a duplex installation.

American Society of Plumbing Engineers; Westlake, California  
Michael Frankel, CIPE, Utility Systems Consultants; Somerset, New Jersey

**DRAINAGE BRANCHES AND STACKS**

**MAXIMUM NUMBER OF FIXTURE UNITS THAT MAY BE CONNECTED TO VARIOUS BRANCHES<sup>1</sup>**

DIAMETER OF PIPE (IN.)	ANY HORIZONTAL FIXTURE BRANCH <sup>2</sup> (DFU)	ONE STACK OF THREE OR FEWER BRANCH INTERVALS (DFU)	STACKS WITH MORE THAN THREE BRANCH INTERVALS	
			TOTAL FOR STACK <sup>3</sup> (DFU)	TOTAL AT ONE BRANCH INTERVAL (DFU)
1 1/2	3	4	8	2
2	6	10	24	6
2 1/2	12	20	42	9
3	20 <sup>4</sup>	48 <sup>4</sup>	72 <sup>4</sup>	20 <sup>4</sup>
4	160	240	500	90
5	360	540	1100	200
6	620	960	1900	350
8	1400	2200	3600	600
10	2500	3800	5600	1000
12	3900	6000	8400	1500
15	7000			

<sup>1</sup> Consult local building codes for exact requirements.

<sup>2</sup> Does not include branches of the building drain.

<sup>3</sup> Size stacks according to the total accumulated connected load at each story or branch interval. Stacks may be

reduced in size as this load decreases, to a minimum diameter of half the largest size required.

<sup>4</sup> No more than 2 water closets or bathroom groups within each branch interval and no more than 6 water closets or bathroom groups on the stack.

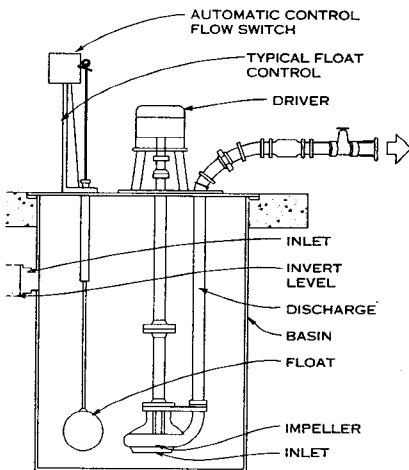

**SUMP OR EJECTOR FOR VERTICAL LIFT SUBMERGED PUMP SYSTEM**

**CAPACITY OF SUMP AND EJECTOR BASINS (GAL/FT DEPTH)**

DIAMETER (FT)	CIRCULAR		SQUARE	
	GALLONS	SIDE (FT)	GALLONS	
2.0	23.50	2.0	30.00	
2.5	36.72	2.5	45.00	
3.0	52.88	3.0	67.50	
3.5	71.91	3.5	90.00	
4.0	94.00	4.0	120.00	
4.5	110.32	4.5	149.60	
5.0	146.89	5.0	187.00	
6.0	158.64	6.0	270.00	
7.0	170.00	7.0	365.50	
8.0	181.00			
9.0	193.00			
10.0	204.00			

3. From pump 2 start, allow 6 in. to pump 1 start.
4. Below pump 1 start, the dimension of the liquid capacity depends on a 1- to 5-min. operating period of the selected pump. The lower level of the storage portion is pump(s) stop. The table on capacity of sump and ejector basins gives the storage capacity of different size basins.
5. Allow 6 in. from pump stop to the inlet of the pump.
6. Allow 1 ft to the basin bottom from the inlet of the pump. This dimension varies according to manufacturer.

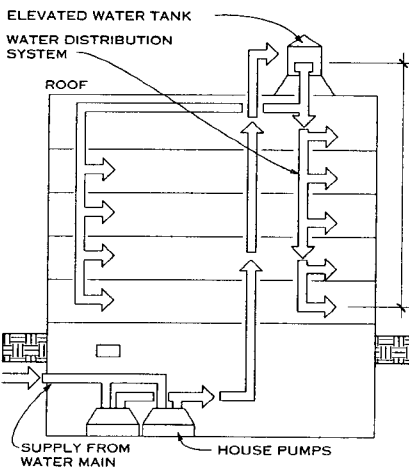

**DOWNFEED WATER SUPPLY SYSTEM**

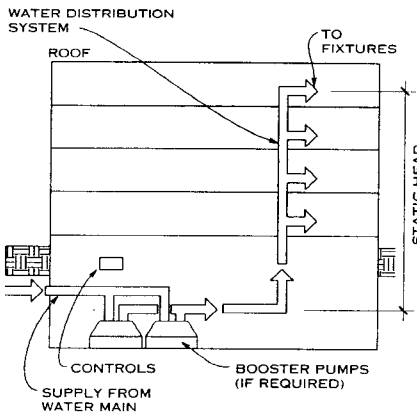

**UPFEED WATER SUPPLY SYSTEM**

7. Sewage and waste effluents have the same hydraulic characteristics as water. Ejector discharge lines should be a minimum of 3 in. and sump discharge lines should be a minimum of 2 in. to prevent stoppages. The pump head is found by adding the distance from the bottom of the basin to one foot higher than the point of discharge and the friction loss of water through the discharge pipe.
8. Duplex pumps generally require a minimum diameter of 4 ft.

**SIZING POTABLE WATER LINES**

Water lines are sized according to flow rate in gallons per minute (GPM), the allowable pressure loss of water flowing through the pipe, and the velocity of the flowing water that has been calculated for each specific project. The GPM is found using "Hunters Curve," which converts water fixture units (WFUs) into GPM. This information is available in the ASPE (American Society of Plumbing Engineers) Data Book. A simplified general procedure for sizing potable water lines is outlined here.

Obtain the elevation and location of the water main and the lowest residual water pressure from the utility company. Also determine the requirements regarding the need for and location of the water meter, backflow preventer (BFP), and shutoff valves. Run the piping from the source into the building on the plans.

When the water source is a well, design the service using good engineering practice. Choose the well location in conjunction with the authority having jurisdiction.

Calculate the available water pressure to a point just inside the building. First, add together all the service losses, such as that caused by the difference in elevation between the main and the point of entry, the water meter, the backflow preventer (if any), valves, and the friction loss of water in the building service. Subtract that figure from the residual pressure in the main.

Calculate the required water pressure for the building by determining the operating pressure for the most remote fixture (ask the manufacturer), the height from the point of entry to the highest fixture, and an estimated friction loss through the water distribution system. If the figure determined is equal to or less than the available pressure, no booster pressure system will be required. If the pressure required is greater than that available, a booster pressure system must be provided.

The friction loss of water flowing through pipes can be obtained from the ASPE Data Book or Cameron's Hydraulic Data (Ingersol Rand). The decision to use an upfeed or downfeed distribution system and the choice of method used to boost the water pressure are based on cost, available space conditions, and aesthetic considerations.

Generally available methods for boosting water pressure include an elevated tank, constant running of booster pumps, and a hydropneumatic system similar to those used for well pump systems. A generally accepted maximum water pressure is 80 psig. Pressures above that require a pressure regulating valve (PRV).

**FUEL GAS LINE SIZING**

Fuel gases are natural gas (mostly methane) and liquefied petroleum gas (LPG), mostly propane. Natural gas has a heating value of about 1,000 British thermal units per cubic foot, although this value varies in different parts of the country.

LPG has a heating value of about 2,500 Btu/cu ft. Most installations require a meter and a regulator to reduce the pressure to about 7 to 10 in. water column pressure at the building, referred to as low pressure. Higher pressures are common, particularly to supply boilers. All pressure requirements are obtained from the utility company. The applicable code is NFPA-54 (the sizing table is used with permission from the National Fire Protection Association, Quincy, Mass.).

Gas lines are sized according to the cubic feet per hour (cfh) flow, allowable friction loss for the piping distribution network, and a diversity factor if applicable. A conservative method of sizing is described here:

1. First, establish the location of equipment using gas, then ask the manufacturer for the cfh flow for each piece of equipment. With the piping network drawn on plans, measure the total horizontal and vertical run, in feet, from the meter to the most remote device. (Vertical runs are ignored for natural gas only.) Next, establish a friction loss for the system. It is common practice to use a loss of 0.3 in. of water column in low pressure systems.
  2. At each design point add the cfh flows for all the equipment. Be sure to apply any applicable diversity factors to allow for the possibility that not all devices will be used at once.
  3. To determine what size gas line is needed, look in the table called "Low-Pressure Gas Pipe Sizing Schedule." First, find the column showing the length of the total pipe run for the application (this is the only distance used). Find the required pipe size in the column on the left at the intersection of the distance column that equals or exceeds the measured distance of the pipe in the project and the row showing the cfh value that meets or exceeds the cfh value calculated for that project.
- The table has been prepared for use with natural gas at a specific gravity of 0.60. To use it for LPG at a specific gravity of 1.50, multiply the cfh figure by 0.63.

**VENT PIPE SIZING**

The purpose of a vent system is to limit the pneumatic pressure in a drainage system to plus or minus one inch of water column. Vent systems terminate in the outside air and connect directly to every fixture trap.

Vent lines are sized using three factors: drainage fixture units (DFUs), the size of the drainage line (or stack) to which the fixtures are connected, and the length of the vent line from the fixture to the vent stack.

The drainage and vent system is assumed to be drawn on the plans and the drainage system sized. At each design point, enter the chart horizontally with the size of the drainage line and the total DFUs. Using the measured length of the vent from the fixture to the vent stack, select a figure equal to or greater than that length. Read vertically up to find the vent line size. The minimum size vent for fixtures is found in the fixture schedule.

**MAXIMUM LENGTH OF TRAP ARM**

DIAMETER OF TRAP ARM (IN.)	DISTANCE FROM TRAP TO VENT (FT)
1 1/4	3 1/2
1 1/2	5
2	8
3	10
4	12

**SIZE AND LENGTH OF VENTS**

SIZE OF SOIL OR WASTE STACK (IN.)	FIXTURE UNITS CONNECTED	DIAMETER OF VENT REQUIRED (IN.)							
		1 1/4	1 1/2	2	2 1/2	3	4		
		MAXIMUM LENGTH OF VENT (FT)							
1.5	8	50	150						
2.0	12	30	75	200					
2.0	20	26	50	150					
2.5	42		30	100	300				
3.0	10		30	100	100	600			
3.0	30			60	200	500			
3.0	60				50	80	400		
4.0	100				35	100	260	1000	
4.0	200				30	90	250	900	
4.0	500				20	70	180	700	
5.0	200					35	80	350	
5.0	500					30	70	300	
5.0	1100					20	50	200	
6.0	350						25	50	200
6.0	620						15	30	125
6.0	960							24	100
6.0	1900							20	70
8.0	600								50
8.0	1400								40
8.0	2200								30
8.0	3600								25
10.0	1000								
10.0	2500								
10.0	3800								
10.0	5600								

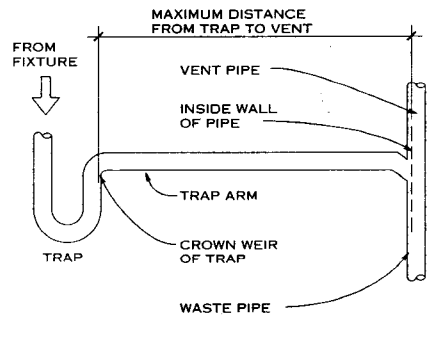

TRAP ARM

**LOW-PRESSURE GAS PIPE SIZING SCHEDULE\***

NOMINAL IRON PIPE SIZE (IN.)	INTERNAL DIAMETER (IN.)	LENGTH OF PIPE (FT)														
		10	20	30	40	50	60	70	80	90	100	125	150	175	200	
1/4	0.364	32	22	18	15	14	12	11	11	10	9	8	8	7	6	
3/8	0.493	72	49	40	34	30	27	25	23	22	21	18	17	15	14	
1/2	0.622	132	92	73	63	56	50	46	43	40	38	34	31	28	26	
3/4	0.824	278	190	152	130	115	105	96	90	84	79	72	64	59	55	
1	1.049	520	350	285	245	215	195	180	170	160	150	130	120	110	100	
1 1/4	1.380	1,050	730	590	500	440	400	370	350	320	305	275	250	225	210	
1 1/2	1.610	1,600	1,100	890	760	670	610	560	530	490	460	410	380	350	320	
2	2.067	3,050	2,100	1,650	1,450	1,270	1,150	1,050	990	930	870	780	710	650	610	
2 1/2	2.469	4,800	3,300	2,700	2,300	2,000	1,850	1,700	1,600	1,500	1,400	1,250	1,130	1,050	980	
3	3.068	8,500	5,900	4,700	4,100	3,600	3,250	3,000	2,800	2,600	2,500	2,200	2,000	1,850	1,700	
4	4.026	17,500	12,000	9,700	8,300	7,400	6,800	6,200	5,800	5,400	5,100	4,500	4,100	3,800	3,500	

\*Maximum capacity of pipe in cu ft of gas per hour for gas pressure of 0.5 psig or less and a pressure drop of 0.3 in water column, based on a 0.60 specific gravity gas (Chart courtesy National Fire Protection Association)

American Society of Plumbing Engineers; Westlake, California  
Michael Frankel, CIPE, Utility Systems Consultants; Somerset, New Jersey

**GENERAL**

Valves are used to turn on or off, control the flow of, prevent the reverse flow of, and adjust the pressure of fluids in a piping system. Operation can be linear (straight up and down) or rotary (multiturn or quarter turn). Valves are classified by the shape of their closure member. Plastic valves are suitable for use in most utility services and are rapidly replacing metallic valves due to their increased corrosion resistance and lower cost. Valves are selected according to resistance to flow; throttling ability; system working pressure; intended service, such as WOG (water, oil, gas), WWP (water working pressure), or WSP (working steam pressure); and jointing method.

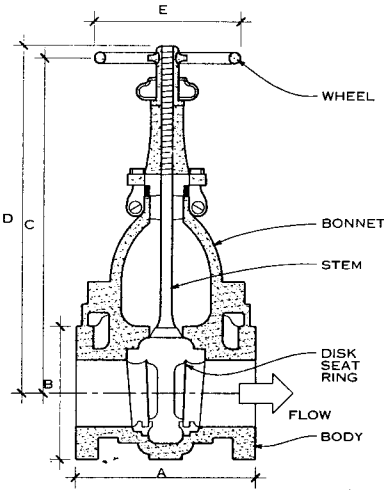

**NOTE**  
Gate valves have a wedge-shaped closure member seated into a metal recess. Used for on-and-off control, generally for liquids, they are available in a wide variety of sizes, body shapes, stem configurations, body and internal materials, and pressure ranges. They are not recommended for throttling service, and they have low resistance to flow.

**GATE VALVE**

**TYPICAL GATE VALVE DIMENSIONS (IN.)**

NOMINAL SIZE	A	B	C	D	E
2	7	6	11 3/4	14 3/8	6
2 1/2	7 1/2	7	12 3/4	16 1/16	6
3	8	7 1/2	14 1/16	18 1/8	8
3 1/2	8 1/2	8 1/2	15 1/4	19 7/8	8
4	9	9	16 7/8	21 3/4	10
5	10	10	20 3/4	26 7/8	12
6	10 1/2	11	23 1/2	30 9/16	12
8	11 1/2	13 1/2	29 3/4	39	14
10	13	16	35 3/4	46 7/8	16
12	14	19	41 1/4	55	18

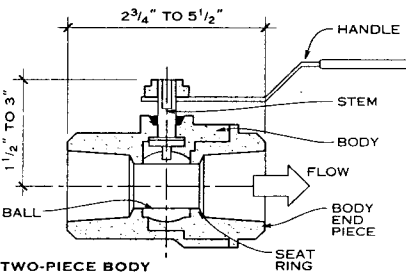

**NOTE**  
Ball valves are named for the round closure member that consists of a round port drilled through the valve and sealed tightly on a resilient seat when turned. Classified as a quarter turn valve, the body is available in one-, two-, or three-

**BALL VALVE**

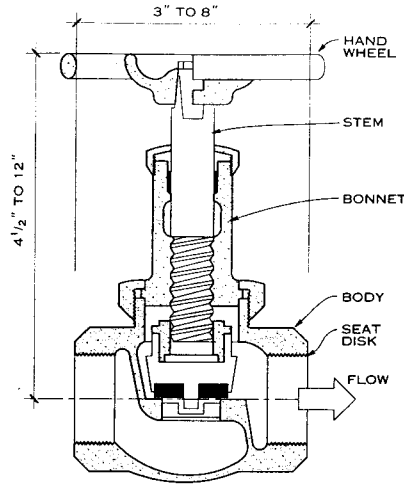

**NOTE**  
Globe valves, named for the round shape of the body, have a closure member that is generally a disc sealed on a resilient seat. Body types include straight through and angle configurations. Used primarily for throttling service, they have a high resistance to flow because of the diverted passage of fluid around the seat.

**GLOBE VALVE**

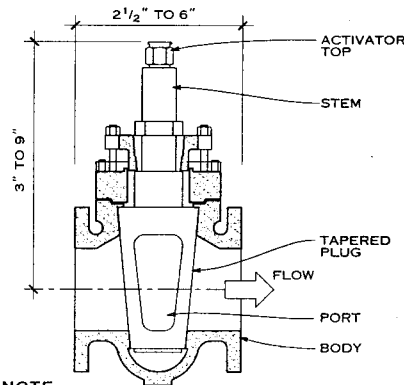

**NOTE**  
Plug valves are named for the tapered, cylindrical closure member, which has a port through it that seals tightly on a resilient seat when turned. Classified as a quarter turn valve, they are available either lubricated (larger sizes) or nonlubricated. They are used primarily for fuel gas service but also for both throttling and shutoff service. They have low resistance to flow and are well-suited for power actuation.

**PLUG VALVE**

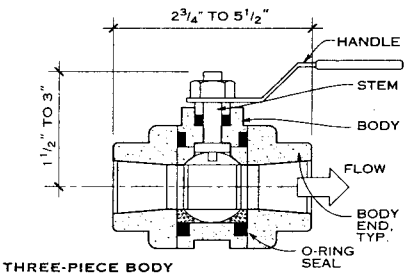

piece construction. Used for throttling and shutoff service, ball valves are suitable for liquids and gases. They are well-suited for power actuation and have low resistance to flow. They are often used for medical gas service when specifically cleaned and packaged for health care facilities.

**THREE-PIECE BODY**

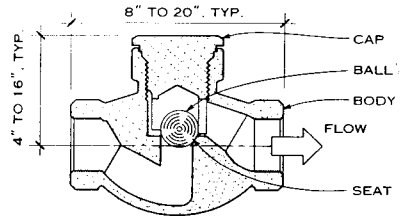

**BALL CHECK**

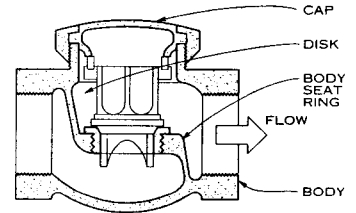

**LIFT CHECK**

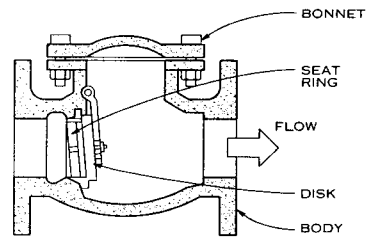

**SWING CHECK**

**NOTE**  
Check valves prevent the reverse flow of fluids. The most commonly used valves are lift and swing types, although ball closures are also available. When used for sanitary drainage service, check valves are referred to as backwater valves.

**CHECK VALVES**

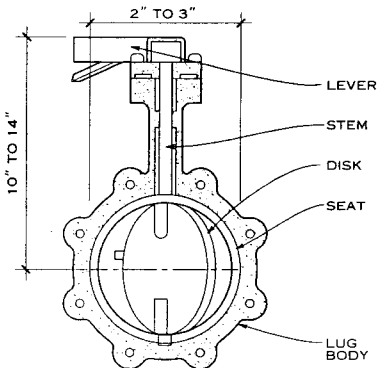

**NOTE**  
Butterfly valves use a thin, rotating disk in the flow path as the closure member, seating on a resilient seal at the perimeter of the valve body. Classified as a quarter turn valve, they are used for both throttling and shutoff service. When no leakage is desired, a "bubble tight" seat is used. Butterfly valves have low resistance to flow and are well-suited for power actuation.

**BUTTERFLY VALVE**

American Society of Plumbing Engineers; Westlake, California  
Michael Frankel, CIPE, Utility Systems Consultants; Somerset, New Jersey

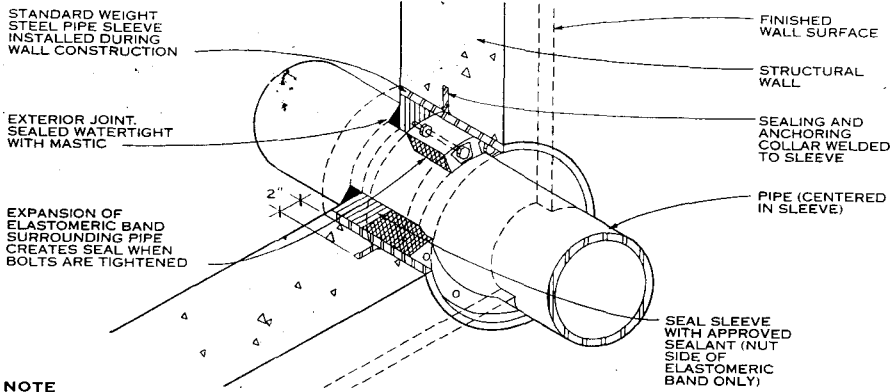

**NOTE**  
This pipe sleeve is for an exterior wall above or below grade. For gas service, extend the sleeve 1 in. beyond the inside face of the wall and 4 in. beyond the outside face of the wall.

**PIPE SLEEVE IN EXTERIOR WALL**

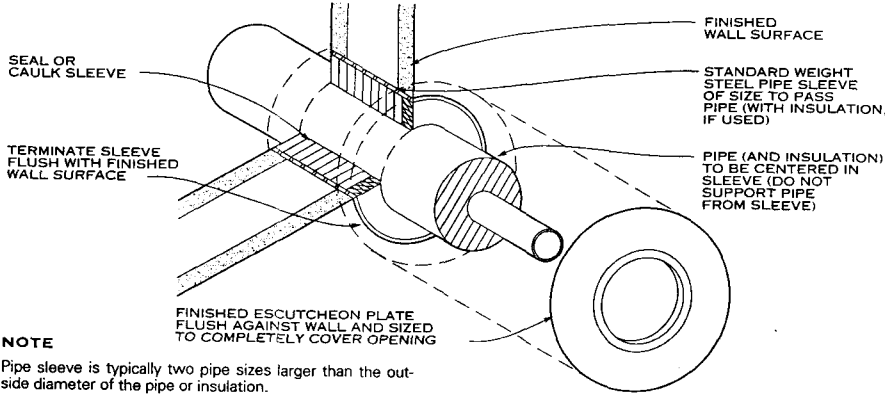

**NOTE**  
Pipe sleeve is typically two pipe sizes larger than the outside diameter of the pipe or insulation.

**PIPE SLEEVE IN INTERIOR WALL**

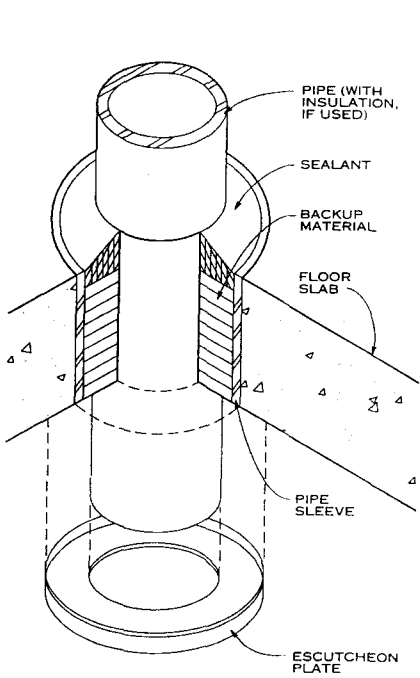

**PIPE SLEEVE IN FLOOR SLAB**

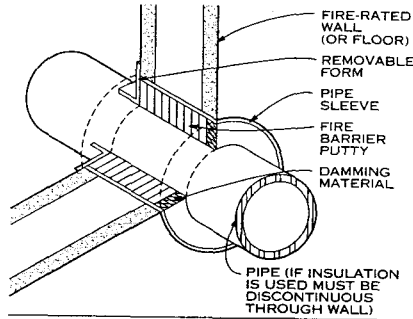

**PIPE SLEEVE IN FIRE-RATED WALL**

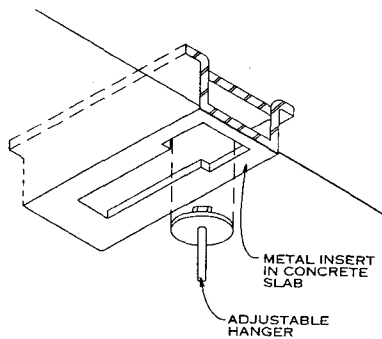

**PIPE HANGER FROM CONCRETE SLAB**

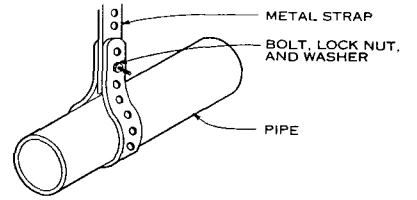

**STRAP HANGER**

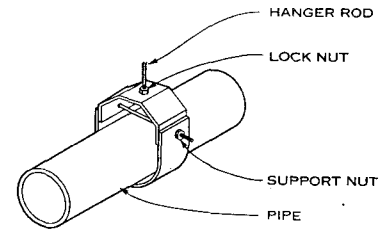

**CLEVIS HANGER**

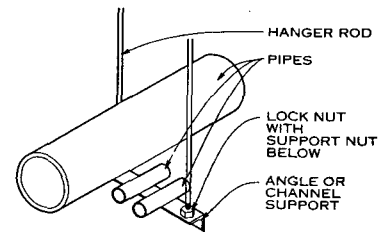

**TRAPEZE HANGER**

**NOTE**  
Hangers are required at all turns and junctions; spacing is determined by pipe size.

**TYPICAL PIPE HANGERS**

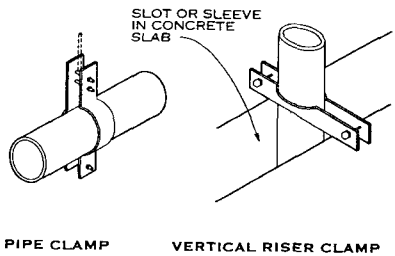
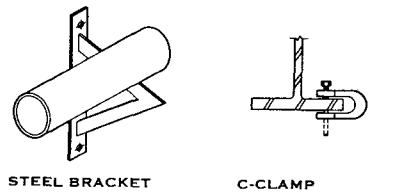
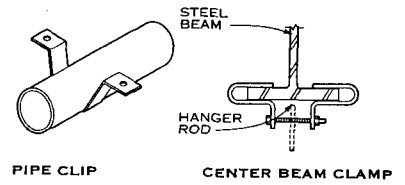

**MISCELLANEOUS PIPE HANGERS AND CLAMPS**

American Society of Plumbing Engineers; Westlake, California  
Michael Frankel, CIPE, Utility Systems Consultants; Somerset, New Jersey

**ADJUSTING WATER PRESSURE**

If the pressure from a water source is sufficient to supply the most hydraulically remote fixture in a building, a street pressure system is the most economical to use. However, when the pressure is not adequate, it must be increased. When it is excessive, it must be reduced.

For high-rise buildings, several height zones are required to keep available pressure within reasonable limits.

**EXCESSIVE WATER PRESSURE**

There is no precise water pressure value below which the pressure will never damage a water distribution system and above which it will always damage the system. Water pressure in a water distribution system is considered excessive if it will damage, or create conditions that will damage, components of the water distribution system or create a nuisance such as water splashing out of a fixture during use or excessive noise in the distribution piping.

A widely accepted maximum water pressure value is 70 psi. Often, the maximum permissible water pressure is stipulated by code.

**PRESSURE-REDUCING METHODS**

Excessive pressure is reduced to an acceptable level by means of a pressure-regulating valve (PRV). This valve lowers and automatically maintains water pressure within predetermined design parameters for both dynamic flow and static conditions. It is a closure device that opens and closes an orifice in response to fluctuations in outlet (regulated) pressure. The degree to which the valve closes depends on the ability of a sensing mechanism to detect changes in water pressure at the outlet side of the valve.

Pressure-regulating valves fall into two general categories: direct-operated and pilot-operated. Very often, a single PRV is not capable of reducing low and high flow rates. When this situation occurs, two PRVs are used in parallel.

**PRESSURE-BOOSTING SYSTEMS**

Water pressure in a building may be increased by means of these pressure-boosting systems: elevated water tanks, booster pumps, and hydropneumatic tanks. A combination of two such systems, called a hybrid system, may be used when a single type is impractical or uneconomical.

**PUMPS USED FOR WATER SYSTEMS**

The pump most often used for water service is the baseplate-mounted centrifugal pump. This type of pump should be directly installed on a housekeeping pad with proper grouting or with vibration isolation devices separating the pump base and the building structure. This arrangement helps prevent noise caused by the transfer of vibration from the pump to the building structure. Vibration isolation devices installed between the pump suction and discharge connections and the distribution piping will prevent transfer of vibration to the connected piping.

**ELEVATED WATER TANK**

In an elevated water tank system, water is pumped from the level where the building water service enters the building up to an elevated water storage tank, commonly called a gravity tank or a house tank. The pump most often used is the centrifugal pump, and it is commonly called a house pump when used for this service.

The house tank is located above the highest and most hydraulically remote point in a building water supply system. The height of the tank provides additional static head, increasing the pressure in the water distribution system.

Advantages of the elevated water tank system are these:

1. It is less complex than either of the other two systems.
2. The least number of components are required to control and operate the system.
3. The system is more efficient and costs less to operate than the other systems.
4. A smaller pump capacity is required than for either of the other two systems.
5. Pressure fluctuations in the system are small.
6. Maintenance requirements are minimized.

Disadvantages of the elevated water tank system in comparison to the other two systems are these:

1. An exposed tank (or the enclosure around it) may be considered unsightly.
2. The building structure may require reinforcement to support the additional weight of the tank and water.

3. The water in the tank and the supply pipes from the tank are subject to freezing if the tank is exposed.
  4. Water pressure on the highest floors may be inadequate for some fixtures.
  5. A catastrophic tank failure could flood the roof.
- The capacity of the house tank depends on the type of facility it will serve. Refer to recommended minimum domestic storage volume for a multiple dwelling gravity tank.

To use the figure, first determine the number of people the system will serve. If this figure is not available, estimate by counting two people per bedroom or four people per apartment, whichever is larger. Multiply the number of people by the gallons (liters) required per person to find the total domestic storage capacity. Add to this figure constant uses of water, such as HVAC makeup and fire protection water storage, if any. Finally, select a standard storage tank size equal to or larger than the required amount of stored water.

The capacity of the house pump(s) is determined by the quantity of water stored for domestic use. In general, a house pump should be capable of replacing the domestic reserve in about 1/2 to 2 hours; 1 hour is a generally accepted value. A duplex pump arrangement (two pumps in parallel), with each pump full size, should be provided so the system is not impaired if one pump is out of service.

A common problem with the gravity tank system is the lack of adequate water pressure on the upper floors of a building unless the tank is elevated to an impractical height. Under these conditions, a hybrid system comprised of an elevated tank plus a small booster pump or small hydropneumatic system used only for the top several floors is suitable.

**BOOSTER PUMP SYSTEM**

A booster pump system is supplied from a water source with insufficient pressure. A control system senses variations in the distribution system and adjusts either the speed of the pump or a pressure-regulating valve to maintain a constant pressure of acceptable value.

Two types of booster pump controls are available for adjusting pressure and flow in the water distribution system: constant speed and constant pressure.

**HYDROPNEUMATIC TANK SYSTEM**

In a hydropneumatic tank system, water is pumped from the water source into a pressure tank for storage. The air in the tank is compressed by the water entering the tank. As the pressure in the tank increases, the pressure in the water distribution system also increases. This arrangement allows the pumps to shut down periodically to conserve energy. During these periods, the system is still able to satisfy the demand for water from that stored in the tank.

A separate air compressor is provided to compensate for any air absorbed by the water. Control of the system is achieved with a combination pressure and level control, which adds water or air to the pressure tank at predetermined levels.

Since the total amount of stored water is relatively small, a pressure tank may run out of water during periods of peak demand unless a very large tank is selected. The fill pumps (house pumps) thus must be sized to meet the peak demands of a building at the lowest calculated system pressure. The piping arrangement of such a system includes a tank bypass arrangement to allow the fill pumps to supply the building directly if a sustained peak demand occurs and there is not enough water in the pressure tank to supply the demand for an extended period.

Because of very high initial cost and the large amount of floor space required, hydropneumatic tank systems are no longer considered for supplying an entire building with water. Booster pumps have replaced hydropneumatic tanks for this application. However, some of these systems still operate in older buildings.

Small hydropneumatic systems are often used with house tank systems or as part of a hybrid system to allow booster pumps to be shut down periodically. A pressure tank may be located anywhere in a building.

**HYBRID SYSTEM**

A hybrid is a combination of two systems. The most common is a small hydropneumatic system used in conjunction with a booster pump for economy in facilities where little or no water is used for extended periods of time. Examples are office buildings or factories that have practically no water usage at night because they are closed. Another hybrid system, with a small booster pump assembly, is used to provide a higher pressure to the upper floors when a house tank is used but the height of the tank is limited.

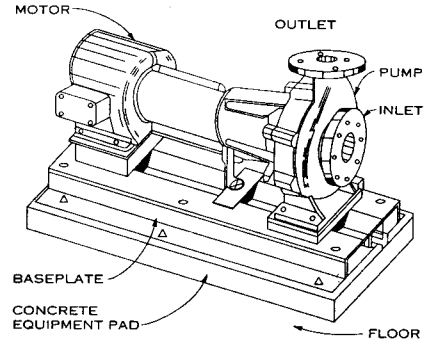

**TYPICAL CENTRIFUGAL PUMP**

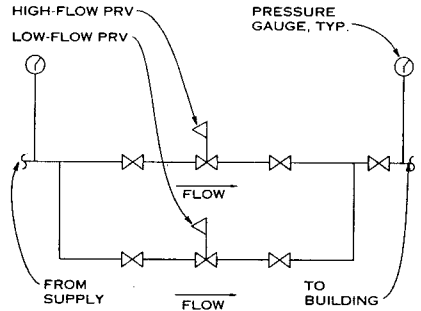

**TYPICAL PRESSURE-REDUCING VALVE (PRV) STATION**

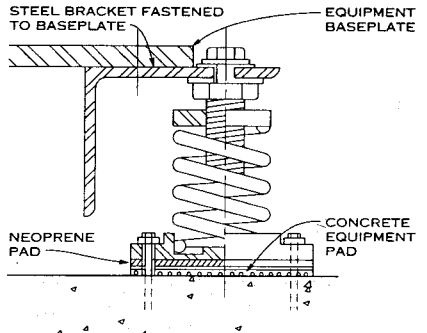

**OPEN-SPRING FLOOR MOUNT**

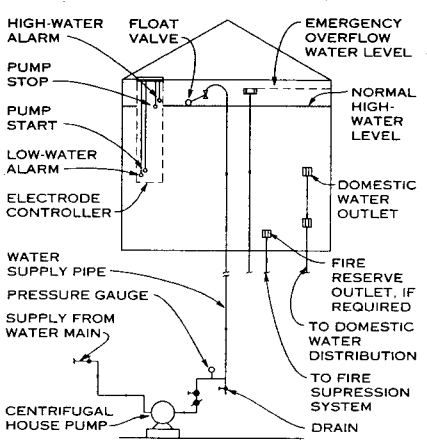

**ELEVATED WATER TANK PIPING ARRANGEMENT**

Michael Frankel, CIPE; Utility Systems Consultants; Somerset, New Jersey



**GENERAL**

Plumbing systems directly affect the health and safety of the public and are distinguished from other piping systems by the following requirements:

1. The design, materials, and installation of the systems are directly regulated by a plumbing code.
2. System design must be approved by an authorized plumbing code official charged with assuring code compliance.
3. A permit for installation of the systems must be obtained from authorities having jurisdiction (AHJ).
4. Systems should be installed by an entity duly licensed by local authorities to install plumbing systems. (This may not be required in some jurisdictions.)
5. Plumbing design plans and installed systems are required to be inspected and approved by an authorized code official charged with code enforcement.

**FIXTURE UNITS**

The fixture unit (FU) is an arbitrary, comparative, dimensionless value assigned to a specific plumbing fixture, device, or piece of equipment. FU values represent the probable flow of water the fixture will discharge into a drainage system or use (demand) from a potable water supply system. The value is assigned by comparison to a lavatory, which has a value of 1 for both water demand and waste discharge.

Since waste discharge and water demand FUs are different, the designation DFU for drainage fixture units and WFU for potable water fixture units can be used to differentiate between them.

**PLUMBING FIXTURES**

A plumbing fixture is any approved receptacle specifically designed and approved to receive human and other waterborne waste and discharge that discharges directly into a sanitary drainage system, usually with the addition of water. Ideal fixture materials should be nonabsorbent, nonporous, nonoxidizing, smooth, and easily cleaned.

Plumbing codes usually mandate the number and type of fixtures that must be provided for specific building uses based on the proposed population. Provisions for persons with disabilities have been made an integral part of code requirements, mandating the number and layout of and barrier-free access to those fixtures.

**EQUIVALENT LENGTH OF PIPING**

When calculating pressure loss through a pressurized piping system, a factor to incorporate is the equivalent length of pipe. This is the actual measured pipe run plus an additional length, expressed as a number of feet of straight pipe that would have the same friction loss as that occurring from turbulence through various fittings, valves, etc. The table entitled "Pressure Loss in Fittings and Valves," shown on the AGS page on Potable Water System Sizing, gives the straight run of pipe for both liquid and gas systems equal to valves and fittings for different pipe sizes. A generally accepted and conservative method of quickly finding the equivalent run is to add 50% of the measured distance to the actual pipe run.

**DEVELOPED LENGTH OF PIPING**

Used only for the vent system, the developed length of an individual or common vent is measured from the connection with the fixture trap arm to the connection with the branch vent or vent stack. This is the measurement used to size vent piping. The developed length of a branch vent is taken from the connection with a waste branch that is farthest from the point being sized. The developed length of a vent stack is taken from its connection with the soil or waste stack to its terminal above the roof.

**PLUMBING SYSTEM TYPES**

The basic plumbing systems are sanitary and waste drainage discharging into a sanitary sewer, vent, storm water drainage, potable water (cold water, hot water, and hot water circulation), and fuel gas systems.

**SANITARY AND WASTE DRAINAGE SYSTEMS**

Sanitary and waste drainage systems convey waterborne effluent from plumbing fixtures and other equipment to an approved point of disposal that discharges into a sanitary sewer or an approved private sanitary treatment system. The drainage system receives all liquid waste except storm water or unacceptably treated process or chemical drainage. Effluent containing bodily waste is referred to as "sanitary drainage." Clear water waste, such as that from equipment, sinks, or showers is referred to as "waste drainage." Untreated waste containing chemical effluent

must be treated before discharge into the sewer system or the environment. Treatment can be carried out either by a public utility or on site with a private treatment plant approved by the local jurisdiction.

The building sewer (or building drain) is the lowest portion of the drainage system inside a building; it is the main line that carries effluent outside the building. The house sewer is a continuation of the building sewer that runs from outside the building to the point of disposal. A stack is a vertical pipe more than three stories high. A shorter stack is considered a branch. A branch line is any drainage line connecting to a stack or the building drain.

**VENT PIPING SYSTEMS**

The purpose of a vent system is to limit the pneumatic pressure in a drainage system to plus or minus one inch of water column. Vent systems terminate in the outside air and connect directly to every fixture trap.

Vent lines are sized using three factors: drainage fixture units, the size of the drainage line (or stack) to which the fixtures are connected, and the developed length of the vent line from the fixture to the vent stack.

**STORM WATER DRAINAGE SYSTEMS**

The purpose of the storm water drainage system is to remove rainwater from roofs and other areas exposed to the weather. Roof drains and gutters convey the storm water to an approved point of disposal. Other areas that require storm water drainage include balconies, walkways, canopies, and awearays. Rainwater enters the storm water drainage system by means of drains.

There are two classifications of roof drainage: conventional and controlled flow (also called limited discharge). Only the conventional roof drainage system, which removes stormwater as quickly as it falls, will be discussed. Information on controlled flow systems can be obtained from the manufacturer of roof drains or standard engineering references.

**FUEL GAS SYSTEMS**

Fuel gas systems deliver gas used to provide light or heat energy in the volume and pressure required to operate all connected devices.

Many different gases are used as fuel gas. Where easily and cheaply available, the two major fuel gases—natural gas (NG) and liquefied petroleum gas (LPG)—are preferred. Other gases are used because of availability. Around the United States, the Btu/cu ft of natural gas can vary from 950 to 1075. Consult the local utility company for the exact value in the project area. The most commonly available natural gas has a Btu value of 1050/cu ft.

**POTABLE WATER DISTRIBUTION SYSTEM**

The water distribution system must be able to provide an adequate quantity of water at acceptable pressure to all fixtures and equipment during periods of maximum building demand and minimum pressure. The actual quantity of water used varies with building use, time of day, and building occupancy.

A street pressure system is suitable when the water pressure supplied from a public water main is sufficient to supply all fixtures and equipment in a building without the use of a pressure boosting system. This generally requires that the static pressure in the public main be no less than 50 pounds per square inch (psi).

A hot water system heats raw water from ambient temperature to a desired higher temperature and delivers the heated water to all plumbing fixtures and equipment requiring hot water. The recommended hot water temperature at the heater is 140°F to avoid the possibility of Legionnaires' disease. A booster hot water system can be used to heat primary service hot water to a higher temperature for a specific purpose.

A hot water recirculation system ensures hot water is quickly available to plumbing fixtures. Generally accepted practice requires that hot water delivered to terminal points of the system reach utilization temperature in 20 seconds or less. Some codes also require a form of temperature maintenance if the distance of a fixture from the heater exceeds a set distance, often 50 ft.

**CODES AND STANDARDS**

Plumbing codes establish minimum acceptable standards for design and installation of plumbing systems and selection of the components they comprise. Regional building codes and the plumbing codes associated with them have found general acceptance in large areas of the country. However, some states and large cities have adopted their own plumbing codes, while some local authorities that use

a regional building code have adopted a plumbing code other than the one usually associated with that building code. Because of the lack of standardization, the plumbing code used for each specific project must be obtained from the responsible jurisdictional authority.

Information pertaining to plumbing system design in local plumbing codes should be the primary criteria for determining accepted methods and sizing. The tables and charts on these AGS pages are used only to illustrate discussions of sizing procedures and design methods. They should not be used for actual design purposes except where no such information is provided in the plumbing code.

The word "approved" is often used in conjunction with components and devices that come in contact with potable water and products used for human consumption or use. Nonetheless, a responsible code official or agency must examine and test these items to determine whether they are suitable for a particular intended use. Only materials and devices approved by the local jurisdiction can be used in plumbing systems. Plumbing design drawings and utility services also must be examined and found to be in compliance with local codes, rules, and regulations.

**DRAINAGE CAPACITY OF PIPING (FLOW CAPACITY IN GAL/MIN)**

PIPE DIAMETER (IN.)	VERTICAL PIPING	HORIZONTAL PIPING (SLOPE IN IN./FT)		
		1/8	1/4	1/2
2	30	—	—	—
2 1/2	54	—	—	—
3	92	36	51	80
4	192	77	110	174
6	563	220	315	449
8	1208	494	696	987
10	2600	943	1302	1800
12	6000	1526	2154	2800
15	—	2973	3500	4950

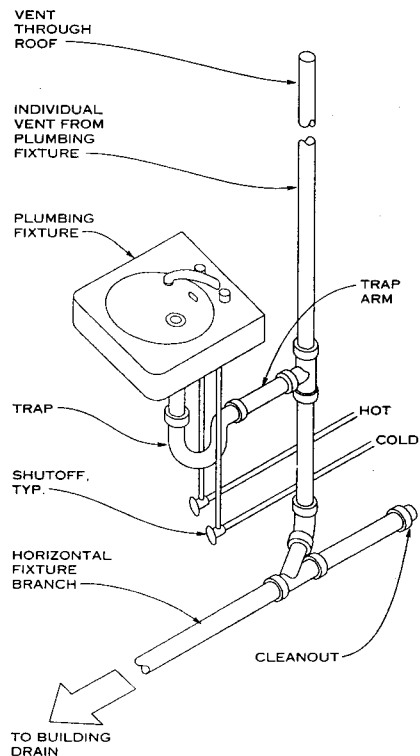

**TYPICAL WATER SUPPLY AND DRAINAGE FROM A PLUMBING FIXTURE**

Michael Frankel, CIPE; Utility Systems Consultants; Somerset, New Jersey

**SANITARY AND WASTE DRAINAGE SYSTEMS**

Sanitary and waste drainage systems remove approved liquid waste from all fixtures and equipment for disposal into the sanitary sewer.

**DESIGN CONSIDERATIONS**

1. Plumbing codes require that any substance harmful to either the building drainage system, the public sewer, or the municipal sewage treatment process be prevented from entering the public sewer system by the installation of an approved interceptor. Such materials include grease, flammable liquids, sand, or other substances local authorities determine are objectionable.
2. When ultra-low flow (ULF) water closets (1.6 gallons per flush) are required by code, take care not to place these fixtures at the end of a long run with shallow pitch and few other fixtures. Field experience has shown such a setup regularly produces stoppages because it does not provide enough water to create the necessary scouring action in the drainage pipe.
3. Where public sewers are available, connect the house sewer to the public sewer. Plugged outlets called laterals are often provided for future connections to the public sewer. If no laterals are available, a direct connection is made. Some jurisdictions require a house trap on the building sewer inside a building; others do not.
4. In the absence of public sewers, a private sewage disposal system must be provided. The most commonly used is a septic tank system, which depends on bacterial action to change most solids into a liquid, which is then discharged into an underground absorption field. The basic principle is to have the volume of household effluent conditioned by the septic tank and the discharge from the tank absorbed into the ground as quickly as it is discharged. Laundry machines should be routed to separate drywells since the soap and other chemicals retard or stop bacterial action in a septic tank. Grease should be disposed of separately. The design, selection, and location of septic tank system components are strictly governed by local codes, requirements of which vary widely.
5. Install piping in trenches with particular care to avoid sagging and other movement. The configuration of the backfill requirements varies between plastic and metal pipe.
6. Construct pipe passing through walls, floors, and roofs so it adequately seals against moisture penetration.

**VENT SYSTEM**

A vent system equalizes the pneumatic pressures, both positive and negative, within a sanitary piping network.

**DESIGN CONSIDERATIONS**

1. The size of a vent stack should be a minimum of half the size of a drainage stack. The size of a branch vent should be a minimum of half the size of the branch drainage line it serves.
2. Each individual fixture vent must rise above the flood level of the fixture served before it is connected to another vent line so as not to act as a waste line in the event the drain line becomes blocked.
3. To size a vent stack, use the DFU (drainage fixture unit) load for the entire drainage stack and the full developed length of the vent from the lowest connection up to the roof. Vent stacks must be undiminished in size for the entire length.
4. For branch vents, use the longest developed length, from the point where the size is being determined to the farthest connection to a branch waste line.
5. Building traps, where installed, should have a vent called a fresh air inlet. The inlet should be half the size of the building drain, with a minimum size of 4 in.
6. Vent pipes that pass through a roof must remain open under all circumstances. The two most common causes of blockage in exposed pipes are frost closure and snow closure. Local codes and authorities will provide the minimum height needed to avoid closure by accumulated snow on a roof. This dimension is often 2 ft 0 in.
7. In the absence of specific code requirements, the following can be used as a guide for locating vent extensions: The vent extension should not be located under or within 10 ft of any window, door, or ventilating opening unless it is 2 ft above that opening. If the terminal is through a building wall, it should be located a minimum of 10 ft from the property line, a minimum of 10 ft above grade, and not under any overhang.

**FUEL GAS SYSTEMS**

Fuel gas systems deliver gas at the required pressure for heat and light energy to all connected equipment and devices in a facility.

**DESIGN CONSIDERATIONS**

1. The specific gravity of the available gas, which varies with the Btu content of the gas, is critical to calculating the pipe size. Gas with a value of 1050 Btu/cu ft has a specific gravity of 0.60. LPG has a specific gravity of 1.50. The local utility company can provide the correct value for the project site. To size piping with a specific gravity different than 0.60, which was used as a basis for the sizing table that appears on the AGS page called Pipe Fittings and Pipe Size Schedule, multiply the flow rate by the factor found in the multipliers table below.
2. A utility company may provide several different types of service, each with a different cost (or rate). Specific types of service may be unavailable or known by different names in various localities:  
**FIRM SERVICE** provides a constant supply of gas under all conditions without exception. This service comes at the highest rate.  
**INTERRUPTIBLE SERVICE** allows the utility company to stop the gas supply to the facility under predetermined conditions and to start it again when these conditions no longer exist. The most common condition usually occurs when the outside temperature falls below a certain point. The rate for interruptible service is lower than that for firm gas; however, it is necessary to have a backup source of fuel, such as fuel oil or liquid petroleum gas, when using this service.  
**LIGHT OR HEAVY PROCESS SERVICE** is used when large volumes of gas are required for manufacturing applications.  
**COMMERCIAL/INDUSTRIAL SERVICE** is used when large volumes of gas are required for space heating and industrial process use.  
**TRANSPORT GAS** is reserved for large users that buy gas at the wellhead and have it transported to the site via utility company mains.

**MULTIPLIERS FOR SPECIFIC GRAVITIES OTHER THAN 0.60**

SPECIFIC GRAVITY	MULTIPLIER	SPECIFIC GRAVITY	MULTIPLIER
0.35	1.31	1.00	0.78
0.40	1.23	1.10	0.74
0.45	1.16	1.20	0.71
0.50	1.10	1.30	0.68
0.55	1.04	1.40	0.66
0.60	1.00	1.50	0.63
0.65	0.96	1.60	0.61
0.70	0.93	1.70	0.59
0.75	0.90	1.80	0.58
0.80	0.87	1.90	0.56
0.85	0.84	2.00	0.55
0.90	0.82	2.10	0.54

**STORM WATER DRAINAGE SYSTEM**

Storm water drainage systems remove rainwater from all exposed portions of a building for discharge to an approved point of disposal.

**DESIGN CONSIDERATIONS**

1. Most codes require a fail-safe method of removing excess rainwater from a roof before water accumulates to the point at which structural damage will occur. The preferred method is use of rectangular holes through the parapet called scuppers to allow water to drain down the side of the building. Another method places secondary drains immediately adjacent to the primary drain but with a water inlet elevation about 3 in. higher than the roof. The applicable plumbing code must be consulted for the size and routing of the secondary roof drainage system.
2. The final point of disposal into a public sewer system can be either a storm water sewer that accepts only storm water or a combined storm water and sanitary sewer into which both types of effluent are drained.
3. When no public sewers are available, storm water is discharged into dry wells, site gullies, watercourses, and recharge basins, which are large storage basins that allow water to both evaporate and be absorbed into the ground.
4. The following information must be obtained before designing a storm water drainage system:  
**ULTIMATE POINT OF DISPOSAL:** Find out whether storm water on the site will drain to a storm sewer (a sewer dedicated to storm water), a combined sewer (a sewer receiving both sanitary drainage and storm water), a watercourse, a street, or a gully on the site.

**RESTRICTIONS:** Find out if any storm water management programs or restrictions are in effect for the project site.

**JURISDICTION:** Find out which authorities are responsible for approval of plumbing plans and installations at the site.

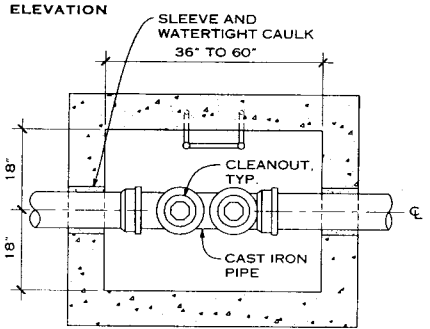
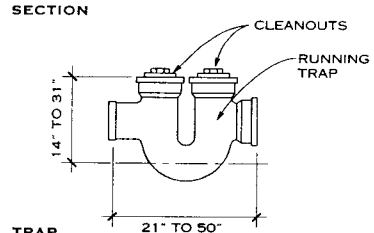
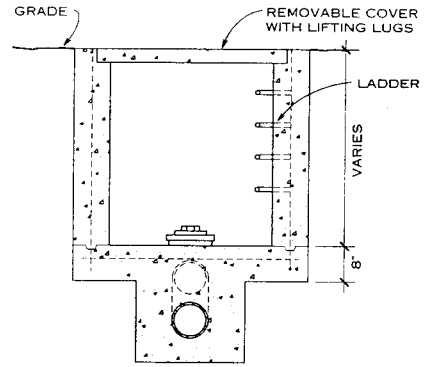

**TYPICAL HOUSE TRAP PIT DETAIL**

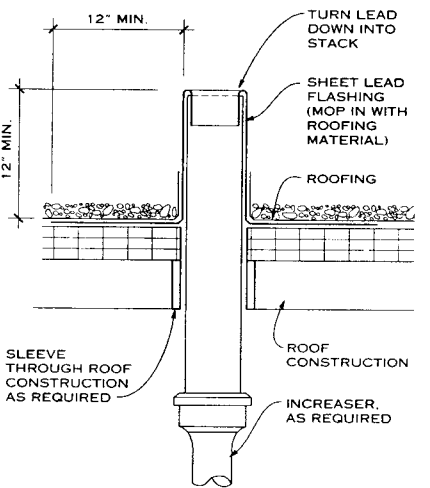

**ROOF VENT DETAIL**

Michael Frankel, CIPE; Utility Systems Consultants; Somerset, New Jersey

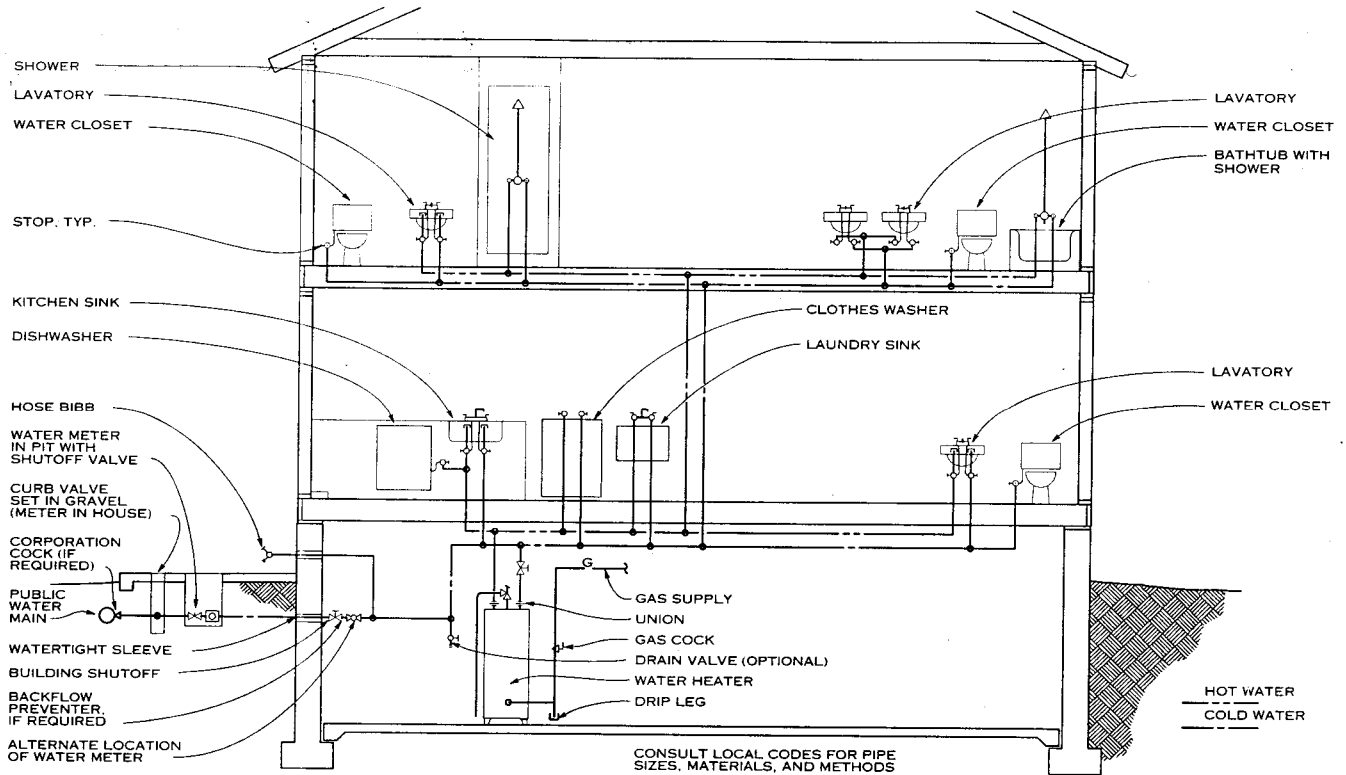

**WATER SUPPLY PIPING**

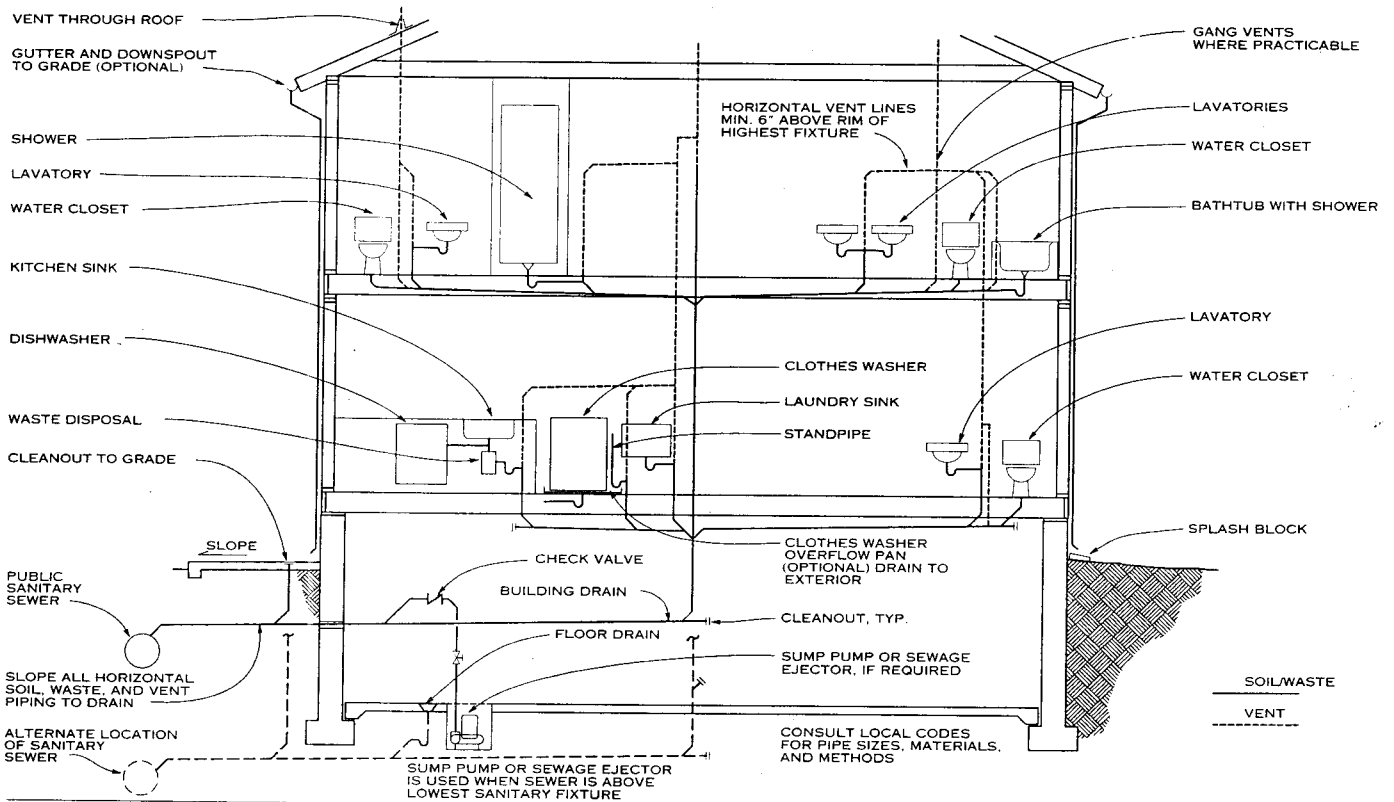

**DRAINAGE AND VENT PIPING**

Brent Dickens, AIA, Architecture & Planning; San Rafael, California  
 Michael Frankel, CIPE, Utility Systems Consultants; Somerset, New Jersey  
 American Society of Plumbing Engineers; Westlake, California

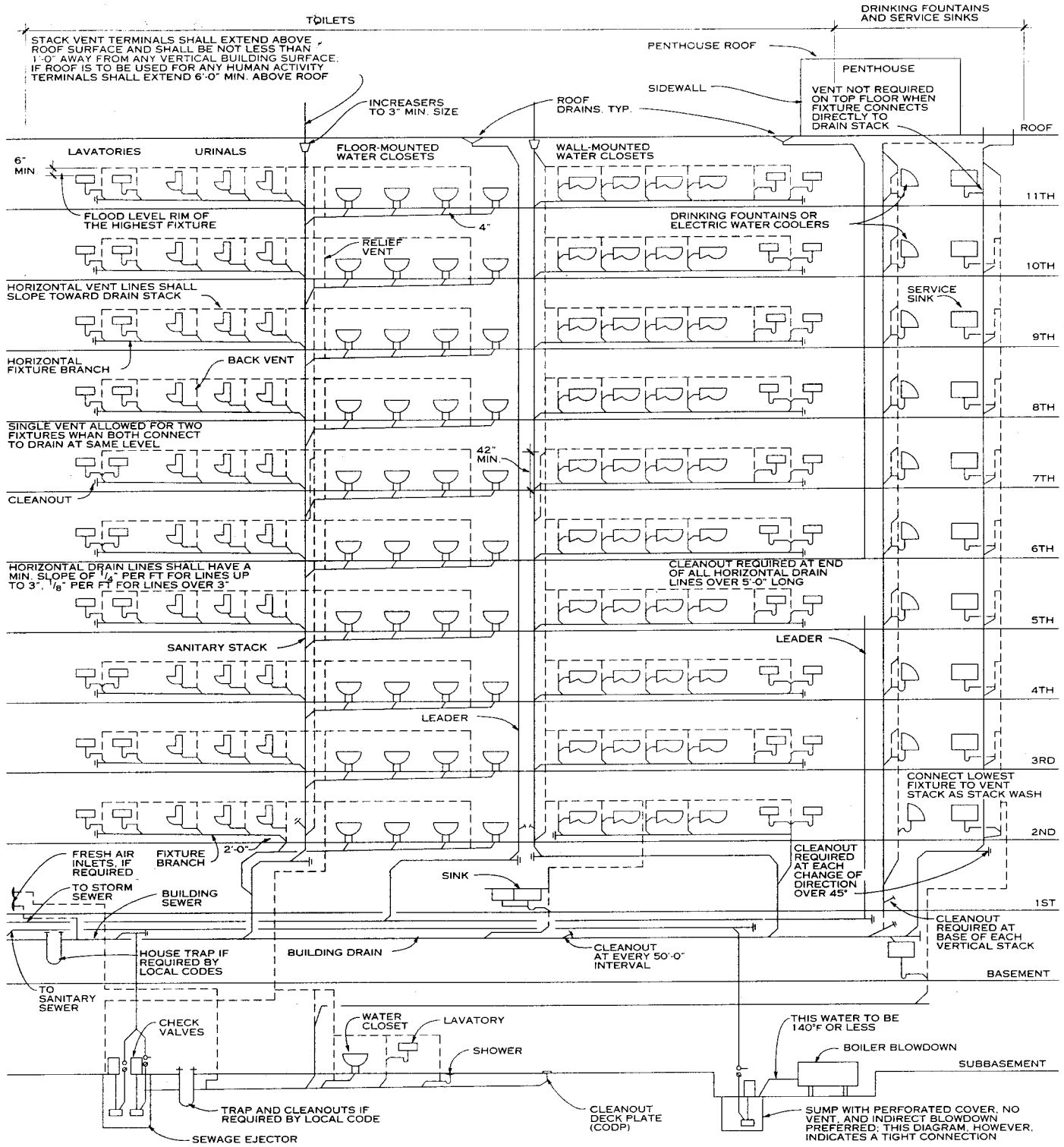

- NOTES**
1. This diagram generally illustrates plumbing drainage solutions that constitute good plumbing practice. Because of variations in local code, some of the items shown may be prohibited in some areas, while others may far exceed the minimum requirements of a local code.
  2. Always consult local codes for exact requirements and for such items as fixture unit values, pipe sizing, pipe materials, general regulations, and special conditions.
  3. Forty-five degrees or less from vertical may be considered as straight stock in sizing, except that no fixtures or branches may be connected within 2 ft. of offset.

Killebrew/Rucker/Associates, Inc., Architects/Planners/Engineers; Wichita Falls, Texas  
 Michael Frankel, CIPE; American Society of Plumbing Engineers, Somerset, New Jersey

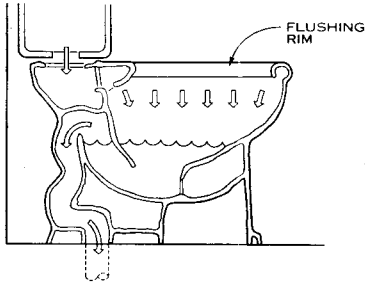

**REVERSE TRAP NOTE**

Water is introduced into the fixture only through the rim by a gravity flush tank. This action is low cost and used mostly for residential projects. Reverse traps may be used with flush tanks or valves.

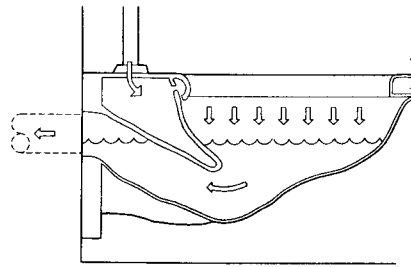

**BLOWOUT NOTE**

Water is introduced at high velocity through jets at the bottom of the waterway in blowout action. This action is used for public facilities and industrial projects because of its ability to remove larger objects thrown into the fixture. Blowouts are used with flush valve water supply only.

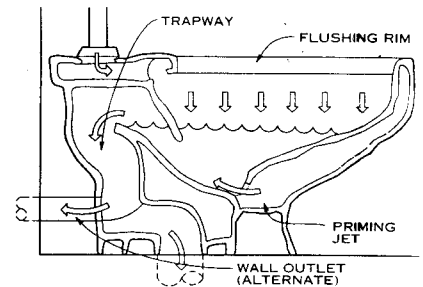

**SIPHON JET NOTE**

Water is introduced into the fixture both through the rim and by a jet at the bottom of the waterway. Quiet flushing and moderate cost make this the most commonly used flushing action. Less costly variations include "washout" and "washdown" actions that do not use the jet. The siphon jet can be used with flush valves or tanks.

**FIXTURE FLUSHING ACTION TYPES**

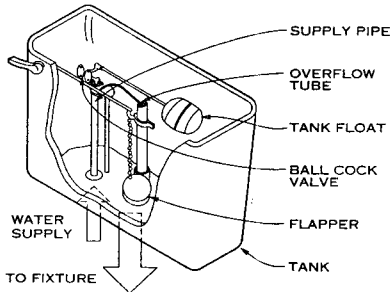

**GRAVITY FLUSH TANK NOTE**

Water enters the tank through a ball cock and is stopped when the float valve reaches a predetermined level. The handle raises the flapper to release all the water in the tank into the fixture and stops when the flapper closes. Gravity flush tanks require 10 psi water pressure.

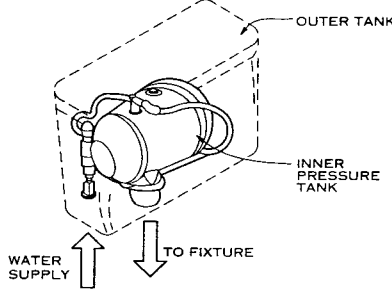

**PRESSURE-ASSISTED FLUSH TANK NOTE**

Water enters a pressure tank installed inside an outer tank, partially filling the tank and compressing the air inside. When flushing is started, the air pressure causes the quick release of water into the fixture. Pressure-assisted flush tanks require 30 psi water pressure.

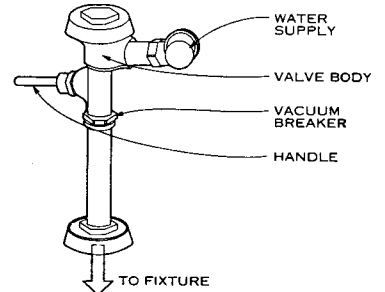

**FLUSH VALVE NOTE**

Flush valves are available in a wide variety of manual and automatic operation fixtures, some with infrared and other proximity sensors. Once flushing has started, a measured quantity of water is quickly introduced into the fixture. Flush valves require 25 psi water pressure.

**FIXTURE WATER SUPPLY TYPES**

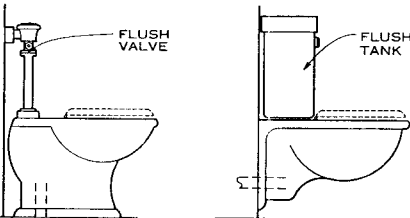

**NOTES**

1. Flush valves and tanks can be installed on either floor-mounted or wall-mounted water closets.
2. ADA 4.16 (Water Closets) describes grab bar requirements for water closets. ADA 4.17 (Toilet Stalls) describes approach, floor space, and grab bar require-

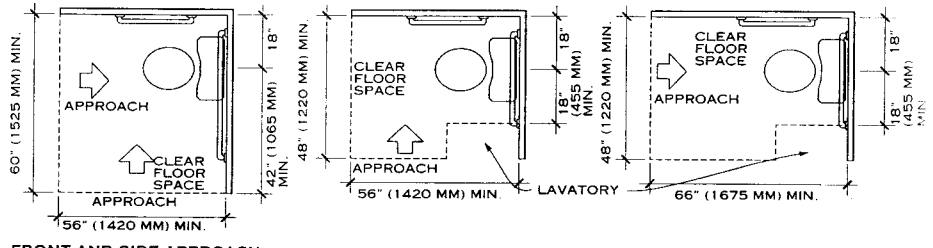

**FRONT AND SIDE APPROACH**

**SIDE APPROACH**

**FRONT APPROACH**

ments for water closets within toilet stalls (see AGS ninth edition page on "Accessible Water Closets, Stalls, Urinals, and Lavatories"). Water closet height should be 17-19 in. to the top of the toilet seat. Seats should not spring up. The force required to activate controls should be a maximum of 5 lbf. Mount controls on the wide side of the toilet no more than 44 in. above the floor.

3. For rough-in dimensions, refer to manufacturers' manuals.
4. Special toilet types are sometimes used, such as vacuum-vented toilets, composting toilets, and chemical toilets.
5. Current code requires that water closet flush valves and tanks be limited to 1.6 gal. maximum per flush of water.

**WATER CLOSET MOUNTING TYPES AND CLEARANCES**

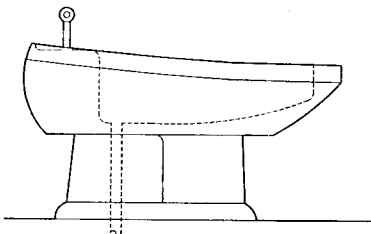

**NOTE**

This low, basinlike plumbing fixture is designed to be straddled for bathing the posterior parts of the body.

**BIDET**

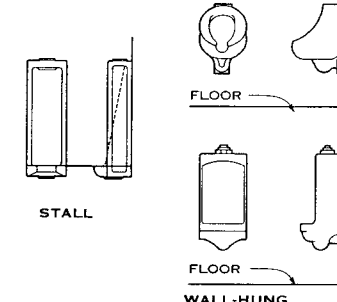

**URINALS**

**NOTES**

1. Urinals require flush valves as source of water supply.
2. ADA 4.18 (Urinals) requires 30 x 48 in. clear floor space in front of urinals to allow a forward approach. Urinals should be stall type or wall-hung with an elongated rim a maximum of 17 in. above the floor. Shields, if provided, should not extend beyond the front of the urinal rim and must have a clearance of 29 in. Flush controls should be accessible and no more than 44 in. above the floor.
3. If used, urinal tanks should be 92-94 in. above the floor.
4. Battery stalls, except accessible ones, should be installed 21-24 in. on center.
5. For styles and rough-in dimensions, refer to manufacturers' manuals.

American Society of Plumbing Engineers; Westlake, California  
Michael Frankel, CIFE, Utility Systems Consultants; Somerset, New Jersey  
Jacqueline Jones (American Standard) and Philip Kenyon (Kohler)

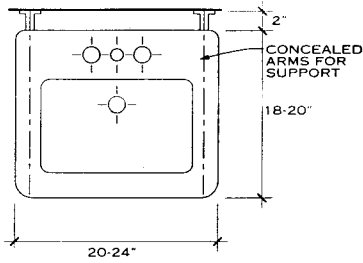

PLAN

**SLAB LAVATORY**

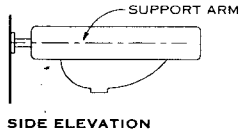

SIDE ELEVATION

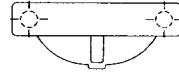

FRONT ELEVATION

**NOTE**

Slab lavatories typically are rectangular with rectangular basins and are spaced from the finish wall with 2-in. escutcheons. A vitreous china leg with brackets can serve as an alternate means of support. A lavatory may be ADA compliant when installed with an offset drain.

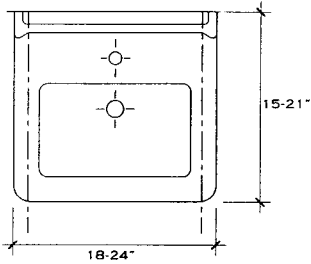

PLAN

**FLAT-BACK LAVATORY**

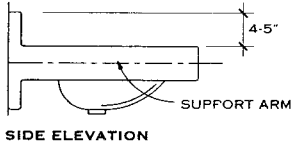

SIDE ELEVATION

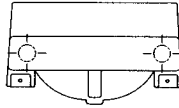

FRONT ELEVATION

**NOTE**

Flat-back lavatories generally are rectangular with rectangular or semi-oval basins. Support is provided by metal legs with brackets or by concealed arms.

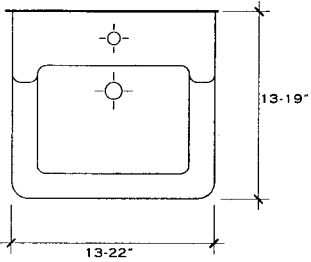

PLAN

**SHELF-BACK LAVATORY**

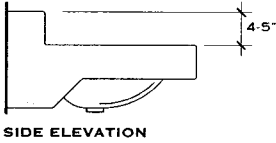

SIDE ELEVATION

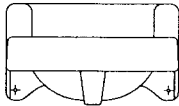

FRONT ELEVATION

**NOTE**

Shelf-back lavatories generally are rectangular with rectangular or semi-oval basins and are supported by integral wall supports or by concealed arms.

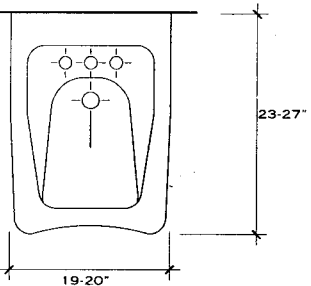

PLAN

**WHEELCHAIR ACCESSIBLE LAVATORY**

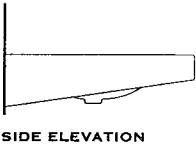

SIDE ELEVATION

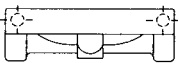

FRONT ELEVATION

**NOTE**

Wheelchair accessible lavatories must be supported with a concealed arm carrier. Pipes should be covered and cannot obstruct access. Faucet levers should be accessible or photoelectric.

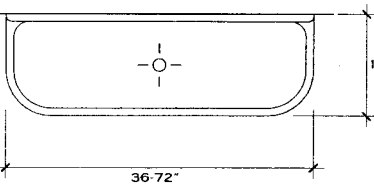

PLAN

**WALL-MOUNTED WASH SINK**

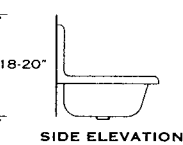

SIDE ELEVATION

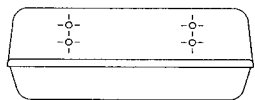

FRONT ELEVATION

**NOTE**

Wash sinks are supported with concealed wall brackets or angle supports.

**GENERAL**

Lavatories are available in vitreous china, cast acrylic resin, enameled cast iron, enameled steel, and stainless steel. The most commonly used means of support is the chair or wall carrier with concealed arms. Consult manufacturers' data for specific fixture design and support recommendations.

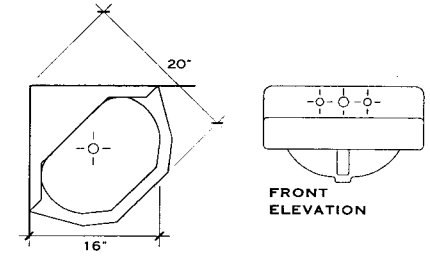

PLAN

**NOTE**

Corner lavatories are available angled with an oval basin or rectangular with an offset rectangular basin. They are supported with wall brackets or concealed arms.

**CORNER LAVATORY**

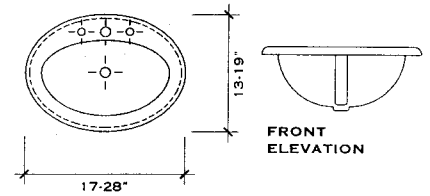

PLAN

**NOTE**

Built-in (or drop-in) lavatories come in oval, rectangular, and circular shapes. Typically self-rimming, they are also available with metal rims or rimless for undercounter installations. They may meet ADA requirements if placed in an accessible counter.

**BUILT-IN LAVATORY**

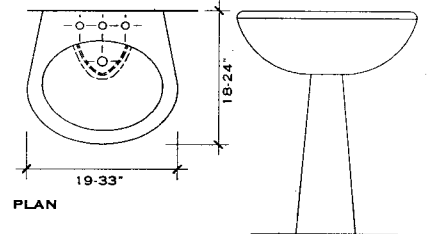

PLAN

**NOTE**

Pedestal lavatories may be either wall-mounted or free-standing. Consult manufacturers for specific designs, forms, and dimensions.

**PEDESTAL LAVATORY**

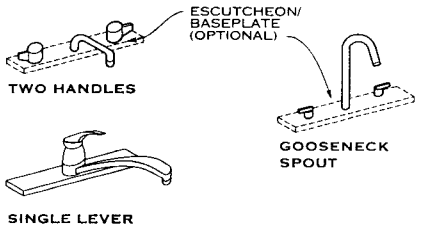

TWO HANDLES

SINGLE LEVER

**TYPICAL LAVATORY AND SINK FAUCETS**

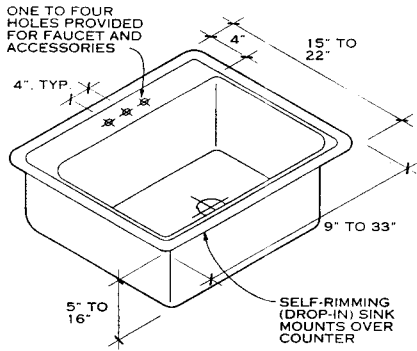

**SINGLE BOWL AND BAR SINK**

**NOTES**

1. Sink materials include stainless steel, enameled iron or steel, and cast resin.
2. The underside of stainless steel sinks typically is coated with a sound-deadening material.
3. Sink accessories include pull-out faucets, instant hot or chilled water dispensers, and soap dispensers.
4. Consult manufacturers for available stainless steel finishes.

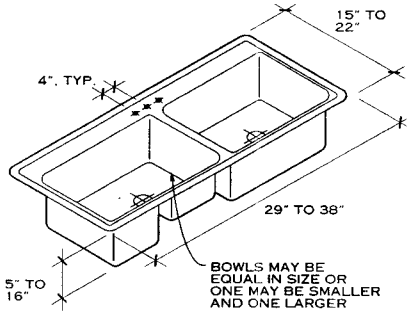

**DOUBLE BOWL SINK**

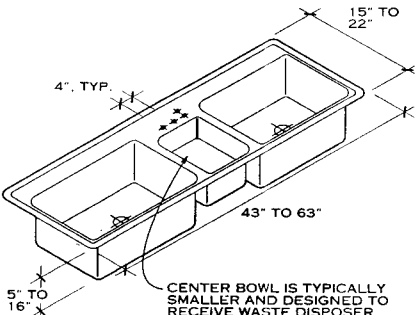

**TRIPLE BOWL SINK**

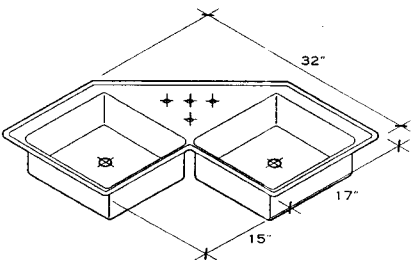

**CORNER BOWL SINK**

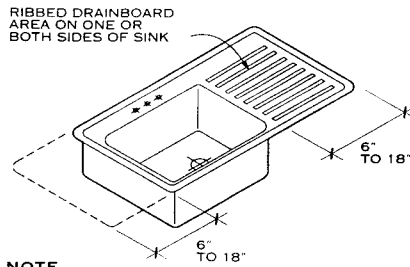

**NOTE**

Drainboard area may be used with single-, double-, and triple-bowl sinks. Institutional kitchen sinks may have longer drainboards. Consult manufacturer.

**SINK WITH DRAINBOARD AREA**

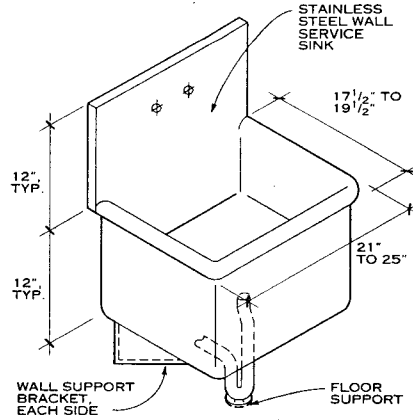

**WALL SERVICE SINK**

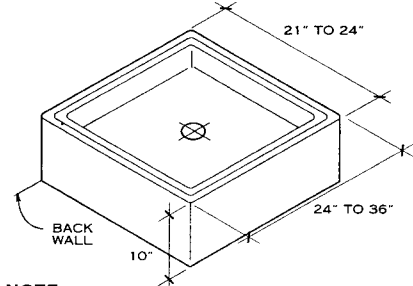

**NOTE**

Available in stainless steel and terrazzo.

**FLOOR SERVICE SINK**

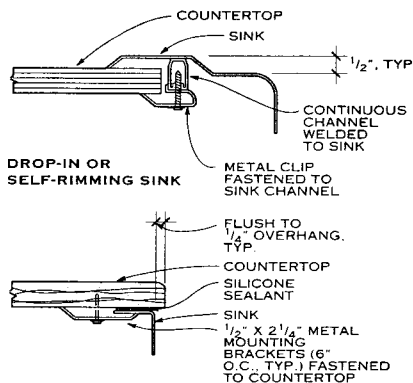

**UNDERMOUNTED SINK**

**SINK MOUNTING DETAILS**

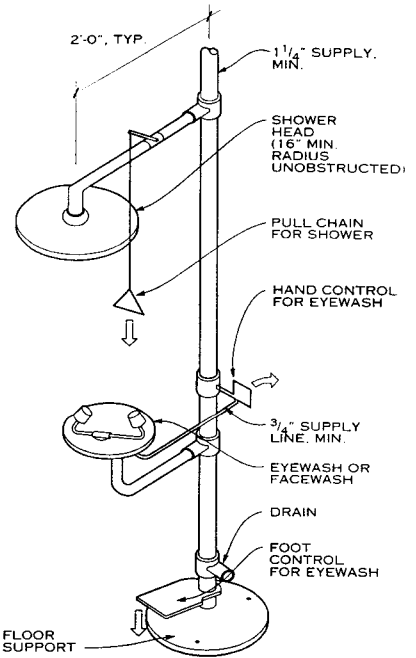

**COMBINATION EMERGENCY SHOWER AND EYEWASH**

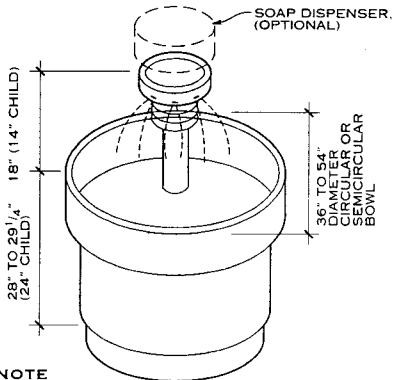

**NOTE**

Materials include stainless steel, terrazzo, and cast resin. Most sinks have foot controls; some have hand controls or sensors. Supply from above, below, or through the wall.

**WASH SINK**

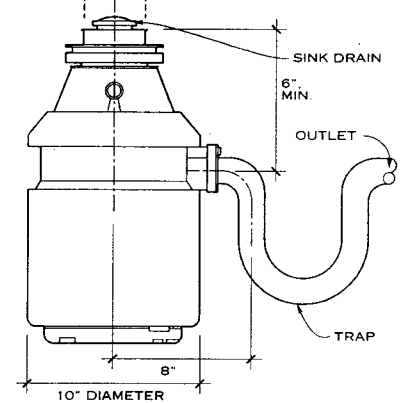

**NOTE**

Disposers are available in 1/2, 3/4, and 1 horsepower units.

**GARBAGE DISPOSER**

American Society of Plumbing Engineers; Westlake, California  
Michael Frankel, CIPE, Utility Systems Consultants; Somerset, New Jersey

**GENERAL**

Bathtubs are available in many shapes and installation types, including rectangular recessed, corner recessed, rectangular or oval drop-in, and clawfoot (freestanding). Bathtubs can be surrounded by ceramic tile, solid surfacing, or molded fiberglass or acrylic one-piece units. Bathtubs are available in the following materials:

**FIBERGLASS:** An economical and common choice, gel-coated fiberglass (also known as FRP) is lightweight and easily installed. Because the material can be molded, fiberglass tubs are available in a variety of shapes. Although not as durable as cast iron or acrylic, fiberglass can easily be repaired.

**ACRYLIC:** In terms of durability, acrylic is a step up from fiberglass, with which it is usually reinforced. Because acrylic is light and easily formed into different shapes, it is a good choice for whirlpools and other large tubs that would be too heavy in cast iron. Acrylic is a good insulator and, thus, keeps water warm longer.

**CAST IRON:** Very heavy and extremely durable, traditional enamel-coated cast iron resists staining and scratching. It cannot be molded as freely as acrylic or fiberglass, so there are fewer shapes and styles from which to choose.

**ENAMELED STEEL:** This is a lighter weight, less expensive alternative to cast iron.

Whirlpool baths are usually made of fiberglass-reinforced acrylic, which can be fabricated in a variety of shapes—standard oblongs, round tubs for two, cloverleaf or hour-glass designs, or free-form shapes. Air mixed with water streams through jets in the side of the tub, giving the whirlpool its soothing, therapeutic character. Models may have 3 to 10 jets, including some aimed to massage feet, back, or neck. Jet direction can usually be adjusted; some jets can also be adjusted to deliver a pulsating or steady stream or to regulate intensity. Pumps range from ½ to 3 horsepower, and the intensity of the flow varies accordingly. In-line heaters are recommended to keep the water warm without refilling the tub.

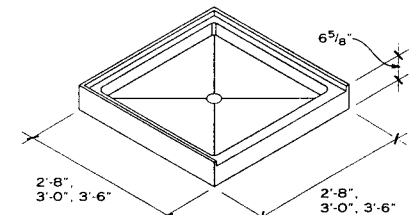

**SQUARE**

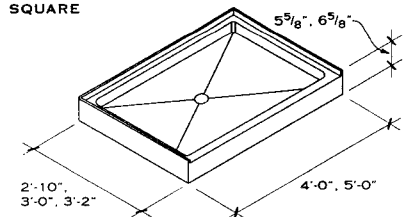

**RECTANGULAR**

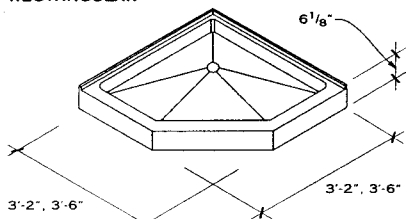

**CORNER NOTE**

Materials for bases include acrylic with fiberglass reinforcement, enameled steel, and terrazzo.

**SHOWER BASE**

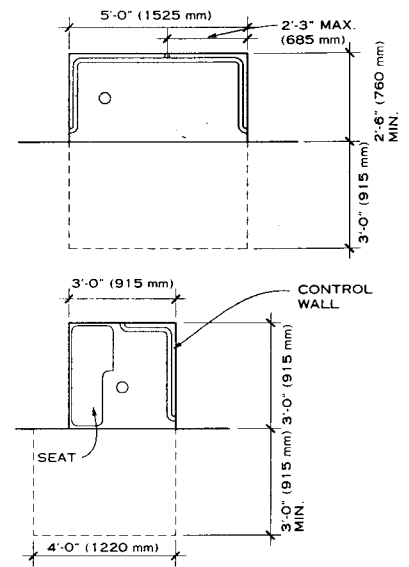

**SITE-BUILT SHOWER PAN**

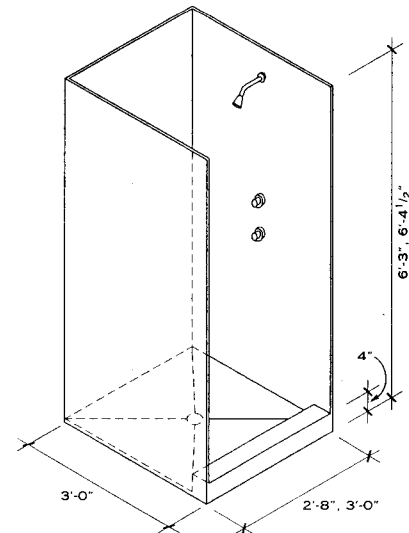

**NOTE**

Variations in shapes and designs are prevalent in fiberglass-reinforced polyester shower units; consult manufacturers.

**BUILT-IN SHOWER UNITS**

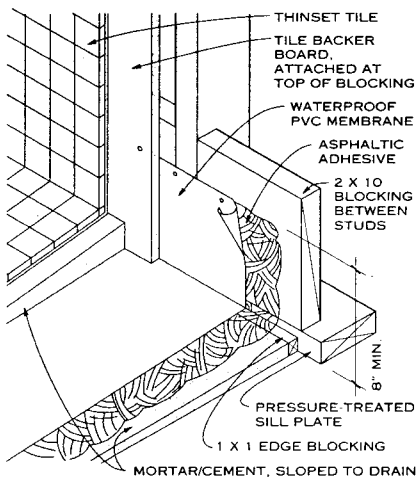

**SHOWER SIZES AND CLEARANCES**

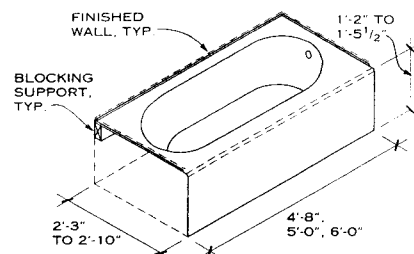

**BUILT-IN RECESSED BATHTUB**

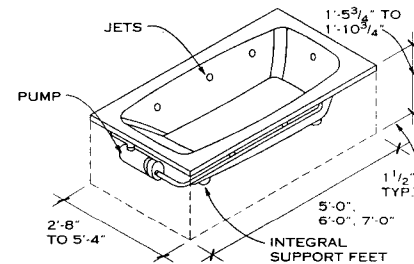

**DROP-IN WHIRLPOOL BATHTUB**

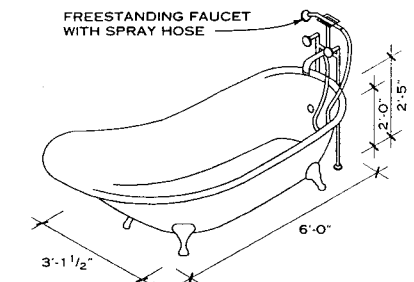

**NOTE**

Dimensions shown are one example of freestanding soaking bathtub types; consult manufacturers for other styles and sizes.

**FREESTANDING SOAKING BATHTUB**

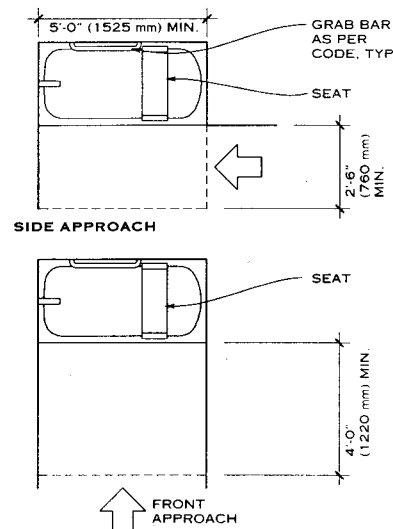

**FRONT APPROACH**

**NOTE**

For tubs with a built-in seat at the head of the tub, the seat must be 15 in. wide (380 mm) and clear floor space must be provided in front of the seat.

**CLEAR FLOOR SPACE FOR ACCESSIBLE BATHTUBS**

Michael Frankel, CIPE; Utility Systems Consultants; Somerset, New Jersey  
K. Shahid Rab, AIA; Friesen International; Washington, D.C.



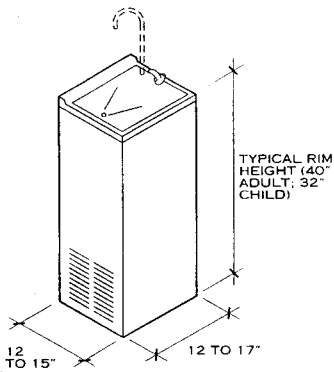

FLOOR MOUNTED

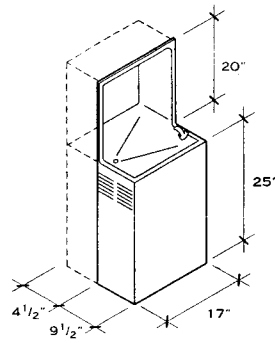

SEMI-RECESSED

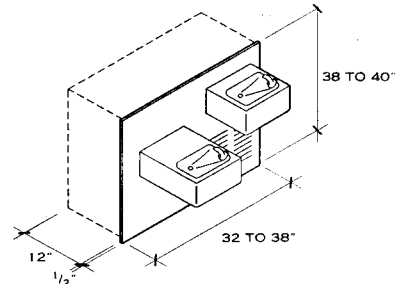

BI-LEVEL

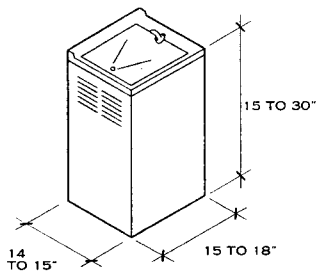

WALL MOUNTED

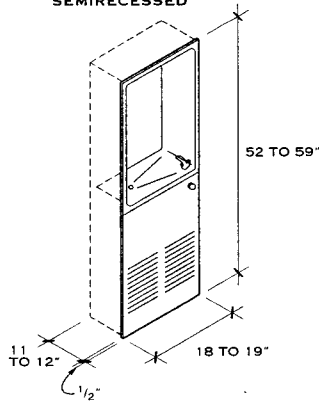

FULLY RECESSED

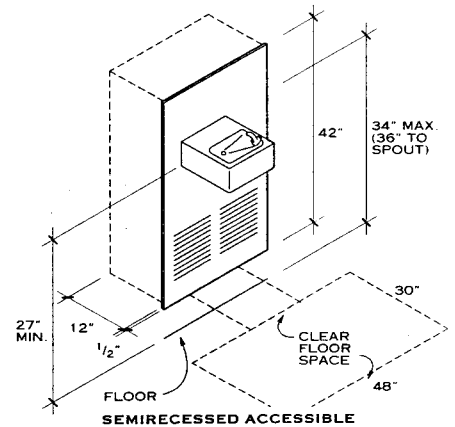

SEMI-RECESSED ACCESSIBLE

TYPICAL INTERIOR ELECTRIC WATER COOLERS

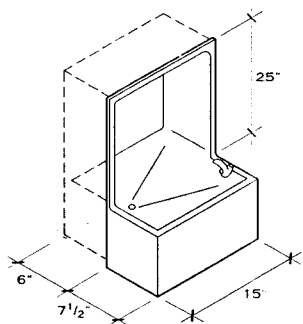

SEMI-RECESSED

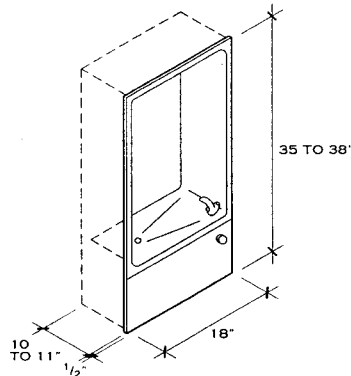

FULLY RECESSED

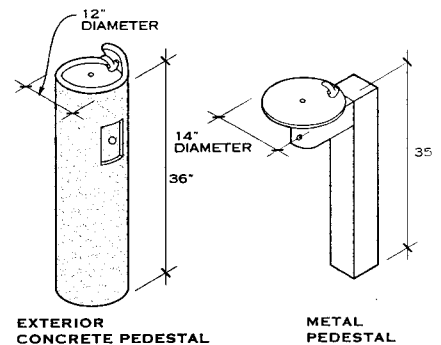

EXTERIOR CONCRETE PEDESTAL

METAL PEDESTAL

TYPICAL EXTERIOR DRINKING FOUNTAINS

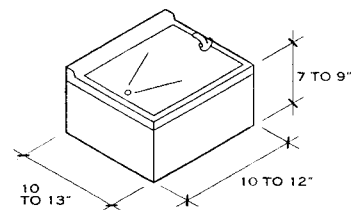

WALL MOUNTED

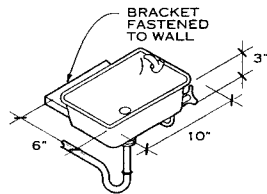

BRACKET FOUNTAIN

TYPICAL INTERIOR DRINKING FOUNTAINS

NOTES

1. Drinking fountains (DF) use only water at ambient temperatures; electric water coolers (EWC) use an integral or remote chiller to cool water for drinking.
2. Use air-cooled condensers for normal room temperatures and water-cooled units for high room temperatures and larger capacities. Many models are available with hot and cold water supply, a cup-filling spout, or refrigerated compartments.
3. Install half of required fountains as accessible, but design the layout so accessible fountains do not obstruct movement of the visually impaired.
4. Special explosion-proof fountains are recommended for use in hazardous atmospheres. Corrosion-resistant fountains are available for harsh environments.
5. Consult local building codes for the minimum number of drinking fountains required.

American Society of Plumbing Engineers; Westlake, California  
 Michael Frankel, CIPE, Utility Systems Consultants; Somerset, New Jersey

**GENERAL**

A domestic hot water (also called service hot water) system heats raw water from the ambient temperature to a desired higher temperature using a unique heat exchanger called a hot water generator. An important ancillary part of the service hot water system is hot water temperature maintenance. This system keeps the water in the piping system hot, so that when hot water is drawn from a fixture or equipment it will reach design temperature quickly even when the system has not been used for some time.

**LEGIONNAIRES' DISEASE**

Outbreaks of Legionnaires' disease in plumbing systems have been traced to domestic hot water distribution systems. The problem originates when the outlet temperature of the water at a heater is lower than 140°F (60°C), the temperature at which bacteria is destroyed. Therefore, it is highly recommended that all water for domestic purposes be heated initially to a temperature of 140°F and lowered to the final temperature with a mixing valve.

**HOT WATER SYSTEM SIZING**

Hot water usage and flow rates are characterized by intermittent periods of peak, sustained, and low-to-zero flows. The pattern of usage varies widely, depending on the building type and use, time of day, time of year, population, and connected equipment and fixtures. The final temperature of the water should be high enough to meet the minimum requirements of the connected equipment.

**STORAGE-TYPE WATER HEATER SIZING**

Storage-type heaters are sized using the total volume of hot water required for the estimated duration of maximum demand. This total volume can be provided by any combination of hot water storage capacity and water heater recovery (makeup) rate. The storage and recovery values depend on the project type. The major advantage of using a storage-type heater is that the instantaneous demand for heating medium is considerably less than that for instantaneous-type heaters.

To estimate the hot water demand for a project, use the table on this page: First, select the facility type in the heading closest to that of the project. Next, count the total number of each type of fixture at the project, and find the hot water demand for each fixture in the facility type column in the table. Multiply the gallons (or liters) per hour value for each fixture by the total number of individual fixtures. Add the resulting figure for all fixture types together to determine the total connected (demand) load for the building in gallons (liters) of water per hour.

Find the actual hourly demand for the facility by multiplying the total connected load by the demand factor shown at the bottom of the hot water demand table. This will yield the total volume of hot water to be used by the facility during a 1-hour period.

**DURATION OF PEAK USE**

BUILDING TYPE	PEAK DURATION (HR)
Motel	2
Hotel	3
Apartment house	3
Nursing home	3
Office	2
Food service	1-4 (varies with type)

In addition to the total hourly demand, a certain amount of hot water should be stored. The recommended volume for storage is a function of the actual hourly demand. The storage requirement is found by multiplying the total hourly demand by the storage capacity factor found at the bottom of the water demand table. This figure is the usable volume of hot water required to be stored.

The recovery requirement and the storage requirement represent one hour's peak use of hot water. Select any combination of heating capacity (recovery) and storage capacity capable of meeting this peak hour. If the duration is longer than one hour, proceed to the next step.

Refer to the duration of peak use table to determine if the facility should have more than a 1-hour peak usage duration. If so, multiply the actual hourly demand by the number of hours of peak duration to find the total volume (in gallons or liters) of hot water required for the entire peak period. Select a recovery rate and storage tank capacity combination to cover the total number of gallons. For example, if the actual hourly demand is 1000 gal/hr for a duration of 3 hours, the total volume of hot water required will be 3000 gal. If the usable storage volume is 1000 gal, the recovery

**MINIMUM HOT WATER TEMPERATURE FOR PLUMBING FIXTURES AND EQUIPMENT**

USE	MIN. TEMP. (°F)
Lavatory	
Hand washing	105
Shaving	115
Showers and tubs	110
Commercial and institutional laundry	180
Residential dishwashing and laundry	140
Commercial spray-type dishwashing*	
Single or multiple tank hood or rack type:	
Wash	150
Final rinse	180-195
Single-tank conveyor type:	
Wash	160
Final rinse	180-195
Single-tank rack or door type:	
Single-temperature wash and rinse	165
Laboratory glass-washer	
Wash	140
Rinse	180

\*Temperatures required by National Sanitation Foundation

rate required for the 3-hr period will be 2000 divided by 3, or 670 gal/hr. The total of 1000 gal storage + 2010 gal makeup (670 GPH x 3) will equal slightly more than the 3000 gal required.

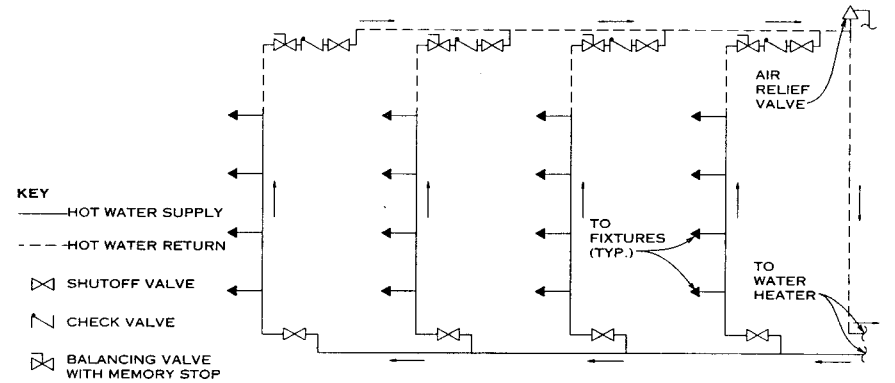

TYPICAL HOT WATER RETURN PIPING SCHEMATIC

**HOT WATER DEMAND IN GALLONS (LITERS) PER HOUR AT 140°F (60°C)**

PLUMBING FIXTURES	APARTMENT HOUSE	CLUB	GYM	HOSPITAL	HOTEL	INDUSTRIAL PLANT	OFFICE BUILDING	PRIVATE RESIDENCE	SCHOOL	YMCA
Basins, private lavatory	2 (7.6)	2 (7.6)	2 (7.6)	2 (7.6)	2 (7.6)	2 (7.6)	2 (7.6)	2 (7.6)	2 (7.6)	2 (7.6)
Basins, public lavatory	4 (15)	6 (23)	8 (30)	6 (23)	8 (30)	12 (45.5)	6 (23)	—	15 (57)	8 (30)
Bathtubs	20 (76)	20 (76)	30 (114)	20 (76)	20 (76)	—	—	20 (76)	—	30 (114)
Dishwashers	15 (57)	50-150 (190-570)	—	50-150 (190-570)	50-200 (190-760)	20-100 (76-380)	—	15 (57)	20-100 (76-380)	20-100 (76-380)
Foot basins	3 (11)	3 (11)	12 (46)	3 (11)	3 (11)	12 (46)	—	3 (11)	3 (11)	12 (46)
Kitchen sinks	10 (38)	20 (76)	—	20 (76)	30 (114)	20 (76)	20 (76)	10 (38)	20 (76)	20 (76)
Laundry tubs, stationary	20 (76)	28 (106)	—	28 (106)	28 (106)	—	—	20 (76)	—	28 (106)
Pantry sinks	5 (19)	10 (38)	—	10 (38)	10 (38)	—	10 (38)	5 (19)	10 (38)	10 (38)
Showers	30 (114)	150 (568)	225 (850)	75 (284)	75 (284)	225 (850)	30 (114)	30 (114)	225 (850)	225 (850)
Service sinks	20 (76)	20 (76)	—	20 (76)	30 (114)	20 (76)	20 (76)	15 (57)	20 (76)	20 (76)
Hydrotherapeutic showers				400 (1520)						
Hubbard baths				600 (2270)						
Leg baths				100 (380)						
Arm baths				35 (130)						
Sitz baths				30 (114)						
Continuous-flow baths				165 (625)						
Circular wash sinks				20 (76)	20 (76)	30 (114)	20 (76)		30 (114)	
Semicircular wash sinks				10 (38)	10 (38)	15 (57)	10 (38)		15 (57)	
<b>DEMAND FACTOR</b>	0.30	0.30	0.40	0.25	0.25	0.40	0.30	0.30	0.40	0.40
<b>STORAGE CAPACITY FACTOR</b>	1.25	0.90	1.00	0.60	0.80	1.00	2.00	0.70	1.00	1.00

Michael Frankel, CIPE; Utility Systems Consultants; Somerset, New Jersey

**HOT WATER GENERATOR TYPES**

Hot water generators can be direct or indirectly fired and are classified as either fully instantaneous, semi-instantaneous, or storage-type heaters. They use a heating medium or fuel source such as oil, fuel gas, electricity, hot water, steam, or solar panels to transfer heat from the heating medium to the water in the heating vessel.

**INSTANTANEOUS-TYPE HEATER**

Fully instantaneous-type heaters consist of a unit that heats water as quickly as the demand flow rate requires. They have no storage and a high water heating (recovery) rate. Advantages include compact size, low initial cost, and factory preparation for installation. Disadvantages are difficult control of outlet water temperature and high instantaneous Btu requirements for the heating medium. This type of heater is almost always indirectly fired using either steam or hot water supplied from a central heating plant, steam utility system, or boiler. An accurate approximation of steam required can be calculated by multiplying the GPM requirements by 50 lb/hr.

Point-of-use heaters are a small, direct-fired instantaneous type used for isolated and remote locations where it is not economical to run piping from the central service hot water system. Often, these units are electric in-line instantaneous heaters installed below an individual fixture or 5-gallon (20-liter) units installed on a shelf or in a hung ceiling adjacent to a toilet room or similar installation.

**SEMI-INSTANTANEOUS TYPE HEATERS**

Semi-instantaneous type heaters are similar to the fully instantaneous type except they have a very small water storage capacity, which permits better control of outlet water temperature. This type of heater can be either directly or indirectly fired and is preferred over the fully instantaneous type.

**STORAGE-TYPE HEATERS**

Storage type heaters have a large storage capacity and lower recovery rate. This type of system consists of either a combination storage tank with a direct or indirect immersion heater inside the tank or a separate water heater and storage tank. Use of this system should be considered when high peak surge loads are encountered for short periods of time and when there is a limited source of heat energy. Disadvantages include the large amount of floor space required and the high initial cost. Advantages include a low instantaneous heat energy demand rate.

**HOT WATER TEMPERATURE MAINTENANCE**

Generally accepted practice requires that hot water delivered to terminal points of the system reach the desired temperature in 20 seconds or less. Some codes also require some form of temperature maintenance if the distance from the heater exceeds a set figure, often 50 ft (15 m). Use of a temperature maintenance system will result in a large saving of water otherwise wasted waiting for hot water to reach the desired temperature at the fixture.

To accomplish heating in 20 seconds, two methods are available to maintain the hot water temperature. The first uses a separate water circulation pump and recirculation piping system to return the cooler hot water from the end of the system back to the heater for reheating, thereby keeping the primary water hot.

The second method uses a self-regulating electrical heater wire attached directly to the primary hot water pipe under the insulation, thereby eliminating the need for a separate circulation piping system. This wire becomes hot only when the temperature of the water pipe drops to a predetermined point. The self-regulating feature supplies only enough heat to keep the water at a predetermined temperature; it is not simply an on or off feature. The use of the self-regulating cable is not generally economical when the length of recirculation piping is less than half the length of the primary hot water pipe.

**BOOSTER HEATERS**

If the temperature of hot water for a project is higher than 140°F (60°C), it is common practice to install a separate booster heater in the area of use rather than to heat water for the entire project to the higher temperature.

**RELIEF VALVE DISCHARGE**

Temperature and pressure relief valves may operate suddenly and at any time to relieve the considerable pressure built up inside a heater. Because scaldingly hot water thus could splash unexpectedly in a large area, it is important to route the discharge from relief valves to a safe location.

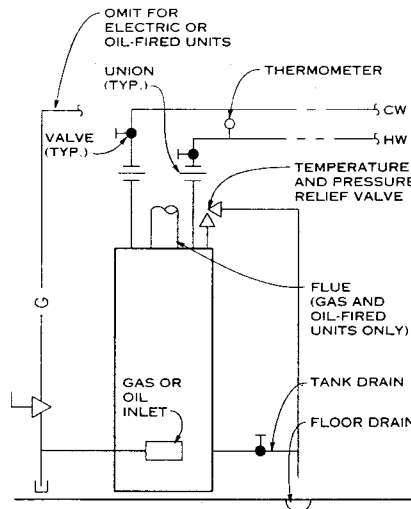

**TYPICAL TANK SIZES**

CAPACITY (GAL.)	HEIGHT (IN.)	DIAMETER (IN.)
30	48	22
50	60	24
75	60	26
100	74	28
120	76	30

**NOTES**

1. Available as gas, oil, or electric-fired models.
2. A flue is required for oil or gas models only.
3. Electric-fired heaters have the lowest initial cost and the highest operating cost.
4. Consult manufacturer for makeup capacity.

**TYPICAL RESIDENTIAL WATER HEATER**

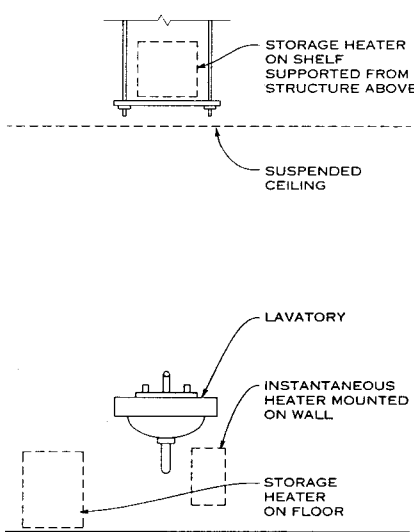

**NOTES**

1. Heater size is based on the size of the faucet and the voltage and capacity available from the electric service.
2. Route temperature and pressure discharge to a safe location.
3. Point-of-use heaters are available in sizes from .25 to 2 GPM; storage is available up to 5 gallons.

**TYPICAL POINT-OF-USE HEATERS**

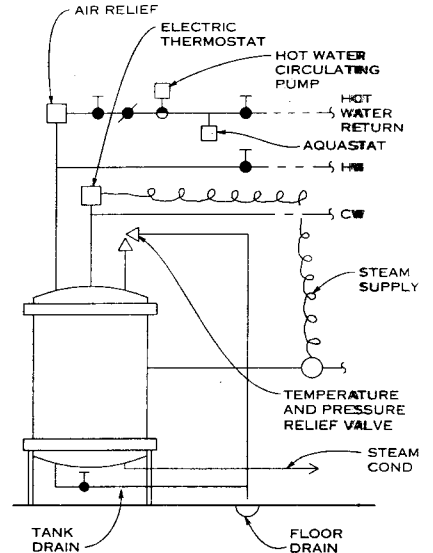

**NOTE**

Typical sizes range from 16 to 36 in. in diameter, up to 80 in. high. Size is based on gallons per minute (GPM) and the temperature difference of inlet cold water (CW) and outlet hot water (HW). For sizes, refer to manufacturers' standards.

**TYPICAL SEMI-INSTANTANEOUS WATER HEATER**

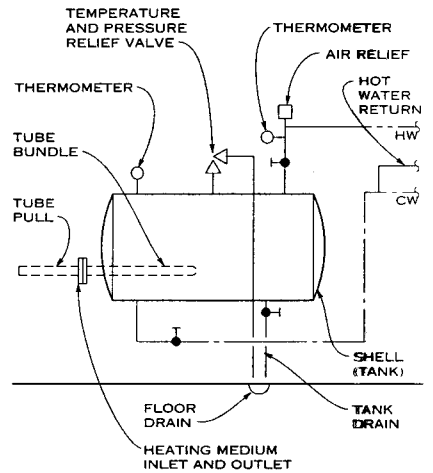

**TYPICAL TANK SIZES**

CAPACITY (GAL.)	LENGTH (IN.)	DIAMETER (IN.)
500	100	48
1000	150	52
1500	170	58
2000	178	64
3000	144	84
4000	144	96

**NOTES**

1. This system is used for projects for which the flow rate of the heating medium, whether hot water, steam, oil, or electric, is limited.
2. Size is based on hourly hot water demand and temperature difference between inlet and outlet water.
3. These dimensions are for horizontal tanks. Vertical tanks are available, as well as custom tanks of various capacities.

**TYPICAL STORAGE HEATER**

Michael Frankel, CIPE; Utility Systems Consultants; Somerset, New Jersey

**POTABLE WATER DISTRIBUTION SYSTEM**

A potable water system delivers water suitable for human consumption at appropriate pressure and volume to all plumbing fixtures and equipment. Water should be delivered to the most remote fixture within an acceptable range of pressures. Water pressure is considered excessive if it will cause damage or create a nuisance. A widely accepted pressure value is 70 psi. Often, the maximum permissible water pressure is stipulated by code.

**DESIGN CONSIDERATIONS**

**ESTIMATING MAXIMUM WATER DEMAND:** Maximum instantaneous water demand is estimated using water supply fixture units (WFU) converted to gallons per minute (gpm). The supply demand curve converts WFU to gpm using "Hunters Curve," which is derived from a statistical method of estimating how often various fixtures would be used simultaneously.

The conversion of WFUs is separated into two categories, one for flush valves and one for flush tanks. Since the flush valve has a much higher flow rate, its conversion from WFUs shows a larger flow rate of water. The section for flush tanks is also used to size all piping networks without flush valves and hot water piping.

**WATER VELOCITY:** Generally accepted practice limits the velocity of water in piping to 8 feet per second (fps) to avoid excessive noise and prevent erosion of the piping. The velocity should be lowered to 4 fps to avoid corrosion when softened water is used and to avoid water hammer when any quick closing valves are installed. All branches containing a flush valve or quick closing valve should have shock absorbers installed downstream of the last fixture.

**FACTORS AFFECTING DESIGN OF A PUBLIC WATER MAIN:** Obtain the location, elevation, and size of the water main from the local water purveyor. Also helpful is a topographical map showing the relative ground elevations and any obstructions (trees, boulders, curbs, etc.) that would interfere with the run from the main into the building. If possible, find out the frost depth for the project site. When this information is unavailable, a dimension of 5 ft 0 in. to the centerline would be a generally safe figure for depth of bury.

**STATIC AND RESIDUAL WATER PRESSURE:** The actual water present in the water main is critical to the design of the water supply system. The static pressure is the water pressure in the main when no water is flowing in an immediate connection adjacent to the project site. The residual pressure is the water pressure available in the main when a considerable amount of water is flowing from any connection, usually a fire hydrant, close to where the building water supply will be connected to the public main. This information is obtained by means of a flow test, often called a hydrant flow test. The residual (lower) pressure is used to size the project water supply distribution network.

**MINIMUM FIXTURE OPERATING PRESSURE:** Various plumbing fixtures and devices require a minimum pressure to ensure proper operation. Generally accepted values are given in the accompanying table, but these must be verified by the manufacturer.

**MINIMUM OPERATING PRESSURES FOR SOME FIXTURES**

FIXTURE	PRESSURE (PSI)
Basin faucet	8
Basin faucet, self-closing	12
Bathtub faucet	5
Dishwasher	15-25
Garden hose, 50 ft (15 m), and sill cock	30
Laundry tub cock, 1/4 in. (0.64 cm)	5
Shower	12
Sink faucet, 3/8 in. (0.95 cm)	10
Sink faucet, 1/2 in. (1.3 cm)	5
Urinal flush valve	15
Water closet, ball cock	15
Water closet, flush valve	15-25
Water closet, low silhouette tank type	30-40
Water closet, pressure tank	20-30

**CALCULATING AVAILABLE WATER PRESSURE**

The pressure available for friction loss in a piping system is that pressure inside the building after all losses through the building service have been subtracted. The building water

service is the run of pipe from the public water main connection to a point inside the building beyond the devices required by the local water authority. Devices that codes or regulations might require include those listed here. The figure after each item is a general loss in pressure caused by the fixture. For exact pressure loss figures, consult the equipment manufacturer.

1. Connection to main, including street elbow (5 psi)
2. Curb valve (usually 2 psi)
3. Building shutoff valves (usually 3 psi each)
4. Strainer (5 psi dirty but varies according to type)
5. Water meter (5 psi but varies according to type and flow)
6. Backflow preventer (maximum 12 psi but varies according to type and flow)
7. Water softener (varies according to manufacturer and flow rate)
8. Pressure lost by the flow of water through the building service pipe run
9. Allowance for future development adjacent to project site, if justified (5 psi)

**PRESSURE LOSS IN FITTINGS AND VALVES EXPRESSED AS EQUIVALENT PIPE LENGTH (FT)**

NPS (IN.)	90 ELL		90 TEE		VALVES		
	ELL	ELL	SIDE RUN	TEE	GATE	CHECK	KGLOBE
1/2	1	.5	2	-.4	4	4	18
3/4	2	.5	3	-.5	5	5	23
1	2.5	1	4.5	-.6	7	7	30
1 1/4	3	1	5.5	-.7	9	9	38
1 1/2	4	1.5	7	-.9	10	10	45
2	5.5	2	9	1	13	13	58
2 1/2	7	2.5	12	1.2	16	16	70
3	9	3.5	15	1.5	20	20	86
4	12.5	5	21	2.1	25	25	113

**NOTE**

Allowances are for streamlined soldered fittings and recessed threaded fittings. For threaded fittings, double the allowances shown in the table.

**SIMPLIFIED PIPE SIZING BASED ON PRESSURE LIMITATIONS**

1. Prepare or obtain complete plans, including a riser diagram, of the building under design. These plans should show the number and location of all plumbing fixtures and equipment requiring water and their WFU values for design purposes.
2. Locate the public water main and determine its elevation and residual pressure. Plan the building water service, determining what connected devices are required by local codes and regulations. Using this information, calculate the available pressure in psi to a point 2 ft 0 in. above the floor elevation inside the building.
3. Determine the elevation of the highest fixture. This is called the static height. A fixed pressure will be required in order to lift the water to that elevation. Multiply the static height by 0.433 to calculate the static height pressure loss in psi.
4. Find out the minimum operating pressure, in psi, required for proper fixture operation.
5. Measure the longest run of piping and add half of that distance to calculate total equivalent run. Divide the total by 100 to convert the figure to pressure loss per 100 ft.
6. Add the figures resulting from items 3 and 4 above to calculate all the fixed pressure losses for the building.
7. Subtract the fixed pressure losses (item 6) from the available pressure (item 2) to find the pressure available to overcome the water friction in the piping network. Dividing the equivalent length of piping (in 100s) into the available pressure will give the friction loss per 100 feet, which is the figure used for sizing purposes. For example: if the available pressure is 10 psi, and the total equivalent run is 200 feet, divide 2 into 10, which results in 5 psi per 100-foot run available for friction loss. In general, if the pressure required for friction loss is more than the pressure available from the building service, a water pressure booster system will be required.
8. Using the riser diagram or plans with the WFU marked and starting from the point farthest from the building supply, add all of the WFU together at each design point where a fixture or branch will connect to the pipe being designed.
9. Convert the WFU into gpm. If a flush valve is connected to the piping, use the flush valve figure. Using the flow of water in copper pipe, enter with the gpm and friction loss. Read the pipe size appearing at the intersection of gpm and friction loss or gpm and velocity, whichever is

the determining factor. Continue this method first for each branch and then the main. Add any continuous demand separately.

**SIMPLIFIED PIPE SIZING BASED ON VELOCITY**

This method is the same as that for pipe sizing based on water pressure, except that the velocity of the water is the determining factor. Use 4 fps where the pressure is marginal and 8 fps where significant pressure is available.

**SUPPLY DEMAND CURVE FOR MORE THAN 240 FIXTURE UNITS**

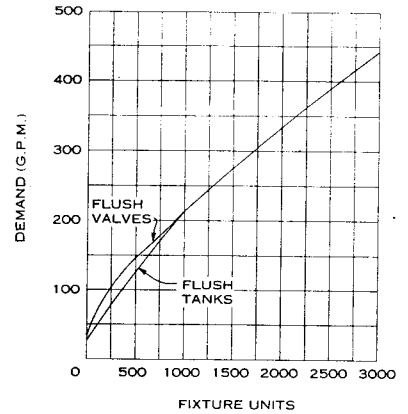

**SUPPLY DEMAND CURVE FOR 240 AND FEWER FIXTURE UNITS**

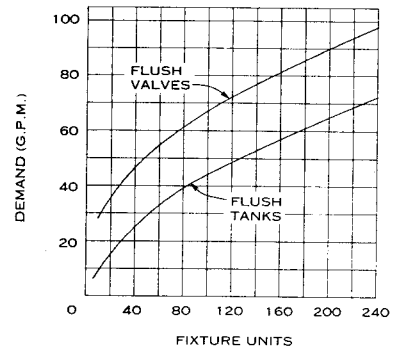

**FLOW OF WATER IN COPPER PIPE (TYPE L ONLY)**

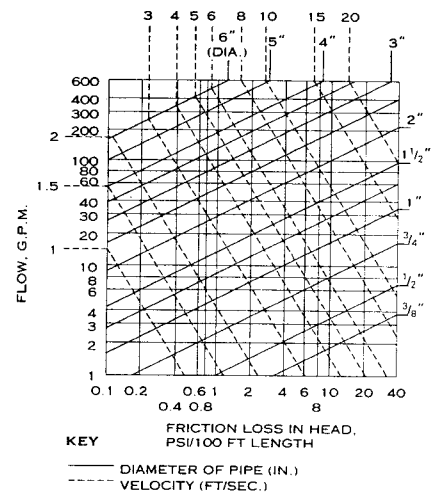

Michael Frankel, CIPE; Utility Systems Consultants; Somerset, New Jersey

**GENERAL**

When a floor-mounted support cannot be installed, wall-mounted supports can be used if the wall structure is strong enough to support the entire weight of the fixture. In such installations, the support arms are attached to a plate bolted directly into the wall structure.

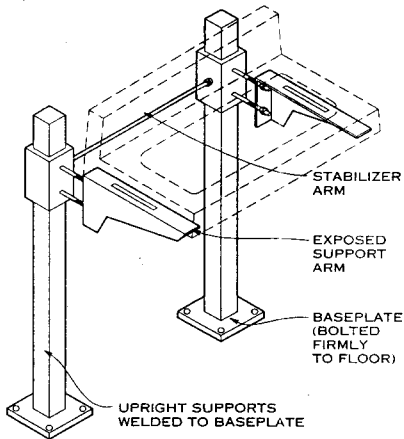

**NOTE**

This support typically is used with a vitreous china lavatory.

**EXPOSED ARM FIXTURE SUPPORT**

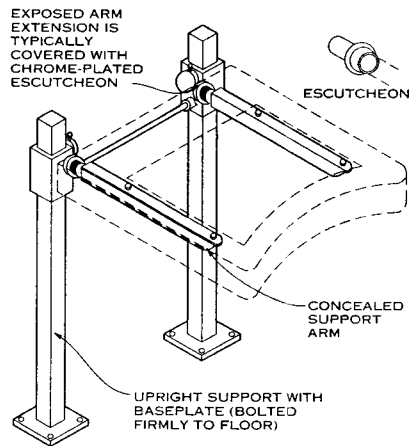

**NOTE**

When using lavatories of the flat slab type (that is, without a backsplash), manufacturers typically require a 2 to 6 in. space between the wall finish and the rear of the lavatory to prevent water accumulation.

**CONCEALED ARM FIXTURE SUPPORT**

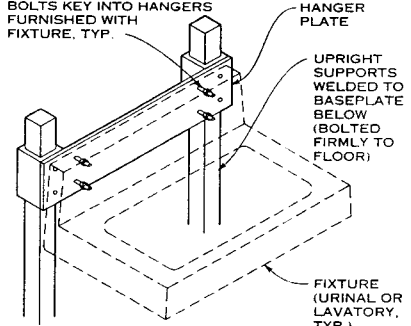

**NOTE**

An enameled cast-iron high-back lavatory is supported on a hanger-type support.

**HANGER-TYPE FIXTURE SUPPORT**

American Society of Plumbing Engineers, Westlake, California  
Michael Frankel, CIPE, Utility Systems Consultants; Somerset, New Jersey

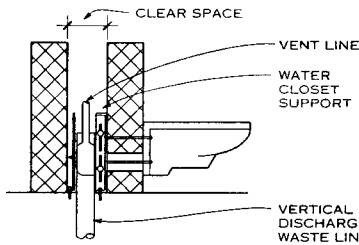

**SINGLE FIXTURE (DOUBLE CMU WALL)**

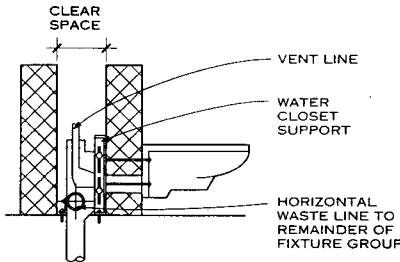

**SINGLE FIXTURE IN FIXTURE GROUP (DOUBLE CMU WALL)**

**SINGLE FIXTURE WATER CLOSET SUPPORTS**

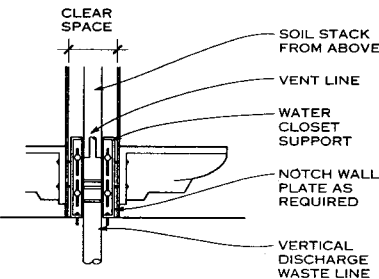

**BACK-TO-BACK FIXTURES (DOUBLE STUD WALL)**

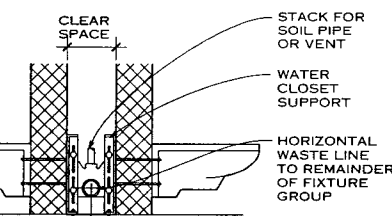

**BACK-TO-BACK FIXTURES IN FIXTURE GROUP (DOUBLE CMU WALL)**

**SUPPORTS FOR WATER CLOSET**

**FIXTURE SUPPORT AND MINIMUM PIPE SPACE REQUIREMENTS**

FIXTURE (ABBREVIATION)	ARRANGEMENT	MINIMUM CLEAR SPACE			MINIMUM WALL THICKNESS (INCLUDES FINISH)
		DOUBLE BLOCK	DOUBLE STUD	SINGLE STUD	
Water closet (WC)	S, V	10	4		4
Water closet (WC)	BB, V	10	5		4
Water closet (WC)	S, FG, V	10	9		4
Water closet (WC)	BB, FG, V	10	11		4
Urinal (WC)	S, BB, FG, V, HP			5	1/2
Lavatory (LAV)	S, BB, FG, V, A			6	1/2
Lavatory (LAV)	S, BB, FG, V, HP			5	1/2
Urinal stall (UR)				4	
Shower (SH)				4	
Sink (SK)				5	
Service sink (SS)				6	
Drinking fountain (DF)				3	

S—single fixture; BB—back to back; FG—fixture group (a battery of two or more fixtures along one wall); V—vertical discharge; A—arm support (concealed or exposed); HP—hanger plate

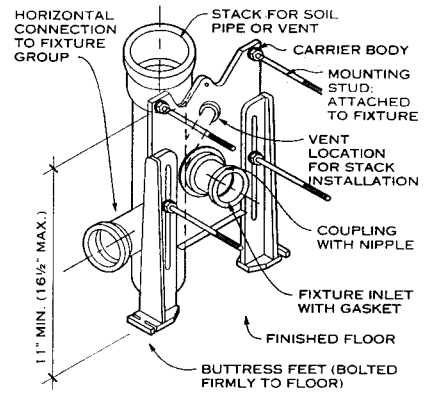

**NOTE**

Cast-iron supports with chrome-plated trim are typically used with blowout and siphon jet water closets.

**ADJUSTABLE WALL-HUNG WATER CLOSET SUPPORT**

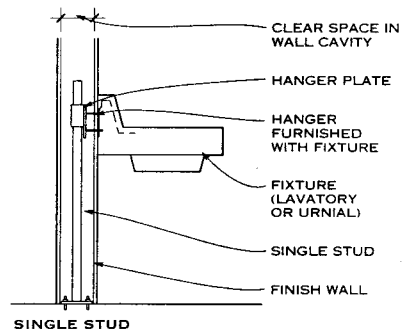

**SINGLE STUD**

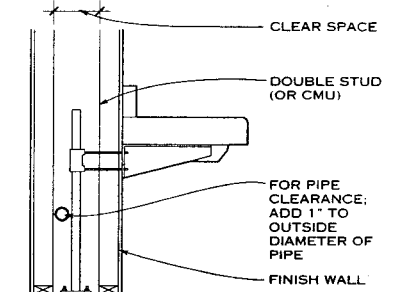

**DOUBLE STUD OR CMU**

**CLEAR SPACE IN WALL FOR LAVATORY AND URINAL SUPPORTS**

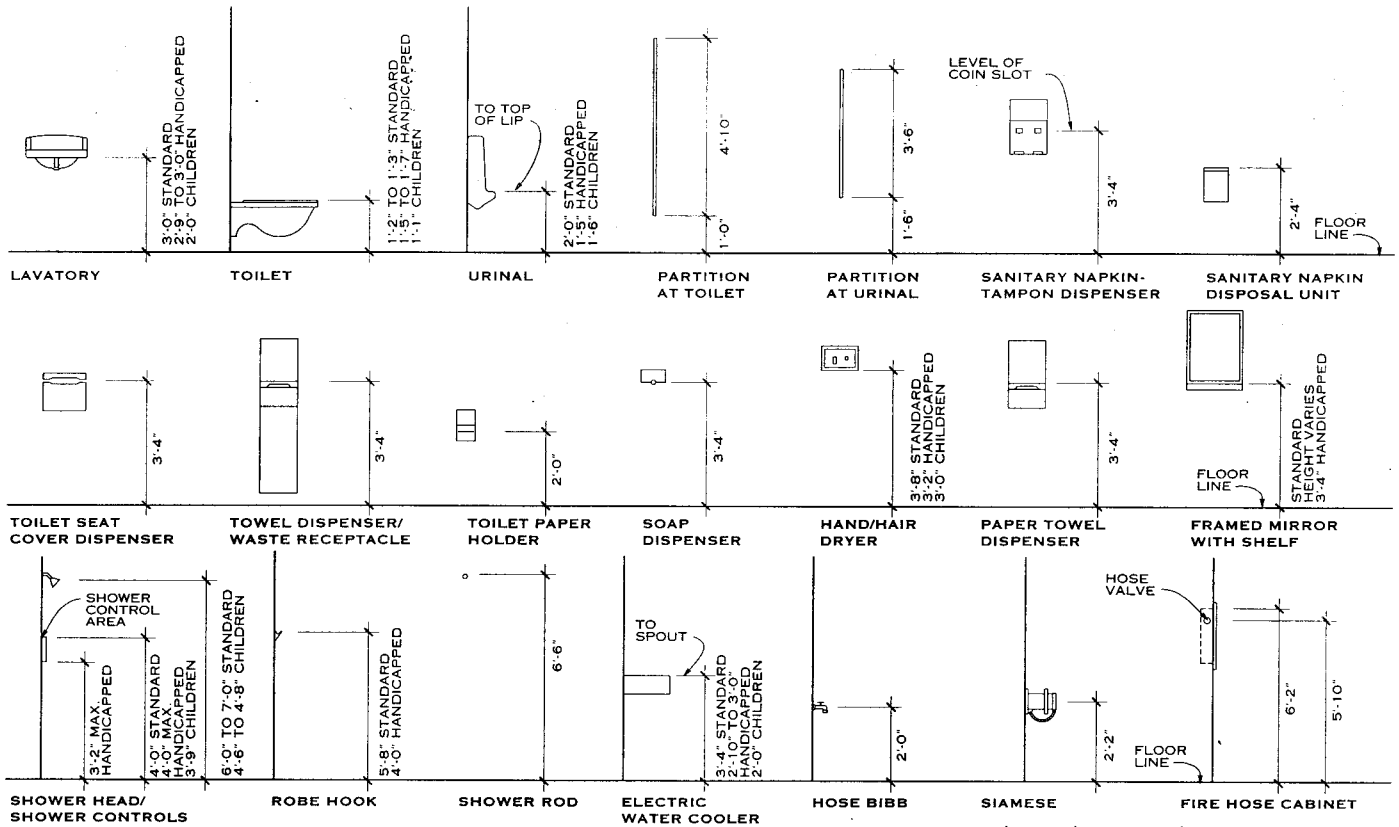

**PRELIMINARY PLUMBING FIXTURE COUNT**

FACILITY TYPE	WC (PEOPLE)	WC (FIXTURE)	UR	LAV	DF	SH	SS	NOTES
Stadiums, arenas, convention halls, terminals	1-100	1						
	101-200	2	Note 1	Note 2	1/1000			Note 4
	201-400	4						
	Addl. 300	1						
Churches, auditoriums, theaters	1-50	1						
	51-300	2	Note 1	Note 2	1/1000			Note 4
	Addl. 300	1						
Restaurants	1-50	2						
	51-100	3	Note 1	Note 2	1/200			
	101-200	4						
	Addl. 200	1						
Sport clubs	1-40	1	Note 1	Note 2	1/75	15/1		Up to 150
Country clubs	Addl. 40	1				30/1		More than 150
Industrial facilities (with lockers)	1-10	1						
	11-25	2						
	26-50	3	Note 1	Note 2	1/75	1/10	1/floor	
	51-75	4						
	76-100	5						
Stores, malls, office buildings—employees	Addl. 50	1						
	1-15	1						
	16-40	2	Note 1	Note 2	1/100		1/floor	
	41-75	3						
Stores, malls, office buildings—customers	Addl. 60	1						
	1-15	1						
	16-40	2	Note 1	Note 2				
	41-75	3		Note 3	1/1000		1/floor	
Dormitories	1-20	2						1 laundry tray
Boardinghouses	Addl. 20	1	Note 1	Note 2		1/unit	1/floor	Addl. 10 people

**NOTES**

WC—water closet; UR—urinal; LAV—lavatory; DF—drinking fountain; SH—shower; SS—service sink.

1. Half of the water closets can be urinals.
2. Half of the lavatories can be water closets.

3. If employee facilities are accessible to customers, no additional fixtures are necessary.

4. Some codes require double or triple the number of water closets for women.

5. Consult local plumbing codes for exact requirements.

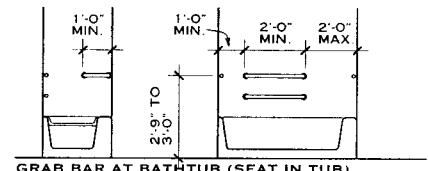

GRAB BAR AT BATHTUB (SEAT IN TUB)

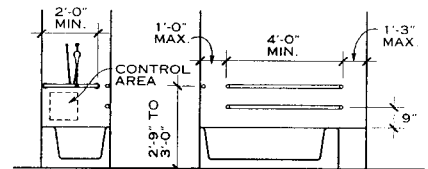

GRAB BAR AT BATHTUB (SEAT AT TUB HEAD)

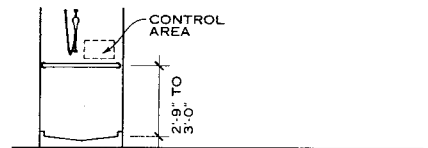

GRAB BAR AT SHOWER STALL

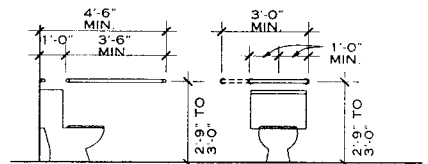

GRAB BAR AT WATER CLOSET

NOTE  
For grab bars at toilet stalls, consult ANSI A117.1.

American Society of Plumbing Engineers; Westlake, California  
Michael Frankel, CIPE, Utility Systems Consultants; Somerset, New Jersey

**INTERCEPTORS**

There are a number of substances that, if discharged into a plumbing system, have the potential to create safety or health problems or cause stoppages. In addition, some substances are not easily treated in a public sewage treatment system. Interceptors separate and retain such substances from drainage effluent, preventing their discharge into the sewage system.

**GREASE INTERCEPTORS (TRAPS)**

Grease is discharged from fixtures within food preparation areas such as kitchens and cafeterias. It is lighter than water and floats to the surface. It coats the inside of piping causing stoppages and is not easily treated in a sewage treatment plant. It must be removed from the waste stream before discharge into the drainage system.

Their size is based on intended capacity of retained grease, inflow into the grease trap, and the total volume of grease laden water that may flow through the grease trap. Grease traps should be located as close to the discharging fixture as practical and may be installed on or under a floor. A device to control the inflow is necessary to slow the water flow and allow grease sufficient retention time to float to the top of the interceptor for storage and removal. A vent connecting to the sanitary vent system should be provided.

**OIL INTERCEPTOR**

Oil and other volatile flammable liquids and vapors are a potential fire hazard, and the toxic vapors released are harmful when inhaled. Relatively small amounts are discharged mainly from machine shops, automobile repair shops, and parking garages. This oil is lighter than water and floats to the surface. It must be removed and stored in a safe location. An oil interceptor collects all volatile liquids entering the interceptor and stores them at the top of the unit for removal.

**HAIR INTERCEPTOR**

Hair discharged from barbershops and beauty parlors will create stoppages in the drainage system. A hair trap, installed on each fixture instead of a standard P trap, will trap all the hair.

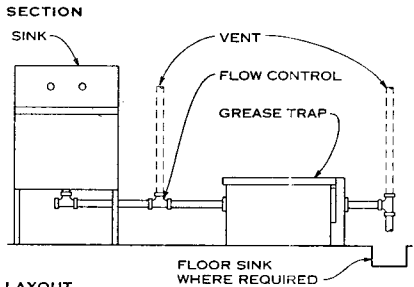
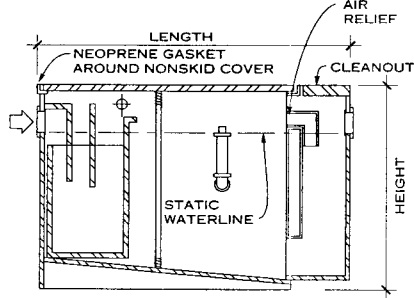

**LAYOUT DIMENSIONS**

FLOW RATE (GPM)	GREASE CAP (LB)	LENGTH	HEIGHT	WIDTH
4	8	16 3/4	11	10
7	14	19	12	10 3/4
10	20	21 1/4	13 1/4	13
15	30	25	15 1/2	14
20	40	28 1/2	17	15 3/4
25	50	30	19 3/4	16 3/4
35	70	32 1/2	21	18 1/4
50	100	35 1/2	24 1/4	20 3/4

**GREASE INTERCEPTOR**

**SAND INTERCEPTOR**

Whenever there is a chance that sand or other small solids heavier than water may enter a drainage system, they must be removed and stored for disposal. A common source is foundation drains that discharge into a public sewer. Sand removal is accomplished with a sand interceptor.

Since the solids are heavier than water, the principle of retention is to have the solids settle to the bottom of the interceptor. When sand reaches a predetermined level, it must be cleaned.

**PRECIOUS METALS INTERCEPTOR**

In precious metal refining, polishing, and jewelry manufacturing, it is desirable to recover the small solids (fines) that would ordinarily be washed down the drain during polishing, cleanup, and washing. Small amounts from fixtures have a fixture trap type. Larger amounts require a floor-mounted type.

**SHOCK ABSORBER**

Whenever a water control valve closes very quickly in normal operation, such as those installed on water closets, clothes and dish washing machines, the sudden stopping of water starts a shock wave. This shock wave, commonly called water hammer, greatly increases pressure in the piping that over a period of time could cause the pipe or joint to fail. A shock absorber, installed in the water line between the source and the equipment, will lower the pressure to acceptable levels. The absorber size is based on line size, flow rate, and water pressure.

**ACID NEUTRALIZER**

Acids are a common class of chemicals discharged from laboratories, schools, and manufacturing facilities. The acids must be neutralized before they are discharged into the sanitary drainage system of a building. For small amounts, this is accomplished with an acid neutralizer that uses limestone chips as the neutralizing agent. Small amounts from fixtures use a fixture trap type. Larger quantities of acid require an acid sump installed either on or under the floor.

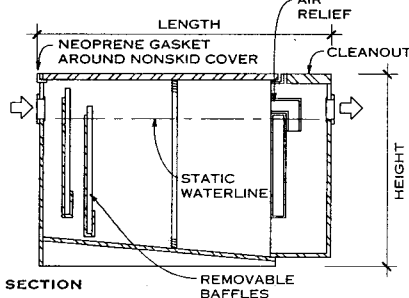

**SECTION DIMENSIONS**

FLOW RATE (GPM)	LENGTH	HEIGHT	WIDTH
10	21 1/4	13 1/4	13
15	25	15 1/2	14
20	28 1/2	17	15 3/4
25	30	19 3/4	16 3/4
35	32 1/2	21	18 1/4
50	35 1/2	24 1/4	20 3/4

**OIL INTERCEPTOR**

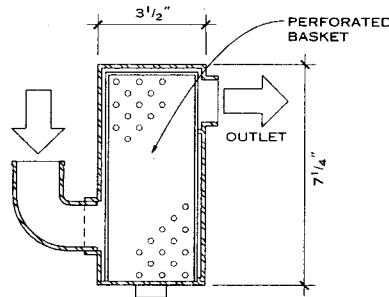

**HAIR INTERCEPTOR**

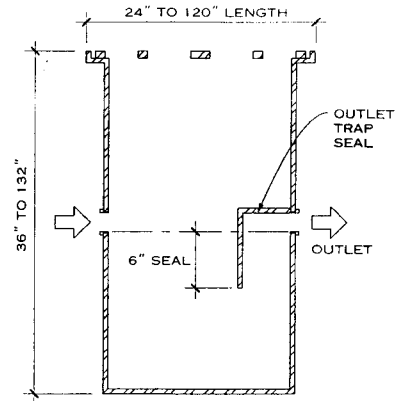

**NOTE**  
Width varies from 24 to 48 in.

**SAND INTERCEPTOR**

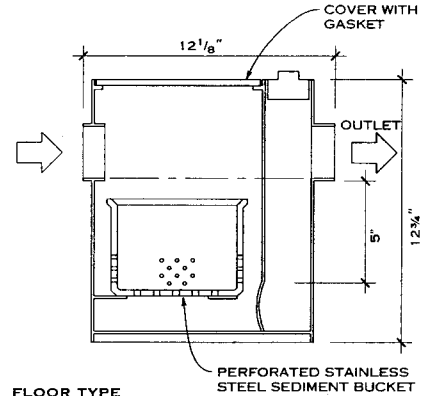

**FLOOR TYPE PRECIOUS METALS INTERCEPTOR**

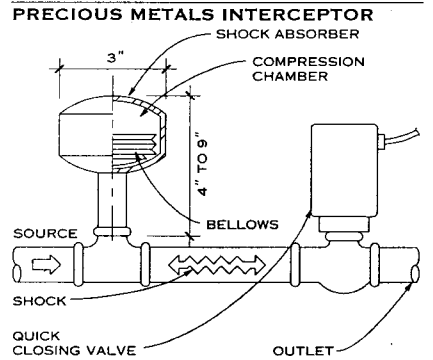

**SHOCK ABSORBER**

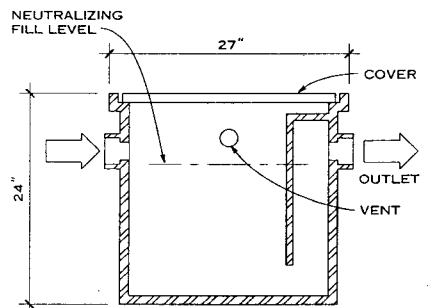

**FLOOR TYPE ACID NEUTRALIZER**

Michael Frankel, CIPE; Utility Systems Consultants; Somerset, New Jersey

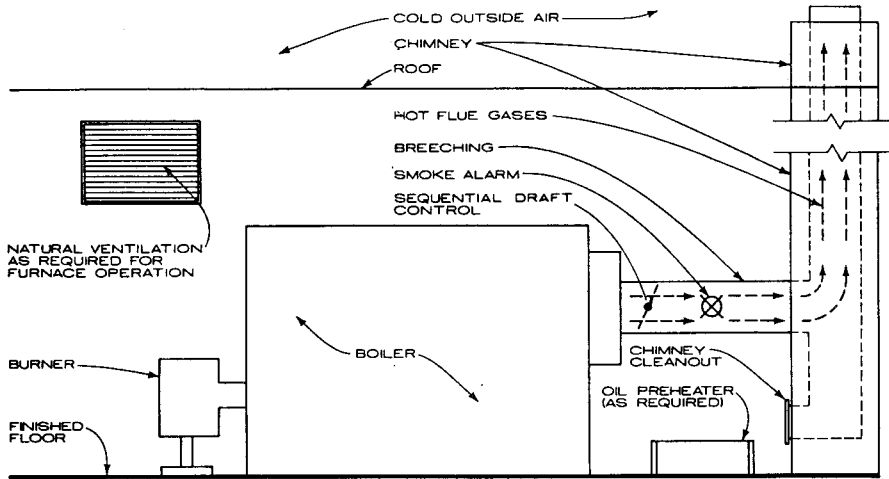

TYPICAL BOILER EQUIPMENT FOR NATURAL DRAFT INSTALLATION

**BOILERS AND BURNERS**

Two main elements determine overall boiler efficiency: (1) heat transfer surface of boiler and its condition—clean or fouled; (2) burner's ability to convert fuel's calorific (heat) value into useful heat.

Burner efficiency depends on the proper combustion of fuel (air-fuel ratio) and the maintenance (annual tune-up) of the burner. To handle a boiler properly and efficiently, the maintenance staff must be trained to operate the unit and to conduct efficiency tests, which include testing for CO<sub>2</sub>, stack temperature, smoke, and draft.

NOTE: Air pollution regulations must be obtained from authorities having jurisdiction.

**RATINGS**

- Gross rating = input in Btu/hr.
- Net rating = output in Btu/hr. = gross rating x efficiency.

**3. FUEL RATINGS**

FUEL	HEAT VALUE	EFFICIENCY (%)
Anthracite coal	14,600 Btu/lb	65-75
No. 2 oil	140,000 Btu/gal	70-80
No. 4 oil	145,000 Btu/gal	70-80
No. 6 oil	150,000 Btu/gal	70-80
Natural gas	1052 Btu/cu ft	70-80
Electricity	1 W = 3.4 Btu/h	95-100

- Example: If boiler-burner combination is 80% efficient, No. 2 fuel oil is burned, and the total heat load is 168,000 Btu/hr, what is the required firing rate?

$$\text{Firing rate} = \frac{\text{gross rating}}{\text{fuel rating} \times \text{efficiency}}$$

$$= \frac{168,000 \text{ (Btu/hr)}}{140,000 \text{ (Btu/gal)} \times 80\% (.8)} = 1.5 \text{ gal/hr}$$

NOTE: Gross and net ratings are found on equipment plates.

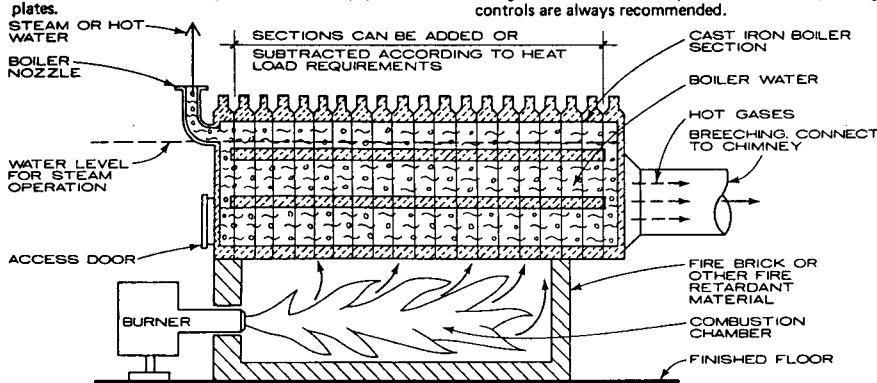

CAST IRON SECTIONAL TYPE BOILER

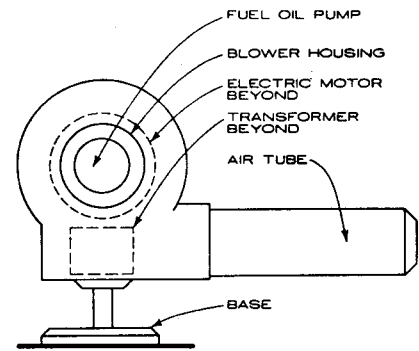

HIGH PRESSURE GUN TYPE BURNER (NO. 2 FUEL OIL)

NOTE: FOR DOMESTIC INSTALLATIONS UP TO 10 FAMILIES AND SINGLE STORY COMMERCIAL INSTALLATIONS UP TO 10,000 SQ FT

**CONTROLS**

Automatic fuel burning equipment requires a control system that will provide a prescribed sequence of operating events and will take proper corrective action if failure occurs in the equipment or its operation. The basic requirements for oil burners, gas burners, and coal burners (stokers) are the same. The controls can be classified as operating controls, limit controls, and interlocks.

Operating controls initiate the normal starting and stopping of the burner in response to the primary sensor acting through appropriate actuators.

Examples of primary sensors are: a room thermostat for a residential furnace; a pressure actuated switch for a steam boiler; a thermostat for a hot water heater. Since the heat output of a burner may be widely distributed, the location of the primary sensor is important.

An actuator is defined as a device that converts the control system signal into a useful function. Actuators generally consist of valves, dampers, or relays.

Ignition for oil or gas burners is achieved by an electric spark or by a pilot gas flame, all supervised by a flame safeguard system which must meet legal and insurance underwriter's requirements. After ignition is proved, the flame safeguard system then permits the main fuel (gas or oil) to enter the burner for on-line combustion.

Limit controls and interlocks function only when the system exceeds prescribed unsafe operating conditions. They actuate electric switches that will close the fuel valve in the event of an unsafe condition, such as (1) excessive temperature in the combustion chamber or heat exchanger, (2) excessive pressure in a boiler or hot water heater, (3) low water level in a boiler and in larger commercial and industrial burners, (4) high or low gas pressure, (5) low oil pressure, (6) low atomizing media pressure, and (7) low oil temperature when firing residual fuel oil. Separate limit and operating controls are always recommended.

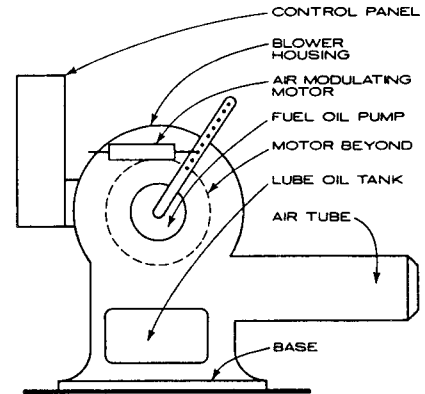

LOW PRESSURE GUN TYPE BURNER (NO. 4 FUEL OIL AND/OR GAS)

NOTE: FOR LARGE DOMESTIC, SEMICOMMERCIAL, AND COMMERCIAL INSTALLATIONS

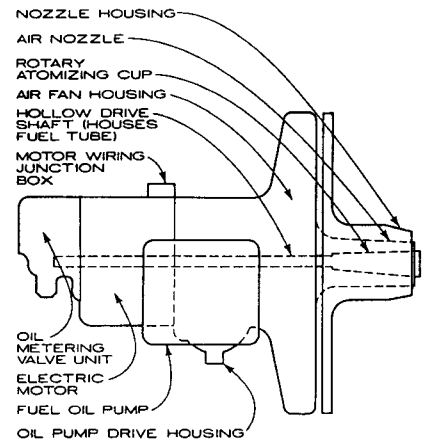

HORIZONTAL ROTARY TYPE BURNER DIRECT DRIVE (NO. 6 FUEL OIL)

NOTE: ALSO AVAILABLE WITH BELT DRIVE, USED IN DOMESTIC, SEMICOMMERCIAL, COMMERCIAL, AND HEAVY INDUSTRIAL

BURNER TYPES



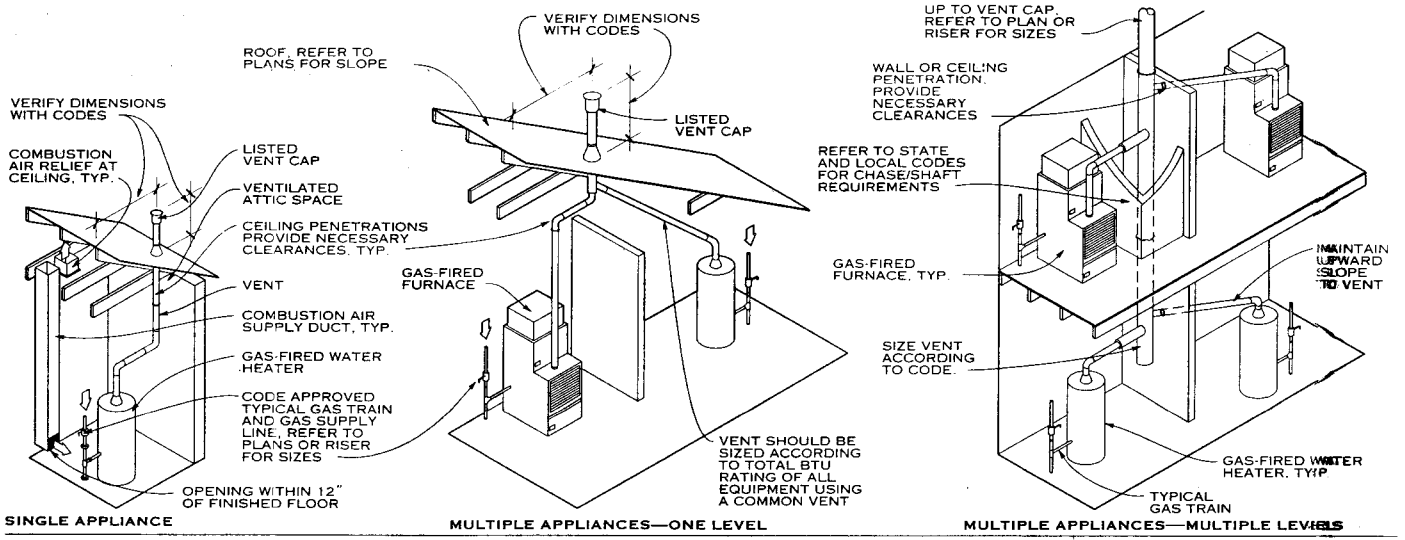

**GAS APPLIANCES WITH VENT ARRANGEMENTS**

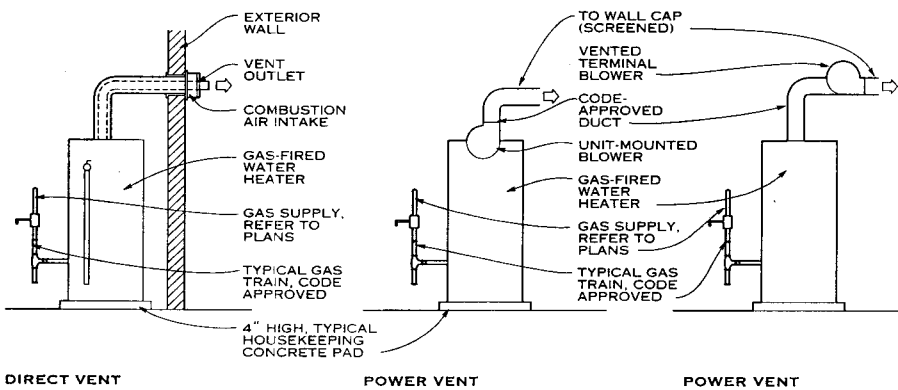

**SIDEWALL VENTED GAS-FIRED WATER HEATERS**

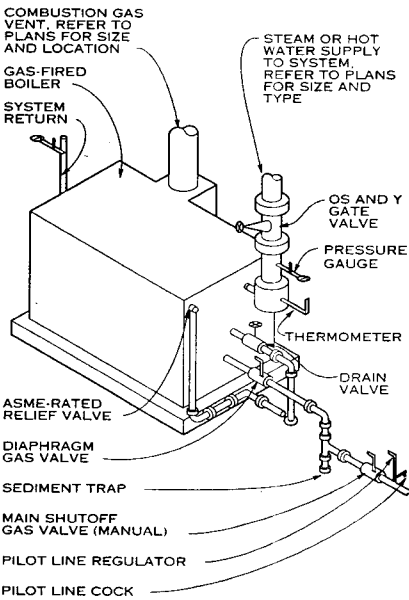

**TYPICAL GAS-FIRED BOILER**

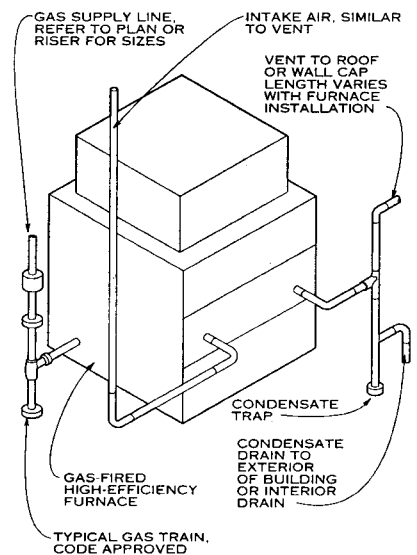

**TYPICAL GAS-FIRED HIGH-EFFICIENCY FURNACE**

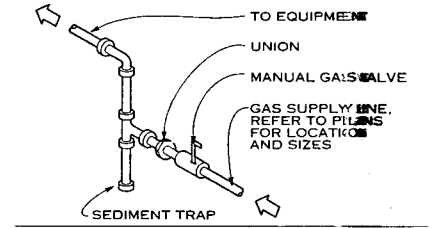

**TYPICAL GAS TRAIN**

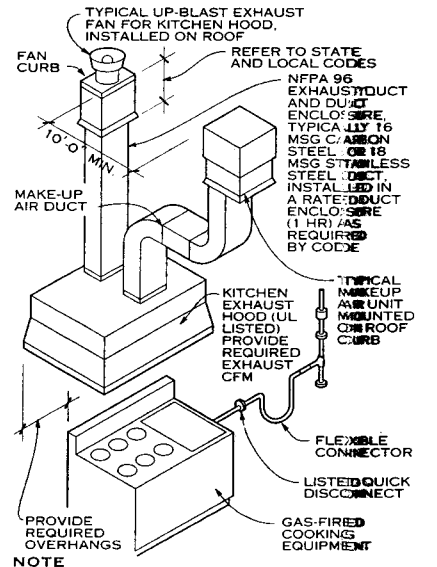

**TYPICAL KITCHEN HOOD INSTALLATION**

**NOTES**

1. For high-efficiency furnaces, contractors have the option of using a combination vent/intake air kit (with either wall or roof installation) when allowed by code.
2. Code requires fire extinguishing systems in kitchen hood installations in commercial facilities.
3. Drawings on this page are for reference only. Refer to state and local codes/ordinances and manufacturers' installation instructions for requirements governing maintenance, clearances, gas piping, combustion air, and venting in specific situations.

NOTE: MSG = manufacturer's standard gauge thickness.

Alfred Greenberg, PE, CEM; Murray Hill, New Jersey  
American Gas Association; Washington, D.C.

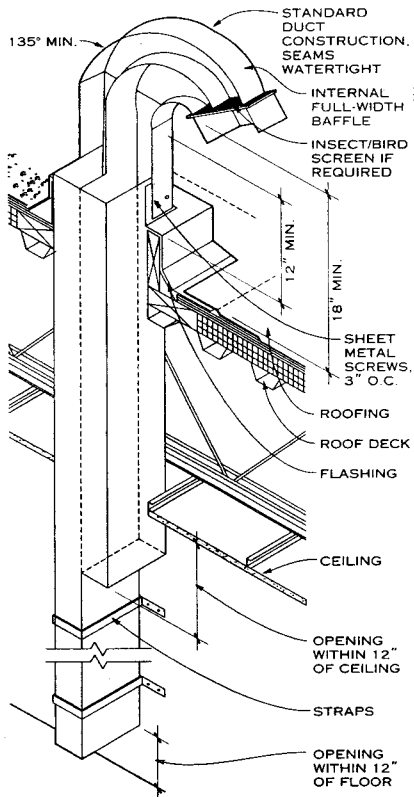

TYPICAL COMBUSTION AIR GOOSENECK

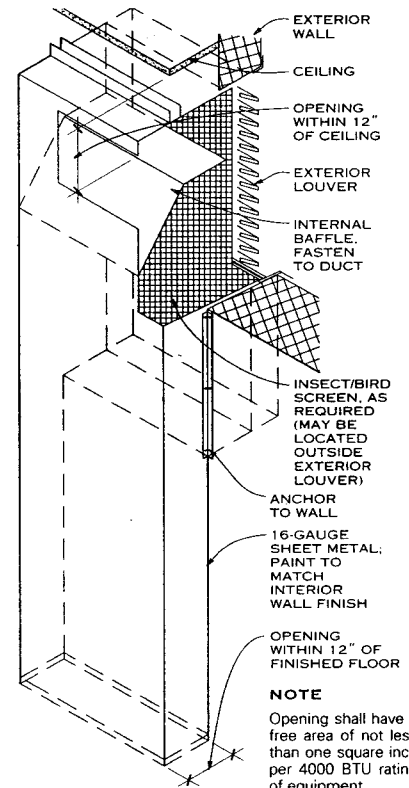

TYPICAL COMBUSTION AIR LOUVER

Alfred Greenberg, PE, CEM; Murray Hill, New Jersey  
American Gas Association; Washington, D.C.

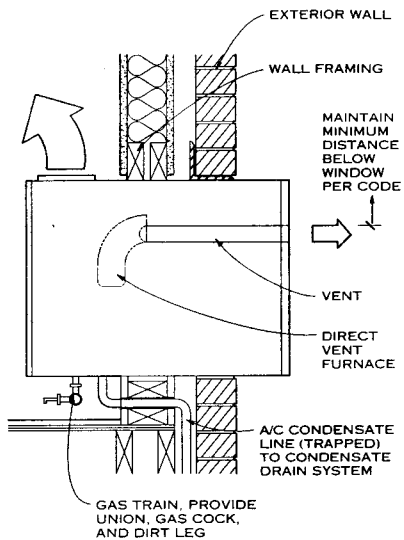

**NOTE**

Weatherproof these through-wall units at the wall.

TYPICAL GAS HEATING/ELECTRIC COOLING THROUGH-WALL UNIT

CODE-APPROVED GAS TRAIN, GAS SUPPLY RUN IN JOISTS WHEN POSSIBLE

REDUNDANT GAS VALVE (OPTIONAL)

CHANNEL SUPPORT ANCHORED TO STRUCTURE, PROVIDE RODS WITH VIBRATION ISOLATORS DEVICES, ALTERNATE MEANS OF SUPPORT AS APPROVED BY JURISDICTION (ROD SIZE AS RECOMMENDED BY HEATER MANUFACTURER)

LOW-INTENSITY POWER-VENTED HEATER

**NOTE**

If venting of gases is not required and code approves, vent piping and power vent may be eliminated.

FLUE (SIZE ACCORDING TO RATING OF UNIT)

CHANNEL SUPPORT ANCHORED TO STRUCTURE, PROVIDE RODS WITH VIBRATION ISOLATOR DEVICES, ALTERNATE MEANS OF SUPPORT AS APPROVED BY AUTHORITY HAVING JURISDICTION

DUCT FURNACE

**NOTE**

A unit heater would be similar but without ducts.

GAS-FIRED HEATERS

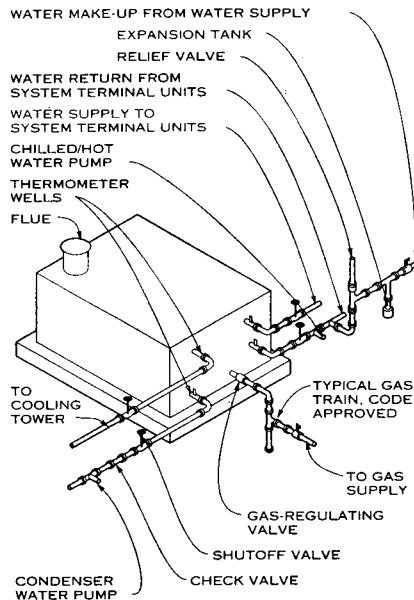

DIRECT GAS-FIRED CHILLER/HEATER

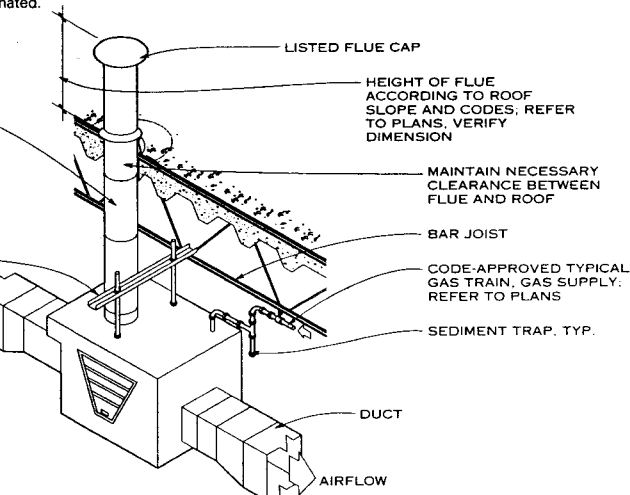
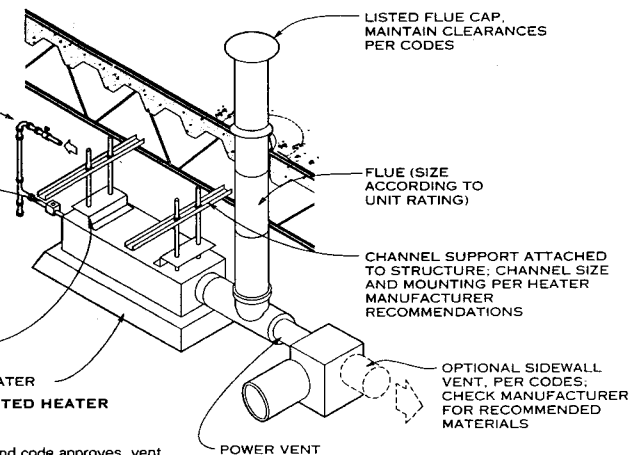

**LOCAL HEATING SYSTEMS**

Electric energy is ideally suited for local space heating because it is simple to distribute and control. Electric heating systems are widely used in residences, schools, and commercial and industrial facilities. Heating units are placed in individual rooms or spaces but may be combined into zones with automatic temperature controls. Electric in-space heating systems may utilize natural convection, radiant, or forced air units.

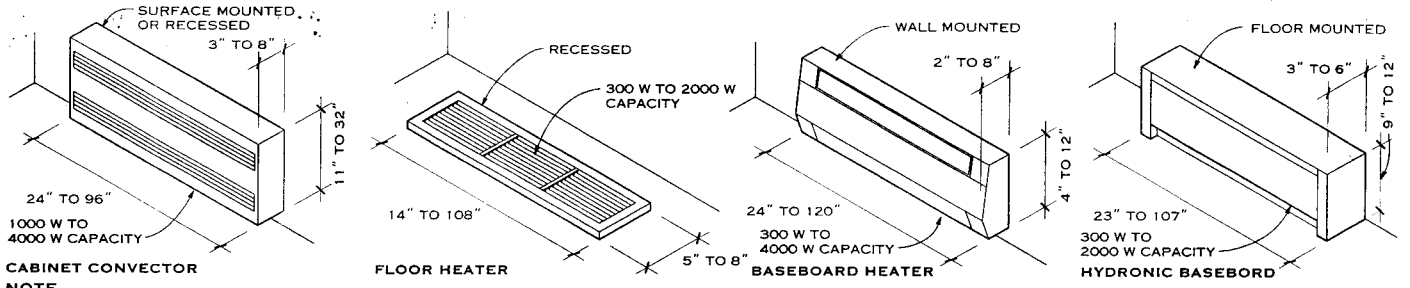

**NOTE**  
 Natural convection units for wall or floor placement (and surface or recessed installations) have elements of bare incandescent wire, bare low-temperature wire, or sheathed

wires. A liner or reflector is usually placed between elements so that part of the heat output is distributed by radiation and part by convection. Small capacity units (up to about 1650 W) operate at 120 V; higher capacity units oper-

ate at 208 V or more. Because natural convection air currents are critical to the distribution of heat from these units, they must be installed so that airflow across the resistor element will not be impeded.

**NATURAL CONVECTION UNITS**

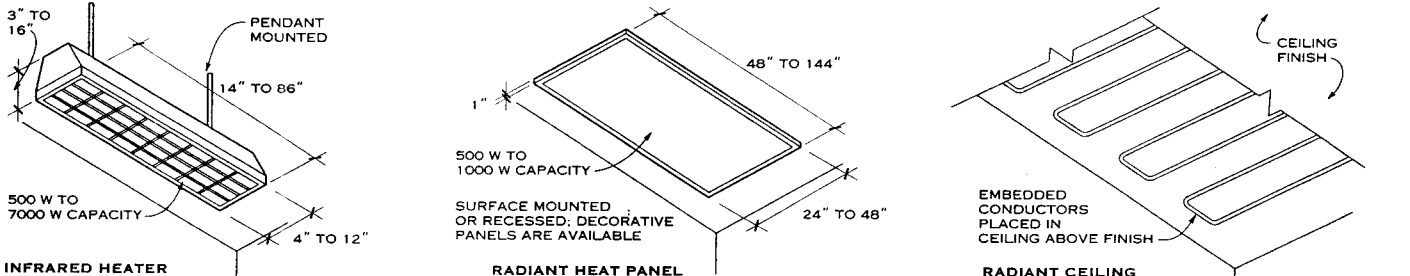

**NOTE**  
 Radiant heating units are designed primarily to heat objects, rather than space. Current flowing through a high-resis-

tance wire heats up the element or surface of the unit. Heat is transferred from the unit to surfaces or occupants primarily by radiation. Manufacturers' recommendations for

installation clearances should be strictly followed. For an effective system, it is important to locate radiant heating units carefully in relation to the objects being heated.

**RADIANT HEATING UNITS**

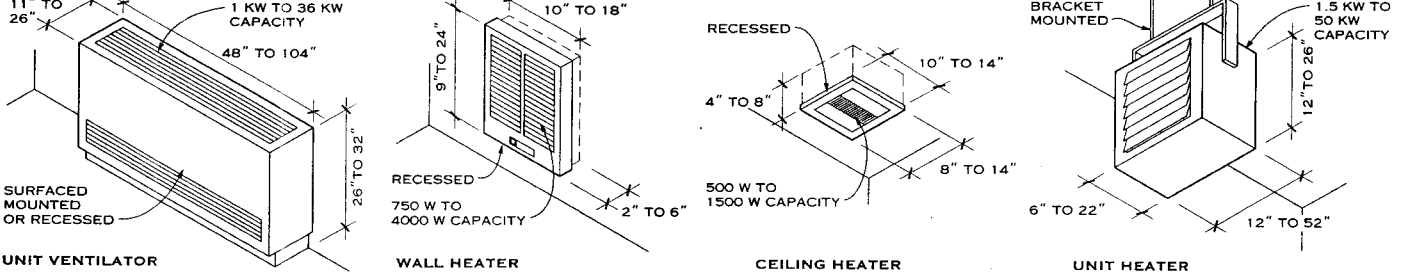

**NOTE**  
 Forced air units combine convection heating with fan-powered air circulation. Such units are available in a wide range

of capacities to suit a variety of heating loads and occupancy types. Unit ventilators are commonly located on an

outside wall, where they have access to outdoor air intake and can prevent cold air downdrafts from window areas.

**FORCED AIR UNITS**

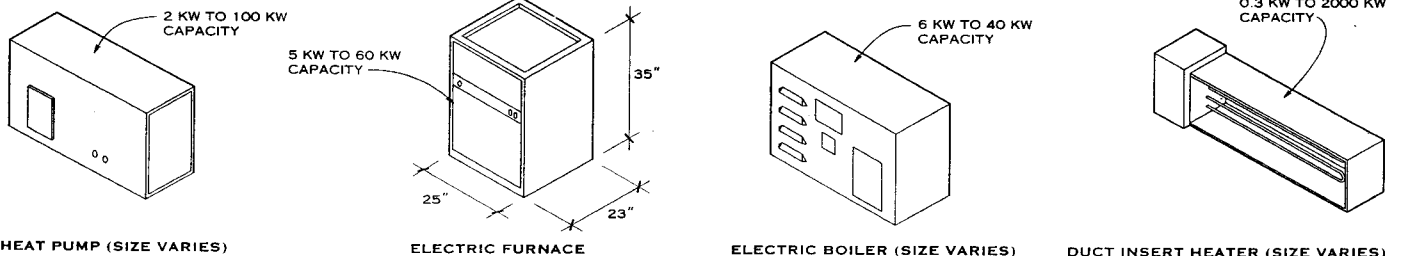

**NOTE**  
 Electric resistance can be used as a heat source in a variety of central heating systems. An electric boiler with an immersion heating element can provide hot water for a heating-only system with radiator or convector terminal units or for an all-water or air-water HVAC system. An electric furnace, with a heating coil, fan, and air filter, can pro-

vide warm air for a central all-air HVAC (or heating-only) system. This system is essentially a small-capacity version of a single-zone, all-air system. Electric resistance elements can also be inserted in ductwork or at terminal boxes to provide heating capability in central HVAC systems. Other means of heating with electricity include heat pumps and

integrated heat recovery systems. In a heat pump, electricity drives a compressor that operates a vapor compression refrigeration loop in a reverse cycle, providing heat at the evaporator coil. Integrated heat recovery captures heat generated by some process (e.g., electric lighting) and uses it to heat a space or building (rather than contributing to the space cooling load).

**CENTRAL HEATING SYSTEMS**

Walter T. Grondzik, P.E.; Florida A&M University, Tallahassee, Florida

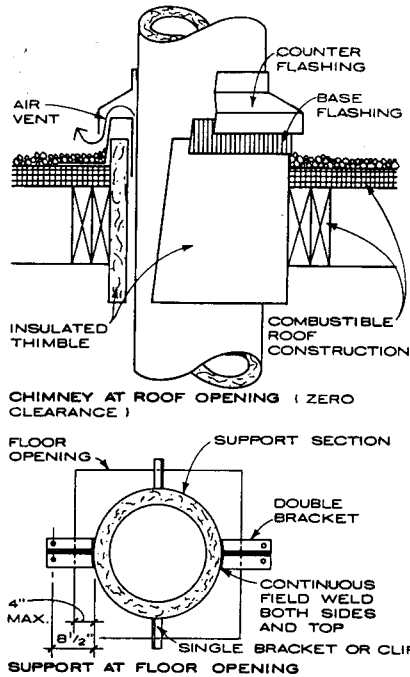
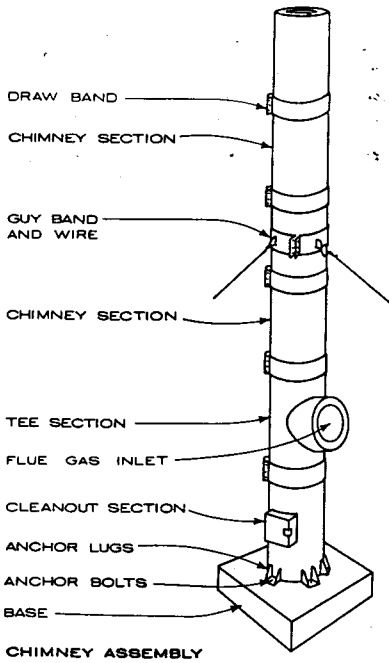

**CHIMNEY CONSTRUCTION**

The chimney should be supported on a foundation of masonry or reinforced concrete or other noncombustible material having a fire resistance rating of not less than 3 hr. When installed on an appliance, the chimney should be so supported as to not place excessive stress on the appliance. The base of the chimney should be secured to prevent movement of the chimney and anchor lugs should be used for this purpose whenever possible.

A cleanout section may be used in the chimney assembly but must not be used above the chimney inlet.

**CLEARANCES**

Chimneys of the medium heat appliance or commercial-industrial incinerator type are not intended to be enclosed in walls of combustible materials. These chimneys should be placed in fire resistive or noncombustible shafts where they extend through any story of a building above that in which the connected appliance is located.

An enclosed chimney may be placed adjacent to walls of combustible material with the following minimum clearances:

- 10 to 15 in. I.D. requires 16 in. clearance
- 15 to 21 in. I.D. requires 18 in. clearance
- 21 to 27 in. I.D. requires 20 in. clearance
- 27 to 36 in. I.D. requires 22 in. clearance

Where the chimney passes through a roof of combustible material it shall be installed with an insulated thimble and flashing. This insulated thimble may be installed at zero inch clearance to combustibles.

The chimney should extend at least 3 ft above the highest point where it passes through the roof and 2 ft higher than any ridge within 10 ft.

**MEDIUM HEAT CHIMNEYS**

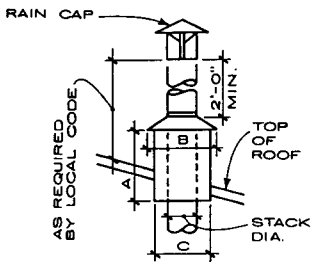

**STACK DIAMETER—SINGLE BOILER VENT OR STACK**

BOILER HORSE-POWER	STACK DIAMETER (IN.)	A (IN.)	B (IN.)	C (IN.)
15-20	6	15	15	12
25-40	8	20	20	16
50-60	10	25	25	20
70-100	12	30	30	24
125-200	16	40	40	32
250-350	20	50	50	40
400-800	24	60	60	48

**VENT STACKS**

The purpose of a vent stack is to conduct the products of combustion to a point of safe discharge (atmosphere). Forced draft design eliminates the need for a stack designed to create a draft. An offset type of stack connection to the stub vent on the boiler is preferred. A direct vertical connection can also be made when boiler vent outlets can withstand the direct vertical load of the stack, including the effect of wind and guy wires.

**STACK CONSTRUCTION**

The stack can be terminated several feet above the top of the roof. (State and local codes may govern the stack height above the roof.) If down drafts are unavoidable, the stack outlet can be provided with a ventilator. Minimum 12 gauge steel is recommended for stack sections. If the stack will be inaccessible, the use of a noncorrosive material (e.g., glass lining) should be considered.

A rain cap or hood should be used at the top of the stack to minimize the entrance of rain or snow.

**ROOF PENETRATION**

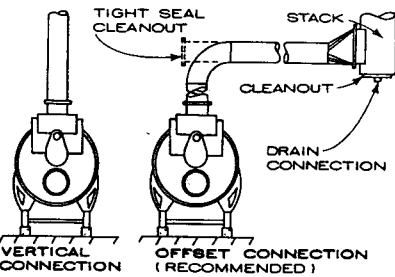

**STACK DIAMETER—MULTIPLE BOILERS: COMMON BREECHING AND STACK**

BOILER HORSE-POWER	MINIMUM STACK DIAMETER (IN.)					
	NUMBER OF BOILERS					
	2		3		4	
	100 FT	200 FT	100 FT	200 FT	100 FT	200 FT
25-40	11	12	13	14	14	16
50-60	13	14	15	16	17	18
70-100	16	17	19	20	21	23
125-200	21	22	24	26	28	30
250-350	26	28	32	34	34	40
400-600	32	34	38	40	42	46

**BREECHING DIAMETER—SINGLE AND MULTIPLE BOILERS**

BOILER HORSE-POWER	MINIMUM BREECHING DIAMETER (IN. OD)			
	A (IN.) 1 BOILERS	B (IN.) 2 BOILERS	C (IN.) 3 BOILERS	D (IN.) 4 BOILERS
15-20	6	8	9	9
25-40	8	10	11	12
50-60	10	12	14	15
70-100	12	15	17	18
125-200	16	20	22	24
250-350	20	25	28	30
400-600	24	30	33	36
700-800	24	34	38	42

Note: Stack diameter should be larger than breeching diameter.

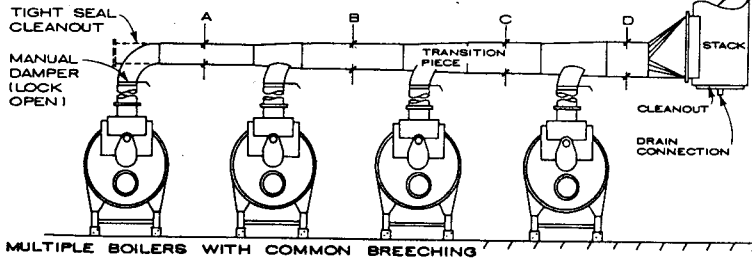

**VENT STACKS**

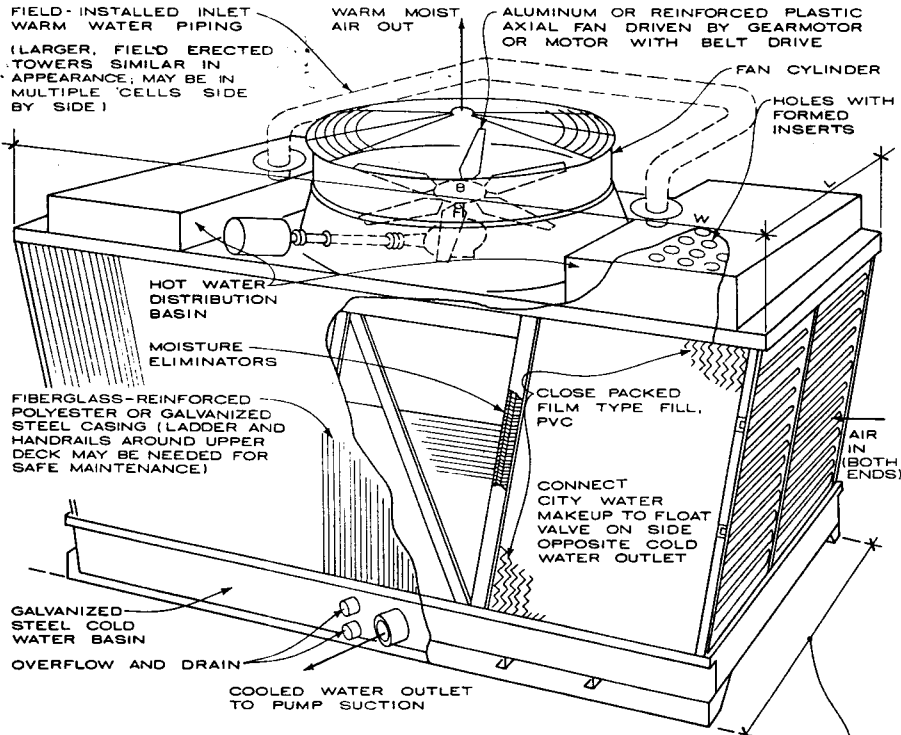

(FIELD ERECTED CUSTOM-DESIGN COOLING TOWERS ARE AVAILABLE FOR USE WITH CASINGS OF MASONRY OR CONCRETE TO BLEND WITH BUILDING APPEARANCE)

SUPPORT ON TWO STEEL BEAMS EACH DESIGN FOR 1/360 SPAN OR MAX. 1/2 IN. DEFLECTION WHEN BEAM IS UNIFORMLY LOADED WITH 65% OF TOWER'S OPERATING WEIGHT

NOTES

- Cooling towers cool water for reuse in refrigeration condensers or other heat exchangers. Standard ratings are in tons of refrigeration when cooling 3 gal/min per ton from 95 to 85°F with ambient air at 78°F wet bulb. Selection is based on performance at local outdoor design conditions. Frequently the local outdoor ambient wet bulb temperature used for selection is equal to or exceeded by 1% of summer hours.
- Fans move air horizontally (crossflow) or up (counterflow) against water falling and wetting the fill or packing, to expose maximum water surface to the air. Reduced air flow reduces tower performance. Architectural enclosures should minimize obstruction to air flow.
- Warm water is distributed at the top of the cooling tower by spray nozzles or basins with multiple orifices, and cooled water is collected in a basin at the bottom and pumped to condensers. Water is cooled by evaporating a very small portion. Water droplets may also be carried out by the air stream. Minerals and impurities present in all water increase concentration as pure water evaporates, so a little water is "bled" and chemicals are added to minimize scaling, corrosion, or biological fouling of condenser tubes. Towers for critical or large systems should be multicell for maintenance without shutdown.
- Fan, motor, and water splashing noise may be a nuisance. Fan noise is reduced by two speed motors (about 8 dB at half speed, 15% power, and 60% capacity) and by intake and discharge attenuators (about 12 dB) with 10% power increase. Tower noise is louder in line with fan discharge and intake than in other directions. Each doubling of distance decreases noise about 6 dB. Barriers can reflect some noise from critical directions. Locate towers for free air movement. Avoid hot air recirculation, long piping from pumps and condensers, and inadequate substructures. Cooling towers should be located so that noise and water droplet carryover and fog at air discharge in cold weather will not be a nuisance. Consider seismic and wind load in anchoring tower to supports; towers are usually designed to withstand 30 psf wind load. Basins may be heated for winter use.

CROSSFLOW INDUCED - DRAFT PACKAGED COOLING TOWER - 200 TO 700 TON CAPACITY PUMPS AVAILABLE IN DUAL CELLS WITH TWICE THE CAPACITY

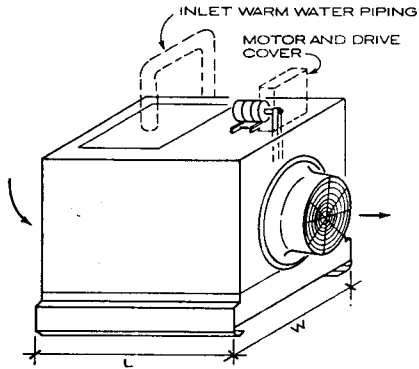

CROSSFLOW INDUCED DRAFT PACKAGE COOLING TOWER

TONS 3 GPM/TON 95-85-78	OVERALL DIMENSIONS (IN.)			OPERATING WEIGHT (LB.)	MOTOR (HP)
	L	W	HT.		
5	69	33	60	940	1/4
25	75	46	80	1600	1
50	84	64	92	2500	3
100	93	100	92	4200	5
150	100	144	112	8000	7 1/2

NOTE

AVAILABLE IN SINGLE MODULES AS SKETCHED, OR END-TO-END OR BACK-TO-BACK DOUBLE INLET

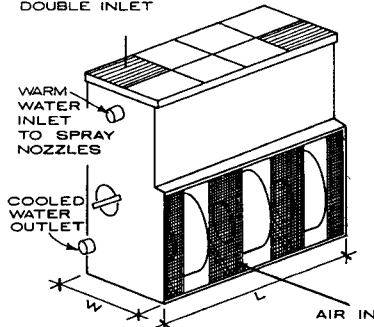

COUNTERFLOW FORCED DRAFT PACKAGE COOLING TOWER

TONS 3 GPM/TON 95-85-78	OVERALL DIMENSIONS (IN.)			OPERATING WEIGHT (LB.)	MOTOR (HP)
	L	W	HT.		
20	36	36	78	950	2
50	72	36	96	1700	7 1/2
150	144	56	122	4800	20
400	140	118	192	14,000	50

ENCLOSURE CONSIDERATIONS

Provide liberal wall openings on air inlet sides and mount tower so that air outlet is at top of enclosure. Consider effect of wind on nearby structure and enclosure to minimize hot, moist discharge air from being recirculated into inlet.

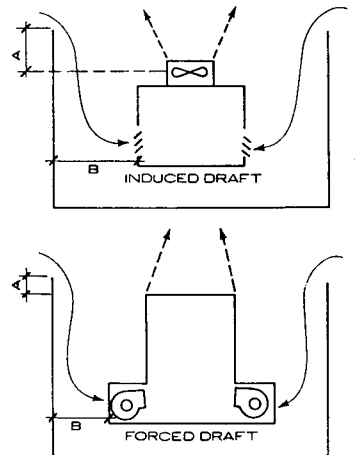

A = Height of enclosure above tower outlet. Minimize or extend shroud up from tower.

B = If enclosure walls have no opening, horizontal distance from tower inlet must increase greatly.

(Power for fan must be increased.)

Consult cooling tower manufacturer for minimum "B" dimension.

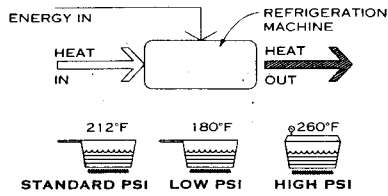

**NOTE**

Refrigeration machines move heat from one place to another: Kitchen refrigerators move heat from the storage compartment to the surrounding room. Air conditioners move heat from a room to the outdoors. The efficiency of air conditioning equipment is indicated by a seasonal energy efficiency rating (SEER), an index of the Btus moved per watt of electrical input energy. The higher its SEER, the more efficient and less costly a piece of equipment is to operate.

A large quantity of heat is required to boil or evaporate a liquid. This latent heat is the key to moving large quantities of heat with a small amount of refrigerant. To move heat from an area of low temperature to an area of high temperature (e.g., a building at 75°F to its surrounding environment at 95°F), the refrigeration equipment or air conditioner utilizes a fluid that boils and condenses within this range of temperatures and operating pressures.

**REFRIGERATION CYCLE**

**TYPICAL BUILDING APPLICATION**

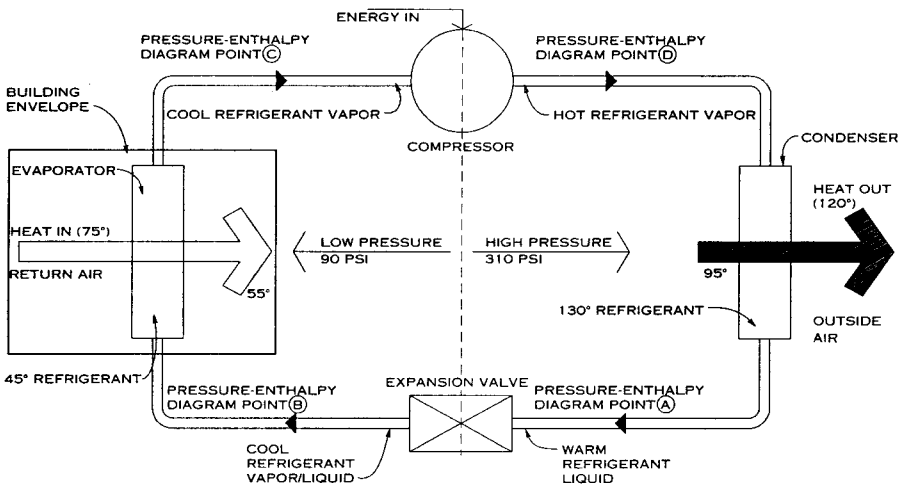

**NOTE**

During a cooling cycle, an evaporator coil absorbs heat from the building interior. This heat is absorbed by the refrigerant as it changes from a low pressure liquid to a vapor. This low pressure refrigerant vapor is then drawn into a compressor, where it is compressed into a high pressure vapor at high temperature. The resulting high pressure refrigerant vapor is discharged into a condenser coil, where it gives up the latent heat absorbed in the evaporator and the heat added during compression and returns to a high pressure liquid state. This high pressure liquid is forced through an expansion device in which the pressure and temperature are rapidly decreased, making it possible for the evaporator to again absorb heat from the building.

See the pressure-enthalpy diagram on the following ACS page on Refrigeration and Heat Transfer Principles.

**TYPICAL COOLING CYCLE TEMPERATURES AND PRESSURES**

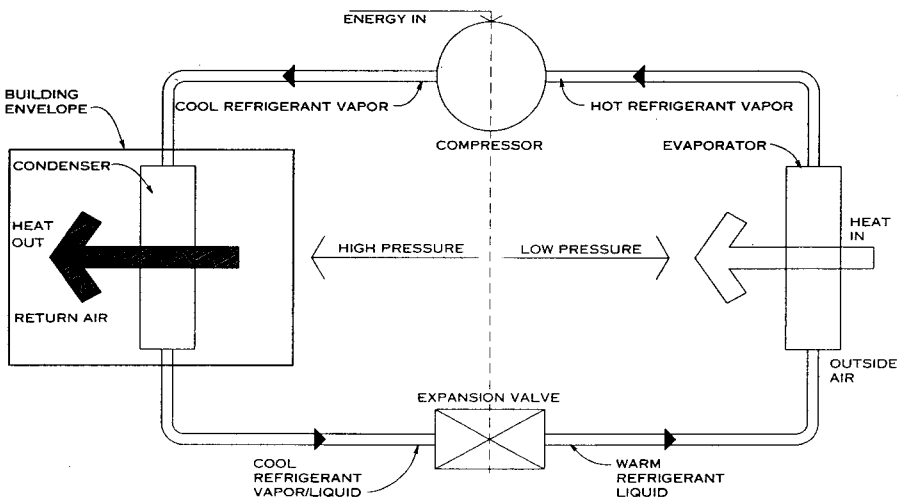

**NOTE**

The cooling cycle may be reversed to extract heat from a low temperature source, such as outside air, to heat a building. The basic equipment is unchanged with the exception of a four-way reversing valve and controls that permit the condenser and evaporator to exchange functions. A heat pump is more efficient than electric resistance heating because the only action required is pumping the refrigerant from a low pressure vapor to a high pressure vapor. The efficiency of a heat pump, measured as a coefficient of performance (COP), is a function of the temperature of the heat source.

**HEAT PUMP**

Jeff Haberl, Ph.D., P.E.; Texas A&M University; College Station, Texas

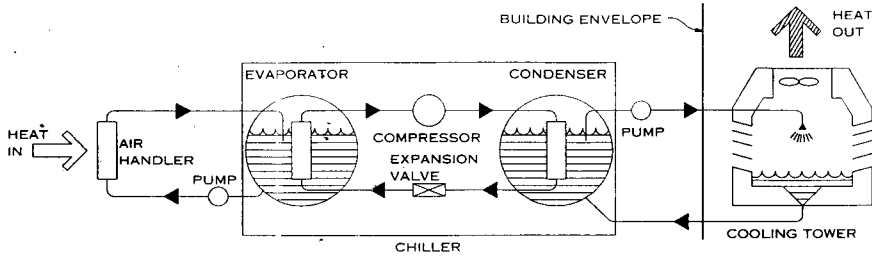

**NOTE**  
A large building air conditioning system typically includes a chiller, cooling tower, and one or more air-handling units. The arrangement shown at left offers substantial flexibility in equipment location and distribution. Chilled water is generated in a chiller (vapor compression or absorption) and circulated to air-handling units strategically located in the building. Condensing water from the chiller is circulated to an exterior cooling tower, where heat from the building is rejected to the outside environment. The chiller and air-handler(s) may be located virtually anywhere in the building and the cooling tower at an appropriate exterior location.

**CHILLER AND COOLING TOWER**

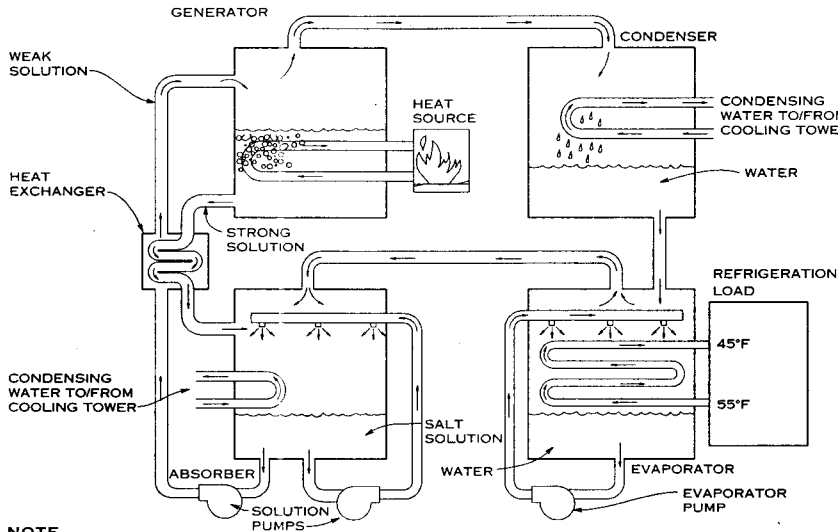

out the building. Cooling towers are typically installed in such large systems to increase efficiency. Air conditioning equipment transferring heat to 85°F water in a cooling tower will require less input energy to the compressor than the same equipment transferring heat to 95°F outside air.

In an absorption cooling cycle, cooling is generated by absorbing and desorbing water in a salt solution. Just as common table salt absorbs water on a damp day, a strong salt solution (e.g., lithium bromide) will draw water out of moist air when it is sprayed into an enclosed tank (absorber). If this moist air is connected to another tank that contains water that is evaporating, it will transfer water vapor to the absorber tank to replace the water that was drawn into the lithium bromide solution. Eventually, this strong lithium bromide solution becomes diluted and is pumped into a generator tank, where excess water is boiled off. The strong solution is then cooled in a heat exchanger and fed back into the absorber, where it can absorb more water. The water that was driven off in the generator is passed into a condenser, where it cools, condenses, and is then drawn back into the evaporator.

The refrigeration effect then draws off the (low pressure) evaporator at 45–55°F to produce chilled water. Since the absorption cycle accomplishes cooling without compressing a vapor, it can operate with reduced amounts of electricity as long as adequate amounts of heat are available for the generator and cooling for the condenser and absorber.

Because an absorption cooling cycle does not use a compressor, it is quieter and vibrates less than a vapor compression chiller. Absorption refrigeration is ozone friendly and can be configured to operate in systems with limited or no electricity (e.g., recreational vehicles).

**NOTE**  
In large buildings it is impractical to move heat with air only because duct sizes would have to be excessively large; therefore, a chiller (water tank) is added to the evaporator, and chilled water is circulated to air-handling units through-

**ABSORPTION CYCLE**

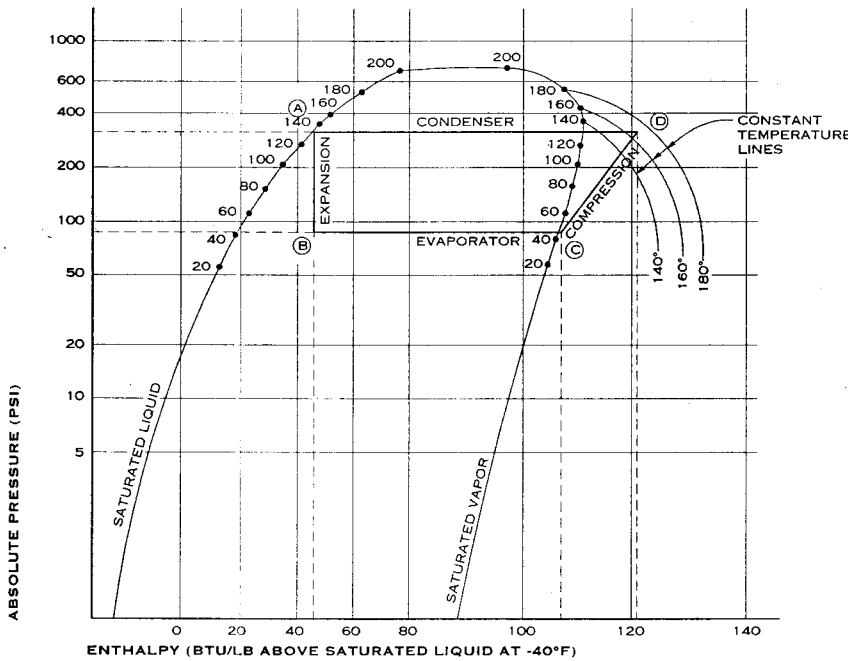

**NOTE**  
Refrigeration cycles are analyzed with a pressure-enthalpy diagram such as the one shown here. Values for the heat absorbed and rejected by the refrigerant and for the work of the compressor can be read from the diagram once the operating temperatures of the refrigeration cycle are known. Following is a sample refrigeration calculation, in which points A, B, C, and D exhibit the following figures for pressure (psi), temperature (°F), and enthalpy (Btu/lb):  
A—310 psi, 130°F, and 47 Btu/lb  
B—90 psi, 45°F, and 47 Btu/lb  
C—90 psi, 45°F, and 109 Btu/lb  
D—310 psi, 170°F, and 122 Btu/lb

Refrigeration equipment is designed with a pressure-enthalpy diagram for the refrigerant being used. The refrigeration effect is calculated by finding the enthalpy difference from Point C to Point A in the diagram at left with this formula:

$$q_{\text{evaporator}} \text{ (heat absorbed in evaporation)} = h_c - h_a$$

In the example, then, 109 - 47 = 62 Btu/lb.

The heat rejected in the condenser is calculated by finding the enthalpy difference from Point D to Point A:

$$q_{\text{condenser}} \text{ (heat rejected by condenser)} = h_d - h_a$$

In the example, 122 - 47 = 75 Btu/lb.

The work required of the compressor is calculated by finding the enthalpy difference from Point D to Point C:

$$q_{\text{work}} = h_d - h_c$$

In the example, 122 - 103 = 13 Btu/lb.

The coefficient of performance (COP), which is a figure of merit for refrigeration cycles, is calculated by comparing the heat absorbed in the evaporator to the work exerted by the compressor.

$$\text{COP} = \frac{\text{heat absorbed in the evaporator}}{\text{heat energy into the compressor}} = \frac{h_c - h_a}{h_d - h_c}$$

In the example, 62 ÷ 13 = 4.76.

**PRESSURE-ENTHALPY DIAGRAM FOR FREON 22**

Jeff Habert, Ph.D., PE; Texas A&M University; College Station, Texas

**GENERAL**

Computers generate great quantities of heat in concentrated areas. To ensure proper operation, a precise temperature and humidity environment is required. The range of control may be as narrow as 72°F (±2°F) temperature and 50% humidity (±5%).

The air conditioning equipment should be able to meet the changing conditions created by relocation of equipment, facility expansion, and changes in heat output. Hot spots can result if flexibility is not built into the system.

**DOWNFLOW AND UPFLOW SYSTEMS**

Downflow systems are preferable for a number of reasons. Air is returned through the top of the unit and supplied out through the bottom into a raised floor, thereby permitting high quantities of air without disturbing the occupants. Perforated floor outlets can easily be moved, providing flexibility in room layout. The units themselves also form part of the floor grid and can easily be moved.

Upflow systems are used in areas where there is no raised floor (often the case in retrofit situations). They are also used in large rooms when the air is distributed by a ductwork system. Upflow systems are not as flexible as downflow systems for reorganizing equipment in a room.

**REUNDANCY**

All systems should be designed with redundancy to provide full, continuous cooling. The degree of redundancy should be weighted against the consequences of downtime of the equipment. A minimum of 25% redundancy is recommended but 100% may be warranted, depending on future expansion and the degree of backup required.

**VAPOR BARRIERS**

It is difficult and costly to maintain a computer room at a relative humidity of 50% (±5%) throughout the year without a vapor barrier. In addition, room partitions should extend beyond the false ceiling to help prevent migration of moisture to and from adjoining areas.

**TYPES OF SYSTEMS**

Spot coolers: Direct forced air, located at ceiling in return air plenum or on floor; short ducting can be used. Capacity: 1 to 3.5 tons.

Local units for small systems: Forced air can be used for direct spot cooling, ducted or for pressurized raised floor. Capacity: 3 to 5 tons.

Local units for large systems: Forced air can be used with pressurized raised floor installation. Capacity: 6 to 25 tons.

Mainframe cooling systems: Independently generated chilled water circulated to computer's coolant distribution unit (CDU), an intertwined coiled heat exchanger that distributes special coolant directly to the computer in a closed loop system. Capacity: 2.5 to 15 tons.

**METHODS OF HEAT REJECTION**

Self-contained air-cooled: Uses air within building return air plenum; limited to small capacity units.

External air-cooled: Uses outdoor condenser unit; refrigerant lines generally are limited to 100 ft above, 30 ft below, or 200 total ft from computer room to outdoor unit.

Water-cooled: Uses closed loop condenser water pumped to an external cooling tower to remove heat from condenser within computer room fan-coil unit. Distance from cooling tower to computer room can be longer than that in an external air-cooled system.

Glycol-cooled: Uses closed loop glycol to carry rejected heat to external dry cooler or cooling tower, which allows greater separation of computer room from outside air. With additional coils, the system can provide "free cooling" during colder weather. This system is preferred in areas where ambient temperature is below -10°F.

Chilled water: Chilled water is pumped from a remote chilled water plant to local fan-coil unit.

Combination unit: May use two or more means of heat rejection to service the system during certain hours of operation or as a backup in case of primary system failure.

**PLANNING ISSUES**

1. Evaluate availability of building services and systems, mechanical chases, and electrical power capacities.

2. Determine the overall heat load and plan size of system with client and engineer. Design for built-in redundancy with multiple circuits.
3. Use qualified engineers to design and engineer the systems and to supervise testing and certification.
4. Detail the construction of walls, ceiling, and floors to provide a complete vapor seal and adequate airflow.
5. Evaluate energy efficiency ratios of various kinds of proposed equipment.
6. Select a system with high reliability and low noise level.
7. Do not ventilate the space when unoccupied.

**RULES OF THUMB FOR COOLING LOAD ESTIMATES**

1. Room design conditions
  - a. Temperature: 72°F (±2°F)
  - b. Relative humidity: 50% (±5%)
2. Sensible heat ratio: 0.85-0.98
  - a. Sensible heat gain: 115-200 Btu/sq ft
  - b. Total heat gain: 120-240 Btu/sq ft
3. Load density (SF/ton): 50-100
4. Air quantity (CFM/ton): 600-900
5. Ventilation rate (CFM/person): 15-20 maximum
6. Humidification (lb moisture/100 CFM of outside air): 3

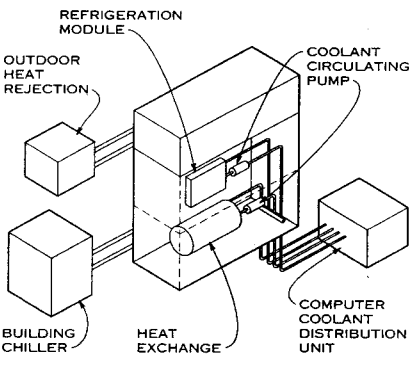

**COMBINED HEAT REJECTION IN MAINFRAME COOLING SYSTEM**

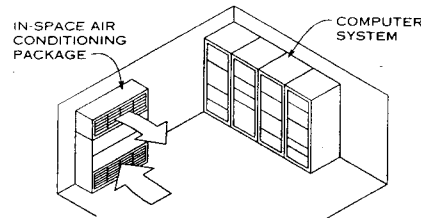

**IN-SPACE LOCAL UNIT APPLICATION**

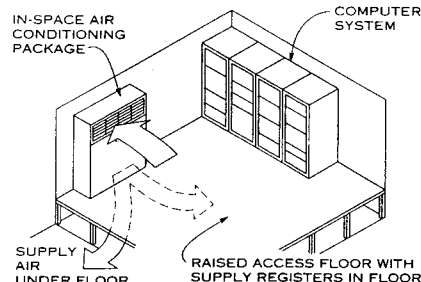

**DOWNFLOW (OR UPFLOW) SYSTEM USED WITH RAISED FLOOR**

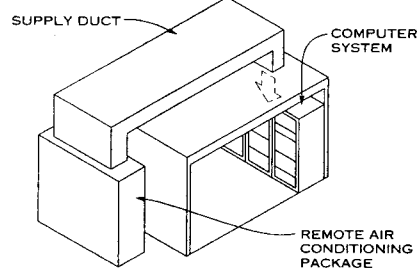

**LARGE REMOTE DUCTED SYSTEM**

**COMPUTER ROOM AIR CONDITIONING TYPES**

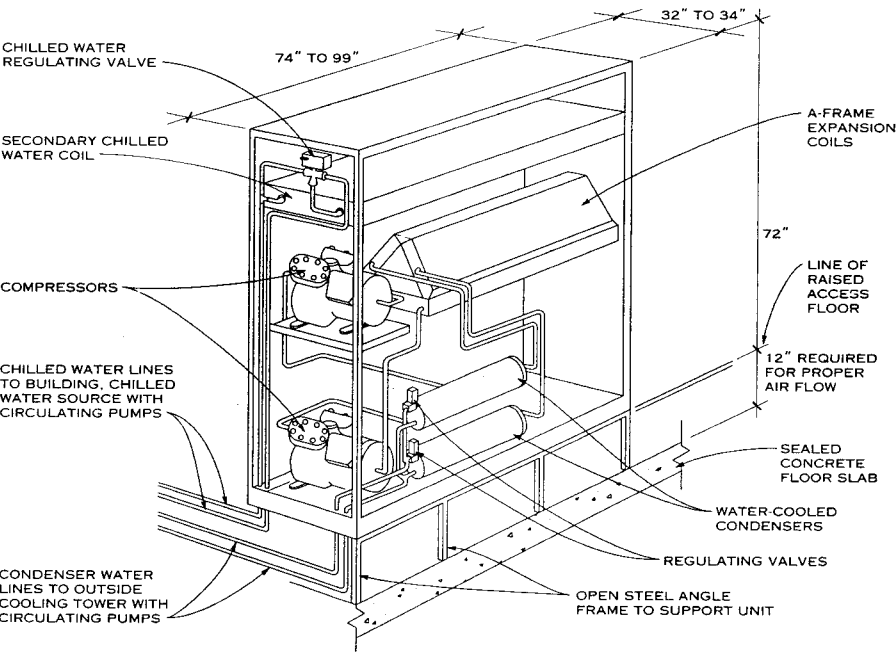

**LARGE FORCED AIR SYSTEM WITH COMBINED HEAT REJECTION SYSTEMS  
COMPUTER ROOM COOLING UNIT**

William R. Arnquist, AIA; Donna Vaughan & Associates, Inc.; Dallas, Texas  
Larry O. Degelman, P.E.; Texas A&M University; College Station, Texas



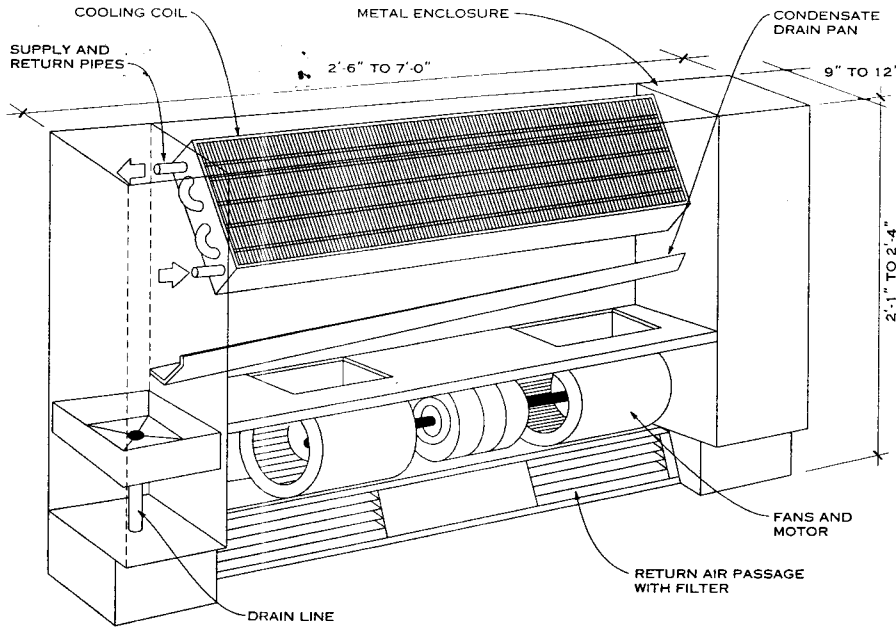

**GENERAL**

A fan-coil unit is the water-to-air heat exchange component of an all-water or air-water HVAC system. In an all-water system, all space conditioning needs are handled by one or more fan-coil units. In an air-water system, the fan-coil units carry the majority of space loads, while a separate central air system handles ventilation requirements. In effect, a fan-coil unit is a small, packaged air-handling unit with a motor and fan, water coil for cooling and/or heating, air filter, condensate pan, housing, and controls. Fan-coil units are available for exposed, recessed, or concealed installations and are located in or adjacent to an occupied space. A short length of ductwork may be used with concealed units to transfer supply/return air to or from the fan-coil housing.

Controls generally are an integral part of the fan-coil package, and each unit establishes a thermal zone. A typical control sequence permits intermittent or continuous air circulation and limited control of airflow; the majority of load control is achieved through operation of a water control valve at the coil. Thermostats are typically integral with the unit. Maintenance of the components occurs in the occupied space, so convenient access must be considered during the design process. Provision for drainage of the condensate from latent cooling must also be addressed.

A complete all-water fan coil system consists of several fan-coil units (one for each thermal zone), a chiller, an air-cooled condenser or cooling tower, a boiler (if central heating is required), a piping distribution network, and necessary circulation pumps. Two-, three-, and four-pipe configurations are used for the water distribution network. In a two-pipe system, each fan-coil unit is connected to a single supply pipe and a single return pipe. The entire system operates in either cooling or heating mode; the supply pipe provides either cold or hot water. This arrangement is economical, but not operationally flexible because one space cannot be heated while another space is cooled.

In a four-pipe system, each fan-coil unit is connected to two supply pipes (one hot, one cold) and two return pipes (one hot, one cold). Independent heating and cooling water networks permit complete flexibility of operation from zone to zone. A four-pipe system is more expensive to install than a two-pipe system. A three-pipe system is a hybrid arrangement that provides two supply pipes to each fan-coil unit (one hot and one cold) but only a single return pipe. Hot and cold return water streams are mixed and returned to the chiller and boiler at some intermediate temperature. Although operationally flexible and cheaper than a four-pipe system, a three-pipe system is very energy inefficient.

Fan-coil units may be installed as part of an air-water HVAC system. In such a system the components noted above would be supplemented with an independent central air supply system (with air-handling units, ductwork, and air supply devices) that provides ventilation air. Often the quantity of supply air is small enough that it can be exhausted without need for a return air system. Although fan-coil units can be provided with outside air intakes (if installed at a wall), adequate control and conditioning of outside airflows in such a configuration is problematic.

**COMPONENTS OF A FAN-COIL UNIT**

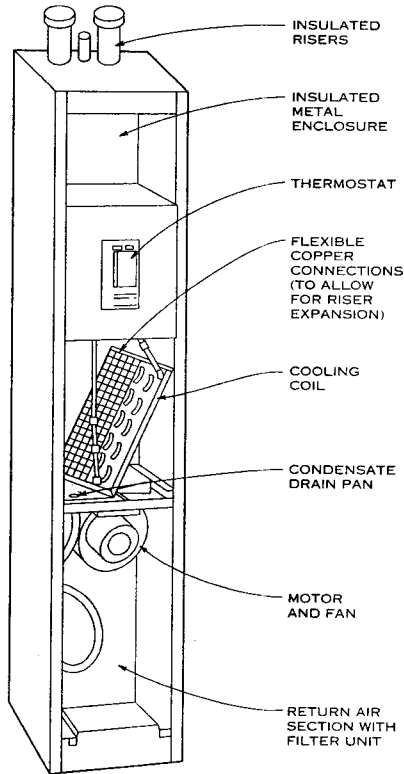

**NOTE**

High-rise fan-coil units are available for stacked, vertical installations. Use of a stacked configuration can minimize the amount of piping required to connect the units to the distribution network and simplify collection of condensate. In this configuration the units are normally furred into the walls of the rooms being served (often in a corner).

**HIGH-RISE FAN-COIL UNIT**

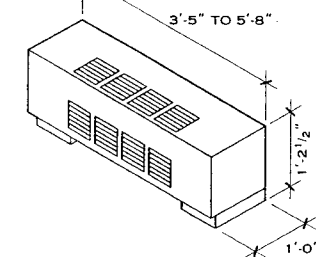
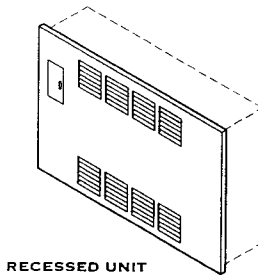
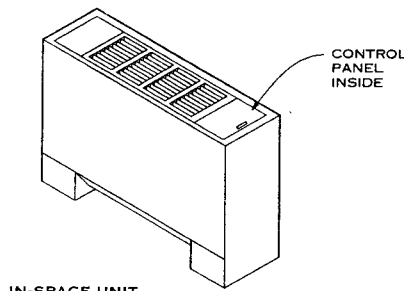

**VERTICAL FAN-COIL CONFIGURATIONS**

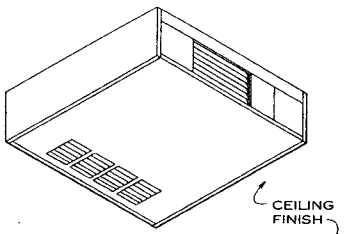
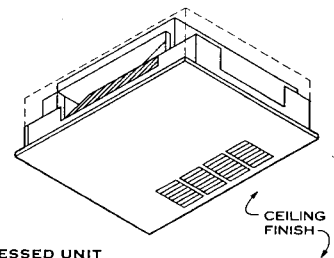

**HORIZONTAL FAN-COIL CONFIGURATIONS**

Walter T. Grondzik, P.E.; Florida A&M University; Tallahassee, Florida

**WASTE HEAT SOURCES FOR HEAT RECOVERY SYSTEMS**

1. Flues of fuel burning heating boilers and furnaces.
2. Refrigeration systems hot gas and condenser water.
3. Exhaust gases from diesel engine and gas turbine driven electric power generating equipment.
4. Cooling water from diesel engine cooling jackets and air compressor aftercoolers.
5. Exhaust steam and condenser water from steam turbine driven electric generators and refrigeration units.
6. Exhaust air from toilet rooms, mechanical equipment rooms, transformer vaults, kitchen range hoods, laundries, laboratory hoods, hospital operating rooms, locker rooms, shower rooms, and swimming pools.
7. Wastewater from washing machines and dishwashers.
8. Internal heat gain from lights, people, and appliances.
9. Heat recovery systems may consist of a direct or indirect heat transfer from airstreams, liquids, refrigerants, water, or gases.

**APPLICATIONS FOR WASTE HEAT RECOVERY SYSTEMS**

1. Building space heating.
2. Preheating ventilation outdoor air intake.
3. Air conditioning systems supply air reheat.
4. Preheating domestic hot water and boiler feed water.

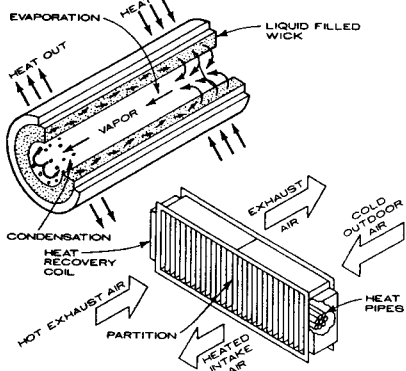

**NOTE**  
Counterflow, indirect air-to-air sensible heat transfer. No leakage between airstreams. Alternate evaporation, condensation, and capillary migration of fluid in porous wick lining of tubes. Coil tilting or fact and bypass damper control. Efficiency 50-70%. Modular sizes to 54 in. x 138 in. x 8 rows deep.

**HEAT PIPE**

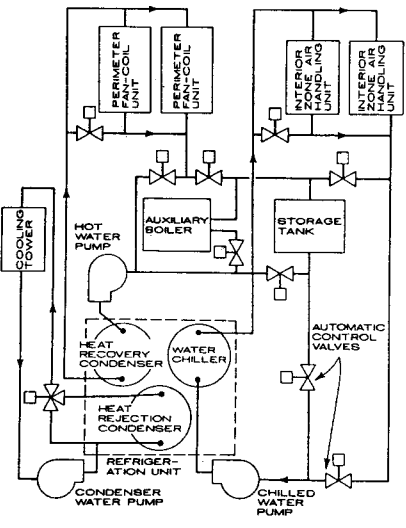

**DUAL CONDENSER WATER CHILLER**

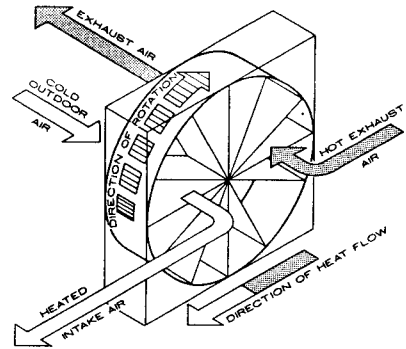

**NOTE**  
Sensible heat absorbing aluminum or stainless steel mesh. Dessicant impregnated for latent heat transfer. Leakage 4-8% between opposing airstreams. Added purging section reduces cross-contamination to less than 1%. Speed variations or face and bypass damper capacity control. Efficiency 70-80%. Sizes to 144 in. diameter.

**THERMAL WHEEL**

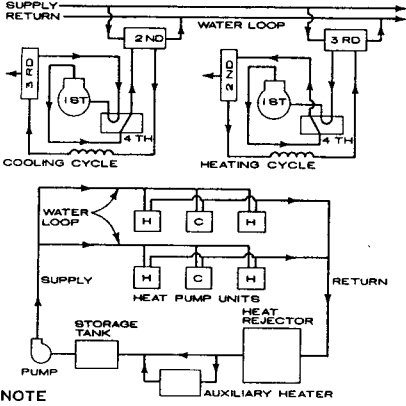

**NOTE**  
Heat transfer from cooled to heated areas. Individually controlled heat pump terminal units with air and water coils. Auxiliary heater operation when heat loss exceeds heat gain. Heat rejector operation when heat gain exceeds heat loss. Tank stores excess capacity. Loop water 60-90°F.

**WATER LOOP HEAT PUMPS**

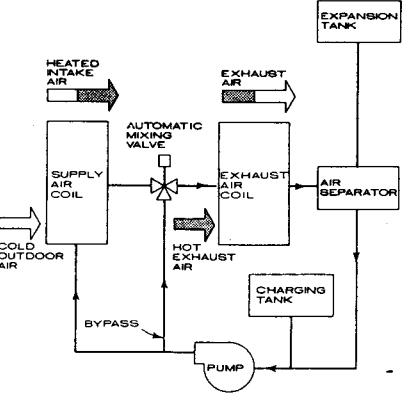

**NOTE**  
Indirect sensible heat transfer between remote airstreams with no cross-contamination. Exhaust airstream coil construction to suit application. Antifreeze fluid for low air temperatures. Bypass valve temperature control. Computerized equipment selection. Efficiency 50-70%. Modular coils to 20,000 cfm.

**RUNAROUND COILS**

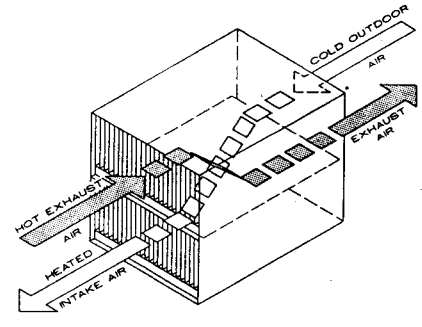

**NOTE**  
Counterflow, direct air-to-air type heat exchanger. Sensible heat transfer only. No leakage between airstreams. Corrugated aluminum or stainless steel construction. Washdown spray manifold for dirty exhaust airstreams. Bypass damper temperature control. Modular sizes to 10,000 cfm. Efficiency 60-80%.

**PLATE TYPE HEAT EXCHANGER**

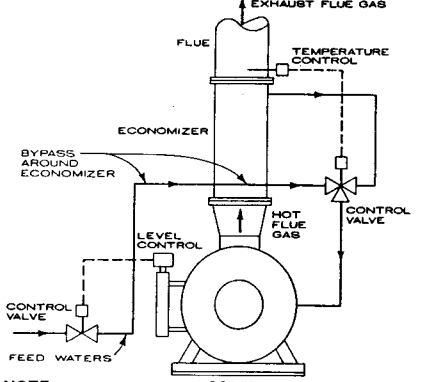

**NOTE**  
Direct flue gas to feed water heat transfer for high pressure steam boilers. Boiler flue gas at 500°F leaving economizer at 325°F, heats feed water from 200 to 248°F. Mixing valve maintains minimum stack temperature leaving economizer to prevent moisture condensation in stack.

**BOILER FLUE ECONOMIZER**

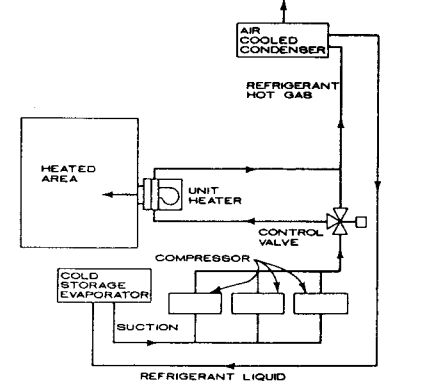

**NOTE**  
Rejected heat from cold storage refrigeration system used to heat occupied areas. For heating, hot gas refrigerant from compressor discharge flows through space heating units to extract heat. When heating is not required, hot gas refrigerant flows directly to air cooled condenser for heat rejection to outdoor air.

**REFRIGERANT HOT GAS**

**GENERAL**

Although shelter from the weather and protection from harsh climates are historic reasons for constructing buildings, the mere act of building does not in itself result in desirable and acceptable interior environments. Thus, climate control is a critical performance attribute of a successful building, and the creation of a comfortable, healthy environment for building occupants is an important goal of the building design process.

An HVAC (heating, ventilating, and air conditioning) system is a requirement in virtually all types and sizes of buildings. Second only to structural systems, HVAC systems represent a technical area of design, which must be generally understood and properly coordinated during the design process. HVAC systems have a significant impact on the budget and space of a building project because they

1. represent a substantial percentage of the construction budget for most building types
2. can consume up to 10% of the floor area of a building
3. reach into and affect aesthetically most building spaces
4. contribute greatly to building energy use and operating expense
5. account for the majority of occupant complaints

The design of HVAC systems is not greatly influenced by building code requirements, except in relation to energy efficiency, ventilation, and central plant equipment safety. Nonetheless, HVAC systems have a major impact on occupant satisfaction, on building construction and operating costs, and often on building layout and spatial efficiency. Lack of specific code requirements for many system aspects makes the architect's role in the design process critical to the successful incorporation of HVAC systems.

Building occupant and owner expectations demand that a climate control system do a good to excellent job of controlling space temperature, interior relative humidity, air distribution (air speed and patterns), and indoor air quality. In many situations such demands can only be met through design of an active (mechanical) HVAC system.

The ASHRAE (American Society of Heating, Refrigerating, and Air-Conditioning Engineers) definition of an HVAC system, in fact, describes a system that must be able to simultaneously control the temperature, relative humidity, speed, and quality of air in occupied spaces. These four factors generally (but not exactly) overlay the factors that define thermal comfort and indoor air quality—mean radiant temperature (MRT) being the critical exception.

Increasing demands for control of indoor air quality tend to require the design and installation of a quality HVAC system. Of the three primary means of mitigating indoor pollutants—source control, filtration, and dilution—dilution (through ventilation and exhaust) and filtration (through system and equipment selection) are directly related to HVAC system design, installation, and operation.

**SYSTEM TYPES**

Climate control systems may be classified as either active or passive in nature. Passive systems use no purchased energy resources, normally are assembled of "architectural" building elements doing double duty (such as glazings, walls, floors, finishes), and require superb design coordination. See the discussion of passive climate control systems in chapter 18 of *Architectural Graphic Standards*.

Active climate control (HVAC) systems use purchased energy resources and employ task-specific, single-purpose elements (such as pumps, fans, ducts, and diffusers). Although engineering consultants usually design HVAC systems, it is wise to coordinate their work with architectural design efforts. Active systems are the focus of this chapter of *Architectural Graphic Standards*.

HVAC systems are categorized by scale and by means of energy transfer to and from occupied spaces of a building:

A LOCAL SYSTEM serves only a single space, and all of the system components are usually located in or directly adjacent to the space being conditioned.

A CENTRAL SYSTEM serves multiple spaces, and the major components are usually located in a dedicated mechanical room or rooms.

A DISTRICT SYSTEM serves multiple buildings, as in a campus or central business district heating-cooling loop, with major components located in a convenient, dedicated plant.

**CENTRAL SYSTEMS**

Central systems are further categorized by the means of heat transfer used to convey heat to and from the spaces served by the system. Two primary media are used for this purpose: water and air. Water is a very effective means of transferring heat, requiring substantially less volume to move a given quantity of heat than is possible with air as a medium. For the same heating or cooling load, the water distribution container (pipe) size will be several times smaller than an equivalent air distribution container (duct). On the other hand, air distribution is convenient, as the air being used to transport heating or cooling from a central location can simply be dumped into the space. Water distribution systems require some type of terminal device to exchange heat between the water and the air in the space to be cooled.

Those central systems that use only air to distribute heating and cooling effects to the occupied spaces are called all-air systems, which require a ductwork distribution tree. An air-water system uses only water to supply and remove heat from the spaces; such a system requires a piping distribution network. Air-water systems deliver both air and water to the occupied spaces and require both ductwork and piping distribution networks:

Central systems are secondarily classified by the location of the primary comfort control mechanism relative to the occupied spaces. In a number of systems, control resides at the air-handling unit, which makes changes in zoning and distribution layout difficult or impossible. Other systems use control mechanisms (terminals) located adjacent to occupied spaces, which provide greater flexibility of change but require distribution of more equipment throughout the building, often in tight or hard-to-reach places.

**SYSTEM COMPONENTS**

A number of components are required for the operation of a typical HVAC system. The components of a local system are generally packaged into a single unit that is installed through a wall or roof; air supply is usually introduced to the space directly from openings in the unit. The implications of installing potentially noisy mechanical equipment in or directly adjacent to an occupied space must be considered when selecting a local HVAC system.

Central system components are distributed throughout a building, with a range of equipment choices available for most systems. The typical central system requires an air-handling unit, ductwork, air supply and return devices, a chiller, a boiler, an exterior condenser, and controls. Some of the many options for locating these components are illustrated in the schematic diagrams on this page. More detailed system schematics for the most common central HVAC systems are included elsewhere in this chapter of *Architectural Graphic Standards*.

It is sometimes helpful to organize HVAC system components into subsystems, that is, source, distribution, delivery, and control components. Source components involve the generation of a heating or cooling effect and typically include chillers (vapor compression or absorption), boilers (electric, gas, oil, coal), cooling towers or air-cooled condensers, heat pumps, and perhaps solar collectors.

Distribution components involve transfer of a heating/cooling effect from the source to occupied spaces and typically include ductwork, piping, air-handling units (with fans, filters, coils, and accessories), pumps, stand-alone fans, and air terminal units. Delivery components are used to introduce a heating-cooling effect into the occupied spaces and typically include baseboard radiators, unit heaters, convector cabinets, fan-coil units, induction units, diffusers, and radiant panels.

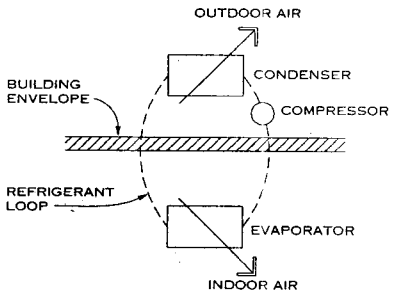

**SPLIT**

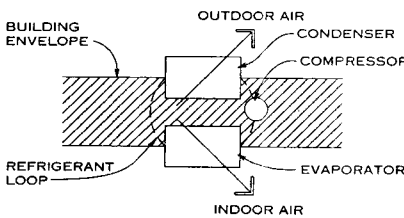

**THROUGH WALL**

**LOCAL SYSTEMS**

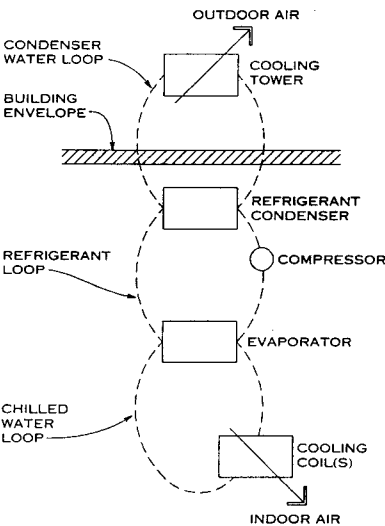

**CENTRAL SYSTEM WITH CHILLER AND COOLING TOWER**

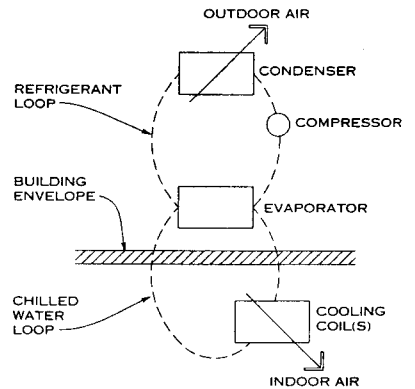

**CENTRAL SYSTEM WITH PACKAGED CHILLER**

Walter T. Grondzik, P.E.; Florida A&M University; Tallahassee, Florida

**DESIGN ISSUES**

The design of an HVAC system should follow a process similar to that used for overall building design. The first steps in the design process are nontechnical and generally independent of the system solution eventually chosen. Active involvement of the architect in these first steps is critical to a successful design. Some key steps in the process are discussed below.

**DESIGN INTENT**

HVAC system design should begin with a clear and explicit statement of what the system is expected to do. Design intent should ideally be defined during the programming phase of a project but certainly no later than the early stage of schematic design. Design intent should examine the operation of the HVAC systems under all possible conditions (weekdays, weekends, emergencies, predictable renovations, and the like). The process of defining the intent will lead to explicit design criteria—measurable targets for system performance—that can be used to select an appropriate system.

**ZONING**

An HVAC zone is an area of a building (not necessarily coincident with a room or rooms) that requires a separate controller in order to reasonably provide conditions amenable to thermal comfort. Such control is typically provided by a thermostat that senses room air temperature. Thus, each thermal zone has its own thermostat.

Ideally, any area of a building that responds to loads differentially across time from other building areas should be considered for separate control. Such differential response usually is caused by the timing of loads, with solar radiation, occupant, and equipment loads affecting this timing. For example, an office with east-facing glazing should not be controlled from a thermostat in an office (even if adjacent) with south-facing glazing. A conference room should not be controlled from an office, even if solar exposures are the same, as the occupancy schedules are so different.

Zoning is a critical part of the HVAC system design process and should involve the active participation of the architect. Using too many zones wastes money, while too few cause discomfort. Establishing appropriate zones is as much a qualitative as a quantitative process and requires a clear understanding of building functions and owner expectations. Zones are so critical to HVAC system success that many systems are defined primarily by their zoning capabilities. As zoning depends on building layout, it should occur during schematic design.

**COMPARISON OF MANAGEMENT, OPERATION, AND DESIGN PROBLEMS IN COMMERCIAL BUILDINGS**

BASIS OF PROBLEM	RELATIVE FREQUENCY
Heating, ventilating, and air conditioning	5.4
Elevators	2.7
Building design	1.5
Loading docks	1.2
Indoor air quality	1.0
Cleaning services	1.0

**NOTE**

Relative frequency suggests that problems with HVAC systems are twice as prevalent as problems with elevator systems and five times as prevalent as problems with cleaning services.

**HVAC SYSTEM SPACE REQUIREMENTS AS A PERCENTAGE OF GROSS BUILDING FLOOR AREA**

GROSS FLOOR AREA (SQ FT)	DOMICILE-RELATED OCCUPANCIES (%)	INSTITUTIONAL OCCUPANCIES (%)	ASSEMBLY-BASED OCCUPANCIES (%)	LABORATORY OCCUPANCIES (%)
10,000	6	8	9	11
50,000-100,000	4	6	7	10
500,000	3	4	5	8

**NOTE**

The values for HVAC systems in this table include space for central equipment (chillers, boilers, pumps) and air circulation equipment (fans). HVAC space requirements tend to

**SYSTEM SELECTION**

Properly done, HVAC system selection can be a complex process. Normally, several system types would function adequately in any given building application. Careful matching of system characteristics to design criteria can help achieve the best match for the system intent. The earlier in the design process a system can be selected, the greater the opportunity for systems coordination.

System characteristics that should be considered during the selection process include life-cycle cost (including purchase, installation, and operating costs), energy consumption, space (and volume) requirements, noise, vibration, locational flexibility, operational flexibility, adaptability to changes in occupancy and/or room layout, ventilation capabilities, smoke control capabilities, aesthetics, reliability, maintainability, appropriateness to owner/operator personnel resources, and ability to provide thermal comfort. The relative importance of these criteria, as well as system capabilities, will vary from project to project. Use of a project-specific, weighted selection matrix can assist in the selection process.

**SYSTEM DESIGN**

The specifics of HVAC system design are normally assigned to an engineering consultant with appropriate expertise. The detailed design, normally conducted during the design development phase, involves selection of a number of manufactured equipment items (such as chillers, cooling towers, air-handling units, diffusers) to meet load and performance requirements, as well as design of numerous field-fabricated elements (such as ductwork and piping networks) to connect and support the major equipment items.

In a typical building, most of the HVAC system components are hidden from view behind mechanical room walls or above suspended ceilings. Thus, detailed design is driven by considerations of functionality and economics. Two exceptions to this "no-see" situation are the air supply and return devices (and/or water terminal units) and the exterior condenser.

**COMMISSIONING**

Commissioning is a systematic process of ensuring that building systems are designed, installed, and operating so they will meet design intent. The dynamic and complex nature of HVAC systems, as well as their direct impact on occupant satisfaction and building operating costs, makes them a good candidate for commissioning.

The commissioning process typically involves functional testing of equipment and performance testing of systems and system interactions. For complex buildings or systems, commissioning may involve peer review of design concepts and solutions. Whatever the scope of commissioning, planning for this activity should begin as early in the design process as possible.

**SAMPLE SYSTEM SELECTION MATRIX**

SELECTION CRITERION	RELATIVE WEIGHT	SYSTEM	
		#1	#2
		RATING/POINTS	RATING/POINTS
First cost	9	5/45	8/72
Space requirements	10	7/70	8/80
Energy use	7	9/63	5/35
Reliability	6	8/48	7/42
Noise	8	7/56	4/32
Aesthetics	4	10/40	8/32
Overall evaluation		322 points	293 points

**DESIGN COORDINATION**

HVAC systems may place substantial space and volume demands on the design process and tend to interact with virtually all other building systems (including envelope, electrical power, lighting, fire protection, acoustical, circulation, data). Key activities for coordinating HVAC and other building systems include (but are not limited to) the following:

1. Ensuring HVAC system design intent supports overall building design intent
2. Coordinating HVAC zones with other zones, such as fire protection and alarm, lighting, and smoke control
3. Locating major equipment components to minimize distribution length and size and to minimize negative aesthetic impacts
4. Locating major equipment components to minimize negative impacts on room acoustics, circulation patterns, and building flexibility
5. Coordinating ductwork with elements of other systems, such as structural beams and columns, lighting fixtures, and plumbing and fire protection pipes
6. Locating terminal device (such as VAV or mixing boxes) and control devices (such as valves, dampers, and actuators) so they are accessible for regular maintenance
7. Giving more than rudimentary consideration to selection of air supply and return devices, such as diffusers, registers, and grilles. (These devices can have a dramatic effect on thermal and acoustical comfort and on aesthetics.)
8. Coordinating system controls with design intent. (Although controls are highly technical in implementation, failures are often conceptual.)
9. Providing operations and maintenance manuals and procedures to assist the owner in running the HVAC system

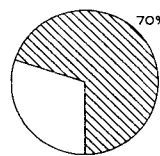

RESIDENTIAL COLD CLIMATE

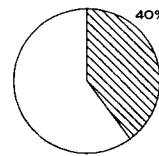

OFFICE COLD CLIMATE

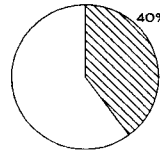

RESIDENTIAL HOT CLIMATE

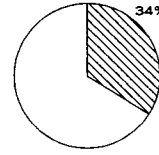

OFFICE HOT CLIMATE

**HVAC SYSTEM AS A PERCENTAGE OF TOTAL BUILDING ENERGY USE**

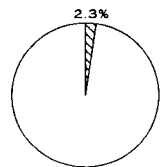

SINGLE-FAMILY RESIDENCE

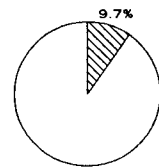

MID-RISE APARTMENT

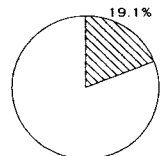

RESTAURANT

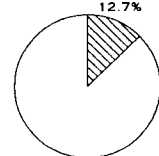

MID-RISE OFFICE

**HVAC SYSTEM COST AS A PERCENTAGE OF TOTAL BUILDING CONSTRUCTION COST**

increase with increased load density and complexity, whereas the percentage space requirements tend to decrease with increased building size.

Walter T. Grondzik, P.E.; Florida A&M University; Tallahassee, Florida

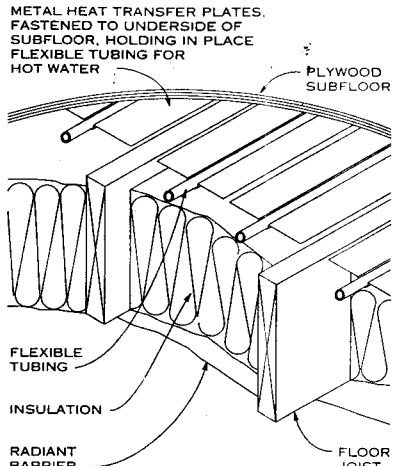

HEAT TRANSFER UNDER SUBFLOOR

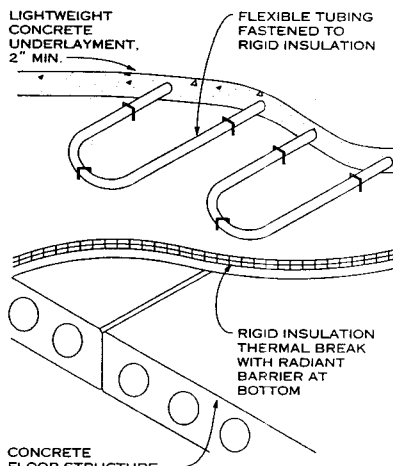

HEAT TRANSFER IN CONCRETE TOPPING SLAB

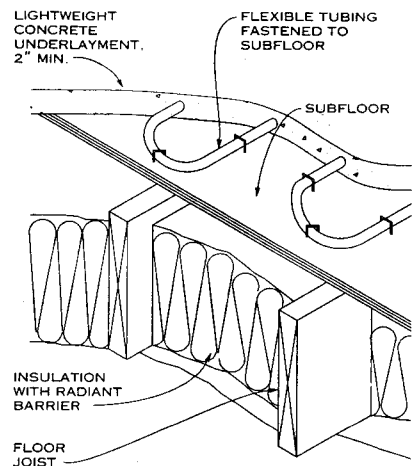

HEAT TRANSFER THROUGH CONCRETE UNDERLAYMENT

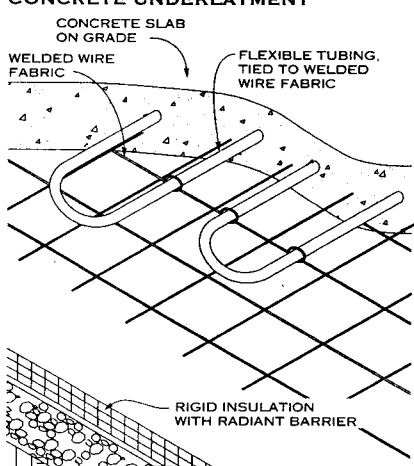

HEAT TRANSFER IN SLAB ON GRADE

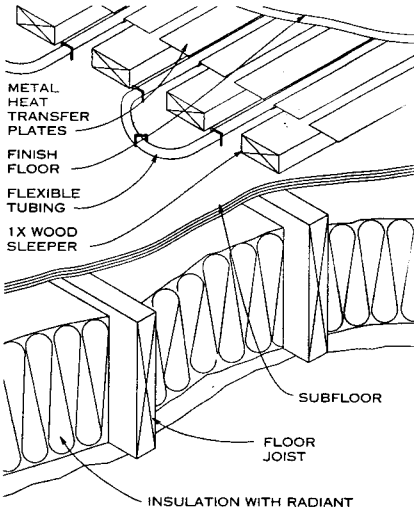

HEAT TRANSFER AT SUSPENDED FLOOR

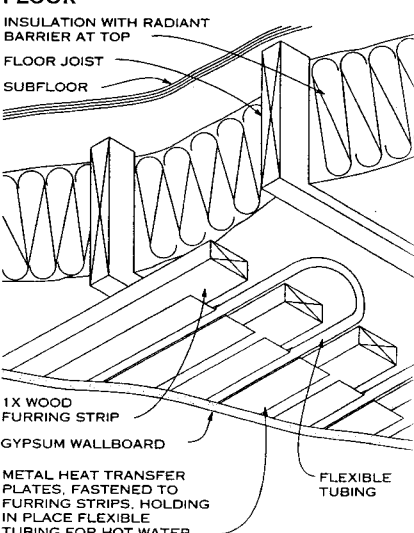

HEAT TRANSFER THROUGH CEILING

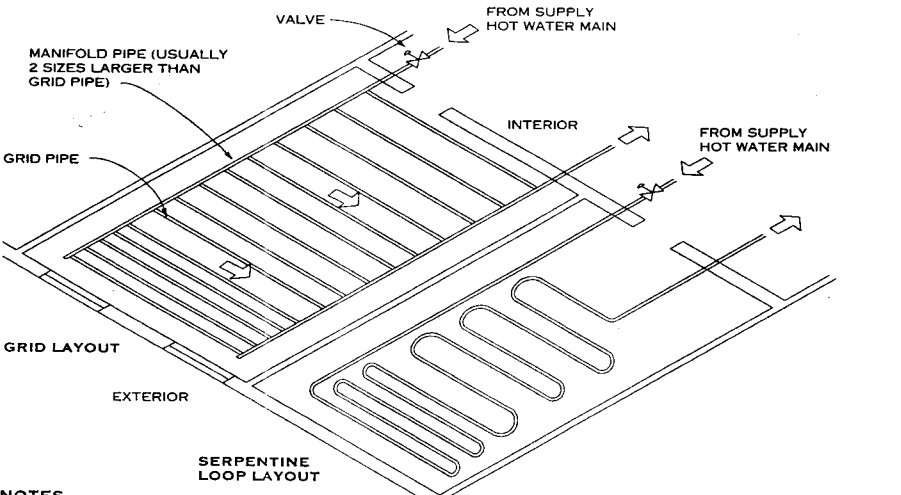

**NOTES**

1. Spacing for grid pipes is closer (3 to 4 in.) at exterior walls than in interior spaces (12 to 18 in. apart).
2. Grid pipe layouts have a lower pressure drop than serpentine pipe layouts. Serpentine layouts are generally

easier to install and less costly to fabricate, but due to the higher pressure drop they are more expensive to operate.

**RADIANT HEATING LAYOUTS**

**GENERAL**

Radiant heating systems transfer heat from hot water tubing (or electric cables) embedded in the floor or ceiling to a medium that will distribute heat to the specified space. The tubing or cables are laid out to maximize heat distribution to the areas of greatest heat loss. The choice of hot water or electric cable heat is made based on installation, energy, and total life-cycle costs and code constraints. Consult a mechanical engineer.

For appropriate applications, properly designed and operated radiant heating systems will provide greater comfort at lower operating costs than other heating systems because of the inherent nature of the human body's thermal functions. About 70% of the body's heat is transferred by radiation (via electromagnetic waves, like light), 25% by convection (via air or water), and 5% by conduction (via physical contact).

In terms of overall system configuration, a radiant floor, wall, or ceiling is equivalent to a radiator, convactor, or any other terminal heating element. The primary caveat is that a suitable control system must be provided to ensure that floor surface temperatures do not rise above 75° F or, if ceiling systems are used, above 120° F. Thermostats for radiant systems can generally be set several degrees lower for heating than thermostats for other types of systems. Finish floor should not be of a thermal insulating material; ceramic tile or wood flooring would be suitable.

Alfred Greenberg, P.E., C.E.M.; Murray Hill, New Jersey

**HVAC SYSTEM FUNDAMENTALS**

In the broadest sense, the term "air conditioning" means that, to the extent required for a particular space condition, a quantity of air must be

1. Mixed with the required amount of outside (fresh) air.
2. Filtered to remove specified amounts of particulate and/or gaseous elements.
3. Heated and/or cooled as conditions dictate and as directed by an appropriate temperature control system.
4. Humidified or dehumidified to meet space requirements.
5. Under certain conditions, ionized, ozonated, or otherwise treated to provide specific space conditions.
6. Delivered to the air-conditioned spaces and distributed in a quiet, draft-free manner.

Conditioning of the air is basically performed within an enclosure called an air-handling unit (shown in its most generalized form). The components need not be located within the central air-handling unit to perform their functions effectively. Space limitations, the operating and control results desired, and energy optimization considerations may affect where the components are situated.

Sources of electric power, heating and cooling media, water, steam, natural gas, etc. are often remote from the air-handling unit. However, in packaged air-conditioning equipment such as air heating units, room air conditioners, and many rooftop units, the heating and/or cooling "plant" is part of the package.

To the extent that an air-conditioning system does not provide all of the functions described above, it may not be furnishing the total space air conditioning required for optimum comfort and health. The tendency to use the term "air conditioning" synonymously with "cooling" should be altogether discouraged. It falsely implies that the other functions of air conditioning, such as proper filtration and humidification, are less important to total health and comfort and may be eliminated.

The types of air-conditioning systems used and the selection and organization of their components are the most critical and complex elements in the proper design of an HVAC system. For the optimum health, safety, and comfort of occupants and materials within the air-conditioned spaces, and to ensure the optimum life-cycle economics for a particular installation, this process should be entrusted only to experienced and knowledgeable engineers.

**ALL-AIR SYSTEMS**

In an all-air system, the heating and refrigerating plants may be located in a central mechanical room some distance from the conditioned space or may be contained within the all-air system as packaged units in the air-conditioned spaces or on the roof. The air-handling unit is designed to mix outside and return air as desired, then to filter, heat, cool, and humidify the air before it is delivered to conditioned spaces. It may also exhaust portions of the return air based on how much return air is brought in.

Air-conditioning functions do not necessarily occur within the air-handling unit. Depending on the specific design criteria and space conditions, some air-conditioning elements may be remote from the air-handling unit.

Some common all-air systems are single-duct, constant or variable volume airflow; dual duct (rarely used); multizone; single-duct with powered terminal and either constant or variable volume airflow; and a single-duct system with self-contained airflow volume controls and thermostats in each diffuser in the conditioned space.

**SPATIAL REQUIREMENTS**

The dimensions between system components shown in the accompanying illustration are the minimum required for proper inspection and maintenance of walk-in units (units with air quantities of 15,000 cu ft/min. or more). Spacing for smaller units may be somewhat less but must allow adequate access for inspection and maintenance.

All spaces between unit components should have hinged access doors designed to prevent air leakage when the doors are closed. For smaller units, the entire panel between components should open. For walk-in units, access doors should be a minimum of 30 x 60 in. Access doors should be designed to open from the inside.

The floors of the sections between components should be pitched to facilitate drainage of liquids that may form. Light switches and electronic controls should be located on the outside of the unit enclosures. If a fan is situated on the inside of a unit enclosure, the return air inlets must have safety screens. Walk-in unit interiors should have permanent vapor-proof and explosion-proof lighting.

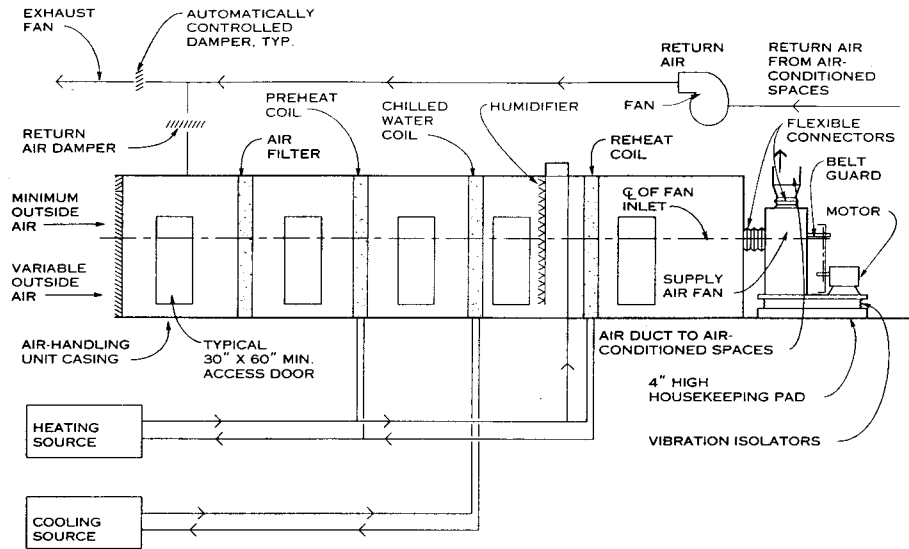

**NOTES**

1. Minimum outside air damper: usually two positions.
2. Variable outside air damper: closed when only minimum outside air is desired (for example, when outside air temperature is extremely high or low). Designed to open in response to the capability of outside air to contribute to a building's heating or cooling needs. Exhaust and return air dampers are controlled to operate in accordance with the setting of the variable outside air damper.
3. Preheat coil (PHC): required only if the temperature and distribution of the return air mixture could cause freezing temperatures within the casing.
4. Air-handling unit (AHU): may be field- or factory-fabricated. Pitch the floor of the AHU casing between components as required and provide piped floor drains to remove any moisture that develops.
5. Direct expansion coil (DXC): cooling coil may be a DXC if refrigerant is used instead of chilled water.
6. Humidifier (H): may use steam or water as the humidification medium.
7. Reheat coil (RHC): used in the air-handling unit only when a fixed discharge air temperature is to be supplied to all areas served by the duct system. If different spaces require varying temperatures, a separate reheat coil may be placed in each duct serving a different temperature zone.

**COMPONENTS OF A BASIC ALL-AIR SYSTEM**

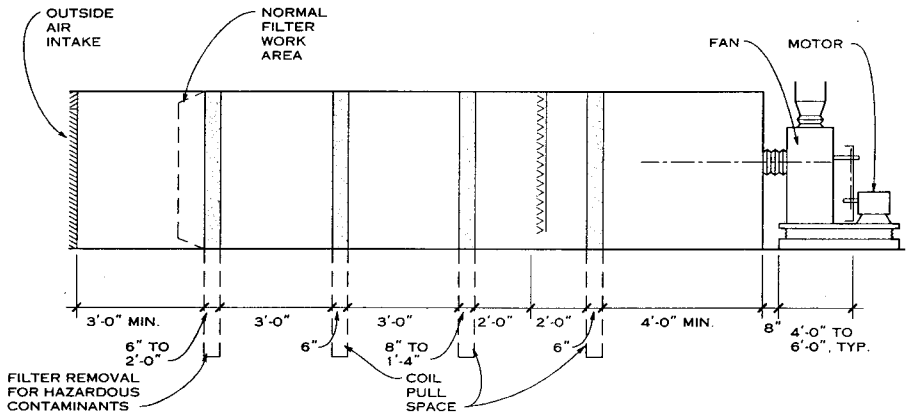

**NOTES**

1. The primary factors in determining spatial requirements for a basic HVAC system are space for proper air flow, thermodynamic heat transfer, and service and maintenance.
2. The net cross-sectional area (in sq ft) of the interior of an air-handling unit should be at least equal to the total air supply (measured in cu ft/min) divided by 500.
3. The aspect ratio of the casing of the air-handling unit should fit the space available, considering maintenance requirements and the ability of personnel to enter the unit to perform required tasks.
4. A single-width single-inlet (SWSI) fan is shown. If a double-width, double-inlet (DWDI) fan is used, it may be incorporated into the air-handling unit casing. This arrangement generally decreases the overall length of the system and the height required at the fan; however, the required width at the fan will increase.

**GENERAL SPATIAL REQUIREMENTS FOR ALL-AIR SYSTEMS**

Air-handling units may be located anywhere that suits building space conditions and offers proximity to the conditioned spaces. However, careful consideration must be given to

the outside air duct location and the noise and vibration that will emanate from the fans.

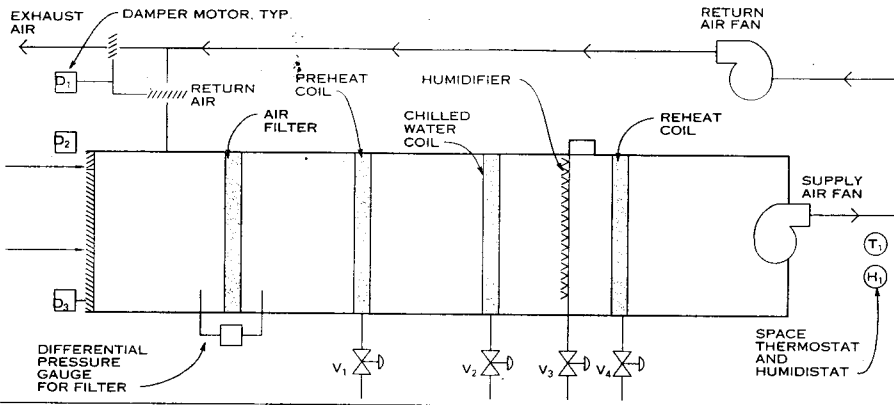

**TEMPERATURE AND HUMIDITY CONTROLS FOR ALL-AIR SYSTEMS**

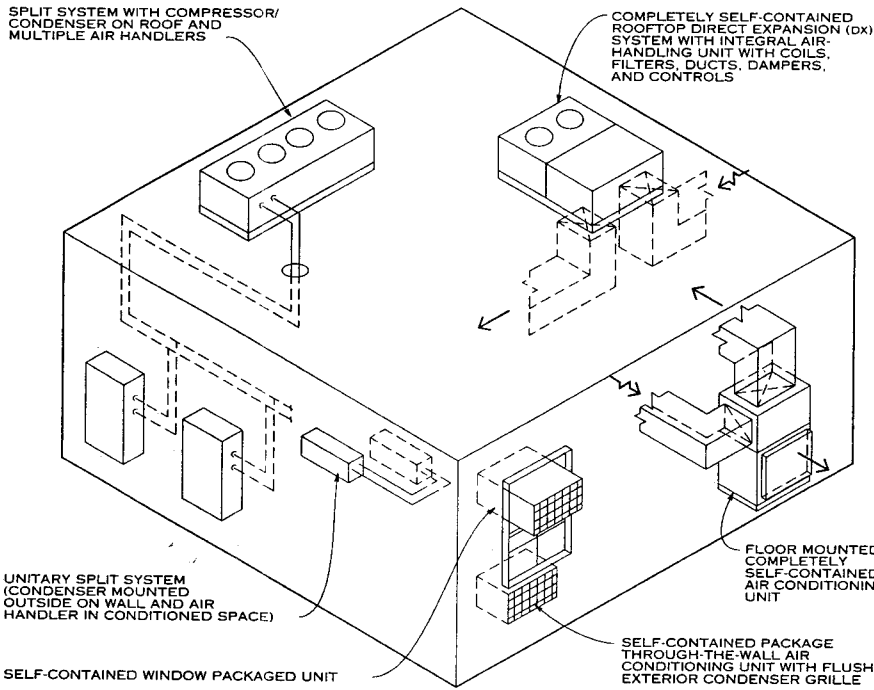

**CONTROLS FOR ALL-AIR SYSTEMS**

The typical sequence of operation for an air-handling system is outlined here:

1. When the supply air fan has been turned on but the motor is not yet turning, minimum outside air damper  $D_1$  and exhaust air damper  $D_2$  open, the latter to its minimum position to match the amount of incoming air. The exhaust air and return air dampers are interlocked: When the exhaust air damper is shut, the return air damper is fully open; when the exhaust air damper is fully open, the return air damper is minimally open.
2. When dampers are in proper open positions, the supply air fan starts running and the return air fan is turned on, either manually or electrically. This sequence is necessary to prevent the supply air fan from sucking air out of the air-handling unit and collapsing the casing and to keep the return air fan from blowing excess air into the casing and "bursting the bubble."
3. Space thermostat  $T_1$  and humidistat  $H_1$  take control of the system. If humidification is required,  $H_1$  controls the operation of control valve  $V_3$  at the humidifier in the air-handling unit. If heating is required,  $T_1$  controls the operation of reheat coil control valve  $V_4$ . If cooling is needed,  $T_1$  controls the cooling coil control valve  $V_2$ . At this time, control valves  $V_1$ ,  $V_3$ , and  $V_4$  are closed. Control valve  $V$  for the preheat coil is controlled by a thermostat on the discharge side of the coil.
4. Many control system variations are possible to improve comfort and conserve energy. In one commonly used variation, an "economizer cycle" is established in which an outdoor thermostat is added to the control system. This permits the system to decide whether  $T_1$  should open the heating or cooling coil control valve damper to initiate heating or cooling, depending on the season, or whether heating or cooling can be accomplished by opening variable outside air damper  $D_3$  proportionally.
5. On a balmy spring or autumn day, it may be possible for total space conditioning needs to be supplied by fully open outdoor air dampers. In this case, damper  $D_1$  would be fully open for exhaust air and fully closed for return air.  $D_2$  and  $D_3$  would be fully open, and  $V_1$  through  $V_4$  fully closed.

**DIRECT-EXPANSION SYSTEMS**

The term "direct expansion" means that a chemical refrigerant is used in the refrigeration circuit to remove heat and reject it, usually to the outdoors. Direct-expansion systems come in "cooling only" mode or in specially designed heat pumps, which can furnish either heating or cooling.

The most common direct-expansion system is the packaged unit installed through the wall or in a window. These can also be floor-mounted in or out of the air-conditioned space or located on the roof. Another type of direct-expansion system is the "split" system, in which the heat rejection components of the condenser and compressor are packaged separately and can be located remotely from the evaporator and fan, which must be in the air-conditioned space. The two subassemblies, which are attached to the system with refrigerant piping, may be as close as on opposite sides of a wall or up to 100 ft away.

**DIRECT-EXPANSION SYSTEM**

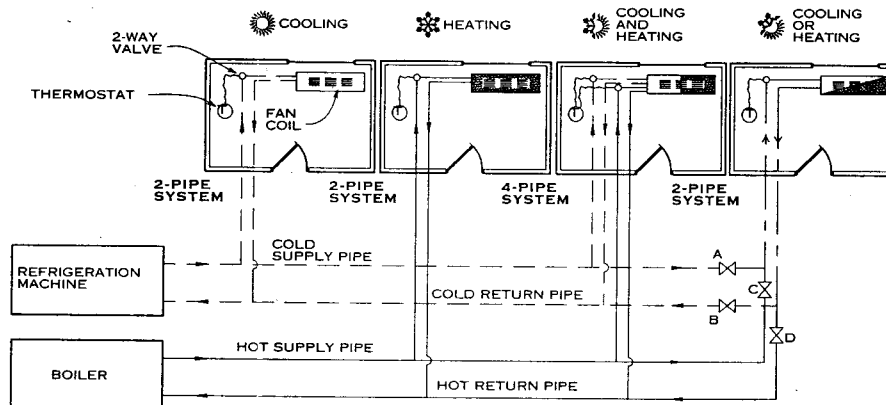

**NOTES**

1. Valves A and B are closed during the heating season.
2. Valves C and D are closed during the cooling season.
3. A majority of existing buildings with central heating and cooling use the two-pipe distribution system.

**ALL-WATER SYSTEM**

**ALL-WATER SYSTEMS**

The term "all-water system" is a misnomer, since all air-conditioning systems furnish conditioned "fresh" air to the air-conditioned spaces. All-water systems may have fan coil or radiant panel terminal units with separate all-air systems to supply the "fresh" air. "Fresh" air furnished through openings in the walls behind the fan coil units is not considered properly conditioned because most fan coil units are not designed to provide satisfactory filtering and humidity control or to prohibit the entry of outdoor noise.

In the vast majority of all-water systems, water is used to provide either heating or cooling through a two-pipe distribution system. A freeze protection chemical can be added to some systems when needed. When clients demand simultaneous heating or cooling everywhere, the piping will be either a three- or four-pipe distribution system and the heating and cooling plants must be able to run at all times. The three-pipe system is seldom used because it is difficult to operate properly and to run efficiently.

Alfred Greenberg, P.E., C.E.M.; Murray Hill, New Jersey

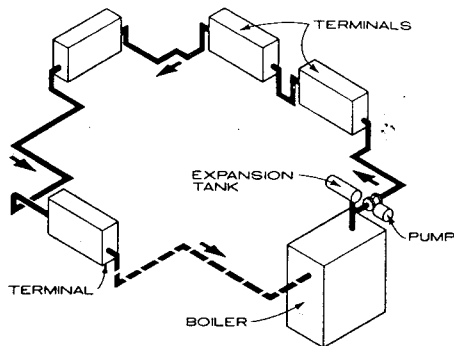

**SERIES SYSTEM**

- (+) MINIMAL PIPING
- (-) LIMITED INDIVIDUAL UNIT CONTROL

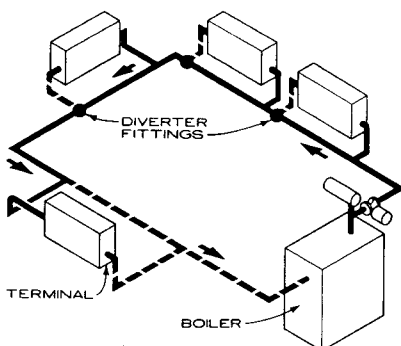

**ONE-PIPE SYSTEM**

- (+) LESS PIPING THAN TWO-PIPE SYSTEM
- (-) REQUIRED DIVERTER FITTINGS INCREASE RESISTANCE OF SYSTEM, LIMITING SYSTEM SIZE

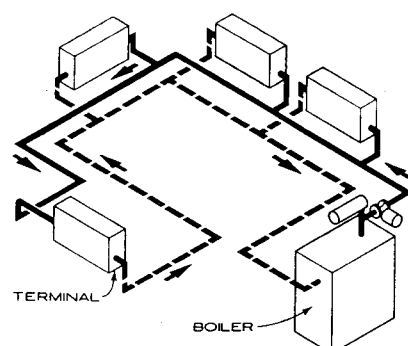

**TWO-PIPE SYSTEM-DIRECT RETURN**

- (+) CAN USE LESS PIPING THAN REVERSE RETURN SYSTEM, ESPECIALLY FOR LINEAR SYSTEM CONFIGURATIONS
- (-) REQUIRES BALANCING DEVICES TO REGULATE FLOW THROUGH EACH TERMINAL

**HYDRONIC HEATING SYSTEM TYPES**

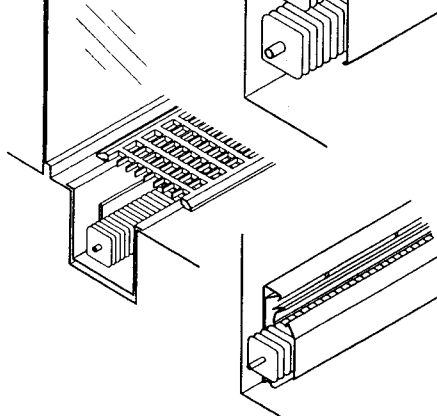
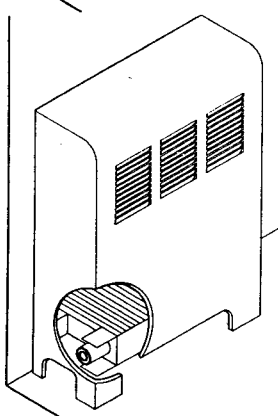
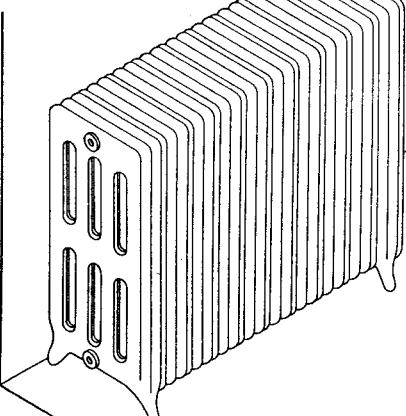
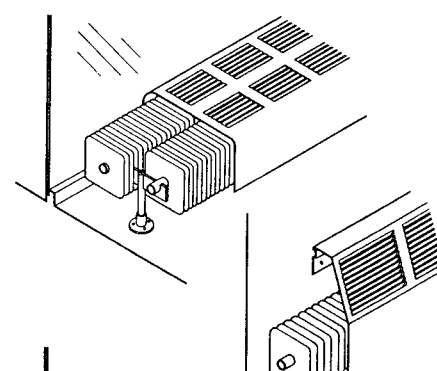
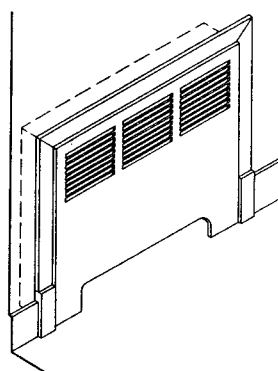
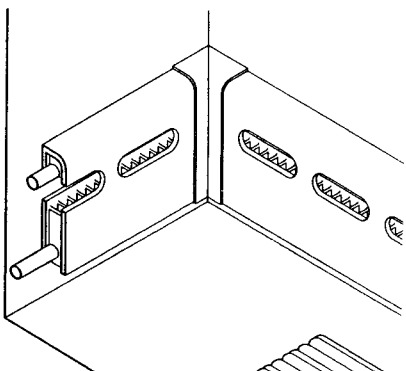

**CAST IRON RADIATORS**

**CONVECTORS**

**FIN TUBE APPLICATIONS**

**COMPARATIVE SIZES AND OUTPUT CAPACITIES OF HYDRONIC HEATING TERMINAL UNITS**

UNIT TYPE	CAST IRON RADIATOR	STERLING CONVECTOR	VULCAN FIN TUBE RADIATORS				RUNTAL STEEL RADIATORS		
			FLOORLINE (BASEBOARD)	DURA-VANE	"H" PANEL	"V" PANEL	"R" COLUMN	"C" CONVECTOR	"G" GRILLE (GV AND GV-2)
Range of sizes	H 12" to 3'-9" L 3'-5" to 8'-8" D 4 1/2" to 1'-1 1/2"	H 1'-8" to 5'-8" L 1'-2" to 3'-0" D 4 1/4" to 8 1/4"	H 8" to 1'-2" L As required D 3 1/2"	H 7" to 2'-0 9/16" L As required D 4 1/2" to 5 5/8"	H 2' to 19'-6" L 2 3/4" to 8'-10 5/8" D 1 5/8" to 3 5/8"	H 2 3/4" to 2'-5" L 1'-7 1/4" to 19'-6" D 1 5/8" to 4 3/4"	H 1'-3 3/8" to 13' L Up to 19'-6" D 3 3/4" to 6 1/4"	H 2 3/4" to 1'-4 1/2" L 1'-7 1/4" to 19'-6" D 1 5/8" to 1'-3 3/4"	H 7 7/8" to 3'-11 1/4" L 1'-7 3/4" to 13'-1 1/2" D 1 1/4" to 2 5/8"
Range of output capacities	110 to 250 Btu/sq ft/hr per unit	Up to 28,000 Btu/hr per unit	Up to 1790 Btu/hr per linear foot	Up to 3180 Btu/hr per linear foot	Up to 2943 Btu/hr per element	Up to 4715 Btu/hr per linear foot	Up to 5354 Btu/hr per element	Up to 7301 Btu/hr per linear foot	Up to 9473 Btu/hr per linear foot

Eric J. Gastier; Darrel Downing Rippeteau Architects, PC; Washington, D.C.



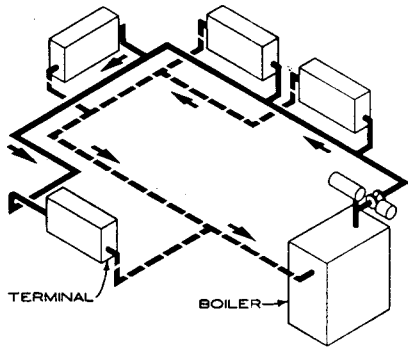

**TWO-PIPE SYSTEM-REVERSE RETURN**

(+) SIMPLIFIED BALANCING OF TERMINAL UNITS  
 (-) REQUIRES MAXIMUM PIPING FOOTAGE  
 (MOST BENEFICIAL WITH LARGE SYSTEMS)

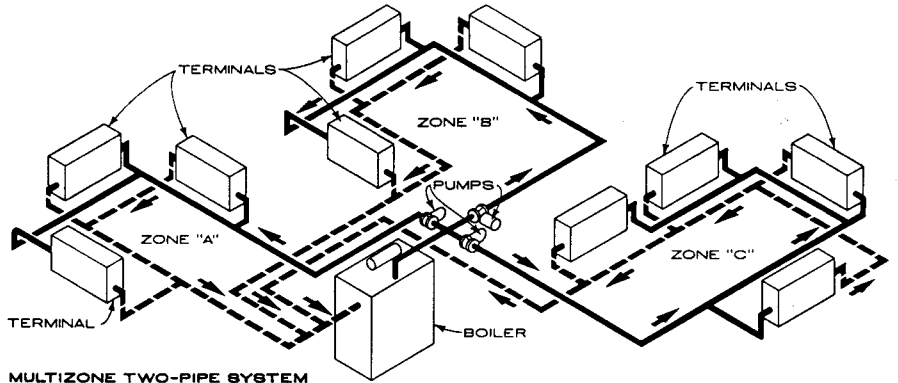

**MULTIZONE TWO-PIPE SYSTEM**

(+) ALLOWS TEMPERATURES TO VARY BETWEEN ZONES, MAXIMIZING COMFORT AND ENERGY EFFICIENCY  
 (-) REQUIRES LARGE INITIAL EQUIPMENT COST  
 (NECESSARY FOR LARGE, MULTIUSE BUILDINGS)

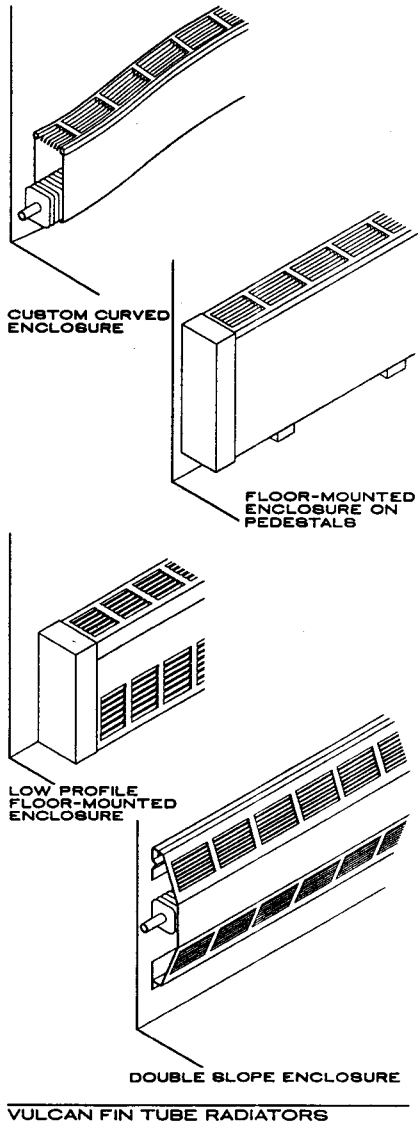

**VULCAN FIN TUBE RADIATORS**

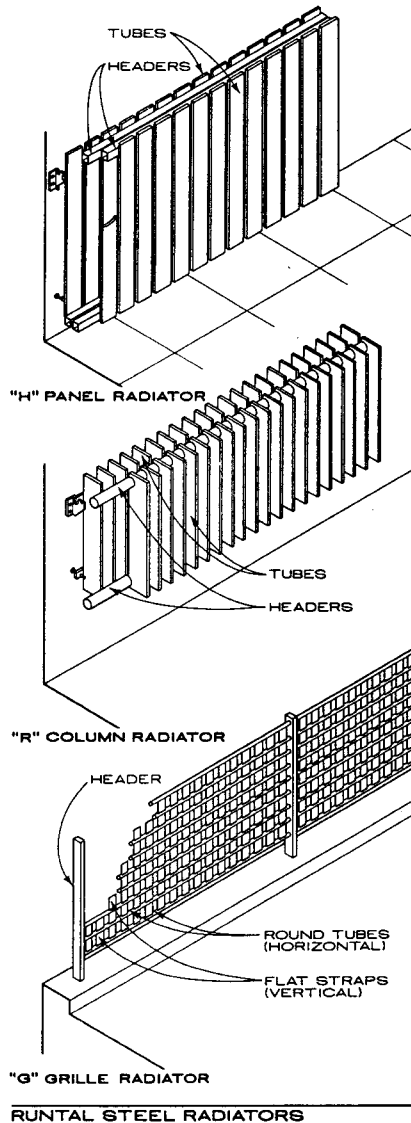

**RUNTAL STEEL RADIATORS**

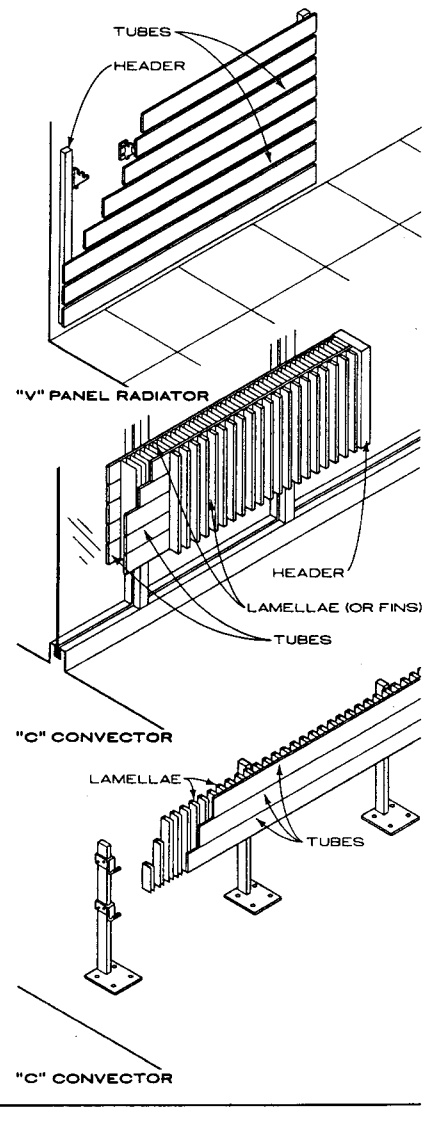

Eric J. Gastier; Darrel Downing Rippeteau Architects, PC; Washington, D.C.

**GENERAL**

The process of removing heat from a refrigerant is called condensing. It is during the condensing process, in a refrigerant cycle, that the refrigerant rejects heat absorbed during the evaporation and compression processes, is reconverted to liquid state, and becomes ready to repeat the cycle.

To convert the refrigerant from gaseous to liquid state heat exchangers called condensers are used. Air-cooled and water-cooled condensers are the predominant types used in the building construction industry.

In the less than 50-ton-capacity range, water-cooled condensers can be used where water sources such as a lake, river, or well are available for once-through use without recirculation of water.

Dry coolers of up to 25-ton capacity are normally used where water is scarce, as well as in computer rooms and other special air conditioning applications. In areas where the winter ambient temperature is below the water freezing temperature, glycol is added to the condenser water. The heat rejection to the outdoor air is by sensible heat transfer, which depends on the dry bulb temperature of the air.

In refrigeration systems larger than 50-ton capacity, water-cooled condensers are used to cool the recirculating condenser water. Both the closed circuit evaporative cooler and the cooling tower operate on the principle of evaporative cooling, which depends on the wet bulb temperature of the air. Closed circuit evaporative coolers are available in sizes up to 300 tons and are used when contamination of the condenser water by direct contact with outdoor air cannot be tolerated.

Use of a cooling tower is generally acceptable in most installations in the building construction industry. The temperature of the water leaving the cooling tower is about 7 to 10°F above the wet bulb temperature of the outside air entering the tower. In cold winter climates the cooling towers can be used directly to make chilled water and thereby eliminate mechanical refrigeration.

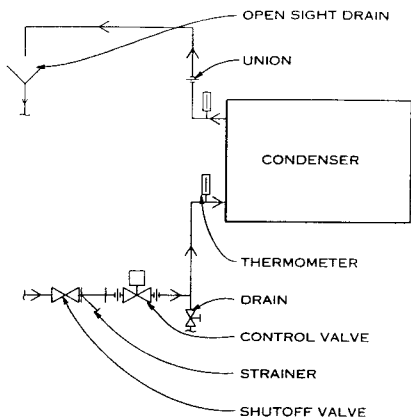

**NOTE**

For water-cooled condensers using city, well, or river water, the return is run higher than the condenser so that it is always full of water. Water flow through the condenser is regulated by a supply line control valve, which is actuated from condenser head pressure control to maintain a constant condensing temperature with variations in load. City water systems usually require check valves and open sight drains, as shown.

**WATER-COOLED CONDENSER**

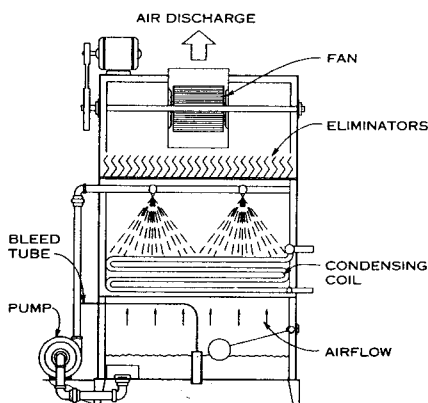

**DRAW-THROUGH TYPE**

**NOTE**

Evaporative condensers combine the functions of a cooling tower and a water-cooling condenser. Latent heat transfer is more effective as a means of heat dissipation. This permits a smaller sized unit than an equivalent tonnage air-cooled unit and considerable energy savings in fan horsepower.

Installations can be either indoors in an equipment room with appropriate ducts or ground or roof mounted outdoors. Adequate protection from freezing must be provided for outdoor installations.

For sizing of condensing units, the manufacturer's rating is the only reliable method of determining unit capacity.

Multiple evaporative condensers may be connected in parallel or an evaporative condenser may be connected in parallel with a shell and tube condenser. Proper piping and traps must be installed in these cases to prevent unequal loading or overloading.

**EVAPORATIVE CONDENSERS**

Walter T. Grondzik, P.E.; Florida A&M University; Tallahassee, Florida

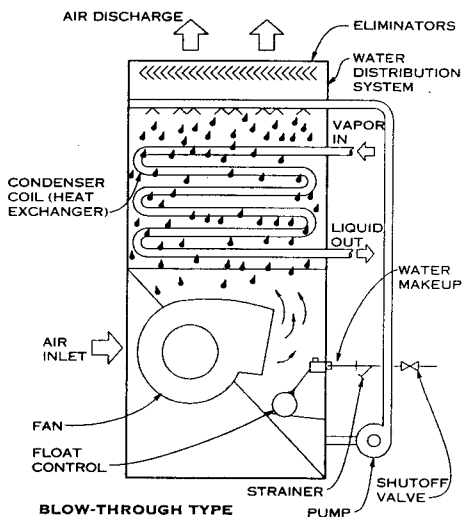

**BLOW-THROUGH TYPE**

The condenser water is circulated inside the tubes of the unit's heat exchanger. Heat flows from the condenser water through the heat exchanger tubes to the spray water outside, which cascades downward over the tubes. Air is forced upward through the heat exchanger, evaporating a small percentage of the spray water, absorbing the latent heat of vaporization, and discharging the heat to the atmosphere.

The remaining water falls to the sump to be recirculated by the pump. The water consumed is the amount evaporated plus a small amount that is bled off to limit the concentration of impurities in the pan.

The condenser water circulates through the clean, closed loop of the heat exchanger and is never exposed to the air-stream or the spray water outside the heat exchanger tubes.

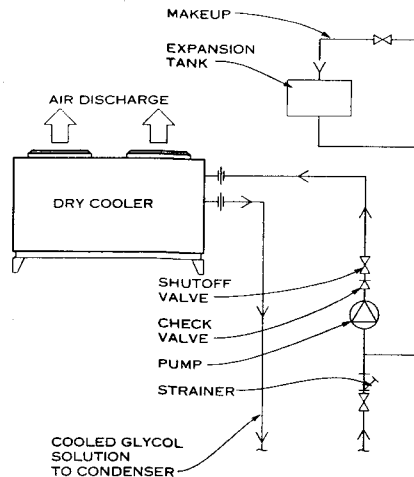

**NOTE**

In the dry cooler, the condenser water-glycol solution is circulated inside the finned tubes of the dry cooler's heat exchanger. Heat flows from the condenser water-glycol solution through the heat exchanger tube walls to the fins. Propeller fans draw air over the fins, and the heat from the fins is transferred to the air passing over them.

An aquastat that senses the temperature of the solution as it leaves the dry cooler cycles the fans to maintain the desired temperature.

**DRY COOLER**

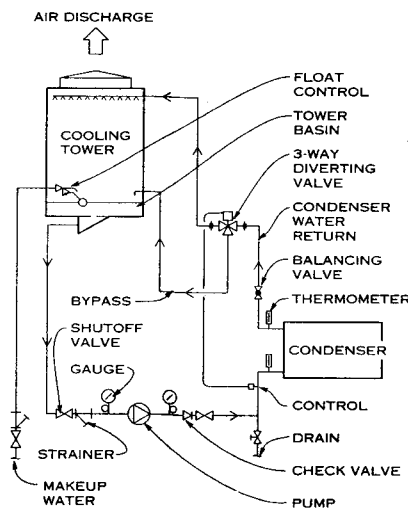

**NOTE**

Water flows from the pump to the tower basin and is discharged under pressure to the condenser and back to the tower, where it is cooled through the spray deck. Since it is usually desirable to maintain condenser water temperature above a predetermined minimum, return water is partially bypassed around the tower through a control valve to maintain desired supply water temperature.

In this condenser water system, air is continuously in contact with the water. Special consideration for chemical treatment and allowance for impurities, scale, and corrosion in the condenser and piping system is then required.

The amount of water flow required depends on the refrigeration system used and the available temperature of the condenser water. Lower condenser water supply temperature results in increased refrigeration machine efficiency.

**COOLING TOWER**

**GENERAL**

Condensing furnaces are high-efficiency units that extract heat from exhaust gases to the point at which water and combustion by-products are condensed out of the gases. The condensed water is typically disposed of in a floor drain. These furnaces contain a multipass heat exchanger that recovers enough hot flue gas heat to yield annual fuel utilization efficiencies (AFUEs) in the range of 89 to 97%. Because the resulting flue gases are at a very low temperature, they can be vented directly through a roof or side wall via PVC plastic pipe.

**VENTING CONSIDERATIONS**

Do not join the vent of a condensing furnace with other flues in the building, such as conventional furnace and boiler flues, hot water heater flues, and laundry vents or fireplace flues. The exhaust gases from a condensing furnace are cooler and therefore are not buoyant enough to create a draft in a large, vertical flue. As a result, the gases will condense inside conventional flues and corrode the flue materials. If abandoned chimneys are to be used, they must be fitted with specially designed chimney liners. Very cold chimneys will require insulation to prevent condensation within the liner.

**INDUCED DRAFT**

Condensing furnaces should be power-vented, so consideration must be given to proper power supply. The exhaust blower is usually a component of the built-in furnace. The fan-induced draft enables the system to be sealed-combustion, so it uses 100% outside air for combustion. Use of indoor air for combustion should be avoided, since it may contain traces of bleach, fabric softeners, salt, paint strippers, or glues that can cause the condensing furnace to corrode rapidly.

**VENT SIZING**

Size the exhaust pipe correctly. Manufacturers specify the maximum length and number of elbows that a given pipe diameter can handle. Exhaust and intake vents are typically no larger than 2-in. diameter PVC pipe.

**VENT SLOPING**

Slope the exhaust pipe down toward the furnace rather than down toward the outside. The exhaust piping must be pitched at least 1/4-in. per foot so condensate can drain freely back through the furnace, where it can be disposed of.

**VENT LOCATIONS**

Run the exhaust and intake pipes out the same side of the building. The pipes must be next to each other so that wind pressure is the same on both pipes.

**FURNACE SIZING**

The furnace must not be oversized, as this leads to short firing cycles and can cause corrosion from "condensate dwell" or excessive "wet-time." Because the furnace seldom gets hot enough to dry out, condensate forms in vulnerable areas. The condensate then becomes increasingly acidic, and corrosion results.

**CONDENSATE DRAINAGE**

The furnace must be level or pitched slightly toward the drain so condensate can drain out. If the condensate cannot be drained by gravity, install a special purpose condensate pump to pump it to an acceptable drain (do not use a sump). Condensing furnaces must be kept away from freezing temperatures because they contain water and will be damaged if they freeze.

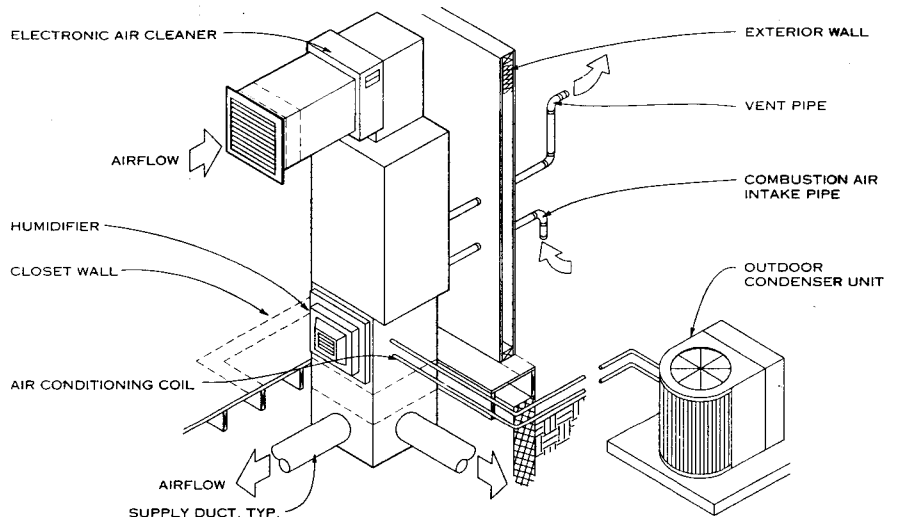

**DOWNFLOW APPLICATION—CLOSET**

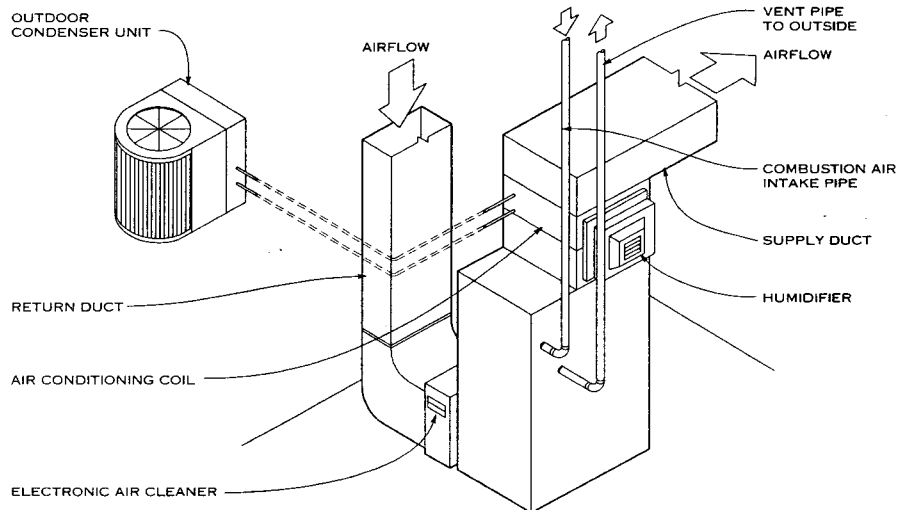

**UPFLOW APPLICATION—BASEMENT**

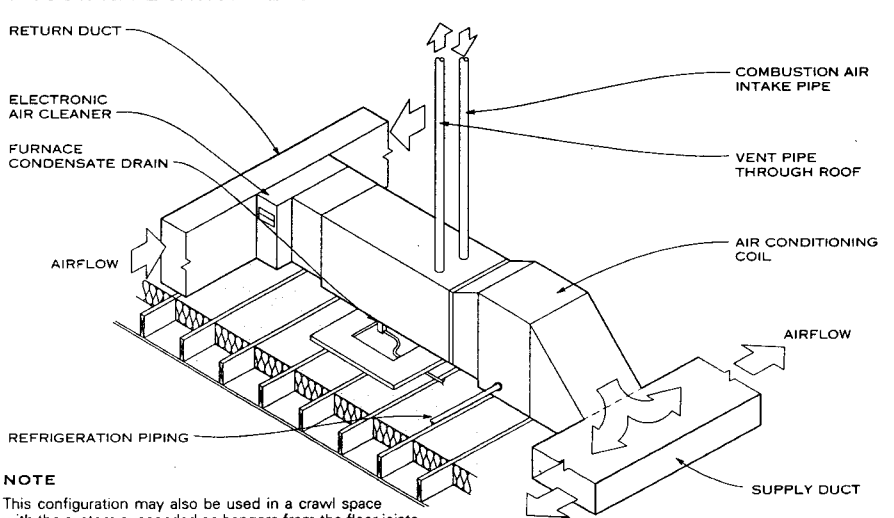

**NOTE**

This configuration may also be used in a crawl space with the system suspended on hangers from the floor joists.

**HORIZONTAL APPLICATION—ATTIC**

Larry O. Degelman, P.E.; Texas A&M University; College Station, Texas

**GENERAL NOTES**

Chilled water is the most common medium for transferring heat from any type of cooling equipment, such as cooling coils and heat exchangers, to some source of refrigeration.

A chilled water system is a closed circuit system that recirculates water between a mechanical refrigeration water chilling unit and remote cooling equipment, usually operating with water temperatures in the range between 40 and 55°F. There are five types of refrigeration units used in chilled water systems:

1. Centrifugal chiller, with electric motor or steam turbine drive.
2. Reciprocating chiller, with electric motor drive.
3. Rotary screw chiller, with electric drive.
4. Steam absorption chiller.
5. Direct-fired absorption chiller, using fuel oil or gas for firing.

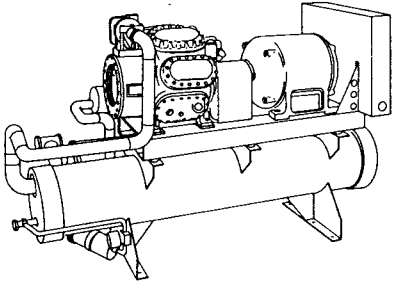

**NOTE**  
A typical reciprocating package chiller, ideally suited to smaller jobs requiring less than 200 tons of cooling. The rotary screw machines are in this range of capacity.

When a chilled water piping system also is used to circulate hot water for winter heating, it is called a dual temperature water system. The design water temperature of chilled water systems usually falls in a rather narrow range because of the necessity for dehumidification and to avoid a possible freeze-up in the chiller. Chilled water supply temperatures usually range from 42° to 60°F for normal comfort applications.

Design flow rates depend on the type of terminal apparatus and the supply temperature. In general, a higher temperature rise (or a greater temperature difference between supply and return temperatures) reduces the initial cost and the operating cost of the distribution system and pumps required and increases the efficiency of the chillers. In a given chilled water system, the selection of the design flow rate and the supply temperature, therefore, are closely related.

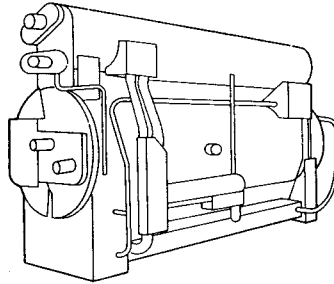

**NOTE**  
A two-stage absorption chiller, steam powered for efficient production of 200 to 800 tons of cooling.

Although lower chilled water temperatures permit higher rises (or larger temperature difference), lower chiller efficiencies result. Water treatment may be required in chilled water systems to control corrosion rate, scaling, or algae growth.

Layout of piping systems for chilled water distribution varies greatly depending on system capacity, extent of distribution, type of terminals used, and control scheme to be employed.

Refrigerants that attack the ozone layer above the earth are being phased out and replaced with refrigeration systems that do not degrade the ozone layer, such as R-123, R-134A, and ammonia. This concern has also expanded the use of absorption chillers, both steam and direct-fired types.

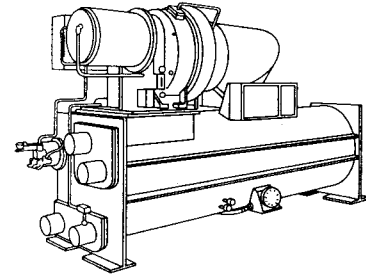

**NOTE**  
A centrifugal chiller with a flooded cooler and condenser. This unit is typically used in ranges of 150 to 1200 tons.

**PACKAGE WATER CHILLERS**

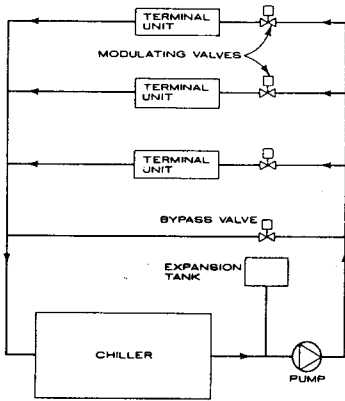

**FIGURE 1**  
**ELEMENTARY CHILLED WATER SYSTEM**

**NOTE**  
A chilled water system basically consists of a refrigeration water chilling unit, a chilled water recirculating pump, terminal cooling equipment, and an expansion tank. A chilled water bypass valve may be required in systems with two-way modulating valve control at the terminal units. As the cooling load on the terminal equipment decreases, the modulating valve closes and reduces the flow through the terminal. When the water flow through the terminal units is significantly throttled, the bypass valve opens gradually to prevent system pressure buildup and to maintain the water flow required for the proper operation of the chiller.

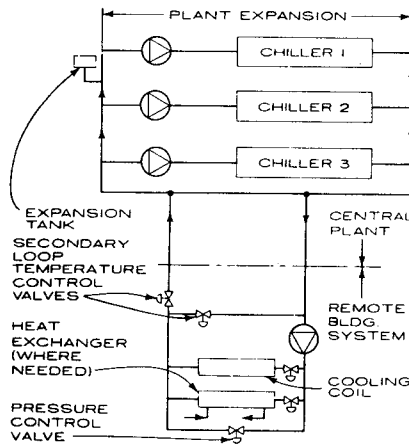

**FIGURE 2**  
**PRIMARY/SECONDARY CHILLED WATER PUMPING AND DISTRIBUTION SYSTEM**

**NOTE**  
In large campus type applications, the chilled water system consists of multiple chillers and primary and secondary system pumps. The terminal cooling equipment may be chilled water cooling coil of a central air-conditioning unit, closed loop heat exchanger or any other secondary or terminal cooling water system.

The primary loop does not require a pressure control device. The secondary loop pressure control valve operates as described under Elementary Chilled Water System.

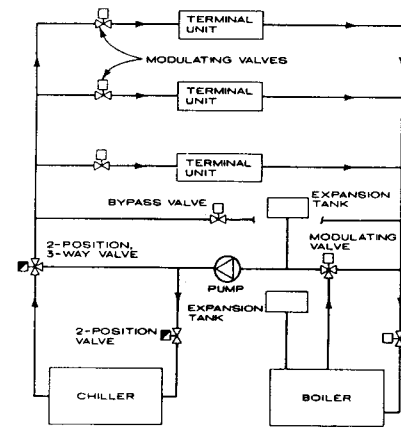

**FIGURE 3**  
**TWO-PIPE DUAL TEMPERATURE SYSTEM**

**NOTE**  
In a two-pipe dual temperature system hot water is circulated through the terminal units during cold weather and chilled water is circulated during the hot weather. The distribution system may be divided into zones, each of which is capable of changeover from heating to cooling, independent of the other zones.

When the hot and chilled water supply to each terminal unit is in two separate pipes, but the return is in a common pipe, the system is called a three-pipe system. In a four-pipe system, separate supply and return mains for both hot and chilled water are run to each terminal unit.

**GENERAL**

This and the accompanying page describe several HVAC systems commonly used in medium to large buildings. Systems covered are single duct with terminal reheat, single duct with variable volume, dual duct, and multizone.

**CONSTANT VOLUME SINGLE-DUCT WITH TERMINAL REHEAT**

This system provides a constant flow of air to the zone(s) served by the HVAC system. Zone temperature is maintained by changing the temperature of the constant airflow. Dehumidification is provided by the combination of a cooling coil and a reheat coil in the terminal mixing box in each zone. Cooling is provided by a cooling coil that uses either direct expansion of the refrigerant or chilled water provided by a central plant. Heating is provided in the outside air preheat coil and in the reheat coil using hot water from a boiler. Normally, the amount of outside air provided corresponds with the amount of ventilation appropriate for anticipated occupancy levels.

Winter and summer operation of the system is best understood by tracing the system state points on a psychrometric

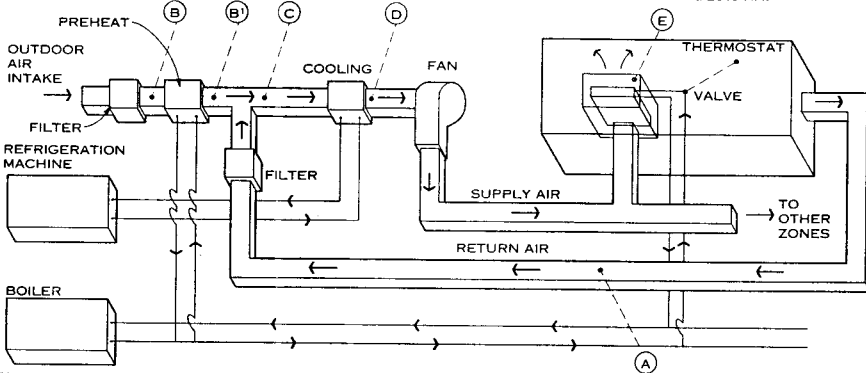

chart. The state points for summer conditions of 95°F, 50% RH outdoor conditions, zonal conditions of 78°F and 50% RH, and system set points of 10% outside air, cooling coil set point of 55°F, and a maximum reheat coil set point of 110°F. The preheat coil is assumed inactive in the summer and the cooling coil is inactive in the winter when the mixed air is less than 55°F.

During summer conditions, the mixed airstream (point C, 80°F, 50% RH), which consists of 10% outside air (points B and B', 95°F, 50% RH) and 90% return air (point A, 78°F, 50% RH), is cooled to 55°F and 90-100% RH as it passes through the cooling coil (point D). This 55°F air is then provided to the terminal box in each zone, where it is reheated to meet the zonal cooling load; in this case, the 55°F, 90-100% RH air is reheated to 65°F and 70% RH in the terminal mixing box before it enters the zone.

During the winter, the preheat coil heats outside air to 45°F. The mixed airstream (point C, 69°F, 50% RH), which consists of 10% outside air (point B, 35°F, 50% RH) that has been preheated to 45°F and 35% RH (point B') and 90% return air (point A, 72°F, 50% RH), passes through the cooling coil where it is cooled to 55°F and 80% RH and is heated in the terminal box to 90°F and 25% RH.

**ADVANTAGES**

1. Can provide heating and cooling as needed.
2. Good dehumidification.
3. Boiler and chiller can be installed at central plant.
4. Air-handling unit runs continuously, providing good ventilation
5. Long equipment life.
6. An economizer can be added to take advantage of free cooling during appropriate conditions.

**DISADVANTAGES**

1. No humidification, so this type of system may produce very dry conditions indoors during winter.
2. Requires distribution ductwork to each zone
3. Air-handling unit runs continuously, which can cause excessive electricity consumption.
4. Reheat coils require plumbing run to each zone or electric resistance heating.
5. Use of reheat during dehumidification uses unnecessary heating in the summer.
6. Chiller and boiler both must operate except in extreme winter conditions.

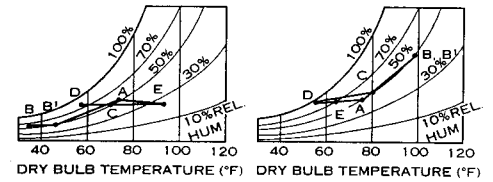

PSYCHROMETRIC CHART—WINTER

PSYCHROMETRIC CHART—SUMMER

**CONSTANT VOLUME SINGLE-DUCT SYSTEM WITH TERMINAL REHEAT**

**VARIABLE VOLUME SINGLE-DUCT WITH REHEAT**

This system provides a variable flow of air to the zone or zones served by the HVAC system. The amount of air is regulated by opening and closing individual terminal mixing boxes in each zone. Static pressure is maintained by varying the fan speed. During cooling, the temperature in each zone is maintained by changing the flow rate of the air. During heating, the cooling coil is inactive and the heating coil heats the main supply air to the minimum temperature necessary to meet the maximum load of any zone served. In the winter a thermostat in each zone regulates the heated airflow to meet the zone load. Dehumidification is provided by the combination of a cooling coil and a reheat coil. Humidification is not provided but can be added by inserting a humidification device immediately after the fan. Cooling is provided by a cooling coil that uses either direct expansion of the refrigerant or chilled water provided by a central plant. Hot water from a boiler provides heating in the outside air preheat coil and in the main reheat coil. Normally, a fixed amount of outside air is provided, corresponding to the amount of ventilation appropriate for anticipated occupancy levels.

Winter and summer operation of the system is best understood by tracing the system state points on a psychrometric

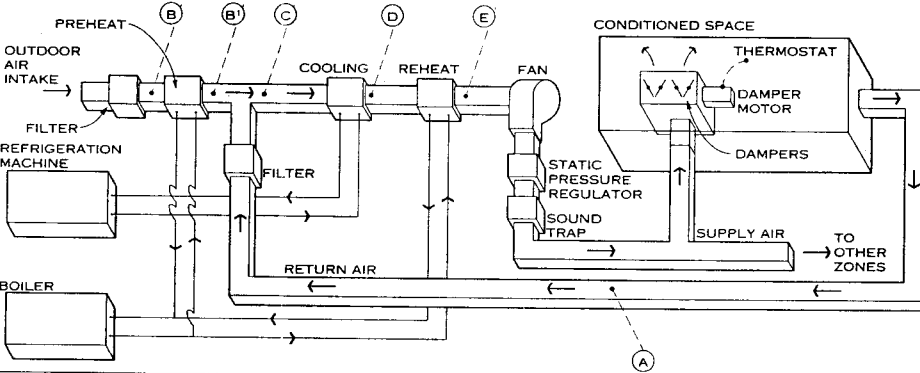

chart. The state points for summer conditions of 95°F and 50% RH outdoors, zonal conditions of 78°F and 50% RH, and system set points of 10% outside air, cooling coil set point of 55°F, and a maximum reheat coil set point of 110°F. The preheat coil is assumed to be inactive in the summer; the cooling coil is inactive in the winter when the mixed air is less than 55°F.

In summer conditions the mixed airstream (point C, 80°F, 50% RH), which consists of 10% outside air (points B and B', 95°F, 50% RH) and 90% return air (point A, 78°F, 50% RH), is cooled to 55°F and 90-100% RH as it passes through the cooling coil (point D). This 55°F air is then reheated to 65°F and 70% RH in the main reheat coil. Reheating must be controlled to maintain RH at or below 60% in all zones served in summer conditions. The amount of air entering each zone is then modulated to meet the cooling load.

During the winter the preheat coil heats outside air to 45°F; the cooling coil is inactive. The mixed airstream (point C, 69°F, 50% RH), which consists of 10% outside air (point B, 35°F, 50% RH) that has been preheated to 45°F and 35% RH (point B') and 90% return air (point A, 72°F, 50% RH), passes through the cooling coil unaffected and is heated in the main reheat coil to 110°F, 15% RH.

**ADVANTAGES**

1. Can provide heating and cooling as needed.
2. Average dehumidification.
3. Boiler and chiller can be installed at central plant.
4. Air-handling unit runs continuously at variable volume, which provides adequate ventilation.
5. Long equipment life.
6. An economizer can be added to take advantage of free cooling during appropriate ambient conditions.
7. Does not require piping into individual zones.

**DISADVANTAGES**

1. No humidification, so this type of system may produce very dry conditions indoors during winter.
2. Requires distribution ductwork to each zone.
3. Volume of air provided to air-handling units varies, which can result in inadequate ventilation if not properly balanced.
4. One main reheat coil for the entire system can result in a very cold building in extremely humid climates. Could require humidity sensor to moderate supply air temperature to maintain humidity at or below 60% RH.
5. Use of reheat during dehumidification uses unnecessary heating in the summer.
6. One main heating coil may cause hot interior zones when internal loads require year-round cooling.

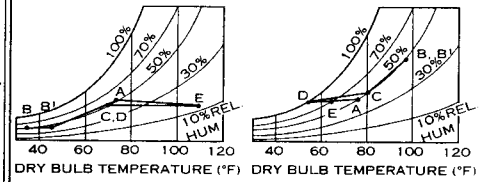

PSYCHROMETRIC CHART—WINTER

PSYCHROMETRIC CHART—SUMMER

**VARIABLE VOLUME SINGLE-DUCT SYSTEM WITH REHEAT**

Jeff Haberl, Ph.D, PE; Texas A&M University; College Station, Texas

**CONSTANT VOLUME DUAL-DUCT**

A constant volume dual-duct system provides a constant flow of air to zone(s) served by the HVAC system. Zone temperature is maintained by changing the temperature of the constant airflow that leaves the terminal mixing box in each zone. Dehumidification is provided by the cooling coil and any remixing of air in the terminal mixing boxes. Humidification is not provided in the system shown but can be added by inserting a humidification device immediately after the main heating coil. Cooling is provided by a cooling coil that uses either direct expansion of the refrigerant or chilled water provided by a central plant. Heating is provided in the outside air preheat coil and in the main heating coil using hot water from a boiler. Normally, the fixed amount of outside air provided corresponds to the appropriate amount of ventilation for anticipated occupancy levels. However, in a dual-duct system both hot and cold airstreams are always available to each terminal mixing box. The temperature of the air leaving the cooling coil is always between 45°F (winter) and 55°F (summer). Air leaving the heating coil is either fixed at 110°F or can be moderated by an outside reset thermostat. Varying amounts of hot and cold air are mixed in the terminal boxes to achieve the required cooling or heating load.

Winter and summer operation of the system is best understood by tracing system state points on a psychrometric chart. The state points for summer and winter are the same as those indicated for the constant volume single-duct system with reheat (see the AGS page on this system).

In summer conditions the mixed airstream (point C, 80°F, 50% RH), which consists of 10% outside air (points B and B', 95°F, 50% RH) and 90% return air (point A, 78°F, 50% RH), is either cooled to 55°F and 35% RH (point B') and 90% return air (point A, 78°F, 50% RH) as it passes through the cooling coil (point D) or heated to 110°F and 20% RH as it passes through the main heating coil. Both the 55°F cold air and 110°F hot air are then made available to the terminal mixing box, where the two airstreams are mixed to produce a constant flow, variable temperature airstream to meet the cooling and dehumidification load (point F).

During winter conditions the preheat coil heats outside air to 45°F. The mixed airstream (point C, 69°F, 50% RH), which consists of 10% outside air (point B, 35°F, 50% RH) that has been preheated to 45°F and 35% RH (point B') and 90% return air (point A, 72°F, 50% RH), passes through the cooling coil where it is cooled to 55°F and 82% RH or is heated in the main heating coil to 110°F and about 15% RH. Both

the 45°F cold air and 110°F hot air are then made available to the terminal mixing box, which mixes the two to produce a constant flow, variable temperature airstream to meet the heating load (point F). This type of system does not provide humidification so may produce extremely dry conditions indoors during the winter.

**ADVANTAGES**

Constant volume dual-duct systems have the same advantages as those listed in numbers 1-5 on the AGS page on constant volume single-duct systems with reheat. An economizer can be added to reduce the mixed air to 55°F so the cooling load can be reduced.

**DISADVANTAGES**

Constant volume dual-duct systems have the same disadvantages as those listed in numbers 1-3 and 5-6 on the AGS page on constant volume single-duct systems with reheat.

**NOTE**

This system can easily be modified to make a variable volume dual-duct system. Install a variable speed controller on the main fan and modify the terminal mixing boxes to allow for varying airflow rates. An economizer can also be added to reduce winter cooling loads.

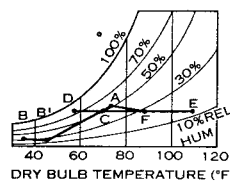
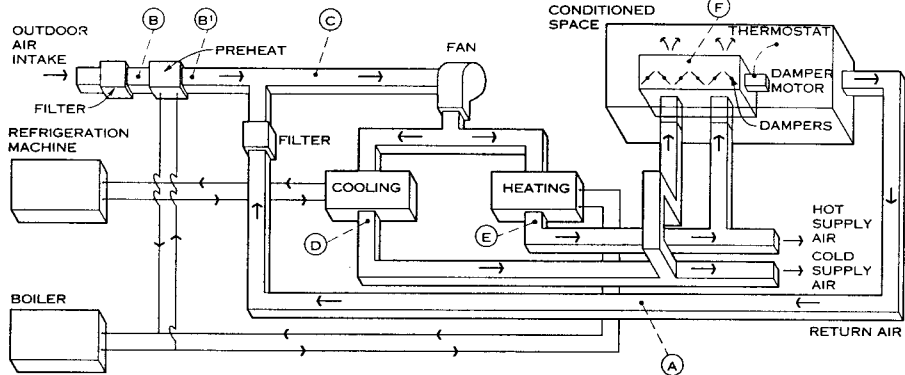

PSYCHROMETRIC CHART—WINTER

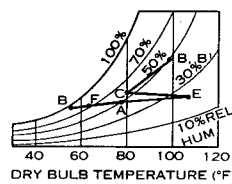

PSYCHROMETRIC CHART—SUMMER

**CONSTANT VOLUME DUAL-DUCT SYSTEM**

**CONSTANT VOLUME MULTIZONE**

A constant volume multizone system provides a constant flow of air to the zones served by the system. Zone temperature is maintained by changing the temperature of the constant airflow that leaves the multizone unit. Dehumidification is provided by the cooling coil and any remixing of air from the heating coil before it enters a zone. The system shown does not provide humidification, but a dehumidification device can be added just after the main heating coil for each zone. Cooling is provided by a cooling coil that uses either direct expansion of the refrigerant or chilled water provided by a central plant. Heating is provided in the outside air preheat coil and in the main heating coil using hot water from a boiler. Normally, a fixed amount of outside air corresponds to the amount of ventilation appropriate for the occupancy level. In a multizone system both hot and cold airstreams are always available to each zone. The temperature of the air leaving the cooling coil is always between 45°F (winter) and 55°F (summer). Air leaving the heating coil is fixed at 110°F

or can be moderated by an outside reset thermostat. Varying amounts of hot and cold air are mixed according to the required cooling or heating load in each zone.

Summer and winter operation of the system is best understood by tracing system state points on a psychrometric chart. The state points for summer and winter conditions are the same as those indicated for the constant volume single-duct system with reheat (see the AGS page on this system).

During summer conditions the mixed airstream (point C, 80°F, 50% RH), which consists of 10% outside air (points B and B', 95°F, 50% RH) and 90% return air (point A, 78°F, 50% RH), is either cooled to 55°F and 35% RH as it passes through the cooling coil (point D) or is heated to 110°F and 20% RH as it passes through the main heating coil. Both the 55°F cold air and 110°F hot air are then made available to each zone to meet the cooling and dehumidification load.

During winter conditions the preheat coil heats outside air to 45°F. The mixed airstream (point C, 69°F, 50% RH), which consists of 10% outside air (point B, 35°F, 50% RH) that has been preheated to 45°F and 35% RH (point B') and 90% return air (point A, 72°F, 50% RH) passes through the cooling coil where it is cooled to 55°F and 80% RH or is heated in the main heating coil to 110°F and about 15% RH. Both the 55°F cold air and 110°F hot air are then made available to the individual zones to meet the heating load (point F). This type of system does not provide humidification and so may produce extremely dry conditions indoors in the winter.

**ADVANTAGES**

Constant volume multizone systems have the same advantages as those listed in numbers 1-6 on the AGS page on constant volume single-duct systems with reheat. An economizer can also be added to reduce winter cooling loads.

**DISADVANTAGES**

Constant volume multizone systems have the same disadvantages as those listed in numbers 1-3 and 5-6 on the AGS page on constant volume single-duct systems with reheat.

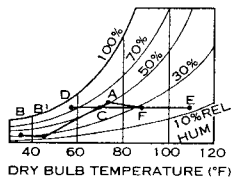
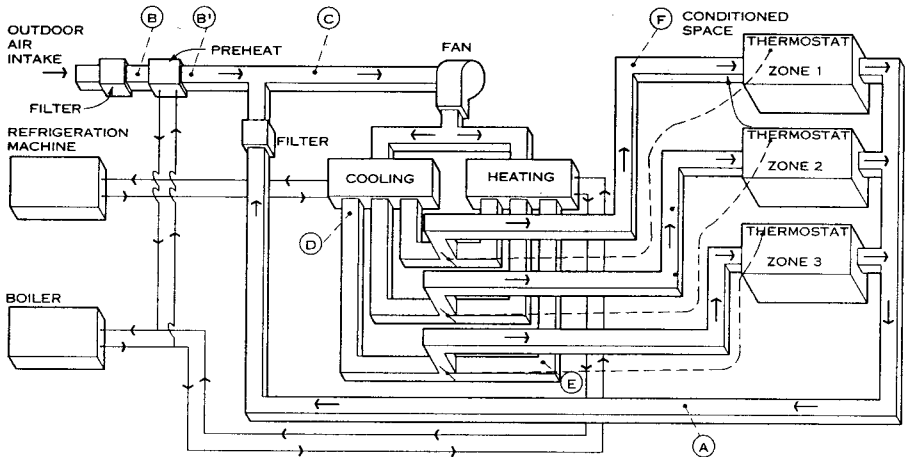

PSYCHROMETRIC CHART—WINTER

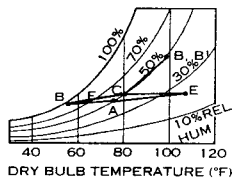

PSYCHROMETRIC CHART—SUMMER

**CONSTANT VOLUME MULTIZONE SYSTEM**

Jeff Habert, Ph.D, PE; Texas A&M University; College Station, Texas

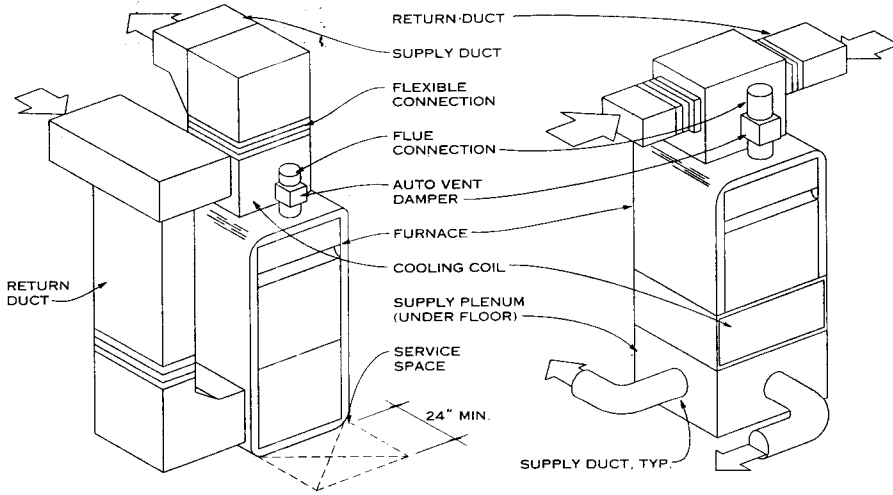

UPFLOW (HIGH BOY)

DOWNFLOW (COUNTERFLOW)

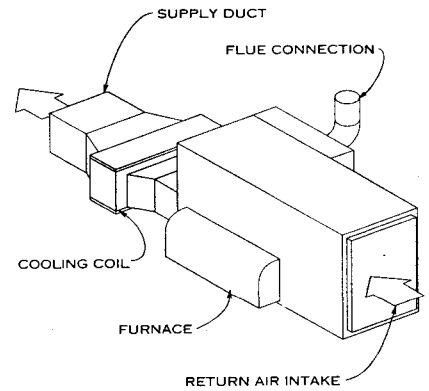

HORIZONTAL

WARM AIR FURNACES

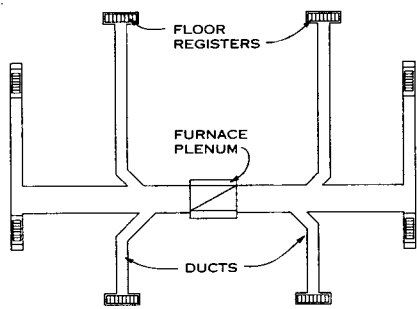

EXTENDED PLENUM SYSTEM

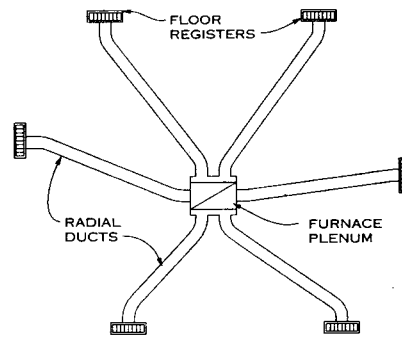

PERIMETER RADIAL SYSTEM

DUCT SYSTEM LAYOUTS

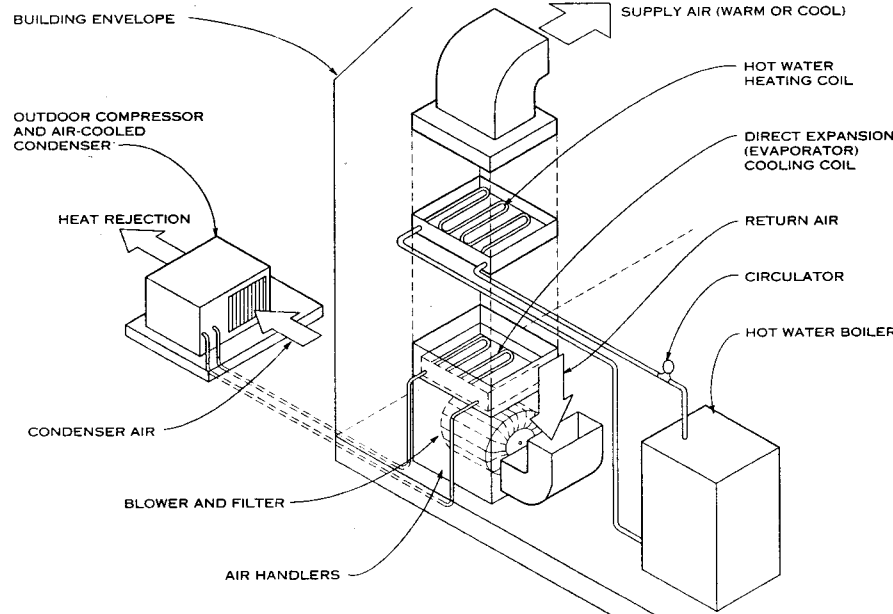

OVERHEAD AIR SYSTEM WITH DUCTED RETURN

NOTES

1. Warm air furnace units are designed primarily for residential, small commercial, or classroom heating. Cooling can be added to these units by installing a cooling coil downstream from the furnace, with refrigerant compressor and condenser located remotely outside the building.
2. A duct system from the furnace unit can be installed above the ceiling or in a furred down soffit. Distribution systems above the ceiling are usually the radial type with high wall registers.
3. Duct systems also may be installed below living spaces, in a crawl space or a basement.
4. Two- or three-story buildings using similar warm air furnace and cooling coil combinations are centrally air conditioned via vertical extension of the branch ductwork through walls and partitions. Since all variations of warm air heating and cooling systems recirculate their air within the building envelope, it is a crucial design requirement to leave adequate return air passage, from each space supplied with air, to the furnace room.

FLOOR AREA REQUIRED BY WARM AIR FURNACE

OUTPUT CAPACITY (BTU/HR)	FURNACE FLOOR AREA (SQ FT)*
Up to 52,000	2.4
52,000-84,000	4.2
84,000-120,000	6.6
120,000-200,000	13.1

\* Based on net floor area occupied by the upflow or downflow furnace. Low-boy unit requires 50% more floor area. Space for combustion air should be added as required by local codes. Provide adequate space for service.

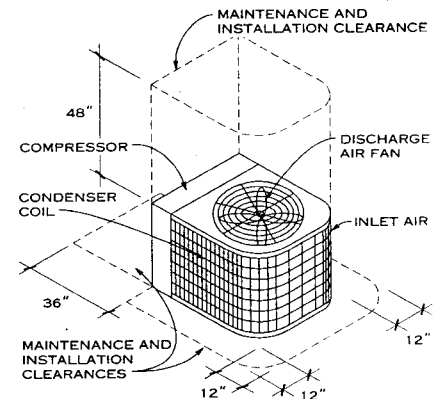

CONDENSING UNIT

Jeff Haberl, Ph.D., P.E.; Texas A&M University; College Station, Texas

**GENERAL**

Three types of devices are used to supply and return air: diffusers, registers, and grilles. Diffusers are generally intended for ceiling-mounted supply air applications and are designed to provide good mixing of supply air with room air. Registers are used for supply or return air applications and may be appropriate for ceiling, sidewall, or floor installations. Grilles are less sophisticated devices primarily intended for return air applications. As the air supply and return devices are often the only element of an HVAC system seen by building occupants, have a direct impact on thermal and acoustical comfort, and have an indirect impact on indoor air quality, selection and specification of these devices is an important part of the design process.

Diffusers and registers are selected to deliver a specified airflow with appropriate throw (in terms of both distance and direction) and acceptable noise generation. Diffusers, manufactured of steel or aluminum, are available in a wide range of shapes, sizes, surface appearances, finishes, and installation detailing. Registers come in a more restricted range of shapes and sizes. Grilles are generally square/rectangular in shape. Typical diffuser designs and installations are shown in the diagrams on this page.

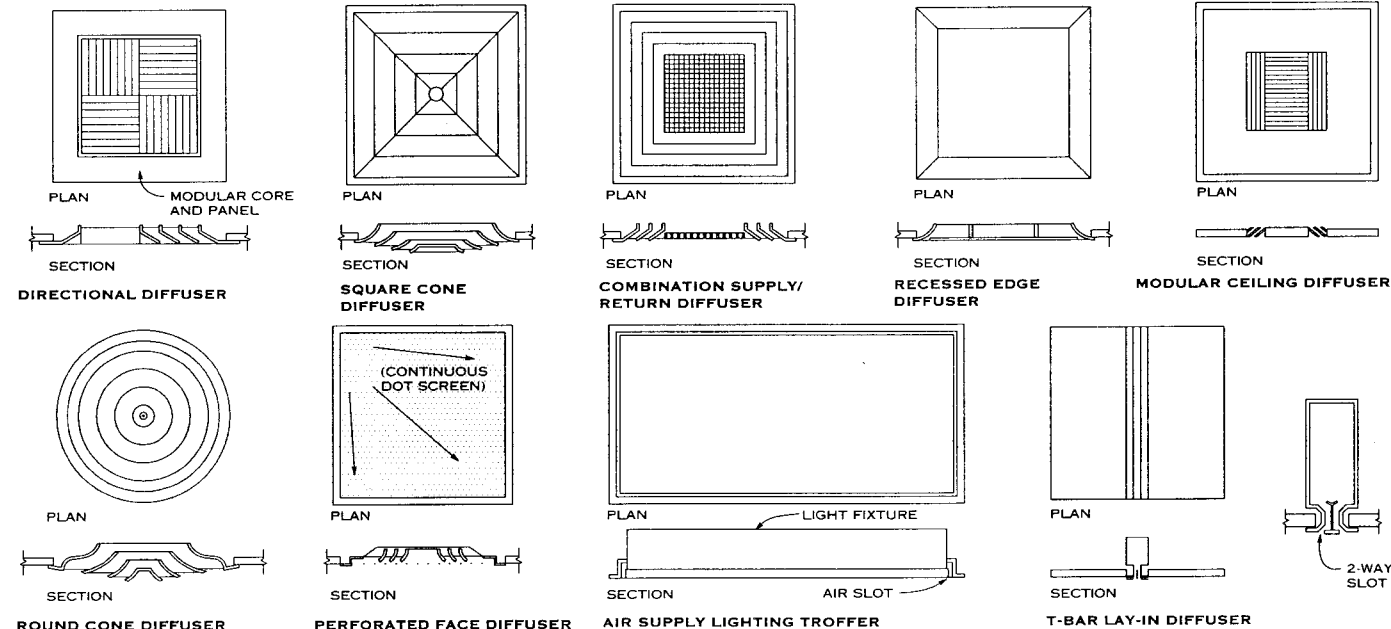
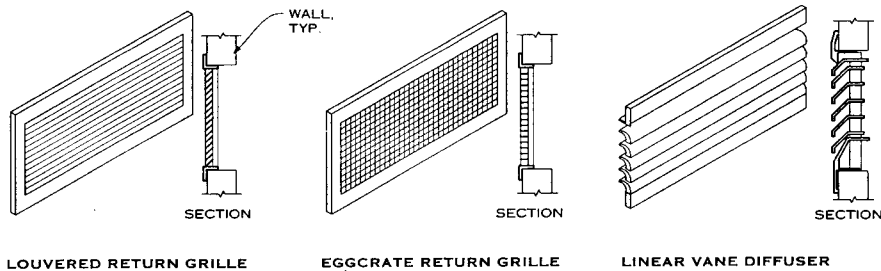

**RETURN GRILLES AND SUPPLY DIFFUSERS**

**NOTE**

Terminal devices (or boxes) are a key element of many common HVAC systems, including variable air volume (VAV) and dual-duct systems. These devices are usually located adjacent to the zones they serve and require space/volume for transitions and connections to the central air distribution network and to the supply air devices. Terminal boxes should be installed in readily accessible locations to permit adjustment and maintenance.

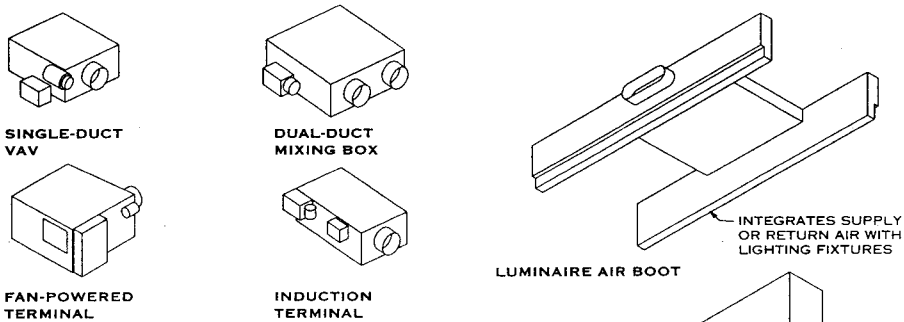

**TYPICAL DIMENSIONS FOR TERMINAL BOXES (IN.)**

BOX CAPACITY (CFM)	DUAL-DUCT MIXING BOX	SINGLE-DUCT VAV BOX	FAN-POWERED TERMINAL BOX	INDUCTION TERMINAL BOX
225	12 x 21 x 34	8 x 12 x 52	16 x 32 x 26	10 x 18 x 42
500	12 x 25 x 34	8 x 12 x 52	16 x 32 x 26	10 x 18 x 42
900	12 x 29 x 39	12 x 12 x 52	16 x 34 x 26	12 x 34 x 48
1400	12 x 34 x 42	12 x 14 x 52	16 x 36 x 26	12 x 34 x 48
2000	12 x 43 x 46	15 x 16 x 52	18 x 44 x 32	16 x 40 x 58

**AIR TERMINAL BOXES**

**AIR BOOTS**

Walter T. Grondzik, P.E.; Florida A&M University; Tallahassee, Florida



**GENERAL**

The six diagrams on the AGS pages on multiple interior zone HVAC systems describe systems found in K-12 schools and small commercial office buildings.

**FOUR-PIPE, SINGLE-ZONE AIR-HANDLING UNIT**

Zonal air-handling units (AHUs) in this system provide heating and cooling for specific zones. Each AHU has a blower, filter, and heating and cooling coils. A fixed amount of fresh air to the units is pretempered to 55°F in a preconditioning unit. Both chilled and hot water are simultaneously provided to zonal and preconditioning units to carry the loads on the cooling and heating coils. Chilled water is provided by a chiller located in a central mechanical room (which contains a heat-rejecting condensing unit), and hot water is provided by a boiler, often located in the same mechanical room. Some single-zone AHUs run continuously. Newer units may

have a variable volume fan that regulates airflow according to zone loads. The chiller or boiler must operate when any single zonal unit requires cooling or heating.

Each unit is controlled by a zone thermostat that adjusts the supply-air temperature to meet heating or cooling loads. The preconditioning unit is controlled to maintain 55°F by preheating air in winter and precooled it in the summer. The temperatures of the chilled water and hot water supplied to the units may be controlled with an outside reset thermostat.

**ADVANTAGES**

1. This system can provide heating and cooling as needed.
2. The system offers good dehumidification.
3. The boiler and chiller are installed at a central location.
4. The system operates with minimal distribution ductwork.
5. Zonal air-handling units can be shut down without affecting adjacent areas.

6. Chiller efficiency is higher than for individual heat pumps.
7. The boiler and chiller have a long life (25 years).

**DISADVANTAGES**

1. A four-pipe system is slightly more expensive than a two-pipe system.
2. The hot water and chiller water loop must run even if only one zone needs heating or cooling.
3. The entire system is shut down when the loop fails.
4. The water-cooled condenser tower needs frequent service and water quality checks.
5. The temperature is higher in an air-cooled condenser than a water-cooled condenser, making chillers less efficient.
6. This system may require more energy than others because of the energy needed to run a four-pipe central loop.
7. The system has no humidification.

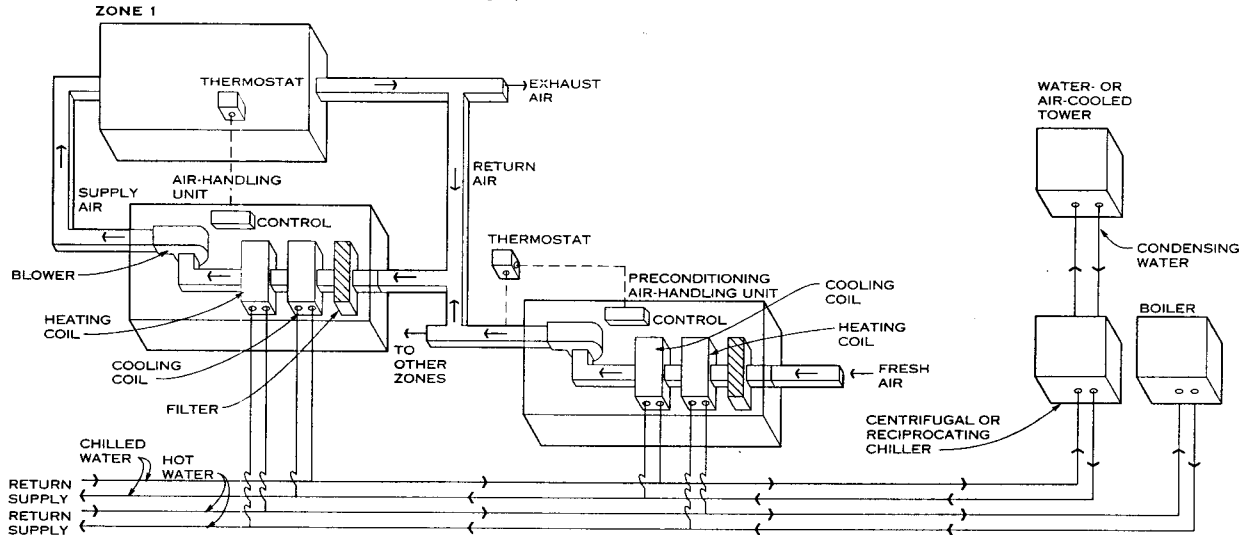

**FOUR-PIPE, SINGLE-ZONE AIR-HANDLING UNIT**

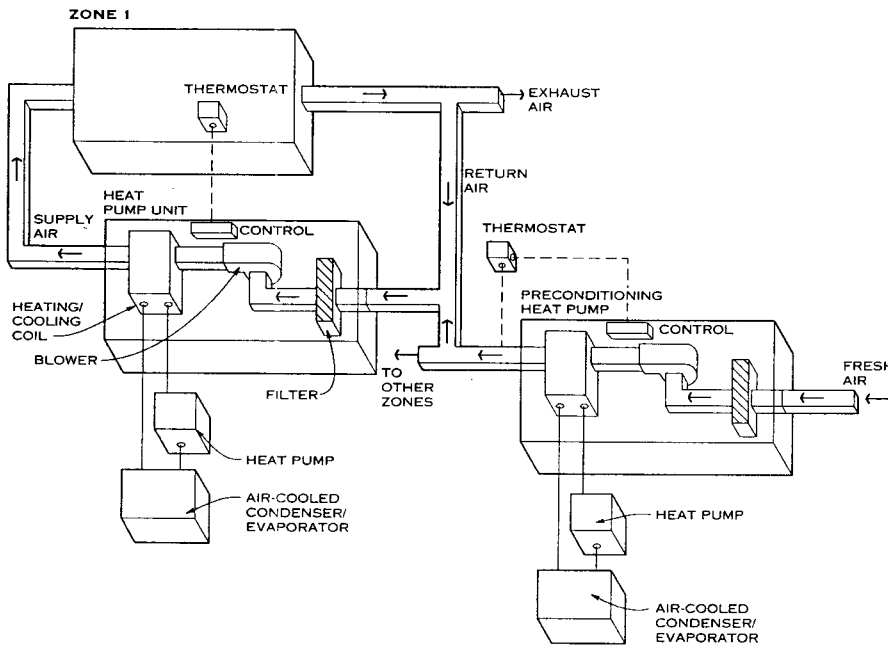

**PACKAGED SPLIT SYSTEM WITH INDIVIDUAL HEAT PUMPS**

**PACKAGED SPLIT SYSTEM WITH INDIVIDUAL HEAT PUMPS**

This system provides heating and cooling for individual zones with zonal heat pumps. Each heat pump unit contains a blower, filter, and heating/cooling coil. A fixed amount of fresh air to the units is pretempered to 55°F in a preconditioning heat pump unit. Each heat pump has its own heat rejection (or ambient heat source during cold weather). Emergency electric resistance heating is often provided for severe conditions.

The zonal heat pumps cycle on and off when the zone thermostat calls for heating or cooling. Airflow to the zones also cycles on and off according to zone demand. In general, the heat pump that preconditions outside air must run continuously to provide adequate preconditioned fresh air.

**ADVANTAGES**

1. Installation, system operation, and maintenance are simple.
2. No mechanical room is required.
3. Ductwork is only required for fresh air.
4. The initial cost is low.
5. This system is well-suited to spaces that require many zones of individual temperature control.

**DISADVANTAGES**

1. The noise level of this system is generally high.
2. Maintenance costs are high.
3. Overall efficiencies of individual heat pumps are less than that of one large chiller.
4. The system needs electric resistance heating when the outside air temperature is below 35°F.
5. Humidity control can be problematic if there is no preconditioning unit and zonal heat pumps are oversized.
6. Wall penetration is required for refrigerant lines to and from the condenser/evaporator.
7. Equipment life may be relatively short (typically 10 years).
8. The system has no humidification.

Jeff Haberl, Ph.D., P.E.; Texas A&M University; College Station, Texas

### TWO-PIPE WATER LOOP HEAT PUMP WITH PACKAGED SPLIT SYSTEM

In this system, zonal heat pumps provide heating and cooling for individual zones. Each heat pump unit has a blower, filter, and heating/cooling coil. A fixed amount of fresh air to the units is pretempered to 55°F in a preconditioning heat pump unit. The system has a heat rejection loop, and each heat pump is connected to it with a heat exchanger. The heat rejection loop is maintained within a preset temperature range (e.g., 40–100°F) using a central boiler in the winter and one or more heat rejecting cooling towers in the summer. Usually, this type of system does not need emergency electric resistance heating for severe conditions. The

heat rejection loop must operate when one or more heat pumps are running. In some cases, a variable speed loop can be used, although care must be taken to provide adequate flow to keep the heat pump heat exchangers from freezing up and/or to avoid heat transfer problems in the boiler caused by low flow.

The zonal heat pumps cycle on and off when the zone thermostat calls for heating or cooling. Air flow to the zones also cycles on and off according to zone demand. In general, to provide an adequate source of preconditioned fresh air, the outside air preconditioning heat pump must run continuously. An air-cooled condenser can be provided for the preconditioning units to allow for the main loop to be shut down.

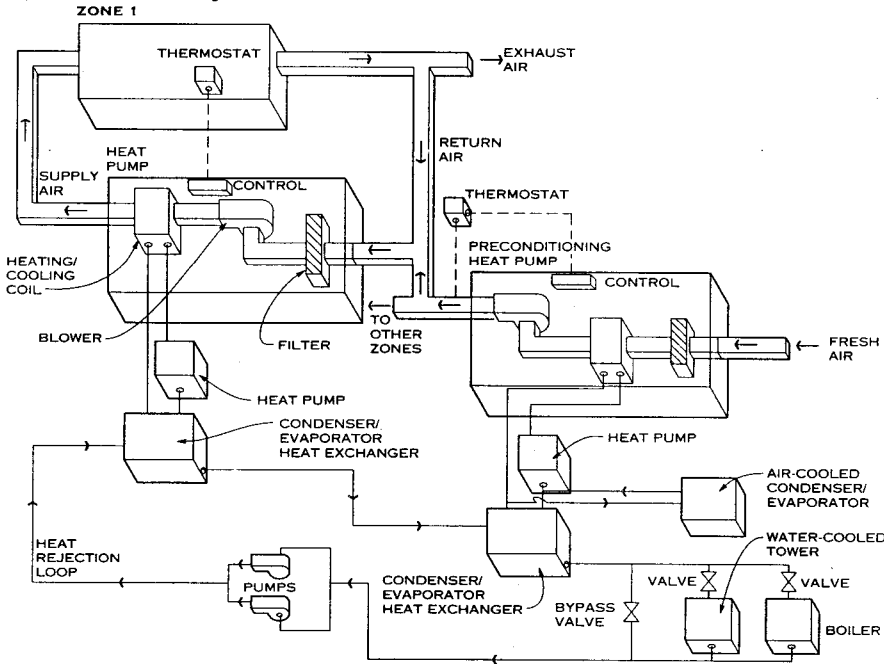

### TWO-PIPE WATER LOOP HEAT PUMP WITH PACKAGED SPLIT SYSTEM

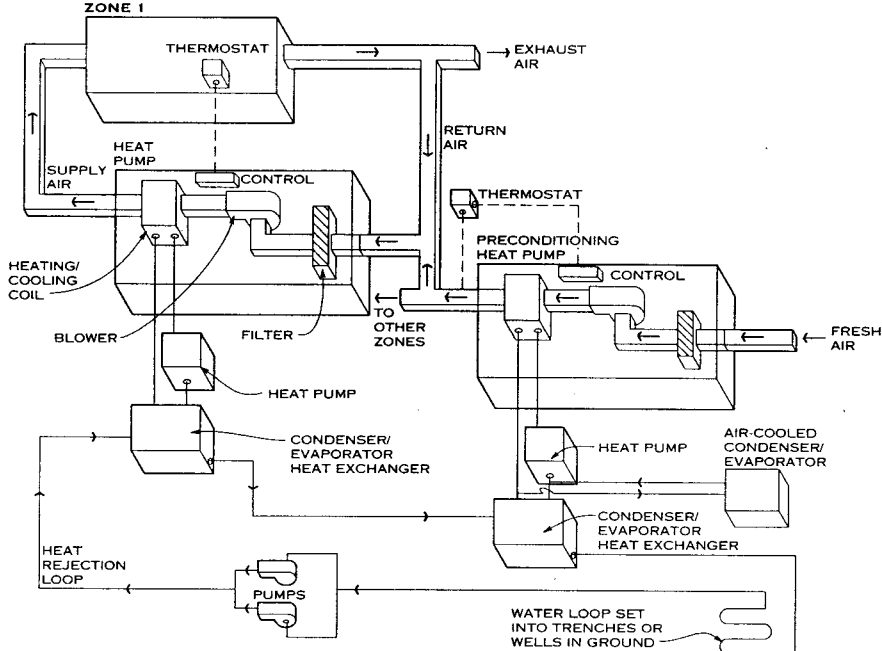

### TWO-PIPE, GROUND-COUPLED WATER LOOP HEAT PUMP WITH PACKAGED SPLIT SYSTEM

Jeff Habert, Ph.D., P.E.; Texas A&M University; College Station, Texas

### TWO-PIPE, GROUND-COUPLED WATER LOOP HEAT PUMP WITH PACKAGED SPLIT SYSTEM

This system has zonal air-handling units (AHUs) that provide heating and cooling for individual zones. Each zonal heat pump contains a blower, filter, and heating/cooling coil. A fixed amount of fresh air to the units is pretempered to 55°F in a preconditioning heat pump unit. Each heat pump is connected to the system heat rejection loop with a heat exchanger. However, in contrast to the water loop system that has an auxiliary boiler and heat rejection tower, this water loop rejects heat in a series of wells or trenches that put it in direct contact with the earth. This heat rejection loop is also maintained within a preset temperature range (e.g., 40–100°F) using the thermal mass of the earth it contacts. This type of system does not need emergency electric resistance heating for severe conditions. The ground-coupled heat rejection loop must operate when one or more heat pumps are running. A variable speed heat rejection loop can be used, although care must be taken to provide adequate flow to avoid freeze-up of the heat pump heat exchangers.

Zonal heat pumps cycle on and off whenever the zone thermostat calls for heating or cooling. Airflow to the zones also cycles on and off according to zone demand. In most cases, the outside air preconditioning heat pump runs continuously to provide an adequate source of preconditioned fresh air.

### EVALUATION OF SYSTEM FEATURES

The following advantages/disadvantages apply to both systems described on this page, unless otherwise noted.

#### ADVANTAGES

1. The systems conserve energy by recovering heat from interior zones and/or waste heat.
2. The systems do not require wall penetrations to provide for the rejection of heat from air-cooled condensers.
3. Air-cooled preconditioning allows fresh air to be supplied without running the main loop.
4. The noise level can be lower than that of air-cooled equipment because individual condenser fans are eliminated and the compression ratio is lower.
5. The systems can be maintained locally, as no special chiller repairmen are required for the heat pumps (a special repairman is needed for the boiler in the system without ground coupling).
6. Units have a longer service life than air-cooled heat pumps.
7. The entire system does not shut down when a zonal unit fails.
8. Ground-coupled systems normally do not need a boiler and cooling tower. The mechanical room to house the loop pumps can be minimized.
9. The life-cycle cost of the two-pipe water loop heat pump with packaged split system (without ground coupling) compares favorably with that of central systems when installation costs, operating costs, and system life are considered.

#### DISADVANTAGES

1. The initial cost for these systems may be higher than for systems that use multiple unitary HVAC equipment.
2. Cleanliness of the piping loop must be maintained.
3. The water-cooled tower needs frequent service and water quality checks (this does not usually apply to the ground-coupled system).
4. If air-cooled preconditioning is not used, the loop must run 24 hr/day when any zone needs cooling or heating.
5. The entire system shuts down when the loop fails.
6. More maintenance will be required than for some other systems since the heat-pump equipment and air-handling units are decentralized.
7. These systems have no humidification.
8. In the ground-coupled system, soil type, moisture content, composition, density, and uniformity affect the success of this method of heat exchange.
9. In the ground-coupled system, the pipe material and the corrosiveness of the local soil and groundwater may affect heat transfer and service life.
10. In the ground-coupled system, a large area is needed in which to drill wells.

**FOUR-PIPE MULTIZONE SYSTEM WITH COLD DECK BYPASS**

Multizone air-handling units (AHUs) provide heating and cooling for several zones (typically 4 to 10). Each multizone unit contains a blower, filter, heating coils, cooling coils, and bypass dampers. Chilled water and hot water are simultaneously provided to the zonal units to carry loads on the cooling and heating coils respectively. Chilled water is provided by a chiller located in a central mechanical room (which contains a heat-rejecting condensing unit) and hot water is provided by a boiler, often located in the same mechanical room. The multizone units run continuously. The chiller or boiler must operate when any multizone unit or pre-conditioning unit requires heating or cooling. Newer units may contain a variable volume fan that regulates the airflow according to the zone loads.

Each zone is controlled by a zone thermostat that changes the temperature of the supply air to meet heating or cooling loads. The supply air is conditioned by an arrangement of dampers that allows the correct portion of air either to flow across or to bypass the cold deck. A reheat coil can be provided for locations with extremely humid conditions. A pre-heat coil can be provided for extreme winter conditions. The temperature of the chilled water and hot water supplied to the units may be controlled with an outside reset thermostat.

**ADVANTAGES**

1. The system supplies several zones from centrally located AHUs.
2. No pipes are required that could leak in occupied areas.

3. The system can provide heating and cooling as needed.
4. The boiler and the chiller are centrally located.
5. Chiller efficiency is often higher than that of individual heat pumps.
6. The system offers good dehumidification.

**DISADVANTAGES**

1. The hot water and chiller water loop must run when only one zone needs heating or cooling.
2. The chiller and boiler require service by specially trained repairmen.
3. A water-cooled condenser tower needs frequent service and water quality checks.
4. Additional space is required for distribution ductwork.
5. The air-cooled condenser temperature is higher than that of a water-cooled condenser, making the chiller less efficient.
6. The central system may use more energy because the loop has to run more often.
7. The system has no humidification.

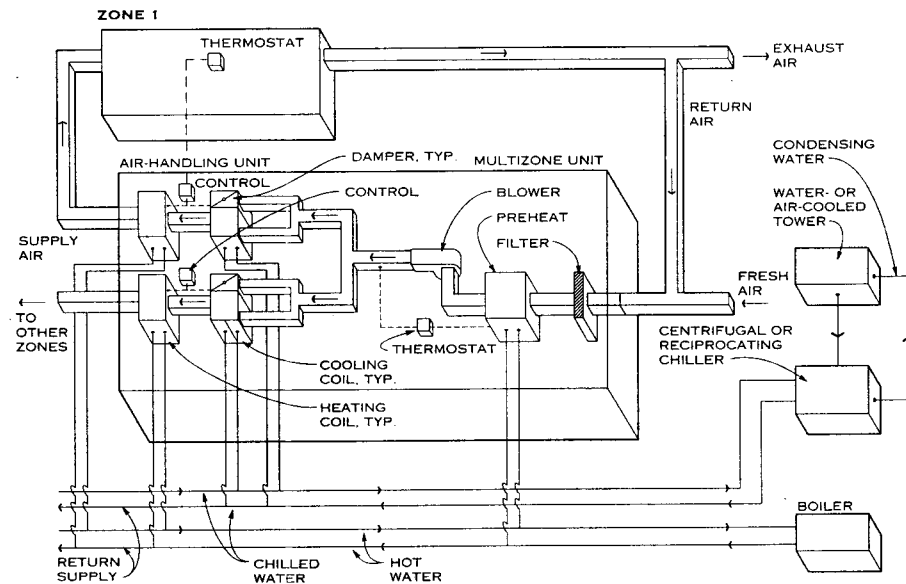

**FOUR-PIPE MULTIZONE SYSTEM WITH COLD DECK BYPASS**

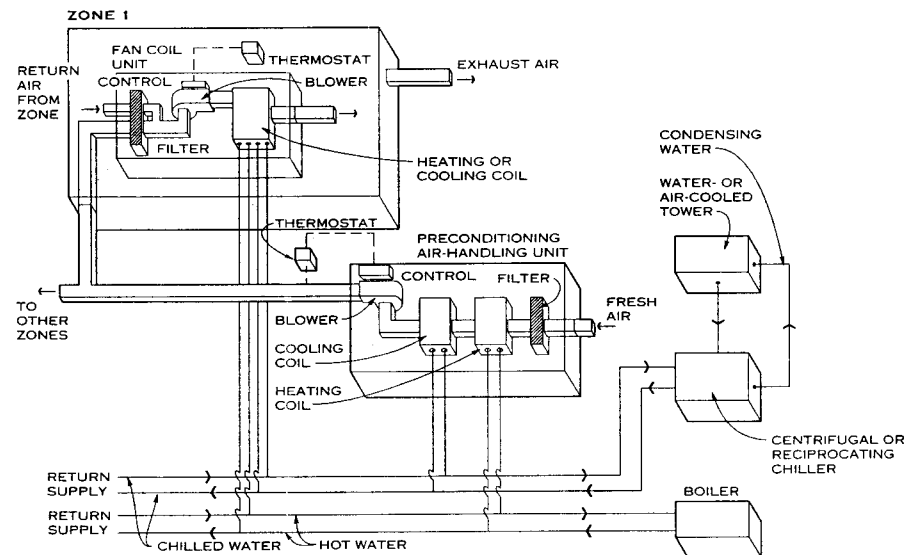

**FOUR-PIPE FAN COIL UNITS**

In this system, fan coil units in each zone provide heating or cooling for that zone. Each fan coil unit contains a blower, filter, and heating-cooling coil. A fixed amount of fresh air to the units is pretempered to 55°F in a preconditioning unit that serves a number of zones. Chilled water and hot water are simultaneously provided to the zonal units and the preconditioning units to carry loads on the cooling and heating coils respectively. Chilled water is provided by a chiller located in a central mechanical room (which contains a heat-rejecting condensing unit) and hot water is provided by a boiler, which is often located in the same mechanical room. The zonal fans can either run continuously and modulate temperature or turn on and off as needed to satisfy the zone thermostat. Newer units may contain a variable volume fan that regulates the airflow depending upon zone loads.

Each zonal fan coil unit is controlled by a zone thermostat, which changes the temperature of the supply air to meet heating or cooling loads. The preconditioning maintains a temperature of 55°F by preheating the air in the winter and precooling it in the summer. The temperature of the chilled water and hot water supplied to the units may be controlled with an outside reset thermostat.

**ADVANTAGES**

1. The system provides all-season heating and cooling at each unit.
2. The boiler and chiller are installed at a central location.
3. The only ductwork needed is for preconditioned air (about 10-20% of fan coil air).
4. Chiller efficiency is higher than that of individual heat pumps.
5. The zonal fan coil unit can be shut down for maintenance without affecting adjacent areas.
6. No summer/winter changeover is required.
7. This system operates more simply than the others described in this AGS section on multiple interior zone HVAC systems.
8. Cooling of preconditioned air may not be required in northern climates with hot, dry summers.

**DISADVANTAGES**

1. Four-pipe systems are slightly more expensive to install than two-pipe systems.
2. The hot water and chilled water loop must run when only one zone needs heating or cooling.
3. The chiller and boiler need servicing by specially trained repairmen.
4. Noise from individual units may be a problem.
5. The water-cooled condenser tower needs frequent service and water quality checks.
6. The air-cooled condenser temperature is higher than that of a water-cooled condenser, making the chiller less efficient.
7. This central system may use more energy because of the frequent running of the loop.
8. Decentralized maintenance of zonal units can require additional maintenance time.
9. Zonal units need a sanitary sewer connection to drain condensate. These drains can be a maintenance concern.
10. The system has no humidification.

**FOUR-PIPE FAN COIL UNITS**

Jeff Haberl, Ph.D., P.E.; Texas A&M University; College Station, Texas

**DUCT CONSTRUCTION**

Ductwork must be permanent, rigid, nonbuckling, and nonrattling. Joints in ductwork should be airtight. Galvanized iron or aluminum sheets are usually used in the construction of ducts. The ducts may be either round or rectangular in cross section.

In general, supply ducts should be constructed entirely of noncombustible material. Supply ducts serving a single family dwelling need not meet this requirement, except for the first 3 ft from the unit, provided they are used in conjunction with listed heating units, are properly constructed from a base material of metal or mineral, and are properly applied. Warm air ducts passing through cold spaces or located in exposed walls should have 1 to 2 in. of insulation.

Supply ducts must be securely supported by metal hangers, straps, lugs, or brackets. No nails should be driven through duct walls, and no unnecessary holes should be cut in them.

Supply ducts should be equipped with an adjustable locking type damper for air volume control. The damper should be installed in the branch duct as far from the outlet as possible, where it is accessible.

Automatic smoke dampers are required wherever ductwork passes through a rated smoke barrier partition.

Return systems having more than one return intake may be equipped with balancing dampers.

Attention should be given to the elimination of noise. Metal ducts should be connected to the unit by strips of flexible fire resistant fabric. Electrical conduit and piping, if directly connected to the unit, may increase noise transmission. Return air intakes immediately adjacent to the unit may also increase noise transmission. Installation of a fan directly under a return air grille should be avoided.

**DUCT MATERIAL THICKNESS**

ROUND DUCT DIA. OR RECTANGULAR DUCT WIDTH (IN.)	GALVANIZED IRON U.S. GAUGE	ALUMINUM B & S GAUGE
	Ducts enclosed in partitions	
14 or less	30	24
Over 14	28	24
	Ducts not enclosed in partitions	
14 or less	28	24
Over 14	26	23

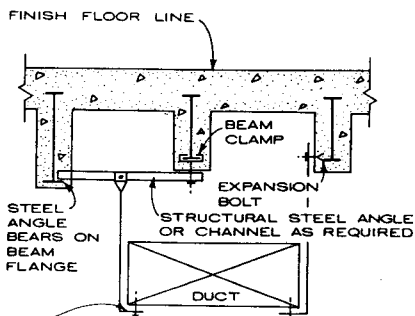

DUCT LESS THAN 60" WIDE USE 1/8" X 1" GALVANIZED IRON HANGER. DUCT OVER 60" WIDE USE 1/8" X 1 3/8" GALVANIZED IRON HANGER

**NOTE**

On ducts over 48 in. wide hangers shall turn under and fasten to bottom of duct. When cross-sectional area exceeds 8 sq ft duct will be braced by angles on all four sides.

**DUCT SUPPORT DETAIL**

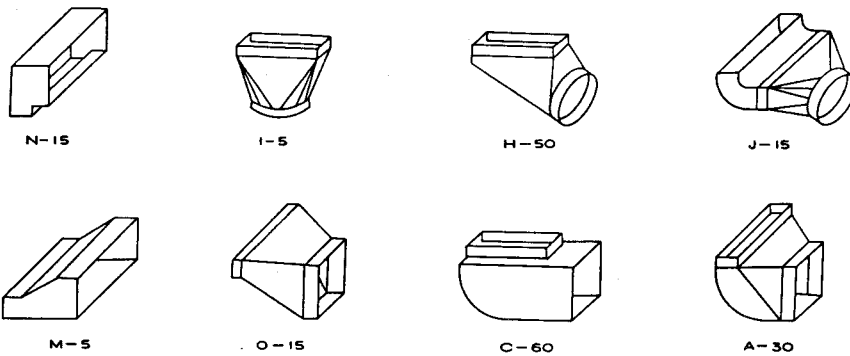

**AIR BOOT FITTINGS**

NOTE: N-15 ← NUMBER = EQUIVALENT LENGTH (FT)  
A ← LETTER = SHAPE DESIGNATION

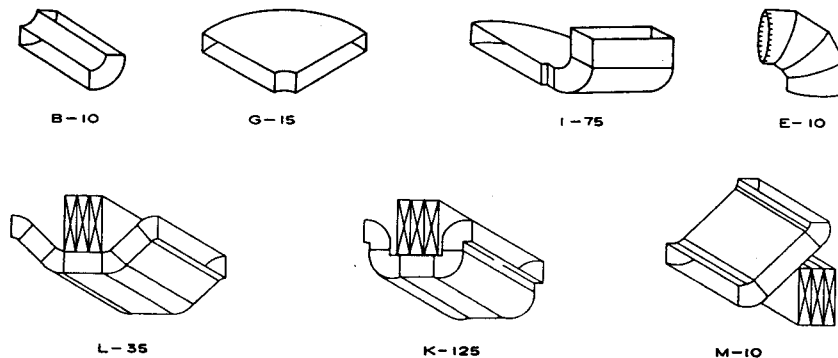

**ANGLES AND ELBOWS FOR BRANCH DUCTS**

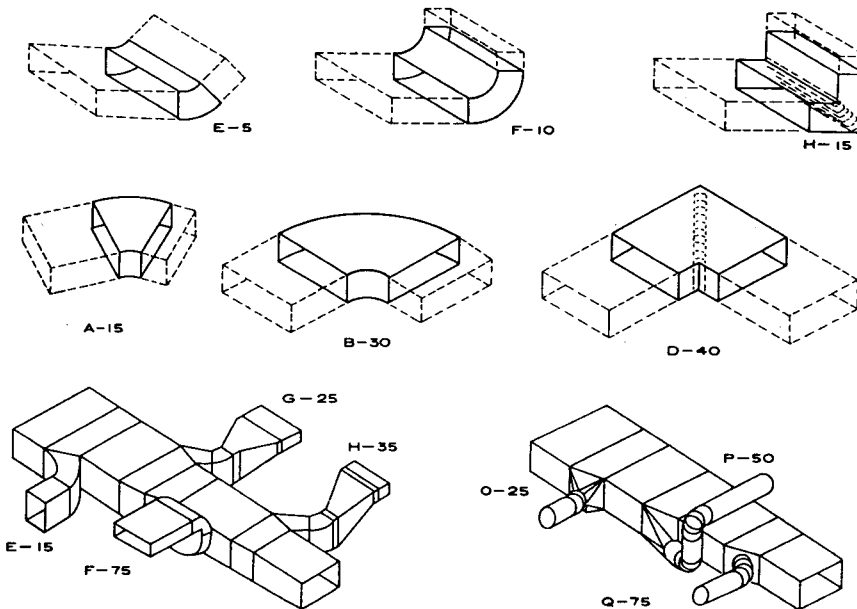

**TRUNK DUCTS AND FITTINGS**

William G. Miner, AIA, Architect, Washington, D.C.

RECOMMENDED AND MAXIMUM AIR VELOCITIES FOR DUCTS

Table with columns: DESIGNATION, RESIDENCES, SCHOOLS, THEATERS, PUBLIC BUILDINGS, INDUSTRIAL BUILDINGS. It contains two sections: RECOMMENDED VELOCITIES (FPM) and MAXIMUM VELOCITIES (FPM).

(a) These velocities are for total face area, not the net free area; other velocities in table are for net free area. (b) For low velocity systems only.

DUCT AREA PER SQUARE FOOT OF FLOOR AREA (IN SQ. IN.)

Table with columns: CUBIC FT PER HOUR/SQ FT, VELOCITY (FT PER MINUTE), NEARLY SQUARE DUCTS LESS THAN 1000 CFM, FRICTION ALLOWANCE = 1.10. It lists velocity values for various duct sizes (30 to 380).

DUCT AREA PER SQUARE FOOT OF FLOOR AREA (IN SQ. IN.)

Table with columns: CUBIC FT PER HOUR/SQ FT, VELOCITY (FT PER MINUTE), NEARLY SQUARE DUCTS MORE THAN 1000 CFM, FRICTION ALLOWANCE = 1.05. It lists velocity values for various duct sizes (150 to 400).

DUCT AREA PER SQUARE FOOT OF FLOOR AREA

Table with columns: CUBIC FT PER HOUR/SQ FT, VELOCITY (FT PER MINUTE), ROUND DUCTS, FRICTION ALLOWANCE = 1.00. It lists velocity values for various duct sizes (30 to 380).

DUCT AREA PER SQUARE FOOT OF FLOOR AREA (IN SQ. IN.)

Table with columns: CUBIC FT PER HOUR/SQ FT, VELOCITY (FT PER MINUTE), THIN RECTANGULAR DUCTS (W TO D 1:5), FRICTION ALLOWANCE = 1.25. It lists velocity values for various duct sizes (30 to 380).

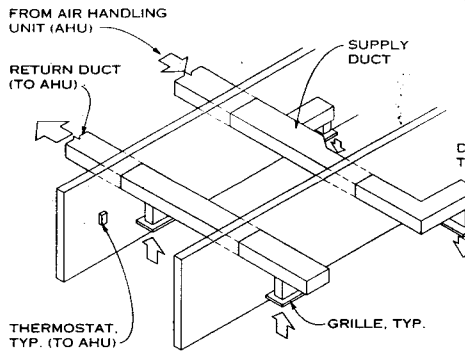

**ABBREVIATIONS**  
 AHU—air-handling unit; VAV—variable air volume

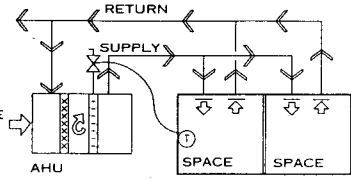

SYSTEM DIAGRAM

**NOTE**

This all-air central system has only one point of control (one thermostat = one zone). The system operates with a constant airflow from the air-handling unit and through the diffusers, with the thermostat controlling supply air temperature in response to load. Any number of diffusers may be provided to meet air distribution needs. Numerous air-handling unit configurations are available. This type of system may be found in residential, retail, and industrial buildings, and in interior (core) spaces of complex buildings. Multiple systems may be used to provide multiple zones.

**SINGLE-ZONE SYSTEM**

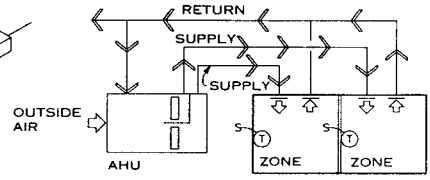
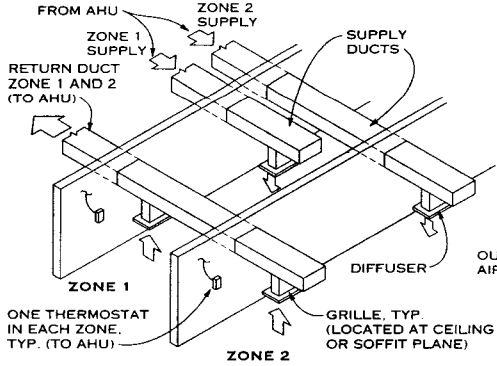

SYSTEM DIAGRAM

**NOTE**

This all-air central system can serve approximately ten zones per air-handling unit. The system operates with constant airflow from the air-handling unit and through the diffusers, with thermostats controlling the supply air temperature of individual zones in response to load. A dedicated supply duct serves each zone and can provide good control of space conditions at moderate energy cost. Because zone control occurs at the air-handling unit, this is not a flexible system. The numerous supply ducts make system layout and coordination critical. Multiple air-handling units may be used to provide additional zoning capability.

**MULTIZONE SYSTEM**

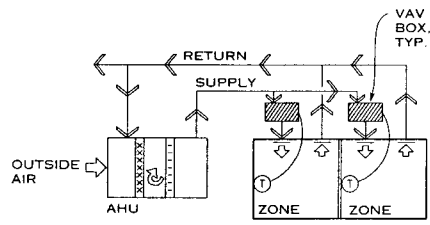
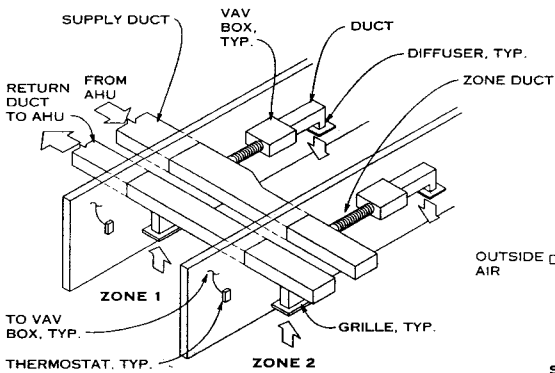

SYSTEM DIAGRAM

**NOTE**

This all-air central system can serve a virtually unlimited number of zones. The system meets loads by providing a varying airflow through the diffusers in each zone under the control of zone thermostats. VAV systems are very flexible because zone control occurs at VAV boxes located near the conditioned spaces. Since a VAV system is essentially a cooling-only system, some means of space heating must be provided (an independent heating system; fan-powered or induction terminals with electric or hot water heating). VAV systems can provide excellent comfort with good energy efficiency, but air-quality issues must be seriously examined during system design. Several fan/air supply control options are available to minimize system energy use at part loads.

**VARIABLE AIR VOLUME (VAV) SYSTEM**

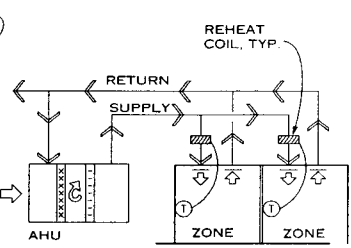
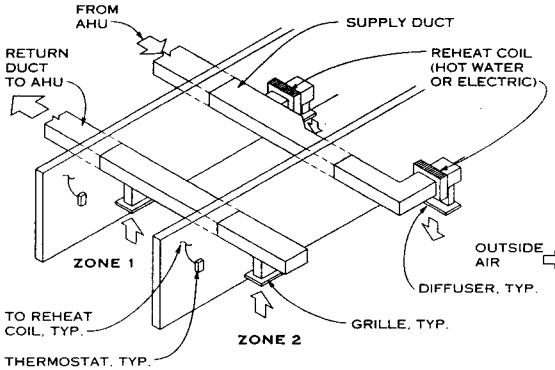

SYSTEM DIAGRAM

**NOTE**

This all-air central system can serve a virtually unlimited number of zones. The system meets loads by varying the supply air temperature through the diffusers in each zone under the control of zone thermostats. The system is very flexible because zone control occurs at coils (electric or hot water) located near the conditioned spaces. A terminal reheat system can provide excellent comfort conditions (by providing constant airflow and humidity control) and simultaneous heating and cooling; unfortunately, the reheat approach wastes substantial energy and is generally to be avoided unless the reheat comes from renewable energy sources (waste or reclaimed heat or solar energy). Terminal heating may be combined with variable volume air delivery.

**TERMINAL REHEAT SYSTEM**

Walter T. Grondzik, P.E.; Florida A&M University; Tallahassee, Florida

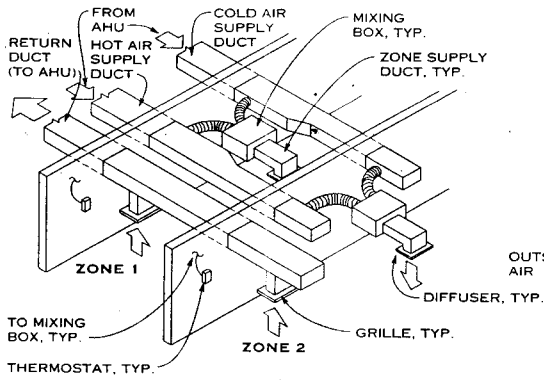

**ABBREVIATION**  
AHU—air-handling unit

**NOTE**

This all-air central system can serve a virtually unlimited number of zones. The system meets loads in the various zones by mixing hot and cold airstreams from the air-handling unit in response to zone thermostats. The system is very flexible because zone control occurs in mixing boxes located near the conditioned spaces. A dual-duct system provides good comfort and air-quality conditions at reasonable energy cost. The need for two separate supply air distribution ducts requires excellent coordination between air distribution and other services. Dual-duct systems may be designed with either constant or variable volume air supply.

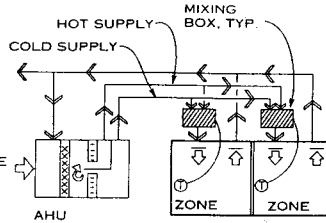

**SYSTEM DIAGRAM**

**DUAL-DUCT SYSTEM**

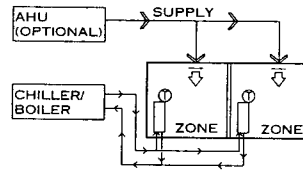
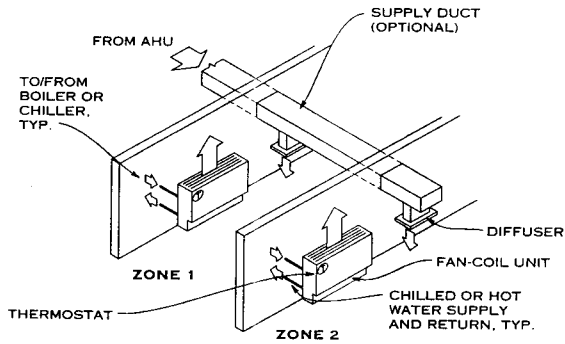

**SYSTEM DIAGRAM**

**FAN-COIL SYSTEM**

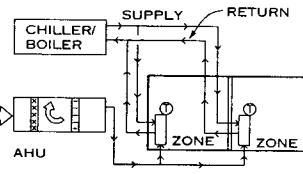
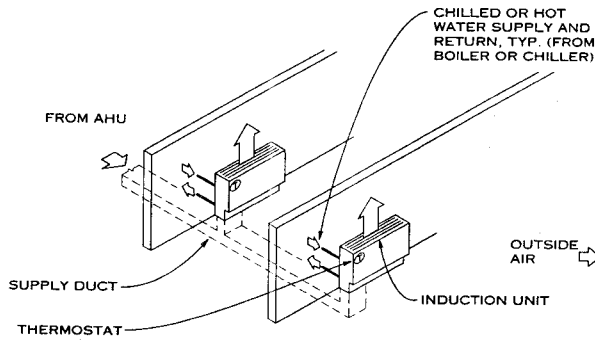

**SYSTEM DIAGRAM**

**INDUCTION SYSTEM**

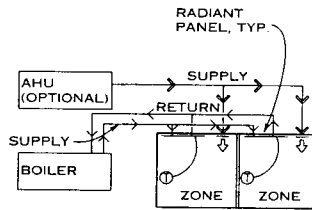
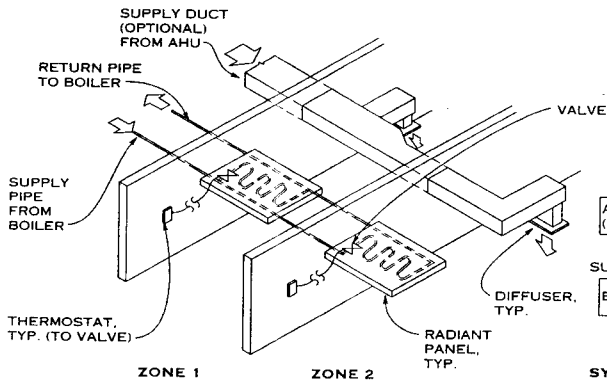

**SYSTEM DIAGRAM**

**RADIANT PANEL SYSTEM**

**NOTE**

This all-water or air-water central system can serve a virtually unlimited number of zones. The system meets loads in the various zones by controlling the flow of chilled or hot water to the radiant panel elements in response to zone thermostats. Design coordination must address the installation of the panel elements within the array of interior surfaces (ceiling, floor, and walls). All-water configurations are not true "air conditioning" systems; with a separate central air supply, the system can provide the control of conditions expected of an air conditioning system. Space cooling with radiant panels is problematic because of condensation from latent cooling loads.

Walter T. Grondzik, P.E.; Florida A&M University; Tallahassee, Florida

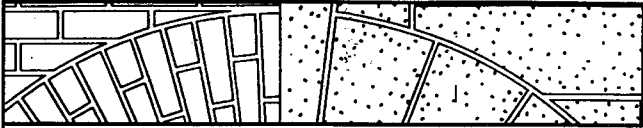

# ELECTRICAL

Basic Electrical Materials and  
Methods 738

Special Systems 745

Transmission and Distribution 748

Lighting 752

Communications 758



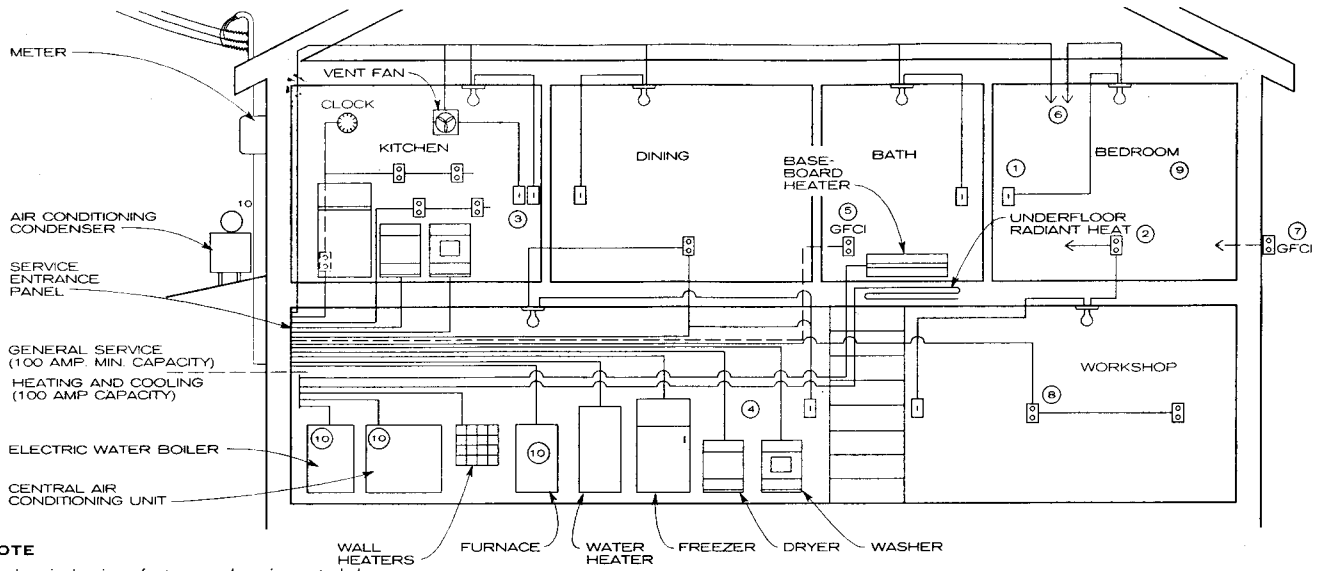

**NOTE**  
Numbers in drawing refer to general requirements, below.

**SCHEMATIC DIAGRAM OF TYPICAL RESIDENTIAL ELECTRICAL LAYOUT**

**GENERAL REQUIREMENTS**

1. A minimum of one wall-switch-controlled lighting outlet is required in every habitable room, hallway, stairway, attached garage, and outdoor entrance. Exception: In habitable rooms other than kitchens and bathrooms one or more receptacles controlled by a wall switch are permitted in lieu of lighting outlets.
2. In every kitchen, family room, dining room, den, breakfast room, living room, parlor, sunroom, bedroom, recreation room, and similar rooms, receptacle outlets must be installed so that no point along the floor line is farther than 12 ft, measured horizontally, from an outlet, including any wall space 2 ft or more wide and the wall space occupied by sliding panels in exterior walls.
3. A minimum of two #12 wire 20-A small appliance circuits are required to serve only small appliance outlets, including refrigeration equipment, in the kitchen, pantry, dining room, breakfast room, and family room. Both circuits must extend to the kitchen; the other rooms may be served by one or both of them. No other outlets may be connected to these circuits, except a receptacle installed solely for an electric clock. In kitchen and dining areas, receptacle outlets must be installed at each and every counter space wider than 12 in.
4. A minimum of one #12 wire 20-A circuit must be provided to supply the laundry receptacle(s), and it may have no other outlets.
5. At least one receptacle outlet must be installed in the bathroom near the basin and must be provided with ground fault circuit interrupter protection.
6. Code requires sufficient 15- and 20-A circuits to supply three watts of power for every square foot of floor space, not including garage and open porch areas. Minimum code suggestion is one circuit per 600 sq ft, one circuit per 500 sq ft is desirable.

7. A minimum of one exterior receptacle outlet is required (two are desirable) and must be provided with ground fault circuit interrupter protection.
8. A minimum of one receptacle outlet is required in basement and garage, in addition to the one in the laundry. In attached garages it must be provided with ground fault circuit interrupter protection.
9. Many building codes require a smoke detector in the hallway outside bedrooms or above the stairway leading to upper floor bedrooms.
10. Disconnect switches are required.

**NOTE**  
Refer to the National Electrical Code (NEC) for further information on residential requirements.

**LEGEND FOR FIRST FLOOR AND BASEMENT PLANS**

- A = Mount receptacles at countertop locations 2 in. above backsplash.
- B = Mount receptacle 48 in. above finish floor (AFF).
- C = Range and oven outlet boxes should be wall mounted, 36 in. AFF. Use flexible connections to units.
- D = Switch and outlet for exhaust fan. The switch should be wall mounted above the sink backsplash and the outlet blank cover mounted adjacent to the fan wall opening. A separate switch may be omitted if the fan is supplied with an integral switch.
- E = Dishwasher receptacle is wall mounted behind unit, 6 in. AFF.
- F = Equipped with self-closing gasketed waterproof cover.
- G = Mount 42 in. AFF.

- NOTES**
1. Wiring shown as exposed indicates absence of finished ceiling in basement level. All BX cable run through framing members. Attachment below ceiling joists is not permitted.
  2. Connect to two incandescent porcelain lamp holders with pull chain. Mount two evenly spaced ceiling fixtures in crawl space.
  3. Connect to shutdown switch at top of stairs.
  4. Boiler wiring safety disconnect switch should have red wall plate, clearly marked "BOILER ON-OFF."

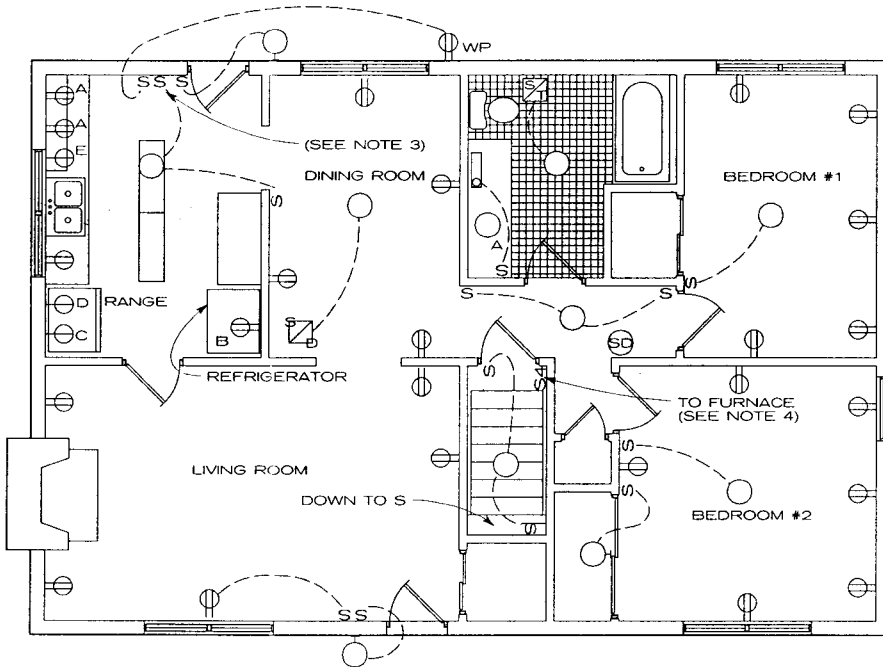

**FIRST FLOOR PLAN OF ELECTRICAL EQUIPMENT AND DEVICES**

Charles B. Towles, P.E.; TEI Consulting Engineers; Washington, D.C.

**AVERAGE WATTAGES OF COMMON ELECTRICAL DEVICES**

TYPE	WATTS
Air conditioner, central	2500-6000
Air conditioner, room type	800-2500
Blanket, electric	150-200
Clock	2-3
Clothes dryer	4000-6000
Dishwasher	1000-1500
Fan, portable	50-200
Food blender	500-1000
Freezer	300-500
Frying pan, electric	1000-1200
Furnace blower	380-670
Garbage disposal	500-900
Hair dryer	350-1200
Heater, portable	1000-1500
Heating pad	50-75
Heat lamp (infrared)	250
Iron, hand	600-1200
Lamp, incandescent	10 upward
Lamp, fluorescent	15-16
Lights, Christmas tree	30-150
Microwave oven	1000-1500
Mixer	120-250
Power tools	up to 1000
Projector, slide or movie	300-500
Radio	40-150
Range (all burners and oven)	8000-14000
Range top (separate)	4000-8000
Range oven (separate)	4000-5000
Refrigerator	150-300
Refrigerator, frostless	400-600
Sewing machine	60-90
Stereo (solid-state)	30-100
Television	50-450
Vacuum cleaner	250-1200
Washer, automatic	500-800
Water heater	2000-5000

**BRANCH CIRCUIT PROTECTION**

Lighting (general purpose)	#14 wires	15 A
Small appliances	#12 wires	20 A
Individual appliances	#12 wires	20 A
	#10 wires	30 A
	#8 wires	40 A
	#6 wires	50 A

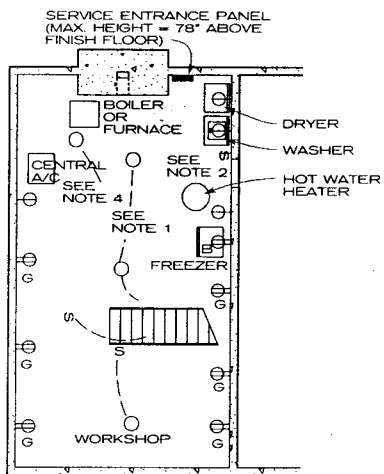

**NOTE**  
See legend on previous page.

**BASEMENT PLAN OF ELECTRICAL EQUIPMENT**

Charles B. Towles, P.E.; TEI Consulting Engineers; Washington, D.C.

**LOADS, CIRCUITS AND RECEPTACLES FOR RESIDENTIAL ELECTRICAL EQUIPMENT**

APPLIANCE	TYPICAL CONNECTED VOLT-AMPERES <sup>1</sup>	VOLTS	WIRES <sup>2</sup>	CIRCUIT BREAKER OR FUSE <sup>3</sup>	OUTLETS ON CIRCUIT	NEMA <sup>11</sup> DEVICE <sup>4</sup> AND CONFIGURATION
<b>KITCHEN</b>						
Range <sup>5</sup>	12000	115/230	3 # 6	60 A	1	14-60R
Oven (built-in) <sup>3</sup>	4500	115/230	3 # 10	30 A	1	14-30R
Range top <sup>3</sup>	6000	115/230	3 # 10	30 A	1	14-30R
Dishwasher <sup>3</sup>	1200	115	2 # 12	20 A	1	5-20R
Waste disposer <sup>3</sup>	300	115	2 # 12	20 A	1	5-20R
Boiler <sup>5</sup>	1500	115	2 # 12	20 A	1 or more	5-20R
Refrigerator <sup>6</sup>	300	115	2 # 12	20 A	1 or more	5-20R
Freezer <sup>6</sup>	350	115	2 # 12	20 A	1 or more	5-20R
<b>LAUNDRY</b>						
Washing machine	1200	115	2 # 12	20 A	1 or more	5-20R
Dryer <sup>3</sup>	5000	115/230	3 # 10	30 A	1	14-30R
Hand iron; ironer	1650	115	2 # 12	20 A	1 or more	5-20R
<b>LIVING AREAS</b>						
Workshop	1500	115	2 # 12	20 A	1 or more	5-20R
Portable heater <sup>7</sup>	1300	115	2 # 12	20 A	1	5-20R
Television <sup>7</sup>	300	115	2 # 12	20 A	1 or more	5-20R
<b>FIXED UTILITIES</b>						
Fixed lighting	1200	115	2 # 12	20 A	1 or more	5-20R
Air conditioner	1200	115	2 # 12	20 A or 30 A	1	5-20R
3/4 hp <sup>8</sup>						
Central air conditioner <sup>9</sup>	5000	115/230	3 # 10	40 A	1	
Sump pump <sup>9</sup>	300	115	2 # 12	20 A	1 or more	5-20 R
Heating plant, i.e., forced-air furnace <sup>9,10</sup>	600	115	2 # 12	20 A	1	
Attic fan <sup>9</sup>	300	115	2 # 12	20 A	1 or more	5-20R

- <sup>1</sup> Wherever possible, use actual equipment rating.
- <sup>2</sup> Number of wires does not include equipment grounding wires. Ground wire is No. 12 AWG for 20-A circuit and No. 10 AWG for 30-A and 50-A circuits.
- <sup>3</sup> May be direct connected. For a discussion of disconnect requirements, see NEC Article 422.
- <sup>4</sup> Equipment ground is provided in each receptacle.
- <sup>5</sup> Heavy-duty appliances regularly used at one location should have separate circuits. Only one such unit should be attached to a single circuit.
- <sup>6</sup> Separate circuit serving only one other outlet is recommended.
- <sup>7</sup> Should not be connected to a circuit with appliances or other heavy loads.
- <sup>8</sup> Separate circuit recommended.
- <sup>9</sup> Recommended that all motor-driven devices be protected by a local motor-protection element unless motor protection is built into the device.
- <sup>10</sup> Connect through disconnect switch equipped with motor-protection element.
- <sup>11</sup> National Electrical Manufacturers Association (NEMA).

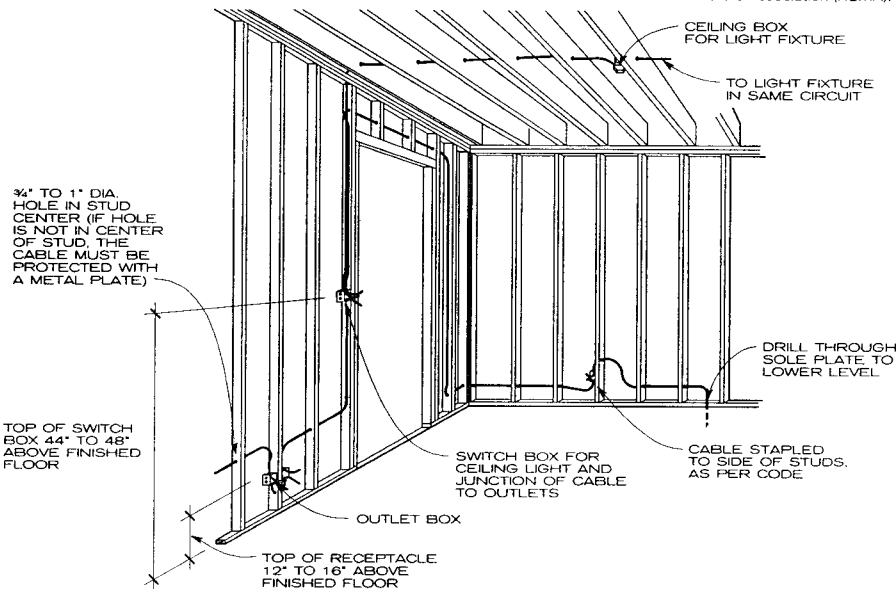

**NOTE**  
In metal stud construction, cables are passed through pre-cut openings in place of field-drilled holes.

**TYPICAL WIRING IN WOOD CONSTRUCTION**

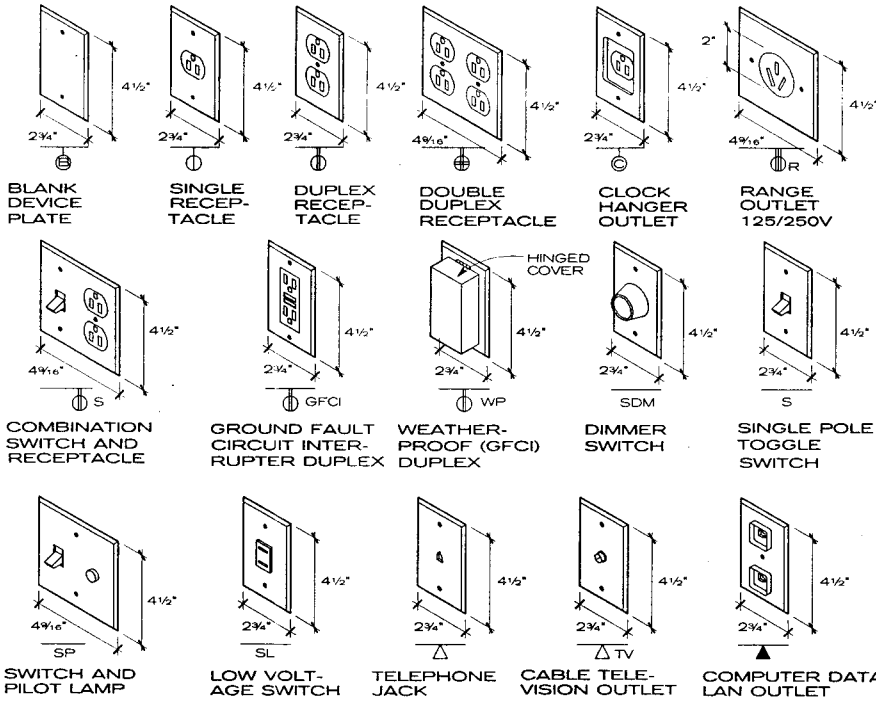

**GANG SIZE**

GANG	HORIZONTAL (IN.)	
	HEIGHT	WIDTH
2	4 1/2	4 7/16
3	4 1/2	6 3/8
4	4 1/2	8 7/16
5	4 1/2	10
6	4 1/2	11 13/16

**NOTES**

1. Add 1 13/16 in. for each added gang. Screws are 1 13/16 in. o.c.
2. Plates are made in plastic, brass (.04 to .06 in. thick), stainless steel, and aluminum.
3. All devices to be approved by Underwriters Laboratories and to comply with the National Electrical Code.
4. All devices to be of NEMA configuration.
5. Ground fault circuit interrupter or circuits are required in baths, garages, unfinished basements, outdoors at grade level, and within 6 ft of kitchen sinks.

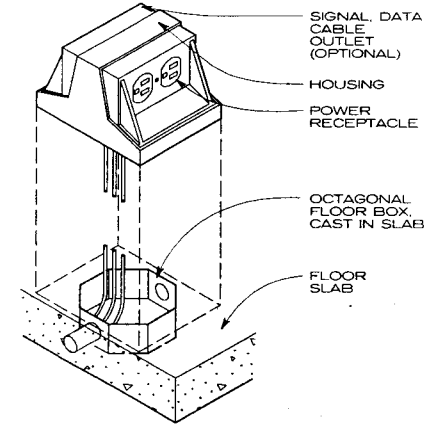

**NOTE**

Outlets and switches shown are those most generally used. The number of gangs behind one wall plate depends on the type of devices used.

**MONUMENT FLOOR OUTLET**

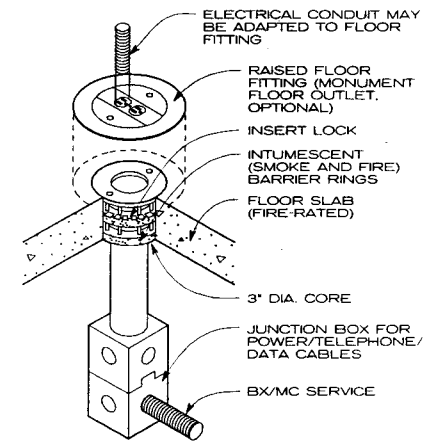

**NOTE.**

Unit is adjustable to accommodate varying floor thicknesses. When abandoned, the floor fitting is replaced with a flat plate.

**POKE-THROUGH ELECTRICAL BOX**

**RECEPTACLES AND SWITCHES**

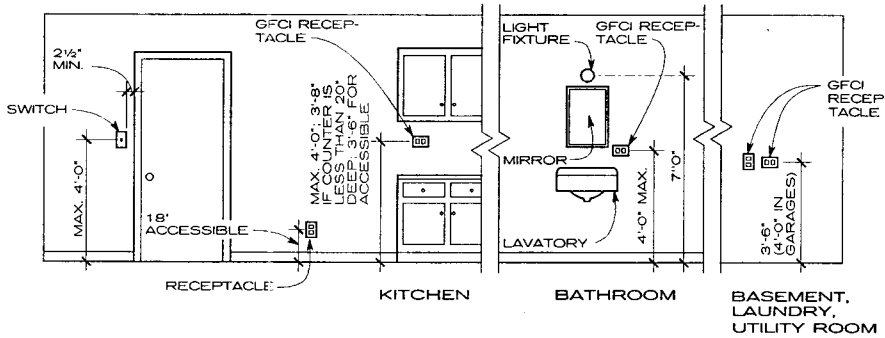

**NOTES**

1. Outlets and switches shown are those most generally used. Number of gangs behind one wall plate depends on the type of devices used.
2. Symbols used are ASA standard.
3. Interchangeable devices (miniature devices) available in various combinations using any of the following—switch, convenience outlet, radio outlet, pilot light, bell button—in one gang. Combined gangs are available.

**SWITCH AND OUTLET LOCATIONS**

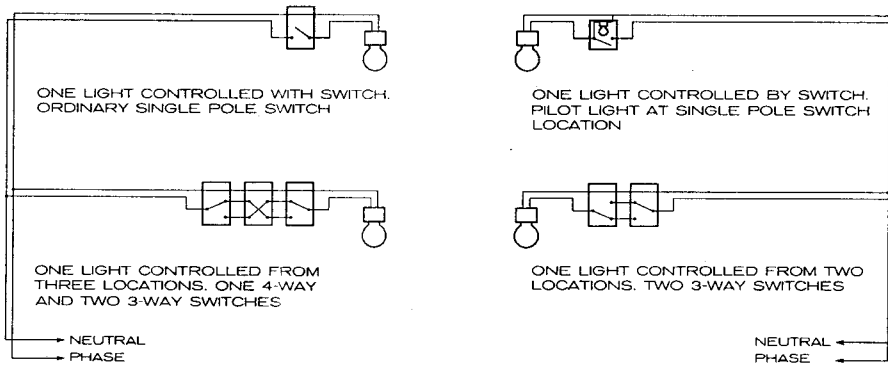

**SWITCH WIRING DIAGRAMS**

Charles B. Towles, P.E.; TEI Consulting Engineers; Washington, D.C.

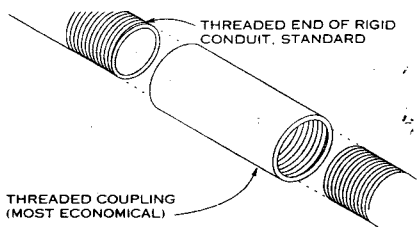

**THREADED COUPLING**

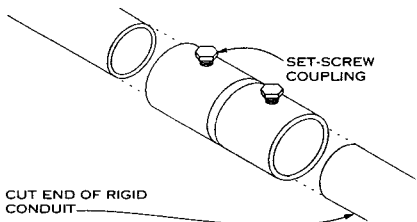

**THREADLESS SET-SCREW COUPLING**

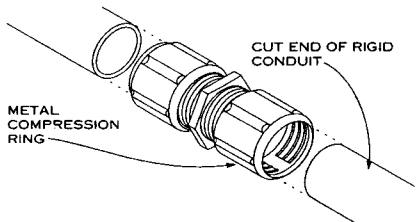

**THREADLESS COMPRESSION COUPLING**

- NOTES**
1. Manufactured in 10 ft lengths in diameters from 1/2 to 6 in. Consult manufacturers.
  2. Rigid steel conduit provides heavy-duty protection of wiring from mechanical injury and corrosion and protects surroundings against fire hazard from overheating or arcing of enclosed conductors.

**RIGID STEEL CONDUIT**

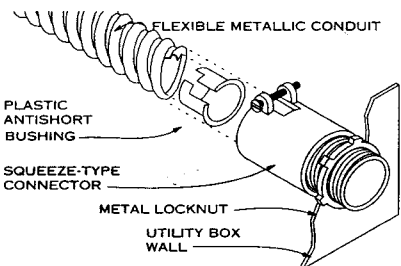

**SQUEEZE-TYPE CONNECTOR**

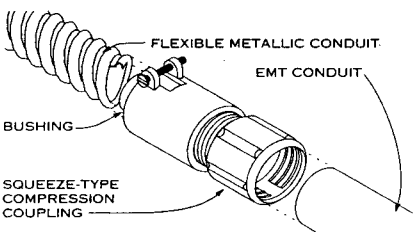

**FLEXIBLE TO EMT COUPLING**

**NOTE**  
Manufactured in diameters from 5/16 to 4 in.

**FLEXIBLE METALLIC CONDUIT**

Robert T. Faass, Consulting Engineer; Seabrook, Maryland  
Richard J. Vitullo, AIA; Oak Leaf Studio; Crownsville, Maryland

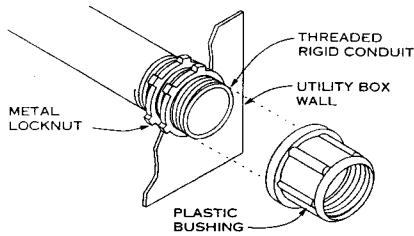

**LOCKNUT BUSHING CONNECTION**

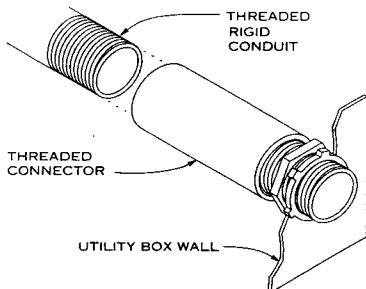

**THREADED CONNECTOR**

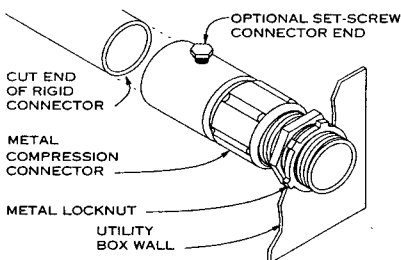

**THREADLESS CONNECTORS**

ing from mechanical injury and corrosion and protects surroundings against fire hazard from overheating or arcing of enclosed conductors.

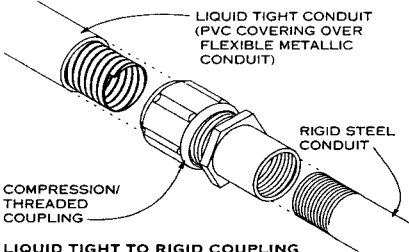

**LIQUID TIGHT TO RIGID COUPLING**

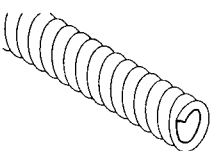

**NONMETALLIC LIQUID TIGHT CONDUIT**

- NOTES**
1. Manufactured in various grades according to temperature, range, and resistance factors (moisture, corrosion, and chemicals) in 1/4 to 6 in. diameters.
  2. Frequently used for equipment connections in damp or wet locations and outdoors. Consult electrical engineer.

**FLEXIBLE LIQUID TIGHT CONDUIT**

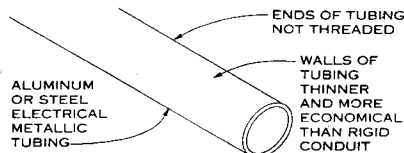

**NOTES**

1. Manufactured in 10 ft lengths and 1/2 to 4 in. diameters. Consult manufacturers.
2. Uses similar types of threadless couplings and connections as rigid steel conduit.

**ELECTRICAL METALLIC TUBING (EMT)**

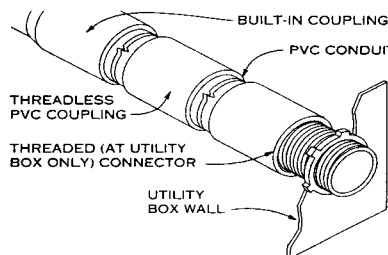

**NOTES**

1. All threadless connections are joined by means of solvent cement.
2. Commonly used for underground installation or cast into concrete.
3. Manufactured in heavy wall and light wall construction, in 10 ft lengths and 1/2 to 6 in. diameters.
4. Ground wire required for power cables.

**RIGID NONMETALLIC CONDUIT**

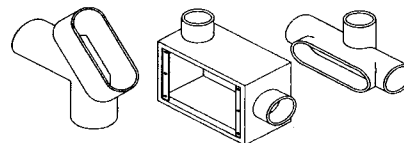

**NOTES**

1. Conduit outlet bodies are installed as pull outlets for conductors.
2. Fittings are manufactured for rigid steel, EMT, and non-metallic conduit. Many shapes are available. Consult manufacturers.

**CONDUIT OUTLET BODIES**

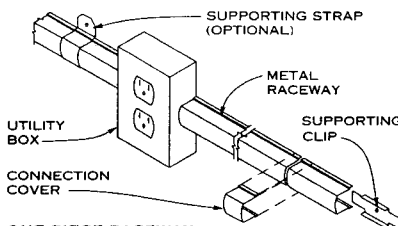

**ONE-PIECE RACEWAY**

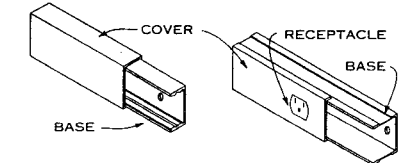

**NONMETALLIC**

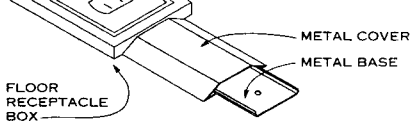

**METAL FLOOR RACEWAY**

**SURFACE RACEWAY SYSTEMS**

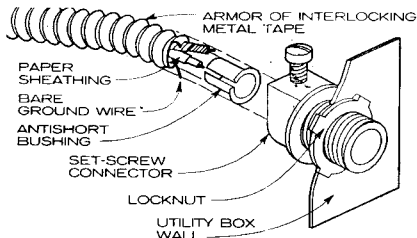

**ARMORED (BX)**  
**NOTE**

Armored cable is manufactured with 2-, 3-, and 4-conductor insulated wire in sizes 14, 12, 10, 8, 6, 4, 2; its internal bonds help the armor itself serve as a bonding conductor.

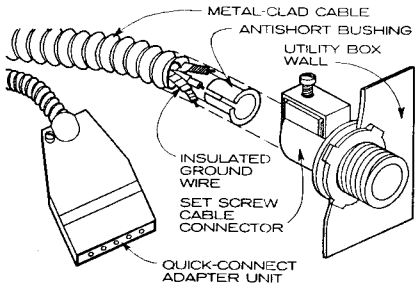

**METAL-CLAD (MC)**  
**NOTE**

Manufactured in sizes and specs similar to armored cable, metal-clad cable is available with a separate insulated ground conductor and in larger sizes. It may be clad in aluminum or steel, corrugated, smooth, or with metal interlocking tape and may be factory assembled with quick connect adapter units for access floor or ceiling wiring systems. Consult an electrical engineer before installation.

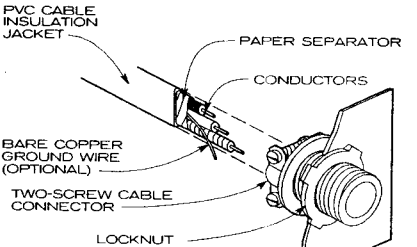

**NONMETALLIC SHEATHED (NM, ROMEX)**  
**NOTE**

Manufactured in 2- and 3-conductor PVC insulated wire in sizes 14, 12, 10, 8, 6, and 4 with or without ground wire, nonmetallic sheathed cable is permitted in residential and many other building types up to three stories.

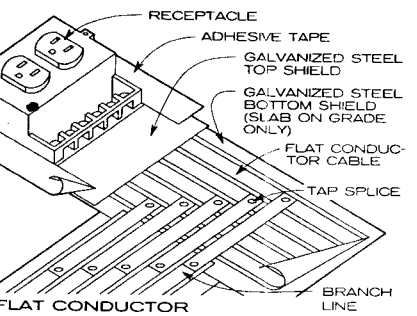

**NOTE**  
Flat conductor cable has combinations of 3, 4, and 5 conductors for easy access under carpet squares; data, communications, and TV flat cable are available. Consult manufacturers before installation.

**CABLES**

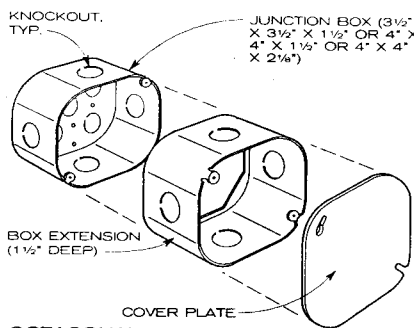

**OCTAGONAL**  
**NOTE**  
Commonly used for flush ceiling outlets, octagonal boxes may also be used as a floor box for monument receptacles.

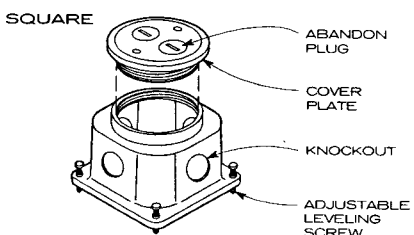
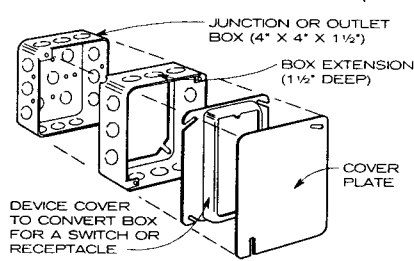

**FLUSH FLOOR**  
**NOTE**  
Boxes are mounted to wood floor structure (nonadjustable) or cast-in-place concrete with leveling screws. Concrete boxes include cast-iron, stamped steel, or nonmetallic materials. This is a heavy-duty box, in comparison to a standard octagonal floor box for monument receptacle.

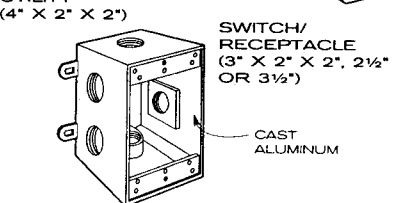
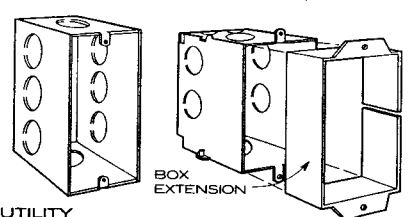

**WEATHERPROOF (4 1/2\"/>
**NOTE**  
Metallic and nonmetallic versions; knockout locations vary. Utility and exterior boxes not gangable; switch and masonry boxes may be. Flush mounting in concrete requires a concrete tight box and rigid conduit and tubing; in CMU construction, a raceway or tubing is threaded through the cavities.**

**ELECTRICAL BOXES**

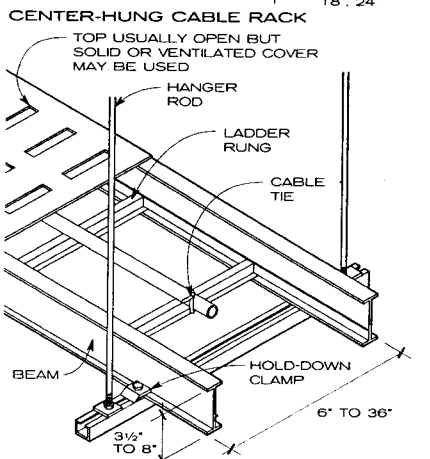
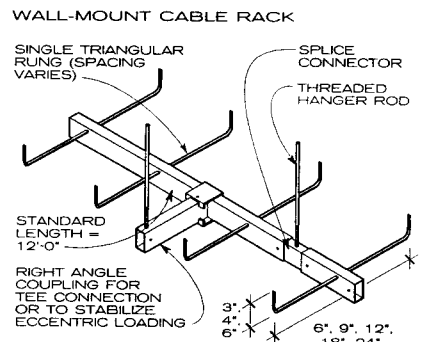
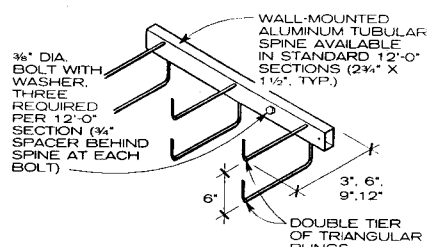

**CABLE TRAY SYSTEM**  
**NOTE**  
Cable trays protect and carry a large number of insulated cables in a limited space. For more protection or where heat buildup is not a problem, perforated or solid bottoms and top covers are available. Many fittings, bends, and tees (horizontal and vertical) are available. Consult manufacturers for materials other than aluminum or steel.

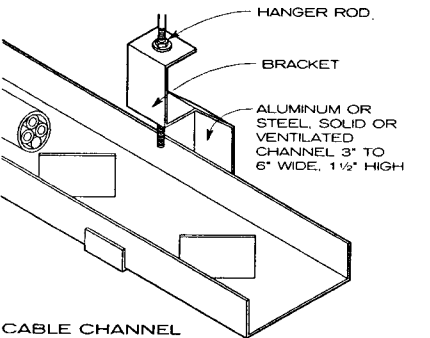

**CABLE CHANNEL**  
**NOTE**  
Cable channel can be used as a branch cable tray to carry a single large cable or conduit or several small ones.

**CONDUIT AND CABLE SUPPORTING DEVICES**

Charles B. Towles, P.E.; TEI Consulting Engineers; Washington, D.C.

**POKE THROUGH SYSTEMS**

Poke-through systems are used in conjunction with overhead branch distribution systems that run in accessible suspended ceiling cavities to outlets in full-height partitions. When services are required at floor locations without adjacent partitions or columns, as in open office planning, they must either be brought down from a wireway assembly (known as a power pole) or up through a floor penetration containing a fire-rated insert fitting and flush or above-floor outlet assembly. To install a poke-through assembly, the floor slab must either be core drilled or contain preset sleeves arranged in a modular grid. Poke-through assemblies are used in conjunction with cellular deck and under-floor duct systems when the service location required does not fall directly above its associated system raceway.

With one floor penetration, the single poke-through assembly can serve all the power, communications, and computer requirements of a work station. Distribution wiring in the ceiling cavity can be run in raceways. The more cost-effective method is to use armored cable (BX) for power and approved plenum-rated cable for communications and data when the ceiling cavity is used for return air. To minimize disturbance to the office space below when a poke-through assembly must be relocated or added, a modular system of prewired junction boxes for each service can be provided, although it is more common to elect this option for power only. A different type of working system must be selected for a floor slab on grade, above a lobby or retail space, above mechanical equipment space, or above space exposed to the atmosphere.

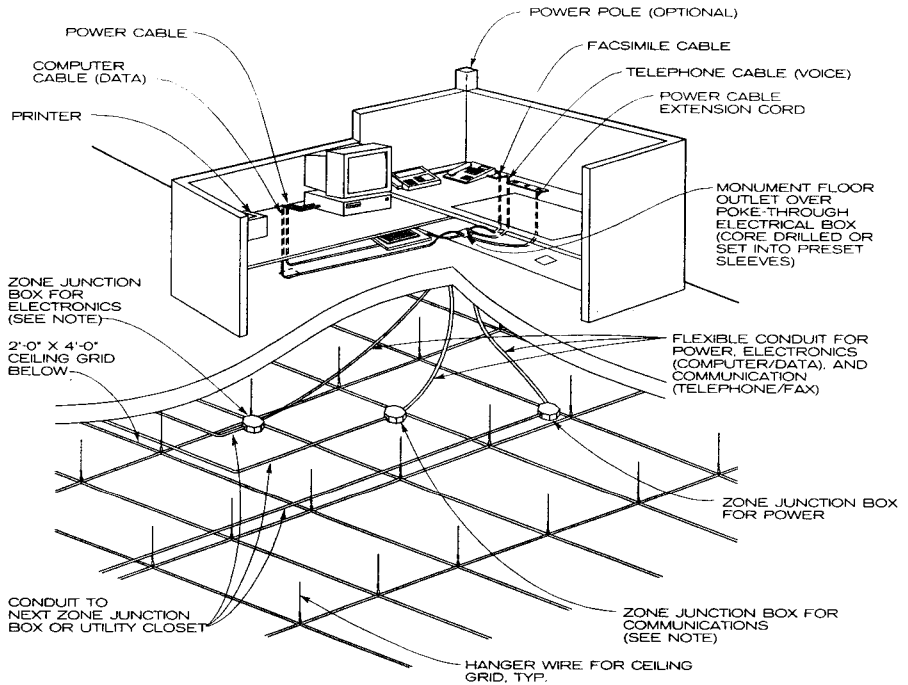

**DESK EQUIPMENT LAYOUT**

**NOTE**

Computer and telephone cabling is often combined as an integrated voice/data cabling system, eliminating the need for three raceways except when extra capacity is needed.

**POKE-THROUGH HARDWARE SYSTEM/ZONE JUNCTION BOX**

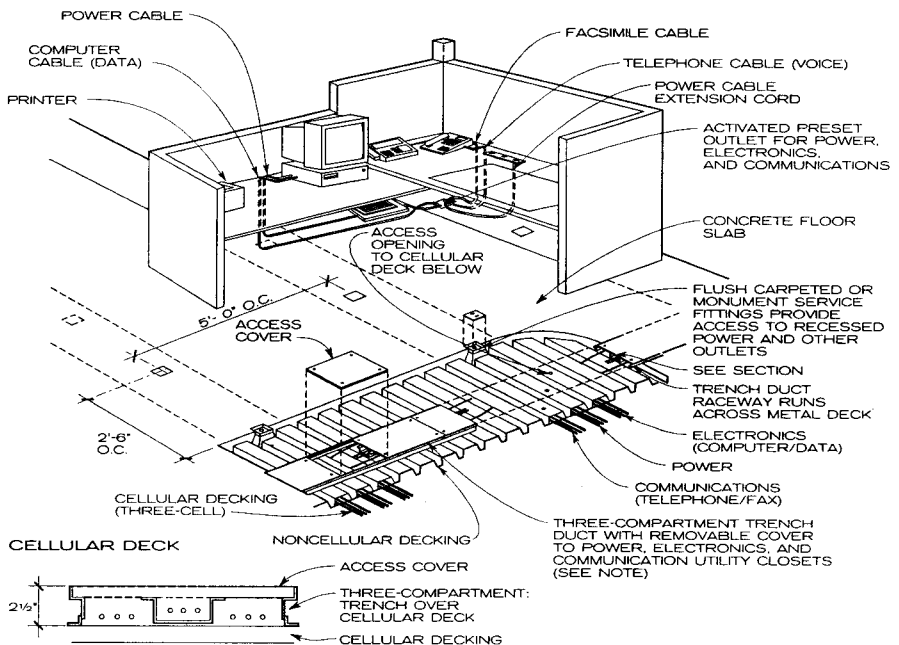

**SECTION**

**NOTE**

Computer and telephone cabling is often combined as an integrated voice/data cabling system, eliminating the need for three raceways except when extra capacity is needed.

**CELLULAR DECK SYSTEM WITH TRENCH HEADER DUCTS**

**CELLULAR DECK SYSTEMS**

The low initial cost of a poke-through system makes it both viable and attractive for investor-owned buildings when tenants are responsible for future changes and for corporate buildings with limited construction budgets. Poke-through systems are effective when office planning includes interconnecting workstation panels containing provisions (base raceways) to extend wiring above the floor, reducing the number of floor penetrations needed for services.

Based on the projected frequency of changes in office furniture layouts, a corporate or government organization may elect to invest in a permanent raceway system to minimize cost and disturbance to occupants when changes or additions are made. When structural design dictates the use of metal decking, a cellular floor raceway system utilizing trench header ducts is the most likely choice.

Cellular raceways come in a variety of sizes and configurations ranging from 1 1/2 to 3 in. high with cells 8 or 12 in. o.c. and 2 or 3 cells per section. An overall floor deck can be full cellular, where bottom plates are provided throughout, or blended as shown.

Trench header ducts come in various sizes and configurations. The height is adjustable for slab depths above cells of 2 1/2 to 4 in. and widths vary from 9 to 36 in. Cover plates are 1/4 in. thick, with lengths from 6 to 36 in., and can either be secured with spring clips or flush, flathead bolts. Two versions of trench design are available: One has a compartmental bottom tray with a grommeted access hole for each cell it crosses; the other has a bottomless trench duct consisting of side rails and a separate wireway in the middle, with grommeted access holes only for the power cells.

When service is needed, the floor is core drilled above the desired cell, the cell top is drilled into, and an afterset insert with above-floor fitting is attached. If data and communication wiring can occupy the same cell, with power wiring in an adjacent cell, two separate service fittings are required for each workstation.

When it is necessary to eliminate or minimize core drilling, a modular pattern of preset service flush outlets can be provided along the cellular sections before the floor is poured (as shown). Upon activation, one flush outlet can serve all the power, communication, and data requirements of a workstation.

The modular grid and frequency of preset locations will determine the convenience of service provisions for the workstations.

Richard F. Humenn, P.E.; Joseph R. Loring & Assoc., Consulting Engineers; New York, New York

NOTES

Where projected frequency of future changes is relatively high, a raised access floor system will provide the maximum flexibility and lowest cost to relocate or add services for workstations. When used in conjunction with a modular system of power, communication and data wiring plug-in receptacles, and cable connector sets, changes can be made without the need of an electrician or wiring technician. Advantages come at a premium, as access floor systems are the highest in initial cost of all systems described in this section.

A raised access floor is essentially a basic computer floor that is restricted in application to distribute only power, communication, and data services to workstations. The absence of air distribution and high density of cabling associated with computers permit raised floor height to be reduced to nominal 6 in. As the depth of standard 2 ft sq formed steel floor panel is less than 2 in., over 4 in. clear height under the panels provides sufficient clearance to accommodate hardware associated with distributing services. Virtually any variety of above-floor or flush outlets can be mounted on a floor panel and connected to lengths of cable with plug or connector fitting at the other end.

Access floors can be provided with or without stringers, which are used to minimize "creep" effect. Laser beam equipment speeds up accurate leveling of pedestal heights. For a custom installation without ramps or steps, the base floor is structurally designed to be depressed below permanent building elements such as lobbies, stairs, and toilets. Panels can be ordered with factory-installed carpeting or, alternatively, magnetic-backed carpet squares can be added after installation.

The introduction of an access floor does not necessarily require an increase in floor-to-floor height, and if so, the cubage added is at a much lower per unit cost than for the rest of the building. When special attention is given to coordinating lighting with other elements in the suspended ceiling or when lighting is provided below as from the workstations, the cavity can be compressed to compensate for the raised floor.

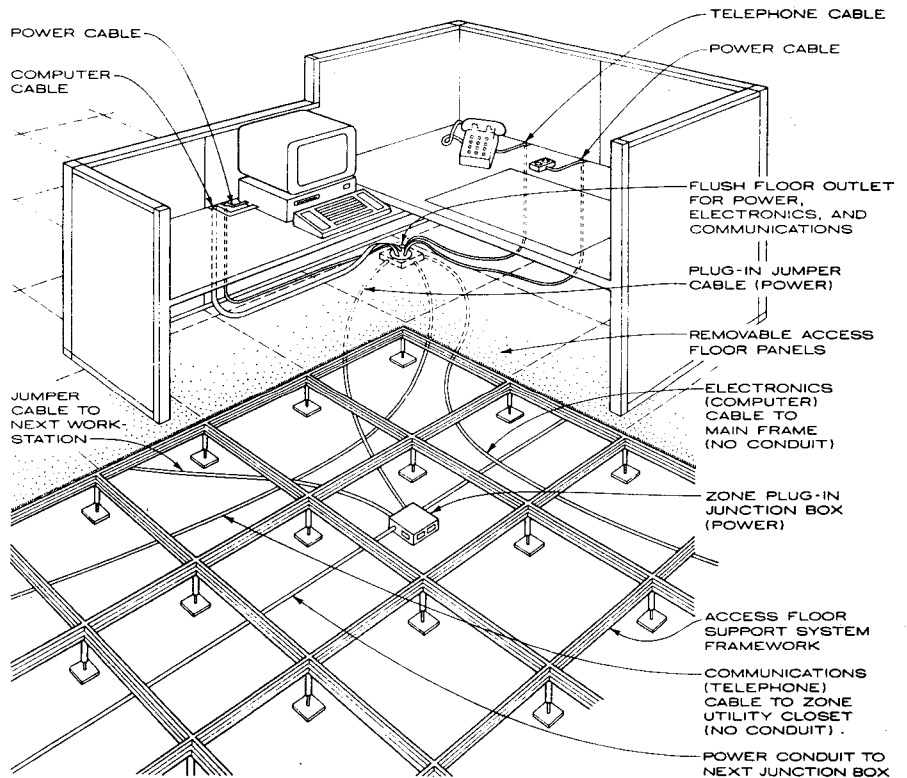

RAISED ACCESS FLOOR SYSTEM / MODULAR PLUG-IN DISTRIBUTION

NOTES

Undercarpet flat cable wiring has developed into a viable system to serve workstations. By code, it can only be used with carpet squares to afford an acceptable degree of access. Although there are some limitations in performance for flat communication (telephone) and computer (data) cables, improvements are continually being made. Flat cables are now available for Local Area Network (LAN) distribution, applicable where communication and data requirements are extensive.

Cables originate at transition boxes located at various intervals along core corridor walls and/or columns that are individually served from distribution centers in utility closets. Boxes can also be cast in the floor or atop a poke-through insert. Cables are not permitted to pass under fixed partitions and must be carefully mapped out to minimize crossovers and clutter.

To install a service fitting, an interface base assembly must first be secured directly to the concrete floor at the flat cable location. The base assembly stabs into conductors of the flat cable and converts them to round wire. When the service fitting is attached, it is activated and ready for use.

Careful consideration must be given to the application of this system based on limitations that may or may not be acceptable under different conditions. For instance, it may be ideal for small areas or renovation of existing buildings where the poke-through or power pole systems are unacceptable or cannot be used. In new buildings where poke-through has been chosen as the base system, the flat cable system is a viable solution in areas where poke-through outlets cannot be installed, such as slab on grade.

Where frequent changes and additions are contemplated, the resulting wear and tear on expensive, glued down carpet tiles may become a distinct disadvantage.

Although this system appears to be simple and inexpensive, it is highly labor intensive and actual installed initial costs and outlet relocation costs are comparable to cellular deck with trench header ducts.

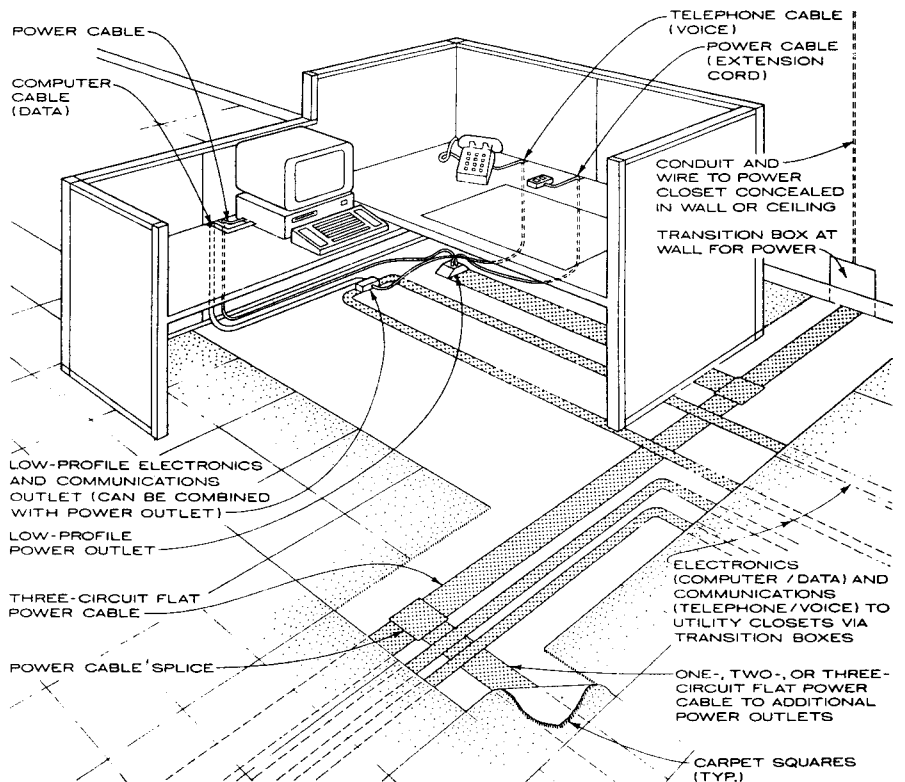

FLAT CABLE WIRING SYSTEM

Richard F. Humenn, PE; Joseph R. Loring & Associates, Inc., Consulting Engineers; New York, New York  
 Gary A. Hall; Hammel Green and Abrahamson; Minneapolis, Minnesota

**GENERAL**

UPS (uninterruptible power supply) is designed to provide continuous power with specific electrical characteristics by conditioning utility company power, battery power, or generator-supplied power.

Uninterruptible power supply (UPS) systems closely control the power supply voltage and frequency to critical equipment such as computers, communications systems, and medical instrumentation.

UPS systems are either on line, with power routing through them continuously, or off line, with power routed through them only when the incoming power is interrupted or departs from the design characteristics. The time required for an off-line, solid-state UPS to automatically switch on varies with the type of switch selected: The quicker the switch, the more expensive the switching equipment in general. The time needs to be matched to the tolerances of the critical equipment being supplied by the UPS to prevent loss of data or other problems.

Battery backup time is selected to allow a controlled shut-down of equipment or to allow a backup generator to be started and stabilize at full power.

Redundant UPS systems may be required if UPS power loss cannot be tolerated for system maintenance or equipment breakdown.

Some equipment can produce electrical disturbances that are fed back into the electrical circuit. This must be prevented through filtering in order to maintain clean power to the other equipment being supplied by the UPS.

The UPS unit and battery should be placed close together. Some UPS cabinets contain sealed batteries; others require separate batteries.

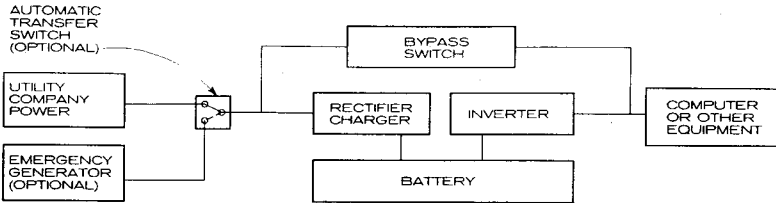

**TYPICAL UNINTERRUPTIBLE POWER SUPPLY SYSTEM DIAGRAM**

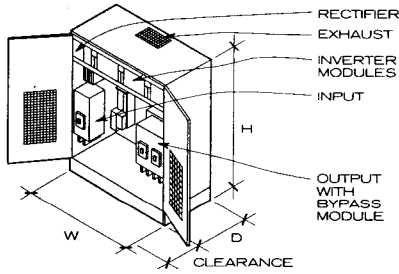

**SOLID-STATE UPS SIZES**

KVA	W (IN.)	D (IN.)	H (IN.)	WEIGHT (LB)
25	28	32	70	1400
50	72	36	72	4000
125	72	36	72	5600
200	72	36	72	6000
350	168	32	76	12,700
500	168	40	76	14,600

**NOTE**

Sound level approximately 65-70 dB. Heat rejection approximately 450-700 Btu/hr/kVA at 50 kVA to 250 Btu/hr/kVA at 500 kVA. Maintain room temperature at 70-80°F. Some units require clearance for access.

**SOLID-STATE UPS**

**ROTARY UPS SIZES**

KVA	W (IN.)	D (IN.)	H (IN.)	WEIGHT (LB)
25	80	24	62	2600
50	80	24	62	3400
125	125	32	74	7000
250	140	32	80	10,000
500	164	60	84	15,000
1000	173	64	98	32,200

**NOTE**

Sound level approximately 60 to 80 dB. Heat rejection approximately 400 Btu/hr/kVA at 50 kVA to 250 Btu/hr/kVA at 500 kVA. Maintain room temperature at 70-80°F. Some units require front and rear clearance for access.

**ROTARY UPS**

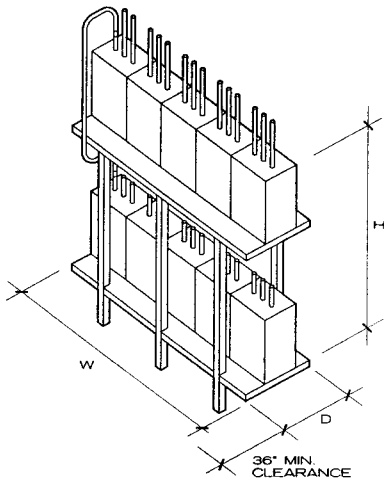
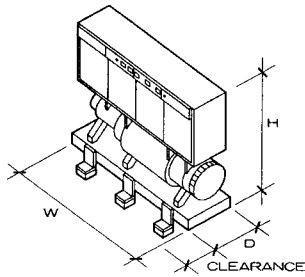

**TWO-TIER RACK SIZES**

KVA	TIME (MIN.)	W (IN.)	D (IN.)	H (IN.)	WGT. (LB)	NUMBER REQUIRED
15	30	96	16	54	3100	2
100	15	168	18	52	1000	4
250	15	108	18	52	20,500	6
500	15	156	18	52	34,600	6

**THREE-TIER RACK SIZES**

KVA	TIME (MIN.)	W (IN.)	D (IN.)	H (IN.)	WGT. (LB)	NUMBER REQUIRED
25	15	108	18	79	4300	1
50	15	108	18	79	5000	1
100	15	108	18	79	10,000	2
250	15	144	18	79	20,500	3
500	15	108	18	79	34,600	6

**NOTE**

Racks can be placed back to back. Provide shower and eye-wash station and ventilation, and maintain approximately 77°F room temperature. Place battery racks close to UPS units. Providing seismic bracing required by code.

**BATTERY RACKS**

Charles B. Towles, P.E.: TEI Consulting Engineers; Washington, D.C.

**BATTERY CABINET**

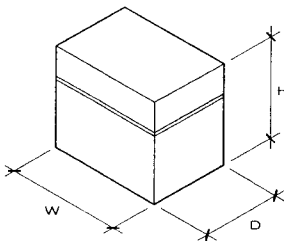

**BATTERY CABINET SIZES**

KV A	TIME (MIN.)	W (IN.)	D (IN.)	H (IN.)	WGT. (LB)	NUMBER REQUIRED
75	15	40	32	76	2300	2
100	15	40	32	76	2300	3
200	15	48	32	76	2300	4
400	10	40	32	76	2300	8
500	7.5	40	32	76	2300	4

**UPS UNDER 10 KVA SIZES**

WATTS	W (IN.)	D (IN.)	H (IN.)	TIME (MIN.)
200	8	15	6	15-20
800	22	16	9	15-20
1500	22	16	18	15-20

KVA	W (IN.)	D (IN.)	H (IN.)	TIME (MIN.)
3.0	26	19	52	10
5.0	36	19	52	10
10.0	36	19	52	10

**NOTE**

A wide variety of UPS systems is available for smaller applications, ranging from desktop models for single microcomputers to floor models that can supply several computers or other equipment.

**UPS UNDER 10 KVA**



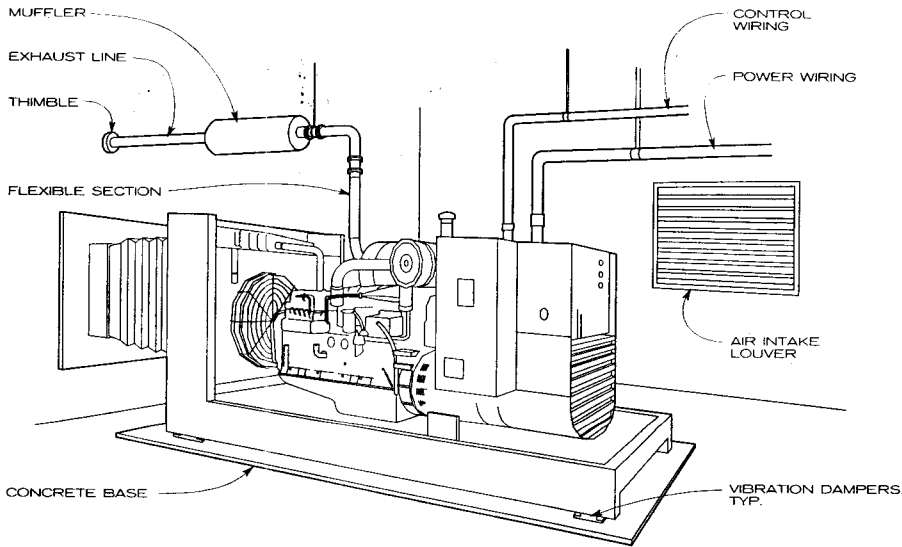

**NOTE**

Standby generators provide emergency power during power outages, when life safety lighting and/or critical equipment power requirements are beyond the capacity of battery units or when required by code (as in hospitals or high-rise buildings). Engines should be located away from main electrical switchgear. Engine rooms must have adequate ventilation for engine- and generator-radiated heat and must be protected against extreme environments under all conditions of airflow.

There must be enough room around a power generating unit to service it and to remove the unit. Standby generators require frequent inspections, tests under load conditions, and maintenance. Provisions must be made to prevent vibration transmission to nearby occupied areas. In addition to the cooling methods illustrated, cooling by remote radiator, heat exchanger, submerged pipe, cooling tower, and evaporative cooler should be considered. See National Electric Code for working space requirements and proper application.

**EMERGENCY ENGINE GENERATOR WITH CONTROL PANEL**

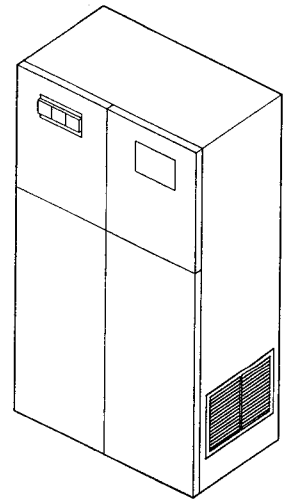

**NOTE**

Battery-powered lighting equipment provides the minimal emergency illumination required for personnel safety and evacuation in buildings not requiring standby generator power. It is also used in buildings requiring standby generator power for the central control, telephone switchboard, generator, and electrical switchgear rooms to provide lighting for critical operations and troubleshooting if the generator fails to start. The batteries, which require frequent inspection, tests, and maintenance, are available in lead calcium, nickel cadmium, and wet lead acid.

**EMERGENCY LIGHTING BATTERY SYSTEMS**

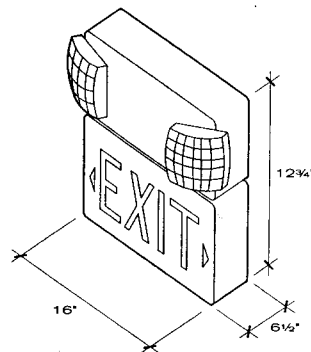
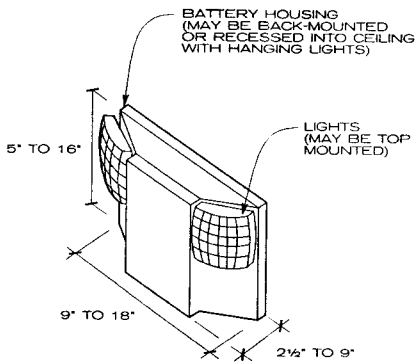

**NOTE**

Used to light exit passageways during power outages. Typically powered by lead calcium or nickel cadmium batteries.

**WITH EMERGENCY LIGHTING**

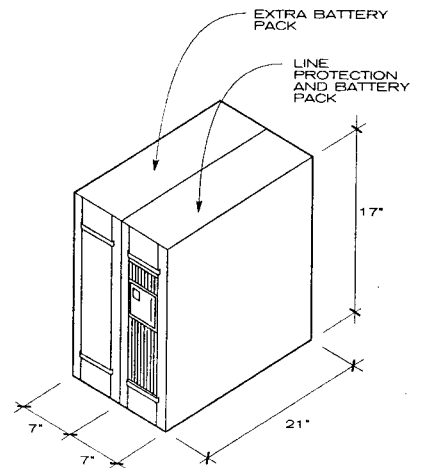
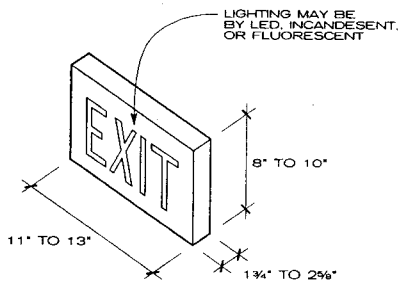
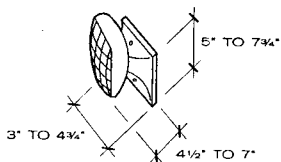

**NOTE**

This unit protects network data and telecommunications equipment and eliminates a wide range of potential power problems: spikes, surges and extended overvoltage conditions, noise, sags, extended brownouts, and harmonics and frequency variations common with standby generator operation. Power rating ranges from 1000 to 3000 V.

**DATA AND TELECOMMUNICATIONS PROTECTION**

**REMOTE FIXTURE**

**NOTE**

Used with an emergency lighting battery system, this remote fixture may have one or two heads.

**EXIT AND EMERGENCY LIGHTING**

**NOTE**

Available in solid acrylic, cast aluminum with acrylic letters, steel, or polycarbonate housing, these signs may be side-top, or back-mounted or recessed. They can be powered by standard AC or battery pack.

**EXIT SIGNS**

Charles B. Towles, P.E.: TEI Consulting Engineers; Washington, D.C.

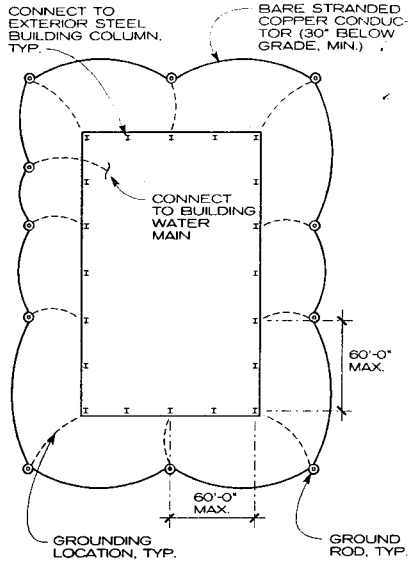

**NOTE**  
All buildings and equipment should be grounded to protect people and equipment from fault currents. A complete interconnected system should be installed according to the requirements of the National Electrical Code and the National Electrical Safety Code. The structural steel of the building is connected to a buried "ground grid" to provide this requirement. All electrical equipment is connected with this system to provide a direct path to earth. Specify the number of ground rods and conductor size according to National Electrical Code requirements.

**BUILDING GROUND GRID**

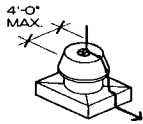

**SMALL EQUIPMENT**

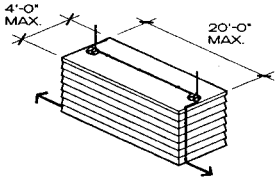

**MEDIUM EQUIPMENT**

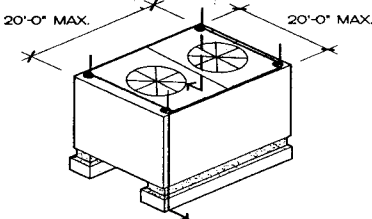

**LARGE EQUIPMENT**

**NOTE**  
Codes vary slightly regarding bonding requirements for metal bodies on rooftops. Generally, if a metal body is in a zone of protection (lower than adjacent air terminals) and within 6 ft or a calculated bonding distance, it should be bonded to the lightning protection system. Smaller, secondary size materials may be used for these connections. Metal bodies taller than the air terminals and less than 3/16 in. thick require air terminal protection. Those greater than 3/16 in. thick are protected if adequately bonded.

**ROOFTOP EQUIPMENT BONDING AND PROTECTION**

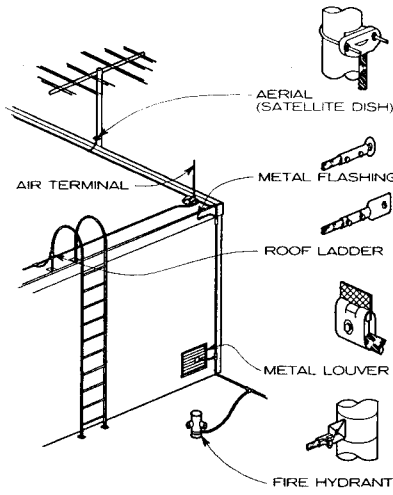

**FASTENER TYPES**

**MISCELLANEOUS ROOFTOP EQUIPMENT**

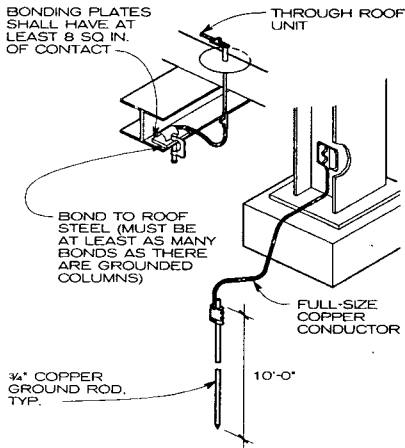

**NOTE**  
In some cases, especially on tall structures, it may be advantageous to substitute the steel frame of a structure for portions of the usual conductor system, normally the downleads. Connections are made to cleaned areas of the building steel, at grade and at roof level, and the columns serve to connect the roof and ground systems.

**STEEL FRAME AS CONDUCTOR**

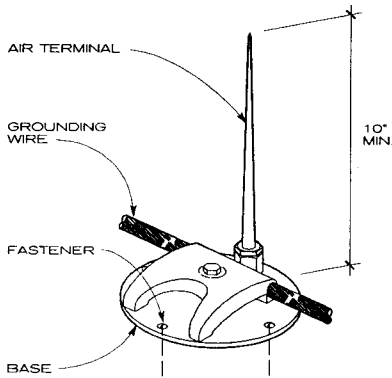

**NOTE**  
Adhesives are typically used for flat roof installation.

**TOP-MOUNTED AIR TERMINAL (LIGHTNING ROD) DETAIL**

**GENERAL**

A lightning protection system is an integrated arrangement of air terminals, bonding connections, arresters, splicers, and other fittings installed on a structure in order to safely conduct to ground any lightning discharge to the structure.

Lightning protection systems and components are grouped into three categories (U.L. classes) based on building height and intended applications. Class I equipment and systems are for ordinary buildings under 75 ft in height. Class II is for those over 75 ft in height, and Class II Modified is a special group covering only large, heavy-duty stacks and chimneys similar to those used at power plants. Each of these system types comprises five or six major groups of components:

1. Air terminals (lightning rods) located on the roof and building projections.
2. Main conductors that tie the air terminals together and connect them with the grounding systems.
3. Bonds to metal roof structures and equipment.
4. Arresters to prevent power line surge damage.
5. Ground terminals, typically rods or plates driven or buried in the earth.
6. Tree protection (usually applicable only to residential work).

Each of these types of equipment and the methods for their installation is covered in the accompanying drawings.

Beyond these material requirements, other factors to be considered relative to lightning protection systems include selection of codes for compliance, inspection criteria (again based on code), criteria to evaluate competence of installing personnel, and requirements for annual inspection and maintenance.

**OVERALL SYSTEMS DESIGN NOTES**

1. Air terminals should be located around the perimeter of flat roof buildings and along the ridge of pitched roof buildings spaced at 20 ft on center maximum and located not more than 2 ft from ridge ends, outside corners, and edges of building walls.
2. Full-size main conductors should connect all air terminals.
3. Additional air terminals should be located in the center of large open flat spacings not to exceed 50 ft.
4. Cable runs connecting these center roof air terminals should be no longer than 150 ft without a lead back to the perimeter cable.
5. Gently sloping roofs are classed as flat under the rules shown above.
6. Downlead cables to ground should be connected to the roof perimeter cable at a maximum spacing of 100 ft on center. Buildings with a perimeter of 250 to 300 ft should have three downleads. For each additional 100 ft or fraction thereof add one downlead.
7. No building or structure should have fewer than two downleads.
8. Arresters should be installed on the electric and telephone services and on all radio and television lead-ins to a structure. Responsibility and jurisdiction for the installation of these devices can vary with locality, so special consideration may have to be given to these items.
9. Trees adjacent to residences pose a special hazard. It is recommended that all trees larger than an adjacent structure and within 10 ft of it be fully protected. Consult codes or manufacturer for recommendations on materials and installation requirements.
10. On-site inspections and certification of completed systems, installer competency certification, and guaranteed inspection/maintenance options are all available under existing standards. Consult codes and standards for specifics.

**REFERENCES**

- The following codes, technical sources, and quality control procedures are standards for lightning protection systems.
- Lightning Protection Institute, "Installation Code LPI-175."
  - National Fire Protection Association, "Lightning Protection Code NFPA 780."
  - Underwriters Laboratories, master labeled program under "U.L. Installation Requirements 96A."

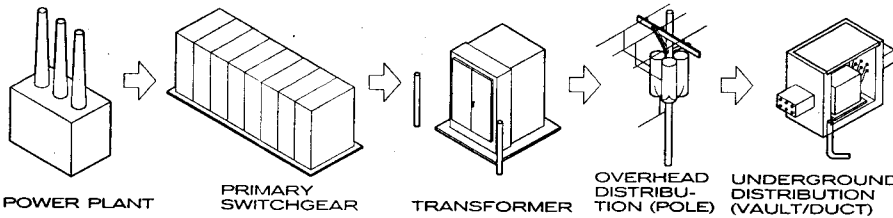

**NOTE**  
 Primary high-voltage service is received at a site via various stages, from the formation of electrical energy (water power, turbines, etc.) to substations that receive the elec-

tricity at high voltage and distribute this energy at a lower voltage via switchgear to the point of use. At each stage, protective devices (switches or circuit breakers) are installed. Transformers are installed to reduce voltage along the lines for the requirements of the end user.

**PRIMARY SERVICE DISTRIBUTION**

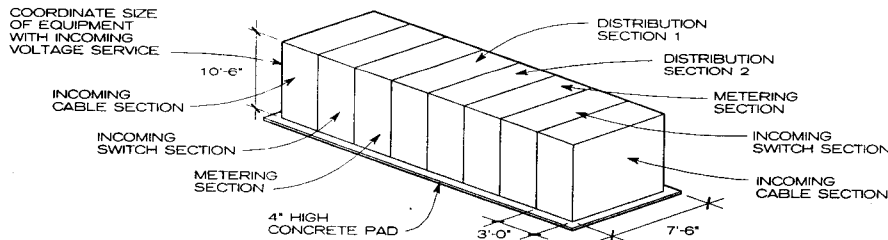

**NOTE**  
 When buildings cover a large area, such as a college campus or medical center, the use of medium voltages of 5 to 34 kV for distribution feeders is usually required. Therefore,

the utility company terminates its primary feeders on the owner's metal-clad or metal-enclosed switchgear, which may be inside or of exterior weatherproof construction. Code clearance in front and back of board must be provided in accordance with the National Electrical Code.

**PRIMARY SWITCHGEAR WITH PRIMARY POWER FROM TWO SERVICES**

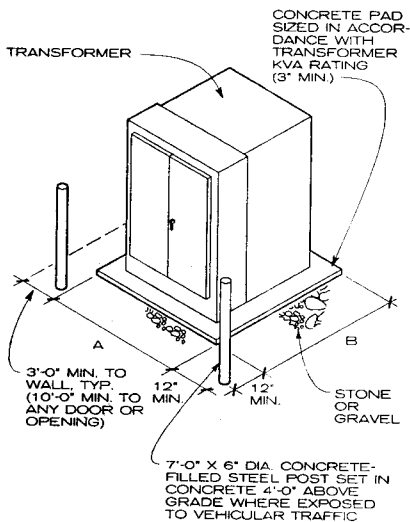

**TYPICAL PAD SIZES**

POWER	A	B
150 - 300 kVA	75 in.	80 in.
500 - 1500 kVA	84 in.	84 in.

**NOTES**

1. Pad-mounted transformers with weatherproof, tamper-proof enclosures permit installation at ground level without the danger of exposed parts. Three-phase units up to 1500 kVA are normally used with underground primary and secondary feeders. The customer's grounding grids or grounding electrical conductors should not be connected at pad-mounted transformer locations.
2. High voltage compartment requires 10-ft clearance for on-off operation of the insulated stick located on the transformer (known as "hot stick" operation).

**PAD-MOUNTED TRANSFORMER**

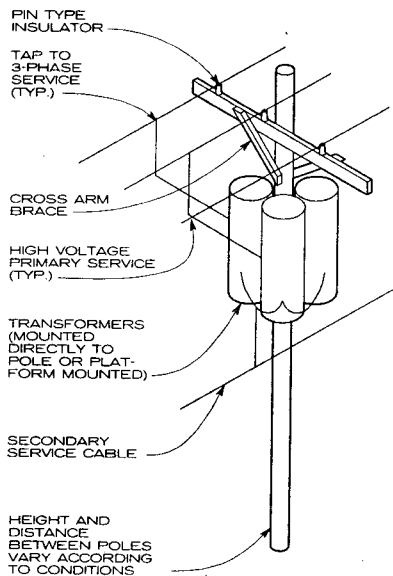

**NOTE**

Overhead distribution lines are supported by poles from the origin of the electrical service to the termination point. Poles are fabricated out of various kinds of wood (e.g., pine or cedar) or steel, depending on the type of equipment to be supported, weather conditions, and cost of materials. Transformers mounted directly onto the poles or on platforms provide the required low voltage service to the final point. Spacing between the poles, height of the poles, and clearances between electrical lines and the ground depend upon the type of terrain, weather environment, and obstructions (e.g., inhabited area, waterways, railroads, roadways, etc.). See the National Electrical Safety Code for restrictions.

**OVERHEAD POLE CONFIGURATION**

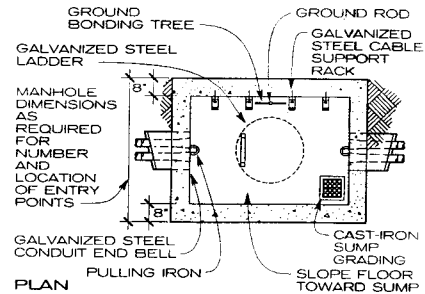

**PLAN**

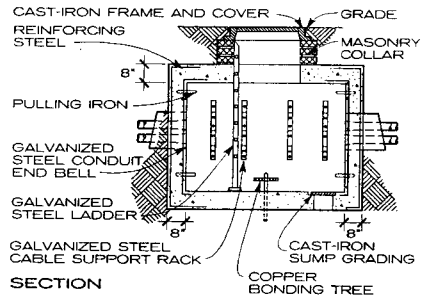

**SECTION**

**NOTE**

Manholes are provided for splicing and pulling of electrical cables for underground distribution. Size ductbanks emanating out of the manhole according to the latest edition of the National Electrical Code.

**MANHOLE DETAILS**

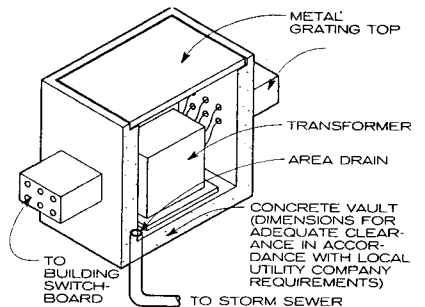

**NOTE**

Underground vaults are generally used for utility company transformers where all distribution feeders are underground. These systems usually constitute a network or spot network. Vaults are often located below the sidewalks and have grating tops. Transformer is usually liquid filled; if an oil-filled transformer is used, an oil interceptor is recommended before discharge to building storm sewer.

**UNDERGROUND VAULT**

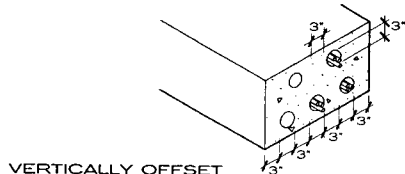

**VERTICALLY OFFSET**

OVERALL DIMENSIONS ARE A FUNCTION OF NUMBER AND SIZE OF CONDUITS

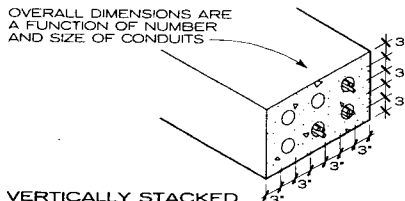

**VERTICALLY STACKED UNDERGROUND DUCT BANK**

Charles B. Towles, P.E.; TEI Consulting Engineers; Washington, D.C.

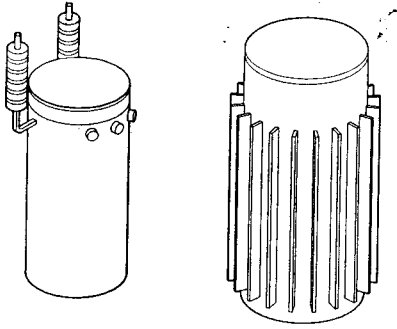

SINGLE-PHASE THREE-PHASE

**NOTE**  
Rated secondary voltages: 208, 240, or 480. Immersed in oil, self-cooled.

**POLE-MOUNTED TRANSFORMERS**

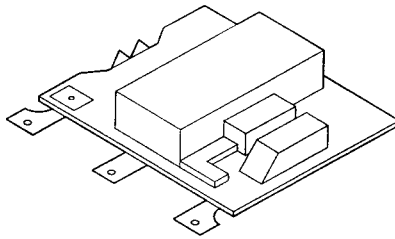

**NOTE**  
Provides convenient control of lighting and power circuits from control stations.

**REMOTE CONTROL SWITCH**

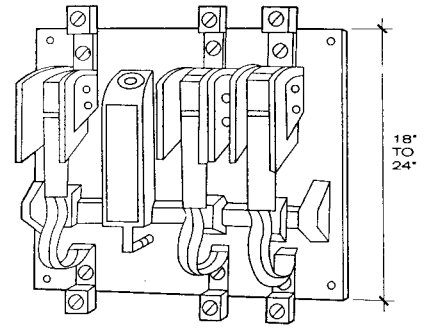

**NOTE**  
Rated voltage: 600 VAC. For circuits that are closed and opened repeatedly, various design combinations are allowed. Used for all classes of magnetically held loads, open or closed.

**CONTACTOR**

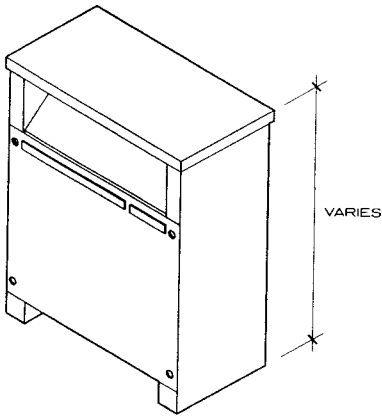

**NOTE**  
Rated secondary voltages: 120/208 or 240 volts or three phase. Primarily mounted on indoor floors and walls.

**DRY TRANSFORMER**

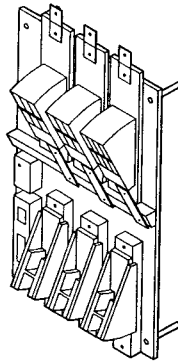

**NOTE**  
Automatically transfers loads from a normal source to the emergency source.

**AUTOTRANSFER SWITCH**

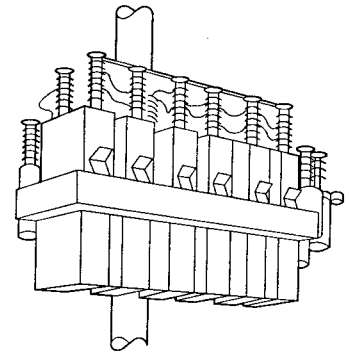

**POLE RACK NOTE**  
Power factor correction on either low or high voltage systems. Types, indoor or outdoor. Size and voltage as required. Switched or floating.

**CAPACITOR**

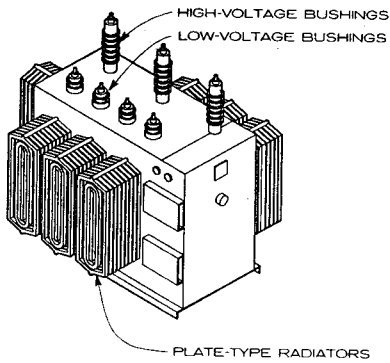

**NOTE**  
Secondary substation transformer with high to low voltage. Primarily a commercial type for the outdoors. Optional external fan cooling.

**LIQUID-FILLED TRANSFORMER**

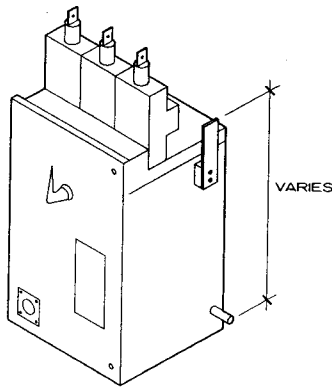

**NETWORK TYPE NOTE**  
Maximum voltage: 125/216 VAC or 277/480 VAC. Interrupting capacity 30,000 and 60,000 A. RMS. SYM. A fault on primary cable or network transformer will open protector to isolate fault from system.

**PROTECTOR**

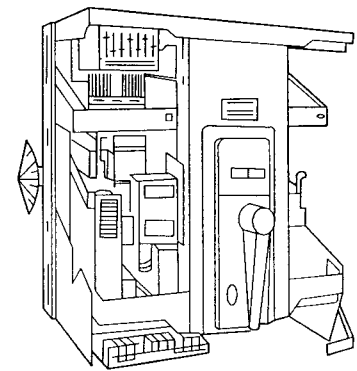

**LOW VOLTAGE NOTE**  
Rated voltages: 240 VAC, 480 VAC, 600 VAC, and 250 VDC. Manual or electric operation. Electromechanical or solid-state breaker trip devices. Stationary or drawout types.

**DISTRIBUTION CIRCUIT BREAKER**

Charles B. Towles, P.E.; TEI Consulting Engineers, Washington, D.C.

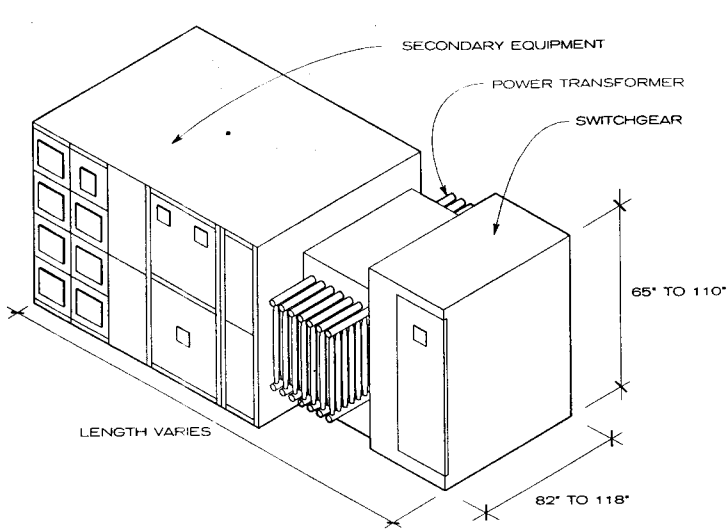

**NOTE**

A secondary unit substation, sometimes called a power center, is a close-coupled assembly consisting of three-phase power transformers, enclosed high voltage incoming line sections, and enclosed secondary low voltage outgoing sections encompassing the following electrical ratings:

Transformer kVA: 112.5 through 2500 (self-cooled rating) liquid-filled, dry-type, or cast coil.  
 Primary voltage: 2.4 kV thru 34.5 kV.  
 Secondary voltage: 208, 240, 480, or 600 V (max.).

See National Electrical Code for aisle space, ventilation, servicing area, and special building condition requirements.

**SECONDARY UNIT SUBSTATION**

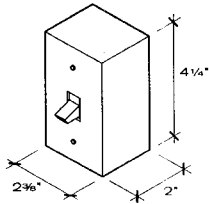

**MANUAL NOTE**

Manual single-phase starters are designed to give positive, accurate, trouble-free overload protection to single phase motors rated up to 1 HP. Typical applications are fans, machine tools, motors, HVAC, etc. Maximum voltage is 240 V AC.

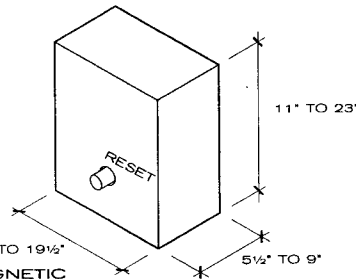

**MAGNETIC NOTE**

Magnetic motor starters are designed for across-the-line control of squirrel cage motors or as primary control for wound rotor motors. Starters can be furnished for non-reversing, reversing and two-speed applications. Maximum voltage is 600 V AC; maximum horsepower is 200 HP.

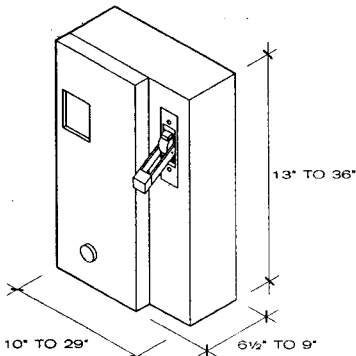

**COMBINATION NOTE**

Magnetic combination starters are designed for across-the-line control of squirrel cage motors or as primary control for wound rotor motors. In addition, they provide a disconnect means and short-circuit protection. They are available for nonreversing or reversing applications.

**MOTOR STARTERS**

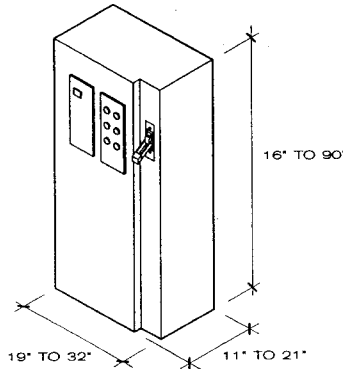

**SOLID-STATE NOTE**

This unit is a reduced voltage motor starter, used to reduce starting current and high starting torque. Typical applications for controllers are in motors used in cranes, belt-driven equipment, conveyors, material handling facilities, compressors, and woodworking equipment. Available for AC motors 5 to 900 HP.

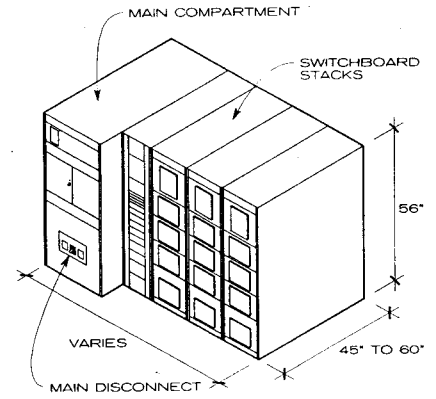

**NOTE**

Metering compartment, main disconnect, check meters, and low voltage distribution section. See manufacturer's literature for type, size, and arrangements. See National Electrical Code for required aisle space, servicing area, and room layout.

**SWITCHBOARD**

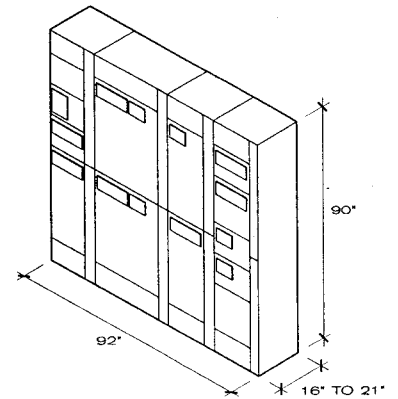

**NOTE**

Motor control centers provide a method for grouping motor control, associated control, and distribution equipment. It is designed to operate machinery, industrial processes, and commercial building systems.

**LOW-VOLTAGE MOTOR CONTROL CENTER**

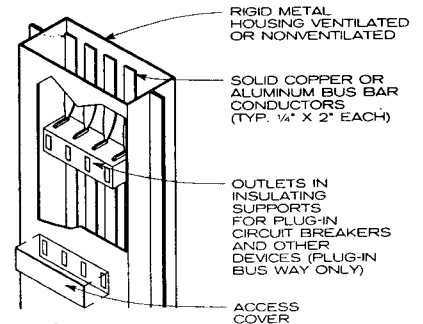

**NOTE**

Plug-in and feeder busways carry current from 50 to 5000 amps. They are utilized when large blocks of low voltage power (up to 600 V) must be transmitted over long distances or when taps must be made at various points, as in vertical risers in office buildings. Codes limit locations in buildings where different types of busways may be installed. Consult an electrical engineer before using this system. Busway housing may be hung from an overhead support, mounted to a wall, or braced to the structure in vertical riser installation.

**BUSWAY SYSTEM**

Charles B. Towles, P.E.; TEI Consulting Engineers; Washington, D.C.

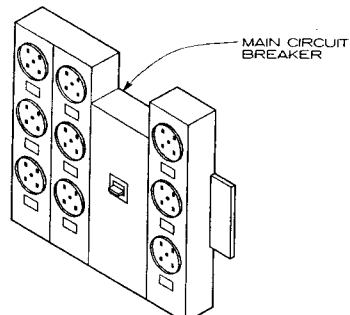
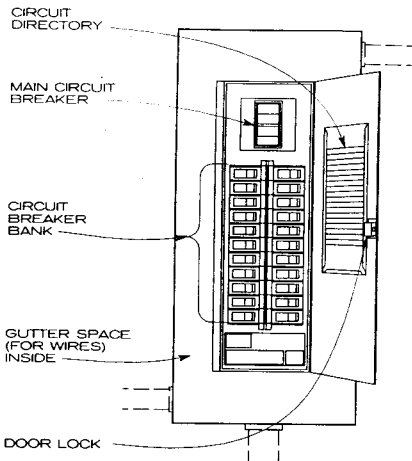

**MULTIPLE METER BANK WITH MAIN CIRCUIT BREAKER**  
 1. Rated voltages: 120/240 V, 3-wire, single-phase or 208/120 V, 4-wire, three-phase.  
 2. Either indoor or outdoor construction.  
 3. Number of sockets as required by application.

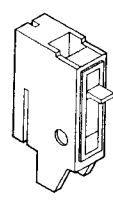

**MOLDED CASE**  
 1. Rated voltages: 120 VAC, 240 VAC, 600 VAC, 125 VDC, and 250 VDC.  
 2. Frame sizes: 100, 150, 225, 400, 600, 800, 1200 A poles, 2 or 3 above 100 A.  
 3. Current limiting types with fuses.

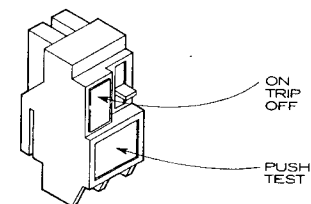

**MOLDED CASE WITH GROUND FAULT**  
 1. Rated voltages: 120 VAC or 120/240 VAC.  
 2. Frame size: 100 A ratings, 15-30 A poles, 1 or 2.

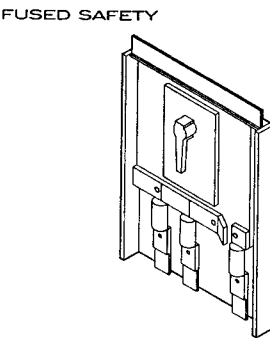
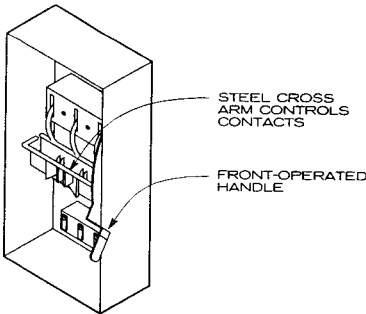

**HIGH-PRESSURE CONTACT**  
**NOTE**  
 High-pressure contact switches may be top or bottom feed; 600 V AC max; 800-4000 A.

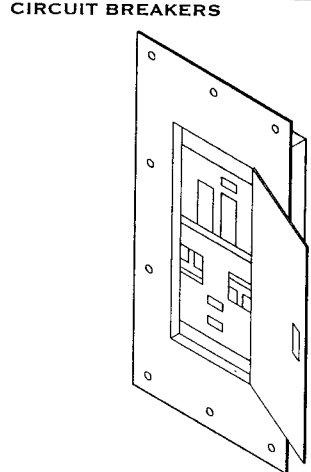

**CIRCUIT BREAKER**

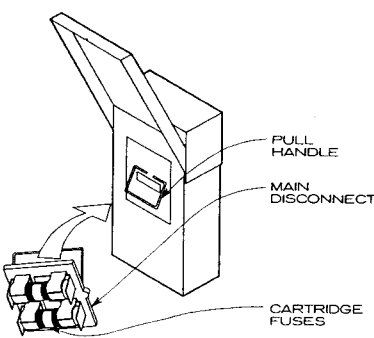

**FUSE BOX DISCONNECT SWITCHES**

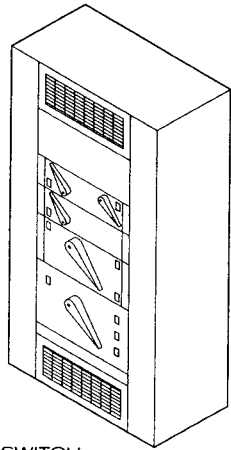

**FUSIBLE SWITCH DISTRIBUTION PANEL BOARDS**

**NOTE**  
 Knockout holes allow conduit connections from all sides.

**PANELBOARD DIMENSIONS**

MAXIMUM NUMBER OF CIRCUITS	BOX DIMENSIONS (IN.)		
	WIDTH	HEIGHT	DEPTH
12	9-15	13-20	3 <sup>3</sup> / <sub>4</sub> -4 <sup>5</sup> / <sub>8</sub>
20	9-15	20 <sup>1</sup> / <sub>4</sub> -24	3 <sup>3</sup> / <sub>4</sub> -4 <sup>5</sup> / <sub>8</sub>
30	12-15	30-33	3 <sup>3</sup> / <sub>4</sub> -4 <sup>5</sup> / <sub>8</sub>
40	14-15	34-39	4-4 <sup>5</sup> / <sub>8</sub>

**RESIDENTIAL AND COMMERCIAL PANELBOARD**

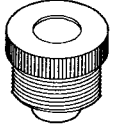

**PLUG FUSE**  
 1. Rated voltage: 125  
 2. Ampere rating: 1-30  
 3. Fuse types: S, T

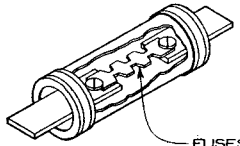

**KNIFE BLADE FUSE**  
 1. Rated voltage: 250 and 600  
 2. Ampere ratings: 70-6000  
 3. Fuse types: K1, RK1, K5, RK5, J, H, G, and L

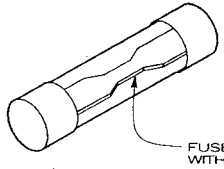

**CARTRIDGE FUSE**  
 1. Rated voltage: 250 and 600  
 2. Ampere rating: 1/10-60  
 3. Fuse types: K1, RK1, K5, RK5, J, H, and G

**NOTE**  
 Cartridge and knife blade fuses are available for short circuit protection up to 200,000 A (Rms).

**FUSES**

Charles B. Towles, P.E.: TEI Consulting Engineers; Washington, D.C.

**GENERAL**

Fluorescent technology offers among the highest efficacies of all lamps for high color quality white light and is three to five times more efficient than incandescent technology. Fluorescent lamps, as well as high-intensity discharge (HID) lamps, work on an electric-discharge principle and require a ballast. Light in a fluorescent lamp is produced when fluorescent powders are activated by ultraviolet-energy generated by a mercury arc.

Fluorescent lamps are available in many types. Variations in phosphor chemistry, gas fill, size, and electrical input make possible many colors, efficiencies, sizes, and light outputs.

**PHOSPHORS**

Phosphors are the chemical powders that line the inside of a fluorescent tube. Their composition is responsible for the color, quality, and efficiency of light emanating from a fluorescent lamp. Among "white" sources, halophosphate phosphors such as cool white and warm white were the most popular types from the 1950s through the 1970s. In the 1980s trichromatic rare earth (RE) phosphors were developed, which offered greater efficiency and improved color rendering. These are now the predominant phosphors available in T10, T8, and compact fluorescent lamps; they are also available in most T12 sizes.

Trichromatic phosphors are available in two grades on the color rendering index (CRI) and a number of color temperatures. So-called "thin-coat" trichromatic phosphors have a CRI in the low to mid 70s; "thick-coat" phosphors have a CRI in the low 80s. By comparison, cool white halophosphate lamps had a CRI of 62. Both triphosphor series are available in a number of color temperatures, including warm-3000K, neutral-3500K, and cool-4100K. Very cool-5000K and 6500K-colors are available in some types.

Other, specialized phosphors are available in some straight-tube fluorescents, although these are usually much less efficient. Some high-CRI white lamps, with CRIs over 90, are available for applications that demand color matching; the lamps highest on the CRI are available at the highest Kelvin temperatures, up to 7500K. Colors, particularly red, blue, and gold, are used for special effects.

**FLUORESCENT STRAIGHT TUBES**

Fluorescent straight-tube lamps are the predominant lamp type in indoor commercial lighting. Because of their widespread use, much attention has been focused on developing a wide variety and more efficacious versions.













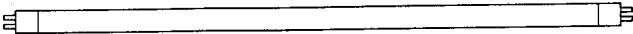

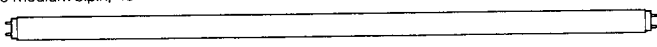

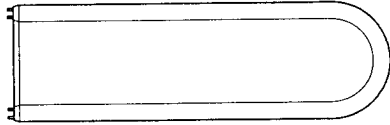

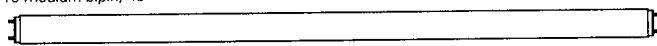
The T12 (1 1/2-in. diameter) was the predominant shape for decades, and by far the most popular of these was the F40T12, rapid-start, 40W, cool white (CW) four-footer. As a requirement of the Energy Policy Act of 1992, manufacturers stopped making this lamp for U.S. use in October 1995.

"Energy-saver" lamps, with krypton added to the gas fill, are direct substitutes for most "standard" or full-wattage lamps. The light output in these lamps is reduced along with the reduction in power input. A 34W lamp is the energy-saver version of the standard 40W F40T12. It is intended for use in environments of 60°F or warmer.

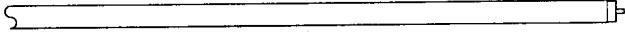
**TUBE DIAMETER**

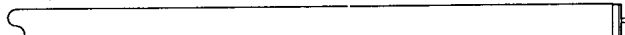
Among straight-tube fluorescents, tube diameter is an important determinant of efficacy. Generally, the narrower the tube, the higher the efficacy. In the 1980s lamps of smaller diameter and thus of higher efficacy were devel-

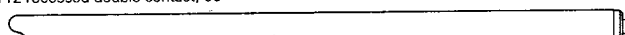
**STRAIGHT TUBE FLUORESCENT SHAPES AND TYPICAL NOMINAL LENGTHS**

TUBE SHAPE	BASE
T2 right angle, 20" 	
T5 miniature bipin, 46" 	
T8 medium bipin, 48" 	
T8 medium bipin u-bent, 22 7/16" 	
T10 medium bipin, 48" 	
T12 medium bipin, 48" 	
T8 single pin slimline, 96" 	
T12 single pin slimline, 96" 	
T12 recessed double contact, 96" 	

**NOTE**

Lamps are not to scale; nominal length is from back of socket to back of socket.

oped. Compared to the "standard" F40 CW, the T10 lamp provides increased light output and improved color, with a slight increase in electrical input. The thick-coat triphosphor T8 lamp provides the same light output, improved color, and a significant decrease in electrical input.

T8 lamps use 20% fewer watts than standard F40s and operate even more efficiently when used on electronic ballasts. In 1995 efficient indoor lighting design generally uses a combination of T8 series lamps with electronic ballasts.

The next straight-tube development is the T5 shape, introduced in Europe in 1995. These lamps, which use miniature bi-pin bases, offer further efficacy gains but are manufactured in lengths compatible with European building module dimensions of 600 mm and 1200 mm rather than the 2-ft and 4-ft dimensions standard in the United States. Therefore, T5 lamps need their own, dedicated luminaires.

**LENGTH AND SHAPE**

Straight-tube fluorescents are available in a wide range of lengths, from 6 to 96 in. In general, the longer the tube, the higher the efficacy.

A number of variants of the straight-tube shape are available. The U-shaped lamp is essentially a straight-tube lamp bent in half. It comes with center-to-center leg-spacings of 1 5/8 in. (16, 24, 31W T8), 3 5/8 in. (35, 40W T12), or 6 in. (32W T8; 34, 40W T12). Circular fluorescents basically are straight tubes bent in a circle. They are available in outside diameters of 6 1/2 in. (20W), 8 1/4 in. (22W), 12 in. (32W), and 16 in. (40W) T9 shapes. Straight tubes with outer glass jackets are designed for locations outdoors or in other sub-zero temperatures.

**REPRESENTATIVE 4-FT AND 8-FT LAMPS AND LAMP/BALLAST COMBINATIONS**

WATTAGE	LENGTH (IN.)	SHAPE	PHOSPHOR TYPE	START MODE	INITIAL LUMENS	LAMP EFFICACY (LPW)	ACTUAL LAMP/BALLAST COMBINATION			
							NUMBER OF LAMPS; BALLAST TYPE: ELECTRONIC/MAGNETIC	BALLAST FACTOR	SYSTEM WATTS	SYSTEM EFFICACY (LPW)
40*	48	T12	Cool White	Rapid	3,050	76	2-L M	0.94	88	65
32	48	T12	RE700	Rapid (Cathode cutout)	2,650	83	2-L M	0.87	67	69
34	48	T12	RE800	Rapid	2,850	84	2-L E	0.88	62	81
42	48	T10	RE800	Rapid	3,700	88	2-L E	0.85	74	85
32	48	T8	RE700	Instant	2,900	91	2-L E	0.95	65	87
32	48	T8	RE800	Instant	3,050	95	2-L E	0.95	63	92
32	48	T8	RE700	Instant	2,900	91	3-L E	0.91	87	91
32	48	T8	RE700	Instant	2,900	91	4-L E	0.89	111	93
75*	96	T12	Cool White	Instant (Slimline)	6,150	82	2-L M	0.94	158	73
59	96	T8	RE800	Instant	6,000	102	2-L E	0.85	105	97

\* These lamps are no longer manufactured; shown as base-case reference only.

Fred Davis, C.L.E.P.; Fred Davis Corp., Energy and Lighting, Medfield, Massachusetts

**BALLASTS AND STARTING MODES**

The ballast provides the proper electrical characteristics to start and operate a fluorescent lamp. The starting process occurs in two stages: First, a sufficient voltage between an electrode and ground ionizes the gas (mercury plus an inert gas) in the lamp. Next, a voltage must develop across the lamp sufficient to extend the ionization throughout the lamp and to develop an arc.

The three starting modes for ballasts for fluorescent lamps are preheat, instant-start, and rapid-start. Each ballast type is used only with compatible lamps. Electronic ballasts are available in both instant-start and rapid-start designs.

For the preheat mode, a separate starter button is often used to heat the electrodes before high voltage is applied across the lamp. The instant-start mode applies a high voltage (400 to 1000 V) across the lamp to ionize the gas and initiate arc discharge. This design provides the lowest energy consumption, sometimes at the expense of lamp life. In the rapid-start mode, electrodes (cathodes) are heated continuously by means of low voltage windings built into the ballast, allowing a gentle start. A variation cuts power to the cathodes after the arc is struck. Ballast factor is the percentage of a lamp's rated lumens produced when operated on a specific commercial ballast.

**ELECTRONIC BALLASTS**

Electronic ballasts improve the efficacy of lamps by driving them at high frequencies, above 15 kHz. Such ballasts eliminate flicker and are much lighter than electromagnetic ballasts. The improvement in efficacy made possible by electronic ballasts alone is approximately 10-12% for 4-ft lamps and 5% for 8-ft lamps, compared to operation at 60 Hz. Electronic ballasts are available that operate one, two, three, or four 4-ft T8 lamps at once.

Like magnetic ballasts, most electronic ballasts are designed so actual lumen output is as close to the rated lumens as possible. However, some electronic ballasts have been designed to deliberately provide higher than rated lumens (ballast factor > 1.0), while others have been designed for lower than rated lumens (ballast factor < 0.9). The ballast factor should be consulted carefully to ensure that the lighting design meets the desired light output.

**FLUORESCENT FAMILIES**

Fluorescent lamp families differ from each other in base type, starting characteristics, and "loading" (the amount of electrical energy applied per length of lamp). Generally, the most efficacious lamp family is the T8, and it should be used where appropriate. Applications requiring high output may call for multiple fluorescent lamps, efficient high-intensity discharge, or one of the higher loading families. For low light levels, any fluorescents are more efficacious than incandescent lamps.

Subminiature lamps use a T2 bulb with a "right-angle" base. They are available in 8-in. 6W, 12-in. 8W, and 20-in. 13W sizes.

Preheat fluorescent lamps utilize separate starters. These T5, T8, T12, and T17 lamps range in length from 6 to 60 in. The smallest of these uses a miniature bipin base. Lamp lifetime is 6000 to 7500 hours for T5s and T8s, 9000 for T12 and T17. These lamps are not commonly used in commercial general lighting.

The rapid-start T12 lamp, which operates at 430 mA with a medium bipin base, was formerly the mainstay of commercial lighting, even though it is available in only F30 36-in. and F40 48-in. sizes. The Energy Policy Act of 1992 eliminated inefficient halophosphate 4-ft full-wattage (40W) versions, leaving trichromatic phosphor types available for full wattage. Energy savers of all phosphors are available in 25W and 34W. 32W cathode-cutout 4-ft lamps cut electrical input to the cathode after starting, but they should not be used in situations with frequent on and off switching.

T8 lamps, operating at 265 mA, are the lamps of choice for energy-efficiency. They are available in 2-ft 17W, 3-ft 25W, 4-ft 32W, 5-ft 40W, and 8-ft 59W sizes. The 8-ft lamp has single-pin bases, for instant start only. The remainder have medium bipin bases and can operate on instant-start or rapid-start ballasts as long as they are specific to the T8 lamp. Rated life on instant-start ballasts is 15,000 hours, as opposed to 20,000 hours on rapid-start ballasts; however, in typical use, with 8- to 12-hr burn cycles on electronic ballasts, actual life difference is minimal.

Slimline lamps are single-pin based and range from 2 to 8 ft. They operate on instant-start ballasts. The F96 T12 lamp was the standard lamp in 8-ft luminaires.

High output lamps operate at 800 mA and produce approximately 45% more light than slimlines of the same length, although at lower efficacy. They have recessed double con-

tact (RDC) bases and rated life ranges from 9000 to 12000 hours. Very high output lamps operate at 1500 mA and range as high as 215 watts.

**COMPACT FLUORESCENTS**

Compact fluorescents were developed in the early 20th century to put the efficiency of fluorescent technology into a package small enough to compete with incandescent lamps in some application niches. Technological improvements have provided several generations of ever smaller, brighter glass shapes.

These glass shapes are fitted to either plug-in pin bases, which need a separate ballast, or to screw-in bases with ballasts built in. Compact fluorescents are used in a variety of luminaires, including most types that were historically designed for incandescent. For best efficiency, fixtures should be designed around the photometrics particular to the compact fluorescent.

Lamps with plug-in pin bases are dedicated for a ballast type. Two-pin lamps are preheat types that contain a glow starter in the lamp base, whereas four-pin lamps work with electronic ballasts that incorporate the starting function. As with straight-tubes, when compared to magnetic ballasts, electronic ballasts for compact fluorescents are lighter and more efficacious and eliminate flicker. Base-down operation of some compact fluorescents yields fewer than rated lumens; others have amalgam chemistry that offsets this phenomenon. Optimum output is close to horizontal.

**REPRESENTATIVE COMPACT FLUORESCENT CHARACTERISTICS**

LAMP	WATTS*	INITIAL LUMENS	MAX. OVER-ALL LENGTH (IN.)
Tube integral screw-in	18	1100	7.19
Twin lamp alone	13	900	7.50
Quad modular side-mount	22	1200	7.75
Triple integral screw-in	15	900	4.94
Triple integral screw-in	25	1750	6.20
Triple lamp alone	32	2200	5.80
Circline lamp alone	22	1100	8.25 O.D.
Flat lamp alone	36	2800	8.50
Reflector modular screw-in	13	860	6.38
Long CFL lamp alone	18	1250	8.94
Long CFL lamp alone	40	1550	6.95

\* Watts exclude ballasts, except for integral units, which use electronic ballasts. All lamps listed have thick-coat trichromatic phosphors.

**REPRESENTATIVE COMPACT FLUORESCENT SHAPES**

GLASS SHAPES	PLUG-IN VERSION (FOR BALLASTED FIXTURE)			SCREW-IN VERSION (FOR USE IN MEDIUM SOCKET)	
	LAMP ALONE	BASE		MODULAR ASSEMBLY (LAMP AND BALLAST)	INTEGRAL (ONE-PIECE)
		2-PIN	4-PIN		
Globe, tube	-	-	-		
Twin					-
Quad					
Triple					
Octic	-	-	-	-	
Helical		-	-	-	
Circline		-			-
2-D			-		-
Flat		-		-	-
Reflector	-	-	-		
Long CFL		-		-	-

Fred Davis, C.L.E.P.; Fred Davis Corp., Energy and Lighting; Medfield, Massachusetts



**GENERAL**

Incandescent lamps are the least efficient electric lighting sources, converting only 7-12% of electrical input to visible light. They operate on the principle of electric resistance: As electric current flows through a filament, resistance causes it to heat to a temperature high enough to glow, or incandescence.

Despite the many efficient alternatives to incandescents, they remain popular in certain applications because they can be dimmed easily and inexpensively and because they sparkle the most brilliantly. Incandescents have traditionally worked best for low-lumen applications, but LED and electroluminescent technologies now offer low-wattage alternatives. Switching on instantly and interchangeability among a variety of wattages are other advantages of incandescents. Most important, the small filament size of halogen reflector lamps makes them the most efficient type in narrow-beam applications.

The low initial price of incandescent lamps and luminaires can be misleading because their operating costs are relatively high. Such costs include not only electricity, but also the cost of replacing lamps. Another factor to consider is lamp life: As a rule, light output decreases over time. Therefore, if a lower lumen level is acceptable, a lower wattage lamp should be considered.

**INCANDESCENT TECHNOLOGY IMPROVEMENTS**

Incandescent technology has improved over the years, but the efficacy of the most efficient incandescents—more than 30 lumens per watt for infrared reflecting halogen—is still far lower than that of the least efficient fluorescents.

Early improvements in incandescent technology included the coiled-coil filament and the use of inert gases as fill material in the lamp. For greater efficacy still, krypton gas is used: It is less conductive than the standard argon-nitrogen mixture but more expensive.

Tungsten-halogen lamps use a halogen regenerative cycle to keep the filament from evaporating. A halogen additive in the fill gas, usually iodine or bromine, reacts chemically with tungsten molecules that have evaporated off the filament. The tungsten is then redeposited onto the filament instead of on the bulb wall. The lamp operates at an extremely high temperature, which necessitates that a special glass envelope, usually quartz, surround the filament.

The high temperature of tungsten-halogen lamps also gives them greater efficacy than standard incandescents—their color temperature is 200 to 300° K higher. The small, vertical filaments in tungsten-halogen lamps allow for very efficient reflectors. As a result, some low-wattage halogen reflectors are more energy-efficient than some compact fluorescent types for relatively narrow-beam applications.

A further improvement in halogen lamps involves infrared-reflective (IR) film. A very thin dichroic coating applied to the halogen lamp or capsule reflects infrared (heat) energy back onto the filament, allowing visible light to pass through. The hotter filament increases lumen output, thus improving efficacy.

Lamps whose outside bulb walls are made of quartz require special handling, as oils from bare hands can damage them. Many manufacturers now enclose the halogen capsule in an outer glass envelope, eliminating this problem.

**AREA SOURCES**

General service area lamps range from a 15-watt A15 to a 1500-watt PS52. They are designed for 120V, 125V, and 130V volt circuits. Besides the most popular A, or arbitrary, shape, other shapes include PS, or pear straight. Halogen capsule versions of A-type shapes provide slightly better efficacy than standard incandescents.

Decorative shapes include FL (flame), B (bulbular), and G (globe). These are usually less efficient than standard incandescents, and efficient design will use low-wattage versions if necessary. The T (tubular shape) has been used in exit signs and for illuminating mirrors and pictures, which can also use linear and compact fluorescents if color is appropriate.

Tungsten halogen lamps are also available in noncapsule versions. Single-ended T3 and T4 tungsten halogen lamps range from 75 to 1500 watts, with the mini-candelabra screw base being the most common base. Double-ended tungsten halogens are linear shapes ranging up to 1500 watts. Small, low-voltage halogen type lamps are often used in reflectorized luminaires; usually under 2 in. in length, they use bipin bases, and range from 5 to 150 watts. IR versions of some linear halogen wattages provide substantial energy savings.

**REFLECTOR SOURCES**

The most popular flood and spot lamps were R (reflector) shapes, both R30 and R40 sizes. Flood R30 lamps had a beam spread of 130 degrees and much of the light in the outer part of the beam was often trapped in luminaires, especially recessed luminaires. Most are no longer manufactured. The newer ER (ellipsoidal reflector) and BR (bulged reflector) shapes maintain more lumens in the center of the beam than the R design.

PAR (parabolic reflector) lamps use a hard glass outside lens and are available in both "spot" (smooth glass lens) and "flood" (stippled lens) versions. Halogen versions range from 35 to 120 watts, in PAR16, 20, 30, and 38 shapes, all of which use a medium screw socket. Beam spread ranges from 8 to 50 degrees. Other designations such as FL (flood), SP (spot), V (very), N (narrow), and W (wide) may not be standardized, and rated beam spreads should be verified. Halogen infrared technology is available in some PAR38 versions and affords the highest efficacy among incandescent reflectors.

Small, low-voltage halogen reflector lamps, usually 12 volts, are used in luminaires with transformers for the purpose. MR11 and MR16 shapes, originally used in slide projectors, became popular in display and other accent lighting applications. Wattages range from 20 to 75. Like line-voltage halogen PARs, MRs come in a very wide range of beam spreads.

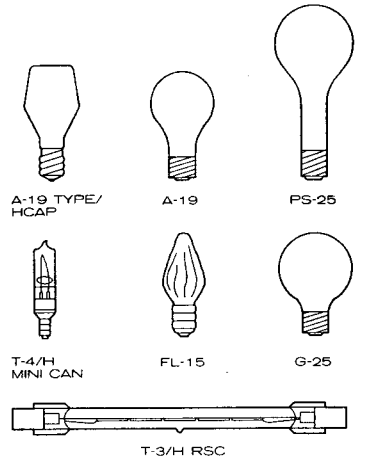

AREA SOURCES

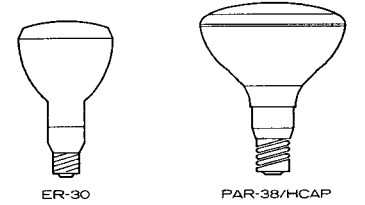

ER-30

PAR-38/HCAP

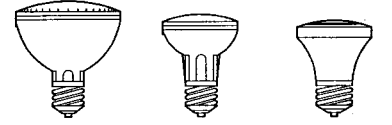

REFLECTOR SOURCES

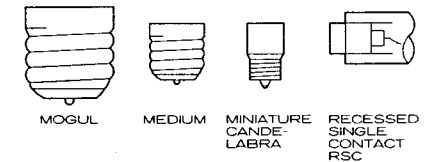

BASES

**REPRESENTATIVE INCANDESCENT SHAPES**

**REFLECTOR INCANDESCENT LAMPS REPRESENTATIVE LAMP RATINGS**

SHAPE/BEAM/HALOGEN	WATTS	CENTER-BEAM CANDLE-POWER	BEAM SPREAD TO 50% OF MAX.	HOURS LIFE	MAXIMUM OVERALL LENGTH (IN.)
MR16/NSP/H 12V	20	5000	8	2000	1.75
PAR20/NFL/HCAP	35	900	30	2500	3.25
PAR38/SP/HCAP	45	5500	12	2500	5.31
PAR20/NFL/HCAP	50	1250	30	2500	3.25
PAR30/WFL/HCAP (long-neck)	50	500	50	2500	4.69
PAR38/FL/HCAP IR	60	3650	30	3000	5.31
R30/FL*	75	470	130	2000	5.38
ER30	75	1500	36	2000	6.38
PAR30/FL/HCAP	75	2000	40	2500	3.63
PAR38/FL/HCAP	90	3750	30	2500	5.31
R40/FL*	100	900	120	2000	6.50
PAR38/FL*	150	4000	30	2000	5.31

\* These lamps no longer manufactured, shown as reference.

**NOTE**

All with medium base except MR.

Fred Davis, C.I.E.P.; Fred Davis Corp., Energy and Lighting; Medfield, Massachusetts

**AREA INCANDESCENT LAMPS REPRESENTATIVE LAMP RATINGS**

SHAPE/HALOGEN/BASE	WATTS	INITIAL LUMENS	HOURS LIFE	MAXIMUM OVERALL LENGTH (IN.)
A15/medium	15	115	2500	3.50
G25/medium	40	410	1500	4.50
A19 type/HCAP/med.	52	770	3500	4.38
A19/medium	60	860	1000	4.44
A-19/medium	75	1180	750	4.44
A21/medium	100	1690	750	5.25
PS25/medium	150	2650	750	6.94
T4/H/mini-can	150	2800	2000	3.00
T4/H/mini-can	250	5000	2000	3.16
T3 linear/HIR/RSC	350	10,000	2000	4.69
T3 linear/H/RSC	500	11,100	2000	4.69
PS40/mogul	500	9100	1000	9.75

H=halogen; CAP=capsule; IR=infrared reflective film

**HIGH-INTENSITY DISCHARGE**

High-intensity discharge (HID) lamps are the most common electric lights other than incandescent and fluorescent. In rough order of increasing efficacy, the categories of HID lamps include mercury vapor, metal halide, high-pressure sodium, and low-pressure sodium. The highest efficacies among them, however, have the poorest color qualities.

Like fluorescents, HID lamps use a ballast to provide proper starting and operating voltages. Light is produced by an electric arc discharging through a mixture of gases. Unlike fluorescents, HID lamps use a fairly compact arc tube that operates under very high temperature and pressure. The small point source makes HID lamps and luminaires compact and powerful. Most are particularly suited to outdoor applications or large rooms with high ceilings, as long as frequent switching is not needed. Clear lamps offer best optical control; coated lamps offer more diffuse light.

Unlike incandescents and fluorescents, HID lamps require a warmup period to reach full light output. After power is applied, temperature and pressure in the mixture of gases and metals gradually builds, forcing vapors into the arc and releasing light. Depending on lamp type, warmup, ranges from 2 to 15 minutes. If power is extinguished, HID lamps must cool before the arc can restrike. Restrike time lasts from 1 to 15 minutes, depending on lamp type. A few "instant restrike" types are available.

Over time, HID lamps may shift in color and the lumen output of some may drop substantially. For these, lamp change-outs should be planned well before the end of rated life. Rating the life of HID lamps is based on 10-hour cycles, as opposed to the three hours for rating incandescents and fluorescents. As with fluorescents, strobe effects with moving machinery should be avoided. HID lamps may have medium, mogul, or numerous other base types. A very few specialized types may be interchanged with metal halide, high-pressure sodium, and mercury vapor lamps.

**METAL HALIDE**

Originally developed in 1965, metal halide technology has continually improved. Today, its high efficacy and good color qualities make metal halide the best choice for many indoor and outdoor applications.

Common metal halide lamps have a color temperature of around 3500-4300K, and a CRI of 65-70. In addition, there are warm color lamps, 2700-3200K. In the early 1990s, some metal halide lamps were developed with very high CRIs, up to 93. Wattages range from 32 to 1500 watts, with a large variety of lamp and base configurations.

Metal halide lamps contain various metal halides and mercury. When the halide vapor approaches the high temperature in the central core of the arc, it dissociates into the halogen and the metal, with the metals radiating the appropriate spectra. Most metal halide lamps must be used in luminaires made to withstand an explosive rupture of the arc tube. Many should be used in luminaires that include a device to automatically turn the lamp off if the fixture is opened or broken. Most lamps should be turned off for a minimum of 15 minutes at least once per week.

Varieties of metal halide lamps include universal position burning, lamps optimized for burning in specific positions, cool or warm color temperatures in clear or phosphor coatings, safety lamps that extinguish if the outer envelope breaks, lamps with internal shielding that can withstand a rupture of the arc tube for use in open luminaires, and compact lamps that produce a high CRI in a small arc tube.

Electronic ballasts available for some metal halide types offer lighter weight, increased efficacy of 4-10%, less flicker, improved color and lumen maintenance, and increased life. Metal halide lamps with ceramic arc tubes have recently been introduced. These provide improved color control, more than 80 CRI, and higher efficacy.

**HIGH-PRESSURE SODIUM**

High-pressure sodium (HPS) lamps are highly efficacious, ranging from 65 to 125 lumens per watt (including ballast losses). They have a gold-pink color, 1900-2100K. CRI is poor, under 25. They are used where color rendering is not critical—in street, security, and industrial lighting.

Using xenon gas as an aid in starting, HPS lamps produce light by electric current passing through vaporized sodium. HPS lamps do not need enclosure (except from precipitation), and are fairly insensitive to operating position. So-called "deluxe" HPS have a CRI of 65. "White" HPS lamps of 2500-2800K have a CRI over 75. These improvements in color quality come at the cost of efficacy.

**ALL LAMPS—COMPARISON OF GENERAL CHARACTERISTICS**

LAMP TYPE	LAMP LUMENS PER WATT	HOURS LIFE	COLOR RENDITION	RELIGHT TIME
Incandescent	10 - 30	750 - 4000	Excellent	Immediate
Fluorescent	55 - 100	7500 - 24000	Good to excellent	Immediate
Metal halide	80 - 125	3000 - 20000	Good to excellent	10-15 min.
High-pressure sodium	65 - 140	16000 - 24000	Fair	Less than 1 minute
Low-pressure sodium	up to 180	18,000	Nonexistent	0-5 minutes
Mercury vapor	30 - 63	16000 - 24000	Fair to good	3-5 minutes

**HID LAMPS—REPRESENTATIVE LAMP RATINGS**

HID/SHAPE/BASE*	WATTS	INITIAL LUMENS	HOURS LIFE	CRI	MAX. OVERALL LENGTH (IN.)
M/ED-17/medium	70	5,200	15000	65	5.44
M/ED-17/medium	70	6,200	10000	85	5.44
M/T-6 1/2/RSC	70	5,000	10000	85	
M/ED-17/medium	100	8,500	15000	65	5.44
M/ED-17/medium	100	9,200	10000	85	5.44
M/ED-17/medium	150	10,800	15000	65	5.44
M/BT-28/mogul	175	11,600	15000	65	5.44
M/BT-28/mogul	250	22,000	10000	65	8.31
M/BT-37/mogul	400	36,000	12000	65	8.31
M/BT-37/mogul	1000	110,000	12000	65	11.50
S/ED-17/medium	70	6,300	24000	21	5.44
S/ED-17/medium	100	9,500	24000	21	5.44
S/ET-23 1/2/mogul	150	16,000	24000	21	5.44
S/ET-18/mogul	250	24,000	24000	21	9.75
S/ET-18/mogul	400	50,000	24000	21	11.50
S/E-25/mogul	1000	140,000	24000	21	15.06
L/T-17/BY22d	35	4,800	18000	NA	12.19
L/T-21/BY22d	90	13,500	18000	NA	20.75
H/A-23/medium	100	4,300	24000	45	5.44
H/ED-28/mogul	250	12,100	24000	45	8.31

\*M = metal halides; S = high-pressure sodium; L = low pressure sodium; H = mercury.

**LOW-PRESSURE SODIUM**

Low-pressure sodium (LPS) lamps were first introduced in 1932 and have the highest efficacy of any light source available. However, the most important characteristic of LPS lamps is that they are monochromatic. The starting gas is neon, which emits a reddish glow as the lamp heats up. At full output, light from LPS is monochromatic yellow, and there is no color rendering ability. LPS comes in tubular lamps, from 18 to 180 watts, and is used for security and some roadway lighting.

**MERCURY VAPOR**

Developed in the early 1900s, mercury vapor is the least efficient of the HID sources. The technology involves excitation of mercury in a vaporized state. It is available in clear or phosphor coatings. The phosphors work much as they do with fluorescents, to convert ultraviolet to visible light and to improve color rendering. Because efficacy and color quality is so much better, metal halide is preferred over mercury vapor in most situations.

**OTHER LAMP TYPES**

Electrodeless lamps first appeared commercially in the 1990s. These are sources excited by electromagnetic energy passing through the glass lamp without using an electrode. Coupling energy into a lamp at high frequencies forms plasma conditions that allow long life and fairly high efficacies. However, these high-frequency and microwave-powered sources must contain radiation within the lamp. The first products range from 23 to 85 watts, with efficacies from 48 to 70. Prototypes of a high-wattage sulfur lamp have shown the potential for high efficacy.

Other efficient lamp types are used in applications requiring low lumen levels, such as in exit signs. Energy consumption in exit signs is important because they are on continuously. Very low wattages allow an exit sign to use under 2 watts, compared to 20-50 watts with incandescent lamps.

Small light-emitting diodes (LEDs) are p-n junction semiconductor lamps. First used as indicator lights, they are now available in exit sign strips. Electroluminescent lamps are thin, flat area sources in which light is produced by a phosphor excited by a pulsating electric field. Typically, green panels are used in LED exit signs. Radioactive tritium tubes are self-contained sources requiring no power supply.

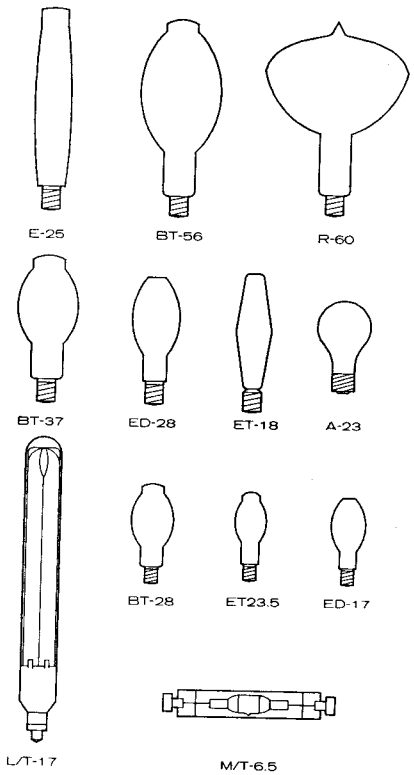

**REPRESENTATIVE HID SHAPES**

**GENERAL**

Horizontal telecommunications cabling may be routed between telecommunications closets and workstations via access floors, cellular decks, ceiling plenums, and under-carpet schemes. Access floor distribution facilitates the installation of future cabling as well as the movement of floor boxes and cable feed-throughs to accommodate furni-

ture relocations. Cellular decks provide similar underfloor cable pathways, yet lack the flexibility of relocatable floor boxes. Other distribution approaches include under floor, plenum routing, which requires poke-through fittings for access to workstations, and ceiling routing which is most appropriate for drywall installations. Under-carpet distribution utilizes special cable to provide a relocatable cabling system with minimal modifications to building structures.

Telecommunications closets provide the transition points between riser and horizontal cabling and accommodate associated cable termination hardware and transport electronics. Closets should be designed with respect to service area, environmental, lighting, fire protection, security, and cable pathway requirements. Overhead cable tray, access floors, and D-rings facilitate cable distribution.

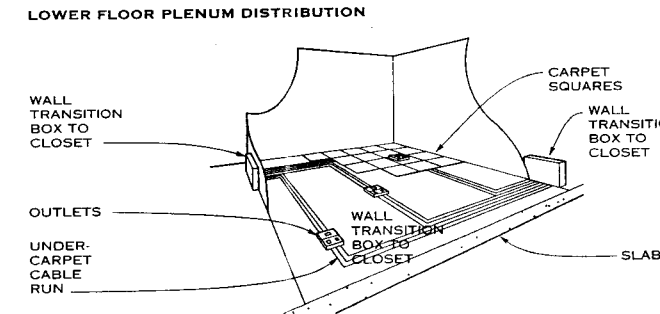
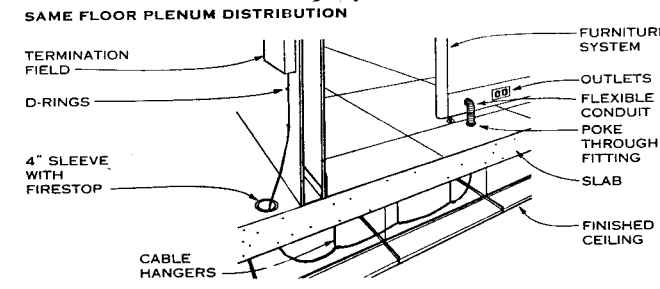
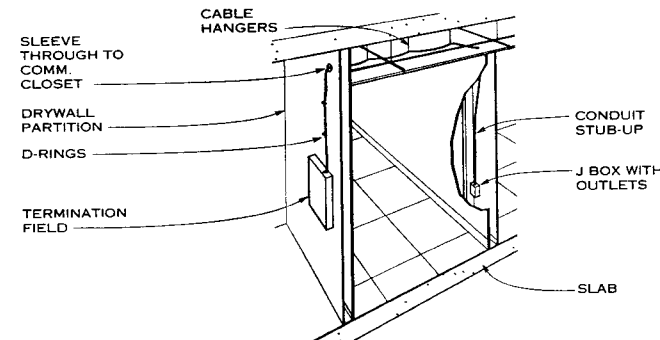
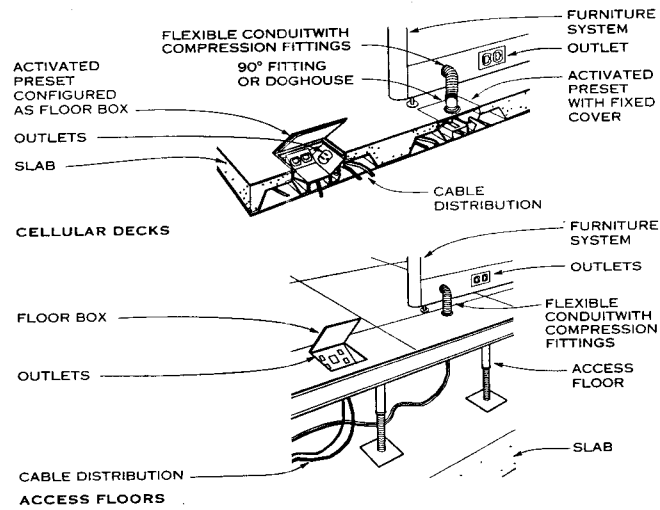

**UNDER-CARPET DISTRIBUTION SYSTEMS  
HORIZONTAL CABLE DISTRIBUTION**

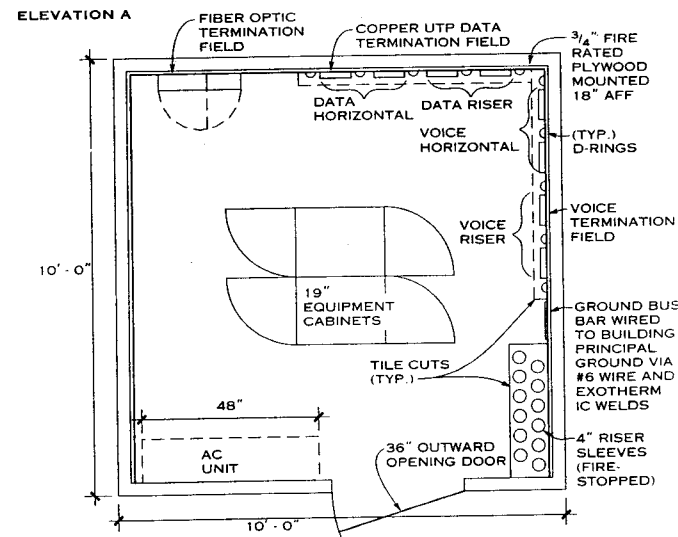
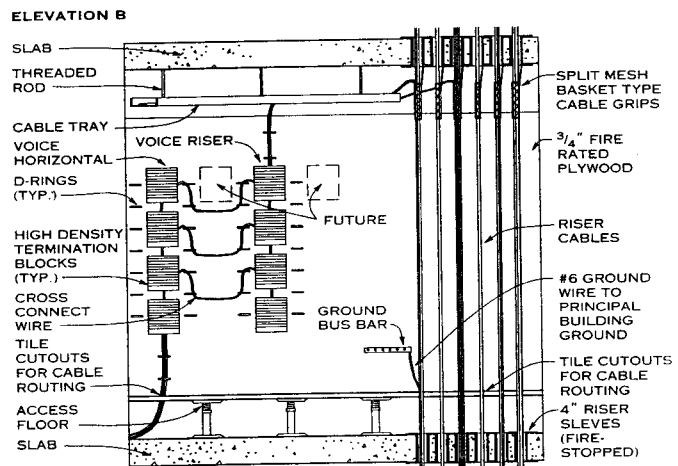
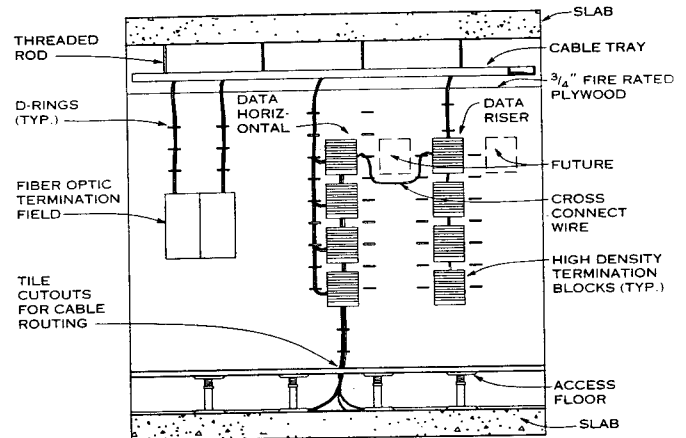

**PLAN  
TELECOMMUNICATION CLOSET**

Flack + Kurtz, Consulting Engineers; New York, New York

# SPORTS AND GAME FACILITIES

Field Sports 760

Aquatics 781

Track and Field 770

Equestrian 790

Court Sports 772

Ice and Snow Sports 791

Table and Bar Sports 780

Target Shooting and Fencing 794

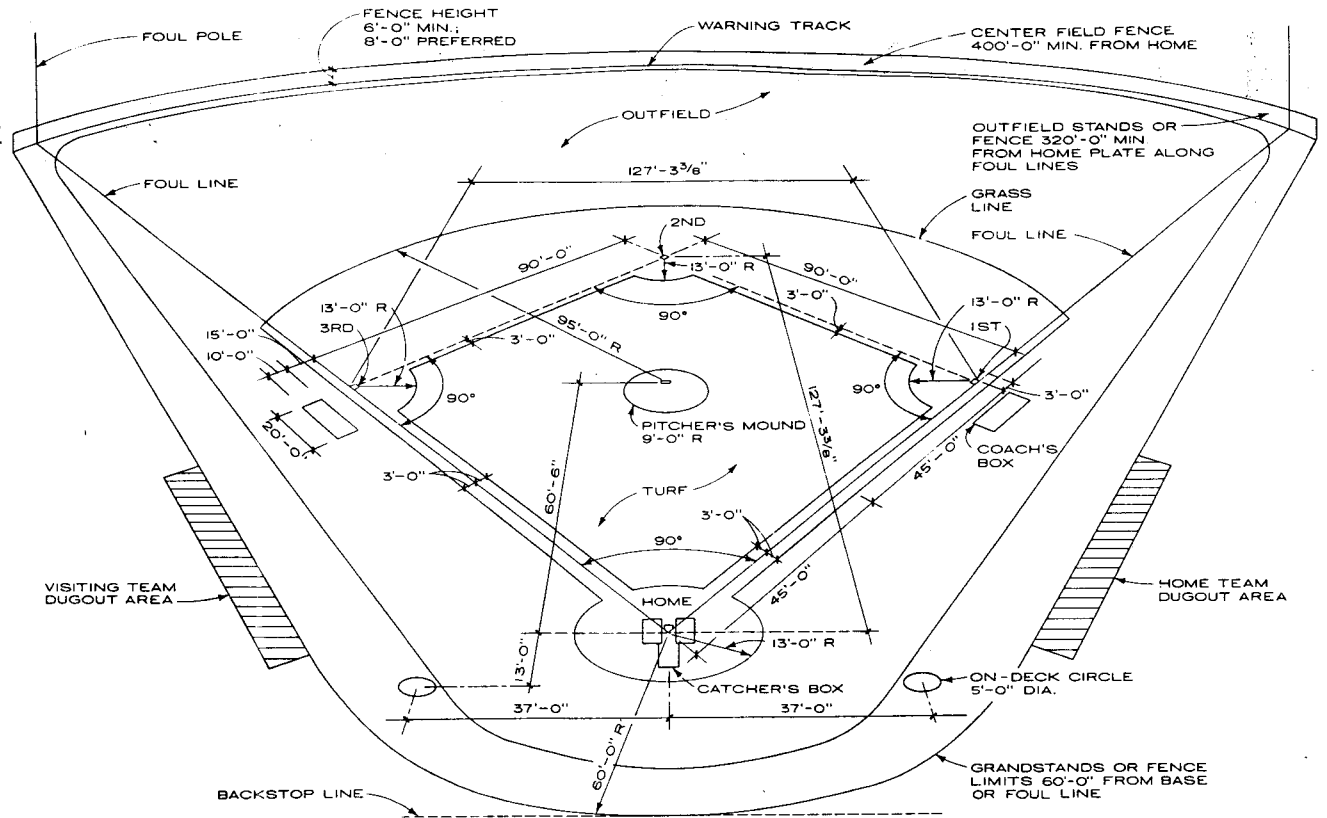

**NOTE**

This information is for preliminary planning and design only. For final layouts and design, investigate current rules and regulations of the athletic organization or other authority whose standards will govern.

**ORIENTATION**

No standard—consider time of day for games; months when played; location of field, surrounding buildings and stands. East-northeast recommended by NCAA (home plate to center field).

**BASEBALL FIELD**

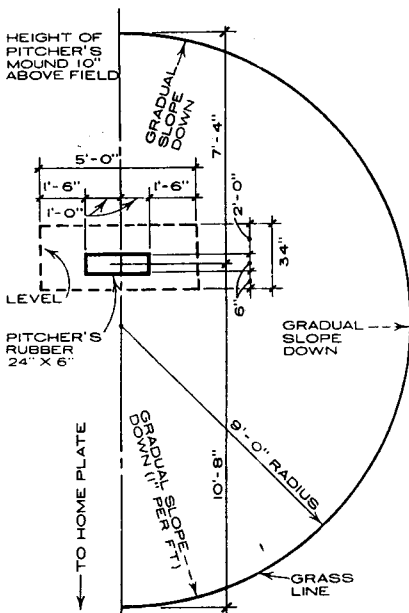

**DETAIL OF PITCHER'S MOUND**

Richard J. Vitullo, AIA; Oak Leaf Studio; Crownsville, Maryland

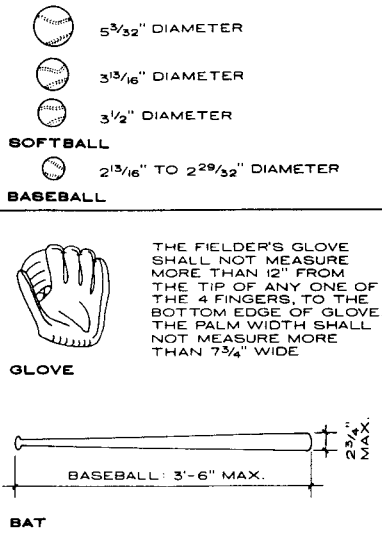

**BASEBALL EQUIPMENT**

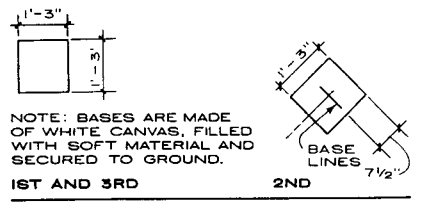

**BASES**

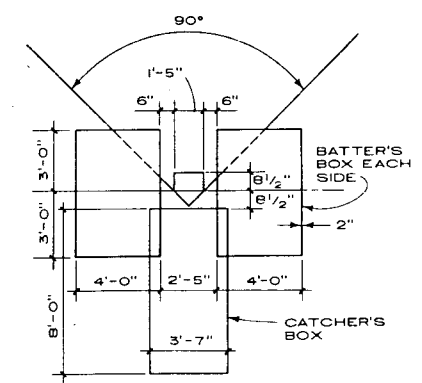

**DETAIL OF HOME BASE BATTER'S AND CATCHER'S BOX**

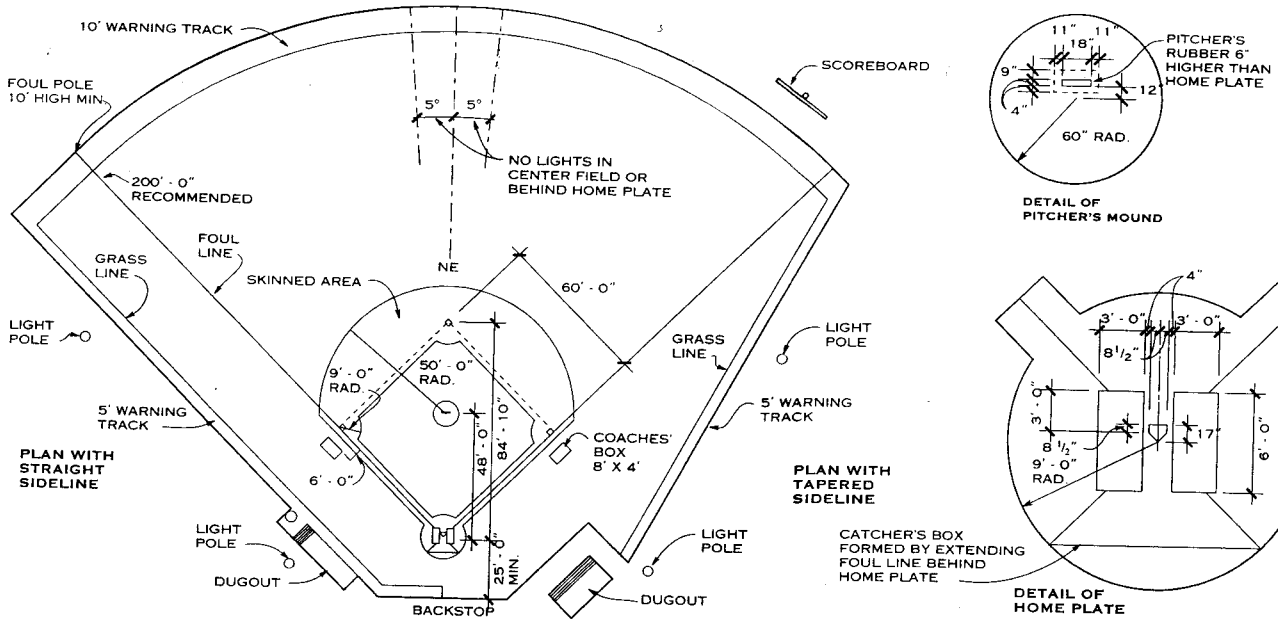

PLAN OF LITTLE LEAGUE BASEBALL FIELD

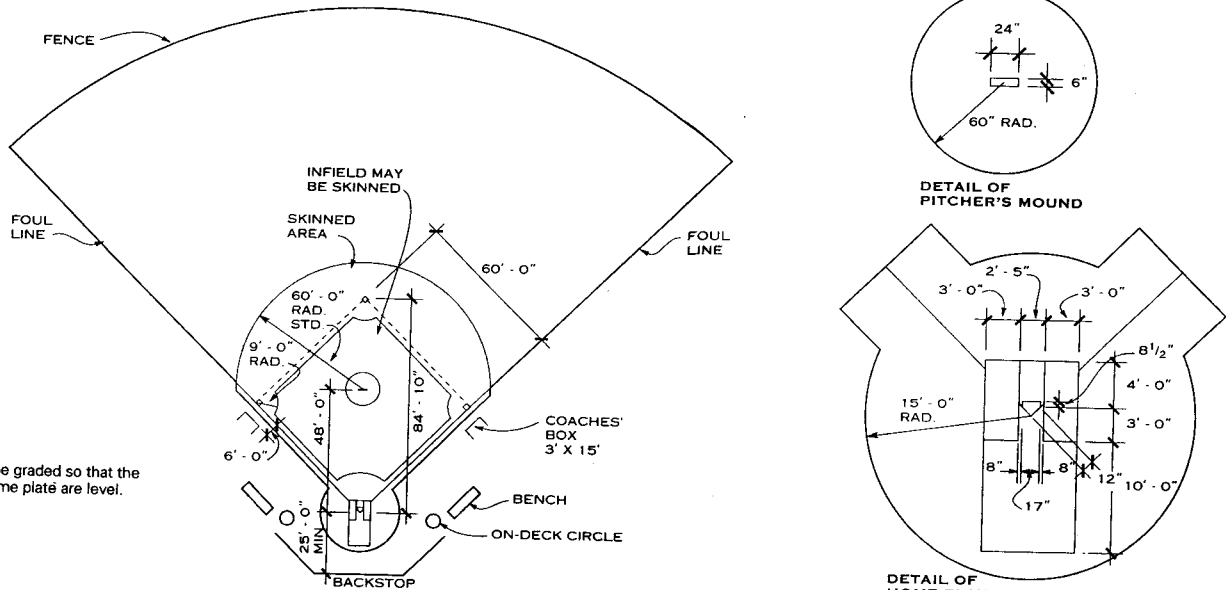

**NOTE**  
The infield shall be graded so that the baselines and home plate are level.

PLAN OF SOFTBALL FIELD

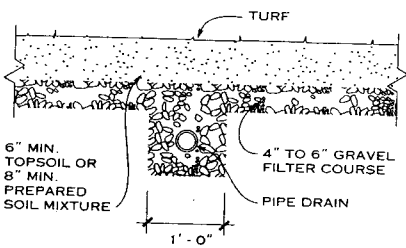

- NOTES**
1. Baselines should be level; if the diamond must pitch, the slope should not be more than 2% from third to first base, or vice versa. The minimum slope of turf areas outside the skinned area is 1% when there is good subsoil drainage, 2.5% when drainage is poor.
  2. The softball backstop is covered in detail on page 674.

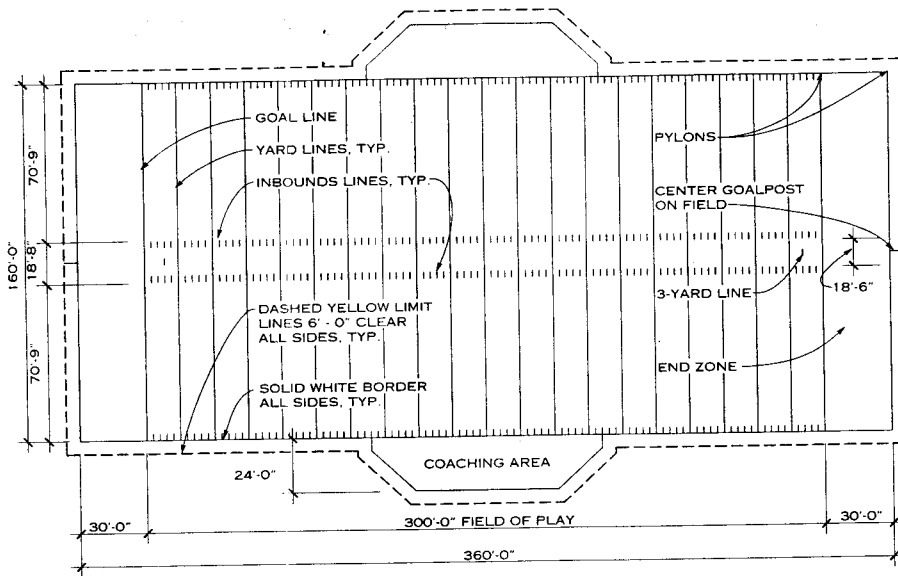

**NOTES**

1. In the National Football League (NFL), the playing field is 360 ft long by 160 ft wide. The preferred orientation of the field is with the long axis stretching northwest to southeast; there is no recommended slope. (For further information, contact the NFL in New York City.)
2. All lines are 4 in. wide, except the goal lines and yellow lines, which are 8 in. wide. All lines are marked with a nontoxic material.
3. The goalpost must be padded as prescribed by the NFL.

**NATIONAL FOOTBALL LEAGUE FIELD**

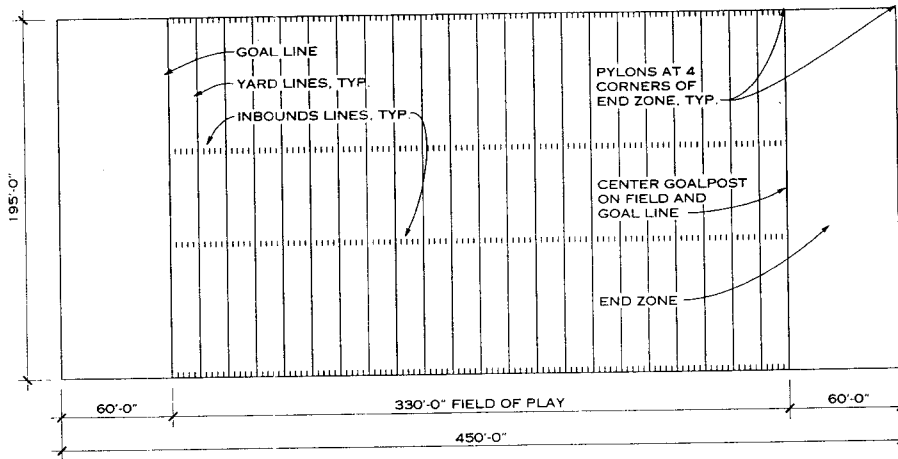

**NOTES**

1. In the Canadian Football League (CFL), the playing field is 450 ft long by 195 ft wide. The preferred orientation is with the long axis running northwest to southeast; there is no recommended slope. (For further information, contact the CFL in Toronto.)
2. All lines are 4 in. wide except the goal lines and yellow lines, which are 8 in. wide. All lines are marked with a nontoxic material.
3. The goalpost must be padded as prescribed by the CFL.

**CANADIAN FOOTBALL LEAGUE FIELD**

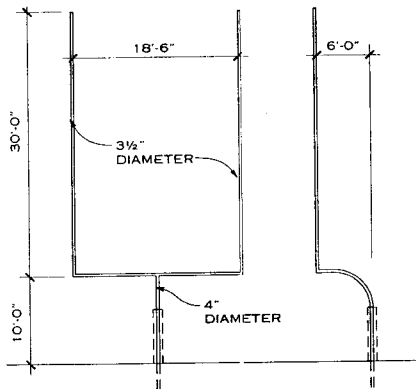

NFL, CFL, NCAA, AND HIGH SCHOOL

**NOTE**

Goalposts should be padded to 6 ft or as prescribed by the NFL or CFL. They should be yellow or white.

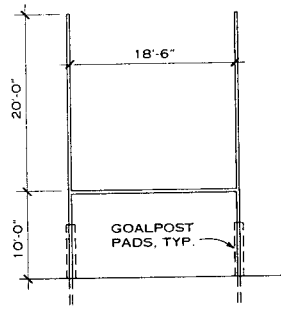

OPTIONAL NCAA AND HIGH SCHOOL

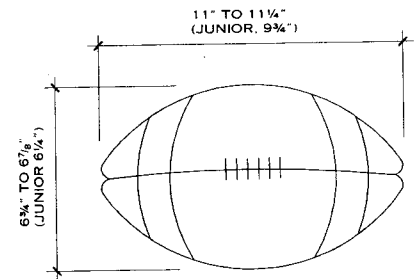

**NOTE**

The football is a prolate spheroid with a long axis of 11 to 11 1/4 in.; it weighs 14 to 15 oz.

**FOOTBALL**

**GOALPOSTS**

Dean Cox, AIA; Collins Rimer Gordon Architects; Cleveland, Ohio

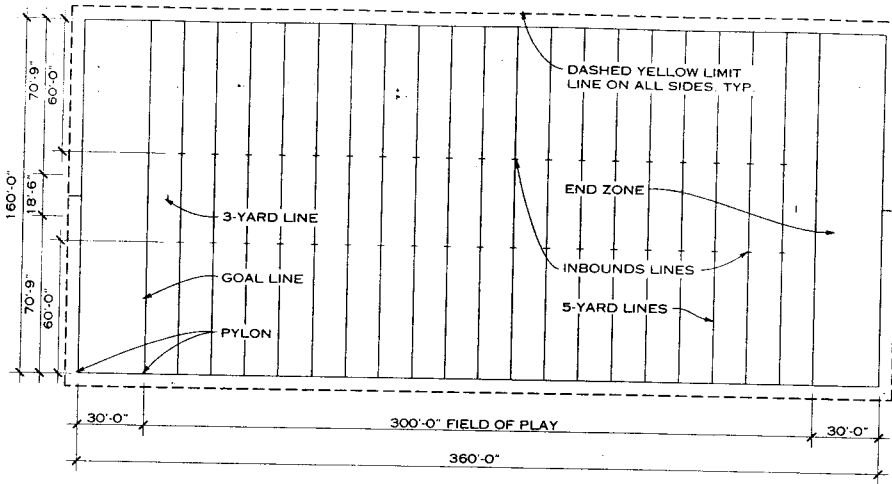

NATIONAL COLLEGIATE ATHLETIC ASSOCIATION FIELD

NOTES

1. In the National Collegiate Athletic Association (NCAA), the playing field is 360 ft long by 160 ft wide, with an additional 12 ft recommended (6 ft minimum required) on all sides. The preferred orientation of the field is with the long axis stretching northwest to southeast. The field should be graded away from the centerline; subsoil drainage may be necessary.
2. All field dimension lines are 4 in. wide and should be marked with a white, nontoxic material. All measurements are from the edge of the line closest to the center of the playing field.
3. End zone marking should not overlap goal lines, sidelines, and end lines.
4. Inbounds lines are located 60 ft from the sidelines for college football (53 ft 4 in. for high school). Marks should be 4 in. wide by 2 ft long.
5. Goalposts should be padded to a height of 6 ft. The color of the posts should be yellow or white.

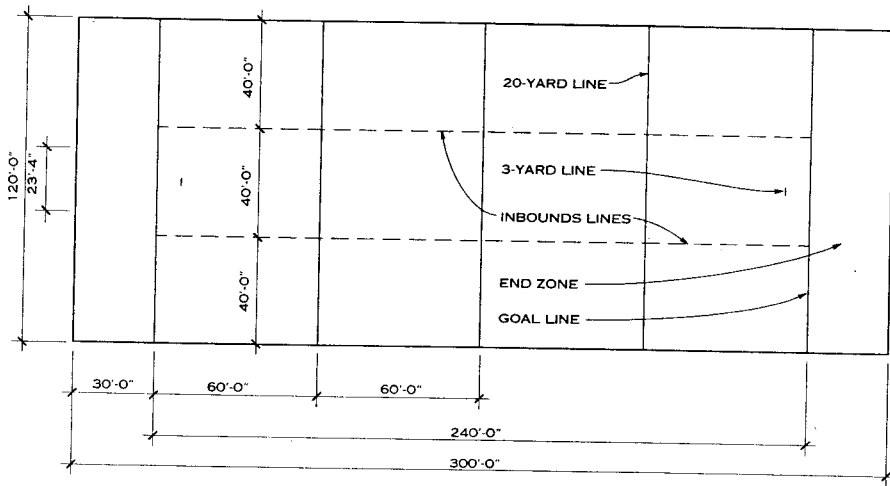

TOUCH FOOTBALL FIELD

NOTES

1. In touch football, the playing field is 300 ft long by 120 ft wide, with an additional 6 ft allowed on all sides. The preferred orientation is with the long axis running northwest to southeast; the recommended slope for proper drainage is 1%, which should run away from each side of the long-axis centerline.
2. All measurements are from the inside edge of the lines, which are 4 in. wide and marked with a white, nontoxic material.
3. The goalposts are similar to those used in college football.

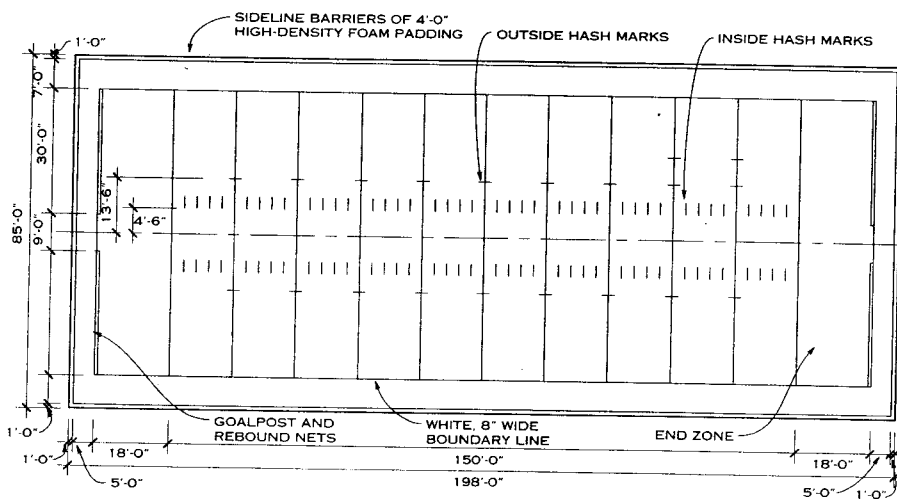

ARENA FOOTBALL FIELD

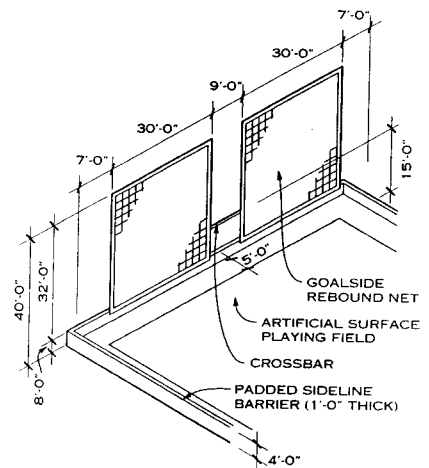

NOTE

The playing field is made of padded artificial turf. For more information, contact Gridiron Enterprises in Chicago.



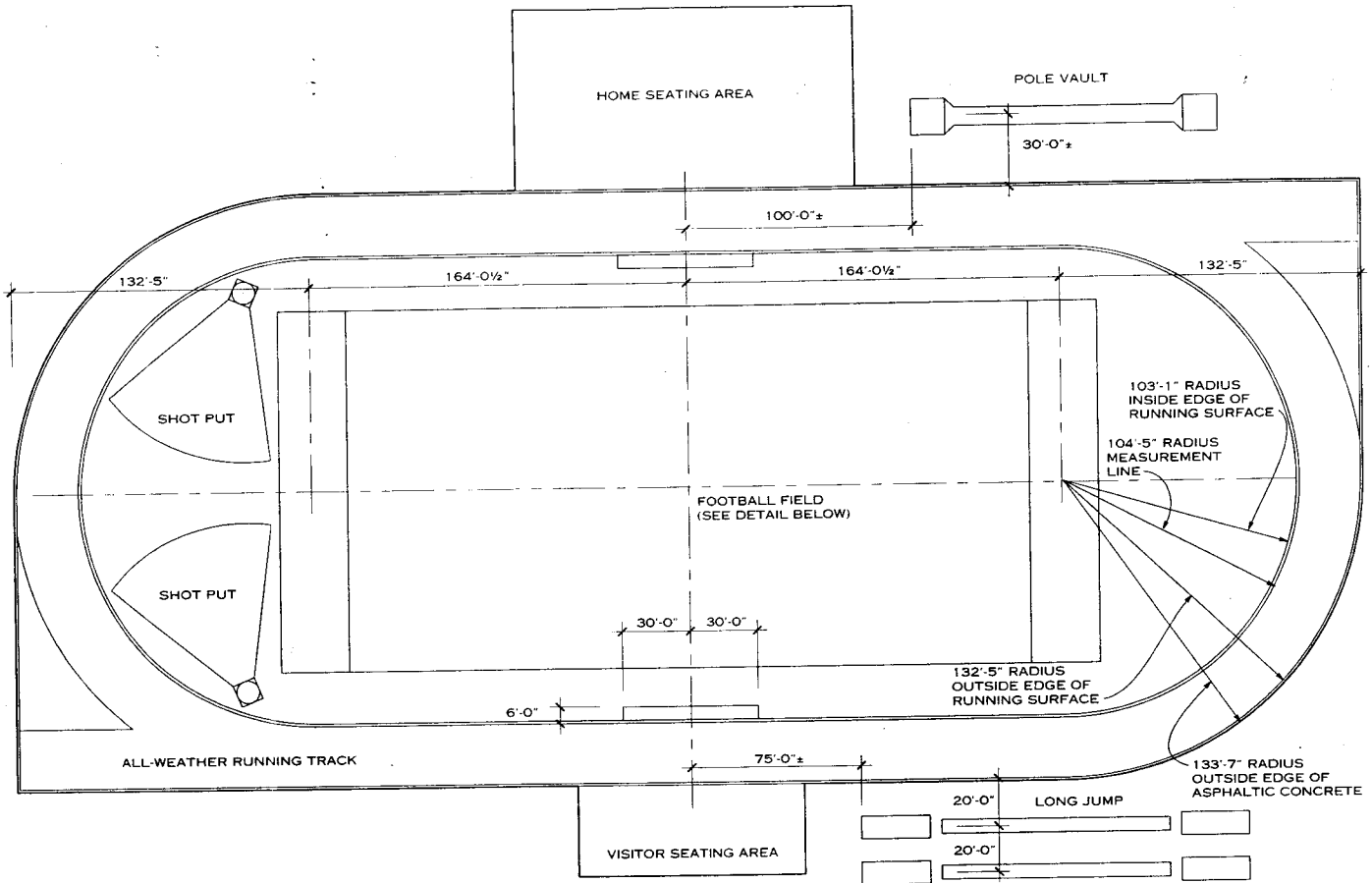

**NOTES**

1. The stadium layout shown is generic and should be modified to suit the needs of a particular project.
2. Lighting, drainage, and fencing systems are not shown on the layout illustrated, but they must be considered when applicable to a project.
3. Refer to other Architectural Graphic Standards sports pages for information regarding individual events that might be held in a multipurpose high school stadium.
4. Seating is shown here schematically; actual sizes should be based on the requirements of a project. It is recommended that the seating assembly be placed over concrete paved areas.
5. A chain-link fence, 4 ft high, is usually located outside the track area and extended around the remaining track and field events.
6. Striping is usually provided on the track to allow for measured lanes for running events.
7. Other support facilities include locker areas, restrooms, concession stands, and additional field equipment storage space.

**MULTIPURPOSE HIGH SCHOOL STADIUM**

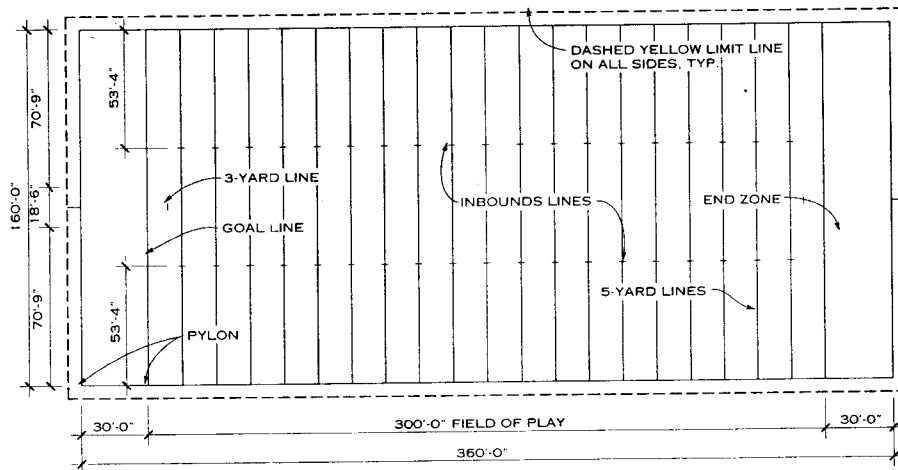

**NOTES**

1. In high school football, the field is 360 ft long x 160 ft wide, with an additional 12 ft recommended (6 ft minimum required) on all sides. The preferred orientation of the field is with the long axis stretching northwest to southeast. The field should be graded away from the centerline; subsoil drainage may be necessary.
2. All field dimension lines are 4 in. wide and should be marked with a white, nontoxic material. All measurements are from the edge of the line closest to the center of the playing field.
3. End zone marking should not overlap goal lines, sidelines, and end lines.
4. Inbounds lines are located 53 ft 4 in. from the sidelines for high school football (as compared to 60 ft for college football). Marks should be 4 in. wide x 2 ft long.
5. Goalposts should be padded to a height of 6 ft. The color of the posts should be yellow or white.

**HIGH SCHOOL FOOTBALL FIELD**

Dean Cox, AIA; Collins Rimer Gordon Architects; Cleveland, Ohio  
Behnke Associates, Inc. Landscape Architects/Planners; Cleveland, Ohio

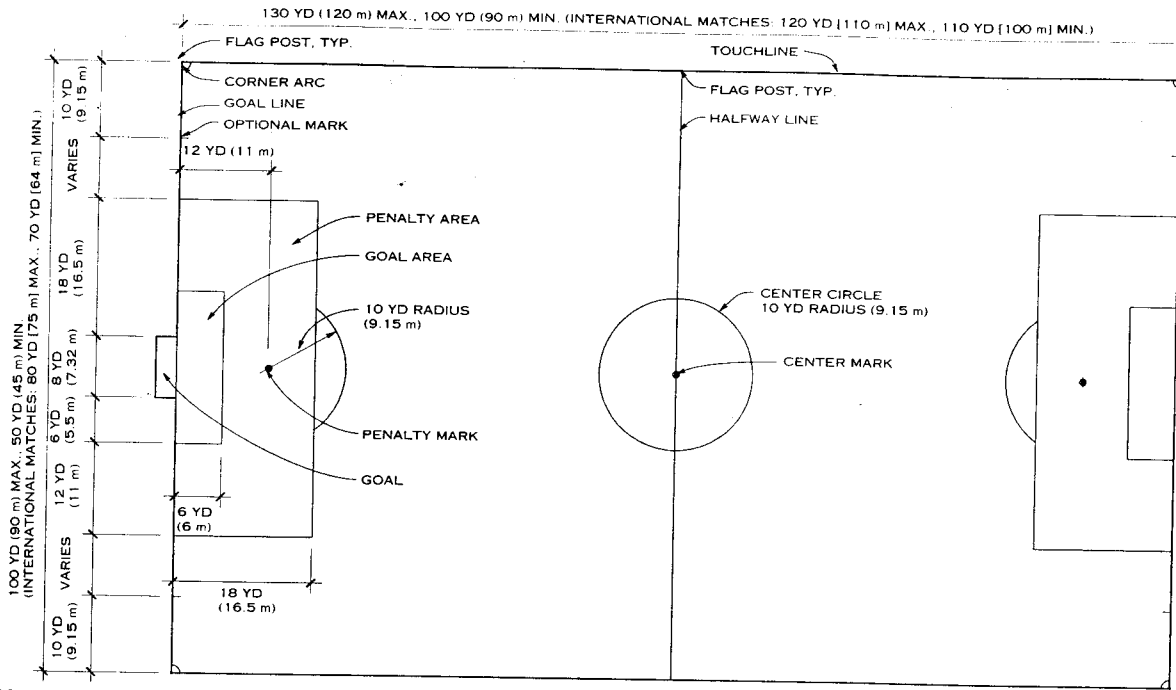

**NOTE**

The dimensions given are in accordance with regulations of the United States Soccer Federation (USSF) and the Federa-

tion Internationale de Football Association (FIFA). All field marking lines should be no more than 5 in. (12 cm) wide.

**PROFESSIONAL SOCCER**

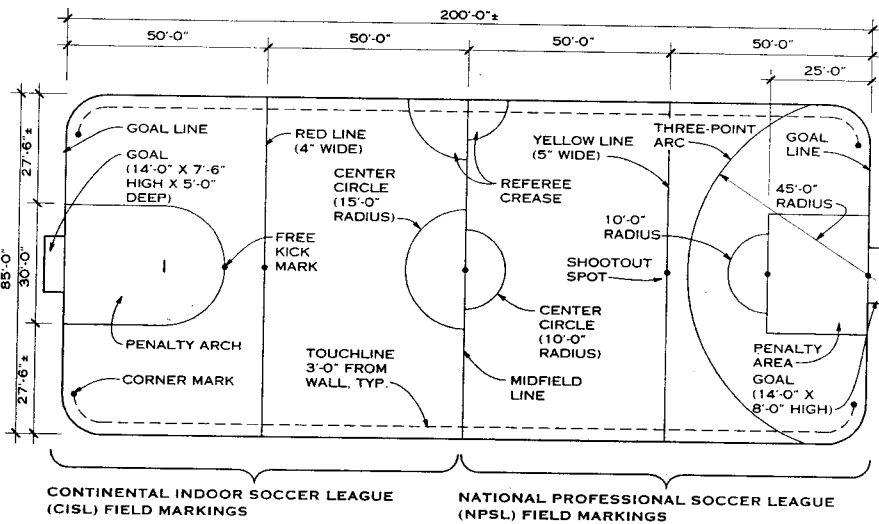

**NOTE**

Indoor soccer, in both the USSF or the FIFA, is typically played in hockey arenas within the existing rink walls on an

artificial playing surface affixed to the rink surface.

**INDOOR SOCCER**

**NOTES**

- Professional soccer balls are 27 in. (68.58 cm) in circumference and weigh 14-16 oz (396-453 grams).
- In the northern hemisphere, the length of the field should be oriented northwest-southeast for the best sun angle during the fall playing season.

- The preferred drainage on a field is a longitudinal crown with a 1% slope from the center to each side.
- In addition to the architectural differences between them, indoor and outdoor soccer are very different in nature. Refer to the appropriate governing bodies for details.

U.S. Soccer Federation; Chicago, Illinois

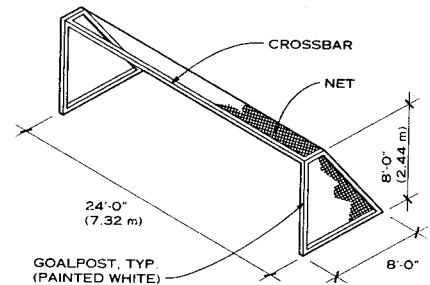

**NOTES**

- The goalposts and crossbar must not be wider than 5 in. or narrower than 4 in. and must present a flat surface to the playing field. The net must be attached to the ground, the goalposts, and the crossbar, and it must extend back from and level with the crossbar for 2 ft (61 cm).
- Indoor soccer goals measure 14 ft wide (inside the posts) and 7 ft 6 in. from the playing surface to the underside of the crossbar.

**SOCCER GOAL**

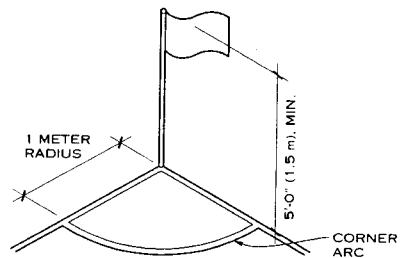

**NOTE**

Use of a corner flag post is compulsory.

**CORNER FLAG POST**

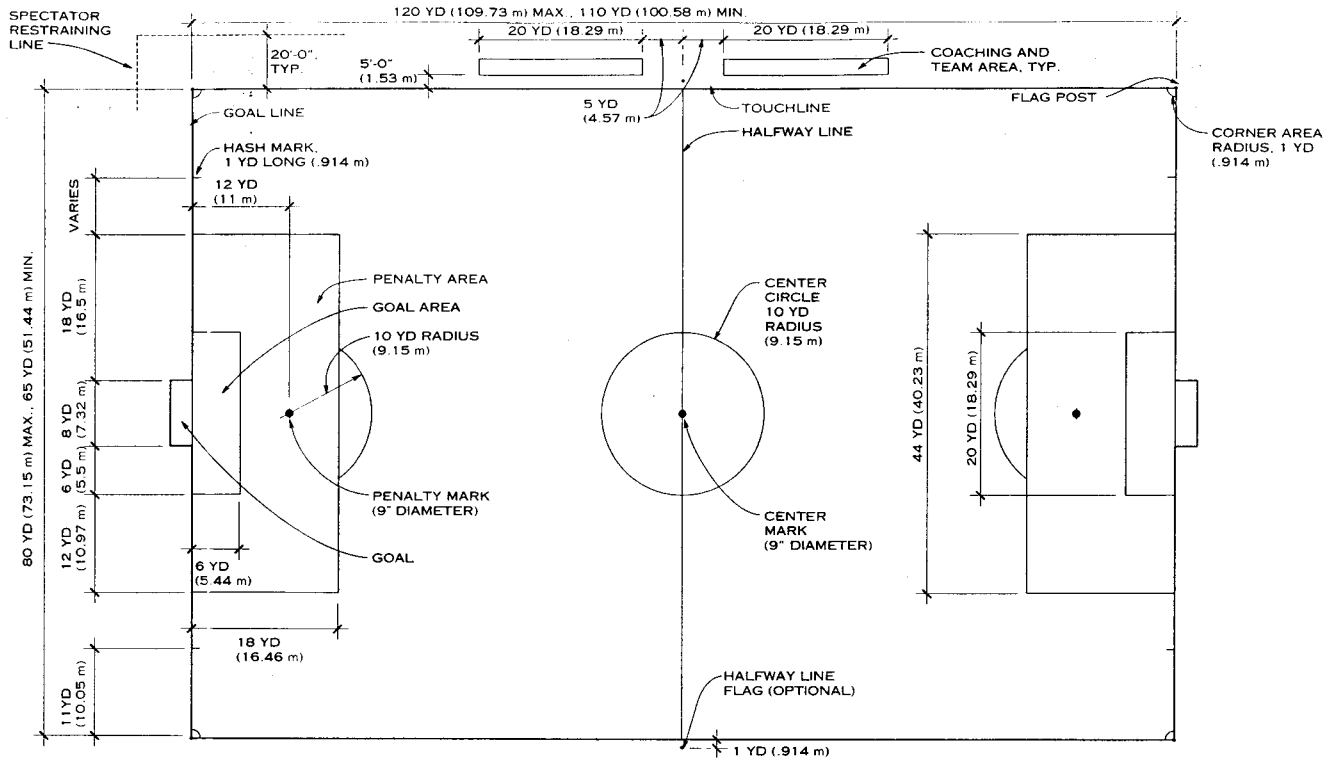

**NOTE**

For new facilities, the minimum width of the field should be 70 yd (64.01 m) and the minimum length 115 yd (105.15 m).

Recommended field dimensions are 75 yd (68.58 m) wide x 120 yd (109.73 m) long.

**NCAA SOCCER**

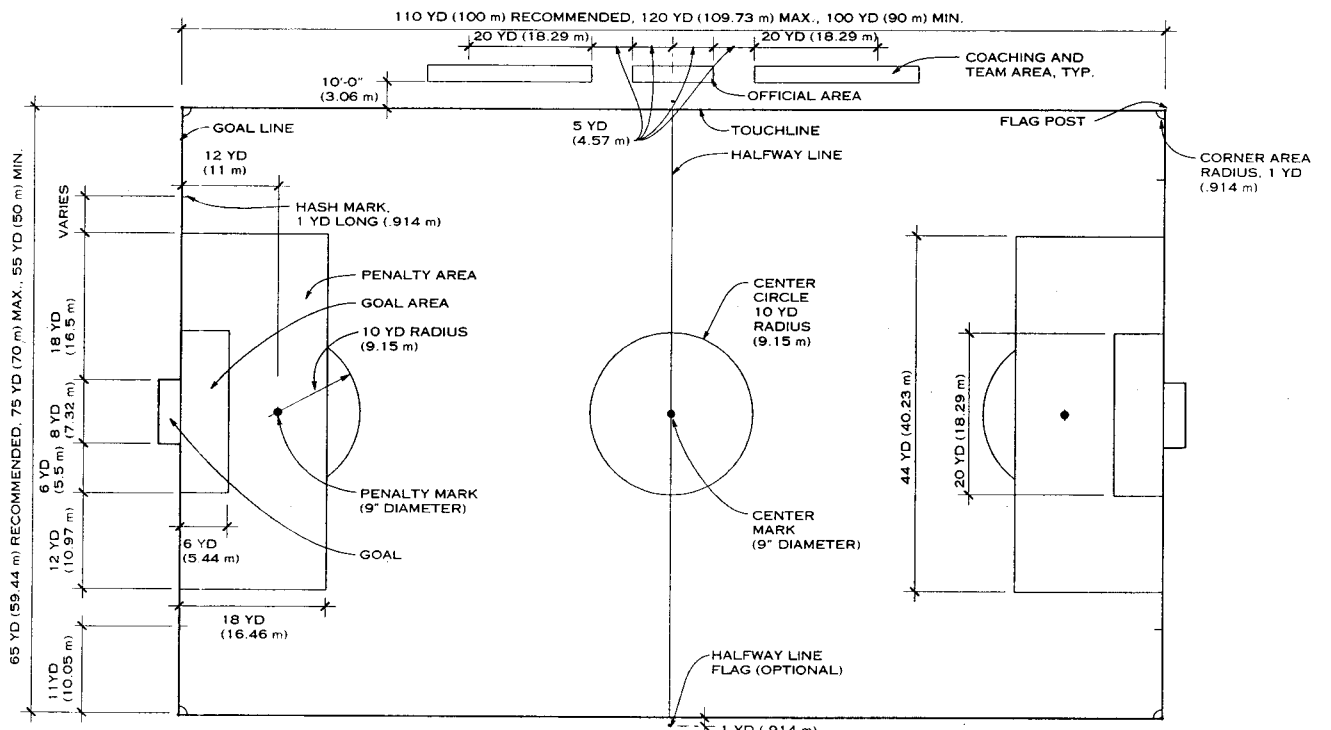

**NOTE**

Recommended field dimensions for middle school soccer are 55 yd (50 m) wide x 100 yd (90 m) long. Field marking lines should be 4 in. (0.10 m) wide.

**HIGH SCHOOL SOCCER**

U.S. Soccer Federation; Chicago, Illinois

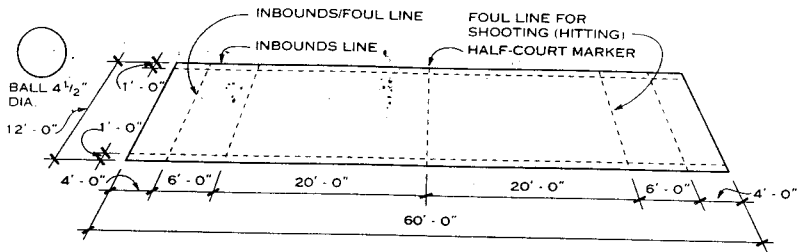

**BOCCE**

The playing field is 60 x 12 ft (18.28 x 3.65 m). Although orientation is of minor importance, it is preferred that the long axis run north-south. The surface should be flat without slope when it is stone, dust, or clay with adequate under-drainage and 1% slope in any direction when turf.

The ball is 4 1/2 in. in diameter and weighs 32 oz.

Further information is available from the International Bocce Association, Inc.

**BOCCE BALL (BOCCIE)**

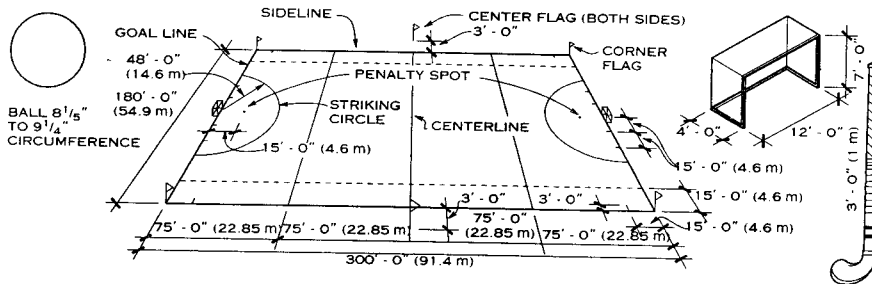

**FIELD HOCKEY**

The playing field is 300 x 180 ft (91.4 x 54.9 m) with an additional 10 ft (3.05 m) safety zone recommended on all sides. The preferred long axis orientation is northwest-southeast. Recommended grading is a 1% slope on each side of the longitudinal axis. All measurements shown are from the inside edge of the lines. Lines are 3 in. wide and marked with a white, nontoxic material.

The field hockey ball is 8 1/8 to 9 1/4 in. (20.8 - 23.5 cm) in circumference and weighs 5 1/2 oz. (155 g). The stick is 3 ft (1 m) long with a wooden head and cane handle with a cork or rubber insert.

Further information is available from the U. S. Field Hockey Association.

**FIELD HOCKEY**

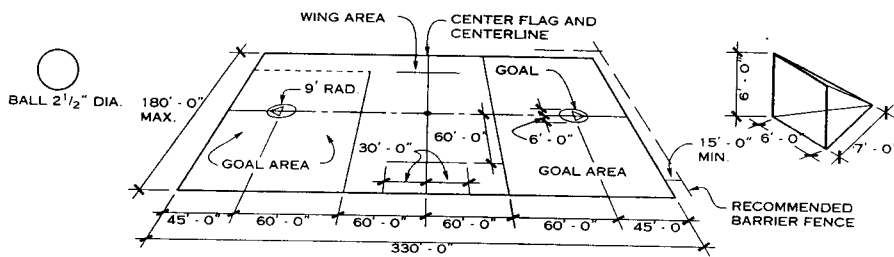

**LACROSSE**

The playing field is 300 ft (100.58 m) long and from 160 to 180 ft (48 - 55m) wide, with an additional 15 ft (6.10 m) recommended on all sides. The preferred long axis orientation is northwest-southeast and preferred drainage is a 1% slope away from each side of the longitudinal axis. All dimensions shown are to the inside of the lines except for the centerline. Lines are 2 in. wide and marked with a white, nontoxic material. Flexible flag markers are placed at each corner and on field sidelines at the centerline.

Diameter of lacrosse ball is 2 1/2 in.; the stick is 3 to 6 ft in length.

Further information is available from the National Collegiate Athletic Association.

**LACROSSE**

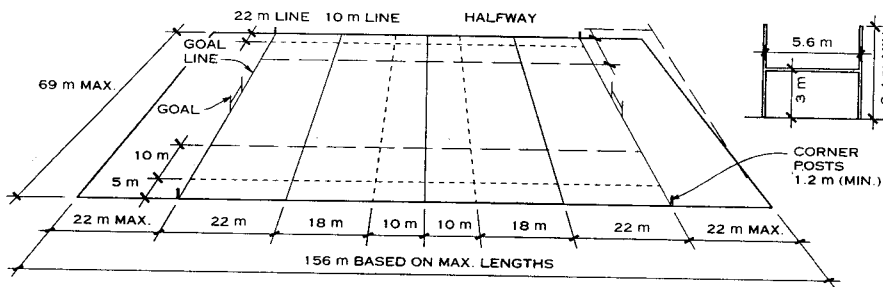

**RUGBY**

The playing field is 156 x 69 m with an additional 3 m safety zone recommended on all sides. The preferred long axis orientation is northwest-southeast; recommended grading is a 1% slope from each side of the axis. All measurements are from the inside line edges, which are marked with a white, nontoxic material.

**RUGBY**

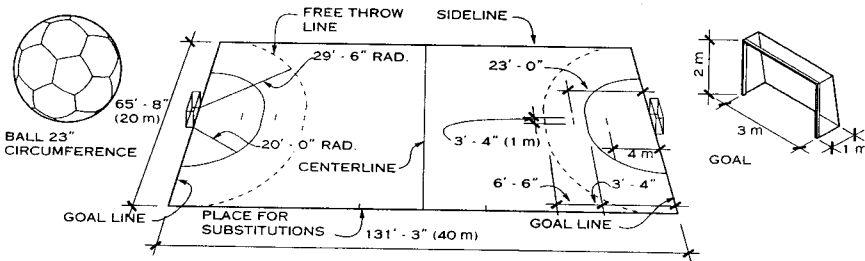

**TEAM HANDBALL**

The playing field is 131 ft 3 in. x 65 ft 8 in. (40 x 20 m), with an additional 6 ft (2 m) unobstructed space on all sides. Preferred orientation is northwest-southeast along the longitudinal axis with a 1% slope away from each side of that axis. All dimensions shown are from the inside line edges except the centerline. All lines are 2 in. wide and marked with a white, nontoxic material.

The men's handball is 23 in. (58.4 cm) in circumference and weighs 16 oz. (453.6 g).

**TEAM HANDBALL**

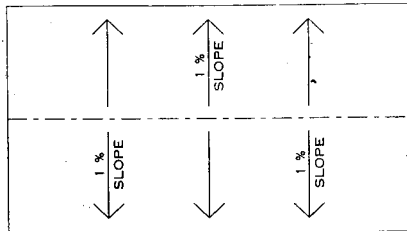

PREFERRED GRADING

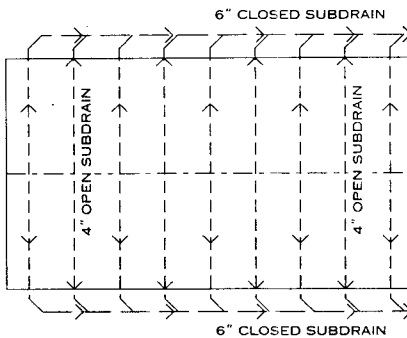

SUBSOIL DRAINAGE  
RECTANGULAR SPORTS FIELDS

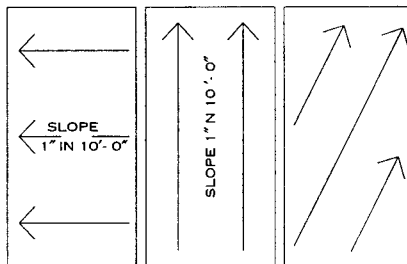

DRAINAGE DIAGRAMS  
SPORTS COURTS

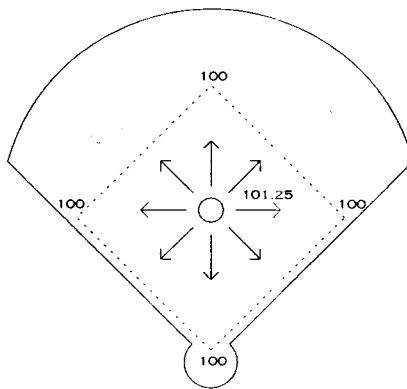

BASEBALL AND SOFTBALL DIAMONDS

NOTES

It is preferable that the baselines be level. If the diamond must pitch, the average slope shall be 2% from first base to third base or vice versa.

The minimum slope for drainage on turf areas outside the skinned area is 1% when adequate subsoil drainage is provided. The maximum is 2.5%.

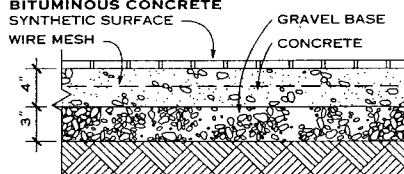
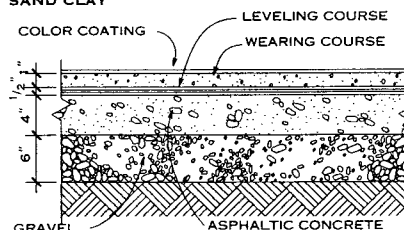
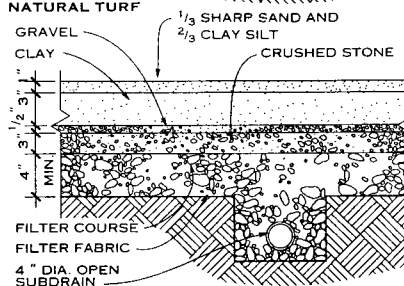
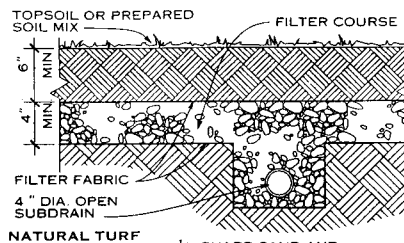

SYNTHETIC SURFACE  
PLAYING SURFACES

TYPICAL GRADING AND DRAINAGE  
DETAILS COURT SURFACES

Paved playing surfaces should be in one plane and pitched from side to side, end to end, or corner to corner diagonally, instead of two planes pitched to or from the net. Minimum slope should be 1 in. to every 10 ft. Subgrade should slope in the same direction as the surface. Perimeter drains may be provided for paved areas. Underdrains are not recommended beneath paved areas.

PLAYING FIELDS

Preferred grading for rectangular field is a longitudinal crown with 1% slope from center to each side.

Grading may be from side to side or corner to corner diagonally, if conditions do not permit the preferred grading.

Subsoil drainage should slope in the same direction as the surface. Subdrains and filter course are to be used only when subsoil conditions require. Where subsoil drainage is necessary, the spacing of subdrains is dependent on local soil conditions and rainfall.

Subdrains are to have a minimum gradient of 0.15%.

Baseball and softball fields should be graded so that the bases are level.

LINE PAINTING

All line markings should be acrylic water-base paint only. Oil-base or traffic paints crack, craze, or peel. Spray painting usually is used. High quality courts should be hand painted. Accuracy of track layouts should be verified by registered land surveyor.

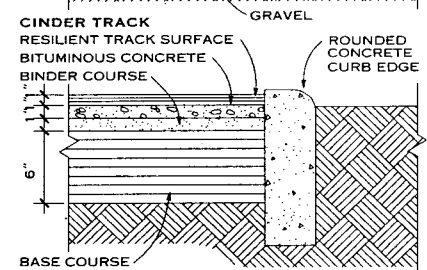
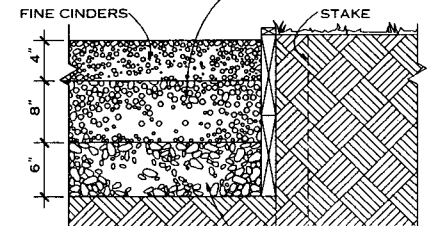
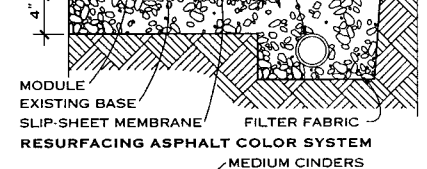
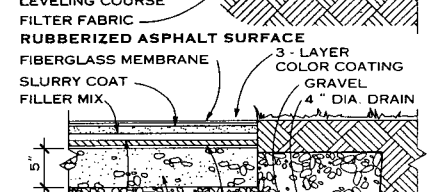
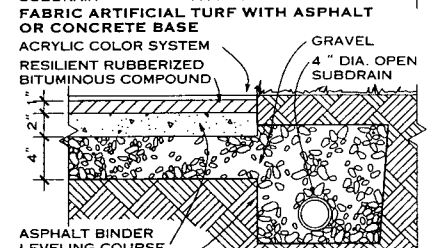
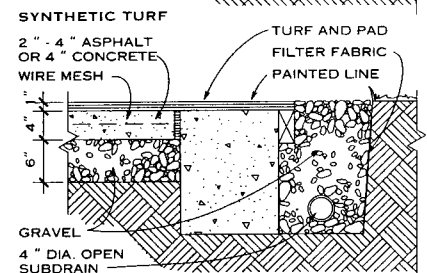
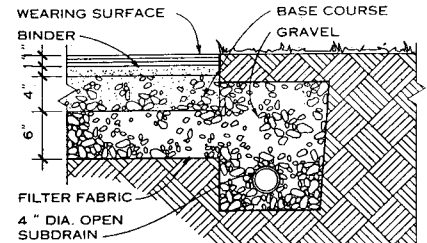

EDGE CONDITIONS

Sheryl Ananich; Tomblinson Harburn Associates; Flint, Michigan  
J. Paul Raeder; Beckett & Raeder, Inc.; Ann Arbor, Michigan  
Lawrence Cook Associates P.C., Architects; Falls Church, Virginia

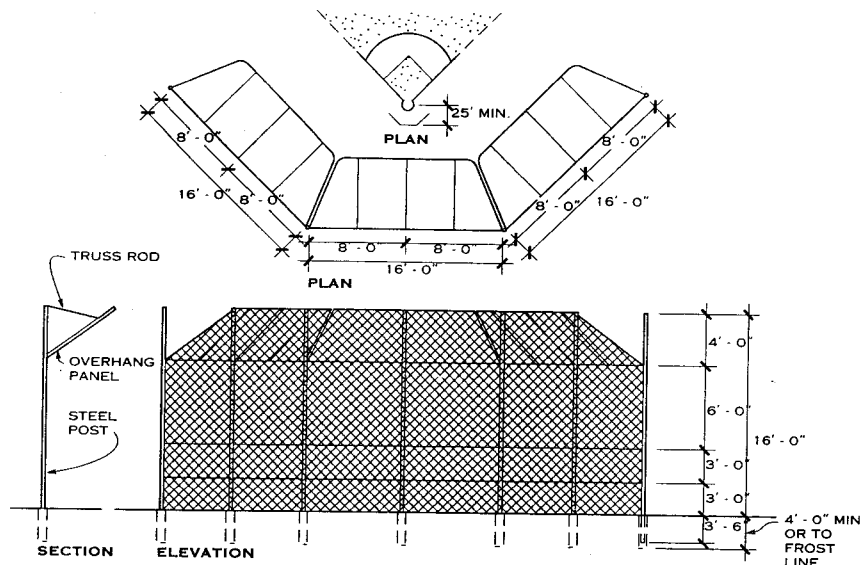

TYPICAL SOFTBALL BACKSTOP

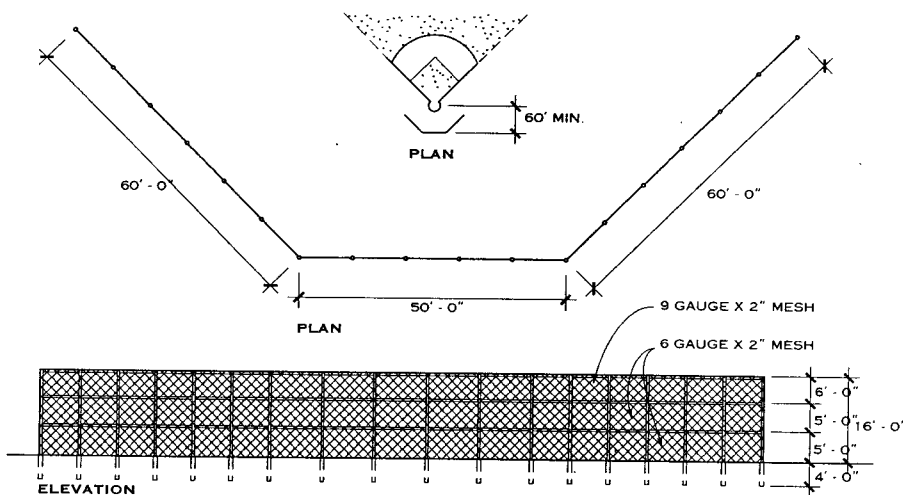

REGULATION BASEBALL BACKSTOP

**BACKSTOP SIZE AND DIMENSION**

Height and width of baseball backstops are to be determined by sports authorities and local requirements.

Posts for backstop heights up to 16 ft: use 3 in. outside diameter; posts for backstop heights 18 to 24 ft: use 4 in. outside diameter; top, intermediate, and bottom rails: 1 5/8 in. outside diameter.

**WIRE MESH FABRIC**

Fabric shall be chain link with galvanized coating or aluminum (optional PVC-coated steel). All ferrous metal parts are to be hot dip galvanized after fabrication.

**BASKETBALL STANDARDS**

NCAA: Minimum backboard support overhang is 4 ft; minimum outside diameter of post is 3 1/2 in.

AAU: 5 ft 5 in. overhang (and optional NCAA overhang of 4 to 6 ft) requires minimum post outside diameter of 4 1/2 in.

Concrete footing: minimum 2 ft diameter and 4 ft depth. Method of bracing and backboard support varies with manufacturer.

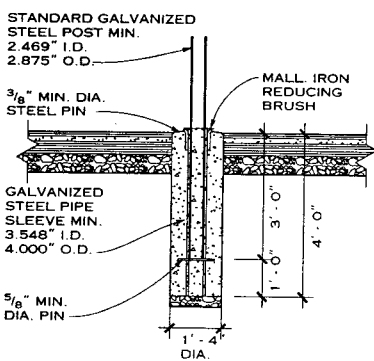

REMOVABLE POST

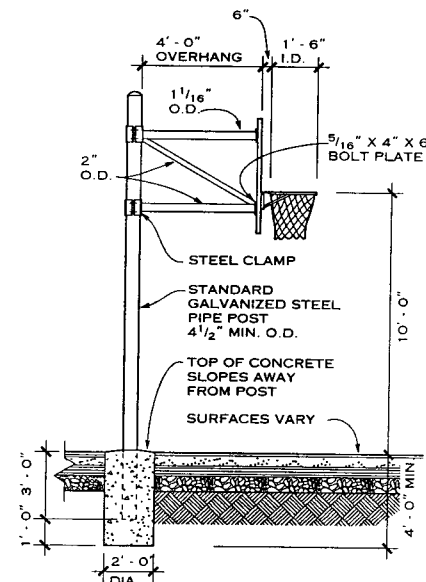
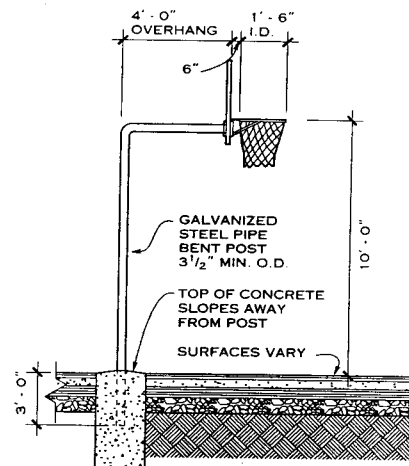

BASKETBALL STANDARDS

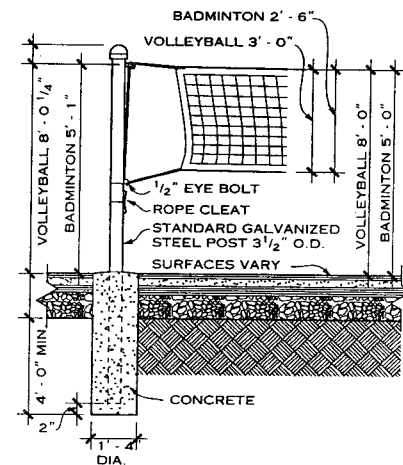

VOLLEYBALL AND BADMINTON NET AND POST

J. Paul Raeder; Beckett Raeder Rankin, Inc.; Ann Arbor, Michigan  
Lawrence Cook & Associates; Falls Church, Virginia

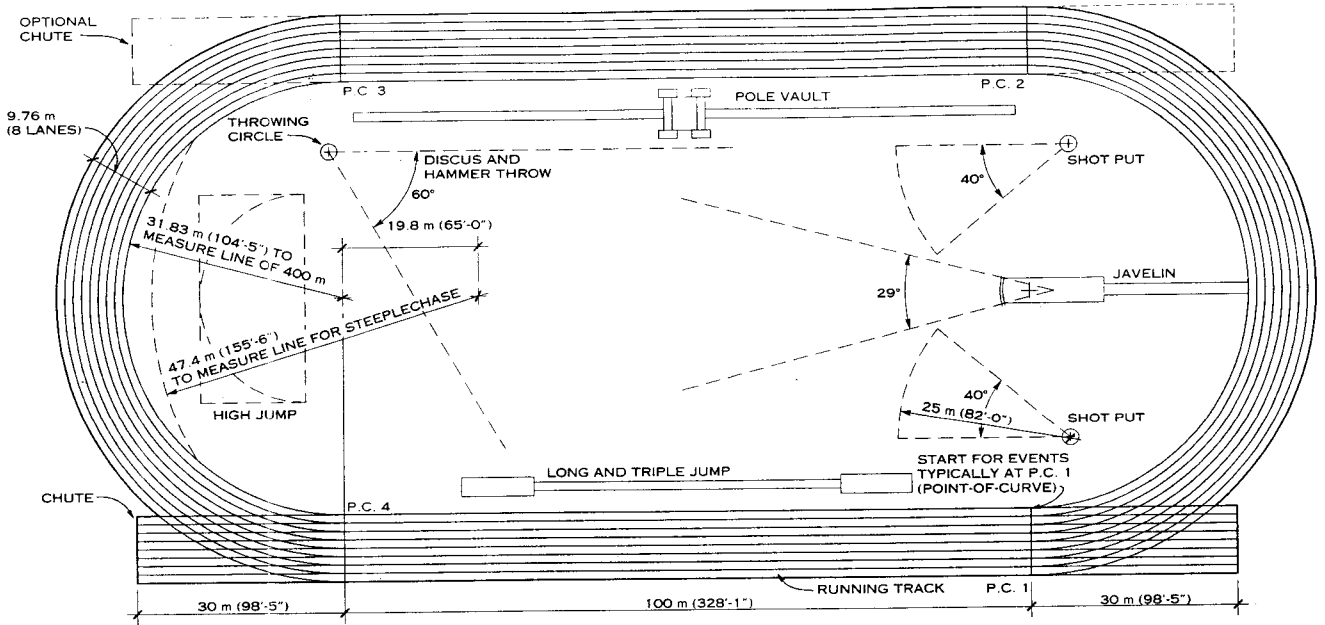

400-METER EQUAL QUADRANT TRACK WITH LAYOUT GUIDE FOR TRACK AND FIELD EVENTS

TRACK SPECIFICATIONS

GOVERNING BODY	LENGTH OF TRACK	WIDTH OF TRACK	RADIUS REQUIREMENTS	INCLINATION	LANE WIDTH	CURB DIMENSIONS AND MATERIAL
International Amateur Athletic Foundation (IAAF)	Not less than 400 m	Minimum 7.32 m (6 lanes), but 8 lanes, each 1.22 m wide, recommended	World records cannot be set on a track when outside lane has a curve radius greater than 50 m	Maximum lateral inclination 1:100; maximum downward inclination in the running direction 1:1000 (lateral inclination down toward inside lane)	Minimum width of 1.22 m (48 in.); the 5 cm wide right lane line is included in the width of the lane	Should be 5 cm x 5 cm, concrete or other material; if curb is raised to allow drainage under it, maximum height is 6.5 cm
National Collegiate Athletic Association (NCAA)	No specified length	6.40 m minimum (6 lanes)	No recommendation	Same as IAAF	Same as IAAF but will permit lanes of at least 91.4 cm (3 ft) if track is not wide enough to accommodate at least 8 wider lanes	Minimum height is 5.08 cm (2 in.) and maximum width is 10.16 cm (4 in.); use concrete, wood, or other suitable material with edges rounded
National Federation of State High School Associations (NFHS)	400 m is standard	No minimum width	No recommendation	Maximum lateral inclination is 2:100; maximum inclination in the running direction is 1:1000	Recommended width 1.07 m (42 in.); the 5 cm wide right lane line is included in the width of the lane	Curb will be 5 cm (2 in.) high with a rounded top of solid material
USA Track and Field (USAT&F)	No specified length	No specified width	Same as IAAF	Same as IAAF	Same as NFHS	Same as IAAF, except must be unbroken on curves and straightaways

NOTE

Information in the chart comes from current rules of the governing bodies of track and field and is subject to change. For

a specific rules determination, contact the appropriate governing body.

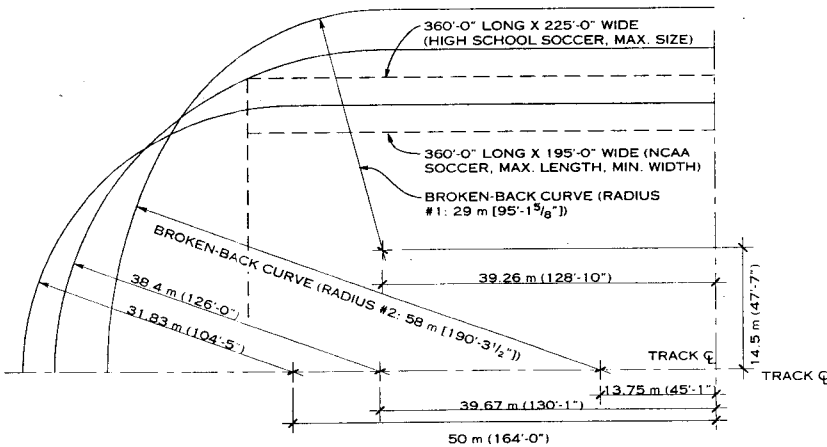

NOTE

When designing a track, consider the official sizes and needs of the interior playing fields and the location and layout of field events. Necessary radii dimensions for several different types of playing field are shown above. Be sure to allow the

necessary sideline area for safety and comfort. Use of the International Broken-Back Curve design can permit a wider facility with a layout that still meets all rules.

TRACK AND PLAYING FIELD CONFIGURATION

Kathleen O'Meara; OM Architecture; Baltimore, Maryland  
 U.S. Tennis Court and Track Builders Association; Ellicott City, Maryland  
 National Federation of State High School Associations; Kansas City, Missouri

ORIENTATION

It is often difficult in siting a track/playing field to reconcile the requirements regarding wind direction and facing the setting sun. Thus, when possible, it is common to provide alternative directions for running, jumping, and throwing.

SURFACE

Synthetic materials provide a consistently good track surface capable of continuous and unlimited use in most weather conditions. Maintenance is minimal, consisting of periodic cleaning with hose or brush, repainting line markings when necessary, and making an occasional repair.

Cinder surfaces require considerable maintenance by a skilled groundsman every time a track is used. They are not suitable for all-weather use and seldom provide a consistently good running surface. They are, however, much cheaper to construct and are suitable for club use and training.

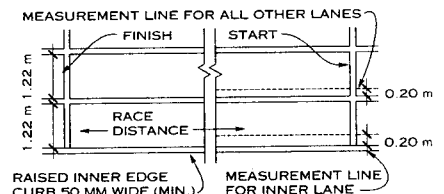

NOTE

All white lines are 55 mm wide.

METHOD OF MARKING LANES

**400 M TRACK AND FIELD EVENTS—CONSTRUCTION DETAILS**

These details are based on international standards. For additional information, consult the International Amateur Athletic Foundation (IAAF).

These details were provided by the National Playing Fields Association, London, England.

**NOTE**

To avoid adverse wind conditions during competition, landing areas for the long and triple jumps are desirable at both ends of the runway. A surround of paving slabs (450 x 600 mm) is an advantage. Takeoff board to be of wood or other suitable rigid material, set level with surface and painted white. See detail.

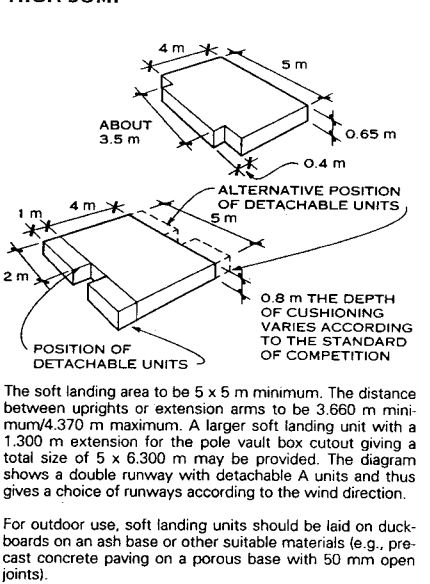
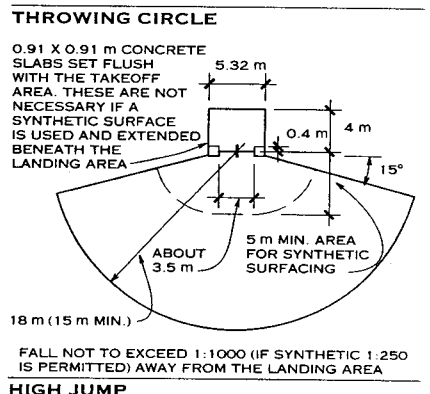
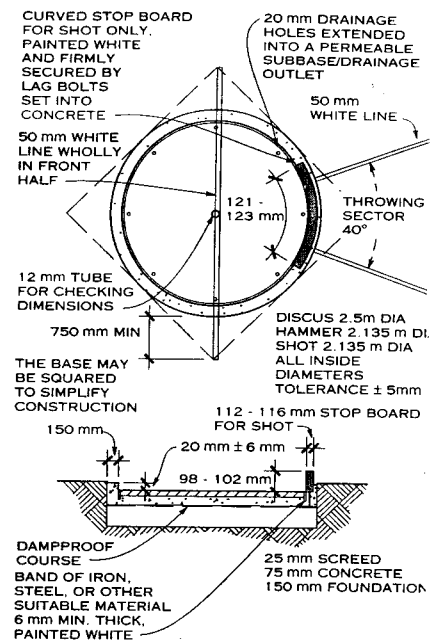
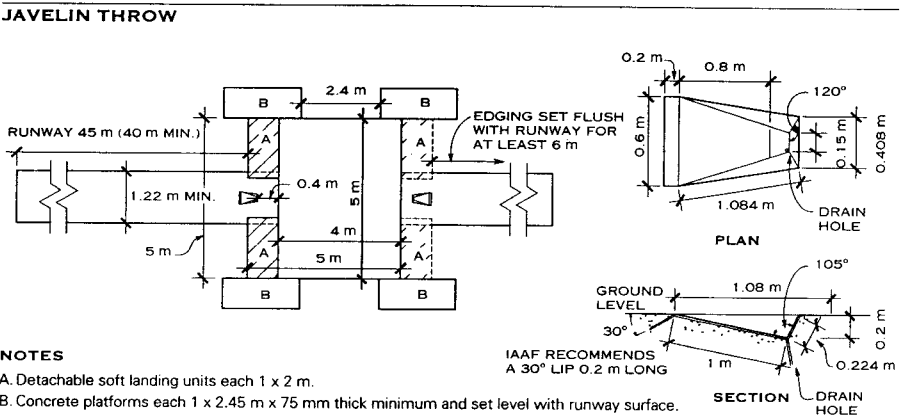
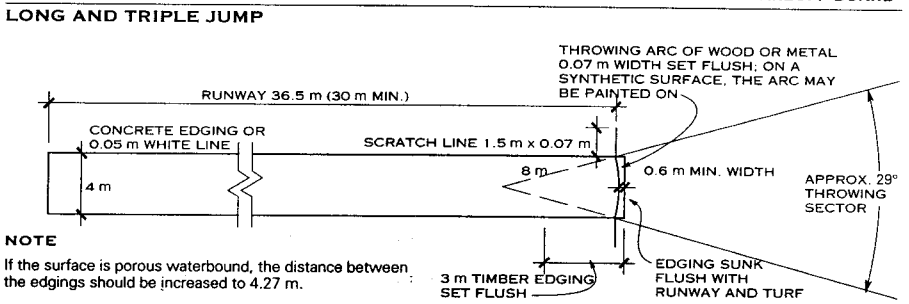
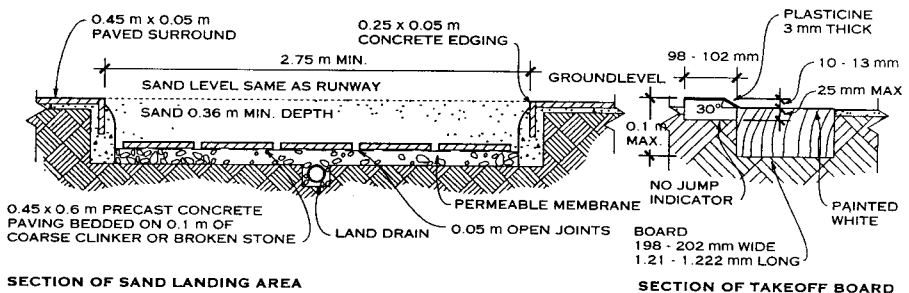
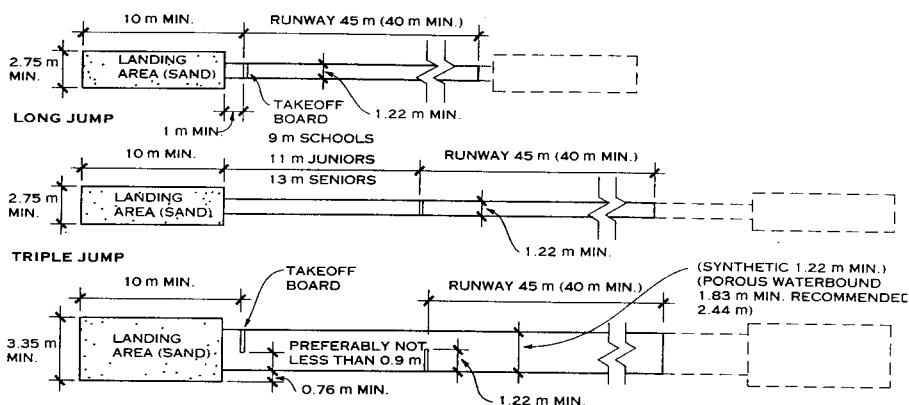

Charles F. D. Egbert, AIA; Egbert, Clarens, and Associates, P.C. Architects; Washington, D.C.



**SITE ISSUES FOR OUTDOOR TENNIS COURTS**

The overall area required for an individual tennis court is at least 60 x 120 ft. The outside dimensions of the playing lines are 36 x 78 ft for doubles.

Consider the position of the sun when deciding how to orient the court. In particular, plan around the extreme sun angles of late afternoon and early morning so players do not have to look directly into the sun when serving or tracking the ball.

Design the area surrounding the court to minimize distractions. A solid, dark background is desirable. White backgrounds and any movement such as pedestrians or traffic, particularly at the ends of the court, can be distracting. Landscaping or background curtains can be used as screens; however, the space directly over the court must be free from overhanging limbs or other obstructions and the minimum clear height at the fence should be 18 ft. When selecting vegetation, avoid species that would distract with irregular shadow patterns, stain the court surface, or require constant maintenance to clean up fallen leaves, needles, or fruit.

If outdoor lighting is used, locate fixtures outside the playing lines, preferably parallel to the alley lines, and outside the fence. Placement is especially important with fast-dry surfaces that can be damaged by rain dripping off the fixtures.

A high, dry site with well-drained, compacted soil is preferable. Ensure proper drainage of the court surface and the sub-surface, and redirect any water from the surrounding area. Water under the court is a prime cause of surface cracking, heaving of fence posts, and undulating pavement. Employ open swales, closed drains, or a combination of the two systems to drain water from the area.

**NOTE**

The Americans with Disabilities Act requires that tennis courts be accessible to both players and spectators in wheelchairs. At least one court must be fully accessible in a small facility; more may be required in a large facility. Curb cuts, walkways to and from the courts, gateways, drinking fountains, restrooms, locker rooms, and other spectator or player amenities must comply with federal, state, and local codes on accessibility. As well, adequate parking for persons with disabilities must be provided.

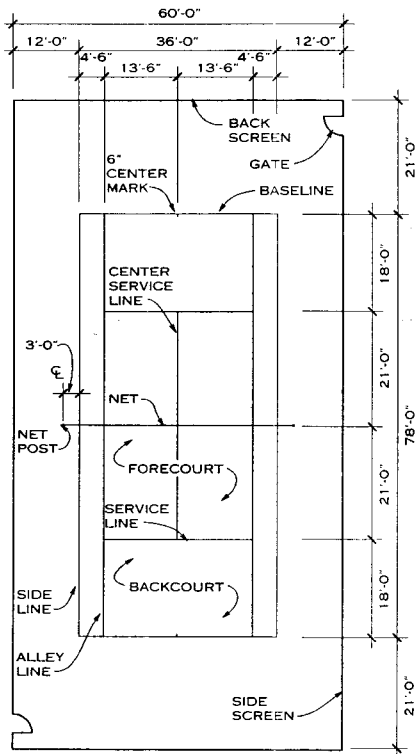

**TYPICAL INDIVIDUAL TENNIS COURT**

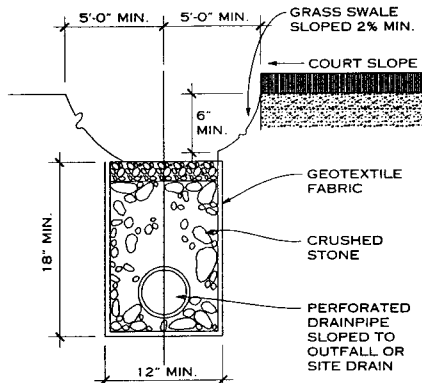
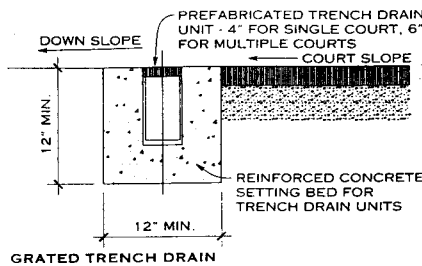

**SWALE WITH GRAVEL TRENCH DRAIN**

**SITE DRAINAGE**

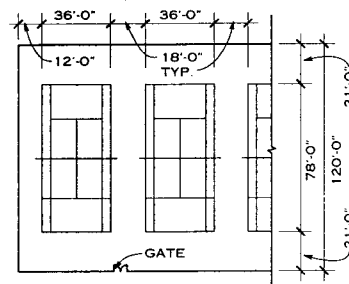

**NOTE**  
Provide at least one gate for every two tennis courts.

**TYPICAL MULTIPLE TENNIS COURT LAYOUT**

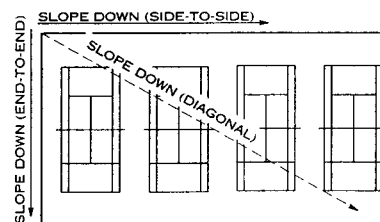

SURFACE TYPE	% SLOPE	RATIO OF SLOPE
Hard surface	0.833% to 1%	1:120 to 1:100
Grass surface	1%	1:100
Soft surface	0.28% to 0.35%	1:360 to 1:288

**NOTES**

- Courts must slope as one true plane, with no more than three courts sloped together in the same direction. A slope from side to side is best, followed by an end-to-end slope; diagonally sloped courts are the least satisfactory.
- Never slope a court to or from the net or to or from the centerline.

**COURT SURFACE SLOPE**

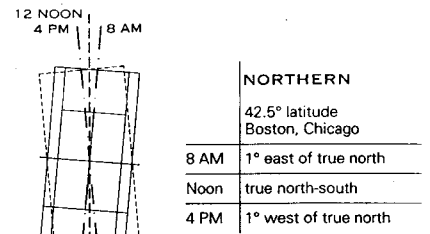

NORTHERN	
42.5° latitude Boston, Chicago	
8 AM	1° east of true north
Noon	true north-south
4 PM	1° west of true north

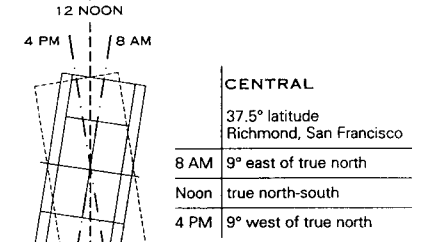

CENTRAL	
37.5° latitude Richmond, San Francisco	
8 AM	9° east of true north
Noon	true north-south
4 PM	9° west of true north

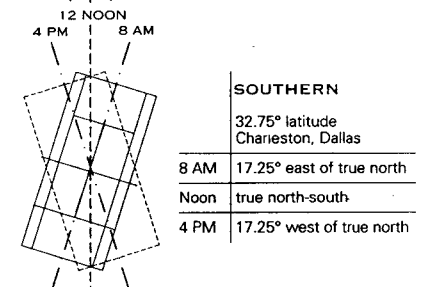

SOUTHERN	
32.75° latitude Charleston, Dallas	
8 AM	17.25° east of true north
Noon	true north-south
4 PM	17.25° west of true north

**NOTE**

Base the orientation of a tennis court on the latitude in which it is built, the season(s) it will be used, and the time of day it will be used. It may be necessary to compromise the three factors. A critical determining factor will be the solar orientation of the court during early morning (8 AM) and late afternoon (4 PM) hours, since the angle of the sun is at its most distracting to players and spectators at those times. It is best to locate the longitudinal axis of the court perpendicular to the azimuth of the sun between 8 AM and 4 PM.

**COURT ORIENTATION**

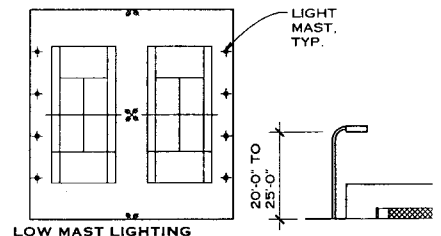
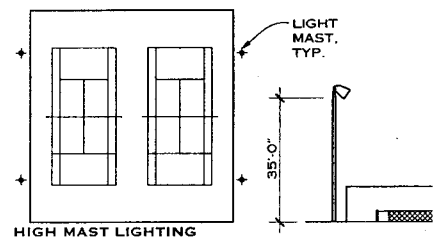

**OUTDOOR LIGHTING FOR TENNIS COURTS**

Kathleen O'Meara; OM Architecture; Baltimore, Maryland  
U.S. Tennis Court and Track Builders Association; Ellicott City, Maryland  
National Federation of State High School Associations; Kansas City, Missouri

**OUTDOOR PLAYING SURFACES**

Tennis playing surfaces are categorized as porous or nonporous. Geographic location is a key factor in the selection of playing surface for a site. The northeastern United States has numerous freeze-thaw cycles per year, which affect maintenance and the useful life of tennis courts. In the western states, the sun bleaches the color out of hard courts and dries out clay or fast-dry courts. Mildew or algae may be problems at courts in southern states like Florida.

Intended use and player preference are considerations in choosing a court surface. Tennis players commonly classify courts as soft- or hard-surfaced.

Soft courts include clay, fast-dry, and sand-filled synthetic turf. Soft courts are easy on a player's feet and legs and provide cool, glare-free surfaces. They are less expensive to construct than hard surfaces but may require annual resurfacing or repair and the daily maintenance of watering, brooming, and rolling the surface.

Hard courts include asphalt and concrete with acrylic coatings or roll or sheet goods coverings. They are generally more durable, require less maintenance, and offer longer playing seasons in cold climates than soft courts. A resilient layer or layers can be incorporated in a hard surface, providing a cushioned, nonporous, all-weather surface that softens the impact on a player's legs and back. Hard surfaces are generally more expensive to construct than soft surfaces and are easily damaged by street shoes and play equipment such as skateboards or in-line skates.

**VISIBILITY IN INDOOR COURTS**

A highly reflective ceiling surface and indirect lighting reduce shadows and provide the most even lighting conditions.

For optimum color contrast between the court, background, and ball, medium dark colors are best up to 8 ft along the sides of the court and 12 to 14 ft high behind the court area. Above these zones, white or light matte finish is best.

Perimeter curtains and dividing nets can also be used to provide a background that reduces distractions and keeps the ball from going into adjacent courts. These are generally black or green and are hung so the top of the divider is 12 ft above the floor, stopping 1/2 to 2 in. above the court surface.

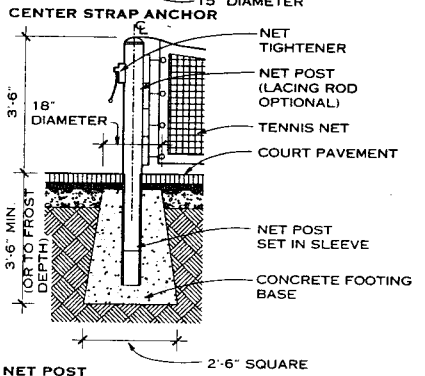
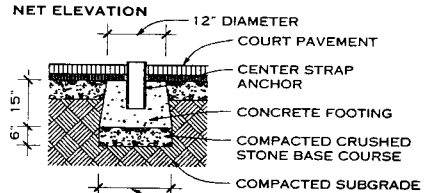
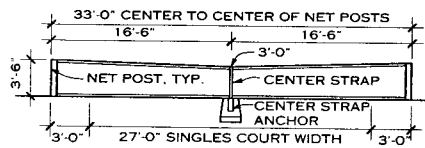

**NOTE**  
The net should be installed with the recommended tension of 500 to 550 lb.

**NET**

Kathleen O'Meara; OM Architecture; Baltimore, Maryland  
U.S. Tennis Court and Track Builders Association; Ellicott City, Maryland

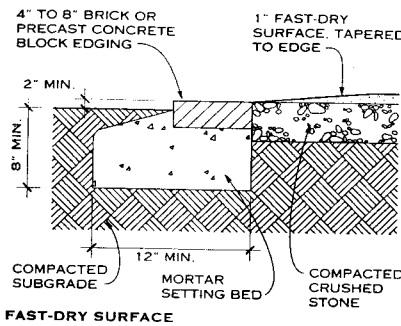

**FAST-DRY SURFACE**

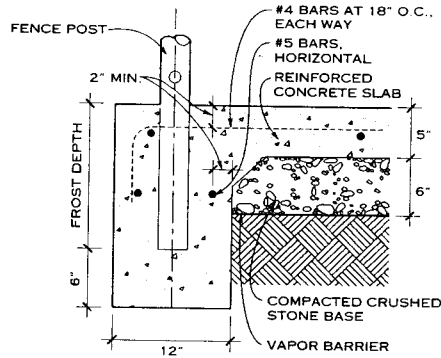

**REINFORCED CONCRETE WITH FENCE POST**

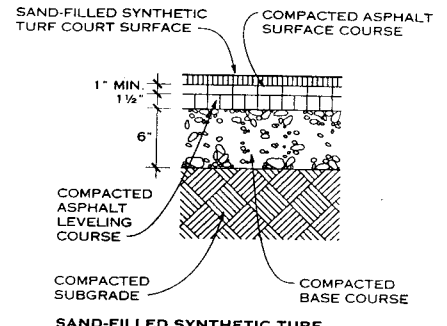

**SAND-FILLED SYNTHETIC TURF**

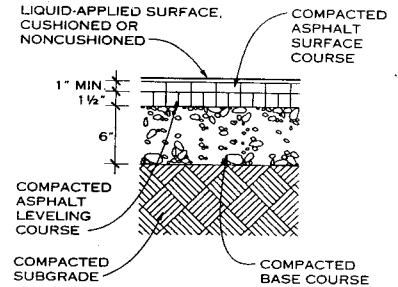

**ASPHALT—FOR FREEZE/THAW**

**OUTDOOR PLAYING SURFACES**

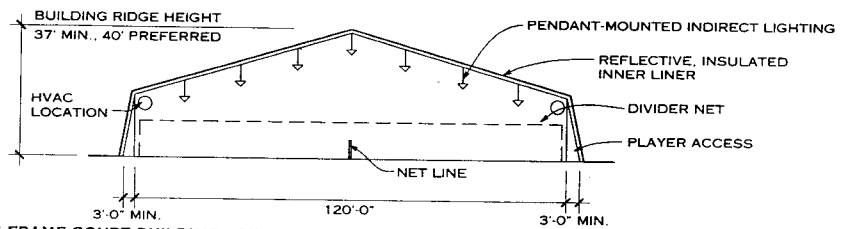

**FABRIC FRAME COURT BUILDING—SECTION**

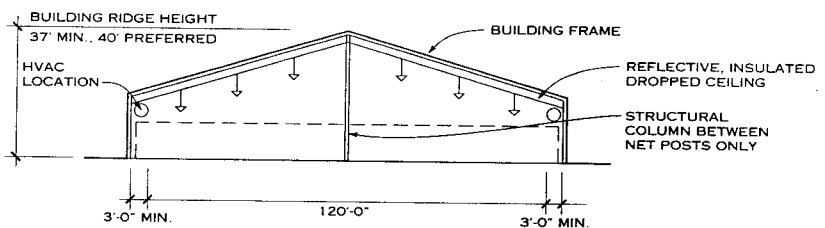

**LONG-BAY STRUCTURE—SECTION**

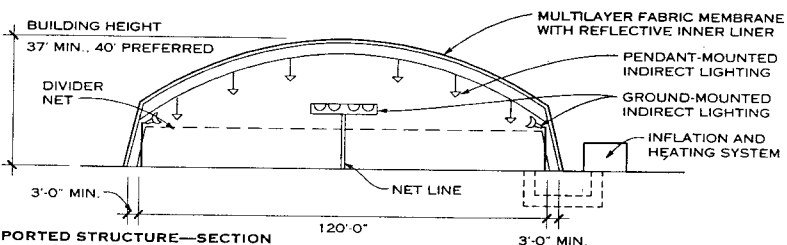

**AIR-SUPPORTED STRUCTURE—SECTION**

**NOTE**  
Enclosures for tennis courts can be either temporary or permanent structures. They are generally constructed of fabric over a rigid frame, air-supported fabric, or wide-span or long-bay steel structures.

**INDOOR COURT BUILDING ENCLOSURES**

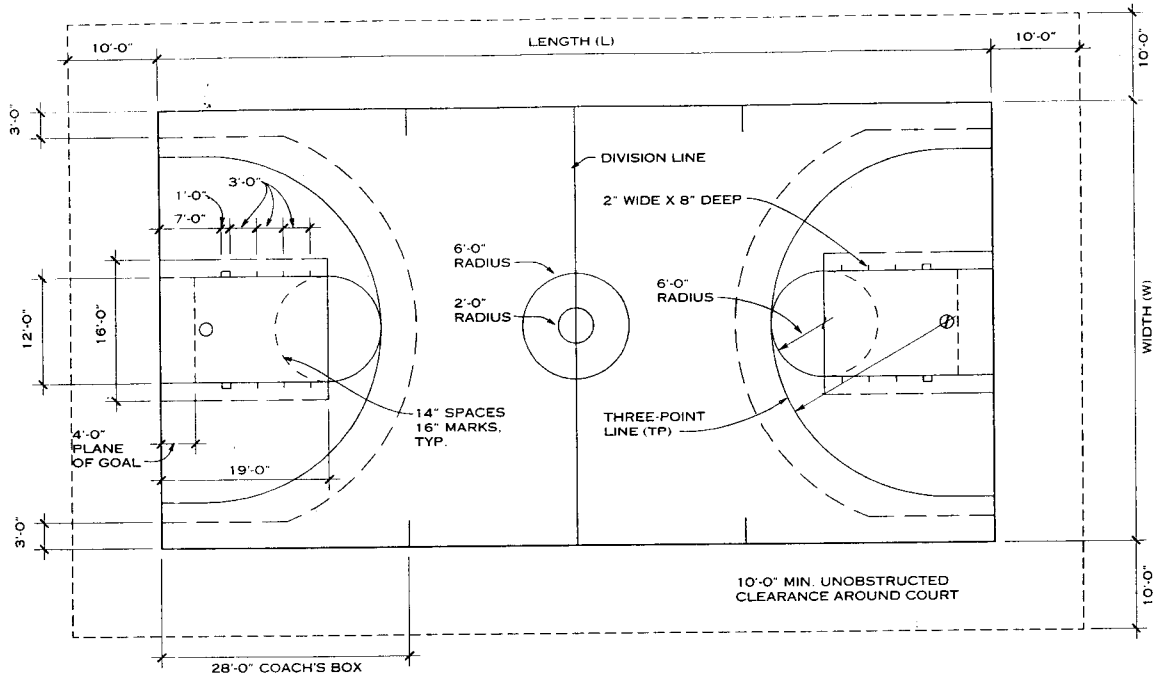

PLAN

**BASKETBALL COURT AND BALL DIMENSIONS**

COURT			BASKETBALL					
TYPE	L (FT)	W (FT)	TP (FT-IN.)	TYPE	MAX. DIAMETER (IN.)	MIN. DIAMETER (IN.)	MAX. WEIGHT (OZ)	MIN. WEIGHT (OZ)
NBA	94	50	23-9 R	NBA	30	29.5	22	20
International	94	50	20-6 1/2 R	International	30	29.5	22	20
NCAA (men)	94	50	19-9 R	NCAA (men)	30	29.5	22	20
WNBA, NCAA (women)	94	50	19-9 R	WNBA, NCAA (women)	29	28.5	20	18
High school (men)	84	50	19-9 R	High school (men)	30	29.5	22	20
High school (women)	84	50	19-9 R	High school (women)	29	28.5	20	18

L-length W-width TP-three point line

**BASKETBALL COURTS**

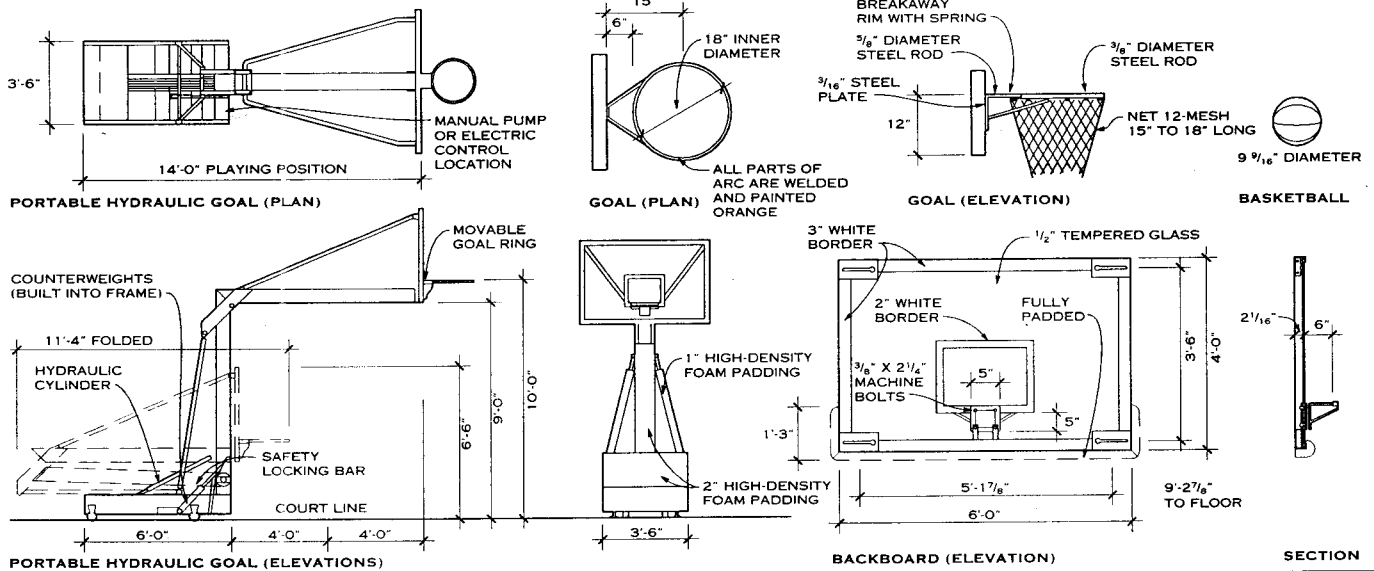

**BASKETBALL BACKBOARD AND GOAL**

Dean Cox, AIA; Collins Rimer Gordon Architects; Cleveland, Ohio

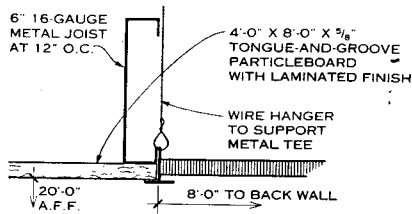

CEILING CONDITION—DETAIL

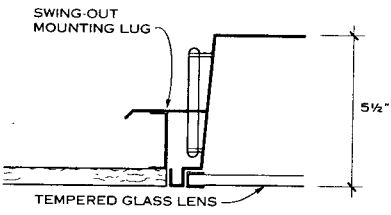

LIGHT FIXTURE—DETAIL

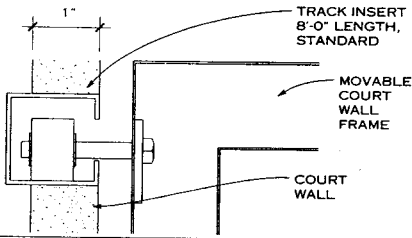

MOVABLE WALL ASSEMBLY FOR COURT CONVERSION—DETAIL

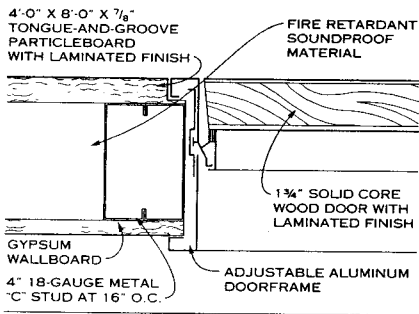

DOOR AT JAMB—DETAIL

NOTES

1. Racquetball and handball use essentially the same size court; however, handball may be played on courts with one, three, or four walls, indoors or outdoors. For a standard one-wall handball court, the wall should be 20 ft from the outside edge of one sideline to the outside edge of the other sideline and 16 ft high, including any top line. For three-wall handball, the side walls should be 44 ft long but the court marked for 40 ft long.
2. Temperature and humidity requirements for racquetball courts must be maintained during storage, installation, and operation. The range for temperature is 65 to 78°F and for humidity is 40 to 60%.
3. All lines should be 1 1/2 in. (38 mm) wide, painted red. Racquetballs are 2 in. in diameter; handballs are 1 7/8 in. in diameter.
4. Materials and installation of glass wall systems must comply with the safety and performance standards for walls established by the appropriate court sport association, the manufacturer, and local building codes. For this and other guidelines, contact the U.S. Handball Association or the U.S. Racquetball Association.
5. A movable rear wall unit may be specified to convert a racquetball court that is 40-ft long into a 32-ft long squash court. The World Squash Federation sanctions the use of a 20-ft wide racquetball court for squash, which normally has a court 21 ft wide.

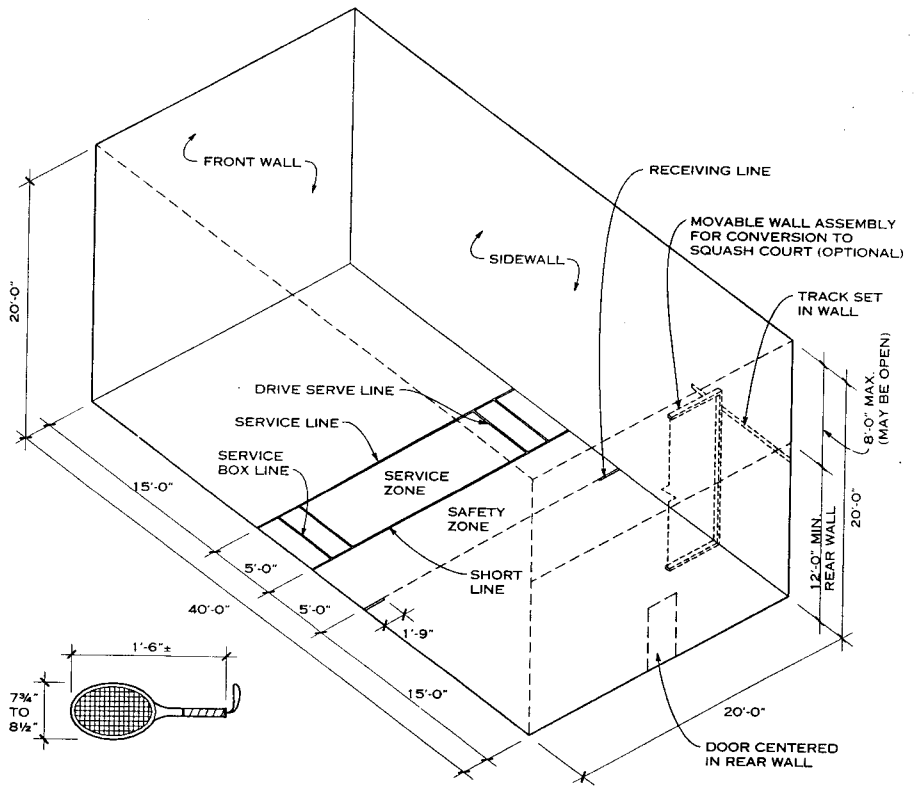

RACQUETBALL COURT

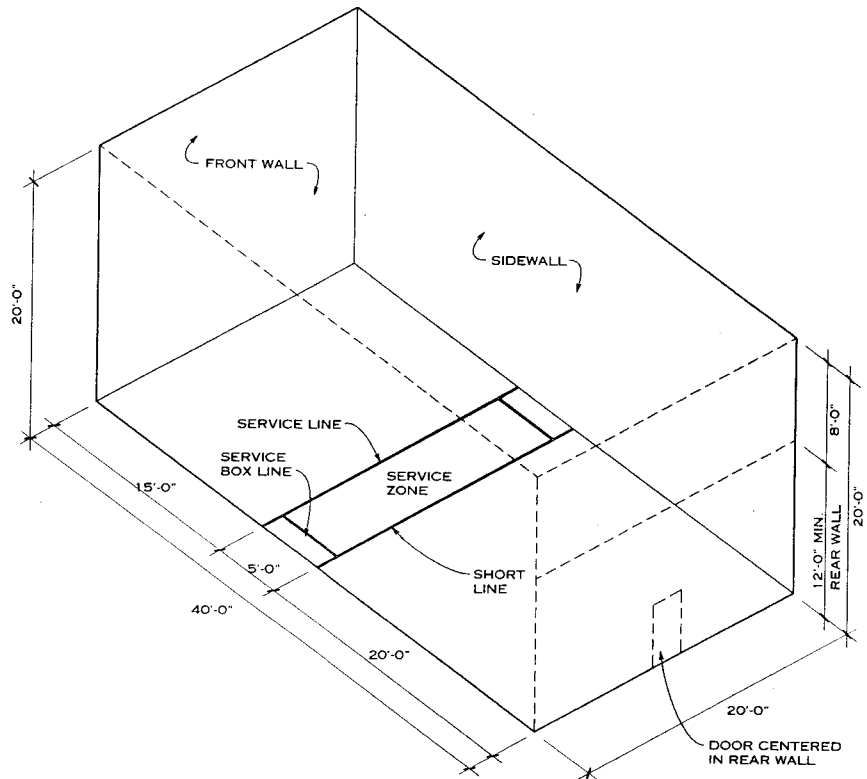

HANDBALL COURT

U.S. Racquetball Association; Colorado Springs, Colorado  
 U.S. Handball Association; Tucson, Arizona

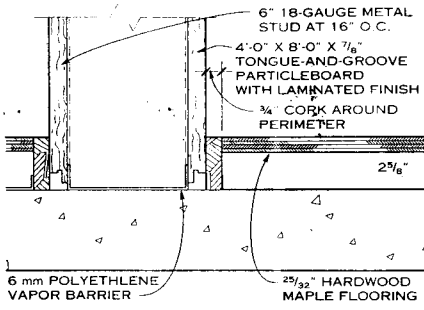

SECTION AT COMMON SIDEWALL

STEEL OR WOOD FRAMING AT 16" O.C.

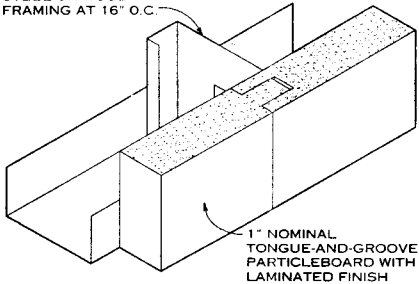

COURT WALL-DETAIL

MATTE FINISH OR UNFINISHED MAPLE OR ASH FLOORING OVER WOOD SLEEPERS, 12" O.C.

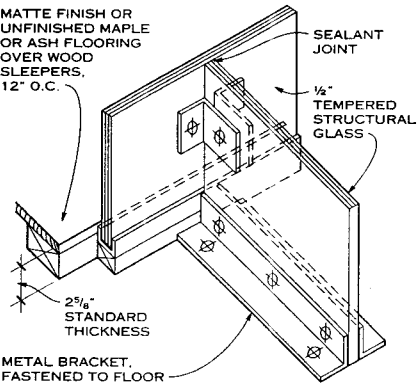

GLASS WALL SYSTEM-DETAIL

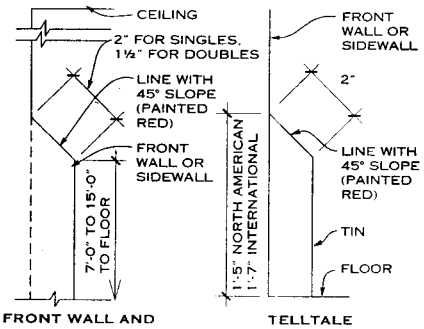

COURT MARKINGS

NOTES

1. All playing walls of the court should be constructed of the same materials, with a hard, smooth finish and strength and deflection characteristics as defined by the World Squash Federation or the United States Squash Racquets Association.
2. A squash court may be constructed from a number of materials, providing they have suitable ball rebound characteristics and are safe for play as recommended by the governing squash association.

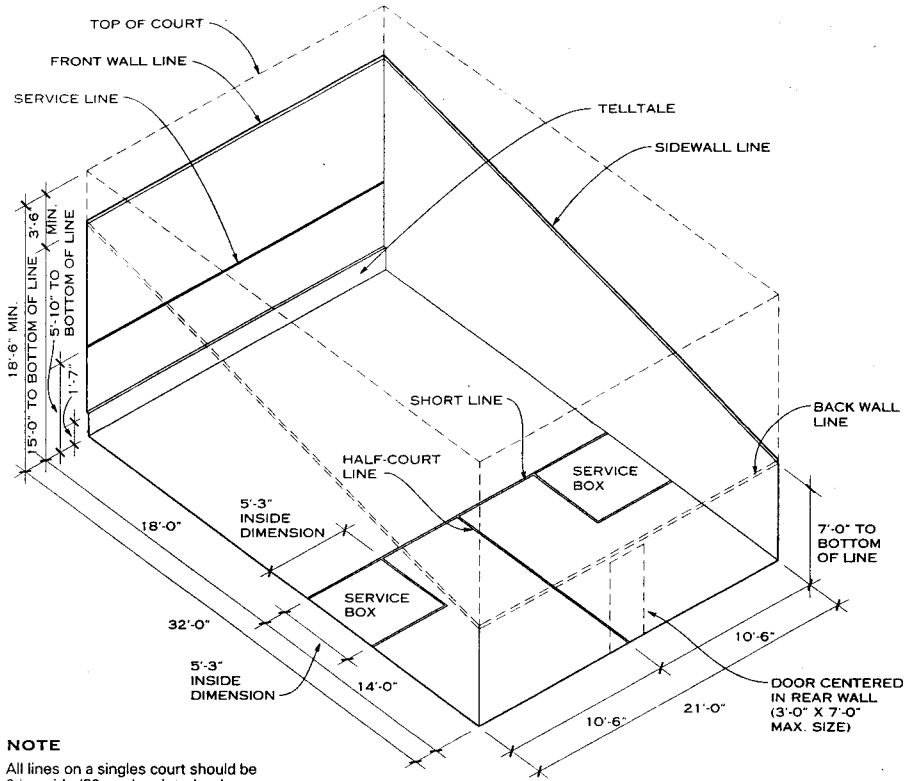

NOTE  
All lines on a singles court should be 2 in. wide (50 mm), painted red.

INTERNATIONAL SINGLES SQUASH COURT (SOFT BALL)

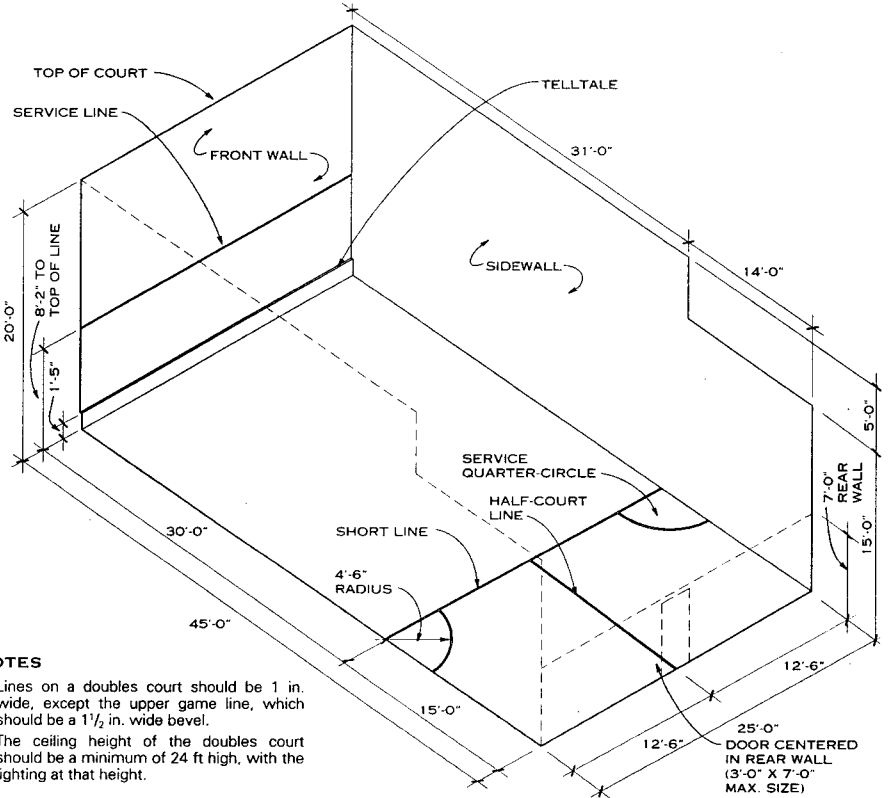

NOTES

1. Lines on a doubles court should be 1 in. wide, except the upper game line, which should be a 1 1/2 in. wide bevel.
2. The ceiling height of the doubles court should be a minimum of 24 ft high, with the lighting at that height.

NORTH AMERICAN DOUBLES SQUASH COURT (HARD BALL)

Kenneth D. Jaffe; U.S. Squash Racquets Association; Bala-Cynwyd, Pennsylvania

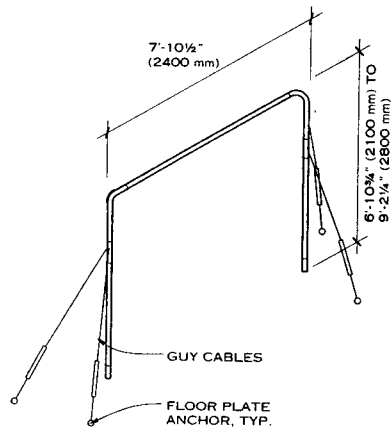
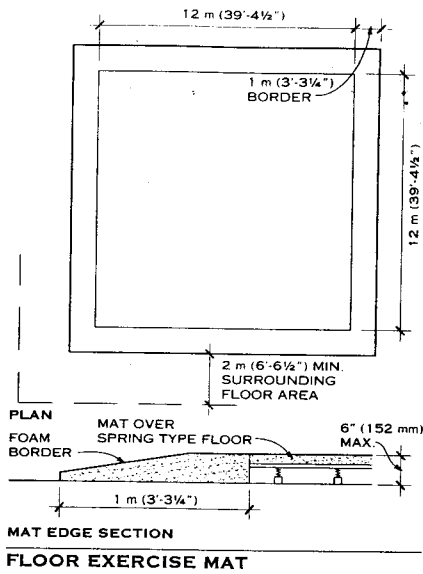

**NOTE**  
Bar height typically adjusts in 50 mm increments.

**HORIZONTAL BAR**

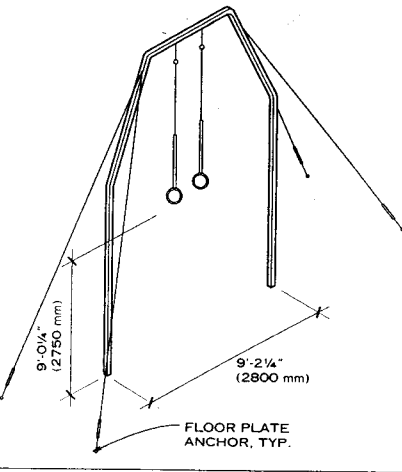

**RINGS AND RING FRAME**

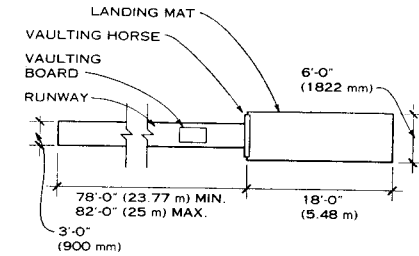

**VAULTING RUNWAY**

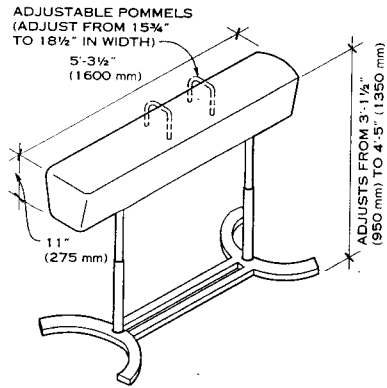

**NOTE**  
A practice vaulting buck is similar to a vaulting horse but is only 2 ft 9 in. (825 mm) long.

**VAULTING AND POMMEL HORSE**

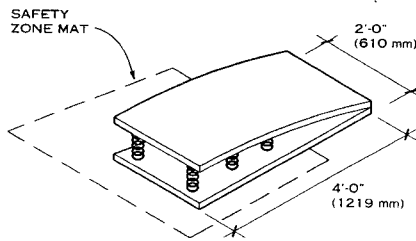

**NOTE**  
A safety zone mat is placed snugly around the board for all round-off entry vaults.

**VAULTING BOARD**

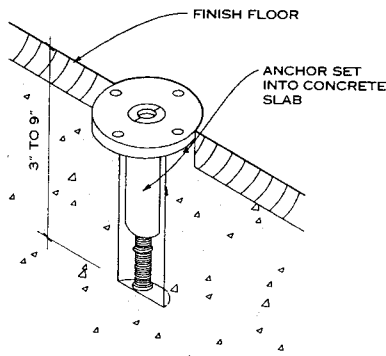

**NOTE**  
Floor plates, installed flush with the top of the floor finish, are used to anchor horizontal bars, ring frames, etc., to the floor. Plates must be used with eye screw attachments.

**FLOOR PLATE DETAIL**

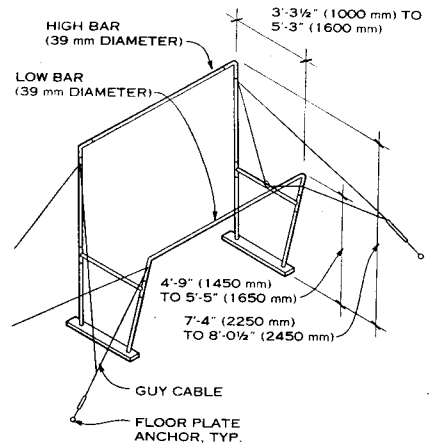

**NOTE**  
Bar height typically adjusts in 50 mm increments.

**UNEVEN BARS**

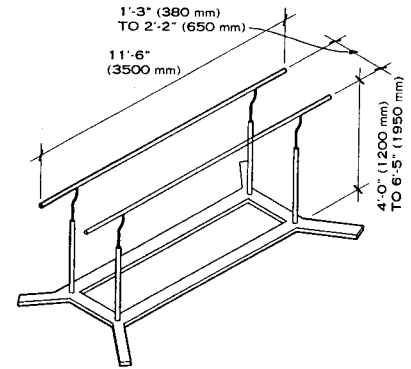

**PARALLEL BARS**

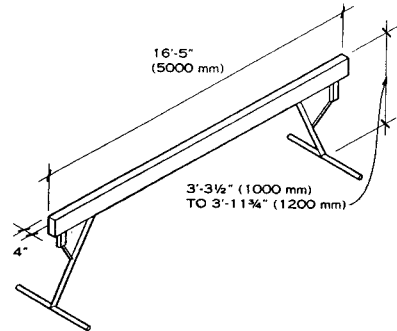

**BALANCE BEAM**

**NOTES**

1. The dimensions and specifications on this page are for general reference only. Refer to the appropriate safety manual for specific requirements for recreational or training gymnastics or for state, regional, national, and international competitions: Federation Internationale de Gymnastique (FIG); U.S.A. Gymnastics (USAG); National Collegiate Athletic Association (NCAA); and National Federation of State High School Associations (NFSH).
2. A clearance of 5 to 6 ft is recommended from one apparatus to another, including corresponding mat area or obstructions such as other apparatus, walls, or columns. Each competitive area must have its own physical space, which may not overlap another competitive area. The floor exercise area must be free of obstructions. Leave room for mounting, dismounting, and vaulting areas.

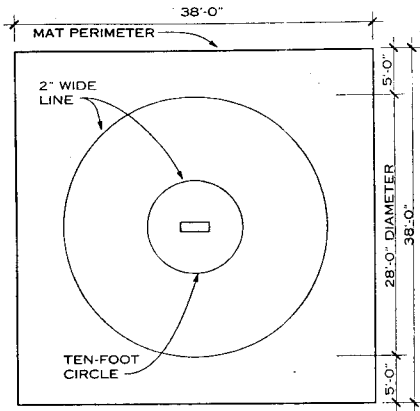

TYPICAL MAT

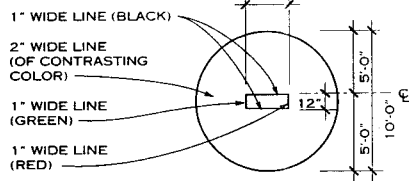

TEN-FOOT CIRCLE—DETAIL

WRESTLING

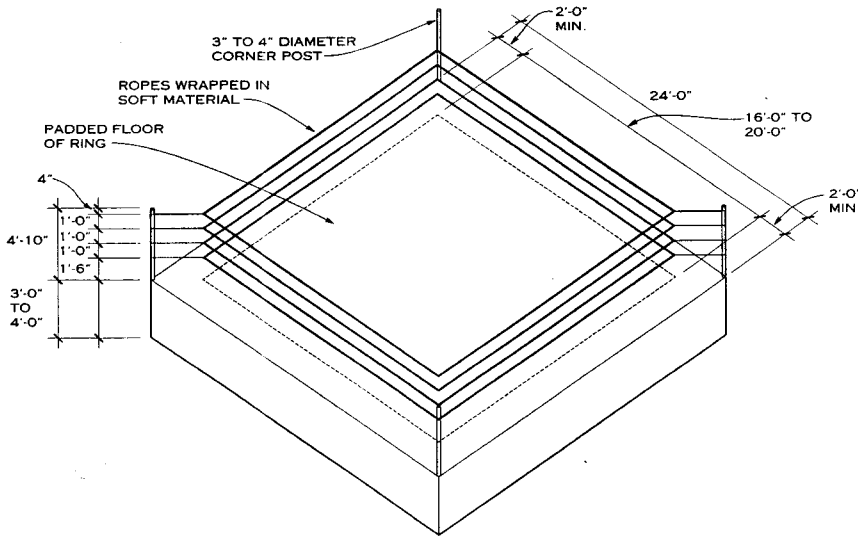

AMATEUR BOXING

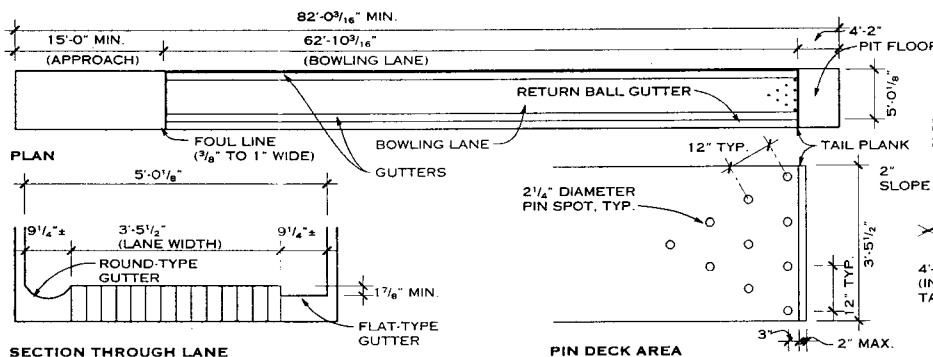

SECTION THROUGH LANE  
BOWLING

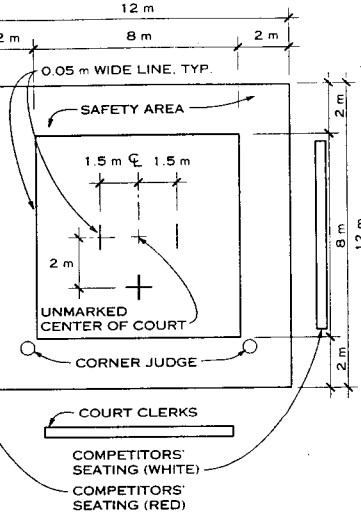

NOTE

Ceilings should be a minimum of 10 ft high to accommodate the swinging of swords and bows. Structural support is needed in the ceiling for the heavy bags used in karate. Eight 100-lb bags are located approximately 4 ft on center. Doors should not open into the mat area, and no mirrors or windows should be nearby.

KARATE

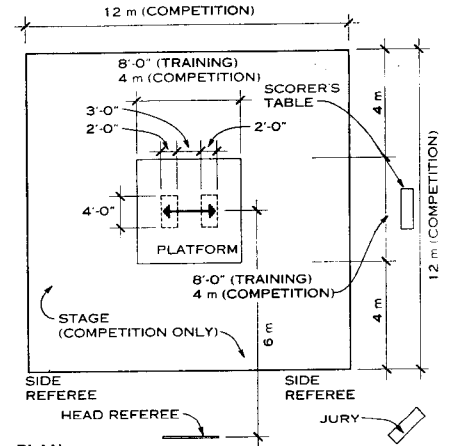

PLAN

2 LAYERS OF 3/4" PLYWOOD SCREWED INTO BASE  
2 LAYERS OF 3/4" RUBBER INSERTED INTO PLYWOOD

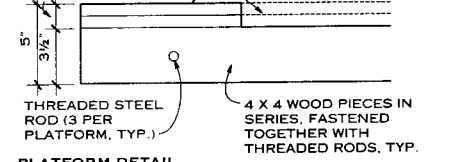

PLATFORM DETAIL

NOTE

Platform is required to be between 5 and 15 cm high (2 to 6 in.), constructed of materials that can absorb the shock caused by normally returned weights.

WEIGHT LIFTING

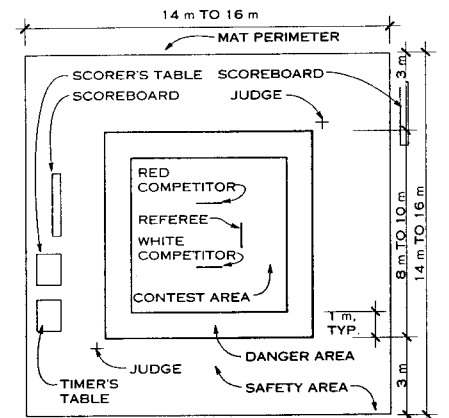

JUDO

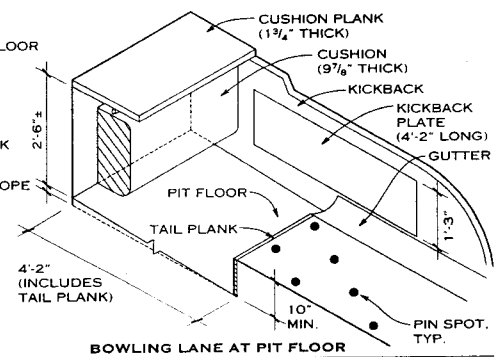

BOWLING LANE AT PIT FLOOR

Richard J. Vitullo, AIA; Oak Leaf Studio Architects; Crownsville, Maryland

5' - 0" BETWEEN COURTS

LINED FOR BOTH DOUBLES AND SINGLES: ALL LINES 1 1/2" WIDE

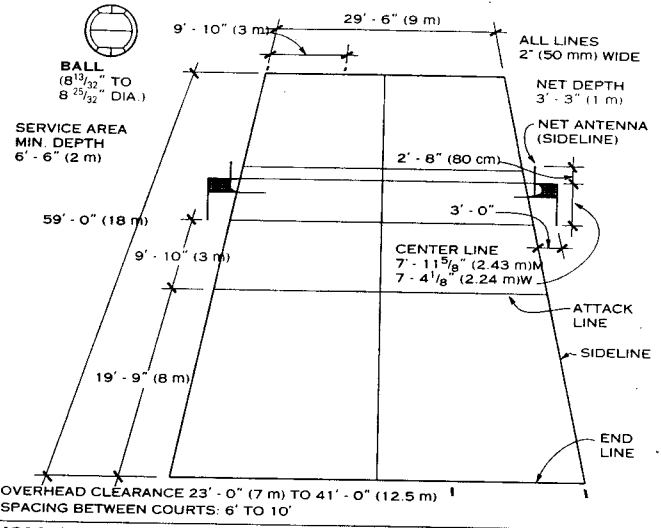
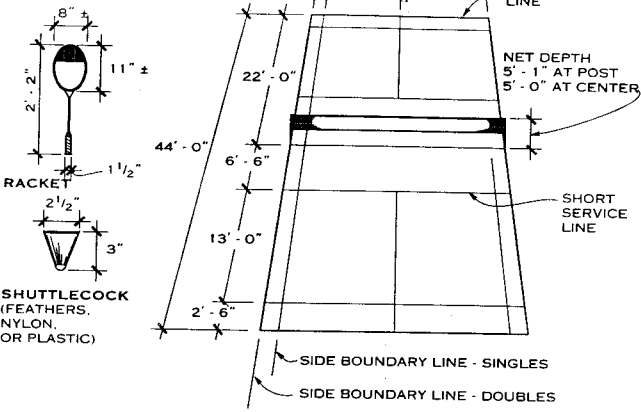

**BADMINTON**

**VOLLEYBALL**

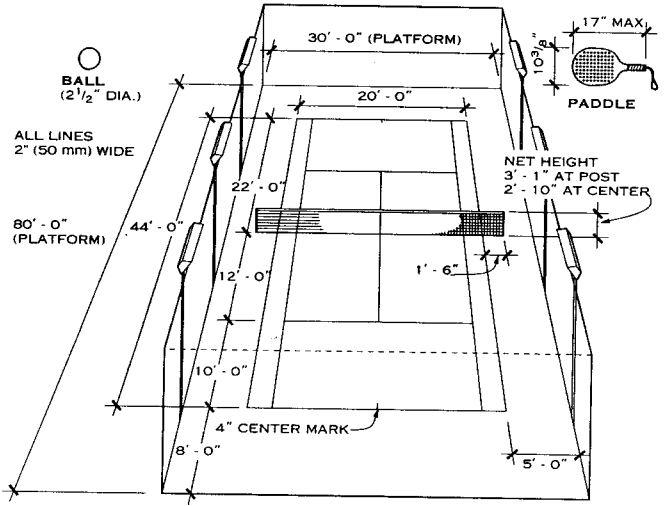
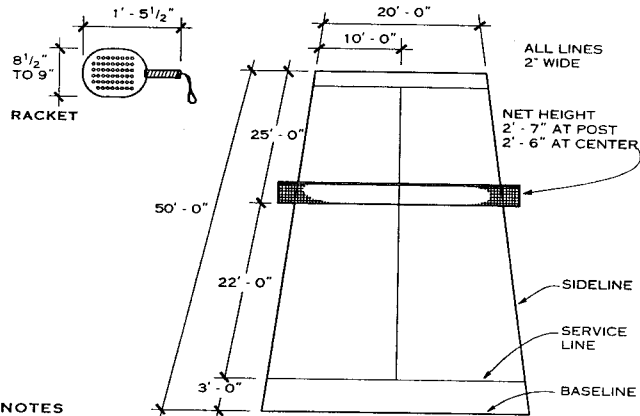

- NOTES**
1. Space behind each baseline to back fence is 15 ft minimum.
  2. Space from each sideline to side fence is 10 ft minimum.
  3. Fence shall be 8 ft high unless otherwise noted.
  4. Ball is a punctured tennis ball.

**PADDLE TENNIS**

**PLATFORM TENNIS**

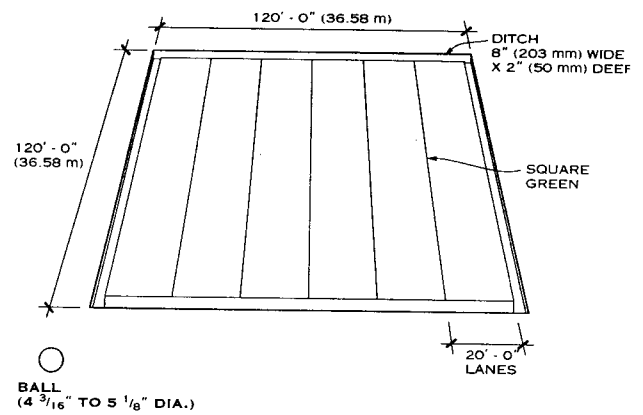
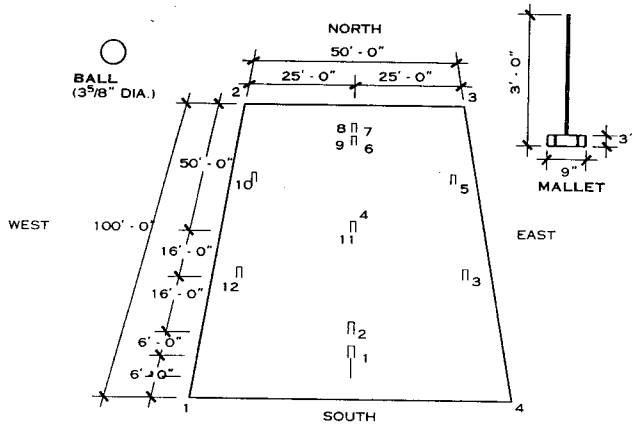

**CROQUET**

**LAWN BOWLING**



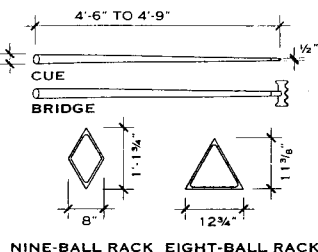
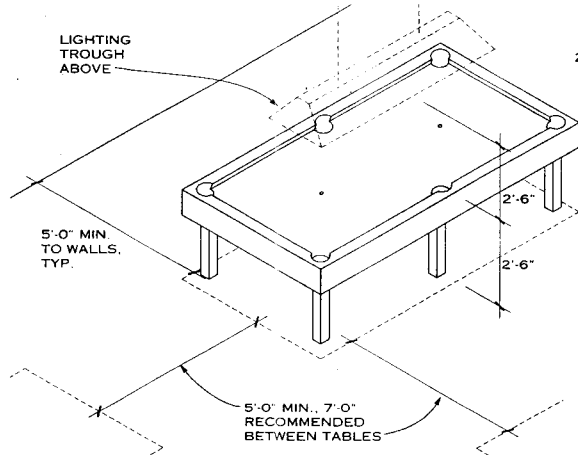

**NOTES**

1. Flooring must be permanently level and able to withstand point loads.
2. Traditionally designed billiard tables weigh about 1.5 tons spread over eight legs.
3. Lighting must not produce harsh shadows, but some modeling of the ball is desirable. Avoid direct or reflected glare. True color rendering is important in snooker. An overall

**TABLE DIMENSIONS (FT.-IN.)**

TYPE OF TABLE	PLAYING SURFACE		TABLE SIZE	
	W	L	W	L
English (Snooker)	7-2	14-4	8-2	15-4
Standard 9 ft	4-2	8-4	5-2	9-4
Standard 8 ft	3-8	7-4	4-8	8-4
Standard 7 ft	3-2	6-4	4-2	7-4
Oversized 8 ft	3-10	7-8	4-10	8-8

bright light is needed for each table; natural lighting is not essential. Lighting at the table surface should be approximately 375 lumens, which can be achieved with three 150-watt tungsten filament lamps suspended in a lighting trough. Fluorescent lamps are unacceptable.

4. Some sound insulation is required to prevent distractions from outside the playing area.

**BILLIARDS, POCKET BILLIARDS, AND SNOOKER**

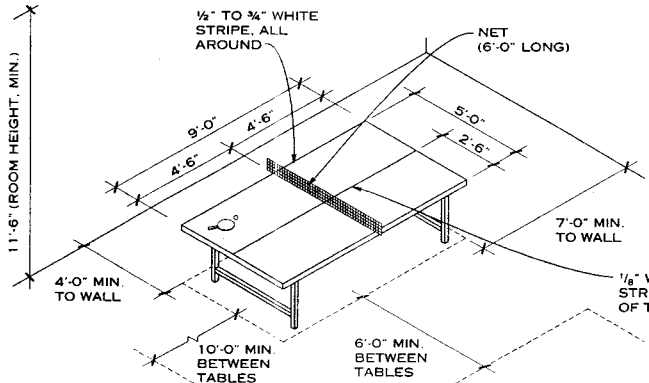

**NOTES**

1. Flooring should be level and slightly resilient; do not use nonskid material.
2. Walls should provide a uniformly dark, matte background with enough contrast to help players follow the ball.
3. Lighting often varies for different standards of play, but 150 to 500 lumens at table height is the acceptable range. Do not use fluorescent or natural lighting; tungsten halogen lighting is preferable.
4. Sectional tables are stored upright when not in use.

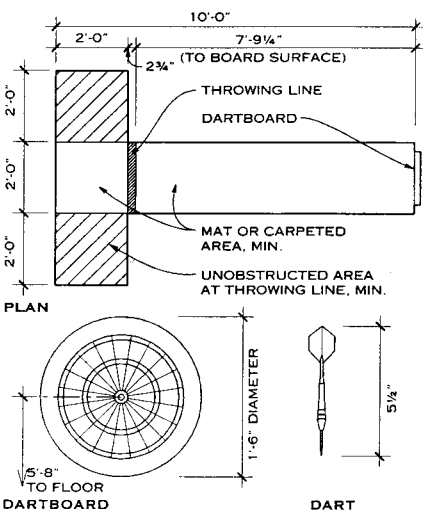

**DARTS**

**TABLE TENNIS**

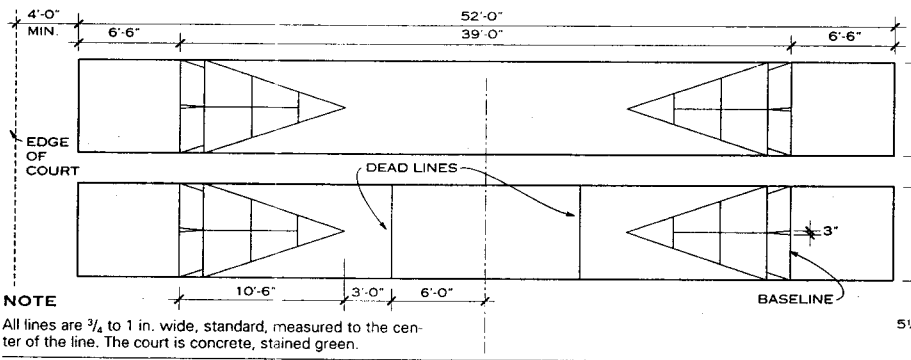

**NOTE**

All lines are 3/4 to 1 in. wide, standard, measured to the center of the line. The court is concrete, stained green.

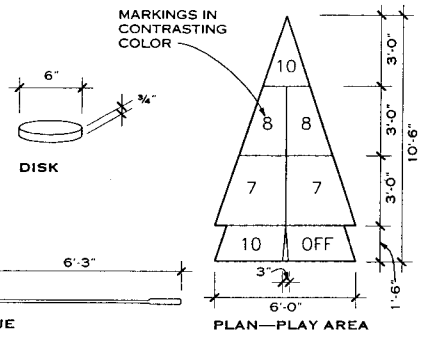

**SHUFFLEBOARD**

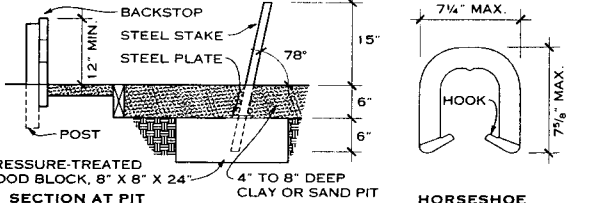
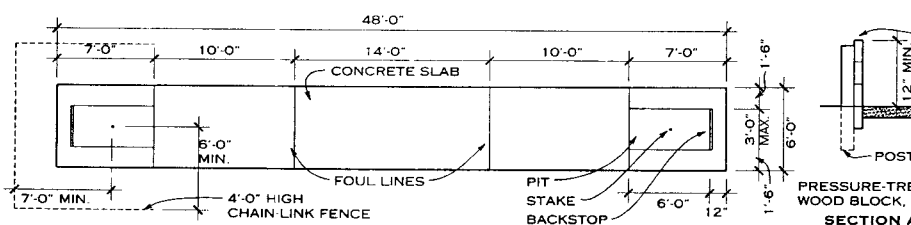

**HORSESHOES**

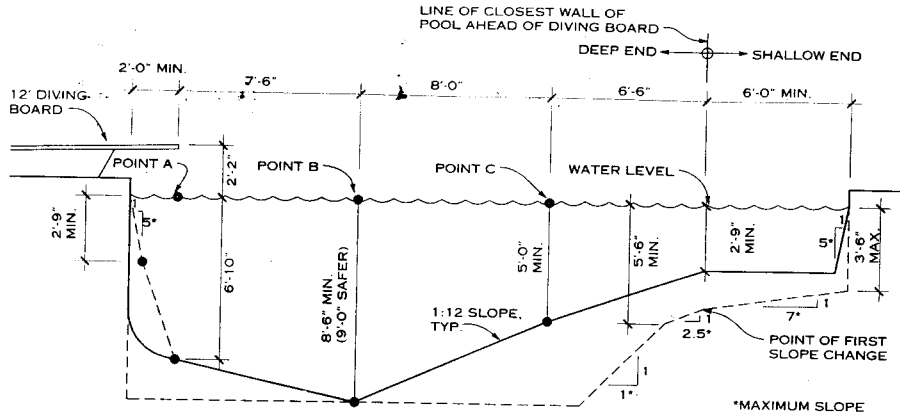

**NOTE**  
For a 10-ft board, Point B must be 8 ft 0 in. (8 ft 6 in. is safer).

**LONGITUDINAL SECTION AT CENTERLINE (TYPE III POOL)**

**PERMITS AND RESTRICTIONS**

In most areas, permits are required from building, health, plumbing, and electrical departments and zoning boards. Check for setback restrictions and easements covering power and telephone lines, sewers, and storm drains.

**CONSTRUCTION AND SHAPES**

Residential pools are generally made of gunite (a mixture of pea stone, sand, cement, fly ash, and water sprayed on a steel reinforcement rod framework), a vinyl liner with a structural wall backup and formed floor (steel or thermoplastic vertical wall sections and lightweight concrete or sand base), or a prefabricated fiberglass shell (used primarily where high water tables and nonfrost penetrating conditions exist). Shapes are virtually unlimited within limitations for safety and minimum dimensions.

**FILTERING**

Filtration is the mechanical process of removing insoluble matter from swimming pool water. Pool water carrying particulate matter, solids, and debris is passed through filtering media and returned to the pool.

Pool water flows through the filters by pressure or vacuum. As water passes through the filter, particulate matter and solids collect on the surface of the filter medium. The ability to hold and screen fine particles varies according to filter type. Three basic media are used for swimming pool filtration—diatomaceous earth, sand, and cartridge filters.

Filters are sized by dividing the pool volume by the required turnover time (established by the local board of health), then dividing that figure by 60 min/hr, which equals the flow rate in GPM. Divide the flow rate in GPM by the filtration rate (established by the board of health), which is in GPM/sq ft. The result is the required filter area in sq ft.

**HEATERS AND PUMPS**

Pool heaters have become a necessity for user comfort and maintenance of proper chemical balance. Heater size is determined by the frequency of pool use, the size of the pool, and the average outside air temperature. Use a pool cover to minimize evaporation. A solar cover can add heat to a pool.

The size of a pool pump establishes the limit of the volume of water that can be recirculated. The pump causes water to flow and determines the direction of flow. Pump capacity is measured in GPM for flow and in feet of head for pressure.

In most swimming pools, filtered pool water is returned below the water surface; thus, after the pump has been primed and all air expelled, the pump need only overcome the friction in the piping system and the pressure drop across the filter to maintain consistent circulation.

**WATER TREATMENT**

Pool water must be disinfected and recirculated. Seven principal factors are balanced by basic chemically treated water: total alkalinity, pH balance, calcium hardness, free available disinfectant, total disinfectant, total dissolved solids, temperature.

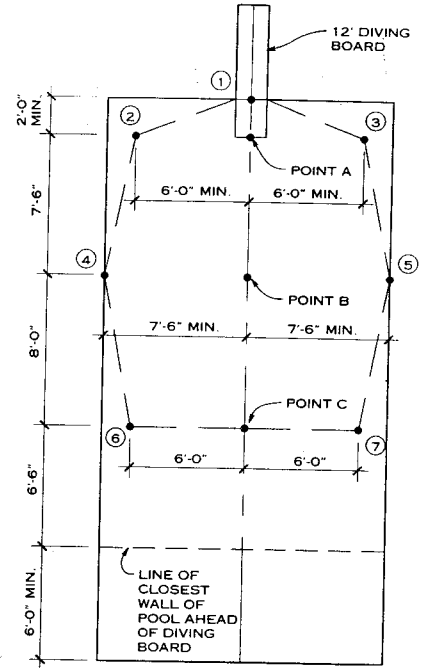

**7-POINT GRID DIMENSION PLAN**

Many alternative combinations of chemicals are available for water treatment, but growing concern over using chemical treatment alone has led to the development of ozone-based systems. Ozone generators are used to disinfect and oxidize the water, making it more easily filtered and decreasing the amount of sanitizer needed.

**NOTES**

1. The drawings above illustrate the use of a 7-point dimension grid that expresses the minimum desirable dimensions to be used when specifying or designing a rectangular pool for residential use.
2. Width, length, and depth dimensions may apply to residential pools of any shape.
3. The minimum length with diving board and wading area is 32 ft. The average length of a residential pool is 32-40 ft.
4. Standards for residential swimming pools have been published by the National Spa and Pool Institute (1989).

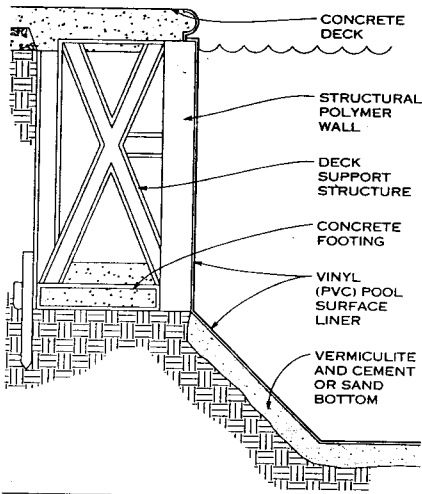

**VINYL POOL LINER OVER STRUCTURAL POLYMER WALL**

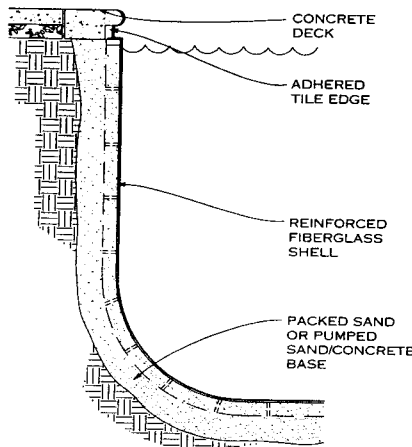

**FIBERGLASS SHELL POOL**

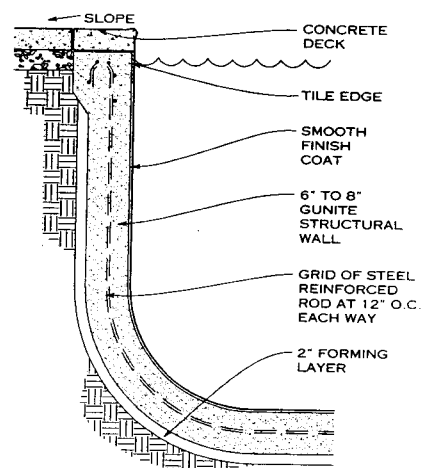

**FORMED CONCRETE (GUNITED) WALL AND DECK**

Robert D. Buckley, AIA; robert d. buckley \* architect; Kalamazoo, Michigan  
D. J. Hunsaker; Counsilman/Hunsaker & Associates; St. Louis, Missouri  
National Swimming Pool Foundation; Merrick, New York

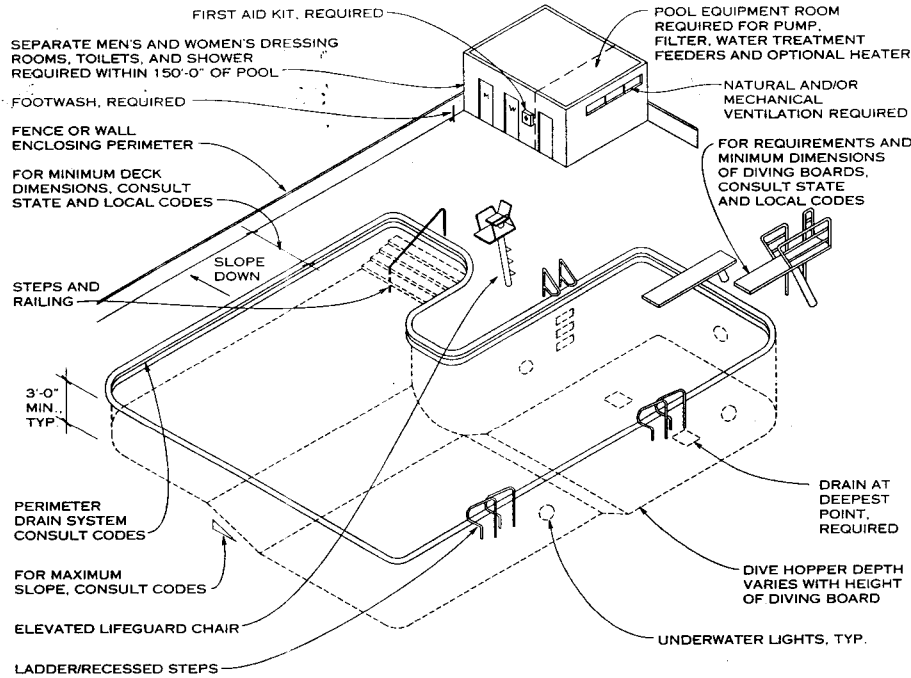

**GENERAL NOTES**

- Public pools are those operated and intended for the collective use of unrelated persons, whether or not a fee is charged. Semipublic pools are those intended for use by housing facility occupants and their invited guests. Private residential pools are those located on private property for use by the owner's family and/or invited guests.
- Special purpose pools are those designed for specific uses and not defined as public, semipublic, or private residential.
- A spa is defined as a special facility that is not drained, cleaned, or refilled after each individual use and may include hydrojet circulation, hot water, cold water, mineral bath, air induction bubbles, or any combination of these.
- The water supply serving a public swimming pool and all plumbing fixtures, including drinking fountains, lavatories, toilets, and showers, must meet all applicable requirements for potable water. All portions of the water distribution system serving the swimming pool and auxiliary facilities must be protected against backflow.
- Swimming pools must be designed and constructed to withstand all anticipated loadings for both empty and full conditions.
- A hydrostatic relief valve must be provided for in-ground swimming pools in areas with a high water table.
- Provisions must be made for complete, continuous circulation of water through all areas of the swimming pool.
- The shape of any swimming pool must not impair swimmer safety or the circulation of water through all areas of the pool.

**NOTES**

- All swimming pools must be equipped with a filtration system for clarifying the water; the system must be an integral part of the circulation system and consist of one or more filter units, either sand, diatomaceous earth, or cartridge type.
- Every swimming pool must be equipped with a disinfectant feeder as required to keep the microbiological, chemical, and physical characteristics of the pool water within prescribed limits.
- All swimming pools must have the water depth marked

plainly at or above the waterline on the vertical wall where possible and on the edge of the deck next to the pool; depth markers must be 25 ft or less on center.

- When visitor or spectator areas are provided at swimming pools, there must be an absolute separation between those areas and the pool area. Provide separate toilets for visitors and spectators.
- Every public pool must have a readily accessible room or area designated and equipped for emergency care.

**TYPICAL PUBLIC SWIMMING AND DIVING POOL REQUIREMENTS**

**STANDARD DIMENSIONS FOR PUBLIC SWIMMING POOLS IN FT-IN. (M)<sup>1</sup>**

POOL TYPE	DIVING EQUIPMENT		MINIMUM DIMENSIONS <sup>2</sup>										MINIMUM WIDTH OF POOL AT POINTS		
	MAX. BOARD LENGTH	MAX. HEIGHT OVER WATER	D <sub>1</sub>	D <sub>2</sub>	R	L <sub>1</sub>	L <sub>2</sub>	L <sub>3</sub>	L <sub>4</sub>	L <sub>5</sub>	A	B	C		
VI	10-0	0-26 (2/3)	7-0 (2.13)	8-6 (2.59)	5-6 (1.68)	2-6 (0.76)	8-0 (2.44)	10-6 (3.20)	7-0 (2.13)	28-0 (8.53)	16-0 (4.88)	18-0 (5.49)	18-0 (5.49)		
VII	12-0	0-30 (3/4)	7-6 (2.29)	9-0 (2.74)	6-0 (1.83)	3-0 (0.91)	9-0 (2.74)	12-0 (3.66)	4-0 (1.22)	28-0 (8.53)	18-0 (5.49)	20-0 (6.10)	20-0 (6.10)		
VIII	16-0	(1)	8-6 (2.59)	10-0 (3.05)	7-0 (2.13)	4-0 (1.22)	10-0 (3.05)	15-0 (4.57)	2-0 (0.61)	31-0 (9.45)	20-0 (6.10)	22-0 (6.71)	22-0 (6.71)		
IX	16-0	(3)	11-0 (3.35)	12-0 (3.66)	8-6 (2.59)	6-0 (1.83)	10-6 (3.20)	21-0 (6.40)	—	37-6 (11.43)	22-0 (6.71)	24-0 (7.32)	24-0 (7.32)		

Source: National Spa and Pool Institute (NSPI), Alexandria, Virginia

<sup>1</sup>The dimensions given are the currently recommended standards for public swimming pools and are not designed for sanctioned competition.

<sup>2</sup>L<sub>2</sub>, L<sub>3</sub>, and L<sub>4</sub> combined represent the minimum distance from the tip of a board to the pool wall opposite the diving equipment.

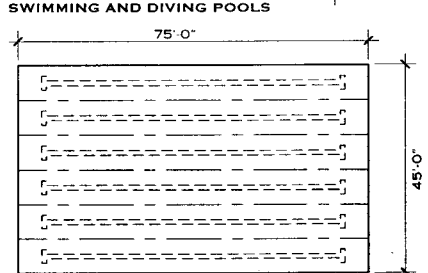
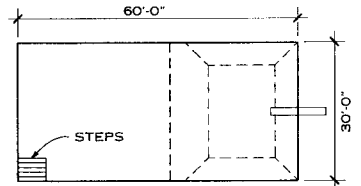
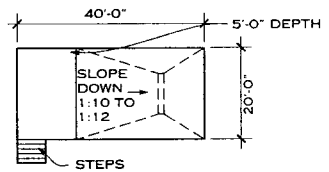

**6-LANE LAP POOL**

**TYPICAL PUBLIC POOL SHAPES**

**DIVING BOARD DIMENSIONS**

There must be a completely unobstructed, clear vertical distance of 13 ft above any diving board, measured from the center of the front end of the board. This area must extend horizontally at least 8 ft behind, 8 ft to each side, and 16 ft ahead of point A (see key).

For diving board placement, observe these minimum distances from the pool edge or adjacent boards:

Deck-level board to pool side:	8 ft
1-meter board to pool side:	10 ft
3-meter board to pool side:	11 ft
1-meter or deck-level board to 3-meter board:	10 ft
1-meter or deck-level board to another 1-meter or deck-level board:	8 ft
3-meter board to another 3-meter board:	10 ft

**STANDARD DIMENSIONS KEY**

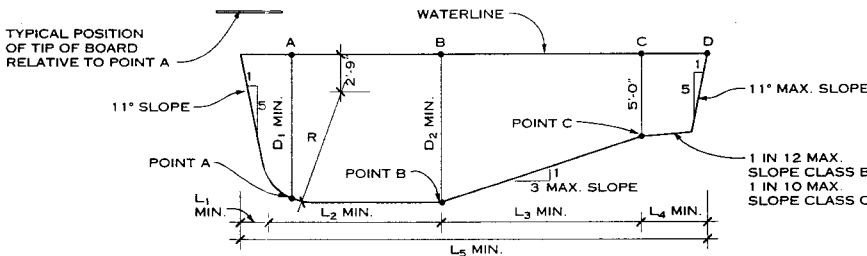

Robert D. Buckley, AIA; robert d. buckley \* architect; Kalamazoo, Michigan  
D. J. Hunsaker; Counsilman/Hunsaker & Associates; St. Louis, Missouri  
National Swimming Pool Foundation; Merrick, New York

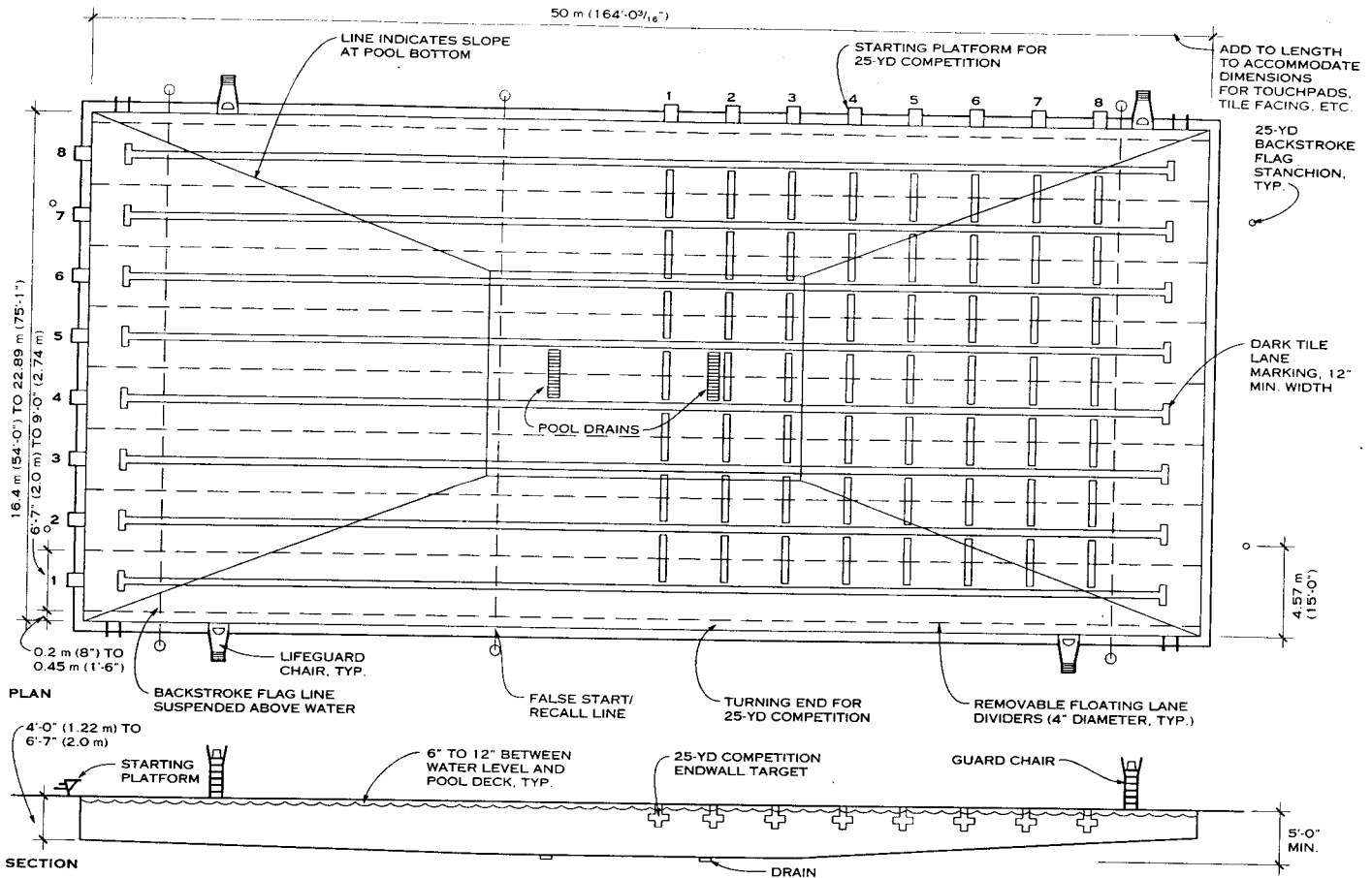

**NOTE**

A 25-meter pool width will provide 10 lanes for training or competition and accommodate international meets of any distance. An economical alternative for pool length is 70

meters with at least one bulkhead to separate training and competition areas.

**50-METER COMPETITION SWIMMING POOL**

**NOTES ON POOL DESIGN**

- The information on this page is based on current standards and rules for swimming races, competition diving, and other aquatic competitions stipulated by the following aquatic sport organizations:  
FINA (Federation Internationale de Natation Amateur) governs international competition, including the Olympic Games.  
US Swimming (United States Swimming, Inc.) governs open and age group levels in the United States.  
US Diving (United States Diving, Inc.) governs open and age group levels in the United States.  
NCAA (National Collegiate Athletic Association) governs all collegiate competition.  
NFHS (National Federation of State High School Associations) governs all high school competition.
- Because they represent different groups and/or skill levels within a sport, the regulatory organizations do not always agree on the dimensions and features required for a pool facility. In addition to complying with the rules of pertinent organizations, the engineering of a swimming pool must follow the design regulations of any local, state, or federal agency that has jurisdiction over the facility. Sanitary and structural considerations vary almost as much between agencies as competitive guidelines do.
- Consult the *Official Swimming Pool Design Compendium* (Merrick, N.Y.: National Swimming Pool Foundation, rev. ed. 1997) for specific rules of all the governing bodies.
- Swimming pool dimensions shall be measured from the inside walls or from the tile or timing devices attached to the walls. Touchpads for automatic timing may be used if they do not shorten the race course beyond minimum specifications. Markings on the finish pad and bulkheads

- must conform to required markings on the endwalls. Visible numbers identifying lanes must be provided.
- Endwalls and movable bulkheads serving as endwalls must be parallel and vertical for a distance of 3 ft 6 in. (1.0668 m) below the overflow level of the water. No protrusions are permitted below the surface. Endwalls should be finished with a nonslip surface.

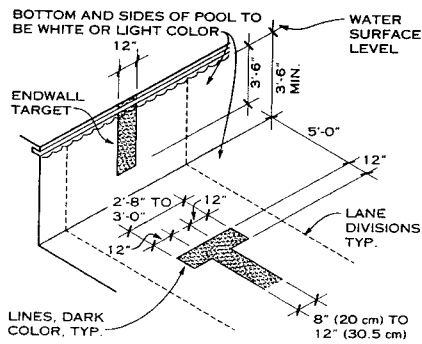

**NOTE**

For endwall target design, see the rules of the appropriate governing organization.

**LANE END MARKINGS**

- All ladders, steps, or stairs must be recessed into side walls or easily removed for competition.
- Lighting at water level should be 100 footcandles. (FINA standards dictate 600 lux at water level.)
- Lane markers must be continuous, clearly visible floats that indicate the lateral limits of each lane. They must be attached to and stretched between the endwalls and anchored at surface water level in a recessed receptacle. Solid color floats are recommended within 15 ft 0 in. (4.572 m) of both endwalls in contrast with the center portion of the lane markers.
- Backstroke flag lines are required for all events in which the backstroke is swum. At least three 12-18 in. long pennants of two or more alternating colors must hang from the line.

**NOTES ON POOL DIMENSIONS**

- When a range of dimensions is given, consult the appropriate governing organization (FINA, USS, NCAA, or NFHS) for specific dimensions.
- Depending on the governing organization, pool size, and competition type, the following information applies for dimensions from the starting platform end of the pool:  
To the backstroke flag line, the dimension ranges from 15 ft 0 in. (4.57 m) to 16 ft 4 in. (4.98 m).  
For 50-m pools, the dimension to the false start/recall stanchion ranges from 42 ft 0 in. (10.973 m) to 65 ft 7 in. (20.0 m).  
For 25-yd and 25-m pools, the dimension to the false start/recall stanchion ranges from 33 ft 1 in. (10.08 m) to 60 ft 1 in. (18.31 m).

Robert D. Buckley, AIA; robert d. buckley \* architect; Kalamazoo, Michigan  
D. J. Hunsaker; Counsilman/Hunsaker & Associates; St. Louis, Missouri  
National Swimming Pool Foundation; Merrick, New York

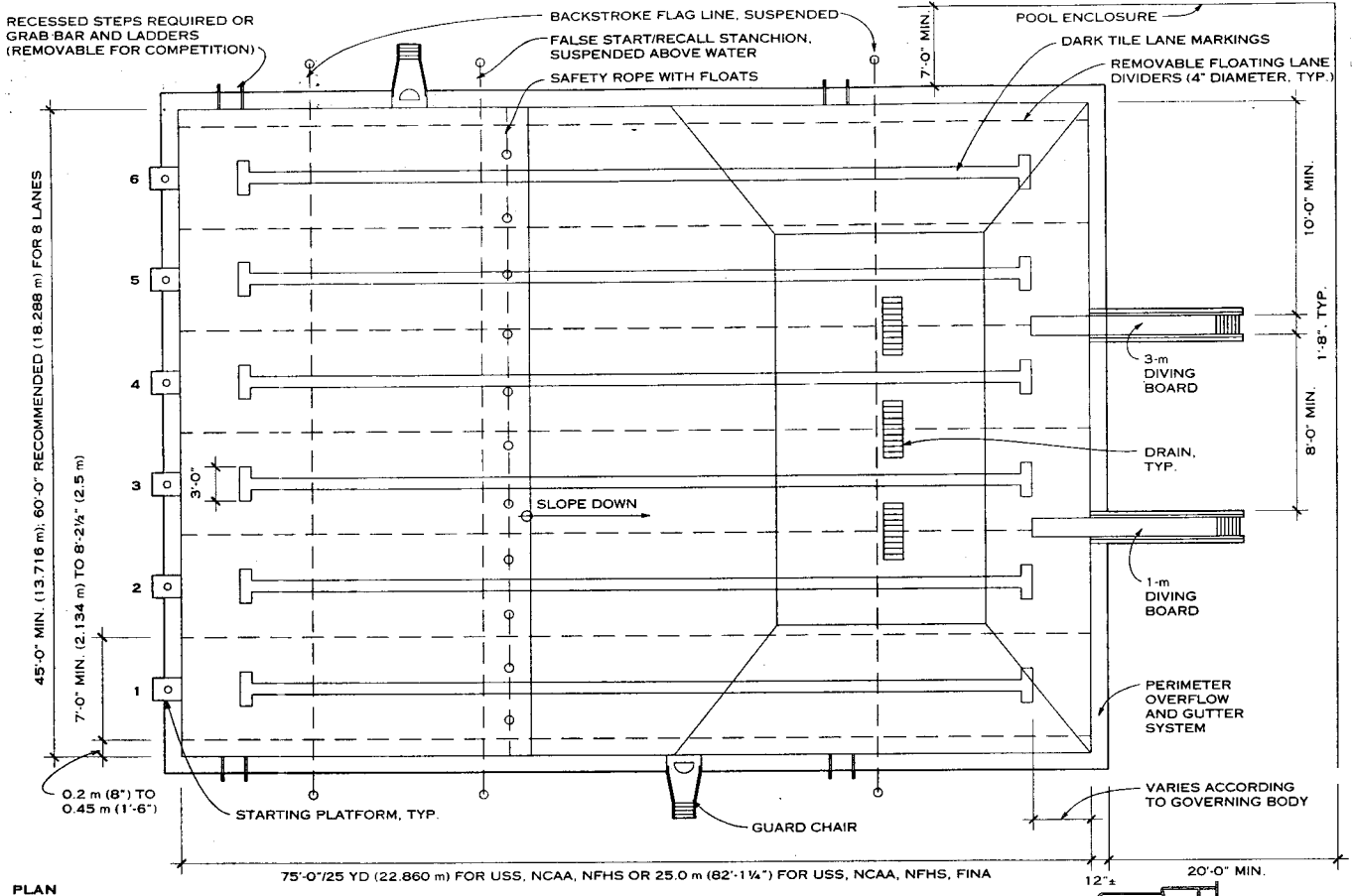

PLAN

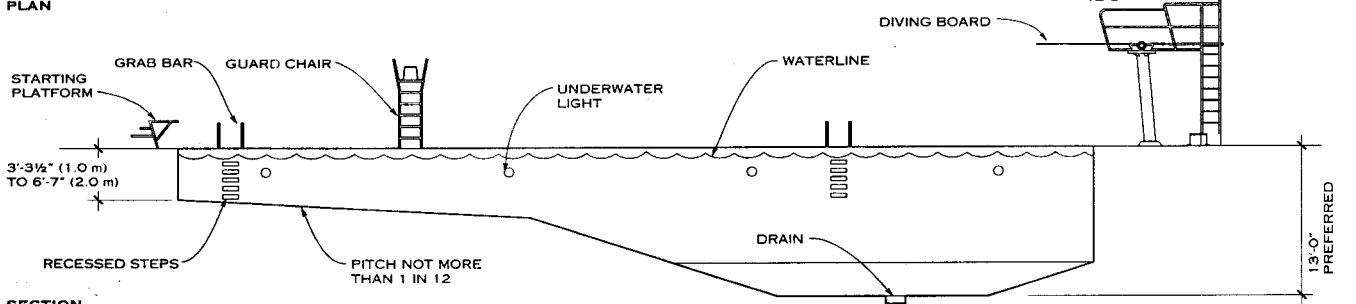

SECTION

25-METER AND 25-YARD COMPETITION SWIMMING AND DIVING POOL

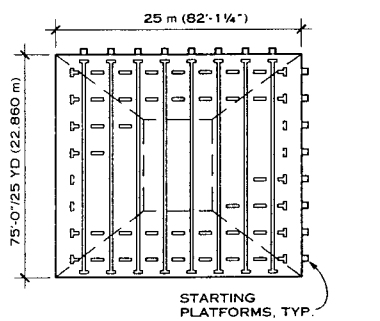
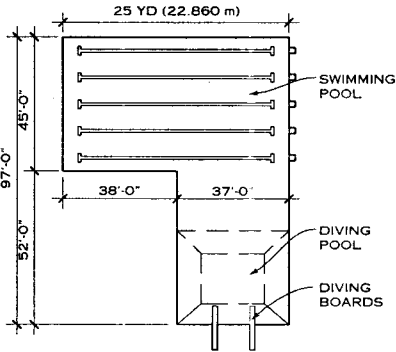

DIVING POOL ATTACHED TO SWIMMING POOL

COMBINED 25-YD AND 25-M SWIMMING POOL

ALTERNATE POOL LAYOUTS

NOTES ON POOL DIMENSIONS

- When a range of dimensions is given, consult the appropriate governing organization (FINA, USS, NCAA, or NFHS) for specific dimensions.
- Depending on the governing organization, pool size, and competition type, the following information applies for dimensions from the starting platform end of the pool:  
 To the backstroke flag line, the dimension ranges from 15 ft 0 in. (4.57 m) to 16 ft 4 3/4 in. (5.0 m).  
 To the false start/recall stanchion, the dimension ranges from 33 ft 1 in. (10.08 m) to 60 ft 1 in. (18.31 m).

Robert D. Buckley, AIA; robert d. buckley \* architect; Kalamazoo, Michigan  
 D. J. Hunsaker; Counsilman/Hunsaker & Associates; St. Louis, Missouri  
 National Swimming Pool Foundation; Merrick, New York

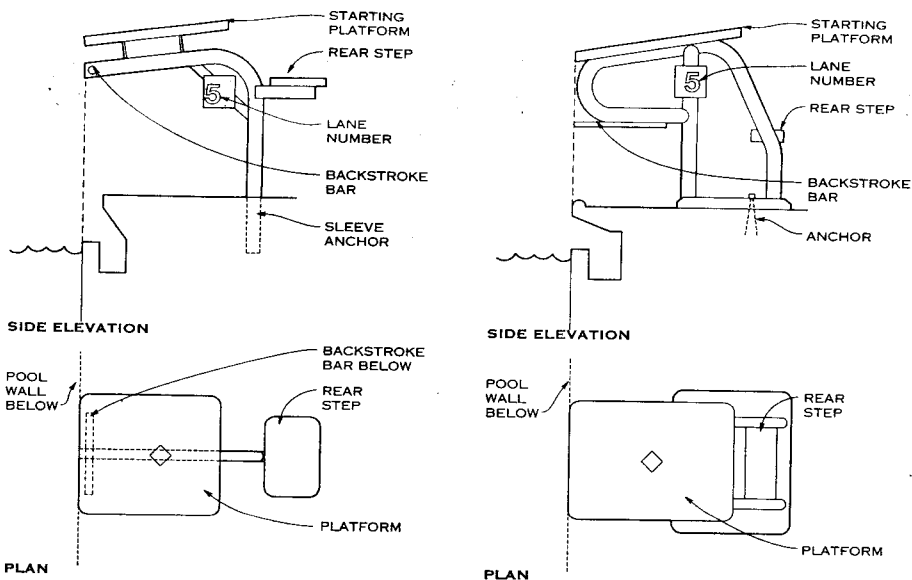
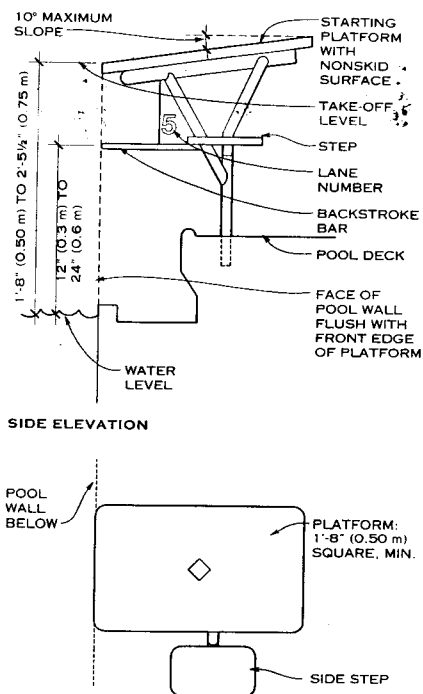

ALTERNATE STARTING PLATFORMS

PLAN NOTES

1. In pools with a water depth of 3 ft 6 in. to 4 ft at the starting end (measured at the end wall or any point within 12 in. of the end wall), starting platforms shall be no more than 18 in. above the water surface; otherwise, the swimmers must start from the deck or in the water.
2. In pools with a water depth less than 3 ft 6 in. in the starting end, the swimmers must start in the water.

STARTING PLATFORM REQUIREMENTS

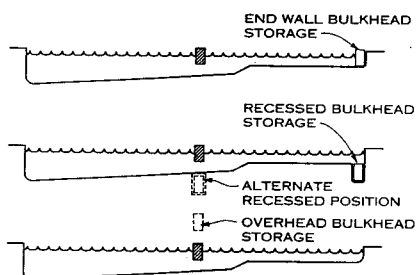
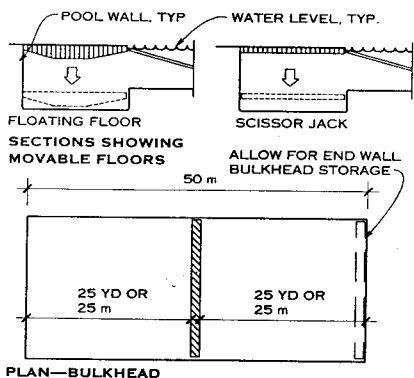

SECTIONS SHOWING BULKHEAD IN VARIOUS STORAGE POSITIONS  
BULKHEADS AND MOVABLE FLOORS

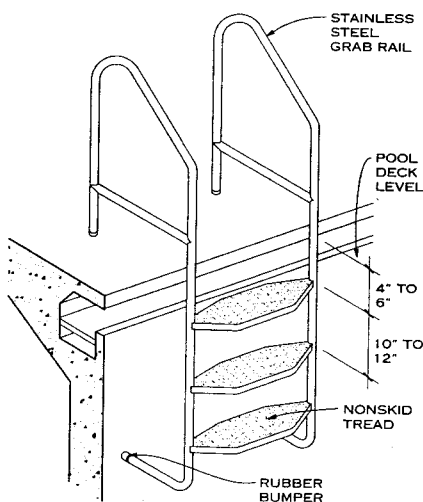

POOL LADDER

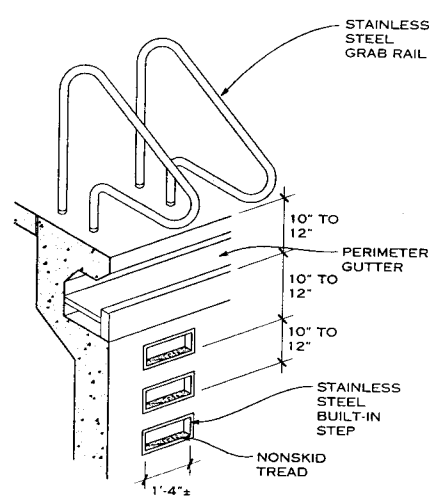

BUILT-IN STEPS WITH GRAB RAILS

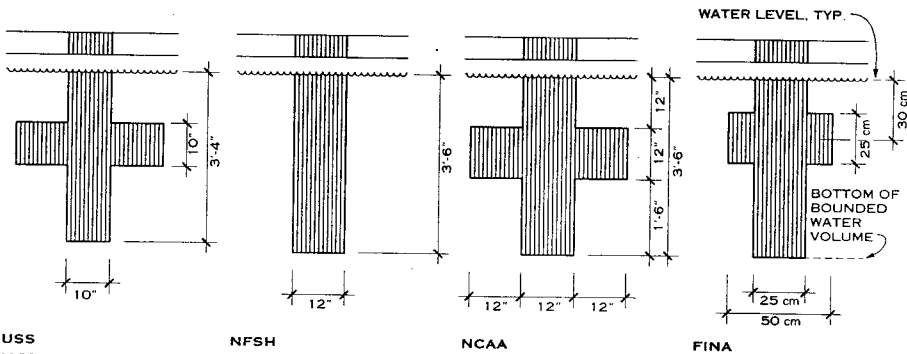

USS NOTES

For placement and dimensions of touch pads specified by the various governing agencies, refer to the section on electronic starting, timing, and judging devices in National Swimming Pool Foundation, *Official Swimming Pool Design Compendium*, updated 5th ed. (1997).

END WALL TARGETS

Robert D. Buckley, AIA; robert d. buckley \* architect; Kalamazoo, Michigan  
D. J. Hunsaker; Counsilman/Hunsaker & Associates; St. Louis, Missouri

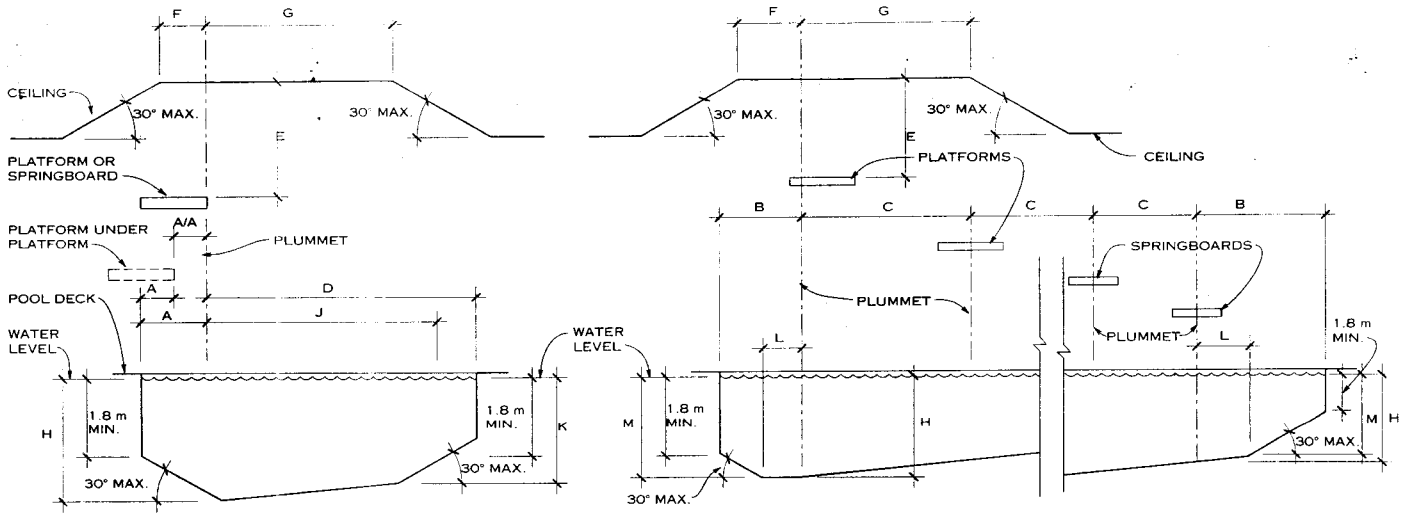

LONGITUDINAL SECTION

TRANSVERSE CROSS-SECTION

DIAGRAM OF RECOMMENDED DIMENSIONS FOR FINA, US DIVING, NCAA, AND NFHS DIVING FACILITIES

DIMENSIONS FOR DIVING FACILITIES

DESIGN CRITERIA	FINA (IN M)												U.S. DIVING AND NCAA (IN FT-IN.) <sup>1</sup>											
	SPRINGBOARD				PLATFORM								SPRINGBOARD		PLATFORM									
	1 meter		3 meter		1 meter		3 meter		5 meter		7.5 meter		10 meter		1 meter	3 meter	5 meter		7.5 meter		10 meter			
	Length	Width	Height	Horiz.	Vert.	Horiz.	Vert.	Horiz.	Vert.	Horiz.	Vert.	Horiz.	Vert.	Horiz.	Vert.	Horiz.	Vert.	Horiz.	Vert.	Horiz.	Vert.	Horiz.	Vert.	
A	Desig. A-1	A-3	A-1PL	A-3PL	A-5	A-7.5	A-10	A-1	A-3	A-5	A-7.5	A-10	A-1	A-3	A-5	A-7.5	A-10	A-1	A-3	A-5	A-7.5	A-10		
	Min. 1.50	1.50	0.75	1.25	1.25	1.50	1.50	5-0	5-0	4-2	5-0	5-0	6-1	6-1	4-2	5-0	5-0	5-0	5-0	5-0	5-0	5-0		
	Pref. 1.80	1.80	0.75	1.25	1.25	1.50	1.50																	
A/A	Desig. A/A																							
	Min.																							
	Pref.																							
B	Desig. B-1	B-3	B-1PL	B-3PL	B-5	B-7.5	B-10	B-1	B-3	B-5	B-7.5	B-10	B-1	B-3	B-5	B-7.5	B-10	B-1	B-3	B-5	B-7.5	B-10		
	Min. 2.50	3.50	2.30	2.80	3.25	4.25	5.25	8-3	11-6	10-8	14-0	17-3	8-3	11-6	12-4	14-10	17-3	8-3	11-6	12-4	14-10	17-3		
	Pref. 2.50	3.50	2.30	2.90	3.75	4.50	5.25	8-3	11-6	12-4	14-10	17-3	8-3	11-6	12-4	14-10	17-3	8-3	11-6	12-4	14-10	17-3		
C <sup>2</sup>	Desig. C-1	C-3, 3-1	C-1-1PL	C-3-3PL, 1PL	C-5, 5-1	C-7.5, 3, 1	C-10-7.5, 5, 3, 1	C-11	C-331	C-531	C-7.5531	C-107.55531	C-11	C-331	C-531	C-7.5531	C-107.55531	C-11	C-331	C-531	C-7.5531	C-107.55531		
	Min. 2.00	2.20	1.65	2.00	2.25	2.50	2.75	6-7	7-3	7-5	8-3	9-1	6-7	7-3	7-5	8-3	9-1	6-7	7-3	7-5	8-3	9-1		
	Pref. 2.40	2.60	1.95	2.10	2.50	2.75	2.75	7-1	8-3	8-3	8-3	9-1	7-1	8-3	8-3	8-3	9-1	7-1	8-3	8-3	8-3	9-1		
D	Desig. D-1	D-3	D-1PL	D-3PL	D-5	D-7.5	D-10	D-1	D-3	D-5	D-7.5	D-10	D-1	D-3	D-5	D-7.5	D-10	D-1	D-3	D-5	D-7.5	D-10		
	Min. 9.00	10.25	8.00	9.50	10.25	11.0	13.50	29-7	33-8	33-8	36-2	44-4	29-7	33-8	33-8	36-2	44-4	29-7	33-8	33-8	36-2	44-4		
	Pref. 9.00	10.25	8.00	9.50	10.25	11.0	13.50	29-7	33-8	33-8	36-2	44-4	29-7	33-8	33-8	36-2	44-4	29-7	33-8	33-8	36-2	44-4		
E	Desig. E-1	E-3	E-1PL	E-3PL	E-5	E-7.5	E-10	E-1	E-3	E-5	E-7.5	E-10	E-1	E-3	E-5	E-7.5	E-10	E-1	E-3	E-5	E-7.5	E-10		
	Min. 5.00	5.00	3.25	3.25	3.25	3.25	4.00	16-5	16-5	10-8	10-8	13-2	16-5	16-5	10-8	10-8	13-2	16-5	16-5	10-8	10-8	13-2		
	Pref. 5.00	5.00	3.50	3.50	3.50	3.50	5.00	16-5	16-5	11-6	11-6	16-5	16-5	11-6	11-6	11-6	16-5	16-5	11-6	11-6	11-6	16-5		
F	Desig. F-1	E-1 R-3	F-1PL	E-1PL F-3PL	E-5 F-5	F-7.5 E-7.5	F-10 E-10	F-1	F-3	F-5	F-7.5	F-10	F-1	F-3	F-5	F-7.5	F-10	F-1	F-3	F-5	F-7.5	F-10		
	Min. 2.50	5.00	2.50	2.75	3.25	2.75	3.25	2.75	3.25	2.75	3.25	2.75	4.00	8-3	16-5	8-3	16-5	8-3	16-5	8-3	16-5	8-3		
	Pref. 2.50	5.00	2.50	2.75	3.50	2.75	3.50	2.75	3.50	2.75	3.50	2.75	5.00	8-3	16-5	8-3	16-5	8-3	16-5	8-3	16-5	8-3		
G	Desig. G-1	E-1 G-3	G-1PL	E-1PL G-3PL	E-5 G-5	G-7.5 E-7.5	G-10 E-10	G-1	G-3	G-5	G-7.5	G-10	G-1	G-3	G-5	G-7.5	G-10	G-1	G-3	G-5	G-7.5	G-10		
	Min. 5.00	5.00	5.00	5.00	3.25	5.00	3.25	5.00	3.25	5.00	3.25	6.00	16-5	16-5	16-5	16-5	10-8	16-5	16-5	16-5	10-8	16-5		
	Pref. 5.00	5.00	5.00	5.00	3.50	5.00	3.50	5.00	3.50	5.00	3.50	6.00	16-5	16-5	16-5	16-5	11-6	16-5	16-5	11-6	16-5	19-9		
H	Desig. H-1	H-3	H-1PL	H-3PL	H-5	H-7.5	H-10	H-1	H-3	H-5	H-7.5	H-10	H-1	H-3	H-5	H-7.5	H-10	H-1	H-3	H-5	H-7.5	H-10		
	Min. 3.40	3.70	3.20	3.50	3.70	4.10	4.50	11-0	12-0	12-2	13-6	14-10	11-0	12-0	12-2	13-6	14-10	11-0	12-0	12-2	13-6	14-10		
	Pref. 3.50	3.80	3.30	3.60	3.80	4.50	5.00	11-6	12-6	12-6	14-10	16-5	11-6	12-6	12-6	14-10	16-5	11-6	12-6	12-6	14-10	16-5		
J/K	Desig. J-1	K-1 J-3	K-3 J-1PL	K-1PL J-3PL	J-5 K-5	J-7.5 K-7.5	J-10 K-10	J-1	K-1	J-3	K-3	J-5	K-5	J-7.5	K-7.5	J-10	K-10	J-1	K-1	J-3	K-3	J-5		
	Min. 5.00	3.30	6.00	3.70	4.50	3.10	5.50	3.40	6.00	3.60	8.00	4.00	11.00	4.25	16-5	10-10	16-5	11-10	19-9	11-10	26-3	13-2		
	Pref. 5.00	3.40	6.00	3.70	4.50	3.20	5.50	3.50	6.00	3.70	8.00	4.40	11.00	4.75	16-5	11-2	19-9	12-2	19-9	12-2	26-3	14-6		
L/M	Desig. L-1	M-1 L-3	L-1PL	M-1PL L-3PL	L-5 M-5	L-7.5 M-7.5	L-10 M-10	L-1	M-1	L-3	M-3	L-5	M-5	L-7.5	M-7.5	L-10	M-10	L-1	M-1	L-3	M-3	L-5		
	Min. 1.50	3.30	2.00	3.60	1.40	3.10	1.80	3.40	3.00	3.60	3.75	4.00	4.50	5-0	10-10	6-7	11-10	19-11	11-10	12-4	13-2	14-10		
	Pref. 2.00	3.40	2.50	3.70	1.90	3.20	2.30	3.50	3.50	3.70	4.50	4.40	5.25	4.75	9-11	11-2	8-3	12-2	11-6	12-2	14-10	14-6		

<sup>1</sup> All dimensions in the US Diving and NCAA section of this chart are rounded up, even when the dimension is only fractionally greater than the next lowest inch.

<sup>2</sup> Dimension C (plummet to adjacent plummet) applies to platforms with widths as specified in this chart. If platform widths are increased, dimension C must be increased by

half the additional width(s).

Robert D. Buckley, AIA; robert d. buckley \* architect; Kalamazoo, Michigan  
 D. J. Hunsaker; Counsilman/Hunsaker & Associates; St. Louis, Missouri  
 National Swimming Pool Foundation; Merrick, New York

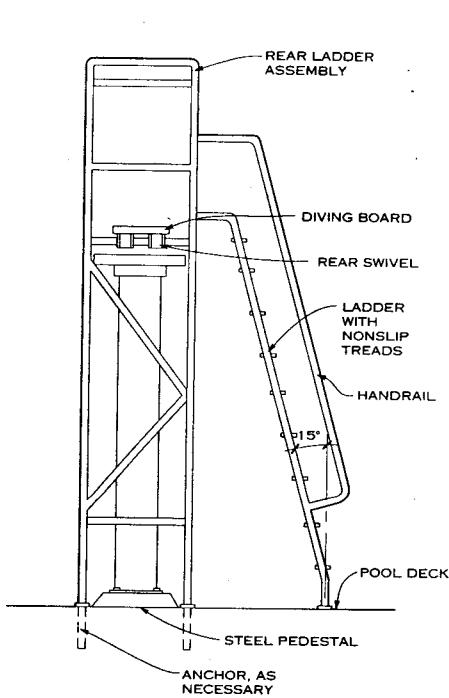

REAR ELEVATION

3-METER DIVING BOARD

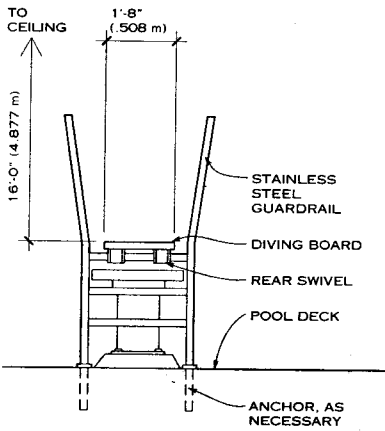

REAR ELEVATION

1-METER DIVING BOARD

NOTES

- Both 1- and 3-meter boards are required for amateur, collegiate, and international meets. Consult the *Official Swimming Pool Design Compendium* (Merrick, N.Y.: National Swimming Pool Foundation, rev. ed. 1997) for specific FINA, US Diving, NCAA, and NFHS details and specifications.
- When a range of dimensions is given, consult the appropriate governing organization for specific dimensions.
- When selecting a 1- or 3-meter diving tower, pay special attention to the materials it is made of. Differences in wall tubing thickness, anchorage, and fulcrum materials influence the flexibility and spring from the tower.

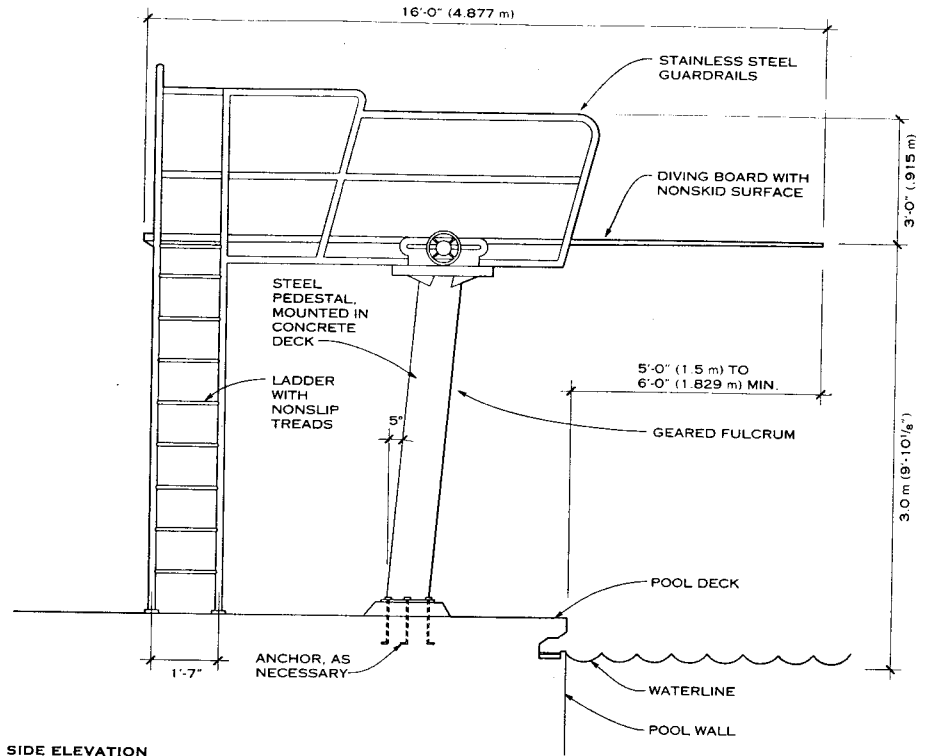

SIDE ELEVATION

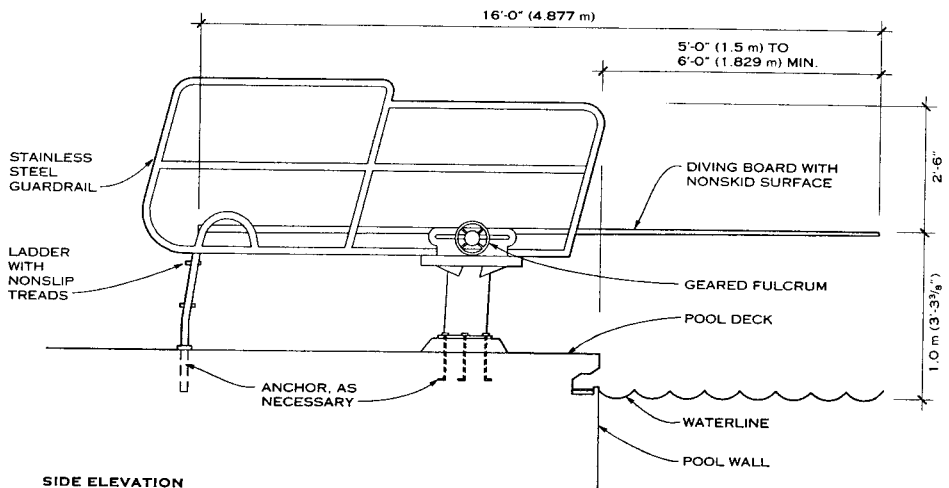

SIDE ELEVATION

- A fulcrum, which can be moved and set at varying positions between 5 ft 6 in. (1.676 m) and 7 ft 6 in. (2.286 m) from the rear of the diving board, is required. The board must remain horizontal with the fulcrum in any position. The range of movement of the fulcrum may be limited under certain conditions. Consult with the appropriate governing body for diving competition regulations.
- A water agitation system is recommended that produces water surface agitation extending 5 ft (1.524 m) beyond the end of the board with a width of 2 ft (0.6096 m).
- The maximum depth reduction rate of diving pools that do not exceed minimum depth requirements shall be 6.25% for a distance of 20 ft (6.096 m) forward and 6 ft (1.829 m) back and to the sides. Deeper pools may have proportionally steeper depth reduction rates.
- Three choices are available for diving board supports for 1- and 3-meter boards: a manufactured cantilevered steel stand; a manufactured cast aluminum stand; and a cast-in-place concrete platform with a fulcrum assembly mounted directly to the top of the slab.

Robert D. Buckley, AIA; robert d. buckley \* architect; Kalamazoo, Michigan  
 D. J. Hunsaker; Counsilman/Hunsaker & Associates; St. Louis, Missouri  
 National Swimming Pool Foundation; Merrick, New York



**NOTE**

In these drawings, S/S stands for stainless steel.

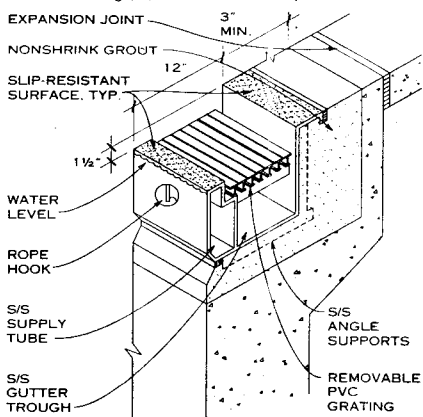

**ROLLOUT GUTTER SYSTEM**

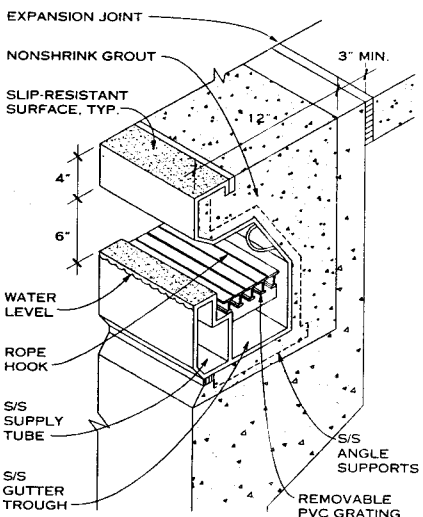

**NOTE**

In addition to the stainless steel system shown, gutters may be designed as an integral part of the concrete deck edge.

**FULLY RECESSED GUTTER SYSTEM**

**NOTES ON PERIMETER OVERFLOW**

1. A perimeter overflow system must be provided on all public swimming pools. The system must be designed and constructed to maintain the water level of the pool at the operating level of the overflow rim or weir device. Applicable codes determine the dimension from the deck to the water level.
2. When used as the only overflow system on a pool, a perimeter overflow system must extend around a minimum of half the swimming pool perimeter. Perimeter overflow systems must be connected to the circulation system with a system surge capacity of not less than 1 gal/sq ft of pool surface.
3. The perimeter overflow system in combination with the upper rim of the pool must constitute a handhold. It must be designed to prevent entrapment of a swimmer's arms, legs, or feet and to permit inspection and cleaning.
4. In some states, the hydraulic capacity of the overflow system must be sufficient to handle 100% of the circulation flow.
5. Rollout and/or zero depth flush perimeter overflow systems are most commonly used in recreational pools and walk-in shallow areas. Competitive pools that have semirecessed gutters along their length to trap wave surge and prevent reflected waves must have fully recessed gutters at the ends or provide a visual barrier that can be seen by competing swimmers.

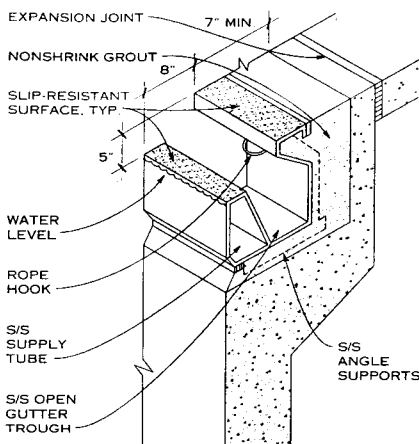

**SEMIRECESSED OPEN GUTTER SYSTEM**

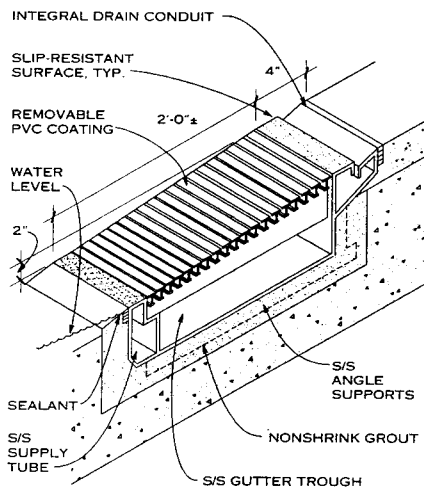

**NOTE**

The zero depth gutter system is typically used for walk-in or leisure-type pools only, if necessary.

**ZERO DEPTH GUTTER SYSTEM**

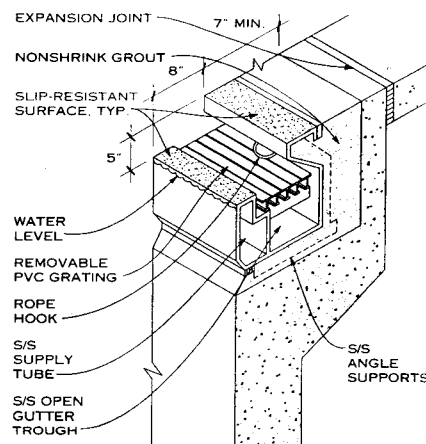

**SEMIRECESSED GUTTER SYSTEM**

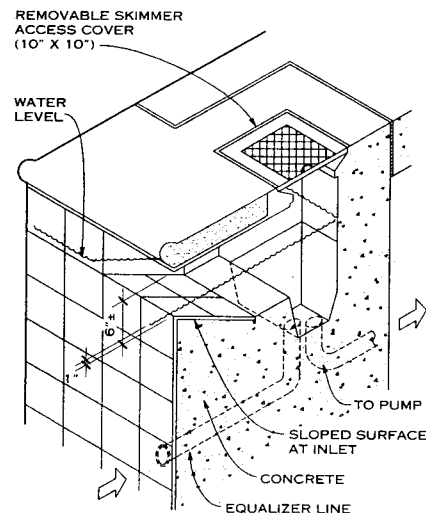

**NOTE**

Surface skimmers are not recommended for use in competitive pools.

**SKIMMER DETAIL**

competitive use the water level is raised to the gutter lip. Waves then flow over the lip and are returned through the surge tank without rebound.

**SURFACE SKIMMERS**

If surface skimmers are used, provide one for each 500 sq ft or fraction thereof of the pool surface. When two or more skimmers are used, they must be located so they maintain effective skimming action over the entire surface of the pool. To obtain the most effective skimming action, locate the skimmers with regard to the prevailing wind and drift, shape of the pool, and water circulation pattern. Use of directional inlet fittings will help ensure a proper circulation pattern.

Skimmers may not be permitted in larger pools; see local health department codes for limitations on public pool use. Skimmers are not recommended for use in competitive pools.

Surface skimmers are available from many swimming pool suppliers. Metal or plastic units come in various capacities. An access cover in the deck provides for removal and cleaning of the strainer. Surface skimmers should comply with the joint National Swimming Pool Institute-National Sanitation Foundation performance standards

Robert D. Buckley, AIA; robert d. buckley \* architect; Kalamazoo, Michigan  
D. J. Hunsaker; Counsilman/Hunsaker & Associates; St. Louis, Missouri  
National Swimming Pool Foundation; Merrick, New York

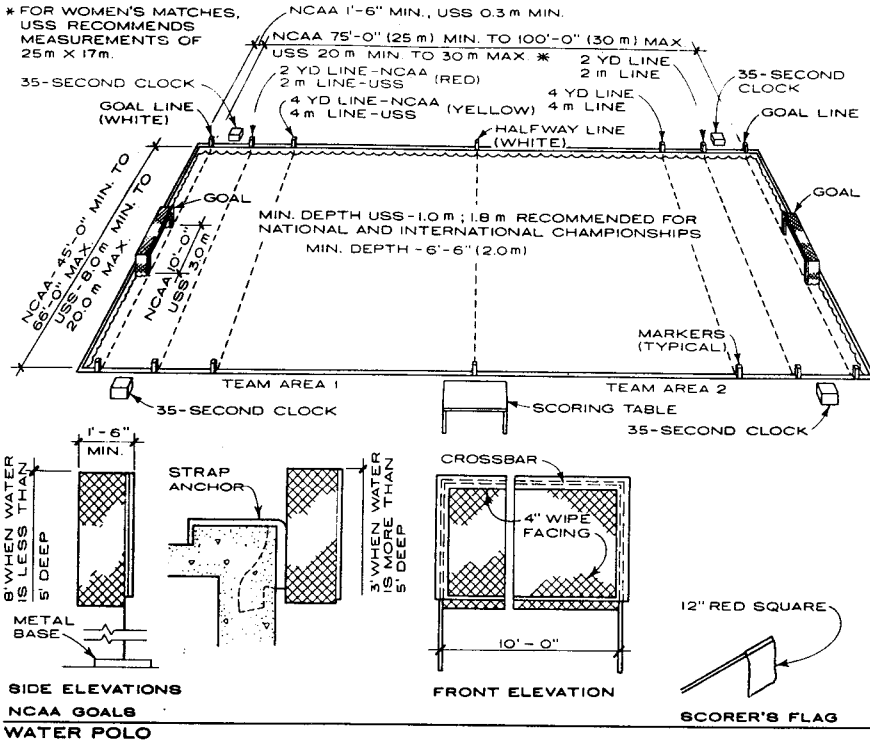

NOTES

1. Distinctive marks must be provided on both sides of field of play indicating goal lines, 2 and 4 yd (or meter) lines, and  $\frac{1}{2}$  distance between goal lines. These must be clearly visible from any position within the field of play. Allow sufficient space on walkways so referees may move freely from end to end of field of play. Provide space at goal lines for goal judges.
2. There must be distinctive markers on both ends of the pool to denote the ejection area on the goal line or the ends of the field of play 2 yd (2.0 m) from the corner of the field of play and to the right of the goal at the corner where the goal judge is located.

GOAL REQUIREMENTS

Posts and crossbar, rigid and perpendicular. USS, wood or metal, 3 in. sq, painted white; NCAA, metal  $\frac{1}{2}$  in. diameter, painted yellow or orange. Nets to hang loosely on frame. For USS, the underside of the crossbar must be 0.90 m above water surface when water is 1.50 m or more in depth, and 2.40 m from the bottom of the bath when the depth of the water is less than 1.50 m.

Frames are custom made, with bracing placed where necessary. It is recommended that they be collapsible for easy storage. Anchorage methods depend on pool design, with those above commonly used, or brass couplings may be placed in pool walls to which frame is attached. If pool is longer than required length, one of the goals may be floated and anchored with guy wires.

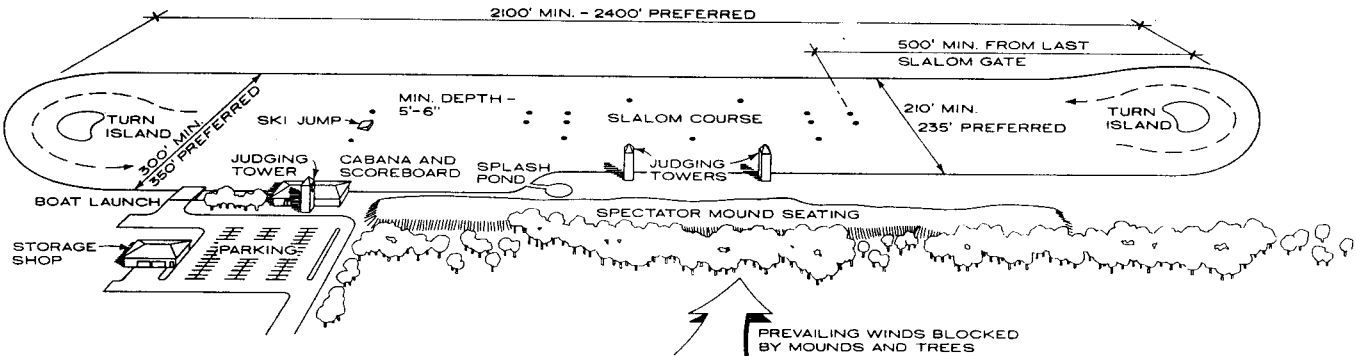

NOTES

1. To decrease turbidity caused by boat wake, an island running down the center of the lake may be built in addition to turn islands. Floating breakwaters may also

- be used; islands should be rippedraped to prevent soil erosion.  
 2. A gradual (ratio 6:1) sandy slope along shorelines lets wave action die without rolling back.

WATER SKI LAKE

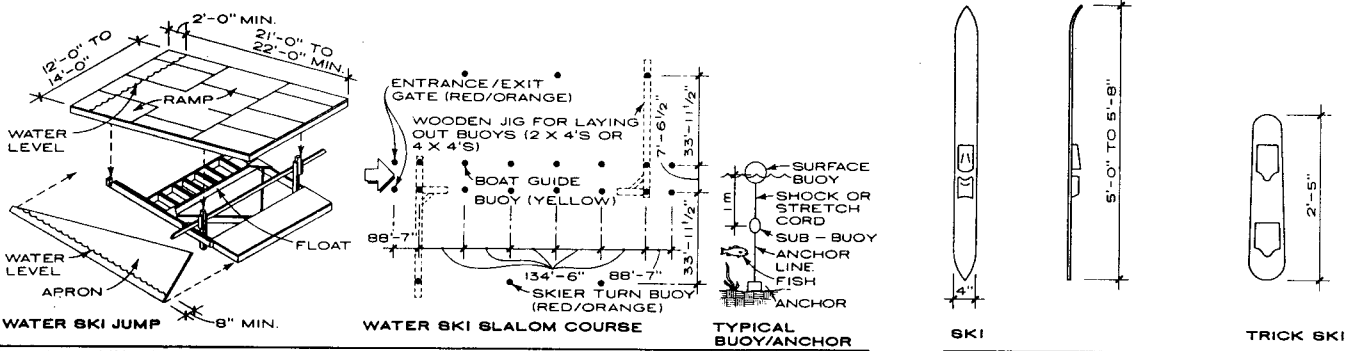

WATER SKIING AND JUMPING

Richard J. Vitullo, AIA; Oak Leaf Studio; Crownsville, Maryland

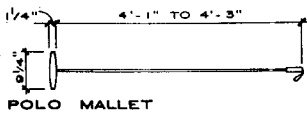

POLO Mallet

POLO BALL 3/4" DIA.

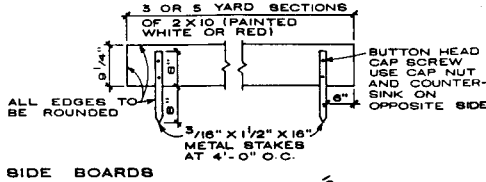

SIDE BOARDS

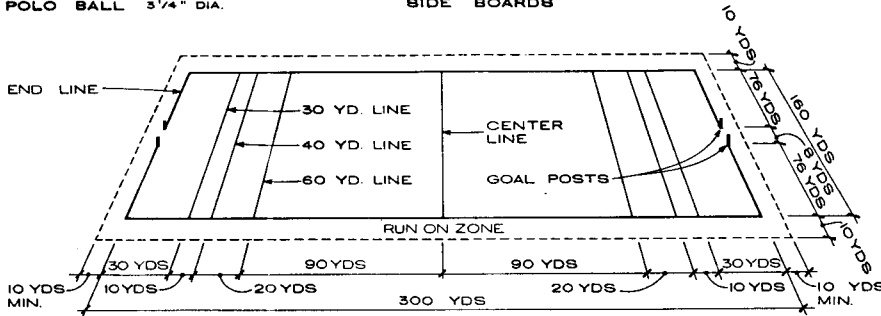

OUTDOOR POLO FIELD

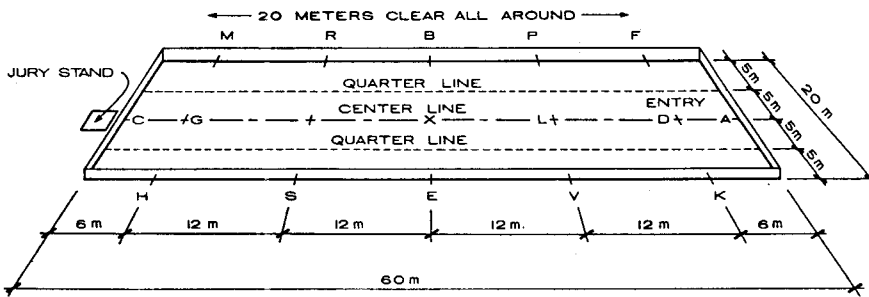

STANDARD DRESSAGE ARENA

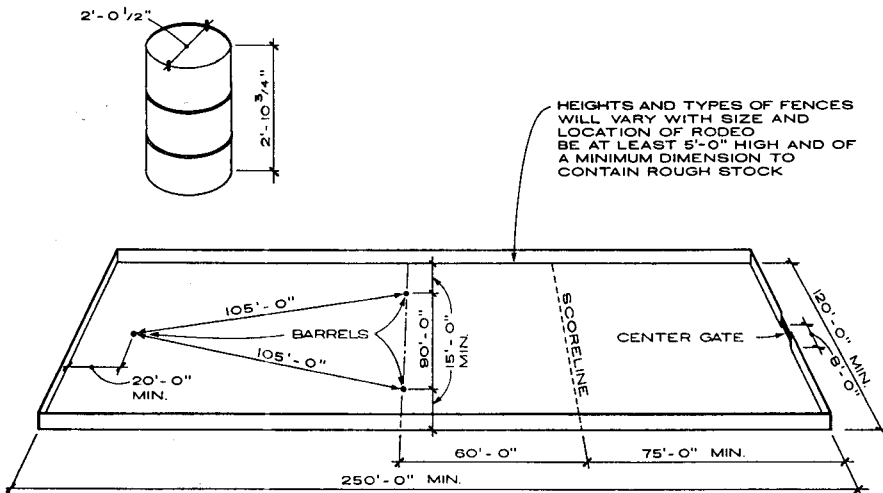

STANDARD BARREL COURSE

**POLO**

Outdoor or high goal polo is played with two teams of four players each. There can be as many as forty horses per team, and stabling and picket areas are needed for the horses. Spectator stands to accommodate three to six thousand people are needed, depending on the level of play.

The field surface should be grass cut smooth and short enough for the ball to roll straight and easily. The field side boundaries are 10 in. high side boards with a minimum of 10 yards run on, known as the safety zone, beyond. Goal posts must be vertical and light enough to break upon collision. Goal posts are 10 ft. high, and 8 yds. apart. About twenty balls are used in a game.

Arena polo is played at smaller clubs or indoors where less space is available. A playing area of 300 ft. by 150 ft. is considered ideal. Goals, at opposite ends of the field, are 10 ft. in width by 12 ft. in height, inside measurement. In smaller arenas the goal size may be reduced, but to not less than 8 ft. in width by 10 ft. in height. The arena shall be clearly marked at the center and at points 15 yds. and 25 yds. perpendicular to each goal. The inflated arena polo ball shall be not less than 4 1/4 in. nor more than 4 1/2 in. in diameter.

Further information: United States Polo Association, Oak Brook, Ill.

**DRESSAGE**

The arena should be on as level ground as possible. The standard arena is 60 meters x 20 meters. The small arena is 40 meters x 20 meters. The enclosure itself should consist of a low fence about 0.30 meters high. The part of the fence at letter A should be easily removable to let competitors in and out of the arena. Arenas must be separated from the public by a distance of not less than 20 meters.

The letters, clearly marked, should be placed outside the enclosure about 0.50 meters from the fence. A red line painted on the fence 20 cm. high locates the exact point of the letters on the track. The center line, throughout its length, and the three points D, X, and G should be as clearly marked as possible, without frightening the horses. It is recommended, on grass arenas, to mow the grass on the center line shorter than other parts of the arena, and on a sand arena, to roll or rake the center line.

An exercise area must be provided far enough away from the arena so as not to disturb the competitors.

**SHOW**

Horse show rings vary in size according to type of activity performed. A basic outdoor ring size for hunters and jumpers is 150 ft. x 300 ft. Combined training requires a stadium show ring of 80 meters x 80 meters, as well as a dressage ring. The appropriate breed or show association should be contacted for current and specific regulations.

Flat classes need a level arena with solid footing. There should be one definite opening for an "in" gate; preferable are separate openings for in and out gates. Rings for flat classes should be large enough to accommodate comfortably the number of horses.

Show management must provide sufficient area for schooling horses. It is recommended that separate schooling areas be provided for hunters and jumpers since different types of jumps are used for each. Jumps may vary from a single jump consisting of a single bar 4 in. in diameter and 6 ft. long, hung in cups from two uprights, to various combinations of two and three fences, water jumps, banks, and ditches—depending on the skill level of the class.

Further information: American Horse Show Association, New York, N.Y.

**RODEO**

Rodeo consists of several events involving timed contests such as calf roping and barrel riding, and rough stock events such as steer wrestling and bull riding. Arenas may vary in size but must be enclosed with fencing to control the various livestock. Barriers and chutes for timed events should be at the opposite end of arena from chutes for rough stock events. Stables, pens, and corrals for holding stock must be provided, as well as area for contestants to exercise their animals. Grandstand seating is standard; the number of spectators varies with the number and competition level of rodeo participants.

Barrels must be regulation 55 gal. size metal or rubber and enclosed on both ends.

Further information: International Professional Rodeo Association, Pauls Valley, Okla.

Theodore M. Ceraldi & Associates, Architects; Nyack, New York

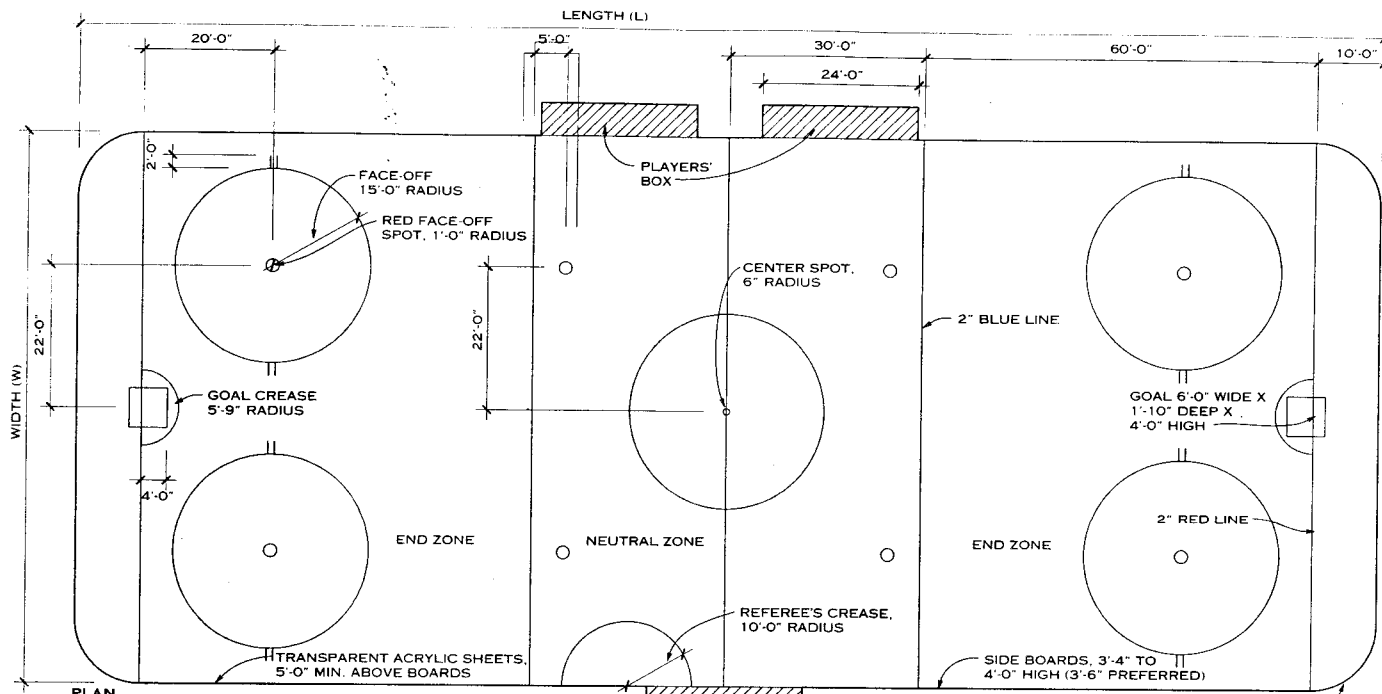

**ICE HOCKEY RINK SIZE**

RINK TYPE	L (FT)	W (FT)
NHL	200	85
Olympic	200	100
NCAA	200	85
High School	200	85



**NOTE**  
For year-round rinks, provide a heating system below the ice surface to prevent permafrost and movement in the subsurface soil.

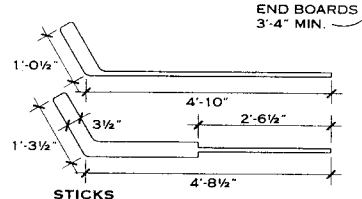

**ICE HOCKEY RINKS**

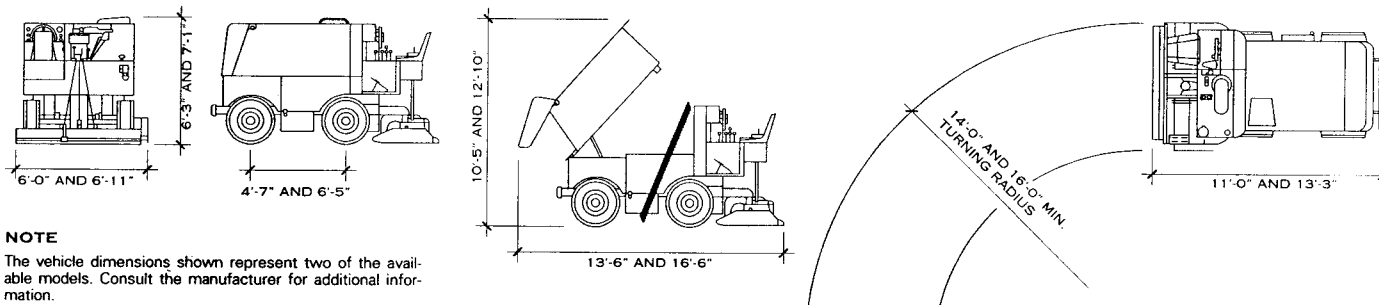

**NOTE**  
The vehicle dimensions shown represent two of the available models. Consult the manufacturer for additional information.

**ZAMBONI ICE RESURFACER**

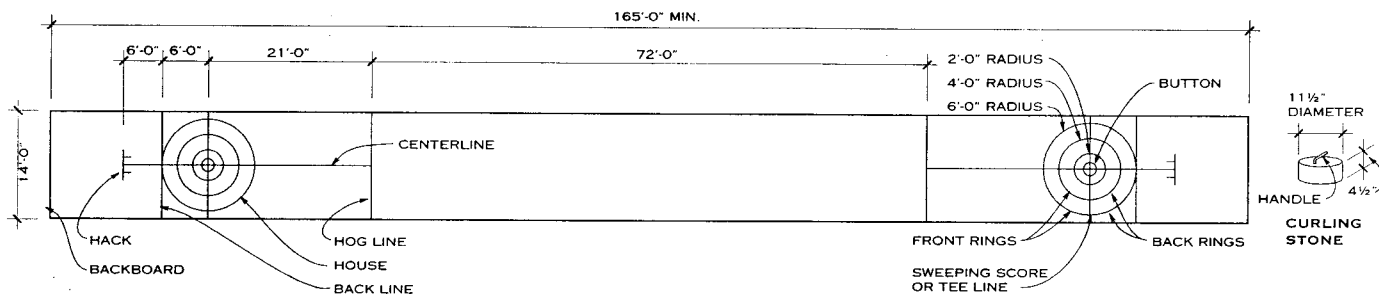

**CURLING**

Dean Cox, AIA; Collins Rimer Gordon Architects; Cleveland, Ohio

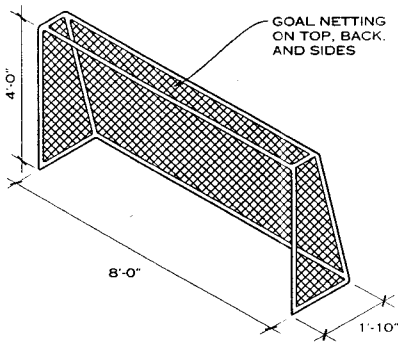
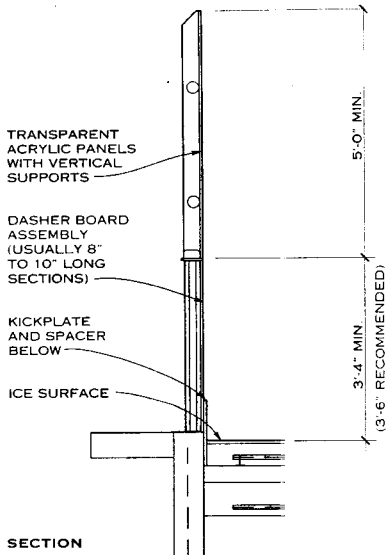

ICE HOCKEY GOAL

**ANCILLARY SPACES AT ICE RINKS**

The design of an ice rink must include planning for the ancillary space requirements described here:

1. Large hinged swing gates that open into the ice rink, usually at one end, are needed to accommodate the Zamboni, a machine used for resurfacing the ice.
2. An area is needed outside the main ice rink for disposal of ice removed by the Zamboni. This space customarily is large enough to allow 1/2 to 1 cu yd of ice to melt into a drainage sump. However, some smaller indoor facilities simply remove the scraped ice to the exterior of the building.
3. A header trench 3 ft wide x 3 ft deep should be located at one side of the ice rink to accommodate piping connections to underfloor systems.
4. Floor surfaces where access to the rink is required for skaters and a Zamboni normally consist of a rubber belting assembly or similar material.

**GENERAL NOTES**

1. The details shown on this page represent typical systems. Actual details must be modified as appropriate for individual projects.
2. The details shown indicate options for seasonal and year-round operations. Which design, detailing, underfloor heating, insulation, and other features are chosen depends on the anticipated operation of a particular rink.
3. Considerations affecting ice rink design and planning include requirements for underfloor drainage, ventilation, and humidity control; subsoil conditions at the site; the requirements of refrigeration plants, the ice-making system, and lighting and other electrical features; and maintenance and operational needs.
4. It is recommended that a qualified consultant be involved in the design and planning of ice rink systems.

Dean Cox, AIA; Collins Rimer Gordon Architects; Cleveland, Ohio

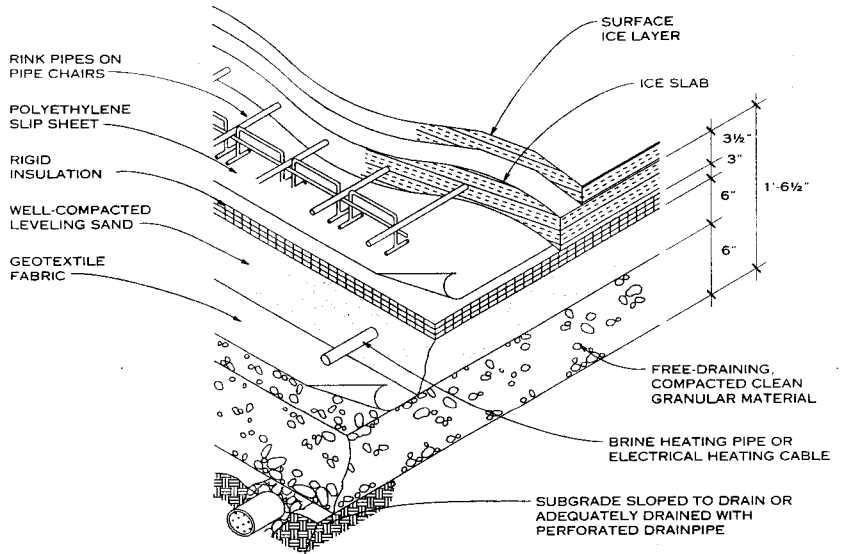

YEAR-ROUND RINK (NATURAL SAND FLOOR WITH INSULATION)

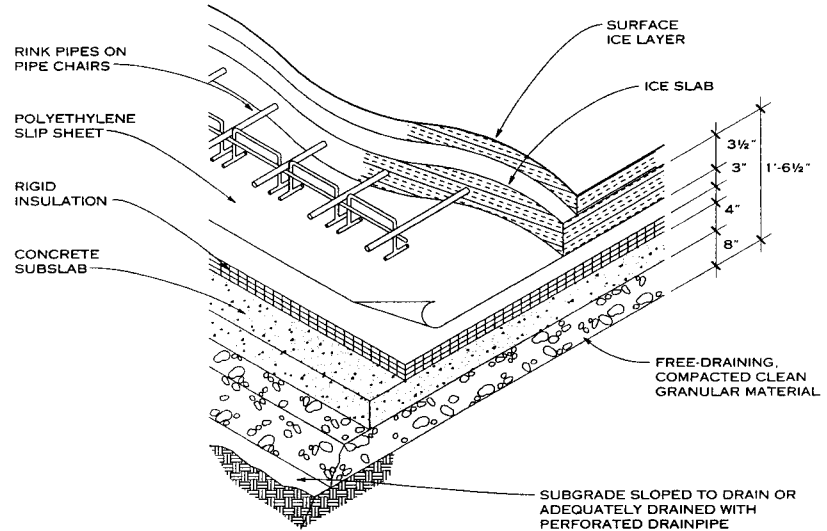

SEASONAL ARENA OR CURLING RINK (CONCRETE FLOOR WITH INSULATION)

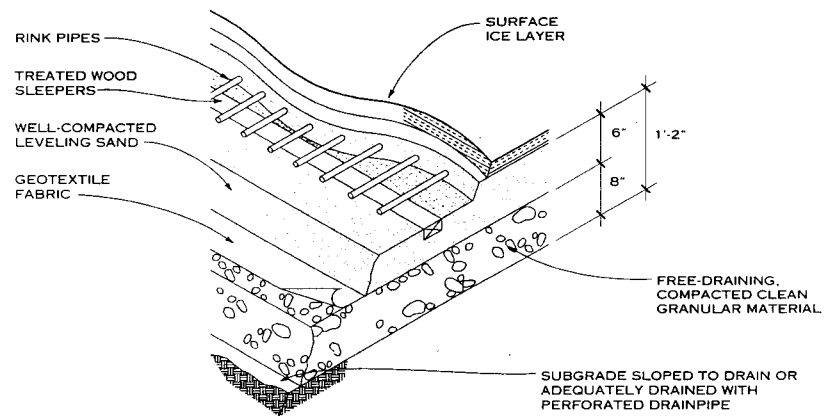

SEASONAL HOCKEY OR CURLING RINK (SAND FLOOR WITH NO INSULATION)

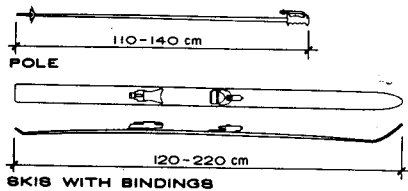

**BASIC EQUIPMENT**

**VERTICAL DROP AND GATE SPECIFICATIONS FOR FIS AND USSA COURSES**

EVENT	FIS DROP (M)		NO. OF GATES		USSA DROP (M)	NO. OF GATES
	MIN.	MAX.	MIN.	MAX.		
DOWNHILL	One-run:					
	500	1000			400	400
	Two-run (each)					
	450					
SLALOM	Men					
	140	220	52	78	120	42
	Women					
	120	180	42	63	120	42
GIANT SLALOM	Men					
	250	400	30	60	250	33
	Women					
	250	350	30	53	250	33
SUPER GIANT SLALOM	Men					
	500	650	35	65	350	30
	Women					
	350	500	30	50	350	30

FIS = Federation Internationale de Ski  
USSA = United States Ski Association

**ACCEPTABLE TERRAIN GRADIENTS FOR SLOPES AND TRAILS**

SKILL LEVEL	TERRAIN GRADIENTS	
	LOW	HIGH
Beginner/novice	8%	25%
Intermediate	15%	40%
Advanced intermediate/expert	25%	70%
Average Olympic downhill	23%	30%

**BASE LODGE**

Base lodge size in sq ft = (mountain capacity/seat turnover rate x sq ft/person).

Seat turnover rate—number of persons served per seat per day depends upon weather and temperature.

Typically: 3 (cold/overcast)  
5 (warm/clear)

Typical sq ft/person at ski lodge:  
30 (local ski area)  
35 (destination ski area)

Edge of lodge to be: minimum 100 ft  
optimal 150 ft  
suitable 100-300 ft  
from lift terminals.

Stairs with long treads (14-16 in.) and low risers (6 in.) to accommodate ski boots.

Protect entry/doorways from snowfall/dripping.

Locate windows above snow level.

Ski rental space = 3 sq ft per rental setup (skis, boots, poles).

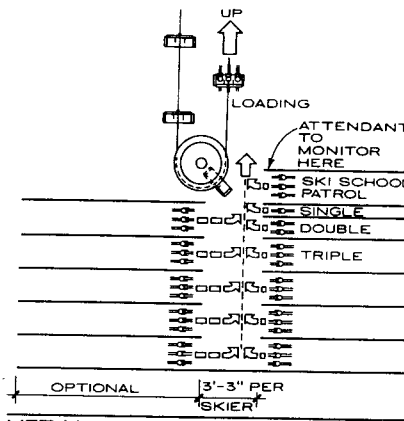

**LIFT MAZE**

**LIFT MAZE AREA REQUIRED FOR 10-MINUTE LIFT LINE**

LIFT TYPE	WIDTH (EACH ROW)	AREA (SQ FT)
Double	5 ft 0 in.	2500
Triple	7 ft 6 in.	3750
Quad	10 ft 0 in.	5000

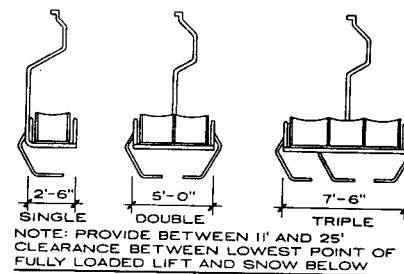

**LIFT CHAIRS**

NOTE: PROVIDE BETWEEN 11' AND 25' CLEARANCE BETWEEN LOWEST POINT OF FULLY LOADED LIFT AND SNOW BELOW

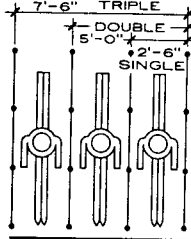

**MAZE ROW**

**NOTE**

Lift mazes to be located downhill of or to the side of loading point.

Mazes to be graded as flat as possible.

Approach to loading point to be graded at 3% downhill for distance of 50 ft minimum.

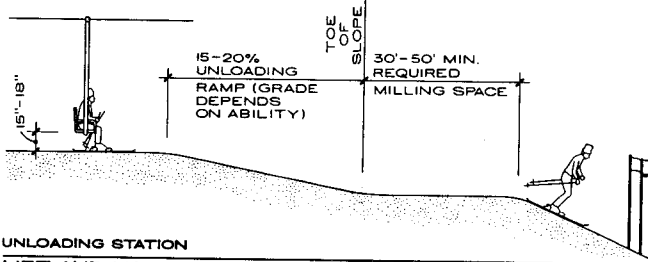

**UNLOADING STATION**

**LIFT AND MAZE**

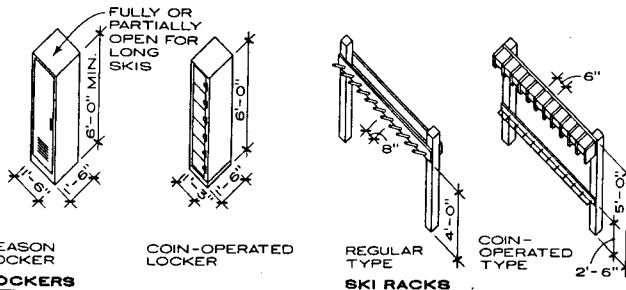

**LOCKERS**

**LOCKERS AND SKI RACKS**

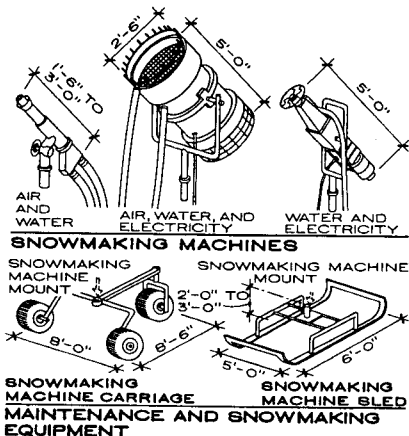

**SNOWMAKING MACHINE CARRIAGE MAINTENANCE AND SNOWMAKING EQUIPMENT**

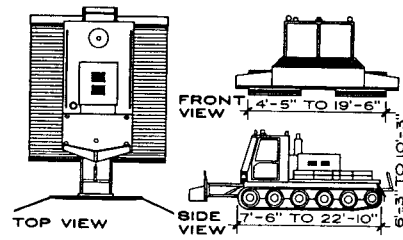

**OVERSNOW VEHICLES**

**MAINTENANCE BUILDING**

Area required: 100 sq ft per oversnow vehicle includes vehicle storage, parts and general storage, office, toilets. Does not include snowmaking system.

Doors: 16-20 ft wide, 14-16 ft high for main vehicle entry doors.

Eliot W. Goldstein, AIA, and Chan Li Lin; James Goldstein & Partners; Millburn, New Jersey

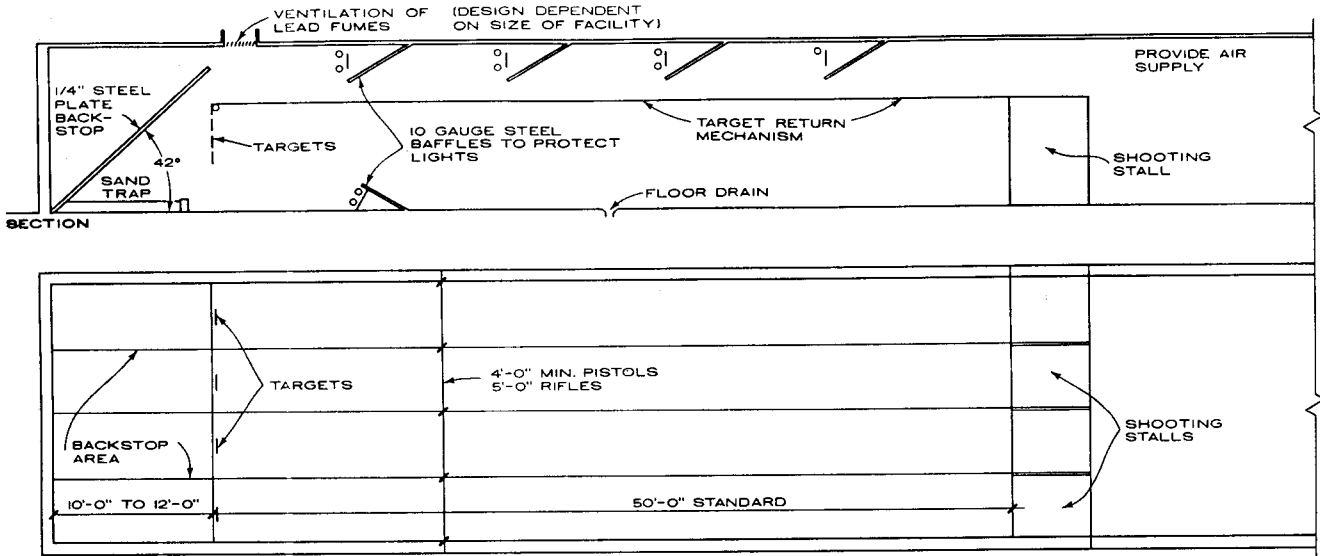

**PLAN DESIGN PROBLEMS**

When planning a firearms range, the following safety considerations must be made:

1. Placement of traps; use of stalls and placement of firing line; provision for space for spectators; protection from ricochet; prevention of spilled powder explosions.
2. Ventilation adequate to dissipate lead fumes.

3. Noise abatement.
4. Lighting.

The use of range design consultants is advisable. Contact the National Rifle Association for information.

**TARGET SHOOTING**

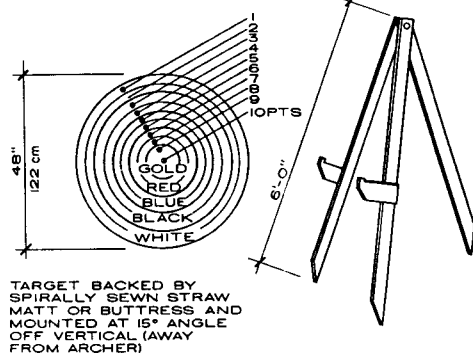

Archery ranges should be orientated, in the northern hemisphere, so the archer is facing north  $\pm 45^\circ$ . The range surface is to be turf, and free from obstructions or hard objects; likewise, spaces behind and to either side should be clear.

Target backings are made of stitched compressed straw rope called mat or buttress. Targets are made of thick paper with five concentric color zones. Both the mat and target are slanted at a  $15^\circ$  angle off vertical away from the archer.

Modern bows often are wood composites, fiberglass, and graphite. Lengths vary from 72 in. (1.82 M) to 62 in. (1.57 M). Bows are categorized by their draw weight, the amount of energy needed to pull a 28 in. (71 cm) arrow to full draw. Male archers usually use a 50 lb. to 55 lb. bow; female archers usually use 35 lb. to 40 lb. bow.

Arrow shafts are made of wood, graphite, or aluminum tubing. The flecking is made of plastic or feathers.

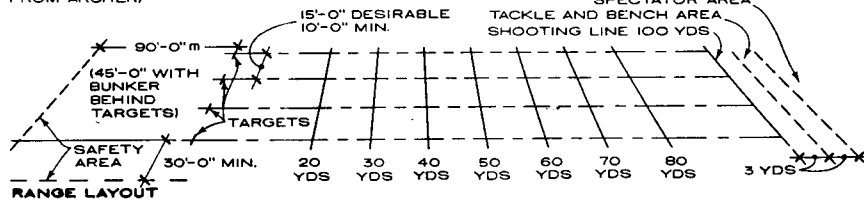
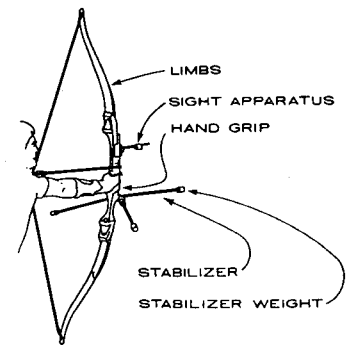

**ARCHERY**

Wooden nonskid flooring is ideal. A rubber piste is used on slippery floors. When a special metallic piste is used, a rubber mat must be placed beneath it to prevent hits on the floor being registered by the electronic scoring device. In competitive fencing, the score is kept by an electronic

apparatus, which records each hit, and is linked to the fencers by wires. The wires are kept from trailing the ground by a spring-loaded spool. These spools often are recessed in a pit at each end of the piste.

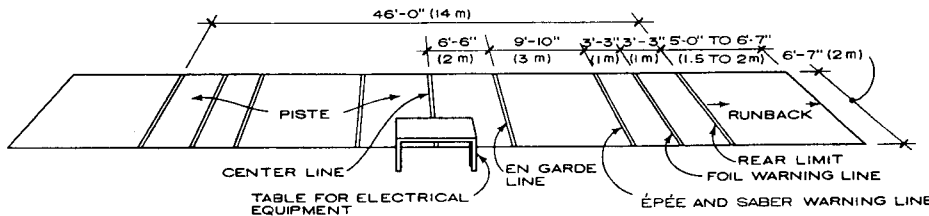

**FENCING**

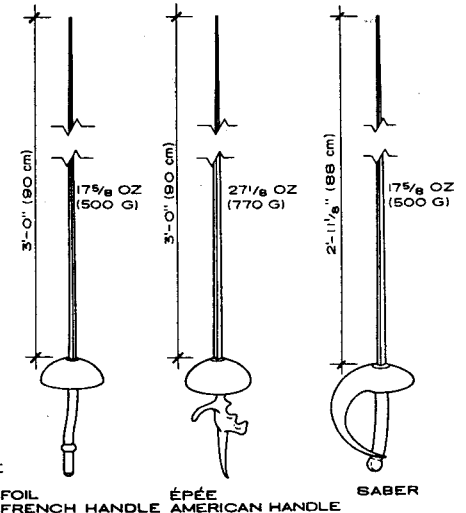

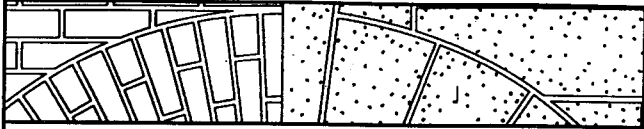

# ENERGY AND ENVIRONMENTAL DESIGN

Climate 796

Solar Radiation and Building Orientation 799

Natural Ventilation 807

Climate Response and Building Design 808

Energy Conservation 813

Passive Solar 819

Active Solar 823

Shading 826

Thermal Transmission 829

Environmental Construction 833



**STRATEGIES OF CLIMATE CONTROL**

The bioclimatic chart (Olgvy, *Design with Climate*, updated by Givoni and Arens) is presented here in standard psychrometric format. Plotting temperature and humidity data on the chart identifies cooling strategies for buildings dominated by envelope loads. The heavy lines in Figure 1 delineate limits within which ventilation, massive construction, evaporative space cooling, and clothing can maintain thermal comfort indoors.

**VENTILATION**

Whole-house (exhaust) fans provide up to 20 air changes per hour and, like continuous cross ventilation, maintain indoor temperatures close to the outdoors. As long as outdoor conditions are within the comfort zone, "air-exchange ventilation" maintains indoor comfort. "Body ventilation" is best provided by ceiling (paddle) fans. They are effective up to 70% relative humidity and 85°F ET\* (effective temperature), with a maximum air speed of 3 fps and light clothing (0.4-0.6 clo).

**THERMAL MASS**

A very massive building envelope can maintain indoor comfort if outdoor air temperature does not exceed the thermal mass limit on the chart (roughly equal to 89°F ET\*). This requires that (1) the envelope is shaded or reflective enough that its average daily outside surface temperature is no higher than the daily mean air temperature; (2) the envelope is massive enough to average daily temperature fluctuations; and (3) there is no daytime ventilation of the indoors. Nighttime ventilation extends the upper limit by cooling the envelope from both sides.

**EVAPORATIVE SPACE COOLING**

Intake ventilation air is evaporatively cooled by drawing it through wetted mats or filters. The technique is suited to arid and semiarid regions and requires a fan-powered ventilation system. The limits are 71.5°F wet-bulb temperature and in excess of 105°F dry bulb, which is a conservative upper bound.

**OTHER CLIMATIC ELEMENTS**

Wind speeds and direction are important for site analysis and for orienting the building for shelter from winter winds and to capture cooling breezes. Solar radiation data ("irradiation" or "insolation") is necessary for solar heating and daylighting design. Insolation, measured in BTU/sq ft/day or per hour, is a function of latitude, sky conditions, and angle of incidence to the receiving surface (see Kusuda and Ishii, 1977). Ground temperatures at various depths can be estimated from well-water temperatures (see Labs, 1981).

**REFERENCES**

1. *Local Climatic Summaries*, National Climatic Center, Environmental Data Service, Asheville, NC 28801.
2. T. Kusuda and K. Ishii, *Hourly Solar Radiation Data for Vertical and Horizontal Surfaces on Average Days in the U.S. and Canada*, NBS BSS 96, National Technical Information Service, #PB 265-551, 1977.
3. *Engineering Weather Data*, Air Force Design Manual 88-29 (Army TM 5-785, Navy NAVFAC P-89), 1978.
4. K. Labs, *Regional Analysis of Ground and Above-Ground Climate*, Oak Ridge National Laboratory (NTIS No. ORNL/Sub-81/40451/1), 1981.
5. D. Watson and K. Labs, *Climatic Design*, McGraw-Hill, New York, 1983.
6. E. Arens et al., "Thermal Comfort under an Extended Range of Environmental Conditions," *ASHRAE Transactions*, vol. 92, part 1B, 1986, pp. 18-26.
7. J. Cook, ed., *Passive Cooling*, vol. 8 of Solar Heat Technologies series, MIT Press (Cambridge, Mass.), 1989.

**TERMINOLOGY**

The effective temperature, ET\*, refers to any set of temperature and humidity conditions that gives the same sensation of comfort as the stated temperature at 50% relative humidity (RH). ET\* plotted here assumes light office clothing (0.6 clo) and very little air movement. One can feel as comfortable at 80°F with 20% RH as at 76°F at 80% RH; both are 78°F ET\*. The ASHRAE comfort zone is bounded by an upper humidity limit of about 62°F dew point; 65°F is a conservative limit. A mean daily dew-point temperature of 50°F produces diurnal air temperature swings in excess of 30°F.

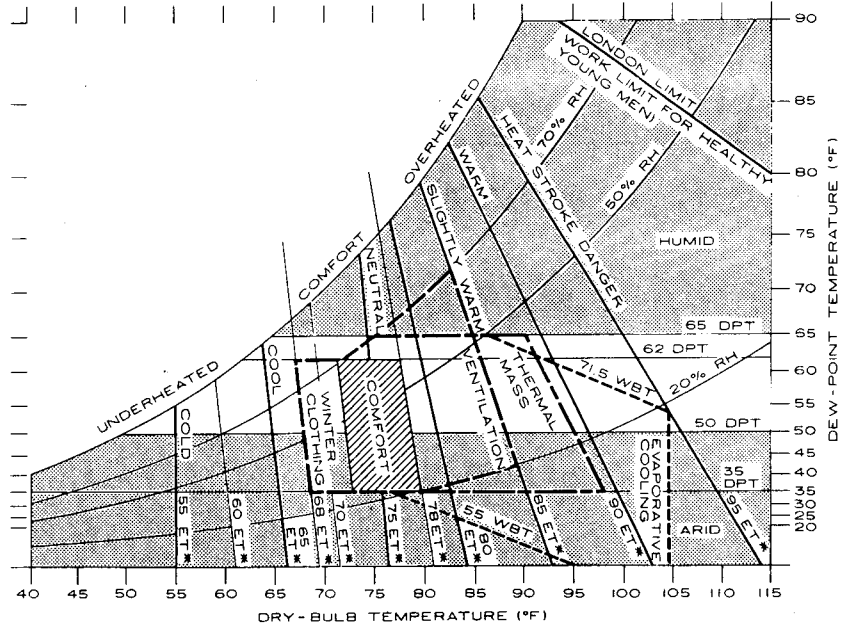

FIGURE 1 BUILDING BIOCLIMATIC CHART (AFTER GIVONI)

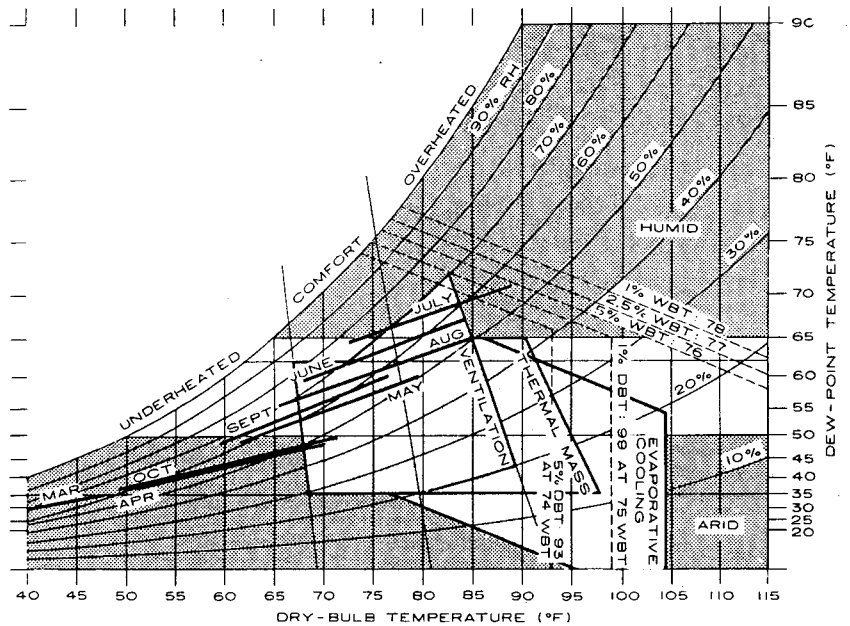

FIGURE 2 EXAMPLE ANALYSIS: KANSAS CITY (WATSON AND LABS)

**PLOTTING DATA ON THE CHART**

Combined temperature and humidity conditions at any moment can be plotted as a point on the chart. Graphing hourly data tracks the daily pattern, but daily maximum and minimum temperatures with their coincident humidities are usually adequate. Plotting a single day for each month summarizes the year at a glance (see Watson and Labs, 1983).

Example: Figure 2 plots 7 months of the year in Kansas City and shows ASHRAE summer air-conditioning design

temperatures. The daily minimum dry-bulb temperature is coupled with the daily minimum dew point, while the daily maximum dry bulb is coupled with the daily maximum wet bulb. Much of the year falls below the lower comfort limit of 68°F ET\* and is "underheated." Conditions exceeding 78°F ET\* are "overheated." Ventilation satisfies most cooling needs, but the fact that design temperatures exceed the ventilation limit shows that some air conditioning is necessary.

Donald Watson, FAIA; Rensselaer Polytechnic Institute; Troy, New York

**DESIGN FOR ENERGY CONSERVATION**

Regional design for energy conservation aims to minimize use of conventionally powered heating, cooling, and lighting by using natural energy available at the building site. Site planning and building orientation, massing, and envelope design are the principal means for managing climate-driven conduction, convection, radiation, and vapor transfer. Climatic design strategies are selected in response to outdoor microclimatic conditions, defined as "underheated" or "overheated" with respect to indoor human comfort parameters.

**CLIMATIC REGIONS (MAP 1)**

Map 1 delineates regions according to climatic control strategies. Regions exceeding 8000 annual heating degree days (HDD) are predominantly "underheated," in which cooling is subordinate to solar heating and heat conservation strategies. Regions with fewer than 2000 annual HDD require little heating in comparison to cooling and are predominantly "overheated" for design purposes. The large temperate region between 2000 and 8000 HDD has both heating and cooling requirements that must be balanced so that design features favoring heating do not add to the cooling load, and vice versa.

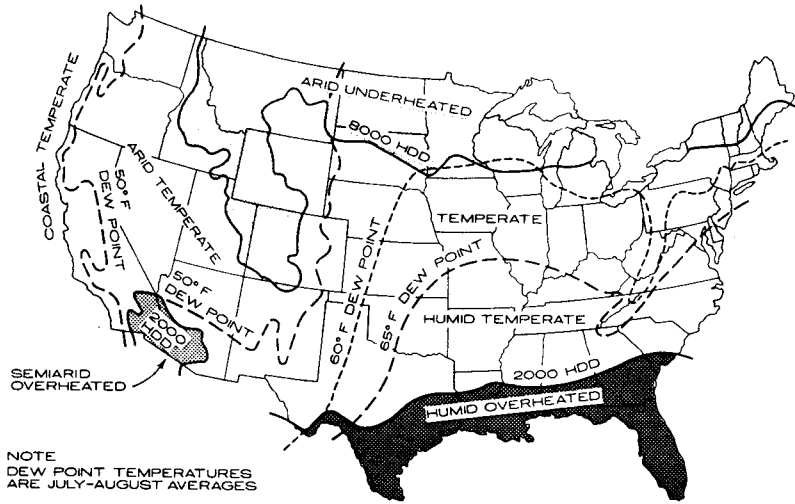

MAP 1: U.S. REGIONS BASED UPON CLIMATIC DESIGN CONDITIONS

Suitability of ventilation and evaporative cooling are related to atmospheric humidity during summer months. Regions having a combined July and August average dew point temperature greater than 65°F may be considered "humid," and those averaging less than 50°F dew point may be considered "arid." The entire southeast quadrant of the U.S. has mean daily humidities exceeding comfort limits under still air conditions. The main control problem in this region is to balance ventilation with dehumidification and mechanical cooling.

The 50°F dew point temperature is an arbitrary way of defining atmospheric aridity, but it is convenient since it produces an outdoor daily temperature range of roughly 30°F dry-bulb. Arid and semi-arid conditions favor evaporative and radiative cooling and generally disfavor summer daytime ventilation. While massive building envelopes can be advantageous in any region with a significant number of days having average daily temperatures in the upper 70s, mass is especially valuable in arid regions with extremely high daily maxima.

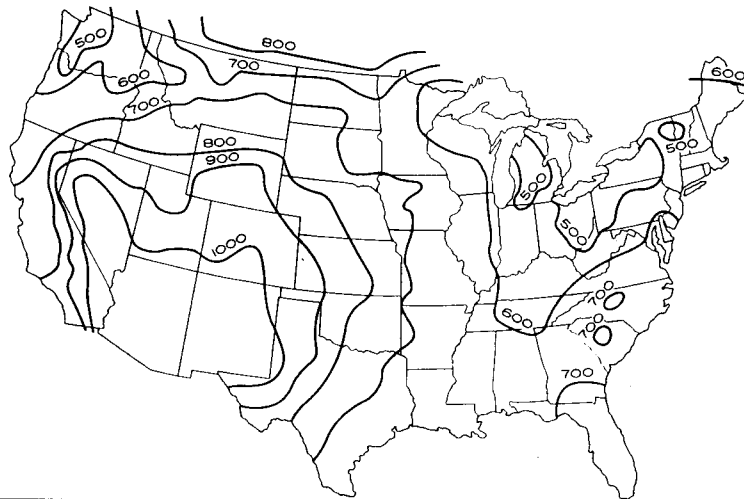

MAP 2: PASSIVE SOLAR HEATING POTENTIAL OF SOUTH WINDOWS (BTU/SQ FT/DAY)  
DATA SOURCE: DR. DOUGLAS BALCOMB, SOLAR ENERGY RESEARCH INSTITUTE

**SOLAR HEATING POTENTIAL (MAP 2)**

Map 2 depicts solar heating capability in relation to heating load for envelope-dominated buildings. The lines plot the average daily solar gain transmitted through vertical south-facing double glazing, coincident with the need for heat. It is calculated by the relation

$$\text{Average solar gain} = \frac{\text{sum}(\text{solar gain} \times \text{HDD})}{\text{sum}(\text{HDD})}$$

HDD is the base 65°F degree days. The units are Btu/sq ft of glazing. Values assume a ground reflection of 30%. The map indicates that, for instance, useful solar gains are the same in Philadelphia, PA; Huntsville, AL; Oshkosh, WI; and Eugene, OR.

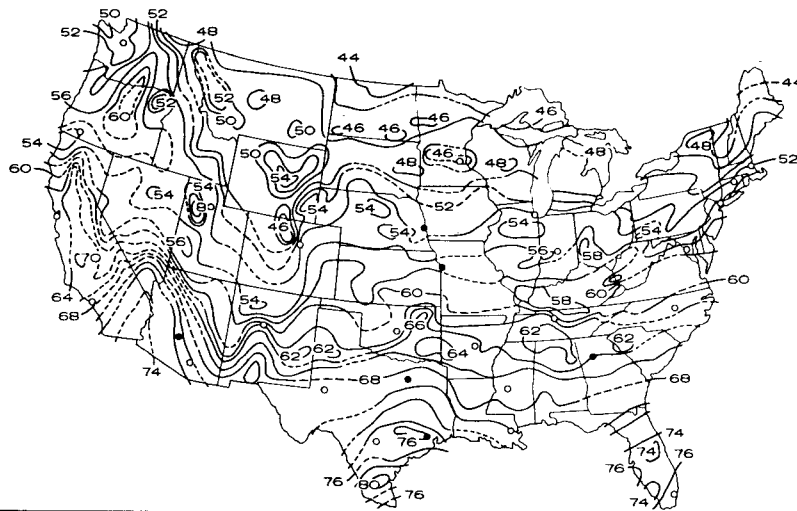

MAP 3: DEEP-GROUND TEMPERATURES (°F)  
DATA SOURCE: NATIONAL WELL WATER ASSOCIATION

**UNDISTURBED GROUND TEMPERATURE (MAP 3)**

At "steady state" depth (20-30 ft), ground temperature is the same as well water temperature, as plotted on Map 3. Ground temperatures vary considerably throughout the first 10 ft of earth and are elevated by heat losses from buildings. Heated buildings lose some heat to the deep ground throughout most of the U.S., but the earth is not an effective heat sink in the regions where cooling is most needed. Earth-tempered design requires special analysis of thermal soil-structure interaction.

Donald Watson, FAIA; Rensselaer Polytechnic Institute; Troy, New York  
Kenneth Labs; New Haven, Connecticut

WINTER WEATHER DATA AND DESIGN CONDITIONS FOR THE UNITED STATES AND CANADA

STATE OR PROVINCE	CITY	LATITUDE (°)	LONGITUDE (°)	ELEVATION (FT)	WINTER DESIGN TEMP. *	AVE WINTER TEMP. †	AVERAGE MONTHLY HEATING DEGREE DAYS ‡											
							SEPT	OCT	NOV	DEC	JAN	FEB	MAR	APR	MAY	TOTAL		
Ala	Birmingham	33.3	86.5	61	21	54.2	6	93	363	555	592	462	363	108	9	2551		
	Mobile	30.4	88.1	119	29	59.9	0	22	213	357	415	300	211	42	0	1560		
Alaska	Fairbanks	64.5	147.5	436	-47	6.7	642	1203	1833	2254	2359	1901	1739	1068	555	14,279		
	Juneau	58.2	134.4	17	1	32.1	83	725	921	1135	1237	1070	1073	810	601	9075		
Ariz.	Flagstaff	35.1	111.4	6973	4	35.6	201	558	867	1073	1169	991	911	651	437	7152		
	Tucson	32.1	111.0	2584	32	58.1	0	25	231	406	471	344	242	75	6	1800		
Ark.	Little Rock	34.4	92.1	257	20	50.5	9	127	465	716	756	577	434	126	9	3219		
Calif.	Bakersfield	35.2	119.0	495	32	55.4	0	37	282	502	546	364	267	105	19	2122		
	Sacramento	38.3	121.3	17	32	54.4	0	62	312	533	561	392	310	173	76	2419		
	San Diego	32.4	117.1	19	44	59.5	21	43	135	236	298	253	214	135	90	1458		
	San Francisco	37.5	122.3	52	40	55.1	102	118	231	388	443	336	319	279	239	3001		
Colo.	Alamosa	37.3	105.5	7536	-6	29.7	279	639	1065	1420	1476	1162	1020	696	440	8529		
	Denver	39.5	104.5	5283	1	37.6	117	428	819	1035	1132	938	887	558	288	6283		
Conn.	Hartford	41.1	73.1	7	9	37.3	117	394	714	1101	1190	1042	908	519	205	6235		
Del.	Wilmington	39.4	75.3	78	14	42.5	51	270	588	927	980	874	735	387	112	4930		
D.C.	Washington	38.5	77.0	14	17	45.7	33	217	519	834	871	762	626	288	74	4224		
Fla.	Miami	25.5	80.2	7	47	71.1	0	0	0	65	74	56	19	0	0	214		
	Tallahassee	30.2	84.2	58	30	60.1	0	28	198	360	375	266	202	36	0	1485		
Ga.	Atlanta	33.4	84.3	1005	22	51.7	18	124	417	648	636	518	428	147	25	2961		
	Savannah	32.1	81.1	52	27	57.8	0	47	246	437	437	353	254	45	0	1819		
Hawaii	Honolulu	21.2	158.0	7	63	74.2	0	0	0	0	0	0	0	0	0	0		
Idaho	Boise	43.3	116.1	2842	10	39.7	132	415	792	1017	1113	854	722	438	245	5809		
Ill.	Chicago	42.0	87.5	658	-4	35.8	117	381	807	1166	1265	1086	939	534	260	6639		
	Springfield	39.5	89.4	587	2	40.6	72	291	696	1023	1135	935	769	354	136	5429		
Ind.	Indianapolis	39.4	86.2	793	2	39.6	90	316	723	1051	1113	949	809	432	177	5699		
Iowa	Des Moines	41.3	93.4	948	-5	35.5	96	363	828	1225	1370	1187	915	438	180	6588		
Kan.	Goodland	39.2	101.4	3645	0	37.8	81	381	810	1073	1166	955	884	507	236	6141		
	Topeka	39.0	95.4	877	4	41.7	57	270	672	980	1122	893	722	330	124	5182		
Ky.	Lexington	38.0	84.4	979	8	43.8	54	239	609	902	946	818	685	326	105	4683		
La.	New Orleans	30.0	90.2	3	33	61.8	0	12	165	291	344	241	177	24	0	1254		
	Shreveport	32.3	93.5	252	25	56.2	0	47	297	477	552	426	304	81	0	2184		
Me.	Portland	43.4	70.2	61	-1	33.0	195	508	807	1215	1339	1182	1042	675	372	7511		
Md.	Baltimore	39.1	76.4	146	3	43.7	48	264	585	905	936	820	679	327	90	4654		
Mass.	Boston	42.2	71.0	15	9	40.0	60	316	603	983	1088	972	846	513	208	5634		
Mich.	Detroit	42.2	83.0	633	6	37.2	87	360	738	1088	1181	1058	936	522	220	6232		
	Escanaba	45.4	87.0	594	-7	29.6	243	539	924	1293	1445	1296	1203	777	456	8481		
Minn.	Duluth	46.5	92.1	14226	-16	23.4	330	632	1131	1581	1745	1518	1355	840	490	10,000		
	Minneapolis	44.5	93.1	822	-12	28.3	189	505	1014	1454	1631	1380	1166	621	288	8322		
Miss.	Jackson	32.2	90.1	330	25	55.7	0	65	315	502	546	414	310	87	0	2239		
Mo.	Columbia	39.0	92.2	778	4	42.3	54	251	651	967	1076	875	716	324	121	5046		
Mont.	Billings	45.5	108.3	3367	-10	34.5	186	487	897	1135	1296	1100	970	570	285	7049		
	Missoula	46.5	114.1	3200	-6	31.5	303	651	1035	1287	1420	1120	970	621	391	8125		
Neb.	North Platte	41.1	100.4	2779	-4	35.5	123	440	885	1166	1271	1039	930	519	248	6684		
	Omaha	41.2	95.5	978	-3	35.6	105	357	828	1175	1355	1126	939	465	208	6612		
Nev.	Las Vegas	36.1	115.1	2162	28	53.5	0	78	387	617	688	487	335	111	6	2709		
	Reno	39.3	119.5	4404	10	39.3	204	490	801	1026	1073	823	729	510	357	6332		
N. H.	Concord	43.1	71.3	339	-3	33.0	177	505	822	1240	1358	1184	1032	636	298	7383		
N. J.	Trenton	40.1	74.5	144	14	42.4	57	264	576	924	989	885	753	399	121	4980		
N. M.	Albuquerque	35.0	106.4	5310	16	12.0	12	229	642	868	930	703	595	288	81	4348		
N. Y.	Buffalo	43.0	78.4	705	6	34.5	141	440	777	1156	1256	1145	1039	645	329	7062		
	New York	40.5	74.0	132	15	42.8	30	233	540	902	986	885	760	408	118	4871		
N. C.	Charlotte	35.0	81.0	735	22	50.4	6	124	438	691	691	582	481	156	22	3191		
	Wilmington	34.2	78.0	30	26	54.6	0	74	291	521	546	462	357	96	0	2347		
N. D.	Bismarck	46.5	100.5	1647	-19	26.6	222	577	1088	1463	1708	1442	1203	645	329	8851		
Ohio	Cleveland	41.2	81.5	777	5	37.2	105	384	738	1088	1159	1047	918	552	260	6351		
	Columbus	40.0	82.5	812	5	39.7	84	347	714	1039	1088	949	809	426	171	5660		
Okla.	Oklahoma City	35.2	97.4	1280	13	48.3	15	164	498	766	868	664	527	189	34	3725		
	Tulsa	36.1	95.5	650	13	47.7	18	158	522	787	893	683	539	213	47	3860		
Ore.	Salem	45.0	123.0	195	23	45.4	111	338	594	729	822	647	611	417	273	4754		
Pa.	Pittsburgh	40.3	80.1	1137	5	38.4	105	375	726	1063	1119	1002	874	480	195	5987		
	Williamsport	41.1	77.0	527	7	38.5	111	375	717	1073	1122	1002	856	468	177	5934		
R. I.	Providence	41.4	71.3	55	9	38.8	96	372	660	1023	1110	988	868	534	286	5954		
S. C.	Columbia	34.0	81.1	217	24	54.0	0	84	345	577	570	470	357	81	0	2484		
S. D.	Rapid City	44.0	103.0	3165	-7	33.4	165	481	897	1172	1333	1145	1051	615	326	7345		
Tenn.	Nashville	36.1	86.4	577	14	48.9	30	158	495	732	778	644	512	189	40	3578		
Texas	Brownsville	25.5	97.3	16	39	67.6	0	0	66	149	205	106	74	0	0	600		
	Dallas	32.5	96.5	481	22	55.3	0	62	321	524	601	440	319	90	6	2363		
	El Paso	31.5	106.2	3918	24	52.9	0	84	414	648	685	445	319	105	0	2700		
	Houston	29.4	95.2	50	32	61.0	0	6	183	307	384	288	192	36	0	1396		
Utah	Salt Lake City	40.5	112.0	4220	8	38.4	81	419	849	1082	1172	910	763	459	233	6052		
Vt.	Burlington	44.3	73.1	331	7	29.4	207	539	891	1349	1513	1333	1187	714	353	8269		
Va.	Lynchburg	37.2	79.1	947	16	46.0	51	223	540	822	849	731	605	267	78	4166		
Wash.	Seattle	47.4	122.2	14	27	46.9	129	329	543	657	738	599	577	396	242	4424		
W. Va.	Charleston	38.2	81.4	939	11	44.8	63	254	591	865	880	770	648	300	96	4476		
Wisc.	Green Bay	44.3	88.1	683	-9	30.3	174	484	924	1333	1494	1313	1141	654	305	8029		
Wyo.	Casper	42.5	106.3	5319	-5	33.4	192	524	942	1169	1290	1084	1020	651	381	7410		
CANADA																		
Alta.	Edmonton	53.34	113.31	2219	-25	-	411	738	1215	1603	1810	1520	1330	765	400	10,268		
B. C.	Vancouver	49.11	123.10	16	19	-	219	456	657	787	862	723	676	501	310	5515		
Man.	Winnipeg	49.54	97.14	786	-27	-	322	683	1251	1757	2008	1719	1465	813	405	10,679		
N. S.	Halifax	44.39	63.34	83	5	-	180	457	710	1074	1213	1122	1030	742	487	7361		
Ont.	Toronto	43.41	79.38	578	-1	-	151	439	760	1111	1233	1119	1013	616	298	6827		
Que.	Montreal	45.28	73.45	98	-10	-	165	521	882	1392	1566	1381	1175	684	316	8203		

\*Based on 97.5% Design Dry-Bulb values found in ASHRAE Handbook of Fundamentals, 1977.

†October-April, inclusive. ASHRAE Systems Handbook, 1976.

‡Based on the period 1931-1960, inclusive. ASHRAE Systems Handbook, 1976.

**NOTES**

To visualize the thermal impacts on differently exposed surfaces four locations are shown approximately at the 24°, 32°, 40° and 44° latitudes. The forces are indicated on average clear winter and summer days. The air temperature variation is indicated by the outside concentric circles. Each additional line represents a 2°F difference from the lowest daily temperature. The direction of the impact is indicated according to the sun's direction as temperatures occur. (Note the low temperatures at the east side, and the high ones in westerly directions.)

The total (direct and diffuse) radiation impact on the various sides of the building is indicated with arrows. Each arrow represents 250 Btu/sq ft · day radiation. At the bottom of the page the radiations are expressed in numerical values.

The values show that in the upper latitudes the south side of a building receives nearly twice as much radiation in winter as in summer. This effect is even more pronounced at the lower latitudes, where the ratio is about one to four. Also, in the upper latitudes, the east and west sides receive about 2½ times more radiation in summer than in winter. This ratio is not as large in the lower latitudes; but it is noteworthy that in summer these sides receive two to three times as much radiation as the south elevation. In the summer the west exposure is more disadvantageous than the east exposure, as the afternoon high temperatures combine with the radiation effects. In all latitudes the north side receives only a small amount of radiation, and this comes mainly in the summer. In the low latitudes, in the summer, the north side receives nearly twice the impact of the south side. The amount of radiation received on a horizontal roof surface exceeds all other sides.

Experimental observations were conducted on the thermal behavior of building orientation at Princeton University's Architectural Laboratory. Below are shown the summer results of structures exposed to the cardinal directions. Note the unequal heat distribution and high heat impact of the west exposure compared to the east orientation. The southern direction gives a pleasantly low heat volume, slightly higher, however, than the north exposure.

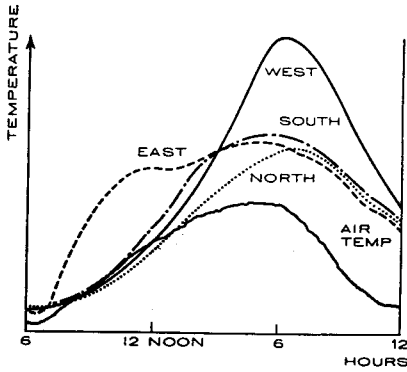

ROOM TEMPERATURE IN DIFFERENTLY ORIENTED HOUSES

**ORIENTATION: CONCLUSIONS**

1. The optimum orientation will lie near the south; however, will differ in the various regions, and will depend on the daily temperature distribution.
2. In all regions an orientation eastward from south gives a better yearly performance and a more equal daily heat distribution. Westerly directions perform more poorly with unbalanced heat impacts.
3. The thermal orientation exposure has to be correlated with the local wind directions.

Victor Olgyay, AIA, Princeton University; Princeton, New Jersey

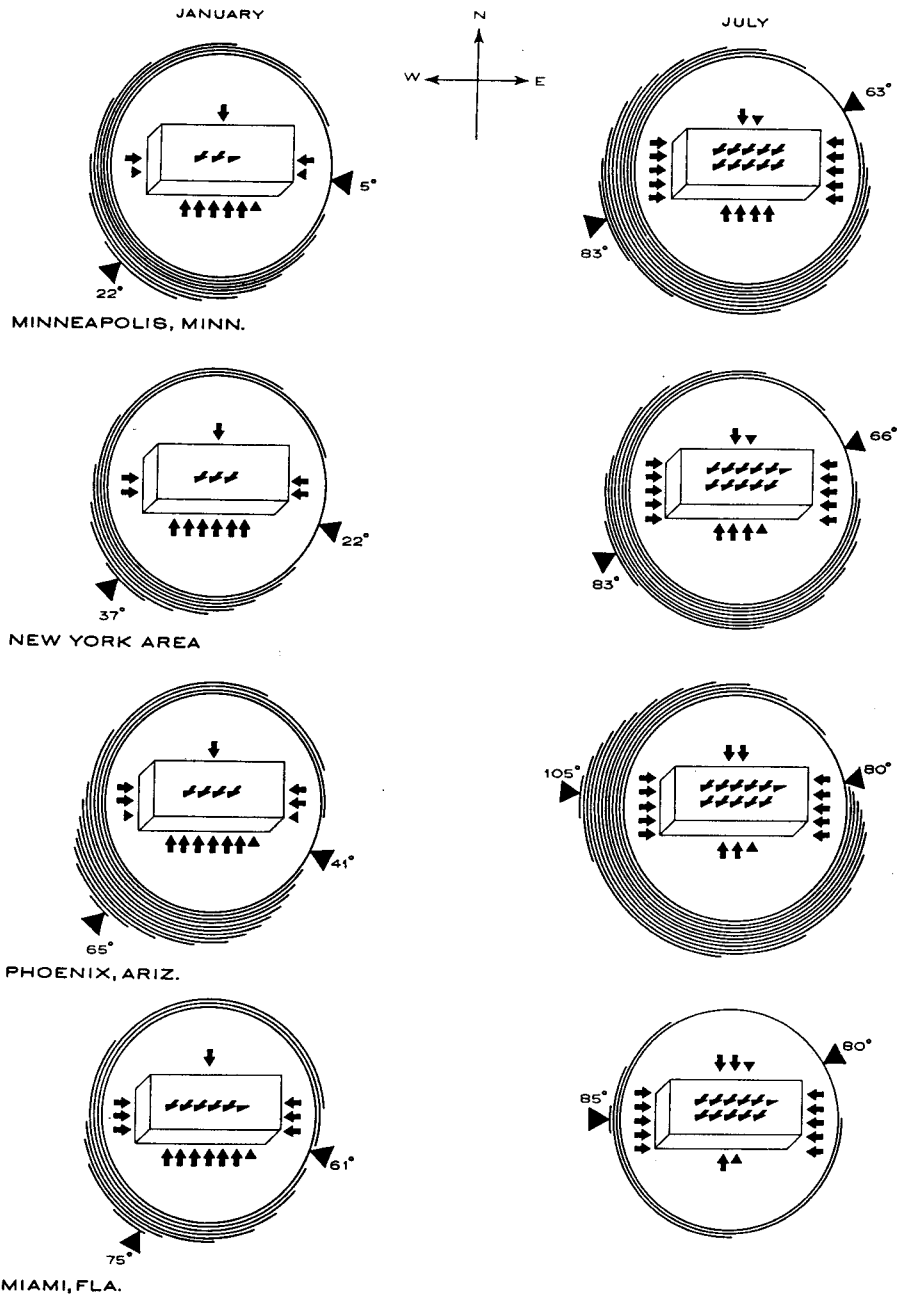

**TOTAL DIRECT AND DIFFUSED RADIATION (BTU/SQ FT · DAY)**

LATITUDE	SEASON	EAST	SOUTH	WEST	NORTH	HORIZONTAL
44° LATITUDE	WINTER	416	1374	416	83	654
	SUMMER	1314	979	1314	432	2536
40° LATITUDE	WINTER	517	1489	517	119	787
	SUMMER	1277	839	1277	430	2619
32° LATITUDE	WINTER	620	1606	620	140	954
	SUMMER	1207	563	1207	452	2596
24° LATITUDE	WINTER	734	1620	734	152	1414
	SUMMER	1193	344	1193	616	2568

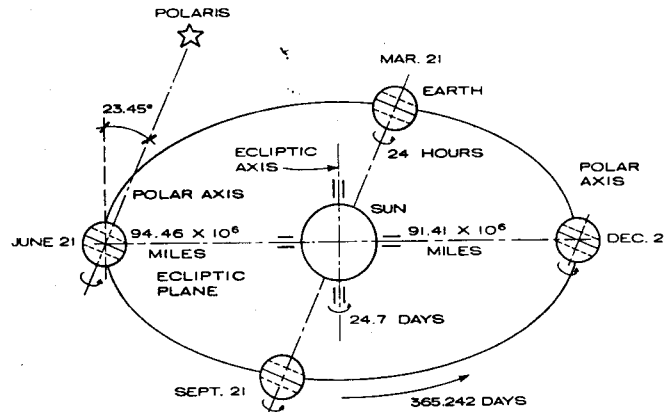

NOTE: THE TILT OF THE EARTH'S AXIS WITH RESPECT TO THE ECLIPTIC AXIS CAUSES THE CHANGING SEASONS AND THE ANNUAL VARIATIONS IN NUMBER OF HOURS OF DAYLIGHT AND DARKNESS

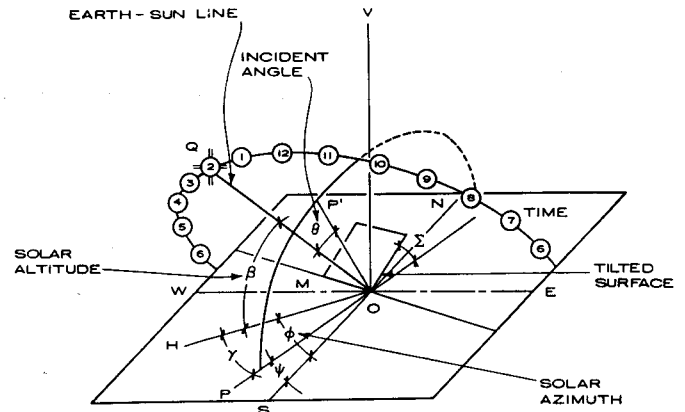

NOTE: Q DESIGNATES THE SUN'S POSITION SO OQ IS THE EARTH-SUN LINE WHILE OP' IS THE NORMAL TO THE TILTED SURFACE AND OQ IS PERPENDICULAR TO THE INTERSECTION, OM, BETWEEN THE TILTED SURFACE AND THE HORIZONTAL PLANE

**ANNUAL MOTION OF THE EARTH ABOUT THE SUN**  
**SOLAR CONSTANT**

The sun is located at one focus of the earth's orbit, and we are only 147.2 million km (91.4 million miles) away from the sun in late December and early January, while the earth-sun distance on July 1 is about 152.0 million km (94.4 million miles).

Solar energy approaches the earth as electromagnetic radiation at wavelengths between 0.25 and 5.0  $\mu\text{m}$ . The intensity of the incoming solar irradiance on a surface normal to the sun's rays beyond the earth's atmosphere, at the average earth-sun distance, is designated as the solar constant,  $I_{sc}$ . Although the value of  $I_{sc}$  has not yet been precisely determined by verified measurements made in outer space, the most widely used value is 429.2 Btu/sq ft · hr (1353 W/sq m) and the current ASHRAE values are based on this estimate. More recent measurements made at extremely high altitudes indicate that  $I_{sc}$  is probably close to 433.6 Btu/sq ft · hr (1367 W/sq m). The unit of radiation that is widely used by meteorologists is the langley, equivalent to one kilogram calorie/square centimeter. To convert from langleys/day to Btu/sq ft · day, multiply Ly/day by 3.67. To convert from W/sq m to Btu/sq ft · hr, multiply the electrical unit by 0.3172.

**SOLAR ANGLES**

At the earth's surface the amount of solar radiation received and the resulting atmospheric temperature vary widely, primarily because of the daily rotation of the earth and the fact that the rotational axis is tilted at an angle of 23.45° with respect to the orbital plane. This tilt causes the changing seasons with their varying lengths of daylight and darkness. The angle between the earth-sun line and the orbital plane, called the solar declination,  $\delta$ , varies throughout the year, as shown in the following table for the 21st day of each month.

JAN -19.9°	APR +11.9°	JUL +20.5°	OCT -10.7°
FEB -10.6°	MAY +20.3°	AUG +12.1°	NOV -19.9°
MAR 0.0°	JUN +23.5°	SEP 0.0°	DEC -23.5°

Very minor changes in the declination occur from year to year, and when more precise values are needed the almanac for the year in question should be consulted.

The earth's annual orbit about the sun is slightly elliptical, and so the earth-sun distance is slightly greater in summer than in winter. The time required for each annual orbit is actually 365.242 days rather than the 365 days shown by the calendar, and this is corrected by adding a 29th day to February for each year (except century years) that is evenly divisible by 4.

To an observer standing on a particular spot on the earth's surface, with a specified longitude, LON, and latitude, L, it is the sun that appears to move around the earth in a regular daily pattern. Actually it is the earth's rotation that causes the sun's apparent motion. The position of the sun can be defined in terms of its altitude  $\beta$  above the horizon (angle HOQ) and its azimuth  $\phi$ , measured as angle HOS in the horizontal plane.

At solar noon, the sun is, by definition, exactly on the meridian that contains the south-north line, and consequently the solar azimuth  $\phi$  is 0.0°. The noon altitude  $\beta$  is:

$$= 90^\circ - L + \delta$$

Because the earth's daily rotation and its annual orbit around the sun are regular and predictable, the solar altitude and azimuth may be readily calculated for any desired time of day as soon as the latitude, longitude, and date (declination) are specified.

**SHADOW CONSTRUCTION WITH TRUE SUN ANGLES**

Required information: angle of orientation in relation

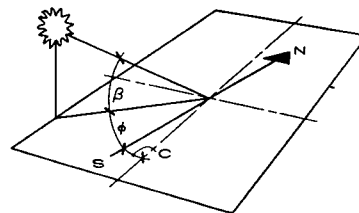

FIGURE 1

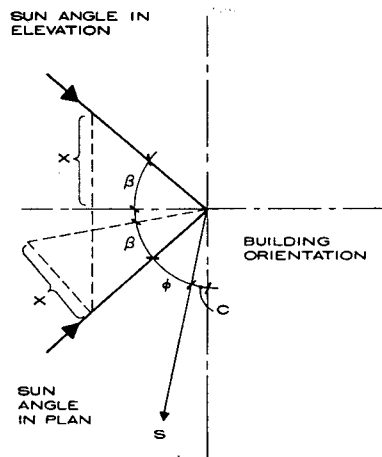

FIGURE 2

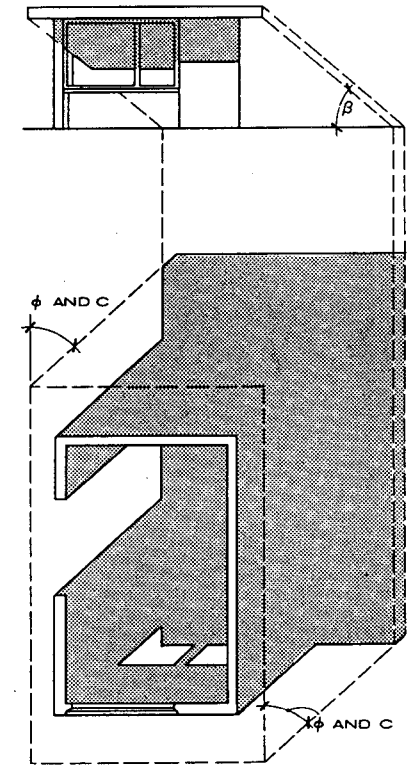
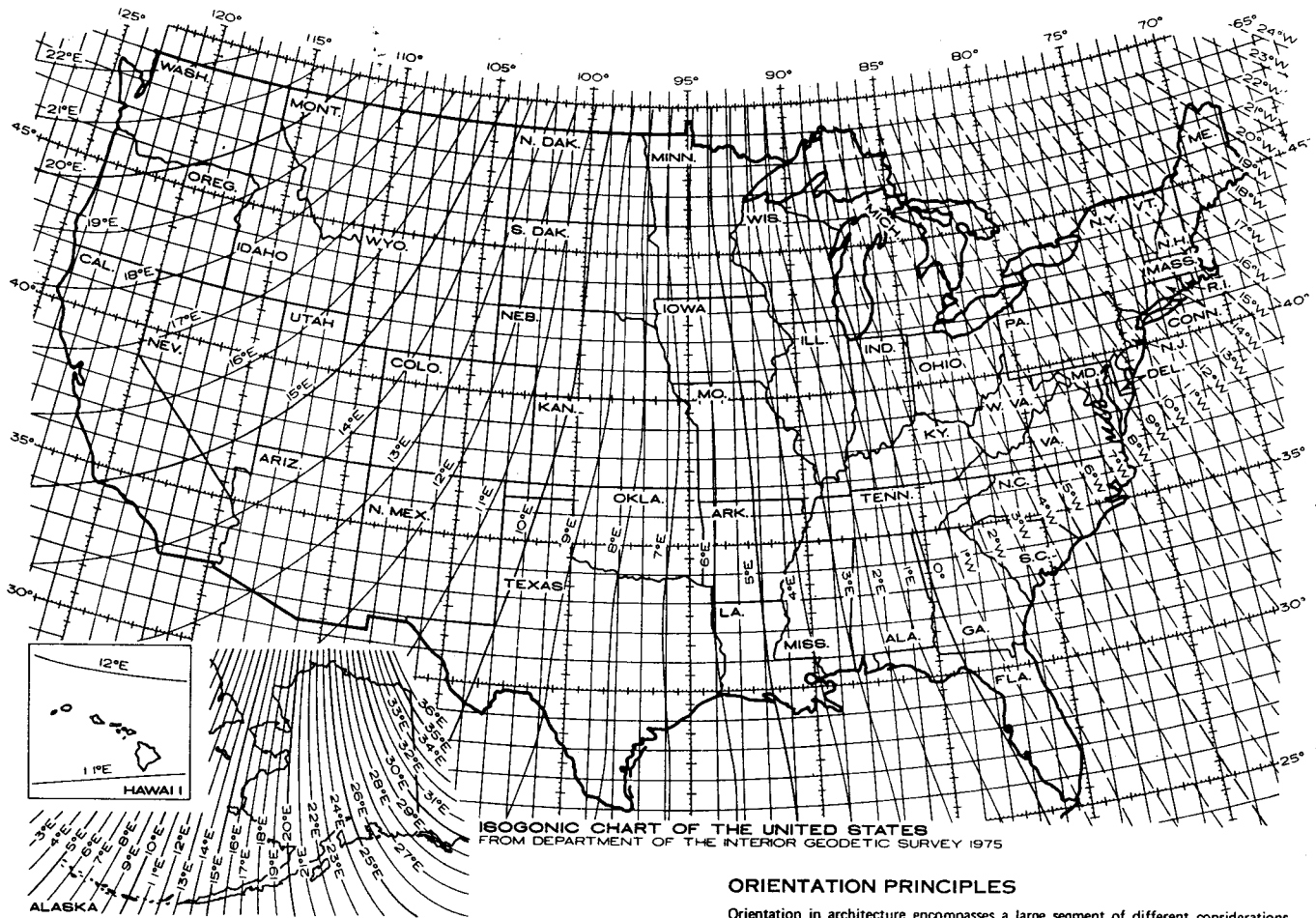

FIGURE 3

John I. Yellott, P.E.; College of Architecture, Arizona State University; Tempe, Arizona



**COMPASS ORIENTATION**

The above map is the isogonic chart of the United States. The wavy lines from top to bottom show the compass variations from the true north. At the lines marked E the compass will point east of true north; at those marked W the compass will point west of true north. According to the location, correction should be done from the compass north to find the true north.

- EXAMPLE:** On a site in Wichita, Kansas, find the true north.
- STEP 1.** Find the compass orientation on the site.
  - STEP 2.** Locate Wichita on the map. The nearest compass variation is the 10°E line.
  - STEP 3.** Adjust the orientation correction to true north. The graphical example illustrates a building which lies 25° east with its axis from the compass orientation.

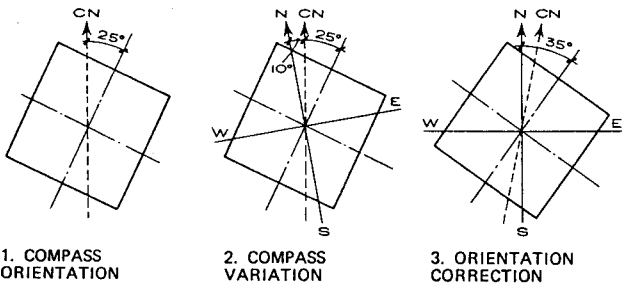

**ORIENTATION PRINCIPLES**

Orientation in architecture encompasses a large segment of different considerations. The expression "total orientation" refers both to the physiological and psychological aspects of the problem.

At the physiological side the factors which affect our senses and have to be taken into consideration are: the thermal impacts—the sun, wind, and temperature effects acting through our skin envelope; the visible impacts—the different illumination and brightness levels affecting our visual senses; the sonic aspects—the noise impacts and noise levels of the surroundings influencing our hearing organs. In addition, our respiratory organs are affected by the smoke, smell, and dust of the environs.

On the psychological side, the view and the privacy are aspects in orientation which quite often override the physical considerations.

Above all, as a building is only a mosaic unit in the pattern of a town organization, the spatial effects, the social intimacy, and its relation to the urban representative directions—aesthetic, political, or social—all play a part in positioning a building.

**THERMAL FORCES INFLUENCING ORIENTATION**

The climatic factors such as wind, solar radiation, and air temperature play the most eminent role in orientation. The position of a structure in northern latitudes, where the air temperature is generally cool, should be oriented to receive the maximum amount of sunshine without wind exposure. In southerly latitudes, however, the opposite will be desirable; the building should be turned on its axis to avoid the sun's unwanted radiation and to face the cooling breezes instead.

At right the figure shows these regional requirements diagrammatically.

Adaptation for wind orientation is not of great importance in low buildings, where the use of windbreaks and the arrangement of openings in the high and low pressure areas can help to ameliorate the airflow situation. However, for high buildings, where the surrounding terrain has little effect on the upper stories, careful consideration has to be given to wind orientation.

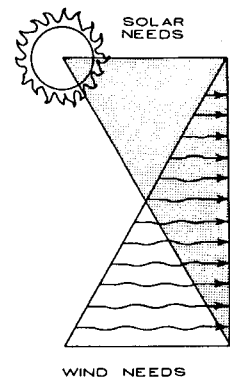

Victor Olgay, AIA; Princeton University; Princeton, New Jersey

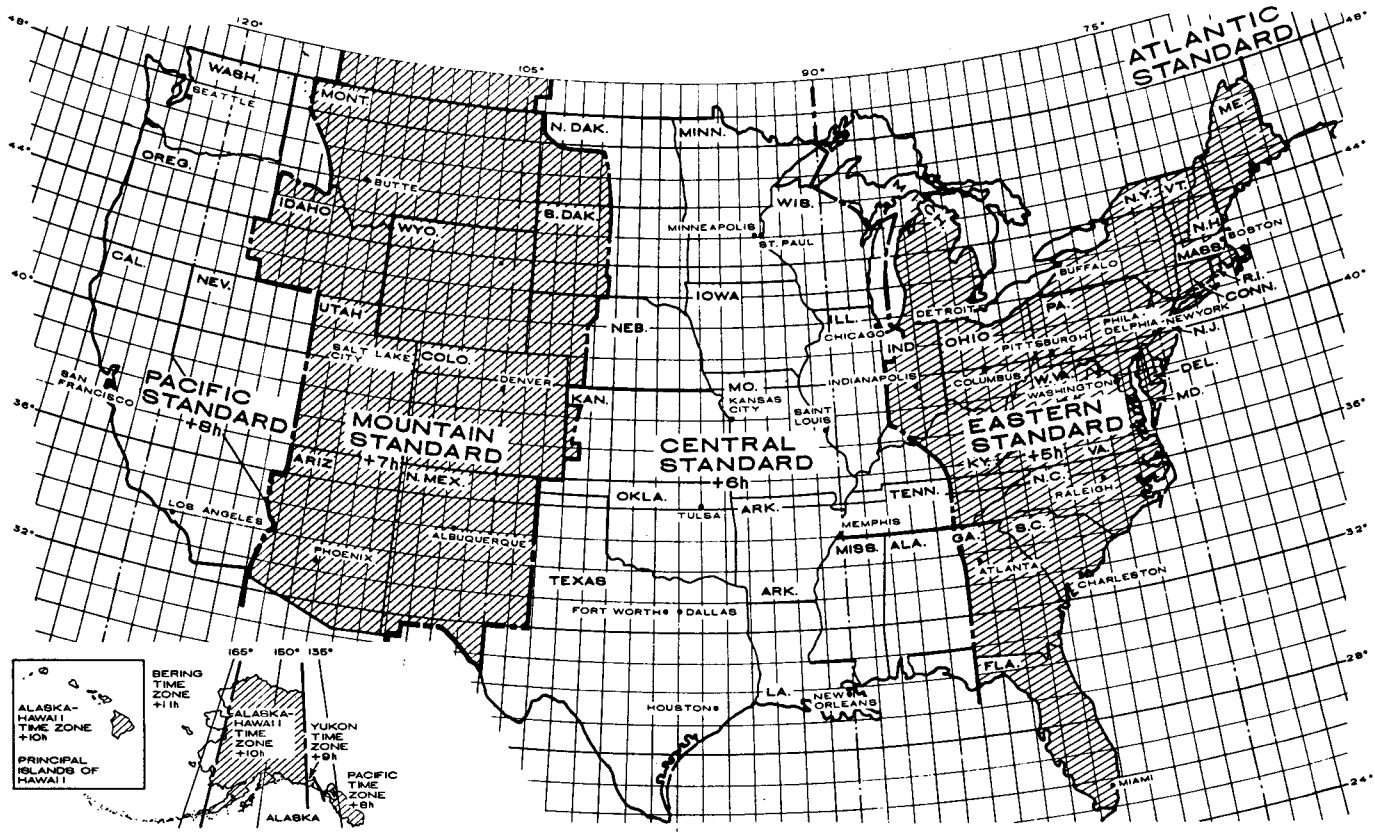

**STANDARD TIME ZONES OF THE UNITED STATES**

NOTE: Greenwich Standard Time is 0 h.

**SOLAR TIME**

Solar time generally differs from local standard or daylight saving time, and the difference can be significant, particularly when DST is in effect.

Because the sun appears to move at the rate of 360°/24 hr, its apparent motion is 4 min/1° of longitude. The procedure for finding AST (apparent solar time), explained in detail in the references cited previously, is

$$AST = LST + ET + 4(LSM - LON)$$

where ET = equation of time (min)

LSM = local standard time meridian (degrees of arc)

LON = local longitude, degrees of arc

4 = minutes of time required for 1.0° rotation of earth

The longitudes of the six standard time meridians that affect the United States are: eastern ST, 75°; central

ST, 90°; mountain ST, 105°; Pacific ST, 120°; Yukon ST, 135°; Alaska-Hawaii ST, 150°.

The equation of time is the measure, in minutes, of the extent by which solar time, as told by a sundial, runs faster or slower than civil or mean time, as determined by a clock running at a uniform rate. The table below gives values of the declination and the equation of time for the 21st day of each month of a typical year (other than a leap year). This date is chosen because of its significance on four particular days: (a) the winter solstice, December 21, the year's shortest day,  $\delta = -23^\circ 27'$  min; (b) the vernal and autumnal equinoxes, March 21 and September 21, when the declination is zero and the day and night are equal in length; and (c) the summer solstice, June 21, the year's longest day,  $\delta = +23^\circ 27'$  min.

**EXAMPLES**

Find AST at noon, local summer time, on July 21 for Washington, D.C., longitude = 77°; and for Chicago, longitude = 87.6°.

**SOLUTIONS**

In summer, both Washington and Chicago use daylight saving time, and noon, local summer time, is actually 11:00 a.m., local standard time. For Washington, in the eastern time zone, the local standard time meridian is 75° east of Greenwich, and for July 21, the equation of time is -6.2 min. Thus noon, Washington summer time, is actually

$$11:00 - 6.2 \text{ min} + 4 \times (75 - 77) = 10:46 \text{ a.m.}$$

For Chicago, in the central time zone, the local standard time meridian is 90°. Chicago lies 2.4° east of that line, and noon, Chicago summer time, is

$$11:00 - 6.2 \text{ min} + 4 \times 2.4 = 11:03 \text{ a.m.}$$

The hour angle, H, for these two examples would be

$$\text{for Washington: } H = 0.25 \times (12:00 - 10:46)$$

$$= 0.25 \times 74 = 18.8^\circ \text{ east}$$

$$\text{for Chicago: } H = 0.25 \times (12:00 - 11:03)$$

$$= 14.25^\circ \text{ east}$$

**YEAR DATE, DECLINATION, AND EQUATION OF TIME FOR THE 21ST DAY OF EACH MONTH; WITH DATA\* (A, B, C) USED TO CALCULATE DIRECT NORMAL RADIATION INTENSITY AT THE EARTH'S SURFACE**

MONTH	JAN.	FEB.	MAR.	APR.	MAY	JUNE	JULY	AUG.	SEPT.	OCT.	NOV.	DEC.
Day of the year†	21	52	80	111	141	173	202	233	265	294	325	355
Declination, ( $\delta$ ) degrees	-19.9	-10.6	0.0	+11.9	+20.3	+23.45	+20.5	+12.1	0.0	-10.7	-19.9	-23.45
Equation of time (min)	-11.2	-13.9	-7.5	+1.1	+3.3	-1.4	-6.2	-2.4	+7.5	+15.4	+13.8	+1.6
Solar noon	Late			Early			Late			Early		
A: Btuh/sq ft	390	385	376	360	350	345	344	351	365	378	387	391
B: 1/m	0.142	0.144	0.156	0.180	0.196	0.205	0.207	0.201	0.177	0.160	0.149	0.142
C: dimensionless	0.058	0.060	0.071	0.097	0.121	0.134	0.136	0.122	0.092	0.073	0.063	0.057

\*A is the apparent solar irradiation at air mass zero for each month; B is the atmospheric extinction coefficient; C is the ratio of the diffuse radiation on a horizontal surface to the direct normal irradiation.  
†Declinations are for the year 1964.

John I. Yellott, P.E.; College of Architecture, Arizona State University; Tempe, Arizona

18 SOLAR RADIATION AND BUILDING ORIENTATION



**SOLAR ANGLES**

The position of the sun in relation to specific geographic locations, seasons, and times of day can be determined by several methods. Model measurements, by means of solar machines or shade dials, have the advantage of direct visual observations. Tabulative and calculative methods have the advantage of exactness. However, graphic projection methods are usually preferred by architects, as they are easily understood and can be correlated to both radiant energy and shading calculations.

**SOLAR PATH DIAGRAMS**

A practical graphic projection is the solar path diagram method. Such diagrams depict the path of the sun within the sky vault as projected onto a horizontal plane. The horizon is represented as a circle with the observation point in the center. The sun's position at any date and hour can be determined from the diagram in terms of its altitude ( $\beta$ ) and azimuth ( $\phi$ ). (See figure on right.) The graphs are constructed in equidistant projection. The altitude angles are represented at  $10^\circ$  intervals by equally spaced concentric circles; they range from  $0^\circ$  at the outer circle (horizon) to  $90^\circ$  at the center point. These intervals are graduated along the south meridian. Azimuth is represented at  $10^\circ$  intervals by equally spaced radii; they range from  $0^\circ$  at the south meridian to  $180^\circ$  at the north meridian. These intervals are graduated along the periphery. The solar bearing will be to the east during morning hours, and to the west during afternoon hours.

(CONTINUED NEXT PAGE)

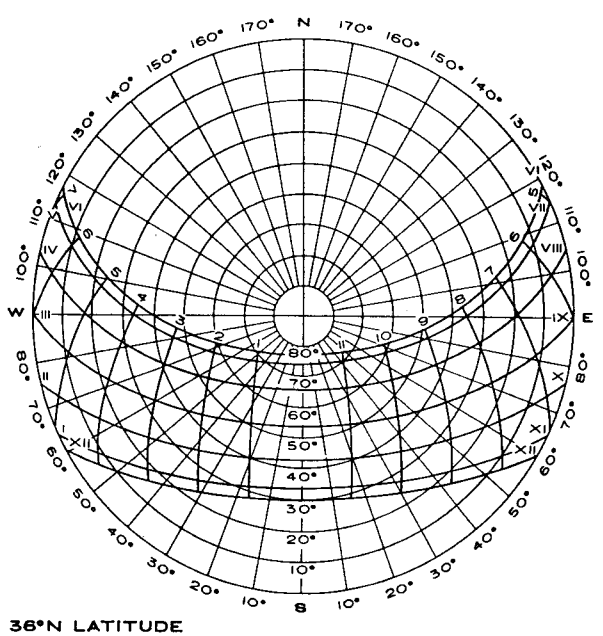
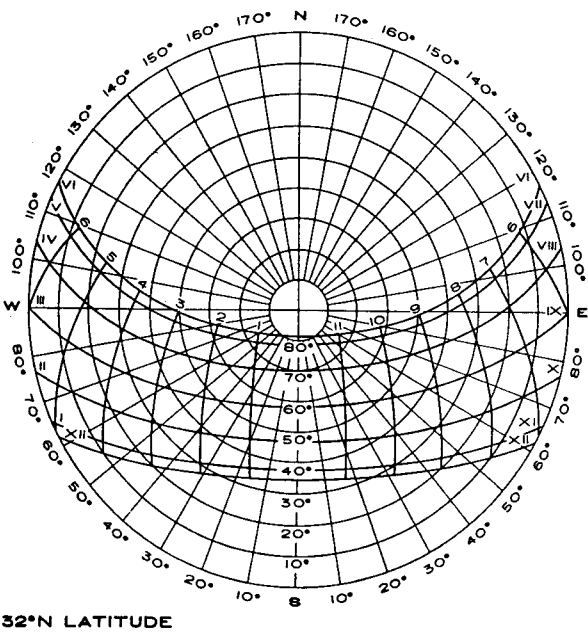
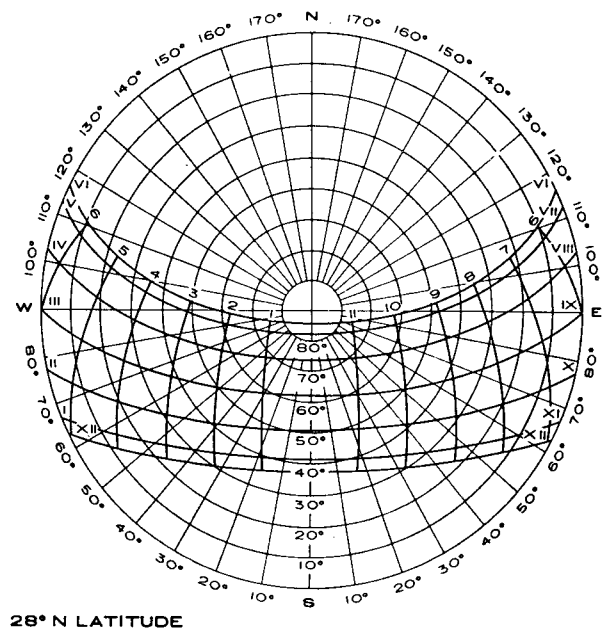
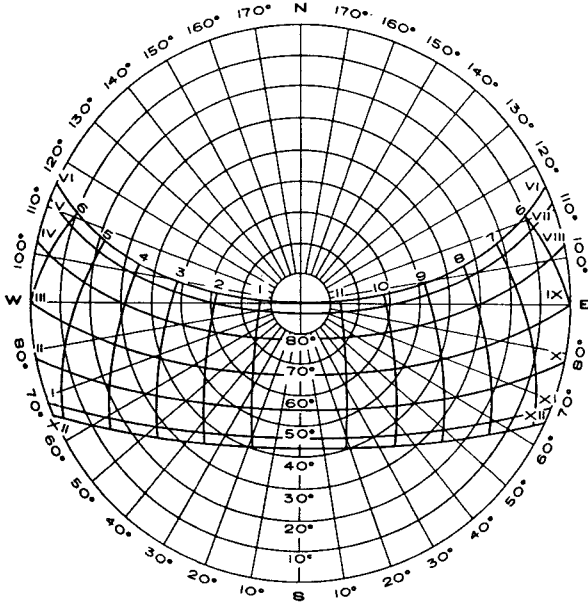
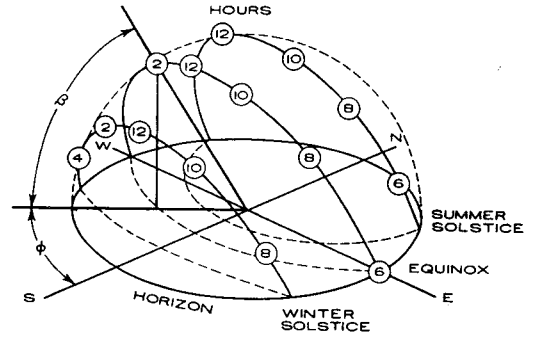

Victor Olgyay, AIA; Princeton University; Princeton, New Jersey



**SOLAR PATH DIAGRAMS (CONTINUED)**

The earth's axis is inclined 23°27' to its orbit around the sun and rotates 15° hourly. Thus, from all points on the earth, the sun appears to move across the sky vault on various parallel circular paths with maximum declinations of ±23°27'. The declination of the sun's path changes in a cycle between the extremes of the summer solstice and winter solstice. Thus the sun follows the same path on two corresponding dates each year. Due to irregularities between the calendar year and the astronomical data, here a unified calibration is adapted. The differences, as they do not exceed 41', are negligible for architectural purposes.

**DECLINATION OF THE SUN**

DATE	DECLINATION	CORRESP. DATE	DECLINATION	UNIFIED CALIBR.
June 21	+23°27'			+23°27'
May 21	+20°09'	July 21	+20°31'	+20°20'
Apr. 21	+11°48'	Aug. 21	+12°12'	+12°00'
Mar. 21	+0°10'	Sep. 21	+0°47'	+0°28'
Feb. 21	-10°37'	Oct. 21	-10°38'	-10°38'
Jan. 21	-19°57'	Nov. 21	-19°53'	-19°55'
Dec. 21	-23°27'			-23°27'

The elliptical curves in the diagrams represent the horizontal projections of the sun's path. They are given on the 21st day of each month. Roman numerals designate the months. A cross grid of curves graduate the hours indicated in arabic numerals. Eight solar path diagrams are shown at 4° intervals from 24°N to 52°N latitude.

**EXAMPLE**

Find the sun's position in Columbus, Ohio, on February 21, 2 P.M.:

STEP 1. Locate Columbus on the map. The latitude is 40°N.

STEP 2. In the 40° sun path diagram select the February path (marked with II), and locate the 2 hr line. Where the two lines cross is the position of the sun.

STEP 3. Read the altitude on the concentric circles (32°) and the azimuth along the outer circle (35°30'W).

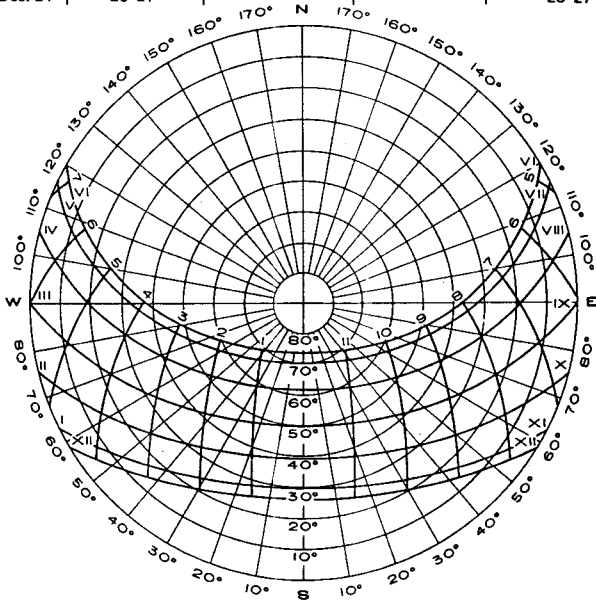

40°N LATITUDE

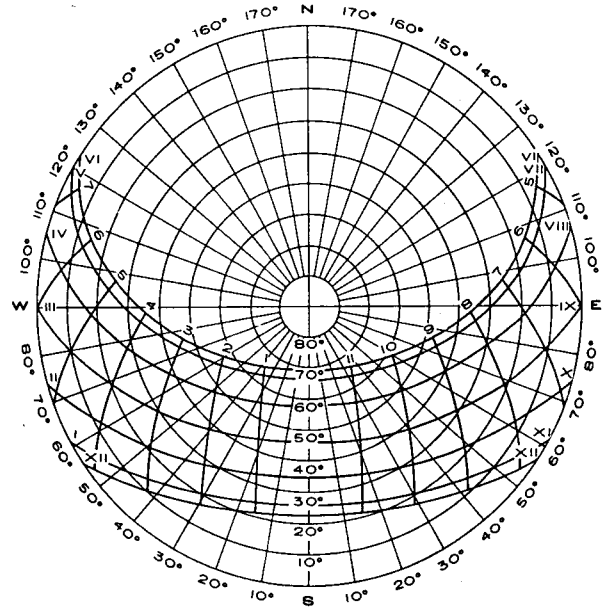

44°N LATITUDE

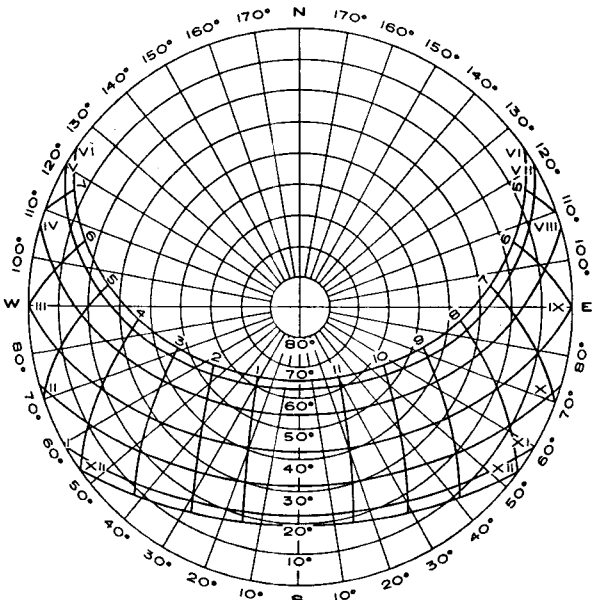

48°N LATITUDE

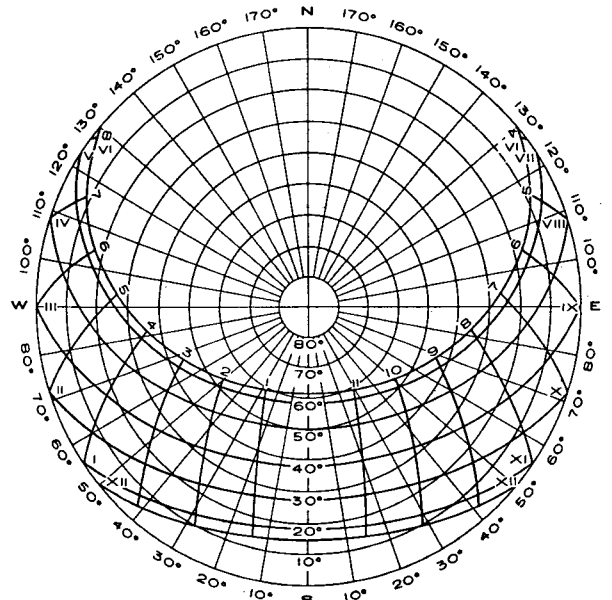

52°N LATITUDE

Victor Olgay, AIA; Princeton University; Princeton, New Jersey

**CALCULATION OF SOLAR POSITION**

The solar position to any location and time can be accurately calculated by relating the spherical triangle formed by the observer's celestial meridian, the meridian of the sun, and the great circle passing through zenith and the sun. The following formulas can be used to find the solar altitude and azimuth angles:

$$\sin \beta = \cos L \cos \delta \cos H + \sin L \sin \delta$$

$$\cos \phi = (\sin \beta \sin L - \sin \delta) / (\cos \beta \cos L)$$

where:

- $\beta$  = solar altitude above the horizon
- L = latitude of the location; conventionally negative for southern hemisphere latitudes
- $\delta$  = declination of the sun at the desired date, which is the angle between the earth-sun line and the equatorial plane (north declinations are conventionally positive; south declinations negative)
- H = hour angle of the sun =  $0.25 \times$  (number of minutes from local solar noon); H is zero at solar noon and changes 15 degrees per hour
- $\phi$  = solar azimuth, which is the angular distance measured from the south between the south-north line and the projection of the earth-sun line in the horizontal plane

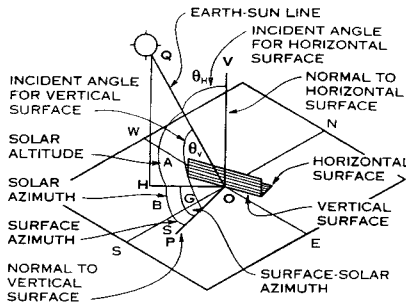

**CALCULATION OF SOLAR IRRADIATION**

It is necessary to know the amount of solar energy falling on exposed surfaces in order to evaluate the importance of solar shading. Because shading devices primarily protect surfaces from direct solar irradiation, only these energy calculations are described here.

The magnitude of direct solar irradiation is, first of all, a function of the sun's altitude and the apparent solar constant and atmospheric extinction coefficient. The latter two parameters take into account the annual variation of the earth-sun distance and the atmospheric water vapor content. The intensity of direct solar irradiation under clear atmospheric conditions at normal incidence can be calculated by:

$$I_{DN} = A \exp (-B/\sin \beta)$$

where:

- $I_{DN}$  = direct normal solar intensity at the earth's surface on clear days
- exp = base of natural logarithms
- A = apparent solar constant or apparent normal incidence intensity at air mass zero
- B = atmospheric extinction coefficient

The following tables indicate direct normal solar irradiation on clear days as a function of solar altitude on the solstices and the equinoxes.

**$I_{DN}$  AS A FUNCTION OF SOLAR ALTITUDE (BTU/SQ FT/HOUR)**

$\beta$	JUNE 21	MAR. 21/ SEPT. 21	DEC. 21
5	33	55	77
10	106	142	173
15	156	195	226
20	189	228	258
25	212	250	279
30	229	266	294
40	251	286	314
50	264	298	325
60	272	306	332
70	277	310	336
80	280	313	339
90	281	314	339

**SOLAR IRRADIATION**

The direct irradiation received by any given surface is also a function of the angle of incidence of the solar beam relative to that surface. The angle of incidence is the angle between the direct solar rays and a line normal to the irradiated surface.

For horizontal surfaces, the cosine of the angle of incidence is equal to the sine of the solar altitude. The direct irradiation on horizontal surfaces is thus calculated by:

$$I_{DH} = I_{DN} \times \sin \beta$$

For vertical surfaces, the incident angle depends on the solar altitude and the surface-solar azimuth. The surface-solar azimuth ( $\gamma$ ) is the angular distance between the solar azimuth and the azimuth of the surface. The surface azimuth is the angle between south and the normal to the surface, measured counterclockwise from south. The direct irradiation on vertical surfaces can thus be calculated by:

$$I_{DV} = I_{DN} \times \cos \beta \cos \gamma$$

In the following tables, calculated values of solar position in degrees, and direct irradiation in BTU/sq ft/hour are given for horizontal surfaces and various vertical orientations. The tables indicate values for 26°N to 46°N latitude at 4° intervals on the solstices and the equinoxes.

**SOLAR-SURFACE ANGLES**

The direction of the earth-sun line OQ is defined by the solar altitude A (angle HOQ) and the solar azimuth B (angle HOS). These can be calculated when the location (latitude), date (declination), and time of day (hour angle) are known. The surface azimuth S is the angle SOP between the south-north line SON and the normal to the surface OP. The surface-solar azimuth G is the angle HOP.

The angle of incidence  $\theta$  depends on the orientation and tilt of the irradiated surface. For a horizontal surface,  $\theta_h$  is the angle QOV between the earth-sun line OQ and the vertical line OV. For the vertical surface shown above as facing SSE, the angle of incidence  $\theta_v$  is the angle QOP between the earth-sun line OQ and the normal to the surface, OP. For surfaces such as solar collectors, which are generally tilted at some angle T upward from the horizontal, the incident angle  $\theta_t$  may be found from the equation:

$$\cos \theta_t = \cos A \cos S \sin T + \sin A \cos T$$

**26°N LATITUDE INCIDENT DIRECT SOLAR RADIATION**

JUNE 21		BTU/SQ FT/HR							
AM	ALT	AZM	S	SE	E	NE	N	SW	HOR
6	6	10.05 111.30		42	98	96	38		19
7	5	22.82 105.97		91	180	164	52		79
8	4	35.93 101.15		110	193	164	38		143
9	3	49.24 96.45		107	171	134	19		199
10	2	62.69 91.17		87	126	91	3		243
11	1	76.15 82.61	9	53	66	41			271
12		87.45 0.00	13	9				9	281
PM	$\beta$	$\phi$	S	SW	W	NW	N	SE	HOR

MARCH/SEPTEMBER 21		BTU/SQ FT/HR							
AM	ALT	AZM	S	SE	E	NE	N	SW	HOR
6	6	0.00 90.00							
7	5	13.45 83.30	21	138	175	109			42
8	4	26.71 75.80	56	196	222	117			115
9	3	39.46 66.33	88	205	202	80			181
10	2	51.11 52.79	114	186	150	25			233
11	1	60.25 31.43	130	148	79		36	266	
12		64.00 0.00	135	95			95	277	
PM	$\beta$	$\phi$	S	SW	W	NW	N	SE	HOR

DECEMBER 21		BTU/SQ FT/HR							
AM	ALT	AZM	S	SE	E	NE	N	SW	HOR
6	6								
7	5	2.23 62.48	5	10	9	3			
8	4	13.76 54.88	120	206	171	36			51
9	3	24.12 45.30	177	252	179	1			113
10	2	32.66 33.01	212	248	138			53	162
11	1	38.46 17.65	232	216	74			112	194
12		40.55 0.00	239	169				169	204
PM	$\beta$	$\phi$	S	SW	W	NW	N	SE	HOR

**30°N LATITUDE INCIDENT DIRECT SOLAR RADIATION**

JUNE 21		BTU/SQ FT/HR							
AM	ALT	AZM	S	SE	E	NE	N	SW	HOR
6	6	11.48 110.59		50	113	110	42		25
7	5	23.87 104.30		97	184	163	47		84
8	4	36.60 98.26		117	194	157	28		146
9	3	49.53 91.79		117	171	125	5		200
10	2	62.50 83.46	14	99	126	79			243
11	1	75.11 67.48	27	66	66	27			270
12		83.45 0.00	32	23				23	279
PM	$\beta$	$\phi$	S	SW	W	NW	N	SE	HOR

MARCH/SEPTEMBER 21		BTU/SQ FT/HR							
AM	ALT	AZM	S	SE	E	NE	N	SW	HOR
6	6	0.00 90.00							
7	5	12.95 82.37	23	137	170	104			40
8	4	25.66 73.90	63	199	218	110			109
9	3	37.76 63.43	100	212	200	71			173
10	2	48.59 49.11	128	196	148	14			223
11	1	56.77 28.19	147	159	79			48	254
12		60.00 0.00	153	108				108	265
PM	$\beta$	$\phi$	S	SW	W	NW	N	SE	HOR

DECEMBER 21		BTU/SQ FT/HR							
AM	ALT	AZM	S	SE	E	NE	N	SW	HOR
6	6								
7	5	0.38 62.40							
8	4	11.44 54.15	110	185	152	30			38
9	3	21.27 44.12	177	246	171			4	96
10	2	29.28 31.73	217	248	134			59	143
11	1	34.64 16.77	240	221	72			119	173
12		36.55 0.00	247	175				175	183
PM	$\beta$	$\phi$	S	SW	W	NW	N	SE	HOR

Gary L. Powell, Ph.D.; Salt River Project; Phoenix, Arizona

34°N LATITUDE INCIDENT DIRECT SOLAR RADIATION  
JUNE 21

AM		ALT AZM		BTU/SQ FT/HR						
		S	SE	E	NE	N	SW	HOR		
6	6	12.86	109.78	57	126	121	45			
7	5	24.80	102.54	103	188	162	42	34		
8	4	37.07	95.28	125	195	151	18	99		
9	3	49.49	87.10	9	127	171	115	158		
10	2	61.79	78.00	31	111	125	67	205		
11	1	73.17	55.10	46	79	66	14	234		
12		79.45	0.00	51	36			36 244		
PM	β	φ	S	SW	W	NW	N	SE	HOR	

MARCH/SEPTEMBER 21

AM		ALT AZM		BTU/SQ FT/HR						
		S	SE	E	NE	N	SW	HOR		
6	6	0.00	90.00							
7	5	12.39	81.48	25	134	165	99	37		
8	4	24.49	72.11	69	201	215	103	103		
9	3	35.89	60.79	110	217	197	61	163		
10	2	45.89	45.92	142	204	147	3	211		
11	1	53.21	25.60	163	170	78		60 241		
12		56.00	0.00	169	120			120 251		
PM	β	φ	S	SW	W	NW	N	SE	HOR	

DECEMBER 21

AM		ALT AZM		BTU/SQ FT/HR						
		S	SE	E	NE	N	SW	HOR		
6	6									
7	5									
8	4	9.08	53.57	93	155	126	23	25		
9	3	18.38	43.12	173	236	162		8 79		
10	2	25.86	30.65	219	246	130		63 123		
11	1	30.81	16.05	245	223	70		123 152		
12		32.55	0.00	253	179			179 162		
PM	β	φ	S	SW	W	NW	N	SE	HOR	

42°N LATITUDE INCIDENT DIRECT SOLAR RADIATION  
JUNE 21

AM		ALT AZM		BTU/SQ FT/HR						
		S	SE	E	NE	N	SW	HOR		
6	6	15.44	107.87		70	147	137	47	43	
7	5	26.28	98.78		115	192	157	30	96	
8	4	37.38	89.19	3	140	196	136		150	
9	3	48.45	77.96	36	146	170	95		196	
10	2	58.95	62.79	64	133	125	43		233	
11	1	67.64	38.62	82	105	66		12	256	
12		71.45	0.00	88	63			63	263	
PM	β	φ	S	SW	W	NW	N	SE	HOR	

MARCH/SEPTEMBER 21

AM		ALT AZM		BTU/SQ FT/HR						
		S	SE	E	NE	N	SW	HOR		
6	6	0.00	90.00							
7	5	11.09	79.84	27	126	151	87	30		
8	4	21.81	68.88	79	201	205	89	88		
9	3	31.70	56.21	128	225	191	45	142		
10	2	40.06	40.79	166	218	143		16 184		
11	1	45.88	21.82	190	188	76		81 211		
12		48.00	0.00	198	140			140 220		
PM	β	φ	S	SW	W	NW	N	SE	HOR	

DECEMBER 21

AM		ALT AZM		BTU/SQ FT/HR						
		S	SE	E	NE	N	SW	HOR		
6	6									
7	5									
8	4	4.28	52.82	35	58	46	8	4		
9	3	12.46	41.63	148	197	131		12 44		
10	2	18.91	29.00	209	229	116		66 82		
11	1	23.09	14.96	242	217	65		125 107		
12		24.55	0.00	253	179			179 115		
PM	β	φ	S	SW	W	NW	N	SE	HOR	

38°N LATITUDE INCIDENT DIRECT SOLAR RADIATION  
JUNE 21

AM		ALT AZM		BTU/SQ FT/HR						
		S	SE	E	NE	N	SW	HOR		
6	6	14.18	108.87		64	137	130	47	37	
7	5	25.60	100.70		109	190	160	36	93	
8	4	37.33	92.25		133	195	144	8	149	
9	3	49.13	82.47	23	137	171	105		199	
10	2	60.68	69.06	48	122	125	55		238	
11	1	70.61	45.67	64	92	66	1		262	
12		75.45	0.00	70	50				50 270	
PM	β	φ	S	SW	W	NW	N	SE	HOR	

MARCH/SEPTEMBER 21

AM		ALT AZM		BTU/SQ FT/HR						
		S	SE	E	NE	N	SW	HOR		
6	6	0.00	90.00							
7	5	11.77	80.63	26	130	158	93	33		
8	4	23.20	70.43	75	202	210	96	96		
9	3	33.86	58.38	120	222	194	53	153		
10	2	43.03	43.16	155	212	145		7 198		
11	1	49.57	23.52	177	180	77		71 227		
12		52.00	0.00	185	131			131 236		
PM	β	φ	S	SW	W	NW	N	SE	HOR	

DECEMBER 21

AM		ALT AZM		BTU/SQ FT/HR						
		S	SE	E	NE	N	SW	HOR		
6	6									
7	5									
8	4	6.69	53.12	69	114	92	16	13		
9	3	15.44	42.30	164	221	149		10 61		
10	2	22.40	29.74	216	240	124		66 103		
11	1	26.96	15.45	246	222	68		126 130		
12		28.55	0.00	255	180			180 139		
PM	β	φ	S	SW	W	NW	N	SE	HOR	

46°N LATITUDE INCIDENT DIRECT SOLAR RADIATION  
JUNE 21

AM		ALT AZM		BTU/SQ FT/HR						
		S	SE	E	NE	N	SW	HOR		
6	6	16.63	106.77		76	155	142	47	48	
7	5	26.82	96.80		121	194	154	23	99	
8	4	37.22	86.15	13	147	195	129		149	
9	3	47.47	73.66	50	155	169	85		192	
10	2	56.95	57.25	80	144	124	31		226	
11	1	64.40	33.33	99	116	65		24	248	
12		67.45	0.00	106	75			75	255	
PM	β	φ	S	SW	W	NW	N	SE	HOR	

MARCH/SEPTEMBER 21

AM		ALT AZM		BTU/SQ FT/HR						
		S	SE	E	NE	N	SW	HOR		
6	6	0.00	90.00							
7	5	10.36	79.09	27	120	142	81	26		
8	4	20.32	67.45	83	199	199	82	80		
9	3	29.42	54.27	134	227	187	37	130		
10	2	36.98	38.75	175	223	140		24 169		
11	1	42.14	20.43	201	195	75		89 194		
12		44.00	0.00	210	148			148 203		
PM	β	φ	S	SW	W	NW	N	SE	HOR	

DECEMBER 21

AM		ALT AZM		BTU/SQ FT/HR						
		S	SE	E	NE	N	SW	HOR		
6	6									
7	5									
8	4	1.86	52.65	3	5	4	1			
9	3	9.46	41.12	122	162	107		11 27		
10	2	15.41	28.41	194	212	105		63 61		
11	1	19.23	14.56	232	207	60		122 84		
12		20.55	0.00	244	173			173 92		
PM	β	φ	S	SW	W	NW	N	SE	HOR	

Gary L. Powell, Ph.D.; Salt River Project; Phoenix, Arizona

**BASIC PRINCIPLES**

The diagrams presented in this discussion are based on an isolated building. Neighboring buildings and landscaping can substantially affect airflow and should be taken into account when evaluating ventilation strategies.

As wind approaches the face of a building the airflow is slowed, creating positive pressure and a cushion of air on the building's windward face. This cushion of air, in turn, diverts the wind toward the building sides. Airflow as it passes along the sidewalls separates from building wall surfaces and, coupled with high-speed airflow, creates suction (negative pressure) along these wall surfaces. On the building leeward side a big slow-moving eddy is created. Suction on the leeward side of the building is less than on the sidewalls (see Figure 1).

If windows are placed in both windward and leeward faces, the building would be cross ventilated and eddies will develop against the main airflow direction (see Figure 2). Ventilation can be enhanced by placing windows in sidewalls due to the increased suction at this location; also, greater air recirculation within the building will occur due to air inertia (see Figure 3). Winds often shift direction, and for oblique winds, ventilation is best for rooms with windows on three adjacent walls (see Figure 4) than on two opposite walls (see Figure 5). However, if wind is from the one windowless side, then ventilation is poor, since all openings are in suction (see Figure 6).

If the building configuration only allows for windows in one wall, then negligible ventilation will occur with the use of a single window, because there is not a distinct inlet and outlet. Ventilation can be improved slightly with two widely spaced windows. Airflow can be enhanced in these situations by creating positive and negative pressure zones by use of architectural features such as wing walls (see Figure 7). Care must be exercised in developing these features to avoid counteracting the natural airflow, thereby weakening ventilation (see Figure 8).

**AIR JETS**

As airflow passes through a well-ventilated room, it forms an "air jet." If the windows are centered in a room, it forms a free jet (see Figure 9). If, however, the openings are near the room walls, ceiling, or floor, the airstream attaches itself to the surface, forming a wall jet (see Figure 10). Since heat removal from building surfaces is enhanced with increased airflow, the formation of wall jets is important in effecting rapid structure cooling. To improve the overall airflow within a room, offsetting the inlet and outlet will promote greater mixing of room air (see Figure 11).

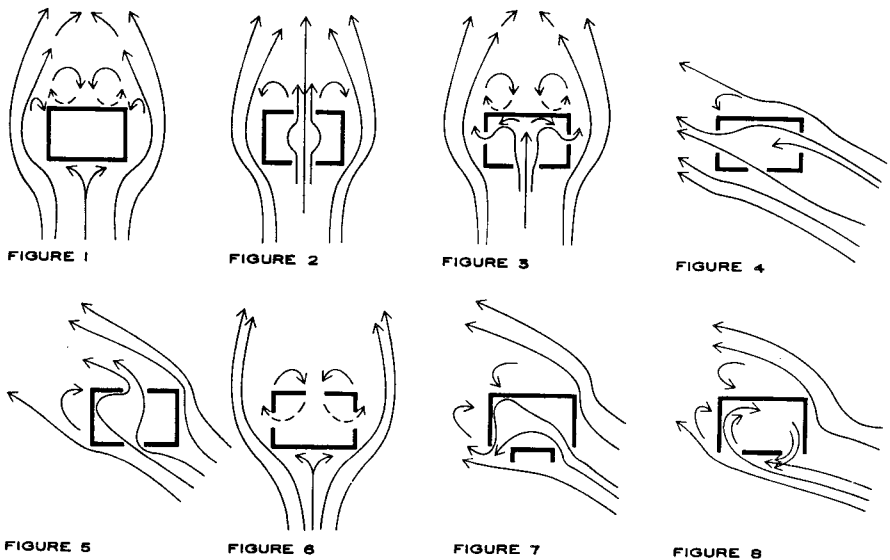

**VENTILATION AIR CHANGE RATE**

The natural air change rate within a building depends on several factors: speed and direction of winds at building site; the external geometry of building and adjacent surroundings; window type, size, location, and geometry; and the building's internal partition layout. Each of these factors may have an overriding influence on the air change rate of a given building.

Natural ventilation can be accomplished by wind-driven methods or by solar chimneys (stack effect). However, the stack effect is weak and works best during hours when air temperatures are highest and ventilation may not be desirable. In many areas ventilation is best accomplished during the night hours when temperatures are lowest. The night average wind speed is generally about 75% of the 24-hr average wind speed reported by weather bureaus. Often wind speeds are insufficient to accomplish effective people cooling; therefore, ventilating for structure cooling rather than people cooling should be the first design goal. As a rule of thumb, an average of 30 air changes per hour should provide adequate structure cooling, maintaining air temperatures most of the time within 1.5°F of outdoor temperatures.

**EXTERNAL EFFECTS**

The leeward wake of typical residential buildings extends roughly four and one-half times the ground-to-eave height. For buildings spaced greater than this distance, the general wind direction will remain unchanged. For design purposes, vegetation should be considered for its effect on wind speed, which can be as great as 30-40% in the vegetation's immediate vicinity. Its effect on wind direction is not well established and should not be relied upon in establishing ventilation strategies.

**RULE OF THUMB EXAMPLE**

Determine inlet window opening area to achieve 30 air changes per hour in a house of 1200 sq ft with a ceiling height of 8 ft and awning windows with insect screens.

Required airflow (CFM)  
= House volume x air changes per hr/60  
Required airflow = (1200 x 8) x 30/60 = 4800 CFM

From local National Oceanic and Atmospheric Administration (NOAA) weather data, determine site wind conditions for design month. For the example above, average wind speed at 10 m above ground level = 7 mph or 616 ft/min at 30° incidence angle to the house face. Note that site wind speeds are generally less than NOAA data, usually collected at airports.

To determine the required inlet area, divide the house airflow by the wind speed passing through openings in the windward building face. To establish this wind speed,

the site wind speed must be modified by the effects of building angle relative to wind direction and porosity of the window opening.

Figure 12 charts the effect of wind incidence angle on airflow rates (based on wind tunnel tests on model buildings with equal inlet and outlet areas equaling 12% of inlet wall areas). Table 1 establishes porosity factors for typical window arrangements. By multiplying the site wind speed by the window air speed factor (WAF) and window porosity factor (WPF), the effective wind speed can be determined. Therefore:

$$\text{Inlet window area} = \frac{\text{Airflow}}{\text{Wind speed} \times \text{WAF} \times \text{WPF}}$$

$$\text{Inlet window area} = \frac{4800}{616 \times 0.35 \times 0.75} = 29.7 \text{ sq ft}$$

In the example above, therefore, providing a total of 60 sq ft of insect screened awning windows will provide the required ventilation of 30 air changes per hour.

For best results, the 60 sq ft of windows should be split equally between inlets and outlets. However, adequate airflows can be maintained for anywhere from 40/60 to 60/40 split between inlets and outlets.

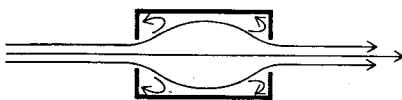

FIGURE 9



FIGURE 10



FIGURE 11

**WINDOW SIZE**

Airflow within a given room increases as window size increases, and to maximize airflow, the inlet and outlet opening should be the same size. Reducing the inlet size relative to the outlet increases inlet velocities. Making the outlet smaller than the inlet creates low but more uniform airspeed.

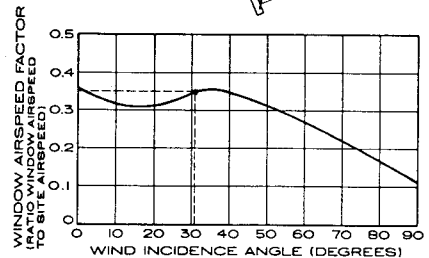
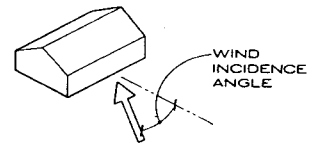

FIGURE 12

TABLE 1 POROSITY FACTORS

WINDOW TYPE	FACTOR
Fully open awning or projecting window	0.75
Awning window with 60% porosity insect screen	0.65
60% porosity insect screen only	0.85

W. Fred Roberts Jr., AIA; Roberts & Kirchner Architects; Lexington, Virginia

**CLIMATE**

Cold climates in North America are generally north of the 40th parallel. Very cold is identified by the southern boundary of the 32°F mean annual temperature and includes most of Canada and Alaska except along the Pacific coast. Permafrost extends from below Hudson Bay and just north of the southern coast of Alaska to the Arctic Circle. The Arctic Circle designates the southernmost point where continuous daylight in summer and continuous darkness in winter exist.

**PLANNING DETERMINANTS**

Cold climates generally require multidisciplinary considerations for extremes of physical, economic, sociological, and environmental conditions. These include very cold temperatures, high winds, drifting snow, continuous darkness and low sun angles, permafrost, minimal and costly transportation and communication, and subsequent isolation.

**DESIGN**

Responses to planning determinants suggest aerodynamic design, isolation from permafrost, maximum insulation, self-sufficient utilities, backup systems for emergency, privacy without isolation, variety, and color. Labor is costly, suggesting maximum prefabrication. (Modular components can be used where barges can navigate.)

**THERMOPILES AND PROBES**

Both self-contained convection (passive) and mechanically refrigerated (active) systems are used for new construction and stabilization of existing foundations, either directly as pipe piles or in smaller pipes (probes) that can be placed beside a pile or under slab or foundation. Passive systems rely on natural convection of a liquid or gas medium to remove heat from the ground to keep it frozen; active systems use pumps and refrigeration technology. Recent concerns regarding global warming have caused renewed interest in the design parameters for passive systems.

**UTILITIES**

Utilidors or utiliducts are the most common way to provide protection, easy access, and insulation of utility lines to avoid disturbance to the permafrost. Human waste at isolated facilities may be handled by compost privies (waterless toilets) and chemical toilets or self-contained treatment systems. Disposal systems include incineration and sewage lagoons.

**PERMAFROST, ICE WEDGES AND LENSES, AND FROST HEAVE**

**DEFINITION OF PERMAFROST:** Ground of any kind that stays colder than the freezing temperature of water throughout several years. Depth can extend to 2,000 ft below active layer.

**TERMS**

**ACTIVE LAYER:** Top layer of ground subject to annual freezing and thawing. Up to 10 ft or only 18 in. over some permafrost.

**FROST HEAVING:** Lifting or heaving of soil surface created by the freezing of subsurface frost-susceptible material.

**FROST-SUSCEPTIBLE SOIL:** Soil that has enough permeability and capillary action (wickability) to expand upon freezing.

**ICE LENSE (TABER ICE):** Subsurface pocket of ice in soil.

**ICE WEDGE:** Wedge-shaped mass of ice within thaw zone. Wedges range up to 3 or 4 ft wide and 10 ft deep.

**PERELETOK:** Frozen layer at the base of the active layer that remains unthawed during some cold summers.

**RESIDUAL THAW ZONE:** Layer of unfrozen ground between the permafrost and active layer. This layer does not exist when annual frost extends to the permafrost, but is present during some warm winters.

**SITE PLANNING**

Blowing snow with high winds, low sun angles, and long periods of darkness are the dominant design factors. Minimizing obstructions that cause snow drifting and

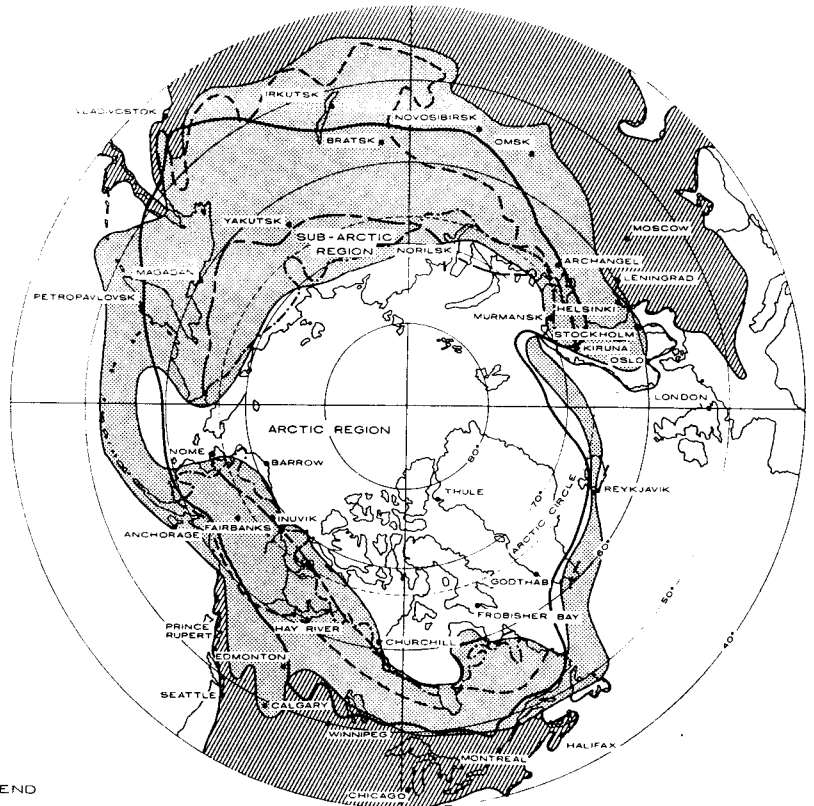

**LEGEND**

- ARCTIC CIRCLE
- 32° F MEAN ANNUAL TEMPERATURE
- - - LIMIT OF CONTINUOUS PERMAFROST
- - - LIMIT OF DISCONTINUOUS OR SPORADIC PERMAFROST
- - - NORTHERN BOUNDARY OF TREES
- [Stippled Box] ARCTIC COLD DRY
- [Cross-hatched Box] SUB-ARCTIC COLD WET

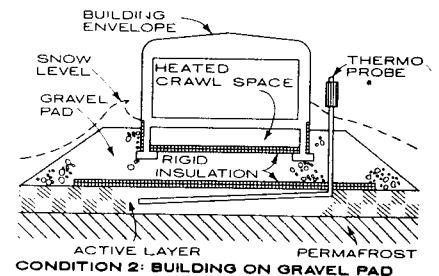
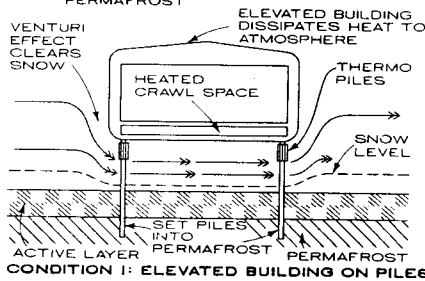

placing the long axis of a structure parallel to the prevailing wind help. Buildings can be spaced to avoid the long shadows cast by low winter sun angles. Darkness is a physical and psychological problem that suggests adequate lighting and signage.

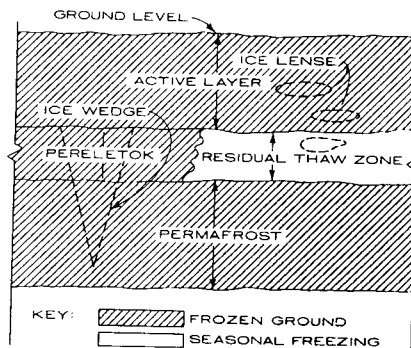

**CONDITION OF BUILDINGS ON PERMAFROST**

**CONDITION 1:** Building elevated on piles allows the dispersion of building heat to prevent ground thaw and allow the wind to remove snow. Wooden piles, with low thermal conductivity, induce minimal heat into frozen ground while thermopiles can remove heat to retain frozen state.

**CONDITION 2:** Building elevated on non-frost-susceptible gravel pad to provide insulation in addition to existing ground cover. Rigid insulation adds to the protection from thaw of the permafrost. Thermoprobes are used to re-freeze fill and keep permafrost frozen.

**REFERENCES**

Johnston, G. H., *Permafrost Engineering, Design and Construction*, National Research Council of Canada, John Wiley & Sons, New York, 1981.  
 Phukan, Arvind, *Frozen Ground Engineering*, Prentice Hall, Englewood, NJ, 1985.  
 Rice, Eb, *Building in the North*, Geophysical Institute, University of Alaska, Fairbanks, AK, 1975.  
 Zrudlo, Leo R., *Psychological Problems and Environmental Design in the North*, Collection Nordicana, Université Laval, Montreal, Canada, 1972.

Edwin B. Crittenden, FAIA, and John N. Crittenden, AIA; Anchorage, Alaska

**GENERAL**

Successful design of building envelopes for cold regions requires that all air-vapor retarders, wind barriers, and insulation be continuous. Air-vapor retarders prevent warm,

moist indoor air from entering and condensing in portions of the envelope. Wind barriers prevent cold outdoor air from entering the insulation. Seal the wind barrier and air-vapor retarder at all joints and penetrations in the envelope to prevent air leakage and moisture problems. Metal or con-

crete bridging across the insulated layer can cause thermal short circuits. Minimize thermal short circuits with continuous insulation; this saves energy and reduces condensation and mold. Adequate slopes and continuity at flashing prevent problems due to snow and ice on roofs.

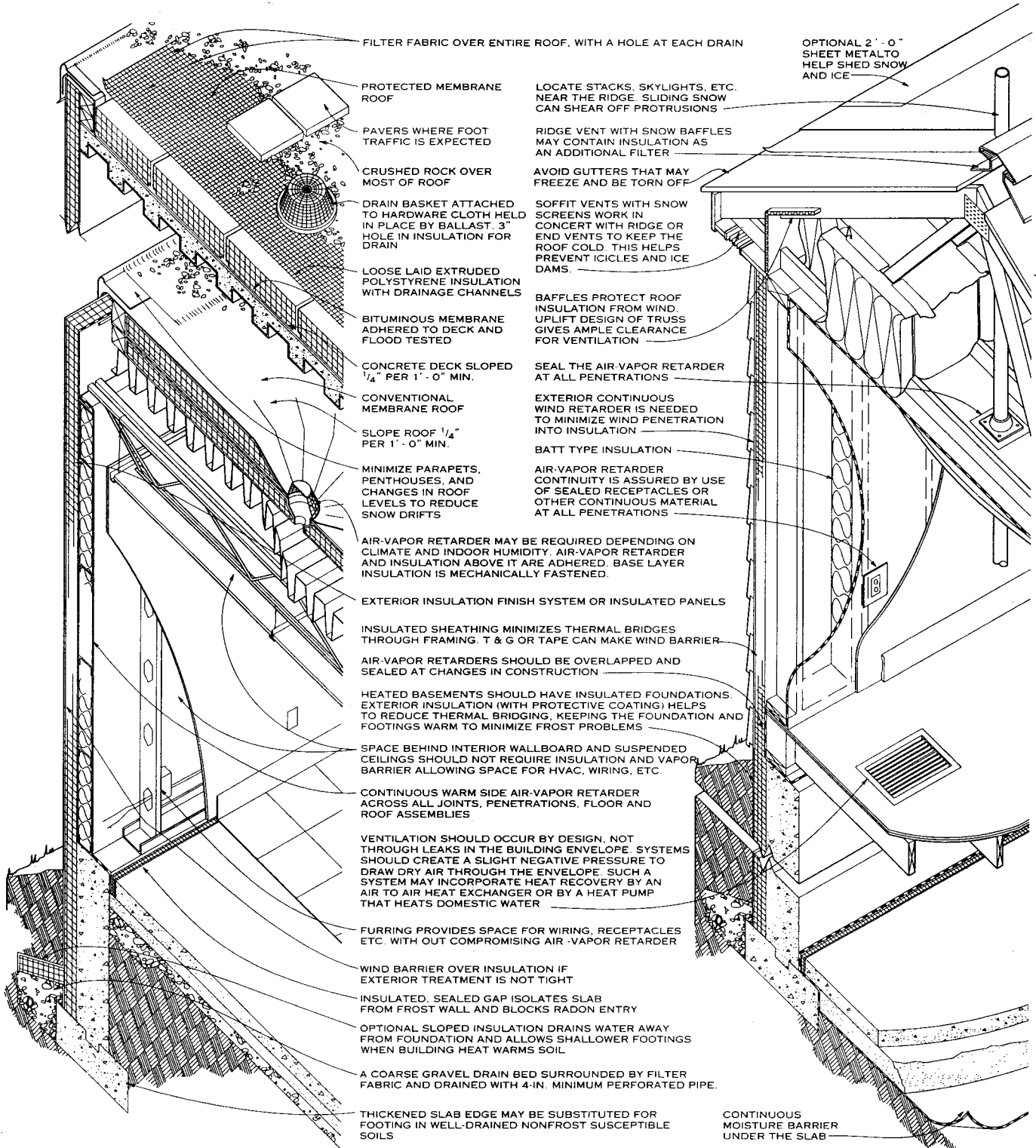

**CONCRETE OR STEEL CONSTRUCTION WITH MEMBRANE ROOF**

**FRAME CONSTRUCTION WITH A COLD ROOF**

Eric K. Beach; Rippeteau Architects, PC; Washington, D.C.  
 Stephen N. Flanders and Wayne Tobiasson; Cold Regions Research and Engineering Laboratory, U.S. Army Corps of Engineers; Hanover, New Hampshire

STRATEGIES OF CLIMATE CONTROL

Underheated conditions occur in both humid and arid regions and dominate much of the U.S. The strategies are to minimize conduction and infiltration losses and to take advantage of winter solar gain. Humidity affects sky clearness and availability of solar radiation, making optimization of solar glazing area one of the main opportunities of regional design. Moisture movement through the building shell must be controlled. It is driven by air leakage (exfiltration) and by vapor diffusion, which is related to temperature differences.

MINIMIZE CONDUCTION LOSSES

Minimize ratio of envelope to heated floor area. Minimize foundation perimeter length. Insulate envelope components in proportion to indoor-outdoor temperature difference. Minimize areas of windows, doors, and other envelope components of inherently low R value. Detail to avoid thermal bridging. Provide movable insulation for glazed areas.

MINIMIZE INFILTRATION LOSSES

Plant vegetation to create wind-sheltered building sites. Shape building to minimize exposure to winter wind. Orient doors and windows away from winter wind. Specify weatherstripping and infiltration barrier.

CAPTURE SOLAR GAIN

Provide high-transmittance south-facing glazing. Provide thermal mass indoors to store solar gains.

INSULATION

Insulation requirements are proportional to heating loads. The foundation is often underinsulated and can be a major source of heat loss. The desirable insulation level depends on basement temperature and insulation levels in the rest of the building. An approximate thermal optimum is:

$$R_{ins} = \frac{T_{bsmt} - T_0}{T_1 - T_0} R_{ref} - R_{wall}$$

$R_{ins}$  = R value to be added to basement wall above grade

$R_{ref}$  = R value of superstructure wall

$R_{wall}$  = R value of uninsulated basement foundation wall

$T_{bsmt}$  = average seasonal temperature of basement

$T_1$  = average seasonal temperature of living space

$T_0$  = average seasonal outdoor temperature

The added foundation insulation above grade is  $R_{ins}$ . It should decrease with depth by R - 2 per foot in ordinary soils and R - 1.5 in wet soils. A horizontal skirt can be used to reduce floor perimeter losses. Exterior insulation keeps the wall warm and eliminates condensation and thermal bridges. As seasonal basement temperature decreases, losses to it from the superstructure increase, and basement ceiling R value should increase. As a very rough rule, the basement ceiling R value should be greater than  $(R_{ref} - R_{ins})$ .

SOLAR DESIGN AND DAYLIGHTING

The most advantageous south glazing area depends on thermal and climatic factors. Rules of thumb have been prepared (Los Alamos National Laboratory) and more sophisticated methods are available for desktop computers.

The advantage of glazing for daylighting has to be weighed against the penalty of winter heat loss. In predominantly cloudy climates, skylighting can be designed without significant shading, but not without concern for glare. In clear, sunny climates and in warmer regions, daylight glazing may require shading to reduce undesired heat gain. South glazing has the combined advantages of daylighting, winter heat gain, and economical summer shading.

REFERENCES

1. Los Alamos National Laboratory, *Passive Solar Heating Analysis*, ASHRAE, Atlanta, 1984.
2. National Research Council, Canada, Ottawa, Ontario, K1A 0R6: *Construction Details for Air Tightness* (nonresidential), NRCC 18291, 1980; *Exterior Walls: Understanding the Problems*, NRCC 21203, 1983; *Humidity, Condensation and Ventilation in Houses*, NRCC 23293, 1984; J. Latta, *The Principles and Difficulties of Designing Durable House Envelopes for the North*, Building Practice Note 52, 1985.

Donald Watson, FAIA, Rensselaer Polytechnic Institute, Troy, New York  
Kenneth Labs, New Haven, Connecticut

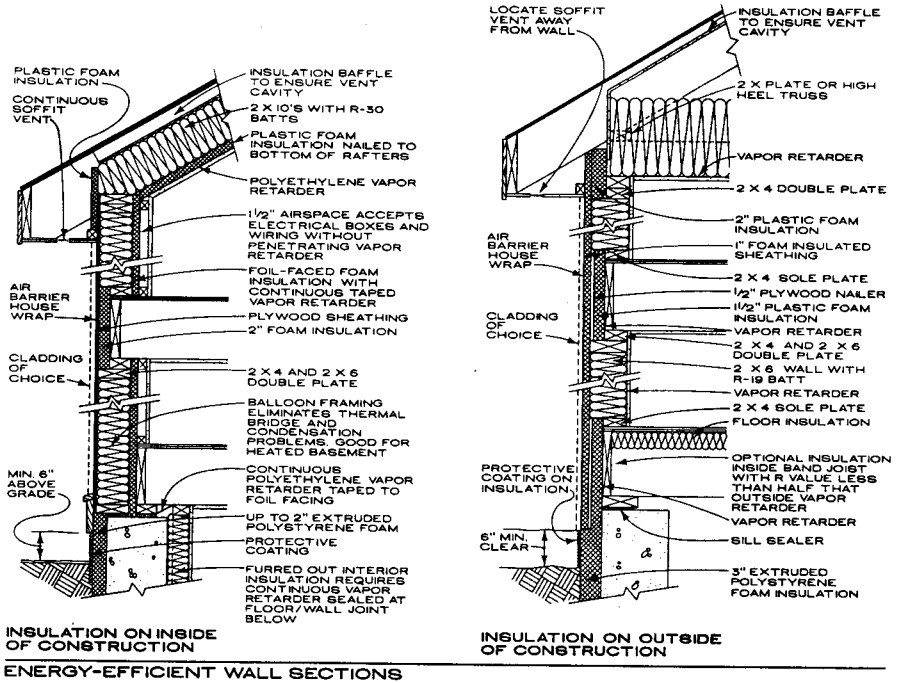

ENERGY-EFFICIENT WALL SECTIONS

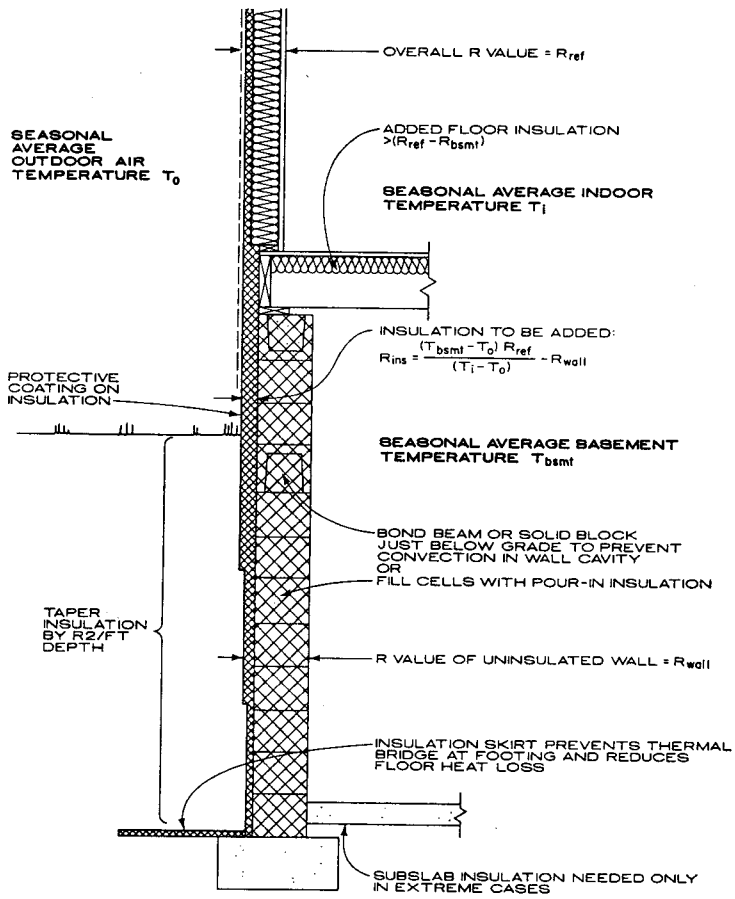

BASEMENT FOUNDATION AND FLOOR INSULATION



**CLIMATE: IMPLICATIONS**

Although classified as arid and overheated, severe desert climates in the United States typically have four distinct periods for determining comfort strategies. The hot dry season, occurring in late spring, early summer, and early fall, has dry, clear atmospheres that provide high insolation levels, high daytime air temperatures, very high sol-air temperatures, and large thermal radiation losses at night producing a 30 to 40°F daily range. Nighttime temperatures may fall below the comfort limits and are useful for cooling. Low humidity allows effective evaporative cooling. The hot humid season occurs in July and August. In addition to high insolation, it is characterized by high dew point temperatures (above 55°F), reducing the usefulness of evaporative cooling for comfort conditioning. Cloudiness and haze prevent nighttime thermal reradiation, resulting in only a 20°F or less daily range. Lowest nighttime temperatures are frequently higher than the comfort limits. Thus refrigeration or dehumidification may be needed to meet comfort standards. The winter season typically has clear skies, cold nights, very low dew point temperatures, a daily range of nearly 40°F, and the opportunity for passively meeting all heating requirements from isolation. The transitional or thermal sailing season occurs before and after the winter season and requires no intervention by environmental control systems. This season can be extended by the passive features of the building. Other desert climates have similar seasons but in different proportions and at cooler scales.

**MINIMIZE SOLAR AND CONDUCTIVE GAINS**

Solar radiation is the greatest liability to comfort conditions in this region. Summer solar intensity is highest on horizontal surfaces. A vented attic above an insulated ceiling is very effective. Ideally the entire building, both transparent and opaque surfaces, should be shaded, as well as outdoor pedestrian and living areas (ramadas and pergolas). Plant trees to shade roof and east and west walls, and to develop a modified microclimate around the building. Shape massing to minimize solar load on envelope; thus multistory schemes with narrow east-west exposures are efficient. Cluster buildings to shade one another; position carport or garage as a buffer on the west side. Use light-colored surfacing on walls and roof.

Insulate envelope components in proportion to the difference between sol-air and indoor temperatures. In addition, use radiant barriers in attic, cathedral ceilings, and walls. Perimeter insulation of slab-on-grade floors is desirable but not critical. In this region, deep-ground temperatures are too high and soil conductivity is too low for the earth to be a useful cooling sink. But low conductivity makes the soil a good buffer against surface conditions. Earth berms work.

**SELECTIVE FENESTRATION**

Shading of glass during the full overheated period also has the highest priority. Minimize glass on the west. Balance fenestration between north and south, although both orientations require solar control. For all uses, residential and light commercial, direct solar gain is not desired except in the coldest months. For small area windows that will be shaded, single pane glazing is acceptable. With larger areas

(over 20 sq ft), in addition to the conductive heat gain, the higher inside surface temperature of single glazing raises the mean radiant temperature and adversely affects comfort. Generally fenestration should be double pane with a low "e" coating on the inside surface of the outside pane. If fenestration is unshaded, replace low "e" coating with "heat mirror," which also reduces visible transmission. Multiple glazing should have low conductance frames, using either thermal breaks, if metal, or thermally resistant materials such as wood or plastic. Clear, sunny skies make daylighting dependable and predictable for design. Although glazings with low shading coefficients block considerable insolation, they also prevent daylighting the space, thus requiring higher wattages for electric lighting. Small windows and skylight areas are effective but apertures need exterior shade to avoid solar gain and high contrast. Reflected light from the ground and from light shelves is useful, but glare from uncontrolled reflecting surfaces must be kept from view.

**VENTILATION**

Although nighttime breezes are slight, design for ventilation. Arrange floor plans for internal air movement, especially to cool thermal mass. Wholehouse fans, powered ventilation and economizer cycle systems are strongly recommended for accelerated night cooling.

**THERMAL MASS AND INSULATION**

Uninsulated Mass Construction: Vernacular house designs in hot, arid regions use low mass construction for sleeping areas, and high mass for daytime activity areas. These strategies also apply to other building types. The low mass zone is ventilated or is mechanically cooled off quickly at night, while the high massive zone has little window area and cools off slowly.

Uninsulated exterior mass delays the transfer of heat to the interior. Its usefulness depends on occupancy and space-conditioning schedules. For example, a masonry west wall can relieve an office building by delaying peak loads during business hours, but would be inappropriate for a west-facing bedroom. The delay rate of most mass materials is approximately 40 to 50 minutes per inch thickness. A completely shaded, uninsulated massive wall can do no better than maintain an average daily temperature near the outdoor average, unless the space is well ventilated at night. Uninsulated mass walls have low R values and generally are not economically suitable for heated and air-conditioned buildings. Insulating a mass wall in a composite construction is beneficial in most climates.

Adobe or rammed earth walls for thermal mass can be more expensive than poured concrete or concrete masonry units. Most economical may be full weight concrete block (not lightweight aggregate) with open cells filled by a weak sand or gravel grout to add mass and conductivity. Free-standing interior walls or partitions of mass materials allow thermal access to both sides, and they are protected from the elements (important if earthen materials).

Insulated Mass Construction: Insulation outside the mass has the greatest benefit. It reduces heat gain while allowing

the wall to discharge heat during nighttime ventilation. In winter it doubles usefulness with thermal storage for passive solar heat. Insulation also allows less mass to be used to reduce interior temperature swings. Calculation of the thermal dampening, delay rate and storage dynamics of composite walls is complex and benefits from computer modeling. A minimum of 2 in. thickness and a maximum of surface area can stabilize the interior environment, whether mechanically or passively conditioned.

Insulating inside the mass or adding mass outside an insulated frame wall (brick veneer) improves performance over either case alone. Both are inferior to outside insulation and slightly less effective than walls with integral insulation (masonry with core insulation). An ideal wall would have thermal mass on both surfaces with resistance insulation between. The optimal insulation and mass combinations vary with climate and conditioning hours of the building. Carpeting on the floor slab and the use of paper faced dry-wall reduces the immediate thermal effect of their mass. Lightweight wall construction, if used, should have minimum R-19.

**MECHANICAL EQUIPMENT**

Zone cooling for two or more units of mechanical equipment to provide comfort control, minimize duct lengths, and allow partial cooling when one unit is inoperative. Thermostat setbacks can be used to discharge the thermal mass at night when costs are lower. Place outdoor equipment away from doors and windows. Because of lower efficiencies, and defrost requirements below 45°F, heat pumps are not preferred. Multiple fuel heating and cooling units are recommended. Refrigeration units should have SEER above 10. (Supply ducts sized for silence have velocities below 600 fpm, for efficiency below 1000 fpm and never more than 1500 fpm.) Ducts should be inside the insulated building envelope.

Evaporative space coolers can provide comfort more than 90% of the cooling season at elevations above 1500 ft and more than 50% of the cooling season at elevations below 1500 ft throughout the Southwest. Operating costs for electricity and water are between 25 to 30% of refrigeration. Two stage evaporative units perform well in the most demanding locations at operating costs of 30 to 35% of refrigeration but cannot provide 100% comfort during peak humid times. Evaporative cooling requires exhaust, and security is a risk if open windows are used. Exhaust through chimneys or provide secondary cooling through barometric dampers to a vented attic or ducted to attached garages or sunspaces.

Multiple speed ceiling fans over seating and beds can add to comfort choices and extend the capacities of cooling systems by providing comfort at higher temperatures.

**CONSTRUCTION DETAILS**

1. Coolant and refrigerant pipes from remote evaporative towers and condensers should be insulated for their entire length.
2. Roof construction similar to the cold climate roof detail is also appropriate in hot locations.
3. Exposed wood (especially in small cross sections) and many plastics deteriorate from excessive heat and high ultraviolet exposure.
4. Although vapor barriers may not be critical to control condensation, they are important as a building wrap or wind shield, both to control dust penetration and to avoid convective leaks from high temperature differentials.
5. Avoid thermal bridges such as extensive cantilevered slabs.
6. Radiant barriers and details appropriate to humid overheated climates are at least as effective, but assembly must avoid holes where convection would leak their thermal advantage.
7. Ventilate building skin (attic or roof, walls) to relieve sol-air heat transfer.

**REFERENCES**

K. Clark and P. Paylore, *Desert Housing: Balancing Experience and Technology for Dwelling in Hot Arid Zones*, Office of Arid Land Studies, University of Arizona, Tucson.

J. Cook, *Cool Houses for Desert Suburbs*, Arizona Solar Energy Commission, Phoenix, 1984.

A. Olgyay and V. Olgyay, *Solar Control and Shading Devices*, Princeton, 1957.

S. Byrne and R. Ritschard, "A Parametric Analysis of Thermal Mass in Residential Buildings," LBL-20288, Lawrence Berkeley Laboratory, Berkeley, CA, 1985.

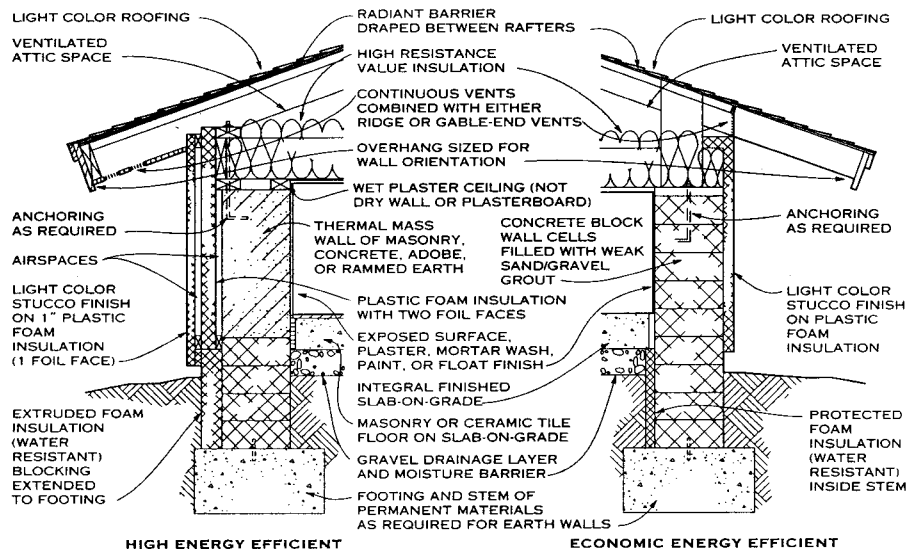

**TYPICAL WALL SECTIONS**

Donald Watson, FAIA; Rensselaer Polytechnic Institute; Troy, New York  
 Jeffrey Cook; Arizona State University; Tempe, Arizona  
 Kenneth Labs; New Haven, Connecticut



**STRATEGIES OF CLIMATE CONTROL**

Humid overheated conditions are most severe along the Gulf Coast, but occur across the entire southeastern U.S. Atmospheric moisture limits radiation exchange, resulting in daily temperature ranges less than 20°F. High insulation gives first priority to shading. Much of the overheated period is only a few degrees above comfort limits, so air movement can cool the body. Ground temperatures are generally too high for the earth to be useful as a heat sink, although slab-on-grade floor mass is useful. The strategies are to resist solar and conductive heat gains and to take best advantage of ventilation.

**MINIMIZE SOLAR GAINS**

1. Plant trees to shade roof and east and west walls.
2. Shape building to minimize solar load on envelope.
3. Shade all glazing during overheated period.
4. Shade north elevation in subtropical latitudes.
5. Use light-colored surfacing on walls and roof.

**MINIMIZE CONDUCTIVE GAINS**

1. Insulate envelope components in proportion to sol-air-indoor temperature difference.
2. Use radiant barrier in attic space.
3. Consider thermally massive envelope materials to reduce peak air-conditioning loads.
4. Use slab-on-grade instead of crawl space and insulate only at perimeter.

**PROMOTE VENTILATION LOSSES**

1. Orient building to benefit from breezes.
2. Use plantings to funnel breezes into building, but be careful not to obstruct vent openings.
3. Use wing walls and overhangs to direct breezes into building.
4. Locate openings and arrange floor plan to promote cross ventilation.

5. Plan interior for effective use of whole-house fan.
6. Ventilate building envelope (attic or roof, walls).

**SPACE VENTILATION**

"Air-change ventilation" brings outdoor temperatures indoors by breezes or whole-house exhaust fans. Whole-house fans yield about 20 air changes per hour (ACH) and are useful only as long as outdoor conditions are within comfort limits (72°-82°F). They may offer 30-50% savings in electricity costs over air conditioning. Whole-house fans do not provide high enough airflow rates for body ventilation. Ceiling (paddle) fans are recommended for air movement and can maintain comfort with indoor temperatures up to 85°F ET\*. Air conditioning is necessary above 85°F ET\*. The issue of when to ventilate and when to air condition is a function of building type, occupancy hours, heat and moisture capacity of the structure, and climatic subregion. Humidity is a factor, as night air may be cool but excessively humid.

**ROOFS AND ATTICS**

The attic should be designed to ventilate naturally. Most of the heat gain to the attic floor is by radiation from the underside of the roof. While ventilation is unable to interrupt this transfer, most of it can be stopped by an aluminum foil radiant barrier. Foil facings on rigid insulation and sheathing can be used as radiant barriers when installed facing an airspace.

Roof spray systems can dissipate most of the solar load, leaving the roof temperature near the ambient dry-bulb instead of the sol-air temperature. The theoretical lowest temperature that the roof can be cooled to by evaporation is the wet-bulb, but is not attainable under real daytime conditions. The cost-effectiveness of spray systems depends on the roof section, R value, building type, climatic region, and other factors. Spray systems are most advantageous for poorly insulated flat roofs.

**WALLS**

Radiant barriers enhance the performance of walls by reducing solar gain. They are most effective on east and west walls and are recommended for predominantly overheated regions (< 2000 heating degree days (HDD), > 2500 cooling degree days (CDD)). They are not recommended on south walls except where CDD exceed 3500. Radiant barriers must face an airspace and can be located on either side of the wall structure. Outside placement allows the cavity to be vented. This enhances summer wall performance, but admitting cold air degrades it during winter. Venting is recommended for regions having more than 3500 CDD. Discharging the cavity into the attic ensures best vent action. Thermal mass in walls reduces peak air-conditioning loads and delays peak heat gain. By damping off some of the peak load, massive walls help keep indoor temperatures in the range where ceiling (paddle) fans and airflow from cross ventilation provide comfort.

**DAYLIGHTING**

Windows and skylights should be shaded to prevent undesired heat gain. North- and south-facing glazing is shaded most easily for predictable daylighting. Light-colored reflective sunshades and ground surfaces will bounce the light and minimize direct gain. Cloudy or hazy sky conditions are a source of brightness and glare.

**REFERENCES**

1. S. Chandra et al. *Cooling with Ventilation*, Solar Energy Research Institute, Golden, CO, 1982.
2. K. E. Wilkes, *Radiant Barrier Fact Sheet*, CAREIRS, Silver Spring, MD.
3. P. Fairey, S. Chandra, A. Kerestecioglu, "Ventilative Cooling in Southern Residences: A Parametric Analysis," PF-108-86, Florida Solar Energy Center, Cape Canaveral, 1986.

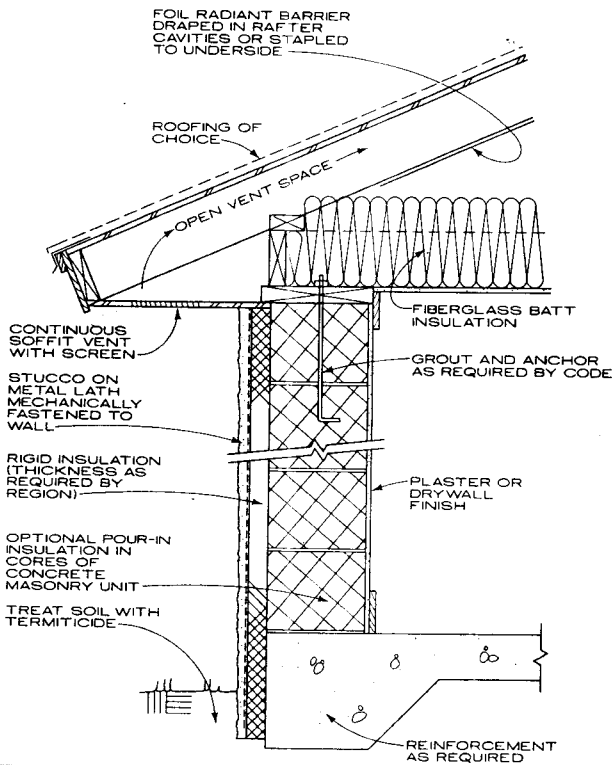

**ENERGY-EFFICIENT WALL SECTION: VENTED SKIN MASONRY WALL WITH INSIDE INSULATION**

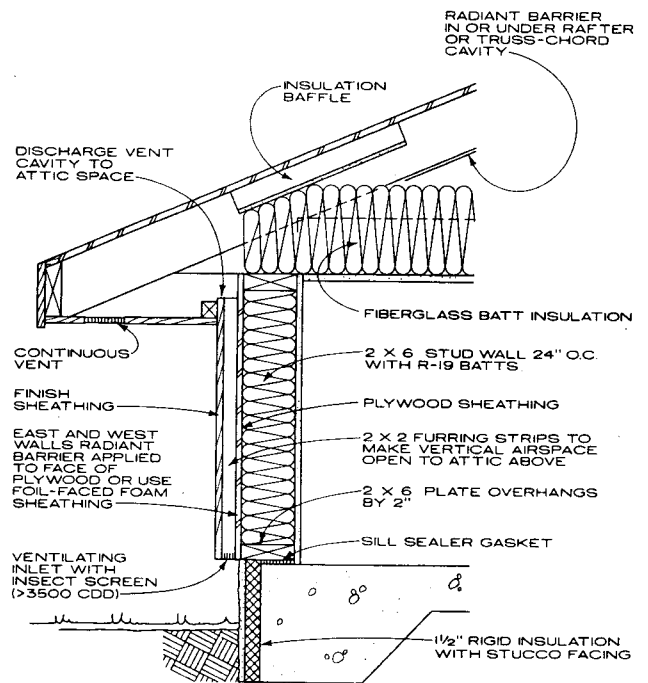

**ENERGY-EFFICIENT WALL SECTION: VENTED SKIN WALL WITH RADIANT BARRIER**

Donald Watson, FAIA; Rensselaer Polytechnic Institute; Troy, New York  
Kenneth Labs; New Haven, Connecticut

The term "alternate energy systems" describes uses of climatic resources—sun, wind, precipitation/humidity, and temperature—to provide all or part of the energy requirements of a building. Their development has paralleled the uncertain cost and availability of conventional energy supplies. New design concepts—passive solar and cooling and daylighting designs—have become part of recommended building practice. More advanced technologies have been developed, but their widespread use awaits either more experience with them or more penalizing energy prices. Some can be easily incorporated into a building design, requiring only careful design integration of architectural and heating, cooling, and lighting systems. A number of factors can change the economic constraints upon what is and is not cost-justified: the need for emergency preparedness, the prospect of interruptible or increasingly costly conventional fuel supplies, environmental pollution from fossil fuel combustion, and limited capacity of existing power plants. These concerns suggest that they be given full consideration together with energy conservation/load reduction techniques so that our long-term reliance upon conventional and nonrenewable energy sources can be minimized.

The practical approach to alternate energy system design begins with analysis of the energy requirement of the building "end use": the temperature, humidity, air flow, and lighting levels required for human comfort, and the related power demands for productive activity. The various sources for supplying heating, cooling, lighting, and electric power can then be matched to the end use in terms of "thermodynamic" efficiency, comfort, operational cost, and reliability. High levels of energy conservation and renewable energy use can make life-cycle economic gains possible, such as by downsizing mechanical system sizes or through "off-peak" loading of the building's energy requirement to reduce or eliminate "demand charges," as is possible when a building has a large energy storage system.

The figure diagrams the various alternate energy system components. The building itself is shown as an energy collection, storage, and distribution system. Choices include system components that are separate from the building (though presumably nearby) and those that must be integrated with it.

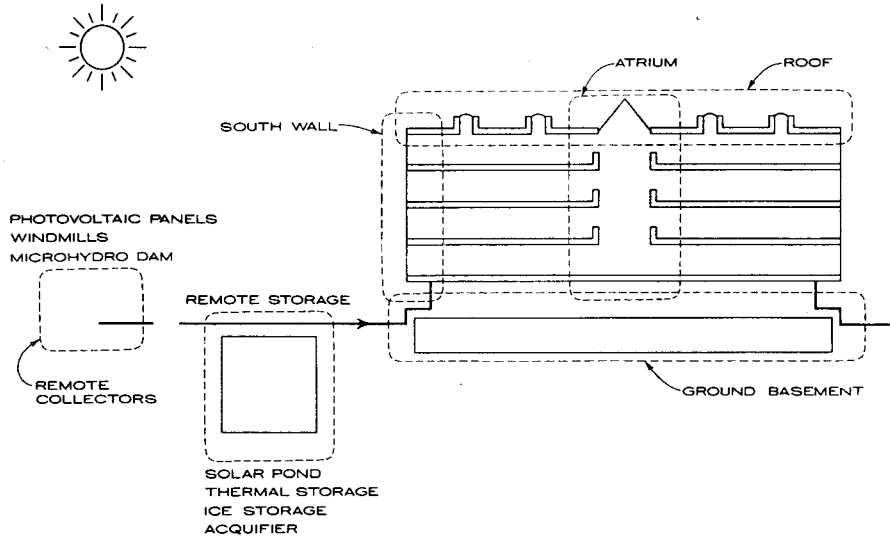

**SITE AND BUILDING AS ENERGY COLLECTION, STORAGE, AND DISTRIBUTION SYSTEM**

**REMOTE ENERGY COLLECTORS (ELECTRICAL)**

Three contenders for alternate electric power are windmills, microhydro dams, and photovoltaic panels. Photovoltaic systems use the photons of sunlight to generate electricity across a grid of cells in a solar collector. These can be mounted on the roof of a building or can be "remote," since electricity is easily distributed from its point of collection. Site engineering concerns are major, but building design criteria are minor, limited only to storage battery location and the electric distribution system within the building. The economic viability of these choices is greatly improved by reduction of the electric load requirement achievable by energy-efficient lighting and equipment.

**REMOTE ENERGY STORAGE (THERMAL)**

Energy storage near a building site has proved to be viable when the site is large enough, made part of seasonal (6-month) storage, and serves groups of buildings (district heating/cooling). These include:

**Underground thermal storage:** Heat generated by solar collectors (either air type or liquid type) can be stored within a large mass of earth, in existing caverns, or in newly dug clay or soil beds. In Kerava Solar Village near Helsinki, Finland, solar collectors mounted on the south-facing roofs of 44 apartments supply solar-heated water to a 400,000 gal water tank which in turn heats 338,500 cu ft of rock surrounding the tank embedded 66 ft in the earth.

**Acquifer systems:** A variation of thermal storage that is "charged" by solar collectors are systems using natural or man-made aquifers for seasonal storage, thus utilizing groundwater temperature for heating and cooling, generally relying upon a water-to-water heat pump to change the groundwater temperature to the end-use requirement for heating and cooling.

**Ice storage systems:** Ice storage systems use ice-making, either "seasonal" for 6-month storage or "diurnal," at night for next-day use, to provide building cooling. The advantage of making ice in winter is obvious, imposing

only the cost of a large storage area logically located within the subgrade basement of a building, but which can also be separate. Diurnal systems are cost-effective when there are advantages of "off-peak" utility rates and/or significantly cooler nighttime temperatures.

**Solar ponds:** Solar ponds are salt ponds that exploit the temperature gradient effect of salt water. First documented by Russian scientist von Kaledzinsky in 1902, water a few feet below a confined body of salt water reaches temperatures up to 185°F due to the varying salinity of the water: The bottom of the pond is a bed of salt in which heat is efficiently stored because heated salt-rich water does not rise, while the surface of relatively fresh water above is clear, allowing solar heat to be transmitted through it and at the same time insulating the denser layers below. In Israel and Australia, such solar ponds have been used as a source of thermal energy and to drive engines for electric generation. While only half as efficient as a solar collector, the relatively low cost of solar ponds (reportedly ten times less costly per unit of collector surface) indicates their potential.

**INTEGRATED BUILDING SYSTEMS**

A building designed to efficiently use climatic resources for heating, cooling, lighting, and electric power generation is properly considered an alternate energy system. Means for doing so are tabulated in the table and summarized below as a checklist for designers.

**South wall:** The south-facing wall of a building (in the Northern hemisphere) is an efficient energy resource. The low-angled winter sun can bring into a building interior the benefits of winter heat and light. Shading the south facade in summer can be efficiently accomplished with relatively short overhangs. Because of this, passive solar heating, summer shading, and year-round daylighting can

and ought to be made part of south-wall design. Solar heat can be stored in thermal storage placed in the sun behind glass or ducted/piped to the building interior.

**Roof:** The roof of a building can be used for mounting "active" solar collectors for heating, photovoltaic collectors for generating electricity, or skylights for daylighting. In hot climates, the roof is also an alternate energy resource if used for evaporative or radiant cooling.

**Atrium:** Atria design can be integrated into a "whole building" daylighting system and combined with the mechanical air movement system wherein it can economically replace ducting in ventilative cooling and heat recovery systems. Skylights, enhanced with light and heat reflectors, can be designed to reflect sunlight deep within a building.

**Below-ground/basement:** The below-ground construction of a building can be used for thermal storage, as described above. In single-storied or low-rise buildings, "ground coupling" utilizes the relatively stable temperatures of the surrounding earth to provide an economical heating/cooling flywheel effect.

**OTHER ENERGY FLOWS WITHIN A BUILDING**

Alternate energy design addresses all energy and resource requirements involved in building construction and use, including plant growth in interior and exterior gardens; water collection, purification, and reuse; and resource recycling and organic waste treatment/nutrient recovery. These energy flows, together with the ecological role of the surrounding landscape, are properly considered as biological system requirements of living efficiently within the limits of climate and environment.

**EXAMPLES OF ENERGY-EFFICIENT ARCHITECTURAL ELEMENTS**

ELEMENTS	HEATING	COOLING	LIGHTING
South wall	South-facing glass Trombe wall Sunspace	Reflective glass Sunshades	Venetian blinds Light shelf
Roof	Active solar collectors South-facing clerestories	Evaporative cooling Skytherm (radiant cooling)	Skylighting Photovoltaic collectors
Atrium	South-oriented glazing Storage mass in sun	Shaded courtyard Ventilating chimney	Light shaft Light reflectors
Ground/basement	Thermal storage	"Coolth" storage	

Donald Watson, FAIA; Rensselaer Polytechnic Institute; Troy, New York

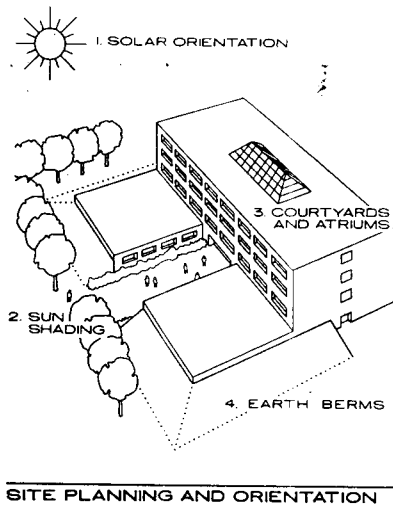

### ENERGY-CONSERVING DESIGN: NONRESIDENTIAL BUILDINGS

Energy-conserving design for nonresidential buildings is justified by savings in operating costs which result in a lower "life-cycle" investment. For large buildings of all types, the best opportunities are most likely to be found in electricity costs; depending upon the demand charges of the local utility, "peak load" reduction and/or "shifting" (diurnal or seasonal) measures may prove to be cost-effective. Concurrently, lower electric use by effective daylighting and by cooling load reduction (window orientation and solar controls) will be cost-effective, since these loads are typically interrelated and use expensive forms of energy. When these loads and costs are reduced, heating cost reduction by solar and energy-conserving techniques also applies to larger buildings. Energy-conserving opportunities are best addressed by a whole-systems team approach of architecture, HVAC, lighting, and controls engineering. For example, high levels of insulation or of thermal mass may be cost justified when these also result in substantially reduced mechanical system sizes and power requirements.

The architect should consider the following items in designing an energy-efficient nonresidential building, regardless of size and building type.

#### SITE PLANNING AND ORIENTATION

##### 1. ORIENT THE LONGER WALLS OF A BUILDING TO FACE NORTH-SOUTH

Walls that face the equator (e.g., the noonday sun) are ideal for windows oriented to admit daylighting with minimum cost for shading or sun control (i.e., relatively small horizontal overhangs create effective shading). Walls and windows facing east and west, on the other hand, are sources of undesirable overheating and are difficult to shade effectively. In a cool climate, windows facing the equator can gain useful wintertime heating from the sun. (See also "Daylighting" criteria.)

##### 2. PROVIDE SUN SHADING TO SUIT CLIMATE AND USE VARIATIONS

Buildings can be located in groups to shade one another. Landscaping and sun shading can be used to shade building surfaces, especially windows, during overheated hours. Functions can be located within a building to coincide with solar gain benefit or liability. For example, cafeterias are ideally exposed to noontime winter sun in cool and temperate climates or placed in the midday shade in warm climates; low-use areas (storage areas) can be used as climatic buffers placed on the east or west in hot climates or on the north in cool climates.

##### 3. CREATE COURTYARDS AND ENCLOSED ATRIUMS

Semienclosed courtyards (in warm climates) and enclosed atriums (in temperate and cool climates) can be formed by groups of buildings to provide areas for planting, shading, water fountains, and other microclimatic benefits. Atriums can also be used as light courts and

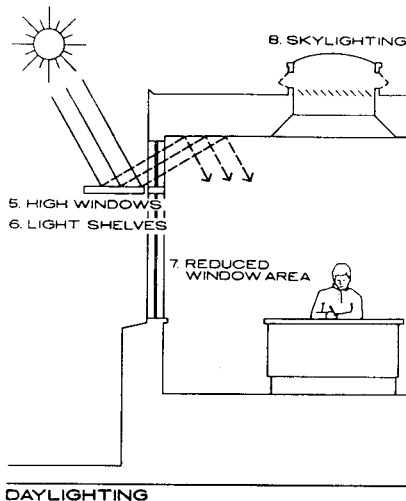

ventilating shafts. Indoor or outdoor planted areas provide evaporative cooling for local breezes when located near buildings.

##### 4. USE EARTH BERMS FOR CLIMATIC BUFFERING

Earth berms (sloped or terraced, formed simply by grading earth against the wall of a building) help to buffer the building against temperature extremes of both heat and cold. The planting on earth berms also provides evaporative cooling near the building. Earth berms can be construction cost savers because the foundation does not have to be as deep (in single-storied construction); the earth and ground cover is often less costly than other wall finishing materials. Its long-term maintenance can also be lower than conventional materials.

#### DAYLIGHTING

##### 5. PLACE WINDOWS HIGH IN THE WALL OF EACH FLOOR

Windows placed high in the wall near the ceiling provide the most daylight for any given window area, permitting daylight to penetrate more deeply into the interior.

##### 6. USE LIGHT SHELVES

Light shelves are horizontal projections placed on the outside and below a window to reflect sunlight into the interior. Typically placed just above eye level, the light shelf reflects daylight onto the interior ceiling, making it a light-reflecting surface (instead of a dark, shaded surface typical of a conventional interior ceiling). At the same time, the light shelf shades the lower portion of the window, reducing the amount of light near the window, which is typically overlit. The result is more balanced daylighting with less glare and contrast between light levels in the interior.

##### 7. SIZE WINDOWS ACCORDING TO USE AND ORIENTATION

Because window glass has little or no resistance to heat flow, it is one of the primary sources of energy waste and discomfort. Window areas should be shaded against direct solar gain during overheated hours. Even when shaded, windows gain undesired heat when the outdoor temperature exceeds the human comfort limit. Window areas should therefore be kept to a reasonable minimum, justified by clearly defined needs for view, visual relief, ventilation, and/or daylighting. Double glazing should be considered for all windows for energy efficiency and comfort in cool and temperate climates. In warm climates, double, tinted, or reflective glass should be considered, depending upon building size and use.

##### 8. USE SKYLIGHTING FOR DAYLIGHTING, WITH PROPER SOLAR CONTROLS

Skylighting that is properly sized and oriented is an efficient and cost-effective source of lighting. Consider that for most office buildings, sunlight is available for nearly the entire period of occupancy and that the lighting re-

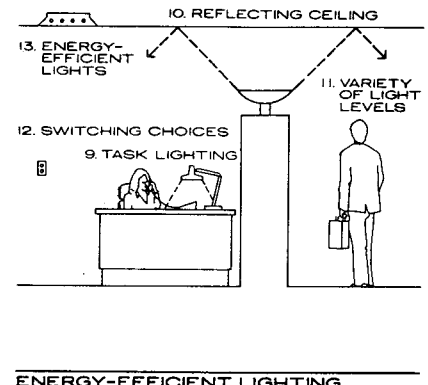

quirement for interior lighting is only about 1% of the amount of light available outside. Electric lighting costs, peak demand charges, and work interruptions during power brownouts can be greatly reduced by using daylight. Cost-effective, energy-efficient skylights can be small, spaced widely, with "splayed" interior light wells that help reflect and diffuse the light. White-painted ceilings and walls further improve the efficiency of daylighting (by as much as 300% if compared with dark interior finishes). Skylights should include some means to control undesired solar gain by one or more of the following means: (a) Face the skylight to the polar orientation; (b) provide exterior light-reflecting shading; (c) provide movable sunshades on the inside, with a means to vent the heat above the shade.

#### ENERGY-EFFICIENT LIGHTING

##### 9. USE TASK LIGHTING, WITH INDIVIDUAL CONTROLS

Lamps for task lighting are ideally located near the work surface and are adjustable to eliminate reflective glare. The energy-efficient advantages are that less light output is required (reduced geometrically as a function of its closer distance to the task) and the lamp can be switched off when not needed.

Note: General light levels should be reduced below conventional standards and sources of reflective glare from ceiling lights and windows eliminated in areas where cathode ray tubes (CRTs) are used.

##### 10. USE THE CEILING AS A LIGHT-REFLECTIVE SURFACE

By using "uplights," either ceiling pendants or lamps mounted on partitions and/or cabinets, the ceiling surface can be used as a light reflector. This has several advantages: (a) fewer fixtures are required for general area ("ambient") lighting; (b) the light is indirect, eliminating the sources of visual discomfort due to glare and reflection, (c) if light shelves are used, the ceiling is the light reflector for both natural and artificial light, an advantage for the occupant's sense of visual order.

##### 11. EMPLOY A VARIETY OF LIGHT LEVELS

In any given interior, a variety of light levels improves visual comfort. Light levels can be reduced in low-use areas, storage, circulation, and lounge areas. Daylighting can also be used to provide variety of lighting, thereby reducing monotone interiors.

##### 12. PROVIDE SWITCHING CHOICES, TO ACCOMMODATE SCHEDULE AND DAYLIGHT AVAILABILITY

Areas near windows that can be naturally lit should have continuous dimming controls to dim lights that are not needed. Other areas should have separate switching to coincide with different schedules and uses. Consider occupant-sensing light switches in areas of occasional use, such as washrooms, storage, and warehouse areas.

Donald Watson, FAIA; Rensselaer Polytechnic Institute; Troy, New York

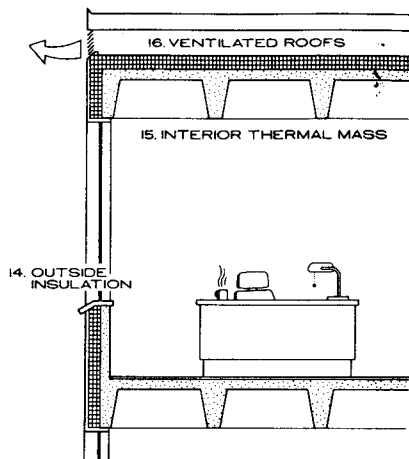

THERMAL CONSTRUCTION

## 13. USE ENERGY-EFFICIENT LIGHTS AND LUMINAIRES

Use the most efficient light source for the requirement: these might be fluorescent bulbs, high-intensity discharge lamps, or high-voltage/high-frequency lights. Compact fluorescent lights with high-efficiency ballasts have advantages of low wattage, low waste heat, long life, and good color rendering. Incandescent lights use less energy when switched on, so these are appropriate for occasional use and short-term lighting. Luminaires should also be evaluated for how efficiently they diffuse, direct, or reflect the available light.

## THERMAL CONSTRUCTION

## 14. PLACE INSULATION ON THE OUTSIDE OF THE STRUCTURE

Insulation is one of the most cost-effective means of energy conservation. Insulation placed on the outer face of a wall or roof protects the structure from the extremes of the outside temperature (with the added benefit of lengthening the life of the roof waterproofing membrane) and adds the massiveness of the structure to the thermal response of the interior (see Criteria 15). In localities where "resistance insulation" is not available, the combination of airspaces and high capacitance materials (such as masonry and/or earth berms) should be designed for effective thermal dampening or time lag (the delay and diffusion of outside temperature extremes that are transmitted to the interior). As an alternative to insulating roof structures in hot climates, a "radiant barrier" consisting of a continuous sheet of reflective foil with a low emissivity coating and an airspace around it serves as an effective shield against undesired heat gain.

## 15. UTILIZE THERMAL MASS ON BUILDING INTERIOR

In office buildings, thermally massive construction (such as masonry and concrete which have good heat storage capacity) benefits the energy-efficient operation of heating and cooling equipment as follows:

(a) Cooling benefits: Thermal mass absorbs the "overheating" that is inevitable in an office space due to the buildup of heat from people, equipment, lighting, rising afternoon temperature, and solar gain. The more thermal mass that is effectively exposed to an interior space (ceiling and walls), the greater is the saving on air conditioning in the afternoon, with the potential to delay the overheating until early evening when electric rates may be lower and/or outdoor air may be low enough to cool the mass by night ventilation. (The "night cooling" option is especially favorable in warm, dry climates due to predictably cooler nighttime temperatures.)

(b) Heating benefits: In temperate and cool climates, thermal mass helps absorb and store wintertime passive solar heat. This is especially effective if the thermal mass is on the building interior and directly heated by the sun (made possible by design of various corridor, stairway, and half-height partition arrangements).

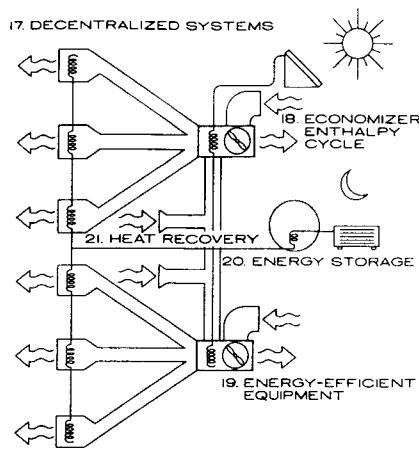

ENERGY-EFFICIENT MECHANICAL SYSTEMS

## 16. USE LIGHT-CONSTRUCTED VENTILATED ROOFS IN HOT CLIMATES

In hot climates, the roof is the primary source of undesired heat gain. Energy-efficient roof designs should be considered. One of the best for hot climates is a ventilated double roof wherein the outside layer is a light-colored and lightweight material which shades the solar heat from the inner roof, which should be well insulated. As described in Strategy 14, a "radiant barrier" can be considered as an alternative to resistance insulation to serve as a shield against thermal transfer through the ceiling portion of the roof structure.

## ENERGY-EFFICIENT MECHANICAL SYSTEMS

## 17. USE DECENTRALIZED AND MODULAR SYSTEMS

Heating and cooling equipment is most efficient when sized to the average load condition, not the "peak" or extreme condition. Use modular unit boilers, chillers, pumps, and fans in series so that the average operating load can be met by a few modules operating at peak efficiency rather than a single unit that is oversized for normal conditions. Zone the distribution systems to meet different loads due to orientation, use, and schedule. Use variable-air-volume (VAV) systems to reduce fan energy requirements and to lower duct sizes and costs (the system can be designed for the predominant load, not the sum of the peak loads). Decentralized air-handling systems have smaller trunk lines and duct losses. Dispersed air handlers, located close to their end use, can be reduced in size from conventional system sizes if hot and chilled water is piped to them (a decentralized air-handling system with a centralized plant).

## 18. USE ECONOMIZER/ENTHALPY CYCLE COOLING

Economizer/enthalpy cycle cooling uses outdoor air when it is cool enough for direct ventilation and/or when the outdoor air has a lower heat content than indoor air (so that it can be cooled evaporatively without raising indoor humidity). Although useful in all climates, direct or indirect evaporative cooling systems are especially effective in hot, dry climates.

## 19. USE ENERGY-EFFICIENT EQUIPMENT

The energy efficiency of mechanical equipment varies greatly. Consider heat pumps for cooling and for heating to replace separate chiller and boiler units. Heat pumps can also use local water sources or water storage (see Criteria 20 below). Newly developed mechanical heating equipment, such as gas-fired pulse combustion boilers, is achieving very high (up to 85%) annual operating efficiencies.

## 20. USE ENERGY STORAGE FOR COOLING

Chilled water storage has several advantages: It permits water chilling or ice-making at night under more favorable ambient conditions and possible lower electric rates;

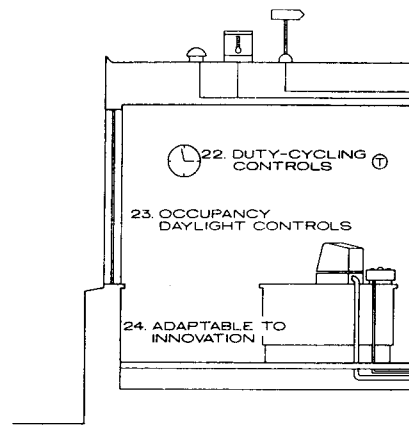

SMART BUILDING CONTROLS

perhaps more important, it reduces or eliminates peak-hour energy consumption, thereby reducing demand charges.

## 21. USE HEAT RECOVERY FOR HEATING

In cool and temperate climates, heat can be recovered from warm zones of a building and recirculated to underheated areas. Recoverable heat sources include equipment, process heat, and passive solar gain. Heat recovery wheels or coils can be used where indoor air needs to be ventilated, transferring heat into the incoming fresh airstream. In all climates, process heat or active solar heat (e.g., from solar collectors) can be used for domestic hot water or for tempering incoming fresh air.

## "SMART BUILDING" CONTROLS

## 22. USE SMART THERMOSTATS

"Duty-cycling" temperature controls can be programmed for different time schedules and thermal conditions, the simplest being the day-night setback. Newer controls are "predictive," sensing outdoor temperature trends and then selecting the system operation most appropriate to the condition.

## 23. USE OCCUPANCY- AND DAYLIGHT-SENSING LIGHTING CONTROLS

Automatic switching of lights according to the building occupant schedule and the daylight condition is recommended, with manual override for nighttime occupancy. Photosensors should be placed in areas that can be predictably lit by natural light.

## 24. BE PREPARED FOR RAPID INNOVATION IN BUILDING CONTROL SYSTEMS

Newly developing "smart" building systems include microprocessing for thermal and light control, fire and air-quality precautions, equipment failure, and operations/maintenance requirements (along with new communication and office management systems). These innovations require that electric wiring be easily changed, such as through "double-floor" construction.

## REFERENCES

- Burt Hill Kosar Rittelmann Associates: *Small Office Building Handbook*, New York: Van Nostrand Reinhold, 1985.
- Burt Hill Kosar Rittelmann Associates: *Commercial Building Design*, New York: Van Nostrand Reinhold, 1987.
- McGuiness, Stein, and Reynolds: *Mechanical and Electric Equipment for Buildings*, New York: John Wiley & Sons, 7th Edition, 1986.
- Solar Energy Research Institute: *Design of Energy-Responsive Commercial Buildings*, New York: John Wiley Interscience, 1985.
- Watson, Donald, editor: *Energy Conservation through Building Design*, New York: McGraw-Hill Book Company, 1979.

**ENERGY-EFFICIENT ATRIUM DESIGN**

In its original meaning, an atrium was the open courtyard of a Roman house. Today an atrium is a glazed courtyard on the side of or within a building. If issues of heating, cooling, and lighting are ignored, atrium designs can add significantly to the energy cost of the building as well as require above-average energy to maintain comfort within them. On the other hand, energy-efficient atrium spaces can contribute savings through natural lighting, passive heating, and natural cooling strategies. (Any multistoried space raises concerns for fire safety and requires special attention.)

Atrium spaces are more responsive to the influence of the outside climate than conventional buildings, and their design therefore will follow local climate requirements. Design also will depend on the specific function and goals of the atrium: to supply daylighting for itself or to adjacent spaces; to provide comfort for sedentary human occupancy or plants; or to serve only as a semiconditioned space for circulation. The challenge of energy-efficient atrium design is to combine various and perhaps conflicting requirements for passive heating, natural cooling, and daylighting using the geometry of the atrium, its orientation, and solar and insulation controls at the glazing surfaces. These architectural choices need to be integrated with the mechanical engineering to assure that the passive energy opportunities will in fact effectively reduce building energy use.

**PASSIVE SOLAR HEATING OPPORTUNITIES**

Atriums designed with large glass areas overheat during the day, providing potentially recoverable heat to parts of the adjacent building, such as its outer perimeter, which can be transferred by air or by an air-to-water heat pump. In cool climates and in buildings with a predominant heat load (such as a residential or hotel structure), using this solar heat gain can be cost-effective. In such a case, vertical glass facing the south captures winter sun while incurring minimum summer heat gain liability. If the atrium space requires sedentary occupant comfort, heat storage within the space and energy-efficient glazing also are beneficial.

**NATURAL COOLING OPPORTUNITIES**

To reduce required cooling in an atrium, protection from the summer sun is essential. Natural cooling can be accomplished by glass orientation, protective coatings as part of the glazing, and shading devices, which may or may not be movable. In hot, sunny climates, relatively small amounts of glass can meet daylighting objectives while reducing the solar gain liability. In warm, humid climates with predominantly cloudy skies (the sky is nonetheless a source of undesirable heat gain), the north-facing orientation should be favored for large glazed areas. Mechanical ventilation should facilitate the upward flow of natural ventilation. Spot cooling by air conditioning lower atrium areas is a relatively efficient means of keeping some areas comfortable for occupancy without fully conditioning the entire volume of air.

**DAYLIGHTING OPPORTUNITIES**

An atrium with the predominant function to provide natural lighting takes its shape from the predominant sky condition. In cool, cloudy climates, the atrium cross-section ideally would be stepped outward as it gets higher in order to increase overhead lighting. In hot, sunny locations with clear sunny skies, the cross-section is like a large lighting fixture designed to reflect, diffuse, and make usable the light from above. Daylighting design is complicated by the movement of the sun as it changes position with respect to the building throughout the day and the year.

**WINTERGARDEN ATRIUM DESIGN**

Healthy greenery can be incorporated in atrium design. The designer needs to know the unique horticultural requirements for the plant species for lighting, heating, and cooling, which could be quite different from those for human occupancy. Generally, plants need higher light levels and cooler temperatures than might be comfortable for humans. The most efficient manner to keep plants heated is with plant bed or root heating, as with water tubes or air tubes in gravel or earth. Plants also benefit from gentle air movement, which reduces excessive moisture that might rot the plants and circulates CO<sub>2</sub> needed for growth.

**RELATIVE IMPORTANCE OF DESIGN PRINCIPLES IN VARIOUS CLIMATES**

ATRIUM ENERGY-DESIGN PRINCIPLE	COLD/CLOUDY SEATTLE CHICAGO MINNEAPOLIS	COOL/SUNNY DENVER ST. LOUIS BOSTON	WARM/DRY LOS ANGELES PHOENIX MIDLAND, TX	HOT/WET HOUSTON NEW ORLEANS MIAMI
<b>HEATING</b>				
H1 To maximize winter solar heat gain, orient the atrium aperture to the south.	●	■	△	
H2 For radiant heat storage and distribution, place interior masonry directly in the path of the winter sun.		■	●	
H3 To prevent excessive nighttime heat loss, consider an insulating system for the glazing.	●	■		
H4 To recover heat, place a return air duct high in the space, directly in the sun.	■	●	△	
<b>COOLING</b>				
C1 To minimize solar gain, provide shade from the summer sun.		■	■	●
C2 Use the atrium as an air plenum in the mechanical system of the building.	■	■	■	■
C3 To facilitate natural ventilation, create a vertical "chimney" effect with high outlets and low inlets.	■	■	■	●
<b>LIGHTING</b>				
L1 To maximize daylight, use a stepped section (in predominantly cloudy areas)	■	△	■	■
L2 To maximize daylight, select skylight glazing for predominant sky condition (clear and horizontal in predominantly cloudy areas)	■			
L3 Provide sun and glare control	■	■	●	■

**KEY**  
 ● = Very important  
 ■ = Positive benefit  
 △ = Discretionary use

**REFERENCES**

William M. C. Lam's *Sunlighting as Forgivever for Architecture* (Van Nostrand Reinhold, 1986) discusses accurate scale modeling to calculate the daylighting contribution of a particular atrium or lightwell design.

"Sizing Atria for Daylighting" (unpublished ms., 1986), by

Virginia Cartwright, describes nomographs to estimate the daylight contribution from lightwells of various length, width, and height ratios.

Michael J. Bednar's *The New Atrium* (McGraw-Hill, 1986) discusses and provides examples of atrium design criteria, including energy, fire safety, circulation, and amenity.

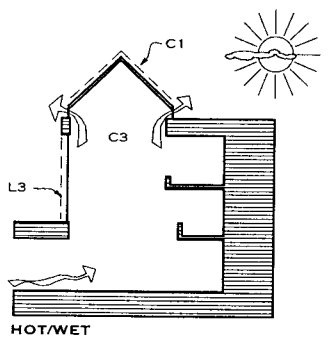
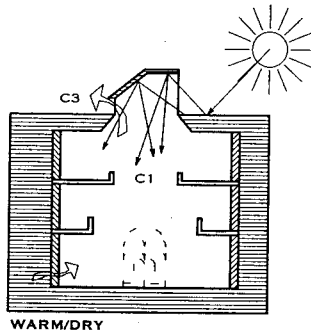
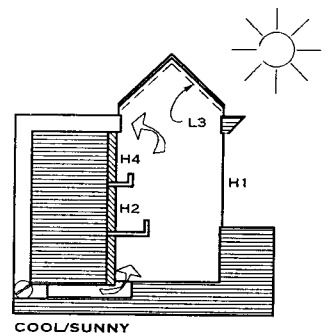
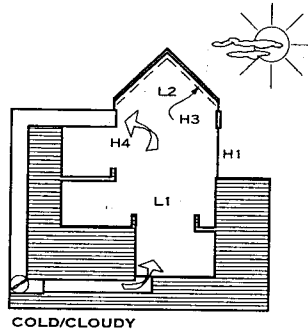

Donald Watson, FAIA; Rensselaer Polytechnic Institute; Troy, New York

## INTRODUCTION

This page concerns thermal storage applications for heating and cooling buildings and heating domestic or service water. Nearly 80% of the energy used in buildings is for these purposes. The discussion here focuses on thermal storage in materials that are not an integral part of the building structure.

### LIMITED CAPACITY HEATING/COOLING DEVICE

This includes applications where the momentary demand for heating/cooling exceeds the capacity of the heating/cooling device. In such cases thermal storage is used in conjunction with limited capacity heating/cooling equipment to meet peak demand.

### LOW-COST ENERGY

The availability of low-cost energy often does not coincide with the need. Thermal storage can be charged with low-cost energy when it is available and discharged when the stored energy is needed later. A conventional heating or cooling appliance may be used to augment stored energy. Waste heat from refrigeration equipment may be useful for heating service water. Because the demand for hot water may not coincide with the availability of waste heat, waste heat storage is required.

## APPLICATIONS

**Limited capacity appliance:** The most widespread application of thermal storage is probably that of storage-type electric resistance water heaters. A tank of water is heated by an electric resistance element that is not of sufficient capacity to heat the water during peak demand for hot water. However, enough hot water is stored so that when the peak demand occurs, there is sufficient hot water stored to satisfy demand.

By using thermal storage in conjunction with a smaller air-conditioning unit than would normally be used to handle a given cooling load, a substantial savings in operating costs can often be realized. The savings comes primarily from operating the unit at night. The lower heat rejection temperature at night means that the compressor does less work even though it accomplishes the same amount of cooling. Since the need for cooling is usually greatest during the day, the coolness generated at night must be stored for use during the day. Chilled water storage, ice reservoirs, and phase change materials are being used increasingly in buildings for coolness storage.

**Off-peak power:** Storage of warmth generated by off-peak power can effectively reduce operating costs. Off-peak power is often available from electric utility companies at a significantly lower cost than normal electric power. Energy storage is essential for the customer to satisfy their needs throughout the day when off-peak power is not available and yet realize the savings resulting from use of off-peak power. Off-peak rates are widely available for domestic water heating and to a lesser degree for space heating and air conditioning.

**Waste heat:** Without thermal storage, use of waste heat may not be feasible because waste heat is often not available when heating is needed. Heat that is normally dumped to the atmosphere from refrigeration condensers can be used to heat buildings and service water. A rapidly growing approach to waste heat recovery is the use of a heat exchanger in the refrigerant line leaving the compressor of an air conditioner.

The envelope and structure of many buildings are of sufficiently low mass that the amount of heat that can be stored in those components is so small as to be not worth the trouble. A wood-frame building is an example of a low-mass structure. A thermal storage chamber could be installed in the building to store coolness during the summer and to store heat during the winter. The chamber could be cooled during the summer by nighttime ventilation, by evaporative cooling, or by the nighttime operation of mechanical cooling equipment. During the winter the storage chamber could be heated by passive gain to the building.

**Active solar heat storage:** Thermal storage is usually an essential part of solar water and space heating systems. Solar heat is collected and stored during the day and released at night as needed. Commercial applications are similar.

## PRINCIPAL DESIGN CONCERNS

**Quality of thermal energy to be stored:** Energy to be stored must be available at a temperature level sufficient for it to be useful when needed.

**Suitability of storage media:** Certain thermal storage materials are more appropriate than others for a given thermal storage task. For example, a phase change material (PCM) with a phase change temperature of 150°F would be inappropriate for passive solar heating/cooling because the temperatures available for storage are not that high.

**Encouraging thermal gradients in the storage media:** A heat source that has a much higher temperature than the heat storage media will give up its heat to that storage much more readily than will a heat source that is close to the temperature of the storage media. A similar effect occurs with storage of coolness. The greater the temperature difference between the stored energy and that needed to satisfy the load, the less energy must be expended to satisfy the load.

**Interface with auxiliary heating/cooling system:** It is usually not cost-effective to size a thermal storage system to handle the entire load under all conditions. Some type of auxiliary system is therefore necessary to supplement the storage system. The two systems should be configured so that the thermal storage can be drawn upon first to satisfy the entire load. Once the quality of energy in the thermal storage has been depleted to the point that it is no longer practical to use alone, then the auxiliary system can be used to augment the flow of heat from the storage media. If the thermal storage is entirely depleted, then the auxiliary system can assume the entire load.

**When both thermal energy generated at off-peak rates and heat such as solar energy are to be stored,** the solar heat storage should be separated from heat produced by off-peak power. If they are not separated, the electric heaters, commonly used for off-peak storage, can heat the stored energy to a temperature level above which the solar collectors would collect little useful heat.

In instances where the cost of conventional energy does not vary with the time of day, the storage and auxiliary systems should be controlled so that the relatively inexpensive stored energy is consumed before the more expensive conventional fuel. This may not be the best practice where the cost of the conventional fuel varies with the time of day.

**Duration of thermal storage:** The duration over which warmth or coolness is stored is an important factor. At present, thermal storage is most often used in applications of several hours' to several days' duration.

**Choice of heat transfer fluid:** All other factors being equal, less energy is needed to transport the same amount of heat in a system using a liquid such as water than in a system using air; that is, the pumping energy used to move water is a fraction of the fan energy needed to move the same amount of heat with air. Often factors other than pumping costs will determine the fluid to be used.

## CHARACTERISTICS OF HEAT STORAGE MATERIALS

Thermal storage materials may be separated into sensible heat storage materials and phase change materials. Sensible heat storage materials such as water and rock change temperature as heat is added or removed, but they do not change in physical state. Phase change materials also change in temperature as heat is added or removed over a portion of their heating/cooling cycle, but at the temperature at which they change phase, heat can be added or removed without a change in temperature.

### SENSIBLE HEAT STORAGE MATERIALS

Both water and rock are commonly used sensible heat storage materials. Water may be contained by a tank, an aquifer, a cavern or mine, or a pond. Rock is most frequently used in pebble form. Heat is added to or removed from the water while it is in liquid form and added to or removed from rock in solid form. In some types of sys-

tems the same water used to store heat can also be used as the heat transfer fluid. This precludes the cost and inefficiency inherent with heat exchangers. Where water is used for thermal storage, thermal gradients can be encouraged by the choice and location of supply and return openings to the tank, by use of a diffuser to minimize mixing of fluid entering the tank, and by use of diaphragms, baffles, segmented tanks, or multiple tanks. Containers having a high ratio of height to diameter are also useful for encouraging stratification.

Water has a higher heat capacity than pebbles; thus the volume of water needed to store a given quantity of heat is about one-third of the volume of pebbles needed.

When air is the heat transfer fluid used to charge and discharge a pebble bed, no heat exchanger is required.

Where pebbles are used for thermal storage, temperature gradients can be developed easily and preserved by charging the bed with air moving through in one direction and discharging it with air moving through in the opposite direction. An alternative approach involves charging and discharging the bed with flow in one direction only. One-way flow significantly lessens the quality of heat available from the pebble bed and results in a considerable lag before recently added heat is available from the bed.

### PHASE CHANGE MATERIALS

Water is often used as a thermal storage medium for cooling buildings. If water is cooled to the freezing point, it changes phase and becomes ice. Once the water reaches its freezing point, then heat must be removed from the water until it has solidified before it can drop further in temperature.

Materials other than water exist which change phase at temperatures suitable for a variety of thermal storage applications. A given PCM can be selected because it has a phase change temperature that is suited for the temperature of the heat available to be stored and for the load.

As a PCM passes through its phase change point, it can absorb a great deal of heat. A PCM continues to absorb heat at a constant temperature until it has completely changed phase. Primarily due to their high heat capacity at the phase change temperature, PCMs store much more heat than can water or pebbles in the same volume. Thus, a phase change system takes up far less space in a building than does a sensible heat storage container to store the same quantity of useful heat.

The efficiency of a solar collector depends on the temperature difference between the collector and the surrounding air. The lower the temperature at which the collector must operate, the higher its efficiency. If a sensible heat storage medium is uniform in temperature because efforts were not made to encourage stratification, then the collectors will not operate as efficiently as they would if they were connected to a stratified storage. Since a PCM can absorb heat for a long time at the phase change point, a solar collector delivering heat to a PCM can often operate more efficiently than it would if it were delivering heat to a sensible heat storage container at a uniform temperature.

## SYSTEM SIZING

The variation of the load over time must be known or estimated. The temperature level of the energy needed to satisfy the load must be known. An estimate must be made of the amount of heat available for storage and of the temperature level of that heat.

A number of computer programs exist that can be used to estimate the heating and cooling load of residential and small commercial buildings. Several such programs are EEDO, CALPASS, SLR, and FLOAD. For large buildings the most well-documented, verified, and maintained computer program for building energy requirement estimating is DOE2.1c. The program has a separate thermal storage module that can be used for thermal storage studies.

### REFERENCE

For detailed information on thermal storage design, see R. L. Cole et al.: "Design and Installation Manual for Thermal Energy Storage," Argonne National Laboratory Report No. ANL-79-15, second edition, 1980.

**ENERGY ANALYSIS**

An energy analysis can be accomplished by a variety of techniques: manual, graphic, calculator, microcomputer, and mainframe computer. The purpose of energy analysis is to evaluate mathematically the energy required to maintain the interior environment of proposed or existing buildings and their support systems. When estimating energy needs of a proposed or existing building, it is necessary to account for the energy use in each of the following categories:

1. Offsetting heat losses through the building envelope (heating).
2. Offsetting heat gains through the building envelope (cooling).
3. Heating or cooling ventilation air.
4. Offsetting or using heat gain from occupants, lights, and process loads.
5. Offsetting or using solar gain.
6. Energy required for lights and miscellaneous use.
7. Motor loads for air movement and energy transfer.
8. Heating domestic hot water.
9. Energy used to reheat and recool.
10. Energy for humidification and dehumidification.
11. Energy for vertical, horizontal movement of people.
12. Miscellaneous—convenience outlets, etc.
13. Food service.

With the wide range of energy analysis tools available, it is important to select the appropriate tool for each design stage. Less sophistication is needed in the early design stages than in the final stages. To obtain maximum benefit from energy analysis, the process should start in the early schematic design stages. Following is a possible energy analysis sequence.

**SCHEMATIC DESIGN PHASE**

Calculated manually, graphically, or with simple computer programs, analysis in the schematic design phase should take into consideration building orientation and solar and daylighting impact on the energy required for heating, cooling, and lighting. The ideal analysis tool is a micro-computer program that permits the designer to incorporate more and more data about the building as the design progresses, without reentering previous data. Results of the schematic analysis should guide the designer in deciding on orientation, massing, and building configuration. The decision made in these early studies will have a major impact on optimum energy use in the final design.

**DESIGN DEVELOPMENT PHASE**

As design decisions become final and construction materials are selected, the energy analysis should be upgraded. The analysis procedure should allow adjustments for daylighting and building mass. Operating, occupancy, lighting, and motor profiles should be accommodated. Also to be considered are mechanical equipment responses and ventilation loads. As a minimum, the analysis procedure should include a variable base degree hour or bin factor for weather data.

**CONSTRUCTION DOCUMENT PHASE**

As the construction documents near completion, a more sophisticated analysis can be made. An hour-by-hour analysis can be made by a mainframe computer. The mechanical equipment can be modeled as it would respond to the hourly heating and cooling loads. Thus, energy wasted by mechanical systems is accounted for. Profiles of building operation, occupancy, lighting, etc. are adjusted to the final design, and the energy needs projection is close to that of the final building.

Energy analysis for existing buildings being modified or recycled can be done by any of the above procedures that track building operation, occupancy, lighting, ventilation, and motor profiles. This can be done by mainframe computers on an hour-by-hour analysis or by microcomputers using programs with a variable base degree hour or bin method of processing weather data. Existing buildings are easier to analyze than new buildings because operational profiles are known.

For an energy analysis to provide maximum benefit to the designer, the building's annual energy use should be broken down as in the example at right. As modifications are made, projected increase or decrease percentages should be shown.

EXAMPLE OF TOTAL ANNUAL ENERGY USE BY FUEL TYPE	ENERGY USE PER YEAR	PERCENT OF TOTAL	REDUCTION IN ENERGY USE	PERCENT OF REDUCTION
<b>ELECTRICITY (In kilowatt hours)</b>				
Cooling	42,424 KWH	(16.3%)	-16,753 KWH	(28.3%)
Lighting	150,573 KWH	(58.0%)		
Motor operation	58,829 KWH	(22.7%)	-21,598 KWH	(26.9%)
Miscellaneous power	7,781 KWH	(3.0%)		
<b>TOTAL ELECTRICAL USE</b>	<b>259,607 KWH</b>		<b>-38,351 KWH</b>	<b>(12.9%)</b>
<b>NATURAL GAS (In thousands of square feet)</b>				
Heating	1,397 MCF	(84.8%)	-1,863 MCF	(57.1%)
Domestic water heating	58 MCF	(3.5%)		
Food service	193 MCF	(11.7%)		
<b>TOTAL NATURAL GAS USE</b>	<b>1,648 MCF</b>		<b>-1,863 MCF</b>	<b>(53.1%)</b>
<b>BREAKDOWN OF TOTAL ANNUAL ENERGY USE</b>				
<b>HEATING (In millions of BTU)</b>				
Roof loss	877.8 MMBTU	(34.0%)	-719.0 MMBTU	(45.0%)
Wall loss	127.1 MMBTU	(4.9%)	-104.1 MMBTU	(45.0%)
Window loss	26.2 MMBTU	(1.0%)	-21.5 MMBTU	(45.0%)
Door loss	115.2 MMBTU	(4.5%)	-94.3 MMBTU	(45.0%)
Slab Edge loss	77.3 MMBTU	(3.0%)	-63.3 MMBTU	(45.0%)
Infiltration loss—doors	166.2 MMBTU	(6.4%)	-136.2 MMBTU	(45.0%)
Ventilation loss	0.1 MMBTU	(0.0%)	-812.9 MMBTU	(100.0%)
Morning warm-up	49.1 MMBTU	(1.9%)	+32.7 MMBTU	(200.0%)
<b>TOTAL</b>	<b>1,439.1 MMBTU</b>	<b>(55.7%)</b>	<b>-1,918.4 MMBTU</b>	<b>(57.1%)</b>
<b>COOLING (In millions of BTU)</b>				
Conduction solid surfaces	13.9 MMBTU	(0.5%)	-1.4 MMBTU	(9.0%)
Conduction glazed surfaces	2.9 MMBTU	(0.1%)	-0.3 MMBTU	(9.0%)
Solar gain	27.8 MMBTU	(1.1%)	+0.3 MMBTU	(1.1%)
Ventilation gain	0.1 MMBTU	(0.0%)	-55.8 MMBTU	(99.9%)
Lighting gain	39.0 MMBTU	(1.5%)	+1.3 MMBTU	(3.4%)
Equipment gain	4.1 MMBTU	(0.2%)		
Occupant gain	35.7 MMBTU	(1.4%)	+1.6 MMBTU	(4.7%)
Air handler gain	21.4 MMBTU	(0.8%)	-2.8 MMBTU	(11.5%)
<b>TOTAL</b>	<b>144.8 MMBTU</b>	<b>(5.6%)</b>	<b>-57.2 MMBTU</b>	<b>(28.3%)</b>
<b>LIGHTING (In millions of BTU)</b>	<b>513.9 MMBTU</b>	<b>(19.9%)</b>		
<b>MOTOR OPERATION (In millions of BTU)</b>	<b>200.8 MMBTU</b>	<b>(7.8%)</b>	<b>-73.7 MMBTU</b>	<b>(26.9%)</b>
<b>DOMESTIC WATER HEATING (In millions of BTU)</b>	<b>60.0 MMBTU</b>	<b>(2.3%)</b>		
<b>MISCELLANEOUS USE (In millions of BTU)</b>				
Convenience electric power	26.6 MMBTU	(1.0%)		
Food Service	198.3 MMBTU	(7.7%)		
<b>TOTAL</b>	<b>224.8 MMBTU</b>	<b>(8.7%)</b>		
<b>TOTAL ANNUAL ENERGY USE (In millions of BTU)</b>				
70,147 BTU/per sq. ft.	2,583.4 MMBTU	<b>TOTAL</b>	<b>-2,049.3 MMBTU</b>	<b>(44.2%)</b>

**ANALYSIS PROCEDURE CAPABILITY AT VARIOUS DESIGN STAGES**

CONCEPT	ANALYSIS MODE	DESIGN STAGE		
		SCHEMATIC	DESIGN	CONSTRUCTION
Orientation	M,G,MC	X	X	X
Solar	M,G,MC	X	X	X
Daylighting	M,G,MC	X	X	X
Configuration	G	X	X	X
Mass	MC	X	X	X
Oper. profiles	M,MC	X	X	X
Occup. profiles	M,MC	X	X	X
Light. profiles	M,MC	X	X	X
Motor profiles	M,MC	X	X	X
Mech. response	MC,MF			X
Hourly analysis	MF			

M = Manual MC = Microcomputer  
G = Graph MF = Mainframe

**COMPONENTS OF ENERGY USE IN BUILDING**

COMPONENT	ENERGY LOADS			IMPACT TOTAL
	HEATING ENERGY	COOLING ENERGY	OTHER ENERGY	
Building envelope	+	+		+
Solar gain	-	+		+ or -
Ventilation	+	+		+
Occupants	-	+		+ or -
Lights	-	+		+
Motors	-	+	+	
Domestic hot water	0	0	+	+
Reheat	+	0		+
Recool	0	+		+
Humidification	+	0		+
Dehumidification		+		+
Vertical and horizontal movement of people	0	0	+	+

+ Add to load  
- Reduces load  
0 Has no impact

Huber H. Buehrer, AIA, PE; Buehrer Group, Maumee, Ohio

**PASSIVE SOLAR DESIGN**

Passive solar heating and cooling systems, which rely on natural energy flow through and around a building, are divided into three generic categories, including:

1. **DIRECT SYSTEMS:** Heat is collected directly within the space or, for cooling, lost or dissipated directly from the space.
2. **INDIRECT SYSTEMS:** Heat gain or loss occurs at the weatherskin.
3. **ISOLATED SYSTEMS:** Heat gain or loss occurs away from the weatherskin. Cooling, for example, can include induced air precooled from the earth's mass using air to earth heat exchangers ("coolth" tubes) or cooling ponds. Systems can be combined depending on thermal needs.

**SPACE HEATING CONCEPTS**

As part of any passive system's development, energy conservation elements should be considered. With passive solar heating, minimizing and preventing heat loss is fundamental to ensure that the heating system is most effective. These elements include adequate insulation, building orientation, surface-to-volume ratios, and appropriate materials, texture, and finish choices. The space heating success depends on adequate solar energy collection, storage, distribution, and control, all of which occur by natural, nonchemical means using the three basic heat transfer processes: conduction, convection, and radiation. Efficient passive system operation often involves some user control to alter or override energy flows within a building or at its weatherskin.

1. Solar collection surfaces generally are transparent or translucent plastics, fiberglass, or glass oriented in a southerly direction. Material degradation can be caused by solar exposure and other weather elements. Insulating these collection areas to control nighttime loss is especially important in extreme climates.
2. Thermal storage materials include concrete, brick, sand, tile, stone, and water or other liquids. Phase change materials such as eutectic salts and paraffins also are feasible. Storage should be placed to receive maximum solar exposure, either directly or indirectly. Adequate thermal storage capacity allows the sun's heat to be absorbed and retained until it is needed, and it helps to reduce internal temperature fluctuations.
3. Heat distribution occurs naturally by conduction, convection, and radiation. Generally, fans and other mechanical energy distribution equipment are avoided; however, sometimes they are required for fine-tuned operations.
4. Control mechanisms such as vents, dampers, movable insulation, and shading devices can assist in balanced heat distribution.

**SPACE COOLING CONCEPTS**

Passive solar cooling, like passive heating, tempers interior space temperatures using natural thermal phenomena. A structure designed for natural cooling should incorporate features that reduce external heat gains and dissipate internal heat gains, including adequate insulation, overhangs, shading, orientation, surface color and texture, proper ventilation, and similar factors. When possible, external heat gain should be controlled before it reaches or penetrates the weatherskin.

When cooling is necessary, heat dissipation is accomplished by cooling interior thermal mass, air, or both with conduction, convection, and radiation. Evaporation in hot arid regions and dehumidification in hot humid regions are primary cooling design concerns. Many passive cooling concepts and methods exist:

1. **Site cooling:** through vegetative control, water bodies, and adjacent land forms and materials.
2. **Earth cooling:** by using groundwater or the earth's mass with earth sheltering or "coolth" tubes.
3. **Radiative cooling:** heat loss to the sky or cooler objects.
4. **Ventilative cooling:** cross ventilation through spaces, double roofs, attics, or walls, induced or forced ventilation by pressure or temperature differences.
5. **Vapor cooling:** evaporative cooling to remove sensible heat, dehumidification to remove latent heat.
6. **Flywheel cooling:** cooling by internal thermal mass or rockbeds.

**PASSIVE SOLAR TYPES**

		HEATING	COOLING
DIRECT SYSTEMS	<b>DIRECT GAIN/LOSS</b> Direct gain is the most common passive solar building approach; most structures use it to some degree. Collection and storage are integral with the space. Southerly oriented glazing (collector) admits winter solar radiation to the space beyond. Thermal storage, incorporated within the building structure, absorbs solar energy. During the cooling season, windows, walls, and roofs can be operable or openable for natural or induced ventilation, cooling both the mass and space.		
	<b>THERMAL STORAGE WALL — MASS WALL</b> Thermal storage walls are based on a "sun to mass to space" concept. Collection and storage are separated from the space, but linked thermally. Energy is transferred by conduction through the wall, then by radiation to the space. A mass wall can be vented during the day, if warranted, to the interior by a convective heat flow. (If vents are used, then the mass wall is often referred to as a Trombe wall.) In the mass wall system, storage usually is in masonry or concrete directly behind the south glazing. Mass walls should be vented to the exterior and shaded during summer months.		
INDIRECT SYSTEMS	<b>THERMAL STORAGE WALL — WATER WALL</b> Water wall systems use a liquid, often held in barrels or tubes directly behind south-facing glass acting as the thermal storage medium. Solar radiation is absorbed by the contained water. This energy is released gradually as needed to the interior. Potential water problems are corrosion and bacteria and algae growth. A water wall should be shaded or vented to the exterior during cooling periods. Provide freeze protection where required.		
	<b>ROOF POND</b> In a roof pond system the liquid storage mass is in the ceiling or roof. During heating seasons, insulation panels are moved to expose the storage mass to the sun in the day. Energy is absorbed by the roof pond. At night the panels are replaced over the storage, allowing stored heat to radiate to the building's interior. The process is reversed in summer. The roof pond, insulated from the high summer sun during the day, absorbs the building's internal heat. At night the insulation is opened to allow stored heat to radiate to the sky.		
ISOLATED SYSTEMS	<b>SUNSPACE</b> In sunspace designs, solar collection and primary thermal storage often are isolated from living spaces, although variations are possible. The solar system functions independently of the building interior, although heat can be drawn from the sunspace as needed. (Thermal storage in the living area is classed as an indirect system.) Even on clear winter days sunspaces may overheat sometimes because of large glazed areas. For cooling, the sunspace can be used to induce a convective flow from the exterior, and should be shaded, preferably on the exterior.		
	<b>THERMOSIPHON</b> Thermosiphon, natural convection systems, rely on the rise and fall of heated and cooled elements such as air. As temperatures change, air moves without mechanical assistance. When the sun warms a collector surface, warm air rises. Simultaneously cooler air is pulled from the storage bottom, causing a natural convection loop. Heat is convected into the space or stored in the thermal mass until needed. In cooling seasons, collectors may be used as a thermal chimney. Warm air rises, inducing precooled air from the ground or other source up through the storage mass to cool it.		

Dennis A. Andrejko, AIA; Andrejko & Associates; Williamsville, New York



### PASSIVE SOLAR HEATING—DESIGN PROCEDURE

The focus of this section is on winter heating between U.S. latitudes 32°N and 48°N. The following design and calculation procedure is applicable to

1. Building types that have space heating requirements dominated by heat loss through the exterior skin of the building.
2. Buildings with a small internal heat contribution from lights, people, and equipment such as residences, small commercial, industrial, and institutional buildings, and large daylight buildings whose internal heat gain is only a small portion of their total heating requirement.

Passive solar heating systems are integral to building design. The concepts relating to system operation must be applied at the earliest stages of design decision making.

Passive systems demand a skillful integration of all the architectural elements within each space—glazing, walls, floor, roof, and in some cases even interior surface colors. The way in which the glazing and thermal mass (heat storage materials, i.e., masonry, water) are designed generally determines the efficiency and level of thermal comfort provided by the system. Two concepts are critical to understanding the thermal performance of passively heated space. They are

1. That the quantity of south glazing, insulating properties of the space, and the outdoor climatic conditions will determine the number of degrees the

average indoor temperature in a space is above the average outdoor temperature on any given day ( $\Delta T$ ).

2. That the size, distribution, material, and in some cases (direct gain systems) surface color of thermal mass in the space will determine the daily fluctuation above and below the average indoor temperature (see Figure 1).

Calculating heat gain and loss is a relatively straightforward procedure. The storage and control of heat in a passively heated space, however, is the major problem confronting most designers. In the process of storing and releasing heat, thermal mass in a space will fluctuate in temperature, yet the object of the heating system is to maintain a relatively constant interior temperature. For each system, the integration of thermal mass in a space will determine the fluctuation of indoor temperature over the day.

#### EXAMPLE

In a direct gain system, with masonry thermal mass, the major determinant of fluctuations of indoor air temperature is the amount of exposed surface area of masonry in the space; in a thermal storage wall system, it is the thickness of the material used to construct the wall. The following is a procedure for sizing both direct gain and thermal storage wall systems.

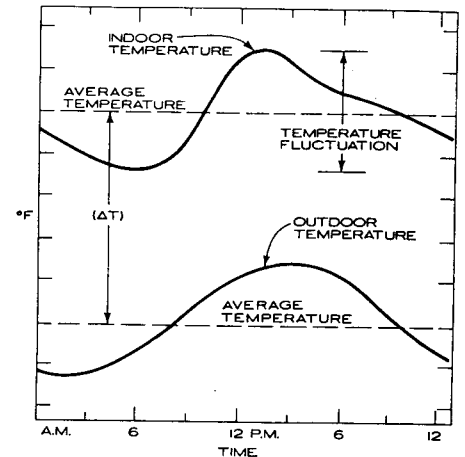

FIGURE 1  
DAILY TEMPERATURE FLUCTUATION

### DIRECT GAIN

Direct gain systems are characterized by daily fluctuations of indoor temperatures, which range from only 10°F to as much as 30°F. The heating system cannot be turned on or off, since there is little control of natural heat flows in the space. To prevent overheating, shading devices are used to reduce solar gain, or excess heat is vented by opening windows or activating an exhaust fan.

The major glass areas (collector) of each space must be oriented to the south ( $\pm 30^\circ$ ) for maximum solar heat gain in winter. These windows can serve other functions as well, such as openings for light and for views.

Each space must also contain enough mass for the storage of solar heat gain. This implies masonry in the building, but the masonry can be as thin as 4 in. in cold climates and 1½–2 in. in very mild climates.

**SOUTH GLAZING:** One criterion for a well-designed space is that it gains enough solar energy, on an average sunny day in winter, to maintain an average space temperature of  $\pm 68^\circ\text{F}$  over the 24-hr period. By establishing this criterion, it is possible to develop ratios for the preliminary sizing of south glazing. Table 1 (see next page) lists ratios for various climates and locations.

In a direct gain system, sunlight can also be admitted into a space through clerestories and skylights as well as vertical south-facing windows. This approach may be taken (1) for privacy, (2) because of shading on the south

facades, (3) because spaces are located along facades other than south, and (4) to avoid direct sunlight on people and furniture. Use the following guidelines when designing clerestories and skylights:

1. **CLERESTORY:** Locate the clerestory at a distance in front of interior mass wall of roughly 1 to 1.5 times the height of the clerestory above the finished floor. Make the ceiling of the clerestory a light color to reflect and diffuse sunlight down into the space. In regions with heavy snowfall, locate the sill of the clerestory glazing 18 in. or more above the roof surface (see Figure 2, next page).
2. **SAWTOOTH CLERESTORIES:** Make the angle (as measured from horizontal) equal to or smaller than the altitude of the sun at noon on December 21, the winter solstice. Make the underside of the clerestories a light color (see Figure 3, next page).
3. **SKYLIGHT:** Use a south-facing or horizontal skylight with a reflector to increase solar gain in winter, and shade both horizontal and south-facing skylights in summer to prevent excessive solar gain (see Figure 4, next page).

**THERMAL STORAGE MASS:** The two most common materials used for storing heat are masonry and water. Masonry materials transfer heat from their surface to the interior at a slow rate. If direct sunlight is applied to the surface of a dark masonry material for an extended period of time, it will become uncomfortably hot, thereby

giving much of its heat to the air in the space rather than heat conducting it away from the surface for storage. This results in daytime overheating and large daily temperature fluctuations in the space. To reduce fluctuations, direct sunlight should be spread over a large surface area of masonry. To accomplish this:

1. Construct interior walls and floors of masonry at least 4 in. in thickness.
2. Diffuse direct sunlight over the surface area of the masonry either by using a translucent glazing material—placing a number of small windows so that they admit sunlight in patches—or by reflecting direct sunlight off a light-colored interior surface first (see Figure 5, next page).
3. Use the following guidelines for selecting interior surface color and finishes:
  - a. Masonry floors of a medium to dark color.
  - b. Masonry walls of any color.
  - c. Lightweight construction (little thermal mass) of a light color to reflect sunlight onto masonry surfaces.
  - d. No wall-to-wall carpeting over masonry floors.

By following these recommendations, one can control temperature fluctuations in the space on clear winter days to approximately 10°–15°F. These temperature fluctuations are for clear winter days and for at least 6 sq ft of exposed masonry surface area for each square foot of south glazing.

### THERMAL STORAGE WALLS

The predominant architectural expression of a thermal storage wall building is south-facing glass. The glass functions as a collecting surface only and admits no natural light into the space. However, windows can be included in the wall to admit natural light and direct heat and to permit a view.

Either water or masonry can be used for a thermal storage wall (a masonry thermal storage wall with thermocirculation vents is often referred to as a Trombe wall). Since the mass is concentrated along the south face of the building, there is no limit to the choice of construction materials and interior finishes in the remainder of the building.

**SOUTH GLAZING:** The criterion for a double-glazed thermal storage wall is the same as for a direct gain sys-

tem—that it transmit enough heat on an average sunny winter day to supply a space with all its heating needs for that day. Tables 1 and 2 (see next page) list guidelines for sizing the glazing of masonry or water walls, respectively.

**WALL DETAILS:** While the procedure above gives guidelines for the overall size (surface area) of a thermal storage wall, the efficiency of the wall as a heating system depends mainly on its thickness, material, and surface color. (See Table 3, next page.) If the wall is too thin, the space will overheat during the day and be too cool in the evening; if it is too thick, it becomes inefficient as a heating source, since little energy is transmitted through it.

The choice of wall thickness, within the range given for each material in Table 3 (see next page), will determine the air temperature fluctuation in the space over the day. As a general rule, the greater the wall thickness, the smaller the indoor fluctuation. Table 4 (see next page) can be used to select a wall thickness.

The greater the absorption of solar energy at the exterior face of a thermal wall, the greater the quantity of incident energy transferred through the wall in the building. Therefore, make the outside face of the wall dark (preferably black) with a solar absorption of at least 85%.

Edward Mazria, AIA, Architect; Edward Mazria & Associates; Albuquerque, New Mexico

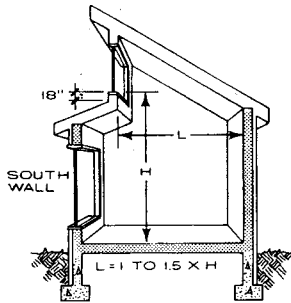

FIGURE 2. CLERESTORY

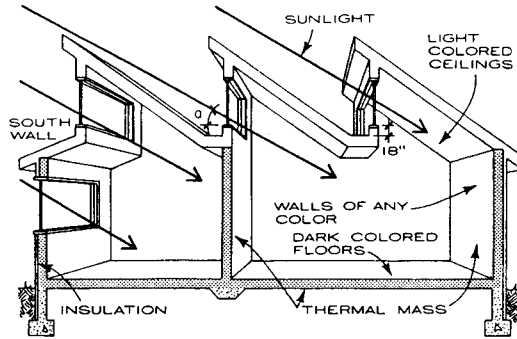

FIGURE 3. SAWTOOTH CLERESTORIES

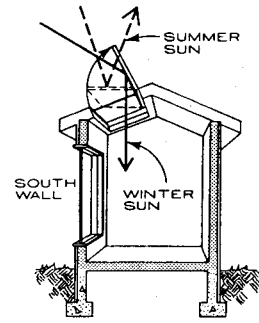

FIGURE 4. SKYLIGHT

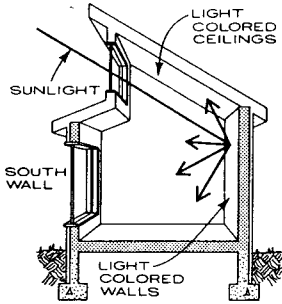

FIGURE 5. REFLECTING DIRECT SUNLIGHT

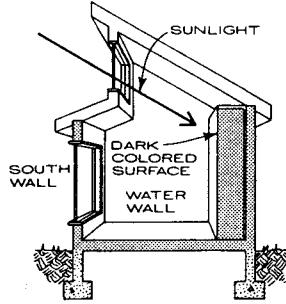

FIGURE 6. WATER WALL

**DIRECT GAIN SYSTEMS**

**TABLE 1. SIZING SOLAR GLAZING FOR DIRECT GAIN, VENTED TROMBE WALL, AND WATER WALL SYSTEMS**

AVERAGE WINTER TEMPERATURE (CLEAR DAY)	SQUARE FEET OF GLAZING NEEDED FOR EACH SQUARE FOOT OF FLOOR AREA			
	36°F NL		44°F NL	
	LOW HEAT LOSS	HIGH HEAT LOSS	LOW HEAT LOSS	HIGH HEAT LOSS
<b>Cold climates</b>				
20°F	0.23	0.46	0.30	0.60
25°F	0.18	0.37	0.23	0.46
30°F	0.15	0.30	0.17	0.34
<b>Temperate climates</b>				
35°F	0.12	0.23	0.13	0.26
40°F	0.09	0.18	0.10	0.20
45°F	0.06	0.13	0.08	0.15

- NOTES**
- 1. Convective connections to building.
  - 2. Temperatures listed are for December and January (usually the coldest months) and are monthly averages.
  - 3. Low heat loss: Space with a net load coefficient (NLC)
  - 4. High heat loss: Space with an NLC = 6 Btu/day/sq ft/°F. A space with a large amount of exposed external surface area.
  - 5. The NLC is the total building heat loss less the loss through the solar aperture.
- = 3 Btu/day/sq ft/°F. A space with little exposed external surface area.

**TABLE 2. SIZING SOLAR GLAZING FOR UNVENTED MASONRY THERMAL STORAGE WALL SYSTEMS**

AVERAGE WINTER TEMPERATURE (CLEAR DAY)	SQUARE FEET OF GLAZING NEEDED FOR EACH SQUARE FOOT OF FLOOR AREA			
	36°F NL		44°F NL	
	LOW HEAT LOSS	HIGH HEAT LOSS	LOW HEAT LOSS	HIGH HEAT LOSS
<b>Cold climates</b>				
20°F	0.33	0.66	0.43	0.85
25°F	0.30	0.60	0.35	0.70
30°F	0.26	0.52	0.30	0.60
<b>Temperate climates</b>				
35°F	0.20	0.40	0.23	0.46
40°F	0.15	0.30	0.17	0.34
45°F	0.12	0.23	0.13	0.26

- NOTES**
- 1. No convective connections to building.
  - 2. Temperatures listed are for December and January (usually the coldest months) and are monthly averages.
  - 3. Low heat loss: Space with a net load coefficient (NLC)
  - 4. High heat loss: Space with an NLC = 6 Btu/day/sq ft/°F. A space with a large amount of exposed external surface area.
  - 5. The NLC is the total building heat loss less the loss through the solar aperture.
- = 3 Btu/day/sq ft/°F. A space with little exposed external surface area.

**TABLE 3. SUGGESTED MATERIAL THICKNESS FOR INDIRECT GAIN THERMAL STORAGE WALLS**

MATERIAL	RECOMMENDED THICKNESS
Brick (common)	10 to 14 in.
Concrete (dense)	12 to 18 in.
Water	6 in. or more

**NOTE:** When using water in tubes, cylinders, or other types of circular containers, have a container of at least a 9 1/2 in. diameter or holding 1/2 cu ft (31 lb, 3.7 gal) of water for each one square foot of glazing.

**TABLE 4. APPROXIMATE SPACE TEMPERATURE FLUCTUATIONS AS A FUNCTION OF INDIRECT GAIN THERMAL STORAGE WALL MATERIAL AND THICKNESS**

MATERIALS	THICKNESS (IN.)					
	4	8	12	16	20	24
Brick (common)	—	24°	11°	7°	—	—
Concrete (dense)	—	28°	16°	10°	6°	5°
Water (31°F)	—	18°	13°	11°	10°	9°

**NOTE:** Assumes a double glazed thermal wall. If additional mass is located in the space, such as masonry walls and/or floors, then temperature fluctuations will be less than those listed. Values are given for clear winter days.

Edward Mazria, AIA, Architect; Edward Mazria & Associates; Albuquerque, New Mexico

**PRINCIPLES**

Thermal storage wall systems are solar space heating devices that can also be used for space cooling in some climates. They consist generally of south-facing massive walls, an airspace, and are then sealed to the exterior by a glass or plastic glazing system. As solar radiation is transmitted through the glazing material, the wall is heated during sunlit hours; in turn the heated wall then radiates warmth to the interior space during the night. Additional components can be added to enhance cold climate performance, such as selective surface foils, night insulation systems, reflectors, and exterior vents to control overheating in mild climates.

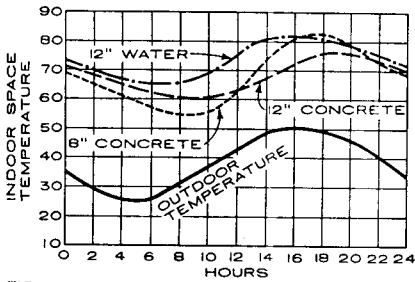

FIGURE 1

**WALL PERFORMANCE**

Figure 1 illustrates the characteristic performance of three thermal storage walls during one clear January day 24-hr cycle in a well-insulated house with 1/2 sq ft of wall for each square foot of room area, located in the U.S. Pacific Northwest. The two thicknesses of concrete wall shown in the graph demonstrate that by adding wall depth the resulting fluctuation in interior space temperature is reduced, and wall peak temperature is shifted toward the night hours when heat is most needed. Also it can be seen that by using a water wall with the same volume as the 12 in. concrete wall, the response of the wall to solar heating is enhanced; however, maximum heat transmission to the building interior occurs earlier in the evening when less heat is needed.

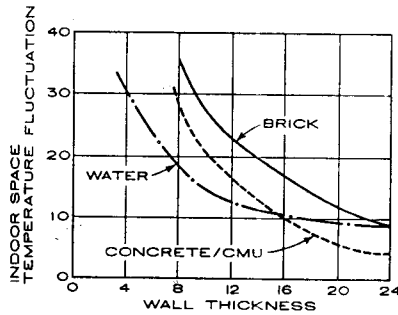

FIGURE 2

**TEMPERATURE FLUCTUATION**

Figure 2 illustrates space temperature fluctuations that can be expected for a one-day cycle using three different wall materials of varying thicknesses and the same design conditions as depicted in Figure 1. The wall types shown are solid brick, concrete or concrete masonry units grouted solid, and water.

**WALL AREA VS. FLOOR AREA**

Figure 3 gives rule of thumb guidelines for surface area of storage wall, using a wall thickness of between 8 and 18 in., compared to square feet of floor area to be heated for four latitudes. Example: Find the required wall area for a 250 sq ft room located at 40° north latitude with an average outdoor temperature of 34°F during the coldest winter month. On the "Y" axis find 34°, move right on the graph to the 40° latitude line, and then down the graph to the "X" axis, finding the wall vs. floor ratio of 0.45. Multiply 0.45 times the floor area of 250 sq ft, for a suggested wall area of 112.5 sq ft.

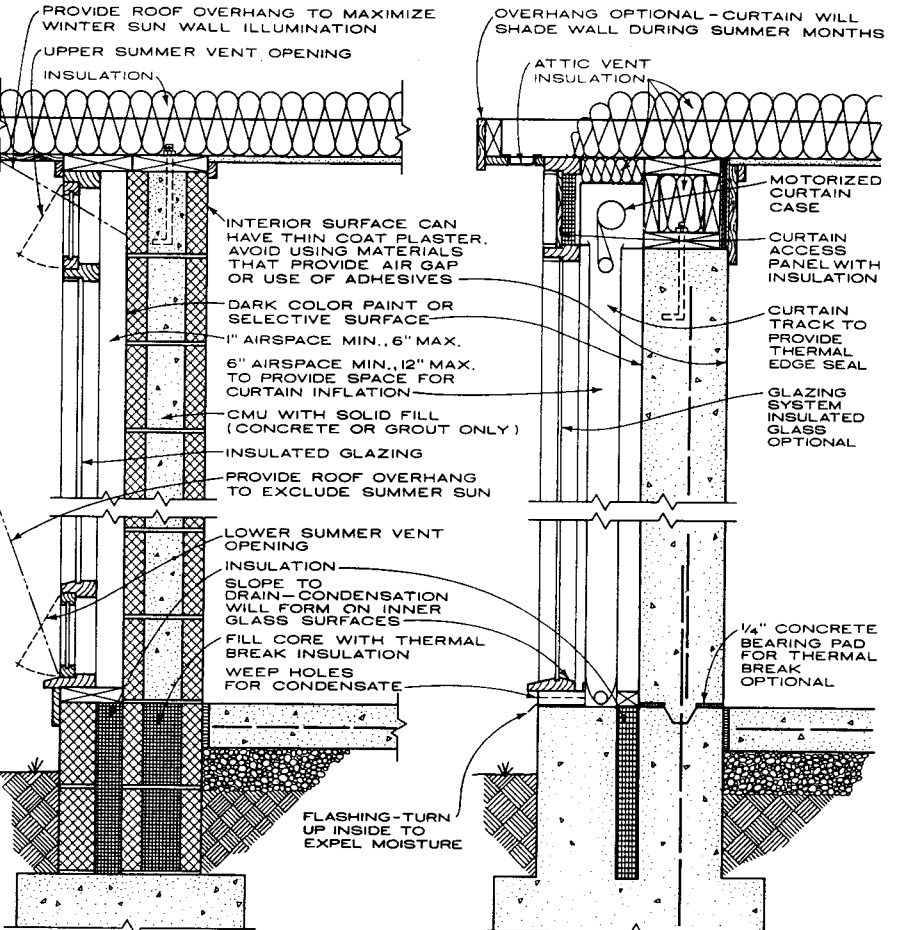

MASS WALL WITH OUTSIDE VENTING

MASS WALL WITH INSULATED CURTAIN

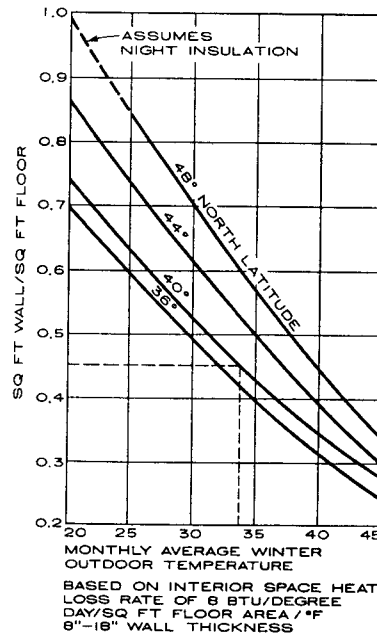

FIGURE 3

**WATER WALLS**

Thermal storage walls of the water container type are generally designed as an integral part of the heated space. Fiberglass, plastic, glass, or metal containers can be used; however, if steel is used, a rust inhibitor should be added to the water, and in all cases algicide should be added to prevent algae growth. Water containers are also manufactured that fit within wood-framed walls and appear as translucent windows from the interior or that can be covered with dry wall.

**INTERNAL MASS**

Mass thermal walls can also be used within rooms that are directly heated by solar radiation entering through windows (direct gain system), but where the wall is not directly illuminated by the sun. In this application the wall acts as a heat sink, absorbing excess spacial heat during sunlit hours and giving back heat during the night, reducing spacial temperature swings. As a rule of thumb, provide internal mass wall area at the rate of six times the direct gain window area.

**COOLING**

The use of thermal storage walls for cooling involves the isolation of the wall from the exterior and, in particular, solar radiation during the sunlit hours, then exposing the wall surfaces to air jets of cool night air either by forced or natural ventilation to reduce the wall's internal temperature. The wall then functions as a heat sink during the warm hours the following day, to absorb internal spacial heat, thereby maintaining comfortable indoor temperatures.

W. Fred Roberts Jr., AIA; Roberts & Kirchner Architects; Lexington, Virginia

## SOLAR RADIANT ENERGY

Solar energy reaches the earth's surface in the form of electromagnetic radiation in the wavelength band between 0.3 and 3.0 micrometers ( $\mu\text{m}$ ). Beyond the earth's atmosphere, at the average earth-sun distance (about 93 million miles) the radiant flux density on a surface normal to the solar rays is now thought to be 1377 W/sq m or 437 Btu/hr · sq ft. This quantity, known as the solar constant, is apparently subject to minor fluctuations caused by small changes in the sun's output of shortwave (ultraviolet) radiation. An earlier value, 1353 W/sq m or 429.2 Btu/hr · sq ft continues to be widely used pending further measurements from outer space.

At the surface of the earth, solar irradiance falling on horizontal surfaces varies from zero at sunrise to a maximum that, at sea level, may be as high as 325 Btu/hr · sq ft (945 W/sq m) at noon on a clear day. The intensity falls to zero again at sunset. Clear day irradiance values for horizontal and tilted surfaces with varying orientations are given in ASHRAE Publication GRP 170. Values for average day conditions can be found in "Hourly Solar Radiation Data for Vertical and Horizontal Surfaces on Average Days in the United States and Canada" published by the National Bureau of Standards in their Building Science Series 96. A wealth of data on horizontal irradiance is to be found in the "Climatic Atlas of the U.S." and in the publications of the National Weather Service, Asheville, NC. Methods of estimating direct, diffuse, and reflected radiation are given in Chapter 26, 1977 ASHRAE Handbook of Fundamentals.

## SOLAR COLLECTION AND UTILIZATION

Solar radiant energy can be put to use at low and moderate temperatures by flat plate collectors, Figure 1, in which a blackened sheet of metal is used to absorb the incoming radiation and convert it to heat. This heat is then conducted to a fluid that passes through tubes or passages integral with or attached to the plate. To minimize loss of heat from the absorber plate, glazing (single or double, with glass or a heat resistant plastic) is used to reduce convection and to suppress longwave radiation exchange with the sky. The rear surface of the collector plate is insulated carefully, preferably with glass fiber that can withstand the relatively high temperatures (300 to 400°F) that can exist under "stagnation" conditions. This occurs when the collector is exposed to full sunshine with no heat transfer fluid flowing through it. The entire unit is contained within a weatherproof box, and connecting pipes or ducts are provided to bring the fluid to the collector and to carry it away after it has been heated. Details of many types of flat plate collectors are given in Chapter 58, 1978 ASHRAE Handbook of Applications. Performance calculations and test data are given in ASHRAE Publication GRP 170.

When high temperatures are required for industrial or power generation applications, concentrating collectors must be used. These reflect or refract a large amount to solar energy onto a relatively small absorber area, thus reducing the surface available for heat loss and enabling the fluid to attain temperatures that can exceed 1000°F. Such collectors must "track the sun" because they can use only the direct beam radiation from the solar disk. Some concentrating collectors remain essentially fixed, but these are limited to concentration ratios of less than 3 : 1.

## SOLAR ENERGY UTILIZATION SYSTEMS

A system for using solar energy consists of an array of collectors, a storage subsystem, and another subsystem, which is generally quite conventional, for distributing the heated fluid and returning it to storage. Pumps or fans are used to circulate the heat transfer fluid, and control devices are used to start and stop the circulators. Auxiliary or standby heat sources are generally needed to carry part of the load when demand is exceptionally heavy and the thermal storage is depleted due to long periods of unfavorable weather.

Figure 2 shows a simple system for providing space heating and domestic hot water, using a drain-down procedure in which the collectors are emptied whenever the pump P1 stops. A differential controller senses the temperatures of the collector plate and the water and starts the circulating pump P1 when the sun has heated the plate above the water temperature. The pump is stopped when the plate temperature drops to

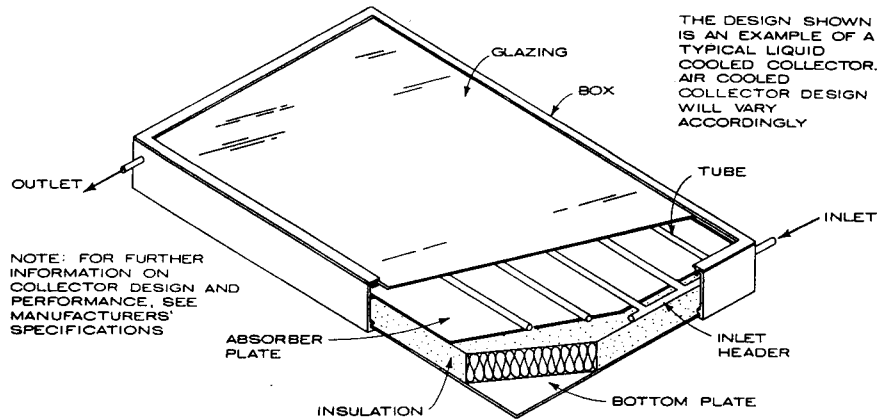

FIGURE 1. TYPICAL FLAT PLATE COLLECTOR

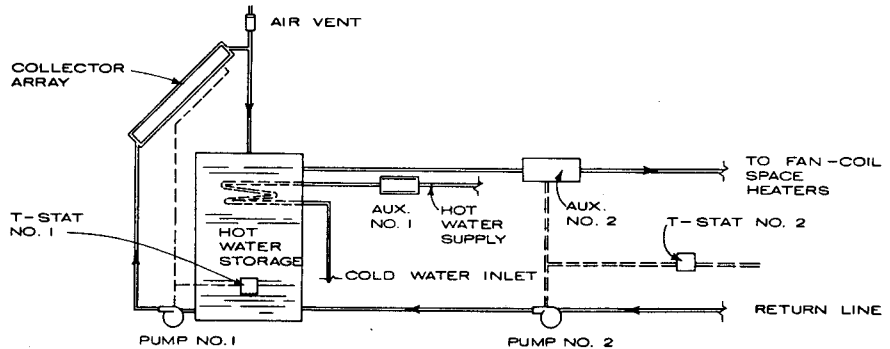

FIGURE 2. DRAIN-BACK SOLAR WATER SYSTEM

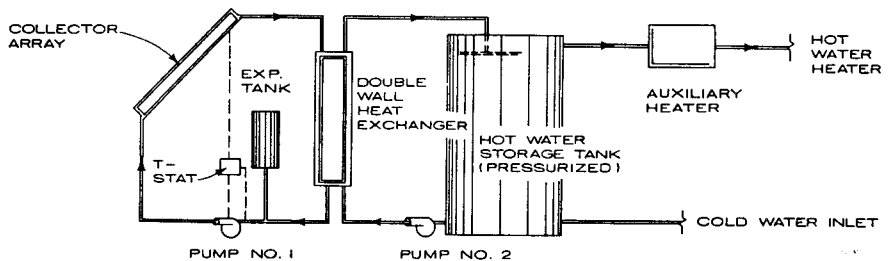

FIGURE 3. SOLAR WATER HEATING SYSTEM

the point where collection of heat is no longer possible.

Domestic hot water is provided by a pipe coil or a small tank located near the top of the main storage tank. The domestic hot water system operates under full line pressure whereas the main tank is at essentially atmospheric pressure, so any leakage would normally be into the main tank. Because of the very remote possibility of a back flow from the main tank into the city water supply, some plumbing codes require a double wall heat exchanger for this service. An auxiliary heater is provided to ensure an adequate supply of hot water at all times.

Since solar heat collection systems work more efficiently when the temperature difference between the collector and the ambient air is relatively low, fancoil units with large areas of finned tube heat transfer surface are generally selected for the space heating assignment. These can be used with water temperatures as low as 100°F. The auxiliary heat source in many solar installations will be electricity, and the heater may use simple direct resistance elements. When cooling is required as well as heating, a heat pump may

prove to be a wise choice, particularly when large amounts of auxiliary energy are likely to be needed.

## FREEZE PROTECTION FOR LIQUID SYSTEMS

When water is used as the heat transfer fluid, freeze protection must always be provided, since there is no location within the continental United States where freezing has never been known to occur. The drain-down system shown in Figure 2 is a fail-safe method to provide such protection but it has certain disadvantages that, in many applications, make the use of a freezing point depressant advisable. Figure 3 shows a widely used system in which water plus ethylene glycol or propylene glycol, or some similar antifreeze fluid, is circulated through the collector array by pump P1. A double wall heat exchanger is used to transfer the collected heat to the service hot water which is under full line pressure, and a standby heater is provided to raise the temperature of the sun heated water to the conventional 140°F. Since domestic hot water is rarely actually used at 140°F, it is beneficial to use a lower thermostat setting for the hot water and to use less cold water for dilution.

**AIR SYSTEMS**

Air collectors carry serious limitations, primarily because the temperatures that they deliver are low and the space requirements for air ducts are high. Air collectors can be appropriate, however, for applications requiring low process heat or involving the regeneration of desiccant material for dehumidification.

The key issue in air system design is to minimize air leakage in areas where cold outside air is present—between collectors, for example, or in uninsulated chases. One effective installation approach entails mounting the collectors integrally with the roof and keeping all duct connections below the roof. Air collectors have also been mounted on flat roofs, at an angle, with housings erected to protect the back of the collector enclosures and their ductwork. Steps should always be taken to prevent exposure of collector connections and ductwork to the weather.

An air system's heat storage container should allow air moving to and from the container to circulate through the entire storage mass, without "short-circuiting." The container should be adequately insulated, and all joints—especially around the top—should be tightly sealed. Do not install a drain at the bottom of the container; it might provide access for animals, insects, or odors.

The system's fan and duct configuration must allow for the delivery of heated air directly from collectors to load, from collectors to storage, and, indirectly, from storage to load. This requires two pairs of interconnected dampers. Solar fan components that provide integral fan dampers and controllers are available. If a coil is to be used to heat water, it should be located beyond the fan to minimize any chance of its freezing.

These issues, reviewed here as a checklist for architects, have been thoroughly documented. Correction measures can be incorporated into the specification, manufacture, and installation of active solar collection systems.

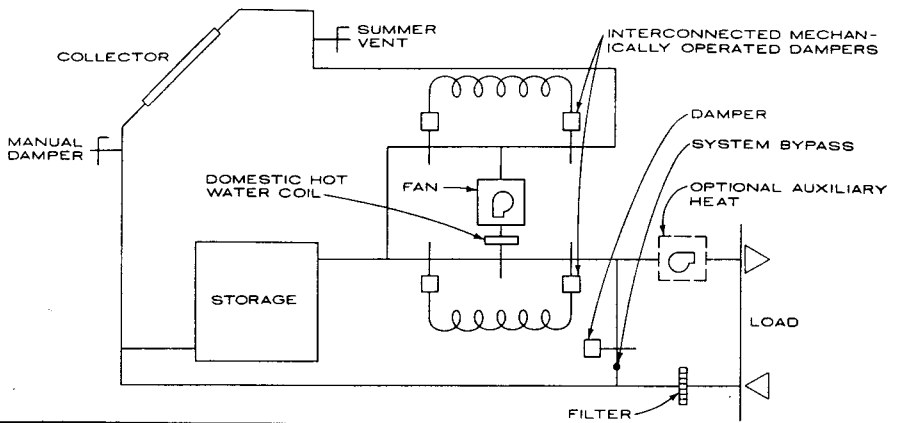

**AIR SYSTEM**

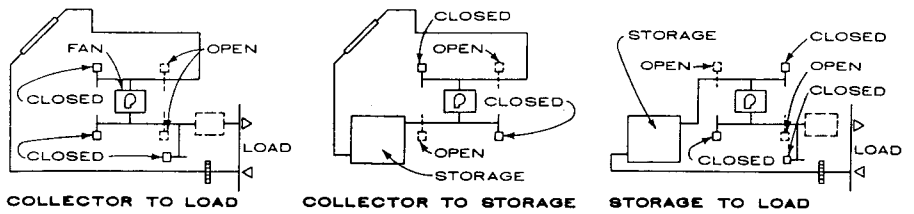

**AIR SYSTEM MODES**

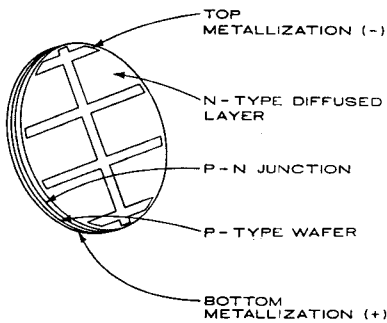

**PHOTOVOLTAIC CELL**

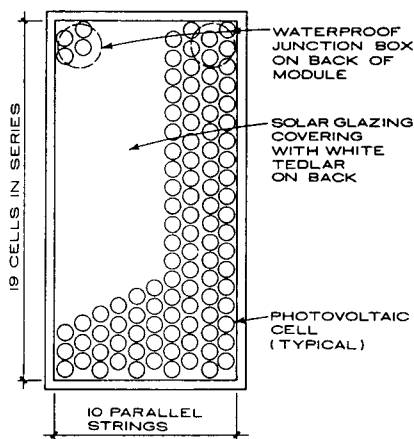

**PHOTOVOLTAIC MODULE**

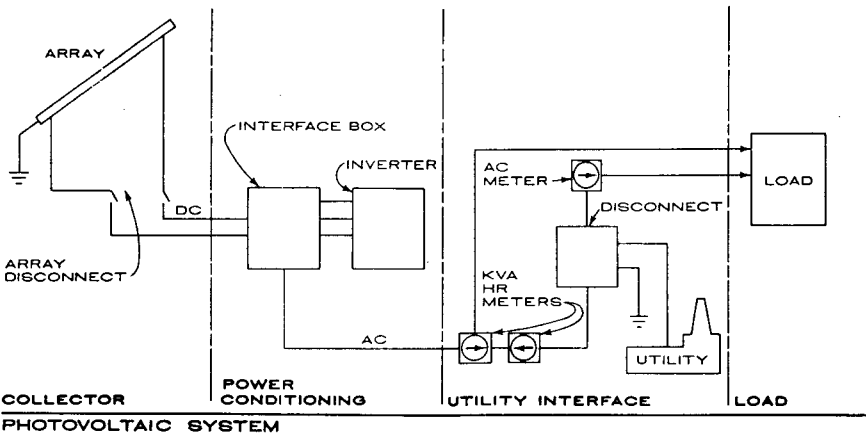

**PHOTOVOLTAIC SYSTEM**

**PHOTOVOLTAIC SYSTEMS**

Photovoltaic (PV) solar systems convert sunlight into direct current. Their rapidly decreasing cost may well make them competitive within the next decade with some sources of electricity. At present, however, the lack of cost-effective battery storage limits common PV system applications to the public utilities, which are uniquely capable of both supplying additional energy and purchasing excess energy.

The basic collection component of a PV system is the photovoltaic cell, a layered semiconductor that is generally fashioned from crystalline silicon. A group of cells, usually interconnected both in series and parallel, is encapsulated to form a module. An array is an assembly of modules.

The major factors considered in the sizing of a PV array are its anticipated loads and its power conditioning system (PCS) capacities. The design of an array depends on the module to be installed. Since no single module provides the commonly required voltage, several modules must be installed in series to achieve the proper voltage; groups of similar modules are then connected in parallel to provide the required amperage. The design of an array must facilitate this grouping of modules in series and parallel.

Modules can be installed in three ways: integrally (replacing the sheathing and roofing); applied (set directly on the sheathing, as roofing, or directly on the roofing itself); and standoff, or rack mounted (above the roof and either parallel or at an angle to it). The primary installation considerations are the tilt and orientation of the roof and the vent requirements of the module. The latter consideration can seriously affect system efficiency. Modules are adversely affected by heat, losing approximately ±0.003% efficiency for each degree Fahrenheit rise in temperature. Applied installations, therefore, are less efficient, because the modules are unable to discharge heat. Rack mounting, which allows air to circulate freely behind the modules, is often the most efficient installation technique. Some PV systems capture the heat discharged by the modules and supply it directly to interior spaces as heated air or exhaust it directly to the exterior; in these installations, the collectors are attached and ducted as they would be in an air collector system.

The major component of the PCS is the inverter, which converts the DC power generated by the array into AC power used by the load. The PCS also synchronizes the PV array's power output to make it compatible with the local utility company's output. The number of available PCS capacities is limited and is thus a controlling factor in the sizing of PV systems.

Stephen Weinstein, AIA; The Ehrenkrantz Group; New York, New York

The design of a solar collector array and its support structure can have an important influence on overall building appearance and be a key determinant of the total cost of the solar heating system. It is also the aspect of the system that the architect can most easily control.

Because there are no industry standards for collector size, piping, or mounting hardware, it is essential that the architect know which collector system will be installed before he or she begins final detailing and design. If the collector array is to be selected as part of a total bid package, for example, sizing and coordination problems may result, and the architect may lose control of the array's structural underpinnings and the building's overall appearance.

**ANCHORING THE SUPPORT STRUCTURE**

Rooftop collector supports should be anchored directly to structural members, not to wood or metal decking; otherwise, wind-induced uplift forces and point loading may cause roofing—and possibly structural—failure. In steel buildings, vertical supports must be secured directly to joists or beams. In wood buildings, securing the collector supports directly to structural members will normally require the installation of some form of blocking, under the decking and between rafters, to transfer the load.

**DESIGNING THE ARRAY**

When a collector array is to be placed on a light steel-framed roof, the direction of the joints in the array's support structure becomes a critical design issue. It is often necessary to stagger the array's vertical supports to ensure an even distribution of the load. Some roofs cannot support such a load and thus must be clear-spanned. The array support structure in such cases is likely to be particularly expensive; intricate long-span space-frame structures are invariably costly and cost-ineffective.

**AVOIDING ROOFING PROBLEMS**

Leaky roofs are a persistent problem in solar installations. Problems can be anticipated and minimized by following these guidelines:

- Minimize roof penetrations. Collector supports constructed of pipe, if used in a large array as shown, require one roof penetration for every 60 sq ft of roof area, approximately; long-span design, by comparison, calls for one roof penetration roughly every 225 sq ft. Roof penetrations can also be avoided by using solar piping supports that rest directly on the roof, as shown; these prevent undue roof stress caused by pipe movement.
- Properly detail the flashing of vertical supports at the roofline. Except on pitched roofs (and often even then), wood-blocking bolted directly through the roof will ultimately generate leaks, regardless of the amount of roofing cement applied. The best approach is to use a neoprene roofing sleeve. The next best is base flashing and canopy detail. Less preferable is a pitch pocket, properly constructed. Other approaches—those using site-fabricated curbs and other techniques—tend to fail. If blocking is to be secured directly to a sloped roof, then roofing cement should be applied between each layer of shingles, between shingles and deck, and between shingles and blocking.

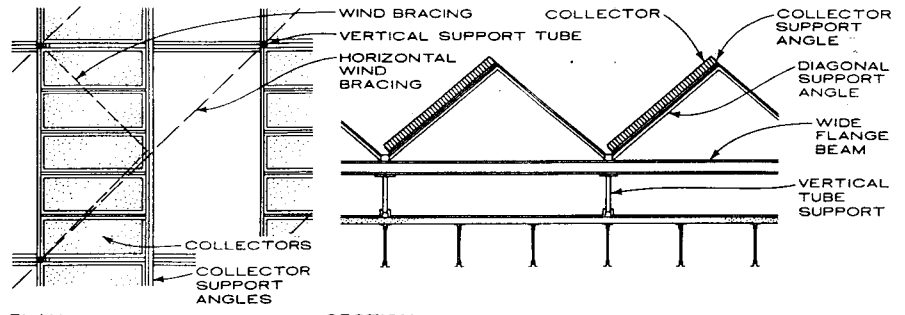

PLAN SECTION  
COLLECTOR SUPPORT

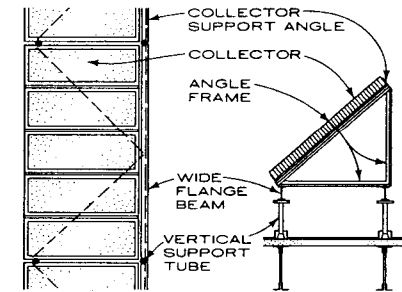

PLAN SECTION  
COLLECTOR SUPPORT

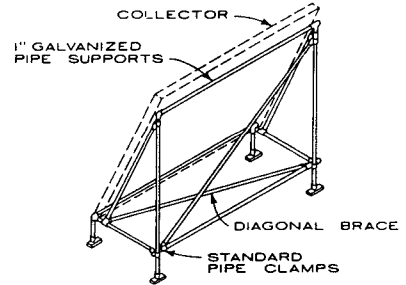

PIPE RACK MOUNTING

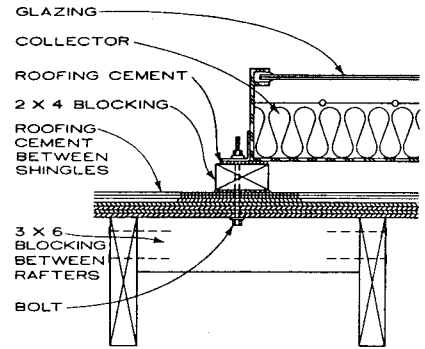

SLOPED ROOF

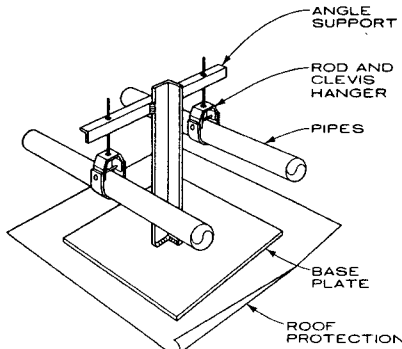

PIPE SUPPORT

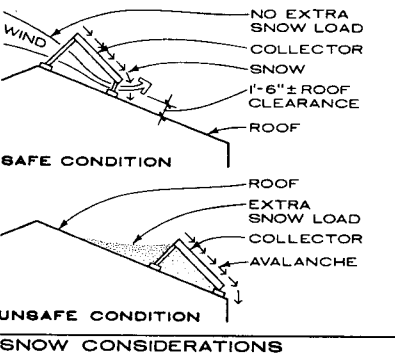

- Do not create dams. Any form of continuous blocking or curb will—unless installed at a right angle to the slope of a pitched roof—invariably dam a portion of the roof and ultimately cause built-up roofing to fail.
- Specify that all work be performed by the appropriate trade. Support flashing, for instance, is often installed by the steel erector or the plumbing contractor rather than by the roofing contractor.
- Protect the roof. Specify that the roof in general be protected during construction and that permanent walkways be installed to provide access to the system once it is in use.
- Mount collectors on a sloped roof unless the pitch is so flat that the loss of year-round efficiency in performance will be too great. When collectors and

- sloped roof are parallel, allow a 1/2 in. airspace between them to prevent deterioration of the roofing material and the collector enclosures. Do not mount collectors integrally with the roofing unless the collectors are specifically designed for integral mounting; as a rule, only air collectors are so designed. In cold regions, mount collectors as near the roof peak as possible to minimize damming and snow buildup and to lessen the chance of a dangerous snow slide—a particular threat when an array is located above an entry.
- On a flat roof, mount collectors between 2 ft 6 in. and 3 ft above the roof rather than directly on the roof. This prevents snow buildup, permits adequately sloped pipe runs, and—most important—allows for the installation of proper roof penetrations and for future roof repair and replacement.

Stephen Weinstein, AIA; The Ehrenkrantz Group; New York, New York

**SHADING DEVICES**

The effect of shading devices can be plotted in the same manner as the solar path was projected. The diagrams show which part of the sky vault will be obstructed by the devices and are projections of the surface covered on the sky vault as seen from an observation point at the center of the diagram. These projections also represent those parts of the sky vault from which no sunlight will reach the observation point; if the sun passes through such an area the observation point will be shaded.

**SHADING MASKS**

Any building element will define a characteristic form in these projection diagrams, known as "shading masks." Masks of horizontal devices (overhangs) will create a segmental pattern; vertical intercepting elements (fins) produce a radial pattern; shading devices with horizontal and vertical members (eggcrate type) will make a combinative pattern. A shading mask can be drawn for any shading device, even for very complex ones, by geometric plotting. As the shading masks are geometric projections they are independent of latitude and exposed directions, therefore they can be used in any location and at any orientation. By overlaying a shading mask in the proper orientation on the sun-path diagram, one can read off the times when the sun rays will be intercepted. Masks can be drawn for full shade (100% mask) when the observation point is at the lowest point of the surface needing shading; or for 50% shading when the observation point is placed at the halfway mark on the surface. It is customary to design a shading device in such a way that as soon as shading is needed on a surface the masking angle should exceed 50%. Solar calculations should be used to check the specific loads. Basic shading devices are shown below, with their obstruction effect on the sky vault and with their projected shading masks.

**SHADING MASK PROTRACTOR**

The half of the protractor showing segmental lines is used to plot lines parallel and normal to the observed vertical surface. The half showing bearing and altitude lines is used to plot shading masks of vertical fins or any other obstruction objects. The protractor is in the same projection and scale as the sun-path diagrams (see pages on solar angles); therefore it is useful to transfer the protractor to a transparent overlay to read the obstruction effect.

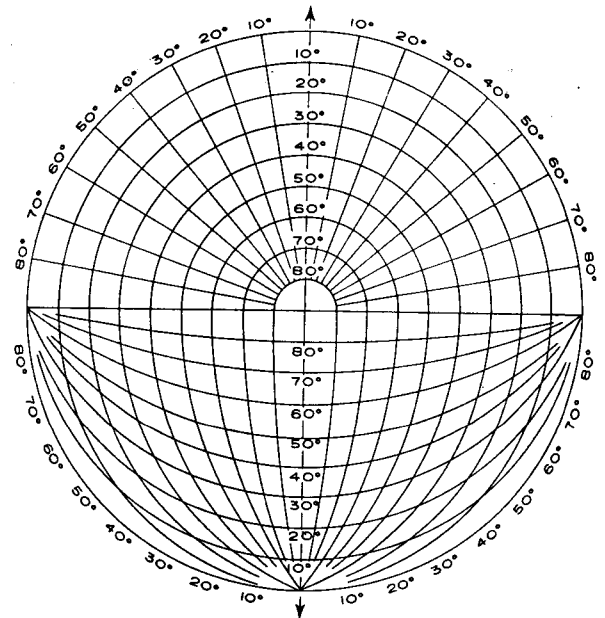

SHADING MASK PROTRACTOR

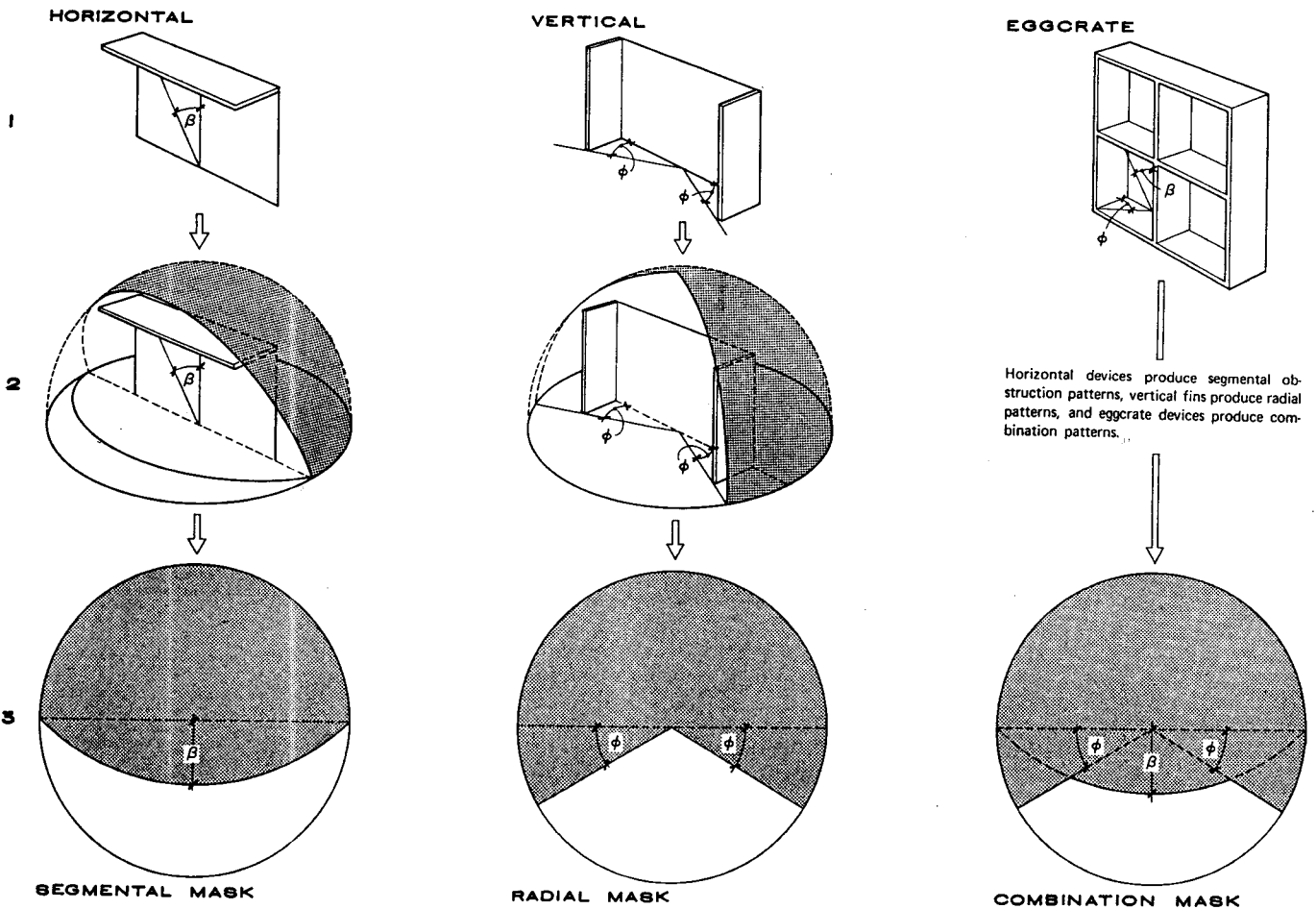

Victor Olgay, AIA; Princeton University; Princeton, New Jersey

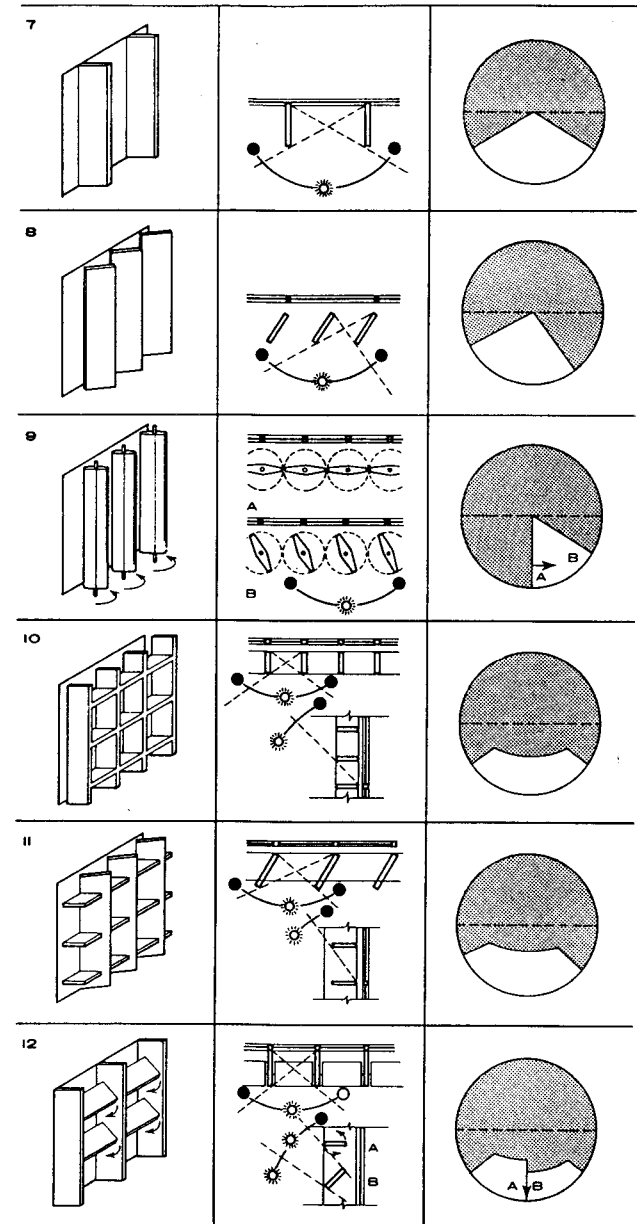
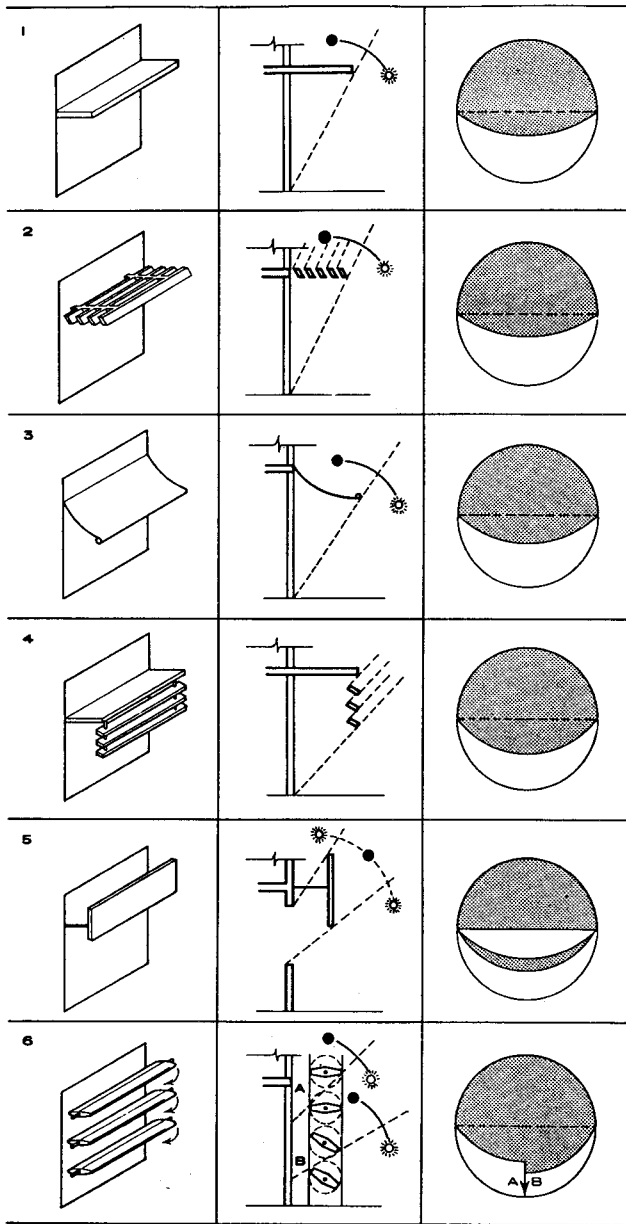

**EXAMPLES OF VARIOUS TYPES OF SHADING DEVICES**

The illustrations show a number of basic types of devices, classified as horizontal, vertical, and eggcrate types. The dash lines shown in the section diagram in each case indicate the sun angle at the time of 100% shading. The shading mask for each device is also shown, the extent of 100% shading being indicated by the gray area.

General rules can be deduced for the types of shading devices to be used for different orientations. Southerly orientations call for shading devices with segmental mask characteristics, and horizontal devices work in these directions efficiently. For easterly and westerly orientations vertical devices serve well, having radial shading masks. If slanted, they should incline toward the north, to give more protection from the southern positions of the sun. The eggcrate type of shading device works well on walls facing southeast, and is particularly effective for southwest orientations. Because of this type's high shading ratio and low winter head admission; its best use is in hot climate regions. For north walls, fixed vertical devices are recommended; however, their use is needed only for large glass surfaces, or in hot regions. At low latitudes on both south and north exposures eggcrate devices work efficiently.

Whether the shading devices be fixed or movable, the same recommendations apply in respect to the different orientations. The movable types can be most efficiently utilized where the sun's altitude and bearing angles change rapidly: on the east, southeast, and especially, because of the afternoon heat, on the southwest and west.

**HORIZONTAL TYPES** 1. Horizontal overhangs are most efficient toward south, or around southern orientations. Their mask characteristics are segmental. 2. Louvers parallel to wall have the advantage of permitting air circulation near the elevation. Slanted louvers will have the same characteristics as solid overhangs, and can be made retractable. 4. When protection is needed for low sun angles, louvers hung from solid horizontal overhangs are efficient. 5. A solid, or perforated screen strip parallel to wall cuts out the lower rays of the sun. 6. Movable horizontal louvers change their segmental mask characteristics according to their positioning.

**VERTICAL TYPES** 7. Vertical fins serve well toward the near east and near west orientations. Their mask characteristics are radial. 8. Vertical fins oblique to wall will result in asymmetrical mask. Separation from wall will prevent heat transmission. 9. Movable fins can shade the whole wall, or open up in different directions according to the sun's position.

**EGGCRATE TYPES** 10. Eggcrate types are combinations of horizontal and vertical types, and their masks are superimposed diagrams of the two masks. 11. Solid eggcrate with slanting vertical fins results in asymmetrical mask. 12. Eggcrate device with movable horizontal elements shows flexible mask characteristics. Because of their high shading ratio, eggcrates are efficient in hot climates.

Victor Olgyay, AIA; Princeton University; Princeton, New Jersey



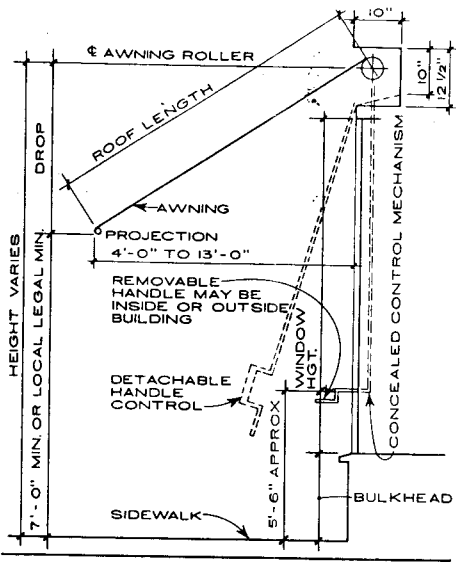

DIAGRAMMATIC SECTION RECESSED BOX INSTALLATION

- AWNING MATERIALS:**
1. Painted cotton duck
  2. Vinyl-coated cotton duck
  3. Vinyl-laminated polyester
  4. Solution-dyed acrylic
  5. Vinyl-coated polyester
  6. Acrylic-coated polyester
  7. Vinyl-coated polycotton
  8. Solution-dyed modacrylic
- AWNING OPERATORS:**
1. Detachable handle control
  2. Gear box & shaft (concealed or exposed) with removable handle inside or outside of building
  3. Electric control

**RETRACTABLE WINDOW AWNINGS:** Retractable awnings are manufactured in widths from 10 to 50 ft. Pitch can vary from horizontal to 45 degrees.

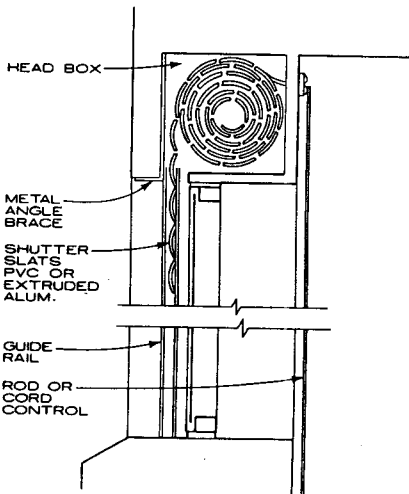

**NOTE**

Rolling shutters provide sun control not only by shading windows from direct sun rays but also by way of two dead airspaces—one between shutter and window, the other within the shutter extrusions to serve as insulation. The dead airspaces work as well in winter to prevent the escape of heat from the interior. In addition, shutters are useful as privacy and security measures. They can be installed in new or existing construction and are manufactured in standard window sizes.

**ROLLING SHUTTERS**

Graham Davidson, Architect; Washington, D.C.

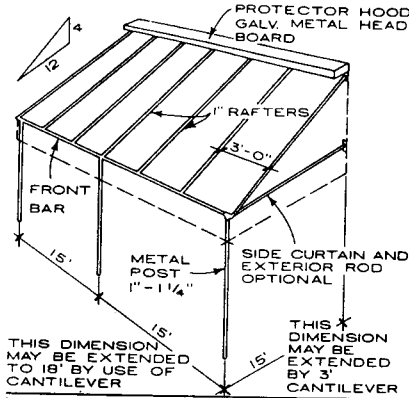

**TERRACE OR ROOF AWNINGS**

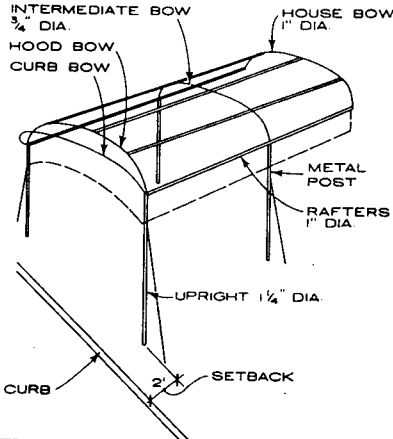

CANOPIES - LOW CURVED BOW SHOWN

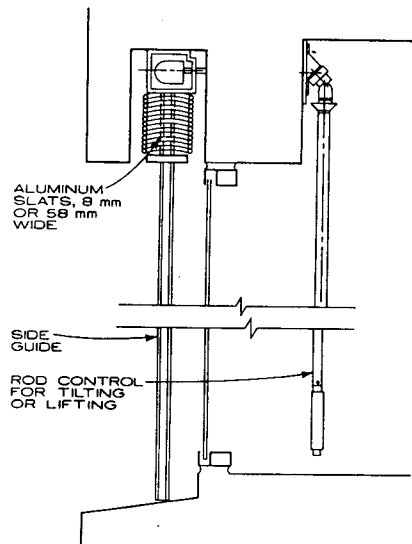

**NOTE**

External blinds protect the building interior from solar gain and glare, but can be raised partially or fully to the head when not needed. Manual or electric control is from inside the building.

**EXTERNAL VENETIAN BLINDS**

**TERRACE OR ROOF AWNINGS**

To provide complete sun protection and shade, the overall length of the awning bar should extend 3 in. past the glass line on both sides. For proper sunshade protection, awnings should project at least as far forward from the face of the window as the bottom of the window is below the front bar of the awning.

The wall measurement of an awning is the distance down the face of the building from the point where the awning attaches to the face of the building (or from the center of the roller in the case of the roller type awning).

The projection of an awning is the distance from the face of the building to the front bar of the awning in its correct projected position.

Right and left of an awning are your right and left as you are facing the awning looking into the building.

Framework consists of galvanized steel pipe, with non-rattling fittings. Awning is lace-on type canvas with rope reinforced eave. Protector hood is galvanized sheet metal or either bronze, copper, or aluminum.

Sizes of members should be checked by calculation for conditions not similar to those shown on this page.

Consult local building code for limitations on height and setback.

**COVERED WALKWAYS**

Covered walkways are available with aluminum fascia and soffit panels in a number of profiles. The fascia panels are supported with pipe columns and steel or aluminum structural members if necessary. Panels can cantilever up to 30% of span. Canopy designs can be supported from above.

Another method of providing covered exterior space is with stressed membrane structures. Using highly tensile synthetic fabric and cable in collaboration with compression members, usually metal, dynamic and versatile tentlike coverings can be created. Membrane structures are especially suited to temporary installations.

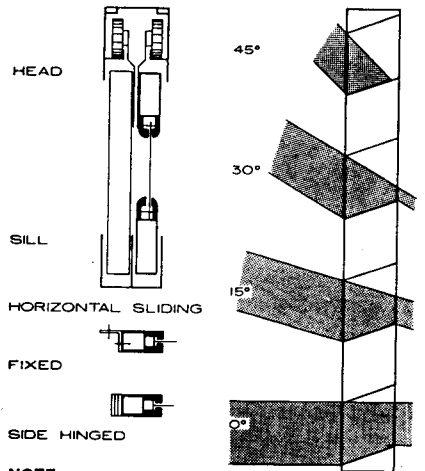

**NOTE**

These miniature external louvers shade windows from direct sunlight and glare while allowing a high degree of visibility, light, ventilation, insect protection, and daytime privacy. Much like a woven metal fabric, they are not strong architectural elements but present a uniform appearance in the areas covered. The solar screen is installed in aluminum frames and can be adapted to suit most applications.

**SOLAR SCREEN SIZES**

MATERIAL	LOUVERS	TILT	VERTICAL SPACING	SIZE (WIDTHS)
Aluminum	17"	17°	1" o.c.	18"-48"
Bronze	17", 23"	20°	1/2" o.c.	Up to 72 1/2"

Aluminum screens are available in black or light green. Bronze screens come in black only.

**SOLAR SCREENS**

THEMAL VALUES OF MATERIALS

MATERIAL & DESCRIPTION	DENSITY (lb per cu ft)	RESISTANCE (R) <sup>a</sup>	
		Per inch thickness (1/k)	For thickness listed (1/C)
<b>BUILDING BOARDS, PANELS, FLOORING, ETC.</b>			
Gypsum or plaster board	50	—	0.32
Gypsum or plaster board	50	—	0.45
Plywood	34	0.04	—
Sheathing, fiberboard	18	—	1.32
	2 <sup>3</sup> / <sub>32</sub> in.	—	2.06
	18	2.44	—
	25	2.28	—
Wood fiberboard, lam. or homogeneous	30	2.00	—
	50	1.37	—
Particleboard	40	—	0.82
Wood subfloor	3/4 in.	—	0.44
<b>BUILDING PAPER</b>			
Vapor-permeable felt	—	—	0.06
Vapor-seal, 2 layers of mopped 15 lb felt	—	—	0.12
Vapor-seal, plastic film	—	—	Negl.
<b>FINISH FLOORING MATERIALS</b>			
Carpet and fibrous pad	—	—	2.08
Carpet and rubber pad	—	—	1.23
Hardwood	2 <sup>3</sup> / <sub>32</sub> in.	—	0.71
Terrazzo	1 in.	—	0.08
Tile-asphalt, linoleum, vinyl, rubber	—	—	0.05
<b>INSULATING MATERIALS</b>			
<i>Blanket and Batt<sup>b</sup></i>			
Mineral wool, fibrous form			
processed from rock, slag, or glass			
	1-3 in.	4.16	—
	3-4 in.	—	11.0
	5 1/2-6 1/2 in.	—	19.0
	9-10 in.	—	30.0
Wood fiber			
<i>Boards and slabs</i>			
Cellular glass	8.5	2.86	—
Glass fiber	4-9	4.00	—
Expanded rubber (rigid)	4.5	4.55	—
Expanded polyurethane (R-11 blown)			
(Thickness 1 in. & greater)	1.5	6.25	—
Expanded polystyrene, extruded			
Cut cell surface	1.8	4.00	—
Smooth skin surface	1.8-3.5	5.00	—
Expanded polystyrene, molded beads	1.0	3.85	—
Mineral fiber with resin binder	15	3.45	—
Mineral fiberboard, wet felted			
Core or roof insulation	16-17	2.94	—
Acoustical tile	18	2.86	—
Acoustical tile	21	2.70	—
Mineral fiberboard, wet molded			
Acoustical tile <sup>c</sup>	23	2.38	—
Wood or cane fiberboard			
Acoustical tile <sup>c</sup>	1/2 in.	—	1.19
Acoustical tile <sup>c</sup>	3/4 in.	—	1.78
Interior finish (plank, tile)	15	2.86	—
Cement fiber slabs (shredded with portland cement boards)	25.0-27.0	2.00	—
<i>Loose Fill</i>			
Mineral fiber			
(glass, slag, or rock)			
	5 in.	0.6-2.0	11.00
	6 1/2-8 1/4 in.	0.6-2.0	19.00
	10 1/4-13 3/4 in.	0.6-2.0	30.00
Vermiculite (exfoliated)	4.0-6.0	2.27	—
	7.0-8.2	2.13	—
Perlite (expanded)	2.0-4.1	3.50	—
	4.1-7.4	3.00	—
	7.4-11.0	2.60	—
Wood fiber, softwoods	2.0-3.5	3.33	—
<b>MASONRY MATERIALS—CONCRETES</b>			
Cement mortar	116	0.20	—
Gypsum-fiber concrete,			
87 1/2% gypsum, 12 1/2% wood chips	51	0.60	—
Lightweight aggregates including	120	0.19	—
expanded shale, clay or slate;	100	0.28	—
expanded slags; cinders; pumice;	80	0.40	—
perlite; vermiculite; also	60	0.59	—
cellular concretes	40	0.86	—
	30	1.11	—
	20	1.43	—
Sand & gravel or stone aggregate	140	0.11	—
(oven dried)			
Sand & gravel or stone aggregate	140	0.08	—
(not dried)			
Stucco	116	0.20	—

THEMAL VALUES OF MATERIALS

MATERIAL & DESCRIPTION	DENSITY (lb per cu ft)	RESISTANCE (R) <sup>a</sup>	
		Per inch thickness (1/k)	For thickness listed (1/C)
<b>MASONRY UNITS</b>			
Brick, common <sup>d</sup>	120	0.20	—
Brick, face <sup>e</sup>	130	0.11	—
Clay tile, hollow:			
1 cell deep	3 in.	—	0.80
1 cell deep	4 in.	—	1.11
2 cells deep	6 in.	—	1.52
2 cells deep	8 in.	—	1.85
Concrete blocks, three oval core:			
Sand & gravel aggregate	4 in.	—	0.71
	8 in.	—	1.11
	12 in.	—	1.28
Cinder aggregate	3 in.	—	0.86
	4 in.	—	1.11
	8 in.	—	1.72
	12 in.	—	1.89
Lightweight aggregate	3 in.	—	1.27
(expanded shale, clay, slate	4 in.	—	1.50
or slag; pumice)	8 in.	—	2.00
	12 in.	—	2.27
Concrete blocks, rectangular core:			
Sand & gravel aggregate			
2 core, 8 in. 36 lb.			1.04
Lightweight aggregate (expanded			
shale, clay, slate or slag; pumice)			
3 core, 6 in. 19 lb.			1.65
2 core, 8 in. 24 lb.			2.18
3 core, 12 in. 38 lb.			2.48
Granite, marble	150-175	0.05	—
Stone, lime or sand	—	0.08	—
<b>METALS</b>			
Aluminum	171	0.0007	—
Brass, red	524-542	0.0010	—
Brass, yellow	524-542	0.0012	—
Copper, cast rolled	550-555	0.0004	—
Iron, gray cast	438-445	0.0030	—
Iron, pure	474-493	0.0023	—
Lead	704	0.0041	—
Steel, cold drawn	490	0.0032	—
Steel,			
stainless, type 304		0.0055	—
Zinc, cast		0.0013	—
<b>PLASTERING MATERIALS</b>			
Cement plaster,			
sand aggregate	116	0.20	—
Sand aggregate	1/2 in.	—	0.10
Sand aggregate	3/4 in.	—	0.15
Gypsum plaster:			
Lightweight aggregate	45	—	0.32
Lightweight aggregate	1/2 in.	45	0.39
Lightweight aggregate,			
on metal lath	3/4 in.	—	0.47
Perlite aggregate	45	0.67	—
Sand aggregate	105	0.18	—
Sand aggregate	1/2 in.	105	0.09
Sand aggregate	3/4 in.	105	0.11
Sand aggregate,			
on metal lath	3/4 in.	—	0.13
Vermiculite aggregate	45	0.59	—
<b>ROOFING</b>			
1-ply membrane	0.048 in.	83	0.50
Asphalt roll roofing		70	0.15
Asphalt shingles		70	0.44
Built-up roofing	3/4 in.	70	0.33
Slate	1/2 in.	—	0.05
<b>SIDING MATERIALS</b>			
(On Flat Surface)			
<i>Shingles:</i>			
Wood, 16 in., 7 1/2 in. exposure			0.87
Wood, double, 16 in.,			
12 in. exposure			1.19
Wood, plus insul. backer board, 3/16 in.			1.40
<i>Siding:</i>			
Aluminum (hollow backed			
over sheathing)			0.61
Vinyl (hollow backed			
over sheathing)	0.04 in.		1.00
Cedar shakes	1/2 in.		0.94
	3/4 in.		1.69
Wood, drop, 1 x 8 in.			0.79
Wood, bevel, 1/2 x 8 in., lapped			0.81
Wood, bevel, 3/4 x 10 in., lapped			1.05
Architectural glass			0.10

D. Richard Stroup, AIA; Craig, Gaulden & Davis, Architects; Greenville, South Carolina

**THERMAL VALUES OF MATERIALS**

MATERIAL & DESCRIPTION	DENSITY (lb per cu ft)	RESISTANCE (R)*	
		Per inch thickness (1/k)	For thickness listed (1/C)
<b>WOODS</b>			
Maple, oak, and similar hardwoods	45	0.91	—
Fir, pine, and similar softwoods	32	1.25	—
Fir, pine, and similar softwoods	25/32 in.	—	0.98
	1 1/2 in.	—	1.89
	2 1/2 in.	—	3.12
	3 1/2 in.	—	4.35
Door, 1-3/4 in. thick solid wood core 1 1/2 in. hollow core			3.13
			2.22

**STEEL DOORS (NOMINAL THICKNESS 1 1/2 IN.)**

MATERIAL & DESCRIPTION	DENSITY (lb per cu ft)	Per inch thickness (1/k)	For thickness listed (1/C)
Mineral fiber core	—	—	1.69
Solid urethane foam core*	—	—	5.56
Solid polystyrene core*	—	—	2.13

\*With thermal break.

**AIR SURFACES**

Position of Surface	Direction of Heat Flow	Type of Surface		
		Non-Reflective Materials	Reflective Aluminum Coated Paper	Highly Reflective Foil
		Resistance (R)	Resistance (R)	Resistance (R)
<b>STILL AIR</b>				
Horizontal	Upward	0.61	1.10	1.32
45° slope	Upward	0.62	1.14	1.37
Vertical	Horizontal	0.68	1.35	1.70
45° slope	Down	0.76	1.67	2.22
Horizontal	Down	0.92	2.70	4.55
<b>MOVING AIR</b> (any position) 15 mph wind 7 1/2 mph wind				
	Any	0.17 (winter)	—	—
	Any	0.25 (summer)	—	—

**AIR SPACES**

Position of Air Space and Thickness (inches)	Heat Flow Dir.	Season	Types of Surfaces on Opposite Sides		
			Both Surfaces Non-Reflective Materials	Aluminum Coated Paper/ Non-Reflective Materials	Foil/ Non-Reflective Materials
			Resistance (R)	Resistance (R)	Resistance (R)
Horizontal	3/4	Up	0.87	1.71	2.23
		Down	0.76	1.63	2.26
4	4	W	0.94	1.99	2.73
		S	0.80	1.87	2.75
45° slope	3/4	Up	0.94	2.02	2.78
		Down	0.81	1.90	2.81
4	4	W	0.96	2.13	3.00
		S	0.82	1.98	3.00
Vertical	3/4	Down	1.01	2.36	3.48
		Up	0.84	2.10	3.28
4	4	W	1.01	2.34	3.45
		S	0.91	2.16	3.44
45° slope	3/4	Down	1.02	2.40	3.57
		Up	0.84	2.09	3.24
4	4	W	1.08	2.75	4.41
		S	0.90	2.50	4.36
Horizontal	3/4	Down	1.02	2.39	3.55
		Up	1.14	3.21	5.74
4	4	W	1.23	4.02	8.94
		S	0.84	2.08	3.25
1 1/2	4	S	0.93	2.76	5.24
		S	0.99	3.38	8.08

D. Richard Stroup, AIA; Craig, Gauden & Davis, Architects; Greenville, South Carolina

**18 THERMAL TRANSMISSION**

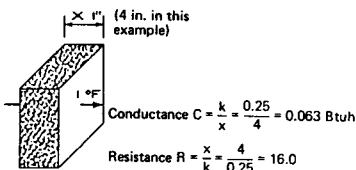
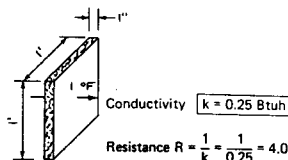

GLASS FIBER INSULATION BOARD

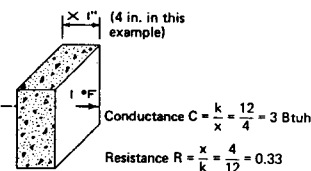
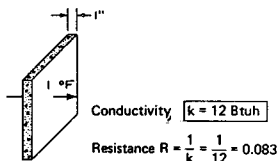

SAND AND GRAVEL CONCRETE

NOTES: Standard unit of area 1 sq ft.  
Standard unit temperature differential 1°F.

**HEAT FLOW RATE**

**FOOTNOTES**

- Resistances are representative values for dry materials and are intended as design (not specification) values for materials in normal use. Unless shown otherwise in descriptions of materials, all values are for 75°C mean temperature.
- Includes paper backing and facing if any. In cases where insulation forms a boundary (highly reflective or otherwise) of an airspace, refer to appropriate table for the insulating value of the airspace. Some manufacturers of batt and blanket insulation mark their products with R value, but they can ensure only the quality of the material as shipped.
- Average values only are given, since variations depend on density of the board and on the type, size, and depth of perforations.
- Thicknesses supplied by different manufacturers may vary depending on the particular material.
- Values will vary if density varies from that listed.
- Data on rectangular core concrete blocks differ from the data for oval core blocks because of core configuration, different mean temperature, and different unit weight. Weight data on oval core blocks not available.
- Weight of units approx. 7 1/2 high by 15 1/2 long are given to describe blocks tested. Values are for 1 sq ft area.
- Thermal resistance of metals is so low that in building constructions it is usually ignored. Values shown emphasize relatively easy flow of heat along or through metals so that they are usually heat leaks, inward or outward.
- Spaces of uniform thickness bounded by moderately smooth surfaces.
- Values shown not applicable to interior installations of materials listed.
- Winter is heat flow up; summer is heat flow down.
- Based on area of opening, not on total surface area. Based on data from ASHRAE Handbook of Fundamentals, 1977, Chapter 22.

## GLASS, GLASS BLOCK AND PLASTIC SHEET

MATERIAL AND DESCRIPTION	OVERALL HEAT TRANSMISSION COEFFICIENT (U)	SEASONS	RESISTANCE (R)
<b>VERTICAL PANELS—EXTERIOR</b>			
Flat Glass Single glass	1.10	Winter	0.91
	1.04	Summer	0.96
Insulating glass, two lights of glass 3/16 in. airspace	0.62	Winter	1.61
	0.65	Summer	1.54
1/4 in. airspace	0.58	Winter	1.72
	0.61	Summer	1.64
1/2 in. airspace	0.49	Winter	2.04
	0.56	Summer	1.79
Insulating glass, three lights of glass 1/4 in. airspaces	0.39	Winter	2.56
	0.44	Summer	2.22
1/2 in. airspaces	0.31	Winter	3.23
	0.39	Summer	2.56
1/2 in. airspaces, low emittance coating e = 0.20	0.32	Winter	3.13
	0.38	Summer	2.63
e = 0.40	0.38	Winter	2.63
	0.45	Summer	2.22
e = 0.60	0.43	Winter	2.33
	0.51	Summer	1.96
Storm windows 1-4 in. airspace	0.50	Winter	2.00
	0.50	Summer	2.00
Glass Block 6 x 6 x 4 in. thick (nom.)	0.60	Winter	1.67
	0.57	Summer	1.76
8 x 8 x 4 in. thick (nom.)	0.56	Winter	1.79
	0.54	Summer	1.85
With cavity divider	0.48	Winter	2.08
	0.46	Summer	2.17
12 x 12 x 4 in. thick (nom.)	0.52	Winter	1.92
	0.50	Summer	2.00
With cavity divider	0.44	Winter	2.27
	0.42	Summer	2.38
12 x 12 x 2 in. thick (nom.)	0.60	Winter	1.67
	0.57	Summer	1.76
Single Plastic Sheet 1/8 in. thick (nom.)	1.06	Winter	0.94
	0.98	Summer	1.02
1/4 in. thick (nom.)	0.96	Winter	1.04
	0.89	Summer	1.12
<b>HORIZONTAL PANELS—EXTERIOR</b>			
Flat Glass Single glass	1.23	Winter	0.81
	0.83	Summer	1.20
Insulating glass, two lights of glass 3/16 in. airspace	0.70	Winter	1.43
	0.57	Summer	1.75
1/4 in. airspace	0.65	Winter	1.54
	0.54	Summer	1.85
1/2 in. airspace	0.59	Winter	1.69
	0.49	Summer	2.04
Glass Block 11 x 11 x 3 in. thick with cavity divider	0.53	Winter	1.89
	0.35	Summer	2.86
12 x 12 x 4 in. thick with cavity divider	0.51	Winter	1.96
	0.34	Summer	2.94
Plastic Bubbles <sup>h</sup> Single walled	1.15	Winter	0.87
	0.80	Summer	1.25
Double walled	0.70	Winter	1.43
	0.46	Summer	2.17

## NOTES

The thermal conductivity of glass is relatively high ( $k = 7.5$ ), and, for single glazing, most of the thermal resistance is imposed at the indoor and outdoor surfaces. Indoors, approximately two-thirds of the heat flows by radiation to the room surfaces and only one-third flows by convection. This can be materially affected by the use of forced airflow from induction units, for example. The inner surface coefficient of heat transfer,  $h_i$ , can be substantially reduced by applying a low emittance metallic film to the glass.

For glazing with airspaces, the U value can be reduced to a marked degree by the use of low emittance films. This process imparts a variable degree of reflectance to the glass, thereby reducing its Shading Coefficient. Manufacturers' literature should be consulted for more details on this important subject. Also consult Chapter 27 of the 1981 ASHRAE Handbook of Fundamentals.

## FOOTNOTES

- Resistances are representative values for dry materials and are intended as design (not specification) values for materials in normal use. Unless shown otherwise in descriptions of materials, all values are for 75°C mean temperature.
  - Includes paper backing and facing if any. In cases where insulation forms a boundary (highly reflective or otherwise) of an airspace, refer to appropriate table for the insulating value of the airspace. Some manufacturers of batt and blanket insulation mark their products with R value, but they can ensure only the quality of the material as shipped.
  - Average values only are given, since variations depend on density of the board and on the type, size, and depth of perforations.
  - Thicknesses supplied by different manufacturers may vary depending on the particular material.
  - Values will vary if density varies from that listed.
  - Data on rectangular core concrete blocks differ from the data for oval core blocks because of core configuration, different mean temperature, and different unit weight. Weight data on oval core blocks not available.
  - Weight of units approx. 7<sup>5</sup>/<sub>8</sub> high by 15<sup>5</sup>/<sub>8</sub> long are given to describe blocks tested. Values are for 1 sq ft area.
  - Thermal resistance of metals is so low that in building constructions it is usually ignored. Values shown emphasize relatively easy flow of heat along or through metals so that they are usually heat leaks, inward or outward.
  - Spaces of uniform thickness bounded by moderately smooth surfaces.
  - Values shown not applicable to interior installations of materials listed.
  - Winter is heat flow up; summer is heat flow down.
  - Based on area of opening, not on total surface area.
- Based on data from ASHRAE Handbook of Fundamentals, 1977, Chapter 22.

**SOLAR GAINS THROUGH SUNLIT FENESTRATION**

Heat gains through sunlit fenestration constitute major sources of cooling load in summer. In winter, discomfort is often caused by excessive amounts of solar radiation entering through south facing windows. By contrast, passive solar design depends largely on admission and storage of the radiant energy falling on south facing and horizontal surfaces. Admission takes place both by transmission through glazing and by inward flow of absorbed energy. With or without the sun, heat flows through glazing, either inwardly or outwardly, whenever there is a temperature difference between the indoor and outdoor air. These heat flows may be calculated in the following manner.

The solar heat gain is estimated by a two-step process. The first step is to find, either from tabulated data or by calculation, the rate at which solar heat would be admitted under the designated conditions through a single square foot of double strength (1/8 in.) clear sheet glass. This quantity, called the solar heat gain factor (SHGF), is set by (a) the local latitude; (b) the date, hence the declination; (c) the time of day (solar time should be used); (d) the orientation of the window.

Tabulated values of SHGF are given in the 1981 ASHRAE Handbook of Fundamentals, Chapter 27, for latitudes from 0° (the equator) to 64° N by 8° increments and for orientations around the compass from N to NNW, by 22.5° increments. Selected values from the 40° table are given in an adjacent column.

Each individual fenestration system, consisting of glazing and shading devices, has a unique ability to admit solar heat. This property is evaluated in terms of its shading coefficient (SC), which is the ratio of the amount of solar heat admitted by the system under consideration to the solar heat gain factor for the same conditions. In equation form, this becomes:

$$\text{solar heat gain (Btu/sq ft} \cdot \text{hr)} = \text{SC} \times \text{SHGF}$$

Values of the shading coefficient are given in Chapter 27 of the 1981 ASHRAE Handbook of Fundamentals for the most widely used glazing materials alone and in combination with internal and external shading devices. Selected values for single and double glazing are given below:

**SHADING COEFFICIENT FOR SELECTED GLAZING SYSTEMS**

TYPE OF GLASS	SOLAR TRANSMISSION	SHADING COEFFICIENT, SC
Clear		
1/8 in.	0.86	1.00
1/4 in.	0.78	0.94
Heat absorbing		
1/8 in.	0.64	0.83
1/4 in.	0.46	0.69
Insulating glass, clear both lights		
1/8 + 1/8 in.	0.71	0.88
1/4 + 1/4 in.	0.61	0.81
Heat absorbing out		
Clear in, 1/4 in.	0.36	0.55

For combinations of glazing and shading devices, see the ASHRAE chapter cited above.

The heat flow due to temperature difference is found by multiplying the U-value for the specified fenestration system by the area involved and by the applicable temperature difference:

$$Q = A \times [\text{SC} \times \text{SHGF} + U \times (t_o - t_i)]$$

The same equation is used for both summer and winter, with appropriate U-values, but in winter the conduction heat flow is usually outward because the outdoor air is colder than the indoor air.

Example: find the total heat gain, in Btu/sq ft · hr, for 1000 sq ft of unshaded 1/4 in. heat absorbing single glass, facing west, in Denver (40°N latitude) at 4:00 P.M. solar time on October 21. Indoor air temperature is 70°F; outdoor air temperature is 40°F.

Solution: from the accompanying table, for 4:00 P.M. on October 21 find the SHGF for west facing fenestration on October 21 to be 173 Btu/sq ft · hr. For 1/4 in. heat absorbing glass, SC = 0.69 and U for winter conditions is 1.10 Btu/sq ft · hr · °F.

$$Q = 1000 \times [0.69 \times 173 + 1.10 \times (40 - 70)]$$

$$= 1000 \times (119.4 - 33.0) = 86,400 \text{ Btu/hr}$$

Even though the outdoor air is 30° cooler than the indoor air, the net heat gain through the window in question would be equivalent to 7.2 tons of refrigeration.

For the same window area in summer, on August 21 at 4:00 P.M. solar time, SHGF = 216, and the air temperatures may be taken as 95°F outdoors and 78°F indoors. The total heat gain will be:

$$Q = 1000 \times [0.69 \times 216 + 1.04 \times (95 - 78)]$$

$$= 1000 \times (149.0 + 17.7) = 166,700 \text{ Btu/hr}$$

$$= 13.9 \text{ tons of refrigeration}$$

The cooling load can be reduced by selecting a fenestration system with lower shading coefficient and U-value. Under the same conditions, a double glazed window with two lights of 1/4 in. clear glass and a highly reflective translucent inner shading device would have U = 0.52 and SC = 0.37. The cooling load would then be reduced to 88,760 Btu/hr or 7.4 tons of refrigeration.

**SOL-AIR TEMPERATURE**

When the opaque surfaces of a structure are struck by solar radiation, much of the energy is absorbed by the irradiated surface, raising its temperature and increasing the rate of heat flow into the roof or wall. The time lag between the onset of irradiation and the resulting rise in the indoor surface temperature depends on the thickness and mass per unit area of the building element and on the thermal conductivity, specific heat, and density of the materials. The time lag is negligible for an uninsulated metal roof, but it can be a matter of hours for a massive concrete or masonry wall.

Heat flow through sunlit opaque building elements is estimated by using the sol-air temperature,  $t_{sa}$ , defined as an imaginary outdoor temperature that, in the absence of sunshine, would give the same rate of heat flow as actually exists at the specified time under the combined influence of the incident solar radiation and the ambient air temperature.

$$t_{sa} = I \times \text{Abs.}/h_o$$

where I = solar irradiance (Btu/sq ft · hr)

Abs. = surface absorptance, dimensionless

$h_o$  = outer surface coefficient (Btu/sq ft · hr · °F)

Surface absorptances range from as low as 0.30 for a white surface to 0.95 for a black built-up roof. Values of  $h_o$  range from the conventional 4.0 for summer with an assumed wind speed of 7.5 mph to a still air value of 3.0.

Example: find the rate of heat flow through a 1000 sq ft uninsulated black built-up roof, U = 0.3, under strong summer sunshine, I = 300 Btu/sq ft · hr, still air with 100°F outdoors, 78°F indoors.

Solution: the sol-air temperature is found from

$$t_{sa} = 300 \times \frac{0.95}{3.0} + 100 = 195^\circ\text{F}$$

The rate of heat flow, neglecting the time lag, is

$$Q = 1000 \times 0.3 \times (195 - 78) = 35,100 \text{ Btu/hr}$$

With no sunshine on the roof, the heat flow is

$$\text{heat flow} = 1000 \times 0.3 \times (100 - 78) = 6600 \text{ Btu/hr}$$

The effect of the solar radiation is thus to increase the heat flow rate by 88%. A more massive roof with a lower U-value would show considerably less effect of the incoming solar radiation.

**SOLAR INTENSITY AND SOLAR HEAT GAIN FACTORS FOR 40°N LATITUDE**

DATE	SOLAR TIME (A.M.)	DIRECT NORMAL (BTUH/SQ FT)	SOLAR HEAT GAIN FACTORS (BTUH/SQ FT)					SOLAR TIME (P.M.)
			N	E	S	W	HOR	
Jan 21	8	142	5	111	75	5	14	4
	10	274	16	124	213	16	96	2
	12	294	20	21	254	21	133	12
Feb 21	8	219	10	183	94	10	43	4
	10	294	21	143	203	21	143	2
	12	307	24	25	241	25	180	12
Mar 21	8	250	16	218	74	16	85	4
	10	297	25	153	171	25	186	2
	12	307	29	31	206	31	223	12
Apr 21	6	89	11	88	5	5	11	6
	8	252	22	224	41	21	123	4
	10	286	31	152	121	31	217	2
May 21	6	144	36	141	10	10	31	6
	8	250	27	220	29	25	146	4
	10	277	34	148	83	34	234	2
June 21	6	155	48	151	13	13	40	6
	8	246	30	216	29	27	153	4
	10	272	35	145	69	35	238	2
July 21	6	138	37	137	11	11	32	6
	8	241	28	216	30	26	145	4
	10	269	35	146	81	35	231	2
Aug 21	6	81	12	82	6	5	12	6
	8	237	24	216	41	23	122	4
	10	272	32	150	116	32	214	2
Sep 21	6	280	35	38	149	38	247	12
	8	230	17	205	71	17	82	4
	10	280	27	148	165	27	180	2
Oct 21	6	290	30	32	200	32	215	12
	8	204	11	173	89	11	43	4
	10	280	21	139	196	21	140	2
Nov 21	6	294	25	27	234	27	177	12
	8	136	5	108	72	5	14	4
	10	268	16	122	209	16	96	2
Dec 21	6	288	20	21	250	21	132	12
	8	89	3	67	50	3	6	4
	10	261	14	113	146	14	77	2
	12	285	18	19	253	19	113	12
			N	W	S	E	HOR	PM

**GENERAL**

For years the building industry in the United States has depended upon a seemingly endless supply of high quality materials, supplies, and energy resources. Manufacturers have been producing building materials abundantly, and architects generally have been specifying them for reasons of aesthetics, budget, performance, code compliance, and availability. Consideration is rarely given to the environmental impact of using these materials, i.e., what environmental "costs" go into extracting, producing, shipping, and installing them. These costs include depletion of nonrenewable raw materials and resources; production of waste by-products; and exposure of toxicity to the air, water, soils, and inhabitants of nearby areas.

For the building industry of the future, it will be good business to use materials that are environmentally friendly, sustainable, and renewable and that contain recycled materials. A building industry that depends upon depletable resources to manufacture its materials will become more and more costly as the resources are depleted. More important, the world in which we build will become more and more uninhabitable because of the toxins and waste left by our present materials and methods of construction. To do its part in keeping the world safe to live in, the architecture profession must incorporate procedures and standards of resource conservation into our design philosophies.

**BUILDING MATERIALS ANALYSIS**

**LIFE CYCLE OF BUILDING MATERIALS**

To analyze a building material from an environmental standpoint, an understanding of the life cycle of that material must be reached. Examine the environmental burdens that accrue through extraction or acquisition of the raw materials and their processing/manufacture and the packaging, distribution, use, and ultimate recovery (reuse/recycling) or disposal of the finished product.

Three aspects of the life of a building material are most significant in considering environmental impact: Is the raw material renewable or nonrenewable? How much total waste or how many toxic by-products are produced in its production and during the life of the product? How much energy is consumed in its life cycle? A building material that is both environmentally "pure" and readily available—that is, one made from a 100% renewable raw material that uses only renewable energy in its extraction, production, and transport and can be infinitely reclaimed and recycled (as well as healthy to the occupants of a building)—will be hard to find. Even to have that "perfect" material as a goal, we need a frame of reference from which to choose materials based on environmental concerns, something like ingredient and nutrition labeling on food products. If this information was available on materials for the building industry, we would be able to specify materials that are healthy and "nutritious" for a sustainable planet.

**EMBODIED ENERGY OF BUILDING MATERIALS**

The embodied energy of a building material comprises all the energy consumed in acquiring and transforming the raw materials into finished products and transporting them to the building site. The life-cycle chart below details where energy is consumed in producing building materials. The embodied energy or energy "content" of a building material will act as a rough guide to its environmental friendliness. The energy content reflects the material's "closeness" to

the earth; the more it is refined or processed, the more energy it "contains" and hence the more "expensive" it is environmentally.

If we must produce and use high-energy materials, it is important that we not waste that energy by burying them in a landfill but rather reuse or recycle them.

To compare one material to another, we must take into account the following characteristics:

1. Regional availability—local extraction/manufacture
2. Recyclability (how many times the material can be recycled and retain viability)
3. Reusability
4. Durability and life span
5. Toxicity of the product or of the materials used to maintain the product during its life
6. Efficiency of product's performance as an architectural component
7. Savings on other materials not used because this product is used
8. Savings in energy not consumed over the life span of the building because this product is used
9. Any combination of these factors

Some construction methods and systems bind materials together to render them difficult or costly to recycle or reuse. One example of this is reinforced concrete, which efficiently uses steel in its role of spanning distances but also makes it impractical to recycle after a building has outlived its usefulness. A structural steel frame, although it uses a great deal more steel than a similar reinforced concrete frame, can be unbolted, disassembled, and reused or melted down and reformed infinitely.

**NOTE**

Evaluating whether a certain material is used in construction is a complicated process involving many factors. Certain regions or markets may be more familiar with or more suitable for certain types of construction or materials, and this may be an unavoidable factor that nullifies all others in determining which structural or other material is used.

**LIFE-CYCLE CHECKLIST FOR BUILDING MATERIALS**

This checklist can be used to analyze the environmental impact of building materials:

1. Raw material acquisition (mining, harvesting, drilling, extraction)
  - a. Is the resource renewable or sustainable (reproducible indefinitely)?
  - b. How much nonrenewable waste is produced?
  - c. What is the amount and type of energy consumed? (Is it sustainable?)
  - d. How does acquisition affect the environment? (Does it destroy forests or other habitats, produce silt or toxic runoff or air pollution?)
2. Raw material processing and manufacturing
  - a. How much nonrecyclable waste is produced?
  - b. What is the type and amount of energy consumed to manufacture the product?
  - c. What toxicity to air, water, or soils is produced by processing?

**APPROXIMATE VALUE OF EMBODIED ENERGY IN BUILDING MATERIALS**

MATERIALS	ENERGY CONTENT (BTU/LB)
Low energy materials	
Sand/gravel	18
Wood	185
Sand-lime brickwork	730
Lightweight concrete	940
Medium energy materials	
Gypsum board	1,830
Brickwork	2,200
Lime	2,800
Cement	4,100
Mineral fiber insulation	7,200
Glass	11,100
Porcelain	11,300
High energy materials	
Plastic	18,500
Steel	19,200
Lead	25,900
Zinc	27,800
Copper	29,600
Aluminum	103,500

3. Product packaging and final packaging (for shipping)
  - a. Is packaging recyclable or made of recycled material?
  - b. Is packaging excessive?
  - c. Does packaging use nonrenewable resources (e.g., petroleum or materials harmful to the environment, such as CFC insulation packing material)?
4. Product distribution
  - a. Would the product travel an excessive distance from the manufacturing site to the building site when more local products could be used?
  - b. What is the type and amount of energy consumed to transport the material?
5. Product installation, use, maintenance
  - a. Does installation produce excessive and/or nonrenewable site waste?
  - b. What energy is consumed to install and maintain the product?
  - c. Does installation, use, or maintenance of the product pollute the outdoor or indoor environment for installers or occupants?
  - d. How durable is the product and what is its rate of degradation?
  - e. Does the product add to the energy efficiency of the building?
6. Disposal, recycling, reuse
  - a. Does the product use virgin materials wisely?
  - b. Is it recyclable after use and, if so, to what degree?
  - c. Can the product be reused?
  - d. What energy is consumed to recycle the product?
  - e. What energy is consumed to dispose of its nonrecyclable elements?
  - f. What is the toxicity to the environment when the product is thrown away?

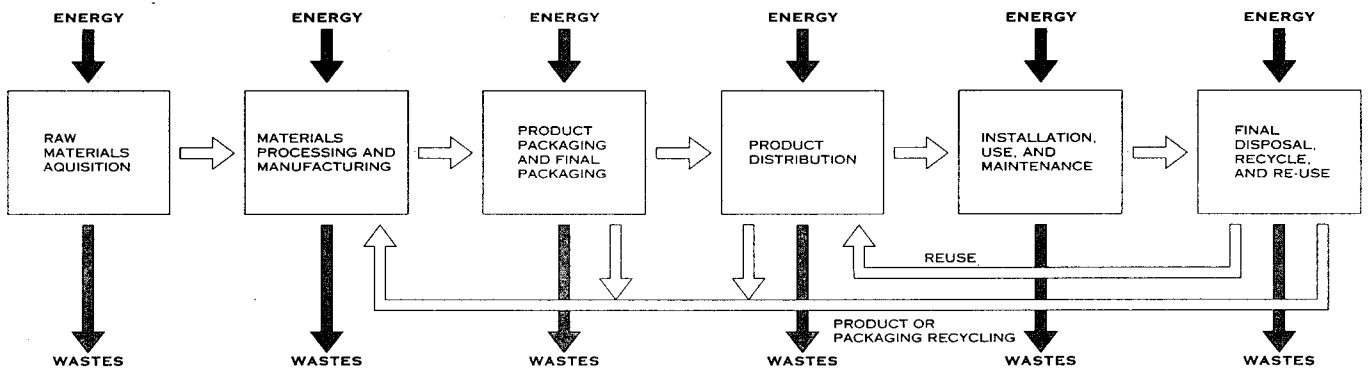

**LIFE-CYCLE CHART**

Energy consumption considerations of building materials should not override basic respect for the earth. Degradation of the landscape in materials extraction, transport, and manufacturing, as well as in construction, should be minimized.

Richard J. Vitullo, AIA; Oak Leaf Studio; Crownsville, Maryland  
AIA Environmental Resource Guide

LIFE CYCLES OF BRICK, GLASS, AND PAINT

	BRICK AND MORTAR	GLASS	PAINT
Raw material acquisition and preparation	<ul style="list-style-type: none"> <li>Most clays, shales, sand, portland cement, and hydrated lime used in brick and mortar production are mined from open pits using modern surface mining equipment, causing land and habitat disturbance.</li> <li>Reclamation of open pits into lakes, landfills, etc. is a common occurrence.</li> <li>Domestic resources of clay and shale are almost unlimited.</li> <li>Energy is consumed in clay mining and processing in the form of fuels (natural gas, propane, oil, coal, etc.) used to mine, crush, and haul the materials.</li> </ul>	<ul style="list-style-type: none"> <li>The principal raw materials used in the formation of soda-lime glass (which accounts for 77% of total glass production) are glass sand, limestone, soda ash, and cullet. Glass sand and limestone are mined from open pits (see brick section for environmental effects).</li> <li>The four main components of glass are all available in large quantity.</li> <li>Atmospheric emissions, runoff into streams and groundwater, and habitat alteration are potential adverse impacts from mining. Suspended solids from mine runoff can increase turbidity of streams.</li> <li>Soda ash is obtained from underground mines, which have minor adverse environmental impact.</li> </ul>	<ul style="list-style-type: none"> <li>The raw materials for titanium dioxide and pigment extenders are mined from the earth, and the environmental impacts of mining operations include runoff from tailings waste, which leads to increased turbidity of water.</li> </ul>
Raw material processing and manufacture	<ul style="list-style-type: none"> <li>Stormwater runoff from clay and shale processing and storage is a concern.</li> <li>"Waste" products are sometimes used as raw materials in production of brick, such as sewage sludge, incinerator ash, fly ash, waste glass, papermaking sludge, metallurgical wastes, and rice husk and slag.</li> <li>Particulate matter is the primary emission in the manufacture of brick: Dust results from materials handling and pollutants such as CO<sub>2</sub>, chlorine, and fluorine from kiln firing.</li> </ul>	<ul style="list-style-type: none"> <li>Wastes generated during the processing of glass sand include solid waste (clay and sand particles), water effluent, and air emissions.</li> <li>Large quantities of water are needed to process glass sand, and the wastewater contains clay particles in suspension.</li> <li>The fabrication of coatings and sealants used with glass can result in some VOC emissions.</li> </ul>	<ul style="list-style-type: none"> <li>The major pigment in paints is titanium dioxide, the manufacture of which can produce wastes such as sulfuric acid, metal sulfates, and metal chlorides.</li> <li>Wastes from manufacture include runoff from equipment cleaning (solvents), obsolete stock, spills, etc.</li> </ul>
Product packaging and final packaging	<ul style="list-style-type: none"> <li>Prepackaged mortar is shipped in bags; ready-mixed mortar is shipped to a site in wet state in bulk.</li> <li>Bricks have very little packaging and are usually bound by steel straps and set on wood pallets.</li> </ul>	<ul style="list-style-type: none"> <li>Because they are so breakable, glass products are packaged with fairly substantial but usually recyclable materials.</li> </ul>	<ul style="list-style-type: none"> <li>Containers for paints are classified as hazardous waste in some jurisdictions.</li> </ul>
Product distribution	<ul style="list-style-type: none"> <li>Transporting bricks to a site requires energy in the form of fossil fuels; however, bricks usually are manufactured close to the site.</li> </ul>	<ul style="list-style-type: none"> <li>Glass is transported easily as it is usually made into fairly lightweight units.</li> </ul>	<ul style="list-style-type: none"> <li>Choose paints that are made as close to the building site as possible to save energy for transportation.</li> </ul>
Product installation, use, and maintenance	<ul style="list-style-type: none"> <li>Bricks not used in a construction project are shipped back to the manufacturer for recycling.</li> </ul>	<ul style="list-style-type: none"> <li>Glass is an inert material and is easily specified for building projects. It is very easily maintained, although care must be exercised with coated glass products to avoid damaging the coating during cleaning.</li> </ul>	<ul style="list-style-type: none"> <li>Paint can generate VOC emissions during application and drying; initial emissions can be significant.</li> <li>Pigments may also contain toxic compounds, a concern when burning demolition waste, sanding surfaces, etc.</li> <li>Citrus oil solvent, an alternative solvent, can cause irritation or allergies but dries quickly.</li> <li>Alternative paints can use natural oils, such as linseed, tung, pine, etc. instead of petrochemicals, as well as alternatives for fillers, driers, pigments, resins, etc. that are less toxic than conventional materials.</li> </ul>
Final disposal, reuse, or recycling	<ul style="list-style-type: none"> <li>The minimum life expectancy of a brick building is 100 years or more. If constructed properly, a brick building can last 1000 years.</li> </ul>	<ul style="list-style-type: none"> <li>A small amount of glass is recycled from older buildings; certain types of flat glass can be recycled into glassphalt, an asphalt substitute, for paint additives, etc.</li> </ul>	<ul style="list-style-type: none"> <li>During demolition and renovation projects, lead contained in paints made before 1978 may be released as dust or chips, causing adverse health effects to building inhabitants.</li> <li>Some paints contain a significant proportion of recycled material, both postconsumer and plant waste.</li> </ul>

ENERGY CONSUMPTION AND WASTE GENERATION

Energy consumption totals	<ul style="list-style-type: none"> <li>The embodied energy at point-of-use for one pound of brick and mortar is approximately 4000 Btus/lb.</li> </ul>	<ul style="list-style-type: none"> <li>The embodied energy in glass is approximately 11,100 Btus/lb.</li> </ul>	<ul style="list-style-type: none"> <li>Embodied energy at the point-of-use for conventional water-based paint is 33,034 Btus/lb; for conventional oil-based paint it is 41,642 Btus/lb.</li> </ul>
Waste generation totals	<ul style="list-style-type: none"> <li>Acid rain is an effect of fluorine and chlorine pollutants in the atmosphere. Greenhouse gases (CO<sub>2</sub>) are released during fuel use in mining and processing.</li> <li>Very little solid waste results from the manufacture of brick; waste materials are recycled into new material.</li> </ul>	<ul style="list-style-type: none"> <li>Air pollutants generated during the melting of glass from the combustion of fuel and vaporization of raw materials include nitrogen oxides, VOCs, etc.</li> </ul>	<ul style="list-style-type: none"> <li>Many of the materials used to manufacture paints are derived from petrochemicals. Oil and natural gas extraction is responsible for a variety of environmental pollutants, such as air emissions and toxic solid wastes.</li> </ul>

DESIGN CONSIDERATIONS

<ul style="list-style-type: none"> <li>Brick construction can help conserve energy by its insulating value, thermal mass qualities (storing solar heat gain), and the efficiency with which it is made and transported to building sites.</li> <li>Brick contributes strength and durability to the life span of a building.</li> <li>Brick has relatively low embodied energy and is a non-toxic inert material that is relatively harmless to the environment throughout its life cycle.</li> <li>Select products with recycled content when possible.</li> <li>To reduce cooling loads in hot climates, specify light-colored facing materials.</li> <li>Make sure brick and mortar facings are properly installed and maintained to ensure optimal, long-term performance, particularly relating to moisture resistance. Use of a masonry backup wall is preferred.</li> </ul>	<ul style="list-style-type: none"> <li>When properly specified and installed, glass is highly energy efficient. It permits less use of artificial lighting, resulting in an energy savings.</li> <li>Glass is inert and has virtually no adverse impact on indoor air quality.</li> <li>Use of glass aids in the solar heat gain of building interiors.</li> <li>Specify high-performance glazing (spectrally selective for commercial buildings, low-E for residential buildings) in almost all geographic regions and building applications.</li> <li>Avoid reusing salvaged glass in exterior building envelopes because of poor energy performance.</li> </ul>	<ul style="list-style-type: none"> <li>Architects and builders must consider the issues surrounding exposure to and disposal of lead-based paint materials during demolition or renovation projects.</li> <li>Paints greatly extend the useful life of the built and manufactured environment, resulting in savings of energy and materials and a corresponding reduction of environmental pollution.</li> <li>If performance won't be compromised, waterborne formulations should be specified rather than oil-based formulations.</li> <li>Always ventilate spaces being painted directly into the outdoors. Never allow contaminated air to circulate into a building's HVAC system.</li> </ul>
--	--	--

LIFE CYCLE OF COMMON BUILDING MATERIALS

	ALUMINUM	STEEL	PARTICLEBOARD
Raw materials acquisition and preparation	<ul style="list-style-type: none"> <li>Manufacturing depletes the mineral bauxite, a finite resource (only 125 years remain at the current rate of consumption).</li> <li>Bauxite strip mining causes loss of large tracts of land, including some loss of tropical forests and habitats.</li> <li>Reclamation of strip mines reduces long-term effects but some species may be lost.</li> <li>Other raw materials consumed during acquisition include lime, caustic, soda, crude oil, and coal.</li> <li>Degradation of ground and surface water and air may occur from mining.</li> </ul>	<ul style="list-style-type: none"> <li>Manufacturing depletes supplies of iron ore, limestone, and coal, all finite resources.</li> <li>Processing of coal into coke produces toxic air pollutants.</li> <li>Deep pit mining causes loss of virgin forests and lands; land reclamation may reduce long term effects.</li> <li>Degradation of ground and surface water and air may occur from mining.</li> </ul>	<ul style="list-style-type: none"> <li>Approximately 90% of the wood component of this product comes from sawmill waste; if managed, sustainable and renewable wood cellulose sources are used, natural resource depletion is eliminated; if sawmill waste from old growth trees is used, those forests and habitats will be lost.</li> <li>Size of wood chips varies from 25mm to particles as fine as flour.</li> <li>98% of the resin binder in particleboard is urea formaldehyde (urea is derived from petroleum and formaldehyde from natural gas); 1.6% of the resin used is phenol formaldehyde (phenol is derived from coal tar and petroleum).</li> </ul>
Raw materials processing and manufacturing	<ul style="list-style-type: none"> <li>Smelting and ingot casting is energy intensive.</li> <li>Different finishes vary in their environmental burdens: anodized and powdered paint coatings have few negative environmental effects, while electroplating and related finishes are highly polluting.</li> </ul>	<ul style="list-style-type: none"> <li>Raw materials and resources used in processing include nickel, manganese, chromium, lubricating oils, solvents, acids, and alkalies.</li> <li>Iron is produced from iron ore, coke, and lime, which is heated in blast furnaces.</li> <li>Steel is made from iron by either the basic oxygen furnace method, using 30% scrap, or the electric furnace method, using all scrap steel and iron.</li> </ul>	<ul style="list-style-type: none"> <li>Gaseous formaldehyde emissions occur in drying and mat pressing stages of processing.</li> </ul>
Product packaging and final packaging	<ul style="list-style-type: none"> <li>Packaging of materials varies; choose products that use minimal packaging or packaging made of recycled materials and/or that is itself recyclable.</li> </ul>		
Product distribution	<ul style="list-style-type: none"> <li>Distribution varies; choose products made and/or distributed from a place as close to the building site as possible.</li> </ul>		
Product installation, use, and maintenance	<ul style="list-style-type: none"> <li>Generally a low maintenance material, depending on finish. Painted aluminum surfaces require periodic repainting; anodized finishes and powdered paint coatings require occasional cleaning.</li> </ul>	<ul style="list-style-type: none"> <li>Maintenance depends on which alloy is used (e.g., stainless steel), whether electrolytic treatment has been done (e.g., galvanized steel), and whether a coating has been applied.</li> <li>Preparation of the surface for repainting or other maintenance may require use of solvents or acids.</li> <li>Weathering steel, which forms a protective oxidized coating, is also available.</li> </ul>	<ul style="list-style-type: none"> <li>Most uses are for applications such as cabinet and furniture core stock (MDF), nonstructural floor underlayment, and manufactured home decking. Since the uses are located in protected and confined areas beneath finishes, degradation and maintenance are minimized. Nonetheless, some interior air pollution from offgassing may occur.</li> </ul>
Final disposal, reuse, or recycle	<ul style="list-style-type: none"> <li>Scrap can be recovered, recycled, and reused endlessly; use of recycled aluminum reduces total energy requirements by 90-95%, however, only 15-20% of aluminum in construction is recovered and recycled since it is "bound up" with other materials and difficult to separate.</li> <li>Final disposal causes no ill environmental effects, except ground water contamination from coatings and landfill overcrowding.</li> </ul>	<ul style="list-style-type: none"> <li>By way of magnetic separating processes, scrap is easily recovered and recycled. Recycled steel saves energy and raw materials and reduces contamination of the environment.</li> <li>Final disposal causes no ill environmental effects except groundwater contamination from coatings and landfill overcrowding; steel eventually oxidizes back into a natural state. Limited sorting of steel alloys required in recycling.</li> </ul>	<ul style="list-style-type: none"> <li>Since particleboard is usually bound tightly into assemblies with other materials and finishes such as laminates, recycling is difficult, although possible.</li> </ul>
Energy consumption totals	<ul style="list-style-type: none"> <li>The aluminum industry accounts for 1.4% of annual world energy consumption.</li> <li>Embodied energy at point-of-use for one pound of aluminum is estimated at 102,500 BTUs. Aluminum produced from recovered scrap and recycled aluminum rather than bauxite ore saves 80% of total energy consumption.</li> </ul>	<ul style="list-style-type: none"> <li>Embodied energy at point-of-use for one pound of steel is estimated at 19,200 BTUs. Processes using scrap steel and iron save energy by skipping blast furnace energy consumption.</li> </ul>	<ul style="list-style-type: none"> <li>Embodied energy at point-of-use for one pound of underlayment particleboard is estimated at 7,000 BTUs, 30-40% of which is derived from the resin adhesive.</li> <li>Energy consumed in production is mostly used for heat to dry particles, heat resins, and create steam for hot presses. Depending on the manufacturing plant, wood, gas, and oil are used for energy; however, 78% of the total energy bound up in wood products comes from the burning of wood waste.</li> </ul>
Waste generation total	<ul style="list-style-type: none"> <li>Bauxite refining yields large volumes of mud containing trace amounts of hazardous waste.</li> <li>Although most airborne emissions are contained by wet scrubbing, small amounts of carcinogenic hydrocarbons escape during smelting and forming.</li> <li>Fabrication and finishing may produce heavy metal sludges and large amounts of waste waters that require treatment with toxic chemicals.</li> <li>Solid wastes include used potliners of carbon, insulation material, fluoride, and cyanide.</li> </ul>	<ul style="list-style-type: none"> <li>Both deep pit and strip mining of iron ore, coal, and limestone yield large amounts of discarded rock and soil, resulting in erosion and contamination of water by dissolved toxic minerals. The production of one ton of steel creates 1.5 tons of waste materials.</li> <li>Mine spoils from coal mining may acidify nearby soils and water.</li> <li>Coke ovens may emit toxic sulphur dioxide fumes, carbon monoxide, and other particulate emissions; processing limestone into lime releases carbon dioxide emissions into the air.</li> <li>Liquid wastes produced by processing include lubricants, electrolytic coatings, pickling solutions, paints, and contaminated water.</li> <li>Solid wastes include by-products from the processing of iron ore, limestone, and coal.</li> </ul>	<ul style="list-style-type: none"> <li>Most solid waste from particleboard manufacturing is recovered in the mill or used as fuel; panel trim pieces and defective panels are ground up and put back into raw material stock.</li> <li>Production of resins results in waste waters that may contain toxic monomers.</li> </ul>
Conclusion for designers	<ul style="list-style-type: none"> <li>Although its embodied energy is very high, when compared pound for pound to alternative materials aluminum may be preferable as it is very strong and durable, lightweight, and readily recyclable.</li> <li>Specify aluminum products that are made fully or partially from recycled scrap.</li> <li>Consider designs that will facilitate recycling; avoid, if possible, mixed-material assemblies.</li> <li>Anodized finishes and powdered paint coatings may be the most environmentally friendly finishes.</li> <li>In applications where the uniquely advantageous characteristics of aluminum are not needed, consider low energy-consuming alternative materials that are recyclable.</li> </ul>	<ul style="list-style-type: none"> <li>Since many steel products are made totally or partially from recycled steel, steel is considered less environmentally harmful than other alternatives.</li> <li>Steel can be used very efficiently in reinforced concrete as a structural material. However, this practice usually binds the steel permanently with the concrete, making it nonrecyclable.</li> <li>Steel, regardless of coating, treatments, and alloys, can be recovered and recycled easily.</li> </ul>	<ul style="list-style-type: none"> <li>Urea formaldehyde (UF) particleboard offgasses formaldehyde into indoor air. Levels of emission are higher in spaces with high temperature and humidity levels; all emission levels decrease over time.</li> <li>Specify low-emitting, UF-bonded particleboard where practical, or consider sealing UF particleboard or using phenol formaldehyde-bonded particleboard (exterior grade plywood, etc.).</li> </ul>

Richard J. Vitullo, AIA; Oak Leaf Studio; Crownsville, Maryland  
AIA Environmental Resource Guide



**RESOURCE CONSERVATION METHODS AND SYSTEMS**

Choosing building materials containing recycled materials is but one step in the process of environmentally conscious design. Sensitive environmental design takes the holistic view, regarding every aspect of how a building works in its context. Consideration must be given to how a building performs and relates to its surroundings throughout its life, before (design and specification), during (construction), and after (lifetime maintenance and energy costs) it is built. The following guidelines can be used for designing with resource conservation goals:

1. Design with nature's patterns in mind so the building works with them and the resources of its site rather than overpowering and controlling them. The following methods will help you achieve this goal:
  - a. Building and site planning. To achieve the goal of overall environmental design, it is critical to orient the building to the landscape at the site. Working with site features will allow you to take advantage of natural systems, such as ventilation by means of windrows and chimneys or full-spectrum light sources.
  - b. Earth-sheltered design. Solar heat and light can be used to reduce the nonrenewable energy requirements of a building. The temperature-moderating feature of the earth is an aspect of the surrounding environment often ignored. Through earth berms, earth-covered roofs, and underground design, a building can make use of the consistent 55° F± of the earth below the local frost line or at least the inherent R-

value of earth material. A well-designed earth-sheltered structure also reduces the need for exterior maintenance of building materials.

2. Preserving existing site features may benefit the local habitat and make the building harmonize with the site.
  - a. Tree, plant, and soil preservation. Establish environmental priorities for the building site. Inventory natural features such as viable trees and shrubs and wetland areas. Trees provide an enormous environmental benefit to the health of buildings (shading, etc.), sites (soil enrichment from leaves, etc.), and birds and other wildlife. Locate buildings, driveways, and land to be disturbed during construction far enough from existing trees to avoid root compaction. A good rule of thumb is to stay out of the drip line of a tree during construction. Have a landscape architect, arborist, forester, or environmental consultant assist in the survey.
  - b. Construction and demolition site waste recycling or reuse. The construction of a single-family home in the U.S. generates 2.5 tons of waste. Since landfill overcrowding has caused dumping fees to increase significantly, it is becoming economically feasible to recycle construction and demolition wastes. Identify materials that could be used more efficiently, salvaged, reused on site, or recycled. Common materials that generally can be recycled from construction sites are (with percentages based on total site waste volume): wood (27%), cardboard/paper (18%), gypsum board (15%), insulation (9%), roofing (8%), metals (7%), concrete/asphalt rubble (6%), landscaping debris (5%), and miscellaneous (5%). These are national averages, and each site will be different. Identify positions for recy-

cling bins on site so materials can be separated as they are recovered. Prevent storm sewer and ground water pollution and reduce soil erosion with sensitive design and site construction methods.

3. Energy-efficient design should reduce or eliminate nonrenewable fossil fuel consumption for heating, cooling, and lighting. Although it is good to create a building with resource conservative materials, it is critical to ensure that once the building is built it either continues to conserve energy resources or uses renewable energy resources throughout its life. Consider using durable, low-maintenance materials. Where practical, design full-cycle systems such as solar water heating that will capture renewable energy on site. The following equipment can help achieve this goal:
  - a. Heat recovery ventilators. This system extracts the heat from the air as it is exhausted and transfers that it to incoming air (or the reverse in the summer). This system allows a tight, energy-efficient building to be ventilated but still retain the heat-energy used to maintain the indoor environment. Depending on the climate, this system can be up to 80% efficient in recovering energy and is recommended for either very cold or very hot, humid climates. Consult with a mechanical engineer or equipment manufacturer.
  - b. Ground source heat pump. Like earth-sheltered building design, this system takes advantage of the stability of underground temperatures. Long lengths of copper tubing are buried either horizontally or vertically in the earth and circulated with a heat-exchanging medium.

**NONTOXIC BUILDING MATERIALS**

Some building materials contain substances or release particles that can be an irritant and cause the medical problem called "sick building syndrome." Some of these airborne substances can also cause long-term problems such as chronic allergies and even cancer. Chemically sensitive people are at risk, as well as otherwise healthy installers or building occupants. The origins of these toxic substances—including by-products of manufacture and installation (e.g., chemicals released as adhesives and mastic cure), by-products of decay and age (e.g., offgassing of particleboard or plywood), and by-products of burning (e.g., toxic fumes from plastics)—are varied.

The U.S. Environmental Protection Agency (EPA) has identified five major causes of indoor air pollution:

1. Biogenic particles—mold, bacteria, etc.
2. Combustion by-products—tobacco products, gas ranges, furnaces, and fireplaces
3. Organic chemicals—benzene, formaldehyde
4. Natural substances—radon, lead
5. Fibrous materials and airborne particles—fiberglass, asbestos, pollen, dust, etc.

Ideally, materials and systems selected for a building should be durable, easily maintained, safe for the installer and user, and produced without excess energy use. Good maintenance features allow a material to be cleaned of other hazards and irritants, such as mold, moisture, and dust, with nontoxic cleaners and treatments. However, building materials should not be chosen for good maintenance features alone, as hazardous materials like vinyl, synthetics, and plastics can be very easy to clean.

As in any design process, designing a healthy building requires establishing priorities. However, this may not be an easy task, as it can be difficult to define "healthy" and difficult to implement "healthy" practices. Alternative products are not as well known or marketed as standard products, making them harder to find. In addition, these products can be more expensive and occasionally more difficult to install or apply if contractors are unfamiliar with them. Nonetheless, carefully selecting appropriate alternatives where possible and minimizing the most toxic materials and methods make constructing a "healthier" building an achievable goal.

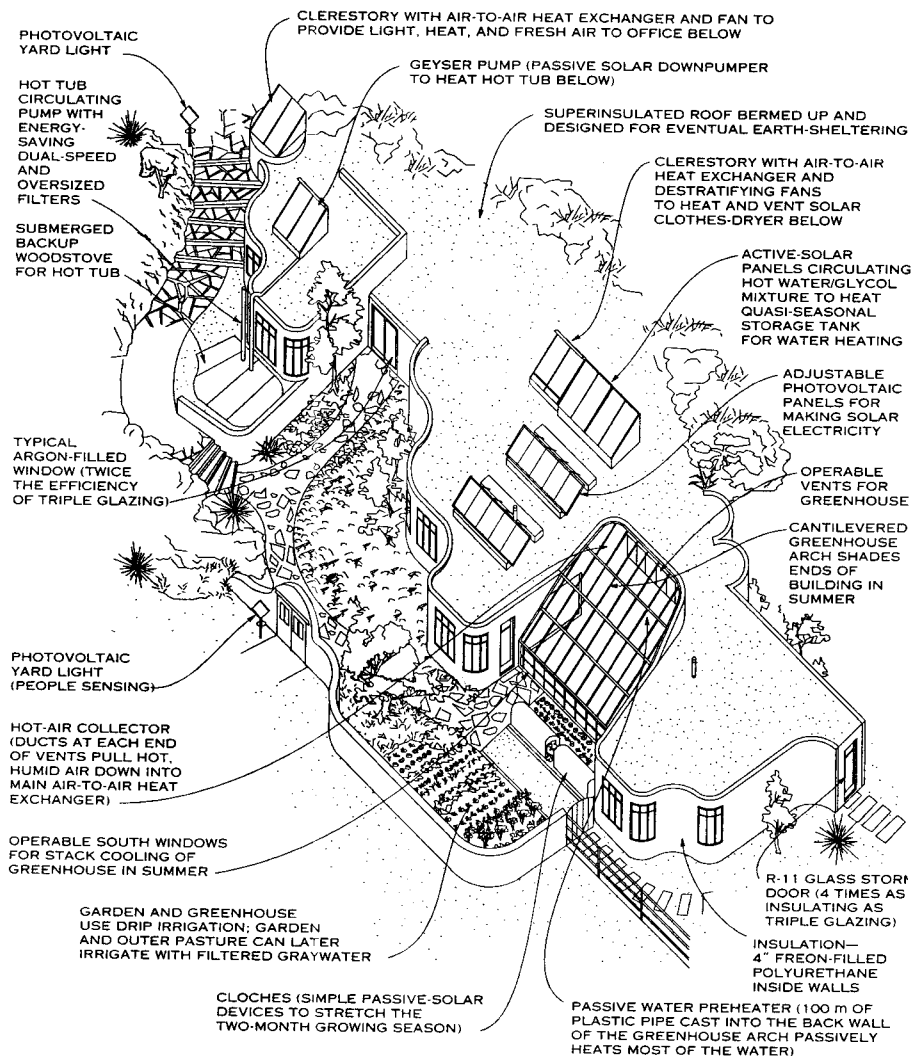

**ENERGY SAVING SYSTEMS (THE ROCKY MOUNTAIN INSTITUTE; SNOWMASS, COLORADO)**

Richard J. Vitullo, AIA; Oak Leaf Studio; Crownsville, Maryland  
AIA Environmental Resource Guide

**BUILDING MATERIALS COMPARISON CHART**

CSI DIVISIONS	STANDARD PRODUCTS	ENVIRONMENTAL IMPACT	TOXICITY TO INDOOR ENVIRONMENT	ENVIRONMENTALLY SOUND ALTERNATIVE PRODUCTS OR SUGGESTIONS	ENVIRONMENTAL IMPACT	TOXICITY TO INDOOR ENVIRONMENT
Concrete	Concrete material	<ul style="list-style-type: none"> <li>Concrete has high embodied energy content</li> </ul>		<ul style="list-style-type: none"> <li>Autoclaved cellular concrete (ACC)</li> </ul>	<ul style="list-style-type: none"> <li>Uses fly-ash, a by-product of coal combustion</li> <li>Aluminum powder additive reacts with lime to create hydrogen bubbles and a lightweight, cellular cementitious material (provides high strength to weight ratio); also self-insulating (R-10 for 8 in. wall)</li> </ul>	<ul style="list-style-type: none"> <li>No harmful by-products</li> </ul>
Metals	Steel studs/ framing members	<ul style="list-style-type: none"> <li>Reduces depletion of old and new growth timber</li> <li>Can be made from recycled scrap into identical product</li> <li>Consumes more energy to produce (high embodied energy content)</li> <li>Steel production pollutes air, water, and soil</li> </ul>	<ul style="list-style-type: none"> <li>Inert; produces no harmful by-products</li> </ul>	<ul style="list-style-type: none"> <li>Use materials with less embodied energy content if recycled steel not available</li> </ul>	<ul style="list-style-type: none"> <li>See alternative product chosen</li> </ul>	<ul style="list-style-type: none"> <li>See alternative product chosen</li> </ul>
Wood	Standard wood framing	<ul style="list-style-type: none"> <li>Depletes old and new growth timber</li> <li>Can be recycled into particleboard and other wood products</li> <li>Pressure-treated woods contain toxic inorganic arsenates (site waste needs to be contained)</li> </ul>	<ul style="list-style-type: none"> <li>Produces no significant harmful by-products</li> </ul>	<ul style="list-style-type: none"> <li>Interior: Engineered lumber Finger-jointed structural lumber Plastic framing members</li> <li>Exterior: Decking - pav lope Mudslis - douglas fir treated with resin oil, beechwood distillates, etc.</li> </ul>	<ul style="list-style-type: none"> <li>Engineered lumber made from recycled wood fiber and small diameter trees</li> <li>Finger-jointed wood made from small wood pieces</li> <li>Plastic members made from recycled soda bottles</li> <li>Pav lope, a plantation grown, rot-resistant hardwood</li> <li>Natural wood treatments not toxic</li> </ul>	<ul style="list-style-type: none"> <li>Engineered lumber may offgas formaldehyde</li> <li>Plastic members may offgas chemical fumes and give off toxic fumes when burned</li> </ul>
	Plywood	<ul style="list-style-type: none"> <li>Made from large diameter, old growth peeler logs</li> </ul>	<ul style="list-style-type: none"> <li>Interior grade offgases high-emitting levels of urea formaldehyde</li> <li>Exterior grade offgases low-emitting phenol formaldehyde</li> <li>Formaldehyde a possible carcinogen and is irritating to respiration</li> <li>Offgassing half-life is ± 6 months</li> </ul>	<ul style="list-style-type: none"> <li>Lumber-core plywood</li> <li>Cellulose fiberboard underlayment</li> <li>Exterior - grade plywood with sealing finishes</li> <li>Tongue and groove pine sheathing</li> </ul>	<ul style="list-style-type: none"> <li>All plywood still made from old growth peeler logs</li> <li>Cellulose fiberboard made from recycled newspapers</li> <li>Tongue and groove pine usually locally grown and can be from smaller diameter trees</li> </ul>	<ul style="list-style-type: none"> <li>Lumber core and exterior grade plywoods have reduced levels of formaldehyde offgassing</li> <li>Cellulose fiberboard and tongue and groove pine have no harmful offgassing</li> </ul>
	Particleboard: Oriented strand board (OSB) Medium density fiberboard (MDF)	<ul style="list-style-type: none"> <li>Can be made from recycled wood scrap, sustainable woods, and cellulose fibers</li> </ul>	<ul style="list-style-type: none"> <li>Same characteristics as plywood</li> </ul>	<ul style="list-style-type: none"> <li>Laminated or sealed MDF</li> </ul>		<ul style="list-style-type: none"> <li>Covering finishes or sealers reduce offgassing</li> </ul>
	Finish woods	<ul style="list-style-type: none"> <li>Use of exotic tropical woods depletes rain forests</li> </ul>	<ul style="list-style-type: none"> <li>Produces no harmful by-products</li> </ul>	<ul style="list-style-type: none"> <li>Domestic temperate hardwoods (plum, cherry, alder, black locust, and persimmon)</li> <li>Veneer woods with recycled backup</li> <li>Reclaimed and re-used woods</li> </ul>	<ul style="list-style-type: none"> <li>Domestic woods can be managed as sustainable tree farms</li> <li>Use of veneers instead of solid woods saves tree resources</li> <li>Use of re-used woods saves tree resources</li> </ul>	<ul style="list-style-type: none"> <li>Some finishes may be harmful to indoor air</li> </ul>
Thermal and moisture protection	Fiberglass batt insulation	<ul style="list-style-type: none"> <li>Can be made from recycled glass</li> </ul>	<ul style="list-style-type: none"> <li>Airborne fibers can be irritating to skin, lungs, and nasal passages</li> <li>Offgases formaldehyde</li> </ul>	<ul style="list-style-type: none"> <li>Cellulose insulation</li> <li>Cotton insulation</li> <li>Cementitious foam insulation</li> <li>Mineral fiber insulation</li> </ul>	<ul style="list-style-type: none"> <li>Cellulose insulation made from recycled newsprint</li> <li>Cotton batt insulation made from recycled cotton denim fibers</li> <li>Cementitious foam made from silicate-based magnesium (CFC-free)</li> <li>Mineral fiber made from mineral slag, a waste by-product of steel production</li> </ul>	<ul style="list-style-type: none"> <li>Cotton and cellulose insulation may be treated with chemical fire treatment</li> </ul>
	Rigid insulation	<ul style="list-style-type: none"> <li>Many types made from nonrenewable petrochemicals</li> <li>Many types also made with CFCs, which are harmful to ozone layer</li> </ul>	<ul style="list-style-type: none"> <li>Gives off toxic fumes when burned</li> <li>Those made with isocyanurate, polyurethane, and phenolic foam offgas chemical fumes</li> </ul>	<ul style="list-style-type: none"> <li>Recycled extruded polystyrene insulation</li> <li>CFC-free insulation</li> <li>Expanded polystyrene</li> </ul>	<ul style="list-style-type: none"> <li>Re-use of recycled plastic does not deplete oil resources</li> <li>HCFE foaming agent 1/20 as damaging to ozone as CFC</li> <li>Expanded polystyrene only R-3.6 per inch (extruded polystyrene R-4.4 per inch)</li> </ul>	<ul style="list-style-type: none"> <li>Some recycled plastic materials may offgas chemical fumes</li> <li>Plastics give off toxic fumes when burned</li> </ul>
	Exterior siding/ trim	<ul style="list-style-type: none"> <li>Vinyl siding made from nonrenewable petrochemical source</li> <li>Wood siding and shakes deplete mature slow growth cedar and redwood trees</li> </ul>		<ul style="list-style-type: none"> <li>Hardboard siding</li> <li>Fiber-cement composite siding</li> <li>Composite trim</li> </ul>	<ul style="list-style-type: none"> <li>Hardboard siding made from recycled wood fiber</li> <li>Fiber cement siding made from wood sawmill chips and portland cement</li> <li>Composite trim made from recycled plastic and recycled wood fiber</li> </ul>	
	Wood and asphalt roof shingles	<ul style="list-style-type: none"> <li>Asphalt is derived from nonrenewable petrochemicals</li> <li>Wood shingles, either cedar or redwood, from old growth, slow growth tree stands</li> </ul>	<ul style="list-style-type: none"> <li>Many contain fiberglass fibers (mostly harmful to installers), an irritant</li> <li>Chemical treatment of wood shingles harmful to installers</li> </ul>	<ul style="list-style-type: none"> <li>Fiber-cement composite shingles</li> <li>Natural slate and terra-cotta</li> <li>Recycled aluminum shingles</li> <li>Recycled plastic shingles</li> <li>Metal roofing of recycled steel or copper</li> </ul>	<ul style="list-style-type: none"> <li>Fiber-cement shingles made from recycled wood sawmill chips or paper and portland cement (also recyclable)</li> <li>Recycled aluminum from soda cans and scrap</li> <li>Recycled plastic from computer housings</li> </ul>	<ul style="list-style-type: none"> <li>Plastic offgases harmful fumes (negligible to indoor air) and gives off toxic fumes when burned</li> </ul>

Richard J. Vitullo, AIA; Oak Leaf Studio; Crownsville, Maryland  
AIA Environmental Resource Guide

**BUILDING MATERIALS COMPARISON CHART**

CSI DIVISIONS	STANDARD PRODUCTS	ENVIRONMENTAL IMPACT	TOXICITY TO INDOOR ENVIRONMENT	ENVIRONMENTALLY SOUND ALTERNATIVE PRODUCTS OR SUGGESTIONS	ENVIRONMENTAL IMPACT	TOXICITY TO INDOOR ENVIRONMENT
Doors and windows	Doors	<ul style="list-style-type: none"> <li>Some doors made with endangered old growth woods such as teak or mahogany (lauan) veneers and solids</li> </ul>	<ul style="list-style-type: none"> <li>Few harmful by-products in wood; finishes may contain offgassing materials</li> </ul>	<ul style="list-style-type: none"> <li>Recycled-content doors</li> <li>Fiberglass doors</li> </ul>	<ul style="list-style-type: none"> <li>Some doors made from recycled plastic and wood waste; also recycled steel</li> <li>Fiberglass uses a few petrochemicals in production</li> </ul>	<ul style="list-style-type: none"> <li>Recycled wood may be bound by urea formaldehyde resin</li> <li>Recycled plastic offgases and gives off toxic fumes when burned</li> </ul>
	Windows	<ul style="list-style-type: none"> <li>Many windows in older structures not energy efficient</li> </ul>	<ul style="list-style-type: none"> <li>Vinyl windows offgas harmful fumes and give off toxic fumes when burned</li> </ul>	<ul style="list-style-type: none"> <li>Recycled-content windows</li> <li>High efficient, low E glass windows</li> <li>Argon-filled insulated glass windows</li> </ul>	<ul style="list-style-type: none"> <li>Fiberglass same coefficient of expansion as glass</li> <li>See doors above</li> </ul>	<ul style="list-style-type: none"> <li>See doors above</li> </ul>
Finishes	Gypsum board wall and ceiling systems	<ul style="list-style-type: none"> <li>Many types use predominantly virgin gypsum mineral, depleting resources</li> </ul>	<ul style="list-style-type: none"> <li>Many carcinogens in standard joint compounds</li> </ul>	<ul style="list-style-type: none"> <li>Wallboard made with recycled or reclaimed materials</li> <li>Nontoxic powdered joint compound</li> </ul>	<ul style="list-style-type: none"> <li>Some alternative "gypsum" board cores contain recycled scrap wallboard, by-product gypsum (from emissions of fossil-fueled factories), recycled cellulose fiber, perlite, ryegrass straw (an agricultural by-product), mixed waste papers. Some wallboard facings made with recycled paper</li> </ul>	<ul style="list-style-type: none"> <li>Nontoxic joint compounds contain no harmful agents (must be site-mixed and may be difficult to use)</li> </ul>
	Flooring	<ul style="list-style-type: none"> <li>PVC and vinyl tiles made from nonrenewable petrochemicals</li> </ul>	<ul style="list-style-type: none"> <li>PVC and vinyls offgas harmful fumes</li> </ul>	<ul style="list-style-type: none"> <li>Natural linoleum tile</li> <li>Recycled-content tile</li> <li>Natural grouts</li> <li>Reclaimed and re-used wood floors</li> </ul>	<ul style="list-style-type: none"> <li>Linoleum made from linseed oil, pine resins, softwood flour, cork, and jute</li> <li>Tile made from recycled light bulbs and auto glass</li> <li>Tile made from recycled auto tires</li> <li>Grouts made from silica, calcium rock, and iron-oxide pigments</li> </ul>	
	Carpet	<ul style="list-style-type: none"> <li>Many made from petrochemicals, a nonrenewable resource</li> </ul>	<ul style="list-style-type: none"> <li>Plastic fibers, backing, mastics, and treatments offgas many gasses harmful to respiratory systems (major component of "sick building syndrome")</li> <li>All carpets may harbor dust and mites, both respiratory irritants</li> <li>Plastic gives off toxic fumes when burned</li> </ul>	<ul style="list-style-type: none"> <li>Natural fiber carpets</li> <li>Recycled-content carpets</li> </ul>	<ul style="list-style-type: none"> <li>Choose untreated carpets made with natural fibers and backing such as wool or cotton</li> <li>Some carpets made from recycled plastic (soft drink bottles)</li> <li>Choose natural jute padding</li> </ul>	<ul style="list-style-type: none"> <li>Use tackable edging instead of adhesives or just edge and seam application of adhesives</li> <li>Use low-voc adhesives</li> <li>Recycled plastic offgases harmful fumes and gives off toxic fumes when burned</li> </ul>
	Paint, finishes, and wood treatments	<ul style="list-style-type: none"> <li>Unused paint etc. can cause groundwater and soil pollution if disposed of improperly</li> <li>Volatile organic compounds (VOCs) can cause smog and ground level ozone pollution</li> </ul>	<ul style="list-style-type: none"> <li>Many enamels, varnishes, and polyurethanes contain VOCs and offgas these causing harmful respiratory reactions</li> </ul>	<ul style="list-style-type: none"> <li>Citrus-based paints</li> <li>Acrylic-based stains</li> <li>Natural wood treatments and finishes</li> </ul>	<ul style="list-style-type: none"> <li>Citrus-based paints have low-bio-cide content but contain some petrochemicals</li> <li>More organic type finishes present less disposal problems</li> </ul>	<ul style="list-style-type: none"> <li>Citrus-based paints have low-bio-cide, nonirritating content (must be thinned and color-mixed by installer)</li> <li>Acrylic-based stains are low-VOC</li> <li>Natural wood treatments of tung oil, ointment of beeswax, etc. contain no harmful irritants (more maintenance required)</li> </ul>
	Adhesives and mastics	<ul style="list-style-type: none"> <li>Unused containers can cause groundwater and soil pollution if disposed of improperly</li> </ul>	<ul style="list-style-type: none"> <li>Some adhesives and mastics offgas hazardous fumes to installers and occupants</li> <li>Many types of adhesives are flammable and give off toxic fumes when burned</li> </ul>	<ul style="list-style-type: none"> <li>Low-voc, environmentally safer adhesives and mastics</li> </ul>	<ul style="list-style-type: none"> <li>Some adhesives and mastics are nontoxic, nonflammable, and safer for disposal (water-soluble)</li> </ul>	<ul style="list-style-type: none"> <li>Low-voc content emits less toxic fumes</li> </ul>
Electrical	Electrical wiring		<ul style="list-style-type: none"> <li>Electromagnetic fields are created around any electrical source and may cause cancer</li> </ul>	<ul style="list-style-type: none"> <li>Electromagnetic shielding</li> </ul>		<ul style="list-style-type: none"> <li>Install shielding for wiring at spaces that will have prolonged exposure to occupants (e.g., bedrooms)</li> </ul>

**NOTES**

- This chart is intended as a guide to selecting environmentally friendly materials. As a rule of thumb, use locally produced environmentally friendly materials to save transportation-related energy.
- In comparing building materials, the choice that promotes resource conservation may not always be as straightforward as it appears. For example, wood may seem a better choice than plastic for a park bench, as it is a natural, renewable material rather than a petroleum-

based one. However, in an outdoor usage, where durability and good maintenance characteristics are preferred, offgassing from plastic is not an issue. When the aesthetics of wood are not important, plastic made from recycled soda bottles may be an appropriate solution. Choosing recycled plastic would conserve wood materials—old-growth cedar, redwood, or chemically treated pine—and reuse something made from a nonrenewable resource, making it an acceptable solution sympathetic

with resource conservation principles. At issue is the definition of a "resource" that must be conserved. A great deal of material and embodied energy are tied up in existing plastic. The reuse of these materials not only allows those resources to continue a useful life but also saves the embodied energy that would have been used to create a new product in its place. Plastic, particularly, is very durable and very slow to degrade.

Richard J. Vitullo, AIA; Oak Leaf Studio; Crownsville, Maryland  
AIA Environmental Resource Guide

SAMPLE LIFE-CYCLE FLOWCHART (STEEL FRAMING AND FASTENERS)

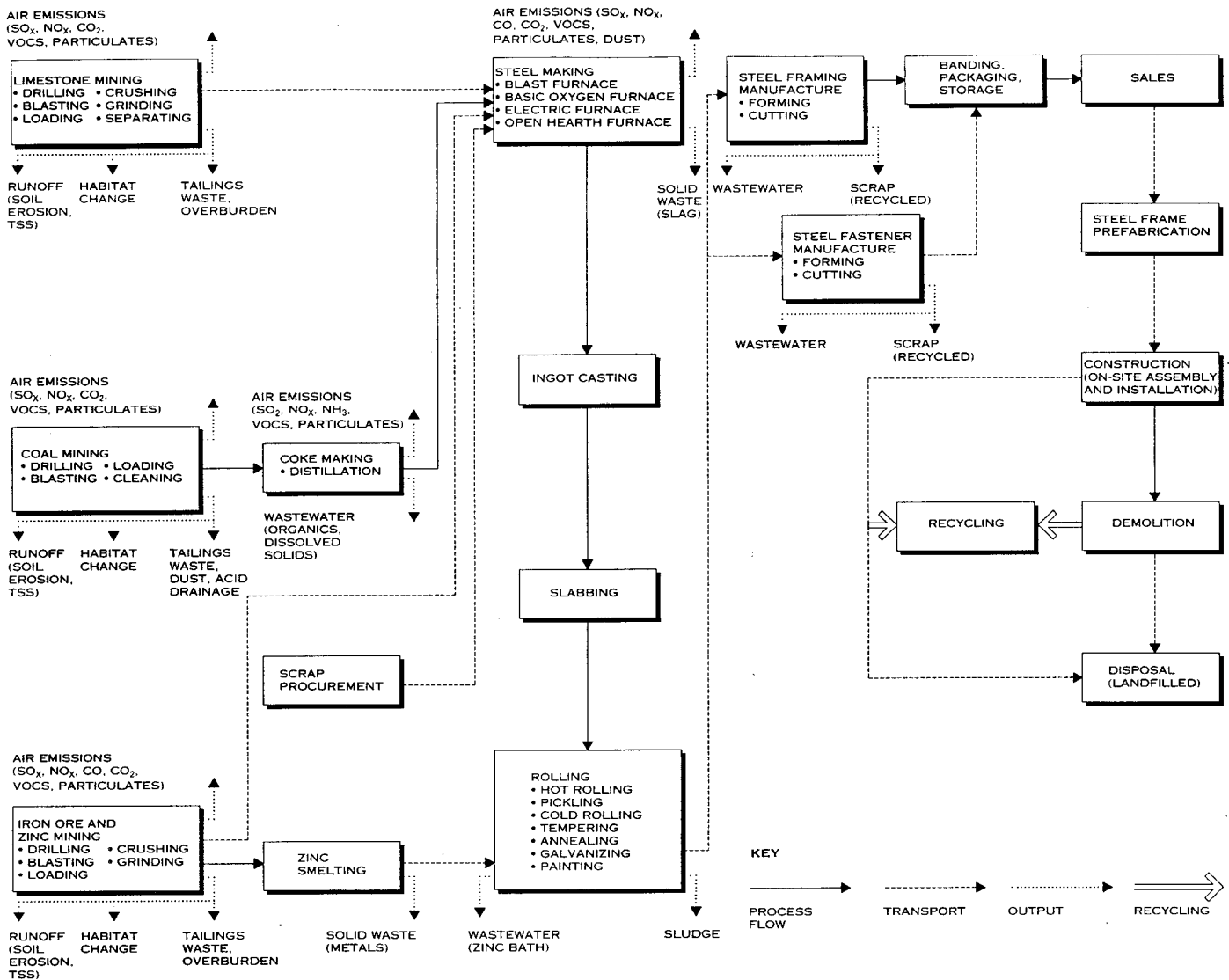

GENERAL

Flowcharts such as that illustrated above are an important element in the documentation of life-cycle analysis findings for building materials. Life-cycle flowcharts provide a comprehensive picture of the resources, energy, and environmental emissions associated with the creation and use of a given building material. Each flowchart encompasses the entire "life" of a material, from cradle to grave or cradle to cradle. (A cradle-to-cradle life cycle reflects the fact that some materials can be reused or recycled.)

Using a "streamlined" life-cycle methodology, the AIA *Environmental Resource Guide* (ERG) combines both quantitative and qualitative analyses. It defines the major life-cycle phases to include

1. Acquisition and preparation of raw materials
2. Manufacture of the building material
3. Installation and use of the material in buildings
4. Reuse, recycling, or disposal of the material at the time buildings are renovated or demolished

The life-cycle flowchart begins by showing the raw materials extracted from the earth, harvested from plants, or obtained from animals. The individual procedures involved in the acquisition processes are identified and related to

specific changes that each raw material undergoes. Each box in the flowchart names a procedure, identifies its components, indicates if one or more materials are combined, and shows what wastes or recyclable/reusable materials are released by the procedure.

Each stage of the life cycle may contain several phases. For example, the manufacturing and fabrication stage may include product packaging and product distribution phases, among others. Regardless of the labels given to each stage, the flowchart depicts the continuous progression of the building material in its various forms, identifying the input and output associated with each process.

The flowchart denotes the release of wastes into air and water and onto the land for each stage of the process. It also indicates points at which recycling and reuse of materials or material by-products occur.

An ideal flowchart shows the consumption and release of energy throughout the life cycle of a building material. The difficulty in obtaining information on exact energy amounts for all processes, however, usually prevents inclusion of these data on the chart. Energy data generally require narrative discussion due to variability that cannot be presented succinctly enough to fit in the chart.

After the material to be studied has been identified and defined ("scoping"), an environmental analysis proceeds in four steps as outlined below. As noted, the life-cycle flowchart is a key component in the first step.

1. INVENTORY ANALYSIS is a fact-finding effort to identify and quantify the environmental inputs and outputs associated with the material being analyzed over its entire life cycle. The life-cycle flowchart pictorially represents the findings of this step, while the report further elaborates on the findings in textual and tabular formats.
2. IMPACT ASSESSMENT classifies the data from the inventory into categories that describe potential impacts on the environment and ecosystems, human health and welfare, energy use, and building operation.
3. IMPACT EVALUATION incorporates the values of stakeholders in determining the importance of the impact categories.
4. INTERPRETATION involves identifying opportunities for improving the life-cycle performance of materials at any point in the life cycle.

Although the material assessments in the ERG are prepared on a generic basis for categories of building materials (e.g., concrete, brick, steel, glass, etc.), the methodology can also be applied selectively to a proprietary product.

David Natella and Joel Ann Todd; The Scientific Consulting Group, Inc.; Gaithersburg, Maryland  
 Chart reprinted from American Institute of Architects, *Environmental Resource Guide* (John Wiley & Sons, 1998)

## PRIORITIES FOR SUSTAINABLE BUILDINGS

It is rarely possible to do everything we would like to reduce the environmental impact of building projects. It takes time to research alternative design and construction systems, new materials may lack proven track records, costs may be excessive, or clients may not be interested. Therefore, it makes sense to determine which efforts will do the most good.

Material selection is one of the most visible green building strategies and often the easiest to point to, but it is not usually the most important. Outlined on this page are other factors to consider and a list of priorities in green design.

### A BASIS FOR ESTABLISHING PRIORITIES

To make objective decisions about which investments of time and money will contribute the most toward reducing environmental impact, consider several related factors:

1. The most significant environmental risks of the project: These may be global in nature or more specific to the region or site. Prioritizing them is difficult as they often are unrelated so cannot be compared directly.
2. How buildings contribute to these risks and how significantly the measures we adopt can help the situation.
3. The specific opportunities presented by each individual project: For some projects an architect can dramatically affect building performance in one area with little investment, while addressing other environmental impacts may prove very expensive and only minimally effective.
4. The available resources and agenda of the client: Often measures can be taken at no additional cost—some may even save money—to reduce environmental impacts. Other measures might increase the first cost of a building but save money over time.

All the measures listed on this page are important and should be implemented whenever feasible within the constraints of a particular project.

## SAVE ENERGY

Design and build energy-efficient buildings. Ongoing energy use is the single greatest source of environmental impact from a building; thus, buildings designed for low energy use can have a significant effect on the environment. An integrated design approach takes advantage of energy savings that result from interaction between separate building elements (e.g., windows, lighting, and mechanical systems).

### SAMPLE STRATEGIES

1. In buildings with skin-dominated energy loads, incorporate high levels of insulation and high-performance windows to make buildings as airtight as possible.
2. Minimize cooling loads through careful building design, glazing selection, lighting design, and landscaping.
3. Meet energy demand with renewable energy resources.
4. Install energy-efficient appliances, lighting, and mechanical equipment.

## RECYCLE BUILDINGS

Reuse existing buildings and infrastructure instead of developing open space. Existing buildings often contain a wealth of material and cultural resources and contribute to a sense of place. As well, the workmanship and quality of materials that went into them is almost impossible to replicate today.

### SAMPLE STRATEGIES

1. Maximize energy efficiency when restoring or renovating buildings.
2. Handle any hazardous materials appropriately (lead paint, asbestos, etc.).

## CREATE COMMUNITY

Design communities to reduce dependence on the automobile and foster a sense of community. Address transportation as part of the effort to reduce environmental impacts. Even the most energy-efficient, state-of-the-art passive solar house will carry a big environmental burden if its occupants have to get in a car to commute 20 miles to work.

### SAMPLE STRATEGIES

1. Design communities that provide access to public transit, pedestrian corridors, and bicycle paths.
2. Work to change zoning to permit mixed use development so homeowners can walk to the store or to work.
3. Plan home offices in houses to permit telecommuting.
4. Site buildings to enhance the public space around them and maximize pedestrian access.

Arkin Tilt Architects; Albany, California  
 Environmental Building News; Brattleboro, Vermont  
 Real Goods Solar Living Center; Hopland, California

## REDUCE MATERIAL USE

Optimize design to make use of smaller spaces, and utilize materials efficiently. Smaller is better relative to the environment. For all materials, using less is almost always preferable, provided the durability or structural integrity of a building is not compromised. Reducing the surface area of a building reduces energy consumption. Reducing waste both helps the environment and reduces cost.

### SAMPLE STRATEGIES

1. Reduce the building footprint and use space more efficiently.
2. Simplify building geometry to save energy and materials.
3. Design building dimensions to optimize material use and reduce waste.

## PROTECT AND ENHANCE THE SITE

Preserve or restore local ecosystems and biodiversity. In fragile ecosystems or ecologically significant environments, such as old-growth forests or remnant stands of native prairie, this might be the highest priority.

### SAMPLE STRATEGIES

1. Protect wetlands and other ecologically important areas on a parcel of land to be developed.
2. On land that has been ecologically damaged, work to reintroduce native species.
3. Protect trees and topsoil during construction.
4. Avoid pesticide use. Provide construction detailing that minimizes the need for pesticide treatments.
5. With on-site wastewater systems, provide responsible treatment to minimize groundwater pollution.

## SELECT LOW IMPACT MATERIALS

Specify low environmental impact, resource-efficient materials. Most environmental impacts associated with building materials occur before installation. Raw materials have been extracted from the ground or harvested from forests, pollutants have been emitted during manufacture, and energy has been invested during production.

### SAMPLE STRATEGIES

1. Avoid materials that generate a lot of pollution (VOCs, HFCs, etc.) during manufacture or use.
2. Specify materials with low embodied energy (energy used in resource extraction, manufacturing, and shipping).
3. Specify materials salvaged from other uses.
4. Avoid materials that unduly deplete limited natural resources.
5. Avoid materials made from toxic or hazardous constituents (benzene, arsenic, etc.).

## MAXIMIZE LONGEVITY

Design for durability and adaptability. The longer a building lasts, the longer the period over which to amortize its environmental impacts. Designing and building a structure that will last a long time necessitates consideration of how the building can be modified to satisfy changing needs.

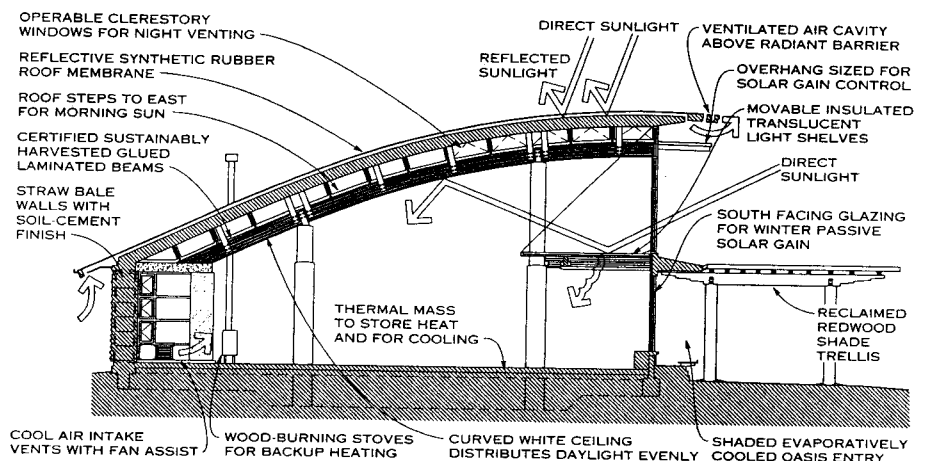

SUSTAINABLE BUILDING EXAMPLE—REAL GOODS SOLAR LIVING CENTER

## SAMPLE STRATEGIES

1. Specify durable materials. This is usually even more important than selecting materials with low embodied energy.
2. Assemble the materials to prevent premature decay.
3. Design for easy maintenance and replacement of less durable components.
4. Design for adaptability, especially in commercial buildings.
5. Allocate an appropriate percentage of building funds for ongoing maintenance and improvement.

## SAVE WATER

Design buildings and landscapes that use water efficiently. This is largely a regional issue. In some parts of the country, reducing water use is much higher on the priority list.

### SAMPLE STRATEGIES

1. Install water-efficient plumbing fixtures and appliances.
2. Collect and use rainwater.
3. Provide low water use landscaping (xeriscaping).
4. Separate and use graywater for landscape irrigation where codes permit.
5. Provide for groundwater recharge through effective storm water infiltration designs.

## MAKE THE BUILDING HEALTHY

Provide a safe, comfortable indoor environment. Although some people separate the indoor and outdoor environments, the two are integrally related and the health of its occupants should be ensured in any "sustainable" building.

### SAMPLE STRATEGIES

1. Design air distribution systems for easy cleaning and maintenance.
2. Avoid mechanical equipment that could introduce combustion gases into the building.
3. Avoid materials with high rates of VOC off-gassing such as standard particleboard, some carpets and adhesives, and certain paints.
4. Control moisture to minimize mold and mildew.
5. Provide for continuous ventilation in all occupied buildings. In cold climates, heat recovery ventilation will reduce the energy penalty of ventilation.
6. Give occupants some control of their environment with features like operable windows, task lighting, and temperature controls.

## MINIMIZE CONSTRUCTION AND DEMOLITION WASTE

Return, reuse, and recycle job site waste. For more and more materials, sorting and recycling job site waste pays off economically. It also can generate a good public image.

### SAMPLE STRATEGIES

1. Sort construction and demolition waste for recycling.
2. Donate reusable materials to nonprofit or community groups that can use them to build or improve housing stock.

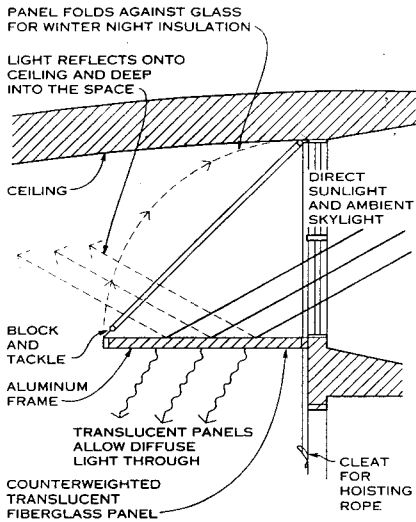

**NOTE**  
Aluminum frame light shelves with insulated translucent fiberglass panels fold against the windows to increase insulation values and reflect light deep into the space.

**LIGHT SHELF**

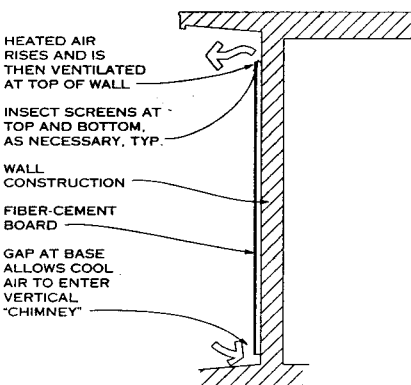
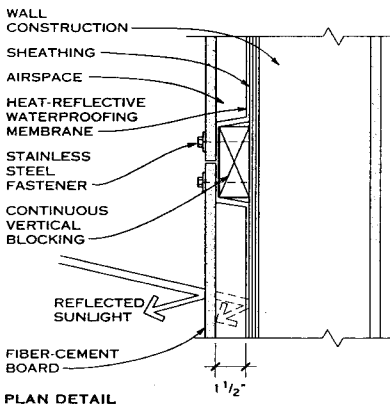

**SECTION**

**NOTE**  
Ventilated wall cavities effectively reduce unwanted heat buildup in extreme cooling climates. An inner membrane reflects solar gain from low afternoon sun and waterproofs.

**VENTILATED WALL CAVITY**

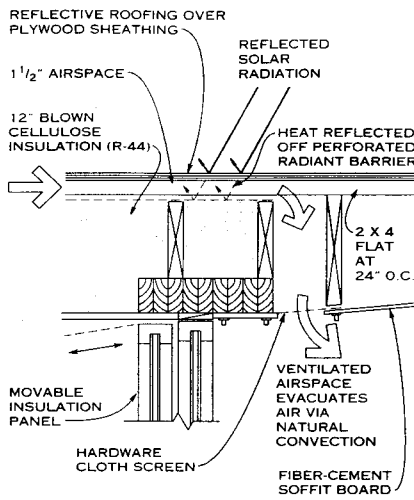

**NOTE**

A ventilated air cavity located over a perforated radiant barrier will carry heat from reflected radiation out of the building before it can migrate down through the insulation.

**VENTILATED AIR CAVITY DETAIL AT ROOF**

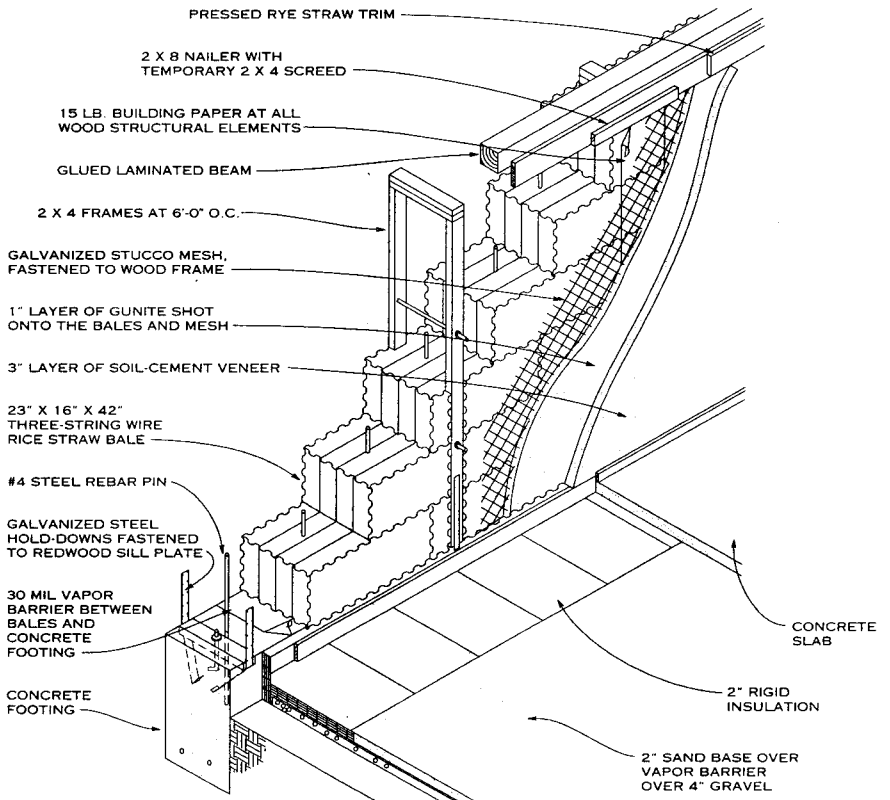

**NOTE**

The two basic methods of straw bale construction are load bearing (the bales carry the weight of the roof) and non-load bearing (typically a post-and-beam system). The illustration shows one of many accepted techniques.

Straw bale construction lends itself to a variety of styles and finishes. The raw material is the waste of another industry, cultivation of grain for food. Straw bale construction is a long-lasting durable building method. Homestead-

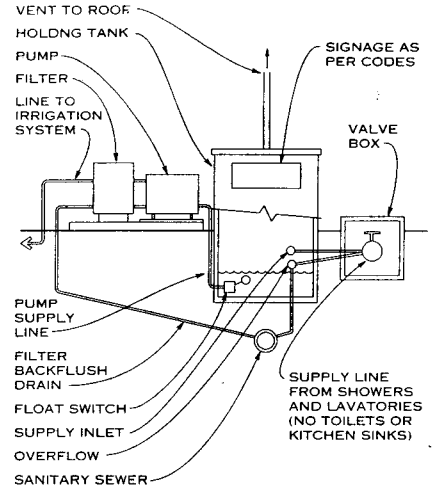

**NOTE**

Graywater systems can be used to "recycle" lavatory and shower water for subsurface plant irrigation.

**GRAYWATER SYSTEM**

Arkin Tilt Architects; Albany, California

**STRAW BALE CONSTRUCTION SYSTEM**

ers in the Great Plains started building with bales in the late 19th century, and many of these structures still stand today.

When laid flat and stacked like bricks in a "running bond" pattern, plastered or stuccoed straw bale walls are ±24 in. thick. They have an insulating value of as much as R-57, three times the value of typical insulated wood walls. These thick walls present opportunities for niches, deep window sills and seating areas, and "truth windows."

**GENERAL**

Indoor environmental quality (IEQ) refers to many complex elements and properties that affect the occupants of a building. A healthy indoor environment promotes the comfort, health, and well-being of the building's users. Unhealthy indoor environments can result in such health problems as headaches, burning and itching eyes, respiratory difficulties, skin irritation, nausea, and fatigue. Conditions associated with poor IAQ are

**SICK BUILDING SYNDROME**, a condition in which at least 20% of a building's occupants experience health or comfort problems that cannot be attributed to a specific illness but are clearly linked to time spent in the building;

**BUILDING-RELATED ILLNESS**, a condition with identifiable symptoms that can be traced to a specific building source (for example, Legionnaires' disease, caused by *legionella* bacteria, which may be found in cooling towers and room unit air conditioners);

**MULTIPLE CHEMICAL SENSITIVITY**, a condition in which a person is sensitive to a number of chemicals, even at very low concentrations.

**FACTORS THAT AFFECT IAQ**

**HVAC DESIGN**

1. The HVAC system can be a source of contaminants; for example, improperly drained condensate pans promote microbial growth.
2. The HVAC system can serve as a pathway for transporting contaminants into the indoor environment; for example, contaminated outside air may be introduced into the building through fresh air intakes.
3. The quantity of outside air should, at a minimum, meet the requirements of ASHRAE 62-1989. Many building codes, such as the Standard Building Code, have officially incorporated the ASHRAE standard by reference, making ventilation standards an enforceable regulation.
4. Negative pressurization of special-use areas, such as smoking lounges, toilets, and garages, in relation to adjacent areas can prevent migration of contaminated air.
5. Pollutants can be transported throughout the building via elevator shafts, crawl spaces, utility tunnels or chases, doors, operable windows, stairways, and party walls. Air movement can also occur through accidental openings such as cracks and holes. All of these pathways are influenced by the HVAC design.

**BUILDING COMMISSIONING**

1. A good building commissioning plan, based on ASHRAE Guideline 1-1989, organizes design, construction, operation, and maintenance efforts and also provides IAQ guidelines for managers and maintenance personnel.
2. A flush-out period allows off-gassing of building products to occur before the building is occupied. Use caution during the flush-out stage to prevent materials from acting as sinks (i.e., absorbing volatile organic compounds [VOCs] released from another material and later releasing those VOCs into the air).

**CONSTRUCTION IN OCCUPIED BUILDINGS**

1. Proper containment of the construction area generally includes shutting off the HVAC, blocking air grilles, installing a temporary exhaust system, and constructing temporary barriers.
2. Contaminants in the airstream can be reduced by using HEPA and activated charcoal filtration.

**BUILDING MATERIALS AND EQUIPMENT**

1. Release of VOCs from materials and equipment starts with installation and diminishes gradually. Use appropriate ventilation to prevent IAQ problems.
2. To analyze the impact of building materials on IAQ, evaluate the total VOCs within a space (taking into account that certain materials act as sinks for other materials), the volume of the space, duration of emissions, and the ventilation capacity of the HVAC system.

**MOISTURE CONTROL**

1. Damp, deteriorating materials provide a breeding ground for microbiological organisms and pests. Prevent water intrusion, which can occur through leaks and inadequate vapor retarders.
2. Contamination from moist areas can spread to other spaces via pollutant pathways.

**OPERATIONS**

1. Spatial changes that increase the occupant population, introduce more physical activity, increase equipment loads, rearrange workstations, or modify spaces to spe-

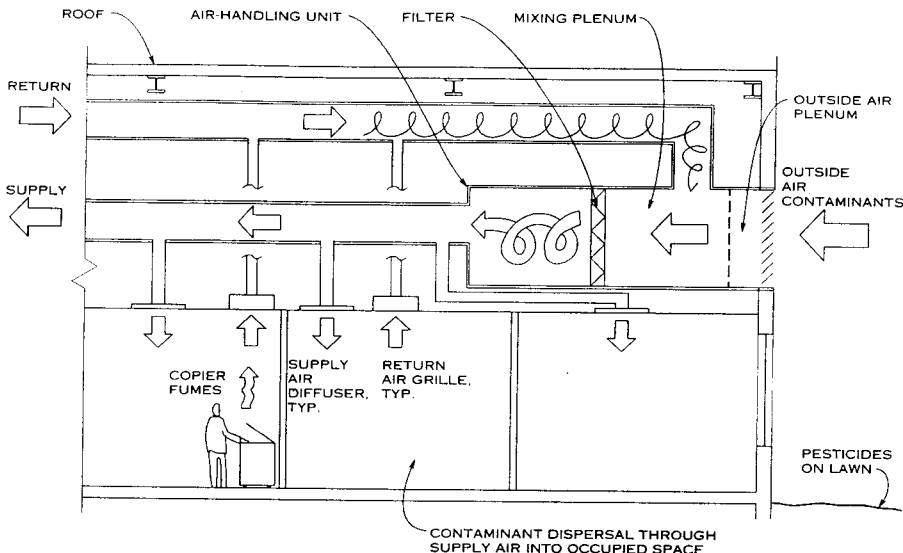

**NOTES**

1. Mineral wool fiber suspended ceiling tile should be installed in a well-ventilated area. Avoid breathing dust from the tile.
2. Install a return air diffuser within 10 ft of photocopy and fax machines and computer printers.

**TRANSPORT OF CONTAMINANTS THROUGH HVAC PATHWAY**

1. Special-use areas, such as smoking lounges, can contribute to IAQ problems.
2. Housekeeping and maintenance should include not only publicly visible areas but also mechanical rooms, crawl spaces, and above-ceiling areas used as air plenums. Special attention should be given to bathrooms, break rooms, and kitchens.
3. Material Safety Data Sheets (MSDSs) provide information on hazardous chemicals in specific cleaning compounds. Discourage use of products high in VOCs that would be used in large quantities, such as wax on hardwood floors. Cleaning products with strong odors or contaminants should be used after business hours, with additional ventilation. These products should be stored according to manufacturers' directions, in proper containers in a storage area maintained under negative pressure with local exhaust properly designed and maintained.

4. The EPA's Integrated Pest Management (IPM) program is geared to educational facilities but can be used for other types of facilities as well. The program uses a combination of methods, many of which are low-cost, aimed at eliminating conditions that attract pests. Caulk or seal cracks, crevices, and holes to prevent pests from entering the building. Architects may also specify that low-toxicity pesticides be applied to interior surfaces or wall cavities during construction.
5. Change HVAC filters regularly.

**EQUIPMENT OPERATION AND MAINTENANCE**

1. Copiers, computers, and laser printers emit VOCs during operation. If possible, isolate this equipment from building occupants by locating it in well-ventilated spaces with independent exhaust systems. Equipment should be turned off when not in use for long periods of time. Large copying or printing jobs may be scheduled for unoccupied times.
2. The chemicals used to maintain and clean this equipment may be additional sources of hazardous emissions.

**HAZARDOUS SUBSTANCES**

1. Asbestos fibers can be released from products and inhaled, causing lung illnesses. (See the page on Asbestos Abatement in this book for health effects and hazard control.)
2. Lead can be found in paint applied before 1978, in some water sources, and in some household products (vinyl mini-blinds, for example). The most significant health hazard associated with lead is neurological damage to children. Lead contamination is usually caused by ingesting lead-based paint chips or inhaling fine lead dust.

**REGULATIONS**

**IAQ:** At this time there are no federal regulations governing indoor air quality. More than twenty federal agencies are involved in policy-making efforts regarding IAQ.

**ASBESTOS:** OSHA and EPA regulations govern asbestos in buildings and asbestos during construction. EPA also has regulations governing disposal of asbestos. The Department of Transportation has regulations governing transportation of asbestos. Also, state and local regulations may be more stringent than federal.

**LEAD:** OSHA regulations govern exposure to lead during construction projects. EPA regulations govern certain lead-based paint activities and disposal of lead. DOT regulations may apply to transportation of waste classified as hazardous. State and local regulations may be more stringent than federal.

**RADON:** There are no current federal regulations regarding radon. The EPA has established guidelines, and some states have established regulations, most of which apply to residential construction.

**RESOURCES**

The following agencies and organizations provide materials on indoor air quality, asbestos, lead, radon, and health issues related to the indoor environment: U.S. Environmental Protection Agency ([www.epa.gov](http://www.epa.gov)); National Institute of Building Sciences ([www.nibs.org](http://www.nibs.org)); Department of Housing and Urban Development ([www.hud.gov](http://www.hud.gov)); American Lung Association ([www.ala.org](http://www.ala.org)).

**CONSULTANTS**

Diagnosing and resolving IEQ issues require a methodical, interdisciplinary approach. Although some problems may be easily resolved, others require lengthy investigations and exhaustive measurements to identify sources and implement controls. A coordinated, comprehensive effort by a team of architects, mechanical engineers, and industrial hygienists is recommended as the most effective way to achieving a healthful indoor environment.

Ronald L. Gobbell, FAIA; Gobbell Hays Partners, Inc.; Nashville, Tennessee

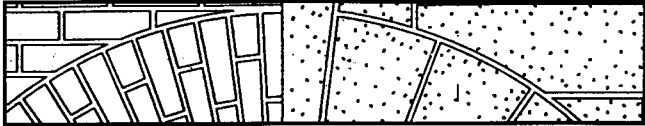

# HISTORIC PRESERVATION

Introduction 844

Historic Masonry 846

Historic Wood 849

Historic Architectural Metals 851

Historic Roofs 852

Historic Windows 853

Historic Entrances and Porches 855

Historic Storefronts 857

Historic Structural Systems 858

Historic Interiors 860



## INTRODUCTION

Historic buildings are tangible evidence of the nation's history and culture. They add interest, identity, and variety to our streets and neighborhoods. At the same time, because of their age, methods of construction, materials, and finishes, they present special challenges to architects. Historic buildings frequently involve materials and systems that are difficult to evaluate in terms of their physical behavior, especially when applying modern standards and codes. Because historic buildings are essentially different from new buildings in these respects, it is important to remember that the approaches that would be taken in designing a new building generally do not apply to the preservation, rehabilitation, or restoration of a historic building.

## UNDERSTANDING HISTORIC PRESERVATION OBJECTIVES

Almost any historic preservation project will involve a variety of work, which may include stabilization, repair, and partial or total replacement of deteriorated historic materials. Overall "preservation objectives" must be balanced against the client's needs for building alterations and additions, life safety, seismic code requirements, and a host of other real-life demands on the building program. When undertaking rehabilitation work on a historic building, there are two basic objectives: to preserve historic materials and to preserve the historic character. If these objectives are met, then the building will continue to convey its sense of history.

Historic materials are those materials used in construction (e.g., the wooden siding, the slate roof, or the terra-cotta cornice) of a building. Although every building has undergone repair, replacement, and alteration over the years, the purpose of any preservation project should be to retain as much as possible of the surviving historic materials in the course of treatment. By historic character we mean those tangible features of the building that help to distinguish it from other buildings. Aspects that give a historic building its individuality may include its overall form or shape, materials, craftsmanship details, interior spaces, and applied detailing. The historic character can be seriously affected by small changes; for example, applying a layer of paint to a historically unpainted building, replacing windows with new ones of different size and shape, or introducing a suspended ceiling within a tall room.

Each historic building is unique in its evolution, use, performance, and maintenance. Part of this uniqueness involves the changes to the building in its past, to its finishes, form, or floor plan. The architect should remember that changes that may have occurred in the past frequently have acquired historic value or possess architectural significance in their own right, just as the new work on historic buildings may acquire some historic significance in the future. A building is not fixed in time at the date of its construction but represents a continuity of history.

Many historic buildings are rehabilitated for new uses. If the primary objective is to preserve the historic building while accommodating new needs, the architect must first understand the building and the character of its materials, features, and spaces. The challenge is to make both the historic building and new uses work together. The federal government's Standards for Rehabilitation, from the Secretary of the Interior's Standards for the Treatment of Historic Properties, rev. 1992, provides a framework to guide work on historic buildings when repairs, alterations, and additions are planned for a continued or new use. (It should be noted that there are separate Standards for Preservation, Restoration, and Reconstruction.) The ten rehabilitation standards are general principles that present a balance between preserving the historic character and making respectful changes in order to accommodate continuing or new uses; the guidelines present recommended treatments and approaches that help meet the Standards and also explain the consequences of undertaking irresponsible work. The Guidelines are organized in broad categories such as materials (masonry, wood and architectural metals); roofs; windows; storefronts; structural systems; interior spaces, features, and finishes; and mechanical systems.

The Standards and Guidelines form the basis for the following historic preservation section in Architectural Graphic Standards. The guidance recommends the identification of character-defining spaces, features, materials, and finishes as a first step in the rehabilitation process and suggests a hierarchy in selecting appropriate work, from minor actions such as maintenance and repair of historic materials to major actions such as the replacement of deteriorated and missing features and design for new additions. Considering the unknown conditions that will be encountered during the progress of any work on historic buildings, frequent reference to the Standards and Guidelines is recommended when planning and executing a project.

Lee H. Nelson, FAIA, and Kay D. Weeks; Preservation Assistance Division, National Park Service; Washington, D.C.  
Eric J. Gastier; Darrell Downing RippetEAU Architects; Washington, D.C.

# 19 INTRODUCTION

## UNDERSTANDING THE HISTORIC BUILDING AS A SYSTEM

The architect should remember that building materials are not inert and that they have many other properties than their compressive or tensile strength. The architect should never look at the materials in isolation, but as part of the historic building system. Such systems will react to changes in the environment, and the materials are frequently chemically active. Both the systems and the materials will react to almost any human intervention. For example, applying a chemical coating to the exterior walls of a building is a treatment that could affect the transmission of moisture and vapor through the walls.

## COMMON REHABILITATION PROJECT PROBLEMS

The following is a list of problem areas that frequently arise in rehabilitation projects which should be investigated and considered in advance. A historic preservation specialist may be required to address some of these problem areas.

1. **Moisture problems:** Perhaps the single most pervasive problem of existing buildings is the penetration of moisture both from within and without. Without understanding the cause (rather than the symptoms) of this problem, it is difficult to select a remedial solution. Many high-tech products (coatings, water repellents) may cause more harm than good. To reduce moisture problems, buildings should be made weathertight (e.g., install proper gutters and downspouts, repair roof, repaint cracks, provide proper surface grading).
2. **Hard-to-find crafts:** Stonecutters, wood-carvers, slaters, stencilers, wood turners, parquet floor layers, ornamental plasterers, gilders, grainers, and marblers provide custom art and craft services, generally for large-scale restoration and rehabilitation projects. The architect should provide a sample or prototype of the specific effect desired to the craftsman in order to establish preservation objectives and work quality. The sample may be an isolated artifact, may be in place on the historic building, or may even be on another building.
3. **Hard-to-find replacement materials:** Careful, long-range planning may be required to obtain special materials such as decorative terra cotta or certain brownstones, sandstones, and marbles. Some metal components may be difficult to repair or fabricate, especially deteriorated ornamental sheet metal cornices, window hoods, roof cresting, and certain ornamental metal shingles.
4. **Energy conservation:** Improving the energy performance of historic buildings is a generally desirable goal, but some energy-conserving features, such as tinted glazing, can alter the historic appearance of the building. Any energy conservation treatments that will visually or physically alter the building's historic features should be carefully evaluated. Furring out the inside surface of exterior walls for insulation will require that paneling and trim be carefully removed and reapplied, otherwise the extra thickness of the insulation and wall finish will change the architectural relationships between openings, wall surfaces, and trim.
5. **The unintended impact of new technology:** Problems can result from the indiscriminate application of modern architectural practices to historic buildings. The introduction of high-strength portland cements, elastomeric compounds, water repellents, or epoxy coatings may create a host of secondary problems not anticipated by the architect; these problems may result from using standardized specifications.

## FOR THE RECORD

Working on a historic building is both a challenge and an opportunity. If the building is significant, the architect has a responsibility not only to preserve it but to leave a record for the future. Such a record should include a summary of the research; measured drawings of the building before rehabilitation; information discovered during work on the building; and documentation of the work as planned and as carried out. Measured drawings should follow the Standards for Architectural and Engineering Documentation, 1983, developed by the Historic American Buildings Survey/Historic American Engineering Record of the National Park Service.

## THE SECRETARY OF THE INTERIOR'S STANDARDS FOR THE TREATMENT OF HISTORIC PROPERTIES (REV. 1992)

### STANDARDS FOR REHABILITATION

1. A property shall be used as it was historically or be given a new use that requires minimal change to its distinctive materials, features, spaces, and spatial relationships.
2. The historic character of a property shall be retained and preserved. The removal of distinctive materials or alteration of features, spaces, and spatial relationships that characterize a property shall be avoided.
3. Each property shall be recognized as a physical record of its time, place, and use. Changes that create a false sense of historical development, such as adding conjectural features or elements from other historic properties, shall not be undertaken.
4. Changes to a property that have acquired historic significance in their own right shall be retained and preserved.
5. Distinctive materials, features, finishes, and construction techniques or examples of craftsmanship that characterize a property shall be preserved.
6. Deteriorated historic features shall be repaired rather than replaced. Where the severity of deterioration requires replacement of a distinctive feature, the new feature shall match the old design, color, texture, and, where possible, materials. Replacement of missing features shall be substantiated by documentary and physical evidence.
7. Chemical or physical treatments, if appropriate, shall be undertaken using the gentlest means possible. Treatments that cause damage to historic materials shall not be used.
8. Archeological resources shall be protected and preserved in place. If such resources must be disturbed, mitigation measures shall be undertaken.
9. New additions, exterior alterations, or related new construction shall not destroy historic materials, features, and spatial relationships that characterize the property. The new work shall be differentiated from the old and shall be compatible with the historic materials, features, size, scale and proportion, and massing to protect the integrity of the property and its environment.
10. New additions and adjacent or related new construction shall be undertaken in such a manner that, if removed in the future, the essential form and integrity of the historic property and its environment would be unimpaired.

## INTRODUCTION

This checklist indicates the range of preservation factors that should be considered when rehabilitating historic buildings. It is not exhaustive, and some factors will not apply to all structures or preservation projects.

## CHECK HISTORIC PRESERVATION DESIGNATION AND AVAILABLE DOCUMENTATION

Is your building a local landmark or located in a locally designated historic district? Is it in a historic district listed in the National Register of Historic Places? Does it contribute to the historic significance of the district?

What historical or architectural documentation is available about the building(s) or site? For example:

- National Register nominations
- recorded by Historic American Buildings Survey/Historic American Engineering Record
- state or local historical survey or inventory
- local documents, views, photographs in libraries, archives, historical societies

## CHECK LEGAL REQUIREMENTS

Are there easements or local ordinances governing alterations to the property (deed records, zoning offices)?

Depending on the current or anticipated use, how does the 1990 Americans with Disabilities Act, a federal civil rights law, apply to your historic building?

How do state and local building codes apply to your historic building? What effect will they have upon its character and integrity? Are code variances available? Are there code equivalency possibilities for your particular building?

Will there be federal funds involved in the project, which will require review by the State Historic Preservation Office and consultation with the Advisory Council on Historic Preservation? Will federal investment tax credits be used? If so, are you familiar with the Secretary of the Interior's Standards for Rehabilitation and Guidelines for Rehabilitating Historic Buildings as well as the National Park Service certification procedures in Chapter 1, Title 36 of the Code of Federal Regulations, Part 67? Have you obtained a copy of the Historic Preservation Certification Application form from the State Historic Preservation Office?

Note that for federal investment tax credits, the Secretary's Standards (36 CFR 67) take precedence over local requirements.

## EVALUATE HISTORIC CHARACTER AND SIGNIFICANCE OF STRUCTURE

Have you identified, listed, and prioritized the character defining aspects of the building? These may include its form, materials, workmanship, features, color, and spatial relationships, that is, those tangible aspects of the building that define its historic character.

Usually, original materials and features are central to the building's historical significance; sometimes, however, an original feature may not be as important as the changes that have been made to it over time. For example, if a brick building was painted at an early date, its painted appearance may be an important aspect of its historic character.

What is the original configuration of the building? What architectural changes have been made over time? Changes may include

- additions such as a porch, wing, or upper story.
- changes to surfaces and finishes (unpainted to painted, slates to asphalt, polychrome to monochrome).
- blocking of windows, removal of shutters.
- changes to grade.
- change to a cornice; loss of stairs or steps.
- false fronts.
- changes to basic plan (single family to multiple family).

Most buildings change over time with different occupancies and uses. These changes are an integral part of the building's historic character and should be evaluated very carefully prior to work.

Has the architectural integrity of the building been assessed? Architectural integrity means the intactness of the building as an architectural system (its plan, features, materials, finishes, structural system, and the presence of architectural features).

## ASSESS PHYSICAL CONDITION

Are there gross physical problems that threaten the building's architectural and structural integrity?

Has a structural survey been performed to determine deficiencies due to settlement, deflection of beams, seismic inadequacy, and cuts through structural members for mechanical pipes and ducts?

Is there inherent materials damage, such as materials failure due to poor original design, poor original materials, severe environmental or moisture problems, neglect, improper maintenance, etc.?

Is there man-inflicted damage, such as ornamentation removed, inappropriate coatings, bad repointing or cleaning, insensitive additions, or partitioning of significant interior spaces? Are historic features hidden behind later alterations? These may include ornamental ceilings or cornices hidden above dropped ceilings.

What aspects of the Americans with Disabilities Act apply to your rehabilitation project? Are there accessible public entrances? Is there proper signage?

## DEVELOP PRESERVATION PROJECT PLANS

Will it be necessary to write unique specifications rather than use standard specifications for work performed on a historic building?

Will testing be needed to determine the performance of the materials or the systems? Note that it may be necessary to review test results with consultants or laboratories.

Will the project involve hard-to-find replacement materials such as terra-cotta or ornamental metals that may require critical path logistical planning?

Will the project require hard-to-find crafts such as stone carving or ornamental plastering? If so, can the necessary expertise be found?

Can samples or models be made available to establish the standard of craftsmanship for the project?

Will the project involve energy conservation measures? Have measures been chosen that retain historic materials and finishes to the maximum extent possible?

Will new uses require upgrading the live loading capacity of wooden floor joists? How do the preservation objectives affect the decision-making? For instance, it is better to double up existing joists with a parallel member than to remove historic materials, and if an ornamental ceiling would be damaged by this approach, a structural engineer should investigate other alternatives.

Are new additions and adjacent new construction sympathetic to the historic building, site, or district? Minimize adverse effects by maintaining the scale, shape, materials, and detailing of the adjacent historic structures.

What protective measures will be taken to preserve important character-defining features and finishes during the construction work?

Will the project involve making bathrooms and amenities accessible to persons with disabilities? Have options been studied to achieve access without threatening or destroying significant interior spaces, features, and finishes?

Will rehabilitation work on the building result in the loss of distinctive historic fabric or seriously damage the historic character? Loss of historic fabric or change of historic character can occur on the exterior when

- storefronts are altered.
- visible skylights are added on top of an existing building.
- new dormers are added on prominent roofs.
- whole new floors are added on top of an existing building.
- porches are enclosed.
- new window openings are created.
- tinted films or reflective coatings are added to windows.
- new window sash are historically inappropriate in configuration and detailing.

Loss of fabric or change of character often occurs on the interior when

- interiors are partitioned and significant sequences of spaces are lost.
- plaster is removed to expose brickwork.
- interiors are gutted to reconfigure spaces, insert new floor levels, or create new atria.
- significant stairs are removed or altered.

Will there be a professional on site during construction to ensure work is carried out according to established preservation principles?

Have construction personnel received adequate training in undertaking historic preservation work?

## SOURCES OF TECHNICAL PRESERVATION INFORMATION

### PRESERVATION ASSISTANCE DIVISION

National Park Service  
P.O. Box 37127  
Washington, DC 20013-7127

The Preservation Assistance Division has developed numerous technical publications on preserving and rehabilitating historic buildings. These publications are available from the Superintendent of Documents, Government Printing Office, Washington, DC 20402. Write to the Preservation Assistance Division at the above address for a free copy of the current Catalog of Historic Preservation Publications, which includes stock numbers and prices. Free leaflets are also available on the preservation of historic landscapes and accessibility to historic buildings. "America's Landscape Legacy" defines designed and vernacular landscapes, and includes a selected bibliography and listing of professional contacts. "Preserving the Past and Making it Accessible for People with Disabilities" explains accessibility and preservation requirements, describes the administrative process in meeting both, and suggests organizations and officials to contact for further information.

### NATIONAL PARK SERVICE REGIONAL OFFICES WITH NATIONAL REGISTER PROGRAMS

Cultural Resources Division  
Alaska Regional Office, National Park Service  
2525 Gambell Street, Room 107  
Anchorage, AK 99503

Preservation Assistance Division  
Mid-Atlantic Regional Office, National Park Service  
Second and Chestnut Street, Second Floor  
Philadelphia, PA 19106

Division of Cultural Resources  
Rocky Mountain Regional Office, National Park Service  
12795 West Alameda Parkway  
P.O. Box 25287  
Denver, CO 80225

Preservation Services Division  
Southeast Regional Office, National Park Service  
75 Spring Street, SW, Room 1140  
Atlanta, GA 30303

National Register Programs  
Western Regional Office, National Park Service  
600 Harrison Street, Suite 600  
San Francisco, CA 94107-1372

### ORGANIZATIONS/CONTACTS

AIA State Preservation Coordinators  
Call the Historic Resources Committee staff director at the AIA Headquarters (Tel: 202.626.7589) to make contact with the AIA state preservation coordinator.

The Association for Preservation Technology International  
P.O. Box 8178  
Fredericksburg, VA 22404

National Trust for Historic Preservation  
1785 Massachusetts Avenue, NW  
Washington, DC 20036

National Alliance of Preservation Commissions  
Hall of States  
444 North Capitol Street, NW, Suite 342  
Washington, DC 20001-1512

The Old-House Journal Corporation  
2 Main Street  
Gloucester, MA 09130

### STATE HISTORIC PRESERVATION OFFICERS

For the name and address of the state historic preservation officer in your state, contact:

The National Conference of State Historic Preservation Officers (NCSHPO)  
Hall of the States  
444 North Capitol Street, NW, Suite 342  
Washington, DC 20001-1512

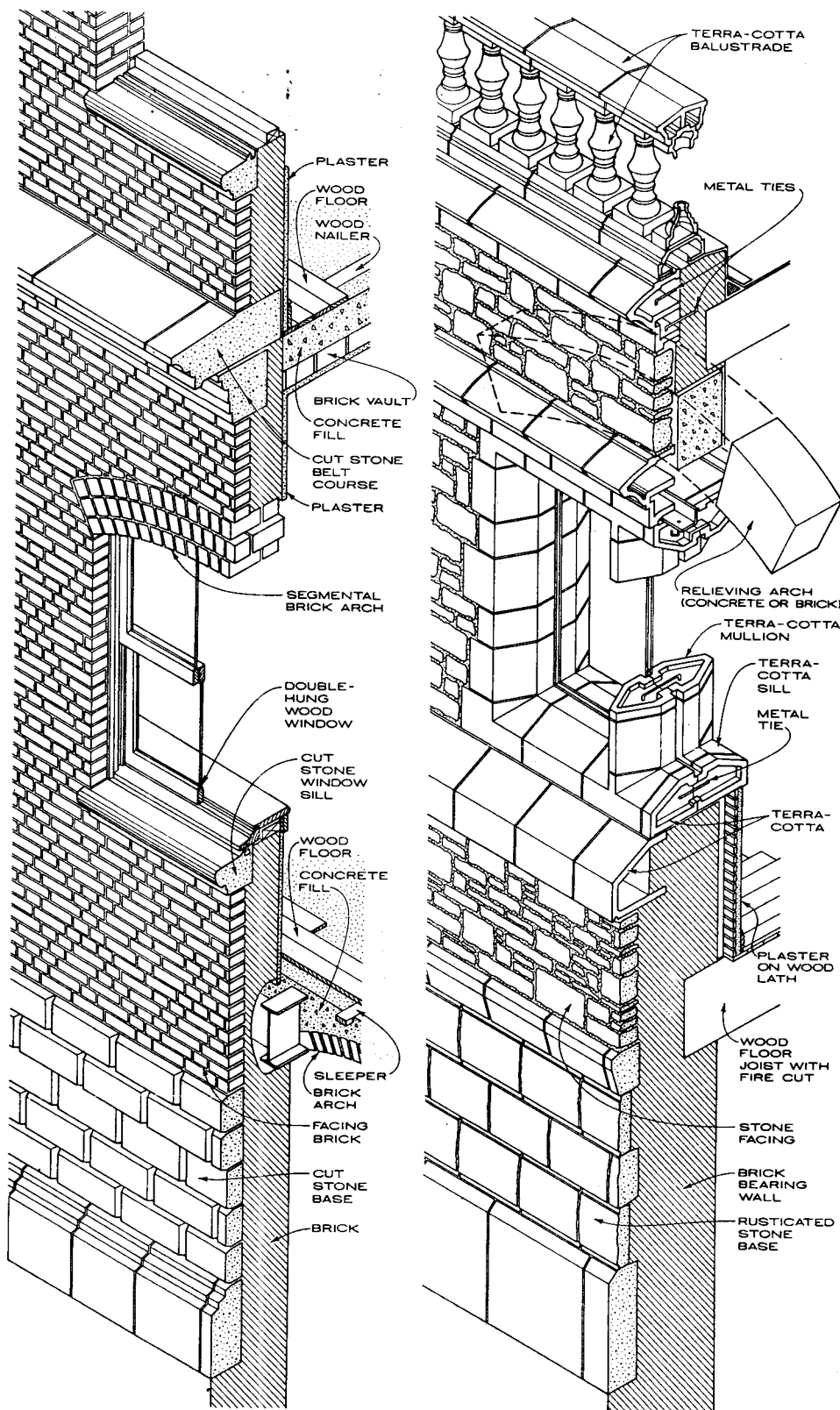

STONE AND BRICK

STONE, RUBBLE AND TERRA-COTTA

## MASONRY - TYPICAL LOAD-BEARING WALL SECTIONS

Lee H. Nelson, FAIA, H. Ward Jandl, Anne Grimmer, Kay D. Weeks; Preservation Assistance Division, National Park Service; Washington, D.C.  
Eric J. Gastier; Darrel Downing Rippeteau Architects, PC, Washington, D.C.

## INTRODUCTION

The function of masonry units such as brick or stone is related to the thickness of a wall, the mortar, the bond, and the quality of workmanship. The relationship of all these materials determines the historic building's structural soundness as well as its appearance. While masonry is among the most durable of historic building materials, it is also the most susceptible to damage by improper maintenance or repair techniques and harsh or abrasive cleaning methods.

Stone is one of the more lasting of masonry building materials and has been used throughout the history of American building construction. In the 17th and 18th centuries, stone was often used only for decorative details, trimwork, foundations, and chimneys on brick buildings. Where stone was plentiful, however, it was used to construct even simple houses and outbuildings. Stonework on most buildings was roughly finished, but more elaborate stone structures often featured finely tooled or carved decorative surfaces. The kinds of stone most commonly encountered on historic buildings in the U.S. include various types of sandstone, limestone, marble, granite, slate, and fieldstone.

Brick varied considerably in size and quality. Before 1870, brick clays were pressed into molds and were often unevenly fired. The quality of brick depended on the type of clay available and the brick-making techniques; by the 1870s—with the perfection of an extrusion process—bricks became more uniform and durable.

Terra-cotta is also a kiln-dried clay product popular from the late 19th century until the 1930s. Brownstone terra-cotta was the earliest type used throughout the last half of the 19th century. It was hollow cast, glazed or unglazed, and was generally used in conjunction with brick to imitate brownstone. Fireproof terra-cotta was developed for use in high-rise buildings. Inexpensive, lightweight, and fireproof, these rough-finished hollow building blocks were well suited to span I-beams in floor, wall, and ceiling construction. Glazed architectural terra-cotta consists of hollow units hand cast in molds or carved in clay and heavily glazed and fired. The development of the steel-frame office building in the early 20th century and the eclectic taste of the time contributed to the widespread use of architectural terra-cotta.

Adobe, which consists of sun-dried earthen bricks, was one of the earliest permanent building materials used in the U.S., primarily in the Southwest where it is still a popular building material.

Mortar is used to bond together masonry units. Historic mortar was generally quite soft and consisted primarily of lime, sand, and other additives such as crushed oyster shells, partially burned lime, animal hair, particles of clay, or pigments to color the mortar to match or contrast with the masonry units. While natural cement was included in some mortars beginning in the early 19th century, most historic mortar did not contain portland cement until after 1880 when it was used in combination with the newly available, harder extruded bricks, which required a more rigid and nonabsorbing mortar.

Traditional stucco, sometimes referred to as plaster, was also heavily lime based and had much the same composition as historic mortar, with regional variations that reflected the availability of certain materials. Like mortar, the composition of stucco increased in hardness with the addition of portland cement toward the end of the 19th century. In the 18th and 19th centuries, stucco was often scored to resemble cut stone and was used as a finish coat directly over stone, brick, or log construction. In the early 20th century, stucco took on significance as a building material in its own right and was applied (often with a decorative textured finish) directly over wood or metal lath attached to the building's structural framework.

Concrete has a long history, being variously made of tabby, volcanic ash, and later of natural hydraulic cements; the latter was first given limited use in the early 19th century in some mortars before the introduction of portland cement in the 1870s. From that time on, concrete has been used in its precast form for structural blocks or "cast stone" to simulate entire stone facades or smaller architectural details. In the 20th century, this has further evolved into precast structural elements.

**PRESERVATION APPROACHES**

Masonry features that are important in defining the overall historic character of the building include walls, brackets, railings, cornices, window architraves, door pediments, steps, and columns, with tooling and bonding patterns, coatings, color, and joint details.

Making inappropriate visual changes to historic masonry surfaces in the process of rehabilitation, such as applying paint or other coatings to masonry that has been historically unpainted, can easily change the entire character of the building. Similarly, paint should not be removed from historically painted masonry.

The various causes of mortar joint deterioration (such as leaking roofs or gutters, differential settlement of the building, capillary action, or extreme weather exposure) should be identified before selecting an appropriate remedial treatment.

Masonry should only be cleaned in order to halt deterioration or to remove heavy soiling. Cleaning masonry surfaces when they are not heavily soiled in order to create a new appearance can needlessly introduce chemicals or moisture into historic materials. If it is determined that cleaning is appropriate, tests should be conducted prior to cleaning and observed over a sufficient period of time so that both the immediate effects and the long-range effects are known.

Brick or stone surfaces should be cleaned with the gentlest method possible, such as water and detergents, using natural bristle brushes. They should never be sandblasted using dry or wet grit or other abrasives. These methods of cleaning permanently erode the surface of the material. Cleaning methods involving water or liquid chemical solutions should not be used when there is any possibility of freezing temperatures, and chemical products should never be used that will damage masonry, such as using acid on limestone or marble.

If repainting of historically painted masonry is necessary, the damaged paint should be removed to the next sound layer using the gentlest method possible prior to repainting. Colors should be used that are historically appropriate to the building and district.

Masonry walls and other masonry features should be repaired whenever there is evidence of deterioration. This may include disintegrating mortar, loose bricks, damp walls, or damaged plasterwork.

In preparation for repointing, deteriorated mortar should be removed by carefully hand-raking the joints to avoid damaging the masonry. Never use electric saws.

Old mortar should be duplicated in strength, composition, color, and texture. Repointing with mortar of high portland cement content can create a bond that is stronger than the historic material, damaging historic masonry as a result of the differing coefficient of expansion and the differing porosity of the material and the mortar.

When repointing, the use of traditional materials and caulking is strongly recommended rather than synthetic caulking compounds and "scrub" coating techniques. Old mortar joints should be duplicated in width and in joint profile.

Stucco should be repaired by removing only the damaged material and patching with new stucco that duplicates the old in strength, composition, color, and texture. Mud plaster should be used as a surface coating over unfired, unstabilized adobe, in order to bond to the adobe. Cement stucco, on the other hand, will not bond properly, enabling moisture to become entrapped between materials. Concrete may be repaired by cutting the deteriorated portion back to a sound surface, then removing the source of deterioration—often corrosion on metal reinforcement bars—by sandblasting or chemical cleaning of the re-bars. The new concrete patch must be applied carefully so it will bond satisfactorily with, and match, the historic concrete.

Masonry features may be repaired by patching, piecing in, or consolidating the masonry using recognized preservation methods. Repair may also include the limited replacement in kind of those extensively deteriorated or missing parts of masonry features such as terra-cotta brackets or stone balusters when there are surviving prototypes.

A masonry feature that is too deteriorated or damaged to repair should be replaced in kind whenever possible. If the historic form and detailing are still evident, they should be used as a model to reproduce the feature.

If a masonry feature is completely missing and there is sufficient historical, pictorial, and physical documentation, the missing feature should be accurately reproduced. In the absence of documentation, the replacement masonry feature may be a new design that is compatible with the size, scale, and color of the historic building.

Finally, for both repair and replacement treatments, using the same kind of material is always preferred; however, if this is not technically or economically feasible, a compatible substitute material with the same visual and physical qualities may be considered.

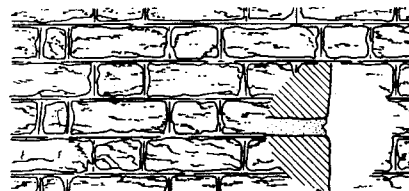

A. COLONIAL GRAPEVINE JOINT, FLEMISH BOND  
CIRCA 1720

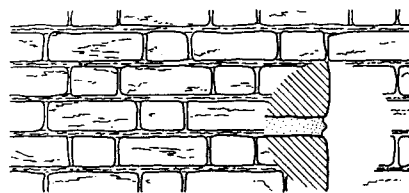

B. BEADED JOINT, FLEMISH BOND  
CIRCA 1809

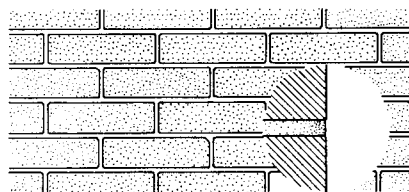

C. FLUSH JOINT, COMMON BOND  
MID-19TH CENTURY

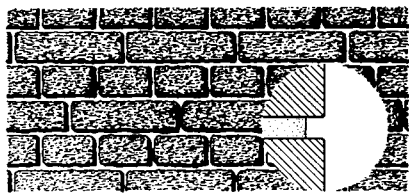

D. RAKED JOINT, ENGLISH BOND  
EARLY 20TH CENTURY

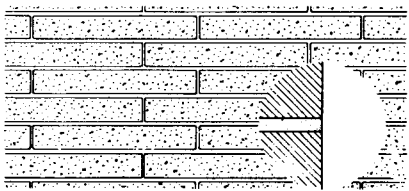

E. FLUSH JOINT, ONE-THIRD RUNNING  
BOND  
EARLY 20TH CENTURY

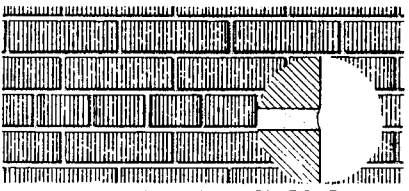

F. CONCAVE JOINT, COMMON BOND  
EARLY 20TH CENTURY

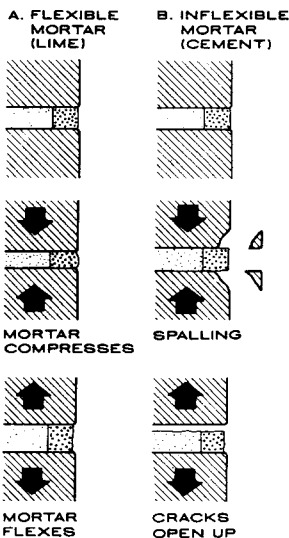

FLEXIBLE MORTAR (A) EXPANDS AND CONTRACTS WITH TEMPERATURE CHANGES. BRICKS BONDED BY INFLEXIBLE MORTAR (B) TEND TO SPALL AT THE EDGES (THE AREA OF GREATEST STRESS) IN HOT WEATHER AND SEPARATE FROM THE MORTAR IN COLD WEATHER.

**EFFECTS OF TEMPERATURE CHANGE ON MASONRY**

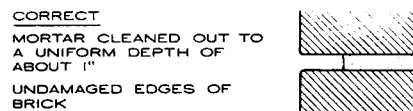
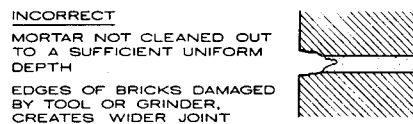

**PREPARATION OF MORTAR JOINTS FOR REPOINTING**

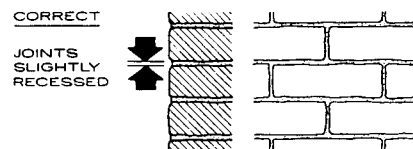
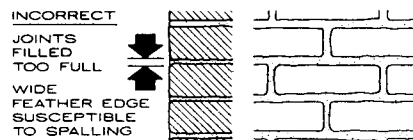

**PROPER REPOINTING OF MASONRY JOINTS**

NOTE THE DIFFERENCE IN UNIFORMITY OF HANDMADE (A AND B) AND MACHINE-MADE (C-F) BRICKS. IN A, B AND F, THE VERTICAL JOINTS WERE STRUCK BEFORE THE HORIZONTALS. IN B AND E, THE VERTICAL JOINTS ARE NARROWER THAN THE HORIZONTALS.

**JOINT TYPES AND BRICK BONDING PATTERNS**

Lee H. Nelson, FAIA, H. Ward Jandl, Anne Grimmer, Kay D. Weeks; Preservation Assistance Division, National Park Service, Washington, D.C.  
Eric J. Gastier; Darrel Downing Rippeteau Architects, PC, Washington, D.C.

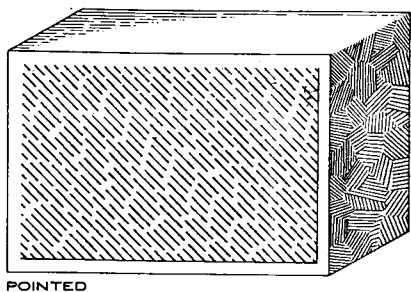

POINTED

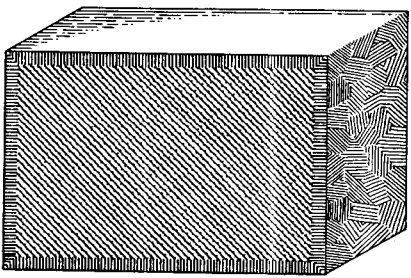

BROACHED

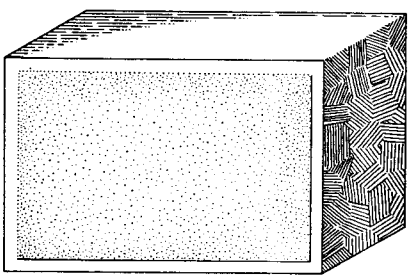

BUSH-HAMMERED

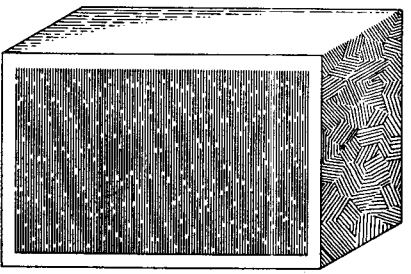

PATENT-HAMMERED

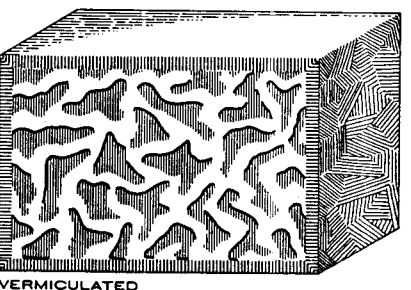

VERMICULATED

STONEMASONRY FINISHES

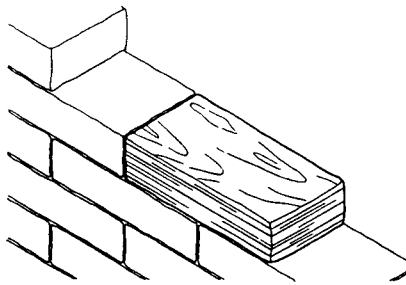

THE CORRECT CONSTRUCTION METHOD IS TO PLACE STONE ON ITS NATURAL BED AS IT ORIGINALLY LAY IN THE QUARRY

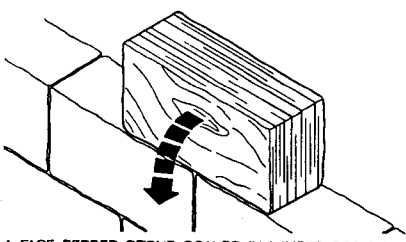

A FACE-BEDDED STONE SCALES IN LAYERS BECAUSE IT WAS PLACED ON END WITH ITS BEDDING PLANES PARALLEL TO THE FACE OF THE WALL. FACE BEDDING ACCOUNTS FOR THE POOR CONDITION OF MANY MID-19TH CENTURY BROWNSTONE BUILDINGS (ARROW INDICATES SCALING)

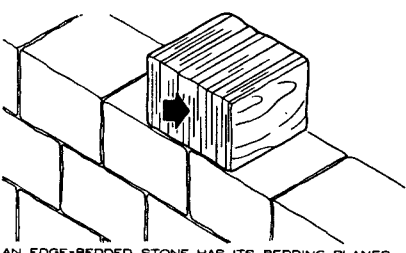

AN EDGE-BEDDED STONE HAS ITS BEDDING PLANES PERPENDICULAR TO THE FACE OF THE WALL. SEAMS ON THE EXPOSED SURFACE (INDICATED BY THE ARROW) WILL WASH OUT IN TIME

STONE BEDDING METHODS

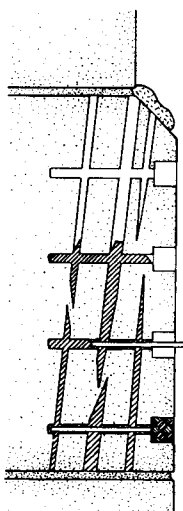

- PROCEDURE
1. SEAL CRACKS WITH NON-OILY CLAY
  2. DRILL STAGGERED ROWS OF HOLES (MAX. DIAMETER 1/4") THROUGH FACE OF STONE
  3. FILL HOLES WITH ADHESIVE GROUT
  4. INSERT AND COUNTERSINK PINS. DIAMETER SHOULD BE 1/8" SMALLER THAN HOLES
  5. PATCH HOLES WITH COMPOSITE PATCHING MATERIAL

THROUGH-SURFACE STONE REPAIR

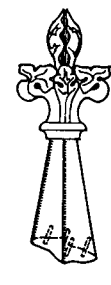

- PROCEDURE
1. CLEAN SURFACES TO BE JOINED
  2. PROTECT ADJACENT SURFACES WITH RUBBER CEMENT
  3. DRILL STAGGERED ROWS OF HOLES; DEPTH = 4 X PIN DIAMETER. DIAMETER = PIN DIAMETER + 1/8"
  4. FILL HOLES WITH RIGID (HIGH MODULUS) EPOXY ADHESIVE
  5. SET PINS
  6. COAT STONE SURFACES TO BE JOINED WITH FLEXIBLE (LOW MODULUS) EPOXY ADHESIVE
  7. SET DETACHED PIECE IN PLACE. GENTLY TAP WITH RUBBER Mallet TO SEAT STONE
  8. CLEAN OFF RUBBER CEMENT

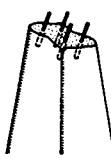

CONCEALED REPAIR FOR STONE

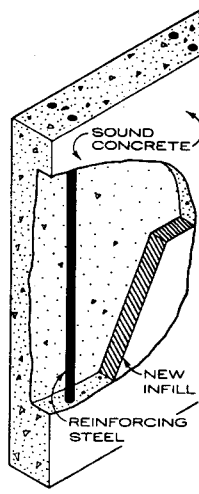

- PROCEDURE
1. REMOVE LOOSE DETERIORATED CONCRETE TO SOUND CONCRETE. CUT SQUARE SHOULDERS AT EDGE OF REPAIR AREA. EXPOSE ALL SIDES OF REINFORCING STEEL
  2. SANDBLAST CONCRETE AND REINFORCING STEEL CLEAN
  3. IMMEDIATELY APPLY PROTECTIVE COATING SYSTEM TO REINFORCEMENT
  4. MOISTEN CONCRETE SURFACE AND ALLOW TO DRY UNTIL DAMP
  5. INSTALL MORTAR, EPOXY-MODIFIED BOND COAT AND CONCRETE, OR EPOXY-MODIFIED BOND COAT AND PORTLAND CEMENT CONCRETE, DEPENDING ON REPAIR DEPTH
  6. CURE AS NECESSARY

SPALLED CONCRETE REPAIR (EXTERIOR WALLS)

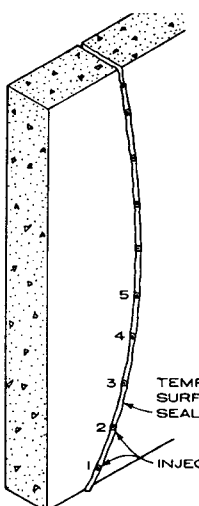

- PROCEDURE
1. INSTALL TEMPORARY SURFACE SEAL AND INJECTION PORTS (SPACING OF PORTS VARIES WITH DEPTH OF CRACKS). ALLOW TO CURE
  2. PUMP EPOXY INTO PORT NO. 1 (LOWEST PORT) UNTIL EPOXY FLOWS FROM PORT NO. 2
  3. SEAL PORT NO. 1 AND MOVE TO PORT NO. 2
  4. REPEAT STEPS 2 AND 3 UNTIL ALL PORTS ARE SEALED
  5. WHEN EPOXY HAS CURED, REMOVE SURFACE SEAL AND INJECTION PORTS

FRACTURED CONCRETE REPAIR (WALLS AND SLABS)

Lee H. Nelson, FAIA, H. Ward Jandl, Anne Grimmer, Kay D. Weeks; Preservation Assistance Division, National Park Service, Washington, D.C.  
Eric J. Gastier; Darrel Downing Rippeteau Architects, PC; Washington, D.C.

**INTRODUCTION**

Wood has played a central role in American building during every period and in every style. Because it can be easily shaped by sawing, planing, carving, and gouging, wood is used for architectural features such as clapboards, cornices, brackets, entablatures, shutters, columns, and balustrades. These features may be important in defining the building's historic character and thus their retention, protection, and repair are important in rehabilitation projects.

**PRESERVATION APPROACHES**

While loss of some exterior wood to weathering is inevitable, taking steps to maximize its retention should be an integral part of any work on a historic building. Radical changes to the historic appearance of wood surfaces should be avoided, such as changing the type of finish or its color, or stripping historically painted surfaces to bare wood, then applying clear finishes or stains in order to create a "natural" look. Special finishes, such as marbling or graining, are evidence of individual craftsmanship and should be preserved. The causes of wood deterioration should be identified and corrected, such as faulty flashing, leaking gutters, cracks and holes in siding, deteriorated caulking, or insect or fungus infestation.

Painted wood surfaces should be inspected to determine whether repainting is necessary or if cleaning is all that is required. Paint should not be removed that is firmly adhering to and, thus, protecting wood surfaces. If surfaces need painting, deteriorated paint should only be removed to the next sound layer, using the gentlest method possible (hand scraping/sanding).

Precautions need to be taken when removing lead-based paint. Personal protective gear should be worn, and the environment should be protected from lead-laden dust and debris. All toxic residue should be disposed of in compliance with applicable laws.

It is never appropriate to use destructive paint removal methods such as propane or butane torches, sandblasting, or waterblasting. These methods can irreversibly damage woodwork and could penetrate through to damage interior fabric. Electric hot-air guns may be used effectively on decorative wood features and electric heat plates on flat wood surfaces when paint is so deteriorated that total removal is necessary.

Wood features can be repaired by patching, consolidating, or otherwise reinforcing the wood using recognized preservation methods. A wood feature too deteriorated to repair should be replaced in kind whenever possible. If the historic form and detailing are still evident, they should be used to restore the feature. If a wood feature is missing and there is sufficient historical, pictorial, and physical documentation, the missing feature should be restored. Replacing a deteriorated or missing wood feature based on insufficient documentation can create a false historic appearance and can have a more significant negative impact on the historic character than not replacing the feature at all. For both repair and replacement, using the same kind of material is always preferred. If this is not feasible, a compatible substitute material may be used if it conveys the same historic appearance as wood and is physically and chemically compatible.

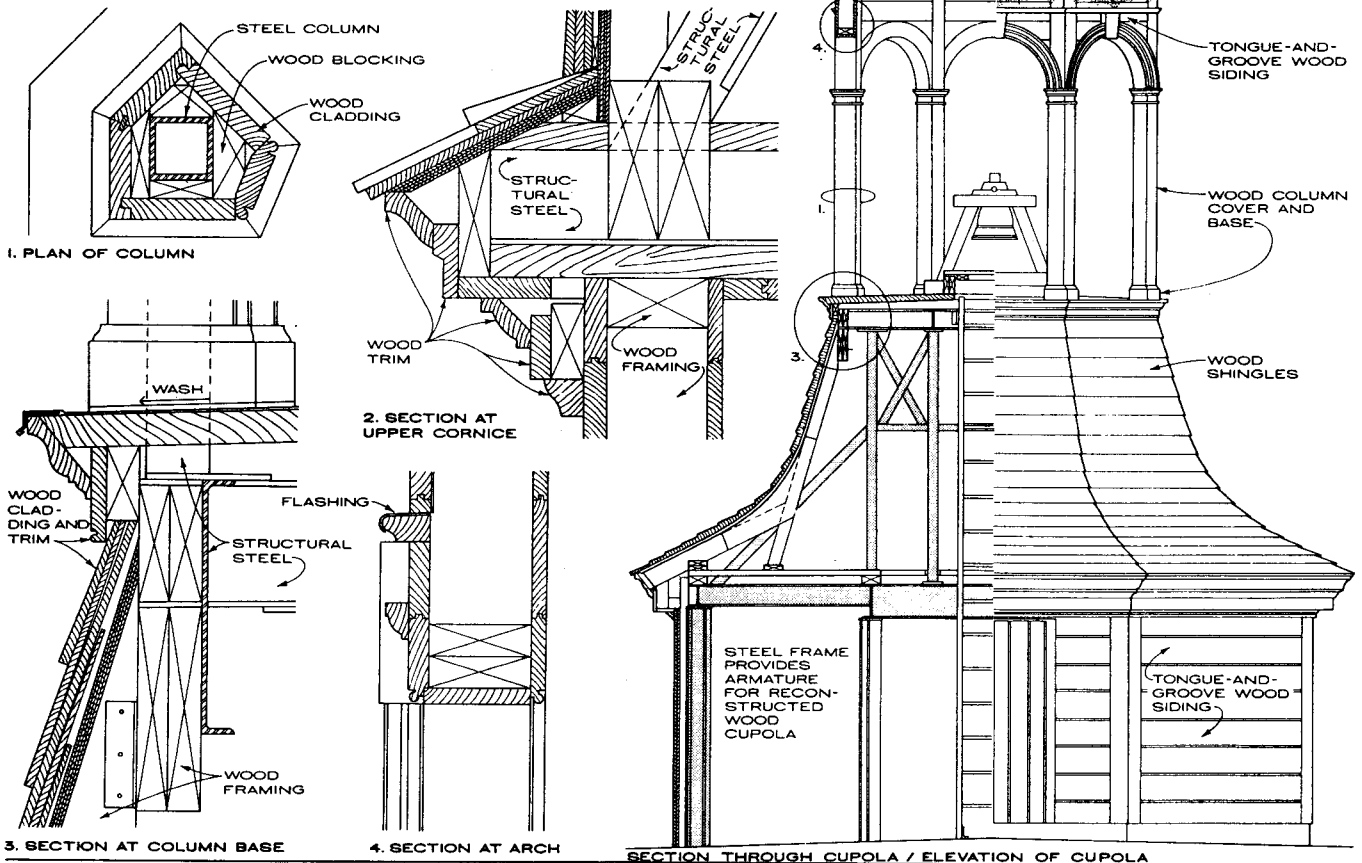

OLD STATE HOUSE, DOVER, DE (McCUNE ASSOCIATES, RESTORATION ARCHITECTS, 1977)

Lee H. Nelson, FAIA, H. Ward Jandt, Sharon C. Park, AIA, Michael J. Auer; Preservation Assistance Division, National Park Service; Washington, D.C.  
 Eric J. Gastier; Darrel Downing Rippeteau Architects, PC; Washington, D.C.



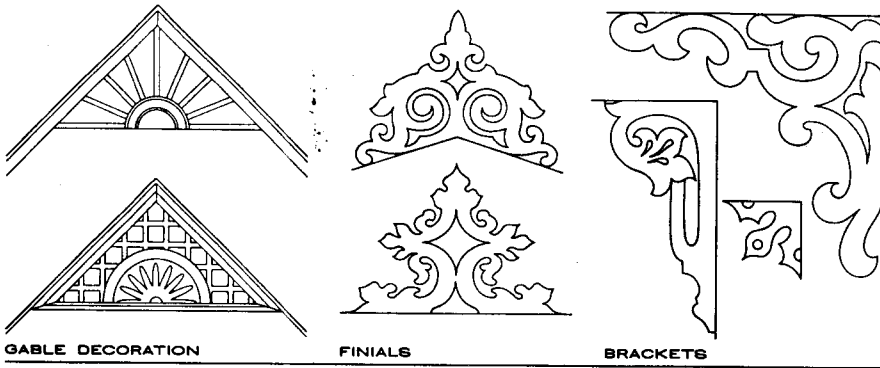

GABLE DECORATION  
FINIALS  
BRACKETS  
DECORATIVE WOOD ELEMENTS

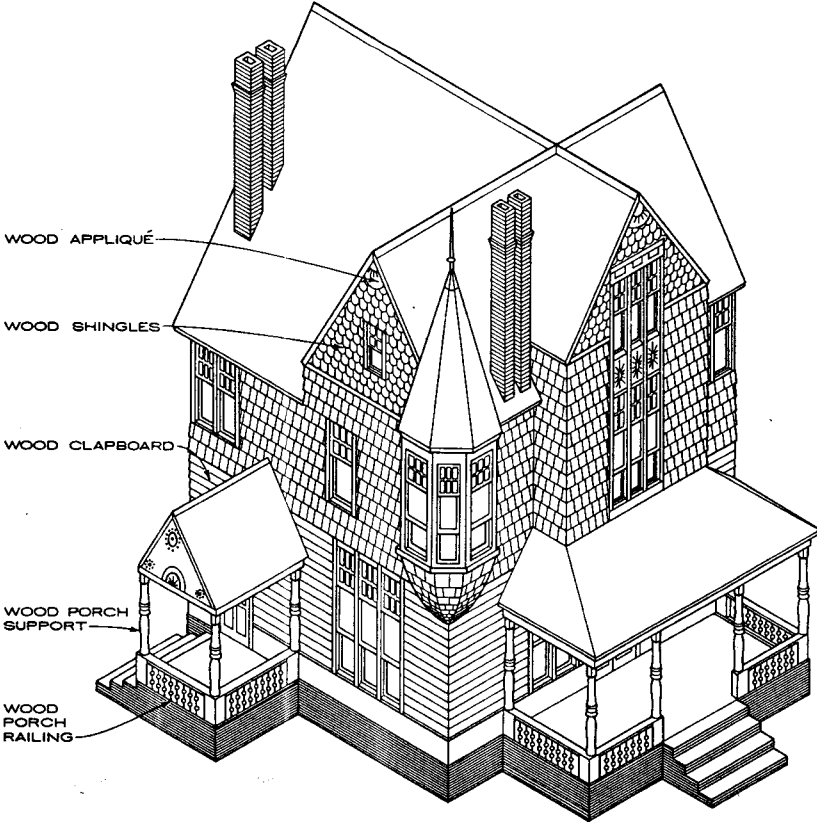

TYPICAL QUEEN ANNE HOUSE, CIRCA 1880 (BASED ON A DESIGN OF LAMB AND WHEELER, ARCHITECTS)

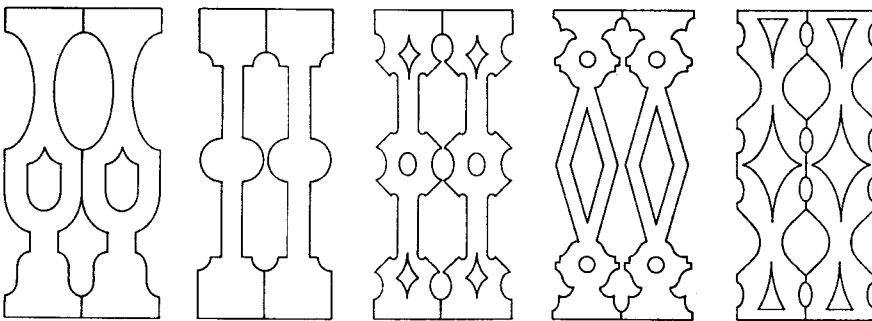

WOOD PORCH RAILING PATTERNS (CUT BY SCROLL SAW FROM THIN WOOD STOCK)

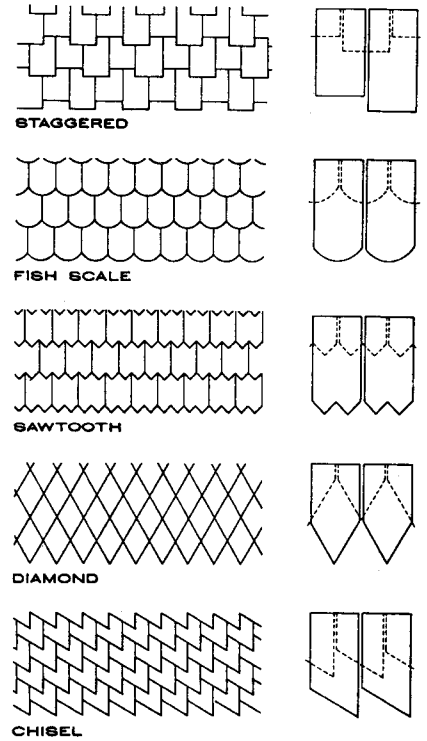

WOOD SHINGLE PATTERNS

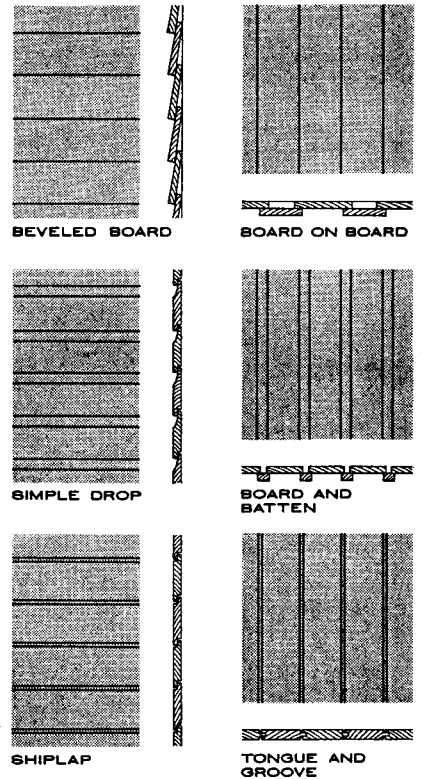

WOOD SIDING - PROFILES AND PATTERNS

Lee H. Nelson, FAIA, H. Ward Jandl, Sharon C. Park, AIA, Michael J. Auer; Preservation Assistance Division, National Park Service; Washington, D.C.  
Eric J. Gastier, Darrel Downing Rippeteau Architects, PC; Washington, D.C.

**INTRODUCTION**

Architectural metal features—such as cast-iron facades, porches, and steps; sheet metal cornices, siding, roofs, roof cresting, and storefronts; and cast or rolled metal doors, window sash, entablatures, and hardware—are often highly decorative and may be important in defining the overall historic character of the building.

Metals commonly used in historic American building construction include lead, tin, zinc, copper, bronze, brass, iron, steel, and, to a lesser extent, nickel alloys, stainless steel, and aluminum. A high degree of craftsmanship went into fabrication of the metals in older American buildings. Often it was local artisans who designed and built fine staircases, exterior light standards, railings, or metal sculptures.

**PRESERVATION APPROACHES**

Before beginning any preservation work on metal features, it is critical that the metal be correctly identified; different metals have unique properties and thus require distinct preservation treatments. Inappropriate treatments to metal features can inadvertently result in their damage or loss.

Changes to architectural metal finishes can result in changing the historic character of a building.

Protecting architectural metals from corrosion should be the focus of a cyclical maintenance program. Proper drainage should be provided so that water does not stand on flat, horizontal surfaces or accumulate in curved, decorative features.

Incompatible metals should never be placed together without a reliable separation material or galvanic corrosion of the less noble metal will occur; e.g., copper corrodes cast iron, steel, tin, and aluminum.

Architectural metals should be carefully cleaned with the gentlest method possible to remove corrosion prior to repainting or applying other appropriate protective coatings. Local codes should also be checked to ensure compliance with environmental safety requirements. For some metals, such as bronze or copper, the surface coating or patina may serve as a protective coating and should not be removed. Soft metals such as lead, tin, copper, terneplate, and zinc should be cleaned with appropriate chemical methods because their finishes can be abraded by blasting methods, such as grit blasting.

The paint used to protect historic metal surfaces often contains lead. Care should be taken if lead-based paints are removed. Workers should wear protective gear, and lead-laden dust and other debris should not be introduced into the air. Any toxic residue that has been removed should be disposed of in compliance with local, state, and federal laws.

Harder metals, such as cast iron, wrought iron, and steel, may be hand scraped and wire-brushed to remove paint buildup and corrosion. If these methods prove ineffective, low-pressure grit blasting may be appropriate if the surface is not damaged or abraded. Adjacent wood or masonry should be protected from all cleaning efforts.

Applying appropriate paint or other coating systems immediately after cleaning decreases the corrosion rate of metals or alloys. If an architectural metal is being repainted, the colors should be appropriate to the historic building or district.

Architectural metal features can often be repaired by patching, splicing, or otherwise reinforcing the metal following recognized preservation methods. Repairs also involve the limited replacement in kind of those extensively deteriorated or missing parts of features when there are surviving prototypes. Examples are porch railings or roof cresting. An architectural metal feature that is too deteriorated to repair should be replaced in kind whenever possible. If the historic form and detailing are still evident, they can be used to guide the new work.

If an architectural metal feature is completely missing and there is sufficient historical, pictorial, and physical documentation, the missing features should be accurately restored. In the absence of sufficient documentation, the replacement metal feature may be a new design that is compatible with the size, scale, material, and color of the historic building.

Finally, for both repair and replacement treatments, using the same kind of metal is always preferred. If this is not feasible, a compatible substitute material may be used if it conveys the same visual appearance as the historic material and is chemically and physically compatible.

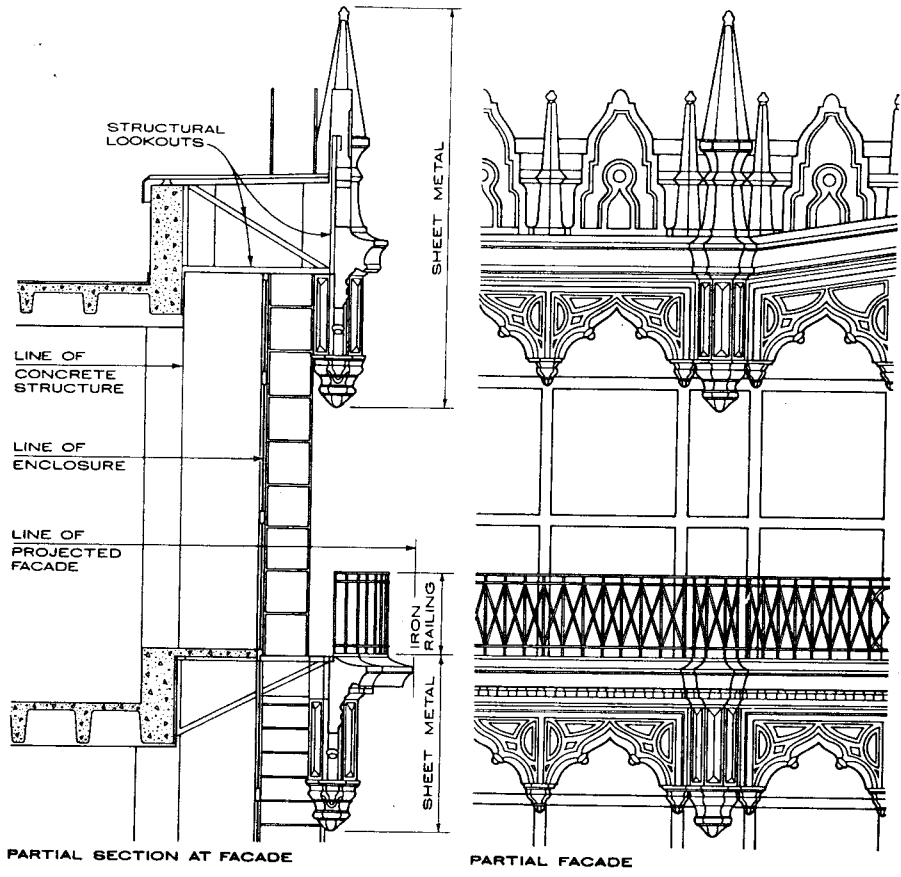

HALLIDIE BUILDING, SAN FRANCISCO, CA, 1918 (WILLIS POLK-ARCHITECT)

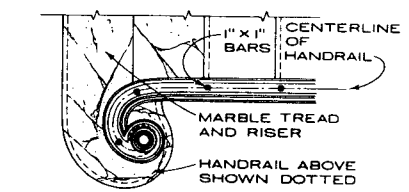
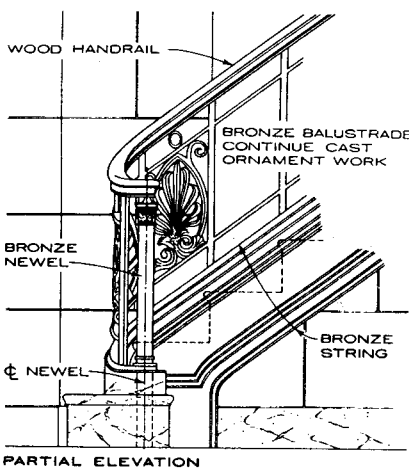

PARTIAL PLAN BRONZE STAIR RAILING METAL ORNAMENT

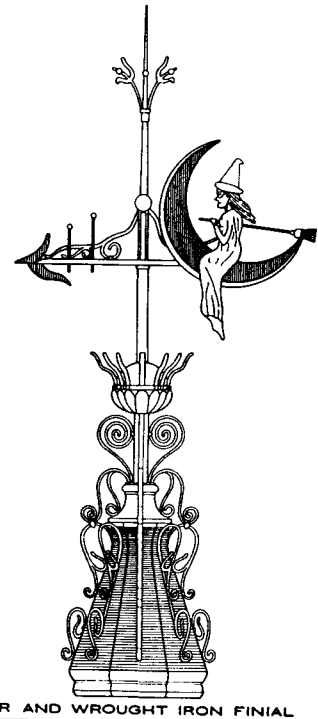

COPPER AND WROUGHT IRON FINIAL

Lee H. Nelson, FAIA, H. Ward Jandl, Camille Martone, Kay D. Weeks; Preservation Assistance Division, National Park Service; Washington, D.C.  
Eric J. Gastier; Darrel Downing Rippeteau Architects, PC; Washington, D.C.



**INTRODUCTION**

The roof—with its shape; features such as cresting, dormers, cupolas, and chimneys; and the size, color, and patterning of the roofing material—is an important design element of many historic buildings. In addition a weathertight roof is essential to the long-term preservation of the entire structure.

Historic roofing is in large measure a reflection of available materials, levels of construction technology, the weather, and cost. For example, throughout the country in all periods of history, wood shingles have been used—their size, shape, and detailing differing according to regional craft practices. European settlers used clay tile for roofing as early as the mid-17th century. In some cities, such as New York and Boston, clay was popularly used as a precaution against fire. The Spanish influence in the use of clay tiles is found in the southern, southwestern, and western states. In the mid-19th century, tile roofs were often replaced by sheet-metal roofs, which were lighter and easier to install and maintain. Another practice settlers brought to the New World was slate roofing, and evidence of its use dates from the mid-17th century. Slate has been popular for its durability, fireproof qualities, and its decorative applications. The use of metals for roofing and roof features dates from the 18th century and includes the use of sheet iron, corrugated iron, galvanized metal, tinplate, and zinc. Awareness of these and other traditions of roofing materials and their detailing will contribute to more sensitive treatments.

**PRESERVATION APPROACHES**

The configuration of a historic building can be radically changed by adding new features to the roof, such as dormer windows, vents, skylights, or mechanical and service equipment. Adding an additional floor or floors at the roofline is possibly the most difficult rehabilitation change to accomplish without dramatically changing the historic character of the building. For this reason, the roof's shape, size, color, and patterning should be retained in any preservation project.

Routine maintenance of the building includes cleaning of gutters and downspouts and replacing deteriorated flashing. Roof sheathing should also be checked for proper venting to prevent moisture condensation and water penetration and to ensure that materials are free from insect infestation. When water and debris are permitted to collect, damage may occur to roof fasteners, sheathing, and the underlying structure.

In certain cases, such as storm or fire damage, only portions of a roof or a damaged roofing feature will need repair. The repaired area should match the visual qualities of the historic roof. Some repairs involve less difficulty than others. Normally, individual slates can be replaced without major disruption to the rest of the roof; replacing flashing, on the other hand, can require substantial removal of surrounding materials. If it is the substrate or a support material that has deteriorated, many of the more durable surface materials such as slate or tile can be reused if handled carefully during the repair.

A roof feature that is too deteriorated to repair should be replaced in kind, whenever possible. With some exceptions, most historic roofing materials are available today. Manufacturers of more common roofing materials can usually fill orders for less frequently requested items, such as unusual tile or embossed metal shingles.

For both repair and replacement of historic roofing, compatible substitute materials may be considered if the same kind of material is technically or economically infeasible; however, the substitute material needs to convey the same visual appearance and be physically and chemically compatible with the surrounding materials.

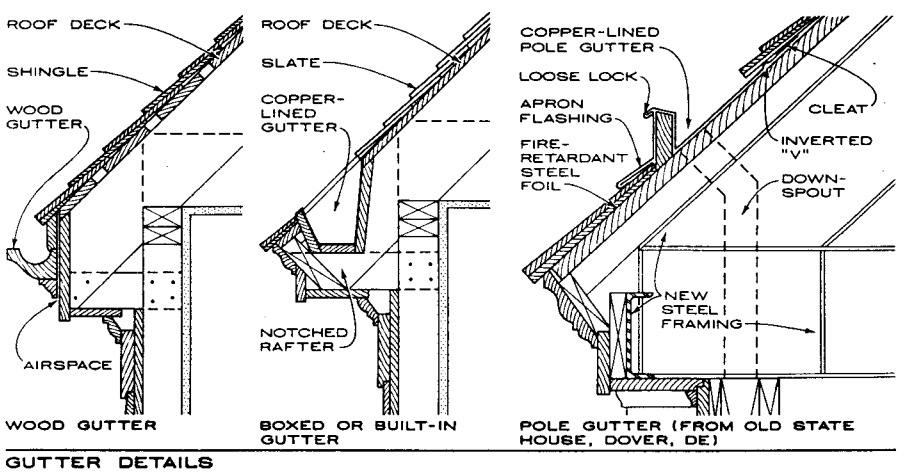
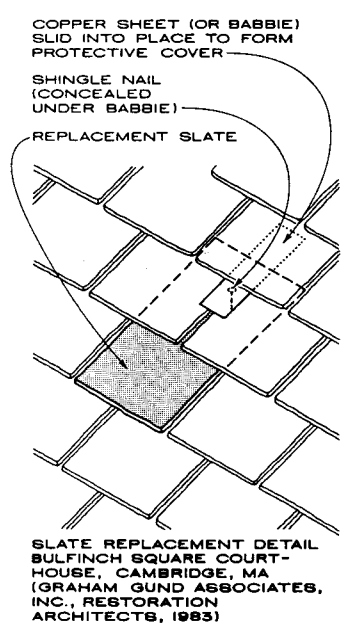
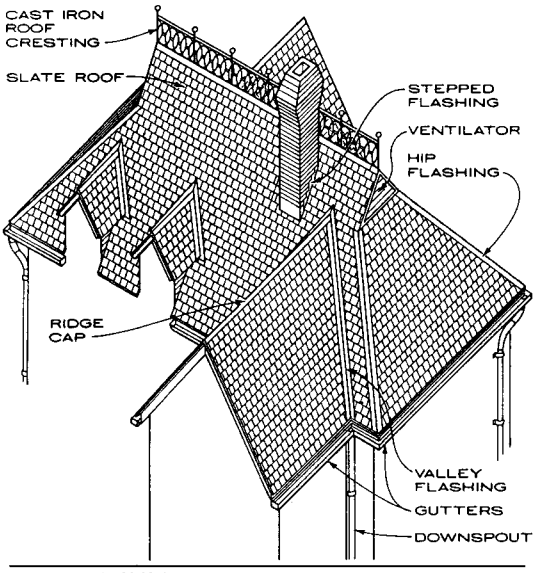
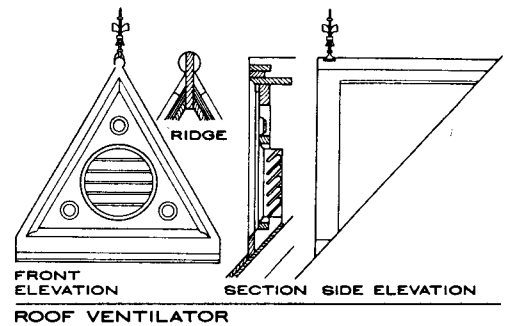
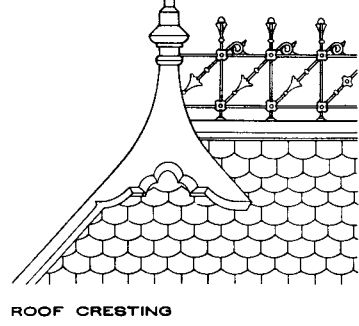
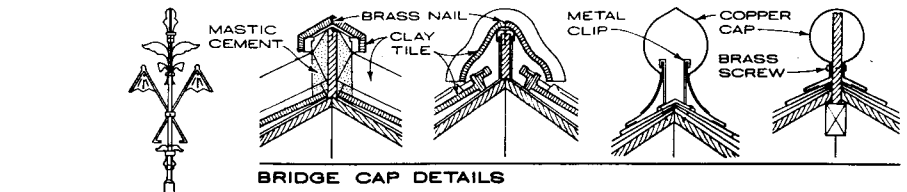

Lee H. Nelson, FAIA, H. Ward Jandl, Sharon C. Park, AIA; Preservation Assistance Division, National Park Service; Washington, D.C.  
Eric J. Gastier; Darrel Downing Rippeteau Architects, PC; Washington, D.C.

**INTRODUCTION**

As one of the few parts of a building serving both as an interior and exterior feature, windows are nearly always an important part of the historic character of a building. In most buildings, windows also comprise a considerable amount of the historic fabric of the wall plane and thus are deserving of special consideration. It is essential that the historic character of the windows be assessed together with their physical condition before specific repair or replacement work is undertaken. Emphasis should be placed on repairing existing windows, where possible, and improving their performance, such as with retrofitting weatherstripping to reduce air infiltration. Replacement windows should closely match the historic ones.

**PRESERVATION APPROACHES**

Technology and prevailing architectural styles have shaped the history of windows in the United States, starting in the 17th century with wooden casement windows with tiny glass panes seated in lead cames. From the transitional single-hung sash in the early 1700s to the true double-hung sash later in the same century,

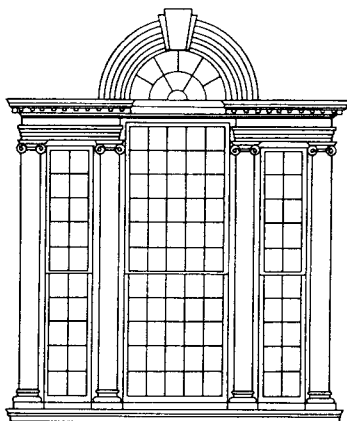

VENETIAN WINDOW FROM THE OLD STATE HOUSE DOVER, DE (MCCUNE ASSOCIATES, RESTORATION ARCHITECTS)

these early wooden windows were characterized by small panes, wide muntins, and the way in which decorative trim was used on both the exterior and interior of the window. As the sash thickness increased by the turn of the 19th century, muntins narrowed in width but increased in thickness according to the size of the window and design practices. Regional traditions continued to have an impact on window design, such as with the long-term use of "French windows" in the deep South. By the mid-19th century, two-over-two lights were common; the manufacturing of plate glass in the United States by the late 19th century allowed for dramatic use of large sheets of glass in commercial and office buildings. With mass-produced windows, mail order distribution, and changing architectural styles, it was possible to obtain a wide range of window designs and light patterns in sash. Popular versions of Arts and Crafts houses constructed in the early 20th century frequently utilized smaller lights in the upper sash set in groups or pairs and saw the reemergence of casement windows. In the early 20th century, the desire for fireproof building construction in dense urban areas contributed to the growth of a thriving steel window industry along with a market for hollow metal and metal clad wooden windows.

ELEVATION	ELEVATION	ELEVATION	ELEVATION	ELEVATION
HEAD	HEAD	HEAD	HEAD	HEAD
RAIL	RAIL	RAIL	MUNTIN	MUNTIN BAR
MUNTIN	MUNTIN	MUNTIN	RAIL	MUNTIN BAR
JAMB	JAMB	JAMB	JAMB	JAMB
SILL	SILL	SILL	SILL	SILL
SINGLE-HUNG WOODEN WINDOW SOLID MORTISE AND TENON FRAME EARLY 18TH CENTURY	DOUBLE-HUNG WOODEN WINDOW MID-19TH CENTURY	STANDARD HOLLOW GALVANIZED IRON DOUBLE-HUNG WINDOW CIRCA 1910	DOUBLE-GLAZED DOUBLE-HUNG WOODEN WINDOW 1930S	HORIZONTAL PIVOTED STEEL WINDOW EARLY 20TH CENTURY

Lee H. Nelson, FAIA, H. Ward Jandt, Charles Fisher; Preservation Assistance Division, National Park Service; Washington, D.C.  
Eric J. Gastier; Darrel Downing Rippeteau Architects, PC; Washington, D.C.

**PRESERVATION APPROACHES**

An in-depth survey of the condition of existing windows should be undertaken early in the planning of a rehabilitation to allow time to fully explore repair and upgrading methods and possible replacement options, if merited. Peeling paint, broken glass, stuck sash, and high air infiltration are no indication that existing windows are beyond repair and that their performance cannot be enhanced.

The wood and architectural metal which comprise the window frame, sash, muntins, and surrounds should be maintained through appropriate surface treatments such as cleaning, rust removal, limited paint removal, reapplication of protective coating systems, and reglazing where necessary.

Windows should be made weathertight by recaulking and replacing or installing weatherstripping. These actions also improve thermal efficiency. Retrofitting or replacing windows should never be a substitute for proper maintenance of the sash, frame, and glazing.

Window frames and sash can be repaired by patching, splicing, consolidating, or otherwise reinforcing historic materials.

Window repair can include replacement of deteriorated components such as sash cords, muntins, and sills.

Serviceable window hardware such as brass lifts and

sash locks can be reused in the course of repairs and should not be discarded in favor of new hardware.

Thermal efficiency can be improved with weatherstripping, storm windows, caulking, interior shades, and, if historically appropriate, blinds and awnings. Replacing historic multipaned sash with new thermal sash is inappropriate when the historic sash are in repairable condition.

Interior storm windows should have airtight gaskets, ventilating holes, and/or removable clips or operability features to ensure proper maintenance and to avoid potential condensation damage to historic windows.

Exterior storm windows should be selected that do not damage or obscure the windows and frames. It is not appropriate to install new exterior storm windows that are inappropriate in size and are not painted the same color as the sash trim.

Tinted or reflective glazing should never be used on character-defining or other conspicuous elevations. Lightly tinted glazing could be used on non-character-defining elevations if other energy retrofitting alternatives are not possible and after conclusively establishing a need for such a treatment.

A historic window that is too deteriorated to repair should in most cases be replaced in kind, that is, using the same kind of material (wood for wood; steel for steel) and

using the same sash and pane configuration and other design details.

In some cases, the historic windows (frame, sash, and glazing) may be completely missing. The preferred option for replacement is always an accurate restoration using historical, pictorial, and physical documentation.

Where fixed windows are being installed, the glass and frames should be set in the same planes as the historic sash, with all detailing duplicated.

When replacing historic multipaned sash with new sash, true integral muntins should be utilized, particularly on smaller buildings, windows on large buildings close to the pedestrianway, on ornate windows, where windows are part of a significant interior space, and where a building has high historic merit.

On certain types of large buildings, particularly high-rises, aluminum windows may be a suitable replacement for historic wooden sash provided wooden replacements are not practical and the design detail of the historic windows can be matched. Historic color duplication, custom contour panning, incorporation of 3/8 in. deep trapezoidal exterior muntin grids where applicable, retention of the same glass-to-frame ratio, matching of the historic reveal, and duplication of the frame width, depth, and such existing decorative details as arched tops should all be components in aluminum replacement windows selected for use on historic buildings.

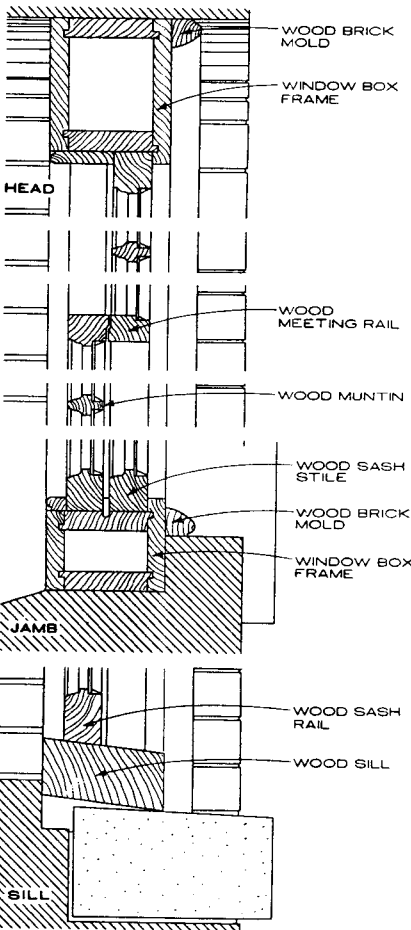

**LATE 19TH CENTURY MILL WINDOW**

REPAIR WHENEVER POSSIBLE. IN SOME CASES, REPLACEMENT OF SASH AND REUSE OF FRAMES AND HARDWARE MAY BE POSSIBLE.

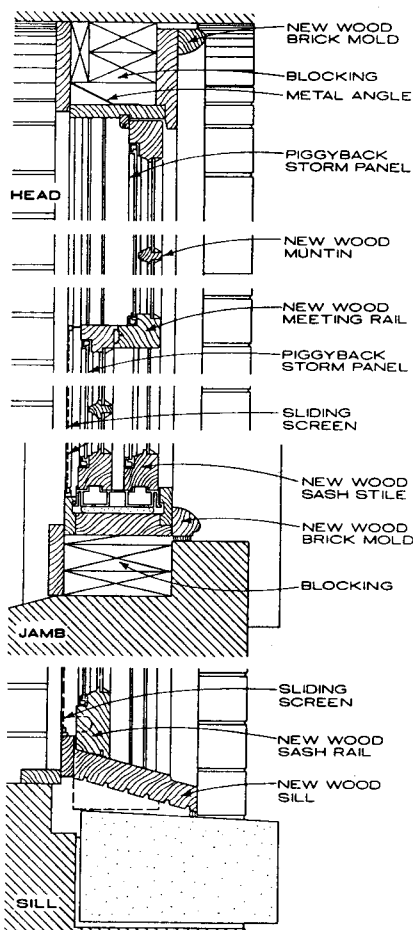

**WOOD REPLACEMENT WINDOW**

APPROPRIATE WHEN HISTORIC WINDOW IS BEYOND REPAIR. IN MANY CASES, PIGGYBACK INTERIOR STORM PANELS ATTACHED TO NEW SASH AND/OR INTERIOR MOUNTED INSECT SCREENS ARE SUITABLE UPGRADED FEATURES. EXTERIOR APPEARANCE OF HISTORIC WINDOW SHOULD BE RETAINED.

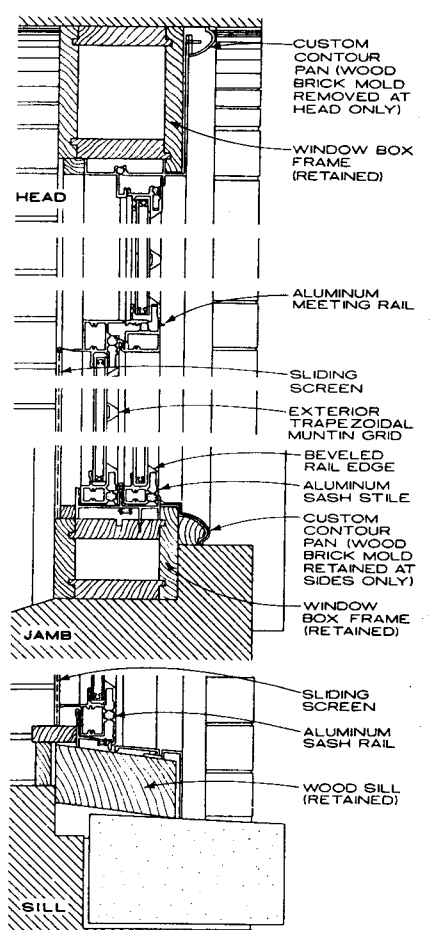

**ALUMINUM REPLACEMENT WINDOW (CUSTOM)**

APPROPRIATE IN SOME CASES, PARTICULARLY IN EARLY 20TH CENTURY HIGH-RISES. SPECIAL FEATURES TO BE SPECIFIED: BEVELED RAIL AND STILE EDGES, CUSTOM CONTOUR PANNING, CUSTOM COLOR, TRAPEZOIDAL EXTERIOR MUNTIN GRID, AND CLOSELY MATCHED SIGHT LINES.

**REPAIR/REPLACEMENT STRATEGIES FOR HISTORIC WOOD WINDOWS**

Lee H. Nelson, FAIA, H. Ward Jandl, Charles Fisher, Preservation Assistance Division, National Park Service, Washington, D.C.  
Eric J. Gastier; Darrel Downing Rippeteau Architects, PC, Washington, D.C.

**ACCESSIBLE ENTRANCE DESIGN**

Providing entrances that are accessible to everyone requires a balance between historic preservation goals and the special needs of persons with disabilities. Careful planning is required to achieve solutions that provide the highest level of access with the fewest level of impact to character-defining materials and features. Each building should thus be evaluated to determine the best design and best placement of accessibility features. Solutions on a primary facade may range from a minimal threshold wedge to a small ramp to much longer ramps, inclines, and grade changes. Designing a ramp that does not exceed 1 in. of rise for every 12 in. of run and is as unobtrusive as possible are dual preservation goals. (It should be noted that regrading to 1 in. of rise for 20 in. of run eliminates the need for handrails.) Retaining existing doors and hardware and using an automatic door opener are also recommended, whenever possible. If a significant primary facade would be threatened or destroyed in the process of providing

access, a secondary facade may be used to provide an alternative public entrance. In general, nonmechanical means of overcoming physical barriers are preferable because mechanical devices require more maintenance and can easily break down.

If there is inadequate space for an accessible ramp, an incline or vertical lift may be considered. Each type of lift requires adequate maneuvering space at the head and foot of steps. Mechanical motors and electrical activators must have proper covers to reduce breakdowns. Lifts are often allowed for retrofit work but are generally not allowed in new construction. If new construction is to be part of an overall rehabilitation project, it may be possible to locate accessible entrances in a new addition with service to the historic building.

New additions, built to achieve accessibility requirements, should be

1. properly scaled (not too large in comparison to adjacent features).

2. of compatible materials (similar in quality, type, color values).
3. of compatible design (differentiated from the historic elements).
4. "reversible" (basic integrity of building left intact if a new accessibility feature were to be removed).

If the historical significance of a major facade would be threatened or destroyed if a new ramp or lift were added, every effort should be made to find a convenient alternative public entrance. Alternative public entrances located close to parking areas may provide a more direct path of travel for persons with disabilities. With careful planning, successful solutions can usually be found to balance accessibility and historic preservation requirements.

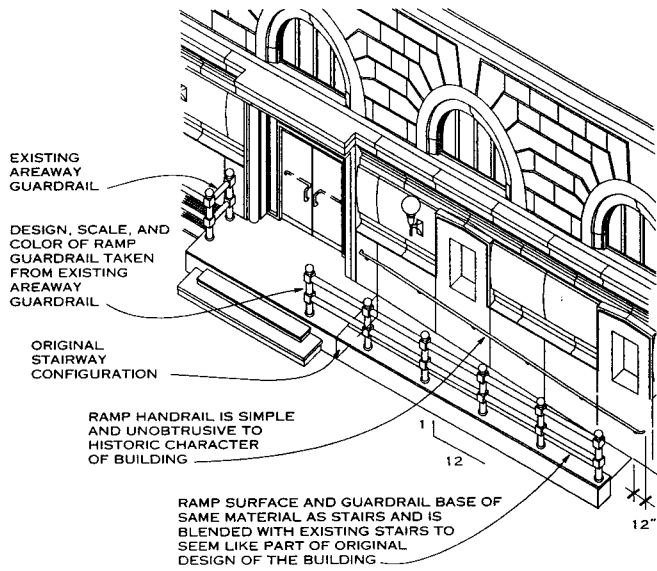

**ACCESSIBLE RAMP INTEGRATED WITH ENTRY**

**NOTES**

1. Temporary ramp solution complies with ADA, and the design is durable and refined enough to be in place until a permanent solution is constructed.
2. Both designs retain the symmetry of the entry portal, allow maximum circulation, and are compatible with building color and historic character.
3. Temporary ramp should be easily "reversible" to original design.

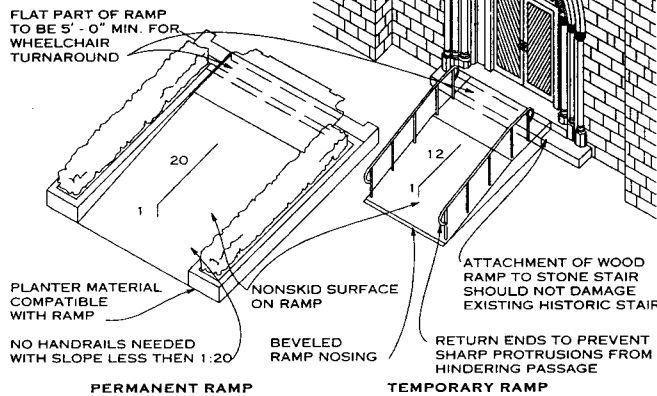

**ACCESSIBLE RAMP REPLACING ENTRY**

H. Ward Jandl, Kay D. Weeks, Sharon C. Park, AIA, Timothy A. Buehner, Preservation Assistance Division, National Park Service; Washington, D.C.  
Richard J. Vitullo, AIA; Oak Leaf Studio; Crownsville, Maryland

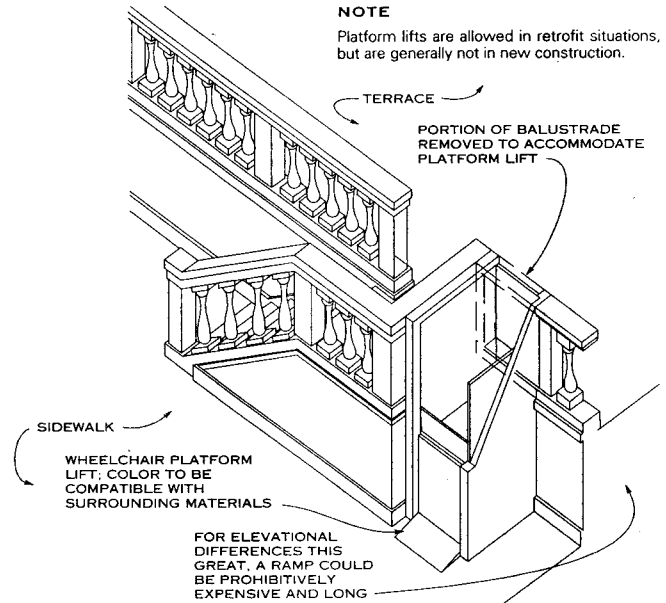

**PLATFORM LIFT INTEGRATED INTO STAIR ENTRY**

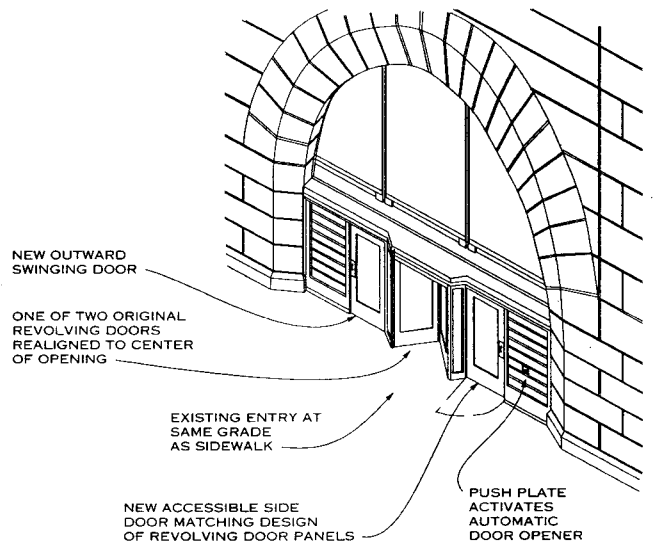

**ACCESSIBLE DOORS INTEGRATED INTO EXISTING ENTRY**

**INTRODUCTION**

Entrances and porches are quite often the focus of historic buildings, particularly when they occur on primary elevations. Together with their functional and decorative features such as doors, steps, balustrades, pilasters, and entablatures, they can be extremely important in defining the overall character of a building.

Usually entrances and porches were integral components of a historic building's design; for example, porches on Greek Revival houses, with Doric or Ionic columns and pediments, echoed the architectural elements and features of the larger building. Central one-bay porches or arcaded porches are evident in Italianate style buildings of the 1860s. Doors of Renaissance Revival style buildings frequently supported entablatures or pediments. Porches were particularly prominent features of Eastlake and Stick Style houses; porch posts, railings, and balusters were characterized by a massive and robust quality, with members turned on a lathe. Porches of bungalows of the early 20th century were characterized by tapered porch posts, exposed post and beams, and low-pitched roofs with wide overhangs. Art Deco commercial buildings were entered through stylized glass and stainless steel doors.

**PRESERVATION APPROACHES**

The materials that comprise entrances and porches—masonry, wood, and architectural metal—should be protected and maintained through appropriate surface treatments such as cleaning, rust removal, limited paint removal, and reapplication of protective coating systems. The overall condition of materials should be evaluated to determine whether more than protection and maintenance are required.

Removing or radically changing primary entrances will in most cases change the overall appearance of the building. Entrances and porches should never be removed be-

cause the building has been reoriented to accommodate a new use.

If barrier-free access is required to a historic building, it should be introduced in a way that does not destroy significant material or interfere with the historic design.

Entrances and porches can be repaired by reinforcing deteriorated historic materials—patching, splicing, and reinforcing with epoxies are examples. Limited replacement in kind of extensively deteriorated or missing parts of repeated features may be undertaken where there are surviving prototypes. Examples include balustrades, cornices, entablatures, columns, sidelights, and stairs.

Only when an entire entrance or porch is too deteriorated to repair—or is missing—should total replacement be considered. If the historic form and detailing are still evident, this evidence should be used to restore the entrance or porch.

If the entrance or porch is missing, restoration should be based on historical, pictorial, and physical evidence rather than on conjectural designs or the availability of elements from neighboring buildings.

When insufficient documentation exists for an accurate restoration, the replacement entrance or porch may be a new design that is consistent with the size, scale, material, and color of the historic building. Care must be taken not to create a false historic appearance in the new work.

Compatible substitute material may be considered if replicating with the historic material is technically or economically infeasible; the substitute material needs to convey the same visual appearance and be physically and chemically compatible. It is important to note that historic exterior wood elements were typically of rot-resistant species.

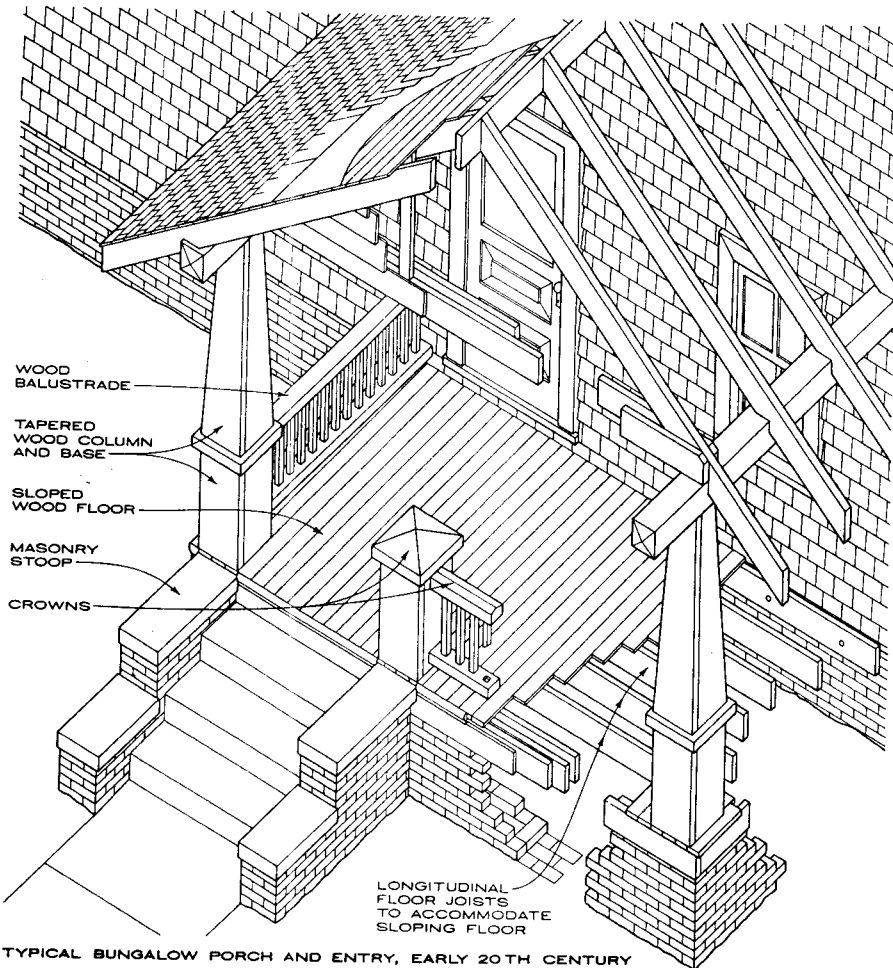

TYPICAL BUNGALOW PORCH AND ENTRY, EARLY 20TH CENTURY

Lee H. Nelson, FAIA, H. Ward Jandi, Camille Martone, Kay D. Weeks; Preservation Assistance Division, National Park Service; Washington, D.C.  
Eric J. Gastier, Darrel Downing Rippeteau Architects, PC; Washington, D.C.

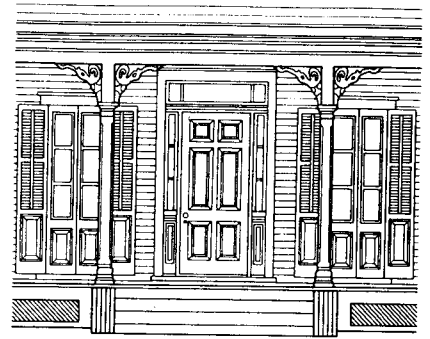

PORCH AND ENTRY

655 HUGHES STREET,  
CAPE MAY, NJ

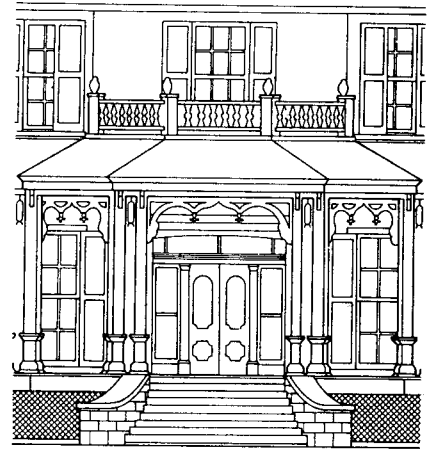

PORCH AND ENTRY

FENDALL HALL, EUFAULA, AL  
(NICHOLAS H. HOLMES,  
RESTORATION ARCHITECT, 1975)

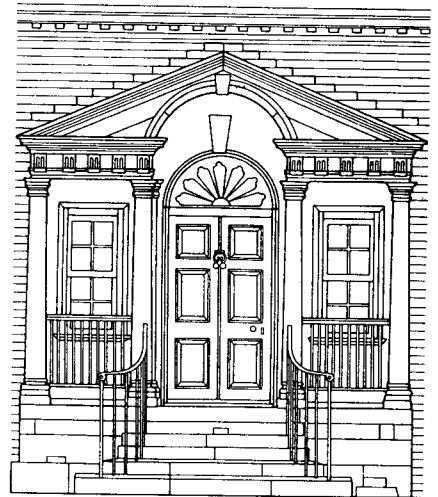

PORCH AND ENTRY

GUNSTON HALL,  
FAIRFAX COUNTY, VA

**INTRODUCTION**

The storefront is usually the most prominent feature of a historic commercial building, playing a crucial role in a store's advertising and merchandising strategy. Although a storefront usually does not extend beyond the first story, the rest of the building is often related to it visually in form and detail. Planning should always consider the entire building; window patterns on the upper floors, cornice elements, and other decorative features should be carefully retained, in addition to the storefront itself.

The earliest extant storefronts in the United States, dating from the late 18th and early 19th centuries, had bay or oriel windows and provided limited display space. The 19th century witnessed the progressive enlargement of display windows as plate glass became available in increasingly larger sizes. The use of cast-iron columns and lintels at ground floor level permitted structural members to be reduced in size. Recessed entrances provided shelter for sidewalk patrons and further enlarged display areas. In the 1920s and 1930s, aluminum, colored structural glass, stainless steel, glass block, neon, and other new materials were introduced to create Art Deco storefronts. The growing appreciation of historic buildings in recent years has prompted many owners to remove inappropriate changes and restore the historic appearance of their storefronts.

**PRESERVATION APPROACHES**

Functional and decorative features that make up the historic storefront include display windows, lower window panels, transoms, business signs, entrance doors, and entablatures. Materials that make up a storefront—cast iron, bronze, wood, pressed metal, structural glass—should be identified before undertaking any preservation work.

Removal of inappropriate, nonhistoric cladding and later alterations such as oversized awnings and signs can enhance a historic storefront.

The historic storefront should be secured by boarding up windows and installing alarm systems prior to and during rehabilitation. Unsecured doors and broken windows permit interior features and finishes to be damaged by weather or vandalism.

Damaged historic features such as cracked display windows, deteriorated wooden panels below windows, and rusted metal structural members should be repaired wherever possible rather than replaced.

Repairs are best made using historic materials; however, substitute materials may be appropriate if they convey the same visual appearance as the surviving components of the storefront.

Only if an entire storefront is missing or is too deteriorated to repair should total replacement be considered. The form and detailing should replicate the historic storefront.

Restoration should be based on historical and pictorial evidence rather than on conjectural designs or the availability of elements from neighboring buildings. When insufficient documentation exists for an accurate restoration, the replacement storefront may be a new design that is consistent with the size, scale, material, and color of the historic building.

Alterations to storefronts for the purpose of providing access to persons with disabilities should not result in the destruction of significant historic materials. For example, if paired door panels are each less than 32 in. wide or if historic decorative hardware is not the "lever-action type," doors and hardware should be retained and automatic door openers considered as a preservation solution.

Whenever possible, high thresholds or one step up should be modified with a ramp. Full sets of steps on a primary facade are often architectural features that cannot be altered without threatening or destroying the building's historical significance; secondary entrances should be considered in such situations.

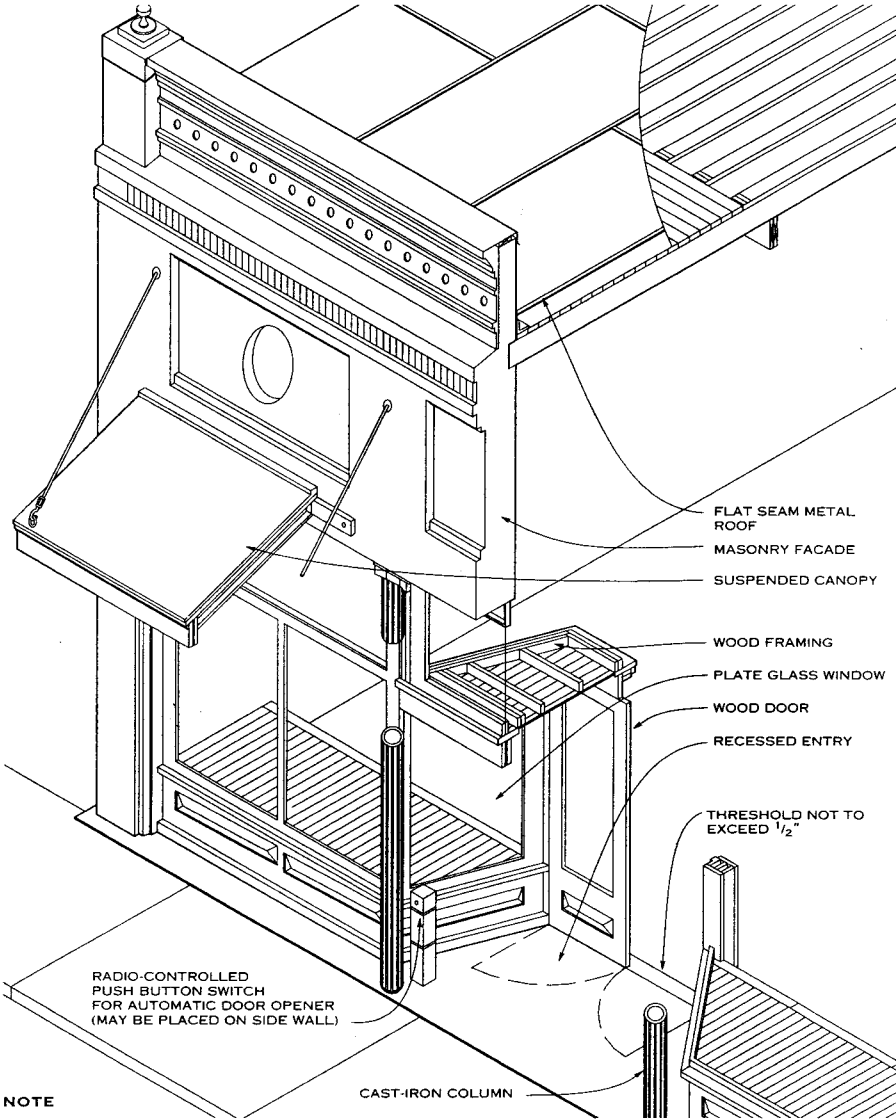

**NOTE**  
Storefront based on 610 Main Street, Van Buren, Arkansas; David Fitts, Architect

**TYPICAL STOREFRONT, LATE 19TH CENTURY, WITH ACCESSIBILITY MODIFICATIONS**

Lee H. Nelson, FAIA, H. Ward Jandl, Michael J. Auer, Kay D. Weeks, Sharon C. Park, AIA, Timothy A. Buehner; Preservation Assistance Division, National Park Service; Washington, D.C.  
Eric J. Gastier; Darrel Downing Rippeteau, Architects;

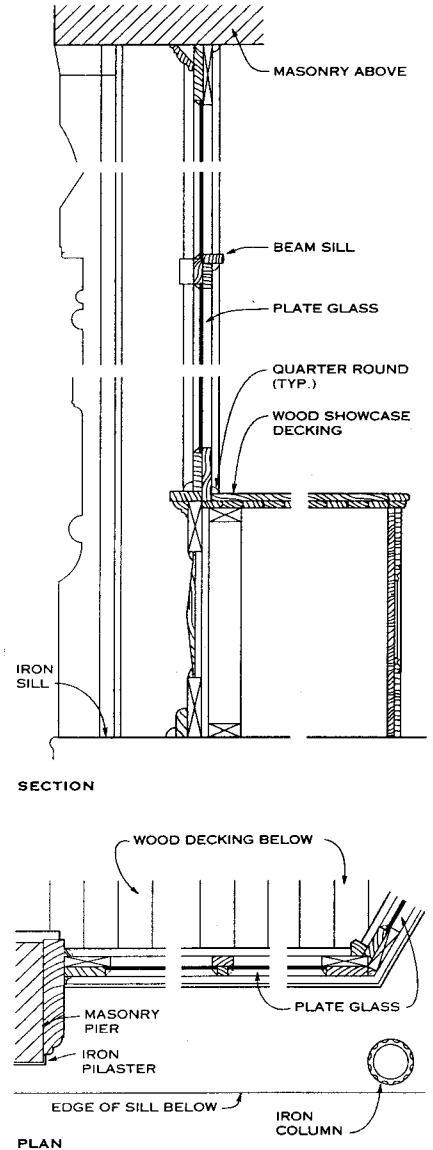

**STOREFRONT DETAILS**

**INTRODUCTION**

Structural systems in architecture are composed of structural elements (such as beams, piers, and trusses) and building materials (wood, steel, and masonry) that together form the walls, floors, and roofing of buildings.

If features of the structural system are exposed, such as load-bearing brick walls, cast iron columns, roof trusses, posts and beams, vigas, or stone foundation walls, they may be important in defining the building's overall historic character.

The types of structural systems found in America include, but certainly are not limited to, the following: wooden frame construction (17th century), balloon frame construction (19th century), load-bearing masonry construction (18th century), brick cavity wall construction (19th century), heavy timber post and beam industrial construction (19th century), fireproof iron beam construction (19th century), heavy masonry and steel construction (19th century), skeletal steel construction (19th century), and concrete slab and post construction (20th century).

**PRESERVATION APPROACHES**

A significant structural system or distinctive structural features should be identified prior to any work. To accommodate new uses within a historic building, structural upgrading should be done in a sensitive manner. Installing equipment or mechanical systems that result in numerous cuts, splices, or alterations to historic structural members should always be avoided.

If excavations or regrading—either adjacent to or within a historic building—are being planned, studies should be

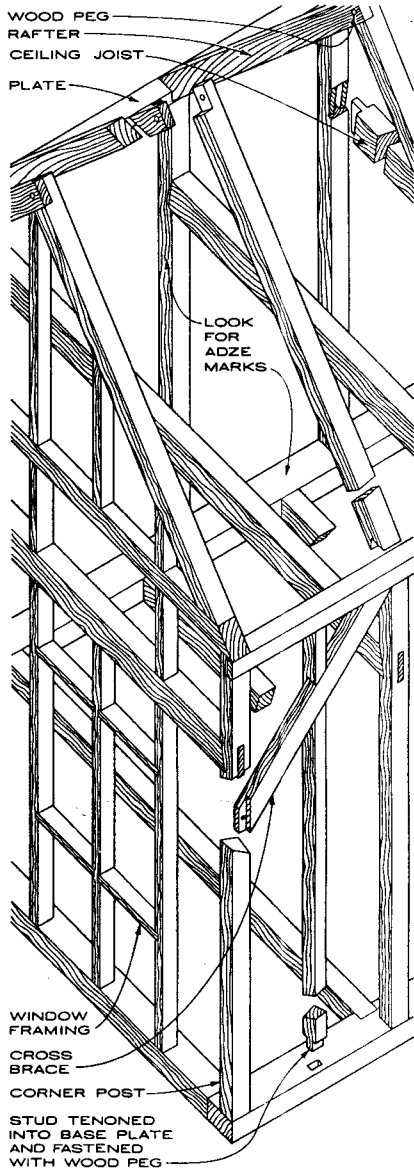

TYPICAL 18TH CENTURY MORTISE AND TENON WOOD FRAMING

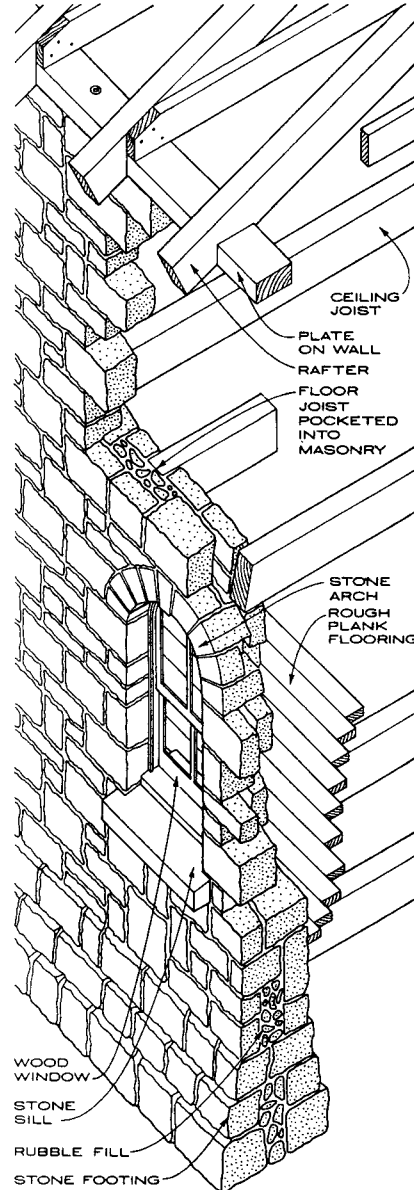

18TH AND 19TH CENTURIES LOAD-BEARING MASONRY

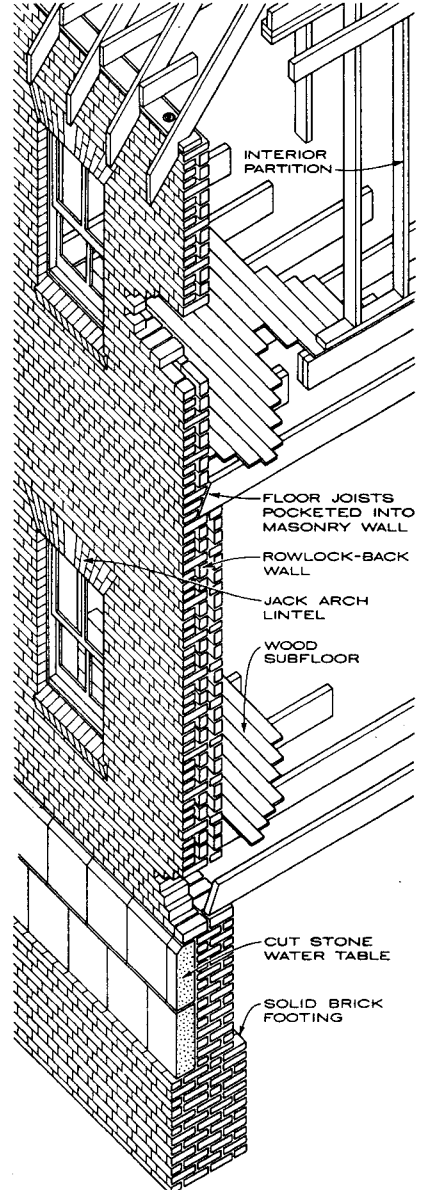

19TH CENTURY BRICK CAVITY WALL

**STRUCTURAL SYSTEMS**

Lee H. Nelson, FAIA, H. Ward Jandl, Sharon C. Park, AIA, Kay D. Weeks; Preservation Assistance Division, National Park Service; Washington, D.C.  
Eric J. Gastier; Darrel Downing Rippeteau Architects, PC; Washington, D.C.



done first to ascertain potential damage to archeological resources and to the historic building itself. If significant archeological resources will be disturbed, appropriate mitigation measures need to be incorporated into the project. Inappropriate excavations can cause the historic foundation to settle, shift, or fail.

Structural problems, such as deflection of beams, racking of structural members, or cracking and bowing of walls, should be treated—not cosmetically covered over. A deteriorated load-bearing masonry wall should be reinforced and retained wherever possible, not replaced with a new wall that is veneered using old brick.

Structural deterioration can be the result of subsurface ground movement, vegetation growing too close to

foundation walls, improper grading, uncontrolled moisture, poor maintenance of exterior materials, leaking roofs, insect infestation, fungal rot, poor interior ventilation that results in condensation, inadequate attention to the effects of moisture in original structural detailing, and general deterioration of materials over time. Cyclical maintenance and annual inspections should be routine for historic buildings.

The structural system should be repaired by augmenting or upgrading individual parts or features. For example, weakened structural members such as floor framing can be paired with a new member sistered, braced, or otherwise supplemented and reinforced.

Permanent structural upgrading should never be undertaken in a manner that diminishes the historic character of the building, such as installing exterior strapping channels.

In instances where seismic upgrading is necessary, it is best to use grouted bolts as opposed to exposed plates and to locate diaphragms on unornamented surfaces or to consider other options that reduce the visual and physical impact of the code-required change.

If exposed elements of the structural system are beyond repair, the replacements need to convey the same form, design, and overall visual appearance as the historic feature, to equal the load-bearing capabilities of the historic material, and to be physically and chemically compatible.

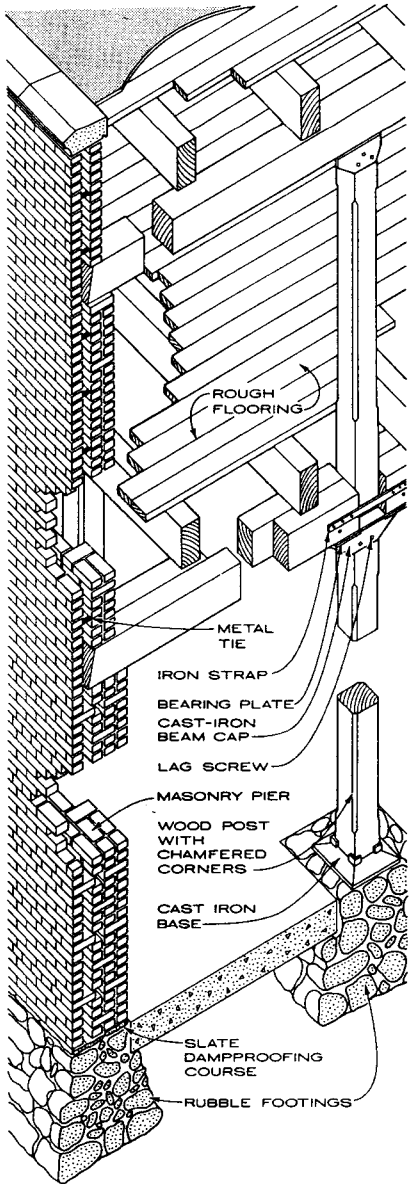

19TH AND EARLY 20TH CENTURIES  
HEAVY TIMBER POST AND BEAM

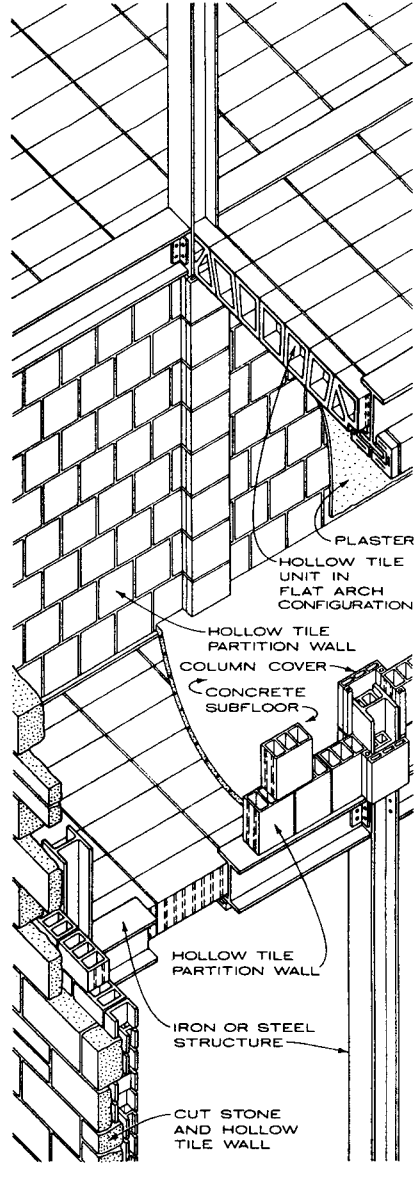

LATE 19TH AND EARLY 20TH CENTURIES  
FIREPROOF CONSTRUCTION

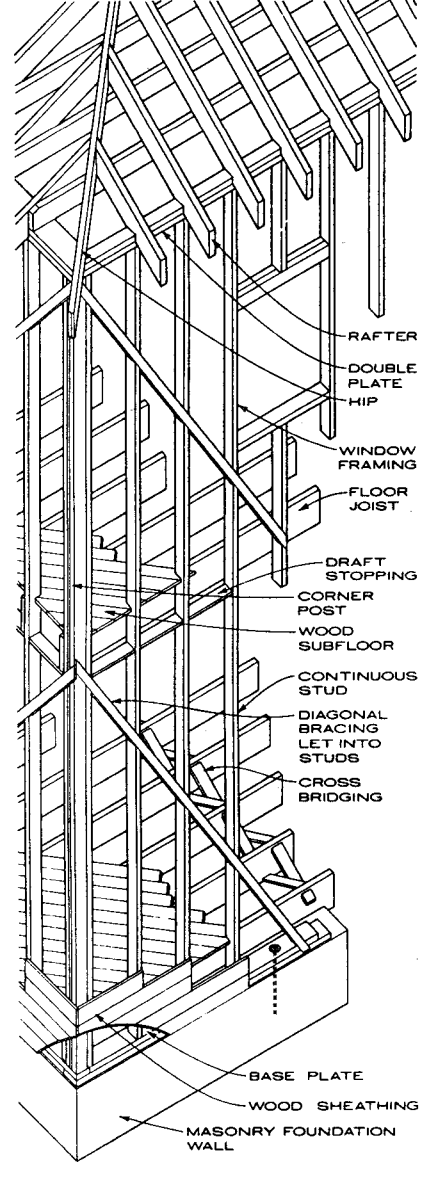

20TH CENTURY  
BALLOON FRAMING

STRUCTURAL SYSTEMS

Lee H. Nelson, FAIA, H. Ward Jandl, Sharon C. Park, AIA, Kay D. Weeks; Preservation Assistance Division, National Park Service; Washington, D.C.  
Eric J. Gastier; Darrel Downing Rippeteau Architects, PC; Washington, D.C.



**INTRODUCTION**

An interior floor plan, the arrangement and sequence of spaces, and built-in features and applied finishes are individually and collectively important in defining the historic character of the building. Their identification, retention, protection, and repair should be given prime consideration in every rehabilitation project.

In evaluating historic interiors prior to rehabilitation, it should be kept in mind that interiors are comprised of a series of primary and secondary spaces. This is applicable to all buildings, from courthouses to cathedrals to cottages and office buildings. Primary spaces, including entrance halls, parlors, living rooms, assembly rooms, and lobbies, are defined not only by their features and finishes, but by the size and proportion of the rooms themselves—purposely created to be the visual attraction or functioning “core” of the building. Care should be taken to retain the essential proportions of primary interior spaces and not to damage, obscure, or destroy distinctive features and finishes.

Secondary spaces include areas and rooms that “service” the primary spaces and may include kitchens, bathrooms, mail rooms, utility spaces, secondary hallways, firestairs, and office cubicles in a commercial or office space. Extensive changes can often be made in these less important areas without having a detrimental effect on the overall historic character.

**PRESERVATION APPROACHES**

Distinctive interior spaces, features, and finishes should be identified, then carefully retained and preserved in any work project. Examples include columns, cornices, baseboards, fireplaces and mantels, paneling, light fixtures, hardware, flooring, and wallpaper, plaster, paint, and finishes such as stenciling, marbling, and graining.

Distinctive interior spaces should not be altered by inserting a floor, cutting through the floor, lowering ceilings, or adding or removing walls.

Historically finished surfaces such as paint, plaster, or other finishes should not be stripped (e.g., removing plaster to expose masonry surfaces such as brick walls or a chimney piece). It is also inappropriate to strip painted wood to a bare wood surface, then apply a clear finish or stain to create a “natural, new look.” Distinctive finishes such as marbling or graining on doors or paneling should be repaired, not covered over or removed. Conversely, paint, plaster, or other finishes should not be applied to surfaces that have been historically unfinished to create a new appearance.

Code-required fire suppression systems (such as a sprinkler system for a wood-frame mill building) should be sensitively designed so that character-defining features are not covered.

Interior features should be protected against gouging, scratching, and denting during project work by covering them with heavy canvas or plastic sheets. Destructive methods of paint removal such as propane or butane torches or sandblasting should never be used because they can irreversibly damage the historic materials that comprise interior features.

Interior features and finishes can often be repaired and preserved by reinforcing the historic materials. Repair may involve the limited replacement in kind of those extensively deteriorated or missing parts of repeated fea-

tures when there are surviving prototypes such as stairs. Examples include balustrades, wood paneling, columns, or decorative wall coverings or ornamental tin or plaster ceilings. If an interior feature or finish is too deteriorated to repair or is missing, its replacement should be based on historical and pictorial evidence rather than on conjectural designs or the availability of elements from neighboring buildings.

In cases where insufficient documentation exists for an accurate restoration of an interior feature or finish, the replacement should be compatible in scale, design, materials, color, and texture with the surviving interior features and finishes. A new design element should be distinguishable from the old and not create a false historic appearance.

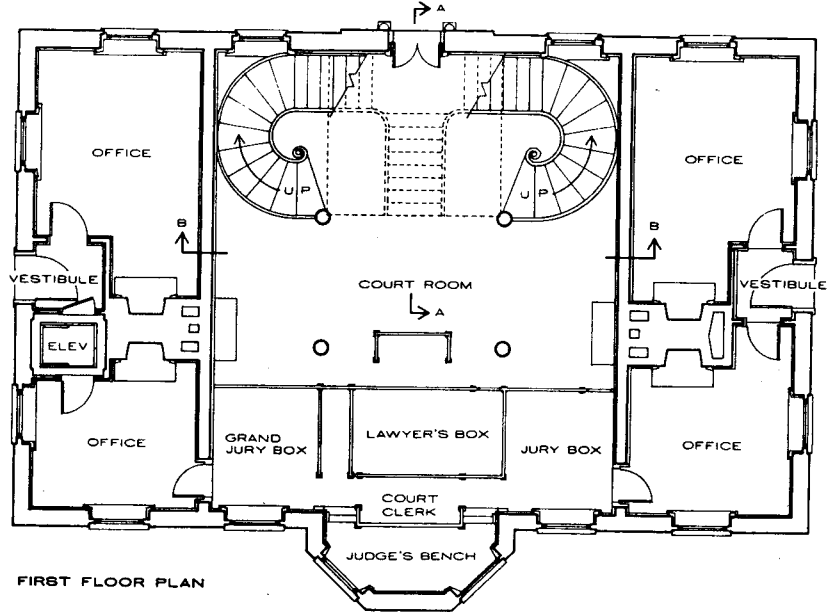

FIRST FLOOR PLAN

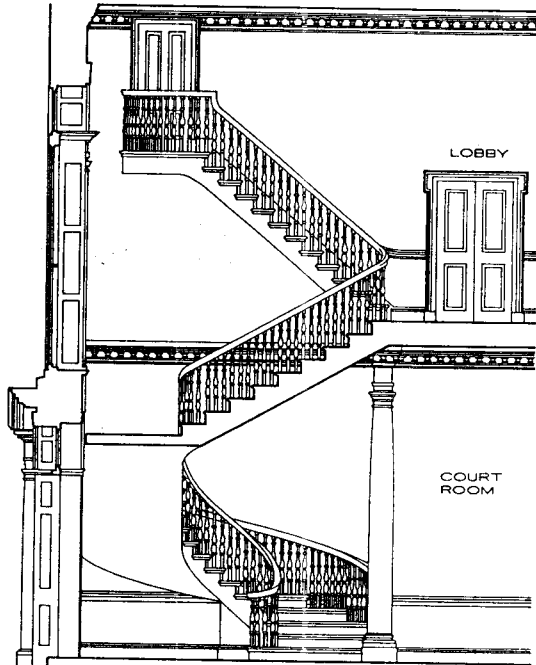

SECTION A

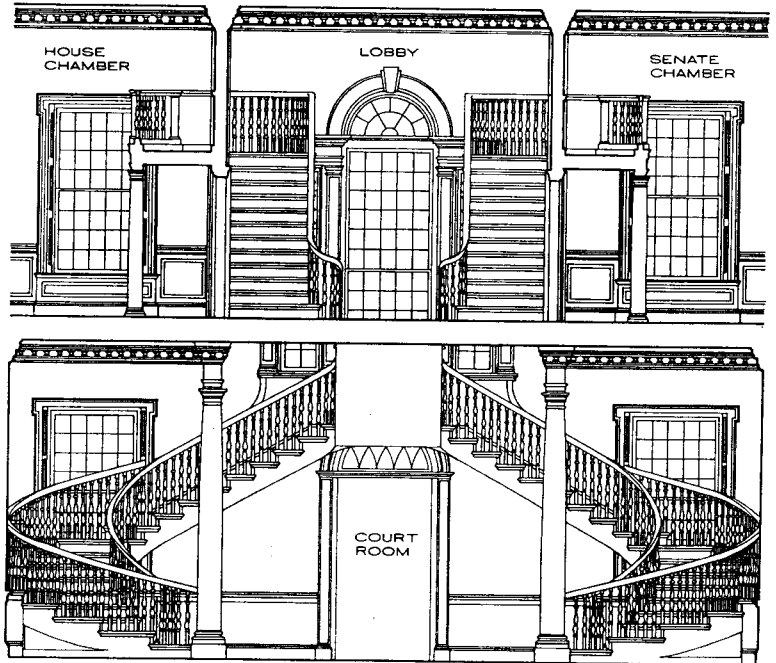

SECTION B

PARTIAL TRANSVERSE SECTION  
 PARTIAL LONGITUDINAL SECTION  
 OLD STATE HOUSE, DOVER, DE (McCUNE ASSOCIATES, RESTORATION ARCHITECTS, 1977)

Lee H. Nelson, FAIA, H. Ward Jandt, Camille Martone, Kay D. Weeks; Preservation Assistance Division, National Park Service; Washington, D.C.  
 Eric J. Gastier; Darrel Downing Rippeteau Architects, PC; Washington, D.C.

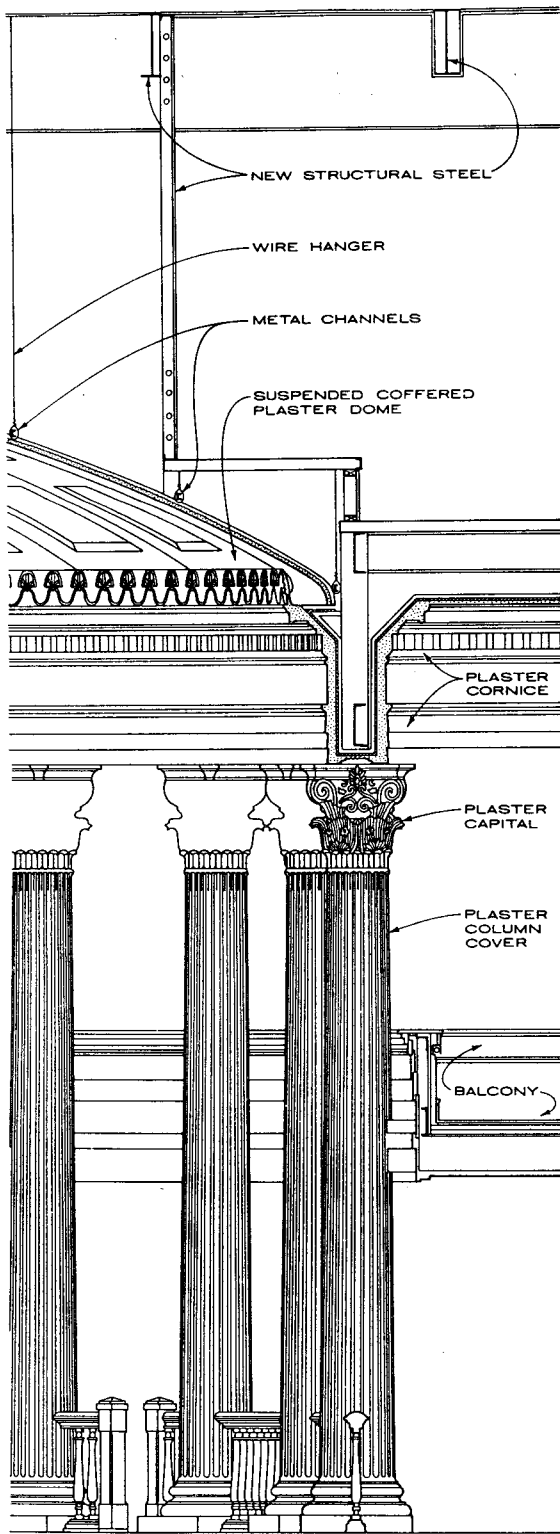

SECTION / INTERIOR ELEVATION  
 OLD CAPITOL BUILDING, SPRINGFIELD, IL  
 (FERRY AND HENDERSON - ARCHITECTS FOR  
 RESTORATION, 1967)

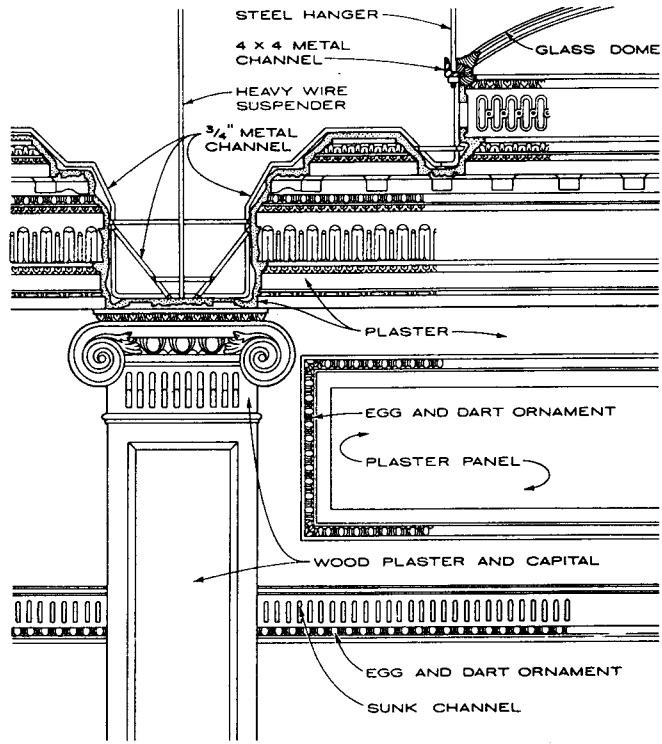

SECTION / INTERIOR ELEVATION  
 VENTURA COUNTY COURTHOUSE, SAN BUENA, VENTURA, CA,  
 1911 (ALBERT C. MARTIN - ARCHITECT)

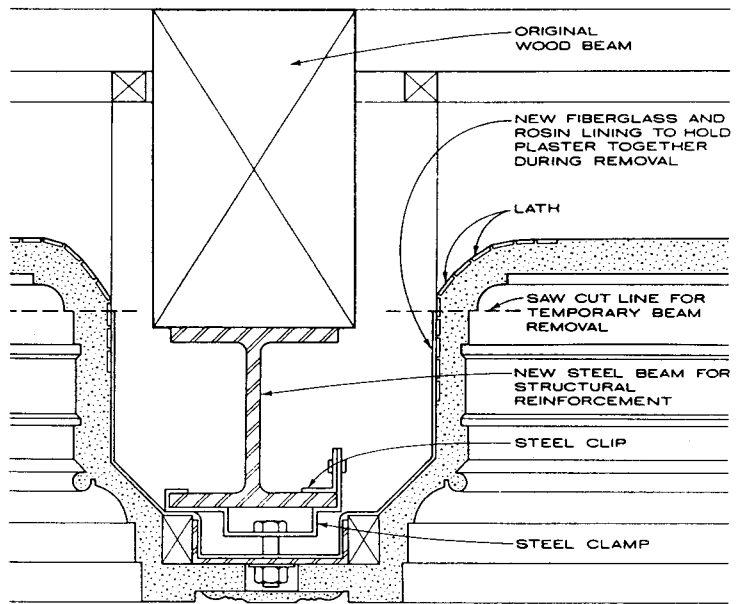

ORNAMENTAL PLASTER BEAM REMOVAL AND REPLACEMENT DETAIL  
 CROCKER ART GALLERY, SACRAMENTO, CA  
 (ROSEKRANS AND BRODER, INC. - ARCHITECTS FOR RESTORATION,  
 1978)

ORNAMENTAL PLASTER

Lee H. Nelson, FAIA, H. Ward Jandt, Camille Martone, Kay D. Weeks; Preservation Assistance Division, National Park Service, Washington, D.C.  
 Eric J. Gastier, Darrel Downing Rippeteau Architects, PC, Washington, D.C.

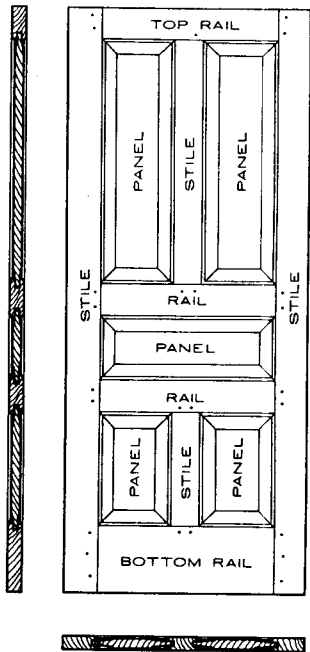

SOLID MOLDED STILE WOOD DOOR

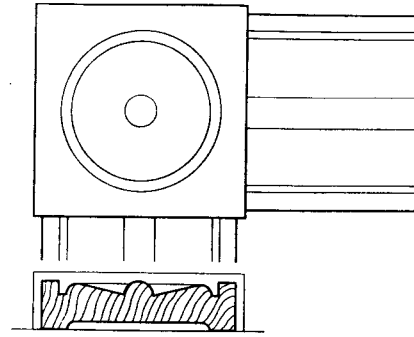

BLOCK AND PILASTER ARCHITRAVE

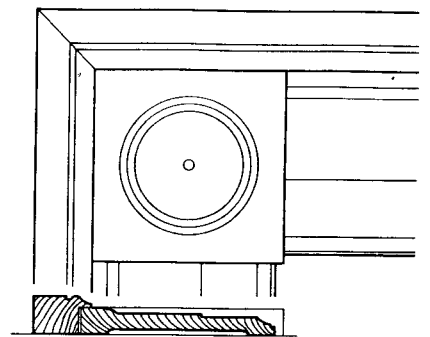

CORNER BLOCK AND MITERED BACKBAND MOLDING

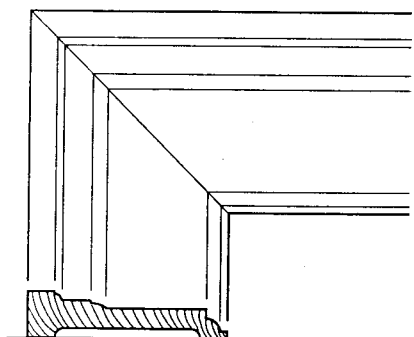

MITERED ARCHITRAVE DOOR TRIM

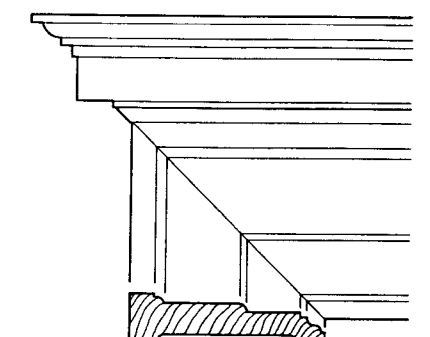

MITERED ARCHITRAVE WITH CORNICE

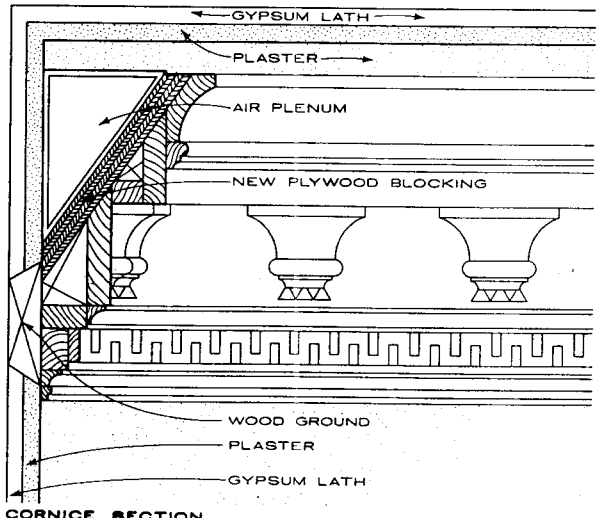

CORNICE SECTION

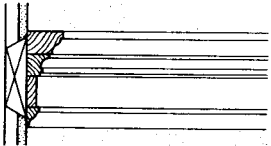

CORNICE SECTION

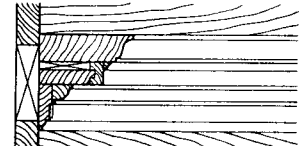

CORNICE SECTION

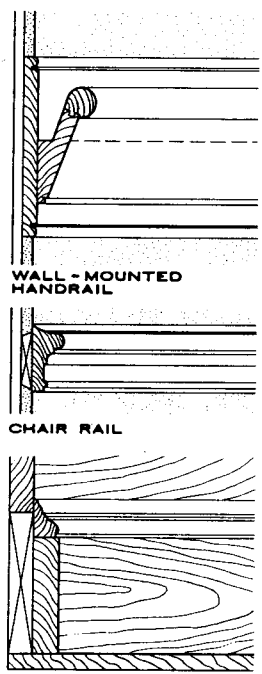

WALL-MOUNTED HANDRAIL

CHAIR RAIL

BASE

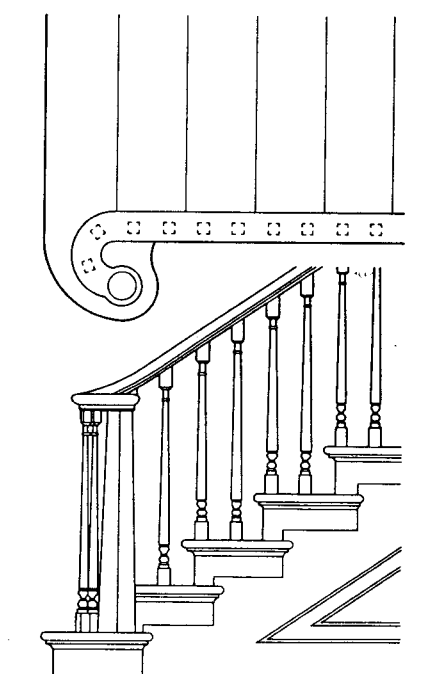

WOOD STAIR AND BALUSTRADE

INTERIOR WOOD DETAILS FROM THE OLD STATE HOUSE, DOVER, DE (McCUNE ASSOCIATES, RESTORATION ARCHITECTS, 1977)

Lee H. Nelson, FAIA, H. Ward Jandl, Camille Martone, Kay D. Weeks; Preservation Assistance Division, National Park Service; Washington, D.C.  
Eric J. Gastier; Darrel Downing Rippeteau Architects, PC; Washington, D.C.

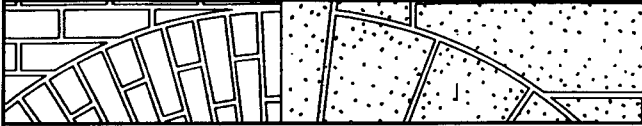

# BUILDING TYPES AND SPACE PLANNING

Residential Room Planning 864

Nonresidential Room Planning  
876

Child Care 889

Health Clubs 891

Museums 892

Airports 896

Health Care 900

Ecclesiastical 904

Detention 907

Justice Facility Planning 908

Assembly 913

Retail 922

Animal Care 926

Greenhouses 931

Housing 932

Waste Management 942

Distribution Facilities 945

Storage Facilities 948

Processing Facilities 949

**BED SIZES (IN.)**

TYPES	W	L
King	72	84
Queen	60	82
Double	54	82
Single	39	82
Daybed	30	75
Crib	30	53

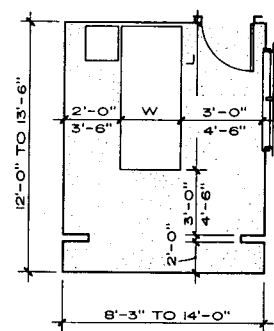
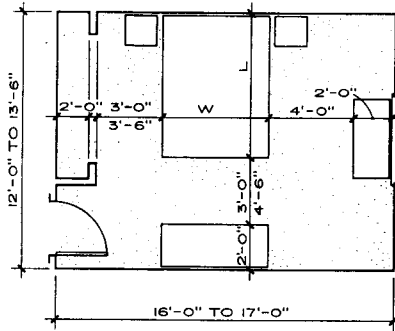
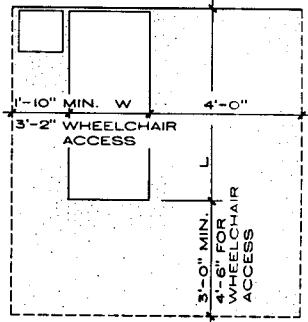
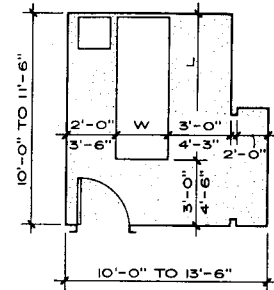
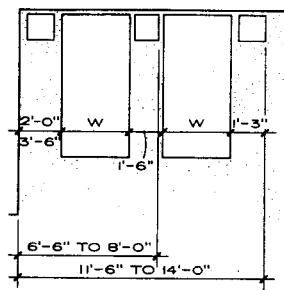

**BED CLEARANCES  
BEDROOM FURNITURE**

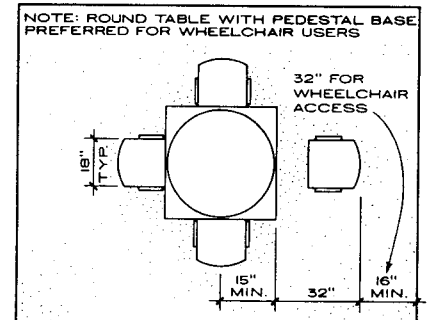
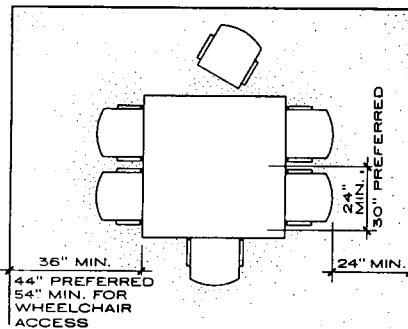
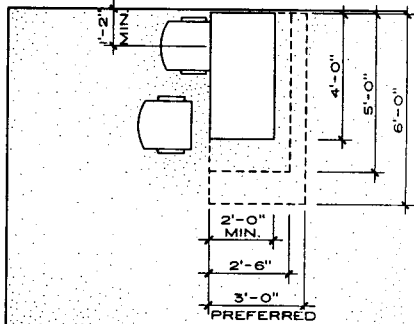

NOTE: ROUND TABLE WITH PEDESTAL BASE PREFERRED FOR WHEELCHAIR USERS

**RECTANGULAR TABLES (IN.)**

SIZE	SEAT	WHEELCHAIR
24 x 48	4	
30 x 48	4	2
30 x 60	4-6	2-4
36 x 72	4-6	4-6
36 x 84	6-8	6

**SQUARE TABLES (IN.)**

SIZE	SEAT	WHEELCHAIR
30 x 30	2	
36 x 36	2-4	
42 x 42	4	2 (TIGHT)
48 x 48	4-8	2
54 x 54	4-8	4

**ROUND TABLES (IN.)**

SIZE	SEAT	WHEELCHAIR
30	2	
36	2-4	
42	4-5	
48	5-6	2
54	5-6	4

**DINING ROOM FURNITURE**

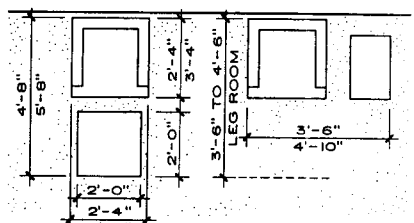

**ARMCHAIR AND OTTOMAN WITH LIVING ROOM FURNITURE**

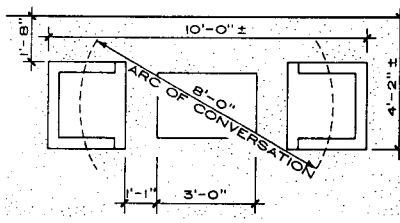

**ARMCHAIRS WITH COFFEE TABLE**

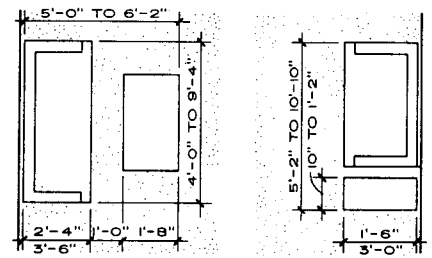

**SOFA WITH COFFEE TABLE**

**SOFA WITH END TABLE**

Robin Andrew Roberts, AIA; Washington, D.C.  
Arthur J. Pettorino, AIA; Hicksville, New York

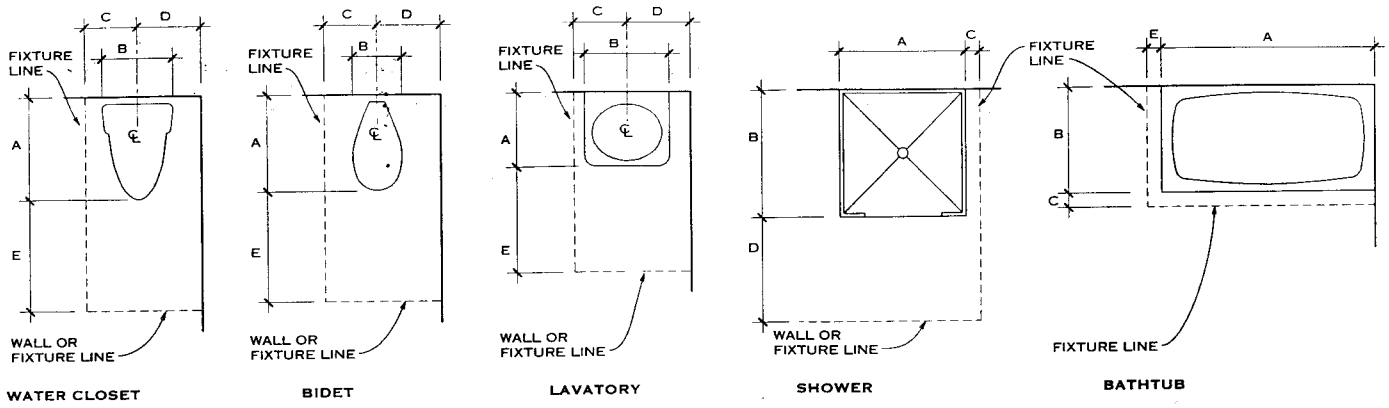

TYPICAL BATHROOM FIXTURE DESIGN PARAMETERS

FIXTURE SIZES AND CLEARANCES (IN.)\*

FIXTURE	A		B		C		D		E	
	MINIMUM	LIBERAL	MINIMUM	LIBERAL	MINIMUM	LIBERAL	MINIMUM	LIBERAL	MINIMUM	LIBERAL
Water closet	27	31	19	21	12	18	15	22	W=18; F=18	W=36; F=34
Bidet	25	27	14	14	12	18	15	22	W=18; F=18	W=36; F=34
Lavatory	16	21	18	30	2	6	14	22	18	30
Shower	32	36	34	36	2	8	18	34		
Bathtub	60 standard	72	30 standard	42	2	8	W=20; F=18	W=34; F=30	2	8

\*W—wall; F—fixture

NOTES

1. A full bathroom can be divided into three areas of activity: the lavatory/grooming, toilet/bidet, and bathing/showing centers. A powder room is a bathroom with only the lavatory/grooming and toilet/bidet centers. In some large bathroom designs, the lavatory/grooming center may be included as part of the bedroom suite.
2. The standard bathtub height is 14 in., with some special tubs ranging up to 24 in. high. The optimum width for a bathtub rim is about 2 1/2 in.
3. Most standard lavatories and pedestal lavatories are mounted from 30 to 32 in. above the finished floor. However,

ever, a more comfortable lavatory mounting height for most activities is 34 to 38 in. above the finished floor. This may be accommodated in a bathroom when a second lavatory is installed.

4. In bathrooms used by more than one person, opening of the entry door should not interrupt another person's use of the lavatory or toilet. Bifold or pocket doors may be a preferred solution to save space.
5. Typical bathroom accessories include a medicine cabinet, mirror, soap dish, toilet paper holder, towel bar, and linen storage space. A general guideline is to allow between 24 and 36 in. of towel bar space for each family member using the bathroom.

6. Convenient electrical outlets for electric toothbrushes, razors, and hair dryers should be provided. These should be grounded with ground fault circuit interrupters (GFCI) and mounted ±36 in. above the finished floor.

7. Bathroom ventilation may be achieved by natural means (window or operable skylight) or with a mechanical exhaust fan. Consult local building codes for requirements.

8. Soundproofing of the more public powder room (typically used by house guests) is important. Locate powder rooms off the entry hall, utility area, or bedroom hallway, rather than off the living, dining, or family room.

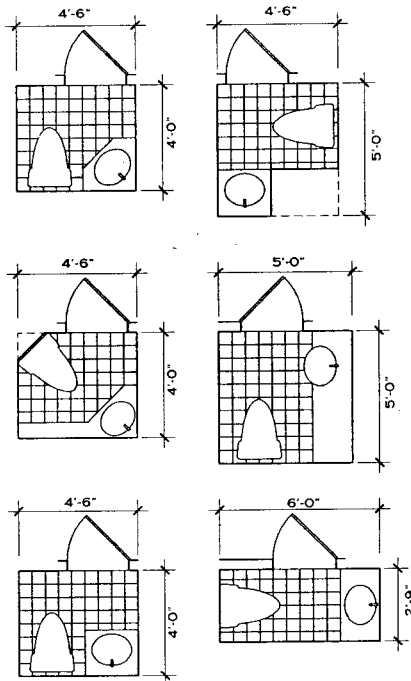

TYPICAL POWDER ROOM LAYOUTS

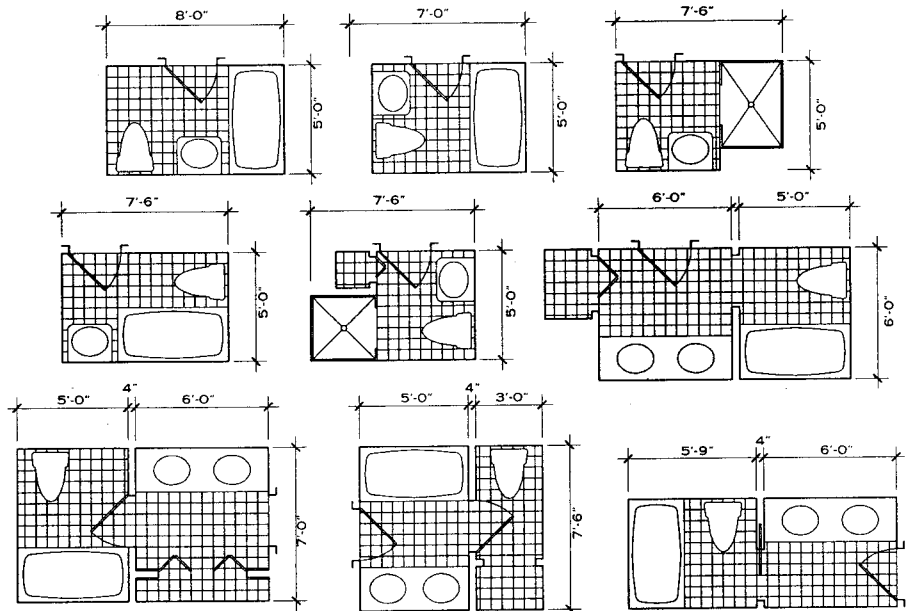

TYPICAL BATHROOM LAYOUTS

**GENERAL**

An ideal home kitchen design depends on a number of factors, in particular the living habits and possessions of the kitchen users. A design that is considered excellent for one user may be unsuitable for another.

The following recommendations are not based on any criteria relating to the square footage of the house because the cooking and socializing preferences of the users are a more significant factor in determining kitchen size than the size of the house. On these two AGS pages on kitchens, a small kitchen is defined as 150 sq ft (13.94 sq m) or less and an average size kitchen as greater than 150 sq ft. Unless specified, the kitchen plans shown are designed for one cook.

The major components of a well-planned kitchen are traffic and workflow, cabinets and storage, appliance placement and use/clearance space, counter surface and landing space, and room, appliance, and equipment controls.

**NOTES**

- Any doorway leading into a kitchen should be at least 2 ft 8 in. (810 mm) wide and not more than 2 ft 0 in. (610 mm) deep in the direction of travel.
- No entry door, appliance door, or cabinet door should interfere with another door.
- All major appliances used for surface cooking should have a ventilation system, with a fan rated at 150 CFM minimum.
- No two primary work centers (the primary sink, refrigerator, preparation, or cooktop/range center) should be separated by a full-height, full-depth tall cabinet (cabinet measured from floor to top of wall cabinets).
- Work aisles (passages between vertical objects, both of which are work counters or appliances) should be at least 42 in. (1070 mm) wide in one-cook kitchens, at least 48 in. (1220 mm) wide in multiple-cook kitchens.
- Open countertop corners should be clipped or radiused; countertop edges should be eased to eliminate sharp edges.
- Controls, handles, and door/drawer pulls should be operable with one hand, require only a minimal amount of strength for operation, and not require tight grasping, pinching, or twisting of the wrist.
- Wall-mounted room controls (i.e., receptacles, switches, thermostats, telephones, etc.) should be located 15 to 48 in. (380 to 1220 mm) above the finished floor.
- Ground fault circuit interrupters should be specified on all receptacles in a kitchen.
- A fire extinguisher should be visibly located in the kitchen, away from cooking equipment and 15 to 48 in. above the floor; smoke alarms should be included near the kitchen.
- Window/skylight area should equal at least 10% of the total square footage of a separate kitchen or of a total living space that includes a kitchen.
- Every work surface in a kitchen should be well-lit by appropriate task and/or general lighting.

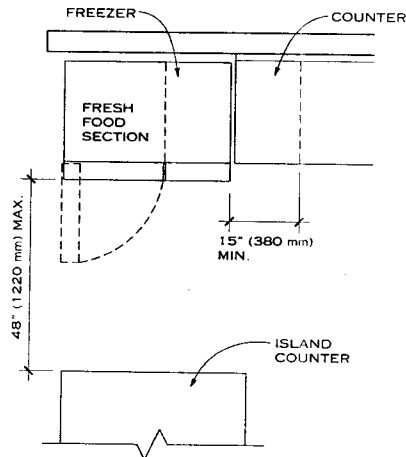

**PLAN**

**NOTE**

When side-by-side refrigerators are specified, it is preferable to design the space so a person using the fresh food section can access the countertop easily.

**REFRIGERATOR WORK AREA**

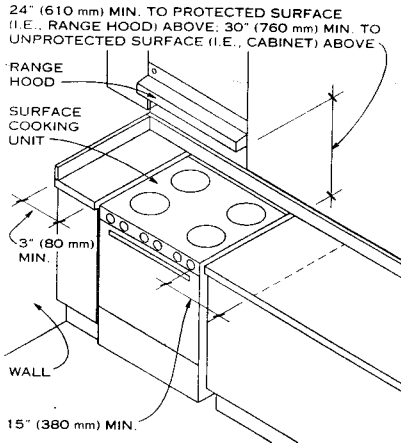

**SURFACE COOKING AT ENCLOSED CONFIGURATION**

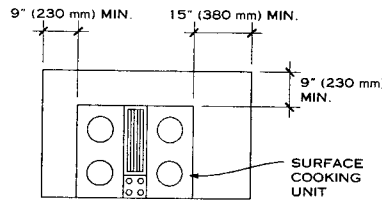

**SURFACE COOKING AT OPEN (ISLAND) CONFIGURATION**

**NOTE**

In an enclosed configuration, at least a 3 in. (80 mm) clearance space should be considered to the side wall, which should be protected with flame retardant surfacing material. For safety, the cooking surface and the counter area adjacent to it should be the same height.

**SURFACE COOKING WORK AREA**

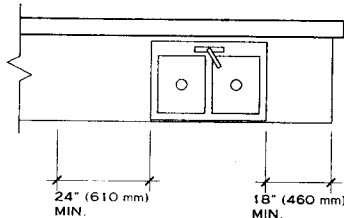

**LINEAR COUNTER FRONTAGE**

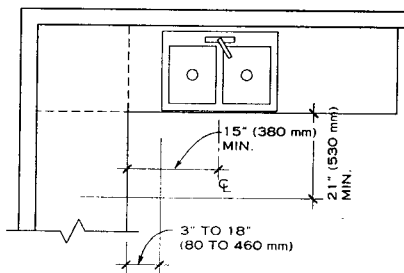

**SINK ADJACENT TO CORNER**

**NOTES**

- A measurement of 15 in. (380 mm) minimum from the adjacent counter to the centerline of the sink makes possible a clear floor space of 30 x 48 in. (760 x 1220 mm) centered on the sink.
- If the kitchen has only one sink, it should be located between or across from the cooking surface, preparation area, or refrigerator.

**SINK WORK AREA**

**CENTERS OF ACTIVITY**

Although the kitchen has evolved around three basic appliances—the sink, the range, and the refrigerator—a kitchen usually has many more centers of activity. A contemporary kitchen may include some or all of the activity center types listed here:

The **PRIMARY CLEANUP SINK CENTER** houses a recycling center, dishwasher, and food waste disposer.

A **SECONDARY SINK CENTER** may serve cleanup functions as well but is generally associated with a food preparation center.

A **PREPARATION CENTER** is a long, uninterrupted counter that may be placed between the sink and the cooking surface or the sink and the refrigerator. In a kitchen for multiple cooks, there will be more than one preparation area.

The **COOKING CENTER** revolves around the cooking surface. A separate built-in oven need not be a part of this center unless it includes a microwave oven.

A **MICROWAVE OVEN CENTER**, because it is used so frequently, must be close to the major areas of activity.

A **PANTRY CENTER** is included in many kitchen plans. This often has storage cabinetry from floor to soffit or floor to ceiling for storing food stuff near the preparation area. This type of tall cabinet may also be used in the serving or dining area.

A **SERVING CENTER** is used to store serving items. It may be in the kitchen or closer to the dining area.

A **DINING AREA** of some sort is typically included in contemporary kitchens.

The **LAUNDRY AREA** is often found in the basement or garage, but it can also be located in the kitchen.

A **HOME OFFICE CENTER** makes space for a telephone, cookbooks, and household records and is an important part of a kitchen.

A **MEDIA CENTER** with a radio and/or television is part of many kitchens today. This center must be located so the TV can be viewed by the cook and other family members in the kitchen.

A **SOCIALIZING CENTER** in the kitchen is as important as some of the more functional areas. A casual furniture setting or an additional seating area for visiting the cook can accommodate this use of the kitchen.

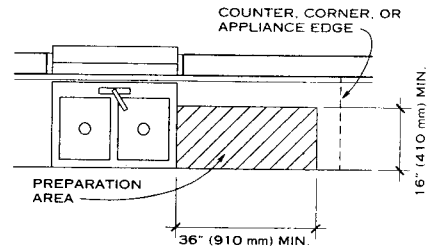

**PREPARATION AREA—ONE PERSON**

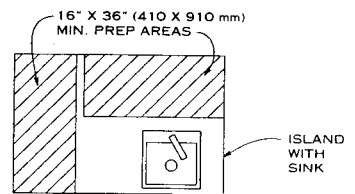

**PREPARATION AREA—TWO PERSONS**

**NOTE**

The preparation area should be immediately adjacent to a sink.

**PREPARATION CENTER**

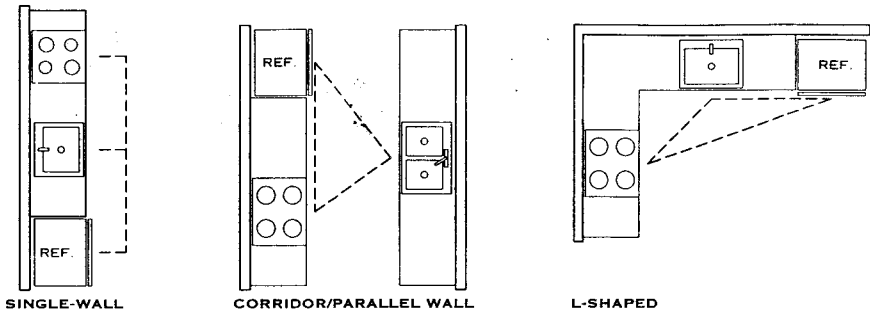

SINGLE-WALL

CORRIDOR/PARALLEL WALL

L-SHAPED

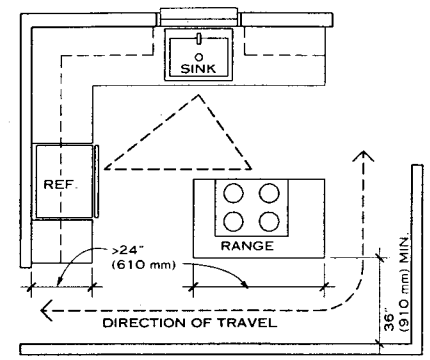

PLAN

**NOTE**

Walkways are passages between vertical objects that are greater than 24 in. (610 mm) deep in the direction of travel of which not more than one is a work counter or appliance. Walkways should be at least 36 in. (910 mm) wide and should not cross through the work triangle.

**TRAFFIC FLOW ADJACENT TO WORK TRIANGLE**

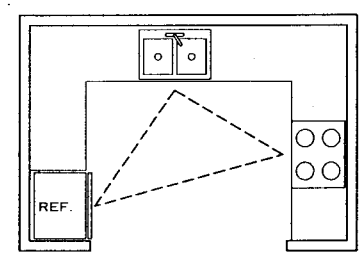

U-SHAPED

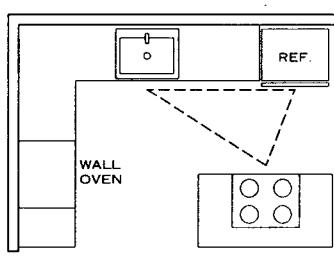

L-SHAPED WITH ISLAND

**NOTES**

1. The single-wall kitchen type is only acceptable in small apartments or efficiency units.
2. A corridor kitchen offers one cook the advantage of an efficient, close grouping of work centers on parallel walls. Disadvantages are that household traffic may cross back and forth through the area and that the shape is typically too small for two cooks.
3. With work centers on two adjacent walls, an L-shaped kitchen forms a natural triangle that allows traffic to pass by the work area. The L shape gives the cook a generous amount of continuous counter space, although generally less than a U-shaped area or an L-shape with an island.
4. If an L shape is combined with a freestanding central structure, all of the benefits of a U-shaped kitchen are available, with a more open, free-flowing plan. The island invites interaction between the cook and visitors and helps as more than one person can work around this open counter.
5. The U-shaped kitchen is usually considered the most efficient plan; steps are saved because the cook is surrounded on three sides with a continuous countertop and storage system. Traffic is also naturally directed around the work area.
6. Kitchen layouts may be customized to suit the needs of each user, and endless variations are possible.

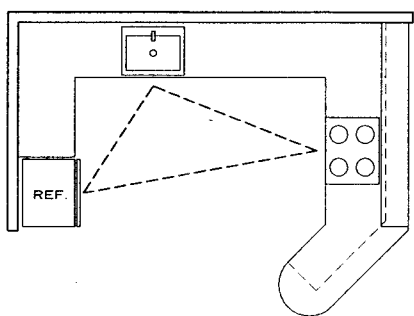

CUSTOM-SHAPED

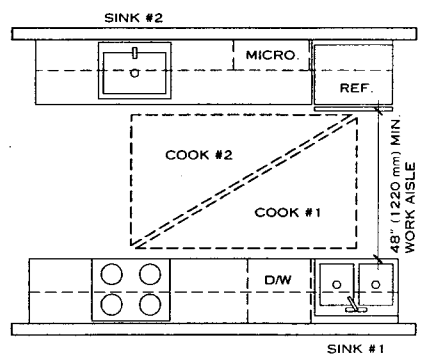

PLAN

**NOTE**

If two or more people cook simultaneously, a work triangle should be placed for each cook. One leg of the primary and secondary triangles may be shared, but the two should not cross one another. Appliances may be shared or separate.

**WORK TRIANGLE—TWO COOKS**

**KITCHEN TYPES**

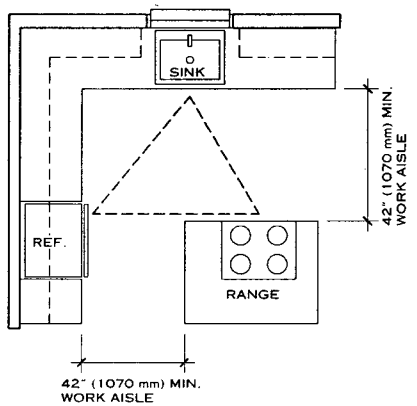

PLAN

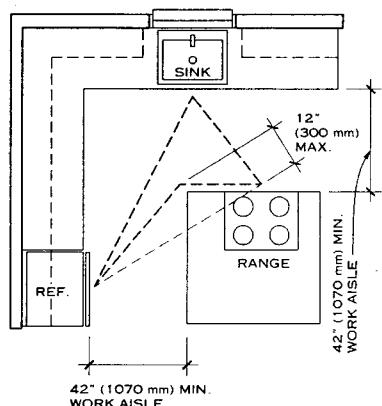

PLAN

**WORK TRIANGLE—ONE COOK**

**NOTE**

Flexibility within the triangle shape is required because of the multiple centers found in many kitchens. The work triangle is the shortest walking distance between the refrigerator, primary food prep sink, and primary cooking surface measured from the center front of each. The following size recommendations are suggested:

1. Each leg of a triangle should be between 4 and 9 ft (1220 to 2740 mm) long.
2. The total of all three legs of the triangle should be less than or equal to 26 ft (7920 mm).
3. Family traffic patterns should not interfere with the primary triangle.
4. Cabinetry should not intersect any one triangle leg by more than 12 in. (300 mm).



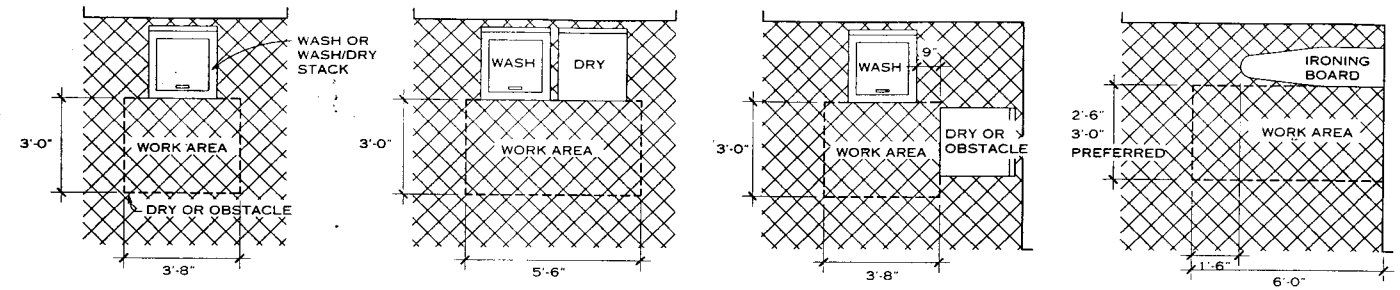

**LAUNDRY EQUIPMENT CLEARANCES**

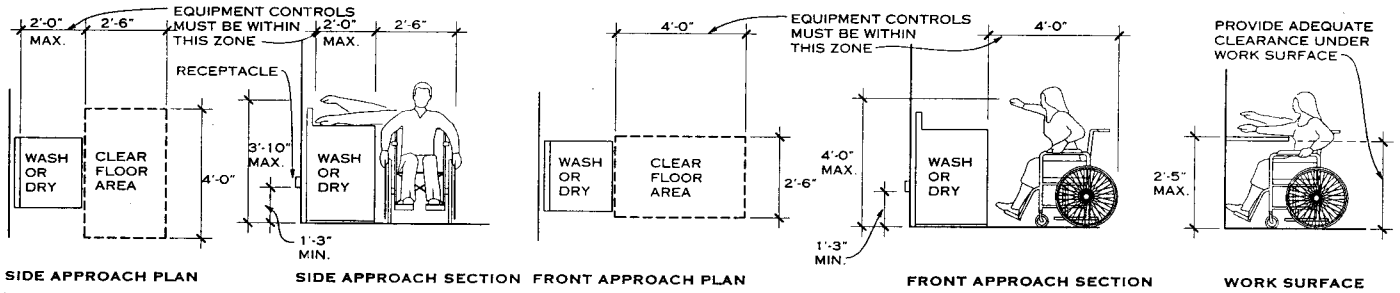

**LAUNDRY EQUIPMENT ACCESSIBILITY**

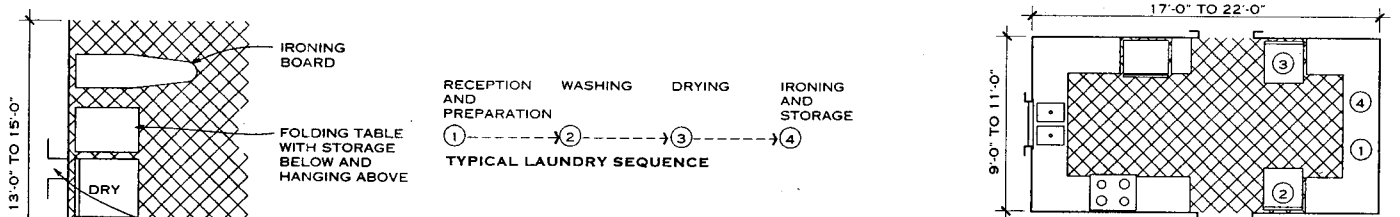

**NOTE**  
Provide a chase from the floor to the top of the machines to allow a fit flush with the wall. Provide 4 to 6 in. of clearance for conditions without chase.

**ONE-WALL LAUNDRY**

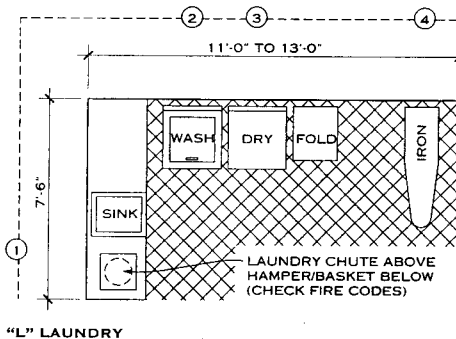

**"L" LAUNDRY**

**NOTE**  
For wheelchair users, having laundry facilities close to the kitchen combines several time-consuming activities with a minimum of movement from place to place.

**LAUNDRY WITH KITCHEN**

**LAUNDRIES FOR WHEELCHAIR USERS**

The basic necessities for an accessible laundry facility are front-loading automatic washer, dryer, storage shelving for supplies, lightweight steam iron, ironing board, and a surface for folding.

Locate laundry equipment controls within high forward or side reach range. Controls should operate with one hand without tight grasping, pinching, or twisting of the wrist.

For an accessible laundry area, provide storage for supplies within high forward or side reach range; all working surfaces should be at a comfortable seated work height of 29 in. with knee clearance below.

**APARTMENT HOUSE LAUNDRIES**

In apartment houses, locate laundry rooms in the basement or on the ground floor of the building near necessary mechanical equipment, piping, and ventilation. Locate laundry rooms on grade to provide surfaces to absorb vibrations from operation and to avoid disturbing the apartment dwellers. Provide convenient access from dwelling units to the laundry room.

Incorporate tables for folding and vending machines for soap, bleach, and other laundry powders into the laundry room design.

Provide for visual inspection of the laundry room for the security of the users. Also, provide an area to accommodate the social aspect of laundry room use in large apartment buildings.

When a laundry is situated above an occupied space, it is best to have a waterproof basin sloped to a drain under the washing machine. This will catch overflow and divert it from the space below.

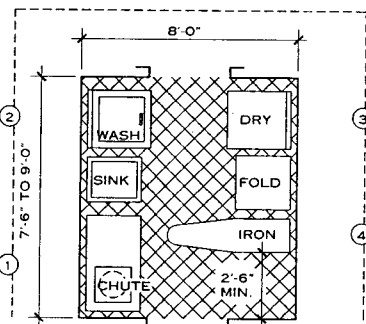

**PARALLEL LAUNDRY**

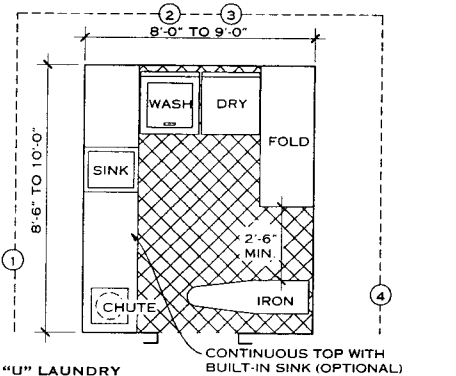

**"U" LAUNDRY**

**TYPICAL LAUNDRIES**

R. E. Powe, Jr., AIA; Robin Andrew Roberts, AIA; Washington, D.C.  
Arthur J. Pettorino, AIA; Hicksville, New York  
Hugh Newell Jacobsen, FAIA; Washington, D.C.

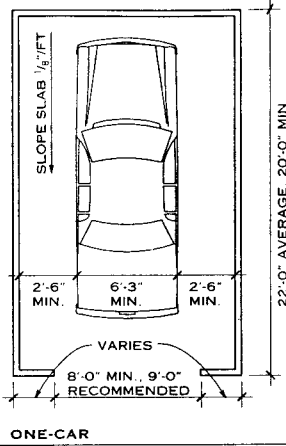
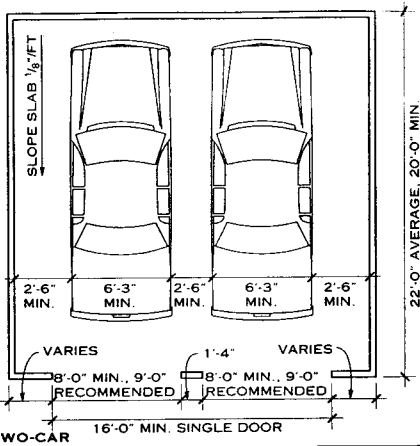

TWO-CAR GARAGES

ONE-CAR

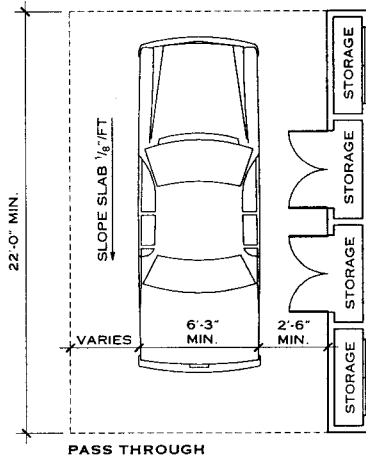
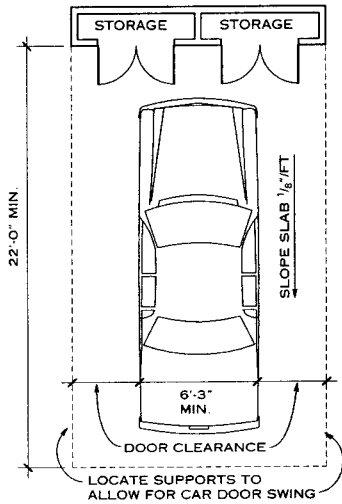

BACKOUT CARPORTS

PASS THROUGH

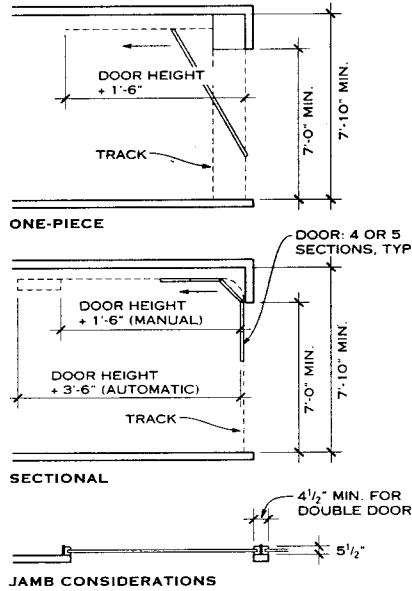

LIFT DOORS—AUTOMATIC OPTIONAL

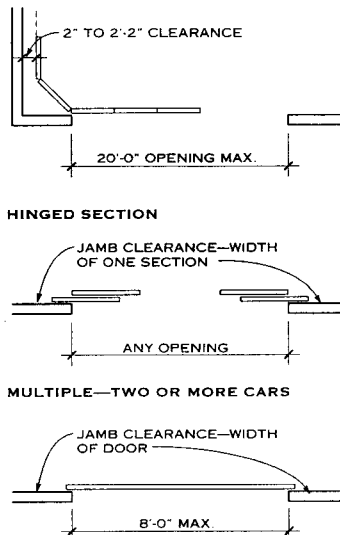

**SINGLE NOTE**  
All sliding doors require a space of 6 1/2 to 9 in. from top of opening to ceiling.

SLIDING DOORS

**NOTES**

1. The width and length of automobiles and other vehicles change every year. See the table of design vehicle dimensions (below) or consult manufacturers for exact dimensions.
2. Design considerations include circulation, visual safety for backing out, and whether the garage will be in public view.
3. Spaces for workshops, photography darkrooms, laundry rooms, and storage areas are often included in the design of garages.
4. Garages may be attached directly to the house or be connected by a covered passageway. The connection with the house is usually at or near the kitchen or a utility area off the kitchen.
5. The design of concealed storage in garages should accommodate the door swing of cupboards.

**DESIGN VEHICLE DIMENSIONS**

VEHICLE	LENGTH (FT-IN.)	WIDTH (FT-IN.)
Small car	15-0	5-7
Composite passenger vehicle*	16-9	6-4
Light truck	17-9	6-6
Van	16-9	6-3
Sport/utility vehicle	16-0	6-4

\* A composite passenger vehicle is a design vehicle that encompasses passenger cars, light trucks, vans, and sport/utility vehicles. It is the vehicle for which a parking facility should be designed.

**SECTIONAL DOOR SIZES**

DOOR WIDTH (FT-IN.)	NUMBER OF PANELS ACROSS
To 8-11	2
9-0 to 11-11	3
12-0 to 14-11	4
15-0 to 17-11	5

**NOTE**

Doors up to 8 ft 6 in. high require four sections.

**HINGED GARAGE DOOR WIDTHS (FT-IN.)**

OPENING	TWO-DOOR	THREE-DOOR	FOUR-DOOR
8-0	4-0	2-8	2-0
8-6	4-3	2-10	2-1 1/2
9-0	4-6	3-0	2-3

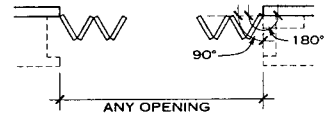

OFFSET HINGE—MULTILEAF

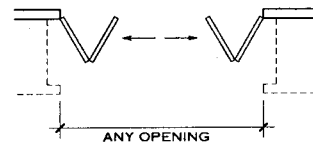

MULTIPLE HINGED DOOR—TWO OR MORE CARS

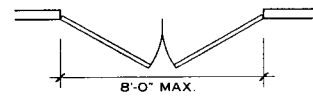

DOUBLE OR TRIPLE HINGED

**NOTE**

For multiple and offset hinged doors, swinging to one or both sides, hinged in or out, and used for two or more cars: a space of 6 1/2 to 11 in. is necessary from top of opening to ceiling. Use of hinged doors is not recommended in snow zones.

HINGED DOORS

Hugh Newell Jacobsen, FAIA; Washington, D.C.  
William T. Cannady, FAIA; Houston, Texas

**GENERAL**

Closet systems can be assembled from prefabricated materials cut in the field to custom fit an existing closet. Closet systems are typically constructed of either solid particleboard covered in plastic laminate, or steel wire coated with vinyl, polyvinyl chloride, or epoxy.

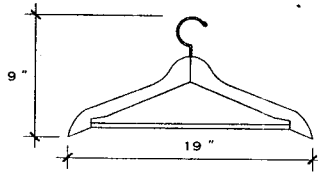

**HANGER**

**TYPICAL LAYOUT DIMENSIONS**

REFERENCE	DIMENSION	DESCRIPTION
A	96"	Minimum ceiling height (typical)
B	42"	Hanging storage for shirts, jackets, pants, and skirts for men and women
C	24"	Standard width for drawers and baskets; height for children's hanging clothes
D	36"	Storage for 3 pairs of men's shoes and 4 pairs of women's shoes
E	68"	Hanging storage for dresses and full length robes, evening gowns
F	14"	Standard shelf depth
G	12"	Distance rod is to be mounted from back of closet
H	04"	Distance from top of shelf above to centerline of rod
J	06"	Distance between shelves to allow for shoe storage
K	24"	Minimum required inside clear depth for closet (typical)
L	12"	Shelf width for 1 stack of clothes
M	06"	Clearance from floor to allow for vacuuming
N	30"	Standard height for children's hanging clothes

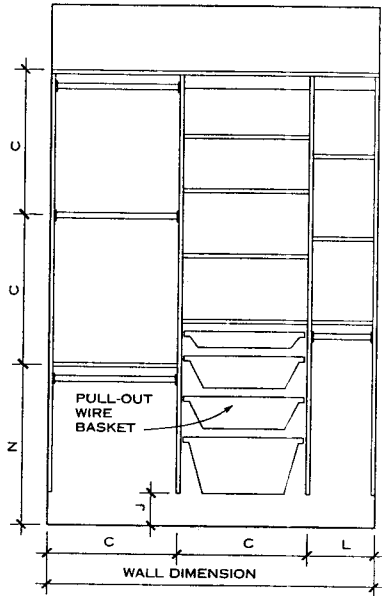

**CHILD'S CLOSET**

**SOLID SHELVING SYSTEMS**

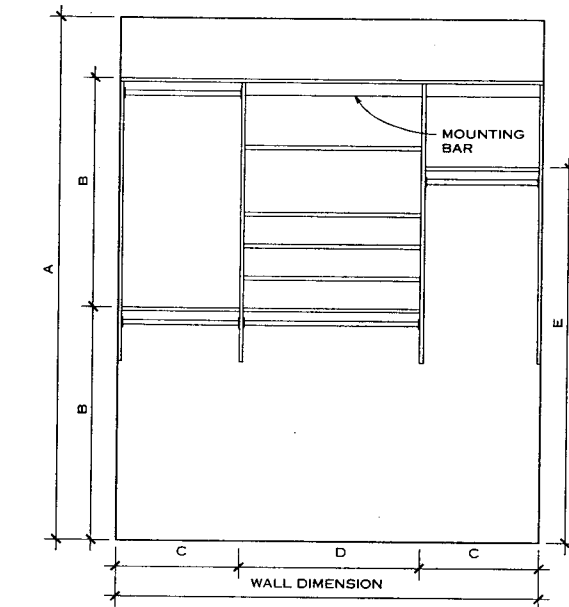

**TYPICAL CLOSET CONFIGURATION FOR MEN AND WOMEN**

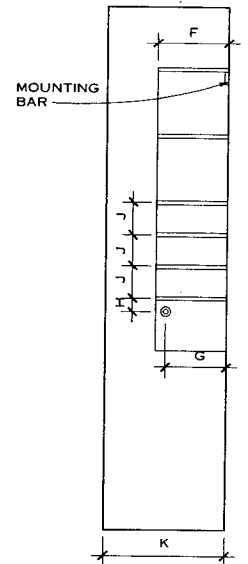

**TYPICAL SECTION**

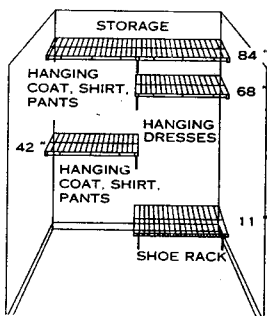

**SPLIT CONFIGURATION**

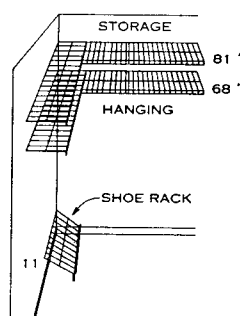

**CORNER CONFIGURATION**

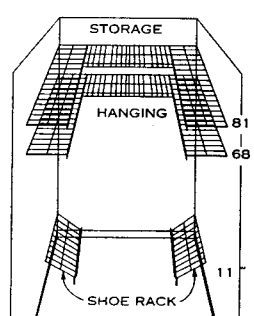

**U - SHAPED WALK-IN**

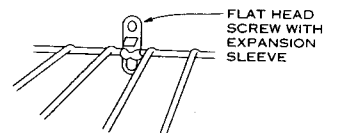

**SHELF SUPPORT**

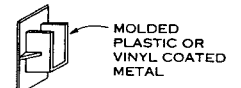

**END BRACKET**

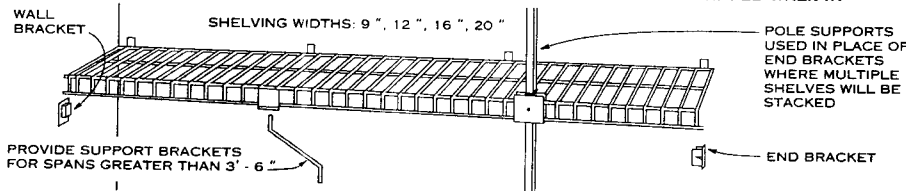

**COATED STEEL WIRE SHELVING SYSTEMS**

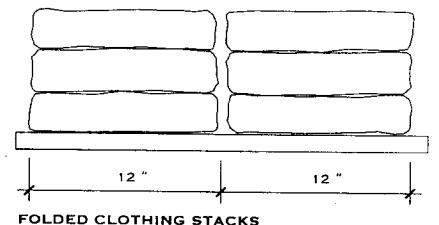

**FOLDED CLOTHING STACKS**

O'Brien - Kilgore, Inc.; Washington, D.C.

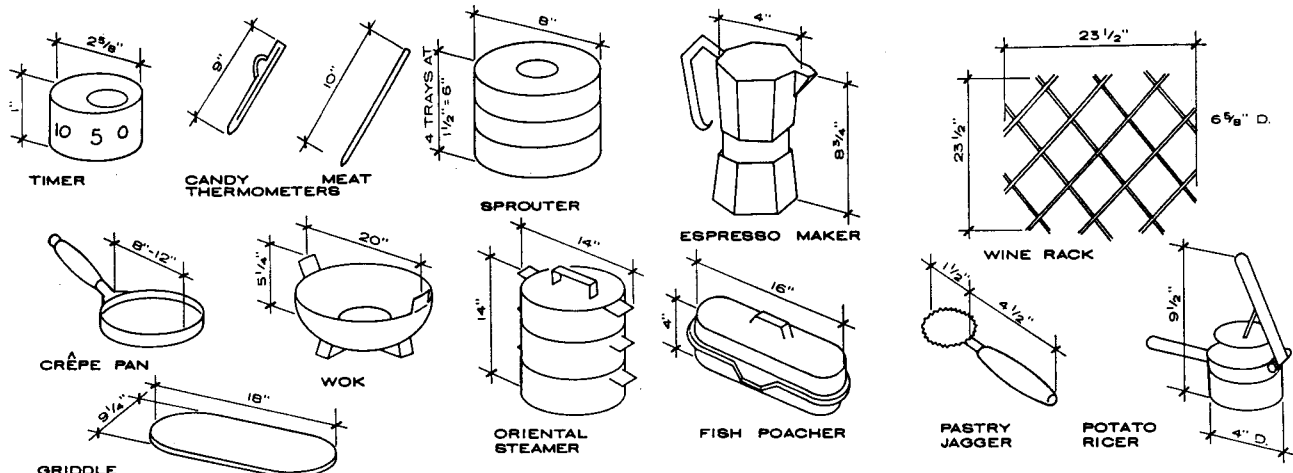

POTS, PANS, AND HAND APPLIANCES

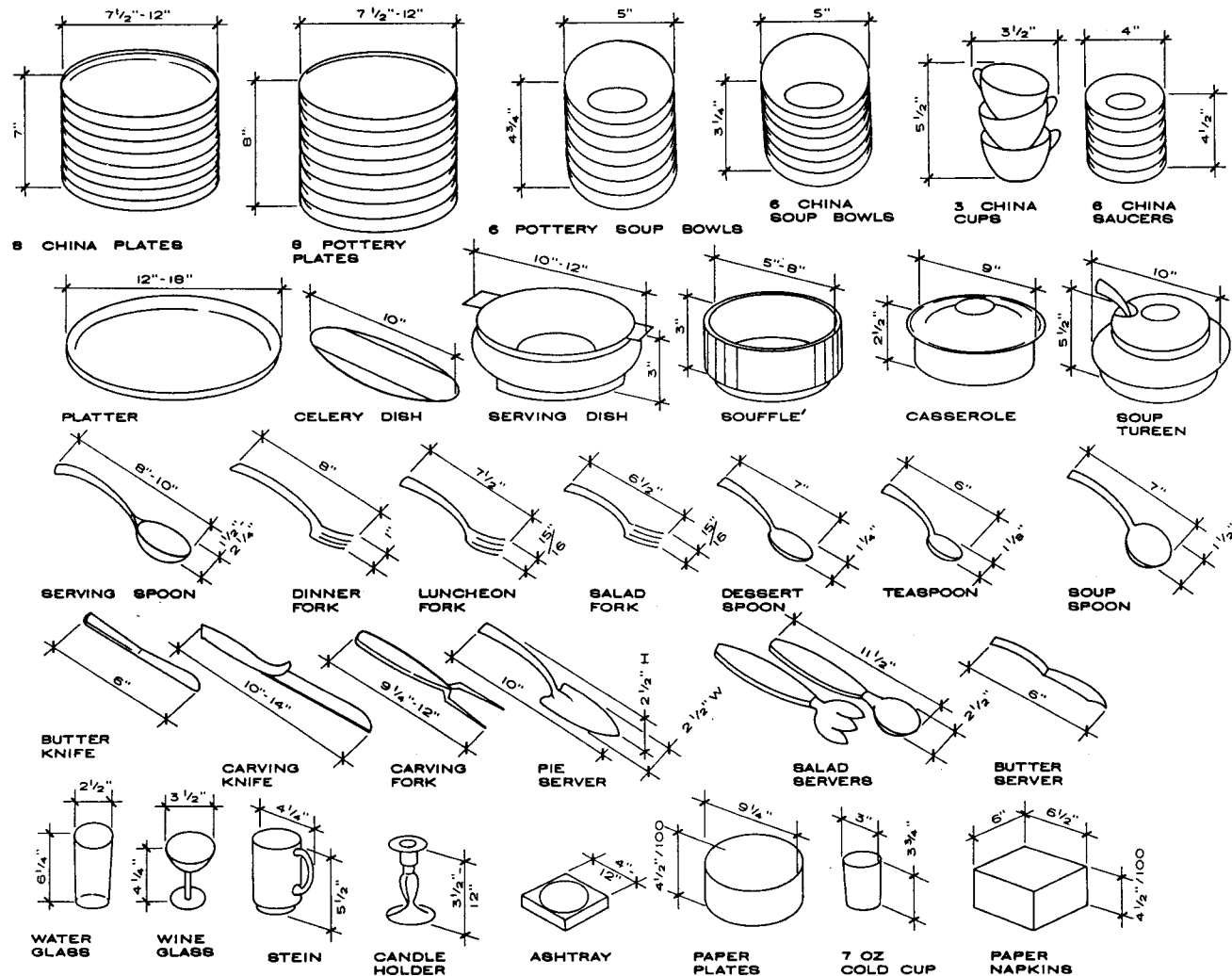

DINING ROOM TABLEWARE

E. H. & M. K. Hunter, Architects; Raleigh, North Carolina

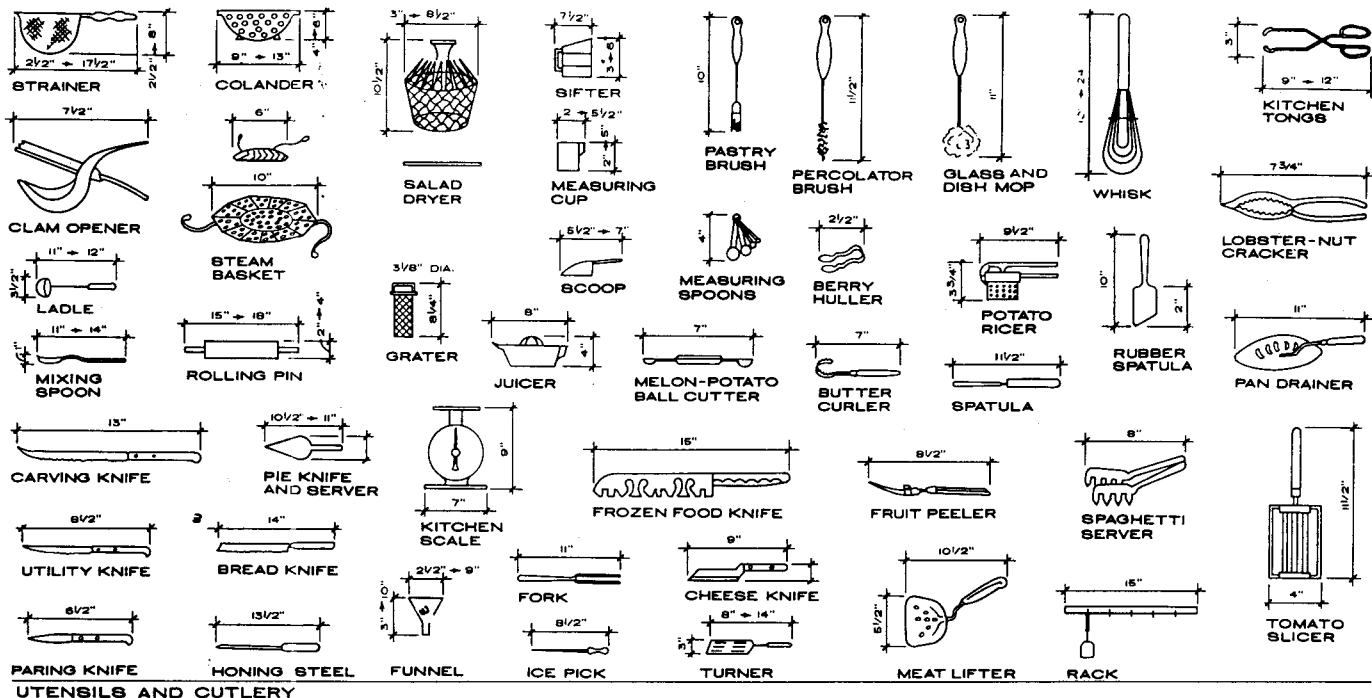

UTENSILS AND CUTLERY

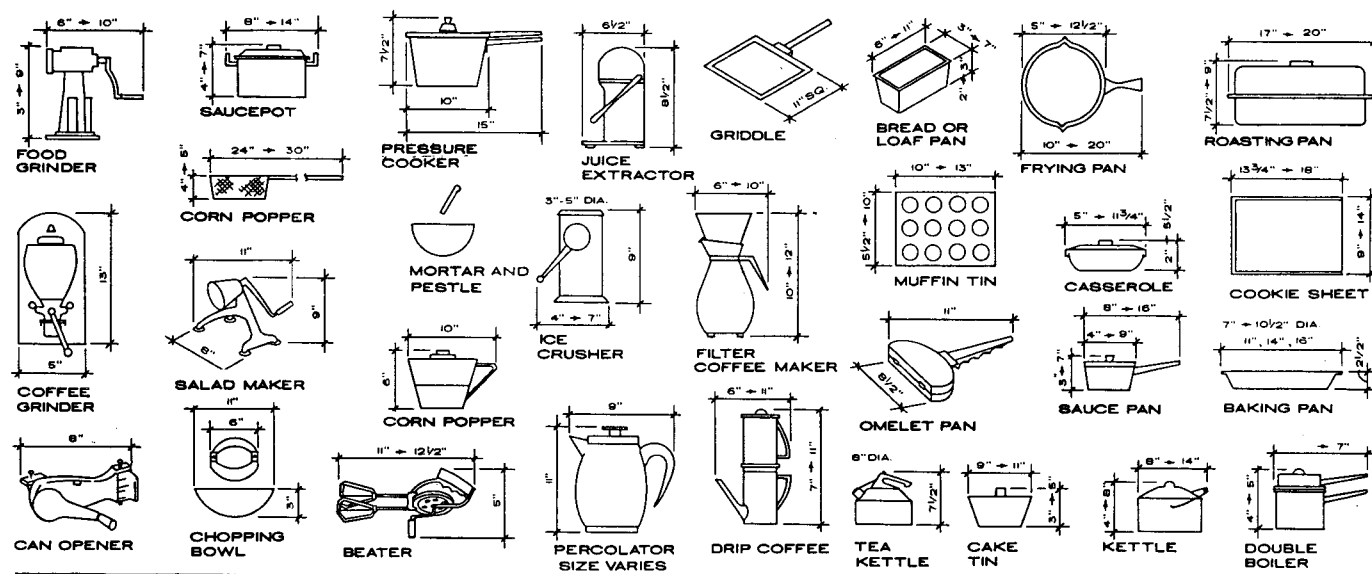

POTS, PANS, AND MECHANICAL APPLIANCES

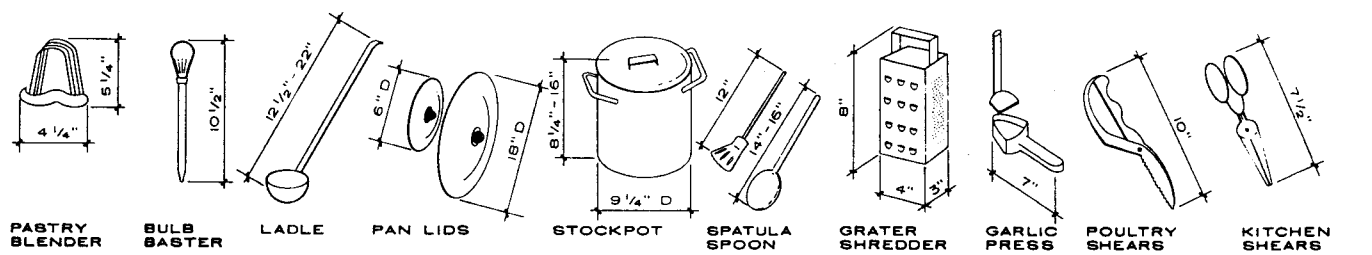

POTS, PANS, AND HAND APPLIANCES

E. H. & M. K. Hunter, Architects; Raleigh, North Carolina

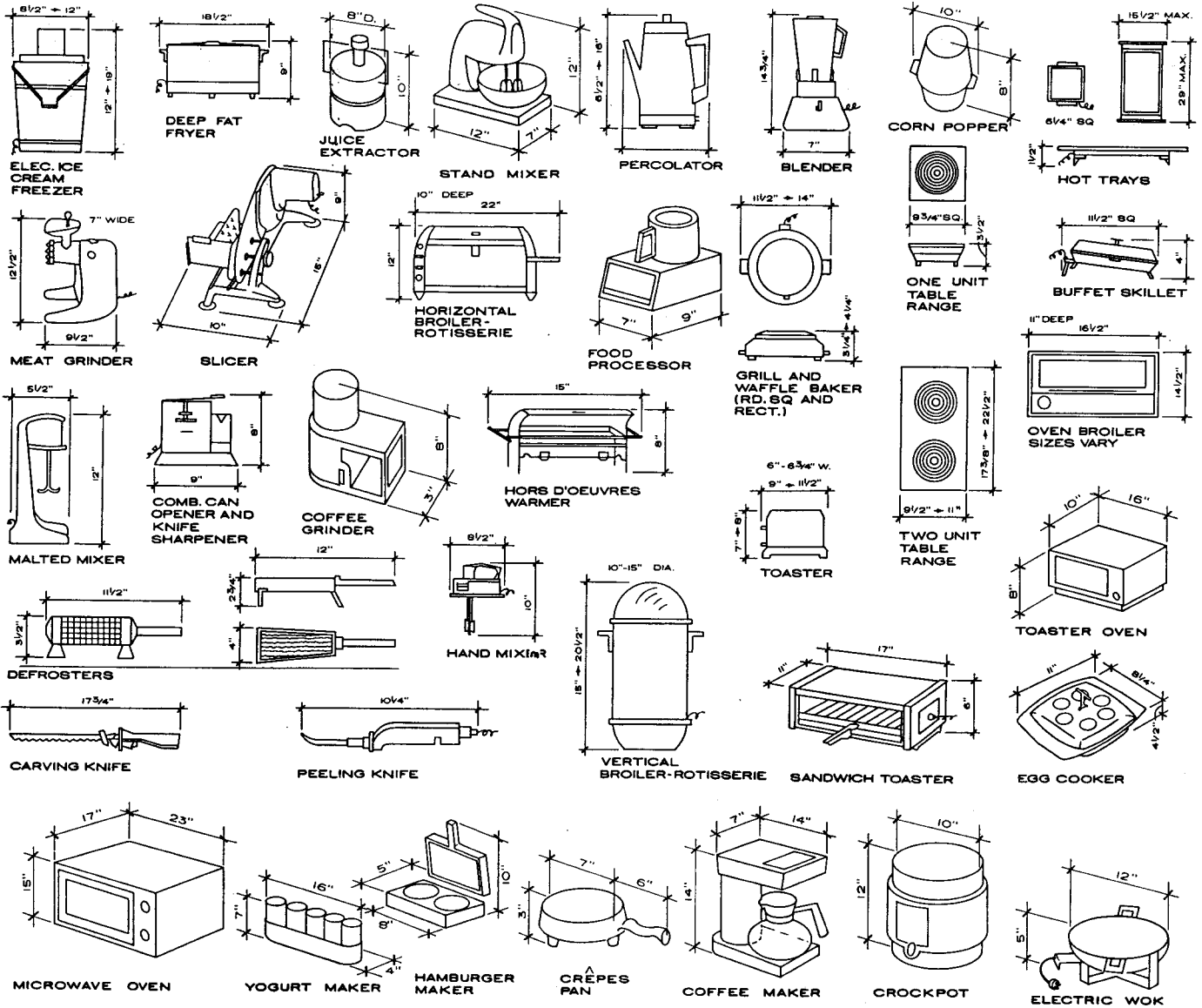

**ELECTRICAL APPLIANCES**

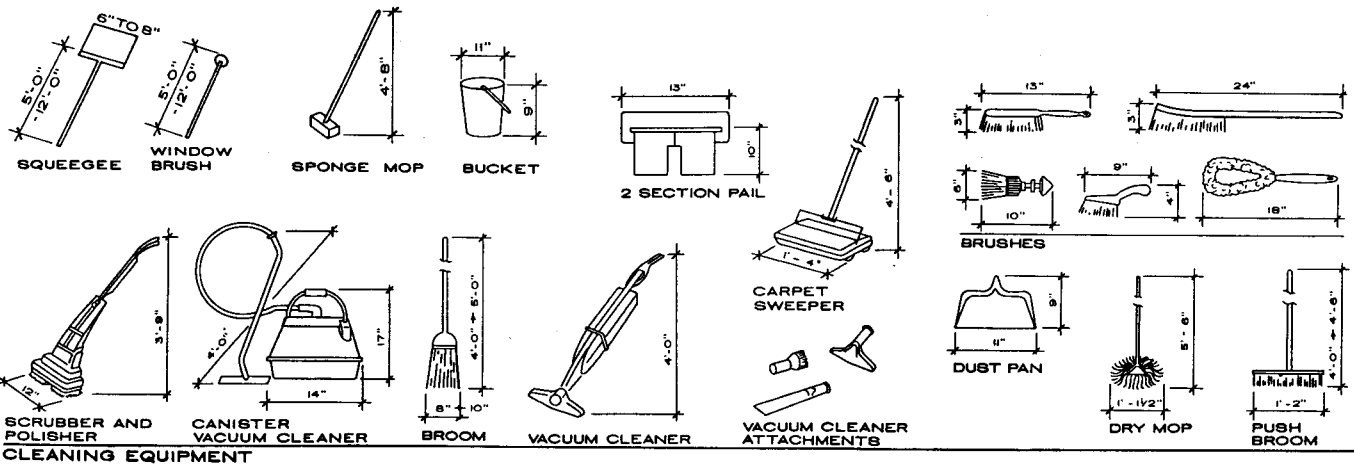

E. H. & M. K. Hunter, Architects; Raleigh, North Carolina

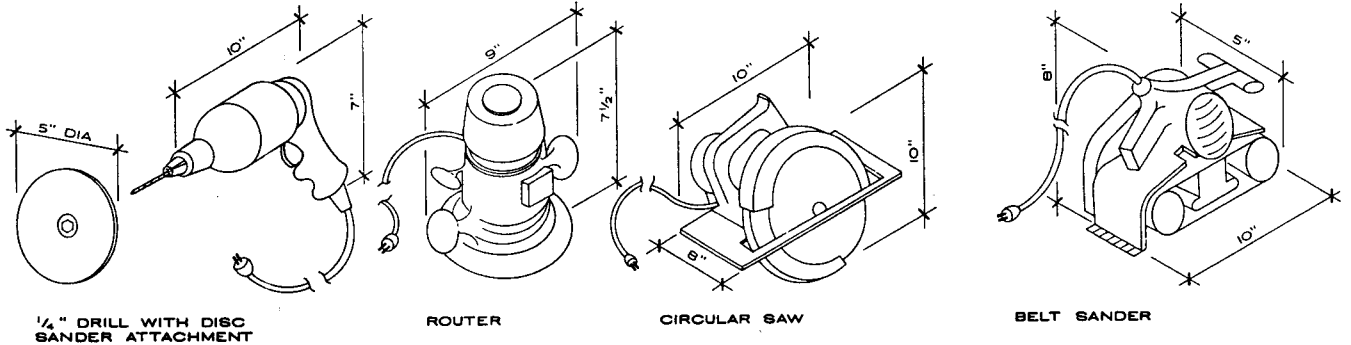
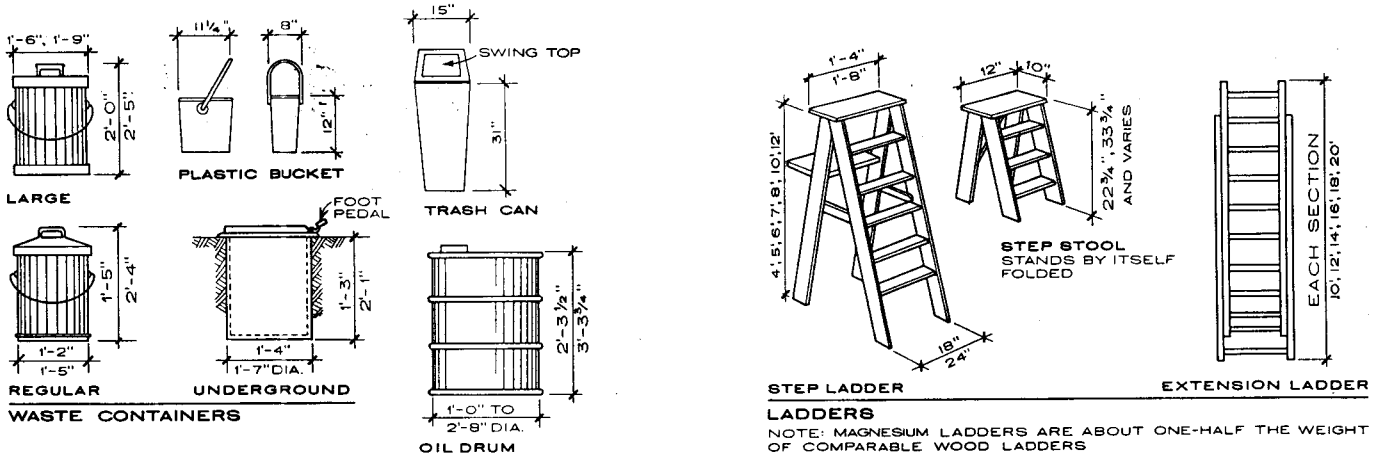

**ELECTRIC HAND TOOLS**

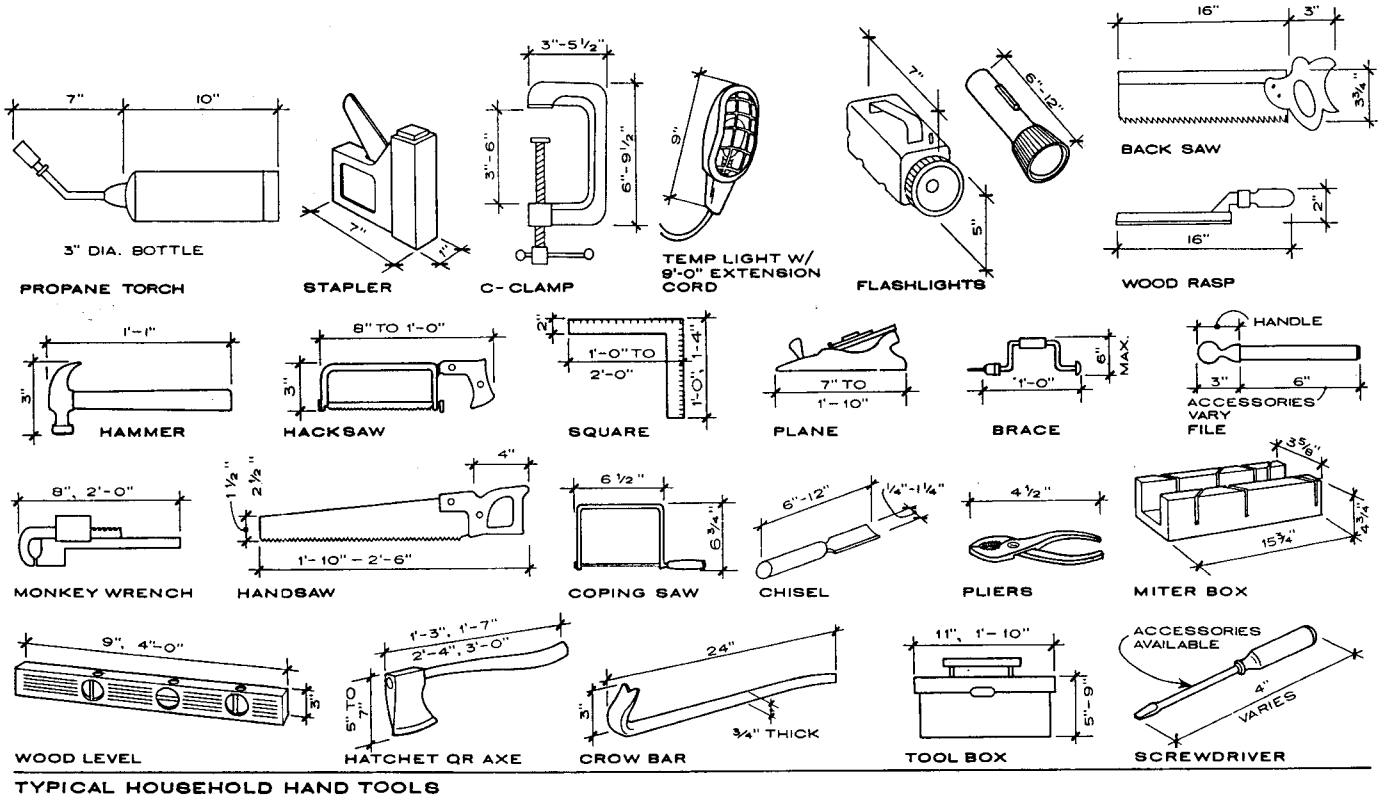

E. H. & M. K. Hunter, Architects; Raleigh, North Carolina

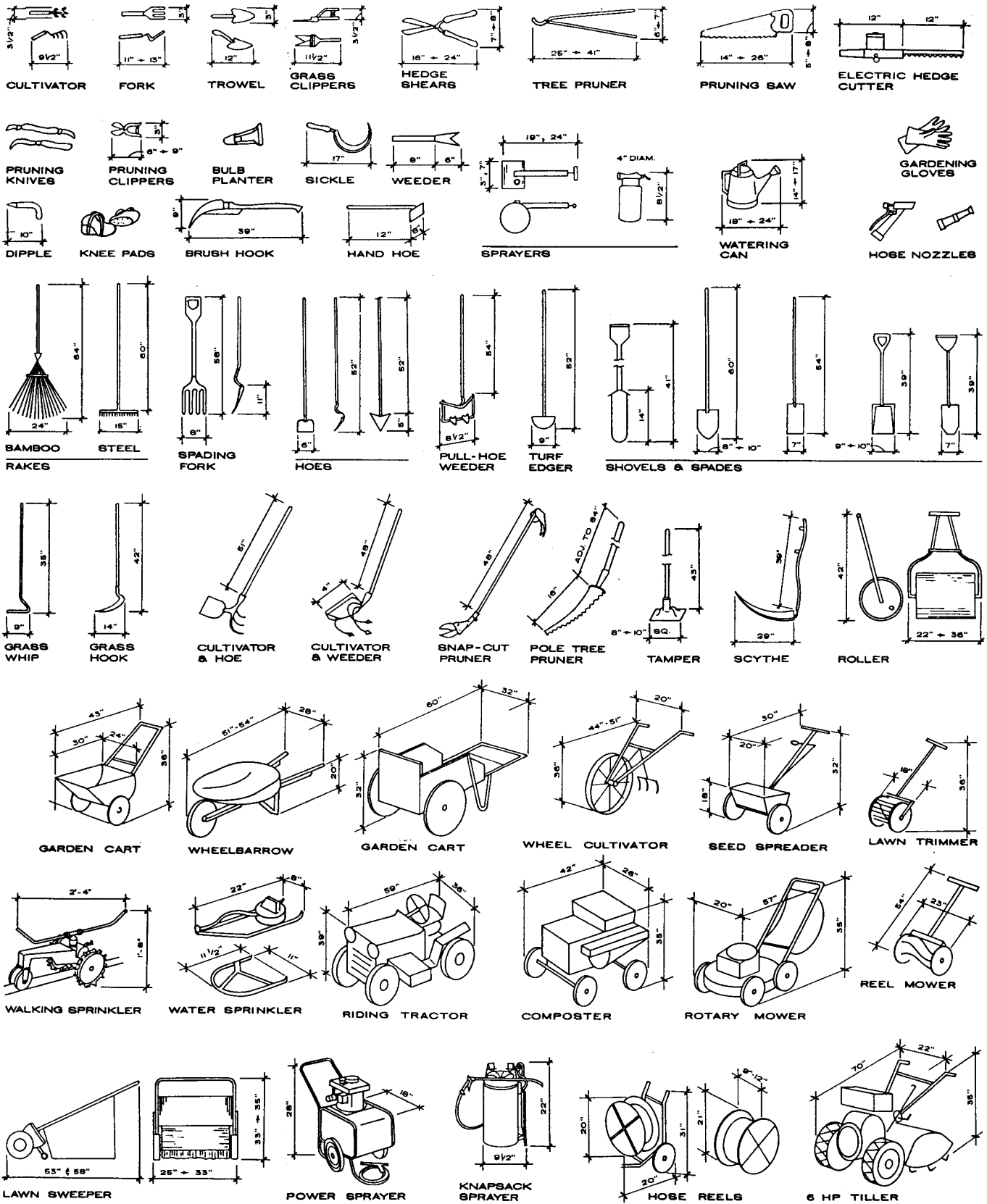

E. H. & M. K. Hunter, Architects; Raleigh, North Carolina



**GENERAL**

1. Typical height for work surface, desk, and credenza is 29 in. Return height is typically 27 in.
2. Universal work surface height is 28 in.
3. Minimum dimension between face of credenza and face of desk is 42 in.
4. Typical transaction counter is 12 to 15 in. deep and 42 to 48 in. high.
5. Freestanding credenzas may be used as computer work surfaces by increasing depth from 20 to 24 in. and by adding a kneehole.
6. Chairman's office may also include an executive storage unit or bookcase.

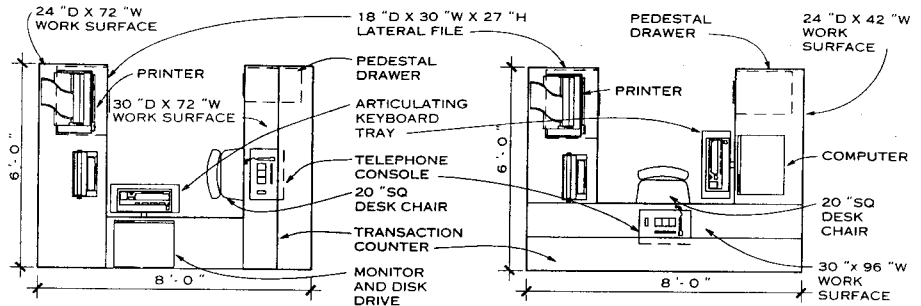

**RECEPTIONIST - OPEN AREA**

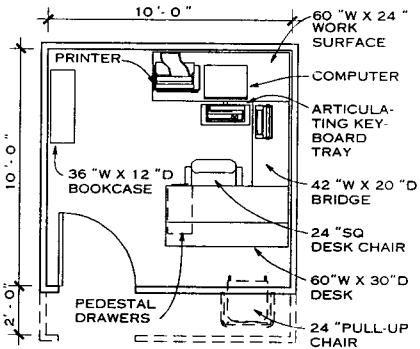
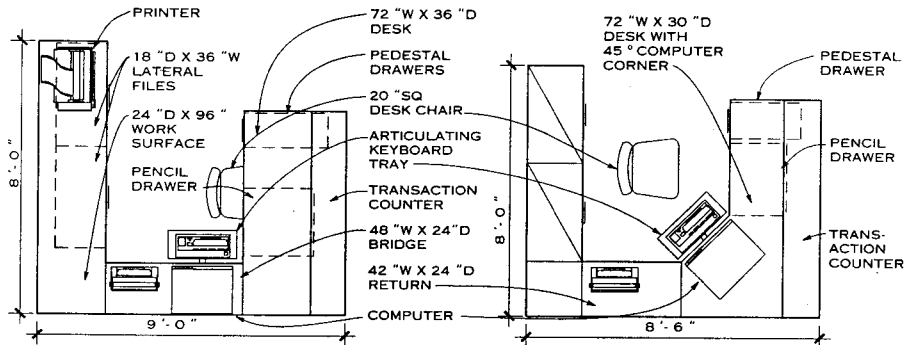

**SUPERVISOR - INTERIOR OFFICE**

**SECRETARY/CLERICAL**

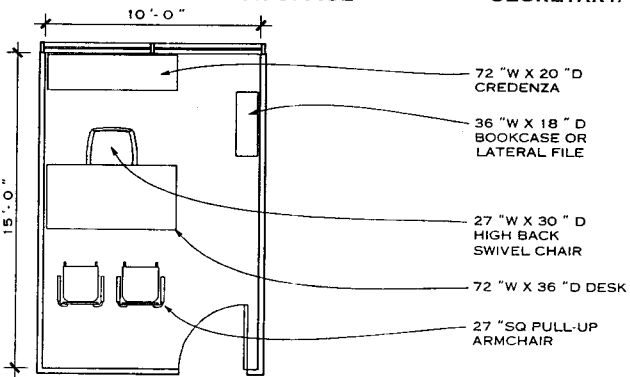

**MANAGER - PERIMETER WINDOWED OFFICE**

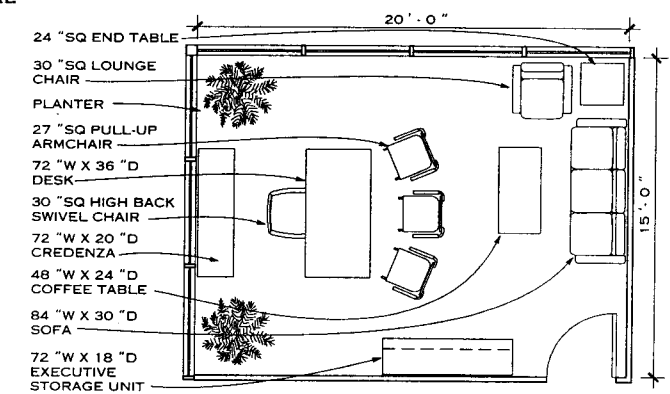

**PRESIDENT - PERIMETER WINDOWED CORNER OFFICE**

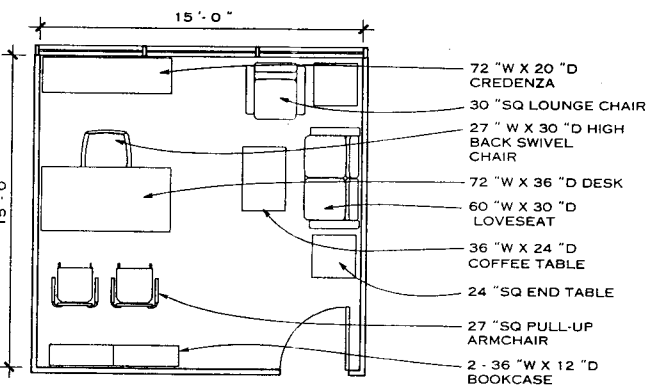

**VICE-PRESIDENT - PERIMETER WINDOWED OFFICE**

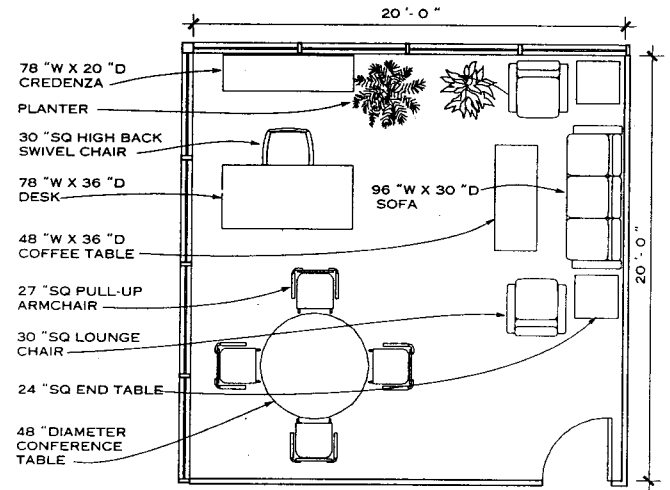

**CHAIRMAN - PERIMETER WINDOWED CORNER OFFICE**

O'Brien - Kilgore, Inc.; Washington, D.C.

**GENERAL**

Conference rooms should be located for proximity to user groups within a building and for accessibility to outside guests. Since a conference room typically serves to communicate a firm's "image" to others, finishes are usually selected from higher quality materials to suggest a prominent and visible location. When a conference room functions as a multiuser or multigroup space, the position of access doors is altered and acoustical folding partitions or movable walls may be used. The designer should note the additional requirements imposed by building codes for assembly occupancy for larger rooms.

**FINISHES**

Carpeted floors, acoustical wall panels, or fabric wall coverings and acoustic ceilings should be used. Avoid using "attention-getting" patterns and colors on walls which may decrease focal emphasis of tables, seating,

and speaker or projection area. All finishes should be carefully examined for flame spread and smoke-generated ratings.

**LIGHTING**

Parabolic lens fluorescent fixtures provide good general lighting with less glare. Directional fixtures such as track lighting may be used for presentation areas. Use dimming switches.

**MECHANICAL**

Provide a minimum of eight air changes per hour plus a minimum of 10 cu ft/min of outside air per person for odor-free air and good ventilation. Provide an exhaust system to be manually controlled from the room. Careful attention should be given to sound attenuation of diffusers.

**TELECONFERENCING**

The space and furniture requirements for teleconferencing are different from the typical conference room. All aspects are geared toward video camera requirements. Typically, the conference is held between groups in separate locations linked by video satellite. The standard layout includes two ceiling-mounted video cameras to cover the participants and an optional direct downward-aimed document camera, a projection television monitor (front or rear projecting) for the remote participants, and a control console which interfaces the video cameras, telephone, and satellite linkage. The room arrangement is such that all participants may view and be viewed simultaneously. Mixing presentation media (projection, boards, flip charts, etc.) becomes more difficult in teleconferencing, while the requirements for acoustics and ventilation remain unchanged from the typical conference room. Lighting must be in accordance with the requirements of the video system used.

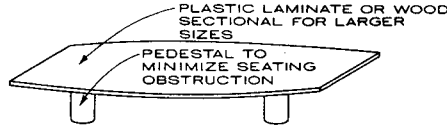
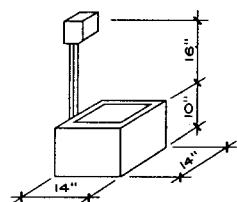
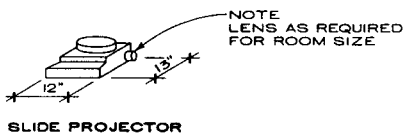

CONFERENCE TABLE REFER TO FURNITURE SECTION FOR SIZE BASED ON SEATING

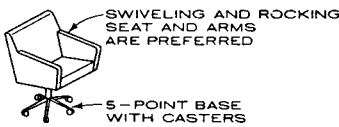

CHAIR

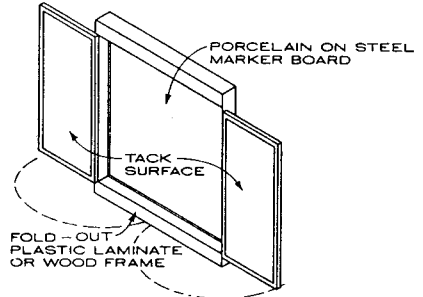

WALL-MOUNTED VISUAL CENTER

**CONFERENCE ROOM FURNITURE AND EQUIPMENT**

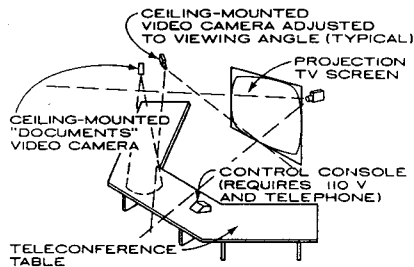

COMPONENTS OF A TYPICAL TELECONFERENCE ROOM

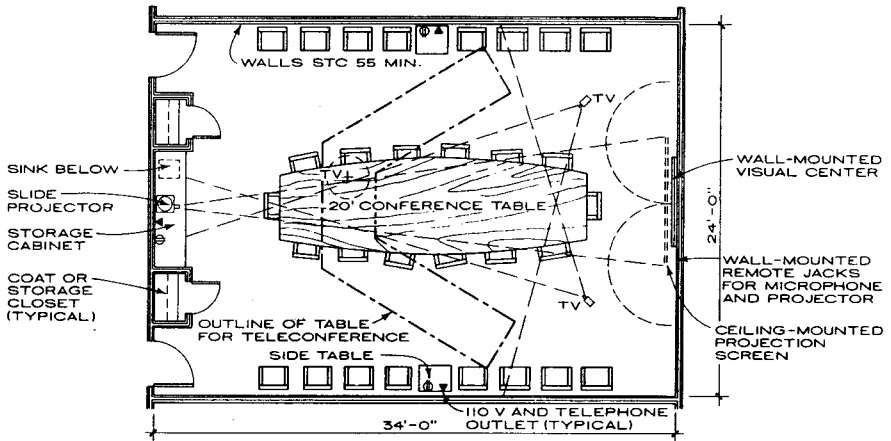

**PLAN NOTE**

Components of both traditional and teleconferencing conference rooms are shown. The "board room" layout rendered here is not recommended for teleconferencing. See dashed layout, components at left, and general notes above.

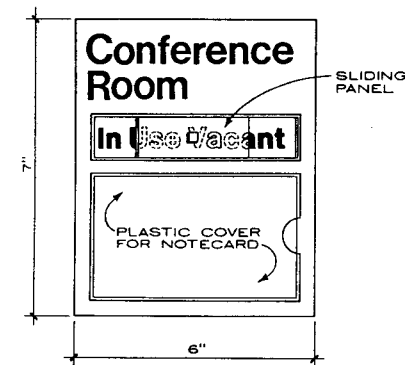

CONFERENCE ROOM SIGN

**SECTION**

TYPICAL CONFERENCE ROOM (25 - 30 PERSONS)

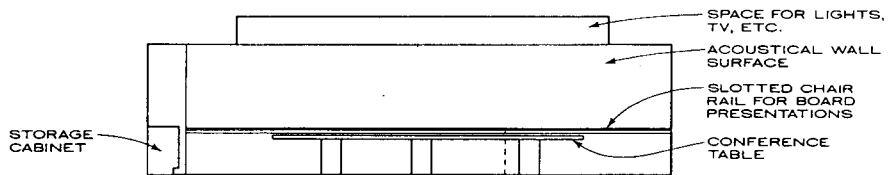

J. Kevin Lloyd, AIA; Barge, Waggoner, Sumner & Cannon; Nashville, Tennessee

**GENERAL PLANNING NOTES**

During the early stages of planning, consult with regional Postmaster General for regulations concerning postal facilities in office buildings.

**PLATFORM**

A dock area that provides off-the-street loading and unloading of mail.

**MAILROOM**

A security type room located at platform level, which has its own access door to the platform for off-hour service. Platform door should be 48 in. wide, security type. If window or lockbox service is provided, the mailroom should be located at the principal building entrance level. Standard interior treatment should apply in this space. Provide heavy-duty wall and corner guards.

**SERVICES**

The size of mailroom and services provided by the post office vary with size and occupancy of the building. The U.S. Postal Service recognizes for its staffing and servicing two types of mailrooms for small, medium, and large office buildings.

- LOCKBOX SERVICE:** Buildings up to 200,000 sq ft of leasable space or with a maximum of 75 tenants. Provide one receptacle for each tenant and rear loading for 11 or more tenants. A building directory must be maintained.

The vertical distance from floor to tenant locks on top tier of receptacles is 66 in. maximum; to bottom lowest tier 10 in. minimum, preferably 30 in. Install only at one entrance. Allow a minimum of 3 ft of clear working space behind units. Provide

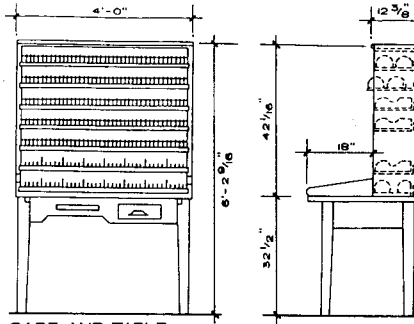

CASE AND TABLE

80 sq ft of working space for each additional carrier. Allow 1 sq ft of working space for every 1000 sq ft of leasable office space. Specifications for construction of mail receptacles shall be identical to those for Type II, horizontal apartment house receptacles as prescribed in USPS Publication 17, except that the minimum inside dimensions shall be 5 3/4 in. high, 10 1/2 in. wide, and 16 in. deep.

- CALL WINDOW SERVICE:** Buildings with 75 or more tenants, one carrier for each 100,000 sq ft of leasable office space up to 500,000 sq ft, plus one carrier for each additional 200,000 sq ft of office building. Allow 1.5 sq ft for every 1000 sq ft of leasable space; the minimum call window service space is 100 sq ft.

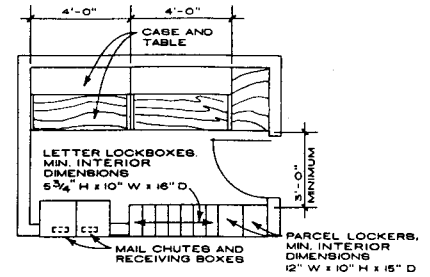

LOCKBOX

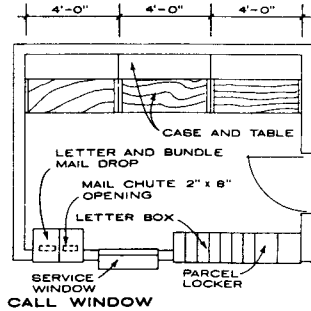

CALL WINDOW

**POSTAL SERVICES**

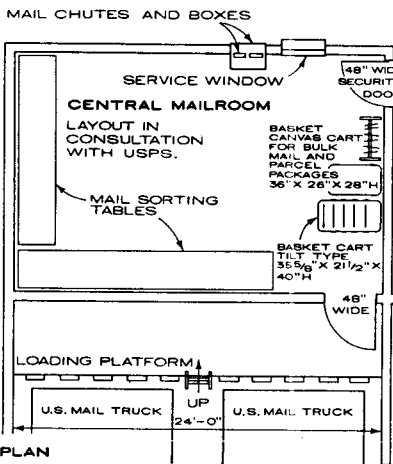

PLAN

**CENTRAL MAILROOM**

Buildings larger than 200,000 sq ft and up to 2,000,000 sq ft of leasable space can be served on each floor from a central mailroom using a containerized mechanical system. Allow a minimum of 400 sq ft for first 50 tenants plus 135 sq ft for each additional 50 tenants, or 2 sq ft for each 1000 sq ft of leasable space.

Service mailrooms shall be provided on each multitenant floor, unless containers are conveyed mechanically to tenant offices. Allow 5 x 7 ft minimum floor area for service mailroom. Mechanical systems accommodating 8 to 19 containers may require a minimum area of 7 x 8 ft. Minimum inside container dimensions are 12 x 16 x 6 in.

Existing mechanical systems often are disbanded. U.S. Postal Service recommends a central mailroom with rear-loading lock boxes and parcel lockers. For high mail and parcel volumes, nutting trucks and BMC containers as shown may be used for transport to mailroom floor (48 in. wide security doors required).

**NOTES**

- Centralized mail delivery: Neighborhood Delivery & Collection Box Units (NDCBU) are popular in home and office complex developments. USPS can help plan centralized mail delivery (Pub. 265, August 1983).

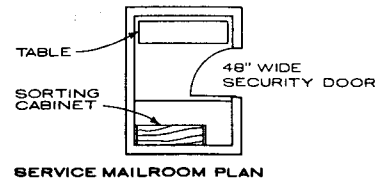

SERVICE MAILROOM PLAN

- USPS lobby layouts in postal buildings designate specific vending machine areas, customer service lobby, and box lobby with parcel lockers having a lock system similar to public lockers, and customer leased box lockers. See USPS guidelines, "New Directions in Lobby Design Practices." Some equipment and features are applicable to office buildings.
- Rehabilitating existing buildings: the form of mail handling should not change, i.e., an original central mailroom installation may not be changed to mail delivery on each floor. Same applies to mail chute installations. Relocation may be necessary, but discontinuation or introduction of a new installation needs approval. In all cases, early consultation with the local Postmaster should be initiated.

**CENTRAL MAILROOM**

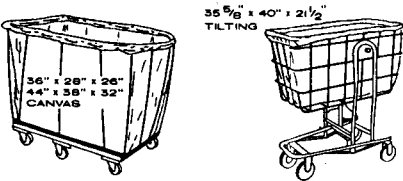

BASKET CARTS EQUIPMENT

- Receiving boxes: Must be placed near the building's main entrance or near the loading, unloading area for USPS mail collection. Using the shortest line, receiving boxes may not be placed more than 100 ft from the entrance used by the collection person. Locations require local Postmaster approval. Receiving boxes must be placed on the same floor the collection person uses to enter the building. Doors must operate freely. Door openings must be at least 12 x 20 in. and not more than 18 x 30 in.
- Auxiliary boxes: Located near receiving box when receiving box is too small to accommodate first class mail volume. Openings must be large enough to receive tied bundles of first class mail.
- Bundle drops: Receiving boxes must have bundle drops with an opening for a bundle at least 6 1/2 in. wide by 11 1/2 in. long and 4 in. high. To prevent removal of mail through it, the deposit opening must be fully protected by inside baffle plates. Inlet doors must be inscribed "Letters" and "Letter Mail Tied in Bundles." Bottom of the opening must be at least 61 in. above floor level.

Reference: USPS Publication 16, August 1989

**NOTES**

- All installations must comply with USPS requirements and are subject to inspection.
- Floor penetrations may need firestopping methods.
- USPS provides listing of approved manufacturers.

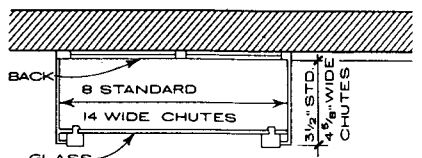

MAIL CHUTE - PLAN

**NOTES**

- May be recessed.
- Use wide chutes for 8 x 10 in. envelopes.
- Tempered glass at least 3/16 in. thick, or heavy, shatterproof plate glass at least 3/4 in. thick, or transparent, fire-resistant plastic material of equal or greater strength than 3/16 in. tempered glass.

**MAIL CHUTES AND RECEIVING BOXES**

- Chutes: Used in buildings of at least four stories for first class mail only. The chute cross section must be approximately 2 x 8 in. and extend in a continuously vertical line from beginning point to receiving box or mailroom. Chute interior must be accessible its entire length. Chutes in pairs have a divider and dual receiving boxes.

**MAIL CHUTES AND RECEIVING BOXES**

© 1989 Hart Associates, AIA; White Plains, New York

**GENERAL NOTES**

Coatrooms should be adjacent to and have line-of-sight connections with lobby or with circulation path between building entry and destination (auditorium, gallery, etc). Care should be taken to provide ample space for orderly queuing out of the mainstream of circulation. This is of particular importance in theaters, concert halls, and similar facilities where check in and out of massive numbers of people occurs in a very brief period of time. In galleries, museums, and restaurants, the flow of people is more even, resulting in a diminished need for queuing space and a smaller staffing requirement for the check-room itself.

For general planning purposes, allow between 1.1 and 1.5 in. of rack space per garment, depending on climate. Hats, umbrellas, and packages should be stored with the garment rather than segregating items by type. Most racks contain from one to three overhead shelves for this purpose. For ease of access, these shelves should not extend above 6 ft 8 in.

For small to medium size facilities, conventional coatrooms are adequate. In large facilities where hundreds of garments will be accommodated, the designer should consider using automated conveyors. These systems save a great deal of time by eliminating the need to access aisles searching for a garment. In addition, the aisles are eliminated, resulting in a more efficient use of space. These systems function as follows:

The coatroom attendant hangs incoming garments on a conveyor in prenumbered slots that correspond to the claim check number. Hats and other items are placed in bins over the patron's garments. When departing patrons present their claim check, the attendant keys in the number on a control panel, and the conveyor revolves until it automatically stops at the correct number.

**COATROOM AREA REQUIREMENTS**

CAPACITY	AREA, CONVENTIONAL	AREA, AUTOMATED
100	75	N.A.
200	140	100
300	200	130
400	240	150
500	310	180
1000	575	320
1500	760	460
2000	1025	600

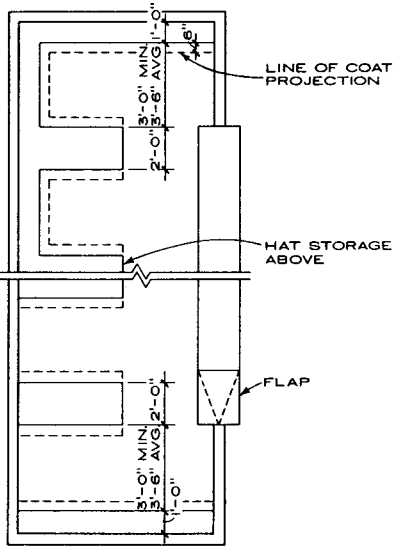

**CONVENTIONAL COATROOM**

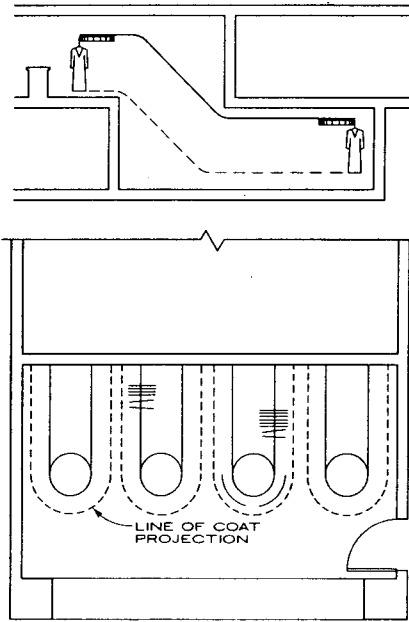
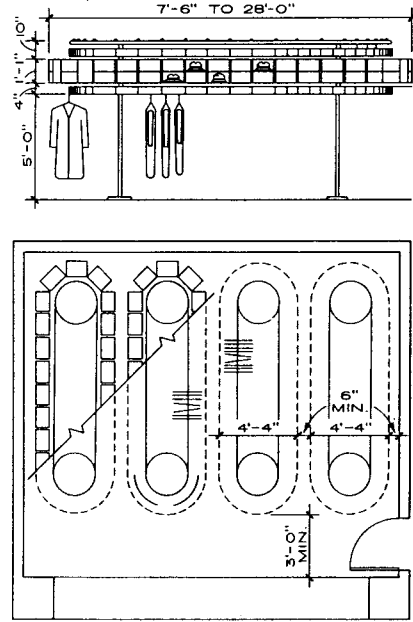

**AUTOMATED COATROOMS**

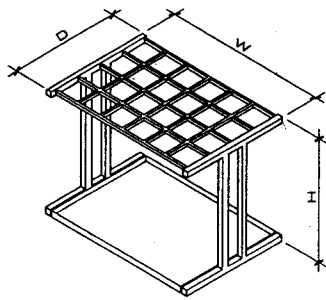

UMBRELLAS	HEIGHT	DEPTH	WIDTH
12	18"	12"	10"
18	18"	9"	18"
24	18"	12"	18"

**UMBRELLA RACK**

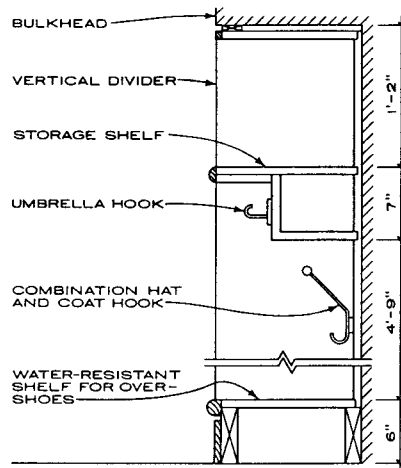

**"CUSTOM" COATROOM RACK**

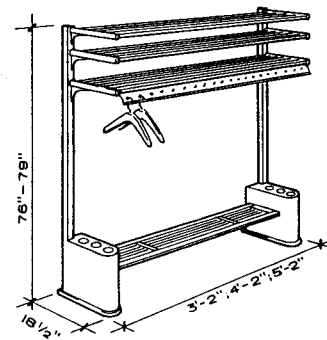

**COMBINATION COAT, HAT, UMBRELLA, OVERSHOE RACK**

Above model may be mounted back-to-back. Portable models are mounted on casters. Models available with or without umbrella and overshoe racks, and some are collapsible.

**COATROOM EQUIPMENT**

Blythe + Nazdin Architects, Ltd.; Bethesda, Maryland

**GENERAL**

Round tables are usually recommended for seating four or more persons.

Dimension "A" depends on the perimeter length necessary for food. Dimension "A" depends on the perimeter length necessary for food. Dimension "A" depends on the perimeter length necessary for food. For cocktails, 1 ft-6 in. is sufficient.

Tables 3 ft 0 in. and wider will seat at least one person at each end.

Smaller sizes are satisfactory for drink service; larger sizes for food. Tables with center bases accommodate coupled table arrangements better than four-legged tables.

The type and style of service affect tables and arrangements. Consider the use of service carts, high chairs, as well as accessibility for the disabled. See the Americans with Disabilities Act (ADA) requirements below.

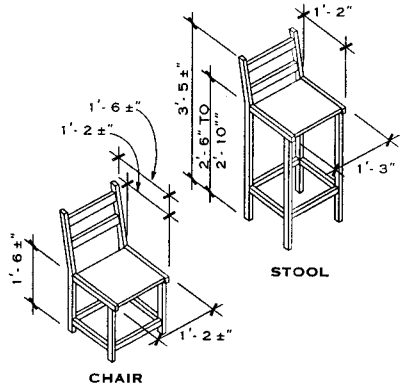

**TYPICAL DIMENSIONS**

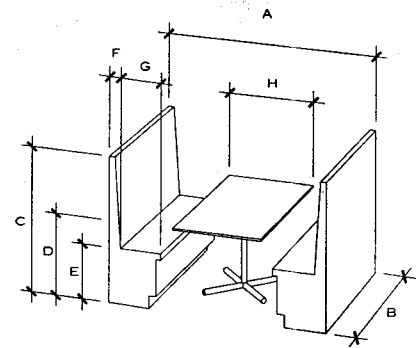

**BOOTH DIMENSIONS**

- A = Seat back to seat back: 5' - 6" to 6' - 2"
- B = One person per side: 2' - 0" to 2' - 6"
- Two persons per side: 3' - 6" to 4' - 6"
- Three persons per side: 5' - 0" to 6' - 2"
- C = 3' - 0" to 4' - 0"
- D = 2' - 6"
- E = 1' - 6"
- F = 2" to 4"
- G = 1' - 6" ±
- H = 2' - 0" to 2' - 6"

**NOTES**

1. Local building codes may determine actual booth sizes. Tables are often 2 in. shorter in length than seats and may have rounded ends. Circular booths have overall diameter of approximately 6 ft 4 in.
2. Eliminate one booth and replace with table to provide access for wheelchair.

**BOOTHS**

**BAR DIMENSIONS**

- A = 8' - 4" to 11' - 7"
- B = 1' - 6" to 2' - 0"
- C = 2' - 4" to 3' - 2"
- D = 2' - 6" to 3' - 0"
- E = 2' - 0" to 2' - 6"
- F = 6" to 7"
- G = 1' - 10" to 2' - 2"
- H = 2' - 6" to 2' - 10"
- I = 11" to 1' - 10"
- J = 7" to 9"
- K = 6" to 9"
- L = 2' - 6"
- M = 3' - 6" to 3' - 9"
- N = 3' - 0" to 3' - 6"
- O = 5' - 0" to 5' - 9"

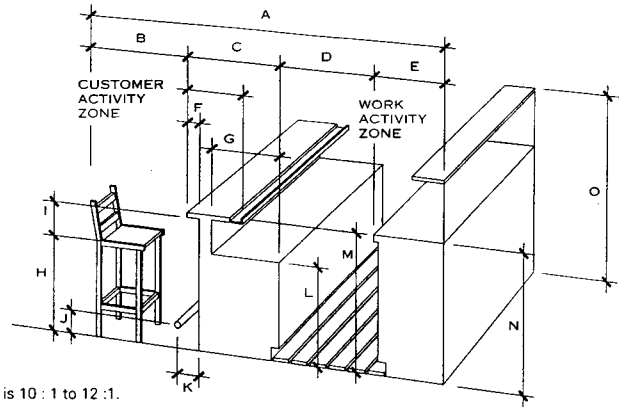

**NOTE**

Ratio of counter seating to servers is 10 : 1 to 12 : 1.

**LOW COUNTER DIMENSIONS**

- A = 4' - 11" to 5' - 6"
- B = 3' - 1" to 3' - 3"
- C = 1' - 10" to 2' - 0"
- D = 1' - 7" minimum
- E = 1' - 6" to 2' - 0"
- F = 2' - 4" to 2' - 8"
- G = 2' - 3" minimum
- H = 4" to 8"
- I = 5' - 0" minimum

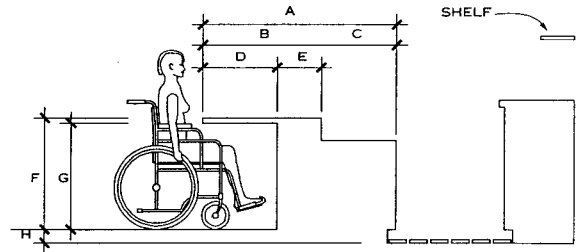

**NOTE**

A continental bar with low seating is one means of achieving accessibility. The bartender's area can be lowered or the seating area can be on a raised platform accessed by ramp.

**BARS AND COUNTERS**

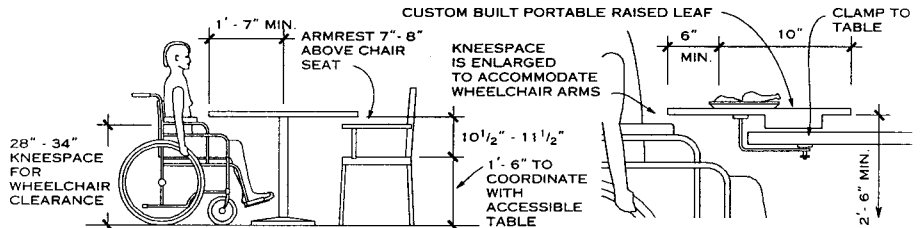

**NOTE**  
A raised leaf is one retrofit option.

**ACCESSIBLE FURNITURE**

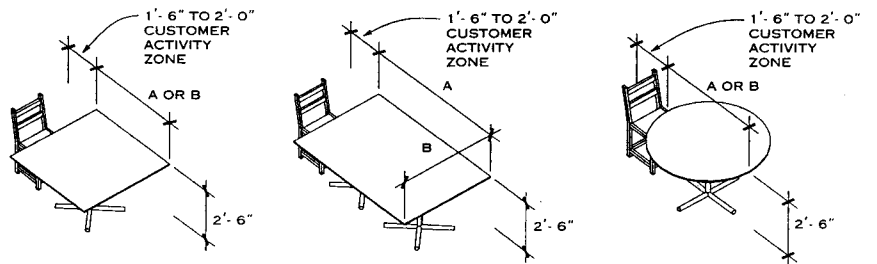

**SQUARE TABLES**

PERSONS	A OR B
2	2' - 0" to 2' - 6"
4	3' - 0" to 3' - 6"

**RECTANGULAR TABLES**

PERSONS	A	B
2 (on one side)	3' - 6" to 4' - 0"	
6 (3 on each side)	5' - 10" to 7' - 0"	2' - 6" to 3' - 0"
8 (4 on each side)	7' - 6" to 9' - 0"	

**ROUND TABLES**

PERSONS	A
4 - 5	3' - 0" to 3' - 6"
6 - 7	3' - 6" to 4' - 6"
7 - 8	4' - 6" to 5' - 0"
8 - 10	5' - 0" to 6' - 0"

**TABLES**

Janet B. Rankin, AIA; Rippeteau Architects; Washington, D.C.  
Cini-Little International, Inc., Food Service Consultants; Washington, D.C.

**CLEARANCES:**

- A = 6" minimum (no passage)
- B = 1' - 6" (limited passage)
- C = 1' - 7"
- D = 2' - 6"
- E = 3' - 0"
- F = 3' - 6"
- G = 4' - 0"
- H = 4' - 6"
- I = 6' - 0"

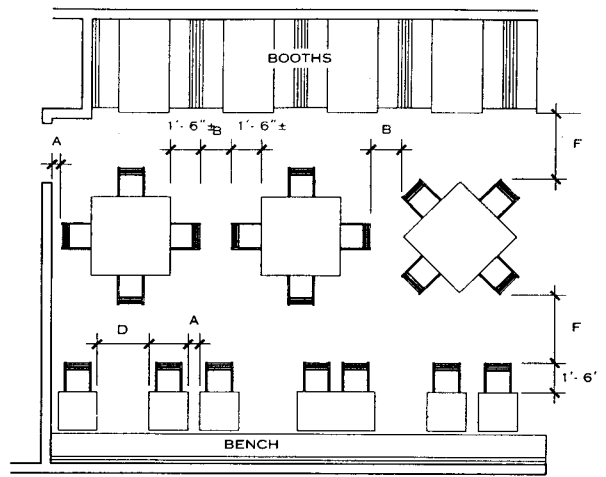
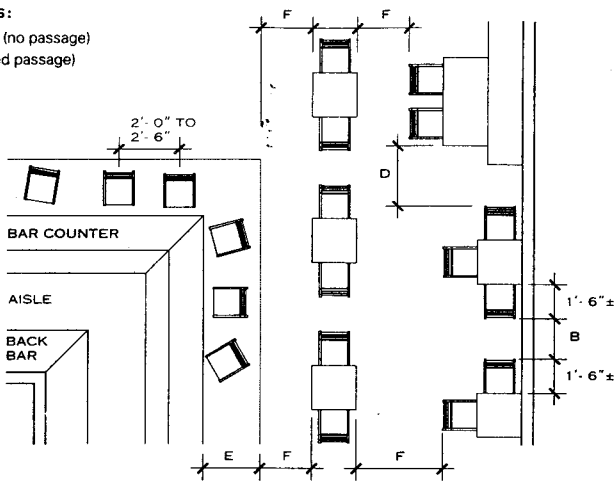

**NOTE**

All dimensions are minimum clearances. Seating layouts show general configurations and are not intended to depict any specific type of operation. Tables may be converted from square to round to generally enlarge seating capacity. Booth seating makes effective use of corner space.

A wheelchair accessible route, at least 36 in. wide, is required to connect the entrance, accessible fixed seating, and restrooms.

**TYPICAL SEATING ARRANGEMENTS**

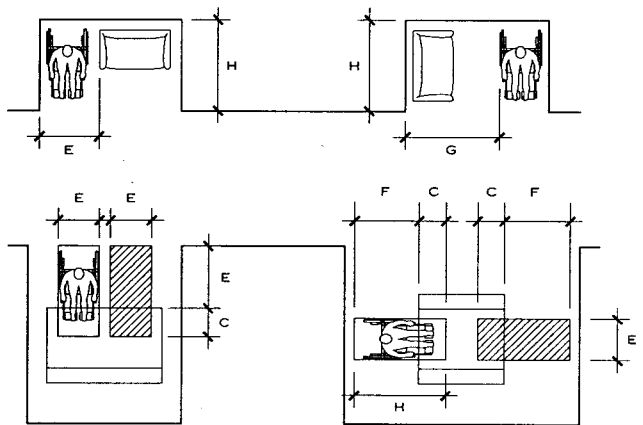
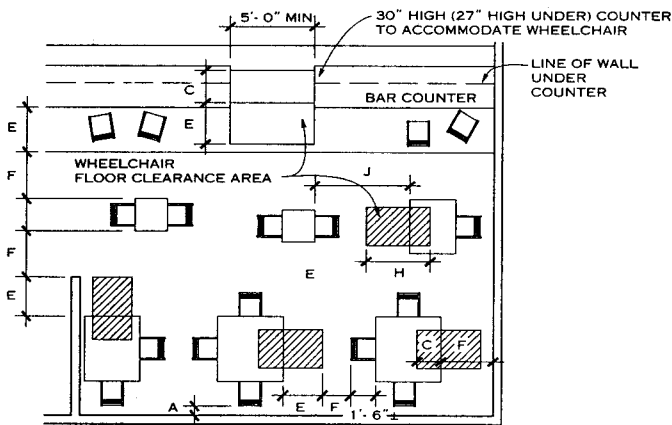

**SEATING ARRANGEMENTS FOR PERSONS USING WHEELCHAIRS**

**GENERAL DESIGN CRITERIA**

**SERVICE AISLES**

1. For square seating, allow 72 in. minimum between tables (30 in. aisle plus two chairs back to back).
2. For diagonal seating, allow 36 in. minimum between corners of tables.
3. For wall seating, allow 30 in. minimum between wall and seat back.
4. Allow a minimum of 30 in. for bus carts and service carts.

**CUSTOMER AISLES**

1. Refer to local codes for restrictions on requirements.
2. For wheelchair access, allow 36-44 in. aisle.
3. For wall seating, allow 30 in. minimum between walls and table.
4. Clear floor space must be provided for table access. Such clear floor space shall not overlap kneespace by more than 19 in.

**TABLE PLACEMENT**

1. Allow circulation space adjacent to doors and food service areas.
2. Restaurants should offer a variety of seating options.

**ACCESSIBLE SEATING**

1. If fixed or built-in seating areas are provided, make at least 5%, or a minimum of one fixed/built-in seating area, accessible. Review ADA requirements.
2. Accessible seating should be integrated within the dining area, and should accommodate both large and small groups.
3. Raised and sunken areas must be accessible. Mezzanines must also be accessible unless certain conditions are met (see ADAAG 5.4).

**TABLE AND COUNTER CRITERIA**

1. Tables average 29 in. high.
2. The tops of accessible tables and counters should be 28 in. to 34 in. high. A portable raised leaf may be provided to adapt lower tables.
3. If seating for people in wheelchairs is provided at tables or counters, kneespace at least 27 in. high, 30 in. wide, and 19 in. deep shall be provided.
4. Where food and drink are served at counters exceeding 34 in. in height, a portion of the main counter, 60 in. in length, should be made accessible, or accessible tables shall be located in the same area.
5. Corners and edges of table and countertops should be rounded for safety.

**SEATING CRITERIA**

1. Chair seat height is usually 18 in. Seat heights should be slightly higher at wheelchair accessible tables.
2. Seats should be a minimum of 16 in. deep and 16 in. wide.
3. Padding and cushions should be firm.
4. Seat backs should be slightly inclined.
5. Armrests should be provided to aid in rising.
6. Table or counter supports should not interfere with seat kneespace so the feet can be positioned for rising.

**DINING SPACE AVERAGES**

TYPE OF ROOM	SQUARE FEET PER PERSON
Banquet	10 - 12
Cafeteria	12 - 18
Tearoom	10 - 16
Lunchroom/coffee shop	12 - 16
Dining room/restaurant	13 - 16
Specialty/formal dining	17 - 22

**NOTE**

Area figures represent the average minimum. Seating requirements may vary widely to suit individual operations.

Janet B. Rankin, AIA; Rippeteau Architects; Washington, D.C.  
Cini-Little International, Inc., Food Service Consultants; Washington, D.C.

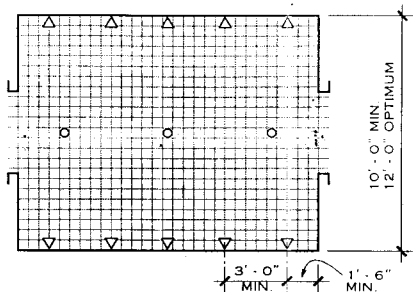

**NOTE**

Educational facilities with time constraints should have 10 shower heads for the first 30 persons and one shower head for every four additional persons. In recreational facilities one shower head for each 10 dressing lockers is a minimum. Temperature controls are necessary to keep water from exceeding 110° F. Both individual and master controls are needed for group showers.

**GROUP SHOWERS**

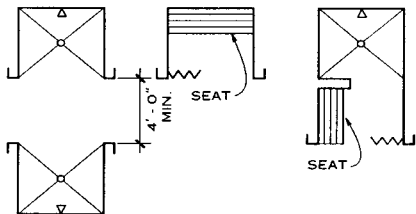

SHOWER PLAN

DRESSING ROOM PLAN

**TYPICAL DIMENSIONS**

	MINIMUM	OPTIMUM
Showers	3'-0" x 3'-6"	3'-6" x 3'-6"
Dressing Rooms	3'-0" x 3'-6"	3'-6" x 4'-0"

**NOTE**

Individual dressing rooms and showers can be combined in a variety of configurations to obtain 1:1, 2:1, 3:1, and 4:1 ratios.

**INDIVIDUAL SHOWERS AND DRESSING ROOMS**

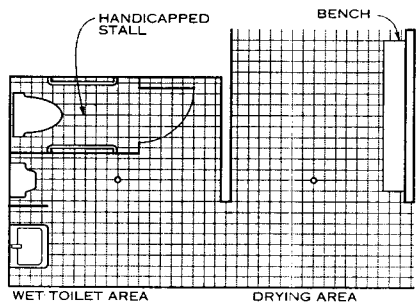

**NOTE**

The drying room should have about the same area as the shower room. Provision for drainage should be made. Heavy duty towel rails, approximately 4 ft from the floor, are recommended. A foot drying ledge, 18 in. high and 8 in. wide as shown in the drawing, is desirable. An adjacent wet toilet is suggested. Avoid curbs between drying room and adjacent space. Size of towel service area (which can be used for distributing uniforms) varies. Size of area varies with material to be stored; 200 sq ft is usually sufficient.

**DRYING ROOM AND WET TOILET**

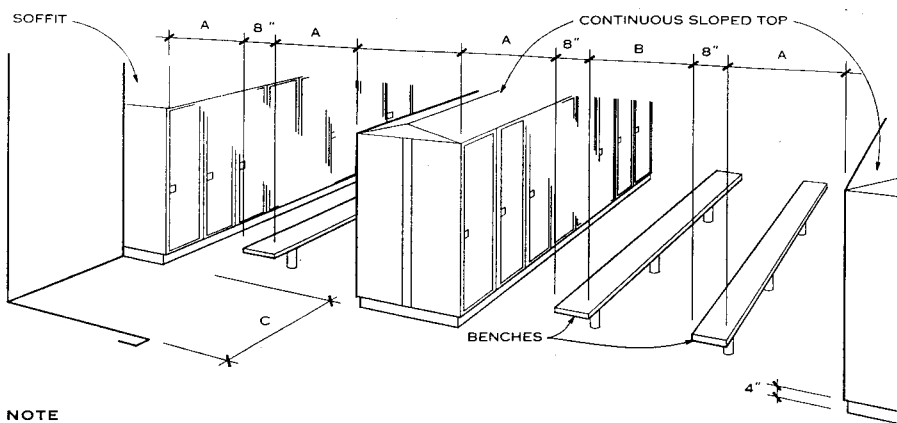

**NOTE**

Bench should be minimally 8 in. wide and 16 in. high. Traffic breaks of 3 ft minimum width should occur at maximum intervals of 12 ft. Main traffic aisle should be wider. Avoid lockers that meet at 90° corner.

	A	B	C
Recreation	2'-2"	1'-8"	3'-6"
School	2'-6"	2'-6"	4'-0"

**LOCKER ROOM**

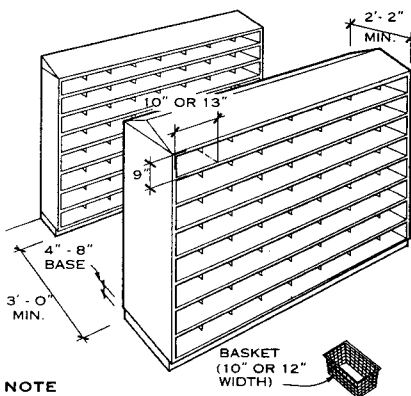

**NOTE**

Basket racks vary from 7 to 10 tiers in height. Wide baskets require 1 ft shelf space, small baskets 10 in. shelf space; both fit 1 ft to 1 1/2 ft deep shelf. Back-to-back shelving is 2 ft 3 in. wide. Height is 9 1/4 in.

**BASKET ROOM AND BASKET RACK**

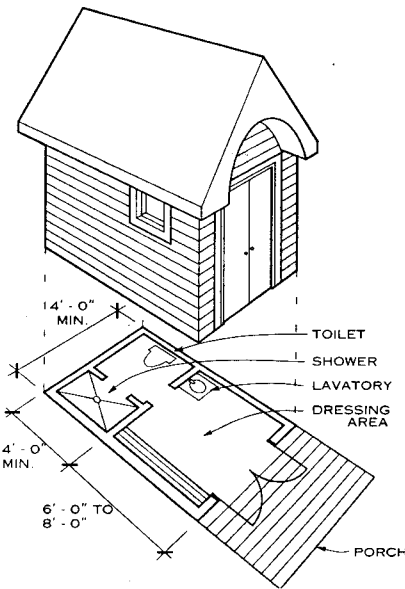

CABANA

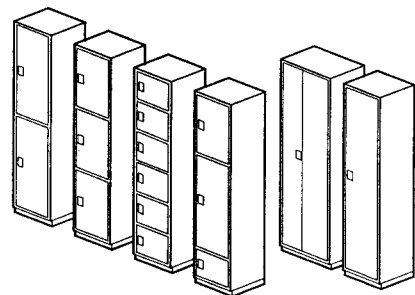

STORAGE

DRESSING

**STANDARD SIZES (IN.)**

	9	12	15	18
Width	9	12	15	18
Depth	12	15	18	
Height	60	72 (overall)		

**NOTE**

For schools, standard storage locker is 9 in. or 12 in. x 12 in. x 12 in. to 24 in. Standard dressing lockers are 12 in. x 12 in. x 60 in. or 72 in. Number of dressing lockers should be equal to the peak period load plus 10 to 15% for expansion.

**LOCKER TYPES**

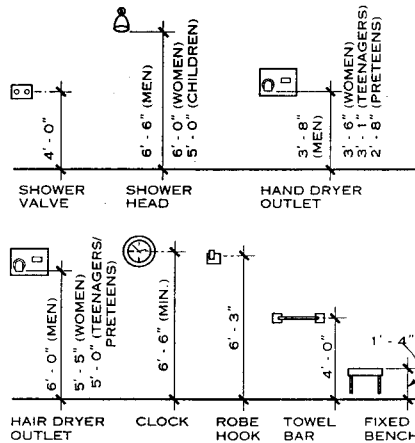

**RECOMMENDED MOUNTING HEIGHTS**

Richard J. Vitullo, AIA, Oak Leaf Studio; Crownsville, Maryland  
BFS Architectural Consulting and Interior Design, YMCA of the USA; Chicago, Illinois

**LOCKER ROOM FACILITIES CHECKLIST**

1. Fixed benches 16 in. high.
2. Lockers on raised base.
3. Locker numbering system.
4. Hair dryers—one per 20 lockers.
5. Mirrors at lavatory.
6. Makeup mirror and shelf.
7. Drinking fountain (height as required).
8. Bulletin board.
9. Dressing booths, if required.
10. Full - length mirror.
11. Clock.
12. Door signs.
13. Sound system speaker, if required.
14. Lighting at mirrors for grooming.
15. Lighting located over aisles and passages.
16. Adequate ventilation for storage lockers.
17. Windows located with regard to height and arrangement of lockers.
18. Visual supervision from adjacent office.

**GENERAL NOTES**

1. The most widely used arrangement of lockers is the bay system, with a minimum 4 ft circulation aisle at each end of the bays. Ordinarily, the maximum number of lockers in a bay is 16. Locate dry (shoe) traffic at one end of the bays and wet (barefoot) traffic at the other end. For long bays with a single bench, make 3 ft breaks at 15 ft intervals.
2. Supervision of school lockers is the easiest if they are located in single banks along the two walls, providing one or more bays that run the length of the room.
3. The number of lockers in a locker room depends on the anticipated number of members and/or size of classes. For large numbers separate locker areas should be encouraged. In small buildings interconnecting doors provide flexibility and allow for the handling of peak loads.
4. Individual dressing and shower compartments and a shower stall for the handicapped may be required.
5. Basket storage, if included, generally is self-service. Maximum height is 8 tiers. A dehumidifying system should be provided to dry out basket contents overnight. Separate auxiliary locker rooms for teams, part-time instructors, faculty, or volunteer leaders may be required. A small room for the coach's use may be desirable.
6. The shower room should be directly accessible to the drying room and locker room that it serves. When a shower room is designed to serve a swimming pool, the room should be located so that all must pass through showers before reaching the pool deck.
7. Separate wet and dry toilet areas are recommended. Wet toilets should be easily accessible from the shower room. When designed for use with a swimming pool, wet toilets should be located so that users must pass through the shower room after use of toilets.
8. Locker room entrance and exit doors should have vision barriers.
9. All facilities should be barrier-free.
10. Floors should be of impervious material, such as ceramic or quarry tile, with a Carborundum impregnated surface, and should slope toward the drains. Concrete floors (nonslip surface), if used, should be treated with a hardener to avoid the penetration of odors and moisture.
11. Walls should be of materials resistant to moisture and should have surfaces that are easily cleaned. All exterior corners in the locker rooms should be rounded.
12. Heavy duty, moisture resistant doors at locker room entrances and exits should be of sufficient size to handle the traffic flow and form natural vision barriers. Entrance/exit doors for the lockers should be equipped with corrosion resistant hardware.
13. Ceilings in shower areas should be of ceramic tile or other material impervious to moisture. Locker room ceilings should be acoustically treated with a material impervious to moisture and breakage. Floor drains should be kept out of the line of traffic, where possible.

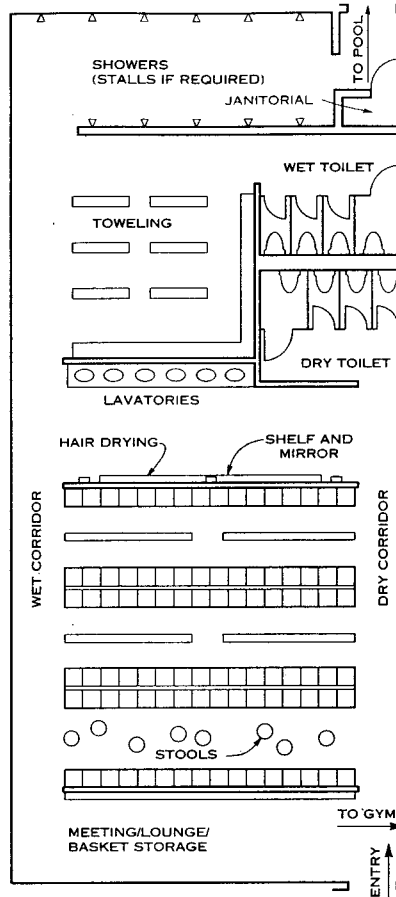

**GYMNASIUM AND POOL LOCKER ROOM**

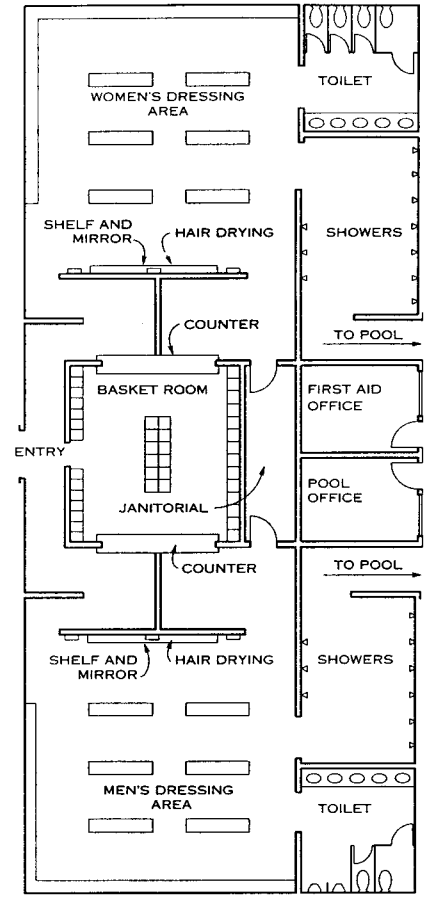

**POOL LOCKER ROOM**

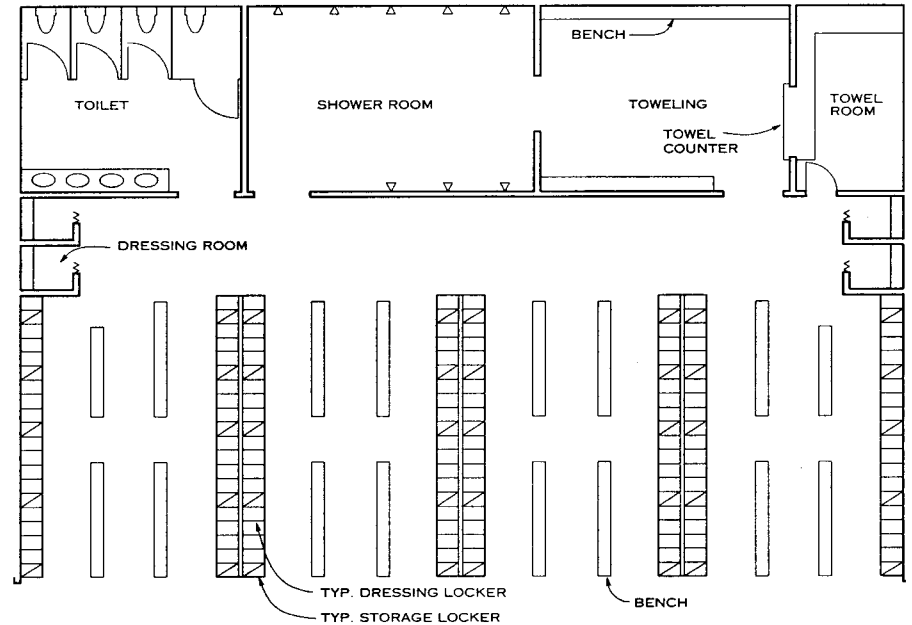

**GYMNASIUM LOCKER ROOM**



**LOCATION WITHIN THE BUILDING**

The courtroom is often the major space in the building and should be centrally located, with primary access to its support spaces (e.g., judge's chamber, jury rooms, witness rooms, court officer's spaces), the public lobby, and toilet facilities.

**REQUIRED SPACES**

Courtrooms require 3 main areas or zones

1. The public space
2. The courtroom, including the jury box
3. The judge's bench and witness stand

The public space is open to the public for observation of the trial proceedings. Defendants and attorneys also use this space as a waiting area before their trial. The public space should have access to the public corridor and good access to public toilet facilities. It is usually divided from the courtroom space by a low divider rail with swinging gates.

The courtroom space is a restricted access space. Access to this space should be from private corridors, jury rooms, court officer offices, or the gates to the public space. This space contains the majority of courtroom activity. The jury, attorneys, defendants, and sometimes the press occupy this space. The jury box, part of the courtroom space, usually has a raised floor to provide better visibility of the trial proceedings. The jury box should have direct access to the jury room(s) or to a private corridor leading to the jury room(s). The courtroom space should not be accessible from any public corridor.

The judge's bench and witness stand have the most restricted access. They are usually divided from the courtroom space by a divider rail. The floor of the judge's bench is usually raised above the raised floor level of the jury box and witness stand to provide the judge(s) the most prominent position in the courtroom space. The judge's bench has direct access to the judge's chamber or to a private corridor leading to the judge's chamber. The witness stand is located adjacent to the judge's bench and is accessible only from the courtroom space. The witness stand has a raised floor, usually at the same level as the jury box.

**SPACE RELATIONSHIPS**

The jury should have direct access to the jury room without crossing the courtroom or any public space. A separate entrance to the jury room should be provided from the building corridor. Private toilet facilities should be provided, with direct access to the jury room. The judge should have direct access to the courtroom from his office. The size of the courtroom and its support spaces varies considerably, depending on the volume of court proceedings. For example, in a small municipal or magistrate's courtroom, 50 seats in the public space and 6 seats for jury members are adequate, whereas in a federal district court or state circuit court, 80-100 seats should be provided for the public, 12-14 for jury members (includes 2 alternates), 3 for judges, 1 for clerk of court, and 1 for court reporter. Seating for the press reporters should be provided in or near the courtroom space. All areas must be accessible to persons with disabilities.

**CONSTRUCTION**

The courtroom does not require natural lighting. A lighting level of 50 fc at the attorneys' table and judge's bench and a lighting level of approximately 30 fc in the public space should be adequate. All perimeter walls should be insulated to reduce sound transmission (STC 47 minimum). Resilient floor covering should be used in the public space and carpet may be used in the courtroom itself.

**AREA REQUIREMENTS FOR SUPPORT SPACES**

The jury room should be approximately 200 sq ft for municipal court and 350 sq ft for federal district court. Multiple jury rooms are often required for busy court facilities. A judge's chamber should be 150-350 sq ft. If pretrial hearings are held in the judge's chamber, the area should be increased to approximately 750 sq ft. A clerk of court's office should be 150-350 sq ft.

**TYPES OF COURTS**

Municipal or magistrate's courtrooms are usually small courtrooms located in City Hall or other municipal buildings. Municipal courts handle traffic and minor criminal cases. Magistrate's courts handle small civil and minor criminal cases.

State circuit courtrooms are usually large courtrooms located in the county courthouse of each county. State circuit courts handle all state trial proceedings, both civil and criminal.

Federal district courtrooms are usually large courtrooms located in federal governmental buildings serving each federal judicial district. Federal district courts handle all federal trial proceedings, both civil and criminal.

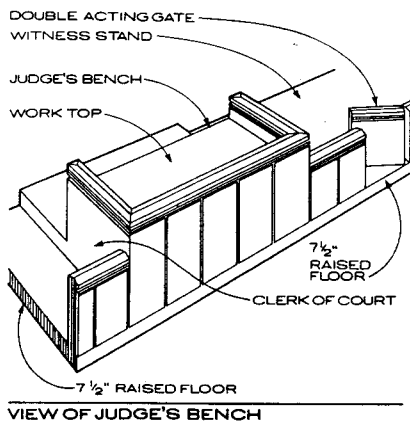

VIEW OF JUDGE'S BENCH

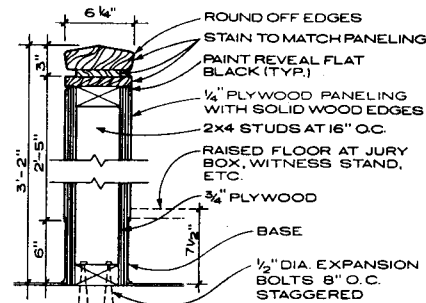

**RAIL DIVIDER**

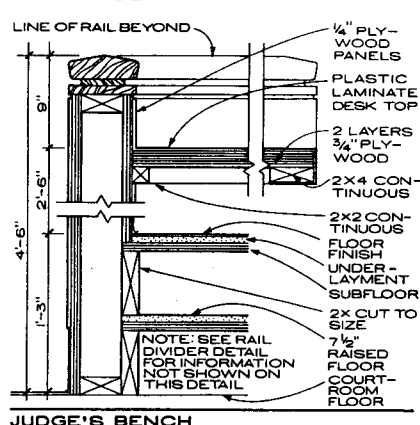

JUDGE'S BENCH

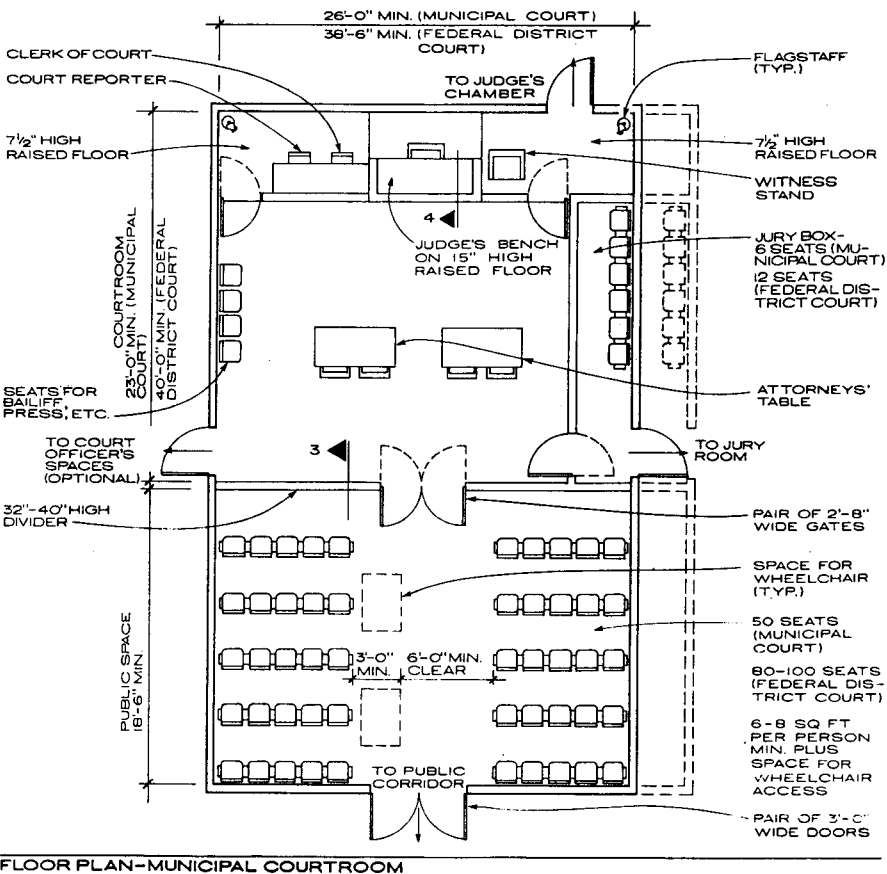

FLOOR PLAN-MUNICIPAL COURTROOM

T. John Gilmore, AIA; O'Cain Forrester Gilmore Architects; Spartanburg, South Carolina

**GENERAL ACUTE CARE**

Patient rooms must be accessible, easily maintained, and spacious enough to contain high-tech life support and monitoring equipment. Entry doors should be a minimum of 48 in. wide. Wider openings are sometimes required to accommodate large equipment and surgical teams during emergency situations. A clear area of 48 in. should be maintained at the foot of patient beds. Equip patient rooms with basic amenities such as a patient chair, visitor chair, television set (VCR optional), wardrobe for full-length garments and luggage, drawers for clothing and personal items, and a countertop for flowers and cards. Patient rooms include toilet facilities, though central bathing areas may be provided in lieu of individual showers. Doors to accessible toilet rooms must provide a clear opening of 32 in. minimum. If doors swing in, equip them with hardware that permits emergency access. Universal precautions require a lavatory in, or near the entrance to, each patient room and a place to store gloves, masks, and gowns. Space for electronic equipment, such as a patient data terminal and printer, may be required. Semiprivate patient rooms should contain cubicle curtains for visual privacy.

**INTENSIVE CARE**

Patients in an intensive care unit are under continuous observation. Each room should be visible from the nurse station or a staffed corridor workstation. Each unit must contain equipment for continuous monitoring. Provide a nurse call at each bed for summoning assistance. Beds should be within view of an exterior window, preferably an operable window. Provide bedside space for visitors and a curtain for visual privacy. Doors should be a minimum of 48 in. wide. Sliding doors may be used for access to rooms or cubicles within a suite. Provide at least one private room or cubicle in each ICU for patients requiring isolation and/or separation. Toilet units can be provided in each bed area, along with a sink, countertop for preparing medications, and universal precautions storage. IV tracks and exam lights are typically placed above each bed. Because of the acuity of illness of these patients, rolling life-support equipment often occupies space at the side and foot of the bed. Maintain a minimum of 48 in. on three sides of each bed. Utility columns allow 360 degree access around the patient.

**FINISHES AND HEADWALLS**

Finishes in patient rooms should be durable and easy to maintain: vinyl flooring, vinyl wall coverings, or painted gypsum board partitions, etc. are typically used. Epoxy paint is sometimes used at wet or medication preparation areas. Some hospitals contain less "institutional" patient rooms with carpeted floors and other homelike finishes. Consult local codes for restrictions on finishes in patient rooms.

Depending on the room type, bed headwalls may include a nurse call button, reading light, room light switches, television controls, electrical outlets, central monitoring capabilities, suction, vacuum, and various medical gas outlets. Headwalls are available as prefabricated units or can be built into the partition. Wall thicknesses may vary depending on the type of equipment used.

Consult the Americans with Disabilities Act (ADA) for specific accessibility guidelines.

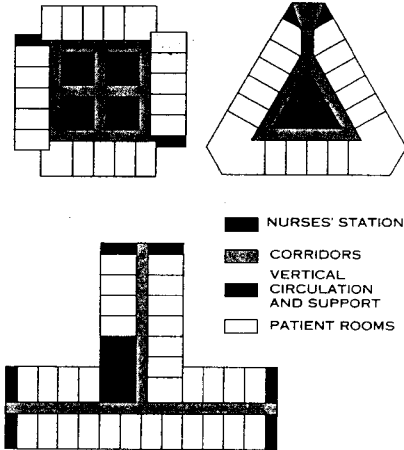

**TYPICAL UNIT CONFIGURATION**

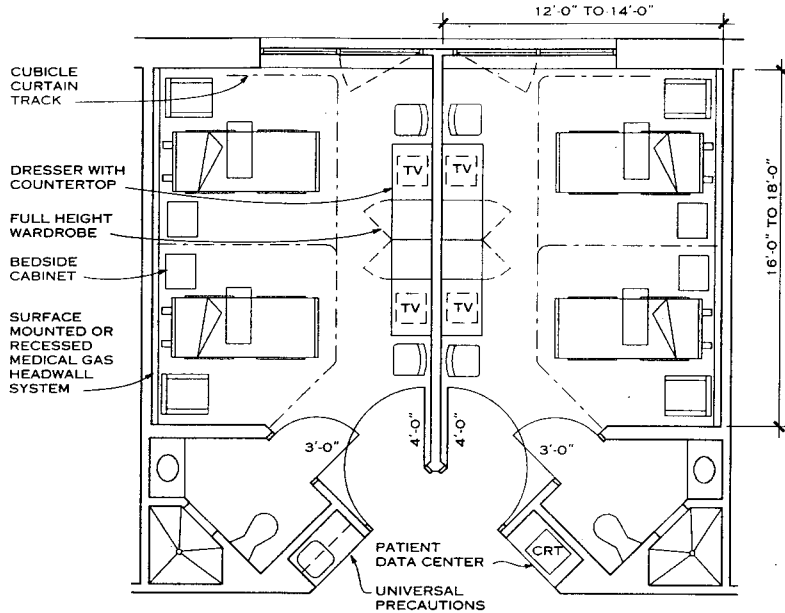

**SEMIPRIVATE PATIENT ROOM**

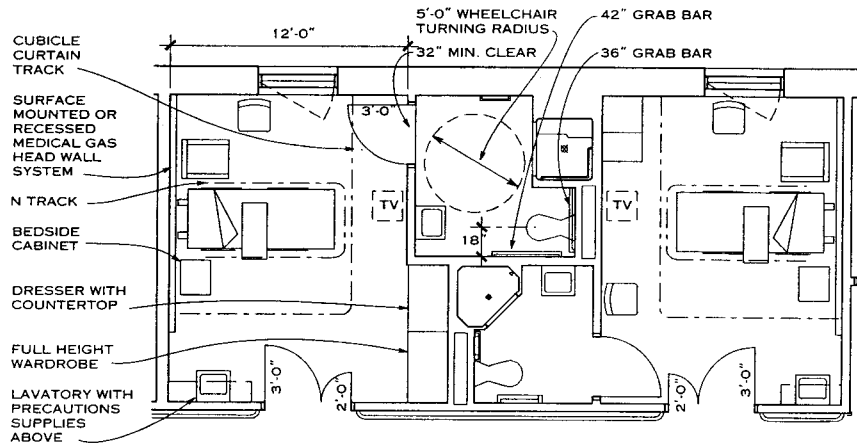

**PRIVATE PATIENT ROOM**

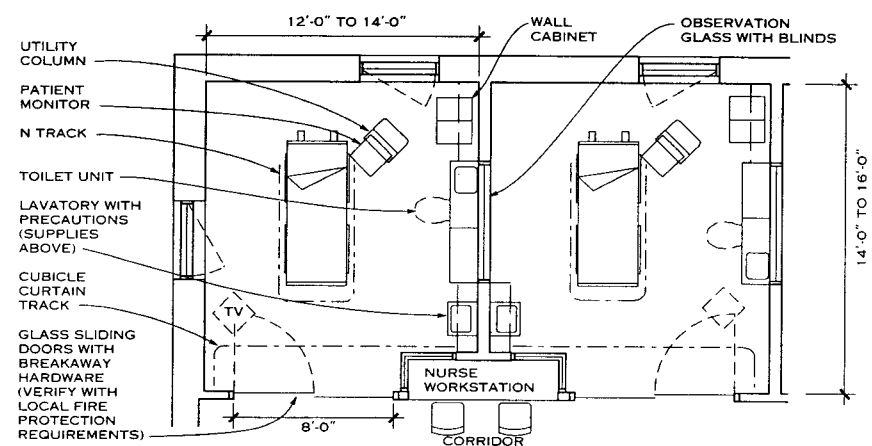

**INTENSIVE CARE UNIT PATIENT ROOM**

Timothy J. Cowan; Burt Hill Kosar Rittelmann Associates; Pittsburgh, Pennsylvania

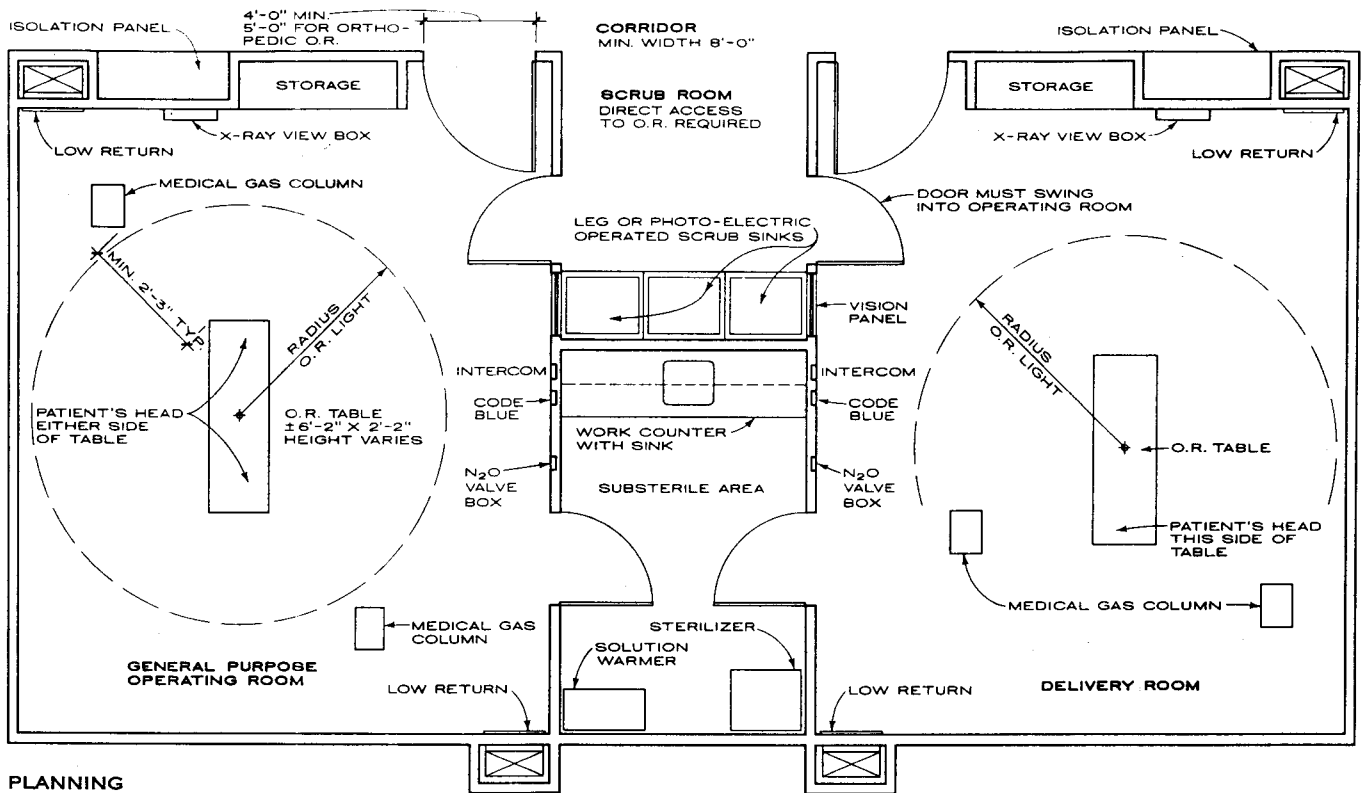

**PLANNING ENCLOSURE**

General purpose operating rooms must be extremely flexible due to widely varying spatial requirements of surgical procedures and personal preferences of the surgical staff. Public health codes limit the minimum size of these operating rooms to 360 sq ft, exclusive of casework. Certain procedures can require significantly more space. Operating rooms should be roughly square in plan and free of columns, with the operating room table located in the approximate center of the room to allow for maximum flexibility in positioning of equipment and personnel. Delivery rooms may be a minimum of 300 sq ft, exclusive of casework, for noncesarian births and 360 sq ft for cesarian. In delivery rooms, the operating room table is typically shifted from the center of the room to provide more space at the foot end. Endoscopy operators may be as small as 250 sq ft, while orthopedic rooms should be at least 450 sq ft. Operating room finished ceiling height should be no lower than 9 ft 0 in., with an ample ceiling cavity for service space above.

**FINISHES**

The primary concern in surgical room finishes is cleanliness. Flooring materials should be seamless and have an

integral base for ease of maintenance. Walls should be finished with a scrubable epoxy base paint or with vitreous ceramic tile and bacteria-resistant grout. Ceiling finishes should be either plaster or gypsum board. Built-in casework, countertops, sinks, and similar items should be stainless steel.

In operating rooms where flammable gases will be used an antistatic flooring surface must be specified to avoid sparks that could cause an explosion. Finishes throughout the operating room should be of light, neutral colors to avoid any distortion in skin color.

**ENVIRONMENTAL CONTROLS**

Temperature and humidity in operating rooms must be strictly regulated to maintain a suitable environment for surgery. Positive air pressure must be maintained with respect to other areas to avoid infiltration of contaminants from outside the operating room. Air should be supplied at low velocities, with diffusers positioned to avoid formation of air eddies. Return registers should be near floor level, adjacent to medical gas columns, and at furthest points from each other for evacuation of an-

esthetic gases, dust, and microbes. In areas where flammable gases will be used, electrical outlets must be explosion-proof or be placed 5 ft 0 in. above finished floor; high-hazard fire protection systems should be installed.

**EQUIPMENT**

Medical gas columns typically contain a variety of gases, vacuum lines, and power used by the anesthesiologist during surgical procedures. They should be located adjacent to the anesthesiologist, who is positioned near the head of the patient. These columns are ceiling mounted and typically extend down to approximately 5 ft 6 in. above the floor. Retractable columns are also available. Depending on the anticipated use of the facility, a great variety of additional, highly specialized equipment will also be required.

Because of the extreme complexity of these areas, extensive participation by doctors, technicians, equipment manufacturers, and engineers is required throughout the design process.

**TYPICAL SURGICAL SUITE**

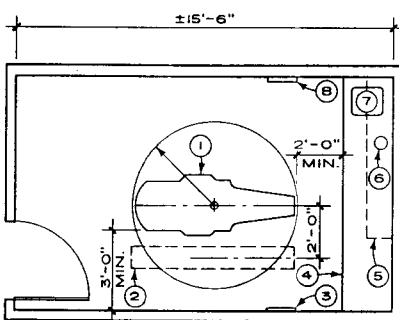

**DENTAL EQUIPMENT KEY**

1. Dental chair
2. Dual operating room light track
3. Medical gas console
4. Counter (cabinets below)
5. Overhead storage
6. Cutout in counter for waste
7. Stainless steel sink with foot control
8. Film illuminators (2)

**PLANNING**

The dental chair base is equipped with hot and cold water, wet suction, compressed air, drainage if required for cuspidor, and power. In addition, a chair-mounted operating light may be used in lieu of a ceiling-mounted fixture.

The wall-mounted medical gas console typically includes nitrogen, oxygen, and nitrous oxide. If nitrous oxide gas is included, a scavenging system should be provided. Medical gases can be supplied by tanks on movable carts.

While room finishes are not as critical in dental operatories as in operating rooms, all surfaces should be washable.

**DENTAL OPERATORIES**

Deborah Hershowitz and Frank Giese; Rogers, Burgun, Shahine and Deschler Architects; New York, New York  
Blythe + Nazdin Architects, Ltd.; Bethesda, Maryland

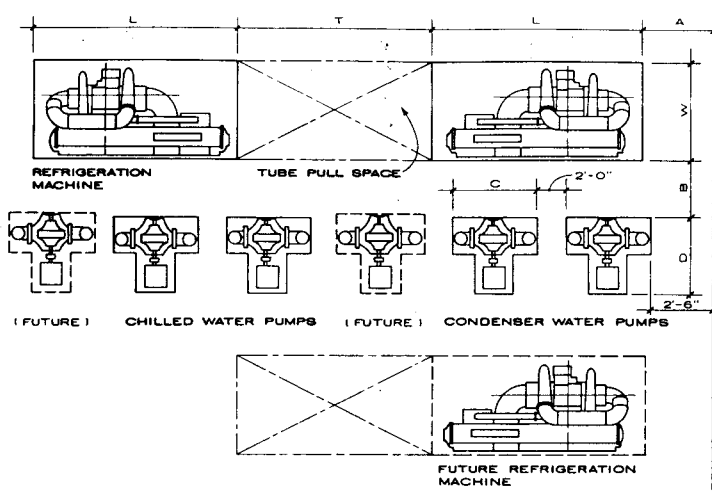

**GENERAL**

The capacity of each refrigeration machine is equal to 50% of the peak cooling load. Each water pump provides the flow requirement of one refrigeration machine. Therefore, one pair of condenser and chilled water pumps is needed for each machine.

The cooling tower may be located on the roof of the refrigeration equipment room or on the ground adjacent to the equipment room. When located on ground, the condenser water outlet(s) on the cooling tower must be not less than 5 ft above the equipment room floor elevation for proper functioning of condenser water pumps.

See ASHRAE Standard 15-1992, "Safety Code for Mechanical Refrigeration," for required ventilation of chiller plant and monitoring of toxic refrigerants.

**EXPANSION OF EQUIPMENT**

For operational flexibility of a refrigeration plant, the size of the future refrigeration machine is generally planned to be the same as of the present machines. It may be economically advantageous to oversize some portions of the chilled and condenser waterpipes to handle the future flow rates.

Provision must also be made for expansion of the cooling tower capacity when the future refrigeration machine is installed.

**REFRIGERATION EQUIPMENT ROOM SPACE REQUIREMENTS**

EQUIPMENT (TONS)	DIMENSIONS								MINIMUM ROOM HEIGHT
	L	W	HEIGHT	T	A	B	C	D	
<b>RECIPROCATING MACHINES</b>									
Up to 50	10'-0"	3'-0"	6'-0"	8'-6"	3'-6"	3'-6"	4'-0"	3'-0"	11'-0"
50 to 100	12'-0"	3'-0"	6'-0"	9'-0"	3'-6"	3'-6"	4'-0"	3'-6"	11'-0"
<b>CENTRIFUGAL MACHINES</b>									
120 to 225	17'-0"	6'-0"	7'-0"	16'-6"	3'-6"	3'-6"	4'-6"	4'-0"	11'-6"
225 to 350	17'-0"	6'-6"	7'-6"	17'-6"	3'-6"	3'-6"	5'-0"	5'-0"	11'-6"
350 to 550	17'-0"	8'-0"	8'-0"	16'-6"	3'-6"	3'-6"	6'-0"	5'-6"	12'-0"
550 to 750	17'-6"	9'-0"	10'-6"	17'-0"	3'-6"	3'-6"	6'-0"	5'-6"	14'-0"
750 to 1500	21'-0"	15'-0"	11'-0"	20'-0"	3'-6"	3'-6"	7'-6"	6'-0"	15'-0"
<b>STEAM ABSORPTION MACHINES</b>									
Up to 200	18'-6"	9'-6"	12'-0"	18'-0"	3'-6"	3'-6"	4'-6"	4'-0"	15'-0"
200 to 450	21'-6"	9'-6"	12'-0"	21'-0"	3'-6"	3'-6"	5'-0"	5'-0"	15'-0"
450 to 550	23'-6"	9'-6"	12'-0"	23'-0"	3'-6"	3'-6"	6'-0"	5'-6"	15'-0"
550 to 750	26'-0"	10'-6"	13'-0"	25'-6"	3'-6"	3'-6"	6'-0"	5'-6"	16'-0"
750 to 1000	30'-0"	11'-0"	14'-0"	29'-6"	3'-6"	3'-6"	7'-0"	6'-0"	17'-6"

Note: Direct-fired absorption machines are roughly the same size as steam absorption machines.

**REFRIGERATION ROOM LAYOUT**

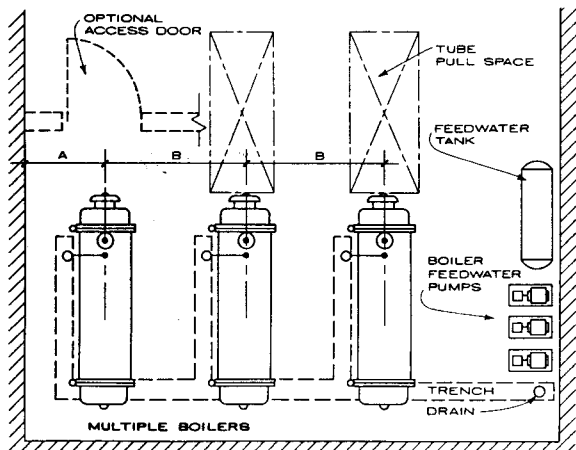

**BOILER ROOM SPACE REQUIREMENTS**

BOILER HP	15-40	50-100	125-200	250-350	400-800
Dimension A	5'-9"	6'-6"	6'-10"	7'-9"	8'-6"
Dimension B	7'-5"	8'-9"	9'-7"	11'-9"	14'-3"

NOTE: Above requirements apply to both steam and hot water boilers.

**BOILER ROOM LAYOUT FOR STEAM BOILERS**

**ROOM DIMENSIONS**

Dimension A allows for a minimum 3 ft 6 in. aisle between the water column on the boiler and the wall. Dimension B between boilers allows for a clear aisle of:

- 3'-6" - 15-200 hp
- 4'-0" - 250-350 hp
- 5'-0" - 400-800 hp

The shortest boiler room length is obtained by allowing for possible future tube replacement (from front or rear of boiler) through a window or doorway. Allowance is only made for minimum door swing at each end of the boiler.

**AIR SUPPLY**

Two permanent air supply openings on opposite walls of the boiler room are recommended. These openings should be located below a height of 7 ft with a total clear area of at least 1 sq ft. Air supply openings can be louvered for weather protection. Check applicable codes for minimum supply air requirements.

Size the openings by using the following formula:

$$\text{area (sq ft)} = \frac{\text{CFM}}{\text{FPM}}$$

Amount of air required (CFM):

- Combustion air—max. boiler HP x 2 CMF/BHP
- Ventilation air—max. boiler HP x 2 CFM/BHP

NOTE: a total of 10 CFM/BHP applies up to 1000 ft elevation. Add 3% more per 1000 ft of added elevation.

Air velocity required (FPM):

- Up to 7 ft height— 250 FPM
- Above 7 ft height— 500 FPM
- Supply air duct to boiler—1000 FPM

If chillers and boilers are located in the same room, combustion air supply must be ducted to boilers (see ASHRAE 15-1992).

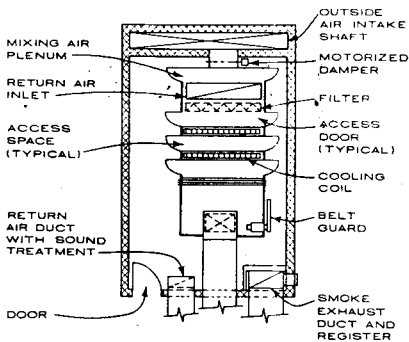

FIGURE 2 EQUIPMENT ROOM PLAN

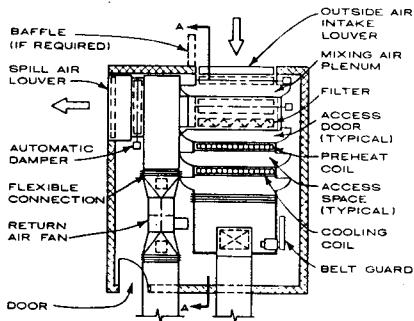
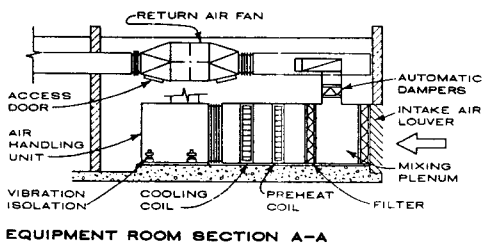

FIGURE 1 EQUIPMENT ROOM PLAN



EQUIPMENT ROOM SECTION A-A

NOTES

1. The air-handling equipment room should be located centrally to reduce distances conditioned air must travel from the equipment room to the farthest air-conditioned space. Fan noise transmission to adjacent spaces also must be considered. If the equipment room is located near conference rooms, sleeping quarters, broadcasting studios, or other sound sensitive areas, special treatment of the equipment room area will be required to provide adequate sound and vibration isolation from surrounding areas.
2. Adequate access space must be provided to maintain and replace heating coils, cooling coils, filters, damper motors and linkage, control valves, bearings, fan motors, fans, belts, pulleys, and other parts.
3. Figure 1 shows a typical equipment room plan with one floor-mounted air-conditioning unit and one suspended return air fan. The air-conditioning unit shown is a horizontal draw-through type consisting of fan, cooling coil, preheat coil, filters, return air plenum, outdoor air intake plenum, and access sections on either side of the coils.
4. The outdoor air intake louver and exhaust air louver are located on different walls. Where both intake and exhaust louver must be located on the same wall, they must be as far apart as possible, but not less than 10 ft. in order to reduce the short circuiting between the exhaust and intake air.
5. Figure 2 shows the same system without a return fan, but with exhaust capability via a remote fan.
6. When a horizontal blow-through unit is used, the length of the unit essentially is the same as shown for the draw-through unit.

7. Where higher headroom is available, a vertical unit, which can be only the draw-through type, may be used to reduce the unit's length. Depending on the size of the unit, this reduction in length will range from 2 ft. to 3 ft. 6 in.
8. Figure 1 shows an axial fan for returning air from the conditioned space. The return air fan may not be required where the air-conditioning system is not designed to operate under economizer cycle (cooling by cold outdoor air) mode.
9. A floor-mounted centrifugal single width, single inlet type fan or double width, double inlet type fan, may be used instead of the suspended axial fan shown; however, this generally increases equipment room width.
10. Outside air intake louvers are weatherproof with 50 percent to 60 percent free area. Louver size for conventional intake and exhaust air systems can be determined by allowing 800 ft. to 1,000 ft. per minute velocity through the free area.
11. The quantity of outside air drawn into a system depends on the ventilation criteria of the space being served and the amount of make-up air needed to balance any exhaust air drawn from the same space. The ratio of outside air to the total amount being supplied to a space may be very small. An office may need 10 percent to 20 percent outside air; a laboratory may require 100 percent outside air because of its non-recirculating aspect.
12. The total air quantity supplied to any individual space may vary from 0.5 CFM per sq. ft. for light occupancy (public circulation type office space) to 2 to 3 CFM per sq. ft. for laboratories, restaurants, ballrooms, and similar areas with large internal or external cooling loads.

EQUIPMENT ROOM SPACE REQUIREMENTS

CFM RANGE	APPROXIMATE OVERALL DIMENSION OF SUPPLY AIR UNITS			RECOMMENDED ROOM DIMENSIONS		
	W	H	L	W	H	L
1,000- 1,800	4'-9"	2'-9"	14'-9"	12'-6"	9'-0"	18'-9"
1,801- 3,000	5'-0"	3'-6"	16'-0"	13'-9"	9'-0"	20'-0"
3,001- 4,000	6'-9"	4'-6"	16'-0"	17'-6"	9'-0"	20'-0"
4,001- 6,000	7'-6"	4'-6"	16'-9"	18'-0"	9'-0"	20'-9"
6,001- 7,000	7'-6"	4'-9"	18'-3"	18'-6"	9'-6"	22'-3"
7,001- 9,000	8'-0"	5'-0"	18'-9"	19'-0"	10'-0"	22'-9"
9,001-12,000	10'-0"	5'-6"	21'-0"	23'-0"	11'-0"	25'-0"
12,001-16,000	10'-3"	6'-0"	22'-0"	23'-6"	12'-6"	26'-0"
16,001-19,000	10'-6"	6'-6"	23'-9"	24'-0"	13'-0"	27'-9"
19,001-22,000	11'-9"	7'-3"	25'-0"	26'-9"	15'-0"	29'-0"
22,001-27,000	11'-9"	8'-6"	26'-0"	27'-0"	16'-0"	30'-0"
27,001-32,000	13'-0"	9'-9"	27'-9"	29'-0"	18'-0"	31'-9"

AIR HANDLING EQUIPMENT ROOM REQUIREMENTS

AIR FILTRATION AND ODOR REMOVAL

Air filter selection is determined by the degree of cleanliness required. The initial cost, ease of maintenance, improvement of housekeeping, health benefits, and product quality are considerations. Size and quantity of dust and contaminants are also factors.

Filters most often are located at the air inlet of the heating, ventilating, and air-conditioning equipment, providing protection to the equipment and the area served. Filters are located at the equipment discharge and at entry of air into clean rooms, operating rooms, critical health care rooms, and various industrial process areas. Filters located in return air and exhaust air limit the contamination of other areas and the atmosphere.

AIR FILTER types are dry media, viscous (sticky) media, renewable media, and electronic. Filter performance tests and ratings have been established by ASHRAE, NBS, and AFI. The three operating characteristics that distinguish the various types of air cleaners are efficiency, air flow resistance, and dust holding capacity. Efficiency measures the ability of the air cleaner to remove particulate matter from an air stream. Average efficiency over the life of the filter is the most important consideration. Airflow resistance is the static pressure drop across the filter at a given airflow rate. Dust holding capacity defines the amount of a particular type of dust that an air cleaner can hold when operated at a specified airflow rate to some

maximum resistance value, or before its efficiency is seriously reduced as a result of the collected dust. Filter efficiency comparisons should always be based on the same test conditions.

PREFILTERS are required to extend the life of costlier high efficiency filters. High efficiency particulate filters (HEPA), and their integral frames, should be tested and certified in place. Filter pressure

drop gauges are recommended as an aid to economical replacement scheduling for all types of filters.

ODOR REMOVAL is best controlled by limiting the source. Dilution of odors by direct exhaust ventilation is the most common control method. Air washer and carbon filters are usually used for reclaiming odorous air. Ozone treatment and aerosol masking of odors are sometimes used.

AIR FILTER CHARACTERISTICS

MEDIA AND TYPE	PERCENT EFFICIENCY RANGE		DUST HOLDING CAPACITY	AIRFLOW RESISTANCE (IN. WATER)
	ATMOSPHERIC DUST	SMALL PARTICLES		
Dry panel throwaway	15-30	NA	Excellent	0.1-0.5
Viscous panel throwaway	20-35	NA	Good	0.1-0.5
Dry panel cleanable	15-20	NA	Superior	0.08-0.5
Viscous panel cleanable	15-25	NA	Superior	0.08-0.5
Mat panel renewable	10-90	0-60	Good to superior	0.15-1.0
Roll mat renewable	10-90	0-55	Good to superior	0.15-0.65
Roll oil bath	15-25	NA	Superior	0.3-0.5
Close pleat mat panel	NA	85-95	Varies	0.4-1.0
High efficiency particulate	NA	95-99.9	Varies	1.0-3.0
Membrane	NA	to 100	NA	NA
Electrostatic with mat	80-98	NA	Varies	0.15-1.25

John O. Samuel; Joseph R. Loring & Associates, Inc., Consulting Engineers; New York, New York

**PURPOSE OF CHILD CARE CENTERS**

Child care centers designed specifically to meet the needs of working parents with pre-school age children are a relatively new institution in the United States. Centers can serve as few as 20 children; however, they are usually sized to accommodate 60 to 150 children. Larger centers are overwhelming to young children and should be subdivided into smaller groupings. Centers provide care for children as young as 6 weeks old, to children of kindergarten age. Some centers also provide before- and after-school care for older children. Centers are expected to provide a rich variety of learning experiences, provide a secure environment, and meet the children's physical needs.

For children, all activities are learning experiences, and the key to good design is providing design elements that enhance the child's self-esteem and relate to the children through scale. Developmentally appropriate environments should be stressed. Materials, interiors, and equipment should be selected to create a non-institutional setting, and include such humanizing elements as soft textures, non-poisonous plants, and animals.

**CRITICAL DESIGN DETERMINANTS**

Major issues that will influence the ultimate design include: the number of classrooms required, and the total number and age of the children in each classroom. State and possibly local regulations pertaining to the requirements for the licensing of child care centers (in addition to building and life safety codes) will be the defining factor in many of these issues. The operator and staff of the center will also provide valuable input.

Many children enrolled in child care centers are too young to walk, talk, or follow directions; therefore, evacuation of the children during an emergency is critical. Cribs are generally used to evacuate infants. Centers, especially those serving infants, should be located only on the ground floor level, and each classroom and napping area should have an exit leading directly to the exterior at grade. Centers should also be designed to meet the requirements of the American National Standards Institute for Accessibility and Usability for Physically Handicapped People.

**MULTI-PURPOSE AREA**

This area should accommodate a wide variety of activities: group games, play in inclement weather, holiday activities, parent meetings, etc. The area should be a minimum of 400 square feet, and provided with adjacent storage space to accommodate the furniture and equipment that will be used at various times in the space. Toilets should be located adjacent to this area. If a before/after school program is provided, it may be located in this space.

**SITE REQUIREMENTS**

In addition to the building, there are numerous special site features that should be considered.

Centers should be located in friendly environments, away from natural and constructed hazards. The best location is a residential neighborhood; also utilized but less desirable locations are employment areas and major commuter routes.

A parking area for the parents to drop off and pick up the children should be located close to the building entrance; parents and children should be able to enter the center without crossing vehicular circulation areas. The main entrance to the center should be controlled to prevent unauthorized visitors. On-site parking for staff and visitors should be provided; however, parking should be divided into several small areas, and screened to support an inviting appearance. Deliveries and trash pickup should occur at a screened service entrance.

Outdoor play should be divided into a minimum of two separate spaces, one for older children and one for younger children. Each area should include developmentally appropriate equipment and activities and be provided with specifically selected landscaping materials.

**SIZES FOR PLANNING PURPOSES**

Child care regulations generally require classrooms of 20-40 net square feet (NSF) per child, with 35 NSF being the average minimum. Support functions will increase the total square footage required. Small classrooms, designed to accommodate two teachers and the related number of children as required by the licensing regulations, are recommended.

**TYPICAL SIZES**

No. of children	60-150
Building size	80-100 sq ft/child
Total building	6000-12,000 sq ft
Outdoor play	75-100 sq ft/child
Overall lot size	1/2-2 acres

**MAJOR FUNCTIONS**

Classrooms are the focal point of a child care center; however, there are many other functions necessary to ensure the smooth operation of the center.

Administrative areas, including reception areas, offices, and a staff lounge are essential to center operations. The staff lounge provides a refuge for teachers from the hectic activities and the demands of the children and provides a space to accomplish paperwork. Conference rooms may also be desirable. Staff and visitors should be provided with toilet facilities separate from the children's toilet rooms.

An isolation area should be provided for children who become sick during the day and need to be separated from

the other children. This area must be provided with adult supervision, whether located in a separate, but nearby space or in a space shared with an office function. This area should be near a toilet, and have adequate space for a cot/crib.

The size of the kitchen and related storage area will vary depending on the kinds of food to be prepared and whether food is prepared at the center, supplied by the parents, or catered. Most centers will provide, at a minimum, snacks, milk, and juice. Many centers rely on paper products, so that dishwashing is not a major concern. However, trash accumulation from these products, as well as from disposable diapers, can be significant; a separate trash area should be provided.

A central storage area is required to store extra furniture, seasonal decorations, toys, educational materials, paper products, and office supplies.

**MULTI-PURPOSE AREA, LIBRARY, ART, AND MEDIA CENTERS**

Depending on the operational needs of the center, and the budget, additional activity areas for the children outside of the classroom may be desired.

A multi-purpose area should accommodate a wide variety of activities: group games, play in inclement weather, holiday activities, and parent meetings. If a before and after school program is provided, it may be located here. The area should be a minimum of 400 square feet, and be provided with adjacent storage space and toilets. Art, media, and library functions are usually found within the classrooms. However, they could be located in separate spaces, providing specialized instruction and an opportunity for the children to be in a different space.

**CLASSROOM ACTIVITIES**

Classrooms should be divided into clearly defined activity areas, using child-scaled furniture and equipment pertinent to each activity. Activity areas should be separated from traffic patterns and segregated by noise level. Classrooms should be designed for easy rearrangement of furniture and equipment to provide flexibility. Most daily activities including napping, eating, and learning should occur within the classroom to promote continuity and develop feelings of security in the children.

Older children, over two, require individual, small group and large group activity spaces. Cubbies should be provided for storage of children's clothing and belongings. Storage areas for cots, paints, and other supplies should be located within each classroom; however, they should be accessible only to the teachers.

Toilet rooms, art and handwashing sinks should be provided within the classroom to improve sanitation and develop healthy habits, independence, and self-reliance. Fixtures should be child-scaled. One toilet and lavatory fixture should be provided for each 10-15 children, depending on regulations and available budget.

**INFANT AREAS**

Most regulatory agencies define infants as children under the age of two. Their physical and developmental needs are very different from those of older children, and the infants should be physically separated from the older children. Infant classrooms should be the smallest groups of children at the center, accommodating 6-12 children, depending on the child/teacher ratios.

Physical needs include frequent and irregular feeding and sleeping patterns. Diapering areas designed to ensure that diapering is a safe, sanitary procedure should be provided in each infant area. All the items that the teacher requires in changing the child including wipes, diapers, water, paper towels, a trash receptacle, etc. should be within easy reach of the changing table. Some jurisdictions require that toilets be provided near the diapering area.

Infant areas require more space because of the need for cribs; one crib should be provided for each infant. Cribs should be permanently located in separate areas adjacent to the classroom so that the infants can sleep on their own schedule and in a quiet area. The amount of physical separation from other activities will be determined by applicable child care regulations, and by the staffing patterns. Napping areas will generally require an additional 20-30 square feet/child, depending on the crib size and the child care regulations for separation between cribs.

Because eating in the infant area occurs frequently and at irregular intervals, a small kitchen area should be provided in each infant classroom. The area requires storage, a sink, refrigerator, and either a microwave or a stove for warming food and milk.

A small laundry area should be provided to wash soiled linens and clothes. Close proximity to the infant area is recommended.

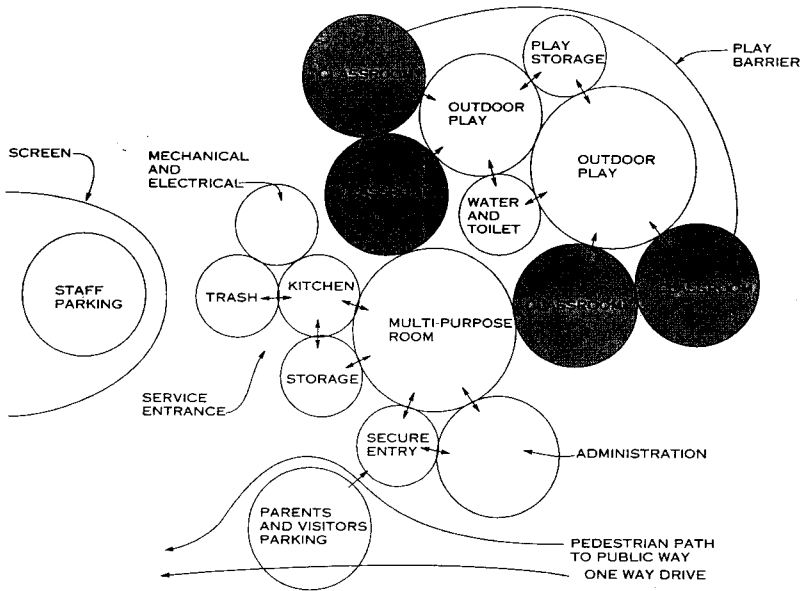

**SITE RELATIONSHIPS**

Linda Clark, AIA; Archi-tots, Inc.; Silver Spring, Maryland

**HVAC, PLUMBING, ACOUSTICAL AND ELECTRICAL REQUIREMENTS**

Design temperatures should range between 68-78 °F, measured at the children's level, 1 to 3 ft. above the floor. Additional humidification should be provided. Buildings that are too hot or cold can create problems at an otherwise smoothly running center. An adequate ventilation system, with provisions for fresh and exhaust air, is critical to the health of the children. Stagnant air filled with bacteria can contribute to the spread of illness, which is one of the major problems associated with child care centers.

Hot and cold water should be provided in each classroom; however, hot water to child accessible fixtures should not exceed 110°F. Drinking water should also be provided in each classroom.

Noise is a major concern. Classrooms, infant napping areas, and offices should be sound insulated from one another. Finishes that absorb sound should be selected.

Lighting should be a combination of natural, fluorescent and incandescent to provide developing eyes with a full spectrum of light. Windows, both to the exterior and to other classrooms are necessary to help the children learn about the world. Receptacles should be either installed above the children's reach, or be of a type which can only be activated when turned or twisted.

**SCALE AND FINISHES**

All furniture, fixtures, and equipment should be sized to accommodate the children and to promote self-esteem, learning, and independence. Building materials should be selected to relate to the children's scale, i.e., small panes of glass instead of picture windows.

Finishes are important and variety in their selection encourages interest and promotes learning. Basic colors should be neutral to offset the intense and often hectic activities of the children, their equipment, and their artwork. However, accent colors could be provided. Finishes should also be selected for their acoustical properties and ease of maintenance. Both carpeting and seamless vinyl flooring should be provided in the classrooms to support different activities.

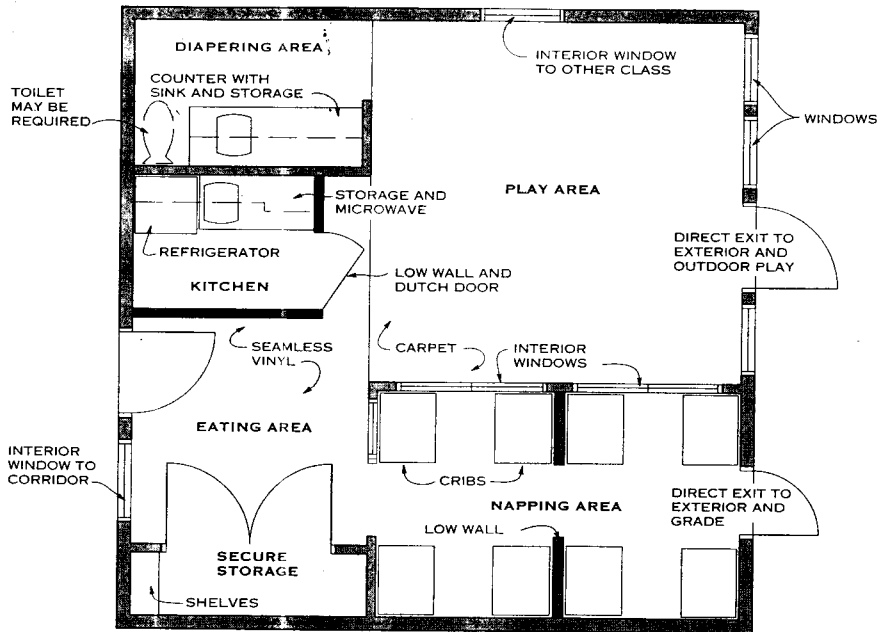

**CLASSROOM FOR EIGHT INFANTS**

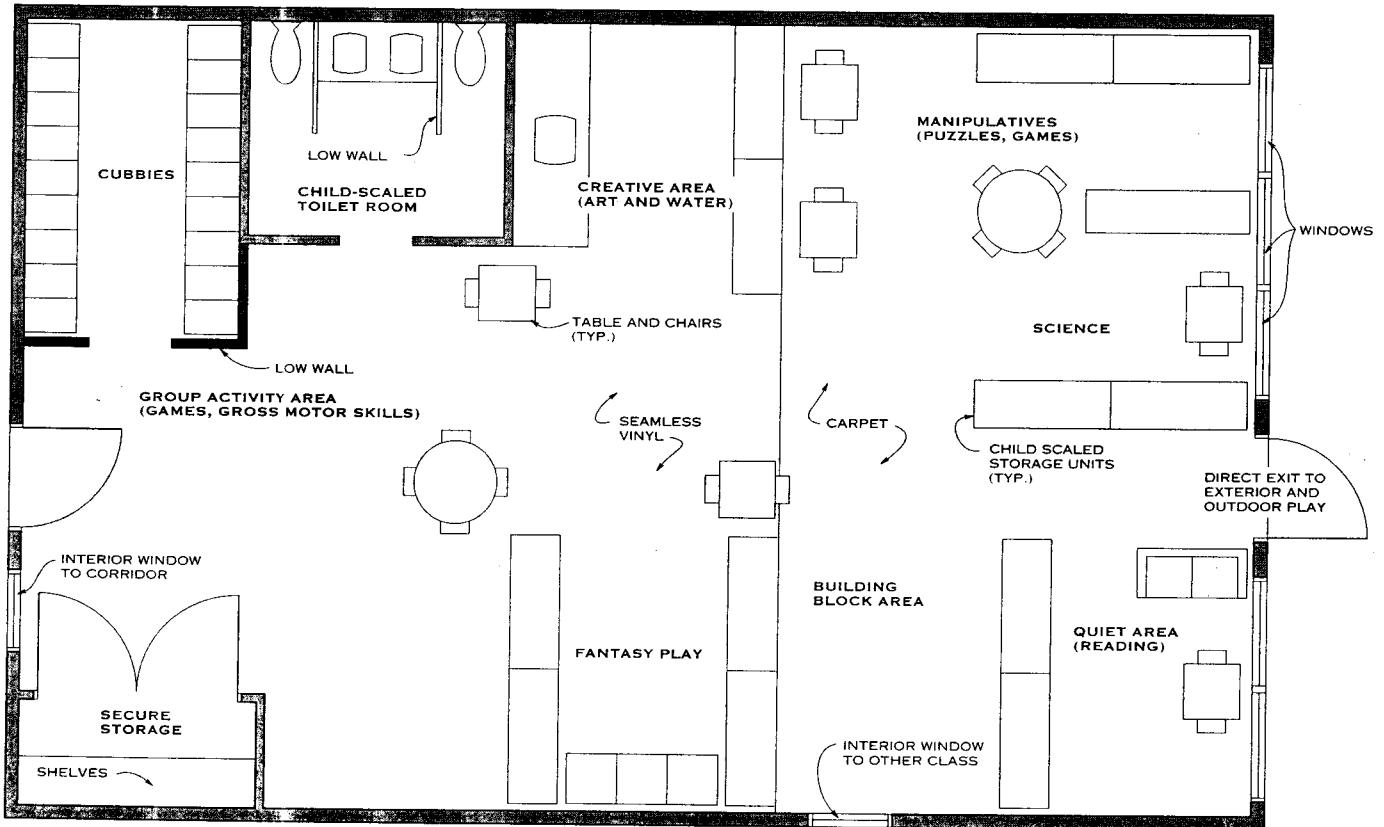

**CLASSROOM FOR TWENTY, THREE- TO FIVE-YEAR-OLDS**

Linda Clark, AIA; Archi-tots, Inc.; Silver Spring, Maryland

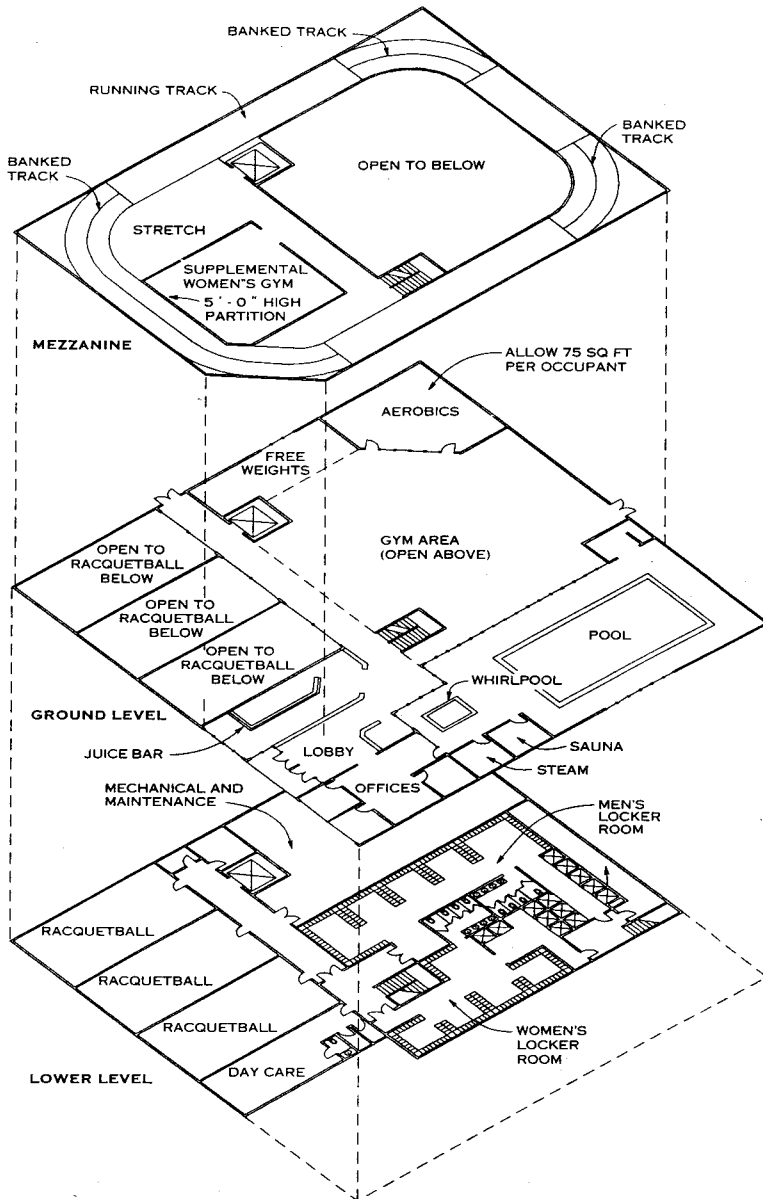

**GENERAL**

Health clubs combine many activities, services, and equipment types under one roof. The areas for each activity are usually open to each other. This promotes interaction and incentive for individuals to continue their participation. This layout visually exposes each member to other activities in which they may want to participate. The visual center of the plan is where the fitness and aerobic machines are located. Some uses are separated for privacy (e.g. locker rooms, supplemental women's gym, etc.) and for particularly high noise activities like aerobics and racquetball. Restaurants, juice bars, and lounges are also incorporated and are usually connected to the common areas.

Planning criteria for health clubs can be broken down into the following four main categories:

1. Aerobic/Cardiovascular
  - a. Running track
  - b. Treadmill/stair climbing machines
  - c. Stationary bicycle
  - d. Rowing machine
  - e. Swimming pool
  - f. Racquetball/squash
  - g. Aerobic exercises
2. Anaerobic/Muscular Development
  - a. Resistance and repetition fitness machines (includes weight, electronic, or air compression resistance)
  - b. Free weights
3. Muscle and Blood Circulation Stimulation
  - a. Whirlpool (hydrotherapy)
  - b. Steam room (heat therapy)
  - c. Sauna (heat therapy)
  - d. Massage (direct muscle therapy)
4. Services and Support
  - a. Fitness profile (check of weight, blood pressure, percentage of body fat, flexibility, grip strength, and cardiovascular endurance)
  - b. Locker and shower rooms
  - c. Restaurant and lounge
  - d. Administration
  - e. Day care
  - f. Mechanical and maintenance

**NOTES**

1. Wet areas such as pools and saunas should be segregated from dry areas such as weight rooms.
2. Heavy traffic and wet areas should be finished with impervious floor materials such as ceramic tile. Wet areas should have a nonslip surface and slope to drains.
3. Open gym areas should be finished in a durable carpet with shock resistant padding.
4. Sound isolation systems should be used in all walls, ceilings, and floors that border occupied spaces. Of particular concern is impact noise from aerobic exercise, running, and free-weight training. Resiliency and mass should be built into the structure to reduce sound transmission.
5. Intense human activity, shower facilities, and the pool and sauna areas all contribute major concentrations of moisture that must be vented to the outside.
6. Lighting quality is an important issue for each activity. A diffuse or indirect system is preferred. However, moods can be created through the use of spot lighting, which can highlight activities. Use water resistant lighting in such areas as pools and steam rooms.

**TYPICAL HEALTH CLUB LAYOUT**

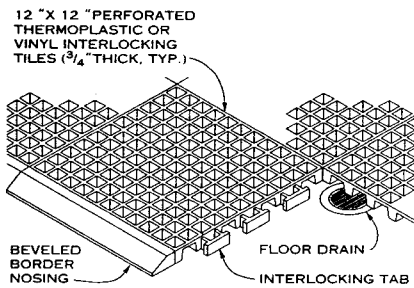

**NOTE**  
Used in pool areas, locker rooms, etc.

**FLOORING FOR WET AREAS**

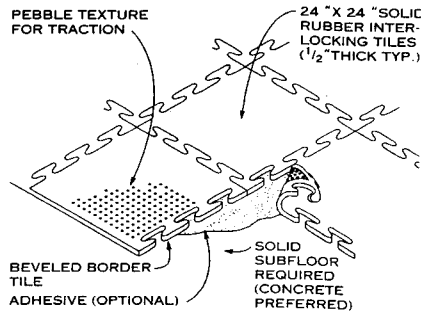

**NOTE**  
Used in weight rooms and for aerobic classes.

**FLOORING FOR HIGH-IMPACT AREAS**

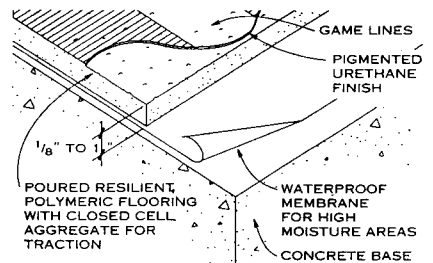

**NOTE**  
Used on running tracks.

**POURED RESILIENT FLOORING DETAIL**

Brosso, Wilhelm, & McWilliams; Baltimore, Maryland  
Richard J. Vitullo, AIA; Oak Leaf Studio; Crownsville, Maryland



**DIFFERENT TYPES OF MUSEUMS**

The defining characteristic of any museum is its collection. Without a collection, an institution should not ordinarily be called a museum. For instance, a scientific public institution that has interpretive and interactive galleries demonstrating scientific principles and perhaps an Imax theater, but no collections, would be referred to as a science center, not a museum. Similarly, an institution that has an art school and an active art exhibition and lecture program, but no collections, would be called an art center, not an art museum.

Museums are as varied as their collections and their exhibitions. Each has its own special character and special requirements. Nevertheless, all museums do have certain things in common, which is the basis for this section of Graphic Standards.

Listed here are a few of the more common kinds of museums:

1. Art museums: paintings and sculpture, decorative arts, folk art, and textiles
2. Children's museums
3. College and university museums
4. History museums: historic houses, historical society museums, archives, military museums, maritime and naval museums and historic ships
5. Nature centers
6. Park museums and visitor centers
7. Science museums: anthropology; ethnology; aquariums and oceanariums; archaeology; entomology; geology, mineralogy and paleontology; herpetology; medical; natural history and natural science; physical science
8. Specialized museums: aeronautics and space, agriculture, architecture, circus, costume, firefighting, forestry, guns, horology, and military

Following are some of the most basic museum design considerations.

**SITE CONSIDERATIONS**

**PUBLIC PARKING.** Urban museum sites generally rely on nearby public parking, while suburban and rural sites require off-street parking convenient to the main public entrance. Typically, daily parking requirements are relatively modest. Maximum requirements will be for special opening events and "blockbuster" exhibitions. Consider sharing parking with nearby churches or businesses that have different peak hours. Valet and remote, bussed parking may be possible for a few events.

**STAFF PARKING.** This should be convenient to the staff entrance, which will be near shipping and receiving and will have special security measures.

**SCULPTURE GARDENS.** Such gardens must be either inside or outside the museum security envelope. If inside, they must be enclosed and secure (e.g., MOMA in N.Y.). If they are outside, they must be inaccessible from within the galleries (e.g., the Hirschorn in Washington, D.C.).

**SHIPPING AND SERVICE FACILITIES.** It is critically impor-

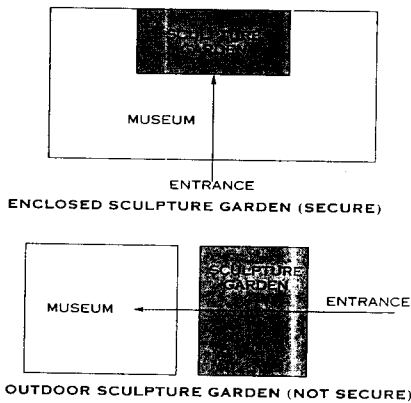

**SCULPTURE GARDENS**

tant for any museum to be able to receive and send large crated and uncrated museum objects safely and efficiently, receive construction and other kinds of materials, and to dispose of trash in a slightly and efficient manner. Requirements vary according to the kinds of objects the museum will house and exhibit, but for most museums the service drive, service yard, and shipping dock must be built to accommodate full-sized over-the-road semi-trailer trucks. Provision also must be made for trash dumpsters and temporary parking for other smaller delivery and service vehicles. A 4 ft high dock will accommodate high-bed trucks but will be very awkward for low-bed trucks and vans. A 2 ft dock will be best for low trucks, but a portable ramp will be required for use with high bed trucks. Two separate docks, one at 2 ft and the other at 4 ft, is ideal. A dock leveler is an alternative. Convenient and attractive accommodation for transformers, emergency generators, chilled water machines, and similar pieces of mechanical equipment should be considered at the beginning of the design process.

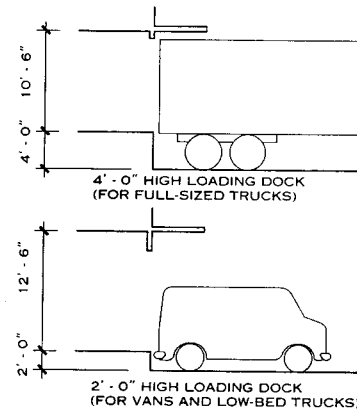

**LOADING DOCKS**

**PLANNING RELATIONSHIPS AND TYPICAL MUSEUM SPACES**

Museums consist of several discrete blocks of space that must be kept separate for secure and efficient operations. Museums consist of several discrete blocks of space that must be kept separate for secure and efficient operations. Usually the main departments include: public services, educational facilities, galleries, temporary exhibitions support facilities, general staff services, collections management, collections storage, and curatorial and administrative offices. The following diagram illustrates how these relate to each other.

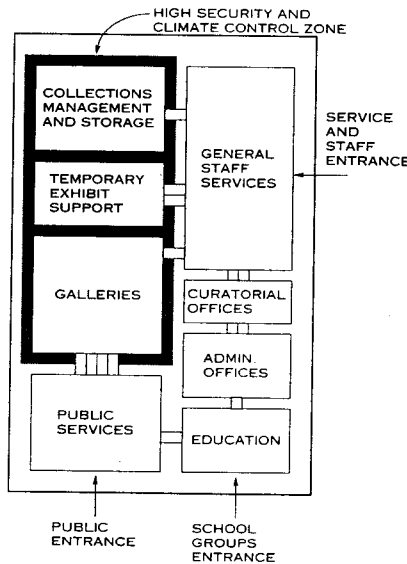

**OVERALL SPACE RELATIONSHIPS**

**PROGRAMMING**

The importance of developing a thorough program for museum planning cannot be overemphasized. Museums are composed of many different spaces, each accommodating a particular function. Different kinds of museums require very different spaces, so each anticipated function must be analyzed and accommodated individually. The two most common program mistakes are

1. Emphasizing public spaces and slighting staff support spaces (which often comprise half the museum).
2. Failing to design for future growth.

The following are the main elements that could be found in most museums, although they vary widely, depending on size, type, location, collecting goals, educational mission, etc.

**PUBLIC SERVICES**

These public non-gallery spaces should be located together near the public entrance. They include vestibule, public lobby, information desk, coat and parcel checkroom, museum shop, auditorium, meeting rooms, A/V presentation/orientation room, public toilets, drinking fountains, and phones.

**PUBLIC LOBBY**

Generally thought of as a monumental space, this lobby has many practical functions: orientation and access to all public service functions (not just the galleries) and a setting for social functions. This is the one space where windows and skylights can be effective. Size is often governed by the capacity needed for banquet dinners (at 10-12 sq ft per person plus entry and circulation space) and/or receptions (at 8-10 sq ft per person plus entry and circulation space). During receptions visitors may be dispersed throughout the galleries as well, depending on the kinds of events being held.

**MEETING ROOMS AND AUDITORIUMS**

These will vary widely according to the expected events program. Smaller museums usually have either a sloped floor auditorium or a multi-purpose room. Larger museums may have both. Rooms may be used for museum events, or rented to other public and private groups. The museum board should develop a policy about the use of these rooms before they are designed. For security and operating economy, auditoriums and meeting rooms must be accessible when the galleries are closed.

**MUSEUM SHOP AND BOOKSTORE**

This sales function is increasingly important both as an educational program and as a source of income. The retail shop should open to the lobby where it will be especially visible and attractive as visitors leave the museum. An adjacent office and inventory space are essential. Size will be determined by the intended marketing and sales program.

**PUBLIC TOILETS**

Toilets should be sized to accommodate the largest anticipated exhibition openings or auditorium audiences. Plumbing codes often overstate fixture requirements for gallery spaces. Galleries are never crowded all of the time. Interpretations should be clarified with appropriate building code officials.

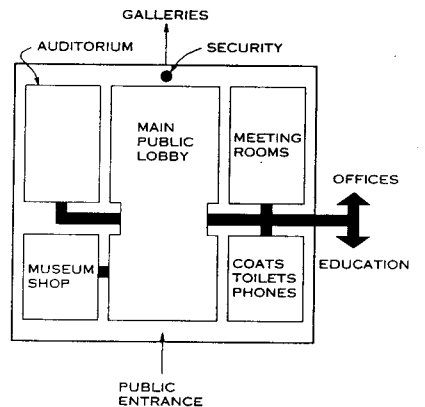

**PUBLIC SERVICE RELATIONSHIPS**

John D. Hilberry, AIA; John Hilberry & Associates Inc., Architects and Museum Planners; Detroit, Michigan

**GALLERIES**

Galleries vary widely according to the objects being exhibited. Gallery sizes and proportions as well as floor, wall, and ceiling materials and lighting must be appropriate for the specific kinds of objects exhibited. Discussed here are some of the most common gallery types:

**ART GALLERIES** generally are well-finished rooms where objects are displayed to aesthetic advantage but with relatively little interpretive material. Art collections include paintings, sculpture, furniture, decorative arts, murals, architectural fragments and reconstructions, prints, drawings, and photographs.

**INTERPRETIVE GALLERIES** are simpler architecturally, but the environment is dominated by interpretive materials (historical reconstructions, photomurals, graphics, explanatory text, etc.). Interpretive exhibits cover subjects such as history and natural history and use techniques such as dioramas, period rooms, and dark rides.

**SCIENCE CENTER GALLERIES** may have no museum objects at all, but may feature educational interactive devices that illustrate scientific principles. These rooms may resemble classrooms or even play areas rather than traditional gallery spaces.

**VISIBLE STORAGE GALLERIES** contain dense presentations of large numbers of museum objects from the collection with little interpretation but with reference materials available for study.

**CHANGING EXHIBITION GALLERIES** are flexible galleries used for a wide variety of exhibitions, each installed for a limited period.

**COMBINATION GALLERIES** integrate several gallery types. Most galleries should be capable of being deinstalled and used for special exhibitions from time to time.

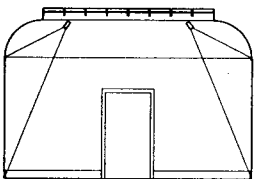

SECTION



PLAN

**TRADITIONAL ART GALLERY**

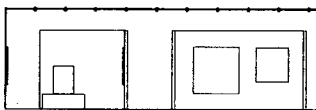

SECTION

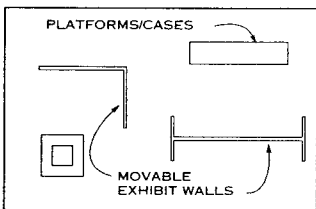

PLAN

**FLEXIBLE OPEN-PLAN GALLERY**

**GALLERY CHARACTERISTICS**

**DISCRETE ROOMS:** Galleries should be isolated spaces conducive to concentrating on the objects exhibited. The museum-viewing experience is a private one and should not be interrupted by other people moving on balconies, peaking in windows, etc. When the museum is closed, the galleries should become secure dark vaults.

**GALLERY FLEXIBILITY:** Even "permanent" exhibitions change over time, and all galleries must provide an appropriate amount of flexibility. Traditional art museums achieve this by providing a variety of well designed, proportioned, and organized gallery rooms of different sizes and characters. This arrangement provides the ability to locate different exhibitions in different rooms at different times. A more modernist approach has been to provide open floor space, a modular ceiling system, and movable exhibition walls, so the space can be reconfigured at will. This solution offers the ultimate in plan flexibility, but sacrifices spatial variety and richness in favor of anonymous continuity. The former may be better for permanent galleries and the latter for contemporary art and changing exhibition galleries. A middle ground is to provide some level of physical changeability within the context of fixed gallery rooms.

**GALLERY PROPORTIONS:** Galleries with pleasing proportions provide the best exhibit spaces. Generally a rectangular floor plan is best. Ceiling heights should be proportional to the plan size of the room and to the objects to be exhibited. Generally 11 to 14 ft is appropriate. Lower ceilings may be acceptable in certain intimate galleries such as those exhibiting old master prints, photographs, or other especially small objects. Ceilings higher than 16 ft are useful occasionally, but generally they are difficult to work with and tend to dwarf the objects being exhibited.

**GALLERY FINISH MATERIALS:** Galleries must be finished as attractive working exhibit spaces. Floors, wall, and (ideally) ceilings all should be capable of having fasteners secured to them that can support considerable weight. Floors and walls should have securely attached 3/4 in. tongue and groove plywood substrate. Suitable flooring materials are tongue and groove hardwood strip flooring or carpet. Suitable wall materials are thin (1/4 or 3/8 in.) drywall or stretched fabric. Wall carpet sometimes is appropriate. Ceilings can be plain painted drywall or an acoustical grid. If the floor is hard, an acoustical ceiling is especially useful. Ceiling grids should be simple, orderly, and unobtrusive. Recessed lighting tracks are less obtrusive than surface-mounted tracks.

**GALLERY SUPPORT SPACES:** Storage space for track lighting fixtures and bulbs, pedestals, vitrines, cases, movable exhibition partitions and panels, and other items should be immediately accessible to the galleries. If necessary, this space can be provided in a remote location, but nearby is much more convenient.

**INDIVIDUAL GALLERY SIZES AND CEILING HEIGHTS**

GALLERY TYPE	FLOOR AREA (SQ FT)	CEILING HEIGHT (FT)
Intimate Galleries	300 - 900	9 - 11
Old Master prints & drawings		
Archival documents		
Jewelry		
Small decorative arts		
Small artifacts		
Miniature dioramas		
Gems & minerals		
Insects, small animals		
Medium Galleries	1,000 - 2,000	11 - 14
14-19 C. paintings		
Traditional sculpture		
Furniture		
Decorative arts		
Small historical exhibits		
Medium-sized artifacts		
Most scientific exhibits		
Interactive galleries		
Most temporary exhibits		
Large Galleries	2,000 - 5,000	14 - 20
Central gallery among smaller galleries		
Large Baroque paintings		
20th C. paintings & sculpture		
Temporary exhibitions		
Industrial history		
Architectural reconstructions		
Historical reconstructions		
Large dioramas		
Large natural history exhibits (dinosaurs, whales, etc.)		

**TEMPORARY EXHIBITION STORAGE AND STAGING**

Adequate spaces must be provided for receiving and handling exhibition materials, which usually arrive by truck in crates. These materials consist of museum objects borrowed from other institutions and/or individuals, which means that conservation-standard climate control and security must be provided in order to avoid liability for damage and to meet the strict requirements sophisticated modern lenders often impose on borrowing institutions. The main temporary exhibition support facilities are discussed here:

**SHIPPING AND RECEIVING FACILITIES:** Receiving and sending major traveling exhibitions require first-rate facilities. A good shipping and receiving room has an appropriate loading dock with a large shipping door and immediate access to the crating/uncrating room and to the freight elevator. Very close monitoring of this space by security personnel is essential.

**CRATING/UNCRATING ROOM:** A large room must be provided as a work space for crating and uncrating borrowed museum objects, for temporarily storing both the objects and their crates, and for examining, photographing, and organizing the objects in preparation for gallery installation. Space may be required to handle several exhibitions simultaneously. The space must be secure and climate controlled to museum conservation standards. This must be a clean room, not a carpentry or paint shop. Appropriate work surfaces, supplies storage, and collection storage equipment must be provided.

**TEMPORARY COLLECTIONS STORAGE:** After objects are removed from their crates, they must be examined, organized, and safely stored prior to installation. After the exhibition closes, they must be stored and prepared for crating.

**TEMPORARY CRATE STORAGE:** While the objects are in the museum, the crates must be stored and maintained under proper humidity conditions.

**COLLECTIONS MANAGEMENT**

These are the facilities that accommodate the handling, care, storage, and conservation of the museum's own collections. Clear unobstructed passageways are essential between the shipping dock to the carpentry shop, crating/uncrating room, galleries, and collections storerooms. Door openings, freight elevators, and passageway heights, widths, and corner configurations must be uniformly large. Placement of ducts and piping must be carefully coordinated to avoid bottlenecks.

The extent of the facilities for collections management will vary widely depending on the extent and nature of the collections and the level of registration, research, and conservation activity that is appropriate or that the institution can afford. Following are discussions of the most important of these facilities.

**REGISTRATION:** This is one of the most basic museum functions. The registrar generally is responsible for handling all museum objects, keeping track of their location within the museum, and maintaining records about each object, whether owned by the museum or loaned as part of a temporary exhibition. Whenever an object enters or leaves the museum, or even if it is moved around within the museum, the registrar must record that event, make a condition report if necessary, and make sure the movement or removal of the object is appropriate and authorized. These activities require office and work space, facilities for extensive paper files and computer operations, and sometimes space for temporary object storage.

**COLLECTIONS STORAGE:** The collection storerooms are extremely important and should be located with the other collections management facilities (see Museum Storage).

**MATTING AND FRAMING:** Any museum that exhibits works of art on paper, photographs, documents, or other two-dimensional paper objects will have an active matting and framing operation. Since paper objects cannot be exhibited for long periods of time without damaging them, they must be constantly taken in and out of frames, and all framed objects must first be matted. This must be a clean room (not a carpentry shop) with work tables and storage for materials. Minor conservation procedures also may take place here if the museum does not have a conservation laboratory.

**CONSERVATION LABORATORIES:** Most smaller museums do not have conservation labs. Larger museums, however, may have extensive facilities, including separate laboratories for specialized conservation procedures such as those required for paintings, sculpture, 3-D decorative arts, textiles, cars, industrial machinery, fossils, taxidermy, or anthropological artifacts. Each kind of conservation requires special facilities and equipment.

John D. Hilberry, AIA; John Hilberry & Associates Inc., Architects and Museum Planners; Detroit, Michigan

**MUSEUM STORAGE**

Collections storage and general storage are very different and should not be confused. General storage space can be inexpensive and its location is not critical. Collections storage, however, must meet the most exacting security and climate control requirements and must be correctly located.

**GENERAL STORAGE**

Museums require large amounts of miscellaneous material that must be stored, either on the premises or in some remote location. On-premises storage is much more convenient. Provision of adequate general storage space is cost-effective, since this space is relatively inexpensive and, if sufficient space is not allowed, general storage items inevitably pre-empt space in more expensive parts of the museum. Storage may be required for grounds and building maintenance equipment and supplies, lifts, ladders, materials-handling equipment, mechanical and electrical equipment and supplies, central office supplies, museum shop inventory, exhibition light fixtures and bulbs, general lighting fluorescent tubes and bulbs, seasonal paraphernalia, volunteer committee supplies, general furniture (tables, desks, chairs, lecterns, etc.), exhibition furniture (pedestals, vitrines, cases, exhibition walls, platforms, etc.), laboratory equipment, audio/visual equipment, and crates (other than those associated with traveling exhibitions). Storage requirements for each of these items should be identified and quantified separately, even if they are to be stored together.

**COLLECTIONS STORAGE**

Proper care of its collections is one of the main responsibilities of any museum. Location and design of the collections storerooms, therefore, should be a primary planning and design consideration. Since the mission of most museums is to collect continuously, provision for growth is fundamental. Collections storerooms must be clean, dry, secure, well lighted, free of overhead pipes containing liquids, and properly air conditioned to conservation climate control standards. They must be located conveniently near shipping and receiving, curatorial offices, and registration and other collections management facilities. An interior location is ideal. Minimizing the possibility of flooding or other water damage is essential. Whether collections storage is separated into distinct rooms or kept together in large open vaults depends on the nature of the collections and on administrative policies about staff responsibilities.

**COLLECTIONS STORAGE EQUIPMENT**

Different objects require different kinds of storage equipment. Types and numbers of storage units and the floor area that will be required must be determined by analysis of the collections in close cooperation with the collections management staff. Space must be provided for storage of fork lifts, dollies, and other materials-handling equipment. Some of the more common types of storage equipment are painting screens, painting bins, open steel shelving, closed steel cabinets, wet specimen cabinets, drawer units, flat files, wardrobe units, rolled textile storage racks, hand racks, pallet racks, floor pallets, and oversized objects storage areas. In addition to the storage units, many museum objects are kept in containers, such as acid-free boxes, slander boxes, textile screens, and rolled textile tubes, which are placed in or on the storage units.

**COMPACTOR SYSTEMS**

A number of companies manufacture systems that permit aisles of shelving units to roll, permitting substantially higher density of objects in storerooms. These systems, though efficient, are costly, less convenient, and may inhibit the ability of fire suppression systems to extinguish flames inside the collections storage units when in the closed position. They require either depressed floor construction for built-in recessed floor tracks or ramps for the surface installation of tracks. Since storage is always at a premium, prudent programming often suggests that adequate storage space be built without compactors, but that provisions be made so they can be added in case of unanticipated collections growth.

**SCIENTIFIC RESEARCH LABORATORIES**

Science museums often involve significant research programs, which require laboratories of various kinds, including clean, dirty, and wet laboratories, and special storage and equipment rooms. The requirements for each of these rooms must be programmed in close cooperation with the scientists involved.

**EDUCATION SPACES**

Many museums have active educational programs, ongoing AV presentations, and orientation talks for groups of both children and adults. The following list includes some important education spaces:

1. Holding areas for children's coats, etc.
2. Orientation rooms
3. Studio classrooms
4. Lecture classrooms
5. Staff and docent offices

**ADMINISTRATIVE AND CURATORIAL OFFICES AND WORK SPACES**

The offices themselves will not be much different from business or academic offices. The appropriate number and size of spaces must be based on projected staff and activities. Generally, museum staffs grow faster than anticipated after new facilities are completed, and ample allowance should be made for "future office" space. These offices can be located with the collections management and general staff areas, or they can be separated. Practical planning considerations often dictate that they be separated. Curators may need larger than usual offices if they will have museum objects in their offices for examination and research. Security and HVAC implications of this possibility must be considered.

**GENERAL STAFF SERVICES**

Back-of-house facilities required for museums to operate efficiently may include shipping and receiving room(s), shipping clerk's office, sallyport, central security station, maintenance shop, carpentry shop, paint shop, graphics studio, typesetting room, exhibition preparation room, taxidermy shop, isolation room, trash room, compactor room, recycling center, dermatid room, greenhouse, X-ray laboratory, photography studio, darkroom, refrigerated specimen room, flammable liquids storeroom, instrument room, AV storage and work room, and guards' toilets, showers, and dressing rooms. Not all museums will have all of these spaces, and in smaller museums some spaces will be combined. In larger ones, several spaces may be dedicated to one function.

**MUSEUM SECURITY**

Good museum security results from a combination of good museum planning, good lock and alarm systems, and good professional and security staff practices. A specialized museum security consultant can assist the museum staff and the architect with all of these issues. Planning for security involves understanding the zones that must be kept separate and how public, staff, and objects will move through the facility under different circumstances. When entering and leaving the galleries, the public should be required to pass one easily monitored checkpoint. Non-gallery public functions (such as auditorium, museum shop, or toilets) should not be accessed through the galleries. When closed, galleries should function as secure vaults. Emergency fire exits from galleries should be minimal, alarmed, and located and designed for easy observation of anyone using them.

Staff areas should be clearly separated from galleries and public services. Shipping and receiving and staff entrances must be tightly monitored and easily controlled by the security staff. Collections storerooms should be treated as vaults and should contain no mechanical or electrical equipment that might require access for maintenance or in emergencies. Mechanical ductwork and grilles must be designed to prevent access by burglars to locked galleries and collection storerooms.

Electronic alarm systems should be designed by professionals specializing in museum security systems. Such specialized professionals also should be consulted with regard to locking systems. Often alarm system work is not part of the general A&E contract for reasons of confidentiality. Sometimes alarm company sales personnel design these systems, but this can produce less than ideal results. Because of the liabilities involved, this issue should be discussed carefully with appropriate museum authorities.

Public and staff movement through the museum must be carefully separated. There should be only one public and one staff/shipping entrance to the museum. Public and staff areas will be open at different times, and each should be securable when not open. Public service areas should be easily accessible during open hours. Ideally, there should be only one point of access to the galleries from the public services area. Access from public to staff areas should be strictly limited and easily monitored. Staff should not need to move through galleries when they are closed. The staff entrance and shipping and receiving dock should be together and both easily monitored and controlled by security personnel.

Auditoriums, theaters, and food service facilities present special service access problems because they operate on different schedules from other museum functions and these operations may conflict with the museum's needs for security and cleanliness. Separate service access for these facilities may be appropriate.

In most small and medium sized museums, the central security station should be located at the service entrance with secure windows opening to the outdoors, to the shipping and receiving room, and to a staff entrance sallyport. In large museums, the central station may be in a more secure location away from all entrances, with a shipping clerk's station at the service entrance. The following is a typical security station layout.

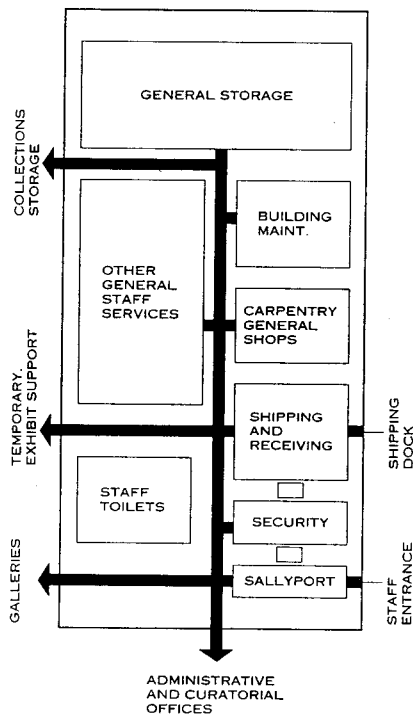

**GENERAL STAFF RELATIONSHIPS**

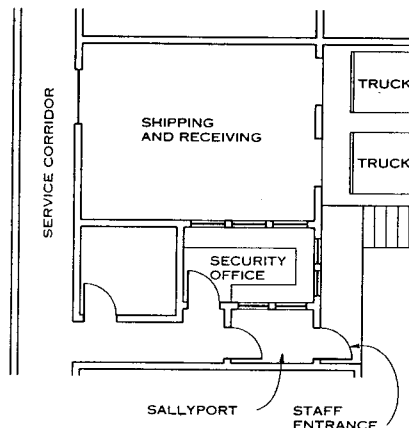

**TYPICAL SECURITY ARRANGEMENT AT SHIPPING AND STAFF ENTRANCE**

John D. Hilberry, AIA; John Hilberry & Associates Inc., Architects and Museum Planners; Detroit, Michigan

**MUSEUM LIGHTING**

Museum lighting presents a fundamental paradox, since the very light that is essential to appreciation of the exhibited objects is also an agent for their destruction. Lighting requirements vary widely from museum to museum and from one part to another of a single museum.

**PUBLIC SERVICES.** Lighting for public functions should be treated in the most architecturally pleasing way, since these spaces set the tone for the entire institution and intrude on the gallery exhibitions. Public service spaces generally do not contain museum objects, so the use of natural light is acceptable if the galleries are distinctly separate from these spaces. If the separation is less distinct, however, natural lighting in the lobby will have to be strictly limited. In any case, lighting levels in the lobby must not be so high that the galleries seem dark by comparison.

**GALLERY LIGHTING.** Basic gallery lighting consists of a good track lighting system properly placed in relation to the exhibition walls (see drawing). Line voltage (120V) track offers more flexibility in selection of fixtures (a key consideration), and the fixtures generally produce a softer effect with less glare. Low voltage fixtures can produce more highly focused beams for special effects. Small low voltage fixtures (MR 16) are less intrusive but more expensive and, since the sources are more concentrated, the light quality is harsher. Concealed or shielded lighting sources are desirable (see drawing). General lighting ordinarily is neither required nor desirable. Track lighting can be exposed, shielded, or concealed.

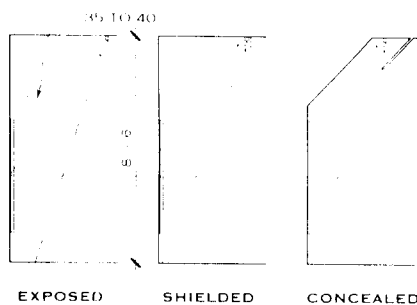

**TRACK LIGHTING CONFIGURATIONS**

**WINDOWS** generally are undesirable in galleries because of glare, photochemical degradation, visual competition with the objects exhibited, and security needs. Sculpture galleries are a possible exception, since stone and bronze are essentially unaffected by light.

**SKYLIGHTING** can be effective, but must be fully understood and very skillfully designed. Many expensive gallery daylighting schemes fail to perform well. Special lighting design consultation is recommended. Risks include photochemical degradation and fading of museum objects due to too high light levels, too much ultraviolet light, too much heat gain, lack of light control for special exhibitions, where natural light may be undesirable, inability to eliminate all light when the galleries are closed, and possible security exposure.

If used, skylighting should be placed in the center of fixed galleries, so that the light generally comes from behind viewers as they look at the exhibition walls. General top lighting in flexible gallery spaces can result in lighting that is too flat and can produce glare. Some of the most successful uses of skylighting have limited the natural light to general diffused reflected light on ceiling surfaces, leaving the actual exhibition lighting to track lighting fixtures. Closets are safer and more easily controlled than horizontal or pitched skylights and can result in satisfactory background light levels. Accent and nighttime lighting still will be required in any case.

The ultraviolet component of gallery lighting is especially dangerous. UV rays can be avoided almost entirely by using incandescent light sources. If natural or other light sources are involved, careful UV filtration is essential. Light reflected from surfaces covered with white titanium dioxide paint contains much less UV than direct light.

The intensity of all forms of light must be carefully controlled. Light intensities should be decreased with a qualified concentration, but the following are commonly recommended maximum lighting levels for various kinds of common museum objects:

**MAXIMUM LIGHT LEVELS FOR VARIOUS MUSEUM OBJECTS**

TYPE OF OBJECT	MAXIMUM LIGHT LEVEL
Oil paintings	200 lux
Prints and drawings	50 lux
Photographs	50 lux
Textiles	50 lux
Organic materials (painted leather, wood, etc.)	50 lux
Bronze and stone	no limit

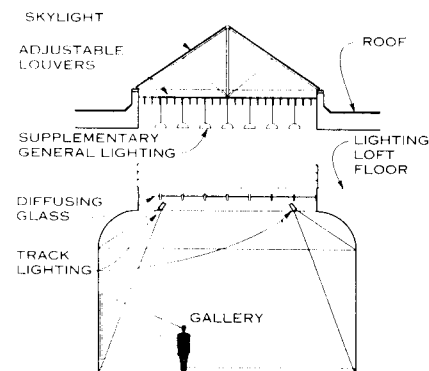

**TRADITIONAL SKYLIT GALLERY**

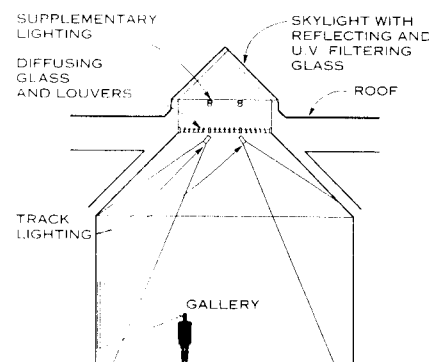

**NOTE**  
All light above and behind observer

**MODERN SKYLIT GALLERY**

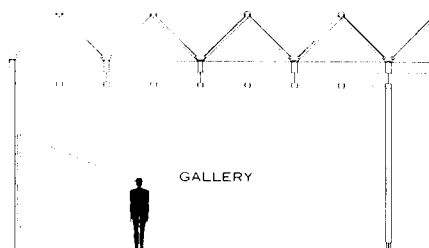

**NOTE**  
Light above but also in front of observer (glare)

**CONTINUOUS SKYLIT GALLERY**

**LIGHTING IN COLLECTIONS STOREROOMS.** Lighting in collections storerooms should provide adequate light for safe handling and examination of objects while protecting them from unnecessary exposure, especially to ultraviolet light. In large storerooms, lighting should be switched so that general light is provided for safe passage in main aisles, and additional light can be switched on when needed in particular areas. This will make for an economical operation and will prevent unnecessary exposure of the objects.

Fluorescent lighting is most common because it is inexpensive, but it must be provided with UV shielding, usually through use of sleeves for individual tubes. Indirect systems that reflect light from a white ceiling painted with titanium dioxide paint will greatly reduce the UV component and result in even light distribution. Light from high pressure sodium bulbs contains almost no ultraviolet light and is excellent from the point of view of conservation. Color discrimination is difficult in this light, however, necessitating separate examining areas with continuous spectrum lighting. Portable lighting also may be used for examination of objects in place.

**CLIMATE CONTROL**

**ZONING.** At the outset of any museum project, it must be decided whether the entire building will be maintained at conservation standards or only those areas containing collections items (galleries and collections storerooms). If the conservation standard areas are limited, the rest of the building can be treated like any other public building. Adequate physical separations, including vapor barriers, must be provided, however, between conservation and human comfort zones. In particular, this may mean the galleries will have to be separated from the main public lobby with glass doors (which are also desirable for security reasons). If galleries and collections storerooms are located in interior zones only, many problems and expenses can be avoided.

**HUMIDITY CONTROL.** Control of relative humidity is the single most critical factor in museum environments. Although ideal conditions vary for different kinds of collections, desirable R.H. for most museum objects is approximately 50%. This level must be held constant, day and night, summer and winter. Fluctuations in R.H. are very destructive, repeatedly stressing the materials of which museum objects are made.

Maintenance of 50% relative humidity throughout the winter months in cold climates tends to produce severe condensation on windows and within the exterior wall construction. Prevention of condensation requires installation of exceptionally good vapor barriers and insulation systems. A completely continuous "zero perm" vapor barrier system is essential in these circumstances. In this context, "zero perm" means a permeability rating of less than 0.1 grams of water per square foot per hour per inch of mercury vapor pressure in accordance with ASTM E 96 test procedure A, B, or BW. The design of wall and roof systems to accommodate such vapor barriers is difficult and should not be undertaken casually.

If, in a cold climate situation, it is determined that installation of zero perm vapor barriers and required mechanical equipment is impossible or impractical, the fall-back position should be to design the wall and roof systems to permit one slow controlled cycle per year, varying from about 25% R.H. in winter to about 50% in summer. Climate control for museums housed in historic buildings reviewed on a case-by-case basis to weigh the importance of protecting the building against the importance of protecting the collection. Hourly, daily, or weekly fluctuations must be avoided under any circumstances.

**AIR FILTRATION.** Requirements for air filtration vary depending on the quality of the outside air and the conservation demands of the museum objects to be housed. Generally, a good choice would be bag filters with throw-away pre-filters, UL Rating Class 1; particulates removed to 95% efficiency on ASHRAE 52/76. Electrostatic filters must not be used because they produce destructive ozone. Activate carbon filters are effective in removing gaseous pollutants, but they are expensive and require active maintenance.

**OPERATING CYCLES.** Heating and cooling loads vary greatly between occupied galleries (with lights and people) and unoccupied ones (closed and dark). When unoccupied, systems should be designed to operate at a low maintenance level. Since air volumes are large and pollutant sources nearly non-existent, when a gallery is closed it should be possible to reduce or eliminate outside air in order to improve environmental stability and operating economy.

**LOCATION OF PIPING.** All piping containing liquids should be kept out of areas containing museum objects. In particular, plumbing should not be located above galleries and collections storerooms.

**LOCATION OF OUTLETS, SWITCHES, AND CONTROLS.** All convenience outlets, switches, HVAC thermostats, humidistats, and other control devices must be kept off gallery walls. Outlets should be in the base and in the floor. Switches should be remote. Thermostats and humidistats can be located in return air ducts. Gallery walls must be for exhibition purposes only.

John D. Hilberly, AIA, John Hilberly & Associates, Inc., Architects and Museum Planners, Detroit, Michigan

**AIRFIELD**

The principal component of an airport site is the airfield, which includes the runways, taxiways, and aprons for navigational aids. The airfield configuration is the primary factor in determining the layout of the airport site. Basic types of runway configurations are illustrated below. Runways are oriented to take advantage of prevailing winds and to minimize crosswind conditions. Runway length varies for climatic conditions (elevation and maximum air temperature) and type of aircraft. The number of runways is a function of the volume of aircraft activity.

**SITE LAYOUT**

The layout plan illustrates a large airport with a diverse assembly of facilities that are typically required to support the principal aviation function of transporting passengers and cargo. The facilities of the terminal area include the aircraft gates, which should be located to optimize aircraft movement to and from the runways, the terminal itself, and the interface with the ground transportation system, which includes access roadways and parking, and may also include a rail or rapid transit station. Facilities with restrictive location requirements include the air traffic control tower (ATCT), which requires clear sightlines to runways, taxiways, and other areas of aircraft operations, and the aircraft rescue and fire fighting (ARFF) facility, whose site is determined by mandatory response time criteria. Another element of the site layout is the security perimeter, which must encompass all aircraft operating areas. Typically, passenger terminals and cargo buildings are incorporated into the security perimeter. Among the recent trends in airport facilities are the use of automated transit systems (people movers) and the incorporation of large commercial developments (hotels, retail, offices, and conference centers) on the landside of the terminal.

**REGULATIONS AND STANDARDS**

In the United States, the Federal Aviation Administration (FAA) is principally responsible for the regulations and standards applicable to the design of airports. On a world-wide basis, the International Civil Aviation Organization (ICAO) defines uniform standards and recommended procedures. Enforcement and practice, however, remain within the jurisdiction of individual countries. The reference section lists FAA and ICAO documents that contain useful planning information.

**RUNWAY AND TAXIWAY CLEARANCES**

The location and height of buildings and other obstacles on or near the airport are regulated by a defined set of imaginary surfaces. The transitional surfaces begin at a prescribed distance from either side of the runway centerline and extend upward at a 7:1 slope. The section illustrates the transitional surface for a precision instrument runway. The approach surfaces extend from beyond the ends of the runway beginning at a 50:1 slope. The runway protection zone, which corresponds to the first part of the approach surface, is usually depicted on site plans. The separation criteria for runway centerlines and taxiway centerlines is based on aircraft wingspan clearances. Clearances illustrated will accommodate a Boeing 747-400.

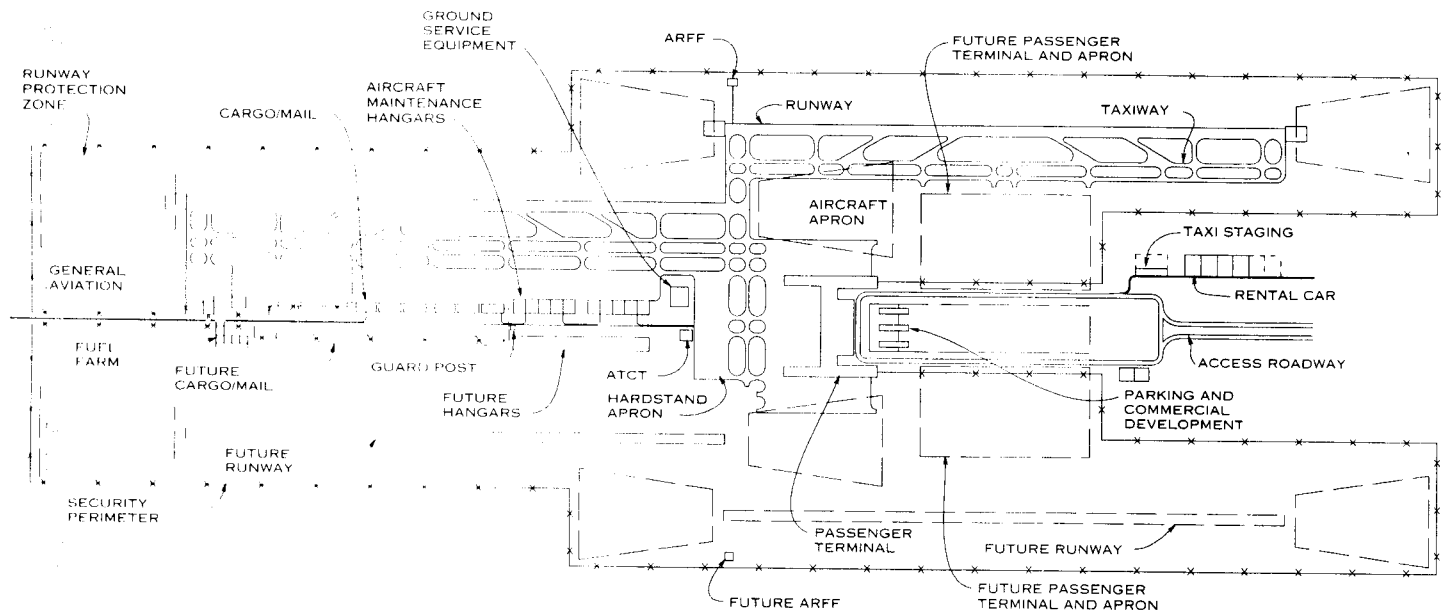
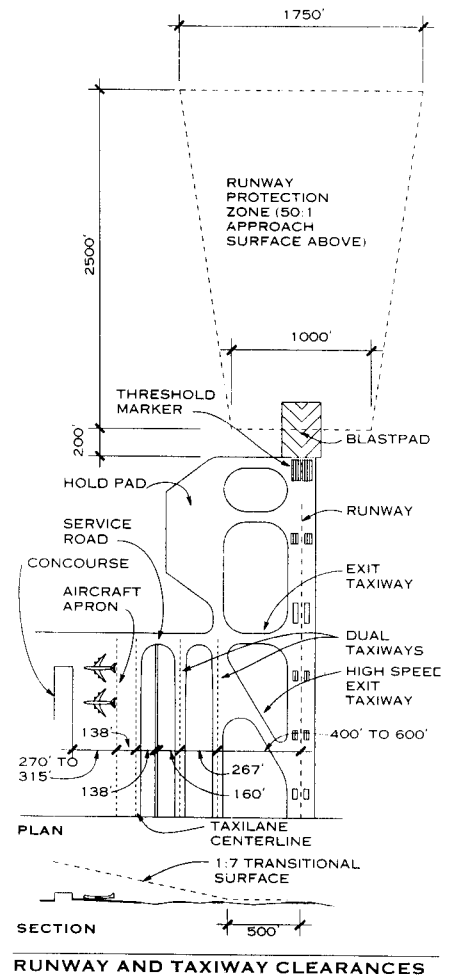
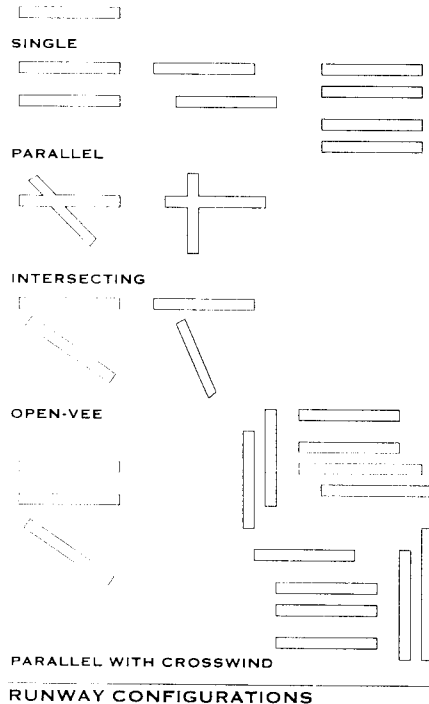

**SITE LAYOUT**

Mark Romack; Perkins & Will; Chicago, Illinois

**AIRCRAFT DESIGN GROUPS**

The FAA groups aircraft into six (6) categories based on wingspan. Representative airplanes of groups I, III, IV, and V are illustrated.

**GROUP I (WINGSPAN UP TO 49')  
NOT DEPICTED**

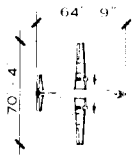

SAAB SF-340

**GROUP II (WINGSPAN 49' TO 79')**

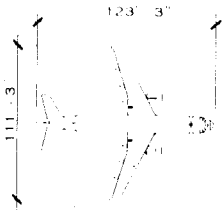

AIRBUS A320

**GROUP III (WINGSPAN 79' TO 118')**

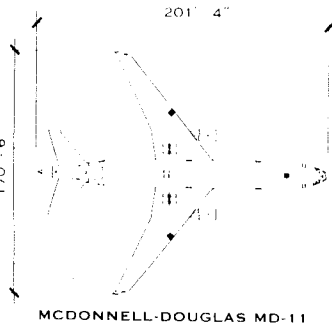

MCDONNELL-DOUGLAS MD-11

**GROUP IV (WINGSPAN 118' TO 171')**

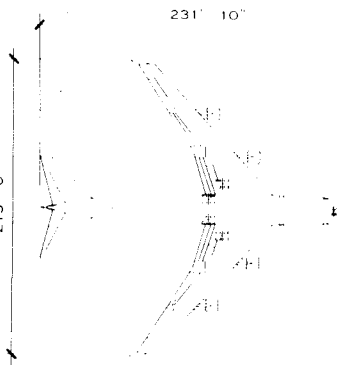

BOEING 747-400

**GROUP V (WINGSPAN 171' TO 214')**

**GROUP VI (WINGSPAN 214' TO 262')  
NOT DEPICTED**

**AIRPLANE CLASSIFICATIONS**

Mark Romack; Perkins & Will; Chicago, Illinois

**TERMINAL CONFIGURATIONS**

The most important determinant in the configuration of the terminal is the arrangement of aircraft gates. The four basic types—pier, linear, satellite, and transporter—are illustrated. The pier arrangement results in a compact aircraft apron but creates cul-de-sacs that can restrict aircraft movement. Linear arrangements offer unrestricted aircraft movement but are problematic for hub locations where an

airline with many gates will find its operations spread over considerable distances. Satellite configurations use under-apron pedestrian corridors or automated transit systems to connect terminal processing areas with remote concourse gates. Transporter schemes use buses or mobile lounges to convey passengers between the terminal and noncontact (hardstand) gates. Many airports have some noncontact gates, but few rely on this concept as the principal terminal configuration. Combinations of the four types are often used.

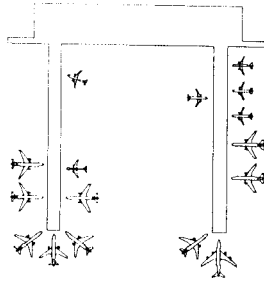

PIER

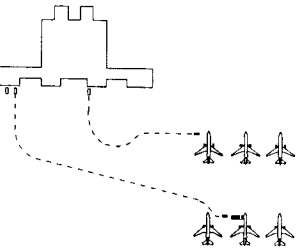
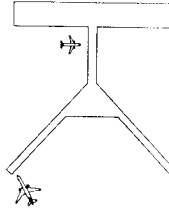

TRANSPORTER

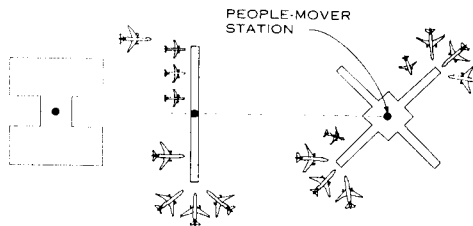

SATELLITE

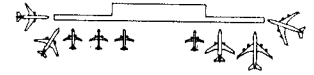

LINEAR

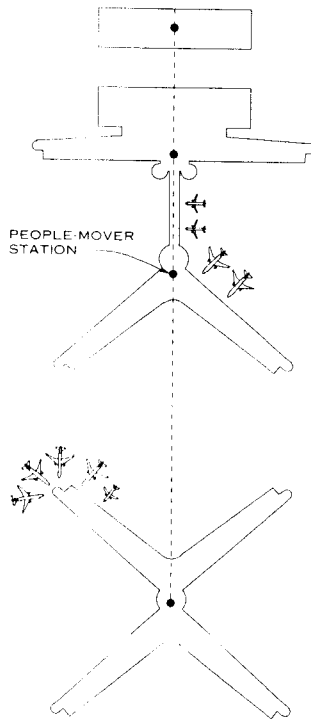

PIER AND SATELLITE

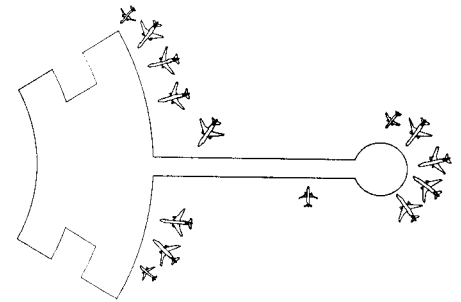

LINEAR AND PIER (TEE)

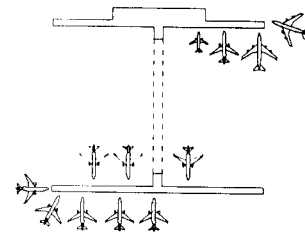

LINEAR AND SATELLITE

**TERMINAL CONFIGURATIONS**

**TERMINAL PLANNING**

The organization of the interior spaces of a terminal chiefly depends on the flow of passengers and their baggage

through a series of processing steps between aircraft and ground transportation, or from aircraft to aircraft in the case of connecting passengers. Typical flows for arrivals and

departures at U.S. airports are diagrammed. Floor plans illustrate the general layout and adjacencies for a small airport serving commuter aircraft and narrow-body jets.

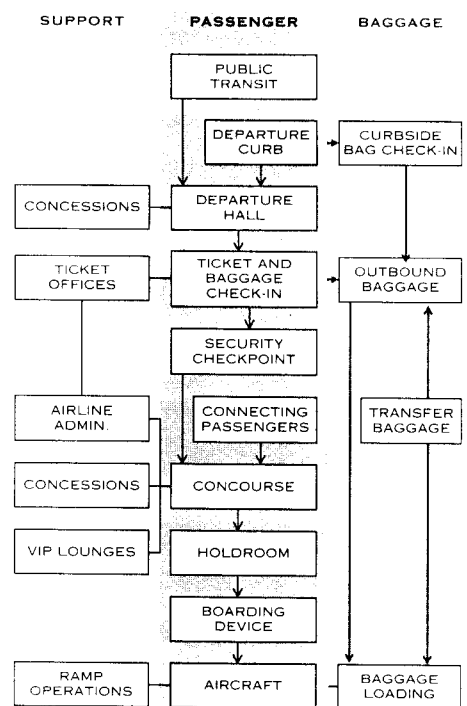
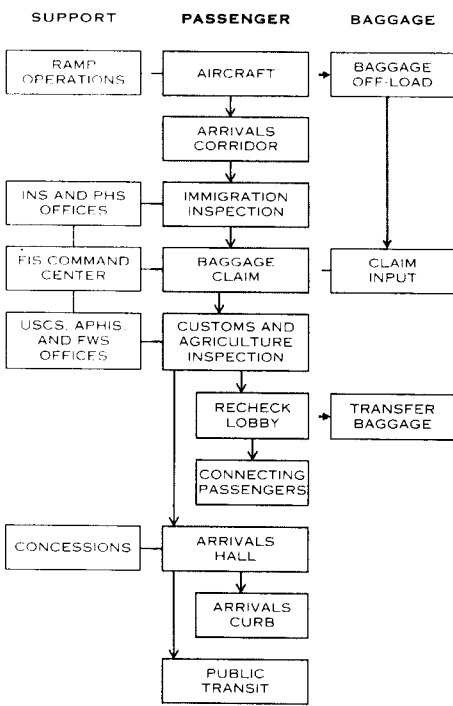
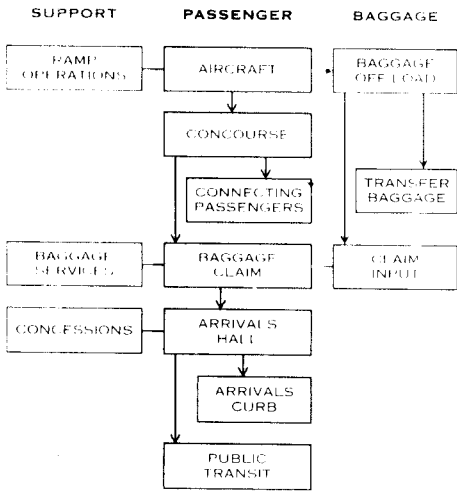

→ PASSENGER FLOW  
 - - - CHECKED BAGGAGE FLOW

**NOTE**  
 Federal Inspection Services (FIS) consist of Immigration and Naturalization Services (INS), Public Health Services (PHS), United States Customs Service (USCS), Animal and Plant Health Inspection Service (APHIS), and Fish and Wildlife Service (FWS).

**ARRIVALS (DOMESTIC) FLOW DIAGRAMS**

**ARRIVALS (INTERNATIONAL)**

**DEPARTURES**

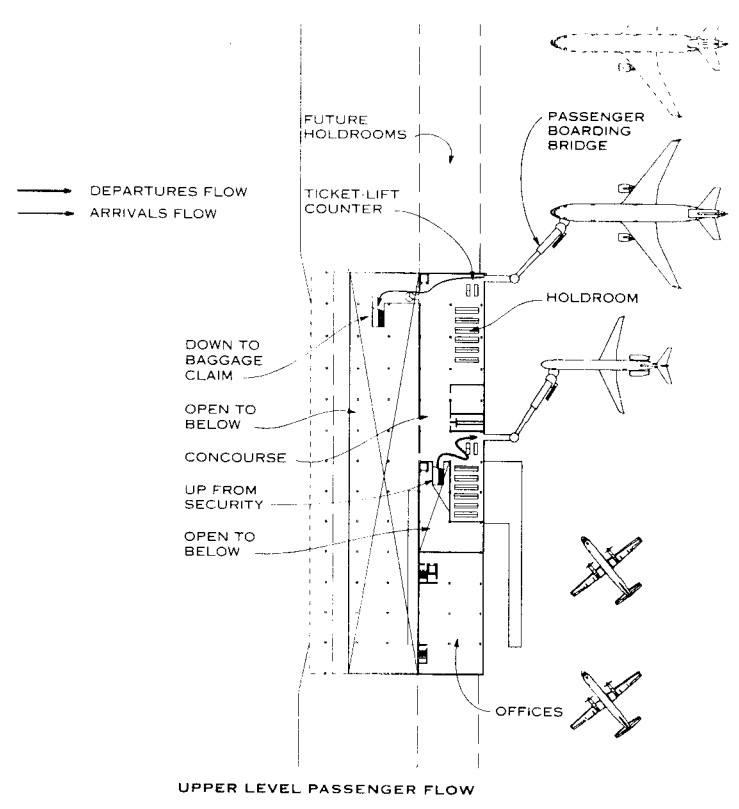
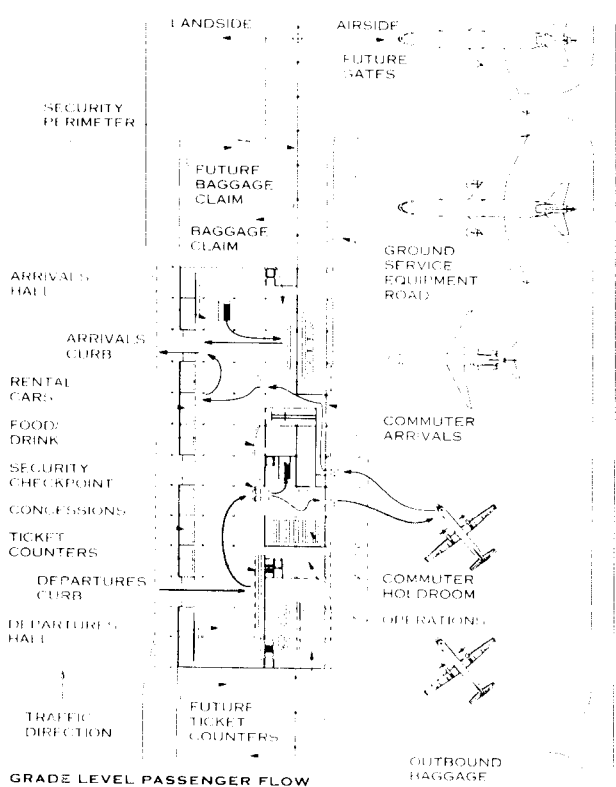

**PASSENGER TERMINAL**

Mark Remick, Perkins & Will, Chicago, Illinois

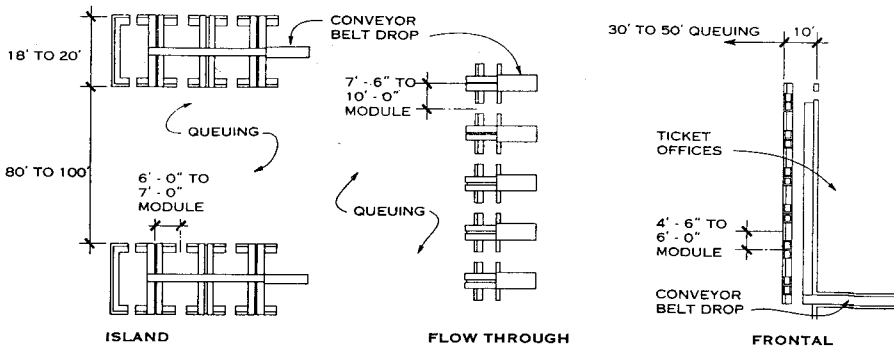

**TICKET COUNTER CONFIGURATIONS**

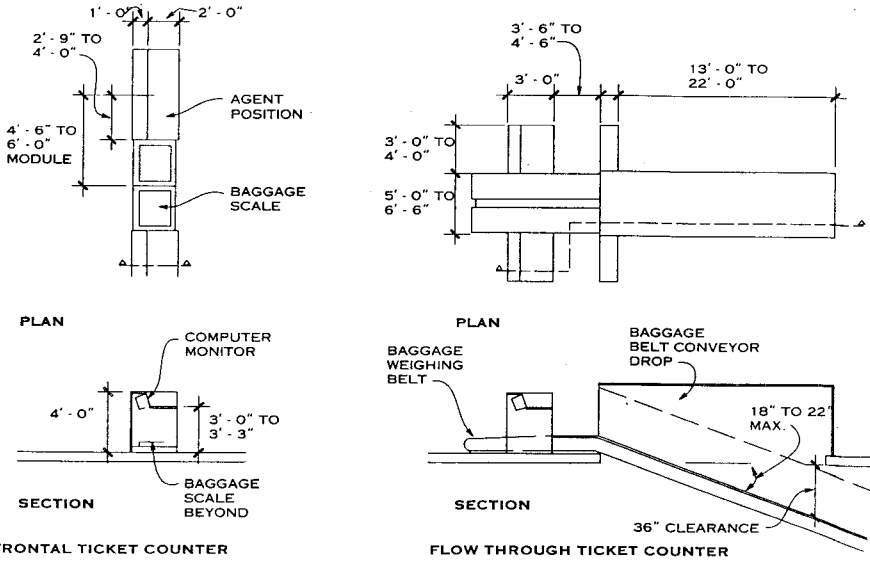

**TICKET COUNTERS**

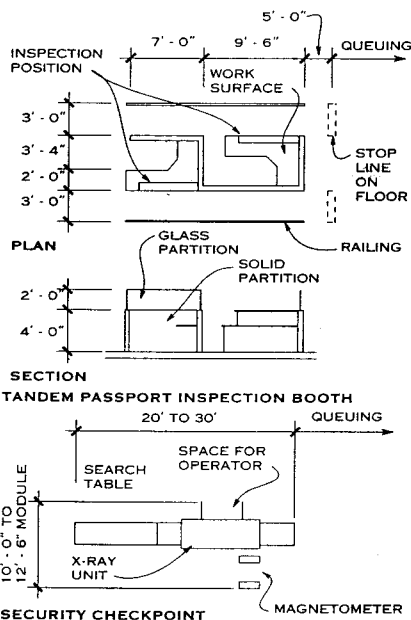

**INSPECTION AREAS**

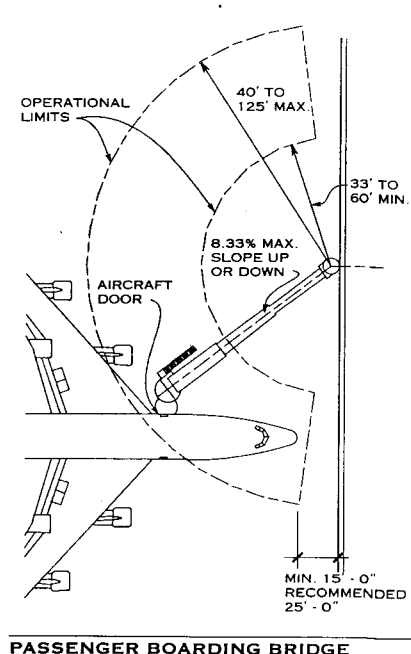

**PASSENGER BOARDING BRIDGE**

**SYSTEMS**

In addition to conventional mechanical and electrical systems, a large amount of space in an airport terminal will be devoted to systems unique to this building type. The baggage handling system requires space for baggage conveyor routes and floor areas for outbound and inbound systems. The types of handling systems vary widely but all include some means of sorting outbound baggage by flight (either manually or with automated devices) and a method of conveying baggage from check-in to gate (typically by a combination of belt conveyors and tug-and-cart trains). Inbound baggage requires a device for displaying baggage for claim by arriving passengers. Several systems are required to support aircraft at the gates: pre-conditioned (PC) air, ground power (400 Hz), and hydrant fueling, among others. These systems can be supplied from mobile ground service equipment but often are incorporated within the terminal building (or apron, in the case of aviation fuel lines) for reasons of economy and efficiency. Space is required for equipment and distribution runs. Communication requirements tend to be extensive due to the multiple number of systems: public address, flight information and display (FIDS), dynamic signage, ground radio, CCTV and security monitoring, as well as individual or shared information systems for airlines, government agencies, and other tenants.

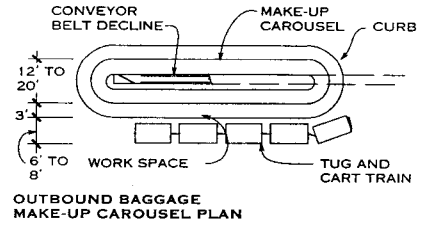

**OUTBOUND BAGGAGE MAKE-UP CAROUSEL PLAN**

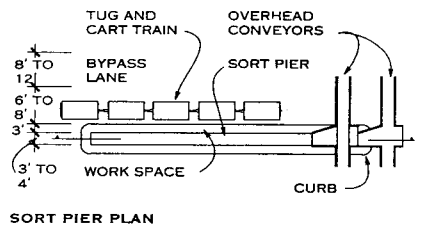

**SORT PIER PLAN**

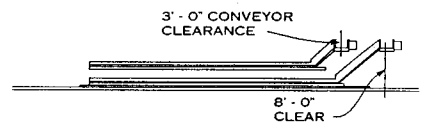

**SORT PIER SECTION**

**OUTBOUND BAGGAGE**

**REFERENCES**

1. Airport Capacity and Delay, FAA Advisory Circular 150/5060-5, September 23, 1983.
2. Airport Design, FAA Advisory Circular 150/5300-13, September 29, 1989.
3. Planning and Design of Airport Terminal Facilities at Non-hub Locations, FAA Advisory Circular 150/5360-9, April 4, 1980.
4. Federal Aviation Regulations Part 77, Objects Affecting Navigable Airspace, FAA, January 1975.
5. Aerodromes, Annex 14 to the Convention on International Civil Aviation, volume 1, ICAO, July 1990.
6. Airport Terminals Reference Manual, International Air Transport Association (IATA), January 1989.

Mark Romack; Perkins & Will; Chicago, Illinois



**INTRODUCTION**

The U.S. health care delivery system has changed enormously since the early 1980s. The federal government now attempts to control health care costs for patients receiving Medicare and Medicaid benefits by assigning fixed costs to hundreds of standard diagnoses (called Diagnostic Related Groups, or DRGs) and reimbursing health care facilities only this amount for each patient stay. The result has been a substantial shift to outpatient treatment for many diagnoses, including surgery. Consequently, hospitals now face a surplus of inpatient beds and great pressures to revise physical plants to accommodate many more outpatients. At the same time, health insurance companies have cut benefits for inpatient care. All of this has changed the way hospitals are planned and has stimulated new conceptual responses to the new functional challenges. In addition, hospitals are no longer the only building types responding to health care needs. The following sections describe typical U.S. health care facilities in the 1990s.

**HOSPITAL BUILDING TYPES**

**PRIMARY CARE/COMMUNITY**

Like the family doctor, the community hospital is the first contact with the health care system for many people. Hospital primary care provides general treatment and diagnostic services within a limited, well-defined geographic area. Such services usually include general surgery, standard radiography and fluoroscopic imaging, routine laboratory tests, and emergency care, as well as general medicine, maternity, and pediatrics. A small unit usually serves as a combined intensive care unit (ICU) and cardiac care unit (CCU). The number of inpatient beds can range from 25-50 for small rural hospitals to 100-150 for facilities in developed areas.

**REGIONAL REFERRAL**

Compared to primary care hospitals, referral hospitals serve larger, less well defined areas and provide not only basic care but also more specialized care, including orthopedics; eye, ear, nose, and throat (EENT); urology, cardiology; oncology; or neurology. Computerized tomography (CT) scanning, magnetic resonance imaging (MRI), ultrasonography, and nuclear medicine imaging are also present to support these specialties. Cardiac catheterization, open-heart surgery, and cancer treatment programs are sometimes available. The emergency department has a heavier workload because of the specialty capabilities available. The number of inpatient beds can range from 150-200 to 300-350 or more.

**TERTIARY CARE/TEACHING**

Because many tertiary care/teaching hospitals have world-class reputations and provide extremely special services, they may attract patients from all over the world. Such facilities seek to provide not just health care but also a setting (and patients) for medical research and education. Balancing these objectives is an important consideration in the design of such hospitals. All the specialties are represented, as well as some state-of-the-art diagnostic and treatment modalities frequently still in development. Imaging devices such as positron emission tomography (PET) scan, procedures such as "gamma knife" treatment for cancer, and "clean rooms" for patients recovering from bone marrow transplants must all be housed in specially designed facilities. Tertiary care hospitals may be physically linked to a medical school's basic science and clinical research laboratories, academic offices, classrooms, and very large outpatient facilities. The number of inpatient beds can vary from 400-450 to 800-900 or more.

**SPECIALTY (REHABILITATION, PSYCHIATRIC, PEDIATRIC)**

Specialty hospitals treat only one kind of patient. Rehabilitation hospitals treat and provide therapy for patients suffering from illnesses or injuries that have restricted their physical and/or cognitive abilities. Because of such patients' disabilities, fully accessible functional areas with generous clearances and circulation space must be planned. Rehabilitation hospitals may include facilities for cardiac rehabilitation and sports medicine.

Psychiatric hospitals treat patients with mental illness. Since most of these patients are fully mobile physically, patient rooms can be designed like dormitory rooms. Security, access, and unit-to-unit separation must also be considered when planning such facilities.

Other specialty hospitals include those devoted to women's and children's health. While they contain most of the treatment and diagnostic areas of a standard hospital, they also have special design needs: patient privacy, appropriate scale, and nonthreatening environments.

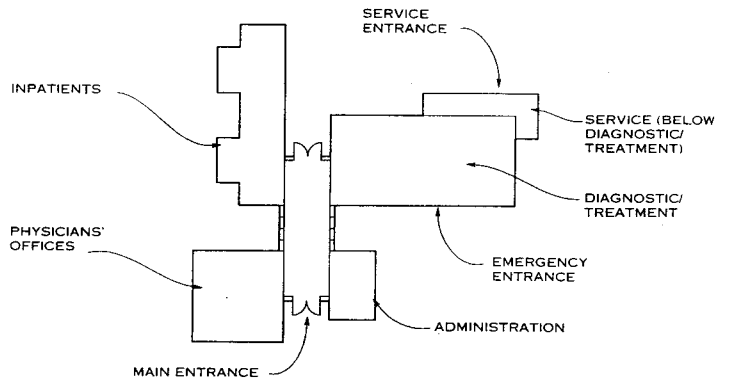

**PRIMARY CARE/COMMUNITY HOSPITAL**

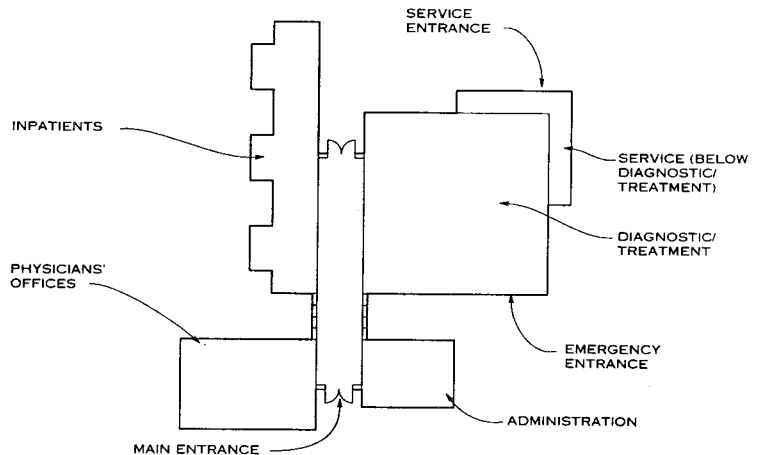

**REGIONAL REFERRAL HOSPITAL**

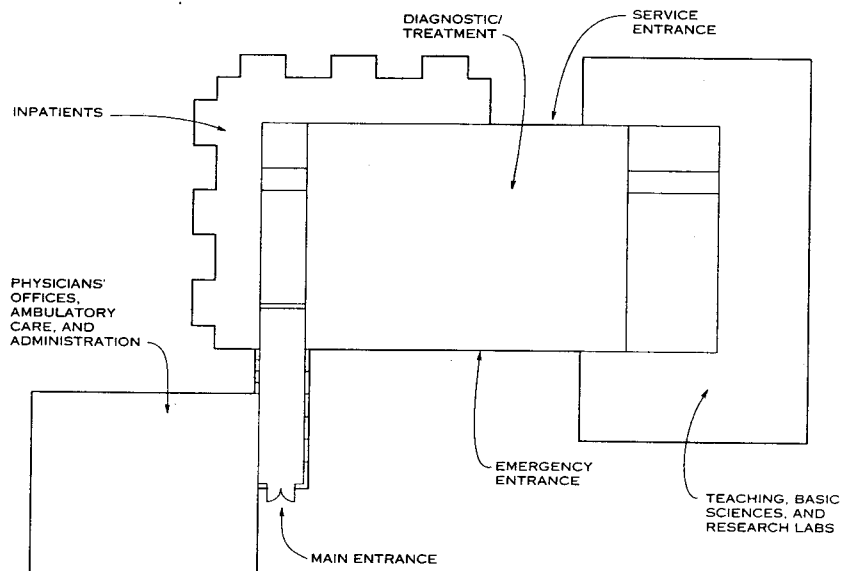

**TERTIARY CARE/TEACHING HOSPITAL**

Donald W. Velsey, AIA; Ellerbe Becket; Washington, D.C.  
Charles F. D. Egbert, AIA; Egbert, Clarens, and Associates, PC Architects; Washington, D.C.

**URGICENTERS**

The movement toward outpatient care has stimulated the development of freestanding facilities, not necessarily associated with a hospital, for patients to use as they might a family doctor—frequently on a walk-in basis without an appointment. Urgicenters can relieve overburdened hospital emergency rooms of nonemergency work. To compete with freestanding urgicenters, hospitals are starting urgicenters contiguous to their own emergency department; a triage nurse can direct walk-in patients to appropriate treatment in the hospital, but in a less-intensive, nonemergency setting.

**SURGICENTERS**

The increase in outpatient surgery has also prompted the development of freestanding surgical facilities, where doctors perform surgery that might otherwise be done in a hospital. State regulations limit patient stays to 24 hours, so the surgery performed must not require the potential support of hospital services. To compete with surgicenters, hospitals are providing outpatient surgery as well: up to 80% of all surgery in some hospitals is outpatient.

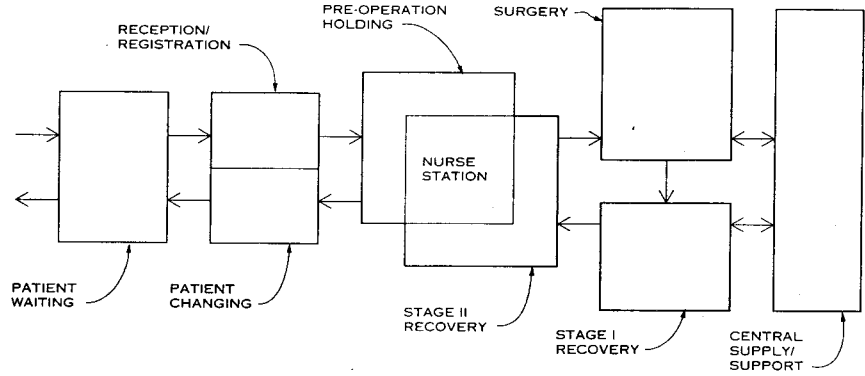

**SURGICENTER FLOW DIAGRAM**

**POSTSURGERY RECOVERY CENTERS**

The recent development of postsurgery recovery centers brings the freestanding facility idea full circle, back to the "hospital" model. Surgicenters have recognized some patients' need to stay longer than 24 hours and have created a kind of surgical hotel. Because the costs and amenities are similar to those of a very good hotel, such facilities cater to an affluent clientele.

**BIRTHING CENTERS**

The movement to limit hospital stays combined with women's increasing desire to deliver babies in a less institutional setting, has resulted in the development of freestanding birthing centers. Such centers provide for normal deliveries, which accounted for 75 to 80% of births in the United States in 1990. Complicated and cesarean-section (C-section) deliveries, which require special support, may remain in the hospital setting. Whether in a hospital or freestanding birthing center, the trend is to reduce the average maternity stay to 24 hours, if possible. Consequently, a new planning theory simplifies and accelerates the functional flow of the maternity patient. Labor, delivery, and postpartum stays are now routinely combined in one room (called the LDRP). The design of the LDRP room must balance the needs for special air conditioning, medical gas outlets, and monitoring capability with the desire to create a homelike atmosphere. To compete with birthing centers, hospitals are providing LDRP suites contiguous to C-section operating rooms.

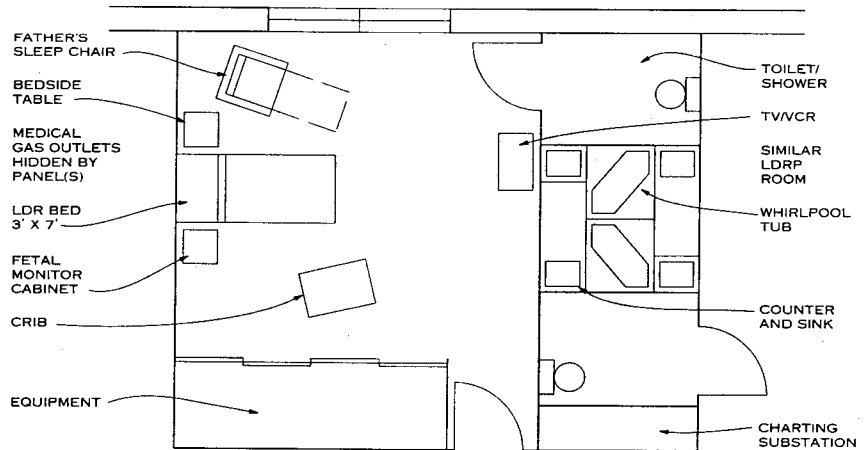

**BIRTHING CENTER - TYPICAL LDRP ROOM**

**AMBULATORY CARE FACILITIES**

Increased demand for outpatient care has stimulated the development of freestanding ambulatory care facilities—large outpatient clinics operated by groups of physicians or health maintenance organizations (HMOs). These facilities can combine versions of the urgicenter, surgicenter, and birthing center with full diagnostic support; the resulting functional grouping has been called a "hospital without beds." Ambulatory care planning modules must be flexible. Scheduling each clinic module by hours of use is the most important programming and planning factor in designing functional outpatient clinics. To compete with such centers, hospitals are providing on-site ambulatory care facilities, ranging from contiguous office buildings for physicians to large outpatient clinics.

**LONG-TERM CARE FACILITIES**

Long-term care facilities manage patients who need supervision of or assistance with long-term, chronic conditions but do not need the treatment and diagnostic support of a hospital. Whereas the number of beds in a typical acute care unit in a hospital is ideally about 25 to 30 per nursing station, as many as 60 beds per station are permitted in long-term care units in some jurisdictions. There are various levels of care within the long-term definition: The skilled nursing facility cares for patients whose chronic conditions require constant nursing support, such as ventilators (assisted breathing). Some hospitals are converting empty bed space to these units, which require a less intense level of staffing. The nursing home traditionally provides care for patients, usually elderly, who need some assistance and supervision. Other levels of care are available in congregate care facilities, eldercare, or assisted living complexes, which offer a variety of living accommodations, ranging from apartments to dormitory-style units to supervised units with nurses on duty.

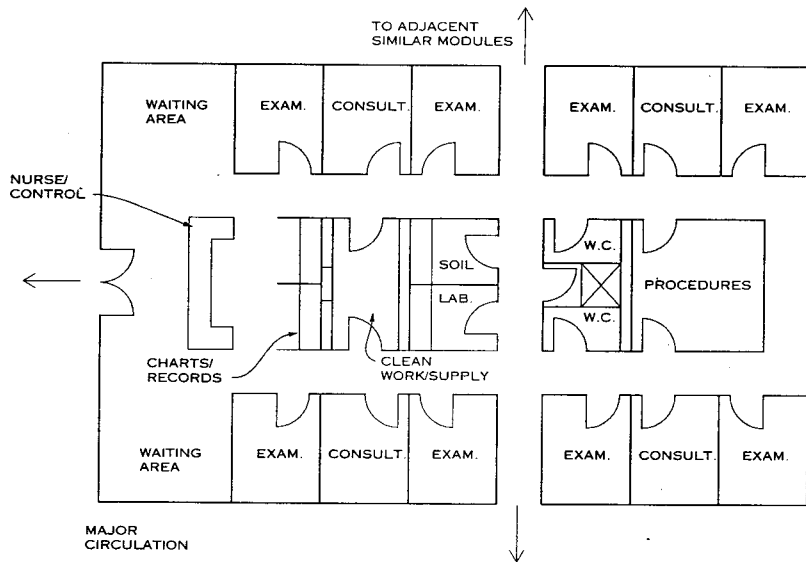

**TYPICAL AMBULATORY CARE/OUTPATIENT CLINIC MODULE**

Donald W. Velsey, AIA; Ellerbe Becket; Washington, D.C.  
Charles F. D. Egbert, AIA; Egbert, Clarens, and Associates, PC Architects; Washington, D.C.

**PROGRAMMING**

**STRATEGIC PLANS**

Health care facilities periodically attempt to identify strategies for satisfying probable future needs. Such strategies may involve adding a new treatment or diagnostic service or expanding to capture a larger market share of a particular service and to encourage physicians to use the facilities. A long-range strategic plan documents such goals.

**MASTER FACILITY PLANS**

Master facility plans are derived from the strategic plan and consist of (1) a projection of future space needs, (2) a comparison of those needs to available existing space, (3) an analysis of existing functional deficiencies, (4) an analysis of existing mechanical and electrical systems and their capacity, (5) block plan diagrams proposing directions for growth and areas of renovation, (6) prioritization and phasing of proposed construction projects, and (7) preliminary construction and project cost estimates based on the proposed phasing.

Note: A reasonable rule of thumb for converting construction cost estimates to project costs is to add 40%. This percentage includes major movable equipment and furnishings, design fees, and design and construction contingencies.

**FUNCTIONAL SPACE PROGRAMMING**

Functional space programming is often developed in two consecutive levels of detail. The first level is conceptual and is expressed in departmental gross square feet (DGSF). This level of programming is used to develop master facility plans. It consists of a department-by-department calculation of the areas within the overall boundaries of each department, including internal departmental circulation and partitions. DGSF is directly derived from projected departmental workloads or personnel numbers. Earlier popular programming methods, which link the size of a department to the numbers of beds in a hospital, are no longer valid because of the large shift to outpatient workloads.

The conceptual program must be completed by adding estimated mechanical/electrical spaces as DGSF, plus an overall factor (in the range of 1.10 to 1.15) to convert all DGSF to total building gross square feet (BGSF), which adds all general circulation, both vertical and horizontal, and exterior walls.

The second level of detail is a space-by-space program listing, in usable net square feet (NSF), all the functions in the facility. Major mechanical and electrical spaces should also be treated as NSF. These areas can then be factored variously at approximately 1.20 to 1.65 (depending on circulation and partitioning needs) to get DGSF; that result factored by 1.10 to 1.15 yields BGSF. If the assumptions used in the conceptual program are still valid, the DGSF of both conceptual and detailed programs should be approximately the same.

**EXAMPLE: A SURGICAL SUITE TO SUPPORT 10,000 PROCEDURES/YR**

**ASSUMPTIONS**

- 260 days/yr of scheduled operation. (A small percentage of emergency surgery will not affect the results.)
- 8 hr/day of scheduled operation.
- 25% of the workload is inpatient procedures requiring general anesthesia in a "major" operating room. Each procedure, including cleanup time, ties up a room for an average of 2.5 hr. Therefore, one room can handle 8 hr divided by 2.5, or 3.2 procedures/day.
- 50% of the workload is outpatient procedures requiring general anesthesia in a "major" operating room. Each procedure, including cleanup time, ties up a room for an average of 1.5 hr. One room can therefore handle 5.3 procedures/day.
- 25% of the workload is outpatient procedures requiring local anesthesia in a "minor" procedures room. Each procedure ties up a room for an average of 0.5 hr. One room can therefore handle 16 procedures/day.

**CALCULATIONS**

- 10,000 procedures/yr divided by 260 = 38 procedures/day (say 40 procedures/day).
- Inpatients: 10/day at 3.2/room/day requires 3.1 major operating rooms.
- Outpatients with general anesthesia: 20/day at 5.3/room/day requires 3.7 major operating rooms.
- Outpatients with local anesthesia: 10/day at 16/room/day requires 0.6 minor procedures rooms.

Donald W. Velsey, AIA; Ellerbe Becket; Washington, D.C.  
Charles F. D. Egbert, AIA; Egbert, Clarens, and Associates, PC Architects; Washington, D.C.

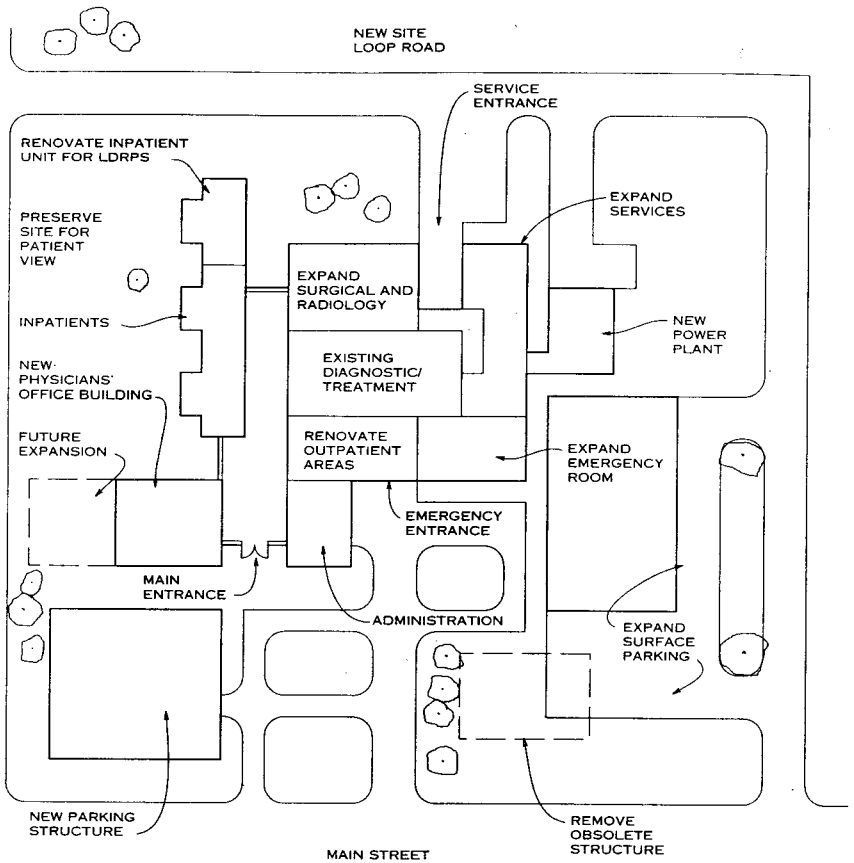

**DIAGRAMMATIC MASTER FACILITY PLAN**

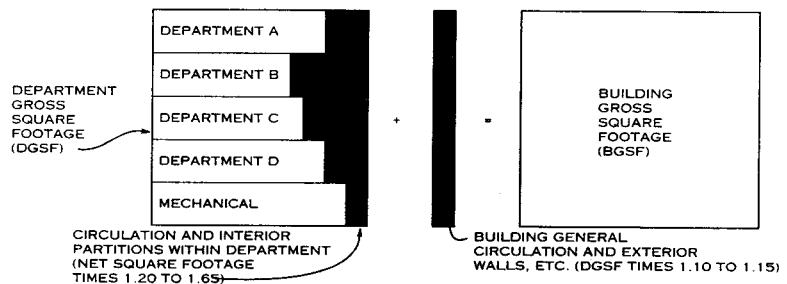

**FUNCTIONAL SPACE PROGRAM**

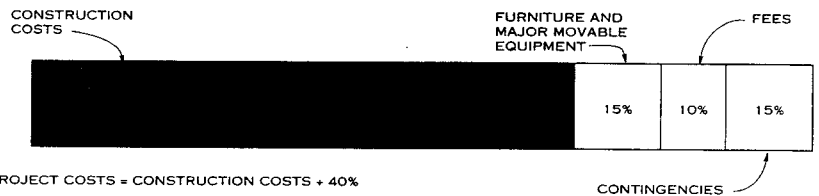

**PROJECT COSTS**

**RESULTS**

A total of 6.8 or 7 major operating rooms is required and only 1 minor procedures room is required.

Rule of thumb for programming: The total area (including all appropriate support spaces) of a surgical suite will be approximately 2200 DGSF/operating room or minor proce-

dures room. Therefore this surgical suite would be 8 rooms x 2200 DGSF, or approximately 17,600 DGSF.

**NOTE**

There are recognized rules of thumb for sizing every department, using workload methodology like this example. See bibliography for more information.

**PLANNING THE HEALTH CARE FACILITY**

Certain attributes of health care facilities clearly distinguish them from other building types. They resemble small towns or cities in the way city planning and zoning criteria can be applied to planning these facilities. Some representative concerns follow along with specific examples.

1. Functional traffic patterns must be kept separate.
  - a. At loading docks, incoming clean supplies should have no contact with soiled linens, trash, recyclables, and hazardous waste.
  - b. In surgery, restricted areas where scrub suits are worn should be separated from areas where street clothes can be worn.
  - c. In all treatment and diagnostic areas, inpatient stretcher traffic should not mix with ambulatory outpatient or waiting area traffic.
  - d. In elevators, hospital staff and supply traffic should be separated from public and visitor traffic.
  - e. In patient units, those with communicable disease should be separated from others.
2. It is important to respect linear, step-by-step functional flows in certain areas.
  - a. Used surgical instruments move, in order, through decontamination, sterile preparation, terminal sterilization, sterile pack storage, and transportation through a restricted zone back to the operating rooms.
  - b. Outpatient surgery patients move from reception/registration, to undressing, to pre-op holding, to the operating room, to stage 1 recovery, to stage 2 recovery, to dressing, to checkout.
  - c. Radiology film goes from film dispenser, to cassette, to exposure at radiographic table, to film processing and developing, then to quality review, radiologist viewing, and files.
3. The proportion of mechanical and electrical costs to architectural costs is very high, due in part to the following:
  - a. Special, filtered air conditioning systems in surgery, with high volumes of air exchange.
  - b. Extensive medical gas systems: oxygen, medical compressed air, vacuum, nitrous oxide, nitrogen.
  - c. Special exhausts for clinical laboratory fume hoods, nuclear medicine xenon gases, and patient isolation rooms.
  - d. Heavy electrical loads in imaging areas, and isolated power and emergency power requirements in many treatment and diagnostic areas.
  - e. Special transportation devices such as pneumatic tubes, and automated tote-box systems.
  - f. Extensive electronic communications: local computer networks, including provisions for medical information systems; nurse call; intercom; pocket paging; radio communication to emergency services; digital imaging transmission; and television systems for security and for educational and hospital programming.
4. Planning must recognize the need for future flexibility and growth
  - a. Structural modules are derived from the various functional planning units. The ideal grid for inpatient units may be different from that for treatment and diagnostic areas.
  - b. It is important to locate potential high-growth departments where they can expand into new construction or into adjacent renovated soft space.
  - c. When planning large areas with a mix of space sizes, find a common modular dimension to facilitate future changes within a department. For example, program a clinic's exam rooms and utility rooms at 120 NSF. Most partition systems that purport to be easily movable are in fact rarely, if ever, moved; it may be better to plan permanent spaces whose uses can be altered as space demands change.
5. Functional "zoning" determines massing relationships:
  - a. Inpatient units have many of the attributes of hotels and dormitories.
  - b. Treatment and diagnostic areas resemble areas in high-tech buildings, where "process" is important for performing delicate procedures.
  - c. Support and service areas where materials are handled are the health care facility's light industry zones.
  - d. Administrative areas are for business functions and thus are suitable to an office building environment.
  - e. Outpatient processing, registration, and clinic areas—along with the necessary public access, shops, services, and lobbies—can be thought of as retail space. In fact as competition for patients steps up, the phrase "medical mall" has been coined to describe the desired atmosphere of such spaces.

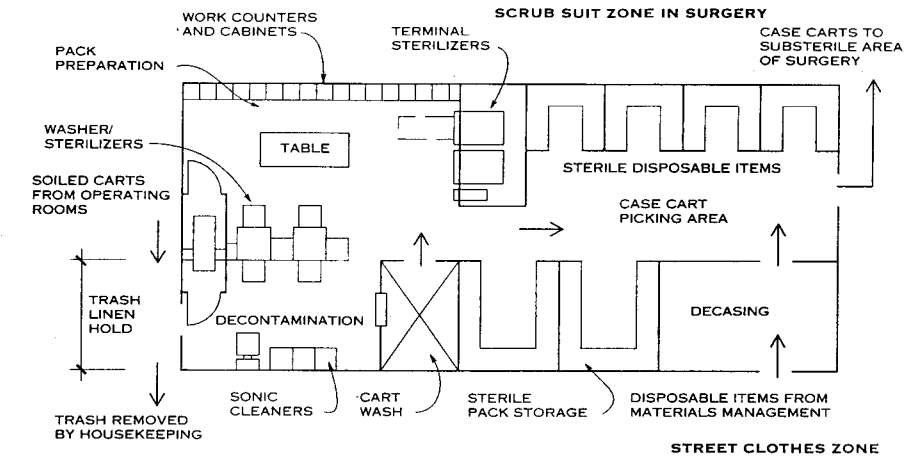

**TYPICAL FLOW DIAGRAM: MATERIALS - CENTRAL SUPPLY**

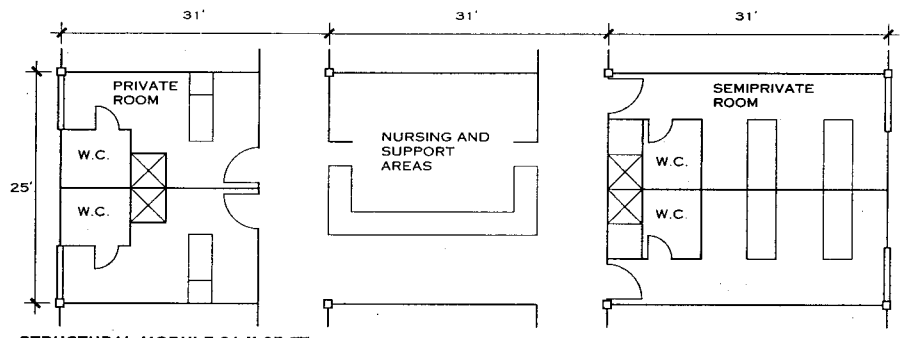

**STRUCTURAL MODULE 31 X 25 FT**

**INPATIENT UNIT**

**A SELECTED BIBLIOGRAPHY**

The American Institute of Architects and the U.S. Department of Health and Human Services. *Guidelines for Construction and Equipment of Hospital and Medical Facilities, 1992-93*. Washington, D.C.: AIA Press, 1993.

American Society for Hospital Engineering Technical Document Series. Chicago: American Hospital Association Publishing, Inc.

Association for the Care of Children's Health. *Child Health Care Facilities Design Guidelines*. Washington, D.C.: Association for the Care of Children's Health, 1987.

Bush-Brown, Albert, and Dianne Davis. *Hospitable Design for Healthcare and Senior Communities*. New York: Van Nostrand Reinhold, 1992.

Carpman, Janet R., and Myron A. Grant. *Planning Health Facilities for Patients and Visitors*. Chicago: American Hospital Association Publishing, Inc., 1993.

*Evaluation and Space Planning Methodology Series*. Ottawa (Canada): Health and Welfare Canada, 1978.

Hardy, Owen B. and Lawrence P. Lammers. *Hospitals: The Planning and Design Process*. Rockville, Md: Aspen Systems Corporation, 1986.

*Health Facilities Review*. Washington, D.C.: AIA Press, various years.

Laufman, Harold, ed. *Hospital Special Care Facilities*. New York: Academic Press, 1981.

Malkin, Jain. *Hospital Interior Architecture*. New York: Van Nostrand Reinhold, 1992.

Malkin, Jain. *Medical and Dental Space Planning for the 1990s*. New York: Van Nostrand Reinhold, 1990.

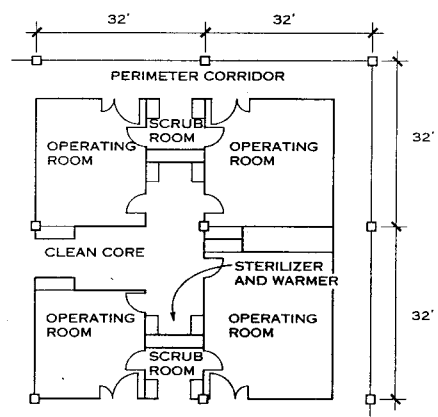

**STRUCTURAL MODULE 32 X 32 FT**

**SURGICAL SUITE**

Rostenburg, Bill. *Design Planning for Free Standing Ambulatory Care Facilities*. Chicago: American Hospital Association Publishing, Inc., 1986.

Snook, I. Donald, Jr. *Hospitals: What They Are and How They Work*. Rockville, Md.: Aspen Systems Corporation, 1981.

Donald W. Velsey, AIA; Ellerbe Becket; Washington, D.C.  
Charles F. D. Egbert, AIA; Egbert, Clarens, and Associates, PC Architects; Washington, D.C.

**INTRODUCTION**

The word "church" simply denotes a space, or group of spaces, that provides a place for devotion, education, and fellowship. Certain images may come to mind when thinking about a church, yet each built form should be a direct response to its particular faith. Belief systems, traditions, and styles of worship may vary widely, even within groups of similar denominations. The architectural vernacular within the region and the neighborhood may impact design decisions. The inclusion and arrangement of liturgical furnishings and symbols should be carefully discussed so that the result reflects the traditions of the group and provides an environment that evokes the appropriate spiritual response.

**SITE PLANNING ISSUES**

**Land capacity:** Actual layouts may vary, but typically a site will accommodate 150 to 200 persons per acre at peak usage. Shared parking on adjacent properties increases this number. Allow for more land for outdoor athletic, worship, or cemetery needs. For long-term growth, plan the possibility of acquiring adjacent land.

**Parking:** Provide one parking space for every 1.6 to 2.2 seats in the main worship area. Consider shared parking on adjacent or nearby properties to reduce the amount of hard surface needed for limited weekly use. Typical parking arrangements accommodate 100 cars per acre.

**Site access:** Parking should be visible upon approach to the site, and the main entrance to the building needs to be easily identifiable. More than one entrance to the site is advisable. Include service drives for delivery and removing trash from the kitchen and other facilities. Provide adequate sidewalks to the facility.

**Building access:** Multiple access points to the building will accommodate the rapid influx of people arriving for services. Where possible, include a covered area to protect people being dropped off or picked up. This is especially important for special services, such as weddings and funerals.

**ELEMENTS TO CONSIDER**

**Worship center (nave, sanctuary, or auditorium):** Allow 8 to 10 sq ft per person in the seating area. Several basic arrangements for seating are shown here. Consider style of worship, site constraints, seating capacity, and sight lines. Many variations are possible.

**Raised platform (sanctuary, chancel, or platform):** Allow room for table or altar, pulpit, reading desk, and usually some seating. Observe rules for sight lines.

**Music, choir, instruments:** Size of choir is typically 10% of the worship center's capacity. Choir seating should be close to the musical instruments and arranged in no more than three rows. Allow room for special performers, handbells, strings, and piano. Consider fixed instruments, such as the organ, in planning the room.

**Special considerations:** Sacred or liturgical items that have specific functions, such as the tabernacle, baptismal font or baptistry, devotional areas, and statuary will vary among churches. Think of symbols, artwork, seasonal decorations, and furnishings as part of the room. Discuss room acoustics and sound reinforcement systems, which are a critical component. Consider both natural and artificial lighting. Include preparation rooms (sacristies or communion preparation) and, for floral arrangements, spaces with access to a sink, storage, and perhaps refrigeration. Special sinks for consecrated wine or water may be needed. Dressing rooms with toilets may be required for immersion/submersion baptisms.

**Gathering space (narthex or commons):** Allow 2 to 3 sq ft for each person in the worship center. This is the circulation hub of the church. Include coat hanging and information areas, as well as other storage space.

**Administrative offices:** Include reception area (25 to 30 sq ft per waiting person), main office (50 to 75 sq ft per clerical staff member), and individual offices (150 to 300 sq ft, depending on function). Provide counseling space where appropriate. Also provide work/storage space for photocopying, filing, and the like. Staff/meeting rooms may be shared as a classroom or library.

**Multipurpose rooms (fellowship rooms or parish hall):** These are used for dining, meetings, sports, and education. Configurations should be flexible and easy to alter.

**Kitchen/serving facilities:** Square footage should be 25% of the multipurpose room square footage. Consider whether the kitchen is full service or only for warming or catering. May house commercial or residential equipment. Check local health department rules. Determine whether to design for staff or volunteer help. If the kitchen is adjacent to the multipurpose room, allow secondary access to serve the rest of the facility.

**Music support spaces:** Provide a seating layout identical to that of the worship center. Design acoustics to match that of the worship center when full. Provide a music storage and retrieval system. Robing rooms, warm-up rooms, music director's office, and practice spaces may need to be included.

**Education spaces:** These may be designed for licensed day care; check with appropriate authorities. The following age groups need to be considered:

1. Nursery (0 to 6 months): 30 to 35 sq ft per person. Provide a drop-off area with security, storage for infant paraphernalia, changing area with sink, staff toilets, and toy storage.
2. Small children (6 months to 3 years): 30 sq ft per person. Provide changing area with sink, child-sized toilet facilities, storage, and proper lighting and ventilation.
3. Children (ages 4 to 11): 25 sq ft per person. Classrooms are much like an elementary school's. Provide display space, storage, access to toilets, and appropriate surface finishes for crafts.
4. Youth (junior high through college): 18 to 20 sq ft per person. This group typically enjoys a more casual style of space, which can be modified to match its particular image. Incorporate soft furniture, storage, and appropriate finishes for hard use.
5. Adults: 12 to 15 sq ft per person. Depending on style of classes, the furnishings may vary widely, from tables and chairs to lounge-type furniture. May be shared space with parlor, lounge, or library.

**PLANNING ISSUES**

Including all programmed spaces described above and support facilities such as toilets and mechanical rooms, the complex will be from 55 to 60 sq ft per seat in the worship center. The center of the complex is the gathering space, which acts as a lobby to orient visitors and users alike. Placing the administrative offices near the main entry provides a measure of security. The worship center, the focus of the complex, is easily accessible to the gathering space. Music support spaces are near the performing location in the worship center.

The gathering space may also serve as a lobby for the multipurpose room. The kitchen should serve the multipurpose room as well as other activity spaces. Food delivery and refuse removal need to be accommodated without using public spaces. Nurseries and young children's rooms should be close to the gathering space. Youth classrooms often have a separate entry, removed from the main entry. Clear, wide, and open circulation paths throughout the entire complex will augment its use, as large numbers of people move through the corridors over very short periods of time.

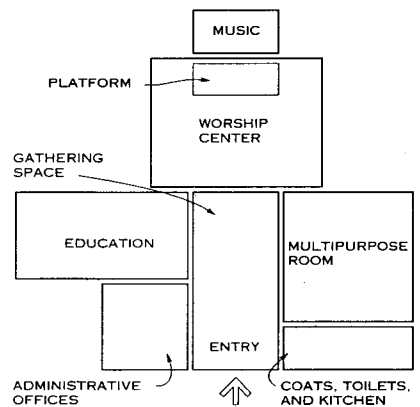

**OVERALL SPACE RELATIONSHIPS**

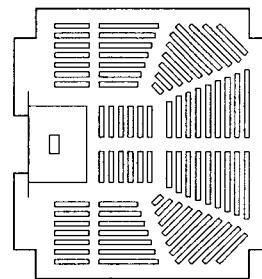
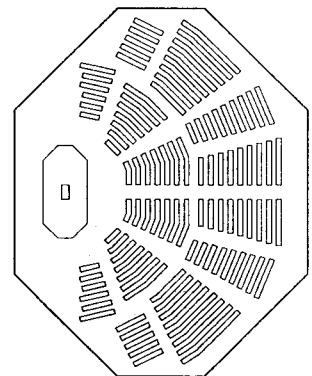
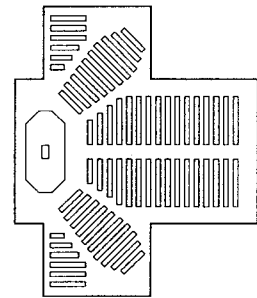
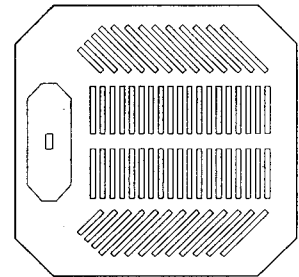
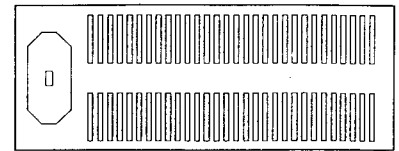

**SEATING CONFIGURATIONS**

David Cooper, AIA; Ware Associates, Inc.; Rockford, Illinois/Chicago/Los Angeles

**GENERAL**

The following are activity and space requirements for synagogues:

**ACTIVITIES**

1. Worship for large and small groups
2. Cantorial (all groups), Music (reform)
3. Bar mitzvah and Bas mitzvah
4. Hospitality/reception
5. Study area
6. Child care
7. School
8. Assembly (non-worship)
9. Food services - Oleg Shabbat
10. Maintenance

**SPACES**

1. Sanctuary (including expansion of 200% for high holidays)
2. Bemah
3. Ark
4. Lectern, reform or conservative
5. Chairs - four for officers
6. Eternal light

**AREAS**

1. Social hall - 12 sq ft per person dining
2. Administration - 30% of sanctuary space
3. Kitchen - 10% of sanctuary space
4. Education
  - a. 30 sq ft per child in nursery/kindergarten
  - b. 30 sq ft per child in grade 1 to 6
  - c. 20 sq ft per child in grades 7 to 12
  - d. 15 to 20 sq ft per adult
5. Seating - 15 sq ft per person net
6. Aisle dimensions
  - a. Main aisle - 5 ft wide
  - b. Side aisle - 3 ft 6 in.

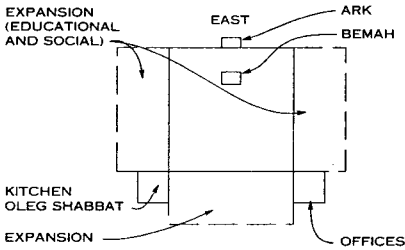

**INTERRELATIONSHIP DIAGRAM**

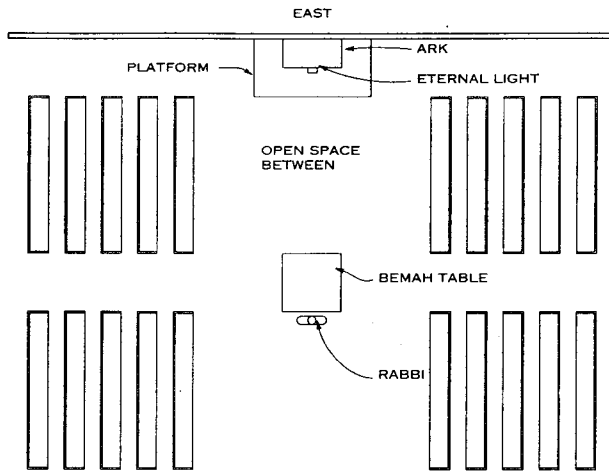

**ORTHODOX LAYOUT**

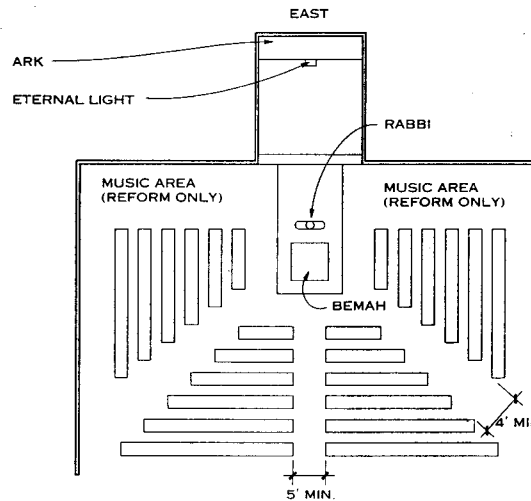

**REFORM AND CONSERVATIVE LAYOUT**

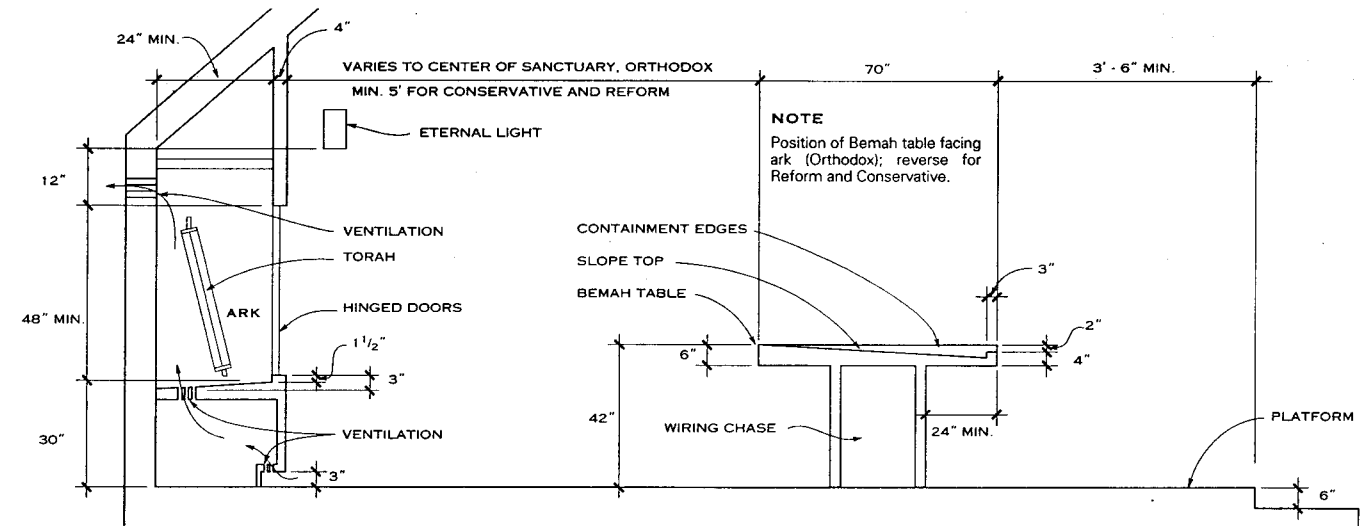

**SECTION**

Norman Jaffe, FAIA; Bridgehampton, New York  
Gulzar Haider; Carleton University; Ottawa, Canada

**SPECIAL DESIGN CONSIDERATIONS**

**SYMBOLIC ELEMENTS:** Most Muslim communities, especially those who consider the pluralistic, freedom, and rights-based Western world as their home, want to express their presence through a structure is easily recognizable as a mosque. The common architectural features that give the mosque a unique silhouette are the domes(s) and minarets(s) that culminate with a clearly visible crescent. A formal entrance, an expressed turn of the prayer hall toward the Qibla, a Mihrab that bulges out on the exterior of the Qibla wall, and some carefully placed arched windows can further enhance the recognizability of the mosque.

**LOBBY:** Some communities require that male and female members of a family separate before entering the mosque, thus requiring two separate entrances. This has important implications for the planning and formal expression of the mosque.

**SHOES AND COAT AREA:** For men and boys; separate facilities for women, young girls, and children.

**WASHROOMS:** Provide regular washrooms, possibly including a European bidet or similar arrangement for washing. One washroom should be planned for fifty prayer spaces. Consideration should be given to providing adequate washrooms for women with children.

**ABLUTION AREA:** Ablution stations are needed for the ritual cleansing of hands, forearms, mouth, sinuses, face, and feet in a prescribed sequence. At least one enclosed shower stall is needed for the ritual shower of Ghusul. Provide a nonskid surface in this area. Some provision should be made for drying feet before entering the prayer area.

**PRAYER HALL:** Rectangular or square floor area with simple linear arrangement for prayer spaces. The prayer rows are parallel to the Qibla wall and directed toward Qibla as indicated by Mihrab. No shoes are worn in the designated prayer areas. A separate area for women, young girls, and children must be provided. Special acoustically separated but visually connected area for nursing mothers and mothers with very young children is recommended.

**AREA FOR NON-MUSLIM VISITORS:** Requests to observe the Islamic prayers are common and should be accommodated.

**MOSQUE CAPACITY:** The mosque should be planned on sound population data and projections. In North America and Europe, construction of a "visible and permanently consecrated" mosque often draws extra people to the congregation.

**WOMEN'S ATTENDANCE:** Women generally comprise 25 to 33 percent of the total congregation. This will probably increase considerably in the West as women assume a more active role in community affairs.

**PARKING:** One parking space should be provided for five adult prayer spaces with contingency arrangements for extra parking on high religious holidays.

**MOVEMENT THROUGH SPACES:** A clear sequence of alternative movement choices from the entrance to the prayer hall should be developed. Areas in which shoes should be removed and stored versus shoeless areas is a planning difficulty. Consult with the client on acceptable situations.

**PRAYER AREA:** The conventional geometry of a prayer area has been a broadside rectangle with its longer side parallel to the Qibla wall. Religious tradition has established a precedent for longer rows to be closer to the Qibla wall. Floor finishes of the prayer hall should clearly indicate the arrangement of prayer rows at every 48 inches parallel to the Qibla wall. The floor should also be soft enough for the knees, which carry a considerable weight as the body is changes postures. Each prayer module should be 24 x 48 in.

**BURIAL PREPARATION:** If facilities for the washing and shrouding of the dead are required, follow relevant health regulations.

**PROGRAMMING ELEMENTS**

1. A marked entrance, gateway
2. A lobby or forecourt with attached facilities
3. Prayer hall and its various sections with clearly marked thresholds of entrances
4. Qibla wall
5. Mihrab
6. Mimbar

Norman Jaffe, FAIA; Bridgehampton, New York  
Gulzar Haider, Carleton University; Ottawa, Canada

**TYPES OF MOSQUES IN THE CONTEMPORARY WEST**

**NEIGHBORHOOD MOSQUE:** Serve those in a community for which the main or the Friday mosque might be beyond convenient transportation.

**FRIDAY MOSQUE** (often called the main or the central mosque or given a special name like Al-Farooq Mosque): Large enough for Salat al-Juma', capacity usually above 200. Imam's residence and a caretaker's apartment may be attached to the mosque.

**ISLAMIC CENTER:** Mosque plus facilities for socioreligious gatherings that cannot be performed in the mosque prayer hall, e.g., weddings, anniversaries, lectures, and light sports. Some centers also have facilities for the ritual washing and shrouding of dead bodies in preparation for burials.

**CAMPUS CENTER:** Caters to the unique setting and requirements of the Muslim population of a university campus.

**HEADQUARTERS MOSQUE:** Built as a marker of an Islamic diplomatic or organizational presence (e.g., Washington Islamic Center, United Nations Mosque). Mosques that belong to special spiritual orders of Islam may also fall under this category.

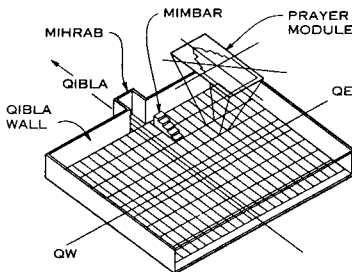

**NOTES**

1. Number of levels for the Mimbar equals 3, 5, or 7 depending on the size of the congregation.
2. Portability of Mimbar is recommended.
3. Coordination of Mimbar and Mihrab design is recommended.
4. When women attendance exceeds 33 percent to total congregation, a separate floor and/or space is recommended.
5. Mihrab design is achieved by relative manipulation of outside and inside surfaces without violating spatial prayer module for Imam.

**PLAN**

**DEFINITIONS**

- Salat: Obligatory Islamic ritual prayer to be offered five times a day, preferably in congregation, in the mosque
- Imam: Religious leader of Muslim community
- Salat al-Juma': Obligatory Friday congregational prayer with khutba by the Imam
- Sijdah: Prostration before God in the body position when the forehead, two palms, two knees, and two sets of toes simultaneously touch the earth plane
- Masjid/Mosque: Literally the place where Sijdah is enacted. Place for collective Salat whose crescendo is Sijdah in unison by the whole congregation.
- Jami Masjid: Mosque large enough hold Salat al-Juma'
- Kaa'ba: The cube shaped, black cloth-draped sanctuary erected by Abraham and Ishma'il as "Bait-Allah," the "house of God." Located at the center of the holy precinct in Makkah. The sacred node to which all mosques of the earth are oriented.
- Qibla: Orientation toward Kaa'ba
- Mihrab: Niche identifying the Qibla wall and the place of the Imam who leads the congregational prayer.
- Mimbar: Mosque pulpit, a simple ladder chair for the Imam to rise to a place of higher visibility among a large congregation. Traditionally the symbolic seat of the prophet.

**QIBLA ORIENTATION**

The following figure and procedure is for cities in the Northern hemisphere west of Makkah. The method can easily be extended to cities over the rest of the globe.

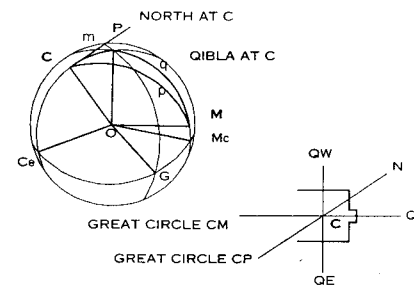

**SPHERICAL GEOMETRY**

The Qibla orientation for a mosque is calculated by the following equations, using equation 1 to solve for unknown angle p, then substitute the value of angle p into equations 2 to solve angle Q, Qibla orientation:

Equation 1:  $\cos p = \cos q \cos m + \sin q \sin m \cos P$

Equation 2:  $\sin Q = \frac{\sin q \sin P}{\sin p}$

where:

- C = City Whose Qibla is to be calculated
- Ce = Geometric location of city meridian on equator
- M = Makkah, location of Kaa'ba
- Me = Geometric location of Makkah meridian on equator
- P = Geometric north pole of earth sphere
- O = Geometric center of earth sphere
- G = 0° meridian at equator

- m = Angle COP (known as 90° - latitude of city C)
- q = Angle POM (known as 90° - latitude of Makkah)
- p = Angle COM
- P = Angle CeOm
- Q = Qibla orientation at C, angle between diametric planes CPO and CMO

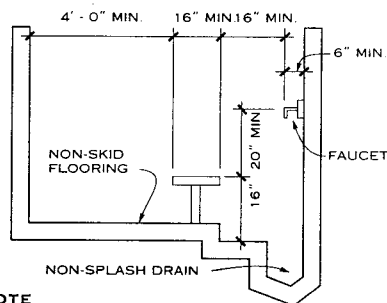

**NOTE**

Ablution stall should be separated a minimum of 24 in. with the recommended distance of 30 in.

**ABLUTION STALL**

**SUMMARY**

It is recommended that before the architect embark on interpretation and invention of a mosque, they acquaint themselves with the many regional traditions and some recent precedents in the design. The following references are recommended:

Burckhardt, T. Art of Islam: Language and Meaning (London, 1976).  
Hoag, J.D. Islamic Architecture (New York, 1977).  
Michell, G. (ed). Architecture of the Islamic World (London, 1978).  
Papadopol, A. Islam and Muslim Art (Abrams, 1976).  
Sevcenko, M.B. (ed). Theories and Principles of Design in the Architecture of Islamic Societies, AKPIA (Cambridge, Mass., 1988).

**PLANNING ISSUES**

Correctional facility design has experienced a dramatic shift away from the classic cellblock system to a centralized living unit concept. This system provides for greater control of a given number of inmates and economizes on staffing requirements by allowing control of several living units from a centralized location. Living units are sized to provide manageable groups of inmates, maximum flexibility in segregating different groups, and a high degree of fire protection without sacrificing security.

The living unit concept typically groups between 24 and 48 single cells around a communal dayroom, which provides areas for television, reading, conversation, and light activities. Each unit contains its own shower facility, with approximately one shower for every 8 inmates. Units are usually two tiers high, with a two-story dayroom. The inclusion of natural light in both cells and dayrooms is strongly encouraged.

There is a growing trend away from indirect inmate supervision (in which guards are placed in a secure control booth) to direct supervision where guards are in direct contact with the inmates, encouraging an environment of greater interaction.

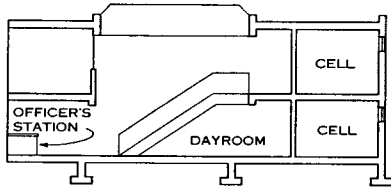

TYPICAL UNIT SECTION

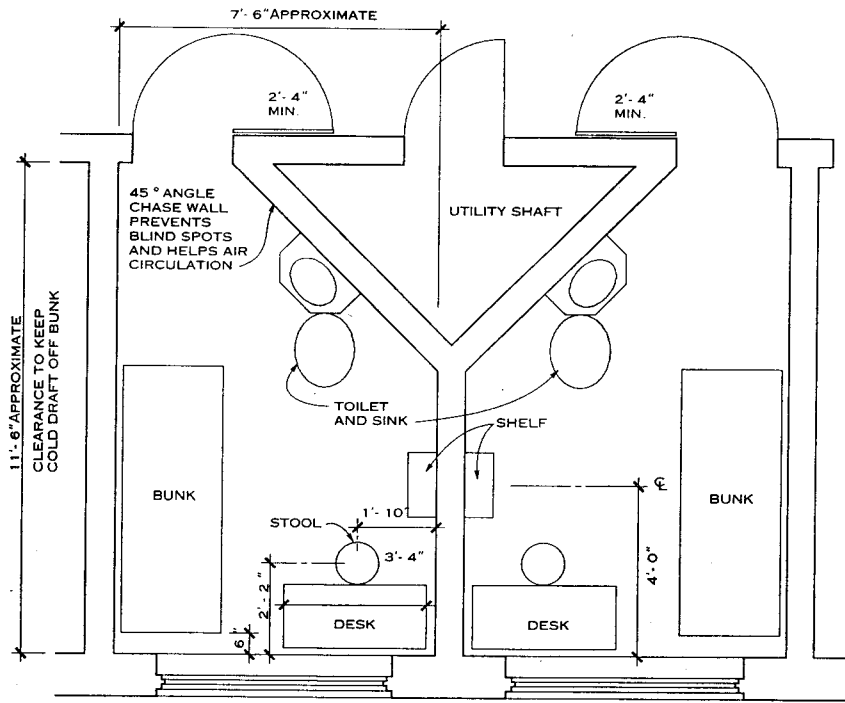

TYPICAL CELL LAYOUT

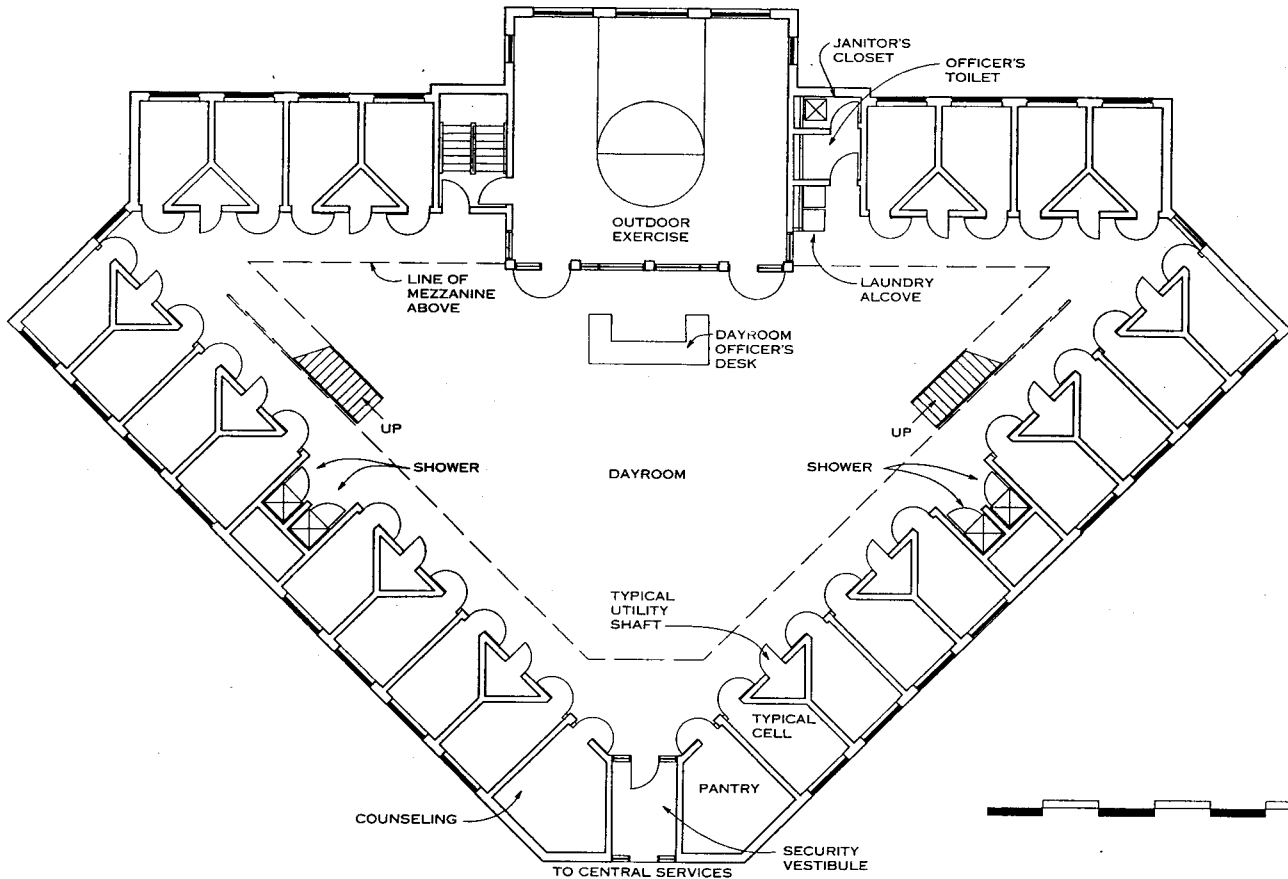

TYPICAL HOUSING UNIT PLAN

Glenn J. Ware, AIA; Hansen Lind Meyer; Orlando, Florida



**TYPES OF COURTS**

There are many different types of courts in the United States, each with its own characteristics and requirements. Federal courts have several levels of jurisdiction, beginning with the magistrate courts and the U.S. district courts. Courts of appeals hear appeals from the district courts, and the U.S. Supreme Court—the court of last resort—hears appeals from the appeals courts. Tax and bankruptcy courts are also part of the federal judiciary.

Each state has its own judicial system. Some states have special jurisdiction courts, such as juvenile or traffic courts. A good source for information on each state's court system is the National Center for State Courts.

Limited jurisdiction courts can be part of a state system or of a smaller municipal entity. They hear only such matters as misdemeanors and traffic offenses. General jurisdiction courts have trial jurisdiction over all matters and may have some authority to renew appeals from limited jurisdiction courts.

**SYMBOLISM AND IMAGE**

Historically, the American courthouse has been characterized by its size, siting, and specific architectural elements such as columns, domes, clock towers, and grand entrances. The architectural elements of a courthouse should reflect the dignity of the judiciary and its importance in the community.

**PLANNING COURTROOM SPACES**

The spaces required in a typical trial courthouse vary considerably from state to state and by level of court. Most contain courtrooms, judicial chambers (offices), jury assembly and deliberation rooms (for courts with jury trials), clerks' offices, records rooms, and prisoner holding cells (in criminal courts). Court clerks, law clerks, court reporters, and administrators need offices, and witness waiting rooms and attorney-client conference rooms are needed. Other offices might include those for the prosecutor (district attorney), public defender, and parole officers. Some courts require special courtrooms, or hearing rooms, for arbitration, mediation, high security criminal cases, and juvenile, family, and traffic cases.

The courthouse must be designed with its special circulation patterns in mind. Separate and distinct circulation paths for the public, judges and their staff, and in-custody defendants help ensure efficiency, safety, and security and are a distinctive feature of modern courthouses.

The public circulation area includes all areas used by the public, attorneys, clients, witnesses, and jurors (before selection), such as the main lobby, corridors, public elevators, public restrooms, waiting areas, and clerk of court counters.

The private circulation area allows judges and trial-related court personnel to move between chambers and courtrooms and jurors to move between courtrooms and jury deliberation rooms. Private circulation usually connects secured, private parking facilities for judges to private elevators and corridors leading to courtrooms and chambers.

Secure circulation provides a path for in-custody defendants, who enter the courthouse through a secure vehicular sally port and are taken to a secure central holding and staging area. A secure prisoner elevator serving holding units between two courtrooms is an easy way to move prisoners to courtrooms without crossing private judicial/juror/staff corridors.

**INTERNAL LOCATION OF COURT FUNCTIONS**

Clerks' offices, windows for paying fines, and other offices that attract heavy visitor traffic should be located near the main entrance. Courtrooms should be located away from the entrance to minimize noise and distractions. Chambers should also be located away from high-volume public areas. Busier traffic, misdemeanor, and other limited jurisdiction courts belong closer to public entrances, while general jurisdiction courtrooms should be less accessible, perhaps on an upper floor. Jury deliberation rooms, courtroom holding facilities, attorney-client conference rooms, witness waiting rooms, and security officers' stations should be near courtrooms.



**LEGEND**

Don Hardenbergh; Courtworks; Williamsburg, Virginia

**OVERVIEW OF COURT TYPES**

	FEDERAL	STATE	LOCAL
Appellate	Supreme Court, Court of appeals	Supreme Court, intermediate, and appellate court	
General jurisdiction	District courts	Circuit Superior District	
Limited jurisdiction	Magistrate courts	Justice, district, and county courts	Municipal, city, and town courts
Special courts (examples)	Bankruptcy, tax	Juvenile, traffic, and small claims	
Administrative law courts (examples)	Hearing officers, U.S. Atomic Energy Comm., Federal Maritime Comm.	Workers' comp., public utility commissions, admin. law judges	

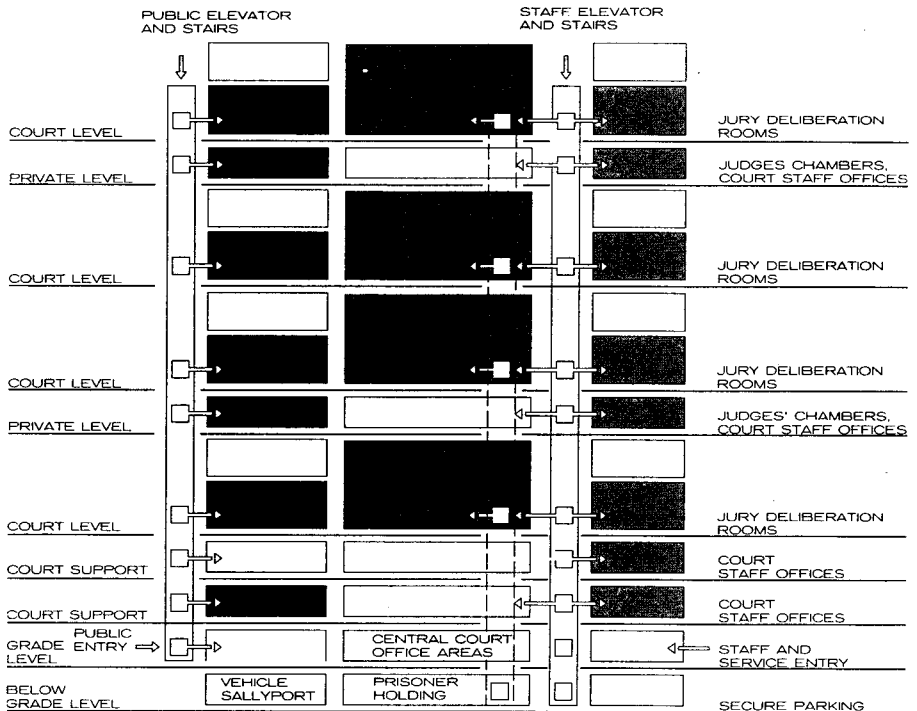

**TYPICAL COURTHOUSE STACKING**

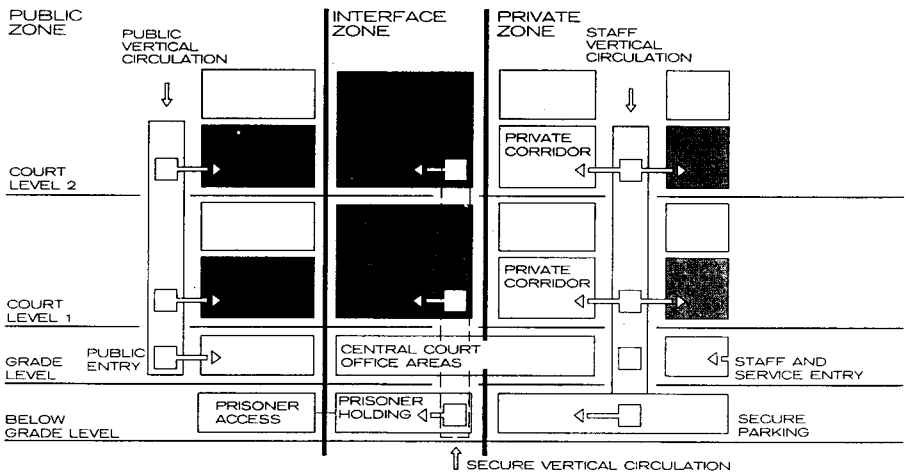

**COURTHOUSE CIRCULATION AND ZONING SECTION**

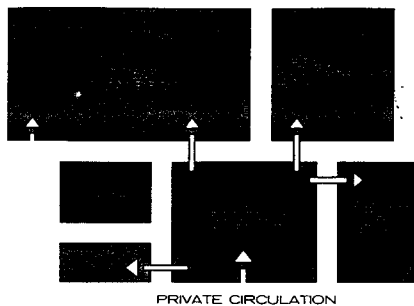

PRIVATE CIRCULATION

TYPICAL CHAMBER DIAGRAM

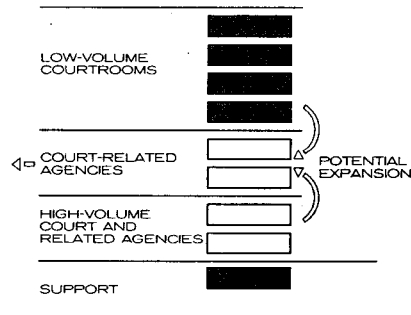

PROVISION FOR FUTURE VERTICAL EXPANSION

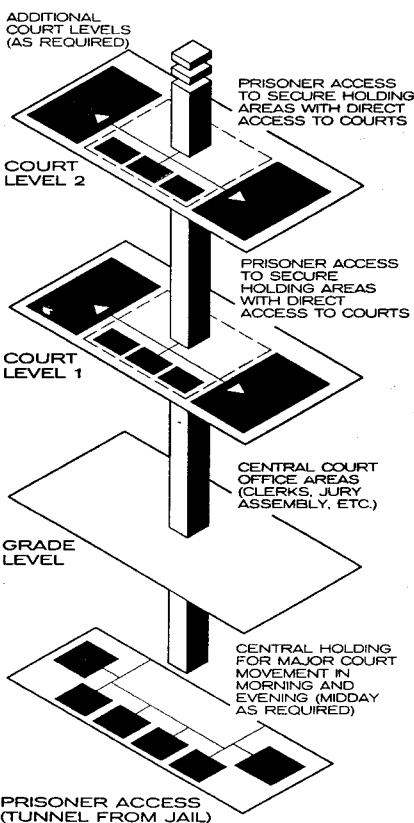

VERTICAL SECURITY CIRCULATION

COURTROOMS

Courtrooms should be easily accessible to the public. In large multistory facilities, they may be on an upper floor, but in small rural courthouses they may be located near the main entrance. Staff and judges should be able to enter the courtroom through a private corridor, and prisoners should enter directly from a secure holding area adjacent to the courtroom. Prisoners and defendants should not enter the courtroom near the public, jurors, or witnesses. Jurors should not pass near the defendant or the public on their way into the courtroom and should be able to move directly from the courtroom to the deliberation room.

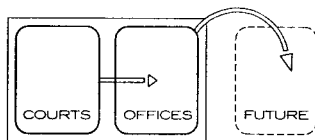

CONVERSION OF ADJACENT SPACE TO COURTROOMS

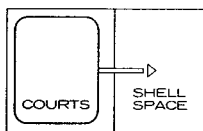

FINISHING OF SHELL SPACE

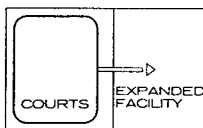

PLANNED ADDITION

PROVISIONS FOR FUTURE HORIZONTAL EXPANSION

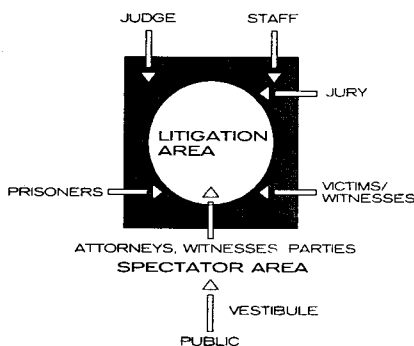

COURTROOM ACCESS

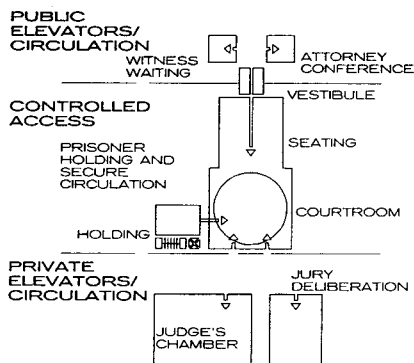

COURT FLOOR ZONING

Judicial chambers contain the judges' private offices and space for judicial staff such as a secretary, court clerk, and law clerk. Chambers may include a conference room and law library. They should be in a private, quiet, and safe area of the courthouse, usually away from the main entrance or on an upper floor. Judges should have quick and easy access to the courtrooms, while persons meeting with them should pass through a reception or screening area.

Traditionally, judicial chambers are adjacent to the judge's courtroom. While this is convenient for the judge, it makes future organizational changes more difficult. In larger courthouses, it is becoming popular to separate judges' chambers from the courtrooms; sometimes they are even on different floors. Such separation permits sharing of common resources such as the law library, conference areas, and court staff rooms; enhances security; and provides flexibility for later adjustments.

GROSSING AND EFFICIENCY FACTORS

Functional courthouses require more space for circulation and building support functions than most other building types. The departmental gross square footage (DGSF) needed for administrative purposes is reasonably consistent with similar requirements in commercial office or government administration buildings. But highly specialized areas such as courtrooms and holding facilities require considerably more internal circulation.

Basic core functions include major public corridors linking departments; private corridors linking courtrooms, judges' chambers, jury deliberation rooms, and other dedicated support spaces; secure corridors linking courtrooms with prisoner detention facilities; public elevators and elevator lobbies; private and secure elevators; stairs; mechanical, electrical, and plumbing chases; public toilet facilities; and the exterior walls of the building.

Because courthouses have unique security and circulation requirements, individual functional areas must be larger than in an office building. To handle the crowds of disparate people, courthouse lobbies, elevator cores and elevator lobbies, and public corridors must be larger than in a typical office building. An appropriate building gross square foot (BGSF) multiplier for courthouses is typically 1.20 to 1.25 of the DGSF.

TYPICAL COURTHOUSE EFFICIENCY FACTORS

Net area	57 to 65%
Departmental gross area	75 to 85%
Building gross area	100%

SECURITY

Effective courthouse security is maintained by combining structural elements, traffic pattern control, security devices, specific security policies, and security staff. The danger of armed violence requires controlled courthouse access; walk-through metal detectors and X-ray devices at the entrance are necessary in larger urban courthouses. The number of public entrances should be limited and lobbies sized and configured to permit queuing at security checkpoints without making people wait outside.

General court floor security should be controlled by a bailiff station in the public area, with access to private corridors restricted by a proximity card access system. Access to private corridors serving judges' chambers, staff, and jury deliberation rooms may be regulated by closed-circuit television (CCTV) and intercom systems or by a receptionist.

Prisoners should move from a secure sally port into a central holding area. Good sight lines in the courtroom are vital to effective control. Bullet-resistant materials should surround the judge's bench, and duress alarms (linked to a CCTV system) are essential for rapid emergency response. Fine and fee payment windows should have security glazing and duress alarms.

FLEXIBILITY AND EXPANSION

Several measures can prolong the operational life of a courthouse. Floor-to-floor heights and bay sizes may be standardized throughout the building to permit future conversion of noncourtroom space into courtrooms. Locating low-to-medium volume office functions on middle floors makes future modifications easier: As these offices outgrow their space they can be moved to adjacent buildings, allowing court functions to expand upward from the high-volume public floors and downward from the trial courtroom floors. Another strategy is to build shell space (an empty floor or room), which can be fitted out and occupied when needed.

Don Hardenbergh; Courtworks; Williamsburg, Virginia

**FUNCTION VS. OPERATION**

Courthouses can be organized by function or by type of court. All courtrooms, all chambers, and all clerks' offices are grouped together in a functional organization. An operational arrangement separates different types of courts or departments, such as criminal courts, general jurisdiction trial courts, traffic courts, or family courts. Judges for each court are housed with their clerks and courtrooms on separate floors, or in separate areas, of the building.

**COURTROOM DESIGN**

Image, symbolism, and functionality are important in courtroom design. The arrangement of the participants and furniture reflects society's view of the relationships between the defendant and judicial authority or, in a civil case, of the relationship between the parties. Furnishings and finishes should reflect the seriousness of the proceedings, yet not be too dark and overbearing.

Courtroom space is needed for the judge, court reporter, clerk, bailiff (security officer), prosecutor or plaintiff and attorney, defendant and attorney, witnesses, jury, and spectators. Other participants include social workers, probation officers, interpreters, police officers, and the press.

The traditional courtroom is rectangular and deeper than it is wide, although some modern courtrooms are round or square. The shape of the courtroom must allow all participants to see and hear one another clearly without having to look back and forth too much.

Functionally, courtrooms are divided into a litigation (well) area and a public (spectator) area, separated by a bar or low railing. The litigation area may be rectangular, with the judge's bench located along the front wall or in the corner of the room.

The depth of the litigation area is determined by whether a jury box is included and the distance needed to separate the judge's bench and attorneys' tables. This separation is necessary both to provide adequate circulation within the litigation area and to give prominence to the judge.

The spectator area in most types of courtrooms should have a minimum seating capacity of 75. Traffic or misdemeanor courts, however, may require a minimum seating of 100 or more depending upon the court's workload.

The height of the courtroom should be proportional to the size of the room and should provide appropriate distance from the ceiling for a judge standing at the bench. The ceiling height over the litigation area may be higher than that over the spectator area.

Acoustics should allow no reverberations or echoes, so that participants are able to hear the proceedings clearly. A public address system is generally recommended.

Soundproofing between courtrooms and surrounding spaces (particularly holding cells), double-door vestibules between the public corridors and courtrooms, and carpeting all reduce noise in the courtroom. Generally, the front wall of the courtroom may be constructed of reflective materials to enhance the sound from the litigation area, while the back wall should be covered with sound-absorptive materials to reduce noise.

Courtrooms with exterior windows can suffer from sunlight shadowing and dappling effects, heating and cooling complications, reduced security, exterior noise, and visual distractions. If the location permits, skylights are an excellent source of natural light without the problems presented by windows.

**ACCESS FOR PERSONS WITH DISABILITIES**

All courtrooms should comply with the Americans with Disabilities Act Accessibility Guidelines for Buildings and Facilities (ADAAG). Areas of the courtroom that need to be accessible are spectator seating, the witness stand, counsel tables, and the jury box. Space should be provided so that all other workstations can be made accessible in the future. The first tier of the jury box may be at floor level, and so may the witness box (the witness box and first tier of the jury box should be the same height).

Allow 48-in.-wide spaces for wheelchairs in the spectator area. The number of wheelchair accessible spaces must meet the seating requirements for assembly areas. All courtrooms with public seating of 51 or more (to a maximum of 300) require four wheelchair locations.

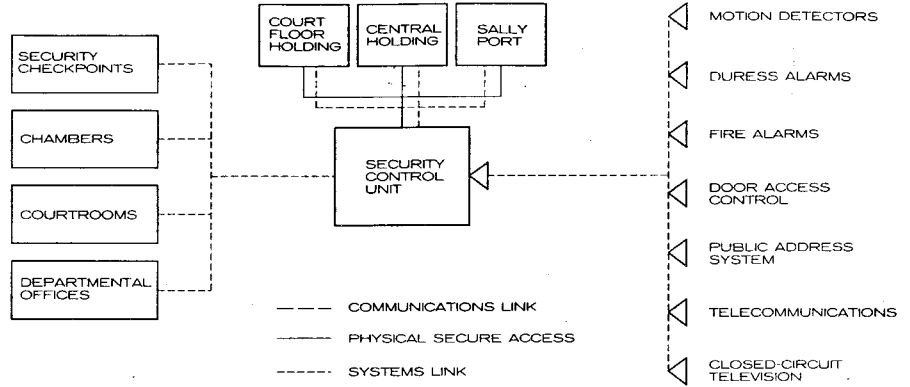

**SECURITY CONTROL DIAGRAM**

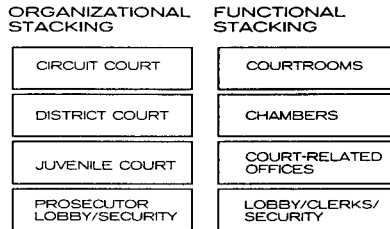

**STACKING DIAGRAMS**

**TYPICAL DIMENSIONS FOR LITIGATION AREAS**

TYPE OF COURTROOM	WIDTH (FT)	DEPTH (FT)	TOTAL AREA (SQ FT)
Formal nonjury hearing room	28	30	840
Jury courtroom (1-tier jury box)	32	32	1024
Jury courtroom (2-tier jury box)	36	32	1152
Jury courtroom (3-tier jury box)	38	32	1216
Ceremonial/large courtroom	40	34	1360

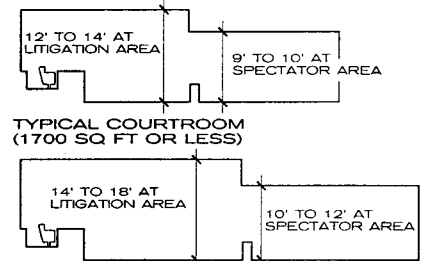

**COURTROOM CEILING HEIGHT**

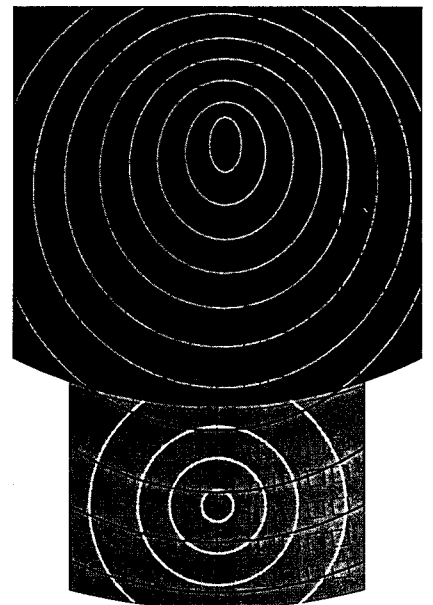

- HARD, SOUND-REFLECTION WALL TREATMENT; CARPETED FLOOR; HIGH, SOUND-REFLECTING CEILING
- SOFT, SOUND-ABSORBING WALL TREATMENT; LOWER, SOUND-ABSORBING CEILING OVER SPECTATORS; SOLID-CORE DOORS ARE FULLY GASKETED OR WITH VESTIBULE

**COURTROOM ACOUSTICS**

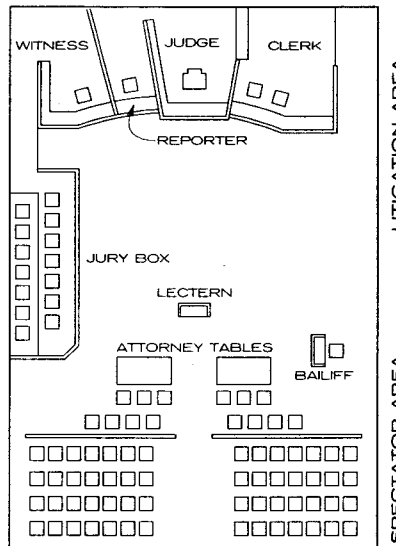

**TYPICAL COURTROOM WITH WITNESS ADJACENT TO JURY**

Don Hardenbergh; Courtworks; Williamsburg, Virginia

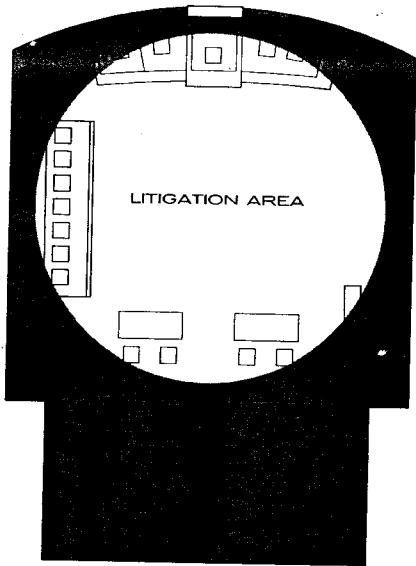

- 70 FOOTCANDLES
- 30 FOOTCANDLES

**MINIMUM COURTROOM LIGHTING LEVELS**

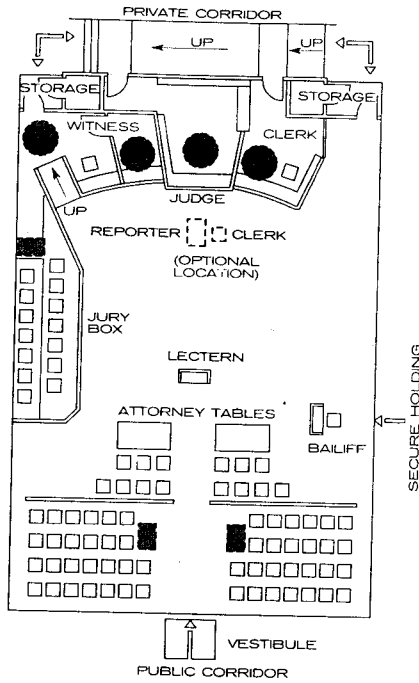

- WHEELCHAIR LOCATION
- WHEELCHAIR TURNING CIRCLE

**WHEELCHAIR ACCESSIBLE COURTROOM**

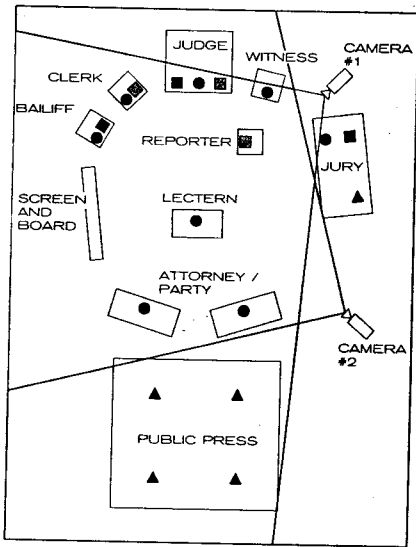

- DURESS ALARM
- ▲ SPEAKER
- MICROPHONE
- COMPUTER

**AUDIOVISUAL EQUIPMENT LOCATIONS**

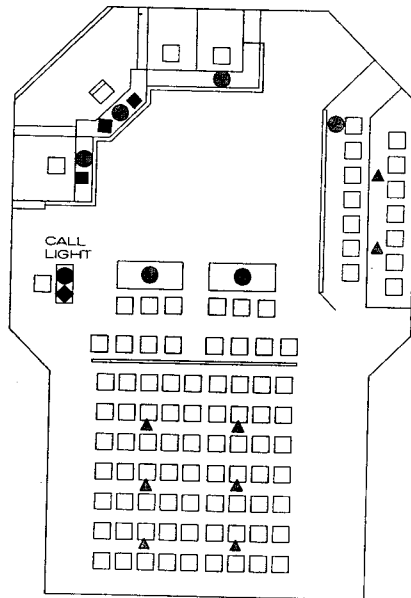

- COMPUTER TERMINAL
- MICROPHONE
- ◆ ALARM BUTTON
- ▲ CEILING-MOUNTED LOUDSPEAKERS

**SYSTEM CONTROL LOCATIONS**

Sound amplification for the hearing impaired must be installed and available. At least half of each type of courtroom, hearing room, jury deliberation room, and jury assembly room should have an assistive listening (either FM, audio loop, or infrared) device.

**SECURITY**

Circulation routes for courtroom participants should be clearly separated, and there should be no spaces where a weapon or bomb might be placed or posts or pillars in the courtroom behind which someone might hide. The judge's bench should be shielded with bullet-absorptive material and equipped with duress alarms connected to the central security station.

**FURNISHINGS AND FINISHES**

The colors and tones of the walls and ceilings should project dignity and calm. Furnishings and finishes should be comfortable, sturdy, durable, vandal-resistant, and easy to clean. Draperies or other window coverings should be used if the courtroom has windows. Seats, benches, and chairs should be comfortable and easy to maintain.

**TECHNOLOGICAL APPLICATIONS**

Judges, court staff, and attorneys increasingly need access to audiovisual and video equipment, computer terminals, and information databases. While live court reporters will continue taking the record in the immediate future, electronic sound and video recording and playback equipment is becoming more popular and should be available in courtrooms, both for recording the trial and for videoconferencing and hearing remote testimony.

**SOUND AND VIDEO EQUIPMENT**

Microphones should be located at the bench, clerk's workstation, witness stand, lectern, jury box, and attorneys' tables. Allow space for video display monitors to be installed at the attorneys' tables, lectern, witness stand, and jury box. Camera locations for potential video court reporting, video arraignment, media coverage, or courtroom security surveillance should be identified. Camera coverage of the court proceedings should avoid coverage of the jurors.

**SOUND AMPLIFICATION SYSTEMS**

All courtrooms should be equipped with sound amplification equipment for assisting the hearing-impaired and for playing back audio exhibits. The master controls should be located at the bench or clerk's station.

**COMPUTER TERMINALS AND OTHER EQUIPMENT**

Plan on future installation of computer terminals and monitors for the bench, court clerk's station, and court reporter's station in all courtrooms. If possible, recess the clerk's and judge's monitor into the millwork.

Allow for installation of additional electrical outlets at the attorneys' tables, jury box, clerk's station, bench, and public seating area.

**THE COURT**

**CLERK'S WORKSTATION**

The court clerk checks case files and records appropriate case dispositions. The clerk frequently passes files to and from the judge and must be close enough to do so easily. The clerk should generally be elevated on one riser so he or she can see the whole courtroom.

The court clerk's work surface should be approximately 30 to 36 in. deep and 4 ft long in order to accommodate case files and computer equipment. The workstation requires the same task lighting as the judge's bench and the clerk's station may have the same duress alarm/intercom link with the central security station as the judge. There should be desk drawers or pigeonholes for paperwork and an inconspicuous, lockable storage area where evidence and trial materials may be stored during recesses.

The court clerk's station should have flush, floor-mounted electrical receptacles, a telephone jack, and cable conduits for computer terminals and a built-in computer monitor. The computer terminal should be equipped with a silent keyboard and laser printer. The control console for the sound amplification system may be located at the court clerk's station, along with a microphone for the clerk.

Don Hardenbergh; Courtworks; Williamsburg, Virginia

**JUDGE'S BENCH**

The judge's bench should convey dignity and authority. From the bench, the judge should be able to see and hear all courtroom participants, exercise a protective influence over witnesses, address all persons in the courtroom, and pass and receive documents from attorneys, the court clerk, and the court reporter.

The size of the judge's bench should be proportionate to the size of the courtroom. There should be at least 4 ft behind the judge's desk so the judge can move freely for sidebar conferences, reach for reference books, and easily enter and exit the bench.

The bench should include several drawers for supplies and personal items, as well as a bookcase at least six ft wide for legal reference books.

The eye level of the judge should be higher than that of a standing person of average height. Generally, the judge's bench should be elevated 21 in. or at least three risers. A barrier such as an ornamental rail along the front of the bench prevents individuals from approaching too close to the bench or reading documents or notes that are on the judge's bench.

Room lighting should be augmented by task lighting directly above the bench. Lighting controls for the entire courtroom should be located at or near the bench or the clerk's station.

Electrical receptacles flush-mounted in the floor and cable conduits for a built-in video display and computer terminal should be installed. The bench should be equipped with a telephone and a microphone connected to an amplifier controlled by the judge or the clerk.

**COURT REPORTER**

The court reporter's station should be adjacent to the witness stand so the reporter can clearly view and hear voice testimony. The court reporter should also have an unobstructed view of the entire litigation area, including the judge, witness box, jury box, and attorneys' tables.

The court reporter's station is generally at floor level, which accentuates the prominence of the judge's bench and keeps clear the judge's and attorneys' view of the witness. It should have space and comfortable seating appropriate to the recording methods being used. The workstation should have several electrical outlets and enough space for electronic recording equipment and sound reinforcement equipment should be provided. It also should be made ready for computer equipment and video recording technology. A silent printer in the courtroom may be needed for producing transcripts.

**WITNESS STAND**

All courtroom participants must be able clearly to hear and see the witness. In addition, because many witnesses testify at a personal sacrifice of time, money, and sometimes safety, they deserve the court's courtesy and protection.

The witness stand is traditionally placed between the jury and the judge, but many courts now use a movable witness box that can face the jury box. The witness stand should be no closer than 4 ft to the jury box so the nearest juror is 7 to 8 ft away. There should be a physical barrier between the witness stand and the judge to prevent the witness from seizing objects from the bench.

The witness stand should be 3 1/2 to 4 ft wide and approximately 5 ft deep to allow for easy entry and exit. Witnesses must frequently receive, examine, and return exhibits; a desk area approximately 15 to 18 in. deep for resting files or evidence may extend from the front or side of the stand.

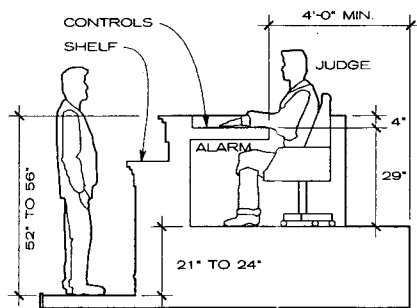

**JUDGE'S BENCH**

The exhibit area for screens, chalkboards, and computer and video monitors should be close to the witness stand and visible to jurors and witnesses. The exhibit area could be placed between the witness stand and the jury box.

There should be electrical receptacles and cable conduits for built-in video display of recorded evidence and taped depositions and for review of automated case transcripts. A movable microphone should be mounted in the witness stand so that it is both unobtrusive and able to pick up the testimony of children and soft-spoken witnesses.

**JURY BOX**

Jurors are temporary "officers of the court" and should be afforded the comfort and courtesies appropriate to their role. The front of the jury box should be shielded with a modesty panel. A 9- or 10-in. shelf should be installed as part of the rail around the jury box, both to allow jurors to examine documents and exhibits and to prevent attorneys from getting too close to the jurors. The first row of seating may be at floor level to permit wheelchair access, with the second tier elevated on one riser. The jury box should accommodate 14 jurors (12 jurors and 2 alternates).

Jurors must be able to hear the judge, witnesses, and attorneys clearly, and they should have unobstructed sight lines to the judge, witness, attorneys, and exhibit area.

The jury box should allow 10 to 12 sq ft per juror. A 14-person jury box needs to be 19 to 21 ft long and approximately 8 ft deep. The jury box should be large enough to accommodate a wheelchair. Audio jacks for earphones for the hearing impaired may be installed at one or two positions. Seats should be fastened to the floor and should swivel and have armrests. Many jury boxes have a footrail.

The jury box should be at least 4 ft from the nearest attorneys' table and 6 ft from the nearest attorney's chair. In addition it should be far enough from the spectator area to inhibit any physical or verbal contact. A bailiff's station may be located between the jurors and the spectators to prevent such communication.

The entrance to the jury box should be near the exit to the jury deliberation rooms. Jurors should not have to cross the courtroom or move through the spectator seating area.

The jury box may be equipped with electrical receptacles, cable conduits, and computer and video terminals for display of recorded and automated evidence, taped depositions, and case transcripts. A microphone may be placed near the jury box.

**ATTORNEYS' TABLES**

Each table should be at least 7 ft long and should seat up to four people. The tabletop should be 3 to 4 ft wide to accommodate books, documents, and other work materials. The area of each attorneys' table, including chairs and 2-ft circulation space behind the chairs, should be approximately 64 sq ft to allow the parties to move freely around the table. The tables should not have drawers or concealed recesses where a weapon or bomb may be placed.

Attorneys should be able to see and hear all courtroom participants clearly. The litigation area lighting above the attorneys' tables may be augmented with direct task lighting if necessary.

Attorneys and litigants should be able to confer in private. To prevent conversations from being overheard, or documents from being read, attorneys' tables should be 4 ft apart and about 6 ft from the nearest juror or spectator.

The front of the judge's bench should be at least 10 ft from the front of the attorneys' tables. This distance conveys judicial objectivity and dignity.

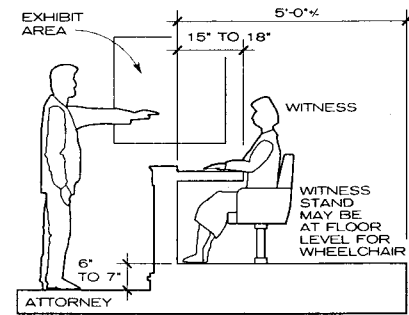

**WITNESS STAND**

Electrical receptacles and cable conduits for built-in computer display terminals may be provided for accessing legal databases, reviewing taped depositions, and video display of evidence, exhibits, and transcripts. There should be flush floor-mounted electrical outlets, microphones, and a telephone line so that attorneys may be connected to their office computers by modem.

**BAILIFF'S STATION**

The bailiff, or deputy sheriff, is responsible for the security of the courtroom and all participants. He or she must have access to an alarm connected to the main security office.

The bailiff generally moves about the courtroom but should be provided with a small table and movable swivel chair, which should occupy no more than 15 sq ft. The area surrounding the bailiff's station should be free of obstacles.

The bailiff should be able to see all areas of the courtroom clearly. The bailiff's station should be located near the defendant's table or by the jury box.

**SPECTATOR SEATING**

Public bench-type seating at floor level allows access by disabled persons and accentuates the raised litigation area and judge's bench. Aisles should be wide enough to allow wheelchair access.

Public entry into the courtroom should be through a vestibule for security purposes and for noise control. The floor should be carpeted and the surrounding walls acoustically treated.

**EVIDENCE DISPLAY AND STORAGE**

After exhibits are introduced into evidence and marked, they should be displayed in full view of the court. Hazardous exhibits, such as firearms and other objects that could be used as weapons, drugs, and toxic substances should be placed away from the witness, jury box, and defendant's table. Usually, the clerk's station is the most suitable location. Charts and displays are best presented either between the witness box and the jury box, so the witness may point to them, or across from the jury box if their detail is large enough to be seen at a distance. Increasingly, evidence, including videotapes, physical evidence, computer animations, X-rays, and documents, will be displayed on video monitors.

The courtroom should have an inconspicuous evidence closet where the clerk may secure items during recess. In addition, approximately 40 sq ft should be provided for storing such items as projectors, television monitors, chart boards, easel pads, tripods, chalk and markers, cleaning cloths, pins and tape, and pointers. These may be stored behind the courtroom.

**ADDITIONAL SOURCES OF INFORMATION**

American Bar Association. *Twenty Years of Courthouse Design Revisited, Supplement to the American Courthouse*. Chicago, 1993.

American Institute of Architects. *Justice Facilities Review*. Washington, D.C. (published annually).

Don Hardenbergh. *The Courthouse, A Planning and Design Guide for Courthouse Facilities*. Williamsburg, Va., 1991.

Hunter Hurst. *Shaping a New Order in the Court: Sourcebook for Juvenile and Family Court Design*. Pittsburgh, Pa., 1992.

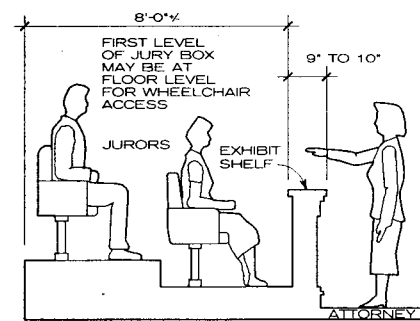

**TWO-TIER JURY BOX**

Don Hardenbergh; Courtworks; Williamsburg, Virginia

**GENERAL**

A stadium is a pitch or track for individual athletics or team competition in an arena surrounded by stepped tiers for standing or seated spectators. Some stadiums are covered, but these coverings do not necessarily enclose the structure.

The design of a stadium is largely dictated by the type of activity it will house and by the number of spectators to be accommodated. The specific sports and number of spectators are usually outlined in the program.

**POSSIBLE ACTIVITIES FOR STADIUMS**

- soccer
- rugby
- football (American)
- baseball
- athletic competition/track and field
- equestrian events: polo, jumping, rodeo
- entertainment concerts
- multi-purpose events

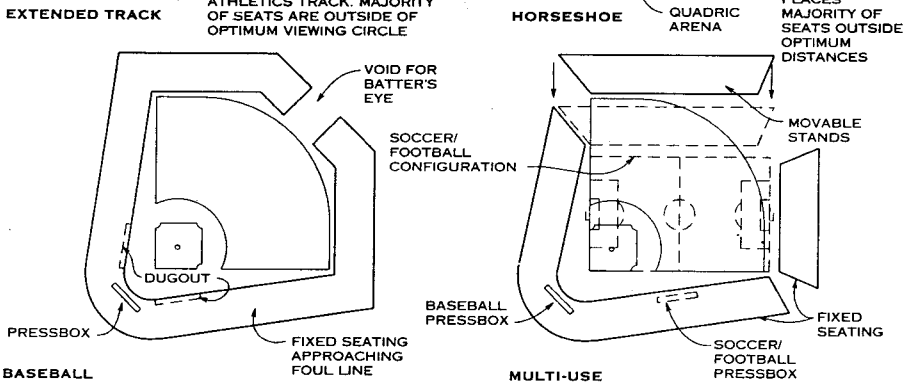
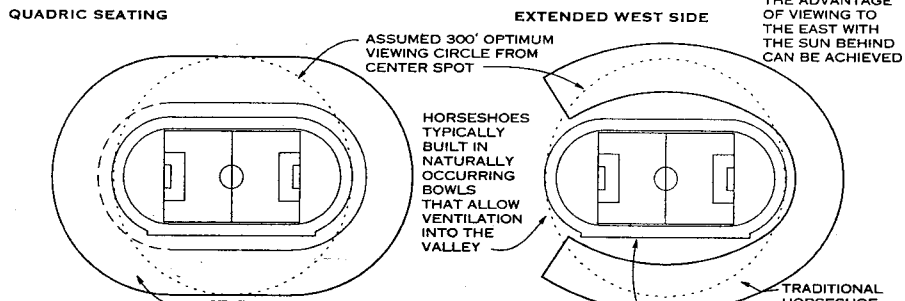
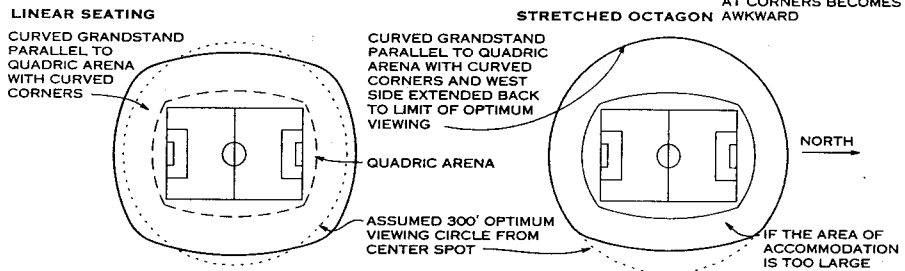
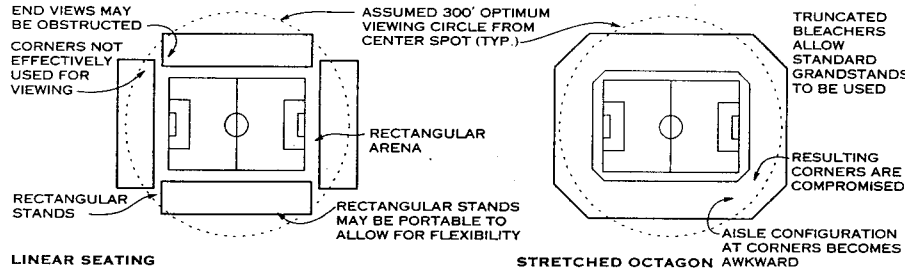
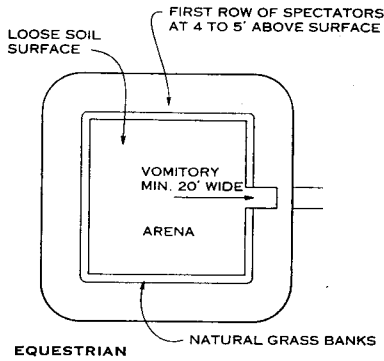

**TYPICAL STADIUM CONFIGURATIONS**

NBBJ; Research Triangle Park, North Carolina

**PRIORITY PLANNING FOR STADIUMS**

1. **SAFE** for all spectators and participants: Usually dictated by local codes and regulations, safety issues relate to crowd control, fire safety, evacuation, circulation, etc.
2. **COMPACT** enough to accommodate all spectators within maximum viewing distances to ensure minimum views of all areas of the field of activity.
3. **CONVENIENT** for spectators and participants: Access to amenities within the complex should be available within minimum time standards.
4. **COMFORTABLE**: To ensure feasibility, the comfort of spectators and participants should be accommodated as much as the budget will allow.
5. **FLEXIBLE**: Ensure flexibility in terms of different venues and future growth potential.
6. **ECONOMICAL**: Evaluate initial capital expenditure and recurring maintenance costs.

**GENERAL STADIUM PLANNING GUIDELINES**

The plan of all stadia is determined first by the regulation size of the activity and auxiliary areas, i.e., the pitch or track on which the activity takes place, the necessary surrounding areas for linesmen, and the need to move back the first row of spectators for improved viewing.

If possible, orient the stadium with the long axis running north and south so most spectators face east and west. Attempt to give both teams, as nearly as possible, identical lighting conditions.

**STADIUM TERMINOLOGY**

- ARENA**: the activity area plus the ancillary area of the stadium.
- ATHLETICS**: track and field events.
- CONTINENTAL SEATING**: a seating arrangement not interrupted by a center aisle.
- CROWN**: the average distance from the eye of the spectator to the top of the head, which is approximately 120mm or 4 3/4 in.
- FOCUS**: the middle of the innermost athletics track or the near touchline in football or soccer.
- HOUSE SEATS**: seats normally reserved for house management or special guests. These are not sold but held out for special use.
- PITCH**: the competition athletic field.
- RAKE**: the angle of rise of seating stands.
- SIGHT LINES**: the lines of vision of the spectators in normal and extreme positions in the facility. Sight lines include upper as well as side views.
- TIER**: one of a series of rows rising one behind and above another.
- VOMITORY**: areaway for circulation within stadium.

**LIMIT OF VIEWING**

The limit of viewing distance is determined by the ability of the spectator farthest from the activity to distinguish the smallest moving object.

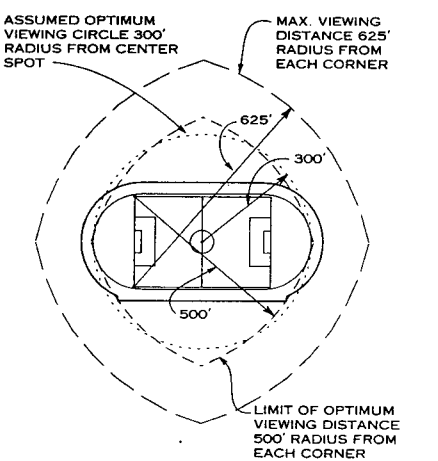

**SEATING GUIDELINES**

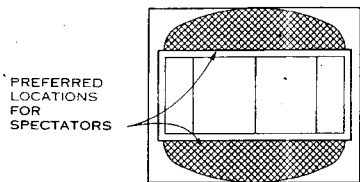

RUGBY

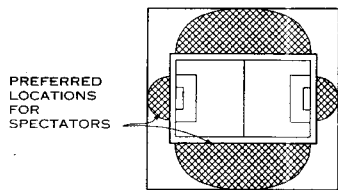

SOCCER

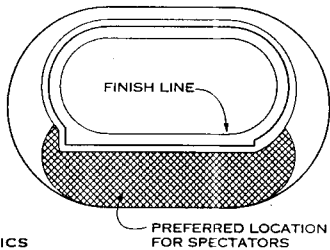

ATHLETICS

**OPTIMUM SEATING**

**STRAIGHT VS. QUADRIC SEATING**

Spectator accommodation in rows parallel to the side lines or touch lines and close to the pitch is self-obscuring. A spectator near a corner of the pitch has difficulty seeing the other corner on the same side, since the view is obscured by other spectators. Quadric, or curved, seating can offer unobscured views (see Tiers Comparison).

**TIERS**

The rake of the tiering is determined either mathematically or graphically in section, where the principal factors are the assumed constant of the crown and these variables: the horizontal distance between consecutive rows, the focus, and the height of the spectator's eye in the first row.

In determining the rake, the lines of sight from the eyes of spectators in each row to the focus should be clear of, or at

A STEPPED TIER SET OUT FROM A TOUCH LINE PRODUCES A PARABOLIC CURVE IN SECTION, WHEN THE LINE OF VISION IS TANGENTIAL TO THE TOP OF THE HEADS OF THE VIEWERS IN FRONT.

CURVED TIERS, HOWEVER, ARE EXPENSIVE AND NOT RECOMMENDED. THE LONG CURVED TIER IN THE DIAGRAM COULD BE REPLACED BY A STRAIGHT TIER OCCUPYING THE SAME VERTICAL DISTANCE IN A SMALLER AREA. THIS COULD BE REPLACED ON ITS OWN AREA WITH A SHALLOW TIER OCCUPYING A SHORTER VERTICAL DISTANCE.

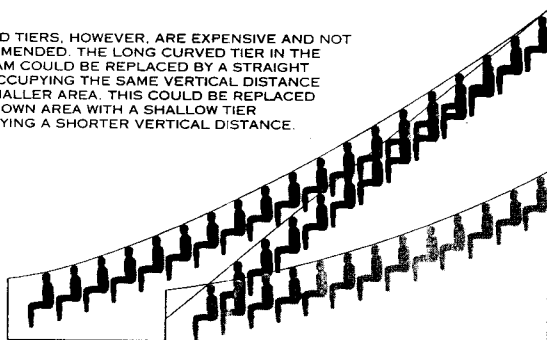

CURVED VS. STRAIGHT

worst tangential to, the top of the head of the spectator in the row in front. This will give a profile that is parabolic, the rake increasing with the viewing distance. Tiers in this profile are not economical to construct and are not safe for crowd movement. The stairs in gangways become unequal and therefore unacceptable.

**OVERLAPPING TIERS**

Overlapping the seating tiers is an obvious method of substantially reducing the maximum viewing distance—the horizontal (plan) distance—by increasing the vertical distance.

**CONCESSIONS**

Stands for food, beverages, and souvenirs should be designed to handle peak impact loads. Events with half-times or periods will induce the largest crowds. Patrons should be able to reach concessions within 40 to 60 seconds.

The general recommendation for concessions is 20 to 25 linear feet of counter space for every 1,000 seats if there are no vending machines. If vending is provided, use 13 to 18 linear feet.

**DRESSING ROOMS**

Dressing rooms should include changing areas with stalls or hangers for clothing, showers, drying rooms, tables for taping, and toilets. Equip stalls with a bench or stool, hangers, a shelf, and possibly a lock box for valuables. There should be a trainer's room for athletes' therapy. Dressing rooms for officials should be separate from those for athletes.

**ACCESS CONTROL**

There should be one turnstile per 1,000 spectators. Viewers, athletes, and staff should be able to empty a stadium in under eight minutes.

If the field is used for concerts, spectators must have access to toilets and concessions. Admissions control should prevent mixing between those who have purchased floor tickets and those with tickets in less expensive seats.

Other items that should be addressed as part of the program include:

- Broadcasting studios/press boxes
- Emergency medicine/first aid/life safety
- Night lighting
- Public address system
- Restrooms
- Scoreboards/sign boards
- VIP seating/hospitality provisions

**CROSS REFERENCE (AGS 10TH ED.)**

Grandstand and bleacher details: p. 915  
 Playing field construction: p. 768  
 Individual sports: polo, soccer, football, baseball, for specific size requirements of playing field and ancillary spaces.

**CONSULTANTS**

Confer with consultants who specialize in athletic surfaces and equipment, long-span structures, lighting, etc.

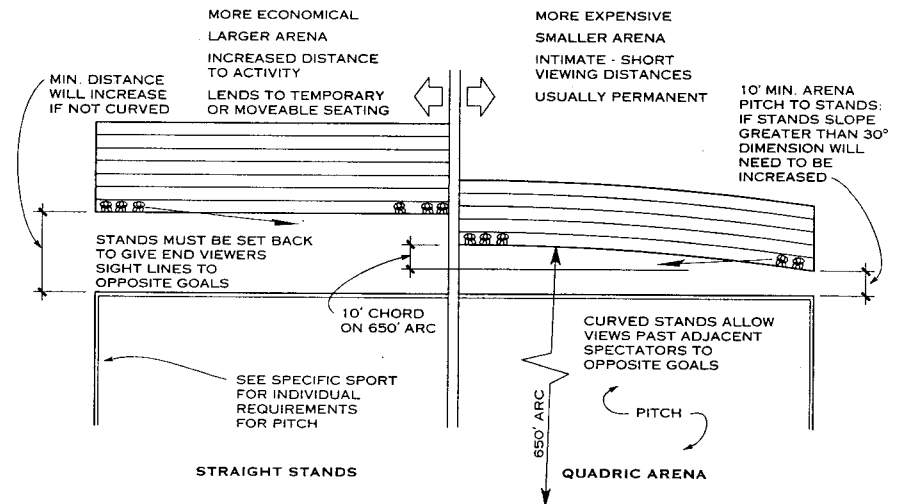

STRAIGHT VS. QUADRIC SEATING

THREE STRAIGHT TIERS APPROXIMATELY TANGENTIAL TO THE THEORETICAL CURVE IN A SINGLE TIER IS ECONOMICAL IN COST BUT NOT IN SPACE. SEPARATING AND OVERLAPPING THE TIERS REDUCES PLAN AREA. THE ANGLE OF RAKE MAY NEED TO BE INCREASED BUT SHOULD NOT BE STEEPER THAN 35°.

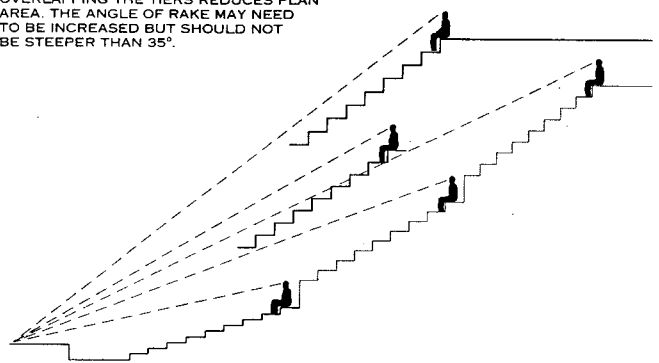

STACKED VS. STRAIGHT RUN

**TIERS COMPARISON**

NBBJ, Research Triangle Park, North Carolina

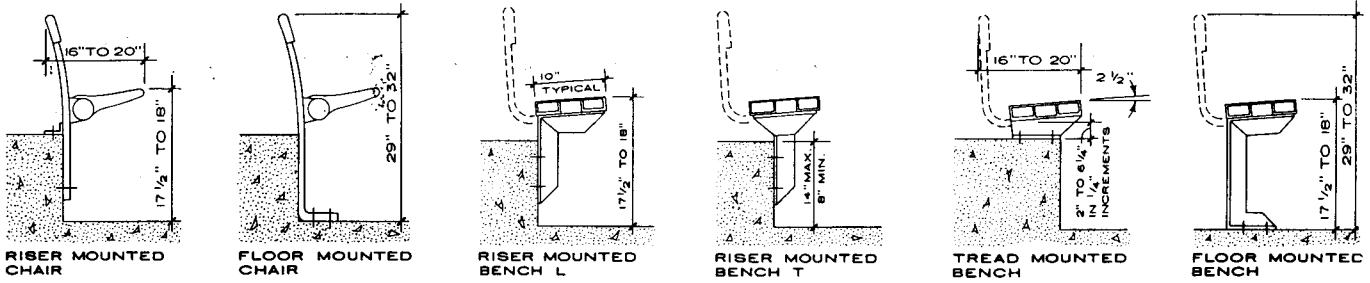

**STANDARD SEATS AND SEAT SUPPORTS**

**SEATING CAPACITY**

Allow 18 in. of bleacher length per person per row. Normal aisle width of 36 in. reduces seating capacity by two seats per row x number of rows x number of aisles. See table below.

**SAFETY AREAS**

1. BASEBALL FIELDS: Minimum 60 ft from seating to foul line or baseline at each side of home plate.
2. SOFTBALL FIELDS: Minimum 25 ft from seating to foul line or baseline at each side of home plate.
3. BASKETBALL COURTS: Minimum 6 ft from seating to court sides, 4 ft minimum to court ends.
4. SWIMMING POOLS: Minimum 5 ft from seating to pool decks. Spectator area must be separate from pool area to avoid mixing dry and wet traffic.

**STADIUM SEATING**

Concrete risers and treads with seating attached. See typical seats and seat supports above.

**FIXED GRANDSTAND**

8 in. rise with 24 in. row spacing typical. Available options include front, end, and back rails, crosswalks, ramps, stairs, aisles, vomitories, closed risers, double foot plates, folding seat backs, and waterproof covers of metal or fiberglass for resurfacing existing wooden bleachers.

**PORTABLE BLEACHERS**

3, 4, or 5 row sections typical. Transportable options include wheels and trailer attachments. Bleachers of up to 25 rows may be assembled of portable sections.

**TELESCOPIC BLEACHERS**

1. LOWRISE: 9<sup>5</sup>/<sub>8</sub> in. normal rise for most uses. 22 in. minimum row spacing gives maximum seating capacity. 24 in. spacing provides extra passage and leg room space and space for optional folding back rests.
2. HIGHRISE: Models with 11<sup>5</sup>/<sub>8</sub> or 16 in. risers are suggested for pools, balconies, hockey rinks, or similarly difficult viewing situations where seating must be banked more steeply than is normal.

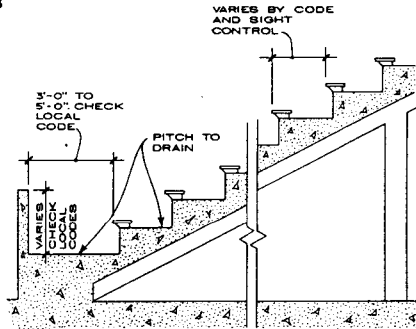

**STADIUM SEATING**

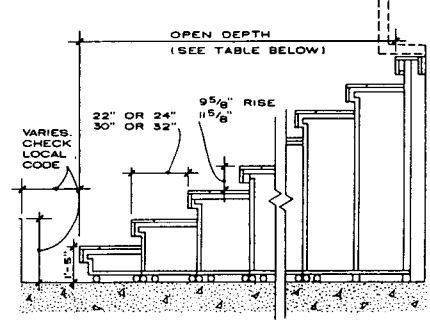

**TELESCOPIC BLEACHERS (HIGHRISE)**

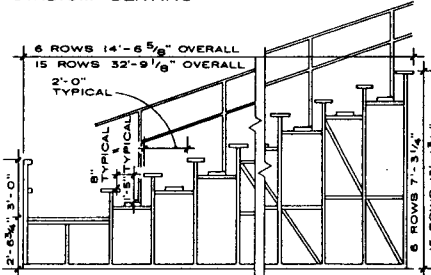

**FIXED GRANDSTAND (ELEVATED)**

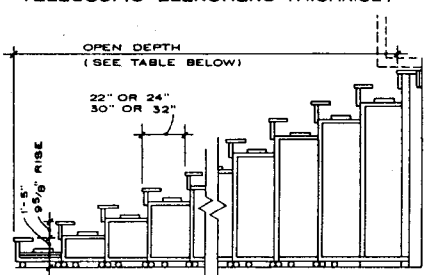

**TELESCOPIC BLEACHERS (LOWRISE)**

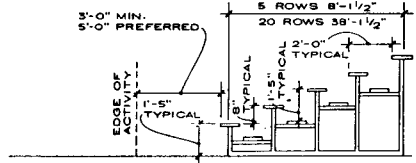

**PORTABLE BLEACHERS**

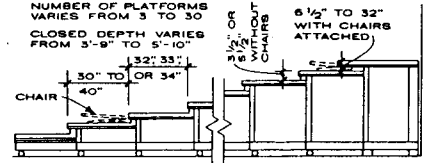

**TELESCOPIC PLATFORM**

**SEATING CAPACITY**

LENGTH (FT)	8	12	16	20	24	28	32	36	40
3	16	24	32	40	48	56	64	72	80
4	21	32	42	53	64	74	85	96	106
5	26	40	53	66	80	93	106	120	133
6	32	48	64	80	96	112	128	144	160
7	37	56	74	93	112	130	149	168	186
8	42	64	85	106	128	149	170	192	213
9	48	72	96	120	144	168	192	216	240
10	53	80	106	133	160	186	213	240	266
12	64	96	128	160	192	224	256	288	320
14	74	112	149	186	224	261	298	336	373
16	85	128	170	213	256	298	341	384	426
18	96	144	192	240	288	336	384	432	480
20	106	160	213	266	320	373	426	480	533

NOTE: Consult manufacturers for additional information.

**GRANDSTANDS AND BLEACHERS DIMENSIONS**

ROW	OPEN DEPTH				9 <sup>5</sup> / <sub>8</sub> " RISE CLOSED DEPTH		11 <sup>5</sup> / <sub>8</sub> " AND 16" RISE CLOSED DEPTH	
	22"	24"	30"	32"	22" OR 24"	30" OR 32"	22" OR 24"	30" OR 32"
3	4'-11 <sup>1</sup> / <sub>2</sub> "	5'-1 <sup>1</sup> / <sub>2</sub> "	6'-3 <sup>1</sup> / <sub>2</sub> "	6'-5 <sup>1</sup> / <sub>2</sub> "	3'-1 <sup>13</sup> / <sub>16</sub> "	3'-9 <sup>13</sup> / <sub>16</sub> "	3'-1 <sup>13</sup> / <sub>16</sub> "	3'-9 <sup>13</sup> / <sub>16</sub> "
4	6'-9 <sup>1</sup> / <sub>2</sub> "	7'-1 <sup>1</sup> / <sub>2</sub> "	8'-9 <sup>1</sup> / <sub>2</sub> "	9'-1 <sup>1</sup> / <sub>2</sub> "	3'-2 <sup>1</sup> / <sub>8</sub> "	3'-10 <sup>1</sup> / <sub>8</sub> "	3'-2 <sup>1</sup> / <sub>8</sub> "	3'-10 <sup>1</sup> / <sub>8</sub> "
5	8'-7 <sup>1</sup> / <sub>2</sub> "	9'-1 <sup>1</sup> / <sub>2</sub> "	11'-3 <sup>1</sup> / <sub>2</sub> "	11'-9 <sup>1</sup> / <sub>2</sub> "	3'-2 <sup>7</sup> / <sub>16</sub> "	3'-10 <sup>7</sup> / <sub>16</sub> "	3'-2 <sup>7</sup> / <sub>16</sub> "	3'-10 <sup>7</sup> / <sub>16</sub> "
6	10'-5 <sup>1</sup> / <sub>2</sub> "	11'-1 <sup>1</sup> / <sub>2</sub> "	13'-9 <sup>1</sup> / <sub>2</sub> "	14'-5 <sup>1</sup> / <sub>2</sub> "	3'-2 <sup>3</sup> / <sub>4</sub> "	3'-10 <sup>3</sup> / <sub>4</sub> "	3'-2 <sup>3</sup> / <sub>4</sub> "	3'-10 <sup>3</sup> / <sub>4</sub> "
7	12'-3 <sup>1</sup> / <sub>2</sub> "	13'-1 <sup>1</sup> / <sub>2</sub> "	16'-3 <sup>1</sup> / <sub>2</sub> "	17'-1 <sup>1</sup> / <sub>2</sub> "	3'-3 <sup>1</sup> / <sub>16</sub> "	3'-11 <sup>1</sup> / <sub>16</sub> "	3'-3 <sup>1</sup> / <sub>16</sub> "	3'-11 <sup>1</sup> / <sub>16</sub> "
8	14'-1 <sup>1</sup> / <sub>2</sub> "	15'-1 <sup>1</sup> / <sub>2</sub> "	18'-9 <sup>1</sup> / <sub>2</sub> "	19'-9 <sup>1</sup> / <sub>2</sub> "	3'-3 <sup>3</sup> / <sub>8</sub> "	3'-11 <sup>3</sup> / <sub>8</sub> "	3'-3 <sup>3</sup> / <sub>8</sub> "	3'-11 <sup>3</sup> / <sub>8</sub> "
9	15'-11 <sup>1</sup> / <sub>2</sub> "	17'-1 <sup>1</sup> / <sub>2</sub> "	21'-3 <sup>1</sup> / <sub>2</sub> "	22'-5 <sup>1</sup> / <sub>2</sub> "	3'-3 <sup>11</sup> / <sub>16</sub> "	3'-11 <sup>11</sup> / <sub>16</sub> "	3'-3 <sup>11</sup> / <sub>16</sub> "	3'-11 <sup>11</sup> / <sub>16</sub> "
10	17'-9 <sup>1</sup> / <sub>2</sub> "	19'-1 <sup>1</sup> / <sub>2</sub> "	23'-9 <sup>1</sup> / <sub>2</sub> "	25'-1 <sup>1</sup> / <sub>2</sub> "	3'-4"	4'-0"	3'-4"	4'-0"
12	21'-5 <sup>1</sup> / <sub>2</sub> "	23'-1 <sup>1</sup> / <sub>2</sub> "	28'-9 <sup>1</sup> / <sub>2</sub> "	30'-5 <sup>1</sup> / <sub>2</sub> "	3'-4 <sup>5</sup> / <sub>8</sub> "	4'-0 <sup>5</sup> / <sub>8</sub> "	3'-4 <sup>5</sup> / <sub>8</sub> "	4'-0 <sup>5</sup> / <sub>8</sub> "
14	25'-1 <sup>1</sup> / <sub>2</sub> "	27'-1 <sup>1</sup> / <sub>2</sub> "	33'-9 <sup>1</sup> / <sub>2</sub> "	35'-9 <sup>1</sup> / <sub>2</sub> "	3'-5 <sup>1</sup> / <sub>4</sub> "	4'-1 <sup>1</sup> / <sub>4</sub> "		
16	28'-9 <sup>1</sup> / <sub>2</sub> "	31'-1 <sup>1</sup> / <sub>2</sub> "	38'-9 <sup>1</sup> / <sub>2</sub> "	41'-1 <sup>1</sup> / <sub>2</sub> "	3'-5 <sup>7</sup> / <sub>8</sub> "	4'-1 <sup>7</sup> / <sub>8</sub> "		
18	32'-5 <sup>1</sup> / <sub>2</sub> "	35'-1 <sup>1</sup> / <sub>2</sub> "	43'-9 <sup>1</sup> / <sub>2</sub> "	46'-5 <sup>1</sup> / <sub>2</sub> "	3'-6 <sup>1</sup> / <sub>2</sub> "	4'-2 <sup>1</sup> / <sub>2</sub> "		
20	36'-1 <sup>1</sup> / <sub>2</sub> "	39'-1 <sup>1</sup> / <sub>2</sub> "	48'-9 <sup>1</sup> / <sub>2</sub> "	51'-9 <sup>1</sup> / <sub>2</sub> "	3'-7 <sup>1</sup> / <sub>8</sub> "	4'-3 <sup>1</sup> / <sub>8</sub> "		

NOTE: For 11<sup>5</sup>/<sub>8</sub>" rise of 18 or more rows and 16" rise of 13 or more rows check with manufacturer for modified closed depth dimensions.

Eric Johnson; Lawrence Cook Associates P.C., Architects; Falls Church, Virginia  
David W. Johnson; Washington, D.C.



**THEATER DESIGN CRITERIA**

The planning of seating areas in places of assembly should involve the following considerations:

- EFFICIENCY:** The floor area efficiency in square feet per seat is a function of the row spacing, the average chair width, and the space allocation per seat for aisles. See following pages for further discussion of these factors.

Efficiency (F) = seat factor + aisle factor

$$F \text{ (sq ft/seat)} = \frac{W_r T}{144} + \frac{I T}{144} \times \frac{1}{S_{avg}}$$

- where  $W_r$  = average seat width (in.)
- $T$  = row to row spacing (tread) (in.)
- $I$  = average aisle width (in.) (42 in. width is typical)
- $S_{avg}$  = average number of seats in a row per single aisle: 8 or fewer—inefficient layout; 14 to 16—maximum efficiency (multiple aisle seating); 18 to 50 and more—continental seating.

- CAPACITY AND AUDIENCE AREA:** Audience area = capacity x efficiency.

35-75	Classroom
75-150	Lecture room, experimental theater
150-300	Large lecture room, small theater
300-750	Average drama theater in educational setting
750-1500	Small commercial theater, repertory theater, recital hall
1500-2000	Medium large theater, large commercial theater
2000-3000	Average civic theater, concert hall, multiple use hall
3000-6000	Very large auditorium
Over 6000	Special assembly facilities

- PERFORMING AREA (not including adjacent support area) (sq ft):**

	MINIMUM	AVERAGE	MAXIMUM
Lectures (single speaker)	150	240	500
Revue, nightclub	350	450	700
Legitimate drama	250	550	1000
Dance	700	950	1200
Musicals, folk opera	800	1200	1800
Symphonic concerts	1500	2000	2500
Opera	1000	2500	4000
Pageant	2000	3500	5000

- ORIENTATION OF SEATED SPECTATOR:** Head strain is minimized by orienting chairs or rows of chairs so that spectators face the center of action of the performing area.
- ANGLE OF VISION OF SPECTATOR:** The human eye has a peripheral spread of vision of about 130°. This angle of view from chairs in the front rows will define the outer limits of the maximum sized performing area.



- ANGLE OF ENCOUNTER:** The angle of encounter is defined by the 130° peripheral spread of vision of a single performer standing at the "point of command." Patrons seated outside the spread of this angle will not have simultaneous eye contact with performer. Natural sound communication will also deteriorate for these patrons.

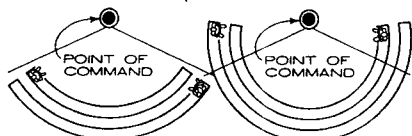

- DISTANCE BETWEEN PERFORMANCE AND LAST ROW OF SPECTATORS:** Achievement of visual and sound communication is enhanced by minimizing this distance while satisfying the preceding parameters.

**SCREEN PROJECTION**

- The minimum distance between the first row and the screen ( $D_f$ ) is determined by the maximum allowable angle between the sightline from the first row to the top of the screen and the perpendicular to the screen at that point. A maximum angle of 30 to 35° is recommended.
- The maximum distance between the screen and the most distant viewer (MDV) should not exceed eight times the height of the screen image. An MDV two to three times the screen width is preferred.
- Screen width (W) is determined by the use of the appropriate aspect ratio between the screen image width and height.
- Curvature of screens may reduce the amount of apparent distortion for a larger audience area. Curvature of larger screens may help to keep the whole of the image in focus and may provide a more uniform distribution of luminance.

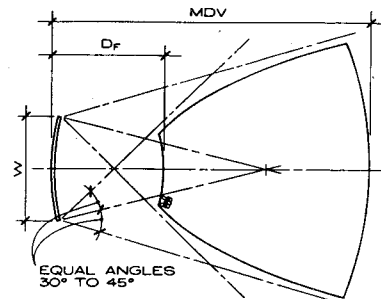

SCREEN PROJECTION

**ZERO ENCIRCLEMENT (PROSCENIUM STAGE, PICTURE FRAME STAGE, END STAGE)**

- The angle of audience spread in front of a masking frame is determined by the maximum size of the corner cutoff from a rectangularly shaped performing area that can be tolerated by seats at the side.
- Audience may not fill angle of encounter from point of command.
- Audience farthest from performing area.
- Large range in choice of size of performing area.
- Provisions for a large amount of scenic wall surfaces without masking sightlines.
- Horizontal movement of scenery typically made in both perpendicularly and parallel to centerline.
- Possibility of short differences in arrival time between direct and reflected sound at the spectator. This may be beneficial to music performances.

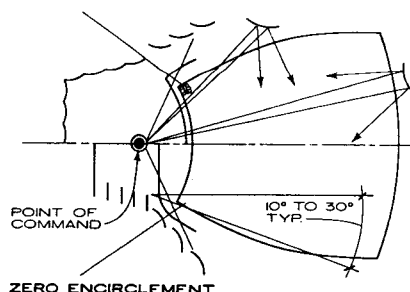

ZERO ENCIRCLEMENT

**90° TO 130° ENCIRCLEMENT (PICTORIAL OPEN STAGE, WIDE FAN, HYBRID, THRUST STAGE)**

- Audience spread defined and limited by angle of encounter from point of command.
- Performing area shape trapezoidal, rhombic, or circular.
- Audience closer to performing area than with zero encirclement.
- Picture frame less dominant.
- Range in choice of size of performing area.
- Provision for an amount of scenic wall surfaces possible without obscuring the performing area.
- Horizontal movement of scenery is possible in directions at 45° to and parallel to centerline.
- Shape of seating area places maximum number of seats within the directional limits of the sound of the unaided voice, beneficial for speech performance.

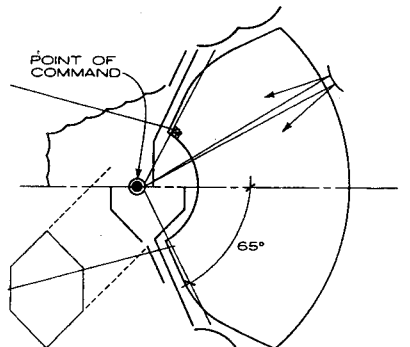

90° TO 130° ENCIRCLEMENT

**180° TO 270° ENCIRCLEMENT (GREEK THEATER, PENINSULAR, THREE-SIDED, THRUST STAGE, 3/4 ARENA STAGE, ELIZABETHAN STAGE)**

- Audience spread well beyond angle of encounter from point of command in order to bring audience closer to performing area.
- Simultaneous eye contact between performer and all spectators not possible.
- Minimum range of choice in size of performing area.
- Provision of a small amount of scenic wall surfaces possible without masking sightlines.
- Horizontal movement of scenery is possible only parallel to centerline.
- Large encirclement by audience usually demands actor vomitory entrance through or under audience.

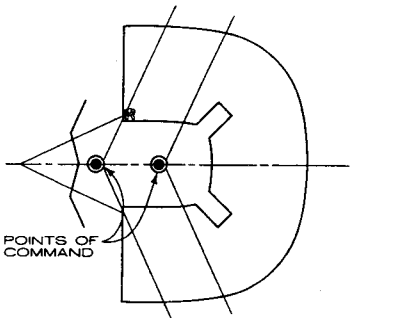

180° TO 270° ENCIRCLEMENT

**360° ENCIRCLEMENT (ARENA STAGE, THEATER IN THE ROUND, ISLAND STAGE, CENTER STAGE)**

- Performer always seen from rear by some spectators.
- Simultaneous eye contact between performer and all spectators not possible.
- Audience closest to performance.
- No range of choice in size of performing area.
- No scenic wall surfaces possible without obscuring the view of the performing area.
- Horizontal movement of scenery not readily possible.
- Encirclement by audience demands actor vomitory entrance through audience area.

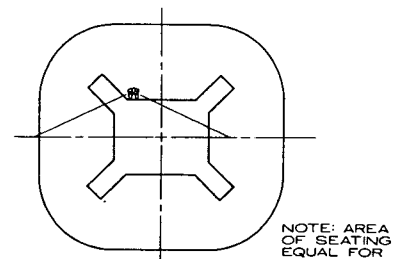

360° ENCIRCLEMENT

NOTE: AREA OF SEATING EQUAL FOR ALL DIAGRAMS

Peter H. Frink; Frink and Beuchat; Architects; Philadelphia, Pennsylvania

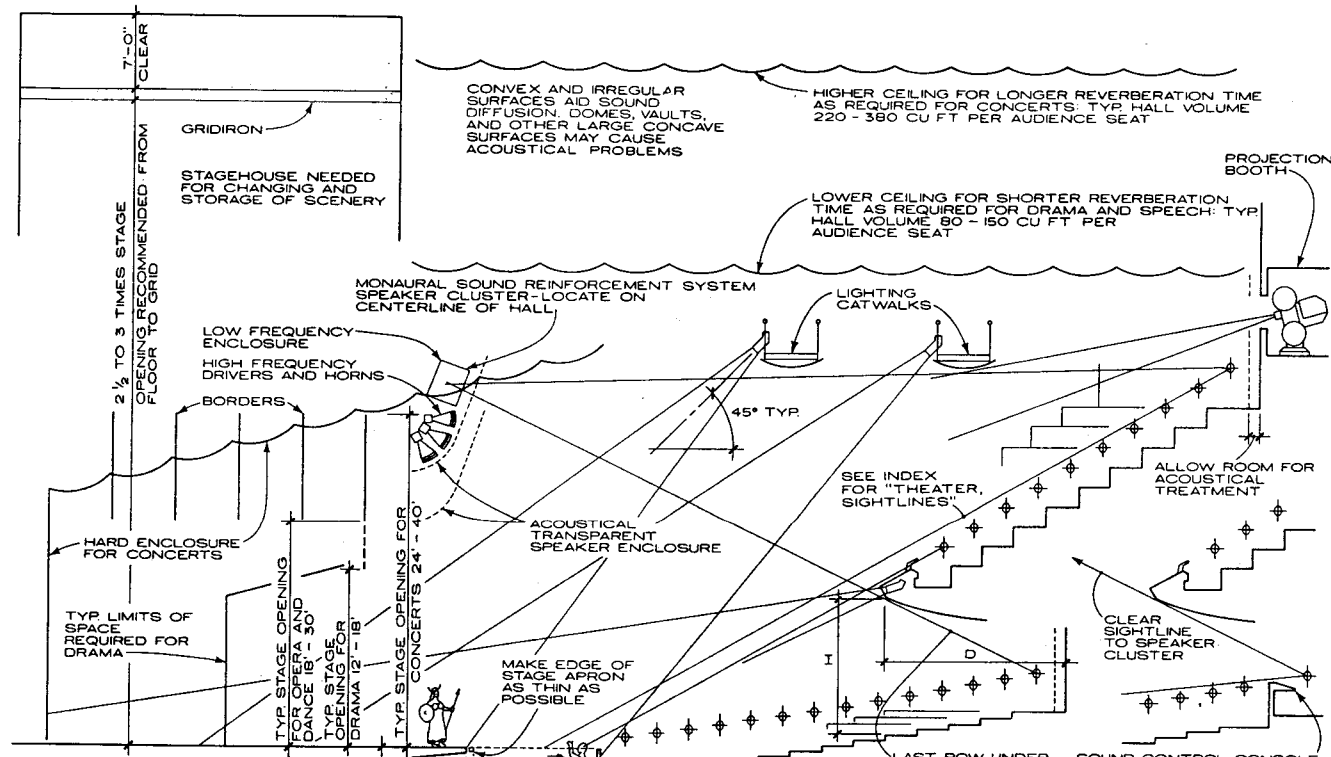

**CONFIGURATIONS FOR LIVE PERFORMANCES**

IN HALLS USED FOR CONCERTS, STAGE AND AUDIENCE SEATING AREA SHOULD BE TREATED AS ONE VOLUME IN MULTIPLE USE HALLS THIS CONDITION IS ACHIEVED WITH A HARD ORCHESTRA SHELL, WHICH MUST BE DEMOUNTABLE TO ALLOW FOR FULL USE OF STAGE FOR SCENERY. ACOUSTICAL REQUIREMENTS MAY DICTATE THAT REFLECTIVE SURFACES AT CEILING OF ORCHESTRA ENCLOSURE EXTEND OUT ABOVE AUDIENCE SEATING

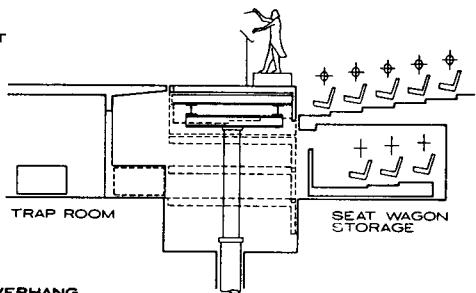

**PROPORTIONS OF BALCONY OVERHANG**

HALL USE	MAX. D:H RECOMMENDED
CONCERTS	1:1
OPERA, DRAMA	2:1
MOVIES	3:1

FLYING BALCONY MAY ALLOW A GREATER D:H RATIO WITHOUT LOSS OF REVERBERATION ENERGY TO SEATS AT REAR OF MAIN FLOOR

33° MAX. ISODEFORMATION ANGLE MEASURED FROM PERPENDICULAR TO TOP OF SCREEN

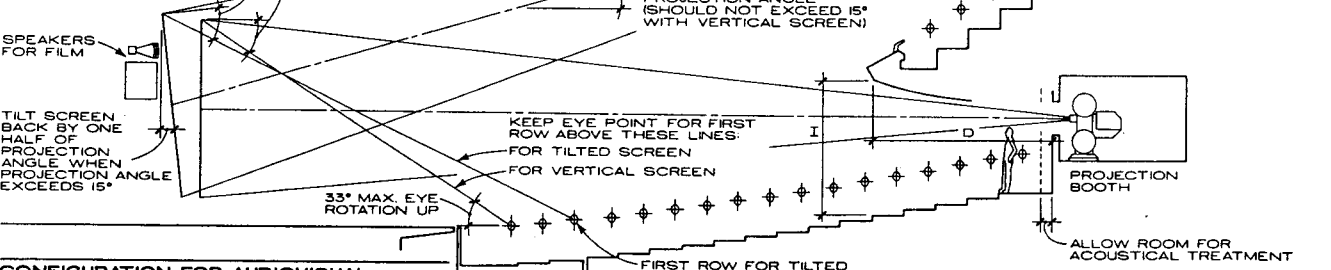

**CONFIGURATION FOR AUDIOVISUAL PRESENTATIONS**

Peter H. Frink; Frink and Beuchat: Architects; Philadelphia, Pennsylvania

APS = ARRIVAL POINT OF SIGHT (FOCAL POINT OR INTERSECTION OF HIGHEST SIGHTLINE WITH FOCAL PLANE)

N = NUMBER OF ROWS IN SEAT BANK

n = ROW NUMBER FOR WHICH COMPUTATIONS ARE BEING MADE

D<sub>1</sub> = HORIZONTAL DISTANCE FROM APS TO FIRST ROW EYE POSITION

D<sub>n</sub> = HORIZONTAL DISTANCE FROM APS TO EYE POSITION AT ROW n

D<sub>B</sub> = HORIZONTAL DISTANCE FROM APS TO EYE POSITION AT FRONT ROW OF BALCONY

L = HORIZONTAL DISTANCE FROM FIRST ROW EYE POSITION TO A VERTICAL FOCAL PLANE

E<sub>1</sub> = ELEVATION OF EYE LEVEL AT FIRST ROW ABOVE APS

E<sub>n</sub> = ELEVATION OF EYE LEVEL AT ROW n ABOVE APS

E<sub>B</sub> = ELEVATION OF EYE LEVEL AT FRONT ROW OF BALCONY ABOVE APS

H<sub>E</sub> = EYE HEIGHT OF SEATED PERSON (44 IN TYPICAL)

H<sub>APS</sub> = HEIGHT OF APS ABOVE FIRST ROW FLOOR LEVEL

C = SIGHTLINE HEAD CLEARANCE, 2 1/2" TO SEE OVER 2 ROWS IN FRONT, 5" TO SEE OVER 1 ROW IN FRONT

T = ROW TO ROW SPACING (TREAD)

R = RISER HEIGHT BETWEEN ROWS

R<sub>n</sub> = RISER HEIGHT AT FRONT OF ROW n

P = PERCENT SLOPE

SEE LOCAL CODE FOR REQUIRED HEIGHT (26" TO 30" TYP)

KEEP HEIGHT OF SOLID RAILING BELOW SIGHTLINE FROM FRONT ROW

BALCONY RAILING

BALCONY - CONSTANT RISE PER ROW

$$R = \frac{T}{D_B} [E_B + (N-1)C] + C$$

$$D_B = \frac{T}{R-C} [E_B + (N-1)C]$$

$$E_B = \frac{D_B}{T} (R-C) - C(N-1)$$

NOTE: BALCONY MAY ALSO BE DESIGNED WITH AN ISCIDOMAL SLOPE

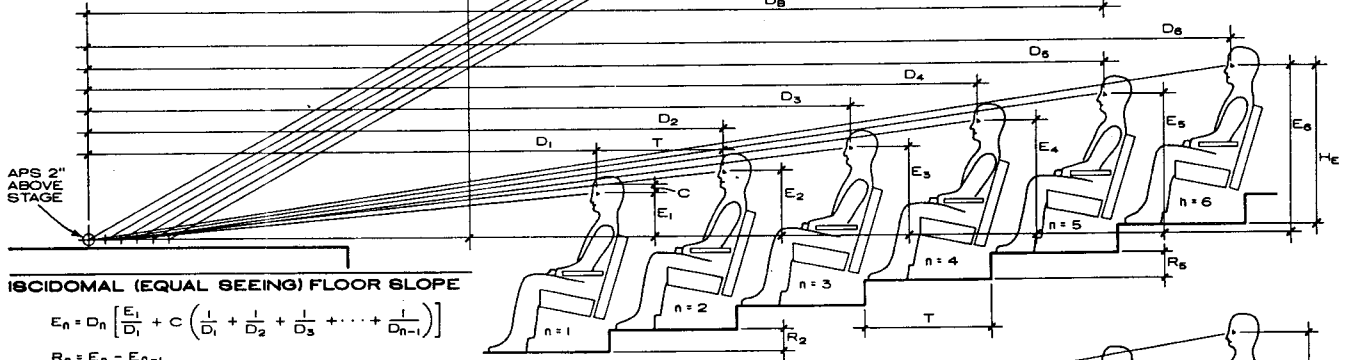
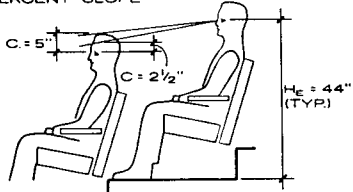

ISCIDOMAL (EQUAL SEEING) FLOOR SLOPE

$$E_n = D_n \left[ \frac{E_1 + C}{D_1} + \frac{1}{D_2} + \frac{1}{D_3} + \dots + \frac{1}{D_{n-1}} \right]$$

$$R_n = E_n - E_{n-1}$$

MAXIMUM STAGE HEIGHT FOR LIVE PERFORMANCE = 42" (E<sub>1</sub> = 0)

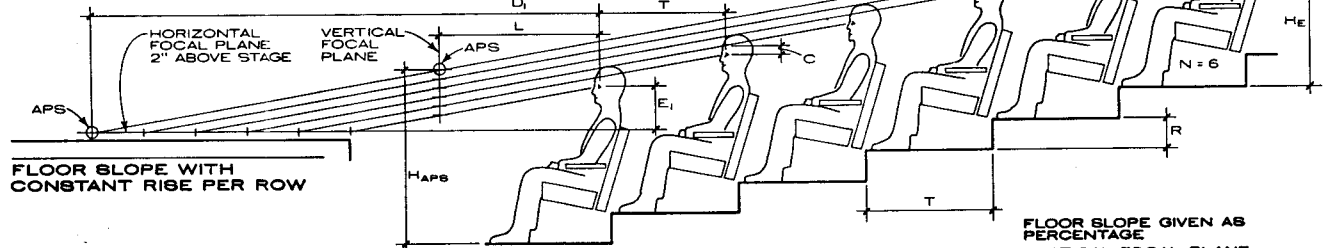

FLOOR SLOPE WITH CONSTANT RISE PER ROW

HORIZONTAL FOCAL PLANE

$$R = \frac{T}{D_1} [E_1 + (N-1)C] + C$$

$$D_1 = \frac{T}{R-C} [E_1 + (N-1)C]$$

$$E_1 = \frac{D_1}{T} (R-C) - C(N-1)$$

VERTICAL FOCAL PLANE

$$R = \frac{T}{L} [H_E - H_{APS} + (N-1)C] + C$$

$$L = \frac{T}{R-C} [H_E - H_{APS} + (N-1)C]$$

$$H_{APS} = H_E - \frac{L}{T} (R-C) + (N-1)C$$

FLAT FLOOR (R = 0)

VERTICAL FOCAL PLANE

$$L = \frac{T}{C} [H_{APS} - H_E - (N-1)C]$$

$$H_{APS} = H_E + \frac{LC}{T} + (N-1)C$$

FLOOR SLOPE GIVEN AS PERCENTAGE

VERTICAL FOCAL PLANE

$$P = \frac{100}{L} [H_E - H_{APS} + (N-1)C] + \frac{100C}{T}$$

$$L = \frac{100T}{PT - 100C} [H_E - H_{APS} + (N-1)C]$$

$$H_{APS} = H_E - \frac{PL}{100} + \frac{LC}{T} + (N-1)C$$

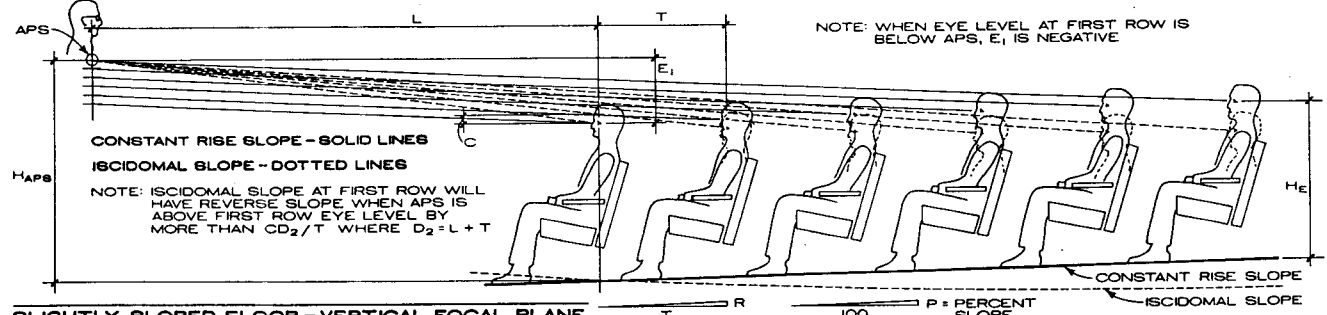

NOTE: ISCIDOMAL SLOPE AT FIRST ROW WILL HAVE REVERSE SLOPE WHEN APS IS ABOVE FIRST ROW EYE LEVEL BY MORE THAN CD<sub>2</sub>/T WHERE D<sub>2</sub> = L + T

NOTE: WHEN EYE LEVEL AT FIRST ROW IS BELOW APS, E<sub>1</sub> IS NEGATIVE

SLIGHTLY SLOPED FLOOR - VERTICAL FOCAL PLANE

Peter H. Frink; Frink and Beuchat; Architects; Philadelphia, Pennsylvania

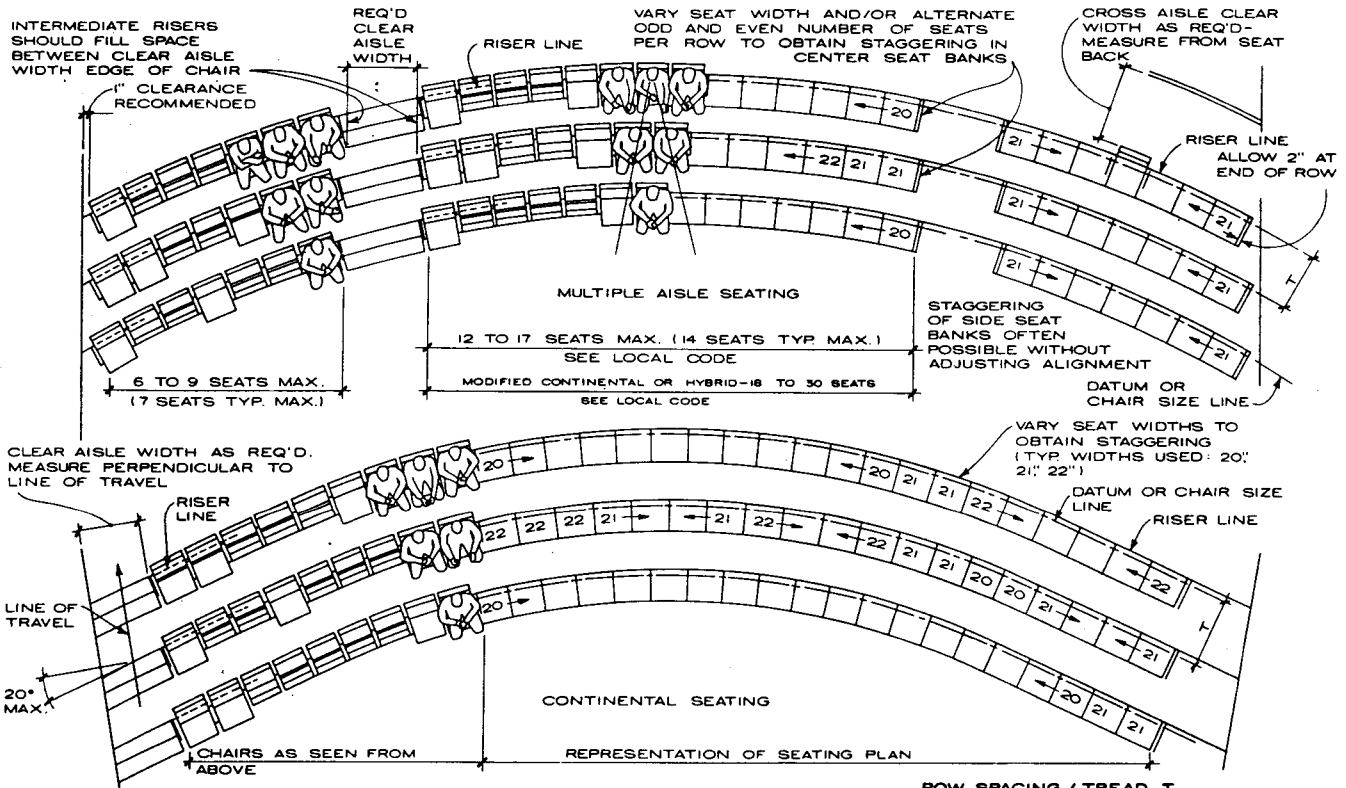

**CHAIR STANDARDS:** Cast iron, steel, riser mounted and floor mounted. Also pedestal mounting using continuous beam support or cantilevered standards. Folding tablet arms usually available.

**CHAIR ARMS:** Upholstered fabric, wood, plastic, metal.

**CHAIR BACKS:** Plastic, molded plywood, rolled stamped metal, upholstered front, rear. Higher backs and bottom extension for scuff protection also available.

**CHAIR SEATS:** Upholstered, plywood, plastic, metal pan, coil or serpentine springs, polyurethane foam.

**ROW SPACING / TREAD T**

**LEGAL CRITERIA:** See local code for required minimum spacing. Codes typically stipulate a minimum clear plumbline distance measured between the unoccupied chair and the rear of the chair in front.

32"-33": typical minimum for multiple aisle seating  
 34"-37": typical minimum for modified continental seating

38"-42": typical minimum for continental seating

**COMFORT FOR THE SEATED PERSON:**

32": knees will touch chair back; uncomfortable  
 34": minimum spacing for comfort  
 36": ideal spacing for maximum comfort  
 38" and up: audience cohesiveness may suffer

**EASE OF PASSAGE IN FRONT OF SEATED PERSONS:**

32"-34": seated person must rise to allow passage  
 36"-38": some seated persons will rise  
 40" and up: passage in front of seated persons possible

**SAFETY:** Excessive plumbline distance may entice exiting persons to squeeze ahead and cause jam.

**EFFICIENCY:** Choice of minimum spacing satisfying criteria above reduces maximum distance to stage.

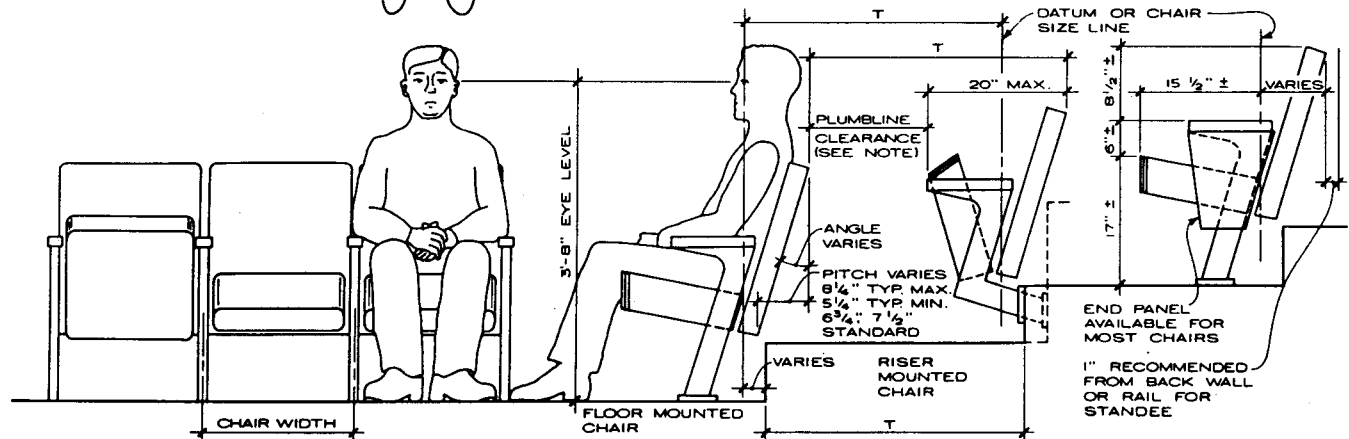
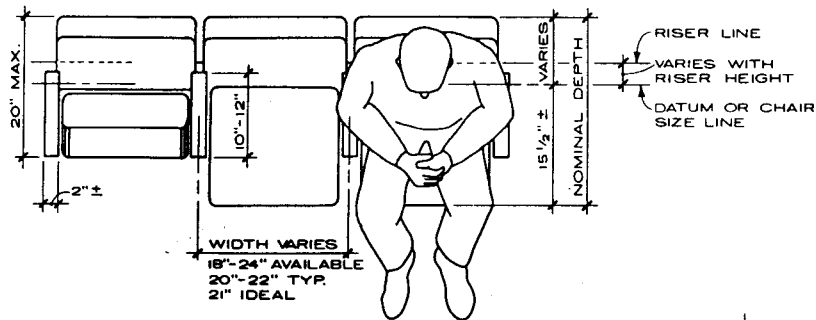

Peter H. Frink; Frink and Beuchat; Architects; Philadelphia, Pennsylvania

**STAGE LIGHTING SYSTEM DESIGN GENERAL COMMENTS**

The purpose of a stage lighting system is to provide a flexible arrangement of dimmers, lighting positions, and outlet devices such that stage lighting fixtures may be placed where needed and controlled individually or in groups according to the differing requirements of each production. While it is impossible to develop rules of thumb which will be adequate or appropriate in all cases, several guidelines have been listed below as an aid to determining the proper scope of system required. Several generic cases have been listed. Common terms and equipment components are defined.

**CONSIDERATIONS**

The planning of a stage lighting system should involve the following considerations:

1. Type of use
2. Size of performing area
3. Size of theater, location of stage lighting positions
4. Budget

Determinations will have to be made about the following subjects:

1. Dimmer-per-circuit or patched circuit system
2. Quantity of dimmers
3. Quantity and distribution of stage lighting circuits
4. Electrical feed size
5. Type of stage lighting outlet devices
6. Type of control console
7. Type and quantity of stage lighting fixtures and accessories

**STAGE LIGHTING SYSTEM TERMS AND COMPONENTS DEFINED**

**DIMMER**

A device which controls the intensity of stage lighting fixtures; a remotely controlled electronic device in current practice. Standard sizes are 1.2 kW, 2.4 kW, 6.0 kW, 12.0 kW, at 120 V. Dimmers may be purchased in rack cabinets in large quantities (96 or more) or in small portable packages which can be wall mounted (6, 12, or 18 dimmers).

**CIRCUIT**

A grounded stage lighting circuit; usually no common neutrals are permitted. Load sizes depend in part on local codes—20 A is average, 15 A is maximum in some areas; some 50 A are often also provided. Circuits are distributed throughout the theater for fixture plug-in and terminate either at a dimmer rack, patch panel, or transfer panel.

**DIMMER-PER-CIRCUIT**

A configuration whereby every stage lighting circuit home runs to an independent dimmer. This is more economical than a patch panel scheme in most cases.

**PATCH PANEL**

A custom-made device for interconnecting a large number of stage lighting circuits to a small number of dimmers. This is more expensive than a dimmer-per-circuit configuration in most cases.

**TRANSFER PANEL**

A custom-made device enabling permanent circuits to be disconnected from the theater's dimming system and connected to a show's touring dimming system. Front-of-house circuits are generally made "transferable" in this way in large multipurpose theaters that must accommodate tours.

**FRONT-OF-HOUSE**

In a proscenium theater, the audience side of the proscenium. Abbreviated "FOH."

**FOLLOWSPOT**

A very bright manually operated spotlight used to "follow" a performer around the stage. Light source can be incandescent, carbon arc, xenon, or HMI.

**LEKO, FRESNEL, ELLIPSOIDAL, PARCAN, SCOOP, FLOODLIGHT**

Theatrical lighting fixtures.

**STRIPLIGHT**

A continuous fixture containing a number of lamps, used for downlight, backlight, footlight, and cyclorama lighting—usually 6 or 8 ft long with 12 lamps in three or four circuits.

**CONTROL CONSOLE**

Often called the "light board." A computerized, manual, or hybrid control device for stage lighting dimmers. Generic types include 2, 5, or 10 scene "preset consoles" (manual) and "memory consoles" (computerized). Older installations may have mechanically operated resistance or autotransformer dimmers in which the control console and the dimmer rack are essentially one device.

**CONNECTOR STRIP**

A type of outlet device for stage lighting circuits; essentially a continuous wireway with outlets or pigtails.

**OUTLET BOX**

An outlet device for stage lighting circuits. Box size and circuit quantities vary. Surface-mounted or recessed styles available. Circuit numbers must appear on the faceplate (with adhesive labels or engraved).

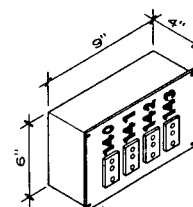

**OUTLET BOX**

**BOX BOOM**

An important front-of-house side wall lighting position in a proscenium theater. See diagram below.

**COVE, BEAM, SLOT, TRUSS**

A front-of-house lighting position located at the auditorium ceiling. See diagram below.

**FOLLOWSPOT BOOTH**

Houses the followspots. Enclosed, if possible, and ventilated as per code. Usually at or near the rear of the house, and quite high; 30°–45° to the edge of the stage preferred. Four spots require a booth nominally 24 ft wide x 10 ft deep; two spots require one 12 ft wide x 10 ft deep.

**CONTROL BOOTH**

Primary location for control console. Good view of stage preferred. Often located on the main level at the rear of the house. Houselighting controls should be duplicated here as well as backstage.

**DIMMER ROOM**

Location for dimmer racks. Can be remote from the stage. Locate for efficiency of load and feed wire conduit runs. Ventilate to accommodate heat load (approximately 5% connected load). Control humidity to protect equipment.

**BOOMS, LADDERS, TORMS, TORMENTORS**

On-stage side lighting positions. Nonarchitectural; located temporarily for each production as required.

**PIPES, BATTENS, ELECTRICS**

On-stage overhead lighting positions. Usually rigging pipes or pipe grid members. In a proscenium theater often one or more rigging pipes will be permanently designated as "electrics" and served with connector strips attached directly to the pipe.

**CYCLORAMA, CYC**

A large seamless white or pale blue backdrop, used scenically to represent the sky or provide a surface on which abstract colors and patterns can be projected with stage lighting fixtures. Usually cloth; some plaster cycs exist, but are difficult (some say impossible) to repair adequately once cracked or marred. Plaster is not recommended.

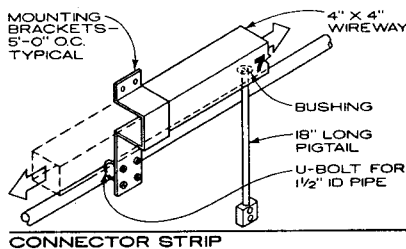

**RECOMMENDED PARAMETERS FOR STAGE LIGHTING SYSTEMS**

THEATER TYPE	NUMBER OF SEATS	FEED SIZE*	CIRCUIT QUANTITY	DIMMER QUANTITY
Elementary school	Varies	100	24-36	18-36†
Junior high, or middle school	Varies	300	75-100	75-100
High school	Varies	400	100-150	100-150
Studio theater	75-300	400	150-200	36-200†
Educational drama theater	300-750	800	200-400	200-400
Small professional theater	750-1500	1200	300-500	300-500
Medium size theater	1500-2000	1600	400-600	400-600
Large multipurpose theater, civic theater, road house	Over 2000	2400	600-800	600-800

\*Feed size shown in amps, 3 phase, 120/208 V Y.

†A simple patch system where the circuits terminate in male pigtails which can be plugged directly into a small quantity of portable dimmer packs is generally more economical for small installations with limited budgets than a dimmer-per-circuit scheme.

Joshua Dachs; Jules Fisher Associates Inc., Theater Consultants; New York, New York

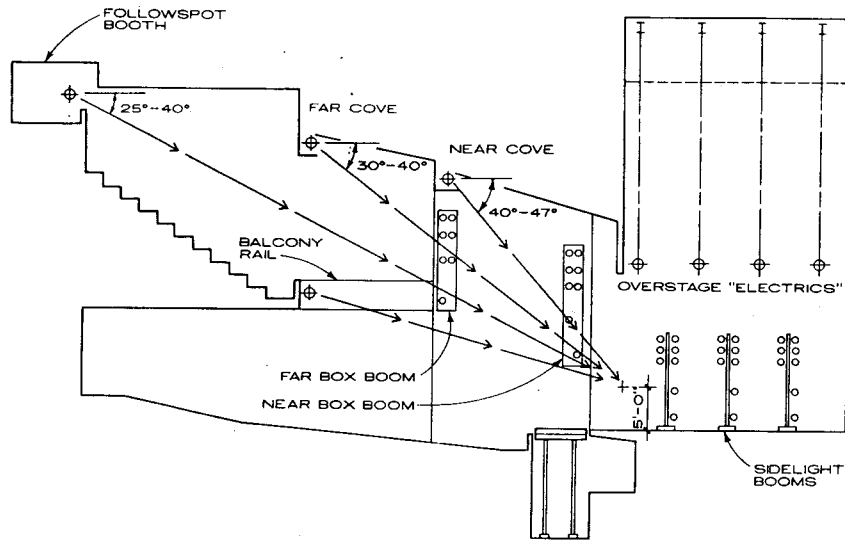

SECTION

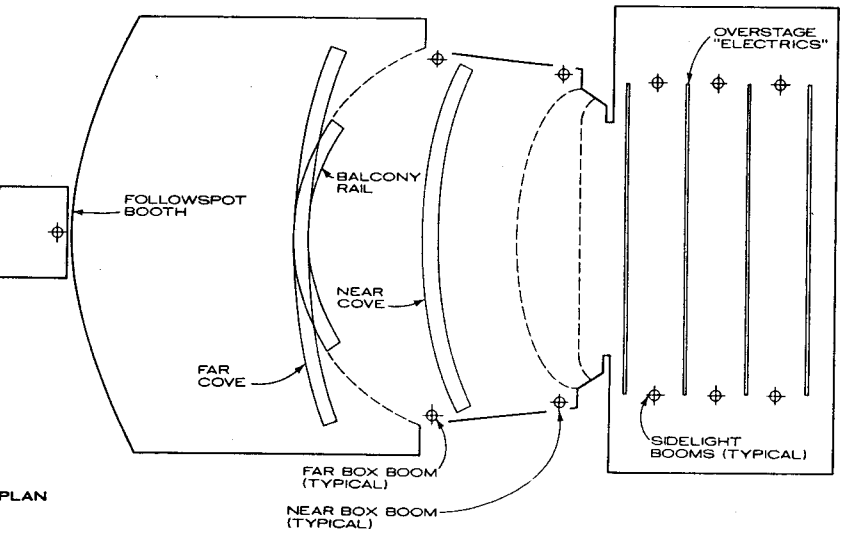

PLAN

PROSCENIUM THEATER

STAGE LIGHTING POSITIONS

It is crucial that a theater be provided with adequate, easily accessible stage lighting positions, served with an adequate quantity of circuits. Accessibility is a key issue. Lighting positions in an active theater need to be accessed daily to maintain, focus, and color the fixtures. Safety and ease must be kept in mind, as well as crew size, which is crucial to theater economics. Using a ladder is both time-consuming and dangerous and requires more than one stagehand. A catwalk is much safer, less time-consuming, and only requires one stagehand.

In a proscenium theater lighting is done from a variety of positions and angles. Frontlighting is provided by side wall positions called box booms, the balcony railing, and ceiling positions which can be recessed within the ceiling or exposed as catwalks. Followspots are generally located in a booth at the top rear of the theater (see definitions). On stage, rigging sets with dedicated stage lighting outlet devices (connector strips or drop boxes) and portable vertical floor-mounted pipes called booms provide positions for downlighting, sidelighting, and backlighting. These positions are all important, and every attempt should be made to provide them.

In flexible studio or black-box theaters a pipe grid or a system of catwalks should be provided over the entire

floor area of the theater to which lighting equipment (and scenery) can be attached. This grid should be well served by stage lighting circuits in boxes or connector strips. A two-way grid of 1/2 in. diameter pipe, nominally 4-6 ft o.c. should be adequate in most cases, accessed by ladder from the floor. The catwalk system is preferable, but requires a taller room.

In a thrust or arena theater, a grid or a series of catwalks should be provided over the main stage area to accommodate downlighting, sidelighting, and backlighting. Catwalks, ceiling slots, or ceiling-mounted pipes should be provided for frontlight and low washes, similar to the balcony rail or second cove in a proscenium theater. If there is a conventional stagehouse behind the thrust, it should be served in the same way as a proscenium theater's stagehouse, with overhead pipes and side booms.

RECOMMENDED REFERENCE MATERIAL

*Stage Lighting - A guide to the planning of theatres and public building auditoriums.* Illuminating Engineering Society Report #CP-45, 1983.

In most cases it is recommended that the services of a qualified theater consultant be retained.

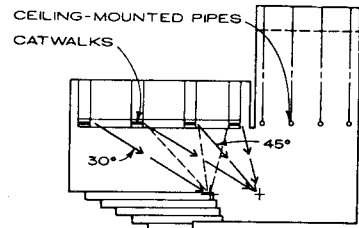

SECTION

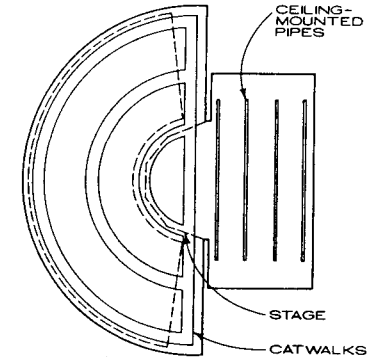

PLAN

THRUST THEATER

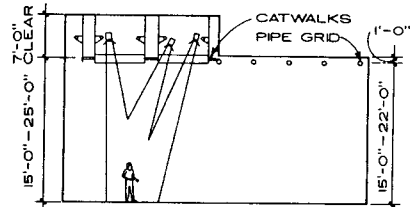

SECTION

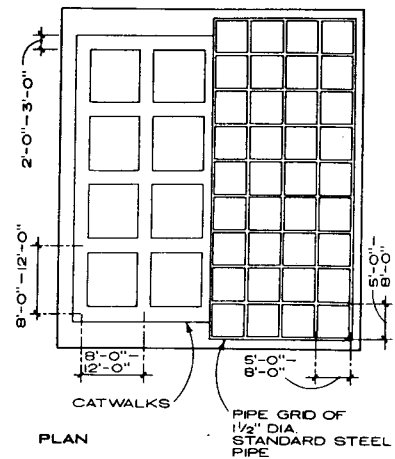

PLAN

STUDIO THEATER ("BLACK BOX")

**GENERAL**

The regional enclosed mall is suburbia's answer to the small town main street. Tenants of all types offer a comprehensive and diverse range of products that fit all budgets, attracting many types of shoppers to this type of facility. In fact, in sparsely populated areas, a regional enclosed mall can draw from a radius of 200 miles.

**LOCATION**

The success of a regional enclosed shopping mall depends on its accessibility to the consumer. Convenient, efficient, and easily recognized access to a facility is essential. Therefore, malls must be located adjacent to several major vehicular routes and within the reach of public transportation. The site must be able to accommodate not only the mall structure itself, but convenient parking for thousands of cars. If a site does not have enough space to meet the parking requirements set forth by the local government, a parking garage may be considered. However, the cost of a garage is enormous and should be avoided if possible.

**PARKING**

The number of parking spaces required for a regional enclosed mall is generally determined in relation to the area of the anchor store at a typical rate of 5-6 cars per 1000 sq ft. Delineation, organization, and facilitation of vehicular distribution among thousands of parking spaces is accomplished with inner and outer ring roads. The inner ring typically follows the contours of the mall, separating the structure from the parking area, while the outer ring (perimeter road) follows the perimeter of the parking area, property line, or site constraints, connecting adjacent roadways to the parking area.

Between the ring roads the parking spaces are oriented in a fan pattern with each row perpendicular to the mall structure. Orientation in this fashion eliminates the hierarchical pitfalls that result from parking rows situated parallel to the mall. When rows are parallel, shoppers often wait for someone to pull out of the rows they consider more desirable, causing traffic jams near mall entrances.

In a warm or moderate climate, long rows of parking should be interrupted by tree islands to provide shade. However, in a climate where snow is a factor, parking lot segmentation should be avoided. Cost-effective, efficient snow removal requires large unobstructed areas.

Regardless of climate, parking lot drainage is a factor and should be considered. Low points should be located so a shopper's path will not cross a wet or icy drainage area en route from car to mall or vice versa.

**ENTRANCES AND EXITS**

Opportunities for shoppers to enter the mall must be provided at regular intervals to limit ambulatory travel distance. Anchor stores often furnish several entrances that allow shoppers to enter the store directly. In fact, 40% of all mall shoppers choose to enter malls in this manner, while the remainder use entrances into the mall.

Mall entrances are typically located at the midpoint between anchor stores. However, if anchor stores are particularly far apart, additional mall entrances should be furnished. Keep both horizontal and vertical travel distances between the mall entrance and the parking area to a minimum. Straight pedestrian sidewalks with few steps and/or ramps are appreciated by both the handicapped and other, package-laden shoppers. Ramps and curb-cuts are required for handicapped access.

Because of the relative size of the mall structure and the number of entrances, it is imperative that each mall entrance be creatively and independently designated with correlating signage. This practice allows shoppers to easily recall which entrance they used to enter the mall.

While all mall and anchor store entrances double as egress locations, most local building codes require interstitial exits. Typically, an exit is required every 400 ft, so that shoppers need not traverse more than 200 ft to reach the nearest exit. Often, emergency exits from the primary and secondary concourses are permitted to connect to delivery halls behind the tenant spaces, which lead to an exterior door. For required door quantities and travel distance limitations, check local codes.

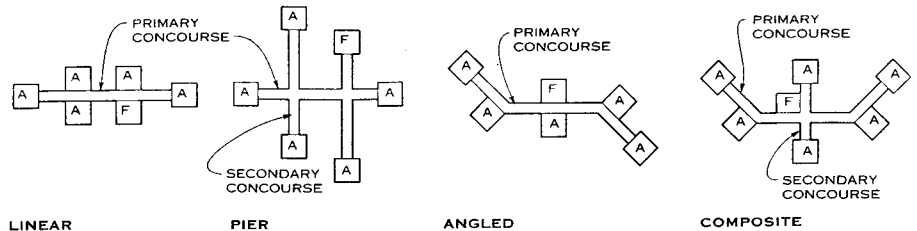

A—anchor store; F—food court

**MALL CONFIGURATION TYPES**

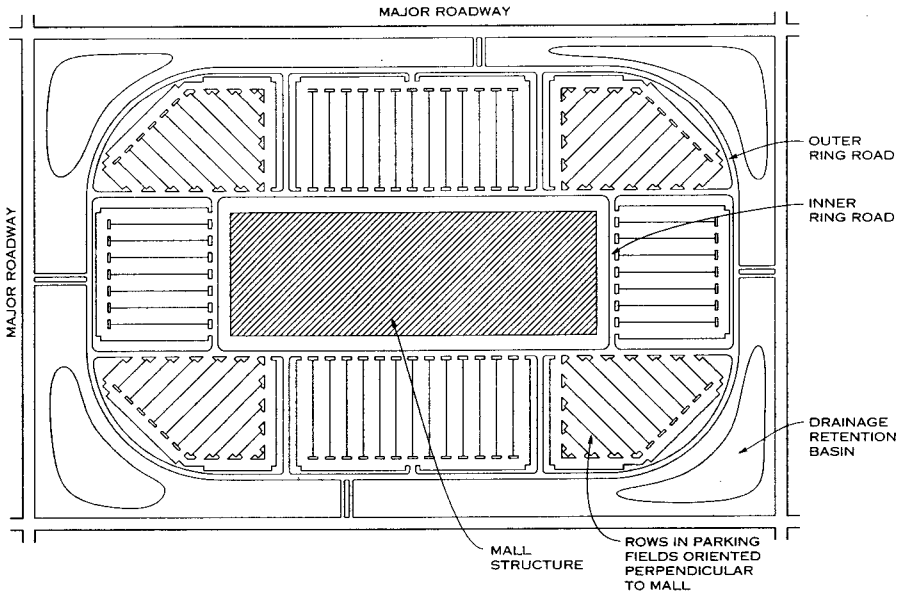

**SHOPPING MALL SITING/PARKING**

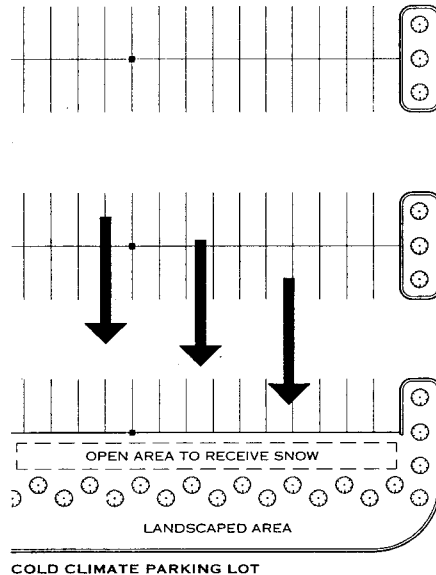

**NOTE**

Parking lots in cold climates must be obstruction free; snow-plows should be able to clear long swaths easily.

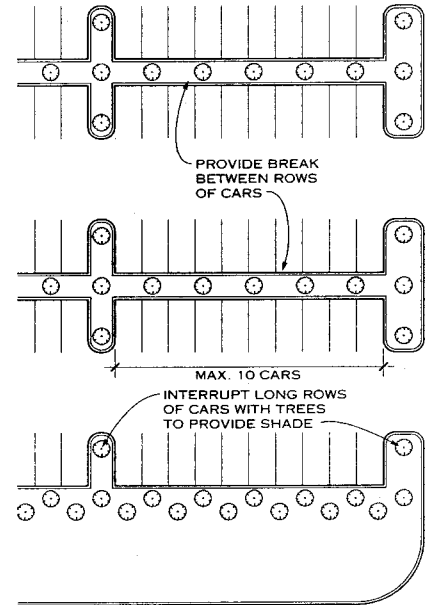

**SHOPPING MALL PARKING LAYOUTS**

Richard M. Roberts, AIA; Omega Design Architects, P.C.; Syracuse, New York

**CONCOURSES**

Regional enclosed malls must be designed in a way that draw visitors through the massive space, past the attractions of storefront display windows. The design feature used to accomplish this is the node, a point element with gravitational qualities. Careful placement of nodes throughout the common areas of a mall will encourage mall visitors to travel to areas beyond the limit of their view. Since this limit at any given moment in a mall is about 300 ft, it is essential to place a magnetic draw—a node—every 300 ft or less. Concourse intersections, mall entrances, and anchor store entrances constitute nodes.

Nodes at concourse intersections offer opportunities to break up long linear spaces and provide soothing features such as landscaping, fountains, and furniture. Nodes also serve as logical pivot points around which to bend mall concourses should that be necessary or desired. Tenant spaces adjacent to concourse intersections command high lease rates, making it desirable to maximize this type of space in a mall.

A typical regional enclosed mall consists of a primary concourse transected by several secondary concourses. The primary concourse is terminated at both ends with an anchor store. These stores and accompanying signage provide focal points that conduct shoppers through the mall space. Secondary concourses end at anchor stores or mall entrances.

A typical concourse should be between 25 and 80 ft wide, and up to 80% of this width should be effective pedestrian traffic area. The concourse ceiling height should be 60-100% of the concourse width. Ceiling heights outside this range result in spatial proportions that discomfit shoppers, resulting in decreased shopper traffic.

In multiple level malls, floor/ceiling penetrations within concourses are essential to allow shoppers to see what is on other levels. These penetrations, which entice shoppers from one level to another, should be placed and sized so a shopper on one level can see the signage of a store above or below on the opposite side of the concourse.

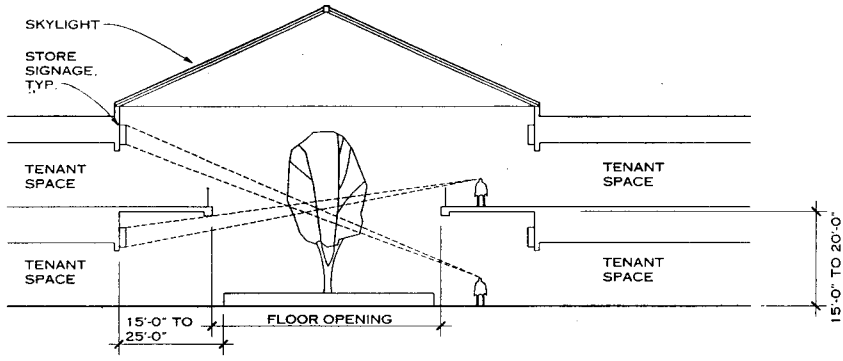

**SIGHT LINES WITHIN MALL CONCOURSE**

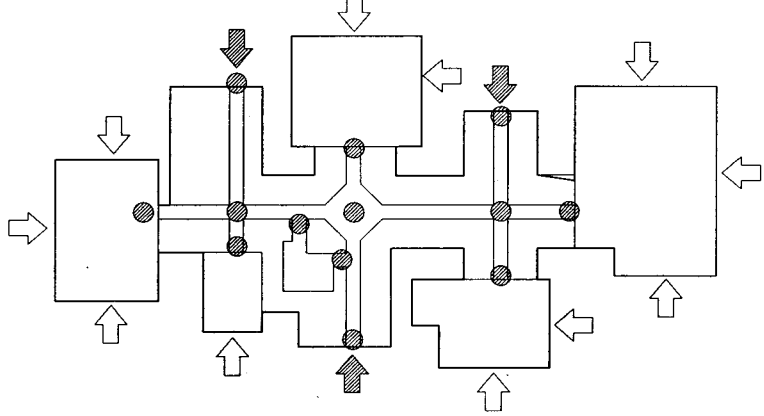

● — spatial node; ↗ — mall entrance; → — anchor store entrance

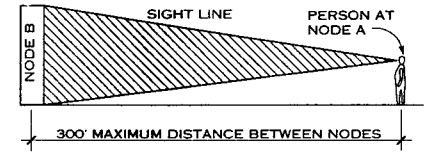

**HORIZONTAL PERCEPTION LIMIT**

**MALL ENTRANCES AND NODES**

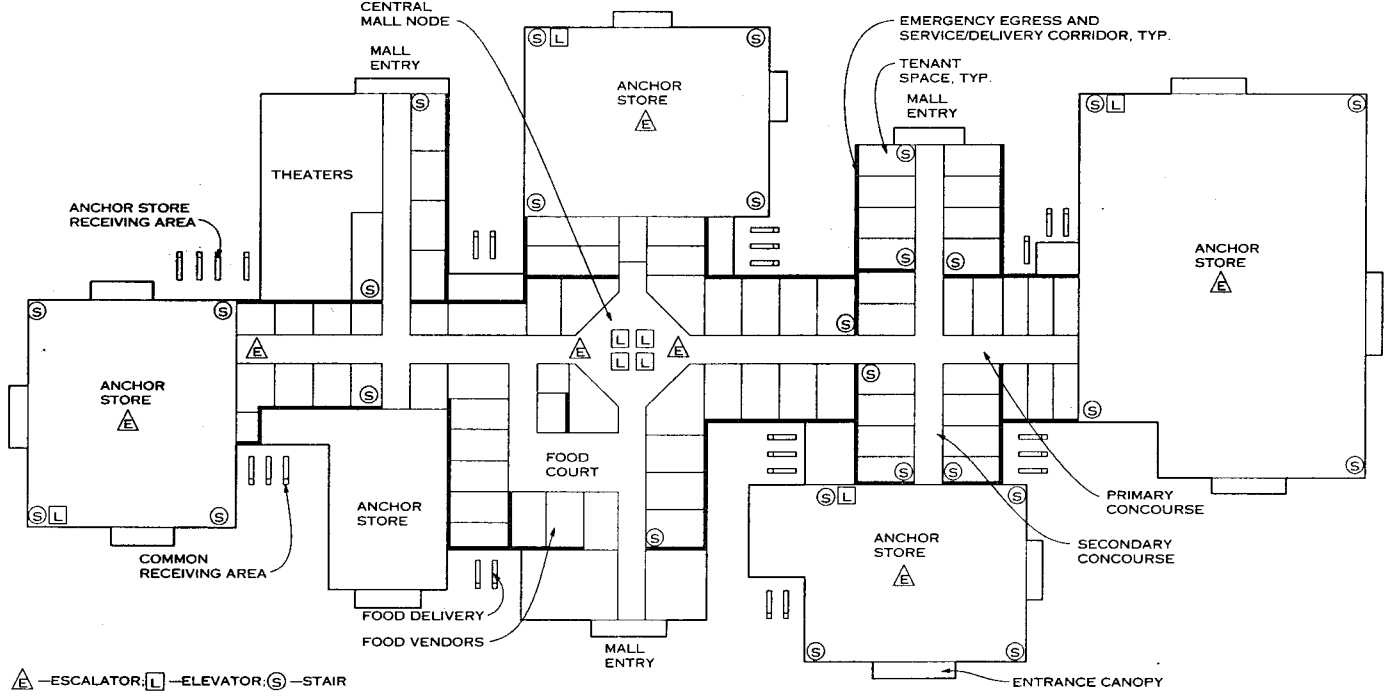

**TYPICAL MALL LAYOUT**

Richard M. Roberts, AIA; Omega Design Architects, P.C.; Syracuse, New York



**VERTICAL TRANSPORTATION**

In multiple story malls it is necessary to provide escalators, stairs, and elevators to accommodate hundreds or thousands of visitors with varying degrees of mobility.

Escalators are the primary mode of interlevel transport in shopping malls as they can handle the greatest volume of people in a given unit of time and can function as stairs in the event of a power outage. Locate escalators in pairs (up and down) in several convenient locations within the primary concourse and in lengthy secondary concourses. Shoppers should be able to see both the point of departure and the destination before committing to the interlevel travel.

Stairs are the secondary mode of interlevel transport in shopping malls. Locate several stairways in the primary and secondary concourses in much the same manner as the escalators. In addition, provide stairs in accordance with local codes to accommodate exiting shoppers in the event of a fire. Fire stairs are typically located every 400 ft, so the maximum travel distance from any point to a fire stairwell is 200 ft. Check local codes to confirm this distance.

Elevators, the tertiary mode of vertical transportation, are required to accommodate shoppers with limited mobility or a handicap, carrying heavy packages, or pushing strollers. Elevators should be clearly identified and located near both a concourse intersection and a mall entrance.

**THEATERS**

Regional enclosed malls often include a theater complex with 6 to 24 screens. Generally, the number of screens is based on the market demand as determined by the theater company. Theaters draw large numbers of visitors in hours that do not coincide with the hours of operation of most stores in the mall. As a result, a dead space in front of the theater entrance is often created. For this reason, a theater complex entrance is often located close to a mall entrance in an area that does not command prime lease rates and does not interrupt pedestrian flow.

Theaters require multiple exits that deposit viewers from the screen area to the exterior of the mall. These exits often open into parking or landscaped areas, so it is necessary to plan landscaping, lighting, and connections to the parking areas to provide adequate security.

**FOOD COURTS/RESTAURANTS**

Food courts draw tremendous numbers of mall visitors. For this reason adjacent tenant spaces are extremely desirable and command prime lease rates. Locate food courts in conjunction with a mall entrance or concourse intersection and

provide direct access to a service hall for food delivery and garbage removal.

The size of a food court and the number of food vendors depends on the size of the mall, the number of out-parcel restaurants nearby, and the developer's vision.

In addition to the many food vendors in the food court, it is typical to see several sit-down restaurants in a regional shopping mall. These restaurants are usually located along exterior walls of the mall near mall entrances and often have their own entrances from the outdoors. A location along outside walls allows these establishments to have windows.

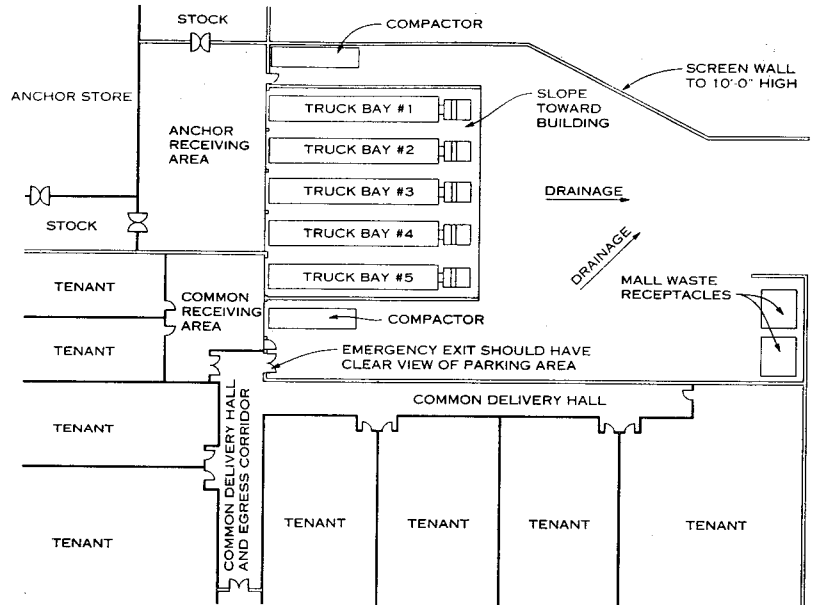

**NOTES**

1. Each anchor store will have its own receiving area comprising three or more truck bays and a compactor.
2. Interstitial tenants do not occupy enough space or move enough product to warrant individual receiving areas. Instead, several tenants (as many as 25) utilize a common receiving area and loading dock, which usually comprises two truck bays and a compactor. Bay depth should be

great enough to allow a delivery vehicle to remain parked without interrupting vehicular traffic in the parking lot.

3. A network of halls behind individual tenant spaces connects stores to the shared receiving area, and each tenant space has one or more doors that access a support hall. Waste collection is performed through this hall.

**TYPICAL MALL DELIVERY AREA**

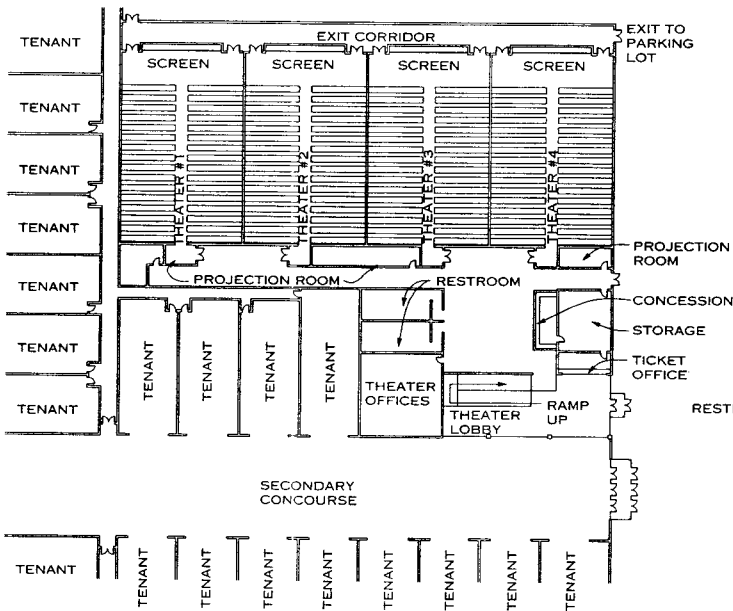

**THEATER COMPLEX**

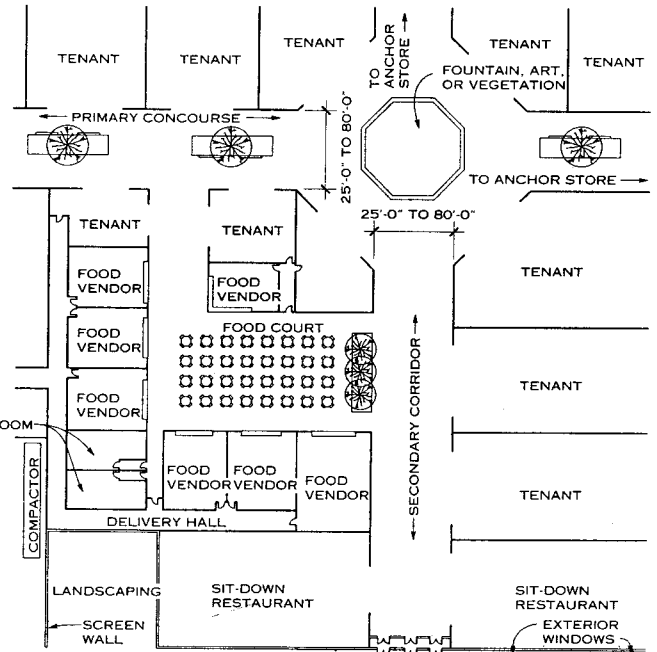

**CENTRAL NODE AND FOOD COURT MALL ENTRANCE**

**TYPICAL MALL COMMERCIAL AMENITIES**

Richard M. Roberts, AIA; Omega Design Architects, P.C.; Syracuse, New York

**MALL GENERAL OFFICES**

All regional enclosed malls have general mall offices located somewhere in the building. Generally included are offices for leasing officers, the mall manager, and the operations manager. Because this office space generates no rent, it is commonly situated in an obscure, although not inaccessible, location far from the typical path of a mall visitor. It is common to see community rooms and space available to the public for rent near mall offices.

**SECURITY OFFICES**

A mall employs several security officers who monitor cameras, traverse the concourses, respond to security emergencies, and provide other security services. These individuals have offices in areas of security risks or low rent generation but not inaccessible to mall visitors. Often security offices are located next to restrooms or adjacent to the mall general offices.

**PUBLIC RESTROOMS**

Restrooms are equally distributed throughout a mall, generally off a secondary concourse. It is essential, however, not to place the restrooms in a remote location where security could be a problem. It is good practice to locate mall restrooms adjacent to mall offices, security offices, community rooms, and information areas, as these elements offer some security. A struggle or scream from an individual in the restroom should be audible in these adjacent spaces. A large restroom must be located adjacent to the food court.

All mall restrooms must be accessible to the handicapped with proper fixtures, partitions, and doors. All materials used in restrooms should be made of vandal-resistant materials.

**ANCHOR STORES**

A mall's success relies heavily on the presence of anchor stores, so much so that mall development proceeds only after anchor store leases have been secured. Anchor stores reside at the prime locations in a mall—the termini of primary and secondary concourses. Store signage is located on all visible exterior faces and above the interior mall entrance. Anchor stores generally comprise as much as 60% of the total gross lease area (GLA) of the mall.

Typically an anchor store is between 50,000 and 150,000 sq ft and has one or more levels. If a store has multiple levels, it will have internal vertical transportation via escalators, stairs, and elevators. An anchor store generally incorporates the following spaces:

The SALES FLOOR occupies 70-80% of the total floor area of a store. The floor, which incorporates shopper circulation paths, is divided into departments with stud walls, fixtures, and material variation.

FITTING ROOMS are provided in departments selling wearable items. They are usually built without a ceiling and with walls that end below the ceiling of the store to prevent shoplifters from concealing items in the ceiling.

STOCK/STORAGE AREAS occupy 5-15% of the total floor area of a store. They have no wall, floor, or ceiling finishes and are adjacent to the receiving area.

The RECEIVING AREA/LOADING DOCK is located on an exterior wall adjacent to the stock/storage area.

STORE OFFICES occupy 3-5% of the total floor area of a store. They are usually grouped in a cluster, often adjacent to the restrooms, but several may be scattered around the sales floor, where they are more accessible to the public.

RESTROOMS are often located near store offices and vertical transportation. Multiple restrooms are provided for shoppers, while separate facilities for employees may be placed elsewhere in the store. Restrooms are built with gypsum wall-board ceilings to prevent shoplifters from concealing items.

**TENANT SPACES**

Mall tenants and their requirements differ so greatly it is difficult to typify tenant space. Occupied area can be as small as 500 sq ft (jewelry or specialty stores) or as large as 40,000 sq ft (book or large chain clothing stores). Generally, tenant space is on a single level, but many larger tenants spread their space between levels, with a vertical transportation connection in the space.

Tenant space generally includes the following:

The SALES FLOOR occupies 80-90% of the total floor area of a tenant space. Most have few, if any, integrated aisles (created with display cases or floor materials), although especially large tenants may use the space more like an anchor store.

Richard M. Roberts, AIA; Omega Design Architects, P.C.; Syracuse, New York

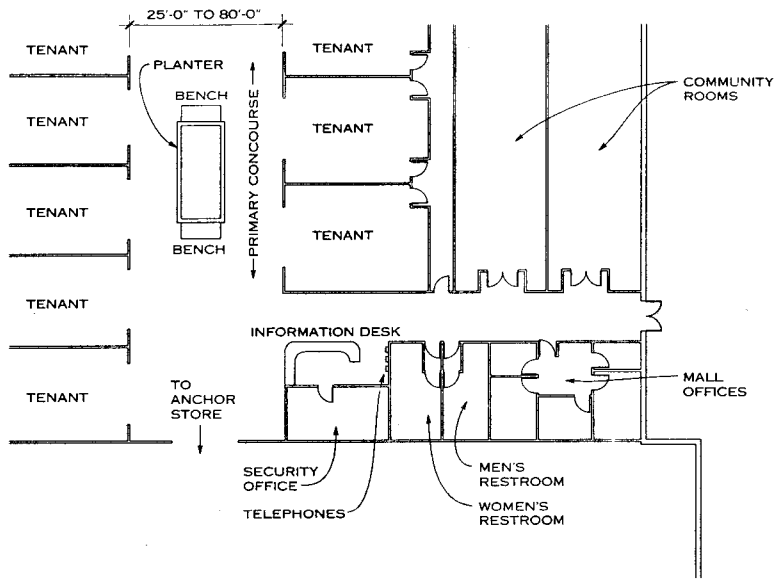

TYPICAL MALL OFFICES, COMMUNITY ROOMS, AND RESTROOMS

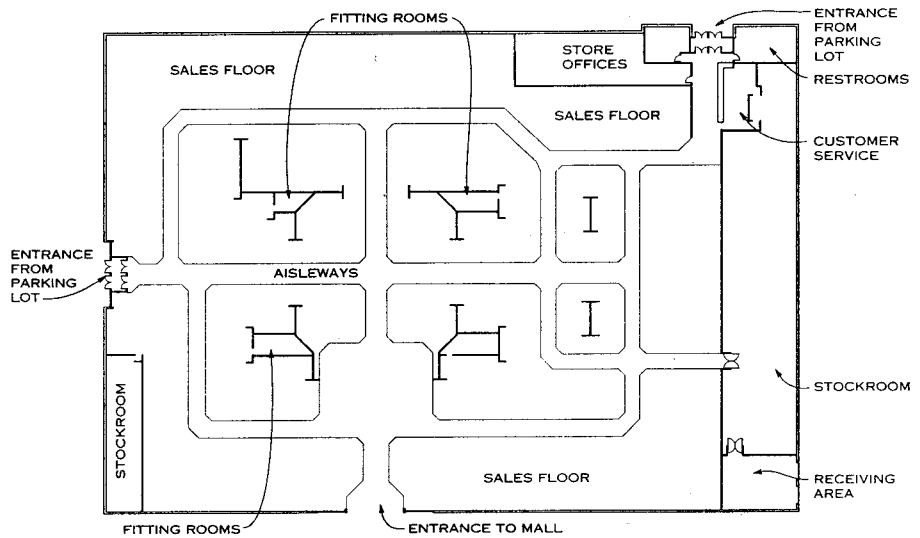

TYPICAL ANCHOR STORE

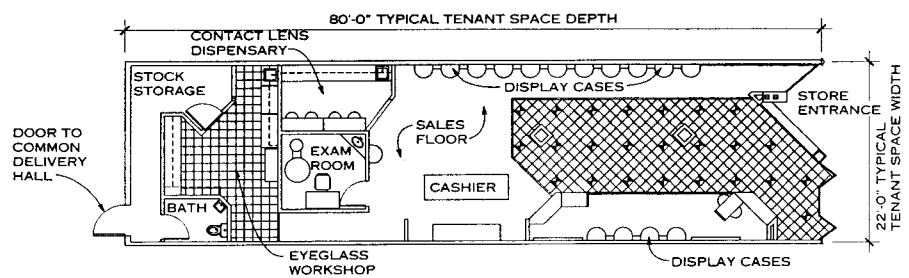

TYPICAL TENANT SPACE (SPECIALTY EYEGLASS SHOP SHOWN)

FITTING ROOMS are often located along rear or side walls of a store and are built without a ceiling and with walls below the ceiling of the store to prevent shoplifters from concealing items in the ceiling.

The STOCK/STORAGE AREA occupies 10-20% of the total floor area in tenant spaces. Located in the rear of the store, it has access to shared receiving areas and delivery halls.

The STORE OFFICE is typically in the rear of the store, where it is used by the store manager. It is not meant to be accessible to the public.

RESTROOMS are provided for employee use only in the stock/storage area. Small stores typically have one unisex restroom, while larger stores have multiple restrooms.

**GENERAL**

Veterinary clinics are typically divided into three zones—public, procedural and patient—based on use, interior finish, and mechanical zones. The current trend is toward providing full service facilities, including boarding, grooming, and retail areas.

**PUBLIC ZONE**

It is desirable to have the traffic flow "one way" within the public areas; in one door to reception and waiting and then out another door to the cashier and exit door.

**RECEPTION DESK.** Allow room for two or three receptionists to work; include space for computer, typewriter, small copier, and files. Files can be accommodated in lateral medical files or an open eggcrate system.

**WAITING AREA.** Ideally, divide this space into separate dog and cat alcoves with approximately 2 to 3 chairs per exam room. Three-foot clearance in front of each chair, apart from the circulation pattern for pets, is required.

**EXAM ROOMS.** 1.5 exam rooms per full-time equivalent veterinarian is typical. Exam rooms can be held to a minimum size (rooms exclusively for cats can be as small as 6 ft x 7 ft 6 in.). Two-way traffic flow—a front door for clients and a back door for the veterinarian and for taking animals to treatment—is desirable. One oversized exam room for consultation or for treating large dogs is recommended. Acoustical batt insulation in the walls surrounding exam rooms is suggested. Based on input from the veterinarian, exam rooms should be equipped with undercounter refrigerators and small sinks.

**PROCEDURAL ZONE**

Includes lab, pharmacy, treatment, X-ray, surgery, and surgery/prep.

**LAB/PHARMACY.** This facility should be immediately accessible to the exam rooms. Often it forms an acoustical and visual barrier between these rooms and the treatment area.

**LAB.** In addition to a sink with exhaust fan (a residential range hood is adequate), the lab should include an area for diagnostic equipment (assume 2 ft per piece of equipment minimum), microscope (with kneespace), centrifuge, and workspace.

**PHARMACY.** This can be a combination of base cabinets with drawers and shelving above (enclosed or open) with risers to make bottles in the back visible. A residential size refrigerator is also necessary.

**TREATMENT.** Provide one workstation per two exam rooms, with a minimum of two workstations, one dry and one wet, with adjacent layout space for equipment. Workstations can be either peninsular or island. Islands should include a utility column for electrical feed and plumbing vent. Many clinics now include a separate wet workstation for dental procedures. Provide a bank of cages in treatment for intensive care and recovery.

**X-RAY.** Either an enclosed or open room opening from the treatment area is suitable, depending on local health regulations and the amount of protection desired. Radiation protection needs vary based on the equipment being used, ranging from two layers of gypsum board to lead shielding. A darkroom should be adjacent to the X-ray equipment. Most veterinarians use automatic processors so the old development tanks are no longer necessary. Storage for X-ray films, approximately 14 x 18 in. each, is also required. Wall-mounted X-ray viewers should be provided in exams, treatment, X-ray, and surgery areas.

**SURGERY/PREP.** This should be a small alcove off the treatment area for preparing packs and scrubbing for surgery. A "hands-free" scrub sink, place for an autoclave, and a work area for preparing packs is required. A cabinet-top pass-through to surgery for prepared packs is often requested.

**SURGERY.** Provide one or two tables and space for parking equipment and carts. High-efficiency particulate airflow filters should be specified on ducts feeding the surgery, which should be a positive pressure room at minimum.

**DOCTORS' OFFICE.** In addition to a doctor's station adjacent to the treatment area for filling out charts, a small doctor's office is usually required.

**TYPICAL ROOM SIZES**

ROOM SIZES	MINIMUM	AVERAGE
Reception	8 x 12	12 x 14
Waiting	8 x 16	10 x 20
Retail		12 x 15
Exam	6 x 8	8 x 10
Oversize exam		10 x 12
Laboratory	6 x 12	8 x 12
Pharmacy	6 x 8	7 x 12
Treatment	14 x 20	18 x 24
X-ray	8 x 10	8 x 12
Darkroom	4 x 6	6 x 6
Surgery		
One table	9 x 10	10 x 12
Two table		12 x 16
Wards	minimum 4' aisle	
Runs	4' aisle, 3 x 5 runs	
Office	8 x 10	12 x 16
Handicap bath	5 x 9	
Grooming	8 x 10	12 x 16
Bathing	8 x 10	10 x 12
Food preparation	6 x 6	8 x 10

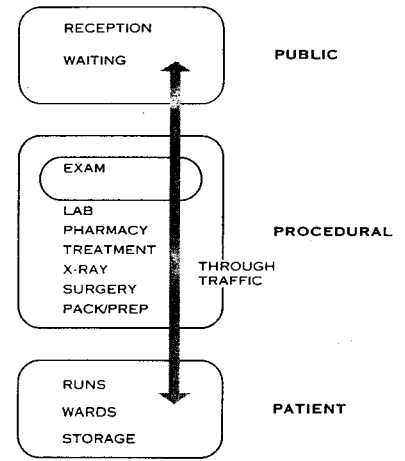

**CONVENTIONAL VETERINARY HOSPITAL BUBBLE DIAGRAM**

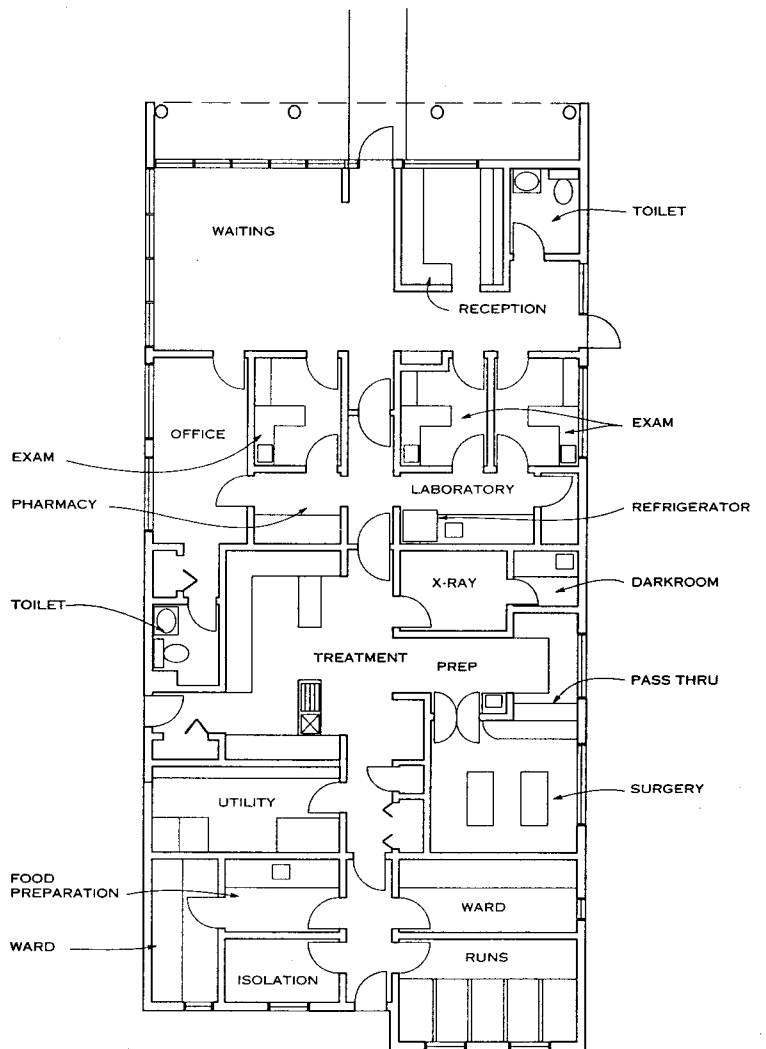

**TYPICAL FLOOR PLAN**

Mark R. Hafen, AIA; Gates Hafen, P.C.; Boulder, Colorado

**PATIENT ZONE**

The patient areas should be acoustically separated from the rest of the facility. The high degree of abuse and constant cleaning requirements of this area make it practical to have painted epoxy concrete block walls, concrete floors, and mylar-faced lay-in acoustical tile ceilings. Ward rooms used for holding small dogs or cats in cages can have walls of drywall.

**WARDS.** These should have space for no more than 25 animals. Assume approximately 1 to 1.25 cages per linear foot of three-tier caging. Where possible runs or cages should not face each other. Cages are typically placed on 4 in. high built-in curbs. Wards should be provided with natural light when possible and exhaust fans.

**RUNS.** The number of runs needed depends on the number of larger dogs treated; minimum size is typically 3 x 5 ft each. Drains should be provided in each run. Slope floors a minimum of 1/4 in. per foot. Caging can be either fabricated aluminum, stainless steel, or chain-link available through veterinary or kennel equipment suppliers. Partitions between runs should be a minimum of 6 ft high with the bottom 4 ft solid to avoid cross-contamination. The solid portion can be of galvanized metal, plastic-laminated exterior plywood, or concrete block. Where possible, noise-reducing baffles and panels should be utilized. Hose bibs with hot and cold water should be provided for hosing down the runs.

**UTILITY/GROOMING.** Room is needed for dry food storage, food preparation, incidental grooming, and washer/dryer. These functions can be separated in larger facilities. The food preparation area should include a double sink, dry food storage bins, work counter, and undercounter refrigerator. A grooming/bathing area should include a raised grooming tub, place for a cage for dog drying, and a small 2 x 4 ft freestanding grooming table. The washer/dryer is used for both washing soiled blankets from the wards and surgery linens. Space is required for a chest-type necropsy freezer. The service entry should be into this room.

**MISCELLANEOUS**

A small isolation ward, including a small bank of cages and one run, is often required for isolating highly contagious animals. Usually it is located immediately adjacent to the service entry, where it will be accessible without going through other wards or the treatment area.

**HEATING, COOLING, AND VENTILATION**

Ideally there should be three mechanical zones: public, procedural, and patient. Three truly separate zones help control acoustical and odor problems. These zones should be pressurized so that air is fed to the public areas and exhausted from the patient areas. Additional exhaust fans should be provided in lab and treatment rooms. A large capacity exhaust fan is necessary in the ward and run areas. Where economically feasible, air should be exhausted to the outside in the run areas to avoid spread of diseases and minimize odors. The acceptable temperature and humidity range in the wards and runs can vary beyond the typical comfort zone, but should not be below 50 or above 85 degrees. Air changes in the wards and runs should be 12 to 14 an hour. The surgery should be a positive pressure room with high-efficiency particulate airflow filters.

**ELECTRICAL**

In addition to the obvious requirements of the X-ray equipment (typically 100 amp), most veterinary clinics utilize a lot of electrical equipment, including autoclaves, dog dryers, and exam and surgery lights. Be careful not to locate too many pieces of equipment on any one circuit.

**MATERIALS**

Cleanable and durable materials are a high priority. In the public areas flooring can be welded sheet vinyl or quarry tile (with latex epoxy grout). Walls can be covered with flat latex or vinyl. Ceilings can be of gypsum board or lay-in acoustical tile.

In the procedural areas a higher degree of cleanability/durability is required. Floors should be of welded seam homogeneous PVC sheet vinyl, and walls can be washable latex. The surgery should have water-based epoxy walls and a painted gypsum board ceiling. Other ceilings can be lay-in acoustical tile.

In the patient areas durability is most important. All areas exposed to water should have concrete block walls painted with water-based epoxy (other walls should be of epoxy painted gypsum board). Ceilings exposed to water hoses should have mylar-faced acoustical tile. Floors in wards should be of sealed and colored concrete. In the runs it is possible to paint or tile the floors, but the most foolproof solution is sealed and colored concrete.

**TYPICAL VETERINARY EQUIPMENT AND SIZES<sup>1</sup>**

EQUIPMENT	HEIGHT	WIDTH	DEPTH
X-ray control center	53"	21"	12 1/2"
X-ray table	22"	57"	39"
X-ray illuminator	19 3/4"	29"	3 1/8"
X-ray film processor	18 1/2"	23"	38"
Surgical equipment sterilizer	14"	19 1/2"	23 1/2"
Walk-on platform scale	34 1/2"	44 1/2"	20"
Electric lift exam and weight table	10 to 40"	44 1/2"	20"
Pedestal base surgery table	37"	58"	19"
Combination tub/exam table with cabinet <sup>2</sup>	38"	60 1/2"	24 5/8"
Combination tub/exam table with legs <sup>2</sup>	35"	60 1/2"	24 5/8"
Kennel assemblies <sup>3</sup>	48 to 84"	48 to 168"	28 1/4"

**NOTES**

1. All dimensions are typical and may vary with manufacturer.
2. Combination tub/exam tables can have tub depth of either 6 or 16 in.
3. Kennel assemblies are modular with cage sizes of 24 x 24 in., 24 x 30in., 30 x 30 in., 36 x 30 in., and 48 x 30 in.

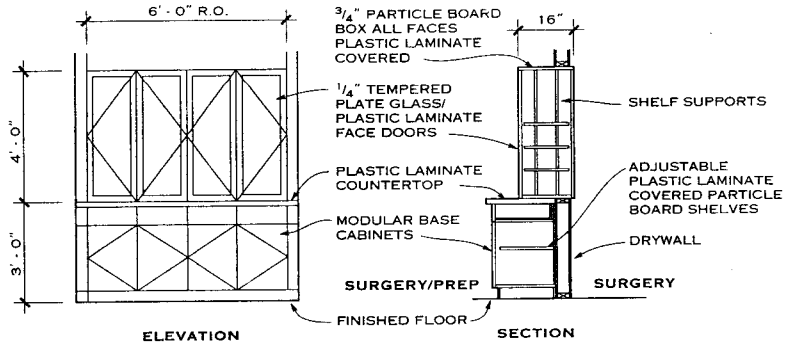

**SURGERY/PREP PASS-THROUGH UNIT**

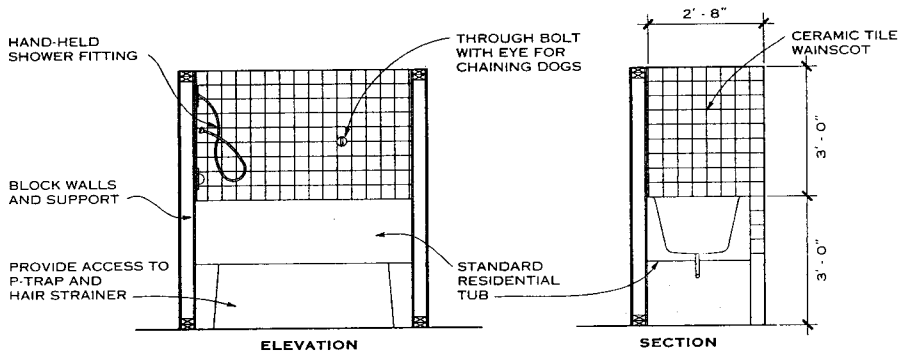

**GROOMING TUB**

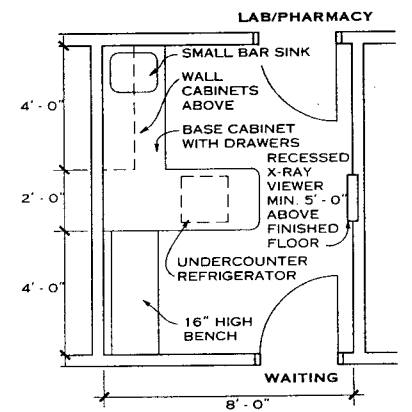

**TYPICAL EXAM ROOM**

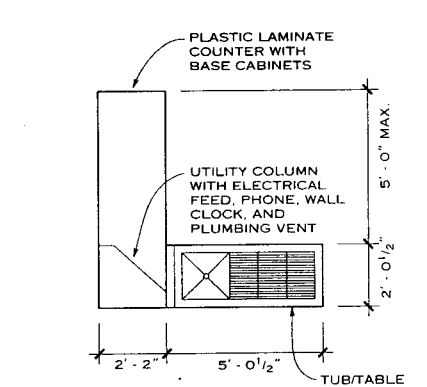

**TYPICAL TREATMENT STATION**

Mark R. Hafen; AIA, Gates Hafen, P.C.; Boulder, Colorado

**GENERAL**

All kennels for boarding dogs must provide for each animal a primary enclosure (usually indoors) for privacy, eating, and resting and a secondary enclosure (usually outdoors) for exercise.

The primary enclosure should consist of solid dividers to separate adjacent runs and provide privacy with a sloped floor to provide for drainage during cleaning. Enclosures should be large enough to allow for normal movements with minimum sizes of 3 x 4 x 4 ft for small breeds and 3 x 6 x 6 ft for larger breeds.

The secondary enclosure is for exercise and should be large enough for the dog to break into a trot with minimum sizes of 3 x 7 x 4 ft for small breeds and 3 x 11 x 6 ft for larger breeds. Separate each run with a barrier to prevent waste from flowing from one to another. Provide hose bibbs to wash down this area.

Cats are boarded in stacked cages of 2 x 3 x 3 1/2 ft with a perch at the rear. The materials can be less durable than those for dogs, since cats are not as destructive and cleaning does not require hose down. Each enclosure should contain a litter box and enough floor space for food and water and lying down. A climbing tree and removable den for hiding can be provided. Cat enclosures are usually vented individually to prevent the spread of diseases.

Cats enjoy interesting views and distractions so good lighting, cheerful colors, music, plants, outside views, caged birds, and fish tanks are recommended. Cats, however, will adapt to boarding faster if they are separated visually from one another. Community play areas are not recommended because of the possible spread of diseases.

**VENTILATION**

Proper ventilation is important to prevent the spread of diseases. Air should be vented to the outside, unless air cleaners are used. Recommended ventilation standards should be 10 to 15 room air changes per hour.

**HEATING AND COOLING**

Temperatures should be designed and maintained between 60-80°F, with humidity maintained between 30-70%. Radiant heat in the floor is highly recommended as it provides heat at the level of the animal.

**DRAINAGE**

The flooring of all runs should be sloped 1/4 in. per foot from the rear to the front. Drainage should be quick and complete, with the floor finish being not so smooth that it becomes slippery when wet or so rough that it is hard to clean and harms the animal. Waste materials should be collected outside the runs or cages and run to minimum 3 in. diameter floor drains.

**LIGHTING**

All areas should be bright and cheerful with abundant natural light for the health of the animals. Skylights and ample windows located a minimum of 6 ft off the floor are desirable. Windows should be operable and hinged at the sill to tilt inward to prevent escapes.

**NOISE CONTROL**

Noise control is important to decrease boarding stress and employee health problems such as hearing loss and to meet local noise ordinances. Noise reducing materials should be considered including ceiling and wall baffles.

**MATERIALS**

All materials used should be durable and easy to clean and maintain. Concrete block sealed or painted is the usual choice. Prefabricated and modular runs are available or chain link fencing can be used. Carpeting is not recommended as a flooring material.

**NOTES**

Kennels for the care and boarding of animals are typically defined as breeding, commercial, private, research, and veterinary/medical. The size, type, quantity, and layout of the equipment is related to the function of the kennel and amount and type of patronage.

The schematic drawing (right) is not meant to dictate a design standard but rather to familiarize the reader with typical characteristics of commercial kennels.

**TYPICAL ROOMS**

ROOM NAME	MINIMUM SIZES
Reception / retail sales	15 x 20
Private office	10 x 10
Customer service office	8 x 10
Pre-entry exam room	6 x 8
Grooming room	10 x 10
Bathing and drying room	8 x 8
Storage	3 x 6
Utilities	8 x 8
Exotics boarding area	8 x 10
Isolation room	6 x 6

ROOM NAME	MINIMUM SIZES
Service corridor	4 wide
Customer toilet	6 x 7
Storage	8 x 10
Kennel kitchen	10 x 15
Employee locker / lounge	8 x 10
Employee toilet / shower	6 x 8
Storage	3 x 6
Cattery	Related to number of cages
Dog kennel	Related to number of runs
Security fence	6-ft-high

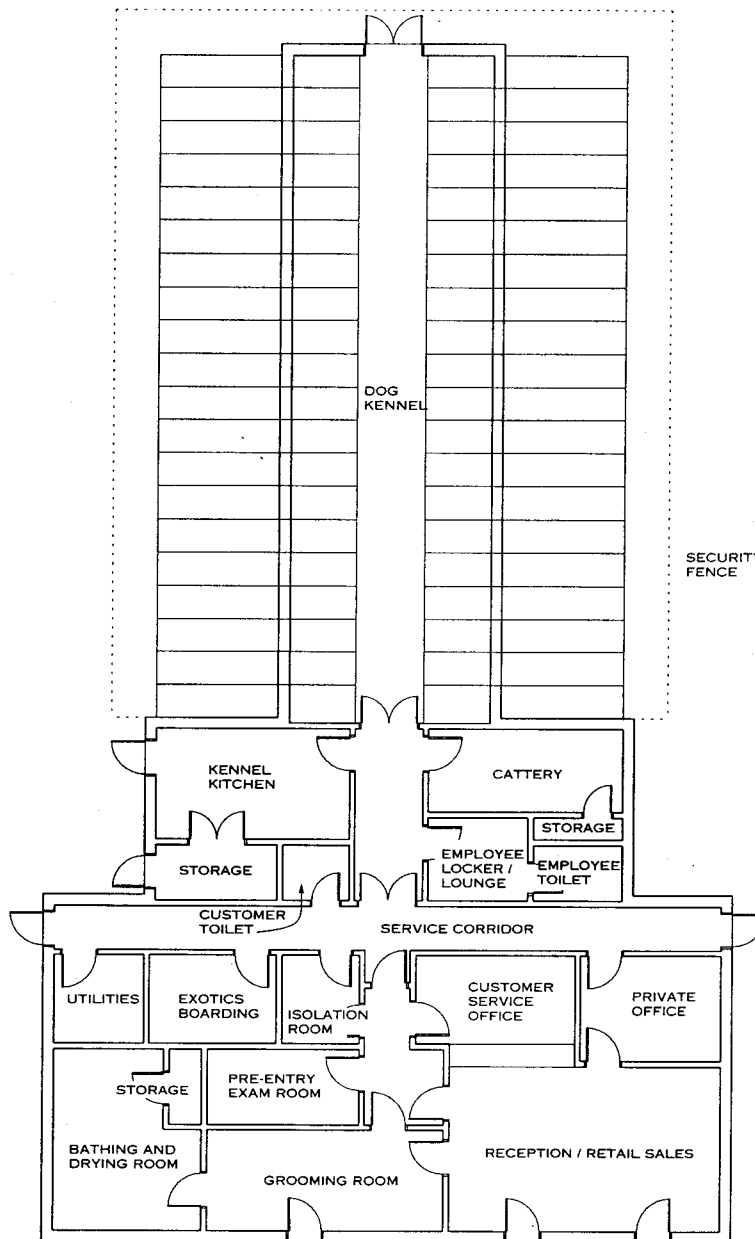

**PLAN OF TYPICAL COMMERCIAL KENNEL**

Jesse Oak; Anderson Cooper Georgelas; McLean, Virginia  
 American Boarding Kennels Association; Colorado Springs, Colorado

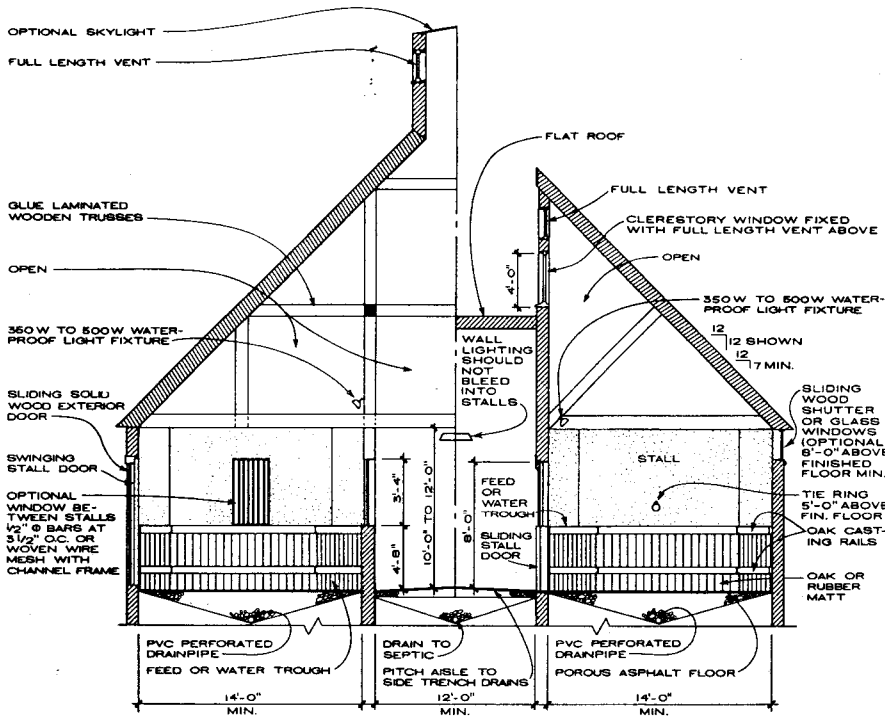

TYPES OF BROODMARE STABLES

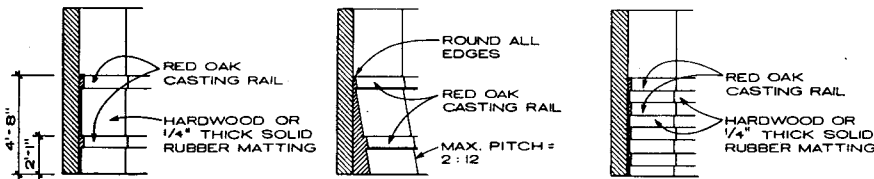

TYPICAL STALL TREATMENT FOR CASTING PREVENTION

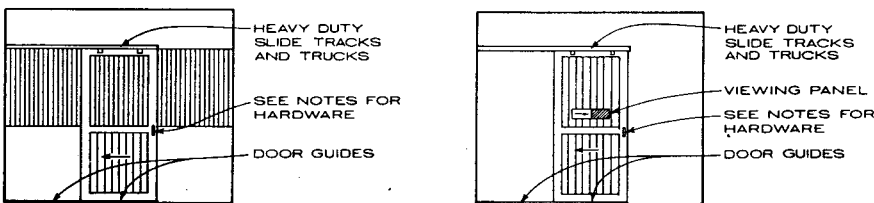

TYPICAL SLIDING AISLE DOOR

SOLID WOOD FOALING STALL WITH VIEW THROUGH

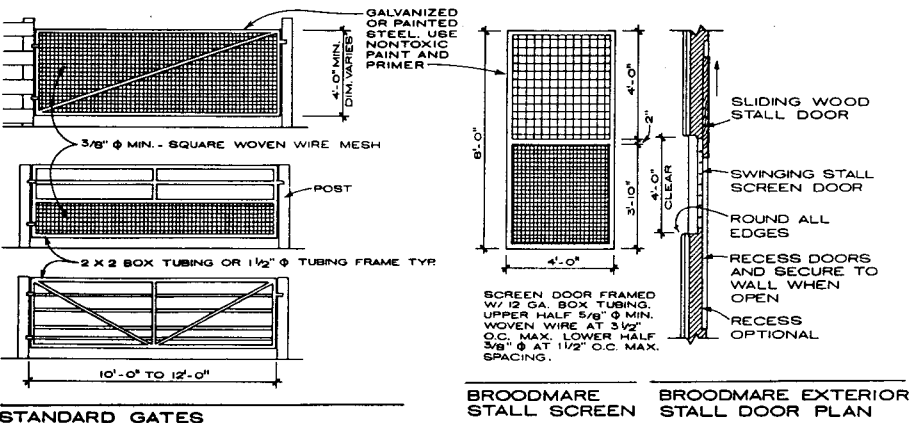

STANDARD GATES

BROODMARE STALL SCREEN

BROODMARE EXTERIOR STALL DOOR PLAN

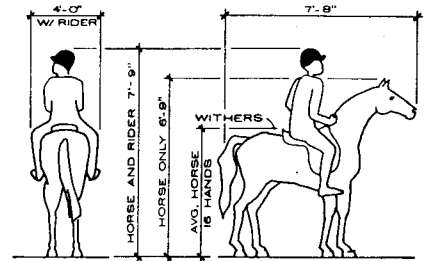

ONE HAND EQUALS 4"  
CLEARANCES FOR HORSE AND RIDER

NOTES

Barns: masonry and glue-laminated construction for fire-resistance. Stalls: furred out, finished with red oak, hardwood, or 1/4 in. rubber matting. Casting rails: 2 in. x 6 in. red oak, edges rounded, sealed with boiled linseed oil. Countersink fastener heads, plug. Stall corners: rounded or 45° walls to casting rail. Ventilation: high open slots with optional sliding wood shutter. Windows: safety glass only, minimum of 8 ft above floor. Floor: 3 in. porous asphalt (percolation of one gallon in ten seconds) over 18 in. crushed stone with a porous drainpipe pitched to take effluent away from barn areas. Check local codes on septic requirements. Floors: rough concrete or skid-resistant brick pavers with a central floor drain to catch basin. Grates: cast iron or precast concrete centered in stall with perforations no larger than 1 in. diameter or 1 in. sq. Floor: sloped to center drain. Provide optional infrared heaters in all horse wash areas at maximum 10 ft above floor. Aisle floors: porous asphalt, paving bricks set in 2 in. sand, or diamond shaped concrete with trench drains to each side.

Tack room area varies with the type of stable. Riding stables have at least one bridle and saddle per horse or pony. Saddle and bridle racks can be fastened in rows, one over another. Additional space is needed for groom equipment, sometimes stored in tack trunks. In broodmare stables, tack is mainly halters and grooming supplies. Tack room and foaling stall must be heated. Foaling stall heat: controllable to raise it as quickly as possible to 75° minimum and to maintain it. Foaling stall floor: seamless, rubberized material, minimum 1 in. thick, textured, and pitched to a separate drain and catch basin (not connected to main barn drainage). Rubberized flooring turned up the walls, minimum of 24 in. Foaling stall adjoined by the situp room (also heated) with a one-way unbreakable glass panel and/or slide shutter for the groom to observe.

All feed and grain storage bins are lined with galvanized steel for vermin control. Feed amounts vary widely. As a guideline, a horse under medium to heavy workload is fed 15 lb of grain plus hay per day. All hay and bedding must be stored in a separate dry barn due to fire risk. As horses are grazing animals, hay managers are not recommended; place hay in a corner of the stall floor. All roofs should have a minimum 7/12 pitch and continuous full length vents under the eaves and at ridges. Sliding doors are preferable. All swinging dutch doors or full doors should have a 180° swing to wall and fasten. Stalls should have heavy duty slide bolts, kick over bolts, and/or locking pins. All hardware should be smooth with no sharp protrusions and inaccessible to horses at the stalls. All light fixtures should be guarded and/or waterproofed. Light switches: located in a central panel away from wet areas. Lighting levels vary. Depending on the program, stalls are lighted with a single floodlight over the inside stall door at the ceiling or 10 to 12 ft. above finished floor. Aisles can be lighted by incandescent or fluorescent lamps. Broodmares and stallions require brighter light and lighting programs to keep fertility levels maximized (approximately 100 footcandles should be achieved at 5 ft 0 in. above finished floor per stall). Aisles may have lower light levels of 40 footcandles, except examination or display areas, which must have additional light available on demand.

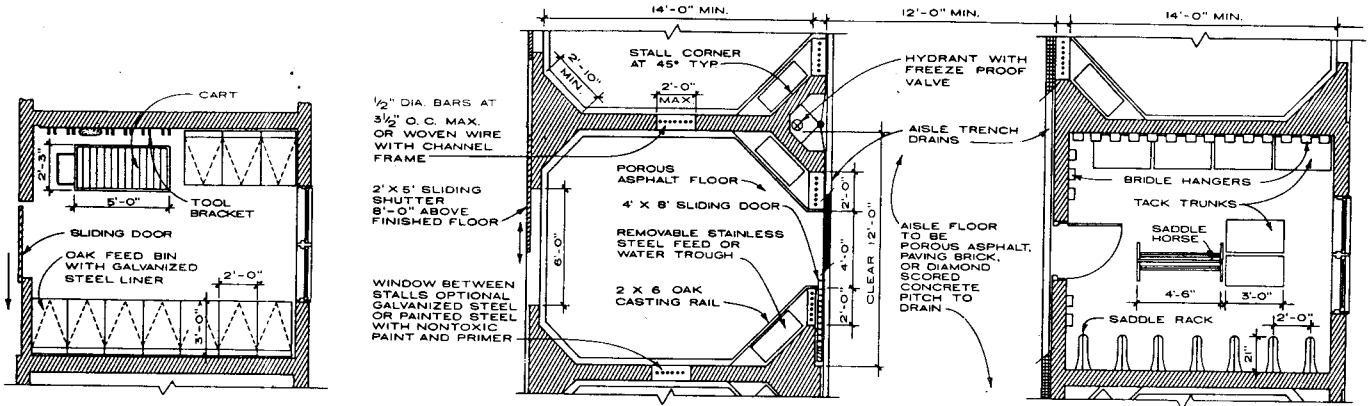

FEED AND EQUIPMENT ROOM PLAN

TYPICAL STALL PLAN

AISLE

TACK ROOM PLAN

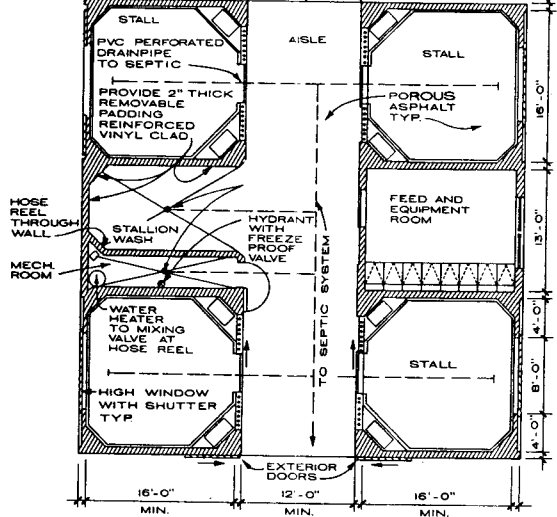

STALLION BARN - 4 STALLS - REFER TO NOTES

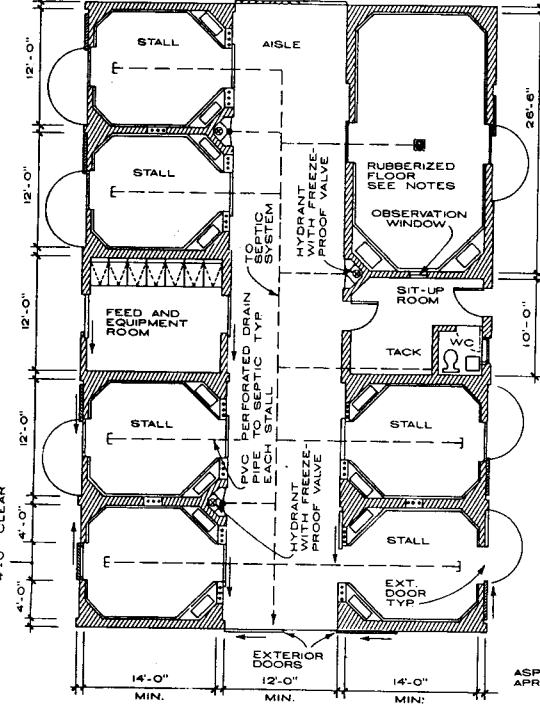

BROODMARE BARN - 7 STALLS - REFER TO NOTES

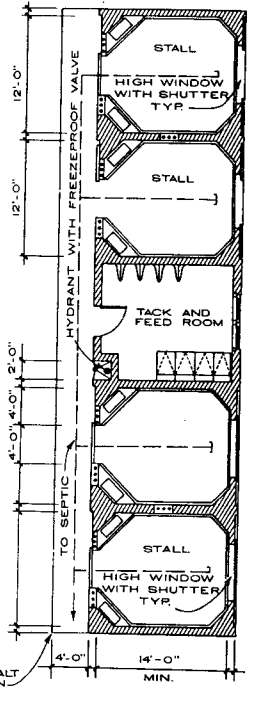

RIDING HORSE BARN 4 STALLS REFER TO NOTES

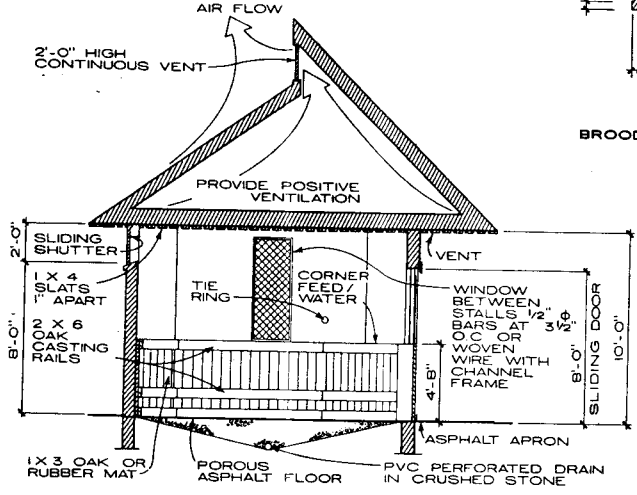

STALL SECTION THROUGH RIDING HORSE BARN

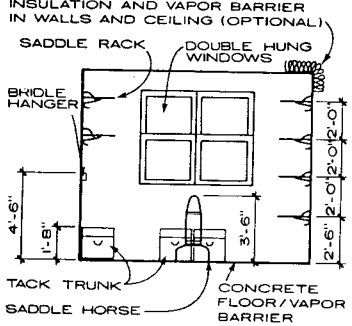

TACK ROOM ELEVATION SERVES 40 STALLS - HEAT AND HUMIDITY CONTROL REQUIRED

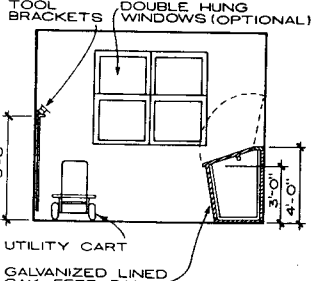

FEED AND EQUIPMENT ROOM ELEVATION CAPACITY OF ONE BIN = 100 LB VENTILATION REQUIRED

Theodore M. Ceraldi & Associates, Architects; Nyack, New York

**INTRODUCTION**

Developments in ventilation, glazing, and horticulture have helped achieve satisfactory plant growth in greenhouses to make the practice economical. Site selection considerations include: topography (flat is advisable), drainage, quantity and quality of water supply, air quality, direction and average wind speed, and, most important, the amount of available light. Orientation for optimal solar gain is east-west except in conditions where shadow casting obstructions outweigh the orientation rule. Once a site has been selected, development of a plan for growth (even if only one greenhouse is built at first) is essential, factoring in access, mechanical room locations, and circulation of materials and labor. Heating and cooling needs will vary with latitude, plant type, skin or glazing, and growth period.

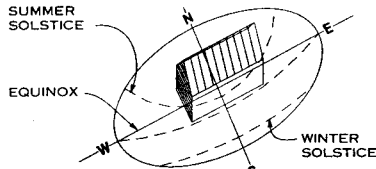

**NOTE**

Use of an uneven span greenhouse allows for optimal solar orientation. Slope of glass is determined by latitude.

**OPTIMAL SOLAR ORIENTATION**

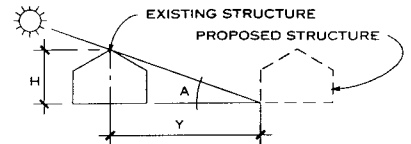
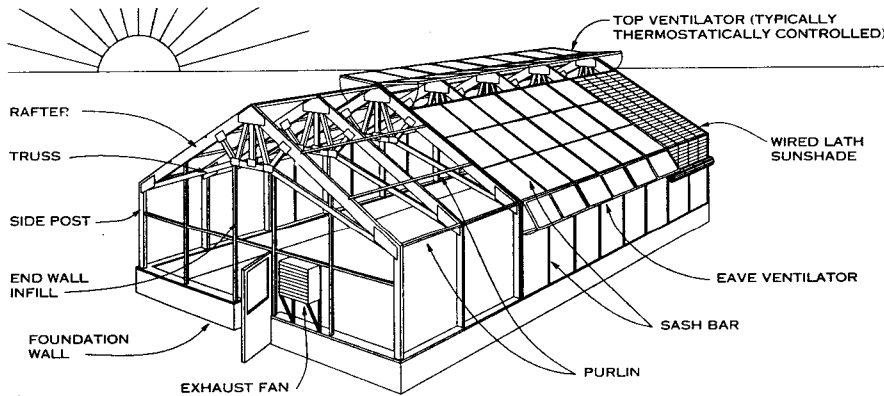

WHERE  
 A = MIN. ANGLE OF SPAN  
 H = HEIGHT  
 Y = CENTERLINE OF HIGHEST POINT TO PROPOSED GREENHOUSE  
 SOLVE FOR Y  
 $TAN A^\circ = HY$

**SPACING OF STRUCTURES**

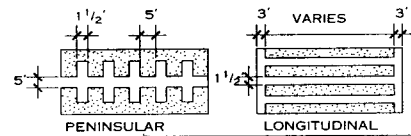

**BENCHING**

**GENERAL**

Reduction of summer heat gain is achieved through shading systems, and natural and fan ventilation systems. Shading is most often achieved with the use of paint on the interior glass, lath rolled on the structure's exterior, or cloth of varying density on the structure's interior.

**EVAPORATIVE COOLING**

Mechanical refrigeration is generally cost prohibitive cooling with the exception of pad systems, or "swamp coolers," involving pulling air through a wet pad the length of the greenhouse wall with a fan mounted high on the opposite wall.

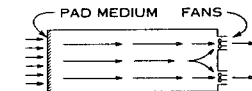

**SWAMP COOLER**

**EXHAUST FANS**

Fan placement depends on greenhouse orientation; optimal placement is the side opposite the normal wind direction. Fans from adjacent greenhouses should be placed opposite each other, spaced at not more than 25 ft. Stratification is desired in summer cooling, where only 15 to 60% of total air volume is moved mechanically.

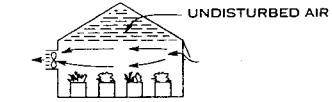

**STRATIFICATION**

**COOLING SYSTEMS**

Air exchange is necessary to moderate interior temperature and humidity. High humidity promotes plant disease and inhibits soil drying. The most common means of ventilation are natural venting, tube ventilation, and fan-jet ventilation.

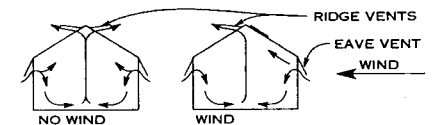

**NATURAL VENTILATION**

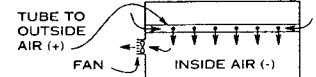

**TUBE SYSTEM**

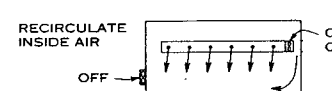
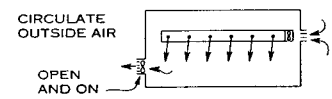

**FAN JET SYSTEM**

**VENTILATION SYSTEMS**

**GENERIC GREENHOUSE**

When properly maintained, a glass greenhouse will last 40 to 50 years. Structural design of a greenhouse is similar to curtain wall design with live loads of wind, snow, piping, and hanging basket plants.

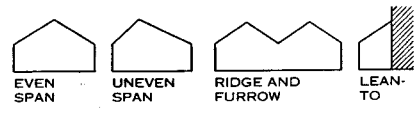

**FRAME TYPES**

MATERIAL	FEATURES
Pipe frame	Economy/simple connections
Steel frame	50' span (installation by professionals)
Aluminum frame	No rust, deeper sections than steel
Wood frame	Pressure treated lifespan: 10-15 yrs.

**GLASS-SHEATHED GREENHOUSE**

Rigid or flexible plastic greenhouses feature economy, ease of fabrication, and flexibility of form making. Plastic's liabilities are its poor durability, reduced light transmission over time, and discoloration or brittleness.

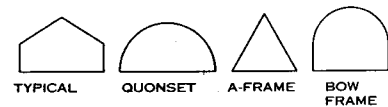

**PLASTIC TYPE MATERIAL**

Flexible	Polyethylene, mylar
Rigid	PVC, acrylic, fiberglass

**NOTE**

The size of a plastic greenhouse is limited only by the width of a single sheet of plastic.

**PLASTIC-SHEATHED GREENHOUSE**

**HEATING SYSTEMS**

Heat distribution is achieved through use of solar, hot air, or radiant pipe systems. Solar heating will usually need the augmentation of the two latter systems at the coolest or windiest part of the year.

**RADIANT/HOT WATER PIPE**

Systems use a boiler to heat and distribute water. Pipes located at the greenhouse perimeter are the most convenient and efficient method of achieving uniform temperature.

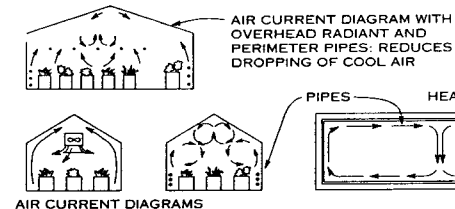

**INSULATION**

Insulation augments heating systems and helps reduce heat loss from convection and radiation. Three basic systems are most widely used: movable night curtains, plastic covering over glass, and permanent reflective insulation of north wall and roof.

**HOT AIR**

Systems burn various fossil fuels and distribute the warmed air with fans.

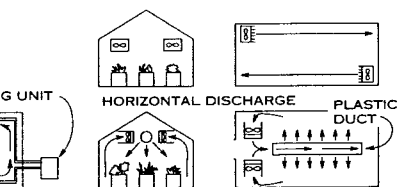

**HEATING SYSTEMS**

Eric K. Beach; Rippeteau Architects, PC; Washington, D.C.



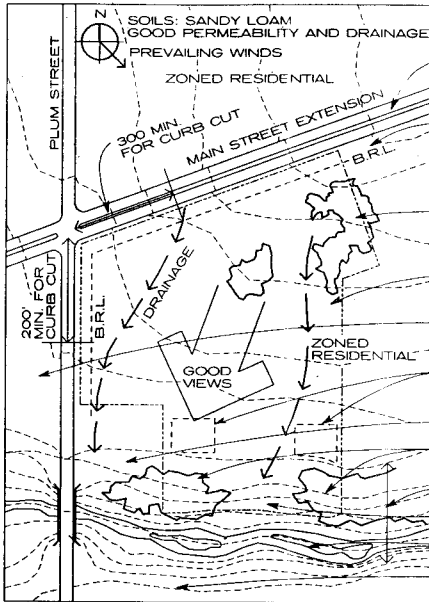

ACOUSTICAL CONCERNS ALONG MAIN STREET

B.R.L. VARIES DEPENDING ON ZONING, POSSIBLE BUILDOUT

EXISTING TREE STANDS, DESIRABLE AS BUFFER

MINIMAL SLOPE, PRIME SITE FOR BUILDINGS AND OPEN SPACE

UNDEVELOPED, POSSIBLE LIGHT COMMERCIAL OR RESIDENTIAL

POSSIBLE STORM WATER MANAGEMENT LOCATIONS (LOW TOPOGRAPHY)

OUTPARCEL, PLANS UNKNOWN, ZONED RESIDENTIAL

EXISTING TREE STANDS

150' FLOODPLAIN

POSSIBLE ACCESS TO STREAM

STREAM

ZONED RESIDENTIAL, EXISTING SINGLE-FAMILY DETACHED

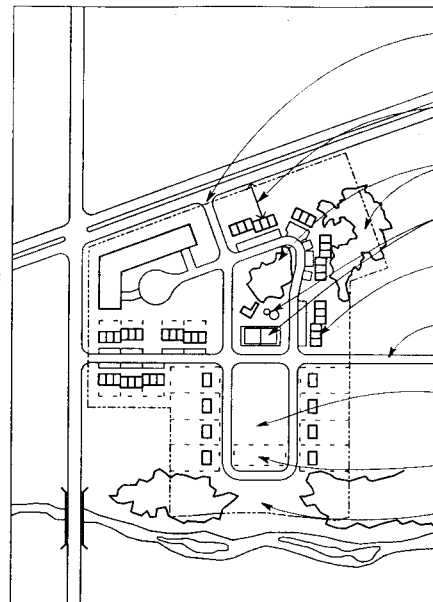

REDUNDANT ACCESS PROVIDED TO MAJOR ROADS AND ADJACENT NEIGHBORHOODS

ATTACHED UNITS SET BACK FOR ACOUSTICAL CONCERNS

EXISTING TREE STANDS PRESERVED

COMMON FACILITIES CENTRALLY LOCATED

SITE SUPPORTS MULTIPLE TYPES AND DENSITIES

CHANGES IN TYPE AND DENSITY OCCUR AT CHANGES IN BLOCK STRUCTURE

CENTRAL GREEN PROVIDED AS FOCUS OF DEVELOPMENT, ALIGNS ALONG VIEW CORRIDOR

STORM WATER MANAGEMENT

PUBLIC ACCESS TO STREAM PRESERVED

**SITE ANALYSIS AND SCHEMATIC SITE PLAN**

**GENERAL**

Residential site planning requires balance among a large number of complex and often competing priorities.

**ORIENTATION**

No unit should be without sun for at least part of a winter day; south-facing units are premium. Prevailing winds, both regional and local, should be studied so that no building is entirely masked. At the same time, harsh winds should be buffered by plantings, and if buildings are differentiated by side, bedroom and service sides should face the harsh wind.

**USE AND ENHANCEMENT OF NATURAL AMENITIES**

Too frequently, housing projects are named for amenities that are destroyed during development. Promontories, mature trees, and water features should be incorporated into the design and, if possible, enhanced.

**PROVISION FOR VIEWS**

Spectacular views can drive the design of a housing project, but every project should strive to provide reasonable views from all units. Although no unit should have a parking area as its only view, many people enjoy views of streets and roadways. Views of green space are important, especially in urban projects.

**CONTEXT**

The designer must strive to identify valuable off-site resources and influences so that they are recognized in the design.

Such resources include the following:

1. Geometries and alignments
2. Slopes and soils
3. Views of singular objects and natural amenities
4. Recreational facilities
5. Topography and drainage
6. Surrounding and adjoining uses
7. Available infrastructure
8. Market and location

**CLEAR DELINEATION OF PRIVATE AND PUBLIC AREAS**

Beyond unit design considerations, the site should be organized so that all territory can be clearly allocated to either private custody or public care and maintenance. It is frequently desirable for each unit to control some private open space. However, in higher density developments such space is often limited or filled in unique ways.

**REGULATORY REQUIREMENTS**

Land available for housing and related uses may face restrictions, including the following:

1. Rights of way for future uses
2. Area required for storm water management and sediment control
3. Mandated unusable areas between projects (called buffers)
4. Building restriction lines: setbacks, build-to lines, height limits, viewsheds, watersheds, separations, rights of way, easements
5. Roadways and parking areas
6. Protection of environmentally sensitive and natural resource areas such as forests, streams, and animal habitats

**DENSITY AND BUILDING TYPES**

These factors are the most critical to the developed character of the site and are prescribed by zoning and by developer preference—as informed by the architect and others. Zoning density is expressed numerically along with limitations that are often intended to suggest unit type. But any prescribed density can be reached by combining building types with associated parking arrangements. The permitted density may ultimately be reduced through restrictions of various sorts and is rarely achievable on small or irregular sites.

**UNITY AND VARIETY**

In site design, monotony and excessive repetition are as undesirable as meaningless variation, which can be disorienting and appear chaotic.

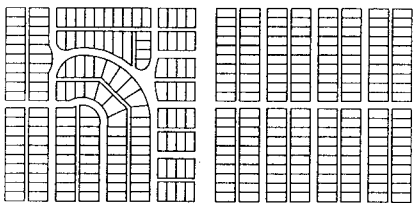

**ARBITRARY VARIATION AND MONOTONOUS REPETITION**

**EMERGENCY ACCESS**

Size and turning radius of emergency equipment, especially fire engines, can mandate street width, turning radius, and access patterns. Access to buildings becomes an issue at higher densities; installation of sprinkler systems can often balance equipment access around buildings. Always consult the fire marshal in the early stages of design.

**SECURITY**

Because projects are produced and marketed as discrete places, security considerations can reinforce their hermetic character and prevent integration into the larger community. At higher densities, this phenomenon can produce gated communities with limited or single access, card-accessed parking areas, and private police.

Conventional urban patterns can replace costly and artificial surveillance systems: building placement, window location, and resident awareness, together with architectural limitations on free circulation, can enhance neighborhood security.

**ACCESS**

Although singular access is frequently desired for marketing and control, redundant access from existing automotive and pedestrian networks provides choice and convenience while reducing concentrations of traffic.

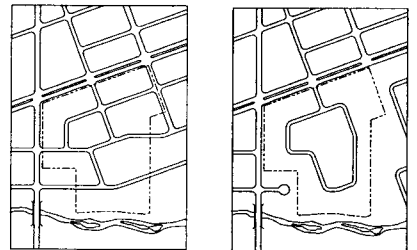

**MULTIPLE ACCESS AND SINGLE ACCESS**

Ralph Bennett; Bennett Frank McCarthy Architects, Inc.; Silver Spring, Maryland

**GENERAL**

Numerical definition of density is the most important planning index in housing but it can also be the most misleading. Density numbers frequently become inflammatory in planning debates, so it is important that the architect provide specific images of the actual appearance of planned settlements.

Density appears in two forms: gross and net. Gross density is the index applied to large areas—15 to 20 acres or more—and includes private as well as public improvements such as roads, schools, parks, and residentially oriented retail uses.

Net density is used in relation to project-sized areas—smaller than 15 to 20 acres—and consists of the number of proposed dwelling units divided by the site area. Net density is usually expressed in acres and includes access drives, parking areas, common and buffer areas, and community facilities.

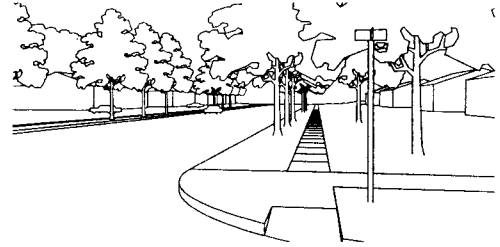
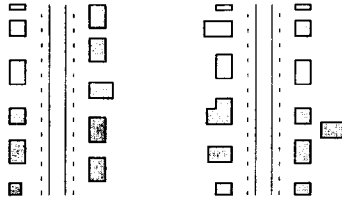

**FACTORS AFFECTING DENSITY**

1. Dwelling unit size and arrangement.
2. Parking: on grade, in garages, in units, structured in large groups.
3. Passive and active open space.
4. Land use restrictions such as buffers, easements, and setbacks.
5. Land price: the owner's objectives are ultimately formed by this factor, in conjunction with market projections.

**TYPICAL DENSITIES**

1. **SINGLE-FAMILY DETACHED HOUSES:** The density in developments of this type is generally 6 dwelling units or fewer per acre. In the example illustrated, the density is 4.5 dwelling units per acre, with on-site parking but no garages and 7,500-sq-ft lots.
2. **SINGLE-FAMILY ATTACHED TOWN HOUSES (parking on grade):** The density in a development of this type is up to 14 dwelling units per acre.
3. **SINGLE-FAMILY ATTACHED TOWN HOUSES WITH GARAGE:** Up to 20 dwelling units per acre will fit in a development of this sort.
4. **TWO-STORY ATTACHED HOUSES:** With carports, these houses are designed at a density of around 10 units per acre.
5. **GARDEN APARTMENTS:** Parking on grade is provided in a garden apartment complex, which contains up to 18 dwelling units per acre. In the example shown, each apartment building has 36 units, for a density of 18 units per acre.
6. **WALK-UP APARTMENTS:** Built over one parking level, a walk-up apartment complex could accommodate up to 30 dwelling units per acre.
7. **ELEVATOR BUILDINGS:** Elevator buildings with structured parking can be built at a density of up to 100 dwelling units per acre. The example shown is a double-loaded corridor slab building with 200 units. With surface parking, it offers a density of 45 units per acre.
8. **MIXED NEIGHBORHOODS:** A mixed neighborhood encompasses a variety of dwelling types and, correspondingly, a variety of housing unit densities. The example shown includes an 8-unit walk-up apartment building on a 16,000-sq-ft lot, with a density of 16 units per acre, and single-family detached houses with garages on 8,000-sq-ft lots, with a density of 4 units per acre. The overall density in this example is 6.4 units per acre.

**SINGLE-FAMILY DETACHED HOUSES**

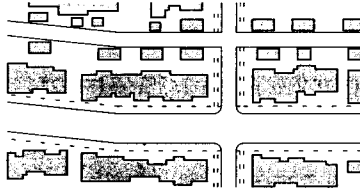

**TWO-STORY ATTACHED HOUSES**

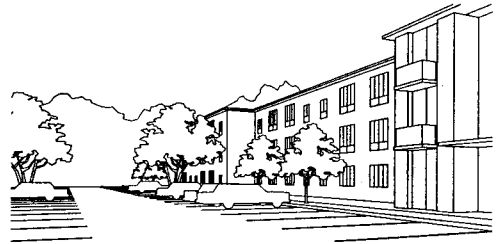
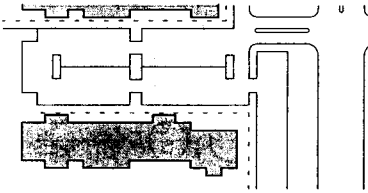

**GARDEN APARTMENTS (THREE-STORY WALK-UP BACK-TO-BACK)**

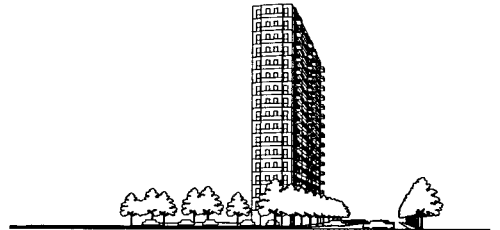
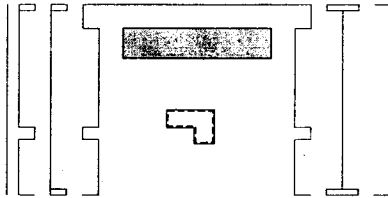

**ELEVATOR BUILDING**

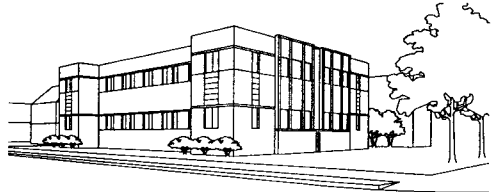
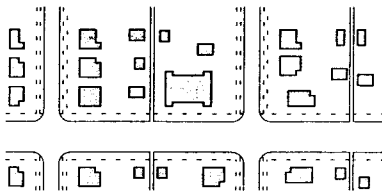

**MIXED NEIGHBORHOOD**

Ralph Bennett; Bennett Frank McCarthy Architects, Inc.; Silver Spring, Maryland

**SITE PLAN CONSIDERATIONS**

**ACCESS**

1. Where possible, access should connect and align with existing systems.
2. Marketing and security considerations frequently dictate single access, but redundant circulation gives choice and improved service.

**PEDESTRIAN CIRCULATION**

1. Rarely provided at lower densities, pedestrian access is essential at higher densities.
2. Pedestrian walkways usually parallel streets.
3. Connections to mass transit are appropriate.

**PARKING**

1. Parking arrangements have a significant impact on density and appearance.
2. On-street parking for guests is desirable at lower densities and essential at higher densities.

**RELATION TO TOPOGRAPHY**

1. ADA and subdivision regulations dictate street and walk grades and mandate site reformation at all but the lowest densities.

**SERVICE**

1. Trash pickup, mail service, and deliveries depend on street access to individual units.
2. Fire apparatus usually dictates road standards.

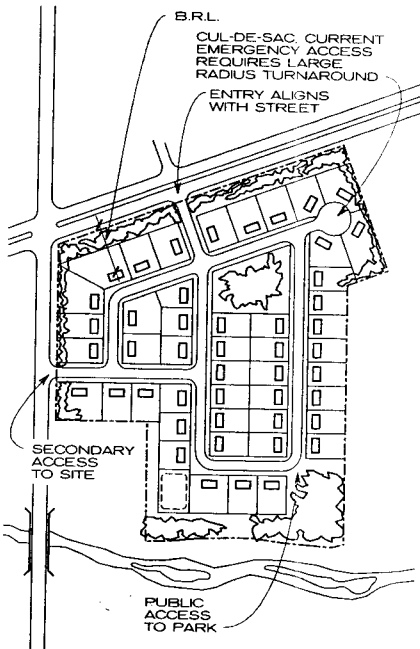

**STREET ACCESS**

**TECHNOLOGY**

**STRUCTURE**

1. Typically wood frame.
2. Fire separation is required for incorporated parking (garage).

**MECHANICAL**

1. Air, water.
2. Oil, gas heat, or heat pump.
3. Compression refrigeration or heat pump cooling.
4. Exterior condenser for heat pump or air-conditioning. This type has greatest flexibility for solar and other alternative energy systems.
5. Sprinklers are required in some jurisdictions.

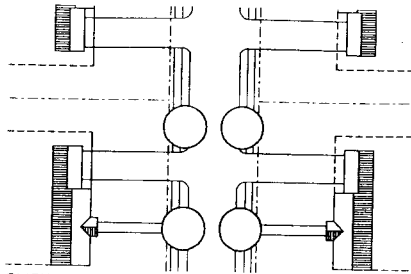

SHOWN AT 2 UNITS PER ACRE ON 100' X 200' LOTS  
**LARGE LOT SINGLE-FAMILY HOUSES**

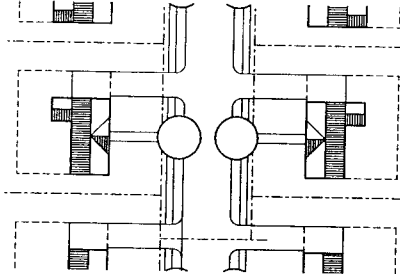

SHOWN AT 5 UNITS PER ACRE ON 75' X 100' LOTS  
**SMALL LOT SINGLE-FAMILY HOUSES**

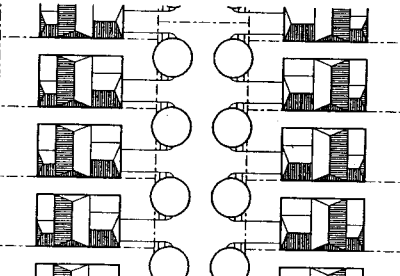

SHOWN AT 10 UNITS PER ACRE ON 40' X 90' LOTS  
**ZERO LOT SINGLE-FAMILY HOUSES**

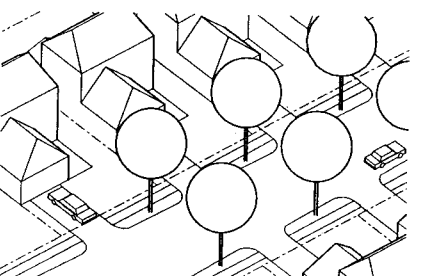
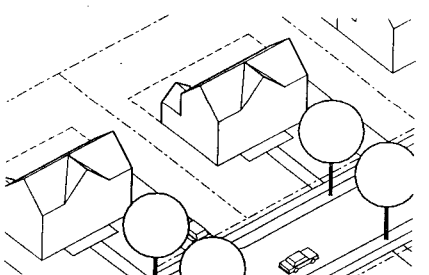
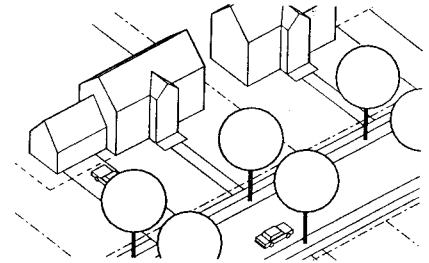

**DENSITY CONFIGURATIONS**

**DETACHED HOUSING CHARACTERISTICS**

TYPE	LOT SIZE (SQ FT)	DENSITY RANGE (D.U./ACRE)*	CHARACTERISTICS
Large lot	20,000 and up	0.5-5	Flexibility in orientation. Building restriction lines not significant. Expansion simple. Site character can be exploited.
Small lot	5000-10,000	4-8	Aggregation becomes important. Community planning important. Services important (fire, mail, rubbish). Pedestrian circulation possible and required. Urban design principles apply. Building restriction lines become important. Public sewer and water needed. Clear delineation between public and private space needed.
Zero lot	3000-5000	8-11.5	Eliminates one-sided setback. Shallower lots possible. Other side yard usable as private space. Windows on property line reduced or eliminated.
Z-lot	3000-5000	8-13	Similar to zero lot. Allows more flexible allocation of land. Lot line views over neighboring ownership must be avoided.
Alternating-width lots	3000-5000	8-11.5	Gives variety along street.

\* D.U.—Dwelling units

Ralph Bennett; Bennett Frank McCarthy Architects, Inc.; Silver Spring, Maryland

**SITE PLAN CONSIDERATIONS**

**ACCESS**

1. Where possible, should connect and align with existing systems.
2. Many arrangements are possible, including alleys, on-site parking, pooled parking and on-street parking.

**PEDESTRIAN CIRCULATION**

1. Necessary to connect dwellings to common facilities and off-site facilities.
2. Usually parallels streets.

**PARKING**

1. Has significant impact on density and appearance.
2. If not pooled, on-street essential for guests and overflow.

**RELATION TO TOPOGRAPHY**

1. ADA, Fair Housing, and subdivision regulations dictate street and walk grades and mandate site reformation at all but the lowest densities.

**SERVICE**

1. Trash pickup, mail service, and deliveries rely on access from street to individual units.
2. Fire apparatus usually dictates road standards.

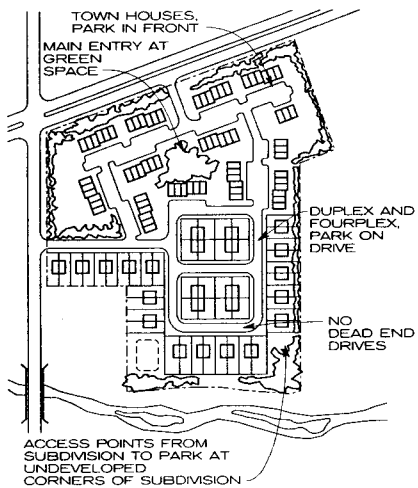

**STREET ACCESS**

**MASSING**

Variety and richness can be achieved by massing buildings so that individual units are not diagrammatically identifiable. Scale is given by secondary elements, room sized or smaller. Basic combinations are manipulated to produce complex unit configurations; the resulting composition is very different from basic types.



**THREE-UNIT BUILDING OF COMBINED TYPES (MANOR)**

**TECHNOLOGY**

**STRUCTURE**

1. Typically wood frame.
2. Gypsum board walls between units (party walls), 2-hour rating. Some jurisdictions require masonry.
3. Parking must have rated separation if sharing wall or ceiling with unit.

**MECHANICAL**

1. Air, gas heat, electric baseboard heat, or heat pump.
2. Compression refrigeration or heat pump cooling.
3. Exterior condenser for heat pump or air-conditioning.
4. Sprinklers required in many jurisdictions.

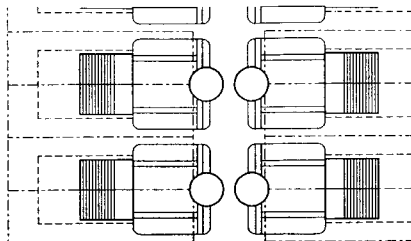

SHOWN AT 9 DWELLING UNITS PER ACRE  
**DUPLEX HOUSES**

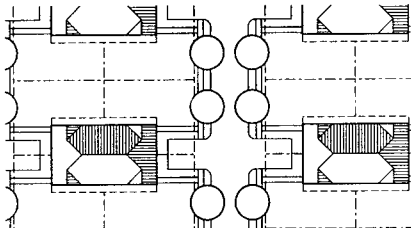

SHOWN AT 10 DWELLING UNITS PER ACRE  
**FOURPLEX HOUSES**

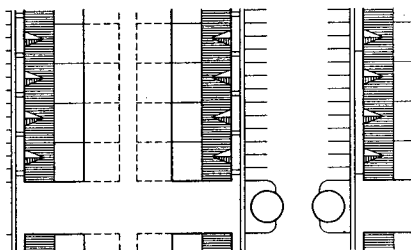

SHOWN AT 13 DWELLING UNITS PER ACRE  
**ATTACHED HOUSES (TOWN HOUSES)**

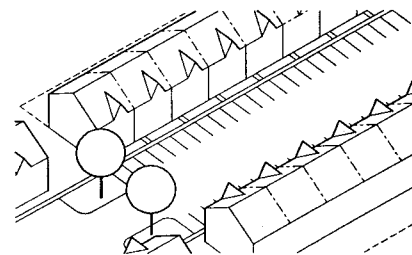
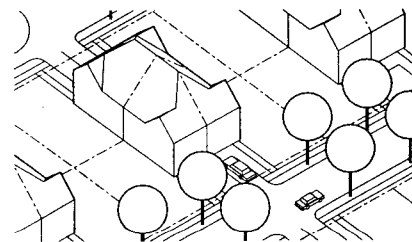
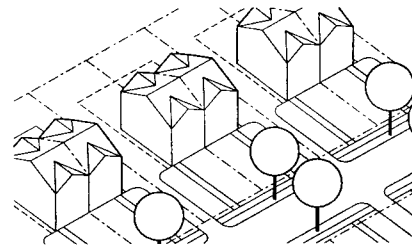

**DENSITY CONFIGURATIONS**

**ATTACHED HOUSING CHARACTERISTICS**

TYPE	LOT SIZE (SQ FT)	DENSITY RANGE (D.U./ACRE)*	CHARACTERISTICS
Duplex	3000 - 5000	8 - 10	Allows grouping of parking, access. Side yard can be used. Houses have three exposures.
Fourplex	2000 - 3000	10 - 15	Houses have two exposures. High level of privacy possible. Masses as larger building.
Townhouse	1000 - 1500	12 - 22	Urban type exported. Public/private clearly delineated. Maximum flexibility for minimum surface. Makes satisfactory streets.

\* D.U. = Dwelling units



**GARAGE UNDER HOUSE—FRONT ENTRY**



**GARAGE UNDER HOUSE—REAR ENTRY**

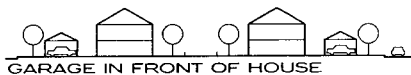

**GARAGE IN FRONT OF HOUSE**



**GARAGE BEHIND HOUSE**

**NOTE**

Attached houses achieve the highest density possible with individual structured parking (garages). Combining this housing type with parking produces many rich variations.

**PARKING**

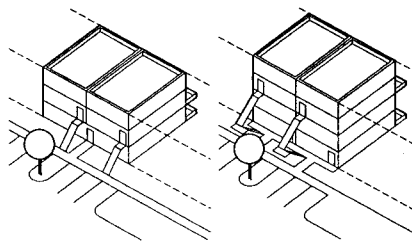

**TOWN HOUSES OVER FLATS**

**TOWN HOUSES OVER TOWN HOUSES**

**NOTE**

Town houses can be stacked upon themselves or on one-story units (flats). Density is increased and fire separations are required horizontally as well as vertically. Individual entries are usually provided.

**MULTISTORY VARIANTS**

Ralph Bennett; Bennett Frank McCarthy Architects, Inc.; Silver Spring, Maryland

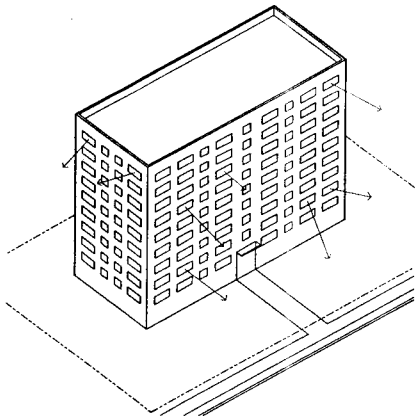

HIGH-RISE BUILDING NOTES

1. In high-rise, single-entry buildings, the views of most residents are distant from public areas.

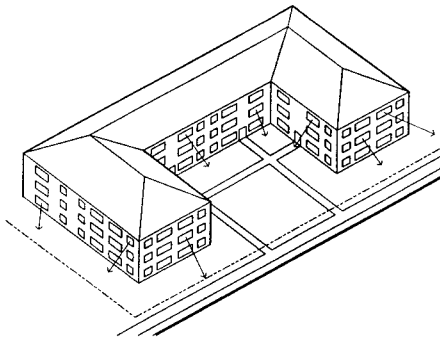

LOW-RISE BUILDING

2. Low-rise, multiple-entry buildings facilitate close supervision of public areas.

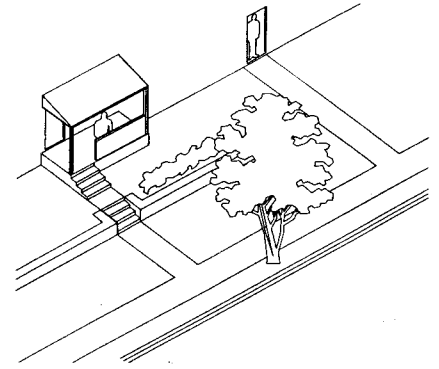

NOTE

Architectural and landscape devices help demarcate private and public spaces between a house front and the street.

**SUPERVISION OF PUBLIC AREAS**

**GENERAL**

Clear delineation of usable exterior space is essential to the success of any housing design. Proper planning of exterior space improves security, reduces maintenance, enhances appearance, and permits residents to act as responsible citizens.

**DESIGN**

On traditional city streets, public and private realms are clearly defined.

The street is in the public realm. Semipublic areas—the entry and foyer—open onto the street from a short distance. The semiprivate areas of the house—living, dining, and/or cooking areas—look out onto the public realm but are screened. The private areas of the house—the bedrooms—are a floor or more above the street, looking out but secluded from view. Semiprivate outdoor areas are at the back of the house, visible to neighbors but secluded from the street.

In multifamily buildings, the provision of a supervised public realm is more complicated than in the attached house. In this case, buildings need to be arranged so that unit windows and common circulation space overlook the public areas of the project. This can be accomplished by

1. Keeping buildings in the two- to six-story height range
2. Clustering the dwelling units so their entrances are distributed rather than concentrated
3. Arranging unit windows so no portion of the ground surface is invisible to dwelling units

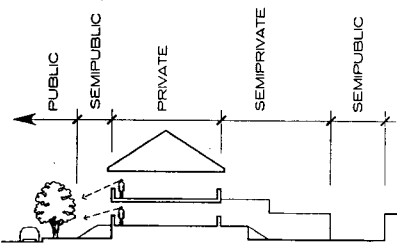

**PUBLIC AND PRIVATE ZONES IN A ROW HOUSE**

**BUILDING LOCATION**

Separation of buildings from parking and minimum distances between buildings are often mandated by zoning and by building codes.

To avoid involuntary eye contact, vertical walls containing windows and balconies should be at least 60 ft apart. This dimension is often reduced; if so, attention must be paid to elements that can provide elective privacy, such as

1. Curtains and blinds
2. Balcony walls with adjustable opacity
3. Deformation of the wall to provide bays and oblique, rather than frontal, views

**ADJACENT USES**

Location of certain site activities near unit windows can cause conflict. Although common practice often places back-to-back garden apartments overlooking parking, this setup is not optimum. This arrangement can be improved if the parking area is planted, illumination is at a low level, and the building design provides other views.

Recreational uses such as basketball, tennis, and other noisy, large-muscle activities should be kept away from unit windows and balconies.

Play areas for small children ideally are located where they can be seen from dwelling unit windows.

**LANDSCAPE DESIGN**

The provision of green space is essential for housing, even in intensely urban areas. Street trees and planted courtyards add value to the densest housing site.

Where space permits, passive green space without specific programmatic purpose can be an attractive addition. Such space should not be so large as to be unsupervisable from the dwellings, and dwellings should be located to take advantage of the amenity it provides.

**DIVISION OF PUBLIC AND PRIVATE SPACE**

**COMMUNITY FACILITIES**

Two houses make a community and offer opportunities for elective socialization and joint use.

In small developments, the ordinary activities of daily life offer opportunities for community focus. These activities include picking up mail, putting out trash, doing laundry, and working on cars.

In larger projects, the following activities may provide opportunity for community activity and physical focus:

1. Marketing and management
2. Activities requiring shelter, such as meeting, fitness, day care, and convenience retail
3. Outdoor recreation, such as swimming, tennis, handball, and racquetball

**DETAILS**

Architectural devices mark and enhance the public and private realms. These devices include fences; walls; changes of level provided by stairs and ramps; zones of planting; and porches, stoops, and terraces.

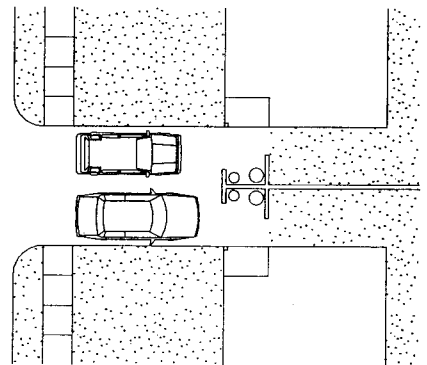

**ADJACENT HOUSE ENTRANCES**

Ralph Bennett; Bennett Frank McCarthy Architects, Inc.; Silver Spring, Maryland

## GENERAL

The regulatory climate for housing is complex and ever-changing. Therefore, designers should consult regulatory agencies at all levels of government before initiating planning or detailed design of any housing project.

Information on this page is related to site design, building arrangement, and design of the exterior path to the dwelling unit and other common facilities. Further information related to housing can be found in Chapters 1, 11, and 20 of the ninth edition of *Architectural Graphic Standards*.

## FAIR HOUSING AMENDMENTS ACT

The Fair Housing Amendments Act (FHAA) was passed in 1988 and applies to all housing scheduled for first occupancy after March 13, 1991. The act is unusual in that it is a civil rights law, not a building code or standard. Although the U.S. Department of Housing and Urban Development (HUD) developed and promulgates the guidelines, HUD has no plans to review its role and will enforce FHAA primarily based on complaints. Compliance will be achieved through complaints by affected individuals and by professional testers.

## FAIR HOUSING ACCESSIBILITY GUIDELINES

The most comprehensive instructions for compliance with the construction provisions of the FHAA are provided by the Fair Housing Accessibility Guidelines (FHAG), which were released in their final form in March 1991.

## WHAT PROJECTS ARE COVERED

Any multifamily project with four or more dwelling units is covered by the legislation, but not all parts of all dwelling units in all covered projects must be accessible.

Other standards that supplement or supersede the FHAG are the following:

1. SPACES FOR COMMON USE: ANSI standard A117.1-1986
2. SPACES FOR PUBLIC USE (if any): Americans with Disabilities Act (ADA) Guidelines
3. ANY SPACE: Any local building code standard that HUD deems more restrictive

In buildings equipped with passenger elevators, all units must be accessible. Multistory dwelling units (except loft units) not located in elevator buildings are exempt from this requirement.

In walk-up multistory buildings, FHAA requires all ground floor units to be accessible where practical, based on site considerations. A minimum of 20% of the units must be accessible. FHAA definition of the ground floor in walk-up buildings is unclear, but the intention of the legislation was to avoid the installation of elevators in buildings not otherwise needing them. Because interpretations of the law vary, guidance should be sought.

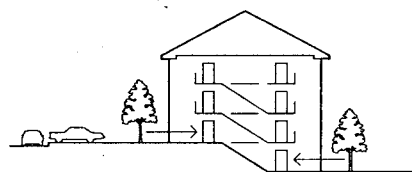

### NOTE

The FHAA does not clearly define "ground floor" in requiring that all ground floor units be accessible when practical. For situations such as that shown here, it may be wise to seek guidance regarding accessibility requirements for ground floor units on the lowest level.

## GROUND FLOOR UNIT ACCESSIBILITY

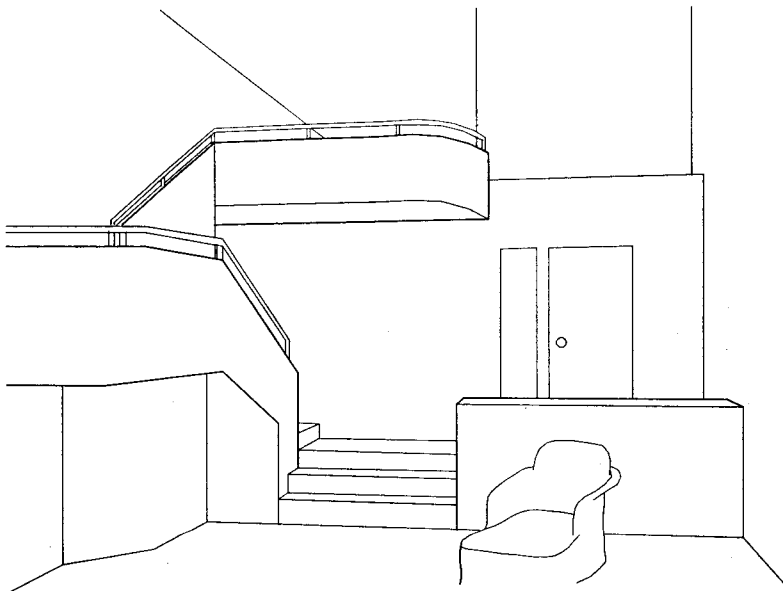

### NOTE

FHAG permits use of both level changes and lofts in dwelling units as long as common areas are accessible.

## DESIGN FEATURES PERMITTED IN ACCESSIBLE UNITS

### SITE PLANNING ISSUES

Site accessibility for housing is defined as the existence of a continuous accessible route of travel from a suitable automobile or transit drop-off point (called the arrival point) to the dwelling unit. Such a route may include parking access aisles, curb ramps, walks, ramps, and lifts and must meet the requirements of ANSI A117.1-1986.

Sloped walkways, when included, are defined as being no steeper than 5%. Steeper walkways are defined as ramps and must have a maximum slope of 8.5%; ramps require handrails.

All community facilities must be connected to all covered dwelling units by an accessible route. In certain circumstances, use of a private automobile may be considered part of such a route.

### SITE PRACTICALITY TESTS

The designer may use either of two tests to determine whether accessibility is practical at a particular site:

1. INDIVIDUAL BUILDING TEST: Locate an arrival point and entrance for each building or entry, and estimate the slope between them. If a line connecting these two points is steeper than 10%, access is deemed impractical. This test must be conducted both before and after regrading.
2. SLOPE ANALYSIS TEST: Calculate the percentage of the site sloped at grades steeper than 10%. This percentage is the percentage of ground floor units (with a minimum of 20%) that must be accessible.

### DWELLING UNIT DESIGN

Dwelling units covered by the FHAA must be designed according to the FHAG. The difference between these requirements and the ANSI A117.1-1986 standard is substantial. Under the FHAG, the unit must be usable and include adaptable features but does not have to be fully accessible according to the ANSI standard. Planning decisions such as door and corridor widths and bathroom and kitchen layouts must meet certain standards, some not as restrictive as the ANSI standard. Items such as accessible plumbing fixtures and counters can be provided as required by specific owners and users.

Units covered by the law must have the following characteristics:

1. Usable doors to enter all rooms
2. An accessible route into and throughout the dwelling unit
3. Switches and controls mounted in accessible locations
4. Usable bathrooms with concealed reinforcing installed in the walls
5. Usable kitchens that permit wheelchair access

Certain design features, including level changes, are permitted. Intermediate levels (lofts) are permitted, although they are not precisely defined. In buildings equipped with elevators, multistory units must include a toilet on the accessible (ground) floor.

Changes in floor level are permitted if they can be defined as "design features" that do not interrupt the accessible route through the remainder of the dwelling.

### ITEMS THAT TYPICALLY ARE NOT AFFECTED BY FHAG

1. Windows
2. Interior door hardware
3. Doors not used for passage
4. Fireplaces
5. Stairs
6. Upper floor levels
7. Lower floor levels
8. Closet shelving
9. Circuit breakers
10. Mechanical equipment
11. Individual garages
12. Lofts
13. Basements

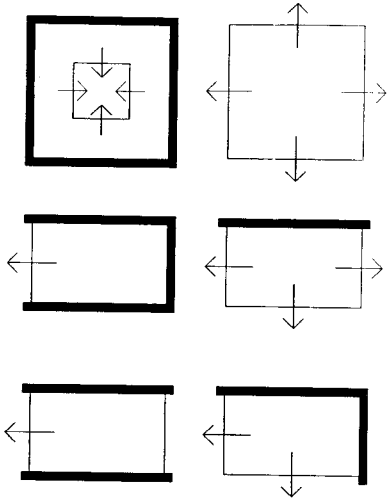

**NOTE**

The number of sides exposed to light and air and whether they are adjacent can be used to describe all dwelling units.

**UNIT DESIGN—POSSIBLE EXPOSURES**

**GENERAL**

Before design of a housing project begins, a unit density and mix of types that suit the site must be determined. Units composing the mix are designed according to standards related to the sales price or monthly rental of the dwelling unit. Unit characteristics can be summarized as follows:

**MINIMAL HOUSING:** No foyer; combined living and dining; small bedrooms (80 sq ft); one bath.

**AFFORDABLE HOUSING:** Small foyer; combined living and dining; large bedroom may have private bath; other bedrooms share bath with common rooms; minimal storage.

**LUXURY HOUSING:** Foyer; living, dining, and family (or great) rooms; circulation in hall, some semiprivate rooms (study/sitting); ample to lavish master bedroom suite; other bedrooms share one or two baths; two- or three-car garage.

**CUSTOM HOUSING:** Large foyer; separate living, dining, and family rooms; porch; large kitchen and pantry; grand circulation; frequent redundant circulation (H&V); many semiprivate rooms; large bedrooms; multiple bathrooms; ample storage; staff service space.

**IDENTITY FROM EXTERIOR**

With the possible exception of deeply subsidized housing, all housing must survive in the market. This means the project must not deviate greatly from the demonstrated preferences of its market, although it must also offer an identifiable image or appearance.

This image, often called "curb appeal," is frequently defined for the architect by advertising and marketing specialists. In single-family houses, the house itself constitutes a statement. Attached houses also make individual statements, as well as developing community imagery for the potential tenant or buyer. In multifamily housing, the identity of the dwelling is submerged within the group and the individual unit is distinguished by its internal arrangement. Thus, group and individual identity must be defined and developed.

**SIDEDNESS**

Dwelling units always benefit when buildings are designed with a clear front or public side and a back or semiprivate side. Sidedness enables the cultivation of other contrasting characteristics such as ceremonial/intimate, open/closed, noisy/quiet, ornamented/plain, and urban/pastoral.

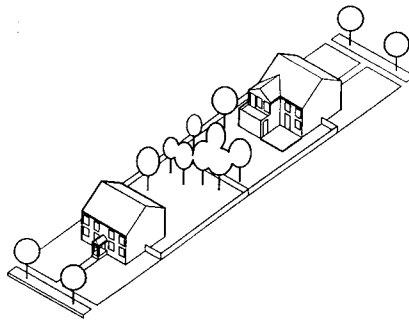

**NOTE**

Housing design should distinguish between public and semiprivate sides of the dwelling unit.

**SIDEDNESS**

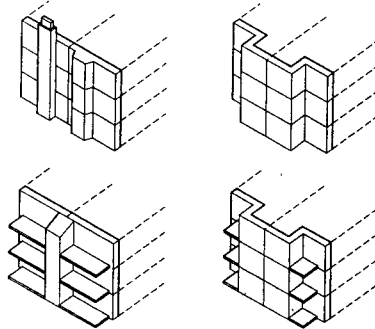

**BUILDING MASSING**

**DWELLING UNIT PLANNING**

Dwellings of all sizes have common elements and sequences that must be identifiable.

**ENTRANCE**

Marketing concerns usually demand a dramatic spatial event at the moment of entry, whether a double-height foyer in a luxury house or a sweep of the living and dining areas in an apartment. However, the architectural organization of this event may require a transitional space, perhaps somewhat enclosed, as compression before expansion into the major semipublic areas of the unit.

**CIRCULATION AND ROOMS**

In large houses it is possible to separate circulation from the rooms served using devices such as corridors, passageways, foyers, vestibules, and the like. Circulation in smaller units occurs through rooms, most often living and dining rooms.

**PLAN BALANCE**

In dwelling unit design, all aspects of the plan must be proportional and consistent. A many-bedroom dwelling with living areas too small to accommodate all the occupants is problematic. So is the house with enormous living and dining areas but too few or too small bedrooms. Kitchens, general storage, and circulation must also be sized according to the number of occupants.

**FOCUS**

All good dwellings offer a hierarchy of experience culminating in a focus, which is commonly the living or living/dining area or family room/kitchen. This spatial focus is often enhanced by spatial definition and/or greater height and by features such as fireplaces (the hearth, of course, is the traditional center of the house), stairs, or access to outdoors.

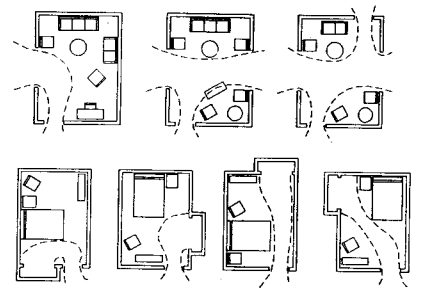

**NOTE**

In small plans, circulation should occur through no more than two adjacent corners of living and dining rooms. After accounting for circulation, sufficient space should remain for reasonable furniture arrangements.

**CIRCULATION**

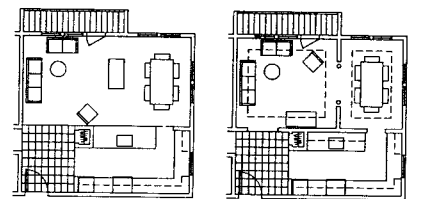
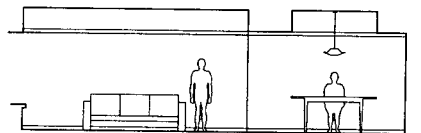

**NOTE**

Spaces defined by walls can be reinforced by articulation of the ceiling. Even in small units, ceiling drops and soffits can provide reinforcement of activity areas and spaces.

**ARTICULATION OF SPACE**

**ACCESS TO EXTERIOR**

Contemporary living requires connection to outdoor space by circulation where possible or at least by view. In apartments, where this connection may take the form of a balcony, it is usually made at the living room. But since a balcony reduces view and light, it may be placed at the bedroom instead, with access from the living room. Bedroom balconies are a luxury amenity.

**UNIT PLAN AND BUILDING MASSING**

Plan arrangement is related to building massing; by projecting and recessing adjacent rooms or parts of rooms, building mass can be broken down. Similarly, continuous alignment of exterior walls leads to large-scale massing and elevations in which surface elements such as windows and textured and colored surface areas can be used to compose and adjust scale.

Components such as balconies, storage closets, and fireplaces are often useful for composing elevations and massing, particularly when simplified plan geometries produce large, basic massing.

Ralph Bennett; Bennett Frank McCarthy Architects, Inc.; Silver Spring, Maryland

**SITE PLAN CONSIDERATIONS**

**ACCESS**

1. Where possible, points of access should connect and align with existing systems.
2. Many arrangements are possible with streets, courts, and freestanding buildings

**PEDESTRIAN CIRCULATION**

1. Pedestrian connections are necessary between apartments and common facilities and off-site facilities.
2. Usually parallels streets except where site plan offers rustic walks.

**PARKING**

1. Parking sites must be pooled or in structures.

**RELATION TO TOPOGRAPHY**

1. ADA and subdivision regulations dictate street and walk grades and mandate site reformation at all but the lowest densities.
2. Breaks between stairwell groups allow adjustment to the terrain.

**COMMON FACILITIES**

1. Rental and management offices are common for 50 units or more.
2. Pools and recreation facilities are common in complexes of more than 100 units.
3. Maintenance and storage facilities are common in larger projects.
4. Tot lots and play areas are required for complexes of 20 units or more in many jurisdictions.
5. RV and boat storage are offered in some areas.

**SERVICE**

1. Mail service and deliveries to stairwells or larger group boxes; trash to Dumpsters distributed in parking lots or other central locations.
2. Fire apparatus usually dictates road standards; sprinklers may permit reduced equipment access.

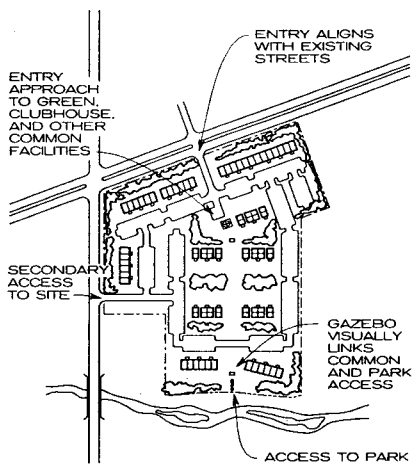

**SITE PLAN**

**TECHNOLOGY**

**STRUCTURE**

1. Wood frame.
2. Walls between stairwell groups must be masonry or heavy gypsum (2-hr rating).
3. Unit wall must be gypsum board on wood or steel studs (1-hr rating).
4. Second stair must be in rated enclosure.

**MECHANICAL**

1. Forced air, gas heat, or heat pump.
2. Compression refrigeration or heat pump cooling.
3. Larger units (two bedrooms or more) have centrally located furnaces with ducts and exterior condensers for heat pumps and refrigeration; smaller units may have through-the-wall units with no exterior condenser.
4. Sprinklers required in many jurisdictions.

Ralph Bennett; Bennett Frank McCarthy Architects, Inc.; Silver Spring, Maryland

**WALK-UP HOUSING CHARACTERISTICS**

TYPE	DENSITY RANGE (D.U./ACRE)*	CHARACTERISTICS
Through unit	Up to 17 (including off-street parking)	Permits sided site planning. Two exposures for each unit. Bedrooms or living areas can be oriented toward parking or view.
Back-to-back unit	Up to 20 (including off-street parking)	Efficient: 4 units per floor. As usually deployed, 50% of units face parking, 50% face view and green.

\* D.U. = Dwelling units

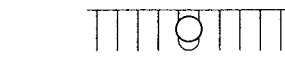
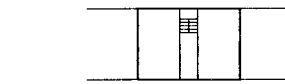

THROUGH UNIT

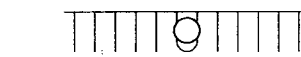
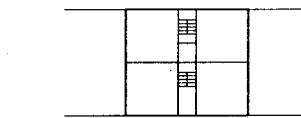

BACK-TO-BACK UNIT

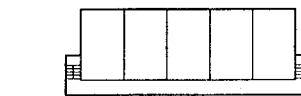

SINGLE-LOADED GALLERY ACCESS

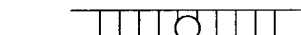
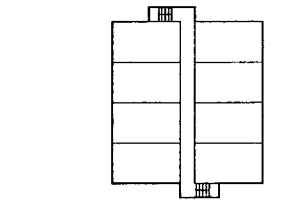

DOUBLE-LOADED GALLERY ACCESS

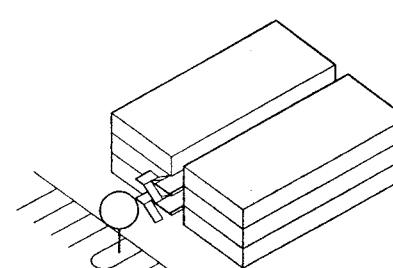
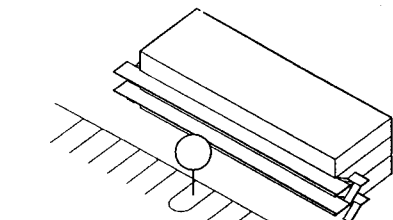
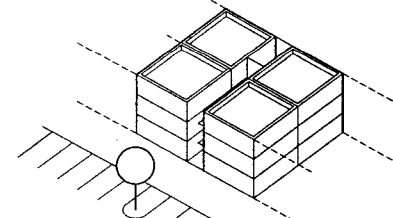
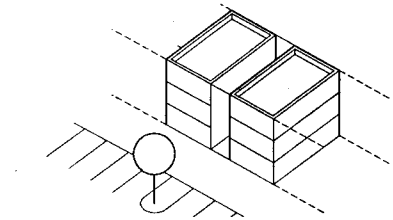

**WALK-UP APARTMENT CONFIGURATIONS**

**CONFIGURATION**

Walk-up apartments are ubiquitous in the United States and come in many varieties. Their appeal lies in the great efficiency of their circulation. Two-story buildings are common and generally require only one stair. Three-story buildings generally require two stairs, one of which must be rated. Buildings higher than three stories present market problems but do exist. Combination walk-up buildings, with elevators going to higher stories, are common in Europe but are uncommon in the United States due to the higher proportional cost of elevators.



**SITE PLAN CONSIDERATIONS**

**ACCESS**

1. Entrances should, where possible, connect and align with existing systems.
2. Many arrangements are possible, including alleys, on-site parking, pooled parking, and on-street parking.

**PEDESTRIAN CIRCULATION**

1. Necessary to connect dwellings to common facilities and off-site facilities.
2. Usually parallels streets.

**PARKING**

1. Has significant impact on density and appearance.
2. If not pooled, on-street essential for guests, overflow.

**RELATION TO TOPOGRAPHY**

1. ADA and subdivision regulations dictate street and walk grades, and mandate site reformation at all but the lowest densities.

**SERVICE**

1. Trash through chutes to compactor in trash room in basement or ground floor; mail to mail room on ground floor; delivery to units or security guard.
2. Fire marshal may request access around building depending on building height and sprinkler system.

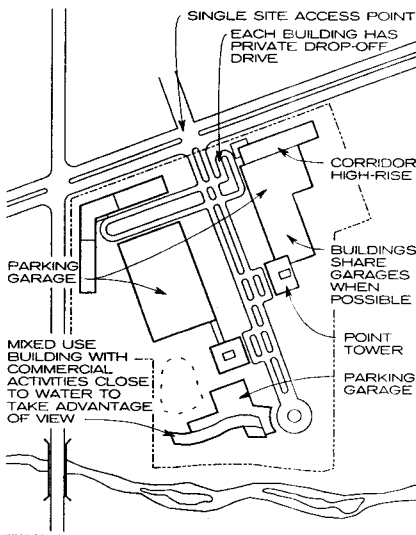

**SITE PLAN**

**TECHNOLOGY**

**STRUCTURE**

1. Masonry or concrete, occasionally fire-protected steel.
2. A full range of high-rise building safety measures are required, especially for structures taller than nine stories, which is generally the maximum reach for rescue equipment.

**MECHANICAL**

1. Decentralized air, gas heat, or heat pump.
2. Compression refrigeration or heat pump cooling.
3. Larger units (two bedrooms or more) have centrally located furnaces with ducts and exterior condensers for heat pumps and refrigeration; smaller units may have through-the-wall units with no exterior condenser.
4. Large and/or luxury buildings may have central systems with boilers, central chillers, and a condenser and two- or four-pipe systems.
5. Sprinklers are required in many jurisdictions.

**GROUND FLOOR PLANNING**

Ground floors in elevator buildings are significantly different from ground floors in other housing structures because larger numbers of people pass through on the way to their dwellings and because the ground floor is a smaller proportion of the area of the building. Urban versions of the type offer opportunities for retail and commercial uses that can be accessed directly from the street.

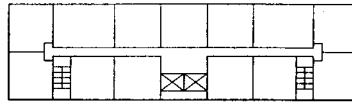

**DOUBLE-LOADED CORRIDOR SLAB**

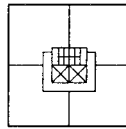
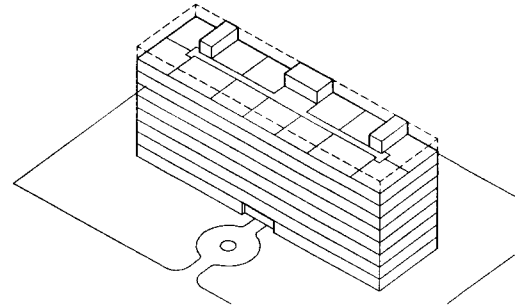

**POINT TOWER**

**SLAB TOWER EXAMPLES**

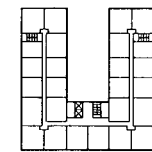

**U-SHAPED PLAN WITH SINGLE CORE**

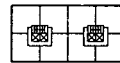

**SLAB COMPOSED OF TWO TOWERS JOINED**

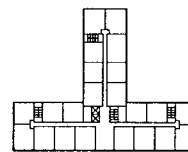

**T-SHAPED PLAN WITH SINGLE CORE**

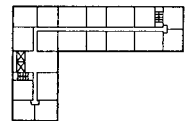

**L-SHAPED PLAN WITH SINGLE CORE**

**SLAB TOWER PLAN VARIATIONS**

**ELEVATOR APARTMENT CHARACTERISTICS**

TYPE	CHARACTERISTICS
Double-loaded corridor (slab)	Units have only one exposure. Corridors are interior spaces. Units can be shallow and wide (lengthening corridors, but bringing much light into unit) or narrow and deep (shortening corridors but making a dark zone on the interior). Stairs are required at ends of corridors (limited dead ends allowed).
Single-loaded corridor (slab)	Less efficient than double-loaded corridor. Useful when oriented east-west because all units can face south. Corridor can be naturally illuminated.
Point tower	Efficient circulation because of small number of units/floor; scissors egress stairs can make circulation more efficient. Units can have two exposures. Casts minimal shadow on lower buildings.

Frequently, therefore, the ground floor of elevator buildings is set aside for common spaces and uses. Lobby and security; mail; meeting space; management offices; trash; and mechanical, electrical, and fire equipment frequently are located at grade. In urban situations, retail and commercial uses are appropriate.

If dwelling units are located on the ground floor, they can offer direct access to outdoors.

**CIRCULATION VARIATIONS**

In the great majority of elevator buildings, the double-loaded corridor is used, which produces a corridor on each floor. By using multifloor units, or by adding stairwell circulation up and down from elevator landings, the number of floors with corridors can be reduced by two-thirds and up to two-thirds of units can have two exposures. Fair Housing Accessibility Guidelines may prohibit some of these variations, especially the skip-stop.

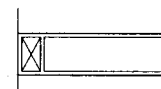

**SINGLE-LOADED UNIT**

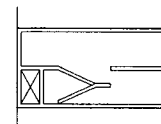

**TWO-STORY UNIT**

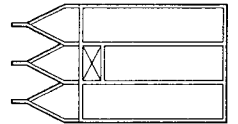

**SKIP-STOP UNIT**

**CROSS-SECTION OF VARIATIONS IN CIRCULATION**

Ralph Bennett; Bennett Frank McCarthy Architects, Inc.; Silver Spring, Maryland

**GENERAL**

Special populations require housing forms suited to their needs. Most significantly, small groups of people with special requirements tend to live together so that their needs can be met in a concentrated and efficient way. Facility size is often dictated by financial and operating considerations; the larger the facility, the more difficulty the designer has in making a residentially scaled environment.

Group residences are available for elderly persons, for persons in transition from addiction and psychiatric programs and from incarceration, for persons with terminal illnesses (hospices), and for those who may share another kind of common need.

These facilities typically provide a number of small, simple rooms along with common spaces that include living, dining, and food preparation areas, as well as recreational and administrative facilities.

A more complex group-housing arrangement recently imported from Scandinavia is co-housing—a form of group living that usually features more elaborate individual accommodations along with the common areas found in group homes.

**SITE CONSIDERATIONS**

1. Direct but controlled access is required from parking and transit facilities to a clearly identifiable entrance.
2. Views from unit windows become especially important in developments where residents spend considerable time in their unit.
3. A variety of views is desirable, from active streets to quiet landscapes. This gives tenants choice in otherwise uniform accommodations.
4. Solar orientation becomes important for such facilities: no unit should be without direct sun at some time during a winter day.
5. Since direct access to outdoors is rarely practical in such housing, exterior access from common spaces becomes more important. Such space should be agreeable for sedentary occupation—sunny but with shade and sheltered from the wind.

**TECHNOLOGY**

**STRUCTURE**

1. Single-story buildings can be wood frame in most jurisdictions if properly protected. Two-story or higher buildings must be masonry or protected steel in most jurisdictions.

**MECHANICAL**

1. Decentralized air, gas heat, or heat pump.
2. Compression refrigeration or heat pump cooling incorporated into through-the-wall units is often used.
3. Common areas have centrally located furnaces with ducts and exterior condensers for heat pumps and refrigeration.
4. Buildings such as hospices, where temperature and humidity control are crucial, use central systems with boilers, central chillers and condenser, and two- or four-pipe systems.
5. Buildings serving persons with special medical needs may require specialized HVAC systems for isolations.
6. Sprinklers are required in most jurisdictions.

**SAFETY**

1. Systems to announce and report emergencies as well as accommodations for egress are strongly related to the level of assistance required to allow residents to exit the building. The more assistance required, the more extensive the measures required.
2. Building code and fire safety requirements for special needs housing are complex and changing. Protected construction, sprinklers, and supervised fire and smoke alarm systems are generally required.
3. Precautions above this level are dictated by the occupants' ability to perceive danger and act to remove themselves from it. Corridor widths, exit requirements including horizontal exits, separations between dwelling and corridor, and resident staff requirements are all subject to negotiation with local authorities, using model codes as the basis.
4. Local building code authorities should be consulted early in the design process.

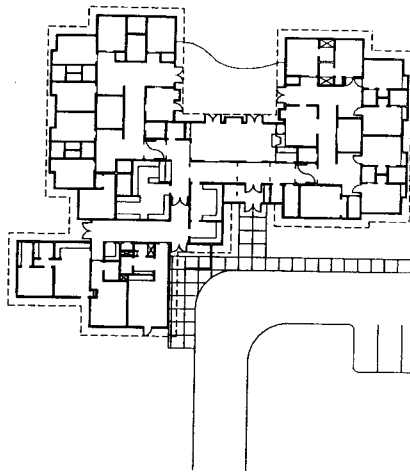

**NOTE**

This 14-unit facility is divided into two clusters of seven rooms, each cluster is served by a lounge and a spa (a room for bathing and personal care). Common facilities include a large living room, kitchen with snack bar, and administration and staff facilities including a residence for the manager. Rooms offer varying aspects from a busy road to a semi-enclosed garden off the common living room to distant landscape views.

HOSPICE RESIDENCE, MONTGOMERY HOSPICE, INC.; OLNEY, MARYLAND  
BENNETT FRANK MCCARTHY ARCHITECTS.

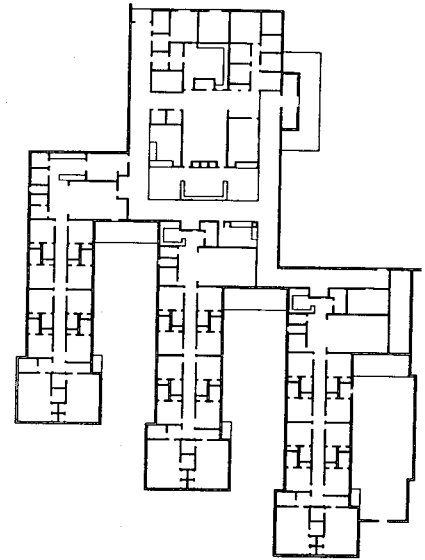

**NOTE**

This 36-room group home is designed for elderly persons suffering from Alzheimer's disease and dementia. Each group and subgroup of units has its own vivid and distinct visual identity. Easily accessed outdoor space is controlled to limit wandering. The plan is organized to permit supervision by limited staff.

WOODSIDE PLACE AT PRESBYTERIAN MEDICAL CENTER; OAKMONT, PENNSYLVANIA  
PERKINS EASTMAN & PARTNERS

**TECHNOLOGY**

**STRUCTURE**

1. Single-story buildings can be wood frame in most jurisdictions if properly protected. Two-story or higher buildings must be masonry or protected steel in most jurisdictions.

**MECHANICAL**

1. Decentralized air, gas heat, or heat pump.
2. Compression refrigeration or heat pump cooling incorporated into through-the-wall units is often used.
3. Common areas have centrally located furnaces with ducts and exterior condensers for heat pumps and refrigeration.
4. Buildings such as hospices, where temperature and humidity control are crucial, use central systems with boilers, central chillers and condenser, and two- or four-pipe systems.
5. Buildings serving persons with special medical needs may require specialized HVAC systems for isolations.
6. Sprinklers are required in most jurisdictions.

**SAFETY**

1. Systems to announce and report emergencies as well as accommodations for egress are strongly related to the level of assistance required to allow residents to exit the building. The more assistance required, the more extensive the measures required.
2. Building code and fire safety requirements for special needs housing are complex and changing. Protected construction, sprinklers, and supervised fire and smoke alarm systems are generally required.
3. Precautions above this level are dictated by the occupants' ability to perceive danger and act to remove themselves from it. Corridor widths, exit requirements including horizontal exits, separations between dwelling and corridor, and resident staff requirements are all subject to negotiation with local authorities, using model codes as the basis.
4. Local building code authorities should be consulted early in the design process.

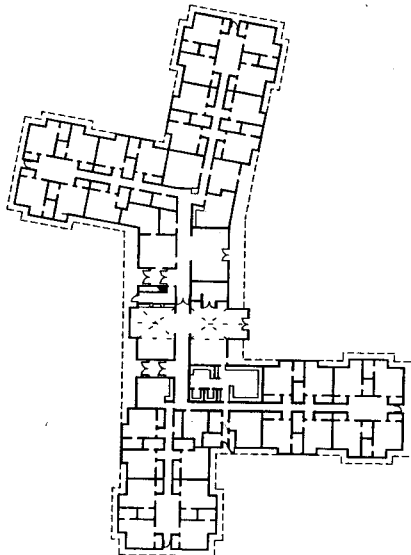

**NOTE**

This 30-unit group assisted-living facility is divided into two fire-separated buildings to meet subsidy requirements that limit facilities to 15 units. Common areas are linked with openings protected by smoke-actuated doors. Common areas include living room, dining room, institutional kitchen, and laundry.

RAPHAEL HOUSE, VICTORY HOUSING; ROCKVILLE, MARYLAND  
BENNETT FRANK MCCARTHY ARCHITECTS, INC.

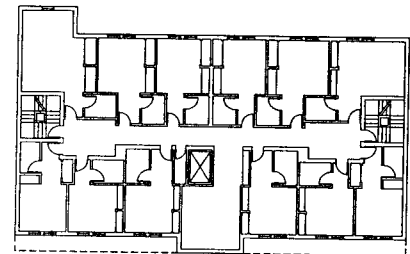

TYPICAL FLOOR

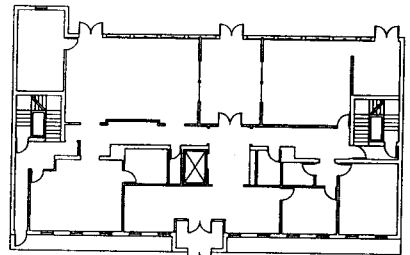

GROUND FLOOR

**NOTE**

This 36-room single-room-occupancy hotel is designed for emotionally disturbed homeless persons. Social services are offered on the ground floor. Bedrooms are enriched with private bathrooms and mini-kitchens. A private garden for the residents is provided at the rear of the building.

NEW YORK SRO; BROOKLYN, NEW YORK  
ARCHITROPE

**EXAMPLES OF SPECIAL NEEDS HOUSING**

Ralph Bennett; Bennett Frank McCarthy Architects, Inc.; Silver Spring, Maryland

**INTRODUCTION**

Solid waste disposal has become a critical issue for society. Landfills and other waste disposal facilities are reaching capacity and siting new facilities is difficult due to environmental and health concerns, including water pollution, loss of wetlands, poisoning of the soil, and the breeding of vermin. As a result, traditional methods of handling solid waste are becoming more costly. Reducing landfill waste extends the life of existing facilities and lessens the need to build new facilities.

Much of what we have called "waste" is not waste, but marketable materials that can be reused to make new products. Reusing materials already extracted from the earth enables sustainable use as raw resources are depleted. Products require great amounts of energy to be produced from raw natural materials. By recycling we are recapturing energy embodied in a material during initial manufacturing processes. Sorting and recycling waste often reduces operating and disposal costs while conserving natural resources and energy.

Most states and municipalities have laws and programs to encourage waste reduction and recycling, including mandatory quotas, deposit/return arrangements, and disposal bans. Buildings should include the spaces necessary to carry out recycling and waste management programs. Once the waste and recyclable materials generation of a building's users are determined, spaces can be designed for sorting, storage, and removal.

**RECYCLABLE MATERIALS**

Separating materials by category or product is the first step in recycling (see table at right). Materials are sorted into like kinds to prevent contamination. Contaminated materials are less readily recyclable and therefore less marketable. Sorting is particularly important for paper and glass. Cleaning food packaging of organic material is usually necessary. Some recyclers will accept "commingled" or mixed waste and will sort and clean materials by hand or by mechanical means. (Paper is easily contaminated and can never be recycled this way; it must always be separated from other waste materials.) Communities that pick up commingled recyclable materials have enjoyed a greater participation rate since it requires little, if any, change in waste disposing habits. However, sorting of recyclable materials at their generation point is less labor intensive and produces higher quality, less contaminated reprocessed materials.

**SYMBOLS**

The recycling symbol signifies the three steps of the recycling loop: collecting materials, manufacturing new products, and selling and using recycled products.

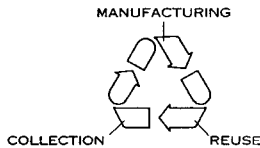

In the marketplace, the recycling symbol is marked on products in the following way:



This conformation of the symbol is used to identify items made from materials that can be recycled.



This conformation of the symbol is used to identify products made entirely or primarily from recycled materials.

**PLANNING AND DESIGN**

When planning a project, make a waste analysis based on the building type or building users and address the following issues:

1. Source generation: identify types and quantities of waste material likely to be generated.
2. Collection and sorting: determine space and equipment needed for the collection and/or separation of waste materials.
3. Disposal: determine the frequency and means of the remover or recycler to collect the waste.

Richard J. Vitullo, AIA: Oak Leaf Studio; Crownsville, Maryland  
Tom Lokey: Northeast Maryland Waste Disposal Authority; Baltimore, Maryland

**RECYCLABLE MATERIALS**

CATEGORY	PRODUCT	MATERIAL DESCRIPTION (RECYCLING LABEL)	CONVERSION OF VOLUME TO WEIGHT
Paper	Ledger paper, white letterhead	SWL - sorted white ledger (high-grade white paper)	Uncompacted - 1 cu yd = 500 lb Compacted - 1 cu yd = 750 lb
	Computer paper	CPO - computer printout	Uncompacted - 1 cu yd = 500 - 600 lb Compacted - 1 cu yd = 1000 - 1200 lb
	Colored paper	SCL - sorted color paper	Uncompacted - 1 cu yd = 500 lb Compacted - 1 cu yd = 750 lb
	Newspaper	Mix - newsprint	Uncompacted - 1 cu yd = 350 - 500 lb Compacted - 1 cu yd = 750 - 1000 lb
	Magazines	Mix - clay-coated paper	Not available
	Telephone books	Mix - mixed papers/adhesives	1 book = 1 - 3 lb
	Cereal boxes	Mix - coated paperboard	Not available
Glass	Shipping boxes	OCC - old corrugated cardboard	Uncompacted - 1 cu yd = 285 lb Compacted - 1 cu yd = 500 lb
	Food jars, beverage bottles	1. Amber glass 2. Green glass 3. Clear glass	Loose, whole - 1 cu yd = 600 lb Manually crushed - 1 cu yd = 1000 lb Mechanically crushed - 1 cu yd = 1800 lb
Plastic	Beverage containers	PET - polyethylene terephthalate	Whole - 1 cu yd = 30 lb
	Milk containers	HDPE - high-density polyethylene	Whole - 1 cu yd = 25 lb Crushed - 1 cu yd = 50 lb Compacted - 1 cu yd = 600 lb
	"Clamshell" containers	Polystyrene plastic foam	Not available
	Film plastic	LDPE - low-density polyethylene	Not available
Metals	Beverage cans	Aluminum/bi-metal	Whole - 1 cu yd = 50 - 70 lb Crushed - 1 cu yd = 300 - 450 lb
	Food and beverage cans	Steel with tin finish	Whole - 1 cu yd = 125 - 150 lb Crushed - 1 cu yd = 500 - 850 lb
Miscellaneous	Pallets	Wood	Not available
	Food waste	Organic solids and liquids	55 gallon drum - 415 lb
	Yard waste	Organic solids	Leaves, uncompacted - 1 cu yd = 250 lb Leaves, compacted - 1 cu yd = 450 lb Wood chips - 1 cu yd = 500 lb Grass clippings - 1 cu yd = 400 lb
	Used motor oil	Petroleum product	1 gallon = 71 lb
	Tires	Rubber	1 passenger car = 20 lb 1 truck = 90 lb

**NOTE**

No building or facility will need space for sorting and storing all or even most of the recyclable materials on this list. Generally paper products should be separated from other

wastes. The number of products to be sorted within a category should be limited for most users; sorting more than two products may result in contamination.

An effective recycling system in the home, school, or workplace integrates materials sorting with the regular collection of waste. Convenience of use is essential. Recycling systems should be as easy to use as a conventional waste basket (and be usable by the elderly and persons with disabilities). Provide extra space alongside regular waste containers for separating and storing recyclable materials. Conveying systems like waste chutes may also be provided. Collection bins should be clearly distinguished by using different-sized containers and effective graphics; differentiation will encourage proper use and reduce contamination, a serious recycling problem.

**NONRESIDENTIAL BUILDINGS**

In most commercial and educational buildings, paper is the predominant recyclable waste product (70%+). Paper is readily recyclable into consumable form. High-grade paper, like bond, is used in great volumes and is a generally marketable recycling commodity. Since paper can be easily contaminated, its separation from other waste is critical.

In health care facilities, biomedical waste must be separated from all other wastes and is generally collected and incinerated by waste disposal specialists. Biomedical waste collection spaces should be provided apart from general waste and recycling spaces.

The design of recyclable waste collection rooms used by individual employees, visitors, students, etc. should adequately accommodate the volume of waste generated. Larger waste collection rooms require less frequent removal resulting in lower labor costs. Collection bin sizes should be based on the material weight-to-volume ratio. For example, office paper has a high weight-to-volume ratio; a 96-gallon container, or equivalent, may be the largest one practicable. Collection containers should be placed adjacent to areas where waste materials are generated. Place bins for recycling paper in copy and computer rooms; place bins for glass, metal, and plastic in kitchens, vending rooms, lounges, etc. If waste chutes are used, they should be similarly placed. Manual crushers should be mounted near bins

for low weight-to-volume materials (such as aluminum cans and plastic bottles) to help reduce space requirements. Most collection areas should be neat and ordered in appearance as befits most office environments.

In some high-rise office buildings, the service core near the maintenance closet and freight elevator can house a secondary waste storage or chute area. Tenants or service personnel deposit waste and recyclable materials there regularly. Since this is a holding area accessible only to a few building occupants, the space can be utilitarian in appearance.

Consult local building codes regarding fire separation or sprinkler requirements for storage rooms, especially for combustibles like paper.

Once you determine the quantities, number of separations, etc. of a building's waste, design the central storage/disposal space. See illustrations for a typical layout of a large office building space and loading dock area. These layouts can be used for other building types that handle a similar volume of waste. Waste chutes and compactor/balers are used where the building configuration, removal service, and/or waste volume warrant it.

**MINIMUM EXTERIOR TRASH AND RECYCLING AREAS FOR NON-RESIDENTIAL BUILDINGS**

BUILDING SIZE (SQ FT)	TRASH (SQ FT)	RECYCLABLE MATERIALS (SQ FT)
0 - 5000	12	12
5001 - 10,000	24	24
10,001 - 25,000	48	48
25,000 +	Each additional 25,000 sq ft requires 48 sq ft each for trash and recyclable materials	

**SOURCE GENERATION\***

CLASSIFICATION	BUILDING TYPES	QUANTITIES OF WASTE GENERATED	TYPES OF WASTE GENERATED
Residential	Studio or one bedroom apartment	1 - 1 1/2 cu yd per unit per month (200 - 250 lb)	Newspaper (38/43) <sup>1</sup> Plastic (18/7) <sup>1</sup>
	Two or three bedroom apartment or single family house	1 1/2 - 2 cu yd per unit per month (250 - 400 lb)	Miscellaneous (13/18) <sup>1</sup> Metals (14/9) <sup>1</sup> Yard waste/compost (10/15) <sup>1</sup> Glass (2/8) <sup>1</sup>
Commercial	Office, general	1 1/2 lb per employee per day or 1 cu yd per 10,000 sq ft per day  (includes 1/2 lb of high-grade paper per person per day)	Plastics, compost, used oil, metals, and glass (30%) <sup>2</sup> High-grade paper (29%) <sup>2</sup> Mixed papers (23%) <sup>2</sup> Newspapers (10%) <sup>2</sup> Corrugated cardboard (8%) <sup>2</sup>
	Department store	1 cu yd per 2500 sq ft per day	Corrugated cardboard, compost, wood pallets, high grade paper, and plastic film <sup>3</sup>
	Wholesale/retail store	Varies with type of tenant	
	Shopping center	Varies with type of tenant	
	Supermarket	1 cu yd per 1250 sq ft per day	Corrugated cardboard, compost, and wood pallets <sup>3</sup>
	Restaurants/entertainment	Varies with number of meals served and type of food	Compost (38%) <sup>2</sup> Corrugated cardboard (11%) <sup>2</sup> Newsprint (5%) <sup>2</sup> High-grade paper (4%) <sup>2</sup>
	Drugstore	1 cu yd per 2000 sq ft per day	Corrugated cardboard and high grade paper <sup>3</sup>
	Bank/insurance company	Survey required (3/4 lb high-grade paper per person per day)	High-grade paper, mixed paper, and corrugated cardboard <sup>3</sup>
Hotel and motel	High occupancy	1/2 cu yd per room per week (plus restaurants)	Glass, aluminum, plastic, high-grade paper, newspaper, and corrugated cardboard <sup>3</sup>
	Average occupancy	1/4 cu yd per room per week (plus restaurants)	
Institutional	Hospital	1 cu yd per 5 occupied beds per day	Compost, high-grade paper, biomedical waste, corrugated cardboard, glass, and plastics <sup>3</sup>
	Nursing home	1 cu yd per 15 persons per day	
	Retirement home	1 cu yd per 20 persons per day	
Educational	Grade school	1 cu yd per 8 rooms per day	High-grade paper, mixed paper, newspaper, corrugated cardboard, compost, plastic, glass, and metals <sup>3</sup>
	High school	1 cu yd per 10 rooms per day	
	University	Survey required	

**NOTES**

1. Percentage by volume/percentage by weight.
2. Percentage by volume.
3. Percentages not available.

4. This table approximates by building type the quantity and type of waste generated; the information should be used as a guideline only. Volume (using varying weights per cubic yard) is derived from nationwide U.S. averages of noncompacted waste.

**MULTIFAMILY HOUSING**

Diverse types of waste are generated in the home; this waste is compounded in multifamily apartment buildings. Waste and recyclable materials often contain organic materials that can attract rodents and insects and produce odors that must be controlled or segregated from the surrounding area. Resident's glass, metal, and plastic materials need to be washed or sealed in containers before placing in collection bins. Consult local health, fire, and building codes regarding these storage areas; sprinklers may be required.

A two-part system is recommended for an effective recycling program in high-rise residential projects. First, provide space in the home kitchen area to collect recyclable and waste products. For multifamily housing, each dwelling unit should have a total of 5 cu ft minimum set aside for waste storage (2.5 cu ft for trash and 2.5 cu ft for recyclable materials). Second, provide convenient space on each floor for sorting and/or deposit of materials. Freight elevator bays or maintenance rooms are usually good locations. In low-rise multifamily buildings or complexes, a central interior space may be desirable. The closer it is to the regular waste drop-off point the better.

In some situations, waste chutes provided on each floor can be effective, especially if deposit space is limited. Two waste chute systems are available. One consists of multiple, separate chutes for trash, metal, plastic, and newspapers. The other is a single waste chute that handles all of the waste, which is "sorted" by a computerized revolving bin in a central storage room. Corrugated cardboard and glass usually cannot be accommodated by the chute system because of jamming and breakage, respectively. Glass also requires color separation and is best handled by other collection methods.

Central storage spaces for recyclable and waste materials may be placed in a variety of locations depending on the layout of the building or complex. When no secondary spaces are possible or practicable for waste drop-off, residents must drop off recyclable and waste materials at a central site. The options for this site are as follows:

**SINGLE EXTERIOR SITE**

Place compartmentalized recycling dumpsters or 90 gallon carts in one central location. This system, easiest for the maintenance staff and the remover, is the least expensive method. However, this is the least convenient arrangement for residents, and a large area on the site may be required.

**MULTIPLE EXTERIOR SITES**

For larger building complexes, place recycling bins or compartmentalized dumpsters adjacent to a conventional waste disposal site. Keep bins separate and clearly marked. Minimum maintenance is required for this layout, designed to be convenient to residents by providing multiple locations. Removal costs may be somewhat higher than a single collection site.

Exterior storage areas are generally prohibited in required front yards, street sideyards, or required parking and landscaped areas. Check local zoning, fire, and building codes.

**SINGLE INTERIOR SITE**

A recycling area can be set up at an interior location using separate containers on wheels - 32-gallon containers, 55- or 90-gallon drums - to collect and store waste and recyclable materials. This central collection area should be convenient to residents, near elevator lobbies, mailrooms, chuterrooms, ends of hallways, or in other common areas like laundry rooms, lounges, or lobbies. If no space is available in any of these locations, use a single storage room that meets code requirements.

**MINIMUM INTERIOR OR EXTERIOR TRASH AND RECYCLING AREAS FOR MULTIFAMILY HOUSING**

NUMBER OF UNITS	TRASH (SQ FT)	RECYCLABLE MATERIALS (SQ FT)
2 - 6	12	12
7 - 15	24	24
16 - 25	48	48
25 +	Each additional 25 dwelling units require an additional 48 sq ft for both trash and recyclable materials	

**SINGLE-FAMILY HOUSING**

Generally, issues regarding collection of recyclable and waste materials in the single-family home are similar to those within an apartment. Sorting of recyclable materials is often accommodated in kitchen base cabinets, especially under the sink, in a trash cabinet "island," or in a nearby utility closet. Most cabinet manufacturers offer a specially designed base cabinet to handle recyclable and waste materials. If organic materials are collected for composting, odors and vermin must be addressed as well as the ability to clean the collection bins. Garages may include recycling storage areas or closets; if adjacent to kitchens, a pass-through system with closable doors can be built.

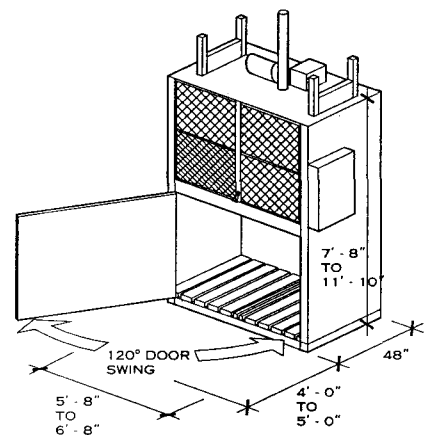

**BALER/COMPACTOR**

**NOTES**

1. All baler dimensions are approximate and vary depending upon the manufacturer. Typical bale sizes (in inches) are: 18 x 18 x 18, 20 x 24 x 18, 30 x 24 x 20, 48 x 30 x 42, 60 x 30 x 48, and 72 x 30 x 48
2. To determine whether a baler is needed, consult a recycler to analyze probable waste quantities. Balers can make recycling more efficient by saving space. For example, if the volume of cardboard boxes is high in a certain building, balers can greatly reduce the amount of storage space needed. The baling of such waste as metal cans, plastic bottles, paper, or cardboard may make the recyclable materials more marketable by increasing trailer payloads.
3. Some balers expand by linking bins together to accommodate a variable recycling program. A sliding ram mechanism will service each bin.

Richard J. Vitullo, AIA; Oak Leaf Studio; Crownsville, Maryland  
Tom Lokey; Northeast Maryland Waste Disposal Authority; Baltimore, Maryland

**DISPOSAL**

To determine waste and recyclable material removal arrangements for a project, contact the municipal or county environmental office for local regulations or guidelines for collection programs. If private arrangements must be made, contact local removal and recycling companies that could service the building. The container type and size compatible with collection vehicles should be noted and provided for in the design. Since recycling is an industry in its infancy, provide extra storage space in or near the building to accommodate future needs.

Some building types, such as grocery stores, generate a large amount of bulky corrugated cardboard, requiring compacting and/or baling. Materials of large volume to weight ratios, such as metal cans and plastic bottles, if not crushed manually at their generation point, may be compacted at a central storage room. The volume of material collected and the number of trips the remover needs to make will generally indicate the cost-effectiveness of a crusher or baler.

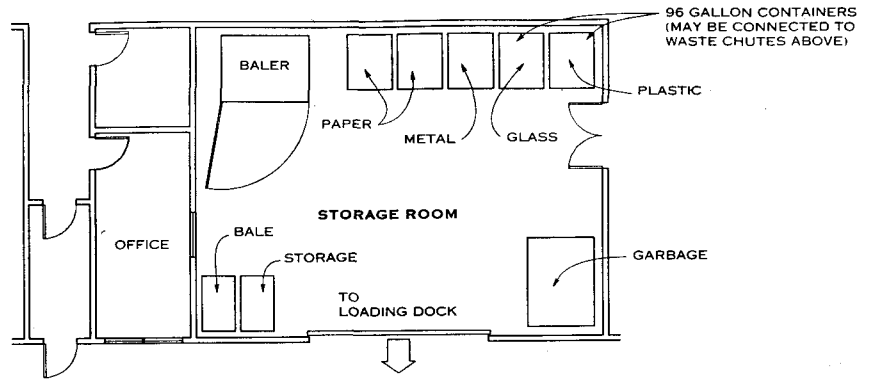

TYPICAL CENTRAL WASTE ROOM PLAN

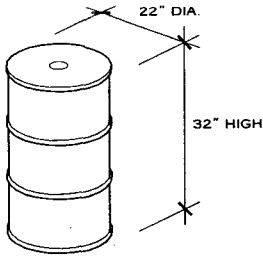

55 GALLON DRUM (.3 CU YD)

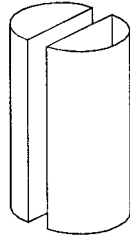

DIVIDERS FOR 55 GALLON DRUM FOR SEPARATION

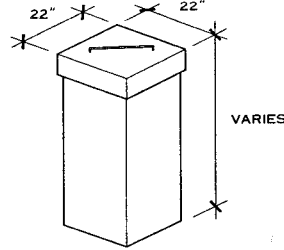

CARDBOARD CONTAINER (CAPACITY VARIES)

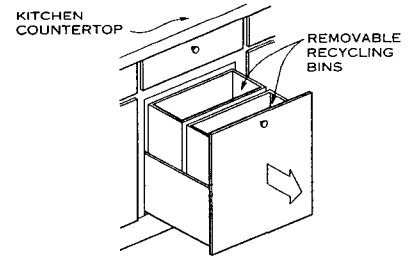

UNDERCOUNTER CENTER

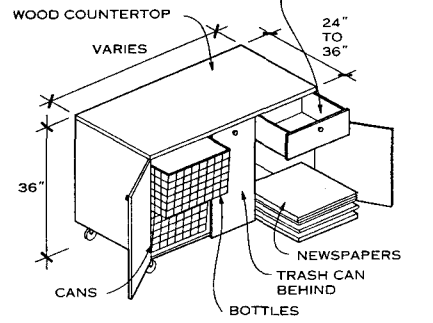

MULTIPURPOSE ISLAND RESIDENTIAL RECYCLING UNITS

TYPICAL CONTAINERS

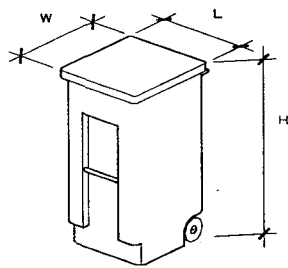

PLASTIC CONTAINER

COMMON SIZES

	LENGTH	WIDTH	HEIGHT
32 gal	21"	19"	36"
64 gal	29"	21"	42"
96 gal	35"	24"	43"

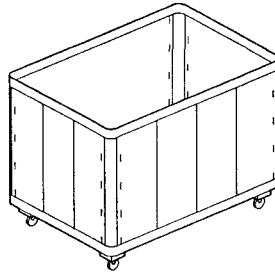

CANVAS BINS

COMMON SIZES

	LENGTH	WIDTH	HEIGHT
8 bushel	35"	26"	21"
16 bushel	42"	30"	30"
18 bushel	44"	31"	29"

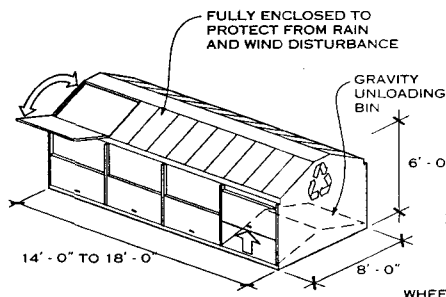

RECYCLING MATERIALS CONTAINER

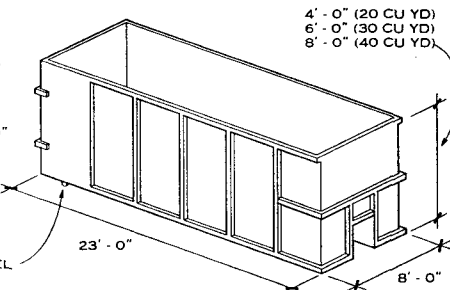

CONVENTIONAL "ROLL OFF" WASTE CONTAINER

STORAGE CONTAINERS

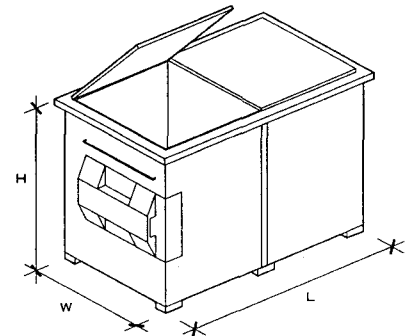

FRONT LOADING STEEL CONTAINER

COMMON SIZES

	LENGTH	WIDTH	HEIGHT	EMPTY WEIGHT
2 cu yd	72"	36"	36"	600 lb
4 cu yd	72"	54"	48"	900 lb
6 cu yd	72"	66"	60"	1200 lb
8 cu yd	72"	66"	80"	1500 lb

Richard J. Vitullo, AIA; Oak Leaf Studio; Crownsville, Maryland  
Tom Lokey; Northeast Maryland Waste Disposal Authority; Baltimore, Maryland

**GENERAL**

Distribution facilities are highly efficient operations in which products are stored and from which orders are filled and shipped to meet customer demand. Distribution facilities house raw materials, parts, or finished products, most commonly at the manufacturing or distribution level. This storage, all along the supply chain, from raw material to product delivery, adds cost, which can be reduced by efficient distribution practices and facilities.

Distribution facilities are designed from the inside out. That is, the size and shape of the product determines how the facility will be operated and what form the building will take. Storage volume can be increased much more cheaply by increasing the height of a building than by increasing its footprint. Column layouts must accommodate a combination of rack types and allow for changes in rack type. Mixed rack types may be placed together in one storage area.

In addition to storage areas, distribution facilities require a battery charging area, a maintenance area, shipping and receiving offices, other business offices, utility equipment spaces, and truck and rail docks.

Truck loading docks are high traffic areas and should be segregated from pedestrian traffic. Railroad access is less commonly required than in previous decades, but when rail sidings are included, the track elevation and geometry control the warehouse location and elevation of the floor.

Most new facilities are built so it will be easy to double the storage area at a later date. Expansion requirements usually direct the organization of storage areas, as it is difficult to expand through a loading dock and disruptive and expensive to expand through utility spaces or offices.

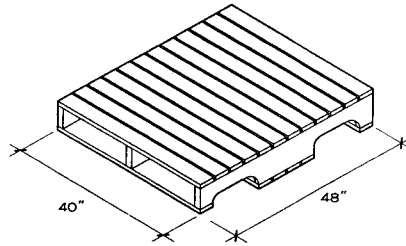

**NOTE**

Identical items are usually packed together to form a case. Typically, cases of only one SKU are stored on a pallet to make a unit load. Heights vary according to gross weight, product durability, and manageable size. The pallet illustrated is used by the Grocery Manufacturers Association.

**TYPICAL GMA PALLET**

**STORAGE BASICS**

The stored product is the module that determines an efficient warehouse size. To provide uniformity in the industry, a common unit load format has developed using a pallet as the tool for shipping, storing, and receiving product. The palletized unit load is now the modular building block from which 90 percent of warehouse dimensions are derived.

The most common method of handling products uses a standardized Grocery Manufacturers Association pallet. Different product combinations can be packed on a single pallet. For identification, each product is called a stock keeping unit (SKU), although the same product in different packaging, or with different cost structures, can be identified as a distinct SKU.

When a unit load is stackable and large amounts of the same SKU are stored in one place (typical at a manufacturing facility), unit loads can be stacked on the floor. Typically, these stacks are no higher than 3 ft in lanes no deeper than 12 unit loads from front to back. Unit loads are also stored in pallet racks. Typically made of steel (cold-rolled or formed), racks are available in numerous types. The type of pallet rack appropriate for any application depends on the variety, quantity, and movement (velocity) of the unit loads being stored and retrieved.

In a typical distribution facility, the contents are rotated ten to twenty times a year. However, depending on many factors, this "inventory turn" number may vary from two turns to 52 turns for perishable products (52 turns means an average product storage time of about a week).

Distribution center management seeks to minimize construction costs by increasing product movement (turns) and choosing storage layouts that minimize the building footprint. It is less expensive to build taller buildings for vertical storage than to increase the building footprint; however, it may be more labor intensive to access very high storage areas. Moving unit loads in and out of pallet racking is very different from selecting cases or individual items from unit loads.

Most distribution centers receive product in full unit loads. Some ship full unit loads, while others ship smaller numbers of cases or less than case quantities. Most distribution centers ship a combination of full unit loads and smaller quantities.

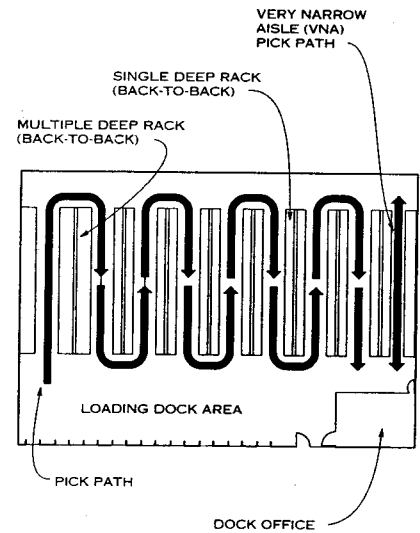
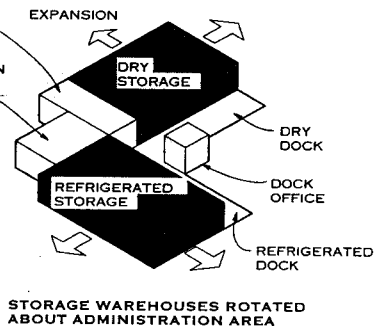
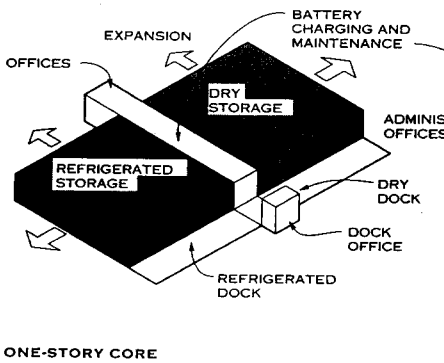
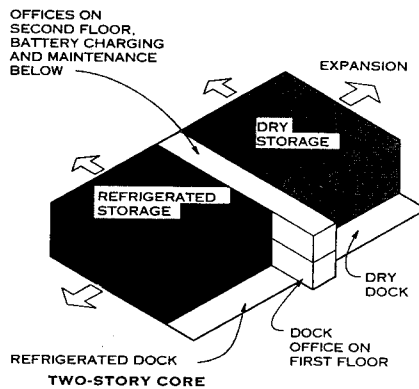
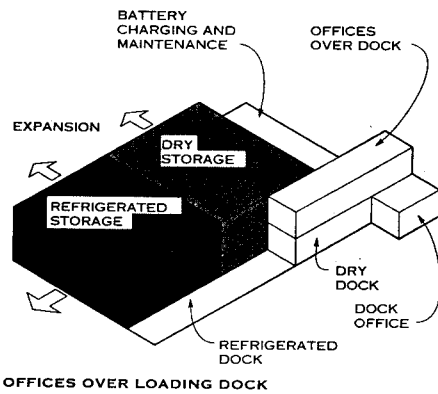

**NOTE**

Grocery distribution facilities exemplify distribution to retail outlets, demonstrating the complexity involved in storing products with varying requirements. Grocery facilities often require five or more coolers with different temperatures, a freezer, and an ice cream freezer, as well as a heated storage area and special fruit-ripening rooms. The building configuration is determined by the temperature-conditioned space requirements.

Illustrated are four configurations for a grocery distribution facility. In each, the architectural plan has been designed

around the facility operation. The storage rooms, with their varying conditions, complicate the space layout. Also, because each space may expand independently, planning for future expansion must consider each space individually.

Refrigerated space is a specialized single use space and, as such, can double the cost of constructing warehouse space. Refrigerated rooms, particularly freezers, should not open directly into unconditioned environments. Typically a refrigerated dock serves as a buffer between these rooms and nonrefrigerated spaces.

**NOTES**

1. The rack layout used determines the building column spacing. Often, the column layout accommodates combinations of different rack types.
2. An even number of selection aisles is preferable so the selection path begins and ends on the dock or at the order assembly area.

**TYPICAL WAREHOUSE PLAN**

**TYPICAL GROCERY DISTRIBUTION FACILITIES**

St. Onge, Ruff and Associates, Inc., York, Pennsylvania

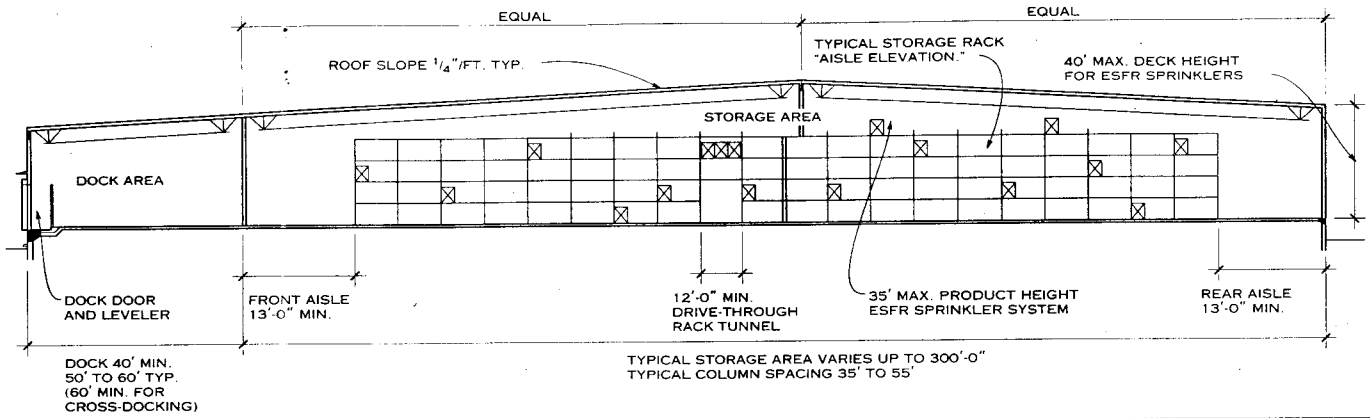

TYPICAL DISTRIBUTION FACILITY CROSS-SECTION

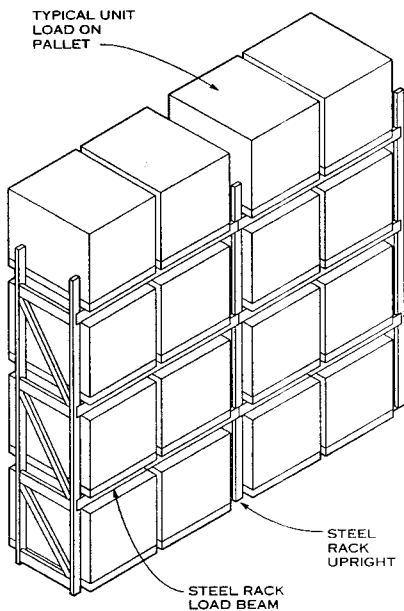

TYPICAL PALLET STORAGE RACK

**TYPICAL DISTRIBUTION FACILITY CROSS-SECTION**

The cross-section of a distribution facility is determined by the storage height requirement and the roof slope. Some building codes require a minimum roof slope of 1/4 in./ft.; a roof slope of 1/8 in./ft. is the minimum for most roof systems.

Because internal roof drainage is expensive, it is preferable to drain the roof using downspouts at the building perimeter.

Depending on the combustibility of the stored product, in-rack sprinklers are required for most storage rack systems. Except in refrigerated spaces, ESFR (early suppression fast response) sprinklers installed at the ceiling can be used in lieu of in-rack sprinklers.

ESFR sprinklers impose a height limitation on warehouses where they are used. They limit the roof height to 40 ft and the top of the stored product to 35 ft.

**TYPICAL PALLET STORAGE RACK**

Although pallet racking design often depends on the height and footprint of a building, it is preferable for this relationship to be the other way around. Distribution centers should be designed "inside out" so the warehousing and material handling needs are free of external constraints. In any case, applicable building codes and fire protection guidelines (NFPA standard 231C) must be followed. Building clearances must allow for lights, steel, etc. but should not be excessive to avoid wasting storage space (measured in cubic volume).

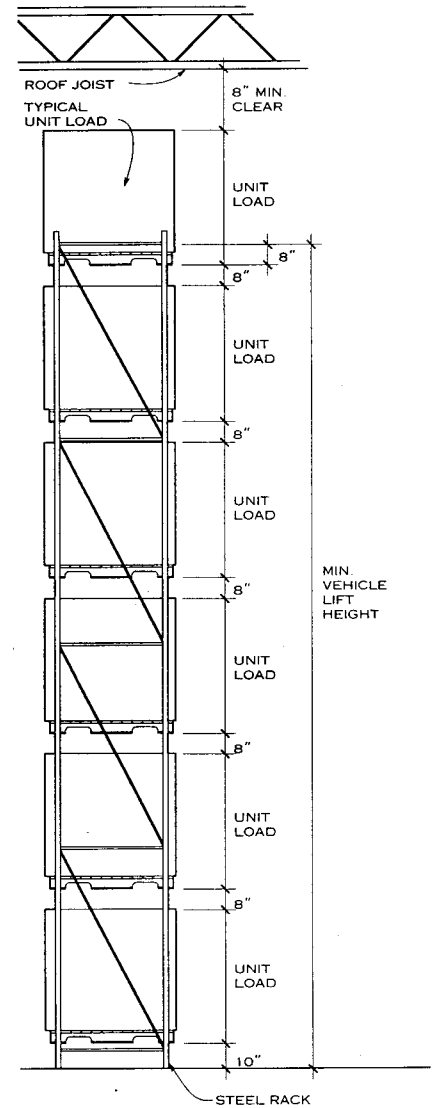

PALLET STORAGE HEIGHT REQUIREMENT

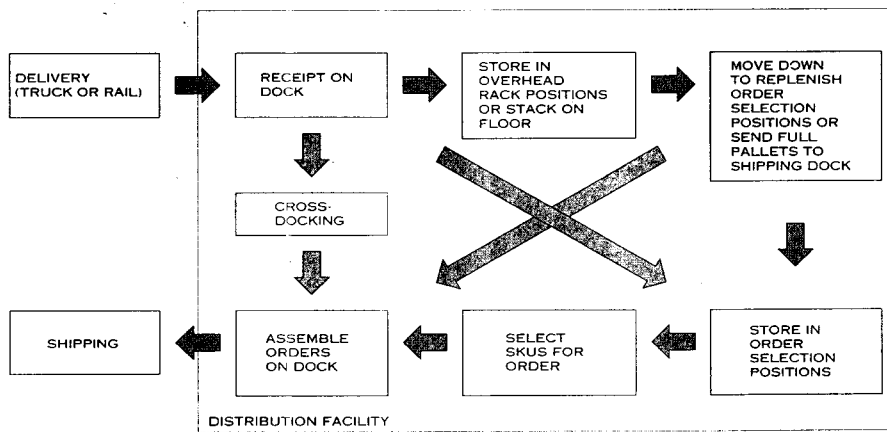

TYPICAL DISTRIBUTION CENTER FLOW CHART

St. Onge, Ruff and Associates, Inc.; York, Pennsylvania

**TYPICAL STORAGE ARRANGEMENT TYPES**

The storage modes illustrated accommodate a wide range of uses. Floor stacking unit loads is the simplest method because it involves no special equipment except the device used to transport the loads. The unit load racking illustrations demonstrate a gradual increase in storage and move-

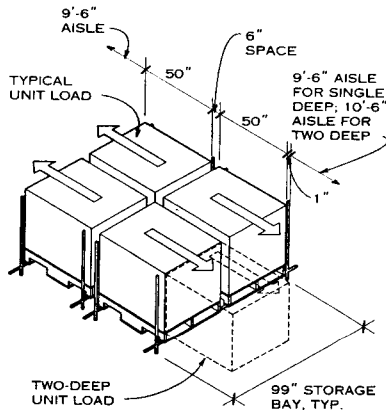

**NOTE**

One-deep (single) or selective racks are the most commonly used. They are typically constructed with two unit loads per storage bay (the space between uprights). When this rack is used, one unit load sits on each side of the aisle.

For product in large groups or lots, two-deep racks may be used to allow for more product in the building footprint. Two deep racks require the use of a vehicle capable of reaching into the rack for the inner unit load. Push-back racks are an alternative arrangement that is similar in plan.

**ONE- AND TWO-DEEP LOAD RACK LAYOUTS**

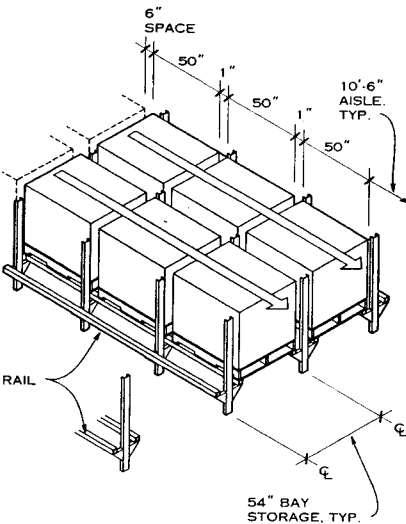

**NOTE**

Drive-in racks, which are one unit load wide, are used to store large quantities of the same unit load. The unit load rests on rails that extend the depth of the rack. Drive-in racks have unit load depths of two or more (3 units are illustrated). To access inner loads, a fork truck must be driven into the rack between the rails that support the unit load.

**DRIVE-IN UNIT LOAD RACK LAYOUT**

ment philosophy. Rack systems require specialized equipment that can access all levels of storage and work efficiently in the aisles. Building columns, in-rack fire protection, and utility lines must be considered when laying out a storage system. When racking is placed back-to-back in a warehouse, a minimum space of 6 in. may be required between racks for in-rack sprinkler system piping or 18 in. for building columns.

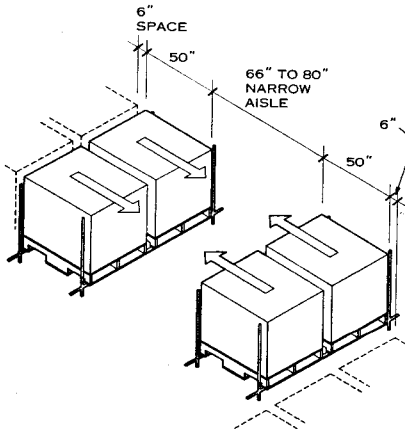

**NOTE**

VNA rack layout is similar to one-deep racks except the aisle is narrower, which both saves space and places opposite sides of the aisle within reach of a specialized order picker. An employee riding the vehicle can select cases from unit loads on the floor and from each of the overhead storage positions. The narrow aisle also requires special equipment for loading. Allow 16 ft clear at the front of the aisle and 12 ft at the rear for VNA vehicle access.

**VERY NARROW AISLE (VNA) RACK LAYOUT**

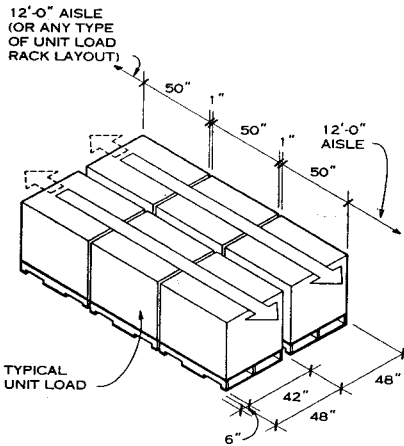

**NOTE**

Floor stacking of unit loads does not require racks, which can save capital costs. However, floor-stacked product is not easily selected as the stacks can only be reached from the top tier. Unit load characteristics usually limit stacking heights to three high. Floor stacking is most often used when large quantities of the same unit are stored.

**THREE-DEEP UNIT LOAD FLOOR STACK LAYOUT**

**BUILDING AREA (SQ FT) PER PALLET POSITION\***

TYPE OF STORAGE	STORAGE HEIGHT BY UNIT LOAD					
	2	3	4	6	8	12
4 deep floor stack	11.5	7.6	-	-	-	-
6 deep floor stack	10.4	7.0	-	-	-	-
Single deep	18.9	12.6	9.5	6.3	-	-
2 deep (MDR)	15.6	10.4	7.8	5.2	-	-
3 deep (MDR)	13.9	9.3	6.9	4.6	-	-
2 deep push back	14.4	9.6	7.2	4.8	-	-
Double deep	14.4	9.6	7.2	4.8	-	-
VNA (turret truck)	-	-	-	5.2	3.9	-
AS/RS (single deep)	-	-	-	-	2.1	1.4

\*Storage area only, does not include end aisles or intermediate cross aisles.

**NOTE**

The square footage in a building footprint occupied by each unit load decreases as stacking height increases, since a vertical stack of unit loads occupies the same floor space as a single load of the same dimension. A reduction in aisle width from the combination of rack usage and equipment type could also reduce building square footage.

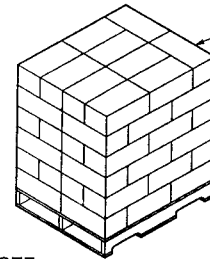

**NOTE**

Unit loads are assembled (or palletized) either manually through case stacking or with an automatic palletizing machine. The tiers of cases in the unit load illustrated are rotated 180 degrees from the adjacent tiers; the interlocked cases stabilize the load.

**TYPICAL UNIT LOAD**

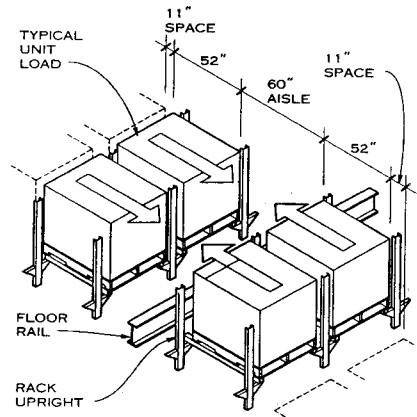

**NOTE**

Automated storage and retrieval systems (AS/RS) incorporate an unmanned storage and retrieval machine or SRM (described in AGS chapter 14). Allow 15 ft minimum clear space at the front runout and 25 ft minimum at the rear for crane access. AS/RS systems, which are often 80 ft tall, automate the distribution operation and can store more unit loads in a smaller space than other rack systems. Often, the AS/RS rack system serves as the building structure as well.

**AS/RS RACK LAYOUT**



**GENERAL**

Cold storage distribution facilities are differentiated from other distribution facilities because they are refrigerated. In addition to the requirement for mechanical refrigeration to provide a cold environment, the construction of these buildings is very different. The cooler or freezer rooms must be well-insulated to reduce energy costs; gaps in the thermal envelope are not acceptable. The low temperatures also cause a vapor drive toward the refrigerated space, which requires that the thermal envelope have a continuous vapor barrier to prevent condensation or frost in the cold space. Specialized materials and details are needed to construct a hermetically sealed vapor envelope.

**NOTES**

1. Small coolers and freezers may be constructed with insulated panels inside a weatherproof building shell. Often these are prefabricated units.
2. The least costly way to build coolers and freezers is to use the walls, roof, and floors of the building as the thermal envelope. This envelope must be vapor-tight and have continuous insulation, particularly at the corners and across penetrations of the envelope. To achieve this requires an extensive amount of specialized detailing and craftsmanship.
3. For rooms with temperatures below 32°F, insulation and subfloor heating must be considered.
4. Refrigeration evaporators must be placed with consideration for maintenance access, effective air circulation, noise, and protection from vehicle or product damage.
5. Air units and piping must be protected from damage, especially when ammonia refrigeration is used. The ammonia hazard inside a building can be reduced by locating the ammonia piping and valves above the roof.
6. Dock areas are subject to a great deal of air infiltration because of the openings for trucks. Select dock equipment that will minimize this infiltration. Refrigerating the dock reduces the amount of moisture vapor that reaches the interior freezer.
7. Dock temperatures below 32°F require features that prevent frost accumulation at truck openings. In cold climates, refrigerated docks may also require heating.

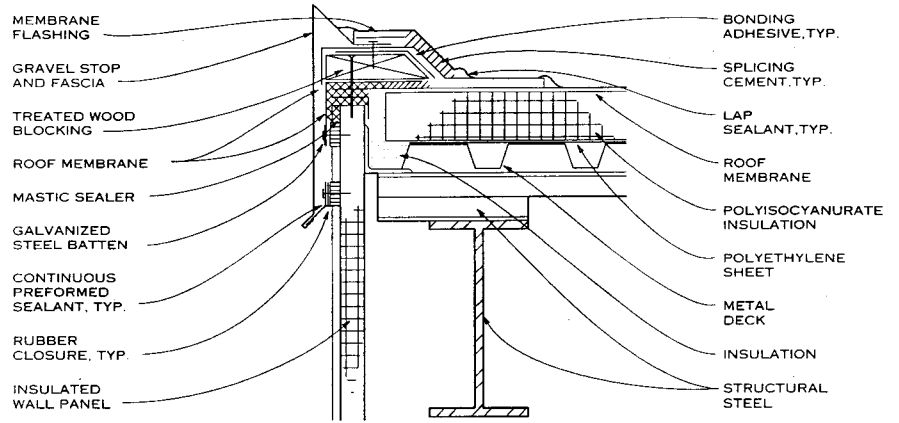

**TYPICAL COLD STORAGE EAVE DETAIL**

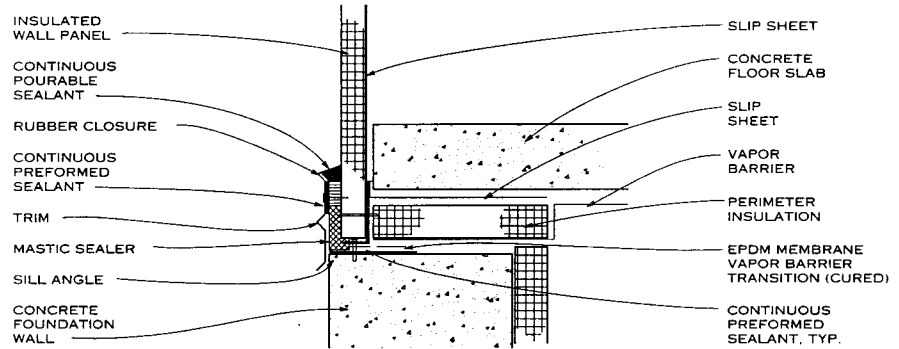

**TYPICAL COLD STORAGE SILL DETAIL**

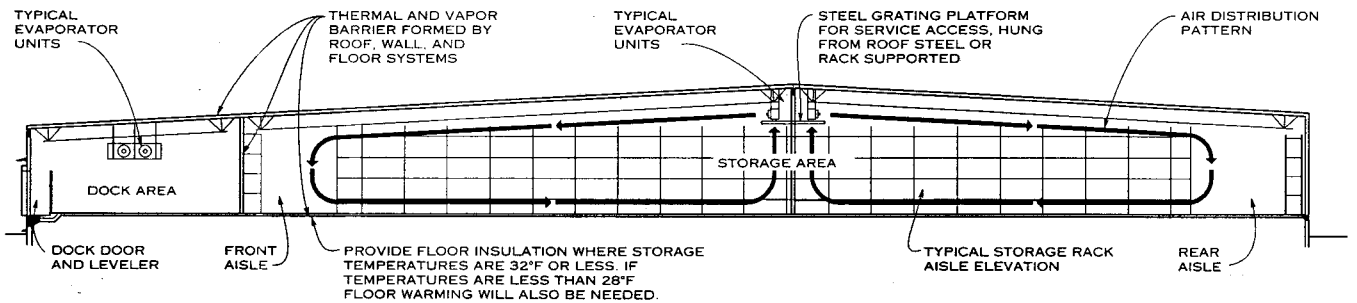

**SECTION—CONVENTIONAL INTERIOR EVAPORATOR PLACEMENT**

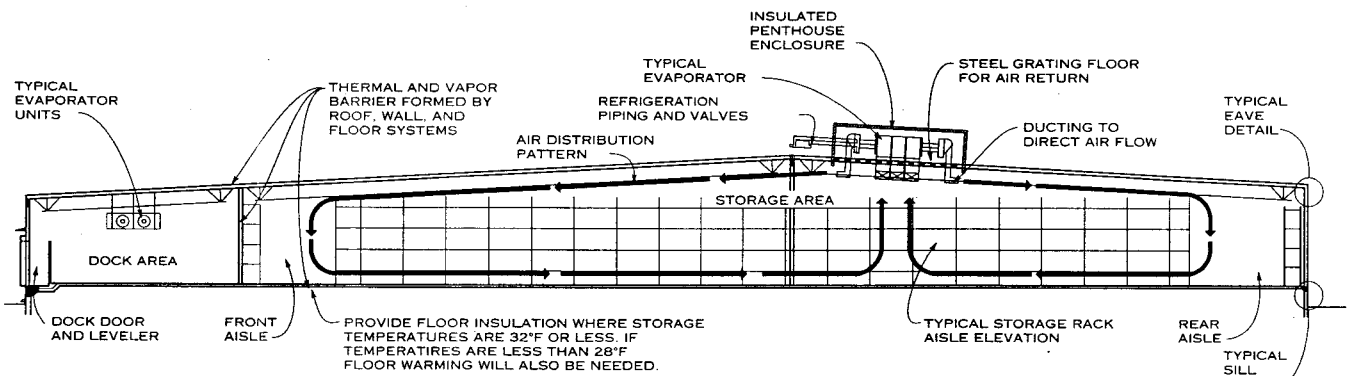

**SECTION—PENTHOUSE EVAPORATOR PLACEMENT**

**COLD STORAGE AIR DISTRIBUTION BUILDING TYPES**

St. Onge, Ruff and Associates, Inc.; York, Pennsylvania

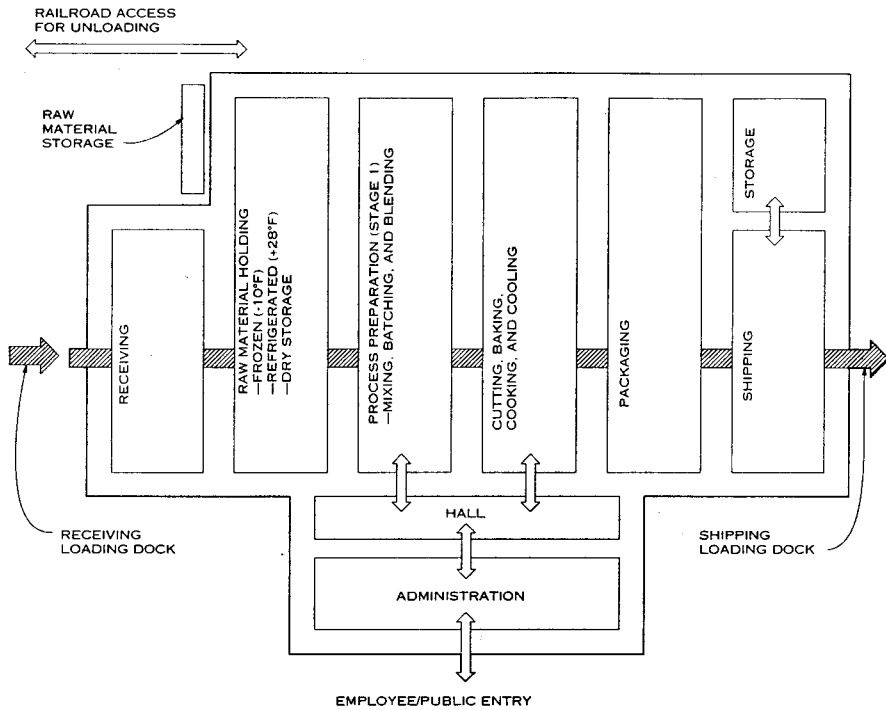

**SPACE RELATIONSHIPS**

**GENERAL**

Food processing facilities process raw materials into either a single food product or a common line of food products, each processed according to its own specifications. Several types of process facilities are described on this page:

1. Fluid processing of products such as milk, beverages, or concentrates
2. Meat, poultry, and fish processing, ranging from slaughter operations to packing individual meat portions for retail sale
3. Fresh or frozen baked goods
4. Cereals and other grain products
5. Fresh, canned, and frozen vegetables
6. Snack foods and sugar and confectionery products
7. Specialty items and food additives

**TYPES OF FOOD PROCESSES**

Each food product can be handled and processed in a variety of ways to produce various end products. For example, fresh vegetables can be canned or frozen for easier distribution and longer shelf life. Food processing facilities can be designed to handle each process in several ways:

1. Batch: In a batch operation the product flows through the process in distinct steps or stages. For example, soups may be cooked in a kettle or juice may be mixed in a large tank before it is packaged.
2. Continuous flow: In this operation the product flows through the process in a continuous stream. For example, milk is produced in a continuous fashion from pasteurization to bottling.
3. Combination of batch processing and continuous flow: A product may begin in a batch form and be finished in a continuous flow. For example, cake batters can be mixed as a batch and then transferred to an oven for continuous baking.

Many products can be processed either in a batch or in a continuous flow mode. For example, juice can be produced from concentrate by mixing a batch in a tank or by mixing it with water in a continuous stream. Higher production runs usually can justify the additional expense of complex equipment needed to run a continuous process.

**TYPICAL PROCESS FACILITY AREAS**

Depending on the food processed and the way it is processed, a typical food manufacturing facility may contain several or all of the following functions:

**RECEIVING**

1. Raw materials such as milk, flour, and granular or liquid sugars can be received in large quantities, either by truck or rail car, and placed in bulk storage tanks.
2. Raw materials are also received on pallets delivered by trucks to loading docks.
3. Materials can also be received in reusable totes and bulk containers. Packaging supplies usually are received on pallets delivered by truck.

**STORAGE**

1. Storage of finished products should be minimized to achieve maximum shelf life in retail stores. Many products are processed and loaded directly onto trucks without being stored in the plant.
2. Many food products must be stored frozen to gain maximum shelf life. Ice cream products are usually stored at -20°F. Some finished products, such as milk, must be tested before distribution to confirm regulation compliance.

**SHIPPING**

Trucks can be loaded with fork trucks or pallet jacks. Some processes lend themselves to staging an entire truckload on the dock and automatically transferring it to the truck.

**ADMINISTRATIVE AREAS AND EMPLOYEE AMENITIES**

Administrative offices support the operations of the plant. Lockers and toilets should be provided so that workers can properly prepare themselves before entering the processing areas. An access hallway is sometimes required to limit entry to sensitive processing areas. Additional sanitary measures may be required in some process spaces.

Lunchrooms, computer rooms, quality control, research and development, and maintenance are other functions typically located in these areas.

**RAW MATERIAL HOLDING**

1. Some raw materials need to be quarantined before they are released for processing. This holding period allows the product to be tested for bacteria or impurities before processing.
2. Dry storage areas are provided for packaging goods and raw materials that do not need to be kept cool or frozen.
3. Refrigerated storage areas can be for fresh or frozen products that would spoil if not refrigerated. Refrigerated rooms may need to be divided to prevent cross-contamination of raw materials. For example, raw meat species need to be separated.
4. Tempering rooms are provided to thaw frozen materials before they are sent to production. Some raw materials requiring tempering include meats and frozen fruits.

**PROCESS PREPARATION, MIXING, BATCHING, AND BLENDING**

1. Most raw materials that are prepared for use in recipes or food processes need to be unboxed, debagged, sorted, weighed, and measured. Raw vegetables must be cleaned and washed. A convenient location needs to be provided to remove trash.
2. To make a food product, several raw ingredients may need to be mixed together. Ingredients such as preservatives and artificial colors and flavors may be weighed separately in a prebatching room.

**CUTTING, BAKING, COOKING, AND COOLING**

Examples of these functions include:

1. cutting steaks and roasts from larger beef portions.
2. baking cake products in continuous ovens.
3. cooking soups and sauces in batches in large kettles.

**PACKAGING**

Finish goods can be packaged manually into boxes or be handled by automatic packing equipment.

**PROCESS FLOW**

A well-designed food processing facility will aid in maintaining sanitary conditions and ensuring production of a safe food product. Typically the facility is wrapped around process functions. The ideal process facility would consist of a process flow that proceeds in linear fashion straight through the facility as shown in the accompanying plans.

A straight-through facility:

1. minimizes cross-traffic.
2. minimizes the potential for cross-contamination of raw and cooked products.
3. eliminates confusion between receiving and shipping functions.

Not all sites lend themselves to a straight-through flow. A U-shaped plan, for example, means the product is received and shipped from the same side of the building.

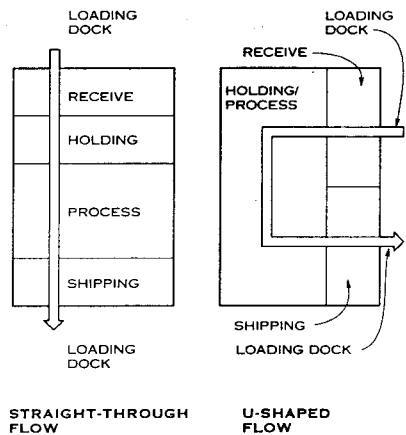

**PROCESS FLOW LAYOUT TYPES**

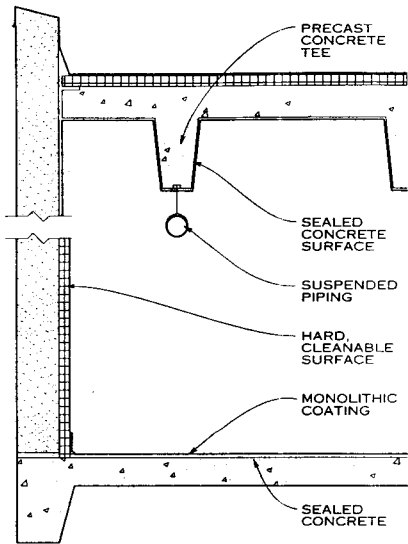

PRECAST CONCRETE

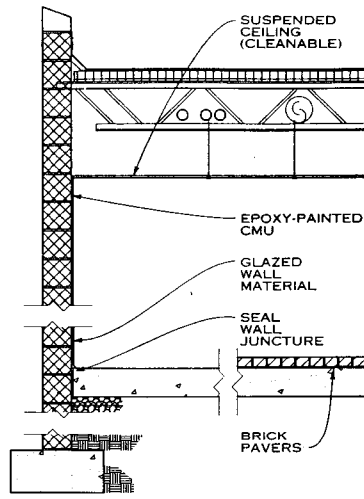

CMU WALL AND STEEL JOIST WITH SUSPENDED CEILING

NOTES

1. In general, sanitary finishes must be hard, durable, smooth, and easy to clean. Food processing rooms should be free of any hidden areas or ledges that may hinder cleaning and sanitizing.
2. Precast concrete tees are often used on process rooms. One disadvantage is that all piping and utilities are exposed and must be cleaned regularly.
3. Precast concrete with a smooth, void-free surface provides a hard surface and is usually sealed to provide good chemical resistance.
4. Monolithic coatings of epoxy and other types of materials are trowel applied in 1/8 to 1/4 in. thickness to provide better resistance to harsh process environments.
5. Fiberglass-reinforced panels or galvanized metal wall panels provide a hard, cleanable surface.
6. Sealed concrete provides minimum protection from processes and clean-up chemicals.
7. Suspended ceilings composed of stainless steel grids and panels provide a cleanable surface. One disadvantage of this type of finish is that the space above must be properly ventilated.
8. Epoxy-painted concrete masonry units (CMUs) provide a resistant surface if "pinholes" are filled to prevent places where bacteria can grow.
9. Ceramic tile or glazed CMU with epoxy joints provides the most durable and long-lasting process room finish.
10. Brick pavers generally provide the best resistance to harsh process and cleanup chemicals. Fill joints with cementitious material or a more chemical and heat resistant material like Furan (a specialized concrete mix).

SANITARY FINISHES ON BUILDING MATERIALS

SANITARY DESIGN

Various government organizations regulate food processing facilities, including the U.S. Department of Agriculture (USDA), the Food and Drug Administration (FDA), and state and local health departments. These organizations attempt to curtail three potential food hazards:

1. Bacteria: Many food products are susceptible to environmental or in-plant contamination. Bacterial cross-contamination of a product can occur when raw products and cooked products are in close proximity. Food processing plants should be arranged to eliminate this possibility.
2. Physical: Process lines should generally be positioned away from overhead piping, walkways, and other features from which contaminants can fall into the product. Metal particles from process pumps and other equipment can also be a physical hazard.
3. Chemical: Pesticides and other chemicals used for rodent control can contaminate processed products. Preservatives and other food additives should be added in proper quantities. Boiler water chemicals and equipment lubricants should be used appropriately.

General sanitary considerations begin with proper landscaping and lighting on the building exterior. Landscape stones placed around the building perimeter help prevent vermin from nesting close to the building. Exterior lights should be located away from doorways because they attract insects at night. On the interior, specify no glass in the process area; unprotected light bulbs could break and fall into the product. There should not be painted surfaces in process rooms; paint can chip and fall into the product.

FACILITY CLEANING

Use a dry process to clean up as much as possible to prevent process wastes from entering the sewer. Provide hose stations and high-pressure, low-flow wash stations.

Some process equipment can be left in place for cleaning. Cleaning and sanitizing solutions are circulated through the process lines. Some equipment should be disassembled and cleaned at a remote site. Foam cleaners, which mix air and foaming chemicals, can be sprayed on processing equipment, tanks, and vessels to help hold detergent on the surface.

PIPING AND UTILITIES

As far as possible, keep utilities and piping to a minimum. Piping runs should not be located over process equipment because pipes can leak and drip condensate into the product. Locate piping away from walls or tight to the wall or other surface and caulk it on both sides. Provide proper insulation and jacketing of all piping.

Typical process utilities include steam and condensate return; process water; hot water; chilled water for cooling jackets; compressed air and control air; gas ovens or hot water heaters; hydraulics for hydraulically operated motors; refrigeration for process or space cooling; electrical; plumbing (no standing water on floors; 400 sq ft/drain); hand-washing and cleanup stations.

PIPING LOCATIONS

Within the processing space, piping should be on pipe racks. To make changes or repairs to piping, the food processing line usually must be shut down to avoid product contamination. An alternative is to locate piping in a crawl space above the process room. This utility service area allows utility drops to occur at the connection point to the processing equipment. Changes and repairs to piping and utilities in the utility service space can usually be made while the food processing line is running.

TEMPERATURE AND LIGHTING OF PROCESS AREAS

Keep temperatures to USDA-specified levels or lower to slow growth of bacteria. Refer to ASHRAE guide for manufacture of particular products. Lighting considerations include proper lighting levels and good color rendition for inspection of products. All fixtures should be enclosed and, possibly, gasketed for wash-down service.

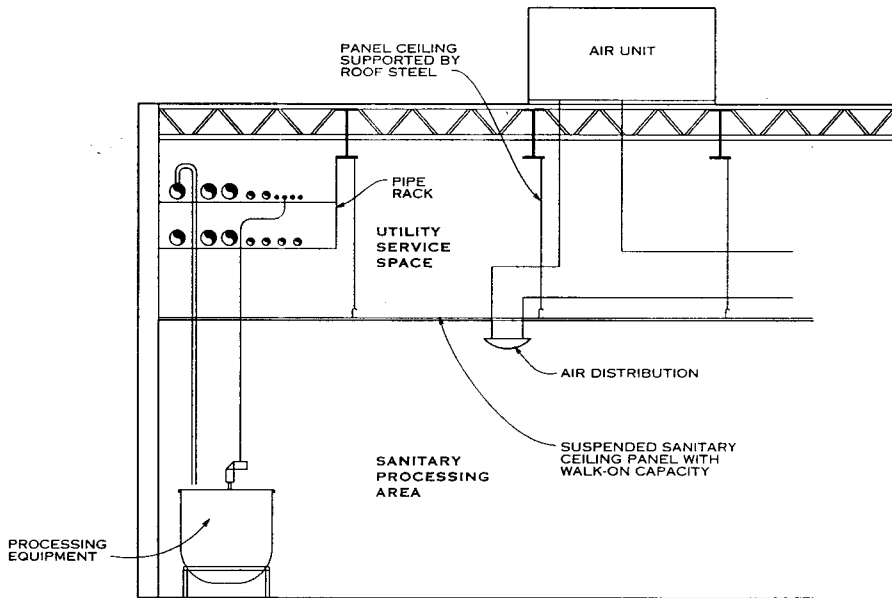

WALK-ON SANITARY CEILING

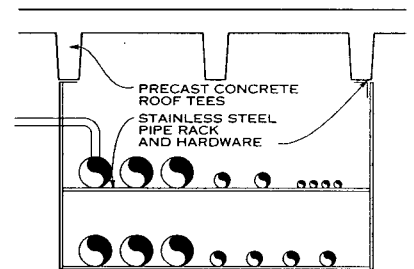

NOTE

Pipe rack may include food processing piping, utility piping, electrical wiring, and control circuits.

PIPE RACK DETAIL

St. Onge, Ruff and Associates, Inc., York, Pennsylvania

# ACCESSIBILITY

Introduction 952

Building Blocks 956

Curbs and Parking 960

Ramps 962

Elevators 963

Doors 966

Communication 967

Mobility Aids 968

Furniture 970

Toilets and Bathrooms 971

Residential 974

**BUILDING CODES AND CIVIL RIGHTS LAWS**

*Accessible* is a design term that was first introduced in the 1950s to describe elements of the physical environment that can be used by people with disabilities. Originally, the term described facilities that could be accessed by wheelchair users, but it has evolved to include designs for a wider group of people with more diverse functional requirements.

Society's need for accessible design has increased as a result of continuing medical advances. For example, the discovery of antibiotics in the 1940s dramatically improved the survival rate for people who sustained spinal cord injuries. Concurrent with the medical advances has been the development of new building technologies, such as residential elevators, wheelchair lifts, and power door operators, that have made the provision of accessible facilities more practical and less expensive. Accessible design will continue to change as medical advances and building technologies continue to evolve.

From an architect's perspective, there is a difference between appropriate accessible design for public facilities and the best approach for private, custom accessible projects. Public accessibility standards establish general design specifications that broadly meet the targeted population's needs. By contrast, custom accessible design should address the specific needs of an individual user. The same design standards, for example, are not always appropriate for paraplegic wheelchair users and wheelchair users with cerebral palsy. Custom accessible design should not, therefore, necessarily follow commercial standards. Rather, it should reflect the individual user's unique capabilities and preferences. Even design details such as the orientation of a bathroom fixture should be evaluated in order to suit the specific client.

Accessible design is a new and still-evolving field. Nonetheless, the proliferation of laws and codes governing its implementation demands that architects educate themselves with regard to both the principles and the legal requirements of accessibility.

**THE REGULATORY HISTORY OF ACCESSIBLE DESIGN**

The American National Standards Institute (ANSI) published the first national standards for accessible design in 1961. After its initial publication, many state and local jurisdictions began to adopt ANSI A117.1 as their accessibility code, although they often modified selected standards to suit their communities. ANSI A117.1 quickly became the most widely used accessibility standard in the United States.

ANSI has periodically revised the A117.1 standard since it was first published. In 1980 it was expanded to include housing standards focused primarily on the needs of wheelchair users (specifically paraplegics). In an effort to encourage states to adopt the standards and to promote uniformity, the 1986 revision eliminated all "scoping" requirements.

*Scoping* is the extent to which a standard is applied; for example, a standard may be applied to *all* project elements or only a *fraction* of the elements. The 1980 ANSI standards, for instance, require provision of a "reasonable number" of wheelchair seating spaces in places of assembly but not fewer than 2 spaces. After publication of the 1986 ANSI A117.1 standard, scoping was left to the discretion of the local adopting authority.

The 1968 Architectural Barriers Act was the first federal legislation that required accessible design in federal facilities. To address the absence of federal accessibility standards and the lack of an enforcement mechanism, Congress enacted the 1973 Rehabilitation Act. In addition, the Act required facilities built with federal funds, and facilities built by entities that receive federal funds, to be accessible to persons with disabilities.

Section 502 of the 1973 Rehabilitation Act created a new federal agency, the Architectural and Transportation Barriers Compliance Board (ATBCB) to develop and issue minimum guidelines for design standards to be established by four standard-setting agencies. In 1984 the ATBCB issued the Uniform Federal Accessibility Standards (UFAS), which were established by the Department of Defense (DoD), the Department of Housing and Urban Development (HUD), the General Services Administration (GSA), and the U.S. Postal Service. UFAS is similar to the format and content of ANSI A117.1, 1980.

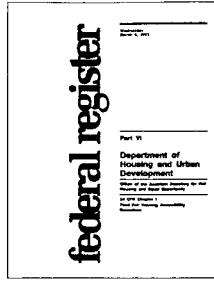

**FHAG: FAIR HOUSING ACCESSIBILITY GUIDELINES**

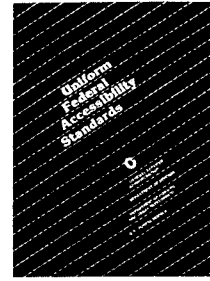

**UFAS: UNIFORM FEDERAL ACCESSIBILITY STANDARDS**

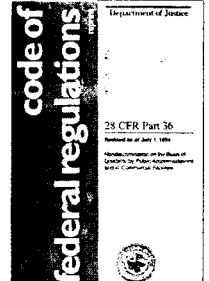

**ADAAG: AMERICANS WITH DISABILITIES ACT ARCHITECTURAL GUIDELINES (TITLE III)**

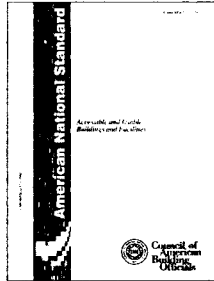

**CABO/ANSI: AMERICAN NATIONAL STANDARDS INSTITUTE A117.1**

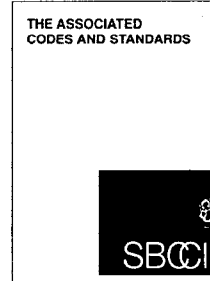

**SBCCI: SOUTHERN BUILDING CODE CONGRESS INTERNATIONAL**

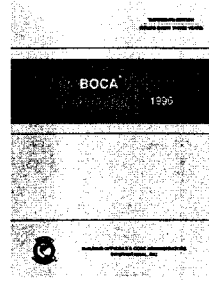

**BOCA: BUILDING OFFICIALS AND CODE ADMINISTRATORS INTERNATIONAL**

In 1988 Congress enacted the Fair Housing Amendments Act (FHAA). Although the Act's guidelines include design requirements, it is a civil rights law, not a building code. Because FHAA is federal law, state or local building authorities cannot officially interpret the Fair Housing standards, nor can local building inspectors enforce them. The 1988 Fair Housing Amendments Act was unprecedented as the first federal law to regulate private residential construction.

Two years later, in 1990, President Bush signed the Americans with Disabilities Act (ADA). This landmark legislation provided new civil rights protections for people with disabilities, and its guidelines included new federal accessibility standards. ADA addresses the design and operation of privately owned public accommodations and state and local government facilities and programs. ADA design standards are very similar to the 1986 ANSI standards. ADA did not include housing design requirements because they were addressed in the earlier Fair Housing Amendments Act.

**RELATIONSHIP BETWEEN CIVIL RIGHTS LAWS AND BUILDING CODES**

Enactment of the 1988 Fair Housing Amendments Act and 1990 Americans with Disabilities Act created a complex relationship between federal laws and the local building codes that already existed throughout the United States. Although many of the accessible design requirements in the civil rights laws and the codes are similar, there are major differences.

Building codes are specific to a legal jurisdiction, such as a state, county, township, or city. These state/local regulations are usually based on national model codes (BOCA, UBC, Southern) that a jurisdiction elects to adopt. The state and local jurisdictions typically modify the model codes and, as part of their review and enforcement process, make administrative rulings and interpretations. Over time, these modifications and interpretations make the design requirements of each municipality unique even though the underlying code is based on a national model.

Building officials use local codes to review architectural and engineering plans before they permit construction. They also perform on-site inspections to verify that the completed construction is in compliance.

Unlike municipal officials, federal agencies do not issue building permits and typically do not inspect construction. As well, the federal government does not issue rulings or interpretations for individual projects. Civil rights law enforcement is a "complaint-based process" that HUD administers for Fair Housing and the Department of Justice administers for ADA. These agencies may choose to act on a citizen complaint, or a complainant may elect to seek direct relief through federal courts. Legal decisions regarding such complaints will gradually refine unclear design and construction components of federal civil rights laws. Architects must therefore monitor federal court rulings made throughout the United States in order to ensure they are apprised of the most current design standard information.

As civil rights laws, Fair Housing and ADA include both provisions for facility design and construction and for facility operation and management. Provisions that address operation and management create new legal responsibilities that are shared between facility designers and facility operators. This arrangement changes the traditional architect-client relationship and alters the way architects must do business. For example, architects should carefully record programming decisions since the intended use of a new space often establishes its accessibility requirements. ADA requirements for an employee work space, for example, are different than those for a public space. If a facility operator later changes the use of a space, compliance becomes the owner's rather than the architect's responsibility. Another change is that architects must now evaluate an owner's project funding sources in order to determine the project's federal accessibility requirements. This precautionary step can prevent an architect's failure to comply with federal laws such as the 1973 Rehabilitation Act as a result of inaccurate funding information.

Terminology common to both civil rights law and building code standards can be confusing because the same words often have different meanings. The term *dwelling*, for example, has a much different meaning in the Fair Housing design guidelines than it does in building codes. Similarly, building use and occupancy categories such as *transient lodging* and *assembly areas* (places of assembly) are not consistent between ADA and the building codes. Because architects must deal with both types of standards, they should carefully review the definitions included in each.

Kim A. Beasley, AIA, and Thomas D. Davies, Jr., AIA; Paralyzed Veterans of America Architecture; Washington, D.C.

**ADA AND FHAA DESIGN REQUIREMENTS**

The Americans with Disabilities Act (ADA) and the Fair Housing Amendments Act (FHAA) are the two broad federal civil rights laws that address accessible design and construction of both public and private facilities. The Fair Housing Amendments Act covers multifamily housing. The Americans with Disabilities Act is applied to a wide range of public accommodations offered by private entities (Title III) and municipal facilities (Title II). Other federal laws, such as the 1973 Rehabilitation Act, may also apply to some projects. Architects should be aware that, in many aspects, federal civil rights laws are different from building codes. Therefore, receiving a building permit does not indicate that a project design complies with these federal laws.

The Americans with Disabilities Act includes design requirements for new facility construction and for additions to and alterations of existing facilities that are owned, leased, or operated by both private entities and local governments. However, design standards and management responsibilities differ between the two owner groups. Standards and responsibilities are described in the Act in Title III for private entities and in Title II for local governments. ADA Title III includes design standards and scoping for general application and also for certain specific building types, including transient lodging, medical care facilities, and libraries. Regulations issued by DOJ are contained in 28 CFR, Part 36.

Owners and operators of existing private facilities that serve the public have ADA construction responsibilities under what is called "barrier removal." Local governments also have the responsibility of making all their new and existing programs accessible. Meeting this ADA responsibility for municipal programs may sometimes require new construction or physical modifications to existing facilities. ADA also prescribes employer responsibilities for changing their policies or modifying their facilities to accommodate employees with disabilities (Title I).

Several ADA concepts determine design requirements such as "path-of-travel" components for renovation projects and the "elevator exception" for small multistory buildings. It is imperative that architects familiarize themselves with all aspects of the law as well as with the design standards.

ADA Title II requirements are based on the concept of "program accessibility," which is similar to Section 504 of the 1973 Rehabilitation Act for Federal Programs. ADA requires state and local governments to provide access to all their programs for people with disabilities. Local government program responsibility includes policies and operations as well as the built environment. In order to provide access to existing inaccessible programs, state and local governments must develop a "transition plan" that lists the necessary changes. Inaccessible programs can be addressed either by altering policies and procedures or by modifying physical structures or by a combination of both strategies.

The Fair Housing Amendments Act addresses new multifamily housing constructed either by private entities or local governments. Which housing types are covered is not completely clear because of minor scoping overlaps between ADA and FHAA and because of imprecise scoping definitions in both laws. Generally, Fair Housing covers apartments, dormitories, and other lodgings included in projects with four or more total dwelling units that are built for sale or lease. Most townhouses are not covered because they are multistory units. Existing housing structures and any remodeling, conversion, or reuse projects are not covered by FHAA. The law's design standards, drafted with an eye toward single-use apartment projects, include requirements for both individual dwelling units and common use facilities such as lobbies, corridors, and parking.

The Fair Housing guidelines allow the exclusion of certain dwelling units because of site considerations such as steep topography and floodplains. The guidelines include site practicality tests for analyzing site constraints. Several major scoping issues such as multistory dwelling units and multiple ground floor levels are discussed in the supplementary information that precedes the guidelines. Prior to project design, architects should carefully review this material as well as the guidelines themselves.

**FEDERAL LEGISLATIVE PROCESS**

To help them understand current civil rights law design requirements and monitor the publication of new standards, architects should be familiar with the federal legislative process. Information on federal design standards is available within specific Acts, in the resultant regulations, and in published guidelines. Additional information is available in the legislative history of an Act and in the numerous documents issued during the "rule-making process."

**APPLICABLE ACCESSIBILITY STANDARDS FOR SAMPLE PROJECTS**

PROJECT DESCRIPTION	FEDERAL LAWS	BUILDING CODES
Federally owned project of any type	1968 Architectural Barriers Act 1973 Rehabilitation Act Other standards as described by the agency	Building codes may or may not be applicable
Project that utilizes federal funds or is built by the recipient of federal funds (private or government)	1968 Architectural Barriers Act 1973 Rehabilitation Act, UFAS Other standards appropriate with ownership use and type	State and/or local building codes may apply
Local government-owned commercial or public facility	ADA Title II 1973 Rehabilitation Act	State and/or local building codes may apply
Local government-owned multifamily housing	ADA Title II 1973 Rehabilitation Act 1988 Fair Housing Amendments Act	State and/or local building codes may apply
Privately owned public accommodation or commercial facility	ADA Title III	State and/or local building codes may apply
Privately owned multifamily housing	1988 Fair Housing Amendments Act (public accommodation spaces must meet ADA)	State and/or local building codes may apply
Privately leased, government-owned public accommodation	ADA Title III-Tenant ADA Title II-Owner	State and/or local building codes may apply
Government-leased, privately owned public accommodation	1973 Rehabilitation Act-Tenant ADA Title II-Tenant ADA Title III-Owner	State and/or local building codes may apply
Church-operated, church-owned facility	None	State and/or local building codes may apply
Privately operated, church-owned facility	ADA Title III-Tenant None-Owner	State and/or local building codes may apply
Church-operated, privately owned facility	None-Tenant ADA Title III-Owner	State and/or local building codes may apply

**NOTE**

Temporary facilities must meet the same federal standards as similar permanent facilities.

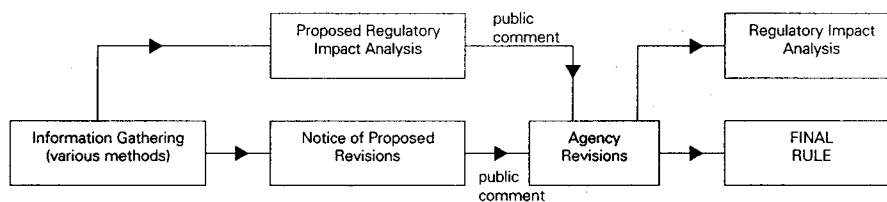

**FEDERAL RULE-MAKING PROCESS**

The administrative process for implementing federal laws requires public notice (in the *Federal Register*) and a public comment period for any proposed new regulations or guidelines. Architects should monitor this ongoing process in order to track the new standards that are periodically added to the existing accessibility guidelines. The architectural guidelines for laws like ADA are also periodically revised through the same rule-making process.

Technical Assistance Manuals (TAMs) are another design information source. Administering agencies such as the Department of Justice and HUD periodically publish these manuals in order to clarify existing guidelines or standards.

**APPLICABLE FEDERAL STANDARDS FOR SPECIFIC PROJECTS**

The first step in evaluating the accessibility requirements for a specific project is to determine what laws and regulations apply. Project accessibility requirements may be determined by the following facts:

1. What type of building or structure will be built
  2. Who owns the facility
  3. Where the construction funds originate
  4. What other federal funding the project's owner receives
  5. Who the intended users of a space or component are
- The accompanying table shows the applicable standards for many types of projects.

**GENERAL**

The flowcharts shown on this and the following AGS page address only the architectural aspects of the following federal laws that govern accessibility: the Architectural Barriers Act of 1968 (ABA), Section 504 of the Rehabilitation Act of 1973 (Section 504), the Fair Housing Amendments Act of 1988 (FHA), and Title II and Title III of the Americans with Disabilities Act (Title II ADA and Title III ADA). Other accessibility laws and standards may apply; consult your client. The charts do not address employee-generated accessibility requirements, auxiliary aids, reasonable accommodations, or human relations issues.

Many conditions apply to the decision points in the flowcharts, and occasionally the appropriate outcome may differ from what is illustrated. Consult relevant standards, regulations (e.g., GSA leasing regulations), and your client to ensure accuracy. As the chart shows, existing noncompliant features may affect your project.

Federal agencies periodically update their accessibility standards; always make sure you are working with the most current copy of any federal law. Listed here are the applicable standards as of August 1999 for the laws specified in the first paragraph above:

ABA: Uniform Federal Accessibility Standards (UFAS)

SECTION 504: UFAS (federal agencies may use amended versions)

FHA: Fair Housing Amendments Accessibility Guidelines (FHAAG)

TITLE II ADA (State and Local Governments): Americans with Disabilities Act Accessibility Guidelines (ADAAG) (without the elevator exception) or UFAS

Title III ADA (Private Entities): ADAAG

**TERMS USED IN THE CHARTS**

**ALTERATION:** Any change that affects usability. This includes remodeling, renovation, rearrangements in structural parts, and changes or rearrangement of walls and full-height partitions. Normal maintenance, re-roofing, painting, wallpapering, asbestos removal, and changes to electrical and mechanical systems are not "alterations," unless they affect usability.

**COMMERCIAL FACILITIES:** This category includes nonresidential facilities whose operations affect commerce but excludes all facilities that are covered or expressly exempted from coverage under the Fair Housing Act.

**CONTINUING OBLIGATION:** Barriers must be removed whenever it becomes readily achievable to do so until all barriers as defined by ADAAG have been removed.

**EXECUTIVE BRANCH:** The federal government has three branches, executive, judicial, and legislative. The executive branch contains most of the federal departments and facilities. The General Services Administration (GSA) manages most of the judicial branch facilities, making these facilities subject to the ABA. The Congressional Accountability Act requires the legislative branch to comply with the ADA.

**MULTIFAMILY HOUSING:** As defined by the ABA, FHA, ADA, and Section 504 of the Rehabilitation Act of 1973, multifamily housing is a "building with four or more dwelling units." Further, they state that "dwelling units within a single structure separated by fire walls do not constitute separate buildings." In other words, according to these standards townhouses are multifamily dwelling units.

**PATH OF TRAVEL:** This is a continuous route connecting an altered area to the entrance and point of arrival. It can include sidewalks, lobbies, corridors, rooms, and elevators, as well as telephones, restrooms, and drinking fountains serving the altered area.

**PLACE OF PUBLIC ACCOMMODATION:** This set of facilities has retroactive requirements. There are twelve categories:

1. Places of lodging (e.g., inns, hotels, motels, except for owner-occupied establishments renting fewer than six rooms)
2. Establishments serving food or drink (e.g., restaurants and bars)
3. Places of exhibition or entertainment (e.g., motion picture houses, theaters, concert halls, stadiums)
4. Places of public gathering (e.g., auditoriums, convention centers, lecture halls)
5. Sales or rental establishments (e.g., bakeries, grocery stores, hardware stores, shopping centers)

Continues on next page

Mark J. Mazz, AIA, P.A.; Hyattsville, Maryland

**21 INTRODUCTION**

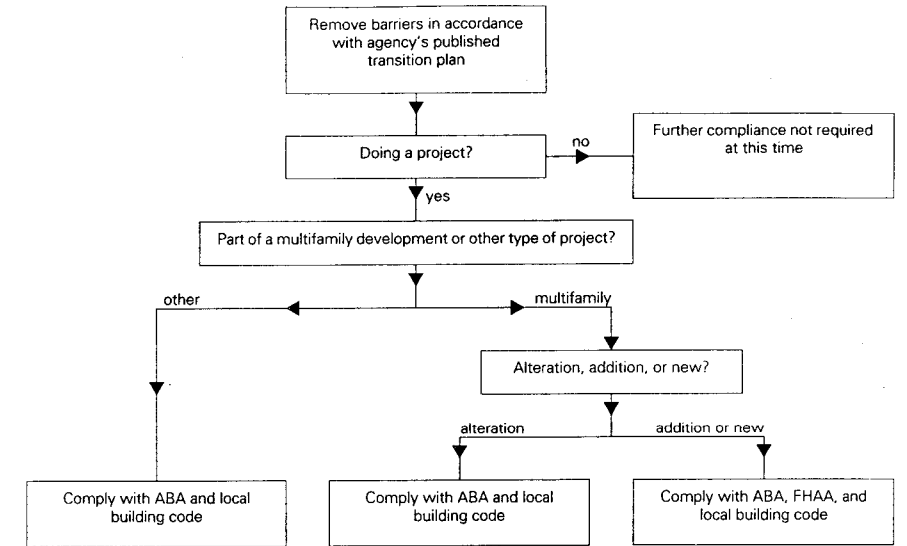

**OWNED OR LEASED BY THE EXECUTIVE BRANCH, FEDERAL GOVERNMENT**

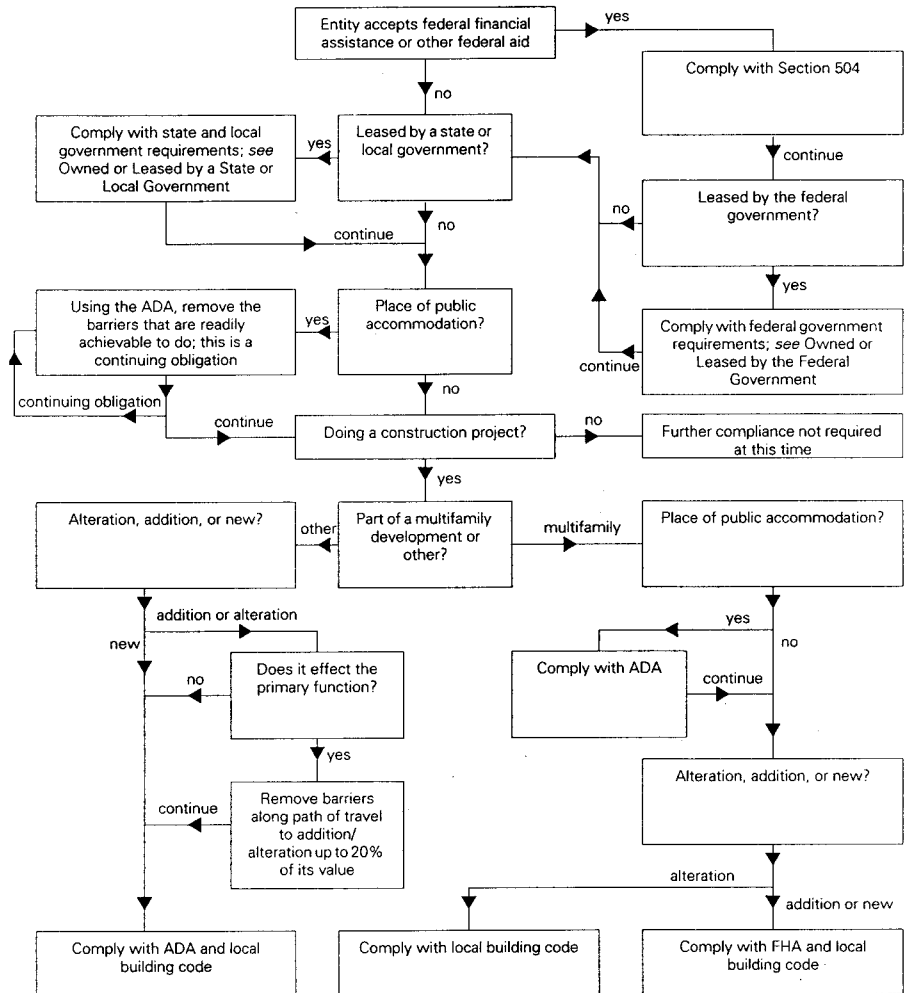

**OWNED OR LEASED BY A PRIVATE ENTITY**

Terms used in the chart (continued)

- 6. Service establishments (e.g., laundromats, dry cleaners, banks, barbershops, beauty shops, travel services, shoe repair services, funeral parlors, gas stations, accounting or law offices, pharmacies, insurance offices, professional offices of health care providers, hospitals)
- 7. Public transportation terminals, depots, or stations (not including facilities relating to air transportation)
- 8. Places of public display or collection (e.g., museums, libraries, galleries)
- 9. Places of recreation (e.g., parks, zoos, amusement parks)
- 10. Places of education (e.g., nursery schools; elementary, secondary, undergraduate, or postgraduate schools)
- 11. Social service center establishments (e.g., day care centers, senior citizen centers, homeless shelters, food banks, adoption agencies)
- 12. Places of exercise or recreation (e.g., gymnasiums, health spas, bowling alleys, golf courses)

**PRIMARY FUNCTION:** Any area in which a major activity takes place. This includes both customer service areas and work areas in places of public accommodation. It does not include mechanical rooms, boiler rooms, supply storage rooms, employee lounges or locker rooms, janitorial closets, entrances, corridors, or restrooms.

**PRIVATE CLUB:** To qualify, these organizations must meet the following criteria:

- 1. Members exercise a high degree of control over club operations.
- 2. The membership selection process is highly selective.
- 3. Substantial membership fees are charged.
- 4. The entity is operated on a nonprofit basis.
- 5. The club was not founded specifically to avoid compliance with federal civil rights laws.

**READILY ACHIEVABLE:** According to the laws, this means "easily accomplishable and able to be carried out without much difficulty or expense." The Department of Justice has 21 examples of what is readily achievable:

- 1. Installing ramps
- 2. Making curb cuts in sidewalks and entrances
- 3. Repositioning shelves
- 4. Rearranging tables, chairs, vending machines, display racks, and other furniture
- 5. Repositioning telephones
- 6. Adding raised markings on elevator control buttons
- 7. Installing flashing alarm lights
- 8. Widening doors
- 9. Installing offset hinges to widen doorways
- 10. Eliminating a turnstile or providing an alternative, accessible path
- 11. Installing accessible door hardware
- 12. Installing grab bars in toilet stalls
- 13. Rearranging toilet partitions to increase maneuvering space
- 14. Insulating lavatory pipes under sinks to prevent burns
- 15. Installing a raised toilet seat
- 16. Installing a full-length bathroom mirror
- 17. Repositioning the paper towel dispenser in a bathroom
- 18. Creating designated accessible parking spaces
- 19. Installing an accessible paper cup dispenser at an existing inaccessible water fountain
- 20. Removing high-pile, low-density carpeting
- 21. Installing vehicle hand controls

**TRANSITION PLAN:** This type of document identifies all "services, programs, and activities" offered by public entities and outlines either how each is accessible or a plan to make it accessible. Both Section 504 and Title II ADA requires covered entities to provide access to all programs in an integrated setting. Entities may view programs in their entirety when determining access.

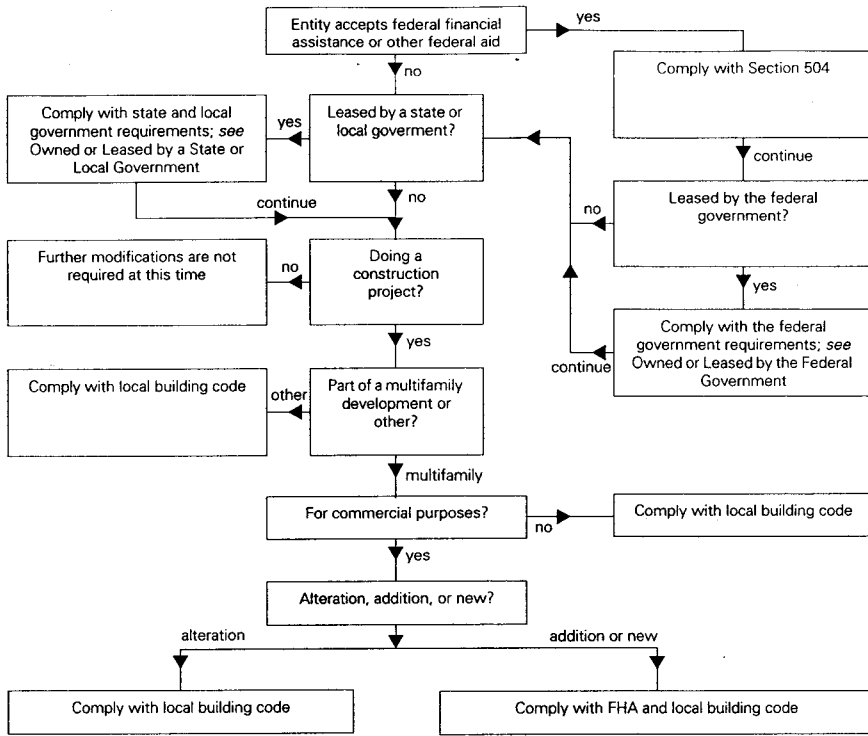

**OWNED BY A RELIGIOUS ORGANIZATION OR PRIVATE CLUB**

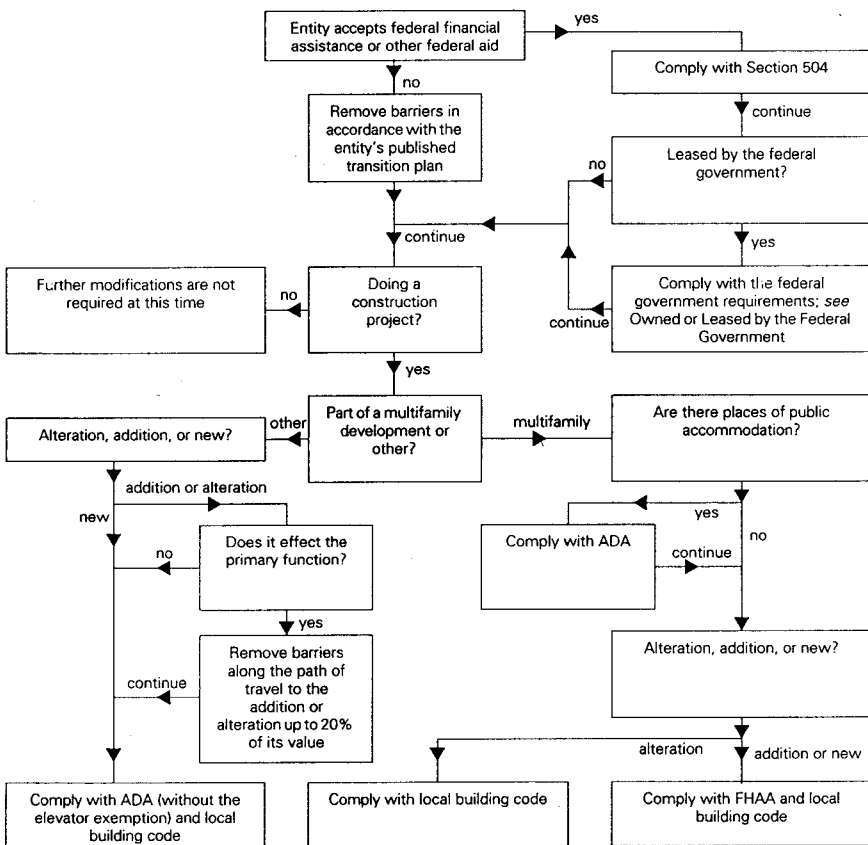

**OWNED OR LEASED BY A STATE OR LOCAL GOVERNMENT**

Mark J. Mazz, AIA, P.A.; Hyattsville, Maryland



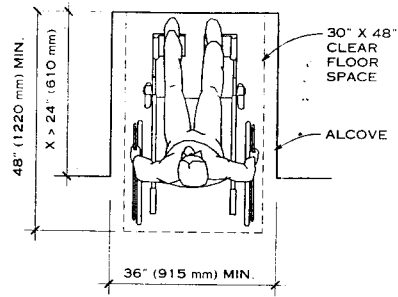

FORWARD APPROACH—ALCOVE

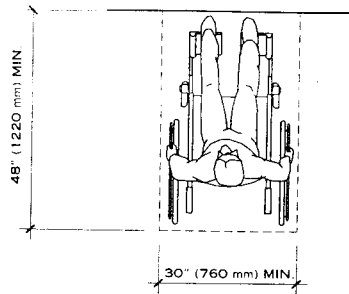

FORWARD

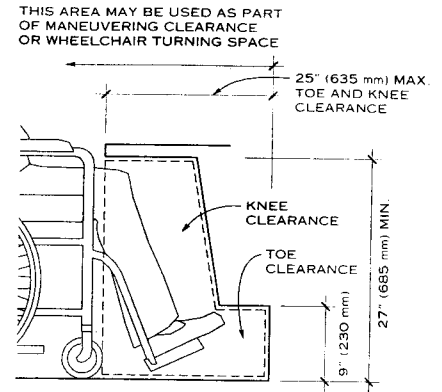

MAXIMUM CLEARANCE

**NOTE**

Additional space can be provided beneath the table, desk, or other element, but that space is not considered knee and toe clearance.

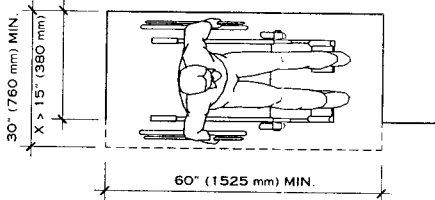

PARALLEL APPROACH—ALCOVE  
MANEUVERING CLEARANCES

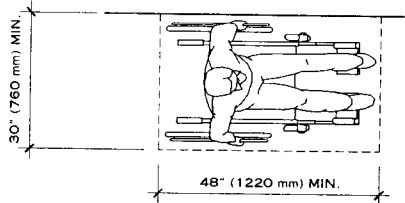

PARALLEL

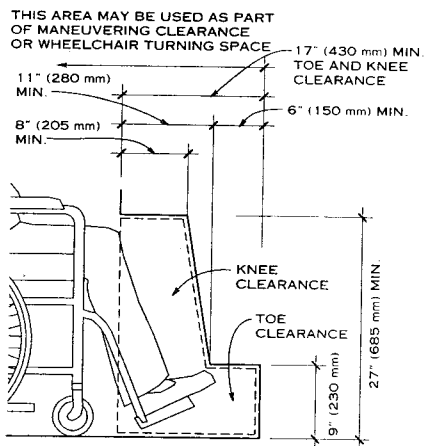

MINIMUM CLEARANCE

**NOTE**

Clearances shown are required at specific accessible elements.

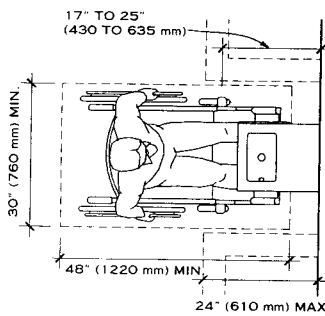
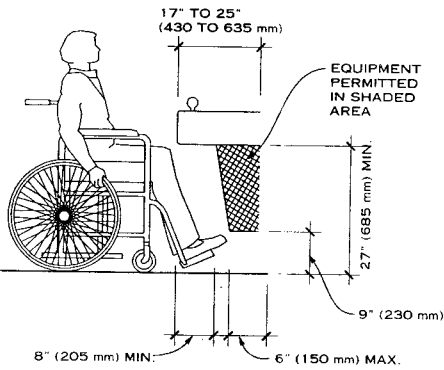

**SAMPLE MANEUVERING CLEARANCE—DRINKING FOUNTAIN**

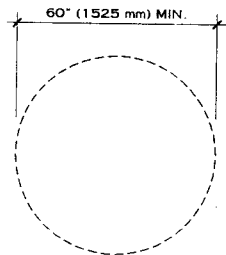

CIRCULAR

**NOTE**

Knee and toe clearance that is included as part of a T-shaped turning space should be provided only at the base of the T or on one arm of the T. In some configurations, the obstruction of part of the T-shape may make it impossible for a wheelchair user to maneuver to the desired location.

**WHEELCHAIR TURNING SPACE**

**GENERAL NOTES**

1. Knee and toe clearance must always be at least 30 in. (760 mm) wide.

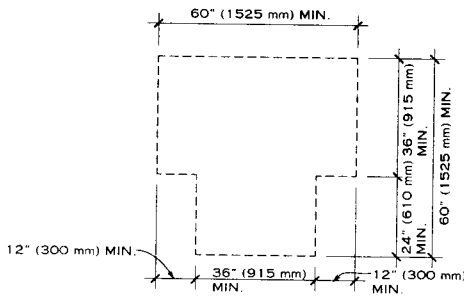

T-SHAPED

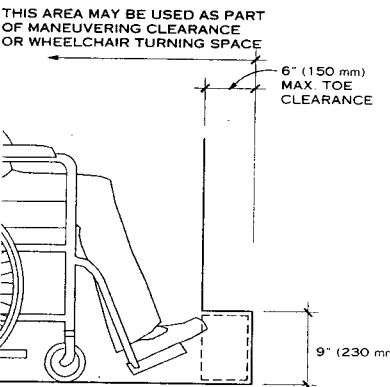

TOE CLEARANCE ONLY  
KNEE AND TOE CLEARANCES

2. Knee and toe clearance can be included as part of the wheelchair turning space and clear floor space at accessible elements. However, the extent and location of knee and toe clearance can affect the usability of the space.

Lawrence G. Perry, AIA; Silver Spring, Maryland

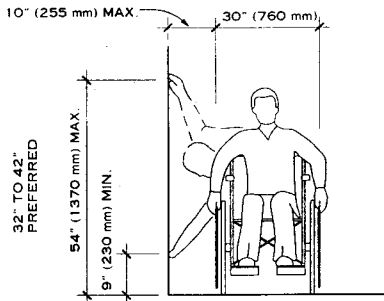

HIGH AND LOW SIDE REACH LIMITS

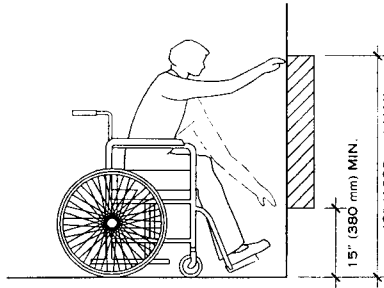

UNOBSTRUCTED FORWARD REACH

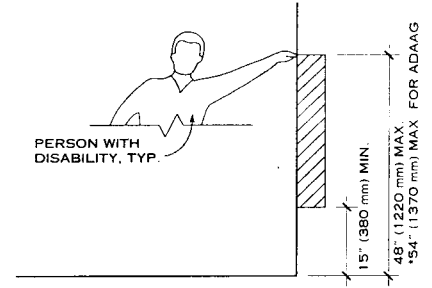

UNOBSTRUCTED SIDE REACH

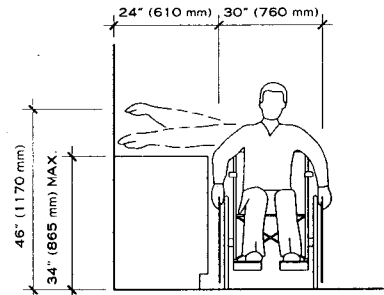

MAX. SIDE REACH OVER OBSTRUCTION

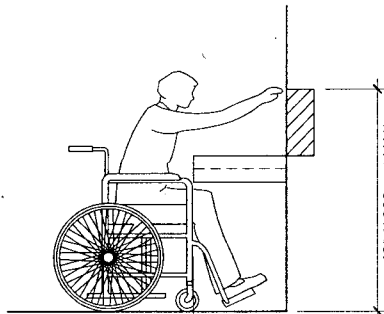

UNOBSTRUCTED FORWARD REACH WITH OBSTRUCTION

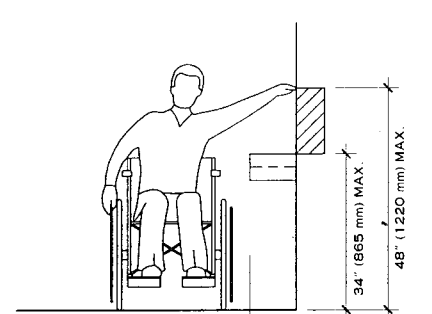

UNOBSTRUCTED SIDE REACH WITH OBSTRUCTION

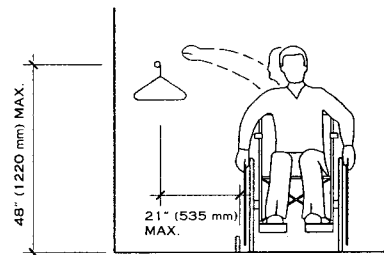

CLOSET

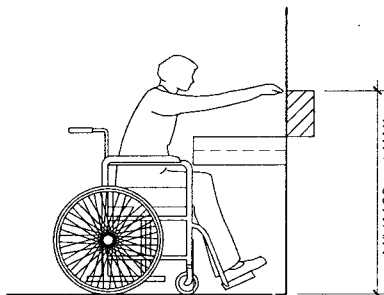

OBSTRUCTED HIGH FORWARD REACH

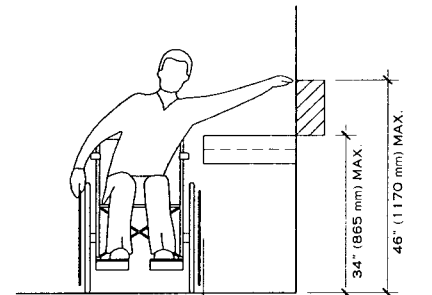

OBSTRUCTED SIDE REACH

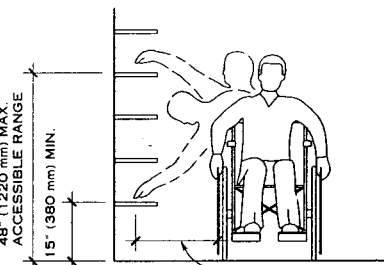

SHELVES

PARALLEL/SIDE REACH LIMITS

REACH RANGE

ANSI A117.1-1998 reduced the maximum reach range from 54 in. to 48 in. for unobstructed side reach and made the height limit the same as that for unobstructed forward reach, with the following exceptions:

- A117.1 provides exception for existing elements located 54 in. maximum above the floor or ground.
- A117.1 provides exception for elevator car controls, allowing buttons at 54 in. maximum, where the elevator serves more than 16 openings. This exception may be revisited in future editions, when the elevator industry has had an opportunity to develop alternate control configurations.

REACH RANGES

3. A117.1 does not apply the 48 in. restriction to tactile signs. Tactile signs must be installed so the tactile characters are between 48 and 60 in. above the floor. Below this height, tactile characters are difficult to read by standing persons, as the hand must be bent awkwardly or turned over (similar to reading upside down) to read the message.

FHAG requires controls and operating mechanisms in covered dwelling units to be installed at a maximum height of 48 in., with the following exceptions:

- FHAG allows inaccessible controls in covered dwelling units if "comparable" accessible controls are provided.
- Floor outlets are permitted if an adequate number of accessible wall outlets is provided.
- Electric outlets above kitchen counters can be located in corners, provided additional outlets are located within reach.

Accessible controls and operating mechanisms should be operable with one hand and not require tight grasping, pinching, or twisting of the wrist, with the following exception: FHAG does not regulate the operating force or type of operation required for controls and operating mechanisms in dwelling units.

CHILDREN'S REACH RANGES FROM A WHEELCHAIR (IN., MM)

FORWARD OR SIDE REACH	AGES 3 AND 4	AGES 5-8	AGES 9-12
High (maximum)	36 (915)	40 (1015)	44 (1120)
Low (minimum)	20 (510)	18 (455)	16 (405)

SPECIFICATIONS FOR WATER CLOSETS SERVING CHILDREN (IN., MM)

DIMENSION	PRE-K, K (AGES 3 AND 4)	1ST-3RD (AGES 5-8)	4TH-7TH (AGES 9-12)
Water closet centerline	12 (305)	12-15 (305-380)	15-18 (380-455)
Toilet seat height	11-12 (280-305)	12-15 (305-380)	15-17 (380-430)
Grab bar height	18-20 (455-510)	20-25 (510-635)	25-27 (635-685)
Dispenser height	14 (355)	14-17 (355-430)	17-19 (430-485)

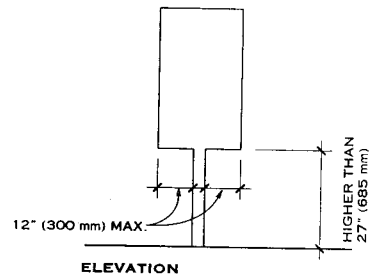
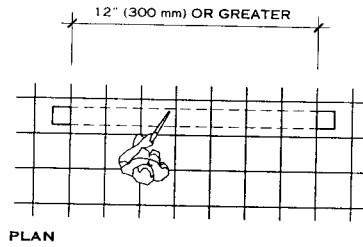
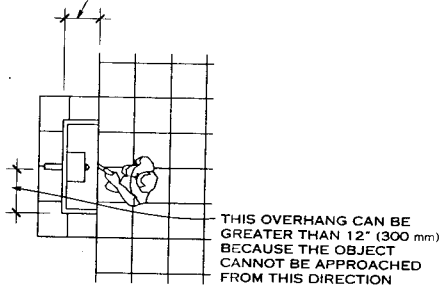
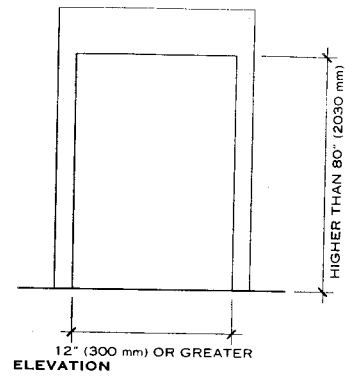
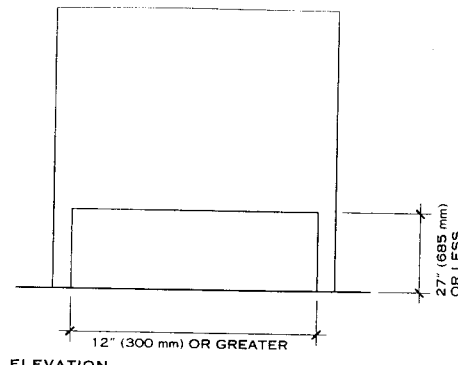
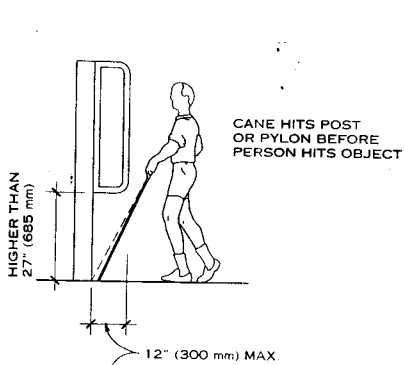

OBJECTS MOUNTED ON POSTS OR PYLONS

POSTMOUNTED PROTRUDING OBJECTS

**FREESTANDING OBJECTS**

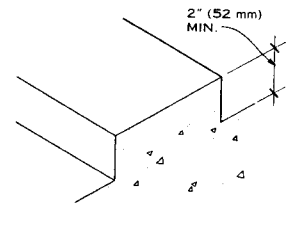
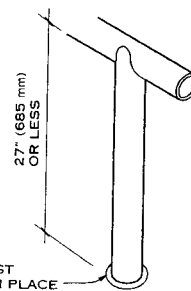
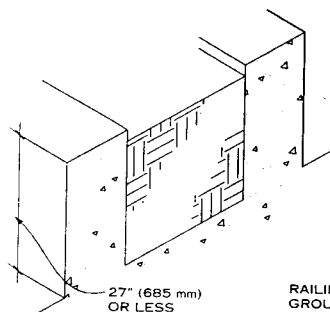
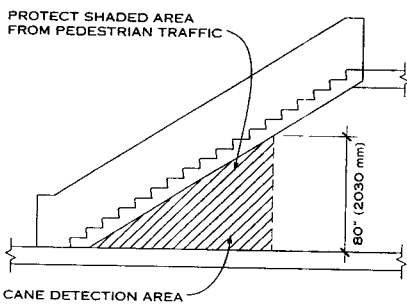

PLANTER NOTES

RAILING

CURB

1. Protection from overhead hazards can be provided by permanent, built-in elements or by movable elements such as furniture and potted plants.
2. Thoughtful, informed design can reduce or eliminate most overhead hazards (e.g., low headroom hazards can be avoided by enclosing areas under stairs and escalators).

**OVERHEAD HAZARDS—EXAMPLE**

**OVERHEAD HAZARD PROTECTION—EXAMPLES**

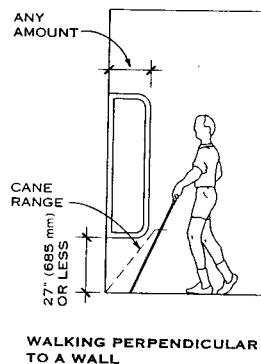
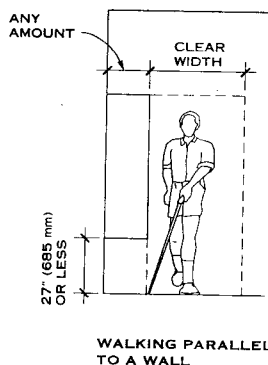
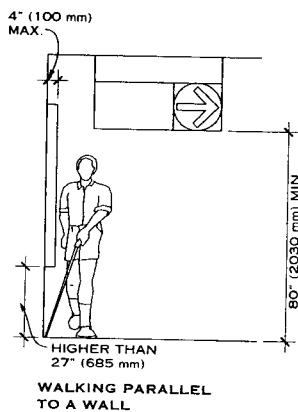

**NOTES**

1. Wall sconces, fire alarm appliances, environmental controls, door hardware, signs, and suspended lighting fixtures are examples of protruding objects.
2. Some standards specify the extent to which doorstops and door closers may protrude into the 80 in. (2030 mm) vertical clearance, generally allowing a 2 in. maximum projection.
3. Protruding objects are not permitted to reduce the required width of an accessible route (36 in., except 32 in. width permitted for a 24 in. length).

**DIMENSIONS OF PROTRUDING OBJECTS**

Lawrence G. Perry, AIA; Silver Spring, Maryland

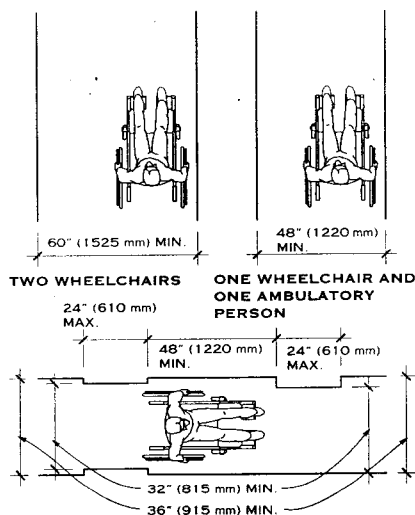

**SINGLE WHEELCHAIR CLEAR WIDTH OF AN ACCESSIBLE ROUTE**

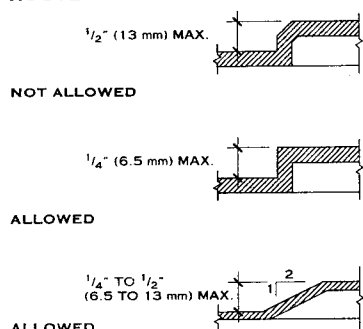

- NOTES**
- Changes in level greater than 1/2 in. (13 mm) must be ramped.
  - Some standards prohibit changes in level in clear floor space, maneuvering clearances, wheelchair turning space, and access aisles.

**CHANGES IN LEVEL**

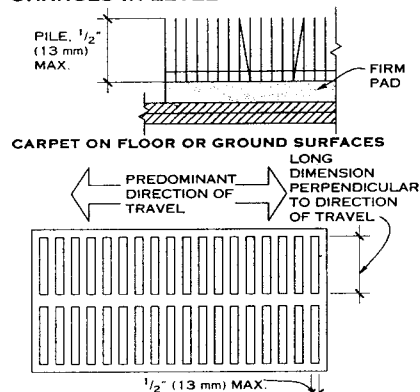

**OPENING IN FLOOR OR GROUND SURFACES NOTES**

- All surfaces must be firm, stable, and slip resistant
- Other openings, such as in wood decking or ornamental gratings, shall be designed so that a 1/2 in. (13 mm) diameter sphere cannot pass through the opening. The potential for wood shrinkage should be considered.

**FLOOR AND GROUND SURFACES**

Lawrence G. Perry, AIA; Silver Spring, Maryland

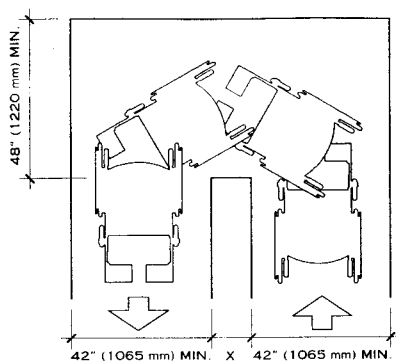

**NOTE**  
Dimensions shown apply when x is less than 48 in. (1220 mm).

**U-TURN AROUND AN OBSTRUCTION**

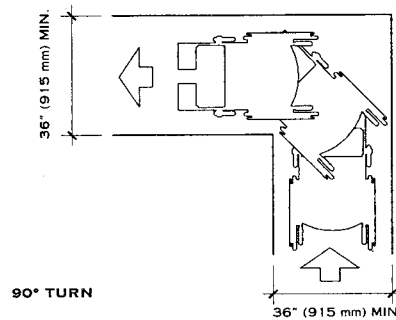

**90° TURN**

**TURNS**

**REQUIREMENTS FOR ACCESSIBLE ROUTES**

Accessible routes are generally required as follows:

**SITE ARRIVAL POINTS:** From each type of site arrival point (public transportation stops, accessible parking spaces, passenger loading zones, and public streets or sidewalks) to an accessible entrance.

Consult the applicable regulation to determine the required number of accessible entrances. Building codes generally require that at least 50% of the entrances, but no less than one, be accessible. Under the Fair Housing Accessibility Guidelines (FHAG), site conditions may allow some buildings to be exempt from this requirement.

**WITHIN A SITE:** Between accessible buildings, facilities, elements, and spaces on the site.

**Intent:** The intent of this requirement is not to require accessible routes where no "connection" is otherwise intended between buildings or facilities, but to ensure that, where a connection is intended, an accessible connection is also provided.

**FHAG vehicular route exception:** FHAG allows a vehicular route to be provided in lieu of an accessible route between covered dwelling units and public and common use site facilities where the slope of the site or other restrictions prevents the use of an accessible route. Accessible parking spaces are required at the covered dwelling units and at the facilities served only by the vehicular route.

**Building code vehicular route exception:** Recent model building codes also allow the use of a vehicular route in lieu of an accessible route, where the only means of access between two accessible facilities is "a vehicular way, not intended for pedestrian access." This exception is not limited to slope or other site restrictions.

**MULTILEVEL BUILDINGS AND FACILITIES:** Between all levels, including mezzanines, in multistory buildings, unless exempted.

**ADA elevator exception:** Buildings with only two floors are exempt from providing an accessible route to the upper or lower level. Buildings with less than 3000 sq ft per floor, regardless of height, are exempt from providing an accessible route to upper or lower floor levels. Neither exception applies to shopping centers, offices of professional health care providers, public transportation terminals, or state and local government facilities.

**Building code elevator exception:** Model building codes generally exempt a maximum aggregate area of 3000 sq ft, regardless of the number of levels. Similar to the ADA restrictions, this exception cannot be used in offices of health care providers, passenger transportation facilities, or mercantile occupancies with multiple tenants. Consult the applicable local code.

**FHAG elevator requirements:** For buildings containing dwelling units, and not public or common use spaces, FHAG does not require accessible routes to all levels. Instead, the existence or lack of an elevator determines the extent of units covered (and the floors required to be served by an accessible route). When elevators are provided, they generally must serve all floors; an exception is provided for elevators serving only as a means of access from a garage to a single floor. When elevators are not provided, only the "ground floor" units are subject to the FHAG requirements. In mixed-use construction, an accessible route is required to the first level containing dwelling units, regardless of its location. Consult FHAG for specific requirements.

**Levels not containing accessible elements or spaces:** For facilities in which only a percentage of the spaces provided are required to be accessible (assembly, residential, institutional, and storage), the model codes do not require an accessible route to serve levels not containing required accessible spaces. For example, an apartment building or a motel would not require an accessible route to upper floors if all required accessible units or rooms were located on the accessible level. Separate requirements for dispersion of accessible elements and spaces may still require multiple accessible levels. Consult the applicable local code.

**ACCESSIBLE SPACES AND ELEMENTS:** To all spaces and elements that are required to be accessible.

**Toilet rooms and bathrooms:** ADA generally requires that all toilet and bathing rooms be accessible. This does not trigger a requirement for accessible routes if the floor level is not otherwise required to have an accessible route.

**Alterations:** ADA and the model building codes generally do not require that altered elements trigger a requirement for accessible routes to the elements, unless covered under specific "primary function" requirements. In alterations involving "primary function" areas, the accessible route obligation is triggered but is subject to specific limitations. Consult ADA and the applicable local code.

**COMPONENTS OF ACCESSIBLE ROUTES**

Accessible routes are permitted to include the following elements: (1) walking surfaces with a slope of less than 1:20, (2) curb ramps, (3) ramps, (4) elevators, and (5) platform (wheelchair) lifts. (The use of lifts in new construction is limited to locations where they are specifically permitted by the applicable regulations. Lifts are generally permitted to be used as part of an accessible route in alterations.)

Each component has specific technical criteria that must be applied for use as part of an accessible route. Consult the applicable code or regulation.

**LOCATION OF ACCESSIBLE ROUTES**

**Interior routes:** Where an accessible route is required between floor levels, and the general circulation path between levels is an interior route, the accessible route should also be an interior route.

**Relation to circulation paths:** Accessible routes should "coincide with, or be located in the same area as a general circulation path." Avoid making the accessible route a "second class" means of circulation. Consult the applicable regulations for additional specific requirements regarding location of accessible routes.

**Directional signs:** Where the accessible route departs from the general circulation path, and is not easily identified, directional signs should be provided as necessary to indicate the accessible route. The signs should be located so that a person does not need to "backtrack."

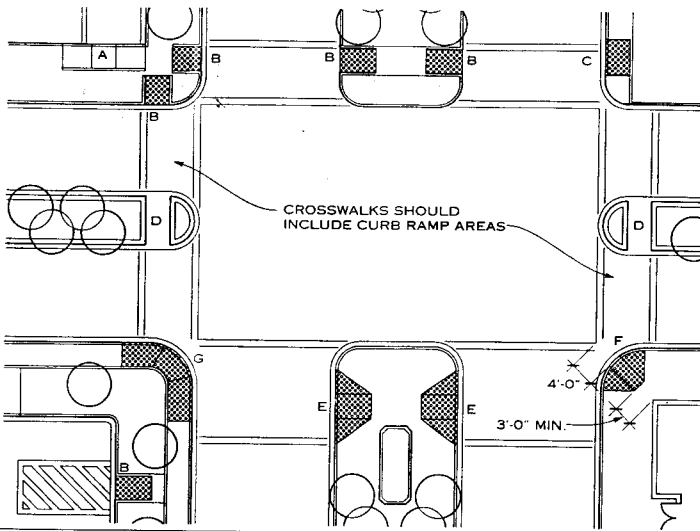

ACCESSIBLE CURB RAMP PLAN

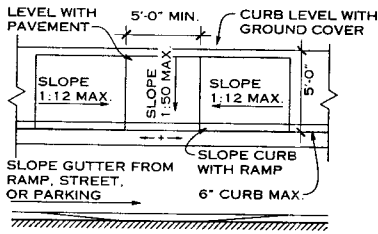

TYPE A

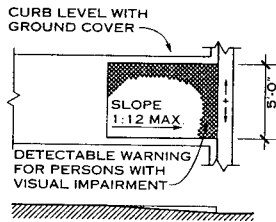

TYPE B

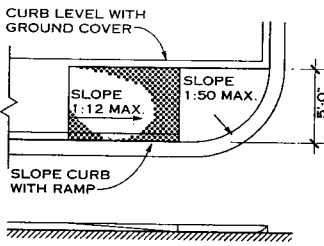

TYPE C

CURB RAMP TYPES

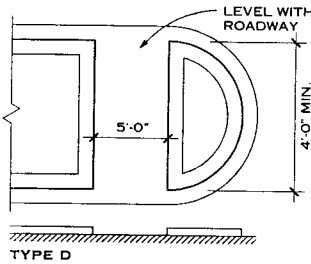

TYPE D

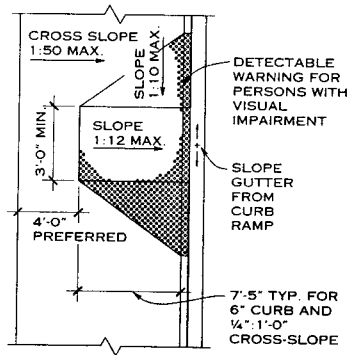

TYPE E

DESIGN CONSIDERATIONS

1. Design storm drain systems to shed water away from curb ramps.
2. The dimensions shown are for new construction. For alterations when these dimensions are impractical, review the Americans with Disabilities Act Accessibility Guidelines (ADAAG) for less strict dimensions.
3. The ADAAG requirement for detectable warnings was suspended by the Architectural and Transportation Barriers Compliance Board, pending revision of the detectable warning detail. FHA and many states continue to require detectable warnings at locations shown on this page but the details specified vary.

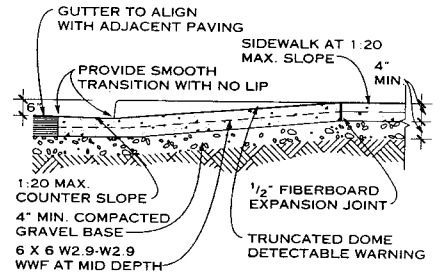

CURB RAMP SECTION

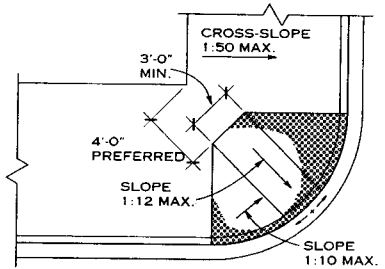

NOTE

If the 4 ft 0 in. minimum dimension cannot be met for type F, the 1:10 slope becomes 1:12 maximum.

TYPE F

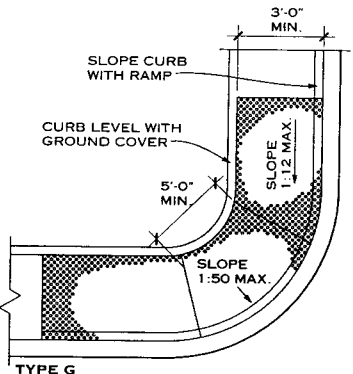

TYPE G

NOTE

If passenger loading zones are provided, at least one must be accessible, with a 5 ft wide x 20 ft long access aisle. The surface slopes of the vehicle standing space and the access aisle must not exceed 1:50 (2%). The path of travel to and from a vehicle standing stall must have a minimum vehicular clearance of 9 ft 6 in. If there are curbs between the vehicle standing space and the access aisle, a curb ramp must be provided.

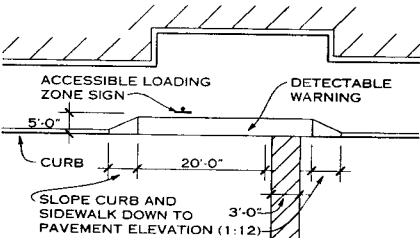

TYPE 1

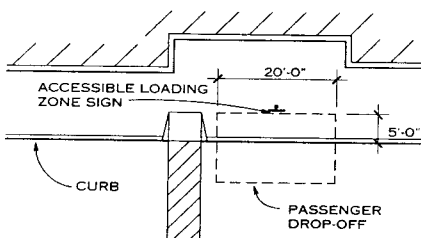

TYPE 2

ACCESSIBLE PASSENGER LOADING ZONE

Mary S. Smith, P.E.; Walker Parking Consultants/Engineers, Inc.; Indianapolis, Indiana  
 Mark J. Mazz, AIA, P.A.; Hyattsville, Maryland

**GENERAL**

The information on this page conforms to the Americans with Disabilities Act Accessibility Guidelines for Buildings and Facilities (36 CFR 1191, July 26, 1991), also known as ADAAG, and Bulletin No. 6: Parking (February 1994), both issued by the Architectural and Transportation Barriers Compliance Board. State and local requirements may differ, but ADA requires that designs conform to the higher requirement.

**NOTES**

1. Accessible parking stalls should be 8 ft wide with an adjacent 5-ft access aisle. No special clearance is required for these stalls.
2. Van-accessible stalls should be 8 ft wide with an adjacent 8-ft access aisle accessible from the passenger side of the vehicle. (Backing into 90° stalls from a two-way aisle is an acceptable method of achieving this.) Vehicular clearance along the path of travel to and from a van-accessible stall should be 8 ft 2 in. In parking structures, van-accessible stalls may be grouped on a single level.
3. It is permissible for all required accessible stalls to conform with Universal Parking Design Guidelines. Since vans may use any accessible stall in this arrangement, universal stalls must have 8 ft 2 in. vehicle clearance.
4. Access aisles should be delineated separately from parking spaces. Access aisles must be at the same level as parking stalls (not above, at sidewalk height). Required curb ramps cannot be located in access aisles. Two spaces may share a single access aisle (except when van stalls require passenger-side access in one-way designs).
5. Parking spaces and access aisles should be level with surface slopes not exceeding 1:50 (2%) in any direction.
6. The stalls required for a specific facility may be relocated to another location if equivalent or greater accessibility in terms of distance, cost, and convenience is ensured.
7. Accessible stalls in the numbers shown in the accompanying table must be included in parking facilities leased or 100% reserved for employees. However, they need not be reserved for accessible parking (i.e., they need not be marked with signs) until or unless an employee with a disability needs the stall in that location.
8. Provide an accessible route from accessible parking stalls to the destination. This should make it possible for persons in wheelchairs to travel without rolling down parking aisles past more than one parked vehicle (other than their own). Crossing a parking aisle at 90° is preferable to rolling down a parking aisle.
9. Provide signs at accessible stalls to reserve the spaces for individuals with disabilities; pavement markings alone are not acceptable. Signs need not be provided for every accessible stall if they clearly delineate the accessible parking spaces.
10. Requirements are per lot, not by total facility parking.

**REQUIRED MINIMUM NUMBER OF ACCESSIBLE PARKING SPACES**

TOTAL PARKING IN LOT	VANS	CARS	TOTAL
1-25	1	0	1
26-50	1	1	2
51-75	1	2	3
76-100	1	3	4
101-150	1	4	5
151-200	1	5	6
201-300	1	6	7
301-400	1	7	8
401-500	2	7	9
501-800	2	2% min., less 2	2% min.
801-1000	3	2% min., less 2	2% min.
1001-1400	3	17+1 for each 100 over 1000	20+1 for each 100 over 1000
1401 and more	12.5% of total	17+1 for each 100 over 1000	20+1 for each 100 over 1000

**NOTES**

1. At facilities providing outpatient medical care and other services, 10% of the parking spaces serving visitors and patients must be accessible.
2. At facilities specializing in treatment or services for persons with mobility impairments, 20% of the spaces provided for visitors and patients must be accessible.

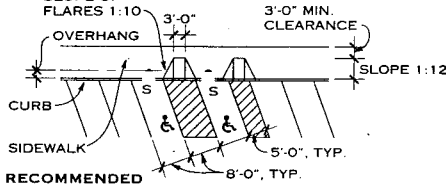
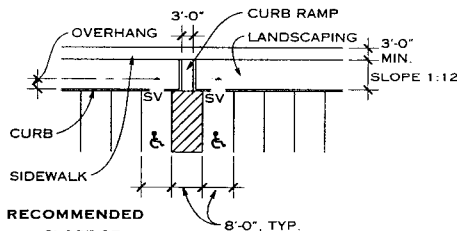
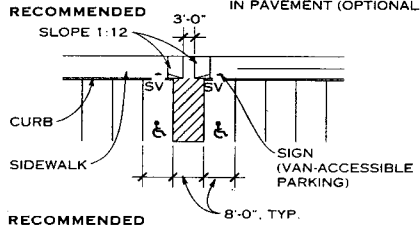
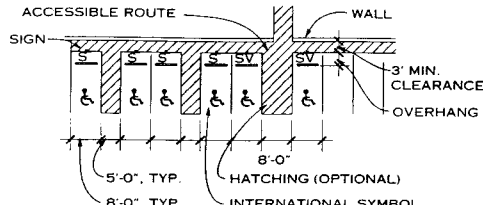

**NOTE**  
S—accessible parking sign; SV—van-accessible parking sign.

**ACCESSIBLE PARKING LAYOUTS**

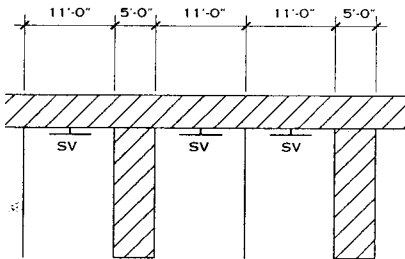

**NOTE**  
SV—van-accessible parking sign. (All universal spaces are van-accessible.)

**UNIVERSAL PARKING DESIGN**

3. The information in this table does not apply to valet parking facilities, but such facilities must have an accessible loading zone. One or more self-park van-accessible stalls are recommended for patrons with specially equipped driving controls.
4. Fair Housing requirements match the ADAAG requirements, except as noted below:
  - a. Van-accessible stalls are not required.
  - b. Two percent of total parking must comply.

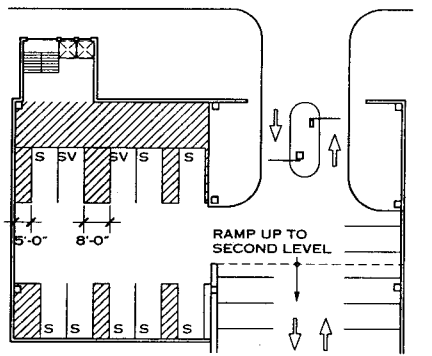
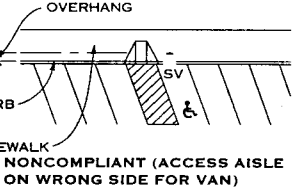
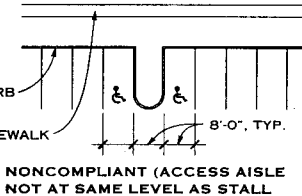
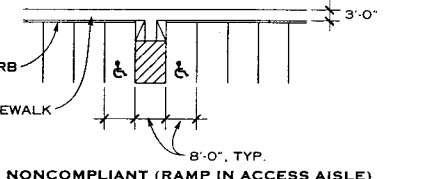
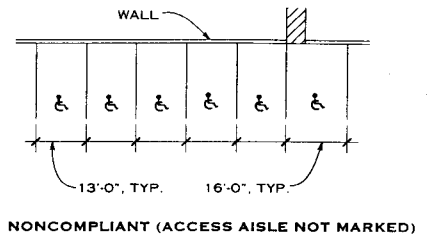

**ACCESSIBLE PARKING IN DEDICATED BAY**

- c. Parking stall may be sloped. Maximum slope of access aisle is 5% with a maximum cross-slope of 2%. Preferred maximum slope and cross-slope of stall and aisle is 2%.
- d. There are no requirements for employee-only stalls.
- e. When sidewalks are not provided, ensure that there is an accessible route through the driveways or provide additional compliant parking at each accessible feature on the property.

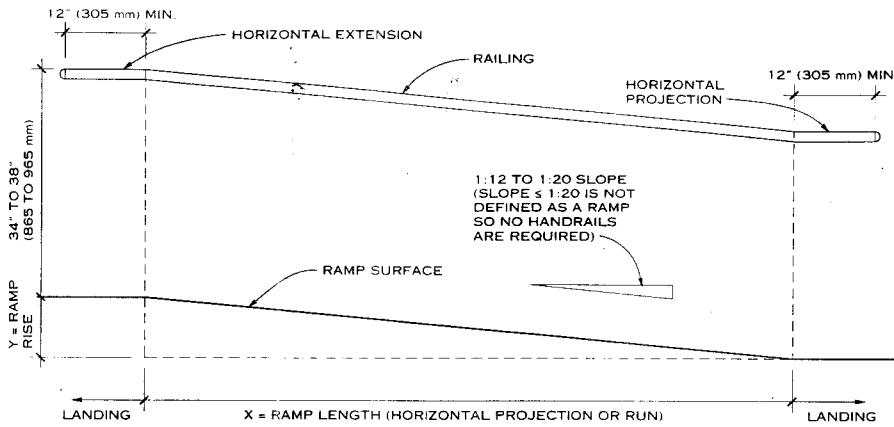

**NOTE**  
Slope = Y:X, where X is a level plane.

**COMPONENTS OF A RAMP**

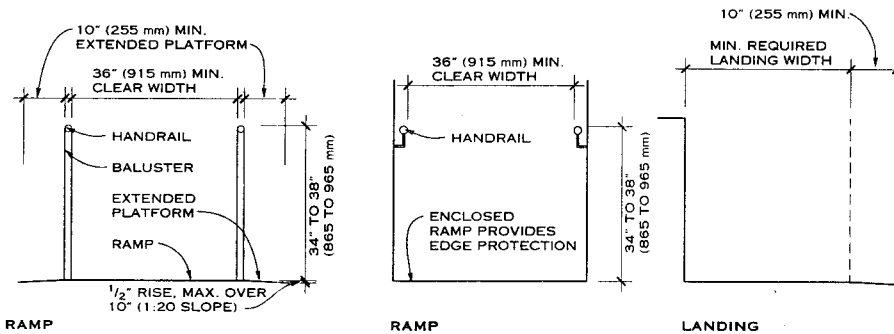

**RAMP NOTES**

1. Accessible ramps must have running slopes of 1:12 or less; surfaces with a running slope greater than 1:20 are considered ramps. All design parameters shown on this page are based on ANSI A117.1-1998.
2. Design outdoor ramps and approaches so water will not accumulate on surface. Maximum cross slope is 1:48.
3. Landings should be level at top and bottom of ramp run

and at least as wide as the run leading to it. A 60 x 60 in. landing is required where ramp changes direction. Provide level maneuvering clearances if there is a door at the landing.

4. Handrails are required on both sides when rise is greater than 6 in.
5. Edge protection is required at ramps and landings that drop off. Refer to local building codes for guardrail requirements.

**RAMP AND LANDINGS—SECTIONS**

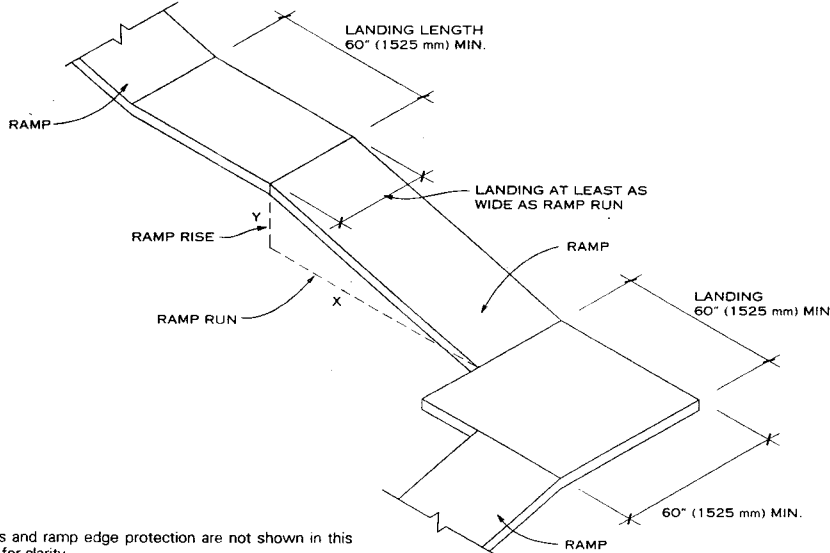

**NOTE**  
Handrails and ramp edge protection are not shown in this drawing for clarity.

**RAMP LANDINGS**

Lawrence G. Perry, AIA; Silver Spring, Maryland

**21 RAMPS**

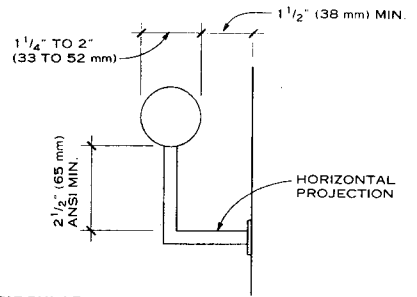

**CIRCULAR**

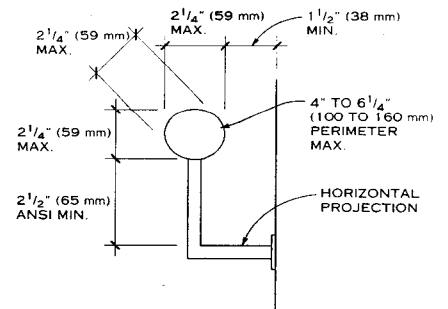

**NONCIRCULAR**

**NOTES**

1. Dimensions are based on 1998 ANSI A117.1
2. Provide continuous handrails at both sides of ramps and stairs and at the inside handrail of switchback or dogleg ramps and stairs.
3. If handrails are not continuous at bottom, top, or landings, provide handrail extensions as shown in the ramp and stair example; ends of handrails to be rounded or returned smoothly to floor, wall, or post.
4. Provide handrails of size and configuration shown and gripping surfaces uninterrupted by newel posts or other construction elements; handrails shall not rotate within their fittings.

**HANDRAIL DESIGN**

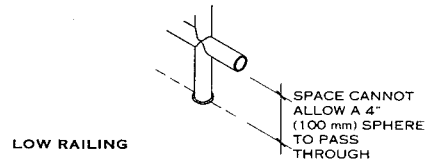

**LOW RAILING**

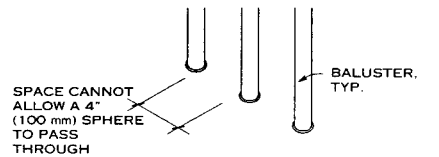

**RAILING WITH BALUSTERS**

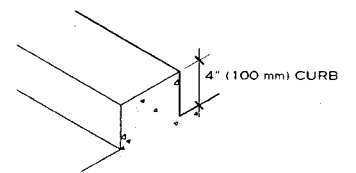

**CURB**

**NOTE**

Ramp and ramp landing edge protection can be any configuration that will prevent the passage of a 4 in. (100 mm) sphere, where any portion of the sphere is within 4 in. (100 mm) of the ramp or landing surface.

**RAMP AND RAMP LANDING EDGE PROTECTION DETAILS**

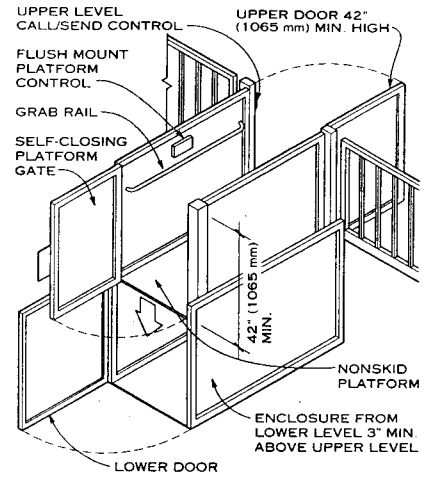
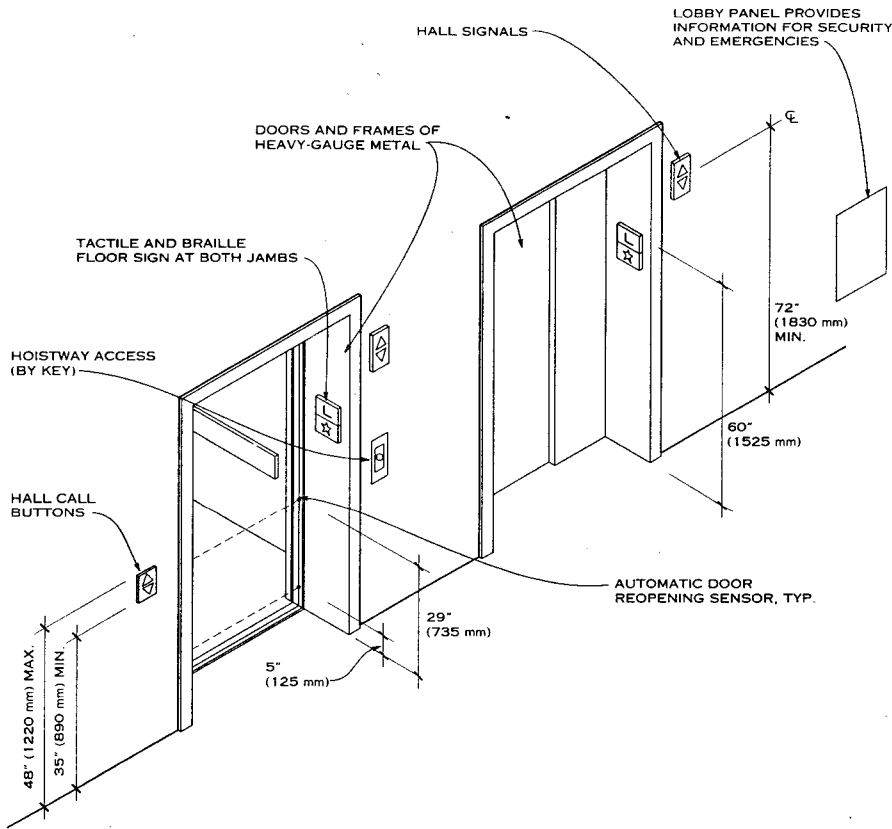

TYPICAL VERTICAL WHEELCHAIR LIFT

**PLATFORM (WHEELCHAIR) LIFTS**

Wheelchair (platform) lifts are generally permitted to be used as part of an accessible route in new construction only to reach performing areas in assembly occupancies; wheelchair spaces in assembly occupancies; spaces not open to the public with an occupant load of no more than 5; and spaces within a dwelling unit. In some regulations, wheelchair lifts are permitted where site constraints prevent the use of ramps or elevators.

When lifts are used in new construction, accessible means of egress may be required from the spaces served by the lifts. Lifts are not permitted to be used as part of an accessible means of egress; therefore, in nonsprinklered buildings horizontal exits or areas of refuge may be required in spaces served by lifts.

Wheelchair (platform) lifts are generally permitted as part of an accessible route in alterations to existing buildings.

Wheelchair (platform) lifts that are part of an accessible route are required to comply with ASME/ANSI A17.1 and must provide a wheelchair-sized clear floor space, level floor surfaces, and accessible operable parts. Lifts are not permitted to be attendant-operated and must allow for unassisted entry and exit.

A117.1-1998 allows manual doors or gates on lifts with doors or gates on opposite sides (a roll-through configuration). Other lifts must have low-energy, power-operated doors or gates that remain open for at least 20 seconds. Doors/gates located on the ends of lifts must provide 32 in. (815 mm) clear width; doors/gates located on the side of a lift must provide 42 in. (1065 mm) clear width.

A new ASME/ANSI standard, A18, Platform Lift and Stair Chair Lift Safety Standard, replaces the portions of A17.1 that address lifts.

**ELEVATOR LOBBY ELEVATORS**

Elevator doors must open and close automatically and have a reopening device that will stop and reopen the car and hoistway door if the door is obstructed. Although the device cannot require contact to activate, contact can occur before the door reverses direction. The device must remain effective for at least 20 seconds.

Tactile designations at each jamb of hoistway doors should be 2 in. (50 mm) high, centered at 60 in. (1525 mm) above the floor. Include a five-pointed star at the main entry level.

Hall call buttons should be raised or flush, 35–48 in. (890–1220 mm) above the floor, with the “up” button located above the “down” button.

Audible hall signals should sound once for cars traveling in the up direction and twice for cars traveling down. Check the applicable regulations for required decibel level and frequency of audible signals. In-car signals are permitted in lieu of hall signals, as long as they meet all the requirements for visibility and timing.

**DESTINATION-ORIENTED ELEVATOR SYSTEMS**

Destination-oriented elevator systems assign passengers to specific cars by requiring them to enter their destination floor at a keypad or by other means, such as use of a coded identification card. A117.1-1998 provides detailed accessibility criteria for this type of elevator system.

Destination-oriented elevator systems must provide both an audible signal/announcement and a visible signal to indicate the car assigned. Therefore, the elevators in the bank must be audibly and visibly differentiated and the signals/announcements provided at the point of input must be the same as those provided at the car upon arrival.

A visible display is required in the car to identify the registered destinations for each trip, and an automatic verbal announcement is required to announce the floor as the car stops. Tactile signs at hoistway jambs are required to identify not only the floor level but also each car.

A117.1-1998 allows use of a telephone-style keypad in lieu of buttons for each floor. Keypads used for destination floor input must have a telephone keypad arrangement, with a tactile dot on the “5” key. Each key must be raised or flush and at least 3/4 in. (19 mm) in its smallest dimension.

**ELEVATOR EMERGENCY COMMUNICATIONS**

Elevator cars must provide an emergency two-way communication system between the car and a point outside the hoistway. Controls must be located within accessible reach ranges. When the system includes a handset, the cord must be at least 29 in. (735 mm) long. The system must provide both audible and visible signals; it cannot be limited to voice communication.

**ELEVATOR CAR POSITION INDICATORS**

Within elevator cars, audible and visible signals are required to identify the location of the car. Visible signals at least 1/2 in. (13 mm) high must be provided for each floor the car serves; these signals must illuminate to indicate the floors at which the car stops or passes.

Audible signals for new elevators must be automatic verbal announcements that indicate the floor at each stop. Exceptions allow the use of audible signals for some low-rise hydraulic elevators.

**ELEVATOR CAR CONTROL PANELS**

A117.1-1998 requires all elevator car controls to be 35 in. (890 mm) minimum and 48 in. (1220 mm) maximum above the floor. An exception is provided for elevator cars serving 16 or more openings, for which controls as high as 54 in. (1370 mm) are allowed. Other standards generally allow controls up to 54 in. (1370 mm) when a side reach is possible.

Buttons must be at least 3/4 in. (19 mm) in diameter and can be raised or flush. Existing recessed buttons are generally permitted to remain. Buttons for floor designations should be located in ascending order. Visual characters, tactile characters, and Braille are required to identify buttons. Tactile characters and Braille should be to the immediate left of each button.

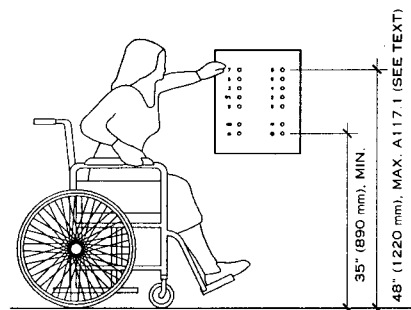

CONTROL PANEL HEIGHT

Lawrence G. Perry, AIA, Silver Spring, Maryland



**GENERAL**

ANSI A17.1, Elevator Safety Standard, covers general elevator safety and operational requirements. It has been adopted in virtually all jurisdictions. All sizes shown on this page are based on A117.1-1998, which contains extensive accessibility provisions for passenger elevators, destination-oriented elevator systems, limited use/limited application elevators, and private residence elevators. Consult the applicable accessibility regulations for elevator exceptions. Model codes, the Fair Housing Act, the Americans with Disabilities Act, and the Architectural Barriers Act each has a different threshold for requirement of elevators.

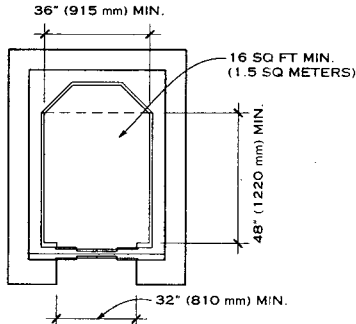

**EXISTING CAR CONFIGURATION NOTES**

1. A  $\frac{5}{8}$ -in. (16 mm) tolerance is permitted at 36 in. (915 mm) elevator doors, allowing the use of industry-standard 900 mm clear-width doors.
2. Any other car configuration that provides a 36-in. door and either a 60-in. (1525 mm) diameter or T-shaped wheelchair turning space within the car, with the door in the closed position, is permitted.
3. Inside car dimensions are intended to allow an individual in a wheelchair to enter the car in a forward direction, turn around within the car with the door closed, and exit in a forward direction. A smaller car size is permitted for existing car configurations, requiring a person in a wheelchair to either enter or exit by maneuvering backwards.

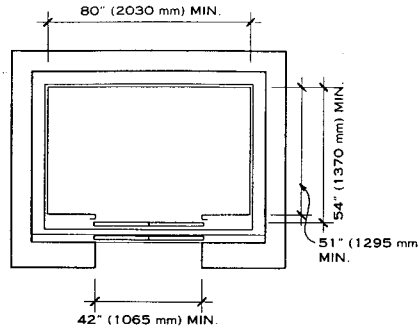

**CENTERED DOOR LOCATION**

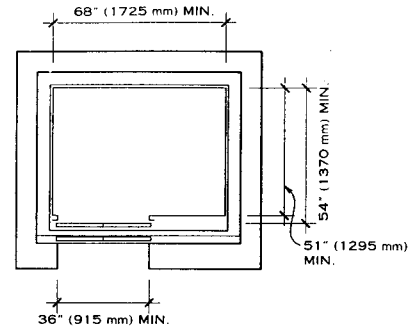

**OFF-CENTERED DOOR LOCATION**

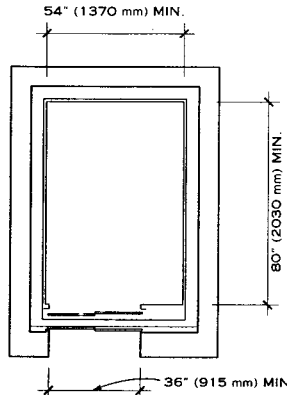

**ANY DOOR LOCATION**

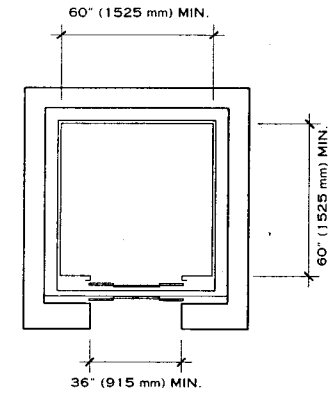

**ANY DOOR LOCATION**

**INSIDE DIMENSIONS OF ACCESSIBLE ELEVATOR CARS**

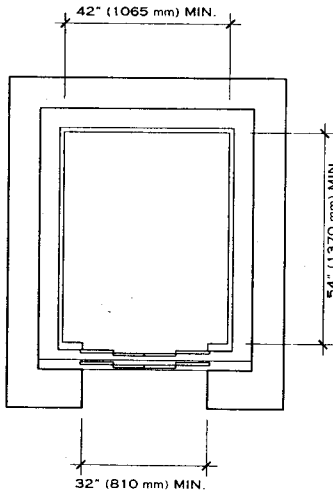

**NEW**

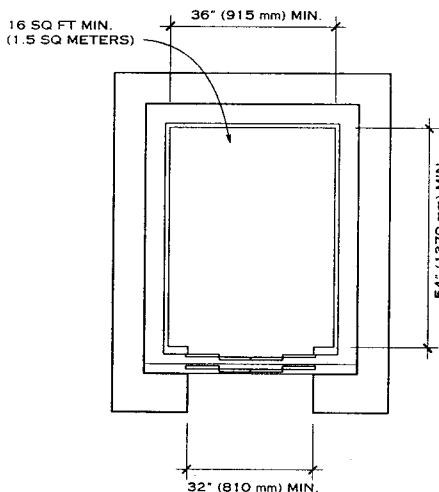

**EXISTING LIMITED USE/LIMITED APPLICATION (LULA)**

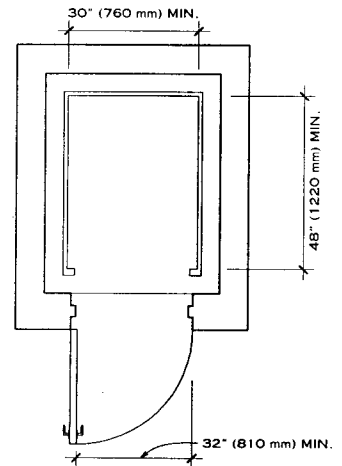

**NOTES**

1. This type of elevator is permitted as part of an accessible route within dwelling units.
2. Car size shown is per A117.1-1998. Verify the car size requirements of applicable accessibility regulations.
3. Controls are located in a side wall 12 in. (300 mm) minimum from an adjacent wall.
4. Doors must be located on the narrow end of the car.
5. Car door/gates are required to be power operated.
6. Cars with openings on only one end require a person in a wheelchair to either enter or exit by moving backwards; therefore, in a single-opening configuration, the hoistway doors/gate must be low-energy, power-operated doors.
7. Cars with openings on each end allow a wheelchair user to roll through (enter and exit in a forward direction); manual, self-closing hoistway doors/gates are permitted.

**NOTES**

1. Limited use/limited application (LULA) elevators are permitted to be used as part of an accessible route in certain conditions. Check applicable accessibility regulations for permitted installations.
2. LULAs must comply with part XXV of ANSI A17.1.
3. LULA elevators have a smaller car size, requiring a person in a wheelchair to either enter or exit by moving backwards unless the car has openings on each end. Car size is limited by A17.1.

4. LULAs move more slowly than other passenger elevators and may not be appropriate when large numbers of people must be served.
5. Car controls are located on a side wall.
6. Low-energy, power-operated swing doors are permitted at the hoistway entrance, provided they remain open for 20 seconds when activated.

**LIMITED USE/LIMITED APPLICATION ELEVATOR**

**PRIVATE RESIDENCE ELEVATOR**

Lawrence G. Perry, AIA; Silver Spring, Maryland

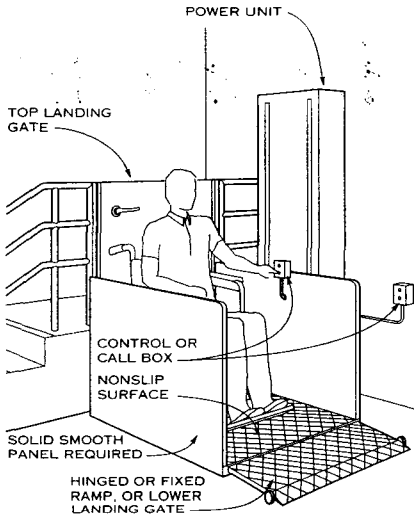

OVERALL VIEW - WHEELCHAIR LIFT

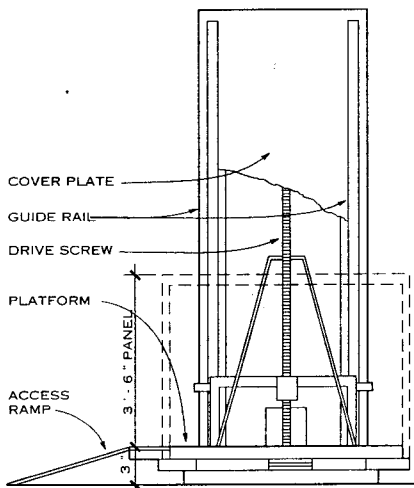

**NOTE**  
Screw driven lift platform is lifted along a threaded rod, which is rotated by the power unit.

CUT-AWAY SECTION

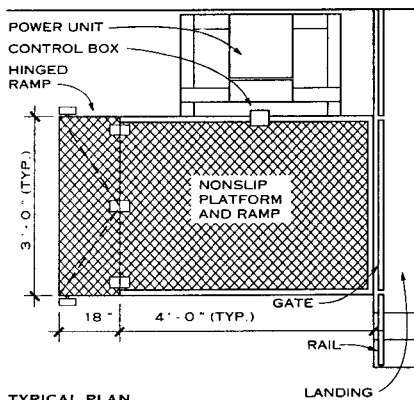

TYPICAL PLAN  
WHEELCHAIR LIFT

**GENERAL**

Not all lifts comply with ADAAG and A117.1-1998 requirements. Verify applicable regulations before selecting a specific type of lift.

Wheelchair lifts are suitable for retrofits of buildings that are not barrier free. Bridges are available from manufacturers for installation over stairs. Recommended speed: 10 to 19 fpm. Capacity: 500 to 750 lb.

Lifts operate on standard household current and are suitable for interior or exterior applications.

**WHEELCHAIR LIFT REQUIREMENTS**

TYPICAL ANSI A17.1, SEC. 2000.1B	PRIVATE RESIDENCE ANSI A17.1, SEC. 2100.1
42 in. door for top and bottom landings, mechanical/electrical interlock, solid construction	36 in. door for top landing; bottom landing can have guard (other requirements similar to 42 in. door)
Platform sides: 42 in. solid construction	Platform 36 in. solid construction
Grab rails	Same
Enclosure or telescoping toe guard	Obstruction switch on platform
Maximum travel 12 ft	Maximum travel 10 ft
	Automatic guard 6 in. at bottom landing in lieu of door
Key operation	Key operation

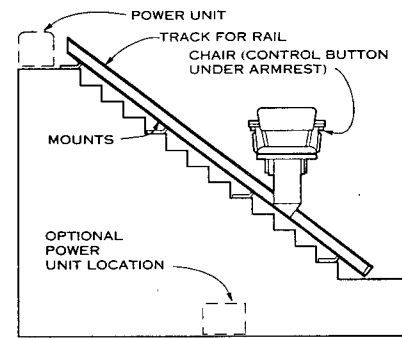

**NOTE**  
Chair lift power unit may also be located in chair chassis. Chair lift's compact size may make this lift type more feasible than others for residential use.

CHAIR LIFT - SECTION

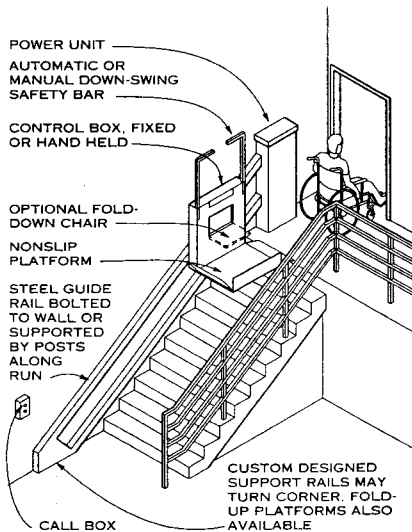

STAIR LIFT OR PLATFORM (STRAIGHT RUN)

Inclined stair lifts can be adapted to straight run and spiral stairs. Standard types run along guide rails or tubes fastened to solid wall, stairs, or floor structure. Power units may be placed at the top or bottom of the lift run or in the lift chassis, depending on the manufacturer. Some inclined lift systems fold up out of the way for daily stair use.

Where stair width necessitates a more compact lift, as in residential use, chair lifts are available for straight run or spiral stairs. However, many inclined stair lifts come with standard fold-down seats.

Recommended speed, 20 to 25 fpm on straight runs, 10 fpm on curved sections. Capacity, 500 lb. Typical platform size, 30 x 40 in. Check local code capacities.

**INCLINED WHEELCHAIR LIFT REQUIREMENTS**

TYPICAL RESIDENCE ANSI A17.1, SEC. 2001	PRIVATE RESIDENCE ANSI A17.1, SEC. 2100
42 in. self-closing door: solid construction, mechanical/electrical interlock, lower landing	36 in. self-closing door: solid construction, mechanical/electrical interlock, upper landing
42 in. platform side guard: not used as exit, solid construction	36 in. platform side guard: not used as exit, solid construction
6 in. guard: permitted in lieu of side guard	6 in. guard: permitted in lieu of side guard
6 in. retractable guard: to prevent wheelchair rolling off platform	6 in. retractable guard: to prevent wheelchair rolling off platform
Door required at bottom landing	Underside obstruction switch bottom landing
Travel 3 floors max.	Travel 3 floors max.
Key operation: attendant operation is push button	Key operation: attendant operation is push button and requires door at bottom landing

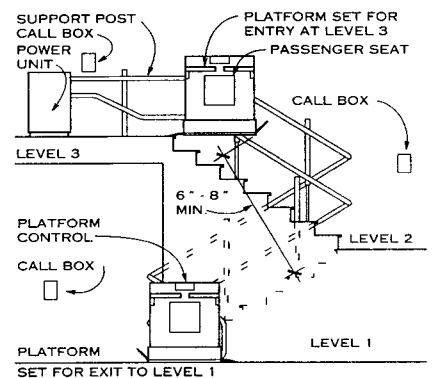

STAIR LIFT OR PLATFORM SECTION

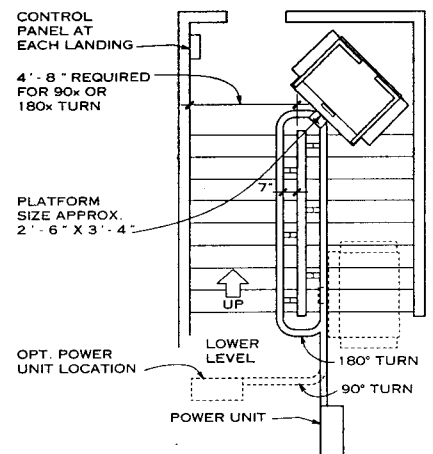

STAIR LIFT CHAIR OR PLATFORM PLAN WITH TURNS

Eric K. Beach; Rippeteau Architects, PC; Washington, D.C.

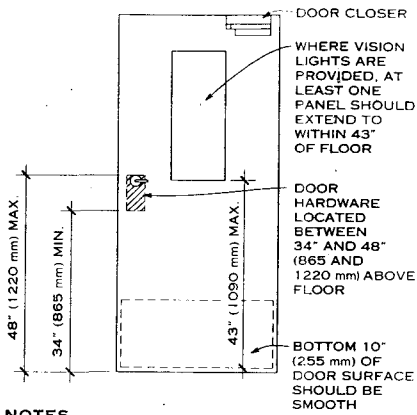

**NOTES**

1. Hardware: Specify hardware that can be operated with one hand, without tight grasping, pinching, or twisting of the wrist.
2. Thresholds: Thresholds are typically limited to 1/2 in. maximum height; however, some standards allow a 3/4 in. height for certain sliding doors.
3. Opening force: Interior doors (other than fire doors) should be able to be operated with 5 lb of force. Exterior doors and fire doors may be regulated by the authority having jurisdiction.

**ACCESSIBLE DOOR FEATURES**

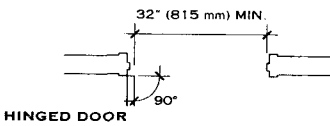

**HINGED DOOR**

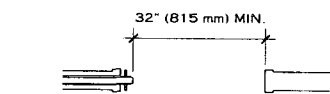

**SLIDING OR FOLDING DOOR**

**NOTES**

1. For a hinged door, the clear width is measured between the face of the door and the door stop with the door open at a 90° angle.
2. For a sliding or folding door, the clear width is measured between the edge of the door and the jamb with the door fully open. Hardware must be accessible with the door in fully open position.
3. Doors in dwelling units covered by FHAG are permitted to have a "nominal" 32 in. clear width. HUD allows a 2 ft 10 in. swing door or a 6-ft exterior sliding door installed in a "typical" manner to satisfy this requirement. ICC/ANSI A117.1-1998 allows a 31 1/4 in. (810 mm) clear width.

**CLEAR WIDTH OF ACCESSIBLE DOORWAYS**

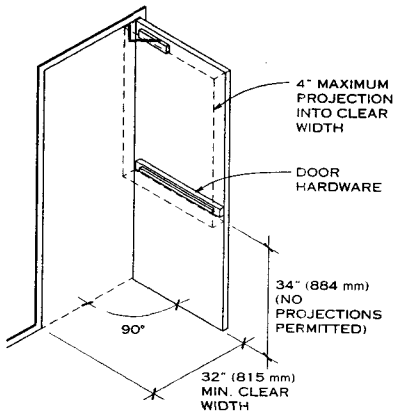

**PROJECTIONS INTO CLEAR WIDTH (1998 ANSI ONLY)**

Lawrence G. Perry, AIA; Silver Spring, Maryland

**21 DOORS**

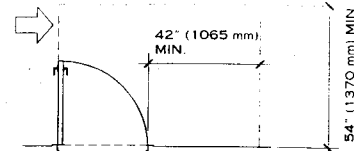

**HINGE APPROACH**

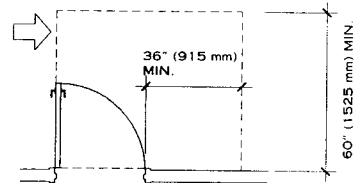

**HINGE APPROACH**

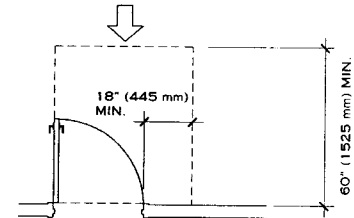

**FRONT APPROACH**

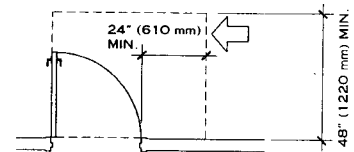

**LATCH APPROACH**

**PULL-SIDE MANEUVERING CLEARANCE AT SWINGING DOORS**

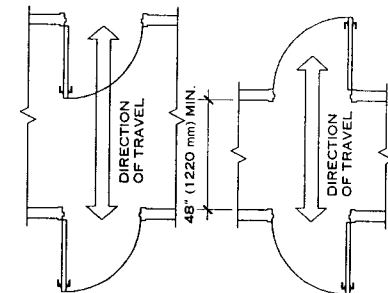

**SWING—SAME DIRECTION      SWING—OPPOSITE DIRECTION**

**MANEUVERING CLEARANCE FOR TWO DOORS IN A SERIES**

**NOTES**

1. Maneuvering clearances are also required at power-assisted doors.
2. Maneuvering clearances are not applicable at full-powered automatic doors or low-energy power-operated doors.
3. The floor and ground surface within the required maneuvering clearance of a door must not slope more than 1:48 and must be stable, firm, and slip-resistant.
4. Where doors are recessed more than 8 in. (such as in an alcove or in a very thick wall), the maneuvering clearances for forward approach should be used.
5. For doors within dwelling units covered by Fair Housing Accessibility Guidelines (FHAG), maneuvering clearances are not required.

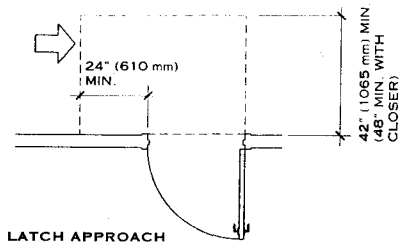

**LATCH APPROACH**

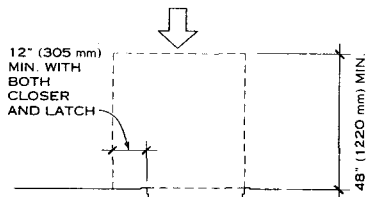

**FRONT APPROACH**

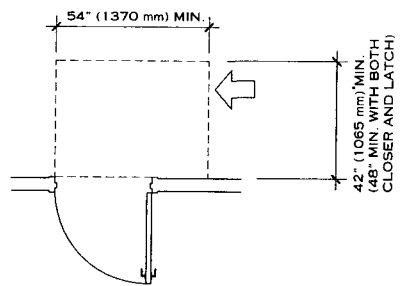

**HINGE APPROACH**

**PUSH-SIDE MANEUVERING CLEARANCE AT SWINGING DOORS**

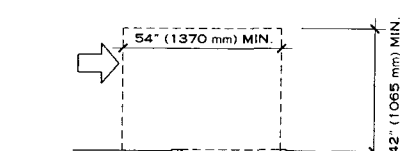

**POCKET OR HINGE APPROACH**

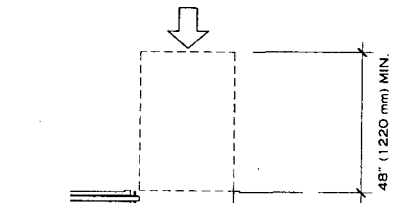

**FRONT APPROACH**

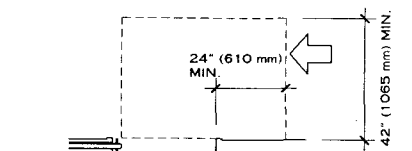

**STOP OR LATCH APPROACH**

**MANEUVERING CLEARANCE AT SLIDING AND FOLDING DOORS**

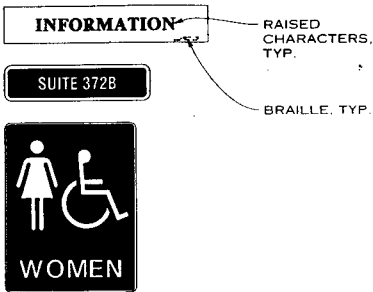

**NOTE**

Tactile signs with raised characters and Braille are required on signs provided as permanent designations of rooms and spaces. A117.1-1998 allows either combined tactile/visual characters or separate tactile characters with redundant visual characters. By providing duplicate characters, the tactile characters can be made easier to read by touch, and a wider variety of visual characters can be used. Room numbers, room names, exit stairs, and restrooms are examples of spaces with "permanent" designations. Tactile characters must be located between 48 in. (1220 mm) and 60 in. (1525 mm) above the floor or ground.

Tactile signs at doors must be located so that a person reading the sign will not be hit by a door that is being opened. A117.1-1998 allows door-mounted tactile signs on the push side of doors with closers, which do not have hold-open devices. Tactile signs located on the pull side of doors should be located so that an 18 in. (455 mm) x 18 in. (455 mm) "safe" zone, centered on the sign, is provided beyond the arc of any door swing between the closed position and the 45-degree open position.

Signs that provide directional information to, or information about, permanent spaces are required to comply with specific requirements for visual characters. Minimum character heights are regulated both by the height of the sign above the floor and by the intended viewing distance. Consult the applicable regulations for signs required to identify specific accessible features, spaces, or elements.

**SIGNS**

**FIRE ALARMS**

Fire alarm systems are not required by accessibility regulations, but they are required to include accessibility-related features. Visible-alarm notification appliances, intended to alert persons with hearing impairments, are the primary accessibility component of fire alarm systems. Criteria for the placement of visible alarms, the intensity of each appliance, the intensity of the signal throughout the covered area, and the cumulative effect of multiple appliances are all regulated in an attempt to ensure that the signal is immediately noticed, without creating light patterns that could trigger seizures in persons with photosensitivity.

The National Fire Alarm Code, NFPA 72-1996 and later editions, contains the state-of-the-art criteria for visible alarms; provisions in A117.1-1998 are identical.

A117.1-1998 introduces a new approach to visible alarm criteria for dwelling units. While previous editions and the model codes have required visible alarms only in wheelchair-accessible units, the new approach requires that all units be capable of adding visible alarms (on an as-needed basis), with the capability to use a single set of visible notification appliances for notification of both unit smoke detector activation and building fire alarm activation.

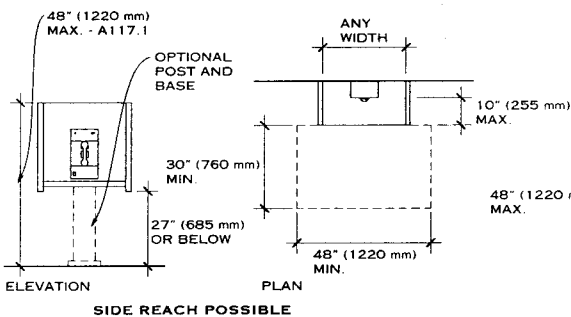

**TELEPHONES**

Lawrence G. Perry, AIA; Silver Spring, Maryland

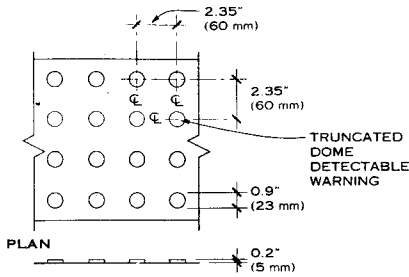

**ELEVATION**

**NOTE**

Detectable warnings are required at passenger transit platforms whose edges border a drop-off where no screen or guard is provided. The detectable warning should be a 24-in. (610 mm) wide strip of truncated domes, contrasting with the adjacent walking surface.

ADAAG requirements for detectable warnings at hazardous vehicular ways and reflecting pools have been suspended.

**DETECTABLE WARNINGS**



**INTERNATIONAL SYMBOL OF ACCESS FOR HEARING LOSS**

**NOTE**

Stadiums, theaters, auditoriums, lecture halls and similar fixed seating assembly areas are required to provide assistive listening systems if they have a capacity of more than 50 persons or if an audio amplification system is provided. Portable systems may be acceptable.

Check the applicable requirements for the number of receivers required, as they vary from just over 1% to 4% of the total capacity of the assembly area. At least 25% of the receivers should be hearing-aid compatible.

Signs should be provided at ticketing areas, or other clearly visible locations, indicating the availability of the assistive listening system. Signs should include the international symbol of access for hearing loss.

**ASSISTIVE LISTENING SYSTEMS**

**AUTOMATIC TELLER MACHINES AND FARE MACHINES**

Where ATMs or fare machines are provided, generally at least one machine is required to be accessible. A117.1-1998 provides extensive criteria addressing the input and output requirements of these machines and is intended to make them usable by someone with a vision impairment or a hearing impairment. A117.1-1998 requires operable parts to be not more than 48 in. (1220 mm) above the floor or ground; other standards may allow operable parts as high as 54 in. (1370 mm) where a side reach is possible.



VOLUME-CONTROLLED TELEPHONE

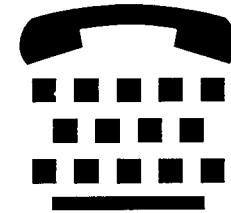

INTERNATIONAL TTY SYMBOL

**NOTE**

Wheelchair-accessible telephones are required where public telephones are provided. One wheelchair-accessible phone is required on each floor or level where phones are provided; where more than one bank (three or more phones) is provided on a floor or level, at least one phone at each bank must be wheelchair accessible. At least one phone per floor or level must allow forward approach.

A117.1-1998 requires that all operable parts of wheelchair accessible phones be located a maximum of 48 in. (1220 mm) above the floor or ground. Other standards may allow operable parts as high as 54 in. (1370 mm) where a side reach is possible. Federal regulations require all new telephone equipment to be hearing-aid compatible.

**VOLUME-CONTROLLED:** All wheelchair-accessible telephones, plus an additional 25% of telephones, must provide volume control. Check the applicable standards for required amplification requirements, as they vary. Telephones with volume control must be identified by signs, unless all telephones have volume control.

**TEXT TELEPHONES (TTYs):** Consult the applicable standards for the required number and location of TTYs. Recent model codes, based on the recommendations of the ADAAG Review Committee, provide for an increased number of TTYs. While the current ADAAG requires only one TTY in many cases, the more recent provisions require additional TTYs based on the number of phones at the site, in the building, on each floor, and at each bank of phones. Additional requirements may apply for hospitals, transportation facilities, highway rest stops, emergency roadside stops, service plazas, stadiums, arenas, hotels, and convention centers.

Public TTYs should be identified by the international TTY symbol. Directional signs to TTYs should be provided at banks of public telephones not providing TTYs. In addition, there may be requirements for shelves and outlets at banks of telephones without TTYs, to allow use of a portable TTY.

**WHEELCHAIR-ACCESSIBLE TELEPHONES**

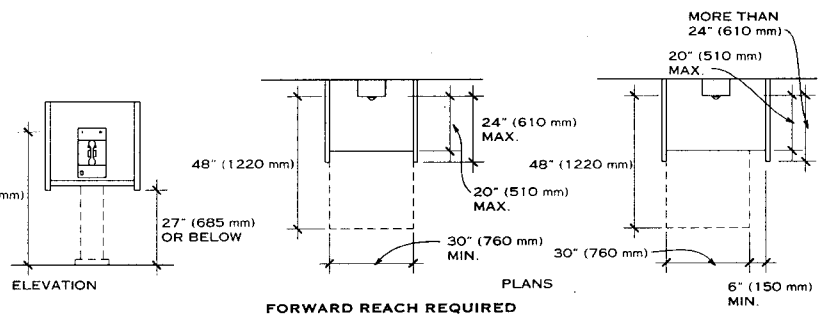

**CANES USED FOR AMBULATING**

1. Canes provide support by shifting some body weight to the user's arm and shoulder and by helping maintain balance.
2. Single-point canes are available in various heights, in adjustable models, and with many different handgrip configurations. Collapsible models also are available.
3. Tripod and quad canes have three or four legs on the base. This configuration increases stability but also increases the weight of the cane.

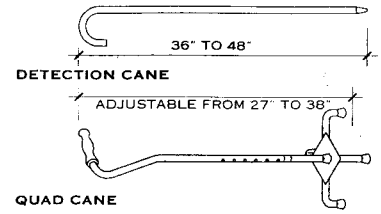
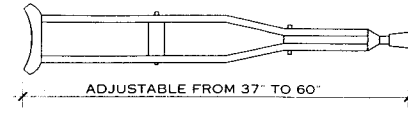

**LONG CANES USED FOR DETECTION**

1. Long canes assist persons who are blind or visually impaired to detect obstructions in their path of travel.
2. Long canes are typically 36 to 48 in. long; they may fold, telescope, or be rigid.
3. Long canes may be used in either the "touch" technique (the cane is moved side to side, touching the floor surface 6 to 8 in. outside each shoulder) or the "diagonal" technique (the angled cane is held stationary with the tip just above the ground surface).
4. When using the touch technique, the cane length and the vertical angle formed with the ground plane serve as the basis for accessibility standards regarding protruding objects.

**CRUTCH**

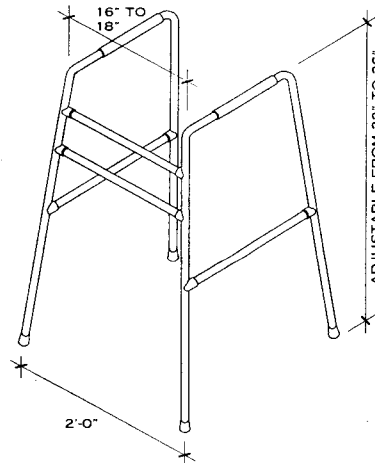

**MISCELLANEOUS CANES**

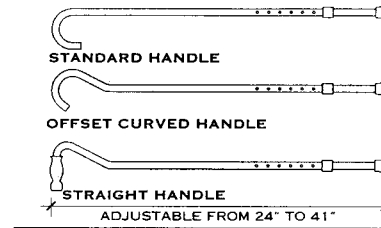

**CRUTCHES**

1. Crutches reduce body weight stress on lower extremities by transferring force either to the user's shoulders or forearms.
2. Axillary crutches have an underarm support to transmit forces to the user's shoulder.
3. Nonaxillary crutches have handgrips and a forearm or upper arm cuff to distribute weight to the user's forearm.
4. Users must be able to stand with one crutch and simultaneously perform other functions with their free hand, such as opening a door.
5. Crutches used for walking are angled approximately 6 in. away from the body for greater stability, so slightly wider corridors and outdoor walks are desirable.

**WALKERS**

1. Walkers can provide some support for users but primarily are used to help maintain balance.
2. They are often used for travel in open areas without handrails, furnishings, or other means of support and balance. For many users, walkers help increase their self-confidence and therefore their independence.
3. Walkers are adjustable in height to suit individual users.
4. Walkers are flared for stability. The handgrip width is typically 16 1/2 to 18 in. The base width is typically 24 in.
5. Folding walkers are generally made of lightweight aluminum tubing and collapse to a width of approximately 4 in. They may have small front wheels, front and rear wheels, or four rubber tips.
6. Basket, or rolling, walkers have three or four wheels and various types of hand brakes. They may also have a shopping basket and/or a seat. The width of most rolling models is 27 to 28 in.

**WALKER**

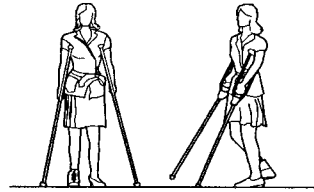

**AXILLARY CRUTCH**

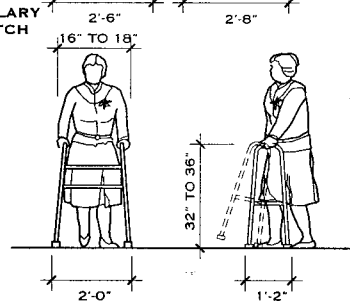

**AMBULATING CANES**

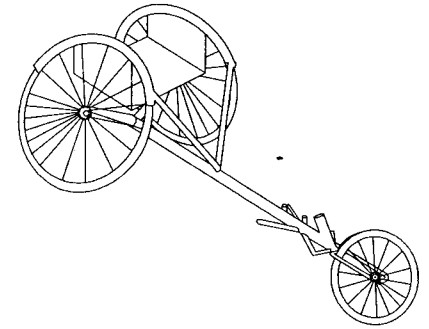

**RACING WHEELCHAIR**

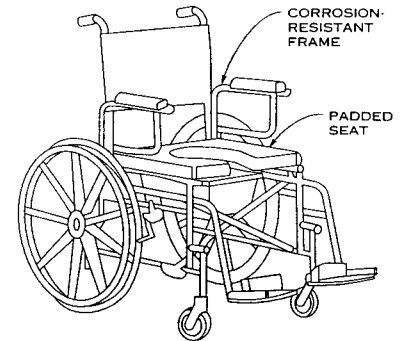

**MANUAL WHEELCHAIRS**

1. Manual chairs are hand-propelled using rims mounted on large front or rear drive wheels. They are available in many different models and sizes and with a variety of removable or adjustable accessories, such as footrests and armrests.
2. The most popular U.S. models have large, rear drive wheels and smaller, front castor wheels. Armrests are usually "cutaway" to allow closer access to tables and counters.
3. Lightweight frames, usually of aluminum, may be either collapsible or rigid.
4. The width and length of wheelchairs vary significantly with the user's personal anthropometrics and with the chair's design. The widest standard model is approximately 26 in.; however, special accessories and extra wheel camber can increase this overall width.
5. Manual chair users have different capabilities for maneuvering and propelling their wheelchairs. Most manual chair users with spinal cord injuries can independently transfer from their wheelchair to a close-by toilet seat, bench, bed, automobile seat, or similar furnishing.
6. Specialized wheelchairs are available for daily activities such as bathing and for athletic competitions such as basketball and tennis.

**WALKER**

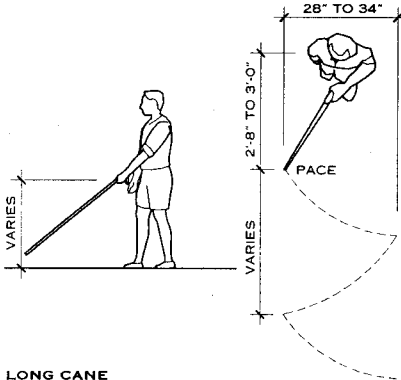

**LONG CANE**

**MOBILITY AID PARAMETERS**

**SHOWER COMMODE WHEELCHAIR**

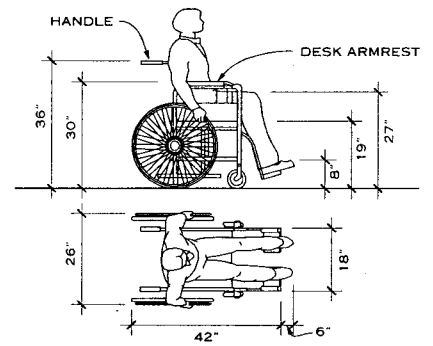

**MANUAL WHEELCHAIR**

Kim A. Beasley, AIA, and Thomas D. Davies, Jr., AIA; Paralyzed Veterans of America Architecture; Washington, D.C.

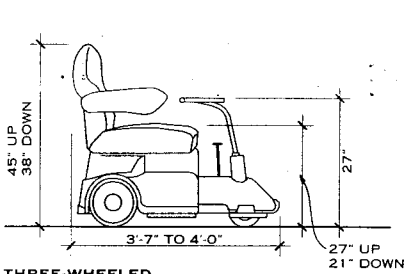

THREE-WHEELED

NOTES

1. Individuals with impaired mobility or with stamina insufficient to travel relatively long distances often use electric scooters.
2. Scooters have either three or four wheels. Three-wheeled models are more maneuverable but less stable than four-wheeled models.

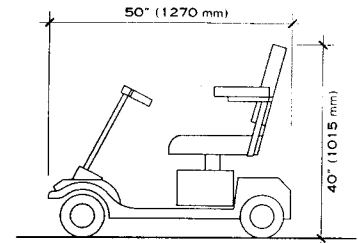
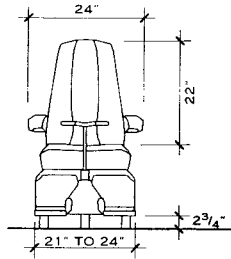

FOUR-WHEELED

3. Short wheelbase scooters are more maneuverable but less stable than models with longer wheelbases.
4. Short, three-wheeled models are more suitable for indoor use; longer, four-wheeled models are more suitable for outdoor use.
5. When operated indoors, scooters are often used differently than wheelchairs. Some compact scooters, however, can turn and maneuver within parameters similar to those of wheelchairs.
6. The scooter seat may swivel to facilitate its use in stationary positions such as in front of a desk. Seat heights are typically adjustable to suit the rider.

ELECTRIC SCOOTERS

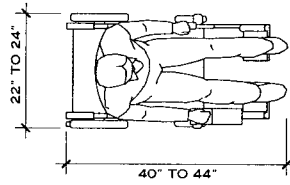
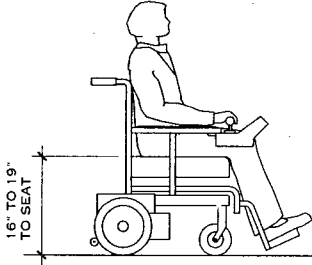

NOTES

1. Motorized wheelchairs are propelled by electric motors powered by rechargeable batteries below the seat.
2. Motorized wheelchairs are usually controlled by a hand mechanism, or joystick, mounted on the chair arm. The joystick restricts access to tables, desks, etc. Some motorized chairs are controlled by sip-and-puff operators.
3. Motorized wheelchairs are similar in overall size to manual wheelchairs, but they are heavier and generally less maneuverable. The frames are not collapsible, although they can be partially disassembled.
4. With a full battery charge, motorized wheelchairs can climb steeper grades than most users can negotiate in manual chairs.
5. Users often need assistance transferring out of their wheelchairs onto a seat, bed, or toilet fixture.

MOTORIZED WHEELCHAIRS

VEHICLES ADAPTED FOR WHEELCHAIR AND SCOOTER USERS

A variety of private and commercial vehicles can provide transportation for wheelchair and scooter users. These vehicles often require special parking and drop-off arrangements so that users can access the vehicles. Most accessible commercial transit vans and some private vehicles may also require additional vertical clearance to accommodate their increased overall height. For most users, the major factor in private vehicle selection is whether they transfer to the car or van seat in order to drive or whether they drive seated in their wheelchair.

CONVENTIONAL PRIVATE AUTOMOBILES

1. Wheelchair and scooter users who can transfer or who are partially ambulant often elect to use conventional automobiles equipped with hand controls.
2. Some wheelchair users drive two-door automobiles equipped with a split-bench front seat. This arrangement allows the user to transfer onto the driver's seat, dismantle his or her wheelchair, and store it in the back seat.
3. In order for wheelchair users to enter and exit conventional automobiles, a clear access aisle is required beside the vehicle. The aisle width must allow for wheelchair passage and permit the chair to be positioned at an angle for transfer to the driver or passenger seat.
4. Special lifts can be installed on the rear bumper, trunk, or even the roof of conventional automobiles to allow a scooter or wheelchair to be transported.

LIFT- AND RAMP-EQUIPPED PRIVATE VANS

1. Minivans, full-size vans, and conversion vans can be equipped with various types of lifts to allow wheelchair users to enter and exit the vehicle while remaining seated in their chairs. Van floors can also be lowered to allow a driver to remain in a wheelchair while driving the vehicle.
2. The best lift arrangement depends on several factors, including the height of the van doors, the van interior, and the user's personal anthropometrics. If a wheelchair user's seated height is more than approximately 44 in., for example, he or she may need either a full-size van or a minivan with a raised roof.
3. The three most common types of wheelchair lifts are side door- or rear door-mounted platform lifts or side door-mounted rotary lifts.

4. Platform lifts are mechanically raised and lowered with either linear tracks or parallel arms. For designers, the important feature common to all lifts is that the user rolls on or off the platform straight ahead. This procedure requires extra ground space either on the passenger side or behind the van for the chair to roll off the lift.
5. Rotary lifts can be installed at the side door to swing out in an arc that will realign the wheelchair parallel to the van before it is lowered to the ground. A rotary lift significantly reduces the required aisle width.
6. Some minivans can be equipped with automatically deployed ramps that can be lowered to the ground or the sidewalk from the passenger side door.
7. Since the ramp user enters or exits straight ahead, ramp-equipped vehicles also require a generous side access aisle, approximately the same as for a platform lift.

LIFT-EQUIPPED COMMERCIAL TRANSIT VANS

1. Commercial transit vans must meet minimum ADA requirements for lift platform size and interior headroom, which typically are more stringent than those for personal vehicles.
2. Most commercial transit vans have raised roofs to provide interior headroom and opening clearance at the entry door sufficient to accommodate passengers seated in wheelchairs. Extra height must therefore be provided at outdoor canopies and other overhangs that protect passengers during loading and unloading; a minimum height of 9 ft 6 in. is recommended.
3. Most commercial vehicles are equipped with slightly larger platform lifts than private vehicles, necessitating generous access aisles.

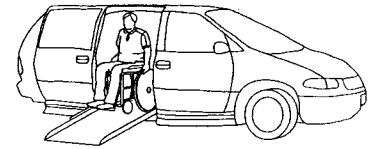

MINIVAN WITH SIDE-DOOR RAMP DEPLOYED

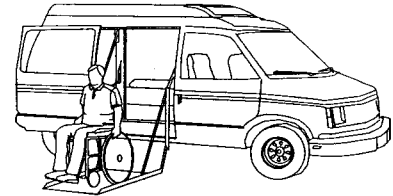

RAISED TOP VAN WITH SIDE-DOOR PLATFORM LIFT  
WHEELCHAIR LIFTS IN VANS

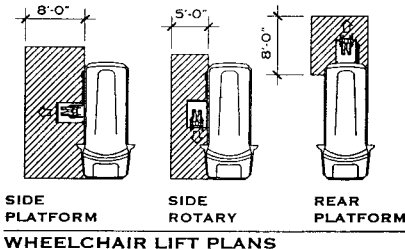

WHEELCHAIR LIFT PLANS

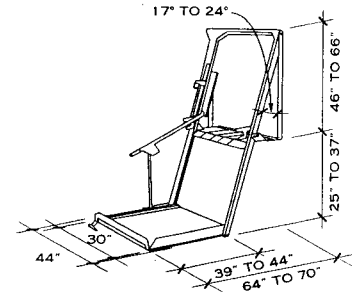

PLATFORM LIFT

Kim A. Beasley, AIA, and Thomas D. Davies, Jr., AIA; Paralyzed Veterans of America Architecture; Washington, D.C.

**RESIDENTIAL BEDS**

For wheelchair users who can independently transfer themselves between bed and chair, bed heights should facilitate their movement back and forth in a sitting position. Transfer is easiest for these users if the mattress top approximately matches their wheelchair seat height (typically 18 to 20 in.).

Quadriplegics or other wheelchair users who cannot independently transfer themselves between bed and chair are typically assisted by attendants, who use a portable lift mounted on a metal stand. In order for the lift frame to be positioned underneath the bed, the boxspring must have sufficient clear space beneath it. Depending on the diameter of the lift wheel, a clearance of approximately 8 in. is typically required. Because the overall bed height is not critical for people who use a lift to transfer, it may be acceptable to block the bed up off the floor to provide sufficient space beneath it.

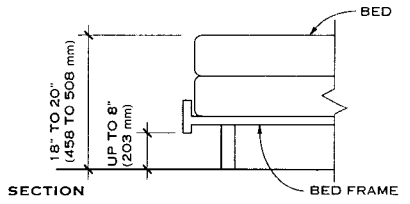
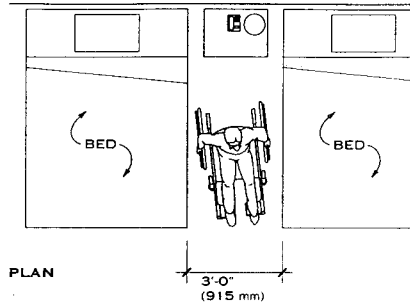

**BEDS**

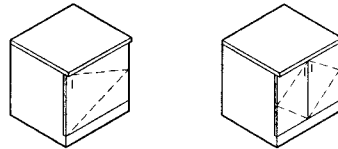

**CABINETS**

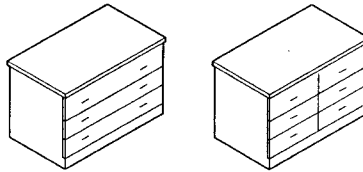

**CHESTS**

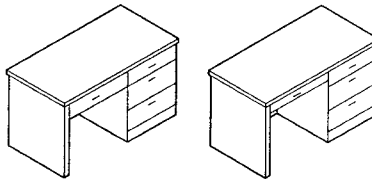

**DESKS**

**DIFFICULT TO OPERATE EASY TO OPERATE**

**FURNITURE OPERATION FOR ACCESSIBILITY**

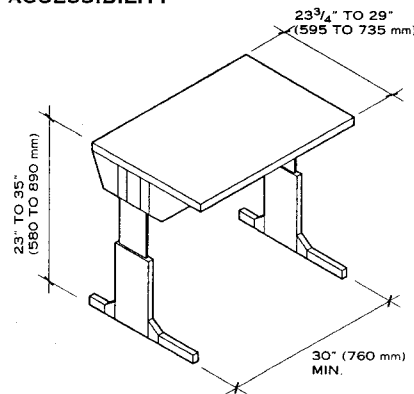

**ADJUSTABLE HEIGHT WORK SURFACE**

**DRESSERS, CHESTS, AND CABINETS**

Dressers and chests for wheelchair users should be situated so there is a clear access aisle in front of the furniture. This aisle should be wide enough (approximately 42 in.) to allow the drawers to be opened when a wheelchair is positioned parallel to the chest. Dressers and chest drawers should be narrow enough to be opened with one hand using a single pull rather than with simultaneous use of two pulls. Drawer hardware profiles should be appropriate for people with limited hand function. Pulls, for example, should be able to be hooked rather than grasped.

Cabinets, tables, stands, and other furniture with doors should have relatively narrow leaves so the arc of the swing when they are opened is small. This makes the leaf easier to operate without moving the wheelchair as the door is opened.

**DESKS, TABLES, AND WORKSTATIONS**

Knee space is integral to the use of desks, tables, and workstations. In order to serve wheelchair users, furniture must offer knee space that can accommodate the chair in a position that places the user's legs fully beneath the horizontal surface and his or her upper body close to the front edge of the top. For most wheelchairs, knee space with a clear height of approximately 2 ft 3 in. is sufficient. Higher knee space also raises the working surface and, for most uses, including writing and eating, it is desirable to have the top surface as low as possible. One option is to use a desk or work table that can be adjusted to the height required by an individual user.

The minimum aisle width required to turn (90°) a wheelchair in and out of any knee space depends on the width and depth of the knee space itself. A deep, narrow knee space requires more maneuvering clearance than a wide, shallow knee space. The recommended minimum width for a knee space is 2 ft 6 in. This width requires an aisle of approximately 3 ft 4 in. in order for most wheelchairs to complete a 90° turn without backing and filling. Pedestal tables and pedestal-supported or cantilevered open worktops offer wider knee spaces. Workstations with adjustable height tops can be tailored to a specific user's needs, but the minimum knee space width should be 30 in.

**CHAIRS**

For ambulatory people who have difficulty maintaining their balance, chairs should be stable in order to provide support. Chairs equipped with armrests help ambulatory users to sit and rise and are generally more comfortable to sit in. Chair leg supports and cross-bracing should not obstruct kick space below the seat. Kick space allows the chair occupant to position his or her feet partially beneath the body in order to rise.

Low chair seats make it more difficult for the occupant to sit and rise. For comfort, the chair seat height (typically 16 to 18 in.) should allow an occupant's feet to rest comfortably on the floor. High stools or chairs should include foot rails or elevator platforms to support the occupant's feet. Chairs that serve tables and desks should be light enough to be easily repositioned.

Ergonomic work chairs allow many aspects of the chair, such as seat height and angle of incline, to be adjusted to suit each individual user. Wheelchair users who wish to sit in conventional chairs typically have individual preferences. People who transfer diagonally can use chairs with armrests, while people who transfer from a parallel position must have clear side access, which is offered by chairs without fixed armrests.

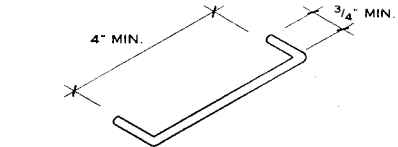

**ACCESSIBLE DRAWER PULL**

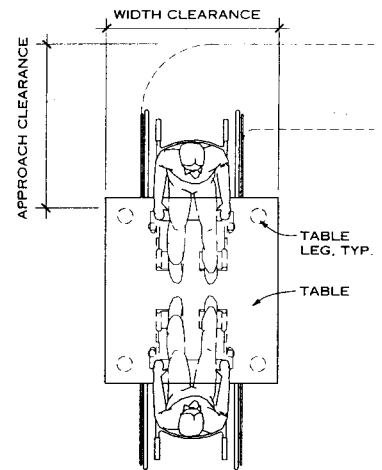

**NOTE**

For knee space below a tabletop with a minimum width of 2 ft 6 in. between obstructions (e.g., table legs), the approach clearance should be 3 ft 6 in. A knee space width of 3 ft 0 in. or more should have an approach clearance of 3 ft 0 in.

**TABLE CLEARANCES**

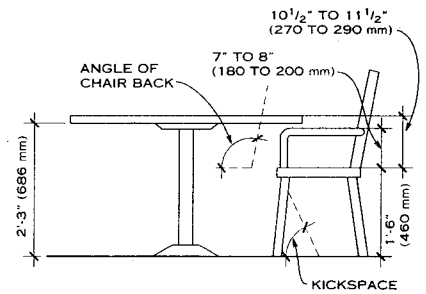

**CHAIR FOR DINING OR DESK**

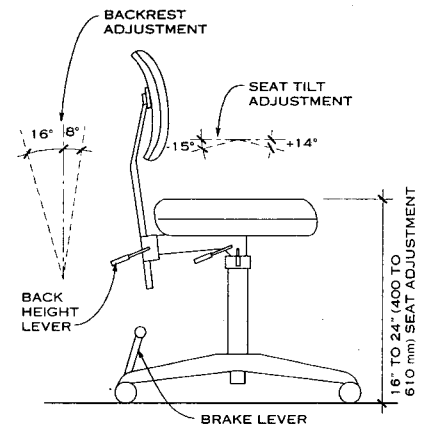

**ERGONOMIC WORKSTATION CHAIR**

Kim A. Beasley, AIA, and Thomas D. Davies, Jr., AIA; Paralyzed Veterans of America Architecture; Washington, D.C.

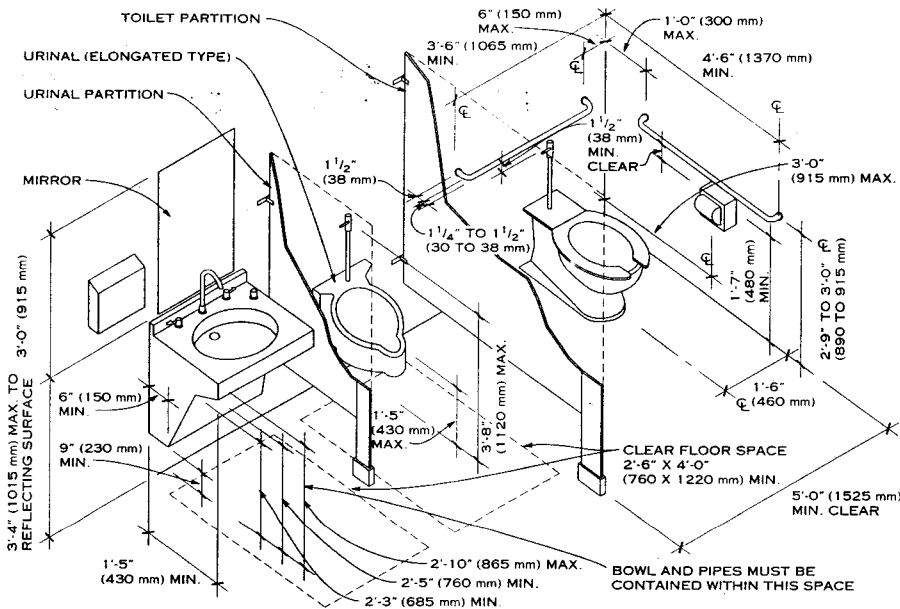

- NOTES**
1. Depending on the configuration of clear floor space, the maximum height of the controls ranges from 3 ft 8 in. (1120 mm) to 4 ft 6 in. (1420 mm), and the minimum height ranges from 9 in. to 2 ft 10 in. (230 to 865 mm).
  2. If the partition is greater than or equal to 2 ft 0 in. (610 mm) deep, urinal clear floor spaces must be 3 ft 0 in. (915 mm) wide. If the partition is less than 1 ft 5 in. (430 mm) deep, urinal clear floor space may be 29 in. (735 mm) wide.

**LOCATION OF ACCESSIBLE FIXTURES AND ACCESSORIES**

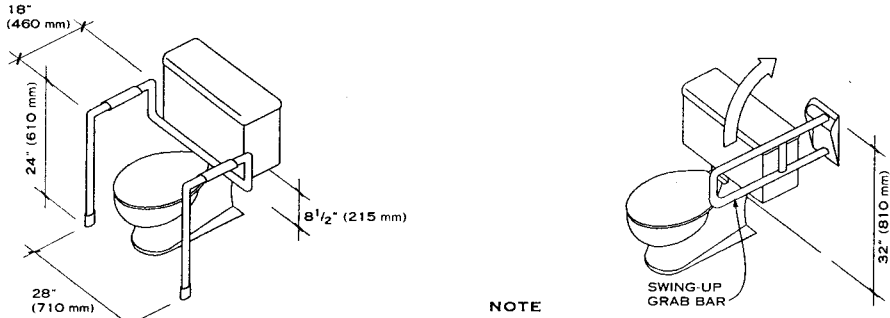

**NOTE**  
These configurations do not comply with UFAS or ADAAG.

**OPTIONAL GRAB BAR CONFIGURATIONS**

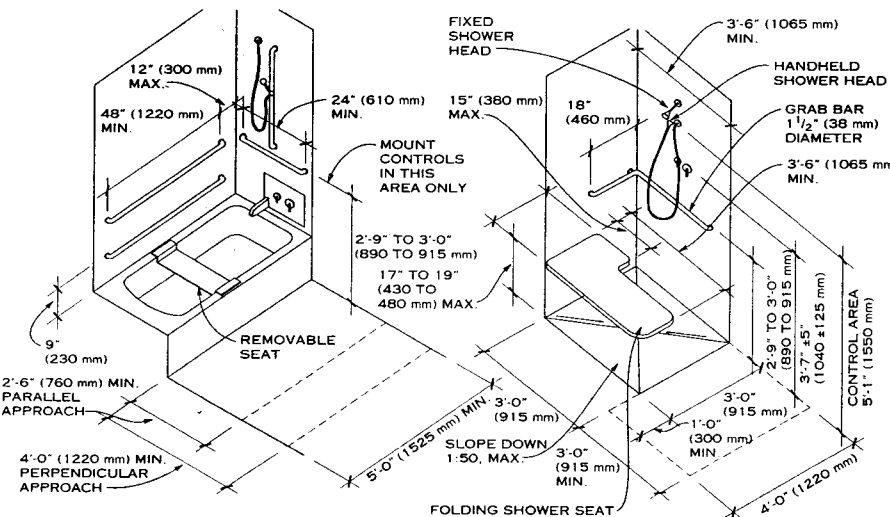

**ACCESSIBLE BATHTUB AND SHOWER**

Mark J. Mazz, AIA, P.A.; Hyattsville, Maryland

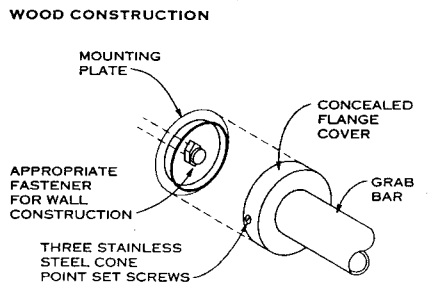
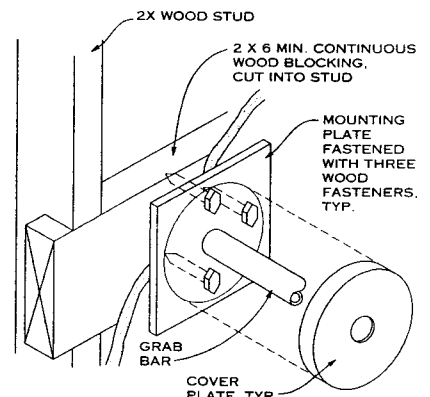
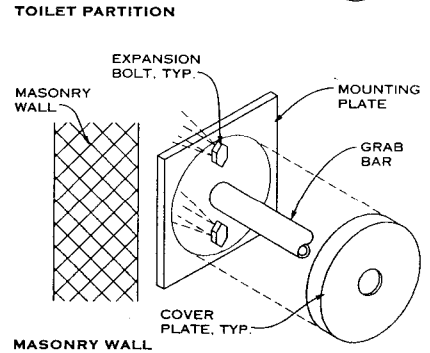
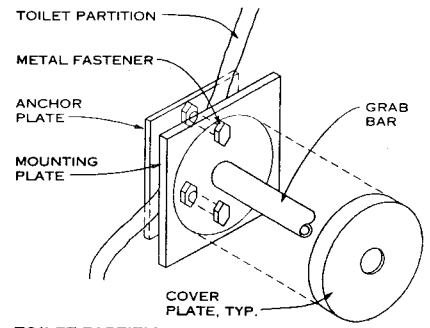

- CONCEALED FLANGE NOTES**
1. Size: 1½ or 1¼ in. O.D. with 1½ in. clearance at wall.
  2. Material: Stainless steel chrome-plated brass with knurled finish (optional).
  3. Installation: Concealed or exposed fasteners; return all ends to the wall, intermediate supports at 3 ft maximum. Use heavy-duty bars and methods of installation.
  4. Other grab bars are available for particular situations.
  5. Consult ANSI and ADAAG requirements, as well as applicable local and federal regulations.

**GRAB BAR ATTACHMENT DETAILS**



**GENERAL NOTES**

1. All dimensional criteria on this page are based on ANSI A117.1-1998, and on adult anthropometrics.
2. In new construction, all public and common use toilet rooms are generally required to be accessible.
3. Where multiple single-user toilet rooms or bathing rooms are clustered in a single location, and each serves the same population, only 5%, but not less than one, of the rooms must be accessible. The accessible room(s) must be identified by signs.
4. Single-user toilet and bathing rooms provided within a private office are permitted to be adaptable. Making the room accessible is permitted to involve replacement of the water closet and lavatory, changing the swing of the door, and installing grab bars in previously reinforced walls.
5. In accessible toilet and bathing rooms, at least one of each type of fixture and accessory provided must be accessible.
6. A wheelchair turning space is required within accessible toilet and bathing rooms.
7. Doors are not permitted to swing into the required clear floor space at any fixture, except in single-user rooms, where a clear floor space is provided beyond the swing of the door.

**UNISEX TOILET AND BATHING ROOMS**

**ASSEMBLY AND MERCANTILE OCCUPANCIES**

1. Recent model codes require accessible unisex toilet and bathing rooms in certain assembly and mercantile occupancies. These unisex rooms are beneficial for parents with small children and for persons with disabilities who require personal assistance in using toilet facilities, since the assistant may be a person of the opposite sex.
2. This requirement applies when a total of six or more water closets (for water closets and urinals) is provided in the facility.
3. Fixtures provided in unisex rooms are permitted to be included in the number of required plumbing fixtures.
4. Unisex facilities must be located within 500 feet, and within one floor, of separate-sex facilities. In facilities with security checkpoints, such as airport terminals, unisex facilities must be located on the same side of the checkpoint as the separate-sex facilities they serve.
5. Unisex toilet rooms require a single water closet and lavatory. Unisex bathing rooms must also provide an accessible shower or bathtub. An exception allows the use of a room containing two water closets (for one water closet and urinal) in lieu of a dedicated unisex room.
6. Doors to unisex toilet and bathing rooms must be secureable from within the room.

**ALTERATIONS**

1. Accessible unisex toilet and bathing rooms are permitted in alterations in lieu of altering existing separate-sex facilities in certain conditions.
2. Unisex rooms must be located in the same area and on the same floor as the existing inaccessible facilities.

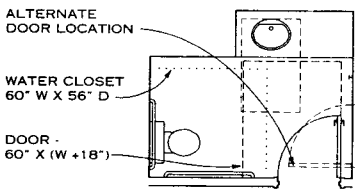
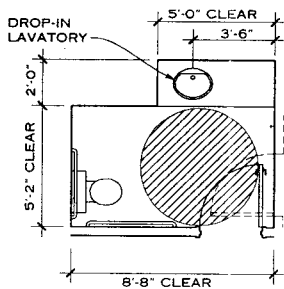

**LAVATORY ON SIDE WALL**

**TOILET ROOM LAYOUTS**

1. Some of the toilet room layouts shown are similar. Variations are in the direction of the door swing and whether the width or depth is the more constraining dimension. Dimensions show comfortable minimums and preferred dimensions.
2. Overall room dimensions include a 2 in. construction tolerance.
3. Each layout shows the required clear floor space for the fixtures and the doors. Frequently, the clear floor space at the fixture is more stringent than the 60-in. diameter or the T-shaped maneuvering space required. Both must be considered.
4. Door maneuvering clearances: see ADAAG (section 4.13.6 and fig. 25) for various requirements and conditions. Variables include direction of swing, direction of approach, size of door, and door hardware.
5. Doors to bathrooms are assumed to be 36 in. wide, with a closer and latch for privacy. Where noted, the overall dimension may decrease if there is no closer.

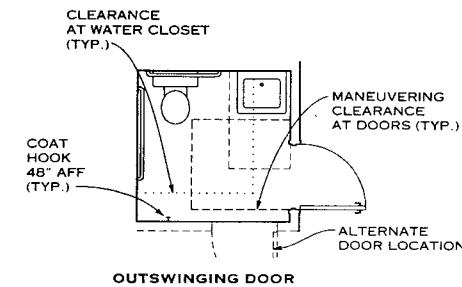
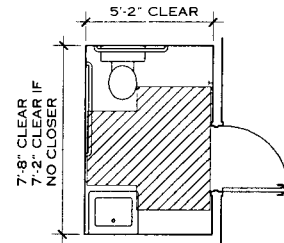
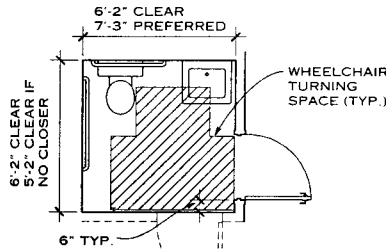

**SHORT AND COMPACT**

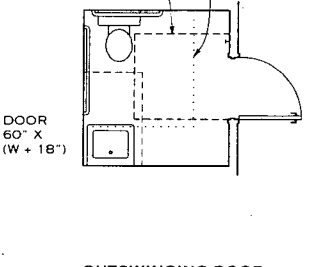
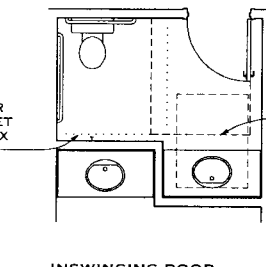
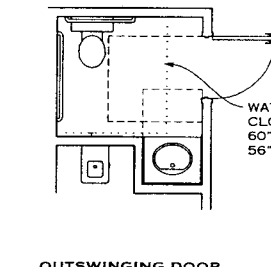
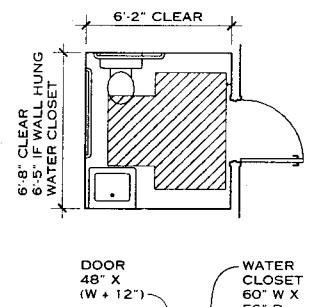
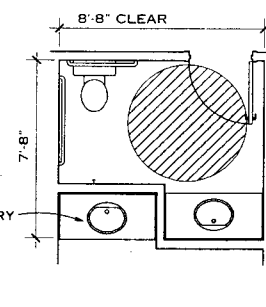
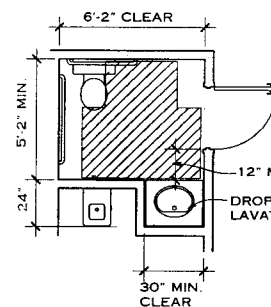

**LAVATORY ON OPPOSITE WALL**

6. Maneuvering clearances at the base of water closets are based on American Standard model #2108 (floor-mounted tank type) and #2257 (wall-mounted, flush-valve type), mounted according to the manufacturer's recommendations. Confirm actual water closet dimensions for other makes and models.
7. Maneuvering clearances below lavatories are based on American Standard model #0355 (wall hung) and #0475 (mounted in countertop). Confirm actual lavatory dimensions for other makes and models.

**TOILET COMPARTMENTS**

1. Where toilet compartments are provided, at least one compartment must be wheelchair accessible.
2. Where six or more toilet compartments are provided in a toilet room, in addition to the wheelchair accessible compartment, a 36-in. (915 mm) wide ambulatory accessible compartment is required.

Lawrence G. Perry, AIA; Silver Spring, Maryland

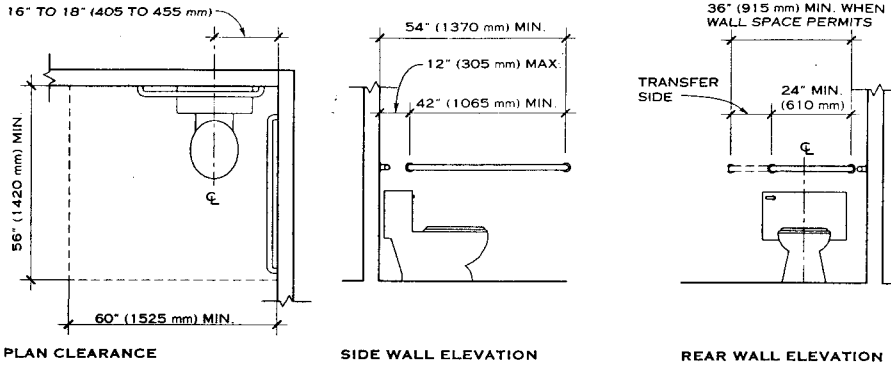

**GENERAL**

See other pages in this chapter for requirements for accessible residential fixtures. All dimensional criteria are based on ANSI A117.1-1998, unless otherwise indicated.

**WATER CLOSETS AND URINALS**

1. A117.1-1998 allows water closets to be located 16 to 18 in. (405 to 455 mm) from the side wall. Previous editions of ANSI as well as other regulations require this dimension to be an absolute 18 in. (455 mm).
2. A117.1-1998 requires the water closet clearance to be unobstructed by lavatory or other fixtures. Previous editions and other regulations allow other configurations with a lavatory within the water closet clearance.
3. The dashed area indicates the allowable location of the toilet paper dispenser. Outlet must be within the range shown. Dispensers should allow continuous paper flow and not control delivery.
4. A117.1 does not require an elongated urinal rim; other regulations may.
5. Manually operated flush controls must be located not more than 44 in. (1120 mm) maximum above the floor.

**WATER CLOSETS**

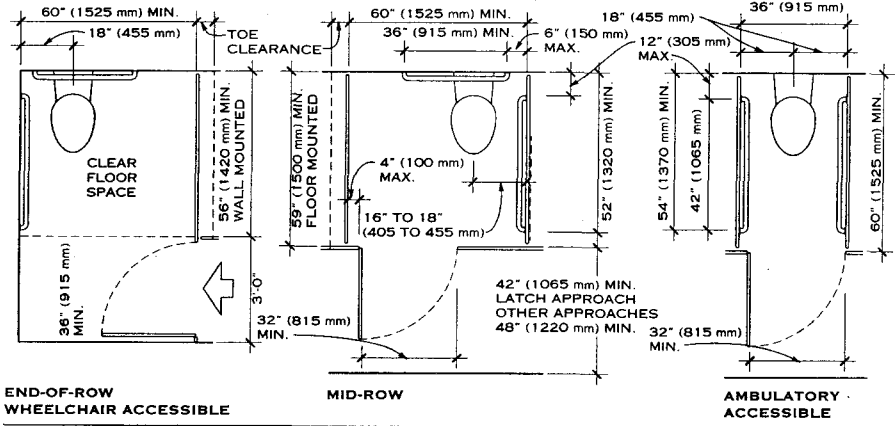

**TOILET COMPARTMENTS**

1. Toe clearance 9 in. (230 mm) high and 6 in. (150 mm) deep is required at the front and at least one side of accessible toilet compartments. Toe clearance is not required when the compartment size exceeds the minimum dimension by 6 in. (150 mm) or more.
2. Left- or right-handed configurations are permitted.

**LAVATORIES**

1. Knee and toe clearance is required below accessible lavatories. The lavatory overflow is permitted to project into the knee clearance.
2. Exposed pipes and water supply pipes located beneath accessible lavatories must be insulated or located so as to protect users from contact with the pipes.
3. Lavatory controls should be within accessible reach range, be operable with one hand, and not require tight grasping, pinching, or twisting of the wrist. Automatic controls are acceptable. Manually activated, self-closing faucets should operate for not less than 10 seconds.

**TOILET COMPARTMENTS**

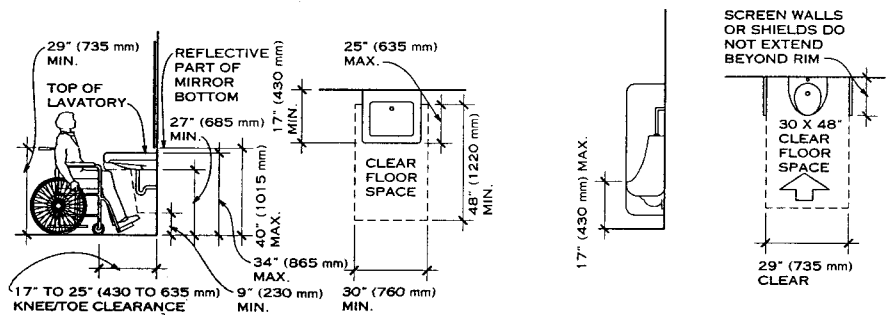

**LAVATORIES**

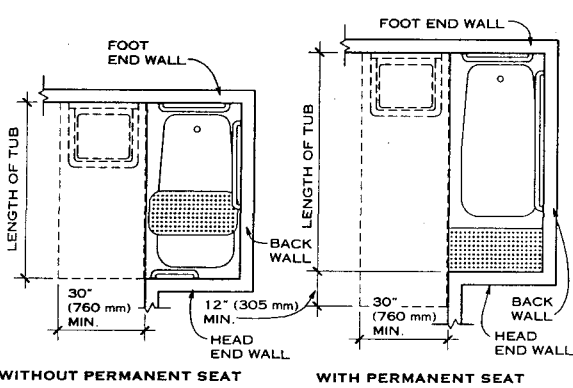

**BATHTUBS**

**URINALS**

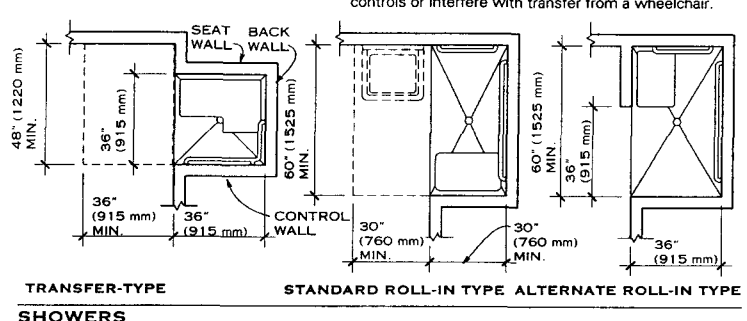

**SHOWERS**

**BATHTUBS**

1. Bathtub controls, other than drain stoppers, must be located on an end wall between the tub rim and grab bar and between the open side of the tub and the midpoint of the tub width.
2. A 59 in. (1500 mm) minimum length shower spray unit is required.
3. Tub enclosures must not obstruct controls or interfere with transfer from a wheelchair to the tub. Enclosures must not have tracks mounted on the tub rim.

**SHOWER COMPARTMENTS**

1. Shower compartment thresholds are not permitted to exceed 1/2 in. (13 mm). Design should anticipate water escaping from the compartment.
2. A fixed, folding, or removable seat is required in transfer-type compartments. Seats in roll-in showers, where provided, should be located on the wall adjacent to the control wall and should be folding-type seats. Seats can be rectangular or L-shaped; see A117.1 for details.
3. A 59 in. (1500 mm) minimum length shower spray unit is required.
4. Shower enclosures, where provided, must not obstruct controls or interfere with transfer from a wheelchair.

Lawrence G. Perry, AIA; Silver Spring, Maryland

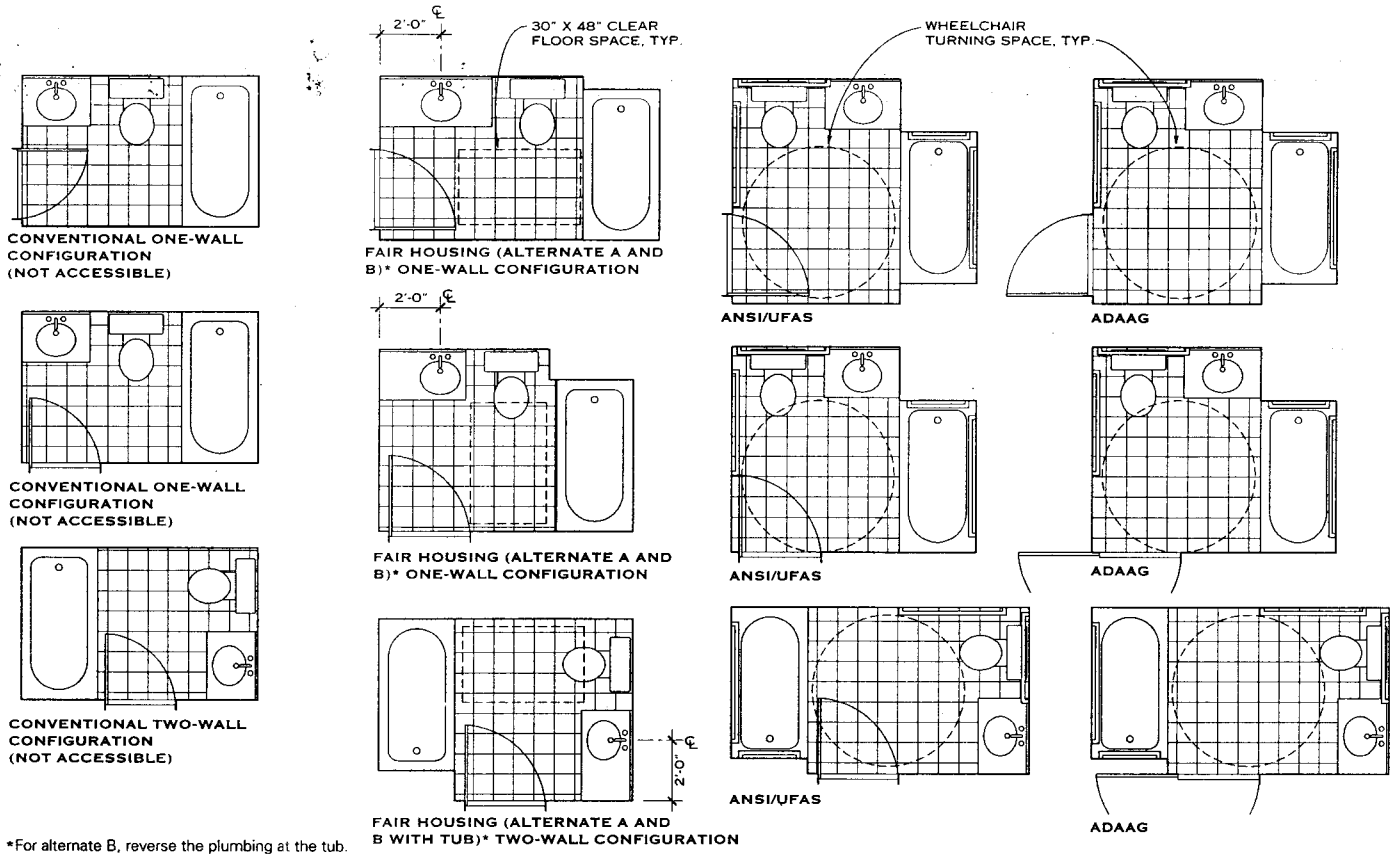

\*For alternate B, reverse the plumbing at the tub.

**BATHROOM LAYOUTS**

**ACCESSIBILITY STANDARDS FOR BATHROOMS**

Residential bathrooms and single-use toilet rooms can be divided into two general categories—private facilities such as those located in single- or multifamily dwellings and public or institutional facilities such as those located in nursing homes, hospitals, dormitories, or hotels.

Although toilet room and fixture design standards were an important part of the first ANSI A117.1 standards in 1961, wheelchair bathroom standards for private dwellings were not included until the 1981 edition. Four years later, the Uniform Federal Accessibility Standard (UFAS) published nearly identical bathroom standards for dwellings included in federal projects. In most multifamily projects, whether privately or publicly funded, between 1 and 5% of the total dwellings must meet the ANSI or UFAS standards for full wheelchair accessibility. The exact scoping requirement depends on the specific local or federal code.

In 1988 the Fair Housing Amendments Act (FHAA), a federal civil rights law that addressed private multifamily housing design, was enacted. FHAA guidelines included new and different standards for residential bathrooms. Although less strict than those found in ANSI and UFAS, the Fair Housing standards must be much more broadly applied, typically to 30–100% of all project units. The specific project scoping depends on the building configuration and whether or not it is equipped with a passenger elevator. The Fair Housing guidelines include two alternative bathroom design standards. In covered dwellings with two or more full bathrooms, the more strict standards can be used for one bath and more minimal standards can be applied to the second bathroom.

In 1991 the Americans with Disabilities Act (ADA) included new design standards called the Americans with Disability Act Accessibility Guidelines (ADAAG). ADAAG standards are not typically applied to private residential facilities because the previously issued Fair Housing standards already apply. However, bathrooms located in “transient lodging” facilities such as hotels or public institutional facilities such as hospitals may be required to meet both ADA and Fair Housing standards.

Architects should carefully verify which bathroom requirements apply to their projects because accessibility design standards vary significantly, even though many use the same technical language and general concepts.

**MANEUVERING SPACE**

An accessible bathroom must meet specified plan requirements, depending on the standards used. Each bathroom plan must provide the fixture clearances required by the applicable standard. In addition, some general maneuvering space must be provided, although the amount of space and the measurement rules vary.

Bathrooms that comply with Fair Housing must be “usable” rather than “accessible” and therefore have lower maneuvering space standards. According to Fair Housing, if the entry door swings into the bathroom, there must be enough clear space to position a wheelchair clear of the door swing. This requirement is described as a rectangular space 30 x 48 in. ANSI, UFAS, and ADAAG describe the required bathroom maneuvering space as either a 5-ft diameter circle or a 5-ft T-shaped area. Maneuvering space can include knee and toe space under fixtures and accessories.

All of the standards permit required floor space for fixtures to overlap with required maneuvering space. Current ADAAG standards, however, do not permit the bathroom door (even in single-user facilities) to swing into any fixture clearance. In almost all instances, this requirement effectively demands that the door swing out into the adjacent hall or bedroom.

**BATHROOM ENTRY DOORS**

Different standards require different size bathroom entry doors. Fair Housing permits a 2 ft 10 in. door to provide a “nominal” 32-in. clear opening. ANSI, UFAS, and ADAAG require installation of at least a 3 ft 0 in. door to provide the full 32-in. clear opening. These three standards also require maneuvering clearances for door operation.

**GRAB BARS**

Grab bar arrangement can influence the floor plan of an accessible bathroom. Fair Housing grab bar standards are less strict, and this permits the design of smaller bathrooms. For example, the grab bar installed adjacent to a water closet can be shorter than that required by ANSI. In fact, Fair Housing permits the installation of swing-down grab bars, so the water closet does not even have to be located adjacent to a wall. The stricter grab bar requirements of ANSI, UFAS, and ADAAG can become critical factors in water closet and bathroom arrangements and thus will affect the overall bathroom plan.

**ADAPTABLE FEATURES**

In residential bathroom design, “adaptability” was a new term when introduced in the 1980 ANSI edition. Adaptability in this case is defined as “the capability of certain...elements...to be altered or added so as to accommodate the needs of persons with or without disabilities, or to accommodate the needs of persons with different types or degrees of disabilities.” In accessible bathrooms, adaptable elements might typically include “removable” base cabinets that can be eliminated, when necessary, to provide knee space below vanities and hidden wall reinforcing that will facilitate later installation of grab bars around certain plumbing fixtures. Some codes and civil rights laws require provisions in certain bathrooms for “adaptable” features.

For single-family custom homes or remodeling projects, bathroom designs should be specially tailored to the individual homeowners. If a master bathroom is planned for a wheelchair user, for example, the design should reflect that person’s individual capabilities and preferences. This might include a specific type of bath fixture or a specific fixture orientation to accommodate better body function on the right or left side.

Kim A. Beasley, AIA, and Thomas D. Davies, Jr., AIA; Paralyzed Veterans of America Architecture; Washington, D.C.

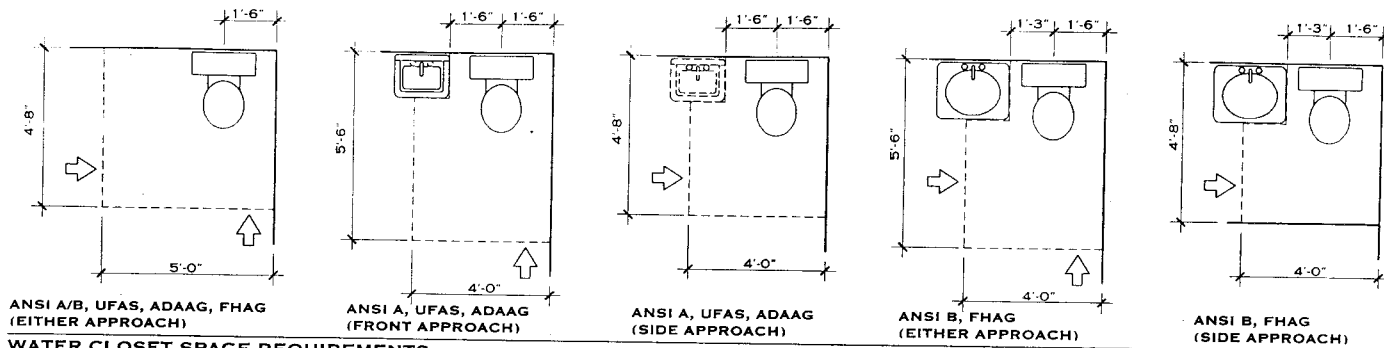

**WATER CLOSET SPACE REQUIREMENTS**

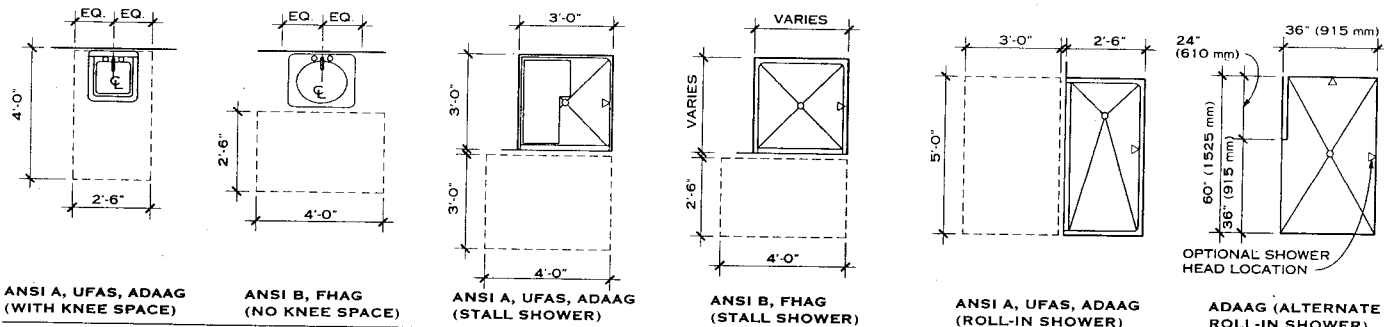

**LAVATORY AND SHOWER SPACE REQUIREMENTS**

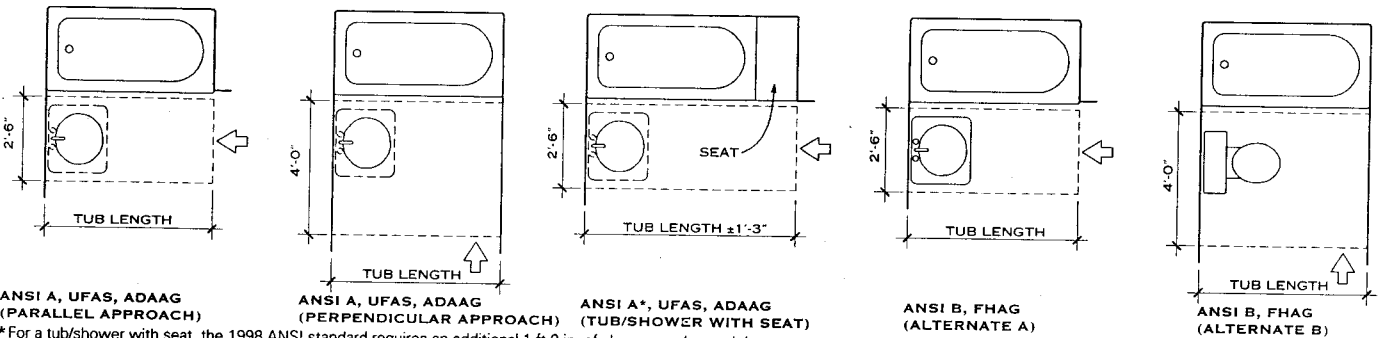

**BATHTUB SPACE REQUIREMENTS**

**PLUMBING FIXTURE REQUIREMENTS**

Although fixture requirements vary among the common accessibility standards and guidelines, the most significant differences are found between the Fair Housing Act and ANSI and UFAS. The current ADAAG requirements are similar to the ANSI/UFAS standards except for some very subtle technical differences. Floor space requirements for the different accessibility standards are illustrated in the accompanying plans. For other requirements, such as grab bar installations or faucet specifications, that depend more on a specific fixture, architects should refer to the code(s) or standard(s) that apply to their projects.

**WATER CLOSET STANDARDS**

Clear floor space requirements for water closets are similar in the Fair Housing, ANSI/UFAS, and ADAAG standards. Several of these include arrows on the floor plans to indicate a wheelchair user's approach direction, although the significance of this is never explained. The major differences between Fair Housing and the other standards are the minimum space required behind the water closet (33 in. as opposed to 36 in. or more) and the configuration of the lavatory or vanity that may be located adjacent to the toilet. In order to meet Fair Housing standards, an adjacent lavatory does not have to include knee space, whereas knee space is an important ANSI/UFAS and ADAAG requirement.

Designers should be aware of other technical requirements such as grab bars, wall reinforcement, and toilet seat heights. For all the standards except Fair Housing, toilet grab bar requirements can significantly affect both the loca-

tion of the water closet and the overall bathroom arrangement. Water closets that meet ANSI/UFAS and ADAAG, for example, must be located adjacent to a long side wall; therefore, they cannot be positioned next to a bathtub or directly inside the entry door. When designing toilets for Fair Housing projects, architects should also reference several other requirements that were added to the 1996 edition of the HUD Fair Housing Act Design Manual.

**LAVATORY AND VANITY STANDARDS**

The major differences between accessibility standards for lavatories and vanities are related to the need for under-basin knee space. Specifically, Fair Housing does not require knee space but the other standards do. In some instances, the knee space height required by ADAAG is greater than that required by ANSI or UFAS. All accessibility standards except Fair Housing include requirements for a maximum sink depth. ADAAG, ANSI, and UFAS also include requirements for faucets, mirrors, and medicine cabinets. The 1996 Fair Housing Act Design Manual amended the original guidelines to require that a parallel approach vanity sink be centered on the required clear floor space.

**BATHTUB AND TUB/SHOWER STANDARDS**

The ADAAG, ANSI (pre-1998), and UFAS accessible bathtub standards also have subtle differences. The bathtub clear floor space requirements are similar to those for water closets in that an approach direction is indicated (either perpendicular or parallel). The significance of the approach direction is similarly unclear, particularly when a knee space lavatory will be installed adjacent to the tub. Wheelchair access to the bathtub faucets and controls is available in

either case, although ambulatory bathers' access is compromised by a lavatory installed in this location. Under the Fair Housing guidelines, it is permissible to locate either a water closet or non-knee space lavatory in this position.

Fair Housing offers two different clear space requirements; the designer may choose to comply with either. Of these alternatives, Alternate B is stricter because it requires clear space adjacent to the foot of the tub.

**STALL SHOWER AND ROLL-IN UNIT STANDARDS**

Accessible showers include both transfer stalls (where a bather moves from a wheelchair to a bench or portable seat) and roll-in stalls (where a bather remains seated in a special shower chair and is either pushed by an attendant or self-propelled into the stall). Stall shower design requirements vary among the different standards. Fair Housing has fewer strict requirements for stall size and requires a smaller clear space in the bathroom outside the shower entrance. ANSI, UFAS, and ADAAG require installation of a built-in stall seat. The standards also address the location and design of the mixing valve, operating controls, and spray head. All accessibility standards require either wall reinforcing or grab bars inside a shower. ANSI, UFAS, and ADAAG include a maximum dam height for stall showers. All the accessibility standards except Fair Housing include specifications for roll-in showers. These stalls are much larger and without a dam in order to permit wheelchair access, making it necessary to lower the floor structure beneath the shower to provide an essentially flush transition with the bathroom floor.

Lawrence G. Perry, AIA; Silver Spring, Maryland

**ACCESSIBILITY GUIDELINES**

The 1980 American National Standards Institute (ANSI) A117.1 and the 1984 Uniform Federal Accessibility Standards (UFAS) were the first to include kitchen design standards that focused on the needs of wheelchair users. In most multifamily housing, ANSI/UFAS standards must be applied to between 1 and 5% of the total dwelling units, depending on local building codes or federal standards. The kitchen standards in the 1988 Fair Housing Amendments Act, a federal civil rights law, include less specialized wheelchair design features for multifamily housing. Fair Housing standards must be applied to between 20 and 100% of the total project units, depending on the configuration of the buildings, whether they are equipped with a passenger elevator, and the site topography.

Architects should carefully verify which kitchen requirements are appropriate for their specific project because accessibility codes and civil rights laws have very different design standards.

Kitchen designs for single-family custom homes or remodeling projects should be based in part on which family member performs cooking or clean-up chores and also on the capabilities of the wheelchair user. Accessible kitchens should reflect conventional layout principles with regard to proper workflow and functional adjacencies.

**FIXTURE AND APPLIANCE REQUIREMENTS**

The three general types of wheelchair standards for residential kitchens are: (1) general kitchen maneuvering space; (2) individual fixture and appliance maneuvering space; and (3) other fixture specifications such as basin depths, switch locations, and faucet configurations. ANSI and UFAS standards for appliances and plumbing fixtures are much more restrictive than Fair Housing (see chart on this page). All of them require that sufficient clear floor space be provided at fixtures or appliances to accommodate either a *parallel* or *front* approach, depending on the applicable design standard.

Some clearance standards do not have a functional basis, however. For example, in order to be useful, a parallel approach to a dishwasher must be offset to allow the bottom-hinged door to be fully lowered. An adjacent knee space at either the kitchen sink or an open, end-of-counter location provides optimum wheelchair access to a dishwasher. A parallel approach to a refrigerator is more practical than a front approach because the user's longer horizontal reach will allow full access to the interior.

The 1998 ANSI appliance clearances are more sophisticated than previous standards. For example, oven clearances depend on whether the unit is a self-cleaning model and on whether the door is side- or bottom-hinged. If the kitchen design is based on specific assumptions regarding appliances, the architect should carefully note that fact on the drawings to ensure that the proper model is purchased and to protect against compliance questions.

A critical point regarding clear floor space and kitchen fixtures and appliances is the requirement to precisely center the floor space on the centerline of the appliance or fixture. Although this requirement was not explicitly stated in the Fair Housing guidelines, HUD interprets this to be a Fair Housing kitchen and bathroom requirement. In a kitchen plan, the impact can be significant. In order to provide a parallel approach, for example, fixtures or appliances less than 48 in. wide must be offset from either an end wall or an inside counter corner. A 30 in. refrigerator, for example, must be located 9 in. away from an end wall; a 24 in. dishwasher must be located 12 in. away from an inside counter corner. Kitchen centerline requirements exceed the 1986 ANSI "safe harbor" requirements.

Requirements for general maneuvering space within the kitchen and for counter heights also vary among standards. ANSI and UFAS require a minimum clearance between counters, countertops, appliances, or walls of (1) a 40-in. galley aisle where required fixture or work area knee space is provided or (2) a 60-in. aisle in U-shaped kitchens. The minimum galley aisle required by Fair Housing is unclear, although designs that meet 1986 ANSI technically meet the federal laws. ANSI and UFAS require either adjustable height counters or fixed counters at a height of 34 in. Fair Housing does not address counter heights.

**ADAPTABLE FEATURES**

The term "adaptability" is defined as "the capability of certain . . . elements . . . to be altered or added so as to accommodate the needs of persons with or without disabilities" For accessible kitchens, "adaptable" elements might include "removable" base cabinets that can be eliminated to provide knee space below countertops, or adjustable height countertop sections that can be raised and lowered.

Lawrence G. Perry, AIA; Silver Spring, Maryland

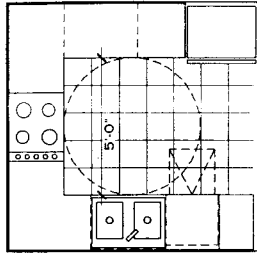

**NOTE**

A U-shaped counter arrangement must include a 5 ft 0 in. clearance between the opposing counters (or appliances or walls) in order to comply with ANSI or UFAS standards. FHAA guidelines require a 5 ft 0 in. clearance if a sink, range, or cooktop is installed in the base leg of the U. If the base leg fixture includes a knee space or removable base cabinets, the 5 ft 0 in. clearance is not required.

**U-SHAPED KITCHEN PLAN**

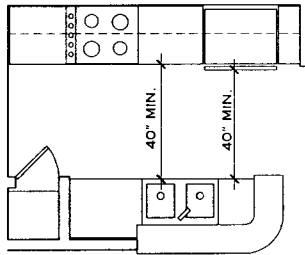

**NOTE**

ANSI and UFAS require 40 in. clearance between kitchen cabinets and opposing walls, cabinets, or appliances where the counters provide knee space. In other instances, an accessible route is required. The FHAA guidelines, however, require a 40 in. clearance in all cases. Passage widths between opposing counter sides or walls and counter sides are not specifically addressed in the FHAA guidelines. If this passage's length does not exceed 24 in., ANSI or UFAS permits the width to be a minimum of 32 in.

**GALLEY KITCHEN PLAN**

**FLOOR SPACE AND KNEE SPACE REQUIREMENTS FOR FIXTURES AND APPLIANCES**

APPLIANCE	REQUIREMENT	FAIR HOUSING	ANSI/UFAS
Sink	Approach	Parallel	Parallel or front
	Knee space	No	Yes
Range/cooktop	Approach	Parallel	Parallel or front
	Knee space	No	Optional
Work space	Approach	Not required	Front
	Knee space	No	Yes
Refrigerator	Approach	Parallel or front	Parallel or front
	Knee space	No	No
Dishwasher	Approach	Parallel or front	Parallel or front
	Knee space	No	No
Oven (self-cleaning)	Approach	Parallel or front	Front
	Knee space	No	No
Oven (non-self-cleaning)	Approach	Parallel or front	Front
	Knee space	No	Yes (off-set)
Trash compactor	Approach	Parallel or front	Parallel or front
	Knee space	No	No

**NOTE**

Fair Housing guidelines and most building code standards require a clear floor space at most kitchen fixtures and appliances. This space can permit a parallel or a perpendicular (front) wheelchair approach, depending on the fixture or appliance selected or the decision of the designer. HUD has interpreted its FHAA guidelines to require centering of the clear floor space on the appliance or fixture. This is not a requirement of the building codes, however, and may exceed the 1986 ANSI "safe harbor" for FHAA.

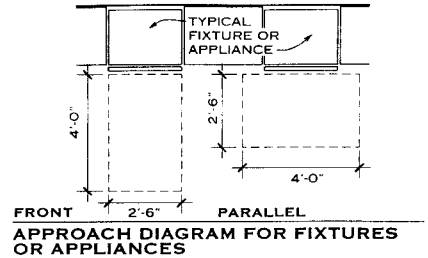

**APPROACH DIAGRAM FOR FIXTURES OR APPLIANCES**

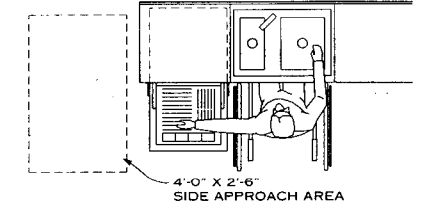

**NOTE**

Locating the kitchen sink next to the dishwasher has accessibility benefits as well as functional advantages. The sink knee space provides convenient access for a wheelchair user to the adjacent dishwasher. The sink itself should be a shallow unit with easy-to-operate faucets. A tall spout and a pullout spray attachment are also recommended. Garbage disposals must be offset in order to provide full knee space under the sink.

**KITCHEN SINK AND DISHWASHER**

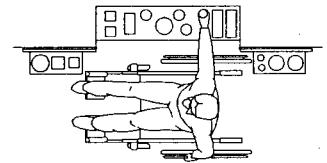

**NOTE**

The design of kitchen storage space for wheelchair users should provide both visual and physical access to wall and base cabinets, drawers, and pantries. Base cabinets, for example, can be specified to include pullout shelves or drawers that will provide easy access to items stored in the back of the cabinets. Similarly, shelf racks on pantry doors make it easier for the user to find and reach stored items.

**KITCHEN STORAGE**

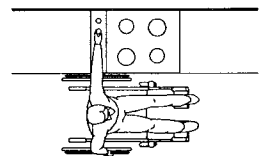

**NOTE**

A range or cooktop should have front- or side-mounted controls so the seated user does not need to reach over the heated surfaces. A smooth cooktop surface allows pots to be slid rather than lifted on and off the burners. Separate cooktop and oven units allow the alternative of providing knee space below the cooking surface, although this arrangement can also create safety issues.

**STOVES AND COOKTOPS**

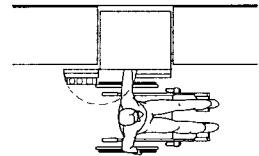

**NOTE**

Side-by-side models offer the user both freezer and refrigerator storage at all height levels from the floor to the top shelf. Over-and-under models can also be a satisfactory choice for many wheelchair users. Models with narrower doors are easier to operate and the desired parallel access is easier to provide if the refrigerator doors swing back a full 180 degrees.

**REFRIGERATORS**

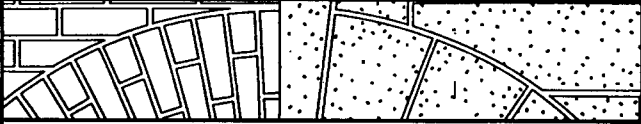

# APPENDIX

Graphic Symbols 978

Drawing Methods 986

Geometry 995

Mathematical Data 1005

Structural Calculations 1008

Classical Architecture 1011

Metric 1017

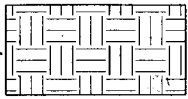

EARTH

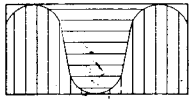

ROCK

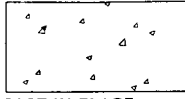

CAST-IN-PLACE CONCRETE

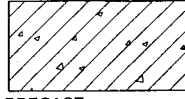

PRECAST CONCRETE



CONTINUOUS ROUGH WOOD FRAMING

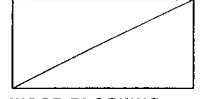

WOOD BLOCKING

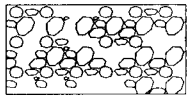

COARSE POROUS FILL (GRAVEL)

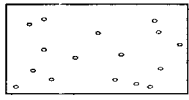

FINE POROUS FILL

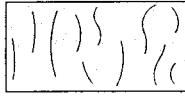

CEMENTITIOUS DECKS AND TOPPINGS



GROUT

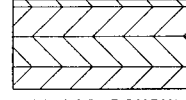

PLYWOOD (ROUGH)



PLYWOOD FOR ARCHITECTURAL WOODWORK

SITework

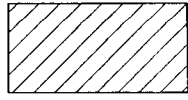

BRICK

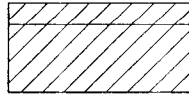

GLAZED BRICK



STRUCTURAL CLAY TILE UNIT MASONRY



GLAZED STRUCTURAL CLAY TILE UNIT MASONRY

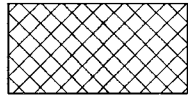

CONCRETE UNIT MASONRY

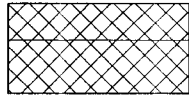

GLAZED CONCRETE UNIT MASONRY

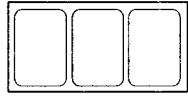

TERRA-COTTA UNIT MASONRY



GLASS UNIT MASONRY

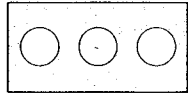

GYPSUM UNIT MASONRY

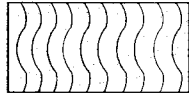

ADOBE UNIT MASONRY

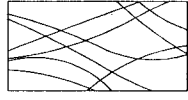

CUT STONE



FIREBRICK

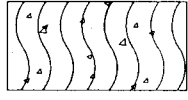

CAST STONE MASONRY

CONCRETE

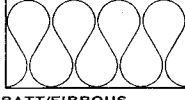

BATT/FIBROUS INSULATION

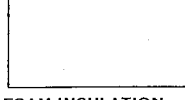

FOAM INSULATION

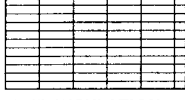

RIGID INSULATION BOARD

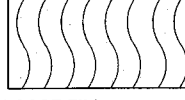

LOOSE FILL INSULATION

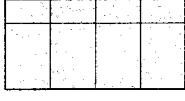

EXTERIOR INSULATION AND FINISH SYSTEM (EIFS)



FIBROUS FIRE SAFING

THERMAL AND MOISTURE PROTECTION

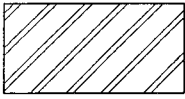

STEEL

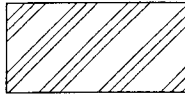

ALUMINUM

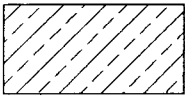

ORNAMENTAL METAL (INDICATE MATERIAL)

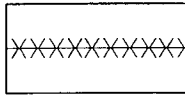

WELDING

METAL

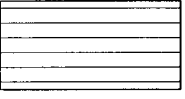

GLASS

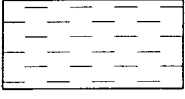

PLASTIC

GLAZING

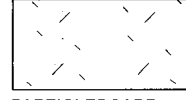

PARTICLEBOARD (ROUGH)

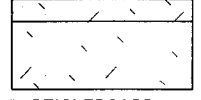

PARTICLEBOARD FOR ARCHITECTURAL WOODWORK

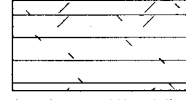

ORIENTED STRAND BOARD (OSB)

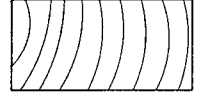

FINISH WOOD FOR ARCHITECTURAL WOODWORK

NOTE

Indicate laminate material used for architectural woodwork.

WOOD

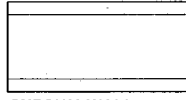

GYPSUM WALL BOARD (GWB)

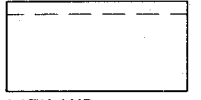

LATH AND PLASTER

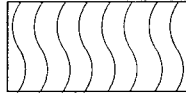

CERAMIC TILE



RESILIENT TILE

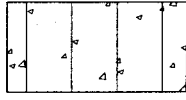

TERRAZZO

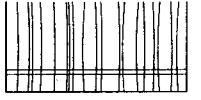

CARPET

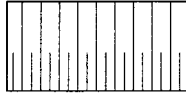

ACOUSTICAL TILE CEILING



CURTAINS

FINISHES AND FURNISHINGS



CENTERLINE OF FASTENER (INDICATE TYPE)

WOOD OR METAL FASTENER

FASTENERS

**GRAPHIC SYMBOLS**

The following symbols are commonly used by architecture firms.

	NOTE INDICATOR
	REVISION INDICATOR
	COLUMN LINE OR GRID INDICATOR
	MATCH LINE (DWG = drawing number for continuation)
	DETAIL INDICATOR
	SECTION INDICATOR
	ELEVATION VIEW INDICATOR
	ROOM IDENTIFIER
	DOOR/OPENING IDENTIFIER
	WINDOW IDENTIFIER
	WALL TYPE IDENTIFIER
	EQUIPMENT IDENTIFIER
	☉ CENTER LINE
	ℙ PROPERTY LINE
	HIDDEN, FUTURE, OR EXISTING CONSTRUCTION
	BREAK LINE
	HATCH MARK ARROW DOT

**DIMENSION LINES**  
NOTE  
In the symbols above: NO.—sequential alphanumeric designation; DWG—drawing number.

**GENERAL SYMBOLS AND CONVENTIONS**

Keith McCormack, AIA; RTKL Associates, Inc; Baltimore, Maryland

	NORTH INDICATOR
	BENCHMARK INDICATOR (BM = coordinate, elevation, or station sequence designation)
	CONTROL ELEVATION INDICATOR
	MONUMENT (elevation at finished grade)
	BORING INDICATOR (*: SB = soil bearing; TW = test well) (elevation at ground level)
	EXISTING ELEVATION INDICATOR
	NEW (FINISH) ELEVATION INDICATOR
	EXISTING PROPERTY CORNER INDICATOR
	NEW PROPERTY CORNER INDICATOR
	EXISTING TEMPORARY GROUND POINT INDICATOR
	NEW TEMPORARY GROUND POINT INDICATOR
	VAULT (indicate invert elevation)
	PULL BOX
	MANHOLE (indicate invert elevation)
	CLEANOUT (indicate invert elevation)
	EMBANKMENT INDICATOR (shown in series)
	SURFACE DRAINAGE (ditch or swale center line indicator with direction of flow)
	EXISTING CONTOUR
	NEW (FINISHED) CONTOUR
	FIRE HYDRANT
	FREESTANDING FIRE PROTECTION WATER SUPPLY (FFW) CONNECTION (indicate number and direction of connections)
	VALVE WITH ABOVE GROUND INDICATOR (PIV = post indicator valve)
	FUEL, STEAM, AND WATER DISTRIBUTION SYSTEM (*: HWS = hot water supply; CHWS = chilled water supply; G = gas; O = oil)
	SEWERAGE AND DRAINAGE (SD = storm drain; SS = sanitary sewer)
	CONDUIT END SECTION (indicate invert elevation)
	SUBSURFACE DRAIN (arrow indicates direction of flow)
	CATCH BASIN (indicate invert (floor of conduit) elevation)
	HEADWALL (indicate invert elevation)
	POWER AND COMMUNICATIONS (*: C = communications; P = power; or T = telecommunications)
	OVERHEAD LINE SUPPORT (schedule type)
	GUY WITH ANCHOR
	FENCE
	GUARDRAIL
	TREE (indicate trunk location, drip line, diameter of trunk, and species)
	METERING DEVICE INDICATOR
	VALVE (indicate configuration, type, function, and control)

**NOTE**  
In the symbols above: EL.—elevation; NO.—sequential alphanumeric designation.

**SITework SYMBOLS**



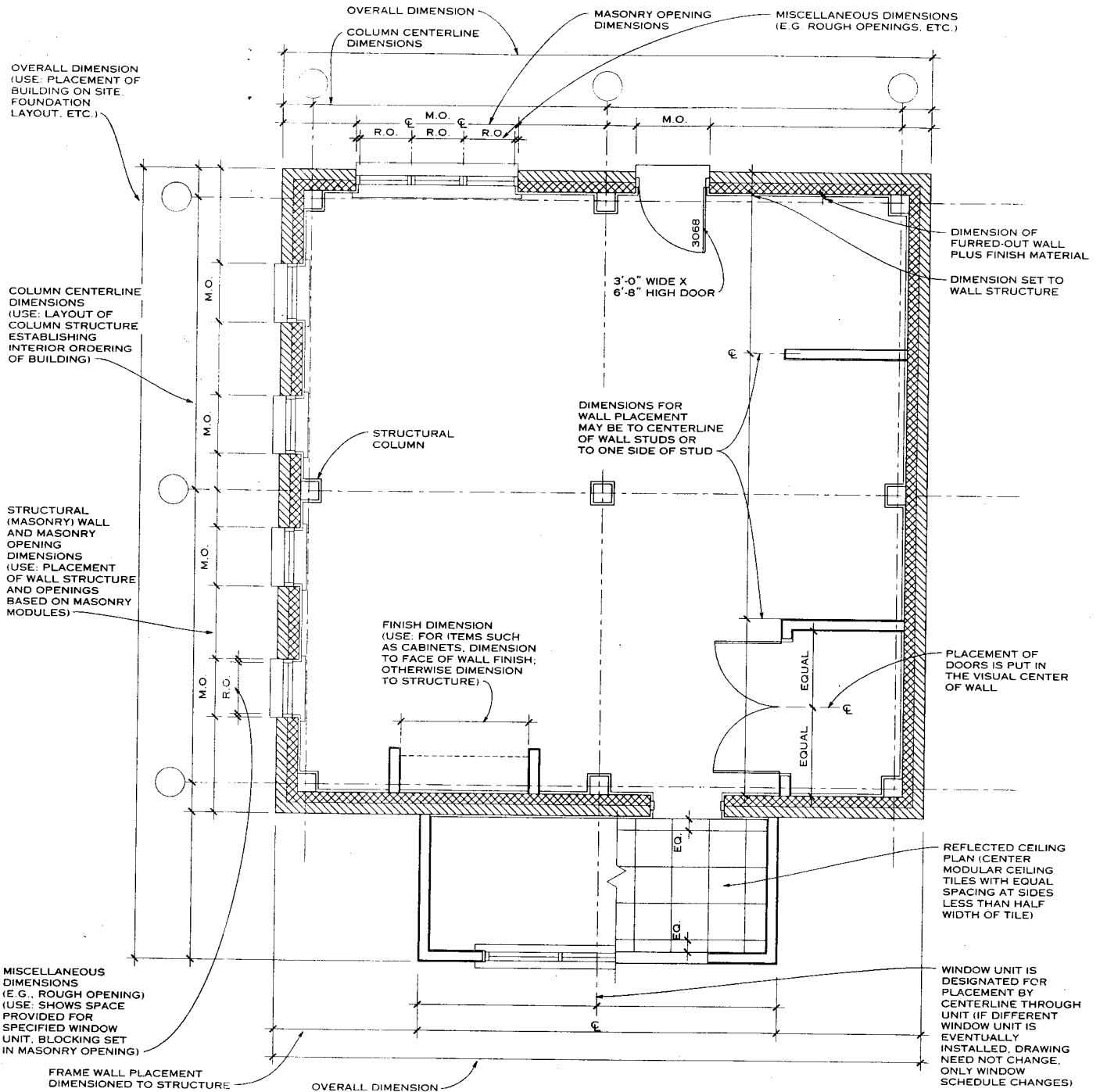

**DIMENSIONING METHODOLOGY**

**GENERAL**

Provide only critical dimensions on plans so as to keep them as uncluttered as possible. Consider the building trades using the dimensions and the sequencing of their work.

Because tolerances vary in construction, the as-built dimensions do not always coincide with the design dimensions. Dimensioning from established grids or structural elements, such as columns and structural walls, assists the trades that must locate their work prior to that of others.

**NOTES**

1. Dimensions under 1 ft should be given in inches. Dimensions 1 ft and over should be given in feet.
2. Use a diagonal line to separate the numerator from the denominator in a fraction. Do not use decimal fractions preceded by a zero (e.g., 0.5).
3. Dimension points should be indicated with a short, blunt 45 line, called a hatch mark. Hatch marks are oriented differently for vertical (↖) and horizontal (↘) dimensions. Modular dimension points may be designated with an arrow or a dot.

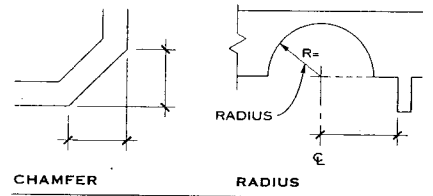

**MISCELLANEOUS DIMENSIONS**

Daniel F. C. Hayes, AIA; Washington, D.C.  
John Ray Hoke, Jr., FAIA; Washington, D.C.

**A** GRAPHIC SYMBOLS

	RIGID CONDUIT (indicate size and material, if required)
	FLEXIBLE CONDUIT (indicate size and material, if required)
	HOMERUN TO PANELBOARD (indicate circuit and panel)
	WIRING, NEUTRAL
	WIRING, HOT
	WIRING GROUND
	WIRING, SWITCH LEG
	JUNCTION BOX (indicate size and type, if required)
	FLOOR JUNCTION BOX (indicate size and type, if required)
	SINGLE RECEPTACLE (indicate nonstandard mounting height; * = GFI—ground fault interrupt; IG—isolated ground; S—integral switch; WP—weatherproof; XP—explosionproof)
	DUPLEX RECEPTACLE (indicate nonstandard mounting height; * = same as above for single receptacle)
	QUADRAPLEX RECEPTACLE (indicate nonstandard mounting height; * = same as above for single receptacle)
	SPECIAL PURPOSE RECEPTACLE (indicate nonstandard mounting height)
	CLOCK RECEPTACLE (indicate nonstandard mounting height)
	DATA COMMUNICATIONS OUTLET (indicate nonstandard mounting height)
	TELEPHONE OUTLET (indicate nonstandard mounting height)
	SINGLE FLOOR RECEPTACLE (indicate nonstandard mounting height; * = GFI—ground fault interrupt; IG—isolated ground; S—integral switch; WP—weatherproof; XP—explosionproof)
	DUPLEX FLOOR RECEPTACLE (indicate nonstandard mounting height; * = same as above for single floor receptacle)

CONDUIT, WIRING, AND OUTLET SYMBOLS

	FLOOR SPECIAL PURPOSE RECEPTACLE (indicate configuration)
	FLOOR TELEPHONE OUTLET
	FLOOR DATA COMMUNICATIONS OUTLET
	RANGE OUTLET
	SPLIT-WIRED DUPLEX RECEPTACLE OUTLET
	FAN HANGER RECEPTACLE
	TELEVISION OUTLET (indicate nonstandard mounting height)
	SWITCH (* = [none]—single pole; 2—two-pole; 3—three-way; 4—four-way; D—door; K—key operated; LV—low voltage; M—momentary contact; P—pilot light)
	DIMMER SWITCH (indicate nonstandard mounting height)
	CEILING PULL SWITCH
	SWITCH AND SINGLE RECEPTACLE
	SWITCH AND DOUBLE RECEPTACLE
	PLUGMOLD (indicate spacing and nonstandard mounting height)

SWITCH AND OUTLET SYMBOLS



























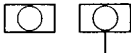

























	CONTROL POWER TRANSFORMER
	POTENTIAL TRANSFORMER
	CURRENT TRANSFORMER
	CABLE POT HEAD (may be used for overhead or underground)
	BUS DUCT (indicate size)
	CIRCUIT BREAKER
	GROUND FAULT RELAY
	FUSE, LOW OR MEDIUM VOLTAGE
	FUSED CUTOUT
	MOTOR STARTER
	COMBINATION MOTOR STARTER
	MANUAL MOTOR STARTER
	MAGNETIC ONLY CIRCUIT BREAKER
	MOTOR (* = horsepower)
	CONTACTOR, NORMALLY CLOSED
	CONTACTOR, NORMALLY OPEN
	TRANSFER SWITCH (* = A—automatic; M—manual; #P—no. of poles; #—amp rating)
	WALL BRACKET (for wall-mounted electrical items)

MISCELLANEOUS ELECTRICAL DEVICE SYMBOLS

SWITCH AND OUTLET SYMBOLS

	GENERATOR
	Y-CONNECTION, LOW OR MEDIUM VOLTAGE
	DELTA CONNECTION, LOW OR MEDIUM VOLTAGE
	CIRCUIT BREAKER, MEDIUM VOLTAGE
	DISCONNECT/INTERRUPTER SWITCH, MEDIUM VOLTAGE (indicate size)

MISCELLANEOUS ELECTRICAL DEVICE SYMBOLS

	PULL STATION, FIRE ALARM		CAPACITOR		CEILING-MOUNTED LIGHT FIXTURE (indicate type)
	FIRE ALARM HORN AND/OR STROBE		SERVICE WEATHERHEAD		EXIT LIGHT (indicate type; shading indicates lighted face)
	FIREFIGHTERS' PHONE		METER (* = A—ammeter; KV—kilovolt meter; KWD—kilowatt demand meter; KWH—kilowatt hour meter; M—meter; PF—power factor meter; V—voltmeter; VAR—VAR meter)		WALL WASHER (indicate type; shading indicates lighted face)
	FIRE ALARM BELL		BATTERY		SPOTLIGHT (indicate type; arrow indicates direction of focus)
	MAGNETIC HOLD-OPEN DEVICE		LIGHTNING ARRESTER		FLUORESCENT FIXTURE (indicate type; draw to scale)
	SPEAKER (F—fire; NC—nurse call; PA—public address)		DRAWOUT CONNECTION		SURFACE-MOUNTED FLUORESCENT
	CLOCK HEIGHT		FLAME DETECTOR		EMERGENCY FLUORESCENT FIXTURE (indicate type; draw to scale)
	ELECTRIC RESISTANCE HEATER		HEAT DETECTOR (indicate type)		FLUORESCENT STRIP LIGHT (indicate type; draw to scale)
	BUZZER		SMOKE DETECTOR (* = I—ionization; P—photoelectric)		LIGHT TRACK (indicate type; show number of fixtures required)
	BUZZER AND BELL COMBINATION		GAS DETECTOR (Indicate type)		DROP CORD
	BELL		DETECTOR OR SELECTOR SWITCH (* = FS—flow switch; LS—level switch; PS—pressure switch; TS—tamper switch; AS—ammeter; VS—voltmeter)		EMERGENCY BATTERY- POWERED LIGHT (indicate single or double lamp)
	PUSH-BUTTON SWITCH (indicate emergency power off [EPO], if required)		DISCONNECT/INTERRUPTER SWITCH, LOW VOLTAGE (indicate size)		EMERGENCY BATTERY-POWERED LIGHT, REMOTE (indicate single or double lamp)
	SWITCH		DISCONNECT SWITCH (indicate size)		ARM-MOUNTED OUTDOOR POLE FIXTURE
	PHOTOELECTRIC CELL		FUSED DISCONNECT (indicate size)		REMOTE EMERGENCY SEALED BEAM HEAD WITH OUTLET BOX
	PNEUMATIC THERMOSTAT (* = A—aspirating; C—cooling; D—day; D/N—day/night; H—heating; H/C—heating/cooling; N—night)		GROUND CONNECTION		OUTLET CONTROLLED BY LOW VOLTAGE SWITCHING WHEN RELAY IS INSTALLED IN OUTLET BOX
	ELECTRIC THERMOSTAT (* = same as above for pneumatic thermostat)		TRANSFORMER, LOW VOLTAGE (for use on single line diagrams)		LAMP HOLDER WITH PULL SWITCH
	HUMIDISTAT		FLUSH-MOUNTED PANELBOARD AND CABINET		BLANKED OUTLET
	SENSOR (* = H—humidity; P—pressure; T—temperature)		SURFACE-MOUNTED PANELBOARD AND CABINET		

ELECTRICAL DEVICES, SWITCHES, AND PANELBOARD SYMBOLS

LIGHTING SYMBOLS

DESCRIPTION GOES HERE

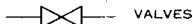

VALVES

DESCRIPTION

Configuration

- 3-way
- 4-way
- Angle
- In-line

Type

- Ball
- Butterfly
- Gate
- Globe

Function

- Balancing
- Pneumatic
- Pressure relief
- Shutoff

Control

- Differential pressure
- Manual
- Pressure regulator
- Pneumatic
- Self-activating
- Solenoid
- Thermostatic

NOTE

Combine modifiers as required.



AUTOMATIC 2-WAY VALVE



AUTOMATIC 3-WAY VALVE



AIR LINE VALVE



AIR ELIMINATOR VALVE



LOCK SHIELD VALVE

\* PIPING

\* DESCRIPTION

A	alkali	N	nitrogen
AW	acid waste	NG	natural gas
C	condensate	NO	nitrous oxide
CA	compressed air	NTW	nontoxic industrial waste
CHW	chilled water	O	oxygen
CO2	carbon dioxide	RFGT	refrigerant
CRW	chrome waste	STM	steam
CW	cold water (domestic)	SW	sea water
CYW	cyanide waste	TW	toxic industrial waste
D	diesel fuel	W	water
DIW	deionized water	WO	waste oil
DSP	dry standpipe	WST	wet standpipe
FO	fuel oil	* FUNCTION	
GAS	gasoline	DR	drain
H	hydrogen	DWW	drain, waste, and vent
HAL	halon	FP	fire protection
HG	hot gas	HY	hydronic
HW	hot water	R	return
LO	lubricating oil	RWL	rainwater leader
LPG	liquefied propane gas	S	supply
MUW	makeup water	SUCT	suction

NOTE

Combine modifiers as required.

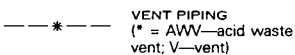

VENT PIPING (\* = AWW—acid waste vent; V—vent)

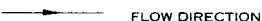

FLOW DIRECTION

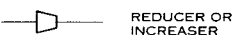

REDUCER OR INCREASER



UNION



PIPE ANCHOR



FLANGES



ALIGNMENT

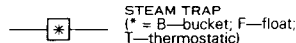

STEAM TRAP (\* = B—bucket; F—float; T—thermostatic)



HOSE BIBB HYDRANT (schedule types)



COCK OR PLUG



CHECK VALVE

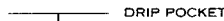

DRIP POCKET

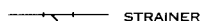

STRAINER



TEMPERATURE GAUGE



PRESSURE GAUGE



THERMOMETER

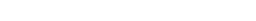

SPRINKLER HEAD (schedule types)



SIDEWALL SPRINKLER HEAD (schedule types)



CLEANOUT AT END OF PIPE



CLEANOUT AT WALL



DRAIN (\* = AD—area drain; FD—floor drain; FS—floor sink; RD—roof drain)



EXPANSION JOINT



FLEXIBLE PIPE CONNECTION



PIPE FLANGE, BLIND



PIPE ELBOW, DOWN



PIPE ELBOW, UP



PIPE TEE, DOWN



PIPE TEE, UP



DUCTWORK, SINGLE LINE (indicate size, shape, and type)



SUPPLY DUCTWORK (indicate size, shape, and type)



RETURN, RELIEF, OR EXHAUST DUCTWORK (indicate size, shape, and type)



FLEXIBLE DUCTWORK (indicate size, shape, and type)



DAMPER (\* = AD—automatic damper; BD—backdraft damper; FD—fire damper; MD—motorized damper; SD—smoke damper; VD—volume damper)



RECTANGULAR DIFFUSER (schedule size, indicate cu ft/min. and directions of throw)



ROUND DIFFUSER (schedule size, indicate cu ft/min. and directions of throw)



LINEAR DIFFUSER (schedule size, indicate cu ft/min. and directions of throw)



RETURN, RELIEF, OR EXHAUST REGISTER (schedule size)



SIDEWALL DIFFUSER (schedule size, indicate cu ft/min. and direction of flow)



RETURN, RELIEF, OR EXHAUST REGISTER (schedule size)



FLOOR REGISTER



DUCT (width X depth)



DIRECTION OF FLOW



DUCTWORK WITH ACOUSTICAL LINING



FLEXIBLE CONNECTION



INCLINED AIRFLOW (\* = R—rise, D—drop)



LOUVER OPENING (schedule size, indicate cu ft/min. and direction of flow)



















PLUMBING AND PIPING SYMBOLS

HVAC SYMBOLS



Keith McCormack, AIA; RTKL, Inc.; Baltimore, Maryland

GRAPHIC SYMBOLS







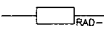
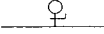
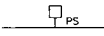
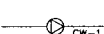
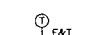

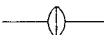
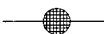
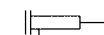

	COMPRESSOR, CENTRIFUGAL
	COMPRESSOR, RECIPROCATING
	COMPRESSOR, ROTARY
	COMPRESSOR, ROTARY SCREW
	CONDENSER, AIR COOLED
	CONDENSER, EVAPORATIVE
	CONDENSER, WATER COOLER (specify type)
	CONDENSING UNITS, AIR COOLED
	CONDENSING UNITS, WATER COOLED
	CONDENSER-EVAPORATOR (cascade system)
	COOLING TOWER
	COOLING TOWER, SPRAY POND TYPE
	EVAPORATOR, FINNED COIL
	EVAPORATOR, FORCED CONVECTION
	EVAPORATOR, IMMERSION COOLING UNIT
	EVAPORATOR, PLATE COIL
	EVAPORATOR, PIPE COIL
	LIQUID CHILLER, DIRECT EXPANSION



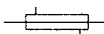

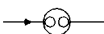











REFRIGERATION

	LIQUID CHILLER, TANK CLOSED
	LIQUID CHILLER, TANK OPEN
	HEAT EXCHANGER, LIQUID
	HEAT TRANSFER SURFACE (indicate type)
	PRESSURE GAUGE AND COCK
	PRESSURE SWITCH
	PUMP (indicate use)
	THERMOSTAT SELF-CONTAINED





REFRIGERATION

	FILTER
	STRAINER
	FILTER AND DRIER
	SCALE TRAP
	DRIER
	VIBRATION ABSORBER
	HEAT EXCHANGER
	OIL SEPARATOR
	SIGHT GLASS
	FUSIBLE PLUG

AUXILIARY REFRIGERANT EQUIPMENT

	CAPILLARY TUBE
	EXPANSION VALVE, HAND
	EXPANSION VALVE, AUTOMATIC
	EXPANSION VALVE, THERMOSTATIC
	FLOAT VALVE, HIGH SIDE
	FLOAT VALVE, LOW SIDE
	THERMAL BULB
	SOLENOID VALVE
	CONSTANT PRESSURE VALVE, SUCTION
	EVAPORATOR PRESSURE-REGULATING VALVE, THERMOSTATIC, THROTTLING-TYPE
	EVAPORATOR PRESSURE-REGULATING VALVE, THERMOSTATIC, SNAP-ACTION TYPE
	EVAPORATOR PRESSURE-REGULATING VALVE, THERMOSTATIC, THROTTLING-TYPE, EVAPORATOR SIDE
	COMPRESSOR SUCTION VALVE, PRESSURE-LIMITING, THROTTLING- TYPE, COMPRESSOR SIDE
	THERMO-SUCTION VALVE
	SNAP-ACTION VALVE
	REFRIGERANT REVERSING VALVE

REFRIGERANT CONTROLS

	MOTOR, ELECTRIC (number for identification of description in specifications)
	ENGINE (indicate fuel)
	GAS TURBINE
	STEAM TURBINE
	STEAM TURBINE, CONDENSING

POWER SOURCES

TYPE _____	CABLE/WIRE (denote type)	10 m (33 ft)	CABLE SLACK (denote slack length)	100 mm (4 in.) EMT	SINGLE CONDUIT RUN, WITH ENDPOINT (denote size and type)
	CABLE TO BE REMOVED		CAP PLACED ON CABLE		SINGLE CONDUIT HOME RUN (denote size, type, and home location)

**CABLE SYMBOLS**

	TERMINATION HARDWARE, NOT PROTECTED (denote terminal size)		CROSS-CONNECT HARDWARE, PRIMARY PROTECTOR INTEGRATED WITH CROSS-CONNECT HARDWARE		SINGLE CONDUIT RUN TURNED DOWN (denote size and type)
	TERMINATION HARDWARE, WITH PROTECTION (denote terminal size)		CROSS-CONNECT HARDWARE, PRIMARY AND SECONDARY PROTECTOR INTEGRATED WITH CROSS-CONNECT HARDWARE		SINGLE CONDUIT RUN TURNED UP (denote size and type)
	CROSS-CONNECT HARDWARE (description, as required)		PRIMARY PROTECTOR, NOT CROSS-CONNECTED		CONDUIT STUB UP (denote size and type)
	CROSS-CONNECT HARDWARE, NOT PROTECTED		PRIMARY PROTECTOR, CROSS-CONNECTED		CONDUIT BANK, PLAN VIEW (denote quantity, size, and type)

**CABLE TERMINATION SYMBOLS**

	CONNECTION TO GROUND (conductor size noted)		CONDUIT PLACED IN SLAB		CONDUIT SLEEVE (denote quantity, size, and type)
--	--	--	------------------------	--	---

**GROUNDING/BONDING SYMBOLS**

	WALL-MOUNTED TELECOMMUNICATIONS OUTLET BOX CONNECTOR (denote size, type configuration, and descriptive information as required)		CEILING DROP POLE		SLOT (denote dimensions)
	FLOOR-MOUNTED TELECOMMUNICATIONS OUTLET BOX CONNECTOR (denote size, type configuration, and descriptive information as required)		SWITCHBOARD		CABLE TRAY (denote size and type)
	CEILING-MOUNTED TELECOMMUNICATIONS OUTLET BOX CONNECTOR (denote size, type configuration, and descriptive information as required)		PULL BOX		UTILITY COLUMN, INTERIOR USE (denote size and type)
	EQUIPMENT RACK (show to scale)		TRENCH HEADER FEED ON CELLULAR OR UNDERFLOOR DUCT SYSTEM		SURFACE-MOUNTED RACEWAY (denote size and type)
	EQUIPMENT CABINET (show to scale)		HEADER DUCT WITH ACCESS UNIT ON CELLULAR OR UNDERFLOOR DUCT SYSTEM		TELEPHONE POLE, EXTERIOR USE (denote size, class, ownership)

**PATHWAY SYMBOLS**

	HANDHOLE (denote dimensions)		BUSWAY		BACKBOARD (denote dimensions)
	MANHOLE (denote dimensions)		WIREWAY		TELECOMMUNICATIONS SPACE (denote name of space)
	PULL BOX (denote dimensions)		WIREWAY TRANSFORMER	<b>SPACE SYMBOLS</b>	
	LARGE (FEEDER) UNDERFLOOR DUCT, TRENCH HEADER, OR HEADER DUCT		TRANSFORMER—MANHOLE OR VAULT		SPlicing LOCATION
	STANDARD (DISTRIBUTION) UNDERFLOOR DUCT OR CELLULAR FLOOR CELL		TRANSFORMER PAD		STRAIGHT SPLICE, NO CHANGES (singly administered)
	AERIAL CABLE OR WIRE		THREE WIRES		STRAIGHT SPLICE, WITH CHANGES (separately administered)
	CONDUIT FOR PLACING GROUND WIRE		FOUR WIRES		SPLICE WITH BRANCH CABLE (separately administered)
	UNDERFLOOR DUCT AND JUNCTION BOX, TRIPLE SYSTEM (number of lines shown indicates number of systems)		CROSS CONNECT		INSULATED SPLICE
	PRIMARY PROTECTOR		SPLICE, BURIED CABLE, IN PEDESTAL	<b>SPLICE SYMBOLS</b>	

**MISCELLANEOUS SYMBOLS**

Debbie Rathgeber Ryon, P.E.; Onancock, Virginia

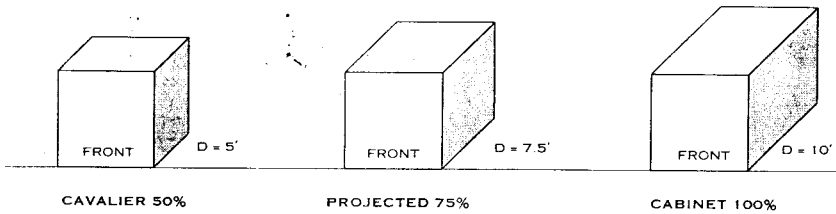

GIVEN:  
WIDTH = 10'  
DEPTH = 10'  
HEIGHT = 10'

**NOTE**

If front elevation is drawn at scale,  $1/4'' = 1' - 0''$   
Depth is  $3/4 \times 1/4'' = 3/16''$   
Use scale:  $3/16'' = 1' - 0''$

**OBLIQUE ELEVATION**

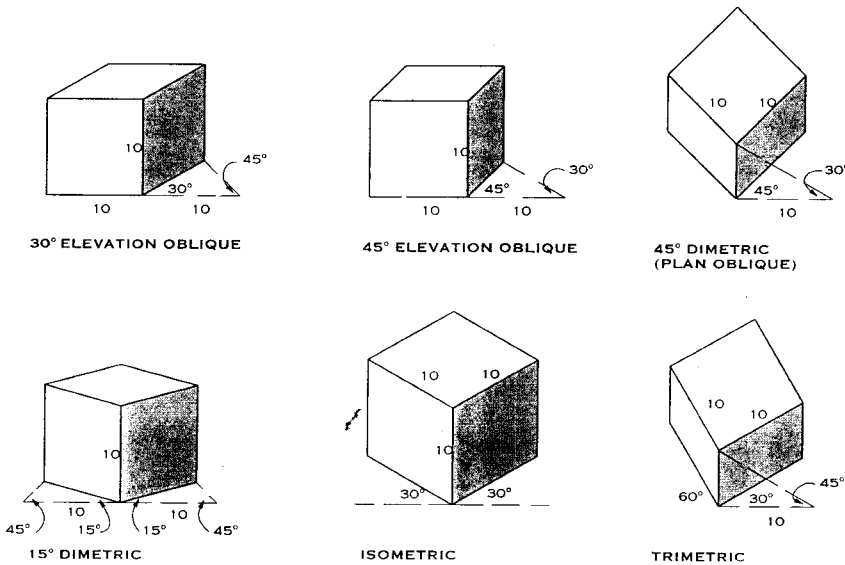

**PARALINE DRAWINGS**

Paraline drawings are sometimes referred to as AXONOMETRIC (Greek) or AXIOMETRIC (English) drawings. These drawings are projected pictorial representations of an object which give a three-dimensional quality. They can be classified as orthographic projections in as much as the plan view is rotated and the side view is tilted. The resulting "front" view is projected at a 90° angle to the picture plane (as illustrated in the projected method). These drawings differ from perspective drawings, since the projection lines remain parallel instead of converging to a point on the horizon.

Drawings prepared using the projection method require three views of the object, which tends to be more time-consuming and complex than drawing by the direct measuring method. The following drawings utilize this method; they are simple to draw and represent reasonably accurate proportions.

**OBLIQUE**

In an oblique drawing one face (either plan or elevation) of the object is drawn directly on the picture plane. Projected lines are drawn at a 30 or 45° angle to the picture plane. The length of the projecting lines is determined as illustrated and varies according to the angle chosen.

**DIMETRIC**

A dimetric drawing is similar to oblique, with one exception: the object is rotated so that only one of its corners touches the picture plane. The most frequently used angle for the projecting lines is an equal division of 45° on either side of the leading edge. A 15° angle is sometimes used when it is less important to show the "roof view" of the object.

**ISOMETRIC**

The isometric, a special type of dimetric drawing, is the easiest and most popular paraline drawing. All axes of the object are simultaneously rotated away from the picture plane and kept at the same angle of projection (30° from the picture plane). All legs are equally distorted in length at a given scale and therefore maintain an exact proportion of 1:1.

**TRIMETRIC**

The trimetric drawing is similar to the dimetric, except that the plan of the object is rotated so that the two exposed sides of the object are not at equal angles to the ground plane. The plan is usually positioned at 30/60° angle to the ground plane. The height of the object is reduced proportionately as illustrated (similar to the 45° dimetric).

**SHADES AND SHADOWS**

Shades and shadows are easily constructed and can be very effective in paraline drawings. The location of the light source will determine the direction of the shadows cast by the object. The shade line is the line (or the edge) that separates the light area from the shaded areas of the object. Shadows are constructed by drawing a line, representing a light ray, from a corner of the lighted surface at a 45° angle to the ground plane. Shadows cast by a vertical edge of the object will be drawn midway in the angle created by the intersection of the projected line of the object and the ground, or baseline (the baseline represents the intersection of the picture plane). The 45° light ray is extended until it meets the shadow line (as illustrated), and this point determines the length of the shadow for any given vertical height of the object. Shadow lines of all vertical edges of the object are drawn parallel to one another.

**AXONOMETRIC - MEASURED METHOD**

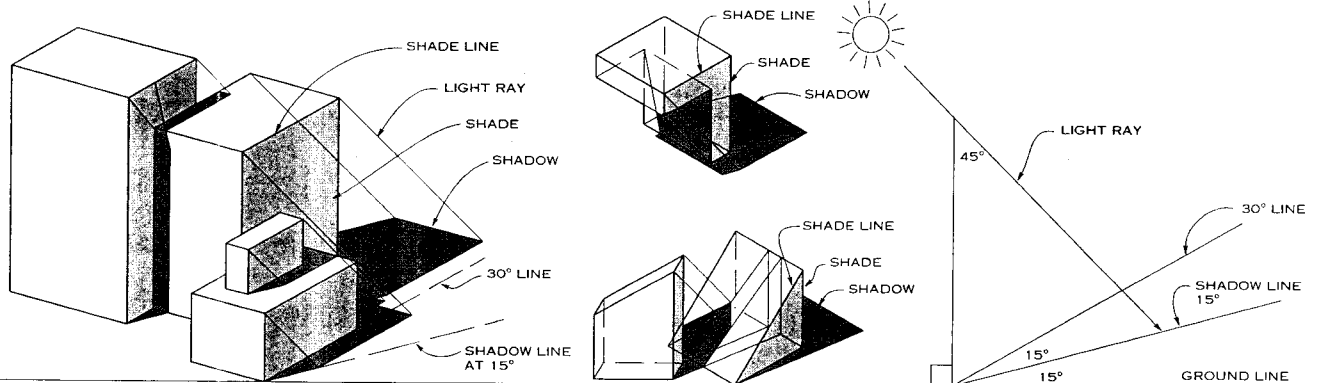

**AXONOMETRIC SHADES AND SHADOWS**

Samuel J. De Santo and Associates; New York, New York  
Alvarado Thrun Maeda and Associates; New York, New York; Eric A. Borch; Newburgh, New York

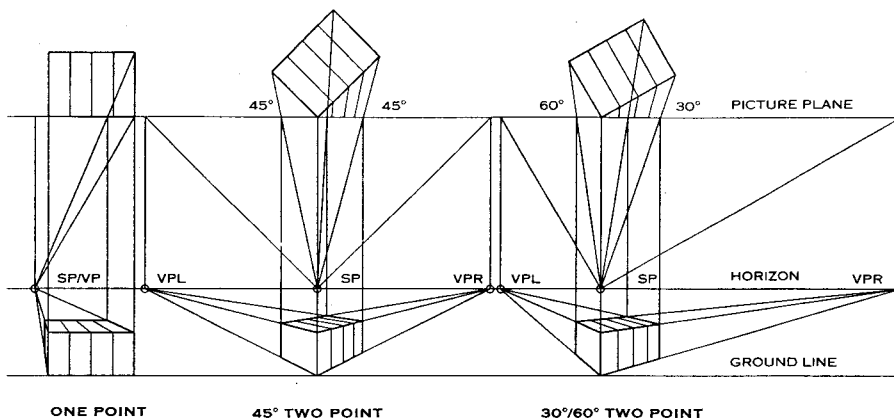

**TERMS AND CONCEPTS**

1. THE OBJECT: Called a building in this example.
2. THE PICTURE PLANE: An imaginary, transparent plane, onto or through which the object is perceived in a perspective rendering. It is:
  - a. Parallel to one face of the drawing paper, if it is a one-point perspective.
  - b. Perpendicular to the ground line and at any angle to the building if it is a two-point perspective.
  - c. Tilted and placed at any angle to the building if it is a three-point perspective.
  - d. A curved plane if it is a wide angle perspective view.
3. HORIZON LINE: A line drawn on the picture plane to represent the horizon. It is usually located at the point where all parallel lines recede away from the viewer and finally converge. This point is aptly designated as the vanishing point. Note that although the horizon is generally thought of as a horizontal line, in certain applications it could be vertical, or even at an angle, to the picture plane. For example, in drawing shades and shadows it appears to be at a 90° angle and in a three-point perspective it appears to be slanted.
4. STATION POINT: The point from which the object is being viewed or, in other words, the point from which the viewer is seeing the building. The location of this point will be the factor that determines the width of the drawing. A 30° cone of vision is drawn from the station point; as the viewer moves away from the object, the cone widens, the object becomes smaller, and more material is included in the area surrounding the object. A common way of determining the distance between the station point and the picture plane is by referring to the following parameters:
  - a. Minimum - 1.73 times the width of the drawing.
  - b. Average - 2.00 times the width of the drawing.
  - c. Maximum - 2.5 times the width of the drawing.
5. VANISHING POINT(S): A specific point or points located on the horizon line, where all parallel lines, drawn in perspective, converge or terminate. The location of the vanishing point varies with the type of perspective drawing. In the two-point perspective, the distance between the vanishing point left and the vanishing point right is estimated as being approximately four times the overall size of the building.
6. VISUAL RAY: An imaginary line drawn from the station point to any specific point lying within the designated scope of the plan layout of the object. The point at which this projected line passes through the picture plane will determine the location of that point in the perspective drawing.
7. GROUND PLANE: The ground on which the viewer is standing. In plan, this is determined at the station point. In perspective, it is the primary plane on which the building is sited. When the lines of this plane are extended to infinity, they become the horizon line. The intersection formed when the picture plane and the ground plane come together is called the ground line. In this way the horizontal dimension of the drawing is determined. The vertical dimension is determined by the vertical distance from the ground line to the horizon line. This should be approximately twice the height of object, in perspective, or a 30° cone in elevation.
8. ONE-POINT INTERIOR PERSPECTIVE: The most frequently used application of a one-point perspective. This is the same method as that used in setting up a one-point exterior perspective, except for the limitations that the confinement of space places on the location of the vanishing point. The vanishing point is usually located at the sitting or standing height of an average person within the space (eye level can be considered to be at 5 ft 4 in. from the floor). In most cases, the vanishing point is located within the confines of the enclosed space being represented in the drawing.
9. TWO-POINT PERSPECTIVE USING THE MEASURING POINT METHOD: This is a simplified alternative to the conventional method of laying out the plan picture plane and projecting the vanishing lines. The measuring point method of drawing a two-point perspective eliminates the necessity of the preliminary layout of the plan. One of the obvious advantages of this method is the ease with which the size of the drawing can be adjusted. A perspective can be made larger by simply increasing the scale of the drawing.

**PERSPECTIVE - PROJECTION METHOD**

**NOTES**

Before the drawing can be laid out, the following information must be obtained:

1. An approximation of the overall dimensions of the building.
2. The location of the building in relation to the picture plane.
3. The orientation of the building, either in front of or behind the picture plane.

While the building can be located anywhere in the drawing—in front of, behind, or at any angle to the picture plane—the simplest approach is to place the building at the picture plane. The horizontal lines of the building would be parallel to the picture plane in a one-point perspective or placed at an angle to the picture plane. Usually this will be a 30/60 or 45° angle in a two-point perspective.

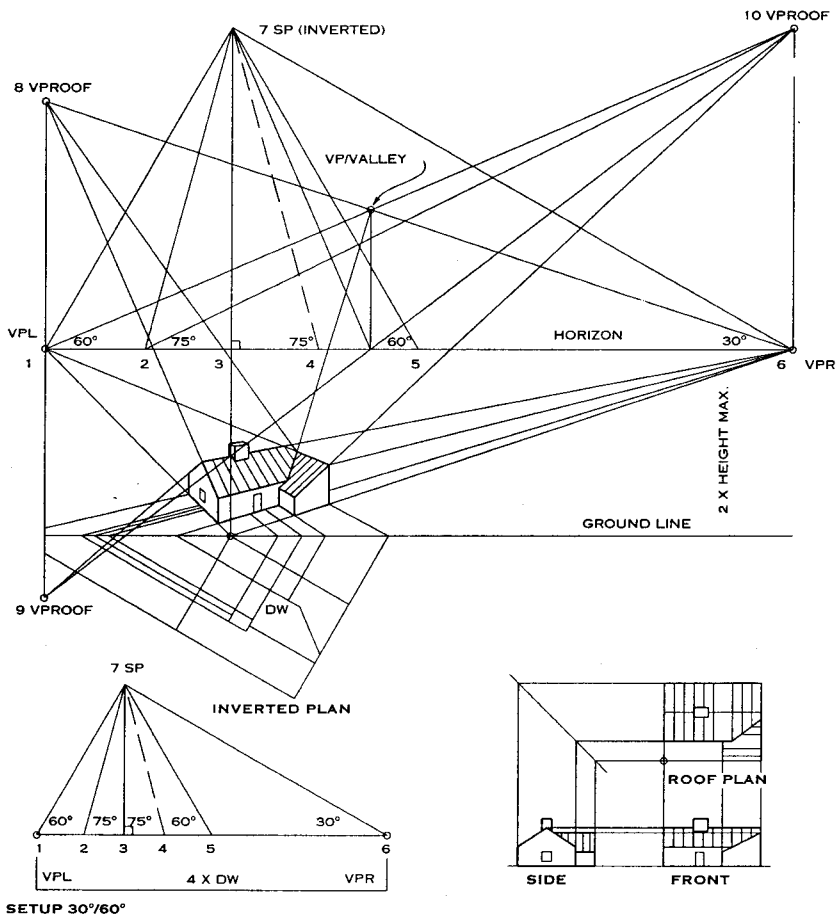

**PERSPECTIVE - TWO-POINT CONVENTIONAL METHOD**

Samuel J. De Santo and Associates; New York, New York  
 Alvarado Thrun Maeda and Associates; New York, New York; Eric A. Borch; Newburgh, New York





GIVEN:  
HEIGHT = 5'-0"  
WIDTH = 6'-0"  
DEPTH = 4'-0"  
0"

TO DESIRED SCALE

FRONT ELEVATION

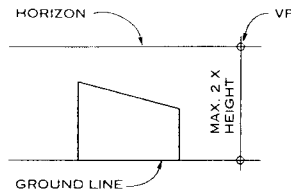

LOCATE HORIZON AND VP

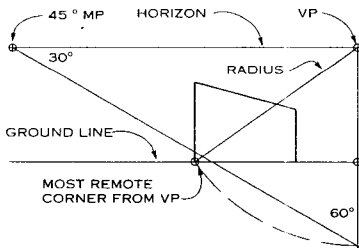

LOCATE 45° MEASURING POINT LEFT

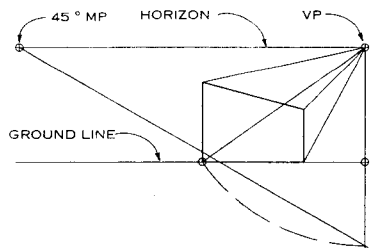

CONNECT CORNERS TO VP

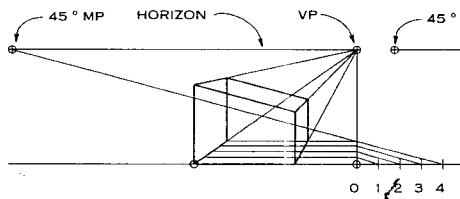

MEASURE DEPTH

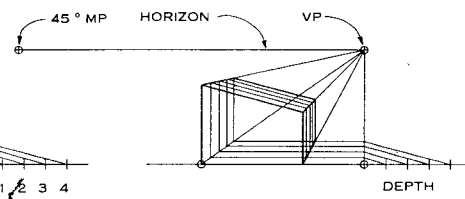

COMPLETE

ONE-POINT PERSPECTIVE BY 45° MEASURING POINT

LOCATE HORIZON  
1/3 UP FROM  
GROUND LINE  
AND VP 1/3 OVER  
FROM ONE WALL

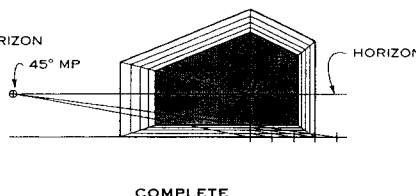
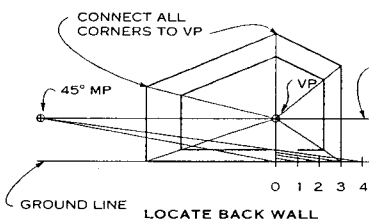
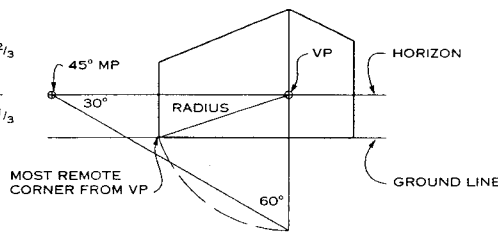
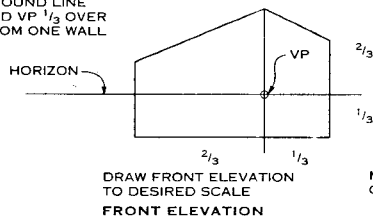

ONE-POINT DIRECT MEASURED INTERIOR PERSPECTIVE

Samuel J. De Santo and Associates; New York, New York  
Alvarado Thrun Maeda and Associates; New York, New York; Eric A. Borch; Newburgh, New York

ONE-POINT PERSPECTIVE

The one-point perspective is probably the least complicated of the projected perspective methods. The primary face of the building or object is placed directly on the picture plane. The adjacent planes, generally connected to the primary plane at right angles, converge to the vanishing point - which can be either in front of or behind the picture plane. The vanishing point, located on the horizon line, also determines the height from which the building is viewed.

The conventional method of laying out a one-point exterior perspective is illustrated on the preceding page. A plan view, roof view, and elevation are required for the layout. The size of the object, and therefore the drawing, can be increased or decreased by moving the plan further in front of or behind the picture plane. This method is more flexible but much more complicated and time consuming than the method that follows.

EXTERIOR ONE-POINT PERSPECTIVE

1. Draw the primary elevation of the building to scale.
2. Locate the horizon above the ground line at the desired level (eye level is approximately 5 ft 4 in.). To ensure that the final perspective will fall within the 60° cone of vision, the height should not exceed 2 times the height of the building. The vanishing point is located left or right arbitrarily depending on the view desired.
3. Locate the 45° measuring point (45° MP) on the horizon by drawing a line from the vanishing point to the most remote corner from the vanishing point to the most remote corner from the vanishing point to the most remote corner, to a vertical line drawn down from the VP. From this intersection draw a line upward, at a 60° angle to meet the horizon. This point (45° MP) will be the vanishing point for all lines that are positioned at a 45° angle and parallel to the picture plane.
4. From each corner of the primary elevation, draw a line to the vanishing point.
5. The room depth is determined by starting at point 0 on the ground line and measuring to the right. Connect this point to the 45° MP on the horizon. The back wall is located where this line intersects the vertical base line drawn from the VP to the ground line.
6. The perspective is completed by constructing the back wall at the location established in step 5 and connecting it to the front wall. Note that the lines that are drawn at 45° angle in the drawing remain parallel to each other as they are extended in perspective.

ONE-POINT INTERIOR AND SECTIONAL PERSPECTIVE

1. Draw the primary elevation, or section, to scale. Locate the horizon line and vanishing point within the confines of the interior space.
2. The 45° measuring point (45° MP), which is also the SP in section, is located similar to the exterior one-point perspective. Strike an arc from the most remote corner of the room to a vertical line drawn from the VP. From this intersection draw a line upward at 60° (to the vertical) to meet the horizon. This intersection shall be the 45° MP.
3. The room depth is determined by starting at point 0 on the ground line and measuring to the right. Connect this point to the 45° MP on the horizon. The back wall is located where the line intersects the vertical base line drawn from the VP to the ground line.
4. Complete the back wall as illustrated. Note that all lines occurring at a 45° angle in the elevation remain parallel in perspective. All surfaces that are parallel to the picture plane will remain parallel in perspective.

**TWO-POINT PERSPECTIVE**

The projection method of constructing a two-point perspective is illustrated on page 197. This is the most widely used and most flexible method of drawing a two-point perspective. It can be taken from any viewpoint by simply turning the plan in front of the picture plane for a larger drawing and behind the picture plane for a smaller drawing. As in all projected methods, an inordinate amount of time and energy is devoted to the layout. The measured method is equally accurate, less time-consuming, and much easier to construct, since it eliminates the need to lay out the drawing in plan. The desired size of the drawing is determined by drawing the primary elevation at the desired scale.

**30°/60° DIRECT MEASURED SYSTEM**

1. **SETUP:** Draw a horizon line and locate vanishing point right (VPR) and vanishing point left (VPL) separated at a distance that is approximately 4 to 4.5 times the maximum width of the building. Follow the illustration to locate the station point and leading corner of the building.
2. **LENGTH:** Measure, to scale, the length of the building along length line L. A perpendicular line is drawn from these designated points to the ground line. The vanishing perspective lines are then drawn directly from these points to the appropriate vanishing point (VPL). In this way the correct length of the line can be determined. Note what happens when equally spaced points are projected from the ground line to the vanishing point. The visual distance (length) between them, as they get closer to the vanishing point, is progressively foreshortened.
3. **WIDTH:** The width is measured along the width line (see illustration) at double scale. That is, if the perspective is drawn at a scale of  $\frac{1}{8}$  in. = 1 ft and a particular line is to be drawn at 5 ft, measure 5 ft at  $\frac{1}{4}$  in. scale starting at the corner and measure to the left of the corner horizontally. A line is drawn from each point on the width line to the appropriate vanishing point (VPR). The intersections of the length and width vanishing lines will define the "plan" in perspective.
4. **HEIGHT:** Since the leading corner of the building is placed directly on the picture plane, the height is measured, to scale, directly on the H line. It is then carried to VPL and VPR as illustrated.

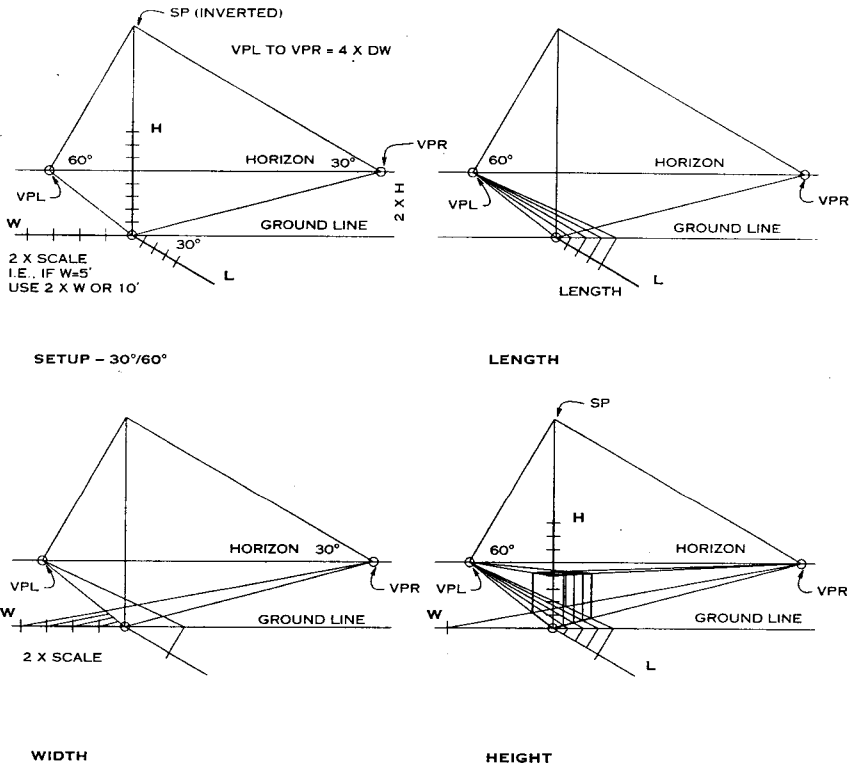

**TWO-POINT PERSPECTIVE - 30°/60° DIRECT MEASURED SYSTEM**

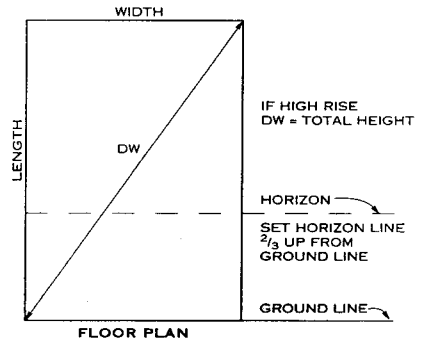
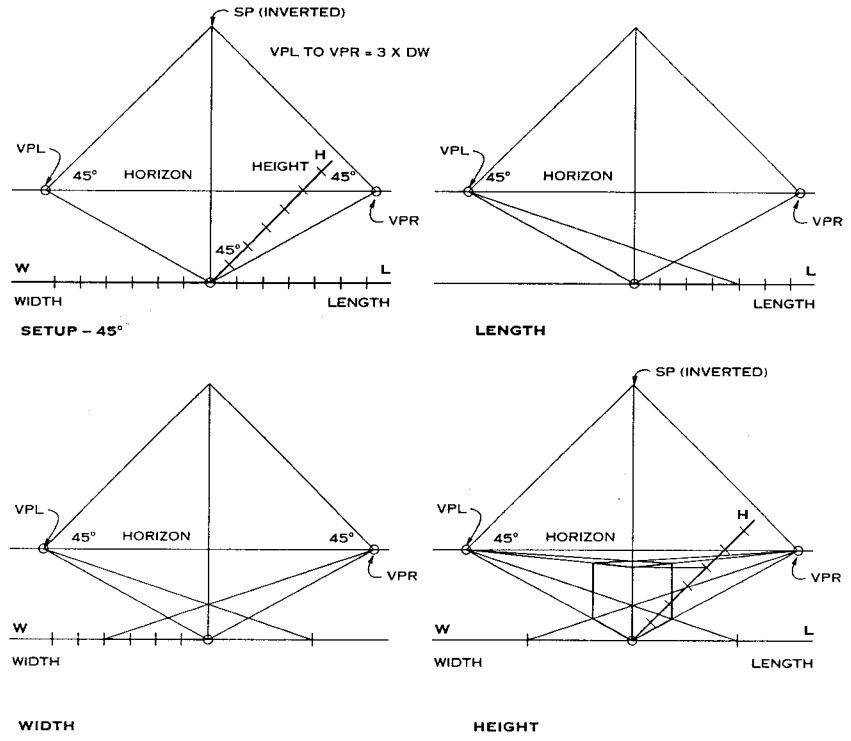

**45° DIRECT MEASURED SYSTEM**

1. **SETUP:** Similar to the method used in the 30°/60° setup, the vanishing points are placed on the horizon line and separated by 3 times the diagonal width. Complete the setup as illustrated.
2. **LENGTH:** Measure, to scale, the length of the building along the length line L. Connect the points directly to VPL.
3. **WIDTH:** In this setup, the width is the same as the length scale. Measure the width of the building along the width line W. The length and width lines will form an outline of the "plan" in perspective.
4. **HEIGHT:** The height line is positioned at a 45° angle and marked off to scale. A line representing the leading corner of the building is drawn perpendicular to the ground line. Connect or draw a line from the measurement points along the height line horizontally to the vertical corner line. As in the 30°/60° setup, these points are then carried to VPR and VPL.

**TWO-POINT PERSPECTIVE - 45° DIRECT MEASURED SYSTEM**

Samuel J. De Santo and Associates; New York, New York  
 Alvarado Thrun Maeda and Associates; New York, New York; Eric A. Borch; Newburgh, New York

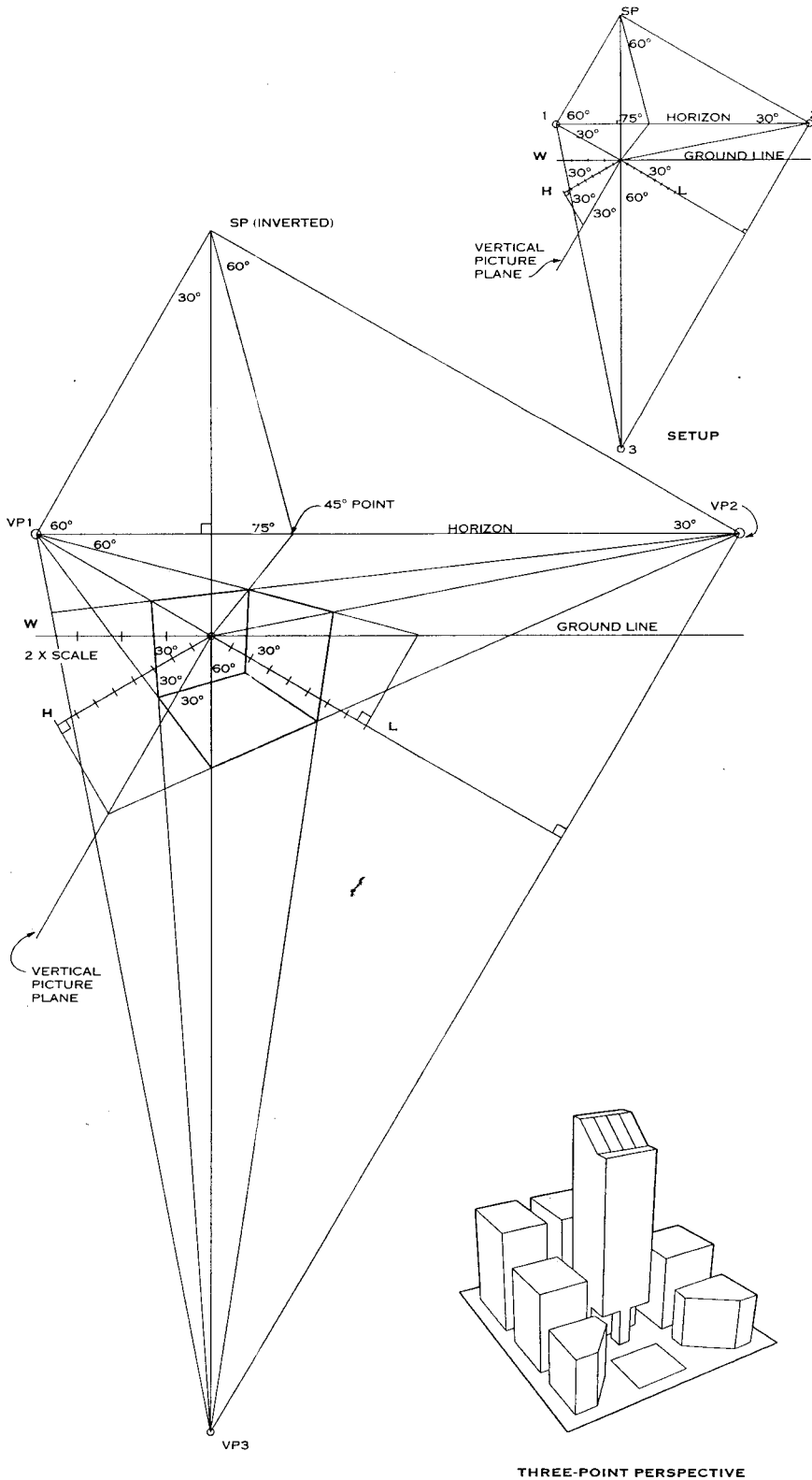

**THREE-POINT PERSPECTIVE**

In a one- or two-point perspective, the vertical lines of the object are usually parallel to each other and perpendicular to the ground plane. In reality, however, the vertical lines also converge, depending on the height of the observer (or the station point). If the station point is higher than the roof plane, the vertical lines will converge as they get closer to the ground plane; if the station point is lower than the roof plane, the vertical lines will converge as they move farther away from the ground plane.

The three-point perspective is very similar in method to the two-point one. The plan is rotated at any angle to the picture plane, and the location of the station point (in plan) is determined in the same way. The right and left vanishing points will likewise be located on the horizon line. The side view, however, differs from the two-point perspective in that the picture plane is now tilted forward when viewing the building (or object) from a point lower than the roof plane or backward when viewing the building from a point higher than the roof plane. When the lines of vision are drawn to the station point in plan and a side elevation, the combined projections result in a three-point perspective as viewed from the "front." As in the other projected perspective methods, a plan view, side view, and picture plan are required before the perspective can be constructed.

Vanishing point left and vanishing point right (indicated as points 1 and 2 in the illustration) are located on the horizon line. The distance between these two points is approximately four times the maximum length of the object. Once these two points are determined, the entire framework of the construction can be drawn using the 30/60 and 45° triangles ( $75^\circ = 30 + 45$ ).

**LENGTH**

The length line is drawn at the same scale as the line connecting points 1 and 2 (which is four times the maximum length of the object). Measured points are projected perpendicularly from the length line L to the ground line (see illustration). From the ground line, the measured points are connected to vanishing point left (or point 1).

**WIDTH**

At double the original scale, that is, if length (L) is at a  $\frac{1}{4}$  in. scale, use  $\frac{1}{2}$  in. scale for width (W). Locate the distances along the width line, and connect these points directly to the vanishing point right (or point 2).

**HEIGHT**

Using the original scale, mark off the measuring points along the height line (H). These points are projected perpendicularly to the line labeled "vertical plane." From these points a line is drawn to vanishing point right (point 2), thereby cutting the vertical lines vanishing to point 2.

**45° POINT**

This point on the horizon is determined by projecting a line from the upside down station point so that it will meet the horizon line at a 75° angle. All lines occurring at a 45° angle to the picture plane (in viewing) will converge to this point; it is, therefore, often convenient to use this as a reference point when converting exact width to length, or vice versa, in plan.

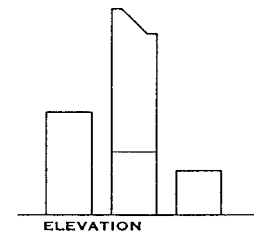
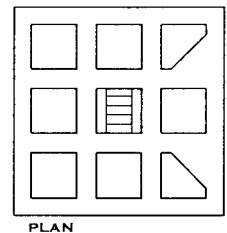

**PROJECTING THE PERSPECTIVE**

Samuel J. De Santo and Associates; New York, New York  
 Alvarado Thrun Maeda and Associates; New York, New York; Eric A. Borch; Newburgh, New York

**GENERAL**

Virtually all computer-aided design (CAD) systems support the concept of layers, which allow grouping of graphic information for display or plotting. Intelligent use of layers can reduce drawing time and improve drawing coordination. For example, a single CAD file can be used to produce a floor plan, a reflected ceiling plan, a power plan, and a lighting plan. In addition to increased drawing productivity, use of standardized CAD layers provides these other benefits:

1. Improved coordination between architects, engineers, and consultants
2. Efficient creation of facility management record drawings from construction documents
3. Symbols and details that can be reused without conversion of layers

In 1990 the first industry standard for the use of CAD layers in architecture, engineering, and facility management was introduced with the publication of *CAD Layer Guidelines*. In 1997 the second edition of *CAD Layer Guidelines* was published, expanding the work begun in the first edition in the following ways:

1. Adds discipline designations for interior design, telecommunications, and other fields
2. Expands layer designations for remodeling projects
3. Designates the "long format" as the single approved layer name format
4. Coordinates with the Construction Specification Institute's Uniform Drafting System
5. Defines a standard for naming and organizing CAD files

**CONVENTIONS FOR NAMING LAYERS**

The CAD layer guidelines are organized using a hierarchical structure that provides for flexibility and expandability. The first level of the hierarchy is the discipline code. Discipline codes follow traditional sheet numbering conventions as shown here:

A	Architectural
C	Civil
E	Electrical
F	Fire protection
G	General
H	Hazardous materials
I	Interiors
L	Landscape
M	Mechanical
P	Plumbing
Q	Equipment
R	Resource
S	Structural
T	Telecommunications
X	Other disciplines
Z	Contractor/shop drawings

Discipline codes are followed by either a hyphen or another letter that designates a specialized discipline. For example, AG is used for architectural graphics.

The second level of the hierarchy is the major group code. This is used to designate a construction system or type of information. For example, a drawing might contain layers with the following discipline and major group codes:

A-WALL	Walls
A-DOOR	Doors
A-GLAZ	Glazing
A-EQPM	Equipment
A-CLNG	Ceiling information
A-ROOF	Roof
E-POWR	Power
S-COLS	Structural columns

Layer names can be further extended with a minor group code and a status code. The minor group is an optional, four-character field used to define subcategories of information. For example, A-WALL-PART indicates architecture, new, wall, partial height. IDEN for identification and PATT for pattern are two commonly used modifiers in the minor group field.

Status codes are four-character designators used to differentiate new construction from demolition, remodeling, and construction that is "existing to remain." They are only needed when a project has phases of work that must be differentiated. Defined values for this field are shown on this page under the heading "Status Field Modifiers."

Layers representing the dominant phase of a project can be named without using a status field. For example, in a small remodeling project, NEWW would indicate new construction, while layers without status fields would indicate parts

of the existing building that will remain. For example, a remodeling plan might contain the following layers:

A-WALL-NEWW	New walls
A-DOOR-NEWW	New doors
A-WALL-DEMO	Walls to be demolished
A-DOOR-DEMO	Doors to be demolished
A-WALL	Existing walls to remain
A-DOOR	Existing doors to remain

Conversely, a remodeling project consisting of mostly new construction might use EXST to indicate layers referring to "existing to remain" construction and layers without status fields to represent new construction.

The status field is always placed as the last field of the layer name. In a simple layer name such as A-WALL, the status field would be the third field (A-WALL-DEMO). In a more detailed layer name, the status field would be the fourth field (A-WALL-FULL-DEMO).

**MASTER LAYER LIST**

The master layer list identifies all defined layers in the CAD layer guidelines. Users are free to add their own layers, but should identify them as "user-defined." The use of an asterisk (\*) indicates a place holder for the discipline code, major group, or minor group. Some layers included in the following list are new or have been revised since the first edition of *CAD Layer Guidelines*.

This list is arranged alphabetically by discipline. Layers within each discipline are arranged by construction system.

**ANNOTATION LAYERS**

*-ANNO-TEXT	Text
*-ANNO-REDL	Redline

*-ANNO-SYMB	Symbols
*-ANNO-LEGN	Legends and schedules
*-ANNO-DIMS	Dimensions
*-ANNO-TTLB	Border and title block
*-ANNO-NOTE	Notes
*-ANNO-NPLT	Construction lines, nonplotting information
*-ANNO-KEYN	Key notes
*-ANNO-REVS	Revisions

**NOTE**

Annotation layer names may be appended with a four-character sheet name designator when needed.

**COMMON MODIFIERS**

*-****-PATT	Cross-hatching, poché
*-****-IDEN	Identification tags
*-****-ELEV	Elevation (vertical surfaces in 3D)
X-RDME	Read-me layer, not to be plotted

**STATUS FIELD MODIFIERS**

*-****-NEWW	New work
*-****-EXST	Existing to remain
*-****-DEMO	Demolition
*-****-FUTR	Future work
*-****-TEMP	Temporary work
*-****-MOVE	Items to be moved
*-****-RELO	Relocated items
*-****-NICN	Not in contract
*-****-PHS1-9	Phase numbers (1-9)

**NOTE**

The status field may also occur as the fourth field, following a minor group.

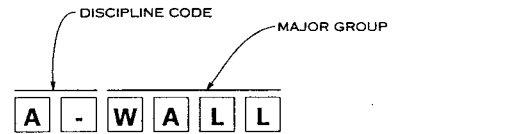

**SIMPLE LAYER NAME WITH ONLY MAJOR GROUP**

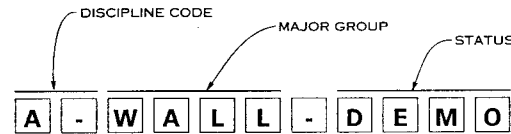

**LAYER NAME WITH MAJOR GROUP AND STATUS FIELD**

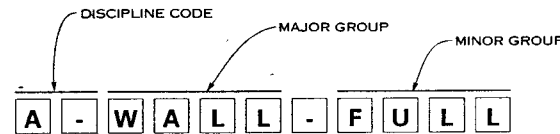

**LAYER NAME WITH MAJOR GROUP AND MINOR GROUP**

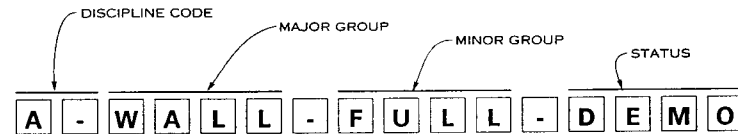

**LAYER NAME WITH MAJOR GROUP, MINOR GROUP, AND STATUS FIELD**

**OPTIONS FOR LAYER NAME FORMATS**

Michael K. Schley, AIA, ed., *CAD Layer Guidelines*, 2d ed. (Washington: The American Institute of Architects Press, 1997)

**ARCHITECTURAL LAYERS**

A-WALL-FULL Full-height walls, stair and shaft walls, walls to structure  
 A-WALL-PRHT Partial-height walls (do not appear on reflected ceiling plans)  
 A-WALL-MOVE Movable partitions  
 A-WALL-HEAD Door and window headers (appear on reflected ceiling plans)  
 A-WALL-JAMB Door and window jambs (do not appear on reflected ceiling plans)  
 A-WALL-PATT Wall insulation, hatching and fill  
 A-WALL-ELEV Wall surfaces: 3D views  
 A-WALL-FIRE Fire wall patterning  
 A-DOOR Doors  
 A-DOOR-FULL Full-height (to ceiling) door: swing and leaf  
 A-DOOR-PRHT Partial-height door: swing and leaf  
 A-DOOR-IDEN Door number, hardware group, etc.  
 A-DOOR-ELEV Doors: 3D views  
 A-GLAZ Windows, window walls, curtain walls, glazed partitions  
 A-GLAZ-FULL Full-height glazed walls and partitions  
 A-GLAZ-PRHT Windows and partial-height glazed partitions  
 A-GLAZ-SILL Windowsills  
 A-GLAZ-IDEN Window number  
 A-GLAZ-ELEV Glazing and mullions—elevation views  
 A-FLOOR Floor information  
 A-FLOOR-OTLN Floor or building outline  
 A-FLOOR-LEVEL Level changes, ramps, pits, depressions  
 A-FLOOR-STRS Stair treads, escalators, ladders  
 A-FLOOR-RISR Stair risers  
 A-FLOOR-HRAL Stair and balcony handrails, guardrails  
 A-FLOOR-EVTR Elevator cars and equipment  
 A-FLOOR-TPTN Toilet partitions  
 A-FLOOR-SPCL Architectural specialties (toilet room accessories, display cases)  
 A-FLOOR-WDWK Architectural woodwork (field-built cabinets and counters)  
 A-FLOOR-CASE Casework (manufactured cabinets)  
 A-FLOOR-OVHD Overhead items (skylights, overhangs—usually dashed line)  
 A-FLOOR-RAIS Raised floors  
 A-FLOOR-IDEN Room numbers, names, targets, etc.  
 A-FLOOR-PATT Paving, tile, carpet patterns  
 A-FLOOR-PFIX Plumbing fixtures  
 A-FLOOR-FIXT Miscellaneous fixtures  
 A-FLOOR-SIGN Signage  
 A-EQPM Equipment  
 A-EQPM-FIXD Fixed equipment  
 A-EQPM-MOVE Movable equipment  
 A-EQPM-NICN Equipment not in contract  
 A-EQPM-ACCS Equipment access  
 A-EQPM-IDEN Equipment identification numbers  
 A-EQPM-ELEV Equipment surfaces: 3D views  
 A-EQPM-CLNG Ceiling-mounted or suspended equipment  
 A-FURN Furniture  
 A-FURN-FREE Furniture: freestanding (desks, credenzas, etc.)  
 A-FURN-CHAR Chairs and other seating  
 A-FURN-FILE File cabinets  
 A-FURN-PNLS Furniture system panels  
 A-FURN-WKSF Furniture system work surface components  
 A-FURN-STOR Furniture system storage components  
 A-FURN-POWER Furniture system—power designations  
 A-FURN-IDEN Furniture numbers  
 A-FURN-PLNT Plants  
 A-FURN-PATT Finish patterns  
 A-FURN-ELEV Furniture: 3D views  
 A-CLNG Ceiling information  
 A-CLNG-GRID Ceiling grid  
 A-CLNG-OPEN Ceiling/roof penetrations  
 A-CLNG-TEES Main tees  
 A-CLNG-SUSP Suspended elements  
 A-CLNG-PATT Ceiling patterns  
 A-CLNG-ACCS Ceiling access  
 A-LITE Light fixtures  
 A-COLS Columns  
 A-HVAC-SDFD Supply diffusers  
 A-HVAC-RDFF Return air diffusers  
 A-GRID Planning grid or column grid  
 A-ROOF Roof  
 A-ROOF-OTLN Roof outline  
 A-ROOF-LEVEL Level changes

A-ROOF-STRS Stair treads, ladders  
 A-ROOF-RISR Stair risers  
 A-ROOF-HRAL Stair handrails, nosings, guardrails  
 A-ROOF-PATT Roof surface patterns, hatching  
 A-ROOF-ELEV Roof surfaces: 3D views  
 A-AREA Area calculation boundary lines  
 A-AREA-PATT Area cross hatching  
 A-AREA-IDEN Room numbers, tenant identifications, area calculation  
 A-AREA-OCPP Occupant or employee names  
 A-ELEV Interior and exterior elevations  
 A-ELEV-OTLN Building outlines  
 A-ELEV-FNSH Finishes, woodwork, trim  
 A-ELEV-CASE Wall-mounted casework  
 A-ELEV-FIXT Miscellaneous fixtures  
 A-ELEV-PFIXT Plumbing fixtures in elevation  
 A-ELEV-SIGN Signage  
 A-ELEV-PATT Textures and hatch patterns  
 A-ELEV-IDEN Component identification numbers  
 A-SECT Sections  
 A-SECT-MCUT Material cut by section  
 A-SECT-MBND Material beyond section cut  
 A-SECT-PATT Textures and hatch patterns  
 A-SECT-IDEN Component identification numbers  
 A-DETL Details  
 A-DETL-MCUT Material cut by section  
 A-DETL-MBND Material beyond section cut  
 A-DETL-PATT Textures and hatch patterns  
 A-DETL-IDEN Component identification numbers

**CIVIL LAYERS**

C-PROP Property lines, survey benchmarks  
 C-PROP-ESMT Easements, rights-of-way, setback lines  
 C-PROP-BRNG Bearings and distance labels  
 C-PROP-CONS Construction controls  
 C-TOPO Proposed contour lines and elevations  
 C-TOPO-SPOT Spot elevations  
 C-TOPO-BORE Test borings  
 C-TOPO-RTWL Retaining wall  
 C-BLDG Proposed building footprints  
 C-PKNG Parking lots  
 C-PKNG-STRP Parking lot striping, handicapped symbol  
 C-PKNG-CARS Graphic illustration of cars  
 C-PKNG-ISLD Parking islands  
 C-PKNG-DRAN Parking lot drainage slope indications  
 C-ROAD Roadways  
 C-ROAD-CNTR Center lines  
 C-ROAD-CURB Curbs  
 C-STRM Storm drainage catch basins, manholes  
 C-STRM-UNDR Storm drainage pipe—underground  
 C-COMM Site communication/telephone poles, boxes, towers  
 C-COMM-UNDR Underground communication lines  
 C-COMM-OVHD Overhead communication lines  
 C-WATR Domestic water—manholes, pumping stations, storage tanks  
 C-WATR-UNDR Domestic water—underground lines  
 C-FIRE Fire protection—hydrants, connections  
 C-FIRE-UNDR Fire protection—underground lines  
 C-NGAS Natural gas—manholes, meters, storage tanks  
 C-NGAS-UNDR Natural gas—underground lines  
 C-SSWR Sanitary sewer—manholes, pumping stations  
 C-SSWR-UNDR Sanitary sewer—underground lines

**ELECTRICAL LAYERS**

E-LITE Lighting  
 E-LITE-SPCL Special lighting  
 E-LITE-EMER Emergency lighting  
 E-LITE-EXIT Exit lighting  
 E-LITE-CLNG Ceiling-mounted lighting  
 E-LITE-WALL Wall-mounted lighting  
 E-LITE-FLOOR Floor-mounted lighting  
 E-LITE-OTLN Lighting outline for background (optional)  
 E-LITE-NUMB Lighting circuit numbers  
 E-LITE-ROOF Roof lighting  
 E-LITE-SITE Site lighting (see also civil group)  
 E-LITE-SWCH Lighting—switches  
 E-LITE-CIRC Lighting circuits  
 E-LITE-IDEN Luminaire identification and text  
 E-LITE-JBOX Junction box

E-POWR Power  
 E-POWR-WALL Power wall outlets and receptacles  
 E-POWR-CLNG Power—ceiling receptacles and devices  
 E-POWR-PANL Power panels  
 E-POWR-EQPM Power equipment  
 E-POWR-SWBD Power switchboards  
 E-POWR-CIRC Power circuits  
 E-POWR-URAC Underfloor raceways  
 E-POWR-UCPT Under-carpet wiring  
 E-POWR-CABL Cable trays  
 E-POWR-FEED Feeders  
 E-POWR-BUSW Busways  
 E-POWR-NUMB Power circuit numbers  
 E-POWR-IDEN Power identification, text  
 E-POWR-SITE Site power (see also civil group)  
 E-POWR-ROOF Roof power  
 E-POWR-OTLN Power outline for backgrounds  
 E-POWR-JBOX Junction box  
 E-CTRL Electric control systems  
 E-CTRL-DEVC Control system devices  
 E-CTRL-WIRE Control system wiring  
 E-GRND Ground system  
 E-GRND-CIRC Ground system circuits  
 E-GRND-REFR Reference ground system  
 E-GRND-EQUI Equipotential ground system  
 E-GRND-DIAG Ground system diagram  
 E-AUXL Auxiliary systems  
 E-LTNG Lightning protection system  
 E-FIRE Fire alarm, fire extinguishers  
 E-COMM Telephone, communication outlets  
 E-DATA Data outlets  
 E-SOUN Sound/PA system  
 E-TVAN TV antenna system  
 E-CCTV Closed-circuit TV  
 E-NURS Nurse call system  
 E-SERT Security  
 E-PGNG Paging system  
 E-DICT Central dictation system  
 E-BELL Bell system  
 E-CLOCK Clock system  
 E-ALRM Miscellaneous alarm system  
 E-INTC Intercom system  
 E-LEGN Legend of symbols  
 E-1LIN One-line diagrams  
 E-RISR Riser diagram  
 E-SITE Site electrical substations, poles  
 E-SITE-LITE Site lighting  
 E-SITE-UNDR Underground electrical lines  
 E-SITE-POLE Electric poles  
 E-SITE-OVHD Overhead lines

**FIRE PROTECTION LAYERS**

F-CO2S CO<sub>2</sub> system  
 F-CO2S-PIPE CO<sub>2</sub> sprinkler piping  
 F-CO2S-EQPM CO<sub>2</sub> equipment  
 F-HALN Halon  
 F-HALN-EQPM Halon equipment  
 F-HALN-PIPE Halon piping  
 F-IGAS Inert gas  
 F-IGAS-EQPM Inert gas equipment  
 F-IGAS-PIPE Inert gas piping  
 F-SPRN Fire protection sprinkler system  
 F-SPRN-CLHD Sprinkler head—ceiling  
 F-SPRN-OTHDR Sprinkler head—other  
 F-SPRN-PIPE Sprinkler piping  
 F-SPRN-STAN Sprinkler system standpipe  
 F-STAN Fire protection standpipe system  
 F-PROT Fire protection systems  
 F-PROT-EQPM Fire system equipment (fire hose cabinet extinguishers)  
 F-PROT-ALRM Fire alarm  
 F-PROT-SMOK Smoke detectors/heat sensors

**GENERAL LAYERS**

G-PLAN Floor plan—key plan  
 G-SITE Site plan—key map  
 G-ACCS Access plan  
 G-FIRE Fire protection plan  
 G-EVAC Evacuation plan  
 G-CODE Code compliance plan

**HAZARDOUS LAYERS**

H-PLAN Floor plan  
 H-SITE Site plan

Michael K. Schley, AIA, ed., *CAD Layer Guidelines*, 2d ed. (Washington: The American Institute of Architects Press, 1997)

**INTERIOR LAYERS**

I-WALL-FULL Full-height walls, stair and shaft walls, walls to structure  
 I-WALL-PRHT Partial-height walls (do not appear on reflected ceiling plans)  
 I-WALL-MOVE Movable partitions  
 I-WALL-HEAD Door and window headers (appear on reflected ceiling plan)  
 I-WALL-JAMB Door and window jambs (do not appear on reflected ceiling plans)  
 I-WALL-PATT Wall insulation, hatching and fill  
 I-WALL-ELEV Wall surfaces: 3D views  
 I-WALL-FIRE Fire wall patterning  
 I-DOOR Doors  
 I-DOOR-FULL Full-height (to ceiling) door: swing and leaf  
 I-DOOR-PRHT Partial height door: swing and leaf  
 I-DOOR-IDEN Door number, hardware group, etc.  
 I-DOOR-ELEV Doors: 3D views  
 I-GLAZ Glazing  
 I-GLAZ-FULL Full-height glazed walls and partitions  
 I-GLAZ-PRHT Windows and partial-height glazed partitions  
 I-GLAZ-SILL Windowsills  
 I-GLAZ-IDEN Window number  
 I-GLAZ-ELEV Glazing and mullions—elevation views  
 I-FLOOR Floor information  
 I-FLOOR-OTLN Floor or building outline  
 I-FLOOR-LEVL Level changes, ramps, pits, depressions  
 I-FLOOR-STRS Stair treads, escalators, ladders  
 I-FLOOR-RISR Stair risers  
 I-FLOOR-HRAL Stair and balcony handrails, guardrails  
 I-FLOOR-EVTR Elevator cars and equipment  
 I-FLOOR-TPTN Toilet partitions  
 I-FLOOR-SPCL Architectural specialties (toilet room accessories, display cases)  
 I-FLOOR-WDVK Architectural woodwork (field-built cabinets and counters)  
 I-FLOOR-CASE Casework (manufactured cabinets)  
 I-FLOOR-OVHD Overhead items (skylights, overhangs—usually dashed lines)  
 I-FLOOR-RAIS Raised floors  
 I-FLOOR-IDEN Room numbers, names, targets, etc.  
 I-FLOOR-PATT Paving, tile, carpet patterns  
 I-FLOOR-PFIX Plumbing fixtures  
 I-FLOOR-FIXT Miscellaneous fixtures  
 I-FLOOR-SIGN Signage  
 I-EQPM Equipment  
 I-EQPM-FIXD Fixed equipment  
 I-EQPM-MOVE Movable equipment  
 I-EQPM-NICN Equipment not in contract  
 I-EQPM-ACCS Equipment access  
 I-EQPM-IDEN Equipment identification numbers  
 I-EQPM-ELEV Equipment surfaces: 3D views  
 I-EQPM-CLNG Ceiling-mounted or suspended equipment  
 I-FURN Furniture  
 I-FURN-FREE Furniture: freestanding (desks, credenzas, etc.)  
 I-FURN-CHAR Chairs and other seating  
 I-FURN-FILE File cabinets  
 I-FURN-PNLS Furniture system panels  
 I-FURN-WKSF Furniture system work surface components  
 I-FURN-STOR Furniture system storage components  
 I-FURN-POWR Furniture system—power designations  
 I-FURN-IDEN Furniture numbers  
 I-FURN-PLNT Plants  
 I-FURN-PATT Finish patterns  
 I-FURN-ELEV Furniture: 3D views  
 I-CLNG Ceiling information  
 I-CLNG-GRID Ceiling grid  
 I-CLNG-OPEN Ceiling/roof penetrations  
 I-CLNG-TEES Main tees  
 I-CLNG-SUSP Suspended elements  
 I-CLNG-PATT Ceiling patterns  
 I-CLNG-ACCS Ceiling access  
 I-LITE Light fixtures  
 I-COLS Columns  
 I-HVAC-SDFF Supply diffusers  
 I-HVAC-RDFF Return air diffusers  
 I-GRID Planning grid or column grid  
 I-AREA Area calculation lines  
 I-AREA-PATT Area cross hatching  
 I-AREA-IDEN Room numbers, tenant identifications, area calculation

I-AREA-OCCP Occupant or employee names  
 I-ELEV Interior and exterior elevations  
 I-ELEV-FNSH Finishes, woodwork, trim  
 I-ELEV-CASE Wall-mounted casework  
 I-ELEV-FIXT Miscellaneous fixtures  
 I-ELEV-PFIXT Plumbing fixtures in elevation  
 I-ELEV-SIGN Signage  
 I-ELEV-PATT Textures and hatch patterns  
 I-ELEV-IDEN Component identification numbers  
 I-SECT Sections  
 I-SECT-MCUT Material cut by section  
 I-SECT-MBND Material beyond section cut  
 I-SECT-PATT Textures and hatch patterns  
 I-SECT-IDEN Component identification numbers  
 I-DETL Details  
 I-DETL-MCUT Material cut by section  
 I-DETL-MBND Material beyond section cut  
 I-DETL-PATT Textures and hatch patterns  
 I-DETL-IDEN Component identification numbers

**LANDSCAPE LAYERS**

L-PLNT Plant and landscape materials  
 L-PLNT-TREE Trees  
 L-PLNT-GRND Ground covers and vines  
 L-PLNT-BEDS Rock, bark, and other landscaping beds  
 L-PLNT-TURF Lawn areas  
 L-PLNT-PLAN Planting plants  
 L-IRRG Irrigation system  
 L-IRRG-SPKL Irrigation sprinklers  
 L-IRRG-PIPE Irrigation piping  
 L-IRRG-EQPT Irrigation equipment  
 L-IRRG-COVR Irrigation coverage  
 L-WALK Walks and steps  
 L-WALK-PATT Walks and steps—cross-hatch patterns  
 L-SITE Site improvements  
 L-SITE-FENC Fencing  
 L-SITE-WALL Walls  
 L-SITE-STEP Steps  
 L-SITE-DECK Decks  
 L-SITE-BRDG Bridges  
 L-SITE-POOL Pools and spas  
 L-SITE-SPRT Sports fields  
 L-SITE-PLAY Play structures  
 L-SITE-FURN Site furnishings

**MECHANICAL LAYERS**

M-BRIN Brine systems  
 M-BRIN-EQPM Brine system equipment  
 M-BRIN-PIPE Brine system piping  
 M-CHIM Prefabricated chimneys  
 M-CMPA Compressed air systems  
 M-CMPA-CEQP Compressed air equipment  
 M-CMPA-CPIP Compressed air piping  
 M-CMPA-PEQP Process air equipment  
 M-CMPA-PPIP Process air piping  
 M-CONT Controls and instrumentation  
 M-CONT-THER Thermostats  
 M-CONT-WIRE Low voltage wiring  
 M-DUST Dust and fume collection system  
 M-DUST-EQPM Dust and fume collection equipment  
 M-DUST-DUCT Dust and fume ductwork  
 M-ELHT-EQPM Electric heat equipment  
 M-ENER Energy management system  
 M-ENER-EQPM Energy management equipment  
 M-ENER-WIRE Energy management wiring  
 M-RCOV Energy recovery  
 M-RCOV-EQPM Energy recovery equipment  
 M-RCOV-PIPE Energy recovery piping  
 M-FUME-EXHS Fume hood exhaust system  
 M-FUME-EQPM Fume hoods  
 M-EXHS Exhaust system  
 M-EXHS-EQPM Exhaust system equipment  
 M-EXHS-DUCT Exhaust system ductwork  
 M-EXHS-RFEQ Rooftop exhaust equipment  
 M-FUEL Fuel system piping  
 M-FUEL-GPRP Fuel gas process piping  
 M-FUEL-GGEP Fuel gas general piping  
 M-FUEL-OPRP Fuel oil process piping  
 M-FUEL-OGEP Fuel oil general piping  
 M-HVAC HVAC system  
 M-HVAC-CDFF HVAC ceiling diffusers  
 M-HVAC-ODFF HVAC other diffusers  
 M-HVAC-DUCT HVAC ductwork  
 M-HVAC-EQPM HVAC equipment  
 M-HVAC-SDFF Supply diffusers  
 M-HVAC-RDFF Return air diffusers  
 M-HOTW Hot water heating system  
 M-HOTW-EQPM Hot water equipment  
 M-HOTW-PIPE Hot water piping  
 M-CWTR Chilled water systems  
 M-CWTR-PIPE Chilled water piping  
 M-CWTR-EQPM Chilled water equipment  
 M-MACH Machine shop equipment  
 M-MDGS Medical gas systems

M-MDGS-EQPM Medical gas equipment  
 M-MDGS-PIPE Medical gas piping  
 M-LGAS Laboratory gas systems  
 M-LGAS-EQPM Laboratory gas equipment  
 M-LGAS-PIPE Laboratory gas piping  
 M-NGAS Natural gas systems  
 M-NGAS-EQPM Natural gas equipment  
 M-NGAS-PIPE Natural gas piping  
 M-PROC Process systems  
 M-PROC-EQPM Process equipment  
 M-PROC-PIPE Process piping  
 M-REFG Refrigeration systems  
 M-REFG-EQPM Refrigeration equipment  
 M-REFG-PIPE Refrigeration piping  
 M-SPCL Special systems  
 M-SPCL-EQPM Special systems equipment  
 M-SPCL-PIPE Special systems piping  
 M-STEM Steam systems  
 M-STEM-CONP Steam systems condensate piping  
 M-STEM-EQPM Steam systems equipment  
 M-STEM-LPIP Low pressure steam piping  
 M-STEM-HPIP High pressure steam piping  
 M-STEM-MPIP Medium pressure steam piping  
 M-TEST-EQPM Test equipment

**PLUMBING LAYERS**

P-ACID Acid, alkaline, oil waste systems  
 P-ACID-PIPE Acid, alkaline, oil waste piping  
 P-DOMW Domestic hot and cold water systems  
 P-DOMW-EQPM Domestic hot and cold water equipment  
 P-DOMW-HPIP Domestic hot water piping  
 P-DOMW-CPIP Domestic cold water piping  
 P-DOMW-RISR Domestic hot and cold water risers  
 P-SANR Sanitary drainage  
 P-SANR-PIPE Sanitary piping  
 P-SANR-FIXT Plumbing fixtures  
 P-SANR-FLODR Floor drains  
 P-SANR-RISR Sanitary risers  
 P-SANR-EQPM Sanitary equipment  
 P-STRM Storm drainage system  
 P-STRM-PIPE Storm drain piping  
 P-STRM-RISR Storm drain risers  
 P-STRM-RFDR Roof drains  
 P-EQPM Plumbing—miscellaneous equipment  
 P-FIXT Plumbing fixtures

**EQUIPMENT LAYERS**

Q-OTLN Equipment outlines  
 Q-POWR Power information  
 Q-PIPE Piping information

**RESOURCE LAYERS**

(information provided by product manufacturers)  
 R-\*\*\*\*-OTLN Outline or profile graphics  
 R-\*\*\*\*-DETL Additional detail graphics  
 R-\*\*\*\*-PATT Textures and hatch patterns  
 R-\*\*\*\*-ANNO Annotation

**STRUCTURAL LAYERS**

S-GRID Column grid  
 S-GRID-EXTR Column grid outside building  
 S-GRID-INTR Column grid inside building  
 S-GRID-DIMS Column grid dimensions  
 S-GRID-IDEN Column grid tags  
 S-FNDN Foundation  
 S-FNDN-PILE Piles, drilled piers  
 S-FNDN-RBAR Foundation reinforcing  
 S-SLAB Slab  
 S-SLAB-EDGE Edge of slab  
 S-SLAB-RBAR Slab reinforcing  
 S-SLAB-JOIN Slab control joints  
 S-ABLT Anchor bolts  
 S-COLS Columns  
 S-WALL Structural bearing or shear walls  
 S-METL Miscellaneous metal  
 S-BEAM Beams  
 S-JOIS Joists  
 S-DECK Structural floor deck

**TELECOMMUNICATION LAYERS**

T-CABL Cable plan  
 T-EQPM Equipment plan  
 T-JACK Data/telephone jacks  
 T-DIAG Diagram



**GENERATIVE GEOMETRY**

The archetypal circle and square can geometrically generate many forms. Ancient cultures recognized these forms and relationships as essential and sacred, a metaphor of universal order. The circle and square in the act of self-division give us three generative roots: the square roots of 2, 3, and 5 (figs. 1a and 1b). These root relationships are all that are necessary to form the five regular (Platonic) solids that are the basis for all volumetric forms (fig. 1c). Also, 2, 3, and 5 are the only numbers required to divide the octave into musical scales.

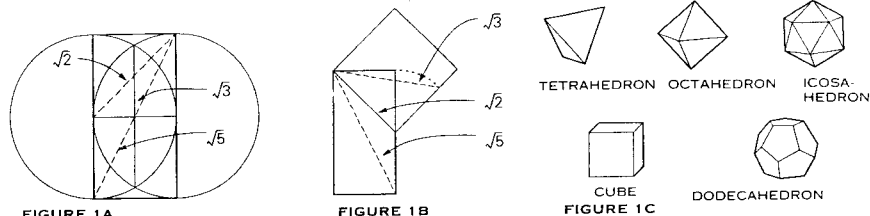

FIGURE 1A

FIGURE 1B

FIGURE 1C

**THE  $\sqrt{2}$**

In seeming paradox, the half of a square produces its double; this is analogous to biological growth from cell division and the generation of musical tone. In fig. 2a, the diagonal of square ABCD (square 1, fig. 2a) is exactly equal to the side of square ACFG (square 2). The area of square 2 is exactly twice that of square 1. The side of a square is called its root. The side of square 1 = 1; the side of square 2 = the square root of 2. The diagonal of square 2 = 2, exactly twice the side of the primary square. The division of the square by the diagonal yields three seemingly contradictory, yet geometrically true, relationships:

$$\text{root} : \text{root} :: \frac{1}{\sqrt{2}} : \frac{\sqrt{2}}{2} \quad \text{root} : \text{diag} :: \frac{1}{\sqrt{2}} : \frac{\sqrt{2}}{2}$$

$$\text{root} : \text{diag} :: \frac{1}{\sqrt{2}} : \frac{\sqrt{2}}{2}$$

The square root of 2 represents the power of multiplicity through the geometric progression a:b::b:c (fig. 2b). The relationship of the side to the diagonal may be written

$$\frac{1}{\sqrt{2}} : \frac{\sqrt{2}}{2} :: \frac{2}{2\sqrt{2}} : \frac{2\sqrt{2}}{4} \quad \text{etc}$$

**GENERATIVE GEOMETRY**

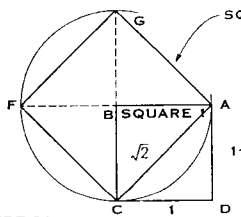

FIGURE 2A

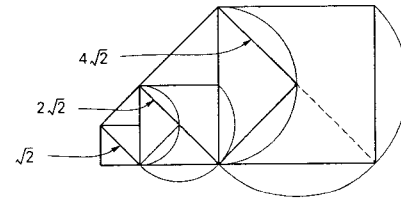

FIGURE 2B

**THE SQUARE ROOT OF 2**

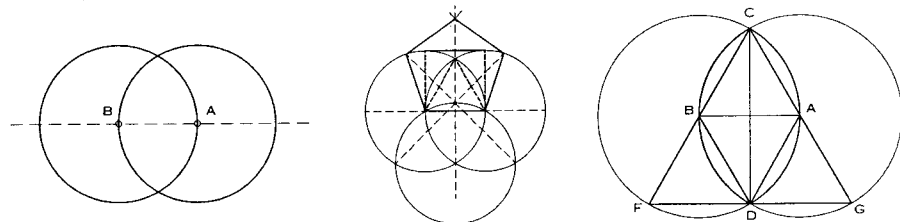

FIGURE 3A

FIGURE 3B

FIGURE 3C

**THE SQUARE ROOT OF 3**

**THE VESICA PISCIS AND THE  $\sqrt{3}$**

The Vesica Piscis is a form generator of the triangle, square, and pentagon—the basic planar elements of the five Platonic solids. The overlapping circles are an excellent representation of a cell or any unity in the midst of becoming dual. Medieval churches and cathedrals incorporated the fish-shaped geometry as a symbol of Christ.

To construct the Vesica Piscis: draw a circle of any radius about center A; at any chosen point on the circumference, draw another circle of equal radius (B). The area and shape defined by the two centers and the overlap of the two circumferences is known as the Vesica Piscis (fig. 3a).

Fig. 3b shows the generation of equilateral triangles.

In fig. 3c, we see that if AB = 1, then DG = 1, CG = 2, and, by the Pythagorean Theorem ( $a^2 + b^2 = c^2$ ), the major axis

$$CD = \sqrt{(CG^2 - DG^2)} = \sqrt{3}$$

**THE SQUARE ROOT OF 5**

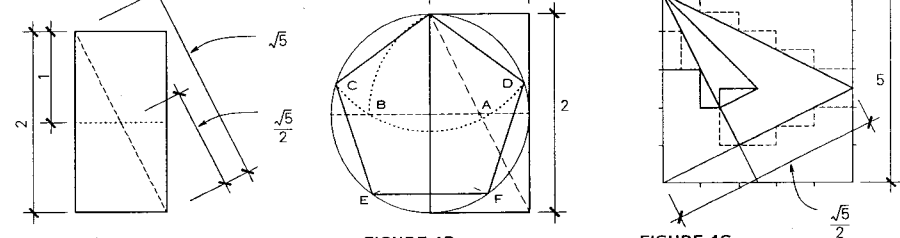

FIGURE 4A

FIGURE 4B

FIGURE 4C

**THE SQUARE ROOT OF 5**

**THE  $\sqrt{5}$**

The square root of 5 may be generated from a 1:2 rectangle (a double square); see fig. 4a. Fig. 4b demonstrates the relationship of the square root of 5, both with the number 5 (as the square of its root) and with the fivefold symmetry of the pentagon. The 3,4,5 "Pythagorean" triangle (fig. 4c) is derived from the crossing of three semidiagonals (square root of 5 divided by 2). The square root of 5 is the proportion that opens the way for the family of relationships called the Golden Proportion.

**THE GOLDEN PROPORTION**

Grand philosophical, natural, and aesthetic considerations have surrounded this proportion ever since humanity began to reflect on the geometric forms of its world. The Golden Proportion can be found in nature, where it governs plant growth patterns and human proportions. Its presence can be found in the sacred art and architecture of Egypt, India, China, Greece, Islamic countries, and other traditional cultures. It was hidden in Gothic cathedrals, celebrated in Renaissance art, and used by modernist architects such as Le Corbusier and Wright.

Discontinuous proportions contain four terms (a:b::c:d). Geometric relationships are of a three-term proportional type (a:b::b:c). There is only one proportional division that is possible with two terms; this is written a:b::b:(a + b). The unique two-term proportion (designated by the Greek letter  $\phi$ ) was called "golden" by the ancients because the original unity is always represented in its division, written

$$\frac{1}{\phi^3} : \frac{1}{\phi^2} : \frac{1}{\phi} : 1 :: \phi : \phi^2 : \phi^3 \quad \text{etc.}$$

Scott C. McBroom, AIA; Alexandria, Virginia

**GOLDEN PROPORTION**

Fig. 5a shows the construction of the Golden Proportion from the 1:2 rectangle. Fig. 5b demonstrates the relationship of three squares related by  $\phi$ . Fig. 5c reveals an important pentagonal relationship: the side of a pentagon is in relation to its diagonal as

$$(1 + \sqrt{5}) \div 2 \quad \text{or} \quad 1:\phi, \text{ the golden section}$$

$\phi$  represents a coinciding of the processes of addition and multiplication called the Fibonacci Series, which manifests itself in some biological growth patterns. The Fibonacci Series is an additive progression in which the two initial terms are added together to form the third term (1, 1, 2, 3, 5, 8, 13...). Any two successive terms tend to be approximately in relation to one another as 1:  $\phi$ , and any three successive terms are as 1:  $\phi$ :  $\phi^2$ ....

**REFERENCES**

1. Brunes, T. *The Secret of Ancient Geometry and Its Use*. 2 vols. Copenhagen: Rhodos, 1967.
2. Critchlow, K. *Order in Space*. New York: Thames and Hudson, 1969.
3. Ghyka, M. *The Geometry of Art and Life*. New York: Dover, 1977.
4. Lawlor, R. *Sacred Geometry: Philosophy and Practice*. New York: Thames and Hudson, 1982. (The information presented on this page is based substantially on this work.)
5. Young, A. *The Geometry of Meaning*. New York: Delta-corte Press, 1976.

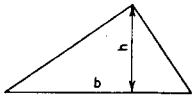

**TRIANGLE**  
 AREA = 1/2 ANY ALTITUDE X ITS BASE (ALTITUDE IS PERPENDICULAR DISTANCE TO OPPOSITE VERTEX OR CORNER.)  
 $A = \frac{1}{2} b \times h$

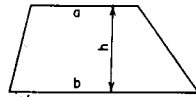

**TRAPEZOID**  
 AREA = 1/2 SUM OF PARALLEL SIDES X ALTITUDE  
 $A = \frac{h(a+b)}{2}$

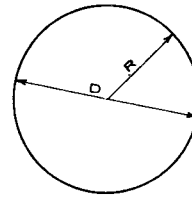

**CIRCLE**  
 AREA =  $\frac{\pi D^2}{4} = \pi R^2$   
 CIRCUMFERENCE =  $2\pi R = \pi D$   
 ( $\pi = 3.14159265359$ )

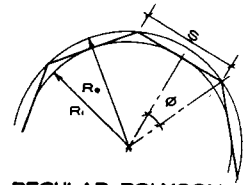

**REGULAR POLYGON**  
 AREA =  $\frac{nSR}{2}$   
 (n = NUMBER OF SIDES)  
 ANY SIDE  $S = 2\sqrt{R^2 - r^2}$

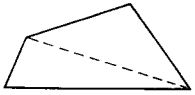

**TRAPEZIUM (IRREGULAR QUADRILATERAL)**  
 AREA = DIVIDE FIGURE INTO TWO TRIANGLES AND FIND AREAS AS ABOVE

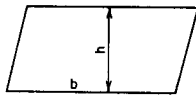

**PARALLELOGRAM**  
 AREA = EITHER SIDE X ALTITUDE

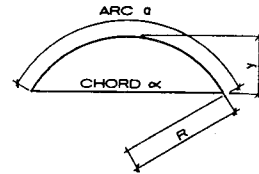

**CIRCULAR SEGMENT**  
 AREA = (LENGTH OF ARC  $\theta$ ) X  $R - \frac{1}{2}(R-y)$   
 CHORD  $c = \frac{2\sqrt{2yR - y^2}}{2} = 2R \sin \frac{\theta}{2}$

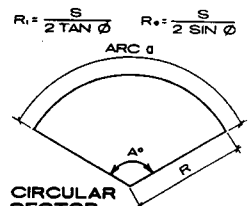

**CIRCULAR SECTOR**  
 AREA =  $\frac{\theta R^2}{2}$   
 = AREA OF CIRCLE X  $\frac{A^\circ}{360}$   
 =  $0.0087R^2 A^\circ$   
 ARC  $a = \frac{\pi R A^\circ}{180} = 0.0175 RA^\circ$

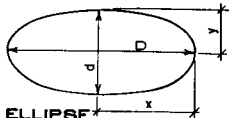

**ELLIPSE**  
 AREA =  $.7854 Dd$   
 APPROX. PERIMETER =  $\pi \sqrt{2(x^2 + y^2)}$

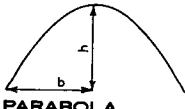

**PARABOLA**  
 AREA =  $\frac{4hb}{3}$

**GEOMETRIC PROPERTIES OF PLANE FIGURES**

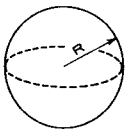

**SPHERE**  
 VOLUME =  $\frac{4\pi R^3}{3} = 0.5236D^3$   
 SURFACE =  $4\pi R^2 = \pi D^2$

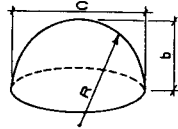

**SEGMENT OF SPHERE**  
 VOLUME =  $\frac{\pi b^2(3R-b)}{3}$  (OR SECTOR - CONE)  
 SURFACE =  $2\pi Rb$  (NOT INCLUDING SURFACE OF CIRCULAR BASE)

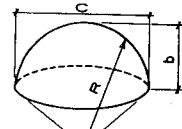

**SECTOR OF SPHERE**  
 VOLUME =  $\frac{2\pi R^2 b}{3}$   
 SURFACE =  $\frac{\pi R(4b+c)}{2}$  (OR: SECTOR + CONE)

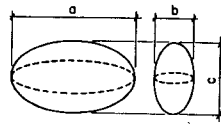

**ELLIPSOID**  
 VOLUME =  $\frac{\pi abc}{6}$   
 SURFACE: NO SIMPLE RULE

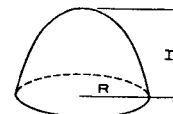

**PARABOLOID OF REVOLUTION**  
 VOLUME = AREA OF CIRCULAR BASE X 1/2 ALTITUDE.  
 SURFACE: NO SIMPLE RULE

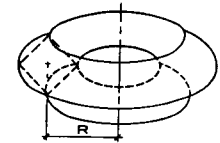

**CIRCULAR RING OF ANY SECTION**  
 R = DISTANCE FROM AXIS OF RINGS TO TRUE CENTER OF SECTION  
 VOLUME = AREA OF SECTION X  $2\pi R$   
 SURFACE = PERIMETER OF SECTION X  $2\pi R$  (CONSIDER THE SECTION ON ONE SIDE OF AXIS ONLY)

**VOLUMES AND SURFACES OF DOUBLE-CURVED SOLIDS**

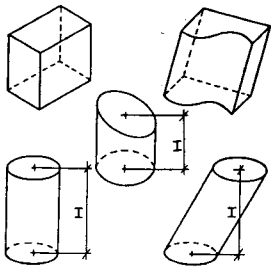

**ANY PRISM OR CYLINDER, RIGHT OR OBLIQUE, REGULAR OR IRREGULAR.**  
 Volume = area of base x altitude

Altitude = distance between parallel bases, measured perpendicular to the bases. When bases are not parallel, then Altitude = perpendicular distance from one base to the center of the other.

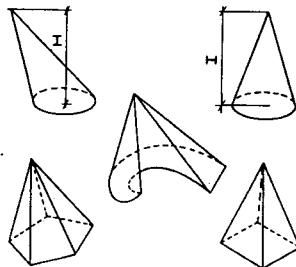

**ANY PYRAMID OR CONE, RIGHT OR OBLIQUE, REGULAR OR IRREGULAR.**  
 Volume = area of base x 1/3 altitude

Altitude = distance from base to apex, measured perpendicular to base.

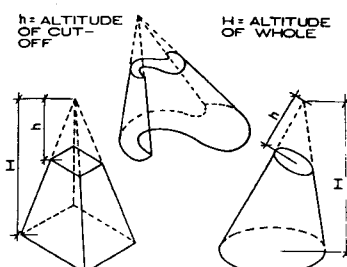

**ANY FRUSTUM OR TRUNCATED PORTION OF THE SOLIDS SHOWN**

Volume: From the volume of the whole solid, if complete, subtract the volume of the portion cut off.

The altitude of the cut-off part must be measured perpendicular to its own base.

**SURFACES OF SOLIDS**

The area of the surface is best found by adding together the areas of all the faces.

The area of a right cylindrical surface = perimeter of base x length of elements (average length if other base is oblique).

The area of a right conical surface = perimeter of base x 1/2 length of elements.

There is no simple rule for the area of an oblique conical surface, or for a cylindrical one where neither base is perpendicular to the elements. The best method is to construct a development, as if making a paper model, and measure its area by one of the methods given on the next page.

**VOLUMES AND SURFACES OF TYPICAL SOLIDS**



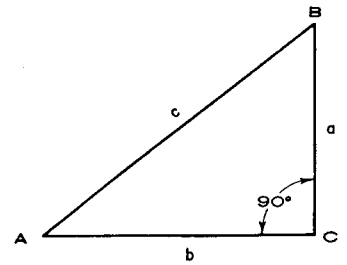
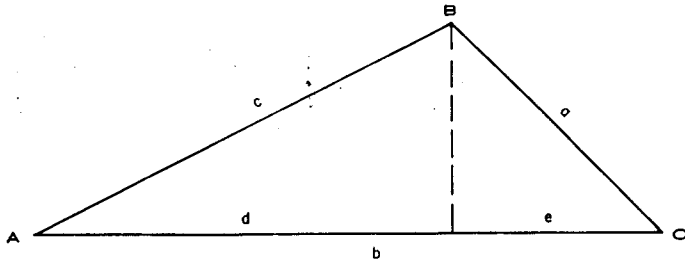

**OBLIQUE TRIANGLES**

**RIGHT TRIANGLES**

FIND	GIVEN	SOLUTION	FIND	GIVEN	SOLUTION
a	A B b	$b \sin A \div \sin B$	A	a b c s	$\sin \frac{1}{2} A = \sqrt{(s-b)(s-c) \div bc}$
	A B c	$c \sin A \div \sin (A+B)$		$\cos \frac{1}{2} A = \sqrt{s(s-a) \div bc}$	
	A C b	$b \sin A \div \sin (A+C)$		$\tan \frac{1}{2} A = \sqrt{(s-b)(s-c) \div s(s-a)}$	
	A C c	$c \sin A \div \sin C$		B a b	$\sin A = a \sin B \div b$
	B C b	$b \sin (B+C) \div \sin B$		B a c	$\tan A = \frac{a \sin B}{c-a \cos B}$
	B C c	$c \sin (B+C) \div \sin C$		C a b	$\tan A = \frac{a \sin C}{b-a \cos C}$
	A b c	$\sqrt{b^2 + c^2 - 2bc \cdot \cos A}$		C a c	$\sin A = a \sin C \div c$
b	A B e	$a \sin B \div \sin A$	B	a b c s	$\sin \frac{1}{2} B = \sqrt{(s-a)(s-c) \div ac}$
	A B c	$c \sin B \div \sin (A+B)$		$\cos \frac{1}{2} B = \sqrt{s(s-b) \div ac}$	
	A C a	$a \sin (A+C) \div \sin A$		$\tan \frac{1}{2} B = \sqrt{(s-a)(s-c) \div s(s-b)}$	
	A C c	$c \sin (A+C) \div \sin C$		A a b	$\sin B = b \sin A \div a$
	B C a	$a \sin B \div \sin (B+C)$		A b c	$\tan B = \frac{b \sin A}{c-b \cos A}$
	B C c	$c \sin B \div \sin C$		C a b	$\tan B = \frac{b \sin C}{a-b \cos C}$
	B a c	$\sqrt{a^2 + c^2 - 2ac \cdot \cos B}$		C a c	$\sin B = b \sin C \div c$
c	A B a	$a \sin (A+B) \div \sin A$	C	a b c s	$\sin \frac{1}{2} C = \sqrt{(s-a)(s-b) \div ab}$
	A B b	$b \sin (A+B) \div \sin B$		$\cos \frac{1}{2} C = \sqrt{s(s-c) \div ab}$	
	A C a	$a \sin C \div \sin A$		$\tan \frac{1}{2} C = \sqrt{(s-a)(s-b) \div s(s-c)}$	
	A C b	$b \sin C \div \sin (A+C)$		A a c	$\sin C = c \sin A \div a$
	B C a	$a \sin C \div \sin (B+C)$		A b c	$\tan C = \frac{c \sin A}{b-c \cos A}$
	B C b	$b \sin C \div \sin B$		B a c	$C = \frac{C \sin B}{a-c \cos B}$
	C a b	$\sqrt{a^2 + b^2 - 2ab \cdot \cos C}$		B b c	$\sin C = c \sin B \div b$
$\frac{1}{2} (B+C)$	A b c	$90^\circ - \frac{1}{2} A$	AREA	a b c	$\sqrt{s(s-a)(s-b)(s-c)}$
$\frac{1}{2} (B-C)$		$\tan = [(b-c) \tan(90^\circ - \frac{1}{2} A)] \div (b+c)$		C a b	$\frac{1}{2} ab \sin C$
$\frac{1}{2} (A+C)$	B e c	$90^\circ - \frac{1}{2} B$	s	a b c	$(a + b + c) \div 2$
$\frac{1}{2} (A-C)$		$\tan = [(a-c) \tan(90^\circ - \frac{1}{2} B)] \div (a+c)$	d	a b c s	$(b^2 + c^2 - a^2) \div 2b$
$\frac{1}{2} (A+B)$	C e b	$90^\circ - \frac{1}{2} C$	e	a b c s	$(a^2 + b^2 - c^2) \div 2b$
$\frac{1}{2} (A-B)$		$\tan = [(a-b) \tan(90^\circ - \frac{1}{2} C)] \div (a+b)$			

FIND	GIVEN	SOLUTION
A	a b	$\tan A = a \div b$
	a c	$\sin A = a \div c$
	b c	$\cos A = b \div c$
B	ab	$\tan B = b \div a$
	ac	$\cos B = a \div c$
	bc	$\sin B = b \div c$
a	Ab	$b \tan A$
	Ac	$c \sin A$
b	Aa	$a \div \tan A$
	Ac	$c \cos A$
c	Aa	$a \div \sin A$
	Ab	$b \div \cos A$
AREA	ab	$ab \div 2$

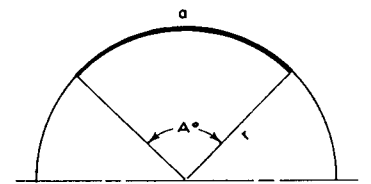

ARC  $a = \frac{\pi r A^\circ}{180^\circ}$   
**ARCS**

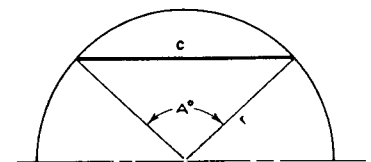

CHORD  $c = 2r \sin \frac{A}{2}$   
**CHORDS**

NATURAL SINES

Table of natural sines for angles 0 to 90 degrees, with columns for angles and sine values.

NATURAL SINES

Table of natural sines for angles 45 to 90 degrees, with columns for angles and sine values.

NATURAL COSINES

Table of natural cosines for angles 0 to 90 degrees, with columns for angles and cosine values.

NATURAL COSINES

Table of natural cosines for angles 45 to 90 degrees, with columns for angles and cosine values.

NATURAL TANGENTS

Table of natural tangents for angles 0 to 90 degrees, with columns for angles and tangent values.

NATURAL TANGENTS

Table of natural tangents for angles 45 to 90 degrees, with columns for angles and tangent values.

NATURAL COTANGENTS

Table of natural cotangents for angles 0 to 90 degrees, with columns for angles and cotangent values.

NATURAL COTANGENTS

Table of natural cotangents for angles 45 to 90 degrees, with columns for angles and cotangent values.



NATURAL SECANTS

ANGLE	0'	10'	20'	30'	40'	50'	60'	ANGLE
0°	1.00000	1.00001	1.00002	1.00004	1.00007	1.00011	1.00015	90°
1	1.00015	1.00021	1.00027	1.00034	1.00042	1.00051	1.00061	89
2	1.00061	1.00072	1.00083	1.00095	1.00108	1.00122	1.00137	88
3	1.00137	1.00153	1.00169	1.00187	1.00205	1.00224	1.00244	86
4	1.00244	1.00265	1.00281	1.00309	1.00333	1.00357	1.00382	85
5	1.00382	1.00408	1.00435	1.00463	1.00491	1.00521	1.00551	84
6	1.00551	1.00582	1.00614	1.00647	1.00681	1.00715	1.00751	83
7	1.00751	1.00787	1.00825	1.00863	1.00902	1.00942	1.00983	82
8	1.00983	1.01024	1.01067	1.01111	1.01155	1.01200	1.01247	81
9	1.01247	1.01294	1.01342	1.01391	1.01440	1.01491	1.01543	80
10	1.01543	1.01595	1.01649	1.01703	1.01758	1.01815	1.01872	79
11	1.01872	1.01930	1.01989	1.02049	1.02110	1.02171	1.02234	78
12	1.02234	1.02298	1.02362	1.02428	1.02494	1.02562	1.02630	77
13	1.02630	1.02700	1.02770	1.02842	1.02914	1.02987	1.03061	76
14	1.03061	1.03137	1.03213	1.03290	1.03368	1.03447	1.03528	75
15	1.03528	1.03609	1.03691	1.03774	1.03858	1.03944	1.04030	74
16	1.04030	1.04117	1.04206	1.04295	1.04385	1.04477	1.04569	73
17	1.04569	1.04663	1.04757	1.04853	1.04950	1.05047	1.05146	72
18	1.05146	1.05246	1.05347	1.05449	1.05552	1.05657	1.05762	71
19	1.05762	1.05869	1.05976	1.06085	1.06195	1.06306	1.06418	70
20	1.06418	1.06531	1.06645	1.06761	1.06878	1.06995	1.07115	69
21	1.07115	1.07235	1.07355	1.07479	1.07602	1.07727	1.07853	68
22	1.07853	1.07981	1.08109	1.08239	1.08370	1.08503	1.08636	67
23	1.08636	1.08771	1.08907	1.09044	1.09183	1.09323	1.09464	66
24	1.09464	1.09606	1.09750	1.09895	1.10041	1.10189	1.10338	65
25	1.10338	1.10488	1.10640	1.10793	1.10947	1.11103	1.11260	64
26	1.11260	1.11419	1.11579	1.11740	1.11903	1.12067	1.12233	63
27	1.12233	1.12400	1.12568	1.12738	1.12910	1.13083	1.13257	62
28	1.13257	1.13433	1.13610	1.13789	1.13970	1.14152	1.14335	61
29	1.14335	1.14521	1.14707	1.14896	1.15085	1.15277	1.15470	60
30	1.15470	1.15665	1.15861	1.16059	1.16259	1.16460	1.16663	59
31	1.16663	1.16868	1.17075	1.17283	1.17493	1.17704	1.17918	58
32	1.17918	1.18133	1.18350	1.18569	1.18790	1.19012	1.19236	57
33	1.19236	1.19463	1.19691	1.19920	1.20152	1.20386	1.20622	56
34	1.20622	1.20859	1.21099	1.21341	1.21584	1.21830	1.22077	55
35	1.22077	1.22327	1.22579	1.22833	1.23089	1.23347	1.23607	54
36	1.23607	1.23869	1.24134	1.24400	1.24669	1.24940	1.25214	53
37	1.25214	1.25489	1.25767	1.26047	1.26330	1.26615	1.26902	52
38	1.26902	1.27191	1.27483	1.27778	1.28075	1.28374	1.28676	51
39	1.28676	1.28980	1.29287	1.29597	1.29909	1.30223	1.30541	50
40	1.30541	1.30861	1.31183	1.31509	1.31837	1.32166	1.32501	49
41	1.32501	1.32838	1.33177	1.33519	1.33864	1.34212	1.34563	48
42	1.34563	1.34917	1.35274	1.35634	1.35997	1.36363	1.36733	47
43	1.36733	1.37105	1.37481	1.37860	1.38242	1.38628	1.39016	46
44	1.39016	1.39409	1.39804	1.40203	1.40606	1.41012	1.41421	45°

FUNCTIONS OF NUMBERS

NO.	SQUARE	CUBE	SQUARE ROOT	CUBE ROOT	LOGARITHM	NATURAL COSECANTS		
						RECIPROCAL	CIRCUM.	AREA
1	1	1	1.0000	1.0000	0.00000	1000.000	3.142	0.7854
2	4	8	1.4142	1.2599	0.30103	500.000	6.283	3.1416
3	9	27	1.7321	1.4422	0.47712	333.333	9.425	7.0686
4	16	64	2.0000	1.5874	0.60206	250.000	12.566	12.5664
5	25	125	2.2361	1.7100	0.69897	200.000	15.708	19.6350
6	36	216	2.4496	1.8171	0.77815	166.667	18.850	28.2743
7	49	343	2.6458	1.9129	0.84510	142.857	21.991	38.4845
8	64	512	2.8284	2.0000	0.90309	125.000	25.133	50.2655
9	81	729	3.0000	2.0801	0.95424	111.111	28.274	63.6173
10	100	1000	3.1623	2.1544	1.00000	100.000	31.416	78.5398
11	121	1331	3.3166	2.2240	1.04139	90.9091	34.558	95.0332
12	144	1728	3.4641	2.2894	1.07918	83.3333	37.699	113.097
13	169	2197	3.6056	2.3513	1.11394	76.9231	40.841	132.732
14	196	2744	3.7417	2.4101	1.14613	71.4286	43.982	153.938
15	225	3375	3.8730	2.4662	1.17609	66.6667	47.124	176.715
16	256	4096	4.0000	2.5198	1.20412	62.5000	50.265	201.062
17	289	4913	4.1231	2.5713	1.23045	58.8235	53.407	226.980
18	324	5832	4.2426	2.6207	1.25527	55.5556	56.549	254.469
19	361	6859	4.3589	2.6684	1.27875	52.6316	59.690	283.529
20	400	8000	4.4721	2.7144	1.30103	50.0000	62.832	314.159
21	441	9261	4.5826	2.7589	1.32222	47.6190	65.973	346.361
22	484	10648	4.6904	2.8020	1.34242	45.4545	69.115	380.133
23	529	12167	4.7958	2.8439	1.36173	43.4783	72.257	415.476
24	576	13824	4.8990	2.8845	1.38021	41.6667	75.398	452.389
25	625	15625	5.0000	2.9240	1.39794	40.0000	78.540	490.874
26	676	17576	5.0990	2.9625	1.41497	38.4615	81.681	530.929
27	729	19683	5.1962	3.0000	1.43136	37.0370	84.823	572.555
28	784	21952	5.2915	3.0366	1.44716	35.7143	87.965	615.572
29	841	24389	5.3852	3.0723	1.46240	34.4828	91.106	660.520
30	900	27000	5.4772	3.1072	1.47712	33.3333	94.248	706.858
31	961	29791	5.5678	3.1414	1.49136	32.2581	97.389	754.768
32	1024	32768	5.6569	3.1748	1.50515	31.2500	100.531	804.248
33	1089	35937	5.7446	3.2075	1.51851	30.3030	103.673	855.299
34	1156	39304	5.8310	3.2396	1.53148	29.4118	106.814	907.920
35	1225	42875	5.9161	3.2711	1.54400	28.5714	109.956	962.113
36	1296	46656	6.0000	3.3019	1.55630	27.7778	113.097	1017.88
37	1369	50653	6.0828	3.3322	1.56820	27.0270	116.239	1075.21
38	1444	54872	6.1644	3.3620	1.57978	26.3158	119.381	1134.11
39	1521	59319	6.2450	3.3912	1.59106	25.6410	122.522	1194.59
40	1600	64000	6.3246	3.4200	1.60206	25.0000	125.66	1256.64
41	1681	68921	6.4031	3.4482	1.61278	24.3902	128.81	1320.25
42	1764	74088	6.4807	3.4760	1.62325	23.8095	131.95	1385.44
43	1849	79507	6.5574	3.5034	1.63347	23.2509	135.09	1452.20
44	1936	85184	6.6332	3.5303	1.64345	22.7273	138.23	1520.53
45	2025	91125	6.7082	3.5569	1.65321	22.2222	141.37	1590.43

NATURAL SECANTS

ANGLE	0'	10'	20'	30'	40'	50'	60'	ANGLE
45°	1.41421	1.41835	1.42251	1.42672	1.43096	1.43524	1.43956	44°
46	1.43956	1.44391	1.44831	1.45274	1.45721	1.46173	1.46628	43
47	1.46628	1.47087	1.47551	1.48019	1.48491	1.48967	1.49448	42
48	1.49448	1.49933	1.50422	1.50916	1.51415	1.51918	1.52425	41
49	1.52425	1.52938	1.53455	1.53977	1.54504	1.55036	1.55572	40
50	1.55572	1.56114	1.56661	1.57213	1.57771	1.58333	1.58902	39
51	1.58902	1.59475	1.60054	1.60639	1.61229	1.61825	1.62427	38
52	1.62427	1.63025	1.63628	1.64236	1.64849	1.65468	1.66092	37
53	1.66092	1.66709	1.67460	1.68117	1.68782	1.69452	1.70130	36
54	1.70130	1.70815	1.71506	1.72205	1.72911	1.73624	1.74345	35
55	1.74345	1.75073	1.75808	1.76552	1.77303	1.78062	1.78829	34
56	1.78829	1.79604	1.80388	1.81180	1.81981	1.82790	1.83608	33
57	1.83608	1.84435	1.85271	1.86116	1.86970	1.87834	1.88708	32
58	1.88708	1.89591	1.90485	1.91388	1.92302	1.93226	1.94160	31
59	1.94160	1.95106	1.96062	1.97029	1.98008	1.98998	2.00000	30
60	2.00000	2.01014	2.02039	2.03077	2.04128	2.05191	2.06267	29
61	2.06267	2.07356	2.08458	2.09574	2.10704	2.11847	2.13002	28
62	2.13002	2.14178	2.15366	2.16568	2.17786	2.19019	2.20267	27
63	2.20267	2.21535	2.22817	2.24116	2.25432	2.26766	2.28117	26
64	2.28117	2.29487	2.30875	2.32282	2.33708	2.35154	2.36620	25
65	2.36620	2.38107	2.39614	2.41142	2.42692	2.44264	2.45859	24
66	2.45859	2.47477	2.49119	2.50784	2.52474	2.54190	2.55932	23
67	2.55932	2.57698	2.59491	2.61313	2.63162	2.65040	2.66947	22
68	2.66947	2.68884	2.70851	2.72850	2.74881	2.76945	2.79043	21
69	2.79043	2.81175	2.83342	2.85545	2.87785	2.90063	2.92380	20
70	2.92380	2.94737	2.97135	2.99574	3.02052	3.04568	3.07125	19
71	3.07125	3.09774	3.12460	3.15185	3.17950</			

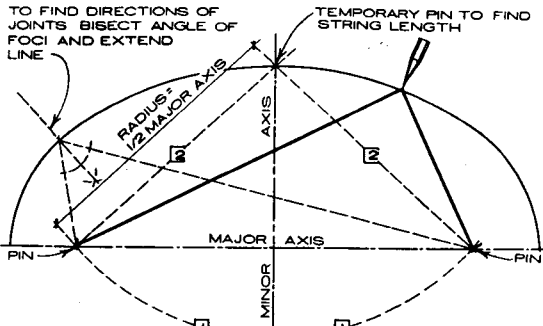

**STRING METHOD**  
(FOR LARGE SCALE AND FULL SIZE)

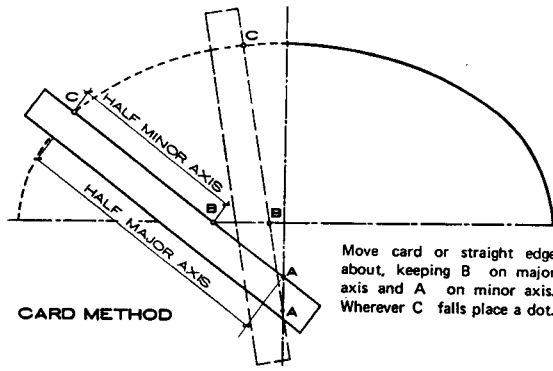

**CARD METHOD**

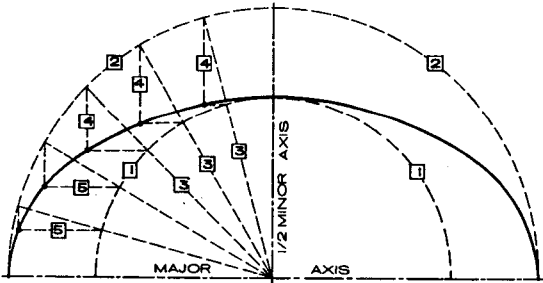

**AUXILIARY CIRCLES METHOD**

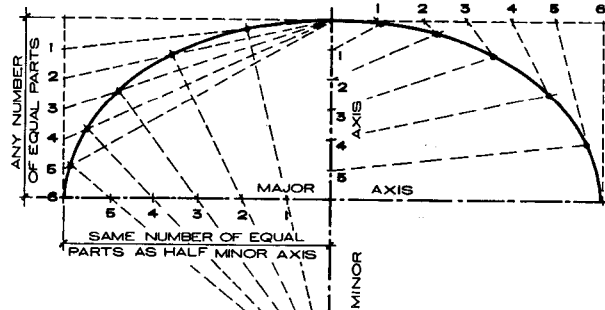

**PARALLELOGRAM METHOD**

Either pair of opposite apex points may be used:

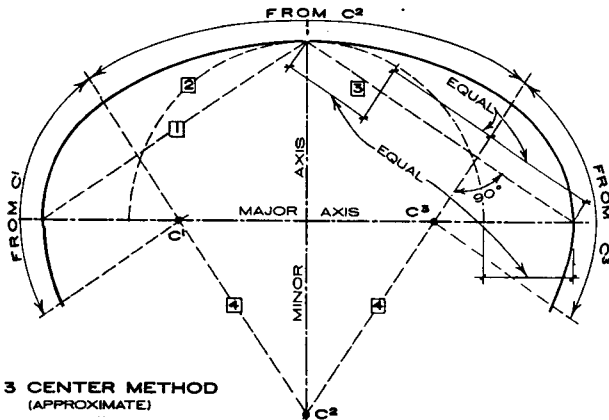

**3 CENTER METHOD**  
(APPROXIMATE)

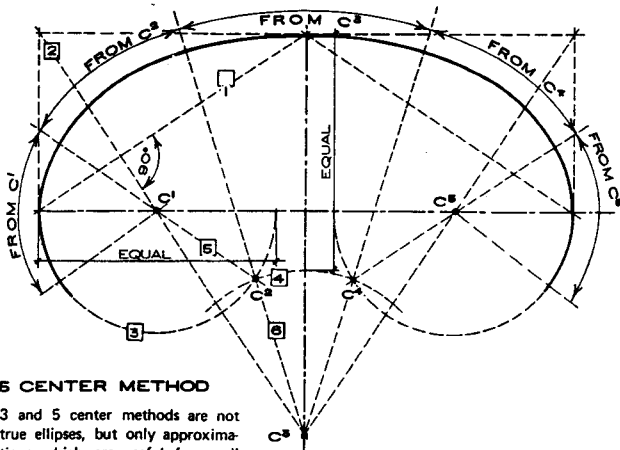

**5 CENTER METHOD**

3 and 5 center methods are not true ellipses, but only approximations which are useful for small scale drawings.

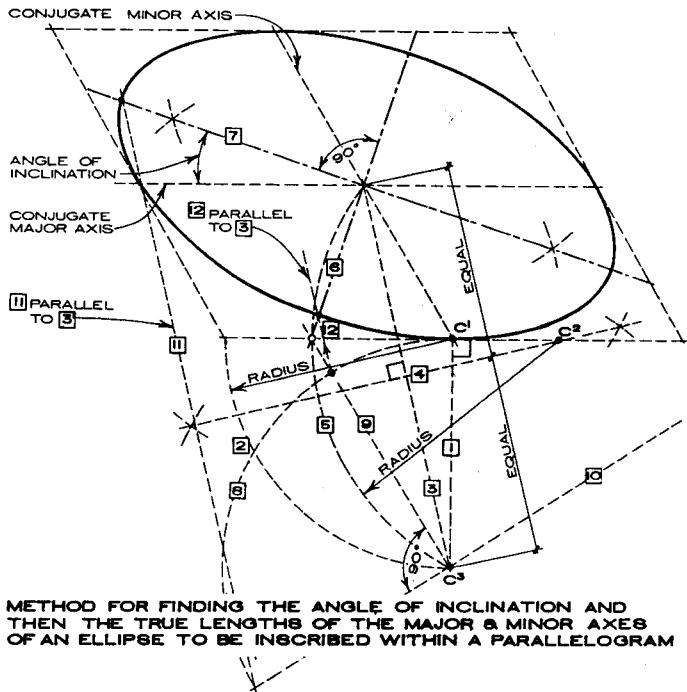

**METHOD FOR FINDING THE ANGLE OF INCLINATION AND THEN THE TRUE LENGTHS OF THE MAJOR & MINOR AXES OF AN ELLIPSE TO BE INSCRIBED WITHIN A PARALLELOGRAM**

**NOTE**

1. Using the conjugate axes, the ellipse can be drawn directly by using the parallelogram method.
2. Using the true lengths of the axes, the ellipse may be drawn with any one of the methods illustrated on this page.

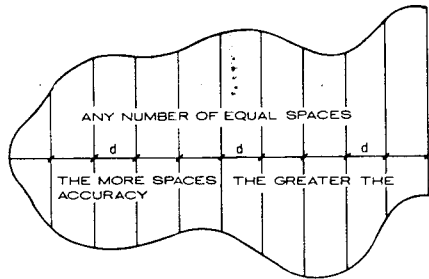

**TO FIND THE AREA OF AN IRREGULAR PLANE FIGURE**

1. Divide the figure into parallel strips by equally spaced parallel lines.
2. Measure the length of each of the parallel lines.
3. Obtain a summation of the unit areas by one of these 3 "rules".

**TRAPEZOID RULE**

Add together the length of the parallels, taking the first and last at  $\frac{1}{2}$  value, and multiply by the width of the internal "d". This rule is sufficiently accurate for estimating and other ordinary purposes.

**SIMPSON'S RULE**

Add the parallels, taking the first and last at full value, second, the fourth, sixth, etc. from each end at 4 times full value, and the third, fifth, seventh, etc. from each end at 2 times the value, then multiply by  $\frac{1}{3}d$ . This rule works only for an even number of spaces and is accurate for areas bounded by smooth curves.

**DURAND'S RULE**

Add the parallels taking the first and last at  $\frac{5}{12}$  value, the second from each end at  $\frac{13}{12}$  value, and all others at full value, then multiply by d. This rule is the most accurate for very irregular shapes.

**NOTE**

Irregular areas may be directly read off by means of a simple instrument called a Planimeter.

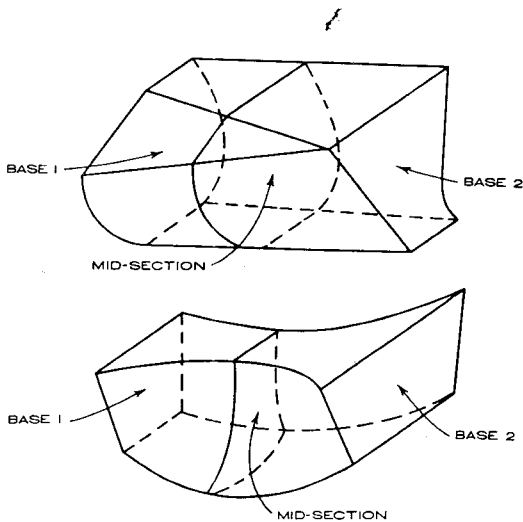
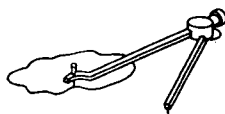

**TO FIND THE VOLUME OF AN IRREGULAR FIGURE BY THE PRISMATOID FORMULA**

Construct a section midway between the bases. Add 4 to the sum of the areas of the 2 bases and multiply the quantity by the area of the mid-section. Then multiply the total by  $\frac{1}{6}$  the perpendicular distance between the bases.

$$V = \left[ (\text{area of base}_1 + \text{area of base}_2 + 4) (\text{area of midsection}) \right] \times \frac{1}{6} \text{ perpendicular distance between bases.}$$

This formula is quite accurate for any solid with two parallel bases connected by a surface of straight line elements (upper figure), or smooth simple curves (lower figure).

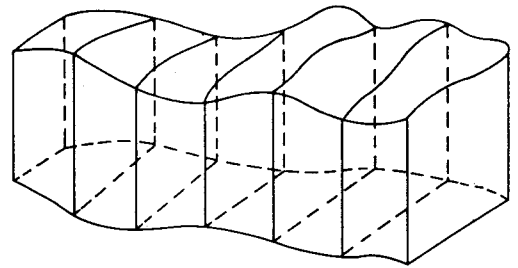

**TO FIND THE VOLUME OF A VERY IRREGULAR FIGURE BY THE SECTIONING METHOD**

1. Construct a series of equally spaced sections or profiles.
2. Determine the area of each section by any of the methods shown at left (preferably with a Planimeter).
3. Apply any one of the 3 summation "rules" given at left, to determine the total volume.

This method is in general use for estimating quantities of earthwork, etc.

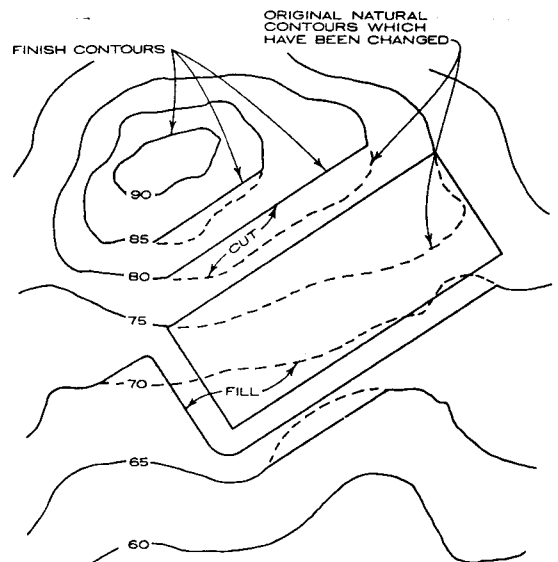

**TO FIND THE VOLUME OF CUT AND FILL DIRECTLY FROM THE CONTOUR PLAN**

1. Draw "finish" and "original" contours on same contour map.
2. Measure the differential areas between new and old contours of each contour and enter in columns according to whether cut or fill.
3. Add up each column and multiply by the contour interval to determine the volume in cubic feet.

**EXAMPLE**

CONTOUR	CUT	FILL
85	300	
80	960	
75	2,460 - 2 = 1,230	3,800 - 2 = 1,900
70	20	2,200
9,200		6,800
x5		x5
<b>TOTALS</b>	46,000 cu. ft.	34,000 cu. ft.

**NOTE**

1. Where a cut or fill ends directly on a contour level use  $\frac{1}{2}$  value.
2. The closer the contour interval, the greater the accuracy.

This method is more rapid than the sectioning method, and is sufficiently accurate for simple estimating purposes and for balancing of cut and fill.

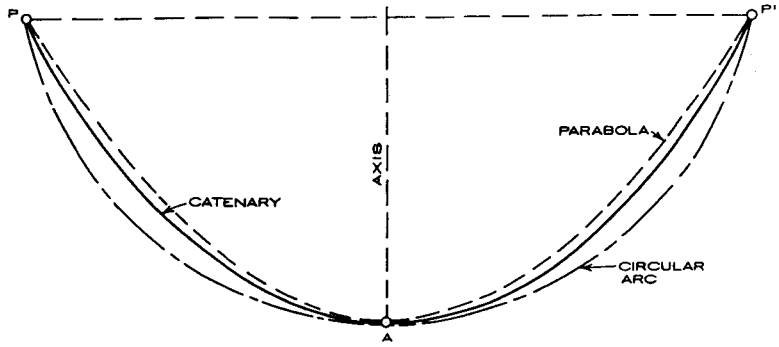

**CATENARY**

A catenary curve lies between a parabola and a circular arc drawn through the same three points, but is closer to the parabola. The catenary is not a conic section. The easiest method of drawing it is to tilt the drafting board and hang a very fine chain on it, and then prick guide points through the links of the chain.

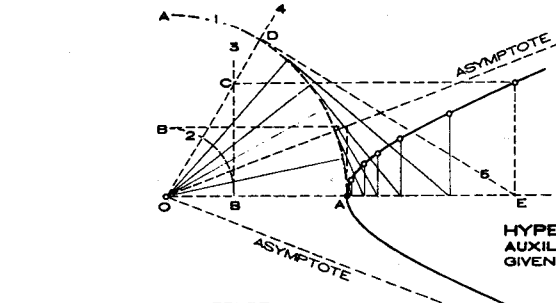

**HYPERBOLA  
AUXILIARY CIRCLES METHOD**  
GIVEN: Axis, Apex, Asymptotes  
(tangents at infinity)

- PROCEDURE:**
1. Draw auxiliary circles with OB and OA as radii: note  $\frac{OB}{OA}$  = slope of asymptote.
  2. Erect perpendicular 3 where circle 2 intersects axis.
  3. Draw any line 4 through O, intersecting circle 1 at B and line 3 at C.
  4. Draw line 5 through C parallel to axis.
  5. Draw tangent 6 at D, intersecting axis at E.
  6. Erect perpendicular 7 at E, intersecting 5 at P, a point on hyperbola.

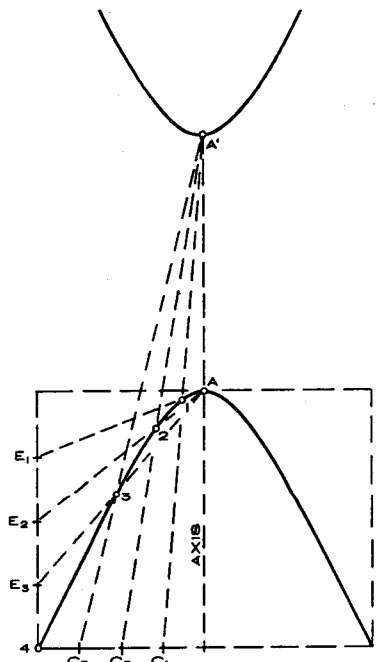

**HYPERBOLA  
PARALLELOGRAM METHOD**

- GIVEN:**  
Axis, two apices (A and A') and a chord.
1. Draw surrounding parallelogram.
  2. Divide chord in whole number of equal spaces ( $C_1, C_2, C_3$ , etc.).
  3. Divide edge of parallelogram into same integral number of equal spaces ( $E_1, E_2, E_3$ , etc.).
  4. Join A to points E on edge; join A' to points C on chord. Intersection of these rays are points on curve.

This method can be used equally well for any type of orthogonal or perspective projection, as shown by example of ellipse.

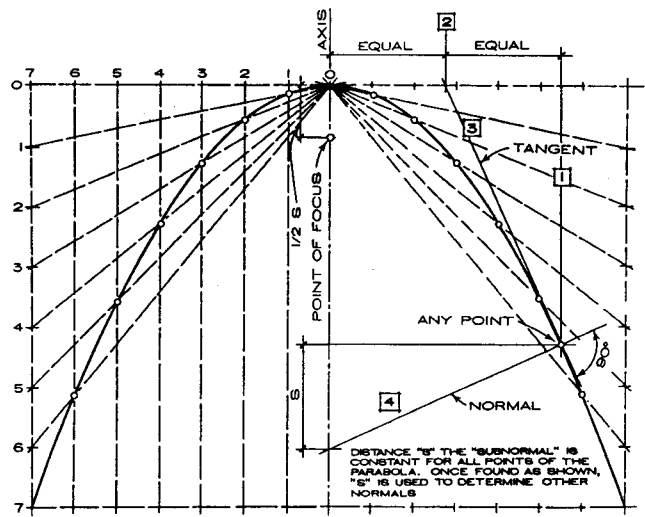

**PARABOLA  
PARALLELOGRAM METHOD**

This method is comparable to the "Parallelogram Method" shown for the hyperbola above and the ellipse on previous page. The other apex 'A' is at infinity.

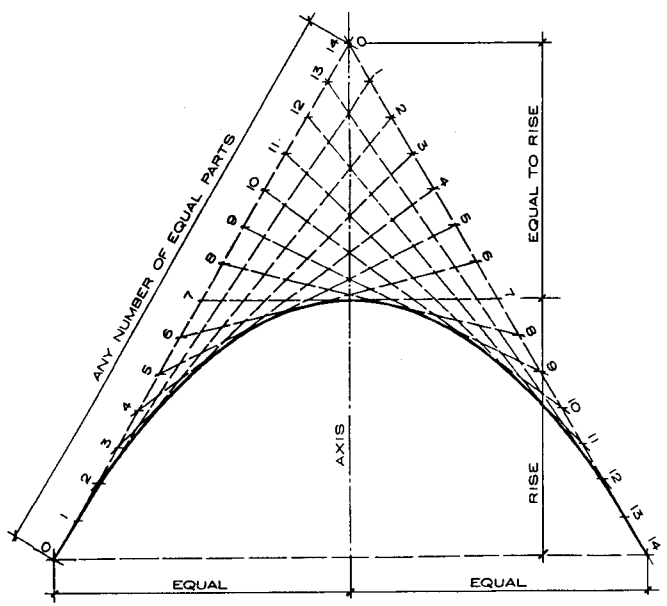

**PARABOLA  
ENVELOPE OF TANGENTS**

This method does not give points on the curve, but a series of tangents within which the parabola can be drawn.

H. Seymour Howard, Jr.: Oyster Bay, New York

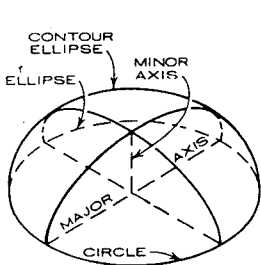

**OBULATE SPHEROID**

An ellipse rotated about its minor axis.

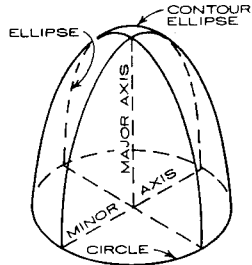

**PROLATE SPHEROID**

An ellipse rotated about its major axis.

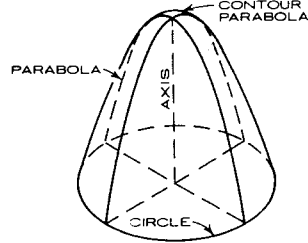

**PARABOLOID OF REVOLUTION**

A parabola rotated about its axis.

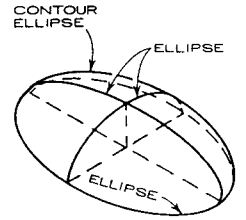

**GENERAL ELLIPSOID**

**NOTES**

1. The dome shapes shown above are SURFACES OF POSITIVE CURVATURE, that is, the centers of both principal radii of curvature are on the same side of the surface.
2. SURFACES OF NEGATIVE CURVATURE (saddle shapes) such as those shown below, are surfaces in which the centers of the two principal radii of curvature are on opposite sides of the surface.

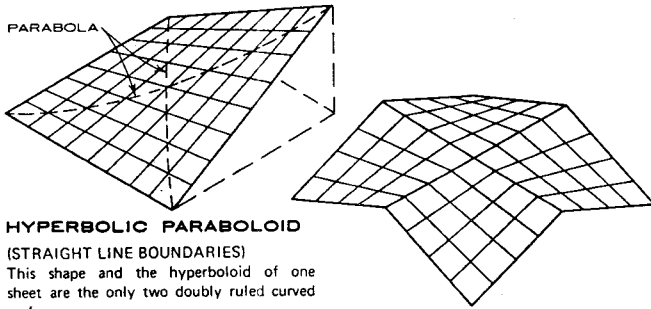

**HYPERBOLIC PARABOLOID**

(STRAIGHT LINE BOUNDARIES)

This shape and the hyperboloid of one sheet are the only two doubly ruled curved surfaces.

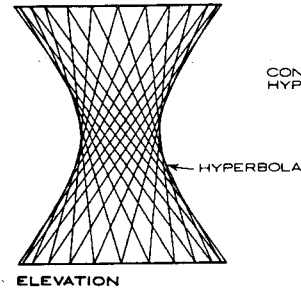

**ELEVATION**

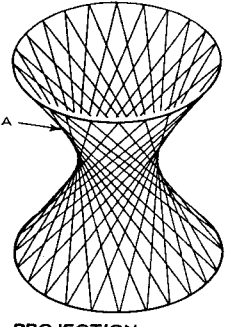

**PROJECTION**

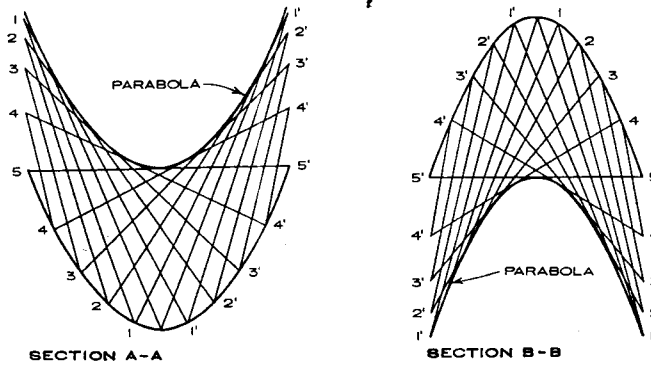

**SECTION A-A**

**SECTION B-B**

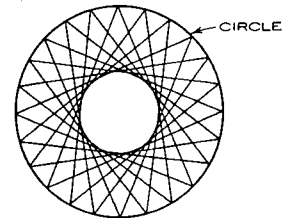

**PLAN HYPERBOLOID OF REVOLUTION (OR HYPERBOLOID OF ONE SHEET)**

**NOTE**

This shape is a doubly ruled surface, which can also be drawn with ellipses as plan sections instead of the circles shown.

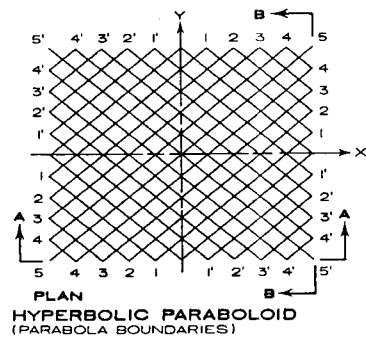

**PLAN HYPERBOLIC PARABOLOID (PARABOLA BOUNDARIES)**

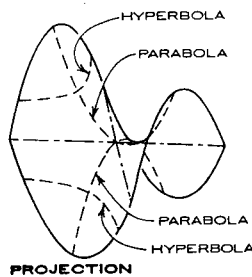

**PROJECTION**

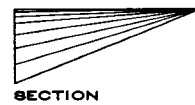

**SECTION**



**ELEVATION**

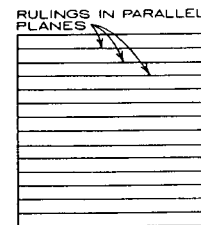

**PLAN CONOID (SINGLY RULED SURFACE)**

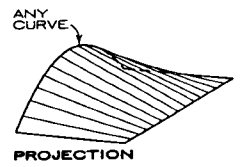

**PROJECTION**

**PROPERTIES OF PLATONIC AND ARCHIMEDEAN POLYHEDRA**

The basic particulars of the Platonic and Archimedean polyhedra are given in the table. The first column of the table gives the names of the polyhedra together with their P-names. The second column lists the numbers of faces, edges, and vertices. For instance, these items for tetrahedron are given as F3:4, E:6, and V:4.

Here, the letter F stands for face and the digit that follows F indicates the number of sides of the face. The letter E stands for edge and the letter V stands for vertex. The items given in the second column for a tetrahedron indicate that it has four triangular faces, six edges, and four vertices. Also, the information given in the second column of the table for P7 (cuboctahedron) indicates that it has 8 triangular faces, 6 square faces, 24 edges, and 12 vertices.

The third column of the table lists the radii of inspheres of the Platonic and Archimedean polyhedra. An insphere is a sphere that is tangent to all the faces of the same type of a polyhedron. A Platonic polyhedron has only one insphere. An Archimedean polyhedron, on the other hand, has either two or three inspheres, depending on whether it has two or three different types of faces. The radius of insphere for an Archimedean polyhedron given in the third column corresponds to the smallest insphere, that is, the insphere that is tangent to the largest faces. Also included at the end of the table are two general formulas for evaluation of the radii of inspheres for Platonic and Archimedean polyhedra. Each value in the third column is given in terms of a parameter L, which represents the edge length of the polyhedron.

The parameter L, representing the edge length, also appears in columns four and five. Columns four and five list the radii of interspheres and circumspheres of the Platonic and Archimedean polyhedra. An intersphere is a sphere that is tangent to all the edges of a polyhedron and a circumsphere is a sphere that passes through all the vertices of a polyhedron. Each Platonic or Archimedean polyhedron has one intersphere and one circumsphere.

The last column of the table lists the dihedral angles of the Platonic and Archimedean polyhedra. A dihedral angle is the angle between two faces of a polyhedron that share an edge. For any Platonic polyhedron, all the dihedral angles are equal. In contrast, an Archimedean polyhedron may have up to three different dihedral angles, as shown in the last column of the table. For an Archimedean polyhedron that has more than one dihedral angle, the faces that correspond to each dihedral angle are specified by the numbers of their sides given in square brackets. For example, in the case of P6 (truncated tetrahedron), the first dihedral angle is preceded by [6-6], indicating that the angle is between two hexagonal faces, and the second dihedral angle is preceded by [6-3], indicating that the angle is between a hexagonal face and a triangular face.

The properties of the Platonic and Archimedean polyhedra, as given in the table, are incorporated into the part of Formian that deals with the processing of polyhedral configurations. The information is built into Formian in terms of the formulas given in the table. The use of formulas will allow the full available accuracy of the computer to be utilized. High accuracy of the basic polyhedral data is essential in many situations. This is the case, for instance, when dealing with complex polyhedral configurations that consist of many thousands of elements, in particular, when the generated geometric details are to be used as a basis for other operations, such as structural analysis.

In regard to the accuracy of the entries in the table, it should be noted that for the snub polyhedra (P15, P16, P19, and P20), the accuracy of the entries for radii of insphere, intersphere, and circumsphere depends on the accuracy of a parameter k. The value of this parameter in the table is given accurate to nine decimal places. The values of the dihedral angles for the snub polyhedra in the table are also given accurate to nine decimal places.

1.  $Rc = \sqrt{Rt^2 + L^2/4}$
2.  $Rt = \sqrt{Rc^2 + L^2/4}$
3.  $Rip = \sqrt{Rc^2 - rp^2}$
4.  $Rip = \sqrt{Rt^2 - bp^2}$
5.  $L = 2\sqrt{Rc^2 - Rt^2}$
6.  $a = 2 \operatorname{asin}(L/2Rc)$
7.  $a = 2 \operatorname{acos}(Rt/Rc)$
8.  $a = 2 \operatorname{atan}(L/2Rt)$

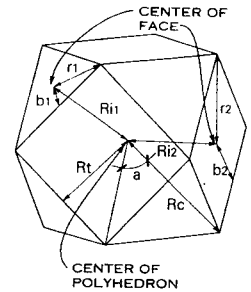

**NOTE**

The relations shown above are applicable to every Platonic and Archimedean polyhedron, where:

L is the edge length.

a is the angle subtended by an edge at the center of the polyhedron.

Rc is the radius of the circumsphere.

Rt is the radius of the intersphere.

Rip is the radius of an insphere, that is, a sphere that is tangent to all the faces of type p.







rp is the distance between the center and a corner of a face of type p.

bp is the distance between the center and the midpoint of a side of a face of type p.

The radius of insphere for an Archimedean polyhedron given in the third column of the table corresponds to the smallest insphere, that is, the insphere that is tangent to the largest faces.

**SOME GENERAL RELATIONS**

**PROPERTIES OF PLATONIC AND ARCHIMEDEAN POLYHEDRA**













POLYHEDRON	FACES, EDGES, VERTICES	RADIUS OF INSHERE	RADIUS OF INTERSPHERE	RADIUS OF CIRCUMSPHERE	DIHEDRAL ANGLE
<b>PLATONIC POLYHEDRA</b>					
P1: Tetrahedron 	F3: 4 E: 6 V: 4	$\frac{\sqrt{6}}{12} L$ (0.204124145 L)	$\frac{\sqrt{2}}{4} L$ (0.353553390 L)	$\frac{\sqrt{6}}{4} L$ (0.612372435 L)	$\operatorname{acos}\left(\frac{1}{3}\right)$ (70.5287794°)
P2: Cube 	F4: 6 E: 12 V: 8	$\frac{L}{2}$	$\frac{L}{\sqrt{2}}$ (0.707106781 L)	$\frac{\sqrt{3}}{2} L$ (0.866025403 L)	90°
P3: Octahedron 	F3: 8 E: 12 V: 6	$\frac{L}{\sqrt{6}}$ (0.408248290 L)	$\frac{L}{2}$	$\frac{L}{\sqrt{2}}$ (0.707106781 L)	$\operatorname{acos}\left(-\frac{1}{3}\right)$ (109.471221°)
P4: Dodecahedron 	F5: 12 E: 30 V: 20	$\frac{\sqrt{25+11\sqrt{5}}}{2\sqrt{10}} L$ (1.11351636 L)	$\frac{3+\sqrt{5}}{4} L$ (1.30901699 L)	$\frac{\sqrt{18+6\sqrt{5}}}{4} L$ (1.40125854 L)	$\operatorname{acos}\left(-\frac{1}{\sqrt{5}}\right)$ (116.565051°)
P5: Icosahedron 	F3: 20 E: 30 V: 12	$\frac{3+\sqrt{5}}{4\sqrt{3}} L$ (0.755761314 L)	$\frac{1+\sqrt{5}}{4} L$ (0.809016994 L)	$\frac{\sqrt{10+2\sqrt{5}}}{4} L$ (0.951056516 L)	$\operatorname{acos}\left(-\frac{\sqrt{5}}{3}\right)$ (138.189685°)
<b>ARCHIMEDEAN POLYHEDRA</b>					
P6: Truncated tetrahedron 	F3: 4 F6: 4 E: 18 V: 12	$\frac{\sqrt{6}}{4} L$ (0.612372435 L)	$\frac{3\sqrt{2}}{4} L$ (1.06066017 L)	$\frac{\sqrt{22}}{4} L$ (1.17260394 L)	[6-6] $\operatorname{acos}(1/3)$ (70.5287794°) [6-3] $\operatorname{acos}(-1/3)$ (109.471221°)
P7: Cuboctahedron 	F3: 8 F4: 6 E: 24 V: 12	$\frac{L}{\sqrt{2}}$ (0.707106781 L)	$\frac{\sqrt{3}}{2} L$ (0.866025403 L)	L	$\operatorname{acos}\left(-\frac{1}{\sqrt{3}}\right)$ (125.264390°)

Hoshyar Nooshin, P. L. Disney, and O. C. Champion, "Computer-Aided Processing of Polyhedral Configurations," in J. François Gabriel, ed., *Beyond the Cube: The Architecture of Space Frames and Polyhedra* (John Wiley & Sons, 1997)





PROPERTIES OF PLATONIC AND ARCHIMEDEAN POLYHEDRA (CONTINUED)

POLYHEDRON	FACES, EDGES, VERTICES	RADIUS OF INSHERE	RADIUS OF INTERSPHERE	RADIUS OF CIRCUMSPHERE	DIHEDRAL ANGLE
<b>ARCHIMEDEAN POLYHEDRA</b>					
P8: Truncated cube 	F3: 8 F8: 6 E: 36 V: 24	$\frac{1 + \sqrt{2}}{2} L$ (1.20710678 L)	$\frac{2 + \sqrt{2}}{2} L$ (1.70710678 L)	$\frac{\sqrt{7 + 4\sqrt{2}}}{2} L$ (1.77882365 L)	[8-8] 90° [8-3] $\arccos\left(\frac{-1}{\sqrt{3}}\right)$ (125.264390°)
P9: Truncated octahedron 	F4: 6 F6: 8 E: 36 V: 24	$\frac{\sqrt{6}}{2} L$ (1.22474487 L)	$\frac{3}{2} L$	$\frac{\sqrt{10}}{2} L$ (1.58113883 L)	[6-6] $\arccos\left(\frac{-1}{3}\right)$ (109.471221°) [6-4] $\arccos\left(\frac{-1}{\sqrt{3}}\right)$ (125.264390°)
P10: Small rhombicuboctahedron 	F3: 8 F4: 18 E: 48 V: 24	$\frac{1 + 2\sqrt{2}}{2} L$ (1.20710678 L)	$\frac{\sqrt{4 + 2\sqrt{2}}}{2} L$ (1.30656297 L)	$\frac{\sqrt{5 + 2\sqrt{2}}}{2} L$ (1.39896633 L)	[4-4] 135° [4-3] $\arccos\left(\frac{-\sqrt{6}}{3}\right)$ (144.735610°)
P11: Great rhombicuboctahedron 	F4: 12 F6: 8 F8: 6 E: 72 V: 48	$\frac{1 + 2\sqrt{2}}{2} L$ (1.91421356 L)	$\frac{\sqrt{12 + 6\sqrt{2}}}{2} L$ (2.26303344 L)	$\frac{\sqrt{13 + 6\sqrt{2}}}{2} L$ (2.31761091 L)	[8-6] $\arccos\left(\frac{-1}{\sqrt{3}}\right)$ (125.264390°) [8-4] 135° [6-4] $\arccos\left(\frac{-\sqrt{6}}{3}\right)$ (144.735610°)
P12: Icosidodecahedron 	F3: 20 F5: 12 E: 60 V: 30	$\frac{\sqrt{5 + 2\sqrt{5}}}{\sqrt{5}} L$ (1.37638192 L)	$\frac{5 + 2\sqrt{5}}{2} L$ (1.53884177 L)	$\frac{1 + \sqrt{5}}{2} L$ (1.61803399 L)	$\arccos\left(\frac{-\sqrt{5 + 2\sqrt{5}}}{\sqrt{15}}\right)$ (142.622632°)
P13: Truncated Dodecahedron 	F3: 20 F10: 12 E: 90 V: 60	$\frac{\sqrt{50 + 22\sqrt{5}}}{4} L$ (2.48989829 L)	$\frac{5 + 3\sqrt{5}}{4} L$ (2.92705098 L)	$\frac{\sqrt{74 + 30\sqrt{5}}}{4} L$ (2.96944902 L)	[10-10] $\arccos\left(\frac{-1}{\sqrt{6}}\right)$ (116.565051°) [10-3] $\arccos\left(\frac{-\sqrt{5 + 2\sqrt{5}}}{\sqrt{15}}\right)$ (142.622632°)
P14: Truncated Icosahedron 	F5: 12 F6: 20 E: 90 V: 60	$\frac{\sqrt{42 + 18\sqrt{5}}}{4} L$ (2.26728394 L)	$\frac{3 + 3\sqrt{5}}{4} L$ (2.42705098 L)	$\frac{\sqrt{58 + 18\sqrt{5}}}{4} L$ (2.47801866 L)	[6-6] $\arccos\left(\frac{-\sqrt{5}}{3}\right)$ (138.189685°) [6-5] $\arccos\left(\frac{-\sqrt{5 + 2\sqrt{5}}}{\sqrt{15}}\right)$ (142.622632°)
P15: Left snub cube 	F3: 32 F4: 6 E: 60 V: 24	$\frac{L}{2k}$ (1.14261351 L)	$\frac{\sqrt{1 + k^2}}{2k} L$ (1.24722317 L)	$\frac{\sqrt{1 + 2k^2}}{2k} L$ (1.34371337 L)	[4-3] 142.983430° [3-3] 153.234588°
P16: Right snub cube 	k is equal to 0.437593286 and represents the ratio of the edge length of a snub cube and that of its parent cube. The angle of rotation of a square face of a snub cube with respect to the corresponding face of its parent cube is equal to 16.4675604°.				
P17: Small rhombicosidodecahedron 	E3: 20 F4: 30 F5: 12 E: 120 V: 60	$\frac{3\sqrt{5 + 2\sqrt{5}}}{2\sqrt{5}} L$ (2.06457288 L)	$\frac{\sqrt{10 + 4\sqrt{5}}}{2} L$ (2.17625090 L)	$\frac{\sqrt{11 + 4\sqrt{5}}}{2} L$ (2.23295051 L)	[5-4] $\arccos\left(\frac{-\sqrt{10 + 2\sqrt{5}}}{2\sqrt{5}}\right)$ (148.282526°) [4-3] $\arccos\left(\frac{-(1 + \sqrt{5})}{2\sqrt{3}}\right)$ (159.094843°)
P18: Great rhombicosidodecahedron 	F4: 30 F6: 20 F10: 12 E: 180 V: 120	$\frac{\sqrt{25 + 10\sqrt{5}}}{2} L$ (3.44095480 L)	$\frac{\sqrt{30 + 12\sqrt{5}}}{2} L$ (3.76937713 L)	$\frac{\sqrt{31 + 12\sqrt{5}}}{2} L$ (3.80239450 L)	[10-6] $\arccos\left(\frac{-\sqrt{5 + 2\sqrt{5}}}{\sqrt{15}}\right)$ (142.622632°) [10-4] $\arccos\left(\frac{-\sqrt{10 + 2\sqrt{5}}}{2\sqrt{5}}\right)$ (148.282526°) [6-4] $\arccos\left(\frac{-(1 + \sqrt{5})}{2\sqrt{3}}\right)$ (159.094843°)
P19: Left snub dodecahedron 	F3: 80 F5: 12 E: 150 V: 60	$\frac{\sqrt{25 + 11\sqrt{5}}}{40k^2} L$ (1.98091595 L)	$\frac{\sqrt{3 + \sqrt{5} + 2k^2}}{(40 - 16\sqrt{5})k^2} L$ (2.09705384 L)	$\frac{\sqrt{7 + 3\sqrt{5} + 8k^2}}{(20 - 4\sqrt{5})k^2} L$ (2.15583737 L)	[5-3] 152.929920° [3-3] 164.175366°
P20: Right snub dodecahedron 	k is equal to 0.562121965 and represents the ratio of the edge length of a snub dodecahedron and that of its parent dodecahedron. The angle of rotation of a pentagonal face of a snub dodecahedron with respect to the corresponding face of its parent dodecahedron is equal to 13.1064034°.				

Hoshyar Nooshin, P. L. Disney, and O. C. Champion, "Computer-Aided Processing of Polyhedral Configurations," in J. François Gabriel, ed., *Beyond the Cube: The Architecture of Space Frames and Polyhedra* (John Wiley & Sons, 1997)

**DECIMAL EQUIVALENTS**

FRACTION	DECIMAL OF AN INCH	DECIMAL OF A FOOT
1/64	0.015625	
1/32	0.03125	
3/64	0.046875	
1/16	0.0625	0.0052
5/64	0.078125	
3/32	0.09375	
1/8	0.109375	
1/4	0.125	0.0104
9/64	0.140625	
5/32	0.15625	
11/64	0.171875	
3/16	0.1875	0.0156
13/64	0.203125	
7/32	0.21875	
15/64	0.234375	
1/2	0.250	0.0208
17/64	0.265625	
9/32	0.28125	
19/64	0.296875	
5/16	0.3125	0.0260
21/64	0.328125	
11/32	0.34375	
23/64	0.359375	
3/8	0.375	0.0313
25/64	0.390625	
13/32	0.40625	
27/64	0.421875	
7/16	0.4375	0.0365
29/64	0.453125	
15/32	0.46875	
31/64	0.484375	
1/2	0.500	0.0417
33/64	0.515625	
17/32	0.53125	
35/64	0.546875	
9/16	0.5625	0.0469
37/64	0.578125	
19/32	0.59375	
39/64	0.609375	
5/8	0.625	0.0521
41/64	0.640625	
21/32	0.65625	
43/64	0.671875	
11/16	0.6875	0.0573
45/64	0.703125	
23/32	0.71875	
47/64	0.734375	
3/4	0.750	0.0625
49/64	0.765625	
25/32	0.78125	
51/64	0.796875	
13/16	0.8125	0.0677
53/64	0.828125	
27/32	0.84375	
55/64	0.859375	
7/8	0.875	0.0729
57/64	0.890625	
29/32	0.90625	
59/64	0.921875	
15/16	0.9375	0.0781
61/64	0.953125	
31/32	0.96875	
63/64	0.984375	
1	1.00	0.0833
2	2.00	0.1667
3	3.00	0.2500
4	4.00	0.3333
5	5.00	0.4167
6	6.00	0.5000
7	7.00	0.5833
8	8.00	0.6667
9	9.00	0.7500
10	10.00	0.8333
11	11.00	0.9167
12	12.00	1.0000

**SCIENTIFIC NOTATION**

Scientific notation is used to abbreviate large numerical values in order to simplify calculations.

$$4.2 \times 10^4 = 4.2 \times (10 \times 10 \times 10 \times 10) = 42,000$$

$$1.0 \times 10^1 = 1 \times 10 = 10$$

$$6.0 \times 10^{-4} = 6.0 \times (1 / 10 \times 10 \times 10 \times 10) = 0.0006$$

**MULTIPLYING AND DIVIDING POWERS**

$$x^n \cdot x^m = x^{n+m} \quad (x^n)^m = x^{nm}$$

$$\frac{x^n}{x^m} = x^{n-m} \quad \frac{1}{x^n} = x^{-n} = \frac{1}{x^n}$$

**PYTHAGOREAN THEOREM**

$$c^2 = a^2 + b^2$$

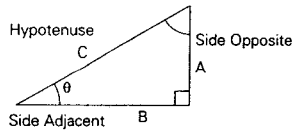

**BASIC TRIGONOMETRY FUNCTIONS**

$$\sin \theta = \frac{\text{opposite}}{\text{hypotenuse}} = \frac{a}{c}$$

$$\cos \theta = \frac{\text{adjacent}}{\text{hypotenuse}} = \frac{b}{c}$$

$$\tan \theta = \frac{\text{opposite}}{\text{adjacent}} = \frac{\sin \theta}{\cos \theta} = \frac{a}{b}$$

$$\cot \theta = \frac{\text{adjacent}}{\text{opposite}} = \frac{1}{\tan \theta} = \frac{b}{a}$$

**RADIANS AND DEGREES**

A radian is a way of measuring angles in addition to degrees. Radians are the primary unit of angular measurement used in calculations.

$$1 \text{ rad} = \frac{180^\circ}{\pi} = 57.3^\circ \quad (\text{approx})$$

$$1^\circ = \frac{\pi}{180^\circ} = 0.01745 \text{ rad} \quad (\text{approx})$$

**LINEAR DISTANCE**

The distance *s* which a point *p* on the rim of a rotating wheel covers is called linear distance. The angle  $\theta$ , the intercepting angle, is measured in radians.

$$s = r\theta$$

**LINEAR SPEED**

The linear speed *v*, of the point *p* around the rim of a rotating wheel, is the time taken *t* for point to travel the distance *s*.

$$v = \frac{s}{t}$$

**ANGULAR SPEED**

The angular speed  $\omega$ , of the point *p* around the rim of a rotating wheel is the time taken, *t*, for the point to travel the angular distance,  $\theta$ . The angular distance can be measured in degrees, revolutions, or radians. The resulting units of angular speed depend on the units used for angular distance and time.

$$\omega = \frac{\theta}{t}$$

**LAW OF REFLECTION**

A light ray reflects from a surface such that the angle of reflection equals the angle of incidence.

$$\theta_1 = \theta_2$$



**LAW OF REFRACTION**

When a light ray traveling through a transparent medium strikes another transparent medium, part of the ray is reflected and part is refracted, entering the second medium. The angle of the refracted ray depends on the angle of incidence and the index of refraction of both mediums.

$$n_1 \sin \theta_1 = n_2 \sin \theta_2$$

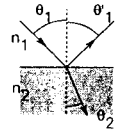

**TOTAL INTERNAL REFLECTION**

When light attempts to move from a medium with a high index of refraction to a medium with a low index of refraction, there is a particular angle of incidence large enough that the angle of refraction reaches 90°. The transmitted light ray moves parallel to the surface of the first medium and no more light is transmitted.

This angle of incidence is called the critical angle and depends on the indexes of refraction of the two mediums. Any angle of incidence larger than the critical angle is reflected back into the first medium.

$$\sin \theta_c = \frac{n_2}{n_1}$$



**Speed of Light in Medium**

$$c_{\text{medium}} = \frac{c_{\text{vac}}}{n_{\text{medium}}}$$

**THERMAL EXPANSION OF LENGTH**

An object of initial length *L*<sub>0</sub> at some temperature. With a change in temperature of  $\Delta T$  the length increases  $\Delta L$ . The constant  $\alpha$  is called the average coefficient of linear expansion for the given material.

$$\Delta L = \alpha L_0 \Delta T$$

**THERMAL EXPANSION OF AREA**

An object of initial area *A*<sub>0</sub> at some temperature. With a change in temperature of  $\Delta T$ , the area increases  $\Delta A$ . The constant  $\gamma$  is the average coefficient of area expansion for the given material.

$$\Delta A = \gamma A_0 \Delta T \quad \gamma = 2\alpha$$

**THERMAL EXPANSION OF VOLUME**

A mass of initial volume *V*<sub>0</sub> at some temperature. With a change in temperature  $\Delta T$ , the volume increases  $\Delta V$ . The constant  $\beta$  is called the average coefficient of volume expansion for a given material.

$$\Delta V = \beta V_0 \Delta T \quad \beta = 3\alpha$$

**USEFUL CONSTANTS**

**INDEXES OF REFRACTION (n)**

Air at 20°C, 1 atm. 1.000

**SOLIDS AND LIQUIDS AT 20°C**

Water	1.333	Polystyrene	1.49
Ice (H <sub>2</sub> O)	1.309	Glass, crown	1.52
Fused quartz	1.458	Glass, flint	1.66

**LINEAR EXPANSION COEFFICIENTS (α)**

Aluminum	24 x 10 <sup>-6</sup>	Concrete	12 x 10 <sup>-6</sup>
Brass & bronze	19 x 10 <sup>-6</sup>	Lead	29 x 10 <sup>-6</sup>
Copper	17 x 10 <sup>-6</sup>	Steel	11 x 10 <sup>-6</sup>
Glass, ordinary	9 x 10 <sup>-6</sup>		

**VOLUME EXPANSION COEFFICIENTS (β) (β = 3α)**

Air 3.67 x 10<sup>-3</sup>

**NATURAL CONSTANTS**

Speed of light in a vacuum	$c = 3.0 \times 10^8 \text{ m/s}$
Standard gravity	$g = 9.80 \text{ m/s}^2$



BRICK AND BLOCK MASONRY		PSF
4" brickwork		40
4" concrete block, stone or gravel		34
4" concrete block, lightweight		22
4" concrete brick, stone or gravel		46
4" concrete brick, lightweight		33
6" concrete block, stone or gravel		50
6" concrete block, lightweight		31
8" concrete block, stone or gravel		55
8" concrete block, lightweight		35
12" concrete block, stone or gravel		85
12" concrete block, lightweight		55
CONCRETE		PCF
Plain	Cinder	108
	Expanded slag aggregate	100
	Expanded clay	90
	Slag	132
	Stone and cast stone	144
Reinforced	Cinder	111
	Slag	138
	Stone	150
FINISH MATERIALS		PSF
Acoustical tile unsupported per 1/2"		0.8
Building board, 1/2"		0.8
Cement finish, 1"		12
Fiberboard, 1/2"		0.75
Gypsum wallboard, 1/2"		2
Marble and setting bed		25-30
Plaster, 1/2"		4.5
Plaster on wood lath		8
Plaster suspended with lath		10
Plywood, 1/2"		1.5
Tile, glazed wall 3/8"		3
Tile, ceramic mosaic, 1/4"		2.5
Quarry tile, 1/2"		5.8
Quarry tile, 3/4"		8.6
Terrazzo 1", 2" in stone concrete		25
Vinyl tile, 1/8"		1.33
Hardwood flooring, 2 5/32"		4
Wood block flooring, 3" on mastic		15
FLOOR AND ROOF (CONCRETE)		PSF
Flexicore, 6" precast lightweight concrete		30
Flexicore, 6" precast stone concrete		40
Plank, cinder concrete, 2"		15
Plank, gypsum, 2"		12
Concrete, reinforced, 1"	Stone	12.5
	Slag	11.5
	Lightweight	6-10
Concrete, plain, 1"	Stone	12
	Slag	11
	Lightweight	3-9
FUELS AND LIQUIDS		PCF
Coal, piled anthracite		47-58
Coal, piled bituminous		40-54
Ice		57.2
Gasoline		75
Snow		8
Water, fresh		62.4
Water, sea		64
GLASS		PSF
Polished plate, 1/4"		3.28
Polished plate, 1/2"		6.56
Double strength, 1/8"		26 oz
Sheet A, B, 1/32"		45 oz
Sheet A, B, 1/4"		52 oz

Insulating glass 5/8" plate with airspace	3.25	
1/4" wire glass	3.5	
Glass block	18	
INSULATION AND WATERPROOFING		PSF
Batt, blankets per 1" thickness	0.1-0.4	
Corkboard per 1" thickness	0.58	
Foamed board insulation per 1" thickness	2.6 oz	
Five-ply membrane	5	
Rigid insulation	0.75	
LIGHTWEIGHT CONCRETE		PSF
Concrete, aerocrete	50-80	
Concrete, cinder fill	60	
Concrete, expanded clay	85-100	
Concrete, expanded shale-sand	105-120	
Concrete, perlite	35-50	
Concrete, pumice	60-90	
METALS		PCF
Aluminum, cast	165	
Brass, cast, rolled	534	
Bronze, commercial	552	
Bronze, statuary	509	
Copper, cast or rolled	556	
Gold, cast, solid	1205	
Gold coin in bags	509	
Iron, cast gray, pig	450	
Iron, wrought	480	
Lead	710	
Nickel	565	
Silver, cast, solid	656	
Silver coin in bags	590	
Tin	459	
Stainless steel, rolled	492-510	
Steel, rolled, cold drawn	490	
Zinc, rolled, cast or sheet	449	
MORTAR AND PLASTER		PCF
Mortar, masonry	116	
Plaster, gypsum, sand	104-120	
PARTITIONS		PSF
2 x 4 wood stud, GWB, two sides	8	
4" metal stud, GWB, two sides	6	
4" concrete block, lightweight, GWB	26	
6" concrete block, lightweight, GWB	35	
2" solid plaster	20	
4" solid plaster	32	
ROOFING MATERIALS		PSF
Built up	6.5	
Concrete roof tile	9.5	
Copper	1.5-2.5	
Corrugated iron	2	
Deck, steel without roofing or insulation	2.2-3.6	
Fiberglass panels (2 1/2" corrugated)	5-8 oz	
Galvanized iron	1.2-1.7	
Lead, 1/8"	6-8	
Plastic sandwich panel, 2 1/2" thick	2.6	
Shingles, asphalt	1.7-2.8	
Shingles, wood	2-3	
Slate, 3/16" to 1/4"	7-9.5	
Slate, 3/8" to 1/2"	14-18	
Stainless steel	2.5	
Tile, cement flat	13	
Tile, cement ribbed	16	
Tile, clay shingle type	8-16	
Tile, clay flat with setting bed	15-20	

Wood sheathing per inch	3	
SOIL, SAND, AND GRAVEL		PCF
Ashes or cinder	40-50	
Clay, damp and plastic	110	
Clay, dry	63	
Clay and gravel, dry	100	
Earth, dry and loose	76	
Earth, dry and packed	95	
Earth, moist and loose	78	
Earth, moist and packed	96	
Earth, mud, packed	115	
Sand or gravel, dry and loose	90-105	
Sand or gravel, dry and packed	100-120	
Sand or gravel, dry and wet	118-120	
Silt, moist, loose	78	
Silt, moist, packed	96	
STONE (ASHLAR)		PCF
Granite, limestone, crystalline	165	
Limestone, oolitic	135	
Marble	173	
Sandstone, bluestone	144	
Slate	172	
STONE VENEER		PSF
2" granite, 1/2" parging	30	
4" granite, 1/2" parging	59	
6" limestone facing, 1/2" parging	55	
4" sandstone or bluestone, 1/2" parging	49	
1" marble	13	
1" slate	14	
STRUCTURAL CLAY TILE		PSF
4" hollow	23	
6" hollow	38	
8" hollow	45	
STRUCTURAL FACING TILE		PSF
2" facing tile	14	
4" facing tile	24	
6" facing tile	34	
8" facing tile	44	
SUSPENDED CEILINGS		PSF
Mineral fiber tile 3/4", 12" x 12"	1.2-1.57	
Mineral fiberboard 5/8", 24" x 24"	1.4	
Acoustic plaster on gypsum lath base	10-11	
WOOD		PCF
Ash, commercial white	40.5	
Birch, red oak, sweet and yellow	44	
Cedar, northern white	22.2	
Cedar, western red	24.2	
Cypress, southern	33.5	
Douglas fir (coast region)	32.7	
Fir, commercial white; Idaho white pine	27	
Hemlock	28-29	
Maple, hard (black and sugar)	44.5	
Oak, white and red	47.3	
Pine, northern white sugar	25	
Pine, southern yellow	37.3	
Pine, ponderosa, spruce: eastern and sitka	28.6	
Poplar, yellow	29.4	
Redwood	26	
Walnut, black	38	

NOTE

To establish uniform practice among designers, it is desirable to present a list of materials generally used in building construction, together with their proper weights. Many building codes prescribe the minimum weights of only a few building materials. It should be noted that there is a difference of more than 25% in some cases.

**ARCHITECTURAL AREA OF BUILDINGS**

The architectural area of a building is the sum of the areas of the floors, measured horizontally in plan to the exterior faces of perimeter walls or to the centerline of walls separating buildings. Included are areas occupied by partitions, columns, stairwells, elevator shafts, duct shafts, elevator rooms, pipe spaces, mechanical penthouses, and similar spaces having a headroom of 6 ft and over. Areas of sloping surfaces, such as staircases, bleachers, and tiered terraces, should be measured horizontally in plan. Auditoriums, swimming pools, gymnasiums, foyers, and similar spaces extending through two or more floors should be measured once only, taking the largest area in plan at any level.

Mechanical penthouse rooms, pipe spaces, bulkheads, and similar spaces having a headroom less than 6 ft and balconies projecting beyond exterior walls, covered terraces and walkways, porches, and similar spaces shall have the architectural area multiplied by 0.50 in calculating the building gross area.

Exterior staircases and fire escapes, exterior steps, patios, terraces, open courtyards and lightwells, roof overhangs, cornices and chimneys, unfinished roof and attic areas, pipe trenches, and similar spaces are excluded from the architectural area calculations. Interstitial space in health care facilities is also excluded.

**ARCHITECTURAL VOLUME OF BUILDINGS**

The architectural volume of a building is the sum of the products of the areas defined in the architectural area times the height from the underside of the lowest floor construction to the average height of the surface of the finished roof above, for the various parts of the building. Included in the architectural volume is the actual space enclosed within the outer surfaces of the exterior or outer walls and contained between the outside of the roof and the bottom of the lowest floor, taken in full: bays, oriels, dormers; penthouses, chimneys; walk tunnels; enclosed porches and balconies, including screened areas.

The following volumes are multiplied by 0.50 in calculating the architectural volume of a building; nonenclosed porches, if recessed into the building and without enclosing sash or screens; nonenclosed porches built as an extension to the building and without sash or screen; areaways and pipe tunnels; and patio areas that have building walls extended on two sides, roof over, and paved surfacing.

Excluded from the architectural volume are outside steps, terraces, courts, garden walls; light shafts, parapets, cornices, roof overhangs; footings, deep foundations, piling caissons, special foundations, and similar features.

**NET ASSIGNABLE AREA**

The net assignable area is that portion of the area which is available for assignment to an occupant, including every type of space usable by the occupant.

The net assignable area should be measured from the predominant inside finish of enclosing walls in the categories defined below. Areas occupied by exterior walls, partitions, internal structural, or party walls are to be excluded from the groups and are to be included under "construction area."

1. "NET ASSIGNABLE AREA": Total area of all enclosed spaces fulfilling the main functional requirements of the building for occupant use, including custodial and service areas such as guard rooms, workshops, locker rooms, janitors' closets, storerooms, and the total area of all toilet and washroom facilities.
2. "CIRCULATION AREA": Total area of all enclosed spaces which is required for physical access to subdivisions of space such as corridors, elevator shafts, escalators, fire towers or stairs, stairwells,

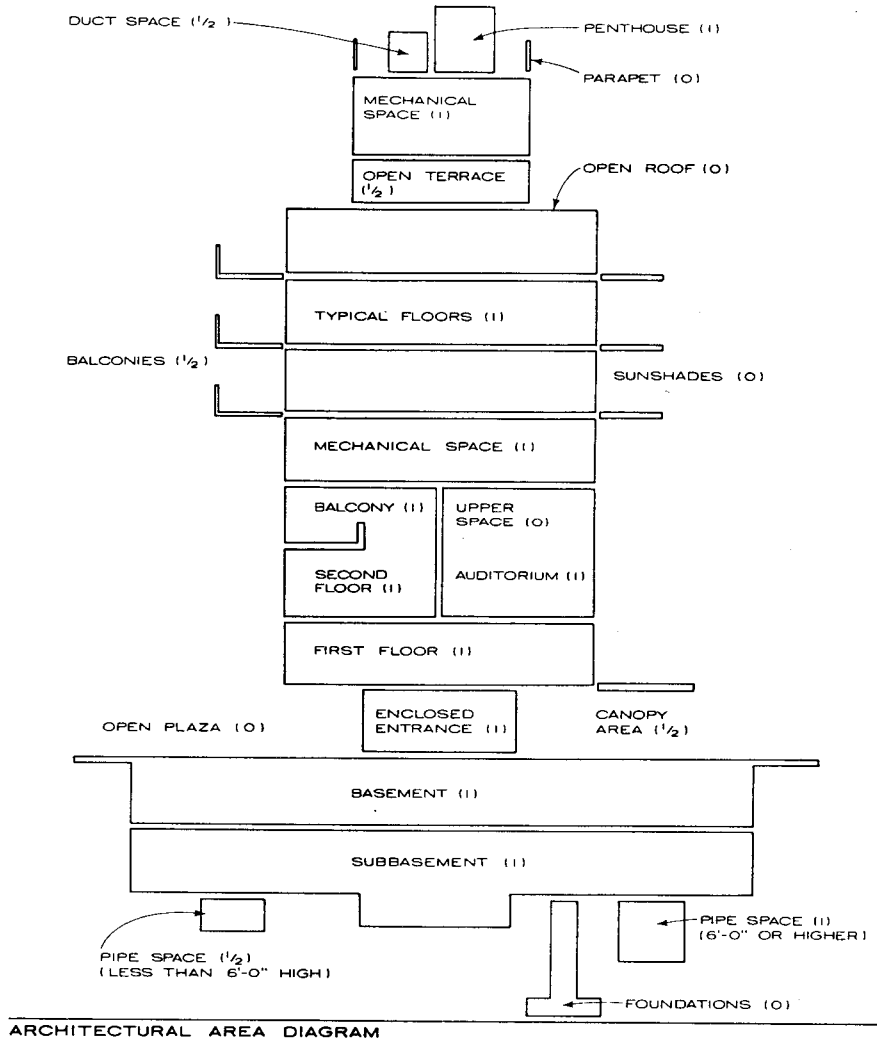

ARCHITECTURAL AREA DIAGRAM

elevator entrances, public lobbies, and public vestibules.

3. "MECHANICAL AREA": Total area of all enclosed spaces designed to house mechanical and electrical equipment and utility services such as mechanical and electrical equipment rooms, duct shafts, boiler rooms, fuel rooms, and mechanical service shafts.
4. "CONSTRUCTION AREA": The area occupied by exterior walls, partitions, structure, and so on.
5. "GROSS FLOOR OR ARCHITECTURAL AREA": The sum of areas 1, 2, 3, and 4 plus the area of all factored non- and semienclosed areas equal the gross floor area or architectural area of a building.

In commercial buildings constructed for leasing, net areas are to be measured in accordance with the "Standard Method of Floor Measurement," as set by the Building Owners and Managers Association (BOMA).

The net rentable area for offices is to be measured from the inside finish of permanent outer building walls, to the office or occupancy side of corridors and/or other permanent partitions, and to the center of partitions that separate the premises from adjoining rentable areas. No deductions are to be made for columns and projections necessary to the building.

The net rentable area for stores is to be measured from the building line in case of street frontages and from the inside finish of other outer building walls, corridor, and permanent partitions and to the center of partitions that separate the premises from adjoining rentable areas. No deductions are to be made for vestibules inside the building line or for columns and projections necessary to the building. No addition is to be made for projecting bay windows.

If a single occupant is to occupy the total floor in either the office or store categories, the net rentable area would include the accessory area for that floor of corridors, elevator lobbies, toilets, janitors' closets, electrical and telephone closets, air-conditioning rooms and fan rooms, and similar spaces.

The net rentable area for apartments is to be measured from the inside face of exterior walls, and all enclosing walls of the unit.

**NOTE**

Various governmental agencies have their own methods of calculating the net assignable area of buildings. They should be investigated if federal authority or funding apply to a project. Also, various building codes provide their own definitions of net and gross areas of building for use in quantifying requirements.

T. Edward Thomas, AIA; Hansen Lind Meyer, Inc.; Orlando, Florida

FORMULAS NOMENCLATURE

- E Modulus of Elasticity of steel at 29,000 ksi.
- I Moment of Inertia of beam (in.<sup>4</sup>).
- M<sub>max</sub> Maximum moment (kip in.).
- M<sub>1</sub> Maximum moment in left section of beam (kip in.).
- M<sub>2</sub> Maximum moment in right section of beam (kip in.).
- M<sub>3</sub> Maximum positive moment in beam with combined end moment conditions (kip in.).
- M<sub>x</sub> Moment at distance x from end of beam (kip in.).
- P Concentrated load (kips).
- P<sub>1</sub> Concentrated load nearest left reaction (kips).
- P<sub>2</sub> Concentrated load nearest right reaction, and of different magnitude than P<sub>1</sub> (kips).
- R End beam reaction for any condition of symmetrical loading (kips).
- R<sub>1</sub> Left end beam reaction (kips).
- R<sub>2</sub> Right end or intermediate beam reaction (kips).
- R<sub>3</sub> Right end beam reaction (kips).
- V Maximum vertical shear for any condition of symmetrical loading (kips).
- V<sub>1</sub> Maximum vertical shear in left section of beam (kips).
- V<sub>2</sub> Vertical shear at right reaction point, or to left of intermediate reaction point of beam (kips).
- V<sub>3</sub> Vertical shear at right reaction point, or to right of intermediate reaction point of beam (kips).
- V<sub>x</sub> Vertical shear at distance x from end of beam (kips).
- W Total load on beam (kips).
- A Measured distance along beam (in.).
- B Measured distance along beam which may be greater or less than "A" (in.).
- L Total length of beam between reaction points (in.).
- W Uniformly distributed load per unit of length (kips per in.).
- W<sub>1</sub> Uniformly distributed load per unit of length nearest left reaction (kips per in.).
- W<sub>2</sub> Uniformly distributed load per unit of length nearest right reaction, and of different magnitude than W<sub>1</sub> (kips per in.).
- X Any distance measured along beam from left reaction (in.).
- X<sub>1</sub> Any distance measured along overhang section of beam from nearest reaction point (in.).
- Δ<sub>max</sub> Maximum deflection (in.).
- Δ<sub>x</sub> Deflection at point of load (in.).
- Δ<sub>x</sub> Deflection at any point x distance from left reaction (in.).
- Δ<sub>x1</sub> Deflection of overhang section of beam at any distance from nearest reaction point (in.).

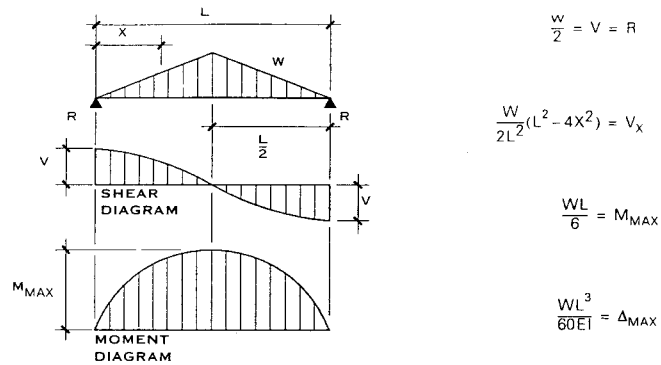

SIMPLE BEAM—LOAD INCREASING UNIFORMLY TO CENTER

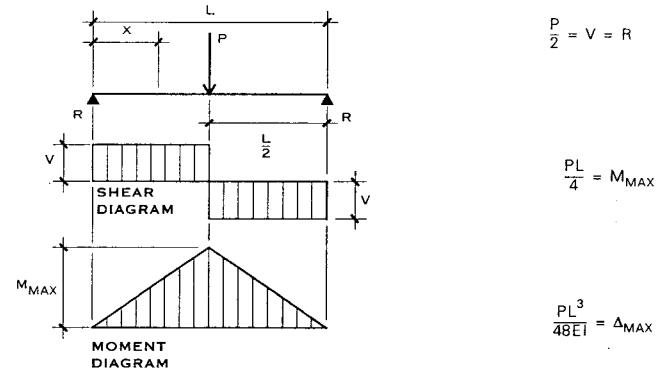

SIMPLE BEAM—CONCENTRATED LOAD AT CENTER

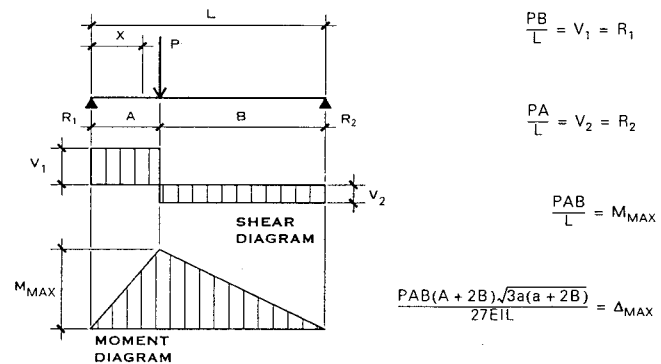

SIMPLE BEAM—CONCENTRATED LOAD AT ANY POINT

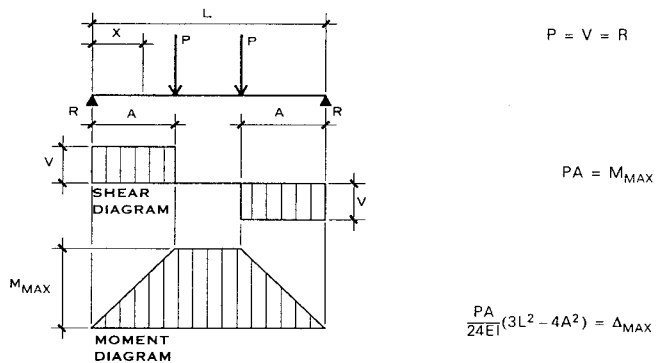

SIMPLE BEAM—UNIFORMLY DISTRIBUTED LOAD

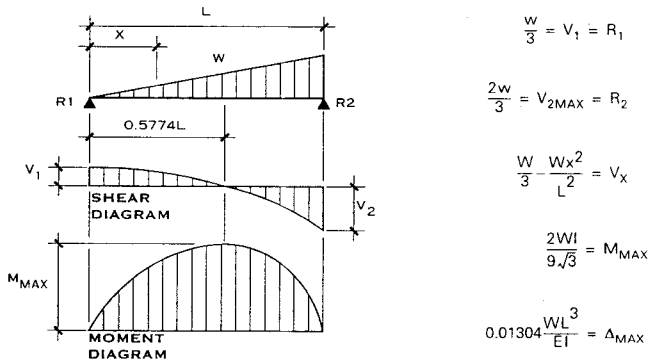

SIMPLE BEAM—LOAD INCREASING UNIFORMLY TO ONE END

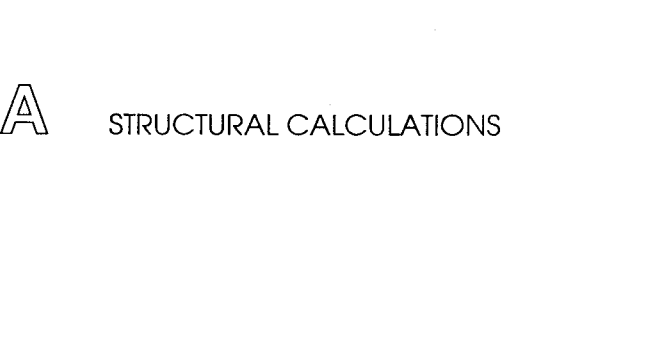

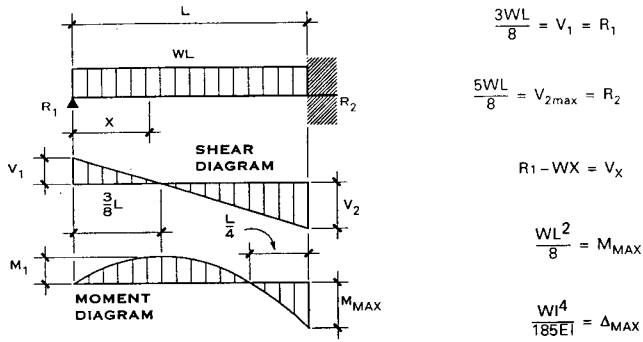

FIXED BEAM AT ONE END AND SUPPORTED AT OTHER—UNIFORMLY DISTRIBUTED LOAD

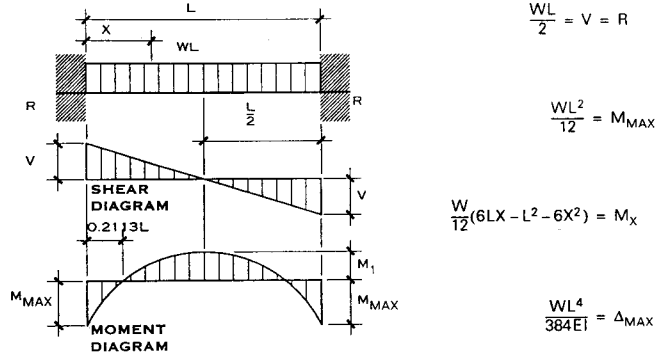

FIXED BEAM—UNIFORMLY DISTRIBUTED LOAD

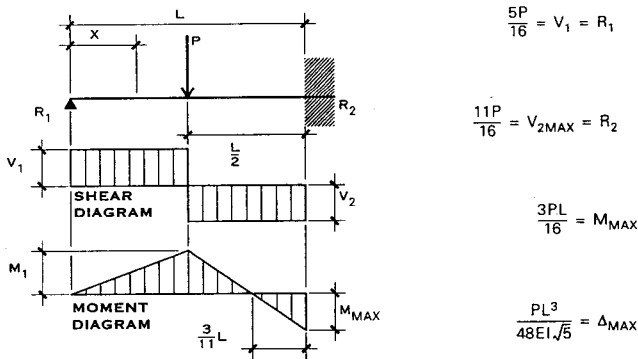

FIXED BEAM AT ONE END AND SUPPORTED AT OTHER—CONCENTRATED LOAD AT CENTER

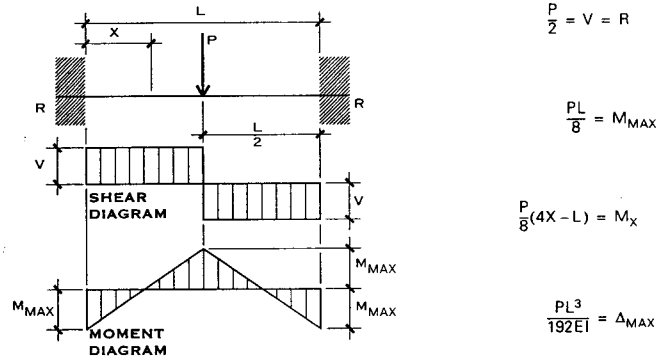

FIXED BEAM—CONCENTRATED LOAD AT CENTER

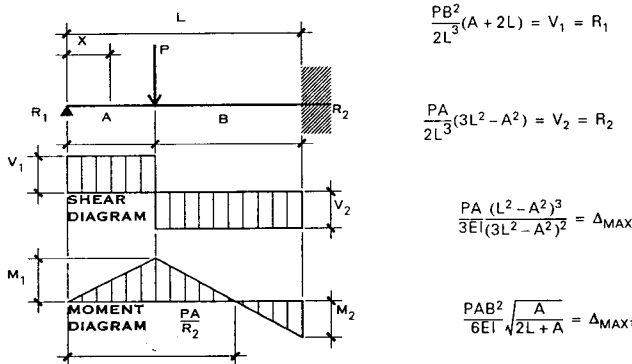

FIXED BEAM AT ONE END AND SUPPORTED AT OTHER—CONCENTRATED LOAD AT ANY POINT

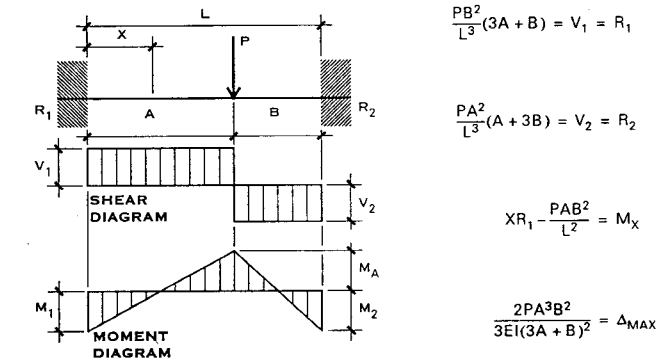

FIXED BEAM—CONCENTRATED LOAD AT ANY POINT

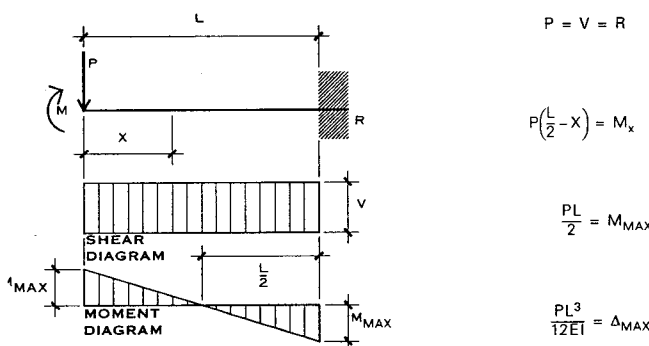

FIXED BEAM AT ONE END AND FREE TO DEFLECT VERTICALLY BUT NOT ROTATE AT OTHER—CONCENTRATED LOAD AT DEFLECTED END

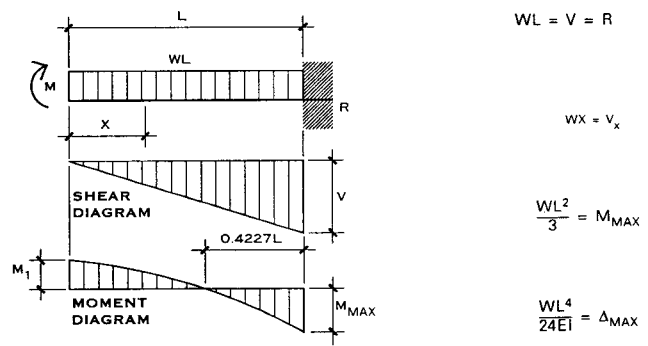

FIXED BEAM AT ONE END AND FREE TO DEFLECT VERTICALLY BUT NOT ROTATE AT OTHER—UNIFORMLY DISTRIBUTED LOAD

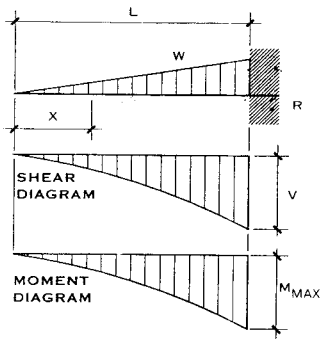

$$W = V = R$$

$$W \frac{x^2}{2} = V_x$$

$$\frac{WL}{3} = M_{MAX}$$

$$\frac{WL^3}{15EI} = \Delta_{MAX}$$

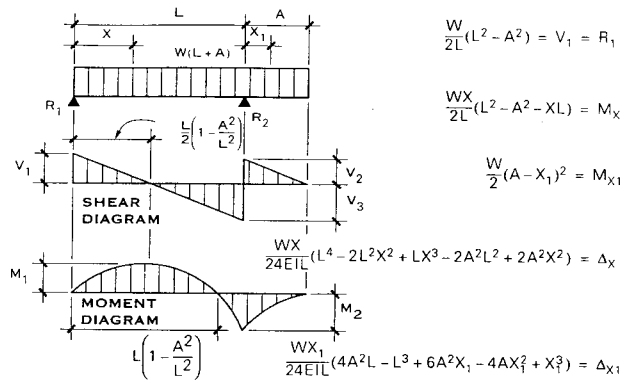

$$\frac{W}{2L}(L^2 - A^2) = V_1 = R_1$$

$$\frac{WX}{2L}(L^2 - A^2 - XL) = M_x$$

$$\frac{W}{2}(A - X_1)^2 = M_{X1}$$

$$\frac{WX}{24EI}(L^4 - 2L^2X^2 + LX^3 - 2A^2L^2 + 2A^2X^2) = \Delta_x$$

$$\frac{WX_1}{24EI}(4A^2L - L^3 + 6A^2X_1 - 4AX_1^2 + X_1^3) = \Delta_{X1}$$

CANTILEVER BEAM—LOAD INCREASING UNIFORMLY TO FIXED END

BEAM OVERHANGING ONE SUPPORT—UNIFORMLY DISTRIBUTED LOAD

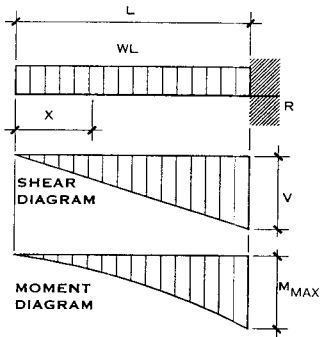

$$WL = V = R$$

$$WX = V_x$$

$$\frac{WL^2}{2} = M_{MAX}$$

$$\frac{WL^4}{8EI} = \Delta_{MAX}$$

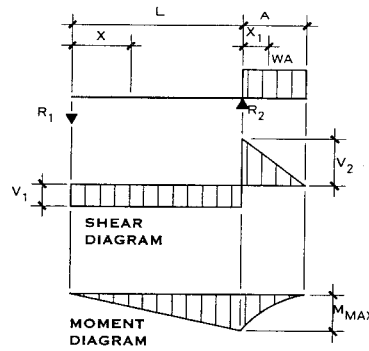

$$\frac{WA^2}{2L} = V_1 = R_1$$

$$\frac{WA^2}{2} = M_{MAX}$$

$$\frac{WA^2L^2}{18\sqrt{3}EI} = \Delta_{MAX}$$

$$\frac{WA^3}{24EI}(4L + 3A) = \Delta_{MAX1}$$

CANTILEVER BEAM—UNIFORMLY DISTRIBUTED LOAD

BEAM OVERHANGING ONE SUPPORT—UNIFORMLY DISTRIBUTED LOAD ON OVERHANG

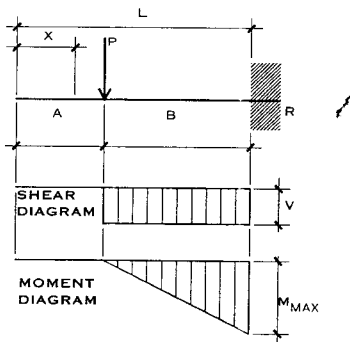

$$P = V = R$$

$$PB = M_{MAX}$$

$$\frac{PB^2}{6EI}(3L - B) = \Delta_{MAX}$$

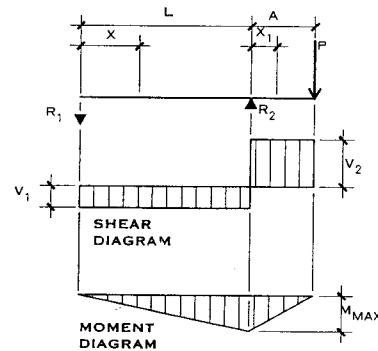

$$\frac{PA}{L} = V_1 = R_1$$

$$PA = M_{MAX}$$

$$\frac{PAL^2}{9\sqrt{3}EI} = \Delta_{MAX}$$

$$\frac{PA^2}{3EI}(L + A) = \Delta_{MAX1}$$

CANTILEVER BEAM—CONCENTRATED LOAD AT ANY POINT

BEAM OVERHANGING ONE SUPPORT—CONCENTRATED LOAD AT END OF OVERHANG

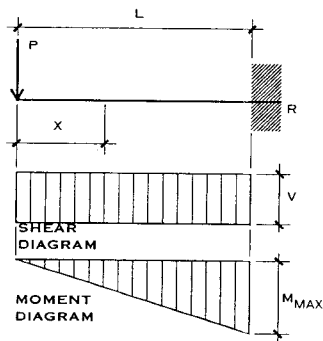

$$P = V = R$$

$$PL = M_{MAX}$$

$$\frac{PL^3}{3EI} = \Delta_{MAX}$$

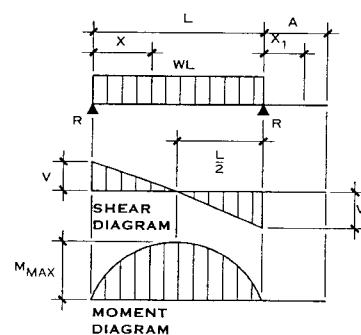

$$\frac{WL}{2} = V = R$$

$$\frac{WL^2}{8} = M_{MAX}$$

$$\frac{5WL^4}{384EI} = \Delta_{MAX}$$

$$W\left(\frac{L}{2} - X\right) = V_x$$

CANTILEVER BEAM—CONCENTRATED LOAD AT FREE END

BEAM OVERHANGING ONE SUPPORT—UNIFORMLY DISTRIBUTED LOAD BETWEEN SUPPORTS

**GENERAL**

Classical architecture is based on five distinct and formalized systems of columns and horizontal supports, called the orders. A proportional system in which the parts and divisions of each order, measured in multiples or divisions of the diameter of the lowest part of the relevant tapered column shaft, distinguishes each unique order.

**NOTE**

A parallel comparison based on Vignola proportions in terms of a constant lower diameter.

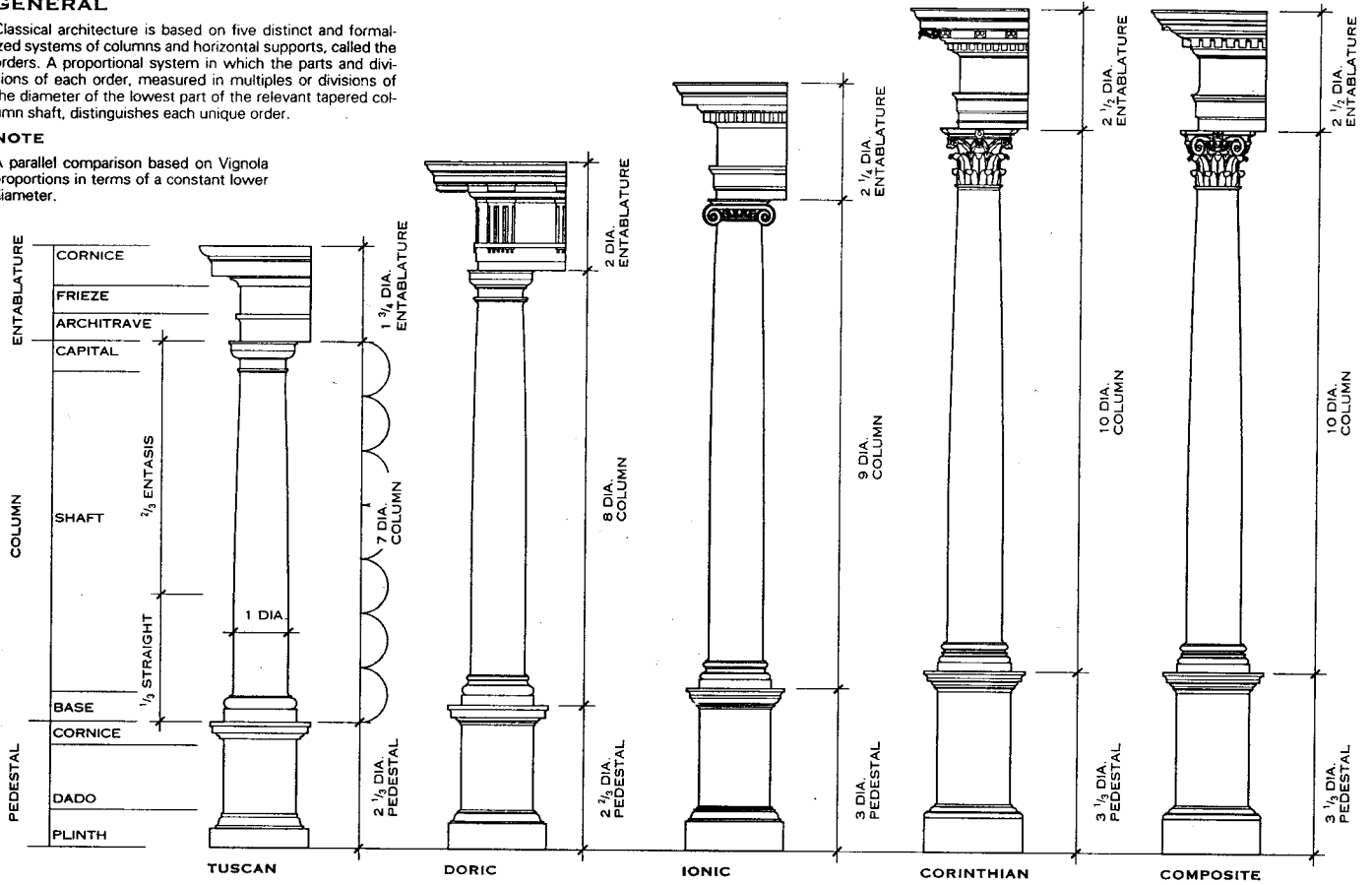

**THE FIVE CLASSICAL ORDERS — RENAISSANCE PROPORTIONS**

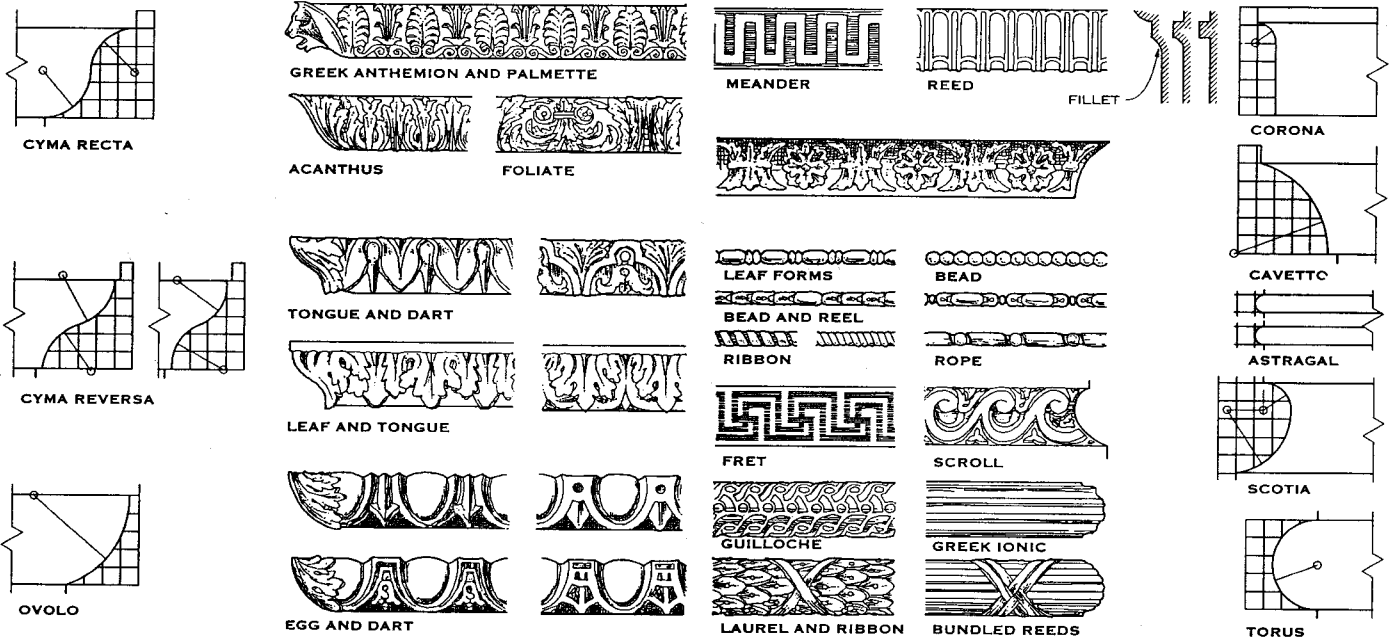

**MOLDINGS — TYPES, PATTERNS, AND DECORATIONS**

Scot C. McBroom, AIA; Alexandria, Virginia



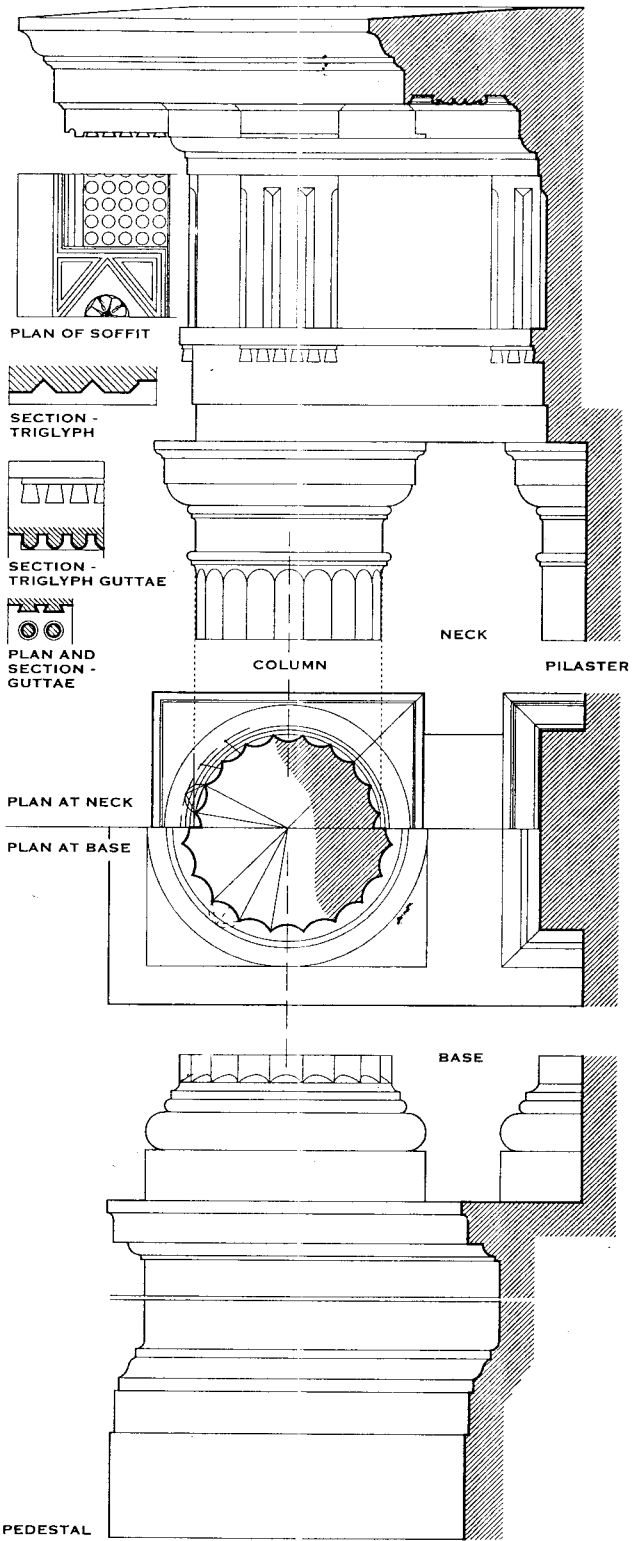

DORIC ORDER (MUTULAR)

Scot C. McBroom, AIA; Alexandria, Virginia

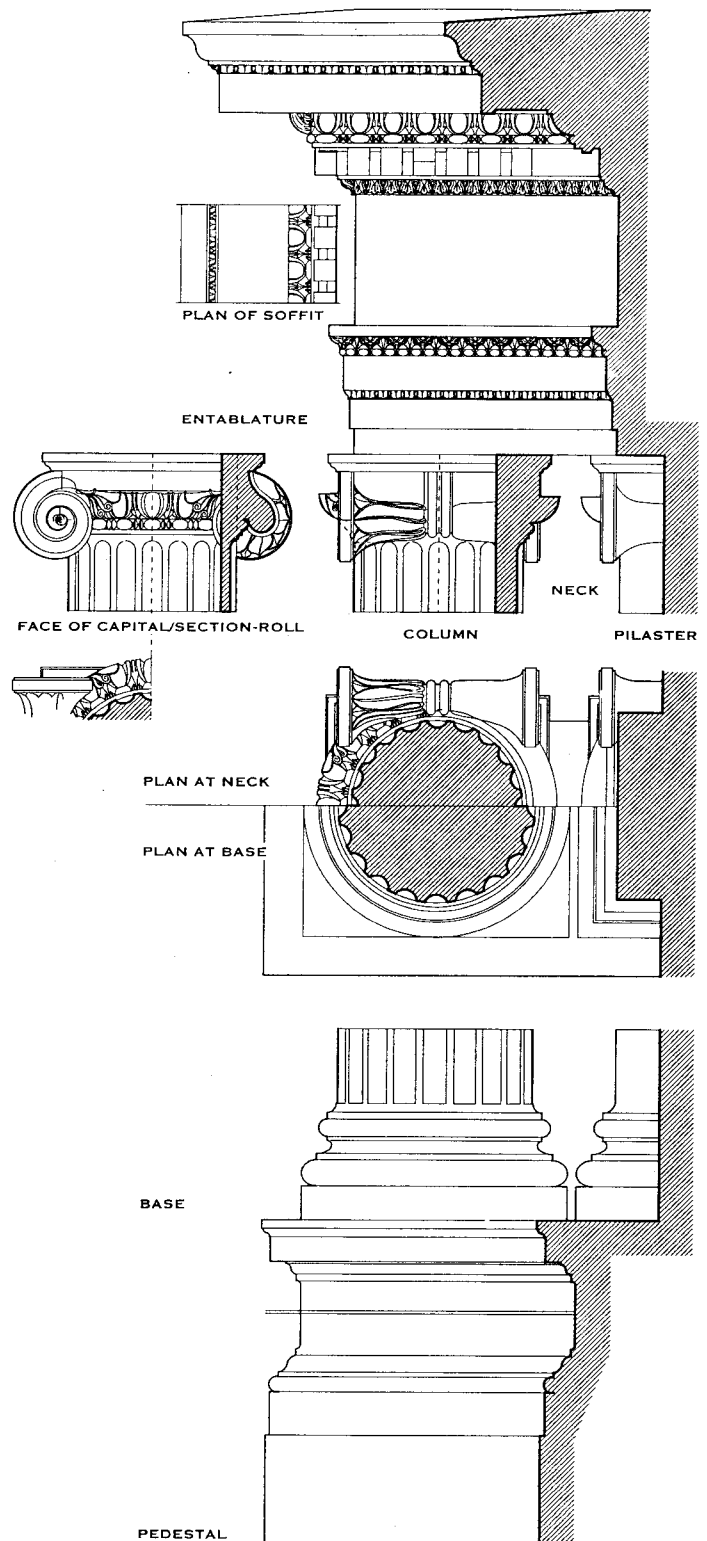

IONIC ORDER

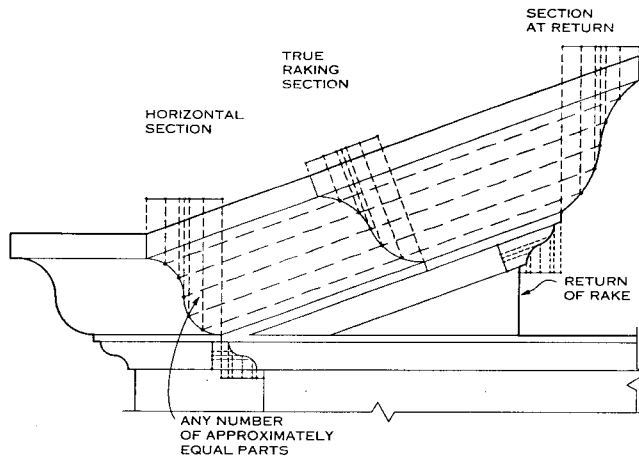
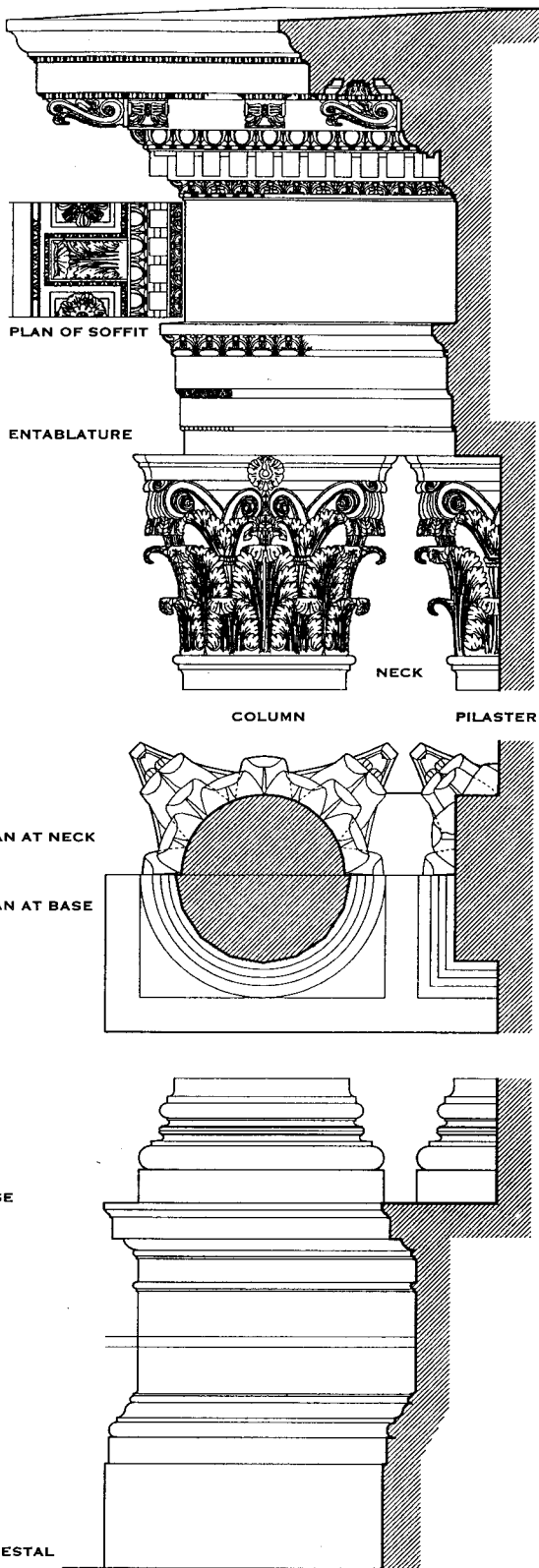

RAKING MOLDINGS

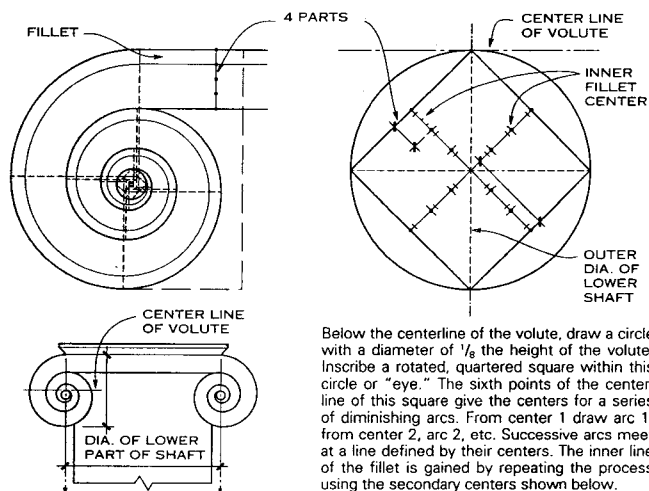

CONSTRUCTING A VOLUTE

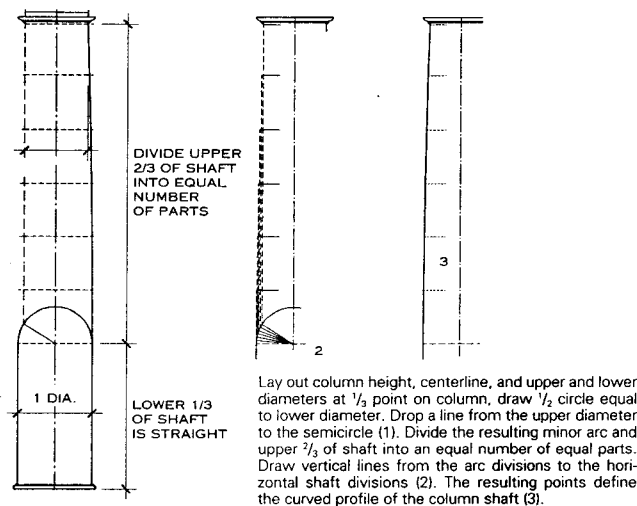

CORINTHIAN ORDER

Scot C. McBroom, AIA; Alexandria, Virginia

ENTASIS



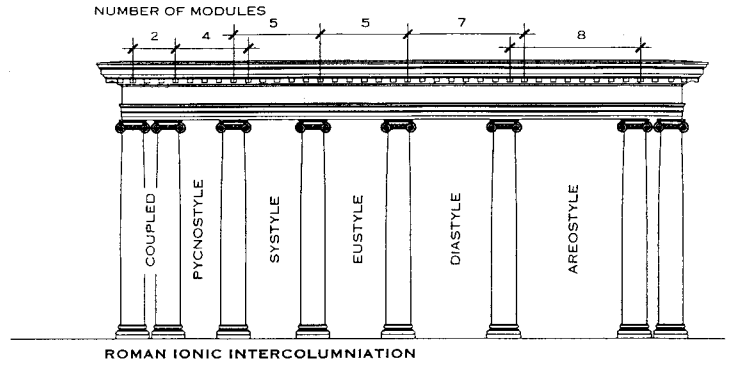
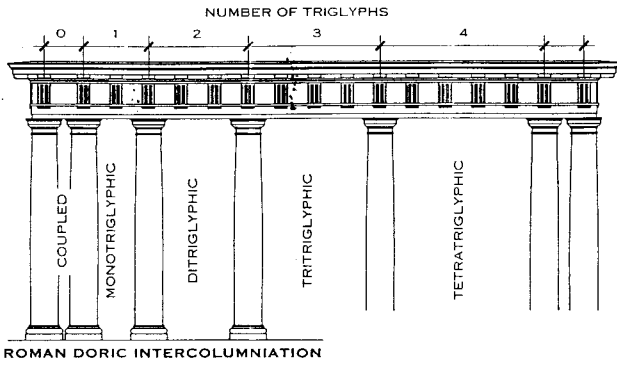

INTERCOLUMNIATION

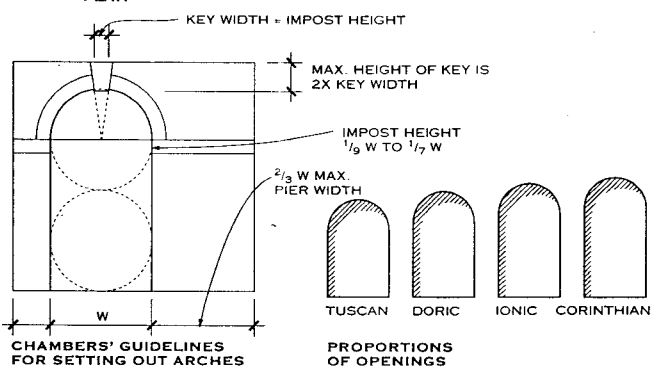
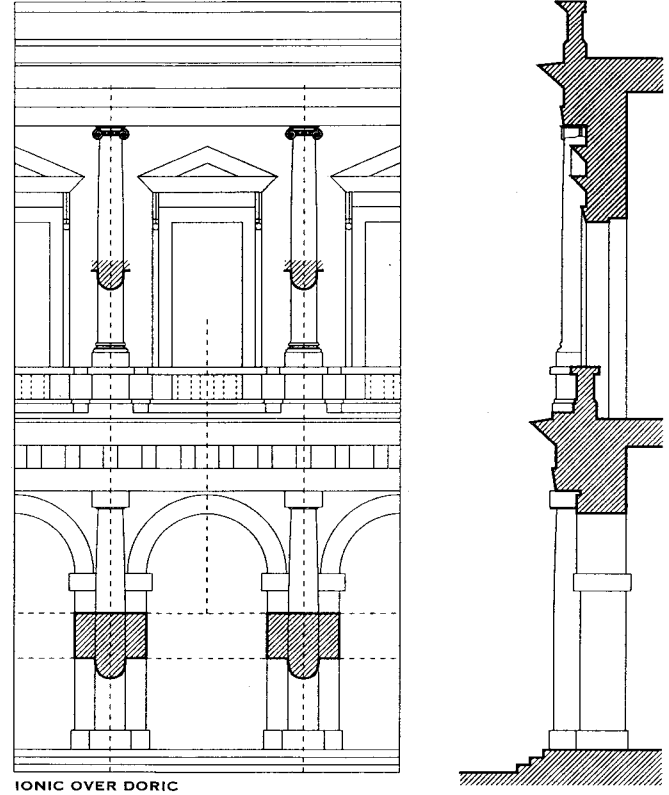
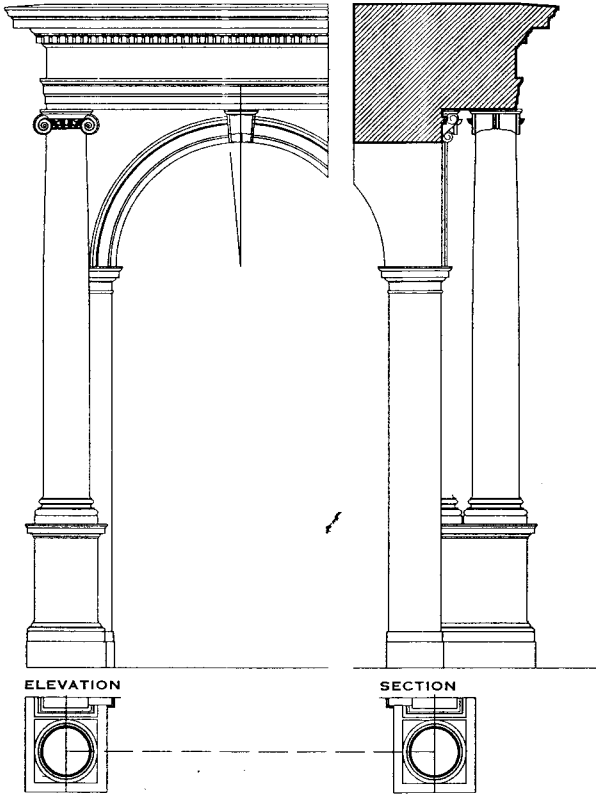

ARCHED DOORWAY

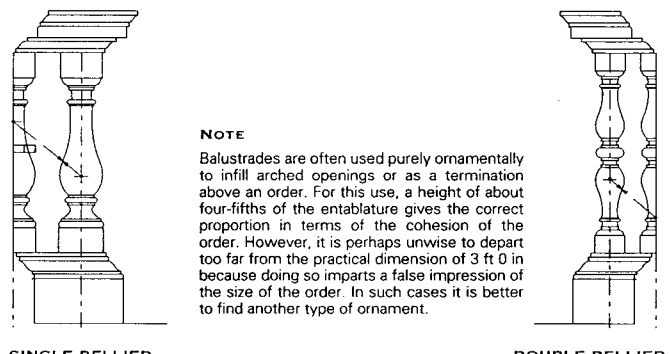

**NOTE**  
Balustrades are often used purely ornamentally to infill arched openings or as a termination above an order. For this use, a height of about four-fifths of the entablature gives the correct proportion in terms of the cohesion of the order. However, it is perhaps unwise to depart too far from the practical dimension of 3 ft 0 in because doing so imparts a false impression of the size of the order. In such cases it is better to find another type of ornament.

BALUSTRADES

Scot C. McBroom, AIA; Alexandria, Virginia

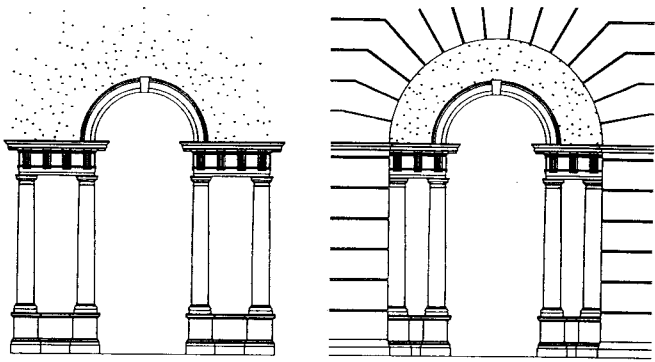

VENETIAN MOTIVE

NOTE  
Doric order shown; other orders may be employed.

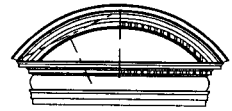
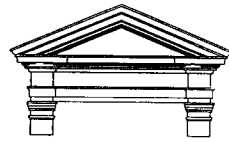
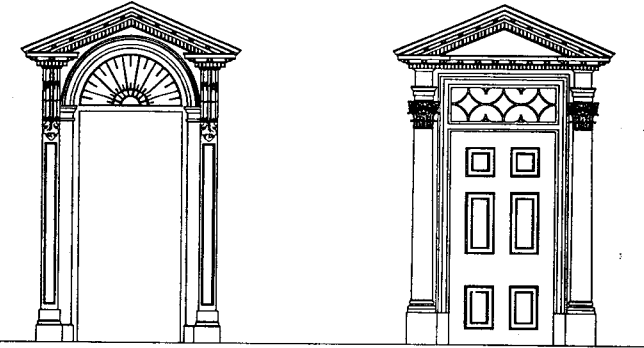

SEGMENTAL

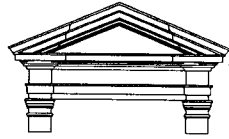

BROKEN SEGMENTAL

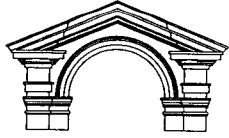

VARIOUS RAKED CORNICES

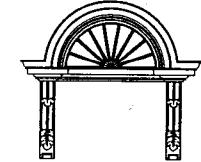

SEMICIRCULAR

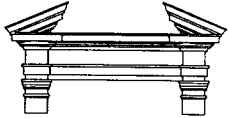

BROKEN CORNICE



ORNAMENTAL

DOORS



PEDIMENTS

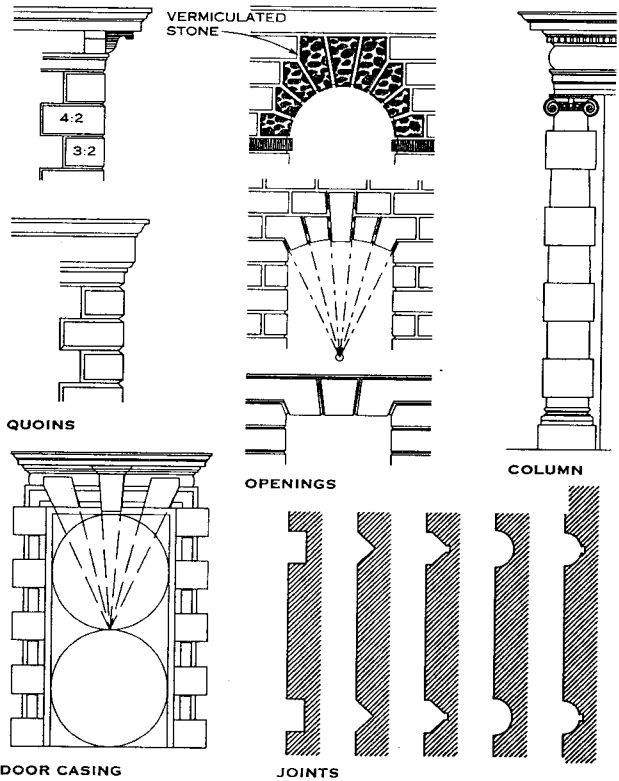

DOOR CASING  
RUSTICATION

WINDOWS

Scot C. McBroom, AIA; Alexandria, Virginia

LOGICAL PROGRESSION AND HIERARCHY OF VERTICAL ELEMENTS

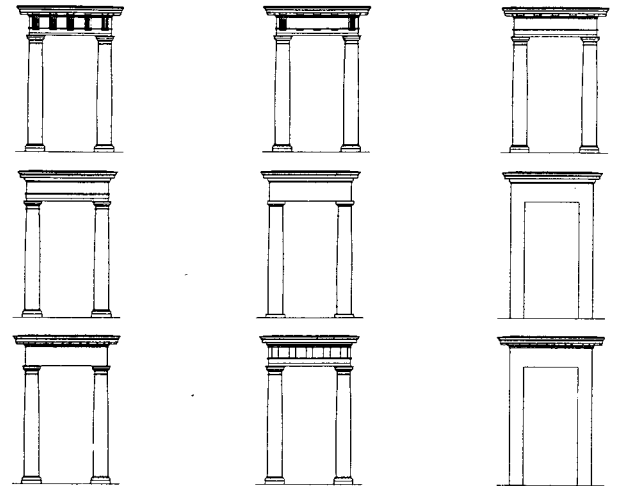
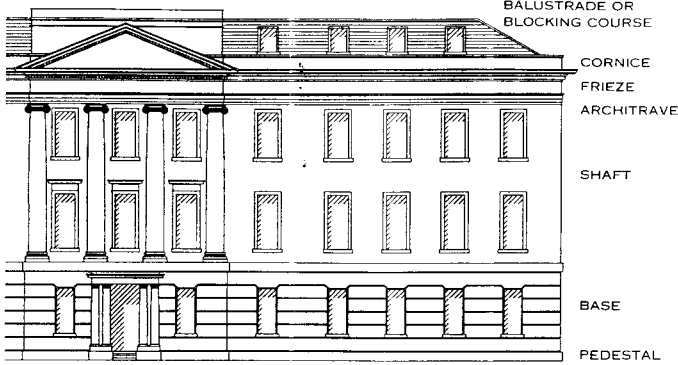

DOMINANCE  
SYMMETRY OF ELEMENTS

REPETITION  
OVERALL SIMPLICITY

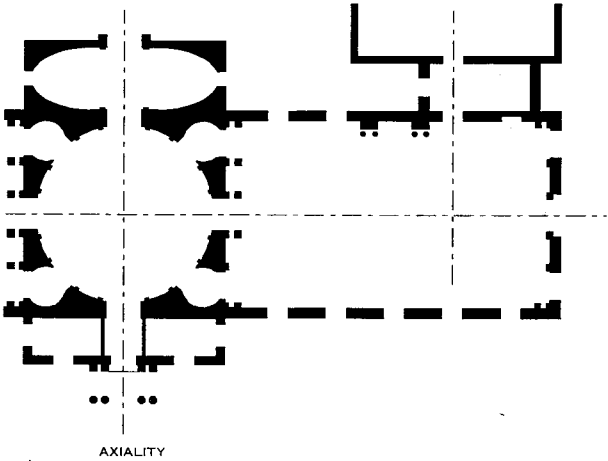

NOTE  
Proportions remain in all examples

SELECTIVE USE OF ELEMENTS — DORIC ORDER



ORDER APPLIED TO BUILDING      ORDER HIDDEN (PROPORTIONS APPLIED)

CHARACTERISTICS OF CLASSICISM

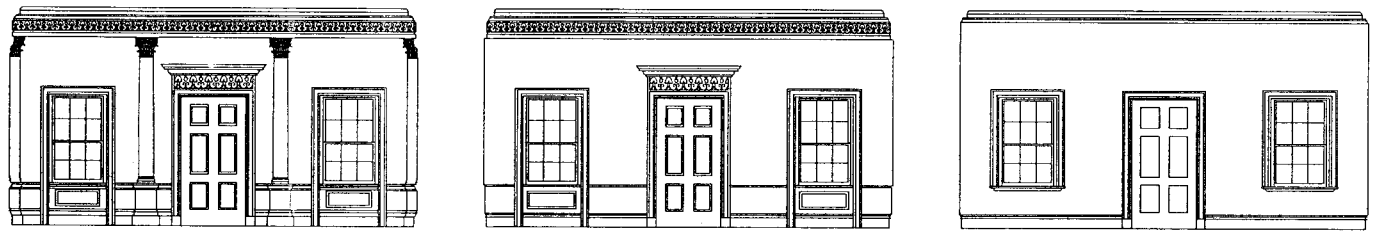

FULL ORDER      PILASTERS REMOVED      ONLY CORNICE, BASE, AND SURROUNDS REMAIN

REMOVAL OF ELEMENTS FOR INTERIORS



PLAIN      STRING COURSES OF HIDDEN SUPERIMPOSED ORDERS      PORCH AND CORNICE      RUSTICATED BASE AND UPPER LOGGIA      COLUMN BASE AND ENTABLATURE      GIANT PILASTER (ONLY CAPITALS ARE FULL ORDER)

ADDING CLASSICAL ELEMENTS

Scot C. McBroom, AIA; Alexandria, Virginia

**GENERAL**

Developed at the time of the French Revolution, the metric system rapidly spread throughout Europe during the Napoleonic wars. It was promoted in the United States by Thomas Jefferson and later by John Quincy Adams, but the federal government did not legalize its use as a measurement system until 1866. In 1893, all standard United States measures were defined in metric units. Today, the United States remains the last industrialized country to commit to metric.

**SYSTEM INTERNATIONAL (SI)**

The modern metric system, known as "System International" (SI) was established by international agreement in 1960. It is the international standard of measurement and the system mandated by the *Metric Conversion Act* for use in the United States.

**THE METRIC CONVERSION ACT**

The *Metric Conversion Act of 1975*, as amended by the *Omnibus Trade and Competitiveness Act of 1988*, establishes the metric system as the preferred system of measurement in the United States. It requires that, to the extent feasible, the metric system be used in all federal procurement, grants, and business-related activities after September 30, 1992.

**METRIC IN CONSTRUCTION**

There has been much speculation about the difficulty of converting to metric in the United States construction industry. The experiences of the British, Australians, South Africans, and Canadians, all of whom converted from the inch-pound system to metric in the past 20 years, showed the following facts.

1. Metric conversion proved much less difficult than anticipated since most work is built in place.
2. There were no appreciable increases in design or construction costs, and conversion costs for most construction industry sectors were minimal or offset by later savings.
3. Architects and engineers liked metric dimensioning because it was less prone to error and easier to use than feet and inches and because engineering calculations were faster and more accurate since there were no unit conversions and no fractions.
4. Metric offered a one-time chance to reduce the many product sizes and shapes that are no longer useful, thus saving production, inventory, and procurement costs.

The following developments should make metric conversion in the United States construction industry easier:

1. The use of computer-aided design and drafting systems continues to increase; almost all engineering and cost calculations are now performed on computers.
2. The codes and construction standards of two of the country's three model building code organizations (BOCA and SBCCI), NFPA, and ASTM contain dual units that specify measurements. Many other standards-writing organizations have added metric measurements to their documents or are preparing to do so.
3. The preliminary results of several recent General Services Administration metric pilot projects in the Philadelphia area indicate no increase in design or construction costs.
4. American design and construction firms report no problems using metric in foreign work.
5. The costs of metric conversion in other industries have been far lower than expected, and the benefits greater. Total conversion costs were less than one percent of original estimates at General Motors, which now is fully metric. Rationalization of fastener sizes at IBM during metric conversion reduced fastener part numbers from 38,000 to 4,000. Some American manufacturers, such as Otis Elevator, are switching to metric to increase their international competitiveness and reduce their parts inventories. Others, such as the wood industry, have shipped exports in metric for many years.

**CONVERSION AND ROUNDING**

In a "soft" conversion, an exact inch-pound measurement is mathematically converted to its exact (or near exact) metric equivalent. In a "hard" conversion, a new rounded, rationalized metric number is created that is convenient to work with and remember.

When converting numbers from inch-pound to metric, round the metric value to the same number of digits as there were in the inch-pound number. In all cases, use professional rounding to determine the exact value.

With professional rounding, the basic module of metric design is 100 mm. Make every effort to keep design dimensions in this increment. Additional multimodules and sub-modules, in preferred order, are 6000, 3000, 1200, 600, 300, 50, 25, 20, and 10.

Example: 1990 BOCA Article 514.7 requires 36 inches (914 mm) of unobstructed pedestrian walkway width. However, 914 mm is not a clean and rational number. It should be rounded to facilitate the easiest construction possible. Since anything less than 914 mm would not meet the code requirements, the preferred number would be 1000 mm. Submodules will produce a rounding of 950, 925, or 920 mm.

**SOFT AND HARD METRIC**

Soft metric means "No Physical Change." This implies the product need not be physically modified to be used in a metric project. More than 95% of currently used building products will not change. In the future, as standard international metric product sizes are developed by the International Standards Organization (ISO) or another standards organization, these products may undergo modification to be compatible in the World market. Custom products, often made by computer controlled machinery, can be specified in any size.

Hard metric means "Product Requires Physical Change." The product must be physically modified to be efficiently used in a metric project, which is planned on a metric grid. A handful of current products must undergo hard metric conversion to new metric sizes.

**HARD METRIC PRODUCTS**

PRODUCT	SIZE (MM)
Brick	90 x 57 x 190 <sup>1</sup>
Concrete masonry unit	190 x 190 x 390
Drywall	1200 x 2400 <sup>2</sup>
Raised access flooring	600 x 600
Suspended ceiling tiles and grids	600 x 600 and 600 x 1200
Fluorescent lighting fixtures (lay-in type only)	600 x 600 and 600 x 1200
Air diffusers and grilles (lay-in type only)	600 and 1200 widths

1. Three vertical courses of metric modular brick with a joint of 10 mm equals 201 mm, which is rounded to 200. Three vertical rows of 200 equal 600 mm. 600 x 600 mm is a preferred nominal module for masonry.
2. Drywall thicknesses remain the same to minimize production impact. The standard thicknesses are 12.7 and 15.9 mm. Standard stud spacing is 400mm.

**SPECIFICATIONS**

Metric specifications should use "mm" for almost all measurements. The use of mm is consistent with the dimensions specified in major codes, such as BOCA and NEC. With the use of mm, the decimal point is used when extreme precision is indicated. Meters may be used only where large, round metric sizes are specified. Centimeters shall not be used in specifications. This is consistent with the recommendations of the AIA and ASTM.

**RULES FOR WRITING METRIC SYMBOLS AND NAMES**

1. Print the unit symbol in upright type and in lower case except for liter (L) or unless the unit name is derived from a proper name.
2. Print decimal prefixes in lower case for magnitudes 10<sup>3</sup> and lower; print the prefixes in upper case for magnitudes 10<sup>6</sup> and higher.
3. Leave a space between the numeral and symbol (example: 12 mm).
4. Do not use the degree mark with kelvin temperatures.
5. Do not leave a space between a unit symbol and its decimal prefix (example: km).
6. Do not use the plural of unit symbols, but do use the plural of written unit names (example: kg, kilograms).
7. For technical writing, use symbols in conjunction with numerals (example: 10 m<sup>2</sup>) and write out unit names if numeral is not used (example: square meters).
8. Indicate the product of two or more units in symbolic form by using a dot positioned above the line (example: kg·m·s<sup>-2</sup>).

9. Do not mix names and symbols (example: N meter).
10. Do not use a period after a symbol except when it occurs at the end of a sentence.
11. Always use decimals, not fractions.
12. Use a zero before the decimal marker for values less than one.
13. Use spaces instead of commas to separate blocks of three digits for any number over four digits (example: 45 138 kg or 0.004 46 kg). In the United States, the decimal marker is a period; in other countries a comma usually is used.

**COMPARISON OF DRAWING SCALES**

INCH-FOOT SCALES	INCH-FOOT RATIO	METRIC SCALE
Full size	1:1	1:1
Half size	1:2	1:2
4" = 1'-0"	1:3	
3" = 1'-0"	1:4	1:5
2" = 1'-0"	1:6	
1-1/2" = 1'-0"	1:8	1:10
1" = 1'-0"	1:12	
3/4" = 1'-0"	1:16	1:20
1/2" = 1'-0"	1:24	1:25
1/4" = 1'-0"	1:48	1:50
1" = 5'-0"	1:60	
1/8" = 1'-0"	1:96	1:100
1" = 10'-0"	1:120	
1/16" = 1'-0"	1:192	1:200
1" = 20'-0"	1:240	1:250
1" = 30'-0"	1:360	
1/32" = 1'-0"	1:384	
1" = 40'-0"	1:480	1:500
1" = 50'-0"	1:600	
1" = 60'-0"	1:720	
1" = 80'-0"	1:960	1:1000

**NOTES**

1. Metric drawing scales are expressed in nondimensional ratios.
2. Metric scales 1:2, 1:25, and 1:250 have limited use.

**DRAWING SHEET DIMENSIONS**

SIZE	SHEET SIZE
A0	1189 x 841 mm (46.8 x 33.1 inches)
A1	841 x 594 mm (33.1 x 23.4 inches)
A2	594 x 420 mm (23.4 x 16.5 inches)
A3	420 x 297 mm (16.5 x 11.7 inches)
A4	297 x 210 mm (11.7 x 8.3 inches)

**NOTES**

1. The ISO's "A" series drawing sizes are preferred metric sizes for design drawings.
2. A0 is the base size with an area of one square meter. Smaller sizes are half the long dimension of the previous size. All "A" sizes have a height-to-width ratio of one to the square root of two. Use a 35 mm microfilm frame to reduce these sizes.

**METRIC PREFIXES**

MULTIPLES	PREFIXES	SYMBOLS
1 000 000 000 000 = 10 <sup>12</sup>	tera	T
1 000 000 000 = 10 <sup>9</sup>	giga	G
1 000 000 = 10 <sup>6</sup>	mega	M
1 000 = 10 <sup>3</sup>	kilo	k*
100 = 10 <sup>2</sup>	hecto	h
10 = 10	deka	da
0.1 = 10 <sup>-1</sup>	deci	d
0.01 = 10 <sup>-2</sup>	centi	c
0.001 = 10 <sup>-3</sup>	milli	m*
0.000 001 = 10 <sup>-6</sup>	micro	μ
0.000 000 001 = 10 <sup>-9</sup>	nano	n
0.000 000 000 001 = 10 <sup>-12</sup>	pico	p

\*Commonly used with base units in design and construction

**BASE UNITS**

PHYSICAL QUALITY	UNIT	SYMBOL
Length	Meter	m
Mass <sup>1</sup>	Kilogram	kg
Time	Second	s
Electric current	Ampere	A
Thermodynamic temperature <sup>2</sup>	Kelvin	K
Luminous intensity	Candela	cd
Amount of substance <sup>3</sup>	Mole	mol

**NOTES**

1. "Weight" is often used to mean "mass."
2. Celsius temperature (°C) is more commonly used than kelvin (K), but both have the same temperature gradients. Celsius temperature is simply 273.15 degrees warmer than kelvin.
3. Mole is the amount of molecular substance and is used in physics.
4. Additional common units of measurement are the hectare (ha), liter (L), and metric ton (t). The hectare is used in surveying for land or sea areas and is equal to 10 000 square meters. The liter is a measurement for liquid volume that is equal to 1/1000 of a cubic meter. The metric ton is used to denote large loads such as those used in excavating and is equal to 1000 kilograms.

**PLANE AND SOLID ANGLES**

The radian (rad) and steradian (sr) denote plane and solid angles. They are used in lighting work and in various engineering calculations. In surveying, the units degree (°), minute (′), and second (″) continue in use.

**DERIVED UNITS**

QUANTITY	NAME	SYMBOL	EXPRESSION
Frequency	hertz	Hz	Hz = s <sup>-1</sup>
Force	newton	N	N = kg m/s <sup>2</sup>
Pressure, stress	pascal	Pa	Pa = N/m <sup>2</sup>
Energy, work, quantity of heat	joule	J	J = N m
Power, radiant flux	watt	W	W = J/s
Electric charge, quantity	coulomb	C	C = A s
Electric potential	volt	V	V = W/A or J/C
Capacitance	farad	F	F = C/V
Electric resistance	ohm	Ω	Ω = V/A
Electric conductance	siemens	S	S = A/V or Ω <sup>-1</sup>
Magnetic flux	weber	Wb	Wb = V s
Magnetic flux density	tesla	T	T = Wb/m <sup>2</sup>
Inductance	henry	H	H = Wb/A
Luminous flux	lumen	lm	lm = cd sr
Illuminance	lux	lx	lx = lm/m <sup>2</sup>

**CONVERSION FACTORS**

QUANTITY	FROM INCH-POUND UNITS	TO METRIC UNITS	MULTIPLY BY
Length	mile	km	1.609 344*
	yard	m	0.914 4*
	foot	m	0.304 8*
		mm	304.8*
Area	inch	mm	25.4*
	square mile	km <sup>2</sup>	2.590 00
		ha (10 000m <sup>2</sup> )	4.046 87
	square yard	m <sup>2</sup>	0.836 127 36*
		m <sup>2</sup>	0.092 903 04*
	square inch	mm <sup>2</sup>	645.16*
Volume	acre foot	m <sup>3</sup>	1 233.49
	cubic yard	m <sup>3</sup>	0.764 555
		m <sup>3</sup>	0.028 316 8
	cubic foot	cm <sup>3</sup>	28 316.85
		L (1000 cm <sup>3</sup> )	28.316 85
	100 board feet	m <sup>3</sup>	0.235 974
	gallon	L (1000 cm <sup>3</sup> )	3.785 41
	cubic inch	cm <sup>3</sup>	16.387 064*
mm <sup>3</sup>		16 387.064*	

\*denotes an exact conversion

**ADDITIONAL CONVERSION FACTORS**

QUANTITY	FROM INCH-POUND UNITS	TO METRIC UNITS	MULTIPLY BY
Mass	lb	kg	0.453 592
	Kip (1,000 lb)	metric ton (1000 kg)	0.453 592
Mass/unit length	plf	kg/m	1.488 16
Mass/unit area	psf	kg/m <sup>2</sup>	4.882 43
Mass density	pcf	kg/m <sup>3</sup>	16.018 5
Force	lb	N	4.448 22
Force/unit length	plf	N/m	14.593 9
Pressure, stress, modulus of elasticity	psf	Pa	47.880 3
	psi	kPa	6.894 76
Bending moment, torque, moment of force	ft-lb	Nm	1.355 82
Moment of mass	lbft	kg m	0.138 255
Moment of inertia	lb ft <sup>2</sup>	kg m <sup>2</sup>	0.042 140 1
Second moment of area	in <sup>4</sup>	mm <sup>4</sup>	416 231
Section modulus	in <sup>3</sup>	mm <sup>3</sup>	16 387.064*
Mass/area (density)	lb/ft <sup>2</sup>	kg/m <sup>2</sup>	4.882 428
Temperature	°F	°C	5/9(°F-32)
Energy, work, quantity of heat	kWh	MJ	3.6*
	Btu	J	1055.056
	ft lbf	J	1.355 82
Power	ton (refrig)	kW	3.517
	Btu/s	kW	1.055 056
	hp (electric)	W	745.700
	Btu/h	W	0.293 071
Heat flux	Btu/ft <sup>2</sup> h	W/m	3.152 481
Rate of heat flow	Btu/s	kW	1.055 056
	Btu/h	W	0.293 071 1
Thermal conductivity (k value)	Btu/ft h °F	W/m K	1.730 73
Thermal conductance (U value)	Btu/ft <sup>2</sup> h °F	W/m <sup>2</sup> K	5.678 263
Thermal resistance (R value)	ft <sup>2</sup> h °F/Btu	m <sup>2</sup> K/W	0.176 110
Heat capacity, entrophy	Btu/°F	kJ/K	1.899 1
Specific heat capacity, specific entrophy	Btu/lb °F	kJ/kg K	4.186 8*
Specific energy, latent heat	Btu/lb	kJ/kg	2.326*
Vapor permeance	perm (23 °C)	ng/(Pa s m <sup>2</sup> )	57.452 5
Vapor permeability	perm/in	ng/(Pa s m)	1.459 29
Volume rate of flow	ft <sup>3</sup> /s	m <sup>3</sup> /s	0.028 316 8
	cfm	m <sup>3</sup> /s	0.000 471 947 4
	cfm	L/s	0.471 947 4
Velocity, speed	ft/s	m/s	0.3048*
Acceleration	ft/s <sup>2</sup>	m/s <sup>2</sup>	0.3048*
Momentum	lb ft/s	kg m/s	0.138 255 0
Angular momentum	lb ft <sup>2</sup> /s	kg m <sup>2</sup> /s	0.042 140 11
Plane angle	degree	rad	0.017 453 3
Power, radiant flux	W	W	1 (same unit)
Radiant intensity	W/sr	W/sr	1 (same unit)
Radiance	W/(sr m <sup>2</sup> )	W/(sr m <sup>2</sup> )	1 (same unit)
Irradiance	W/m <sup>2</sup>	W/m <sup>2</sup>	1 (same unit)
Frequency	Hz	Hz	1 (same unit)
Electric Current	A	A	1 (same unit)
Electric Charge	A hr	C	3600*
Electric potential	V	V	1 (same unit)
Capacitance	F	F	1 (same unit)
Inductance	H	H	1 (same unit)
Resistance	W	W	1 (same unit)
Conductance	mho	S	100*
Magnetic flux	maxwell	Wb	10 <sup>8</sup> *
Magnetic flux density	gamma	T	10 <sup>9</sup> *
Luminous intensity	cd	cd	1 (same unit)
Luminance	lambert	kcd/m <sup>2</sup>	3.183 01
	cd/ft <sup>2</sup>	cd/m <sup>2</sup>	10.763 9
	footlambert	cd/m <sup>2</sup>	3.426 26
Luminous flux	lm	lm	1 (same unit)
Illuminance	footcandle	lx	10.763 9

\*denotes an exact conversion



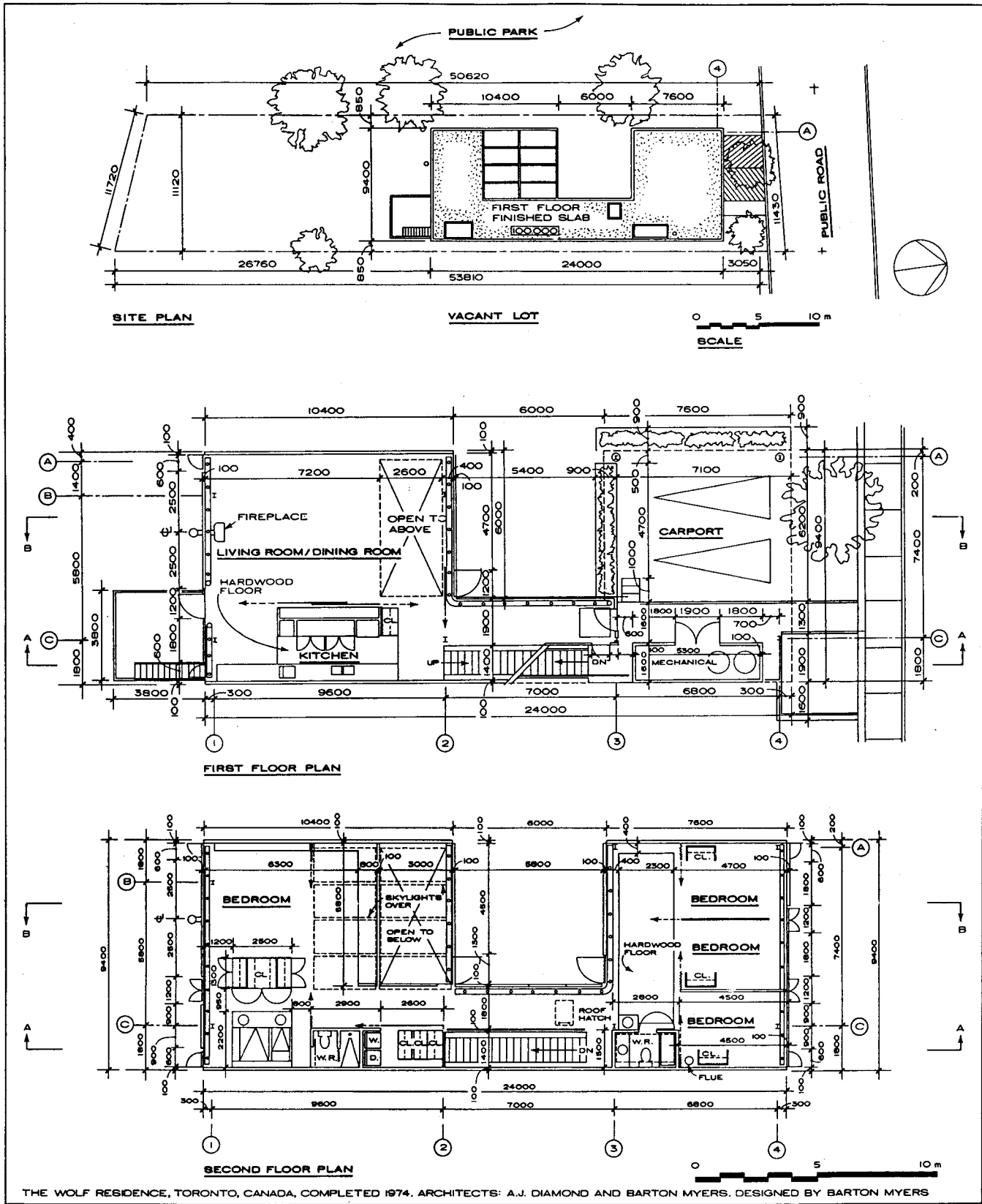

THE WOLF RESIDENCE, TORONTO, CANADA, COMPLETED 1974. ARCHITECTS: A.J. DIAMOND AND BARTON MYERS. DESIGNED BY BARTON MYERS

Robert Hill, Barton Myers Associates; Toronto, Canada



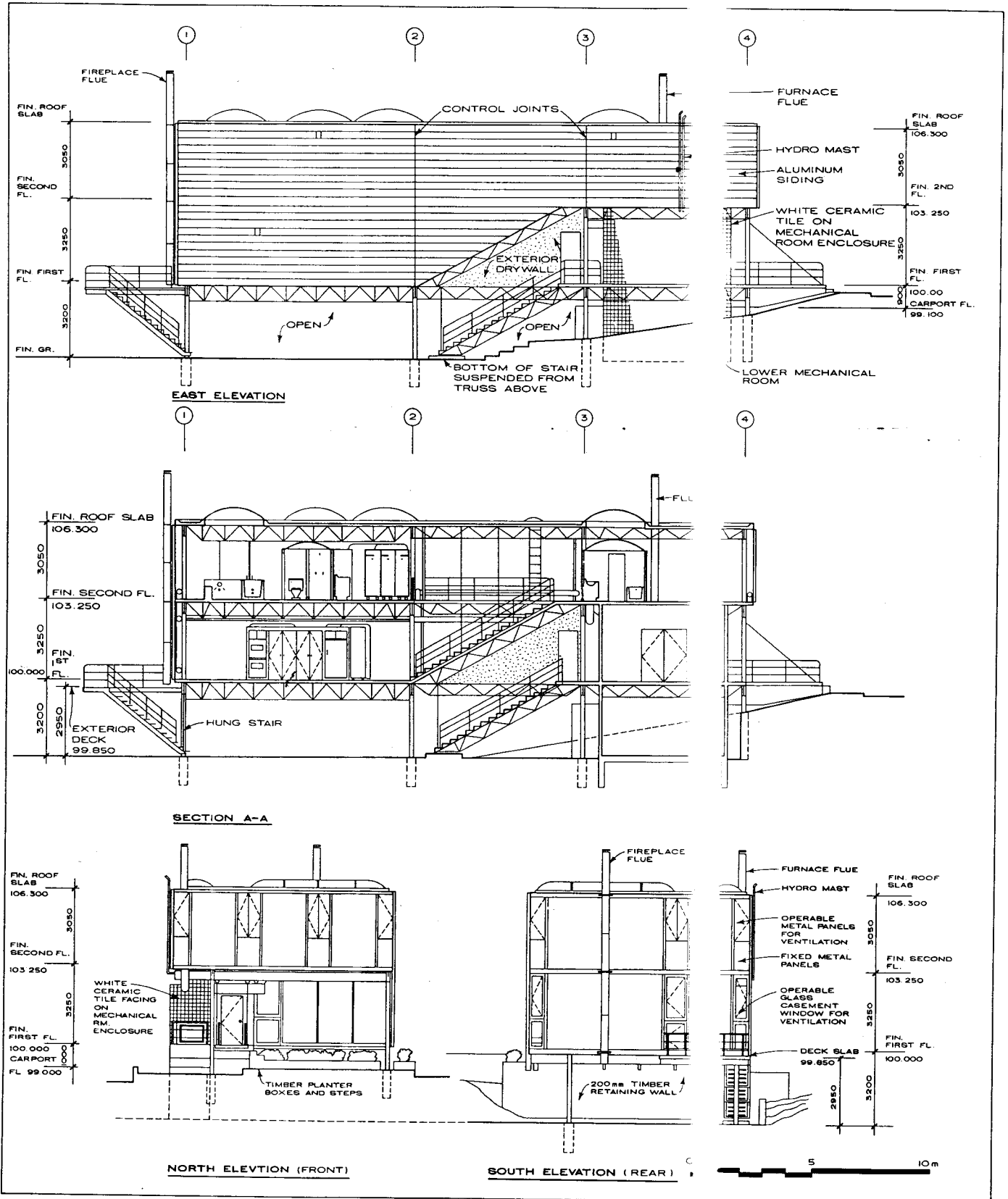

Robert Hill, Barton Myers Associates; Toronto, Canada

**A** METRIC

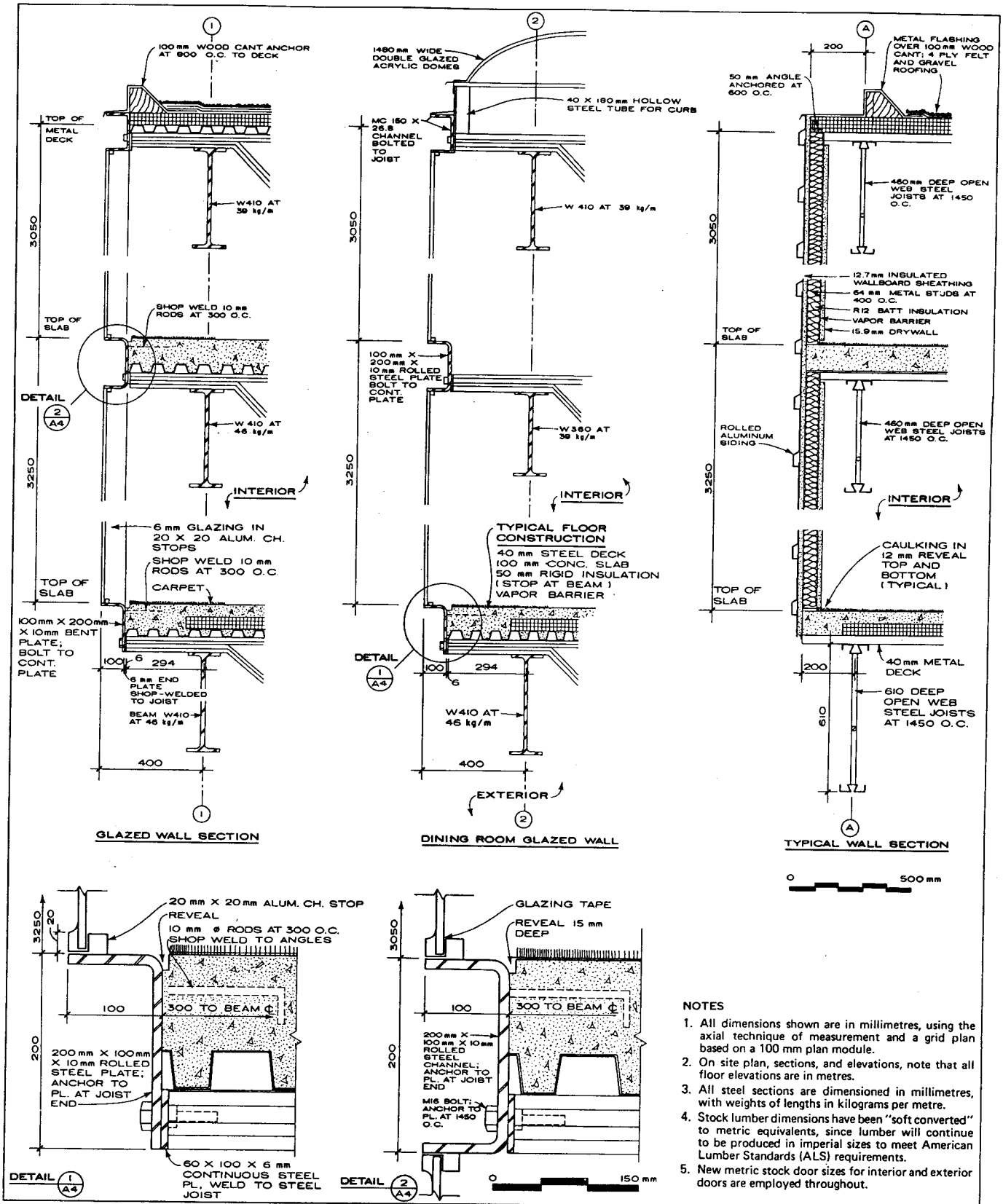

NOTES

1. All dimensions shown are in millimetres, using the axial technique of measurement and a grid plan based on a 100 mm plan module.
2. On site plan, sections, and elevations, note that all floor elevations are in metres.
3. All steel sections are dimensioned in millimetres, with weights of lengths in kilograms per metre.
4. Stock lumber dimensions have been "soft converted" to metric equivalents, since lumber will continue to be produced in imperial sizes to meet American Lumber Standards (ALS) requirements.
5. New metric stock door sizes for interior and exterior doors are employed throughout.

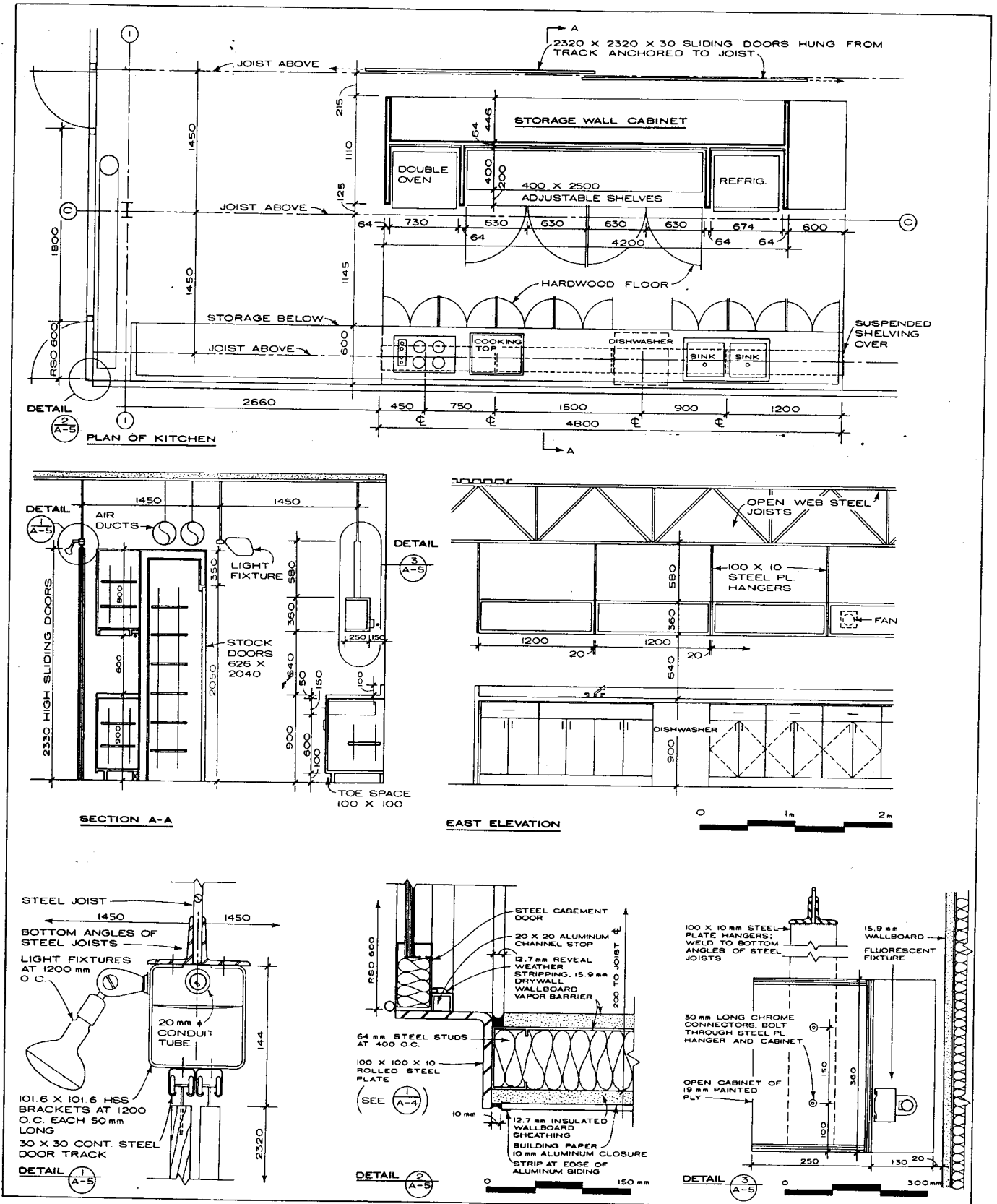

Robert Hill, Barton Myers Associates; Toronto, Canada

**A** METRIC

# DIRECTORY

## CHAPTER 1 - GENERAL PLANNING AND DESIGN DATA

### HUMAN DIMENSIONS

Building Officials and Code Administrators International (BOCA)

4051 W. Flossmoor Rd.  
Country Club Hills, IL 60478-5795  
(708) 799-2300  
Fax: (708) 799-4981  
URL: <http://www.bocai.org>

National Accreditation & Management Institute, Inc. (NAMI)

207 S. Washington St.  
Berkeley Springs, WV 25411  
(304) 258-5100  
Fax: (304) 258-5111

National Association of Home Builders National Housing Library

1201 15th St. NW  
Washington, DC 20005  
(800) 368-5242

Small Homes Council/Building Research Council (SHC)

University of Illinois, Urbana Champaign  
One E. St. Mary's Road  
Champaign, IL 61820  
(217) 333-1801  
Fax: (800) 336-0616  
URL: <http://www.arch.uiuc.edu/brc>

Southern Building Code Congress International, Inc. (SBCCI)

900 Montclair Road  
Birmingham, AL 35213-1206  
(205) 591-1853  
Fax: (205) 591-0775  
URL: <http://www.sbcci.org>  
E-mail: [info@sbcci.org](mailto:info@sbcci.org)

### EGRESS PLANNING

American National Standards Institute (ANSI)

11 West 42nd Street,  
13th Floor  
New York, NY 10036-8002  
(212) 642-4900  
Fax: (212) 398-0023  
URL: <http://www.ansi.org>

American Society of Safety Engineers

1800 East Oakton  
Des Plaines, IL 60018-2187  
(847) 699-2929  
Fax: (847) 296-3769  
URL: <http://www.asse.org>  
E-mail: [customerservice@asse.org](mailto:customerservice@asse.org)

Building Officials and Code Administrators International (BOCA)

4051 W. Flossmoor Rd.  
Country Club Hills, IL 60478-5795  
(708) 799-2300  
Fax: (708) 799-4981  
URL: <http://www.bocai.org>

Building Owners and Managers Association International (BOMA)

1201 New York Ave. NW, Ste. 300  
Washington, DC 20005  
(202) 408-2662  
Fax: (202) 371-0181  
URL: <http://www.boma.org>

Building and Fire Research Laboratory National Institute of Standards and Technology

Building 226 Room B216  
Gaithersburg, MD 20899  
(301) 975-6850  
URL: <http://www.bfrl.nist.gov>  
E-mail: [richard.wright@nist.gov](mailto:richard.wright@nist.gov)

Council on Tall Building and Urban Habitat (CTBUH)

Lehigh University/Fritz Engineering Lab  
11 E. Packer Ave.  
Bethlehem, PA 18015  
(610) 758-3515  
Fax: (610) 758-3515  
URL: <http://www.lehigh.edu/~inctbuh>

HSB Industrial Risk Insurers

85 Woodland St.  
Hartford, CT 06102-5010  
(860) 520-7300  
Fax: (860) 549-5780  
URL: <http://www.industrialrisk.com>

International Association of Auditorium Managers (IAAM)

4425 W. Airport Freeway, Ste. 590  
Irving, TX 75062  
(972) 255-8020  
Fax: (972) 255-9582  
URL: <http://www.iaam.org>

International Conference of Building Officials (ICBO)

5360 S. Workman Mill Road  
Whittier, CA 90601-2298  
(562) 699-0541  
Fax: (562) 692-3853  
URL: <http://www.icbo.org>

National Conference of States on Building Codes and Standards (NCSBCS)

505 Huntmar Park Drive, Suite 210  
Herndon, VA 20170  
(703) 742-8127  
Fax: (703) 481-3596  
URL: <http://www.ncsbcscs.org>

National Fire Protection Association

One Batterymarch Park  
P.O. Box 9101  
Quincy, MA 02269-9101  
(617) 770-3000  
Fax: (617) 770-0700  
URL: <http://www.nfpa.org>  
E-mail: [Library@NFPA.org](mailto:Library@NFPA.org)

National Institute of Building Sciences (NIBS)

1090 Vermont Ave., NW, Ste. 700  
Washington, DC 20005  
(202) 289-7800  
Fax: (202) 289-1092  
URL: <http://www.nibs.org>

National Research Council (NCR)

2101 Constitution Ave. NW  
Washington, DC 20418  
(202) 334-3000  
URL: <http://www.nas.edu/ncr>

Occupational Safety and Health Administration (OSHA)

200 Constitution Avenue  
Washington, DC 20210  
(202) 219-8148  
URL: <http://www.osha.gov>

Southern Building Code Congress International, Inc. (SBCCI)

900 Montclair Road  
Birmingham, AL 35213-1206  
(205) 591-1853  
Fax: (205) 591-0775  
URL: <http://www.sbcci.org>  
E-mail: [info@sbcci.org](mailto:info@sbcci.org)

### BUILDING SYSTEMS

International Conference of Building Officials (ICBO)

5360 S. Workman Mill Road  
Whittier, CA 90601-2298  
(562) 699-0541  
Fax: (562) 692-3853  
URL: <http://www.icbo.org>

Southern Building Code Congress International, Inc. (SBCCI)

900 Montclair Road  
Birmingham, AL 35213-1206  
(205) 591-1853  
Fax: (205) 591-0775  
URL: <http://www.sbcci.org>  
E-mail: [info@sbcci.org](mailto:info@sbcci.org)

### SEISMIC DESIGN

Building Officials and Code Administrators International (BOCA)

4051 W. Flossmoor Rd.  
Country Club Hills, IL 60478-5795  
(708) 799-2300  
Fax: (708) 799-4981  
URL: <http://www.bocai.org>

Building Seismic Safety Council (BSSC)

National Institute of Building Sciences  
1090 Vermont Ave., Suite 700  
Washington, DC 20005  
(202) 289-7800  
Fax: (202) 289-1092  
URL: <http://www.nibs.org>

Council on Tall Building and Urban Habitat (CTBUH)

Lehigh University/Fritz Engineering Lab  
11 E. Packer Ave.  
Bethlehem, PA 18015  
(610) 758-3515  
Fax: (610) 758-3515  
URL: <http://www.lehigh.edu/~inctbuh>

Federal Emergency Management Agency (FEMA)

Federal Center Plaza  
500 C Street, SW  
Washington, DC 20472  
(202) 646-2500  
URL: <http://www.fema.gov>  
E-mail: [eipa@fema.gov](mailto:eipa@fema.gov)

National Conference of States on Building Codes and Standards (NCSBCS)

505 Huntmar Park Drive, Suite 210  
Herndon, VA 20170  
(703) 742-8127  
Fax: (703) 481-3596  
URL: <http://www.ncsbcscs.org>

**Note:** For the most up-to-date listing of URLs, please see *Architectural Graphic Standards* CD-ROM Version 3.0.

National Institute of Building Sciences (NIBS)  
1090 Vermont Ave., NW, Ste. 700  
Washington, DC 20005  
(202) 289-7800  
Fax: (202) 289-1092  
URL: <http://www.nibs.org>

National Research Council (NCR)  
2101 Constitution Ave. NW  
Washington, DC 20418  
(202) 334-3000  
URL: <http://www.nas.edu/ncr>

Southern Building Code Congress International, Inc. (SBCCI)  
900 Montclair Road  
Birmingham, AL 35213-1206  
(205) 591-1853  
Fax: (205) 591-0775  
URL: <http://www.sbcci.org>  
E-mail: [info@sbcci.org](mailto:info@sbcci.org)

#### LIGHTING DESIGN

American Lighting Association  
2050 Stemmons Freeway, Suite 10046  
Dallas, TX 75207  
(800) 605-4448  
Fax: (214) 698-9899  
URL: <http://www.americanlightingassoc.com>

Architectural Lighting  
1515 Broadway, 32nd Floor  
New York, NY 10036  
(212) 869-1300  
URL: <http://www.archlighting.com>  
E-mail: [cdliouie@mfi.com](mailto:cdliouie@mfi.com)

Association of Edison Illuminating Companies  
600 North 18th Street  
P.O. Box 2641  
Birmingham, AL 35291-0992  
(205) 257-2530  
Fax: (305) 257-2540  
URL: <http://www.aeic.org>

Department of Energy (DOE)  
Forrestal Building  
1000 Independence Ave. SW  
Washington, DC 20585  
(202) 586-5000  
URL: <http://www.home.doe.gov>

Illuminating Engineering Society of North America (IES)  
120 Wall Street, 17th Floor  
New York, NY 10005  
(212) 248-5000  
Fax: (212) 248-5017  
URL: <http://www.iesna.org>  
E-mail: [iesna@iesna.org](mailto:iesna@iesna.org)

International Association of Auditorium Managers (IAAM)  
4425 W. Airport Freeway, Ste. 590  
Irving, TX 75062  
(972) 255-8020  
Fax: (972) 255-9582  
URL: <http://www.iaam.org>

International Association of Lighting Designers (IALD)  
The Merchandise Mart  
200 World Trade Center, Suite 487  
Chicago, IL 60654  
(312) 527-3677  
Fax: (312) 527-3680  
URL: <http://www.iald.org>  
E-mail: [iald@iald.org](mailto:iald@iald.org)

Lawrence Berkeley Laboratory (LBL)  
Lighting Systems Research Group  
Mail Stop 46-125  
1 Cyclotron Road  
Berkeley, CA 94720  
(510) 486-5388  
Fax: (510) 486-6940  
URL: <http://www.lbl.gov>

Lighting Research Center (LRC)  
Rensselaer Polytechnic Institute  
Greene Bldg., #115  
Troy, NY 12180-3590  
(518) 276-8716  
Fax: (518) 276-2999  
URL: <http://lighting.lrc.rpi.edu>

Lighting Research Institute (LRI)  
120 Wall St.  
New York, NY 10005-4001  
(212) 248-5014  
URL: <http://lighting.lrc.rpi.edu>

National Institute of Building Sciences (NIBS)  
1090 Vermont Ave., NW, Ste. 700  
Washington, DC 20005  
(202) 289-7800  
Fax: (202) 289-1092  
URL: <http://www.nibs.org>

National Lighting Bureau (NLB)  
2101 L St. NW  
Washington, DC 20037  
(202) 457-8437  
Fax: (202) 457-8437

Office Systems Research Association (OSRA)  
901 S. National Ave. Tel:  
Springfield, MO 65804  
URL: <http://www.osra.org>  
E-mail: [info@osra.org](mailto:info@osra.org)

Southern Building Code Congress International, Inc. (SBCCI)  
900 Montclair Road  
Birmingham, AL 35213-1206  
(205) 591-1853  
Fax: (205) 591-0775  
URL: <http://www.sbcci.org>  
E-mail: [info@sbcci.org](mailto:info@sbcci.org)

#### ACOUSTICAL DESIGN

Acoustical Society of America (ASA)  
2 Huntington Quadrangle  
Suite 1N01  
(516) 576-2360  
Fax: (516) 576-2377  
URL: <http://asa.aip.org/index.html>  
E-mail: [asa@aip.org](mailto:asa@aip.org)

Institute of Noise Control Engineering  
P.O. Box 3206, Arlington Branch  
Poughkeepsie, NY 12603  
(914) 462-4006  
Fax: (914) 463-0201  
URL: <http://www.ince.org>

National Council of Acoustical Consultants (NCAC)  
66 Morris Avenue, Suite 1A  
Springfield, NJ 07081-1409  
(973) 564-5859  
Fax: (973) 564-7480  
URL: <http://www.ncac.com>  
E-mail: [info@ncac.com](mailto:info@ncac.com)

National Institute of Building Sciences (NIBS)  
1090 Vermont Ave., NW, Ste. 700  
Washington, DC 20005  
(202) 289-7800  
Fax: (202) 289-1092  
URL: <http://www.nibs.org>

National Research Council (NCR)  
2101 Constitution Ave. NW  
Washington, DC 20418  
(202) 334-3000  
URL: <http://www.nas.edu/ncr>

Office Systems Research Association (OSRA)  
Morehead State University  
Dept. of Information Systems  
UPO 910  
150 University Blvd.  
Morehead, KY 40351-1689  
(606) 783-2724  
Fax: (606) 783-5025  
URL: <http://www.osra.org>  
E-mail: [dkizzier@morehead-st.edu](mailto:dkizzier@morehead-st.edu)

Southern Building Code Congress International, Inc. (SBCCI)  
900 Montclair Road  
Birmingham, AL 35213-1206  
(205) 591-1853  
Fax: (205) 591-0775  
URL: <http://www.sbcci.org>  
E-mail: [info@sbcci.org](mailto:info@sbcci.org)

#### BUILDING SECURITY

Building Owners and Managers Association International (BOMA)  
1201 New York Ave. NW, Ste. 300  
Washington, DC 20005  
(202) 408-2662  
Fax: (202) 371-0181  
URL: <http://www.boma.org>

Council on Tall Building and Urban Habitat (CTBUH)  
Lehigh University/Fritz Engineering Lab  
11 E. Packer Ave.  
Bethlehem, PA 18015  
(610) 758-3515  
Fax: (610) 758-3515  
URL: <http://www.lehigh.edu/~inctbuh>

International Facility Management Association (IFMA)  
1 East Greenway Plaza, Ste. 1100  
Houston, TX 77046  
(713) 623-4362  
Fax: (713) 623-6124  
URL: <http://www.ifma.org>  
E-mail: [ifmahq@ifma.org](mailto:ifmahq@ifma.org)

National Alarm Association of America  
P.O. Box 3409  
Dayton, OH 45401  
(800) 283-6285  
URL: <http://www.naaa.org>

National Burglar and Fire Alarm Association (NBFAA)  
7101 Wisconsin Avenue, Suite 901  
Bethesda, MD 20814-4805  
(301) 907-3202  
Fax: (301) 907-7897  
URL: <http://www.alarm.org>  
E-mail: [membership@alarm.org](mailto:membership@alarm.org)

National Crime Prevention Institute (NCPI)  
University of Louisville  
Burhan Hall, Room 134  
Louisville, Kentucky 40292-0001  
(502) 852-6987  
Fax: (502) 852-6990  
URL: <http://www.louisville.edu>

Southern Building Code Congress International, Inc. (SBCCI)  
900 Montclair Road  
Birmingham, AL 35213-1206  
(205) 591-1853  
Fax: (205) 591-0775  
URL: <http://www.sbcci.org>  
E-mail: [info@sbcci.org](mailto:info@sbcci.org)

US Department of Justice  
Public Access Section  
Civil Rights Division  
P.O. Box 66738  
Washington, DC 20035-6738  
(202) 307-0663  
Fax: (202) 307-1197  
URL: <http://www.usdoj.gov>

#### SITE, COMMUNITY, AND URBAN PLANNING

Alliance for Historic Landscape Preservation  
82 Wall Street  
Suite 1105  
New York, NY 10005  
(617) 491-3727  
URL: <http://www.mindspring.com/~ahlp>

American Institute for Conservation (AIC)  
1717 K Street N.W., Suite 301  
Washington, DC 20006  
(202) 452-9545  
Fax: (202) 452-9328

American Institute of Certified Planners/American Planning Association (AICP/APA)  
1776 Massachusetts Avenue, NW,  
Suite 400  
Washington, DC 20036  
(202) 872-0611  
Fax: (202) 872-0643  
URL: <http://www.planning.org>  
E-mail: [aicp@planning.org](mailto:aicp@planning.org)

American Planning Association  
1776 Massachusetts Avenue, NW,  
Suite 400  
Washington, DC 20036  
(202) 872-0611  
URL: <http://www.planning.org>  
E-mail: [apa@planning.org](mailto:apa@planning.org)

American Planning Association Planners Advisory Service (PAS)  
122 S. Michigan Ave, Ste. 1600  
Chicago, IL 60637  
(312) 431-9100  
Fax: (312) 431-9985  
URL: <http://www.planning.org>  
E-mail: [pasinfo@planning.org](mailto:pasinfo@planning.org)

American Public Transit Association (APTA)  
1201 New York Ave. NW  
Washington, DC 20005  
(202) 898-4000  
Fax: (202) 898-4049  
URL: <http://www.apta.com>  
E-mail: [info@apta.com](mailto:info@apta.com)

American Resort Development Association (ARDA)  
1220 L St. NW, Ste. 510  
Washington, DC 20005  
(202) 371-6700  
Fax: (202) 298-8544  
URL: <http://www.arda.org>

American Society of Landscape Architects  
636 Eye Street, NW  
Washington, DC 20001-3736  
(202) 898-2444  
Fax: (202) 898-1185

American Society of Landscape Architects (ASLA)  
636 Eye Street, NW  
Washington, DC 20001-3736  
(202) 898-2444  
Fax: (202) 898-1185  
URL: <http://www.asla.org>  
E-mail: [scahill@asla.org](mailto:scahill@asla.org)

American Solar Energy Society (ASES)  
2400 Central Avenue, Unit B-1  
Boulder, CO 80301  
(303) 443-3130  
Fax: (303) 443-3212  
URL: <http://www.ases.org>

Association of University Architects (AUA)  
Office of Physical Planning  
Princeton University  
Princeton, NJ 08544  
(609) 258-3356

Association of University Related Research Parks (AURRP)  
1730 K. Street NW, Suite 700  
Washington, DC 20006  
(202) 828-4167  
Fax: (202) 223-4745  
URL: <http://www.aurrrp.org>

Board on Infrastructure and the Constructed Environment (BICE)  
2101 Constitution Ave. NW  
Washington, DC 20418  
(202) 334-2000  
URL: <http://www4.nas.edu/cets/bice.nsf>

Council of Landscape Architecture Registration Boards  
12700 Fair Lakes Circle, Suite 110  
Fairfax, VA 22033-4905  
(703) 818-1300  
Fax: (703) 818-1309  
URL: <http://www.clarb.org>

Department of Housing and Urban Development  
451 Seventh Street, SW  
Washington, DC 20410  
(202) 708-1112  
URL: <http://www.hud.gov>

Department of Transportation (DOT)  
400 Seventh St. SW, Rm. 10424  
Washington, DC 20590  
(202) 366-4000  
URL: <http://www.dot.gov>

Environmental Protection Agency (EPA)  
401 M Street, SW  
Washington, DC 20460  
Asbestos Information Hotline:  
(202) 554-1404  
School Related: (800) 835-6700  
(202) 260-2090  
General Information:  
URL: <http://www.epa.gov>  
E-mail: [public-access@epamail.epa.gov](mailto:public-access@epamail.epa.gov)

Institute of Urban Development (IUD)  
2201 G Street, NW, Ste 507  
Washington, DC 20052

International Association of Amusement  
Parks and Attractions (IAAPA)  
1448 Duke Street  
Alexandria, VA 22314  
(703) 836-4800  
Fax: (703) 836-4801  
URL: <http://www.iaapa.org>  
E-mail: [iaapa@iaapa.org](mailto:iaapa@iaapa.org)

International City Management Association  
(ICMA)  
777 N. Capitol St. NE, Ste. 500  
Washington, DC 20002  
(202) 289-4262  
Fax: (202) 962-3500  
URL: <http://www.icma.org>

National Arborist Association (NAA)  
Route 101  
P.O. Box 1094  
Amherst, NH 03031-1094  
(603) 673-3311  
Fax: (603) 672-2613  
URL: <http://www.natlarb.com>

National Association of Home Builders  
(NAHB)  
Home Builder Press/NAHB Bookstore  
1201 15th Street, NW  
Washington, DC 20005  
(800) 368-5242 or (202) 822-0200  
Fax: (202) 822-0559  
URL: <http://www.nahb.org>  
E-mail: [info@nahb.com](mailto:info@nahb.com)

National Park Service  
P.O. Box 37127  
Washington, DC 20013-7127  
URL: <http://www.nps.gov>

National Research Council (NCR)  
2101 Constitution Ave. NW  
Washington, DC 20418  
(202) 334-3000  
URL: <http://www.nas.edu/ncr>

Office of Urban Rehabilitation  
Department of Housing and Urban  
Development  
451 Seventh Street, SW  
Washington, DC 20410  
(202) 708-1422  
URL: <http://www.hud.gov>

Small Homes Council/Building Research  
Council (SHC)  
University of Illinois, Urbana Champaign  
One E. St. Mary's Road  
Champaign, IL 61820  
(217) 333-1601  
Fax: (800) 336-0616  
URL: <http://www.arch.uiuc.edu/brc>

Society for College & University Planning  
(SCUP)  
311 Maynard St.  
Ann Arbor, MI 48104  
(734) 998-7832  
Fax: (734) 998-6532  
URL: <http://www.scup.org>  
E-mail: [scup@scup.edu](mailto:scup@scup.edu)

Southern Building Code Congress  
International, Inc. (SBCCI)  
900 Montclair Road  
Birmingham, AL 35213-1206  
(205) 591-1853  
Fax: (205) 591-0775  
URL: <http://www.sbcci.org>  
E-mail: [info@sbcci.org](mailto:info@sbcci.org)

Urban Design and Preservation Division of  
the American Planning Association  
(UDPD/APA)  
110 Higgins Hall  
Pratt Institute School of Architecture  
Brooklyn, NY 11205  
(718) 399-6090  
URL: <http://www.planning.org>

Urban Land Institute (ULI)  
1025 Thomas Jefferson St., NW, Suite  
500W  
Washington, DC 20007-5201  
(202) 624-7000  
Fax: (202) 624-7140  
URL: <http://www.uli.org>

Urban Land Magazine  
Urban Land Institute  
1025 Thomas Jefferson St., NW, Suite  
500W  
Washington, DC 20007-5201  
(202) 624-7000  
URL: <http://www.uli.org>  
E-mail: [campbell@uli.org](mailto:campbell@uli.org)

**FLOOD DAMAGE CONTROL**

Army Corps of Engineers (ACE)  
20 Massachusetts Ave, NW  
Washington, DC 20314  
(202) 761-0660  
URL: <http://www.usace.army.mil>

Environmental Protection Agency (EPA)  
401 M St. NW  
Washington, DC 20460  
(202) 260-2090  
URL: <http://www.epa.gov>

Federal Emergency Management Agency  
(FEMA)  
Federal Center Plaza  
500 C Street, SW  
Washington, DC 20472  
(202) 646-2500  
URL: <http://www.fema.gov>  
E-mail: [eipa@fema.gov](mailto:eipa@fema.gov)

Southern Building Code Congress  
International, Inc. (SBCCI)  
900 Montclair Road  
Birmingham, AL 35213-1206  
(205) 591-1853  
Fax: (205) 591-0775  
URL: <http://www.sbcci.org>  
E-mail: [info@sbcci.org](mailto:info@sbcci.org)

Water Environment Federation (WEF)  
601 Wythe St.  
Alexandria, VA 22314-1994  
(703) 684-2400  
Fax: (703) 684-8928  
URL: <http://www.wef.org>

**AUTOMOBILES, ROADS, AND  
PARKING**

American Public Transit Association (APTA)  
1201 New York Ave. NW  
Washington, DC 20005  
(202) 898-4000  
Fax: (202) 898-4049  
URL: <http://www.apta.com>  
E-mail: [info@apta.com](mailto:info@apta.com)

American Road and Transportation Builders  
Association (ARTBA)  
1010 Massachusetts Ave. NW  
Washington, DC 20001  
(202) 289-4434  
Fax: (202) 289-4435  
URL: <http://www.artba.org>

Eno Transportation Foundation (ETF)  
One Farragut Square South  
Washington, DC 20006-4003  
(202) 879-4700  
Fax: (202) 879-4719  
URL: <http://www.enotrans.com>

Institute of Transportation Engineers (ITE)  
525 School St. SW, Ste. 410  
Washington, DC 20024  
(202) 554-8050  
Fax: (202) 863-5486  
URL: <http://www.ite.org>  
E-mail: [itehq@io.com](mailto:itehq@io.com)

National Parking Association  
1112 16th Street, NW, Suite 300  
Washington, DC 20036  
(800) 647-7275  
Fax: (202) 331-8523  
URL: <http://www.npapark.org>

Society of Automotive Engineers (SAE)  
International  
400 Commonwealth Dr.  
Warrendale, PA 15096-0001  
(724) 776-4841  
Fax: (724) 776-5760  
URL: <http://www.sae.org>

Southern Building Code Congress  
International, Inc. (SBCCI)  
900 Montclair Road  
Birmingham, AL 35213-1206  
(205) 591-1853  
Fax: (205) 591-0775  
URL: <http://www.sbcci.org>  
E-mail: [info@sbcci.org](mailto:info@sbcci.org)

US Architectural and Transportation Barriers  
Compliance Board  
1331 F Street, NW  
Suite 1000  
Washington, DC 20004-1111  
(202) 272-5434  
Fax: (202) 272-5447  
URL: <http://www.access-board.gov>  
E-mail: [info@access-board.gov](mailto:info@access-board.gov)

US Department of Transportation  
400 Seventh Street, SW  
Room 10424  
Washington, DC 20590  
(202) 366-9305 (V) or (202) 755-7687  
(TDD)  
URL: <http://www.dot.gov>

**TRUCKS, TRAINS, AND BOATS**

American Association of State Highway and  
Transportation Officials (AASHTO)  
444 North Capitol St., NW, Suite 249  
Washington, DC 20001  
(202) 624-5800  
Fax: (847) 303-5774  
URL: <http://www.aashto.org>

American Petroleum Institute (API)  
1220 L St., NW, Suite 900  
Washington, DC 20005-8029  
(202) 682-8000  
URL: <http://www.api.org>

American Public Transit Association (APTA)  
1201 New York Ave. NW  
Washington, DC 20005  
(202) 898-4000  
Fax: (202) 898-4049  
URL: <http://www.apta.com>  
E-mail: [info@apta.com](mailto:info@apta.com)

Eno Transportation Foundation (ETF)  
One Farragut Square South  
Washington, DC 20006-4003  
(202) 879-4700  
Fax: (202) 879-4719  
URL: <http://www.enotrans.com>

Institute of Transportation Engineers (ITE)  
525 School St. SW, Ste. 410  
Washington, DC 20024  
(202) 554-8050  
Fax: (202) 863-5486  
URL: <http://www.ite.org>  
E-mail: [itehq@io.com](mailto:itehq@io.com)

Society of Automotive Engineers (SAE)  
International  
400 Commonwealth Dr.  
Warrendale, PA 15096-0001  
(724) 776-4841  
Fax: (724) 776-5760  
URL: <http://www.sae.org>

Southern Building Code Congress  
International, Inc. (SBCCI)  
900 Montclair Road  
Birmingham, AL 35213-1206  
(205) 591-1853  
Fax: (205) 591-0775  
URL: <http://www.sbcci.org>  
E-mail: [info@sbcci.org](mailto:info@sbcci.org)

US Department of Transportation  
400 Seventh Street, SW  
Room 10424  
Washington, DC 20590  
(202) 366-9305 (V) or (202) 755-7687  
(TDD)  
URL: <http://www.dot.gov>

**CONSTRUCTION INFORMATION  
SYSTEMS**

American Association of Cost Engineers  
209 Prairie Ave., #100  
Morgantown, WV 26505  
(304) 296-8444  
Fax: (304) 291-5728  
URL: <http://www.aacei.org>  
E-mail: [74757.2636@compuserve.com](mailto:74757.2636@compuserve.com)

American Consulting Engineers Council  
1015 15th Street, NW, #802  
Washington, DC 20005  
(202) 347-7474  
Fax: (202) 898-0068  
URL: <http://www.acec.org>  
E-mail: [acec@acec.org](mailto:acec@acec.org)

The American Institute of Architects  
1735 New York Ave., NW  
Washington, DC 20006  
(202) 626-7300  
Fax: (202) 626-7587  
URL: <http://www.aiaonline.com>  
E-mail: [sandstromc@aiaemail.aia.com](mailto:sandstromc@aiaemail.aia.com)

American Institute of Building Design (AIBD)  
991 Post Road "E"  
Westport, CT 06880  
(800) 366-2423  
Fax: (203) 227-8625  
URL: <http://www.aibd.org>  
E-mail: [aibdnat@aol.com](mailto:aibdnat@aol.com)

American Insurance Association (AIA)  
1130 Connecticut Ave., NW, Suite 1000  
Washington, DC 20036  
(202) 828-7100  
Fax: (202) 293-1219  
URL: <http://www.aiadc.org>

American Planning Association Planners  
Advisory Service (PAS)  
122 S. Michigan Ave, Ste. 1600  
Chicago, IL 60637  
(312) 431-9100  
Fax: (312) 431-9985  
URL: <http://www.planning.org>  
E-mail: [pasinfo@planning.org](mailto:pasinfo@planning.org)

American Resort Development Association  
(ARDA)  
1220 L St. NW, Ste. 510  
Washington, DC 20005  
(202) 371-6700  
Fax: (202) 298-8544  
URL: <http://www.arda.org>

American Society for Quality (ASQ)  
611 East Wisconsin Ave.  
Milwaukee, WI 53201-3005  
(414) 272-8575  
(800) 248-1946  
Fax: (414) 272-1734  
URL: <http://www.asq.org>

American Society of Civil Engineers (ASCE)  
1801 Alexander Graham Bell Drive  
Reston, VA 20191-4400  
(703) 295-6300  
Fax: (703) 295-6222  
URL: <http://www.asce.org>  
E-mail: [memapp@asce.org](mailto:memapp@asce.org)

American Society of Interior Designers  
(ASID)  
608 Massachusetts Avenue, NE  
Washington, DC 20002  
(202) 546-3480  
Fax: (202) 546-3240  
URL: <http://www.asidla.org>  
E-mail: [peppermatrix@earthlink.net](mailto:peppermatrix@earthlink.net)

American Society of Landscape Architects  
(ASLA)  
636 Eye Street, NW  
Washington, DC 20001-3736  
(202) 898-2444  
Fax: (202) 898-1185  
URL: <http://www.asla.org>  
E-mail: [scahill@asla.org](mailto:scahill@asla.org)

American Society of Professional Estimators  
11141 Georgia Avenue,  
Suite 412  
Wheaton, MD 20902  
(301) 929-8848  
Fax: (301) 929-0231  
URL: <http://www.cmpi.com/asp>  
E-mail: [asp@gate.vegas.com](mailto:asp@gate.vegas.com)

Associated General Contractors of America  
(AGC)  
1957 E Street, NW  
Washington, DC 20006  
(202) 393-2040  
Fax: (202) 347-4004  
URL: <http://www.agc.org>  
E-mail: [info@agc.org](mailto:info@agc.org)

Association of Collegiate Schools of Architecture (ACSA)  
1735 New York Avenue, NW  
Washington, DC 20006-5292  
(202) 785-2324  
Fax: (202) 628-0448  
URL: <http://www.acsa-arch.org>

The Association of Independent Scientific, (ACIL)  
Engineering, and Testing Firms  
1629 K St., NW, Suite 400  
Washington, DC 20006  
(202) 887-5872  
Fax: (202) 887-0021  
URL: <http://www.acil.org>

Building Officials and Code Administrators International (BOCA)  
4051 W. Flossmoor Rd.  
Country Club Hills, IL 60478-5795  
(708) 799-2300  
Fax: (708) 799-4981  
URL: <http://www.bocai.org>

Canadian General Standards Board (CGSB)  
Sales Centre  
Ottawa K1A 1G6  
CANADA  
(819) 956-3500  
Fax: (819) 956-5644  
URL: <http://www.pwgsc.gc.ca/cgsb/text/eng-e.html>

Canadian Society of Landscape Architects (CSLA)  
1339 15th Avenue, SW, unit 310  
Calgary Alberta, Canada T3C 3V3  
(613) 232-6342  
URL: <http://www.csla.ca>  
E-mail: [rodneyc@clr.utoronto.ca](mailto:rodneyc@clr.utoronto.ca)

The Construction Specification Institute  
601 Madison Street  
Alexandria, VA 22314  
(703) 684-0300  
Fax: (703) 684-0465  
URL: <http://www.csinet.org>  
E-mail: [dstirba@csinet.org](mailto:dstirba@csinet.org)

Construction Specifier  
601 Madison Street  
Alexandria, VA 22314  
(703) 684-0300  
Fax: (703) 684-0465  
URL: <http://www.csinet.org>

General Services Administration  
GSA Library  
General Services Bldg., Rm. 1033  
1800 F St. NW  
Washington, DC 20405  
(202) 501-0788

General Services Administration (GSA)  
Property Management  
18 and F Sts. NW  
Washington, DC 20405  
(202) 708-5082  
URL: <http://www.gsa.gov>

International City Management Association (ICMA)  
777 N. Capitol St. NE, Ste. 500  
Washington, DC 20002  
(202) 289-4262  
Fax: (202) 962-3500  
URL: <http://www.icma.org>

International Code Council (ICC)  
5203 Leesburg Pike #708  
Falls Church, VA 22041  
(703) 931-4533  
Fax: (703) 379-1546  
URL: <http://www.intlcode.org>

Materials and Methods Standards Association (MMSA)  
c/o Harvey Powell, Noble Co.  
P.O. Box 350  
Grand Haven, MI 49417  
(616) 842-7844  
Fax: (616) 842-1547

National Council of Architectural Registration Boards (NCARB)  
1735 New York Avenue, NW, Ste.700  
Washington, DC 20006-5292  
(202) 783-6500  
Fax: (202) 783-0290  
URL: <http://www.ncarb.org>

Occupational Safety and Health Administration (OSHA)  
US Department of Labor  
200 Constitution Ave. NW  
Washington, DC 20210  
(202) 693-1999  
URL: <http://www.osha.gov>

Southern Building Code Congress International, Inc. (SBCCI)  
900 Montclair Road  
Birmingham, AL 35213-1206  
(205) 591-1853  
Fax: (205) 591-0775  
URL: <http://www.sbcci.org>  
E-mail: [info@sbcci.org](mailto:info@sbcci.org)

## CHAPTER 2 - SITEWORK SUBSURFACE INVESTIGATION

The Association of Engineering Firms Practicing in the Geosciences (ASFE)  
8811 Colesville Rd  
Suite G106  
Silver Spring, MD 20910  
(301) 565-2733  
Fax: (301) 589-2017  
URL: <http://www.asfe.org>  
E-mail: [info@asfe.org](mailto:info@asfe.org)

US National Society for the International Society of Soil Mechanics and Foundation Engineering (USNS/ISSMFE)  
c/o Professor Harvey E. Wahls  
CE Department, Box 7908  
North Carolina State University  
Raleigh, NC 27695  
(919) 737-7244

## EXCAVATION SUPPORT SYSTEMS

Geosynthetic Research Institute (GRI)  
475 Kedron Ave.  
Folsom, PA 19033-1208  
(610) 522-8440  
Fax: (610) 522-8441  
URL: <http://www.drexel.edu/gri>

US National Society for the International Society of Soil Mechanics and Foundation Engineering (USNS/ISSMFE)  
c/o Professor Harvey E. Wahls  
CE Department, Box 7908  
North Carolina State University  
Raleigh, NC 27695  
(919) 737-7244

## PILES AND CAISSONS

The Association of Engineering Firms Practicing in the Geosciences (ASFE)  
8811 Colesville Rd  
Suite G106  
Silver Spring, MD 20910  
(301) 565-2733  
Fax: (301) 589-2017  
URL: <http://www.asfe.org>  
E-mail: [info@asfe.org](mailto:info@asfe.org)

Deep Foundations Institute (DFI)  
120 Charlotte Place, Third Floor  
Englewood Cliffs, NJ 07632  
(201) 567-4232  
Fax: (201) 567-4436  
URL: <http://www.dfi.org>  
E-mail: [dfihq@dt.net](mailto:dfihq@dt.net)

US National Society for the International Society of Soil Mechanics and Foundation Engineering (USNS/ISSMFE)  
c/o Professor Harvey E. Wahls  
CE Department, Box 7908  
North Carolina State University  
Raleigh, NC 27695  
(919) 737-7244

## WATER DISTRIBUTION

Water Systems Council (WSC)  
Building C, Suite 20  
800 Roosevelt Rd.  
Glen Ellyn, IL 60137  
(630) 545-1762  
Fax: (630) 790-3095

## SEWERAGE AND DRAINAGE

Cast Iron Soil Pipe Institute (CIPSI)  
5959 Shallowford Road, Suite 419  
Chattanooga, TN 37421  
(423) 892-0137  
Fax: (423) 892-0817  
URL: <http://www.cispi.org>  
E-mail: [blevan@mindspring.com](mailto:blevan@mindspring.com)

National Clay Pipe Institute (NCPI)  
P.O. Box 759  
Lake Geneva, WI 53147  
(414) 248-9094  
Fax: (414) 248-1564  
URL: <http://www.ncpi.org>

Sump and Sewage Pump Manufacturers Association (SSPMA)  
P.O. Box 647  
Northbrook, IL 60065-0647  
(847) 559-9233  
Fax: (847) 559-9235  
URL: <http://www.sspma.org>

## PAVING AND SURFACING

American Society of Concrete Contractors (ASCC)  
38800 Country Club Drive  
Farmington Hills, MI 48331-3411  
(800) 877-2753  
Fax: (248) 848-3711

Asphalt Institute  
P.O. Box 14052  
Research Park Drive  
Lexington, KY 40512-4052  
(606) 288-4960  
Fax: (606) 288-4999  
URL: <http://www.asphaltinstitute.org>

Concrete Paver Institute/National Concrete Masonry Association (CPI/NCMA)  
2302 Horse Pen Road  
Herndon, VA 22071-3406  
(703) 713-1900  
Fax: (703) 713-1910  
URL: <http://www.ncma.org>  
E-mail: [ncma@ncma.org](mailto:ncma@ncma.org)

Geosynthetic Research Institute (GRI)  
475 Kedron Ave.  
Folsom, PA 19033-1208  
(610) 522-8440  
Fax: (610) 522-8441  
URL: <http://www.drexel.edu/gri>

National Asphalt Pavement Association (NAPA)  
NAPA Building  
5100 Forbes Blvd.  
Lanham, MD 20706-4413  
(301) 731-4748  
Fax: (301) 731-4621  
URL: <http://www.hotmix.org>

## SITE IMPROVEMENTS AND AMENITIES

American Planning Association Planners Advisory Service (PAS)  
122 S. Michigan Ave, Ste. 1600  
Chicago, IL 60637  
(312) 431-9100  
Fax: (312) 431-9985  
URL: <http://www.planning.org>  
E-mail: [pasinfo@planning.org](mailto:pasinfo@planning.org)

American Society of Civil Engineers (ASCE)  
1801 Alexander Graham Bell Drive  
Reston, VA 20191-4400  
(703) 295-6300  
Fax: (703) 295-6222  
URL: <http://www.asce.org>  
E-mail: [memapp@asce.org](mailto:memapp@asce.org)

American Society of Golf Course Architects (ASGCA)  
221 North LaSalle Street, 35th Floor  
Chicago, IL, 60601  
(312) 372-7090  
Fax: (312) 372-6160  
URL: <http://www.golfdesign.org>  
E-mail: [asgcaweb@selz.com](mailto:asgcaweb@selz.com)

American Society of Landscape Architects (ASLA)  
636 Eye Street, NW  
Washington, DC 20001-3736  
(202) 898-2444  
Fax: (202) 898-1185  
URL: <http://www.asla.org>  
E-mail: [scahill@asla.org](mailto:scahill@asla.org)

Associated Landscape Contractors of America  
150 Elden Street, Suite 270  
Herndon, VA 20170  
(703) 736-9666  
Fax: (703) 736-9668  
URL: <http://www.alca.org>

Association of University Architects (AUA)  
Office of Physical Planning  
Princeton University  
Princeton, NJ 08544  
(609) 258-3356

Association of University Related Research Parks (AURRP)  
1730 K. Street NW, Suite 700  
Washington, DC 20006  
(202) 828-4167  
Fax: (202) 223-4745  
URL: <http://www.aurp.org>

Board on Infrastructure and the Constructed Environment (BICE)  
2101 Constitution Ave. NW  
Washington, DC 20418  
(202) 334-2000  
URL: <http://www4.nas.edu/cts/bice.nsf>

Chain Link Fence Manufacturers Institute (CLFMI)  
9891 Broken Land Pkwy, Suite 300  
Columbia, MD 21046  
(301) 596-2584  
Fax: (301) 840-1252  
URL: <http://www.baileadership.com>

Golf Course Builders Association of America (GCBA)  
930 Airport Rd., Suite 204  
Chapel Hill, NC 27514  
(919) 942-8922  
Fax: (919) 942-6955  
URL: <http://www.gcbaa.org>  
E-mail: [staff@gcbaa.org](mailto:staff@gcbaa.org)

Institute of Transportation Engineers (ITE)  
525 School St. SW, Ste. 410  
Washington, DC 20024  
(202) 554-8050  
Fax: (202) 863-5486  
URL: <http://www.ite.org>  
E-mail: [itehq@io.com](mailto:itehq@io.com)

National Park Service  
P.O. Box 37127  
Washington, DC 20013-7127  
URL: <http://www.nps.gov>

Society for College & University Planning (SCUP)  
311 Maynard St.  
Ann Arbor, MI 48104  
(734) 998-7832  
Fax: (734) 998-6532  
URL: <http://www.scup.org>  
E-mail: [scup@scup.edu](mailto:scup@scup.edu)

Turfgrass Producers International (TPI)  
1855-A Hicks Rd.  
Rolling Meadows, IL 60008  
(847) 705-9898  
Fax: (847) 705-8347  
URL: <http://www.turfgrassprod.org>

## RETAINING WALLS

US National Society for the International Society of Soil Mechanics and Foundation Engineering (USNS/ISSMFE)  
c/o Professor Harvey E. Wahls  
CE Department, Box 7908  
North Carolina State University  
Raleigh, NC 27695  
(919) 737-7244

## PLANTING

American Nursery & Landscape Association  
1250 I Street, NW, Suite 500  
Washington, DC 20005  
(202) 789-2900  
Fax: (202) 789-1893  
URL: <http://www.anla.org>

American Society of Landscape Architects  
636 Eye Street, NW  
Washington, DC 20001-3736  
(202) 898-2444  
Fax: (202) 898-1185  
URL: <http://www.asla.org>  
E-mail: [scahill@asla.org](mailto:scahill@asla.org)

Associated Landscape Contractors of America  
150 Elden Street, Suite 270  
Herndon, VA 20170  
(703) 736-9666  
Fax: (703) 736-9668  
URL: <http://www.alca.org>

Association of Official Seed Analysts (AOSA)  
201 N. 8th St., Suite 400  
P.O. Box 81152  
Lincoln, NE 68501-1152  
(402) 476-3852  
Fax: (402) 476-6547  
URL: <http://www.zianet.com/AOSA>

Golf Course Builders Association of America (GCBA)  
930 Airport Rd., Suite 204  
Chapel Hill, NC 27514  
(919) 942-8222  
Fax: (919) 942-6955  
URL: <http://www.gcbaa.org>  
E-mail: [staff@gcbaa.org](mailto:staff@gcbaa.org)

National Arborist Association (NAA)  
Route 101  
P.O. Box 1094  
Amherst, NH 03031-1094  
(603) 673-3311  
Fax: (603) 672-2613  
URL: <http://www.natlarb.com>

National Landscape Association  
1250 Eye Street, NW, Suite 500  
Washington, DC 20005  
(202) 789-2900  
URL: <http://www.anla.org> or  
<http://www.growzone.com>

Turfgrass Producers International (TPI)  
1855-A Hicks Rd.  
Rolling Meadows, IL 60008  
(847) 705-9898  
Fax: (847) 705-8347  
URL: <http://www.turfgrassod.org>

**CHAPTER 3 - CONCRETE  
CONCRETE FORM AND  
ACCESSORIES**

American Cement Alliance (ACA)  
1225 Eye Street, NW, Suite 300  
Washington, DC 20005-3987  
(202) 408-9494  
Fax: (202) 408-0877

Portland Cement Association (PCA)  
5420 Old Orchard Road  
Skokie, IL 60077-1083  
(847) 966-6200  
Fax: (847) 966-9781  
URL: <http://www.portcement.org>

**CONCRETE REINFORCEMENT**

American Concrete Institute (ACI)  
P.O. Box 9094  
Farmington Hills, MI 48333  
(248) 848-3700  
URL: <http://www.aci-int.org>

American Society for Testing and Materials (ASTM)  
100 Barr Harbor Drive  
West Conshohocken, PA 19428-2529  
(610) 832-9585  
Fax: (610) 832-9555  
URL: <http://www.astm.org>  
E-mail: [cifalco@astm.org](mailto:cifalco@astm.org)

American Society of Concrete Contractors (ASCC)  
38800 Country Club Drive  
Farmington Hills, MI 48331-3411  
(800) 877-2753  
Fax: (248) 848-3711

Concrete Reinforcing Steel Institute (CRSI)  
933 N. Plum Grove Road  
Schaumburg, IL 60173-4758  
(847) 517-1200  
Fax: (847) 517-1206  
URL: <http://www.crsi.org>  
E-mail: [mary@crsi.org](mailto:mary@crsi.org)

Wire Reinforcement Institute (WRI)  
301 E. Sandusky Street  
P.O. Box 450  
Findlay, OH 45839  
(419) 425-9473  
Fax: (419) 425-5741  
URL: <http://www.bright.net/~wwri>  
E-mail: [wwri@bright.net](mailto:wwri@bright.net)

Woven Wire Products Association  
2515 North Nordica Ave.  
Chicago, IL 60635  
(312) 637-1359

**CAST-IN-PLACE CONCRETE**

American Concrete Institute (ACI)  
P.O. Box 9094  
Farmington Hills, MI 48333  
(248) 848-3700  
URL: <http://www.aci-int.org>

American Concrete Pipe Association  
222 W. Las Colinas Blvd.  
Suite 641  
Irving, TX 75039-5423  
(972) 506-7683  
Fax: (972) 506-7682  
URL: <http://www.concrete-pipe.org>

Concrete Sawing and Drilling Association (CSDA)  
4900 Blazer Parkway  
Dublin, OH 43017  
(614) 766-3656  
Fax: (614) 766-3605  
URL: <http://www.csda.org>  
E-mail: [cobrien@csda.org](mailto:cobrien@csda.org)

International Association of Concrete Repair Specialists  
P.O. Box 17402, Dulles International Airport  
Washington, DC 20011  
(703) 260-0009  
Fax: (703) 661-8013

National Ready-Mixed Concrete Association (NRMCA)  
900 Spring Street  
Silver Spring, MD 20910  
(301) 587-1400  
Fax: (301) 585-4219  
URL: <http://www.nmca.org>

**PRECAST CONCRETE**

American Association of State Highway and Transportation Officials (AASHTO)  
444 North Capitol St., NW, Suite 249  
Washington, DC 20001  
(202) 624-5800  
Fax: (847) 303-5774  
URL: <http://www.aashto.org>

American Concrete Institute (ACI)  
P.O. Box 9094  
Farmington Hills, MI 48333  
(248) 848-3700  
URL: <http://www.aci-int.org>

Architectural Precast Association (APA)  
P.O. Box 08669  
Fort Meyers, FL 33908-0669  
(941) 454-6989  
Fax: (914) 454-6787  
URL: <http://www.archprecast.org>

Flexicore Systems, Inc.  
7941 New Carlisle Pike  
Huber Heights, OH 45424  
(937) 879-5775  
Fax: (937) 879-0826  
URL: <http://www.dnaco.net/~fsi/>

National Precast Concrete Association (NPCA)  
10333 N. Meridian Street, Suite 272  
Indianapolis, IN 46290  
(317) 571-9500  
Fax: (317) 571-0041  
URL: <http://www.precast.org>  
E-mail: [ncpa@precast.org](mailto:ncpa@precast.org)

Post-Tensioning Institute (PTI)  
1717 West Northern Avenue, Suite 114  
Phoenix, AZ 85021  
(602) 870-7540  
Fax: (602) 870-7541

Precast/Prestressed Concrete Institute (PCI)  
175 West Jackson Blvd., Suite 1859  
Chicago, IL 60604  
(312) 786-0300  
Fax: (312) 786-0353  
URL: <http://www.pci.org>  
E-mail: [info@pci.org](mailto:info@pci.org)

Tilt-Up Concrete Association (TCA)  
107 First St. W.  
P.O. Box 204  
Mount Vernon, IA 52314  
(319) 895-6911  
Fax: (319) 895-8830  
URL: <http://www.tilt-up.org>  
E-mail: [esauter@tilt-up.org](mailto:esauter@tilt-up.org)

**CHAPTER 4 - MASONRY  
MASONRY MORTAR**

American Cement Alliance (ACA)  
1225 Eye Street, NW, Suite 300  
Washington, DC 20005-3987  
(202) 408-9494  
Fax: (202) 408-0877

American Society for Testing and Materials (ASTM)  
100 Barr Harbor Drive  
West Conshohocken, PA 19428-2529  
(610) 832-9585  
Fax: (610) 832-9555  
URL: <http://www.astm.org>  
E-mail: [cifalco@astm.org](mailto:cifalco@astm.org)

International Masonry Institute (IMI)  
823 15th Street, NW, Suite 1001  
Washington, DC 20005  
(800) IMI-0988  
Fax: (202) 783-0433  
URL: <http://www.imiweb.org>  
E-mail: [hbradford@imiweb.org](mailto:hbradford@imiweb.org)

Mason Contractors Association of America  
1910 S. Highland Ave.  
Suite 101  
Lombard, IL 60148  
(630) 705-4200

Masonry Institute of America (MIA)  
2550 Beverly Blvd.  
Los Angeles, CA 90057-1085  
(213) 388-0472  
Fax: (213) 388-6958  
URL: <http://www.masonryinstitute.org>

The Masonry Society (TMS)  
2619 Spruce Street  
Boulder, CO 80302  
(303) 939-9700  
Fax: (303) 444-3239  
URL: <http://www.masonrysociety.org>

National Concrete Masonry Association (NCMA)  
2302 Horse Pen Road  
Herndon, VA 20171-3499  
(703) 713-1900  
Fax: (703) 713-1910  
URL: <http://www.ncma.org>  
E-mail: [ncma@ncma.org](mailto:ncma@ncma.org)

National Lime Association (NLA)  
200 North Glebe Road, Suite 800  
Arlington, VA 22203  
(703) 243-LIME  
Fax: (703) 243-5489  
URL: <http://www.lime.org>

Portland Cement Association (PCA)  
5420 Old Orchard Road  
Skokie, IL 60077-1083  
(847) 966-6200  
Fax: (847) 966-9781  
URL: <http://www.portcement.org>

**MASONRY ACCESSORIES**

American Society for Testing and Materials (ASTM)  
100 Barr Harbor Drive  
West Conshohocken, PA 19428-2529  
(610) 832-9585  
Fax: (610) 832-9555  
URL: <http://www.astm.org>  
E-mail: [cifalco@astm.org](mailto:cifalco@astm.org)

**MASONRY UNITS**

American Society for Testing and Materials (ASTM)  
100 Barr Harbor Drive  
West Conshohocken, PA 19428-2529  
(610) 832-9585  
Fax: (610) 832-9555  
URL: <http://www.astm.org>  
E-mail: [cifalco@astm.org](mailto:cifalco@astm.org)

Brick Association of the Carolinas (BAC)  
8420 University Executive Park Dr.  
Charlotte, NC 28262  
(704) 510-1500  
Fax: (704) 510-0042  
URL: <http://www.gobrick.com>

Brick Institute of America (BIA)  
11490 Commerce Park Drive, Suite 300  
Reston, VA 22091-1525  
(703) 620-0010  
Fax: (703) 620-3928  
URL: <http://www.bia.org>  
E-mail: [brickinfo@bio.org](mailto:brickinfo@bio.org)

International Masonry Institute (IMI)  
823 15th Street, NW, Suite 1001  
Washington, DC 20005  
(800) IMI-0988  
Fax: (202) 783-0433  
URL: <http://www.imiweb.org>  
E-mail: [hbradford@imiweb.org](mailto:hbradford@imiweb.org)

Mason Contractors Association of America  
1910 S. Highland Ave.  
Suite 101  
Lombard, IL 60148  
(630) 705-4200

Masonry Institute of America (MIA)  
2550 Beverly Blvd.  
Los Angeles, CA 90057-1085  
(213) 388-0472  
Fax: (213) 388-6958  
URL: <http://www.masonryinstitute.org>

The Masonry Society (TMS)  
2619 Spruce Street  
Boulder, CO 80302  
(303) 939-9700  
Fax: (303) 444-3239  
URL: <http://www.masonrysociety.org>

National Association of Brick Distributors (NABD)  
Brick Industry Association  
11490 Commerce Park Dr.  
Reston, VA 20191-1525  
(703) 620-0010  
Fax: (703) 620-3928  
URL: <http://www.bia.org/brickvalue/index.htm>  
E-mail: [info@bia.org](mailto:info@bia.org)

National Clay Pipe Institute (NCPI)  
P.O. Box 759  
Lake Geneva, WI 53147  
(414) 248-9094  
Fax: (414) 248-1564  
URL: <http://www.ncpi.org>

National Concrete Masonry Association (NCMA)  
2302 Horse Pen Road  
Herndon, VA 20171-3499  
(703) 713-1900  
Fax: (703) 713-1910  
URL: <http://www.ncma.org>  
E-mail: [ncma@ncma.org](mailto:ncma@ncma.org)

**GLASS UNIT MASONRY**

Mason Contractors Association of America  
1910 S. Highland Ave.  
Suite 101  
Lombard, IL 60148  
(630) 705-4200

**STONE**

Allied Stone Industries (ASI)  
8632 N. Foothills Hwy  
Boulder, CO 80302  
(614) 228-5489

Building Stone Institute (BSI)  
P.O. Box 3507  
Purdys, NY 10578  
(914) 232-5725  
Fax: (914) 232-5259



Cast Stone Institute (CastSI)  
1850 Lee Road, Suite 230  
Winter Park, FL 32789-2106  
(407) 740-7721  
Fax: (407) 740-5321  
URL: <http://www.caststone.org>  
E-mail: [staff@caststone.org](mailto:staff@caststone.org)

Indiana Limestone Institute of America (ILIA)  
400 Stone City Bank Building  
Bedford, IN 47421  
(812) 275-4426  
Fax: (812) 279-8682  
URL: <http://www.iliai.com>  
E-mail: [jim@iliai.com](mailto:jim@iliai.com)

International Masonry Institute (IMI)  
823 15th Street, NW, Suite 1001  
Washington, DC 20005  
(800) IMI-0988  
Fax: (202) 783-0433  
URL: <http://www.imiweb.org>  
E-mail: [hbradford@imiweb.org](mailto:hbradford@imiweb.org)

Italian Marble Center (IMC)  
Italian Trade Commission  
499 Park Avenue  
New York, NY 10022  
(212) 980-1500 or (213) 879-0950

Marble Institute of America  
30 Eden Alley Suite 301  
Columbus, OH 43215  
(614) 228-6194  
Fax: (614) 461-1497  
URL: <http://www.marble-institute.com>  
E-mail: [miaadmin@marble-institute.com](mailto:miaadmin@marble-institute.com)

Mason Contractors Association of America  
1910 S. Highland Ave.  
Suite 101  
Lombard, IL 60148  
(630) 705-4200

Masonry Institute of America (MIA)  
2550 Beverly Blvd.  
Los Angeles, CA 90057-1085  
(213) 388-0472  
Fax: (213) 388-6958  
URL: <http://www.masonryinstitute.org>

National Building Granite Quarries  
Association, Inc. (NBGQA)  
1220 L. St., NW, Suite 100-167  
Washington, DC 20005  
(800) 557-2848  
URL: <http://www.nbgqa.com>

National Stone Association (NSA)  
1415 Elliot Place, NW  
Washington, DC 20007  
(202) 342-1100  
Fax: (202) 342-0702  
URL: <http://www.aggregates.org>  
E-mail: [ksolomon@aggregates.org](mailto:ksolomon@aggregates.org)

## CHAPTER 5 - METALS

### METAL MATERIALS

Aluminum Association Inc.  
900 19th Street, NW, Suite 300  
Washington, DC 20006-2168  
(202) 862-5100  
Fax: (202) 862-5164  
URL: <http://www.aluminum.org>

Aluminum Extruders Council (AEC)  
1000 North Rand Road, Suite 214  
Wauconda, IL 60084  
(847) 526-2010  
Fax: (847) 526-3993  
URL: <http://www.aec.org>

American Bearing Manufacturers  
Association (ABMA)  
(Formerly Anti-Friction Bearing  
Manufacturers Association)  
1200 19th St., NW, Suite 300  
Washington, DC 20036-2422  
(202) 429-5155  
Fax: (202) 828-6042  
URL: <http://www.abma-dc.org>

American Galvanizers Association  
12200 East Iliff Avenue, Suite 204  
Aurora, CO 80014  
(800) 468-7732  
Fax: (303) 750-2909  
URL: <http://www.usalink.net/aga> and  
<http://www.galvanizeit.org>  
E-mail: [aga@netway.net](mailto:aga@netway.net)

American Institute of Steel Construction,  
Inc. (AISC)  
1 East Wacker Drive, Suite 3100  
Chicago, IL 60601-2001  
(312) 670-2400  
Fax: (312) 670-5403  
URL: <http://www.aiscweb.com>  
E-mail: [cattan@aiscmail.com](mailto:cattan@aiscmail.com)

American Iron & Steel Institute  
1101 17th Street, NW, Suite 1300  
Washington, DC 20036  
(202) 452-7100  
Fax: (202) 463-6573  
URL: <http://www.steel.org>

Cold Finished Steel Bar Institute (CFSBI)  
700 14th Street, NW,  
Suite 900  
Washington, DC 20005  
(202) 508-1030  
Fax: (202) 508-1010  
URL: <http://www.cfsbi.com>

Copper Development Association (CDA)  
260 Madison Avenue  
New York, NY 10016-2401  
(212) 251-7200  
Fax: (212) 251-7234  
URL: <http://www.copper.org>  
E-mail: [The-Copper-Page@cda.copper.org](mailto:The-Copper-Page@cda.copper.org)

Ductile Iron Pipe Research Association  
(DIPRA)  
245 Riverchase Pkwy East, Suite O  
Birmingham, AL 35244  
(205) 402-8700  
Fax: (205) 402-8730  
URL: <http://www.dipra.org>

Iron and Steel Society  
186 Thorn Hill Rd.  
Warrendale, PA 15086-0430  
(724) 776-1535 ext. 1  
Fax: (724) 776-0430  
URL: <http://www.issource.org>

The Materials Properties Council  
345 East 47th Street, 14th Floor  
New York, NY 10017  
(212) 705-7693  
Fax: (212) 752-4929  
URL: <http://www.forengineers.org/mpc>

Metal Treating Institute  
1550 Roberts Drive  
Jacksonville Beach, FL 32250  
(904) 249-0448  
Fax: (904) 249-0459  
URL: <http://www.metaltreat.com>

NACE International (NACE)  
1440 South Creek Dr.  
Houston, TX 77084-4906  
(281) 228-6200  
Fax: (281) 228-6300  
URL: <http://www.nace.org>

National Association of Architectural Metal  
Manufacturers (NAAMM)  
8 South Michigan Avenue, Suite 1000  
Chicago, IL 60603  
(312) 332-0405  
Fax: (312) 332-0706  
URL: <http://www.naamm.org>  
E-mail: [naamm@naamm.org](mailto:naamm@naamm.org)

National Coil Coaters Association (NCCA)  
401 N. Michigan Ave.  
Chicago, IL 60611  
(312) 321-6894  
Fax: (312) 527-6640  
URL: <http://www.coilcoaters.org>

National Corrugated Steel Pipe Association  
(NCSPA)  
1255 23rd St., NW, Suite 850  
Washington, DC 20037  
(202) 452-1700  
Fax: (202) 833-3636  
URL: <http://www.ncspa.org>

Nickel Development Institute (NDI)  
214 King Street West, Suite 510  
Toronto, ON  
Canada M5H 2S6  
(416) 591-7999  
URL: <http://www.nidi.org>

Society for Protective Coatings  
40 24th Street, 6th Floor  
Pittsburgh, PA 15222-4656  
(412) 281-2331  
Fax: (412) 281-9992  
URL: <http://www.sspc.org>  
E-mail: [lipoaky@sspc.org](mailto:lipoaky@sspc.org)

Steel Tank Institute (STI)  
570 Oakwood Rd.  
Lake Zurich, IL 60047  
(847) 438-8265  
Fax: (847) 438-8766  
URL: <http://www.steel-tank.com>

### METAL FASTENINGS

American Welding Society  
550 NW LeJeune Road  
Miami, FL 33126  
(305) 443-9353  
Fax: (305) 443-7559  
URL: <http://www.amweld.org>

Compressed Air and Gas Institute (CAGI)  
c/o Thomas Associates, Inc.  
1300 Sumner Ave.  
Cleveland, OH 44115-2851  
(216) 241-7333  
Fax: (216) 241-0105  
URL: <http://www.cagi.org>

Concrete Reinforcement  
American Welding Society, Inc. (AWS)  
550 NW LeJeune Road  
Miami, FL 33126  
(305) 443-9353  
Fax: (305) 443-7559  
URL: <http://www.aws.org>

Light Gage Structural Institute (LGSi)  
P.O. Box 560746  
The Colony, TX 75056  
(972) 625-4560  
Fax: (972) 370-0968  
URL: <http://www.loseke.com>

Powder Actuated Tool Manufacturers'  
Institute (PATMI)  
1603 Boonslick Rd.  
St. Charles, MO 63301-2244  
(314) 947-6610  
Fax: (314) 946-3336  
URL: <http://www.tek-efx.com/patmi/>

Research Council on Structural Connections  
(RCSC)  
Sargent & Lundy  
55 E. Monroe St.  
Chicago, IL 60603  
(312) 269-2000  
URL: <http://www.boltcouncil.org>

Truss Plate Institute (TPI)  
583 D'Onofrio Dr., Suite 200  
Madison, WI 53719  
(608) 833-5900  
Fax: (608) 833-4360

Welding Research Council  
345 E. 47th Street, Rm. 1301  
New York, NY 10017  
(212) 705-7956  
Fax: (212) 371-9622  
URL: <http://www.forengineers.org/wrc/>

### METAL JOISTS

Steel Joist Institute (SJI)  
3127 10th Ave., North Ext.  
Myrtle Beach, SC 29577-6760  
(843) 626-1995  
Fax: (843) 626-5565  
URL: <http://www.steeljoist.org>

### METAL DECK

National Roof Deck Contractors Association  
(NRDCA)  
600 South Federal Street, Suite 400  
Chicago, IL 60605  
(312) 922-6222  
Fax: (312) 922-2734  
URL: <http://www.nrdca.org>

Steel Deck Institute  
Post Office Box 25  
Fox River Grove, IL 60021-0025  
(847) 462-1930  
Fax: (847) 462-1940  
URL: <http://www.sdi.org>  
E-mail: [Steve@sdi.org](mailto:Steve@sdi.org)

### COLD-FORMED METAL FRAMING

Iron and Steel Society  
186 Thorn Hill Rd.  
Warrendale, PA 15086-0430  
(724) 776-1535 ext. 1  
Fax: (724) 776-0430  
URL: <http://www.issource.org>

Light Gage Structural Institute (LGSi)  
P.O. Box 560746  
The Colony, TX 75056  
(972) 625-4560  
Fax: (972) 370-0968  
URL: <http://www.loseke.com>

Metal Building Manufacturers Association  
(MBMA)  
1300 Sumner Avenue  
Cleveland, OH 44115-2851  
(216) 241-7333  
Fax: (216) 241-0105  
URL: <http://www.mbma.com>  
E-mail: [administrator@mbma.com](mailto:administrator@mbma.com)

Metal Framing Manufacturers Association  
(MFMA)  
401 N. Michigan Ave.  
Chicago, IL 60611  
(312) 644-6610  
Fax: (312) 245-1081

Metal Lath/Steel Framing Association  
Division of NAAMM (ML/SFA)  
8 South Michigan Avenue, Suite 1000  
Chicago, IL 60603  
(312) 332-0405  
Fax: (312) 332-0706  
URL: <http://www.naamm.org/mlsfa.htm>

### METAL FABRICATIONS

American Iron & Steel Institute  
1101 17th Street, NW, Suite 1300  
Washington, DC 20036  
(202) 452-7100  
Fax: (202) 463-6573  
URL: <http://www.steel.org>

Industrial Perforators Association  
710 North Plankinton Avenue  
Milwaukee, WI 53203  
(414) 271-2263  
Fax: (414) 271-5154  
URL: <http://www.iperf.org>  
E-mail: [iperf@iperf.org](mailto:iperf@iperf.org)

Iron and Steel Society  
186 Thorn Hill Rd.  
Warrendale, PA 15086-0430  
(724) 776-1535 ext. 1  
Fax: (724) 776-0430  
URL: <http://www.issource.org>

Lead Industries Association (LIA)  
13 Main Street  
Spark, NY 07871  
(973) 726-5323  
Fax: (973) 726-4484  
URL: <http://www.leadinfo.com>  
E-mail: [miller@leadinfo.com](mailto:miller@leadinfo.com)

National Ornamental and Miscellaneous  
Metals Association (NOMMA)  
804 Main Street, Suite F  
Forest Park, GA 30297  
(404) 363-4009  
Fax: (404) 366-1852  
URL: <http://www.nomma.org/nomma>

Ornamental and Miscellaneous Metal  
Fabricator  
National Ornamental and Miscellaneous  
Metals Association  
532 Forest Pkwy  
Suite A  
Forest Park, GA 30297  
(404) 363-4009

Specialty Steel Industry of North America  
(SSINA)  
c/o Collier, Shannon Rill & Scott  
3050 K St., NW, Suite 400  
Washington, DC 20007  
(202) 342-8630  
Fax: (202) 342-8451  
URL: <http://www.ssina.com>

**ORNAMENTAL METAL**

**American Iron & Steel Institute**  
1101 17th Street, NW, Suite 1300  
Washington, DC 20036  
(202) 452-7100  
Fax: (202) 463-6573  
URL: <http://www.steel.org>

**Brass and Bronze Ingot Manufacturers**  
300 W. Washington, Rm 1500  
Chicago, IL 60606  
(312) 236-2715

**Iron and Steel Society**  
186 Thorn Hill Rd.  
Warrendale, PA 15086-0430  
(724) 776-1535 ext. 1  
Fax: (724) 776-0430  
URL: <http://www.issource.org>

**National Institute of Steel Detailing**  
PO Box 121484  
Arlington, TX 76012  
(817) 860-9890  
URL: <http://www.nisd.org>

**National Ornamental and Miscellaneous Metals Association (NOMMA)**  
804 Main Street, Suite F  
Forest Park, GA 30297  
(404) 363-4009  
Fax: (404) 366-1852  
URL: <http://www.nomma.org/nomma>

**Ornamental and Miscellaneous Metal Fabricator**  
National Ornamental and Miscellaneous Metals Association  
532 Forest Pkwy  
Suite A  
Forest Park, GA 30297  
(404) 363-4009

**CHAPTER 6 - WOOD AND PLASTICS**

**INTRODUCTION**

**American Forest and Paper Association**  
(formerly National Forest Products Association)  
1111 19th Street, NW, Suite 800  
Washington, DC 20036  
(202) 463-2700  
Fax: (202) 463-2785  
URL: <http://www.afandpa.org>  
E-mail: [info@afandpa.org](mailto:info@afandpa.org)

**American Wood Council National Forest Products Association (AWC/NFPA)**  
1111 Nineteenth Street, NW, Suite 800  
Washington, DC 20036  
(202) 463-2766  
Fax: (202) 463-2791  
URL: <http://www.afandpa.org/WoodDesign/index.html>  
E-mail: [AWCINFO@afandpa.org](mailto:AWCINFO@afandpa.org)

**California Redwood Association (CRA)**  
405 Enfrente Drive  
Suite 200  
Novato, CA 94949  
(415) 382-0662  
Fax: (415) 382-8531  
URL: <http://www.calredwood.org>  
E-mail: [cfrgrover@worldnet.att.net](mailto:cfrgrover@worldnet.att.net)

**Canadian Wood Council (CWC)**  
P.O. Box 88828  
Seattle, WA 98138  
(613) 731-7800  
Fax: (206) 731-7899  
URL: <http://www.cwc.ca>  
E-mail: [pmaxikins@cwc.ca](mailto:pmaxikins@cwc.ca)

**Forest Products Research Society**  
2801 Marshall Court  
Madison, WI 53705-2295  
(608) 231-1361  
Fax: (608) 231-2152  
URL: <http://www.forestprod.org>  
E-mail: [info@forestprod.org](mailto:info@forestprod.org)

**National Association of Home Builders**  
National Housing Library  
1201 15th St. NW  
Washington, DC 20005  
(800) 368-5242

**National Lumber Grades Authority (NLGA)**  
#406-First Capital Pl.  
960 Quayside Dr.  
New Westminster, BC V3M 6G2  
CANADA  
(604) 524-2393  
Fax: (604) 524-2893  
E-mail: [nlga@axionet.com](mailto:nlga@axionet.com)

**Northeastern Lumber Manufacturers Association, Inc. (NLMA)**  
272 Tuttle Road, P.O. Box 87A  
Cumberland Center, ME 04021  
(207) 829-6901  
Fax: (207) 829-4293  
URL: <http://www.neilma.org>

**Small Homes Council/Building Research Council (SHC)**  
University of Illinois, Urbana Champaign  
One E. St. Mary's Road  
Champaign, IL 61820  
(217) 333-1801  
Fax: (800) 336-0616  
URL: <http://www.arch.uiuc.edu/brc>

**Southern Cypress Manufacturers Association**  
400 Penn Center Blvd., Suite 530  
Pittsburgh, PA 15235-5605  
(412) 829-0770  
Fax: (412) 829-0844

**Southern Pine Inspection Bureau (SPIB)**  
4709 Scenic Hwy  
Pensacola, FL 32504-9094  
(850) 434-2611  
Fax: (850) 433-5594  
URL: <http://www.spib.org>

**West Coast Lumber Inspection Bureau (WCLIB)**  
P.O. Box 23145  
Portland, OR 97281-3145  
(503) 639-0651  
Fax: (503) 684-8928  
URL: <http://www.wclib.org>

**World Forest Institute (WFI)**  
4033 SW Canyon Road  
Portland, OR 97221  
(503) 228-0819  
Fax: (503) 228-3624

**DESIGN LOAD TABLES**

**National Lumber Grades Authority (NLGA)**  
#406-First Capital Pl.  
960 Quayside Dr.  
New Westminster, BC V3M 6G2  
CANADA  
(604) 524-2393  
Fax: (604) 524-2893  
E-mail: [nlga@axionet.com](mailto:nlga@axionet.com)

**WOOD TREATMENT**

**American Wood Preservers Institute**  
2750 Prosperity Ave., Suite 550  
Fairfax, VA 22031-4312  
(703) 204-0500  
Fax: (703) 204-4610  
URL: <http://www.awpi.org>

**American Wood-Preservers Association**  
3246 Fall Creek Highway, Suite 190  
Granbury, TX 76049-7979  
(817) 326-6300  
Fax: (817) 326-6306  
URL: <http://www.awpa.com>  
E-mail: [awpa@itexas.net](mailto:awpa@itexas.net)

**Wood Protection Council**  
National Institute of Building Sciences  
1090 Vermont Avenue, NW, Suite 700  
Washington, DC 20005  
(202) 289-7800  
Fax: (202) 289-1092  
URL: <http://www.nibs.org>

**WOOD AND PLASTIC FASTENINGS**

**Adhesive and Sealant Council (ASC)**  
7979 Old Georgetown Road, Suite 500  
Bethesda, MD 20814  
(301) 986-9700  
Fax: (301) 986-9795  
URL: <http://www.ascouncil.org>  
E-mail: [webmaster@ascouncil.org](mailto:webmaster@ascouncil.org)

**Adhesives Manufacturers Association**  
401 North Michigan Avenue, Suite 2400  
Chicago, IL 60611  
(312) 644-6610  
Fax: (312) 527-6783  
URL: <http://www.adhesives.org/ama>

**Plastics Institute of America (PIA)**  
333 Aiken Street  
Lowell, MA 01854-3686  
(508) 934-3130  
Fax: (508) 459-9420  
URL: <http://www.eng.uml.edu/dept/PIA/>  
E-mail: [pia@cae.uml.edu](mailto:pia@cae.uml.edu)

**Powder Actuated Tool Manufacturers' Institute (PATMI)**  
1603 Boonslick Rd.  
St. Charles, MO 63301-2244  
(314) 947-6610  
Fax: (314) 946-3336  
URL: <http://www.tek-efx.com/patmi/>

**Society of the Plastics Industry, Inc. (SPI)**  
1801 K Street, NW, #600K  
Washington DC, 20006-1301  
(202) 974-5200  
Fax: (202) 296-7005  
URL: <http://www.socplas.org>  
E-mail: [feedback@socplas.org](mailto:feedback@socplas.org)

**Truss Plate Institute (TPI)**  
583 D'Onofrio Dr., Suite 200  
Madison, WI 53719  
(608) 833-5900  
Fax: (608) 833-4360

**ROUGH CARPENTRY**

**American Plywood Association (APA)**  
7011 S. 19th St.  
Tacoma, WA 98466  
(253) 565-6600  
Fax: (253) 565-7400  
URL: <http://www.apawood.org>

**American Wood Council National Forest Products Association (AWC/NFPA)**  
1111 Nineteenth Street, NW, Suite 800  
Washington, DC 20036  
(202) 463-2766  
Fax: (202) 463-2791  
URL: <http://www.afandpa.org/WoodDesign/index.html>  
E-mail: [AWCINFO@afandpa.org](mailto:AWCINFO@afandpa.org)

**Canadian Wood Council (CWC)**  
P.O. Box 88828  
Seattle, WA 98138  
(613) 731-7800  
Fax: (206) 731-7899  
URL: <http://www.cwc.ca>  
E-mail: [pmaxikins@cwc.ca](mailto:pmaxikins@cwc.ca)

**Forest Products Research Society**  
2801 Marshall Court  
Madison, WI 53705-2295  
(608) 231-1361  
Fax: (608) 231-2152  
URL: <http://www.forestprod.org>  
E-mail: [info@forestprod.org](mailto:info@forestprod.org)

**Manufactured Housing Institute**  
2101 Wilson Blvd.  
Suite 610  
Arlington, VA 22201-3062  
(703) 558-0400  
Fax: (703) 558-0401  
URL: <http://www.mfghome.org>  
E-mail: [kami@mfghome.org](mailto:kami@mfghome.org)

**National Association of Home Builders (NAHB)**  
Home Builder Press/NAHB Bookstore  
1201 15th Street, NW  
Washington, DC 20005  
(800) 368-5242 or (202) 822-0200  
Fax: (202) 822-0559  
URL: <http://www.nahb.org>  
E-mail: [info@nahb.com](mailto:info@nahb.com)

**Southern Forest Products Association**  
P.O. Box 641700  
Kenner, LA 70064-1700  
(504) 443-4464  
Fax: (504) 443-6612  
URL: <http://www.sfpa.org>  
E-mail: [info@sfpa.org](mailto:info@sfpa.org)

**Western Red Cedar Lumber Association**  
1200 - 555 Burrard Street  
Vancouver, BC V7X 1S7  
(604) 684-0266  
Fax: (604) 687-4930  
URL: <http://www.wrcla.org>  
E-mail: [wrcla@cofiho.cofi.org](mailto:wrcla@cofiho.cofi.org)

**Western Wood Products Association (WWPA)**  
522 SW 5th Avenue, Suite 500  
Portland, OR 97204  
(503) 224-3930  
Fax: (503) 224-3934  
URL: <http://www.wvpa.org>  
E-mail: [info@wwpa.org](mailto:info@wwpa.org)

**STRUCTURAL PANELS**

**American Plywood Association (APA)**  
7011 S. 19th St.  
Tacoma, WA 98466  
(253) 565-6600  
Fax: (253) 565-7400  
URL: <http://www.apawood.org>

**Composite Particle Association**  
18928 Premier Court  
Gaithersburg, MD 20879-1569  
(301) 670-0604  
Fax: (301) 840-1252  
URL: <http://www.pbmdf.com>  
E-mail: [info@pbmdf.com](mailto:info@pbmdf.com)

**Forest Products Research Society**  
2801 Marshall Court  
Madison, WI 53705-2295  
(608) 231-1361  
Fax: (608) 231-2152  
URL: <http://www.forestprod.org>  
E-mail: [info@forestprod.org](mailto:info@forestprod.org)

**HEAVY TIMBER CONSTRUCTION**

**American Institute of Timber Construction (AITC)**  
7012 South Revere Parkway, Suite 140  
Englewood, CO 80112  
(303) 792-9559  
Fax: (303) 792-0669  
URL: <http://www.aitc-glulam.org>  
E-mail: [info@aitc-glulam.org](mailto:info@aitc-glulam.org)

**Southern Forest Products Association**  
P.O. Box 641700  
Kenner, LA 70064-1700  
(504) 443-4464  
Fax: (504) 443-6612  
URL: <http://www.sfpa.org>  
E-mail: [info@sfpa.org](mailto:info@sfpa.org)

**Western Wood Products Association (WWPA)**  
522 SW 5th Avenue, Suite 500  
Portland, OR 97204  
(503) 224-3930  
Fax: (503) 224-3934  
URL: <http://www.wvpa.org>  
E-mail: [info@wwpa.org](mailto:info@wwpa.org)

**WOOD DECKING**

**American Institute of Timber Construction (AITC)**  
7012 South Revere Parkway, Suite 140  
Englewood, CO 80112  
(303) 792-9559  
Fax: (303) 792-0669  
URL: <http://www.aitc-glulam.org>  
E-mail: [info@aitc-glulam.org](mailto:info@aitc-glulam.org)

**National Roof Deck Contractors Association (NRDCA)**  
600 South Federal Street, Suite 400  
Chicago, IL 60605  
(312) 922-6222  
Fax: (312) 922-2734  
URL: <http://www.nrdca.org>

**WOOD TRUSSES**

**American Plywood Association (APA)**  
7011 S. 19th St.  
Tacoma, WA 98466  
(253) 565-6600  
Fax: (253) 565-7400  
URL: <http://www.apawood.org>

**Forest Products Research Society**  
2801 Marshall Court  
Madison, WI 53705-2295  
(608) 231-1361  
Fax: (608) 231-2152  
URL: <http://www.forestprod.org>  
E-mail: [info@forestprod.org](mailto:info@forestprod.org)

Truss Plate Institute (TPI)  
583 D. Onofre Dr., Gate 210  
Madison, WI 53719  
(608) 833-5900  
Fax: (608) 833-4340

Wood Truss Council of America  
One WITCA Center  
64 Normandy Lane  
Madison, WI 53719 1139  
(608) 274-4849  
Fax: (608) 274-3379  
URL: <http://www.woodtruss.com>

#### GLUED-LAMINATED CONSTRUCTION

American Institute of Timber Construction (AITC)  
7012 South Revere Parkway, Suite 100  
Englewood, CO 80112  
(303) 792-9559  
Fax: (303) 792-0649  
URL: <http://www.aitecglulam.org>  
E-mail: [info@aitcglulam.org](mailto:info@aitcglulam.org)

Forest Products Research Society  
2801 Marshall Court  
Madison, WI 53705-2795  
(608) 231-1361  
Fax: (608) 231-2152  
URL: <http://www.forestprod.org>  
E-mail: [info@forestprod.org](mailto:info@forestprod.org)

Southern Forest Products Association  
P.O. Box 641700  
Kenner, LA 70064-1700  
(504) 443-4464  
Fax: (504) 443-6612  
URL: <http://www.sfpa.org>  
E-mail: [info@SFPA.org](mailto:info@SFPA.org)

Western Wood Products Association (WWPA)  
522 SW 5th Avenue, Suite 500  
Portland, OR 97204  
(503) 224-3930  
Fax: (503) 224-3934  
URL: <http://www.wwpa.org>  
E-mail: [info@wwpa.org](mailto:info@wwpa.org)

#### FINISH CARPENTRY

American Hardboard Association  
1210 W. Northwest Highway  
Palatine, IL 60067  
(847) 934-8800  
Fax: (847) 934-8803  
E-mail: [aha@ahardbd.org](mailto:aha@ahardbd.org)

American Society for Testing and Materials (ASTM)  
100 Barr Harbor Drive  
West Conshohocken, PA 19380-2929  
(610) 832-9585  
Fax: (610) 832-9555  
URL: <http://www.astm.org>  
E-mail: [cfalco@astm.org](mailto:cfalco@astm.org)

American Wood Council National Forest Products Association (AWC/NFPA)  
1111 Nineteenth Street, NW, Suite 200  
Washington, DC 20036  
(202) 463-2766  
Fax: (202) 463-2791  
URL: <http://www.afandpa.org/WoodDesign/index.html>  
E-mail: [AWCINFO@afandpa.org](mailto:AWCINFO@afandpa.org)

Architectural Woodwork Institute  
1952 Isaac Newton Sq. West  
W. Reston, VA 20190  
(703) 733-0600  
Fax: (703) 733-0584  
URL: <http://www.awinet.org>

California Redwood Association (CRA)  
405 Enfronte Drive  
Suite 200  
Novato, CA 94949  
(415) 382-0662  
Fax: (415) 382-8531  
URL: <http://www.calredwood.org>  
E-mail: [cfgrover@worldnet.att.net](mailto:cfgrover@worldnet.att.net)

Canadian Wood Council (CWC)  
P.O. Box 88828  
Seattle, WA 98138  
(613) 731-7800  
Fax: (206) 731-7899  
URL: <http://www.cwc.ca>  
E-mail: [pmaxikins@cwc.ca](mailto:pmaxikins@cwc.ca)

Composite Panel Association  
1952 Isaac Newton Sq. West  
W. Reston, VA 20190  
(703) 733-0600  
Fax: (703) 733-0584  
URL: <http://www.companel.com>

Composite Panel Association  
18328 Premier Court  
Gaithersburg, MD 20879-1569  
(301) 670-0600  
Fax: (301) 646-1267  
URL: <http://www.companel.com>  
E-mail: [info@companel.com](mailto:info@companel.com)

Hardwood Plywood and Veneer Association  
P.O. Box 2789  
Reston, VA 22195-0789  
(703) 435-2900  
Fax: (703) 435-2527  
URL: <http://www.hpva.org>  
E-mail: [hpva@hpva.org](mailto:hpva@hpva.org)

Laminating Materials Association (LMA)  
116 Lawrence St.  
Hillsdale, NJ 07642-2730  
(201) 664-2700  
Fax: (201) 665-5655  
URL: <http://www.lma.org>

Manufactured Housing Institute  
2101 Wilson Blvd.  
Suite 610  
Arlington, VA 22201-3062  
(703) 558-0400  
Fax: (703) 558-0401  
URL: <http://www.mfghome.org>  
E-mail: [kam@mfghome.org](mailto:kam@mfghome.org)

National Association of Home Builders (NAHB)  
Home Builders Press/NAHB Bookstore  
1201 15th Street, NW  
Washington, DC 20005  
(800) 368-5249 or (202) 822-0200  
Fax: (202) 822-0559  
URL: <http://www.nahb.org>  
E-mail: [info@nahb.com](mailto:info@nahb.com)

National Hardwood Lumber Association (NHLA)  
P.O. Box 34518  
Memphis, TN 38184-0518  
(901) 377-1818  
Fax: (901) 382-6419  
URL: <http://www.nathardwood.org>

Southern Cypress Manufacturers Association  
400 Penn Center Blvd., Suite 530  
Pittsburgh, PA 15235-5605  
(412) 829-0770  
Fax: (412) 828-0844

Southern Forest Products Association  
P.O. Box 641700  
Kenner, LA 70064-1700  
(504) 443-4464  
Fax: (504) 443-6612  
URL: <http://www.sfpa.org>  
E-mail: [info@SFPA.org](mailto:info@SFPA.org)

Wood Siding Institute (SI)  
355 Lexington Avenue, 11th Floor  
New York, NY 10017  
(212) 351-5400  
Fax: (212) 697-0156

Western Red Cedar Lumber Association  
1700 - 555 Burdard Street  
Vancouver, BC V7X 1S7  
(604) 684-0260  
Fax: (604) 687-4930  
URL: <http://www.wrccla.org>  
E-mail: [wrccla@cofiho.cofi.org](mailto:wrccla@cofiho.cofi.org)

Western Wood Products Association (WWPA)  
522 SW 5th Avenue, Suite 500  
Portland, OR 97204  
(503) 224-3930  
Fax: (503) 224-3934  
URL: <http://www.wwpa.org>  
E-mail: [info@wwpa.org](mailto:info@wwpa.org)

#### ARCHITECTURAL WOODWORK

American Wood Council National Forest Products Association (AWC/NFPA)  
1111 Nineteenth Street, NW, Suite 200  
Washington, DC 20036  
(202) 463-2766  
Fax: (202) 463-2791  
URL: <http://www.afandpa.org/WoodDesign/index.html>  
E-mail: [AWCINFO@afandpa.org](mailto:AWCINFO@afandpa.org)

Architectural Woodwork Institute  
1952 Isaac Newton Sq. West  
W. Reston, VA 20190  
(703) 733-0600  
Fax: (703) 733-0584  
URL: <http://www.awinet.org>

Architectural Woodwork Institute Library  
P.O. Box 1550  
Centerville, VA 22920  
(703) 222-1160

Hardwood Plywood and Veneer Association  
P.O. Box 2789  
Reston, VA 22195-0789  
(703) 435-2900  
Fax: (703) 435-2527  
URL: <http://www.hpva.org>  
E-mail: [hpva@hpva.org](mailto:hpva@hpva.org)

Kitchen Cabinet Manufacturers Association (KCMCA)  
1899 Preston White Drive  
Reston, VA 20191-5435  
(703) 264-1690  
Fax: (703) 620-6530  
URL: <http://www.kcmca.org>  
E-mail: [comments@kcmca.org](mailto:comments@kcmca.org)

National Hardwood Lumber Association (NHLA)  
P.O. Box 34518  
Memphis, TN 38184-0518  
(901) 377-1818  
Fax: (901) 382-6419  
URL: <http://www.nathardwood.org>

Wood Moulding & Millwork Producers Association (WMMMPA)  
507 First St.  
Woodland, CA 95695  
(530) 661-9591  
Fax: (530) 661-9586  
URL: <http://www.wmmmpa.com>

Woodwork Institute of California (WIC)  
P.O. Box 980247  
West Sacramento, CA 95798-0247  
(916) 372-9943  
Fax: (916) 372-9950  
URL: <http://www.wicnet.org>

#### CHAPTER 7 - THERMAL AND MOISTURE PROTECTION

##### WATERPROOFING AND DAMPPROOFING

American Society for Testing and Materials (ASTM)  
100 Barr Harbor Drive  
West Conshohocken, PA 19380-2929  
(610) 832-9585  
Fax: (610) 832-9555  
URL: <http://www.astm.org>  
E-mail: [cfalco@astm.org](mailto:cfalco@astm.org)

Asphalt Roofing Manufacturers Association (ARMA)  
4041 Powder Mill Road  
Suite 404  
Calverton, MD 20705-3106  
(301) 348-2002  
Fax: (301) 348-2020  
URL: <http://www.asphaltroofing.org>

Sealant, Waterproofing, and Restoration Institute  
2841 Main  
Kansas City, MO 64108  
(816) 472-7374  
Fax: (816) 472-7765  
URL: <http://www.swrionline.org>  
E-mail: [info@swrionline.org](mailto:info@swrionline.org)

#### THERMAL PROTECTION

Cellulose Insulation Manufacturers Association  
c/o Dan Lee  
136 South Keokuk Street  
Dayton, OH 45401  
(937) 272-2462  
Fax: (937) 272-5763  
URL: <http://www.cellulose.org>  
E-mail: [cima@dayton.net](mailto:cima@dayton.net)

Center for Insulation Technology  
Drexel University  
Mechanical Engineering and Materials Dept.  
Philadelphia, PA 19104  
(215) 895-1633  
Fax: (215) 895-1475

Expansion Joint Manufacturers Association (EJMA)  
25 N. Broadway  
Tarrytown, NY 10591-5201  
(914) 332-0040  
Fax: (914) 332-1517  
URL: <http://www.ejma.org>

National Insulation and Environment Contractors Association  
99 Canal Center Plaza, Suite 222  
Alexandria, VA 22314  
(703) 683-6472  
Fax: (703) 549-4635  
URL: <http://www.insulation.org>

National Roof Deck Contractors Association (NRDCA)  
600 South Federal Street, Suite 400  
Chicago, IL 60605  
(312) 922-6222  
Fax: (312) 922-2734  
URL: <http://www.nrdca.org>

North American Insulation Manufacturers Association  
44 Canal Center Plaza, Suite 310  
Alexandria, VA 22314  
(703) 684-0084  
Fax: (703) 684-0427  
URL: <http://www.naima.org>  
E-mail: [insulation@naima.org](mailto:insulation@naima.org)

Perlite Institute (PI)  
88 New Dorp Plaza  
Staten Island, NY 10306-2994  
(718) 351-5723  
Fax: (718) 351-5725  
URL: <http://www.perlite.org>  
E-mail: [inquiries@perlite.org](mailto:inquiries@perlite.org)

Polyisocyanurate Insulation Manufacturers Association (PIMA)  
1001 Pennsylvania Ave. NW, 5th Floor  
Washington, DC 20004  
(202) 624-2709  
Fax: (202) 628-3658  
URL: <http://www.pima.org>  
E-mail: [pima@pima.org](mailto:pima@pima.org)

Society of the Plastics Industry, Inc. (SPI)  
1801 K Street, NW, #600K  
Washington, DC 20006-1301  
(202) 374-5200  
Fax: (202) 296-7005  
URL: <http://www.socplas.org>  
E-mail: [feedback@socplas.org](mailto:feedback@socplas.org)

Vermiculite Association (VA)  
6476 Fiesta Drive  
Columbus, OH 43235  
(614) 760-5430  
Fax: (614) 760-5431  
URL: <http://www.vermiculite.org>  
E-mail: [va@vermiculite.org](mailto:va@vermiculite.org)

#### EXTERIOR INSULATION AND FINISH SYSTEMS

EIFS Industry Members Association  
3000 Corporate Center Dr., Suite 270  
Marietta, GA 30060-4116  
(770) 968-7945  
Fax: (770) 968-5815  
URL: <http://www.eifsfacts.com>

**VAPOR RETARDERS**

Asphalt Roofing Manufacturers Association (ARMA)  
4041 Powder Mill Road  
Suite 404  
Calverton, MD 20705-3106  
(301) 348-2002  
Fax: (301) 348-2020  
URL: <http://www.asphaltroofing.org>

**SHINGLES, ROOF TILES, AND ROOF COVERINGS**

American Society for Testing and Materials (ASTM)  
100 Barr Harbor Drive  
West Conshohocken, PA 19428-2529  
(610) 832-9585  
Fax: (610) 832-9555  
URL: <http://www.astm.org>  
E-mail: [cfalco@astm.org](mailto:cfalco@astm.org)

Asphalt Roofing Manufacturers Association (ARMA)  
4041 Powder Mill Road  
Suite 404  
Calverton, MD 20705-3106  
(301) 348-2002  
Fax: (301) 348-2020  
URL: <http://www.asphaltroofing.org>

Cedar Shake & Shingle Bureau (CSSB)  
P.O. Box 1178  
Umas, WA 98295  
(604) 462-8961  
Fax: (604) 462-9386  
URL: <http://www.cedarbureau.org>  
E-mail: [cssblind@nwlink.com](mailto:cssblind@nwlink.com)

Midwest Roofing Contractors Association (MRCA)  
4840 W. 15th St., Suite 1000  
Lawrence, KS 66049-3876  
(785) 843-4888  
Fax: (785) 843-7555  
URL: <http://www.mrca.org>

National Roofing Contractors Association (NRCA)  
O'Hare International Center  
10255 W. Higgins Road, Suite 600  
Rosemont, IL 60018  
(708) 299-9070  
Fax: (708) 299-1183  
URL: <http://www.nrca.net>  
E-mail: [member-service@NRA.org](mailto:member-service@NRA.org)

National Tile Roofing Manufacturers Association, Inc.  
P.O. Box 40337  
Eugene, OR 97404  
(541) 689-0366  
Fax: (541) 689-5530  
URL: <http://www.ntrma.com>  
E-mail: [info@ntrma.com](mailto:info@ntrma.com)

Underwriters Laboratories (UL)  
333 Pfingsten Road  
Northbrook, IL 60062  
(847) 272-8800  
Fax: (847) 272-8129  
URL: <http://www.ul.com>  
E-mail: [corpcomm@ul.com](mailto:corpcomm@ul.com)

Western Red Cedar Lumber Association  
1200 - 555 Burrard Street  
Vancouver, BC V7X 1S7  
(604) 684-0266  
Fax: (604) 687-4930  
URL: <http://www.wrcla.org>  
E-mail: [wrcla@cofiho.cofi.org](mailto:wrcla@cofiho.cofi.org)

**ROOFING AND SIDING PANELS**

Asphalt Roofing Manufacturers Association (ARMA)  
4041 Powder Mill Road  
Suite 404  
Calverton, MD 20705-3106  
(301) 348-2002  
Fax: (301) 348-2020  
URL: <http://www.asphaltroofing.org>

**MEMBRANE ROOFING**

American Society for Testing and Materials (ASTM)  
100 Barr Harbor Drive  
West Conshohocken, PA 19428-2529  
(610) 832-9585  
Fax: (610) 832-9555  
URL: <http://www.astm.org>  
E-mail: [cfalco@astm.org](mailto:cfalco@astm.org)

Asphalt Roofing Manufacturers Association (ARMA)  
4041 Powder Mill Road  
Suite 404  
Calverton, MD 20705-3106  
(301) 348-2002  
Fax: (301) 348-2020  
URL: <http://www.asphaltroofing.org>

Midwest Roofing Contractors Association (MRCA)  
4840 W. 15th St., Suite 1000  
Lawrence, KS 66049-3876  
(785) 843-4888  
Fax: (785) 843-7555  
URL: <http://www.mrca.org>

National Roofing Contractors Association (NRCA)  
O'Hare International Center  
10255 W. Higgins Road, Suite 600  
Rosemont, IL 60018  
(708) 299-9070  
Fax: (708) 299-1183  
URL: <http://www.nrca.net>  
E-mail: [member-service@NRA.org](mailto:member-service@NRA.org)

PVC Geomembrane Institute/Technology Program  
University of Illinois-Urbana Champaign  
205 N. Mathews Ave.  
Urbana, IL 61801  
(217) 333-3929  
Fax: (217) 244-2839  
URL: <http://pgi-tp.ce.uiuc.edu>

Roof Consultants Institute (RCI)  
7424 Chapel Hill Road  
Raleigh, NC 27607  
(919) 859-0742  
Fax: (919) 859-1328  
URL: <http://www.rci-online.org>

Roofing Communications Network (RCN)  
3690 Bohicket Road, Suite 1D  
John's Island, SC 29455  
(800) 522-7663 or (843) 768-1333  
Fax: (843) 768-1716

Roofing Industry Educational Institute (RIEI)  
14 Inverness Drive  
East, Building H, Suite 110  
Englewood, CO 80112-5608  
(303) 790-7200  
Fax: (303) 790-9006  
URL: <http://www.riei.org>

Rubber Manufacturers Association (RMA)  
1400 K Street, NW, Suite 900  
Washington, DC 20005  
(202) 682-4800  
Fax: (202) 682-4854  
URL: <http://www.rma.org>

Single Ply Roofing Institute (SPRI)  
200 Reservoir Street, Suite 309A  
Needham, MA 02494  
(781) 444-0242  
Fax: (781) 444-6111  
URL: <http://www.spri.org>  
E-mail: [spri@spri.org](mailto:spri@spri.org)

**FLASHING AND SHEET METAL**

Midwest Roofing Contractors Association (MRCA)  
4840 W. 15th St., Suite 1000  
Lawrence, KS 66049-3876  
(785) 843-4888  
Fax: (785) 843-7555  
URL: <http://www.mrca.org>

**MANSARD-TYPE METAL ROOFING**

Asphalt Roofing Manufacturers Association (ARMA)  
4041 Powder Mill Road  
Suite 404  
Calverton, MD 20705-3106  
(301) 348-2002  
Fax: (301) 348-2020  
URL: <http://www.asphaltroofing.org>

International Copper Association, Ltd.  
260 Madison Avenue, 16th Floor  
New York, NY 10016  
(212) 251-7240  
Fax: (212) 251-7245  
URL: <http://www.copper.org/centers>

National Roof Deck Contractors Association (NRDCA)  
600 South Federal Street, Suite 400  
Chicago, IL 60605  
(312) 922-6222  
Fax: (312) 922-2734  
URL: <http://www.nrdca.org>

**FLASHING**

Asphalt Roofing Manufacturers Association (ARMA)  
4041 Powder Mill Road  
Suite 404  
Calverton, MD 20705-3106  
(301) 348-2002  
Fax: (301) 348-2020  
URL: <http://www.asphaltroofing.org>

International Copper Association, Ltd.  
260 Madison Avenue, 16th Floor  
New York, NY 10016  
(212) 251-7240  
Fax: (212) 251-7245  
URL: <http://www.copper.org/centers>

**ROOF SPECIALTIES AND ACCESSORIES**

Asphalt Roofing Manufacturers Association (ARMA)  
4041 Powder Mill Road  
Suite 404  
Calverton, MD 20705-3106  
(301) 348-2002  
Fax: (301) 348-2020  
URL: <http://www.asphaltroofing.org>

Concrete Paver Institute/National Concrete Masonry Association (CPI/NCMA)  
2302 Horse Pen Road  
Herndon, VA 22071-3406  
(703) 713-1900  
Fax: (703) 713-1910  
URL: <http://www.ncma.org>  
E-mail: [ncma@ncma.org](mailto:ncma@ncma.org)

**GUTTERS AND DOWNSPOUTS**

Asphalt Roofing Manufacturers Association (ARMA)  
4041 Powder Mill Road  
Suite 404  
Calverton, MD 20705-3106  
(301) 348-2002  
Fax: (301) 348-2020  
URL: <http://www.asphaltroofing.org>

**CHAPTER 8 - DOORS AND WINDOWS**

**FIRE RATING AND SECURITY**

American National Standards Institute (ANSI)  
11 West 42nd Street,  
13th Floor  
New York, NY 10036-8002  
(212) 642-4900  
Fax: (212) 398-0023  
URL: <http://www.ansi.org>

American Society for Testing and Materials (ASTM)  
100 Barr Harbor Drive  
West Conshohocken, PA 19428-2529  
(610) 832-9585  
Fax: (610) 832-9555  
URL: <http://www.astm.org>  
E-mail: [cfalco@astm.org](mailto:cfalco@astm.org)

Associated Laboratories, Inc. (ALI)  
P.O. Box 152837  
Dallas, TX 75315  
(214) 565-0593/1400  
Fax: (214) 565-1094  
URL: <http://www.assoc-labs.com>

Building Owners and Managers Association International (BOMA)  
1201 New York Ave. NW, Ste. 300  
Washington, DC 20005  
(202) 408-2662  
Fax: (202) 371-0181  
URL: <http://www.boma.org>

Building and Fire Research Laboratory  
National Institute of Standards and Technology  
Building 226 Room B216  
Gaithersburg, MD 20899  
(301) 975-6850  
URL: <http://www.bfrl.nist.gov>  
E-mail: [richard.wright@nist.gov](mailto:richard.wright@nist.gov)

**National Fire Protection Association**

One Batterymarch Park  
P.O. Box 9101  
Quincy, MA 02269-9101  
(617) 770-3000  
Fax: (617) 770-0700  
URL: <http://www.nfpa.org>  
E-mail: [Library@NFPA.org](mailto:Library@NFPA.org)

Steel Window Institute (SWI)  
1300 Sumner Avenue  
Cleveland, OH 44115-2851  
(216) 241-7333  
Fax: (216) 241-0105  
URL: <http://www.steelwindows.com>

**DOOR AND WINDOW OPENINGS**

National Sash and Door Jobbers Association (NSDJA)  
2500 East Devon Avenue  
Des Plaines, IL 60018  
(708) 299-3400  
Fax: (708) 299-0489  
URL: <http://www.nsdja.com>  
E-mail: [mpalmer@nsdja.com](mailto:mpalmer@nsdja.com)

**METAL DOORS AND FRAMES**

Door and Access Systems Manufacturers Association, (DASMA)  
International  
c/o Thomas Associates, Inc.  
1300 Sumner Ave.  
Cleveland, OH 44115-2851  
(216) 241-7333  
Fax: (216) 241-0105  
URL: <http://www.dasma.com>

Insulated Steel Door Institute  
30200 Detroit Road  
Cleveland, OH 44145-1967  
(216) 899-0010  
Fax: (216) 892-1404  
URL: <http://www.isdi.org>

**National Sash and Door Jobbers Association (NSDJA)**

2400 East Devon Avenue  
Des Plaines, IL 60018  
(708) 299-3400  
Fax: (708) 299-0489  
URL: <http://www.nsdja.com>  
E-mail: [mpalmer@nsdja.com](mailto:mpalmer@nsdja.com)

**WOOD AND PLASTIC DOORS**

American Hardboard Association  
1210 W. Northwest Highway  
Palatine, IL 60067  
(847) 934-8800  
Fax: (847) 934-8803  
E-mail: [aha@ahardbd.org](mailto:aha@ahardbd.org)

**National Sash and Door Jobbers Association (NSDJA)**

2400 East Devon Avenue  
Des Plaines, IL 60018  
(708) 299-3400  
Fax: (708) 299-0489  
URL: <http://www.nsdja.com>  
E-mail: [mpalmer@nsdja.com](mailto:mpalmer@nsdja.com)

**National Wood Window and Door Association, Inc.**

1400 E. Touhy Avenue  
Suite G54  
Des Plaines, IL 60018  
(708) 299-5200  
Fax: (708) 299-1286  
URL: <http://www.nwwda.org>

Steel Door Institute (SDI)  
30200 Detroit Road  
Cleveland, OH 44145-1967  
(440) 899-0010  
Fax: (440) 892-1404  
URL: <http://www.steeldoor.org>

**SPECIALTY DOORS**

Door and Access Systems Manufacturers Association, (DASMA)  
International  
c/o Thomas Associates, Inc.  
1300 Sumner Ave.  
Cleveland, OH 44115-2851  
(216) 241-7333  
Fax: (216) 241-0105  
URL: <http://www.dasma.com>

1000 North Rand Road, Suite 214  
Wauconda, IL 60084  
(847) 526-2010  
Fax: (847) 526-3993  
URL: <http://www.aec.org>

**ENTRANCES AND STOREFRONTS**

Aluminum Association, Inc.  
600 18th Street, NW, Suite 300  
Washington, DC 20006-2168  
(202) 862-5100  
Fax: (202) 862-5164  
URL: <http://www.aluminum.org>

Aluminum Extruders Council (AEC)  
1000 North Rand Road, Suite 214  
Wauconda, IL 60084  
(847) 526-2010  
Fax: (847) 526-3993  
URL: <http://www.aec.org>

American Architectural Manufacturers Association  
1827 Waiden Office Square, Suite 101  
Schaumburg, IL 60173-4628  
(847) 303-6664  
Fax: (847) 303-5774  
URL: <http://www.aamanet.org>

**WINDOWS**

Aluminum Association, Inc.  
600 18th Street, NW, Suite 300  
Washington, DC 20006-2168  
(202) 862-5100  
Fax: (202) 862-5164  
URL: <http://www.aluminum.org>

Aluminum Extruders Council (AEC)  
1000 North Rand Road, Suite 214  
Wauconda, IL 60084  
(847) 526-2010  
Fax: (847) 526-3993  
URL: <http://www.aec.org>

American Architectural Manufacturers Association  
1827 Waiden Office Square, Suite 101  
Schaumburg, IL 60173-4628  
(847) 303-6664  
Fax: (847) 303-5774  
URL: <http://www.aamanet.org>

Insulating Glass Certification Council  
P.O. Box 9  
Henderson Harbor, NY 13651  
(315) 938-7444  
Fax: (315) 938-7453

National Fenestration Rating Council (NFRC)  
1300 Spring Street, Suite 500  
Silver Spring, MD 20910  
(301) 588-6372  
Fax: (301) 588-6342  
URL: <http://www.nfrc.org>  
E-mail: [NFRCUSA@aol.com](mailto:NFRCUSA@aol.com)

National Wood Window and Door Association, Inc.  
1400 E. Touhy Avenue  
Suite G54  
Des Plaines, IL 60018  
(708) 299-5200  
Fax: (708) 299-1286  
URL: <http://www.nwwda.org>

Sealant, Waterproofing, and Restoration Institute  
2641 Main  
Kansas City, MO 64108  
(816) 472-7974  
Fax: (816) 472-7785  
URL: <http://www.swrionline.org>  
E-mail: [info@swrionline.org](mailto:info@swrionline.org)

Steel Window Institute (SWI)  
1300 Sumner Avenue  
Cleveland, OH 44115-2851  
(216) 241-7333  
Fax: (216) 241-0105  
URL: <http://www.steelwindows.com>

**SKYLIGHTS**

Association of Manufacturers of Skylight  
1000 North Rand Road, Suite 214  
Wauconda, IL 60084  
(847) 526-2010  
Fax: (847) 526-3993  
URL: <http://www.aec.org>

**HARDWARE**

Association of Window Manufacturers  
Association (AWMA)  
8311 Plaza Drive  
Channahon, IL 61723-1977  
(815) 403-1100  
Fax: (815) 654-1093  
URL: <http://www.awma.org>  
E-mail: [info@awma.org](mailto:info@awma.org)

Builders Hardware Manufacturers Association, Inc.  
888 Exchange Avenue, 17th Floor  
Columbus, GA 31917-6603  
(706) 277-2100  
Fax: (706) 277-2100  
URL: <http://www.buildershardware.com>

Door and Hardware Institute (DHI)  
12770 Nevamook Drive  
Charlottesville, VA 20151-2232  
(703) 222-2810  
Fax: (703) 222-2410  
URL: <http://www.dhi.org>  
E-mail: [membership@dhi.org](mailto:membership@dhi.org)

National Retail Hardware Association  
5527 West 74th Street  
Indianapolis, IN 46278  
(317) 290-0238  
Fax: (317) 290-0378  
URL: <http://www.nrha.org>  
E-mail: [nrha@quest.net](mailto:nrha@quest.net)

**GLAZING**

Art Glass Suppliers Association  
1100-H Brandywine Blvd.  
P.O. Box 2188  
Bensenville, OH 43702-2188  
(614) 452-4541  
Fax: (614) 452-2552  
URL: <http://www.creativeindustries.com/agsa/>  
E-mail: [agsa.info@offinger.com](mailto:agsa.info@offinger.com)

Flint Glass Marketing Association (FGMA)  
Clyde Lakes Professional Building  
5310 SW Harrison Street  
Maplewood, KS 66061-2779  
(913) 768-7613  
Fax: (913) 268-0272

Glass Association of North America  
12877a  
11711 Fair Avenue  
Newport, UT 84703  
(801) 320-9277  
Fax: (801) 931-9088  
URL: <http://www.gasinfo.com/info/gana.html>

National Glass Association (NGA)  
2900 Greenboro Drive, Suite 302  
Falls Church, VA 22102  
(703) 442-4800  
Fax: (703) 442-0630  
URL: <http://www.glass.org>  
E-mail: [nga@glass.org](mailto:nga@glass.org)

Sign Glazing Certification Council (SGCC)  
P.O. Box 9  
Henderson Harbor, NY 13651  
(315) 938-7444  
Fax: (315) 938-7453  
URL: <http://www.sgcc.org>

Sign Insulating Glass Manufacturers Association  
19777 Michigan Ave., Suite 2400  
Chicago, IL 60611  
(773) 844-6810  
Fax: (773) 827-6783  
URL: <http://www.sigmaonline.org/sigma/>

Society of Glass and Ceramic Decorators  
1027 K Street, NW, Suite 800  
Washington, DC 20006-3959  
(202) 228-4112  
Fax: (202) 229-4133  
URL: <http://www.ceramics.com/sgcd/>  
E-mail: [sgcd@sgcd.org](mailto:sgcd@sgcd.org)

United Glass Association of America  
100  
P.O. Box 22042  
Kansas City, MO 64110  
(816) 302-6690  
URL: <http://www.unitedglass.org>  
E-mail: [ugaa@aol.com](mailto:ugaa@aol.com)

Underwriters Laboratories, Inc.  
322 Plingsten Road  
Northbrook, IL 60062  
(847) 272-8300  
Fax: (847) 272-8129  
URL: <http://www.ul.com>  
E-mail: [ulcertcomm@ul.com](mailto:ulcertcomm@ul.com)

**CHAPTER 9 - FINISHES  
PLASTER AND GYPSUM BOARD**

Associated Laboratories, Inc.  
P.O. Box 152837  
Dallas, TX 75315  
(214) 968-0593/1400  
Fax: (214) 965-1094  
URL: <http://www.assoc.labs.com>

Association of Wall and Ceiling Industries  
803 West Broad Street, Suite 600  
Falls Church, VA 22046  
(703) 534-8300  
Fax: (703) 534-8307  
URL: <http://www.awci.org>  
E-mail: [info@AWCI.org](mailto:info@AWCI.org)

Building and Fire Research Laboratory  
National Institute of Standards and Technology  
Building 226 Room B216  
Gaithersburg, MD 20899  
(301) 975-6850  
URL: <http://www.bfrl.nist.gov>  
E-mail: [richard.wright@nist.gov](mailto:richard.wright@nist.gov)

Ceilings and Interior Systems Construction Association (CISCA)  
1500 Lincoln Highway, Suite 202  
St. Charles, IL 60174  
(630) 584-1919  
Fax: (630) 584-2003  
URL: <http://www.cisca.org>

Foundation of the Wall and Ceiling Industry (FWCI)  
803 West Broad St. Suite 600  
Falls Church, VA 22046  
(703) 534-8300  
Fax: (703) 534-8307  
URL: [www.fwci.org](http://www.fwci.org)

Gypsum Association  
210 First St., NE, Suite 510  
Washington, DC 20002  
(202) 289-5440  
Fax: (202) 289-3707  
URL: <http://www.gypsum.org>  
E-mail: [info@gypsum.org](mailto:info@gypsum.org)

International Institute for Lath and Plaster  
411 St.  
820 Transfer Road  
St. Paul, MN 55114-1106  
(612) 645-0208  
Fax: (612) 645-0209  
E-mail: [mimlph@pro-ns.net](mailto:mimlph@pro-ns.net)

Metal Lath/Steel Framing Association  
Division of NAAMM (ML/SFA)  
8 South Michigan Avenue, Suite 1000  
Chicago, IL 60603  
(312) 332-0405  
Fax: (312) 332-0706  
URL: <http://www.naamm.org/mlsta.htm>

**TILE**

Ceramic Tile Institute of America, Inc.  
12061 West Jefferson Blvd  
Culver City, CA 90230-6219  
(310) 574-7800  
Fax: (310) 821-4655

Italian Tile Association (ITA)  
305 Madison Avenue, Suite 3120  
New York, NY 10165  
(212) 661-0435  
Fax: (212) 949-8192  
URL: <http://www.cerisale.it>

Marble Institute of America, Inc.  
1000 North Rand Road, Suite 214  
Wauconda, IL 60084  
(847) 526-2010  
Fax: (847) 526-3993  
URL: <http://www.marbleinstitute.com>  
E-mail: [literature@marbleinstitute.com](mailto:literature@marbleinstitute.com)

**STONE FLOOR AND WALL COVERINGS**

Grinding Stone Institute (GSI)  
P.O. Box 3507  
Raripays, NY 10578  
(518) 232-5726  
Fax: (518) 232-5258

Floor Covering Installation Contractors Association (FCICA)  
P.O. Box 948  
310 Holiday Ave.  
Dalton, GA 30722-0948  
(706) 226-5488  
Fax: (706) 226-1775

Italian Marble Center (IMC)  
Italian Trade Commission  
498 Park Avenue  
New York, NY 10022  
(212) 980-1500 or (212) 879-0950

Marble Institute of America  
30 Eden Alley Suite 301  
Columbus, OH 43215  
(614) 278-6194  
Fax: (614) 461-1497  
URL: <http://www.marble-institute.com>  
E-mail: [maadmin@marble-institute.com](mailto:maadmin@marble-institute.com)

Window Covering Manufacturers Association (WCMA)  
355 Lexington Ave., 17th Floor  
New York, NY 10017-6603  
(212) 297-2122  
Fax: (212) 370-9047  
URL: <http://www.windowcoverings.org>

**TERRAZZO**

National Terrazzo and Mosaic Association, Inc.  
110 East Market Street, Suite 200A  
Leesburg, VA 20178  
(703) 779-1022  
Fax: (703) 779-1026  
URL: <http://www.ntma.com>  
E-mail: [info@ntma.com](mailto:info@ntma.com)

**SPECIAL CEILING SURFACES**

Ceilings and Interior Systems Construction Association (CISCA)  
1500 Lincoln Highway, Suite 202  
St. Charles, IL 60174  
(630) 584-1919  
Fax: (630) 584-2003  
URL: <http://www.cisca.org>

**SPECIAL FLOORING**

Floor Covering Installation Contractors Association (FCICA)  
P.O. Box 948  
310 Holiday Ave.  
Dalton, GA 30722-0948  
(706) 226-5488  
Fax: (706) 226-1775

**UNIT MASONRY FLOORING**

Mason Contractors Association of America  
1910 S. Highland Ave  
Suite 101  
Lombard, IL 60146  
(630) 705-4200

**WOOD FLOORING**

Fine Hardwood Veneer Association (FHVAA)  
260 S. First St. #2  
Zionsville, IN 46077  
(317) 873-8780

Hardwood Manufacturers Association (HMA)  
400 Penn Center Blvd., Suite 530  
Pittsburgh, PA 15235-5605  
(412) 829-0770  
Fax: (412) 829-0844  
URL: <http://www.hardwood.org>

**Hardwood Plywood and Veneer Association**  
 P.O. Box 2789  
 Reston, VA 22195-0789  
 (703) 435-2900  
 Fax: (703) 435-2537  
 URL: <http://www.hpva.org>  
 E-mail: [hpva@hpva.org](mailto:hpva@hpva.org)

**Maple Flooring Manufacturers Association**  
 60 Revere Drive, Suite 500  
 Northbrook, IL 60062-1563  
 (847) 480-9138  
 Fax: (847) 480-9282  
 URL: <http://www.maplefloor.com>  
 E-mail: [mfma@maplefloor.org](mailto:mfma@maplefloor.org)

**National Hardwood Lumber Association (NHILA)**  
 P.O. Box 34518  
 Memphis, TN 38184-0518  
 (901) 377-1818  
 Fax: (901) 382-6419  
 URL: <http://www.natllhardwood.org>

**National Oak Flooring Manufacturers Association**  
 P.O. Box 3009  
 Memphis, TN 38173-0009  
 (901) 526-5016  
 Fax: (901) 526-7022  
 URL: <http://www.nofma.org>

**National Wood Flooring Association**  
 233 Old Meramec Station Road  
 Manchester, MO 63021  
 (800) 422-4556  
 Fax: (314) 391-6137  
 URL: <http://www.woodfloors.org>

**RESILIENT FLOORING**

**Floor Covering Installation Contractors Association (FCICA)**  
 P.O. Box 948  
 310 Holiday Ave.  
 Dalton, GA 30722-0948  
 (706) 226-5488  
 Fax: (706) 226-1775

**Resilient Floor Covering Institute**  
 966 Hungerford Drive, Suite 12-B  
 Rockville, MD 20850  
 (301) 340-8580  
 Fax: (301) 340-7283

**Rubber Manufacturers Association (RMA)**  
 1400 K Street, N.W., Suite 900  
 Washington, DC 20005  
 (202) 682-4800  
 Fax: (202) 682-4854  
 URL: <http://www.rma.org>

**CARPET**

**Carpet Cushion Council (CCC)**  
 P.O. Box 546  
 Riverside, CT 06878  
 (203) 637-1312  
 URL: <http://www.carpetcushion.org>

**Carpet and Rug Institute**  
 7310 Holiday Ave.  
 Dalton, GA 30722-2048  
 (706) 278-0232  
 Fax: (706) 278-8835  
 URL: <http://www.carpet-rug.com>

**Jute Carpet Backing Council, Inc. (JCBC)**  
 30 Rockefeller Plaza, 27th Floor  
 New York, NY 10112  
 (212) 408-1040  
 Fax: (212) 489-0387

**WALL COVERINGS**

**Painting and Decorating Contractors of America (PDCA)**  
 3913 Old Lee Hwy, Suite 33-B  
 Fairfax, VA 22030  
 (703) 359-0826  
 URL: <http://www.pdca.com>

**Window Covering Manufacturers Association (WCMA)**  
 355 Lexington Ave., 17th Floor  
 New York, NY 10017-6603  
 (212) 297-2122  
 Fax: (212) 370-9047  
 URL: <http://www.windowcoverings.org>

**SPECIAL WALL SURFACES**

**Wallcoverings Association**  
 401 N. Michigan Avenue  
 Chicago, IL 60611-4267  
 (312) 644-6610  
 Fax: (312) 527-6705  
 URL: <http://www.wallcoverings.org>

**ACOUSTICAL TREATMENT**

**Acoustical Society of America (ASA)**  
 2 Huntington Quadrangle  
 Suite 1N01  
 Melville, NY 11747-4502  
 (516) 576-2360  
 Fax: (516) 576-2377  
 URL: <http://asa.aip.org>  
 E-mail: [asa@aip.org](mailto:asa@aip.org)

**National Council of Acoustical Consultants (NCAC)**  
 66 Morris Avenue, Suite 1A  
 Springfield, NJ 07081-1409  
 (973) 564-5859  
 Fax: (973) 564-7480  
 URL: <http://www.ncac.com>  
 E-mail: [info@ncac.com](mailto:info@ncac.com)

**Underwriters Laboratories (UL)**  
 333 Pfingsten Road  
 Northbrook, IL 60062  
 (847) 272-8800  
 Fax: (847) 272-8129  
 URL: <http://www.ul.com>  
 E-mail: [corpcomm@ul.com](mailto:corpcomm@ul.com)

**PAINTS AND COATINGS**

**Architectural Spray Coaters Association (ASCA)**  
 895 Doncaster Dr.  
 West Deptford, NJ 08066  
 (609) 848-6120  
 Fax: (609) 251-1243  
 URL: <http://www.ascassoc.com>

**Color Association of the United States (CAUS)**  
 589 Eight Ave., 12th Floor  
 New York, NY 10018  
 (212) 582-8884  
 URL: <http://www.colorassociation.com>

**National Paint and Coatings Association (NPCA)**  
 1500 Rhode Island Avenue, N.W.  
 Washington, DC 20005  
 (202) 462-6272  
 Fax: (202) 462-8549  
 URL: <http://www.paint.org>  
 E-mail: [nPCA@paint.org](mailto:nPCA@paint.org)

**Painting and Decorating Contractors of America (PDCA)**  
 3913 Old Lee Hwy, Suite 33-B  
 Fairfax, VA 22030  
 (703) 359-0826  
 URL: <http://www.pdca.com>

**Wallcoverings Association**  
 401 N. Michigan Avenue  
 Chicago, IL 60611-4267  
 (312) 644-6610  
 Fax: (312) 527-6705  
 URL: <http://www.wallcoverings.org>

**SPECIAL COATINGS**

**Architectural Spray Coaters Association (ASCA)**  
 895 Doncaster Dr.  
 West Deptford, NJ 08066  
 (609) 848-6120  
 Fax: (609) 251-1243  
 URL: <http://www.ascassoc.com>

**National Paint and Coatings Association (NPCA)**  
 1500 Rhode Island Avenue, NW  
 Washington, DC 20005  
 (202) 462-6272  
 Fax: (202) 462-8549  
 URL: <http://www.paint.org>  
 E-mail: [nPCA@paint.org](mailto:nPCA@paint.org)

**CHAPTER 10 - SPECIALTIES**

**COMPARTMENTS AND CUBICLES**

**American National Standards Institute (ANSI)**  
 11 West 42nd Street,  
 13th Floor  
 New York, NY 10036-8002  
 (212) 642-4900  
 Fax: (212) 398-0023  
 URL: <http://www.ansi.org>

**American Society for Testing and Materials (ASTM)**  
 100 Barr Harbor Drive  
 West Conshohocken, PA 19428-2529  
 (610) 832-9585  
 Fax: (610) 832-9555  
 URL: <http://www.astm.org>  
 E-mail: [cfaico@astm.org](mailto:cfaico@astm.org)

**Cosmetic, Toiletry, and Fragrance Association**  
 1101 17th Street, NW  
 Suite 300  
 Washington, DC 20036  
 (202) 331-1770  
 Fax: (202) 331-1969  
 URL: <http://www.ctfa.org>

**International Sanitary Supply Association**  
 7373 North Lincoln Avenue  
 Lincolnwood, IL 60646-1799  
 (847) 982-0800  
 Fax: (847) 982-1012  
 URL: <http://www.issa.com>  
 E-mail: [info@issa.com](mailto:info@issa.com)

**North American Association of Mirror Manufacturers**  
 2945 Southwest Wanamaker Dr.,  
 Suite A  
 Topeka, KS 66614-5321

**Porcelain Enamel Institute**  
 P.O. Box 158541  
 4004 Hillsboro Pike, Suite 224-B  
 Nashville, TN 37215  
 (615) 385-5357  
 Fax: (615) 385-5463  
 URL: <http://www.porcelainenamel.com>  
 E-mail: [penamel@aol.com](mailto:penamel@aol.com)

**SERVICE WALLS**

**Underwriters Laboratories (UL)**  
 333 Pfingsten Road  
 Northbrook, IL 60062  
 (847) 272-8800  
 Fax: (847) 272-8129  
 URL: <http://www.ul.com>  
 E-mail: [corpcomm@ul.com](mailto:corpcomm@ul.com)

**WALL AND CORNER GUARDS**

**Wallcoverings Association**  
 401 N. Michigan Avenue  
 Chicago, IL 60611-4267  
 (312) 644-6610  
 Fax: (312) 527-6705  
 URL: <http://www.wallcoverings.org>

**FIREPLACES AND STOVES**

**Hearth Products Association**  
 1101 Connecticut Avenue, NW, Suite  
 700  
 Washington, DC 20036  
 (202) 857-1181  
 Fax: (202) 223-4579  
 URL: <http://www.hearth.com>

**Masonry Heater Association of North America**  
 Beverly J. Marois, Administrator  
 RR2, Box 33M  
 Randolph, Vermont 05060, USA  
 (802) 728-5896  
 Fax: (802) 728-6004  
 URL: <http://www.mha-net.org>

**National Clay Pipe Institute (NCPI)**  
 P.O. Box 759  
 Lake Geneva, WI 53147  
 (414) 248-9094  
 Fax: (414) 248-1564  
 URL: <http://www.ncpi.org>

**FLAGPOLES**

**National Association of Architectural Metal Manufacturers (NAAMM)**  
 8 South Michigan Avenue, Suite 1000  
 Chicago, IL 60603  
 (312) 332-0405  
 Fax: (312) 332-0706  
 URL: <http://www.naamm.org>  
 E-mail: [naamm@naamm.org](mailto:naamm@naamm.org)

**IDENTIFYING DEVICES**

**International Sign Association**  
 707 North St. Asaph Street  
 Alexandria, VA 22314  
 (703) 836-4012  
 Fax: (703) 836-8353  
 URL: <http://www.signs.org>

**Marking Device Association International**  
 222 Wisconsin Ave.  
 Suite 1  
 Lake Forrest, IL 60045  
 (847) 283-9810  
 Fax: (847) 283-9808  
 URL: <http://www.mdai.org>  
 E-mail: [MDAI@MDAI.org](mailto:MDAI@MDAI.org)

**National Association of Display Industries (NADI)**  
 234 Fifth Ave., Ste. 407  
 New York, NY 10001  
 (212) 725-4490  
 Fax: (888) 477-6234  
 URL: <http://www.nadi.org>

**National Electric Sign Association**  
 801 North Fairfax Street,  
 Suite 205  
 Alexandria, VA 22314  
 (703) 836-4012  
 Fax: (703) 836-8353

**World Sign Associates (WSA)**  
 8774 Yates Drive  
 Westminster, CO 80030  
 (303) 427-7252  
 Fax: (303) 427-7090  
 URL: <http://wsanetwork.org>

**FIRE PROTECTION SPECIALTIES**

**Building Owners and Managers Association International (BOMA)**  
 1201 New York Ave. NW, Ste. 300  
 Washington, DC 20005  
 (202) 408-2662  
 Fax: (202) 371-0181  
 URL: <http://www.boma.org>

**Fire Equipment Manufacturers Association**  
 1300 Sumner Avenue  
 Cleveland, OH 44115-2180  
 (216) 241-7333  
 Fax: (216) 241-0105  
 URL: <http://www.taol.com/fema>

**Industrial Safety Equipment Association**  
 1901 N. Moore St.  
 Arlington, VA 22209-1762  
 (703) 525-1695  
 Fax: (703) 528-2148  
 URL: <http://www.safetycentral.org/isea>

**International Facility Management Association (IFMA)**  
 1 East Greenway Plaza, Ste. 1100  
 Houston, TX 77046  
 (713) 623-4362  
 Fax: (713) 623-6124  
 URL: <http://www.ifma.org>  
 E-mail: [ifmahq@ifma.org](mailto:ifmahq@ifma.org)

**International Municipal Signal Association**  
 165 E. Union St.  
 Newark, NY 14513  
 (315) 331-2182  
 Fax: (315) 331-8205  
 URL: <http://www.imsasafety.org>

**National Association of Fire Equipment Distributors**  
 1 East Wacker Drive  
 Chicago, IL 60601  
 (312) 644-6610  
 Fax: (312) 321-4658  
 URL: <http://www.nafed.org>

**Indiana Library Association**  
 One Battery March Lane  
 P.O. Box 9101  
 Quincy, MA 02269-0101  
 (617) 770-3000  
 Fax: (617) 770-3700  
 URL: <http://www.inliba.org>  
 E-mail: [library@inliba.org](mailto:library@inliba.org)

**Society of Fire Protection Engineers (SFPE)**  
 7315 Wisconsin Avenue, Suite 200  
 Bethesda, MD 20814  
 (301) 718-2910  
 Fax: (301) 718-2217  
 URL: <http://www.sfpe.org>  
 E-mail: [sfpehdctis@sfpe.org](mailto:sfpehdctis@sfpe.org)

**Underwriters Laboratories of Canada (ULC)**  
 7 Crouse Rd.  
 Scarborough, Ontario M1P 2A2 Canada  
 (416) 757-3611  
 URL: <http://www.ulc.ca>

**PROTECTIVE COVERS**  
**American Society for Testing and Materials (ASTM)**  
 100 Barr Harbor Drive  
 West Conshohocken, PA 19380-1502  
 (610) 832-9565  
 Fax: (610) 832-9555  
 URL: <http://www.astm.org>  
 E-mail: [cfalco@astm.org](mailto:cfalco@astm.org)

**PARTITIONS**  
**Screen Manufacturers Association (SMA)**  
 2850 S. Ocean Blvd., Suite 114  
 Palm Beach, FL 33480-5535  
 (561) 533-0991  
 Fax: (561) 533-7466  
 E-mail: [fscottfitzgerald@compuserve.com](mailto:fscottfitzgerald@compuserve.com)

**CHAPTER 11 - EQUIPMENT SECURITY AND VAULT EQUIPMENT**

**American National Standards Institute (ANSI)**  
 11 West 42nd Street  
 13th Floor  
 New York, NY 10036-8002  
 (212) 647-4900  
 Fax: (212) 398-0023  
 URL: <http://www.ansi.org>

**International Approval Services (IAS)**  
 8501 East Pleasant Valley Rd  
 Cleveland, OH 44131-5575  
 (216) 524-4990  
 URL: <http://www.iasapprovals.org>

**National Independent Bank Equipment and Systems Association (NIBESA)**  
 1411 Peterson Street  
 Park Ridge, IL 60068  
 (847) 825-8419  
 Fax: (847) 825-8445

**Underwriters Laboratories (UL)**  
 333 Pfingsten Road  
 Northbrook, IL 60062  
 (847) 272-9800  
 Fax: (847) 272-8129  
 URL: <http://www.ul.com>  
 E-mail: [corpcomm@ul.com](mailto:corpcomm@ul.com)

**TELLER AND SERVICE EQUIPMENT**  
**National Alarm Association of America (NAAA)**  
 P.O. Box 3409  
 Dayton, OH 45401  
 (800) 283-6285  
 URL: <http://www.naaa.org>

**National Burglar and Fire Alarm Association (NBFAA)**  
 7101 Wisconsin Avenue, Suite 90  
 Bethesda, MD 20814-4805  
 (301) 907-3702  
 Fax: (301) 907-7897  
 URL: <http://www.alarm.org>  
 E-mail: [membership@alarm.org](mailto:membership@alarm.org)

**National Independent Bank Equipment and Systems Association (NIBESA)**  
 1411 Peterson Street  
 Park Ridge, IL 60068  
 (847) 825-8419  
 Fax: (847) 825-8445

**INSTRUMENTAL EQUIPMENT**

**American Harp Society**  
 8331 Quebec Drive  
 Hollywood, CA 90068-2637  
 (323) 463-0775  
 Fax: (323) 464-2950  
 URL: <http://harpssociety.org>  
 E-mail: [drenseahs@aol.com](mailto:drenseahs@aol.com)

**Associated Pipe Organ Builders of America**  
 P.O. Box 155  
 Chicago Ridge, IL 60415  
 (800) 473-5271  
 URL: <http://www.theorg.com/APOBA>

**International Music Products Association**  
 5790 Armada Drive  
 Carlsbad, CA 92008  
 (760) 438-8011  
 Fax: (760) 438-8257  
 URL: <http://www.nammi.com>

**National Association of Band Instrument Manufacturers**  
 38 West 21st Street  
 5th Floor  
 New York, NY 10010-6906  
 (212) 924-9175

**National Piano Foundation**  
 4020 McEwen, Suite 105  
 Dallas, TX 75244  
 (214) 233-9107  
 Fax: (214) 249-4219  
 URL: <http://www.pianonet.com>  
 E-mail: [npfinfo@pianonet.com](mailto:npfinfo@pianonet.com)

**COMMERCIAL LAUNDRY AND DRY CLEANING EQUIPMENT**

**Coin Laundry Association**  
 1315 Butterfield Road  
 Suite 212  
 Downers Grove, IL 60515  
 (708) 963-5547  
 Fax: (708) 963-5864  
 URL: <http://www.coinlaundry.org>  
 E-mail: [info@coinlaundry.org](mailto:info@coinlaundry.org)

**Laundry Workers International**  
 307 Fourth Avenue  
 Bank Tower, Suite 405  
 Pittsburgh, PA 15222  
 (412) 471-4879  
 Fax: (412) 471-1840

**Multi-Housing Laundry Association**  
 4101 Lake Boone Trail, Suite 201  
 Raleigh, NC 27607  
 (919) 787-5181  
 Fax: (919) 787-4916  
 URL: <http://www.mhla.com>  
 E-mail: [bhuggins@olsonmgmt.com](mailto:bhuggins@olsonmgmt.com)

**VENDING EQUIPMENT**

**National Automatic Merchandising Association**  
 20 N. Wacker Drive, Suite 3500  
 Chicago, IL 60606-3102  
 (312) 346-0370  
 Fax: (312) 704-4140  
 URL: <http://www.vending.org>

**National Bulk Vendors Association**  
 200 N. LaSalle Street  
 Suite 2100  
 Chicago, IL 60601-1095  
 (312) 621-1400  
 Fax: (312) 621-1750  
 URL: <http://www.nbva.org>

**National Coffee Service Association (NCSA)**  
 1899 Preston White Drive  
 Reston, VA 20191  
 (703) 715-1181  
 Fax: (703) 715-1194

**AUDIO VISUAL EQUIPMENT**

**Audio Engineering Society**  
 80 East 42nd Street, Room 2520  
 New York, NY 10165  
 (212) 661-8128  
 Fax: (212) 682-0417  
 URL: <http://www.aes.org>  
 E-mail: [HW@aes.org](mailto:HW@aes.org)

**LOADING DOCK EQUIPMENT**

**Loading Dock Equipment Manufacturers Association**  
 8720 Red Oak Blvd., Suite 201  
 Charlotte, NC 28217-3992  
 (704) 522-7826  
 Fax: (704) 522-7826

**Material Handling Equipment Distributors Association (MHEDA)**  
 201 US Highway #5  
 Vernon Hills, IL 60061-2398  
 (847) 680-3500  
 Fax: (847) 362-0933  
 URL: <http://www.mheda.org>  
 E-mail: [Connect@MHEDA.org](mailto:Connect@MHEDA.org)

**Material Handling Industry of America**  
 8720 Red Oak Blvd., Suite 201  
 Charlotte, NC 28217-3992  
 (704) 676-1190  
 Fax: (704) 676-1199  
 URL: <http://www.mhia.org>  
 E-mail: [cdalton@mhia.org](mailto:cdalton@mhia.org)

**Material Handling Systems Association of Professional Material Handling Consultants**  
 8720 Red Oak Blvd., Suite 224  
 Charlotte, NC 28217-3957  
 (704) 568-4749

**SOLID WASTE HANDLING EQUIPMENT**

**American Society of Sanitary Engineering (ASSE)**  
 28901 Clemens Road, Suite 100  
 Westlake, OH 44145  
 (440) 835-3046  
 Fax: (440) 835-3488  
 URL: <http://www.asse-plumbing.org>  
 E-mail: [ASSL@IX.netcom.com](mailto:ASSL@IX.netcom.com)

**Association of State and Territorial Solid Waste Management Officials (ASTSWMO)**  
 444 North Capitol Street NW  
 Suite 388  
 Washington, DC 20001  
 (202) 624-5825  
 URL: <http://www.astswmo.org>  
 E-mail: [swmtrina@ssso.org](mailto:swmtrina@ssso.org)

**Institute for Solid Wastes American Public Works Association (ISW/APWA)**  
 106 West 11th Street  
 Suite 1800  
 Kansas City, MS 64105-1806  
 (816) 472-6100 or (202) 393-2792  
 URL: <http://www.apwa.net>

**National Sanitation Foundation**  
 789 North Dixboro Road  
 Ann Arbor, MI 48105  
 (734) 769-8010  
 Fax: (734) 769-0109  
 URL: <http://www.nsf.org>  
 E-mail: [info@nsf.org](mailto:info@nsf.org)

**Solid Waste Association of North America (SWANA)**  
 1100 Wayne Avenue  
 Suite 700  
 Silver Spring, MD 20910  
 (301) 585-2898  
 Fax: (301) 589-7068  
 URL: <http://www.swana.org>  
 E-mail: [techn.ca\\_services@swana.org](mailto:techn.ca_services@swana.org)

**Waste Equipment Technology Association (WASTECA)**  
 4301 Connecticut Ave. NW, Suite 300  
 Washington, DC 20008  
 (202) 244-4700  
 Fax: (202) 966-4924  
 URL: <http://www.wastec.org>

**FOOD SERVICE EQUIPMENT**

**National Association of Food Equipment Manufacturers**  
 401 N. Michigan Avenue  
 Chicago, IL 60611  
 (312) 644-6610  
 Fax: (312) 321-6869  
 URL: <http://www.nafem.org>

**National Restaurant Association (NRA)**  
 1200 17th St. NW  
 Washington, DC 20036  
 (202) 331-5900  
 URL: <http://www.restaurant.org>  
 E-mail: [info@dnireout.org](mailto:info@dnireout.org)

**Wine Institute**  
 425 Market Street  
 Suite 1000  
 San Francisco, CA 94105  
 (415) 512-0151  
 Fax: (415) 442-0742  
 URL: <http://www.wineinstitute.org>

**RESIDENTIAL EQUIPMENT**

**Association of Home Appliance Manufacturers (AHAM)**  
 20 North Wacker Drive  
 Suite 1231  
 Chicago, IL 60606  
 (312) 984-5800  
 Fax: (312) 984-5823  
 URL: <http://www.aham.org>

**National Kitchen and Bath Association**  
 687 Willow Grove Street  
 Hackettstown, NJ 07840  
 (908) 852-0033  
 URL: <http://www.nkba.org>

**National Retail Federation (NRF)**  
 325 7th St. NW, Ste. 1000  
 Washington, DC 20004  
 (202) 783-7971  
 Fax: (202) 737-2849  
 URL: <http://www.nrf.com>

**North American Retail Dealers of America (NARDA)**  
 10 East 22nd Street  
 Suite 310  
 Lombard, IL 60148  
 (708) 953-8950  
 Fax: (708) 953-8957

**Small Homes Council/Building Research Council (SHC)**  
 University of Illinois, Urbana Champaign  
 One E. St. Mary's Road  
 Champaign, IL 61820  
 (217) 333-1801  
 Fax: (800) 336-0616  
 URL: <http://www.arch.uiuc.edu/brc>

**Society of Certified Kitchen Designers**  
 687 Willow Grove St.  
 Hackettstown, NJ 07840  
 (908) 852-0033  
 URL: <http://www.nkba.org>

**DARKROOM EQUIPMENT**

**International Center of Photography**  
 1130 5th Avenue  
 New York, NY 10128  
 (212) 860-1777  
 Fax: (212) 360-6490  
 URL: <http://www.icp.org>  
 E-mail: [info@icp.org](mailto:info@icp.org)

**Photographic and Imaging Manufacturers Association**  
 550 Mamaroneck Avenue, Suite 307  
 Harrison, NY 10528-1612  
 (914) 698-7603  
 Fax: (914) 698-7609  
 URL: <http://www.pima.net>  
 E-mail: [pima@pima.net](mailto:pima@pima.net)

**CHAPTER 12 - FURNISHINGS**

**GENERAL**  
**Americas Mart**  
 240 Peachtree Street, NW, Suite 2200  
 Atlanta, GA 30303  
 (404) 220-3000  
 Fax: (404) 220-3030  
 URL: <http://www.americasmart.com>

**Architectural Digest**  
 6300 Wilshire Blvd., 11th Floor  
 Los Angeles, CA 90048  
 (213) 965-3700  
 URL: <http://www.condenet.com/mags/archdigest/index.html>

**Boston Design Center**  
 One Design Center Place  
 Boston, MA 02210  
 (617) 338-5062  
 URL: <http://www.bostondesign.com>  
 E-mail: [laura@cross.net](mailto:laura@cross.net)

**Contract Design**  
 One Penn Plaza, 10th Fl.  
 New York, NY 10119-1198  
 (212) 615-2608  
 URL: <http://www.contractdesign.com>

**Dallas Design Center**  
 1025 N. Stemmons Freeway, Suite  
 605A  
 Dallas, TX 75207  
 (214) 747-2411

**Denver Design Center**  
 595 South Broadway  
 Denver, CO 80209  
 (303) 733-2455  
 URL: <http://www.denverdesign.com>  
 E-mail: [info@cross.net](mailto:info@cross.net)

**Interior Design**  
 245 West 17th Street  
 New York, NY 10011  
 (212) 463-6675  
 Fax: (212) 463-6667  
 URL: <http://www.cahners.com/mainmag/id.htm>  
 E-mail: [interiordesign@cahners.com](mailto:interiordesign@cahners.com)

**Interiors**  
 Gralla Publications  
 1515 Broadway  
 New York, NY 10036  
 (212) 764-7300

**International Furnishings and Design Association**  
 1200 19th St., NW 300  
 Washington, DC 20036-2422  
 (202) 857-1897  
 Fax: (202) 223-4579  
 E-mail: [info@ifda.com](mailto:info@ifda.com)

**International Interior Design Association**  
 341 Merchandise Mart  
 Chicago, IL 60654-1104  
 (312) 467-1950  
 Fax: (312) 467-0779  
 URL: <http://www.iida.com>  
 E-mail: [idahq@aol.com](mailto:iidahq@aol.com)

**International Interior Design Association (IIDA)**  
 341 Merchandise Mart  
 Chicago, IL 60654-1104  
 (312) 467-1950  
 Fax: (312) 467-0779  
 URL: <http://www.iida.org>

**International Market Square**  
 275 Market Street  
 Minneapolis, MN 55405  
 (612) 338-6250

**The L.A. Mart**  
 1933 S. Broadway, Suite 244  
 Los Angeles, CA 90007  
 (213) 749-7911  
 URL: <http://www.lamart.com>

**Marketplace Design Center**  
 2400 Market Street  
 Philadelphia, PA 19103  
 (215) 561-5000  
 URL: <http://www.marketplaccdc.com>

**The Merchandise Mart**  
 222 Merchandise Mart Plaza, Suite 470  
 Chicago, IL 60654  
 (800) 677-6278  
 URL: <http://www.mmart.com>  
 E-mail: [regmart@mmart.com](mailto:regmart@mmart.com)

**Miami International Merchandise Mart**  
 777 NW 72nd Avenue  
 Miami, FL 33126  
 (305) 261-2900, ext. 169  
 Fax: (305) 261-3659  
 URL: <http://www.mimm.com>  
 E-mail: [mimm@mimm.com](mailto:mimm@mimm.com)

**Pacific Design Center**  
 8687 Melrose Avenue, M-60  
 Los Angeles, CA 90069  
 (310) 657-0800  
 URL:  
<http://www.pacificdesigncenter.com>

**Saint Louis Design Center**  
 917 Locust Street  
 St. Louis, MO 63101  
 (314) 621-6446

**San Diego Design Center**  
 6455 Lusk Blvd.  
 San Diego, CA 92121  
 (619) 452-7332

**The San Francisco Mart**  
 1355 Market Street  
 San Francisco, CA 94103  
 (415) 552-2311  
 URL: <http://www.sfmart.com>

**United Engineering Center**  
 345 East 47th Street  
 New York, NY 10017  
 (212) 705-7000

**The Washington Design Center**  
 300 D Street, SW  
 Washington, DC 20024  
 (202) 554-5053

**GENERAL USE FURNITURE**

**American Association of Textile Chemists and Colorists**  
 P.O. Box 12215  
 Research Triangle Park, NC 27709-2215  
 (919) 549-8141  
 Fax: (919) 549-8933  
 URL: <http://www.aatcc.org>  
 E-mail: [daniels@aatcc.org](mailto:daniels@aatcc.org)

**American Furniture Manufacturers Association**  
 P.O. Box HP-7  
 High Point, NC 27261  
 (336) 884-5000  
 Fax: (336) 884-5303  
 URL: <http://www.afmahp.org>

**American Society of Furniture Designers (ASFD)**  
 1309 Johnson Street  
 P.O. Box 2688  
 High Point, NC 27262  
 (919) 884-4074  
 URL: <http://www.asfd.com>

**American Society of Interior Designers (ASID)**  
 608 Massachusetts Avenue, NE  
 Washington, DC 20002  
 (202) 546-3480  
 Fax: (202) 546-3240  
 URL: <http://www.asidla.org>  
 E-mail: [peppermatrix@earthlink.net](mailto:peppermatrix@earthlink.net)

**American Textile Manufacturers Institute**  
 1130 Connecticut Ave., NW, Suite 1200  
 Washington, DC 20036-3954  
 (202) 862-0500  
 Fax: (202) 862-0570/0590  
 URL: <http://www.atmi.org>

**Chemical Fabrics & Film Association, Inc. (CFFA)**  
 c/o Thomas Associates, Inc.  
 1300 Sumner Ave.  
 Cleveland, OH 44115-2851  
 (216) 241-7333  
 Fax: (216) 241-0105  
 URL: <http://www.taol.com/cffa>

**Composite Panel Association (CPA)**  
 18928 Premiere Ct.  
 Gaithersburg, MD 20879-1569  
 (301) 670-0604  
 Fax: (301) 840-1252  
 URL: <http://www.pbmdf.com>

**Contract Furnishings Council (CFC)**  
 1190 Merchandise Mart  
 Chicago, IL 60654  
 (312) 321-0563

**Industrial Fabrics Association International (IFA)**  
 1801 Country Rd. B W.  
 Roseville, MN 5513-4601  
 (651) 222-2508  
 Fax: (651) 631-0334  
 URL: <http://www.ifai.com>  
 E-mail: [generalinfo@ifai.com](mailto:generalinfo@ifai.com)

**Institute of Store Planners (ISP)**  
 25 N. Broadway  
 Tarrytown, NY 10591  
 (800) 379-9912  
 URL: <http://www.ispo.org>

**National Restaurant Association (NRA)**  
 1200 17th St. NW  
 Washington, DC 20036  
 (202) 331-5900  
 URL: <http://www.restaurant.org>  
 E-mail: [info@dineout.org](mailto:info@dineout.org)

**National Retail Federation (NRF)**  
 325 7th St. NW, Ste. 1000  
 Washington, DC 20004  
 (202) 783-7971  
 Fax: (202) 737-2849  
 URL: <http://www.nfr.com>

**Upholstered Furniture Action Council (UFAC)**  
 P.O. Box 2436  
 High Point, NC 27261  
 (336) 885-5065  
 URL: <http://www.ufac.org>

**SCHOOL AND LIBRARY FURNITURE**

**American Association of School Administrators (AASA)**  
 1801 N. Moore Street  
 Arlington, VA 22209  
 (703) 528-0700  
 Fax: (703) 841-1543  
 URL: <http://www.aasa.org>  
 E-mail: [phouston@aasa.org](mailto:phouston@aasa.org)

**American Library Association**  
 50 East Huron Street  
 Chicago, IL 60611  
 (800) 545-2433  
 Fax: (312) 440-9374  
 URL: <http://www.ala.org>  
 E-mail: [ala@ala.org](mailto:ala@ala.org)

**Art Libraries Society of North America (ARLIS)/NA**  
 4101 Lake Boone Trail, Ste. 201  
 Raleigh, NC 27607  
 (919) 787-5181  
 Fax: (919) 787-4916  
 URL: <http://www.lib.duke.edu/fily/arlis>  
 E-mail: [arlisna@olsonmgmt.com](mailto:arlisna@olsonmgmt.com)

**Association for Childhood Education International (ACEI)**  
 17904 Georgia Ave, Ste. 215  
 Olney, MD 20832  
 (301) 570-2111  
 Fax: (301) 570-2212  
 URL: <http://www.acei.org>

**Association of Higher Education Facilities Officers (APPA)**  
 1643 Prince St.  
 Alexandria, VA 22314  
 (703) 684-1446  
 Fax: (703) 549-2772  
 URL: <http://www.appa.org>

**Association of University Architects (AUA)**  
 Office of Physical Planning  
 Princeton University  
 Princeton, NJ 08544  
 (609) 258-3356

**Council of Educational Facility Planners (CEFPI)**  
 641 Chatham Lane, Suite 217  
 Columbus, OH 43221  
 (614) 792-8103  
 URL: <http://www.cefpi.com>  
 E-mail: [cefpi@cefpi.com](mailto:cefpi@cefpi.com)

**International Federation of Library Associations and Institutions (IFLA)**  
 Postbus 95312 NL-2509 CH  
 The Hague Fax: (Netherlands)  
 31703140884  
 31703834827  
 URL: <http://www.ifla.org>

**National School Boards Association (NSBA)**  
 1680 Duke St.  
 Alexandria, VA 22314  
 (703) 838-6722  
 Fax: (703) 683-7590  
 URL: <http://www.nsba.org>  
 E-mail: [info@nsba.org](mailto:info@nsba.org)

**National School Supply and Equipment Association**  
 8300 Colesville Road, Suite 250  
 Silver Spring, MD 20910  
 (301) 495-0240  
 Fax: (301) 495-3330  
 URL: <http://www.nssea.org>  
 E-mail: [NSSEA@nssea.org](mailto:NSSEA@nssea.org)

**Scientific Equipment and Furniture Association (SEFA)**  
 7 Wildbird Lane  
 Hilton Head Island, SC 29926  
 (843) 689-6878  
 Fax: (843) 689-9958  
 URL: <http://www.sefalaburn.com>

**Society of American Archivists (SAA)**  
 527 S. Wells, 5th Floor  
 Chicago, IL 60607  
 (312) 922-0140  
 Fax: (312) 347-1452  
 URL: <http://www.archivists.com>  
 E-mail: [info@archivists.org](mailto:info@archivists.org)

**Special Libraries Association (SLA)**  
 1700 18th Street, NW  
 Washington, DC 20009  
 (202) 234-4700  
 Fax: (202) 234-4700  
 URL: <http://www.sia.org>  
 E-mail: [sia@sla.org](mailto:sia@sla.org)

**RESIDENTIAL FURNITURE**

**Kitchen Cabinet Manufacturers Association (KCMCA)**  
 1899 Preston White Drive  
 Reston, VA 20191-5435  
 (703) 264-1690  
 Fax: (703) 620-6530  
 URL: <http://www.kcma.org>  
 E-mail: [comments@kcma.org](mailto:comments@kcma.org)

**National Association of Housing and Redevelopment Officials (NAHRO)**  
 630 Eye Street, NW  
 Washington, DC 20001  
 (202) 289-3500  
 Fax: (202) 289-8181  
 URL: <http://www.nahro.org>  
 E-mail: [nahro@nahro.org](mailto:nahro@nahro.org)

**National Home Furnishings Association (NHFA)**  
 P.O. Box 2396  
 High Point, NC 27261  
 (919) 883-1650  
 Fax: (919) 883-1195  
 URL:  
<http://www.homefurnish.com/NHFA/>  
 E-mail: [nhfa@homefurnish.com](mailto:nhfa@homefurnish.com)

**National Housing and Rehabilitation Association (NH&RA)**  
 1625 Massachusetts Ave, NW, Ste. 601  
 Washington, DC 20036  
 (202) 939-1750  
 URL: <http://www.housingonline.com>

**National Multi-Housing Council (NMHC)**  
 1850 M Street, NW Suite 540  
 Washington, DC 20036  
 (202) 974-2300  
 Fax: (202) 775-0112  
 URL: <http://www.nrmhc.org>

**National Retail Federation (NRF)**  
 325 7th St. NW, Ste. 1000  
 Washington, DC 20004  
 (202) 783-7971  
 Fax: (202) 737-2849  
 URL: <http://www.nfr.com>

**Upholstered Furniture Action Council (UFAC)**  
 P.O. Box 2436  
 High Point, NC 27261  
 (336) 885-5065  
 URL: <http://www.ufac.org>



**CLASSIC AND CONTEMPORARY FURNITURE**

National Home Furnishings Association (NHFA)  
P.O. Box 2396  
High Point, NC 27261  
(919) 883-1650  
Fax: (919) 883-1195  
URL: <http://www.homefurnish.com/NHFA/>  
E-mail: [nhfaa@homefurnish.com](mailto:nhfaa@homefurnish.com)

**ECCLESIASTICAL FURNITURE**

Interfaith Forum on Religion, Art and Architecture (IFRAA)  
c/o American Institute of Architects  
1735 New York Ave. NW  
Washington, DC 20006  
(202) 626-7300  
URL: <http://www.e-architect.com/pia/ifraa/veicom.asp>

Partners for Sacred Places (PSP)  
1616 Walnut St., Ste. 2310  
Philadelphia, PA 19102  
(215) 546-1288  
Fax: (215) 546-1180  
URL: <http://www.sacredplaces.org>  
E-mail: [sacredplaces.org](mailto:sacredplaces.org)

**OFFICE FURNITURE**

Business Products Industry Association  
301 North Fairfax Street  
Alexandria, VA 22314  
(703) 549-9040  
Fax: (703) 683-7552  
URL: <http://www.bpia.org>

Business and Institutional Furniture Manufacturers Association (BIFMA)  
2680 Horizon Drive, SE, Suite A1  
Grand Rapids, MI 49546  
(616) 285-3963  
Fax: (616) 285-3765  
URL: <http://www.bifma.com>  
E-mail: [email@bifma.com](mailto:email@bifma.com)

Computer and Business Equipment Manufacturers Association (CBEMA)  
1250 I Street, NW, Suite 200  
Washington, DC 20005  
(202) 737-8888  
Fax: (202) 638-4922  
URL: <http://www.cbema.org> or  
<http://www.itic.org>

Contract Furnishings Council (CFC)  
1190 Merchandise Mart  
Chicago, IL 60654  
(312) 321-0563

Office Products Manufacturers Association  
301 North Fairfax Street  
Alexandria, VA 22314  
(703) 549-9040  
Fax: (703) 683-7552  
URL: <http://www.bpia.org>

**INTERIOR PLANTS AND PLANTERS**

American Nursery & Landscape Association  
1250 I Street, NW, Suite 500  
Washington, DC 20005  
(202) 789-2900  
Fax: (202) 789-1893  
URL: <http://www.anla.org>

American Society of Landscape Architects  
636 Eye Street, NW  
Washington, DC 20001-3736  
(202) 898-2444  
Fax: (202) 898-1185

American Society of Landscape Architects (ASLA)  
636 Eye Street, NW  
Washington, DC 20001-3736  
(202) 898-2444  
Fax: (202) 898-1185  
URL: <http://www.asla.org>  
E-mail: [scahill@asla.org](mailto:scahill@asla.org)

Associated Landscape Contractors of America  
150 Eldon Street, Suite 270  
Herndon, VA 20170  
(703) 736-9666  
Fax: (703) 736-9668  
URL: <http://www.alca.org>

**CHAPTER 13 - SPECIAL CONSTRUCTION****AIR-SUPPORTED STRUCTURES**

Industrial Fabric Association International (IFA)  
1801 Country Rd. B.W.  
Roseville, MI 513-4601  
(651) 222-2508  
Fax: (651) 631-0334  
URL: <http://www.ifa.com>  
E-mail: [generalinfo@ifa.com](mailto:generalinfo@ifa.com)

**SPECIAL PURPOSE ROOMS**

American Hospita Association (AHA)  
1 North Franklin, Suite 2700  
Chicago, IL 60606  
(312) 422-3000  
URL: <http://www.aha.org>  
E-mail: [gmitchel@aha.org](mailto:gmitchel@aha.org)

American Industrial Hygiene Association (AIHA)  
2700 Prosperity Ave., Suite 250  
Fairfax, VA 22031  
(703) 849-8888  
Fax: (703) 707-3561  
URL: <http://www.ahai.org>  
E-mail: [info@aiha.org](mailto:info@aiha.org)

Institute of Environmental Sciences (IES)  
940 East Northwest Highway  
Mount Prospect, IL 60056  
(708) 255-1561  
Fax: (708) 255-1699  
URL: <http://www.onweb.com/cov/mall/institute.html>  
E-mail: [instenvsci@aol.com](mailto:instenvsci@aol.com)

National Spa and Pool Institute (NSPI)  
2111 Eisenhower Avenue  
Alexandria, VA 22314  
(703) 838-0033  
Fax: (703) 549-0493  
URL: <http://www.nspi.org>

Scientific Equipment and Furniture Association (SEFA)  
7 Wildbird Lane  
Hilton Head Island, SC 29926  
(843) 689-6678  
Fax: (843) 689-9958  
URL: <http://www.sefalabfurn.com>

US Pharmacopeia (USP)  
12601 Twinbrook Pkwy  
Rockville, MD 20852  
(800) 877-6733  
Fax: (301) 416-8747  
URL: <http://www.usp.org>

**SOUNDS, VIBRATION, AND SEISMIC CONTROL**

Audio Engineering Society  
60 East 42nd Street, Room 2520  
New York, NY 10165  
(212) 661-8128  
Fax: (212) 652-0417  
URL: <http://www.aes.org>  
E-mail: [HV@aes.org](mailto:HV@aes.org)

National Council of Acoustical Consultants (NCAC)  
66 Morris Avenue, Suite 1A  
Springfield, NJ 07081-1409  
(973) 564-5859  
Fax: (973) 504-7480  
URL: <http://www.ncac.com>  
E-mail: [info@ncac.com](mailto:info@ncac.com)

**RADIATION PROTECTION**

American Hospital Association (AHA)  
1 North Franklin, Suite 2700  
Chicago, IL 60606  
(312) 422-3000  
URL: <http://www.aha.org>  
E-mail: [gmitchel@aha.org](mailto:gmitchel@aha.org)

National Council on Radiation Protection and Measurements (NCRP)  
7910 Woodmont Ave., Suite 800  
Bethesda, MD 20814-3095  
(301) 657-2652  
Fax: (301) 907-8768  
URL: <http://www.ncrp.com>

**PRE-ENGINEERED STRUCTURES**

American Institute of Steel Construction, Inc. (AISC)  
1 East Wacker Drive, Suite 3100  
Chicago, IL 60601-2901  
(312) 670-2400  
Fax: (312) 670-5403  
URL: <http://www.aiscweb.com>  
E-mail: [cattan@aiscmail.com](mailto:cattan@aiscmail.com)

Manufactured Housing Institute  
2101 Wilson Blvd.  
Suite 610  
Arlington, VA 22201-3062  
(703) 558-0400  
Fax: (703) 558-0401  
URL: <http://www.mfhome.org>  
E-mail: [kami@mfhome.org](mailto:kami@mfhome.org)

Metal Building Manufacturers Association (MBMA)  
1300 Sumner Avenue  
Cleveland, OH 44115-2851  
(216) 241-7333  
Fax: (216) 241-0105  
URL: <http://www.mbma.com>  
E-mail: [administrator@mbma.com](mailto:administrator@mbma.com)

National Association of Architectural Metal Manufacturers (NAAMM)  
8 South Michigan Avenue, Suite 1000  
Chicago, IL 60603  
(312) 332-0405  
Fax: (312) 332-0706  
URL: <http://www.naamm.org>  
E-mail: [naamm@naamm.org](mailto:naamm@naamm.org)

**CONTROL**

Building Owners and Managers Association International (BOMA)  
1201 New York Ave. NW, Ste. 300  
Washington, DC 20005  
(202) 408-2662  
Fax: (202) 371-0181  
URL: <http://www.boma.org>

Council on Tall Building and Urban Habitat (CTBUH)  
Lehigh University/Fritz Engineering Lab  
11 E. Packer Ave.  
Bethlehem, PA 18015  
(610) 758-3515  
Fax: (610) 758-3515  
URL: <http://www.lehigh.edu/~inctbu/>

Home Automation Association (HAA)  
1444 I Street, NW, Suite 700  
Washington, DC 20005  
(202) 712-9050  
Fax: (202) 216-9646  
URL: <http://www.homeautomation.org>

International Facility Management Association (IFMA)  
1 East Greenway Plaza, Ste. 1100  
Houston, TX 77046  
(713) 623-4362  
Fax: (713) 623-6124  
URL: <http://www.ifma.org>  
E-mail: [ifmahq@ifma.org](mailto:ifmahq@ifma.org)

**DETECTION AND ALARM**

American Society for Testing and Materials (ASTM)  
100 Barr Harbor Drive  
West Conshohocken, PA 19428-2529  
(610) 832-9555  
Fax: (610) 832-9555  
URL: <http://www.astm.org>  
E-mail: [ctaico@astm.org](mailto:ctaico@astm.org)

Building Owners and Managers Association International (BOMA)  
1201 New York Ave. NW, Ste. 300  
Washington, DC 20005  
(202) 408-2662  
Fax: (202) 371-0181  
URL: <http://www.boma.org>

Fire Suppression Systems Association  
5024-R Campbell Blvd.  
Baltimore, MD 21236  
(410) 931-8100  
Fax: (410) 931-8111  
URL: <http://www.podi.com/fssa>  
E-mail: [fssahq@aol.com](mailto:fssahq@aol.com)

International Facility Management Association (IFMA)  
1 East Greenway Plaza, Ste. 1100  
Houston, TX 77046  
(713) 623-4362  
Fax: (713) 623-6124  
URL: <http://www.ifma.org>  
E-mail: [ifmahq@ifma.org](mailto:ifmahq@ifma.org)

National Burglar and Fire Alarm Association (NBFAA)  
7101 Wisconsin Avenue, Suite 901  
Bethesda, MD 20814-4805  
(301) 967-3202  
Fax: (301) 907-7897  
URL: <http://www.alarm.org>  
E-mail: [membership@alarm.org](mailto:membership@alarm.org)

National Crime Prevention Institute (NCPI)  
University of Louisville  
Burhan Hall, Room 134  
Louisville, Kentucky 40292-0001  
(502) 852-6987  
Fax: (502) 852-6990  
URL: <http://www.louisville.edu>

National Fire Sprinkler Association  
Route 22 and Robin Hill Corporate Park  
Box 1000  
Patterson, NY 12563  
(914) 878-4200  
Fax: (914) 878-4215  
URL: <http://www.nfsa.org>  
E-mail: [info@nfsa.org](mailto:info@nfsa.org)

National Independent Bank Equipment and Systems Association (NIBESA)  
1411 Peterson Street  
Park Ridge, IL 60068  
(847) 825-8419  
Fax: (847) 825-8445

Society of Fire Protection Engineers (SFPE)  
7315 Wisconsin Avenue, Suite 1225W  
Bethesda, MD 20814  
(301) 718-2910  
Fax: (301) 718-2242  
URL: <http://www.sfpe.org>  
E-mail: [sfpehdqts@sfpe.org](mailto:sfpehdqts@sfpe.org)

Underwriters Laboratories (UL)  
333 Pfingsten Road  
Northbrook, IL 60067  
(847) 272-8800  
Fax: (847) 272-8129  
URL: <http://www.ul.com>  
E-mail: [corpcomm@ul.com](mailto:corpcomm@ul.com)

**FIRE SUPPRESSION**

Factory Mutual Engineering Corp.  
P.O. Box 9102  
Norwood, MA 02062-9102  
(781) 762-4300  
Fax: (781) 762-9375  
URL: <http://www.factorymutual.com/engr.htm>  
E-mail: [norfm\\_info@factory-mutual.com](mailto:norfm_info@factory-mutual.com)

Fire Research Section (FRS/NRCC)  
National Research Council Canada  
Ottawa, Canada K1A 0R6  
(613) 993-9101  
URL: <http://www.nrc.ca>

Fire Suppression Systems Association  
5024-R Campbell Blvd.  
Baltimore, MD 21236  
(410) 931-8100  
Fax: (410) 931-8111  
URL: <http://www.podi.com/fssa>  
E-mail: [fssahq@aol.com](mailto:fssahq@aol.com)

National Fire Protection Association  
One Batterymarch Park  
P.O. Box 9101  
Quincy, MA 02269-9101  
(617) 770-3000  
Fax: (617) 770-0700  
URL: <http://www.nfpa.org>  
E-mail: [Library@NFPA.org](mailto:Library@NFPA.org)

National Fire Sprinkler Association  
Route 22 and Robin Hill Corporate Park  
Box 1000  
Patterson, NY 12563  
(914) 878-4200  
Fax: (914) 878-4215  
URL: <http://www.nfsa.org>  
E-mail: [info@nfsa.org](mailto:info@nfsa.org)

Society of Fire Protection Engineers (SFPE)  
7315 Wisconsin Avenue, Suite 1225V  
Bethesda MD 20814  
(301) 718-2910  
Fax: (301) 718-2242  
URL: <http://www.sfpe.org>  
E-mail: [sfpehdqtrs@sfpe.org](mailto:sfpehdqtrs@sfpe.org)

Underwriters Laboratories (UL)  
333 Pfingsten Road  
Northbrook, IL 60062  
(847) 272-8800  
Fax: (847) 272-8129  
URL: <http://www.ul.com>  
E-mail: [corpcomm@ul.com](mailto:corpcomm@ul.com)

Underwriters Laboratories of Canada (ULC)  
7 Crouse Rd.  
Scarborough, Ontario M1R 3A9 Canada  
(416) 757-3611  
URL: <http://www.ulc.ca>

**CHAPTER 14 - CONVEYING SYSTEMS ELEVATORS**

Accessibility Equipment Manufacturers Association  
PO Box 380  
Metamora, IL 61548-0380  
(800) 514-1100  
Fax: (309) 923-7964  
URL: <http://www.aema.com>  
E-mail: [host@aema.com](mailto:host@aema.com)

Elevator Escalator Safety Foundation  
P.O. Box 6273  
Mobile, AL 36660  
(334) 479-2199  
URL: <http://www.eesf.com>

The Elevator Industries Association, Inc. (EIA)  
233-43 Bay Street  
Douglaston, NY 11363  
(718) 279-3859  
Fax: (718) 423-6576

Elevator World, Inc.  
P.O. Box 6507  
Mobile, AL 36660  
(334) 479-4514  
Fax: (334) 479-7043  
URL: <http://www.elevator-world.com>  
E-mail: [sales@elevator-world.com](mailto:sales@elevator-world.com)

Hydraulic Institute (HI)  
9 Sylvan Way  
Parsippany, NJ 07054-3802  
(888) 786-7744  
Fax: (973) 267-9055

International Union of Elevator Constructors (IUEC)  
Suite 310, Clark Building  
5565 Sterrett Place  
Columbia, MD 21044  
(410) 997-9000

National Association of Elevator Contractors (NAEC)  
1298 Wellbrook Circle N.E.  
Conyers, GA, 30207  
(404) 496-1270  
Fax: (404) 496-1272  
URL: <http://www.naec.org>  
E-mail: [naec@mindspring.com](mailto:naec@mindspring.com)

National Association of Elevator Safety Authorities  
67 East Weldon, Suite 103  
P.O. Box 15643  
Phoenix, AZ 85012  
(602) 760-9660  
Fax: (602) 760-9714  
URL: <http://www.pcslink.com/~naesa>

National Association of Vertical Transportation Professionals (NAVTP)  
PO BOX 636  
Bowie, MD 20718  
(301) 262-3150  
Fax: (301) 262-3194

National Elevator Industry Educational Program (NEIEP)  
11 Larson Way  
Attleboro Falls, MA 02763  
(508) 699-2200  
Fax: (508) 699-2495

National Elevator Industry, Inc. (NEI)  
400 Frank W. Burr Boulevard  
Teaneck, NJ 07666-6801  
(201) 928-2828  
Fax: (201) 928-4200

**ESCALATORS AND MOVING WALKS**

Elevator Escalator Safety Foundation  
P.O. Box 6273  
Mobile, AL 36660  
(334) 479-2199  
URL: <http://www.eesf.com>

**MATERIAL HANDLING**

Automatic Guided Vehicle Systems  
8720 Red Oak Blvd., Suite 201  
Charlotte, NC 28217-3992  
(704) 676-1190  
Fax: (704) 676-1199  
URL: <http://www.mhia.org>

Conveyor Equipment Manufacturers Association  
6724 Lone Oak Blvd.  
Naples, Florida 34109  
(941) 514-3441  
Fax: (941) 514-4370  
URL: <http://www.cermanet.org>  
E-mail: [cema@cermanet.org](mailto:cema@cermanet.org)

Crane Manufacturers Association of America  
8720 Red Oak Blvd., Suite 201  
Charlotte, NC 28217-3957  
(704) 676-1190  
Fax: (704) 676-1199  
URL: <http://www.mhia.org>

Loading Dock Equipment Manufacturers Association  
8720 Red Oak Blvd., Suite 201  
Charlotte, NC 28217-3957  
(704) 522-7826  
Fax: (704) 522-7826

Material Handling Equipment Distributors Association (MHEDA)  
201 US Highway 45  
Vernon Hills, IL 60061-2398  
(847) 680-3500  
Fax: (847) 362-6989  
URL: <http://www.mheda.org>  
E-mail: [Connect@MHEDA.org](mailto:Connect@MHEDA.org)

Material Handling Industry of America  
8720 Red Oak Blvd., Suite 201  
Charlotte, NC 28217-3992  
(704) 676-1190  
Fax: (704) 676-1199  
URL: <http://www.mhia.org>  
E-mail: [cdalton@mhia.org](mailto:cdalton@mhia.org)

Material Handling Systems Association of Professional Material Handling Consultants  
8720 Red Oak Blvd., Suite 224  
Charlotte, NC 28217-3957  
(704) 558-4749

Power Crane and Shovel Association  
A subsidiary of Construction Industry Manufacturers Association  
111 East Wisconsin Avenue, Suite 1000  
Milwaukee, WI 53202-4879  
(414) 272-0943  
Fax: (414) 272-1170  
URL: <http://www.cimanet.com>  
E-mail: [cima@cimanet.com](mailto:cima@cimanet.com)

**CHAPTER 15 - MECHANICAL**

**MECHANICAL INSULATION**

American Society of Mechanical Engineers (ASME)  
1828L Street, NW, Suite 906  
Washington, DC 20006  
(202) 785-3756  
Fax: (202) 429-9417  
URL: <http://www.asme.org>  
E-mail: [infocentral@asme.org](mailto:infocentral@asme.org)

Mechanical Contractors Association of America (MCAA)  
1385 Piccard Dr.  
Rockville, MD 20850-4329  
(800) 556-3653  
Fax: (301) 990-9690  
URL: <http://www.mcaa.org>

**BUILDING SERVICES PIPING**

American Society of Mechanical Engineers (ASME)  
1828L Street, NW, Suite 906  
Washington, DC 20006  
(202) 785-3756  
Fax: (202) 429-9417  
URL: <http://www.asme.org>  
E-mail: [infocentral@asme.org](mailto:infocentral@asme.org)

Plastic Pipe and Fittings Association (PPFA)  
800 Roosevelt Rd., Building C, Suite 20  
Glen Ellyn, IL 60137-5833  
(630) 858-6540  
Fax: (630) 790-3095  
E-mail: [nicolec@cmservnet.com](mailto:nicolec@cmservnet.com)

Plastics Pipe Institute (PPI)  
1801 K St., NW, Suite 600K  
Washington, DC 20006-1301  
(202) 974-5318  
Fax: (202) 293-0048  
URL: <http://www.plasticpipe.org>

Plumbing and Drainage Institute (PDI)  
45 Bristol Dr., Suite 101  
South Easton, MA 02375  
(508) 230-3516  
URL: <http://www.pdionline.org>

Uni-Bell PVC Pipe Association (UNI)  
2655 Villa Creek Dr., Suite 155  
Dallas, TX 75234  
(972) 243-3902  
Fax: (972) 243-3907  
E-mail: [members.aol.com/unibell](mailto:members.aol.com/unibell)

**PLUMBING**

American Society of Plumbing Engineers  
3617 East Thousand Oaks Blvd.  
Suite 210  
Westlake Village, CA 91362  
(805) 495-7120  
Fax: (805) 495-4861  
URL: <http://www.aspe.org>

American Water Works Association (AWWA)  
6666 W. Quincy Ave.  
Denver, CO 80235  
(303) 794-7711  
URL: <http://www.awwa.org>

Cast Iron Soil Pipe Institute (CISPI)  
5959 Shallowford Road, Suite 419  
Chattanooga, TN 37421  
(423) 892-0137  
Fax: (423) 892-0817  
URL: <http://www.cispi.org>  
E-mail: [blevan@mindspring.com](mailto:blevan@mindspring.com)

Corrugated Polyethylene Pipe Association (CPPA)  
Division of PPI  
1825 Connecticut Ave., NW  
Suite 680  
Washington, DC 20009  
Tel: (888) 314-6774  
Fax: (202) 462-9779  
URL: <http://www.cppa-info.org>

International Association of Plumbing and Mechanical Officers (IAPMO)  
20001 Walnut Drive South  
Wainut, CA 91789-2825  
(909) 595-8449  
Fax: (909) 594-3690  
URL: <http://www.iapmonet.org>  
E-mail: [iapmo@earthlink.net](mailto:iapmo@earthlink.net)

Manufacturers Standardization Society of the Valve and Fittings Industry (MSS)  
127 Park St., NE  
Vienna, VA 22180-4602  
(703) 281-6613  
Fax: (703) 281-6671  
URL: <http://www.mss-hq.com>

National Association of Plumbing-Heating-Cooling Contractors (NAPHCC)  
180 South Washington Street  
P.O. Box 6808  
Falls Church, VA 22046-1148  
(703) 237-8100  
Fax: (703) 237-7442  
URL: <http://www.naphcc.org>  
E-mail: [naphcc@naphcc.org](mailto:naphcc@naphcc.org)

National Solid Waste Management Association (NSWMA) (11.20)  
c/o Environmental Industry Associates  
4301 Connecticut Ave., NW  
Suite 300  
Washington, DC 20008  
(202) 244-4700

Plastic Pipe and Fittings Association (PPFA)  
800 Roosevelt Rd., Building C, Suite 20  
Glen Ellyn, IL 60137-5833  
(630) 858-6540  
Fax: (630) 790-3095  
E-mail: [nicolec@cmservnet.com](mailto:nicolec@cmservnet.com)

Plastics Pipe Institute (PPI)  
1801 K St., NW, Suite 600K  
Washington, DC 20006-1301  
(202) 974-5318  
Fax: (202) 293-0048  
URL: <http://www.plasticpipe.org>

Plumbing Fixtures and Equipment American Society of Sanitary Engineering  
28901 Clemens Rd., Suite 100  
Westlake, OH 44145  
(440) 835-3040  
Fax: (440) 835-3488  
URL: <http://www.asse-plumbing.org>

Plumbing Manufacturers Institute (PMI)  
1340 Remington Rd., Suite A  
Schaumburg, IL 60173  
(847) 884-9764  
Fax: (847) 884-9775  
URL: <http://www.pmihome.org>  
E-mail: [info@pmihome.org](mailto:info@pmihome.org)

Plumbing and Drainage Institute (PDI)  
45 Bristol Dr., Suite 101  
South Easton, MA 02375  
(508) 230-3516  
URL: <http://www.pdionline.org>

Submersible Wastewater Pump Association (SWPA)  
1866 Sheridan Rd., Suite 210  
Highland Park, IL 60035  
(847) 681-1868  
Fax: (847) 681-1869  
URL: <http://www.swpa.org>

Sump and Sewage Pump Manufacturers Association (SSPMA)  
P.O. Box 647  
Northbrook, IL 60065-0647  
(847) 559-9233  
Fax: (847) 559-9235  
URL: <http://www.sspma.org>

Uni-Bell PVC Pipe Association (UNI)  
2655 Villa Creek Dr., Suite 155  
Dallas, TX 75234  
(972) 243-3902  
Fax: (972) 243-3907  
E-mail: [members.aol.com/unibell](mailto:members.aol.com/unibell)

Water Systems Council (WSC)  
Building C, Suite 20  
800 Roosevelt Rd.  
Glen Ellyn, IL 60137  
(630) 545-1762  
Fax: (630) 790-3095

**HEAT GENERATION EQUIPMENT**

American Boiler Manufacturers Association (ABMA)  
950 North Glebe Rd., Suite 160  
Arlington, VA 22203-1824  
(703) 522-7350  
Fax: (703) 522-2665  
URL: <http://www.abma.com>

American Gas Association  
400 N. Capitol Street, NW  
Washington, DC 20001  
(202) 824-7000  
Fax: (202) 824-7115  
URL: <http://www.aga.com>  
E-mail: [dyocum@aga.com](mailto:dyocum@aga.com)

American Society of Heating, Refrigerating and Air Conditioning Engineers, Inc. (ASHRAE)  
1791 Tullie Circle, NE  
Atlanta, GA 30329  
(404) 636-8400  
Fax: (404) 321-5478  
URL: <http://www.ashrae.org>  
E-mail: [ashrae@ashrae.org](mailto:ashrae@ashrae.org)

Compressed Gas Association (CGA)  
1725 Jefferson Davis Hwy., Suite 1004  
Arlington, VA 22202-4102  
(703) 412-0900  
Fax: (703) 412-0128  
URL: <http://www.cganet.com>

Cooling Tower Institute (CTI)  
530 Wells Fargo Drive, Suite 218  
Houston, TX 77090  
(281) 583-4087  
Fax: (281) 537-1721  
URL: <http://www.cti.org>

Industrial Heating Equipment Association  
1901 North Fort Meyer Drive, Suite 303  
Arlington, VA 22209  
(703) 525-2513  
Fax: (703) 525-2515  
URL: <http://www.iheta.org>  
E-mail: [iheta@iheta.org](mailto:iheta@iheta.org)

International Approval Services (IAS)  
8501 East Pleasant Valley Rd.  
Cleveland, OH 44131-5575  
(216) 524-4990  
URL: <http://www.iasapprovals.org>

International District Energy Association  
1200 19th Street  
Suite 300  
Washington, DC 20036  
(202) 429-5111  
URL: <http://www.districtenergy.com>

#### REFRIGERATION AND HEAT TRANSFER

Air Conditioning Contractors of America  
Wholesalers Association  
1712 New Hampshire Ave., NW  
Washington, DC 20009  
(202) 483-9370  
Fax: (202) 234-4721  
URL: <http://www.acca.org>  
E-mail: [admin@acca.org](mailto:admin@acca.org)

Air Conditioning and Refrigeration Institute (ARI)  
4301 North Fairfax Drive  
Suite 425  
Arlington, VA 22203  
(703) 524-8800  
Fax: (703) 528-3816  
URL: [www.ari.org](http://www.ari.org)

Air Conditioning and Refrigeration  
Wholesalers Association  
1650 South Dixie Drive  
5th Floor  
Boca Raton, FL 33432  
(561) 338-3495  
Fax: (561) 338-3496  
URL: <http://www.arw.org>

Air Conditioning and Refrigeration Institute (ARI)  
4301 Northwest Fairfax Drive  
Suite 425  
Arlington, VA 22203  
(703) 524-8800  
Fax: (703) 528-3816  
URL: <http://www.ari.org>  
E-mail: [ari@ari.org](mailto:ari@ari.org)

Association of Energy Engineers  
4025 Pleasantdale Road, Suite 420  
Atlanta, GA 30340  
(404) 447-5083  
Fax: (404) 446-3969  
URL: <http://www.aeecenter.org>

Fluid Controls Institute (FCI)  
c/o Thomas Associates, Inc.  
1300 Sumner Ave.  
Cleveland, OH 44115-2851  
(216) 241-7333  
Fax: (216) 241-0105  
URL: <http://www.taol.com/fci>

Heat Exchange Institute (HEI)  
c/o Thomas Associates, Inc.  
1300 Sumner Ave.  
Cleveland, OH 44115-2851  
(216) 241-7333  
Fax: (216) 241-0105  
URL: <http://www.heatexchange.org>

National Association of Plumbing-Heating  
Cooling Contractors (NAPHCC)  
180 South Washington Street  
P.O. Box 6806  
Falls Church, VA 22046-1148  
(703) 237-8100  
Fax: (703) 237-7442  
URL: <http://www.naphcc.org>  
E-mail: [naphcc@naphcc.org](mailto:naphcc@naphcc.org)

Refrigeration Service Engineers Society (RSES)  
1666 Rand Road  
Des Plaines, IL 60016  
(708) 297-6464  
Fax: (708) 297-5038  
URL: <http://www.rses.org>  
E-mail: [rses@starnetinc.com](mailto:rses@starnetinc.com)

#### HVAC SYSTEMS

Air Conditioning Contractors of America  
1712 New Hampshire Ave., NW  
Washington, DC 20009  
(202) 483-9370  
Fax: (202) 234-4721  
URL: <http://www.acca.org>  
E-mail: [admin@acca.org](mailto:admin@acca.org)

Air Conditioning and Refrigeration Institute (ARI)  
4301 North Fairfax Drive  
Suite 425  
Arlington, VA 22203  
(703) 524-8800  
Fax: (703) 528-3816  
URL: [www.ari.org](http://www.ari.org)

Air Conditioning and Refrigeration  
Wholesalers Association  
1650 South Dixie Drive  
5th Floor  
Boca Raton, FL 33432  
(561) 338-3495  
Fax: (561) 338-3496  
URL: <http://www.arw.org>

Air Diffusion Council (ADC)  
104 South Michigan Avenue, Suite 1500  
Chicago, IL 60603  
(312) 201-0101  
Fax: (312) 201-0214

Air Movement and Control Association (AMCA)  
30 West University Drive  
Arlington Heights, IL 60004  
(847) 394-0150  
Fax: (847) 394-0066  
URL: <http://www.amca.org>  
E-mail: [amca@amca.org](mailto:amca@amca.org)

Air Conditioning and Refrigeration Institute (ARI)  
4301 Northwest Fairfax Drive  
Suite 425  
Arlington, VA 22203  
(703) 524-8800  
Fax: (703) 528-3816  
URL: <http://www.ari.org>  
E-mail: [ari@ari.org](mailto:ari@ari.org)

American Institute of Plant Engineers (AIPE)  
8180 Corporate Park Dr., Ste. 305  
Cincinnati, OH 45242  
(513) 489-2473  
Fax: (513) 241-7422  
E-mail: [aipe@ix.netcom.com](mailto:aipe@ix.netcom.com)

Cooling Tower Institute  
Box 73383  
Houston, TX 77273  
(713) 583-4087  
URL: <http://www.cti.org>  
E-mail: [vmanser@cti.org](mailto:vmanser@cti.org)

Department of Energy  
1000 Independence Avenue, SW  
Washington, DC 20585  
(202) 586-5000  
URL: <http://www.doe.gov>

Department of Energy (DOE)  
Corral Building  
1000 Independence Ave. SW  
Washington, DC 20585  
(202) 586-5000  
URL: <http://www.home.doe.gov>

Home Ventilating Institute Division of the Air  
Movement and Control Association  
30 West University Drive  
Arlington Heights, IL 60004  
(708) 394-0150  
URL: <http://www.amca.org>  
E-mail: [amca@amca.org](mailto:amca@amca.org)

Hydronics Institute (HI)  
P.O. Box 218  
Berkeley Heights, NJ 07922  
(908) 464-8200  
Fax: (908) 464-7818  
URL: <http://www.gamanet.org>

Intertek Testing Services (ITS)  
3933 US Route 11  
Cortland, NY 13045-7902  
(607) 753-6711  
URL: <http://www.itsglobal.com>

Manufacturers Standardization Society of  
the Valve and Fittings Industry (MSS)  
127 Park St., NE  
Vienna, VA 22180-4602  
(703) 281-6613  
Fax: (703) 281-6671  
URL: <http://www.mss-hq.com>

Mechanical Contractors Association of  
America (MCAA)  
1385 Piccard Dr.  
Rockville, MD 20850-4329  
(800) 556-3653  
Fax: (301) 990-9690  
URL: <http://www.mcaa.org>

National Association of Plumbing-Heating-  
Cooling Contractors (NAPHCC)  
180 South Washington Street  
P.O. Box 6808  
Falls Church, VA 22046-1148  
(703) 237-8100  
Fax: (703) 237-7442  
URL: <http://www.naphcc.org>  
E-mail: [naphcc@naphcc.org](mailto:naphcc@naphcc.org)

Sheet Metal and Air Conditioning  
Contractors National Association  
(SMACNA)  
4201 Lafayette Center Drive  
Chantilly, VA 20151-1209  
(703) 803-2980  
Fax: (703) 803-3732  
URL: <http://www.smacna.org>  
E-mail: [info@smacna.org](mailto:info@smacna.org)

#### AIR DISTRIBUTION

Air Diffusion Council (ADC)  
104 South Michigan Avenue, Suite 1500  
Chicago, IL 60603  
(312) 201-0101  
Fax: (312) 201-0214

Air Distributing Institute  
4415 West Harrison Street  
Suite 242C  
Hillside, IL 60162  
(708) 449-2933

Air Movement and Control Association  
(AMCA)  
30 West University Drive  
Arlington Heights, IL 60004  
(847) 394-0150  
Fax: (847) 394-0066  
URL: <http://www.amca.org>  
E-mail: [amca@amca.org](mailto:amca@amca.org)

American Society of Heating, Refrigerating  
and Air Conditioning Engineers, Inc.  
(ASHRAE)  
1791 Tullie Circle, NE  
Atlanta, GA 30329  
(404) 636-8400  
Fax: (404) 321-5478  
URL: <http://www.ashrae.org>  
E-mail: [ashrae@ashrae.org](mailto:ashrae@ashrae.org)

Associated Air Balance Council (AABC)  
1518 K St., NW, Suite 503  
Washington, DC 20005  
(202) 737-0202  
Fax: (202) 638-4833  
URL: <http://www.aabchq.com>

## CHAPTER 16 - ELECTRICAL

### BASIC ELECTRICAL MATERIALS AND METHODS

American National Standards Institute  
(ANSI)  
11 West 42nd Street  
13th Floor  
New York, NY 10036-8002  
(212) 642-4900  
Fax: (212) 398-0023  
URL: <http://www.ansi.org>

American Society for Testing and Materials  
(ASTM)  
100 Barr Harbor Drive  
West Conshohocken, PA 19380-2529  
(610) 832-9585  
Fax: (610) 832-9555  
URL: <http://www.astm.org>  
E-mail: [ctalco@astm.org](mailto:ctalco@astm.org)

Edison Electric Institute (EEI)  
701 Pennsylvania Ave., NW  
Washington, DC 20004  
(202) 508-5000 or Tel: (800) F-F1 4688  
Fax: (202) 508-5794  
URL: <http://www.eei.org>  
E-mail: [eeionline@eei.org](mailto:eeionline@eei.org)

Electric Power Research Institute  
Box 10412  
Palo Alto, CA 94303-0613  
(415) 855-2000  
Fax: (415) 855-2954  
URL: <http://www.eprl.com>  
E-mail: [ccole@eprl.com](mailto:ccole@eprl.com)

Institute of Electrical and Electronics  
Engineers  
Corporate Office  
3 Park Avenue  
New York, NY 10016  
(212) 419-7900  
Fax: (212) 752-4929  
URL: <http://www.ieee.org>

Institute of Electrical and Electronics  
Engineers (IEEE)  
Standards Department  
445 Hoes Lane  
P.O. Box 1331  
Piscataway, NJ 08855-1330  
(908) 562-3800  
Fax: (908) 562-1571  
URL: <http://www.ieee.org>

Insulated Cable Engineers Association  
(ICEA)  
P.O. Box 440  
South Yarmouth, MA 02864  
(508) 394-4424  
Fax: (508) 394-1194  
URL: <http://www.icea.net>

International Electrotechnical Commission  
(IEC)  
11 West 42nd St., 13th Floor  
New York, NY 10036-8002  
(212) 642-4900  
Fax: (212) 398-0023  
URL: <http://www.ansi.org>

Lightning Protection Institute (LPI)  
3335 N. Arlington Heights Rd., Suite E  
Arlington Heights, IL 60004-7700  
(847) 577-7200  
Fax: (847) 577-7276  
URL: <http://www.lightning.org>

National Electrical Contractors Association  
(NECA)  
3 Bethesda Metro Center, Suite 1100  
Bethesda, MD 20814-3299  
(301) 657-3110  
Fax: (301) 215-4500  
URL: <http://www.necanet.org>  
E-mail: [webmaster@necanet.org](mailto:webmaster@necanet.org)

National Electrical Manufacturers  
Association (NFMA)  
1300 N 17th Street, Suite 1847  
Rosslyn, VA 22209  
(703) 841-3200  
Fax: (703) 841-3300  
URL: <http://www.nema.org>

Underwriters Laboratories (UL)  
333 Pfingsten Road  
Northbrook, IL 60062  
(847) 272-8800  
Fax: (847) 272-8129  
URL: <http://www.ul.com>  
E-mail: [corpcomm@ul.com](mailto:corpcomm@ul.com)

**TRANSMISSION AND DISTRIBUTION**

American Institute of Plant Engineers (AIPE)  
8180 Corporate Park Dr., Ste. 305  
Cincinnati, OH 45242  
(513) 489-2473  
Fax: (513) 247-7422  
E-mail: [aipe@ix.netcom.com](mailto:aipe@ix.netcom.com)

International Electrical Testing Association (NETA)  
106 Stone Street  
P.O. Box 687  
Morrison, CO 80465  
(303) 697-8441  
Fax: (303) 697-8431  
URL: <http://www.electriconet.com/neta>

International Society for Measurement and Control (ISA)  
67 Alexander Dr.  
Research Triangle Park, NC 27709  
(919) 549-8411  
Fax: (919) 549-8288  
URL: <http://www.isa.org>

**LIGHTING**

American Lighting Association  
2050 Stemmons Freeway, Suite 10046  
Dallas, TX 75207  
(800) 605-4448  
Fax: (214) 698-9899  
URL: <http://www.americanlightingassoc.com>

Architectural Lighting  
1515 Broadway, 32nd Floor  
New York, NY 10036  
(212) 869-1300  
URL: <http://www.archlighting.com>  
E-mail: [cdilouie@mfi.com](mailto:cdilouie@mfi.com)

Association of Edison Illuminating Companies  
600 North 18th Street  
P.O. Box 2641  
Birmingham, AL 35291-0992  
(205) 257-2530  
Fax: (305) 257-2540  
URL: <http://www.aeic.org>

Certified Ballast Manufacturers Association  
355 Lexington Avenue, 17th Floor  
New York, NY 10017  
(212) 297-2122  
Fax: (212) 370-9047  
URL: <http://www.certbal.org>  
E-mail: [maxtond@apk.net](mailto:maxtond@apk.net)

Edison Electric Institute (EEI)  
701 Pennsylvania Ave., NW  
Washington, DC 20004  
(202) 508-5000 or Tel: (800) EEI-4688  
Fax: (202) 508-5794  
URL: <http://www.eei.org>  
E-mail: [eeionline@eei.org](mailto:eeionline@eei.org)

Illuminating Engineering Society of North America (IES)  
120 Wall Street, 17th Floor  
New York, NY 10005  
(212) 248-5000  
Fax: (212) 248-5017  
URL: <http://www.iesna.org>  
E-mail: [iesna@iesna.org](mailto:iesna@iesna.org)

International Association of Lighting Designers (IALD)  
The Merchandise Mart  
200 World Trade Center, Suite 487  
Chicago, IL 60654  
(312) 527-3677  
Fax: (312) 527-3680  
URL: <http://www.iald.org>  
E-mail: [iald@iald.org](mailto:iald@iald.org)

Lawrence Berkeley Laboratory (LBL)  
Lighting Systems Research Group  
Mail Stop 46-125  
1 Cyclotron Road  
Berkeley, CA 94720  
(510) 486-5388  
Fax: (510) 486-6940  
URL: <http://www.lbl.gov>

Lighting Research Center (LRC)  
Rensselaer Polytechnic Institute  
Greene Bldg., #115  
Troy, NY 12180-3590  
(518) 276-8716  
Fax: (518) 276-2999  
URL: <http://lighting.lrc.rpi.edu>

Lighting Research Institute (LRI)  
120 Wall St.  
New York, NY 10005-4001  
(212) 248-5014  
URL: <http://lighting.lrc.rpi.edu>

National Lighting Bureau (NLB)  
2101 L St. NW  
Washington, DC 20037  
(202) 457-8437  
Fax: (202) 457-8437

**COMMUNICATIONS**

Alliance for Telecommunications Industry Solutions (ATIS)  
1200 G St., NW, Suite 500  
Washington, DC 20005-3837  
(202) 628-6380  
URL: <http://www.atis.org>

Audio Engineering Society  
60 East 42nd Street, Room 2520  
New York, NY 10165  
(212) 661-8528  
Fax: (212) 682-0417  
URL: <http://www.aes.org>  
E-mail: [HW@aes.org](mailto:HW@aes.org)

Electronic Industries Association (EIA)  
2500 Wilson Blvd.  
Arlington, VA 22201-3834  
(703) 907-7500  
URL: <http://www.eia.org>

Institute of Electrical and Electronics Engineers  
Corporate Office  
3 Park Avenue  
New York, NY 10016  
(212) 419-7900  
Fax: (212) 752-4929  
URL: <http://www.ieee.org>

Institute of Electrical and Electronics Engineers (IEEE)  
Standards Department  
445 Hoes Lane  
P.O. Box 1331  
Piscataway, NJ 08855-1330  
(908) 562-3800  
Fax: (908) 562-1571  
URL: <http://www.ieee.org>

International Municipal Signal Association  
165 E. Union St.  
Newark, NY 14513  
(315) 331-2182  
Fax: (315) 331-8205  
URL: <http://www.imsasafety.org>

Multimedia Telecommunications Association  
2500 Wilson Boulevard, Suite 300  
Arlington, VA 22201  
(703) 907-7472  
Fax: (703) 907-7478

**CHAPTER 17 - SPORTS AND GAMES FACILITIES**

**FIELD SPORTS**

Amateur Athletic Union of the United States (AAU)  
c/o Walt Disney World Resorts  
PO Box 10000  
Lake Buena Vista, FL 32830-1000  
(407) 934-7200  
URL: <http://www.aausports.org>

American Professional Soccer League  
122 C Street, NW  
Washington, DC 20001  
(202) 638-0022  
Fax: (202) 638-4185  
URL: <http://www.a-league.com>

American Society of Golf Course Architects (ASGCA)  
221 North LaSalle Street, 35th Floor  
Chicago, IL, 60601  
(312) 372-7090  
Fax: (312) 372-6160  
URL: <http://www.golfdesign.org>  
E-mail: [asgcaweb@selz.com](mailto:asgcaweb@selz.com)

National Association of Collegiate Directors of Athletics (NACDA)  
PO Box 16428  
Cleveland, OH 44116  
(440) 892-4000  
Fax: (440) 892-4007  
URL: <http://www.nacda.com>

National Association of Professional Baseball Leagues  
201 Bayside Drive SE  
St. Petersburg, FL 33701  
(727) 822-6937  
Fax: (727) 821-5819  
URL: <http://www.minorleaguebaseball.com>  
E-mail: [napbl@intnet.net](mailto:napbl@intnet.net)

National Collegiate Athletic Association  
6201 College Blvd.  
Overland Park, KS 66211  
(913) 339-1906  
Fax: (913) 339-1950  
URL: <http://www.ncaa.org>

National Football League (NFL)  
280 Park Avenue  
New York, NY 10017  
(212) 450-2000  
Fax: (212) 681-7599  
URL: <http://www.nfl.com>

National Golf Foundation  
1150 South US Highway 1  
Jupiter, FL 33477  
(407) 744-8006  
Fax: (407) 744-6107  
URL: <http://www.ngf.org>  
E-mail: [ngf@ngf.org](mailto:ngf@ngf.org)

National Recreation and Park Association (NRPA)  
22377 Belmont Ridge Road  
Asburn, VA 20148  
(703) 858-0784  
Fax: (703) 858-0794  
URL: <http://www.nrpa.org>  
E-mail: [info@nrpa.org](mailto:info@nrpa.org)

Sports Turf Managers Association (STMA)  
1375 Rolling Hills Loop  
Council Bluffs, IA 51503-8552  
(712) 366-2669  
Fax: (712) 366-9119  
URL: <http://www.aip.com/stma>

United States Olympic Committee (USOC)  
1 Olympic Plaza  
Colorado Springs, CO 80909  
(719) 632-5551  
Fax: (719) 578-4654  
URL: <http://www.usoc.org>

United States Soccer Federation  
National Headquarters  
1801-1811 South Prairie Avenue  
Chicago, IL 60616  
(312) 808-1300  
Fax: (312) 808-1301  
URL: <http://www.us-soccer.com>  
E-mail: [SOCFED@aol.com](mailto:SOCFED@aol.com)

**TRACK AND FIELD**

Amateur Athletic Union of the United States (AAU)  
c/o Walt Disney World Resorts  
PO Box 10000  
Lake Buena Vista, FL 32830-1000  
(407) 934-7200  
URL: <http://www.aausports.org>

National Association of Collegiate Directors of Athletics (NACDA)  
PO Box 16428  
Cleveland, OH 44116  
(440) 892-4000  
Fax: (440) 892-4007  
URL: <http://www.nacda.com>

National Collegiate Athletic Association  
6201 College Blvd.  
Overland Park, KS 66211  
(913) 339-1906  
Fax: (913) 339-1950  
URL: <http://www.ncaa.org>

United States Olympic Committee (USOC)  
1 Olympic Plaza  
Colorado Springs, CO 80909  
(719) 632-5551  
Fax: (719) 578-4654  
URL: <http://www.usoc.org>

**COURT SPORTS**

Amateur Athletic Union of the United States (AAU)  
c/o Walt Disney World Resorts  
PO Box 10000  
Lake Buena Vista, FL 32830-1000  
(407) 934-7200  
URL: <http://www.aausports.org>

International Racquet Sports Association  
263 Summer Street  
Boston, MA 02110  
(617) 951-0055  
Fax: (617) 951-0056  
URL: <http://www.ihrsa.org>  
E-mail: [web@ihrsa.org](mailto:web@ihrsa.org)

National Association of Collegiate Directors of Athletics (NACDA)  
PO Box 16428  
Cleveland, OH 44116  
(440) 892-4000  
Fax: (440) 892-4007  
URL: <http://www.nacda.com>

National Basketball Association (NBA)  
645 Fifth Avenue  
10th Floor  
New York, NY 10022  
(212) 826-8000  
Fax: (212) 826-3861  
URL: <http://www.nba.com>

National Collegiate Athletic Association  
6201 College Blvd.  
Overland Park, KS 66211  
(913) 339-1906  
Fax: (913) 339-1950  
URL: <http://www.ncaa.org>

National Council of Young Men's Christian Association (YMCA-USA)  
101 N. Wacker Drive  
Chicago, IL 60606  
(312) 977-0031  
Fax: (312) 977-9063  
URL: <http://www.ymca.net>

US Professional Tennis Association  
One USPTA Center  
3535 Briarpark Drive  
Houston, TX 77042  
(713) 978-7782  
Fax: (713) 978-7780  
URL: <http://www.uspta.org>  
E-mail: [uspta@uspta.org](mailto:uspta@uspta.org)

US Tennis Association  
70 West Red Oak Lane  
White Plains, NY 10604  
(914) 696-7000  
Fax: (914) 696-7167  
URL: <http://www.usta.com>

United States Olympic Committee (USOC)  
1 Olympic Plaza  
Colorado Springs, CO 80909  
(719) 632-5551  
Fax: (719) 578-4654  
URL: <http://www.usoc.org>

United States Tennis Court and Track Builders Association (USTCTBA)  
3525 Ellicott Mills Dr., Suite N.  
Ellicott City, MD 21043  
(410) 418-4875  
Fax: (410) 418-4805  
URL: <http://www.ustctba.com>  
E-mail: [info@ustctba.org](mailto:info@ustctba.org)

**TABLE AND BAR SPORTS**

Billiard and Bowling Institute of America  
200 Castlewood Drive  
North Palm Beach, FL 33408  
(561) 840-1120  
Fax: (561) 863-8984  
E-mail: [sdsigma@aol.com](mailto:sdsigma@aol.com)

National Collegiate Athletic Association  
6201 College Blvd.  
Overland Park, KS 66211  
(913) 339-1906  
Fax: (913) 339-1950  
URL: <http://www.ncaa.org>

United States Olympic Committee (USOC)  
1 Olympic Plaza  
Colorado Springs, CO 80909  
(719) 632-5551  
Fax: (719) 578-4654  
URL: <http://www.usoc.org>

**AQUATICS**

Amateur Athletic Union of the United States (AAU)  
c/o Walt Disney World Resorts  
PO Box 10000  
Lake Buena Vista, FL 32830-1000  
(407) 934-7200  
URL: <http://www.aausports.org>

American Water Ski Association  
799 Overlook Drive  
Winterhaven, FL 33884  
(941) 324-4341  
Fax: (941) 325-8259  
URL: <http://www.usawaterski.org>

National Association of Collegiate Directors of Athletics (NACDA)  
PO Box 16428  
Cleveland, OH 44116  
(440) 892-4000  
Fax: (440) 892-4007  
URL: <http://www.nacda.com>

National Collegiate Athletic Association  
6201 College Blvd.  
Overland Park, KS 66211  
(913) 339-1906  
Fax: (913) 339-1950  
URL: <http://www.ncaa.org>

National Spa and Pool Institute (NSPI)  
2111 Eisenhower Avenue  
Alexandria, VA 22314  
(703) 838-0083  
Fax: (703) 549-0493  
URL: <http://www.nspi.org>

National Swimming Pool Foundation  
10803 Guffdale  
Suite 300  
San Antonio, TX 78216  
(210) 525-1277  
URL: <http://www.nspf.com>

United States Olympic Committee (USOC)  
1 Olympic Plaza  
Colorado Springs, CO 80909  
(719) 632-5551  
Fax: (719) 578-4654  
URL: <http://www.usoc.org>

**EQUESTRIAN**

American Horse Shows Association  
220 East 42nd Street, Suite 409  
New York, NY 10017-5876  
(212) 972-2472  
Fax: (212) 963-7286  
URL: <http://www.ahsa.org>

National Collegiate Athletic Association  
6201 College Blvd.  
Overland Park, KS 66211  
(913) 339-1906  
Fax: (913) 339-1950  
URL: <http://www.ncaa.org>

Professional Rodeo Cowboys Association  
101 Prorodeo Drive  
Colorado Springs, CO 80919-9989  
(719) 593-8840  
Fax: (719) 593-9315  
URL: <http://www.prorodeo.com>  
E-mail: [prca@prorodeo.com](mailto:prca@prorodeo.com)

United States Olympic Committee (USOC)  
1 Olympic Plaza  
Colorado Springs, CO 80909  
(719) 632-5551  
Fax: (719) 578-4654  
URL: <http://www.usoc.org>

United States Equestrian Federation  
4050 Iron Works Parkway, Suite 1  
Lexington, KY 40511-8462  
(606) 255-0982  
Fax: (606) 291-9738  
URL: <http://www.usafe.org>  
E-mail: [info@usafe.org](mailto:info@usafe.org)

**ICE AND SNOW SPORTS**

Amateur Athletic Union of the United States (AAU)  
c/o Walt Disney World Resorts  
PO Box 10000  
Lake Buena Vista, FL 32830-1000  
(407) 934-7200  
URL: <http://www.aausports.org>

American Hockey League  
425 Union Street  
West Springfield, MA 01089  
(413) 781-2030  
Fax: (413) 733-4767  
URL: <http://www.canoe.com/ahl/>  
E-mail: [americanhockeyleague@worldnet.att.net](mailto:americanhockeyleague@worldnet.att.net)

National Collegiate Athletic Association  
6201 College Blvd.  
Overland Park, KS 66211  
(913) 339-1906  
Fax: (913) 339-1950  
URL: <http://www.ncaa.org>

National Hockey League (NHL)  
1800 McGill College Avenue  
26th Floor  
Montreal, Quebec H3A 3J6  
(514) 288-5270  
Fax: (514) 284-1663  
URL: <http://www.nhl.com>

Snow Sports Industries America  
8377-B Greensboro Drive  
McLean, VA 22102  
(703) 556-9020  
Fax: (703) 821-8276  
URL: <http://www.snowlink.com>  
E-mail: [jaarson@snowsports.org](mailto:jaarson@snowsports.org)

United States Olympic Committee (USOC)  
1 Olympic Plaza  
Colorado Springs, CO 80909  
(719) 632-5551  
Fax: (719) 578-4654  
URL: <http://www.usoc.org>

United States Skiing Association  
1500 Kearns Blvd  
Park City, UT 84060  
(801) 649-9090  
Fax: (801) 649-3613  
URL: <http://www.usssa.org>  
E-mail: [76574.3213@compuserve.com](mailto:76574.3213@compuserve.com)

**TARGET SHOOTING AND FENCING**

National Collegiate Athletic Association  
6201 College Blvd.  
Overland Park, KS 66211  
(913) 339-1906  
Fax: (913) 339-1950  
URL: <http://www.ncaa.org>

National Rifle Association of America  
1600 Rhode Island Ave., NW  
Washington, DC 20036  
(202) 828-6000  
Fax: (202) 861-0306  
URL: <http://www.nra.org>  
E-mail: [member-service@NRA.org](mailto:member-service@NRA.org)

National Shooting Sports Foundation (NSSF)  
11 L'Anie Hill Road  
Newtown, CT 06470  
(203) 426-1320  
Fax: (203) 426-1087  
URL: <http://www.nssf.org>  
E-mail: [info@nssf.org](mailto:info@nssf.org)

United States Olympic Committee (USOC)  
1 Olympic Plaza  
Colorado Springs, CO 80909  
(719) 632-5551  
Fax: (719) 578-4654  
URL: <http://www.usoc.org>

**CHAPTER 18 - ENERGY AND ENVIRONMENTAL DESIGN**

**SOLAR RADIATION AND BUILDING ORIENTATION**

Solar Collection  
American Solar Energy Society  
2400 Central Avenue G-1  
Boulder, CO 80301  
(303) 443-3130  
Fax: (303) 443-3212  
URL: <http://www.ases.org/solar/>

Solar Energy Industries Association  
777 N. Capitol Street, N.E., Suite 805  
Arlington, VA 20002  
(202) 408-0660  
Fax: (202) 408-8536  
URL: <http://www.seia.org>  
E-mail: [info@seia.org](mailto:info@seia.org)

**CLIMATE RESPONSE AND BUILDING DESIGN**

Board on Infrastructure and the Constructed Environment (BICE)  
2101 Constitution Ave. NW  
Washington, DC 20036  
(202) 334-2000  
URL: <http://www4.nas.edu/cets/bice.nsf>

Energy Efficient Building Association (EEBA)  
1300 Spring Street, Suite 500  
Silver Spring, MD 20910  
(301) 589-2500  
Fax: (301) 588-0854  
URL: <http://www.eeba.org>  
E-mail: [info@eeba.org](mailto:info@eeba.org)

Lawrence Berkeley Laboratory (LBL)  
Lighting Systems Research Group  
Mail Stop 46-125  
1 Cyclotron Road  
Berkeley, CA 94720  
(510) 486-5388  
Fax: (510) 486-6940  
URL: <http://www.lbl.gov>

Lighting Research Center (LRC)  
Rensselaer Polytechnic Institute  
Greene Bldg., #115  
Troy, NY 12180-3550  
(518) 276-6716  
Fax: (518) 276-2995  
URL: <http://lighting.rc.rpi.edu>

Natural Environmental Balancing Bureau (NEBB)  
8575 Grovemont Circle  
Gaithersburg, MD 20877  
(301) 977-3698  
Fax: (301) 977-9589  
URL: <http://www.nebb.org>

Water Environment Federation (WEF)  
601 Wythe St.  
Alexandria, VA 22314-1994  
(703) 684-2400  
Fax: (703) 684-8926  
URL: <http://www.wef.org>

**ENERGY CONSERVATION**

American Council for an Energy-Efficient Economy (ACEEE)  
100 Connecticut Ave., NW, Suite 801  
Washington, DC 20036  
(202) 429-8873  
URL: <http://www.aceee.org>  
E-mail: [info@aceee.org](mailto:info@aceee.org)

American Institute for Conservation (AIC)  
1717 K Street NW, Suite 301  
Washington, DC 20006  
(202) 452-9545  
Fax: (202) 452-9326

American Solar Energy Society (ASES)  
2400 Central Avenue, Unit B-1  
Boulder, CO 80301  
(303) 443-3130  
Fax: (303) 443-3212  
URL: <http://www.ases.org>

Association of Energy Engineers  
4025 Pleasantdale Road, Suite 420  
Atlanta, GA 30340  
(404) 447-5083  
Fax: (404) 446-3969  
URL: <http://www.aeecenter.org>

Department of Energy  
1000 Independence Avenue, SW  
Washington, DC 20585  
(202) 586-5000  
URL: <http://www.doe.gov>

Department of Energy (DOE)  
Forestal Building  
1000 Independence Ave. SW  
Washington, DC 20585  
(202) 586-5000  
URL: <http://www.home.doe.gov>

Energy Efficient Building Association (EEBA)  
1300 Spring Street, Suite 500  
Silver Spring, MD 20910  
(301) 589-2500  
Fax: (301) 588-0854  
URL: <http://www.eeba.org>  
E-mail: [info@eeba.org](mailto:info@eeba.org)

International District Energy Association  
1200 19th Street  
Suite 300  
Washington, DC 20036  
(202) 429-5111  
URL: <http://www.districtenergy.com>

National Renewable Energy Laboratory (NREL)  
(formerly the Solar Energy Research Institute)  
1617 Cadole Blvd.  
Golden, CO 80401-3393  
(303) 231-7000  
Fax: (303) 231-1199  
URL: <http://www.nrel.gov>

**PASSIVE SOLAR**

American Solar Energy Society (ASES)  
2400 Central Avenue, Unit B-1  
Boulder, CO 80301  
(303) 443-3130  
Fax: (303) 443-3212  
URL: <http://www.ases.org>

Interstate Solar Coordination Council  
P.O. Box 65874  
St. Paul, MN 55165  
Fax: (651) 296-4737 or (651) 297-1959

National Renewable Energy Laboratory (NREL)  
(formerly the Solar Energy Research Institute)  
1617 Cadole Blvd.  
Golden, CO 80401-3393  
(303) 231-7000  
Fax: (303) 231-1199  
URL: <http://www.nrel.gov>

Passive Solar Industries Council  
1511 K Street, NW, Suite 600  
Washington, DC 20005  
(202) 626-7400  
Fax: (202) 393-5043  
URL: <http://www.psic.org>  
E-mail: [PSICCouncil@aol.com](mailto:PSICCouncil@aol.com)

Solar Collection  
American Solar Energy Society  
2400 Central Avenue G-1  
Boulder, CO 80301  
(303) 443-3130  
Fax: (303) 443-3212  
URL: <http://www.ases.org/solar/>

Solar Energy Industries Association  
777 N. Capitol Street, N.E., Suite 805  
Arlington, VA 20002  
(202) 408-0660  
Fax: (202) 408-8536  
URL: <http://www.seia.org>  
E-mail: [info@seia.org](mailto:info@seia.org)

**ACTIVE SOLAR**

American Solar Energy Society (ASES)  
2400 Central Avenue, Unit B-1  
Boulder, CO 80301  
(303) 443-3130  
Fax: (303) 443-3212  
URL: <http://www.ases.org>

Interstate Solar Coordination Council  
P.O. Box 65874  
St. Paul, MN 55165  
Fax: (651) 296-4737 or (651) 297-1959

National Renewable Energy Laboratory (NREL)  
(formerly the Solar Energy Research Institute)  
1617 Cadole Blvd.  
Golden, CO 80401-3393  
(303) 231-7000  
Fax: (303) 231-1199  
URL: <http://www.nrel.gov>

Passive Solar Industries Council  
1511 K. Street, NW, Suite 600  
Washington, DC 20005  
(202) 628-7400  
Fax: (202) 393-5043  
URL: <http://www.psic.org>  
E-mail: [PSICouncil@aol.com](mailto:PSICouncil@aol.com)

Solar Collection  
American Solar Energy Society  
2400 Central Avenue G-1  
Boulder, CO 80301  
(303) 443-3130  
Fax: (303) 443-3212  
URL: <http://www.ases.org/solar/>

Solar Energy Industries Association  
777 N. Capitol Street, NE, Suite 805  
Arlington, VA 22002  
(202) 408-0660  
Fax: (202) 408-8536  
URL: <http://www.seia.org>  
E-mail: [info@seia.org](mailto:info@seia.org)

**ENVIRONMENTAL CONSTRUCTION**

Asbestos Information Association of North America  
1745 Jefferson Davis Highway  
Suite 509  
Arlington, VA 22202  
(703) 412-1150  
Fax: (703) 412-1152

Energy Efficient Building Association (EEBA)  
1300 Spring Street, Suite 500  
Silver Spring, MD 20910  
(301) 589-2500  
Fax: (301) 588-0854  
URL: <http://www.eeba.org>  
E-mail: [info@eeba.org](mailto:info@eeba.org)

Environmental Construction Association (EDRA)  
Environmental Design Research Association (EDRA)  
PO Box 24083  
Oklahoma City, OK 73124  
(405) 843-4863  
URL: <http://www.telepath.com/edra/home.html>

Environmental Protection Agency  
401 M Street, SW  
Washington, DC 20460  
Asbestos Information Hotline:  
(202) 554-1404  
School Related: (800) 835-6700  
(202) 260-2090  
URL: <http://www.epa.gov>  
E-mail: [public-access@epamail.epa.gov](mailto:public-access@epamail.epa.gov)

Environmental Protection Agency (EPA)  
401 M St. NW  
Washington, DC 20460  
(202) 260-2090  
URL: <http://www.epa.gov>

Renewable Natural Resources Foundation  
5430 Grosvenor Lane  
Bethesda, MD 20814  
(301) 493-9101  
URL: <http://members.aol.com/rnrf/>

Small Homes Council/Building Research Council (SHC)  
University of Illinois, Urbana Champaign  
One E. St. Mary's Road  
Champaign, IL 61820  
(217) 333-1801  
Fax: (800) 336-0616  
URL: <http://www.arch.uiuc.edu/brc>

Toxic Substance Control Act  
Toxic Materials Information Hotline  
(202) 554-1404

**CHAPTER 19 - HISTORIC PRESERVATION**

**INTRODUCTION**

AIA Committee on Historic Resources (AIA/CHR)  
1735 New York Ave., NW  
Washington, DC 20006-5292  
(202) 626-7482  
Fax: (202) 626-7518  
URL: <http://www.e-architect.com/pia/hrc/home.asp>

Advisory Council on Historic Preservation  
1100 Pennsylvania Avenue, NW, Suite 809  
Washington DC, 20004  
(202) 786-0503  
URL: <http://www.achp.gov>  
E-mail: [achp@achp.gov](mailto:achp@achp.gov)

Alliance for Historic Landscape Preservation  
82 Wall Street  
Suite 1105  
New York, NY 10005  
(617) 491-3727  
URL: <http://www.mindspring.com/~ahlp>

American Historical Association  
400 A Street, SE  
Washington, DC 20003-3389  
(202) 544-2422  
Fax: (202) 544-8307  
URL: <http://www.chnm.gmu.edu/aha/index.html>  
E-mail: [aha@theaha.org](mailto:aha@theaha.org)

Association for Preservation Technology  
P.O. BOX 3511  
Williamsburg, VA 23187  
(540) 373-1621  
Fax: (888) 723-4242  
URL: <http://www.apti.org>

Association of Specialists in Cleaning & Restoration  
10830 Annapolis Junction Road, Suite 312  
Annapolis Junction, MD 20701  
(301) 604-4411  
URL: <http://www.ascr.org>

Avery Architectural and Fine Arts Library  
Columbia University  
New York, NY 10027  
(212) 854-3501

Campbell Center for Historic Preservation Studies  
203 E. Seminary, Box 66  
Mt. Carroll, IL 61053  
(815) 244-1173  
Fax: (815) 244-1619  
URL: <http://sul-server-2.stanford.edu/bytopic/education/campbell>

Center for Public Buildings  
Georgia Institute of Technology  
245 4th Street, Room 225  
Atlanta, GA 30332-0155  
(404) 894-3390  
Fax: (404) 894-8738  
URL: <http://www.edi.gatech.edu/cpb>  
E-mail: [www@mail.edi.gatech.edu](mailto:www@mail.edi.gatech.edu)

Colonial Williamsburg Foundation Library  
Special Collections  
415 N. Boundary St.  
Williamsburg, VA 23187  
(804) 220-7420

Getty Center for the History of Art and the Humanities  
Resource Collections  
401 Wilshire Blvd., Ste. 400  
San Monica, CA 90401  
(310) 458-9811

Heritage Canada Foundation (HCF)  
1 Observatory Crescent  
Ottawa, Ontario K2P 0M8  
(613) 237-1066

Historic American Buildings Survey  
800 North Avenue Street, NW  
Suite 300  
Washington, DC 20001  
(202) 343-9604  
URL:  
<http://www.cr.nps.gov/habshaer/habs>

Historical Society of Washington DC (HSW)  
1307 New Hampshire Avenue, NW  
Washington, DC 20036  
(202) 785-2068  
URL: <http://www.hswdc.org>

International Association of Concrete Repair Specialists  
P.O. Box 17402, Dulles International Airport  
Washington, DC 20011  
(703) 260-0009  
Fax: (703) 661-8013

League of Historic American Theaters (LHAT)  
1511 K St., NW, Suite 923  
Washington, DC 20005  
(202) 783-6966  
URL: <http://www.lhat.org>

League of Historic American Theatres (LHAT)  
34 Market Place, Ste 320  
Baltimore, MD 21202  
(410) 659-9533  
Fax: (410) 837-9664  
URL: <http://www.lhat.org>  
E-mail: [info@lhat.org](mailto:info@lhat.org)

National Alliance of Preservation Commissions  
c/o University of Georgia  
609 Caldwell Hall  
Athens, GA 30602  
(706) 542-4731  
Fax: (706) 542-4485

National Alliance of Statewide Preservation Commissions  
c/o Historic Massachusetts  
45 School Street  
Boston, MA 02108  
(617) 723-3383

National Conference of State Historic Preservation Officers  
444 North Capitol Street, NW, Suite 342  
Washington, DC 20001-1512  
(202) 624-5465  
URL: <http://www.achp.gov/shpo.html>

National Endowment for the Arts  
1100 Pennsylvania Ave., NW  
Washington, DC 20506  
(202) 682-5400  
URL: <http://arts.endow.gov>  
E-mail: [neapao@tmn.com](mailto:neapao@tmn.com)

National Endowment for the Arts (NEA)  
1100 Pennsylvania Ave. NW  
Washington, DC 20506  
(202) 682-5400  
URL: <http://www.arts.endow.gov>

National Institute of Building Sciences (NIBS)  
1090 Vermont Ave., NW, Ste. 700  
Washington, DC 20005  
(202) 289-7800  
Fax: (202) 289-1092  
URL: <http://www.nibs.org>

National Preservation Institute (NPI)  
National Building Museum  
401 F St., NW, Suite 301  
Washington, DC 20001  
(202) 393-0038  
URL: <http://www.npi.org>  
E-mail: [info@npi.org](mailto:info@npi.org)

National Register of Historic Places  
National Park Service  
P.O. Box 37127 (413)  
Washington, DC 20013-7127  
(202) 343-9536  
URL:  
<http://www.cr.nps.gov/nr/nrhome.html>

National Trust for Historic Preservation  
1785 Massachusetts Avenue, NW  
Washington, DC 20036  
(800) 944-6847  
Fax: (202) 588-6166  
URL: <http://www.nthp.org>

National Trust for Historic Preservation  
Library  
McKeldin Library/University of Maryland  
College Park, MD 20742  
(301) 405-6320  
URL:  
<http://www.lib.umd.edu/UMCP/NTL/ntl.html>

Office of Park Historic Architecture/National Park Service (OPHA/NPS)  
800 North Capitol St., NW, Room 360  
Washington, DC 20002  
(202) 343-8146  
URL: <http://www.nps.gov>

Preservation Action  
1350 Connecticut Ave., NW, Suite 401  
Washington, DC 20036  
(202) 659-0915  
Fax: (202) 659-0189  
URL: <http://www.preservationaction.org>  
E-mail: [preservationaction@worldnet.att.net](mailto:preservationaction@worldnet.att.net)

Preservation Assistance Division  
National Park Service  
P.O. Box 37127  
Washington, DC 20013-7127  
(202) 343-9573  
URL: <http://www.cr.nps.gov/nr/bulletins/nrbroch2.html>

Society of American Archivists (SAA)  
527 S. Wells, 5th Floor  
Chicago, IL 60607  
(312) 922-0140  
Fax: (312) 347-1452  
URL: <http://www.archivists.com>  
E-mail: [info@archivists.org](mailto:info@archivists.org)

Society of Architectural Historians  
Charnley-Parsky House  
1365 North Astor Street  
Chicago, IL 60610-2144  
(312) 573-1365  
URL: <http://www.sah.org>  
E-mail: [info@sah.org](mailto:info@sah.org)

Theatre Historical Society of America (THSA)  
152 N. York Rd.  
Elmhurst, IL 60126  
(630) 782-1800  
Fax: (630) 782-1802  
URL:  
<http://www2.hawaii.edu/~angell/thsa/welcome.html>  
E-mail: [thrhistsoc@aol.com](mailto:thrhistsoc@aol.com)

University of Maryland  
National Trust for Historic Preservation  
Library Collection  
College Park, MD 20742  
(301) 405-6320

Urban Design and Preservation Division of the American Planning Association (UDPD/APA)  
110 Higgins Hall  
Pratt Institute School of Architecture  
Brooklyn, NY 11205  
(718) 399-6090  
URL: <http://www.planning.org>

**HISTORIC MASONRY**

National Park Service  
P.O. Box 37127  
Washington, DC 20013-7127  
URL: <http://www.nps.gov>

**HISTORIC WOOD**

American Institute of Timber Construction (AITC)  
7012 South Revere Parkway, Suite 140  
Englewood, CO 80112  
(303) 792-9559  
Fax: (303) 792-0669  
URL: <http://www.aitc-glulam.org>  
E-mail: [info@aitc-glulam.org](mailto:info@aitc-glulam.org)

National Park Service  
P.O. Box 37127  
Washington, DC 20013-7127  
URL: <http://www.nps.gov>

**HISTORIC WINDOWS**

Sealant, Waterproofing, and Restoration  
Institute  
2841 Main  
Kansas City, MO 64108  
(816) 472-7974  
Fax: (816) 477-7765  
URL: <http://www.swrionline.org>  
E-mail: [info@swrionline.org](mailto:info@swrionline.org)

**CHAPTER 20 - BUILDING TYPES AND SPACE PLANNING****RESIDENTIAL ROOM PLANNING**

Fair Housing Information Clearinghouse  
P.O. Box 9146  
McLean, VA 22102  
(800) 343-3442 (V) or Tel: (800) 290-1617 (TDD)  
URL:  
<http://www.circsoi.com/fairhousing>  
E-mail: [fairhousing@circsoi.com](mailto:fairhousing@circsoi.com)

International Association for Housing  
Science (IAHS)  
41 Sutter St., #1077  
San Francisco, CA 94104  
(415) 543-3940  
Fax: (415) 543-3732  
URL: <http://www.hdccongress.com>  
E-mail: [info@hdccongress.com](mailto:info@hdccongress.com)

Manufactured Housing Institute  
2101 Wilson Blvd.  
Suite 610  
Arlington, VA 22201-3062  
(703) 558-0400  
Fax: (703) 558-0401  
URL: <http://www.mfghome.org>  
E-mail: [kam@mfghome.org](mailto:kam@mfghome.org)

National Apartment Association (NAA)  
201 North Union St., Ste. 200  
Alexandria, VA 22314  
(703) 518-6141  
Fax: (703) 518-6191  
URL: <http://www.naahq.org>

National Association of Housing and  
Redevelopment Officials (NAHRO)  
630 Eye Street, NW  
Washington, DC 20001  
(202) 289-3500  
Fax: (202) 289-8181  
URL: <http://www.nahro.org>  
E-mail: [nahro@nahro.org](mailto:nahro@nahro.org)

National Housing and Rehabilitation  
Association (NH&RA)  
1625 Massachusetts Ave, NW, Ste. 601  
Washington, DC 20036  
(202) 939-1750  
URL: <http://www.housingonline.com>

National Kitchen and Bath Association  
687 Willow Grove Street  
Hackettstown, NJ 07840  
(908) 852-0033  
URL: <http://www.nkba.org>

Society of Certified Kitchen Designers  
687 Willow Grove St.  
Hackettstown, NJ 07840  
(908) 852-0033  
URL: <http://www.nkba.org>

**NONRESIDENTIAL ROOM PLANNING**

American Hotel & Motel Association  
(AHMA)  
1201 New York Ave, NW, Ste. 600  
Washington, DC 20005  
(202) 289-3100  
Fax: (202) 289-3199  
URL: <http://www.ahma.com>  
E-mail: [info@ahma.com](mailto:info@ahma.com)

Association for Childhood Education  
International (ACEI)  
17904 Georgia Ave, Ste. 215  
Oiney, MD 20832  
(301) 570-2111  
Fax: (301) 570-2212  
URL: <http://www.acei.org>

Association of Higher Education Facilities  
Planners (AHEF)  
1643 Prince St.  
Alexandria, VA 22314  
(703) 684-1446  
Fax: (703) 549-6772  
URL: <http://www.ahfef.org>

National School Boards Association (NSBA)  
1800 Duke St.  
Alexandria, VA 22314  
(703) 838-6722  
Fax: (703) 683-7990  
URL: <http://www.nsba.org>  
E-mail: [info@nsba.org](mailto:info@nsba.org)

Office Planners and Users Group (OPUG)  
Box 11182  
Philadelphia, PA 19136  
(215) 335-9400

Office Systems Research Association  
(OSRA)  
Morehead State University  
Dept. of Information Systems  
C/O 910  
150 University Blvd.  
Morehead, KY 40351-1689  
(606) 783-2724  
Fax: (606) 783-0325  
URL: <http://www.osra.org>  
E-mail: [dkizzier@morehead-st.edu](mailto:dkizzier@morehead-st.edu)

**CHILD CARE**

National Child Care Association  
1029 Railroad Street, NW  
Corryers, GA 30207-5275  
(800) 543-7161  
Fax: (404) 388-7772  
URL: <http://www.nccanet.org>

**MUSEUMS**

American Association of Museums (AAM)  
1225 Eye Street NW, Suite 200  
Washington, DC 20005  
(202) 289-1818  
Fax: (202) 289-6578  
URL: <http://www.aam-us.org>

**AIRPORTS**

Aviation Safety Institute  
P.O. Box 690  
Washington, DC 43085-0304  
(202) 685-4212  
Fax: (202) 614-7951 (TDD)  
URL: <http://www.avsionline.com>

Federal Aviation Administration (FAA)  
US Department of Transportation  
800 Independence Ave. SW  
Washington, DC 20591  
(202) 267-3484  
URL: <http://www.faa.gov>

International Airport Transport Association  
(IATA)  
1001 Pennsylvania Ave., NW, Ste. 285  
Washington, DC 20004  
(202) 642-2977  
URL: <http://www.iata.org>

National Aeronautics and Space  
Administration (NASA)  
300 L St. SW  
Washington, DC 20456  
(202) 368-0000  
URL: <http://www.nasa.gov>

**HEALTH CARE**

American Alliance for Health, Physical  
Education, Recreation, & Dance  
(AAHPERD)  
1900 Association Drive  
Reston, VA 22091  
(703) 476-3400  
Fax: (800) 213-7193  
URL: <http://www.aaahperd.org>

American Association of Healthcare  
Consultants (AAHC)  
11208 Waples Mill Rd., Ste. 109  
Fairfax, VA  
(703) 691-2242

American Association of Retired Persons  
(AARP)  
601 E. St. NW  
Washington, DC 20049  
(202) 434-2277  
URL: <http://www.aarp.org>

American Hospital Association (AHA)  
11 North Franklin, Suite 2100  
Chicago, IL 60606  
(312) 422-3000  
URL: <http://www.aha.org>  
E-mail: [gmitchell@aha.org](mailto:gmitchell@aha.org)

American Society for Healthcare  
Environmental Services (ASHES)  
Division of the American Hospital  
Association  
One North Franklin  
Chicago, IL 60606  
(312) 422-3860  
Fax: (312) 422-4577  
URL: <http://www.ashes.org>

Forum for Health Care Planning (FHCP)  
11208 Waples Mill Rd., Ste. 109  
Fairfax, VA 22030  
(703) 691-2879  
Fax: (703) 691-2247

Joint Commission on the Accreditation of  
Healthcare Organizations (JCAHO)  
1 Renaissance Blvd  
Oakbrook Terrace, IL 60181  
(630) 792-5000  
Fax: (630) 792-5005  
URL: <http://www.jcaho.org>

US Department of Health and Human  
Services  
Division of Health Facilities Planning  
5600 Fishers Lane, Room 17A10  
Parklawn Building  
Rockville, MD 20857  
(301) 443-2265  
URL: <http://www.os.dhhs.gov>

US Pharmacopeia (USP)  
12601 Twinbrook Pkwy  
Rockville, MD 20852  
(800) 877-6733  
Fax: (301) 816-8247  
URL: <http://www.usp.org>

US Veterans Administration Architectural  
Services  
810 Vermont Avenue, NW  
Washington DC, 20420  
(202) 273-5400  
URL: <http://www.va.gov>

**ECCLESIASTICAL**

Interfaith Forum on Religion, Art and  
Architecture (IFRAA)  
c/o American Institute of Architects  
1735 New York Ave. NW  
Washington, DC 20006  
(202) 626-7300  
URL: <http://www.e-architect.com/pia/ifraa/welcom.asp>

Partners for Sacred Place (PSP)  
1616 Walnut St., Ste. 2310  
Philadelphia, PA 19103  
(215) 546-1288  
Fax: (215) 546-1180  
URL: <http://www.sacredplaces.org>  
E-mail: [sacredplaces.org](mailto:sacredplaces.org)

**DETENTION**

The American Correctional Association  
(ACA)  
4380 Forbes Boulevard  
Lenham, MD 20706-4322  
(800) 222-5646  
Fax: (312) 422-4796  
URL: <http://www.corrections.com/aca/>  
E-mail: [jeflw@aca.org](mailto:jeflw@aca.org)

American Jail Association (AJA)  
2053 Day Road, Suite 100  
Hagerstown, MD 21740  
(301) 790-3930  
Fax: (301) 790-2941  
URL: <http://www.corrections.com/aja/>  
E-mail: [jails@worldnet.att.net](mailto:jails@worldnet.att.net)

Community Research Association  
309 West Clark  
Champaign, IL 61820  
(217) 398-3120  
Fax: (217) 398-3132  
URL: <http://www.community-research.com>

Federal Bureau of Prisons  
Facilities Development Division  
(FB/P/FDD)  
320 First Street, NW  
Washington, DC 20534  
(202) 367-3198  
URL: <http://www.bop.gov>  
E-mail: [pjones@bop.gov](mailto:pjones@bop.gov)

National Center for State Courts (NCSC)  
300 Newport Avenue  
Williamsburg, VA 23185  
(757) 253-2000  
Fax: (757) 270-0449  
URL: <http://www.ncsc.dnig.org>

National Criminal Justice Reference Service  
PO Box 6000  
Rockville, MD 20850  
(800) 851-3420  
URL: <http://www.ncjrs.org>  
E-mail: [look@ncjrs.org](mailto:look@ncjrs.org)

National Institute of Corrections, US  
Department of Justice (NIC/USDOJ)  
1860 Industrial Circle, Suite A  
Longmont, CO 80501  
(303) 682-0213  
URL: <http://www.usdoj.gov>  
E-mail: [web@usdoj.gov](mailto:web@usdoj.gov)

US Department of Justice  
Public Access Section  
Civil Rights Division  
P.O. Box 65808  
Washington, DC 20035-5808  
(202) 514-2151  
Fax: (202) 514-0293  
URL: <http://www.usdoj.gov>

**ASSEMBLY**

American Association of Design and  
Production Professionals in the  
Performing Arts (USITT)  
6443 Ridings Rd  
Syracuse, NY 13206-1111  
(315) 463-6463  
Fax: (315) 463-6525  
URL: <http://www.culturenet.ca/usitt>

International Association of Auditorium  
Managers (IAAM)  
4425 W. Airport Freeway, Ste. 590  
Irving, TX 75062  
(972) 255-8020  
Fax: (972) 255-9582  
URL: <http://www.iaam.org>

League of Historic American Theaters  
(LHAT)  
1511 K St., NW, Suite 923  
Washington, DC 20005  
(202) 783-6966  
URL: <http://www.lhat.org>

League of Historic American Theatres  
(LHAT)  
34 Market Place, Ste. 320  
Baltimore, MD 21202  
(410) 659-9533  
Fax: (410) 837-9664  
URL: <http://www.lhat.org>  
E-mail: [info@lhat.org](mailto:info@lhat.org)

Theatre Historical Society of America (THSA)  
152 N. York Rd.  
Elmhurst, IL 60126  
(630) 782-1800  
Fax: (630) 782-1802  
URL: <http://www2.hawaii.edu/~angell/thsa/welcome.html>  
E-mail: [thrhistsoc@aol.com](mailto:thrhistsoc@aol.com)

US Institute for Theater Technology  
6443 Ridings Rd.  
Syracuse, NY 13206-1111  
(315) 463-6463 or (800) 938-7488  
Fax: (315) 463-6525  
URL: <http://www.usitt.org>  
E-mail: [usitt@ppmail.appliedtheory.com](mailto:usitt@ppmail.appliedtheory.com)

**RETAIL**

Institute of Store Planners (ISPI)  
25 N. Broadway  
Tarrytown, NY 10591  
(800) 379-9912  
URL: <http://www.ispi.org>

International Council of Shopping Centers (ICSC)  
665 5th Ave.  
New York, NY 10022  
(212) 421-8181  
Fax: (212) 486-0849  
URL: <http://www.icsc.org>  
E-mail: [icsc@icsc.org](mailto:icsc@icsc.org)

**GREENHOUSES**

American Nursery & Landscape Association  
1250 I Street, NW, Suite 500  
Washington, DC 20005  
(202) 789-2900  
Fax: (202) 789-1893  
URL: <http://www.anla.org>

National Greenhouse Manufacturers Association  
7800 South Elati, Suite 113  
Littleton, CO 80120  
(800) 792-6362  
Fax: (303) 798-1315  
URL: <http://www.ngma.com>

**HOUSING**

American Association of Homes for the Aging (AAHA)  
901 E St. NW, Suite 500  
Washington, DC 20004-2011  
(202) 783-2242  
Fax: (202) 783-2255  
URL: <http://www.aahsa.org>  
E-mail: [info@aahsa.org](mailto:info@aahsa.org)

American Association of Housing Educators (AAHE)  
Texas A&M  
College of Architecture  
College Station, TX 77843  
(409) 845-0986

Department of Housing and Urban Development  
451 Seventh Street, SW  
Washington, DC 20410  
(202) 708-1112  
URL: <http://www.hud.gov>

Federal Housing Administration (FHA)  
US Department of Housing and Urban Development  
451 Seventh St. SW  
Washington, DC 20410  
(202) 755-7430  
URL: <http://www.hud.gov>

International Association for Housing Science (IAHS)  
41 Sutter St., #1077  
San Francisco, CA 94104  
(415) 543-3940  
Fax: (415) 543-3232  
URL: <http://www.hdccongress.com>  
E-mail: [info@hdccongress.com](mailto:info@hdccongress.com)

National Apartment Association (NAA)  
201 North Union St., Ste. 200  
Alexandria, VA 22314  
(703) 518-6141  
Fax: (703) 518-6191  
URL: <http://www.naahq.org>

National Association of Home Builders  
National Housing Library  
1201 15th St. NW  
Washington, DC 20005  
(800) 368-5242

National Association of Housing and Redevelopment Officials (NAHRO)  
630 Eye Street, NW  
Washington, DC 20001  
(202) 289-3500  
Fax: (202) 289-8181  
URL: <http://www.nahro.org>  
E-mail: [nahro@nahro.org](mailto:nahro@nahro.org)

National Housing Conference (NHC)  
815 15th Street NW, Ste. 538  
Washington, DC 20005  
(202) 393-5772  
Fax: (202) 393-5656  
URL: <http://www.nhc.org>  
E-mail: [nhc@nhc.org](mailto:nhc@nhc.org)

National Housing and Rehabilitation Association (NH&RA)  
1625 Massachusetts Ave, NW, Ste. 601  
Washington, DC 20036  
(202) 939-1750  
URL: <http://www.housingonline.com>

National Multi-Housing Council (NMHC)  
1850 M Street, NW Suite 540  
Washington, DC 20036  
(202) 974-2300  
Fax: (202) 775-0112  
URL: <http://www.nmhc.org>

Small Homes Council/Building Research Council (SHC)  
University of Illinois, Urbana Champaign  
One E. St. Mary's Road  
Champaign, IL 61820  
(217) 333-1801  
Fax: (800) 336-0616  
URL: <http://www.arch.uiuc.edu/brc>

US Department of Housing and Urban Development Library  
451 7th St. SW, Rm. 8141  
Washington, DC 20410  
(202) 708-2370

**WASTE MANAGEMENT**

National Solid Waste Management Association (NSWMA)  
c/o Environmental Industry Associates  
4301 Connecticut Ave., NW  
Suite 300  
Washington, DC 20008  
(202) 244-4700

Waste Equipment Technology Association (WASTEC)  
4301 Connecticut Ave. NW, Suite 300  
Washington, DC 20008  
(202) 244-4700  
Fax: (202) 966-4824  
URL: <http://www.wastec.org>

**DISTRIBUTION FACILITIES**

Industrial Development Research Council (IDRC)  
35 Technology Parkway, Ste. 150  
Norcross, GA 30092  
(770) 446-8955  
Fax: (770) 263-8825  
URL: <http://www.idrc.org>  
E-mail: [idrc.info@conway.com](mailto:idrc.info@conway.com)

National Association of Industrial and Office Properties (NAIOP)  
2201 Cooperative Way  
Herndon, VA 22071  
(800) 666-6780  
Fax: (703) 904-7942  
URL: <http://www.naiop.org>  
E-mail: [feedback@naiop.org](mailto:feedback@naiop.org)

**STORAGE FACILITIES**

Industrial Development Research Council (IDRC)  
35 Technology Parkway, Ste. 150  
Norcross, GA 30092  
(770) 446-8955  
Fax: (770) 263-8825  
URL: <http://www.idrc.org>  
E-mail: [idrc.info@conway.com](mailto:idrc.info@conway.com)

National Association of Industrial and Office Properties (NAIOP)  
2201 Cooperative Way  
Herndon, VA 22071  
(800) 666-6780  
Fax: (703) 904-7942  
URL: <http://www.naiop.org>  
E-mail: [feedback@naiop.org](mailto:feedback@naiop.org)

**PROCESSING FACILITIES**

Industrial Development Research Council (IDRC)  
35 Technology Parkway, Ste. 150  
Norcross, GA 30092  
(770) 446-8955  
Fax: (770) 263-8825  
URL: <http://www.idrc.org>  
E-mail: [idrc.info@conway.com](mailto:idrc.info@conway.com)

National Association of Industrial and Office Properties (NAIOP)  
2201 Cooperative Way  
Herndon, VA 22071  
(800) 666-6780  
Fax: (703) 904-7942  
URL: <http://www.naiop.org>  
E-mail: [feedback@naiop.org](mailto:feedback@naiop.org)

**CHAPTER 21 - ACCESSIBILITY**

**INTRODUCTION**

American National Standards Institute (ANSI)  
11 West 42nd Street,  
13th Floor  
New York, NY 10036-8002  
(212) 642-4900  
Fax: (212) 398-0023  
URL: <http://www.ansi.org>

American Planning Association  
1776 Massachusetts Avenue, NW,  
Suite 400  
Washington, DC 20036  
(202) 872-0611  
URL: <http://www.planning.org>  
E-mail: [apa@planning.org](mailto:apa@planning.org)

American Society of Landscape Architects (ASLA)  
636 Eye Street, NW  
Washington, DC 20001-3736  
(202) 898-2444  
Fax: (202) 898-1185  
URL: <http://www.asla.org>  
E-mail: [scahill@asla.org](mailto:scahill@asla.org)

Americans with Disabilities Act Information Office  
US Department of Justice  
Civil Rights Division  
P.O. Box 66378  
Washington, DC 20035-998  
(202) 514-0301 (V) or (202) 514-0383 (TDD)  
URL: <http://www.ada.ufl.edu>  
E-mail: [Ken\\_Osfield@sfa.ufl.edu](mailto:Ken_Osfield@sfa.ufl.edu)

Americans with Disabilities Act Information Office (ADAIO)  
US Department of Justice/Civil Rights Division  
P.O. Box 66738  
Washington, DC 20035  
(202) 514-6193  
Fax: (800) 514-0301  
URL: <http://www.usdoj.gov/crt/ada>

The Center for Accessible Housing (CAH)  
School of Design  
North Carolina State University  
P.O. Box 8613  
Raleigh, NC 27695-8613  
(919) 515-3082  
Fax: (919) 515-3023  
URL: <http://www.design.ncsu.edu/cud/>

Fair Housing Information Clearinghouse  
P.O. Box 9146  
McLean, VA 22102  
(800) 343-3442 (V) or Tel: (800) 290-1617 (TTY)  
URL: <http://www.circsol.com/fairhousing>  
E-mail: [fairhousing@circsol.com](mailto:fairhousing@circsol.com)

Occupational Safety and Health Administration (OSHA)  
US Department of Labor  
200 Constitution Ave. NW  
Washington, DC 20210  
(202) 693-1999  
URL: <http://www.osha.gov>

US Architectural and Transportation Barriers Compliance Board  
1331 F Street, NW  
Suite 1000  
Washington, DC 20004-1111  
(202) 272-5434  
Fax: (202) 272-5447  
URL: <http://www.access-board.gov>  
E-mail: [info@access-board.gov](mailto:info@access-board.gov)

**CURBS AND PARKING**

US Architectural and Transportation Barriers Compliance Board  
1331 F Street, NW  
Suite 1000  
Washington, DC 20004-1111  
(202) 272-5434  
Fax: (202) 272-5447  
URL: <http://www.access-board.gov>  
E-mail: [info@access-board.gov](mailto:info@access-board.gov)

**ELEVATORS**

Accessibility Equipment Manufacturers Association  
PO Box 380  
Metamora, IL 61548-0380  
(800) 514-1100  
Fax: (309) 923-7964  
URL: <http://www.aema.com>  
E-mail: [host@aema.com](mailto:host@aema.com)

American National Standards Institute (ANSI)  
11 West 42nd Street,  
13th Floor  
New York, NY 10036-8002  
(212) 642-4900  
Fax: (212) 398-0023  
URL: <http://www.ansi.org>

**FURNITURE**

American Furniture Manufacturers Association  
P.O. Box HP-7  
High Point, NC 27261  
(336) 884-5000  
Fax: (336) 884-5303  
URL: <http://www.afmahp.org>

**TOILETS AND BATHROOMS**

American National Standards Institute (ANSI)  
11 West 42nd Street,  
13th Floor  
New York, NY 10036-8002  
(212) 642-4900  
Fax: (212) 398-0023  
URL: <http://www.ansi.org>

National Kitchen and Bath Association  
687 Willow Grove Street  
Hackettstown, NJ 07840  
(908) 852-0033  
URL: <http://www.nkba.org>

**RESIDENTIAL**

American National Standards Institute (ANSI)  
11 West 42nd Street,  
13th Floor  
New York, NY 10036-8002  
(212) 642-4900  
Fax: (212) 398-0023  
URL: <http://www.ansi.org>

The Center for Accessible Housing (CAH)  
School of Design  
North Carolina State University  
P.O. Box 8613  
Raleigh, NC 27695-8613  
(919) 515-3082  
Fax: (919) 515-3023  
URL: <http://www.design.ncsu.edu/cud/>

Society of Certified Kitchen Designers  
687 Willow Grove St.  
Hackettstown, NJ 07840  
(908) 852-0033  
URL: <http://www.nkba.org>

**CHAPTER 22 - APPENDIX**

**AIA CHAPTERS**

**ALABAMA**

Alabama Council/AIA  
1521 Mulberry Street  
Montgomery, AL 36106  
Phone: (334) 264-3037  
Fax: (334) 263-6377  
E-mail: [council@aiaalabama.com](mailto:council@aiaalabama.com)  
URL: <http://www.aiaalabama.com>

**AIA Birmingham**

107 21st Street South  
Birmingham, AL 35233  
Phone: (205) 322-4386  
Fax: (205) 322-4347  
E-mail: [bhamaia@iconserv.com](mailto:bhamaia@iconserv.com)  
URL: <http://www.aiaabham.com>

**ALASKA**

**AIA Alaska**

807 "G" Street, Suite 200  
Anchorage, AK 99510  
Phone: (907) 276-2834  
Fax: (907) 276-5758  
E-mail: [aiak@alaska.net](mailto:aiak@alaska.net)  
URL: <http://www.alaska.net/~aiak>



## ARIZONA

## AIA Arizona

802 North 5th Avenue  
Phoenix, AZ 85003-1316  
Phone: (602) 752-4290  
Fax: (602) 752-6162  
E-mail: una@aia.arizona.org  
URL: <http://www.aia.arizona.org>

## AIA Southern Arizona

10 N. Norton, Suite 120  
Tucson, AZ 85719  
Phone: (520) 622-6248  
Fax: (520) 622-6248  
E-mail: brentdavis@theriver.com

## ARKANSAS

## AIA Arkansas

1818 North Taylor, PMB 327  
Little Rock, AR 72207  
Phone: (501) 663-8820  
Fax: (501) 666-3828

## CALIFORNIA

## AIA/California Council

1303 J Street, Suite 200  
Sacramento, CA 95814-2935  
Phone: (916) 448-9087  
Fax: (916) 442-5346  
E-mail: mail@aiaacc.org  
URL: <http://www.aiaacc.org>

## AIA Long Beach/South Bay

3575 Long Beach Blvd  
Long Beach, CA 90807  
Phone: (562) 989-1399  
Fax: (562) 989-0180  
E-mail: aialbsb@lws.net

## AIA Central Valley

1025 19th Street, Suite 8  
Sacramento, CA 95814  
Phone: (916) 444-3658  
Fax: (916) 444-3005  
E-mail: giniaiacvc@jps.net

## AIA East Bay

1800 Harrison St  
Oakland, CA 94612  
Phone: (510) 464-3600  
Fax: (510) 464-3616  
E-mail: aiaeb@aol.com  
URL: <http://www.aiaeb.org>

## AIA Inland California

10391 Corporate Drive  
Redlands, CA 92374-4509  
Phone: (909) 799-7213  
Fax: (909) 799-7243  
E-mail: aiaic@empirenet.com

## AIA Los Angeles

8687 Melrose Avenue, Suite BM3  
Los Angeles, CA 90069-8687  
Phone: (310) 785-1809  
Fax: (310) 785-1814  
E-mail: aialosang@aol.com  
URL: <http://www.hometown.aol.com/aialosang/index.htm>

## AIA Monterey Bay

PO Box 310  
Monterey, CA 93942-0310  
Phone: (831) 372-6527  
Fax: (831) 372-6035  
E-mail: aiamb@redshift.com  
URL: <http://www.aiamb.org>

## AIA Orange County

1617 Westcliff Dr #204  
Newport Beach, CA 92660  
Phone: (949) 645-6742  
Fax: (949) 645-6675  
E-mail: info@aiaoc.org  
URL: <http://www.aiaoc.org>

## AIA Pasadena &amp; Foothill

555 South Oak Knoll Ave.  
Pasadena, CA 91101-3459  
Phone: (626) 796-7601  
Fax: (626) 796-1357  
E-mail: director@aiapf.org  
URL: <http://www.aiapf.org>

## AIA Redwood Empire

PO Box 4178  
Santa Rosa, CA 95402-4178  
Phone: (707) 576-7799  
Fax: (707) 576-7819  
E-mail: exec@aiare.org  
URL: <http://www.aiare.org>

## AIA San Diego

732 A Street, Suite 700  
San Diego, CA 92101-4692  
Phone: (619) 732-6109  
Fax: (619) 237-4512  
E-mail: aiasandiego@msr.com

## AIA San Fernando Valley

PO Box 261279  
Encino, CA 91426-1279  
Phone: (818) 907-7151  
Fax: (818) 907-7152

## AIA San Francisco

130 Sutter Street, Suite 600  
San Francisco, CA 94104-4021  
Phone: (415) 362-7397  
Fax: (415) 362-4802  
E-mail: info@aia.sf.org  
URL: <http://www.aia.sf.org>

## AIA San Joaquin

764 P Street, Suite L  
Fresno, CA 93771-2705  
Phone: (559) 266-0389  
Fax: (559) 266-9414

## AIA San Mateo County

15 North Ellsworth Avenue #104  
San Mateo, CA 94401-4032  
Phone: (650) 349-5133  
Fax: (650) 348-7427  
E-mail: aiasmc@ix.netcom.com  
URL: <http://www.web.com/~smccaia>

## AIA Santa Barbara

229 East Victoria Street  
Santa Barbara, CA 93101-2020  
Phone: (805) 965-6307  
Fax: (805) 966-6861  
E-mail: afsb@aia.com  
URL: <http://www.aiasb.com>

## AIA Santa Clara Valley

34 South First Street  
San Jose, CA 95113-2406  
Phone: (408) 299-0611  
Fax: (408) 296-0619  
E-mail: AIAASCV@flash.net.com  
URL: <http://www.resources.com/aiaascv/index.htm>

## COLORADO

## AIA Colorado

**AIA Denver**  
**AIA Colorado North**  
**AIA Colorado South**  
**AIA Colorado West**  
1526 15th Street  
Denver, CO 80202  
Phone: (303) 446-2266  
Fax: (303) 446-0066  
E-mail: aiadenco@aol.com  
URL: <http://www.aiacolorado.org>

## CONNECTICUT

## AIA Connecticut

87 Willow Street  
New Haven, CT 06511-2627  
Phone: (203) 865-2195  
Fax: (203) 567-1378  
E-mail: aiainfo@aiact.org  
URL: <http://www.aiact.org>

## DELAWARE

## AIA Delaware

100 W. 10th St #106  
Wilmington, DE 19801  
Phone: (302) 654-9817  
Fax: (302) 654-7687  
E-mail: aiade@erols.com

## DISTRICT OF COLUMBIA

## Washington Chapter/AIA

1777 Church Street, NW  
Washington, DC 20036  
Phone: (202) 667-1798  
Fax: (202) 667-4327  
E-mail: mfitch@aii.net  
URL: <http://www.aiadc.com>

## FLORIDA

## AIA Florida

104 East Jefferson Street  
Tallahassee, FL 32301  
Phone: (850) 222-7500 dia 22  
Fax: (850) 224-9048  
E-mail: ctees@aiainfo.org  
URL: <http://www.aiafla.org>

## AIA Florida Gulf Coast

2537 Jefferson Circle  
Sarasota, FL 34239  
Phone: (941) 562-9786  
Fax: (941) 262-9786  
E-mail: jvrice@hour@aol.com

## AIA Ft. Lauderdale

227 SW 2nd Avenue  
Ft. Lauderdale, FL 33301  
Phone: (954) 728-9690  
Fax: (954) 728-9790  
E-mail: aiaflc@gate.net

## AIA Miami

800 Douglas Entrance, #119  
Coral Gables, FL 33134  
Phone: (305) 448-7488  
Fax: (305) 448-0136  
E-mail: aiamiami@worldnet.att.net

## AIA Orlando

930 Woodcock Road, #226  
Orlando, FL 32803  
Phone: (407) 898-7006  
Fax: (407) 898-3399  
E-mail: aiaori@gdinet  
URL: <http://www.aiaorlando.com>

## AIA Palm Beach

504 Pinto Circle  
Wellington, FL 33414  
Phone: (561) 790-2514  
Fax: (561) 798-4905  
E-mail: aiapalmbeach@worldnet.att.net

## AIA Tampa Bay

200 N Tampa Street, Suite 100  
Tampa, FL 33602  
Phone: (813) 229-3411  
Fax: (813) 229-1762

## GEORGIA

## AIA Georgia/AIA Atlanta

231 Peachtree Street, NE  
Suite B-04  
Atlanta, GA 30303  
Phone: (800) 850-4299  
Fax: (404) 222-9916  
URL: <http://marietta.bentley.com:591/aiaatlanta/default1.htm>

## HAWAII

## Hawaii State Council/AIA

1128 Nuuanu Avenue  
Honolulu, HI 96817  
Phone: (808) 545-4242  
Fax: (808) 537-1463  
E-mail: aia@aiahonolulu.org  
URL: <http://www.aiahonolulu.org>

## AIA Honolulu

1128 Nuuanu Avenue  
Honolulu, HI 96817  
Phone: (808) 545-4242  
Fax: (808) 537-1463  
E-mail: aia@aiahonolulu.org  
URL: <http://www.aiahonolulu.org>

## AIA Maui

PO Box 929  
Wailuku Maui, HI 96793  
Phone: (808) 244-9574  
Fax: (808) 244-9574

## IDAHO

## AIA Idaho

2419 W. State Street, #5  
Boise, ID 83702  
Phone: (208) 388-8536  
Fax: (208) 343-8046  
E-mail: aiaid@cyberhighway.net

## ILLINOIS

## AIA Illinois

520 South Second St., #802  
Springfield, IL 62701  
Phone: (217) 522-2309  
Fax: (217) 522-5370  
E-mail: aiail@aol.com  
URL: <http://www.aiail.org>

## AIA Central Illinois

520 South Second St., #802  
Springfield, IL 62701  
Phone: (217) 522-0581  
Fax: (217) 522-5370  
E-mail: aiaicent@aol.com  
URL: <http://www.aiaillinois.edu/aia-cic>

## AIA Chicago

222 Merchandise Mart #1049  
Chicago, IL 60654  
Phone: (312) 670-7770  
Fax: (312) 670-2427  
E-mail: aiachgo@ms.com  
URL: <http://www.aia-chicago.org>

## AIA Northeast Illinois

412 Green Valley Drive  
Naperville, IL 60563  
Phone: (630) 527-8500  
Fax: (630) 357-4815  
E-mail: AIA\_NI@earthlink.net

## INDIANA

## AIA Indiana

47 South Pennsylvania Street  
Indianapolis, IN 46204  
Phone: (317) 634-6893  
Fax: (317) 266-0515  
E-mail: aia@indy.net

## IOWA

## AIA Iowa

1000 Walnut Street, #101  
Des Moines, IA 50309  
Phone: (515) 244-7502  
Fax: (515) 244-5347  
E-mail: aiaowa@netins.net  
URL: <http://www.netins.net/showcase/aiaowa>

## KANSAS

## AIA Kansas

700 Jackson Street, #209  
Topeka, KS 66603-3731  
Phone: (800) 444-9853  
Fax: (785) 357-6450  
E-mail: aia@aiaks.org

## KENTUCKY

## AIA Kentucky

106A St. James Court  
Frankfort, KY 40601  
Phone: (502) 223-7671  
Fax: (502) 227-8101  
E-mail: aiaky@mis.net

## LONDON/UK

## AIA London/UK

216 Oxford St.  
London W1R 1AH UK  
Phone: 011 44 17 16 36 2006  
Fax: 011 01 71 16 36 1987  
E-mail: karen.whittle@bhk.com  
URL: <http://www.aiak.org>

## LOUISIANA

## AIA Louisiana

521 America Street  
Baton Rouge, LA 70802  
Phone: (225) 387-5579  
Fax: (225) 387-2743  
E-mail: hq@aiala.com  
URL: <http://www.aiala.com>

## AIA New Orleans

321 St. Charles Avenue  
New Orleans, LA 70130  
Phone: (504) 525-9320  
Fax: (504) 525-9327  
E-mail: aiaono@america.net

## MAINE

## AIA Maine

9 Sylvan Way  
Manchester, ME 04351  
Phone: (207) 623-1218  
Fax: (207) 623-1218  
E-mail: jharvie@mint.net

## MARYLAND

## AIA Baltimore

11 1/2 West Chase Street  
Baltimore, MD 21201  
Phone: (410) 625-2585  
Fax: (410) 727-4620  
E-mail: aiaobal@erols.com  
URL: <http://www.goucher.edu/aia/>

**AIA Chesapeake Bay**  
 #1 State Circle  
 Annapolis, MD 21401  
 Phone: (410) 268-3534  
 Fax: (410) 286-2225  
 E-mail: aiabc@toad.net  
 URL: <http://www.aiachesapeakebay.org>

**AIA Maryland**  
 #1 State Circle  
 Annapolis, MD 21401  
 Phone: (410) 263-0916  
 Fax: (410) 268-2225  
 E-mail: webmaster@msaia.org  
 URL: <http://www.msaia.org>

**AIA Potomac Valley**  
 Anacostia Bldg - UMCP  
 3907 Metzger Rd.  
 College Park, MD 20740  
 Phone: (301) 935-5544  
 Fax: (301) 935-5375  
 E-mail: lloyd@aiaipc.org  
 URL: <http://www.aiaipc.org>

**MASSACHUSETTS**

**AIA Massachusetts**  
**Boston Society of Architects/AIA**  
 52 Broad Street  
 Boston, MA 02109  
 Phone: (617) 951-1433 x232  
 Fax: (617) 951-0845  
 E-mail: bsarch@architects.org  
 URL: <http://www.architects.org>

**AIA Central Massachusetts**  
 52 Broad Street  
 617-951-1433, ex 227 (phone)  
 617-951-0845 (Fax)  
 E-mail: bsarch@architects.org  
 URL: <http://www.architects.org>

**AIA Western Massachusetts**  
 52 Broad Street  
 Boston, MA 02109  
 Phone: (617) 951-1433 x232  
 Fax: (617) 951-0845  
 E-mail: alee@architects.org  
 URL: <http://www.architects.org>

**MICHIGAN**

**AIA Michigan/AIA Detroit**  
 553 East Jefferson Street  
 Detroit, MI 48226  
 Phone: (313) 965-4100  
 Fax: (313) 965-1501  
 E-mail: aiami@aiami.com  
 URL: <http://www.aiami.com>

**MINNESOTA**

**AIA Minnesota**  
**AIA Minneapolis/AIA St. Paul**  
**AIA Northern Minnesota**  
 International Market Square  
 275 Market Street, Suite 54  
 Minneapolis, MN 55405  
 Phone: (612) 338-6763  
 Fax: (612) 338-7981  
 E-mail: info@aia-mn.org  
 URL: <http://www.aia-mn.org>

**MISSISSIPPI**

**AIA Mississippi**  
 4273 155 N., Suite 104  
 Jackson, MS 39206  
 Phone: (601) 321-4622  
 Fax: (601) 321-4628  
 E-mail: kjax@undial.com

**MISSOURI**

**AIA Missouri**  
 204 East High Street  
 Jefferson City, MO 65101  
 Phone: (573) 635-8555  
 Fax: (573) 636-5783  
 E-mail: pamick@sockets.net

**AIA Kansas City**

104 West Ninth Street  
 Kansas City, MO 64105  
 Phone: (816) 221-3485  
 Fax: (816) 221-5653  
 E-mail: feedback@aiakc.org  
 URL: <http://www.aiakc.org>

**AIA St. Louis**  
 911 Washington Street, #225  
 St. Louis, MO 63101-1203  
 Phone: (314) 621-3484  
 Fax: (314) 621-3489  
 E-mail: aiaatl@icon-stl.net  
 URL: <http://www.aiaatlouis.org>

**MONTANA**

**AIA Montana**  
 PO Box 20996  
 Billings, MT 59104  
 Phone: (406) 259-7300  
 Fax: (406) 259-4211  
 E-mail: assocmgt@in-tch.com

**NEBRASKA**

**AIA Nebraska**  
 University of Nebraska-Lincoln  
 PO Box 80045  
 Lincoln, NE 68501-0045  
 Phone: (402) 472-1456  
 Fax: (402) 472-3806  
 E-mail: gkrueger@unlinfo.unl.edu  
 URL: <http://www.aiane.org>

**NEVADA**

**AIA Las Vegas**  
 Paul B. Sogg Architecture Building  
 4505 South Maryland Parkway, Box 454018  
 Las Vegas, NV 89154  
 Phone: (702) 895-0936  
 Fax: (702) 895-4417  
 E-mail: admin@aianeveda.org  
 URL: <http://www.aianeveda.org>

**AIA Northern Nevada**  
 PO Box 607  
 Reno, NV 89504-0607  
 Phone: (775) 827-6600  
 Fax: (775) 827-3692  
 E-mail: aiann@aiann.reno.nv.us

**NEW ENGLAND**

**AIA New England**  
 PO Box 654  
 Montpelier, VT 05601-0654  
 Phone: (802) 229-2778  
 Fax: (802) 229-2651  
 E-mail: bconrey@vtc.vsc.edu

**NEW HAMPSHIRE**

**AIA New Hampshire**  
 PO Box 247  
 Concord, NH 03302-0247  
 Phone: (603) 226-4550  
 Fax: (603) 226-4550  
 E-mail: aianh@aianh.nv.com

**NEW JERSEY**

**AIA New Jersey**  
 196 West State Street  
 Trenton, NJ 08608  
 Phone: (609) 393-5690  
 Fax: (609) 393-9691  
 E-mail: joes@njlobbyist.com  
 URL: <http://www.aia-nj.org>

**NEW MEXICO**

**AIA Albuquerque**  
 215 Gold Ave. SW, #102  
 Albuquerque, NM 87102  
 Phone: (505) 244-3737  
 Fax: (505) 244-3756  
 E-mail: aia@aianewmexico.com  
 URL: <http://www.aianewmexico.com>

**NEW YORK**

**AIA New York State**  
 235 Lark Street  
 Albany, NY 12210  
 Phone: (518) 449-3334  
 Fax: (518) 426-8176  
 E-mail: aianys@aianys.org  
 URL: <http://www.aia.nys.org>

**AIA Buffalo**

PO Box 876  
 Derby, NY 14047  
 Phone: (716) 856-3861  
 Fax: (716) 852-2761  
 E-mail: aiabwny@BuffNet.net  
 URL: <http://www.members.aol.com/MVMeier/aiabwny.html>

**AIA Eastern New York**  
 235 Lark Street  
 Albany, NY 12210  
 Phone: (518) 465-3191  
 Fax: (518) 426-8176  
 E-mail: aianys@aianys.org  
 URL: <http://www.crisny.org/users/enyaia>

**AIA Long Island**

499 Jericho Turnpike  
 Mineola, NY 11501  
 Phone: (516) 294-0971  
 Fax: (516) 294-0973  
 E-mail: ALomo3535@aol.com  
 URL: <http://www.aialongisland.com>

**AIA New York Chapter**

200 Lexington Avenue, 6th Floor  
 New York, NY 10016  
 Phone: (212) 683-0023  
 Fax: (212) 696-5022  
 E-mail: info@aiany.org  
 URL: <http://www.aiany.org>

**AIA Rochester**

311 Alexander Street, Suite 217  
 Rochester, NY 14604  
 Phone: (716) 232-7650  
 Fax: (716) 262-2525  
 E-mail: aiaroch@frontiernet.net  
 URL: <http://www.aiaroch.org>

**AIA Westchester/Mid-Hudson**

PO Box 611  
 Katonah, NY 10536  
 Phone: (914) 232-7240  
 Fax: (914) 232-8211  
 E-mail: aiawmh@bestweb.net

**NORTH CAROLINA**

**AIA North Carolina**  
 115 West Morgan Street  
 Raleigh, NC 27601  
 Phone: (919) 833-6656  
 Fax: (919) 833-2015  
 E-mail: aianc@interpath.com  
 URL: <http://www.aia-nc.org>

**AIA Charlotte**

19700 Swiss Stone Lane  
 Cornelius, NC 28031  
 Phone: (704) 895-0422  
 Fax: (704) 895-0422-9  
 E-mail: lrinker@aiacharlotte.org

**NORTH DAKOTA**

**AIA North Dakota**  
 419 E Brandon Dr  
 Bismarck, ND 58501  
 Phone: (701) 223-5560

**OHIO**

**AIA Ohio**  
 17 South High Street, Suite 200  
 Columbus, OH 43215-3458  
 Phone: (614) 221-0338  
 Fax: (614) 221-1989  
 E-mail: aiaohio@infinet.com

**AIA Akron**

13152 Sugarbush Ave NW  
 Mogadore, OH 44260  
 Phone: (330) 699-9788  
 Fax: (330) 699-9788  
 E-mail: aiakron@worldnet.att.net

**AIA Cincinnati**

Longworth Hall Design Center  
 700 West Pete Rose Way  
 Cincinnati, OH 45203  
 Phone: (513) 421-4661  
 Fax: (513) 421-4665  
 E-mail: aiacinti@fuse.net  
 URL: <http://www.aiacincinnati.org>

**AIA Cleveland**

The Park Building  
 140 Public Square, #502  
 Cleveland, OH 44114  
 Phone: (216) 771-1240  
 Fax: (216) 771-3218  
 E-mail: aiacleve@en.com

**AIA Columbus**

21 W. Broad St., Suite 200  
 Columbus, OH 43215  
 Phone: (614) 469-1973  
 Fax: (614) 469-1976

**AIA Dayton**  
 5816 Daffodil Circle  
 Dayton, OH 45449  
 Phone: (937) 291-1913  
 Fax: (937) 436-4994  
 E-mail: aiaday@erinet.com  
 URL: <http://www.aiaday.org>

**AIA Eastern Ohio**

Ricciuti Balog & Partners Archs.  
 1500 Metropolitan Tower  
 Youngstown, OH 44503  
 330-744-4401  
 Fax: 330-744-2370  
 E-mail: rbparch@aol.com

**AIA Toledo**

1845 Collingwood Boulevard  
 Toledo, OH 43624  
 Phone: (419) 255-9222  
 Fax: (419) 241-8636  
 E-mail: sbyrn@cccouncil.com

**OKLAHOMA**

**AIA Oklahoma**  
 PO Box 18714  
 Oklahoma City, OK 73154-1305  
 Phone: (405) 810-8809  
 Fax: (405) 840-5730  
 E-mail: aiaok@worldnet.att.net

**AIA Central Oklahoma**

3000 Gen. Pershing Blvd.  
 Studio 4  
 Oklahoma City, OK 73107  
 Phone: (405) 948-7174  
 Fax: (405) 948-7397  
 E-mail: aiacentralok@worldnet.att.net  
 URL: <http://www.nstr.com/aiaccoc/>

**AIA Eastern Oklahoma**

2210-R South Main Street  
 Tulsa, OK 74114-1153  
 Phone: (918) 583-0013  
 Fax: (918) 583-0026  
 E-mail: chapter@aiaarchitects.com  
 URL: <http://www.aiaarchitects.com>

**OREGON**

**Architects Council of Oregon/AIA**  
 1207 SW 6th Avenue  
 Portland, OR 97204  
 Phone: (503) 223-0275  
 Fax: (503) 228-4529  
 E-mail: dianam@teleport.com

**AIA Portland**

315 SW Fourth Avenue  
 Portland, OR 97204  
 Phone: (503) 223-8757  
 Fax: (503) 220-0254  
 E-mail: aia@aiaportland.com  
 URL: <http://www.aiaportland.com>

**AIA Southwest Oregon**

44 W. Broadway, Suite 304  
 Eugene, OR 97401  
 Phone: (541) 485-2278  
 Fax: (541) 485-2478  
 E-mail: aiaswo@efn.org

**PENNSYLVANIA**

**AIA Pennsylvania**  
 1405 N. Front St.  
 Harrisburg, PA 17102  
 Phone: (717) 236-4055  
 Fax: (717) 236-5407  
 E-mail: aiapaed@ptd.net  
 URL: <http://www.aiapa.org>

**AIA Central Pennsylvania**

140 Roosevelt Ave. #209  
 York, PA 17404  
 Phone: (717) 854-2246  
 Fax: (717) 852-7708  
 E-mail: aiapcc@cyberia.com

**AIA Philadelphia**

117 South 17th Street  
 Philadelphia, PA 19103-5055  
 Phone: (215) 569-3186  
 Fax: (215) 569-9226  
 E-mail: architect@aiaiphia.org  
 URL: <http://www.libertynet.org/aia/>

**AIA Pittsburgh**

211 Ninth Street  
Pittsburgh, PA 15222  
Phone: (412) 471-9548  
Fax: (412) 471-9501  
E-mail: ajsvager@coconet.net  
URL: <http://www.aiapgh.org>

**SOUTH CAROLINA****AIA South Carolina**

1522 Richland Street  
Columbia, SC 29201  
Phone: (803) 252-6050  
Fax: (803) 256-0816  
E-mail: aiactbw@loicssouth.com  
URL: <http://www.aiaisc.org>

**SOUTH DAKOTA****AIA South Dakota**

PO Box 1596  
Sioux Falls, SD 57101  
Phone: (605) 334-2422  
Fax: (605) 334-7540  
E-mail: elissa@w.net

**TENNESSEE****AIA Tennessee**

209 10th Avenue South #506  
Nashville, TN 37203  
Phone: (615) 255-3860  
Fax: (615) 254-1186  
E-mail: assnptnrs@aol.com

**AIA Chattanooga**

4407 South Choctaw Drive  
Chattanooga, TN 37411  
Phone: (423) 629-4540  
E-mail: crmiller25@hotmail.com

**AIA East Tennessee**

10 Emory Place  
Knoxville, TN 37917  
Phone: (423) 637-5003  
Fax: (423) 637-2046  
E-mail: aiaetn@bellsouth.net  
URL: <http://www.aiaetn.org>

**AIA Memphis**

22 North Front Street #840  
Memphis, TN 38103  
Phone: (901) 525-3918  
Fax: (901) 527-7566  
E-mail: aiamem@bellsouth.net

**AIA Middle Tennessee**

209 10th Avenue South #415  
Nashville, TN 37203  
Phone: (615) 259-9664  
Fax: (615) 742-0954  
E-mail: cpedigo@aiamidtn.org  
URL: <http://www.aiamidtn.org>

**TEXAS****Texas Society of Architects/AIA**

816 Congress Avenue, #970  
Austin, TX 78701  
Phone: (512) 478-7386  
Fax: (512) 478-0528  
E-mail: davidson@texasarchitect.org  
URL: <http://www.texasarchitect.org>

**AIA Austin**

503 West 38th Street, #205  
Austin, TX 78705  
Phone: (512) 452-4332  
Fax: (512) 452-2284  
E-mail: aiaaustin@aol.com  
URL: <http://www.aiaaustin.org>

**AIA Dallas**

2811 McKinney, Suite 20  
Lock Box 104  
Dallas, TX 75204-2537  
Phone: (214) 871-2788 press 6  
Fax: (214) 871-2324  
E-mail: gwise@dallasaia.org  
URL: <http://www.dallasaia.org>

**AIA Fort Worth**

1425 Eighth Avenue, Suite 100  
Fort Worth, Texas 76104  
Phone: (817) 927-2411  
Fax: (817) 927-2444  
E-mail: aiafw@flash.net  
URL: <http://www.aiafortworth.org>

**AIA Houston**

5225 Richmond, Suite 500  
Houston, TX 77056  
Phone: (713) 421-0155  
Fax: (713) 528-8134  
E-mail: martha@aboutx.org  
URL: <http://www.aiahoutx.org>

**AIA Lower Rio Grande Valley**

572 North 6th Street  
McAllen, TX 78501  
Phone: (956) 652-7070  
Fax: (956) 686-2223

**AIA San Antonio**

1443 East Commerce, #200  
San Antonio, TX 78205  
Phone: (210) 225-4879  
Fax: (210) 226-0662  
E-mail: aiasa@v.netcom.com

**UTAH****AIA Utah/Salt Lake**

75 E. Broadway  
Salt Lake City, UT 84111  
Phone: (801) 532-1727  
Fax: (801) 532-4576  
E-mail: aiautal@sisa.com  
URL: <http://www.aiautah.org>

**VERMONT****AIA Vermont**

1662 McCullough Highway  
Sayston, VT 05673  
Phone: (802) 496-3761  
Fax: (802) 496-3294  
E-mail: aiavt@madriver.com

**VIRGINIA****Virginia Society/AIA**

15 South Fifth Street  
Richmond, VA 23219  
Phone: (804) 644-3041  
Fax: (804) 643-4607  
E-mail: ajohnson@avava.org  
URL: <http://www.avava.org>

**AIA Hampton Roads**

17 Koger Center #103  
Norfolk, VA 23502  
Phone: (757) 461-2899  
Fax: (757) 461-2899  
E-mail: aiahr@erols.com

**AIA Northern Virginia**

205 S. Patrick Street  
Alexandria, VA 22314  
Phone: (703) 549-9747  
Fax: (703) 549-9783  
E-mail: aianova@aol.com  
URL: <http://www.aianova.org>

**AIA/James River Chapter**

13612 Village Hill Drive  
Midlothian, VA 23113  
Phone: (804) 794-9128  
Fax: (804) 794-9129

**WASHINGTON****AIA Washington**

TMN Architects  
801 2nd Ave., Suite 501  
Seattle, WA 98104  
Phone: (206) 662-3460  
Fax: (206) 343-9388  
E-mail: aiawac@ic@aol.com  
URL: <http://www.aiawa.org>

**AIA Seattle**

1911 First Avenue  
Seattle, WA 98101  
Phone: (206) 448-1938  
Fax: (206) 448-9862  
E-mail: nrhancok@AIASeattle.org  
URL: <http://www.aiaSeattle.org>

**AIA Southwest Washington**

602 South 11th Street  
Tacoma, WA 98402  
Phone: (253) 677-4006  
Fax: (253) 572-2834  
E-mail: cpaasw@nwrain.com

**AIA Spokane**

335 W. Sprague Avenue  
Spokane, WA 99201-3710  
Phone: (509) 477-5498  
Fax: (509) 477-3688  
E-mail: spoka@icor.com

**WEST VIRGINIA****West Virginia Society of Architects/AIA**

PO Box 813  
Charleston, WV 25323  
Phone: (304) 344-9872  
Fax: (304) 343-0205  
E-mail: aiawv@newwave.net

**WISCONSIN****Wisconsin Society of Architects/AIA**

321 South Hamilton Street  
Madison, WI 53703  
Phone: (608) 257-8477  
Fax: (608) 257-0242  
E-mail: aiaw@aiaw.org  
URL: <http://www.aiaw.org>

**FEDERAL GOVERNMENT AGENCIES**

Air Force/Division of Civil Engineering and  
Housing Headquarters (USAF)/CEH  
1260 Air Force Pentagon  
Washington, DC 20330  
Tel: (850) 283-6114  
URL: <http://www.ceh.af.mil/>

Americans with Disabilities Act Information  
Office (ADAIO)  
US Department of Justice/Civil Rights  
Division  
P.O. Box 66738  
Washington, DC 20035  
Tel: (202) 514-6193  
Fax: (800) 514-0301  
URL: <http://www.usdoj.gov/crt/ada>

Architect of the Capitol (AC)  
US Capitol Building, Room SD-15  
Washington, DC 20515  
Tel: (202) 228-1793  
URL: <http://www.aoc.gov/>

Army Corps of Engineers (ACE)  
20 Massachusetts Ave, NW  
Washington, DC 20314  
Tel: (202) 761-0660  
URL: { HYPERLINK  
<http://www.usace.army.mil>

Code of Federal Regulations (CFR)  
Superintendent of Documents  
Government Printing Office  
Washington, DC 20402  
Tel: (202) 512-1800  
Fax: (202) 512-2250  
URL: <http://www.access.gpo.gov>

Department of Energy (DOE)  
Forrestal Building  
1000 Independence Ave. SW  
Washington, DC 20585  
Tel: (202) 566-5000  
URL: <http://www.home.doe.gov>

Department of Housing and Urban  
Development (HUD)  
451 Seventh St. SW  
Washington, DC 20410  
Tel: (202) 708-1112  
URL: <http://www.hud.gov>

Department of Transportation (DOT)  
400 Seventh St. SW, Rm. 10474  
Washington, DC 20590  
Tel: (202) 366-4000  
URL: <http://www.dot.gov>

Environmental Protection Agency (EPA)  
401 M St. NW  
Washington, DC 20460  
Tel: (202) 260-2090  
URL: <http://www.epa.gov>

Federal Aviation Administration (FAA)  
US Department of Transportation  
800 Independence Ave. SW  
Washington, DC 20591  
Tel: (202) 267-3484  
URL: <http://www.faa.gov>

Federal Emergency Management Agency  
(FEMA)  
500 C St. SW  
Washington, DC 20472  
Tel: (202) 646-2500  
URL: { HYPERLINK  
<http://www.fema.gov>

Federal Housing Administration (FHA)  
US Department of Housing and Urban  
Development  
451 Seventh St. SW  
Washington, DC 20410  
Tel: (202) 755-7430  
URL: <http://www.hud.gov>

General Services Administration (GSA)  
Property Management  
Eighteenth and F Sts. NW  
Washington, DC 20405  
Tel: (202) 708-1112  
URL: <http://www.gsa.gov>

National Endowment for the Arts (NEA)  
1100 Pennsylvania Ave. NW  
Washington, DC 20506  
Tel: (202) 682-5400  
URL: <http://www.arts.endow.gov>

National Institute of Standards and  
Technology (NIST)  
US Department of Commerce  
100 Bureau Drive  
Gaithersburg, MD 20899  
Tel: (301) 975-2000  
URL: <http://www.nist.gov>

Navel Facilities Engineering Command  
(NAVFAC)  
US Department of the Navy-  
Washington Navy Yard  
1322 Patterson Ave., SE, Ste 1000  
Washington, DC 20374 5065  
Tel: (202) 685-9126  
URL: <http://www.navfac.navy.mil>

Occupational Safety and Health  
Administration (OSHA)  
US Department of Labor  
200 Constitution Ave. NW  
Washington, DC 20210  
Tel: (202) 693-1999  
URL: { HYPERLINK  
<http://www.osha.gov>

US Architectural and Transportation Barriers  
Compliance Board  
1331 F Street, NW  
Suite 1000  
Washington, DC 20004-1111  
Tel: (202) 272-5434  
Fax: (202) 272-5447  
URL: <http://www.access-board.gov>

US Department of Health and Human  
Services (HHS)/DHFP  
Division of Health Facilities Planning  
200 Independence Ave. SW  
Washington, DC 20201  
Tel: (202) 619-0257  
URL: <http://www.hhs.gov>

US Department of Housing and Urban  
Development (HUD)  
451 7th Street, SW  
Washington, DC 20410  
Tel: (202) 708-1112  
URL: { HYPERLINK <http://www.hud.gov>

US Department of Justice  
Public Access Section  
Civil Rights Division  
P.O. Box 66738  
Washington, DC 20035-6738  
URL: { HYPERLINK  
<http://www.usdoj.gov>

US Department of Transportation Federal  
Highway Administration (USDHHA)  
400 Seventh St. SW  
Washington, DC 20590  
Tel: (202) 366-0630  
URL: <http://www.fhwa.dot.gov>

US Postal Service (USPS)  
475 L'Enfant Plaza SW  
Washington, DC 20260  
Tel: (202) 268-2000  
URL: <http://www.usps.gov>

Veterans Affairs (VA)  
810 Vermont Ave. NW  
Washington, DC 20420  
Tel: (800) 827-1000  
URL: { HYPERLINK <http://www.va.gov>

**DOMESTIC AND INTERNATIONAL TRADE PUBLICATIONS**

**Abitare**  
 Editrice Segesta s.p.a.  
 15 c.so Monfrote 20122  
 Milan, Italy  
 URL: <http://www.abitare.it>

**Architecture**  
 1515 Broadway, 11th Fl.  
 New York, NY 10036  
 Tel: (212) 536-6221  
 Fax: (212) 382-6016  
 URL: { HYPERLINK  
<http://www.architecturemag.com>  
<http://www.architecturemag.com>

**Architectural Digest**  
 6300 Wilshire Blvd., Suite 1100  
 Los Angeles, CA 90048  
 Tel: (323) 965-3700  
 URL: { HYPERLINK  
<http://www.archdigest.com>  
<http://www.archdigest.com>

**Architectural Lighting**  
 1515 Broadway, 32nd Floor  
 New York, NY 10036  
 Tel: (212) 869-1300  
 URL: { HYPERLINK  
<http://www.archlighting.com>  
<http://www.archlighting.com>

**Architectural Record**  
 Two Penn Plaza  
 New York, NY 10121  
 Tel: (212) 904-2594  
 Fax: (212) 904-4256  
 URL: { HYPERLINK  
<http://www.archrecord.com>  
<http://www.archrecord.com>

**Architectural Review**  
 Architectural Press, Ltd.  
 33-35 Bowling Green Lane  
 London EC1R 0DA England  
 Tel: (071) 837-1212  
 URL: <http://www.emap.com/construct/arhome.htm>

**Building Design & Construction**  
 1350 East Touhy Ave.  
 Des Plaines, IL 60018  
 Tel: (847) 390-2776

**Construction Specifier**  
 601 Madison Street  
 Alexandria, VA 22314  
 Tel: (703) 684-0300  
 Fax: (703) 684-0465  
 URL: { HYPERLINK  
<http://www.csinet.org>  
<http://www.csinet.org>

**Contract Design**  
 One Penn Plaza, 10th Fl.  
 New York, NY 10119-1198  
 Tel: (212) 615-2608  
 URL: { HYPERLINK <http://www.contractdesign.com>  
<http://www.contractdesign.com>

**Daidalos**  
 Bertelsmann Druck + Dienstleistung  
 Berlin GmbH  
 Schlusterstrasse 42  
 D-1000 Berlin 15 Germany

**Design Book Review**  
 1418 Spring Way  
 Berkeley, CA 94708  
 Tel: (510) 486-1956

**Domus**  
 Editoriale Domus  
 Ufficio Abbonamenti  
 via A Grandi 5-720089 Rozzano  
 Milano, Italy  
 URL: [http://www.domus.edidomus.it/domus\\_eng/home.html](http://www.domus.edidomus.it/domus_eng/home.html)

**El Croquis**  
 Barcelo 15  
 28004 Madrid, Spain  
 Tel: 34-1-445 21 49  
 Fax: 34-1-593 21 92  
 URL: <http://www.elcroquis.es>

**Harvard Architecture Review**  
 Harvard University Graduate School of Design  
 Gund Hall  
 48 Quincy Street, #301  
 Cambridge, MA 02138  
 Tel: (617) 495-2591  
 URL: { HYPERLINK  
<http://www.gsd.harvard.edu>  
<http://www.gsd.harvard.edu>

**House and Garden**  
 Conde Nast Publications  
 350 Madison Avenue  
 New York, NY 10017  
 Tel: (212) 880-8800  
 URL: <http://www.house-and-garden.com>

**Interior Design**  
 345 Hudson St.  
 4th Floor  
 New York, NY 10014  
 Tel: (212) 519-7000

**Interiors**  
 Gralla Publications  
 1515 Broadway  
 New York, NY 10036  
 Tel: (212) 764-7300  
 Topics: 12000

**Japan Architect**  
 Japan Architect Co., Ltd.  
 31-2 Yushima 2-chome Bunkyo-ku  
 Tokyo 113, Japan  
 Tel: (03) 811-7101

**Landscape Architecture**  
 American Society of Landscape Architects  
 636 Eye St., NW 20001  
 Tel: (202) 898-2444  
 Fax: (202) 898-1185

**Lotus International**  
 Electa Periodici Srl  
 via D. Trentacoste 7  
 20134 Milan, Italy  
 Tel: (02) 215631

**Metropolis**  
 61 W. 23rd St.  
 4th Floor  
 New York, NY 10010  
 Tel: (212) 627-9977  
 Fax: (212) 627-9988  
 URL: <http://www.metropolismag.com>

**Ornamental and Miscellaneous Metal**  
 Fabricator  
 National Ornamental and Miscellaneous Metals Association  
 532 Forest Pkwy  
 Suite A  
 Forest Park, GA 30297  
 Tel: (404) 363-4009

**Urban Land Magazine**  
 Urban Land Institute  
 1025 Thomas Jefferson St., NW, Suite 500W  
 Washington, DC 20007-5201  
 Tel: (202) 624-7000  
 URL: { HYPERLINK <http://www.uli.org>  
<http://www.uli.org>

**ARCHITECTURAL COLLECTIONS**

**American Institute of Architect's Knowledge Center**  
 1735 New York Ave. NW  
 Washington, DC 20006  
 Tel: (202) 626-7492

**American Planning Association Library**  
 122 S. Michigan Ave.  
 Chicago, IL 60603  
 Tel: (312) 431-9100

**Architectural Woodwork Institute Library**  
 P.O. Box 1550  
 Centreville, VA 22020  
 Tel: (703) 222-1100

**Arizona State University**  
 Architecture and Environmental Design Library  
 College of Architecture  
 Tempe, AZ 85287  
 Tel: (602) 965-6400

**Art Institute of Chicago**  
 Ryerson & Burnham Libraries  
 Michigan Ave. at Adams St.  
 Chicago, IL 60603  
 Tel: (312) 443-3666

**Athenaeum of Philadelphia**  
 219 S. Sixth St.  
 Philadelphia, PA 19106  
 Tel: (215) 925-2688

**Atlanta Historical Society**  
 Archives/Library  
 3101 Andrews Dr., NW  
 Atlanta, GA 30305  
 Tel: (404) 261-1837

**Auburn University Archives**  
 Ralph Brown Draughon Library  
 Auburn, AL 36849  
 Tel: (205) 844-1705

**Avery Architectural and Fine Arts Library**  
 Columbia University  
 New York, NY 10027  
 Tel: (212) 854-3501

**Boston Architectural Center Library**  
 320 Newbury St.  
 Boston, MA 02115  
 Tel: (617) 536-9018

**Boston Public Library**  
 Fine Art Department  
 Copley Square  
 P.O. Box 286  
 Boston, MA 02117  
 Tel: (617) 536-5400

**California Polytechnic State University**  
 Environmental Design Resource Library  
 3801 W. Temple Ave., Bldg. 7  
 Pomona, CA 91768  
 Tel: (714) 869-2665

**California Polytechnic State University**  
 Robert E. Kennedy Library  
 San Luis Obispo, CA 93407  
 Tel: (805) 756-2344

**California State University, Fresno**  
 Henry Madden Library  
 Department of Special Collections  
 Fresno, CA 93740  
 Tel: (209) 278-2595

**Chicago Public Library**  
 Visual and Performing Arts, Art Information Center  
 Harold Washington Library Center  
 400 S. State St.  
 Chicago, IL 60605  
 Tel: (312) 747-4800

**Cleveland Public Library**  
 Fine Arts and Special Collections Department  
 Fine Arts Section  
 325 Superior Ave.  
 Cleveland, OH 44114  
 Tel: (216) 623-2848

**Colonial Williamsburg Foundation Library**  
 Special Collections  
 415 N. Boundary St.  
 Williamsburg, VA 23187  
 Tel: (804) 220-7420

**Cornell University**  
 Fine Arts Library  
 Sibley Dome  
 Ithaca, NY 14853  
 Tel: (607) 255-3710

**Detroit Public Library**  
 Art and Literature Department  
 5201 Woodward Ave.  
 Detroit, MI 48202  
 Tel: (313) 833-1470

**El Paso Public Library**  
 Southwest Collection  
 501 N. Oregon St.  
 El Paso, TX 79901  
 Tel: (915) 543-5440

**Engineering Societies Library**  
 United Engineering Center  
 345 E. 47th St.  
 New York, NY 10017  
 Tel: (212) 705-7611

**Frank Lloyd Wright School of Architecture**  
 Library  
 Talesin West  
 Scottsdale, AZ 85261  
 Tel: (602) 860-2700

**Free Library of Philadelphia**  
 Art Department  
 Logan Square  
 Philadelphia, PA 19103  
 Tel: (215) 686-5403

**Furniture Library Association Library**  
 1009 N. Main St.  
 High Point, NC 27262  
 Tel: (919) 883-4011

**General Services Administration**  
 GSA Library  
 General Services Bldg., Rm. 1033  
 Eighteenth and F Sts. NW  
 Washington, DC 20405  
 Tel: (202) 501-0788

**Georgia Institute of Technology**  
 Price Gilbert Memorial Library  
 Architecture Library  
 Architecture Library  
 225 North Ave., NW  
 Atlanta, GA 30332  
 Tel: (404) 894-4877

**Getty Center for the History of Art and the Humanities**  
 Resource Collections  
 401 Wilshire Blvd., Ste. 400  
 San Monica, CA 90401  
 Tel: (310) 458-9811

**H2M Group (Holzmacher, McLendon & Murrell, P.C.)**  
 575 Broad Hollow Rd.  
 Melville, NY 11747  
 Tel: (516) 756-8000

**Harrington Institute of Interior Design**  
 Design Library  
 410 S. Michigan Ave.  
 Chicago, IL 60605  
 Tel: (312) 939-4975

**Harvard University**  
 Graduate School of Design  
 Frances Loeb Library  
 Gund Hall  
 Cambridge, MA 02138  
 Tel: (617) 495-2574

**Hellmuth, Obata & Kassabaum, Inc.**  
 HOK Library  
 1831 Chestnut St.  
 St. Louis, MO 63103  
 Tel: (314) 421-2000

**Historical Society of Palm Beach County**  
 Library  
 3650 Summit Blvd.  
 West Palm Beach, FL 33406  
 Tel: (407) 471-1492

**Illinois Institute of Technology**  
 Paul V. Galvin Library  
 35 W.33rd St.  
 Chicago, IL 60616  
 Tel: (312) 567-6844

**Indiana Historical Society**  
 William Henry Smith Memorial Library  
 315 W. Ohio St.  
 Indianapolis, IN 46202  
 Tel: (317) 232-1879

**Knox County Public Library**  
 McClung Historical Collection  
 500 W. Church Ave.  
 Knoxville, TN 37902  
 Tel: (615) 544-5744

**Library of Congress**  
 Humanities and Social Sciences Division  
 Microform Reading Room Section  
 Thomas Jefferson Building, LJ-140B  
 Washington, DC 20540  
 Tel: (202) 707-5471

**Library of Congress**  
 Prints & Photographs Division  
 James Madison Memorial Building, LM 339  
 Washington, DC 20540  
 Tel: (202) 707-5836

- Maryland Historical Society Library  
201 W. Monument St.  
Baltimore, MD 21201  
Tel: (410) 685-3750
- Massachusetts Institute of Technology  
Fotich Library of Architecture and  
Planning  
Rm. 7-238  
Cambridge, MA 02139  
Tel: (617) 258-5599
- Massachusetts Institute of Technology  
Fotich Library of Architecture and  
Planning  
Visual Collections  
Rm. 7-304  
Cambridge, MA 02139  
Tel: (617) 253-7098
- Metropolitan Museum of Art  
Photograph and Slide Library  
1009 Fifth Ave.  
New York, NY 10028  
Tel: (212) 879-5500
- Milwaukee Public Library  
Wisconsin Architectural Archives  
814 W. Wisconsin Ave.  
Milwaukee, WI 53233  
Tel: (414) 286-3897
- Montana State University Library  
Special Collections  
P.O. Box 173320  
Bozeman, MT 59717  
Tel: (406) 994-4242
- Museum of the City of New York  
Photo Archives  
Fifth Ave. & 103 St.  
New York, NY 10029  
Tel: (212) 534-1672
- National Archives & Records Administration  
Cartographic & Architectural Branch  
8th & Pennsylvania Ave. NW  
Washington, DC 20408  
Tel: (703) 756-6700
- National Association of Home Builders  
National Housing Library  
1201 15th St. NW  
Washington, DC 20005  
Tel: (800) 368-5242
- National Gallery of Art  
Gallery Archives  
Washington, DC 20565  
Tel: (202) 847-6614
- National Gallery of Art Library  
6th & Constitution Ave. NW  
Washington, DC 20565  
Tel: (202) 842-6511
- New York City Municipal Archives  
Department of Records and Information  
Services  
31 Chambers St.  
New York, NY 10007  
Tel: (212) 566-5292
- New York Public Library  
Miriam and Ira D. Wallach Division of  
Art, Prints & Photographs  
Art and Architecture Collection  
Fifth Ave. & 42nd St., Rm. 313  
New York, NY 10018  
Tel: (212) 930-0834
- New Jersey Public Library  
New Jersey Reference Division  
5 Washington St.  
Box 630  
Newark, NJ 07101  
Tel: (201) 733-7776
- Oak Park Public Library  
Local Author and Local History  
Collections  
834 Lake St.  
Oak Park, IL 60301  
Tel: (708) 393-8200
- Ohio College  
Clarence Ward Art Library  
Allen Art Bldg.  
Oberlin, OH 44074  
Tel: (216) 775-8635
- Pavette Associates, Inc. Library  
28 S. Summer St.  
Boston, MA 02210  
Tel: (617) 842-8201
- Princeton University  
Marquand Library  
McCormick Hall  
Princeton, NJ 08544  
Tel: (609) 258-5860
- Princeton University  
Rare Books and Special Collections  
Firestone Library  
Princeton, NJ 08544  
Tel: (609) 258-3184
- Princeton University  
School of Architecture Library  
Princeton, NJ 08544  
Tel: (609) 258-3756
- Robert Scott Small Library  
Special Collections  
College of Charleston  
Charleston, SC 29401  
Tel: (803) 953-8016
- Smithsonian Institution Libraries  
Cooper-Hewitt Museum of Design  
2 F. 91st Street  
New York, NY 10128  
Tel: (212) 860-6887
- Society for the Preservation of New England  
Antiquities Library  
141 Cambridge St.  
Boston, MA 02114  
Tel: (617) 227-3956
- Society of the Four Arts Library  
Four Arts Plaza  
Palm Beach, FL 33480  
Tel: (407) 655-2716
- St. Louis Public Library  
Fine Arts Department  
1301 Oliver St.  
St. Louis, MO 63103  
Tel: (314) 539-0393
- Syracuse University  
E. S. Bird Library  
Fine Arts Department  
Syracuse, NY 13244  
Tel: (315) 443-2440
- The Foundation for San Francisco  
Architectural Heritage  
2007 Franklin St.  
San Francisco, CA 94109  
Tel: (415) 441-3600
- Theatre Historical Society Archives  
York Theatre Bldg., 2nd Floor, Ste. 200  
152 N. York Rd.  
Elmhurst, IL 60126  
Tel: (708) 782-1800
- Tulane University  
Howard-Tilton Memorial Library  
Southeastern Architectural Archives  
7061 Ereret St.  
New Orleans, LA 70118  
Tel: (504) 865-5697
- Tuskegee University, Architecture Library  
Wilcox Building A  
Tuskegee, AL 36088  
Tel: (205) 727-8351
- US Department of Housing and Urban  
Development Library  
451 7th St. SW, Rm. 8141  
Washington, DC 20410  
Tel: (202) 708-2370
- University of California, Berkeley  
Environmental Design Library  
210 Wurster Hall  
Berkeley, CA 94720  
Tel: (510) 642-4818
- University of California, Los Angeles  
Arts Library  
2250 Dickson Art Center  
Los Angeles, CA 90024  
Tel: (310) 825-3817
- University of Kansas  
Kansas Collection  
720 Spencer Research Library  
Lawrence, KS 66045  
Tel: (913) 864-4274
- University of Maryland  
National Trust for Historic Preservation  
Library Collection  
College Park, MD 20742  
Tel: (301) 405-6320
- University of Minnesota  
Manuscripts Division  
826 Berry St.  
St. Paul, MN 55114  
Tel: (612) 627-4199
- University of Missouri-Kansas City  
Western Historical Manuscript  
Collection  
302 Newcomb Hall  
Kansas City, MO 64110  
Tel: (816) 235-1543
- University of Nevada, Reno  
Special Collections  
Department/University Archives  
University Library  
Reno, NV 89557  
Tel: (702) 784-6538
- University of Oregon Library  
Architecture & Allied Arts Library  
Eugene, OR 97403  
Tel: (503) 346-3637
- University of Pennsylvania  
Architectural Archives  
Furness Building  
220 S. 34th St.  
Philadelphia, PA 19104  
Tel: (215) 898-8323
- University of Pennsylvania  
Fisher Fine Arts Library  
Furness Building  
220 S. 34th St.  
Philadelphia, PA 19104  
Tel: (215) 898-8325
- University of Southern California  
Helen Topping Architecture & Fine Arts  
Library  
800 Watt Way, Rm. 4  
Los Angeles, CA 90089  
Tel: (213) 740-1956
- University of Southern California  
School of Architecture  
Greene and Greene Library, c/o  
Huntington Library  
1151 Oxford Rd.  
San Marino, CA 91108  
Tel: (818) 405-2232
- University of Texas Libraries  
Humanities Research Center  
Austin, TX 78713  
Tel: (512) 471-9119
- University of Utah  
Special Collections Department  
Marriott Library  
Salt Lake City, UT 84112  
Tel: (801) 581-8863
- University of Virginia  
Fiske Kimball Fine Arts Library  
Bayly Dr.  
Charlottesville, VA 22903  
Tel: (804) 924-7024
- University of Washington  
Collections & Preservation Division  
Seattle, WA 98195  
Tel: (206) 543-1929
- Urban Land Institute  
Information Center  
625 Indiana Ave. NW  
Washington, DC 20004  
Tel: (202) 624-7117
- Virginia Historical Society Library  
428 North Blvd.  
Box 7311  
Richmond, VA 23221  
Tel: (804) 358-4901
- Virginia Polytechnic Institute  
International Archive of Women in  
Architecture  
Special Collections Department  
P.O. Box 90001  
Blacksburg, VA 24062  
Tel: (703) 231-6308
- Yale University  
Art and Architecture Library  
Yale Station, Box 1650A  
New Haven, CT 06520  
Tel: (203) 432-2640

# INDEX

- Absorber, for refrigeration, 712  
Absorption cycle, 712  
Absorption time, acoustical design, 64  
Abutments, bridge, 350-351  
Access  
to fire apparatus, 100  
floors, 14  
floor supports, 744  
to residential sites, 932, 934, 938  
roof, 391-395, 453-458  
Access control, 73, 75, 914  
residential sites, 932, 934, 938  
Accessibility, 951-976. *See also* Americans with Disabilities Act Accessibility Guidelines; Fair Housing Accessibility Guidelines  
bathrooms, 971-975  
bathtubs, 697  
codes, laws, and regulations, 952-953  
communication features, 967  
compliance, 954-955  
in courtrooms, 910-912  
curb ramps and passenger loading, 960  
doors, 474, 503, 855, 966  
drinking fountains, 698  
elevators and lifts, 963-965  
fair housing guidelines, 937  
furniture, 970  
guardrails, 295  
to historic structures, 855-856  
human dimensions, 7  
kitchens, 976  
maneuvering clearances, 956, 966, 975  
mobility aids, 968-969  
parking, 110, 112, 961  
required minimum number of spaces, 961  
ramps, 962  
reach ranges, 957  
residential, 974-976  
routes and walking surfaces, 958  
standards for sample projects, 953  
symbol, 574  
toilets, 971-972  
Acid neutralizer, 704  
Acoustical design, 63-72  
theaters, 915  
Acoustical treatment, 552-555  
barriers, 555  
ceiling units, 540, 555  
insulation, 555  
masonry units, 554  
materials, sound absorption properties, 64  
for open plan offices, 70  
panels, 540, 550  
in performance spaces, 69  
roof decks, 555  
seals, 555  
sound isolation construction, 67  
spray-on material, 554  
tiles, 296, 540  
walls, 554  
Acoustic detectors, 75  
Acrylic  
bath and shower units, 697  
carpet, 547  
dome skylights, 500  
permeance and permeability to water vapor, 405  
plexiglass, 514  
Acrylic resin flooring, 541  
Active solar heating, 817, 823-825  
Adaptability, definition, 975  
Adhesives  
bonding, 426  
environmental impact, 838  
organic, 532-533  
wood, 317-319  
Adobe construction, historic building preservation, 846  
Adult measurements, 2-7  
AI (Articulation index), 70  
Air barriers, house wrap, 810  
Air boots, 729  
Air fittings, 733  
Air conditioning. *See also* HVAC systems  
compressors, 711  
for computer rooms, 713  
and distribution systems, 726-727  
electrical circuits for, 738  
evaporators, 711  
refrigeration principles, 711-712  
symbols for, 984  
system types, 719-720, 723, 725, 726-727, 730-732  
thermal storage in conjunction with, 817  
Air diffuser, 530  
Air distribution systems, 726-736. *See also* Air conditioning; HVAC systems  
delivery devices and terminal boxes, 729  
duct materials and fittings, 733  
ductwork sizing, 734  
multizone, 726, 730-732  
warm air, for small buildings, 728  
Airfields, 896  
Air filters, 888  
Air filtration, trees and, 177  
Airflow  
natural, 807  
quantities, 646  
Air-handling equipment rooms, 730-732, 888  
Air-handling units  
four-pipe, single-zone, 730  
multizone, 730-732  
for refrigeration, 712  
Air leakage rating, 486  
Air pollution control, 705  
Airports, 896-899  
Air quality, trees and, 177  
Air-supported structures, 644  
Airtight doors, 511  
Aisle lighting, for warehouses, 58  
Alarms  
bank, 589  
fire, 662  
accessible, 967  
security, 589, 662  
selection, 80  
Alleys, 96-97, 99  
Allowable lengths. *See* Load tables  
Allowable loads. *See also* Load tables  
roof, laminated wood decking, 352  
Altars, 636  
Aluminum  
alloy fasteners, 162  
angles, tees, zees, and channels, 284  
doors, 484  
finishes, 262-263  
flashing, 438, 450  
frames, 498, 514  
tubular, 498, 502  
gauges and weights, 293  
grating, 290  
gutters, 460  
historic use, 851, 854  
life cycle, 834  
nosings with concrete filler, 12  
properties, 260  
roofing, 413  
saddles and thresholds, 509  
shapes, 284  
siding, 413  
sliding doors, 485  
tubing, 285  
window frames, 491, 493, 854  
Amateur Athletic Union (AAU), basketball standards, 769  
Ambient lighting, 61  
Ambulances, 104  
dimensions, 104  
turning dimensions, 105  
Ambulatory care facilities, 901  
American Architectural Manufacturers Association (AAMA), window standards, 487  
American Concrete Institute (ACI), 201  
American Forest and Paper Association, 324  
American Institute of Architects (AIA)  
documents, 122-125  
Masterspec, 132-142  
American Institute of Steel Construction (AISC), Manual of Steel Construction, 266  
American National Standards Institute (ANSI)  
acceptable nosing profiles, 12  
accessibility guidelines, 952, 962-967, 971-975  
fire escape standards, 289  
nosing design standards, 12  
wheelchair lift standards, 965  
American Plywood Association (APA), 324, 356, 359-360  
plywood grades, 357  
plywood trademarks, 355  
siding construction recommendations, 379  
American Society for Testing and Materials (ASTM), 274, 295  
brick standards, 219  
exterior, 230  
concrete masonry unit standards, 220  
masonry anchor standards, 213  
masonry reinforcement standards, 214  
PVC roof membrane standards, 424  
reinforcing bar standards, 225  
siding construction standards, 379  
specifications, 210  
stone cladding standards, 247  
waterproofing standards, 399-401  
American Society of Heating, Refrigerating and Air Conditioning Engineers (ASHRAE), 796, 798, 832  
vapor permeance standards, 405  
American Society of Mechanical Engineers (ASME), accessibility guidelines, 963  
Americans with Disabilities Act (ADA)  
design requirements, 953  
playgrounds, growth and development, 165  
vending machines, 594  
Americans with Disabilities Act Accessibility Guidelines (ADAAG), 952  
areas of rescue assistance (ARAs), 669  
ATMs, 589  
for bathrooms, 971-975  
for booths, prefabricated, 649  
building code stairway requirements, 10  
and building security, 73  
for cashier booths (parking), 632  
for curb ramps, 960  
for doors, 474  
for drinking fountains, 698  
for elevators, 669  
nosings, 388  
open riser stairs, 388  
parking, 110, 112, 961

- Americans with Disabilities Act Accessibility Guidelines (ADAAG), *continued*  
 restaurant seating, 681  
 for sound systems, 69  
 for tennis courts, 777  
 wood stairs, 387
- American Wood Preservers Association, 310  
 standards, 315
- Amplifiers, 72
- Anchors and anchorage, 212, 213, 319-320  
 for architectural fabric structures, 657  
 beams, 201, 232, 365, 376  
 bolts, 255-256, 320, 323, 535, 537, 656  
 brick, 233  
 brick veneer, 232, 235  
 cast-in-place, 295  
 columns, 213, 226, 229, 232, 354, 376  
 concrete construction, 201, 376, 509  
 decks, metal floor and roof decks,  
 275-276  
 doorframes, metal, 470-471  
 dovetail, 224, 226, 229-230  
 earth, 145  
 expansion, 320  
 fixed arch, 376  
 flexible, 224  
 floor tie, 319  
 framing, 342  
 glass blocks, 245  
 hinge, 376  
 joists, 347  
 liner, 254  
 masonry, 212-213, 224-225, 248  
 post, 354  
 riveted strap, 12  
 rock, 188, 245  
 rods, 145, 253, 535  
 rooftop collector supports, 825  
 seismic design for, 40  
 shear wall, 326  
 shields and, 320  
 sill plate, 219, 544  
 sills, 331, 335, 354  
 solid rail, 328  
 split-tail, 252  
 steel, 213, 252  
 stone, 248, 251, 255-256, 535, 537  
 stone veneer, 253-254  
 truss, 319  
 uplift, 319  
 walls, 217, 248  
 cavity, 213, 229, 232  
 details, 325  
 multiwythe, 226-227  
 single wythe, 224  
 wire, 535  
 wood, 354  
 Z-type, 213, 226, 230
- Anchor stores, in shopping malls, 925
- Angles  
 metal, 284, 569  
 wood fastener, 319  
 steel, bearing shoe detail, 351
- Animal care facilities  
 kennels, 928  
 shelters, 928  
 stables, 929-930  
 veterinary hospitals, 926-927
- Anodic coatings, 263
- Anthropometric data  
 adults, 2  
 children, 3
- Antimony, melting temperature, 261
- Apartment houses  
 hot water requirements, 699  
 laundries, 868  
 mailboxes, 583
- Apartments  
 elevator, 933, 940  
 garden, 933  
 laundry equipment and dishwashers, 603  
 walk-up, 933, 939
- Appliances  
 large  
 circuits for, 738  
 design standards for accessible  
 kitchens, 976  
 residential, 609-611  
 small kitchen, storage, 872-874
- Aquatics, 781-788
- Aquifer systems, 813
- ARAs (areas of rescue assistance), 669
- Arcade, 94
- Archery range specifications, 794
- Arches  
 classical, 1014  
 in glulam construction, 373, 376  
 lamella, 35  
 masonry, 234  
 relieving, 846  
 segments, brick, 218  
 stone, 234, 258, 819  
 timber bridge, 350
- Archimedean polyhedra, properties,  
 1003-1004
- Architectural elements, seismic design for,  
 41
- Architectural fabric structures, 656-657  
 anchorage, 657  
 environmental considerations and, 656
- Architectural materials symbols, 978
- Architectural programming, 130-131
- Architectural woodwork, 380-396  
 cabinet details, 382-383  
 interior wall paneling details, 386  
 joints, 380-381  
 ornaments, screens, blinds, and shutters,  
 389-390, 396  
 shelving, 385  
 stairs, 387-388  
 trim and moldings, 391-392  
 wood veneers and panel products,  
 393-395
- Architectural Woodwork Institute (AWI),  
 298  
 premium grade standards, 387  
 quality standards, 386
- Architraves, 862, 1013
- Arcs, in geometry, 936
- Area  
 calculations, 995, 1000  
 thermal expansion, 1005
- Area dividers, 420
- Area floodlighting, 59
- Areas of rescue assistance (ARAs), 669
- Arena football, 763
- Armchairs, 624  
 contemporary, 633  
 dimensions, 625  
 folding, 626
- Articulation index (AI), 70
- Ash cumps, 235, 240
- Ashlar masonry, 248
- Ash pits, 235, 237, 240
- Ash urns, 167
- Asphalt, 415  
 bridge surface, 351  
 emulsion glass blocks, 245  
 felts, 408  
 glass fiber felt, 415  
 plank flooring, 541  
 shingles, 408, 827  
 high wind resistance detail, 458  
 repair, 452  
 strips, flashings, 450  
 surface, rubberized, 768
- Assembly facilities, 913-921  
 auditorium seating, 919  
 grandstands and bleachers, 915  
 stadiums, 913-914  
 stage lighting, 920-921  
 theater design criteria, 916-917  
 theater sightlines, 918
- Assistive listening systems, 69, 71, 967
- Association for Preservation Technology,  
 845
- Astragals, 392, 506, 510
- Athletic facilities  
 aquatic, 781-788  
 court sport, 772-779  
 equestrian, 790-793  
 fencing, 794  
 field sport, 760-769  
 track and field, 770-771
- ATMs (automated teller machines),  
 589-590, 927
- Atrium design  
 for energy conservation, 814, 816  
 wintergarden, 816
- Attics  
 and ceiling joist allowable spans, 278  
 condensing furnace in, 724  
 framing, 309  
 ventilation, 335-351
- Audio equipment rooms, 72
- Audiovisual equipment, 595-597
- Audiovisual facilities, 595  
 tables for, in schools, 620
- Auditoriums  
 plumbing fixture counts for, 703  
 reverberation time, 69  
 seating, 919
- Automated teller machines (ATMs),  
 589-590  
 accessible, 967
- Automation systems, building  
 energy management, 660  
 lighting control, 661
- Automobiles  
 accessible parking spaces for, 961  
 design data, 103-106  
 overhang requirements, 112  
 turning dimensions, 105
- Avenues, 96-97  
 landscaping, 95
- Awnings, 579-580, 828  
 shapes, 579
- AWPA. *See* American Wood Preservers Association
- Backboard, basketball, 769, 774
- Backflow preventer, 679, 692
- Background noise  
 criteria, 68  
 in open plan offices, 70
- Backsplash, 382-383
- Backstops, 761, 769
- Badminton, 769, 779
- Baffles, 539  
 ceiling system, 539  
 chamber, 237  
 insulation, 451, 812
- Bakery, food service, 605
- Balance beam, gymnastics, 777
- Balcony  
 railings for, 11, 34  
 wood deck, 282
- Ballasts  
 electronic, and fluorescent lamps,  
 754-755  
 protected membrane roofing  
 aggregate, 427  
 paver, 427, 455-456  
 PVC roofing, 424
- Ball sports, facilities for  
 baseball, 760  
 basketball, 774  
 football, 762-764  
 handball, 775  
 polo, 790  
 racquetball, 775  
 rugby, 767  
 soccer, 765-766  
 softball, 760  
 squash, 776  
 tennis, 772-773  
 volleyball, 779
- Balusters, 11, 295, 387-388
- Balustrades, 862, 1014  
 stone, 249  
 terra-cotta, 846
- Bank equipment, 588-590. *See also* Auto-  
 mated teller machines
- Banners (signs), 167
- Banquet halls, seating capacities, 881
- Baptismal fonts and baptistries, 636
- Bargeboards, 337
- Barns, 929
- Baracades  
 beam-type, 164  
 lift plate, 164
- Barrier-free design  
 in historic buildings, 855-856  
 space layout, 6
- Barriers  
 acoustical, 70, 555  
 in open plan offices, 70  
 plenum, 555  
 radiation shielding, 655  
 retractable, 164  
 security, 163-164
- Bars and night clubs  
 food service, 607-608  
 seating for, 880-881
- Bar sports, facilities for, 780
- Bars, reinforcing, 189-190  
 doors, 504
- Baseball, 760, 768-769  
 Little League, 761  
 Major League, 760
- Baseboards, 391  
 chase behind, 346
- Base isolation, in seismic design, 40
- Basements  
 condensing furnace in, 724  
 finished, 335  
 foundation, 810  
 unfinished (unheated), 335  
 walls, 221, 324
- Base plates, steel, 376
- Bases  
 cabinets, 382, 384  
 column, metal, 319  
 moldings, 391-392
- Basketball, 769, 774  
 dimensions, court and ball, 774
- NBA standards, 774  
 NCAA standards, 774
- Basket racks and rooms (locker rooms), 576,  
 882
- Bathrooms  
 accessible, 6, 971-975  
 accessories, 564  
 cabinets, 564  
 fixtures, 697  
 accessible, 972  
 sizes and clearances, 865  
 residential, 865  
 saunas, 647
- Bathtubs, 697  
 accessible, 697, 971-972, 974  
 grab bar for, mounting height, 703  
 operating pressures for, 701  
 pipe sizes for, 682  
 tile enclosures, 533  
 water temperature requirements, 699
- Battens, 392  
 metal roofing, 437  
 plywood siding, 379  
 wood siding, 378
- Batteries, cabinets and racks for, 745
- Bays, vehicle  
 accessible parking, 961  
 loading docks, 598  
 truck docks, 116
- Beads  
 casing, 516  
 corner, 516
- Beams  
 anchorage, 201, 232, 365, 376  
 bond, 40, 173, 225  
 box, 345  
 sill wire chase, 346  
 cable crash, 163-164  
 cantilever, static loads for, 1010  
 castellated, 36  
 collar, 329  
 column connection, 266  
 composite, framing, 327  
 composite structure, 36  
 concrete  
 covers, 568-569  
 in floor systems, 197  
 formwork for, 184, 187  
 long span, precast, 203  
 post-tensioned, 201  
 precast, 203  
 precast and CMU, 233  
 prestressed, 201  
 fixed, static loads for, 1009  
 flitch, 36  
 framing, 327, 342  
 header, 279  
 in glulam construction, 373-374, 377  
 gypsum board at, 528  
 heavy timber, 859  
 load tables, 203, 306-308  
 longitudinal, 350  
 and plank construction, 341  
 socket, 326  
 post and, laminated wood, 23  
 reinforced brick, 233  
 ridge, 372  
 size, spacing, and span, 306-307  
 spanning, 326  
 splices, 377, 435  
 static loads for, 1008-1010  
 steel  
 load tables, 266  
 wall anchorage in, 232  
 straining, 343  
 summer, 343-344  
 tie, 329  
 wood, load tables, 306-308
- Beds and bedroom furniture, 626  
 accessible, 6, 970  
 arrangements, 864
- Bell pier foundation, 193
- Benches, 617  
 courtroom, 884, 911  
 garden, 175  
 outdoor, 618  
 saunas, 647-648  
 schools, 619
- Bents, 350  
 girt, 343  
 upper, 344
- Berms  
 in energy-saving design, 814  
 as fencing, 160  
 in parking lots, 112  
 Bermuda roof, 436
- Best management practices, urban, 153
- Bicycle paths, 95, 97
- Bidets, 694, 865

- Bike rail, 351  
 Billiard tables, 780  
 Bioclimatic chart, 796  
 Birthing centers, 901  
 Blast-resistant doors, 511  
 Bleachers, 915  
 Blinds  
   integral, 828  
   Venetian, 661  
   wood window, 396  
 Blocking  
   corner, 334  
   insulation, 451  
   lateral load, 371  
   solid, 282  
 Boardinghouses, plumbing fixture counts for, 703  
 Boats  
   design data, 118-119  
   floating docks for, 121  
   ladders, 288  
   launching ramps for, 120  
 Bocce, 767  
 Boiler rooms, room planning for, 887  
 Boilers, 705  
   electric, 708  
   flue economizers, 715  
   gas-fired, 706  
   range, 700  
   vents, 709  
 Bollards, 59-60, 100, 110, 163, 166  
 Bolsted stone, 257  
 Bolts, 321, 323, 658  
   for concrete formwork, 188  
   corrosion-resistant, 383  
   door, 503  
   expansion, stone veneer, 253  
   extension flush, 503  
   flush, 503  
   high-strength, 266, 270  
   lag, shields for, 320  
   Lewis, 253  
   mortise, 503  
   sill anchor, 331  
   stonework anchoring, 255-256, 535, 537  
   toggle, 322  
 Bomb resistance strategies, 76, 80  
 Bond breakers, waterproofing, 399  
 Bonding, symbols, 985  
 Bonding units, stone walls, types, 258  
 Bond patterns, 158, 218  
 Bookcases, open classroom furniture, 620  
 Book shelves, 385  
 Booths  
   accessible cashier, 110  
   parking lot, prefabricated, 649  
   restaurant, 880-881  
 Boulevards, 96-97  
   landscaping, 95  
 Bowling, 778  
   lawn, 779  
 Bowstring trusses, 362, 367  
 Boxing, 778  
 Braces, 323, 347  
   core system, 271  
   corner, 323  
   cross, 120, 271, 361  
   diagonal, 271  
   excavations, 145  
   exterior walls, 323  
   knee, 187, 343-344  
   trusses, 362  
   lateral, wood truss, 361  
   metal buildings, 658  
   for vibration control, 653  
   wood decks, 354  
   wood framing, 330  
   wood trusses, 361, 364  
 Bracing  
   in steel framing, 280  
   for tilt-up concrete, 208  
 Brackets  
   cam lock, 188  
   floor mounting, 288  
   wall, 295  
 Brass  
   gauges and weights, 261, 293  
   instruments, dimensions, 592  
   pipe, 661  
   properties, 260  
   saddles and weather stripping, 509  
   tubing, 285  
 Breaching, boilers, 709  
 Brick, 218-219  
   anchorage, 233  
   arches, 234, 846  
   ASTM standards, 219  
   bonds, 218, 847  
   coping, 174  
   exposure, grade requirements, 219  
   face  
     cavity walls, 230  
     grade requirements for exposures, 219  
   flooring, 542  
   historic building preservation, 846-847  
   joints, 211, 218, 847  
   life cycle, 835  
   masonry, 225, 230, 233, 1006  
   masonry stoves, 237  
   modular work, 218  
   paving, 156-158  
   permeance and permeability to water vapor, 405  
   reinforced beams, columns, and pilasters, 233  
   reinforced lintels, 217  
   reinforced masonry, 542  
   repointing, 847  
   rowlocks, 295  
   seismic-resistant design for, 186  
   sizes, 218  
     standard nomenclature for, 219  
   veneer, 16, 231-232, 335-336  
     in space frame building, 25  
     window in, 493  
   walls, 174, 217, 233  
     cavity, 228, 230, 858  
     curtain, 233  
     garden, 174-175  
     grouted hollow, 233  
     recess and sill details, 226  
     reinforced load-bearing, 225  
     retaining, 171, 233  
     watertables, 219, 445  
 Bridges, timber, 350-351  
 Bridging, 273-274  
   floor joists, 323  
   joists, 273-274, 280  
   rafters, 280  
   wall framing, 332  
   walls, 280  
   wood/steel, 331  
 Bronze  
   nosings, 12  
   properties, 260-261  
   saddles and weather stripping, 509  
   stair railings, 851  
   tinted glazing, 489-490  
   weight for buildings, 261  
 Brownstone, 243  
   finishes, 848  
   preservation, 846  
 Bucks, 467  
   metal, 470-471  
 Builders Hardware Manufacturers Association (BHMA), 503  
 Building codes, civil rights laws and, 952  
 Building envelope design, 13-27  
   climate response and, 808-812  
   flat plate concrete, 18  
   flying form, 21  
   laminated wood post and beam, 23  
   lightweight mobile modular, 24  
   lightweight steel frame and brick veneer, 16  
   metal, 26  
   post-tensioned concrete, 19  
   precast concrete frame, 20  
   space frames, 25  
   staggered steel truss, 15  
   steel bar joist, with bearing wall, 13  
   steel frame, with access floor and curtain wall, 14  
   tension fabric structures, 27  
   tilt-up wall, 22  
   wood roof truss and wood floor truss, 17  
 Building materials  
   bullet-resistant, 650  
   comparison chart, 837-838  
   corrugated, 148, 460, 852  
   embodied energy, 833  
   environmental impact, 837-838  
   environmental impact analysis, 833  
   fibrous, 403  
   heat transmission resistance, 830  
   high-energy, environmental impact, 833  
   historic, 844  
   insulation, 403  
   life-cycle analysis, 833-834  
   masonry, historic, 847  
   metals, 260-263, 403  
     historic, 851  
     properties of, 260-261  
     movement, 215  
     nontoxic, 836  
   permeance and permeability to water vapor, 405  
   recyclable, 942  
   recycled, 836  
   sound absorption properties, 64  
   steel framing, cold-formed, 277-283  
   symbols for, 978  
   thermal resistance values, 829-830  
   transmission loss properties, 66  
   weights, 1006  
   wiring, 738-743  
   wood, historic, 850  
 Building motion, period, 37  
 Building Officials and Code Administrators International (BOCA), 952  
   fire alarm system, 662  
   National Building Code stairway requirements, 10  
   occupant loads, 8  
 Building panels, structural, 339-340  
 Building papers  
   permeance and permeability to water vapor, 405  
   thermal resistance, 829  
 Buildings  
   automation systems for, 660-661  
   commercial, 814-815  
   healthy, 840  
   historic preservation, 1012-1013  
   loads and calculations, 34, 734  
   metal, pre-engineered, 658-659  
   nonresidential, 814  
   orientation, 799-806  
   recycling, 840  
   residential types, 932  
   smart, 814  
   timber frame, 343  
 Building security, 72-80  
 Building Seismic Safety Council (BSSC), National Earthquake Hazard Reduction Program, 42  
 Building structure  
   air-supported, 644  
   composite elements, 36  
   flat plate concrete, 18  
   frame construction with cold roof, 809  
   hardened, 163  
   historic, 858-859  
   integration, 13-27  
   lightweight steel frame and brick veneer, 16  
   long-span, 35, 203, 644  
   post-tensioned concrete, 19  
   precast concrete frame, 20  
   preengineered, 658  
   staggered steel truss, 15  
   steel bar joist with bearing wall, 13  
   steel frame with access floor and curtain wall, 14  
   technologies, 13-27  
   tensile, 35  
   wood roof truss and wood floor truss, 17  
 Building systems, 13-36  
   comparative, 26-36  
   continuous span, 373  
   energy design, 808, 810-816  
   envelope design, 13-27  
   flat plate concrete, 18  
   flying form, 21  
   integrated, 13-27, 813  
   interiors, 13-36  
   laminated wood post and beam, 23  
   lighting, 48  
   lightweight mobile modular, 24  
   mechanical systems, 13-36, 692-693, 718-720, 726-733  
   metal, 26  
   post-tensioned concrete, 19  
   precast concrete frame, 20  
   rigid frame, 270, 658  
   security, 75  
   service piping, 679-688  
   space frames, 25  
   staggered steel truss, 15  
   steel bar joist with bearing wall, 13  
   steel frame  
     with access floor and curtain wall, 14  
     lightweight, and brick veneer, 16  
   tension fabric structures, 27  
   tilt-up wall, 22  
   ventilation, 807  
   wood roof and floor truss, 17  
 Building types, 92, 863-950  
   airports, 896-899  
   child care centers, 889-890  
   churches, 904  
   detention centers, 907  
   distribution, 945-948  
   food processing, 949-950  
   greenhouses, 931  
   health care facilities, 900-903  
   health clubs, 891  
   housing, 932-941  
   justice facilities, 908-912  
   mosques, 906  
   museums, 892-895  
   shopping malls, 922-925  
   stables, 929-930  
   stadiums, 913-915  
   synagogues, 905  
   theaters, 916-921  
   veterinary hospitals, 926-927  
   waste facilities, 942-944  
 Bulkheads, of swimming pools, 785  
   movable, 783  
 Bulletin boards, 575  
 Bullet-resistant construction, 650  
 Gypsum board wall, 529  
 B. U. R. See Modified bitumen membrane  
 Burglary alarm systems, banks, 589  
 Buses  
   dimensions, 104  
   turning radii, 105  
 Bush hammered stone, 257  
 Butyl tape, skylights, 498  
 Cabanas, 882  
 Cabinets  
   accessible, 970  
   bar, dry storage, 608  
   base, 382-383  
   bathroom, 564  
   battery, 745  
   classifications, 382  
   custom grade, 382-384  
   darkroom, 612  
   details, 382-383  
   fire, 578  
   ice cream, 606, 608  
   kitchen, 866-867, 976  
   library, 623  
   material thicknesses for, 384  
   mobile banquet, 603  
   open classroom furniture, 620  
   steel frame backing for, 282  
   wall, 382-384  
 Cables  
   crash beams, 163-164  
   electrical, 742-744  
   steel, in fabric structures, 27  
   symbols for, 985  
   telecommunications distribution, 758  
   trays, 742  
 CAD (computer-aided design) layer guidelines, 991-993  
   layer name formats, 991  
   master layer list, 991  
 Cadmium, melting temperature, 261  
 Cafeterias, seating capacities, 881  
 Caissons, 146  
 Calculations  
   of area, 995, 1000  
   cut and fill, 1000  
   of energy, 805-806  
   structural, 1008-1010  
   of volume, 1007  
 Camber, 361, 373  
 Cameras, surveillance, 589-590  
 Campers, dimensions, 103  
 Canadian Football League (CFL), 762  
 Canes, for ambulating, 968  
 Canoes, 118  
 Canopies, 579-580  
   canvas, 828  
   roof, ornamental, 433  
   security design strategies for, 76  
   shapes, 579  
   storefront, 482  
 Cantilever, 370  
   beams, static loads for, 1010  
   floors, 282, 332  
   trusses, 365  
   framing, 328, 341  
   overhang with, 369  
   retaining wall, 173  
   sheeting, 145  
   spans, 373  
   trusses, 365-366  
 Capacitors, 749  
 Capitals, 1013  
   plaster, 861  
 Caps  
   and copings, 174  
   on fencing, 160  
   flashing, 320, 439-441, 454  
   mineral-surfaced sheet built-up roofing, 416  
   parapet, light metal, 419, 425-428  
   rain, 455  
   on retaining walls, 173  
   snap, 434



- Card catalogs, cabinets, 623  
 Card readers  
   access control, 75  
   accessible, 110  
   parking lot, 110  
 Carousels, 620  
 Carpentry  
   decks, 353-354  
   eaves and overhangs, 335  
   exterior stairs, 354  
   finish, 378-379  
   flooring, 543, 545  
   framing, 335  
   plywood  
     design data, 355  
     roof decks and soffits, 360  
     subflooring on wood framing, 359  
   rough, 323-338  
   stairs, 388  
 Carpet, 547-548  
   environmental impact, 838  
   fiber characteristics, 548  
   in laminated wood building, 23  
   maintenance programming, 548  
   in metal building systems, 26  
   in tilt-up wall building, 22  
 Carports, 869  
 Carriages  
   stair framing, 328  
   wood stairs, 387  
 Cashier booth, parking lot, accessible, 110  
 Casings, 467  
   interior wood, 391  
 Cast iron  
   architectural, 851  
   bases, 859  
   bath and shower units, 697  
   channels, 150  
   columns, 857  
   pipes, 681  
   radiators, 721  
   sectional type burner, 705  
 Cast metal  
   abrasive surface thresholds, 509  
   nosings, 12  
   saddles, 509  
   uses for, 166-167  
 Cast plaster  
   cornice, 521  
   two-piece column, 522  
 Cast stone  
   coping, for garden walls, 174  
   uses for, 167  
 Catch basins, 149, 152  
 Cathedral pattern, unit pavers, 158  
 Cathedrals, reverberation time, 69  
 Catwalks, 7, 918, 921  
   marine, 120  
 Caulking, lead wedge, 251  
 Cavity absorption (sound), 64  
 Cavity height diagram, for lighting design, 18  
 Cavity walls, 217, 228-230, 248  
   anchors, 213, 229  
   angle support, 213  
   brick, 228, 230, 858  
   flashing, 216, 230  
   ventilated, 841  
 Cedar  
   fences, 162  
   shingles and shakes, 406  
 Ceilings, 273  
   access doors in, 480  
   acoustical materials, 552  
   acoustical ratings, 524, 528  
   acoustical tile, 296, 552-553, 555  
   acoustical units, 540  
   baffle system, 539  
   cast (molded) units, 540  
   cathedral, 283  
   closure rings, fastened, 569  
   closures wood paneling, 386  
   coffered, 522  
   courtrooms, height in, 910  
   coves, 530  
   decking, 360  
   finishes, 539-540, 569  
   fire ratings, 528, 553  
   fixtures, 614  
   in flying form building, 21  
   gypsum board, 527-528  
     with spacers, 346  
   heaters, 708  
   joists, 778, 309, 329-330  
   lath and plaster, 518-519  
   in lightweight mobile modular building, 24  
   linear, 539  
   metal, 552-553  
   in metal building systems, 26  
   nodular units, 540  
   open-plan office, 778  
   panels  
     interior wall system, 551  
     roof eave with, 340  
     suspended, 540  
   radiant heating, 708  
   in seismic areas, 41  
   skipped, roof eave with, 340  
   soffits, at: interior, 530  
   and sound absorption, 65, 70  
   spread criteria, 65  
   sound isolation construction, 67, 529  
   in space frame building, 25  
   special surfaces, 539-540  
     suspended, 296, 318, 539-540, 552-553, 708  
     lath and plaster, 518-519  
   tilt-up wall building, 22  
   trig and-groove, 345  
   types, 552-553  
   varied, 367  
   vent-felted units, 340  
 Ceiling, wine storage, 600  
 Cellular insulation materials, 403  
 Cement  
   grout channels, 150  
   magically colored, 199  
   mortar, 532  
   portland, 210  
   and preservation of masonry, 847  
 Cement-water ratios, slab strengths, 194  
 Cement wood tiles, roofing, 411  
 Centralized heating, electric systems, 708  
 Central processing unit (CPU), 597  
 Ceramic slate, 411  
 Ceramic tile, 531-533  
   countertops, 533  
   expansion joints, 532  
   flooring, 533  
   grout and mortar types, 532  
   installation, 532-533  
   thresholds for, 533  
   tile enclosures, 533  
   walls, 532  
 Ceramic veneer, 243  
 Chain-link fences, 161  
   baseball backstop, 769  
   for high school stadium, 764  
 Chair rails, 392, 862  
 Chairs, 625  
   accessible, dimensions, 970  
   anthropometric data, 5  
   for children, 621  
   church equipment, 636  
   classic, 627-631  
   contemporary, 632, 634  
   folding, 616  
   Ht, 793  
   lounge, 624  
   office, 639  
   outdoor, 618  
   for restaurants/bars, 880  
   school, 619  
   shopping, 616, 631-636  
   stacks, 965  
 Chase lounges, outdoor, 618  
 Channels  
   cluttering, 277, 283, 528  
   hydraulic properties, 150  
   metal, 284, 544  
   resilient, and sound isolation, 67  
   runner, 277  
   runoff, 150, 170  
   slots and anchors, 213  
   steels, 277, 520  
   surface drainage, 149-150  
   suspension systems, 528  
 Chases  
   baseboard, 346  
   service, under floor, 346  
   wainscot, 346  
   wire, 339  
   surface-mounted, 346  
   timber sill, 346  
 Check dams, 151  
 Checkroom equipment, 879  
 Chests, equipment, 638  
 Chemical resistance, 262  
   coatings for, 567  
 Chests, accessible, 970  
 Child care centers, 889-890  
 Children  
   anthropometric data, 3  
   furniture for, 621  
   growth and development, 165  
   patient rooms for, 885  
   reach ranges from wheelchair, 957  
 Chilled water systems, 725  
   air conditioning, 711, 726-730, 732  
   pumps, 887  
   terminal units, 714  
 Chiller  
   with HVAC system, 716  
   unit heaters/chillers, 707-708  
   water, 715, 725  
 Chimneys, 235, 238-239, 709  
   caps, 238  
   clearances, 238, 572  
   connector systems, 238  
   construction, 239  
   downdrafts, 238  
   flashings, 442  
   flues, 238-239  
   hoods, 238, 709  
   industrial, 238  
   insulation, 239  
   medium heat, 709  
   metal, 570  
     UL-approved, 238  
   pots, 238, 709  
   prefabricated, 709  
   types, 572  
   vent stacks, 709  
   wood framing members, 235  
 Chinking, log construction, 348  
 Chords, in geometry, 996  
 Chromium  
   melting temperature, 261  
   properties, 260  
 Churches, 904  
   chimney requirements, 238  
   liturgical equipment, 589, 635-636  
   plumbing fixture counts for, 703  
   reverberation time, 69  
 Circular helix, 106  
   in parking structure, 113  
 Circulation paths, protruding objects in, 958  
 Cisterns, 147  
 Cities, 87  
 City blocks, 89  
   patterns, 87  
   types, 89-90  
 Civil rights laws, and building codes, 952  
 Cladding, 378-379, 412-414  
 Clamping ring, 425  
 Clamps, for pipes, 688  
 Clapboard, historic preservation, 849  
 Classical architecture, 1011-1016  
   columns, 1012-1013, 1016  
   details, 1012  
   doors, windows, pediments, and rustica-  
   tion, 1015  
   entasis, fluting, volutes, and pilasters,  
   1013  
   intercolumnation, superposition, arches,  
   and balustrades, 1014  
   moldings, 1011  
   orders, 1011-1013  
     hidden, 1016  
   use of elements, 1016  
 Classrooms  
   child care centers, 890  
   early learning equipment, 621  
   latches and locks, 504  
   lighting, 57  
   open, furniture, 620  
   reverberation time, 69  
 Clay  
   chimney pot, 238  
   flue liners, 235-239  
   masonry units, 219, 225  
   tennis court surfaces, 772  
 Clay tile  
   channels, 150  
   roofing, 412, 852  
   structural, 242  
 Cleaning equipment, storage for, 873  
 Cleaning methods, masonry surfaces,  
   847-848  
 Cleanouts, 237, 240, 682, 693  
 Cleanroom, 646  
 Clear width  
   accessible doorways, 966  
   accessible routes, 959  
 Cleats, in metal roofs, 43b  
 Clerestories, 61, 486  
   solar heating, 820-821  
   trusses, 366  
 Climate, 796-798  
   Arctic region map, 808  
   bioclimatic chart, 796  
   buffering, 814  
   and building design, 808, 812  
   cold, design for, 808-809  
   control strategies, 796, 810-812, 895  
   control systems, 796  
   design conditions and strategies, 796-  
   797  
   energy and resource conservation, 795,  
     813, 818  
   environmental site analysis, 84  
   hot and, design for, 811  
   humid or overheated, design for, 812  
   terms, 808  
   underheated, design for, 810  
 Clinch strips, flashings, 440  
 Clips  
   for column covers, 568  
   gypsum lath system, 516  
   wood fasteners, 319  
   roof truss, 319  
 Clocks, 167, 662  
 Closets, 507  
 Closets  
   condensing furnace in, 724  
   dimensions, 6  
   mirrored doors, 626  
   storage arrangements, 870  
 Closet, telecommunications, 765  
 Closures, acoustical, 555  
 CMUs, See Concrete masonry units  
 Coatings, 556-557  
   abrasion-resistant, 561  
   ceiling surfaces, special, 539-540  
   cementitious, 561  
   chemical-resistant, 561-562  
   clear, 557  
   for concrete surfaces, 200  
   exterior systems, 559-561  
   floor, special, 541  
   glazed, high build, 561  
   graffiti-resistant, 561  
   interior systems, 560-561  
   liquid-applied, permeance and permeabil-  
   ity to water vapor, 405  
   low-VOC, for windows, 486-489  
   on metal, 262-263  
   solar control, 487  
   special, 541, 561-562  
   for steel, 561  
   substrate conditions and, 558  
   types and uses, 559-560  
   wall surfaces, special, 551  
 Coat racks, classic, 628  
 Coatrooms, 879  
 Cobalt, melting temperature, 261  
 Cobblestone, pavers, 157  
 Coffee shops, seating capacities, 881  
 Coin-operated laundries, 583  
 Cold climate design, 808-809  
 Cold deck bypass, 732  
 Cold storage  
   distribution facilities, 948  
   rooms, 645  
 Collars  
   flex-tube, 420  
   framing, 330  
   ties, 343-344  
 Columns, 233  
   anchorage, 229  
   wood, 354  
   angle guards for, 567  
   base connections, 206  
   beam connection, 266, 270  
   caps, 377  
   cast-in-place, 18  
   cast-iron, 857  
   cast plaster, two-piece, 522  
   classical, 1011-1014  
   concrete, 232  
   concrete filled, 36  
   concrete formwork for, 185  
   connections, 342, 377  
   construction, 233  
   corner, shelf angle at, 229  
   covers, 568-569  
     plaster, 861  
     precast concrete connections, 207  
   drop panels, 185  
   equipment support, 455  
   exterior, 342  
   fireproofed, U.L.-rated, 286  
   fire-resistant construction, 577  
   flashing, 443  
   flat drop, 196  
   footings, 185  
   gas medical, 886  
   glulam construction, 374-375  
   guards, 567  
   gypsum board at, 527  
   gypsum plaster, glass fiber reinforced,  
     two-piece, 522  
   installation, 248  
   interior, 342  
   lally, 286  
   load tables, 266, 305  
   load transfer, 371

- masonry anchors, 213  
 metal bases, 319  
 plaster, 522  
   covers, 861  
 reinforcement, 191, 233  
 roof beam, 342  
 splices, 266  
 steel, 286  
   concrete-encased, 36  
   connections, 377  
   fire protection, 36  
   load tables, 266  
   prefabricated fireproofed, 286  
   reinforced, 233  
 for steel frames, 271  
 stone, 248  
 tapered, wood, 376  
 tube, 285  
 wood  
   anchored with steel baseplate, 376  
   load tables, 305  
   wood footing, 326  
 wood footing, 326  
 Combustion chambers, 237  
 Comfort zone, climate control, 796  
 Commercial property  
   building codes for, 81  
   building entrance, 81  
   food service equipment, 602  
   glazing materials for, 490  
   HVAC system problems in, 717  
   lighting for, 55-56  
   local planning regulations for, 81  
   maximum building height, 81  
   parking arrangements, 81, 112  
   security design strategies for, 77  
   service access, 81  
   shopping malls, 922-925  
   site development for, 81, 149  
   utilities, 81  
 Communications  
   accessible features, 967  
   fire alarm systems, 662  
   telecommunications cabling, 758  
 Communion preparation rooms, 904  
 Communion rails and tables, 635-636  
 Community facilities, 936  
 Community planning, 81-100  
 Compass orientation, 801  
 Composite order, 1011  
 Computer  
   equipment, office, 597  
   lighting, for offices, 55  
   workstations, 597  
 Computer-aided design (CAD) layer guide-  
   lines, 991-993  
 Computer rooms  
   air conditioning, 713  
   cables, 743-744  
   carrels, 620  
 Concourse, of shopping mall, 923  
 Concrete, 183-208  
   admixtures, 192  
   aggregate, 192, 194, 199  
   exposed, 199  
   air content, 192  
   anchorage, 201, 376, 509  
   architectural, 195-199, 205  
   bases, anchorage, 201, 376  
   beams, 184, 187, 203, 227, 232  
   bituminous, 768  
   bollards, 163, 166  
   bush-hammered, 199, 848  
   cast-in-place, 192-200, 296, 400, 441  
   channel anchorage in, 509  
   channels, 150  
   coatings, 200  
   color, integral, 198-199  
   columns, 184-185, 232  
   composite construction, 36  
   connections  
     alignment, 207  
     precast, 206-208  
   construction, 200  
   coping, 174  
   corner details, 198-199, 254  
   counterflashing, 418, 431  
   curbs, 498  
   decks, 202-203  
   defect prevention, 200  
   economy of formwork, 184  
   environmental impact, 837  
   extruded, high wind resistance detail, 458  
   -filled columns, 36  
   -filled masonry, 323  
   -filled steel pans, 287  
   finishes, 198-200, 208, 561  
   flat plate, 18  
   floor systems, 196-197  
   in flying form building, 21  
   footings, 158, 171-172, 175, 184-185, 398  
     of fence, 160  
   form liners, 198-199  
   formwork, 184-188  
     hardware, 184, 188  
   foundations, 193, 398  
   frames, for stone stairs, 537  
   historic building preservation, 846  
   inserts, 199  
   Jersey barrier, 164  
   joints, 194, 199, 204, 401  
   lead lining in, 654  
   lightweight, weights, 1006  
   panels, wall, 204-205, 208  
   parapet, counterflashing, 418  
   pavers, 156-158, 427  
     on existing slab, 542  
   permeance and permeability to water vapor, 405  
   pile foundations, 146  
   planter barriers, 163  
   post-tensioned, 19, 201  
   precast, 201-208, 233  
     connections, 206  
     crib wall systems, 173  
     decks, 202  
     frame, 20  
     lintels, 217  
     panels, 204, 243  
     retaining walls, 173  
     riprap, 170  
     systems, 36  
   pressed  
     bricks and pavers, 158  
     unit flooring, 542  
   prestressed and pretensioned, 20, 201  
   reinforced, 189-191, 217, 233  
     bars and wire for, 189-190  
     floor systems, 194, 199  
     masonry lintels, 217  
     repairs, 200, 848  
     retaining walls, 172-173  
     rustication, 186  
     seismic-resistant details, 40  
     slabs, 187, 194, 196-197  
     in building systems, 21-23, 25-27  
     cracking in, 200  
     mortared, 542  
     mortarless pavers on, 542  
     pavers on, 157  
     precast, 202  
     waterproofing under, 398  
   spalled, repairs, 848  
   stairs, 195  
   stone veneer on, 253  
   strengths, 194  
   surfaces, 198-200, 208, 561  
   symbol for, 978  
   thermal resistance, 829  
   tile roofing, 410  
   tilt-up, 184, 208  
   in tilt-up wall building, 22  
   trash receptacles, 167  
   treads, 12  
   tree grates, 166  
   trench drain, 151  
   walls, 184, 186, 204-205  
     single-pitch side wall detail, 501  
   waterproofing, 400  
   weights, 202, 1006  
 Concrete masonry units (CMUs), 220, 230  
   anchorage, 224-225  
   beams, 233  
   brick veneer on, 232  
   lintels, 217  
   in space frame building, 25  
   types, 220  
   walls, 223, 225  
     cavity, 228  
     electrical outlet box in, 223  
     retaining, 173-174  
     single wythe, 225  
 Condensation, analysis, 405  
 Condensers  
   air conditioning, 711  
   for refrigeration, 712  
   warm air heating, 728  
   water pumps, 887  
   water systems, 723  
 Condensing furnaces, 724  
 Conductance, thermal, 829  
 Conduction  
   climate control, 810-812  
   climatic design strategies, 797  
   conductivity, thermal, 829  
   conductor heads, 461  
   conduit symbols, 981  
   Cone diffusers, 729  
 Conference furniture, 595  
   tables, 6, 630-632, 638  
 Conference rooms, 595, 877  
   lighting plan, 54, 877  
 Connections, 206  
   beam, 266, 376  
   concrete, precast, 206-207  
   glulam construction, 374-377  
   long-span structures, 35  
   metal plate, 366  
   metal space frames, 272  
   moment-resisting, column-to-beam, 270  
   open-web steel joints, 360  
   pier, 208  
   precast concrete, 206  
   seismic design for, 40  
   shear, 266, 271  
   split ring, 361  
 Conoid, 1000  
 Conservation  
   of energy. *See* Energy conservation; Envi-  
     ronmental design  
   of resources, 840-841  
     methods and systems, 836  
   of water, 840-841  
 Construction  
   heavy timber, 341-351  
   straw bale, 841  
   timber frame, 343-346  
   wood I-joint details, 370-372  
   wood truss, 366-367  
 Construction cost, HVAC systems and, 717  
 Construction information systems, 122-142  
 Construction materials. *See* Building materi-  
   als  
 Construction Specifications Institute (CSI)  
   documents, 126-127  
   Masterformat, 128-129  
 Contaminants, in HVAC system, 842  
 Control joints, 212, 216, 517-518  
   concrete slabs, 194  
   gypsum wallboard, 523  
   masonry, 215  
     horizontal, 230  
   premolded, 194  
   retaining walls, 172-173  
   strips, 538  
   tongue and groove, 194  
 Convection  
   climatic design strategies, 797  
   electric heating, 708  
 Convectors, 721  
 Conveying systems, 665-676  
 Conveyors, 674  
   baggage claim, 675  
   baggage, crescent, 675  
   belt, 674  
   screw, 674  
   segmental, 674  
   unit, 675  
   vibratory, 674  
 Cooktops, accessible, 976  
 Coolers, 713  
   dry, 723  
   refrigerated, 645  
 Cooling  
   air conditioning, 711, 713, 726-727, 738, 984  
   annual use, 818  
   computer rooms, 713  
   concepts, 819  
   condensing and evaporative systems, 723  
   economizer/enthalpy cycle, 814  
   energy storage for, 814  
   equipment interface, 817  
   four-pipe systems, 714, 730, 732  
   greenhouses, 931  
   HVAC systems, 719-720, 730-732  
   kennels and animal shelters, 928  
   limited capacity devices, 817  
   mainframe systems, 713  
   multizone systems, 726-733  
   natural, 816  
   passive solar, 819  
   thermal storage walls, 822  
   towers, 710-711, 723  
   unit, electric, through-wall, 707  
 Coordinator (door hardware), 503  
 Copings  
   flashings, 440  
   for garden walls, 174  
   metal, 226, 440, 450  
   stone, 249, 252-255  
   for stone walls, 176  
   through-wall flashing under, 429  
 Copper  
   architectural, 851  
   dovetail slots, 213  
   finishes, 262  
   flashing, 438, 450  
   gutters, 459-460  
   melting temperature, 261  
   nails, 409  
   properties, 260  
   and radio frequency (RF) shieldings, 651-652  
   roofing, 436  
   tubing, 285, 681  
   weight for buildings, 261  
   weights and gauges, 293  
 Corbel, 389  
 Corinthian order, 1011, 1013  
 Cork tile flooring, 546  
 Corners, 392  
   blocking, 334  
   cavity wall columns, 230  
   concrete details, 198-199, 254  
   connections, 342  
   gravel stops, 450  
   guards, 567  
   inside, 551  
   interior stone details, 535  
   ironwork, ornamental, 291  
   outside  
     details, 551  
     protection for, 325  
   wall, 334  
   wall framing, 332  
 Cornices, 391  
   classical, 1012  
   columns, 1013  
   flashings, 439  
   plaster, 861  
   preservation of wood, 849  
   stone, 249, 251  
   support detail, 336  
   types, 521  
 Corridors  
   accessibility, 7  
   dimensions, 6  
   lighting for, 54  
 Corrosion, 260  
   galvanic, 214, 261, 438, 851  
   -resistant bolts, 383  
   -resistant steel, 294  
 Corrugated materials  
   gutters, 460  
   iron roofs, 852  
   metal drain pipes, 148  
   steel channels, 150  
 Counterflashings, 430-431, 439, 441, 450  
   concrete, 431  
   concrete parapet, 418  
   at existing wall, 431  
   expansion joint, 431  
   installation, 430  
   non-masonry wall, 431  
   parapet, 418, 422-423  
   with receiver, 430  
   at sloped roof, 431  
   snap-in, 430  
   springlocked, 430  
   structural steel, 431  
   systems, 430-1  
   at tile roof, 431  
   two-piece, 430  
   without receiver, 430-431  
 Counters, 382, 880-881  
   heights and clearances, 5  
   tops, 383-384, 533  
 Country clubs, plumbing fixture counts for, 703  
 Courthouses  
   design, 908-909  
   equipment interface, 817  
   security, 909  
   types, 908  
 Courtrooms, 884, 909-912  
   accessibility, 908, 911  
   design and layout, 909-911  
   furnishings and finishes, 911  
   security, 911  
   technology needs, 911  
 Court sports, 772-779  
 Court construction, 768  
 Courtyard building, 92  
 Covers  
   beam, 568-569  
   column, 568-569  
     precast concrete connections, 207  
   protective  
     awnings and canopies, 579-580  
     metal louvers, 581-582  
 Coves  
   ceiling, 530  
   light, 530  
   moldings, 392  
 Crandalled stone, 267

- Crawl spaces, 7, 335  
 ventilation, 335, 395, 451  
 walls, 324
- Credenzas, 637
- Cresote, 314-315
- Crib wall system, precast concrete, 173
- Crime prevention through environmental design (CPTED), 73, 74  
 concepts, 73  
 and site selection, 74
- Croquet, 779
- Cross bracing  
 connection, 271  
 docks, 120  
 wood truss, 361
- Crowns, masonry, 238
- Crutches, 968
- C steel shapes, 268
- Cube, 1003  
 snub, 1004  
 truncated, 1004
- Cubicles, bathrooms, 504
- Cuboctahedron, 1003
- Cul-de-sac, dimensions, 105, 107
- Cupboards, highboy, 589
- Cupolas, 849
- Curb ramps  
 accessible, 960  
 types, 960
- Curbs  
 detail, 500  
 equipment, membrane roofing, 420  
 equipment support, continuous, 455  
 as fencing, 160  
 guards, 567  
 insulated, 498, 500  
 nonmountable, 163  
 pond, 169  
 radius, 97  
 skylight, 330, 498  
 stone, 249  
 vent, with polyurethane foam, 428  
 vertical frame, detail, 501  
 wood, 498, 500-501
- Curling, 791
- Curtain walls  
 brick, 233  
 glass, insulating, 830  
 insulated thermal storage, 822  
 metal, finishes, 267  
 shop bonded stone, 256
- Curves  
 broken-back, for track, 770  
 drawing, 999, 1001
- Cut rock, channels, 150
- Cut stonework, 255-256, 535, 537  
 paving, 157  
 window sills, 846
- Cylinders, door, 503-504
- Dampers, 237  
 arrangements, 241  
 automatic intake, 582  
 chimneys, 238-240  
 dimensions, 240  
 fireplaces, 235-236  
 masonry heaters, 237  
 solar collection, 824  
 types, 240
- Dampproofing, 221, 398-401  
 of foundation walls, 222  
 in metal building systems, 26
- Darkrooms, 612
- Dartboards, 780
- Daylighting, 61-62, 811-816  
 analysis tools for, 62  
 atriums and, 816  
 Venetian blinds and, 661
- Deadbolt, 503
- Decay resistance, heartwood, 314
- Decibel scale, 63
- Decimal equivalents, 1005
- Decks, 347, 353-354  
 accessories, 276  
 cellular systems, 743  
 flat, 202  
 floor, 345  
 glulam, 352  
 glulam attachment, 351  
 laminated, 350, 352  
 loads for, 352  
 longitudinal, 350  
 long-span, precast concrete, 203  
 machine-shaped, 352  
 metal, 275-276, 428  
 horizontal support for, 223  
 non-wall-supported, base flashing for, 418  
 panelized, nail laminated, 350  
 plainsawed, shrinkage distortion, 299  
 plywood, 360  
 precast concrete, 192, 203  
 roof, 275, 360  
 acoustical treatment, 555  
 steel, 273  
 mull-up wall building, 27  
 steel base, 542  
 steel frame, insulated, 419  
 stemmed, 203  
 double tee, 203  
 stress laminated, 350  
 wall supported, base flashing for, 418  
 weight/insulation values, 352  
 wood, 168, 352-354  
 tongue and groove, 352
- Declination of the earth, 800, 803-804
- Defensible space, 73
- Deflection  
 limits  
 beams, 306-307  
 planks, 341  
 long span structures, 35
- Degree days, 798
- Delivery areas, in shopping malls, 924
- Density, residential, 932-935
- Dental rooms, 886
- Dentils, 391, 521
- Depth ratio, long-span structures, 35
- Depths  
 dimension lumber, 373  
 rafter spans, 364
- Design and general planning data  
 acoustical design, 63-72  
 automobiles, roads, and parking, 103, 114  
 building systems, 13-36  
 classical architecture, 1011-1015  
 construction information systems, 122-142  
 dwelling unit, 937-938  
 egress planning, 6-12  
 flood damage control, 101-102  
 human dimensions, 2-7  
 lighting design, 47-62  
 security design, 73-80  
 seismic design, 37-46, 225  
 site, community, and urban planning, 81-100  
 trucks, trains, and boats, 115-121
- Design considerations  
 daylighting calculations, 62  
 HVAC, 716-717  
 plumbing systems, 690-691  
 wood, 298-299
- Desks  
 accessible, 970  
 classic, 627  
 library charge, 623  
 office, 637  
 open classroom furniture, 620  
 reading/songleader, 635  
 school, 619
- Destination-oriented elevator systems, 963
- Detention basins, 153
- Detention center rooms, 907
- Diaphragms, 40  
 connections for masonry, in seismic design, 44  
 in seismic design, 39-40
- Dictionary stands, 623
- Diffusers, 530, 729
- Dining rooms  
 formal seating capacities, 881  
 furniture arrangements, 864  
 furniture space requirements for, 6  
 table systems, 638
- Dining tables  
 accessible, dimensions, 970  
 classic, 628, 630-631  
 contemporary, 637
- Directional diffuser, 729
- Directories and signs, 574-575
- Disabilities, persons with. *See also* Accessibility; Americans with Disabilities Act; Accessibility Guidelines; Fair Housing Accessibility Guidelines  
 anthropometric data, 6  
 bathroom layout, 865, 971  
 design data, 2  
 kitchen layout, 867  
 laundry layout, 868  
 playgrounds, 165  
 preservation approaches for, 857  
 residential elevators for, 667  
 signs, 574-575  
 stairs, 12
- Discs, stone veneer, 254
- Dishwashers, 606, 609  
 accessible, 976  
 operating pressures for, 701
- pipe sizes for, 687  
 water temperature requirements, 699
- Disposal systems  
 for feminine napkins, 564  
 waste compactors, 599, 609, 976
- Distribution facilities, 945-948  
 cold storage, 948
- Divided light  
 true, 488  
 types, 488
- Diving boards  
 competition pools, 784  
 dimensions, 782, 786  
 FINA standards, 786-787  
 public pools, 782  
 residential pools, 781  
 towers, 787
- Docks  
 bumpers, 598  
 floating, 121  
 marine, 120  
 trucks, 116
- Documentation, for restoration of interiors, 860
- Dodecahedron, 1003  
 truncated, 1004
- Domes  
 air-supported, 644  
 canopies, 579  
 gypsum, 522  
 cast glass fiber-reinforced, 522  
 laminated, 373  
 long-span structures, 35  
 plaster, 521  
 space frame, 272  
 unit skylight, 500
- Doorframes, 467, 474, 504. *See also* Doorways  
 bullet-resistant, 650  
 fire-rated, 464  
 gauges, 469  
 installation details, 468  
 in masonry walls, 468  
 metal, 161, 469-472  
 radiation-shielded, 654  
 trim, 391, 862  
 weatherproof installations, 469  
 wood, 468
- Door hardware, 476, 503-511  
 bevels, 506  
 for bypass doors, 476  
 closers, 507  
 cylinders, 503-504  
 detectors, 507  
 exit devices, 508  
 for fire-rated openings, 464-465  
 glossary, 503  
 handles, 504, 506  
 hinges, 505  
 holders, 504, 507-508  
 institutional, 508  
 knobs, 504, 506  
 location, 504  
 locks, 504, 506  
 mortise templates, 506  
 mutes, 508  
 pivots, 508  
 push-pull bar, 504  
 for rolling doors, 479  
 saddles, 509, 537  
 for sectional doors, 478  
 stiles, 506, 862  
 stops, 503-504, 508  
 track, 476  
 types and finishes, 503
- Doors, 464-485  
 accessible, 474, 503, 855, 966  
 bathroom, 975  
 accordion, 477  
 airtight, 511  
 all-glass, 477  
 aluminum, 484-485  
 balanced, 475  
 ballistic, 481  
 bifold, 477  
 blast-resistant, 511  
 bullet-resistant, 650  
 bypass, 476  
 in ceiling, 480  
 classical, 1015  
 clearances, 472  
 closet, mirrored, 626  
 combination, 477  
 coolers and freezers, 645  
 curtain, 479  
 dimensioning methods, 980  
 double egress, 508  
 emergency release, 508  
 entrance, 482
- environmental impact, 838  
 finishes, 472  
 fireplaces, 240  
 fire-rated, 464, 465, 480  
 flashing, 446, 468  
 in floor, 480  
 flush, 473, 480  
 folding, accessible, 966  
 forced entry, 481  
 framed, 477  
 French, 474  
 frequency of operation, 505  
 garages, 869  
 glass, 477  
 cabinet, 384  
 revolving, 484  
 sliding, 485  
 glazed/louvered, 474  
 grilles, 479  
 hands, 503  
 jambs, 414, 467, 468, 476-477  
 kaiaamen, 506  
 labels, for fire rating, 464  
 lead-lined, 654-655  
 leaves  
 double, 475  
 single, 475  
 lightproof, 511  
 metal, 161, 469-471, 474  
 fire rated, 464-465  
 hollow, 465, 470-473  
 sectional, 478  
 openings, 327, 464, 467-468  
 panels, prefabricated hinged walk-in, 645  
 pocket, sliding, 476  
 radio frequency-shielded, 657  
 with removable storm/screen panel, 477  
 revolving, 484  
 rolling, 479  
 sectional, 478  
 security, 466  
 sliding, 466, 468, 476, 485  
 accessible, 966  
 solid molded stile, 862  
 sound tight, 511  
 specialty, 163, 476, 481, 485, 511  
 stairway, 10  
 stile and rail, 474  
 stone surrounds, 250  
 storm/screen, 477  
 swinging, 468, 476  
 accessible, 966  
 thresholds, 509-510  
 trim, 391, 862  
 types, 472  
 units, 504  
 upward acting  
 rolling, 479  
 sectional, 478  
 watertight/airtight, 511  
 weatherproofing, 469  
 wood, 384, 473-474, 862  
 hollow core, 473  
 sectional, 478  
 solid core, 473
- Doorways  
 arched, 1014  
 Palladian, 338
- Doric order, 1011-1012, 1014, 1016
- Dormers, 329, 497  
 flashing, 432
- Dormitories, plumbing fixture counts for, 703
- Dovetail  
 corners, 349  
 joints, 381
- Dowels  
 with control joints, 194  
 grouted, 206  
 steel bar reinforcement, 225  
 stone veneer, 253-254
- Downflow condensing furnace, 724
- Downlights, 51-52, 58
- Downspouts, 459, 462  
 sizing, 459
- Drafting conventions  
 drawing methods, 986-994  
 graphic symbols, 978-983
- Drafting room equipment, 639
- Drainage, 148-155, 685  
 catch basins, 152  
 in cold storage rooms, 645  
 easement, and commercial site development, 81  
 kennels and animal shelters, 928  
 membranes, 398  
 for paving, rigid, 158  
 pipe sizing, 684-685  
 piping, capacity, 690

- pump systems, 685  
 for retaining walls, 171-173  
 runoff control, 153-155  
 sanitary and waste, 691  
 stormwater, 690-691  
 subsoil, 768  
 subsurface, 148  
 surface, 144, 149-152  
 details, 768  
 tennis court, 772
- Drains**  
 branches and stacks, 685  
 building, 685, 693  
 covers, 166  
 floor, 684, 700  
 pipe sizes for, 682  
 gravel, 172  
 heavy-duty, 700  
 inlets, 152  
 perforated, 148  
 pipes, 148, 692  
 riser diagrams  
   for high-rise building, 693  
   for residences, 692  
 roof, 273, 420, 423-428, 459, 684  
   with polyurethane foam, 428  
 shower, 684, 697, 700  
 storm, 684, 690-691  
 termination at, 401  
 trench, 151-152  
 types, 150
- Drawer pulls, accessible, 970**  
**Drawers, 383**  
 lipped, 382
- Drawings, 986-994**  
 CAD layer guidelines, 991-993  
 conventional, 987  
 conventions and symbols, 979  
 geometry, 999, 1001  
 methods, 986-994  
 paraline, 986  
 perspective, 987-990  
 symbols, 979
- Dressage, 790**  
**Dressers, accessible, 970**  
**Dressing rooms, 882**  
 stadium, 914
- Drinking fountains, 698**  
 accessible, 698, 956  
 pipe sizes for, 682  
 pipe space requirements for, 702
- Drives, 96**  
**Driveways, 107**  
 layouts, 100, 107  
 lights, 166
- Drove stone, 257**
- Dryers**  
 automatic, 609  
 laundry rooms, 593, 868  
 residential, 609
- Drying rooms (locker rooms), 882**  
**Drywall construction, 523-525, 528**  
 ceiling furring system, 553  
 in laminated wood building, 23  
 in lightweight mobile modular building, 24  
 suspension system, 529
- Dry wells, 148**  
**Dual-duct air distribution system, 736**  
 terminal box, 729
- Duckboard flooring, in sauna, 648**
- Ducts**  
 air distribution, 726-733  
 air velocities, 734  
 branch, 733  
 maximum air velocities, 734  
 radio frequency-shielded, 651  
 residential buildings, 733  
 sizing, 734  
 trench header, 743  
 trunk, 733  
 underfloor electrical, 276  
 warm air heating, 728, 730-732  
 in wood truss construction, 364, 367
- Ductwork systems for air distribution, 735-736**  
 in flying form building, 21  
 in laminated wood building, 23  
 in metal building systems, 26  
 in space frame building, 25  
 in tilt-up wall building, 22
- Dumbwaiters, 676**  
**Dwelling unit design, 937-938**
- Earth ditch, 150**  
**Earthquakes, 37-46**  
 hazardous building types in, 42  
 safe areas in, 38
- Earthwork, 145**
- Eaves, 335**  
 flashings, 408  
 with gutter, ice dam detail at, 456  
 height, metal buildings, 658  
 historic, 336  
 metal roofs, 435  
 with panel ceiling, 340  
 with sloped ceiling, 340  
 steel framing, 283  
 strut, 270  
 ventilation, 335, 451  
 wood, 335
- Ecclesiastical equipment, 589, 635-636**  
**Ecclesiastical facilities, 904-906**
- Economy**  
 in architectural programming, 130  
 of concrete formwork, 184
- Edges**  
 accessible ramps and landings, 962  
 bridge condition, 351  
 embellishments, 346  
 roof  
   at gutter, 428  
   heavy metal, 418  
   metal, 426, 428  
   scupper through, 418
- Effective aperture (EA), 62**  
**Eggcrate air return grille, 729**  
**Egress planning, 8-12**  
**Ejector basins, capacity, 685**  
**Elastomeric coatings, 561**  
 protective, 428
- Elastomeric liquid flooring, 541**  
**Elastomeric tape, compressible, 422**
- Elderly persons**  
 design data for, 4-5  
 group residences for, 941
- Electrical equipment**  
 box, radiation-shielded, 655  
 branch circuit protection, residential, 739  
 busways, 750  
 cables, 742  
 cable-supporting devices, 742  
 capacitors, 749  
 circuit breakers, 739, 749, 751  
 conduits, 741-742  
 connection boxes, 609, 742  
 contactors, 749  
 controls, 660-661  
 disconnect switches, 751  
 environmental impact, 838  
 exit signs, 746  
 fuses, 739, 751  
 gang sizes, 740  
 lighting, 746, 752-757  
 materials, 738-744  
 metallic tubing, 741  
 meter bank, 751  
 motor starters, 750  
 outlet boxes, 223, 740-742  
 outlets and plates, 740  
 outlets, gang size, 740  
 panelboards, 751  
 plates, 740  
 plug-in strips, 740  
 protectors, 749  
 raceways, 276, 741-742  
 receptacles, 739-740  
 residential, 738-739  
 seismic design for, 41  
 switchboards, 750  
 switches, 738-740, 749  
 switchgears, 748  
 telephone jacks, 740  
 transformers, 748-749  
 tumblers, 740  
 wiring, 738-744  
   environmental impact, 838  
   material, 741  
   residential, 738-739  
   in wood construction, 739  
   for workstations, 743
- Electrical symbols, 981-982**  
**Electrical systems, 737-758**  
 for daylighting designs, 62  
 distribution, 749-751  
 emergency generators, 746  
 emergency power, 745-746  
 floor wiring for workstations, 743-744  
 grounding, 748  
 methods, 738-740  
 modular plug-in distribution, 744  
 requirements  
   child care centers, 890  
   veterinary hospitals, 927  
   residential wiring, 748  
   service, 743-744  
   site distribution, service, and grounding, 746
- in space frame building, 25  
 special, 745-746  
 standby generators and battery systems, 746  
 substations, 750  
 supporting devices, 742  
 switching, multilevel, 660  
 switch wiring diagrams, 740  
 uninterruptible power supply, 745  
 voltage control, 749
- Electricity, annual use, 818**  
**Electric strike, 503**  
**Electrodeposition, 262**  
**Electromagnetic spectrum, 651**  
**Electronic equipment**  
 ballasts, and fluorescent lamps, 754-755  
 locks, 481  
 masking systems, 65, 70  
 security planning for, 80  
 sound systems, 71-72  
   in performance spaces, 69
- Elevator buildings, 933, 940**  
**Elevators, 666-671, 965**  
 accessible, 963-964  
 area of rescue assistance, 669  
 building characteristics and, 666  
 cabs, lobbies, and special design, 666-667  
 car position indicators, 963  
 cars, glass-walled, 669  
 control panels, 963  
 dimensions  
   freight, 671  
   hydraulic, 670  
   traction, 668  
   freight, 671  
   gearless, 668  
   hoistway, 666-668, 671  
   hydraulic, 667, 670  
   freight, 671  
 installation, preparation for, 669  
 limited use/application, 964  
 lobby, 666, 669  
 machine room, 666, 668, 670  
 planning for, 669  
 residential, 667  
 security design strategies for, 76  
 seismic design for, 41  
 systems, 666  
 threshold, 510  
 traction, 666, 668  
   freight, 671  
 types, 666  
   winding-drum, 667
- Ellipsoid, 1000**  
**Embankment stabilization, 170**  
**Emergency access, residential site planning, 932**  
**Emergency vehicles**  
 dimensions, 104  
 turning radii, 105
- Emitance, definition, 486**  
**Enamels, baked polyester, 539**  
**End grain box, wood veneer pattern, 395**  
**Endwalls**  
 for drainage systems, 151  
 of swimming pools, 783  
 targets, 785
- Energy conservation, 813-818**  
 alternative energy systems, 813  
 atrium design for, 816  
 commercial buildings, 814-815  
 daylighting and, 62  
 energy analysis, 818  
 historic buildings, 844  
 regional design for, 797  
 site factors, 799, 801  
 thermal storage, 817
- Energy design, 795-842**  
 active solar, 817, 823-825  
 atrium, 816  
 building insulation, 831  
 for commercial buildings, 814-815  
 compass orientation, 801  
 glazing assemblies, 488  
 glazing materials, 489-490  
 for nonresidential buildings, 814  
 passive solar, 797, 819-822  
 solar angles, 800, 803-806  
 solar time, 802  
 sun control, 799-800, 826-828  
 thermal transmission, 818, 832  
 weather stripping, 510
- Energy efficiency. See also Energy conservation**  
 in lighting controls, 49  
 in lighting design, 49
- Energy Policy Act of 1992, 49, 753**
- Energy systems, 833**  
 alternative, 813  
 analysis, 805-806, 818  
 calculations, 805-806  
 loads, 818  
 low-cost, 817  
 management, 660  
 remote collectors, 813  
 remote storage, 813  
 storage for cooling, 814  
 total annual use, 818
- Energy use, HVAC systems and, 717**  
**Enlarger, darkroom, 612**  
**Entablature, 1012**  
**Entasis, 1013**  
**Enthalpy diagram, for freon, 712**  
**Entrances, 482-485**  
 commercial, 81, 482  
 environmental factors, 482  
 historic, 855-856  
 Palladian window and doorway, 338  
 retail design, 482  
 security design for, 79
- Environmental construction, 833-842**  
 entrances and storefronts, 482  
 environmental impact of materials, 833, 837-838  
 resource conservation and nontoxic materials, 836
- Environmental design, 795-842. See also Energy conservation**  
 building orientation, 799-806  
 climate data, 796-798  
 climate response, 808-812  
 indoor environmental quality, 842  
 natural ventilation, 807  
 shading, 826-828  
 solar design, 819-825  
 thermal transmission, 829-832
- Environmental impact of materials, 833, 837-838**  
**Environmental Protection Agency (EPA), 120**  
**Environmental site analysis, 83-85**  
 commercial site development, 81
- EPDM (ethylene-propylene-diene monomer), single-ply roofing, 422, 426**
- Épée, 794**
- Epoxy**  
 abrasive, 12  
 adhesive, 533  
 flooring  
   marble chip, 541  
   resin, 541  
 grout, 206  
 joints  
   preassembled stone panels, 256  
   wood butt, 199  
   mortar, 532-533
- Equestrian facilities, 790, 929-930**  
**Equipment, 587-612**  
 airports, 899  
 athletic, 777, 793, 915  
 audiovisual, 595-597  
 bank security, 589-590  
 bar, commercial, 607-608  
 checkroom, 879  
 cleaning, 873  
 computer, 597  
 cooling, interface, 817  
 darkroom, 612  
 drafting room, 639  
 ecclesiastical, 589, 635-636  
 education, 621  
 electrical. *See* Electrical equipment  
 electronic, 65, 69-72, 80, 481, 592, 754-755  
 food service, 600-608  
   commercial, 601-606  
 gardens, 875  
 gymnasium, 545, 777, 882-883, 915  
 household, 871-875  
 kitchens  
   commercial, 601-606  
   residential, 609-611, 871-873  
   storage planning, 871-874  
   utensils, 871-873  
   waste compactors, 599, 609, 976  
 laundry room, 593  
 lawn, 175, 618, 875  
 library, 622-623  
 liturgical, 589, 635-636  
 loading dock, 598  
 mailroom, 878  
 mechanical, hot arid conditions, 811  
 musical instruments, 591-592  
 operating rooms, 886  
 pipe organs, 591  
 play, 621  
 residential, 609-611, 871-875



- concrete, 191, 194, 196-197, 199, 542  
 construction, 273  
   sound and impact noise ratings, 28-29, 528  
 deck, 345  
   metal, 273, 275-276  
 diaphragm, for seismic areas, 45  
 drains in, 684, 700  
   pipe sizes for, 682  
 duckboard, in sauna, 648  
 environmental impact, 838  
 fireplace framing, 239  
 framing, 28-29, 332  
 glued, 359  
 high-impact area, 891  
 hinge threshold, 509  
 industrial  
   design, 194  
   wheel loads, 194  
   wood block, 290, 543, 545  
 insulation, 810  
 joists, 229, 323, 326, 340, 348  
   concrete, 196  
   glued systems, 359  
   load tables, 300-304  
   trussed/residential, 364  
   wood, 326, 544  
   wood rafters, 309-313  
 in lightweight mobile modular building, 24  
 loads, 34  
 nail-in-channel system, 545  
 noncomposite systems, 270  
 openings, 273  
 parquet, 395, 543  
 plastic laminate, 541  
 pool, moveable, 785  
 poured resilient, 891  
 precast hollow core, 229  
 pressed concrete unit, 542  
 quartz, seamless, 541  
 radiant heating systems in, 718  
 rails mounted on, 295  
 resilient, 545-546  
 resinous, 541  
 service chases under, 346  
 service sinks, 696  
 sleepers, 325, 544-545  
 slip-resistant treatment, 541  
 sound-resistant, detail, 346  
 in space frame building, 25  
 special, 541  
 special coatings for, 541  
 sprung system, 545  
 steel joist, 229  
 stone, 536-537  
 strip, 543, 545  
 suspended-wood, 325  
 thermal resistance, 829  
 tie anchor, 319  
 ties between, 334  
 tile, 533, 546  
 in tilt-up wall building, 22  
 treatment, 541  
 trusses, 17  
   cantilevered, 365  
   wood, 368  
   4 x 2, 367  
 unit masonry, 156-158, 542  
 wall connections, 206  
 wet area, 891  
 wiring systems, 743-744  
 wood, 229, 543-546  
   grades and dimensions, 543  
   installation details, 545  
   materials and patterns, 543  
   resilient systems, 545  
   sleeper system, 325  
 Fluës, 237-239  
   fire clay liners, 235-236  
   furnace, boiler, and heater, 709  
   linings, 442  
   prefabricated, 709  
 Flue stack, roof penetration, 455  
 Fluorescent lighting, 295, 753-755  
 downlighting, 58  
 thermal controls, 661  
 Flushing action  
   blowout, 694  
   reverse trap, 694  
   siphon jet, 694  
   types, 694  
 Fluting, 389, 1013  
 Flying form, 21  
 Foam  
   in fire suppression systems, 664  
   spray-applied roofing, polyurethane, 428  
 Foam-core panels, 346  
 nonstructural, on roof purlins, 345  
 surface-mounted wire chases at, 346  
 wall system, 345  
 Foil, 794  
   wallcovering material, 549  
 Food courts, in shopping malls, 924  
 Food processing facilities, 949-950  
   building materials, 950  
   functional areas in, 949  
   lighting and temperature, 950  
   piping and utilities, 950  
   sanitary design for, 950  
   space relationships in, 949  
 Food service  
   bar equipment, 607-608  
   environmental conditions, 646  
   equipment, 600-606  
   kitchen layout, 603, 866-867  
 Football, 762-764  
   arena, 763  
   CFL, 762  
   high school field, 764  
   NCAA, 763  
   NFL, 762  
   touch, 763  
 Footings, 354  
   bubble, 859  
   column, 185  
   concrete, 158, 160, 171-172, 184, 398  
   concrete formwork, 185  
   drain, 148  
   foundations, 398  
   shallow, 324  
   spread, 193  
   step, 193  
   stepped, detail, 326  
   stone, 859  
   wall, 184-185  
   wood column, 326  
   wood fences, 162  
 Forces  
   in-plane, 37  
   out-of-plane, 37  
 Forecourt, 94  
 Forklifts, 673  
 Form hangers, 188  
 Form, in architectural programming, 130  
 Forms  
   concrete surfaces, 184-188, 198-199  
   flying, 187  
   fountains, 159  
   inserts, rubber, 199  
   liners  
   concrete, 198-199  
   reusable plastic, 184  
   one-way joists, 196  
   plyform, 187  
   suspended, 187  
 Foundations, 144, 146, 335, 342, 348  
   basement, 810  
   bell pier, 193  
   concrete, 193, 398  
   failures, causes, 38  
   masonry walls, 221-222  
   pier, 193  
   pile, 146  
   seismic design for, 40  
   treated wood, 324-326  
   wall anchorages, 213  
   waterproofing, 398  
   water-resistant, 398  
 Fountains, 159, 169  
   drinking. *See* Drinking fountains  
   plumbing for, 159  
 Frames  
   braced, 40, 330  
   door. *See* Doorframes  
   and grates for drainage, 152  
   hollow metal, 470-472  
   moment-resisting, 40, 270  
   space, 25, 272  
   polyhedra, 1003-1004  
   steel, single wythe masonry wall with, 223  
   window. *See* Window frames  
   wood, single wythe masonry wall with, 223  
 Framing  
   balloon, 333, 810, 858  
   cantilevered, 341  
   stair landing, 328  
 details  
   cold-formed steel, 279-283  
   floor, 270, 282, 332  
   Greek return, 333  
   joist and sill, 281, 331, 659  
   opening, 279, 327  
   rafter and post, 330  
   roof, 283, 329, 335, 659  
   rough carpentry, 327-334  
   stair, 328  
   wall, 271, 283, 332, 333-334, 659  
 fireplace, 239  
 floor, 28-29, 270, 282, 332  
 load tables  
   ceiling joist and rafter, 309  
   floor, 34  
   floor and roof beam, 306-308  
   floor joist, 300-304  
   rafter and roof joist, 310-313  
   steel beam and column, 266  
   wood column, 305  
 metal  
   building components, 658  
   cold-formed steel, 277-283  
   hollow, 470-471  
   joists, 273-274  
   partitions, 525, 527-528  
   preengineered building, 658-659  
   structural, 266-272  
   plank and beam, 341-342  
   platform, 323, 331  
   roof, 283, 309, 329, 335, 339, 659  
   assembly specs, 30-31  
   seismic design, 39-40, 45-46  
   sill, 279, 323, 331, 335, 345, 354, 446, 470, 659  
   stair, 328  
   stone, 537  
 steel, 223, 272, 470-471  
   beams and columns, load tables, 266  
   cold-formed, 277-283  
   fire-rated, 464  
   joists. *See* Steel, joists  
   life-cycle chart, 839  
   in lightning protection, 747  
   lightweight, 16, 280  
   materials, environmental impact, 837  
   opening details, 279-280  
   seismic-resistant, 39-40, 42-46  
   shapes, 267-269  
   stone on, 253, 256  
   stone panels, 251-252  
   for stone stairs, 537  
   systems, 270-271  
   skylight, 498-502  
   timber, 343-346  
   Western, 323  
   wall, 271, 283, 332, 333-334, 659  
   gypsum board assemblies, 529  
   wood, 17, 520  
   columns, load tables, 305  
   composite members, 36  
   decks, 353-354  
   design, 298-299  
   details, 327-335, 353-354  
   eaves, overhangs, and foundations, 335  
   environmental impact, framing members, 837  
   exterior stairs, 354  
   fireplace floors, 235  
   floor joist load tables, 300-304  
   in lightweight mobile modular building, 24  
   mortise and tenon, 858  
   partitions, 524  
   plywood subflooring on, 359  
   roof rafter load tables, 309-313  
   roofs, 335, 458  
   seismic-resistant design, 45-46  
   stairs, 387-388  
 Freezers, 645  
   commercial, 603  
   residential, 611  
 Freon, enthalpy diagram, 712  
 Frontage types, site planning, 94  
 Frost heaving, 808  
 Frost penetration map, 144  
 Frost susceptibility, 808  
 FRT standards. *See* Fire-retardant treatment standards  
 Fuel gas lines, 690-691  
   sizing, 686  
 Fuels  
   burning equipment, automatic, 6  
   ratings, 705  
   types, 818  
   weights, 1006  
 Function, in architectural programming, 130  
 Furnaces  
   circuits, 738  
   condensing, 724  
   duct, 707  
   gas-fired, 706  
   vents, 709  
   warm air, 728  
 Furniture/furnishings, 613-642  
   accessible, 970  
   accessible/adaptable, 880  
   accessories, 614, 617  
   arrangements, 864  
   artwork, 514  
   auditorium seating, 919  
   bedroom, 6, 626, 864  
   classic, 627-631, 633-634  
   coatings, 262  
   contemporary, 632-634  
   ecclesiastical, 635-636  
   educational, 619-621  
   folding, 616  
   garden, 175  
   general use, 615-618  
   information-related, 166-167  
   library, 622-623  
   modular, 615  
   office, 597, 615, 620, 637-640  
   outdoor, 618  
   residential, 618, 624-626, 638  
   school, 619-621  
   site, 166-167  
   space requirements, 6  
   stacking, 616  
   street, 100, 166-167  
   symbols for, 978  
   systems, 616  
 Furring, 519  
   channels, 277, 283  
   exterior wall, 529  
   foundation walls, 335  
   shielded construction, 654  
 Gabions, 170  
 Gables, 329, 360, 435  
   decorative wood elements, 850  
   edge, 337  
 Galleries  
   museum, 893  
   skylights, 895  
 Galvanic series, 260-261  
 Galvanized metal roofing, high wind resistance detail, 458  
 Game facilities. *See also* Sports facilities  
   court and lawn, 779  
   table and bar, 780  
 Gangway, 121  
 Garages, 107, 869  
   concrete slab floors, 194  
   doors, 869  
   driveways and, 107  
 Garbage disposers, 696  
 Garden apartments, 933  
 Garden city neighborhoods, towns, and villages, 87  
 Garden  
   apartments, 933  
   common, 86  
   equipment, 875  
   furnishings, 175  
   hoses, operating pressures for, 701  
   sculpture, 892  
   structures, 168-169  
   walls, 171-176  
   wintergarden design, 816  
 Gas  
   based fire suppression systems, 663  
   fill in window assemblies, 486  
   heaters, boilers, and furnaces, 706  
   medical columns, 886  
   natural  
   annual use, 818  
   water heaters, 699  
   piping, standard ICU outlets, 566  
   supply, 679-680  
 Gaskets  
   airtight, 854  
   compression, pipe joints, 683  
   elastomeric, 401  
   windows, 414  
 Gatehouse, 163  
 Gates  
   chain-link, 161  
   crash, 163-164  
   design, 160  
   folding, 584  
   at Jersey barrier, 164  
 Gazebos, 168  
 General Services Administration (GSA), recommendations for security standards, 79  
 Generator, for refrigeration, 712  
 Geometry, 995-1002  
   catenary curves, 1001  
   double curved surfaces, 1002  
   ellipses, 999  
   hyperbolas, 1001  
   irregular figures, area and volume, 1000  
   parabolas, 1001  
   plane and solid, 995

- Geometry, continued  
 proportions, 994  
 rotated, 1007  
 triangular and circular, 996
- Geotechnical analysis, in commercial site development, 81
- Geotextile fabric, 350  
 for drainage systems, 148
- German masonry heater, 237
- Girders  
 connections, 377  
 gypsum wallboard, 527  
 hybrid steel, 36  
 long-span, precast concrete, 203  
 wood/steel, 331
- Girts, 270  
 bent, 343  
 upper, 344  
 metal buildings, 658  
 slab and beam forming, 187
- Glare control, with trees, 177
- Glass, 512  
 bent, 513  
 bullet-resistant, 589, 650  
 cathedral, 512  
 chemically treated, 512  
 clear, types, 512-513  
 coated, 513  
 decorative, 514  
 silk-screened, 513  
 doors, 477  
 cabinets, 384  
 revolving, 484  
 sliding, 485  
 elevator car walls, 669  
 energy performance, 488-490  
 exterior wall assemblies, 32-33  
 float, 512  
 frames, 514  
 frit, 513  
 heat-absorbing, 512  
 heat loss and gain, 489-490, 830  
 heat-treated, 512  
 industry quality standards for, 512  
 insulating curtain walls, 830  
 laminated, 513  
 lead (radiation shielding), 655  
 leaded art, 250, 514  
 life cycle, 835  
 obscure, 512  
 panels, 295  
 patterned, 512  
 performance, 513  
 photovoltaic, 513  
 pipes, 681  
 plate, 512  
 products, 512-513  
 protective, 250  
 rail system, flush-mounted, 295  
 security, 513  
 multilayer, 513  
 spaced construction, 513  
 shading devices, 826-827  
 sheathed greenhouse, 931  
 sheet, 512  
 sound control, 512  
 spandrel, 512  
 stained, 514  
 storefronts, 482  
 strengthened, 512  
 sun control devices, 826-828  
 thermal transmission, 830-831  
 tinted, 512  
 ultraclear, 513  
 uncoated, performance values, 513  
 unit masonry, 244-246  
 wire, 512  
 x-ray, 655
- Glass block, 244-246  
 hollow units, 244  
 in space frame building, 25  
 thermal resistance, 831
- Glass fiber  
 asphalt felt, 415  
 -reinforced gypsum cornice, 521  
 -reinforced gypsum dome, cast, 522  
 -reinforced gypsum plaster column, two-piece, 522
- Glazing, 488-490, 499, 501, 512-514  
 bronze tint, 489-490  
 clear, 489-490  
 for daylighting, 62  
 double, 486, 489-490, 830  
 energy performance, 488-490  
 gray tint, 490  
 insulating, 514  
 leaded glass, 514  
 liquid-applied, permeance and permeability to water vapor, 405  
 lead-coating, 489-490  
 materials, thermal resistance values, 531  
 panels, fire safety requirements for, 466  
 partitions, interior, 538  
 reflective coating, 489  
 safety design, 486  
 single, 489-490  
 sliding doors, 485  
 stopped, 277  
 for daylighting, 62  
 solar, 821  
 spandrel, 821  
 south, 820  
 spectrally selective, 486  
 symbols for, 978  
 triple, 490  
 types, 489
- Gleed floors, 359
- Gleed (laminated construction) (glulam)  
 273-377  
 connections, 376-377  
 deck attachment, 351  
 framing, 377  
 structural timber shapes, 373  
 (Gleiss) uses and properties, 247
- Goal  
 for basketball, 774  
 for ice hockey, 792  
 for soccer, 765
- Goalposts  
 for arena football, 763  
 for professional football, 762
- Goals, in architectural programming, 130
- Golden section, 994
- Gold, melting temperature, 261
- Gothic glulam timber, 373
- Grab bars, 971, 975  
 mounting heights, 709  
 for steps, 785
- Grades  
 glued floor systems, 359  
 lumber, 355  
 plywood panels, 357  
 wood flooring, 348
- Gradients, bare soils, 170
- Grading, and erosion control, 170
- Grandstands, 915
- Granite, 534, 536  
 in concrete aggregate, 199  
 for stone walls and ledges, 176  
 uses and properties, 247
- Graphics  
 dimensioning building plans, 980  
 drawing symbols and conventions, 979  
 methods, 986-990, 995, 999-1002  
 parametric drawings, 888  
 perspective drawings, 987-990  
 shades and shadows, 986  
 signs and directories, 575  
 signs and symbols, 574  
 symbols, 978-985  
 architectural materials, 978  
 electrical, 981-982  
 heat, power, and refrigeration, 984  
 HVAC, 983  
 lighting, 982  
 plumbing and piping, 983  
 refrigeration and power control, 984  
 telecommunications, 985
- Grass pavers, types, 156
- Grates  
 for drainage systems, 151-152
- Gratings, 290  
 bicycle safety and, 151  
 for trees, 182  
 types, 290
- Gravel  
 drains, retaining walls, 171-173  
 for paving, 156-158  
 stops, 419, 425, 450, 461-462  
 expansion joint at, 452  
 metal, 450  
 splice joints, 450
- Gravities, specific, multipliers for, 691
- Gravity retaining wall, 172
- Gravity tanks, 100
- Gravity ventilators  
 goose-neck, 455  
 roof, stationary, 415
- Graywater system, 511
- Grease interceptor, 704
- Grease perforation, 294
- Grease return, 333
- Green corridors, 86
- Greenhouses, 931  
 solar orientation, 931  
 ventilation, 642, 931
- Green spaces, 91
- Grid layout, types, 89
- Grid strut systems, 256
- Gripes and louvers, 179, 364  
 supply and exhaust air, 720
- Grillwork, ornamental ironwork, 387
- Grid stay insert, 253
- Grocery distribution facilities, 348
- Grocery Manufacturers Association (GMA), 945
- Grooves, wood siding, 378
- Groove welds, 264-265
- Grounding/bonding, symbols, 985
- Ground motion, period, 37
- Ground temperature, map, 797
- Group residences, 941
- Grout, 206, 532  
 masonry, 210-211  
 retaining walls, 173
- Grundofen (masonry heater), 237
- Guardrails, 10, 295  
 accessible, dimensions, 285
- Guards, wall and corner, 587-589
- Gussets  
 plate, 271, 347  
 T-stub, 271
- Gutters, 336, 459, 462, 468, 694  
 details, 852  
 eaves with, ice dam detail at, 456  
 multiple-grid section, 507  
 pole, 852  
 roof edge at, 428  
 and scupper combination, 454  
 sizing, 459  
 swimming pool, 788  
 wood, 852  
 wood box, 336
- Gymnasium equipment  
 bleachers, 915  
 flooring, 545  
 gymnastics, 777  
 lockers and shower rooms, 882-883
- Gymnasium lighting, in classroom, 57
- Gymnastic equipment, 777
- Gypsum  
 cornice, glass fiber-reinforced, 521  
 definition, 516  
 dome, cast glass fiber-reinforced, 522  
 lathing, 516, 520  
 plaster column, two-piece glass fiber-reinforced, 522  
 wall panels, prefinished, 529
- Gypsum board, 522-528, 552  
 accessories, 523  
 acoustical tile ceilings, 552  
 bullet-resistant wall, 529  
 at ceiling, beams, and soffits, 528  
 ceiling, with spacers, 346  
 construction at partitions, columns and ceilings, 527  
 environmental impact, 838  
 lead-coated, 654-655  
 metal-frame partitions, 525, 527-528  
 partitions, 524-527  
 permeance and permeability to water vapor, 405  
 sheathing, 358  
 solid partitions and shaft walls, 526  
 special conditions, 530  
 types, 526  
 wall assemblies, 529  
 wood-frame partitions, 524
- Hair interceptor, 704
- Half timber, 337
- Halon alternatives, in fire suppression systems, 663
- Hammer throw, 770
- Hand (door), 503
- Handball, 767, 775
- Hand dryers, electric, 564
- Handles  
 door, 503  
 doors, 504  
 lever, 504, 506
- Handrails, 11, 34  
 accessible, 295  
 of accessible ramps, 962  
 with bumper cushions, 567  
 escalators and moving walks, 672  
 for floating dock, 121  
 lighted, 295  
 symbols, 984  
 two pipe systems, 722  
 warm air, 728
- Heat-power apparatus symbols, 984
- Heat pumps, 708  
 air-to-water, 816  
 ground source, 836  
 individual, 730  
 in metal building systems, 26  
 operations, 711  
 two-pipe ground-couple water loop, 731  
 two-pipe water loop, 731  
 water loop, 715
- Heat rejection, methods, 713
- Heat transfer, 710-715, 718  
 coefficient, 402, 831  
 fluids, 817  
 mechanisms, 403
- Hangers, 688  
 acoustical ceiling suspension, 133  
 beam, 376  
 clevis, 688, 678, 825  
 for concrete formwork, 167, 169  
 gutters, 360  
 gypsum wallboard ceiling, 428  
 isolation, 552  
 joist, 319, 365, 371  
 resilient, 653  
 selection, 519  
 strap, 688  
 supports, 287  
 suspended form, 188  
 trapeze, 688
- Hardboard, 363, 527  
 permeance and permeability to water vapor, 405
- Hardboard core, 393
- Hardware  
 concrete formwork, 167  
 door, 476, 503-511  
 fire door, 465  
 hospitals, institutional buildings, and nursing homes, 508  
 poke-through, 743, 744  
 window, 503-510
- Hardwood, 382  
 flooring, 543-544  
 plywood, types, 393
- Hazardous substances, and indoor air quality, 842
- Hazard symbols, 574
- Headers  
 joist, 371  
 joist, 281  
 openings, 279  
 roof framing, 345
- Headwalls, 151
- Health care facilities, 565-566, 900-903  
 See also Hospitals  
 functional space programming, 907  
 master facility plans, 902
- Health clubs, 891
- Healthy buildings, 840
- Hearths, 237, 543, 545  
 fireplace, 235-236  
 framing, 239
- Heartwood, decay resistance, 314
- Heat detectors, 507
- Heaters  
 gas-fired, 706  
 masonry, 237  
 for residential swimming pools, 781  
 for saunas, 648  
 solid-fuel, metal, 571-572  
 swimming pools, 761  
 unit heaters/chillers, 707, 708  
 water. See Water heaters
- Heat generation, 705-707, 721-722
- Heating. See also HVAC systems; Solar heating  
 annual use, 818  
 average monthly degree days, 798  
 baseboard, 708  
 concepts, 819  
 degree days, U.S., 798  
 electric systems, 705  
 forced air, electric, 708  
 for greenhouses, 931  
 hydronic systems, 721-722  
 for kennels and animal shelters, 928  
 in lightweight mobile modular building, 24  
 limited capacity devices, 817  
 manifold loop systems, 721  
 masonry, 237  
 one-pipe systems, 721  
 pipes, 715  
 plate-type exchangers, 715  
 radiant, 708, 718, 736  
 for saunas, 647  
 symbols, 984  
 two pipe systems, 722  
 warm air, 728
- Heat-power apparatus symbols, 984
- Heat pumps, 708  
 air-to-water, 816  
 ground source, 836  
 individual, 730  
 in metal building systems, 26  
 operations, 711  
 two-pipe ground-couple water loop, 731  
 two-pipe water loop, 731  
 water loop, 715
- Heat rejection, methods, 713
- Heat transfer, 710-715, 718  
 coefficient, 402, 831  
 fluids, 817  
 mechanisms, 403

- overall, 831  
 principles, 711-712  
 recovery systems, 715, 814  
 resistance, 830  
 walls, 822
- Heavy timber  
 construction, 341-351  
 stairs, 388
- Hedges, as fencing, 160
- Height standards, anthropometric data, 5
- Helices  
 circular, 106, 113  
 in parking structures, 113-114
- HEPA (high-efficiency particulate air), 646
- Herringbone pattern  
 parquet floor, 395  
 unit paver, 158
- Hexagonal grid, 272
- Highboy cupboards, banks, 589
- High-efficiency particulate air (HEPA), 646
- High-energy materials, environmental impact, 833
- High-intensity discharge (HID) lighting, 54, 59, 753  
 downlights, 51-52, 58
- High jump, 770-771
- High-rise building, plumbing riser diagrams for, 693
- High school facilities  
 basketball court and ball dimensions, 774  
 football field, 764  
 multipurpose stadium, 764  
 soccer, 766
- Highways, 96-97
- High wind resistance  
 detail for composition and asphalt shingles, 458  
 detail for extruded concrete, 458  
 detail for galvanized metal roofing, 458  
 detail for S-type tile roofing, 458
- Hinges, 384, 505  
 cabinet, 384  
 floor threshold, 509
- Hip and ridge detail, 410
- Historic American Buildings Survey (HABS), 844
- Historic buildings  
 accessible entrances, 855  
 architectural metals, 851  
 documentation, 845  
 eaves, 336  
 entrances, 855-856  
 evaluating character, 845  
 interiors, 860-862  
 materials, 844  
 masonry, 847  
 metal, 851  
 wood, 850  
 overhangs, 336  
 porches, 855-856  
 roofs, 852  
 seismic rehabilitation, 42  
 storefronts, 857  
 structural systems, 858-859  
 windows, 853-854
- Historic preservation, 843-862  
 checklist for rehabilitation, 845  
 legal requirements, 845  
 materials, 844  
 objectives, 844
- Hockey  
 field, 767  
 ice, 791-792
- Holders, door, 504, 507-508
- Hollow metal doors and frames, 465, 469-472  
 anchorage and accessories, 471  
 types and installation, 471
- Hollow walls, 227, 233, 859  
 grouted, 227  
 tile, 859
- Hook strips, interlocking, 510
- Horizontal bar, gymnastics, 777
- Horizontal condensing furnace, 724
- Horizontal joints  
 control, 230  
 interior stone details, 535  
 ladder type, 230  
 metal framing, 279  
 precast concrete, 203  
 reinforcement, 225  
 siding, 379
- Horizontal perception limit, and shopping mall concourses, 923
- Horses  
 clearances for, 929  
 shows, 790
- Horseshoes, 780
- Hoses  
 garden, operating pressures for, 701  
 racks and cabinets, 578
- Hospitals, 900-903. *See also* Health care facilities  
 concrete slabs, 194  
 hardware, 508  
 intensive care unit modules, 565-566  
 patient beds, 565-566  
 patient rooms, 565, 885  
 surgical and dental rooms, 886  
 veterinary, 926
- Hot-air guns, electric, 849
- Hot arid climate, design for, 811
- Hot water storage tanks, 700
- Household equipment, 871-875
- Houses  
 double, 935  
 fourplex, 935  
 single-family  
 large lot, 934  
 small lot, 934  
 zero lot, 934  
 two-story attached, 933
- House wrap, air barrier, 810
- Housing, 932-941  
 affordable, 938  
 custom, 938  
 elderly, 941  
 fair, 937  
 luxury, 938  
 multifamily  
 mail boxes for, 583  
 security strategies for, 78  
 projects, 938  
 requirements, 937  
 single-family attached, 933, 935  
 multistory variants, 935  
 single-family detached, 933-934  
 single-family, security strategies for, 78  
 special needs, 941  
 townhouses, 935
- Howe truss, flat, 363
- HP steel shapes, 268
- Human dimensions, 2-7
- Humid overheated climate, design for, 812
- Hurricane clips, 347
- HVAC systems, 716-725  
 all-air, 719-720  
 all-water systems, 720  
 for child care centers, 890  
 design considerations for, 716-717  
 direct-expansion, 720  
 and indoor air quality, 842  
 local, 716  
 multiple interior zone, 730-732  
 percentage of total building energy use, 717  
 problems, 717  
 seismic design for, 41  
 space requirements, 717  
 split  
 with individual heat pumps, 730  
 with water loop heat pump, 731  
 symbols for, 983  
 types, 719-720  
 for veterinary hospitals, 927
- Hydrants  
 fire, 100, 680  
 wall, 679  
 pipe sizes for, 682
- Hydronic heating systems, 721-722
- Hyperbola, 1001
- Hyperbolic paraboloid, 1000  
 fabric structure, 656  
 space frame, 272
- Hyperboloid, 1000
- Ice and snow sports, 791-792
- Ice dam, at eave with gutter detail, 456
- Ice hockey, 791-792
- Ice lense, 808
- Ice rinks, 791-792
- Ice wedge, 808
- Icosahedron, 1003  
 truncated, 1004
- Icosidodecahedron, 1004
- Identifying devices, 574
- Igneous rock, uses and properties, 247
- Joints, wood  
 connection, 371  
 construction details, 370-372  
 headers, 371  
 typical, 370
- Illuminance values, for indoor activities, 48
- Illuminating Engineering Society of North America, 48, 59
- Illumination criteria  
 for commercial spaces, 55  
 for industrial spaces, 58  
 for office spaces, 53  
 for schools, 57  
 for site lighting, 60
- Illumination, lamps, 752-753
- Impact loads, 34
- Impact noise design criteria, 67
- Impervious paving, 149
- Incandescent lamps, 752-753  
 light fixtures, 295
- Indoor air quality, 842
- Induction ductwork system, 736
- Induction terminal box, 729
- Industrial property  
 lighting for, 58  
 plumbing fixture counts for, 703  
 security design strategies for, 77
- Inert gases, in fire suppression systems, 663
- Infrared detectors, heaters, 708
- Inlets, surface drainage, 149, 152
- In-plane discontinuity, 39
- Insect protection  
 masonry foundation walls, 221  
 screens, 455, 477, 812  
 wood, 299, 386
- Inserts  
 concrete, cavity walls, 206  
 helical, 321
- Institutions  
 chimney requirements, 238  
 furniture, stacking and folding, 616  
 hardware, 508
- Insulation, 451  
 acoustical, 555  
 baffle, 812  
 blocking and baffle, 451  
 bonded metal wall panels, 421, 645, 689  
 buildings, 402-403, 830-831  
 compressible, 423  
 concepts, 811  
 elastomeric plastic, 678  
 environmental impact, 837  
 exterior, and finish systems, 404  
 factors affecting performance, 402  
 fiberglass batt, 402, 812, 829  
 environmental impact, 837  
 floor, 810  
 for greenhouses, 931  
 hot arid conditions, 811  
 masonry detail, 404  
 mechanical, 678  
 metal, 403  
 metal panels, 414  
 plank and beam framing, 342  
 R value, sheathing materials, 358  
 solar, 799  
 structural board, permeance and permeability to water vapor, 405  
 taper, 810  
 tapered roofs, 426  
 thermal, 403, 405, 830  
 types, 678  
 weights, 1006  
 wood frame detail, 404
- Insurance Services Office (ISO), bank vault specifications, 588
- Interceptors, plumbing, 704
- Intercolumniation, classical, 1014
- Interiors, preservation, 860-862
- Interior systems design, 13-27  
 flat plate concrete, 18  
 flying form, 21  
 laminated wood post and beam, 23  
 lightweight mobile modular, 24  
 lightweight steel frame and brick veneer, 16  
 in metal building, 26  
 post-tensioned concrete, 19  
 precast concrete frame, 20  
 for security, 79  
 space frames, 25, 272  
 staggered steel truss, 15  
 steel bar joist with bearing wall, 13  
 steel frame with access floor and curtain, 14  
 tension fabric structures, 27  
 tilt-up wall, 22  
 wood roof truss and wood floor truss, 17
- International Amateur Athletic Foundation (IAAF), 770-771  
 track specifications, 770
- International Broken-Back Curve design, for track, 770
- International Building Code, seismic requirements, 37
- Ionic order, 1011-1012, 1014
- Ionization detection systems, 507
- Iron  
 cast  
 architectural, 851  
 bases, 859  
 bath and shower units, 697  
 channels, 150  
 columns, 857  
 radiators, 721  
 sectional type burner, 705  
 construction, 858  
 corrugated roofs, 852  
 finials, 851  
 finishes for, 262  
 galvanized, double-hung windows, 853  
 malleable, 260  
 melting temperature, 261  
 noisings, 12  
 properties, 260  
 wrought, 260
- Ironwork, ornamental, details, 291
- Isogetic chart of the U.S., 801
- Isolation rooms, sound and vibration, 67  
 acoustical correction, 653
- Isolators, 653
- Jackets, 678
- Jambs, 467  
 door, 414, 467-468, 476-477  
 freezers and coolers, 645  
 glass blocks, 245  
 metal frames, 470-471  
 revolving, 484  
 sliding metal, 485  
 steel framing, 279  
 weather stripping, 511  
 window, 497  
 x-ray rooms, 654
- Javelin throw, 770-771
- Jersey barriers  
 concrete, 164  
 gate at, 164
- Joinery, 343, 348
- Joints  
 batten, 381  
 beaded, Flemish bond, 847  
 beltline, 378  
 brick, 211, 218, 847  
 butt, 199, 401  
 concrete slabs, 194  
 vertical, 551  
 wood, 382  
 cabinet details, 382, 384  
 cold, 215  
 colonial grapevine, 847  
 column covers, 568  
 concave, common bond, 847  
 concrete, 194, 199  
 precast, 204  
 construction (cold), 215  
 control, 194, 212, 215-216, 517-518, 523, 529  
 horizontal, 230  
 retaining walls, 172-173  
 strips, 538  
 coped, 391  
 cover, 425  
 dovetail, 381  
 epoxy, stone on steel frame with, 256  
 expansion, 194, 215, 228, 244-245, 419, 422-425, 517, 532, 535  
 counterflashings, 431  
 covers for, 296  
 flashing, 448-449  
 glass block, 245  
 gutters, 460  
 loose laid, 422-423  
 parapet, 448-449, 453  
 retaining walls, 172  
 roof, 421, 426, 448-449, 453  
 stone veneer, 254  
 waterproofing, 399-401  
 expansion strips, glass blocks, 245  
 flush, 847  
 form, 199  
 horizontal, 203, 230, 279  
 interior stone details, 535  
 reinforcement, 225  
 siding, 379  
 isolation, 215  
 lap, 344, 381, 535  
 in flashing, 431  
 interior stone details, 535  
 wood, 376  
 masonry, 215, 218, 847  
 repointing at, 847  
 in metal roofing, 436-437  
 miter, wood, 380-381  
 mortar, 211



- Joists, continued  
 masonry or concrete block movement, masonry, 273  
 nestable, 777  
 pipe, 683  
 plant coatings, 341  
 raked, English bond, 342  
 reinforcement, 517  
   concrete slab, 401  
   ladder-type horizontal, 230  
   masonry cavity walls, 230  
   waterproofing, 401  
 scarf, 344  
 shoulder, beveled, 344  
 siding, 279  
 sliding, 289  
 splice, 450  
 spline, 535  
 steel, load tables, 277  
 stone  
   interior, 535  
   rusticated, 257  
   spacing, 257  
   wall, 248, 258  
 in stonework, 254, 256, 535, 537  
 vertical, 251, 379  
 in wallboards, 523, 526  
 wall control, 529  
 waterproofing, 400, 401  
 wood, 299, 380-381
- Joists, 364  
 anchors, 347  
 bar, 13  
 base, wood, 542  
 bearings, 273-274  
 bevel cut, 370  
 bracing, 279  
 bridging, 273-274, 280, 323  
 C, 277  
 ceiling, 278, 309, 329, 330  
   allowable spans, 278  
   load tables, 309  
 closures, 277  
 composite, 36  
 floor, 229, 323, 326, 340, 348  
   bridging, 323  
   concrete, 196  
   load tables, 300-304  
   trussed/residential, 364  
   wood rafters, 309-313  
 framing details, 331  
 glued floor systems, 359  
 hangers, 319, 365, 377  
   framing, 327, 332  
 I, 370-372  
 load tables  
   ceiling, 278, 309  
   floor, 300-304  
   roof, 310-313  
   steel, 277-278  
   wood, 300-304, 309  
 metal, 273-274, 281  
 pole construction, 347  
 rim, 334, 370  
 roof, load tables, 310-313  
 selection, 273, 274  
 skip, 197  
 slab and beam forming, 187  
 steel, 13, 36, 188, 229, 277, 360, 518  
   allowable spans, 277-278  
   details, 281  
   diaphragm connection for, 44  
   floor, 229  
   lath and plaster, 518-519  
   long span, 273, 274  
   open-web, 273  
 timber, 345  
 Western or platform framing, 323  
 wood, 36, 309-313, 331, 364-365  
 base, 542  
 connections, 365  
 diaphragm connection for, 44  
 I, 370-372  
 laminated, 306, 327  
 load tables, 300-304, 309  
 rafters, 309, 313  
 wood floor, 326, 544
- Judo, 778  
 Junction boxes, zone, 743-744  
 Jury box, 912  
 Jury rooms, 884, 908, 909  
 Justice facilities, 884, 908-912
- Kakeiugi masonry heaters, 237  
 Karate, 778  
 Kennels, 928  
 Kickers, slab and beam forming, 187  
 Kick plates, wood stairs, 328  
 Kindergarten equipment, 621  
 Ladders, 364  
 escape, 289  
 fixed metal, 288  
 household, 874  
 rungs, 288  
 swimming pool, 783, 785
- Lakes, on-site, 100  
 Lamb's tongue, end embellishment, 346  
 Laminates. *See also* Glued-laminated construction  
 decorative, high pressure, 393  
 joints, 382  
 Lamplamps, 614, 752-757  
 characteristics, 752-753  
 fluorescent, 68, 295, 753-755  
   thermal controls, 661  
 halogen, 756  
 HID, 753, 757  
 incandescent, 753, 756  
 mercury vapor, 753  
 metal halide, 757  
 sodium, 757  
 types, 752-753
- Landings  
 of accessible ramps, 962  
 cantilevered, 328  
 slip resistant, 195  
 soft areas, 771  
 stair, 9-10
- Land planning, 101-102  
 landscape design, 896  
 landscaping, 177-182, 641-642  
 garden walls, 174, 176  
 interior, 641, 642  
 lights, 59, 166  
 parking lots, 112  
 retaining walls, 170, 176  
 trees and shrubs, 177  
 urban planning, 98  
 walks, paths, and terraces, 161, 537
- Lane markings, for swimming pools, 783  
 Lanes, 96-97  
 Lap joints, 344, 376, 431, 535  
 metal roofing, 434, 453  
 wood, 381
- Latches, 504  
 roller, 505  
 Latch rack, for weather stripping, 510  
 Lateen, 119  
 Lateral loads, metal buildings, 658  
 Latex  
 Portland cement mortar, 533  
 resin flooring, 541
- Lath and plaster, 518, 520  
 accessories, 517  
 ceilings, 518  
 furred with radiant heating, 708  
 suspended, 519, 708  
 furring for fire protection, 275  
 gypsum, 520  
 materials, 516  
 metal, 516, 520  
 steel bar reinforcement, 195  
 steel joists, 516, 519  
 partitions, 520  
 span, 519
- Laundry equipment, 603, 609  
 chutes, 676  
 hot water requirements, 609  
 Laundry rooms, 589, 608  
 Leaded glass, 247  
 wall studs, 289, 344, 345  
 accessible, 671, 672, 974  
 inaccessible to children, 971  
 accessories for, 694  
 built-in, 695  
 frames, 695  
 facets for, 695  
 flat back, 695  
 mounting height, 703  
 pedestal, 695  
 pipe sizes for, 682  
 pipe space requirements for, 702  
 shelf back, 695  
 size, 695  
 supports for, 702  
 types, 695  
 water temperature requirements, 699
- Lawn, 94  
 Lawn bowling, 779  
 Lawn equipment, 876  
 benches, 175, 818  
 Lays of reflection and refraction, 1005  
 Layer name formats, CAD, 991
- Lead  
 acrylic, 655  
 glass, 655  
 melting temperature, 261  
 properties, 260  
 in radiation shielding, 654-655
- Leaders, 693  
 gutter and downspout, 459  
 size, 684
- Lecterns, 635
- Ledge  
 stone, flashing, 432  
 wood pediment, flashing, 432
- Ledge rock pattern, 248  
 Ledgers, 365  
 wood floor truss detail, 368  
 wood stairs, 328
- Legionnaires' disease, water heaters and, 699  
 Length, thermal expansion, 1005  
 Level changes, in accessible routes, 958  
 Libraries, furniture, 622-623  
 Life-cycle chart, 833, 839  
 Life cycle of materials, 834-835  
 Lift plate barricade systems, 164  
 Lifts, 965  
 accessible, 963, 965  
 pallet, vertical, 551  
 platform, 855, 965  
 ski, 793  
 stair, 965  
 in vans, 969  
 wheelchair, 965
- Light  
 borrowed, 486  
 distribution, with skylights, 62  
 levels, 47, 50, 74  
   with daylighting designs, 61  
 penetration into space, 61  
 pollution, 59  
 shelf, 841  
 sources, selection guide, 47  
 trespass, 59  
 well, 62
- Lightbulbs, electric, 752-753  
 Light fixtures, 51-52  
 fluorescent, 295  
 high-intensity discharge, 753  
 ornamental metal, 295  
 seismic design for, 41
- Lighting, 47-62, 752-757  
 annual use, 818  
 circuits, 738  
 coefficients of utilization, 599  
 controls, 49-50, 661, 814  
 for corridor, 54  
 coves, 530  
 daylighting, 61, 62, 811-816  
   analysis tools for, 62  
   atriums and, 816  
   Venetian blinds and, 661  
 decorative, 52  
 direct, 51-53  
 direct-indirect, 51-53  
 doors proof against, 511  
 electric, for daylighting designs, 62  
 emergency, 746  
 energy efficiency, 49, 752  
 exit signs, 746  
 in fabric structures, 27  
 fluorescent, 295, 753-755  
   downlighting, 58  
   thermal controls, 661  
 in flying form building, 21  
 for food processing facilities, 950
- facilities, 48  
 fixtures, 58  
 high-intensity discharge (HID), 641, 691, 753  
 low-voltage, 811, 52, 59  
 light mast, 59  
 indirect, 51, 53  
 in laminated wood building, 23  
 lamp characteristics, 752-753  
 in lightweight mobile modular building, 24  
 luminaire types, 47, 48, 51-52  
 in metal building systems, 26  
 minimum starting temperatures for, 60  
 radiator, 59, 100, 772  
 safety, 17  
 quantity, 47  
 for racquetball/handball courts, 775  
 for security, 74  
 site, 60  
 in space frame building, 25  
 suspended, 53  
 for swimming pools, 783  
 symbols for, 982  
 systems, 48, 59  
 task, 55, 81-82  
 for tennis courts, 772  
 in tilt-up wall building, 27  
 troffers, 729  
 walkover, 156  
 wall, for offices, 55
- Lighting calculations  
 formulas for, 49  
 for spaces with partitions, 50
- Lighting design, 47-62, 752, 814  
 billiards, 780  
 codes for, 49  
 color issues, 47, 53, 55, 57-58, 60, 752  
 for commercial spaces, 55-56  
 conference rooms, 54, 877  
 courtrooms, 884  
 criteria, 47  
 driveways, 166  
 electronic ballasts, 754  
 energy-efficient, 49, 752, 753  
 food processing facilities, 950  
 formulas for calculating number of luminaires, 49  
 for industrial spaces, 58  
 kennels and animal shelters, 928  
 landscape, 59, 166  
 for lobbies, 54  
 lumen method, 48  
 luminaire design, 51-57  
 museums, 935  
 for office spaces, 53, 55  
 for partitions, 50  
 schools, 57  
 for security, 74  
 site, 60  
 stage systems, 920-921  
 workstation, 50
- Light loss factor (LLF), 49  
 Lightning protection, 747  
 Lightproof doors, 511  
 Light-to-solar-gain ratio (LSG), 486  
 Lightweight mobile modular building systems, 24  
 Lime, hydrated, 210  
 Limestone, 247, 534, 536  
   concrete aggregate, 199  
 Limousine, dimensions, 103  
 Linen chutes, 676  
 Line painting, 768  
 Linoleum, 546  
 Lintels  
   ceiling soffit at, 530  
   fireplaces, 236  
   framing details, 327  
   jack arch, 858  
   masonry, 217  
   stone, 258  
   through-wall flashing at, 429
- Lips, fountains, 158  
 Liquefaction, soil, 38  
 Liquid-applied roofing, 425  
 Liquid flooring, elastomeric, 541  
 Liquid weight, 1006  
 Little League baseball and softball, 761  
 Liturgical equipment, 589, 635, 636
- Live loads  
 beams, 306-307  
 floor, 34  
 planks, 341  
 rafter spans, 364
- Living rooms  
 furniture arrangements, 664  
 furniture space requirements, 6  
 Load blocking, lateral, 371  
 Loading conditions, lintels, 247

- Loading docks, 598  
   security design strategies for, 76  
 Load paths, 39  
 Load tables, 300-313. *See also* Allowable loads  
   ceiling joist and rafter sizes, 309  
   flat deck members, 202  
   floor, 34  
   floor and roof beam, 306-308  
   floor joist, 300-304  
   joist designation, 273-274  
   rafter and roof joist, 310-313  
   steel beam and column, 266  
   wood column, 305  
 Load transfer  
   column, 371  
   seismic design for, 45  
 Lobbies  
   elevator accessibility and, 963  
   elevator and, 669  
   lighting, 54  
   modular furniture for, 615  
   security design strategies for, 76  
 Local area networks (LANs), 597  
 Lockboxes, mailrooms, 878  
 Locker rooms, 882-883  
   facilities checklist, 883  
 Lockers, 576  
   gymnasium, 882-883  
   ski, 793  
 Locks, 504  
   cylinder, 503, 506  
   door, 504  
   electronic, 481  
   metal roofing, 434  
   mortise, 503  
   Pittsburgh, 434  
   reversible, 503  
   snap, 434  
   types, 504  
 Lock set, 503  
 Logs  
   construction, 348-349  
   settling in, 349  
   large, sawing, 298  
   prefabricated structures, 348  
   shrinkage distortions by position, 299  
 Long jump, 764, 771  
 Long-span steel joists, 274  
 Long-span structures, 35, 203, 644  
 Long-term care facilities, 901  
 Lot coverage, in commercial site development, 81  
 Loudspeakers, 72  
   installation, 71  
 Lounge chairs, 615, 624  
   classic, 628-631  
   contemporary, 632-634  
 Lounges, modular furniture for, 615  
 Louvers, 360  
   air return grille, 729  
   in doors, 473-474  
   metal, 581-582  
   storm-resistant, 582  
   for sun control, 827  
   wood  
     dadoed slats, 396  
     pivot pin movable slats, 396  
     routed slats, 396  
 Low-bay layouts, 58  
 Low-conductance spacers, 486  
 Low-emittance coatings, 486, 489-490  
 Low-rise buildings, 15  
 L steel shapes, 268  
 Lug sill, stone, 250  
 Lumber  
   column load tables, 305  
   design values, for seismic conditions, 46  
   dimensional, 373  
   grading, 299  
   joist and rafter load tables, 300-304, 309-313  
   production, 298  
   Southern Pine preservative retentions and AWPAs standards, 315  
 Lumen method, 48  
 Luminaires, 752-753  
   air boot, 729  
   commercial and industrial fixtures, 52  
   design, 51-52  
   direct, 51-53  
   direct/indirect, 51-53  
   indirect, 51-53  
   for street and parking lighting, 59  
   styles, 47  
   types, 51  
 Lunchrooms, seating capacities, 881  
 Machine finish, stone, 257  
 Magnesium  
   melting temperature, 261  
   oxychloride flooring, 541  
   properties, 260  
 Mailboxes, 583  
 Mail chutes, 676, 878  
 Mailrooms, 878  
   apartments, 583  
 Major League baseball, 760  
 Malls, 922-925  
   configuration types, 922  
   layout, 923  
   plumbing fixture counts for, 703  
   security, 73  
 Maneuvering clearances (accessibility), 956  
   bathrooms, 975  
   doorways, 966  
 Manholes, 149, 152  
 Manning formula, 150  
 Mansard roof, 329, 336, 433  
 Mantels, 235-236, 390  
 Maple Flooring Manufacturers Association, 543, 545  
 Maps of the U.S.  
   climatic design, 797  
   deep-ground temperatures, 797  
   frost penetration, 144  
   insulation zones, 403  
   isogonic chart, 801  
   passive solar heating, 797  
   rainfall intensity, 459  
   seismic acceleration, 37  
   sun time, 802  
   weathering indexes, 219  
 Marble, 534, 536  
   cabinet details, 382  
   concrete aggregate, 199  
   epoxy chip flooring, 541  
   uses and properties, 247  
   veneer patterns, 534  
   wall facing patterns, 534  
 Marine development, 120  
 Marquee, 579  
 Marsh systems, runoff control, 154-155  
 Masking systems, electronic, 65, 70  
 Masonry, 209-258  
   accessories, 212-217, 225  
   acoustical units, 554  
   anchors, 212-213, 224-225  
   stone, 248  
   applications, 171  
   arches, 234  
   brick, 225, 230, 233, 542, 1006  
   channel slots, 213  
   chimneys, 408  
   clay units, 219  
   concrete-filled, 323  
   concrete units (CMUs), 220, 230  
   anchorage, 224-225  
   brick veneer on, 231-232  
   lintels, 217  
   in space frame building, 25  
   types, 220  
   walls, 173-174, 223, 225, 228  
   exterior insulation and finish systems, 404  
   fireplaces, 235-241  
   flashings, 216, 441, 446  
   and garden walls, 174-175  
   glass block, 244-246  
   grout, 210-211  
   heaters, 237  
   historic, 846-848  
   lintels, 217  
   load-bearing, 225, 233, 859  
   materials, preservation, 847  
   mortar, 210-211  
   selection guide, 211  
   movement joints, 215  
   permeance and permeability to water vapor, 384, 405  
   pilasters, 225, 233  
   reinforced brick, 233, 542  
   reinforcement, 40, 212, 225, 230  
   materials selection for, 225  
   precautions, 225  
   repointing at joints, 847  
   retaining walls, 171  
   rubble stone, 248  
   seismic-resistant design, 40-41, 43-44  
   in space frame building, 25  
   split-stone, 248  
   stone, 234, 247-258, 535, 537  
   stoves, 237  
   structural facing tile, 242  
   surfaces, 561  
   cleaning, 847-848  
   symbol for, 978  
   temperature effects on, 847  
   thermal mass, 814, 820  
   thermal resistance of materials, 829  
   ties, 213  
   unit, 218-243  
     clay, 219  
     flooring, 156-158, 542  
     glass, 244-246  
     terra-cotta veneer, 243  
   veneer, 16, 231-232, 446  
   walls, 216-217, 225, 230, 233  
   bearing, 13  
   cavity, 228-230  
   circular, 218  
   details, 258  
   door frame in, 468  
   exterior sections, 846  
   as fencing, 160  
   foundation, 221-222  
   freestanding, 176  
   multiwythe, 226-227  
   reinforcing for seismic areas, 43  
   single-pitch back wall detail at top, 501  
   single wythe, 223-225  
   window in, 493  
   weights, 1006  
   watertables, 445  
 Mass irregularity, seismic design for, 39  
 Master facility plans, 902  
 Master layer list, CAD, 991  
 Mastics, 317  
   applied flooring system, 545  
   environmental impact, 838  
   fills, 541  
   grout, 532  
 Matching patterns, wood veneer  
   book, 394  
   box, 395  
   diamond, 395  
   8-piece sunburst, 395  
   end, 394  
   herringbone, 395  
   options, 395  
   parquet, 395  
   random, 394  
   reverse diamond, 395  
   sketch face, 395  
   slip, 394  
   swing, 395  
   V-book, 395  
 Material handling systems, 673-676  
   conveyors, 249  
 Materials. *See* Building materials  
 Materials, phase change (PCM), 817  
 Mathematical data, 997-998, 1005-1007  
   areas and volumes, 1002  
   decimal equivalents, 1005  
   geometric construction, 999, 1001  
   multiplying powers, 1005  
   nomenclature, 1008  
   triangles, arcs, and chords, 996  
   trigonometric functions, 997-998  
 Mat sports, 778  
 MC steel shapes, 268  
 Measurement, metric units, 1018  
 Mechanical systems, 677-736  
   design, 13-27  
   equipment, hot arid conditions, 811  
   in flying form, 21  
   heat generation, 706-707  
   HVAC systems, 718-720  
   insulation for, 678  
   in laminated wood post and beam, 23  
   in lightweight mobile modular design, 24  
   lightweight steel frame and brick veneer, 16  
   in metal building, 26  
   noise and vibration control, 68  
   piping and related equipment, 681-688  
   plumbing riser diagrams, 692-693  
   post-tensioned concrete, 19  
   potable water, 701  
   precast concrete frame, 20  
   seismic design for, 41  
   in space frames, 25  
   staggered steel truss, 15  
   steel bar joist, with bearing wall, 13  
   steel frame with access floor and curtain wall, 14  
   in tension fabric structures, 27  
   in tilt-up wall, 22  
   wood roof truss and wood floor truss, 17  
 Medicine, environmental conditions, 646  
 Membranes  
   drainage, 398  
   EPDM roofing, 426  
   liquid-applied, 401  
   types, 425  
   modified bitumen, roofing, 417  
   PVC, 424  
   reinforced, 425  
   roofing, 415-428  
   protected, 427  
   repair, 452  
   unreinforced, 425  
   waterproofing, 399-401  
   water-resistant, 398  
 Membrane structures, 656  
 Men, measurements, 2  
 Message boards, 167  
 Metal, 259-296  
   anchors, glass blocks, 245  
   angles, 284, 319, 569  
   architectural, 851  
   bucks, 470-471  
   buildings, pre-engineered, 658-659  
   building systems, 26  
   cast  
     abrasive surface thresholds, 509  
     nosings, 12  
     saddles, 509  
     uses for, 166-167  
   ceilings, 552-553  
   ceiling system, linear, 539  
   channels, 284, 544  
   chimneys, 238, 570  
   coatings, 262-263  
   column bases, 319  
   coping, 226, 440, 450  
   cavity walls, 230  
   corrosion, 260-261  
   covers and column guards, 567  
   decks, 275-276, 428  
     horizontal support for, 223  
   doorframes, 161, 469-472  
   fire-rated, 464-465  
   doors, 469-474  
   fire-rated, 464-465  
   sectional, 478  
   downspouts and gutters, 459-462  
   expanded, 516-520  
   fabrications, 11-12, 260-261, 284-288, 295, 461-462  
   fasteners, 264-265, 320-322  
   fences, 161  
   ferrous, 260  
   films, permeance and permeability to water vapor, 405  
   finishes on, 262-263  
   fire escapes and escape ladders, 289  
   flashing, 429-432, 438  
   fuses, 709  
   foils, permeance and permeability to water vapor, 405  
   framing  
     cold-formed, 277-283  
     details, 331  
     gypsum board partitions, 525, 527-528  
     structural, 266-272  
   galvanic series, 261  
   gratings, 151-152, 290  
   gravel stops, 450  
   guardrails, 295  
   gutters, expansion, 460  
   halide lamps, 753  
   handrails, 295  
   historic, 851  
   insulation, 403, 414, 421, 645, 689  
   interior thresholds, 509  
   jamb, 470-471, 485  
   joists, 273-274, 281  
   ladders, 288  
   lath, 516, 520  
     steel bar reinforcement, 195  
     steel joists, 518-519  
   louvers, 581-582  
   materials, 260-263  
   melting temperatures, 261  
   muntz, 261  
   nonferrous, 260  
   nosing, 12  
   ornamental, 291-295, 851  
   panels, insulated, 414  
   parapet cap, 419, 425-428  
   perforated, 292-294  
   pipes, 148, 285  
   plate connector, 366  
   plates, 319  
   on roof beam, 342  
   pool liner with overflow, 788  
   posts, 295  
   precious, interceptor, 704  
   properties, 260-261  
   rails, 295  
   reglets, 438

- Metal**, continued  
 inserts and treads, 12  
 roofing, 425, 433-452  
 batten and ribbed seam, 437  
 Bermuda type, 436  
 edge, 418, 426, 426  
 flat seam, 434  
 high wind resistance detail, 458  
 lock seam, 434  
 panels, 425, 452, 457, 659  
 standing seam, 435  
 tiles, 411  
 walking surface, 456  
 shear, 293, 429-452  
 fabrications, 461-462  
 flashing, 429-432, 438-449  
 form inserts, 199  
 gutters and downspouts, 459-460  
 in lightweight mobile modular building, 24  
 roofing, 433-452, 852  
 screws, 322  
 siding, 413-414  
 solid fuel heaters, 571-572  
 stars, 287  
 strap, on roof beam, 342  
 structural systems, 26, 266-272  
 studs, 280, 520, 569  
 subrails, 295  
 support systems, 521-523  
 surfaces, 561  
 symbols for, 978  
 tees, 271, 284  
 ties, 217, 237  
 tiles, 411  
 treads, 290  
 trench drain assembly, 151  
 trim, 295  
 tubing, 285, 741  
 types, 260  
 walls  
 cavity, 230  
 curtain, 414  
 weights, 231, 1006  
 window frames, 491, 495  
 windows, casement, 495  
**Metric system**, 1017-1022  
 drawing dimensions, 980, 1017  
 measurements, 244  
 plane and solid angles, 1018  
 prefixes, 1017  
 rules for writing symbols and names, 1017  
 sample SI units and relationships, 1019-1022  
 units and conversions, 1018  
**Microcomputers**, uninterruptible power supply systems, 745  
**Microtiche reader** carrels, 622  
**Microphones**, 72  
**Microwave detectors**, 75  
**Microwave ovens**, 594, 610  
**Milwork**, flat, relieved backs in, 299  
**Mineral cellular materials**, insulation, 403  
**Mineral fibrous materials**, insulation, 403  
**Minimum centerline radius**, 97  
**Minimum operating pressures**, plumbing fixtures, 701  
**Mirrors**  
 bathroom cabinets, 564  
 bedroom closet doors, 626  
 mounting height, 703  
**Mobile modular buildings**, lightweight, 24  
**Mobility aids** (accessibility), 968-969  
**Modems**, 597  
**Modified bitumen flashing strip**, 419  
**Modified bitumen membrane**, 418-419  
 roofing, 417  
 details, 418-420  
 NRCA standards, 420  
 three-ply, 417  
 two-ply, 417  
**Modular systems**  
 building, lightweight mobile, 24  
 furniture, 615  
 wall, 586  
**Modulus of elasticity**  
 lumber, 306  
 wood, 373  
**Moisture penetration**, paints and coatings, 558  
**Moisture protection**, 402  
 in historic buildings, 844  
 and indoor air quality, 842  
 logs, 348  
 symbol for, 978  
 venting, 405  
 in window assembly, 467  
 for wood, 299  
 for wood decks, 354  
**Modeling**, 517  
 classical, 1011  
 decorations and patterns, 1011  
 flush, 386  
 interior wood, 391-392  
 base, 391-392  
 bent, 391-392  
 cap, 391-392  
 crown, 392  
 lap, 391  
 panel, 392  
 picture, 391-392  
 rake, 392  
 rosette, 391  
 standard wall, 340  
 wood, 391  
 mitered backhand, 662  
 picture, 386  
 raised, 386  
 types, 1012  
 wood, 391, 862  
**Monel**, 260, 293  
**Monitors**  
 computer, 597  
 video, 595  
**Mortar**, 210-211  
 ASTM specifications, 210  
 ceramic tile, 533  
 cover, 225  
 dry-sat, 532-533  
 functions, 218  
 glass block, 244-245  
 historic building preservation, 846  
 inflexible (cement), 847  
 placement, 410  
 selection guide, 211  
 stone walls, 176, 249  
 types, 532  
 weights, 1006  
**Mortise**, 503  
 bolts, 503  
 templates, 506  
 wood, 508  
**Mortise-and-tenon joints**, 381  
**Mosques**, 906  
**Motels**, laundry rooms, 593  
**Motion detectors**, 75  
 for room boundaries, 75  
**Motor homes**, dimensions, 104  
**Motor operation**, annual use, 818  
**Motor starters**, 750  
**Mounting**  
 assemblies, for sound absorption tests, 64  
 mailboxes, 583  
 methods and materials, 575  
 solar heat collectors, 825  
**Mouse** (computer), 597  
**Movie theaters**, reverberation time, 69  
**M steel snaps**, 267  
**Mudslabs**, 398  
**Mullions**, 486  
 removable, 508  
 storefront, 483  
**Multifamily housing**  
 mailboxes for, 583  
 security strategies for, 78  
**Multiple interior zone (MIZ) VAC systems**, 730-732  
**Multiple space detectors**, 75  
**Multipliers**, for specific gravities, 691  
**Multivythe walls**, 226-227  
**Multi-zone ductwork system**, 735  
**Muntin**, 486  
**Museums**, 882-895  
**Music**  
 practice rooms, 663  
 reverberation time, 69  
**Musical instruments**, dimensions, 591-592  
**Mutes**, 508  
**Nailers**  
 horizontal wall system, 345  
 wood, on roof purlins, 345  
**Nailing blocks**, for masonry walls, 212  
**Nailing**, roof slope procedures, 410  
**Nails**, 318  
 APA panel roofs, 360  
 framing, 330  
 gypsum wallboard partitions, 573-575  
 roofs, 409  
 rough construction, 318  
 sheathings, 359-360  
 shingles and shakes, 406-408  
 siding, 378  
 wood decking, 354-345  
**National Alliance of Preservation Commissions**, 845  
**National Basketball Association (NBA)**  
 basketball standards, 774  
 court and ball dimensions, 774  
**National Building Code**, seismic requirements, 37  
**National Collegiate Athletic Association (NCAA)**  
 baseball standards, 760  
 basketball standards, 769, 774  
 diving standards, 786-787  
 end wall standards, 785  
 football standards, 763  
 gymnastics standards, 777  
 soccer standards, 766  
 swimming pool standards, 783-784  
 track specifications, 770  
 water polo standards, 789  
**National Conference of State Historic Preservation Officers (NCSHPO)**, 845  
**National Earthquake Hazards Reduction Program**, 37, 42  
**National Federation of State High School Associations**, 777  
 diving standards, 786-787  
 end wall standards, 785  
 swimming standards, 783-784  
 track specifications, 770  
**National Fenestration Rating Council (NFRC)**, 487-488  
**National Fire Protection Association (NFPA)**  
 diamond symbols, 100  
 fire alarm systems, 662  
 life safety code, 464  
 standards, 507  
 standards for fire escapes, 289  
**National Flood Insurance Program (NFIP)**, 101-102  
**National Football League (NFL)**, 762  
**National Oak Flooring Manufacturers Association**, 543  
**National Oceanic and Atmospheric Administration (NOAA)** weather data, 807  
**National Park Service (NPS)**, National Register of Historic Places, 845  
**National Register of Historic Places**, 845  
**National Roofing Contractors Association (NRCA)**  
 build-up and modified bitumen roofing detail standards, 420  
 ratings, 555  
**National Trust for Historic Preservation**, 845  
**Natural surveillance**, 73  
 for commercial property, 73  
**NC** (noise criteria) curves, 64  
**Needs**, in architectural programming, 130  
**Neighborhoods**  
 garden city, 87  
 mixed, 933  
 open space, 90  
 plan elements, 98  
 rural, 86  
 traditional design, 98-99  
 urban, 86  
**Neoprene**, and sound isolation, 67  
**Net, tennis**, 773  
**Network layout**, types, 88  
**Newspaper racks**, 388, 623  
**New York State Uniform Fire Prevention and Building Code**, 119  
**Nickel**  
 melting temperature, 261  
 properties, 260  
**Nightclubs**, 880  
**Noise control**, 68  
 exterior walls, 32-33  
 floor structure, 28-29  
 in kennels and animal shelters, 978  
 roof structure, 30-31  
 noise criteria (NC) curves, 64, 68  
 noise reduction, 64-68  
 coefficient (NRC), 64-65  
 design criteria, 67  
**Nosings**, 12  
 accessible, 387  
 ADAAG acceptable, 388  
 slip-resistant, 12, 135  
 stone, 537  
 types, 12  
**Notches**  
 saddle, 349  
 V, 349  
**Nozzles**, for fire suppression systems, 663-664  
**Nursery**, 90  
 church, 904  
**Nurses' station layout**, 885  
**Nursing homes**, 901  
 hardware, 508  
**Obstructions**  
 in fire protection planning, 100  
**Occupant loads**, 8  
**Occupational Safety and Health Administration (OSHA)**  
 excavations standards, 145  
 fire escape standards, 289  
 sound requirements, 65  
 strand covering standards, 12  
**Octagonal perforation**, 294  
**Octahedron**, 1003  
 truncated, 1004  
**Odor removal**, 888  
**Office buildings**  
 lighting for, 53-55  
 postal facilities, 876  
**Offices**  
 acoustical design for, 70  
 churches, 904  
 computer equipment, 597  
 furniture, 615, 620, 637, 640  
 lighting for, 53-55  
 light paths to, 61  
 open areas, 876  
 open plan, 70, 620  
 planning, anthropometric data, 6  
 seating, 639  
 security design strategies for, 77  
**Official Swimming Pool Design Compendium**, 785, 787  
**Offset bond**, 158  
**Oil interceptor**, 704  
**Olgay, Victor**, bioclimatic chart, 796  
**Openings**  
 fire-rated, 464-465  
 framing details, 279-280, 377  
 roofs, 273, 275  
**Open plan office**, 70  
 furniture for, 620  
**Open space**, types, 90-91  
**Opera**, reverberation time, 69  
**Orchestra pit**, acoustical design for, 69  
**Organs**, 591-592  
**Orientation**, residences, 932  
**Oriented-strand board (OSB)**, 339  
**Ornaments**  
 classical, 1011  
 frieze, 390  
 metal, 291, 295, 851  
 types, 1012  
 wood, 389-390  
**OSB**. See **Oriented-strand board**  
**Outdoor lighting systems**, 59  
**Outlet symbols**, 981  
**Outrigger**, wood I post rafter with, 372  
**Ovens**, 604-605, 610  
 accessible, 976  
 built-in, 610  
**Overhangs**, 335-336, 369, 372  
 gable end, 340  
 gable endwall, 457  
 gable roof detail, 369  
 historic, 336  
 static loads for, 1010  
 sun shading, 826-827  
 vehicle, 103-104, 109, 112, 115  
**Overhead hazards**, accessibility, 985  
**Paint**, 556-557  
 clear, 556  
 environmental impact, 838  
 finish on metal, 262  
 fire-resistant, 561  
 high-gloss, 556  
 intumescent, 561  
 life cycle, 835  
 opaque, 556-557  
 prime coat, 556  
 removal methods, 849  
 semitransparent, 556  
 substrate conditions, 555  
 types and uses, 556, 559-560  
 undercoat, 556  
**Painting**, 556-560  
**Pallets**  
 GMA, 945  
 lifts, 553  
 position, building area per, 947  
 storage, 945  
**Paneboards**, electrical, 751  
 symbols, 982  
**Panels**  
 absorptive, 64, 554  
 acoustical, 540, 550  
 ceiling  
 roof eave with, 340  
 textured, 540  
 at ceiling, joint with wall, 551  
 clips, 358

- composite, 413-414  
 continuous, detail at roof, 340  
 control, elevators, 963  
 decorative, thermally fused, 393  
 donut, 208  
 door, 477, 645  
 double tee, 204  
 drop, for columns, 185  
 ductwork system, radiant heating, 736  
 fabric-wrapped, track system, 550  
 foam-core, 345-346  
 glass, 295, 465  
 glass block, 244-245  
 hard stone, 251  
 high-impact, 550, 554  
 insulated metal, 414  
 interior wall, 551  
   details, 386  
 intermediate spline, 339  
 leaded glass, 514  
 low frequency, 554  
 metal, 414, 421, 425, 452, 645, 689  
 metal roof, 425, 452, 457, 659  
 modular wall systems, 586  
 nail-laminated deck, 350  
 panel strips, 392  
 performance-rated, 356  
 plenum, 550  
 plywood, 356-357, 386  
   minimum bending radii for, 379  
 precast concrete, 204, 243  
 prefabricated  
   cold storage room, 659  
   fabric-wrapped, 550  
 prefinished gypsum wall, 529  
 products, 393-395  
   reflective, 554  
 roof, 360, 413-414, 425, 454, 457  
   pre-engineered metal building, 659  
 roof system, 407  
 sandwich, 414  
 sidewall, 407  
 siding, 379, 413-414  
 sill, interior wall, 551  
 skylights, flat unit, 500  
 spandrel, flashing, 251, 447  
 splices, 435  
 stone, 251-252  
   preassembled, 256  
   on steel framing, 251  
 structural building, 339-340  
 suspended, 555  
 tackable, 550, 554  
 tee, 208  
 thermal break, 339  
 thermal resistance, 829  
 thickness, 208  
 types, 356  
 variations, 204  
 wall, 659  
   gypsum, prefinished, 529  
   interior, 551  
   precast concrete, 204-205, 243  
   reinforcements, 174, 233, 244  
   widths, 208  
 wood, 381, 386  
 Panic exit mechanisms, 508  
 Pantries, 866  
 Paper towel dispensers, 564  
 Parabola, 1001  
   glulam timber, 373  
 Paraboloid, 1000  
   hyperbolic, 272, 656, 1000  
 Parallel bars, gymnastics, 777  
 Parapets  
   aluminum siding, 413  
   cap, light metal, 419, 425-428  
   counterflashing, 418, 422-423  
   edges, 450  
   expansion joints, 448-449, 453  
   flashings, 424, 441, 448  
   insulated metal walls, 414  
   roof, 251-252, 426, 453  
   seismic design, 44  
   stone, 249, 255  
   walls, 230  
   scupper detail at, 454, 461-462  
 Parking, 108-114  
   accessible, 961  
   required minimum number of spaces,  
   961  
   areas, lighting for, 60  
   design parameters, 108  
   garages, 107  
   design, 113-114  
   lighting, 59  
   security design strategies for, 76  
   guidelines for traditional neighborhood de-  
   sign, 99  
   lighting, luminaires for, 59  
   museum, 892  
   requirements, for commercial property,  
   81  
   security design for, 79-80  
   for shopping malls, 922  
   space dimensions, 109  
 Parking lot design, 107, 111-112  
   drainage, 149  
   entries and exits, 110  
   guidelines, 112  
   required accessible spaces, 111  
 Parks, 90-91  
 Parquet flooring  
   installation, 544  
   patterns, 395, 543  
 Partial loads, 34  
 Particleboard, 393  
   environmental impact, 837  
   life cycle, 834  
 Partitions, 584-586  
   acoustical ratings, 524-525  
   design criteria, 65  
   framing, 330  
   gypsum board, 524-527  
   hollow, 516  
   interior glazed, 508  
   lath and plaster, 520  
   and lighting levels, 50  
   modular wall systems, 586  
   NC curves, 64  
   nonbearing interior, 332  
   open plan offices, 70  
   operable, 584-585  
   partial-height, 70, 530  
   for seismic areas, 41  
   solid, 516  
   sound-isolated, intersection, 529  
   sound transmission loss, 524-525  
   terminals, 517  
   at toilet, mounting height, 703  
   wire mesh, 584  
 Passages, 6, 96-97  
   accessible, 7  
   locks, 504  
 Passenger vehicles  
   accessible loading, 960  
   dimensions, 103  
 Passive infrared detectors, 75  
 Passive solar, 819-822  
   cooling, 819  
   heating, 816, 819-821  
   map, 797  
 Patent bush hammer, 257  
 Patent-hammered finishes, 848  
 Paths, 96-97  
 Pathway symbols, 985  
 Pavers  
   ballast, 427, 455-456  
   cobblestone, 157  
   concrete, 156-158, 427  
   on existing slab, 542  
   grass, 156  
   mortarless, on concrete slab, 542  
   stone, 536  
   tile trim units, 531  
   unit, 156-158  
 Paving, 156-158  
   blocks, 537  
   flashings, 446  
   materials  
     impervious, 149  
     porous, 149-150  
   soil interconnection under, 181  
   surface drainage, 149-150  
   tile, 531  
   types and patterns, 158  
   unit, 156-157  
 Pean hammered stone, 257  
 Pedestrian areas, 98  
 Pedestrian crossing time, 97  
 Pediments, 1013  
   wood, ledge flashing, 432  
 Peraleto, 808  
 Perforated face diffuser, 729  
 Perforated metal, 292-294  
 Performance spaces, acoustical design for,  
 69  
 Perimeter yard building, 92  
 Permafrost, design conditions for, 808  
 Permeability and permeance, of materials to  
 water vapor, 405  
 Pews, 635  
 Pharmaceuticals, environmental conditions  
 for, 646  
 Phase change materials, 817  
 Phenol formaldehyde, metal coating, 263  
 Phosphors, 754  
 Photocells, 660  
 Photoelectric detection systems, 507  
 Photographic equipment, 612  
 Pictograms, 574  
 Picture moldings, 391-392  
   wood, 386  
 Pier foundation, 193  
   for garden walls, 174  
 Pilasters, 186, 1013  
   architrave, 862  
   brick masonry, reinforced, 233  
   classical, 1013  
   masonry, 225, 233  
 Piles, 146  
   composite, 146  
   excavations, 145  
   foundations, 146  
   Southern Pine preservative retentions and  
   AWPA standards, 315  
   supporting foundations, 193  
   types and characteristics, 146  
 Pipe joints, 683  
   caulked, 683  
   compression coupling, 683  
   compression gasket, 683  
   flanged, 683  
   flared, 683  
   heat-fused, 683  
   soldered and brazed, 683  
   solvent cement, 683  
   split coupling, 683  
   threaded, 683  
   welded, 683  
 Pipe organs, 591  
 Pipes, 681-683, 686  
   brass, 681  
   cast-iron, 681  
   cleanout installation for, 682  
   connections, 262  
   connection types, 681  
   fire hydrant and standpipe connections,  
   100  
   fittings, 682  
   gas, standard ICU outlets, 566  
   glass, 681  
   hangers, 688  
   heating, 715  
   insulation, 678  
   joints, 683  
   leaning, 166  
   lines, sizing, 686  
   materials, 681  
   metal, 148, 285  
   penetrations, 398, 400-401, 420  
   single, 420, 425, 428  
   plastic, 148, 681  
   prefabricated flashing, 422  
   premolded covers, 426  
   properties, 681  
   rails, 295  
   roller support, 420  
   Siamese, mounting height, 703  
   sizing, 682, 685-686  
   pressure limitations and, 701  
   sleeves, 688  
   in fire-rated wall, 688  
   smoke clearances, 238  
   steel, 166, 286, 328, 681  
   coating system for, 561  
   stove, 238  
   supports, 688  
   symbols, 983  
   systems, 714  
   tall, flashings, 443  
   vent  
     premolded, 426  
     sizing, 686  
 Piping  
   drainage capacity, 690  
   equivalent length, 690  
   for food processing facilities, 950  
   insulation, 678  
   mechanical, 679-688, 701, 704  
   in radio frequency-shielded rooms, 652  
   space requirements for, 702  
   for water heaters, 699  
   water supply, 653, 685, 692  
   for water tanks, 689  
 Pitcher's mound  
   Little League baseball, 761  
   Major League baseball, 760  
 Pitch face, 257  
 Pitch pockets, 443  
 Pivots, door, 508  
 Planks  
   construction, 341  
   flooring, 543, 545  
   framing, 342  
   staging, slab and beam forming, 187  
 Planning  
   commercial site development, 81  
   community, 81-100  
   egress, 8-12  
   elevator installation, 669  
   general data, 1-142  
   regional, 82, 86  
   residential site, 932-935  
   site, community, and urban, 81-100  
   town, 82  
   traditional neighborhood development, 99  
 Planters, 163, 167-168, 642  
 Planting, 177-182  
   details, 178  
   interior, 641-642  
   design considerations, 642  
   parking areas, 112  
   plant forms and sizes, 641  
   rooftops, 182, 642  
   tree, 178-182  
 Plants. See Landscaping  
 Plaques, 574-575  
 Plaster, 516-520  
   accessories, 517  
   cast  
     cornice, 521  
     two-piece column, 522  
   ceilings, 518-519  
   dome, 521  
   gypsum, two-piece, glass fiber-reinforced  
     column, 522  
   materials, 516  
   ornamental, 521-523, 861  
   partitions, 520  
   permeance and permeability to water  
     vapor, 405  
   weights, 1006  
 Plasterboard, gypsum. See Gypsum board  
 Plastic  
   caps, tendon installation, 201  
   cushions, tendon installation, 201  
   drainpipes, 148  
   fastenings, 317-322  
   foils, permeance and permeability to  
     water vapor, 405  
   form liners, 184, 199  
   laminated flooring, 541  
   permeance and permeability to water  
     vapor, 405  
   pipes, 681  
   pocket formers, tendon installation, 201  
   safety panels, posts and railings, 295  
   sheathing, 358  
   sheets, thermal resistance, 831  
   shims, stone panels, 251-252  
 Plates  
   concrete, 196  
   metal, 319, 342  
   connector, 366  
 sill  
   anchors, 319, 544  
   reduced, 334  
   splice, 325  
   steel, bearing shoe, 351  
   steel framing, 282  
   wood, double beveled, 372  
 Platform lifts, 855, 963  
   in vans, 969  
   wheelchair and stair, 965  
 Platforms  
   diving, dimensions, 786  
   diving facilities, 786  
   materials, spiral stairs, 11  
   rest, for fixed metal ladders, 288  
   for swimming pools, 783, 785  
 Platform tennis, 779  
 Platonic polyhedra, properties, 1003-1004  
 Platonic solids, 994  
 Platting, 92  
 Play equipment, 621  
 Playgrounds, 90, 165  
 Playing field construction, 768-769  
 Plazas, tree planting and, 181  
 Plexiglass, acrylic, 514  
 Plotters (computer), 597  
 Plucker finish, stone, 257  
 Plugs, wall, for masonry walls, 212  
 Plumbing fixtures, 682, 690, 694-698  
   accessories, 704  
   counts, 703  
   flushing action, 694  
   minimum operating pressures, 701  
   mounting heights, 703  
   supply demand curve for, 701  
   supports, 702  
   trap, 682, 691  
   trap arm, 686  
   vent stack, 425  
   water supply to, 694

- Plumbing riser diagrams, 692-693  
   for high-rise building, 693  
   for residence, 692  
 Plumbing systems, 690-703  
   child care centers, 890  
   codes and standards for, 690  
   seismic design for, 41  
   symbols for, 983  
   types, 690  
 Plyform for concrete formwork, 187  
 Plywood  
   APA-rated, 356  
   beams, framing, 327  
   butt joints, 199  
   cabinet details, 383-384  
   classifications, 355  
   composite, 36  
   decks, 360  
   decorative, 356  
   design data, 355  
   environmental impact, 837  
   exposure durability, 355  
   grades, 355, 360  
   hardwood types, 393  
   in laminated wood building, 23  
   lead-lined, 655  
   marine, 327  
   panels, 356-357, 386  
     minimum bending radii for, 379  
   permeance and permeability to water vapor, 405  
   sheathing, 323, 342, 358, 360  
   siding, 379  
   slab and beam forming, 187  
   soffits, 360  
   Southern Pine preservative retentions and AWWPA standards, 315  
   span ratings, 355  
   stair framing, 328  
   subflooring, 332, 359  
   thicknesses, 360  
   types, 356  
   underlayment application, 359  
   uses, 357  
   veneer core, 393  
 Pocket billiards, 780  
 Pocket doors, sliding, 476  
 Pocket wetlands, 154-155  
 Pointed finish, stone, 257  
 Pole construction, 347  
 Poles  
   Southern Pine preservative retentions and AWWPA standards, 315  
   transformer on, 749  
 Pole vault, 764, 770-771  
 Pollution control, 705  
 Polo, 790  
 Polyester enamels, baked, 539  
 Polyester metal finishes, 263  
 Polyethylene  
   chlorosulfonated, metal finishes, 263  
   foundations, 398  
   vapor retarder, 810  
 Polygon, skylight assembly, 500  
 Polyhedra, 1003-1004  
 Polymers, silicone-modified, metal finishes, 263  
 Polyurethane foam, spray-applied roofing, 428  
 Polyvinylchloride (PVC)  
   characteristics, 424  
   gutters, 460  
   metal finishes, 263  
   rosings, 12  
   single-ply roofing, 423-424  
   window frames, 491  
 Pommel horse, gymnastics, 777  
 Ponds  
   fish, 169  
   roof, 819  
   solar, 813  
   storage, 153  
   wetland system, 154-155  
 Pools  
   decorative, 159  
   swimming, 781-788  
 Porcelain tile, 531  
 Porches, 94  
   historic, 855-856  
   wood railing patterns, 850  
 Porous paving materials, 149-150  
 Portland cement, 210  
   based grouts, 532  
   mortar, 531, 533  
 Post  
   and beam, laminated construction, 23  
   bumping, 117  
   chain-link fences, 161  
   corner, framing, 330  
   framing details, 330  
   hammer, 346  
   heavy timber, 859  
   king, 366  
   leaning, 165  
   metal, 295  
   modified queen, 366  
   mounting, 295  
   newel, 387-388  
   protective, 958  
   queen, 343  
   rail-and-fence, 160  
   Southern Pine preservative retentions and AWWPA standards, 315  
   sport facilities, removable, 769  
   wood decks, 354  
   wood stairs, 388  
 Postal facilities, 583  
   for multifamily housing, 583  
   for office buildings, 878  
 Post-tensioned concrete construction, 201  
   technology, 19  
 Potable water  
   distribution system, 690  
   sizing, 701  
   service, 679  
 Powder coating, 262  
 Power control, symbols for, 984  
 Practice rooms, 653  
 Pratt truss, flat, 363  
 Precast concrete. *See* Concrete, precast  
 Precious metals interceptor, 704  
 Pre-engineered structures, 656-658  
 Prefabricated structures, 649  
   batten roofs, 437  
   chimney stacks, 709  
   columns, 286  
   door panels, 645  
   logs for, 348  
   panels, 550, 659  
   pipe flashing, 422  
   shelters and booths, 649  
   shower stalls, 697  
   stone panels, 256  
   trusses, 17, 364  
   wood, 361, 364-365, 373-375  
 Prefilters, 888  
 Preservation, historic. *See* Historic preservation  
 Preservatives  
   oilborne, 315  
   organic, 314  
   waterborne, 120, 315  
   inorganic, 314  
   wood, 314-315  
 Pressed concrete unit flooring, 542  
 Primers, exterior, 262  
 Printers, computer, 597  
 Privacy index, 67  
 Private driveways and roads, 107  
 Problem, in architectural programming, 130  
 Property survey, in commercial site development, 81  
 Protection board  
   foundations, 398  
   waterproofing, 399, 401  
 Protruding objects, accessibility in circulation paths, 958  
   in doorways, 966  
 Psychometric chart, 726-727  
 Public assembly  
   bleachers and grandstands, 915  
   seating, 919  
   theater design, 916-918  
 Public roads, 107  
 Pulpits, 635  
 Pumps, 689  
   chilled water, 725  
   ejector, 685  
   for fountains, 159  
   heat. *See* Heat pumps  
   for residential swimming pools, 781  
   sump, 685, 692-693  
     capacity, 685  
   systems, 685  
   turbine, 159, 689  
   water, 887  
   for wells, 147  
 Purlins, 329, 343, 345, 348, 377  
   beam system, 374  
   push plates, doors, 504  
   push-pull bars, 504  
   push-pull latch, 508  
   PVC. *See* Polyvinylchloride  
   pylons, protective, 958  
 Pyramid, space frame, 272  
 Pythagorean theorem, 994, 1005  
 Quartz  
   concrete aggregate, 199  
   seamless flooring, 541  
 Quartzite, 247  
 Queenpost, 361  
 Quirk miter, 535  
   corner, 208  
 Quoins, stone, 249  
 Rabbet, 503  
 Raceways, 742  
   wiring for workstations, 743  
 Rack layouts, 947  
 Racquetball, 775  
 Radians, 1005  
 Radiant heating, 708, 718  
   panel ductwork system, 736  
 Radiation  
   climatic design strategies, 797  
   fin tube, 721  
   protection, 654-655  
   shielding, 654-655  
 Radiators, 721-722  
   steam, 722  
 Radio frequency shielding, 651-652  
 Radon, 221  
 Rafters, 372  
   fly, 372  
   framing details, 329-330, 342  
   jack, 330  
   load tables, 309-313  
   log construction, 348  
   lookout, 329  
   plank and beam framing, 342  
   rough carpentry, 329-330, 335-336  
   spans, wood truss, 364  
   steel framing  
     bridging, 280  
     opening, 281  
   ties, 319  
   trussed, 364  
   Western or platform framing, 323  
   wood, 309, 313  
     trussed, 36  
 Railroads, 117  
 Rails, 295. *See also* Handrails  
   accessible, 295  
   -and-post fence, 160  
   balcony, 11, 34  
   caps, 386  
   crash, 567  
   escalators and moving walks, 672  
   floor mounting, 295  
   lighted, 295  
   low, 295  
   metal, 295  
   newel, 387-388  
   pedestrian, 351  
   pipe, 295  
   stair, 10, 287, 388, 851  
   systems, 351  
   top, 295  
   vehicle, 351  
   vinyl, 295  
   wood, 386-387  
   wood decks, 353  
   wood porch, 850  
 Rain  
   cap, stationary gravity roof ventilator, 455  
   penetration, 558  
   spouts, 461-462  
 Rainfall intensity map for U.S., 459  
 Raker brace, 145  
 Ramps, 114  
   accessible, 354, 855, 962  
   moving, 672  
   stairs, pitches, 7  
   widths, 106  
   wood, 354  
 Ranges. *See* Stoves  
 Reach ranges, 957  
 Rear yard building, 92  
 Rebar positioners, 227  
 Recreational vehicles, dimensions, 103-104  
 Recreation facilities  
   athletic equipment, 777  
   sports and games, 762-771, 791-792  
   swimming pools, 781-783, 788  
 Recycling  
   buildings, 840  
   materials and methods, 833-838, 942  
   solid waste, spaces, 947-944  
 Reflectances, 486  
 Reflection, law of, 1005  
 Refraction, law of, 1005  
 Refrigeration, 710-714  
   chilled water systems, 705, 725  
   coolers, 645  
   cooling systems, 723  
   cooling towers, 710  
   cycle, 711  
   equipment rooms, 887  
   machines, 887  
   principles, 711-712  
   residential, 611  
   symbols for, 984  
 Refrigerators, 611  
   commercial, 603, 606  
   residential, 611  
 Refuse chutes, 599  
 Regional planning, 82, 86  
   for energy conservation, 797  
   types, 87  
 Regional referral centers, 900  
 Reglets  
   chimney masonry, 408  
   flashings, 439  
   metal, 438  
   roofing, 426  
 Rehabilitation of historic structures. *See also* Historic buildings; Historic preservation  
   checklist, 845  
   common problems, 844  
   documentation, 845  
   legal requirements, 845  
   seismic design, 42  
   standards for, 844  
 Reinforced concrete. *See* Concrete, reinforced  
 Reinforcement  
   of bank vaults, 588  
   bars and wires, 189-190  
   concrete, 189-191  
   of entrances and porches, 856  
   foundation wall, 222  
   intervoven fiberglass mesh, 404  
   masonry, 40, 212, 225, 230  
   panels, 244  
   panel walls, 174, 233  
   plates, metal deck, 275  
   precautions, 225  
   safe loads, 203  
   single wythe walls, methods, 225  
   steel, 40, 174, 190, 233  
   walls, 193  
 Relief angles  
   cavity walls, 230  
   stone veneer, 253  
   supports, 254  
 Renaissance proportions, 1011  
 Repairs  
   concrete, 200, 848  
   roof, strategies, 457  
   stone, 848  
   on wood, 849  
 Rescue assistance, areas of, 669  
 Reservoir, for drainage system, 150  
 Residential design  
   accessibility, 667, 964, 974-976  
   bathrooms, 865  
   closet storage systems, 870  
   electrical systems, 733, 738-739, 748  
   furniture, 618, 624-626, 638  
   kitchens, 6, 866  
   equipment, 609-611, 871-873  
   landscape, 95  
   neighborhood, 86-87  
   plumbing riser diagrams, 692  
   room planning, 864-875  
   security strategies, 78  
   site planning, 81-100, 932-935  
   swimming pools, 781  
   water supply piping, 653  
 Residential equipment, 609, 611, 871-875  
   elevators, 667  
   garbage disposers, 696  
   sinks, 696  
   waste compactors, 599, 609, 976  
   water heaters, 700  
 Resilient flooring, 545-546  
 Resource conservation, 840-841  
   methods and systems, 836  
 Restaurants  
   chimney requirements, 238  
   insulated coolers and freezers, 645  
   plumbing fixture counts for, 703  
   seating for, 880-881  
   in shopping malls, 924  
 Restrooms, in shopping malls, 925  
 Retail design  
   entrances and storefronts, 482  
   lighting for, 55-56  
   shops, in malls, 922-925  
 Retaining walls, 170-176, 233  
   concrete, 172-173  
   dimensions and reinforcement for, 173  
   drainage details for, 173

- as fencing, 160  
gravity, 172  
preliminary dimensions, 172  
for security, 163  
stone bank as, 171  
wood, 171
- Retrofits  
roofing, metal, 452  
weather stripping, 853-854  
wheelchair lifts, 965
- Reverberation control, acoustical design, 64  
Reverberation time, 65, 68-69  
Rhombicosidodecahedra, 1004  
Rhombicuboctahedra, 1004  
Ridge boards, 283  
Ridgepole, 343  
Ridges  
connections, 340  
construction, 435  
detail, 410  
flashings, 442, 444  
metal buildings, pre-engineered, 659  
roof beams, 342  
roof caps, 852  
shingles, 408  
skylights, 498
- Rigid frame membrane structures, 656  
Rings, gymnastics, 777  
Riprap, 170, 351  
Riser diagrams, 692-693  
drains and drainage, 692-693  
for high-rise building, 693  
for residence, 692  
Risers, 12  
proportioning, 9-10  
stair, 328, 387-388  
stone, 537  
tables, 11  
wood, 387-388
- Rivets, 322  
Roads, 107  
design parameters, 106  
lighting for, 59  
nomenclature, 96  
types, 97  
Robe hook, mounting height, 703  
Rock  
anchors, 145, 188  
classification, 247  
cut, channels, 150  
Rock face, 257  
Rocking chairs, classic, 628  
Rodeos, 790  
Roman baths, 648  
Roman cobble pattern, 158  
Roman intercolumniation, 1014  
Roof ponds, 819  
Roofs, 410-428, 433-458  
accessories, 450-458  
access to, 391-395, 453-458  
aluminum, 413  
assemblies, 30-31, 274  
barrel tile, high wind resistance detail, 458  
batten, 436-437  
beams, 306-307, 342, 374  
Bermuda, 436  
built-up, 21, 405, 415-416, 421, 440-441, 448-449  
aggregate surface, 415  
details, 418-420  
mineral-surfaced cap sheet, 416  
smooth surface, 416  
catchment, for cistern design, calculation, 147  
at cavity wall, 228  
clay tile, 412, 852  
cold, 809  
comparative, 30-31  
concrete tile, 410  
construction, 273  
continuous panel detail at, 340  
coverings, 406-412  
cresting, 852  
decks, 360  
acoustical treatment, 555  
metal, 275-276, 428  
nailable, 415-417  
non-nailable, 415-417  
diaphragm, for seismic areas, 45  
drains, 273, 420, 423-428, 459, 684  
with polyurethane foam, 428  
edges  
at gutter, 428  
heavy metal, 418  
light metal, 426  
metal, 428  
scupper through, 418  
vented, 335  
EPDM single-ply, 422, 426  
expansion joints, 421, 436-437, 448-449, 453  
factory-assembled systems, 414  
field-assembled systems, 414  
flashings, 429-432, 440-441, 443-444  
flat, 329  
retrofit with metal panel roof, 457  
flat low-pitched, 360  
flat seam, metal, 434  
flat to sloped connection detail, 428  
flexible sheet, 424  
framing, 309, 335, 339  
criteria for, 30-31  
details, 329  
framing headers, 345  
gable, 329, 360, 435  
decorative wood elements, 850  
edge, 850  
overhang detail, 369  
galvanized metal, high wind resistance detail, 458  
gambrel, 309, 329  
gutters, 684  
historic, preservation, 852  
insulated metal panels, 414  
intersecting, 329  
iron, 852  
jack flange, 455  
lath, 348  
light, equipment support on, 419  
in lightweight mobile modular building, 24  
liquid-applied, 425  
load tables, 34, 310-313, 658  
log, 349  
mansard, 329, 336, 433  
manufactured, 413-414  
materials, wind uplift design for, 458  
membrane, 415-428, 455, 809  
repair, 452  
metal, 425, 433-452  
aluminum, 413  
batten and ribbed seam, 437  
Bermuda type, 436  
expansion joints, 436-437  
locks and seams, 434  
sheet, 433-452, 852  
specialty details, 452  
standing seam, 435  
metal panels, 425, 452, 659  
retrofit with, 457  
modified bitumen membrane, 417-420  
nails for, 318  
openings, 273, 275  
ornamental canopy, 433  
overhangs, wood framing, 335  
panels, 360, 407, 413-414, 425, 452, 457  
parapets, 251-252, 426, 453  
peaks, framing, 330  
percentage required for skylighting, 499  
pitched, flashings, 440  
planting, 182, 642  
plywood sheathing for, 360  
preformed, 378-379, 412-414  
protected membrane, 427  
purlins, 343, 345  
PVC, 423-424  
rafter sizes and spans, 309-313  
repairs, 457  
repair strategies, 452  
ribbed seam, metal, 437  
scuppers, 418, 426  
scuttles, 428, 499-502  
security design strategies for, 76  
sheathing, 323, 358, 360  
shed, 329, 335  
vent at wall for, 451  
sheet metal, 433-452, 852  
shingles, 406-407, 413, 444, 852  
single-ply EPDM, 424  
single-ply PVC, 424  
slate, 337, 409, 852  
sloped, 408, 410  
counterflashing at, 431  
nailing procedures on, 410  
vent in, 455  
solar collectors, 825  
in space frame building, 25  
special, details, 455-456  
specialties, 450-458  
spray-applied polyurethane foam, 428  
standing seam, metal, 437  
steel framing, 283  
structural member through, 419  
ties, for seismic areas, 44  
tile, 410-412, 458, 852  
counterflashing at, 431  
tinplate, 852  
transitions, waterproofing at, 456  
truss clips, 319  
trusses, 283, 367, 369  
prefabricated, 17  
ventilation, 335, 360, 451, 455, 691, 852  
walking surfaces, 456  
wood frame design, 335, 458  
zinc, 852  
Room cavity ratio, 48  
Room planning  
cold storage, 645  
office, computer furniture, 597  
residential, 864-875  
videoconference, 595  
Rooms  
acoustics, 65  
radiation-shielded, 654-655  
radio frequency-shielded, 651-652  
Root ball sizes, 178  
Roots, protection, 179  
Rose, 503  
Rot damage, 348  
Rough carpentry, 323-372  
nails for, 318  
openings, 327  
Round cone diffuser, 729  
Routes, accessible, 958  
Rowing shell, 118  
Rubber  
asphalt surface, 768  
chlorinated metal finish, 263  
fastening strips, 426  
form inserts, 199  
nosings, slip-resistant, 12  
tile, 546  
Rugby, 767  
Runners, channels, 277, 544  
Running bond patterns, 158  
Runoff  
calculation, 149  
velocity, 149, 170  
Runoff control, 153-155  
stormwater wetlands, 154-155  
trees and, 177  
urban best management practices, 153  
Ruolo, 391  
Rural neighborhood, 86  
Rural roads, 95-97  
Rural village design, 85  
Russian masonry heater, 237  
Rustication  
classical, 1015  
concrete, 186  
at construction joint, 199  
stone bases, 846  
R-value, 486  
Saber, 794  
Sabins, 65  
Sacristies, 904  
Saddle notches, 349  
Saddles, 467  
interior, 509  
stone, 537  
Safe areas, in earthquake, 38  
Safe deposit vault, 588  
Safety cage, 288  
Sailboats, 119  
Sally ports, 163  
Sandblast finishes, 208  
Sand clay, 768  
Sand interceptor, 704  
Sand-set bed, 542  
Sandstone, 247  
Sanitary design, for food processing facilities, 950  
Sanitary drainage systems, 691  
Sanitary napkin units, mounting height, 703  
Sanitary stack, 693  
Sash, 486  
Saunas, 647-648  
Sawed finish, stone, 257  
Scanners, office computer equipment, 597  
School buses, 104  
dimensions, 104  
turning dimensions, 105  
Schools  
chimney requirements, 238  
concrete slabs, 194  
early learning equipment, 621  
furniture, 619-620, 623  
lighting for, 57  
Science cabinets, 620  
Scientific notation, 1005  
Scooters, 969  
vehicles adapted for, 969  
Scoping, definition, 952  
Screeds, 517  
Screens  
audiovisual, 596  
door, 477  
insect, 455, 812  
partitions, 584  
soffit, 360  
transparent, 162  
window, 485  
wood, 396  
Screws, 320-322  
Sculpture gardens, 892  
Scuppers, 454, 461-462  
assembly elevation, 454  
detail at parapet wall, 454, 461-462  
and flashing, 432  
and gutter, combination, 454  
roofs, 426  
sizing procedures, 454  
through roof edge, 418  
Scuttles, 499-502  
with polyurethane foam, 428  
Sealants  
with backer rod, 251  
concrete surfaces, 200  
elastomeric, 424-426, 441  
waterproofing, 399  
Sealing compound, 244  
Seals, acoustical, 555  
Seams  
butt, 434  
flat, 434  
hook, 434  
lap, 434  
lock, 434  
metal roofing, 434  
metal roofing panels, 457  
profiles, 433  
standing, 434  
Seating  
accessible, 881  
anthropometric data, 5-6  
auditorium, 916-919  
capacities, 881, 915  
courtroom, 912  
grandstands and bleachers, 915  
modular, 615  
office, 639  
for restaurants and bars, 880-881  
stadium, 913-914  
stadium, 913-914  
Seat walls, 175  
Security equipment  
access controls, 65, 914  
alarms, 80, 589, 662  
banks, 589-590  
barriers, site, 163-164  
control systems, 63  
doors, 466  
file cabinets, 640  
glass, 513  
sensors, 75  
systems, 75  
vaults, 588  
video surveillance, 75  
windows, 466  
Security evaluation, 73-74, 79  
Security offices, in shopping malls, 925  
Security planning and design, 76  
and ADA, 73  
airport checkpoints, 899  
barriers, site, 163-164  
building, 72-80  
commercial, office and industrial, 77  
crime prevention through environmental design, 73-74, 77-78  
fire ratings and, 464-465  
flagpoles, 573  
glazing, 466  
justice facilities, 909-911  
layering, 74, 79  
lighting, 74  
long-span buildings, 35  
museums, 894  
parking garages, 76  
residential, 78  
site selection, 74  
stairs, 12  
storefronts, 483  
strategies, 76  
territorial reinforcement, 73, 77-78  
for terrorism, 79-80  
walls, 529  
Seismic acceleration, 37  
Seismic areas  
building configuration for, 39  
lumber design values for, 46  
site design, 38  
Seismic codes, 37, 42  
Seismic design, 37-46, 225, 653  
anchorage and connections, 40  
for architectural and mechanical components, 41  
base isolation, 40, 42

- Seismic design, continued:  
 connector framing, 334  
 definitions, 37  
 framing, 39-40, 45-46  
 load paths, 39  
 for masonry construction, 43-44  
 shear walls, 43, 46  
 for wood framing, 45-46
- Seismic rehabilitation, 42
- Seismic use groups, 41
- Seismic zonation, 38
- Seminar seating, 619
- Semitrailers, 115
- Sensor security systems, 75
- Service access, commercial site development and, 81
- Service chase, under floor, 346
- Service walkways, on roofs, 456
- Service wall systems, 565-566
- Setting beds, stone floors, 537
- Sewage disposal, 564
- Sewage ejector, 692-693
- Sewer  
 connections to, 685  
 sanitary, 692-693  
 manhole, 152
- Severage, 148-155
- Shading, 826-828, 986  
 coefficients, 486, 488, 490, 513, 832  
 for daylighting, 62  
 devices, 826-828  
 trees and, 177
- Shadow construction, 800, 802
- Shadow drawings, 986
- Shakes, 406-407  
 wood, 406, 407
- Shale, expanded lightweight, concrete aggregate, 199
- Shank, 503
- Shear panel, seismic design for, 46
- Shear plates, 271  
 wood truss, 361
- Shear-resisting control joint, for retaining wall, 173
- Shear walls  
 seismic design for, 40, 43, 46  
 support, 255
- Sheathing, 355-360  
 APA-rated, 356  
 column clamps, 185  
 liner joints, 199  
 plywood, for roofs and soffits, 360  
 rated, 355  
 roof, 323, 356  
 stone panels, 251  
 structural, 356  
 wall, 358  
 wood, 378
- Shed, roofs, 329, 451  
 framing, 335
- Sheet glass, 512
- Sheet metal, 293, 429-452  
 fabrications, 461-462  
 flashing, 429-432, 438-449  
 form inserts, 199  
 gutters and downspouts, 459-460  
 in lightweight mobile modular building, 24  
 roofing, 433-452, 852  
 screws, 322
- Sheet Metal and Air Conditioning Contractors National Association (SMACNA), gutter standards, 460
- Sheep, 145
- Shelf angles  
 brick veneer, 231  
 cavity walls, 229-230
- Shelters, prefabricated, 649
- Shelves, 385  
 box frame, 385  
 cabinet, 383  
 coated steel wire, 870  
 commercial  
 bar, 608  
 food service, 602, 606  
 edge details, 385  
 fixed and semi-fixed, 385  
 glass block details, 245  
 library, 622  
 light, 814  
 solid, 870  
 track, 622  
 wood, 385
- Shields  
 for lag bolts and screws, 320  
 termite, 340, 432
- Shims  
 pads, 206  
 plastic, stone panels, 251-252
- Shingles, 406-408, 410-411  
 asphalt, 408  
 environmental impact, 837  
 high wind resistance detail, 458  
 repair, 452  
 composition, 408  
 high wind resistance detail, 458  
 drip edges, 408  
 hip, 408  
 historic preservation, 849  
 red cedar, 406  
 roof flashings, 444  
 for siding, 407  
 slate, 409  
 repair, 452  
 underlayment and sheathing, 406  
 wood, 406-407  
 environmental impact, 837  
 patterns, 850  
 roofs, 852
- Shingle, 378, 850
- Shock absorber, 704
- Shoes  
 bearing, 351  
 wal, 186
- Shooting stalls, 794
- Shopping malls. See Malls
- Shops. See also Storefronts  
 coffee, seating capacities, 881  
 plumbing fixture counts for, 703
- Shoring, excavation support systems, 145
- Shortspans  
 precast structural systems, 202  
 slabs, 702
- Shot sawed finish, stone, 257
- Shower rooms, 882-883
- Shower  
 accessible, 971, 974  
 compartments, accessible, 972  
 controls, mounting height, 703  
 drain receptors, 687  
 drains, 684, 700  
 head, mounting height, 703  
 and locker rooms, 882-883  
 operating pressures for, 701  
 pipe sizes for, 682  
 pipe space requirements for, 702  
 receptors, 532-533  
 residential, 865  
 rod, mounting height, 703  
 water temperature requirements, 699  
 wheelchair for, 968
- Shower stalls  
 accessible, 971, 974  
 grab bar for, mounting height, 703  
 pipe sizes for, 682  
 prefabricated, 687
- Shredders, 599
- Shrubs  
 interior landscaping, 621  
 planting details, 175
- Snuffboard, 780
- Shutters, 828  
 counter, 479  
 wood, 396  
 flat panel, 396  
 covered, 396  
 raised panel, 396
- Siamese pipe, mounting height, 703
- Sick building syndrome, 836
- Sidelight, 467
- Sidewalks  
 covered, 828  
 moving, 672  
 network, 96  
 traditional neighborhood, 98
- Side yard building, 92
- Siding, 412-414  
 aluminum, 413  
 APA, 341, 355  
 bevel, 378  
 board-and-batten, 299, 850  
 chisel, 850  
 diamond, 850  
 exterior, environmental impact, 837  
 face grades, 356  
 factory-assembled systems, 414  
 field-assembled systems, 414  
 fish scale, 850  
 industrial, 262  
 lap, 379  
 manufactured, 413-414  
 metal, 413-414  
 panels, 413-414  
 APA-rated, 356  
 plywood, 356  
 residential, 262  
 shiplap, 850
- staggered wood, 850  
 tongue and groove, 378, 850  
 walls, insulated metal, 414  
 wood, 378, 850  
 eave at, 336  
 profiles and patterns, 850  
 shingles and shakes, 406-407, 917  
 sliding joints, 299
- Sightlines, theater, 916-918
- Signs, 574-575  
 accessible, 967  
 lights, 59  
 support flashings, 443  
 and symbols, common, 574
- Silicates, inorganic, metal finishes, 263
- Silicone, rubber grout, 532
- Sills, 467  
 anchor bolts, 331  
 anchors and wood framing details, 335, 354  
 attachments, 279  
 box beam, wire chase, 346  
 door, 468, 476-477  
 door saddles, 509, 537  
 flashings, 447  
 frame construction, 446  
 framing details, 331  
 interior wall panel, 551  
 masonry construction, 446  
 metal frames, 470  
 plates  
 anchors, 319, 544  
 expansion, 544  
 reduced, 334  
 sections, glass blocks, 245  
 skylights, 498  
 sliding doors, 485  
 steel framing, connections at jambs, 279  
 stick frame, 345  
 stone, 257  
 stone panels, 252  
 stone veneer, 254  
 through-wall flashing at, 429  
 timber, 345  
 wire chase, 346  
 Western or platform framing, 323  
 window, 493-496  
 brick, 493, 496  
 stone, 253, 255, 493-495, 537, 846
- Silver, melting temperature, 261
- Single-duct terminal box, 729
- Single-family housing  
 attached, 935  
 detached, 933-934  
 security strategies for, 78
- Single-zone ductwork system, 735
- Sinks, 696. See also Laboratories  
 accessible, 971  
 bar, 607  
 eyewash, 696  
 floor service, 696  
 food service, 602, 606  
 freestanding, 696  
 kitchen, accessible, 976  
 lavatories and faucets, 695  
 mounting details, 696  
 operating pressures for, 701  
 pipe sizes for, 682  
 pipe space requirements for, 702  
 wall service, 696
- Site design, for seismic areas, 38
- Site development, 82-99  
 analysis map, 85  
 building orientation, 799, 814  
 for commercial property, 81  
 drainage, 144, 152  
 for tennis courts, 772  
 for fire protection, 100  
 furnishings, 166-167  
 gradings, 170  
 improvements, 111-112, 159-169  
 lighting, 60  
 parking lots, 112  
 plans, 82  
 playing fields, 769  
 security barriers, 163-164
- Site improvements, 159-169
- Site practicality tests, 937
- Site security. See Security planning and design
- Site selection and planning, 81-100  
 in cold climates, 808  
 crime prevention through environmental design and, 73  
 fair housing issues, 937  
 greenhouses, 931  
 process, 82  
 residential, 932-935
- suburban analysis, 83  
 urban analysis, 83
- Stitework, 143-182  
 drainage  
 subsurface, 148  
 surface, 144, 149-152  
 embankment stabilization, 170  
 excavation support systems, 145  
 fountains and pools, 159  
 land planning and development, 101-102  
 landscaping, 177-182, 641-642  
 marine, 120  
 paving and surfacing, 156-158  
 planting, 177-182  
 playing fields, 769-771  
 retaining walls, 171-173  
 runoff control, 153-155  
 subsurface investigation, 144  
 symbols for, 978-979  
 walls and fences, 161-162, 174-176  
 water distribution, 147
- SI units, 1019-1022
- Ski equipment, 793
- Skimmers, 788
- Skylights, 498-502, 530  
 construction, 498  
 curbs, 330, 498  
 for daylighting, 62, 814  
 dome unit, 500  
 double-pitch framed assembly, 501  
 flat panel unit, 500  
 framing, 372  
 multiple-grid, 502  
 in museums, 895  
 percentage of roof area required for, 499  
 polygon-framed assembly, 501  
 with polyurethane foam, 478  
 pyramid-framed, 500  
 single-pitch framed assembly, 501  
 solar heating, 820-821  
 in tilt-up wall building, 22  
 unit section, 500
- Slabs  
 cavity walls, 230  
 concrete, 187, 194, 196-197  
 in building systems, 21-23, 25-27  
 cracking in, 200  
 in fabric structures, 27  
 flat, 202  
 on grade, 194, 340  
 minimum strength, 194  
 mortared, 542  
 mortarless pavers on, 542  
 pavers on, 157  
 precast, 202-208  
 two-way, 18  
 waterproofing under, 398  
 concrete floor, 196-197  
 concrete formwork for, 187  
 exposed, 228, 230  
 hollow core, 202, 206  
 mud, 398  
 thickened, 197  
 thickness, 202
- Slalom course  
 skiing, 793  
 water skiing, 789
- Slate, 534, 536  
 ceramic, 411  
 patterns, 536  
 paving, 537  
 roofing, 337, 409, 852  
 shingles, repair, 452  
 uses and properties, 247
- Slats  
 dadoed, 396  
 pivot pin movable, 396
- Sleepers  
 floor system, 325, 544-545  
 wood, 325, 345
- Slide projectors, 877
- Sliding doors, 466, 468, 476, 485  
 pocket, 476
- Slip corner, 535
- Slip resistance  
 finish nosings, 12  
 stairs and steps, 195
- Slips, marine, 120
- Slopes  
 analysis, 84  
 drainage, 399  
 embankment stabilization, 170  
 flashings, 444  
 roofing, 408  
 runoff channels, 170  
 ski, 793
- Slots, masonry ties, 213
- Smart buildings, 814

- Smoke  
 chamber, 235  
 connections, 238  
 detection systems, 507, 662  
 pipes, clearances, 238  
 shelves, fireplaces, 235  
 venting, 499, 502
- Smooth finish, stone, 257
- Snooker, 780
- Snow, accumulation on building surfaces, 456
- Snowmaking machines, 793
- Snub polyhedra  
 cube, 1004  
 dodecahedron, 1004
- Soap dispensers, mounting height, 703
- Soapstone slate, 382
- Soccer  
 indoor, 765  
 NCAA and high school, 766  
 professional, 765
- Socket pier foundations, 193
- Sofa beds, 626
- Sofas, 624  
 classic, 627, 629-630  
 contemporary, 632, 634  
 seating systems, 615
- Soffits, 340  
 ceiling, at lintel, 530  
 classical, 1012  
 continuous vent, 810  
 gypsum board at, 528  
 plaster and lath ceilings, 518  
 plywood, 335, 360  
 stairs, 287  
 stone, 535  
 stone veneer, 253-254  
 vented, 335
- Softball, 761, 768-769
- Soft story, seismic design, 39
- Softwood, moisture shrinkage, 299
- Soil  
 bearing capacity, 144  
 conditions, and trees, 177  
 gradient ratio, 170  
 improvement, 178, 180  
 interconnected under paving, 181  
 liquefaction, 38  
 mechanics, 144  
 patterns, 84  
 planting, structural, 181  
 protection from compaction and degradation, 180  
 subsoil drainage, 768  
 surface drainage, 149  
 types, 144  
 volume requirements for trees, 180  
 weights, 1006
- Sol-air temperature, 811, 832
- Solar absorption, 820
- Solar angles, 800, 803-806
- Solar collectors, 823-825  
 air and photovoltaic systems, 824  
 liquid systems, 823  
 rooftop, 825
- Solar constant, 800
- Solar controls  
 building orientation, 799  
 energy conservation, commercial buildings, 814  
 glass block, 244  
 screens, 253  
 shades, 826-828  
 use of trees, 177
- Solar cooling, passive, 819
- Solar heat gain coefficient, 486
- Solar heat gain/loss, 805-806, 811-812  
 direct systems, 819-821  
 fenestration systems, 487, 832  
 glazing, 489-490, 830  
 sliding doors, 485
- Solar heating  
 active, 817, 823-825  
 air temperature, 817  
 floor area, 822  
 heat exchangers, 817  
 off-peak power, 817  
 passive, 797, 816, 819-822  
 snow considerations, 825  
 storage, 817, 823  
 tankless coils, 817
- Solar ponds, 813
- Solar position, 805-806
- Solar radiation, 799-806  
 calculation, 805
- Solar tanks, 700
- Solar time, 802
- Solar transmission, of fabrics, 657
- Soldier piles, 145
- Solid waste, collection and recycling spaces, 942-944
- Sound  
 absorbing pad, 552  
 absorption, 64-65  
 attenuation blanket, 555  
 background noise criteria, 68  
 control, 653  
 for open plan offices, 70  
 decibel scale, 63  
 frequencies, 63  
 isolation, 65-68, 653  
 criteria, 67  
 levels, typical, 63  
 masking, 70-71  
 noise reduction, 64-68  
 patterns, 65  
 pressure levels, 63, 68  
 principles, 63  
 properties, 65  
 transmission, 65-67  
 ceilings, 528  
 gypsum wallboard partitions, 524-525
- Sound absorption  
 coefficients, 64, 65, 70  
 guidelines for, 65  
 materials for, 70  
 properties, 64  
 trees and, 177
- Soundboard, 346
- Sound control, glass, 512
- Soundproofing, in courtrooms, 910
- Sound systems  
 electronic, 71-72  
 elements, 72  
 for performance spaces, 69
- Sound-tight doors, 511
- Sound transmission class (STC), 65-66, 526  
 gypsum wallboard, 526  
 ratings curve, 66-67
- Southern Building Code Congress International, accessibility guidelines, 952
- Southern Pine Council Inspection Bureau, 543  
 preservative retentions, 315  
 space frames, 25, 272  
 polyhedra, 1003-1004
- Space planning, 6, 863-950  
 counters and seating, 880-881  
 detention centers, 907  
 health club design, 891  
 hospital patient rooms, 885  
 kitchens, 866  
 lockers, 882-883  
 shower rooms, 882-883  
 solid waste collection and recycling spaces, 942-944  
 vending room layout and equipment, 594  
 workstation design, 876
- Spacers  
 gypsum board ceiling with, 346  
 insulated, 488  
 low-conductance, 486  
 space symbols, 985
- Spaciousness (sound quality), 69
- Spalling, 847
- Span/depth ratio, 35
- Spandrels  
 beams, 184, 447  
 cavity walls, 229  
 flashings, 251, 447  
 precast concrete, 204  
 for steel frames, 271  
 stone, 252  
 through-wall flashing at, 429
- Span ratings  
 APA panel roofs, 360  
 laminated decks, 352  
 plywood, 355  
 sturd-i-floor, 359
- Spans  
 cantilevered and continuous systems, 373  
 concrete, 203  
 for joists and rafters, 300-304, 309-313  
 live/dead loads, 273-274, 277  
 long span structures, 35  
 planks, 341  
 rafters, 364  
 for steel beams and columns, 305
- Span tables  
 exterior wall assemblies, 32-33  
 floor structure, 28-29  
 gypsum wallboard partition height, 523  
 roof structures, 30-31
- Spatial definition, 93
- Spatial enclosure, 93
- Special coatings, 561-562  
 ceiling surfaces, 539-540  
 floor, 541  
 types, 561  
 wall surfaces, 551
- Special needs housing, 941
- Special purpose rooms, 647-652
- Specifications, metric, 1017
- Specific gravities, multipliers for, 691
- Spectrally selective coating, 490
- Speech, reverberation time, 69
- Speed, calculation  
 angular, 1005  
 linear, 1005
- Sphere, 272
- Spheroid, 1000
- Spindle, door hardware, 503
- Splash pans, gutters, 460
- Splices  
 connections, in glulam timber, 373  
 framing, 341  
 moment, 341, 377  
 standing seam metal roofing, 435  
 steel framing, 282  
 symbols, 985
- Spline, structural building panels, 339
- S pocket, metal roofing, 434
- Sport clubs, plumbing fixture counts for, 703
- Sports facilities, 759-794  
 aquatics, 781-789  
 boating, 118-119  
 court, 768, 772-779  
 equestrian, 790, 929-930  
 field, 760-770  
 gymnastics, 777  
 ice and snow, 791-792  
 table and bar, 780  
 track and field, 770-771  
 wrestling, 778
- Sports flooring, wood, 545
- Springboards, dimensions, 786
- Springs, and sound isolation, 67
- Sprinkler systems, 664  
 seismic design for, 41
- Square, 272  
 columns, steel straps for, 185  
 cone diffuser, 729
- Squash courts, 776  
 conversion from racquetball court, 775  
 doubles, North American, 776  
 markings, 776  
 singles, international, 776
- S steel shapes, 268  
 Ts cut from, 269
- Stables, 790, 929-930
- Stack patterns, 158
- Stacks, 685  
 for boilers, 709  
 shelving, 622
- Stack vent, 693
- Stadiums, 913-914  
 high school, multipurpose, 764  
 plumbing fixture counts for, 703  
 seating, 914-915  
 guidelines, 913
- Stage lighting, 920-921
- Stain, 557
- Stained glass windows, 250, 514
- Stainless steel  
 angles, 284  
 cleats, 435  
 dovetail slots, 213  
 dowels, 254  
 fasteners, 162  
 flashings, 450  
 flats and other shapes, 285  
 gauge and use, 601  
 gutters, 460  
 helical inserts, 321  
 properties, 260  
 split-tail anchors, 252  
 stone walls, 248
- Stain resistance, 262
- Stairs  
 accessible, 9, 12  
 building code requirements, 10  
 carriage connection, 371  
 circular, 11  
 closed riser, 388  
 concrete, 195  
 deck, 354  
 design, 9-12  
 fire escapes, 289  
 framing details, 328  
 freestanding, 195  
 heavy timber, 388  
 industrial and service, 287  
 landings, cantilevered, 328  
 lifts, 965  
 moving, 672  
 openings, 327  
 open riser, 388  
 pan type construction, 287  
 for persons with disabilities, 12  
 proportioning graph, 10  
 railings, 34, 287, 851  
 risers, 12, 290  
 safe, design, 12  
 in shopping malls, 924  
 spiral, 11  
 steel, 287  
 stone, 12, 249, 537  
 of swimming pools, 783  
 terrazzo, 538  
 treads, 11-12, 287, 289  
 U-type, 195  
 wood, 387-388, 862
- Stairwells, security design strategies for, 76
- Stalls, 929-930
- Standard Building Code (SBC)  
 occupant loads, 8  
 seismic requirements, 37  
 stairway requirements, 10
- Standpipe connections, 100
- Staples, APA panel roof decking, 360
- Starting platforms, for swimming pools, 785
- Static loads. *See also* Allowable loads; Load tables  
 for beams, 1008  
 for cantilever beams and overhangs, 1010  
 for fixed beams, 1009
- STC. *See* Sound transmission class
- Steam rooms, 648
- Steel  
 anchors, 213, 252  
 angle bearing shoe, 351  
 angles, 236, 268, 284  
 flashings, 443  
 architectural, 851  
 ash urns, 167  
 bank vault doors, 588  
 bar joist with bearing wall building system, 13  
 bars, masonry, 225  
 bath and shower units, 697  
 beam hangers, 376  
 beams, 36  
 load capacity, 266  
 bollards, 166  
 cables, in fabric structures, 27  
 carbon, 260, 262, 294  
 channels, 150  
 C joists, load tables, 277  
 cleats, 435  
 coating systems for, 561  
 cold-formed members, 16  
 cold-rolled, 294  
 columns, 286  
 concrete-encased, 36  
 connections, 377  
 fire protection, 36  
 load tables, 266  
 prefabricated fireproofed, 286  
 reinforced, 233  
 composite construction, 36  
 conduits, 741  
 corrosion-resistant, 294  
 dampers, 240  
 deck base, 542  
 decks  
 concrete-topped, 36  
 floor, 273, 276  
 roof, 275  
 in tilt-up wall building, 22  
 doors and doorframes, 470-471  
 fasteners, 162, 254  
 finishes, 262  
 flashings, 450  
 flats, 285  
 fitch plates, 327  
 forms, 188  
 framing, 223, 272, 470-471  
 bridging, 331  
 cold-formed, 277-283  
 environmental impact, 837  
 fire-rated, 464  
 life-cycle chart, 839  
 in lightning protection, 747  
 lightweight, 16, 280  
 with masonry wall, 223  
 in metal building systems, 26  
 seismic-resistant, 39-40, 42-46  
 stone on, 253, 256  
 stone panels on, 251-252  
 for stone stairs, 537  
 stone veneer on, 253, 256  
 systems, 270-271



- Steel, continued  
galvanized, 262  
goveital slots, 213  
flashing, 438, 450  
gauge and use, 601  
gutters, 460  
gauges and weights, 293, 601  
graders, framing, 331  
gratings and treads, 290  
gutters, 450  
horizontal, 225  
hot-rolled, 294  
hybrid, 36  
insulated deck frame, 419  
joists, 13, 36, 188, 229, 277, 360, 518  
allowable spans, 277-278  
details, 281  
diaphragm connection for, 44  
floor, 229  
lath and plaster, 518-519  
long span, 273-274  
open web, 273  
leaning pipes and posts, 166  
library shelving, 622  
life cycle, 834, 839  
lintels, 217, 327  
lockers, 576  
open web truss, 365  
ornamental details, 291  
pans, 12, 287  
for perforating applications, 294  
piles, 146  
pipes, 286, 328, 681  
plate bearing shoe, 351  
plates, 328  
compression, 341  
properties, 260  
reinforcement, 40, 174, 180, 233  
parapet wall, 230  
rolled shapes, 267-269  
sections, 267-269, 284-285  
shapes, 267-269, 284  
sheeting, 145  
shelf angles, stone panels, 251  
space frames, 272  
stainless. *See* Stainless steel  
stairs, 287  
with stone veneer, 248, 254  
straps, square columns, 185  
structural, counterflashing, 431  
structural tube, 271  
studs, 231, 251-252, 277, 279-281  
environmental impact, 837  
subtreads, 12  
trash receptacles, 167  
trusses, 15, 36  
tubing, 286  
weights for buildings, 261  
window frames, 491, 493  
windows, 853  
casement, 495  
wire  
ash urns, 167  
coated, 870
- Steel Joist Institute (SJI), technical digest, 274
- Steps  
built-in, with grab rails, 785  
concrete, 195  
footings, 193  
lights for, 59  
masonry, 175  
stone, 249, 537  
swimming pool, 783
- Stiffeners, web, 370
- Stiles  
door, 506  
edge profiles, 472  
wood door, 962  
wood paneling, 386
- Stirrups, reinforced brick masonry, 233
- Stone, 247-258, 534. *See also* Masonry  
anchorage, 248, 251, 255-256, 535, 537  
arches, 234, 258, 859  
ashlar, 158, 248  
balustrades, 249  
bank, as retaining wall, 171  
bases, rusticated, 846  
bedding methods, 848  
cast, 167, 174  
classification, 247  
columns, 248  
continuous coping, 252  
coping, 174, 176, 249, 252-255  
cornices, 249, 251  
curbs, 249  
cut, 255-256, 535, 537  
windowsills, 846  
details, 257  
window surrounds, 250  
wastage system reservoir, 150  
expansion, 247  
facing, 534-535  
fining, 160  
finishes, 257, 535, 537, 848  
flooring, 536, 537  
footings, 859  
garden walls, 174  
bridges, 176  
historic building preservation, 846  
interior details, 525  
ledge, flashing, 432  
log sill, 250  
masonry patterns, 246  
panels, 251-252  
preassembled, 256  
parapets, 249, 255  
pavers, 157  
properties, 247  
quoins, 249  
repairs, 848  
ramp, 170, 351  
rubble, 248  
saddles, 537  
shop-bonded, 256  
soffit, 535  
spandrel, 252  
stairs, 12, 249, 537  
thresholds, 537  
tiles and pavers, 536  
treads, 12, 537  
types, for freestanding walls and hedges, 176  
uses and properties, 247  
veneer, 248, 253-255  
wall panels, common sizes for interior use, 534  
walls, 258  
freestanding, 176  
water absorption, 247  
weatherproofing tolerances, 253  
weights, 1006  
windowsills, 255, 493-495, 537, 846  
window surrounds in, 250
- Stoops, 391, 617, 880  
drafting, 639
- Stoop, 94
- Stops, 392, 467  
door, 503-504, 508  
gravel, 419, 461-462  
of lock, 503  
wine cellars, 600
- Storage  
arrangement types, distribution facilities, 447  
for cooling energy, 814  
for distribution facilities, 945  
in early learning centers, 621  
hot water tanks, 700  
kitchen layout, accessible, 867, 976  
overflow, 640  
of pallets, 946  
planning, 871-875  
remote ene. gy, 813  
thermal, 817, 819, 820, 822  
wine cellars, 600
- Storage facilities, 948
- Storage ponds, 153
- Storage tanks, steel, coating systems for, 561
- Storefronts, 94, 482-485. *See also* Shops  
all-glass, 482  
awnings, 828  
canopies, 482  
design, 482-483  
environmental factors, 487  
historic, 857  
revolving doors, 484  
sliding, 485
- Stormwater  
drainage systems, 690-691  
pipe sizing, 684  
wetlands, 153-155
- Stoves, 570  
accessible, 976  
masonry, 237  
metal solid-fuel heaters, 571-572  
residential, 610
- Strainer, roof drain, 425
- Strand designation code, 202
- Straps  
hurricane, 458  
ridge uplift, 334  
ties, 319
- Straw bale construction system, 841
- Stream bank stabilizer, 170
- Streets, 95-97  
design parameters, 106  
driveways and roadways, 107  
finishings, 109, 166, 167  
guidelines for traditional neighborhood design, 99  
lighting, 59  
patterns, 87  
tree planting and, 181
- Strength rates, for concrete, 189
- Stress  
in bending, 306-307  
ranges, structural glulam timber, 373
- Strike, 504  
electric, 503
- Stringers, stairs, 287, 387
- Strips  
rustication, 186  
thin-set terrazzo, 538  
wood floor installation, 544
- Strongback, 368
- Structural building panels, 339-340
- Structural calculations, 1008-1010  
formula nomenclature, 1008
- Structural elements, composite, 36
- Structural Engineers Association of California, 37
- Structural member, through roof, 419
- Structural systems  
air-supported, 644  
composite, elements, 36  
design, 13-27  
flat plate concrete, 18  
flying form, 21  
frame construction with cold roof, 809  
historic, 858-859  
laminated wood post and beam, 23  
lightweight mobile modular, 24  
lightweight steel frame and brick veneer, 16  
long-span, 35, 203, 644  
metal, 26, 266-272  
post-tensioned concrete, 19  
precast concrete frame, 20  
preengineered metal, 658-659  
preservation, 858-859  
space frames, 25, 272  
staggered steel truss, 15  
steel bar joist with bearing wall, 13  
steel frame with access floor and curtain, 14  
tension fabric structures, 27  
tilt-up wall, 22  
wood roof truss and wood floor truss, 17
- Struts  
eave, 270  
supports, 287
- Stucco  
half timber, 337  
historic building preservation, 846
- Studio theaters, stage lighting, 921
- Studs  
lap, 325  
metal, 520, 569  
metal framing, 280  
shear, 36, 275  
spacing, 520  
steel, 231, 251-252, 277, 279-281  
ties, 319  
wall, 188  
Western or platform framing, 323  
wood  
exterior system, 345  
infill stud system, 345  
wood framing, 332
- Study carrels, 619, 622
- Subcasing, definition, 467
- Subdivisions, 88  
residential, 86  
security strategies for, 78
- Subfloors  
APA panel, 359  
nailing schedule, 359  
plywood, 328, 332, 359  
for wood and resilient flooring, 543-544
- Subsidence, seismic design, 38
- Substrates  
concrete decks, 401  
conditions, paints and coatings, 558  
waterproofing, 399-400
- Subsurface  
drainage and filtration, 148  
investigation, 144
- Subtreads, steel, 12
- Sump pans, metal roof deck, 275
- Sump pumps, 685, 692-693
- Sun  
altitude, 800, 803, 804  
angles, 800  
control, 799-800, 826-828  
shades, 826, 828  
time, 802
- Sunscreens, 253
- Sunspaces, 519
- Superposition, 1014
- Superwindow, 486
- Supply air boot, 726
- Supply demand curve, for plumbing fixture units, 701
- Support systems, metal, 521-523
- Surface  
area and volume, 995, 1000, 1002  
ceiling, special, 539-540  
concrete, 198-199, 208, 561  
curved, geometry, 1002  
drainage, 149-152  
films, 403  
light-reflective, 814  
playing, 788, 772-773  
preparation for coatings, 561  
roof walking, 456  
tennis court, 772  
walls, special, 551
- Surfacing, 156-158
- Surfing, 118
- Surgical rooms, 886
- Surgicenters, 901
- Surveillance, 66-68, 73  
systems, 65, 589-590
- Suspension, timber bridges, 350
- Sustainable materials, 840
- Sweedish masonry heater, 237
- Swimming pools, 781-788  
bulkheads, 783, 785  
coatings, 262  
competition, 783-784  
dimensions, 783-784  
construction, 781  
diving boards, dimensions, 782, 786  
diving towers, 787  
endwalls, 783  
endwall targets, 783, 785  
gutters, 788  
heaters, 781  
ladders, 783, 785  
lane markings, 783  
layouts, alternate, 784  
lighting, 783  
lockers and shower rooms, 882-883  
movable bulkheads, 783  
movable floors, 785  
perimeter overflows, 785  
public, 782-783, 788  
dimensions for, 782  
pumps, 781  
residential, 781  
shapes, 781-782  
skimmer, 788  
starting platforms, 783, 785  
steps, 783  
trim, 531  
water treatment, 781
- Switch symbols, 981-982
- Symbols, 574  
of accessibility, 574  
air conditioning and heating, 984  
common, 574  
electrical, 981-982  
graphic, 978-985  
lighting, 982  
plumbing and piping, 983  
power and refrigeration, 984  
readability, 583  
telecommunications, 985  
welds, 265
- Synagogues, 905
- System International d'Unites (SI), units, 1019-1022
- Tavernacles, 636
- Tables  
accessible, 970  
audiovisual facilities, 620  
billiards, 780  
classic, 627-631  
coffee, 6  
conference, 6, 630-632, 632  
contemporary, 632-634  
dining, 628, 630-632  
folding, 593, 616, 619  
food service, 602-603, 605-606  
low, 617  
mailrooms, 878  
occasional, 6, 617  
open classroom furniture, 620  
outdoor, 618  
for restaurants/bars, 880, 881  
school, 619  
side, 617  
snooker, 780  
stacking, 616

- Table sports, 780  
 table dimensions for, 780  
 Table tennis, 780  
 Tableware, storage, 871  
 Tack rooms, 929-930  
 Tampon dispenser unit, mounting height, 703  
 Tanks  
   gravity, 100  
   gravity flush, 694  
   hot water storage, 700  
   pressure-assisted flush, 694  
   solar, 700  
   storage, steel, coating systems for, 561  
   water, 680, 689, 700  
     capacities, 147  
     piping for, 689  
 Target shooting, 794  
 T-bar diffuser, 729  
 Team handball, 767  
 Tearooms, seating capacities, 881  
 Tees  
   ceiling support system, 540  
   metal, 271, 284  
   structural, 269  
 Telecommunications  
   cabling distribution, 758  
   symbols, 985  
 Teleconferencing, 595, 877  
 Telephones  
   accessible, 967  
   cables, 743-744  
 Tellers, 589-590  
 ballistic/forced entry windows, 481  
 Temperatures  
   air-sol, 832  
   deep-ground, maps, 797  
   dew-point, 796  
   dry-bulb, 796  
   high sol-air, 811  
   two-pipe systems, 714, 725  
   winter designs and averages, 798  
 Templates, mortise, 506  
 Tendons, steel reinforcing, stretching, 190  
 Tennis courts, 772-773  
   indoor visibility, 773  
   layout, 772  
   outdoor, 772-773  
 Tennis net, 773  
 Tennis, paddle and platform, 779  
 Tensile structures, 657  
 Tension fabric structures, 27  
 Terminal boxes, dimensions, 729  
 Terminal reheat system, 726, 735  
 Termite protection, 314  
   shields, 335, 340, 432  
 Terracing, 170-171  
 Terra-cotta, 243  
   brownstone, 243  
   finishes, 848  
   historic building preservation, 846  
   coping, for garden walls, 174  
   planters, 167  
 Terrazzo, 538  
 Territorial reinforcement, 73  
   for commercial property, 73  
   for subdivisions, 78  
 Terrorism, security site planning for, 79-80  
 Tetrahedron, 272, 1003  
   truncated, 1003  
 Theaters  
   acoustical design, performance spaces, 69  
   design criteria, 916-917  
   plumbing fixture counts for, 703  
   reverberation time, 69  
   in shopping malls, 924  
   sightlines, 918  
   stage lighting systems, 920-921  
 Thermal construction, 815  
 Thermal detectors, 75  
 Thermal expansion, of area, length, and volume, 1005  
 Thermal insulation, 403, 830  
 Thermal mass  
   climate data, 796  
   hot arid conditions, 811  
   masonry, 814, 820  
   time delay, 811  
   utilization, 814  
 Thermal performance, time lag, 811  
 Thermal protection, 402-403  
   masonry, 221  
   symbol for, 978  
 Thermal resistance values  
   of building materials, 829-830  
   of glazing materials, 830-831  
 Thermal storage, 817  
   mass, 820  
   walls, 819-822  
 Thermal transmission, 818, 829-832  
   cold regions building design, 809  
   hot arid region building envelope, 811  
 Thermopiles, 808  
 Thermosiphons, 819  
 Thoroughfares, 96, 98  
   types, 97  
 Thresholds, 467  
   assembled and cast, 509  
   ceramic tile, 532  
   exterior, weather stripping, 510  
   interior metal, 509  
   interlocking, 510  
   latch track, 510  
 Throwing circle, construction, 771  
 Ticket counters, 899  
 Tiebacks, 145, 207  
 Tie holes  
   exposed, 184  
   treatment, 200  
 Tie rods, accessories, 188  
 Ties, 230  
   collar, 283, 343-344  
   concrete formwork, 188  
   floor, 319  
   between floors, 334  
   hurricane, 334  
   masonry, 213, 225, 230  
   metal, 237  
   pintel, 230  
   rafter, 319  
   reinforced brick masonry, 233  
   stone wall, 248  
   strap, 319  
   stud, 319  
   wall, 188, 213  
     metal, 217  
     wire, selection, 519  
   Z-type, 213, 226, 230  
 Tiles, 531-533  
   acoustical, 296, 540, 552-553, 555  
   barrel, 458  
   carpet, 548  
   cement wood, 411  
   ceramic, installation, 532-533  
   clay  
     channels, 150  
     roofs, 412, 852  
     structural, 242  
   composite, 411  
   concrete, 410  
   cork, 546  
   fiber cement, 411  
   flat, 410  
   floor, 533, 546  
   floor framing for, 332  
   metal, 411  
   placement, 410  
   ready-set, 531  
   roll, 410  
   roof, 410-411, 458, 852  
     counterflashings at, 431  
     rubber, 546  
     shower receptors, 532  
   stone, 536  
   S type, high wind resistance detail, 458  
   types, shapes, and sizes, 531  
   vinyl composition, 546  
   walls  
     glazed, 531  
     hollow, 859  
 Tilt-up concrete, 208  
 Tilt-up wall, 22  
 Timber  
   bridges, 350-351  
   construction, heavy, 350-351  
   frame construction, 343-346  
   glulam, 373-374  
   half, 337  
   heavy, 341-351, 388  
   lagging, 145, 398  
   piles, 146  
   sill and joist system, 345  
   site-formed pavers, 157  
   Southern Pine preservative retentions and AWPAs standards, 315  
   walls, 171  
 Time  
   in architectural programming, 130  
   zones, 802  
 Tin  
   melting temperature, 261  
   pressed, 851  
   properties, 260  
 TL. See Transmission loss  
 TND. See Traditional Neighborhood Development  
 T.O.D. (Transit-oriented design), 87  
 Toe clearances, wheelchair, 956  
 Toilet paper holder, mounting height, 703  
 Toilets, 694. See also Water closets  
   accessible, 565, 971-972  
   accessories for, 564  
   compartments, 971  
   grab bars, 971  
   mounting height, 703  
   museum, 892  
   paper holders, 564  
   planning, 882-883  
   wet area, 882  
   wheelchair for, 968  
 Tooled finish, stone, 257  
 Tooth chisel finish, stone, 257  
 Touch bar, 508  
 Touch football, 763  
 Towels  
   bars, 564  
   dispensers, mounting height, 703  
   racks, for handicapped, 971  
 Townhouses, 935  
 Town planning  
   block types, 89  
   building types, 92  
   environmental site analysis, 83-85  
   frontage types, 94  
   landscape types, 95  
   open space types, 90-91  
   plan types, 88  
   process, 82  
   regional types, 87  
   spatial definition, 93  
   thoroughfares, 96-97  
   traditional neighborhood development, 98-99  
 Track  
   construction, 768  
   layout, 770  
 Track and field, 770-771  
 Track splice, 282  
 Traditional neighborhood development (TND), 86-87, 98-99  
   guidelines for, 99  
 Traffic control, 112  
   mechanical barriers, 163-164  
 Traffic survey, in commercial site development, 81  
 Trailers  
   dimensions, 103  
   facility design for, 115  
   turning radii, 105, 115  
 Transformers, 749  
 Transit-oriented design (T.O.D.), 87  
 Transmission loss (TL), 66  
 Transmission rates, water vapor, 405  
 Transmittance, 486  
   visible, 486  
 Transom, 338, 467  
   storefront, 483  
 Transportation, 103-104, 115-117  
   accessible passenger loading, 960  
   airports, 896-899  
 Trap pit, 691  
 Traprock, physical properties, 247  
 Traps, plumbing, 682, 686, 691, 694, 704  
 Trash compactors, 599, 609  
   accessible, 976  
 Trash containers, 167, 564, 599, 874  
 Trash trucks, 115  
   turning dimensions, 105  
 Travel distances, lifts, 965  
 Treads, 12  
   accessible stairs, 12  
   coverings, 12  
   fire escapes, 289  
   ladders, 288  
   metal, 290  
   proportioning, 9-10  
   replacement, 12  
   slip-resistant, 195  
   spiral stairs, 11  
   stair framing, 328  
   steel, 287  
   stone, 12, 537  
   wood decks, 354  
   wood stairs, 387-388  
 Tree guards, 182  
 Trees  
   construction around, 179  
   environmental effects, 177  
   as fencing, 160  
   growing characteristics, 180  
   interior landscaping, 641-642  
   planting, 178-179  
   in urban areas, 180-182  
   protection, 166, 179, 182  
   root ball sizes for, 178  
 Trellis, wood, 169  
 Trench drains, 151-152  
 Trench duct, electrical, 276  
 Trenches, header ducts, 743  
 Trigonometric functions, 997-998, 1005  
 Trim  
   door and base, 391, 862  
   exterior, environmental impact, 837  
   gypsum wallboard, 523  
   stone, 250  
   tile, 531  
   wood, 862  
     interior, 391-392  
 Triple jump, construction, 771  
 Troffers, 51, 55  
   air supply/lighting, 729  
   in classroom, 57  
 Trowels  
   notched, 317  
   slip-resistant, 12  
 Trucks, 103-104, 115  
   dimensions, 103  
   docks, 116  
   turning radii, 105, 115  
 Truncated polyhedra  
   cube, 1004  
   dodecahedron, 1004  
   icosahedron, 1004  
   octahedron, 1004  
   tetrahedron, 1003  
 Trusses, 15, 17, 350  
   anchors, 319  
   bowstring, 362, 367  
   cantilever, 365-366  
   clerestory, 366  
   double fink, 366  
   dual-pitch, 367  
   exterior lightweight wood system, 345  
   fink, 366  
   flat, 363  
   floor, 17, 365, 367-368  
   forms, in flying form building, 21  
   gypsum wallboard, 527  
   Howe, 366  
   jack, 369  
   metal building frame, 658  
   monopitch, 367  
   monoplaner, 364  
   open web, 365  
   panels, 204  
   parallel chord, 367  
   pitched, 361-362, 366-367  
   plywood web, 365  
   prefabricated, 17, 364  
   roof, 283, 319, 367, 369  
   scissors, 361, 367  
   space frames, 272  
   split-ring, 361-363  
   steel, 15, 36  
   step-down system, 369  
   triple W, 366  
   vaulted ceiling, 367  
   wood, 36, 361-372  
     exterior lightweight system, 345  
 TTys, accessible communication, 967  
 Tubing  
   aluminum, 285  
   compressed flexible, 426  
   copper, 285, 681  
   electrical, 741  
   flexible, 423  
   framed systems, 271  
   metal, 285, 741  
 Tudor glulam timber, 373  
 Turbine pump, 159, 689  
 Turf, natural and synthetic, 768  
 Turnbuckles, 322, 347  
 Turning radius, 106, 108  
   cars, 105  
   trucks and trailers, 105, 115  
   vehicles, 105  
   wheelchair, 956  
 Turns, in accessible routes, 958  
 Tuscan order, 1011  
 U-factor, 486  
 UFAS (Uniform Federal Accessibility Standards), 952, 974  
 Ultrasonic detectors, 75  
 Ultraviolet reduction rates, 485  
 Umbrella racks, 879  
 Umbrellas, outdoor furniture, 618  
 Underheating, design conditions for, 810  
 Underlayment  
   carpet, 548  
   low slope roofs, 408  
   nailing schedule, 359  
   plywood panel sheathing, 356  
 Underwriters Laboratories (UL), 274  
   fire-rated openings, 464  
   metal chimney system, 238

- Underwriters Laboratories (UL), continued  
 performance vaults, 589  
 rated fireproofed columns, 286  
 Uneven bars, gymnastics, 777  
 Uniform Building Code (UBC)  
 fire protection criteria, 464  
 occupant loads, 8  
 seismic requirements, 37  
 stairway requirements, 10  
 Uniform Federal Accessibility Standards (UFAS), 952  
 Uninterruptible power supply (UPS) systems, 745  
 diagrams, 745  
 Unisex toilet/bathing rooms, 971  
 U.S. Handball Association, 775  
 U.S. Postal Service (USPS), 878  
 U.S. Racquetball Association, 775  
 U.S. Soccer Federation, 765  
 Unit heaters/chillers, 708  
 combustion air  
 gooseneck, 707  
 louver, 707  
 gas-fired, 707  
 through-wall unit, 707  
 Unit load, 947  
 Unit masonry, 218-243. *See* Concrete masonry units  
 brick veneer, 231-232  
 cavity walls, 228-230  
 ceramic veneer, 243  
 clay, 219  
 corner layout, 218  
 flooring, 156-158, 542  
 foundation walls, 221-222  
 glass, 244-246  
 multiwythe walls, 226-227  
 single wythe walls, 223-225  
 terra-cotta veneer, 243  
 Unit pavers, 156-158  
 assembly types, 156  
 details, 157-158  
 patterns, 158  
 shapes, 156  
 sizes, 156  
 Universal Parking Design guidelines, 961  
 Unstable sites, site design for, 38  
 Upflow condensing furnace, 724  
 UPS (uninterruptible power supply) systems, 745  
 diagrams, 745  
 Urban areas, tree planting in, 180-182  
 Urban best management practices, for runoff control, 153  
 Urban design, 82, 86-99  
 Urbanism, elements, 86  
 Urban planning, 81-100  
 contextual analysis, 83  
 site analysis, 83  
 Urgicenters, 901  
 Urinals, 694  
 accessible, 971-972  
 mounting height, 703  
 operating pressures for, 701  
 pipe sizes for, 682  
 pipe space requirements for, 702  
 USA Gymnastics, 777  
 USA Track and Field (USAT&F), track specifications, 770  
 US Diving, 783  
 diving standards, 786-787  
 US Swimming, 783-784  
 Utensils, kitchen, 872-874  
 Utilities  
 in cold climates, 808  
 for commercial property, 81  
 connection boxes, 609  
 tables, 620  
 Vacuum cleaners, 873  
 Valleys  
 flashings, 444  
 roofing, 435  
 shingles, 408  
 Valves  
 ball, 687  
 butterfly, 687  
 check, 687  
 curb, 679  
 gate, 687  
 dimensions, 687  
 globe, 687  
 plug, 687  
 post indicator, 680  
 pressure loss in, 701  
 pressure-reducing, 689  
 types, 687  
 Vane diffuser, 729  
 Vanities, accessible, 974  
 Vans, 103-104  
 accessible parking spaces for, 961  
 dimensions, 103, 108  
 lift and ramp-equipped, 969  
 turning radius, 103  
 Vapor  
 barriers, sheathing materials, 358  
 retarder, 405  
 flexible, 418-419  
 polyethylene, 810  
 transmission, 405  
 water, permeance and permeability of materials to, 405  
 Vapor barrier, 402  
 and coating, 713  
 in fabric structures, 27  
 in flying form building, 21  
 in laminated wood building, 23  
 in lightweight mobile modular building, 24  
 in metal building systems, 26  
 in space frame building, 25  
 Variable air volume (VAV) ductwork system, 735  
 Vaulting equipment, gymnastics, 777  
 Vaults, 588  
 Vehicles, 103-104  
 adapted for wheelchair/scooter users, 969  
 automatic guided, 673  
 automobiles, 103, 109, 112, 961  
 circulation, design parameters, 106  
 clearances, 108  
 design parameters, 106  
 dimensions, 103-104, 112, 115, 673  
 forklifts, 673  
 height, 108  
 oversnow, 793  
 turning radius, 105, 115  
 Vending machines and rooms, 594  
 Veneer  
 brick, 16, 231-232, 335-336  
 in space frame building, 25  
 ceramic, 243  
 on concrete, 208, 232  
 concrete masonry backup, 253  
 grades, plywood, 355  
 masonry, 16  
 flashings, 446  
 masonry anchors, 213  
 plywood panels, 357  
 on steel frame, 253  
 stone, 247-248, 253-256  
 hanging systems, 535  
 walls, 217, 248  
 wood, 393-395  
 cope, 393  
 marble cutting, 534  
 matching patterns, 394-395  
 plain sliced, 393  
 quarter sliced, 393  
 rift sliced (rift cut), 393  
 rotary cut, 393  
 Venetian blinds, 601  
 Ventilation/vents  
 air distribution, 726-733  
 attics, 335, 451  
 building panels, structural, 340  
 cavity walls, 841  
 climate data, 796  
 cold storage rooms, 645  
 crawl space, 335, 395, 451  
 curb, with polyurethane foam, 428  
 eave, 335, 451  
 fire and smoke, 499, 502  
 flashings, 426, 443  
 gravity  
 gooseneck, 455  
 stationary, 455  
 greenhouses, 642, 931  
 heat recovery, 836  
 hot and conditions, 811  
 HVAC systems, 730-732  
 kennels and animal shelters, 928  
 losses, 811-812  
 in masonry walls, 212  
 metal solid-fuel heater, 572  
 moisture protection, 405  
 natural, 807  
 piping, 692  
 plumbing stack, 425  
 range hoods, 610  
 residential, 238  
 ridge, 340, 451  
 roof, 335, 360, 451, 455, 691, 852  
 rotating, 455  
 sauna, 647  
 screened, 360  
 shed roof, at wall, 451  
 size and length, 686  
 sloped roof, 455  
 soffit, 335, 810  
 space, 812  
 stable, 930  
 stacks, 425, 693, 709  
 strategies, 807  
 systems, 690-691  
 units, 708  
 wall cavity, 841  
 Vermiculite, 516  
 Vertical conductors, size, 684  
 Vesica Piscis, 994  
 Veterinary hospitals, 926-927  
 Vibration, 273  
 control, 68, 653  
 detectors, 75  
 Videoconference equipment, 595-596  
 Video security system, 75  
 Villages, 86  
 garden city, 87  
 rural, 85  
 Vinyl  
 composition tile, 546  
 insert threshold, 510  
 nosings, 12  
 rails, 295  
 wall coverings, 549  
 window frames, 491  
 Vitreous tile, 531  
 V-notches, 349  
 Volleyball, 769, 779  
 Voltage distribution, 748  
 Volumes  
 calculation, 1007  
 of solids, 995, 1000  
 thermal expansion, 1005  
 Volume/seat ratios, 69  
 Volutes, 1013  
 Waffle slab, 197  
 Wainscots, 386  
 Walers  
 channels, 145  
 wall, 188  
 Walking surfaces, accessible, 958  
 Walkways  
 accessible, 354  
 covered, 828  
 lighting, 60  
 moving, 672  
 roof, 456  
 surfaces, 456  
 traditional neighborhood design, 98  
 wood pallet-type, 456  
 Wallboards, gypsum. *See* Gypsum board  
 Wall coverings, 549-550  
 acoustical wall treatment, 552  
 panels, fiber-reinforced, plastic-coated, 551  
 Walls  
 access doors in, 480  
 acoustical treatment, 554  
 anchorage, 213, 217, 224, 227, 229, 232, 248  
 details, 226, 325, 428  
 areaway, 193  
 back, single-pitch, detail at top, 501  
 basement, 221, 324  
 bearing, 13, 16, 371  
 bonded veneered, 248  
 bowlock-bak, 858  
 brackets, 295  
 brick, 174-175, 217, 233, 858  
 recess and sill details, 226  
 reinforced load-bearing, 225  
 brick veneer, 335  
 bridging, 280, 332  
 bullet-resistant, 529, 650  
 cabinets, 382-384  
 canted, with light cove, 530  
 cavity, 213, 216-217, 242, 529  
 brick, 228, 230, 858  
 CMU, 228  
 concrete inserts in, 206  
 masonry, 228-230  
 through-wall flashing at, 429  
 veneered, 248  
 ventilated, 841  
 ceramic tile, 532  
 circular, masonry, 218  
 combustible, clearances from, 238  
 comparative assemblies, 32-33  
 concrete, 172-173, 184, 186, 204-205, 208  
 single pitch side wall detail, 501  
 concrete formwork, 186  
 concrete masonry unit, 173-174, 223, 225, 228  
 electrical outlet box in, 223  
 control joint, 529  
 for convertible courts, 775  
 corners, 332, 334  
 counterflashing, 431  
 coverings, 549, 551-552  
 crawl space, 321  
 curtain, 233, 256, 262, 414, 822, 830  
 brick, 233  
 diffusive treatment, 551  
 energy-efficient, 810  
 exterior, 323, 342  
 assemblies, 32-33, 445  
 floor framing at, 281  
 furring, 529  
 intersection, 529  
 masonry, 846  
 watertables, 445  
 feature, with light cove, 530  
 fences on, 164  
 fireproof, 217, 441  
 fire-rated, pipe sleeve in, 688  
 flashings, 217, 429, 439-441, 444, 446, 449  
 floor-to-bearing connections, 206  
 foam-core panel system, 345-346  
 footings, 184-185  
 foundation, 221-222  
 sections, 335  
 foundation connections, 206  
 framing, 223, 332, 347  
 gable end, 457  
 garden, 171-176  
 glass, 32-33  
 elevator, 669  
 guards, 567-569  
 heaters, 708  
 heat transmission, 822  
 hollow, 227, 233, 859  
 grouted, 227  
 tile, 859  
 horizontal nailer system, 345  
 hydrants, 679  
 pipe sizes for, 682  
 interior  
 foundation for, 222  
 paneling details, 386  
 intersections, 334, 348  
 knee, 324  
 lathing and plaster systems, 520  
 lighting, office, 55  
 liquid-applied membranes, 401  
 masonry, 212, 216-218, 223, 225, 230, 233  
 details, 258  
 door frame in, 468  
 exterior sections, 846  
 nailing blocks for, 212  
 plugs for, 212  
 reinforcing for seismic areas, 43  
 single-pitch back wall detail at top, 501  
 window in, 493  
 massive, 811  
 mass, thermal storage, 819, 822  
 modular systems, 586  
 moldings, standard, 540  
 multiwythe, 226-227  
 non-loadbearing, 222-223  
 operable, 585  
 panels, 345, 534, 659  
 details, 386  
 gypsum, prefinished, 529  
 interior, 551  
 precast concrete, 204-205, 243  
 reinforcement, 174, 233, 244  
 parapet, 230, 414  
 scupper detail at, 454, 461-462  
 pilasters, concrete, 186  
 pipe penetration at, 398  
 plugs, for masonry walls, 212  
 purlins, 343  
 radial, 218  
 rake, 333  
 retaining, 170-176, 233  
 as fencing, 160  
 for security, 163  
 sandwich, 204  
 section at storefront, 483  
 security, 529  
 service, 565-566  
 shaft, 526  
 shear, 38, 326  
 seismic design for, 40  
 support, 255  
 sheathing, 358  
 shoes, 186  
 side, single-pitch, detail, 501  
 single wythe, 223-225  
 CMU, 225  
 sinks, 696  
 solid veneered, 248

- and sound isolation, 67  
 sound resistance, 33, 653  
 of squash court, 776  
 stone, 258  
   cut and veneer, 255-256, 535  
   freestanding, 176  
   installation details, 248  
 structural facing tile, 242  
 studs, 188  
 surfaces, special, 551  
 thermal storage, 819-822  
 ties, 188, 213, 217  
 tile  
   ceramic, 532  
   glazed, 531  
   hollow, 859  
 tilt-up, 184  
 Trombe, 821  
 veneer, 217, 248  
 walers, 188  
 water, passive solar, 819-822  
 water-resistant, 529  
 watertables, 445  
 window, 251, 486  
 windowless, 252  
 wood frame, 335  
 Wardrobe units, bedroom, 626  
 Warehouses  
   lighting for, 58  
   plan, 945  
 Warren truss, 363  
 Washers, 609  
   laundry rooms, 593, 868  
   pipe sizes for, 682  
   residential, 609  
   water temperature requirements, 699  
 Waste drainage systems, 691  
 Waste heat recovery, 715, 817  
 Waste management, 833  
   chutes, 676  
   collection and recycling spaces, 942-944  
   compactors, 599, 609, 976  
   receptacles, 167, 564, 599, 874  
   mounting height, 703  
 Waste room plan, 944  
 Water agitation system, for diving pools, 787  
 Water-based fire suppression systems, 663  
 Waterbeds, 626  
 Water-cement ratios, 194  
 Water chillers, 725. *See also* Chilled water systems  
   dual condenser, 715  
 Water closets, 694, 865. *See also* Toilets  
   accessible, 972, 974  
   for children, accessible, 957  
   clearances, 694  
   grab bar for, mounting height, 703  
   mounting types, 694  
   operating pressures for, 701  
   pipe sizes for, 682  
   pipe space requirements for, 702  
   supports for, 702  
   ultra-low-flow, 689  
 Water conservation, 840-841  
 Water coolers  
   electric, 698  
   mounting height, 703  
 Water distribution. *See* Water supply and distribution  
 Water heaters  
   circuits, 738  
   domestic, 699  
   annual use, 818  
   gas-fired, sidewall vented, 706  
   loop pumps, 715  
   radiators, 722  
   requirements, 699  
   seismic design, 41  
   smoke pipe, 238  
   solar, 823  
 Water lines, potable, sizing, 686  
 Water main, public, 692  
 Water meter, 679  
 Water pool, 789  
 Water pressure  
   adjustment, 689  
   calculation, 701  
 Waterproofing, 398-401  
   of foundations, 221, 398  
   membranes, 399-401, 424  
   at roof transitions, 456  
   under slab, 398  
   stone walls, 248  
 Water purification, 147  
 Water resistance  
   foundations, 398  
   under slabs, 399  
 Water ski jump, 789  
 Waterstops  
   for concrete slabs, 187  
   foundations, 398  
 Water supply and distribution, 679-680  
   building water and gas service, 679-680  
   domestic, 147  
   flush valve, 694  
   gravity flush tank, 694  
   to plumbing fixtures, 690  
   types, 694  
   pressure adjustments, 689  
   pressure-assisted flush tank, 694  
   pump capacities, 147  
   pumps, 887  
   riser diagrams, 692-693  
   system for, 690  
 Water supply systems, 685  
   domestic, 147  
   graywater, 841  
   piping for, 653, 685, 692  
   sizing, 701  
 Watertables, 219, 335, 445, 858  
 Water tanks, 680, 689, 700  
   capacities, 147  
 Watertight doors, 511  
 Water treatment, for residential swimming pools, 781  
 Water vapor  
   migration, 405, 558  
   penetration, 558  
   permeance and permeability of materials to, 384, 405  
 Water walls, passive solar, 819-822  
 Wattages  
   lamps, 752-753  
   residential electrical devices, 738  
 Wearing courses, waterproofing, 399  
 Weatherability, of brick joints, 211  
 Weatherboard, historic preservation, 849  
 Weathering indexes, in U.S., 219  
 Weatherproofing  
   doors, 469  
   stone tolerances, 253  
   windows, 467  
 Weather stripping  
   exterior thresholds, 510  
   retrofitting, 853-854  
   windows, 510  
 Weather, winter data and design conditions, 798  
 Weep holes, 212  
   brick masonry, 233  
   cavity walls, 230  
   retaining walls, 172-173  
   spandrel flashings, 447  
   stone panels, 252  
   stone veneer joints, 254  
 Weight lifting, 778  
 Weights, of materials, 1006  
 Welds, 260-262  
   fillet, 264-265  
   flange, 264  
   groove, 264-265  
   joint prequalification, 264  
   pipe joints, 683  
   plug, 264-265  
   precast concrete, 206-207  
   slot, 264-265  
   stairs, 287  
   structural, 264  
   symbols, 265  
   wire fabric, 189, 202  
 Wells, 147  
 Western framing, 323  
 Western Wood Products Association, 543  
 Wet bench (darkroom), 612  
 Wetlands  
   constructed, 153-155  
   natural, 153-154  
 Wheelchairs. *See also* Accessibility  
   accessible bathrooms, 865, 971  
   clearances, 880, 956  
   lifts, 963, 965  
   manual, 968  
   racing, 968  
   restaurant seating arrangements for persons using, 881  
   shower commode, 968  
   telephone access for, 967  
   vehicles adapted for, 969  
 Wheel loads, industrial floors, 194  
 Wheel stops, carports, 869  
 Whirlpool baths, 697  
 Winding channel, 150  
 Wind loads, metal buildings, 658  
 Window frames  
   aluminum, 491, 493  
   for decorative glass, 514  
   composite, 486  
   detail, 326  
   fiberglass, 491  
   hybrids, 491  
   installation details, 493-496  
   metal, 491, 495  
   seismic design for, 40  
   steel, 491  
   types, 491  
   vinyl, 491  
   wood, 491  
   wood with cladding, 491  
 Windows, 486-514  
   assembly  
     heat loss in, 487  
     moisture protection in, 467  
   awning, 492-493  
   installation, 493  
   ballistic, 481  
   bay, 329, 486  
   bullet-resistant, 650  
   casement, 492, 494  
   steel, 495  
   classical, 1015  
   condensation potential, 487  
   configurations, 486  
   for daylighting, 62  
   definitions, 486  
   dimensioning methods, 980  
   dormer, 486, 497  
   double-hung, 496, 853  
   dual action, 492  
   egress requirements, 465  
   environmental impact, 838  
   faceted stained glass, 514  
   fire-rated, 464-465  
   flashing, 432, 467, 493-494, 496  
   forced entry, 481  
   frames. *See* Window frames  
   gasketed, 414  
   glazing, 488-490  
   greenhouse, 492  
   hardware, 503-510  
   heads, 252  
   historic, 853-854  
   hopper, 492-493  
   jalousie, 492  
   manufactured units, 487, 489  
   in metal building systems, 26  
   mill, 854  
   openings, 279, 327, 467-468  
   operation types, 492  
   oriel, 486, 497  
   Palladian, 338  
   parts, 486  
   pivot, 492, 494  
   projected, 492-493  
   rehabilitation and replacement, 853  
   replacement, 854  
   reversible, 492  
   ribbon, 486  
   screens, 485  
   security, 466  
   selection, 487  
   sills, 252, 254, 337, 493-496  
     brick, 493, 496  
     stone, 253, 255, 493-495, 537, 846  
   size, ventilation, 807  
   sliding  
     horizontal, 492, 496  
     vertical, 492, 496  
   stained glass, 514  
   standards for, 487  
   steel  
     casement, 495  
     horizontal pivoted, 853  
     stone panel heads, 252  
     stone veneer, 253-254  
     storefront, 482  
     storm, 830, 854  
     super, 486  
     surrounds, stone, 250  
     technological improvements in, 487  
     transom, 338, 467  
     types, characteristics, 488  
     walls, 251, 486  
     hard stone panel at, 251  
   weatherproofing, 467  
   weatherstrips for, 510  
   well, 221  
   wood  
     double hung, 853  
     historic preservation, 854  
     wood and plastic, 853  
 Window seat, 486  
 Window wall, 486  
 Wind protection, trees and, 177  
 Wind resistance, high  
   detail for composition and asphalt shingles, 458  
   detail for extruded concrete, 458  
   detail for galvanized metal roofing, 458  
   detail for S-type tile roofing, 458  
 Windsurfing, 118  
 Wind uplifts, 458  
   design for roofing materials, 458  
   flashings, 439, 441  
 Wine storage cellars, 600  
 Wintergarden design, 816  
 Winter weather data, 798  
 Wire(s)  
   chases, 339  
   box beam sill, 346  
   surface-mounted at foam-core panel, 346  
   timber sill, 346  
   electrical, 738-744  
   diagrams, 740  
   environmental impact, 838  
   material, 741  
   fabric, welded, 189, 202  
   flat cable, 744  
   hangers, 522  
   management, 758  
   masonry ties, 213  
   reinforcing, 189-190  
   steel  
     ash urns, 167  
     coated, 870  
     strength, 201  
 Wire mesh  
   baseball backstop, 769  
   chain link fences, 161  
   gabions, 170  
   partitions, 584  
 Wire pulls, 384  
 Wiring symbols, 981  
 Witness stands, 884  
 Women, measurements, 2  
 Women's National Basketball Association (WNBA), court and ball dimensions, 774  
 Wood, 297-396  
   adhesives, 317-319  
   anchorage, 354  
   ash urns, 167  
   beam connections, 377  
   blinds, 396  
   bonding, 317  
   bridging, 331  
   burning fireplaces, 236  
   cabinets, 384  
   and cement tiles, 411  
   clips, 319  
   column footing, 326  
   columns  
     anchored with steel baseplate, 376  
     load tables, 305  
     tapered, 856  
   combustibility, 299  
   compression, 373  
   curbs, 498, 500-501  
   decay, 299  
   decay-resistant, 314, 386  
   decks, 168, 352-354  
   balcony, 282  
   design load tables, 300-313  
   deterioration, 849  
   doorframes, 468  
   doors, 384, 473-474, 862  
     hollow core, 473  
     sectional, 478  
     solid core, 473  
   eaves, 335  
   electrical wiring and, 739  
   exterior stairs, 354  
   fastenings, 317-322  
   fences, 160, 162  
   finish, 298, 387-388  
     environmental impact, 837  
   fire-retardant treated, 316  
   floors, 229, 543-546  
     installation details, 544  
     joist load tables, 300-304  
     materials and patterns, 543  
     prefinished, 544  
   resilient systems, 545  
   sports, 545  
   suspended, 325  
   form inserts, 199  
   foundations  
     system, 324  
     treated, 324-326  
   framing, 17, 335, 520  
   column load tables, 305  
   composite members, 36  
   decks, 353-354  
   design, 298-299  
   double layer resistant, 529

- Wood, continued  
 framing, continued  
 environmental impact, 837  
 exterior insulation and finish systems, 404  
 exterior stairs, 354  
 fabric-wrapped panels, 550  
 fireplace floors, 235  
 floor joist load tables, 300-304  
 leaded glass, 514  
 light, 335, 353-354  
 in lightweight mobile modular building, 24  
 mortise-and-tenon, 858  
 plywood subflooring on, 359  
 roof rafter load tables, 309-313  
 roofs, 335, 458  
 seismic design for, 45-46  
 single wythe masonry wall with, 223  
 stairs, 388  
 thin brick veneer on, 231  
 vertical frame curb detail, 501  
 window, 491  
 girders, 331  
 gutter box, 336  
 gutters, 852  
 handrails, 386-388  
 heavy timber construction, 341-351, 376-377  
 historic, 849-850  
 I-joists, 370-372  
 insect protection, 299, 386  
 interior details, 862  
 interior trim, 391  
 introduction to, 298-299  
 joinery, 343  
 joints, 299, 376, 380-382  
 joist base, 542  
 joists, 36, 306, 309-313, 327, 331, 364-365, 370-372, 544  
 connections, 365  
 diaphragm connection for, 44  
 floor, 326, 544  
 load tables, 300-304, 309  
 laminated  
 joists, 306-308, 327  
 post and beam, 23  
 landscape lights, 166  
 library shelving, 622  
 light  
 decks, 353-354  
 rafters and joists, 36, 300-304, 309-313  
 lintels, 327  
 marine applications, 120  
 materials, historic, 850  
 moisture movement in, 299  
 moldings, 391-392, 540, 862  
 mortise and tenon, 858  
 nailers, on roof purlins, 345  
 open web truss, 365  
 ornaments, 389-390  
 pallet-type walkways, 456  
 paneling, 386  
 paving, 157-158  
 pediment ledge flashing, 432  
 permeance and permeability to water vapor, 405  
 picture molding, 386  
 planters, 167-168  
 plate, beveled, 372  
 plywood composite, 36  
 prefabricated structural, 361, 364-365, 373-375  
 preservation, 314-315, 348, 849-850  
 pressure-treated, 314, 324  
 fences, 162  
 marine applications, 120  
 rafters, 309-313  
 load tables, 310-313  
 trussed, 36  
 rails, 295, 386  
 ramps, 354  
 retaining walls, 171  
 roof framing, 335, 458  
 roofing, 406  
 rough carpentry, 323-338  
 screens, 396  
 screws, 322  
 seismic-resistant details, 40, 45-46  
 shakes, 406-407, 917  
 sheathing, 355-360  
 shelving, 385  
 shingles, 406-407, 852  
 environmental impact, 837  
 shutters, 396  
 siding, 378, 850  
 eave at, 336  
 profiles and patterns, 850  
 sills, 331, 335  
 sleepers, 345  
 floor system, 325  
 sliding joints, 299  
 species, 373  
 stairs, 387-388, 862  
 as structural material, 298  
 studs, 345  
 brick veneer on, 231  
 symbol for, 978  
 tension, 373  
 trash receptacles, 167  
 treads, 290  
 treated, 347  
 treatments, 314-316  
 environmental impact, 838  
 trellis, 169  
 trim, 862  
 interior, 391-392  
 trusses, 36, 361-372  
 floor, 368  
 lightweight exterior system, 345  
 roof, 369  
 veneers, 393-395, 534, 549  
 matching patterns, 394-395  
 water tables, 445  
 window frames, 491  
 windows  
 double hung, 853  
 historic preservation, 854  
 Woodwork  
 architectural, 380-396  
 half timber, 337  
 interior wall paneling, 386  
 joints, 380-381  
 Palladian window and doorway, 338  
 shelving, 385  
 stairs, 387-388  
 Work centers, 620  
 Working drawings, dimensioning, 980  
 Workstations  
 accessible, 5, 970  
 anthropometric data, 4-5  
 design, 876  
 floor wiring for, 743-744  
 lighting, 50  
 light paths to, 61  
 Work triangles, kitchen layout, 866  
 World Squash Federation, 775  
 Wrestling, 778  
 W steel shapes, 267  
 Ts cut from, 269  
 X-ray components  
 application guidelines for, 655  
 cassette transfer box, 655  
 X-ray glass, 655  
 X-ray protection, 654  
 Xylophones, 592  
 Yield plan, environmental site analysis, 85  
 Zamboni ice resurfer, 791  
 Z-clip, 319  
 Zees, 284  
 Zinc  
 architectural, 851  
 coated steel, framing, 331  
 dovetail slots, 213  
 gauges and weights, 293  
 melting temperature, 261  
 properties, 260  
 roofs, 852  
 uses and properties, 260  
 Zirconium, melting temperature, 261  
 Z-lots, 934  
 Zone junction boxes, 743-744  
 Zoning  
 for commercial property, 81  
 interior, 811  
 town planning, 82  
 Z-ties, 213, 226, 230